

DEPARTMENT OF THE ARMY TECHNICAL MANUAL

DEPARTMENT OF THE AIR FORCE TECHNICAL ORDER

TM 11-685
TO 31R-1-9

FUNDAMENTALS OF
SINGLE-SIDEBAND
COMMUNICATION



DEPARTMENTS OF THE ARMY AND THE AIR FORCE

JANUARY 1961

TECHNICAL MANUAL }
 No. 11-685 }
 TECHNICAL ORDER }
 No. 31R-1-9 }

DEPARTMENTS OF THE ARMY
 AND THE AIR FORCE

WASHINGTON 25, D. C., 27 January 1961

FUNDAMENTALS OF SINGLE-SIDEBAND COMMUNICATION

	Paragraph	Page
CHAPTER 1. INTRODUCTION TO SINGLE-SIDEBAND COMMUNICATION		
Section I. General.....	1-6	2
II. Comparison of single-sideband with am. and fm systems.....	7-12	8
III. Nature of single-sideband signals.....	13-18	14
IV. Sideband filters.....	19-21	19
CHAPTER 2. SINGLE-SIDEBAND EXCITERS		
Section I. General.....	22-24	25
II. Sideband generator.....	25-30	27
III. Frequency translation.....	31-35	37
IV. Linear amplifiers.....	36, 37	44
CHAPTER 3. RF LINEAR-POWER AMPLIFIERS AND OUTPUT CIRCUITS		
Section I. Introduction.....	38-41	46
II. Power amplifier circuits.....	42-45	49
III. Linear-power amplifier tuning and loading.....	46, 47	54
CHAPTER 4. SINGLE-SIDEBAND RECEIVER		
Section I. Introduction.....	48-50	66
II. Stage-by-stage analysis.....	51-62	70
CHAPTER 5. FREQUENCY STANDARDS, FREQUENCY SYNTHESIS, AND STABILIZED MASTER OSCILLATOR		
Section I. Introduction.....	63, 64	90
II. Frequency controls.....	65-72	92
III. Frequency synthesis.....	73-76	98
IV. Stabilized master oscillator.....	77-85	102
CHAPTER 6. SSB SYSTEM TESTING	86-98	112
GLOSSARY		135
INDEX		139

CHAPTER 1

INTRODUCTION TO SINGLE-SIDEBAND COMMUNICATION

Section I. GENERAL

1. Scope

a. This manual covers the fundamental principles and theory involved in generating, transmitting, and receiving single-sideband (ssb) signals. Single-sideband and independent-sideband methods of communication are described.

b. The student technician should familiarize himself with the contents of TM 11-662 and TM 11-665 before reading this manual.

c. This manual is intended to aid the technician in understanding the operation, theory, and maintenance of military ssb communication equipment. It is not a substitute for the operation and maintenance manuals issued with such equipment.

2. Purpose and Use

a. Single-sideband communication systems have been in use by the military for many years. The greater part of these system applications has been in large fixed stations for long-range, point-to-point communication in the high-frequency (HF), 3- to 30-megacycle (mc) spectrum. Because of its many inherent advantages, ssb is replacing amplitude-modulated (AM) portable, vehicular, and avionics communication equipment for use in the crowded hf and very high-frequency (vhf) spectrum.

b. Single-sideband is being used in applications where it is desired to:

- (1) Obtain greater reliability.
- (2) Conserve frequency spectrum.
- (3) Limit size and weight of equipment.
- (4) Increase effective output without increasing antenna voltage.
- (5) Operate a large number of radio sets without heterodyne interference from radiofrequency (RF) carriers.

- (6) Operate over long ranges without loss of intelligibility due to selective fading.

3. History of Single-Sideband Communication

a. The possibility of single-sideband transmission as a communication method was discovered in 1915. This concept was derived in a purely mathematical analysis resulting from studies related to modulation of a continuous-wave (cw) carrier. It was during this same year that scientists at the U. S. Naval Radio Station at Arlington, Virginia tuned the antenna of a low-frequency (LF) transmitter to one side of the carrier and discovered that one sideband was passed and the other sideband greatly reduced. This proved that only one sideband was necessary to reproduce modulating intelligence. During this same period it was discovered that the carrier could also be suppressed at the transmitter and reinserted at the receiver to recover the modulation.

b. In 1918, the ssb concept was used in commercial wire carrier telephone equipment. The reduction in bandwidth resulting from the elimination of one sideband permitted the operation of twice as many channels.

c. The first transatlantic ssb signal was transmitted in 1923. Further experimentation with ssb transmission resulted in the first transoceanic ssb radiotelephone service between New York and London in 1927. Since these systems operated at low frequencies (57 kilocycles (kc)), the narrow resonance band of efficient antennas made it necessary to use ssb transmission at this time. During the next few years, standard am. transmitters were used in the hf spectrum for transoceanic service because the single-sideband art had not progressed sufficiently to enable ssb transmission at these frequencies.

d. Starting in 1936, ssb equipments were available in the hf spectrum for long-distance radio communications and were put to use in transoceanic radiotelephone service. During World War II, the military found wide use for ssb. Most of the communications between the United States and various parts of the world were supplied by ssb systems, providing the connecting link for multichannel teletypewriter circuits and special-purpose speech channels.

e. At the present time, improved ssb equipments are available to military, commercial, and amateur services. Single sideband is recognized as the standard for long-range, point-to-point communication systems and is appearing in its new role as spectrum conserver in hf portable, vehicular, and avionics applications.

4. Description of Single-Sideband Signal

a. The name single sideband arises from the fact that the spectrum of this signal contains only one of the two sidebands that are part of an amplitude-modulated signal (fig. 1A). A single-sideband signal normally consists of a low-frequency modulating signal converted to a radiofrequency signal. In all discussions of theory and operation of single-sideband transmission and receiving systems, reference is made to audio-modulating frequencies only for convenience in explanation. As an example of the frequencies that comprise an ssb signal, consider the spectrum distribution in figure 1B. In this figure, an audiofrequency (AF) signal ranging from 100 to 3,000 cycles per second (cps) is converted to rf by mixing with an rf carrier at 100 kc. If the rf carrier is suppressed in the mixing circuits and the lower sideband (lsb) is filtered out, an ssb upper sideband (usb) signal remains. The selected sum frequencies appear in the illustration as a signal varying between 0.1 and 3 kc above the 100-kc suppressed carrier and spaced between 100.1 kc and 103 kc in the RF spectrum.

b. Selection of the upper sideband frequencies as an ssb transmission leaves open that portion of the RF spectrum normally occupied by the lower sideband of an AM signal. Since an ssb signal is produced through a mixing operation, both sum and difference frequencies are developed. In *a* above, the upper sideband of frequencies was chosen as the ssb signal.

The lower sideband frequencies contain the same modulating intelligence as the upper sideband frequencies; the choice of sideband depends on the characteristics of the sideband filter employed. In figure 1C, the audiofrequencies and radiofrequencies used in the description given in *a* above are mixed, the carrier is suppressed, and the upper sideband frequencies are filtered out. This action produces an ssb lower sideband signal 0.1 to 3 kc below the suppressed-carrier frequency and spaced between 99.9 kc and 97 kc in the RF spectrum.

c. One form of ssb in common use in long-range communication is independent sideband transmission. This type of signal consists of two independent sidebands with one positioned above and the other below a suppressed carrier (fig. 1D). (The carrier maybe included at a reduced level.) In the illustration, the independent-sideband signal originates as separate groupings of modulating intelligence, A and B, each from 0.1 kc to 3 kc. The unrelated audio signals are mixed in separate modulators with the 100-kc carrier. The outputs of the individual modulators are added to form an upper and lower sideband, referenced to the suppressed carrier. Upper sideband A, from 100.1 kc to 103 kc, contains one grouping of modulating audiofrequencies and lower sideband B, from 99.9 kc to 97 kc, contains the second grouping of modulating audiofrequencies.

5. Basic Single-Sideband Transmitting System (fig. 2)

a. Figure 2 shows the basic functional units of a single-sideband transmitting system. For this example, a voice signal has been used only for convenience in explanation. In ordinary use, the input signal can be one or more signals in the 100-cps to 3,000-cps audiofrequency range.

b. A conventional audio amplifier without audio filtering is used in this basic system. The audio filter is not required because the highly selective filtering which takes place in the ssb generator attenuates unnecessary frequencies below 100 cps and above 3,000 cps. The upper frequency of 3,000 cps is determined by the channel bandwidth and the upper cutoff

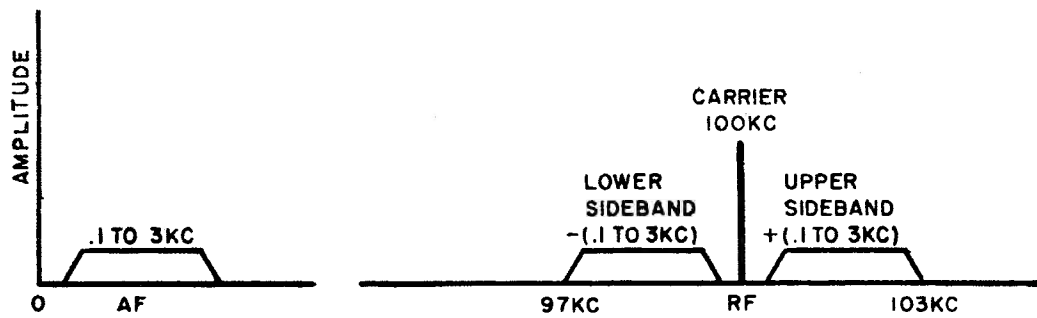

A. LOCATION OF AM SIGNAL IN RF SPECTRUM

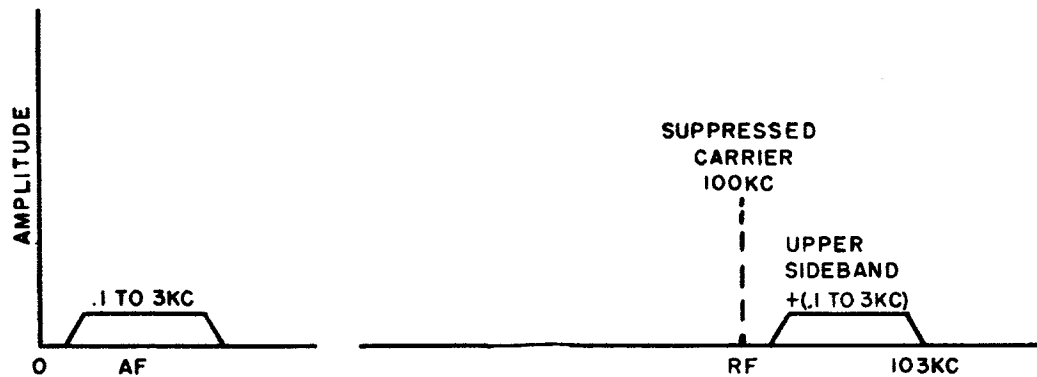

B. LOCATION OF SSB UPPER-SIDEBAND SIGNAL IN RF SPECTRUM

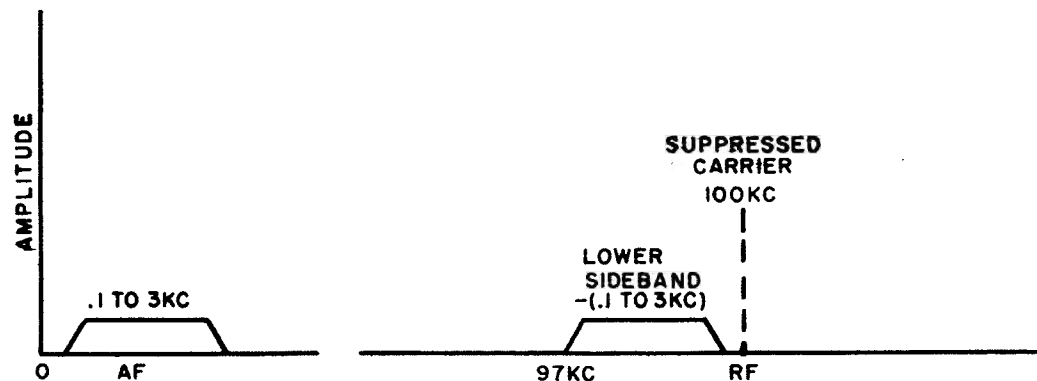

C. LOCATION OF SSB LOWER-SIDEBAND SIGNAL IN RF SPECTRUM

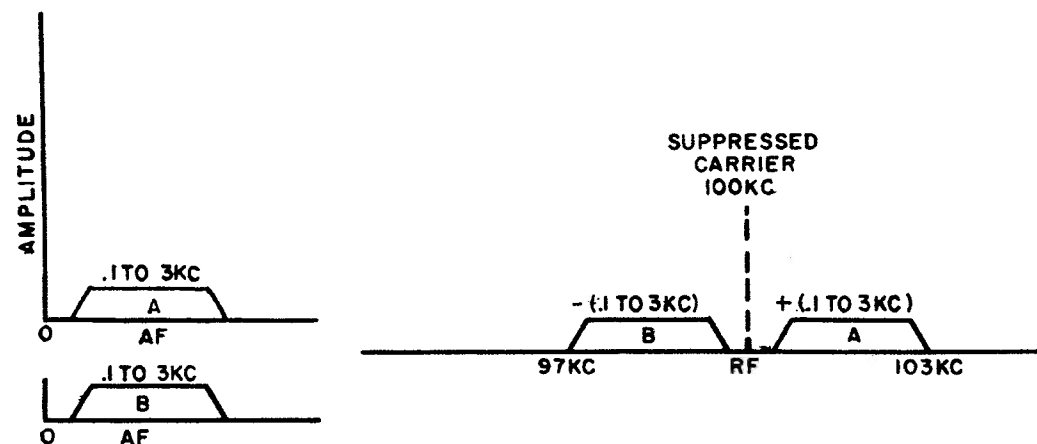

D. LOCATION OF INDEPENDENT-SIDEBAND SIGNAL IN RF SPECTRUM

TM685-1

Figure 1. Location of AM and ssb signals in RF spectrum.

frequency of the filter used in the ssb generator. The lower-frequency limit of 100 cps is determined by the low-frequency response of the audio amplifier and the lower cutoff frequency of the filter in the ssb generator.

c. The ssb generator in the figure produces an ssb signal at an intermediate frequency (IF) of 300 kc. In the *filter method* (ch 2) of ssb generation, a double-sideband (dsb), suppressed-carrier signal is first produced. The dsb signal is then passed through a very high Q (highly selective) filter to reject the unwanted sideband. Most equipments in use today generate on ssb signal at a carrier frequency normally below 500 kc. The choice of carrier frequency is limited to the lower radio-frequencies because the highly selective circuits required in the *filter method* are difficult to design and fabricate at the higher frequencies (although crystal filters effective to 20 mc are in development) Either crystal or mechanical filters have the high Q characteristics necessary for rejection of the unwanted sideband and to provide passage for the narrow band of desired sideband frequencies.

d. The block diagram in figure 2 illustrates a practical arrangement of a simplified ssb transmitter. This diagram illustrates the single standard frequency synthesizer principle that is discussed in detail in chapter 5. The frequency synthesizer consists of a single crystal frequency standard and a stabilized master oscillator (smo). The frequencies generated by the smo are referenced to the frequency standard to provide accuracy and stability of output frequency. A harmonic of the frequency standard furnishes a carrier frequency at the carrier-generator output. Frequency multipliers, driven from the smo, develop the frequencies required for multiple conversion of the intermediate frequency to the final operating radiofrequency.

e. The mixers at the output of the ssb generator heterodyne the 300-kc intermediate frequency with the frequencies from the smo and frequency multipliers. These frequency-conversion operations, necessary for obtaining the final output frequency, produce sum and difference frequencies and higher-order mixing products. Fortunately, proper choice of intermediate and smo frequencies results in at-

tenuation of undesirable sum or difference frequencies and higher-order products within the interstage tuned circuits. The double-conversion stages (fig. 2), are supplied with frequencies from the smo and multipliers so that the second conversion frequency is a multiple of the first conversion frequency. The difference frequencies are passed in the first conversion stage while the sum frequencies are selected in the second conversion stage. Considering the smo frequency range and the multiplier factors in the example, an upper sideband rf output from 1.7 mc to 31.7 mc is applied to the amplifiers of the exciter. This range overlaps the high-frequency range.

f. The amplifiers in the exciter are linear in operation to minimize distortion of the low-level modulated signal from the mixers. The amplifiers raise the power level of the signal to an amount sufficient to drive the power amplifiers at the output of the transmitter.

g. The ssb exciter (consisting of the ssb generator, carrier generator, mixers and amplifiers, and frequency multipliers) drives the linear power amplifier (pa). Linear pa operation is essential in an ssb transmitter. The pa output must be as exact a reproduction of the driving signal waveform as is practically possible. Nonlinear pa operation results in intermodulation or mixing of the input frequencies. Intermodulation produces distortion within the transmission channel and generates frequencies that *spill over* into adjacent channels. Low distortion in a linear power amplifier can be achieved by a considered choice of amplifier tube; setting of tube operating conditions for highest degree of linearity; and linearization of the pa tube transfer characteristic with rf feedback circuits. The low distortion obtainable in modern linear power amplifiers is not primarily to effect good voice transmission, but it is essential to minimize the guard band between channels and thereby permit full utilization of spectrum space.

h. An independent-sideband transmitter is composed basically of two similar ssb generators (fig. 3). The inputs of the individual generators are independently activated by separate groupings of intelligence and a common carrier frequency; the outputs of the generators are combined in parallel and applied

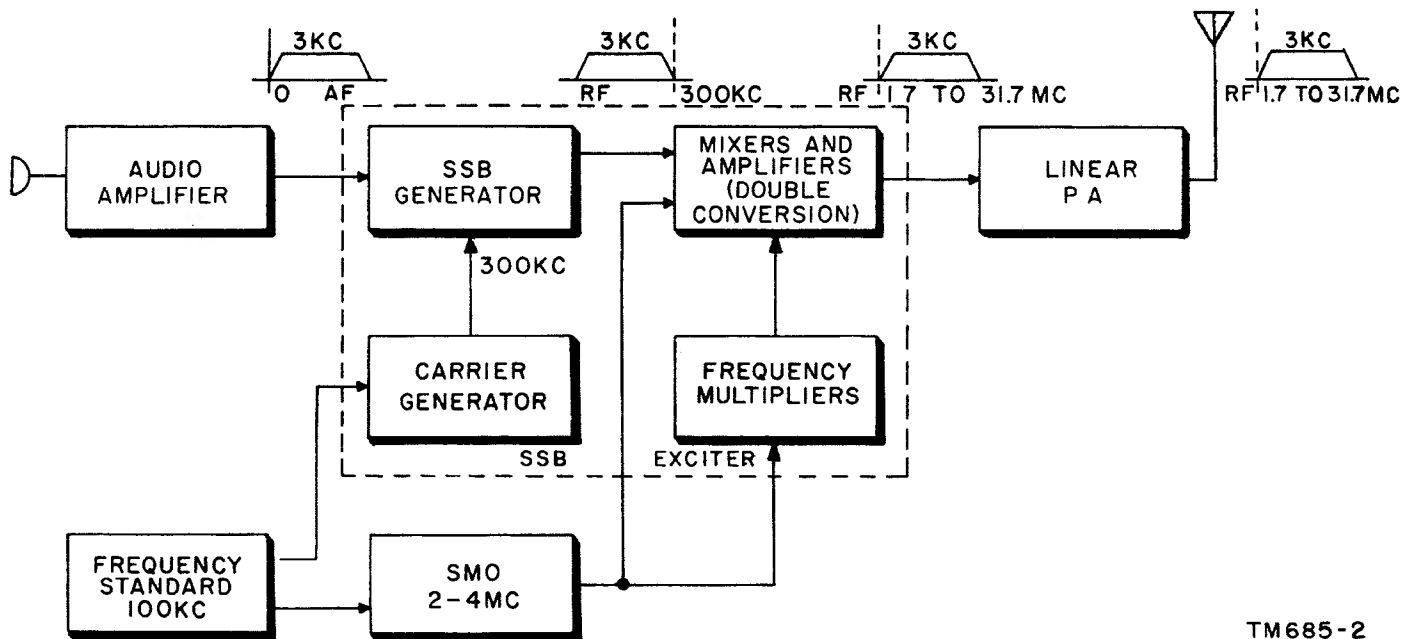

TM685-2

Figure 2. Functional units of an ssb transmitting system.

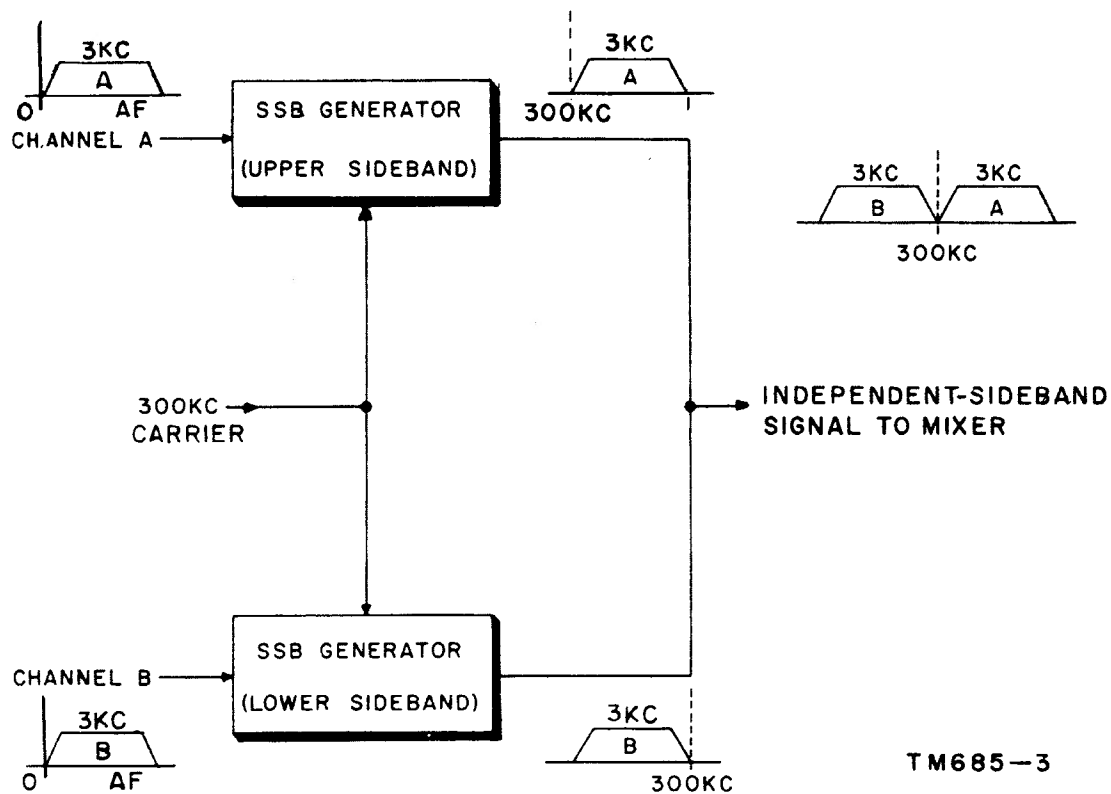

TM685-3

Figure 3. Generation of independent-sideband signal.

to the mixers and amplifiers for further processing as in the transmitter (fig. 2). In the block diagram (fig. 3), the upper sideband of one signal is selected and appears as channel A. The lower sideband of the second and different signal is passed to form channel B. The carriers are suppressed in each ssb generator. The final output frequencies of an independent-sideband transmitter are contained in two sidebands placed above and below the suppressed carrier in the radiofrequency spectrum (fig. 1D).

6. Basic Single-Sideband Receiving System (fig. 4)

The reception of ssb signals requires a heterodyning system that will convert the ssb rf signals to the original modulating frequencies. The block diagram of figure 4 illustrates the basic functional sections of an ssb receiver. The single-sideband circuit, in general, resembles an AM receiver circuit. The ssb receiver differs in the method of demodulation and the use of higher-stability oscillators.

a. The ssb signal at the antenna is amplified by the RF amplifier and applied to the mixers and intermediate-frequency amplifiers for conversion to a lower frequency. The intermediate frequency passes through highly selective

interstage filters, between the mixers and amplifiers, to reduce the effects of spurious signals generated in the frequency-conversion processes. The demodulator heterodynes the final IF with the locally generated carrier frequency. This mixing action converts the ssb signal to the original modulating audiofrequencies. A conventional audio amplifier completes the ssb receiver.

b. The stabilized master oscillator and frequency multipliers provide the conversion frequencies necessary to produce the final intermediate frequency at the demodulator. The frequencies developed in these units are *locked* to a single standard frequency so that the stability of the standard frequency prevails throughout the ssb receiver. Good choice of conversion frequencies and the final intermediate frequency produces a minimum of spurious (unwanted) frequencies at the output of the mixers. The use of harmonically related conversion frequencies allows full frequency range coverage with one stabilized master oscillator.

c. Comparison of figure 2 with figure 4 shows that many of the sections of an ssb transmitter and an ssb receiver have similar functions. The stabilized master oscillator,

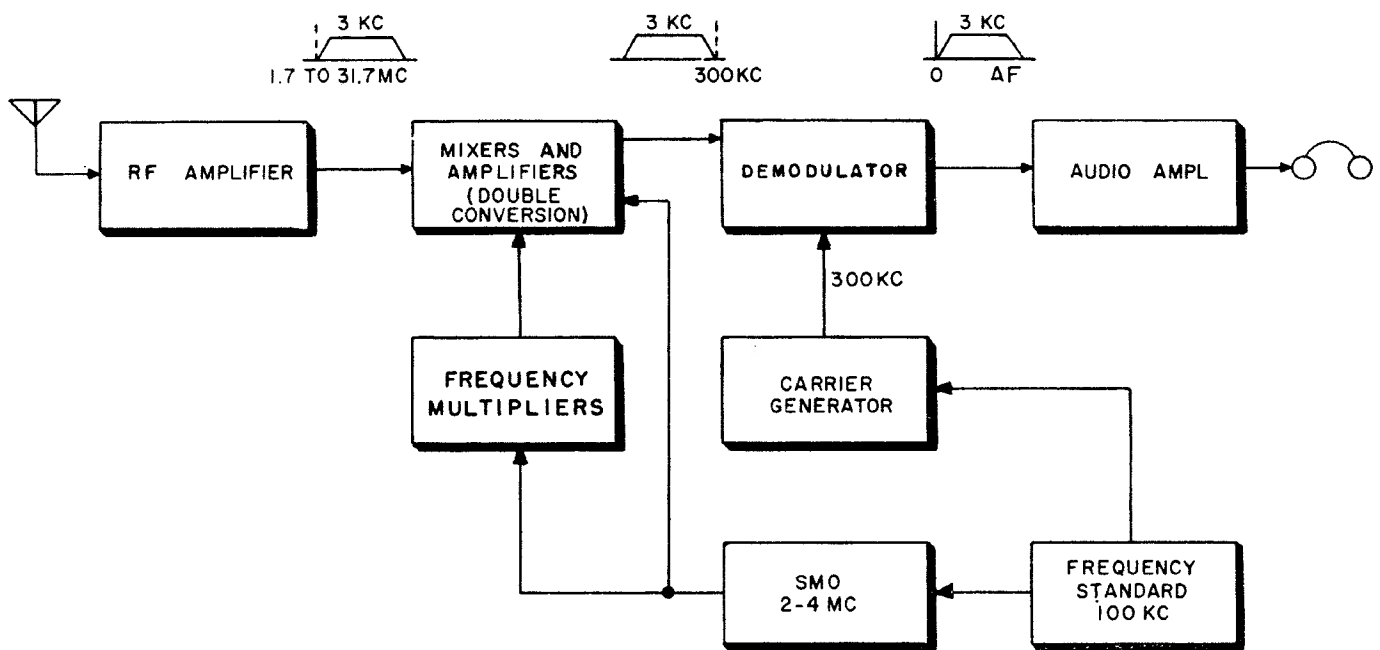

TM685-4

Figure 4. Functional units of an ssb receiving system.

frequency standard, and carrier generator of the transmitter and receiver are identical. The mixer and amplifier circuits that provide multiple conversion in the receiver can be constructed identical with similar sections in the transmitter. The fact that many sections perform similar functions permits the use of cir-

uits common to both transmitter and receiver. Compact transmitter-receiver (transceiver) combinations using many common circuits can be realized by the addition of switches to reverse the path of signal flow. Reduction of size and weight of equipment is an outcome of the use of these dual function circuits.

Section II. COMPARISON OF SINGLE-SIDEBAND WITH AM AND FM SYSTEMS

7. Power Comparison

The transmitter power necessary to produce a given signal-to-noise (s/n) ratio is one means of comparing the power requirements and relative performance of AM and ssb systems. The propagation conditions are assumed to be ideal for the comparisons given in this paragraph. Signal-to-noise ratio comparison is fair because it determines to a great degree the intelligibility of the received signal.

a. Figure 5 compares the power output of an am. transmitter rated at 1 unit of carrier power with an ssb transmitter (upper sideband operation) rated at 0.5 unit of peak-envelope power (pep). Peak-envelope power is defined as the root-mean-square (rms) power developed at the crest of the modulation envelope. One hundred percent modulation of the AM transmitter produces a total of 1.5 units of RF power. The 1.5 units of power is composed of 0.25 unit of power in each sideband and 1 unit of carrier power. The ssb transmitter rated at 0.5 unit of pep produces the same s/n ratio in the output of a receiver as 1.5 units of carrier plus sideband power from an am. transmitter.

b. The voltage vectors for the AM and ssb transmitter power outputs, assumed in *a* above, are shown in figure 5B. The carrier is considered the reference vector in this figure. The lower sideband frequency and upper sideband frequency are represented by vectors rotating in opposite directions about the carrier reference frequency. The AM power in A results in a voltage of 0.5 unit in each sideband and 1 unit of carrier voltage; the assumed power in A is the square of the voltage in B. In the modulating process, the vector sum of the two sidebands is either in phase or directly out of phase with the carrier. The in-phase condition adds the resultant sideband voltage to the car-

rier voltage while a difference voltage is developed during the time the two are directly out of phase. The ssb voltage vector is a single vector (carrier and lower sideband suppressed) of 0.7 unit of voltage at the upper sideband frequency.

c. The RF waveforms traced by the voltage vectors (fig. 5B) are shown in figure 5C. The rf envelope of the am. signal rises to a peak-envelope voltage (pev) of 2 units. This value represents the sum of the two sideband voltages (0.5 unit each) plus the carrier voltage (1 unit). The peak-envelope power of the AM signal is 4 units; the pep at the output of a transmitter is considered as the peak-envelope voltage squared. The pev of the ssb signal is 0.7 unit and the pep is 0.5 unit.

d. In a receiver demodulation of the AM signal develops an audio voltage at the output of the detector that is the sum of the upper and lower sideband voltages (fig. 5D). The carrier voltage, at a fixed frequency and amplitude, appears at the demodulator output as an average direct-current (dc) level, which does not contribute to the audio voltage. Having assumed 0.5 unit of voltage in each AM sideband, 1 unit of audio voltage results in the detector output. This demodulation process is known as coherent detection because the two sideband voltages are added at the detector. When the ssb signal is demodulated, the 0.7 unit of voltage in the single sideband is converted to 0.7 unit of audio voltage. The ssb signal is demodulated by heterodyning the RF signal with a locally generated carrier signal.

e. In figure 5E, a broadband noise level of 0.1 unit of voltage is chosen for the 6-kc bandwidth necessary to permit passage of both sidebands of the am. signal. The same noise level results in the generation of 0.07 unit of voltage for the 3-kc bandwidth required for the ssb

signal. These values represent the same noise power level per kc of bandwidth; that is, $(0.1)^2/6$ is equal to $(0.07)^2/3$.

f. As shown in figure 5F, with the broadband noise level as assumed in e above, the s/n ratio for the AM system is 20 decibels (db) (20 long s/n). The s/n ratio for the ssb system is also 20 db. The s/n ratios are identical for both

systems; therefore, 0.5 unit of pep from the ssb transmitter produces the same signal intelligibility as the 1 unit of carrier from the AM transmitter. Restating the conclusion of the AM and ssb comparison, it is evident that under ideal propagation conditions, but in the presence of broadband noise, an AM and an ssb system perform equally (same s/n ratio)

	AM SINGLE TONE, SINE-WAVE MODULATION	SSB SINGLE TONE, SINE-WAVE MODULATION
A	<p>RATED POWER IN UNITS</p> <p>RATED CARRIER POWER = 1 TOTAL POWER = 1.5</p>	<p>RATED PEP POWER = .5</p>
B	<p>VOLTAGE VECTORS 100% MODUATION</p> <p>LSB .5 C .5 USB PEP = 2</p>	<p>PEV = .7</p> <p>USB .7 PEP = .7</p>
C	<p>RF ENVELOPE</p> <p>PEV = 2 PEP = 4</p>	<p>PEV = .7 PEP = .5</p>
D	<p>RCVR AUDIO SIGNAL VOLTAGE</p> <p>USB + LSB = 1</p>	<p>.7</p>
E	<p>NOISE VOLTAGE (ARBITRARY NOISE POWER PER KC OF BANDWIDTH EQUAL IN AM AND SSB)</p> <p>VOLTAGE = .1 PER 6KC BANDWIDTH</p>	<p>VOLTAGE = .07 PER 3KC BANDWIDTH</p>
F	<p>S/N RATIO = $20 \text{ LOG } \frac{1}{.1} = 20 \text{ DB}$</p>	<p>$20 \text{ LOG } \frac{.7}{.07} = 20 \text{ DB}$</p>

Figure 5. Ssb and am. comparison.

TM685-5

if the two transmitters are radiating equal sideband power. On an equal output power basis (under ideal conditions) ssb outperforms am. by eight to one for on apparent system gain of 9 db.

8. Antenna Voltage Comparison

In vehicular and avionics applications, where the physical size of a transmitting antenna is important, the ssb method of communication holds a distinct advantage over the AM method. In this type of installation, the corona breakdown point of an antenna is one of the limiting factors in transmitter output power.

a. Referring to the transmitter rf envelopes in figure 5C, it is evident that a pev of 2 units from the AM transmitter is equivalent to 0.7 unit of pev from the ssb transmitter. An antenna designed for ssb radiation handles approximately one-third of the voltage to achieve the same effective performance as an am. antenna.

b. Because of the ratio of antenna voltage between the am. transmitter and ssb transmitter, as indicated above, a large increase in power efficiency can be effected by using an ssb transmitter. For example, if the antenna for a certain type of vehicular or avionics application is limited to 400 watts peak-envelope power, an ssb transmitter having eight times the sideband power of an AM transmitter may be used. This is true because a 100-watt carrier, modulated by 50 watts of audio, also produces a pep of 400 watts.

9. Advantage of Single-Sideband Under Selective Fading

Regardless of the comparative power used, on long-distance transmissions the ssb communication systems out-perform AM communication systems. Am. transmissions are subject to fading of the signal under poor propagation conditions. Fading depends on frequency; therefore each frequency component of a modulated wave is affected differently. This effect is called selective fading and results in distortion of the modulation envelope. In multihop transmissions, frequencies only 100 cycles apart may fade independently of each other. Selective fading subject AM transmissions to severe deterioration under poor propagation conditions but has no appreciable effect on ssb signals

except for attenuation of signal strength. Selective fading can affect either or all of the three components (lsb, usb, carrier) of an AM signal, necessary to faithfully reproduce the transmitted intelligence.

a. One type of selective fading is sideband fading (fig. 6A). In sideband fading, the loss of one of the two transmitted sidebands results in loss of signal voltage at the output of the receiver demodulator. This loss causes some distortion but is not entirely detrimental to the signal because both sidebands contain the same intelligence. The loss of one sideband does reduce the signal-to-noise ratio because the receiver is designed to receive a double-sideband signal. The disappearance of one sideband of the received signal is equivalent to a 6-db decrease in signal-to-noise ratio. Although the complete loss of one sideband is an extreme case, partial decay of either sideband will reduce the signal-to-noise ratio.

b. The most common, yet the most serious, form of selective fading is carrier-amplitude fading (fig. 6B). Reduction of the carrier level of a 100 percent modulated wave will make the carrier voltage less than the vector sum of the two sidebands. The carrier-plus-sideband signal does not retain its original shape, and distortion is severe. This condition is similar to the effect of overmodulation in an AM transmitter. A carrier voltage equal to or greater than the sum of the sidebands is required for true reproduction of the received signal. The distortion caused by carrier fading can be overcome by using the exalted carrier technique of reception. In this method of reception, the weak carrier is amplified separately and reinserted before demodulation of the signal.

c. A third cause of selective fading is carrier phase shift (fig. 6C). Consider the effect on the transmitted signal of a carrier shift of 90° from its original position. The relative positions of carrier and sideband vectors of the received signal bring about a decided change in the modulation envelope. This signal, phase-modulated by a carrier phase shift, will not produce an intelligible output when demodulated by the AM detector. Although a carrier phase shift of 90° is an extreme case, any shift in the phase of the carrier from its original position will

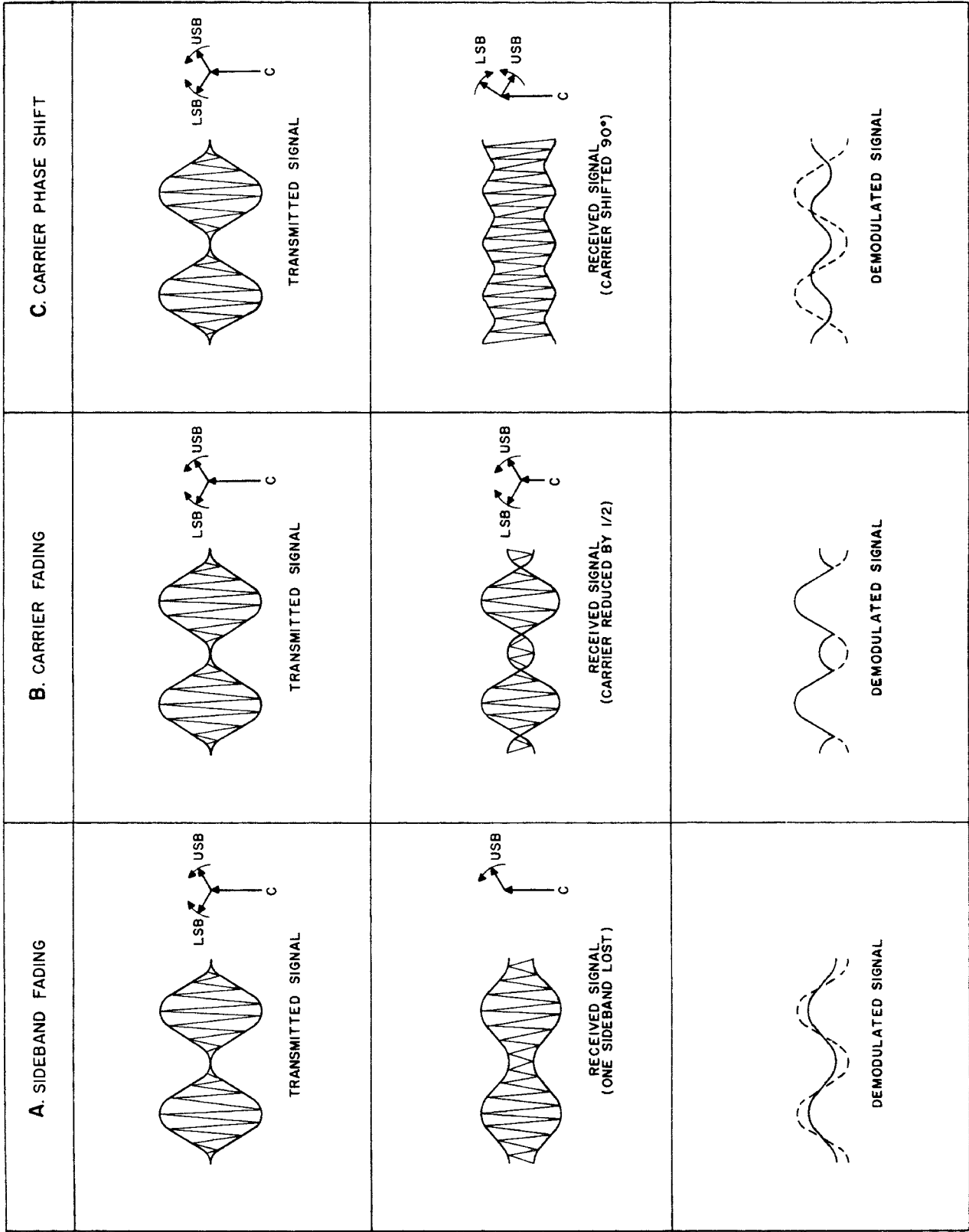

Figure 6. Deterioration of an am. signal with selective fading.

produce some phase modulation and result in considerable distortion of the received signal.

d. Signal-sideband transmission is not subject to the various types of selective fading because the ssb signal normally consists of only one sideband without the carrier. Carrier phase shift and carrier fading, therefore, cannot occur. Sideband fading only changes the amplitude and frequency response of the signal. These changes do not produce sufficient distortion to cause loss of intelligibility in the received signal.

10. Comparison Under Limiting Propagation Conditions (fig. 7)

One important advantage of ssb transmission over am. transmission in long-range communications is the ability of the ssb transmission to get through under limiting propagation conditions. Propagation conditions are worsened by the effects of atmospheric noise, severe selective fading, and narrow-band interference. The system gain of an ssb transmitter over an AM transmitter, as propagation conditions worsen, is plotted in the graph of figure 7. In the figure, the am. transmitter is the reference system

from which the ssb transmitter gain is judged. The transmitters chosen for the study radiate equal amounts of sideband power. The 100-watt (carrier power) am. transmitter contains a total of 50 watts of sideband power. (One-hundred percent modulation produces 25 watts in each sideband.) The ssb transmitter delivers 50 watts of power in its one sideband. Thus, as indicated in the graph, under ideal conditions (noise alone), the ssb transmitter radiating 50 watts of sideband power is equivalent to the 100-watt AM transmitter output with 50 watts of total sideband power. Under good propagation conditions, the ssb transmitter shows a 3-db system gain. As propagation conditions deteriorate, the system gain of the ssb transmitter increases to 6 db under poor conditions and to 9 db under bad propagation conditions (severe fading and interference).

11. Comparison of Single-Sideband and Frequency Modulation

The graph in figure 8 illustrates the predicted result of a study of the relative merits of a mobile ssb system as compared to a mobile frequency-modulation (FM) system of equal physical size. The two systems involved employ

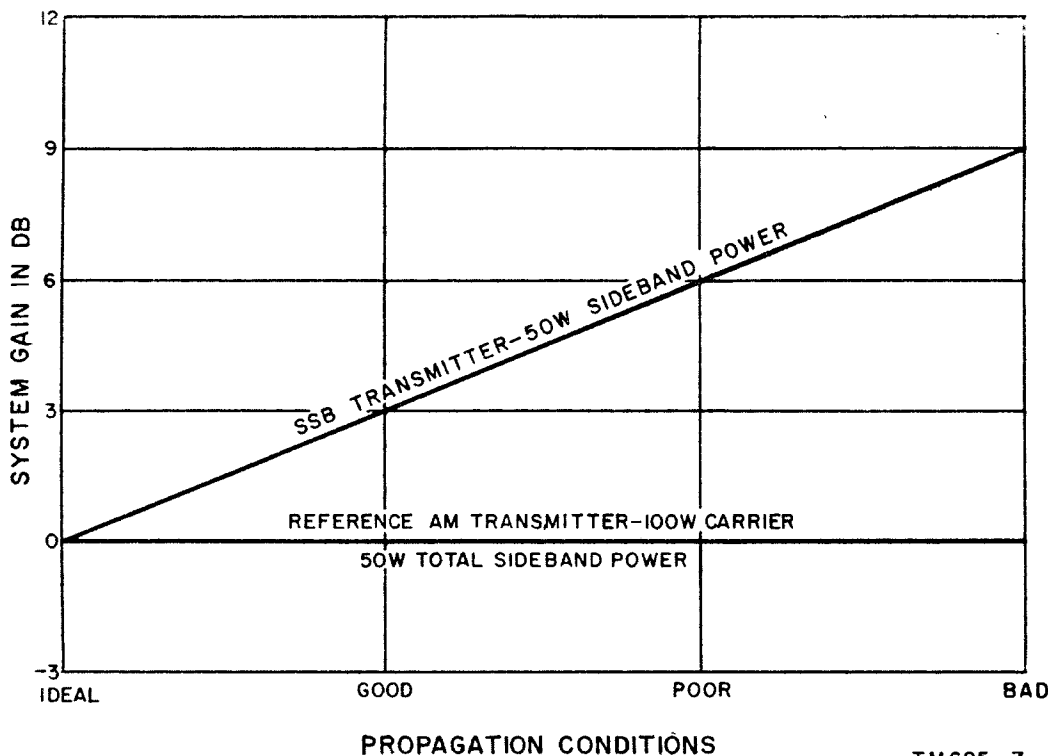

Figure 7. Relative advantage of ssb over am. under limiting propagation conditions.

identical output tubes, under the same operating conditions, and are driven to their full capacity. This assures that equal power is developed in the final rf amplifiers of each system. Figure 8 plots the s/n ratio at a receiver as affected by the attenuation of signal between transmitter and receiver. (Greater attenuation means less signal at the receiver antenna.) Zero db, represented by a broken line, is the signal-to-noise level where the detected intelligence is equal in amplitude to the noise. Inspection of the graph shows that for strong signals, 150-to 160-db attenuation, the narrow-band fm system (12-kc bandwidth) furnishes a better s/n ratio than the ssb system. But as the received signal deteriorates to 168 db attenuation or greater, the ssb system provides the better s/n ratio. The dropoff in the fm system s/n ratio, on reception of weak signals, occurs because of insufficient signal voltage available for operation of the fm receiver limiter circuits. Another advantage of the ssb system over the fm system is in conservation of spectrum space. As noted on the individual curves in the graph, the ssb system (4-kc bandwidth) occupies one-third the spectrum space of the narrow-band fm system (12-kc bandwidth).

12. Spectrum Conservation

The main advantage in suppressing the carrier and one sideband of a double-sideband

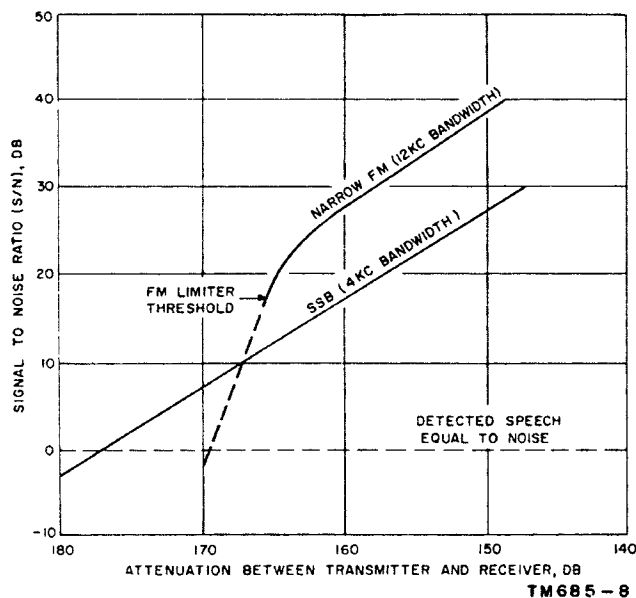
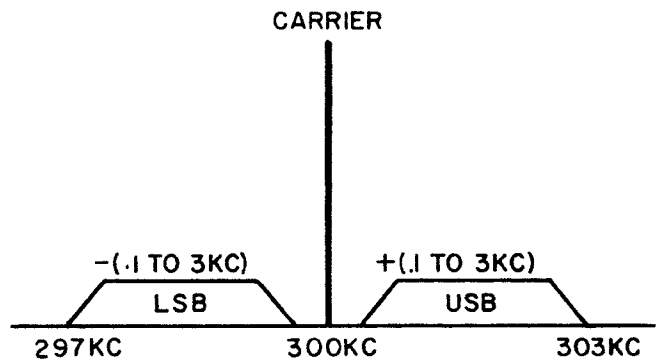

Figure 8. Comparison of ssb and FM performance.

signal is the conservation of radiofrequency spectrum space. The sideband frequencies of an amplitude-modulated signal are mirror images of each other (contain identical information); therefore, ordinary AM is wasteful of spectrum space. In an ssb system, suppression of the carrier and elimination of one sideband reduce the channel space requirements to less than half the space required by the double-sideband AM system.

a. Figure 9A illustrates the bandwidth of frequencies generated by an AM system modulated by audiofrequency signals from 0.1 to 3 kc. As shown in the figure, modulation of a carrier frequency of 300 kc produces an upper sideband frequency limit of 303 kc and a lower sideband frequency limit of 297 kc. A simple calculation results in a figure of 6 kilocycles of spectrum space in use for the AM transmission.



A. AMPLITUDE-MODULATED SYSTEM

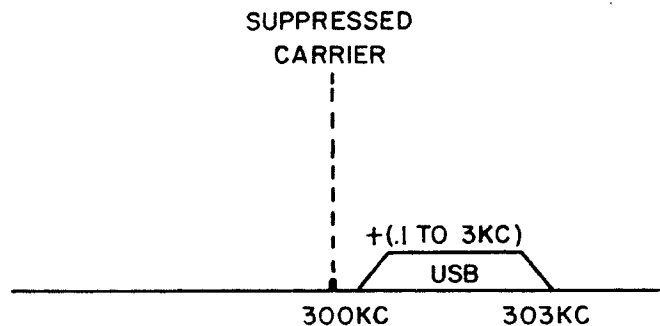

B. SINGLE-SIDEBAND SYSTEM

TM685-9

Figure 9. Frequency spectrum comparison of am and ssb.

An ssb system modulated by the same range of audiofrequencies would generate a bandwidth of frequencies that occupy less than 3 kilocycles of spectrum space (fig. 9B).

b. An ssb system has a clear advantage over an AM system in that, with identical carrier (suppressed) and modulating signals, the bandwidth of the ssb system is less than half that

required for the ordinary am. system. It then becomes a theoretical possibility to operate twice as many ssb channels as AM channels in any particular portion of the frequency spectrum. This two-for-one advantage offers an invaluable aid to users of the hf part of the frequency spectrum where the heaviest concentration of communication traffic exists.

Section III. NATURE OF SINGLE-SIDEBAND SIGNALS

13. Introduction

As discussed in the preceding sections, a single-sideband signal is derived from an amplitude-modulated, double-sideband signal. An ssb signal is obtained upon suppression of the carrier frequency and elimination of one of the two identical intelligence-bearing sidebands. To explain the generation of a suppressed-carrier, double-sideband wave and subsequent conversion to a single-sideband signal, pure sine-wave tones are used. Single-tone or two-tone combinations are the modulating signals throughout this section. A 100-kc carrier frequency is employed to produce the two sideband frequencies at the output of the modulator. The *filter method* serves as the basis for the single-sideband generator in the remaining paragraphs of the chapter; the *phase-shift method* of ssb generation is covered in detail in chapter 2.

14. Single-Sideband Generator

Of the two common methods of single-sideband generation (filter method and phase-shift method), the filter method is presently more widely accepted. In this method, the modulating and carrier signals are heterodyned to produce a double-sideband signal with suppressed carrier. A highly selective filter at the modulator output passes the desired sideband and firmly rejects the other.

a. A simplified ssb generator (filter method) consisting of a balanced modulator, a carrier generator, and sideband filter, is shown in block diagram form in figure 10. A 3-kc audiofrequency tone and the 100-kc carrier are applied to the inputs of the balanced modulator. A double-sideband signal, composed of an upper sideband frequency of 103 kc and a lower sideband frequency of 97 kc, appears at the modu-

lator output; the 100-kc carrier is theoretically suppressed because the modulator is balanced for this frequency. The degree of carrier level suppression depends on the exactness of match between components in the balanced modulator.

b. The double-sideband signal (103 kc usb and 97 kc lsb) at the output of the modulator is applied to the sideband filter. The *high Q* sideband filter eliminates the lower sideband frequency (97 kc) and passes the upper sideband frequency (103 kc). The filter also rejects spurious (unwanted) frequencies developed in the modulator and further suppresses the carrier-frequency (100 kc) amplitude that leaks through because of imperfect balanced-modulator action. In the block diagram of figure 10, the sideband filter passes the upper sideband frequency of 103 kc. This frequency is an intermediate frequency, single-sideband signal that is now ready for application to the mixers and amplifiers of a frequency translator for conversion to the final operating frequency of the transmitter. A pilot or reduced carrier (controlled low-level carrier) can be transmitted with the single-sideband signal by employing the *carrier reinsert* function shown in the diagram.

15. Single-Tone, Double-Sideband Waveform, Carrier Suppressed

a. Figure 11 illustrates the double-sideband output waveform of a balanced modulator when activated by a single-tone, audio signal. This waveform is processed by the ssb generator at an intermediate frequency. The intermediate frequency is converted up in frequency to the final operating frequency in succeeding stages of the ssb transmitter. In the preceding paragraph, it was shown that the output of the modulator (fig. 10) contained a 103-kc upper

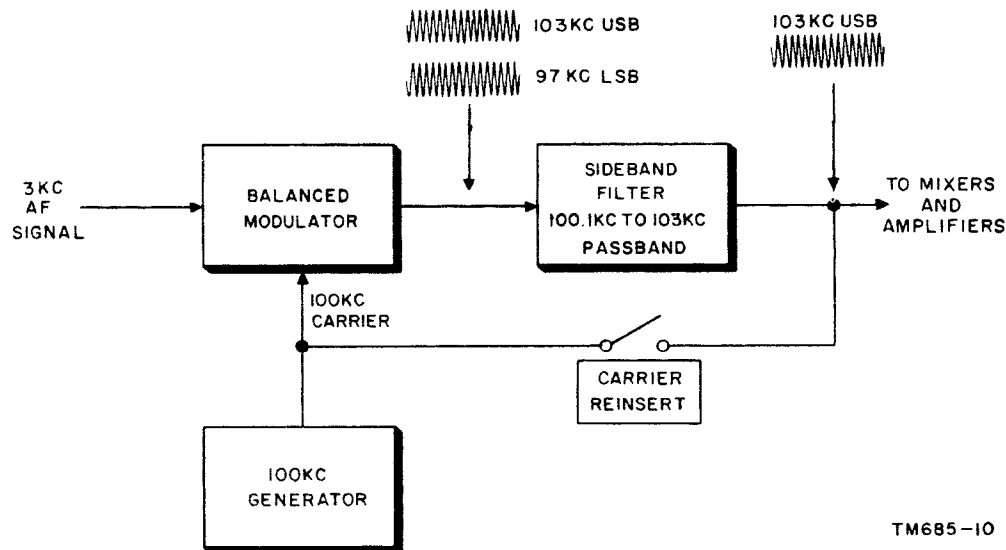

Figure 10. Filter-type, single-sideband generator, block diagram.

sideband frequency and a 97-kc lower sideband frequency. These two sideband frequencies are of equal amplitude and produce the wave form shown in figure 11. The repetition rate of this waveform, formed by a 3-kc modulating tone, is 6 kilocycles. This rate is readily seen to be the difference between the two sideband frequencies (103 kc—97 kc) that constitute the double-sideband waveform.

b. When the single-tone output of the modulator is passed through a highly selective filter, the waveform in figure 12 is the result. The audio-modulating signal (fig. 10) is displaced upward in the frequency spectrum from the original low-frequency position (3 kc) by an amount equal to the carrier frequency (100 kc). The single-sideband signal selected by the filter is an upper sideband signal, because the filter output frequency is greater than the carrier frequency. To demodulate a single-sideband signal, it is necessary to convert this signal down in frequency to the original modulating frequency. This is accomplished by heterodyning the single-sideband signal with a 100-kc, locally generated frequency at the receiver

16. Single-Tone, Single-Sideband Waveform With Carrier

a. The generation of a single-tone, single-sideband signal with carrier is a simple operation since the carrier can be reinserted after sideband filtering by the *carrier reinsert* function

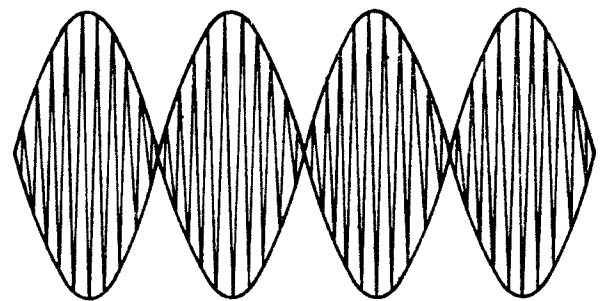

Figure 11. Single-tone, Double-sideband waveform, carrier suppressed.

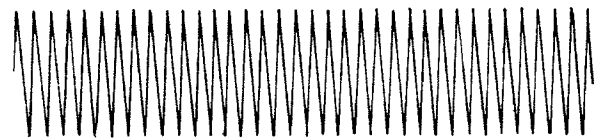

Figure 12. Single-tone, balanced-modulator output after sideband filtering.

(fig. 10). The waveform illustrated in figure 13 results when the output of the sideband filter and the reinserted carrier are of equal amplitude. This waveform is similar to the waveform in figure 11; however, the frequency components are different. The frequency components produced by reinsertion of the carrier in figure 10 are 103 kc and 100 kc. The repetition rate of this waveform is 3 kilocycles and represents the difference between the sideband frequency and the reinserted carrier frequency

(103 kc—100 kc). A single-sideband signal with full carrier (carrier and sideband of equal amplitude) can be demodulated in standard AM receivers without serious distortion and loss of intelligibility.

b. When the level of the reinserted carrier is lower than that of the single-tone, single-sideband signal, the waveform in figure 14 results. To demodulate this signal, the carrier must be separated, amplified, and reinserted in the receiver (exalted carrier system), or locally supplied from a separate source. The locally generated carrier is usually *locked* to the pilot carrier frequency (if supplied) to maintain a stable relationship between local carrier and received signal. When the exalted carrier system is used, the separate carrier amplification must be sufficient to raise the carrier to an amplitude greater than that of the sideband signal. The waveform shown in figure 14 is the output signal waveform in a single-sideband transmitter with low-level pilot carrier reinsertion.

17. Two-Tone, Single-Sideband Waveform

a. A two-tone, ssb waveform is generated by combining two audio tones and injecting both into a balanced modulator. When the carrier is balanced out and the undesired sideband is

removed by the sideband filter, the resulting waveform has the appearance of the waveform illustrated in figure 15. This waveform is similar in appearance to the single-tone, dsb waveform carrier suppressed (fig. 11) and the single-tone, ssb waveform with carrier (fig. 13). This waveform differs in that the component frequencies, after sideband filtering, contain two sideband frequencies of equal amplitude generated by the two modulating tones. As an example, consider the injection of 1.5-kc and 3-kc audio signals and a 100-kc carrier into the balanced modulator. After removal of the lower sideband, the remaining frequencies in the upper sideband are 101.5 kc and 103 kc. When a pilot carrier is reinserted with the two-tone test signal, the presence of the pilot carrier is indicated by a distinguishable sine-wave ripple on the two-tone waveform (fig. 16).

b. The generation of the two-tone envelope (fig. 15) can be clearly shown with vectors representing the two audiofrequencies (fig. 17). In the figure, e_1 and e_2 are audio-frequency voltages of equal amplitude. The vectors are rotating with reference to each other. When the two vectors are exactly opposite in phase, the envelope value is zero. When the two vectors

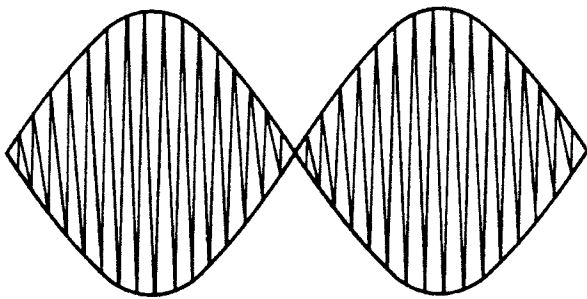

TM685-13

Figure 13. Single-tone, Single-sideband signal with carrier, carrier level equal to sideband level.

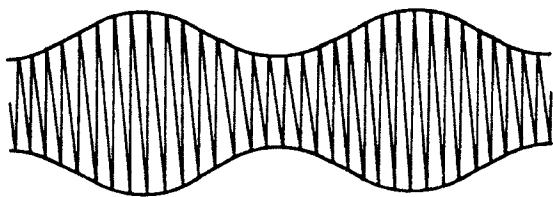

TM685-14

Figure 14. Single-tone, single-sideband signal with carrier, carrier level below sideband level.

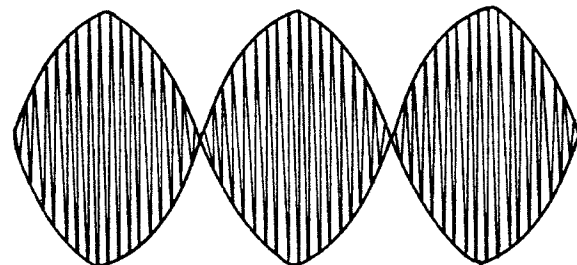

TM685-15

Figure 15. Two-tone, ssb signal with tones of equal amplitude.

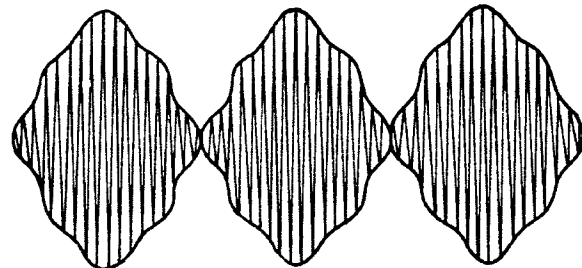

TM685-16

Figure 16. Two-tone, ssb signal with small reinserted pilot carrier.

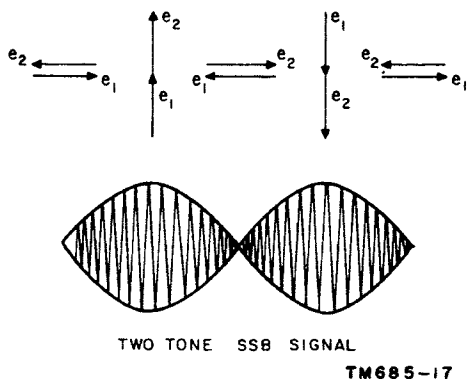

Figure 17. Two-tone, ssb signal and vector presentation.

are exactly in phase, the envelope value is maximum. This action develops the half sine waveform of the two-tone, ssb envelope. The repetition rate of this signal is the difference between the two frequencies (example, 103 kc — 101.5 kc, above *a*) that comprise the two-tone, single-sideband waveform.

c. The two-tone, ssb envelope is of particular interest in that it is from this envelope that power output from an ssb transmitter is determined in practice. An ssb transmitter is rated in peak-envelope-power output with the power measured when the input is a two-tone test signal with the two tones equal in amplitude. With such a test signal, the actual power dissipated in a matched load is half the peak-envelope power. When the half sine-wave signal (fig. 17) is fed into the load, a peak-reading, rms-calibrated vacuum-tube voltmeter (vtvm) measures the rms value of the peak-envelope voltage developed across the load. This voltmeter reading (V_{vtvm}) is equal to the in-phase sum of $e_1 + e_2$ (rms voltages of the two test tones). Since $e_1 = e_2$ in the two-tone test signal, the pep equals $4e_1^2/R$ or $4e_2^2/R$. Represents the matched-load resistance. The average power dissipated in the load equals the sum of the powers in the low tones, $e_1^2/R + e_2^2/R = 2e_1^2/R$ or $2e_2^2/R$ ($e_1 = e_2$). Therefore, with a two-equal-tone ssb test signal, the average power dissipated in the load is equal to one-half the pep, and the power in each tone is equal to one-fourth the pep. Peak-envelope power can be determined from the following equation: $pep = V_{vtvm}^2/R$. The average power can be determined from the following formula: $P_{average} = \frac{1}{2} V_{vtvm}^2/R$.

The equations are correct only when the vtvm used an rms-calibrated voltmeter.

d. The analysis in *c* above can be carried further to show that with a three-equal-tone ssb test signal, the power in each tone is one-ninth the pep, and the average power dissipated in the load is one-third the pep. These relationships are true only if there is no distortion of the ssb envelope, but since distortion in an ssb system is very low, its effects are usually neglected

e. Two equal amplitude audio tones have become a standard test signal for distortion measurements because:

- (1) One signal does not produce intermodulation.
- (2) More than two signals result in so many intermodulation products that analysis is impractical.
- (3) Tones of equal amplitude place more demanding requirements on the system than it is likely to encounter in normal use

18. Generating Voice Waveform

a. The human speech mechanism produces a wide range of frequencies all woven into a highly complex waveform. Although no two human voices are exactly alike, statistical averages of frequencies and relative amplitudes have been calculated. The average power level of speech has been found to be much lower than the peak power level. The audiofrequency waveform of an \bar{a} sound is shown in figure 18. The same \bar{a} sound, as an audiofrequency modulating signal, appears as the resultant single-sideband signal in figure 19. From the large peak to valley difference in the shape of the waveform, it is evident that, the peak power reached by the converted audio-frequency is much higher than the average power in the signal.

b. Figure 20 shows a power-versus-frequency distribution curve for the average human voice; frequencies below 200 cps and above 3,000 cps are filtered out. This curve shows that the high-power components of speech are concentrated in the low frequencies. It is the low-frequency components of speech that contribute little to intelligibility since

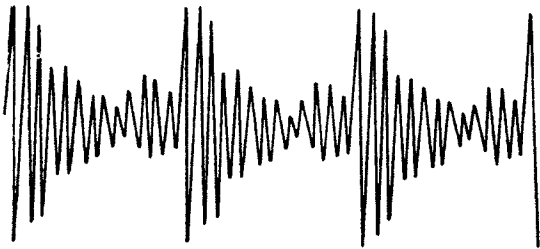

Figure 18. Voice signal at audiofrequency (\bar{a} sound).

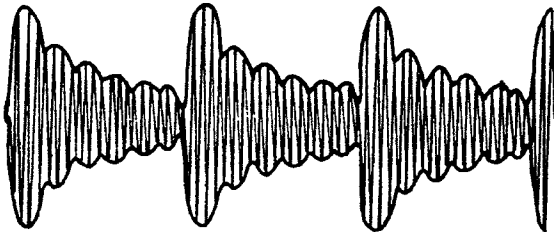

Figure 19. Ssb signal (\bar{a} sound).

these frequencies are concentrated in the vowel sounds. The low frequencies, therefore, may be attenuated without destroying intelligibility of speech. The low-power, high-frequency components present in a voice signal can be pre-emphasized to increase the average power level of the signal. Since the high-frequency components consist of the consonant sounds, some emphasis of high frequencies will aid intelligibility. Preemphasis of the high frequencies, sufficient to raise the average power level significantly, requires deemphasis at the receiver to prevent loss of fidelity.

c. Transmission efficiency depends on the ratio of average-to-peak power output of a transmitter. For maximum transmission efficiency, the average power output must be increased without affecting the peak power output. For voice transmission, the following forms of speech-shaping circuits are available to increase the average-to-peak power ratio:

- (1) Clipping the speech peak voltages.
- (2) Emphasizing the low-power, high-frequency components of the signal and attenuating the high-power, low-frequency components.
- (3) Automatic gain control or speech compression.

d. Clipping of power peaks flattens the waveform at the clipping level. With severe clip-

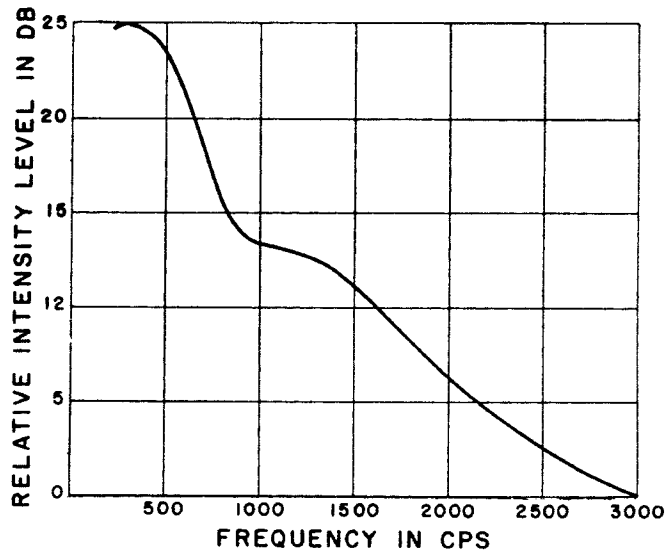

TM685-20

Figure 20. Power distribution in speech frequencies with low and high frequencies removed.

ping, the voice signal waveshape approaches a series of square waves. Since an ssb square-wave envelope requires infinite amplitude as well as infinite bandwidth for reproduction, the audio must be clipped carefully. In an ssb transmitter, automatic load control rather than clipping is used to control the average power level input and to prevent overdriving the power amplifier. Clipping is used to remove the occasional power peaks.

e. Speech-processing methods for single-sideband transmission are continually being reinvestigated to determine the most suitable method or combination of methods. At present, several circuits used in ssb transmitters perform some speech-processing functions. The purpose of most of these circuits is to process the input signal to increase average output power and to prevent overdriving the power amplifier. These circuits and their functions are as follows:

- (1) *Automatic load control* maintains signal peaks at the maximum rating of the power amplifier.
- (2) *Speech compression, with some clipping*, maintains a constant signal level to the single-sideband generator.
- (3) *Highly selective filters* are used in filter-type ssb exciters to attenuate some of the high-power, low-frequency components of the voice signal.

f. There are also several speech-processing circuits under investigation which, if effective and practical, will be used to improve the efficiency of voice transmission. These circuits will function as follows:

- (1) Increase audio clipping with additional filtering to remove the harmonics generated.

- (2) Reduce the power level of frequencies below 1,000 cps by shaping the audio-amplifier characteristics for low-frequency attenuation.
- (3) Use speech clipping at an intermediate-frequency level where the generated harmonics can be filtered without much difficulty.

Section IV. SIDEBAND FILTERS

19. General

a. Single-sideband transmitters, employing the *filter method* of ssb generation, and ssb receivers require highly selective filter circuits for proper operation. Most ssb transmitters use filter networks that act in the frequency range of 100 kc to 500 kc (dependent on carrier-generator frequency). The filter pass band restricts the single-sideband bandwidth within specified limits and rejects the unwanted sideband, the residual carrier frequency, and the spurious frequencies generated in the modulator. In an ssb receiver, the sideband filter finds application in the rejection of adjacent channel interference and undesirable mixer products. Sideband filters designed to meet the needs of ssb transmitters and receivers have a very steep skirt characteristic and a flat bandpass characteristic. A sideband filter can be either inductive-capacitive (lc), crystal, or mechanical in composition. Ceramic-type filters are presently in a latter stage of development.

b. Inductive-capacitive filters have been used in the past to produce ssb signals at intermediate frequencies of about 20 kilocycles. Equipments operating on the lower-frequency bands in the early days of experimental and commercial ssb transmission used lc filters to provide necessary bandpass and rejection. At the present time, most of the ssb transmissions are centered in the high-frequency part of the radio spectrum. The desired highly selective characteristics cannot be obtained satisfactorily in an lc filter; therefore, it would be necessary to generate an intermediate ssb signal at about 20 kc. Lc filters become impractical because of the number of mixing operations required in the conversion of the IF signal (20 kc) to the much higher transmitter output frequency.

c. Crystal filters, in general, have the high Q and excellent stability characteristics necessary for adaptation to ssb transmitters and receivers. Crystal filters used in early ssb equipments were large and bulky and were limited to a maximum operating frequency of 100 kc. Their large size made them vulnerable to shock and vibration, thus limiting their use to large fixed-station installations. Recent developments have scaled down crystal filter components considerably and have extended the filter operating frequency limit above 5 mc. These filters are used in many new equipments that are designed for the hf and vhf portions of the radio spectrum. Figure 21 illustrates a crystal filter that is relatively small in size (compared with a miniature vacuum tube).

d. Recent advances in the development of electromechanical filters have resulted in their acceptance as sideband filters in ssb equipments. Electromechanical filters, commonly called mechanical filters, are used in a variety of military communication transmitters and receivers. These filters, small enough to be used in vehicular or avionics equipment, are extremely rugged and have excellent rejection characteristics. Figure 22 illustrates a typical mechanical filter and shows the relative size of the unit.

20. Crystal Filters

a. The crystal-lattice filter is a commonly used sideband crystal filter circuit. A typical crystal-lattice filter circuit is illustrated in figure 23. The filter consists of two pairs of identical crystals (Y1 and Y2, Y3 and Y4) connected between input and output transformers T1 and T2. Crystals Y1 and Y2 are series-connected and Y3 and Y4 are shunt-connected. Each pair of crystals is matched in frequency,

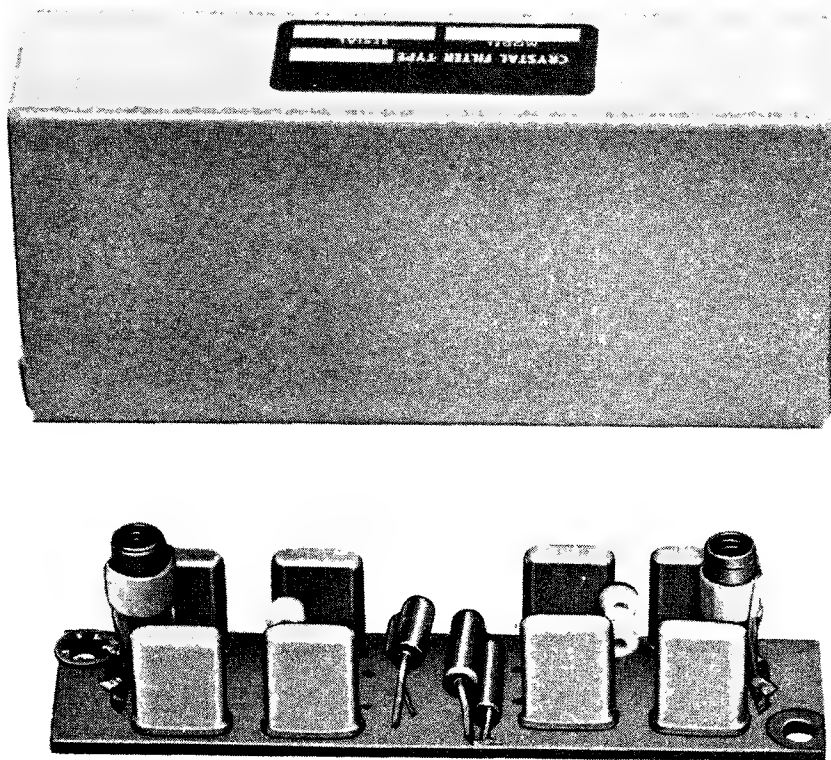

TM 685-21

Figure 21. Crystal sideband filter.

within 10 to 20 cps of each other. As an example (fig. 25), assume an intermediate frequency of 100 kc and upper sideband frequencies of 100.1 kc to 103 kc. To pass this band of frequencies, series-connected crystals Y1 and Y2 are 100.1-kc crystals and the shunt-connected crystals Y3 and Y4 are 103-kc crystals. Input and output transformers T1 and T2 are tuned to the center frequency of the pass band (101.5 kc) and act to spread the difference between the series-resonant and parallel-resonant frequencies of the crystals. Capacitors C1 and C2 are used to correct any overspreading of frequency difference under matched crystal conditions. Although figure 23 shows only a single-section crystal filter, in actual practice, at least two sections of filters are required for complete rejection of unwanted frequencies.

b. The operation of the crystal filter is similar to the operation of a bridge circuit. When the reactances of the bridge arms are equal and have the same sign (inductive or capacitive), the signals through the two possible paths of

the bridge will cancel out. When the reactances are of opposite sign, there will be partial transmission through the network. The maximum signal is transmitted in the pass band at the points where the reactances are equal in amplitude and opposite in sign.

c. Figure 24 illustrates a typical attenuation curve for a crystal-lattice filter. The maximum attenuation occurs at frequencies slightly less than 100.1 kc and at frequencies slightly higher than 103 kc. The insertion loss of a crystal-lattice filter varies from 1.5 db to 3 db. Insertion loss of a filter is the ratio of power in the output impedance with the filter out of the circuit to the power in the output impedance with the filter in the circuit.

21. Mechanical Filters

a. Although the use of mechanical filters is relatively new, the basic principles upon which they operate are well-established. The mechanical filter is a mechanically resonant device

which receives electrical energy at its input, converts it into a mechanical vibration, and then converts the mechanical vibration back into electrical energy at its output. The mechanical filter consists of four basic elements (fig. 25). The four elements are described in order along the signal flow path.

- (1) The input transducer coil, bias magnet, and magnetostrictive driving rod, which convert the electrical energy input into mechanical oscillations (vibrations).
- (2) The mechanically resonant metal disks.

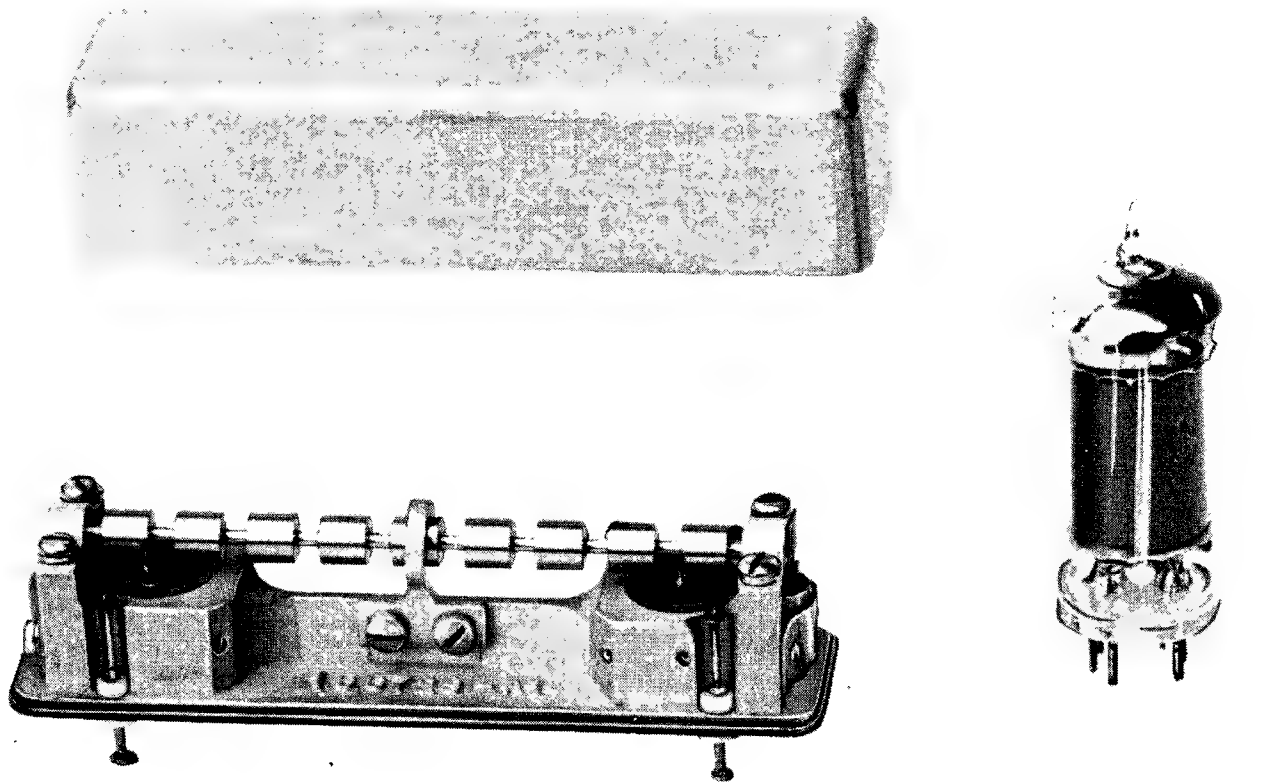
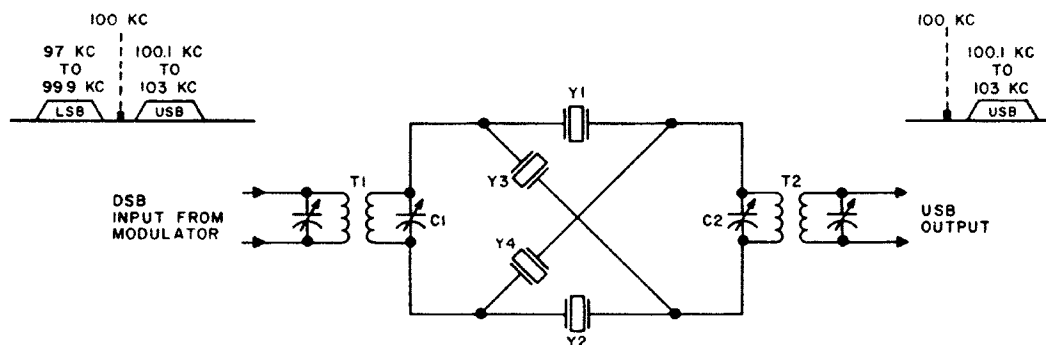

Figure 22. Mechanical sideband filter.



- NOTES.
1. Y1 AND Y2 ARE 100.1 KC
 2. Y3 AND Y4 ARE 103 KC.
 3. T1 AND T2 ARE TUNED TO 101.5 KC

TM685-23

Figure 23. Crystal-lattice filter, schematic diagram.

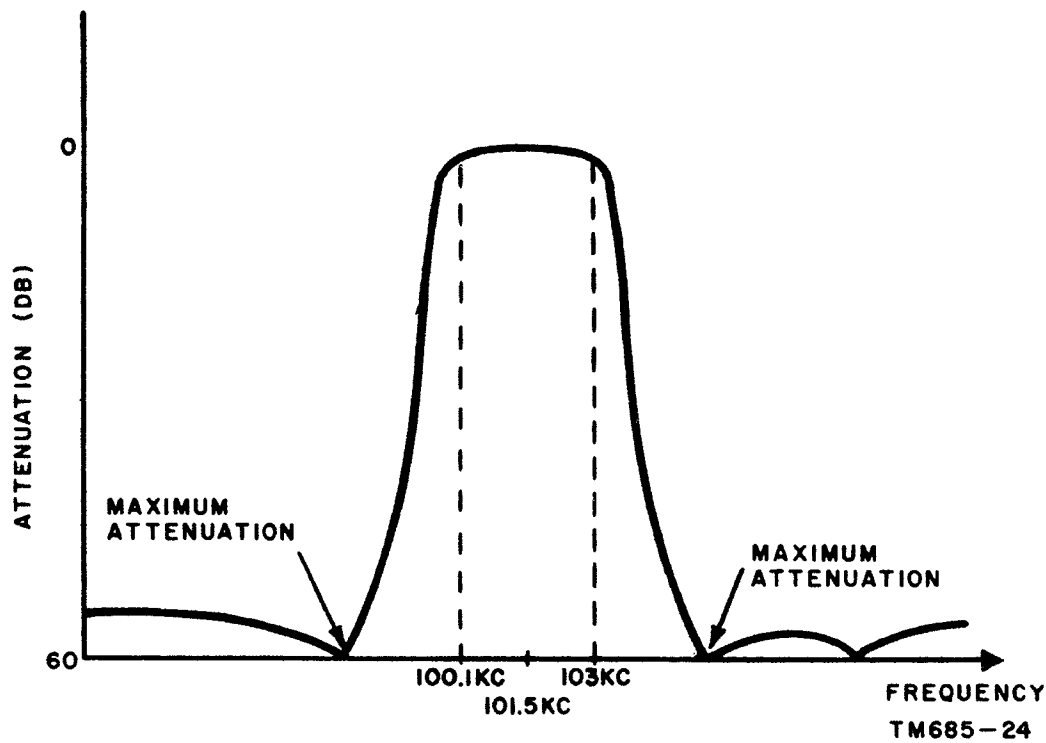

Figure 24. Crystal filter, characteristic curve.

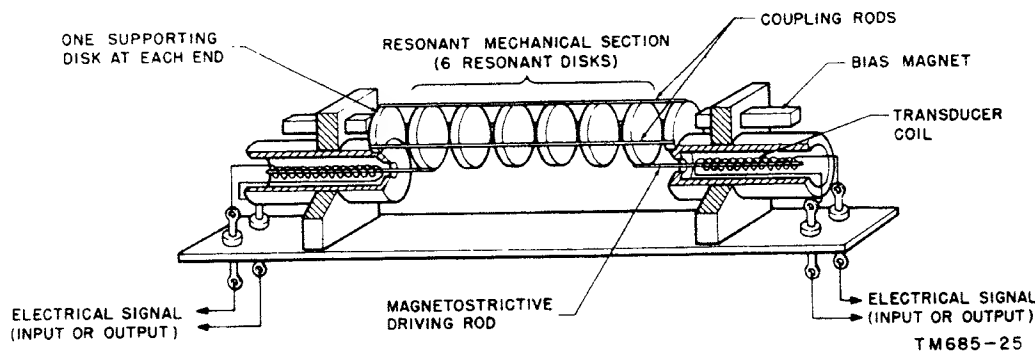

Figure 25. Elements of mechanical filter.

- (3) The coupling rods which couple the metal disks.
- (4) The output transducer coil, bias magnet, and magnetostrictive rod, which convert the mechanical oscillations back into electrical energy.

b. In the electrical analogy of the mechanical filter illustrated in figure 26, series-resonant circuits $L_1 C_1$ represent the metal disks. The coupling capacitors C_2 represent the coupling rods, and the input and output resistances R represent the matching mechanical loads. From this equivalent circuit, it is seen that the center frequency of the mechanical filter

is determined by the series-resonant circuit formed by $L_1 C_1$, which represents the metal disks.

c. The transducers may be either magnetostrictive devices or electrostrictive devices. The magnetostrictive transducer is based on the principle that certain materials elongate or shorten when in the presence of a magnetic field. Therefore, if an electrical signal is sent through the transducer coil containing the magnetostrictive material as the core, the electrical oscillation will be converted into mechanical vibrations of the core material. The mechanical vibration then drives the mechanical

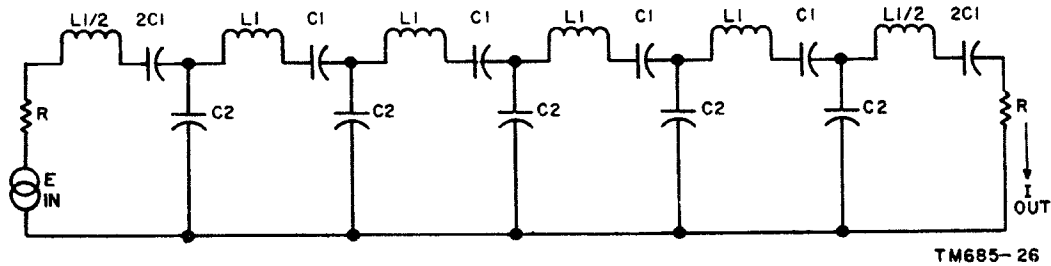

Figure 26. Electrical analogy of mechanical filter.

elements of the filter. The electrostrictive transducer is based on the principle that certain materials, such as piezoelectric crystals, will distort when subjected to an electric field. In practice, the magnetostrictive transducer is more commonly used. The transducer converts electrical energy into mechanical energy at the input to the mechanical filter and acts in the reverse order at the output. It also provides proper termination for the mechanical network.

d. Each disk in a mechanical filter represents a series-resonant circuit; therefore, increasing the number of disks increases skirt selectivity of a filter. The shape factor, the ratio of bandpass 60 db below peak to bandpass 6 db below peak, determines the skirt selectivity (fig. 27). Present filters have a limit of eight or nine disks. A six-disk filter has a shape factor of approximately 1.85. A nine-disk filter has a shape factor of approximately 1.5. The future development of mechanical filters promises even greater skirt selectivity.

e. In the electrical analogy (fig. 26), coupling capacitors C_2 are the equivalents of the rods which couple the disks. By varying C_2 , the bandwidth of the equivalent circuit is changed. Variation in thickness of the coupling rods also affects the bandwidth of the mechanical filter. Because the bandwidth changes approximately with a change in the total area of the coupling rods, an increase in bandwidth can be obtained by using larger coupling rods, having more surface area, or a greater number of coupling rods. Mechanical filters with bandwidths as narrow as 0.5 kc and as wide as 35 kc are practicable in the 100-kc to 500-kc range.

f. Although an ideal filter would have a flat nose or pass band, practical limitations prevent the ideal from being attained. The term *ripple amplitude* or *peak-to-valley ratio* is used to

specify the nose characteristic of the filter. The peak-to-valley ratio is the ratio of maximum-to-minimum level of the ripple across the useful bandpass of the filter (fig. 27). A peak-to-valley ratio of 3 db can be obtained on a production basis by careful control of materials and assembly. Mechanical filters with a peak-to-valley ratio of 1 db can be produced by accurate adjustment of filter elements during manufacture.

g. Spurious frequencies (undesirable responses) appear in the output of a mechanical filter because of mechanical resonances that occur outside of the filter pass band. By proper design, spurious mechanical resonances can be kept far enough from the pass band to permit

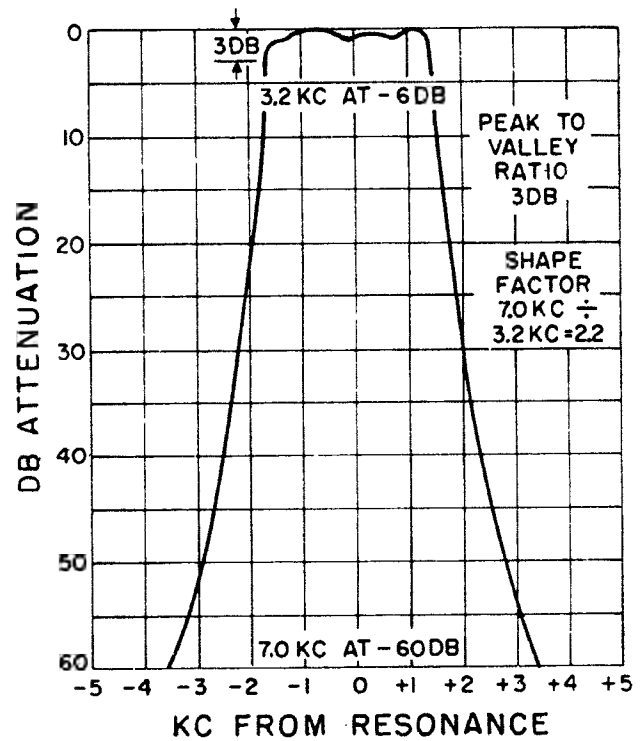

Figure 27. Mechanical filter, characteristic curve.

tuned circuits later in the system to attenuate these frequencies.

h. Mechanical filter characteristics of importance include insertion loss, transmission loss, input impedance, and output impedance. Because the input and output transducers of the mechanical filter are inductive, capacitors shunted across the coils are used to resonate the input and output impedances at the filter center frequency. With the addition of the capacitors, the input and output impedances are largely resistive and range in value from 1,000 ohms to 50,000 ohms. The insertion loss, measured under matched conditions (input and output), ranges between 2 db and 16 db and is dependent on the type of transducer. The transmission loss is an indication of the filter loss with source and load impedances

mismatched. The transmission loss is important when using a mechanical filter in pentode if. amplifiers, where both source and load impedance are much greater than the filter input and output impedances.

i. Mechanical filters other than the disk type are presently being used. One such filter is the plate type, which consists of a series of flat plates assembled in a ladder arrangement. Another type which has recently been developed is the neck-coupled type. This filter consists of a long cylinder turned down at regular intervals to form the necks which couple the remaining raised sections of the cylinder. The raised portions or slugs are the resonating elements of the filter. All mechanical filters are similar in that they function on the principle of mechanical resonance.

CHAPTER 2

SINGLE-SIDEBAND EXCITERS

Section I. GENERAL

22. Introduction

a. A typical single-sideband exciter performs three basic functions: It generates a single-sideband signal at an intermediate frequency when the circuits involved are activated by a modulating signal and an RF carrier frequency, raises the intermediate ssb frequency to the RF output frequency of the transmitter, and amplifies the ssb signal to furnish the necessary drive for the RF power amplifier. To explain the operation and theory of these three functions, the ssb exciter is divided into three major sections: the sideband generator, the frequency translator (consisting of mixers and amplifiers), and the linear amplifiers.

b. Two methods of generating an ssb signal at a level sufficient to excite the rf power amplifier in an ssb transmitter are the *filter method* and the *phase-shift method*. The two methods differ in the means of carrier suppression and the need for frequency translation to a higher frequency before application of the ssb signal to the rf power amplifiers. The filter method is given wider coverage in this manual. A phase-shift exciter is fully described in paragraph 30.

23. Filter-Type Ssb Exciter (fig. 28)

The block diagram in the figure is an example of a filter-type ssb exciter that is used to drive the rf power amplifiers of an ssb transmitter. To simplify the discussion, no reference is made to the *locking* of the carrier and mixing frequencies to a single crystal frequency standard. This paragraph will follow the flow of modulating and mixing frequencies in the exciter without becoming involved with frequency standards and frequency stability at this time. System dependency on rigid fre-

quency stability requirements and circuits that fulfill these requirements are described in chapter 5. The frequencies shown on the figure are only examples; in practice, frequencies depend on the system used.

a. *Sideband Generator*. The audio-modulating signal is applied to the audio amplifier. This amplifier contains the audio-processing circuits (compressor, clipper, filter) that shape the characteristics of the audio signal to fit the requirements of the ssb system. After processing, the audio signal is fed to the balanced modulator for combination with the radiofrequency carrier signal. The carrier generator supplies the radiofrequency (250 kc) that is injected into the balanced modulator. The output of the balanced modulator, consisting primarily of the sideband frequencies (the carrier wave is suppressed by the balanced modulator action), passes through the sideband filter. The sideband filter selects either an upper or lower sideband for application to the frequency translator.

b. *Frequency Translator*. The low-frequency ssb signal generated and filtered in the sideband generator is converted to the final operating frequency in the frequency translator. The final operating frequency is arrived at by using one or more mixing (heterodyning) operations. In the double-conversion translator (fig. 28), the low-frequency ssb signal input to the translator is injected into the medium-frequency (mf) mixer to beat with a locally generated frequency from a variable-frequency oscillator (vfo). The vfo is variable in frequency from 2,750 kc to 3,750 kc. The sum frequencies pass through the tuned circuits at the output of the selective amplifiers. The filtering action of the tuned circuits removes unwanted spurious frequencies generated in the preceding stages. The range of frequencies from the selective

amplifier (3 to 4 mc) can be the final operating frequencies. The signal output of the selective amplifier is fed to the high-frequency mixer to beat with one of two fixed frequencies generated by a crystal oscillator. The crystal oscillator can be switched to either 4 mc or 11 mc. Application of the 4-mc crystal frequency to the hf mixer results in a final operating range of 7 to 8 mc. Switching to injection of the 11-mc oscillator frequency furnishes a final operating range from 14 to 15 mc.

c. *Linear Amplifiers.* The linear amplifiers in the amplifier section of an ssb exciter raise the power level of the signal to that required to drive the rf power amplifier. The low-level modulated ssb signal requires processing by highly linear amplifiers to limit the introduc-

tion of distortion products in addition to the undesirable mixer products. The broken line that ties into the vfo, selective amplifier, and linear amplifiers indicates ganged tuning of the inductance-capacitance circuits of the individual blocks. This ganging provides tracking the vfo and amplifiers to realize the maximum in output and efficiency of the exciter.

24. Phase-Shift Exciter

The principle of generating a single-sideband signal by the phase-shift method is the use of two separate and simultaneous modulation processes and the combination of the modulation products (fig. 29). The audio signal is split into two components that differ by 90°.

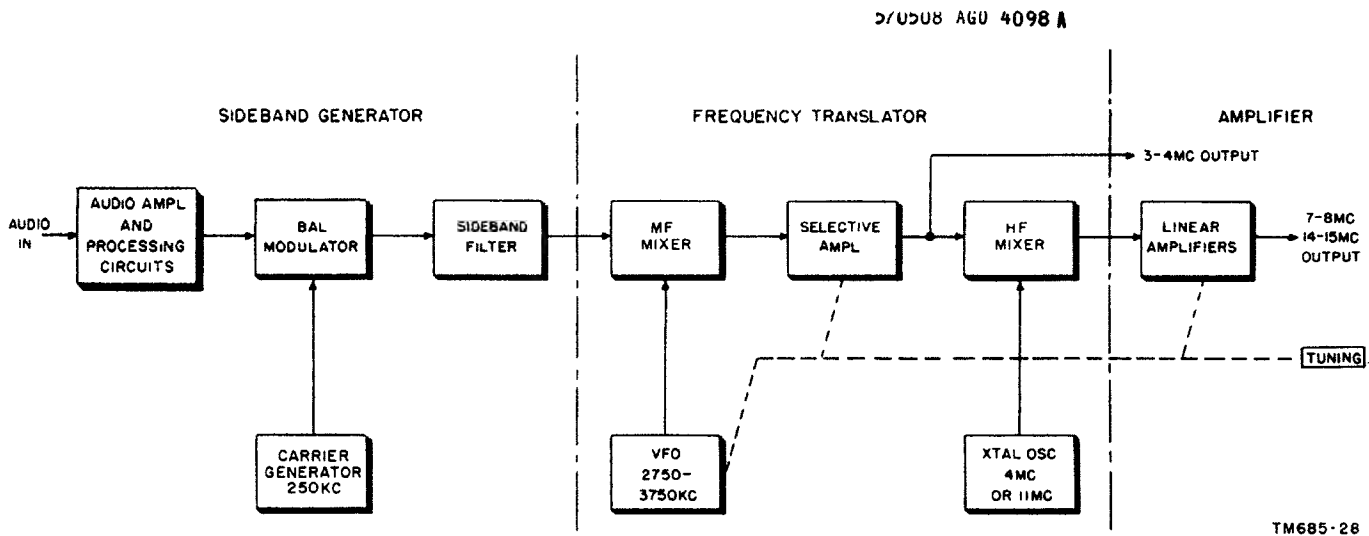

Figure 28. Single-sideband exciter, functional diagram.

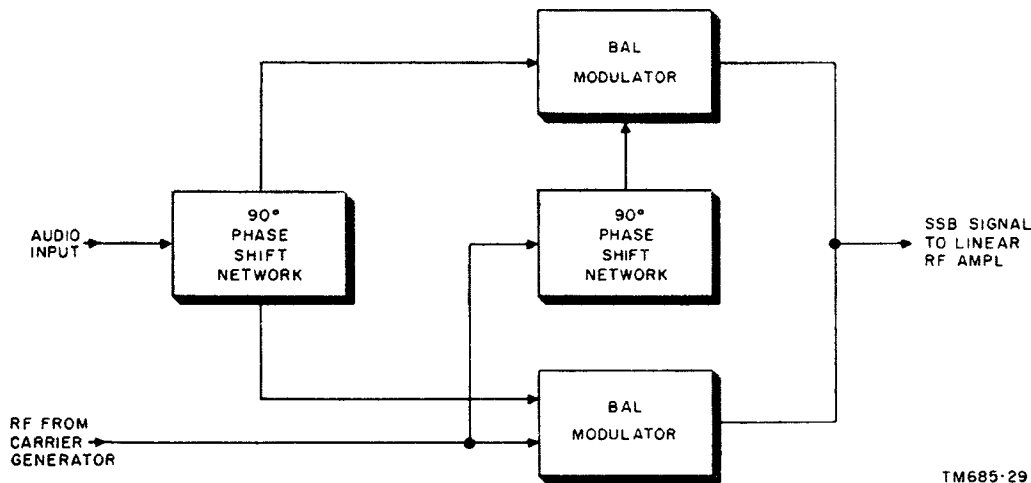

Figure 29. Basic phase-shift exciter, block diagram.

The output of the carrier generator (RF) is also split into two components having a 90° phase difference. One RF and one audio component are combined in each of the two balanced modulators. The relative phases of the sidebands are such that one sideband is balanced out while the other sideband appears in the output. The RF carrier frequency to the

exciter can be the same as the final operating frequency; this eliminates the need for frequency-translation stages. The output of this exciter is either fed to the linear amplifiers for further amplification or applied directly to the rf power amplifier. A more detailed analysis of the phase-shift exciter appears in paragraph 30.

Section II. SIDEBAND GENERATOR

25. Audio Signal Processing

a. Processing of the audio signal is important in generating single-sideband signals. A single tone, or group of tones, of constant amplitude (such as the signal from a data-gathering device), requires only a limited degree of processing. However, if the modulating signal is a complex voice signal, audio processing circuits are necessary to obtain the best results.

b. As discussed in paragraph 18, most of the energy content of a voice signal is confined to frequencies below 1,000 cycles per second. These low audio frequencies are responsible for the vowel sounds and contribute little to the intelligibility of speech. The consonant sounds are largely higher audio frequencies and make up the intelligence portion of the voice signal. Intelligibility of a voice signal is improved by amplifying the high frequencies more than the low frequencies. This can be accomplished by preemphasis of the high-frequency sounds (consonants) in the audio signal processing circuits before application to the balanced modulator of the single-sideband generator.

c. The amount of audio amplification required for injection into the balanced modulator depends on the voltage at the voice-signal source and the input-signal voltage requirements of the modulator. Since most modulators require an audio signal from 0.1 to 1 volt, the output of a microphone or a telephone line is amplified 100 to 1,000 times to reach the required voltage level. To avoid overloading of the power amplifiers, the gain of the audio amplifiers is adjusted to a point where maximum output is obtained at the peaks of the audio signal.

d. With peak-to-average audio signal voltage variations of 4 to 1 or 12 db (fig. 30), the aver-

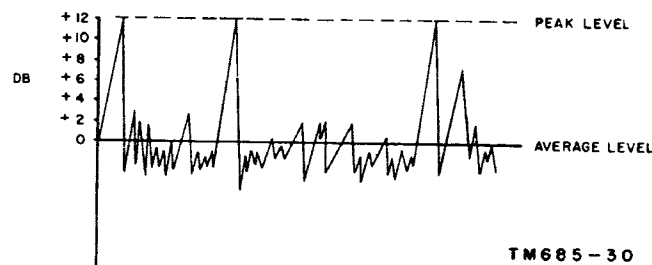

Figure 30. Peak-to-average level variations of speech.

age transmitter power level is only one-fourth the maximum power output (down 6 db) than the transmitter is capable of producing. To raise the average power of the transmitter, the dynamic range of the audio signal is reduced. Two methods commonly used to limit the dynamic range are compression and clipping.

26. Compressor Circuit

A compressor is a variable-gain amplifier, containing a feedback loop that samples the amplifier output to regulate the amplifier gain. The circuit time constants are long to prevent motorboating and distortion in the output of the amplifier. Audio signal amplitude compression of about 10 db is possible with circuits of this type.

a. The compressor circuit (fig. 31) consists of an af amplifier V1, of buffer V2, and full-wave rectifier V3. Tube V3 rectifies the output of af buffer V2 and applies the voltage developed across R1 and C1 as bias to the control grid of af amplifier V1. A signal impressed on the control grid of V1 is amplified by V1 and V2 and appears at the secondary of transformer T2. The signal applied to the cathodes of rectifier V3 causes the diodes to conduct in a direction that makes the voltage in the feedback loop negative with respect to ground. This negative voltage, when applied to the grid

circuit of an af amplifier V1, reduces the gain of that tube and lowers the audio-output signal of the compressor.

b. The combination of R1 and C1 filters the negative control voltage output of rectifier V3. Resistors R2 and R3 form a voltage divider that supplies a delay voltage to the cathodes of V3. This voltage delays rectifier conduction until a signal voltage greater than the delay voltage appears across each half of the secondary of transformer T2. The ratio of R2 to R3 is adjusted to allow conduction of rectifier V3 on large amplitude signals only. This results in normal af amplifier gain for weak or average signals and reduced gain for large signals. The dynamic range (peak-to-average level) of an audio signal is decreased by processing the signal in a compressor circuit.

c. In figure 31, the potentiometer across the secondary of T1, at the input of V2, is a variable audio takeoff control. The voltage present between the variable arm and ground is fed to succeeding audio stages for further amplification. Bias for V1 and V2 is developed across the resistor in the cathode circuit of each tube. The capacitor across each cathode resistor bypasses the ac components in the cathode currents of V1 and V2. The capacitor from the audio-input point to the grid of V1 couples the audio signal to V1. The resistor in the grid circuit of V1, and in series with the feedback loop, prevents shorting out of the audio-input signal by C1.

27. Clipper Circuit

The clipper circuit limits the amplitude of a signal to a predetermined level by clipping the signal waveform peaks. The clipper circuit differs in operation from the compressor circuit in that the amount of distortion introduced by the amplitude limiting action causes a loss in clarity of speech and widens the spectrum content in the audio waveform. Low-pass filters at the output of a clipping circuit tend to reduce the effects of this distortion by rejecting the higher-frequency components in the processed audio signal. The only apparent advantage of a clipper is simplicity of circuit arrangement and the use of comparatively few components. For a detailed analysis of some basic clipper circuits, refer to TM 11-665.

28. Balanced Modulators

In a single-sideband transmitter, the carrier can be suppressed by using either extremely sharp cutoff filters or balanced-modulator circuits. A sharp cutoff filter that provides sufficient attenuation of a carrier so close to its pass band is difficult to design. The balanced modulator combines carrier suppression with its modulator function; therefore, the balanced modulator has come into widespread use. The basic principle of a balanced modulator is the introduction of the RF carrier in such a way that it does not appear in the output of the stage. There is an output signal, however, when both the audio modulation and the rf

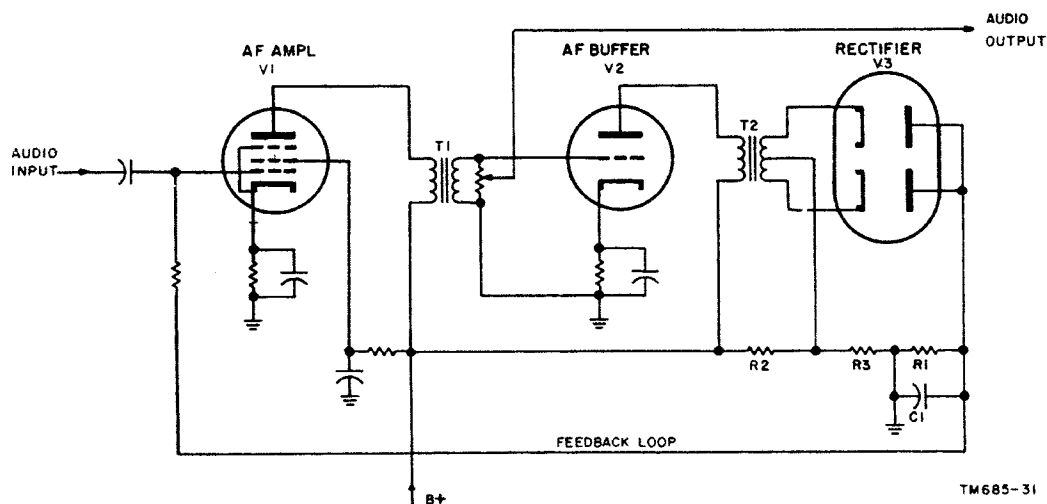

Figure 31. Compressor circuit, schematic diagram.

carrier signals are present at the same time at the modulator input. This output signal consists of only the upper and lower sideband frequencies generated by the mixing of the two input signals in the balanced modulator. The original audio and RF inputs are suppressed because of the operational characteristics (rf-tuned output and balancing action) of this type of circuit. There are two basic configurations of balanced-modulator circuits: the configuration using diodes and that using amplifier vacuum tubes. Diode-balanced modulators will be discussed first, since their operation is relatively simple to understand.

a. Diode-Balanced Modulators. Semiconductor diodes are well-suited for use in diode-balanced modulator circuits. They are very stable, require no external power source, have long life, and need very little maintenance. Semiconductor diodes can be connected in either a balanced-bridge or a lattice or ring-type balanced modulator circuit arrangement. The basic circuits of the balanced bridge and the lattice or ring-type modulator are shown in figure 32 and 33. The output of the two modulator circuits consists of a series of rf pulses, the repetition rate of which is determined by the switching or rf carrier frequency and the amplitude of which is controlled by the level of the audio-modulating signal. An analysis of the frequency components of the pulses in the modulator output reveals the presence of an upper sideband and lower sideband, above and below the carrier frequency. The carrier is suppressed and does not appear in the composite modulator output signal.

(1) *Balanced-bridge modulator.* The operation of a balanced-bridge modulator (fig. 32) completely depends on the switching action of the diodes (D_1 through D_4 under the influence of two separate voltages simultaneously applied to the circuit across opposite pairs of bridge terminals. The carrier-controlled switching action for each half cycle either forward biases (low resistance) or reverses biases (high resistance) the diodes.

(a) In the equivalent circuit (A, fig. 32), E_c is the carrier voltage applied to the bridge (terminals A

and C) through carrier-generator source resistance R_c . The modulating signal voltage (E_s) is fed to terminals B and D through its source resistance R_s . The modulated output signal develops across load resistance R_L . The semiconductor diodes are D_1 through D_4 .

(b) Assume, upon starting of the carrier and the modulating signal generators, that both are applying a positive half cycle of voltage to their respective terminal pairs. As shown in A, the RF carrier voltage makes terminal C of the bridge negative with respect to terminal A. This voltage reverse biases (high resistance) diodes D_1 through D_4 and presents a virtual open circuit to the modulating signal voltage applied between B and D. In B, the modulating signal voltage drives a pulse of current I_L through load R_L . The direction of this pulse of current depends on the polarity of the modulating signal and does not involve the polarity of the carrier signal. Current flows through the load for the duration of the positive half cycle of carrier voltage as indicated by the dark area in D. Although the carrier does not appear in the modulator output, it is shown in D to illustrate the basic modulator principle.

(c) During the negative half cycle of carrier voltage, terminal C of the bridge is positive with respect to terminal A (A, fig. 32). When the terminals are thus polarized, the diodes are forward biased (low resistance) and the bridge short circuits the modulating signal voltage applied between terminals B and D. In C, the path of modulating signal current flow is through the closed switch (forward-biased diodes), completely shunting load R_L . The waveform in D indicates the absence of current in the load for the negative half cycle of carrier voltage.

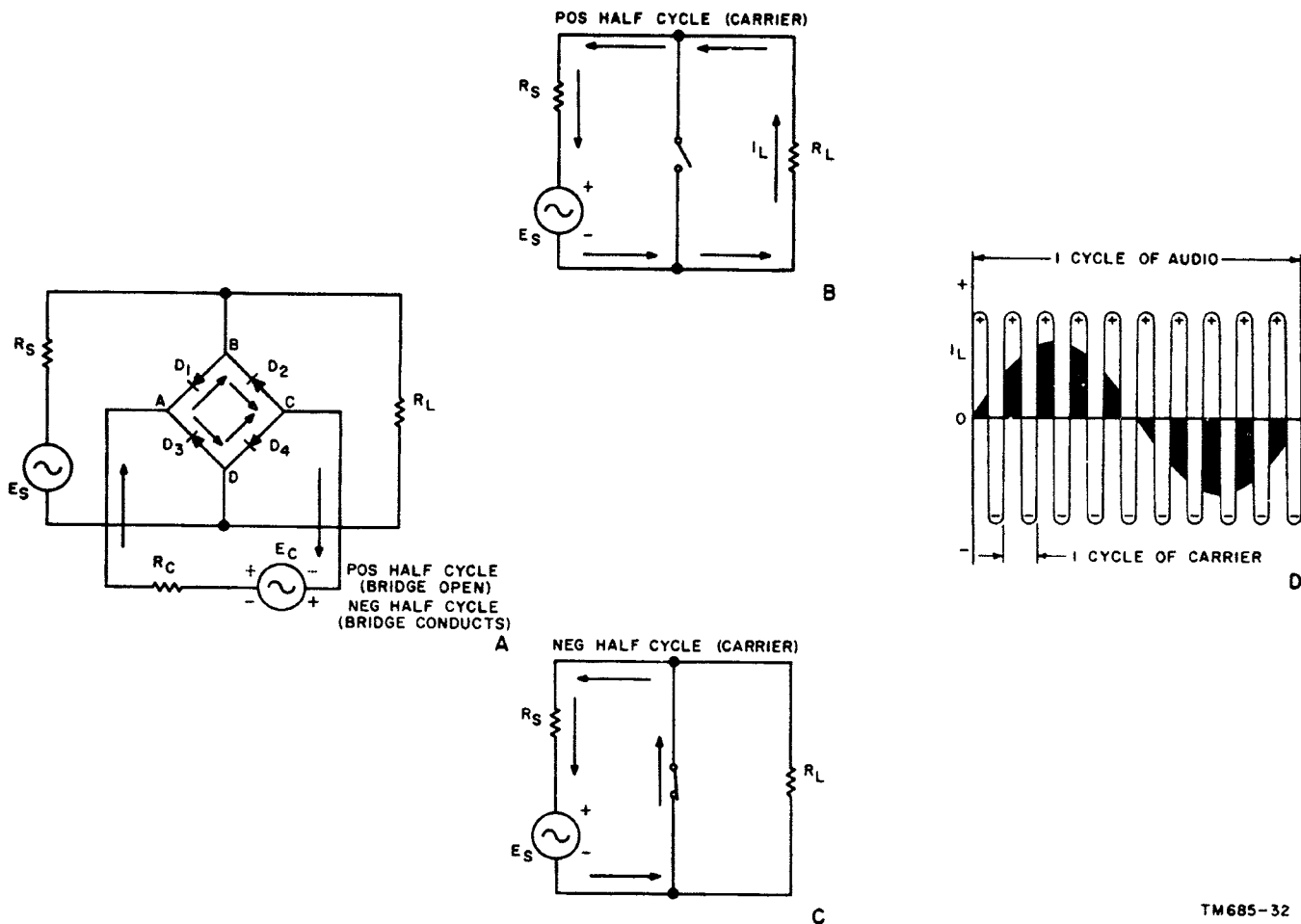

TM685-32

Figure 32. Basic balanced-bridge modulator, equivalent circuits and output waveform.

- (d) The pulses of output current (D, fig. 32) follow the amplitude and direction of the modulating signal waveform. Since no carrier current flows in the load because of the balanced-bridge action, the output waveform consists of a series of pulses (dark areas in D) that are mainly a composite of the upper and lower sideband frequencies.
- (2) *Lattice or ring-type balanced modulator.* The lattice or ring-type balanced modulator (fig. 33) is capable of developing twice the output voltage of a balanced-bridge modulator. The operation of a lattice modulator depends on alternate switching of series or parallel diode pairs to provide pulses of current that are periodically changing in polarity with each switching alternation.
- (a) In the basic circuit (A, fig. 33),

E_C is the applied carrier voltage and R_C is the carrier generator source resistance. The audio signal (E_S) is supplied through generator source resistance R_S . Transformer T_1 is an input transformer with the secondary center tapped to allow connection to one leg of the carrier generator. Transformer T_2 is the modulator output transformer with the primary center tapped to permit connection to the remaining leg of the carrier generator. The secondary of T_2 supplies current to load R_L . Diodes D_1 and D_2 are the series-connected diodes in the circuit. Diodes D_3 and D_4 , although not directly shunting either transformer T_1 or T_2 , are considered as the parallel-connected diodes.

- (b) Assume, on starting of the modulator, that a positive half cycle of

RF carrier voltage is applied between the center taps of T_1 and T_2 (A, fig. 33). The polarity of the carrier-generator output, as indicated in the illustration, forward biases (low resistance) D_1 and D_2 (series diodes) and reverse biases (high resistance) D_3 and D_4 (parallel diodes). Highly conductive D_1 and D_2 establish two paths for rf carrier current flow. In A, current flow (shown with solid arrows) is in opposite directions through the halves of the tapped windings of T_1 and T_2 . If D_1 and D_2 are exactly matched, equal and opposite rf carrier currents flow through the two paths and no rf carrier voltage is transferred to load R_L through T_2 ; neither is any rf energy reflected into the source of the audio signal by T_1 .

- (c) The equivalent circuit (B, fig. 33) illustrates the condition that exists upon application of a positive half cycle of carrier voltage. Forward-biased D_1 and D_2 are represented by closed switches and reverse-biased D_3 and D_4 are equivalent open switches. The audio signal is assumed to be impressing voltage E_s (polarity as indicated) on the circuit through internal source resistance R_s . The arrows in B outline the path and direction of the pulse of audio signal current I_1 that flows through load R_L . The position of this initial pulse of current I_1 in the modulator output waveform is indicated in D. Note that the duration of the pulse of current I_1 is controlled by the width of the half cycle of rf carrier voltage E_c .
- (d) To complete the explanation of circuit operation, consider the interchange of the state of conduction of the diode pairs that occurs when the negative half cycle of RF carrier voltage is introduced. Now D_3 and D_4 are forward biased (low resistance) and D_1 and D_2 are reverse

biased (high resistance). The broken arrows in A, figure 33, show the direction and the two separate paths of carrier current flow through D_3 and D_4 (forward-biased diodes). Note that the opposing directions of rf carrier current flow parallel the situation that existed for the positive half cycle of rf carrier voltage (*b* above). Opposite directions of rf carrier flow through the upper and lower sections of the tapped windings of T_1 and T_2 cause no transformation of rf carrier energy either to load R_L or back into the audio signal source.

- (e) The equivalent circuit (C, fig. 33) shows the direction of the second pulse of current I_2 and the path travelled by this current. Equivalent switches D_1 and D_2 (reverse-biased diodes) are open; D_3 and D_4 (forward-biased diodes) are closed and complete the path for the second pulse of output signal current I_2 . Although the audio signal is of the same polarity as that for current I_1 , switching of the states of the diode pairs has reversed the direction of current flow through load R_L . The position of this second pulse of current I_2 in the modulator output waveform is shown in D. As for I_1 , the duration of the pulse of current I_2 is controlled by the width of the rf carrier half cycle. Note that the amplitude of each pulse depends on the waveshape and voltage of the audio signal.
- (f) The pulses of output current that comprise the output waveform in D follow the amplitude variations in the audio signal and are alternately reversed in direction as each half cycle of rf carrier voltage switches the conducting states of the diode pairs (D_1 - D_2 and D_3 - D_4). The output waveform is characteristic of the double-sideband, suppressed-carrier waveshape (fig. 13) and is composed of upper and lower sideband frequencies.

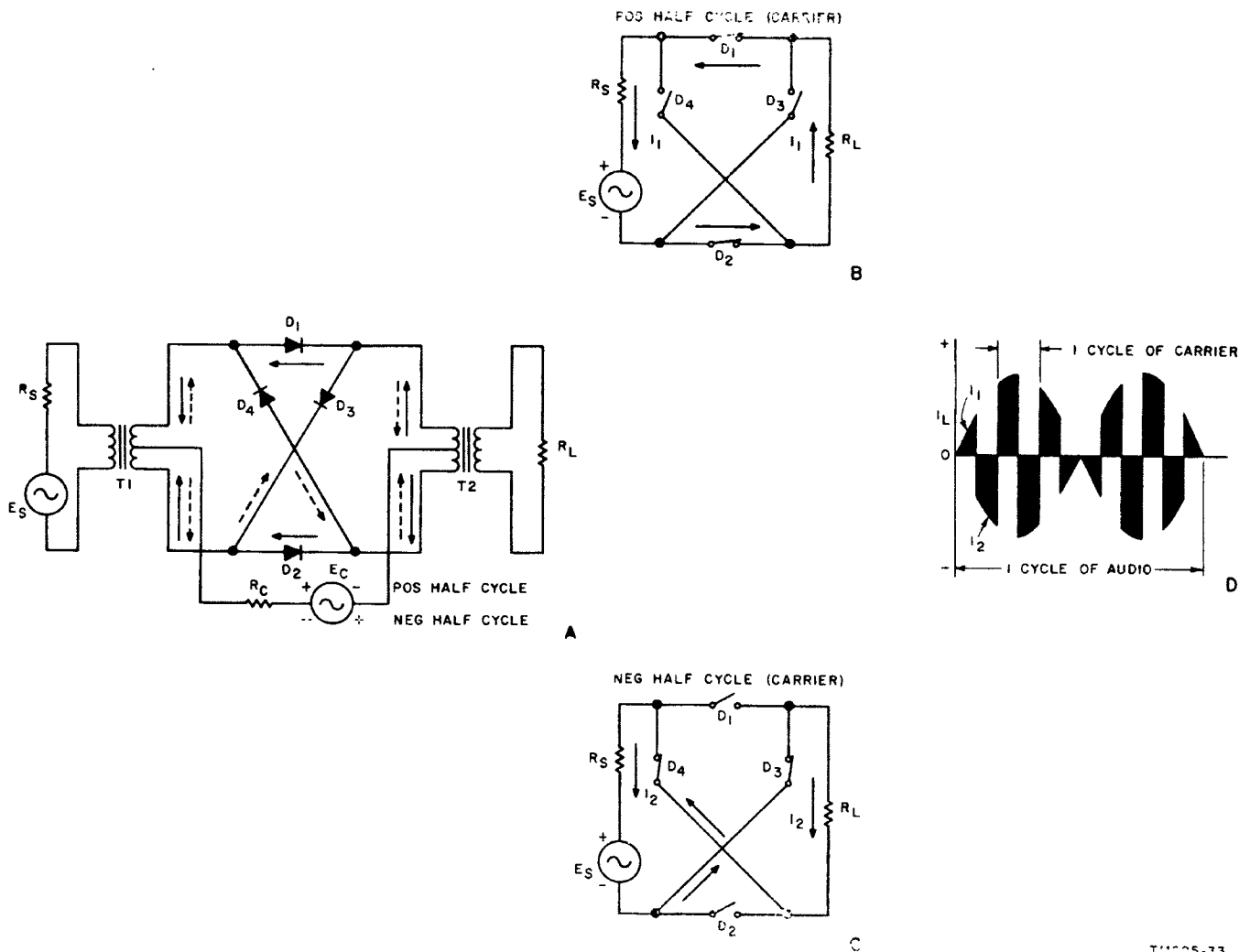

Figure 33. Basic lattice or ring-type balanced modulator.

b. *Amplifier-Type Vacuum-Tube Balanced Modulators.* Many methods are possible for combining audio and carrier signals, using vacuum-tube circuits to produce suppressed-carrier, double-sideband signals. To accomplish the modulation of one signal by another, the vacuum tubes are operated on the nonlinear portion of their transfer characteristic curves. Vacuum tubes used in balanced-modulator circuits can be either triodes, tetrodes, or pentodes. As described in earlier paragraphs, balanced-modulator circuits produce no output with application of carrier voltage only. Audio voltage, injected into the circuit the same time as the carrier voltage, produces the upper and lower sideband frequencies in the output of the modulator (carrier suppressed).

(1) One type of vacuum-tube balanced modulator is illustrated in figure 34.

In this circuit, the rf carrier is introduced in parallel, and the audio signal in push-pull; the modulator plate circuits are connected in push-pull. In the parallel connection, equal and in-phase RF carrier voltages are applied to the control grids of the balanced-modulator tubes. If only the carrier is present, there is no output from the modulator, because this signal is balanced out or canceled in the push-pull plate circuits.

(2) As an example, consider a positive half cycle of rf carrier applied to both control grids at the same time. The positive signal causes both tube plate currents to change by equal amounts and develop equal and opposite voltages across upper and lower halves

of the output transformer primary. The opposite polarity and equal amplitudes of the two plate circuit signals result in cancellation of the carrier in the balanced-modulator output. Injection of the audio signal in push-pull, with the carrier signal applied in parallel, furnishes upper and lower sideband frequencies in the output (carrier suppressed).

29. Sideband Selection

The output of the balanced modulators discussed in paragraph 28 is a double-sideband signal consisting of a pair of sidebands equally spaced above and below the suppressed-carrier frequency. Since the single-sideband generator produces one sideband only, the balanced-modulator output must be modified to meet this requirement. This requirement is satisfied by using either the *filter method* or the *phase-shift method*. A general discussion of the factors that influence the choice of a frequency selective network for use in the *filter method* of ssb generation is given in *a* below. The *phase-shift method* is presented in detail in paragraph 30.

a. The *filter method* uses frequency selective networks to pass the desired sideband and to reject the unwanted sideband. The sideband selective circuits must pass a very narrow band of frequencies; the band is narrow by comparison to the carrier reference frequency at the output of the modulator. The two sidebands are separated from each other by a minimum of 200 cycles (assuming a 100-cycle, low-frequency limit of the audio signal). To adequately suppress the unwanted sideband, the filter must provide a rapid increase of attenuation with frequency change as the range of signal frequencies moves out of the filter band-pass region. The filter is made up of high Q components to meet this requirement. The quality or Q factor of the sideband filter is determined for a given frequency of filter operation and a specified amount of sideband suppression. The higher the frequencies involved or the lower the ratio of bandwidth to center frequency passed by the filter, the greater must be the filter Q. This means that for low-frequency sideband selection (low center frequency), a lower Q filter circuit is re-

quired for the same bandwidth as for high-frequency sideband selection (high center frequency). Inductance capacitance filters have relatively low circuit Q factors and are used as sideband filters at lower transmission frequencies (to 50 kc). Mechanical filters and quartz crystal networks have extremely high Q factors and when used as sideband filters are capable of operation at higher frequencies. Mechanical filters are currently usable up to 600 kc; crystal filter circuits currently work at frequencies as high as 5 mc.

b. The use of a selective filter for elimination of the undesired sideband has the advantage of simplicity of circuit and good stability in respect to long-term operation of the equipment. The degree of sideband suppression is inherent in the design of the sideband filter. The stability of the sideband filter network depends on the quality and tolerance of the elements used in the fabrication of the filter. The circuit stability factor is increased by selecting components that show little change in characteristics with change in temperature. Another design expedient is counteraction of the effect of one temperature unstable component with a second component, the characteristics of which changes in a direction to counterbalance the change in the first component.

30. Phase-Shift Sideband Generator

In the *phase-shift method* of single-sideband generation, the undesired sideband is canceled in the output circuits. This method eliminates the need for the sideband filter network that is required in the filter method. The sideband filter, mechanical or crystal, limits the highest frequency that can be processed; therefore, in the phase-shift method, choice of carrier-generator frequency does not hinge upon filter operating frequencies (although it does depend on practical design considerations). The carrier generator can be operated at the transmitter output frequency and thereby make mixer and filter circuits following the single-sideband generator unnecessary.

a. The input to a phase-shift sideband generator (fig. 35) is a straightforward audio amplifier that contains the speech-processing circuits. The output of the audio amplifier

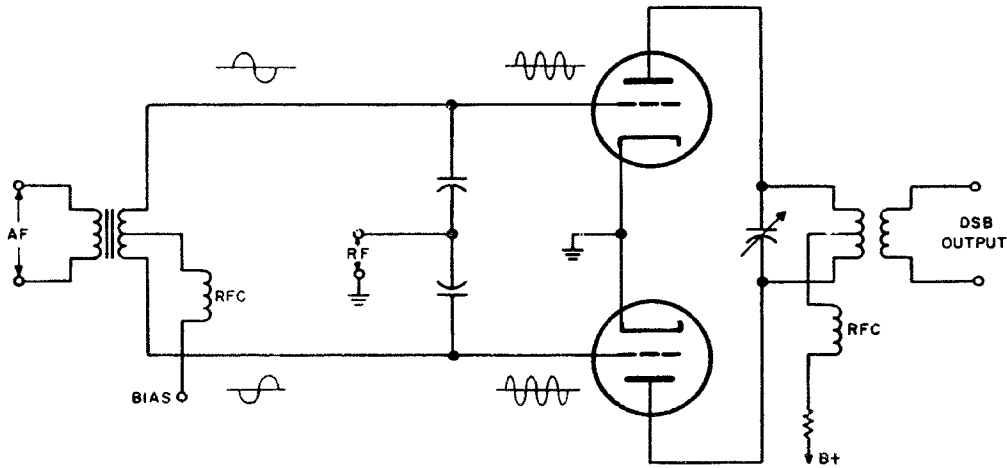

Figure 34. Vacuum-tube balanced modulator.

TM685-34

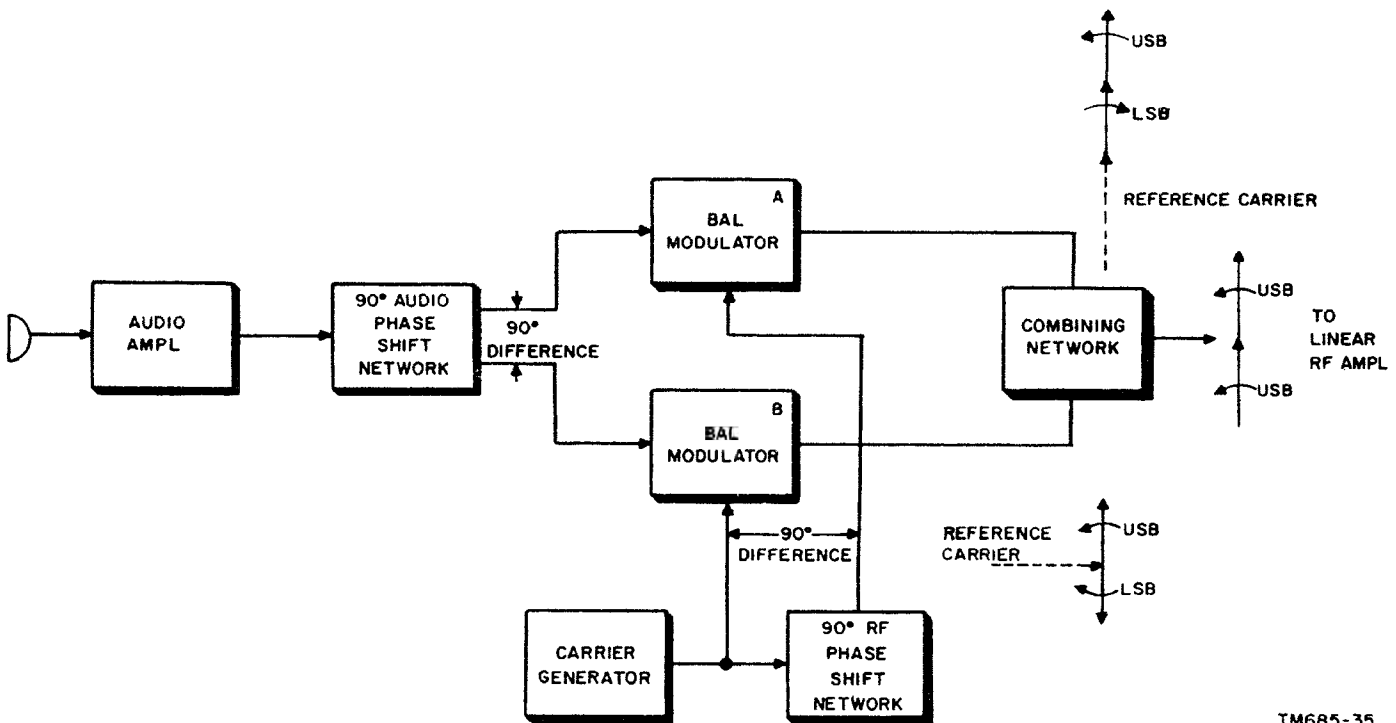
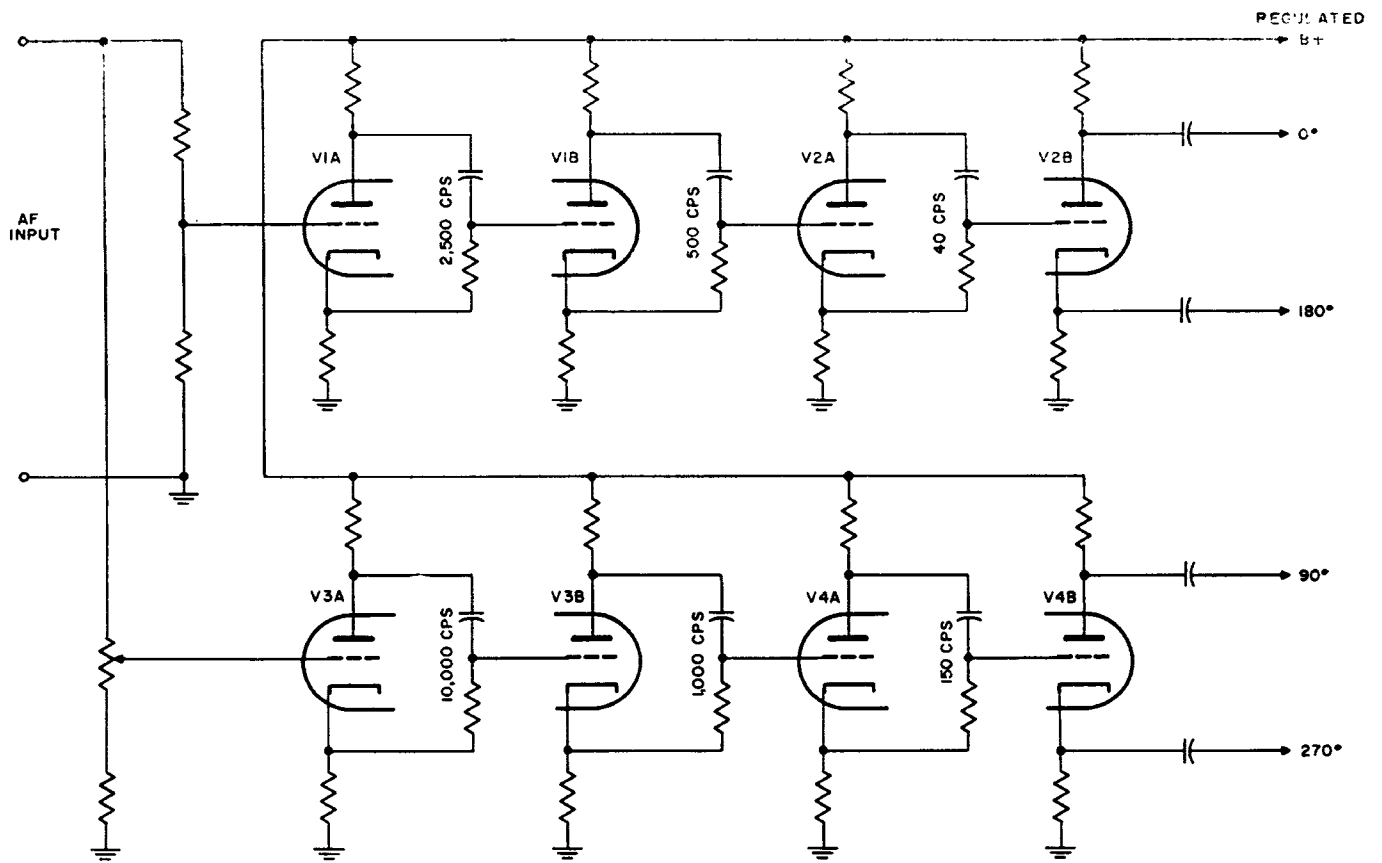

Figure 35. Phase-shift sideband generator, block diagram.

TM685-35

passes into the 90° audio phase-shift network where two audio signals, equal in amplitude but 90° out of phase, are developed. One output of the 90° audio phase-shift network is fed to balanced-modulator A. The second output, shifted 90° from the first, is injected into balanced-modulator B. Audio phase-shift networks are classified as two distinct types: active and passive. The difference between the two networks is the absence of power sources or amplifier vacuum tubes in the passive network.

- (1) An active audio phase-shift network that is typical of circuits in use is shown in A, figure 36. This network has a relatively wide frequency response (50 to 5,500 cps) and maintains a 90° difference between the individual output terminal pairs. The single-phase audio signal is applied, in parallel, to the two cascaded elements of the network. The output of the network is composed of four terminals that provide a two-phase



A. ACTIVE NETWORK

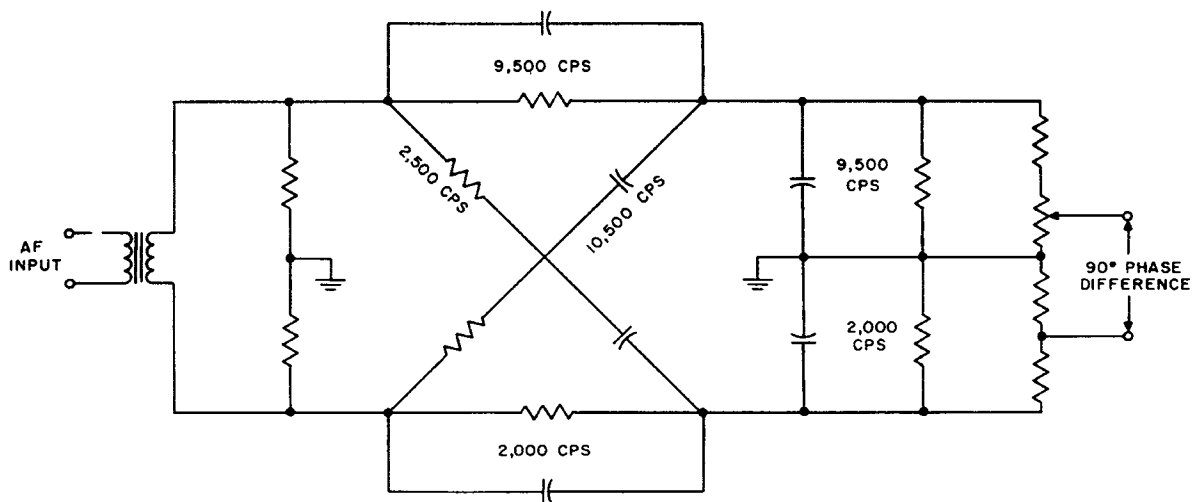

B. PASSIVE NETWORK

NOTE:
FREQUENCIES LISTED ARE THOSE
AT RC HALF-POWER POINTS.

TM685-36

Figure 36. Audio phase-shift networks, active and passive.

balanced signal with a constant 90° phase shift between equal amplitude voltages. The phase-shifting components are the resistance-capacitance (R/C) branches between plate and cathode of the phase-inverter connected vacuum tubes. Each R/C branch and associated phase inverter is tuned to a particular frequency. The combination of cascaded tubes and circuits gives the specified network response.

- (2) A typical passive phase-shift network is illustrated in B, figure 36. The response of the passive phase-shift network (150 to 2,700 cps) is narrower than the active network. Six R/C elements in a lattice configuration comprise this network. The R/C elements are tuned to specific frequencies that, in combination, produce the response of the network. Here, as in the active network, two voltages at a constant 90° phase difference and of equal amplitude are available at the output terminals.

b. The carrier generator of a phase-shift sideband generator, as in the filter method, produces the carrier frequency necessary to complete the modulation process. The generator output is applied directly to balanced-modulator B and through the 90° RF phase-shift network to balanced-modulator A. The 90° RF phase-shift network supplies a signal at the carrier-generator frequency but is displaced 90° from the RF carrier input to balanced-modulator B. The carrier generator produces a single frequency; therefore, the 90° phase-shift network can be a relatively simple circuit as compared to the wide band response requirements of the 90° audio phase-shift network.

- (1) A, figure 37, is a double-tuned, over-coupled transformer rf phase-shift network. There is a 90° phase difference between the secondary and primary voltages of transformer T when each winding is resonated by the variable capacitor across it and the coupling is slightly greater than the critical value.

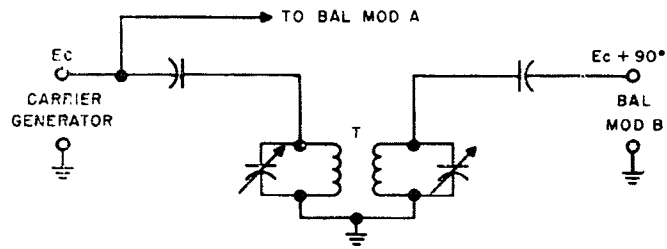

A. DOUBLE-TUNED OVERCOUPLED TRANSFORMER

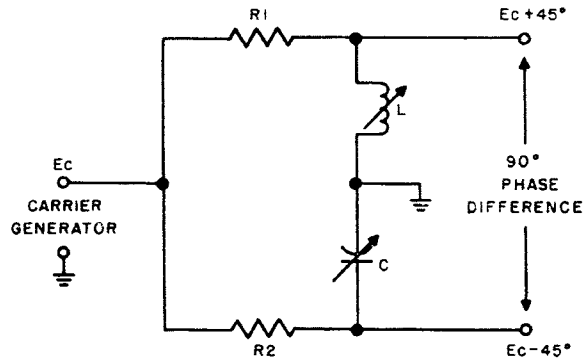

B. RLC NETWORK

TM685-37

Figure 37. Rf phase-shift networks.

- (2) B, figure 37, is a resistance-inductance-capacitance (R/L/C) phase-shift network. Series elements of R/L and R/C are placed across RF carrier-generator output E_C . Resistance $R/1$ is selected equal to the reactance of inductance L at the carrier frequency, and $R/2$ is equal to the reactance of capacitor C . Referenced to ground, the voltage across the inductance leads E_C by 45° ($E_C + 45^\circ$) and the voltage across the capacitor lags E_C by 45° ($E_C - 45^\circ$). The result is two rf voltages equal in amplitude and 90° out of phase.

c. Balanced-modulators A and B (fig. 35) are identical in theory and operation with the modulators discussed in paragraph 28. The output of each modulator is a double-sideband signal; the carrier is suppressed in both. The two output signals are added in the combining network to obtain the single-sideband signal that drives the linear amplifiers.

- (1) Assume that the upper sideband and lower sideband frequencies are in phase with the reference carrier at

the output of balanced-modulator A (fig. 35). The sidebands are shown as vectors rotating in opposite directions about the reference carrier. (The broken-line vector indicates suppression of the carrier in the balanced modulator.) The sideband vectors are placed above one another to show that when they are in phase, the vectors add.

- (2) At the same instant as in (1), the output of modulator B contains a reference carrier vector (broken line) 90° away from the reference carrier at the output of modulator A. This is true because the carrier inputs to the modulators are 90° out of phase. The upper and lower sideband vectors, rotating in opposite directions, have departed 90° from the sideband vectors at the modulator A output. (The audio inputs are 90° out of phase.) This results in the right angle arrangement of sideband and reference carrier vectors at modulator B output.
- (3) Finally, the separate output signals of modulators A and B are merged in the combining network to form the single-sideband signal output of the exciter. Note the relative positions of the sideband vectors in the figure. Here, the upper sideband vectors from A and B are in phase and naturally add to reinforce each other. The lower sideband vectors are canceled since they are exactly opposite in

phase and equal in amplitude (circuit component and input signal matching assumed). The reference carriers provided by the carrier generator are balanced out in the modulation process; therefore, the output of the phase-shift exciter in the figure consists of only the combined upper sideband products of the two modulators. The choice of the lower sideband from a phase-shift sideband generator can be effected by reversing the phase of either the audio or rf carrier inputs to the modulators.

d. In the discussion of the filter method of ssb transmission in this section, it was emphasized that the degree of undesired sideband attenuation was totally dependent on the design of the sideband filter network at the modulator output. In the phase-shift method of ssb transmission, the wide band audio phase-shift network and the RF carrier phase-shift network determine the degree of attenuation. The relative complexity of circuit design of the audio phase-shift network makes it the more critical of the two input networks. Complete elimination of the undesired sideband is possible only when both networks (audio and carrier) maintain an exact 90° phase difference between their output signal voltages. Proper design minimizes the amount of deviation from the exact 90° difference and, in practice, provides 35 to 40 db attenuation of the undesired sideband over the range of frequencies to the modulators.

Section III. FREQUENCY TRANSLATION

31. General

When using the filter method, the output of the sideband filter is a low-frequency, low-level modulated signal that requires further processing to lift it to the final operating frequency. Here, as with low-level modulated signals, the signal is to be translated to a higher frequency portion of the radiofrequency spectrum without affecting the sideband to carrier relationship. The translation of a particular signal frequency to a higher frequency is accomplished by mixing the signal with a locally generated oscillation to produce a higher frequency.

a. A mixer combines two frequencies and produces a number of new frequencies one of which is selected for further processing. The most important new frequencies are the sum and difference frequencies. Either unbalanced or balanced mixers are used in practice. An unbalanced mixer combines two input signals which appear with the sum and difference frequencies in the output. In the balanced mixer, one of the original signals may be completely removed from the output circuit.

b. The balanced mixer functions essentially as a balanced-modulator circuit. The tubes used

in a balanced mixer are biased to operate on the nonlinear portions of their transfer characteristic curves to permit the heterodyning of the two input signals. In one circuit arrangement, the single-sideband signal is applied to the control grids of the balanced mixer in push-pull, and the local-oscillator voltage is applied to the same control grids in parallel. The local oscillation is balanced out in the push-pull plate circuit. As in the balanced modulator, the amount of local-oscillator frequency suppression depends largely on the degree of balance between the two tubes and their associated circuit components. Balancing the low-frequency, single-sideband signal is unnecessary because the mixer plate load is tuned to pass either the sum or the difference frequencies generated in the mixer stage.

c. Balanced mixers and linear low-power amplifiers are used in the frequency-translating steps in single-sideband transmitters, instead of frequency multipliers and class C amplifiers, so as not to impair the frequency relationship between the sideband components. In the filter-method, these balanced mixers are used to heterodyne a local-oscillator frequency with the low-frequency, low-power, single-sideband signal to produce a signal of a higher frequency. A filter and amplifier system follows each mixer to pass either the sum frequencies or the difference frequencies and eliminates all other frequencies. Two or more of these frequency-translating steps may be used if the transmitter-output frequency greatly exceeds that of the rf carrier frequency at the sideband generator.

d. As stated in paragraph 30, the carrier frequency for the phase-shift exciter can be the actual final operating frequency. Unfortunately, exciter operation at the final output frequency is not practical for a multichannel (variable-output frequency) transmitter. If modulation in a multichannel transmitter were to be performed at the output frequency, the carrier generator would, of necessity, be a variable-frequency oscillator. Matters would be complicated by the need for tuning the RF 90° phase-shift network over a wide range of frequencies (transmitter-output frequency range). The main design problem that arises is the difficulty of maintaining exactly 90°

phase difference in a variable rf phase-shifting network. Rather than become involved with such complex and hard to maintain requirements, it is simpler to modulate at a low-carrier frequency and heterodyne the phase-shift generated ssb signal with a variable high-frequency oscillation to obtain the required transmitter-output frequency range.

32. Mixer Fundamentals

a. Two alternating currents of different frequencies produce beat frequencies (new frequencies) when combined in a mixer stage. If these two alternating currents are injected into a fixed resistance (resistance does not change with current variations), no beat frequencies are produced. The two currents combine to form a more complex wave than either component wave. An analysis of the resultant waveform shows the existence of the original frequencies only. No new frequencies have been formed because of the combining action. Either current flowing separately through the resistance develops a voltage that is directly proportional to that current (Ohm's law). If a voltage-versus-current graph (A, fig. 38) is drawn, the relationship plots a straight line. This graph is called a linear relationship and the resistance a linear device. The slope of a straight line is constant and, in this case, is representative of the fixed resistance. Neither the shape of the individual currents nor that of the resultant current has been changed by application to the fixed resistance.

b. Note that a device with a linear characteristic does not produce beat-frequency currents. A mathematical analysis of the output waveform of a device that has a nonlinear voltage-current characteristic (B, fig. 38) shows that new frequencies, other than the original mixing frequencies, have been produced. As an example, if the output current of the device varies as the square of the applied voltage (such as in a square-law detector), the following prominent frequencies are produced as a result of applying two sine waves of different frequencies:

- (1) The original frequencies of the applied alternating currents.
- (2) Frequencies twice the applied frequencies (second harmonic).

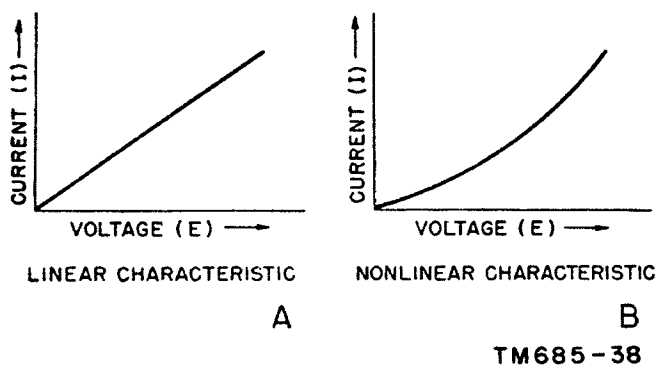

Figure 38. Voltage-current characteristics.

- (3) A frequency equal to the sum of the applied frequencies.
- (4) A frequency equal to the difference of the applied frequencies.

c. If the nonlinear device has a greater curvature in the relationship between driving voltage and resulting current, many frequencies, additional to those listed in *b* above, will be present in the output. For frequency-translation purposes, either the sum or difference frequency is of interest, and all other frequencies in the output of the mixing device are filtered out. One of the simplest of nonlinear devices suitable for service as a frequency translator is the ordinary vacuum tube. Mixing is possible by operating the vacuum tube on a curved part of its transfer characteristic.

33. Types of Mixers

a. The simplest type of frequency mixer is the unbalanced mixer. In the unbalanced mixer (fig. 39), the ssb signal and on oscillator voltage from a vfo are fed to the grid of a triode tube. The triode tube, in the illustration, is so biased that operation is on a nonlinear portion of its transfer characteristic curve. Mixing of two or more signals is possible only when applied to a nonlinear device (par. 32). The plate current of the tube contains, in addition to the original frequencies, new frequencies which, among others, are the sum and difference combinations of the exciting low-frequency ssb signal and vfo frequencies. If the difference frequency is selected, the converted ssb signal is inverted in the output of the mixer. That is, a usb signal becomes an lsb signal and vice versa.

b. The balanced mixer is essentially a balanced-modulator circuit. The tubes in this circuit (fig. 40) are biased to operate on the nonlinear portion of their respective transfer characteristic curves so that heterodyning (mixing) of the two input signals can take place in the circuit. The single-sideband signal from the sideband generator is applied to the control grids of the balanced mixer in push-pull, and the vfo signal is applied to the same control grids in parallel. As in the vacuum-tube balanced modulator (par. 28b), the amount of vfo signal suppression (or balance) depends on the degree of balance between the two tubes and their associated circuit components. A fair degree of balance can be obtained with the setting of the *bal adj* control in the cathode returns of the modulator tubes. The low-frequency ssb signal does not appear in the output because the mixer plate load is tuned to reject frequencies far beyond its pass band and to respond to the sum or difference frequencies generated by the mixer tubes.

c. A bandpass filter similar to the sideband filter (par. 29) is used between the medium-frequency and high-frequency mixers (where more than one mixing operation is used). A highly selective filter is needed to remove the unwanted sum or difference frequency when each product is close to the vfo frequency. Refer to paragraph 35 when more than one stage of frequency translation is used to obtain the final operating frequency.

34. Spurious Mixer Products

a. Spurious mixer products are undesired frequencies that are generated in a mixer stage. To explain, consider the circuit where signal and oscillator voltages are applied to the same grid of a mixer tube. To generate sum and difference frequencies, operation on a nonlinear or curved portion of the grid voltage-plate current (transfer) characteristic is necessary. To extract the desired sum or difference frequencies, all other mixer products must be filtered out. The generation of sum and difference frequencies would be a simple matter since a mixer tube with second-order curvature (plate current is proportional to only the first and second powers of the signal voltages involved) in its transfer characteristic curve

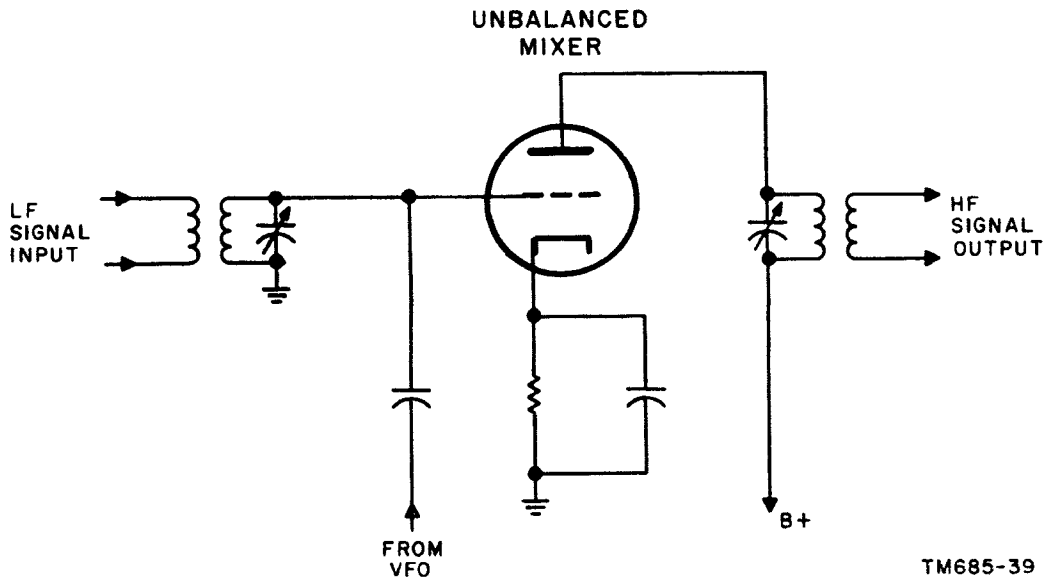

Figure 39. Triode unbalanced mixer.

TM685-39

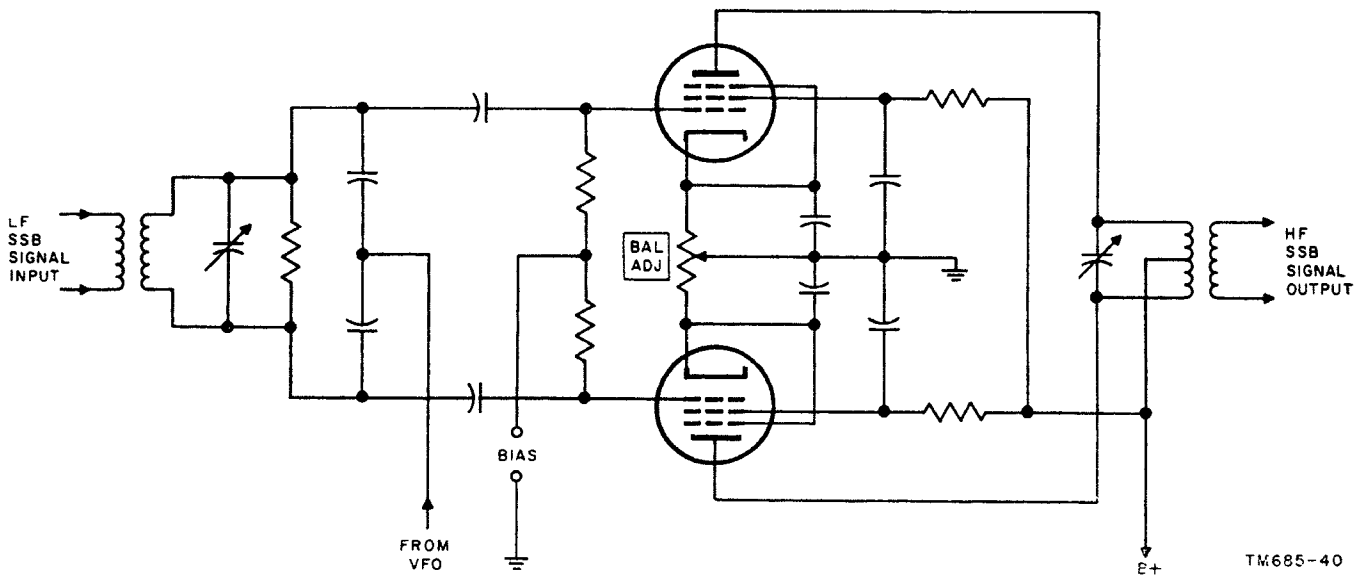

Figure 40. Balanced mixer.

TM685-40

would provide the required frequencies. Unfortunately, the transfer characteristic curves of all practical tubes exhibit higher than second-order curvature. The higher-order curvatures contribute additional unwanted frequency components to the output current. Some of these unwanted frequency components are far removed from the desired output frequency and are easily filtered out. Some higher-order mixer products are very close to the desired band of sum or difference frequencies and fall within the pass band of the filter used in the mixer-output circuit. The amplitudes of the

unwanted mixer products vary from tube to tube and change with the selection of the operating point. Therefore, it is a particularly difficult task to accurately design a mixer circuit using tubes which have characteristics that show higher than second-order curvature. The circuit designer selects his mixer tubes after a series of experiments in which the amplitudes of the undesired mixer products are measured.

b. Figure 41 is a listing of the calculated frequency products contained in the plate current of a typical dual-triode mixer. Terms d and g are directly related to the mixing fre-

CALCULATED FREQUENCY PRODUCTS CONTAINED IN THE
PLATE CURRENT OF A DUAL-TRIODE MIXER

$$e_{osc} = P \cos pt = 2V_{rms} \quad e_{sig} = Q \cos qt = .2V_{rms}$$

$$E_b = 250V \quad E_k = 10V \quad E_{bb} = 415V \quad R_L = 10K$$

TABLE DERIVED FROM POWER SERIES EXPANSION

$$\text{WHERE } e_{in} = P \cos pt + Q \cos qt$$

ZERO DB REFERENCE IS MAGNITUDE OF $(p \pm q)$

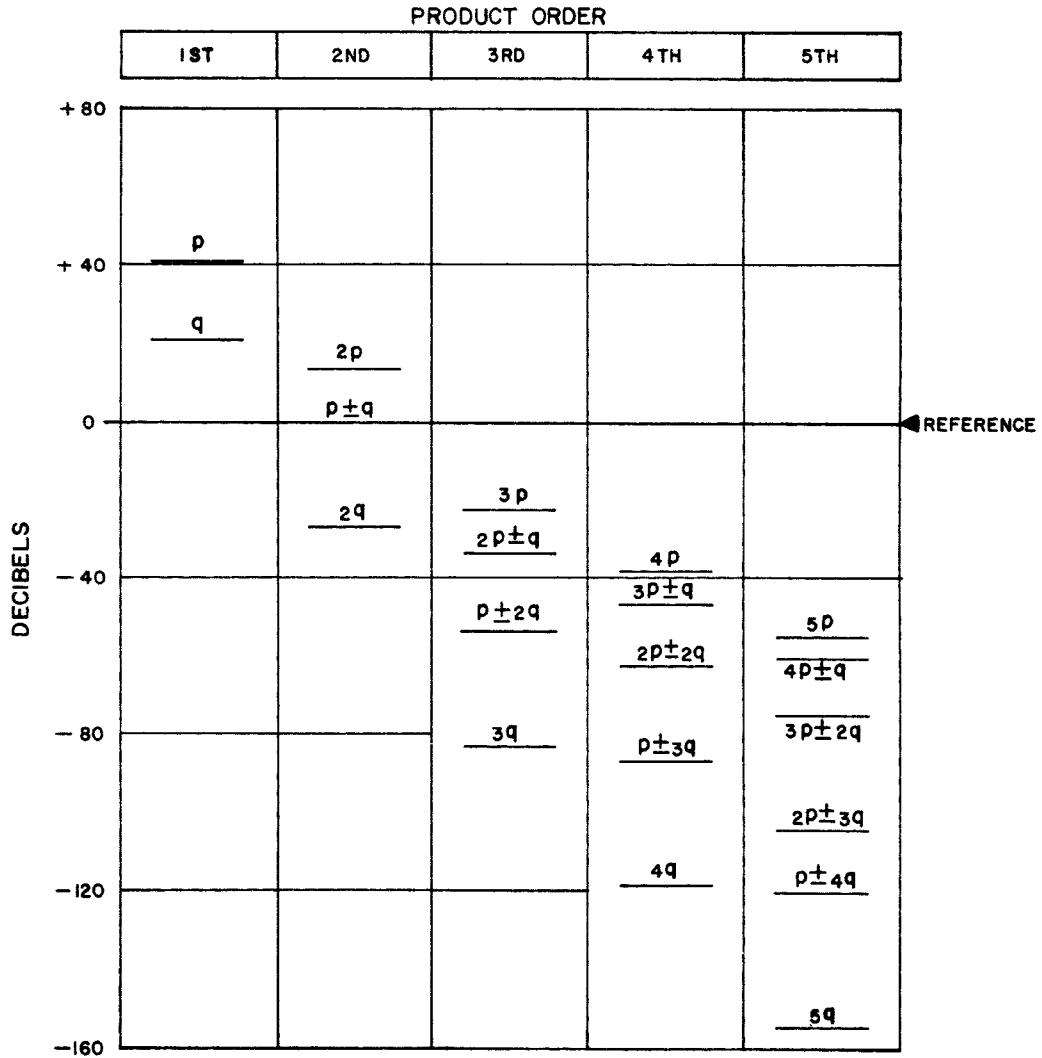

TM 685-41

Figure 41. Chart of calculated frequency products in the output of a dual-triode mixer.

quencies. The voltage level of the sum and difference frequency terms ($p \pm q$) is the amplitude (0 db) to which all other mixer products are referenced. The first-order product contains the original frequency terms (p & q) at a greater amplitude than the second-order sum and difference frequency terms ($p \pm q$). As we progress to the higher-order products, the frequencies generated show a gradual decrease in amplitude. The effects of unwanted mixer products can be reduced by proper selection of signal and oscillator frequencies. Proper choice of frequencies is a solution to the problem of undesired mixer products when the operating frequency is fixed. However, a variable-frequency oscillator presents a more complicated problem in a wide-frequency range transmitter. Charts, in which spurious mixer products are listed for different signal and oscillator frequencies, are an invaluable aid to the designer whose task it is to minimize the effects of spurious responses in an ssb system.

35. Medium-Frequency and High-Frequency Circuits

Figure 42 is a schematic layout of a basic frequency translator. The medium- and high-frequency oscillators (mf crystal oscillator and hf vfo) are not shown. Various oscillator circuits are described in chapter 5. Two stages of mixing raise the low-frequency output of the single-sideband generator to the final operating frequency. Normally, a low-frequency amplifier precedes the mf balanced mixer. The low-frequency amplifier (not shown) develops the required driving level for the balanced mixer.

a. Medium-Frequency Mixer. The input to the mf unbalanced mixer is a single-sideband signal coupled from the sideband generator. This ssb signal is heterodyned with a locally generated signal coupled from a crystal oscillator. Mixer VI is a multigrid frequency converter. In this converter, the sideband generator signal output and a fixed oscillator frequency are applied to separate grids of the tube. Coupling of the two signals for mixing is accomplished through the vacuum-tube common electron stream. The

output of the mf mixer is passed to the mf bandpass filter where the sum or difference frequency is selected and fed to the mf linear amplifier.

b. Medium-Frequency Bandpass Filter. The medium-frequency bandpass filter is, in most cases, a circuit consisting of crystals and lc components so arranged to provide the necessary filter response. The crystal-lattice filter (par. 20) is widely used for this particular application. This filter circuit is most adaptable as an mf bandpass filter, for it furnishes the required narrow band width at a frequency that is considerably higher than that at the ssb generator output. The narrow bandwidth of filter response is required because the sum and difference frequencies and oscillator frequency at the mf mixer output are very close together.

c. Medium-Frequency Amplifier. Mf amplifier V2 is a linear amplifier that compensates for the losses in the mf bandpass filter and raises the signal level to provide enough drive for the high-frequency balanced mixer. The mf amplifier is a conventional tuned rf amplifier that uses a pentode tube and is so biased that it delivers a reproduction of the input mf signal and produces a minimum of spurious signals.

d. High-Frequency Balanced Mixer. The oscillator signal from the vfo is coupled in parallel to the high-frequency balanced mixer, (V3 and V4) to beat with the ssb signal fed in push-pull, from the mf amplifier. The output of the hf balanced mixer is the final operating frequency that is further amplified by the linear amplifiers, to the power level required to drive the rf power amplifier. The hf balanced mixer is identical with the balanced mixer circuit discussed in paragraph 33b. Note the similarity of this circuit and the vacuum-tube balanced modulator of figure 34. The output circuit of the hf balanced mixer does not require the sharp-tuning characteristics that are important at the output of the mf mixer. Here the sum and difference frequencies are relatively far apart and can be separated by a tuned circuit of moderate.

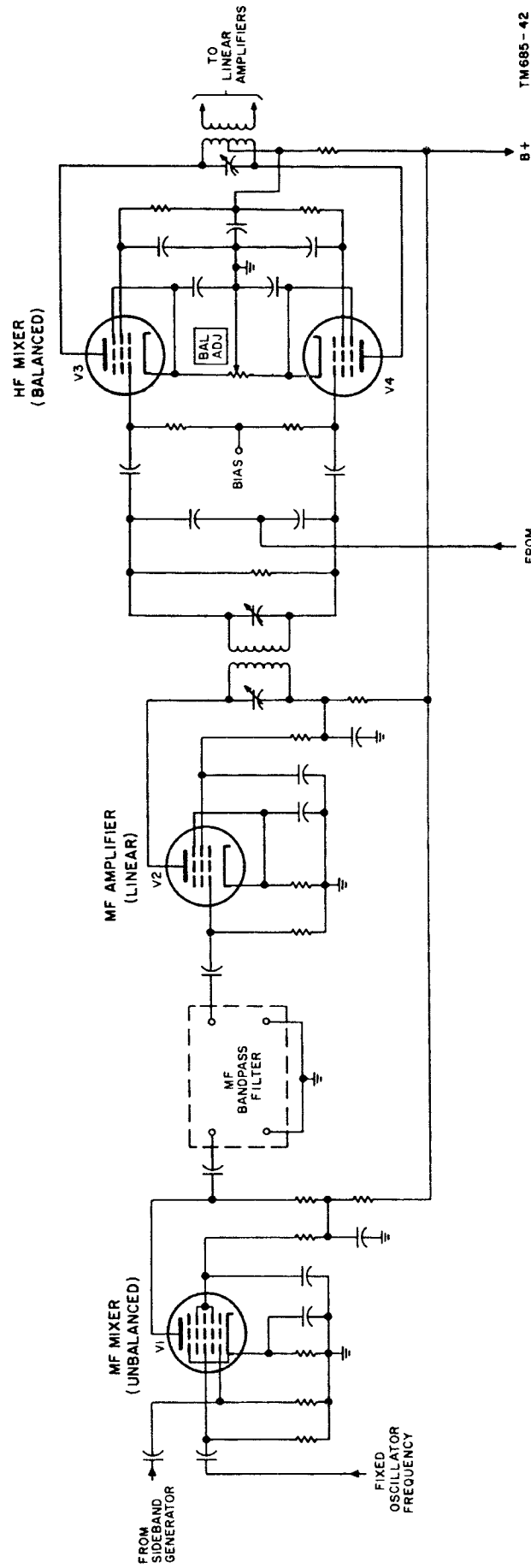

TM 685-42

Figure 42. Frequency translator, schematic diagram.

Section IV. LINEAR AMPLIFIERS

36. General

a. Linear amplifiers are used exclusively in single-sideband transmitters in which low-level modulation is used. An ssb signal is essentially an amplitude-modulated signal and, when modulated at a low level, the amplitude relationships of the sideband components must be maintained. The principal distortion components produced in tuned rf amplifiers are the third-order intermodulation products. Intermodulation is defined as the production in a nonlinear circuit, of elements of frequencies equal to the sums and differences of integral (1, 2, 3, etc) multiples of two or more frequencies which are applied to that circuit. Note that the harmonic and intermodulation frequencies that appear in the output are not present in the impressed signals but are generated by the nonlinear circuit. Third-order intermodulation products are created by the degree of curvature of the amplifier-tube transfer characteristic. Tuned radiofrequency linear amplifiers differ from audio linear amplifiers in that they handle a narrow band of frequencies as compared to the wide-frequency range of audio amplifiers. The tuned RF amplifiers are, therefore, seldom disturbed by second-order intermodulation products (sum and difference frequencies and harmonics). The second-order products usually are far removed from the tuned-circuit pass band and do not occur in the amplifier-tube output. This is not the case with third-order intermodulation products. These products are present in an amplifier output circuit whenever two tones or frequencies are so near each other (in frequency) that the second harmonic of one beats with the fundamental of the other to yield a third frequency situated within the tuned-amplifier pass band. Third-order intermodulation products are minimized by limiting the input-signal voltage variations to a linear part of the tube transfer characteristic. Relatively large voltage gain and power output is possible with receiving-type tubes while still fulfilling the requirement that third-order intermodulation products be limited to 50 db below the power level of the desired output frequencies.

b. Ssb transmission results in an increase of the number of available channels in an usable

portion of the radiofrequency spectrum. As stated in chapter 1, twice as many channels are possible, for the same spectrum width, in ssb systems as in am. systems. To realize this greater use of frequency spectrum, it is important to reduce all spurious radiation to a negligible amount. All spurious signals at the amplifier outputs (harmonics and third- and higher-order intermodulation products) must be attenuated to as low a level as the state of the art will allow. Lack of control over these interfering frequencies can cancel the ssb advantage of spectrum conservation.

37. Linear Amplification

The power output of an ssb exciter must be of sufficient level to obtain maximum output from the power amplifier tubes on peak driving signals. The necessary driving power depends on the type of tubes used and the class of operation required to provide linear-power amplification. Methods for linearizing of the pa stage output are discussed in chapter 3. High-gain tetrodes are normally used in pa stages and require a very small amount of driving power (fraction of a watt). A small power output, with a linear relation between input and output signals, is easily obtained by using standard receiving-type tubes.

a. The low grid-to-plate capacitance of a pentode is an important characteristic that, in part, determines the effectiveness of the tube as a linear amplifier. High grid-to-plate capacitance causes excessive positive feedback from plate to grid and results in distortion of the input signal. High mutual conductance is another very important characteristic because it is possible to develop the required amount of pa driving power with a minimum of linear-amplifier stages. Receiving-type power pentodes are normally used to provide the pa driving power. Power pentodes specifically designed for service as video amplifiers (lower grid-to-plate capacitance) are suitable for use as linear rf amplifiers.

b. The tuned-plate load of a linear amplifier performs a dual function. The tuned-plate circuit offers the proper load impedance to the linear-amplifier output and thereby provides sufficient voltage gain and the required power

output (pa driving power). The tuned circuit is also a selective filter which attenuates undesired intermodulation distortion and further suppresses residual mixer products generated in the medium- and high-frequency mixer stages. It is often necessary to use double-tuned and triple-tuned circuits to obtain the required selectivity characteristics.

c. A linear-power amplifier that produces the radiated transmitter power must be driven to furnish maximum output power with peak-applied signal. At the same time the possibility of over-driving the pa and introducing damaging intermodulation distortion into the output signal must be prevented. This means that there must be a very tight control over the amplitude of the input signal to the pa. It is understood, from fundamental lc tuned-circuit considerations, that the load impedance of the individual amplifier stages of the exciter will change for each channel frequency of opera-

tion. This will alter the gain of the tuned-circuit loaded amplifier stages and the pa driving power will be either reduced or raised to a level beyond that required for maximum transmitter output. Tube characteristics that affect stage gain vary from tube to tube and deteriorate with tube age. Temperature and other *area of operation* effects also change amplifier gain. A very effective and widely used method of reducing the effects of variation in amplifier gain (and change in pa driving power) is to rectify a sampling of the pa output voltage and, through a dc feedback loop, control the gain of one or more linear-amplifier stages in the exciter. Remote-cutoff tubes are used as linear amplifiers in the controlled stages; the action is very much like that of an automatic-gain-control circuit in an am. receiver. This system of control is called *automatic load control (alc)*. A discussion of *alc* appears in paragraph 45.

CHAPTER 3

RF LINEAR-POWER AMPLIFIERS AND OUTPUT CIRCUITS

Section I. INTRODUCTION

38. General

A linear amplifier is an amplifier so adjusted that the amplified output voltage or power is proportional to the exciting voltage applied to the amplifier. Since modulation takes place in the ssb exciter at a low-power level, the single-sideband signal must be amplified in one or more power amplifiers to bring its power level up to that which is required for transmission. Any such amplification of the signal following modulation must be performed in amplifiers which introduce minimum distortion into the amplified signal. In addition to low distortion, the amplifiers should also have high efficiency for economy of operation. The type of amplifier circuit best suited for ssb applications is a high-gain linear amplifier. The following paragraph is a brief review of the classes of operation in which a vacuum tube can serve as an amplifier. This review encompasses all amplifier operating conditions and discusses the relative merits and shortcomings of each class with a view towards selection of those operating conditions which provide optimum usage of a particular tube in a linear-amplifier circuit. For a detailed description of classes of operation, refer to TM 11-662.

39. Classes of Operation

a. Class A Operation. In a class A amplifier, plate current flows for the full 360° of each cycle of applied signal voltage (plate current flows at all times). The grid bias voltage is set at about the midpoint between zero bias and plate current cutoff on the transfer characteristic curve; the input-signal voltage varies about this bias point. The peak-to-peak signal amplitude never exceeds either zero grid voltage or plate current cutoff voltage. This prevents the distortion that results from the waveform clipping that occurs when

grid current flows (positive grid voltage) or when the grid voltage is driven below the plate current cutoff value. Restricting the input-signal voltage to a limited travel along the transfer characteristic curve furnishes an amplified output signal with a minimum of distortion generated within the tube. The very-low distortion is offset by a poor plate efficiency of about 20 percent and a high static condition (nondriven) plate current.

b. Class B Operation. In a class B amplifier, plate current flows for approximately 180° (one-half) of each input cycle. The amplifier is biased at or slightly above plate current cutoff, and plate current flows for at least the full positive half-cycle of the input-signal voltage. This necessarily introduces distortion components since the negative half-cycle is not reproduced in the amplifier output signal. This internally generated distortion can be attenuated or entirely eliminated in the tuned output of an rf linear amplifier. Push-pull operation and careful choice of operating point at slightly above cutoff (projected cutoff) help to minimize distortion. The plate efficiency of a class B amplifier is between 40 and 60 percent and results in a lessening of power supply requirements over requirements for class A operation.

c. Class AB Operation. The class AB amplifier is an amplifier in which the grid bias is adjusted to a value between that which is used for class A amplification and that point of operation for class B amplification. With this bias setting, plate current flows for appreciably more than 180° of each cycle of applied signal (but less than 360°). It is understandable that considerable distortion is introduced on a single tube basis; however, if a push-pull circuit is used, most of these distortion products are canceled. With the addition of negative feedback, a fairly clean output signal results.

The two subclasses of class AB operation denote either the absence of grid current (AB_1) or the presence of grid current on positive signal peaks (AB_2). Class AB efficiency lies between the efficiency figures for class A and class B. Class AB amplifiers are widely used for generating moderate amounts of radiofrequency power. Where greater power output is required, with no change in types of tubes employed, they have displaced the class A amplifier circuits in most applications. The class AB amplifier has the advantage over the class B amplifier of being less critical in bias adjustment but has the disadvantage of somewhat lower plate efficiency and less available power output for a particular plate supply voltage.

d. Class C Operation. A class C amplifier is normally biased far below the plate current cutoff point; between one and a half and four times cutoff bias. At the point of operation, plate current flows for appreciably less than 180° (less than half) of each cycle of input signal. The class C output waveform consists of pulses of current stimulated by the positive peaks of the input signal. The class C amplifier is characterized by a high plate efficiency and is used to develop considerable radiofrequency power where the generation of distortion in the output signal does not affect the overall performance of the system. Although the class C amplifier has a plate efficiency of between 60 and 80 percent and is capable of greater power output than classes A and B, it cannot be used where proportionality between input- and output-signal voltages is required.

40. Choice of Operating Point

a. An ordinary class A amplifier would satisfy the linearity requirement, but this type of amplifier has low efficiency and its use as a power amplifier in a high-power transmitter is costly and wasteful of applied power. Although a class C power amplifier meets the high efficiency requirement, it is not suitable for use in voice modulated ssb transmitters. Class C operation causes excessive distortion of the audio components which are impressed on the rf carrier. Therefore, as a compromise between the low distortion and high efficiency requirements, linear-power amplifiers, operated

class AB (AB_1 or AB_2) or class B, are used as the output amplifiers in ssb transmitters.

b. The class B linear-power amplifiers used in ssb transmitters are usually operated at *projected cutoff*; that is, the point where the linear portion of the grid voltage-plate current curve is projected to zero plate current (fig. 43). The *projected cutoff* point of operation can be located by extending the linear portion of the curve as a straight line to cutoff (zero plate current), where the line meets the grid voltage axis. This type of operation allows plate current to flow for slightly more than half of the input cycle. Although harmonics of the applied signals are developed with this class of amplifier, the linearity of the input signal is not appreciably distorted. Some distortion is to be expected in all class B amplifiers, but by properly tuning these amplifiers, or by using push-pull circuits, it is possible to reduce distortion to a minimum. Since each amplifier generates some distortion, it is an advantage to keep to a minimum the number of linear-amplifier stages used in a particular transmitter.

41. Choice of Tubes

The brief discussion of classes of amplifier operation indicates that class C operation, although capable of highest power output and plate efficiency, produces distortion products which nullify its use in an rf linear-power amplifier. The remaining classes of operation (A, AB_1 , AB_2 , B) are adaptable for rf linear-power amplification with the addition of some circuit features that provide the highest degree of linearization. Consideration will now be given to a study of the particular characteristics of a tube that influence its selection for service as an rf linear-power amplifier.

a. Grid-to-Plate Capacitance. Grid-to-plate capacitance depends on the proximity of the surface of the grid wire to the plate. This capacitance is a feedback path from the output (plate) to the input (grid) circuits. At a critical value of feedback energy, the circuit oscillates at a frequency governed by the circuit constants. To avoid this oscillation, grid-to-plate capacitance must be reduced to as low a value as possible. An examination of fundamental capacitor theory reveals that in an electron tube, the closer the spacing or the

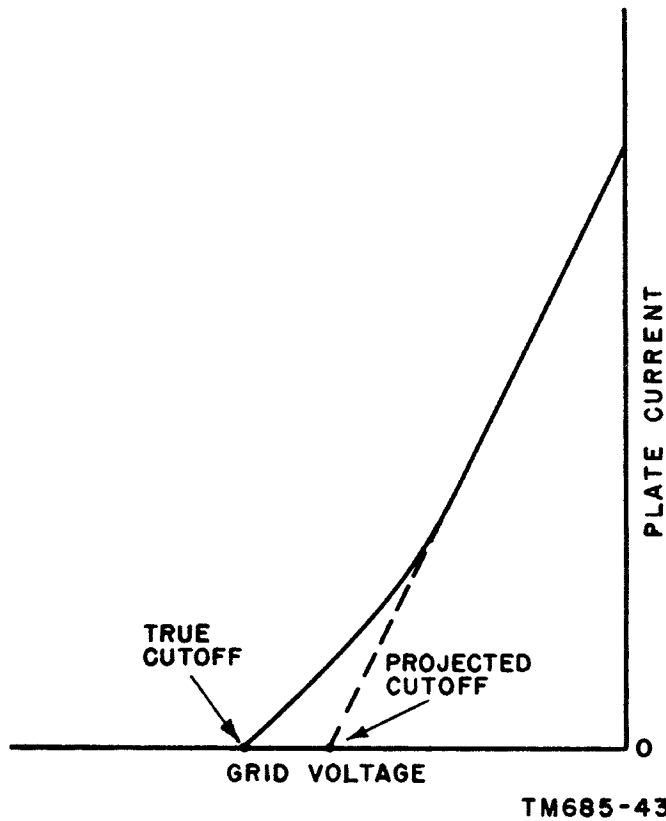

Figure 43. Transfer characteristic curve showing method of arriving at projected cutoff bias voltage.

larger the element areas (grid and plate), the greater the capacitance between them. A triode, with no intervening element between grid and plate and close spacing between elements to provide large transconductance (effect of grid on plate current), has a relatively large grid-to-plate capacitance. Two solutions for a lower feedback capacitance (output to input) are: the use of a grounded-grid (cathode-driven) amplifier circuit (par. 42b) and the addition of new elements within the vacuum tube to reduce the grid-to-plate capacitance. Tubes that use additional elements to reduce grid-to-plate capacitance are the tetrode and the pentode. The following is a brief description of the tetrode and pentode and the merits and disadvantages of each type.

- (1) *Tetrode*. The tetrode is a four-element vacuum tube. It is basically a triode to which has been added a grid structure situated between the grid (now called the control grid) and the plate. The additional grid is known as a screen grid and affords two main advantages over the triode. The first

advantage is a large reduction in grid-to-plate capacitance because the screen grid electrically shields the control grid from the plate. Secondly, the application of a positive voltage to the screen grid lessens the effectiveness of the plate in controlling plate current while the control grid effectiveness (transconductance) is not appreciably changed. The net result of including a second grid, positioned as described above, is to decrease significantly the amount of plate-to-grid feedback neutralization required. When a positive voltage is applied to the screen grid, the realizable gain of the tube is increased. A disadvantage of the tetrode is the necessity to limit the grid drive so that the instantaneous plate voltage is not depressed below the applied screen-grid voltage. Driving beyond this point introduces excessive distortion of the signal waveform, because of secondary emission effects.

(2) *Pentode*. The pentode is a five-element vacuum tube which contains the four elements of the tetrode, arranged in the same order, plus a third grid called a suppressor grid that is situated between the screen grid and the plate. The addition of this grid modifies the characteristics of the tetrode so that the disadvantage of limited plate voltage swing is eliminated. A pentode power tube can provide more available power output because the instantaneous plate voltage can be driven below the screen-grid voltage without adverse effects on the output-signal waveform. The disadvantages of the pentode are that it is a more com-

plicated construction than the tetrode and requires additional circuitry for the suppressor grid.

b. *High Gain*. One of the most desirable characteristics of a vacuum tube chosen for operation as a linear amplifier is high gain. Since distortion generated in an amplifier depends on curvature of the transfer characteristic and drive requirements, the use of fewer high-gain stages to yield the required gain results in a decrease in overall distortion. High gain is readily obtained from a tetrode power amplifier tube with the application of a small amount of driving voltage and with a fraction of the plate-to-grid feedback neutralization required for a triode tube.

Section II. POWER AMPLIFIER CIRCUITS

42. Basic Power Amplifier Circuits

From the discussion in the preceding section on classes of amplification, it is evident that class C operation, the class that is most often used in plate modulated AM transmitters, seriously distorts low-level modulated ssb signals. For linear-power amplifier operation, class A, AB₁, AB₂, or class B (projected cutoff, par. 40b) can be used with an understanding of the limitations of each class as regards available power output, plate efficiency, and the number and relative amplitude of distortion products that are generated. The two circuits most commonly used as linear-power amplifiers are the grounded-cathode (grid-driven) amplifier and the grounded-grid (cathode-driven) amplifier.

a. *Grounded-Cathode Amplifier*. Figure 44 illustrates the basic circuit of a grounded-cathode (grid-driven) amplifier. The vacuum tube used is a triode tube but can be a tetrode or pentode. The triode tube has a large grid-to-plate capacitance and therefore must be neutralized to cancel positive feedback from the plate-to-grid circuit and thereby prevent circuit oscillation. Neutralization of an amplifier stage is accomplished by transferring, through an external coupling, an amount of energy equal to but opposite in character to the energy coupled through grid-to-plate capacitance. The

use of swamping resistor R_{sw} presents a fixed low impedance to the preceding stage. Addition of a low resistance swamping resistor maintains a relatively constant impedance as the signal voltage drives the grid from a no-current condition to beyond the zero grid-cathode voltage point where grid current is drawn. The flow of grid current places a load across the preceding (driving) stage but, since this intermittent loading (only on positive peaks) is small compared to the loading by the swamping resistor, very little change in the driving voltage waveform occurs. Although the swamping resistor requires greater driving power, this expenditure of power is partially compensated for by providing more available power output without appreciable increase in distortion. The swamping resistor is also an aid to the overall stability of the amplifier stage by setting a low impedance to ground and absorbing energy coupled back into the input through the grid-to-plate capacitance of the tube.

b. *Grounded-Grid Amplifier*. Figure 45 illustrates the basic circuit of a grounded-grid (cathode-driven) amplifier. The grounded-grid circuit is used to avoid the necessity of neutralizing a triode amplifier. In this circuit, the grounded grid acts as a shield to reduce the capacitance that normally exists between plate and cathode. This capacitance, as the grid-to-plate capacitance in a grounded-cathode con-

figuration, represents the feedback path of energy from the output to the input circuits. The reduction of this capacitance (input to output) increases the frequency limit of operation of the amplifier and decreases the amount of positive feedback that introduces undesired distortion components in the rf power amplifier. The only drawback in the use of the grounded-grid amplifier is the higher input driving power required to excite the amplifier. This is so because the input impedance of the amplifier is relatively low. The input driving power must produce a voltage difference between grid and cathode to modulate the plate current in addition to supplying energy that flows to the plate load through the plate resistance of the vacuum tube; the input driving voltage is effectively in series with the vacuum tube plate resistance. Although the input driving power of a grounded-grid amplifier greatly exceeds the power required by a grounded-cathode amplifier, much of this power appears in the plate circuit and flows into the load in addition to the amplified power.

43. Output Circuits

In the preceding paragraphs, the discussion

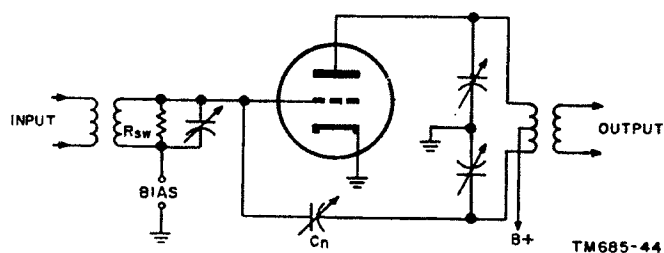

Figure 44. Grounded-cathode (grid-driven) neutralized power amplifier.

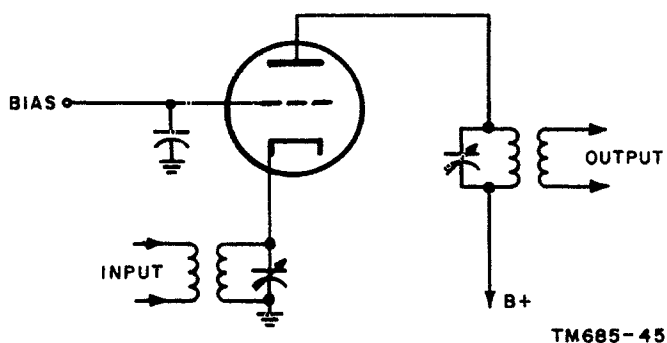

Figure 45. Grounded-grid (cathode-driven) power amplifier.

has centered about the need for linear amplifiers in ssb systems and the classes of operation that are best suited for this purpose. Before examining circuits that can further linearize an RF amplifier, first explore the function, requirements of, and circuits for a few possible output networks that lend themselves for adaptation to RF linear-power amplifier plate circuits. A class AB or B amplifier supplies an output current that contains a high order of harmonics generated within the tube. The amount and the intensity of these harmonics is dependent on the angle of plate current flow; the most harmonics are produced of the smaller angles of conduction. Harmonic production increases as we modify class AB operation in a direction that approaches class B operation. These harmonics and other undesired frequencies, caused by the periodic cessation of plate current in the above classes of operation, must be as completely attenuated as the state of the art will allow to produce linear operation of the stage. The choice of plate loading circuit is made in view of the above requirements for an RF linear-power amplifier stage.

a. To conform to the requirements for linear-amplifier operation, the plate load impedance must be closely controlled. This requires a coupling device that will transform the antenna impedance to a value that satisfies the requirements of the pa stage for linear operation. In addition, the coupling network must provide a reduction in harmonic output and good plate efficiency. The network components are selected so that with a minimum of manipulation, the power amplifier will be resonated and matched into the antenna transmission line at all frequencies of the transmitter range.

b. The pi-L network (fig. 46) is ideal for attenuation of harmonic content in the output current of a linear pa tube; second harmonic attenuation of about 50 db below the fundamental is possible. The network readily matches the pa tube load to a 52-ohm coaxial transmission line. Loads with standing wave ratios as large as 4 to 1 find a convenient match when the pi-L network is used as a coupling element. The four available elements shown in the figure affect tuning and loading of the pa plate circuit. The tuning components

are L1 and C1; L2 and C2 are the adjustable parts for obtaining optimum loading.

c. There is usually a servosystem that positions the variables (L1-C1, L2-C2) of the network. Tuning and loading comparator circuits furnish information to the servosystem which, in turn, adjusts the components of the network for best operation at each output frequency. The circuit components are deliberately chosen to yield a null or zero error signal when the loading and tuning of the pa stage are the proper values. An error signal voltage, other than zero, will drive the servomotors in a direction to position the network controls for optimum pa stage functioning. A detailed discussion of tuning and loading servocontrol networks is covered in paragraphs 46 and 47.

44. RF Feedback to Improve Linearity

In our search for a high order of linearity in the power amplifier stage, we have limited ourselves to those characteristics that are inherent in a vacuum tube. We arrived at a compromise of operating conditions that provides a high degree of linearity in transferring a driving signal at the input of the tube to the output circuits. Since we have all but exhausted the linearizing possibilities afforded by the internal characteristics and sets of operating conditions, it now seems a logical approach to apply some technique external to the tube, to further linearize the amplifier. A most important and often used technique is to feed back a signal, negative in character, from the output to the input circuits of the amplifier. Negative RF feedback is the most effective external linearizing circuit that can be employed to reduce the amount of distortion in-

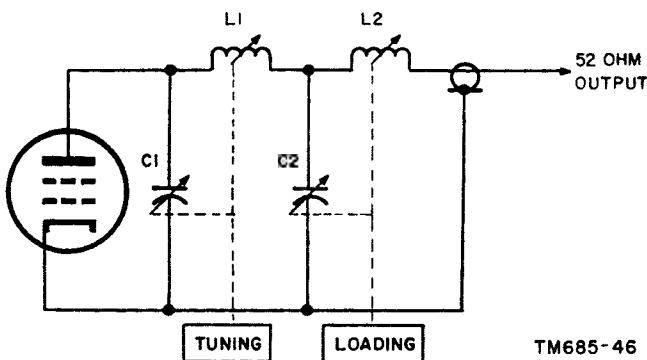

Figure 46. Pi-L output network.

duced by the vacuum tube. It is easy to realize the same db reduction in distortion as that amount of db energy feedback; this reduction is maintained at all levels. Along with distortion reduction is a decrease in tube output equal to the amount of feedback power. This loss of power is fully compensated for by the elimination of many distortion products in the output signal. Two feedback arrangements will be described. These are the single-stage feedback circuit and the two-stage feedback circuit.

a. Figure 47 illustrates a single-stage RF amplifier with negative feedback. The dc voltage source and the dc returns (grid-return resistor, bias circuit) are not included in the illustration. Neutralization components for the stage are also omitted in the illustration for the sake of simplicity. Capacitors C2 and C3, across the plate tank circuit, form a voltage divider that controls the amount of feedback. The voltage across C3 is in series with the input signal voltage developed across the tuned circuit. Assume an instantaneous signal voltage polarity across L1-C1 (as indicated in the figure) which makes the control grid positive with reference to the other end of the input tank circuit. Inversion of the signal applied to the output tank circuit, L2-C2-C3, produces a negative voltage at the plate with reference to the grounded end (ac ground) of the tank circuit. The distribution of voltage across capacitive voltage divider C2-C3 makes the junction of the capacitors negative with reference to ground. The combination of the voltage across C3, in series opposition to the voltage across input tank circuit L1-C1, results in a reduction in the driving signal voltage feeding the amplifier. Distortion that is produced because of some residual nonlinear tube characteristic is also applied out of phase to the amplifier input. This action cancels a portion (dependent on amount of feedback) of the distortion in the amplifier output signal.

b. Figure 48 illustrates a two-stage RF amplifier (driver and pa) that employs negative feedback from the pa plate circuit to the cathode of the driver. Capacitance voltage divider Cf, C1, and C2 is the feedback network that couples the pa plate signal, in phase, to

the cathode of the driver tube. The feedback voltage between cathode and ground (across C2) of the driver tube is in series with the signal voltage at the grid and is a bucking voltage that reduces the distortion produced in the tubes of the driver-pa combination. Variable capacitor, Cn, is part of pa neutralizing network (capacitive divider) Cf, Cn, and C3. The distinct advantage of two-stage feedback is more realizable tube gain with the same amount of distortion reduction for the amount of feedback power.

45. Automatic Load Control

Automatic load control (alc) presents an acceptable solution to the problem of maintaining the power amplifier at maximum power output capability while preventing overdriving of the

amplifier on modulation peaks. The alc circuit samples the output signal of the power amplifier, rectifies a small percentage of this output voltage, and feeds back a filtered negative dc voltage to control the gain of one or more linear amplifiers in the preceding stages.

a. Figure 49 shows a simplified diagram of an alc circuit, the driver-pa block from which the output signal is sampled, and the controlled linear amplifiers. The two linear-amplifier stages utilize remote-cutoff tubes; the gain of the tubes varies with bias setting. The driving signal to the pa is amplified by the two stages; consequently, the magnitude of this signal is affected by the level of the feedback dc bias voltage. For a large signal (above a predetermined level), the gains of amplifiers V1 and V2 decrease, reducing the drive to the pa and thereby, the tendency to overdrive the amplifier and introduce distortion into the output signal. For an average signal, the linear amplifiers function normally, since no amplifier gain control bias is developed.

b. The ssb signal is coupled to the grid of V1 and appears across R1. The amplified output signal of V1 is applied to the grid of V2 and develops a voltage across R2. Amplifiers V1 and V2 are usually located in the ssb exciter section of an ssb transmitter. The amplified output signal of V2 is coupled to the driver and power amplifier stages where the

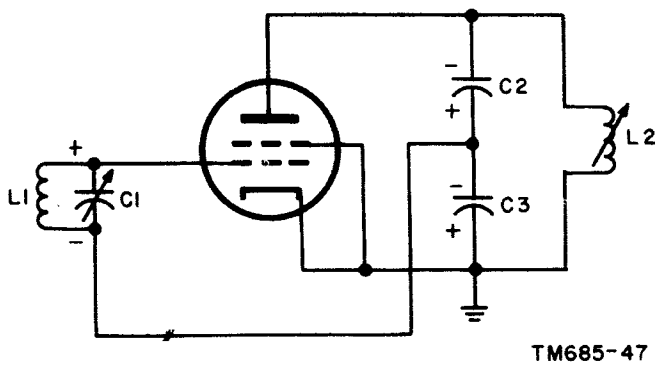

Figure 47. Single-stage RF amplifier with negative feedback.

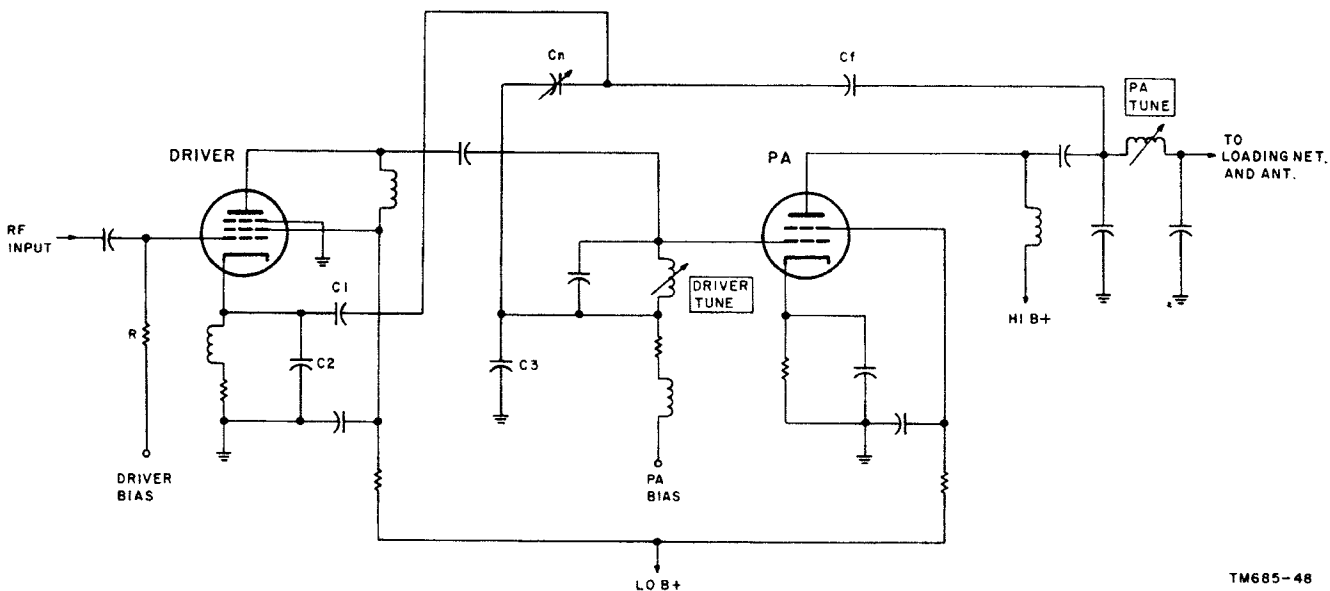

Figure 48. Two-stage RF amplifier with negative feedback.

final operating power is produced and fed to the antenna for radiation. A capacitive voltage divider, C1-C2, connected to the pa plate, selects a small percentage of the pa output voltage for application to alc rectifier V3. Resistor R7, the *delay bias adj* control, biases diode V3 in a direction (cathode positive with reference to plate) that delays conduction until the rf voltage across C2 exceeds this diode bias setting. Resistor R6 isolates the sample voltage from R7. Resistors R4 and R5 and capacitor C3, together, are that part of the diode V3 load located between plate and ground. The negative alc voltage that is dependent upon the amount of conduction in the diode, develops across this network. The values of the capacitor and resistors are so chosen as to form time constants that will act on rapid rises in pa peak output as well as allow the system to return to normal operation under the influence of an average signal level. Resistor R3 and capacitor C4 are a resistance-capacitance (rc) combina-

tion that furnishes additional filtering of the alc voltage which is then applied in series with the grid-return resistors of V1 and V2.

c. Alc acts to restrict the dynamic range of the signal very much like the compressor circuit in the audio processing circuits that precede the modulator in the ssb generator. A dynamic range of 12 db is usually the range maintained by the alc circuits which automatically reduce peaks on the order of 20 db above the level at which alc action begins. If the possibility of developing higher peaks exists, incorporation of a compressor circuit in the audio input circuits will limit the rise, and make the alc circuits more effective. Adjustment of *delay bias adj* control R7 sets the beginning of diode V3 conduction at a point which will satisfy the conditions for operation of the pa at maximum power capability with no distortion created because of overdriving of the pa on peak signals.

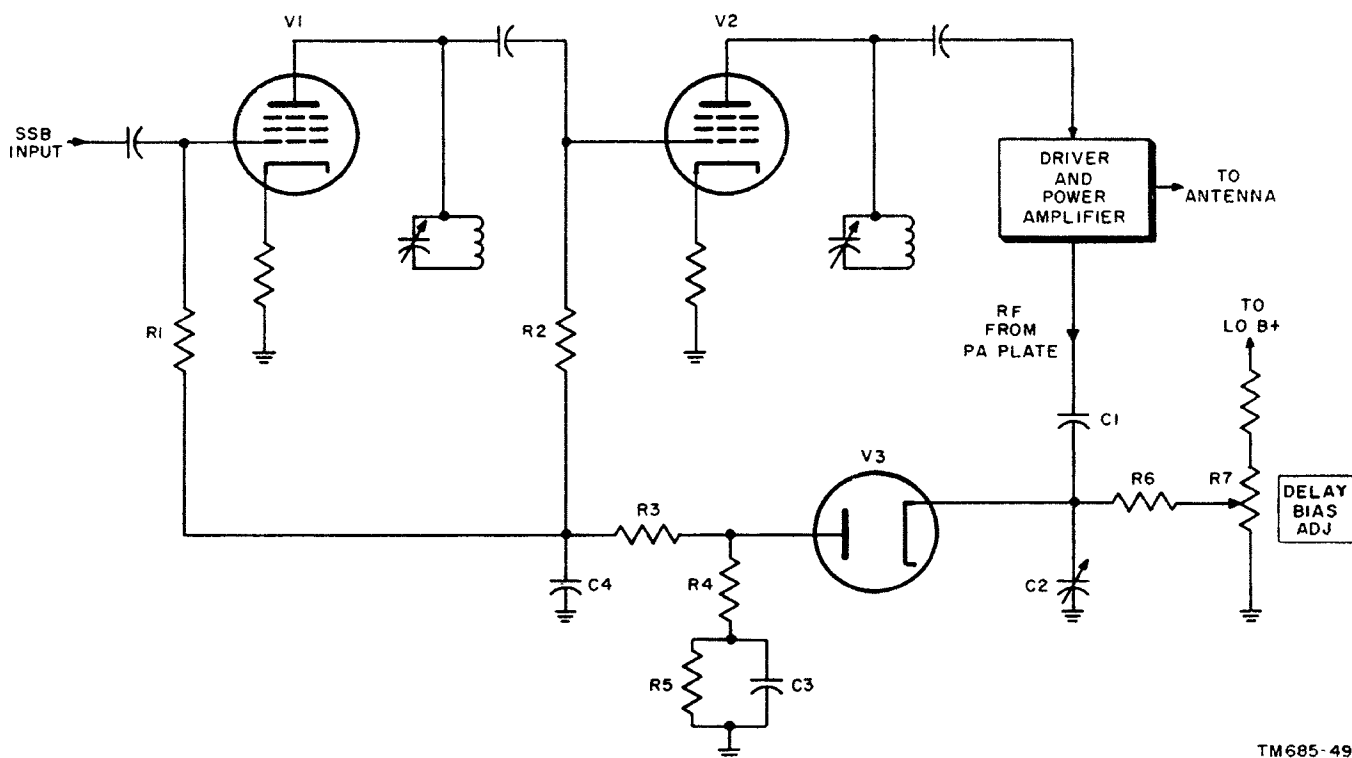

Figure 49. Automatic load control, partial schematic diagram.

TM685-49

Section III. LINEAR-POWER AMPLIFIER TUNING AND LOADING

46. Tuning Linear-Power Amplifier

Tuning of a power amplifier, operated under class C conditions, is a relatively simple matter. A fair degree of tuning accuracy is obtained by monitoring grid and plate current, while manipulating input and output tank circuits for a peak (maximum) in grid current and a dip (minimum) in plate current. The grid current results from driving the pa into the positive region of grid-to-cathode voltage. The plate current dip appears when the plate tank circuit is tuned to maximum impedance (at the frequency of operation) where the average plate current drawn is decidedly reduced. In a linear-power amplifier the application of this method of pa tuning is limited. A class A amplifier is normally not driven past the point where grid current flows, and the average plate current does not change with the output tank circuit setting. Although a class AB amplifier is at times driven into grid current flow (class AB₂) and the average plate current shows a dependency on output tank circuit impedance, the amounts of grid current flow or average plate current change are relatively small. It is difficult, under these conditions, to detect the degree of change necessary to properly tune a linear-power amplifier. Another very important consideration in tuning a power amplifier is the fact that in low Q tank circuits (less than 10), maximum impedance does not coincide with unity power factor where the plate load becomes completely resistive in appearance (resonance). Therefore, a false indication is conveyed by the dip in the average plate current while the tank circuit may be somewhat off resonance. The most damaging effect of an off-resonance condition is the shift in phase of the negative rf feedback voltage. Correct feedback phase is necessary for stage linearization and elimination of undesirable distortion products. Below is a description of one method for accurate adjustment of the pa plate tank circuit (for circuit resonance) and for maintaining correct feedback phase.

a. A closed-loop servo, consisting of a coarse-positioning control, phase discriminator, servo-amplifier, and servomotor, performs the function of positioning and maintaining the pa

plate tank circuit at resonance. The coarse-positioning control and the phase discriminator develop polarized error voltages that indicate the amount of correction to be made by the servomotor to reduce the error to a negligible amount. The individual error output voltages are combined and applied to the servoamplifier from which the servomotor control voltages are derived. The servomotor drives the variable tuning components of the pa plate output network in a direction to bring the output tank circuit into resonance.

b. A simplified block diagram illustrating the electrical and mechanical interrelationship in the closed-loop servo appears in figure 50. The RF signal input to the coarse-positioning control develops a direct-current (dc) error voltage at the control output that is indicative of the amount that the servomotor must turn to bring the pa tank circuit close to resonance at the input frequency. The phase discriminator combines a sampling of the rf signal from the pa plate circuit with an rf signal from the driver output. The result is a dc error signal that reflects the difference from a 180° phase shift (grid-to-plate signal inversion with resistive load) between the pa input- and output-signal voltages. The dc error voltage from the phase discriminator output is combined with the dc error voltage from the coarse-positioning control and applied to the chopper and servoamplifier. The chopper converts the combined dc error voltage into an ac voltage that is fed to the servoamplifier. The output of the servoamplifier is an ac motor-control voltage that actuates the servomotor in a direction to cancel the error and bring the plate tank circuit into resonance at the transmitter operating frequency.

c. Figure 51 is a simplified schematic diagram of a coarse-positioning control that is part of the closed-loop servo (*b* above). Basically, this configuration is a bridge circuit that is balanced when the voltage between points B and A (E3) becomes zero. A followup capacitor (C1) tracks with the pa output tank circuit tunable elements to bring the circuit towards resonance at the transmitter operating frequency that is applied to the control from

the exciter output. The function of each component in the figure and the distribution of voltages that combine to form the error voltage are discussed below.

- (1) The rf input signal from the exciter is applied to low resistance matching resistor R1 and develops rf voltage drops across the series branch of followup capacitor C1 and fixed resistor R2. The individual voltage drops determine the current that flows through crystal diodes CR1 and CR2 and fix the charge on capacitors C2 and C3, respectively. Thus, the potential difference that develops across each capacitor (C2 and C3) is dependant upon the rf voltage drop across the shunting component (C1 or R2); the polarity of each potential difference is set by the in-circuit connections of crystal rectifiers CR1 and CR2.
- (2) Upon completion of the charging portion of the RF cycle, capacitors C2 and C3 attempt to discharge through the high resistance paths of diode-shunt resistors R3 and R4 and equal-value resistors R5 and R6 in the remaining leg of the bridge. These paths contain much higher resistance than the charging paths through forward-biased diodes CR1 and CR2. Since the discharge time constant for the higher combination r_c is quite long, the charging portion of the next rf cycle arrives after only a small quantity of the C2 and C3 charges has leaked off. The C2 and C3 discharge path, which is of primary importance in this discussion, is shown in B, figure 51. Here we find equal voltage drops across R5 and R6 with the polarities as indicated. Matching resistor R1 has a very low resistance value (compared to R5 and R6) and consequently contributes a negligible voltage drop within the discharge loop. Therefore, the total voltage drop across R5 and R6 is the sum of the potential differences across C2 and C3. Note that the direction of conduction

of CR1 and CR2 has established the potential differences across the capacitors as aiding each other. The magnitude of each charge (C2 or C3) depends upon the distribution of RF voltage between C1 and R2. If the RF voltage across C1 is the larger of the two, the potential difference across C2 is greater than the potential difference across C3 at a value that approximates the peak rf voltage across C1. Conversely, if the voltage drop across R2 is the larger, then C2 is charged to the greater potential difference.

- (3) The dc error voltage output is concerned with the effects of dc voltages in the bridge that arise from the relative magnitudes of potential differences across C2 and C3. The size of these potential differences is fixed by the RF signal voltage drops across C1 and R2 ((1) above). Let us first consider the dc equivalent bridge (C, fig. 51) to further the analysis of how the dc error voltage output is arrived at and then conclude with a description of the effect of rf signal frequency on the C1-R2 combination and how repositioning of followup capacitor C1 balances the dc bridge.
- (4) The dc error output voltage is taken between point B and ground (A, fig. 51). The equivalent dc bridge in C, figure 51, indicates that dc bridge balance voltage (and dc error output voltage) E3 is the sum of dc voltages E2 (across R6) and E1 (across C3); the dc voltage drop across R2 is neglected since it must be less than the negligible dc voltage drop across low-resistance matching resistor R1 ((2) above). Therefore, E3 is both the dc error voltage output to ground and the dc balancing voltage of the bridge (between points B and A, A, fig. 51).
- (5) The dc bridge is balanced and E3 is 0 volt when E2 is equal to E1. Note that the polarities of voltages E2 and E1 are opposite to each other as connected into the bridge circuit. This

equality can only occur when the potential differences across C2 and C3 are equal in magnitude. Under the condition of identical potential differences across the capacitors, the voltage distribution across equal resistors R5 and R6 produces equal and opposite voltages E2 and E1, and the dc error output voltage is 0 volt. When the potential difference across C2 exceeds that across C3, E2 is greater than E1 (across C2) and produces a positive dc error voltage. When the potential difference across C3 is larger than that across C2, E2 is less than E1 and a negative dc error voltage is produced.

(6) Let us return to the input branches of the positioning control and observe the manner in which the rf signal frequency affects the distribution of RF voltages across C1 and R2 which, in turn, control the magnitude of the potential differences across C2 and C3 and the dc error voltage output of the bridge. Since the dc bridge is balanced only for identical potential differences across C2 and C3, this condition of balance is only true for equal rf voltage drops across C1 and R2. Equal rf voltage drops are possible only when the value of capacitance of C1 is such that at the rf signal frequency its reactance is equal to the resistance of R2. If, as is true of a lower frequency than the resonance frequency, the reactance of C1 is greater than the resistance of R2, the potential difference across C2 is greater than that across C3 ((2) above). This produces a positive error voltage ((5) above) that results in a repositioning of C1, by the servomotor, to a capacitance that provides equal RF voltage drops across C1 and R2 and dc bridge balance. An RF signal frequency greater than the resonance frequency finds the reactance of C1 less than the resistance of R2. The potential difference across C3 is now the larger and a negative dc error voltage is

produced. Repositioning of C1 in a direction opposite to that required for a positive error voltage balances the dc bridge.

(7) A, figure 53 graphically illustrates the response of a coarse-positioning control. The dc error voltage output of the control extends in either direction (dependent upon initial position of followup capacitor C1) and reaches a null (0 volt at bridge balance) when C1 is positioned to where its reactance is equal to the resistance of resistor R2 (A, fig. 51). The coarse-positioning control is normally used to automatically tune to a selected transmitter operating frequency. This circuit is limited to an approximate tuning of the pa tank circuit since, by itself, it cannot provide the exact resonant condition that is a necessity in a linear-power amplifier that employs some form of negative feedback (par. 44).

d. A coarse-positioning control (c above) is not the final answer to the problem of accurate servotuning of the pa tank circuit. Additional error information that will provide a foolproof indication of the point of exact resonance must be channelled to the servosystem. The circuit selected to perform this function must establish the existence of resonance by detecting a purely resistive condition in the pa tank circuit. A practical resonance detector circuit monitors the phase difference between the input and output RF signal voltages of the pa stage and furnishes information to the remainder of the servosystem which, in turn, positions the pa tank tuning elements to produce a phase shift of exactly 180° . Remember that a 180° phase shift is in evidence only when the pa tank acts like a pure resistance. The practical resonance detector, above, is actually a phase discriminator circuit which produces a null (0-volt output) when a complete inversion (180° phase shift) of the driving signal appears at the output of the pa stage. A phase discriminator that is similar in appearance and operation to the well-known Foster-Seely discriminator is described below. This description includes a simplified analysis of the vector relations that

exist between the two rf voltages applied to the circuit.

- (1) The input to the phase discriminator consists of two signals at the same frequency that are to be compared in relative phase. One signal is an RF voltage from the driver stage which normally feeds the input to the pa stage. This signal is applied as a reference signal to the series combination of C1-R1 in the discriminator; C3 represents a negligible reactance in series with C1-R1. The ratio of the reactance of C1 and the resistance of R1 is usually about 30 to 1. This ratio causes the voltage, E1, across R1 to lead the RF driving voltage to the pa stage by 90° .
- (2) Transformer T furnishes an RF voltage to the discriminator induced by the pa output tank circulating current. This voltage, E, is 180° out of phase with the signal voltage output of the pa stage. Identical resistors R2 and R3 split voltage E so that each half, E2 or E3, is opposite in phase to the other. As was noted earlier, E1 across R1 is 90° out of phase with the RF from the driver ((1) above). It is also true, from a fundamental viewpoint, that for a resonant condition in the pa tank circuit, a 180° phase difference exists between input and output signals (*d* above). Therefore, voltage E1 is 90° out of phase with voltage E2 and E3 across R2 and R3, respectively.
- (3) Note that the in-circuit connections of crystal diodes CR1 and CR2 provide a direction of conduction through identical resistors R4 and R5 such that the voltage developed across one opposes the voltage developed across the other. The sum of these two voltages is the error voltage output of the discriminator. Equal currents through CR1 and CR2 produce equal voltages across R4 and R5. This equality of voltages results in a total error voltage of 0 volt. If CR1 current is larger than CR2 current, the error voltage is negative. Conversely, if CR2 passes the larger current, the error voltage is positive. Capacitors C2 and C3 are RF bypass capacitors.
- (4) Now let us return to the voltages that produce the currents through crystal diodes CR1 and CR2 these voltages decide the polarity and magnitude of the dc error voltage output of the discriminator. The voltage (E1 + E2) applied to CR1 is the vector sum of E1 across R1 and E2 across R2. The voltage (E1 + E3) applied to CR2 is the vector sum of E1 (common to both diodes) and E3 across R3. Remember that E2 across R2 is 180° out of phase with E3 across R3; each voltage is 90° out of phase with common-voltage E1 ((2) above). Vector diagrams C and D (fig. 52) show the relative magnitudes of the voltages applied to the diodes for three phase-difference conditions between input- and output-signal voltages of the pa stage.
- (5) B, figure 52 vectorially illustrates the properly tuned condition of the pa output tank circuit; where the output-signal voltage is exactly 180° out of phase with the input-signal voltage. Both voltages, E2 and E3, are equal in magnitude and opposite in direction to each other as well as at right angles (90°) with reference to E1. The resultant voltages, E1 + E2 and E1 + E3, that are applied to the diodes, are equal and develop equal and opposite dc voltages across diode-load resistors R4 and R5 at the output of CR1 and CR2, respectively. The dc error voltage is 0 volt and no correcting action takes place in the servosystem.
- (6) For a pa output tank circuit in a resonant condition above the signal frequency, the vector relations of the voltages are as shown in C, figure 52. The tank circuit is inductive in nature, so that the phase relations produced upset the resultant equal magnitude voltages applied to CR1

and CR2 under resonant tank conditions (B, fig. 52). The greater angular difference between the voltages applied to CR1 results in a smaller voltage to that diode. The smaller angular distance between the voltages feeding CR2 produces a larger applied voltage. With the above voltages applied to the diodes, CR2 conduction exceeds CR1 conduction and the voltage developed across diode-load resistor R5 is greater than the voltage developed across R4. A net positive dc error voltage appears across the series branch of R4-R5. The servomotor, under the influence of the positive error voltage, repositions the tunable element of the pa output tank circuit to lower the output circuit resonant frequency to that of the signal frequency at the pa input.

(7) The vector diagram of D, figure 52 illustrates the relative rf voltage positions when the pa tank circuit is resonant at a frequency below the input-signal frequency. The tank circuit now has a capacitive characteristic causing the vector, E, ($E_2 + E_3$ in C of the figure) to rotate clockwise to a position beyond the vertical position for the resonant condition in B. The smaller angular difference between the voltages applied to CR1 results in a larger voltage, $E_1 + E_2$,

than the voltage, $E_1 + E_3$, applied to CR2. The conduction of CR1 exceeds the conduction of CR2 and the voltage developed across R4 is larger than the voltage developed across R5. A net negative error voltage causes the servomotor to reposition the tunable element of the pa tank circuit to raise the resonant frequency of the output circuit and reduce the error voltage to 0 volt.

(8) B, figure 53 graphically illustrates the response of a phase discriminator. The response pattern is the familiar "S" curve that limits the active region of discriminator operation to the frequency range between the upper and lower peaks. The limited response range of the phase discriminator makes this error detector incapable of providing the coarse servo-positioning information required in an automatically-tuned ssb transmitter.

e. C, figure 53 is a composite response characteristic formed by combining the coarse-positioning control and phase discriminator dc error voltages. Note that combining of the two dc error voltages modifies the phase discriminator response by extending the response range; the accurate lock-in feature of the discriminator is retained.

f. Automatic tuning has represented the main theme of this paragraph because this

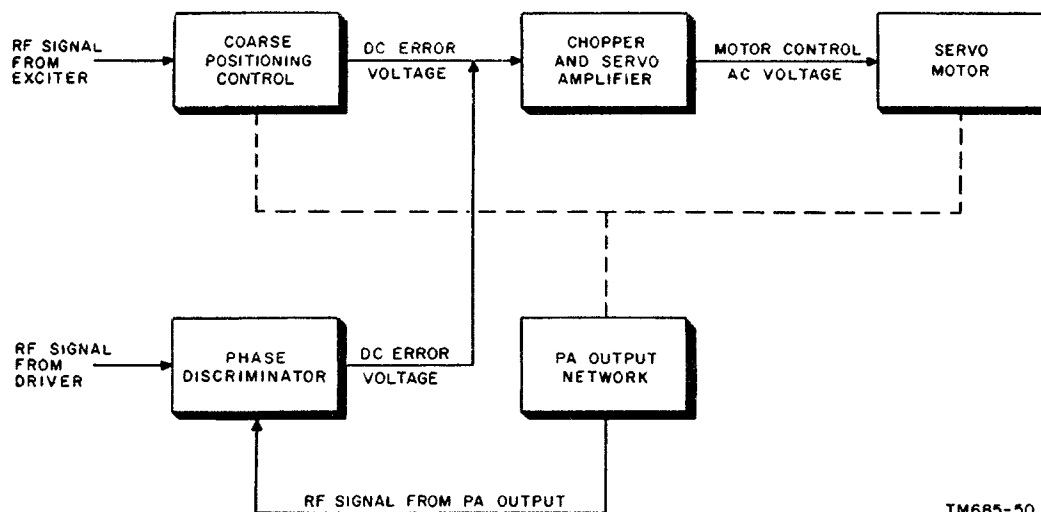
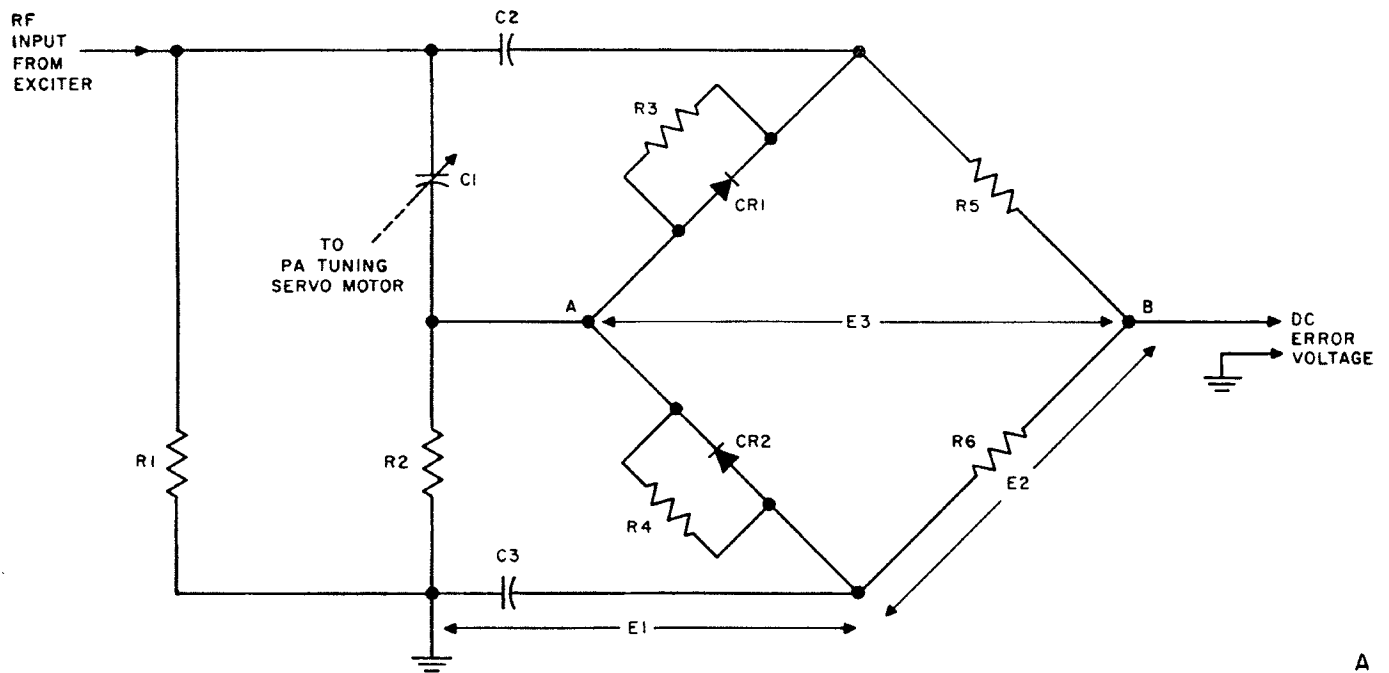
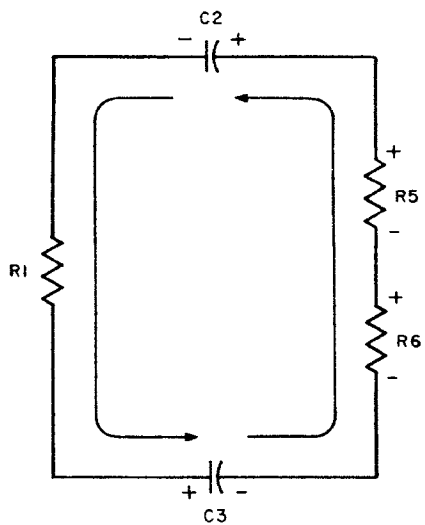

Figure 50. Power amplifier servotuning system, block diagram.

TM685-50



A



B

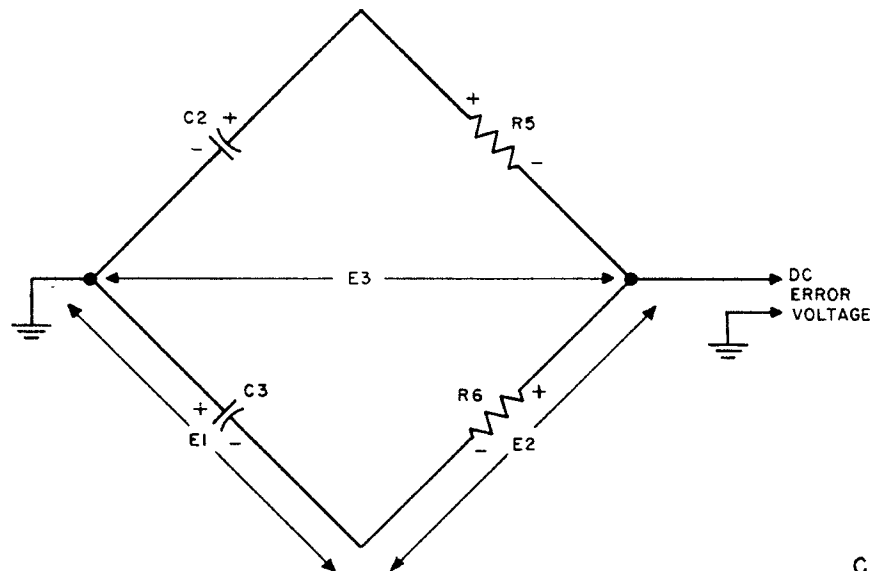

C

TM685-51

Figure 51. Coarse-positioning control for pa tuning servo, simplified schematic and equivalent dc bridge networks.

means of tuning is common practice. It is important for the technician to understand the control circuits involved in achieving automatic operation. Finally, nothing more than an observation of their existence has been made of the chopper and servoamplifier and the servomotor blocks of figure 50. Refer to TM 11-674 for a detailed coverage of servo-systems.

47. Loading Linear-Power Amplifier

Tuning of the pa output tank circuit is dependent upon adjustment of the loading circuit. The pa output network of a multiband transmitter is so designed that it is capable of tuning and loading into a transmission line or directly into an antenna where different impedances are reflected into the pa stage at dif-

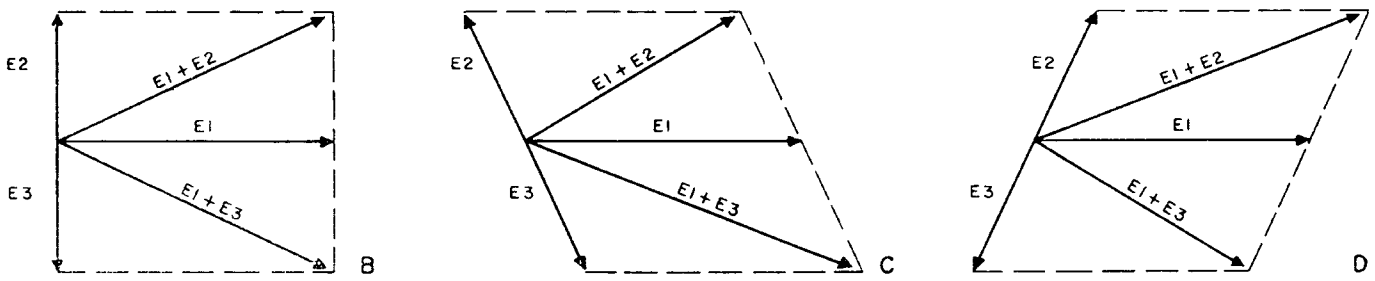
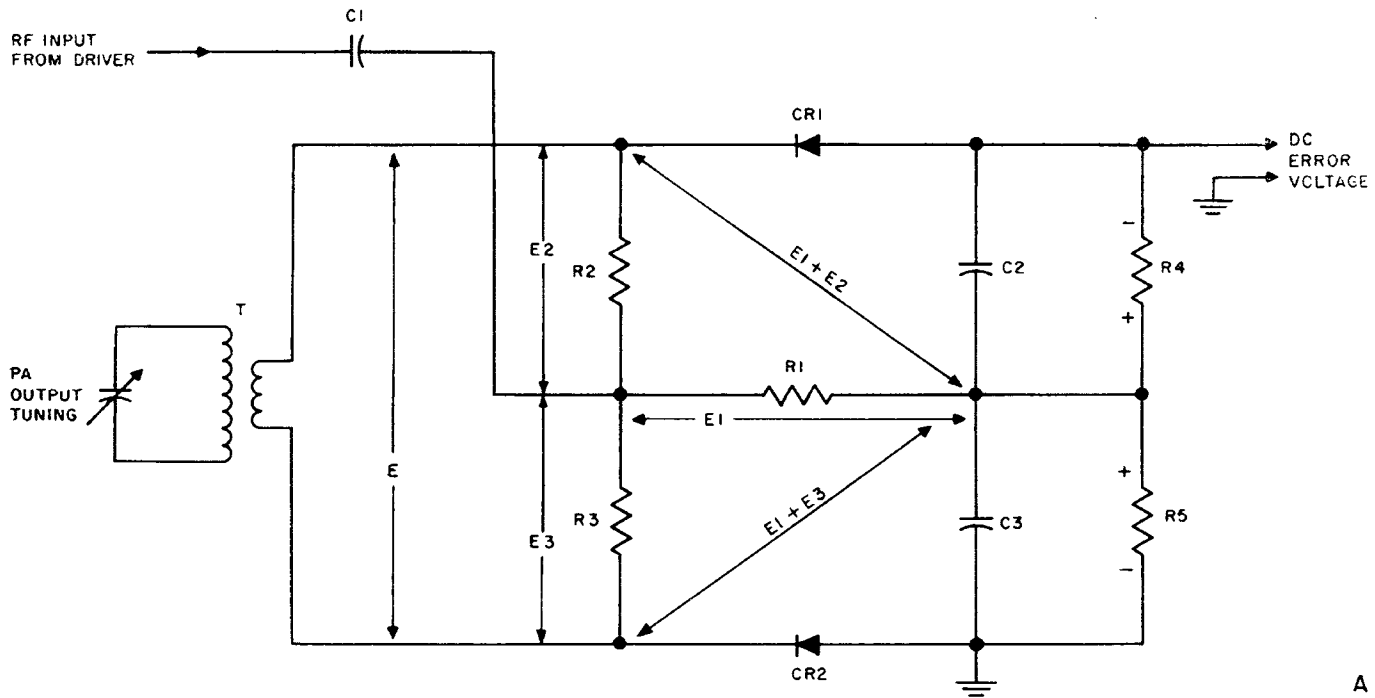

TM685-52

Figure 52. Power amplifier tuning-servo phase discriminator, simplified schematic and vector relationships.

ferent frequencies. The antenna impedance is transformed to a value which provides optimum loading (matched conditions) for the pa output.

a. The most important factor in the design of a loading network is that it match the antenna to the pa stage and provide proper loading and, in addition, transfer maximum power to the antenna. In fixed station equipment, the pa stage is usually loaded by a transmission line and an antenna that exhibit little change in impedance as the transmitter operating frequencies are switched and, therefore, present no appreciable matching problem. In vehicular and avionics equipment, however, the pa delivers power to a transmission line that may be terminated by one of a variety of short and inadequate antennas. The two pa output networks illustrated in figure 54 are proper

loading and tuning networks for fixed and mobile applications.

- (1) A simplified pa tuning and matching pi-L network can be used to fulfill output circuit requirements in a fixed station equipment (A, fig. 54). The network can be either band-switched (ganged to a motor bandswitch) or can be continuously variable with only two control shafts to affect the necessary adjustments. One control shaft has a marked effect on pa tuning while the remaining control adjusts for optimum output load impedance match for the pa stage. Choice of component values is governed by the need to resonate and match the pa output into the transmission line for

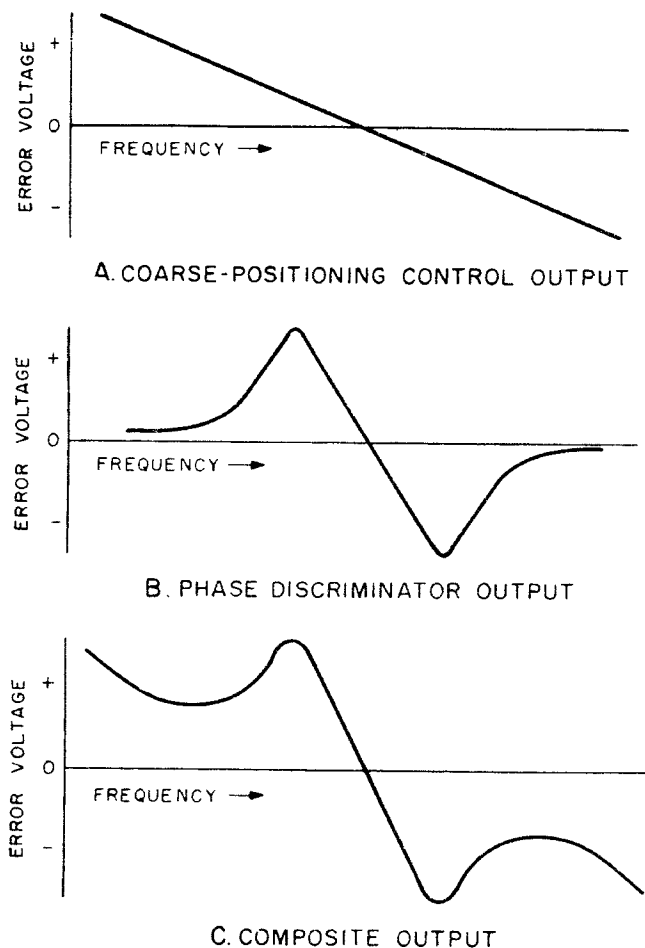

Figure 53. Characteristic response curves for error detectors for automatic pa tuning. TM685-53

the range of transmitter operating frequencies.

- (2) The output network in B, figure 54 is separated into two distinct parts; the pi-connected tank circuit for pa tuning, and the antenna coupler for phasing and matching the antenna to the pa output. Positioning of the coupler at the antenna base permits the use of a single transmission line for all frequencies and by providing proper impedance matching of the antenna reduces transmission line losses. Two controls in the antenna coupling element provide individual adjustments for phasing (cancellation of the reactive characteristic of the antenna) and impedance matching for maximum realizable power transfer to the antenna. In this network, as in the network in (1) above, the circuit components are selected to provide proper loading over the range of transmitter operating frequencies.

b. Automatic control of the pa output load is a significant factor in the loading of a linear-power amplifier. Improper loading of the pa not only affects radiated transmitter power but introduces undesired distortion products

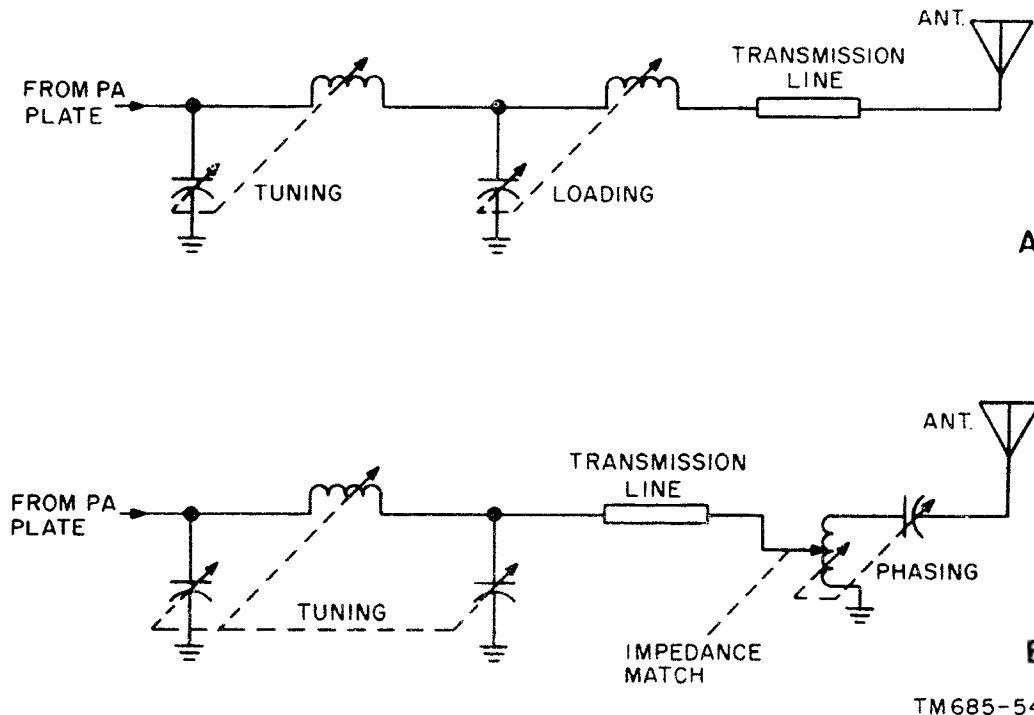

Figure 54. Pi-type power amplifier output networks. TM685-54

(intermodulation products). A method of developing control information that furnishes proper pa output loading under a variety of conditions (change of operating frequency, type of antenna), employs a simple voltage comparison circuit known as a comparator. It is well-known, from fundamentals of electron tube theory, that the voltage gain (ratio of output-signal voltage to input-signal voltage) of an electron tube is proportional to the value of plate circuit load resistance. Comparison of the input and output signal voltages provides a clear picture of power amplifier loading conditions. Continuous monitoring of input- and output-signal voltages provides information that is forwarded to a servosystem that changes control element positions in the pa output network and achieve proper loading of the power amplifier. The loading comparator circuit samples the output and input signals of the pa stage and develops a zero error voltage at a predetermined ratio of output- to input-signal voltages that indicates proper pa loading. The outputs of two crystal diodes that produce opposite polarity dc voltages, are combined to provide the dc error voltage output of the comparator. The comparator circuit described below is used to provide error information in conjunction with a coarse load position followup potentiometer that is slaved to (changes with) the pa output tuning servomotor.

(1) The comparator circuit of figure 55 samples signals from both the output and input of the pa stage. Capacitors C1 and C2 form an RF voltage divider that applies a small percentage of the pa output signal to crystal-diode CR1. Diode CR1 conducts in a direction that makes the top side of adjustable resistor R1 negative with reference to ground. Resistor R1 is adjustable to permit calibration of the comparator for a null (zero error voltage output) at a predetermined pa output-to-input-signal voltage ratio. Capacitor C3 bypasses the rectified rf component to ground.

(2) Capacitor C4 and C5 form an rf voltage divider that applies a small percentage of the pa stage input-

signal voltage to crystal diode CR2. In-circuit connection of CR2 allows conduction in a direction that makes the top side of adjustable resistor R2 positive with reference to ground. Resistor R2, like R1 ((1) above), is adjustable to permit calibration of the comparator to a null at proper pa loading. Capacitor C6 bypasses R2 for rectified rf voltages.

(3) The dc voltages developed across adjustable resistors R1 and R2 are combined through isolating resistors R3, R4, and R5 and form the dc error voltage output of the comparator. Crystal-diode CR3 clamps the rectified percentage of the input-signal voltage at the variable arm of R2 to the voltage drop across pa tube cathode resistor R6. This grid-to-cathode clamp is inserted into the circuit to prevent the transmission of an ambiguous error signal to the servosystem when the amplifier is driven into plate saturation. In this condition (plate saturation), an additional rise in input-signal voltage effects no change in plate current and hence no output-signal voltage change. Clamping-diode CR3 prevents the rectified sampling of the input-signal voltage from exceeding a voltage which is proportional to plate current; that is, the voltage across cathode resistor R6.

(4) Monitoring of pa output- and input-signal voltages with the action of clamping-diode CR3 to compromise amplifier plate saturation under light load conditions, are the main functions of the comparator circuit. Comparator error voltages provide corrective information that results in proper pa loading over a wide range of operating conditions. Proper loading must not disturb amplifier output network resonance at the operating frequency; therefore, steps are always taken to provide followup between tuning and loading servosystems.

c. The pi output network, with antenna coupler (B, fig. 54), employs a phase discrimi-

nator to automatically position the phasing control and balance the reactive components of the antenna, thus presenting a pure resistance to the transmission line. The phase angle of the impedance presented to the power amplifier by the antenna coupler and the antenna is monitored by noting the phase difference between the transmission line voltage and current. Monitoring is accomplished by sampling both transmission line voltage and current, and comparing a dependent phase condition in the phase discriminator circuit. Figure 56 illustrates a phase discriminator circuit that uses a toroidal current transformer as one of the methods for introducing to the circuit a voltage that is dependent on the transmission line current. The center conductor of the transmission line is passed through the center of a toroid winding to inductively couple the line current to the discriminator circuit. The line current sample produces a voltage which is compared with the voltage between the center conductor and ground. The error voltage output of the phase discriminator is applied to a servoamplifier and servomotor. The servomotor positions the phasing control (B, fig. 54), and maintains a purely resistive load on the transmission line. A phase discriminator that includes a toroidal current transformer is described below. This circuit is similar to the phase discriminator shown in figure 52 and described in paragraph 46*d*.

- (1) The induced rf voltage that is developed in the toroid winding produces a voltage, E, proportional to the transmission line current and 90° out of phase with it. Voltage E produces equal voltages E2 and E3 across identical resistors R2 and R3, respectively. The rf voltage between the transmission line center conductor and ground is divided by resistors R6 and R1 and develops voltage E1 across R1. Voltage E2 is 180° out of phase with voltage E3 as referenced to the junction of R2 and R3. Each voltage, E2 and E3, is 90° out of phase with voltage E1.
- (2) This sampling of transmission line current and voltage ((1) above) provides the essential voltages at the re-

quired phase so that vector addition of these voltages results in the same error-producing factors as in the phase discriminator of figure 52. The vector sum of E2 and E1 drives a unidirectional current through crystal-diode CR1 and produces a voltage across diode-load resistor R4 with the indicated polarity. The vector sum of E3 and E1 produces a current in an opposite direction through crystal-diode CR2 and a voltage is developed across diode-load resistor R5 with the marked polarity. The addition of oppositely polarized dc voltages across resistors R4 and R5 in series determines the magnitude and polarity of the resultant dc error voltage. Capacitors C1 and C2 filter the rf components at the outputs of CR1 and CR2. For a more detailed analysis, including vector diagrams, of the rf voltage combining action of the discriminator, refer to figure 52 and paragraph 46*d*.

- (3) For an in-phase condition between voltage and current in the transmission line, the error voltage output is 0 volt and no repositioning of the phasing control takes place. If transmission line current and voltage are not in phase, the discriminator circuit furnishes a dc error voltage of a polarity and magnitude that indicates whether the line current leads or lags the voltage, and the amount of the phase difference.

d. The impedance match control of (B, fig. 54) can also be coupled to an automatic-positioning servomotor. Information fed to the servosystem detects the existence of a deviation from a proper impedance match to the transmission line. The impedance is the ratio of the transmission line voltage from center conductor to ground and the line current. Monitoring of the relative magnitude of each offers a view of this ratio. The impedance discriminator circuit compares two rf voltages; one voltage depends on the line voltage and the other on line current. The circuit component values are selected to furnish rf voltages that *zero out* when the matched transmission line

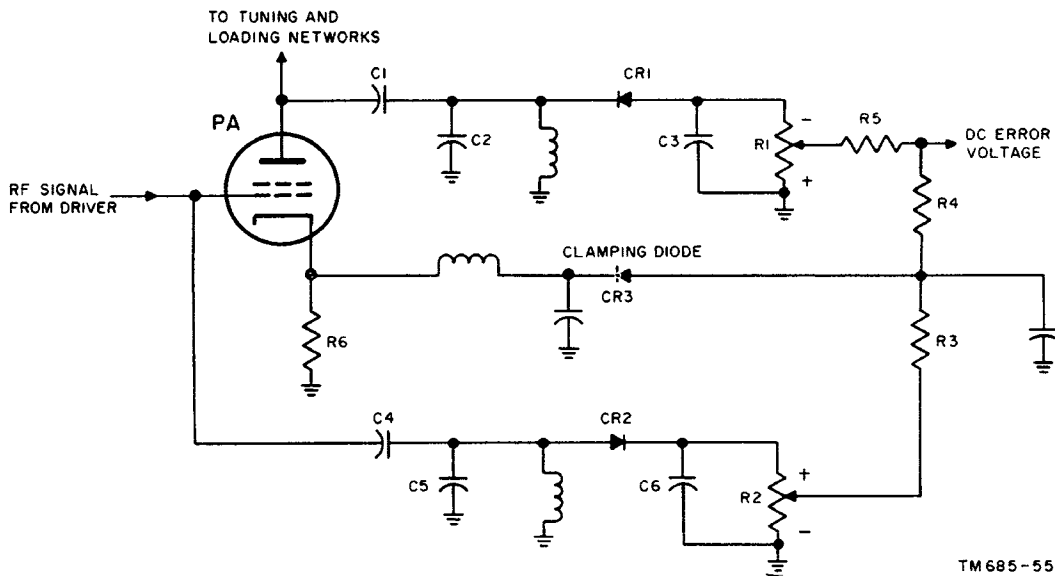

TM 685-55

Figure 55. Power amplifier loading comparator, simplified schematic diagram.

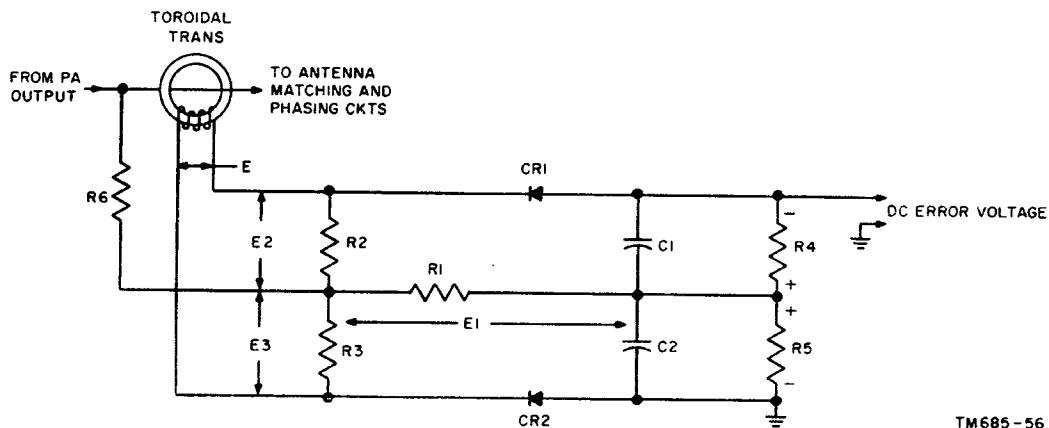

TM 685-56

Figure 56. Phase discriminator using toroidal transformer, simplified schematic diagram.

terminating impedance is reached. The two voltages are rectified, as in previously discussed discriminators, and added in polarity opposition to obtain the dc error voltage output. If the terminating impedance is not matched to the transmission line, the discriminator provides a dc error voltage of a polarity that depends upon whether the existing impedance is more or less than the required matching impedance. A circuit that is typical of impedance error detectors in use is described below.

(1) Figure 57 is a schematic diagram of a circuit that detects a mismatch that occurs in the relation of antenna loading to transmission line during transmitter tuning operations. The circuit consists of a toroidal transformer, (similar to the transformer shown

in figure 56) inductively coupled to the center conductor of the transmission line. The toroidal transformer provides an indication of the amount of rf current flowing through the line. Adjustable capacitor C5 couples a voltage to the circuit which is indicative of the voltage between the center conductor and ground. Keep in mind that it is the ratio of transmission line voltage and current that, by proper proportioning of voltages in the detector circuit, provides a null (0 volt) for a matched antenna to line condition.

(2) Resistor R1 and capacitor C1 form an rc voltage divider that applies an rf voltage to crystal-diode CR1 that is

solely dependent on line current and is independent of the frequency-sensitive coupling factors of the toroidal transformer. The RF voltage across C1 determines the amount of CR1 conduction, and the in-circuit connection of the crystal diode fixes the polarity of the voltage drop across diode-load resistor R2. Capacitor C2 bypasses the rf component at the output of CR1.

- (3) Adjustable capacitor C5 is part of an rf voltage divider that includes paralleled resistor R4 and capacitor C1. Capacitor C5 is adjustable to calibrate the error detector output for a null condition at the desired transmission line terminating impedance. The purpose for the particular series-parallel arrangement of C5-R4-C4 is to make the divider independent of frequency and entirely dependent on the magnitude of the voltage across the transmission line. The voltage across paralleled R4-C4 determines the amount of crystal diode CR2 conduction and develops a voltage across diode-load resistor R3 with the indicated polarity. Capacitor C3 filters the rf component at the output of CR2.
- (4) As in error detectors described previously, the error voltage is taken across resistors R2 and R3 in series. At the desired impedance, equal voltages of opposite polarity result in a 0-volt output. At an impedance greater than the proper terminating impedance, the transmission line cur-

rent decreases and the line voltage increases. The shift in current and voltage reduces the voltage across R2 (less line current) and increases the voltage across R3 (more voltage across line) and results in a negative dc error voltage output. A lower terminating impedance which increases line current and reduces the voltage across the line results in a positive dc error voltage. The dc error voltage (negative or positive), after processing by the chopper and servoamplifiers of the servo feedback loop (not described), positions the impedance matching control (B, fig. 54) to zero out the error detector when proper terminating impedance is reached.

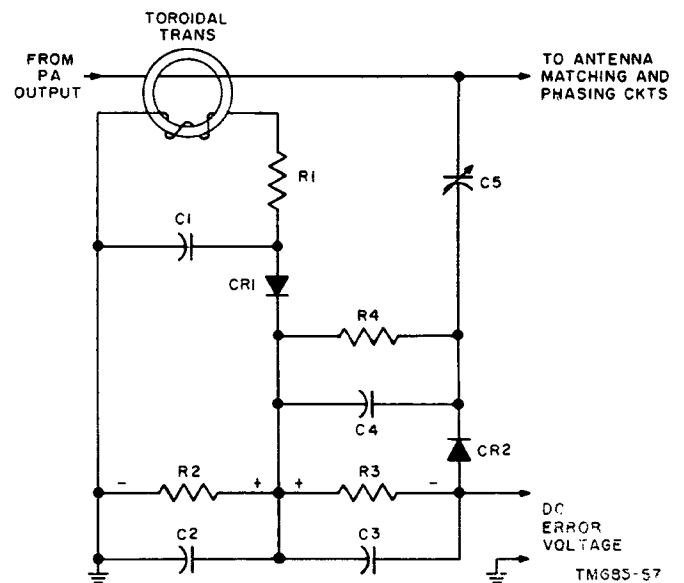

Figure 57. Impedance error detector, schematic diagram.

CHAPTER 4

SINGLE-SIDEBAND RECEIVER

Section I. INTRODUCTION

48. General

a. A single-sideband receiver in many of its circuits parallels conventional AM receiver. The distinction between the two receivers centers about requirements necessary to effect proper demodulation of the modulated RF signals. The use of extremely stable high-frequency oscillators, a heterodyne form of demodulator, and high Q filters is indicative of the distinction between ssb and AM receivers. One common feature of both is a multiple-conversion system that precedes the demodulator. Double or triple conversion is a prevalent design in ssb communications receivers.

b. An AM receiver can be adapted to receive and demodulate ssb signals by beating the output of the beat-frequency oscillator that is used to convert continuous-wave (cw) signals to intelligible code, against the intermediate-frequency ssb signal. Most AM receivers do not contain the circuits necessary to provide the stability of beat-frequency oscillator, narrowness of frequency bandpass, and low-noise demodulation necessary to obtain the advantages that have been outlined for the ssb system. The use of an AM receiver for the reception and demodulation of ssb signals is definitely not suitable for either fixed (point-to-point) or mobile military applications. A simplified block diagram of an AM receiver, showing the point of injection of the beat-frequency oscillator signal for ssb signal demodulation, is illustrated in figure 58.

c. The AM receiver (fig. 58) is a single-conversion superheterodyne receiver. The signal induced into the antenna is selected and amplified in the RF amplifier. The RF amplifier output is injected into a mixer stage along with a locally generated frequency from the

local oscillator. The difference frequency is usually selected from the number of frequencies that appear at the mixer output. The difference frequency is known as an intermediate-frequency (IF) signal. This signal is applied to the IF amplifier section of the receiver. (The IF section is normally comprised of one or more identical amplifier stages.) The amplified IF signal is fed to the demodulator for restoration of the original modulating frequencies. The function of the beat-frequency oscillator in an am receiver and its use for demodulation of an ssb signal are discussed in *b* above.

d. The discussion of the single-sideband receiver begins with a study of the reasons for the inclusion of particular design features that are part of the ssb receiver, and relates how these particular features differ from their AM receiver counterparts in circuit configuration and theory of operation. This section also includes a block diagram description of an ssb receiver. It is important to note that most of the blocks are similar to blocks in a standard AM multiple-conversion superheterodyne receiver.

49. Ssb and AM Receiver Differences

Several factors are involved in deciding on the type of receiver design and the particular types of communications services it should provide. An ssb receiver should be capable of single-sideband or independent sideband operation with either partially (pilot) or fully suppressed carrier, as well as possible use for double-sideband operation or continuous-wave telegraph. The receiver must have low distortion in multiple tone operation, good selectivity, and freedom from crosstalk when operating in the vicinity of powerful transmitters.

a. In a single-sideband receiver, the ssb sig-

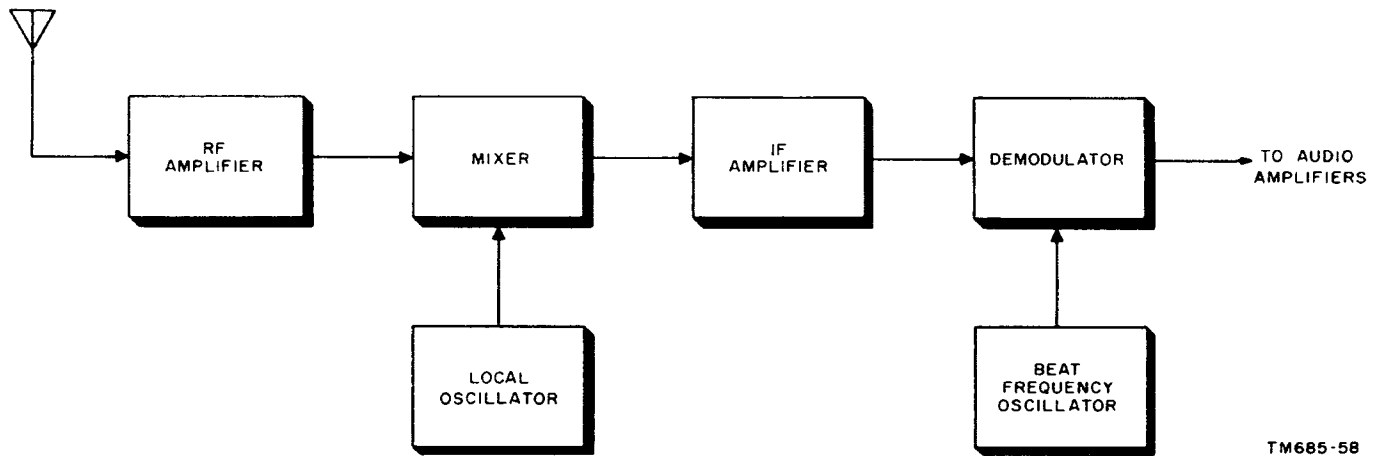

TM685-58

Figure 58. Am. receiver, simplified block diagram.

nal is amplified, processed through a number of mixing operations (multiple-conversion), and demodulated by heterodyning the final intermediate-frequency signal with either a locally generated frequency (suppressed carrier operation) or a reconditioned carrier frequency (pilot carrier operation). The result of demodulation of an ssb signal is the recovery of the original modulating frequencies. Note that the order of ssb signal processing in the receiver is the reverse of the single-sideband signal generator and the frequency translator in the transmitter exciter (ch 2).

b. The transmission of the ssb signal from transmitter antenna to receiver antenna undergoes the same changes, because of the transmission medium, that would affect any mode of communication employing the same range of frequencies. The transmission of one RF component at a time in an ssb transmission does not result in detrimental modification of the modulation; an undesired change occurs in a multicomponent AM transmission (two sidebands and a carrier). Receivers designed for ssb reception are invariably of the superheterodyne type. (Final demodulated RF is lower than the incoming signal frequency.) The main distinction between the ssb superheterodyne receiver and the AM superheterodyne receiver is the necessity for reestablishing the carrier for demodulation of the ssb signal.

c. An ssb signal induced into the receiving antenna travels through circuits in the ssb receiver that are similar to circuits in an AM

receiver through the IF system. A marked difference appears at the output of the final IF mixer. Here we find a high Q filter, mechanical or crystal, that accepts a band of frequencies that has the limits of the ssb grouping of frequencies to define its sharp bandpass characteristics. For an independent-sideband signal, the upper and lower sideband frequencies are channeled for individual demodulation by selecting each sideband with a narrow bandpass mechanical or crystal filter. If a reduced carrier (pilot carrier) is part of the incoming ssb signal, an extremely selective filter, with about a 20-cycle bandpass, passes the carrier frequency to carrier amplifiers for either reconditioning (amplification to a higher level) and reinsertion for ssb signal demodulation or for synchronizing a local carrier generator.

d. In an am receiver, the modulating intelligence is recovered by applying the final IF signal to an envelope detector. The envelope detector that is used almost universally in AM equipment is a simple diode, vacuum-tube or crystal, that rectifies the applied if. at its input and produces the original modulating frequencies at its output. In an ssb demodulator, the carrier (reconditioned or local) is heterodyned with the final IF ssb signal to produce the original modulating frequencies. Although a diode can serve as the demodulator, the introduction of excessive noise and spurious mixing products makes its use undesirable. Improved performance, which includes low noise and distortion, can be obtained by using a product demodulator. A product demodulator

also provides conversion gain which is non-existent in a diode demodulator.

e. The application of automatic gain control (agc) presents a problem in the absence of carrier in a completely suppressed-carrier single-sideband signal. An agc circuit is used to control the gain of the receiver so that the receiver output remains constant for moderate variations of signal levels at the antenna. The AM receiver supplies agc to its IF and rf stages by feeding back a negative dc voltage that is a function of signal carrier level. Since the average carrier level of an AM signal remains constant for all modulating amplitudes, it is suitable for developing a control voltage to vary the gain of receiver rf and IF stages. For single-sideband suppressed-carrier operation, the agc operation depends on the sideband level which varies with the amplitude of the modulating frequencies. In a combination single-sideband, independent-sideband, AM receiver, an agc select switch sets the agc system to operate on the type of incoming signal.

f. The necessity for providing a highly stable reference frequency for demodulation of an ssb signal calls for a tight control of the local oscillators. It is common practice to use an automatic-frequency control (afc) system to stabilize these oscillators. In the use of afc, a problem arises when the pilot carrier disappears momentarily or is completely shaded by a burst of noise. An erratic control signal, under these conditions, will drive the afc correction device to introduce a change of local oscillator frequency when no such change is warranted. Squelch circuits have been devised which disable the afc circuits in the event of a carrier fade or a decided rise in noise level.

g. The audio amplifiers that follow the demodulator are the same for both ssb and AM receivers. Once the ssb signal is demodulated, the retrieved intelligence is processed according to the particular application involved.

50. Ssb Receiver Block Diagram

Figure 59 is a simplified block diagram of an ssb receiver that is typical of receiving equipment in use in ssb systems. The ssb receiver in the figure is an independent-sideband suppressed or pilot (reduced) carrier receiver

that also detects individual upper or lower sideband signals. Automatic-gain-control circuits and automatic-frequency control squelch circuits have been omitted for the simplification. Automatic-gain-control circuits that operate with pilot or reduced carrier ssb signals are described in paragraph 62. Automatic-frequency control squelch circuits are explained in paragraph 61. The RF and IF circuit descriptions are not detailed because these blocks apply equally to a typical double-conversion superheterodyne AM receiver.

a. The *rf amplifier* (a preamplifier) amplifies the signal input from the antenna. This stage provides increased selectivity, image rejection, and better signal-to-noise ratio. The amplified signal is then applied to the *first mixer*.

b. The *first mixer* beats the amplified signal from the RF amplifier with a locally generated signal from the *variable-frequency oscillator (vfo)*. The resultant difference frequency is selected by a tuned circuit and coupled to the *first IF amplifier*.

c. The *first IF amplifier* amplifies the difference signal output of the *first mixer*. The amplified IF signal is coupled to the *second mixer*.

d. The second mixer beats the output of the *first IF amplifier* against a fixed frequency supplied from the *fixed frequency oscillator*. The frequency of the *fixed frequency oscillator* is calibrated against the *100-kc crystal oscillator*.

e. The *second IF amplifier* amplifies the difference signal from the output of the *second mixer*. This band of frequencies is usually centered at 100 kc and contains the sideband frequencies.

f. The output of the *second IF amplifier* contains the original sideband frequencies and the carrier frequency (considering a reduced or pilot carrier transmission). At this point, the upper sideband, the lower sideband, and the carrier (if any) are separated from one another. This is accomplished with sharply tuned filters. The *A-sideband filter* passes one of the sidebands to the *A-demodulator*. The *B-sideband filter* passes the other sideband to the *B-demodulator*. The *carrier filter* is tuned to the carrier frequency and passes it to the *carrier amplitude limiters*.

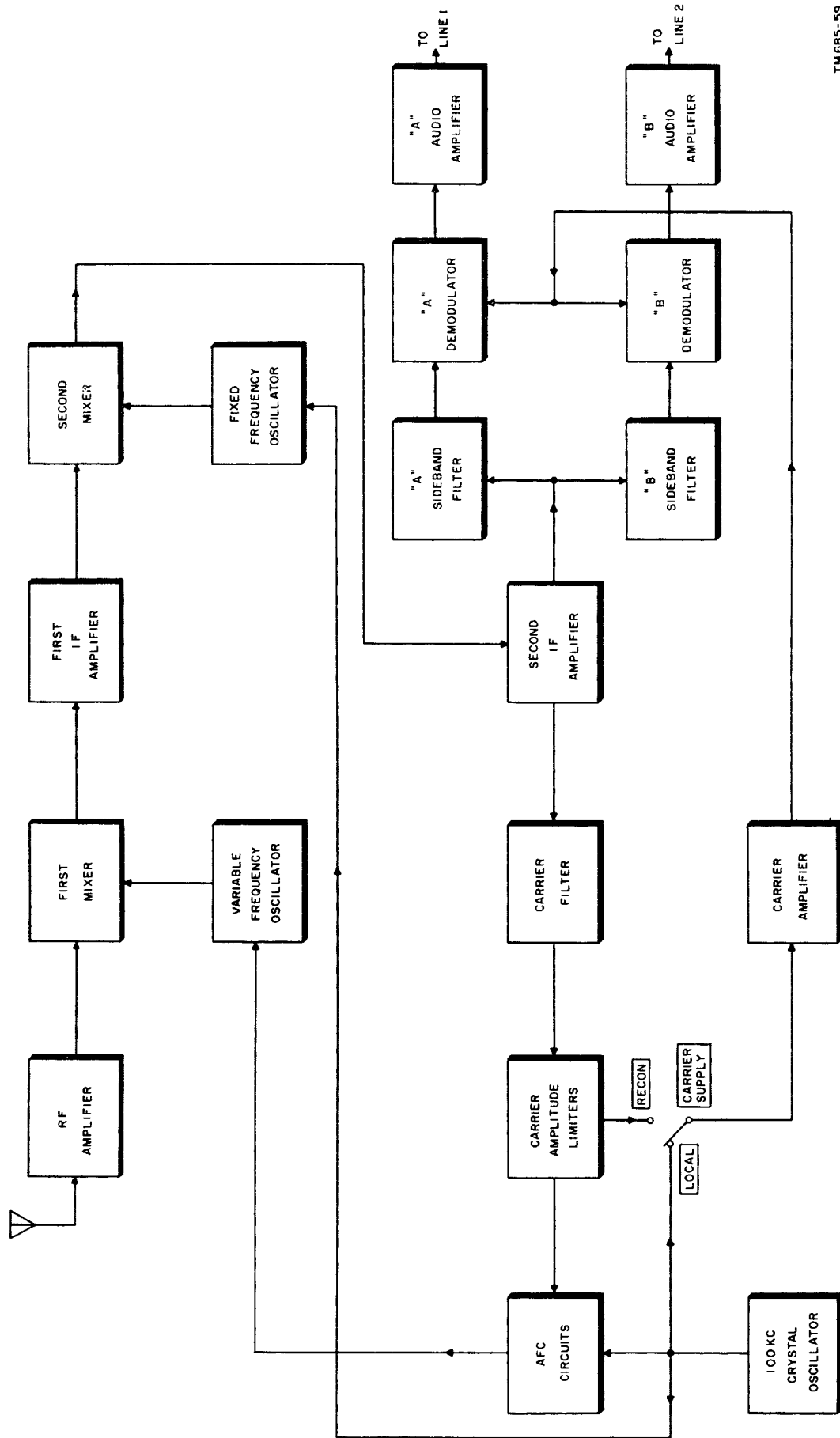

Figure 59. Ssb receiver, block diagram.

g. The *A- and B- demodulators* are identical in operation. The separated upper and lower sideband are fed to the demodulators; one sideband to each demodulator. The demodulators differs radically from conventional AM diode detectors. Each demodulator is normally a triode or pentagrid mixer (product detector) that beats the injected sideband frequencies against either a locally generated and tightly controlled carrier frequency or the reconditioned (separated and amplified) pilot carrier. The *A- and B- audio amplifiers* amplify the retrieved intelligence output of demodulators A and B. The audio amplifiers supply the required power levels to independent lines 1 and 2 for distribution.

h. The *second if. amplifier* output is also applied to the *carrier filter*, through which only the pilot carrier frequency passes. The pilot carrier is fed to the *carrier amplitude limiters* where the carrier amplitude level is both amplified and limited. Limiting of the carrier amplitude sets a level above which no increase in carrier signal output occurs with an increase in carrier signal input to the limiters. This results in a substantial decrease in noise (atmospheric and receiver internal) that rides the peaks of the carrier signal. The limiters assure application of a noise-free reconditioned carrier of constant amplitude to the demodulators and to the *automatic-frequency control*

(*afc*) *circuits*. An additional function of the limiters is to supply a noise signal to a squelch circuit (not shown in diagram) where the noise voltage disables the *afc* sensing circuits to prevent *afc* reaction to the noise frequencies.

i. The output of the *carrier amplitude limiters* is distributed to the *afc circuits* and to a *carrier supply* switch. The *carrier supply* switch is for selection of either *recon* (*reconditioned carrier*) or *local* (*local carrier*) for amplification in the *carrier amplifier* and injection into the *A- and B- demodulators* for mixing with the upper and lower sideband frequencies from the *second IF amplifier*. The limiters output is coupled to the *afc circuits* for comparison of the pilot carrier frequency with a highly accurate and stable fixed-crystal frequency.

j. The *100-kc crystal oscillator* is the standard frequency to which the pilot carrier output of the limiters is referenced. Comparison of the crystal and pilot carrier frequencies in the *afc circuits* furnishes a tight control of the *variable-frequency oscillator* and the *fixed frequency oscillator*. The *fixed frequency oscillator* is maintained at a fixed integral relationship to the *100-kc crystal oscillator* frequency. This frequency mixes with the *first IF amplifier* output signal to form the 100-kc pilot carrier frequency and the accompanying sideband frequencies.

Section II. STAGE-BY-STAGE ANALYSIS

51. Introduction

This section contains a stage-by-stage analysis of a typical ssb receiver. It begins with a detailed description of the input circuits which follows the ssb signal through the receiver to the output of the demodulators, and then discusses the carrier filter and amplifier, the carrier limiters, the *afc* control circuits, the squelch circuits, and the automatic-gain-control circuits. Before proceeding with a stage-by-stage analysis, it is important to mention the factors which limit the sensitivity of a receiver and describe how we can best amplify a very weak signal in view of these limitations. The sensitivity of a receiver is primary dependent on the amount of noise contributed to the signal in the circuits preceding the first mixer stage.

Signal-to-noise ratio limits the readability of a demodulated signal. Three noise sources disturb low-level signal operation at the input circuits of a receiver. These noise sources are the antenna, the input resistance to the receiver, and the equivalent noise in the grid circuit of the amplifier tube caused by random variations in plate current. Additional noise sources originate from atmospheric disturbances and manmade electrical devices. In the hf band (3–30 mc), this external interference increases the noise threshold above which the signal must be maintained to penetrate the noise. Since our analysis is based on the most favorable conditions for signal propagation, only receiver input circuit noise generation is discussed.

52. Sources of Noise

Noise voltages are generated in a conductor because of a random (haphazard) motion of electrons in the body of the conductor. This random motion is stimulated by thermal effects of ambient or other localized temperatures. This thermal agitation noise is proportional to the resistance of the conductor and its temperature. Noise currents are composed of an infinite range of frequencies. Therefore, the magnitude of a noise voltage affecting a network is proportional to the frequency bandwidth of acceptance of the network.

a. Thermal agitation noise is present in an antenna and produces a voltage equal to a noise voltage that would appear across a resistance equivalent to the radiation resistance of the antenna. A weak signal induced into the antenna must compete with this noise voltage to make itself readable at the receiver output.

b. The noise contributed by a vacuum tube is a result of irregularities in electron flow. Tube noise is a composite of the effects of the following irregularities:

- (1) *Shot effect.* Random changes in the electron emission rate from the cathode.
- (2) *Partition noise.* Caused by variations in cathode current division between positively charged elements.
- (3) *Induced grid noise.* Produced by variation in current density of the electron stream passing close to a grid.
- (4) *Gas noise.* Caused by random collisions of electrons with residual gas molecules.
- (5) *Secondary emission noise.* Caused by random rate of secondary electron emission from positively charged elements.
- (6) *Flicker effect.* A low-frequency variation in emission produced primarily from oxide-coated cathodes.

c. Sources of noise in the input circuits to a receiver can be considered as equivalent generators driving minute currents through the circuit resistances within which random electron motion prevails, or through equivalent values of resistance which describe the

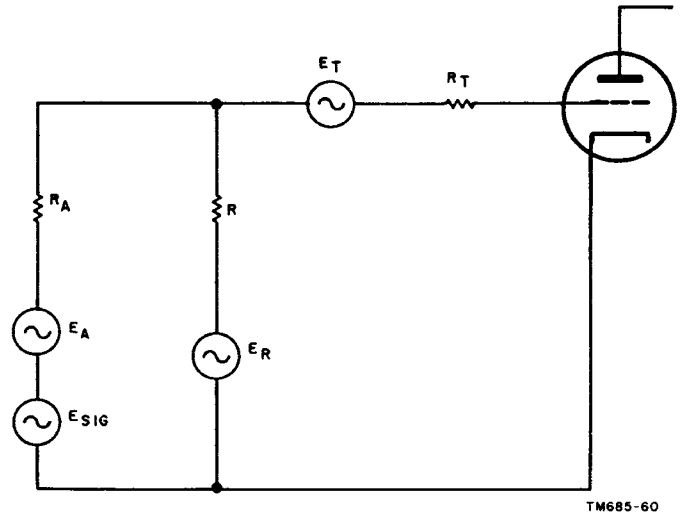

Figure 60. Noise sources in rf input circuits, represented as equivalent generators.

noise generating qualities of those circuit elements. A schematic representation of equivalent noise generators and resistances is shown in figure 60. E_{sig} is the equivalent generator for the signal induced into the antenna. Equivalent generator E_A is the antenna noise voltage that drives current through the antenna radiation resistance R_A . Equivalent generator E_R is the voltage produced in resistances that are in the grid-cathode circuit of the tube; R is the total value of these resistances. Equivalent generator E_T is the composite noise voltage of the vacuum tube that produces a current through equivalent noise resistance R_T . Equivalent noise resistance of a triode is lower than that of a pentode. Pentodes, however, provide more amplification than triodes and do not require neutralization. Amplifiers exhibit lower noise qualities than mixers.

53. Rf Section (fig. 61)

The rf section of an ssb receiver includes the input network that couples the received signal from the antenna to the RF amplifier, and a mixer which heterodynes the incoming signal against a locally generated oscillator frequency. An RF amplifier, situated between the antenna and the first mixer, in a double-conversion superheterodyne, provides increased sensitivity and reduction of spurious signals. Improved sensitivity results from the lower noise attributed to an amplifier as compared to mixer noise.

Spurious signals are reduced because of the additional LC tuned circuits that are the input and output networks of the RF amplifier. Insertion losses of the tuned networks are offset by the gain of the amplifier.

a. Input Circuit. The input circuit to an ssb receiver contains attenuating networks between the antenna and the input to the RF amplifier. The incoming signal is normally coupled to the tuned-grid circuit of the RF amplifier through an *input attenuation* switch which connects to a resistive step attenuator. Reduction of the signal level to the rf amplifier prevents the occurrence of cross modulation (due to overdriving of the rf amplifier) between the desired incoming signal and strong interfering signals near the desired signal frequency. The *input attenuation* switch controls the amount of attenuation in the input circuit; selection of the amount of attenuation depends on the relative strength of the interfering signals. A T-attenuator is used instead of a simple potentiometer, because the T-configuration presents a constant impedance to both the antenna and the tuned-grid circuit of the RF amplifier regardless of switch position and amount of attenuation.

b. RF Amplifier. The RF amplifier is a conventional tuned-grid, tuned-plate amplifier that uses a remote cutoff pentode tube to permit use of automatic gain control. The rf amplifier

is designed to provide sufficient gain to offset the noise generated in the first mixer. If excessive gain is used, the effects of cross modulation become quite noticeable. The selectivity of the input and output tuned circuits of the RF amplifier is designed to provide good image frequency rejection.

c. First Mixer. The first mixer heterodynes the output of the RF amplifier against a signal injected from the vfo. The mixer is an unbalanced circuit; neither the ssb signal nor the oscillator signal frequency is cancelled in the mixer output circuit. This mixer is identical in operation with the unbalanced mixer discussed in the description of the frequency translator section of the ssb exciter in the transmitter (ch. 2). Ssb signal voltage from the RF amplifier is applied to the control grid, and the oscillator voltage is applied to the suppressor grid. The mixing action produces varying plate currents composed primarily of the original frequencies, the sum and difference frequencies, and harmonics of the mixing frequencies. The mixer output circuit is tuned to accept the difference frequencies and reject all other frequencies generated in the mixer.

54. IF Amplifiers and Second Mixer (fig. 62)

a. First IF Amplifier. The first IF amplifier is usually a conventional IF amplifier circuit

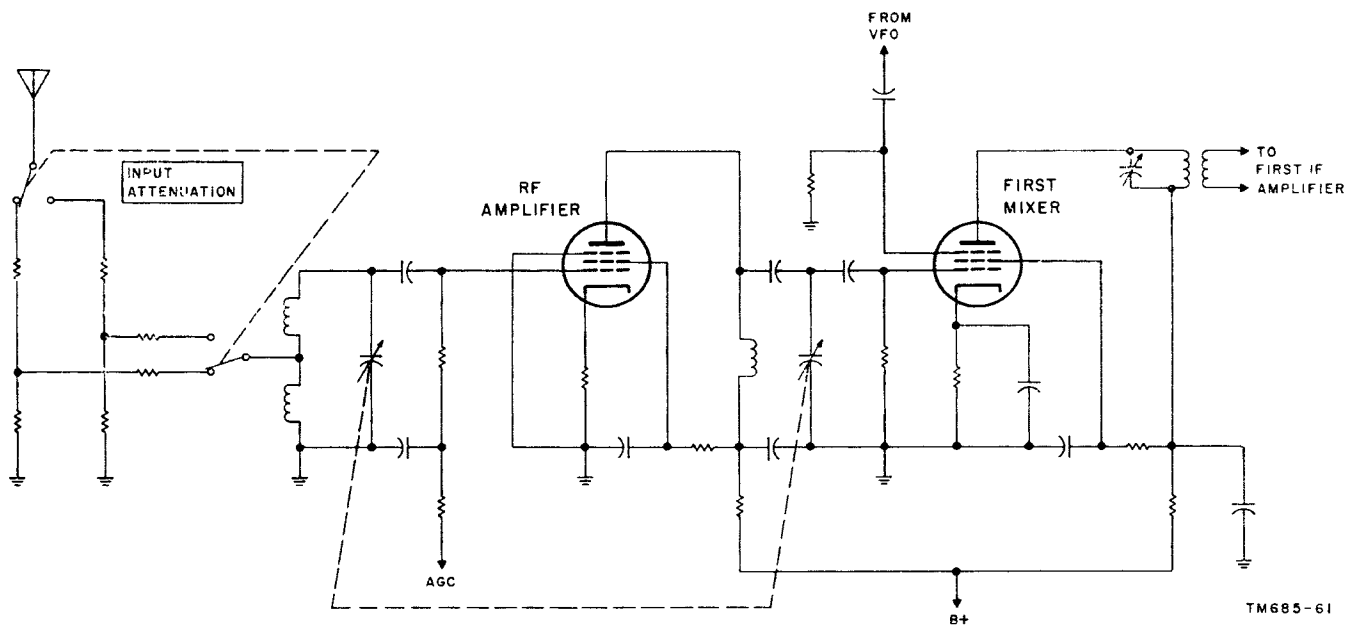

Figure 61. RF section, schematic diagram.

that amplifies the difference frequency output of the first mixer and applies its output to the second mixer for further reduction to the final IF (second IF). The ssb IF input signal to the first IF amplifier is a fixed frequency regardless of the setting of the rf amplifier and vfo tuned circuits. The fixed frequency is tuned by the constant lc relationship of the IF amplifier input and output tuned circuits, as indicated by the basic idea of the superheterodyne circuit. The input and output filters are normally factory adjusted to a center frequency (center of response characteristic) that is the first if. The output signal is coupled to the second mixer, shown in the figure, for reduction to the second IF. Damping resistors are connected in parallel with each tuned circuit to broaden the response of the IF and mixer stages.

b. Second Mixer. The second mixer in the illustration is a pentagrid-unbalanced mixer circuit that uses separate and isolated grids to perform its heterodyning function. The rf ssb signal is applied to the No. 3 grid (counting from cathode) and a locally generated fixed frequency is injected into the No. 1 grid. The No. 2 and 4 grids surround the ssb signal injection grid and electrostatically shield it from the No. 1 grid. The mixing action takes place because of the control of the common electron stream within the tube by the individual mixing frequencies. The resultant varying plate current contains components of the original mixing frequencies, the sum and difference frequencies, and harmonics of the input frequencies. The pentagrid mixer output network is tuned to the difference frequency and passes this frequency to the second if. amplifier. A balanced mixer (para 33) may be used instead of the pentagrid mixer.

c. Second IF Amplifier. The output of the second mixer (difference frequency) enters the second IF amplifier. The second IF amplifier handles the lowest if. in the double-conversion superheterodyne circuit; it is common practice to provide most of the receiver amplification at this point. Considerations of gain per stage and overall stability are the criteria that govern the choice of where to obtain the most gain along the signal route in the ssb receiver. It is customary to use three or four stages of second IF amplification. (Only one such stage

appears in the figure.) The input to the amplifier group is passed through a sharply tuned filter network (not shown) to remove the spurious mixer products that are situated very close to the edges of the range of sideband frequencies that constitute the desired output of the second mixer. The IF amplifier stages and circuits are conventional IF amplifiers that are broad tuned, by resistance damping, to pass the sideband frequencies.

a. The IF ssb signal from the second IF amplifier is coupled to the control grid of the upper sideband amplifier through capacitor C1 and resistor R1. The signal arriving at the grid is attenuated by the voltage division that takes place across resistor R1 in series with resistor R2. The purpose of this network, and the corresponding network of the lower sideband IF amplifier, is to isolate the two sideband IF amplifiers from other stages that derive their input signals from the output of the second IF amplifier. (See output circuit, fig. 62.) Both sideband IF amplifiers are normally sharp cut-off plate-tuned pentodes. The tuned-plate load of the upper sideband if. amplifier is composed of the primary winding of transformer T1 and capacitor C4. This parallel tuned network is designed to resonate at the center of the upper sideband IF and to present a relatively flat response for the entire usb frequency range. Resistor R6, across C4, lowers the Q of the tuned circuit to obtain the required bandpass at the amplifier output.

55. Upper and Lower Sideband IF Amplifiers and Filters (fig. 63)

a. Two identical stages in the receiver amplify and separate the sidebands into upper sideband frequencies and lower sideband frequencies; the pilot carrier is eliminated in the individual outputs by the exact bandpass of the filters used. Since both stages are identical except for the band of frequencies passed, only the upper sideband IF amplifier and filter are fully described below. The lower sideband amplifier contains the same components physically, with some electrical differences which are discussed. Component symbols are used in the figure only where the amount of detail in the explanation calls for the use of individual symbols.

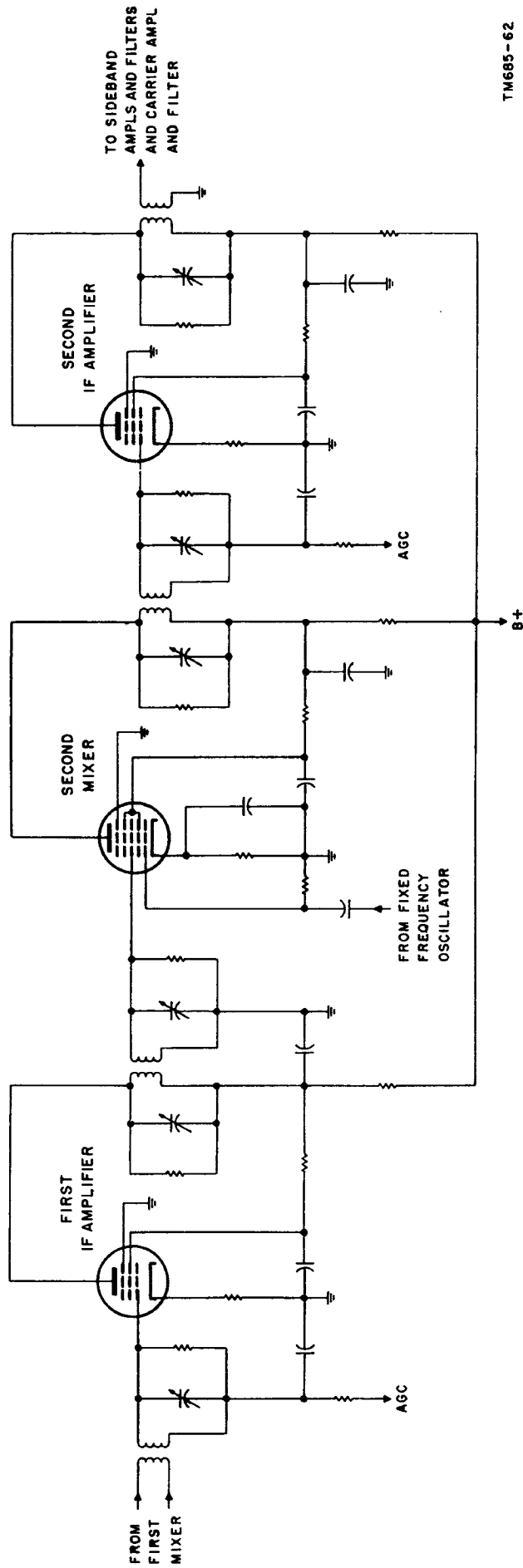

Figure 62. If. amplifiers and second mixer, schematic diagram.

TM685-62

b. The signal transferred to the secondary of T1 is applied to an upper sideband filter through the resistive T-pad networks connected to the filter input terminals. These networks match the input impedance of the filter to the output impedance of the upper sideband IF amplifier and also isolate the filter to prevent detuning and other undesirable effects. The upper sideband filter can be either a crystal configuration or an electromechanical unit. The filter is a sharply tuned bandpass component that permits free transfer of the range of upper sideband IF and, because of its steep off-bandpass characteristics, rejects the pilot carrier frequency, the lower sideband frequencies, and all other frequencies outside the filter pass band.

c. The output of the upper sideband filter, consisting of the upper sideband frequencies, is applied to the untuned primary of transformer T2 through resistive impedance matching L-pads. Proper impedance matching at the input and output of the filter preserves the intended bandpass characteristics. The secondary of T2 delivers the upper sideband frequencies to a demodulator for recovery of the original modulating frequencies.

d. Those components in the upper sideband IF amplifier not explained in the above description are part of a conventional plate-tuned amplifier. Resistor R3 is an unbypassed cathode resistor that provides self bias for the pentode amplifier. Absence of a cathode resistor-bypass capacitor introduces a degenerative feedback voltage that stabilizes the amplifier stage and linearizes the tube transfer characteristic to avoid spurious frequency generation. Resistor R4 and capacitor C2 are, respectively, a screen voltage-dropping resistor and an rf bypass capacitor. Resistor R5 and capacitor C3 form a plate and screen circuit decoupling network.

e. The lower sideband IF amplifier stage, with its associated filter, processes the lower sideband frequencies and rejects all other frequencies. The function of each component is identical with similarly situated components in the upper sideband IF amplifier described above. It is evident that some electrical differences must exist because of the band of frequencies passed in each amplifier and filter. For this reason, the plate-tuned circuit of the lower side-

band IF amplifier is broad-tuned about a center frequency that is the middle of the range of lower sideband frequencies. The sharply tuned filter is a lower sideband filter designed to pass only the lower sideband frequencies. This intermediate-frequency lower sideband output signal is applied to a demodulator for conversion to the original modulating frequencies.

56. Sideband Demodulation

The demodulator stages of an ssb receiver transform the sideband signals into the original modulating frequencies. Demodulation is accomplished by use of circuits that mix the particular sideband to be demodulated with either a reconditioned or locally generated carrier frequency. Diodes are used in a lattice or ring-type arrangement to demodulate an ssb signal. A lattice or ring-type demodulator is described in *a* below. Three types of *product demodulators*, using amplifier vacuum tubes are described in *b* below.

a. Lattice or Ring-Type Demodulator (fig. 64). A lattice or ring-type demodulator usually uses semiconductor devices as the diode elements. This demodulator, in circuit configuration and theory of operation, is similar to the lattice modulator used in the transmitter exciter (ch. 2). The difference is in the input and output frequencies of the respective circuits. The lattice demodulator is essentially a balanced circuit which has the advantage of elimination of the reconditioned or the locally generated carrier from the output signal. The modulating intelligence appears in the output; the rf components are bypassed from the output circuit. The locally generated or reconditioned carrier (usually 100 kc) is applied between the center tap of T1 and ground. The electrical center of the primary of T2 is at ground potential for the carrier frequency because of series resonant L1C1 and L2C2 (each resonant at the carrier frequency) across the primary of T2. The virtual ground at the T2 primary electrical center results from the grounding of the junction of the series lc combinations. Since the carrier signal is, in effect, applied to the center of T2, the carrier potential at both ends of the T2 primary is the same. This results in cancellation of the carrier signal in the T2 primary and no coupling of the carrier fre-

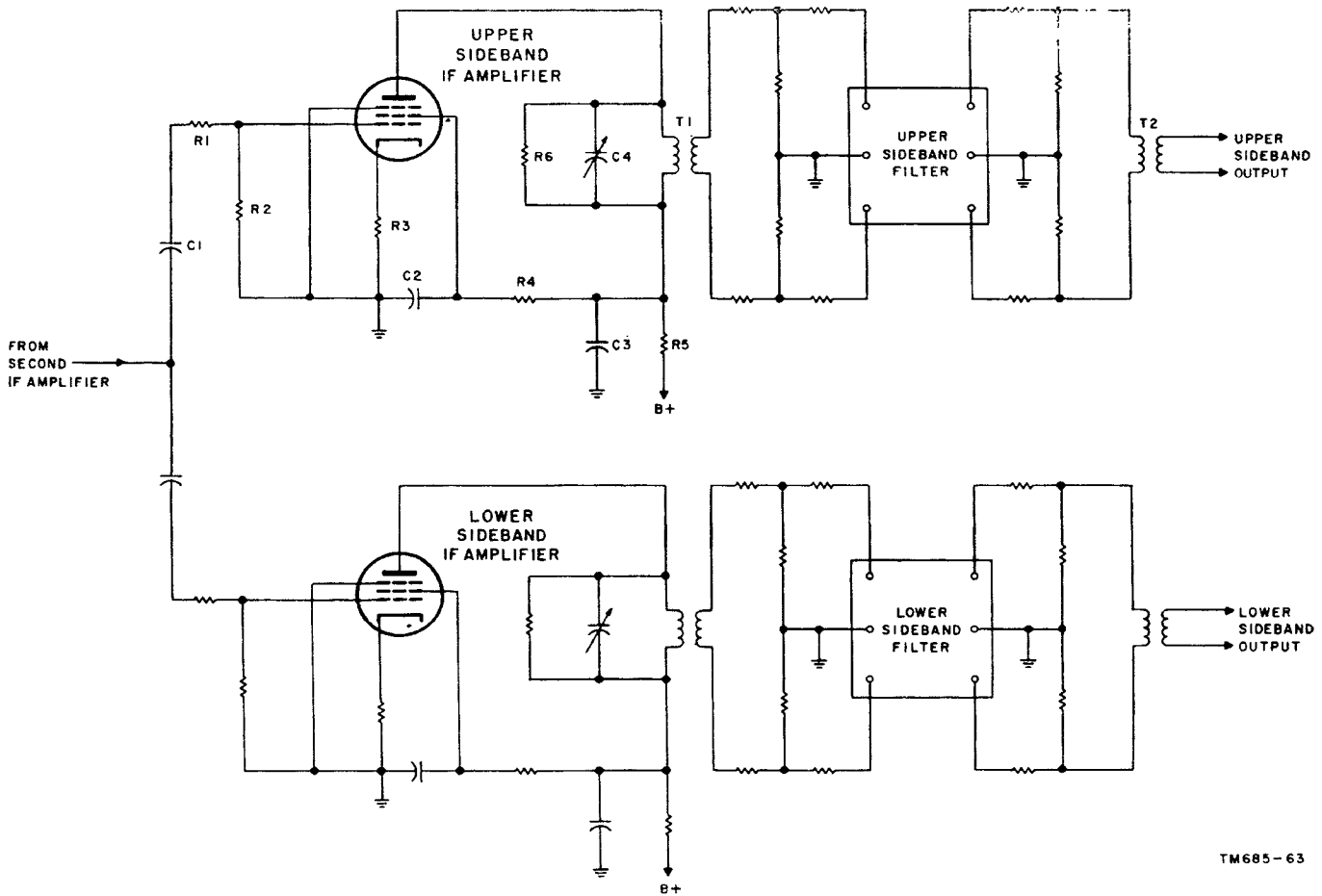

TM685-63

Figure 63. Sideband IF amplifiers and filters, schematic diagram.

quency to the secondary of T2. The amplitude of the carrier frequency signal is much greater than that of the ssb if. signal. The large amplitude carrier determines the extent of conduction of the diodes. For this reason, the diodes are placed into deep conduction, whereby the conducting diodes are effectively short circuits. The conducting states of the diodes are therefore unaffected by the application of the lower level ssb IF signal through transformer T1. When the polarity of the applied carrier frequency voltage makes both outer terminals of the secondary of T1 positive with reference to ground, diodes D1 and D2 conduct heavily and diodes D3 and D4 are reverse biased and are effective open circuits. When these same terminals (secondary of T1) are negative with reference to ground, D3 and D4 are conducting, and D1 and D2 are the open-circuited diodes. The ssb signal applied through T1 is under the influence of the diode switching action of the carrier frequency. The direction of ssb signal

current flow through the primary of T2 not only depends the polarity of the ssb signal, but also follows the path that is outlined by each cycle of applied carrier frequency; therefore, the ssb signal current flow is reversed at a rate corresponding to the carrier frequency. The waveform that develops across the primary of T2 contains the original IF signal, sum and difference frequencies, and harmonics of the IF signal. The original IF signal is short-circuited by the L1C1 and L2C2 resonant circuits across the T2 primary, and the harmonic and sum frequencies disappear in the coupling network. The remaining difference frequencies are the original modulating intelligence frequencies. They are coupled to the T2 secondary for amplification and application to transducers for conversion to their original form (audio-frequencies to sound).

b. *Product Demodulator.* The product demodulator has characteristics that favor its use for ssb detection. The name *product demodula-*

tor was chosen because the demodulated signal output level is proportional to the mathematical product of the two mixing signal levels; thus, in a product demodulator when either input is missing (zero level), the demodulator output is zero. No output signal exists when either the ssb signal or carrier frequency is not applied to the demodulator. A product demodulator operates as well on am., double-sideband, and cw signals. It is less vulnerable to the effects of selective fading than other forms of demodulators. One distinct advantage of the product demodulator is that cross modulation effects between incoming signals or sidebands are minimized. The product demodulator provides conversion gain, reduced conversion noise, and permits efficient demodulation with a low-level reinserted (reconditioned or local) carrier. A product demodulator is either of the pentode type, pentagrid-converter type, or the triple-triode type.

- (1) *Pentode type.* A pentode-type product demodulator is shown in figure 65. The ssb signal from the final IF amplifier is applied to the control grid of a pentode tube through tuned transformer T. The carrier is applied to the suppressor grid of the pentode tube. The plate circuit passes the demodulated intelligence to the next stage. The plate current of the pentode is simultaneously controlled by both the ssb IF signal and the local carrier, and therefore contains sum and difference frequencies of the original mixing frequencies. The plate also contains the original mixing frequencies, since the product demodulator is not balanced for either input frequency. All frequency components in the plate current other than the difference frequencies are suppressed in the output circuit by a low-pass filter formed by L, C4, and C5; only the desired modulating frequencies are passed through C6 to the following stage. Capacitor C1 couples the local or reconditioned carrier to the suppressor grid of the pentode tube; carrier frequency voltage develops across resistor R1. Resistor R2 and bypass

capacitor C2 set the bias conditions for proper operation of the demodulator. Resistor R3 is the screen voltage-dropping resistor that is bypassed for rf by capacitor C3. Resistor R4 is the demodulator plate load resistor across which the demodulated output signal develops.

- (2) *Pentagrid-Converter type.* The pentagrid-converter type product demodulator is illustrated in figure 66. The ssb IF signal is applied to the injector grid (No. 3 grid from the cathode), and the local or reconditioned carrier frequency is applied to the No. 1 grid. Biasing is such that both grids are operated on linear portions of their transfer characteristic curves. This demodulator is considered to be of the linear type (as differs from a square law demodulator) in which the signal at one grid controls the amount of gain presented to the signal at the other grid as the RF instantaneous driving voltage on the first grid varies. The output of this demodulator, as in all product demodulators, is proportional to the product of the individual amplitudes of the two input frequencies; the output signal is proportional to the square of the input voltages if the rms amplitudes of both input signals vary. A square law relationship can exist when the carrier input frequency is a reconditioned pilot carrier, since this carrier is subject to atmospheric effects (fading). Limiting of the carrier level in the receiver as well as application of a fully compensating agc voltage can avoid square law operation of the demodulator. Use of a locally generated carrier frequency can completely overcome this tendency toward square law operation. It is evident, from the above, that if the rms amplitude of one of the inputs is held constant, then the demodulated output signal is a linear (straight line) function of the other

input signal. In the illustration, the ssb signal is coupled to the injector grid through tuned transformer T. The local or reconditioned carrier frequency is coupled to the No. 1 grid by capacitor C1 and develops a voltage across resistor R1. Resistor R2 is a variable resistor which establishes the bias condition of the pentagrid tube. Capacitor C2 bypasses resistor R2 for RF. Resistor R3 and capacitor C3 are a screen voltage-dropping resistor and an RF bypass capacitor respectively. Capacitor C4, in the pentagrid tube plate circuit, removes all mixing frequencies but the desired difference frequencies which represent the demodulated output signal. The intelligence-bearing difference-frequency signal develops across plate load resistor R4 and is coupled to the next stage by capacitor C5. A disadvantage of the pentagrid-converter type product demodulator is that the bias required for linear operation of one grid is not necessarily the proper linear operation bias for the other grid. Aging or replacement of the tube may require readjustment of the supply voltages. To minimize this possibility, the ssb signal and carrier voltages are introduced to the demodulator grids at a low level.

(3) *Triple-triode type.* A triple-triode product demodulator is shown in figure 67. Two of the triodes illustrated function as cathode-follower

circuits and the third triode is a cathode-driven grounded-grid amplifier circuit. The ssb if signal is applied to the grid of cathode follower V1, and the local or reconditioned carrier frequency is applied to the grid of cathode follower V2. Mixing of the two signals takes place because both cathode-follower signal currents flow through common load resistor R3. The resulting sum, difference, and original mixing frequencies, feed the cathode circuit of grounded-grid amplifier V3. Capacitor C3 in the plate circuit of V3 shunts the high sum and original mixing frequencies to ground. The intelligence-bearing difference-frequency signal develops across plate load resistor R4 and is coupled through capacitor C4 to the next stage. Capacitor C1 couples the incoming ssb if. signal to the grid of V1; signal voltage develops across resistor R1. Capacitor C2 couples the local or reconditioned carrier to the grid of V2; carrier frequency voltage develops across resistor R2. Resistor R3, the common cathode resistor for V1 and V2, provides the mixing action in this demodulator circuit. Grounded-grid amplifier V3 is biased for linear operation by a bias source in series with the grid. Capacitor C3 in the plate circuit of V3 bypasses the mixer output rf components. Plate load resistor R4 develops the demodulated signal output. Capacitor C4 is the

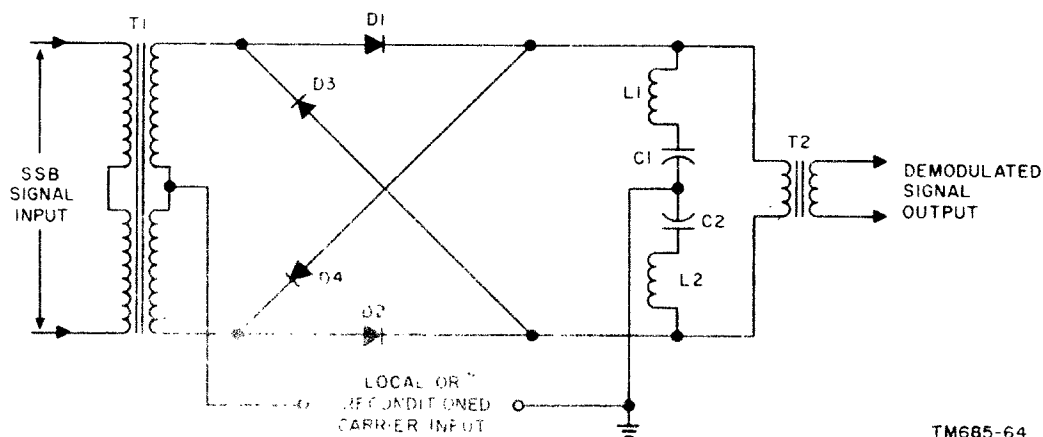
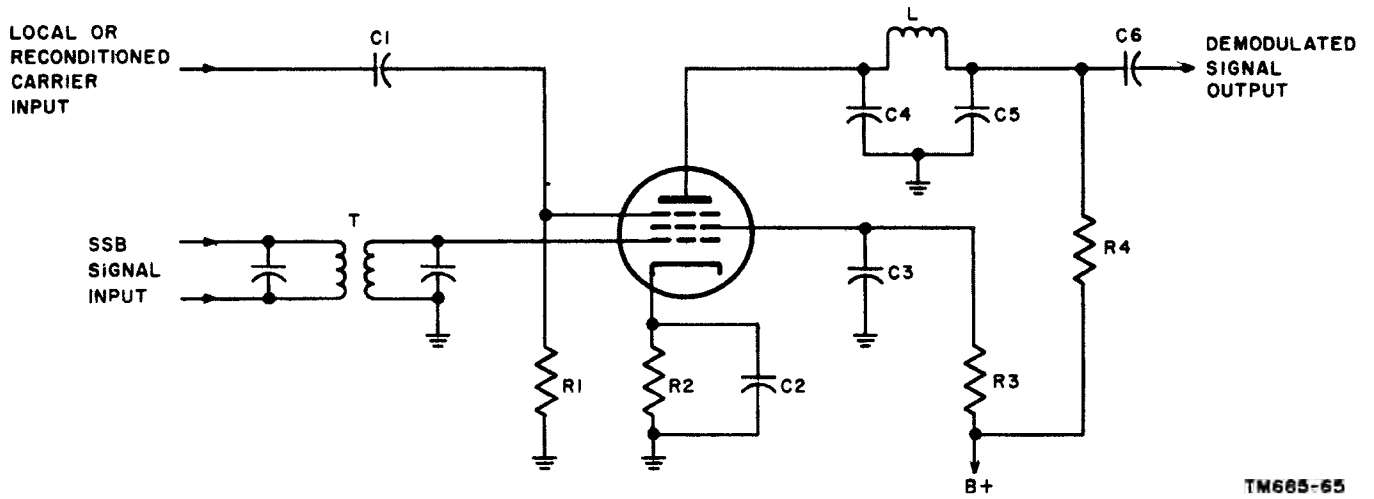
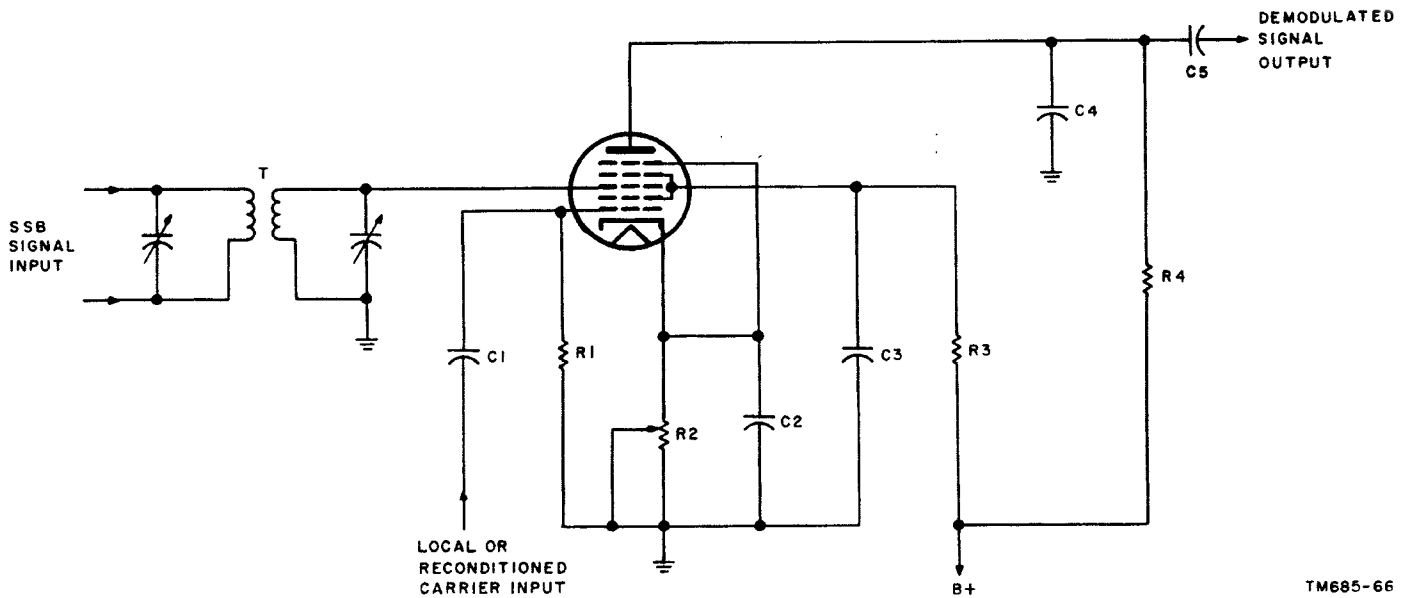

Figure 64. Lattice- or ring-type demodulator, schematic diagram.



TM685-65

Figure 65. Pentode-type product demodulator, schematic diagram.



TM685-66

Figure 66. Pentagrid converter type product demodulator, schematic diagram.

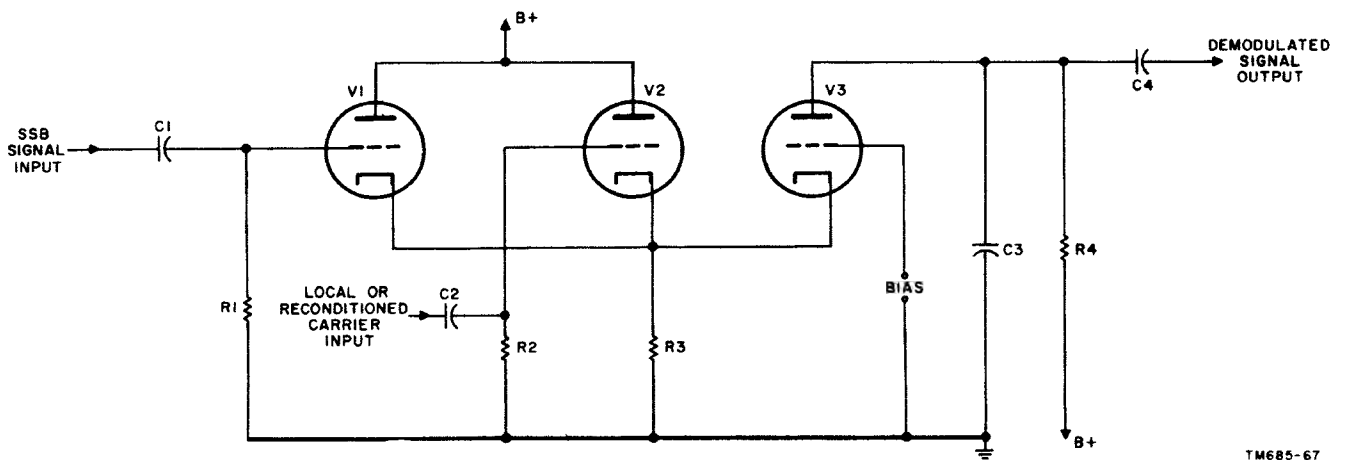

TM685-67

Figure 67. Triple-triode type product demodulator, schematic diagram.

demodulator output coupling component. The use of separate tubes for application of the ssb IF signal and the carrier frequency avoids the difference of grid transfer characteristics that can occur in a pentagrid-converter type product demodulator. Another advantage is that only a low-level carrier voltage is required.

57. Carrier IF Amplifier, Filter, and Carrier Amplifier (fig. 68)

The output of the second IF amplifier is applied to a cascaded amplifier. The carrier IF amplifier amplifies and passes the carrier signal and the sidebands that are fed to it. The output of the amplifier is coupled to a carrier frequency amplifier through an extremely selective filter which removes the sideband frequencies completely and passes only the carrier frequency (100 kc in the figure). The carrier frequency receives further amplification in the carrier amplifier; the output of the amplifier is used as a reconditioned carrier. This output is also used for development of automatic gain control voltage and for automatic frequency control of the first and second heterodyne oscillators in the receiver.

a. The carrier and sideband frequencies are coupled to a high-gain pentode carrier if. amplifier through capacitor C1; the signal is developed across resistor R1. Bias voltage for V1 is derived across cathode resistor R2, which is bypassed for the applied IF by capacitor C2. Resistor R3 is a screen voltage-dropping resistor that is bypassed for if. by capacitor C3. Transformer T1 is the plate load and couples the amplified carrier frequency and sidebands to the 100-kc filter.

b. The secondary of T1 delivers the V1 output signal to the 100-kc filter through a resistive network consisting of resistors R4, R5, R6, and R7. This resistive network forms a pad which minimizes reflections caused by an impedance mismatch which occurs outside the bandpass of the filter. The attenuation of the signal by the pad also protects the sensitive filter from damage by high-level input signals. The 100-kc filter is an extremely narrow bandpass filter (± 10 cps) that passes the carrier

frequency and rejects the entire range of sideband frequencies.

c. The output of the 100-kc filter is terminated by capacitors C4 and C5 and resistor R8 which, together, provide proper impedance matching. The carrier frequency signal developed across resistor R8 is applied to carrier amplifier V2. Carrier amplifier V2 is a conventional RF amplifier that provides additional gain for the carrier frequency and compensates for the signal loss in the 100-kc filter and the attenuating pad. Pentode tube V2 is biased by the voltage drop across cathode resistor R9, which is bypassed for the applied carrier frequency by capacitor C6. Resistor R10 and capacitor C7 are a screen voltage-dropping resistor and an rf bypass capacitor. The carrier amplifier output signal is developed across the primary of transformer T2 and inductively coupled to the output terminals of the stage. The output signal is used to furnish agc voltage and is applied to limiters to provide a reconditioned carrier and afc squelch action.

58. Carrier Limiters and Amplifier (fig. 69)

The carrier frequency that has been separated and amplified in the carrier filter and amplifier stages is applied to a carrier limiter-amplifier section in the receiver. The limiter stages in this section assure application of a noise-free reconditioned carrier at a constant amplitude to the afc and the demodulator circuits. Noise that is present in the incoming signal to this section appears in the screen circuit of the second limiter and is applied to the afc squelch circuits, where the noise voltage, if excessive, disables the afc circuit.

a. Capacitor C1 couples the carrier frequency signal from the carrier amplifier to the control grid of first limiter V1; the applied signal voltage is developed across R1. Resistor R3 is a screen voltage-dropping resistor, and resistor R4 is a plate voltage-dropping resistor for tube V1. Capacitors C3 and C4 are carrier frequency bypass capacitors. Resistors R3 and R4 are high value resistors that are chosen to provide very low screen and plate voltages to effect limiter action. Tuned circuit Z1 resonates at the carrier frequency and is the plate load for the first limiter. Capacitor C6 couples

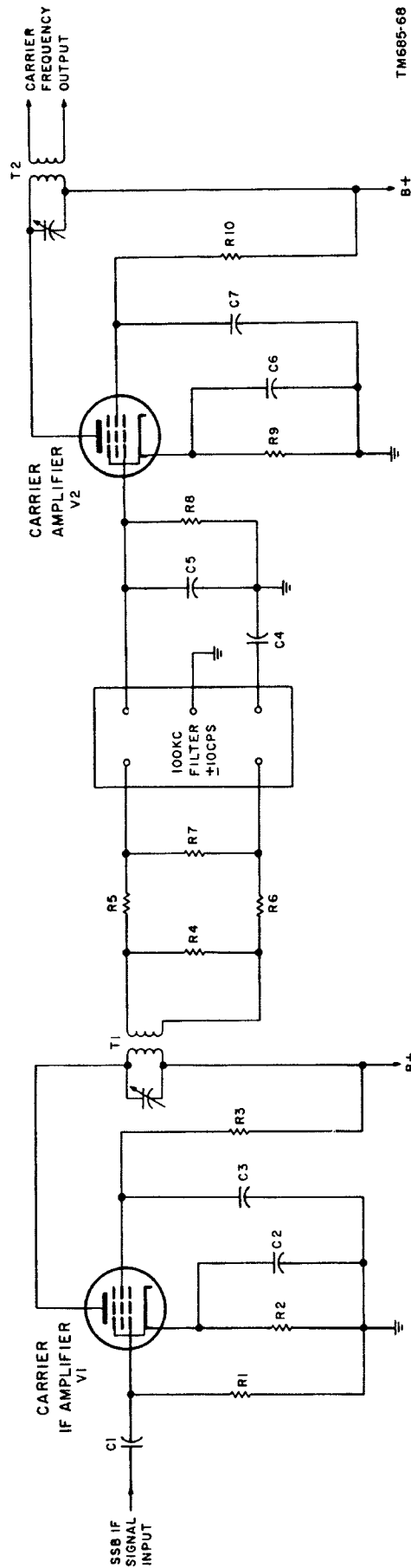

TM685-68

Figure 68. Carrier amplifiers and filter, schematic diagram.

the limited amplitude carrier frequency output of first limiter V1 to second limiter V2. Resistor R5 and capacitor C5 form a decoupling network to prevent V1 carrier frequency current from affecting the B-supply voltage and other stages in the receiver.

b. The carrier frequency signal applied to first limiter V1 drives the low voltage supplied pentode tube into saturation on positive carrier voltage peaks and into cutoff on negative carrier voltage peaks. This substantially flattens or limits the peak amplitudes of the applied signal. The first limiter is biased only by grid current that flows during positive alternations of the applied signal. The zero axis of the applied signal is effectively shifted downward until the positive peaks of the signal drive the grid just enough positive to draw grid current and maintain the necessary bias. The output of V1 is coupled to the control grid of second limiter V2. For a detailed description of limiters, refer to TM 11-668.

c. Second limiter V2 acts in the same manner as the first limiter to further limit the peak amplitudes of the carrier frequency signal from V1 (*b* above). Large noise impulses that are only partially removed by the first limiter are more thoroughly eliminated by the second limiter. The time constants in the grid circuits of V1 and V2 are usually made unequal to provide noise suppression for different noise waveforms.

d. The second limiter is identical in operation with the first limiter except for the screen circuit (*d* below). All components in the second limiter stage perform the same functions as similarly located components in the first limiter stage (*a* above). Resistor R6 develops the input signal. Resistors R8 and R9 are a screen voltage-dropping resistor and a plate voltage-dropping resistor respectively. Capacitors C8 and C9 bypass these voltage-dropping resistors for rf. Tuned circuit Z2 is the plate load for tube V2. Capacitor C11 couples the output signal to the following carrier amplifier (through the *carrier supply* switch). Resistor R10 and capacitor C10 form the B-supply decoupling network for the stage.

e. The screen current of the second limiter is cut off later than the plate current during

negative signal peaks; therefore noise components of the signal appear in the screen circuit. Capacitor C8 bypasses the carrier frequency ripple, and the noise components are coupled, through capacitor C15, to a squelch noise amplifier for operation of the afc squelch circuits. Capacitor C16 couples the amplitude limited carrier signal to an afc amplifier for stabilization of the high-frequency oscillator of the receiver. The *carrier supply* switch connects either a locally generated frequency (coupled through C17 from the crystal frequency standard) in the *local* position, or the reconditioned carrier output of the two limiter stages in the *recon* position.

f. Carrier amplifier V3 is a conventional RF amplifier that supplies either the locally generated frequency or the reconditioned carrier frequency to the receiver demodulators for heterodyning with the sideband frequencies. The input frequency to V3 is applied across resistor R11. Resistor R12 develops self-bias for the amplifier; capacitor C12 bypasses R12 for RF. Resistor R13 is a screen voltage-dropping resistor that is bypassed for rf by capacitor C13. The primary of transformer T is the plate load for pentode tube V3. The output signal is inductively coupled to the secondary of T and applied to the receiver demodulators. Resistor R14 and capacitor C14 form a B-supply decoupling network.

59. Carrier Amplifier and 100-kc Amplifier (fig. 70)

The afc system incorporated in the receiver depends on variations in the vfo setting for its operation. Afc insures that the pilot carrier frequency part of the signal (converted to a lower frequency) applied to the if. amplifiers and, thus, the reconditioned carrier is an exact frequency (usually 100 kc). The carrier element must be restricted to an exact frequency in the IF system; otherwise, full IF gain at this frequency will not be realized; the carrier and sideband elements would not pass through their respective filters and would cause improper output from the receiver. The inputs to the afc circuit consist of two signals; one signal from the 100-kc crystal oscillator and the other (the reconditioned carrier) from the carrier limiters and amplifier section (par. 58).

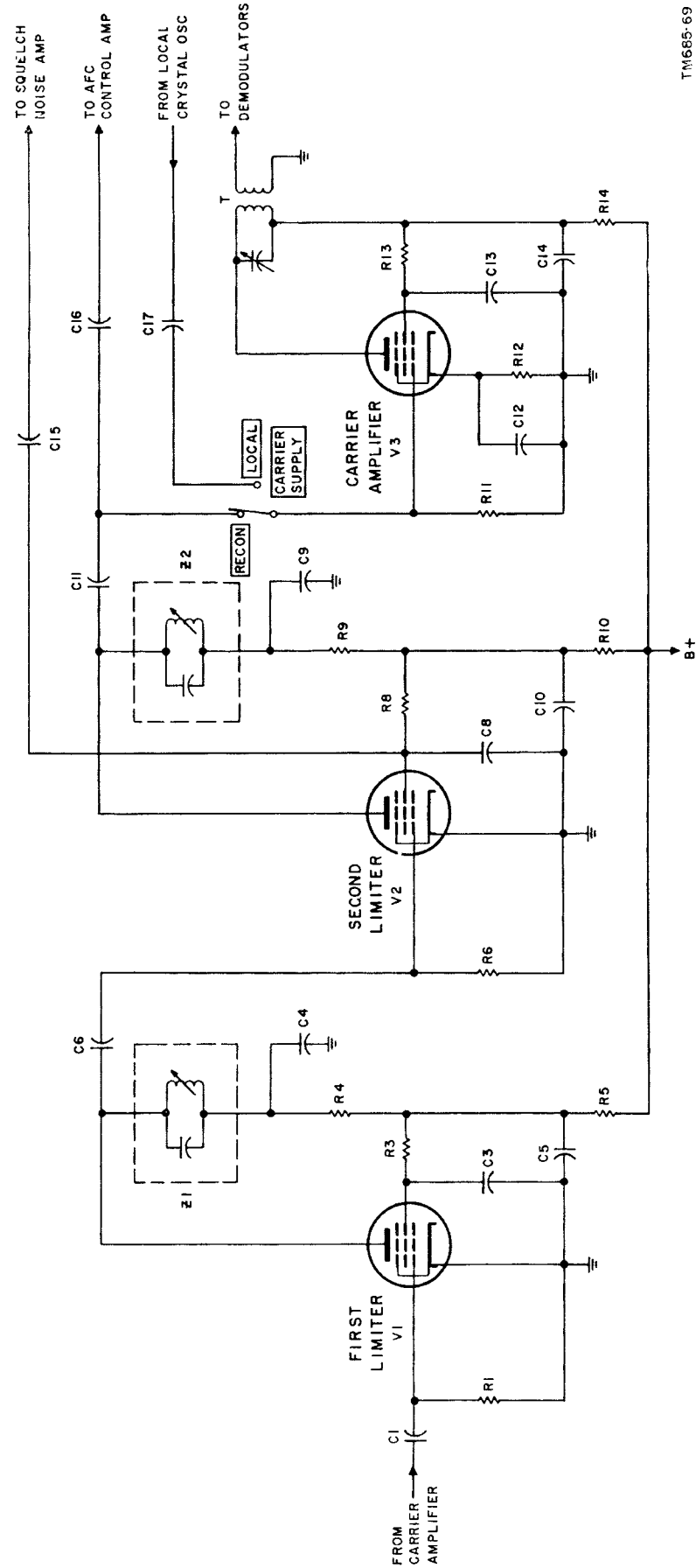

Figure 69. Carrier limiters and amplifier, schematic diagram.

The carrier amplifier and 100-kc amplifier stages are part of the afc system of the receiver. The two stages are amplifiers that amplify the reconditioned carrier and the 100-kc crystal oscillator frequency. The two frequencies are combined in the output circuits to form four voltages in phase quadrature (90° phase difference). When the input signals to the stages are not identical in frequency, the frequency difference applied to an afc motor winding causes a rotation of the motor. The afc motor drives a capacitor in the vfo tank circuit that progressively reduces the frequency difference to the afc motor and draws the reconditioned carrier frequency to exactly the 100-kc crystal standard frequency.

a. The 100-kc crystal standard frequency is applied to the grid of the 100-kc amplifier, pentode tube V1, through transformer T1. Cathode resistor bias is developed across resistor R1, which is bypassed for RF by capacitor C1. Resistor R2 and capacitor C2 are a screen voltage-dropping resistor and an rf bypass capacitor. The primary of transformer T2 is the plate load of V1. Resistor R3 and capacitor C3 form a plate circuit decoupling network.

b. The voltage inductively coupled to the secondary of T2 appears across the quadrature network which produces the four quadrature voltages. The values of the resistors and capacitors that comprise the quadrature network are selected so that the resistances and capacitive reactances are equal at 100 kc. The output voltages at the quadrature network terminals are 90° apart. These voltages are applied to the afc amplifiers and rectifiers.

c. The reconditioned carrier from the limiters is applied to the control grid of the carrier amplifier, pentode tube V2, through transformer T2. The carrier amplifier stage is similar to the 100-kc amplifier stage except for the input and output networks. Resistor R4 and capacitor C4 form a grid decoupling network that is in series with the control grid and the reconditioned carrier voltage. Either a radical drop in signal-to-noise ratio or a complete loss or stoppage of ssb signal in the receiver transfers a high negative voltage from the squelch circuits (par. 61) to the carrier amplifier and cuts off the tube. This effectively

disengages the afc system from the noise voltage and maintains the afc motor position that preceded the surge of noise.

d. Resistor R5 is a cathode-bias resistor and capacitor C5 is a cathode resistor rf bypass. Resistor R6 is the screen voltage-dropping resistor and capacitor C6 is an rf bypass capacitor. Resistor R7 and capacitor C7 form a plate circuit decoupling network. The primary of output transformer T4 is the V2 plate load. The secondary of T4 applies the amplified reconditioned carrier to the center tap of the secondary of 100-kc amplifier output transformer T2.

e. Application of the reconditioned carrier signal to the center tap of the secondary of T2 places the outer terminals of the T2 secondary at the same potential for the carrier. Thus, the end terminals of the secondary of T2 are in phase. The reconditioned carrier adds to each of the four quadrature voltages. The four combined signals, which consist of the four quadrature voltages obtained from the 100-kc amplifier and the carrier amplifier, are applied to the afc amplifiers and rectifiers.

60. Afc Amplifier and Rectifier (fig. 71)

The four quadrature voltages formed in the quadrature network (para. 59) are applied to four afc amplifiers which feed four afc rectifiers. The afc rectifier circuits act as diode mixers to heterodyne the 100-kc crystal oscillator frequency and the reconditioned carrier signal, filter the difference frequency, and apply it to the afc motor. Rotation of the afc motor changes the receiver vfo frequency, and the reconditioned carrier frequency moves toward 100 kc. When the exact reconditioned carrier frequency of 100 kc is reached, the difference frequency at the diode mixer output is zero, and the afc motor stops.

a. The afc motor has four terminals that connect to two tapped windings; the taps are usually connected together and grounded to the motor housing. Each external terminal is connected to an afc rectifier that is driven by an afc amplifier. There are four afc amplifier and rectifier groups; the output of each group is applied to a separate external terminal on the

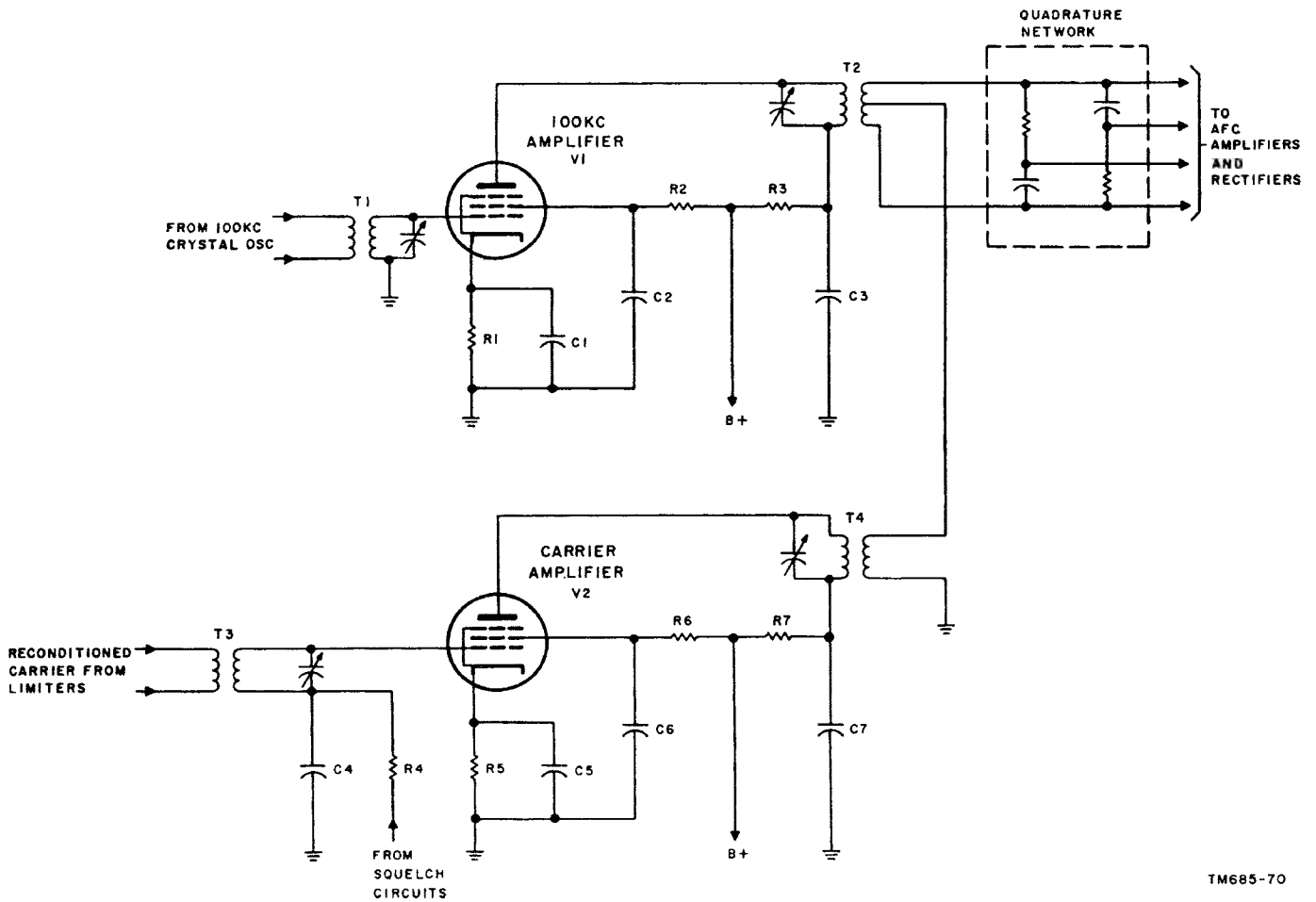

Figure 70. Carrier amplifier and 100-kc amplifier, schematic diagram.

afc motor. Since all the amplifier and rectifier groups are identical, only one group is described.

b. Afc amplifier V1 is a conventional RF amplifier. The input signal to the amplifier is one of the four quadrature phase voltages from the carrier amplifier and 100-kc amplifier (para. 59). Pentode tube V1 is biased as a class A amplifier by the voltage drop across cathode resistor R1. Resistor R1 is bypassed for rf by C1. Resistor R2 is a screen voltage-dropping resistor bypassed for rf by C2. Resistors R3 and R4 and capacitors C3 and C4 form a dual rc plate decoupling network. The primary of transformer T tuned to 100 kc by the shunting capacitor, is the plate load for V1.

c. The quadrature phase signal output is transferred to the secondary of transformer T and applied to the plates of afc rectifier V2. Afc rectifier V2 is a full-wave rectifier configuration that functions as a mixer. The ap-

plied signal consists of the 100-kc oscillator frequency and the reconditioned carrier frequency. The two input signal elements are mixed in V2. The rectifier output, taken from the center tap of the transformer secondary, consists of the original frequencies and sum and difference frequencies. Only the difference frequency beat signal reaches the afc motor through the low-pass filter which is composed of inductor L and capacitors C5 and C6.

d. The reconditioned carrier is applied, in phase, to the quadrature network (para. 59); therefore, the carrier applied to all four rectifiers is the same. The phase difference between the low-difference frequency signals is identical with the quadrature phase difference of the 100-kc oscillator voltages at the output of the quadrature network. Thus, when the frequency of the reconditioned carrier is not exactly 100 kc, four difference frequency signals, 90° apart in phase, are developed at the output of the afc rectifiers. The signals are applied to

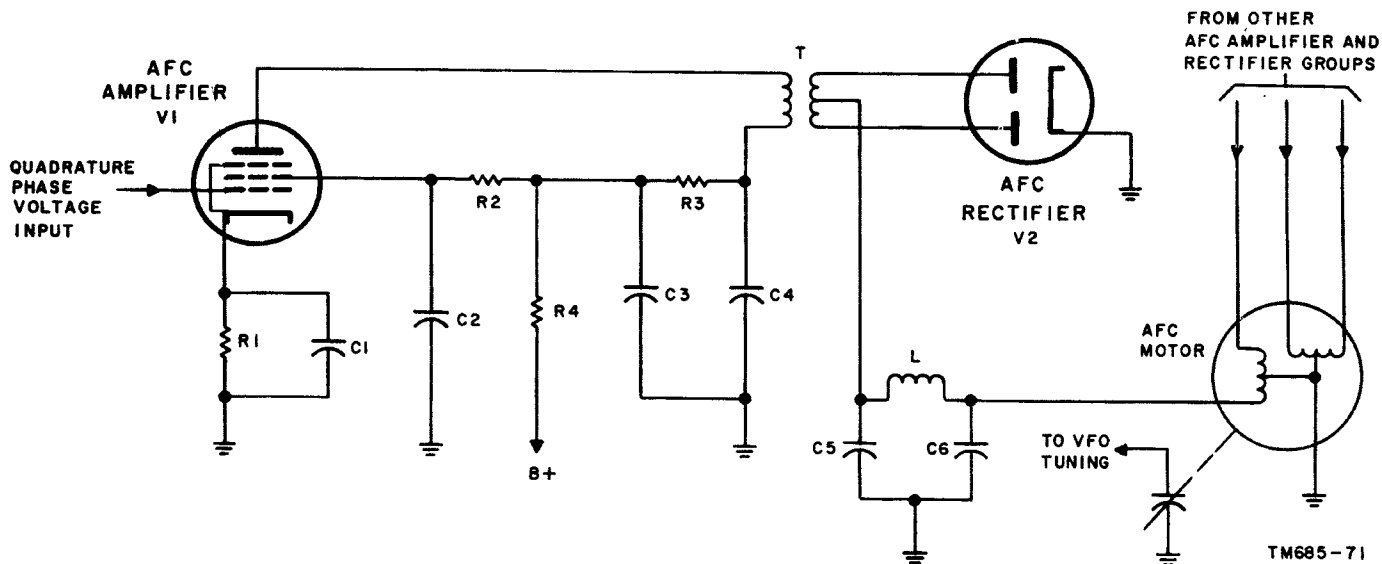

Figure 71. Afc amplifier and rectifier, schematic diagram.

individual external terminals of the afc motor to cause the motor to rotate in a direction to cancel the vfo error. The mechanical linkage, shown in the figure, connects the afc motor shaft to a variable capacitor in the vfo.

61. Squelch Circuits (fig. 72)

The squelch circuits consist of carrier rectifier V1, carrier dc amplifier V2, noise amplifier V3, and noise detector V4. The squelch circuit output voltage prevents the afc motor from operating during severe noise conditions or when the pilot carrier fades below the noise level. The afc motor becomes inoperative at the point where the signal-to-noise ratio falls below a satisfactory predetermined level. The output voltage is applied as bias to the carrier amplifier portion of the carrier amplifier and 100-kc amplifier section (para. 59). This bias voltage cuts off the carrier amplifier stage when either excessive noise is present or a deep fade of the pilot carrier occurs.

a. Transformer T inductively couples a carrier frequency signal from the output of the carrier IF amplifier, filter, and carrier amplifier section of the receiver (para. 57) to carrier rectifier V1. Current flow through diode-load resistor R1, filtered by the action of shunting capacitor C1, develops a dc voltage that is applied to dc amplifier V2. The V1 plate end of R1 is negative with reference to

the other end of the resistor; thus, an increase in carrier strength will act like an increase in the bias applied to the grid of V2.

b. The operating bias for dc amplifier V2 is developed across variable resistor R2, in series as a voltage divider, with resistor R3. Variable resistor R2, a carrier gain control, fixes the V2 output level that operates the squelch circuit whenever the carrier drops below a predetermined normal amplitude. Tube V2 plate current, flowing through load resistor R4, provides the squelch voltage output that is applied to the carrier amplifier as bias (para. 59).

c. A deep fade of carrier signal input to carrier rectifier V1 reduces the voltage drop across diode-load resistor R1, and decreases the bias applied to the grid of dc amplifier V2. This action results in an increase in current through plate load resistor R4, and a decrease in the positive squelch output voltage to the grid of the carrier amplifier. The increased bias to the carrier amplifier drives the tube into cut-off and makes the afc motor inoperative for the duration of the carrier fade.

d. Capacitor C3 couples the noise signal from the carrier limiters and amplifier section (para. 58) to the control grid of noise amplifier V3; the noise signal voltage is developed across grid-return resistor R7. Cathode resistors R8 and R9 form a combination fixed and self-bias network for tube V3. Potentiometer R10 is the plate load resistor for V3 and functions as

a *noise gain control* at the output of the noise amplifier. Resistor R11 and capacitor C4 form the V3 plate circuit decoupling network.

e. Capacitor C5 couples the noise amplifier output signal to the grid of noise detector V4; the noise signal voltage is developed across grid-return resistor R12. Cathode resistor R13 and resistor R14 form the biasing network for tube V3. The value of bias voltage is selected to operate V4 as a detector. Resistor R4 is the plate load for V4 (and dc amplifier V2, *b* above); capacitor C2 bypasses the varying components in the detected noise signal. Resistors R5 and R6 form a divider network that reduces the plate supply voltage to a level that provides proper dc amplifier V2 and noise detector V4 operation.

f. An increase of noise signal to noise detector V4 increases the plate current through

R4. The larger current decreases the positive voltage common to the noise detector plate and the grid return of the carrier amplifier (fig. 70), and results in an increase in bias to the carrier amplifier. If the noise input is above a predetermined level (set by the *noise gain control*), the increase in bias cuts off carrier amplifier plate current and makes the afc motor inoperative for the duration of the excessive noise level input to noise amplifier V3.

62. Automatic Gain Control Circuits (fig. 73)

The automatic gain control circuits control the gain of the RF and if. stages in the receiver to effect a constant level signal output at the demodulator with moderate variations of signal intensity at the antenna. Application of agc to a receiver results in a decrease in receiver sensitivity; therefore, a delaying voltage

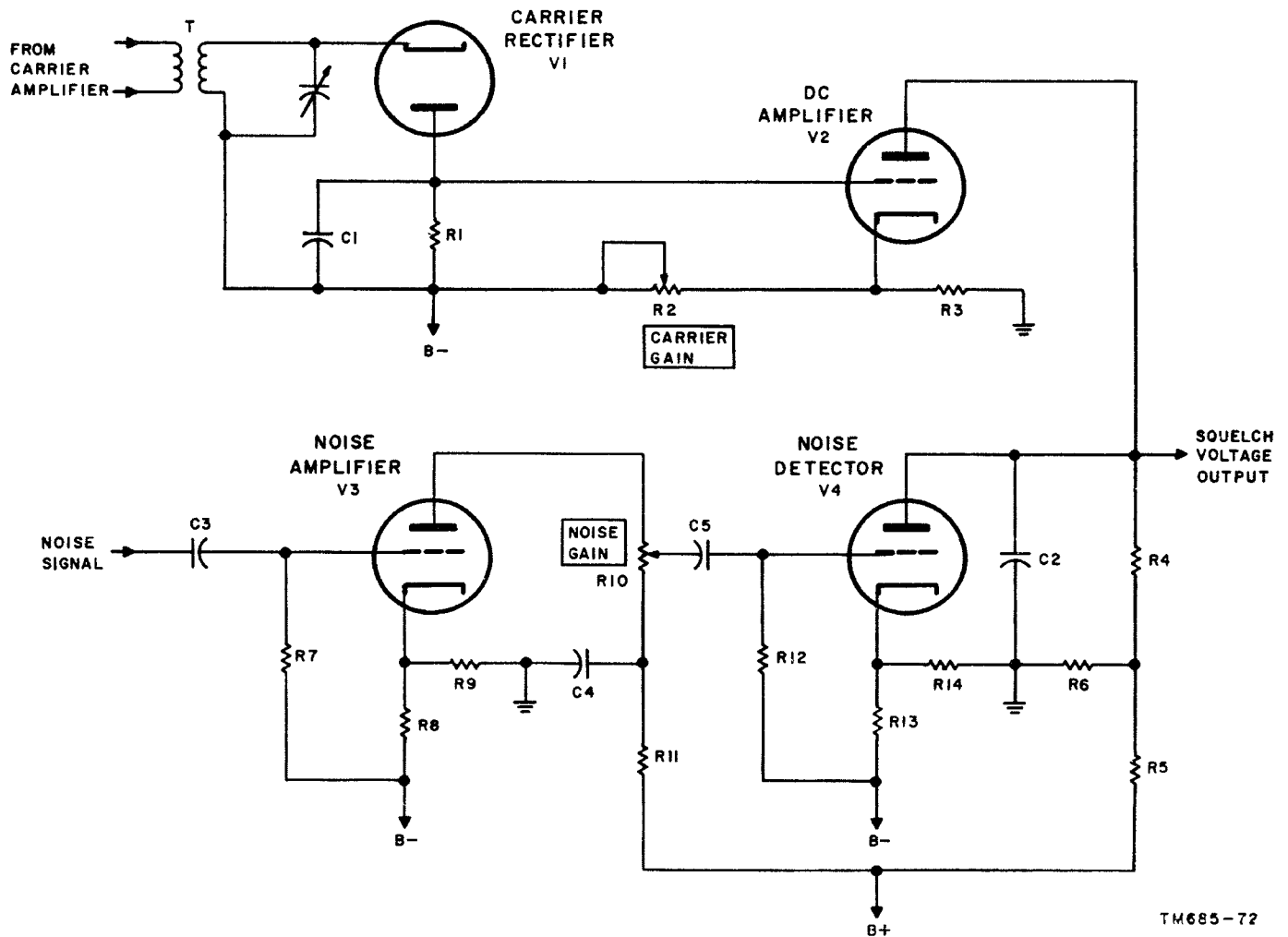

Figure 72. Squelch circuits, schematic diagram.

is introduced to provide maximum receiver gain for weak signals. The *agc delay* potentiometer is set during initial receiver adjustment to prevent application of agc voltages to the RF and if. grid returns until the signal level exceeds a predetermined value. Three resistors at the output of the circuits form a voltage divider to provide lower than full agc output voltages. Proper distribution of the agc voltages is necessary to minimize cross modulation of incoming signals to the receiver. A small amount of agc voltage is applied to the RF amplifier to improve the signal-to-noise ratio. A choice of manual control of sensitivity is usually provided in a receiver. In the figure, the choice is made through a single-pole, double-throw switch that removes the agc output voltage divider from the agc circuits and connects it to the variable section of a voltage divider across the negative supply voltage. Manual rotation of the potentiometer (R12) shaft then controls the receiver gain.

a. The agc circuits consist of a rectifier stage and a dc amplifier stage. Transformer T receives a carrier signal from the carrier if. amplifier, filter, and carrier amplifier section (para. 57), and applies the signal voltage across carrier rectifier V1 and load resistor R1 shunted by RF filter capacitor C1. Tube V1 conducts during positive half-cycles of the applied carrier frequency to charge capacitor C1 to approximately the average of the carrier peak amplitude; thus, the rectifier output circuit senses changes in average carrier signal strength by developing a voltage that is directly proportional to the carrier of the incoming signal. Since the carrier contains no intelligence-bearing component and is radiated from the transmitter at a constant amplitude, it is a better index of average signal strength than the sideband level, which changes in amplitude with modulating signal levels.

b. Carrier rectifier current through resistor R1 makes the diode cathode end of the resistor positive with reference to the B- connection. The voltage developed across R1 is also applied to the grid of dc amplifier V2 through resistor R2; R2 and C2 form a relatively long time-constant network. This long time-constant circuit prevents sudden changes in agc voltage as a result of noise peaks or flutter fading. In-

stead, the agc voltage follows the average value of the receiver signal carrier strength and is effective in compensating for slow fading.

c. DC amplifier V2, with its associated components, acts as an amplifier for the carrier amplitude, sensing voltage output of rectifier V1 and performs an *agc delay* and *agc gain* function. Tube V2 is connected between B- and ground. The plate of V2 is at a small negative voltage with reference to ground; the agc voltage is taken directly from the plate. The cathode of V2 is connected to a point on the negative voltage divider, consisting of *agc delay* variable resistor R4 and resistor R3, to obtain proper tube operating conditions. The bias voltage for V2 is established by the voltage drop across resistor R3. Setting of R4 fixes the point of V2 conduction, and thus controls the input level necessary to result in an agc voltage output from the circuit. Plate voltage for V2 is supplied from a tap on the voltage divider consisting of *agc gain* variable resistor R6 in series with resistor R5 and connected across the B-supply. The position of the variable arm of R6 fixes the no signal biasing voltage on the RF and IF amplifiers in the receiver. Resistor R7 is the dc amplifier plate loading resistor.

d. During initial adjustment of the receiver, *agc gain* resistor R6 is normally set to provide a noise level approximately 5 db below normal speech output. *Agc delay* resistor R4 is then adjusted to where V2 operates below plate current cutoff; thus, the voltage developed across R1 by weak incoming signals is insufficient to bring V2 out of cutoff, and no agc voltage is generated. For an incoming signal that drives V2 into conduction, plate current through plate load resistor R7 causes a voltage drop across the resistor which makes the V2 plate more negative with reference to ground; thus, a change in the V2 static plate voltage occurs, and this increment of voltage is applied as agc voltage to agc voltage divider R8, R9, and R10. The increase of negative voltage applied to the grids of the RF and if. tubes reduces the gain of the receiver.

e. The *gain control selector* switch in the output circuit of dc amplifier V2 selects either agc voltage (*agc* position) or manually controlled voltage (*manual* position) for applica-

cation to agc voltage divider R8, R9, and R10. In the *manual* position, the divider network is placed across the variable portion (with reference to ground) of potentiometer R12. Resistor R11, in series with R12, form a voltage divider

connected across the B-supply. Capacitor C3 bypasses ac components that might feed through the B-supply. Positioning of the variable arm of R12 determines the bias on the RF and if. tubes and controls the receiver gain.

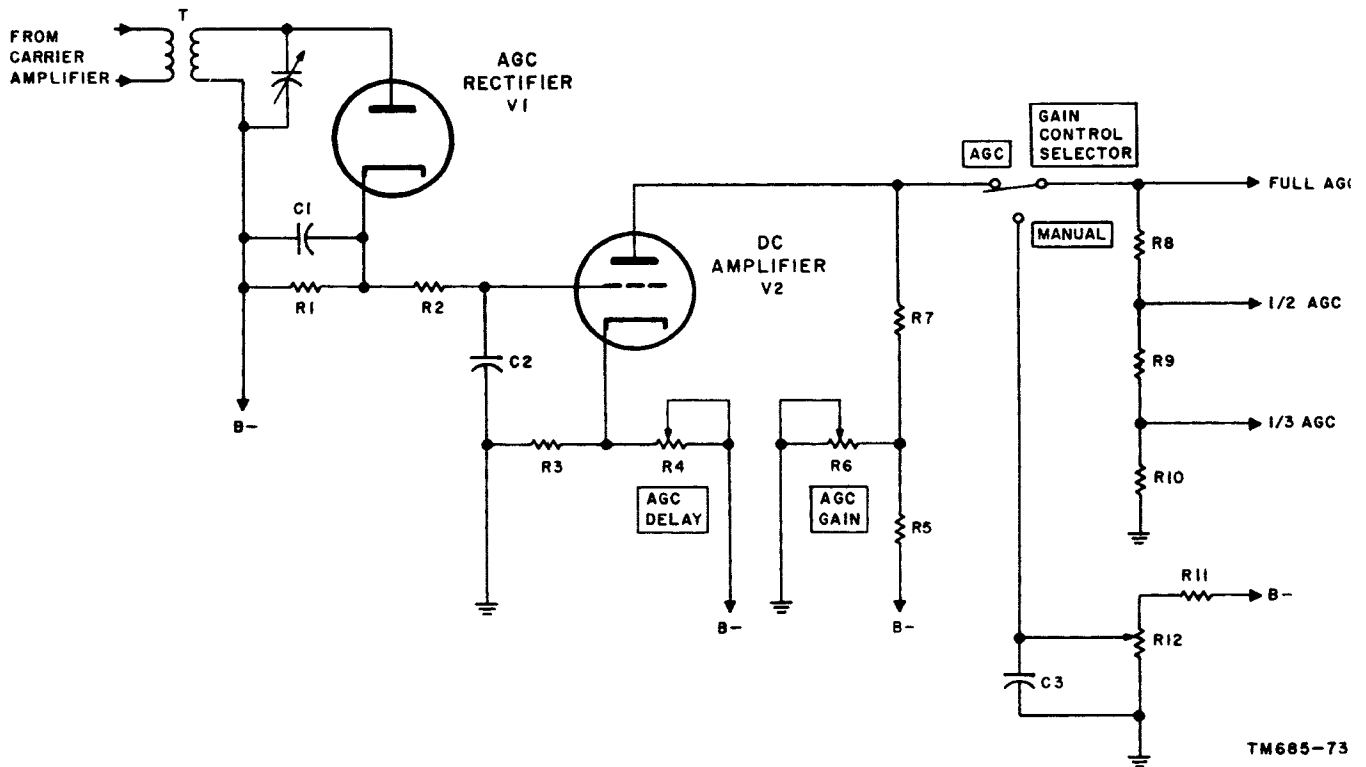

Figure 73. Automatic gain control circuits, schematic diagram.

TM685-73

CHAPTER 5

FREQUENCY STANDARDS, FREQUENCY SYNTHESIS, AND STABILIZED MASTER OSCILLATOR

Section I. INTRODUCTION

63. General

Throughout chapter 2, the description of the ssb exciter stressed the necessity for an exact control of the carrier and mixing frequencies. This control is necessary to furnish a final operating frequency that approaches the highest possible degree of accuracy and stability. This attention to frequency tolerances is dictated by the effects of inaccurate frequency setting and time-drift factors on the modulating signal. The ultimate value of an ssb system, as an advantageous communication system, hinges on the quality of the transmitted intelligence that is recovered at the receiver. The proper operation of an ssb system depends on the ability of an operator, at both the transmitter and the receiver of the system, to perform an accurate adjustment of the equipment to an assigned frequency and the ability of the equipment to maintain these set frequencies.

a. The only limiting factor that has delayed full acceptance of ssb communications in the past has been the lack of the precision frequency controls that are essential to a properly functioning ssb system. To recover the full meaning of the modulated intelligence from an ssb signal, the carrier that is reinserted for demodulation of the ssb signal must be in the exact position with reference to the received sideband as is the suppressed carrier at the transmitter. Reinserted-carrier frequency errors in excess of 50 cycles can cause appreciable *garbling* of the demodulated signal; therefore, for maximum performance, accuracy or tolerance of the carrier frequencies must approach a minimum of one part in a million in the high-frequency range of the radio spectrum. The intelligibility of a received signal decreases with an increase in frequency error. At 100 cycles of error, the modulating

signal suffers a severe loss in *readability*. A slight frequency error, under low signal-to-noise conditions can also result in poor modulation intelligibility.

b. Although the carrier frequency contains no modulating intelligence, it must be reinserted at the receiver demodulator at the proper frequency to form a faithful reproduction of the sideband modulating intelligence. In a properly operating balanced modulator at the transmitter, the carrier is practically eliminated (down 30 to 50 db) and does not appear at the transmitter antenna. A locally generated carrier at the receiver is necessary for demodulation of the sideband signal. The frequency of the locally generated carrier must be identical with the frequency of the suppressed carrier at the transmitter. This exact frequency requirement is essential since the modulating intelligence is inherent in the difference frequency between the carrier and the sideband frequencies. A frequency relationship between carrier and sideband in the receiver that does not duplicate the relationship at the transmitter will result in a change in the demodulated frequencies. If there is no change in the sideband frequencies of an upper sideband relative to the transmitter carrier, then a reinserted carrier above the transmitter carrier frequency results in a lowering of the tones of the modulating signal. A reinserted carrier frequency that is below the original carrier (upper sideband transmission) results in a raising (increased pitch) of the tones of the modulating signal. For a lower sideband transmission, the change in tonal qualities of the demodulated intelligence is just as severe as in the upper sideband transmission, but is reversed for the direction of shift of the reinserted carrier. Tonal quality is also affected

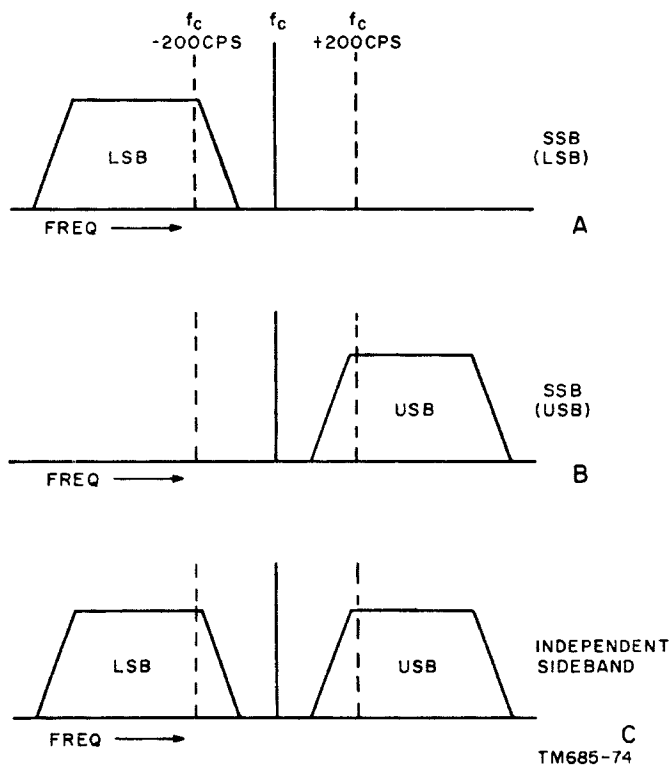

Figure 74. Carrier reinsertion frequencies above and below original carrier frequency.

by a shift in sideband frequencies caused by a shift of either the transmitter carrier generator frequency or the frequencies used for mixing with the low-level modulated signal to arrive at the final operating frequency. A locally generated carrier in an ssb receiver must be within 50 cycles of the correct frequency to give the detected voice signal the proper tonal qualities.

c. Figure 74 illustrates the shift that takes place in a demodulated signal when the reinserted carrier, f_c , is either above or below that carrier referenced at the transmitter. A, figure 74, shows a lower sideband transmission with a possible carrier reinsertion frequency of either f_c , $f_c - 200$ cycles, or $f_c + 200$ cycles. At the exact carrier reinsertion frequency (f_c), all components of the sideband are faithfully reproduced. At a frequency of $f_c - 200$ cycles, the reinserted carrier falls into the interval of sideband frequencies. To illustrate the shift that takes place, a sideband frequency that normally is demodulated as 350 cycles is now demodulated as 150 cycles. At a frequency of $f_c + 200$ cycles, the reinserted carrier appears to the right of the true carrier and the

original 350 cycles becomes 550 cycles at the demodulator output. B, figure 74, shows the effect of an incorrect reinserted carrier on an upper sideband signal. In this case, the demodulated frequencies are the reverse of the order for the lower sideband described above. For an independent sideband signal (C, fig. 74), each sideband will be affected as the equivalent sideband in A and B.

64. Frequency Deterioration

Frequency deterioration or conditional shifts in received frequency and degeneration of modulating intelligence can be caused by Doppler shift, frequency changes because of propagation medium characteristics, and the effects of changes in circuit component values because of mechanical vibration and environmental temperature changes.

a. *Doppler Shift.* Relative motion between transmitter and receiver antennas produces a shift in frequency to either above or below the original carrier frequency; the direction of frequency shift depends on the direction of the motion with reference to the transmitter. Since the speed of radio signal propagation is 186,000 miles per second, a signal radiated from a transmitter antenna that is traveling at any given speed will be either advanced or delayed in arrival at a receiver antenna; this is also true if the transmitter and receiver antenna locations are reversed. A change of relative speed of 670 miles per hour or 0.186 miles per second, as in an aircraft approaching a stationary transmitter, results in a frequency shift of 1 part in 1 million. If the transmitter is operating at 10 mc, the received frequency will be 10 mc + 10 cycles. If two aircraft are in radio communication and are approaching each other at speeds of 670 miles per hour, then the total shift in frequency will be twice that of a single aircraft approaching a stationary transmitter. An aircraft that is moving away from the transmitter will cause a frequency shift to below the original carrier frequency; the magnitude of the frequency shift will vary in the same manner as for an aircraft approaching the transmitter. Normal ship-to-ship communication and communication between ground vehicles account for a change of 1 part in 10 million. The shift for man-carried backpack radios is negligible.

b. Propagation Medium Shift. Radio communication at the lower frequencies is possible mainly through the reception of the ground-wave and is not appreciably affected by the presence of varying conditions in the atmosphere that surrounds the earth. At the higher frequencies part of the radio spectrum (2 to 30 mc), the groundwave is dissipated rapidly and restricts communications along ground-wave paths to short distances. Almost all long-distance transmissions on the shorter wavelengths are by way of reflections from the ionospheric layers in the atmosphere. Frequency shifts introduced by the ionosphere at the high frequencies may approach 2 parts in 10 million. The frequency variations are introduced by changes in path length that result from the constant movement of the reflection point in the ionized layers. The depth of penetration of the ionized layers depends on frequency; therefore, total traveltime of the radio wave between transmitter and receiver varies with the frequency. This variation results in an apparent difference in phase between frequency components of a transmission other than the original relationship radiated at the transmitter. Errors introduced in vhf and ultrahigh-frequency (uhf) scatter propagation are not well-known, but available data indicate that they may be several parts in 100 million.

c. Shifts Affected by Circuit Element Instability. The circuit elements that are part of a transmitter or receiver (resistors, capacitors, inductors, tubes, etc.) can be contributing factors that cause additional phase or frequency shifts in the signal. Circuit elements are subject to the effects of mechanical vibration and sudden temperature changes which distort their electrical characteristics and thereby affect the behavior of the networks which they comprise. Mechanical vibrations cause oscillatory shifts in signal phase which appear as frequency shifts. A phase shift of 360° ahead of the original phase adds 1 cycle to the signal frequency; thus, a phase shift as seemingly slight as 1° on a frequency of 100 kc results in a frequency shift of 3 parts in 100 million. Vibration of elements of a tuned network can introduce, even under tightly controlled conditions, a frequency shift of 1 part in 100 million. Under practical operating conditions, normal vibration and temperature changes, if not compensated, can cause relatively large frequency errors; therefore, where small shifts in frequency are detrimental to the radiated intelligence, rigid components and compensating elements are used in all tuned networks.

Section II. FREQUENCY CONTROLS

65. Historical Development

a. It is interesting to trace the development of frequency control elements and networks that came about because of extreme spectrum crowding and the opening of the higher frequencies for radio communications. In the early days of radio, the lower frequencies were the sole communications frequencies, and the sparse distribution of spectrum users was true of an art in its infancy. The simplest lc oscillator was used for frequency generation. Later, crowding of the low-frequency spectrum called for closer spacing between adjacent channels of operation or for expansion of operation into the higher frequencies of the radio spectrum. To achieve satisfactory operation under these new conditions required more accurate and stable frequency controls. Quartz crystal reso-

nators (crystal oscillators) individually provided the necessary accuracy and stability, but a new problem of logistical support arose in the delivery of crystals to multiple-frequency systems in military installations. After World War II, the need of military set users was for a choice of hundreds of different frequencies, each selectable at the turn of a knob. The requirement of more channels for military communications placed a heavy demand on spectrum space. It also resulted in further reduction of guard bands between channels and accelerated the movement into the higher frequencies (vhf, uhf). Soon thereafter, military communication development was faced with the problem of supplying a multitude of possible operating frequencies with each equipment. The solution to this problem resulted in the multiple-crystal frequency synthesizer. The

multiple-crystal frequency synthesizer produced a great number of possible operating frequencies by mixing, in a progressing order, the outputs of several quartz crystal resonators. Today the single-crystal frequency synthesizer is the mostly used means of producing a desired range of operating frequencies. The single-crystal frequency synthesizer depends on a single crystal to generate all the desired frequencies. The accuracy and stability of this system, therefore, depends on only one crystal as against several in the multiple-crystal frequency synthesizer. A refinement of the single-crystal frequency synthesizer employs the synthesizer output frequencies as a control for a master oscillator that supplies the range of operating frequencies.

b. In the past few years, considerable progress has been made in the development of accurate and stable frequency control devices. The new developments have been in the production of highly stable quartz crystals, controlled constant temperature ovens, and oscillator networks with almost completely compensating components. The present indication is that crystal oscillator stabilities far better than those considered acceptable today are possible in the near future. The atomic frequency standard has recently come into the frequency control picture as the most accurate frequency standard to date.

66. Oscillator Theory

a. The theory of operation of an oscillator is an analysis of an amplifier with sufficient feedback from the output to the input circuit to overcome the losses in the feedback path and sustain oscillation with no stimulation at the input other than the feedback energy. The frequency of operation of an oscillator depends on the selective elements that compose the network within which the oscillator acts. The oscillator circuit is adjusted at a point where the feedback energy is just sufficient to maintain oscillations. If oscillatory power is to be drawn from the oscillating network into some other network, the oscillator should be so constructed as to meet the additional requirement of supplying energy to overcome the circuit losses introduced by the removal of this power.

b. In a crystal-controlled oscillator, a crystal

is so located that the crystal-equivalent electrical network comprises part or all of the resonant circuit that determines the generated frequency of oscillation. The outstanding characteristic of the crystal is its high Q which is the reason for the extreme sharpness of the resonance curve. This characteristic restricts oscillations of the crystal oscillator circuit to a very narrow frequency range; consequently, the frequency stability of the oscillator is extremely high.

67. Oscillator Circuit Analysis

One method of oscillator analysis employs the concept of the formation of a *negative* resistance in the oscillator feedback termination. Figure 75 shows an equivalent circuit of an oscillator that contains a resonant tank circuit. The input impedance, Z_{in} of the equivalent circuit is a purely negative resistance, R_{in} ; the resonator impedance (at resonance), Z_r , is effectively R_r (A, fig. 75). The power dissipated in the resonator is I^2R_r , and the power generated by the negative resistance is I^2R_{in} . If the power supplied by the hypothetical generator is greater than the power consumed in the resonator, the circuit will sustain oscillations. If the power consumed is greater, oscillations will begin, quickly fall off in amplitude, and vanish. The negative resistance is a function of the current, I; the negative resistance decreases as oscillations increase. A stable condition is reached when R_{in} equals R_r . The equivalent circuit in B, figure 75 illustrates an oscillator in which the input impedance, Z_{in} , includes a negative resistance, R_{in} , in series with a reactive component, X_{in} . The resonator impedance, Z_r , consists of a reactive component, X_r , in series with effective resistance, R_r . This network oscillates at a frequency where $X_r = -X_{in}$; the power relationships remain the same as in the purely resistive network. All types of oscillators can be analyzed on the basis of the above equivalent circuit that treats the negative resistance as having the characteristics of a generator.

68. Crystal Oscillators

Oscillators of some form are the generating sources for radio transmitting stations. Because of the requirement that a great many

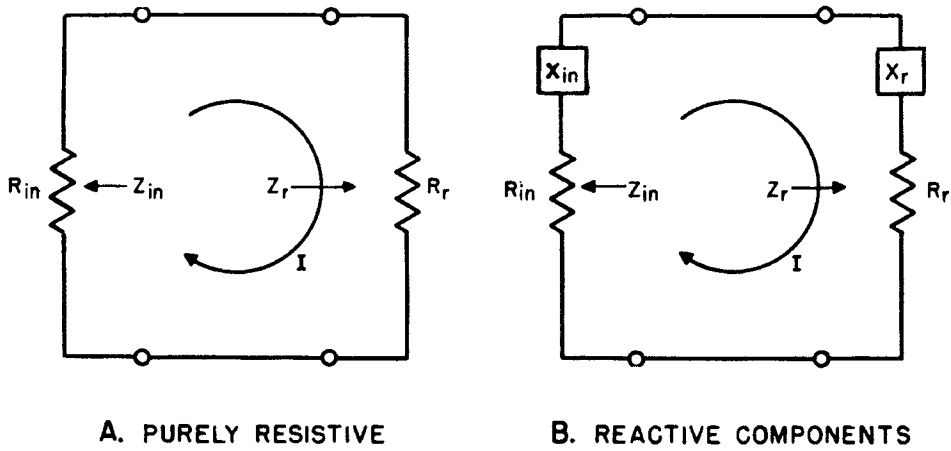

TM685-75

Figure 75. Equivalent oscillator circuit.

radio stations operate simultaneously with a minimum of interference, each station must stay closely on its assigned channel. This requirement makes frequency stability an important design factor in an oscillator circuit. Since a crystal acts as an electrical resonant circuit, it is only natural that it be employed as the frequency-determining device for an oscillator. Two crystal oscillator circuits in common use are the Miller circuit (fig. 76) and the Pierce circuit (fig. 77). The Miller circuit is comparable to a tuned-plate, tuned-grid oscillator in which the crystal represents the tuned-grid tank circuit. The Pierce circuit is basically a Colpitts circuit where the crystal is an integral part of the feedback and tank circuit. A third crystal oscillator circuit, a bridge stabilized circuit (fig. 78), is used in some equipments.

a. The circuit arrangement in figure 76 is the Miller circuit. When the crystal is replaced by its equivalent electrical network, the resultant circuit (B, fig. 76) is a conventional tuned-plate, tuned-grid circuit. The crystal is operated just between its parallel-resonant and series-resonant frequencies to produce the inductive reactance required by a tuned-plate, tuned-grid circuit for starting and sustaining oscillations. The circuit oscillates when the tuned-plate network is set for a frequency slightly higher than the vibrational frequency of the crystal mode that is excited. The amplitude of the generated oscillations depends on the amount of inductive reactance in the plate circuit.

b. The circuit arrangement in figure 77 is a Pierce circuit. The equivalent electrical network of the crystal, as located within the circuit, appears as tuned elements of a Colpitts oscillator. The crystal in this circuit operates at a frequency just below its parallel resonance frequency to provide an inductive reactance that resonates with tube and wiring capacitances. The Pierce circuit oscillates at a frequency at which the equivalent tank circuit is slightly on the inductive side of parallel resonance. Unlike the Miller oscillator, the Pierce oscillator does not require circuit lc adjustment when a crystal resonant at one frequency is replaced by a crystal resonant at some other frequency. This characteristic of the Pierce circuit permits multichannel operation by only switching crystals; no further changes are made in the oscillator circuit. However, this poses a slight problem of crystal selection, since this circuit will oscillate on whatever mode of vibration is most active. Thus, if there is an undesired mode of high activity at a frequency differing significantly from the desired resonant frequency, the Pierce circuit may very likely excite the undesired rather than the desired mode. The Miller oscillator cannot operate in this manner, because the plate circuit is tuned to excite the desired mode.

c. The circuit arrangement in figure 78 is a bridge-stabilized circuit. The series resistance of the crystal represents one arm of the bridge circuit; the remaining three arms of the bridge are resistances (R_1 , R_2 , and R_3). One of the resistances (R_2) is the filament of a lamp.

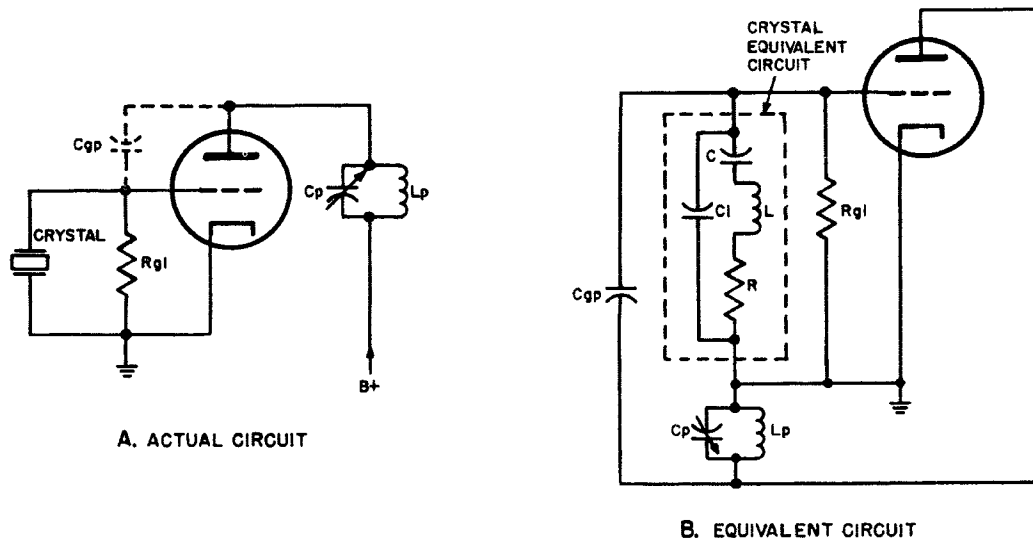

TM685-76

Figure 76. Miller crystal oscillator, actual and equivalent circuits.

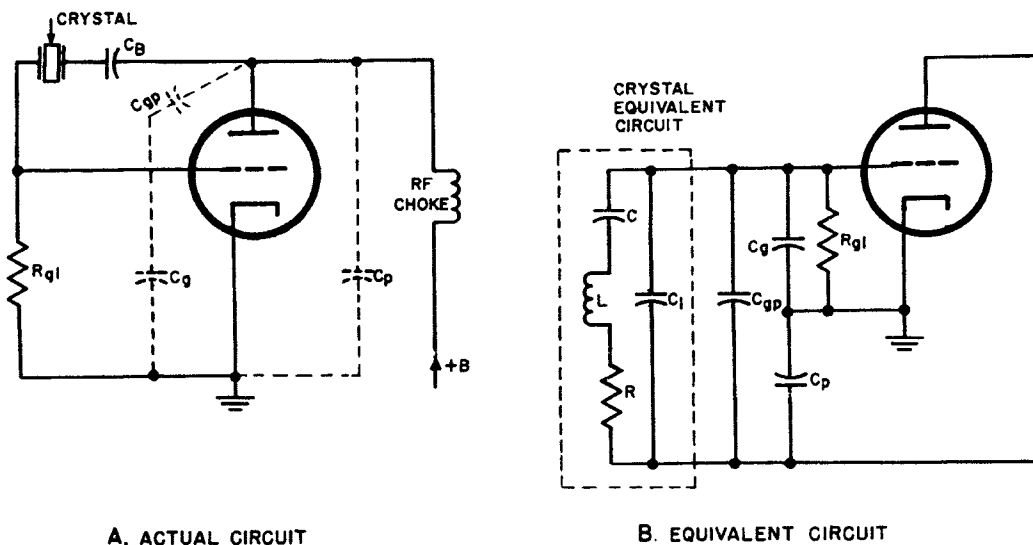

TM685-77

Figure 77. Pierce crystal oscillator, actual and equivalent circuits.

The component values of the bridge arms are such that when the lamp is cold, the ohmic ratios moderately unbalance the bridge. The input terminals of a tuned amplifier are connected across one diagonal of the bridge, while the amplifier output is applied to the remaining diagonal. In the starting condition, when oscillations have not yet begun, the bridge is unbalanced. A regenerative action from the output to the input of the amplifier takes place, since the unbalanced bridge acts to couple energy from the plate to the grid circuit (through tuned transformers T1 and T2). Oscillations begin at a frequency determined by

the series-resonant characteristic of the crystal; at this frequency, current in the crystal arm is limited solely by the resistance equivalent of the mechanical damping that occurs within the crystal. As the amplitude of the oscillations increases, the increase in power consumed by the lamp increases the resistance of the lamp filament and brings the bridge more closely into balance. An equilibrium condition is established at an oscillation amplitude that just unbalances the bridge circuit and at a frequency that is very close to the series-resonant frequency of the crystal. In the bridge-stabilized oscillator circuit, the fre-

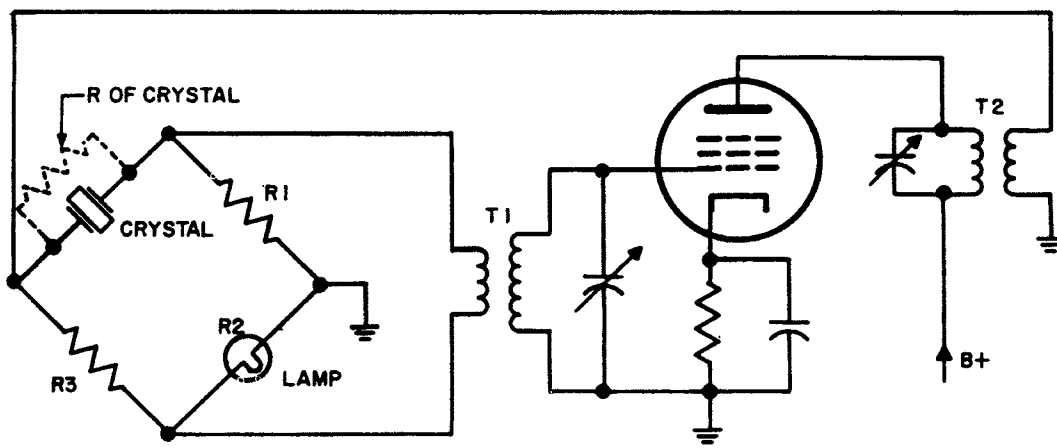

Figure 78. Bridge-stabilized crystal oscillator circuit.

TM685-78

quency is maintained solely by the crystal stability and is almost completely independent of tube characteristics and circuit quantities.

69. Power Output and Frequency Stability

a. The maximum power that can be safely generated by a crystal oscillator is limited at the low frequencies by the maximum amplitude of vibration that is possible without the crystal cracking under the influence of the severe mechanical stress. Maximum realizable output power at the high frequencies is limited by heat generated in the mechanical resistance of the crystal. Although a crystal can be constructed to generate considerable power, it is more desirable to operate the crystal at a low power and apply the crystal output to an amplifier to furnish the required higher power.

b. Frequency stability of a crystal or the ability of a crystal to stay on frequency is very great. A frequency stability of a few parts per million is easily obtainable. With modern crystal processing and fabricating techniques, a degree of precision can be achieved that provides a stability that approaches 1 part per 100 million over a long period of operating time.

70. Crystal Oscillator Design

In the design of a precision oscillator, several factors that tend to minimize circuit instability must be taken into consideration. The Use of a crystal resonator is of prime importance to assure a high degree of precision. Some precautions that are taken when using a crystal resonator in an oscillator circuit are described below.

a. The components of the oscillator circuit must be in a tightly controlled environment to reduce the effects of mechanical shock and local temperature variations.

b. The amplitude of the oscillating wave must be limited to avoid instability that arises because of irregularities in the crystal resonator vibrational pattern at higher amplitudes.

c. Undesired coupling from external circuits must be at a minimum, because reactive components that are coupled into the oscillator circuit can cause instability.

d. Observe optimum linear operation. Non-linear operation of the amplifier portion of the oscillator produces undesirable harmonics. The fundamental frequency component of the more complex oscillator output is unstable in the presence of the harmonic components.

71. Temperature Characteristics

a. The resonant frequency of a quartz crystal is practically unaffected by changes in oscillator loading; however, quartz expands slightly with increase in temperature, which affects the resonant frequency of the crystal. The temperature coefficient of the crystal refers to the increase or decrease in the resonant frequency, usually expressed in parts per million. The temperature coefficient varies widely with different crystal cuts, which is one of the chief reasons for the preference of particular cuts. The selected cuts have practically zero temperature coefficient in normal use. The temperature coefficient also depends on the surrounding temperature at which it is measured,

and whether a thickness or width vibration pattern of the crystal is activated.

b. Heating of the crystal can be caused by external conditions, such as the high temperature of transmitter tubes and other components, and by excessive radio frequency (RF) currents flowing through the crystal. The slow shift of the resonant frequency resulting from crystal heating, known as *frequency drift*, can be avoided by the use of crystals with nearly zero temperature coefficient and by maintaining the crystal at a constant temperature.

c. To maintain the extremely close frequency tolerances required, the entire oscillator assembly is constructed in such a manner as to provide for nearly constant temperatures. This helps to avoid frequency drift resulting from contraction and expansion of circuit elements. The tube voltages are kept as constant as possible by suitable voltage-regulator circuits. In addition, the crystal is operated in a constant-temperature oven, which is heated electrically and is held at constant temperature by special thermostatic sensing circuits. The thermostatic control devices determine accurately any temperature variation and cause more or less current to flow through the heater element. The oven assembly usually is constructed of an aluminum shell enclosed by thick layers of insulating material. For extreme stability, the entire compartment can be placed inside still another temperature-controlled box. In this way, frequency stabilities as high as 1 part in 10 million or better can be attained.

72. Constant-Temperature Ovens

Two basic types of constant-temperature ovens are in use at present. One is the cycling type, which uses a thermostatic switch that disconnects the heater supply current at a predetermined high temperature and makes contact again when the temperature falls below a predetermined point. The second type uses a system of proportional control to detect and correct a very small change in temperature from the desired value. The cycling type is self-evident in operation (use of thermostatic switch); therefore, only the proportional type is explained below.

a. A proportional type of oven control is the

oscillator circuit (fig. 79). Amplifiers V1 through V5 function together as a multistage oscillator which receives positive feedback through transformer T. The oscillator depends on an unbalanced resistance bridge to sustain oscillations. Amplifier V1 is a tuned amplifier with an output circuit (oscillator tune) that functions as the frequency-determining element of the oven oscillator. Feedback voltage is coupled from the resistance bridge to the control grid of V1. Oscillations in the output of V1 are coupled to the control grid of V2. The output of V2 is applied to the control grid of V3, which acts as a split-load phase inverter. The signal developed at the plate of V3 is 180° out of phase with the signal developed between cathode and ground. The two signals developed by the phase splitter are coupled to the control grids of push-pull amplifiers V4 and V5.

b. The output signal from the push-pull amplifiers is coupled through transformer T to the resistance bridge. The bridge performs two functions: it represents both the heating elements for the oven and the control element for the oven oscillator. Two arms of the bridge are made of nickel wire; the other two arms are made of low-ohm wire. The arms are of selected lengths; their resistances at the desired oven temperature are almost equal. When the oven temperature is low, the nickel wire has less resistance than the low-ohm wire, and the bridge is unbalanced. As a result, the unbalanced voltage is applied as positive feedback to the first amplifier stage. This feedback action sustains oscillations; the amount of feedback, determined by the amount of bridge unbalance, controls the amplitude of oscillation. When the bridge comes into balance (as the temperature approaches the desired value), the amount of feedback is reduced until it is just sufficient to sustain oscillations.

c. If the oven temperature is too high, the feedback to the amplifier is degenerative and oscillations do not occur. If the oven temperature exceeds a value that may lead to permanent damage to the crystal, a thermal switch (similar to the switch in the cycling type of oven) short circuits the secondary of transformer T, and the oscillator ceases to function.

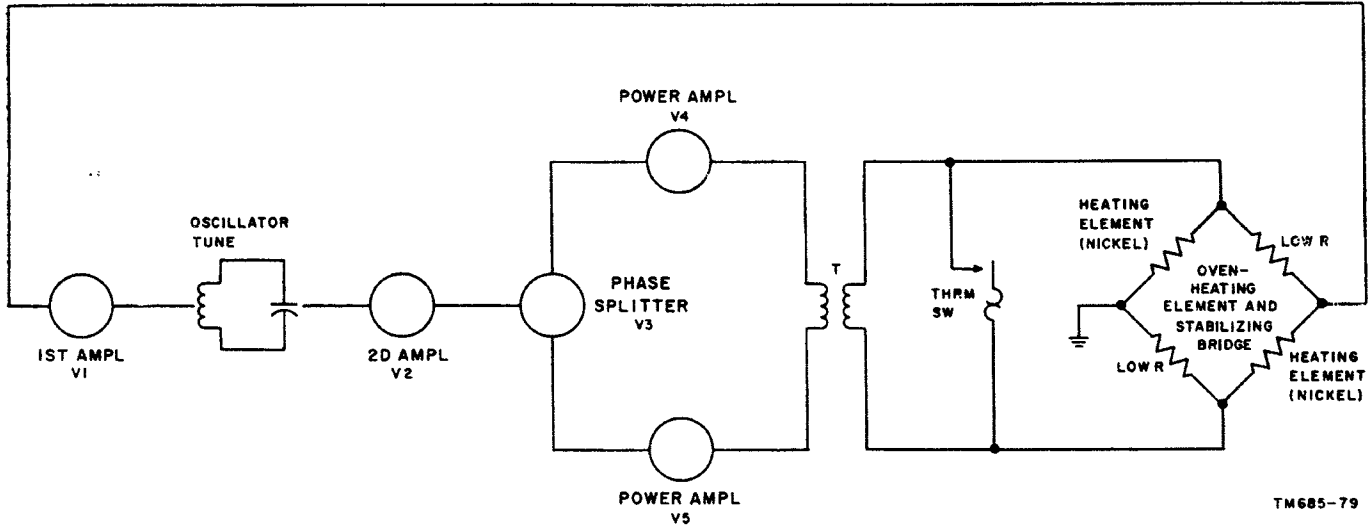

TM685-79

Figure 79. Oven control oscillator.

Section III. FREQUENCY SYNTHESIS

73. Introduction to Frequency Synthesizer

In view of the high degree of crystal oscillator stability required in ssb service, it is usually impractical to provide a large number of crystals for multichannel operation. Hence, it becomes necessary to derive the various signals required for frequency conversion from one or a very small number of stable crystal oscillators. This process is known as frequency synthesis.

a. There are two main classes of frequency synthesizers, direct and indirect. In direct frequency synthesis, the frequencies of one or more crystal oscillators are divided, multiplied, and added to produce the desired output, while undesired output frequencies are attenuated by fixed or variable filters. In the indirect type, a variable-frequency oscillator is locked to the correct frequency by an afc system that includes crystal oscillators and mixers. Direct synthesis is a more straightforward method of generating the desired frequency, but the elimination of spurious frequencies is very difficult.

b. In either type, the desired output is selected by a digital process involving switching of crystals in oscillators, switching or step-tuning of harmonic-selecting filters, or tuning of a variable-frequency oscillator. The number of frequencies available depends on the number of digits or choices to be made and on the num-

ber of values of each. For example, 1,000 frequencies could be obtained by mixing the output of three oscillators, each having 10 switched crystals.

c. Any number frequencies can be produced, each related by an exact predetermined ratio to the frequency of one highly stable crystal reference oscillator. Since the stability of any selected output frequency then depends entirely on this oscillator, a great effort can be concentrated on making it stable. The most favorable frequency for oscillator stability can be chosen, and it is also possible to use a large and expensive crystal and more complicated oven circuits.

d. In an indirect system, a variable-frequency oscillator is locked by a control loop, containing a frequency discriminator and a phase detector, to a signal derived from a frequency standard. The locking function can be achieved by using either a servomotor, or variable reactance device (reactance tube, saturable inductor, or voltage-sensitive capacitor). Reactance tubes suffer from poor long-term stability, since their reactance depends on the transconductance of the tube. Saturable inductors have slow response, require appreciable control power, are usually affected by temperature, and tend to have magnetic hysteresis; however, reliability and long-term stability of saturable inductors are excellent. Voltage-sensitive capacitors, consisting of reverse-biased

silicon junctions, require moderate control voltage at high impedance, are reliable, and are only slightly affected by temperature.

74. Multiple-Crystal Frequency Synthesizer (fig. 80)

The operation of the multiple-crystal frequency synthesizer is very simple to understand. The output frequencies of two or more crystal oscillators are combined in a mixer and the sum or difference mixer-output frequency is selected to form the desired frequency. Each oscillator contains a switch which permits a choice of any one of several crystals to produce the range of desired frequencies.

a. The individual crystal oscillators are crystal oscillator A and crystal oscillator B. Attached to a 10-position switch in each crystal oscillator are 10 crystals. The choice of a crystal determines the frequency of operation of that crystal oscillator. In the illustration, crystal oscillator A can be switched from 100 kc to 190 kc in 10-kc steps. Crystal oscillator B can be switched from 1,000 kc to 1,900 kc in 100-kc steps.

b. As an example, the 130-kc crystal is chosen to provide the mixing frequency from crystal oscillator A, and the 1,500-kc crystal provides the mixing frequency from crystal oscillator B. The 130-kc signal and the 1,500-kc signal are combined in the mixer. In this instance, the sum mixer frequency of 1,630 kc is chosen as the synthesized output frequency of the multiple-crystal frequency synthesizer. If the difference mixer-output were chosen, 1,370 kc would appear at the synthesizer output terminals.

c. As evident, a wide range of frequencies in 10-kc steps is possible at the synthesizer output by selection of all possible sum and difference frequency combinations of the crystal oscillator A crystals and the crystal oscillator B crystals. Considering the crystal frequencies used in the illustration, a range of 810 kc through 2,090 kc in 10-kc steps is synthesized. One hundred and twenty-eight different frequencies are synthesized by the use of 20 crystals.

d. Although the multiple-crystal frequency synthesizer scales down the number of crystals

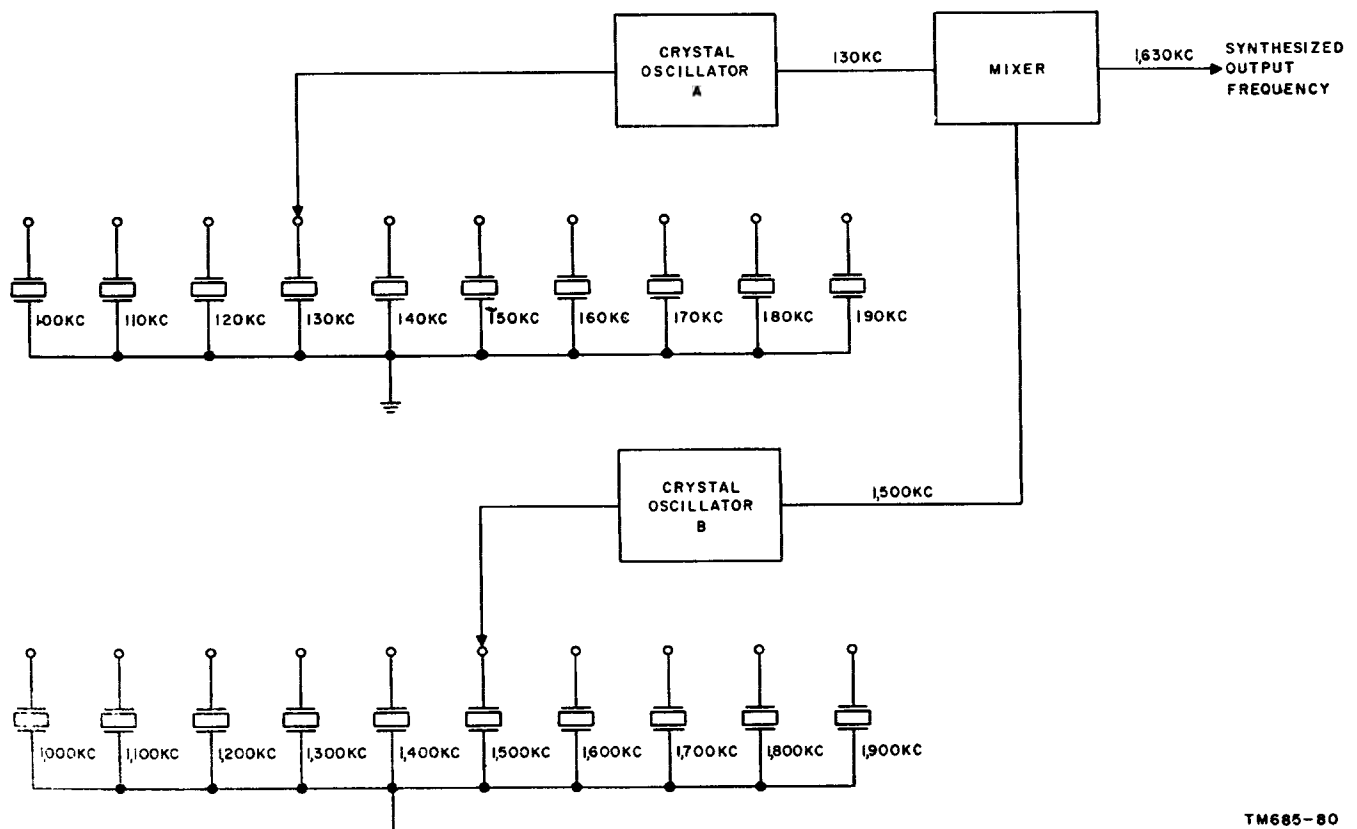

Figure 80. Multiple-crystal frequency synthesizer.

necessary to provide a desired range of frequencies, it has one major drawback that involves elaborate technical requirements and a very costly scheme to maintain all the crystals to the accuracy and high degree of stability required in an ssb system. A solution to this problem is to use one highly accurate and stable crystal to provide a reference frequency to generate the entire range of desired synthesized output frequencies.

75. Single-Crystal Frequency Synthesizer

A single-crystal frequency synthesizer uses a single crystal in an oscillator circuit which generates a reference frequency. A system of frequency division and multiplication and the combination of the derived frequencies provide a wide range of output signals which are all harmonically related to a subharmonic of the reference frequency. A simplified block diagram of a basic single-crystal frequency synthesizer is illustrated in figure 81. The major advantage of this frequency synthesizer is that the accuracy and stability of the output signal are the same as for the reference oscillator. Furthermore, as the state of the crystal art improves, the accuracy and stability of the frequency synthesizer are improved by replacing the existing reference crystal with a crystal of higher accuracy and

stability. The main difficulty encountered in the design of this type of frequency synthesizer is the production of spurious (unwanted) frequencies along with the desired frequencies. By very careful selection of mixing frequencies and extensive filtering, spurious frequency output can be minimized.

a. The block diagram of a basic single-crystal frequency synthesizer (fig. 81) contains a 100-kc reference oscillator. The reference oscillator output is applied to both a *divide by 10* frequency divider and a *times 20* frequency multiplier. The subharmonic output of the frequency divider (10 kc) is applied to a *times 30* frequency multiplier which follows the frequency divider. The 300-kc output of this frequency multiplier is coupled to one input to the mixer.

b. The 100-kc reference signal applied to the *times 20* frequency multiplier (a above) produces a 2,000-kc signal at the multiplier output. The 2,000-kc signal is applied to a second input to the mixer.

c. The resultant sum frequency of 2,300 kc (300 kc + 2,000 kc) is filtered in the tuned network to remove spurious frequencies. The output of the tuned network is the output of the frequency synthesizer.

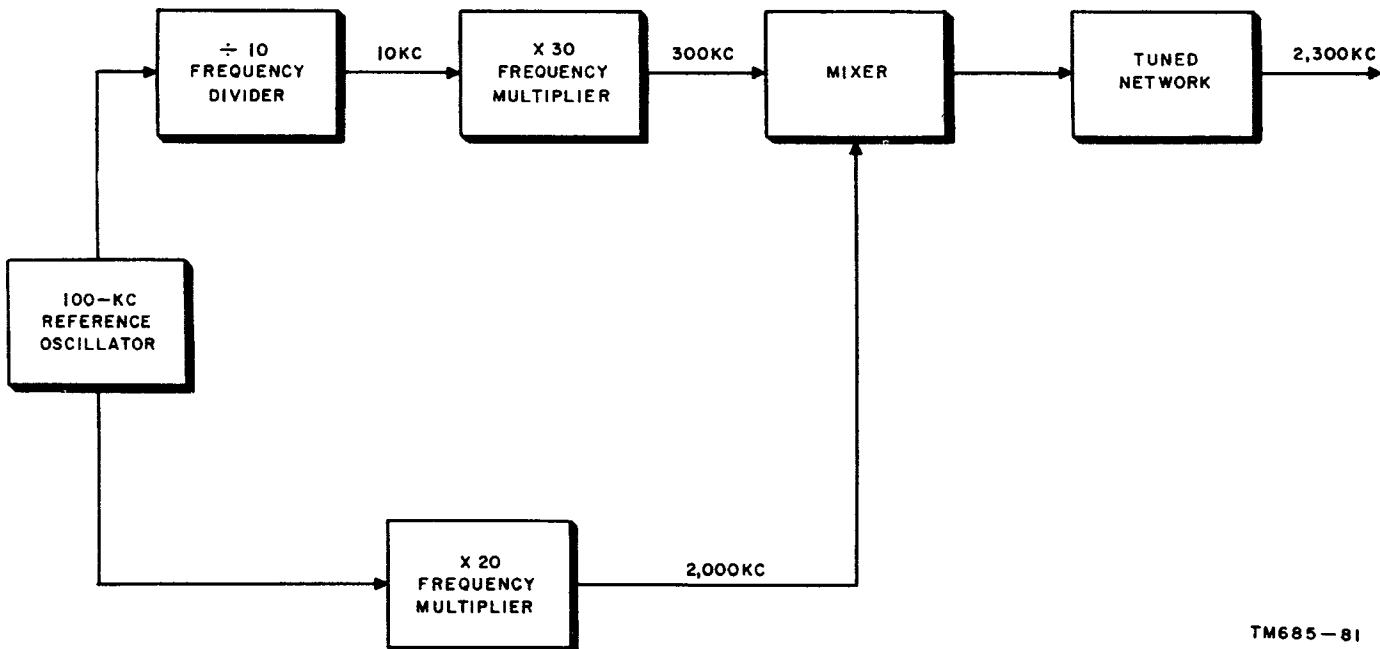

Figure 81. Single-crystal frequency synthesizer, block diagram.

76. Synthesizer Using Superheterodyne Principle

The single-crystal frequency synthesizer in figure 81 is one of a number of possible single-crystal frequency synthesizer designs. Another type of design is illustrated in figure 82. In this synthesizer, the output of a 100-kc crystal reference oscillator is subdivided to a 10-kc signal in a multivibrator stage. The 10-kc multivibrator output, although rich in harmonic content, does not furnish the required synthesizer output directly. Instead, the superheterodyne principle is used to achieve a single-frequency output from the synthesizer with the adjacent frequencies (separated by 10 kc) fully rejected.

a. The 100-kc output of the 100-kc crystal oscillator is applied to the 10-kc multiplier which is triggered at every 10th cycle of the 100-kc signal. The nonsinusoidal multivibrator output is applied to the harmonic amplifier. The tuned output circuit of the harmonic amplifier selects the desired harmonic of 10 kc and applies it to the first mixer. This frequency is the value of the frequency at the

synthesizer output. The harmonic amplifier tuned output may contain frequencies displaced by 10 kc on either side of the desired frequency because of the inability of the tuned circuit at the high radiofrequencies involved to provide the sharp-tuning characteristics required to pass the desired frequency only. The superheterodyne principle furnishes the necessary rejection of the unwanted side frequencies.

b. The harmonic amplifier output tuned circuit is mechanically linked to the tuning elements of the vfo. The output signal of the vfo is coupled to the first mixer along with the desired signal from the harmonic amplifier. The vfo tracks the harmonic amplifier output, through the mechanical linkage, to produce, at the first mixer output, a difference frequency of 400 kc throughout the tuning range. The 400-kc signal is coupled to the 400-kc amplifier.

c. The 400-kc amplifier is a highly selective amplifier that can easily be designed to yield an attenuation of 100 db or more for the adjacent undesired signals (± 10 kc from the desired signal). The high Q required to pro-

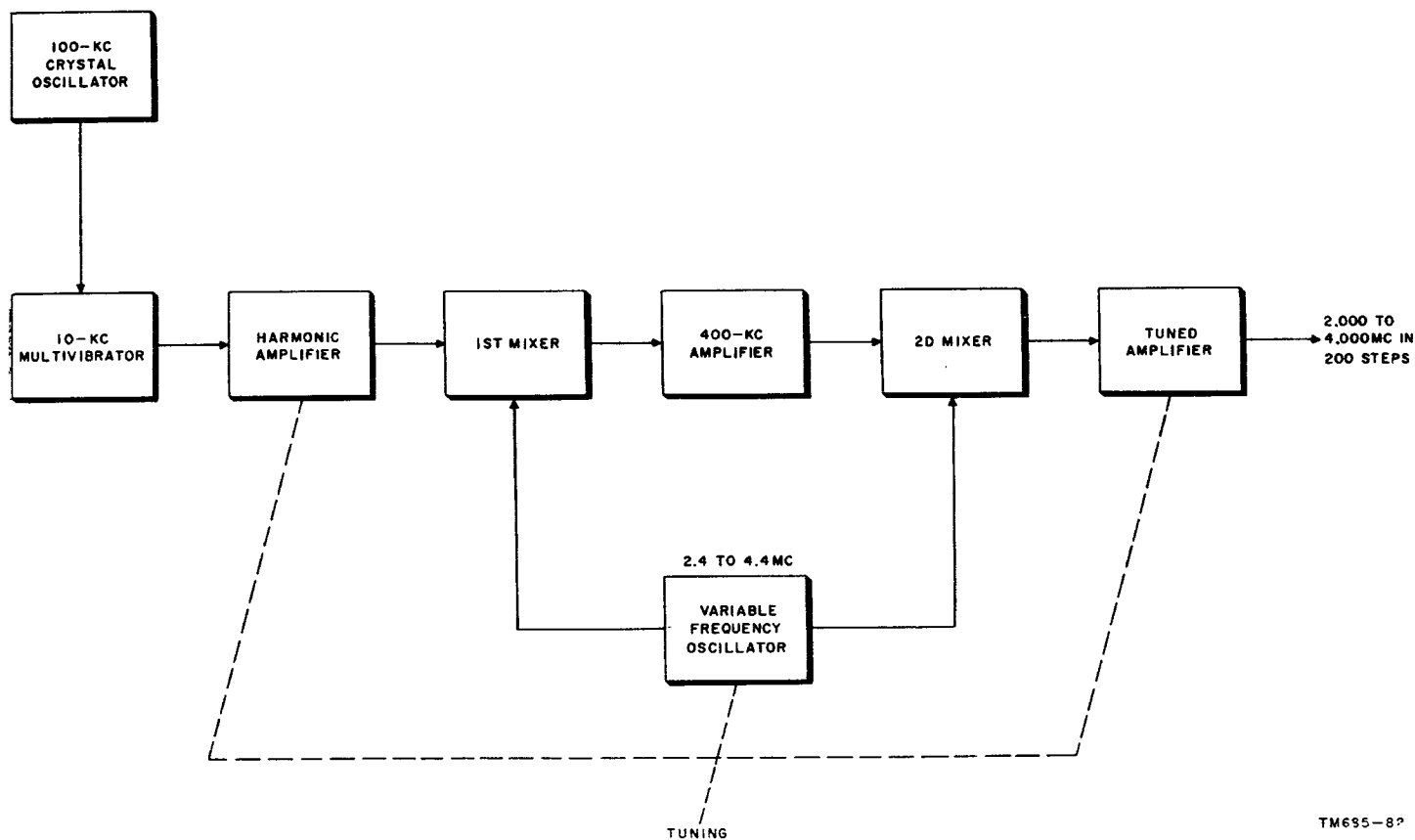

Figure 82. Single-crystal frequency synthesizer using superheterodyne principle, block diagram.

vide the necessary rejection characteristics is readily obtained at this lower frequency. A crystal or a mechanical filter can provide the necessary rejection.

d. The 400-kc output of the 400-kc amplifier is applied to a second mixer along with the signal from the vfo (*b* above). The vfo signal that is used to convert the harmonic amplifier output to 400 kc is also heterodyned with the 400-kc signal in the second mixer. The difference frequency is selected at the mixer output and fed to a tuned amplifier. The difference frequency is of the same value as the desired frequency at the harmonic amplifier output (*a* above). The synthesizer output frequency is passed through several tuned circuits in the tuned amplifier to the synthesizer output terminals. Relatively narrow bandpass is required in the tuned amplifier to eliminate the

oscillator injection frequency and the sum frequency present at the second mixer output.

e. To illustrate the frequency scheme in this synthesizer, assume a vfo range of 2.4 to 4.4 mc. This oscillator range supplies a synthesizer output range of 2.000 to 4.000 mc in steps of 10 kc, to provide 200 different frequencies. If a desired frequency of 2.000 mc at the harmonic amplifier output is considered, the tracking vfo sets to 2.4 mc. The 400-kc difference frequency at the output of the first mixer is applied to the second mixer through the 400-kc amplifier. The 400-kc signal mixes with the 2.4-mc signal from the vfo. The resultant difference frequency of 2.000 mc is the desired synthesizer output frequency.

f. Extreme accuracy and stability of the vfo are not necessary, since the same error is introduced to both the first and the second mixer.

Section IV. STABILIZED MASTER OSCILLATOR

77. Introduction

The frequency synthesizer synthesizes desired frequencies directly from a reference oscillator (by frequency division and multiplication). A major disadvantage of this synthesizer is the generation of spurious (unwanted) frequencies. Spurious frequencies pose a greater problem for wider output frequency ranges and closer channel spacing. The elimination of these spurious frequencies demands extensive filtering and extreme care in component placement to reduce undesired coupling between stages. This problem can be avoided by use of the synthesized signal solely for the control of a vfo which produces the operating frequencies. A vfo used in this manner is called a stabilized master oscillator (smo). An smo does not react to the low-level spurious frequencies that result from frequency synthesis, and only the frequency determined by the smo tuning elements is generated. The smo is locked to a reference signal derived from a standard single-crystal oscillator of extremely high accuracy and stability.

a. The smo in figure 83 is stabilized by a feedback error voltage which is partly formed by comparison of the phase of a signal derived

from the smo with the phase of a signal derived from the single-crystal reference oscillator. A frequency discriminator is normally also used to increase the control pull-in range. The output signal from the smo is mixed with a harmonic of a signal which is derived from the reference oscillator. The desired mixing product is passed through a bandpass filter to the second mixer where the smo signal is further translated to bring it to a frequency of 250 kc. The 250-kc signal from the second mixer is applied to a frequency discriminator and to a phase detector along with a 250-kc signal derived from the reference oscillator to obtain the error voltage. The error voltage is used to control either a saturable reactor, a reactance tube, or some other frequency control device connected to the smo; thus, the smo frequency is locked to the frequency at the reference oscillator for accuracy and stability.

b. The manner in which frequency selection takes place can best be understood by considering, independently, the effect of frequency changes at each of the mixers included in the feedback loop. Assuming that the injection frequency at the second mixer remains fixed and the injection frequencies to the first mixer track the smo by a difference frequency of

1,800 kc, it can be seen that as the smo frequency is varied, the feedback loop stabilizes the smo at multiples of 100 kc. If the smo is tuned to within ± 5 kc of 4,000 kc, the converted signal frequency is within the pass band of the bandpass filters (particularly, the 245- to 255-kc bandpass filter) and the smo is locked at exactly 4,000 kc. If the smo drifts, the feedback loop counteracts the frequency change until the limit of correction of the frequency control device is reached.

c. The effect of varying the injection frequencies at the second mixer will be considered now. In the illustration, these injection frequencies are spaced 10 kc apart from 1,550 kc to 1,460 kc. At an injection frequency of 1,550 kc, the smo is stabilized at frequencies that are exact multiples of 100 kc. Now, if the injection frequency at the second mixer is increased by a 10-kc increment, the smo is stabilized at a frequency that is 10 kc higher in frequency than the 100-kc stabilized frequency. By tuning through the range of the injection frequencies to the second mixer, stabilized smo frequencies can be realized at 10-kc intervals within the 100-kc steps.

d. The accuracy of the stabilization obtained by the feedback system described above depends on the accuracy of the injection frequencies supplied to the first and second mixers and to the phase detector. To obtain the required accuracy, all of the injection frequencies are derived from a single-crystal reference oscillator of high stability and accuracy. The use of a phase error signal in the feedback loop insures that any slight remaining error in the smo frequency, after correction, is in degrees of phase angle between controlled and reference oscillators rather than cycles of frequency difference if only a frequency discriminator were used. However, a frequency discriminator is still a necessary part of the feedback loop, because the pull-in range of the phase detector is not great enough to compensate the smo for large frequency errors.

78. Smo, Block Diagram

Discussion of the block diagram in figure 83 is given below to gain a clear picture of the basic configuration and the signal flow paths in

an smo and in smo control circuits. The combined purpose of the injection signals is to heterodyne the smo output frequency down to 250 kc for comparison with a 250-kc signal derived from the frequency standard.

a. The output signal from the smo is applied to the first mixer where it is heterodyned with harmonics of 100 kc derived from the reference oscillator in the frequency standard. A bandpass filter, tuned to pass from 1,700 to 1,800 kc, couples the first mixer-output signal, that lies within the filter bandpass, to the second mixer.

b. The 10-kc harmonic injection signals to the second mixer are tuned and tracked with the smo to establish smo output signals referenced to the frequency standard at frequencies 10 kc apart. As the smo tuned circuits are varied, the input to the second mixer applies frequencies in 10-kc increments to stabilize the smo at 10-kc points. The second mixer-output signal of 250-kc, plus or minus the smo error frequency, is applied through a 245-kc to 255-kc bandpass filter to both the frequency discriminator and the phase detector. The frequency discriminator establishes the pull-in range of the feedback loop and the phase detector *locks* the smo to the accuracy and stability of the signal derived from the frequency standard.

c. The second mixer-output signal (250 kc plus or minus error frequency) applied to the frequency discriminator and phase detector produces an error voltage that is fed through a low-pass filter to the smo control stage. The low-pass filter rejects high-frequency components that appear at the frequency discriminator and phase detector output terminals. The frequency discriminator is tuned to produce zero error voltage at exactly 250 kc. The phase detector compares the output of the second mixer with a 250-kc signal from the frequency standard.

d. The error voltage to the smo control determines the amount of change that the smo control element will effect in the smo tuned circuit and cause a shift in the output frequency toward the desired frequency. The larger the frequency error, the larger the error voltage and the greater the control element

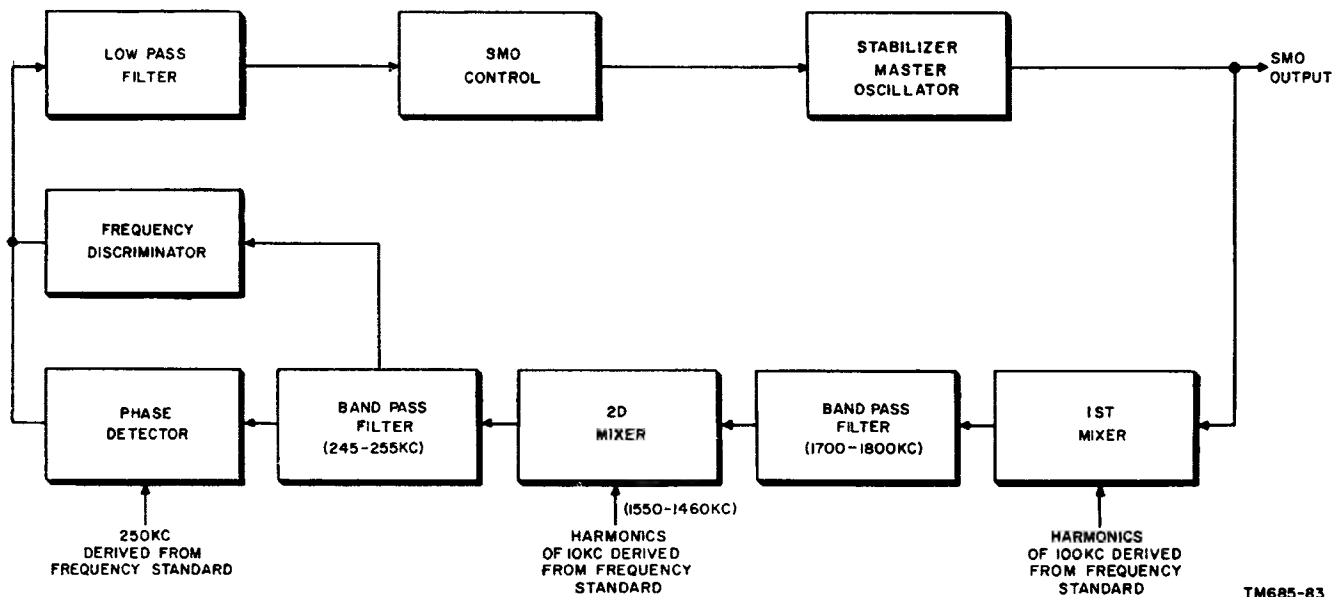

TM685-83

Figure 83. Basic stabilized master oscillator, block diagram.

change. The smo frequency is varied by the error voltage until an exact 250-kc signal is present at the second mixer output and the error voltage *zeros out*.

e. The effect of varying the injection frequency to the second mixer at 10-kc intervals (adjustable to 10 different frequencies from 1,550 to 1,460 kc) is to provide stabilized smo output frequencies at 10-kc points. The first mixer-output frequencies are chosen so that the frequency of 1,550 kc corresponds to the condition in which the smo is stabilized at frequencies that are exact multiples of 100 kc. When the frequency injected at the second mixer is increased by a 10-kc increment, the smo is stabilized at a frequency that is 10 kc higher than the preceding frequency.

79. Smo and Smo Control Circuits

The detailed schematic diagram of an smo and smo control circuit (fig. 84) presents a clear, although simplified, picture of a typical smo and smo control configuration. For simplicity, the frequency discriminator normally used in the circuit does not appear in the figure. The purpose of the frequency discriminator is outlined in the block diagram discussion (par. 78).

a. The smo, V3, is in a series-fed Hartley oscillator circuit. Inductor L2 and capacitor C9 form the tuning elements of the smo. In-

ductor L1 is not inductively coupled to L2 but is in a position to affect the permeability of a saturable core common to both inductors and thus affect the inductance of L2. Capacitor C10 and resistor R10 are a relatively long time-constant capacitor and grid leak combination that provides proper operating bias for the smo stage. Resistor R11 is the plate load for the electron-coupled smo output circuit. Resistor R12 and capacitor C11 form a screen voltage-dropping and RF bypass combination. Resistor R13 and capacitor C12 are plate and screen circuit decoupling components. The signal which represents the smo output is also coupled through capacitor C1 to the feedback loop that, in the end, functions to compensate the smo for inherent inaccuracy and instability.

b. The signal coupled to the feedback loop from V3 is translated in frequency in a series of frequency converters and filters (par. 78) to a lower frequency for comparison with a reference signal from a frequency standard. The converted smo signal is applied across resistor R1 and to the control grid of smo amplifier V1. Tube V1 acts as an amplifier to raise the converted smo signal to a level sufficient to drive the succeeding stage, and also functions as a buffer stage to isolate the preceding frequency converter from the effects of loading by the phase detector. The amplified V1 output signal is developed across

the primary of T1 and then inductively coupled to the secondary for application to the phase detector diodes. Resistor R2 and capacitor C2 are a self-bias and RF bypass combination for V1. Resistor R3 and capacitor C3 form a plate and screen circuit decoupling network.

c. The second signal applied to the phase detector, for comparison with the converted smo signal from V1, is an amplified reference signal that has the required accuracy and stability characteristics. Reference amplifier V4 amplifies the reference signal voltage that is developed across grid resistor R14. The V4 output signal appears across the primary of transformer T2 and is inductively coupled to the secondary where it is applied in series with the split-phase converted smo signal in the secondary winding of transformer T1. Resistor R15 and capacitor C13 are a self-bias and RF bypass combination for V4. Resistor R16 and capacitor C14 form a plate and screen circuit decoupling network.

d. The phase detector, in the figure, is conventional in configuration; the theory of operation is similar to the operation of the phase detectors discussed in chapter 3. The secondary of transformer T1 is tuned by C4 to a frequency that approximates the frequency of either input signal to the phase detector. Diodes CR1 and CR2 are the unilateral conduction elements that provide the voltages across equal-valued diode-load resistors R4 and R5. Capacitors C5 and C6 bypass the RF components in the diode currents around the diode-load resistors. The voltage drops across the series-connected diode-load resistors are in opposition and cancel completely when the diode currents are equal. The error voltage that is formed when the converted smo signal is not exactly equal in frequency and phase to the reference signal, and the diode-load voltages are unequal, is applied through isolating resistor R6 to the control grid of smo control V2.

e. The error voltage from the phase detector is developed across low-pass filter C7 and R7 and applied to the control grid of smo control V2. The error voltage varies the plate current through V2; plate current also flows through saturable reactor L1. A change in V2 plate current through L1 results in a change in the

permeability of the common core material on which L1 and L2 are wound, and effects a change in the inductance of L2. Inductor L2 is a tuning element of the smo; thus, the change in L2 inductance shifts the smo frequency to a corrected value. Variable cathode resistor R8 sets the proper operating conditions for the smo control stage. Resistor R9 and capacitor C8 form a plate and screen circuit decoupling network.

80. Derived Frequencies

The frequencies used in the smo control circuits (par. 79) are derived from a single-crystal reference oscillator in the frequency standard by frequency division and multiplication. Frequency division is a more complex process than frequency multiplication. Frequency multiplication is obtained by distortion of a sine wave. The distorting action results in the generation of harmonics of the applied frequency; no subharmonics or a division of the applied frequency is possible by this process. Most frequency dividers use some form of low-frequency oscillator synchronized by the higher frequency input. Blocking oscillator or multivibrator dividers are of this type. Frequency dividers which operate by a counting process, usually binary, produce no output in the absence of an input signal. Still another type of synchronized oscillator is the regenerative divider, which consists of a mixer, a filter, and frequency multipliers. A block diagram of a two-section regenerative divider appears in figure 85. The blocking oscillator and the binary counter types are not illustrated and discussed because these are well-known circuits. In the regenerative divider, the input at the frequency to be divided is mixed with the output of a frequency multiplier. The final divider output frequency is the difference frequency resultant of the mixing operation. Filters eliminate undesired frequencies from the feedback loop. Sufficient gain is required to stabilize the divider once sustained feedback is established. However, the regenerative divider may not start, because the frequency multipliers in the circuit, unlike amplifiers, do not provide gain at very low input levels. If the filter circuits have sufficiently broad response and the mixer and frequency multiplier

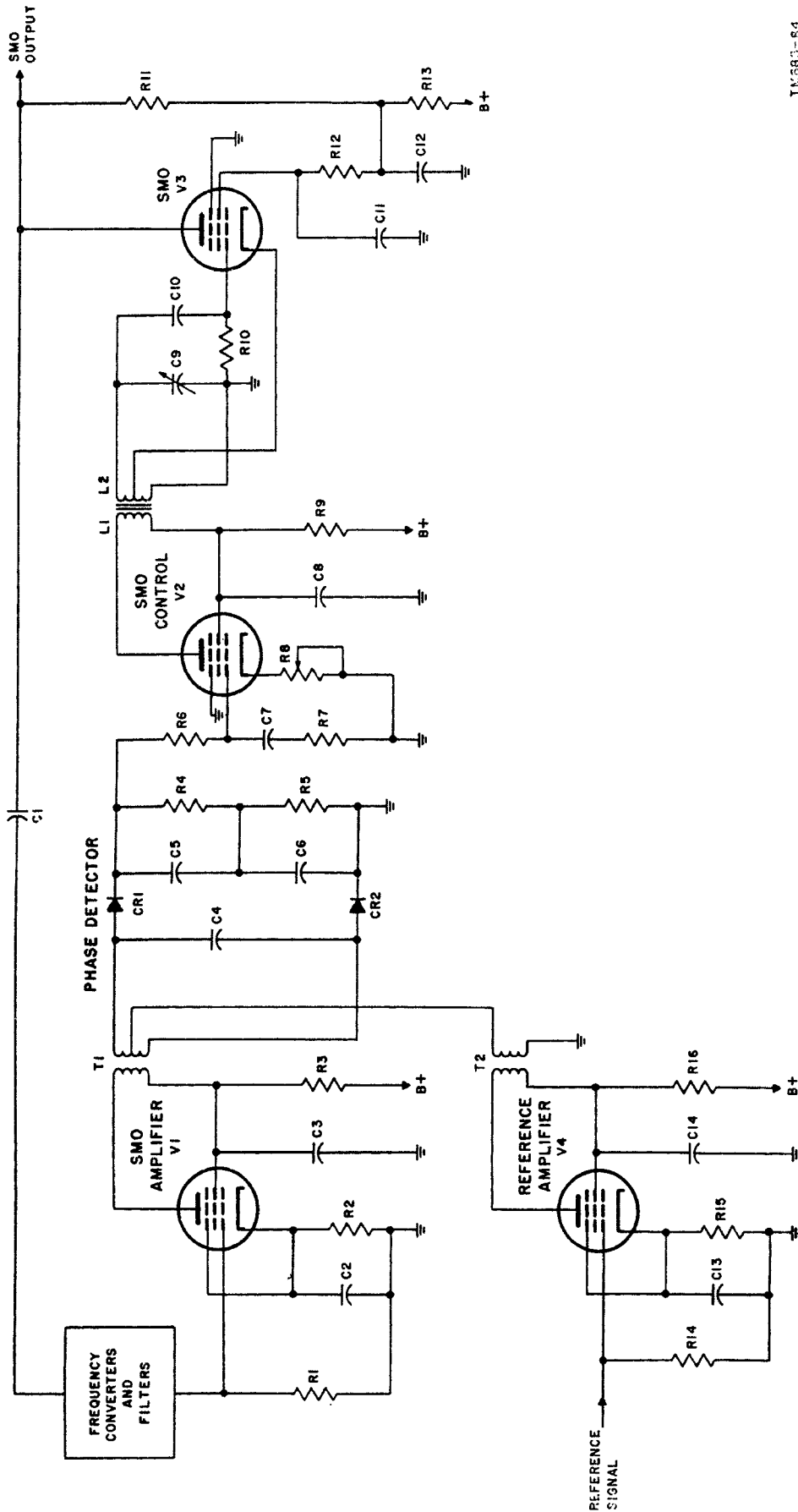

TM 583-54

Figure 8A. Stabilized master oscillator and phase detector circuit, schematic diagram.

combinations provide enough gain, ordinary oscillation will take place at some frequency with or without the input signal. Under proper conditions, this oscillation can combine with the input signal to start the desired frequency divider action. Regenerative dividers that use transistors have recently been devised; however, operation and adjustment of transistorized dividers is critical because of the starting problem.

81. Regenerative Frequency Divider, Block Diagram Discussion

The regenerative frequency divider, illustrated in block form in figure 85, is a two-section divider. The two sections are identical in theory of operation and differ only in the frequencies processed in the feedback networks. The theory of operation of this type of frequency divider is as follows:

a. The 1-mc input signal frequency to be divided is applied to the mixer along with a 900-kc component of noise energy developed in the output circuit of the multiplier (900-kc output) stage. The resultant difference frequency of 100 kc is applied to a feedback loop that returns to the mixer. In the path of the signal, along the feedback loop, is a multiplier (300-kc output) stage which multiplies the 100-kc signal at its input by a factor of 3. The 300-kc output signal from this multiplier is applied to a second multiplier stage (multiplier (900-kc output)) which selects the third

harmonic of the frequency at its input. The 900-kc output signal implements the weak 900-kc noise component that initiated circuit regeneration, and the dividing action is sustained. The 100-kc output signal from this section is channeled to an output terminal and also into the mixer of the second section of the divider for further division to 10 kc.

b. The action of the second section, identical in operation with the first section, produces the 10-kc signal at the output of its mixer. A 90-kc noise component that is present in the output circuit of the multiplier (90-kc output) is heterodyned in the mixer with the 100-kc signal applied from the first section. The resultant difference frequency of 10 kc is multiplied by 3 in the multiplier (30-kc output). The 30-kc multiplier output signal is coupled to the multiplier (90-kc output) where the third harmonic (90 kc) is selected and fed to the mixer, implementing the very low-level initiating noise component and sustaining the dividing action.

82. Regenerative Frequency Divider Circuit Theory

When a 1-mc signal of sufficient amplitude to make the circuit regenerative is applied to the input, the circuit acts as a frequency divider. A description of the regenerative frequency divider circuit illustrated in figure 86 is detailed below.

a. When the circuit is first energized, noise

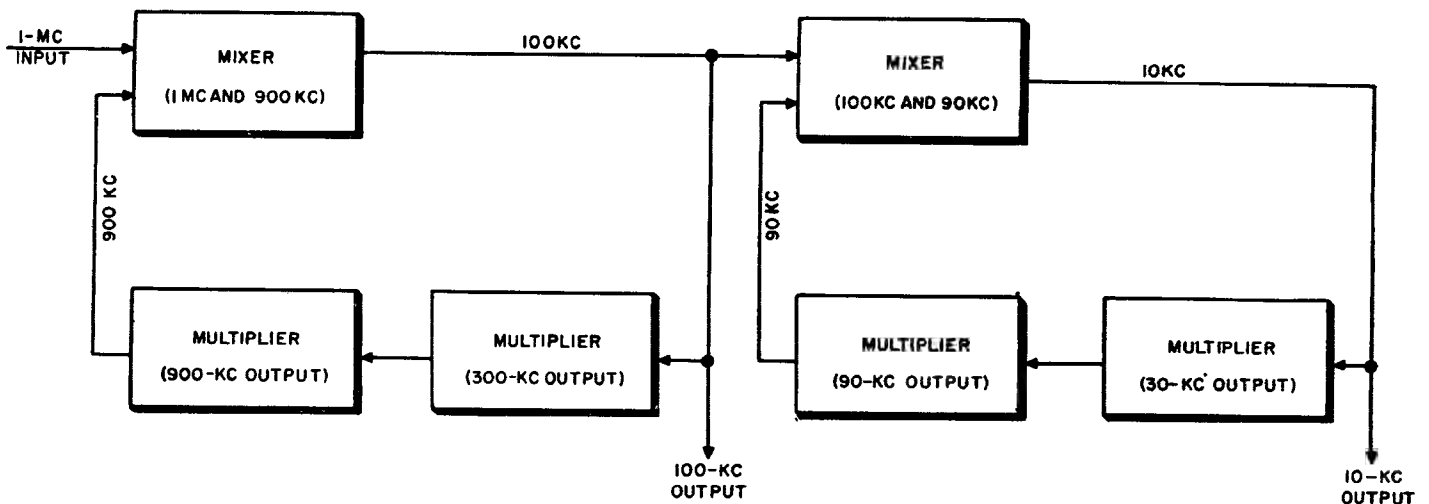

Figure 85. Two-section regenerative frequency divider, block diagram.

in the loop results in the development of a 900-kc component across the multiplier V2B output tank circuit (L3 and C10) which is tuned to that component frequency. This 900-kc noise component is coupled to grid 1 of mixer V1 and is developed across grid resistor R2. The second input to V1 is the 1-mc reference signal which is developed across resistor R1 and applied to grid 3 of V1. The mixing action in V1 produces, among other frequencies, a 100-kc difference frequency signal which is selected by the tuned-plate load consisting of inductor L1 and capacitor C4. The 100-kc output signal, representing the desired frequency divider output, is fed to a divider output terminal through capacitors C6 and also through capacitor C5 to multiplier V2A. Cathode-resistor R3 and rf bypass capacitor C1 set the proper operating bias for mixer action in V1. Resistor R4 is a screen voltage-dropping resistor which is bypassed for rf by capacitor C2. Resistor R5 and capacitor C3 form a plate and screen supply decoupling network.

b. The 100-kc signal applied to the grid of multiplier V2A is developed across resistor R6. The output load of V2A is a tank circuit consisting of inductor L2 and capacitor C8 and is tuned to the third harmonic (300 kc) of the input frequency. The 300-kc output signal is coupled through capacitor C7 to the grid of multiplier V2B. Resistor R8 and capacitor C9 form a plate supply decoupling network.

c. The 300-kc signal applied to the grid of V2B is developed across resistor R7. The output load of V2B is a tuned circuit (L3 and C10) across which the 900-kc noise component develops when the circuit is first energized. The multiplier input signal is distorted by the action of V2B, and the third harmonic (900-kc) is selected in the output tuned circuit. The 900-kc signal is coupled to mixer V1 through C12 (as is the 900-kc noise component during circuit starting), and the circuit continues to provide a 100-kc signal at its output terminals. Resistor R9 and capacitor C11 provide plate supply decoupling for V2B. This circuit ceases functioning only if the 1-mc input reference signal is removed or falls below the level that is necessary to sustain the divider action.

83. Harmonic Generators

The generation of harmonics of low-frequency signals represents an increasingly difficult problem as attempts are made to generate the higher order of harmonics. Several schemes are used to obtain stable signals which are exact multiples of a low frequency. An ordinary class C amplifier generates harmonics with appreciable energy content up to the ninth harmonic. Diode clipper circuits form square or rectangular waves which contain a high harmonic content but, unfortunately, the higher harmonics are of a low amplitude. A blocking oscillator synchronized to a reference frequency generates short, sharp

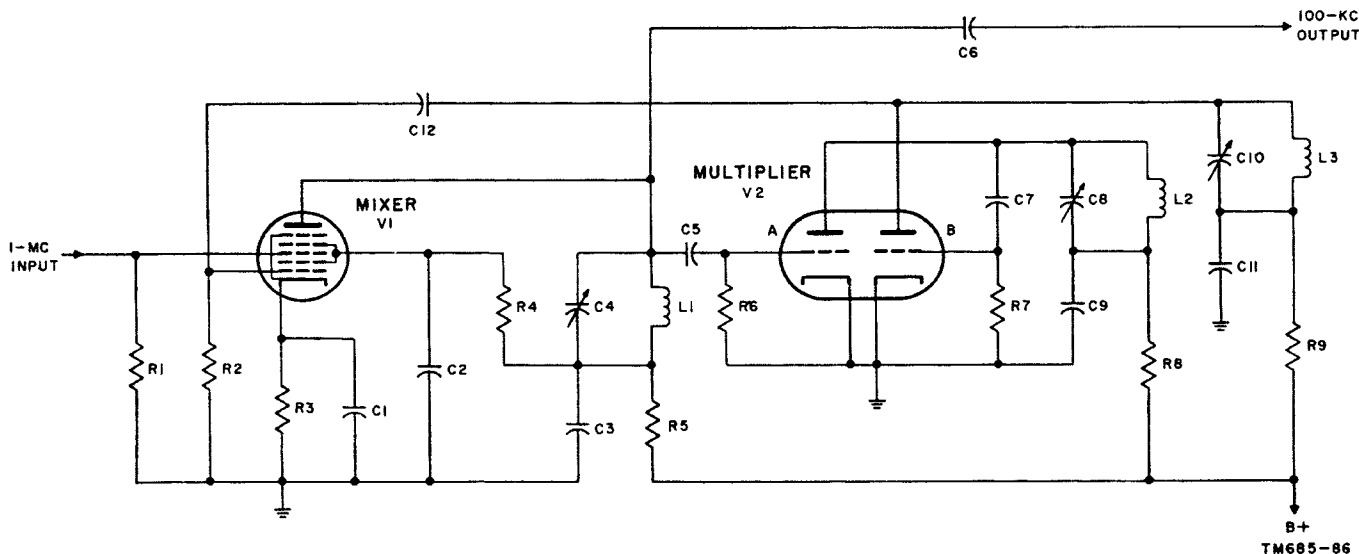

Figure 86. Regenerative frequency divider, schematic diagram

pulses which contain considerable higher harmonic energy. A very effective harmonic generator is the keyed-oscillator circuit (fig. 87). In this circuit, the low-frequency reference signal is shaped by a clipper to provide an off-on keying signal which is used to trigger (turn on and off) a free-running oscillator tuned to the approximate frequency of the desired harmonic of the keying signal frequency. The resulting oscillator output is a train of rf pulses. The spectrum of the output wave consists of a number of components having various amplitudes grouped around the oscillator free-running frequency. The frequency of each component is an exact integral multiple of the keying signal frequency.

84. Keyed-Oscillator Circuit

The keyed-oscillator circuit (fig. 87) consists of a buffer amplifier, a pair of crystal diodes for distorting the signal from the buffer amplifier, and a multivibrator which is influenced by the diode output signal. The diode output signal is rich in harmonic energy. The tuned network in the multivibrator output circuit selects the desired harmonic of the keyed-oscillator circuit input signal.

a. The reference oscillator signal is developed across resistor R1 and applied to the control grid of buffer amplifier V1. Buffer amplifier V1 isolates the reference oscillator output circuit from the effects of loading by the crystal diode networks which follow V1. The output signal is developed across the tuned network (L1 and C3) and coupled to crystal diodes CR1 and CR2 through capacitor C4 and series-limiting resistor R4. Cathode resistor R2 and RF bypass capacitor C1 provide self-bias for V1. Resistor R3 is a screen voltage-dropping resistor, and capacitor C2 returns the screen to ground for rf.

b. The amplified reference sine wave signal is clipped by crystal diodes CR1 and CR2 to produce a square wave which is applied to the grid of multivibrator section V2A. The square wave acts as a keying voltage to trigger and hold the V2 output frequency of operation to one of the harmonics of the clipped reference signal.

c. Normally, multivibrator section V2B conducts because the grid of this section is re-

turned to the positive end of common cathode resistor R8. The grid of the other multivibrator section, V2A, is returned to ground through resistor R5; therefore, the voltage drop across R5, which results from V2B cathode current through R5, appears as cathode bias on V2A. This cathode bias is sufficient to cut-off V2A under multivibrator starting conditions. Each positive half-cycle of the square wave (*b* above) at the multivibrator input drives V2A into conduction. When V2A conducts, the circuit oscillates at a frequency determined by the setting of variable capacitor C6. Capacitor C6 and inductor L2 form a tuned network in the plate circuit of V2A. Signals at integral multiples of the reference frequency at the input to buffer amplifier V1, as determined by the V2A plate tuned network, can be obtained from the keyed-oscillator circuit.

d. Multivibrator V2 is a cathode-coupled multivibrator circuit. Cathode-coupled multivibrator action is furnished by the location of capacitor C7 which places cathode resistors R6 and R7 at the same rf potential (R6 and R7 are made electrically common to both V2A and V2B). When V2A conducts under the stimulus of the proper square wave component at the 2A grid, V2A plate voltage is lowered and a negative-going signal is coupled to the V2B grid through capacitor C5. This action decreases V2B plate current and lowers the voltage drop across resistor R8. Tube V2A goes further into conduction until V2B is driven into cutoff. Discharge of coupling capacitor C5 through grid resistor R9 restores conduction through V2B, and the foregoing action is repeated to provide sustained oscillations in the presence of a keying square wave at the multivibrator input.

e. The output of the keyed-oscillator circuit is at the plate of multivibrator section V2A. Resistor R10 and capacitor C9 form a plate supply decoupling network. Capacitor C8 is a cathode resistor bypass capacitor.

85. SMO, SMO Control, and Interpolation Oscillator

The block diagram in figure 88 illustrates a more sophisticated smo and smo control circuit than the circuit described in paragraph 79 because of the addition of an interpolation

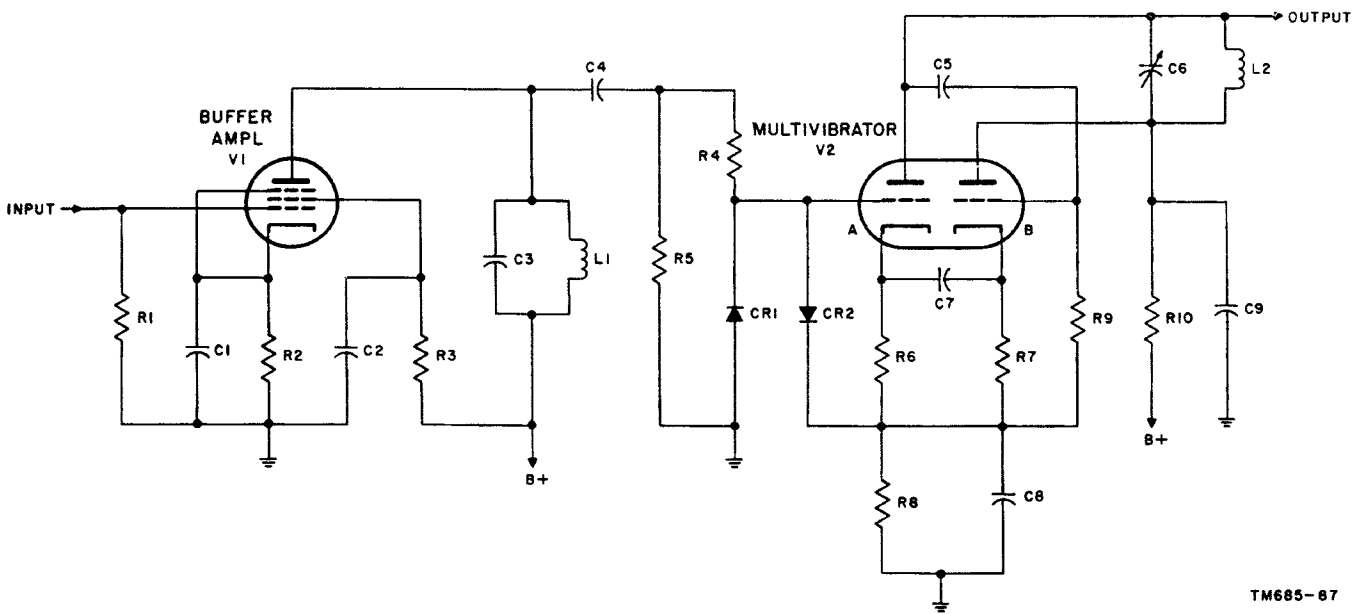

TM685-87

Figure 87. Keyed oscillator and buffer amplifier, schematic diagram.

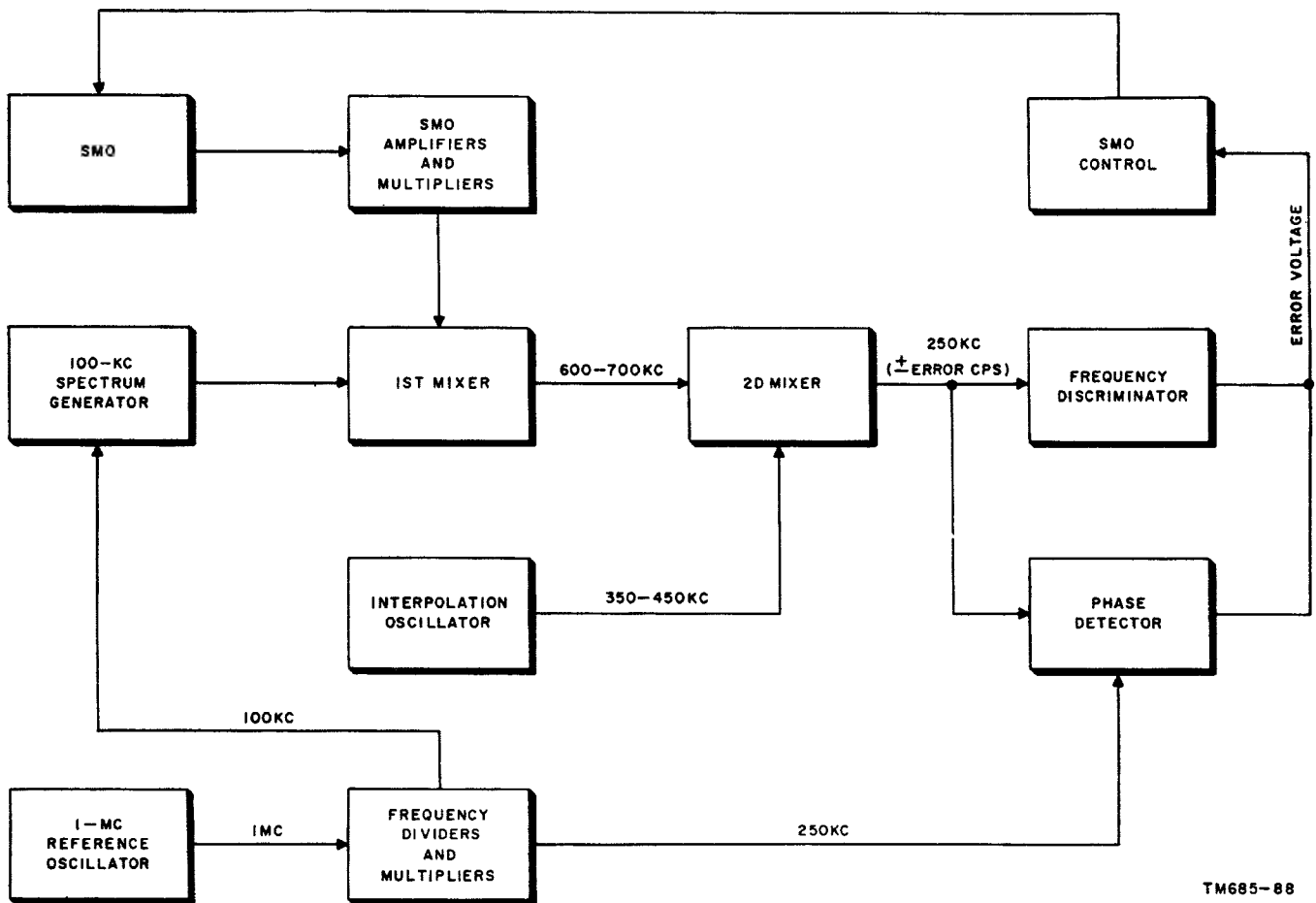

TM685-88

Figure 88. Smo, smo control, and interpolation oscillator, block diagram.

oscillator. The use of the interpolation oscillator parallels the function of the variable injection frequency in figure 84. Whereas the variable injection frequency permits accurate and stable smo frequency generation of 10-kc intervals, the interpolatilon oscillator allows stable operation through the full range of the smo. A brief description of this block diagram follows.

a. The smo output signal is coupled to the smo amplifiers and multipliers and then from that block to the first mixer. A second signal, which is also applied to the first mixer, is derived from the output of the 100-kc spectrum generator. The 100-kc spectrum generator is driven with a 100-kc sine wave signal from the frequency dividers and multipliers in the frequency standard. The output of the 100-kc spectrum generator is normally tuned to track with the smo tuning elements. The first mixer produces a difference beat frequency within the range of 600 to 700 kc (dependent on the smo output frequency). This beat frequency is applied to the second mixer.

b. The 600- to 700-kc range of frequencies

is present at the second mixer input along with a range of 350 to 450 kc coupled from the interpolation oscillator. The interpolation oscillator is mechanically linked to the smo in such a manner as to follow the smo tuning elements and interpolate for the smo output frequencies within the 100-kc intervals tracked by the 100-kc spectrum generator. The second mixer produces a frequency of 250 kc plus or minus the error frequency (normally cps). This 250-kc signal is applied to both the frequency discriminator and the phase detector to derive an error voltage for correcting any frequency inaccuracy or instability in the smo.

c. A 250-kc signal is derived from the 1-mc reference oscillator signal in the frequency standard (through the frequency dividers and multipliers) and applied to the phase detector along with the converted 250-kc signal from the smo. The combined error voltage output of the phase detector and frequency discriminator is applied to an smo control stage. The smo control varies the current through a saturable inductor within the smo and corrects the smo output frequency.

CHAPTER 6

SSB SYSTEM TESTING

86. Introduction

a. The ultimate purpose of a communication system is to deliver a signal that is a replica of the signal at the input to the system. The accuracy of reproduction or system linearity is, therefore, of prime importance. Communications systems can tolerate 25 percent of total harmonic distortion (generation of harmonics of the fundamental frequencies used throughout the system) and remain usable on a specific channel. However, the generation of new frequencies results in interference with other channels and lowers the maximum information rate or intelligibility. Since spectrum conservation is a main advantage of an ssb system over the other usable systems, considerable effort must be made to limit the production of spurious frequencies that fall outside as well as inside the desired channel limits. System linearity can be evaluated when the spurious frequency levels as related to the desired frequency levels are measured under proper transmitter loading conditions.

b. The input test signal used to simulate a loaded condition can be a single-frequency tone, two or more different frequencies but of equal amplitude tones, or random noise. If a single-frequency tone is used to load the ssb transmitter under test, the percentage of total harmonic distortion is measured. This type of measurement is of some value for audio amplifiers but is entirely inadequate for a linear rf amplifier under suppressed-carrier conditions, since a single audio tone is converted to single rf frequency with the harmonic output depending to a greater degree on the bandpass of the tuned output circuits than upon the degree of nonlinearity that exists in the transfer characteristic of the amplifiers. The bandpass distortion is all that will be detected by a receiver tuned to a single-frequency signal; therefore, a useful distortion test must use at

least two tones impressed simultaneously, so that the distortion products fall within and near the bandpass of the equipment.

c. Odd-order distortion in a selective amplifier causes the appearance of currents having new frequencies, many of which fall in and near the bandpass of the device. System linearity is degraded and interference results. In contrast, even-order distortion results only in new frequencies (harmonics) which fall outside the bandpass region. Measuring equipment generating two-tone signals may be used as input signals to evaluate the linearity of an amplifier or of the complete system (transmitter and receiver).

d. Another important factor that governs proper operation of an ssb system is the ability of the system to be accurately adjusted to an assigned frequency and maintain this frequency over a long period of time. Periodic checks of the assigned frequency are required to maintain the accuracy and stability so necessary in an ssb system. Frequency errors can be minimized by proper equipment design and component selection for minimum change in characteristics with change in environmental and operational conditions (heat rise, shock excitation, etc). Normally a frequency measuring device, such as a heterodyne-frequency meter or a counter-type frequency meter, is used to monitor the assigned frequency of an ssb system.

e. This chapter is concerned mainly with those adjustments, tests, and measurements that are required to maintain or restore normal operation to ssb equipment. In the course of this discussion, test equipment is explained briefly in theory and operation to provide the reader with a better understanding of the principles that underly equipment operation. Simple test procedures whereby a minimum of complex test equipment is used to provide

satisfactory indications of normal ssb equipment operation are also described.

87. Frequency Measurement

Two types of frequency-measuring equipment can be used to furnish an accurate indication of an assigned transmitter emission frequency. The two frequency meters detailed in *a* and *b* below represent the most accurate frequency-measuring devices of a larger number of frequency meters that could be used. Consideration has been given to these particular equipment types, because they contain inherent standards for measurement which are of a greater degree of accuracy than the ssb equipment under test. Advances in radio communication technology that support ssb systems in achieving effective, completely suppressed-carrier operation have evolved extremely accurate and stable internal frequency standards to generate assigned emission frequencies. These internal frequency standards approach laboratory expectancies. To assure proper maintenance of transmitter and receiver standard frequencies, test equipment employed for ssb frequency testing must equal or excel the system frequency standards in both accuracy and stability.

a. Heterodyne-Frequency Meter. The basic heterodyne-frequency meter, shown in block diagram form in figure 89, consists mainly of a calibrated variable oscillator which produces a frequency that beats or heterodynes with the frequency to be measured. The output signal of the device under test is coupled to the frequency meter. The calibrated oscillator frequency is then varied until the difference frequency between the oscillator frequency and the unknown frequency is heard in the headset. This difference frequency is the beat frequency which results from the combining or mixing of the two signals and provides the first indication of an approaching equivalence of the two frequencies. Further variation of the calibrated oscillator frequency produces a *zero beat* or null at which point no sound is heard in the headset. At *zero beat*, the calibrated oscillator frequency and the unknown frequency are identical in value (cps). The calibrated oscillator dial indication corresponds to the frequency of the signal under test.

(1) A heterodyne-frequency meter contains an accurate and stable crystal oscillator which is used to calibrate the frequency of the variable oscillator. This crystal oscillator produces a number of harmonics which permit calibration of the heterodyne-frequency meter at integral multiples of the crystal fundamental frequency. These calibration points are called crystal checkpoints. The frequency of each checkpoint is normally listed in a calibration book (frequency versus dial setting). The calibration book also lists dial-frequency relationships in the intervals between crystal harmonic checkpoints. The interval calibration has been checked against a more accurate frequency standard. Assume that the calibration book shows a crystal checkpoint at a frequency of 2,000 kc. The dial setting of the meter is adjusted to correspond to the number given in the calibration book for 2,000 kc. With the crystal calibrate switch closed, the output of the variable oscillator beats with the output of the crystal oscillator. If a small difference between the two frequencies exists, an audible beat note is produced. If the frequency of the beat note is 300 cycles, the variable oscillator frequency is either 300 cycles above or below 2,000 kc. The variable oscillator is adjusted to the exact frequency with a *corrector* knob. The *corrector* knob is adjusted until a zero beat is obtained.

(2) Figure 90 shows a simplified schematic diagram of a typical frequency meter. Tube V1 is the variable oscillator. The output frequency of V1 beats with the unknown frequency coupled to mixer V2 through capacitor C7. Tube V1 is in an electron-coupled oscillator circuit to furnish good stability under varying load conditions. Switch S1 permits operation on two frequency ranges. Variable capacitors C2 and C3 resonate with coils L1 and L2, respectively, to pro-

vide full range coverage. Capacitor C1 is directly connected to the V1 control grid and is ganged with both C2 and C3. The capacitors are the main variable tuning elements and are adjustable at the front panel. Capacitor C4 is the CORRECTOR trimmer capacitor which corrects for any frequency deviations of the oscillator frequency detected during calibration.

(3) The circuit of tube V2 is the mixer stage. Tube V2 also serves as a pentagrid converter when the variable oscillator is being calibrated. With switch S2 at *off*, the first grid of V2 is grounded and V2 functions solely as a mixer stage. The output of V1 is applied to the mixer through capacitor C8 along with the unknown frequency which is injected through capacitor C7. For calibration of the frequency meter, S2 is at ON and V2 functions as a pentagrid converter, with the crystal-oscillator section consisting of the cathode and the two adjacent grids. The variable-oscillator frequency injection to the mixer section is at the third grid. The output of V2 is coupled through capacitor C11 to audio amplifier V3. The output of tube V3 is fed to the headphones. The potentiometer in the V3 grid circuit controls the difference-frequency input level to the audio amplifier.

b. Counter-Type Frequency Meter. The counter-type frequency meter is a high-speed electronic counter which uses a highly accurate and stable crystal-controlled, time-base generator. This frequency meter automatically counts and displays the number of cycles occurring in a precise time interval. This frequency meter does not generate a signal but merely counts the frequency of a signal applied to it. The basic idea is that a scaler (pulse counting device) is allowed to count cycles of an unknown input frequency for a predetermined length of time (usually counting intervals range from 10 milliseconds to 1 second). The time interval is, in turn, controlled by the known internal time-base generator frequency.

(1) The basic circuit of a counter-type frequency meter is shown in block form in figure 91. It consists of an input for application of an unknown frequency, an electronic signal gate, a crystal-controlled time-base generator, and a series of electronic counters which display the digits that represent the input signal frequency.

(2) The counter-type frequency meter uses a new type of frequency-measuring circuit known as a frequency counter. The frequency to be measured is passed from the input terminal to an electronic signal gate the opening and closing of which are controlled by a precision time-base generator. When the gate is open, the frequency to be measured is applied to

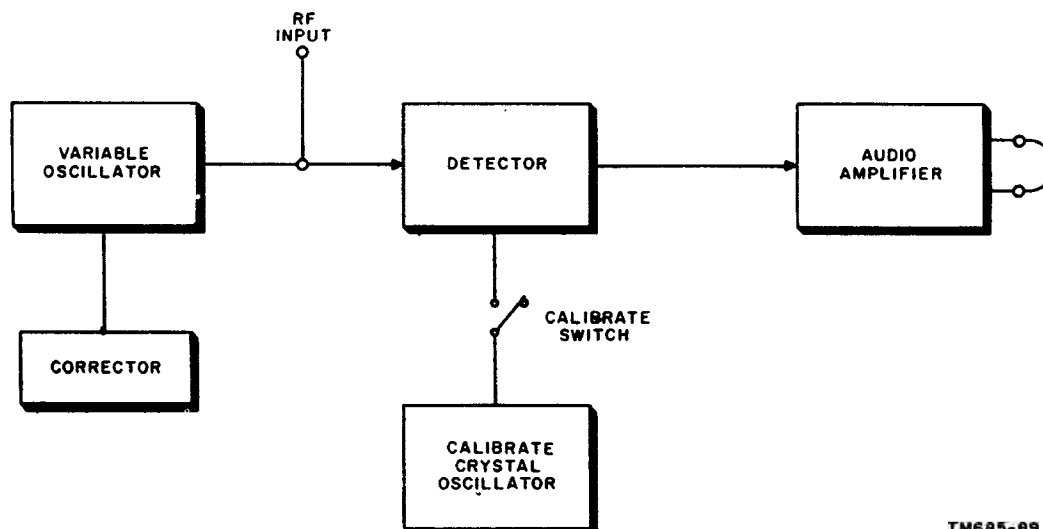
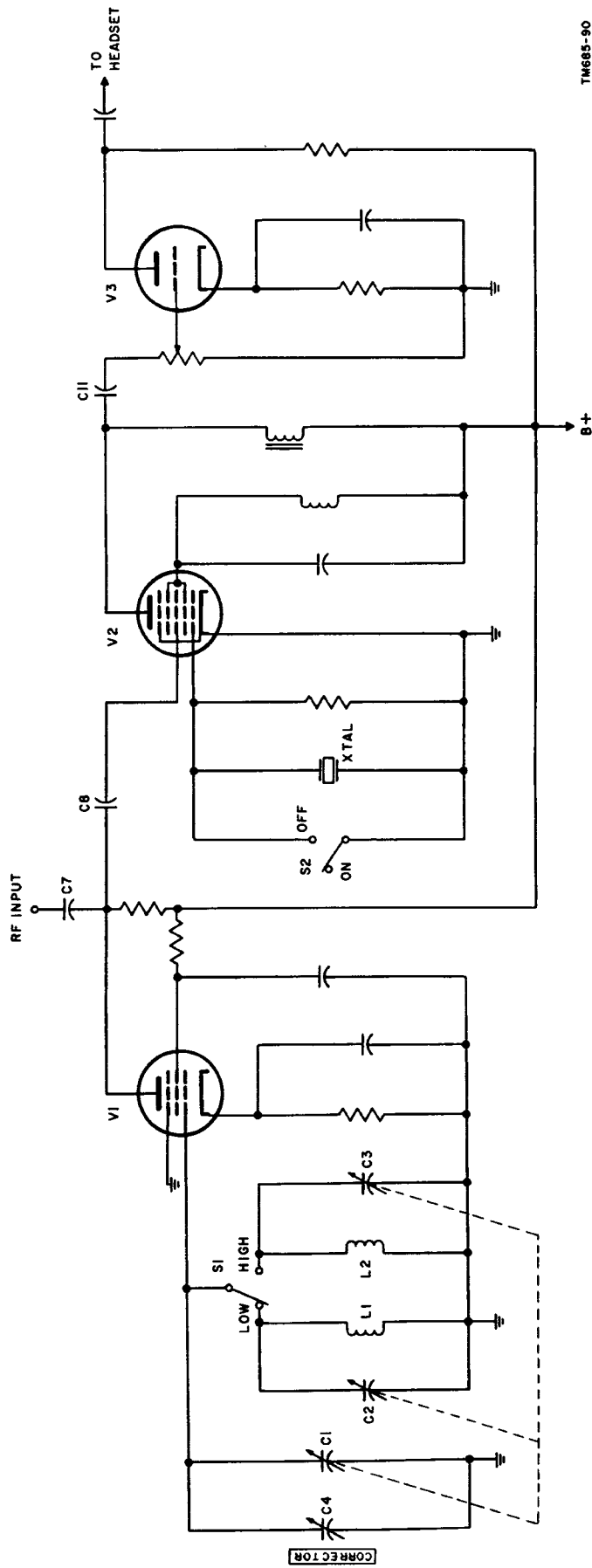

Figure 89. Heterodyne-frequency meter, block diagram.

TM685-89



TM685-90

Figure 90. Heterodyne-frequency meter, schematic diagram.

a series of digital-type counter circuits. When the gate is closed, the counters visually display the total number of cycles applied while the gate was open. Since the precision time-base generator holds the gate open for an accurately known interval of time, the displayed count has the dimensions of frequency; that is, the total number of cycles divided by time.

- (3) The counter-type frequency meter permits the determination of frequency rapidly without involved interpolation and avoids the possibility of producing ambiguous results. The measurement of a large number of different frequencies in quick succession is also facilitated. When the unknown frequency is heterodyned with a fixed frequency within the unit, the frequency range of the test equipment may be extended from its basic range of about 100 kc to approximately 30 mc. The primary limitation of this type of frequency meter is that it cannot be used directly for receiver calibration, since it is a passive device and, therefore, does not produce signals.
- (4) The counter-type frequency meter cannot provide an accurate count of an assigned frequency of an ssb transmitter in the presence of modulating signals (other than a single tone).

The modulating signals result in a complex wave emission (nonsinusoidal). The system must be relieved of all modulating signals and the frequency-measuring test performed on the reinserted carrier only.

88. Methods of Power Measurement

The power output of a transmitter is measured under conditions which simulate, as closely as possible, actual operating loading. The simulated impedance of the loading and measurement device must be within the range of impedances into which the transmitter is designed to operate. Several methods and devices for power output measurement can be used. The selection of a particular method and device depends on the frequency of operation and the transmitter rated power output. Low-frequency, low-power transmitter power output can be determined with some degree of accuracy by measurement of the I^2R consumption in a suitable group of properly terminating nonreactive resistors (*a* below). High-frequency, high-power transmitter power output can be measured accurately by the calorimetric method (*d* below). At the high frequencies, nonreactive resistors capable of dissipating the high transmitter power output are very difficult to design and fabricate.

a. RF Power Meter. When extreme accuracy in the measurement of RF output power is not a vital consideration, compact test equipments, called RF power meters, can be used to furnish a direct reading of low or moderate transmit-

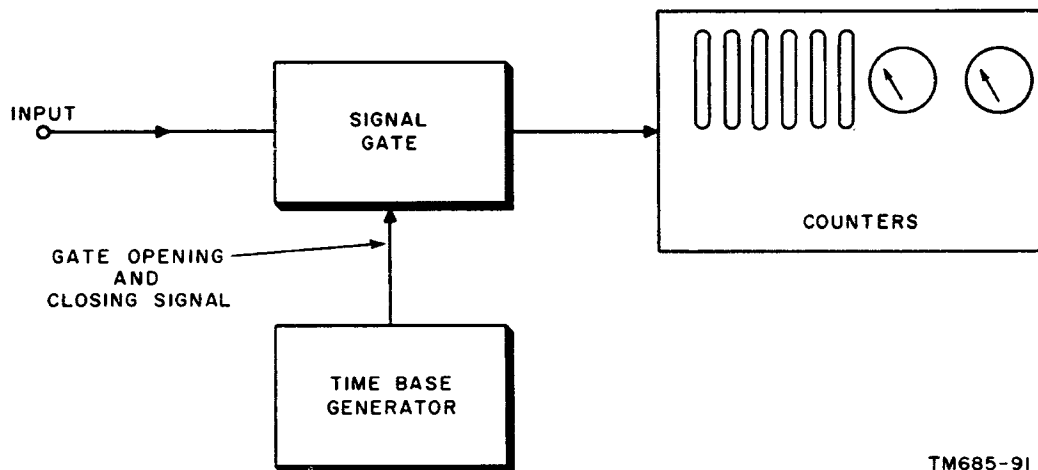

TM685-91

Figure 91. Counter-type frequency meter, basic block diagram.

ter-output power. The principle of operation of an RF power meter is very simple. The full transmitter-output power is dissipated in a matched resistance, and the resulting voltage across the resistance is applied to a voltmeter calibrated in watts. A compact and portable RF power meter is normally designed for use on transmitting equipment rated up to 500 watts of power. An RF power meter is generally most useful for frequencies ranging from 3 mc to 300 mc.

- (1) Figure 92 shows a typical circuit of an RF power meter. The transmitter-output loading resistor is shunted directly across the transmitter-output terminals. This resistor must be capable of dissipating the rf energy delivered to it, or the heat generated will ruin the resistor and possibly cause other damage to the test equipment. *Do not overload the power meter.* For low-power meters, of the type shown in the figure, carbon piles are often used as the power dissipating resistor. The carbon piles are composed of disks of carbon mounted on a suitable form and comprise the transmitter loading resistance. At the higher frequencies, the value of resistance must closely approximate the characteristic impedance of the transmission line used to couple the transmitting equipment to the antenna. When the transmission line is properly terminated by the carbon pile, the standing wave ratio on the line is negligible and practically the full power of the transmitter is applied to the rf power meter.
- (2) Capacitors C1 and C2 form an RF voltage divider. Capacitor C1 is chosen as a small value (about 5 micromicrofarads ($\mu\mu\text{f}$)) to minimize additional loading (reactive) or otherwise upset the proper terminating impedance for the transmitter under test. By maintaining the capacitive reactance shunted across the load resistor high, the effect on the standing wave ratio is negligible. A relatively small voltage drop appears across C2

(C2 is usually about 0.25 microfarad (μf)). Positioning of the crystal diode in parallel with C2 provides a low-impedance path to ground for the negative half cycles of RF energy. The resultant voltage across C2 is thus positive with reference to ground; the amplitude is proportional to the voltage developed across the carbon-pile load resistor by the absorbed transmitter - output power. This voltage deflects the meter indicator across a scale that is calibrated directly in watts. A suitable resistive multiplier is switched in series with the meter movement; the resistor value depends on the amount of power involved (range setting of the RF power meter). A resistance-capacitance filter is shunted across the meter to remove RF fluctuations in the rectified output of the crystal diode.

- (3) Small amounts of power can be applied continuously to the meter, but, to avoid overheating and possible damage to the carbon-pile load resistor, larger amounts must be applied for a length of time just sufficient to obtain a reading. The upper frequency limit of the device is determined by the capacitive voltage divider. Eventually, a frequency is reached at which the reactance across the loading resistor causes a mismatch in the termination of the transmission line. The standing wave ratio is then so high that the meter readings are inaccurate.

b. Electronic Wattmeter. The power-measuring device described below uses an electronic wattmeter circuit based on the balanced modulator principle discussed in chapter 2. As shown in figure 93, a source of RF power is connected to the load through the two equal-value series resistors, R2. These two resistors are small enough in value so that the affect on the load voltage is negligible. In contrast, resistor R1 is very large so that its power consumption is negligible. These conditions make the voltage across R1 equal to the load voltage,

and the voltage across either series resistor, R_2 , proportional to the load current. As shown in the figure, the voltage across the grid circuit of the upper tube is E_1 plus E_2 , and the voltage applied to the lower tube is E_1 minus E_2 . Resistances R_L in the plate circuits of the tubes are equal. This last condition makes the difference of potential between the plates proportional to the difference in the plate currents of the tubes. The average value of the difference is indicated by the direct-current meter connected between the plates. For the circuit to function as a wattmeter, the tubes must be

operated over the nonlinear portion of their characteristic curves. The operation causes the difference current to consist of a number of components. The components proportional to either E_1 or E_2 make no contribution to the reading, because the average value of a sine wave is zero. (E_1 and E_2 are root-mean-square (rms) values of sine-wave voltages.) The only other appreciable component is the one proportional to the product of E_1 and E_2 ; that is, proportional to the product of the load voltage and current. The average value of such a component is proportional to the product of E_1 and

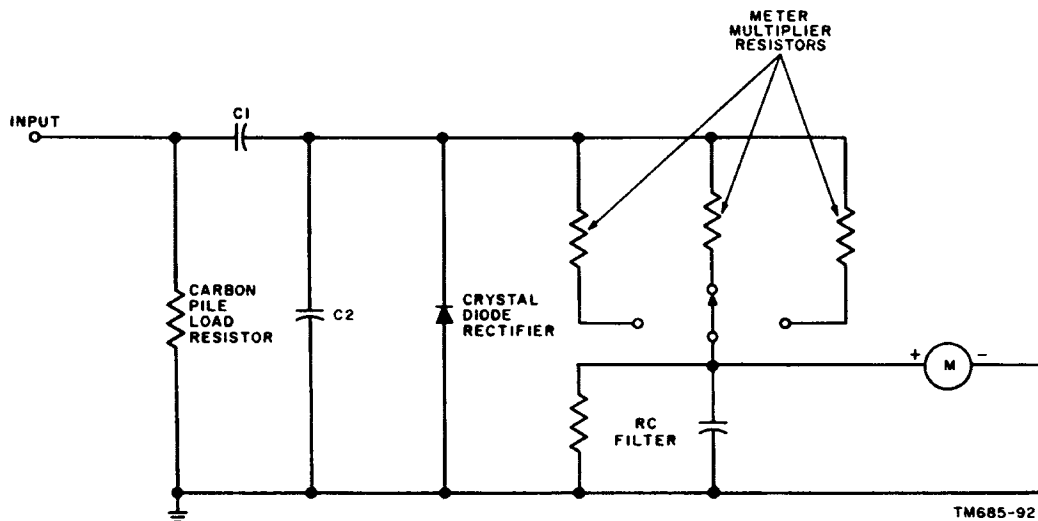

Figure 92. RF power meter, schematic diagram.

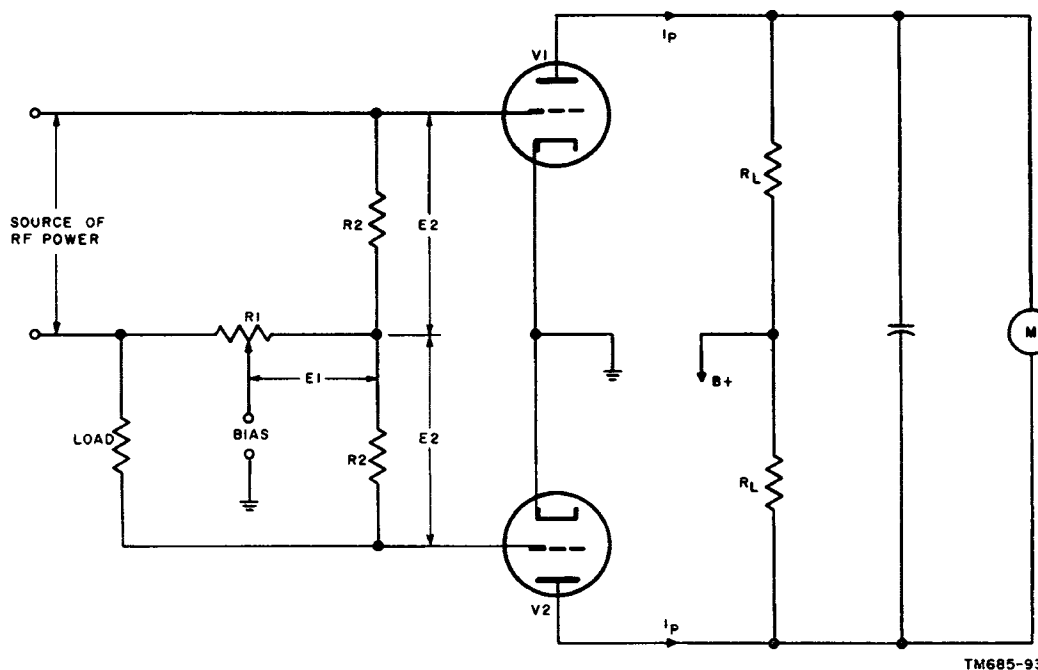

Figure 93. Electronic wattmeter, schematic diagram.

E2 multiplied by the cosine of their phase difference (power factor). Consequently, the meter reading is proportional to the real power consumed by the load, and the scale is calibrated to indicate in watts.

c. Frequency Limitations of Power Measurements With RF Power Meters and Electronic Wattmeters.

- (1) The use of power meters and electronic wattmeters for the direct measurement of RF power is satisfactory only when the frequency is fairly low. As the frequency increases, a number of serious difficulties are experienced. The most injurious effect is that of stray capacitance and inductance in the metering devices. Up to a point, the physical size of RF components in the older types of power-measuring equipment could be scaled down to extend their upper frequency limit. Nevertheless, the benefit of such a procedure is so restricted that development of entirely new methods has been necessary. Other conditions to be overcome are skin-effect resistance, the problem of determining the power factor at high frequencies, and the difficulties encountered in measuring large magnitudes of RF power.
- (2) A substantial reduction of power does not significantly decrease operating range, so that the precise measurement of RF power may appear to be unnecessary. This is a false conclusion. One reason is that a change in the power output may result from altered operating conditions that are capable of causing equipment breakdown unless remedied. In addition, power measurements are often the surest way of determining whether the overall performance of a transmitter is normal and, in general, consistent with the design specifications.

d. Calorimetric Method.

- (1) In the calorimetric method of power measurement, a liquid acts as a coolant into which the transmitter-output power is fed and within which this

power is dissipated. Characteristics of the liquid coolant, such as the specific gravity and specific heat, are known and the rate of flow is controlled. The heat developed in the matched load is transferred to the liquid coolant. The load is designed to minimize heat loss resulting from conduction and radiation from the measuring device. The load contains precision gages, which register the rate of coolant flow (variable) and the coolant temperatures at the inlet and outlet of the power-measuring apparatus.

- (2) After the transmitter-output power has been applied to the calorimetric-type device, the coolant rate of flow is adjusted to provide a clear difference between the inlet and outlet temperature readings. After the individual temperature indications are stabilized and remain fixed for a sufficient length of time, both these temperatures and the rate of coolant flow are noted. The average power dissipated in the load is given by substituting the data above in the following formula:

$$W_p = 264QGS (T_2 - T_1)$$

The literal symbols are:

W_p = Average power dissipated in watts.

Q = Rate of coolant flow in U. S. gallons per minute.

G = Specific gravity of coolant (1 for water).

S = Specific heat of coolant (1 for water).

T_2 = Outlet temperature of coolant in degrees centigrade.

T_1 = Inlet temperature of coolant in degrees centigrade.

e. Photometric Method. In this method, the load consists of one or more incandescent lamps. The brightness of the lamps, when acting as the transmitter load, is measured with a photometer. The power absorbed by the lamps is then calibrated at the same brightness level by replacing the transmitter with an ac or dc power source.

f. Directional Wattmeter Method. This method uses a device that is designed usually

for specified impedance and frequency ranges and calibrated to measure the incident and reflected power in the transmission line. The difference is the power absorbed by the load.

89. Transmitter Power Output Measurement Procedures

Many factors that are external to the radio transmitter affect its power output. When making measurements, these factors should be considered and noted. Some of the most important are line voltage setting, operating temperature, humidity, altitude, duty cycle, and load impedance.

a. Continuous Power Output Test Procedure.

- (1) Adjust the line voltage and loading to the values specified for the particular equipment under test.
- (2) Reduce the carrier level to a negligible amount.
- (3) Apply, to the transmitter input, a single-tone sine-wave signal at a frequency that produces an ssb output signal within the flat portion of the nominal transmitter band.
- (4) After a sufficiently long warmup time (to assure proper operating temperature), measure the power output; use one of the methods described in paragraph 88.
- (5) Operate the equipment for a number of hours and note that the operation has been continuous, without failure, and free of difficulty or damage from overheating or flashover.
- (6) Recheck the power output measurement.

b. *Peak-Envelope Power Output Test Procedure.* Modulation with a two-tone signal provides two radiofrequency output signals, plus harmonics, intermodulation products, and other spurious outputs. In a properly adjusted ssb transmitter, the spurious responses are negligible; therefore, the peak-envelope power is essentially twice the measured average power.

- (1) Adjust the line voltage, loading, and other factors that affect power output

to the values specified for the particular equipment under test.

- (2) Reduce the carrier level to a negligible amount.
- (3) Apply a two-tone test signal to the transmitter input.
- (4) The peak-envelope power output is twice the average power measured under these conditions. Use one of the power-measuring methods described in paragraph 88.
- (5) Operate the transmitter continuously for a number of hours to detect possible failures and recheck the peak-envelope power measured ((4) above).

c. *Test Setup for Peak-Envelope Power Measurement.* A test setup for measuring peak-envelope power output of an ssb transmitter is illustrated in figure 94. In this test setup, the output of a two-tone test generator (audio) is used to modulate the ssb transmitter under test. The transmitter is loaded with a matched-load resistor (R_L) to absorb the full power output of the transmitter; the voltage developed across the resistor depends on the absorbed power. The voltage across the resistor can be measured (as illustrated in the test setup) with either an oscilloscope or an rms reading vacuum-tube voltmeter. The oscilloscope indication is a peak voltage (E_P) measurement; the pep can be calculated from the voltage and the known matched-load resistor value (R_L) by use of the following equation:

$$pep = \frac{(0.707E_P)^2}{R_L}$$

When the voltage across R_L is measured with an rms reading vacuum-tube voltmeter, the preceding equation is modified to the form:

$$pep = \frac{(E_{vtvm})^2}{R_L}$$

Where E_{vtvm} is the meter rms voltage reading.

90. Distortion Testing

Distortion testing is used to evaluate the degree of nonlinearity of an ssb transmitter emission. A distortion test can be either a measurement of the overall distortion (related to the desired output) or a waveform analysis which

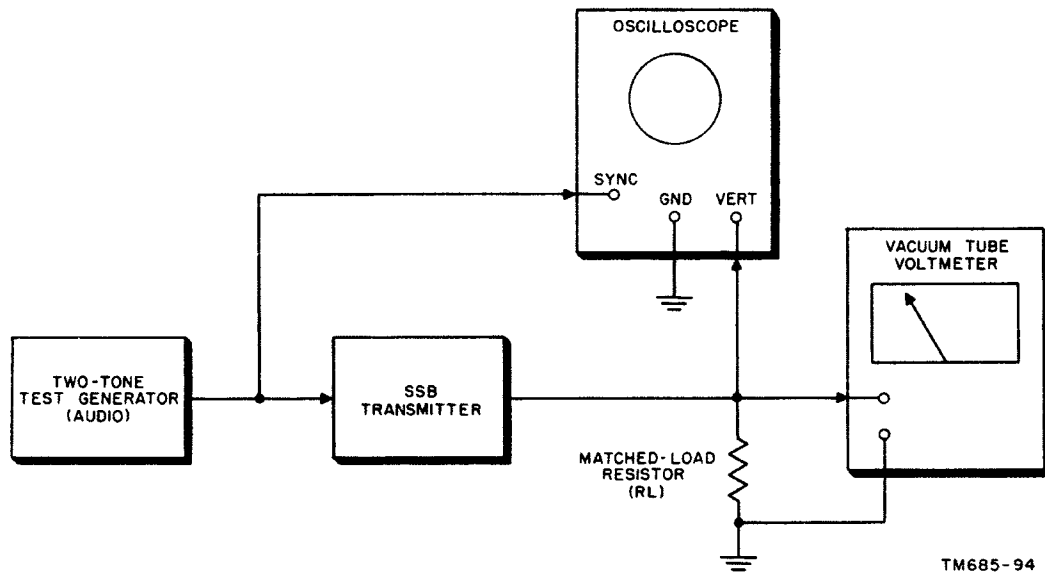

Figure 94. Test setup for measuring peak-envelope power during two-tone test.

displays the number, spectrum locations, and amplitudes of the important distortion frequency components. The relative amplitudes and spectrum locations of the distortion components are in direct relation to the interference caused by the affected transmitter in spectrum space outside the limits of its assigned channel. A method for measurement of total distortion (as a signal-to-distortion ratio) is described in paragraph 91. The standard and an alternate method of waveform analysis are discussed in *a* through *d* below. Waveform analysis as a measure of intermodulation distortion is described in paragraph 92.

a. The test procedure for detecting non-linearity in an ssb transmitter is to apply a two-tone test signal to the transmitter input terminals and to measure those newly generated frequencies (spurious responses) that appear within or near the assigned channel pass band. Those frequencies which are most troublesome are the odd-order (third order is most prevalent) products which result from the intermodulation of the components of the two-tone test signal (either in the transmitter audio amplifiers or in the radiofrequency stages). The third-order intermodulation products appear at locations on both sides of the two-tone test signal in the transmitter output spectrum (fig. 101). Each third-order product is spaced from the adjacent test signal by a frequency that represents the difference

frequency between the two test signals. Signal to third-order intermodulation distortion is evaluated as a ratio by comparison of the amplitude of one of the equal amplitude test signals with the amplitude of either third-order product.

b. Analysis of an ssb transmitter-output frequency spectrum is best made by using a *radiofrequency* spectrum analyzer. This method of spectrum analysis is considered the standard method since the test equipment is specifically designed as a complete unit for waveform component measurement; no auxiliary radio receiver is required to perform a waveform analysis. An alternate method of waveform analysis is performed after the transmitter-output frequency spectrum is amplified and demodulated in a high-quality radio receiver and the audiofrequencies are displayed on the screen of an audiofrequency spectrum analyzer. The distortion components of the measured audiofrequencies are of the same relative amplitude and frequency separation as the equivalent components of the transmitter-output frequency spectrum.

c. For either the standard or the alternate method of distortion measurement, a two-tone test signal is required to drive the transmitter amplifiers. The test signal is a combination of the output frequencies of two sinusoidal oscillators properly isolated from each other to minimize intermodulation at the two-tone

source. The two frequencies that comprise the two-tone test signal are adjusted to equal amplitudes. The individual frequencies are selected in compliance with the characteristics of the particular transmission system.

d. In the standard method, a sample of the transmitter-output power is applied to the test equipment through a shielded, connecting cable at a suitable input level. Extreme care is necessary to avoid coupling of frequencies other than the grouping of frequencies that compose the transmitter-output frequency spectrum. The linearity of the measuring set is usually tested by application of a known spectrum. The output of the measuring set is presented as a panoramic display on a calibrated oscilloscope screen. The distortion components can be easily identified in relation to the two-tone test signal in both frequency and amplitude.

91. Signal-to-Distortion Measurement

a. If the principal consideration is the total harmonic distortion (during a single-tone signal test) rather than knowledge of individual distortion components (as during a two-tone signal test), the fundamental-suppression method of measuring distortion is used. In this method, the transmitter-output signal is demodulated and applied to a network that suppresses the fundamental component and passes the harmonic frequencies with negligible attenuation. A thermocouple or a square-law electronic voltmeter serves as the indicating device; the rms value of all the harmonic components is indicated on the meter.

(1) A number of networks can be used for removing the fundamental frequency. One such network is a high-pass filter, which attenuates the fundamental to a negligible amplitude but passes the harmonic frequencies. A bridge circuit may also be used for fundamental suppression. When the bridge is tuned to balance at the fundamental frequency, a meter placed across the null points indicates the rms value of the harmonics (for which the bridge is unbalanced).

(2) Distortion meters which operate on the principle of fundamental suppression

are simple and relatively inexpensive but cannot be used when the amplitudes of the individual distortion components are to be measured. However, a network that suppresses the fundamental frequency can be used to advantage in combination with other types of analyzers, such as tuned circuit and heterodyne meters. Two benefits are gained; the reduction of the amount of harmonic distortion generated in the analyzer itself, and the less stringent selectivity requirements. These benefits are important when frequency drift of the signal is being analyzed.

b. A simplified block diagram of a fundamental-suppression analyzer is shown in figure 95; a front panel view appears in figure 96. The analyzer consists of two major circuits: a frequency selective amplifier and a vacuum-tube voltmeter circuit.

(1) *Frequency selective amplifier.* The frequency selective amplifier section consists of a preamplifier, a Wien bridge circuit, and a bridge amplifier. The preamplifier amplifies the incoming signal and passes it to the bridge. The bridge may be switched in or out of the circuit as required. When switched into the circuit, it is tuned to reject the fundamental frequency of the incoming signal and allows all of the remaining harmonics to pass through the bridge amplifier. When it is switched out of the circuit, all frequencies in the incoming signal are passed from the preamplifier directly to the bridge amplifier. The bridge amplifier amplifies the output of the bridge when the bridge is switched into the circuit and functions as additional stages of amplification when the bridge is switched out of the circuit. The bridge is responsive to input signals having fundamental frequencies from 20 to 20,000 cps. When the analyzer is used for making distortion readings, the bridge is first switched out of the circuit. A reference reading is obtained

on the meter in the voltmeter circuit; then the bridge is switched into the circuit and tuned to reject the fundamental frequency and thus allow the remaining harmonics to be measured. The meter reading obtained is then the percent of distortion, or the difference in db between the fundamental frequency and its harmonics.

- (2) *Vacuum-tube voltmeter.* The vacuum-tube voltmeter section consists of a voltage amplifier, a meter rectifier circuit, and a meter. The voltage amplifier amplifies the output of the bridge amplifier and applies this amplified ac voltage to the meter rectifier circuit. The meter rectifier circuit provides the dc voltage required to actuate the meter. The meter is usually calibrated in both rms volts and decibels.

92. Waveform Analysis

Spurious responses that appear outside of the transmitter pass band consist mainly of harmonics of the fundamental signal frequencies, products of frequency synthesis and frequency translation, and broadband noise. Since, in the filter method of ssb generation, modulation is performed at a low frequency, subsequent translation to the final transmitter-output frequency introduces many undesired mixer products. Usual equipment characteristics show these responses to be from 70 to 80 db below the desired signal output. Broadband noise does not normally cause interference on the assigned transmitter channel; particularly severe noise can cause adjacent channel interference. Another and most important undesired transmitter power output contains spurious component frequencies inside or very close to the assigned channel pass band. These in- or

near-band frequencies are a result of intermodulation distortion which appears because of nonlinear operation of the transmitter amplifiers.

a. The procedure for producing and measuring intermodulation distortion is to introduce two tones of equal amplitude at the transmitter input (two-toned test signal) and to measure the amount of variation from a normal two-tone test pattern on an oscilloscope or determine the location and relative amplitude (referenced to either of the two modulating tones) of the distortion products on a panoramic indicator (fig. 97). Although any two tones can comprise a two-tone test signal, resolving intermodulation products at many possible frequency ratios is difficult. A three-to-five frequency ratio produces distortion products that are easily identifiable.

b. Since a two-tone test signal is a standard test signal for determining output power and intermodulation distortion in an ssb transmitter, it is pertinent at this point to describe a simplified audio two-tone test generator before beginning a description of panoramic display waveform analyzers. The generator shown in simplified block form in figure 98 consists of two highly stable and accurate audio oscillators, the outputs of which are amplified, filtered, and combined to form the two-tone test signal. The output of each audio amplifier is amplified and passed through a low-pass filter to remove harmonics (second harmonic is most predominant) of the desired tone that may be generated in the amplifiers. For this purpose, the low-pass filter in the path of the 1,500-cps signal has a 2-kc cutoff (to remove a 3-kc second harmonic). The low-pass filter in the 2,500-cps line cuts off at 3 kc and attenuates the 5-kc second harmonic. Isolation pads (not shown) at each input to the combining network minimize possible intermodulation between the

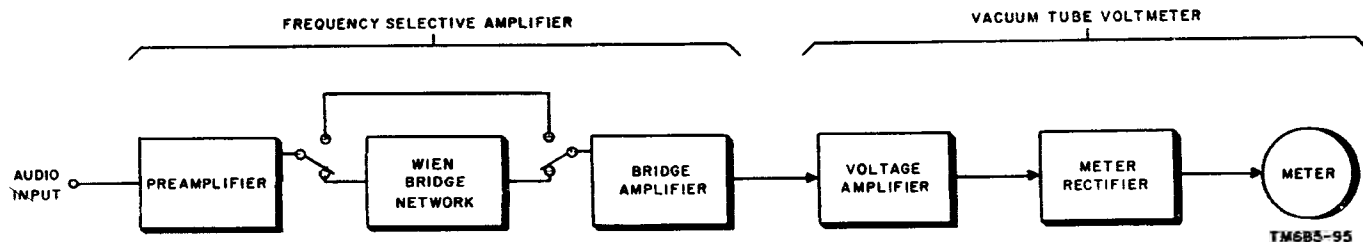
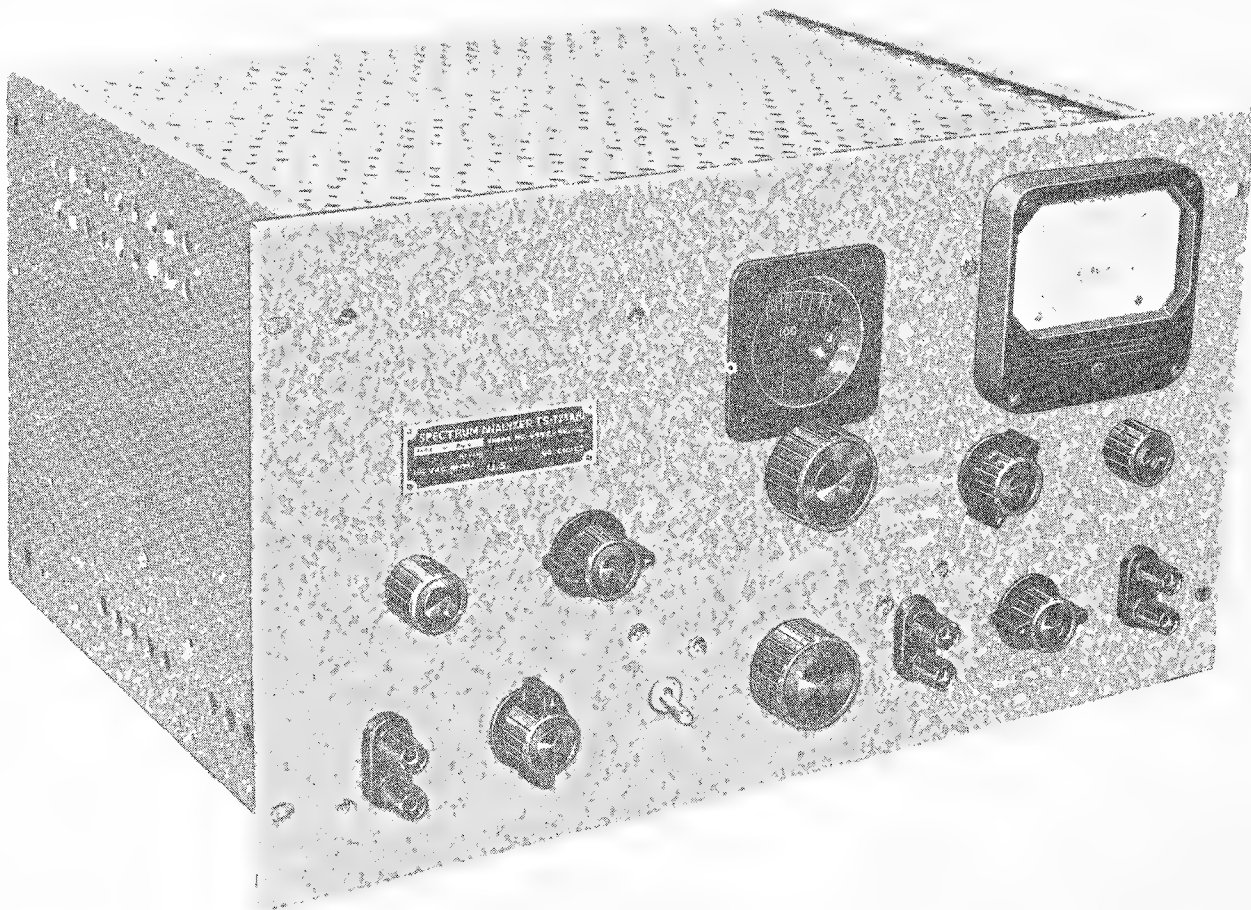

Figure 95. Fundamental-suppression analyzer, block diagram.



TM685-96

Figure 96. Fundamental-suppression analyzer.

frequencies from the two amplifiers. Step attenuators (usually 1- and 10-db per step) between the combining network and the generator output terminals provide for intermodulation distortion measurements at a variety of progressively increasing or decreasing two-tone levels. A practical generator can provide a 100-db range of attenuation where a 3-volt maximum output per tone can be reduced to 30 microvolts.

93. Panoramic Waveform Analyzer

A panoramic waveform analyzer, commonly called a panoramic indicator or spectrum analyzer, is a test instrument that uses automatic-scanning, superheterodyne-type circuits for visual analysis of both the frequency and amplitude characteristics of one or more rf signals. These signals, referred to as test signals, are fed directly to an input jack of the indicator unit through a coaxial cable. The signal being examined appears as a single pip or a group of pips on the cathode-ray (crt) screen (fig. 97B). The horizontal axis of the trace represents frequency, and the vertical axis represents amplitude. A calibrated scale on the face of the crt enables interpretation of the frequency and amplitude characteristics of the test signals. The width or band of frequencies displayed can be adjusted continuously to enable separation of two or more closely re-

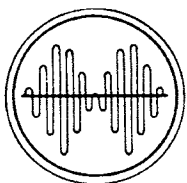

A. AS OBSERVED ON AN OSCILLOSCOPE

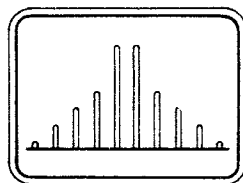

B. AS OBSERVED ON A PANORAMIC INDICATOR
TM685-97

Figure 97. Ssb transmitter-output signal during two-tone test.

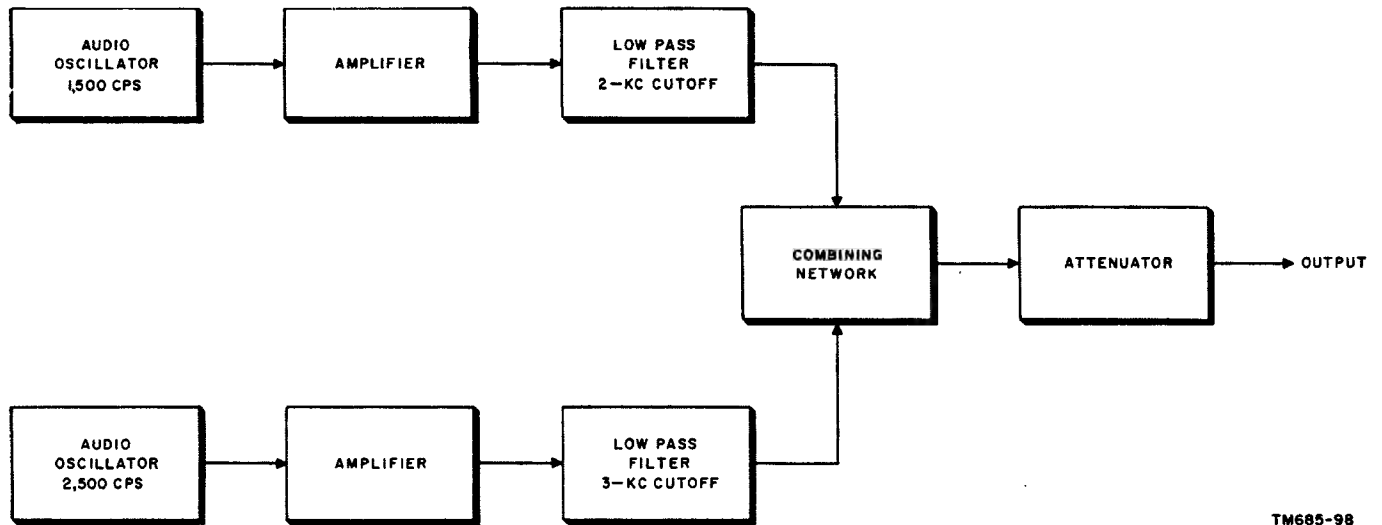

TM685-98

Figure 98. Two-tone test generator (audio), block diagram.

lated signal deflections. A typical panoramic indicator is illustrated in figure 99.

a. The simplified block diagram in figure 100 illustrates a typical panoramic indicator configuration. A calibrated external oscillator or signal generator is used with the panoramic indicator to translate the test signals to conform to the input pass band of the indicator. The frequency of the external oscillator signal at which the signal deflection appears allows the operator to determine the frequency of the test signal. The external oscillator is connected by a coaxial cable to the same input stage of the indicator as the test signal but through a separate input jack. The input stage of the indicator unit is mixer A, where the external oscillator signal and the test signal are heterodyned to produce a beat-frequency difference output. The beat-frequency products are coupled from mixer A through the bandpass circuits to mixer B. A frequency-modulated oscillator signal is also applied to mixer B. The frequency-modulated oscillator signal and the beat-frequency difference signal from the bandpass circuits are mixed and produce beat-frequency sum and difference outputs. The beat-frequency difference signal is selected, amplified in the if. amplifier detected, amplified in the video amplifier, and applied to the crt deflection circuits. The sawtooth voltage output of the sweep oscillator is applied to the crt deflection circuits to provide the horizontal sweep for the crt electron beam. The sweep oscillator

also controls the rate and amount of the frequency deviation at the frequency-modulated oscillator. This dual usage of the sweep oscillator provides the necessary synchronization which results in a fixed screen display.

b. When the calibrated external oscillator is tuned so that the heterodyning of the external oscillator signal and the test signals in mixer A results in the proper beat-frequency differences (for the particular panoramic indicator), a signal deflection appears at the calibrated center marking of the crt screen. Other test signals present at the input will simultaneously appear as signal deflections on either side of the center frequency marking, if the signals occur within the frequency range calibrated on the indicator screen.

c. If a two-tone test signal comprised of equal amplitude tones at 1,000 cps and 1,575 cps is applied to a transmitter under test, the display on a panoramic indicator screen will appear as illustrated in figure 101. Although the relative amplitudes in the display depend on the amount of third-order intermodulation in the transmitter, the distortion frequency components depend solely on the frequencies of the two tones selected as the test signal. The lower third-order intermodulation frequency is separated from the lower test signal tone by the difference frequency between the two tones. The upper third-order intermodulation frequency is above the higher test signal tone by the difference frequency. For a 1,000-cps and

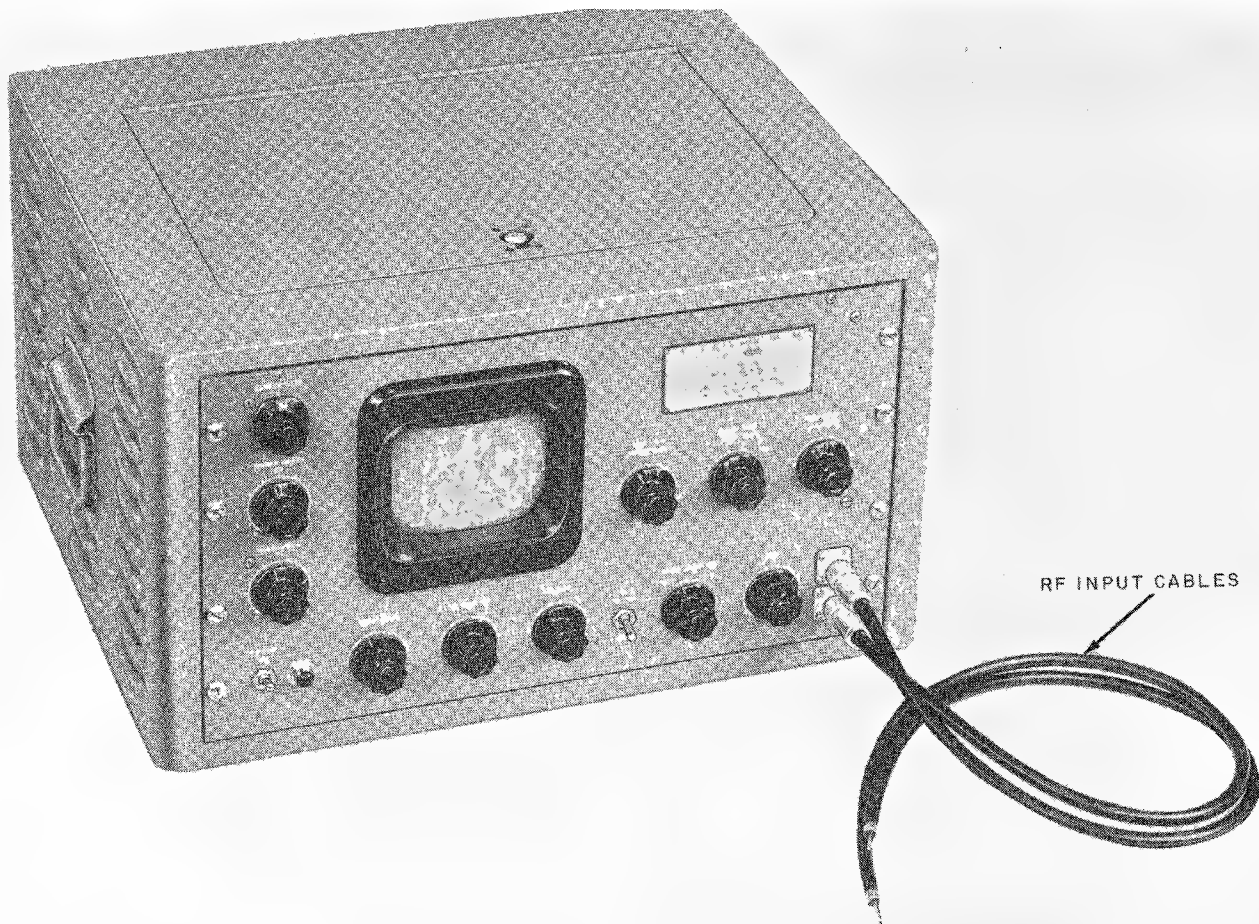

TM685-99

Figure 99. Panoramic indicator.

1,575-cps two-tone test signal, the difference frequency of 575 cps results in third intermodulation products at 425 cps and 2,150 cps from the carrier frequency.

94. Signal-to-Noise Test

a. In the performance of a signal-to-noise test, the transmitter carrier level is reduced to a minimum and an audio signal is applied to the input at a level sufficient to drive the transmitter to the required output. The audio signal frequency is selected to provide a transmitter-output frequency in the upper part of the nominal transmitter band. The audiofrequency is chosen so that harmonics of its frequency will fall outside the transmitter band.

b. A panoramic indicator is the standard equipment for measuring noise components in relation to the desired output. The analyzer must have sufficient stability, selectivity, and sensitivity to resolve and measure noise com-

ponents which are adjacent (in frequency) to the desired output signal. A measurement of all noise components in the nominal transmitter band is obtained and converted to a power figure. The ratio of the power in the desired output to the power in the undesired noise components forms the numerical signal-to-noise ratio at the specified transmitter power output level. The numerical ratio is normally converted to a db figure.

c. Other methods of measuring signal-to-noise ratio may be used. One alternate method uses an ssb receiver, with the required stability and low-noise characteristics, to sample the transmitter-output spectrum. The receiver output signal level is measured on an rms voltmeter. A highly selective filter circuit is then inserted between the receiver output and the voltmeter to remove the signal frequency energy so that only the noise energy is indicated on the voltmeter. The ratio of the two

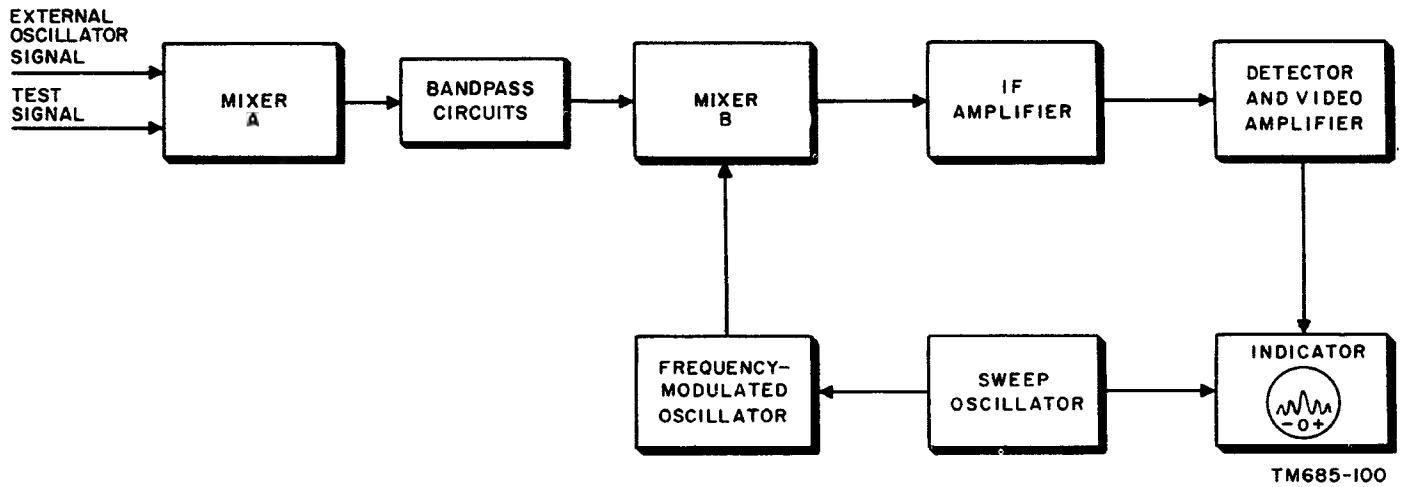

Figure 100. Panoramic indicator, simplified block diagram.

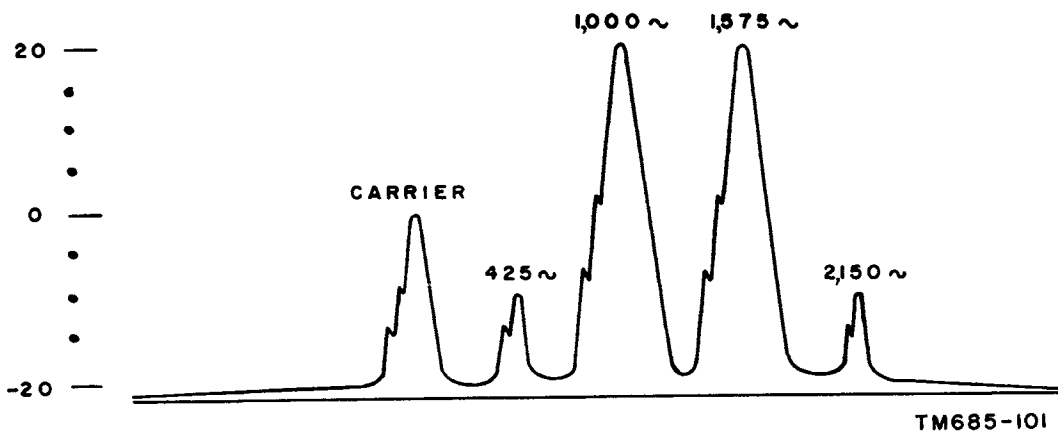

Figure 101. Panoramic display of two-tone test for intermodulation distortion.

readings, converted to power terms, is the signal-to-noise ratio. The receiver bandwidth must be greater than the nominal transmitter band so that no noise components are attenuated.

95. Ssb Transmitter Monitoring

Transmitter monitoring provides a continual check on the quality of the transmitter emission under actual operating conditions. Most large ssb transmitters have monitoring circuits and metering devices that are an integral part of the equipment. These monitoring devices sample the products of a variety of circuits within the transmitter to detect deviations from the normal indications. The monitoring device commonly used for sampling transmitter circuit products is the oscilloscope. An oscilloscope can be used to monitor the output of an ssb transmitter and to determine the amount

and cause of distortion by comparing the observed screen display to the optimum waveform expected at the point of measurement.

a. *Two-Tone Test Ssb Transmitter-Output Waveforms.* The oscilloscope screen displays in figure 102 represent typical waveforms (optimum and distorted) when the ssb transmitter under test is modulated by a two-tone test signal. The optimum waveform for a properly operating transmitter appears in A. In B, excessive grid bias on one or more linear amplifiers produces the distorted waveform shown by the solid-line portion of the pattern. In all the distorted displays in the figure, the broken-line waveform superimposed on the solid-line distortion pattern is the optimum waveform of A. The distortion in C occurs when either the linear amplifier is overdriven (signal in excess of normal) or the amplifier output loading has changed from the proper or design loading.

Display D is a result of a combination of the defects that cause the distorted waveforms of B and C. If the audio is distorted in the audio amplifiers that precede the balanced modulators, the display in E will be the transmitter-output waveform.

b. Testing Phase Shift and Linearity in Linear Amplifier. An alternate method to the method in *a* above, provides an oscilloscope trace which indicates the phase shift and linearity in a linear amplifier. This method uses the test setup illustrated in A, figure 103. In the lower half of the figure are typical patterns that are possible under a number of malfunctioning conditions that affect proper ssb transmitter operation and produce distortion in excess of the negligible amount in a normal transmitter emission. Oscilloscope connections are made to the input and output of the linear amplifier under test (as illustrated). For the following patterns, a single tone is applied to the balanced modulator of the transmitter. The trace in B is the optimum pattern that is observed under the test conditions where no phase shift other than the normal 180° amplifier inversion is noted and optimum linearity exists in the amplifier. The pattern in C is an elliptical trace which is an indication of a phase shift in addition to the normal amplifier inversion. This pattern may also be due to a phase shift caused by the connection of the oscilloscope to the linear amplifier input and output circuits. When the test setup provides a continuous monitoring of a normally operating linear amplifier to detect subsequent changes, various resistor and capacitor combinations are first tried at the oscilloscope to obtain the optimum pattern. In D, either a signal level in excess of the normal is being applied at the input of the linear amplifier or the amplifier output loading has changed. The pattern in E is a result of the application of grid bias (to the linear amplifier) in excess of normal operating bias. The pattern in F is a result of a combination of the defects in D and E.

c. Monitoring Phase-Shift Ssb Transmitter. The test setup illustrated in figure 104 shows the application of an oscilloscope when monitoring a phase-shift ssb transmitter. As shown in block form in the figure, one of the balanced modulators (balanced-modulator B) is disabled

and a sample of the audio signal to the operating balanced modulator (balanced-modulator A) and a sample of the output signal of the linear power amplifiers are applied to the horizontal and vertical terminals of the oscilloscope. The oscilloscope patterns observed are double trapezoid and are an indication of transmitter performance. The connections of the oscilloscope are similar to connections for modulation percentage measurement in an amplitude-modulated transmitter. The individual trapezoids of the double-trapezoid patterns characterize proper or abnormal circuit operation. The patterns in figure 105 can be interpreted to indicate malfunctions in the transmitter. The optimum pattern appears in A. Excessive grid bias on one or more of the linear amplifiers can result in the curvature of the normally straight slopes (solid-line trace in B, of figure). The broken-line trace superimposed on the distortion trace is the optimum pattern and is for comparison purposes. In C, excessive signal drive at the linear amplifier input or improper output loading results in peak clipping of the double-trapezoid pattern. Incomplete carrier elimination caused by an unbalance in balanced-modulator A is illustrated in D. Balanced-modulator B can be tested by transferring the oscilloscope horizontal probe to the input of balanced-modulator B and activating that modulator while balanced-modulator A is disabled.

96. Carrier Balance Adjustment

A balanced modulator performs two functions in an ssb transmitter. It provides a dsb output and also suppresses the carrier frequency. (A desired level of carrier is reinserted, beyond the modulator, for reduced carrier operation.) Although a well-designed balanced modulator readily depresses the carrier to a level about 10 to 15 db below the sideband level, adjustments are required to obtain the necessary 35- to 40-db suppression for satisfactory suppressed-carrier ssb operation. These adjustments are built into the modulator to compensate for component values which may vary with environmental conditions (temperature, humidity, etc). The adjustments are made under operating conditions.

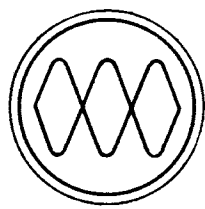

A. OPTIMUM WAVEFORM

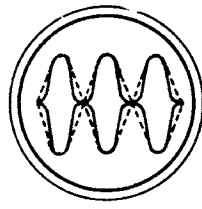

B. EXCESSIVE GRID BIAS

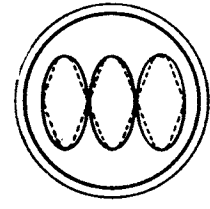

C. EXCESSIVE SIGNAL DRIVE OR IMPROPER LOADING

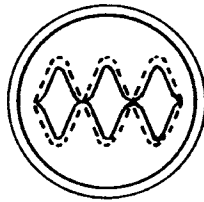

D. COMBINATION OF B AND C

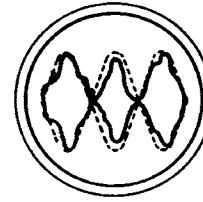

E. AUDIO DISTORTED

TM685-102

Figure 102. Possible two-tone test outputs of linear amplifier.

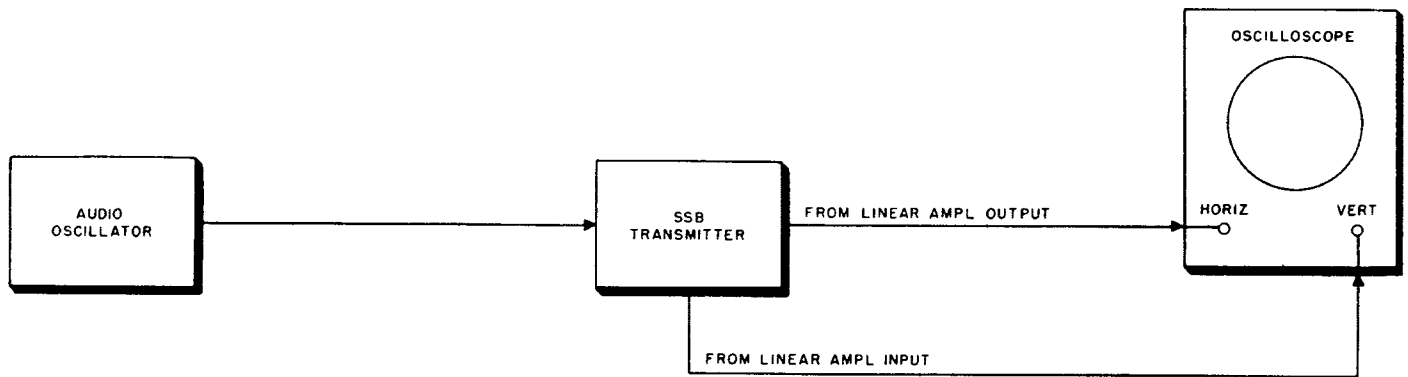

A TEST SETUP

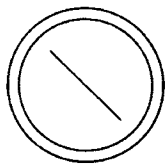

B. OPTIMUM PATTERN

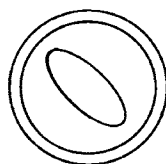

C. ADDITIONAL PHASE SHIFT

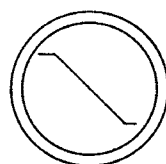

D. EXCESSIVE SIGNAL DRIVE OR IMPROPER LOADING

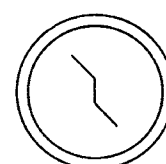

E. EXCESSIVE GRID BIAS

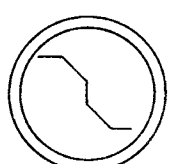

F. COMBINATION OF D AND E

TM685-103

Figure 103. Test setup for linear amplifier monitoring with possible scope patterns.

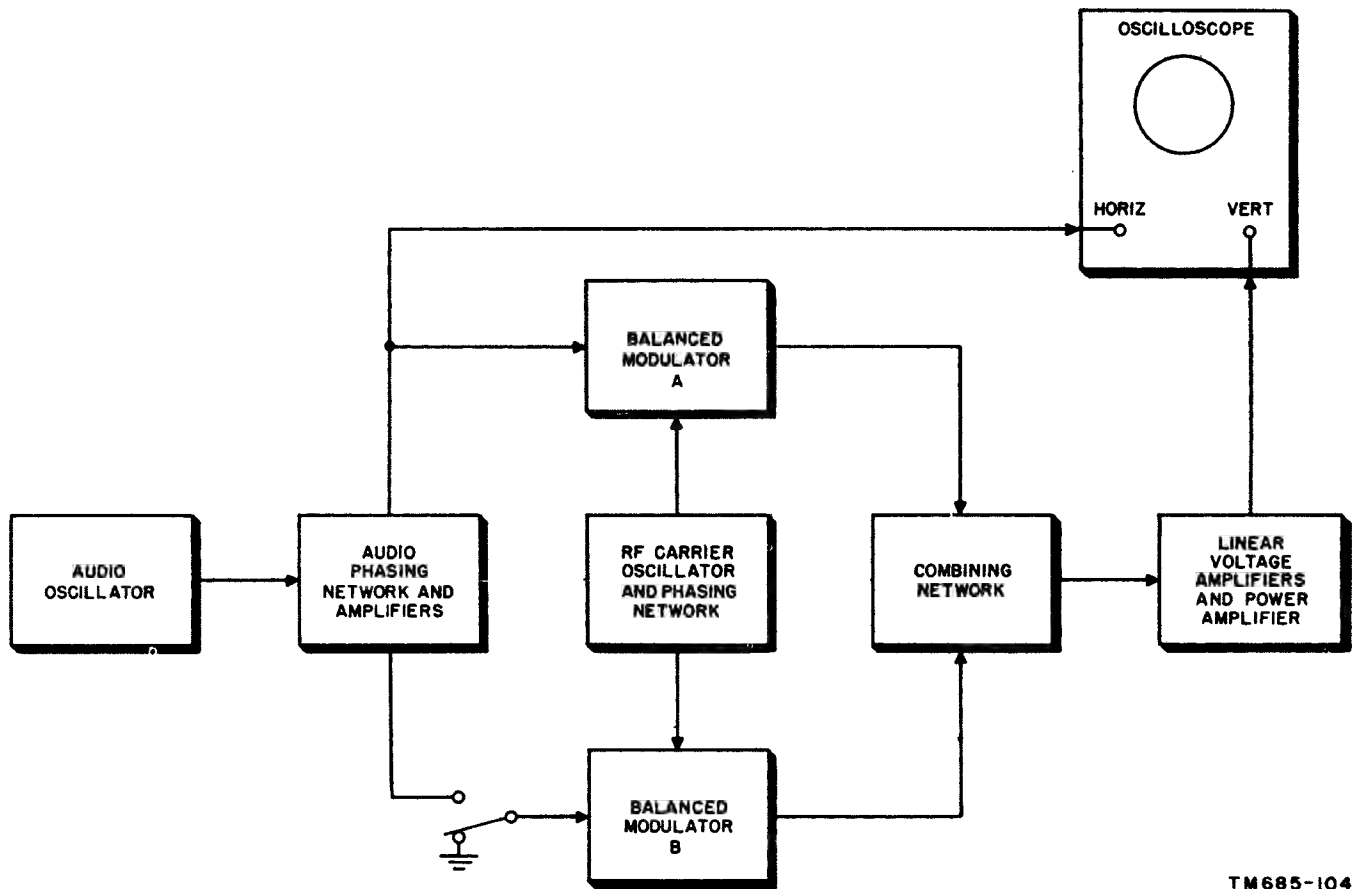

TM685-104

Figure 104. Test setup for obtaining double-trapezoid test patterns, block diagram.

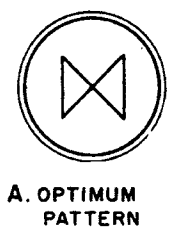

TM685-105

Figure 105. Double-trapezoid patterns observed on phase-shift ssb transmitter.

a. Carrier balance can be adjusted by use of the test setup illustrated in figure 106. An audio oscillator that produces a single tone (about 1,000 cps) modulates the ssb transmitter under test to provide a single radiofrequency suppressed-carrier output (no reinserted carrier). The ssb transmitter exciter output signal is coupled to the antenna of an am. receiver. The am. receiver must be capable of tuning to the output frequency of the exciter.

b. The principle involved in this test setup is the use of the normal characteristics of am. demodulation to furnish an indication of maximum transmitter carrier suppression. A carrier frequency signal is necessary to demodulate properly a signal introduced into an am. receiver. When the carrier is removed and only the sideband is applied to an am. demodulator, no audio tone is produced. Also, the level of the demodulated tone varies directly as the level of the carrier component.

c. To proceed with the carrier balance adjustment, the audio oscillator output level is set to meet the requirement as specified in the technical characteristics of the transmitter under test. The audio output level at the am. receiver is adjusted to a comfortable listening level; then, varying the balance adjustments on the balanced modulator provides a null in the level of the tone at the receiver output. The receiver output can be metered with an ac meter for a more exact null.

97. Sideband Suppression Measurement

The amount of sideband suppression in an ssb transmitter can be measured with a fair degree of accuracy by using the test setup illustrated in A, figure 107. In this test setup, a single tone derived from an audio oscillator is applied to the input of the ssb exciter; the output rf signal from the exciter is fed to the vertical input terminals of an oscilloscope (the

connection from the exciter input to the sync terminal of the oscilloscope provides a steady pattern). A properly operating suppressed-carrier ssb transmitter, modulated with a single audio tone, produces a single audiofrequency pattern on the oscilloscope screen (B, fig. 107). When the undesired sideband is not completely suppressed, a multiple frequency signal is displayed as a waveform similar in appearance to the pattern in C. Before performing a test for sideband suppression, check for proper carrier balance (para 96). The presence of carrier in the exciter output signal results in a waveform that can be misinterpreted as insufficient sideband suppression. The audio test oscillator output must be free of harmonics and the audio signal to the exciter maintained at a low level to minimize the possibility of producing distortion in the audio amplifiers of the exciter. Audio distortion produces an ssb exciter output waveshape that is multifrequency in composition.

98. Ssb Receiver Testing

Of primary importance in the adjustment and testing of an ssb receiver is the use of a highly accurate signal generator to generate the necessary test signals. Signal generators are available that can produce either upper or lower sideband frequencies and continuously variable, highly accurate and stable carrier frequencies. These generators can be used to test the fixed bandpass of the mechanical or crystal filters and to align the radiofrequency and intermediate-frequency circuits to provide the required pass band. When a measurement of the local reinsertion oscillator frequency is indicated during a troubleshooting procedure, a counter-type frequency meter (para 87b) can be used.

a. *Carrier Reinsertion Frequency and Reference Oscillator.* Replacement of tubes or components in the carrier reinsertion or reference

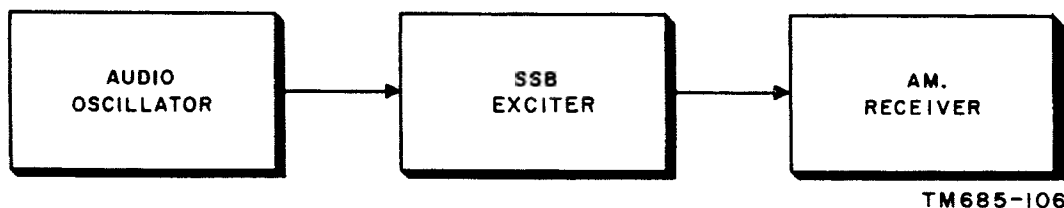
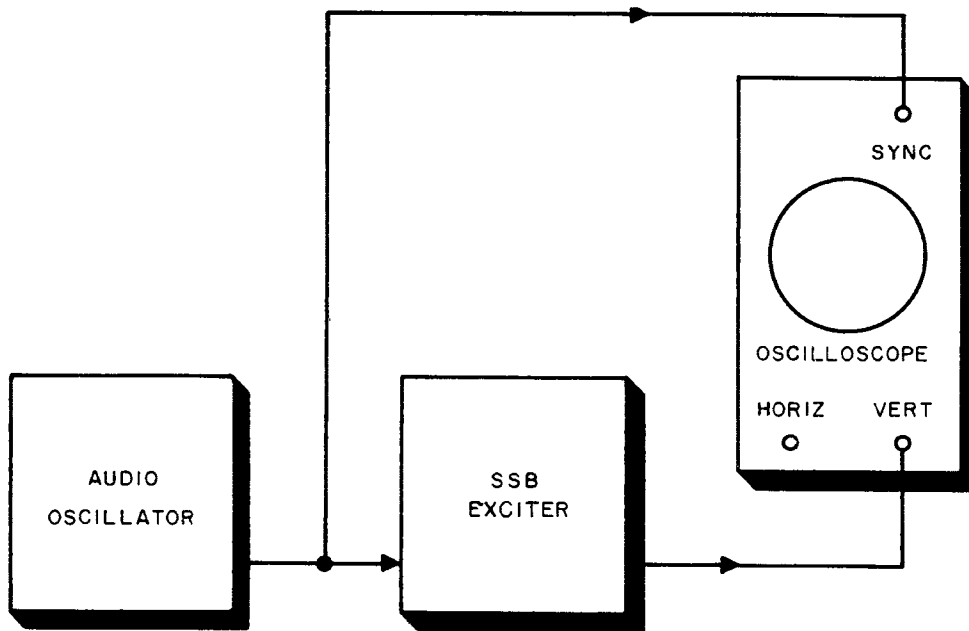
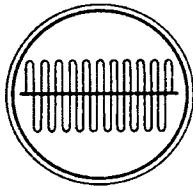

Figure 106. Test setup for adjustment of carrier balance.



A. TEST SETUP



B. COMPLETE SIDEBAND SUPPRESSION

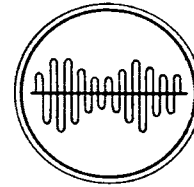

C. INCOMPLETE SIDEBAND SUPPRESSION

TM685-107

Figure 107. Test setup for measuring sideband suppression with observed waveforms.

oscillator (heterodyne oscillator frequencies are referenced to this oscillator) requires a check of the oscillation frequency. This check is usually made with a counter-type frequency meter, and adjustments are made to correct a deviation from the proper operating frequency. A trimmer capacitor, normally part of the reference oscillator, provides a small variation in frequency to compensate for changes in reference oscillator component values or environmental conditions. In ssb receivers that are equipped to receive pilot or reduced carrier ssb signals, the carrier reinsertion frequency is adjusted to correspond to the center frequency of

the carrier filter pass band. This method of reference oscillator adjustment is required, because the center frequency of the carrier filter (at the carrier takeoff point in the receiver) determines the carrier reinsertion frequency. When reference oscillator tests and adjustments are performed, sufficient warmup time is necessary to establish stable operating conditions for both the reference oscillator and the test generator.

b. Heterodyne Oscillators. The heterodyne oscillators provide the locally generated mixing frequencies for heterodyning or beating the in-

coming signal down to sideband frequencies about the local carrier reinsertion frequency. The heterodyne oscillators are usually *locked* to the local reference oscillator frequency through an automatic frequency control (afc) feedback loop. A difficulty traced to the heterodyne oscillators can be caused by faulty afc operation.

c. Intermediate-Frequency Amplifiers and Filters. Ssb IF amplifier alignment procedures are similar to those for am. alignment, with an additional IF response characteristic limitation. In an ssb receiver, the response of the filters (electromechanical or crystal) determines the pass band of the IF section. The IF tuned circuits are adjusted to pass the band of frequencies passed by the filters. In an ssb receiver designed to receive both suppressed- and pilot-carrier upper and lower sideband signals, three filters are used. Two of the filters pass the upper and lower sideband signals and the third filter is centered at the carrier frequency. The carrier frequency filter is usually designed to have a bandpass of approximately 20 cycles. This very narrow bandpass is necessary to avoid introduction of sideband signal into the carrier amplifier circuits. No attempt should be made to adjust electromechanical filters. A fault in receiver response localized to an electromechanical filter is sufficient reason for filter replacement. Although crystal filters normally allow for slight adjustments (small trimmer capacitors or variable inductors), any change to these adjustable components must be made with the proper and accurate signal-generating and response characteristic display equipment. The frequency response characteristic must follow the exact shape and frequency limits illustrated in the technical literature for the particular filter.

d. Balanced Demodulators. A balanced demodulator, as is true of a balanced modulator, depends on the degree of balance for proper operation. The effects of unbalance are a rise in demodulator output noise level and the production of spurious signals (heterodyning of unwanted signal components). To adjust the balance of a balanced demodulator, remove the sideband signal from the demodulator input, disable the signal input circuits, and vary the carrier balance controls for minimum noise at the demodulator output. This noise is a result

of mixing of the carrier with components of noise adjacent to the carrier. After adjusting for proper balance on the carrier signal, remove the carrier, disable the carrier injection input to the balanced demodulator, and reinsert the sideband. The adjustment control settings for balance with only a carrier signal input should also give minimum noise output for the sideband input. Product demodulators are checked out in the same manner as balanced demodulators. When the signals (sideband and carrier) to a product demodulator are applied separately, each signal is affected by a constant transfer characteristic and is thus amplified linearly in the absence of the other signal. The output signal is then an RF signal which is by-passed in the low-frequency output circuits. Noise output results from nonlinear operation of either signal amplifier section of the product demodulator. Balance can be effected by removing the signal from either injection grid and adjusting for minimum noise output and then switching the procedure to check the remaining grid.

e. Carrier Amplifier and Limiter Circuits. The purpose of adjustment procedures in carrier amplifier and limiter circuits is to provide sufficient carrier signal to the demodulator and thus furnish noise-free intelligence at the demodulator output. Carrier signal applied to the demodulator is maintained at a constant level by the limiters to avoid injection of too high a level on strong signals. High-level carrier signals to the demodulator decrease the signal-to-noise ratio at the output; therefore, the carrier signal should be tested at the demodulator input to determine its level as related to the sideband signal level. The proper ratio is about 10 units of carrier signal to 1 unit of sideband signal at the demodulator inputs. A fault which appears as low-carrier signal level at the demodulator should be traced back through the limiters and carrier amplifiers. Automatic gain control (agc) is obtained by sampling the carrier signal level (before limiting) and, through a dc feedback loop, controlling the gain of the IF and rf stages in the receiver. This agc voltage can be interpreted as an indication of carrier signal level and may be used as a guide to determine the condition of the carrier amplifier circuits.

f. Distortion in RF Amplifier. The signal level input to an ssb receiver is usually controlled to prevent overdriving of the RF amplifier and the generation of distortion components (spurious responses) because of intermodulation or cross modulation. Intermodulation distortion results when two or more signals are mixed in the RF amplifier. This distortion can be caused by either nonlinear amplifier operation or overdriving (too strong signals) of the RF amplifier. Cross modulation results when the carrier or sidebands are modulated by the sidebands of an adjacent channel. (Cross modulation can also occur during independent sideband reception.) Most of the effects of overdriving of the RF amplifier are minimized by controlling the signal input level to the amplifier. Many ssb receivers use an attenuator between the antenna and the RF amplifier input circuits to reduce these effects. The proper setting of the attenuator prevents overdriving of the RF amplifier during reception of high-level signals. A switch which selects different agc filter time constants is also used as an aid

to reduce distortion. Overdriving is also damaging to ssb reception, because the carrier reinsertion signal at the demodulator is maintained at a constant level by the carrier limiters (*e* above); thus, a sideband signal level increase results in a demodulator output signal that is similar to reception under a condition of overmodulation in an am. system.

g. Independent Sideband Reception. The foregoing discussion on ssb receiver testing also applies to independent sideband reception. Since the two sidebands containing separate intelligence are separated at a point preceding the demodulators, equal gain beyond this point is a prime consideration. Tubes and circuits that follow the point of separation can cause different level signals at the receiver output and should be checked when an inequality exists. Crosstalk between sidebands can be caused by cross modulation in the RF circuits or by leakage (because of the insufficient shielding or decoupling) beyond the sideband separation point.

GLOSSARY

- Active electric network*—An electric network containing one or more internal sources of energy.
- Antenna matching*—The process of adjusting impedances so that the impedance of an antenna equals the characteristic impedance of its transmission line.
- Antenna matching device*—A device that matches the antenna to its transmission line by introducing an impedance which, together with the impedance of the antenna, equals the characteristic impedance of the line.
- Attenuator*—An adjustable network, usually calibrated, for reducing the amplitude of a wave without causing appreciable distortion.
- Automatic frequency control (afc)*—The control of the frequency of an oscillating circuit within a given range. Usually control of local oscillator frequency as a means of keeping the receiver accurately tuned.
- Automatic gain control (agc)*—A type of circuit used to maintain the output of a receiver constant, regardless of variations in the signal strength applied to the receiver.
- Average power output*—In a transmitter, the RF power delivered to the transmitter output terminals averaged over a modulation cycle.
- Bandpass (bandwidth)*—The number of cycles per second expressing the difference between the limiting frequencies at which the desired fraction (usually half power) of the maximum output is obtained.
- Bandpass filter*—Filter which allows free passage to frequencies within its designed range, and which effectively bars passage to all frequencies outside that range.
- Bandwidth, nominal*—The nominal bandwidth is the maximum band of frequencies, inclusive of guard bands, assigned to a channel.
- Beat frequency*—One of the two additional frequencies produced when two different frequencies are combined. One of these beat frequencies is the sum of the two original frequencies, and the other is the difference between them.
- Beat-frequency oscillator (bfo)*—An oscillator which produces a desired frequency by combining two other frequencies. This frequency may be an audiofrequency produced by combining two radiofrequencies, or it may be some desired radiofrequency, such as the intermediate frequency of superheterodyne circuit.
- Broad-band interference*—Radio interference energy which is concentrated in wide band of frequencies.
- Carrier*—A carrier is a wave suitable for modulation by the intelligence to be transmitted over a communication system. For ssb purposes, the carrier is a sinusoidal wave.
- Carrier level*—The ratio of the carrier power to the peak-envelope-power. It is normally expressed in db.
- Characteristic impedance*—The ratio of voltage to current at every point along a transmission line on which there are no standing waves.
- Chopper*—A device for interrupting a current at regular intervals.
- Crosstalk*—Crosstalk is the phenomena in which a signal transmitted in one circuit or channel of a transmission system is detectable in another circuit or channel.
- Cross modulation*—A type of crosstalk in which the carrier frequency being received is interfered by an adjacent carrier, so that the modulated signals of both are heard at the same time.
- Decibel (db)*—The unit used to express power, voltage, or current ratios.
- Distortion, total-harmonic* — Total-harmonic distortion is the ratio of the power at the fundamental frequency, measured at the output of the transmission system considered, to the power of all harmonics observed at the

output of the system because of its nonlinearity, when a single frequency signal of specified power is applied to the input of the system. The ratio is normally expressed in db.

Electrostriction—The contraction or expansion of a quartz or other crystal along an electric axis when subjected to an electric field in that direction.

Exalted carrier reception—Exalted carrier reception is a method of receiving either amplitude- or phase-modulated signals in which the carrier is separated from the sidebands, filtered and amplified, and then combined with the sidebands again at a higher level prior to, or at, the demodulation point.

Fading—Fading is the fluctuation in intensity of any or all components of a received radio signal due to changes in the characteristics of the propagation path.

Fading, selective—Selective fading is that type of fading in which the various components of the received radio signal fluctuate independently.

Frequency divider—A device for delivering an output wave whose frequency is a proper fraction, usually a submultiple, of the input frequency.

Frequency stability—The ability of an oscillator to maintain its operation at constant frequency.

Frequency standard—A stable low-frequency oscillator used for frequency calibration. It usually generates a fundamental frequency with a high degree of accuracy, and harmonics or subharmonics of this fundamental provide reference points for the generation of a range of frequencies.

Frequency tolerance—The frequency tolerance is the maximum permissible deviation of the transmitted carrier frequency with respect to the assigned frequency. It is normally expressed either as a percentage of the assigned frequency, in cycles per second, or in parts per million.

Guard band—A guard band is an unused frequency band between two channels to give a margin of safety against mutual interference.

Insertion loss—The insertion loss, in a trans-

mission system, of a component inserted between two impedances is the ratio of the power measured at the output impedance before insertion to the power measured after insertion. It is expressed in db.

Intermodulation—The modulation of the components of a complex wave by each other, producing waves having frequencies equal to the sums and differences of integral multiples of the component frequencies of the complex wave.

Lattice network—A network composed of four impedance branches connected in series to form a closed circuit, two nonadjacent junction points serving as input terminals, while the remaining two junction points serve as output terminals.

Limiter—A limiter is a device which reduces the power of an electrical signal when it exceeds a specified value. The amount of reduction or compression increases with increase of the input power.

Linear amplification—Amplification in which changes in output current are directly proportional to changes in the amplifier exciting voltage.

Magnetostriction—The change in the dimensions of a ferromagnetic object when placed in a magnetic field.

Modulation—Modulation is the process of varying some characteristic of the carrier wave in accordance with the instantaneous value, or samples of the intelligence to be transmitted.

Modulation, amplitude—Amplitude modulation is the form of modulation in which the amplitude of the carrier is varied in accordance with the instantaneous amplitude of the modulating signal.

Modulation, frequency—Frequency modulation is modulation in which the instantaneous frequency of a sine wave carrier is caused to depart from the carrier frequency by an amount proportional to the instantaneous amplitude of the modulating wave.

Modulation, phase—Phase modulation is the form of modulation in which the angle relative to the unmodulated carrier angle is varied in accordance with the instantaneous amplitude of the modulating signal.

Narrow-band interference—Radio interference energy which is concentrated in a narrow band of frequencies.

Neutralization—The method of modifying the effect of spurious feedback in an amplifier.

Noise—Noise is the summation of the unwanted or disturbing power introduced into a communication by system power induction, atmospheric conditions, electronic circuit components, etc.

Noise figure—A term used to rate the noise qualities of radio receivers. It is equal to the ratio between the signal to noise for an ideal receiver and an actual receiver.

Nonlinear—Having an output that does not vary in direct proportion to the input.

Nonsinusoidal waveform—A waveform having a shape other than that of a sine wave.

Passive electric network—An electric network containing no internal source of energy.

Phase shift network—A network for altering the phase of wave applied to it.

Photometer—An instrument for measuring the intensity of a light source or the amount of illumination, usually by comparison with a standard light source.

Piezoelectric—Having the ability to generate a voltage when mechanical force is applied, or having the converse ability to produce a mechanical force when a voltage is applied.

Pilot—In a transmission system, a pilot is a signal wave, usually a single frequency, transmitted over the system to indicate or control its characteristics.

Quadrature—Quadrature expresses the phase relationship between two periodic quantities of the same period when the phase difference between them is one-fourth of a period.

Reference level—The reference level for voice-frequency input power to a single-sideband transmitter is the power of one of two equal tones which together cause the transmitter to develop its full rated power output.

Repetition rate—Repetition rate signifies broadly the number of repetitions per unit time.

Saturable reactor (saturable core reactor)—A magnetic core reactor in which a low value of current produces magnetic saturation of the

core, thereby reducing the effective inductance and reactance above the saturation point. Sometimes called a nonlinear coil.

Servosystem—A complete electromechanical system for amplifying and transmitting accurate mechanical position from one point to another by electrical means.

Spurious response—The response of an electric device at a frequency or frequencies other than the desired frequency of response.

Squelch circuit—A circuit for preventing a radio receiver from producing audiofrequency output in the absence of signal having predetermined characteristics. A squelch circuit may be operated by signal energy in the receiver pass band, by noise quieting, or by a combination of the two.

Standing wave—A distribution of current and voltage on a transmission line formed by two sets of waves traveling in opposite directions, and characterized by the presence of a number of points of successive maxima and minima in the distribution curves. Standing waves indicate that power is being lost in transmission; therefore, efforts are made to keep standing waves to a minimum.

Standing-wave ratio—The ratio of current (or voltage) at a loop (maximum) in a transmission line to the value at a node (minimum). It is equal to the ratio of the characteristic impedance of the line to the impedance of the load connected to the output end of the line.

Thermal noise—Random noise in a circuit associated with the thermodynamic interchange of energy necessary to maintain thermal equilibrium between the circuit and its surroundings.

Toroidal coil or transformer—Coil or transformer wound on a closed circular core.

Transducer—A device that transfers or changes one type of energy into another form. An example is a loudspeaker, which changes electrical energy into acoustic (mechanical) energy.

Transfer characteristic—A relation, usually shown by a graph, between an electrode voltage and current, other electrode voltages being maintained constant.

Transmission, double-sideband—Double-sideband transmission is that method of com-

munication in which the frequencies produced by the process of modulation are symmetrically spaced both above and below the carrier frequency and are all transmitted.

Transmission, independent sideband—Independent sideband transmission is that method of communication in which the frequencies produced by the process of modulation on opposite sides of the carrier are not related to each other, but are related separately to two sets of modulating signals. The carrier frequency may be either transmitted or suppressed.

Transmission, single-sideband — Single-sideband transmission is that method of communication in which the frequencies produced by the process of modulation on one side of the carrier are transmitted and those on the other side are suppressed. The carrier

frequency may be either transmitted or suppressed.

Transmission, suppressed carrier—Suppressed carrier transmission is that method of communication in which the carrier frequency is suppressed either partially or to the maximum degree possible. One or both of the sidebands may be transmitted.

Vector—A line drawn from a point and at an angle to a base. It represents the amplitude and direction (phase) of an alternating voltage or current.

Vector diagram—An arrangement of vectors showing the phase relations between alternating quantities.

Zero beat—The condition where two frequencies are exactly the same, and therefore produce no beat note.

INDEX

	Paragraph	Page		Paragraph	Page
Adjustment, carrier balance	96	128	Differences, ssb and am. receiver	49	66
Advantages of ssb:			Distortion testing	90	120
Antenna voltage comparison	8	10	Intermodulation	92a	123
Comparison with fm	11	12	Doppler shift	64	91
Limiting propagation conditions	10	12	Electronic wattmeter	88b	117
Power comparison	7	8	Error detector	47	59
Selective fading conditions	9	10	Exciter:		
Spectrum conservation	12	13	Filter type	23	25
Amplifier, linear	36, 37	44	Phase-shift type	24	26
Amplifier, linear power	42, 43,	49, 50,	Feedback:		
	44	51	Single-stage	44a	51
Analysis, waveform	92	123	Two-stage	44b	51
Analyzer, fundamental suppression	91b	122	Filter, crystal	20	19
Analyzer, waveform	93	124	Filter, mechanical	21	20
Audio signal processing	25	27	Filter, sideband	19	19
Automatic frequency control	60	84	Frequency controls, history	65	92
Automatic gain control	62	87	Frequency deterioration:		
Automatic load control	45	52	Circuit effects	64c	92
Balanced modulator	28	28	Doppler	64a	91
Bridge-stabilized oscillator	68c	94	Propagation medium	64b	92
Carrier:			Frequency divider, regenerative	81, 82	107
Amplifier	57c	80	Frequency measurement	87	113
Filter	57b	80	Frequency meter:		
If. amplifier	57a	80	Counter	87b	114
Limiters	58	80	Heterodyne	87a	113
Carrier balance adjustment	96	128	Frequency modulation, comparison with ssb.	11	12
Clipper	27	28	Frequency synthesizer:		
Conservation, spectrum	12	13	Multiple crystal	74	99
Comparator	43c, 47b	51, 61	Single crystal	75	100
Comparison of ssb and am	7, 8,	8, 10,	Frequency translation:		
	10	12	Mixer fundamentals	32	38
Comparison of ssb and fm	11	12	Mixer types	33	39
Compressor	26	27	Spurious mixer products	34	39
Coarse-positioning control	46c	54	Fundamental suppression analyzer	91b	122
Constant-temperature ovens	72	97	Generating voice waveform	18	17
Control, smo	79	104	Generator, harmonic	83	108
Counter-type frequency meter	87b	114	Generator, ssb	14	14
Crystal filter	20	19	Harmonic generator	83	108
Crystal oscillator	68	73	Heterodyne frequency meter	87a	113
Design	70	96	History:		
Frequency stability	69b	96	Frequency controls	65	92
Power output	69a	96	Ssb communications	3	2
Demodulation, sideband	56	75	Impedance-matching control	47d	63
Demodulator:			Intermodulation distortion testing	92a	123
Lattice- or ring-type	56a	75	Interpolation oscillator	85b	111
Product:			Keyed oscillator	84	109
Pentagrid-converter	56b (2)	77	Lattice-type demodulator	56a	75
Pentode	56b (1)	77	Limiters, carrier	58	80
Triple triode	56b (3)	78			
Derived frequencies	80	105			
Deterioration, frequency	64	91			

	Paragraph	Page		Paragraph	Page
Linear amplification.....	37	44	Power amplifier circuits:		
Linear amplifier:			Grounded cathode.....	42a	49
Linearity test.....	95a	123	Grounded grid.....	42b	49
Rf feedback.....	44	51	Power amplifier, linear.....	42	49
Pentode.....	41a	47	Power amplifier output circuits:		
Phase shift and linearity test.....	95b	128	Comparator.....	43c, 47b	51, 61
Tetrode.....	41a	47	Pi-L network.....	43b	50
Lower sideband IF amplifier.....	55e	75	Power comparison, ssb and am.....	7	8
Linear power amplifier:			Power measurement:		
Basic circuits.....	42	49	Calorimetric method.....	88d	119
Choice of operating point.....	40	47	Directional-wattmeter method.....	88f	119
Choice of tubes.....	41	47	Electronic wattmeter.....	88b	117
Classes of operation.....	39	46	Frequency limitations.....	88c	119
Output circuits:			Photometric method.....	88e	119
Automatic load control.....	45	52	Rf power meter.....	88a	116
Comparator.....	43a, 47b	50, 61	Power meter, RF.....	88a	116
Loading.....	47	59	Power output, crystal oscillator.....	69a	96
Tuning.....	46	54	Power output test:		
RF feedback.....	44	51	Continuous.....	89a	120
Measurement:			Peak-envelope-power.....	89b, c	120
Sideband-suppression.....	97	131	Product demodulator:		
Signal-to-distortion.....	91	122	Pentagrid converter.....	56b (2)	77
Measurement procedures, power output.....	89	120	Pentode.....	56b (1)	77
Mechanical filter.....	21	20	Triple triode.....	56b (3)	78
Miller oscillator.....	68a	94	Propagation medium shifts.....	64b	92
Mixer:			Receiver testing.....	98	131
Fundamentals.....	32	38	Regenerative frequency divider.....	81, 82	107
Types.....	33	39	Rf power meter.....	88a	116
Spurious products.....	34	39	Ring-type demodulator.....	56a	75
Monitoring, ssb transmitter.....	95	127	Selective fading.....	9	10
Modulator, balanced.....	28	28	Sideband:		
Multiple crystal frequency synthesizer.....	74	99	Demodulation.....	56	75
Noise sources:			Filter.....	19	19
Equivalent generators.....	52c	71	Generator:		
Thermal.....	52a	71	Audio processing.....	25	27
Tube.....	52b	71	Balanced modulators.....	28	28
Oscillator:			Clipper.....	27	28
Bridge-stabilized.....	68c	94	Compressor.....	26	27
Circuit analysis.....	67	93	Phase-shift.....	30	33
Interpolation.....	85b	111	Sideband selection.....	29	33
Keyed.....	84	109	Suppression measurement.....	97	131
Stabilized master.....	77, 78, 102, 103,	79, 104	Signal-to-distortion test.....	91	122
Theory.....	66	93	Signal-to-noise test.....	94	126
Output circuits, power amplifier.....	43	50	Single-crystal frequency synthesizer.....	75	100
Automatic load control.....	45	52	Single sideband:		
Comparator.....	43a, 47b	50, 61	Exciter.....	22	25
Loading.....	47	59	Filter type.....	23	25
Tuning.....	46	54	Phase-shift.....	24	26
Output waveforms, two-tone test.....	95a	127	Generator.....	14	14
Over, constant-temperature.....	72	97	History.....	3	2
Over, control, proportional-type.....	72	97	Receiver:		
Panoramic waveform analyzer.....	93	124	Block diagram.....	50	68
Peak-envelope-power measurement.....	89b, c	120	IF amplifier.....	54a	72
Phase-shift exciter.....	24	26	RF section.....	53	71
Phase-shift generator.....	30	33	Second mixer.....	54b	73
Phase-shift test, linear amplifier.....	95b	128	Signal:		
Phase-shift transmitter, monitoring.....	95c	128	Description.....	4	8
Pierce oscillator.....	68b	94	Nature.....	13	14
			Transmitter monitoring.....	95	127

	Paragraph	Page		Paragraph	Page
Single sideband—Continued			Temperature coefficient, quartz crystal	71a	96
Waveform:			Test:		
Single-tone ssb, carrier-suppressed.	16	15	Distortion	90	120
Two-tone ssb	17	16	Receiver	98	131
Single-tone dsb waveform, carrier suppressed.	15	14	Signal-to-noise	94	126
Single-tone ssb waveform, with carrier	16	15	Tuning linear power amplifier	46	54
Sources of noise:			Two-tone ssb waveform	17	16
Equivalent generators	52c	71	Two-tone test output waveforms	95a	127
Thermal	52a	71	Two-tone test signal	92b	123
Tube	52b	71	Upper sideband IF amplifier	55a, b	73, 75
Spectrum conservation	12	13	Voice waveform	18	17
Squelch	61	86	Wattmeter, electronic	88b	117
Ssb and AM receiver differences	49	66	Waveform analysis	92	123
Stabilized master oscillator	77	102	Waveform analyzer	93	124
Block diagram	78	103	Waveform:		
Control circuits	79	104	Single-tone dsb, carrier-suppressed.	15	14
Synthesizer using superheterodyne principle.	76	101	Single-tone ssb with carrier	16	15
			Two-tone ssb	17	16
			Voice	18	17

BY ORDER OF THE SECRETARIES OF THE ARMY AND THE AIR FORCE:

G. H. DECKER,
General, United States Army,
Chief of Staff.

OFFICIAL:

R. V. LEE,
Major General, United States Army,
The Adjutant General.

THOMAS D. WHITE,
Chief of Staff, United States Air Force.

OFFICIAL:

J. L. TARR,
Colonel, United States Air Force,
Director of Administrative Services.

Distribution:

Active Army:

To be distributed in accordance with DA Form 12-7 requirements for TM 11 Series (UNCL) Plus the following formula:

USASA (2)	11-7
CNGB (1)	11-16
Tech Stf, DA (1) except	11-57
CSigO (36)	11-97
DASA (5)	11-117
US ARADCOM (2)	11-155
US ARADCOM Rgn (2)	11-500 (AA-AE) (4)
MDW (1)	11-557
Seventh US Army (2)	11-587
EUSA (2)	11-592
Units org under fol TOE (2 copies each except as indc):	11-597

NG: State AG (3); units—same as Active Army except allowance is one copy to each unit.

USAR: None.

For explanation of abbreviations used, see AR 320-50.