

1

CAP

TM 9-1940

DEPARTMENT OF THE ARMY TECHNICAL MANUAL

LAND MINES



DEPARTMENT OF THE ARMY

• MAY 1956

TECHNICAL MANUAL

LAND MINES

TM 9-1940

CHANGES No. 2

HEADQUARTERS,
DEPARTMENT OF THE ARMY
WASHINGTON 25, D. C., 7 October 1957

TM 9-1940, 17 May 1956, is changed as follows:

65. Firing Device, Release Type, M1

a. General. This firing device * * * time of installation. The firing device is restrained from firing as long as there is a load **greater than 3 pounds** on the top face of latch.

* * * * *

d. Preparation for Use.

(2) *Installation and arming.*

(h) Place the restraining * * * of the latch.

Caution: The weight placed on the latch must be greater than 3 pounds to prevent firing device from functioning when safety devices are withdrawn.

* * * * *

Change the nomenclature in figure 80, RA PD 65184B, as indicated below.

	<i>From</i>		<i>To</i>
WEIGHT (2 pounds or more)		WEIGHT (greater than 3 pounds)	
[AG 476.1 (1 Oct 57)]			

By Order of *Wilber M. Brucker*, Secretary of the Army:

MAXWELL D. TAYLOR,
General, United States Army,
Chief of Staff.

Official:

HERBERT M. JONES,
Major General, United States Army,
The Adjutant General.

Distribution:

Active Army:

CNGB	Gen Depots
ASA	Ord Sec. Gen Depots
Technical Stf, DA	Ord Depots
Ord Bd	Ord Ammo Comd
USCONARC	Ports of Emb (OS)
USARADCOM	OS Sup Agey
OS Maj Comd	Trans Terminal Comd
MDW	Army Terminals
Armies	Ord PG
Corps	Ord Arsenals
Div	Mi Dist
Ord Gp	Ord Proc Dist
Ord Bn	MAAG
Ord Co	Mi Mis
Ft & Camps	Fld Comd, AFSWP
Svc Colleges	JBUSMC
Br Svc Sch	JUSMAG (Greece)
PMST Sr Div Ord Units	

NG: State AG; units—same as Active Army.

USAR: None.

For explanation of abbreviations used, see AR 320 50.

TECHNICAL MANUAL

LAND MINES

TM 9-1940
CHANGES No. 1

HEADQUARTERS,
DEPARTMENT OF THE ARMY
WASHINGTON 25, D. C., 5 June 1957.

TM 9-1940, 17 May 1956, is changed as follows:

21. Mine, Antipersonnel, NM, M14, With Integral Fuze

* * * * *

d. (Superseded) *Laying and Arming.*

- (1) Unscrew the shipping plug from the bottom of the mine body. The wrench (fig. 17) may be used to remove the shipping plug.

Caution: Examine the inner end of the shipping plug (the end nearest the firing pin) for any evidence of distortion or "splaying out" that would be caused by a dangerously long or a fired firing pin. DO NOT INSERT THE DETONATOR if there is any such indication that the firing pin is not in a normal position. Inserting the detonator against an abnormally long or fired firing pin may cause the mine to detonate. Examine well the detonator holder for any obstructions that might cause improper fitting or possible detonation when the detonator is inserted. Destroy any defective mines, as prescribed in TM 9-1903.

- (2) Turn the pressure plate in a clockwise direction with the wrench (arming tool), so the indicating arrow points to A (fig. 15). This places the pressure plate in the armed position. Withdraw the safety clip to determine if the mine will malfunction. Replace the safety clip.
- (3) Screw in the detonator holder with the detonator gasket attached. Use the wrench (arming tool) to screw the detonator holder down tightly against the detonator gasket to obtain a watertight joint. Do not exert any pressure on the pressure plate.
- (4) Place the mine in the ground so the pressure plate extends just above ground level, otherwise a shoe or boot may bridge over the mine. Be sure the ground beneath the mine is sufficiently stable to support the mine when pressure is applied to the pressure plate. If the ground is not sufficiently stable, place a block of wood or other nonmetallic object in the bottom of the hole to provide a firm bearing surface for the mine.

- (5) Camouflage the mine and remove any excess spoil from the immediate vicinity of the installation.
- (6) Remove the safety clip by pulling on the safety-clip pull cord. DO NOT throw away the safety clip. Conceal it or remove it from the vicinity of the installation.

Caution: Use extreme care when handling the detonators for this mine. A severe shock or dropping a detonator on a solid surface will cause it to function. Detonators should never be carried in pockets or otherwise on the person. After the mine has been armed it should be handled with care. Do not drop or throw it. Place it in position carefully.

* * * * *

[AG 476.1 (10 May 57)]

By Order of *Wilber M. Brucker*, Secretary of the Army:

MAXWELL D. TAYLOR,
General, United States Army,
Chief of Staff.

Official:

HERBERT M. JONES,
Major General, United States Army,
The Adjutant General.

Distribution:

Active Army:

CNGB	Engr Co
Tec Svc, DA	Ord Co
Ord Bd	Ft & Cp
Hq CONARC	Svc Colleges
Army Air Def Comd	Br Svc Sch
OS Maj Comd	PMST Sr Div Ord Units
OS Base Comd	Gen Depots
Log Comd	Ord Sec, Gen Depots
MDW	Ord Depots
Armies	POE (OS)
Corps	Trans Terminal Comd
Div	Army Terminals
Regt/Gp	OS Sup Agencies
Engr Bn	Ord PG
FA Bn	Ord Arsenals
Inf Bn	Mil Dist
Ord Bn	Ord Proc Dist
Armor Bn	MAAG
AAA Bn	Mil Msn

NG: State AG; units—same as Active Army.

USAR: None.

For explanation of abbreviations used, see SR 320-50-1.

TAGO 6867B

TECHNICAL MANUAL }
No. 9-1940 }

DEPARTMENT OF THE ARMY
WASHINGTON 25, D. C., 17 May 1956

LAND MINES

	Paragraphs	Page
CHAPTER 1. GENERAL		
Section I. Introduction	1-3	2
II. General discussion	4-14	3
CHAPTER 2. ANTIPERSONNEL MINES, FUZES, RELATED DEVICES, AND COMPLETE ROUND CHART		
Section I. Antipersonnel service mines and fuzes	15-24	22
II. Antipersonnel practice mines and fuzes	25-29	52
III. Antipersonnel-mine-clearing devices	30, 31	66
CHAPTER 3. ANTITANK MINES, FUZES, AND RELATED ITEMS		
Section I. Antitank service mines and fuzes	32-38	69
II. Antitank practice mines and fuzes	39-47	91
III. Antitank-mine-clearing device	48	108
CHAPTER 4. MISCELLANEOUS MINE COMPONENTS AND RELATED ITEMS		
Section I. Explosive items	49-73	110
II. Nonexplosive items (general supply)	74-78	163
III. Instruments and tools (general supply)	79-87	165
CHAPTER 5. DESTRUCTION OF AMMUNITION TO PREVENT ENEMY USE	88, 89	171
APPENDIX I. REFERENCES		174
II. COMPLETE ROUND DATA		177
INDEX		180

* This manual supersedes TM 9-1940, 15 July 1943, including C 1, 7 August 1944; TB 9-1940-7, 20 April 1944; TB 9-1940-8, 17 August 1944; TB 9-1940-10, 19 April 1945; TB 9-1940-11, 2 August 1950; and TB 9-1940-12, 15 June 1953.

CHAPTER 1

GENERAL

Section I. INTRODUCTION

1. Scope

a. This manual is intended to give authorized personnel the necessary technical information for the proper care, handling, and use of antipersonnel and antitank mines, and related items which are the responsibility of the Ordnance Corps.

b. For information on doctrine and technique for the tactical employment of antipersonnel and antitank mines and related items, refer to FM 20-32.

c. This manual differs from that part of TM 9-1940, 15 July 1943, and C 1, 7 August 1944, as follows:

(1) Adds information on—

- (*a*) Mine, antipersonnel, NM, M14, w/integral fuze.
- (*b*) Mine, antipersonnel, M16.
- (*c*) Mine, antipersonnel, practice, M8.
- (*d*) Mine, antipersonnel, NM, practice, T34, w/integral fuze.
- (*e*) Fuze, mine, combination, M10A1.
- (*f*) Fuze, mine, combination, M605.
- (*g*) Bomb, fragmentation, 4-lb, M83.
- (*h*) Mine, antitank, HE, practice, M10.
- (*i*) Mine, antitank, HE, practice, M12.
- (*j*) Mine, antitank, HE, heavy, M15.
- (*k*) Fuze, mine, antitank, M603.
- (*l*) Fuze, mine, antitank, practice, M604.
- (*m*) Destructor, universal, M10.
- (*n*) Explosive, TNT, 8-pound block.
- (*o*) Miscellaneous items (ch. 4) used in mine warfare, which are also covered in TM 9-1946, Demolition Material.

(2) Deletes the information on—

- (*a*) Fuze, mine, antipersonnel, M2-series.
- (*b*) Fuze, mine, antipersonnel, M3.
- (*c*) Mine, antitank, M1-series.
- (*d*) Mine, antitank, M4-series.
- (*e*) Mine, antitank, M5-series.
- (*f*) Fuze, mine, antitank, M1-series.
- (*g*) Fuze, mine, antitank, M4-series.
- (*h*) Fuze, mine, antitank, M5-series.

- (i) Fuze, mine, antitank, M600.
- (j) Fuze, mine, antitank, M601.
- (k) Fuze, mine, antitank, practice, M602.
- (l) Firing device, combination, M1.

2. Arrangement of Text

a. Chapter 1 consists of the introduction and general discussion of types of mines, terminology, complete round, explosive trains, classification, identification, care, handling, and preservation, storage, transportation, and packing and marking for shipment.

b. Chapter 2 presents description, data, and technical instruction for the use of antipersonnel mines and related items.

c. Chapter 3 presents description, data, and technical instructions for the use of antitank mines and related items.

d. Chapter 4 covers miscellaneous explosive and nonexplosive mine components, and items related to the use of mines or training therefor.

e. Chapter 5 gives information for the destruction of ammunition to prevent enemy use.

f. Appendixes I and II give references and complete round data.

3. Field Report of Accidents

If an accident or malfunction involving the use of ammunition occurs during training or combat, the range officer for a unit in training or the officer or noncommissioned officer in charge of the unit in training or combat will immediately discontinue use of the lot which malfunctions, and then report the occurrence and all pertinent facts of the accident or malfunction to the technical service officer under whose supervision the ammunition for the unit involved is maintained or issued in order that the action prescribed in SR 700-45-6 and AR 385-63 may be taken. If conditions of combat prevent immediate compliance, the action prescribed above will be taken as soon as practicable.

Section II. GENERAL DISCUSSION

4. Types of Land Mines

a. *General.* Land mines, representative types of which are shown in figure 1, consist of a charge of high explosive contained in a metallic or nonmetallic casing fitted with either a fuze or a firing device, or in some cases both, for actuation by enemy vehicles or personnel. Land mines are designed primarily to delay and restrict enemy movements. The "casualty" producing effect of a mine is secondary even though it helps achieve the primary function of the mine. The two general types of land mines are—

- (1) *Antipersonnel mines.* Antipersonnel mines, which are used against enemy personnel, consist of a small amount of high explosive, generally less than 1 pound, in a metallic or nonmetallic con-

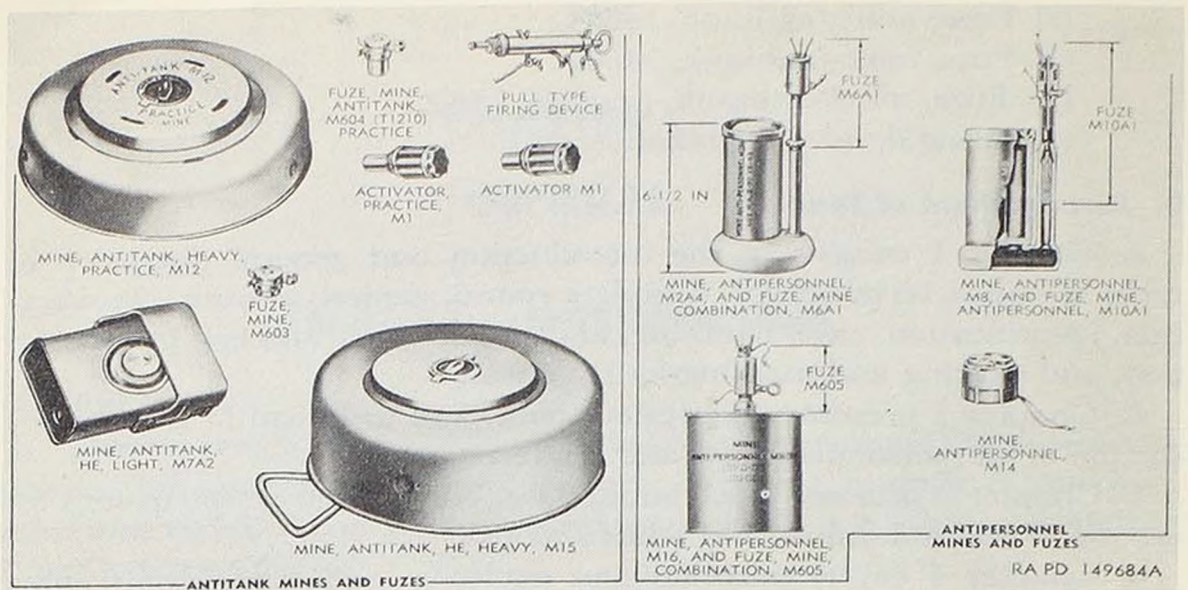

Figure 1. Representative types of land mines.

tainer fitted with a detonating fuze arranged for actuation by pressure or release of pressure, by pull on a trip wire, or by release of tension (cutting) of a taut trip wire. The mines are usually laid slightly below the surface of the ground. They may be laid in conjunction with antitank mines or obstacles to delay breaching operations. They are also used in separate antipersonnel minefields or in isolated locations for nuisance effect in delaying and harassing enemy utilization of areas and facilities. Antipersonnel mines are useful devices for giving warning of enemy approach in addition to their casualty-producing effects. The two general types of antipersonnel mines are the bounding type and the blast type.

- (2) *Antitank mines.* Antitank mines, which are used to immobilize or destroy enemy tanks or other vehicles, are normally employed in areas called minefields and are usually laid on, or slightly below, the surface of the ground. They consist of a charge of high explosive, usually 3 to 22 pounds in currently standard mines, in a metallic or nonmetallic casing fitted with a primary detonating fuze and with provisions for attachment of one or two secondary detonating fuzes. Ordinarily, antitank mines require a pressure of 300- to 400-pounds to actuate them. However, they might be exploded by running personnel. The two general types of antitank mines are the heavy and the light.

b. General Purpose Mines. This type, in metallic and in nonmetallic cases, is intended for a combination of antipersonnel and antitank purposes.

c. Development Types. In addition to mines described in this manual, there are various specific metallic and nonmetallic types, falling in one

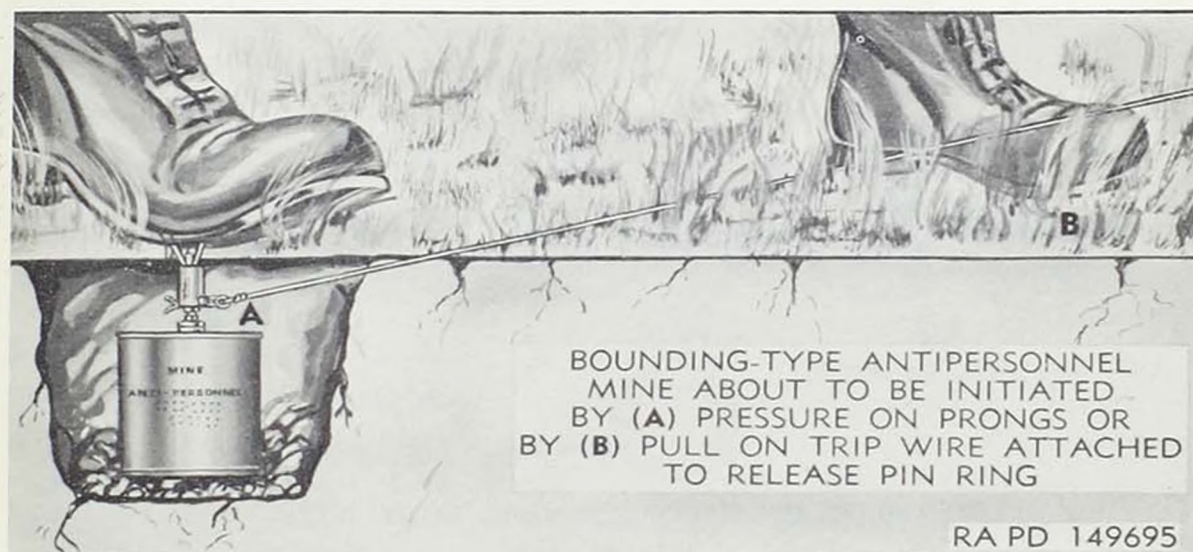

Figure 2. Initiation of action in mines.

or the other of the categories in *a* or *b* above, in the development stage designed to provide for all phases of mine warfare.

d. Improvised Mine. An improvised mine is one which is made of any available material. Improvised mines are used when standard mines are not available or are incapable of producing the desired results.

Caution: In view of the nature of improvised mines, appropriate precautions should be observed in laying, marking, reporting, and breaching of minefields.

e. Phony Mines. Phony mines, as the name implies, are not real mines. They usually consist of scrap material or some disturbed earth improvised in the field to simulate an actual mine emplacement. Phony minefields may be used to supplement a live minefield. They are laid principally to deceive, delay, and confuse the enemy. Phony mines should not be confused with *inert issue mines*, which are used for training in handling *live issue mines*. For information on employment of phony mines, refer to FM 20-32.

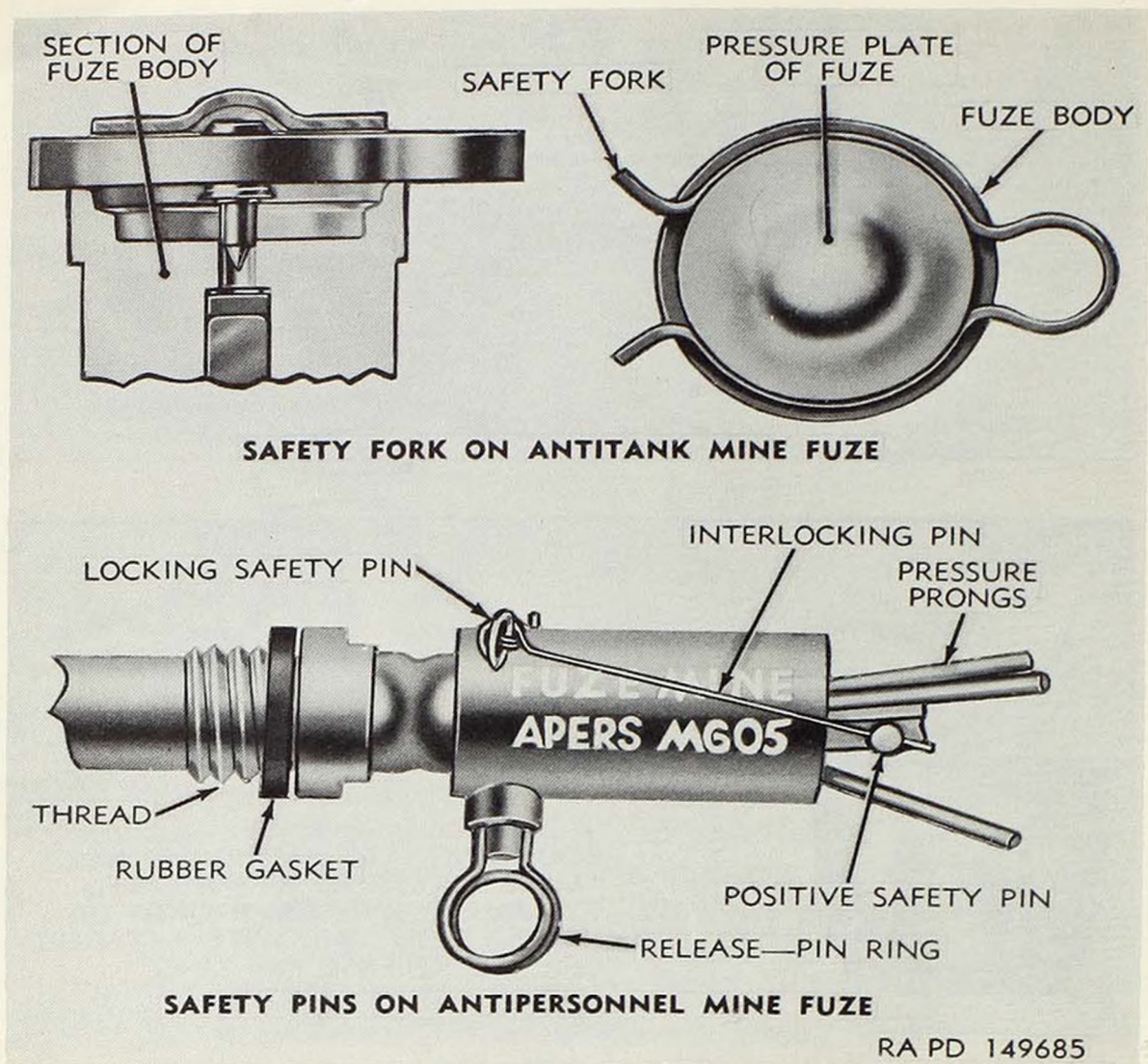

Figure 3. Typical safety devices.

f. Practice and Training Mines. Practice mines, which are the same size, weight, and shape as service mines but which contain a small smoke puff and noise charge consisting of black powder or pyrotechnic composition instead of a high explosive, are provided for practice. Inert mines, usually metal or plastic parts of service mines, either empty or filled with inert material such as sand (contain no explosive or burning mixture), are provided for training in handling.

g. Nonmetallic Mines. This type is in a plastic case and contains practically no metal parts. It is therefore nondetectable by magnetic mine detectors.

h. Initiation. Initiation (actuation) is accomplished by the action of personnel or vehicles on pressure or pull elements of fuzes (fig. 2). All mine fuzes incorporate safety devices, examples of which are shown in figure 3.

5. Boobytraps

A boobytrap is a hidden mine or charge having its firing mechanism so placed that the mine or charge is detonated when an apparently harmless object is disturbed by an unsuspecting person. Boobytraps may be employed in minefields, or they may be also employed in trees and buildings. Boobytraps are initiated by action on a concealed explosive device by pressure, by lifting or disturbing an object which might be thought to be an attractive souvenir thus releasing pressure, by causing a pull on a concealed trip wire, or by breaking or cutting a taut cord or trip wire. In general, boobytraps are initiated by firing devices or by improvised electric circuits connected to an electric blasting cap. For information on the employment of boobytraps, refer to FM 5-31.

6. Boobytrap Installation

A boobytrap installation can be made in connection with regular secondary fuze wells provided in some types of mines, can be made up of a firing device with nonelectric blasting cap and an appropriate amount of explosive material such as a demolition block or a coil of detonating cord. Current antipersonnel mines are not provided with secondary fuze wells. Some types of current antitank mines are provided with one or more secondary fuze wells threaded to receive a firing device; other types are threaded to receive an activator. Figure 4 illustrates one of the many methods that could be employed to boobytrap a mine. An activator, which is required in boobytrapping some types of mines, is an explosive item which is essentially a detonator-booster that acts as an adapter between firing device and mine in a secondary fuzing arrangement. Activator, M1 (fig. 57), is used as part of the secondary fuzing of heavy antitank service mines. Activator, practice, M1 (fig. 59), is used as a part of the secondary fuzing of the antitank practice mines.

7. Terminology

Following are definitions of terms used in connection with mines and their use (definitions of terms pertaining to the tactical employment of mines are given in FM 20-32):

a. Boobytrapped Mine. Mines, either antipersonnel or antitank, may be "boobytrapped." A boobytrapped mine is one which has one or more secondary fuzes (usually a firing device and activator in the case of an antitank mine (fig. 4)) which will cause such boobytrapped mine to detonate when a regularly laid mine, or other object to which the secondary fuze is attached by a pull wire, is moved. The firing device and activator can be fitted to either mine or to an auxiliary charge located beneath or beside a mine.

b. Activator. An assembly consisting of a plastic body containing a detonator and a plastic cup containing a tetryl booster charge. The body is threaded internally at one end to receive the activator shipping

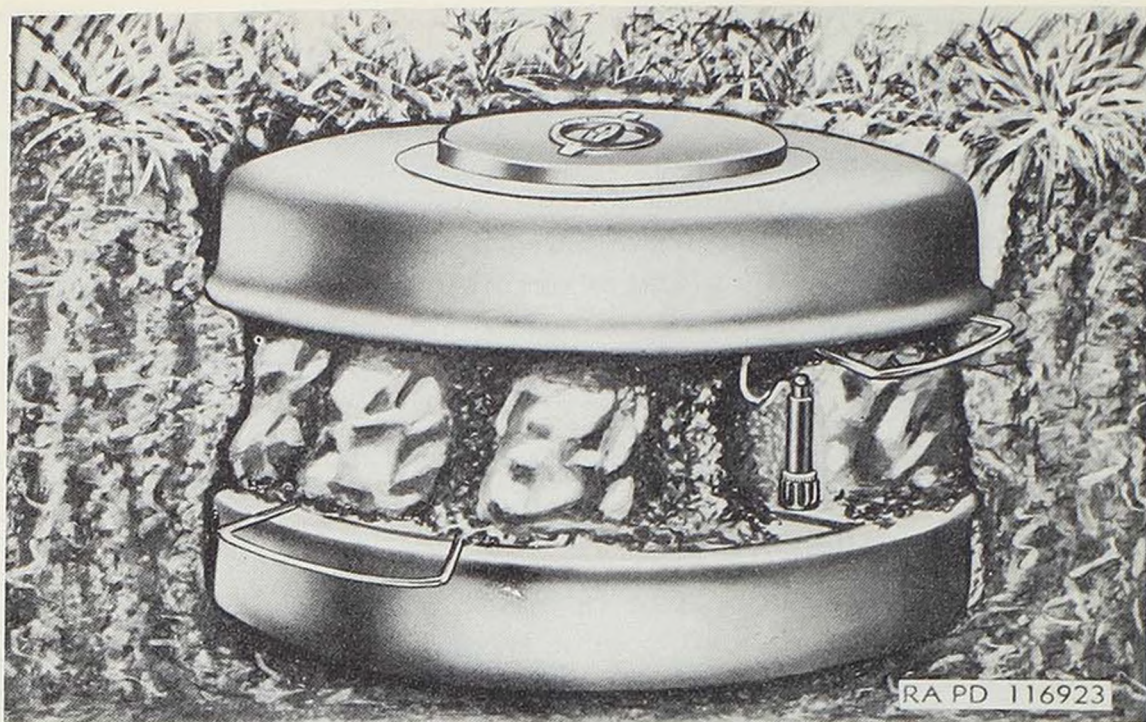

Figure 4. Installation of a boobytrapped antitank mine.

cap or a firing device and threaded externally at the other end to screw into the fuze well of an M6 type or an M15 antitank mine. A practice activator is similar in external appearance but it contains an igniter and a smoke charge instead of a detonator and a booster, and the body is threaded externally to screw into the fuze well of an M12 type practice antitank mine.

c. Adapter, Priming. A threaded plastic connector used to connect detonating cord, safety fuse (or time blasting fuse), or electric firing systems to an M7-series antitank mine or an explosive charge. This adapter, which may be either cylindrical or hexagonal, has the same size thread as that on the nipple end of the coupling base of a firing device. It will, therefore, fit any fuze well on a mine or demolition block threaded to receive a firing device. It will also fit the internal thread of activator M1 and practice activator M1.

d. Antilift Device. Any of the firing devices, used as a secondary fuze, installed in a mine, hand grenade, or explosive charge to explode when disturbed.

e. Arming. In the case of antipersonnel mines—removing safety pins or forks (clips). In the case of “heavy” type service and practice antitank mines—removing the safety fork from the fuze and turning the knob of the arming plug to A (armed) so that the mine is ready to function. In the case of “light” type service and practice antitank mines—removing the safety fork from the fuze and sliding the movable pressure plate to its position over the fuze.

f. Arming Plug. A device which is screwed into the pressure plate of heavy antitank mines after fuzing. The arming plug is fitted with two lugs and a setting knob which can be turned to either the safe or the armed position.

g. Block, Demolition. Term applied to a quantity (such as ½ pound, 1 pound, or 2½ pound) of high explosive, such as trinitrotoluene, tetrytol, or COMP C-series explosives to which a detonating device may be attached for use in demolition work or as an improvised mine. Refer to TM 9-1946.

h. Boobytrap. An explosive charge which is exploded when an unsuspecting person disturbs an apparently harmless object.

i. Boobytrapped Mines. A boobytrapped mine is one installed with one or more antilift devices (known also as secondary fuzes) so arranged as to cause an explosion if the mine is moved. Secondary fuzes may be attached either to the mine itself or to a second mine or auxiliary explosive charge.

j. Booster. A quantity of explosive (usually tetryl) interposed between a detonator and a bursting charge.

k. Cap Well. Secondary fuze well in certain types of mines, threaded to receive a firing device to which a blasting cap is to be attached, or to receive an adapter to which a detonating cord or safety fuse (or time blasting fuse) and a blasting cap are to be attached.

l. Chain, Firing. All the explosive elements (figs. 5 and 6) in a mine complete round, sometimes referred to as explosive train. These usually include a primer, a detonator, relay and delay elements, a booster, and a main charge. They may include other elements of a like nature.

m. Mine Clearing. Recovery and collection and/or destruction of all mines in an entire minefield.

n. Coupling Base. A metal coupling containing a percussion primer and having a nipple to which a blasting cap or igniter may be attached. The coupling base is threaded at one end to screw into the firing mechanism of a firing device and at the other end to screw into a cap well (⅞-in. diam.) of certain types of mines or into a service activator or a practice activator. The service activator is used only with service antitank mines of the M6 or M15 type, and the practice activator is used only with the practice antitank mine ("heavy" type).

o. Crimper. This is a special plier-like tool called crimper, cap (w/fuze cutter), M2, used for cutting detonating cord or safety fuse (or time blasting fuse) and for crimping a nonelectric blasting cap to safety fuse (or time blasting fuse) and for crimping a nonelectric blasting cap or an igniter to the coupling base of a firing device.

p. Danger Area. That area within which fragments of a mine may produce casualties. Personnel in this area, but outside the "effective casualty radius," are relatively safe. The "effective casualty radius" is that radius within which 50 percent of all personnel will become casual-

ties when a mine explodes. This radius is usually stated in yards.

q. Defuzing. Refer to *ay* below.

r. Demolition Material. The devices, equipment, and explosives used in demolition work. If conditions require, antitank mines may be used for demolition purposes and demolition blocks may be rigged as mines. Refer to TM 9-1946, FM 5-25, and FM 20-32.

s. Destructor. An explosive adapter for fitting a firing device and non-electric blasting cap or for fitting a firing device and activator to artillery shell, bombs, rockets, mines, or explosive charges and thus providing a booster in an explosive train. The destructor may be used in conjunction with improvised mines, boobytraps, fougasses, or for destruction of abandoned or unserviceable ammunition.

t. Detonation. Detonation is the reaction which takes place when a "high explosive" is exploded. As the mass of high explosive is initiated, a detonation wave is created which progresses through the mass transforming it instantly into gases.

u. Detonator. A small amount of sensitive high explosives in a tubular or other shape container usually initiated by a friction wire or by detonation waves and intended to detonate a mine or other explosive charge.

v. Detonator, Concussion. A device designed for initiation by concussion resulting from underwater detonation waves and intended to detonate an underwater explosive mine or charge.

w. Detonator, Delay. A device consisting of a priming composition charge, a delay element, and one or more high-explosive charges of different compositions arranged in the order of decreasing sensitivity and increasing quantities used for exploding detonating cord which may be attached to demolition charge or improvised mine. Refer to TM 9-1946.

x. Disarming. Replacing safety pins, clips, forks, keys, and other safety devices or removal of fuzes so that a mine cannot be exploded accidentally by vehicle or personnel. A disarmed mine is not necessarily safe for transport and storage; it ordinarily must be restored to its original condition and packing before transporting or storing. The term "disarming" also applies to turning the setting knob of the arming plug in M6 or M15 type service and M12 type practice antitank mines to the "safe" position. It also applies to sliding the pressure plate away from the fuze on M7 type service and M10 type practice antitank mines.

y. Phony Minefield. An area or space containing simulated mines employed to confuse and delay the enemy.

z. Explosives. Explosives are classified as low or high depending on the rate at which the reaction of explosion takes place. The rates of transformation of explosives into gases vary over a wide range.

- (1) *Low explosives.* Low explosives, which includes propellants and black powder, are classified from the viewpoint of use characteristics as "burning" explosives. These explosives undergo autocombustion at rates that vary from a few centimeters per minute to 400 meters per second.

(2) *High explosives.* These explosives, which include TNT, RDX, Compositions A, B, and C, PETN, tetryl, nitrostarch, and many others, are classified from the viewpoint of use characteristics as "high" explosives. This group undergoes detonation at rates from 1,000 to 8,500 meters per second.

aa. Firecracker. A small cylinder of compressed paper or pasteboard material containing a small low explosive charge and a time fuse. It is used for training purposes to simulate the noise of exploding charges in land mines, hand grenades, rifle fire, and artillery fire.

ab. Firing Pin. A pointed metal plunger in the firing mechanism of a fuze or of a firing device which, when released, strikes a sensitive explosive in a primer or detonator and explodes it.

ac. Firing Device. A device designed to initiate a train of fire or detonation in demolition devices, demolition charges, boobytraps, or mines. It is generally a separate item of issue. When fitted with a nonelectric blasting cap, it may be used as a mine fuze, antilift or boobytrapping device, or to set off prepared explosive charges.

ad. Firing Mechanism. The firing pin assembly with its spring and housing. A firing device less primed coupling base is an example of a firing mechanism.

ae. Flare, Trip. An illuminating device usually employed as a warning device against the approach of foot troops and in front of antitank minefields to warn of the approach of an enemy minefield breaching party.

af. Fougasse, Ordinary Type. A locally constructed improvised "mine," which may consist, for example, of 20 to 60 pounds of ammonium nitrate or other explosive laid in the bottom of a hole about 4½ feet deep with the opening toward the enemy sloped at 45 degrees. The charge is then overlaid with a board and 4 to 6 inches of stones. When detonated, by appropriately arranged initiating and priming materials, the stones are thrown in the direction of the enemy.

ag. Fougasse, Flame Type. Gasoline in drums or napalm in containers ignited by 81-mm mortar white phosphorus (WP) shell fired electrically from a remote-controlled post. Acts as an instantaneous flame-thrower. If used for illumination, the gasoline or napalm should be unconfined.

ah. Fuze, Mine. A mechanical, magnetic, or electrical device which, depending on the type of mine, contains a primer, detonator and booster, or a primer and an igniter (known also as squib), or a primer and a blasting cap, which is designed to initiate an explosion of the mine at the time and under the circumstances desired. A "mine fuze" is normally used in a primary fuze well, as contrasted with the firing device and activator, or firing device and blasting cap arrangement, which are normally used as a secondary fuze in a secondary fuze well (activator well or cap well).

ai. Fuze Well. Threaded opening in a mine to receive a fuze.

aj. Fuzing. Refer to *Installing (am below)*.

ak. Grapnel. A grappling hook used to drag over the ground to catch trip wires of suspected enemy minefields.

al. Igniter. A small metallic tube containing a charge of black powder. Used as a component of certain antipersonnel mine fuzes.

am. Installing. Installing a fuze in a mine is to "fuze" the mine. Installing a mine is "laying," "emplacing," or "planting" it.

an. Mine, Practice. A replica of a service mine having the same features and weight as the service mine it represents but containing a smoke puff and noise-making charge instead of a high explosive.

ao. Mine, Service. A mine used in combat operations. It usually contains a high-explosive charge.

ap. Mine Clearing. Recovering and collecting and/or destroying all mines in a whole minefield.

aq. Minefield. An area of terrain containing mines laid with or without pattern.

ar. Neutralizing. Replacing all safety pins, clips, forks, and all other safety devices so as to prevent a mine fuze from functioning, and then removing the fuze.

as. Planting. Term sometimes used to mean "laying."

at. Primer. A small cylindrical metal device containing an internal cup filled with a sensitive high explosive and an anvil arranged so that, when the cup (showing at the head of the primer) is struck by a firing pin, the explosive is detonated and flame is spurted from the bottom for the purpose of exploding a detonator or igniting charge. The two types of primers are percussion type and stab type. In the percussion type the metal of the cup containing the initiating explosive is not pierced; in the stab type, such metal is pierced.

au. Projector. The tubular body of the bounding-type antipersonnel mine from which the projectile is fired.

av. Protector, Shipping. The small celluloid or fiberboard cup-shaped cover with which the nipple of the coupling base of a firing device is protected during shipment.

aw. Trip Wire. A wire attached at one end to an antipersonnel mine fuze, or to an antitank secondary (boobytrapping) fuze, or to an initiating arrangement of a boobytrap, and at the other end to a stationary object such as a stake driven into the ground.

ax. Release. The term used in the designation of certain specific types of mine fuzes and firing devices.

ay. Removing the Fuze. The reverse of installing.

az. Safeties. The term "safeties" refers to organic safety devices (those incorporated in design) characteristic of fuzes, firing devices, or related components to help prevent accidental functioning. The removal of "safeties" as in the case of safety pins (cotter pin type) of firing devices or turning a knob as in the case of the arming plug of a heavy antitank mine constitutes the process called "arming." The reinsertion of "safeties," as in the case of preparing to "take up" or "remove" a mine, constitutes the process called "disarming."

ba. Secondary Fuze Well. Threaded opening in a mine to receive a sec-

ondary fuze. A secondary fuze well threaded to receive a firing device or adapter may be called a cap well. Either a secondary fuze threaded to receive a service activator or a well threaded to receive a practice activator may be called an activator well.

bb. Shaped Charge. A quantity of high-explosive having a bell- or conical-shaped recess.

bc. Simulator. A device containing a small amount of explosive or pyrotechnic mixture used to simulate combat noises and flashes.

bd. Sympathetic Detonation. One which is induced by the explosion of another charge.

8. Mine Complete Round

a. Description. A complete round consists of all the components of the mine necessary for it to function. The complete round is issued with components in separate compartments of the same packing container or with certain components shipped separately for assembly in the field. The components of a mine are: body, fuze, and if desired, secondary (activating) fuze or fuzes consisting of firing device and activator, or firing device and blasting cap.

- (1) *Body.* The body of the bounding-type antipersonnel mine (fig. 8) consists of a cylindrical part called a projector to which is connected, at the base, a pipe nipple and coupling, or fuze well into which a firing device-type fuze may be screwed. The projector contains a high-explosive fragmentation type projectile and is closed at the top by a cover. A newer design bounding-type antipersonnel mine (fig. 18) has a cylindrical body with the fuze well in the center; it also has a high-explosive fragmentation-type projectile. The body of the blast-type antipersonnel mine (fig. 14) is squat, cylindrical in shape (approx. 2¼ in. diam.), is composed of olive drab colored plastic, and contains a high explosive, there being an opening in the bottom for a special detonator assembly. The bodies of antitank mines (figs. 31, 38, and 43) are relatively light metallic or nonmetallic cases containing high-explosive charges with provision at the top for a main fuze and at one side and the bottom for secondary fuzes. The bodies of training mines are the same size, shape, and weight as service mines, and are either empty or filled with inert material.
- (2) *Fuze.* A primary mine fuze is a device designed to initiate a train of fire or a detonation of mines under the circumstances desired, principally by action on an intermediate charge such as a detonator or booster. A secondary (boobytrapping) mine fuze consists of a firing device, which includes a primed coupling base, and either an activator or a blasting cap. Mine fuzes are of several types depending upon the types of mines with which they

are to be used and depending upon the manner in which they are expected to be actuated.

- (a) *Antipersonnel mine fuzes.* There are two general types of antipersonnel mine fuzes, namely, the tri-pronged combination type (actuated by pressure on any one of the prongs or by pull on a trip wire attached to the release pin ring) shown in figure 8, and the belleville spring type (actuated by pressure) shown in figure 14. The tri-pronged combination type fuze has a helical spring-driven firing mechanism which is used with coupling base (or similar base) and an igniter in the M2 series and M16 service antipersonnel mines, in the M8 practice antipersonnel mine, and in the parachute trip flare M48. The belleville spring-type mine fuze is said to be integral with the M14 antipersonnel mine and the T34 practice antipersonnel mine. Inerted service fuzes with appropriate inerted mines may be used for training in handling mines.
- (b) *Antitank mine fuzes.* There are several types of antitank mine fuzes currently for issue or under development. The current issue type is the pressure type embodying a belleville spring-actuated firing pin used with the M6 series, M7 series, and M15 antitank mines. The service model of this type mine fuze is the M603 (fig. 36) and the practice model is the M604 (fig. 49). Newer types of antitank mine fuzes under development are the tilt rod, the electrical impulse, the magnetic influence, the vibration influence, and combinations thereof. In addition to the use of practice fuzes with practice mines, inerted service fuzes with inerted mines may be used for the appropriate type of training.
- (c) *Secondary fuzes.* A secondary (boobytrapping) fuze, provision for one or more of which is made in the form of secondary fuze wells in certain types of antitank mines (figs. 31, 38, and 43), consists of a firing device and an activator installed in a service heavy antitank mine, a firing device and a practice activator in a practice heavy antitank mine, a firing device with blasting cap in a service light antitank mine, or a firing device without blasting cap in a practice light antitank mine.

Note. A blasting cap or an igniter cannot be used with an activator.

- (3) *Activator.* An activator (fig. 57) is used with certain models of antitank mines. It is a small cylindrical plastic container in which are incorporated a detonator and a booster. It is screwed into the side or bottom, or both, of an antitank mine, and then the shipping cap of the activator is removed and a firing device (a firing device has a primed coupling base but igniter or blasting cap is omitted) is screwed into the activator.

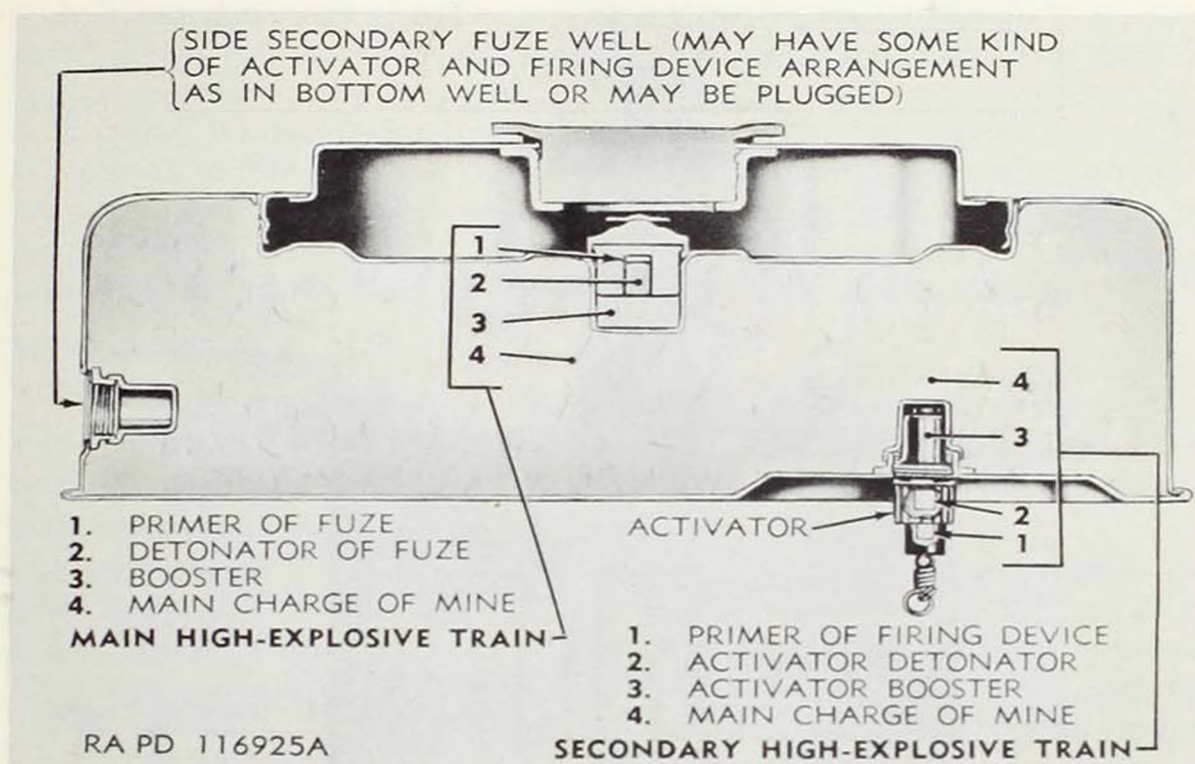

Figure 5. Schematic arrangement of the four parts of the main high-explosive train and the four parts of the secondary high-explosive train of an antitank mine.

b. Explosive Trains.

- (1) The high explosive used for the main charge in a mine is comparatively insensitive thereby providing safety in handling, transit, and storage. To insure high-order detonation of the charge, a series of explosives consisting of a small amount of sensitive high explosive suitable for firing by firing pin, friction, or electricity, followed by one or more high explosives, each of progressively lower sensitivity and larger quantity, is required. Such a series together with main charge is called a high-explosive train. It normally consists of primer, detonator, booster, and main charge. Delay elements may be incorporated between adjacent components of a train to meet delay action requirements.
- (2) In the bounding-type antipersonnel mine, a propelling charge expels a high-explosive missile from the mine body into the air and initiates the high-explosive train of the missile. A series of explosives consisting of a percussion element and one or two low explosive elements ignites the propelling charge. This series together with the propelling charge is called the propelling charge train.
- (3) Antitank mines employ essentially a main high-explosive train of four parts and may in addition employ one or two secondary

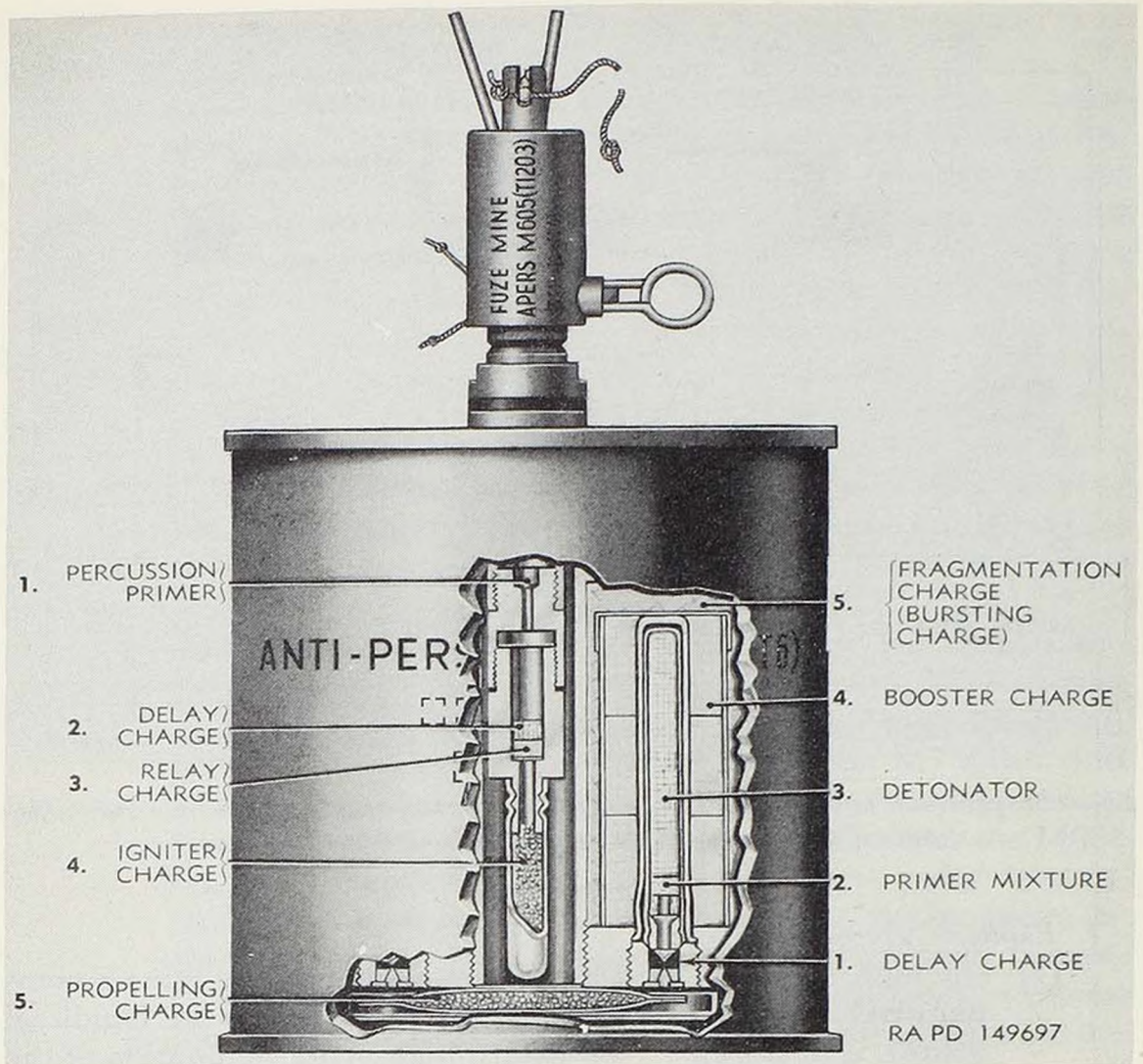

Figure 6. Schematic arrangement of the five parts of the propelling charge explosive train and the five parts of the high-explosive train in the bounding type antipersonnel mine.

high-explosive trains of four parts each (fig. 5). (Some anti-tank mines of older manufacture employ a five-part main high-explosive train.) Bounding type antipersonnel mines employ essentially a propelling charge train of five parts and a high-explosive train of five parts (fig. 6).

9. Classification

a. Land mines are classified according to the use for which they are designed as antipersonnel and antitank. Under very limited conditions an antitank mine might be used for antipersonnel purposes but if so used it would be very inefficient. Antipersonnel mines would be ineffective against tanks. Antitank mines could be used under special conditions for improvised demolition purposes, and some demolition explosives could be used as improvised mines.

b. Land mines are classified according to purpose as service and practice. Phony mines, which are simulated mines and can be improvised of any appropriate scrap material, are not classed as mines.

c. Land mines are classified as to filler as high explosive or inert. In the case of service antitank mines, the designation HE appears in nomenclature. In the case of practice mines, the word "practice" appears in nomenclature. In the case of inert mines, which are used for training in handling, the word "inert" or "empty" appears in nomenclature.

10. Identification

a. *General.* Land mines are identified by standard nomenclature, lot number, model, painting, marking, and ammunition identification code symbol. Such means of identification are used on all packing containers and, unless the item is too small, on the item itself.

b. *Ammunition Lot Number.* When ammunition is manufactured, an ammunition lot number, which becomes an essential part of the marking, is assigned in accordance with pertinent specifications. The lot number for mines consists, in general, of the loader's initials or symbols, and the number of the lot. This lot number is stamped or marked on every mine and on all packing containers. It is required for all purposes of record, including reports on condition, functioning, or accidents in which the ammunition may be involved. In any one lot of ammunition, the components used in the assembly are manufactured under as nearly identical conditions as practicable.

c. *Model.* To identify a particular design, a model designation is assigned at the time the item is classified as an adopted type. This model designation becomes an essential part of the standard nomenclature and is included in the marking on the item. The present method of model designation consists of the letter M followed by an Arabic numeral. Modifications are indicated by adding the letter A and appropriate Arabic numeral. Thus, M6A1 indicates the first modification of an item for which the original model designation was M6. Modifications which are functionally identical with the original model but which have manufacturing differences may be designated by the letter B and an Arabic numeral. When a particular design has been accepted only for a limited procurement and service test, the model designation is indicated by the letter T and an Arabic numeral, and modifications by the addition of E and an Arabic numeral. In such cases, if the design subsequently should be standardized, the M designation is assigned; hence there may be encountered some lots still carrying the original T designation (not yet remarked to show the later standardized M designation). There is no direct relationship between the numerical designation of a T item and that of the item when standardized and assigned an M designation. Items of Navy design are designated by Mk (abbreviation for "Mark") instead of M, and Navy modifications are designated by "Mod" and appropriate Arabic numeral instead of A and appropriate Arabic numeral.

d. Painting. Metallic service land mines are painted to prevent rust and in colors to provide a means of identification. Metallic service mines are painted lusterless olive drab with marking in yellow. Metallic practice mines are painted blue with marking in white; the color blue indicates the type of training which involves an item containing a small amount of explosive for simulating or spotting purposes. This type of training is known as "practice." Metallic inert mines are painted black with marking (including either the words INERT or EMPTY) in white; the color black in conjunction with the word INERT or EMPTY and with holes, where practicable, indicates that the item is for the type of training which involves no explosive. Plastic land mines are made of the particular color of plastic appropriate to their use, as service or the particular type of training. Refer to SR 385-410-1 for safety identification of inert ammunition and components.

e. Marking. Land mines are marked by stamping or stencilling with the type, size, model, and lot number.

f. Data Card. The "ammunition data card" is a 5- by 8-inch card prepared in accordance with pertinent specifications for each lot of ammunition. Copies are forwarded with each shipment of ammunition. In addition to the ammunition lot number, the data card gives the lot numbers of the components and other pertinent information concerning the ammunition.

g. Federal Stock Number and Department of Defense Identification Code. These have replaced the ammunition identification code (AIC) and the Ordnance stock number. There is a different Federal stock number for each item of supply as packed. The first four digits of the Federal stock number represents the class number in which the item belongs. Ammunition (all types) belongs in Group 13, class 1300 series, supply manuals, for example, 1345 represents the class to which land mines and components belong. The next seven digits in the Federal stock number are called the Federal item identification number (FIIN). In a particular supply manual, there is a different FIIN for each item, as packed. Thus, the Federal stock number is composed of the class number (first four digits) and the FIIN (next seven digits). In addition to the Federal stock number, a Department of Defense identification code consisting of four characters (letter and three digits) has been suffixed to the Federal stock number. This identification code groups together those items which are completely interchangeable as to function and use. Using units will ordinarily requisition ammunition by class number and identification code only, for example, 1345-K001. The requisition would then be filled with any one of the items in the K001 category in any one of its packings. If a particular item, model, or packing is desired by the requisitioner, such item will be requisitioned by the Federal stock number and identification code, e. g., 1345-028-5111-K001, but in this case a justification for requisitioning a specific item or a specific item in a specific packing must be shown on the requisition. During the period of transition from the

ammunition identification code system to the Federal stock number system of requisitioning, ammunition identification code symbols representing current ammunition items as packed will be carried in parentheses under the corresponding Federal stock numbers in the supply manuals of the class 1300 series.

11. Care, Handling, and Preservation of Mines

a. Mines must be handled with appropriate care at all times. The explosive elements in fuzes, primers, detonators, and boosters are particularly sensitive to undue shock, friction, static electricity, and high temperature. Boxes or crates containing mines should not be dropped, dragged, tumbled, walked on the corners, or struck, as in lining up a stack. They should be grounded whenever practicable and protected from high temperature.

b. Mines are packed to withstand conditions ordinarily encountered in the field. Items that are not waterproofed are packed in moisture-resistant containers. Care must be observed to keep containers and packing boxes from becoming broken or damaged. All broken containers and packing boxes must be repaired immediately and careful attention given to the transfer of all marking to the new parts. Such containers should not be opened until the mines are about to be used or prepared for use. Items unpacked but not used should be repacked and the containers sealed. Such items should be used first in subsequent operations in order that stocks of opened containers and packing boxes may be kept to a minimum.

c. When it is necessary to leave mines in the open, raise them on dunnage at least 6 inches from the ground and cover them with a double thickness of paulin (tarpaulin), leaving enough space for the circulation of air. Suitable trenches should be dug to prevent water from running under the pile.

d. Mines and components in their packings should be protected against moisture.

e. Boxes should not be opened in a magazine or at an ammunition dump, nor should they be opened within 100 feet of any store of explosives. Safety tools, if available, should be used in unpacking and repacking operations. Safety tools are those made of copper, wood, or other material incapable of producing sparks when struck.

f. No attempt will be made to fuze a mine closer than 100 feet to a magazine or other such store of explosives or ammunition.

g. No disassembly of mines or components thereof will be permitted except as specifically authorized by the Chief of Ordnance.

h. Safety pins, safety forks (clips), and other safety devices are designed to prevent accidental initiation of the mine while being handled. They should be left in place until the last practicable moment before arming a mine, which should be done as prescribed in arming procedures for the particular item. Before removing ("picking up") mines, safety devices should be replaced, that is, the mines should be properly "disarmed."

i. Care will be exercised to see that firing device wells, cap wells, activator wells, and fuze cavities are clear of obstruction and free of foreign matter before attempting to install the fuze or detonator.

j. Mines, in general, will function satisfactorily at temperatures of -40° to 160° F. Metallic mines are not appreciably affected by temperature changes.

Note. If the temperature fluctuates above and below freezing, necessary steps must be taken to prevent moisture or water from accumulating around the mine and subsequently freezing; otherwise, the mine may become neutralized by the formation of ice.

Refer to FM 20-32 relative to winter mine laying.

k. Mines may be reused (taken up and relaid) any number of times provided that proper procedures as explained in this manual and in FM 20-32 are observed and that no components show evidence of damage or deterioration.

12. Field Storage and Preservation

The following general conditions govern the storage of mines, fuzes, and detonators:

a. Mines generally are stored in isolated buildings or abandoned pill boxes which have been designated for this purpose. When specially constructed magazines are not available, buildings used should afford good protection against moisture and dampness, have adequate ventilation, and be on well-drained ground. They must not be heated with open fires or stoves.

b. Mines that must be stored in the open are stacked in small piles and protected from dampness and weather with tar paper and paulins (tarpaulins).

c. Boxes, cases, and other mine containers must be clean and dry when stored. Before storing, damaged containers should be repaired or replaced, but not within 100 feet of magazines.

d. No oily rags, paint, turpentine, or other flammable material are to be left in a magazine.

e. Mines should be piled by type in small piles so arranged that individual containers are accessible for inspection and air can circulate freely. The tops of piles should be below the level of the eaves to avoid the heated space directly below the roof. The bottom of the piles should be raised off the floor or ground at least 2 inches. Stacks must not be so high that containers or mines on the bottom will be crushed.

f. Individual magazines, or stacks of mines stored in the open, should be separated by distances adequate to prevent propagation of an explosion from one to another. Refer to TM 9-1900 for such distances.

g. Magazines or storage areas must be kept free of dry leaves, grass, trash, empty boxes, scrap lumber, and similar flammable material. A 50-foot firebreak should surround each magazine.

h. Smoking, carrying matches, and using lights other than approved electric lights are forbidden in magazines or mine-storage areas.

i. Mines should be neutralized and defuzed before being stored. Fuzes and detonators should be stored separately from mines.

j. Captured enemy mines and explosives should be stored in dumps at least a quarter of a mile from the nearest dump of American ammunition. Mixed storage of enemy and American ammunition is not permitted.

13. Transportation

Transportation of explosives by rail or truck in the United States is regulated by "Interstate Commerce Commission Regulations for Transportation of Explosives and Other Dangerous Articles by Freight," published by the Bureau of Explosives, 30 Vesey Street, New York 7, New York. Obtain a copy of the regulations and follow them exactly. Refer also to AR 55-155 and AR 55-228.

14. Packing and Marking for Shipment

a. Packing data for land mines and their components are given in Department of the Army Supply Manual 9-5-1345.

b. In addition to nomenclature and lot number, packages offered for shipment are marked with the Interstate Commerce Commission shipping name or classification of the article, the names and addresses of consignor and consignee, volume and weight, the Department of Defense identification code which replaces the ammunition identification code symbol formerly used, and the Ordnance Corps escutcheon.

CHAPTER 2

ANTIPERSONNEL MINES, FUZES, RELATED DEVICES, AND COMPLETE ROUND CHART

Section I. ANTIPERSONNEL SERVICE MINES AND FUZES

15. General

a. Antipersonnel service mines, which are used primarily in minefields to provide obstacles for the purpose of restricting enemy movement, depend upon action of the enemy on fuzes, with which mines are fitted as laid, for initiation. The explosive charges used in the different types of antipersonnel mines are not normally effective against armored vehicles. Depending on the particular type of mine, a pressure on the mine fuze or a pull on a trip wire connected to the mine fuze is required for initiating action. Enemy foot troops have a larger field of vision than tank personnel, hence when laying an antipersonnel mine, special attention should be given to concealment and maintenance of its neutral appearance. Improvised antipersonnel mines may be rigged as described in paragraph 4*d.* For technique in tactical employment of mines, refer to FM 20-32. Types of antipersonnel mines are shown in figure 7.

b. Depending on the particular type, antipersonnel service mine fuzes are designed for exploding a mine by pressure of 10 to 35 pounds on the fuze, or by pull of 3 to 8 pounds on a trip wire connected to the fuze. Secondary (boobytrapping) mine fuzes may be made up of firing devices in conjunction with blasting caps. Pull type or pull-friction type firing devices designed for initiation by pull on a trip wire, or, pull-release type firing devices designed for initiation by either pull on, or release of, a trip wire, may be used as a component of such secondary fuzes. The M6A1 fuze is the present fuze used with the older type bounding antipersonnel mine, and the M605 fuze is the present fuze used with the newer type bounding antipersonnel mine. Both of these fuzes are characterized by a tri-pronged head and a safety pin opposite the release pin ring; in these fuzes the "positive" safety pin is in a hole in the firing pin between the prongs. The fuze used in the M14 antipersonnel mine is a belleville spring type integral with the mine.

16. M2 Series Modifications

The several modifications of the M2 series (bounding type) antipersonnel service mines, all for use with the combination mine fuze M6A1, are the M2, M2A1, M2A3, M2A3B1, and M2A4. The differences between

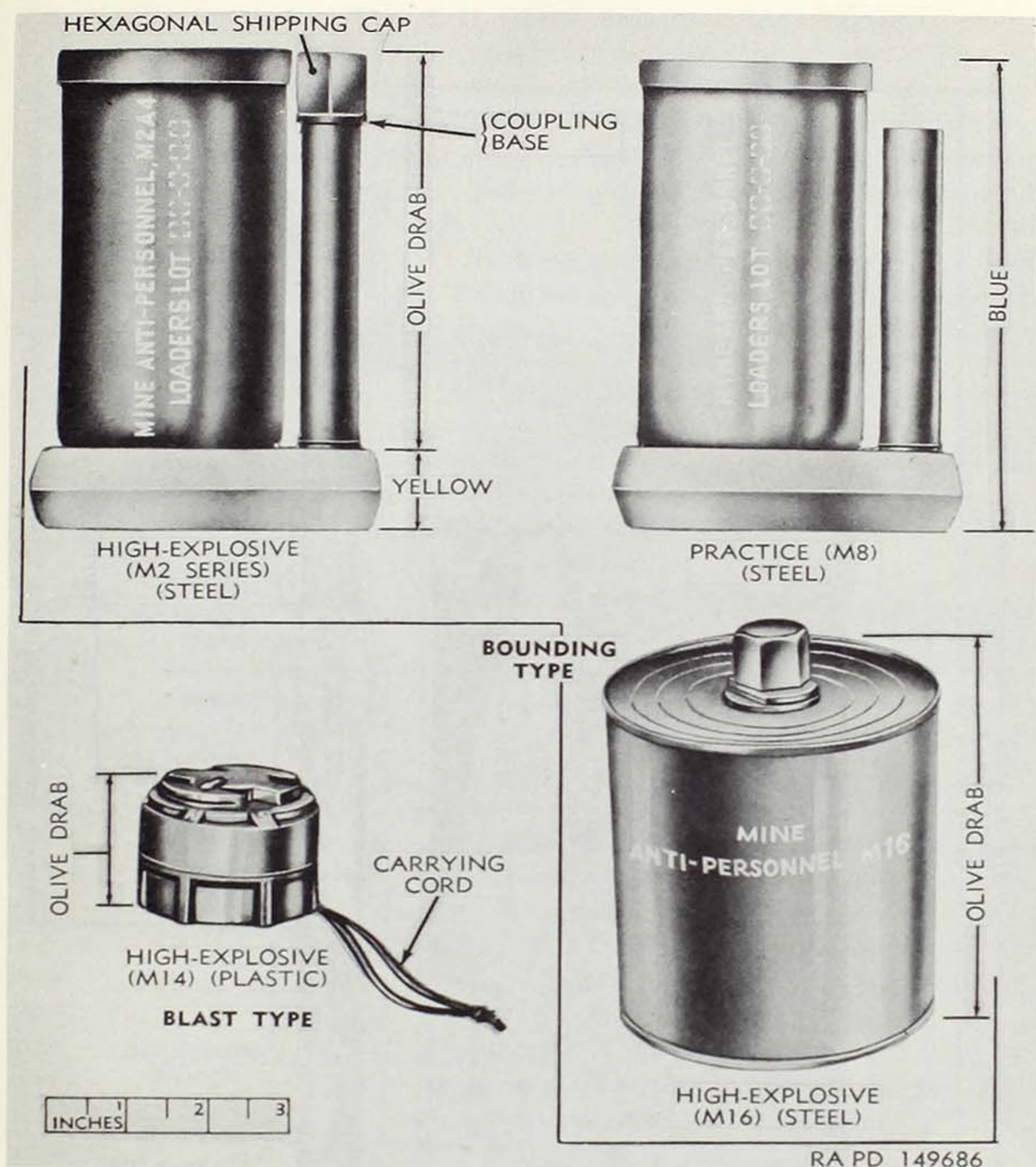

Figure 7. Types of antipersonnel mines.

earlier and later modifications are in minor improvements in design. For description, functioning, laying and arming, disarming and removal, precautions, painting and marking, and packing, applying generally to all M2 series modifications, refer to paragraph 17, which describes the latest modification in this series, the M2A4.

17. Mine, Antipersonnel, M2A4, and Fuze, Mine, Combination, M6A1

a. *General.* This mine (fig. 8) and earlier modifications are of the fragmentation bounding type. The shell in the M2 series mine is a modified

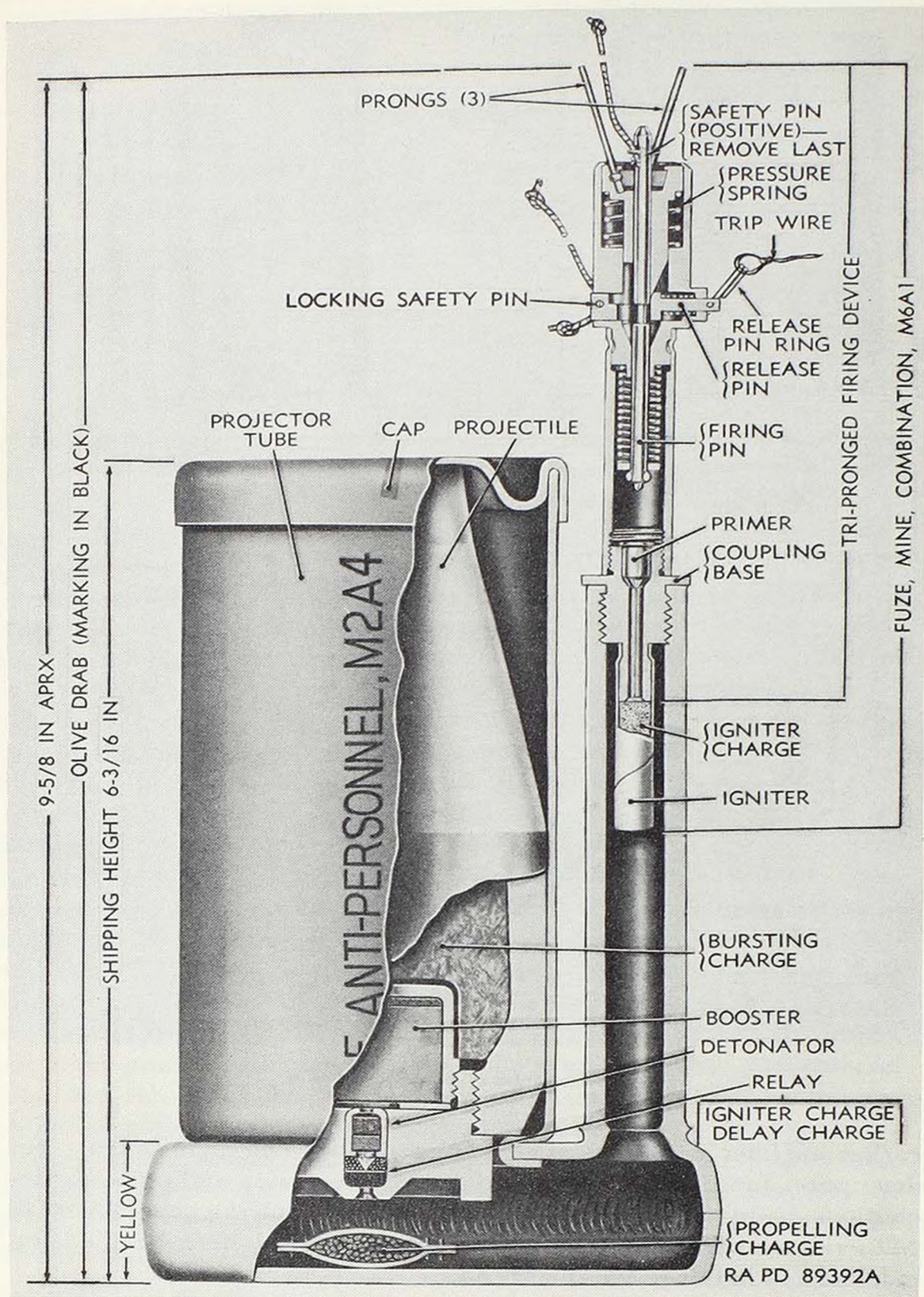

Figure 8. Mine, antipersonnel, M2A4, and fuze, mine, combination, M6A1.

60-mm mortar shell. The shell, which contains a high-explosive charge with delay fuse and booster, is contained in a tube (projector). The projector is fitted to a base which contains a black powder propelling (expelling) charge. Also fitted to the base is a short tube which forms a fuze well for a combination (pressure or pull) fuze. As shipped, a coupling base, which contains a primer and is fitted with an igniter, is in place in the fuze well of the mine and closed by a hexagonal cap. As laid, the coupling base (after removal of the hexagonal cap) is fitted with the firing mechanism of the fuze. The firing mechanisms are shipped in separate containers in the box with the mines.

b. *Description* (fig. 8).

(1) *Mine.*

Model number—M2A4.

Type—bounding, fragmentation.

Weight, loaded and fuzed—5.01 pounds.

Dimensions—height, fuzed, $9\frac{3}{8}$ inches; diameter plus portion of base for fuze, $3\frac{3}{4}$ inches.

Material—steel.

Fuze well—capped (hex cap) as shipped; located in tube extending upward from base.

Relay—consists of delay and igniter charges—located in base plug of projectile.

Detonator—consists of primary and secondary detonating charges—located adjacent to relay in base plug of projectile.

Booster (tetryl)—located adjacent to detonator in base plug of projectile.

Weight of explosive charge (TNT)—0.34 pound.

Weight of expelling charge (black powder)—40 grains, located in base of mine near opening to delay charge in base plug of projectile.

Painting—body, olive drab; base, yellow.

Marking—nomenclature of mine, month and year loaded, and lot number (including loader's initials and symbol)—all in black.

Shipping cap—hexagonal shipping cap is on coupling base which is in fuze well as shipped. Coupling base contains primer and is fitted with crimped-on igniter.

Packing method (fig. 9)—packed 1 complete mine with one spool of four 26-foot lengths of steel wire in a carton, 6 cartons (6 complete mines) per wooden box.

Note. Hexagonal shipping cap is removed from coupling base *in the field* and replaced with firing mechanism (fuze less primed coupling base with crimped-on igniter).

Packing weight (6 mines and accessories)—50 pounds. Dimension of packing box—length, 15 inches; width, $10\frac{1}{4}$ inches; height, $9\frac{3}{8}$ inches.

(2) *Fuze* (refer also to par. 18).

Model number—M6A1.

Components—firing mechanism and primed coupling base with crimped-on igniter.

Type—combination.

Weight of igniter charge (black powder)—10 grains.

Length—7.18 inches (approx.).

Thread size— $\frac{1}{16}$ -inch.

Material—zinc-base alloy.

Safeties—locking safety pin (cotter pin type) in release pin at end opposite release pin ring; positive safety pin (cotter pin type) in end of firing pin between pressure prongs.

Painting—olive drab.

Packing method—packed 3 per carton, 16 or 30 cartons (48 or 90 fuzes) per wooden box, or, packed 3 per carton, 2 or 4 cartons per waterproof package, 15 or 4 packages (90 or 48 fuzes) per wooden box.

Packing weight—48 fuze boxes, 36 pounds (approx); 90 fuze boxes, 67 pounds (approx.).

c. Functioning.

- (1) Pressure of 8 to 30 pounds acting on one or more of the three prongs of the fuze, or, pull of 3 to 10 pounds on a trip wire attached to the release pin ring of the fuze causes release of firing pin which will be forced downward by the firing pin spring to hit the primer.
- (2) Primer projects a flame to igniter charge.
- (3) Igniter transmits flame to propelling charge.
- (4) Propelling charge transmits flame to delay charge and projects the shell (modified 60-mm mortar shell) from mine.
- (5) Delay charge then transmits flame to ignite charge which causes detonator, booster, and bursting charge to function, bursting the shell at 6 feet (approx) from mine.

d. Laying and Arming.

- (1) Prepare a hole in the ground with a firm foundation at the bottom and of appropriate dimensions (*b* above).
- (2) After unpacking a mine and a firing mechanism (packed in the carton with the mine), test the locking safety pin and the positive safety pin for freedom from binding. If either of these safety pins binds when twisted in their holes, turn the mine in to appropriate technical personnel for inspection.
- (3) Unscrew the hexagonal shipping cap from the coupling base in the mine, inspect the fuze well for any foreign matter, and screw the firing mechanism to the coupling base handtight.
- (4) Lay the mine in the hole so that the tips of the prongs on the fuze will be just above ground level. Pack dirt tightly around and over the mine to just below the release pin level.
- (5) Install one or more trip wires by attaching them first to firmly driven anchor stakes and then to the release pin ring, leaving enough slack in the trip wires to allow the top of the fuze to rotate in order to receive a direct pull on the release pin ring by any one of the trip wires. This is necessary for proper functioning of the fuze.

Caution: Be sure that there is no tension on the trip wires.

- (6) Remove locking safety pin by pulling on the cord to which it is attached.
- (7) Finish filling the hole with dirt up to the tips of the prongs, making sure that the dirt around the trip wire(s) and around

the cord attached to the positive safety pin is loose enough to permit their free movement.

- (8) The effective pressure area may be increased by installing a board, fixed at one end and in such a position that pressure on the board would bring pressure on the prongs of the fuze. If a board is installed, care must be exercised *not to allow the weight of the board to exert any pressure on the fuze.*
- (9) Camouflage the whole installation.
- (10) Remove the positive safety pin by pulling on the end of the cord attached to it, thus arming the fuze.

Caution: Do not disturb the trip wires.

- (11) Save the hexagonal shipping cap and both safety pins for possible use in disarming the fuze.

e. Boobytrapping. As there is no provision in the form of an extra fuze well in this mine for a secondary boobytrapping fuze, any boobytrapping will be done only by especially trained personnel. Refer to FM 5-31.

f. Disarming and Removal (Neutralizing).

Warning: Do not attempt to disarm or remove any mine that is frozen into the ground.

- (1) Carefully inspect the installation for boobytraps and boobytrapping devices before EACH of steps (2) through (7) below.
- (2) Carefully remove the camouflage material and pressure board, if any.
- (3) Carefully remove the dirt from around the top of the mine to expose both the positive safety pin hole and the locking safety pin hole.
- (4) Insert the positive safety pin *first*, and then insert the locking safety pin.
- (5) Disconnect the trip wires.
- (6) Remove the remaining dirt in the hole and remove mine.
- (7) Unscrew the firing mechanism from the fuze, taking care *not* to remove the coupling base containing the primer from the mine.
- (8) Replace the hexagonal shipping cap and return the mine and firing mechanism each to their original condition and packing.

g. Effectiveness.

- (1) Casualty radius when exploded, 10 yards.
- (2) Danger radius, 150 yards.
- (3) Ten percent as effective as M16 mine (par. 22).

h. Special Precautions.

- (1) No attempt will be made to disassemble the mine except to unscrew the firing mechanism from the coupling base when a mine is removed from a "laid" position.
- (2) Mines with loose projector caps or with a loose primer in the coupling base will not be used until inspection by ordnance technical service personnel shows that the igniter charge and propelling charge have not been damaged by moisture, and the

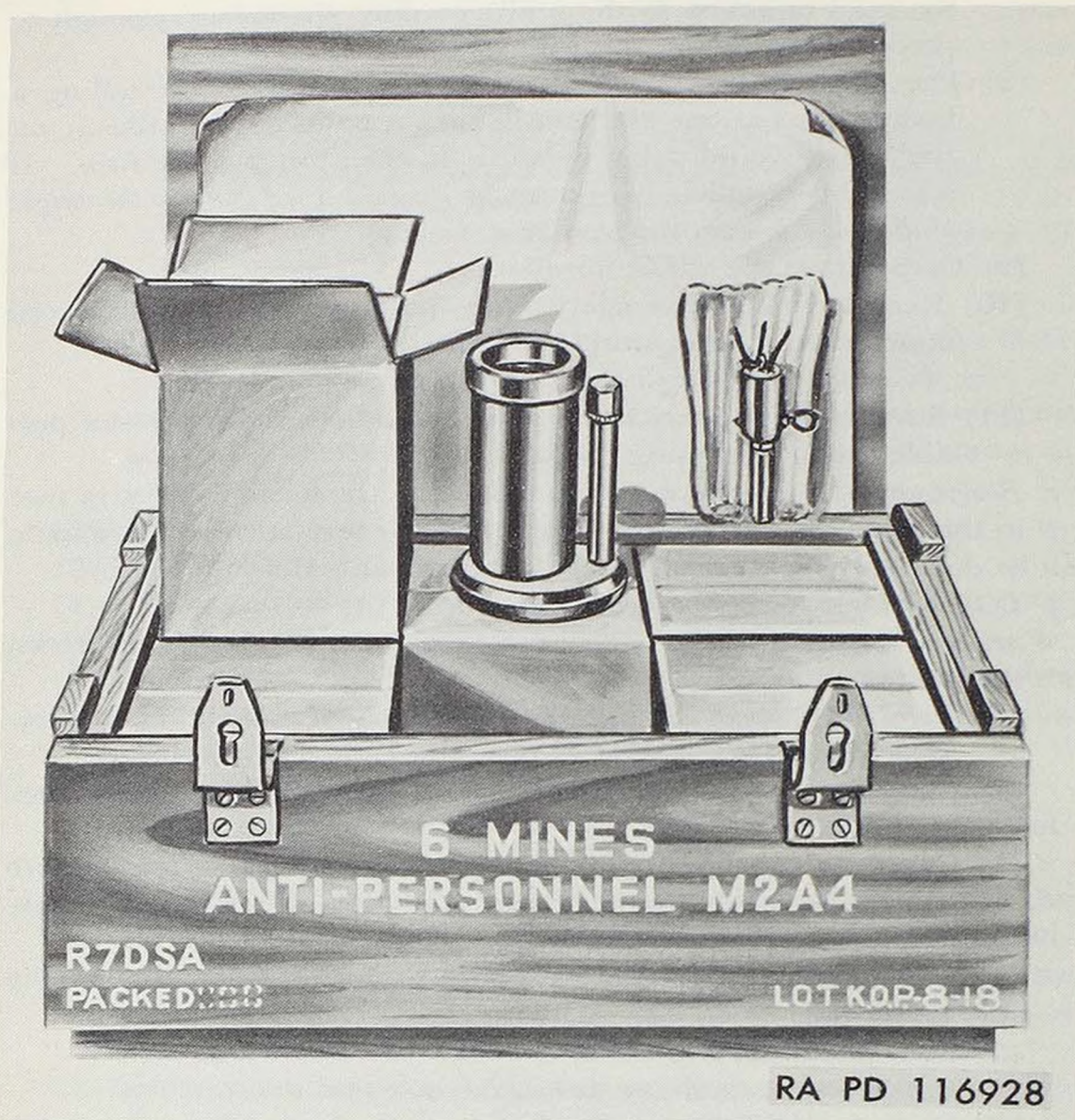

Figure 9. Packing box for antipersonnel mine M2A4.

- projector cap and the primed coupling base with igniter charge (primer and igniter assembly) have been resealed.
- (3) Although the mine is water resistant, it should not be expected to function after prolonged submergence in water.

Note. The mine may be laid and removed any number of times if not damaged or deteriorated, and if the above instructions are followed. Do not use mines if either the mine projector cap or the coupling base containing the primer are loose, except as provided in (2) above.

i. Packing. Each mine is packed in a corrugated paper carton which also contains a tri-pronged firing mechanism (fuze less assembly of primed coupling base and igniter) and one spool of four 26-foot lengths of olive drab or sand-colored trip wires. The assembly of the primed

coupling base and igniter is in place in the mine and protected by a hexagonal shipping and storage cap. Six containers are packed in a wooden box. The weight of the box with six mines and accessories is 50 pounds (approx). The dimensions of the box are 15 x 10 $\frac{1}{4}$ x 9 $\frac{3}{8}$ inches (fig. 9). Some M2A4 mines and manufacturing alternatives M2A4B1 or M2A4B2 may be on hand packed in cartons, 10 cartons per wooden box.

Note. Hexagonal shipping and storage cap is removed from coupling base in the field and replaced with firing mechanism.

18. Fuze, Mine, Combination, M6A1

a. General. This fuze (fig. 8) is used with all antipersonnel mines of the M2 series. As shipped, part of the fuze M6A1, that is, the primed coupling base with the black powder igniter attached, is in the mine and covered by a hexagonal shipping cap; the other part of the fuze, that is, the firing mechanism, is in a container in the box with the mine.

b. Description. The fuze consists of a tri-pronged firing mechanism and a coupling base fitted with a percussion cap primer and a black powder igniter. This coupling base assembly is assembled to the mine as issued, and the firing mechanism is packed separately in the mine packing box. The firing mechanism consists of a cylindrical head and body, the head being of slightly larger diameter. The head contains a spring-loaded trigger pin to which the three pressure prongs are attached. The head contains also a spring-loaded release pin with the locking safety pin and with a release pin ring for attachment of a pull or trip wire. The head and body of the firing mechanism contain a firing pin which consists of a $\frac{1}{8}$ -inch steel rod recessed near the center for engagement of the release pin. The positive safety pin is located near the top of the firing pin between the prongs of the firing mechanism head.

c. Functioning. The firing mechanism is initiated by a pull on a trip wire attached to the release pin ring thus releasing the firing pin, or by pressure on one or more of the prongs of the head. Such pressure depresses the trigger pin which operates the release pin which in turn releases the firing pin. A pull of 3 to 10 pounds on the release pin ring or a force of 8 to 30 pounds on one or more of the prongs protruding from the top of the head thus depressing the head about nine thirty-seconds of an inch will cause the fuze to function.

Caution: When the fuze is unpacked for use, it should be inspected to insure that the trigger pin in which the prongs are set (fig. 8) is fully seated against the crimping at the top of the head, that the release pin is fully seated, and that the safety pins do not bind. If the fuze fails to meet any of these requirements, it is unsafe and should not be used.

d. Packing. In addition to fuzes packed with mines, fuzes are packed three per carton, 16 or 30 cartons (48 or 90 fuzes) per wooden box, or, packed three per carton, two or four cartons per waterproof package, 15 or 4 packages (90 or 48 fuzes) per wooden box. Boxes with 48 fuzes

weigh 36 pounds (approx); boxes with 90 fuzes weigh 67 pounds (approx).

19. Mine, Antipersonnel, M3, and Fuze, Mine, Combination, M7A1

a. General. This mine (fig. 10) is of the fragmentation type consisting of a cast-iron block-shaped shell containing TNT and fuze M7A1. Three threaded fuze wells provide for use, as required, of one, two, or three M7A1 fuzes or any standard firing devices fitted with nonelectric blasting caps. This mine has an effective radius against personnel of 10 yards when actuated at the surface. The effective radius is increased when the mine is several feet above ground level and decreased when the mine is buried. Fragments of the mine may be thrown more than 100 yards, and suitable protection should be provided for friendly personnel within this radius.

b. Description.

(1) *Body.* The cast-iron body is filled with 0.90 pound of flake TNT. In two opposite sides and one end, there are threaded fuze wells. The fuze, (M7A1) which consists of a firing mechanism and a primed coupling base to which a nonelectric blasting cap is crimped, may be inserted in any one of these wells. As shipped, the holes are closed with slotted plastic plugs. In one end, opposite the end containing the threaded well, is a filling hole which is closed with a metal disk. The mine is painted olive drab except for the closing disk which is painted yellow.

(2) *Fuze.* The fuze M7A1 is described in paragraph 20.

Note. Fuze M7A1 is not interchangeable with the M6A1 (par. 18).

c. Functioning. A pressure of 10 to 20 pounds on any of the prongs of the fuze or a pull of 6 to 10 pounds on the release pin ring will release the firing pin. The firing pin hits the primer which explodes the non-electric blasting cap crimped to the coupling base of the fuze. This, in turn, causes detonation of the TNT bursting charge.

d. Installation and Arming. Prepare the mine for use by testing the safety pins (cotter pins) for freedom from binding. The mine may be installed with any one or all of the fuzes arranged for trip-wire operation, pressure operation, or both.

(1) *For trip-wire operation.*

(a) Anchor the mine firmly by partially burying it and packing with earth, tying or taping to stakes, or other means.

(b) Remove 1, 2, or all 3 of the closing plugs depending upon how many fuzes are to be used for the particular operation. Use wrench packed with mines. Conceal the plugs for possible future use in "neutralizing" in accordance with FM 20-32.

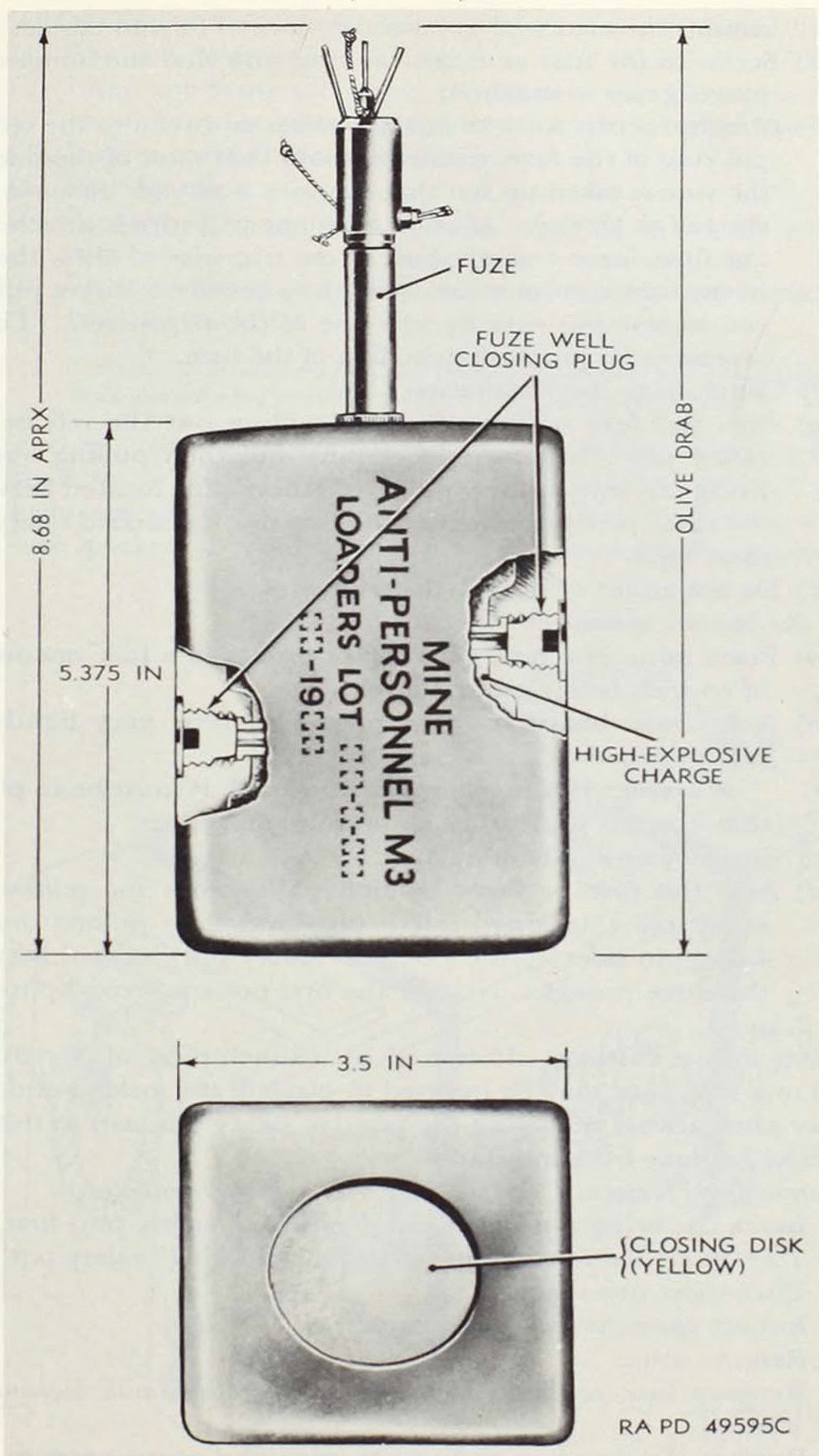

Figure 10. Mine, antipersonnel, M3, and fuze, mine, combination, M7A1.

- (c) Inspect threaded well to insure absence of foreign matter.
 - (d) Screw in the fuze or fuzes, making sure that the nonelectric blasting cap is attached.
 - (e) Attach the trip wires to anchor stakes and then to the release pin ring of the fuze, making certain that most of the slack of the wire is taken up but that the wire is *not tight enough to exert any pull on the ring*. If more than one trip wire is attached to one fuze, leave enough slack in the trip wire to allow the top of the fuze to rotate just enough to receive a direct pull on the release pin ring by any one of the trip wires. This is necessary for proper functioning of the fuze.
 - (f) Camouflage the installation.
 - (g) Arm the fuze or fuzes by first pulling out the release pin safety pin ("locking" safety pin) and then pulling out the firing pin safety pin ("positive" safety pin) located between the three prongs. Neither the first nor the second safety pin must bind.
 - (h) Do not adjust or disturb the trip wires.
- (2) *For pressure operation.*
- (a) Place mine in a hole with top of prongs of a fuze one-fourth of an inch below ground level.
 - (b) A pressure board may be placed to bear very lightly on prongs of mine.

Warning: If a pressure board is used, it must be so placed that it exerts practically no pressure on prongs.

- (c) Cover mine and camouflage.
- (d) Arm the fuze or fuzes by first pulling out the release pin safety pin ("locking" safety pin) and then pulling out the firing pin safety pin ("positive" safety pin) located between the three prongs. Neither the first nor the second pin must bind.

e. Arming From a Distance. If desired, an 18-inch piece of No. 16 wire attached to a long cord may be inserted in place of the locking and positive safety pins (always removing the positive safety pin last) so that the arming may be done from a distance.

f. Disarming and Removal (Neutralizing) a Trip-Wire Installation.

- (1) Insert the firing pin safety pin ("positive" safety pin) first, and then insert the release pin safety pin ("locking" safety pin).
- (2) Disconnect trip wires.
- (3) Inspect carefully for boobytraps.
- (4) Remove mine.
- (5) Remove fuze or fuzes *including coupling base with blasting cap attached*.
- (6) Replace closing plugs and return mine and components to their original packings.

g. *Disarming and Removal (Neutralizing) a Pressure Installation.*

- (1) Remove pressure board, if any.
- (2) Insert the firing pin safety pin ("positive" safety pin) first, and then insert the release pin safety pin ("locking" safety pin).
- (3) Inspect carefully for boobytraps.
- (4) Remove mine.
- (5) Remove fuze or fuzes *including coupling base with blasting cap attached.*
- (6) Replace closing plugs and return mine and components to their original packings.

Note. The mine may be laid and removed according to the above instructions any number of times if not deteriorated or damaged.

h. Packing. Six mines are packed (fig. 11) in a wooden packing box with six fuzes. The dimensions of the box are $17\frac{7}{8} \times 8\frac{3}{4} \times 9\frac{1}{2}$ inches. The fuzes are packed in sealed cylindrical fiber containers which, in turn, are packed in compartments in one end of the packing box.

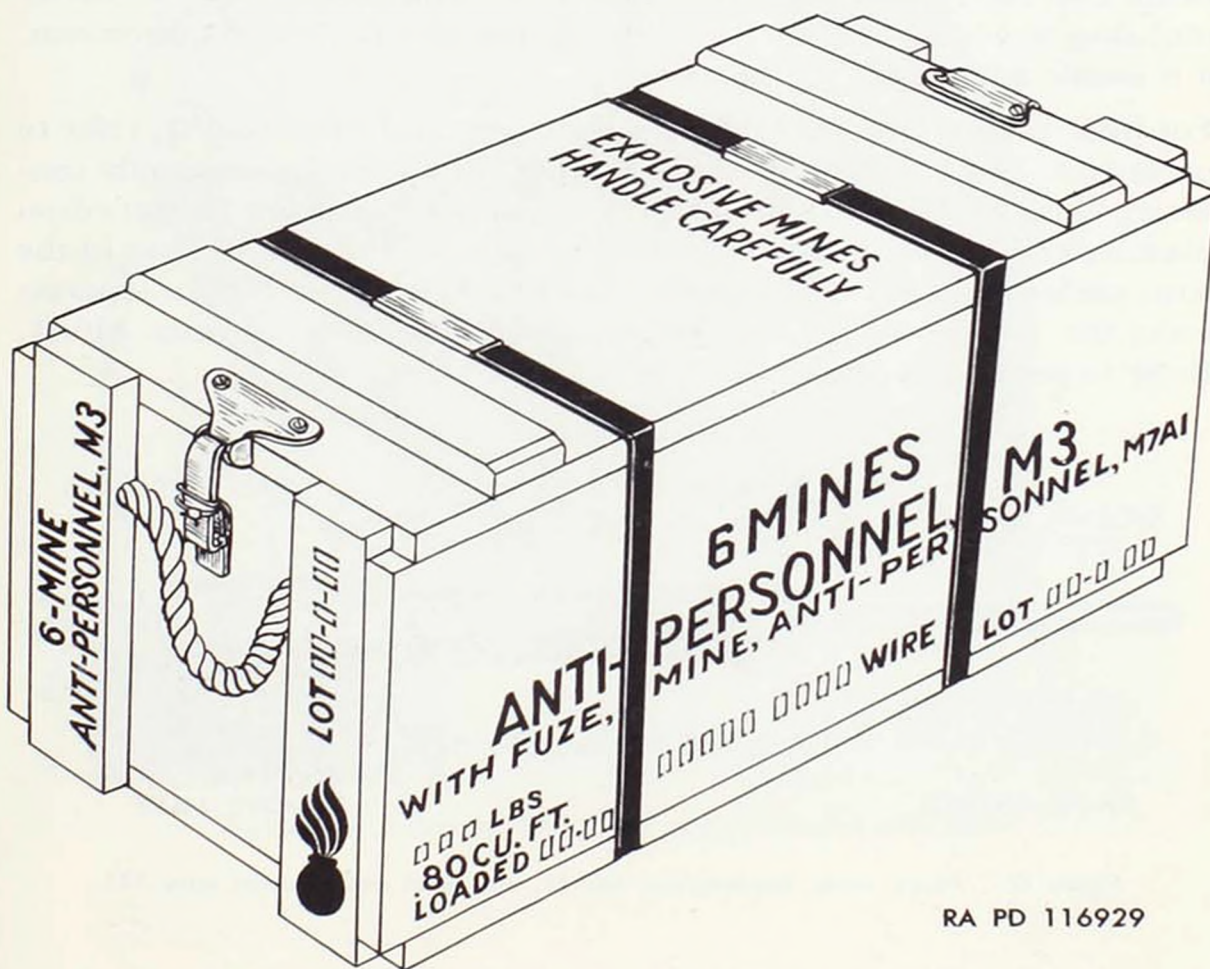

RA PD 116929

Figure 11. Packing box for six anti-personnel mine M3 and six anti-personnel mine fuze M7A1.

Packed in the box is a small wrench which fits the square holes in the plastic plugs in the mine and is used for unscrewing them prior to assembling the fuzes. Six spools of wire for use as trip wires, each having four 26-foot lengths, are also packed in each box. The wire supplied with some mines is olive drab; that supplied with others is sand colored. The weight of the box with mines and accessories is 73 pounds (approx).

20. Fuze, Mine, Combination, M7A1

This fuze (figs. 12 and 13) consists of a three-pronged firing mechanism of the same type used with the fuze M6A1 (par. 18) and a primed coupling base which is fitted with a blasting cap. The coupling base used with the fuze M7A1 is one-fourth inch shorter than the one used with fuze M6A1. A blasting cap is employed by fuze M7A1 because it is used with the antipersonnel mine M3 in which the high-explosive is directly exploded by the cap, whereas the igniter of the fuze M6A1 used with M2 series mines is merely required to ignite a propelling charge in the bottom of the mine.

Caution: When the fuze is unpacked for use, it should be inspected to insure that the trigger pin is seated against the crimping at the top of the head, that the release pin is fully seated, and that the safety pin (cotter pin) does not bind. If the fuze fails to meet any of these requirements, it is unsafe and should not be used.

For information on installation and arming, and neutralizing, refer to paragraph 19. As shipped, the fuze M7A1 is a complete assembly consisting of firing mechanism and primed coupling base with crimped-on blasting cap. This complete assembly is packed separately but in the same packing box with the mine. The fuzes are also packed for separate issue, the method of packing being identical to that for fuzes M6A1. Refer to paragraph 19h.

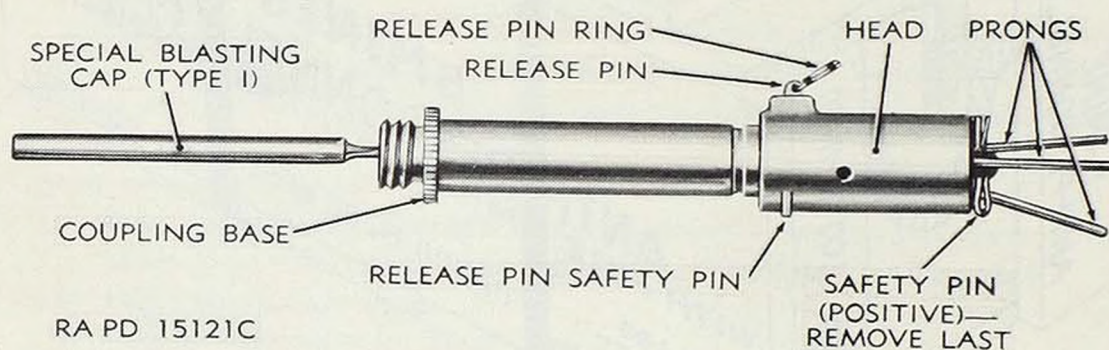

Figure 12. Fuzes, mine, combination, M7A1, used with antipersonnel mine M3.



Figure 13. Installing fuze M7A1 in antipersonnel mine M3.

- (6) Arm the firing device by removing safety pins, always removing the "positive" safety pin *last*.
- (7) Save and conceal all safety pins, activator plug, and its gasket for possible future use in disarming and removal.

f. *Disarming and Removal (Neutralizing).*

- (1) Carefully uncover the concealed mine and examine the side and bottom secondary fuze wells for any boobytrapping devices (secondary fuzes). *Trip wire may have been installed that will initiate a secondary fuze by either pull or release.*

- (2) *Do not cut any taut trip wires, but cut all slack trip wires.*

Warning: If taut trip wires are encountered when attempting to neutralize the mine, do not cut the wires under any circumstances. The best procedure is to attach a long rope or wire to the mine without disturbing the taut trip wire and then remove the mine from the ground by pulling on the long rope or wire from a protected position, making sure that such protected position is not mined. If this method is not practicable, the matter should be referred to local technical service personnel.

- (3) Replace all safety pins in the firing devices, if any, always replacing the so-called "positive" safety pin *first*. Refer to paragraphs 49 through 73 for instructions pertaining to the particular firing device involved.
- (4) Unscrew firing device from activator.
- (5) Unscrew activator. Replace plug and gasket in head of activator.
- (6) Turn the setting knob of the arming plug to the SAFE position.
- (7) Remove arming plug by unscrewing it in a counterclockwise direction.
- (8) Remove the fuze, grasping the fuze pressure plate with the fingers. It should come out easily. *Do not attempt to remove the fuze if it is frozen in place.* Insert the safety fork (clip) in the fuze.
- (9) After removing the fuze, screw arming plug with retainer spring back into place handtight with pointer on setting knob pointing to SAFE.
- (10) Remove the trip wire and replace tape over secondary fuze well, if used.
- (11) Restore the mine and fuze to its original position and packing. The mine may be laid and removed any number of times provided neither fuzes nor mines show evidence of damage or deterioration.

g. *Effectiveness.*

- (1) When buried 3-inches deep, this mine will disable a medium tank such as the 90-mm gun tank M48 by breaking the track.
- (2) When laid flush with ground, it will disable a medium tank such as the 90-mm gun tank M48 by breaking the track and bogies (road wheels or other parts of the suspension system).

h. Sympathetic Detonation.

- (1) When buried 3-inches deep, sympathetic detonation will occur when mines are 5-feet apart.
- (2) When laid on top of ground, sympathetic detonation will occur when mines are 14-feet apart.

i. Packing. The mine M15 is packed 1 mine, with 1 fuze M603 and 1 activator M1 each in a metal container, all contained in a wooden box. The dimensions of the box are 18 x 15 $\frac{1}{8}$ x 7 $\frac{1}{2}$ inches. The box with contents weighs 49 pounds (approx).

Section II. ANTITANK PRACTICE MINES AND FUZES

39. General

a. The antitank mines and fuzes which are specifically designated "practice" in nomenclature are of the same size, shape, weight, and casing material as the service mines and fuzes they simulate. These practice mines contain no high explosive but they do contain small smoke-puff and noise-making charges of low explosive (black powder or pyrotechnic composition) to simulate the explosion of a service mine. These practice mines are provided for practice and training in identification, care, handling and use of antitank *service* mines.

b. The antitank mines and fuzes which are specifically designated "inert" in nomenclature consist of the same metal or plastic parts as service mines and fuzes. The "inert" mines are filled with inert material such as sand, when practicable, or they may be empty. The inert mines and fuzes contain no explosive of any kind and are used only in practice and training in the applicable aspects of handling mines.

c. The following safety precautions prescribing conditions under which practice mines may be employed in practice and training will be observed:

- (1) Do not mix service, practice and inert mines and fuzes. Practice and inert mines should be painted their proper color and have the appropriate identifying terms stenciled upon their bodies.
- (2) "Inert" antitank mines, since they contain no explosive, require no special safety precautions, and they should be used whenever possible in training. Personnel should be trained to handle all ammunition and ammunition components as potentially dangerous, even though the items have been designated "inert" or "empty."
- (3) No special safety precautions are necessary when tanks or other combat vehicles, unaccompanied by ground troop trainees, are negotiating a practice antitank mine course whether the mines are inert or contain the small amounts of low explosive (black powder or pyrotechnic composition) contained in "practice" mines.

21. Mine, Antipersonnel, NM, M14, With Integral Fuze

a. General. This mine (figs. 14, 15, and 16) is a blast type high-explosive antipersonnel mine consisting of a main charge of tetryl, an all plastic body with an integral fuze composed of the same material except that the firing pin is of steel. The mine is designed with a relatively small high-explosive charge in order to effect nonlethal casualties to enemy foot troops. Being of practically all plastic construction, it is nondetectable by magnetic mine detectors. The mine is generally cylindrical in shape. Six ribs on the outside of the body provide strength, and serve as a means for identifying the mine in darkness. The detonator holder, which contains a detonator, is in the form of a plug and is of the same plastic material as the mine. The detonator holder has a hexagonal partially slotted head (fig. 15). It is similar in external shape to the shipping plug (fig. 16) except that the shipping plug has a circular partially slotted head. The pressure plate has a yellow indicating arrow and is indented to accommodate the mine and fuze wrench (fig. 17). Two letters A and S on the top of the fuze body signify "armed" and "safe" respectively. The slots in the pressure plate are for insertion of the steel U-shaped safety clip (fig. 16). The pull cord is for use in removing the safety clip from the mine when testing and arming. Beneath the safety clip slots is a circular groove for a rubber gasket which makes a watertight joint between the pressure plate and the fuze body. A lock key is fastened to the center of the under side of the pressure plate. The lock key holds the lock ring firmly when the arrow on the pressure plate is pointed to "S." The lock ring prevents the mine from firing prematurely. The spider spaces the parts within the fuze and supports the pressure plate when this plate is in the "safe" position. The three projections on the inside of the center hole of the spider prevent the lock ring, belleville spring, and firing pin assembly from rotating when the pressure plate is turned. The belleville spring with the attached lock ring and firing pin assembly is seated against the spider and is held in place by a ridge on the rim of the partition. The partition also holds the main charge in place and prevents any explosive from getting into the firing mechanism of the fuze.

b. Description.

(1) *Mine.*

Model number—M14.

Type—blast.

Weight, loaded and fuzed (integral fuze and detonator)— $3\frac{1}{2}$ ounce (approx).

Weight of explosive charge (tetryl)—1 ounce.

Dimensions—height, $1\frac{1}{6}$ inches; diameter, $2\frac{3}{16}$ inches.

Material—plastic.

Fuze—integral.

Detonator—M46, in plastic hexagonal-head detonator holder (installed in the field).

Booster—none required.

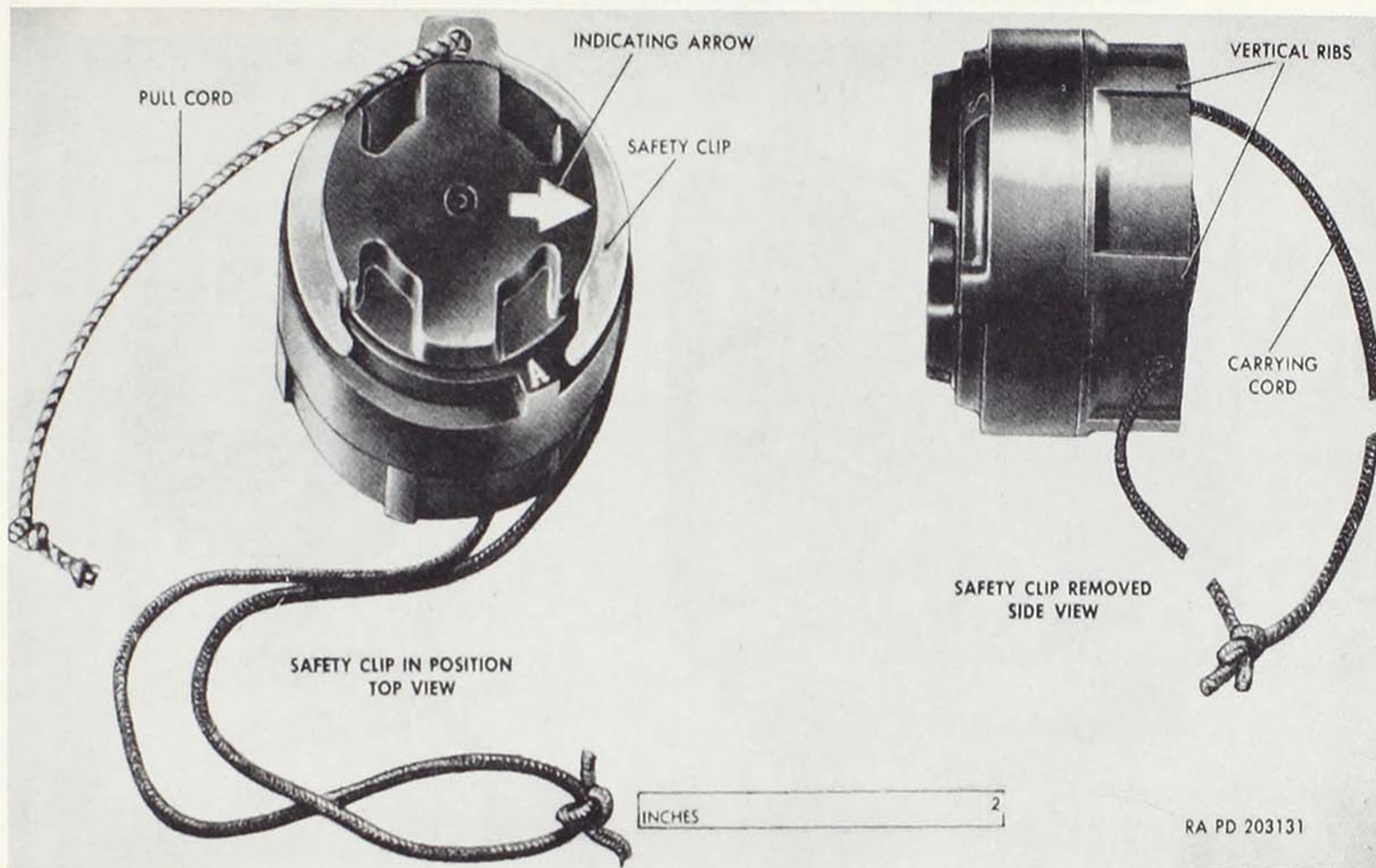

Figure 14. Mine, antipersonnel, NM, M14, with integral fuze—top and side.

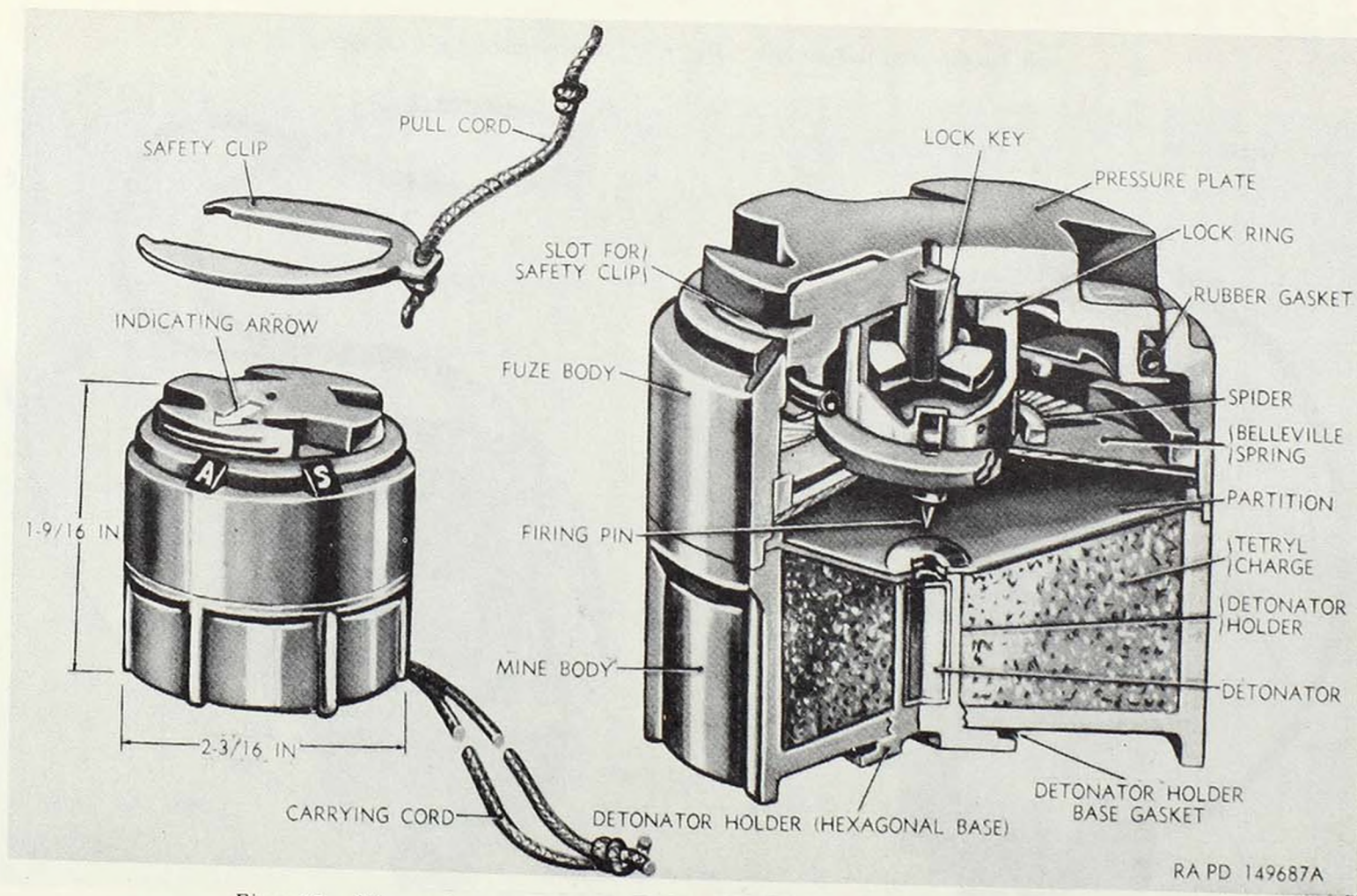

Figure 15. Mine, antipersonnel, NM, M14, with integral fuze—external and one-third section—detonator installed.

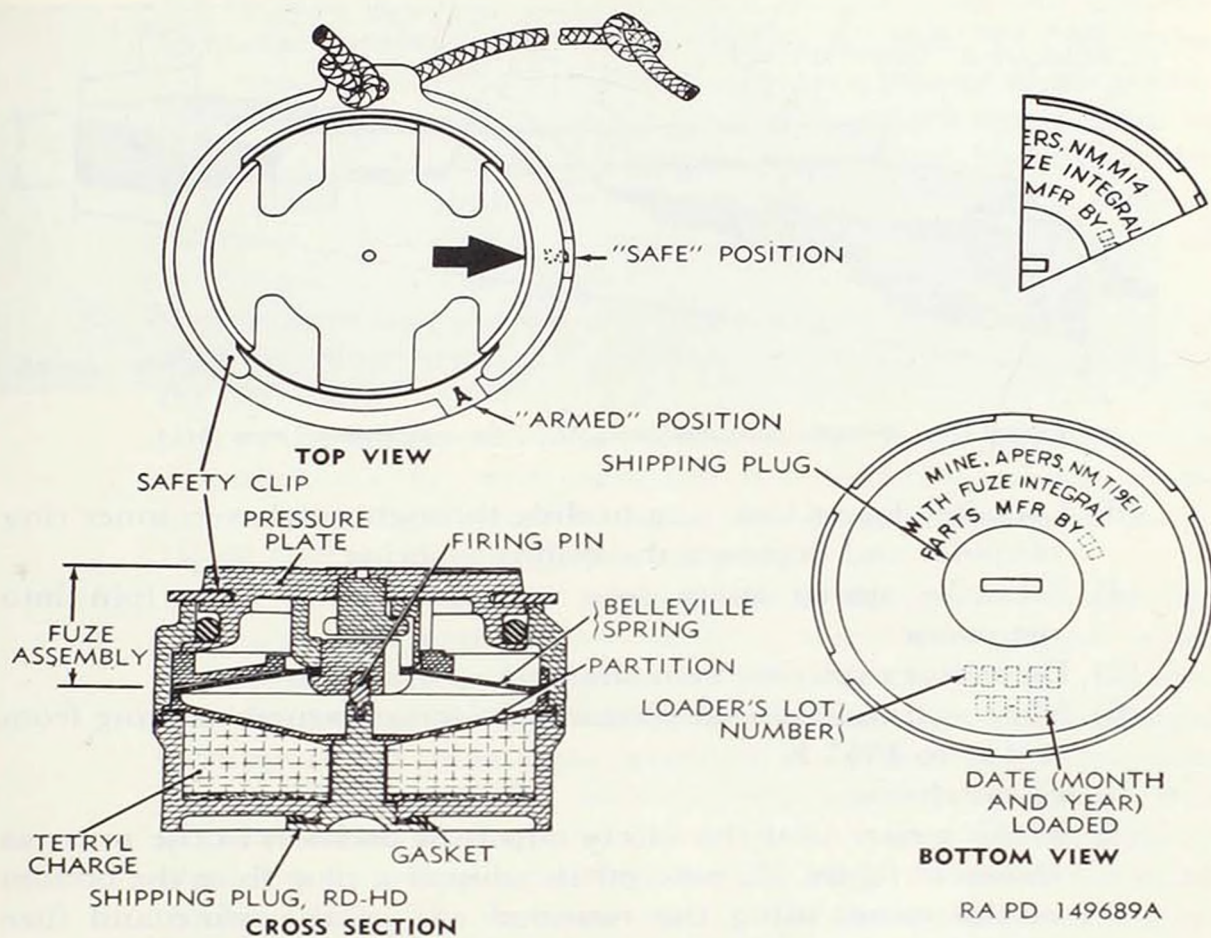

Figure 16. Mine, antipersonnel, NM, M14, with integral fuze—top, bottom, and cross section.

Color—olive drab.

Marking (on bottom)—nomenclature, symbol of parts manufacture, loader's lot number, date (month and year) loaded.

Shipping plug—circular-head partially slotted shipping plug, in place as shipped, to be replaced by detonator holder in the field.

Packing method—1 mine with shipping plug in a carton, 90 cartons (90 mines), 90 detonator holders with detonators in a set-up box, and 9 mine and fuze wrenches, all packed in wooden box. Earlier packing includes 6 wrenches.

Packing weight—44 pounds (approx).

(2) *Fuze.*

Model number—none.

Components—pressure plate, lock key, spider, lock ring, belleville spring, and firing pin.

Type—belleville spring—integral.

Material—plastic (except steel firing pin).

Safeties—clip (U-shaped) with pull cord; provision for turning pressure plate from safe position (yellow pointer at S) to armed position (yellow pointer at A).

Color—olive drab.

c. *Functioning.*

- (1) A force of 20 to 35 pounds will depress pressure plate.
- (2) Pressure plate depresses lock key.

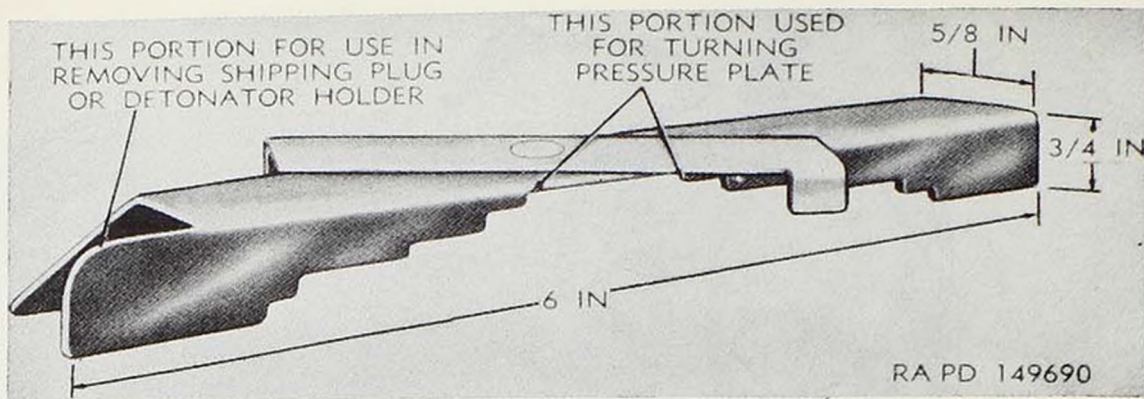

Figure 17. Wrench, mine and fuze, M22, for antipersonnel mine M14.

- (3) Lock key forces lock ring to slide through notches in inner ring of spider and depresses the belleville spring.
- (4) Belleville spring snaps into reverse, driving firing pin into detonator.
- (5) Detonator explodes main charge.
- (6) Mine will function satisfactorily in temperatures ranging from -45° to 135° F.

d. *Laying and Arming.*

- (1) Making sure that the safety clip is in position in the mine as shown in figure 15, unscrew the shipping plug from the bottom of the mine, using the rounded end of the mine and fuze wrench.
- (2) Using the wrench as indicated in figure 17, turn the pressure plate of the mine in a clockwise direction from S until the indicating arrow points to A.
- (3) Test the fuze by temporarily withdrawing the safety clip from the mine, then observing to see that the firing pin remains in its "unfired" position when the clip is so withdrawn. If the firing pin does remain in its unfired position, the integral firing mechanism of the mine may be considered satisfactory. If the firing pin does not so remain, discard the mine. Replace the safety clip and turn the pressure plate from A in a counter-clockwise position back to S.
- (4) Examine the inner end of the shipping plug (the end toward the firing pin) for any evidence of distortion or "splaying out" that could be caused by dangerously long or "fired" firing pin. The "unfired" position of the firing pin is when the belleville spring and firing pin assembly is in the position shown in figures 15 and 16.

Warning: Do not insert a detonator if there are any indications that the firing pin is not in its "unfired" position because inserting the detonator against an abnormally long or "fired" firing pin might cause the mine to explode. Carefully examine

the detonator holder and the aperture in the mine for any deformation or obstructions that might cause detonation when the detonator is inserted. Use extreme care when handling detonator as shock or dropping detonators might cause them to explode. Detonators should not be carried in pockets on the person. They should be transported only in their regular packings. Any defective detonators or mines will be destroyed as prescribed in TM 9-1900.

- (5) Making sure that there are no obstructions or distortions in the shipping plug, detonator assembly, or mine aperture, and that the detonator (M46) is properly placed (red end to face firing pin) in the detonator holder, screw the detonator assembly with its gasket into the mine, using the mine and fuze wrench, to insure a watertight joint between detonator holder and mine.
Do not exert any force on the pressure plate.
- (6) Lay the mine carefully in a small hole in the ground so that the pressure plate extends just slightly above the ground level, otherwise a shoe or boot may bridge over the mine. Be sure that the ground beneath the mine is sufficiently stable and solid to support the mine when pressure is applied to the pressure plate. If the ground is not sufficiently stable, place a block of wood or other nonmetallic object in the bottom of the hole to provide a firm bearing surface for the mine. Anchor the mine in place, using the carrying cord. Tie the mine down so that it will not float above ground level in case of a heavy rainfall.
- (7) Holding the mine firmly with one hand and *making sure that no force is put on the pressure plate*, turn the pressure plate from S in a clockwise direction to A, using the mine and fuze wrench, and remove the safety clip by pulling on the safety clip pull cord.
- (8) Save the safety clip for possible future disarming of the mine. Safety clips, being made of steel, should be removed to a point where they could not expose the mines to possible mine-detection by the enemy.
- (9) Camouflage the mine and remove any excess soil from the immediate surroundings of the installation.

Note. In camouflaging the mine, use an appropriate mixture of material such as dirt, clay, grass, gravel, and fine twigs, arranged so that they are not likely to be washed entirely away by heavy rains.

e. Boobytrapping. No provision is made for boobytrapping the mine. There are no secondary fuze wells.

f. Disarming and Removal.

- (1) Carefully uncover the concealed mine. *Do not exert any pressure on the pressure plate.*
- (2) Enlarge the hole very carefully and examine the ground around

and underneath the mine for any evidence of damage, malfunctioning, or possible improvised boobytrapping.

- (3) If there is any evidence of damage, boobytrapping, or malfunctioning, do not attempt to disarm the mine. Mark the spot for subsequent destruction in place as prescribed in TM 9-1900.
- (4) Making sure that the mine is held firmly in place, and before the mine is otherwise disturbed, insert the safety clip in the slots in the pressure plate. If the safety clip cannot be inserted relatively easily, it is an indication that the mine has malfunctioned or has been damaged. In such case, discontinue any further attempt to disarm the mine and mark the spot as in (3) above.
- (5) With the mine and fuze wrench, turn the pressure plate in a counterclockwise direction from A to S.
- (6) Remove the mine from the ground.
- (7) Unscrew the detonator holder from the bottom of the mine body using the mine and fuze wrench.
- (8) Replace the shipping plug and gasket.
- (9) Restore the mine to its original condition and packing.

g. Effectiveness.

- (1) Not effective against armored vehicles.
- (2) When buried so that top of pressure plate is flush with ground (normal procedure) and stepped on by a person, will cause a nonlethal casualty.

h. Packing. The mine M14 is packed one mine with shipping plug in a carton, 90 cartons (90 mines), 90 detonator holders with detonators in a set-up-box, and 9 mine and fuze wrenches, all packed in a wooden box. The dimensions of the box are $18\frac{7}{8} \times 18 \times 8\frac{3}{4}$ inches. The weight of the box and contents is 44 pounds (approx). An earlier method of packing the mines is similar except that only 6 wrenches are included in the box; the dimensions of the box are $19\frac{3}{4} \times 17\frac{1}{4} \times 8\frac{3}{4}$ inches, and the weight is 46 pounds (approx).

22. Mine, Antipersonnel, M16 (T6), and Fuze, Mine, Combination, M605

a. General. This mine (figs. 18 and 19) is of the bounding fragmentation type. It consists of a cylindrical cast-iron shell containing high-explosive detonators, boosters, and bursting charge with axial fuze well. The shell is contained in a sheet steel cup which is in turn contained in an outer sheet steel container inclosing the mine body. At the bottom of the steel cup and in a recess in the bottom of the shell is a black powder propelling (expelling) charge. As shipped, a hexagonal shipping plug closes the fuze well. As laid, the mine is fitted with a combination (pressure or pull) type fuze. The mine is completely waterproof. It is readily detected by magnetic mine detectors.

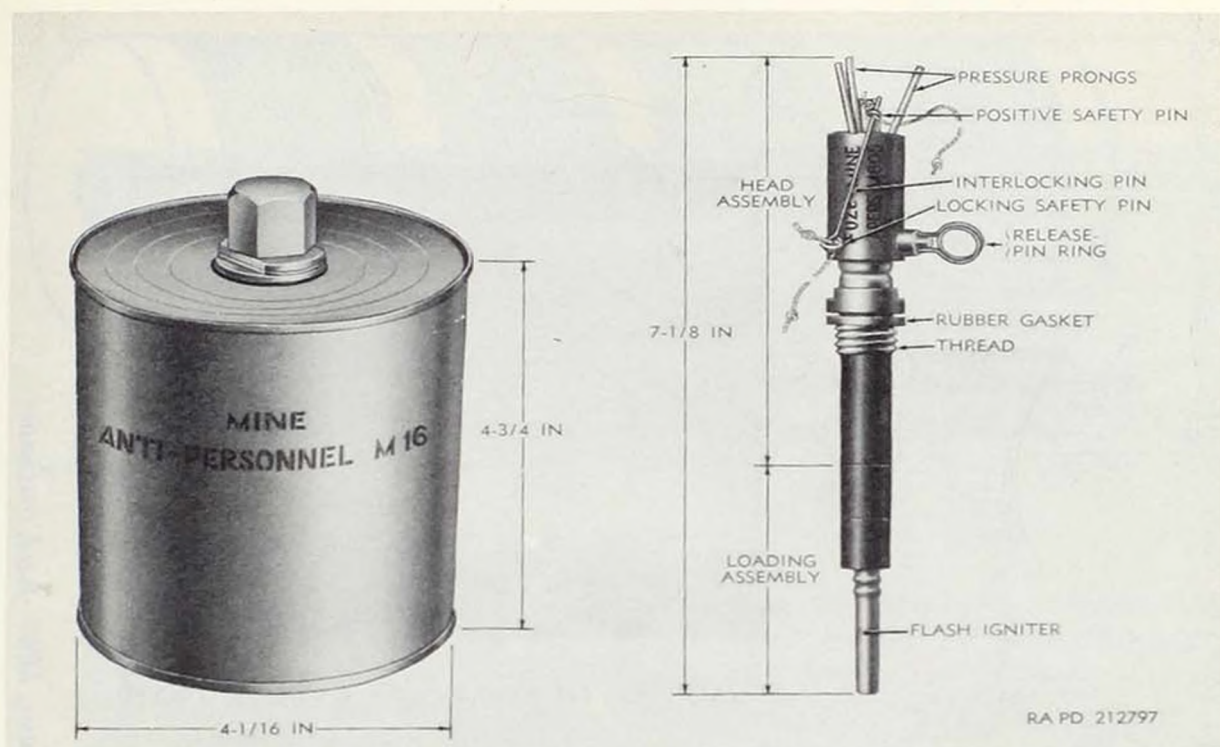

Figure 18. Mine, antipersonnel, M16, as packed, and fuze, mine, combination, M605—external.

b. Description.

(1) Mine.

Model number—M16.

Type—bounding, fragmentation.

Weight, loaded and unfuzed—7 $\frac{1}{8}$ pounds (approx).

Dimensions—height, shipping, 5 $\frac{1}{2}$ inches (approx); height, fuzed, 8 inches (approx); diameter, 4 $\frac{1}{16}$ inches.

Material—steel and cast iron.

Fuze well—in center of mine, closed with hexagonal shipping plug, as shipped.

Two delay charges.

Two detonators.

Two boosters (tetryl).

Weight of bursting charge (TNT)—1 pound.

Weight of expelling charge (black powder)—75 grains (approx).

Painting—olive drab.

Marking—nomenclature of mine, month and year loaded, and lot number (including loader's initials and symbol)—all in yellow.

Shipping plug—hexagonal shipping plug is in place in the fuze well (in center of mine) as shipped. This plug is removed and replaced with fuze in the field.

Packing method—4 mines, 4 fuzes in a metal container, 4 spools of trip wire, and 1 fuzing wrench, in wooden box.

Packing weight—45 pounds.

(2) Fuze.

Model number—M605.

Components—firing mechanism and primed fuze body with crimped-on igniter with black powder charge.

Type—combination.

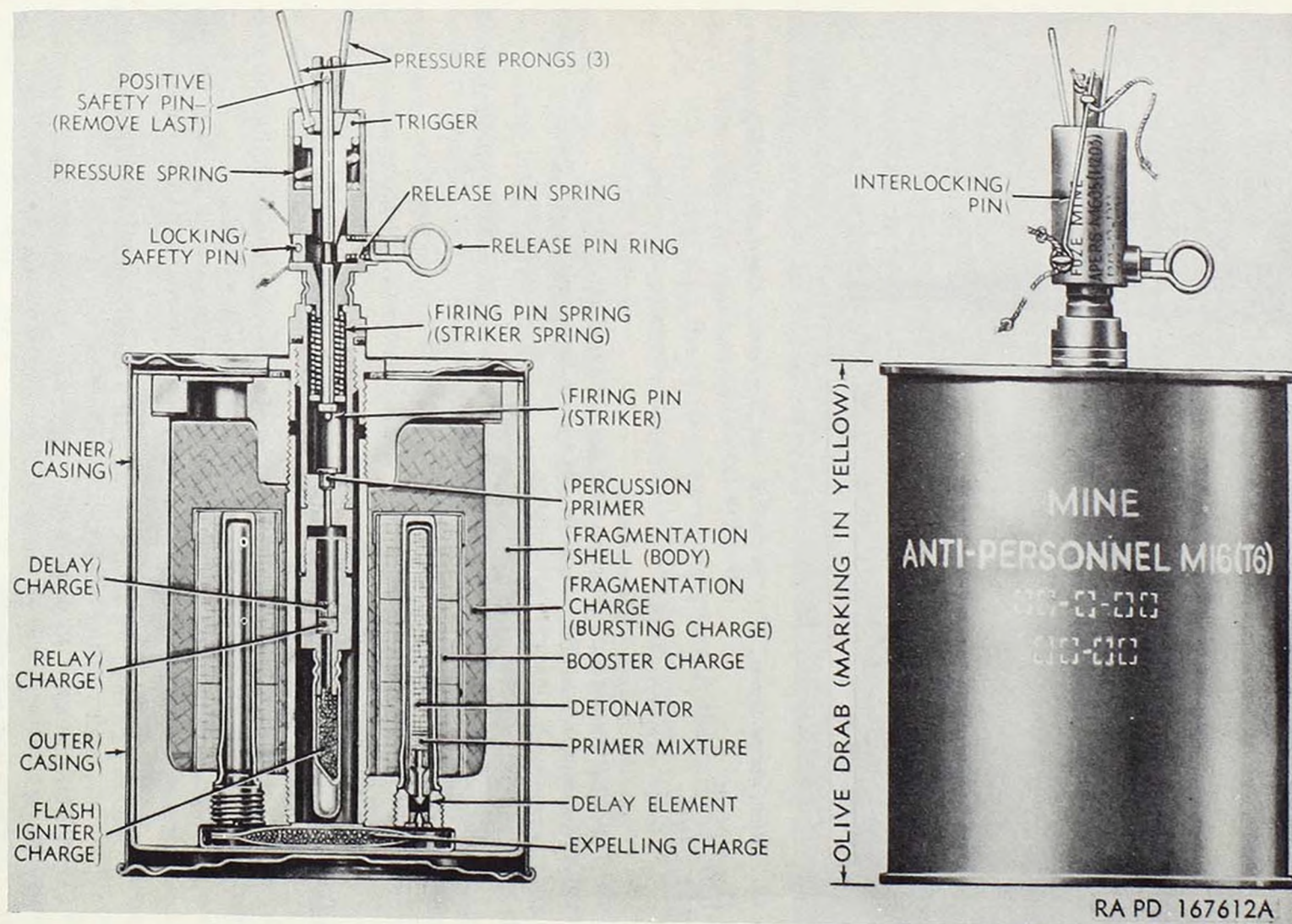
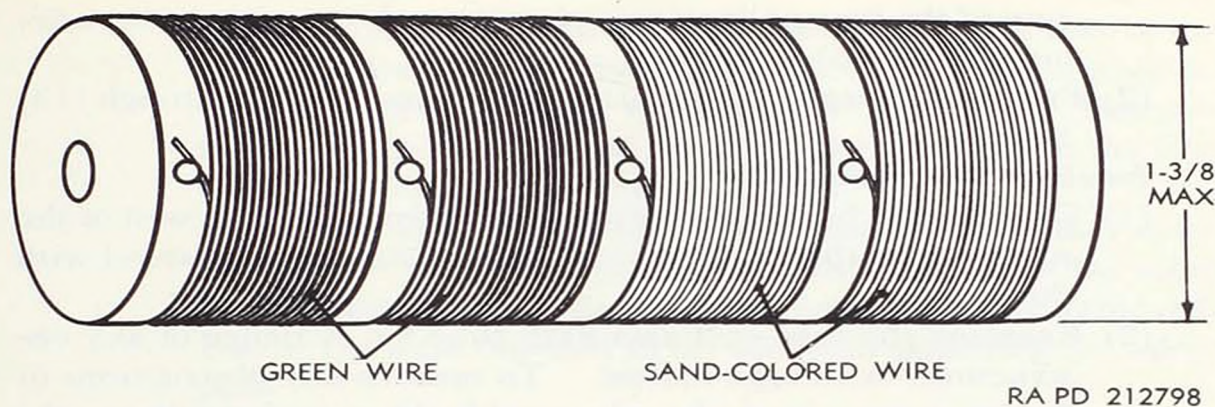

Figure 19. Mine, antipersonnel, M16, and fuze, mine, combination, M605—fuzed, cross section and external.



RA PD 212798

Figure 20. Spool with four 39-foot lengths of trip wire, for use with antipersonnel mine M16.

Dimensions—length, $7\frac{1}{8}$ inches; diameter (overall), $1\frac{3}{4}$ inches.

Material—zinc-base alloy.

Safeties—locking safety pin (cotter pin type) in release pin at end opposite release-pin ring; positive safety pin (cotter pin type) in end of firing pin between pressure prongs; interlocking pin between safety pins.

Painting—olive drab.

Marking—nomenclature of fuze.

c. *Functioning by Pressure.*

- (1) Pressure of 8 to 20 pounds on either of the three prongs of the fuze compresses the pressure spring.
- (2) Pressure spring forces the trigger downward.
- (3) Wedge-shaped tip of trigger forces release pin outward to position where firing pin (striker) is released.
- (4) Firing pin spring forces firing pin downward.
- (5) Firing pin hits primer, which ignites the fuze delay charge.
- (6) Fuze delay charge while burning allows time for person stepping on prong(s) to move from directly above mine.
- (7) Fuze delay charge then ignites the fuze relay charge, which ignites the fuze igniter charge.
- (8) Fuze igniter charge ignites the mine propelling (expelling) charge.
- (9) Mine propelling charge projects cast-iron shell upward from mine body and at the same time ignites the two detonator delay charges.
- (10) As shell reaches 2 to 4 feet above the ground the detonator delay charges have burned through initiating the detonators.
- (11) Detonators explode boosters which in turn explode bursting charge.
- (12) Explosion of bursting charge shatters shell scattering metal fragments in all directions.
- (13) The mine will of course explode even if restrained by sufficient resistance (weight or barrier) from being projected upward.

d. *Functioning by Pull.*

- (1) Pull of 3 to 8 pounds on a trip wire attached to the release pin

ring of the fuze pulls release pin outward to position where firing pin (striker) is released.

- (2) Functioning from this point on is the same as c(4) through (13) above.

e. Installing and Arming.

- (1) Unscrew the hexagonal shipping plug from the fuze well of the mine. Use the closed end of fuzing wrench M25 issued with the mine.
- (2) Examine the fuze well and flash tube for evidence of any obstructions or foreign matter. To remove any obstructions or foreign matter, turn the mine upside down and gently tap the bottom. If any mines appear to be damaged or in an unsatisfactory condition, they should be carried to a safe place and destroyed with explosives by authorized personnel as prescribed in TM 9-1900.
- (3) Carefully examine the fuze assembly for evidence of damage including the crimping at the top of the fuze head where it touched the top of the trigger. Check the safety pins to see that they move freely in the safety pin holes. Be sure the rubber gasket is around the fuze case.
- (4) Screw the fuze assembly into the fuze well of the mine and tighten it down securely against the rubber gasket. Use the open end of the combination wrench M25.
- (5) Dig a hole about 6 inches deep and about 5 inches in diameter.
- (6) Place the mine in the hole. It can be installed so that it will detonate by pressure alone; or it may be installed with trip wires in which case the mine can be detonated either by pressure on the pressure prongs or by pull on the trip wires.
 - (a) *For pressure actuation.* Cover the mine with spoil (dirt) from the hole pressing it firmly into place around the sides of the mine. Leave the release-pin ring and pressure prongs exposed. Arrange the pull cords on the safety pins for easy withdrawal. Camouflage the installation in accordance with instructions in FM 20-32. Remove the locking safety pin. After the locking safety pin is removed, the interlocking pin can be removed from the positive safety pin, which is located between the prongs. Finally, remove the positive safety pin, thus arming the fuze.

Warning: If the positive safety pin is hard to remove, it indicates that the striker has been released and the fuze should be replaced with a new one.

- (b) *For trip-wire actuation.* Cover the mine with spoil (dirt) pressing it firmly in place around the sides of the mine. Leave the release-pin ring and pressure prongs exposed. Drive two anchor stakes approximately 30 to 35 feet from the mine. Locate the stakes so that the trip wires, when attached, will

form a wide V. A third trip wire and anchor stake may be installed, if desired, midway between the two outside trip wires. This prevents any lateral movement of the enemy. Fasten a separate trip wire to each anchor stake, then fasten the free ends to the release-pin ring of the fuze.

Caution: Do not install the trip wires so taut that they exert any pull on the release-pin ring as this might cause the mine to detonate accidentally when the safety pins are removed. Follow the steps outlined in (a) above for removing the safety pins.

f. *Boobytrapping.* No secondary fuze wells for boobytrapping are provided in the M16 mine.

g. *Disarming and Removal.*

- (1) After locating the mine, carefully uncover the top and examine it for evidence of malfunctioning or damage from blast.

Caution: If the mine is damaged, do not attempt to neutralize it. Either destroy it in place with a prepared charge, or attach a 50-yard length of wire or rope to the head of the fuze and from a protected position pull the mine from the hole. Be sure to examine such protected position for mines before occupying it.

- (2) If the mine does not appear to be damaged, insert the original or a like safety pin (cotter), a length of steel wire, or a nail of proper diameter through the *positive* safety pin hole (located between the prongs of the fuze).
- (3) Then, insert safety pin, length of steel wire, or a nail through the *locking* safety pin hole (located in the head of the fuze, opposite the release-pin ring).

Warning: The positive safety pin *must* be inserted FIRST. In case the fuze malfunctions, the positive safety pin stops any action that starts.

- (4) Cut all slack trip wires attached to the release-pin ring.

Warning: Never cut a taut trip wire until the other end has been examined to see that it is not anchored to another mine.

- (5) Carefully dig around the sides and bottom of the mine and check for boobytrapping devices. If the mine is boobytrapped, proceed as outlined in (1) above including CAUTION.
- (6) Lift the mine from the ground.
- (7) Unscrew and remove the fuze assembly from the mine.
- (8) Replace the shipping plug.
- (9) Restore mine to original condition and packing.

h. *Effectiveness.*

- (1) Casualty radius when exploded, 35 yards (approx).
- (2) Danger radius 200 yards.
- (3) The M16 mine is a highly effective weapon capable of killing or injuring personnel in the vicinity of the mine. It is approximately 10 times more effective than the M2 series bounding-

type antipersonnel mine. Because of its effective area coverage, this mine is primarily employed in mixed minefields to protect antitank mines against enemy breaching parties. However, it can be used by itself in the preparation of ambushes or in the nuisance mining of areas likely to be occupied by enemy troops. Because of its wide effective radius, it is necessary to use only about one M16 for every two M14 pressure-actuated antipersonnel mines.

- (4) Since both the pressure prongs and trip wires will be exposed after the mine is installed, the M16 is best employed where at least 3 inches of natural cover is available. When installed for trip-wire actuation, a maximum of front can be covered with a single mine. Normally, 2 trip wires are used with each mine. The spool of trip wire packed with each mine contains 4 separate 39-foot lengths. Two are green, and two are sand colored. Always select the color that blends better with the terrain or vegetation. If it is necessary to install this mine in bare ground or sparsely covered ground, the use of trip wires is undesirable; a soldier walking erect is not likely to detect the pressure prongs unless alerted to the presence of the mines.

i. Sympathetic Detonation. When buried so that the tops of the pressure prongs are about even with the surface of the ground, sympathetic detonation will occur when M16 mines are laid 5 feet apart.

j. Special Precautions.

- (1) No attempt will be made to disassemble the mine except as required in *e* and *g* above, to unscrew the shipping plug in preparation for fuzing or to unscrew and remove the fuze in neutralizing operations.
- (2) Mines with broken or jammed outer casing or fuzes from jammed or dented metallic containers will not be used until inspection by ordnance technical service personnel shows that neither the propelling charge of the mine nor the fuze has been damaged by moisture or otherwise.

k. Packing. The mine M16 is packed 4 mines, 4 fuzes in a metal container, 4 spools of trip wire, and 1 fuzing wrench, all in a wooden box. The dimensions of the box are $15\frac{5}{8}$ x $10\frac{1}{8}$ x $8\frac{1}{2}$ inches. The weight of the box and contents is 45 pounds (approx).

23. Fuze, Mine, Combination, M605

This fuze consists of two main assemblies, the head assembly and the loading assembly. Although designed along somewhat similar lines, the M605 and the M6A1 (par. 18) are not interchangeable.

a. Head Assembly. The head assembly contains the firing mechanism and safety devices. It includes the three pressure prongs projecting from the top of the fuze case, the positive safety pin which passes through the firing pin between the pressure prongs, the interlocking pin located on

the side of the head and assembled to both the positive and locking safety pins, and the locking safety pin which passes through one side of the fuze case and through one end of the release pin. Attached to the other end of the release pin is the release-pin ring to which trip wires may be attached. Threads for assembling the fuze in the fuze well of the mine are located about midway on the head assembly. At this point the fuze case is shaped to permit the use of a wrench in tightening the fuze to the mine. The interlocking pin is designed to assure that the safety pins will be withdrawn in the proper sequence, that is, the locking safety pin first and the positive safety pin last.

b. Loading Assembly. The loading assembly, which is screwed to the head assembly to complete the fuze assembly, consists of the primer assembly and the delay and relay charge assembly to which the igniter is crimped.

c. Functioning. Refer to paragraph 22c and d.

d. Wrench, Fuzing, Antipersonnel Mine, M25. This wrench (fig. 21) is stamped from a piece of strip steel 6 inches long, 1¼ inches wide and about ⅛-inch thick. One end is "closed-end" having a hexagonal opening, 0.775 inch across flats to engage the shipping plug of antipersonnel mine M16 (par. 22). The other end is "open-end" having an opening of 0.64 inch to engage the shoulder on the combination mine fuze M605, which is used with the M16 mine. The "handle" portion of the wrench is five-eighths of an inch wide.

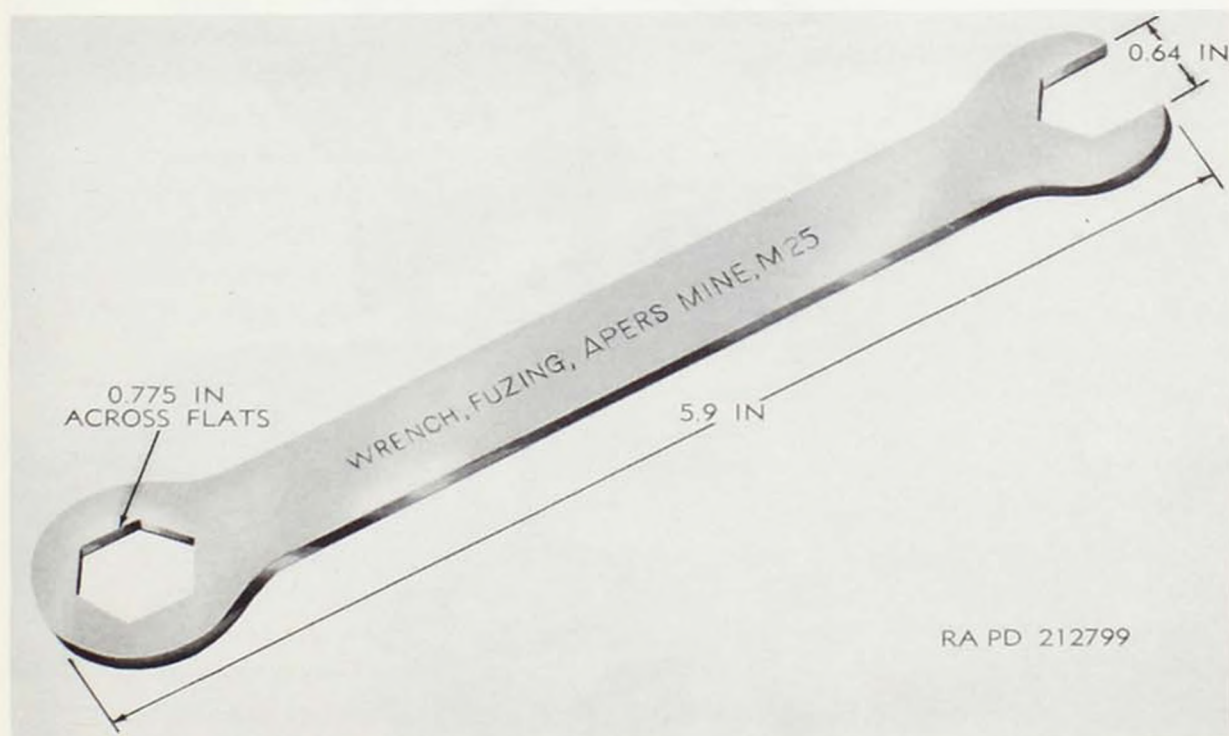

Figure 21. Wrench, fuzing, antipersonnel mine, M25—for use with antipersonnel mine M16 and combination mine fuze M605.

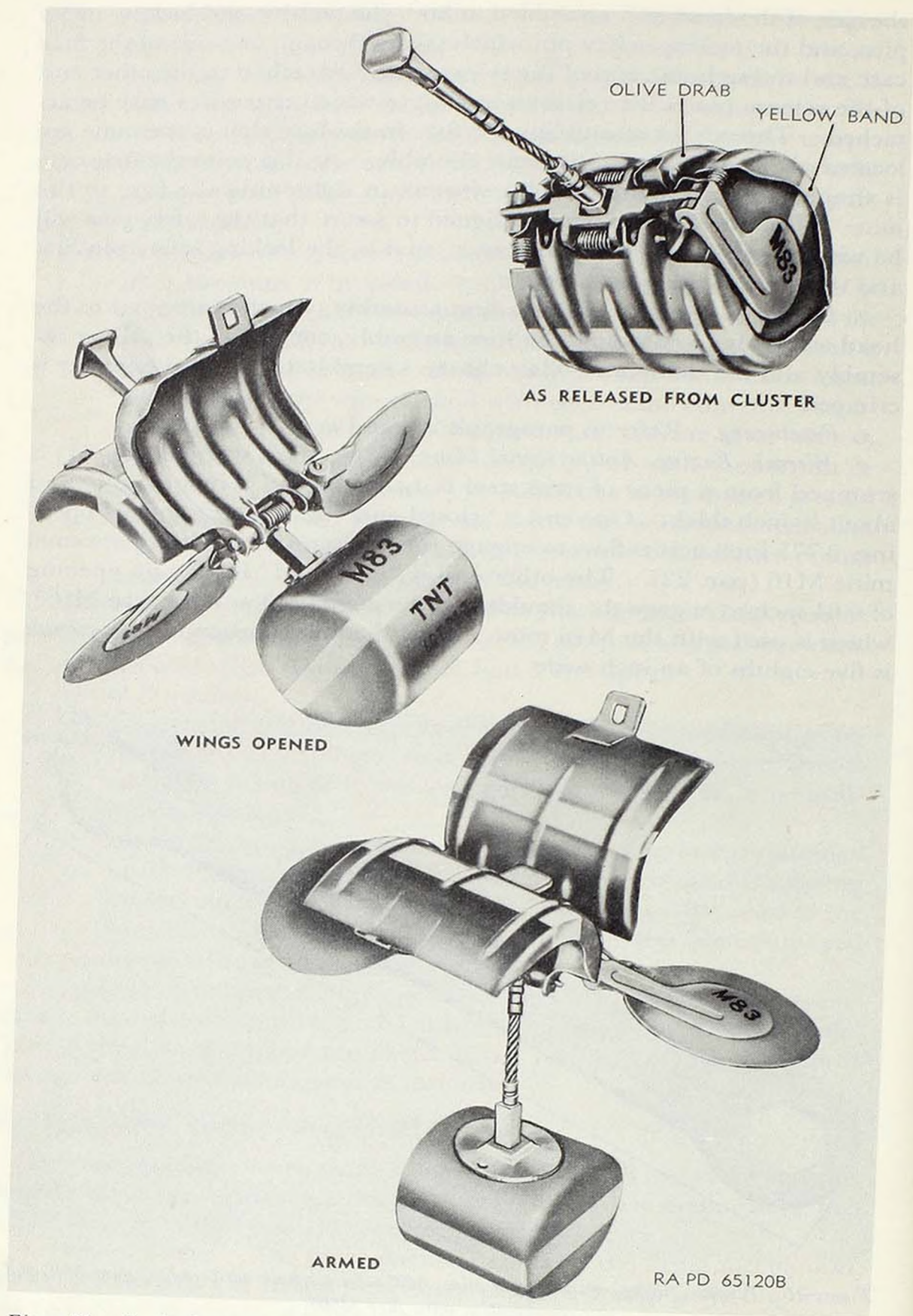

Figure 22. Bomb, fragmentation, 4-pound, M83, with antilift fuze M131, used as an antipersonnel mine.

24. Bomb, Fragmentation, 4-Pound, M83

a. Bomb Assembly. This bomb (fig. 22) is used with an antilift fuze as an antipersonnel mine dropped from aircraft. It is a small cylindrical high-explosive item assembled in the form of wafers which are in turn assembled in clusters. The cluster of the M29 series (500-pound size) contains 90 bombs (10 bombs strapped together in the form of wafer, nine wafers per cluster). The M28 series cluster (100-pound size) contains 24 bombs. The antilift fuze M131 is contained in a fuze well in the bomb. The fuze has a cable extension on which the bomb case assembly (butterfly wings) is mounted. When the bomb is released from the cluster, the wings are opened by spring action and are forced by the air stream to the top of the cable extension. In this position, the butterfly wings retard the fall of the bomb and begin to rotate. The rotation of the wings twists the cable and withdraws the arming stem in the fuze, thus arming the fuze. The type of fuze action, antilift in this case, is marked on the cluster. The model number of the fuze is stamped on the fuze body. As the fuze is assembled inside the bomb, no fuzing operation or preparation are required.

b. Fuze, Bomb, M131.

- (1) *General.* The M131 is a body (integral) type fuze which is inside the 4-pound fragmentation bomb M83. It is a mechanically-operated fuze designed to detonate if, after landing on the ground, it should in any way be disturbed (such as the movement caused by handling an unexploded bomb). This fuze is therefore known as an antilift fuze.
- (2) *Description.* The fuze consists of three parts: the cap assembly which contains the arming stem; the body assembly which contains fuze mechanism, firing pin assembly, and primer; the booster assembly which consists of a tetryl-loaded aluminum cup and detonator assembly. In this fuze, the booster is screwed directly to the base of the fuze body.
- (3) *Functioning.* The arming of this fuze requires three steps. The initial arming or first release takes place when the arming stem is withdrawn by the action of the bomb's "butterfly" wings. This permits a clockwork spring to advance a tripping mechanism to a latch device. This latter device jars free when the bomb strikes the ground—this action being known as second release. After the second release, the tripping mechanism advances to the third release device. The advance requires about 2 seconds; this delay is provided to permit the bomb to stop moving or fuze parts to stop vibrating after impact. The third release is the antilift device and is extremely sensitive. Further movement of the bomb on the ground causes the fuze to function and detonate the bomb. For further information on this bomb, refer to TM 9-1980.

Section II. ANTIPERSONNEL PRACTICE MINES AND FUZES

25. General

a. The antipersonnel mines and fuzes which are specifically designated "practice" in nomenclature are of the same size, shape, weight, and casing material as the service mines and fuzes they simulate. These practice mines contain no high explosive but they do contain small smoke puff and noise-making charges of low explosive (black powder or pyrotechnic composition) to simulate the explosion of a service mine. These practice mines are provided for practice and training in identification, care, handling and use of antipersonnel *service* mines.

b. The antipersonnel mines and fuzes which are specifically designated "inert" in nomenclature consist of the same metal or plastic parts as service mines. These "inert" mines are filled with inert material such as sand, when practicable, or they may be empty. The "inert" mines and fuzes contain no explosive of any kind and are used only in training in the applicable aspects of handling mines.

c. The following safety precautions prescribing conditions under which practice mines may be employed in practice and training will be observed:

- (1) Do not mix service, practice, and inert mines and fuzes. Practice and inert mines should be painted their proper color and have the appropriate identifying terms stencilled upon their bodies.
- (2) "Inert" antipersonnel mines, since they contain no explosive, require no special safety precautions, and they should be used whenever possible in training. Personnel should be trained to handle all ammunition and ammunition components as potentially dangerous, even though the items have been designated "inert" or "empty."
- (3) All rules, regulations, and precautions pertaining to antipersonnel service mines and practice mines in this manual and in AR 385-63; will be observed in the use of antipersonnel practice mines.

d. Antipersonnel practice mine fuzes consist of a tri-pronged firing mechanism assembled to an igniter and primer assembly (primed coupling base to which a black powder igniter is crimped); the firing mechanism is arranged for initiation by either pressure on the prongs or by pull on a release pin. Inert service mines fitted with inert service fuzes are also provided for training.

e. Antipersonnel practice mines are shipped unfuzed. Fuzes are in containers in the same packing box with the mine but positioned so that accidental functioning of any component of a fuze will not cause functioning of the mine.

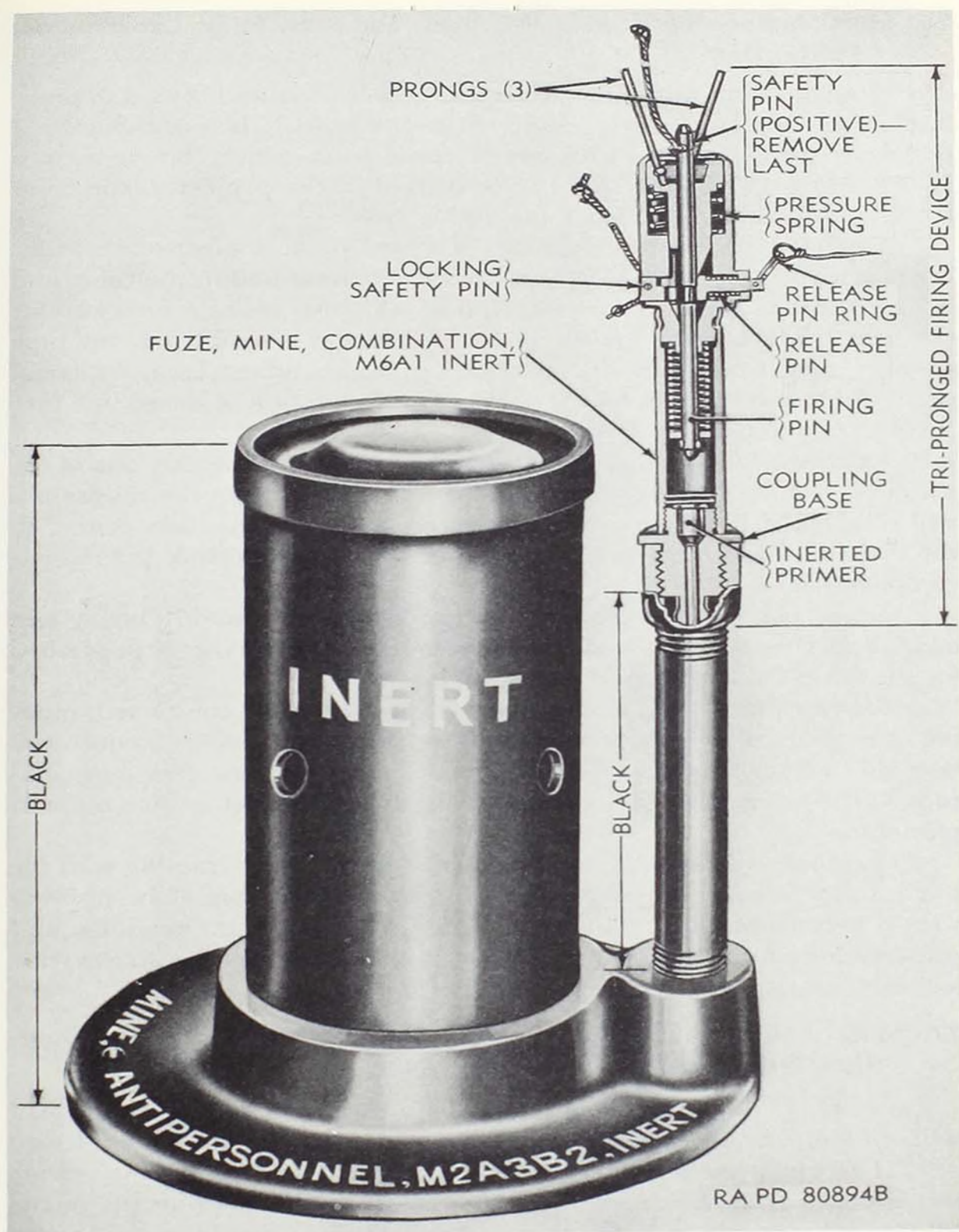

Figure 23. Mine, antipersonnel, M2A3B2, inert, and fuze, mine, combination, M6A1, inert.

26. Mine, Antipersonnel, M2A3B2, Inert, and Fuze, Mine, Combination, M6A1, Inert

a. General. This mine (fig. 23) is completely inert and is used to simulate an antipersonnel service mine of the M2 series. It is constructed of the same metal parts as the service mine from which, however, it is readily distinguished by four holes drilled in the projector, the color (black), and the word INERT marked in white.

b. Description. The mine consists of a base plate, a piece of steel tubing attached to the base plate, an inert shell contained in the tube, and a 1/4-inch pipe nipple and pipe coupling which serves as a fuze well for the fuze. The inert coupling base of the fuze is assembled to the pipe coupling and is protected during shipment and handling by a hexagonal cap. An inerted fuze M6A1 is used. For description of the service fuze M6A1, refer to paragraph 18.

c. Functioning. An applied load of 20 to 30 pounds on any one of the pressure prongs of the fuze or a pull of 3 to 8 pounds on the release pin will release the firing pin. The firing pin then hits the inert primer in the coupling base of the fuze. No other action occurs since the mine is completely inert.

d. Laying and Arming. The same procedure will be used in laying and arming this inert antipersonnel mine employed in training or prescribed for the antipersonnel service mine in paragraph 17*d*.

e. Boobytrapping. Practice in boobytrapping will be conducted under the supervision of especially trained personnel. The same procedure will be used in disarming and removal of this inert antipersonnel mine employed in training, as prescribed for the antipersonnel service mine in paragraph 17*f*.

f. Precautions. No special precautions are required in training with the inert antipersonnel mine (par. 25). However, personnel in training should become familiar with all the general rules in care, handling, and preservation of mine (par. 11) and the precautions applying to the service counterpart of the mine (par. 17*h*).

27. Mine, Antipersonnel, Practice, M8 (T4), and Fuze, Mine, Combination, Practice, M10 (T14) or M10A1

a. General. This practice mine and fuze, which simulates the M2 series of antipersonnel service mines, is shown with fuze installed in figure 24. The metal parts of this mine are the same as those of the service mine M2A4 (par. 17) except for the projectile. The projectile in the M8 is cardboard and contains a spotting charge assembly which resembles a blank-loaded shotgun shell with a delay fuse element instead of a primer. The M8 practice mine may be used many times by replacing the following separately requisitionable components which are fired or damaged in use: Igniter and primer assemblies (primed coupling base with black powder igniter crimped on) for the mine fuze, mine caps (covers), cardboard projectiles, and spotting charges for the mine. Fir-

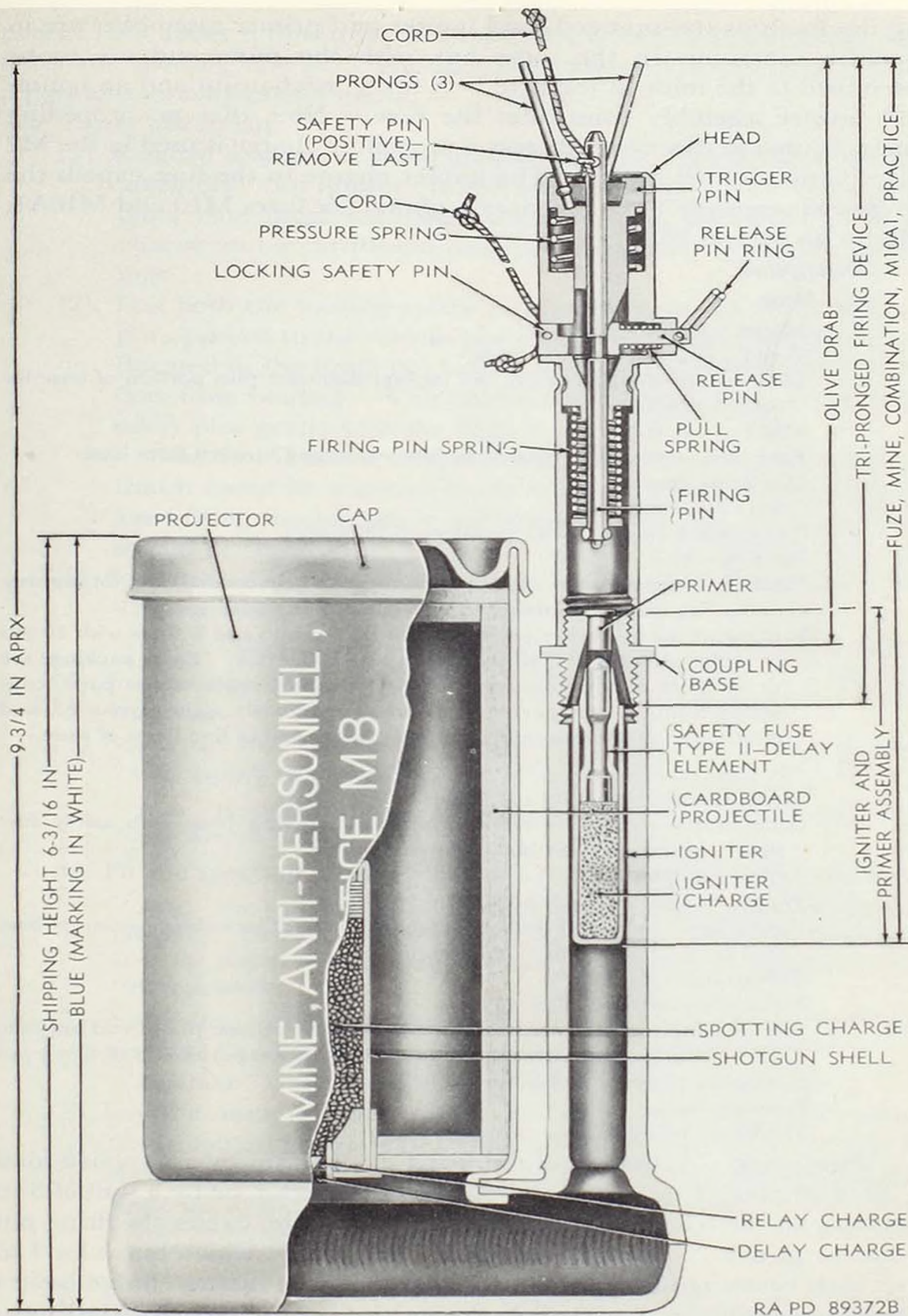

Figure 24. Mine, antipersonnel, practice, M8 (T4), and fuze, mine, combination, practice, M10 (T14) or M10A1.

ing mechanisms (tri-pronged) and igniter and primer assemblies are in separate containers in the same box with the mine and are to be assembled to the mine in the field. A firing mechanism and an igniter and primer assembly constitutes the fuze. Note that no propelling charge is used in this mine whereas a propelling charge is used in the M2 series antipersonnel mines. The igniter charge in the fuze expels the cardboard projectile. For description of practice fuzes M10 and M10A1, refer to paragraph 28.

b. Description.

(1) *Mine.*

Model number—M8.

Weight, unfuzed—3.63 pounds.

Dimensions—height, fuzed, $9\frac{3}{4}$ inches; diameter plus portion of base for fuze, $3\frac{3}{4}$ inches.

Material—steel.

Fuze well—uncapped, located in tube extending upward from base.

One delay charge.

One relay charge.

One spotting charge (black powder—0.38 ounce).

Painting—blue.

Marking—nomenclature of mine, month, and year loaded, and lot number (including loader's initials and symbol)—all in white.

Packing method—earlier packings contain 2 mines and 2 fuzes with 20 sets of replacement parts, all packed in a wooden box. Later packings are designed to contain only mines and fuzes, the replacement parts, consisting of mine cap (cover) projectile (cardboard), spotting charge, and igniter and primer assembly, to be requisitioned as line items of issue.

(2) *Fuze.*

Model number—M10A1 (or M10).

Components—firing mechanism; primed coupling base with safety fuse; delay and crimped-on black powder igniter.

Type—combination.

Weight of igniter (black powder)—15 grains.

Dimensions—height (fuzed), $9\frac{3}{4}$ inches; diameter including portion of base for fuze well, 4 inches.

Thread size— $\frac{5}{16}$ -inch.

Material—zinc-base alloy.

Safeties—locking safety pin (cotter pin type) in release pin at end opposite release pin ring; positive safety pin (cotter pin type) in end of firing pin between pressure prongs.

Painting—olive drab.

Marking—nomenclature of fuze.

c. Functioning. Actuation of the firing mechanism by an applied load of 20 to 30 pounds on any of the prongs of the head, or by a pull of 3 to 8 pounds on the release pin by means of a trip wire, causes the firing pin to hit the primer. The primer ignites a delay train which burns for 4 to 5 seconds before igniting the igniter charge. The igniter charge ignites the delay element in the spotting charge and expels the cardboard projectile (canister) from the projector, blowing off the mine cap. After a short delay during which part of the projectile containing the spotting

charge rises about 6 feet in the air, the flame from the delay charge initiates the spotting charge. The spotting charge explodes with a loud report and accompanying smoke.

d. Laying and Arming.

- (1) Remove a mine, a firing mechanism, an "igniter and primer assembly" (an igniter and primer assembly consists of a coupling base fitted with both a primer and igniter), a spotting charge and a cardboard projectile (canister) from their packings.
- (2) Test both the locking safety pin (located in end of the release pin opposite to the release-pin ring) and the positive safety pin (located in the firing pin between the pressure prongs) for freedom from binding. This testing may be done by twisting these safety pins gently with the fingers.

Caution: If either of these safety pins is not free enough so that it could be removed easily when arming the fuze, a damaged firing mechanism is indicated. Such a firing mechanism should be replaced.

- (3) Screw the firing mechanism to an igniter and primer assembly. This becomes the fuze M10A1.

Note. Use only the 4½-second delay flash igniter which is colored black.

- (4) Inspect the fuze well of the mine and remove any foreign material.
- (5) Screw the fuze into the fuze well of the mine as shown in figure 24, grasping the knurled edge of the coupling base.

Note. If the coupling base has a hexagonal edge, use antipersonnel mine fuzing wrench M25.

- (6) Fit the spotting charge into the cardboard projectile (canister).

Note. The spotting charge does not always fit easily into the cardboard projectile. Do not strike the spotting charge when inserting it. Either enlarge the projectile hole, or twist and press the spotting charge in with a steady pressure.

- (7) Insert the cardboard projectile with spotting charge into the projector and snap the mine cap (cover) over the projector.

Caution: This should be done after the fuze is installed.

- (8) Lay the mine in a hole (about 10-inches deep and appropriate diameter) on a firm foundation so that the tips of the prongs on the fuze will be just above ground level. Pack dirt around the mine up to the mine cap (cover) so that the mine is solidly and firmly emplaced.

Note. Do not cover the projector with dirt or rocks.

- (9) Install one or more trip wires by attaching them first to firmly driven anchor stakes and then to the release-pin ring, leaving enough slack in the trip wires to allow the top of the fuze to rotate in order to receive a direct pull on the release-pin ring

by any one of the trip wires. This is necessary for proper functioning of the fuze.

- (10) Remove the locking safety pin by pulling on the cord to which it is attached.
- (11) Camouflage the installation in accordance with instructions in FM 20-32.
- (12) Remove the positive safety pin (located between the three prongs) by pulling on the cord to which it is attached, thus arming the fuze.

Caution: Do not disturb the trip wires.

- (13) Save the safety pin for subsequent disarming of the fuze.

Note. The mine may be installed for pressure and trip-wire operation or, it may be installed for pressure operation only by omitting the trip wires.

e. Disarming and Removal (Neutralizing).

- (1) Carefully inspect the installation for boobytrapping devices.
- (2) Carefully remove the camouflage material.
- (3) Insert the "positive" safety pin first, and then insert the locking safety pin.
- (4) Disconnect trip wires (if a trip-wire installation).
- (5) Remove the mine from the hole.
- (6) Remove the mine cap (cover) from the mine projector and remove the cardboard projectile (canister). Remove the spotting charge from the cardboard projectile.
- (7) Remove the fuze. Unscrew the firing mechanism from igniter and primer assembly.
- (8) Restore mine, firing mechanism, igniter and primer assembly, spotting charge cardboard projectile, and mine cap to their original condition and packings.

f. Functioned Mine and Fuze.

- (1) The mine body and firing mechanism of the fuze which have functioned are reusable. The fired igniter and primer assembly (primed coupling base with crimped-on igniter) should be either replaced by a new one or prepared for reuse by renewing the primer and igniter, depending on instructions from the responsible technical service.
- (2) The functioned firing mechanism must be recocked for reuse. This may be done by placing the end of a stick, pencil, or nail against the firing pin and pushing it back until it is held in place by the release pin. The safety pins are installed in the firing mechanism after it has been recocked.
- (3) The mine body and fuze (firing mechanism, and igniter and primer assembly), when restored to their original condition, are restored to their original packing; or they are prepared for immediate reuse by following the procedure included in paragraph *d* above, using replacement parts as required.

g. *Special Precautions.*

- (1) When this practice mine functions, the mine cap (cover) and part of the cardboard projectile are projected upward; hence, in order to prevent injury in case of accidental functioning, the hands and other parts of the body should not be directly over the mine at any time.
- (2) If the spotting charge fails to detonate, the cardboard projectile (canister) is propelled into the air. Personnel must be alert to avoid the falling projectile. The falling cardboard projectile must be recovered and the unfired spotting charge removed.
- (3) Do not open replacement part containers until ready for use.
- (4) Protect spotting charges and igniter and primer assemblies, in opened containers, from exposure to moisture.

h. *Packing.* Earlier packings of the mine M8 contain 2 mine bodies and 2 tri-pronged firing mechanisms (fuze M10 or M10A1 without igniter and primer assembly), with 20 sets of replacement parts, all packed in a wooden box (fig. 25). The dimensions of the box are 20 $\frac{3}{4}$ x 12 $\frac{1}{4}$ x 9 inches. The box with contents weighs 30 pounds (approx). Later packings are designed to contain mine bodies and firing mechanisms only; the replacement parts (igniter and primer assembly, card-

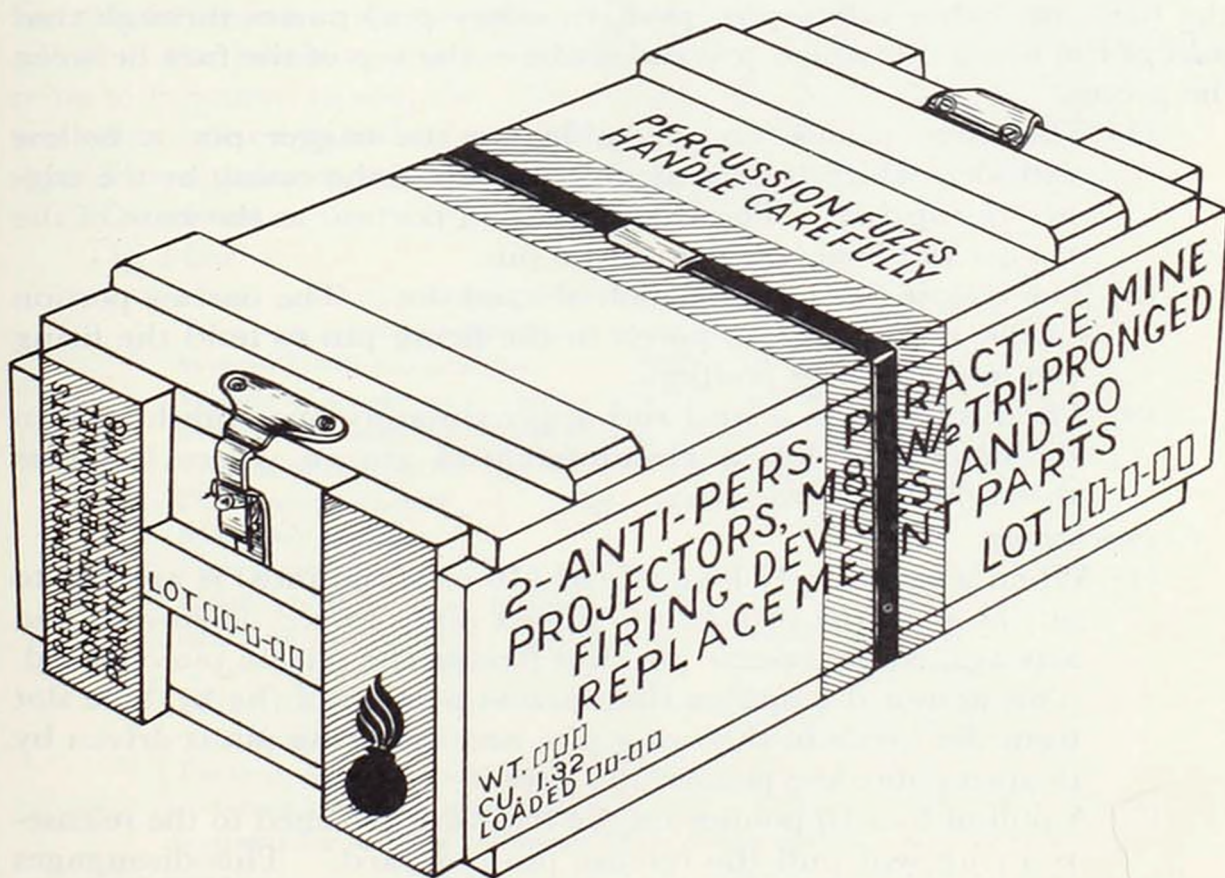

RA PD 116931

Figure 25. Packing box for two antipersonnel practice mines M8 and 20 of each replacement part.

board projectile (canister), spotting charge, and mine cap (cover)) are to be requisitioned as live items of issue.

28. Fuze, Mine, Combination, Practice, M10 or M10A1

a. General. This fuze is a combination fuze of the pull-pressure type, used with the antipersonnel practice mine M8 (T4) to ignite the spotting charge. It is shown assembled to the mine in figure 24. The M10A1 fuze can be used interchangeably with the M10, the principal difference being in the primer. The difference between the M39A1 primer which is used with the fuze M10A1 and the Mk 5 primer which is used with fuze M10 is that the M39A1 has a sharper pointed anvil and a flat bottom cup, thus providing more reliable functioning.

b. Description. This fuze consists of a tri-pronged firing mechanism and a base to which an igniter containing 15 grains of black powder is attached. The base contains a primer and a safety fuse which provides a delay of 4 to 5 seconds. The firing mechanism consists of a cylindrical metal case containing a trigger pin, a release pin, and a firing pin—each pin being fitted with a coil spring to provide necessary action when the fuze is functioned. Two safety pins are provided to render the fuze safe during shipment and handling. One safety pin (locking safety pin) passes through the end of the release pin and bears against the body of the fuze; the other safety pin (positive safety pin) passes through that part of the firing pin which protrudes above the top of the fuze between the prongs.

- (1) The three prongs are assembled to the trigger pin, a hollow cylinder, which is held against the top of the casing by the trigger pin spring. The wedge-shaped portion at the base of the trigger pin bears on the release pin.
- (2) The release pin has a keyhole-shaped slot. The narrow portion of the slot engages a notch in the firing pin to hold the firing pin in the cocked position.
- (3) The firing pin is a steel rod approximately one-eighth inch in diameter and has a circumferential groove where it passes through the release pin.

c. Functioning.

- (1) When a sufficiently heavy load (10 to 20 pounds) is applied to any or all of the prongs, the trigger pin is forced downward and acts against the release pin thus forcing the release pin outward. This action disengages the narrow portion of the keyhole slot from the notch in the firing pin, and the firing pin is driven by its spring into the primer and fires it.
- (2) A pull of 6 to 10 pounds on the trip wire attached to the release-pin ring will pull the release pin outward. This disengages and releases the firing pin, which is then driven by its spring into the primer firing it.

(3) The functioning of the primer ignites the safety fuze which, after 4 to 5 seconds, ignites the black powder igniter charge.

d. Arming and Disarming. Refer to paragraph 17.

e. Packing. This fuze is packed with the antipersonnel mine M8 (T4). Refer to paragraph 27*h*.

29. Mine, Antipersonnel, NM, Practice, T34 with Integral Fuze (figs. 26 and 27)

a. General. This mine is an antipersonnel nonmetallic practice mine with integral fuze designed to simulate mine, antipersonnel, NM, M14, with integral fuze (par. 21). The T34, like the M14, is designed to give no significant signal in metallic type mine detectors, and is not reuseable. Unlike the M14, the T34 provides a 1- to 2-second delay for proper functioning as a practice item. The mine is designed so as not to cause injury to the person initiating it or personnel in the immediate vicinity. To provide the visible and audible signal required for practice mines, the T34 contains an expelling charge, a smoke charge and two small firecrackers. The expelling charge blows the fuze portion of the mine and the two firecrackers out of the ground. The firecrackers function either in the air or on top of the ground. The smoke charge stays in the ground and burns for approximately 5 seconds causing a smoke cloud to issue from the hole made by the expelled fuze. The T34 practice mine has the following characteristics: A force between 20 and 35 pounds applied to the pressure plate (fig. 26) of the armed mine will cause the mine to function; in use, the T34 will function under the weight of a person when buried in soil to a depth of one-half inch or less; the T34 is designed to withstand exposure through freezing and thawing periods.

b. Description.

(1) *Mine.*

Model number—T34.

Type—practice (simulating blast type).

Weight (with integral fuze)—4 ounces (approx).

Weight of smoke tube charge (smoke composition)—200 grains (approx).

Weight of expelling charge (black powder)—60 grains (approx).

Weight of firecracker detonator charge—1.75 grains (approx).

Dimensions—height, 1 $\frac{1}{16}$ inches; diameter, 2 $\frac{3}{16}$ inches.

Material—plastic.

Fuze—integral.

Color—blue (arming arrow in white).

Marking (on bottom)—nomenclature, symbol of parts, manufacturer, loader's lot number, date (month and year) loaded.

Plug (in bottom)—head of plug is same size and shape (hexagonal) as head of detonator holder of M14 mine, which the T34 simulates.

Packing method—packed 125 mines in carton with egg crate separators between mines, 5 layers with 25 mines in each layer. Six wrenches M22 (used for arming) are included in each carton.

(2) *Fuze.*

Model number—none.

Components—pressure plate, lock key, spider, lock ring, belleville spring, and firing pin.

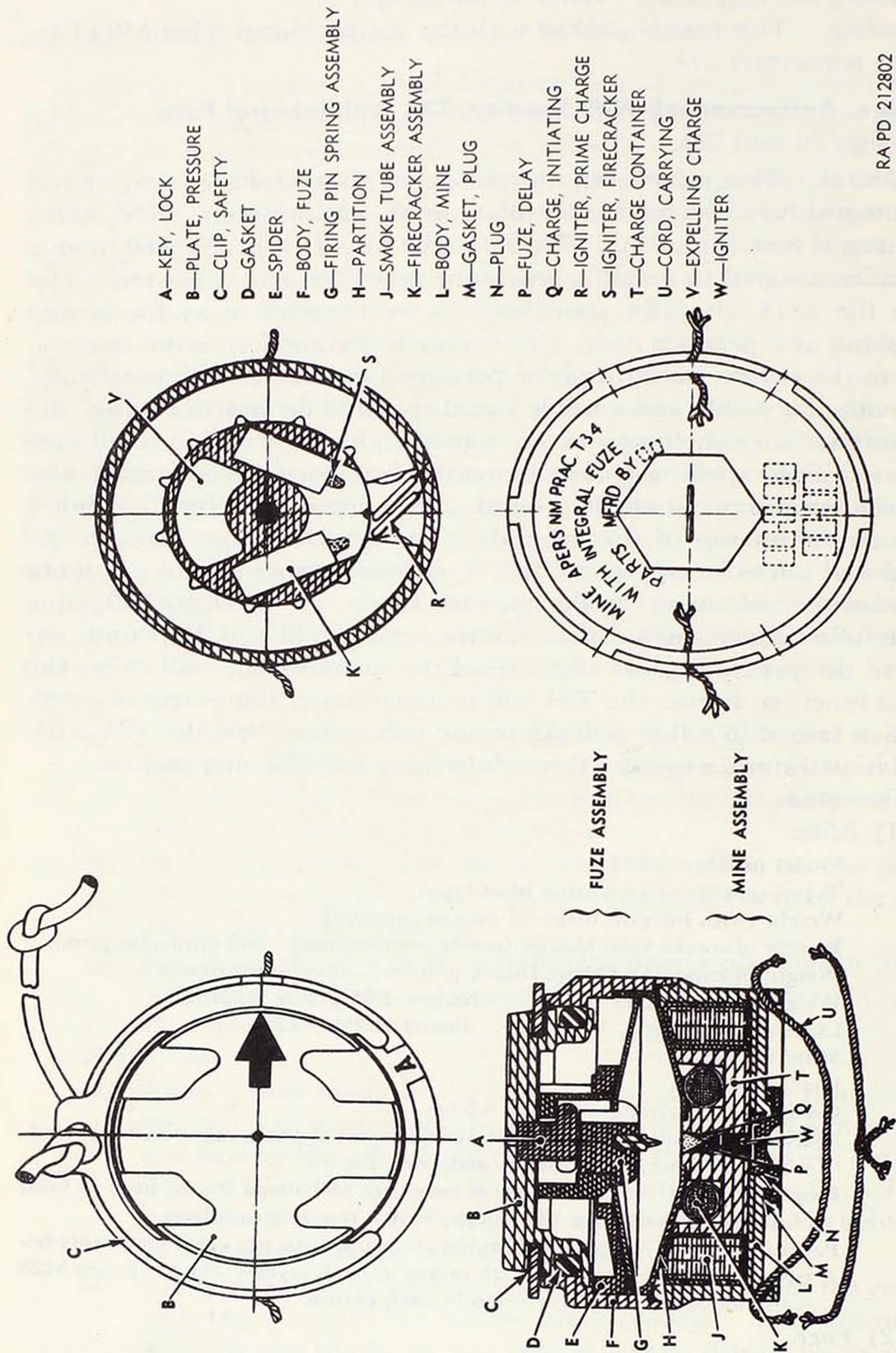

- A—KEY, LOCK
- B—PLATE, PRESSURE
- C—CLIP, SAFETY
- D—GASKET
- E—SPIDER
- F—BODY, FUZE
- G—FIRING PIN SPRING ASSEMBLY
- H—PARTITION
- J—SMOKE TUBE ASSEMBLY
- K—FIRECRACKER ASSEMBLY
- L—BODY, MINE
- M—GASKET, PLUG
- N—PLUG
- P—FUZE, DELAY
- Q—CHARGE, INITIATING
- R—IGNITER, PRIME CHARGE
- S—IGNITER, FIRECRACKER
- T—CHARGE CONTAINER
- U—CORD, CARRYING
- V—EXPPELLING CHARGE
- W—IGNITER

RA PD 212802

Figure 26. Mine, antipersonnel, NM, practice, T34, with integral fuze.

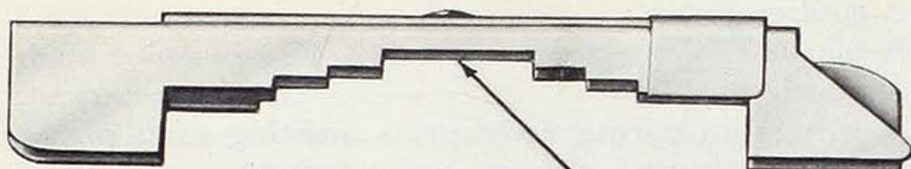

WRENCH, MINE AND FUZE, M22

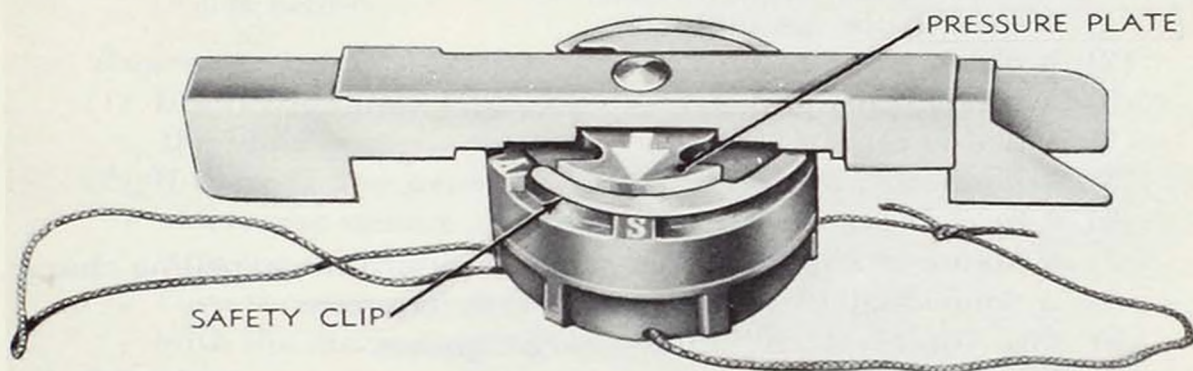

PRESSURE PLATE IN UNARMED POSITION WITH SAFETY CLIP IN PLACE

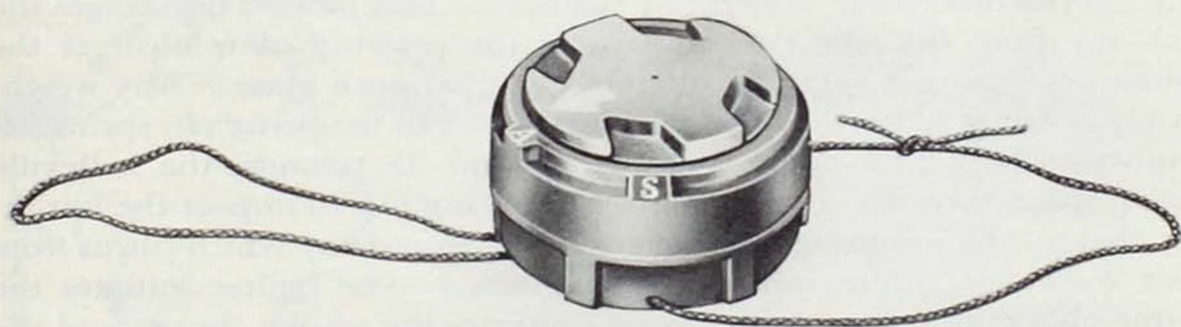

PRESSURE PLATE IN ARMED CONDITION WITH SAFETY CLIP REMOVED

RA PD 212803

Figure 27. Mine, antipersonnel, NM, practice, T34—method of using arming wrench M22.

Type—belleville spring—integral.

Material—plastic (except steel firing pin).

Safeties—clip (U-shaped) with pull cord; provision for turning pressure plate from safe position (white pointer at S) to armed position (white pointer at A).

Color—blue.

c. *Fuze Assembly.* The fuze assembly contains the following parts which are identified by letter in figure 26:

- (1) A plastic lock key.
- (2) A plastic pressure plate.
- (3) A steel safety clip.

- (4) A rubber gasket.
- (5) A plastic spider.
- (6) A plastic fuze body.
- (7) A firing pin spring assembly consisting of a plastic belleville spring, a plastic lock ring, and a firing pin assembly.
- (8) A plastic partition.

d. Mine Assembly. The mine assembly consists of the following parts which are identified by letter in figure 26:

- (1) A smoke tube assembly.
- (2) A plastic mine body.
- (3) A rubber plug gasket.
- (4) A plastic plug.
- (5) An initiating charge.
- (6) A fuze delay.
- (7) A plastic charge container which contains the expelling charge, a "quickmatch" igniter, and two firecrackers.
- (8) Two "quickmatch" prime charge igniters.
- (9) A carrying cord.

e. Functioning. Prior to arming the mine, downward motion of the pressure plate is prevented by the safety clip. If the safety clip is removed, the mine remains safe until the pressure plate is turned from the safe (S) position to the armed (A) position. This motion disengages the lock key from the lock ring and turns the pressure plate clear of the spider permitting downward motion of the pressure plate. Any weight on the pressure plate will then be transmitted to the firing pin spring assembly. At some weight between 20 and 35 pounds, the belleville spring snaps through center, causing the firing pin to impact the initiating charge; the initiating charge ignites the fuze delay which burns from 1 to 2 seconds before initiating the igniter. The igniter initiates the prime charge igniters which in turn initiates the smoke charge and the firecrackers; the igniter also initiates the expelling charge which blows the fuze assembly out of the ground.

f. Preparation for Use. The mine is assembled and shipped with the arrow on the pressure plate turned to safe (S) and with the safety clip in place. The plug in base of the T34 mine must *not* be removed. Unlike the M14 mine, it is *not* necessary to remove a shipping plug and insert a detonator. The T34 mine is complete as shipped.

g. Laying and Arming.

- (1) Make certain that the safety clip is in place.
- (2) Lay the mine in a small hole in the ground so that pressure plate is within one-half inch of surface of the ground. The ground beneath the mine should be sufficiently firm to support the mine when pressure is applied to pressure plate. The mine should be anchored, using the carrying cord in such a manner that the mine will not float above ground level should there be a heavy rainfall.

- (3) Turn the pressure plate from (S) in a clockwise direction, with the arming wrench M22 (fig. 27), until the indicating arrow on the pressure plate points to (A).
- (4) Hold the mine firmly with one hand without touching the pressure plate. With the other hand, remove the safety clip by pulling the safety clip pull cord. The mine is now fully armed.

Note. Save safety clip. If the mine is ever to be disarmed, the safety clip will be needed.

h. Disarming.

- (1) Insert the safety clip into the slots in the pressure plate before the mine is otherwise disturbed.
- (2) If there is any evidence of damage or malfunctioning or if the safety clip cannot be replaced, discontinue any attempt to disarm the mine.
- (3) Turn the pressure plate from (A) in a counterclockwise direction with the arming wrench until the arrow points to (S).

i. Precautions.

- (1) *In use.* All precautions normally followed in the storage, ship-

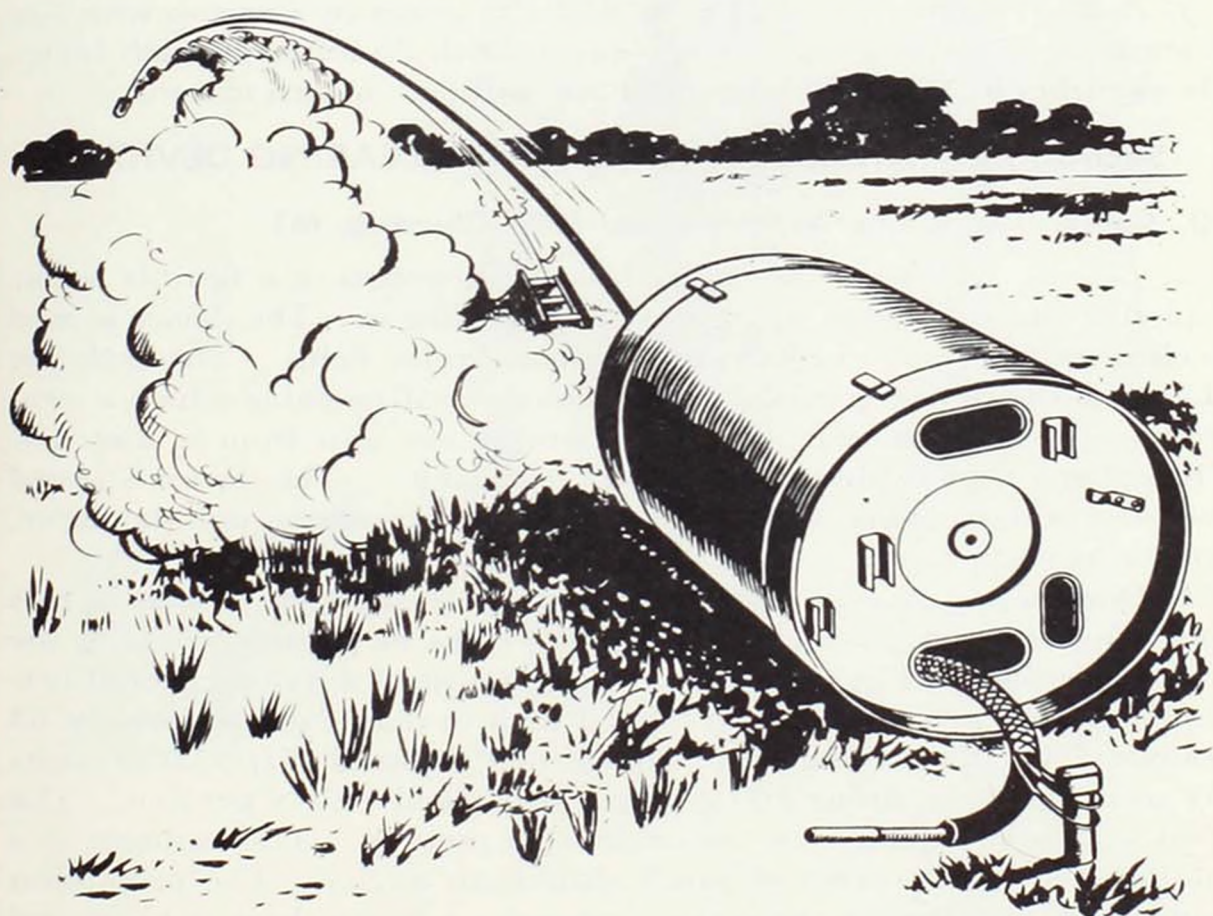

RA PD 131039

Figure 28. Cable, detonating, antipersonnel-mine-clearing, MI—over minefield.

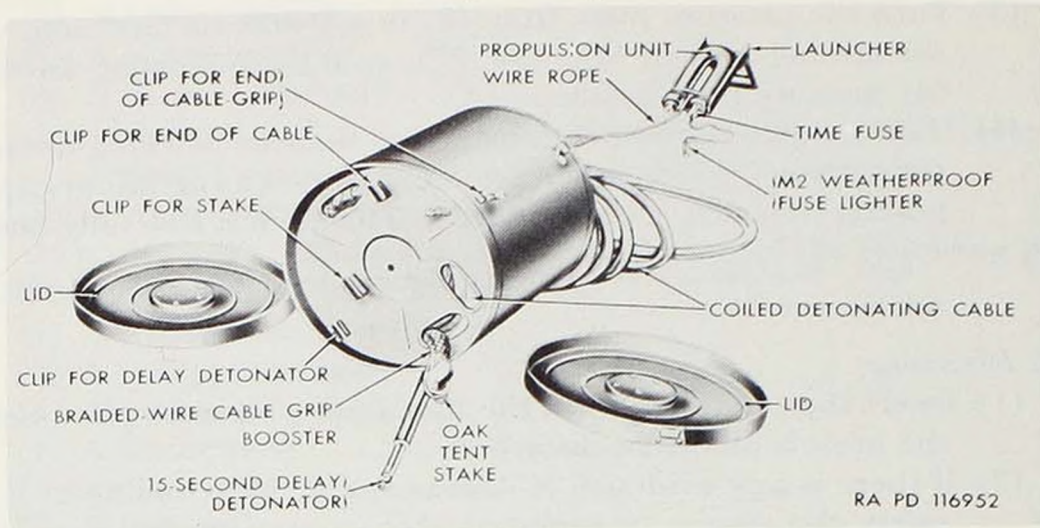

Figure 29. Cable, detonating, antipersonnel-mine-clearing, M1—emplaced for firing.

ment, handling, and use of military pyrotechnics fireworks should be followed. Refer to TM 9-1981 and TM 9-1900.

(2) *In storage.* The practice mine should be stored in accordance with TM 9-1900.

j. Packing. The mine T34 is packed 125 mines in a carton with egg crate separators between mines, 5 layers with 25 mines in each layer. Six wrenches M22 (used for arming) are included in each carton.

Section III. ANTIPERSONNEL-MINE-CLEARING DEVICES

30. Cable, Detonating, Antipersonnel-Mine-Clearing, M1

a. General. This device (figs. 28 and 29) consists of a flexible linear explosive charge and the apparatus for projecting it. The device is used to clear narrow lanes in enemy antipersonnel mine fields. The explosive charge of the device consists of a special detonating cable which is projected across the mine field by a jet propulsion unit from a launcher. The cable is then exploded by a delay detonator. The device is issued complete with carrying case, detonating cable, propulsion unit, launcher, and firing equipment.

b. Description. A cylindrical aluminum carrying case, which is 16½ inches in diameter, 20-inches long, and weighs 92 pounds, contains the entire assembly. The explosive charge consists of a nylon-covered detonating cable which is 170 feet long, 1 inch in diameter, and weighs 63 pounds. The detonating cable consists of 19 strands of special detonating cord, each containing 100 grams of oil-soaked PETN per foot. The total weight of explosive in the cable is 46 pounds. The launcher is a folding stand constructed of small aluminum angles. The propulsion unit which operates on the rocket principle, a fuze lighter, a 15-second delay detonator for exploding the cable, and an oak tent stake for anchoring one end of the cable during flight are included in the carrying

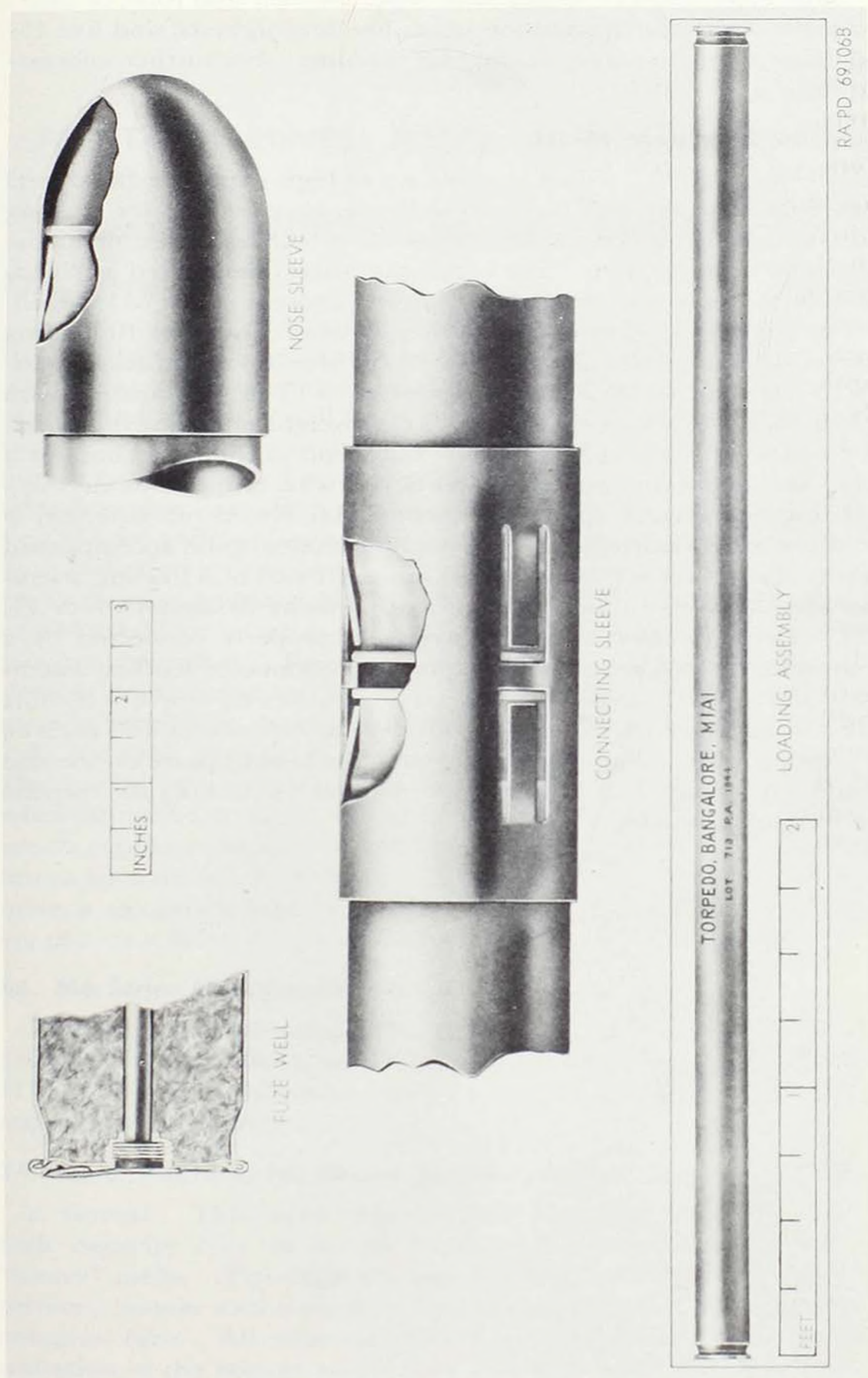

Figure 30. Torpedo, bangalore, M1A1.

case. Simulated cables of ½-inch wire rope, 1⅛-inch sisal rope, or inert-loaded cables, with live propulsion units, live fuze lighters, and live 15-second delay detonators may be used for training. For further information, refer to TM 9-1946.

31. Torpedo, Bangalore, M1A1

This device (fig. 30), which is made up of high-explosive-filled steel tubes in 5-foot lengths with connecting sleeve, may be used for blasting a path through an antipersonnel minefield, or through wire entanglements or other obstruction. The individual tubes, designated as "loading assemblies," may also be used as explosive charges in the M3 demolition snake (par. 48). The complete item of issue consists of 10 loading assemblies, 10 connecting sleeves, and 1 nose sleeve. Each loading assembly (5-feet long by 2⅛ inches in diameter) is filled with amatol, with about 4 inches of TNT at each end. Total weight of explosive in each loading assembly is about 9 pounds. Each end of the tube contains a threaded well to accommodate a firing device with crimped-on nonelectric blasting cap (Army special or commercial No. 8 (or stronger) is required), or a delay detonator. Detonation may also be accomplished by 6 turns of detonating cord wrapped around 1 end of a loading assembly and appropriately initiated such as with a delay detonator (8- or 15-second). Detonation of 1 loading assembly properly connected by a connecting sleeve to a series of other properly connected loading assemblies will detonate the whole series. The connecting sleeve is a short tube into which the ends of the 2 loading assemblies can fit and each be held by spring clips. The nose sleeve, which is held in place on the end of a loading assembly, has a round point for ease in pushing the torpedo past or through obstacles.

CHAPTER 3

ANTITANK MINES, FUZES, AND RELATED ITEMS

Section I. ANTITANK SERVICE MINES AND FUZES

32. General.

a. An antitank mine is an explosive charge, usually encased in relatively light metallic or plastic material, with provisions for a main fuze and one or more secondary fuzes. The mine is intended to be laid in the ground so that it will be exploded by being run over by an enemy tank or vehicle, or by its attempted removal by enemy troops. In addition to types described in this section, antitank mines can be improvised from bangalore torpedoes, explosive demolition materials such as demolition blocks, and similar explosive items appropriately primed and fitted with initiation means such as firing devices. Antitank mines will generally function satisfactorily at temperatures of -40° to 160° F. Refer to FM 20-32 for information pertaining to the tactical aspects of the employment of mines. Refer to TM 9-1946 for technical information on demolition material and FM 5-25 for discussion of methods of employment of demolition material in field operations.

b. Antitank mine fuzes are currently of the mechanical pressure type. The mechanical pressure type fuze contains a belleville spring which, when subjected to heavy pressure, drives a firing pin into a detonator which explodes the mine. Secondary fuzes may be used with antitank mines for antiremoval or boobytrapping. Depending upon the type of mine, a secondary fuze may consist of a firing device fitted with a blasting cap, or a firing device used in conjunction with an activator.

33. M6 Series Modification

The earlier modifications of the M6-series antitank heavy service mines are the M6 and M6A1, which have been renovated as the M6A2 (fig. 31). The difference between earlier and later modifications are in minor improvements in design.

34. Mine, Antitank, HE, Heavy, M6A2, and Fuze Mine, AT, M603.

a. General. This mine (figs. 31 and 32) was formerly considered a high capacity type as it was considered effective against the former "heavy" tanks. The mine consists of a TNT-loaded body containing a primary booster and secondary booster and formerly was initiated by a chemical fuze. All mines of the M6 series were later renovated by installation in the bottom of the fuze well of booster M120 and a booster

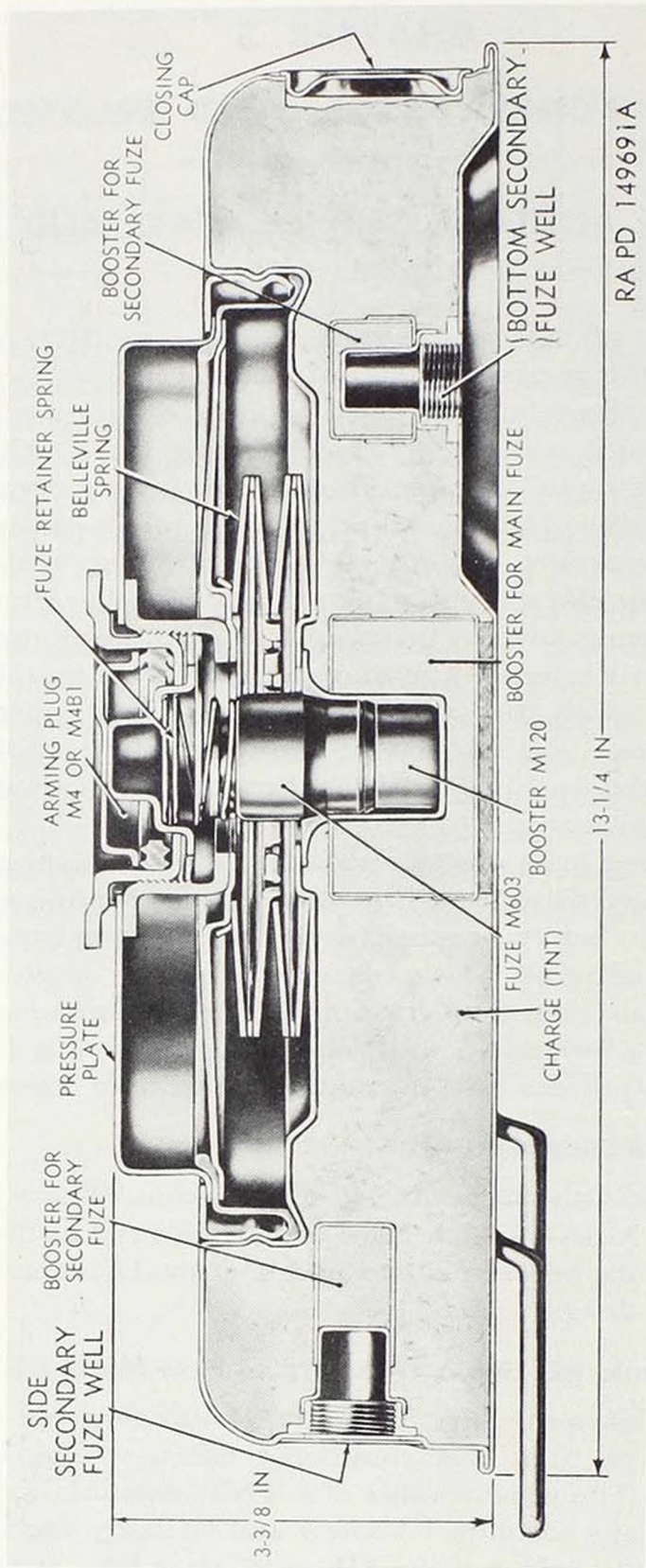

Figure 31. Mine, antitank, HE, heavy, M6A2 and fuze, mine, antitank, M603—cross section.

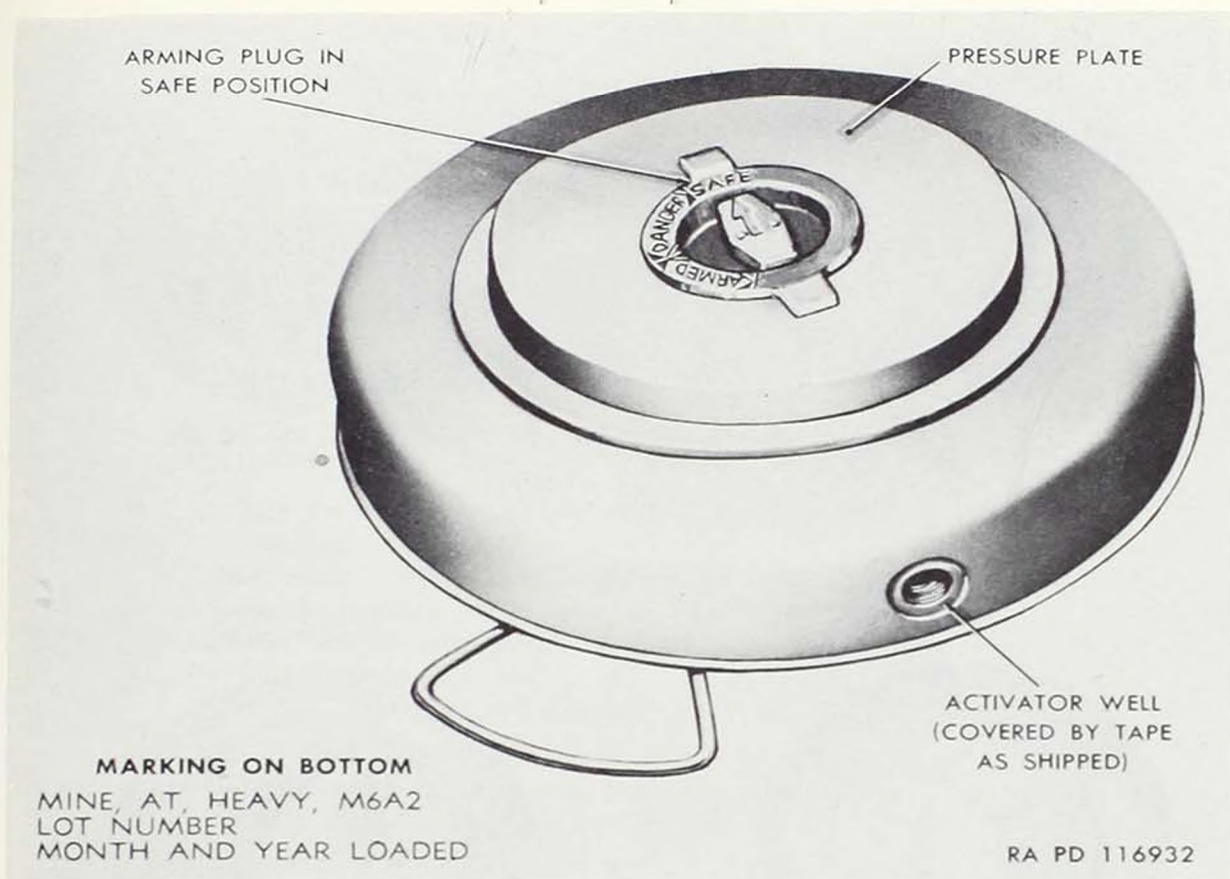

Figure 32. Mine, antitank, HE, heavy, M6A2—top, arming plug in "Safe" position.

retainer, thus adapting the mine for use of the M603 mine fuze which is of the mechanical belleville spring type, and by installation of the new knob and shutter type arming plug (fig. 33) in place of the old reversible type arming plug. In order to use this mine against later type heavier tank, an auxiliary explosive charge (b(1) below) may be used.

b. Description.

(1) Mine.

Model number—M6A2.

Weight, unfuzed—20 pounds.

Weight of explosive charge (TNT)—12 pounds.

Dimensions—height, 3¼ inches; diameter, 13¼ inches.

Material—steel.

Fuze well—main (primary) fuze well located in center of mine.

Fuze arming mechanism—arming plug M4 or M4B1. This plug is in place over main fuze well of mine as shipped. This plug (fig. 33) has a steel shutter which moves from a side position to the center position as the setting knob is moved from SAFE through DANGER to ARMED position. Arming plug M4 or M4B1 may be used with HE antitank mines of the M6 series or the M15. Arming plug M4 is used with AT practice mine M12.

Caution: The setting knob must never be left pointing to DANGER.

Secondary fuze wells—

Number and location—2 wells, 1 located in side and 1 in bottom; covered by tape as shipped.

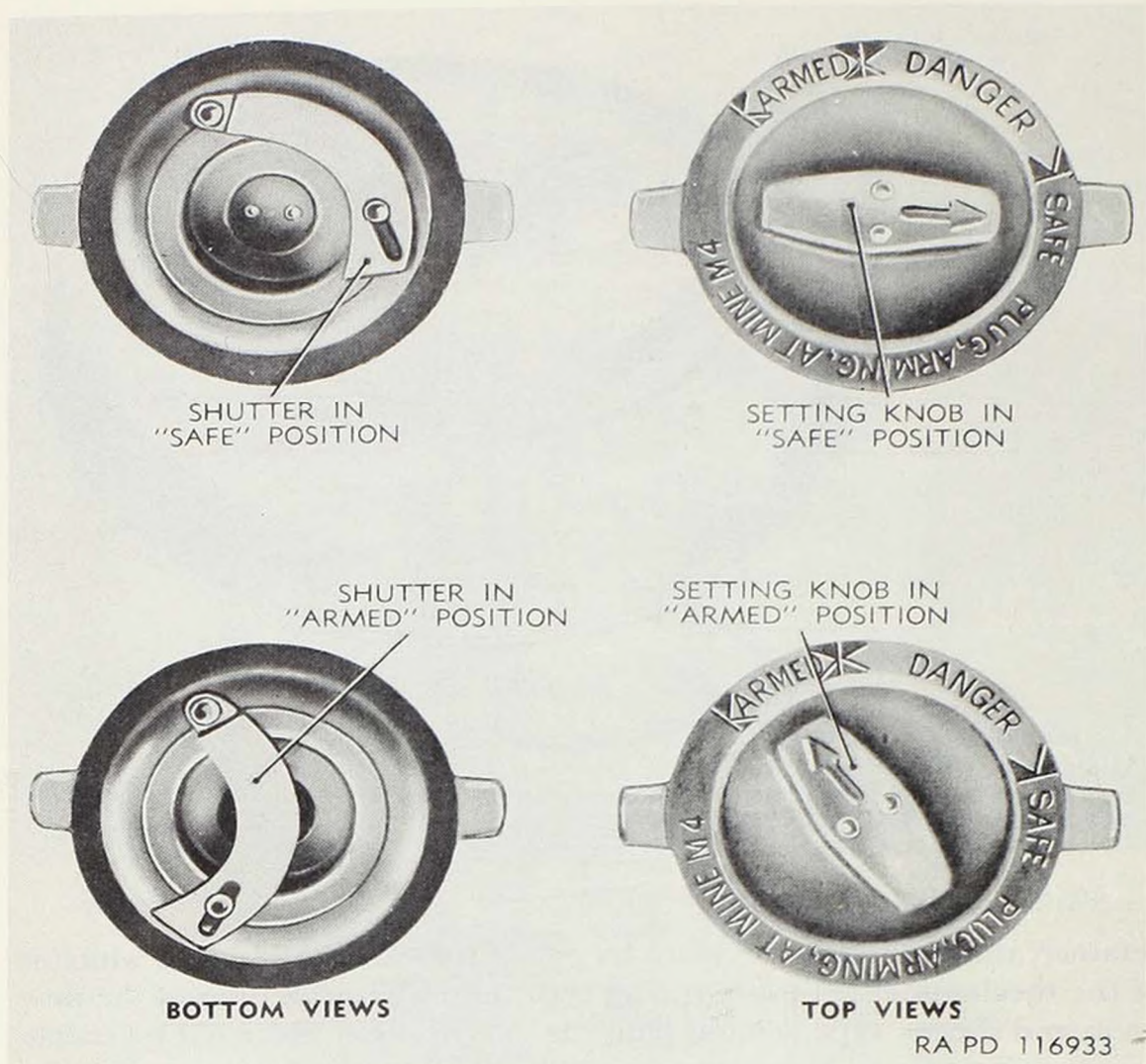

Figure 33. Arming plug M4 or M4B1, for antitank mines M6 series, M12 practice or M15—safe and armed positions of setting knob and shutter.

Type of boobytrapping (secondary) fuze for which threaded—any firing device and activator M1 (pars. 49 through 73).

Boosters—booster M120 in bottom of main fuze well, a “fuze booster” surrounding main fuze well, and booster surrounding the secondary fuze well.

Painting—olive drab.

Marking—nomenclature, lot number, month and year loaded, and loader’s initials—on bottom of mine in yellow.

Packing method—2 mines, with 2 fuzes M603 in metal container and 2 activators M1 in metal containers, in a wooden box.

Packing weight—60 pounds (approx).

Note. Explosive, TNT, 8-pound block, is a 12 by 6 by 2-inch auxiliary charge, which may be laid with an M6 series antitank mine, as appropriate, to augment the force of the explosive of the mine.

(2) *Fuze (Primary).*

Model number—M603.

Type—mechanical, belleville spring.

Weight—1.56 ounces.

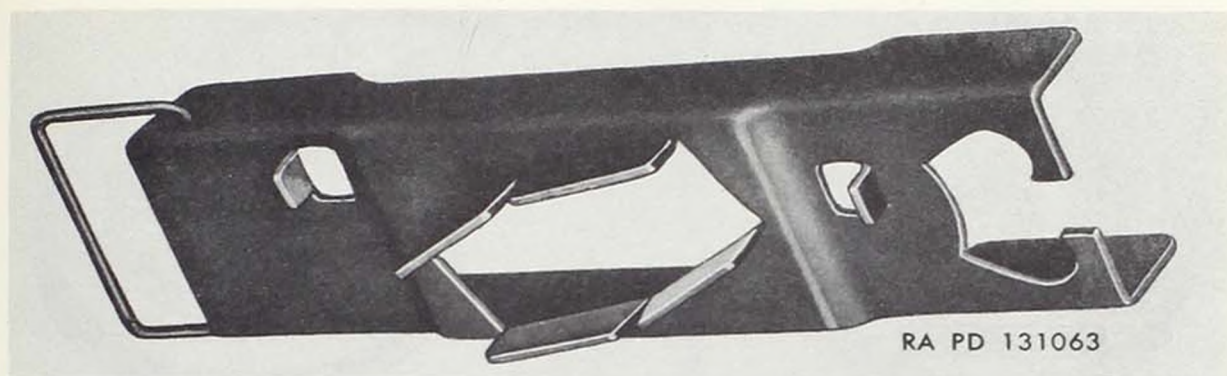

Figure 34. Wrench, arming plug, M20, for arming plug M4 or M4B1.

Weight of explosive (primer mixture, lead azide, and RDX)—7 grains (approx).

Dimensions—height, 1.17 inches; diameter, 1.125 inches.

Material—steel.

Safeties—safety clip (fork).

Painting—uncolored.

Marking—nomenclature stamped in metal.

(3) *Fuze (Secondary) (Boobytrapping).*

Firing device type and model number—any regular type having $\frac{3}{16}$ -inch thread, usually pull type M1 or pull-friction type M2.

Activator name and model number—activator M1.

c. *Functioning.*

- (1) When shutter of arming plug is in “armed” position, a force of 300 to 400 pounds on pressure plate of mine depresses belleville spring of mine causing shutter to depress pressure plate of fuze (fig. 36).
- (2) Pressure plate of fuze depresses belleville spring of fuze which snaps into reverse, driving firing pin into detonator exploding it.
- (3) Explosion of detonator explodes booster (M120) which in turn explodes mine charge.

d. *Laying and Arming.*

- (1) Unscrew the arming plug from the mine, using the arming plug wrench M20 (fig. 34).
- (2) Inspect the fuze well and arming plug threads to see that no foreign matter is present.

Caution: It is particularly important during freezing weather to see that there is no ice in the fuze well during the fuzing operation as the presence of ice during fuzing may cause a serious accident.

Be sure that booster M120 is held properly in place in the bottom of the mine fuze well by the booster retainer.

- (3) Remove fuze M603 from its metal shipping container and inspect it to see that it is serviceable and that the green end of the detonator shows in the bottom of the fuze.

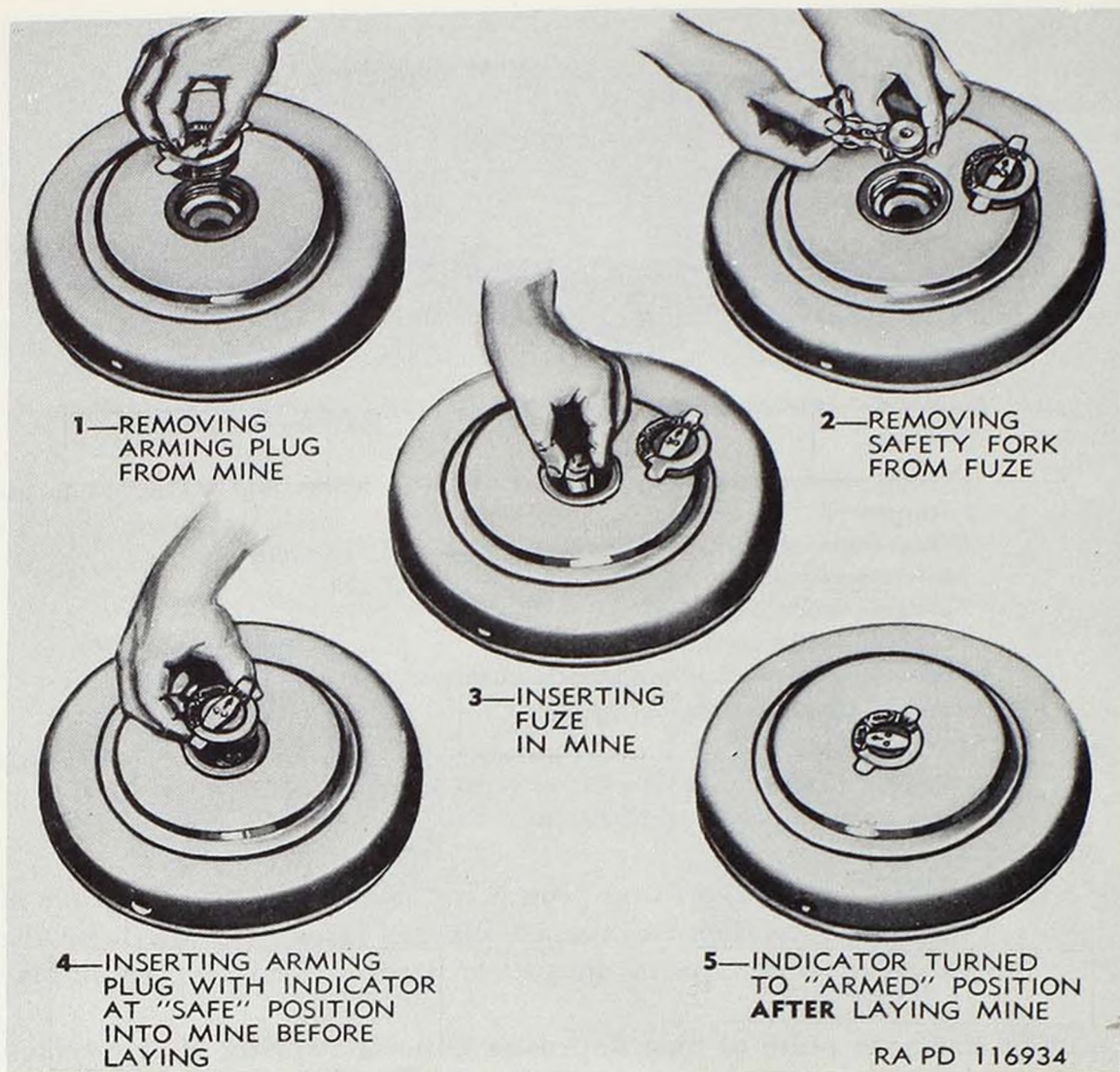

Figure 35. Five steps in method of fuzeing and arming antitank mines M6 series and M15 with fuze, mine, AT, M603.

- (4) Just before insertion of the fuze into the mine, remove the safety fork from the cover assembly of the fuze. The fingers or hook end of the arming wrench may be used for this purpose. Save and conceal the safety fork (clip) for possible use in disarming the fuze.
- (5) Insert the fuze into the fuze well of the mine (fig. 35), pushing it down gently until it seats.

Note. The main (primary) fuze will always be inserted before installing any secondary fuzes.

Caution: No pressure must be put on the pressure plate of the fuze when inserting it into the fuze well.

To assure proper clearance between the fuze pressure-plate but-

ton and the shutter of the arming plug, it is essential that the fuze be fully seated on the internal shoulder of the mine fuze well. If the fuze is not fully seated, the button on the fuze pressure plate will interfere with the movement of the shutter in arming the fuze. Hence if the fuze does not seat fully, it must be removed and the cause investigated.

- (6) Making sure that the setting knob and shutter are in the SAFE position, screw the arming plug with helical spring fuze retainer into the mine securely, using the arming wrench in order to make a watertight joint.
- (7) Lay the mine on a firm foundation with the top surface of the pressure plate not more than 3 inches beneath the ground level. If it is desired to augment the explosive force of this mine, the 8-pound TNT explosive charge (*b* above) may be laid on the mine foundation and the mine laid on top of the charge, allowance being made for such charge when preparing the foundation.
- (8) Just before the mine is covered, arm the mine by turning the setting knob with red pointer from SAFE through DANGER to ARMED. The arming wrench may be used for this purpose. The fuze will not function if the pointer on the arming plug points to SAFE.

Caution: Because of tolerances permitted in the manufacture, it is possible that in some cases the pressure plate of the fuze M603 extends too high, making it difficult if not impossible to turn the knob on the arming plug to the ARMED position. Do not attempt to force the knob but if necessary unscrew the arming plug just enough to allow the knob to be turned freely. The setting knob should at no time be left pointing to DANGER.

- (9) Camouflage the mine in accordance with instructions in FM 20-32.

e. Boobytrapping. Boobytrapping of the M6-series mine requires activator M1 (par. 50) and a firing device of the pull, pull friction, or pull-release type (pars. 62 through 64) with appropriate trip wire.

- (1) Remove tape and shipping sleeve from secondary fuze well (side well, bottom well, or both).
- (2) Inspect activator well carefully to make certain it is free of foreign matter.
- (3) Remove plug and its gasket from head of activator (activator M1) and screw the activator handtight into the secondary fuze well of the mine.
- (4) Making sure that the small rubber gasket is in place inside the activator, screw firing device handtight into activator (the firing device requires no blasting cap when used with an activator).
- (5) Install trip wires as required, fastening them to anchor posts first and to the firing device in the mine last. Make sure there is

no tension on the wires except on the pull-release type firing device (par. 63) which must be installed, when required, by special troops only.

- (6) Arm the firing device by removing safety pins, always removing the "positive" safety pin *last*.
- (7) Save and conceal all safety pins, activator plug, and the gasket for possible future use in disarming and removal.

f. *Disarming and Removal (Neutralizing)*.

- (1) Carefully uncover the concealed mine and examine the side and bottom secondary fuze wells for any boobytrapping devices (secondary fuzes). *Trip wires may have been installed that will initiate a secondary fuze by either pull or release.*

- (2) *Do not cut any taut trip wires, but cut all slack trip wires.*

Warning: If taut trip wires are encountered when attempting to neutralize the mine, do not cut the wires under any circumstances. The best procedure is to attach a long rope or wire to the mine without disturbing the taut trip wire and then remove the mine from the ground by pulling on the long rope or wire from a protected position, making sure that such protected position is not mined. If this method is not practicable, the matter should be referred to local technical service personnel.

- (3) Replace all safety pins in the firing devices, if any, always replacing the so-called "positive" safety pin *first*. Refer to paragraphs 49 through 73 for instructions pertaining to the particular firing device involved.
- (4) Unscrew firing device from activator.
- (5) Unscrew activator. Replace plug and gasket in head of activator.
- (6) Turn the setting knob of the arming plug to the SAFE position.
- (7) Remove arming plug by unscrewing it in a counterclockwise direction.
- (8) Remove the fuze, grasping the fuze pressure plate with the fingers. It should come out easily. *Do not attempt to remove the fuze if it is frozen in place.* Insert the safety fork (clip) in the fuze.
- (9) After removing the fuze, screw arming plug with retainer spring back into place handtight with pointer on setting knob pointing to SAFE.
- (10) Remove the trip wire and replace tape over secondary fuze well if used.
- (11) Restore the mine and fuze to its original position and packing. The mine may be laid and removed any number of times provided neither fuzes nor mines show evidence of damage or deterioration.

g. *Effectiveness.*

- (1) When buried 3-inches deep, this mine will disable a light tank

such as the 76-mm gun tank M41 or M41A1 by breaking the track.

- (2) When laid flush with the ground, it will disable a light tank such as the 76-mm gun tank M41 or M41A1 by breaking the track.

Note. The effectiveness of a mine M6A2 when buried under 2 to 3 inches of dirt is equal to, or greater than, its effectiveness when laid flush with the ground.

h. Sympathetic Detonation.

- (1) When buried 3-inches deep, sympathetic detonation will occur when mines are 5-feet apart.
- (2) When laid on top of the ground, sympathetic detonation will occur when mines are 8-feet apart.

i. Packing. The mine M6A2 is packed 2 mines, with 2 fuzes M603 and 2 activators M1 each in an individual metal container, all contained in a wooden box. The dimensions of the box are $18\frac{1}{8} \times 16 \times 9\frac{3}{4}$ inches. The weight of the box and contents is 60 pounds (approx). The mine M6A2 is also packed 1 mine, with 1 fuze and 1 activator each in a metal container, or with 1 fuze in a metal container and without an activator, all contained in a metal crate. The dimensions of the crate are $14 \times 13\frac{3}{4} \times 14\frac{1}{8}$ inches. The crate and contents weigh 31 pounds (approx) when the activator is included or 29 pounds (approx) when packed without the activator.

35. Fuze, Mine, AT, M603

a. General. This fuze (figs. 36 and 37) is of the instantaneous mechanical pressure type used with the heavy antitank mine M6A2 (par. 34), the light antitank mine M7A2 (par. 37), and the heavy antitank mine M15 (par. 38).

b. Description. The fuze consists of an aluminum body $1\frac{1}{8}$ inches in diameter and $1\frac{3}{16}$ inches high. The body contains a firing pin assembly, a cover assembly, a safety fork (clip), and a detonator. The firing pin

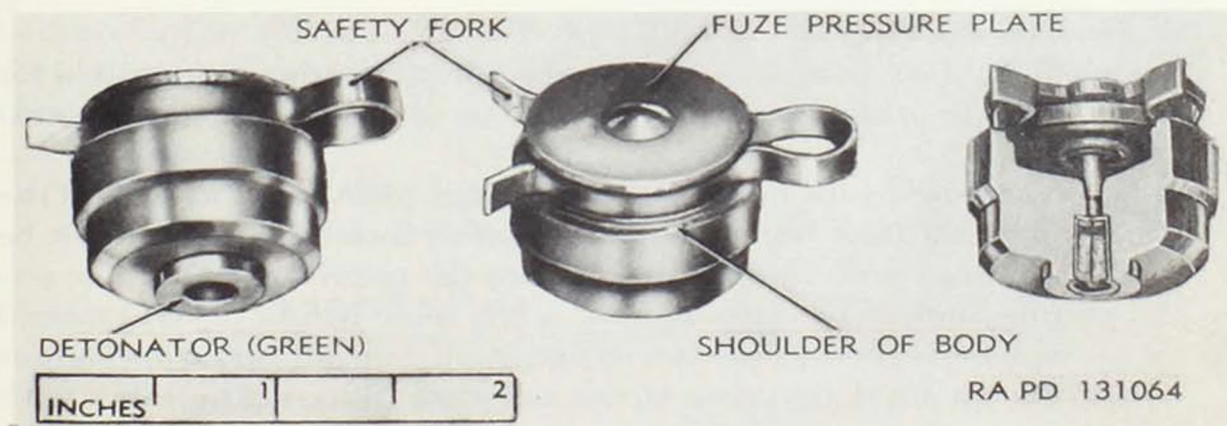

Figure 36. Fuze, mine, AT, M603 (T17E2)—bottom, top, and cross section.

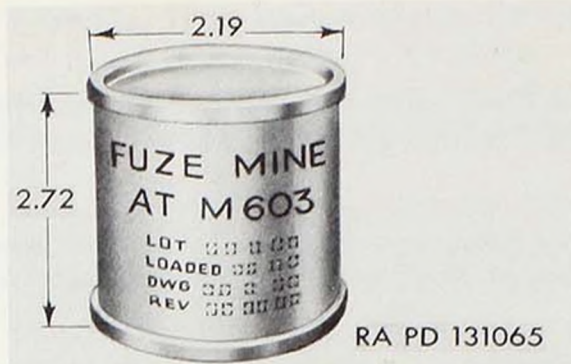

Figure 37. Metal ammunition container for fuze, mine, AT, M603 (T17E2).

assembly consists of a firing pin and two nested steel belleville springs held together by a retainer which is crimped to the firing pin. The cover assembly consists of a metal cover for the top of the fuze body and a pressure plate which is attached to the cover in such a manner that the safety fork may be inserted between the fuze body and the pressure plate. A detonator is provided in the detonator well and is crimped to the body of the fuze. A projection at the bottom of the fuze body permits the detonator (bottom end identified by its green color) to come into close proximity to the booster charge when the fuze is inserted into the mine. All mines using fuze M603 are fitted with booster M120 in the bottom of the fuze well.

c. Functioning. This fuze will function when a load of 140 to 240 pounds is applied to the fuze pressure plate. The fuze functions when the belleville springs *in the fuze* are depressed by that pressure and snapped into reverse, causing the firing pin to be driven into the detonator. When this fuze is used in the heavy antitank mine M6A2 and the heavy antitank mine M15, a load of 300 to 400 pounds actuates the fuze. This load is required on the *mine* pressure plate of these mines to overcome the resistance of the belleville spring *in these mines*. When the fuze is used in the light antitank mine M7A2, a load of 140 to 240 pounds on the *mine* pressure plate is sufficient to actuate the fuze and mine.

d. Precautions in Use.

- (1) As the fuze contains a detonator, all precautions prescribed for handling high explosives should be observed. Refer to paragraph 11.
- (2) When used with heavy antitank mines M6A2 and M15, and the light antitank mine M7A2, the safety fork (clip) should not be removed until immediately before the mine is fuzed. The setting knob of the arming plug of the mine M6A2 or M15 should not be turned to the armed position *until* all other operations except final covering of the pressure plate of the mine with earth or other camouflaging material have been completed.
- (3) For cautionary measures in laying and arming, and disarming

and removal (neutralizing), in connection with the use of this fuze in heavy antitank mines M6A2 and M15, and light antitank mine M7A2, refer to paragraphs 34, 38, and 37 respectively.

e. Temperature Limits. The fuze M603 will operate normally at temperatures between -65° and 160° F.

f. Packing.

- (1) *With M6 series heavy antitank mines.* Two fuzes and 2 activators (for use with a firing device to make up secondary fuzes), each in a metal can, are packed with 2 mines in a wooden box. One fuze in a metal container or 1 fuze and 1 activator each in a metal container, are packed with 1 mine in a metal crate.
- (2) *With M7 series light antitank mines.* Eight fuzes, each in individual metal cans M182 are packed, 4 per carton, in 2 cartons with 8 mines in metal box M156 (fig. 41), or 10 fuzes, each in individual metal cans M182 are packed, with 10 mines, in metal box M156. Twelve fuzes, each in an individual metal container are packed, with 12 mines, in a wooden box.
- (3) *With heavy antitank mine M15.* One fuze and 1 activator, each in individual metal container, are packed with 1 mine in a wooden box (fig. 44).
- (4) Fuzes for separate issue are packed in individual metal containers, 144 or 180 fuzes per wooden box.

36. M7 Series Modifications

The earlier modifications of the M7 series antitank mines are the M7 and M7A1, which have been renovated as the M7A2 (par. 37). The differences between earlier and later modifications are in minor improvement in design.

37. Mine, Antitank, HE, Light, M7A2, and Fuze, Mine, AT, M603

a. General. This mine (figs. 38 and 39) consists of an explosive charge in a quart-size rectangular light steel container intended for use against trucks and light tanks. Two to five of these mines employed together, laid preferably side by side, will disable large tanks. These mines may also be used, if occasion requires, as antipersonnel mines or demolition charges.

b. Description.

(1) *Mine.*

Model number—M7A2.

Weight, unfuzed— $4\frac{7}{8}$ pounds.

Weight of explosive charge (tetrytol)— $3\frac{3}{8}$ pounds.

Dimensions—height, $2\frac{1}{2}$ inches; length, 7 inches; width, $4\frac{1}{2}$ inches.

Material—steel.

Fuze well—main (primary) fuze located in center of top of mine.

Fuze arming mechanism—sliding pressure plate.

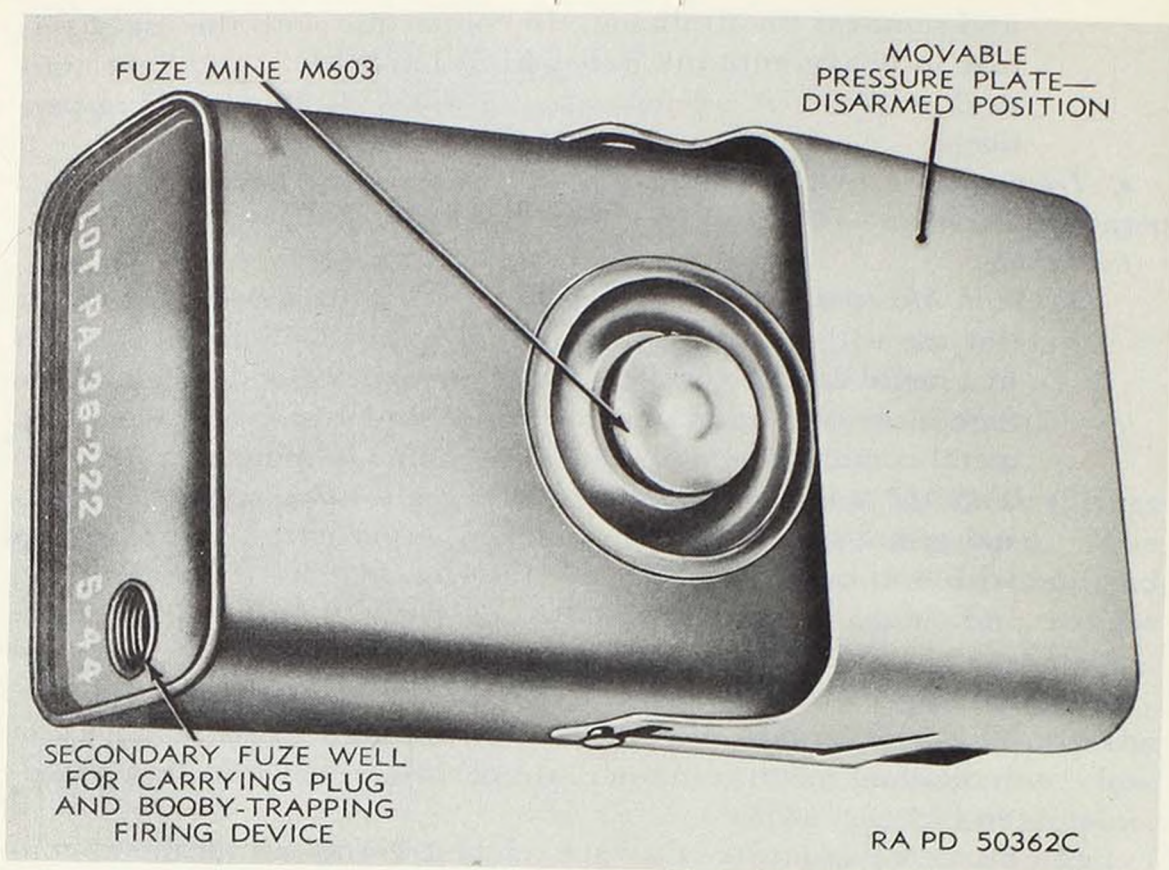

Figure 38. Mine, antitank, HE, light, M7A2, and fuze, mine, AT, M603—fuzed, after removal of safety fork.

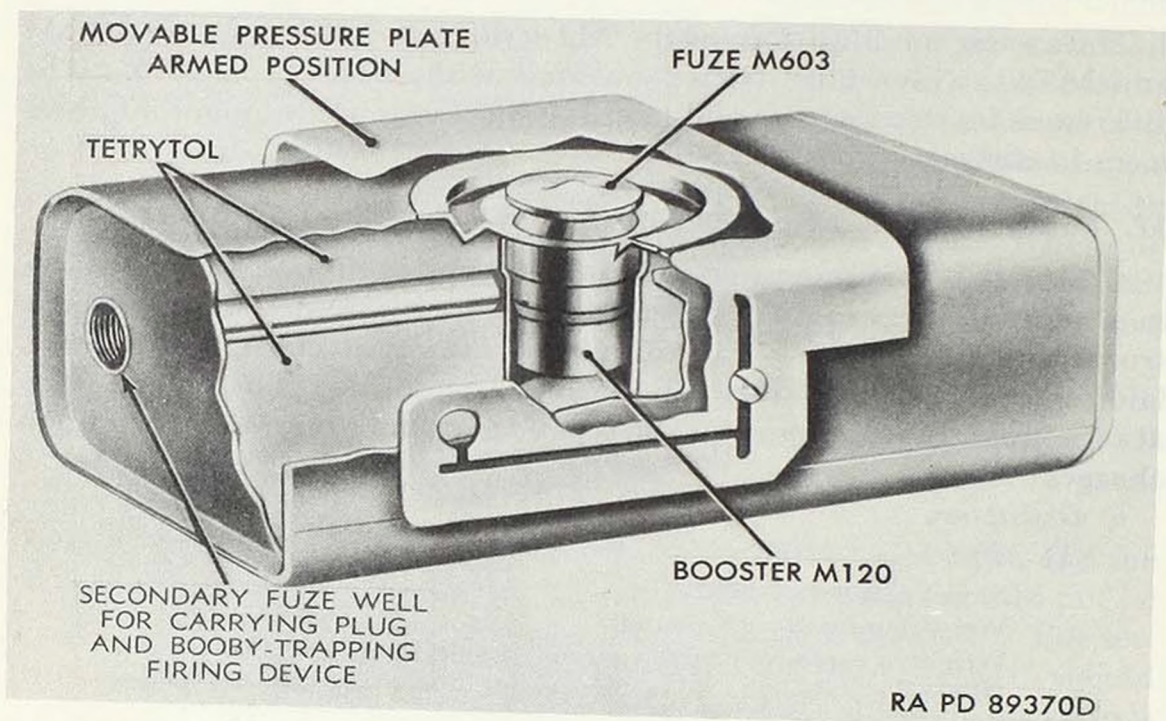

Figure 39. Mine, antitank, HE, light, M7A2, and fuze, mine, AT, M603—cutaway view, movable pressure plate, in armed position.

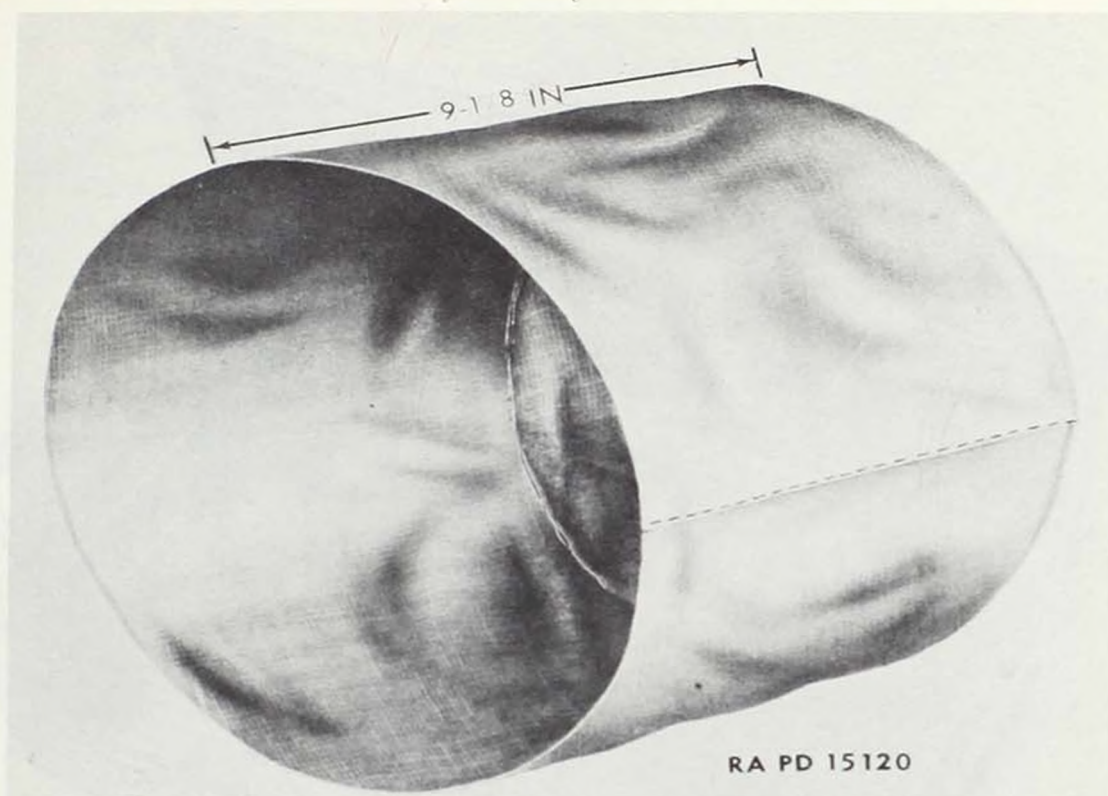

Figure 40. Cover, for mine, antitank, HE, light, M7 series (service or inert), and for mine, antitank, practice, M10.

Secondary fuze wells (fitted with carrying plug and cord as shipped).

Number and location—1 well located in one end of mine.

Type of boobytrapping (secondary) fuze for which threaded—any regular firing device with $\frac{1}{16}$ -inch thread and a crimped-on blasting cap. Booster—booster M120 at bottom of main fuze well.

Cover—a moisture-resistant mildew-proof cloth bag (fig. 40), $8\frac{3}{4}$ inches long and 9 inches in diameter, is used to cover the mine as laid to protect the sliding pressure plate from dirt and stones.

Painting—olive drab.

Marking—nomenclature, loader's initials, lot number, month and year loaded.

Packing method—8 mines, with 8 fuzes M603, each in a metal container, are packed in metal box M156 (fig. 41), or 12 mines, with 12 fuzes M603, each in a metal container, are packed in a wooden box.

Packing weight—8 mines and 8 fuzes, 56 pounds; 12 mines and 12 fuzes, 75.5 pounds.

(2) *Fuze (primary).*

Model number—M603.

Type—mechanical, belleville spring.

Weight—1.56 ounces.

Weight of explosive (primer mixture, lead azide, and RDX)—7 grain (approx).

Dimensions—height, 1.17 inches; diameter, 1.125 inches.

Material—steel.

Safeties—safety clip (fork).



RA PD 116937

Figure 41. Metal packing box M156.

Painting—uncolored.

Marking—nomenclature stamped in metal.

(3) *Fuze (secondary) (boobytrapping).*

Firing device type and model number—any regular type having $\frac{1}{16}$ -inch thread.

Activator model number—no activator used.

c. *Functioning.*

- (1) Force of 140 to 240 pounds on pressure plate of mines when in armed position depresses pressure plate of fuze.
- (2) Belleville spring of fuze snaps into reverse and drives firing pin into detonator exploding it.
- (3) Explosion of fuze detonator explodes booster, which is a component of the mine.
- (4) Explosion of booster explodes mine explosive charge.

d. *Laying and Arming.*

- (1) Slide pressure plate of mine to position shown in figure 38, exposing fuze well.

- (2) Inspect fuze well to see that no foreign matter is present. Be sure that the fuze retainer and booster M120 with its retainer are properly in place in primary fuze well of mine.
- (3) Remove fuze M603 from its metal container and inspect to see that it is serviceable and that the green end of the detonator shows in the bottom of the fuze.
- (4) Just before insertion of fuze into mine, remove the safety fork (clip) from the cover assembly of the fuze. The fingers or the hook end of the arming wrench may be used for this purpose.
- (5) Insert fuze into main (primary) fuze well of mine, pushing it down gently until it seats. To assure proper clearance between fuze pressure plate button and the steel pad on underside of pressure plate of mine, fuze must be fully seated on internal shoulder in fuze well.

Caution: The main (primary) fuze will always be inserted before installing any secondary fuzes. No pressure must be put on the pressure plate of fuze when inserting it into fuze well.

- (6) Slide pressure plate of mine into position over fuze. Center the pressure plate so that rivets in sides of mine are in vertical slots of pressure plate. The fuze is now armed.
- (7) To prevent dirt and stones from getting between mine body and pressure plate, insert mine into the cover (fig. 40) provided for this purpose, or into a burlap bag. Put no undue pressure on pressure plate of mine.
- (8) Lay the mine on a firm foundation in a place not likely to be flooded. The pressure plate side may be up or down. Whichever side is up as laid should be flush with, or not more than one inch below, the ground level with the longer axis of the mine parallel to the probable approach of the enemy. This is required because of the narrow pressure plate which does not cover the mine completely.
- (9) Camouflage in accordance with instructions in FM 20-32.

e. Boobytrapping.

- (1) Unscrew carrying plug with ring handle from secondary (boobytrapping) fuze well in end of mine.
- (2) Crimp a blasting cap to the particular firing device to be used, usually the pull type, or pull-release type (pars. 49 through 73). Do not use a pull-friction type firing device in boobytrapping an M7A2 mine.

Note. The pull-release type firing device will be installed only by especially trained troops.

- (3) Screw firing device with crimped-on blasting cap (which now becomes the secondary fuze) into the secondary fuze well hand-tight.
- (4) Arm this secondary fuze in accordance with instructions pertain-

ing to the particular type of firing device used (pars. 49 through 73) installing a trip wire, and anchoring the mine if necessary.

f. *Disarming and Removal (Neutralizing).*

- (1) Carefully uncover the camouflaged mine and examine it for any boobytrapping device (secondary fuze).

Caution: Great care must be taken with regard to antilift or boobytrapping devices (secondary fuzes).

- (2) *Do not cut any taut trip wires* but cut all *slack* trip wires.

Caution: If taut trip wires are encountered when attempting to neutralize the mine, do not cut the wires under any circumstances. The best procedure is to attach a long rope or wire to the mine without disturbing the taut trip wire and then remove the mine from the ground by pulling on the long rope or wire from a protected position, making sure that such protected position is not mined. If this method is not practicable, neutralize the secondary fuze according to procedure prescribed in FM 20-32.

- (3) If the secondary fuze has only a slack trip wire attached to it, cut it and remove the COVER or burlap bag and replace safety pins in the firing device, replacing the "positive" safety pin *first*. Refer to paragraphs 49 through 73, for instructions pertaining to the particular firing device.
- (4) Unscrew secondary fuze from the secondary fuze well grasping the knurled edge of the coupling base or using fuzing wrench M25 if the edge of the coupling base is hexagonal.
- (5) Unscrew the coupling base with blasting cap crimped thereto from the firing mechanism. Discard the coupling base with blasting cap. Restore the firing mechanism to its packing.

Warning: Do not attempt to remove the blasting cap that is crimped to the coupling base.

- (6) Slide pressure plate away from its position over the fuze.
- (7) Remove fuze.

Warning: Do not attempt to remove a fuze that is frozen in the fuze well. Mines of the M7 series which appear to have frozen, or ice-bound fuzes, will be handled as prescribed in FM 20-32.

- (8) Insert the safety fork (clip) in the primary fuze.
- (9) Restore mine and fuze each to its original packing.

g. *Effectiveness.*

- (1) When buried 2-inches deep, this mine will disable a light tank such as the 76-mm gun tank M41 or M41A1 by breaking the track.
- (2) When laid flush with ground, it will disable a light tank such as the 76-mm gun tank M41 or M41A1 by breaking the track.
- (3) When 5 mines are buried 3-inches deep, they will disable a medium tank such as the 90-mm gun tank M48 by breaking the track.

h. Sympathetic Detonation.

- (1) When buried 2-inches deep, sympathetic detonation will occur when mines are 5-feet apart.
- (2) When laid on top of the ground, sympathetic detonation will occur when mines are 12-feet apart.

i. Packing. The mine M7A2 is packed 8 mines, with 8 fuzes M603 each in a metal container, in metal box M156 (fig. 41); or 12 mines, with 12 fuzes M603 each in a metal container, in a wooden box. The dimensions of the metal box are $19\frac{1}{4} \times 11 \times 8\frac{1}{4}$ inches, and the weight of the box with contents is 56 pounds (approx). The dimensions of the wooden box are $23\frac{3}{8} \times 11\frac{3}{4} \times 9\frac{1}{2}$ inches, and the weight of the box with contents is 71.5 pounds (approx).

38. Mine, Antitank, HE, Heavy, M15 (T27), and Fuze, Mine, AT, M603

a. General. This mine (figs. 42 and 43) is a high capacity type of mine intended for use against heavy tanks. The mine is practically identical with the mine M6A2 (par. 34), except that it is thicker and is loaded with 22 pounds of COMP B instead of 12 pounds of TNT as in the M6A2—also in that it requires no booster aside from the booster M120, which is

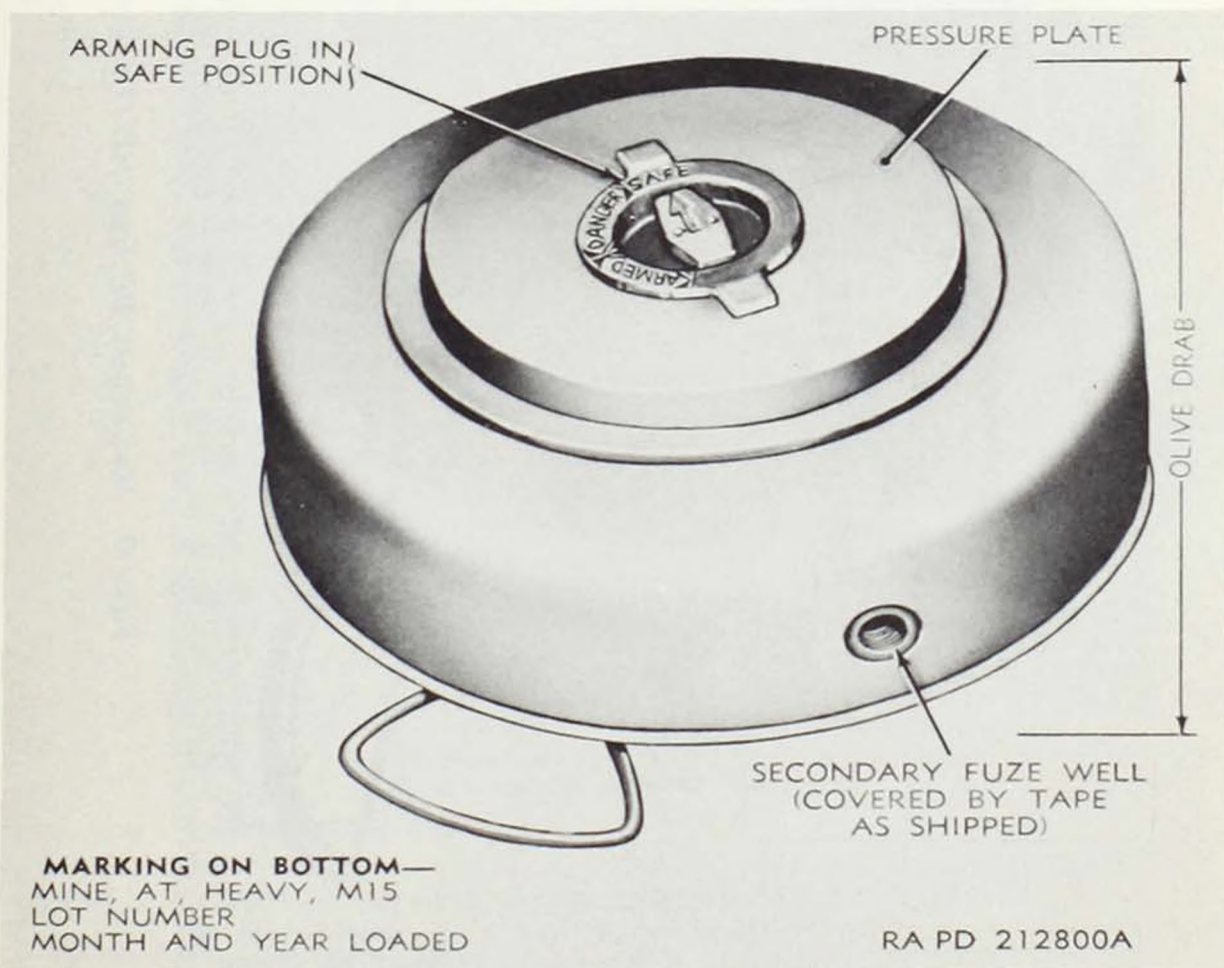

Figure 42. Mine, antitank, HE, heavy, M15 (T27)—arming plug in SAFE position.

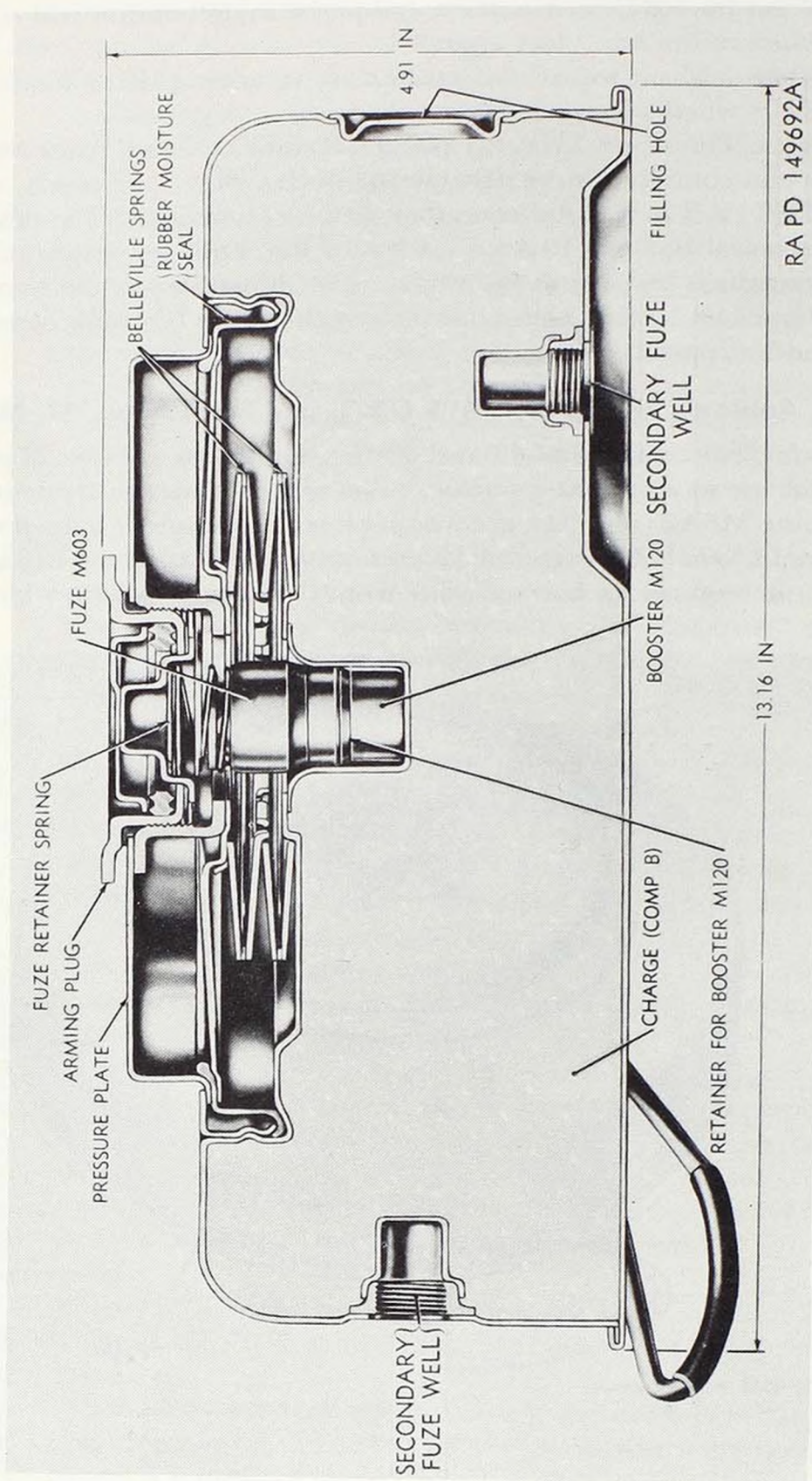

Figure 43. Mine, antitank, HE, heavy, M15 (T27)—cross section with fuze M603 installed.



Figure 44. Packing box for mine, antitank, HE, heavy, M15 (T27).

incorporated in the bottom of the main fuze wells of both the M6A2 and the M15.

b. Description.

(1) *Mine.*

Model number—M15.

Weight, unfuzed—30 pounds.

Weight of explosive charge (COMP B)—22 pounds.

Dimensions—height, 4 $\frac{1}{8}$ inches; diameter, 13 $\frac{1}{8}$ inches.

Material—steel.

Fuze well—main (primary) fuze well located in center of mine.

Fuze arming mechanism—arming plug M4 or M4B1. This plug is in place over main fuze well of mine as shipped. This plug (fig. 33) has a steel shutter which moves from a side position to the center position as the setting knob is moved from SAFE through DANGER to ARMED position. Arming plug M4 or M4B1 may be used with HE antitank mines of the M6 series or the M15. Arming plug M4 is used with AT practice mine M12.

Caution: The setting knob must never be left pointing to DANGER.

Secondary (boobytrapping) fuze wells:

Number and location—2 wells, 1 located in side and 1 in bottom; covered by tape as shipped.

Type of secondary (boobytrapping) fuze for which threaded—any firing device and activator M1 (pars. 49 through 73).

Booster—booster M120 in bottom of main fuze well; no other booster required.

Painting—olive drab.

Marking—nomenclature, lot number, month and year loaded, and loader's initials—on bottom of mine in yellow.

Packing method—1 mine, with 1 fuze M603 in metal container and 1 activator, M1, in metal container, in wooden box.

Packing weight—49 pounds.

(2) *Fuze (primary).*

Model number—M603.

Type—mechanical, belleville spring.

Weight—1.56 ounces.

Weight of explosive (primer mixture, lead azide, and RDX)—7 grain (approx).

Dimensions—height, 1.17 inches; diameter, 1.125 inches.

Material—steel.

Safeties—safety clip (fork).

Painting—uncolored.

Marking—nomenclature stamped in metal.

(3) *Fuze (secondary) (boobytrapping).*

Firing device type and model number—any regular type having $\frac{1}{16}$ -inch thread, usually pull-type M1 or pull friction-type M2.

Activator name and model number—activator M1.

c. *Functioning.*

(1) When shutter of arming plug (fig. 33) is in the ARMED position, a force of 300 to 400 pounds on pressure plate of mine depresses belleville spring of mine causing shutter to depress pressure plate of fuze (fig. 36).

(2) Pressure plate of fuze depresses belleville spring of fuze which snaps into reverse, driving firing pin into detonator exploding it.

(3) Explosion of detonator explodes booster (M120) which in turn explodes main charge.

d. *Laying and Arming.*

(1) Unscrew the arming plug from the mine, using the arming wrench (fig. 34).

(2) Inspect the fuze well and arming plug threads to see that no foreign matter is present.

Caution: It is particularly important during freezing weather to see that there is no ice in the fuze well during the fuzing operation as the presence of ice during fuzing may cause a serious accident.

Be sure that booster M120 is held properly in place in the bottom of the mine fuze well by the booster retainer.

(3) Remove fuze M603 from its metal shipping container and inspect it to see that it is serviceable and that the green end of the detonator shows in the bottom of the fuze.

(4) Just before insertion of the fuze into the mine, remove the safety fork from the cover assembly of the fuze. The fingers or hook end of the arming wrench may be used for this purpose. Save and conceal the safety fork (clip) for possible use in disarming the fuze.

(5) Insert the fuze into the fuze well of the mine (fig. 35), pushing it down gently until it seats.

Note. The main (primary) fuze will always be inserted before installing any secondary fuzes.

Caution: No pressure must be put on the pressure plate of the fuze when inserting it into the fuze well.

To assure proper clearance between the fuze pressure-plate button and the shutter of the arming plug, it is essential that the fuze be fully seated on the internal shoulder of the mine fuze well. If the fuze is not fully seated, the button on the fuze pressure plate will interfere with the movement of the shutter in arming the fuze. Hence if the fuze does not seat fully, it must be removed and the cause investigated.

- (6) Make sure that the setting knob and shutter are in the SAFE position, screw the arming plug with helical spring fuze retainer into the mine securely, using the arming wrench in order to make a watertight joint.
- (7) Lay the mine on a firm foundation with the top surface of the pressure plate not more than 3 inches beneath the ground level.
- (8) Just before the mine is covered, arm the mine by turning the setting knob with red pointer from SAFE through DANGER to ARMED. The arming wrench may be used for this purpose. The fuze will not function if the pointer on the arming plug points to SAFE.

Caution: Because of tolerances permitted in the manufacture, it is possible that in some cases the pressure plate of the fuze M603 extends too high, making it difficult if not impossible to turn the knob on the arming plug to the ARMED position. Do not attempt to force the knob but if necessary unscrew the arming plug just enough to allow the knob to be turned freely. The setting knob should at no time be left pointing to DANGER.

- (9) Camouflage the mine in accordance with instructions in FM 20-32.

e. Boobytrapping. Boobytrapping of the mine M15 requires activator M1 (par. 50) and a firing device of the pull, pull-friction, or pull-release type (par. 62 through 64) with appropriate trip wire.

- (1) Remove tape and shipping sleeve from secondary fuze well (side well, bottom well, or both).
- (2) Inspect secondary fuze well carefully to make certain it is free of foreign matter.
- (3) Remove plug and its gasket from head of activator (activator M1) and screw the activator handtight into the secondary fuze well of the mine.
- (4) Making sure that the small rubber gasket is in place inside the activator, screw firing device handtight into activator (the firing device does *not* have a blasting cap).
- (5) Install trip wires as required, fastening them to anchor posts *first*, and to the firing device of the mine *last*. Make sure there is no tension on the wires, except on the pull-release type firing device (par. 63), which must be installed, when required, by special troops only.

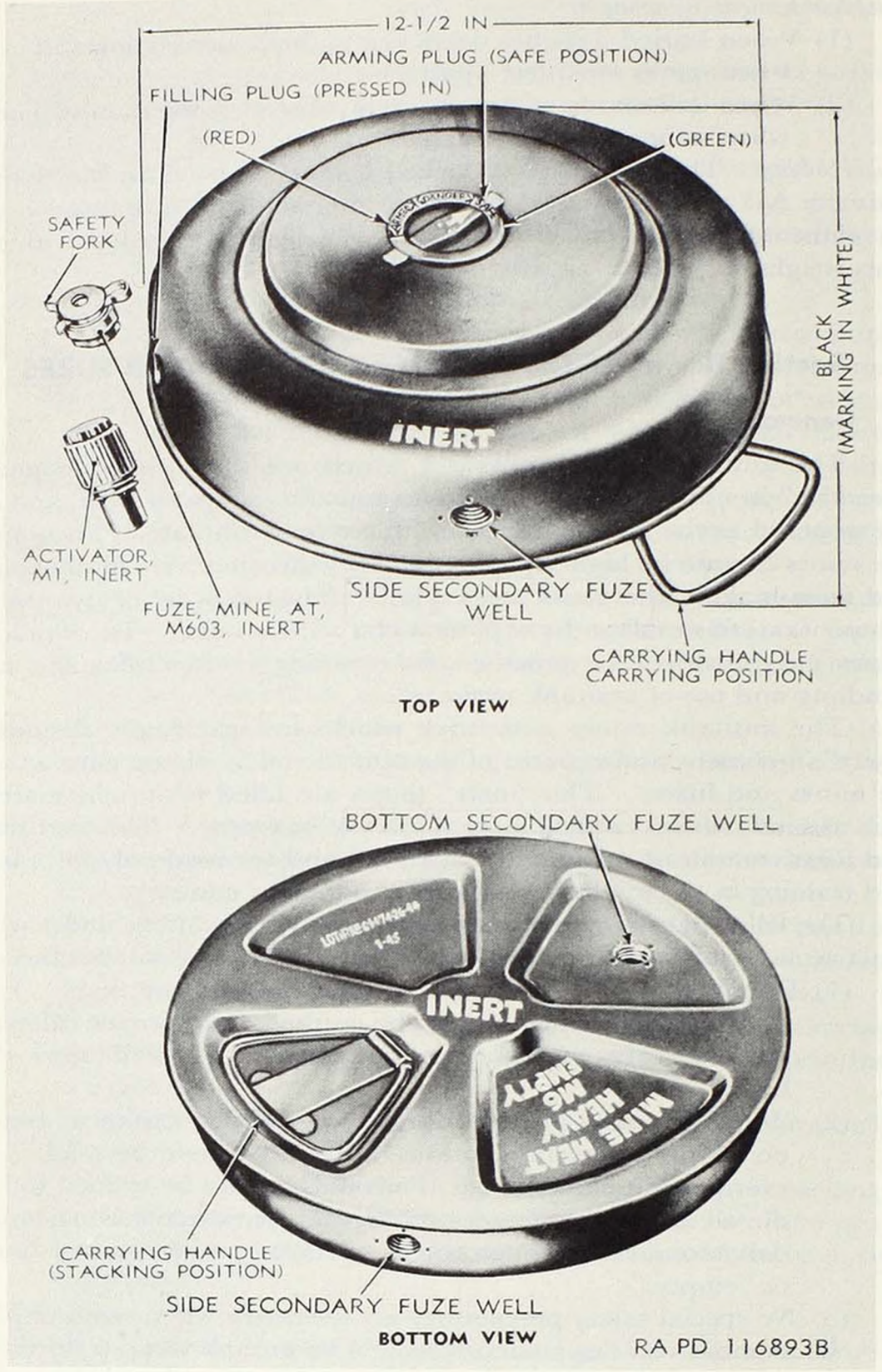

Figure 45. Mine, antitank, heavy, M6, empty—top view showing arming plug in unarmed (safe) position and bottom view showing marking.

- (4) All rules, regulations, and precautions pertaining to antitank service mines and practice mines in this manual and in AR 385-63, will be observed in the use of antitank practice mines.

d. Antitank practice mine fuzes are of the chemical or mechanical type. The chemical type (M12) has a plastic body. The fuze is initiated by breaking of a glass ampoule under pressure. Acid solution released from the ampoule ignites a primer mixture. Subsequent action releases a cloud of yellow smoke from the fuze body in the mine and propels a spotting charge cap (plastic container) several feet into the air, where it explodes, producing a bright flash and loud report. The mechanical type practice mine fuze (M604) has an aluminum body. The fuze is initiated in the same manner as the service fuze M603 (par. 35). Upon initiation, the firing pin is driven into an igniter, causing it to function and ignite a smoke composition charge. A report and a cloud of smoke, which issues from the top of the mine, are produced. Inert service fuzes are also provided for use with inert mines.

e. A secondary (boobytrapping) fuze for a practice antitank mine consists of a practice activator with firing device or of a firing device alone. The firing device contains a primer but no blasting cap or igniter is used with a firing device for boobytrapping a practice antitank mine. A secondary (boobytrapping) fuze for an inert mine consists of an inert activator with inert firing device or of an inert firing device alone. An inert firing device does not contain a primer and may consist of a standard firing device with an unprimed coupling base.

40. Mine, Antitank, Heavy, M6, Empty, and Inert Fuze M603 and Inert Activator M1

This mine (fig. 45) is completely inert (contains no explosive). It is used for training in handling the heavy type antitank mines of the M6-series. The mine is constructed of the same metal parts as the M6-series service mines and employs an inert fuze and an inert activator. The mine is used for training in laying and arming, boobytrapping (using a firing device without primer), and disarming and removing (neutralizing). In such training, exactly the same procedure and observance of safety precautions will be followed as in performing those operations with their service counterparts, which contain high explosive. For instruction in those operations, refer to paragraph 34. Inert mines are painted black with marking in white in accordance with the color scheme for painting and marking ammunition.

Note. If this mine packed without fuze and without activator is requisitioned, an inert fuze M603 and an inert activator M1 must also be requisitioned.

41. Mine, Antitank, Light, M7A1 or M7A2, Inert, and Fuze, Mine, AT, M603, Inert

This mine (fig. 46) is completely inert (contains no explosive). It is used for training in handling the light weight type antitank mine of the

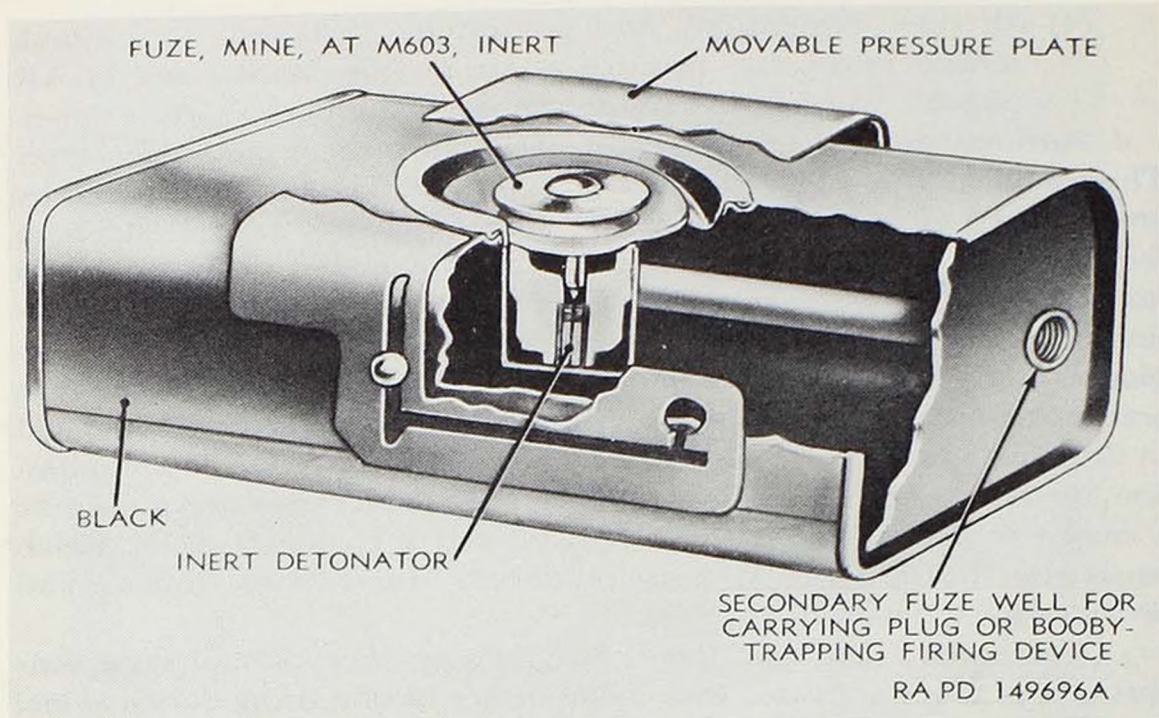

Figure 46. Mine, antitank, light, M7A1 or M7A2, inert, and fuze, mine, AT, M603, inert.

M7-series. The mine is constructed of the same metal parts as the M7-series service mines and employs an inert fuze. The mine is used for training in laying and arming, boobytrapping (using a firing device without primer and without blasting cap) and disarming and removal (neutralizing). In such training, exactly the same procedure and observance of safety precautions will be followed as in performing those operations with their service counterparts, which contain high explosives. For instructions in those operations refer to paragraph 37. Inert mines are painted black with marking in white in accordance with the color scheme for painting and marking ammunition.

42. Mine, Antitank, NM, Practice, M9 (T3E1), and Fuze, Mine, Chemical, AT, NM, M12 (T3E1), Practice

a. General. This practice mine (fig. 47), although simulating a service mine which is now obsolete, is made of nonmetallic (NM) materials to prevent detection by magnetic type mine detectors. The mine body has approximately the same capacity as the M6-series heavy antitank mine but is deeper and of somewhat smaller diameter. Dimensions and other characteristics are shown in table III.

b. Description.

- (1) *Body.* The mine body consists of a clay (ceramic) bowl and base plate containing an inert filler. The base plate and bowl are separated by a thick sponge rubber ring and inclosed in a tough paper jacket. There is a threaded opening in the top of the mine to receive the fuze and a threaded opening in the bot-

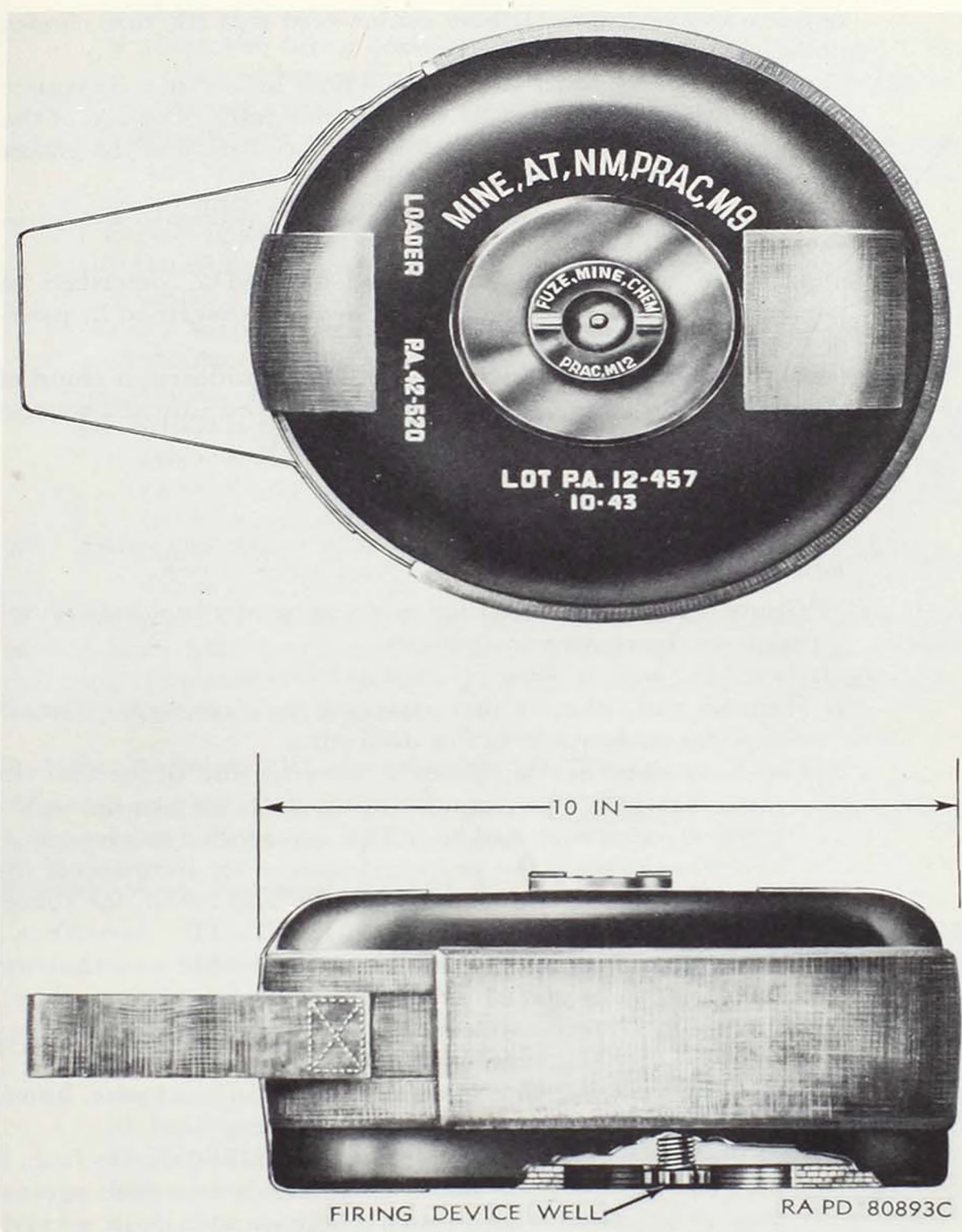

Figure 47. Mine, antitank, NM, practice, M9, and fuze, mine, chemical, AT, NM, M12 (T3E1), practice-tape removed and fuze in place.

tom to receive any standard firing device which may be installed for boobytrapping purposes. Until ready to insert such firing device, the bottom opening should be kept closed by the plastic plug. Being waterproof, this mine may be planted

under water or mud. It is so constructed that the fuze cannot be jammed by stones or dirt.

- (2) *Clearance gage.* A hardwood plug which serves as a clearance gage is in the fuze well of the mine as shipped. The top of the plug should be flush with or below the top surface of the gasket on which the fuze is to seat.

Note. In no case should an attempt be made to fuze the mine if the clearance gage projects above the top of the fuze gasket.

- (3) *Fuze.* The practice chemical mine fuze M12, described in paragraph 44, and standard firing devices, described in paragraph 48, are used with this mine.

c. Functioning. Two to 3 seconds after the fuze is initiated, a cloud of smoke is produced, and a spotting charge is projected upward several feet where it explodes with a flash and a loud report.

d. Preparation for Use.

- (1) *Installation and arming (fuzing).*

Note. The outer paper jacket on the mine will be left in place. This mine is designed to use a practice fuze, firing device, or both.

- (a) Prepare a firm foundation for mine, generally in a hole of appropriate depth for concealment.
- (b) If fuze M12 only is used, proceed as follows:
 1. Remove the adhesive tape covering the fuze well. Retain tape for subsequent use in disarming.
 2. Check for presence of rubber safety ring and to see that the clearance gage (hardwood plug) is flush with or below the top surface of fuze gasket. This is intended to give assurance that there is the proper clearance for insertion of the fuze. Remove the clearance gage and retain for subsequent use in disarming.
 3. Examine the fuze to see that it is serviceable and that the safety cap is in place.
 4. Unscrew the safety cap from bottom of fuze. Retain safety cap for subsequent use in disarming.
 5. Insert the fuze into the mine and screw in clockwise, hand-tight. This seats fuze against safety ring.
 6. Lay the mine, remove safety ring (partially unscrew fuze, if necessary, to remove safety ring, then screw fuze against fuze plug gasket, handtight), and camouflage in accordance with provision of FM 20-32. Retain safety ring for subsequent use in disarming.
- (c) If firing device only is used, proceed as follows:
 1. Remove plastic plug from firing device well in bottom of mine. Retain plug for subsequent use in disarming.
 2. Screw firing device without blasting cap into firing device well.

3. Lay and camouflage mine.

4. Arm the firing device in accordance with instructions contained in paragraph 48. Retain safety device for subsequent use in disarming.

(d) If both fuze and firing device are to be used, install both fuze and firing device as described in (b) and (c) above. Then lay and camouflage mine.

(2) *Disarming and removal.*

(a) Carefully remove any materials used for camouflaging the mine.

(b) If a firing device is installed, insert safety device, cut or disconnect trip or anchor wire, and remove firing device from mine. Insert plastic plug in firing device well.

(c) If fuze is installed and has not functioned, remove fuze and screw safety cap in bottom of fuze. If fuze has functioned, remove and discard. Install clearance gage and safety ring in mine and place adhesive tape over fuze well.

(d) Restore mine and all serviceable components to original condition and packings.

e. Packing. The mine M9 is packed four complete mines with four practice fuzes M12 (each in a metal can)—all in a wooden box. Approximate dimensions of the box are 26 x 13 $\frac{1}{8}$ x 11 $\frac{5}{8}$ inches; the complete packing weighs 88.7 pounds.

43. Mine, Antitank, NM, Practice, M9 (W/O Fuze)

This mine is the same as the M9 practice mine described in paragraph 11, except that it is issued without fuze.

44. Fuze, Mine, Chemical, AT, NM, M12 (T3E1), Practice

a. General. This fuze (fig. 48) is used with the nonmetallic antitank practice mine M9 (T3E1) described in paragraph 42.

b. Description and Functioning.

(1) The fuze consists of a cylindrical plastic body closed at the top by a plastic plug and at the bottom by a plastic cap (safety cap). The safety cap has the following instruction marked on its base in embossed letters REMOVE THIS CAP BEFORE FUZING MINE. The designation of the fuze appears in embossed letters on top of the plug assembly. The lot number and date loaded (month and year) are marked, in white, lengthwise on the fuze body.

(2) When the fuze is assembled to the mine and armed (par. 42), the fuze piston is positioned directly over a pressure pin in the mine. A pressure of approximately 350 pounds applied to the mine forces the fuze downward until the piston (interrupted in travel by the pressure pin) crushes a glass ampoule containing an acid solution. The solution ignites the primer mixture and

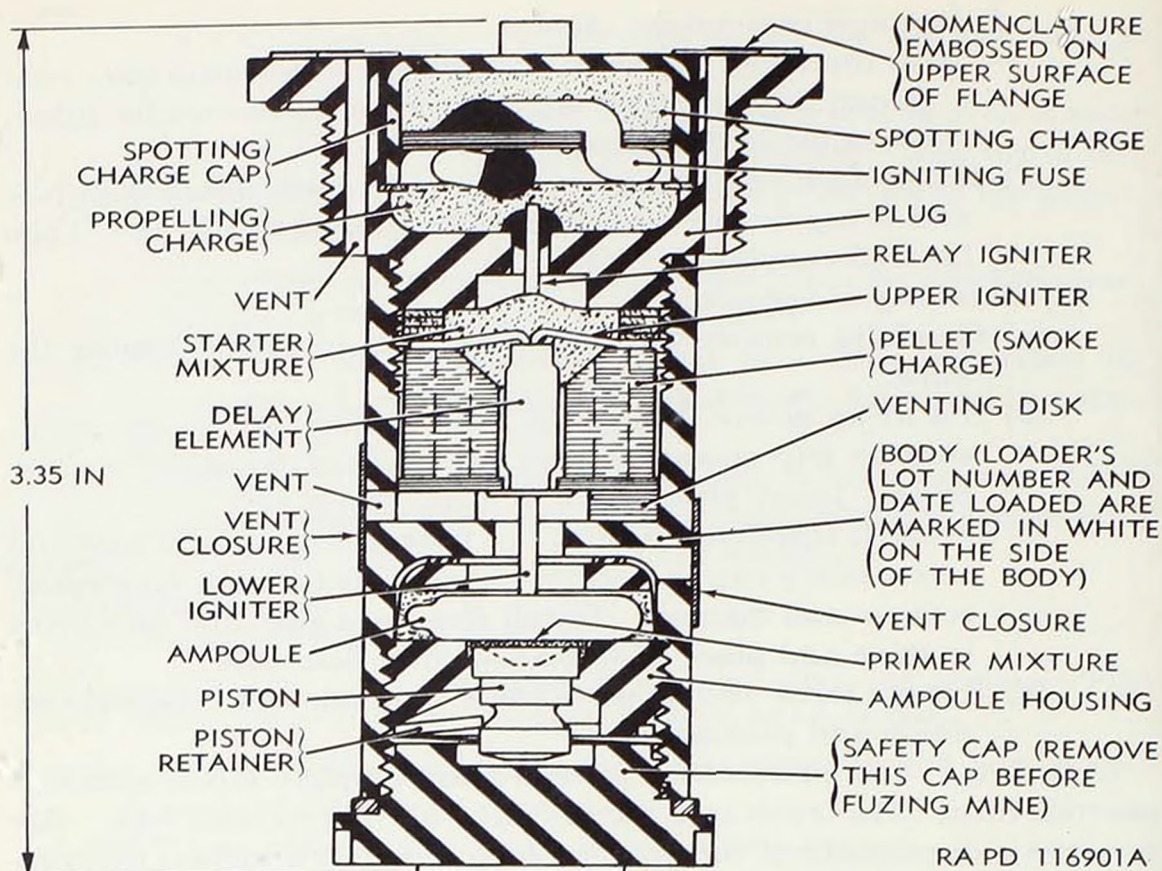

Figure 48. Fuze, mine, chemical, AT, NM, M12 (T3E1), practice.

flame is relayed through a delay element to the smoke charge contained in the body of the fuze. Yellow smoke is released from the fuze through two horizontal vent holes in the side of the fuze body and passes into the air through four equally spaced vent holes in the fuze plug assembly to form a cloud of smoke above the mine. At approximately the same time the smoke charge is ignited, flame is relayed to a black powder propelling charge in the fuze plug assembly. The propelling charge ejects a plastic container (spotting charge cap) containing a spotting charge of photographic flashlight powder several feet into the air. After a short delay, provided by ignition cord contained in the spotting charge cap, the spotting charge explodes and produces a bright flash accompanied by a loud report.

c. Packing. This fuze, packed 1 each per metal can, is issued either in the same packing box as the nonmetallic antitank practice mine M9 (T3E1) as described in paragraph 42 or separately in quantities of 200 per wooden box which measures $29\frac{3}{4} \times 23\frac{3}{4} \times 10\frac{1}{2}$ inches, and weighs 101 pounds.

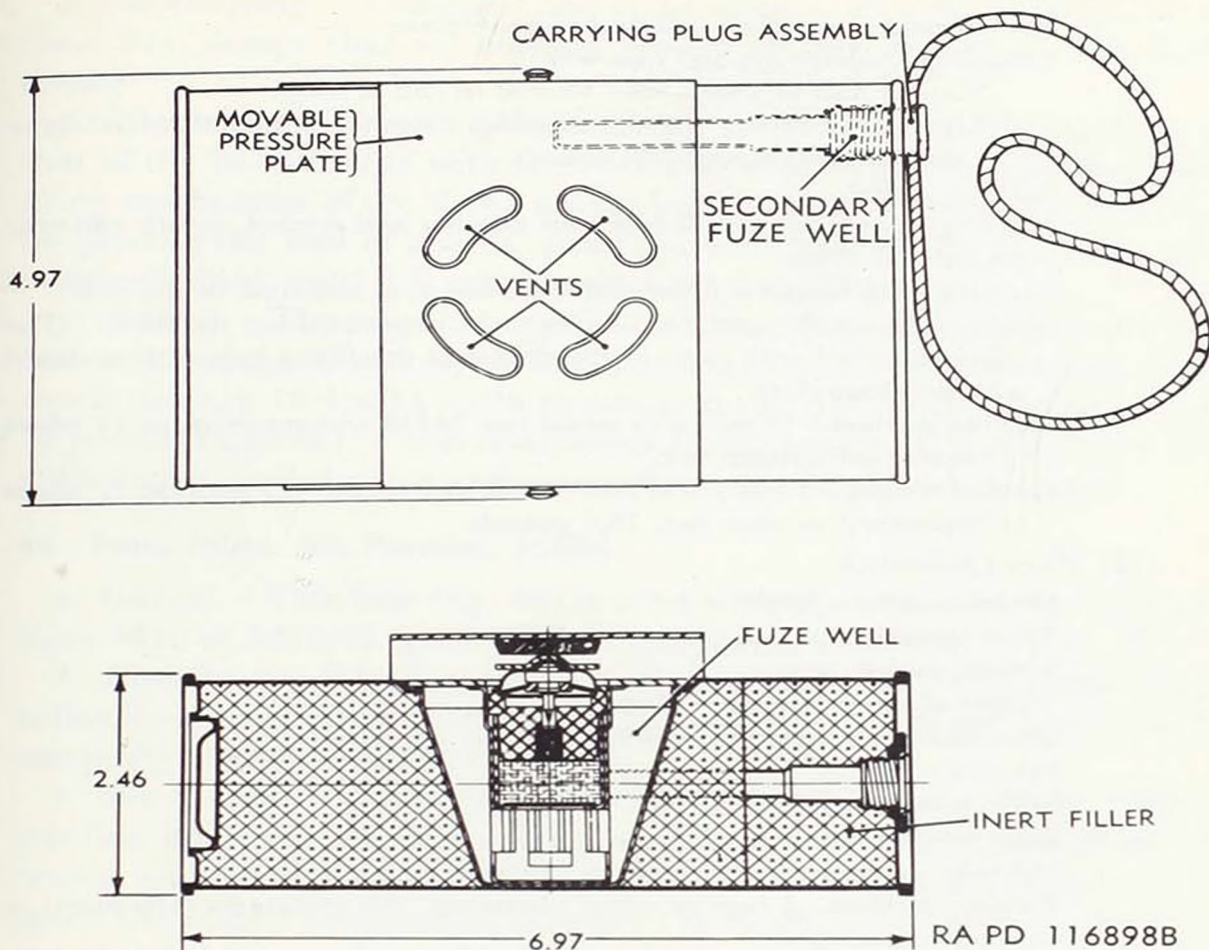

Figure 49. Mine, antitank, light, practice, M10A1, and fuze, mine, AT, practice, M604.

45. Mine, Antitank, Light, Practice, M10A1, and Fuze, Mine AT, Practice, M604

a. *General.* This *practice* mine (fig. 49) is used for training personnel in the precautions and proper method to be observed in the care, handling and laying of high-explosive light *service* antitank mines of the M7 type (pars. 36 and 37). Except for the smoke charge contained in the main fuze, and the primer contained in the firing device (when used as a secondary fuze), this practice mine is inert. The mine is shipped empty and is to be loaded with sand in the field. When so loaded, its weight will be approximately that of the M7-series high-explosive antitank mine which it simulates. The mine is laid so that the weight of a truck or light tank passing over it will cause the main fuze to function.

b. *Description.*

(1) *Mine.*

- Model number—M10A1 (or M10), simulates the M7A2 mine (par. 37).
- Type—practice.
- Weight, unfuzed— $4\frac{7}{16}$ pounds.
- Dimensions—height, $2\frac{1}{2}$ inches; length, 7 inches; width 5 inches.
- Material—steel.
- Fuze well—main (primary) fuze well located in center of top of mine.

Fuze arming mechanism—sliding pressure plate.

Secondary (boobytrapping) fuze well:

Number and location—one, located in end of mine.

Type of secondary (boobytrapping) fuze for which threaded—any regular firing device ((3) below).

Painting—blue.

Marking—nomenclature, loader's lot number and symbol, month and year loaded—in white.

Carrying plug—mine is fitted with carrying plug and cord, as shipped.

Closing cap—as shipped, the closing cap is separate from the mine. The mine is loaded with sand in the field and the filling hole is then closed with the closing cap.

Packing method—12 mines in metal box M156 without fuzes, as 12 mines in improvised wooden box.

Packing weight—12 mines in box M156 with fuzes, 70.3 pounds; 12 mines in improvised wooden box, 76.0 pounds.

(2) *Fuze (primary).*

Model number—M604.

Type—practice.

Weight—2½ ounces.

Weight of smoke charge—17 grains.

Dimensions—height, 1¾ inches; diameter, 1½ inches.

Material—steel.

Safeties—safety clip (fork).

Painting—none.

Marking—nomenclature, stamped in metal.

Packing method—1 fuze in metal container, 100 containers (100 fuzes) in wooden box.

Packing weight—55.5 pounds.

(3) *Fuze (secondary) (boobytrapping).*

Firing device type and model number—any regular type firing device having ¼-inch thread, usually pull-type M1 or pull-friction type M2.

Note. No igniter charge or blasting cap should be used on the firing device when used with this mine.

c. Functioning.

(1) A force of 140 to 240 pounds on striker plate of mine when in armed position depresses pressure plate of fuze, causing belle-ville spring of fuze to snap into reverse driving firing pin into igniter of fuze causing it to function.

(2) Igniter of fuze ignites smoke charge of fuze.

(3) Functioning of smoke charge of fuze causes a cloud of smoke to rise from mine accompanied by a noise (report).

d. Laying and Arming. This operation is the same as that of the M7A2 mine with the M603 fuze. Refer to paragraph 37*c*. After mine has functioned, it may be taken up and if in good condition refitted with a new M604 fuze and a new or reprimed firing device, and laid again.

Note. The booster M120, which is a component of the M7A2 mine assembly, is not used in the M10 or M10A1 practice mine assembly. The M604 fuze takes up the same space in the M10 or M10A1 practice mine as the M603 fuze and the M120 booster together take up in the M7A2 mine.

e. Boobytrapping. This operation is the same as that of the M7A2 mine (par. 37e) except that no blasting cap or igniter is used on the firing device.

f. Disarming and Removal (Neutralizing). This operation is the same as that of the M7A2 mine with the M603 fuze (par. 37f) except that if the firing mechanism of the firing device has functioned, it may be recocked by placing the end of a stick, pencil or nail against the firing pin and pushing it back until it is held in place by the release pin.

g. Packing. The mines are packed without fuzes, 12 mines in a metal box or 12 mines in an improvised wooden box. The dimensions of the metal box are $19\frac{1}{8}$ x 11 x $8\frac{1}{8}$ inches and the box with contents weighs 70 pounds (approx). The dimensions of the wooden box are $18\frac{5}{8}$ x $14\frac{7}{8}$ x $9\frac{1}{2}$ inches, and the box and contents weighs 76 pounds (approx).

46. Fuze, Mine, AT, Practice, M604

a. General. This fuze (fig. 49) is used with the light practice antitank mine M10 or M10A1 (par. 45) and the practice mine M12 (par. 47).

b. Description. The fuze consists of an aluminum body containing a belleville spring, fitted with a firing pin, an igniter charge, and a smoke composite charge weighing 17 grains.

c. Functioning. A force of 140 to 240 pounds on the pressure plate of this fuze depresses the belleville spring in the fuze causing it to snap into reverse and drive the firing pin into the igniter causing it to function and ignite the smoke composition charge. A cloud of smoke issues from the top of the mine accompanied by a noise (report). Mines which use this fuze have no booster. The space taken in the fuze well by the M604 fuze equals the space taken by the M603 fuze and the M120 booster together in the fuze well of service mines.

47. Mine, Antitank, Practice, M12, and Fuze, Mine, AT, Practice, M604

a. General. This *practice* mine (figs. 50 and 51) is used for training personnel in the precautions and proper method to be observed in the care, handling, and laying of high-explosive heavy *service* antitank mines of the M6 series (pars. 33 and 34) and the M15 (par. 38). Except for the smoke charge contained in the main fuze and, when secondary (boobytrapping) fuzes are used, the detonator and smoke charges in practice activator M1 and the primer in the firing device which is fitted to the practice activator, this mine is inert. The mine is shipped empty and is to be loaded with sand ($11\frac{1}{8}$ pounds (approx.)) in the field. When so loaded, its weight will be approximately that of the M6 series high-explosive mine which it simulates. The mine is laid so that the weight of an intermediate or heavy tank passing over it causes the main fuze to function.

b. Description.

(1) *Mine.*

Model number—M12.

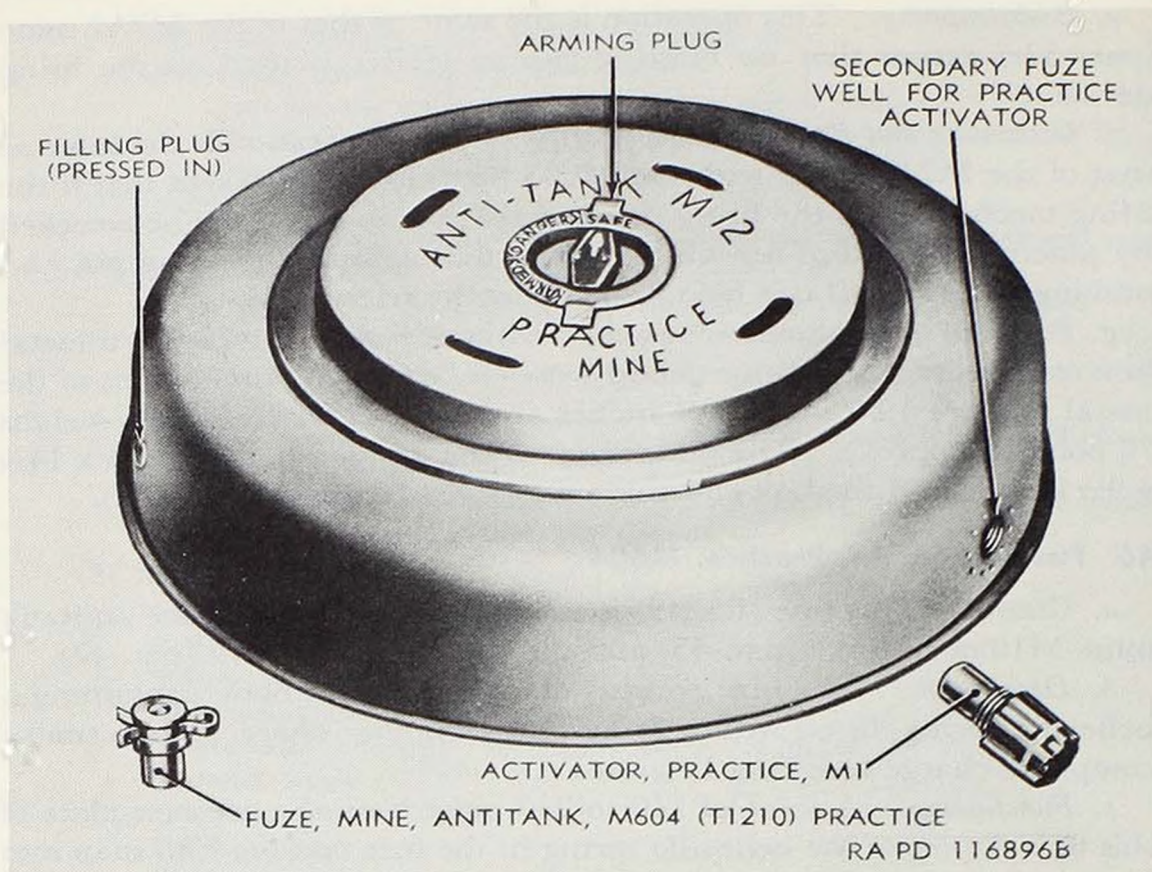

Figure 50. Mine, antitank, heavy, practice, M12—top.

Weight, sand-loaded—20 pounds.

Weight of explosive charge—none.

Dimensions—height, 3½ inches; diameter, 13¼ inches.

Material—steel.

Fuze well—main fuze well is in center of mine underneath arming plug.

Arming mechanism—arming plug M4 is in place over main fuze well, as shipped. This plug (fig. 33) has a steel shutter which moves from a side position to a center position as the setting knob is moved from SAFE through DANGER to ARMED position.

Caution: Setting knob is never to be left pointing to DANGER.

Note. Arming plug M4 or the M4B1 may be used with high-explosive mines M6 series or M15. Arming plug M4 is used with the M12 practice mine.

Secondary (boobytrapping) fuze wells:

Number and location—one in side and one in bottom, each threaded for practice activator M1.

Type of secondary (boobytrapping) fuze for which threaded—any firing device and practice activator M1 (pars. 49 through 73).

Painting—blue.

Marking—nomenclature, loader's lot number and symbol, and date (month and year) loaded.

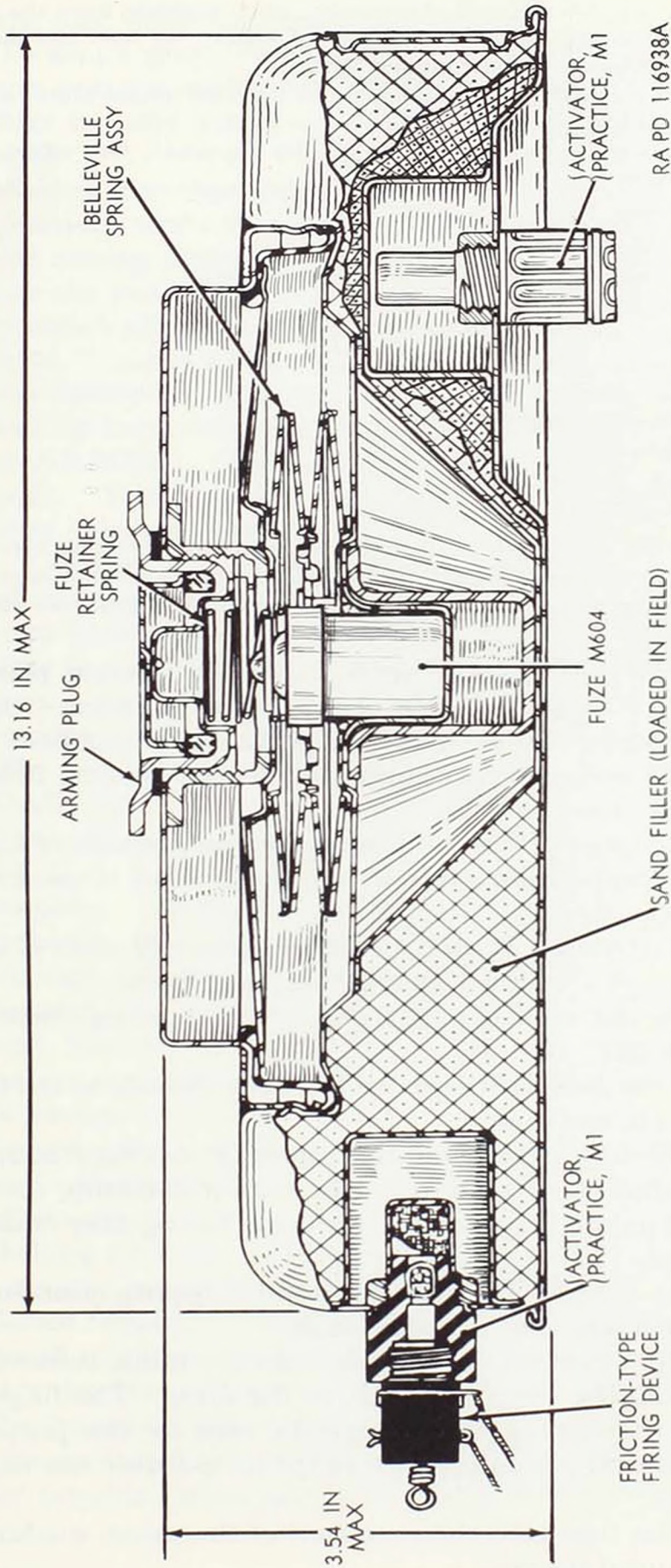

Figure 51. Mine, antitank, heavy, practice, M12, and fuze, mine, antitank, practice, M604.

Closing cap—as shipped, the closing cap is separate from the mine. The mine is loaded with 11.16 pounds of sand in the field and the filling hole is then closed with the closing cap.

Packing method—one mine without fuze per metal crate; or two mines without fuzes per wooden box.

Packing weight—one mine, 19 pounds (approx); two mines, 39 pounds (approx).

(2) *Fuze (primary).*

Model number—M604.

Type—practice (mechanical-belleville spring).

Weight—2½ ounces.

Weight of smoke charge—17 grains.

Dimensions—height, 1¼ inches; diameter, 1½ inches.

Material—steel.

Safeties—safety clip (fork).

Painting—none.

Marking—nomenclature.

(3) *Fuze (secondary) (boobytrapping).*

Firing device type and model number—any regular type having ⅜-inch thread, usually pull-type M1 or pull friction-type M2. Activator name and model number—activator, practice, M1.

c. *Functioning.*

- (1) A force of 300 to 400 pounds depresses pressure plate of mine.
- (2) Shutter of arming plug in pressure plate of mine (when shutter is in armed position) depresses pressure plate of fuze.
- (3) Belleville spring of fuze snaps into reverse driving firing pin into charge of fuze.
- (4) Igniter charge of fuze ignites smoke composition of fuze.
- (5) Smoke composition explodes emitting cloud of smoke and noise (report).

d. *Laying and Arming.* Primary (main) fuzes will always be inserted before installing any secondary (boobytrapping) fuzes.

- (1) Unscrew the arming plug from the mine, using the arming plug wrench M20 (fig. 34).
- (2) Inspect the fuze well and arming plug threads to see that no foreign matter is present.

Caution: It is particularly important during freezing weather to see that there is no ice in the fuze well during the fuzing operation as the presence of ice during fuzing may cause a serious accident.

- (3) Remove fuze M604 from its metal shipping container and inspect it to see that it is serviceable.
- (4) Just before insertion of the fuze into the mine, remove the safety fork from the cover assembly of the fuze. The fingers or hook end of the arming wrench may be used for this purpose. Save and conceal the safety fork (clip) for possible use in disarming the fuze.
- (5) Insert the fuze into the fuze well of the mine, pushing it down gently until it seats.

Caution: No pressure must be put on the pressure plate of the fuze when inserting it into the fuze well.

To assure proper clearance between the fuze pressure-plate button and the shutter of the arming plug, it is essential that the fuze be fully seated on the internal shoulder of the mine fuze well.

- (6) Making sure that the setting knob and shutter are in the SAFE position, screw the arming plug into the mine securely, using the arming wrench in order to make a watertight joint.
- (7) Lay the mine on a firm foundation with the top surface of the pressure plate not more than three inches beneath the ground level.
- (8) Just before the mine is covered, arm the mine by turning the setting knob with red pointer from SAFE through DANGER to ARMED. The arming wrench may be used for this purpose. The fuze will not function if the pointer on the arming plug points to SAFE.

Caution: Because of tolerances permitted in the manufacture of antitank mines, it is possible that the pressure plate of the fuze M604 extends too high, making it difficult if not impossible to turn the knob on the arming plug to the ARMED position. Do not attempt to force the knob but unscrew the arming plug just enough to allow the knob to be turned freely. The setting knob should at no time be left pointing to DANGER.

- (9) Camouflage the mine in accordance with instructions in FM 20-32.

e. Boobytrapping. Boobytrapping of the M12 practice mine requires a practice activator (par. 51) and an appropriate primed firing device (pars. 62 through 64) with one or more trip wires.

- (1) Remove tape and shipping sleeve from secondary fuze well (side well, bottom well, or both).
- (2) Inspect secondary fuze well carefully to make certain it is free of foreign matter.
- (3) Remove plug and its gasket from head of practice activator M1 and screw the activator handtight into the secondary fuze well of the mine.
- (4) Making sure that the small rubber gasket is in place *inside* the activator, screw firing device handtight into activator (the firing device requires no blasting cap when used with an activator).
- (5) Install trip wires as required.
- (6) Arm the firing device by removing safety pins, always removing the "positive" safety pin *last*.
- (7) Save and conceal all safety pins, activator plug, and its gasket for possible future use in disarming and removal.

f. Disarming and Removal (Neutralizing).

- (1) Carefully uncover the concealed mine and examine the side and bottom secondary fuze wells for any boobytrapping devices (secondary fuzes). *Trip wire may have been installed that will initiate a secondary fuze by either pull or release.*

- (2) *Do not cut any taut trip wires, but cut all slack trip wires.*

Warning: If taut trip wires are encountered when attempting to neutralize the mine, do not cut the wires under any circumstances. The best procedure is to attach a long rope or wire to the mine without disturbing the taut trip wire and then remove the mine from the ground by pulling on the long rope or wire from a protected position. If this method is not practicable, the matter should be referred to local technical service personnel.

- (3) Replace all safety pins in the firing devices, if any, always replacing the "positive" safety pin *first*. Refer to paragraphs 49 through 73, for instructions pertaining to the particular firing device involved.
- (4) Unscrew firing devices from activators.
- (5) Unscrew activator. Replace plug and its gasket in head of activator.
- (6) Turn the setting knob of the arming plug to the SAFE position.
- (7) Remove arming plug by unscrewing it in a counterclockwise direction.
- (8) Remove the fuze by grasping the fuze pressure plate with the fingers. It should come out easily. Do not attempt to remove the fuze if it is frozen in its place. Insert the safety fork (clip) in the fuze.
- (9) After removing the fuze, screw arming plug back into place handtight with pointer on setting knob pointing to SAFE.
- (10) Remove the trip wire and replace tape over secondary fuze well if used.
- (11) If required, remove sand from mine.
- (12) Restore the mine and fuze to its original position and packing. The mine may be laid and removed any number of times provided neither fuzes, nor mines show evidence of damage or deterioration.

g. Functioned Mine and Fuze. If mine and fuzes have functioned and the mine casing is undamaged, replace the main fuze with a new fuze, replace the practice activator with a new one, and retain the firing mechanism of the firing device. The coupling base with fired primer may be discarded or reprimed depending on its condition and pertinent instructions from the responsible technical service. The firing mechanism may be *recocked* by placing the end of a stick, pencil, or nail against the firing pin and pushing it back until it is held in place by the release pin. Install safety pin. Restore mine, new fuze, new practice

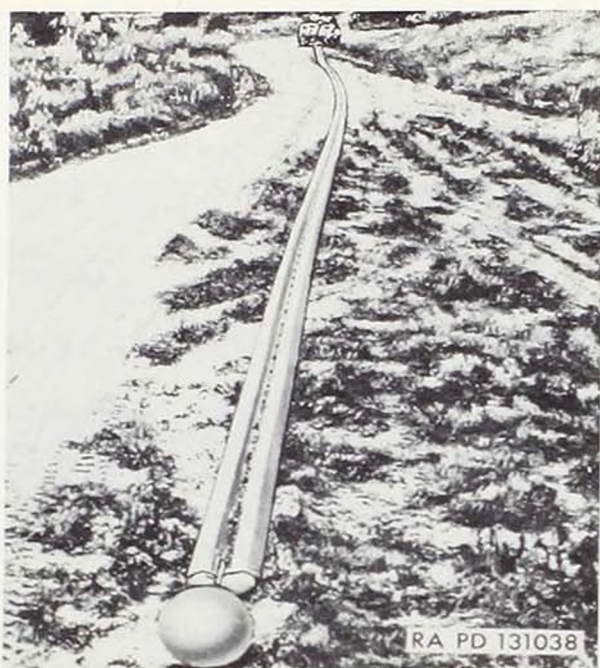

Figure 52. Medium tank pushing snake, demolition, M3.

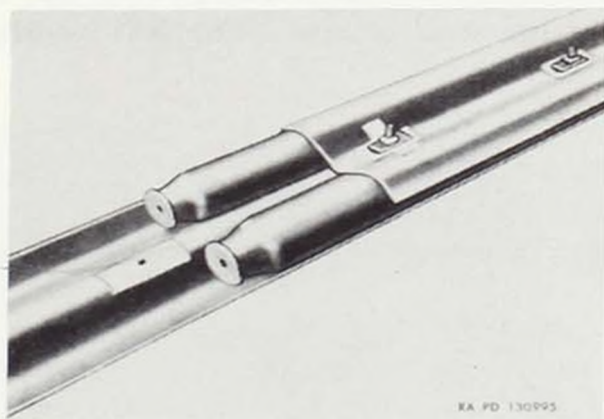

Figure 53. Snake, demolition, M3—loaded with charge, for snake, demolition, M2A1 and M3.

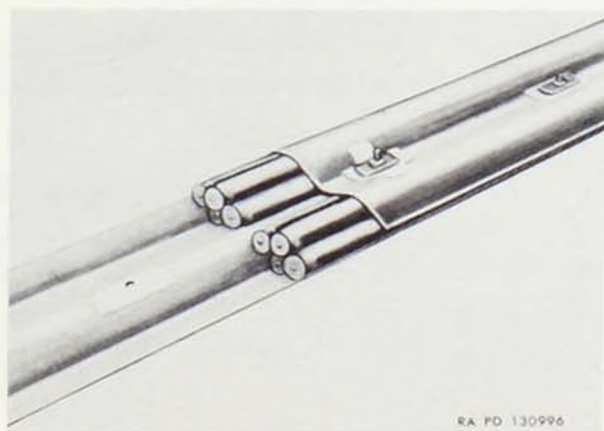

Figure 54. Snake, demolition, M3—loaded with bangalore torpedo loading assembly.

activator, and firing device to original condition and packing.

h. Packing. The mines are packed without fuzes; one mine in a metal crate or two mines in a wooden box. The dimensions of the crate are 14 x 13 $\frac{3}{4}$ x 4 $\frac{1}{8}$ inches and the crate with contents weighs 19 pounds (approx). The dimensions of the box are 17 $\frac{1}{2}$ x 16 x 9 $\frac{3}{4}$ inches, and the box weighs 39 pounds (approx).

Section III. ANTITANK-MINE-CLEARING DEVICE

48. Snake, Demolition, M3, and Snake, Demolition, M2A1

These snakes (figs. 52 through 56) are used to breach mine fields and other obstacles. Each consists of two parallel linear sectional explosive charges encased between corrugated metal plates, bolted together to form an assembly which can be towed or pushed across terrain by a medium or light tank. The snakes are flexible in the vertical plane to permit them to pass over rough terrain and rigid enough in the horizontal plane to maintain an approximately straight course when being pushed. The assembled snakes are 14-inches wide, 5-inches high, and 400-feet long. They are practically identical except that the M3 has aluminum plates and the M2A1 has steel plates. The M3 weighs 9,000 pounds in-

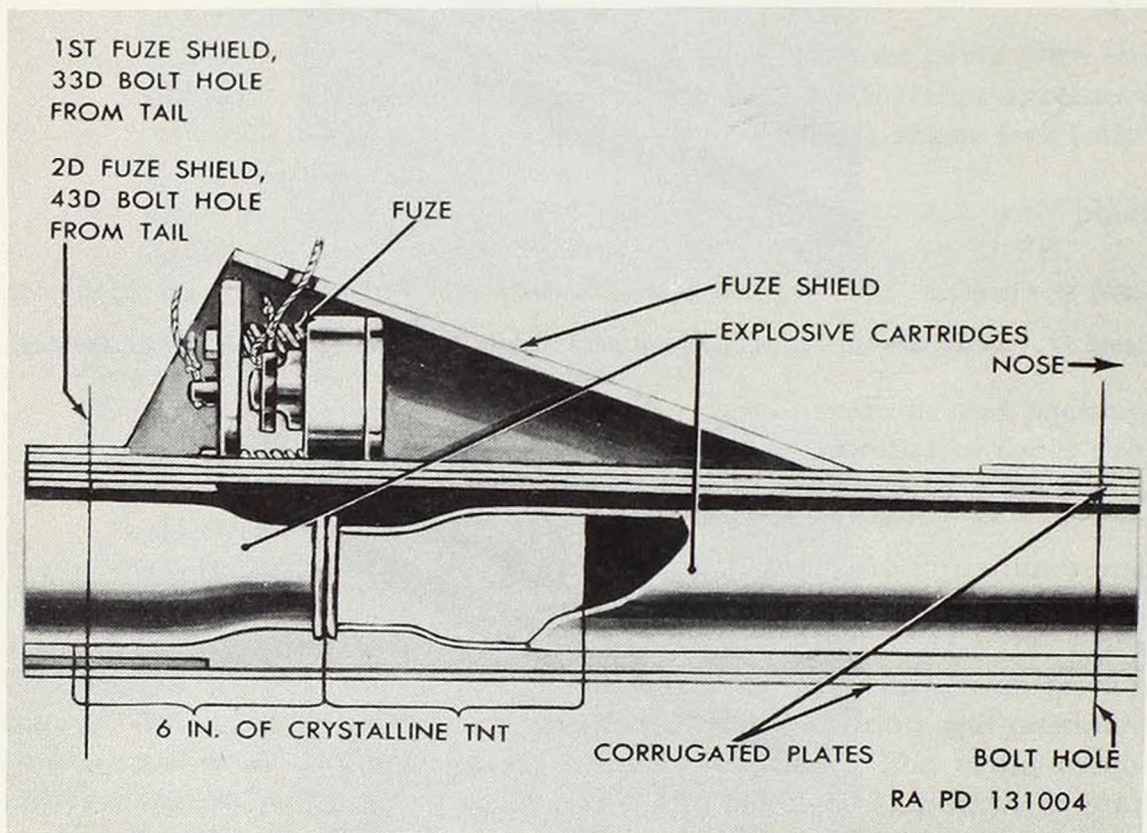

Figure 55. Snake, demolition, M3—longitudinal section at bullet impact fuze.

cluding 4,500 pounds of high explosive and the M2A1 weighs 15,000 pounds also including 4,500 pounds of high explosive. For detailed information on these snakes, refer to TM 9-1946.

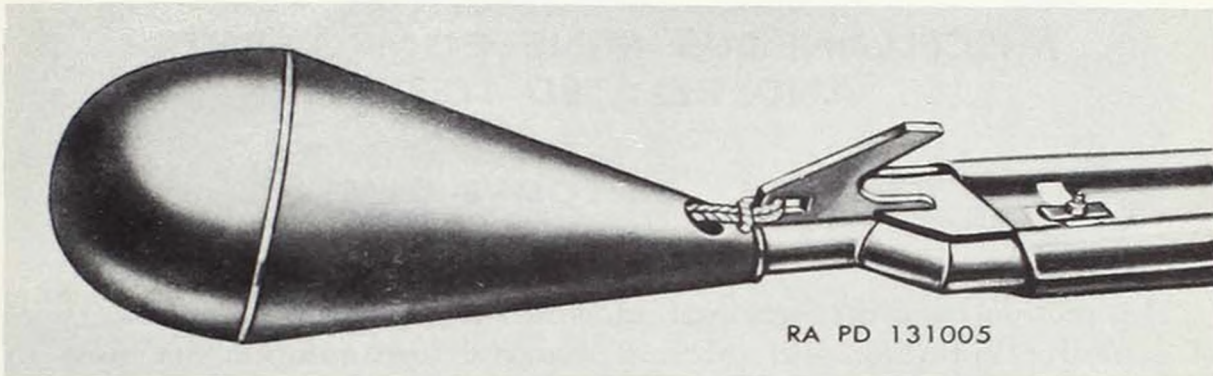

Figure 56. Snake, demolition, M3—nose assembly.

CHAPTER 4

MISCELLANEOUS MINE COMPONENTS AND RELATED ITEMS

Section I. EXPLOSIVE ITEMS

49. General

This section contains technical information pertaining to various types of explosive initiating and priming material and components, used in connection with the employment of mines, boobytraps, and related items. Tactical information pertaining to this material will be found in FM 20-32. For information pertaining to items covered herein, when used in connection with the employment of "demolition" material, refer to TM 9-1946, and FM 5-25. The "initiating" material covered in this section includes such items as detonators, firing devices, and lighters. "Priming" material includes such items as safety fuze, detonating cord, and blasting caps.

50. Activator, M1

a. Description. This activator (fig. 57) is essentially a detonator-booster. It is for use in conjunction with any one of several kinds of firing devices (usually the pull-type, pull-friction-type, or the pull-release-type) to supply an antitank mine of the M6 series or the M15 with a secondary fuze for antilift or boobytrapping purposes. The activator performs the function of an adapter between firing device and mine, it being threaded at one end for insertion into a mine and threaded at the other end to receive the primed coupling base of the firing device. The activator, which is about 2 inches in length, is made of a black (newer type, olive drab) plastic material and has a threaded closing plug and gasket. It contains a detonator and has a cylindrical unthreaded cup which is cemented to the opposite end of the body and contains a tetryl booster charge. The thread, which screws into the mine, is three-fourths of an inch in diameter. Note that activator M1 will *not* fit the secondary fuze well of antitank practice mine M12 (par. 47), and that practice activator M1 (par. 51) will *not* fit the M6-series or the M15 antitank mines.

b. Precautions Against Activator Misfires. Misfires of activator M1, which in this case is the failure of the detonator or the booster to fire, have been encountered. This may be due to presence of cap-sealing compound in flash hole of firing device used with activator. The detonator may fail to ignite from the flash of the firing device when fired if an appreciable amount of wax-like compound is deposited on top of detonator. Hence,

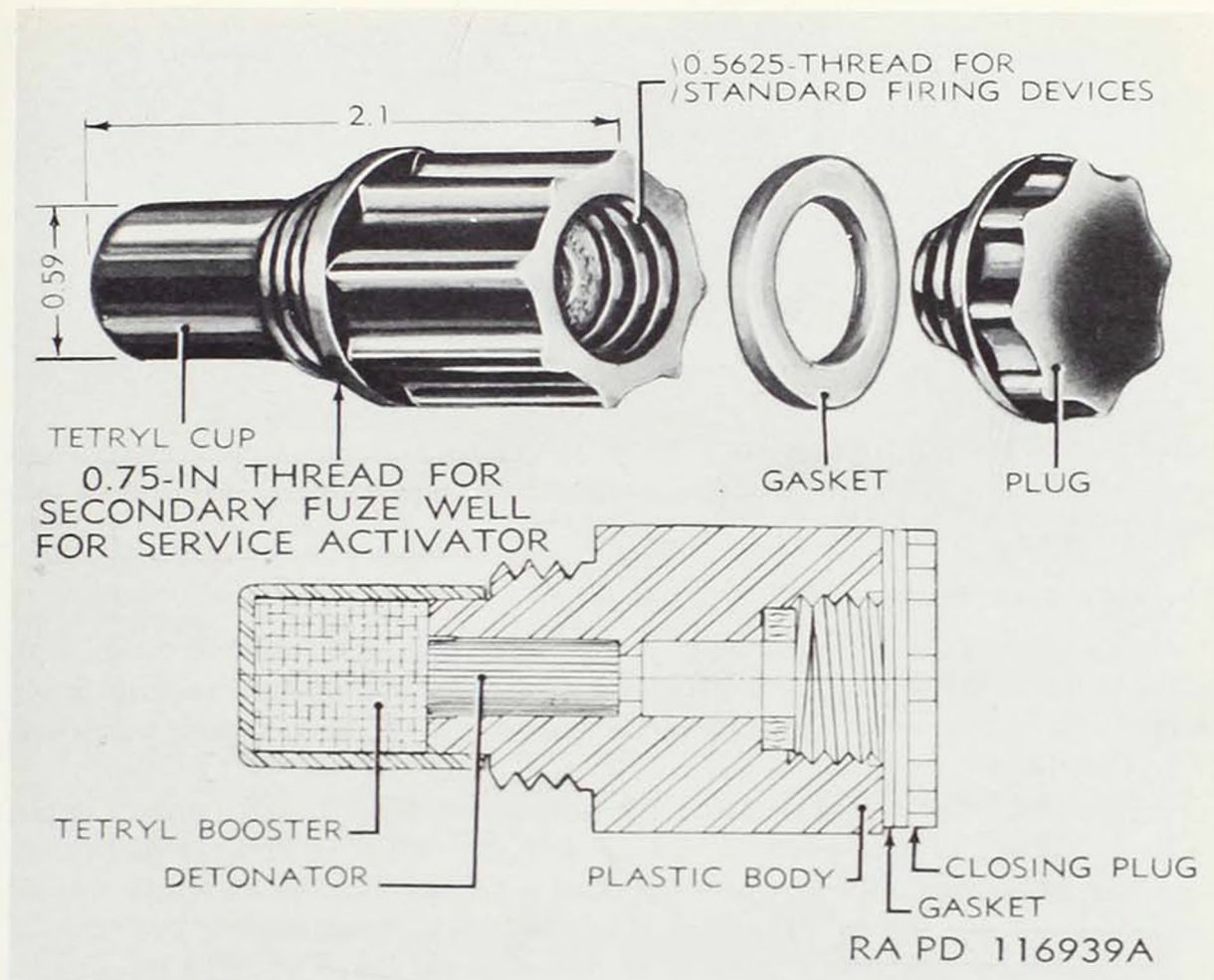

Figure 57. Activator, M1.

for proper functioning of activator M1 when used with firing devices, the following precautions must be observed:

- (1) After removing the plug and gasket from the activator, examine the cavity in body of the activator to be sure that it is free of foreign matter.
- (2) The activator should be screwed handtight into the secondary fuze well.
- (3) After removing the protective cap from the nipple on the coupling base of the firing device, examine the tip, and especially the flash hole in the tip, to be sure they are free of cap-sealing compound or other foreign matter.
- (4) The firing device should be screwed handtight into the activator.
- (5) The firing device may then be armed according to the method prescribed for the particular type of firing device used for mine boobytrapping. Refer to paragraphs 62 through 64.

c. Packing. Activator, M1 is packed: 2 activators, each in a metal container (fig. 58), with 2 M6-series mines in a wooden box, or, one acti-

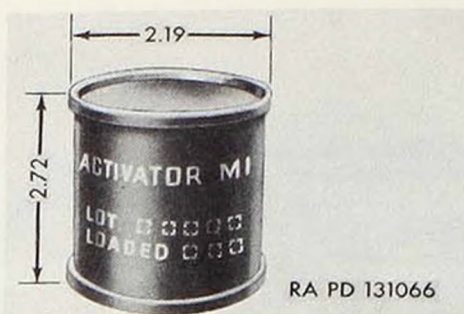

Figure 58. Metal ammunition container for activator, M1.

vator in metal container with 1 mine M15 in a wooden box. Activators are also packed for separate issue, 1 per metal container, 100 or 144 per wooden box.

51. Activator, Practice, M1

a. General. This activator (fig. 59) is used to adapt the heavy antitank practice mine M12 (T8E1) to the use of a practice boobytrapping firing device. It contains an igniter, and a smoke charge for spotting purposes.

b. Description.

- (1) The practice activator (fig. 59) is made of black (newer type, blue) plastic parts and contains an igniting charge of photographic flashlight powder and a smoke charge of white smoke composition. The booster cup, which contains the smoke charge, is blue. The body has eight equally spaced longitudinal ribs and is internally threaded to receive a firing device ($\frac{1}{16}$ -inch thread diam); this end is closed during shipment by a threaded plug. The other end is externally threaded (0.6875-inch thread diam) to fit the secondary fuze well for practice activator in the mine. Note that the practice activator M1 has an external thread that will not fit any mine except the M12 practice mine.
- (2) The activator operates when the action of a firing device initiates the igniter charge which in turn ignites the smoke charge, thus releasing a puff of white smoke with accompanying noise (report).

c. Precautions. For precautions against misfires, refer to paragraph 50b.

d. Packing. This practice activator is packed individually in the metal container M182 in quantities of 100 or 180 per wooden packing box. The 100 practice activators as packed weigh 38.5 pounds; the 180 activators 54.5 pounds.

52. Blasting Caps

a. General. Blasting caps, used for priming explosives, are the Army electric and nonelectric types, and the commercial electric type. The

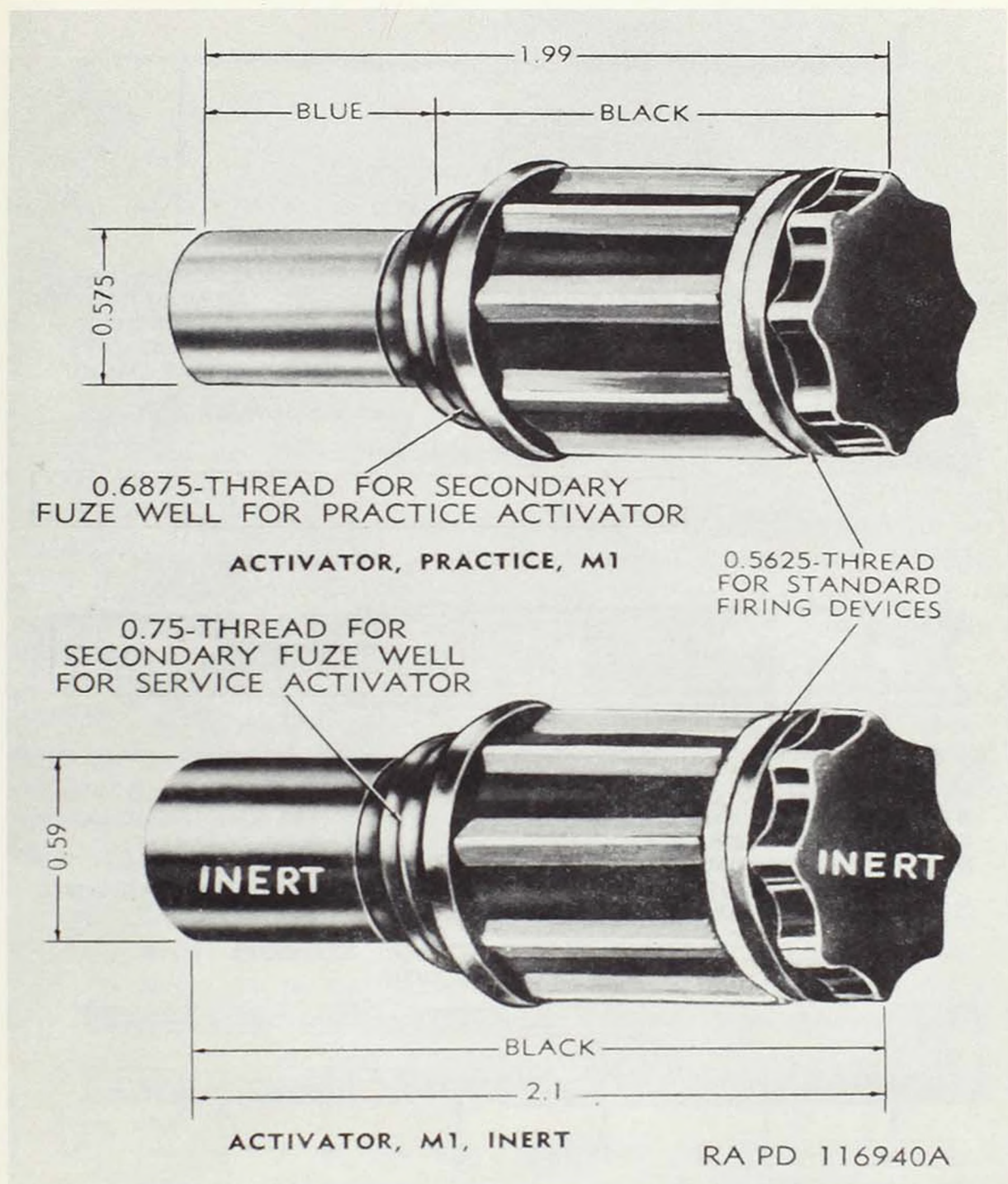

Figure 59. Comparison of activator, practice, M1, for use in practice mine M12, and activator, M1, inert, for use in antitank mine M6-series, inert.

Army type consists of a thin tubular metallic shell of noncorrosive material about $2\frac{1}{2}$ -inches long and about one-fourth of an inch in diameter (figs. 60 and 61) filled with a sensitive high explosive. Blasting caps are used for initiating demolition explosives and used as the detonating element for certain types of land mine fuzes. The caps are designed to be inserted into secondary fuze wells (cap wells), the electric type being

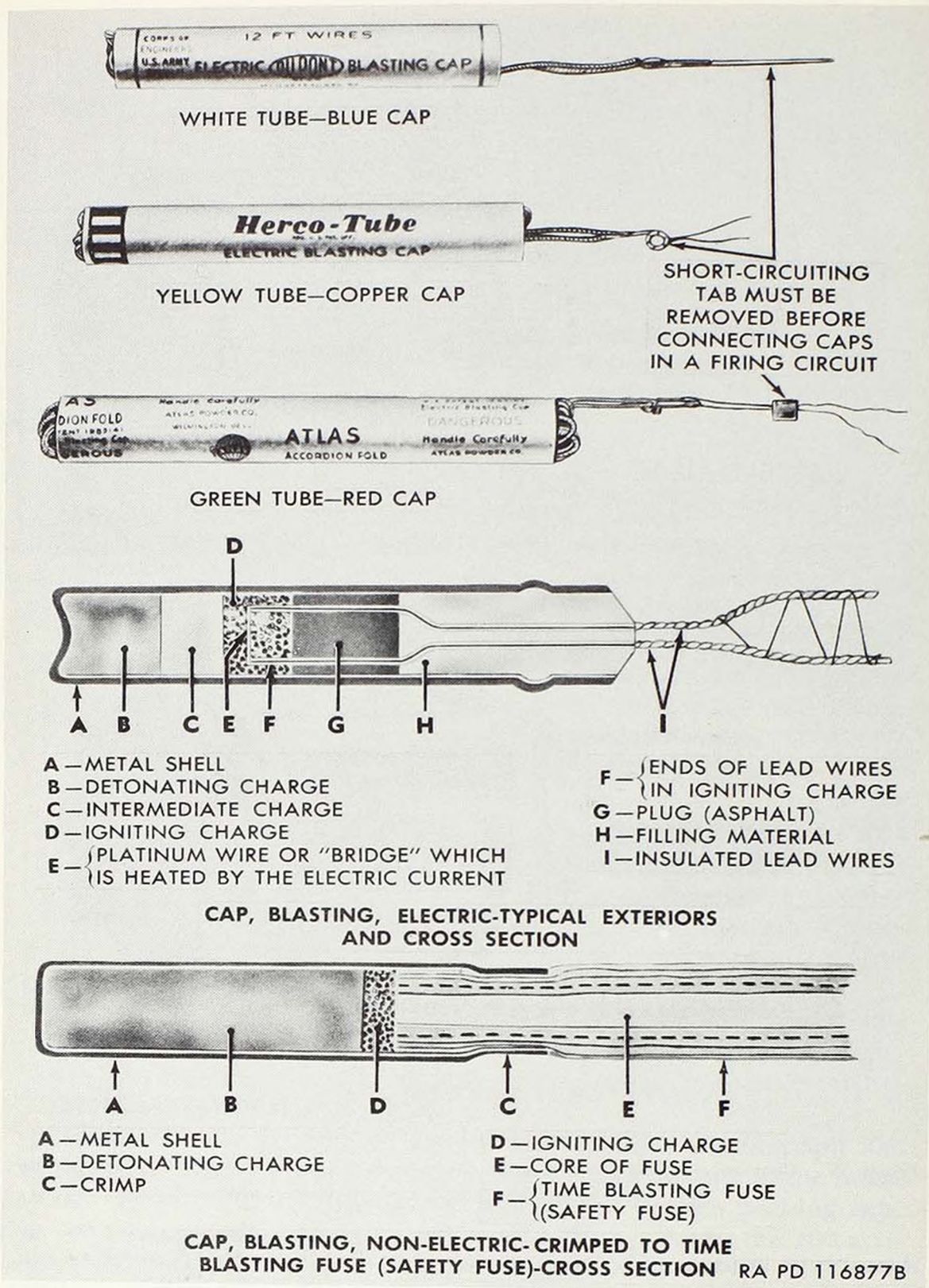

Figure 60. Blasting caps.



Figure 61. Blasting caps—packed in cartons.

fitted with lead wires for attachment to a blasting circuit and the non-electric type crimped to any standard firing device or to safety fuze fitted with a fuze lighter. Special Army electric (type II (J2 PETN)) and nonelectric (type I (J1 PETN)) caps similar in size and shape to the caps illustrated in figure 60 are used to detonate the less sensitive military explosives such as demolition blocks and ammonium nitrate cratering charge. Commercial caps, principally the No. 6 and No. 8, may be used to detonate the more sensitive explosives, such as dynamite, gelatin dynamite, or nitrostarch. The No. 8 cap is more powerful than the No. 6, hence the No. 8 cap may be used to detonate a less sensitive explosive than one which can be detonated by a No. 6 cap.

b. Precautions in Use of Blasting Caps.

- (1) Blasting caps should not be removed from their box until they are to be used. After removing the cover, a single cap can be taken out by tipping the box and allowing it to slide gently into the hand. A blasting cap should never be picked out of a box with a wire, knife blade, stick, or other hard tool. Damp caps or any that may be suspected to have absorbed moisture should not be used.
- (2) *Blasting caps are extremely sensitive and may explode unless handled carefully. They must be protected from shock and extreme heat and must not be tampered with. They are never to be stored with any other explosives. Blasting caps and explosives must not be carried on the same truck except in emergency. Refer to FM 5-25 for priming and firing systems.*

c. Electric Blasting Caps.

- (1) When two or more electric caps are connected in the same circuit, they must be the product of the same manufacturer. This is essential to prevent misfires because caps of different manufacturers do not have the same electric characteristics.

A current of at least 0.5 ampere is required to insure detonation of electric blasting caps.

- (2) Issue electric caps have lead wires of various lengths for connecting them to the circuit. The most commonly used caps have 12-foot lead wires. A short-circuiting tab, or shunt fastens the loose ends of the wires together. This shunt prevents accidental electric firing of the cap and must be removed before the cap is connected in a firing circuit.

d. Nonelectric Blasting Caps. Because nonelectric caps are extremely difficult to waterproof, their use should be avoided in priming charges placed under water or in wet boreholes. Such charges, if they are to be fired nonelectrically, should be primed with the nonelectric blasting cap secured to the detonating cord and kept above the water or ground level. If it becomes necessary to use nonelectric caps in damp boreholes, they should be moisture-proofed with waterproofing compound and fired immediately after placing.

e. Types. Following is a list of blasting caps currently used in priming explosives.

(1) *Army.*

- (a) CAP, blasting, special, electric, type II (J2 PETN).
- (b) CAP, blasting, special, nonelectric, type I (J1 PETN).
- (c) CAP, blasting, tetryl, electric, waterproof (fuze, submarine mines) (4-ft lead wires).
- (d) CAP, blasting, tetryl, nonelectric.

(2) *Commercial.*

- (a) CAP, blasting, electric, No. 6.
- (b) CAP, blasting, commercial, electric, No. 6, medium length lead (12 through 40 ft).

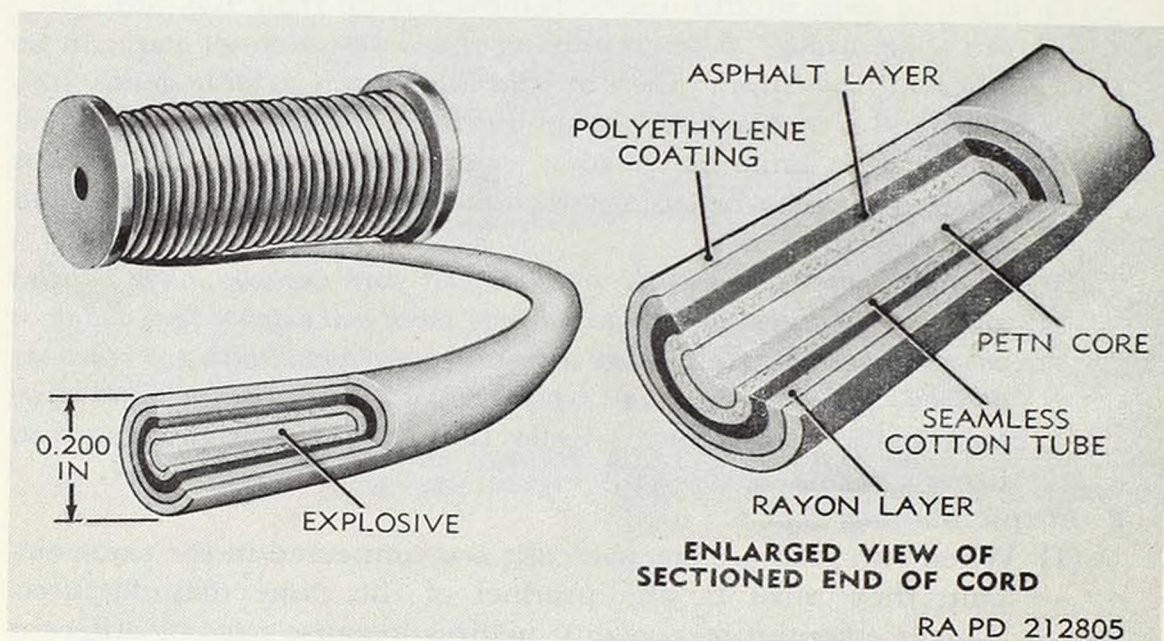

Figure 62. Cord, detonating, waterproof.

- (c) CAP, blasting, commercial, electric, No. 6, long lead (50 through 100 ft).
- (d) CAP, blasting, nonelectric, No. 6.
- (e) CAP, blasting, nonelectric, No. 8.
- (f) CAP, blasting, electric, No. 8, 1st delay, 1.00 sec (approx).
- (g) CAP, blasting, electric, No. 8, 2d delay, 1.18 sec (approx).
- (h) CAP, blasting, electric, No. 8, 3d delay, 1.35 sec (approx).
- (i) CAP, blasting, electric, No. 8, 4th delay, 1.53 sec (approx).
- (j) CAP, blasting, commercial, electric, No. 8, medium length lead (12 through 40 ft).
- (k) CAP, blasting, commercial, electric, No. 8, long lead (50 through 100 ft).

f. Boxes for Blasting Caps. Especially designed empty boxes of various capacities are provided for carrying nonelectric blasting caps in field operations. These boxes consist of rectangular wooden blocks filled with blasting caps as needed. Holes in the block-like interior of the box are receptacles for nonelectric blasting caps.

53. Cord, Detonating, Waterproof

a. Description. This cord (figs. 62 and 63) consists of a flexible polyethylene-covered colorless tube filled with PETN in amount of 49 grains per foot (7 pounds per 1,000 feet). It is for general use in military de-

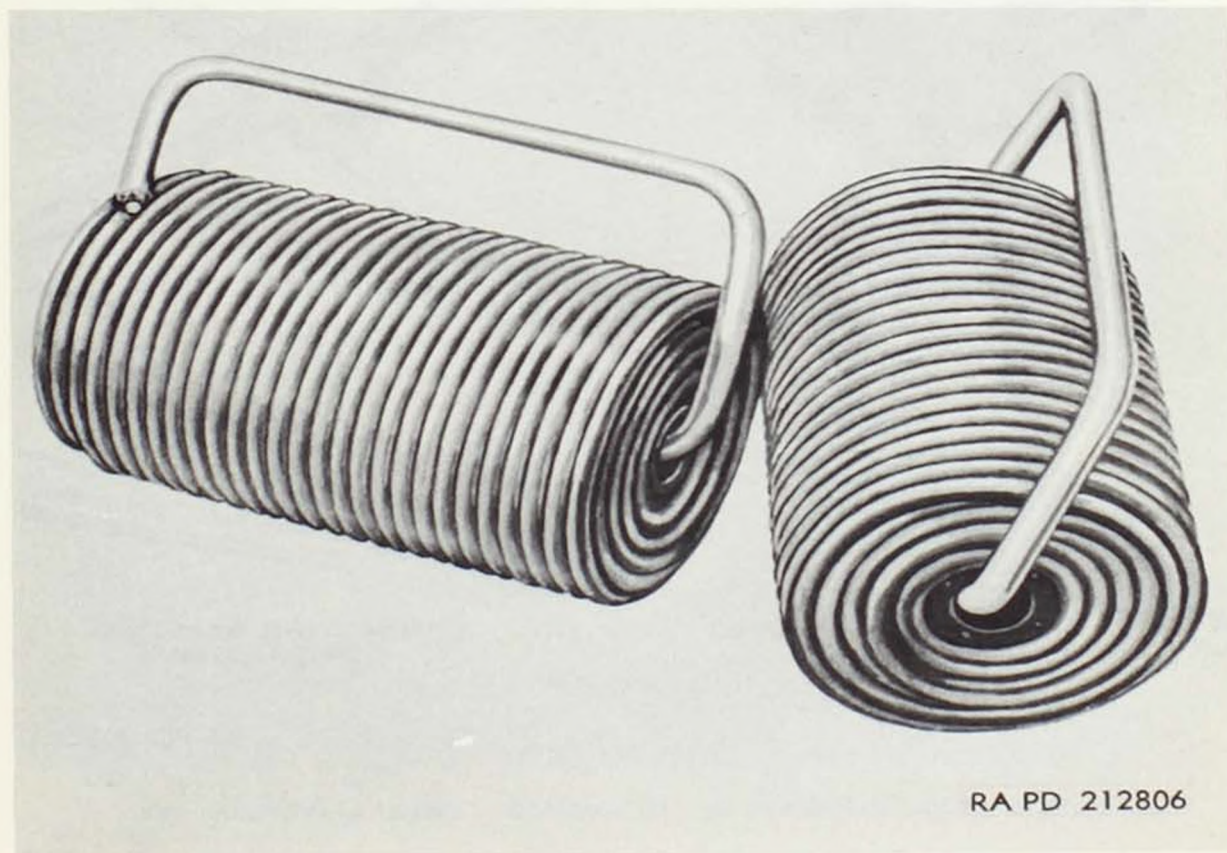

Figure 63. Cord, detonating, waterproof—on spool with plastic handle.

molitions, both on land and under water. It will transmit a detonation from a primed blasting cap or from a delay detonator to a charge of high explosive or from one charge of high explosive to another with or without requiring the use of a second blasting cap. It may also be used as the main charge of an improvised antipersonnel mine planted as a boobytrap. Such an antipersonnel mine may be rigged by making a flat coil about 3 inches in diameter of 12 to 20 feet of detonating cord and taping nails, empty cartridge cases, or other metal fragments around it, and fitting it with a firing device with blasting cap. CORD, detonating (PETN) (FUZE, PRIMACORD) is a limited standard item, authorized for training only. Detonating cord is connected using methods shown in figure 64. See paragraph 75. See FM 5-25 for priming methods. CORD, detonating, reinforced, pliofilm wrapped, is a variety of primacord for use when extra tensile strength or resistance to abrasion is desirable. Primacord contains 42 grains PETN per foot (6 pounds per 1,000 feet).

b. *Packing.* The cord is packed in 50-, 100-, 500-, and 1,000-foot spools in hermetically sealed cans in fiberboard boxes, some boxes containing a total of 1,000 feet and some containing 4,000 feet.

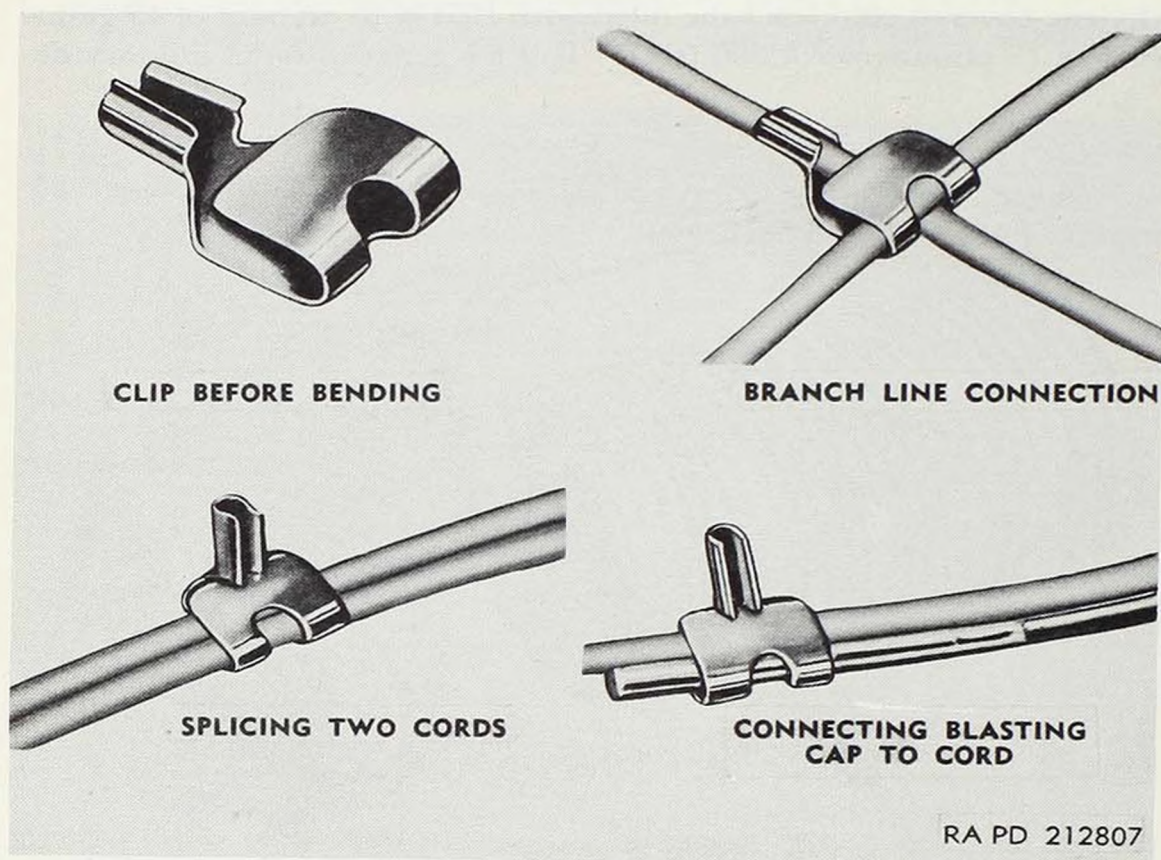

Figure 64. Clip, cord, detonating, M1—methods of connecting detonating cord.

54. Destructor, HE, Universal, M10

a. *General.* This destructor (fig. 65) is essentially an adapter-booster designed for a variety of uses in conjunction with the setting up of booby-trap, fougasse, or improvised mine arrangements using artillery shell, bombs, rockets, or other explosive items as main charges.

b. *Description.* The destructor is a tubular sheet-steel roll-threaded assembly consisting of:

- (1) *Closing plug and cork gasket.* This plug is identical with the closing plug used with activator M1 (par. 50).
- (2) *Blasting cap bushing.* This bushing is threaded to receive any issue firing device.
- (3) *Activator bushing with felt washer.* This bushing is threaded to receive activator M1.
- (4) *Booster assembly.* This assembly consists of two identical externally and internally threaded booster cups screwed together. The cup to which the activator bushing is attached contains cylindrical tetryl pellets with central holes which allow for the insertion, without interference, of either a blasting cap or an activator. The other cup contains cylindrical tetryl pellets (without central holes) and a felt pad.
- (5) *Ammunition bushing.* This bushing is a hexagonal-edged steel collar with two different size external threads and an internal thread. The internal thread of 1½-inch diameter fits the exter-

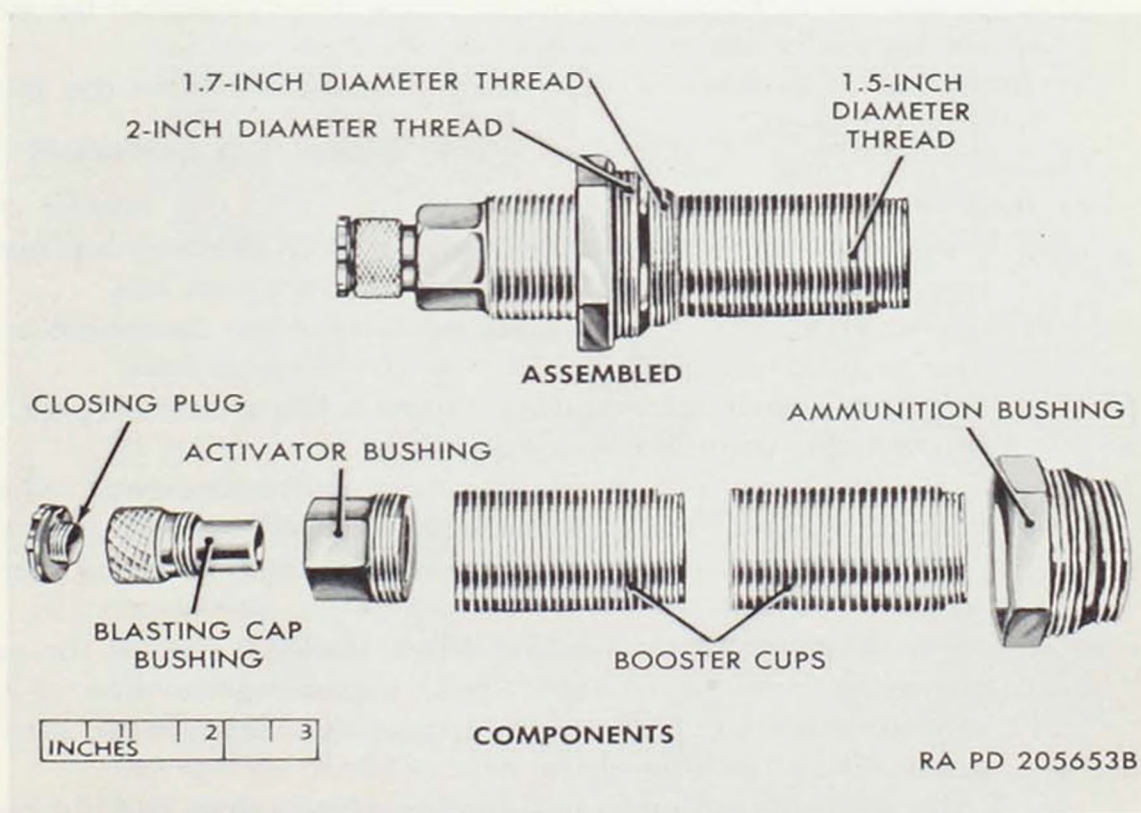

Figure 65. Destructor, HE, universal, M10.

nal thread of the booster cups and adapts the destructor for use with any ammunition having 1.7-inch or 2-inch diameter right-hand-threaded fuze cavities.

c. Initiation and Adaptation. This destructor is designed for initiation by a firing device and blasting cap, or by a firing device and activator M1 (activator, practice, M1, cannot be used with this destructor). The destructor assembly has three external threads of different diameter available for attachment to ammunition items having three corresponding fuze well sizes. These three available threads are the 2-inch external thread on the ammunition bushing, the 1.7-inch external thread on the ammunition bushing, and the 1.5-inch external thread of the booster cup. Thus, there is a proper size external thread available for attachment of the destructor to artillery shell, bombs, and rockets having corresponding size fuze wells.

d. Functioning.

- (1) Removing the locking and the positive safety pins of the particular firing device selected for use in initiating the destructor, by pulling on cords attached to them, arms the destructor.

Note. The locking safety pin must always be removed first, and the positive safety pin must always be removed last.

- (2) A pull of 3 to 8 pounds on a wire attached to the firing device allows the firing pin of the firing device to strike its primer.
- (3) Explosion of the primer explodes the blasting cap, or detonator and booster of an activator, as the case may be.
- (4) Explosion of blasting cap (or activator detonator and booster) explodes the booster of the destructor.
- (5) Explosion of booster of destructor is transmitted to the main charge involved.

e. Installing and Arming.

(1) *Initiation by firing device and blasting cap.*

- (a) Unscrew closing plug and cork gasket from blasting cap bushing.
- (b) Inspect opening in blasting cap bushing to see that there is no foreign material in the well.
- (c) Crimp a nonelectric blasting cap to a firing device (pars. 62 through 64) using crimper (par. 79).
- (d) Screw this assembly (firing device and blasting cap), which now becomes a fuze, into the blasting cap bushing, using the cork gasket removed in (1) above, handtight or using fuzing wrench M25.
- (e) Screw the destructor thus fuzed into the fuze well of the ammunition item to be destroyed, matching the size of the ammunition fuze well to the appropriate size thread on the ammunition bushing of the destructor.
- (f) If the ammunition items involved (such as mines) do not have fuze wells of sizes on the destructor, attach the destructor to

the ammunition or explosive charges to be exploded, using detonating cord. For information on the priming of explosive items, refer to FM 5-25.

- (g) Attach pull wires to firing device as required.
- (h) Arm the firing device as described in paragraphs 62 through 64.
- (2) *Initiation by firing device and activator.*
 - (a) Unscrew the blasting cap bushing from the activator bushing of the destructor.
 - (b) Unscrew the closing plug from an activator M1.
 - (c) Screw a firing device into the activator.
 - (d) Screw this assembly (firing device and activator), which now becomes a fuze, into the activator bushing, handtight.
 - (e) Same as *e(1)(e)* above.
 - (f) Same as *e(1)(f)* above.
- (3) *Initiation by blasting cap, electric or nonelectric.*
 - (a) If using an electric blasting cap, thread the lead wires through a priming adapter of the M1 series. If using a nonelectric blasting cap, crimp the cap to a suitable length of safety fuse and thread the fuse through the adapter.
 - (b) Screw the assembly into the blasting cap bushing.
 - (c) Same as *e(1)(e)* above.
 - (d) Same as *e(1)(f)* above.
 - (e) If using an electric blasting cap, initiate the cap through a suitable blasting circuit. If using a nonelectric blasting cap, initiate the cap and safety fuse by means of a fuse lighter. See FM 5-25.

55. Detonator, Concussion, Delay Type, M1

a. General.

- (1) *Description.* The concussion detonator M1 (fig. 66) is a mechanical firing device which is actuated by a concussion wave of a blast. It can be used to fire several charges, such as improvised land mines, simultaneously without interconnecting the charges with wires or detonating cord. A single charge fired in water or in air will detonate all charges equipped with concussion detonators within range of the main charge or each other. Table I gives ranges at which concussion detonators function reliably in either air or water.
- (2) *Functioning.* The detonator consists of a diaphragm-type-spring-loaded striker, restrained by a safety ball. The ball is held in place against the beveled shoulders of the striker by a spacer and a safety pin. When the safety pin is pulled, the positioning spring pushes the striker forward. This moves the safety ball and spacer upward, freeing the striker. A concussion wave strong enough to overcome the snap diaphragm causes the detonator to function.

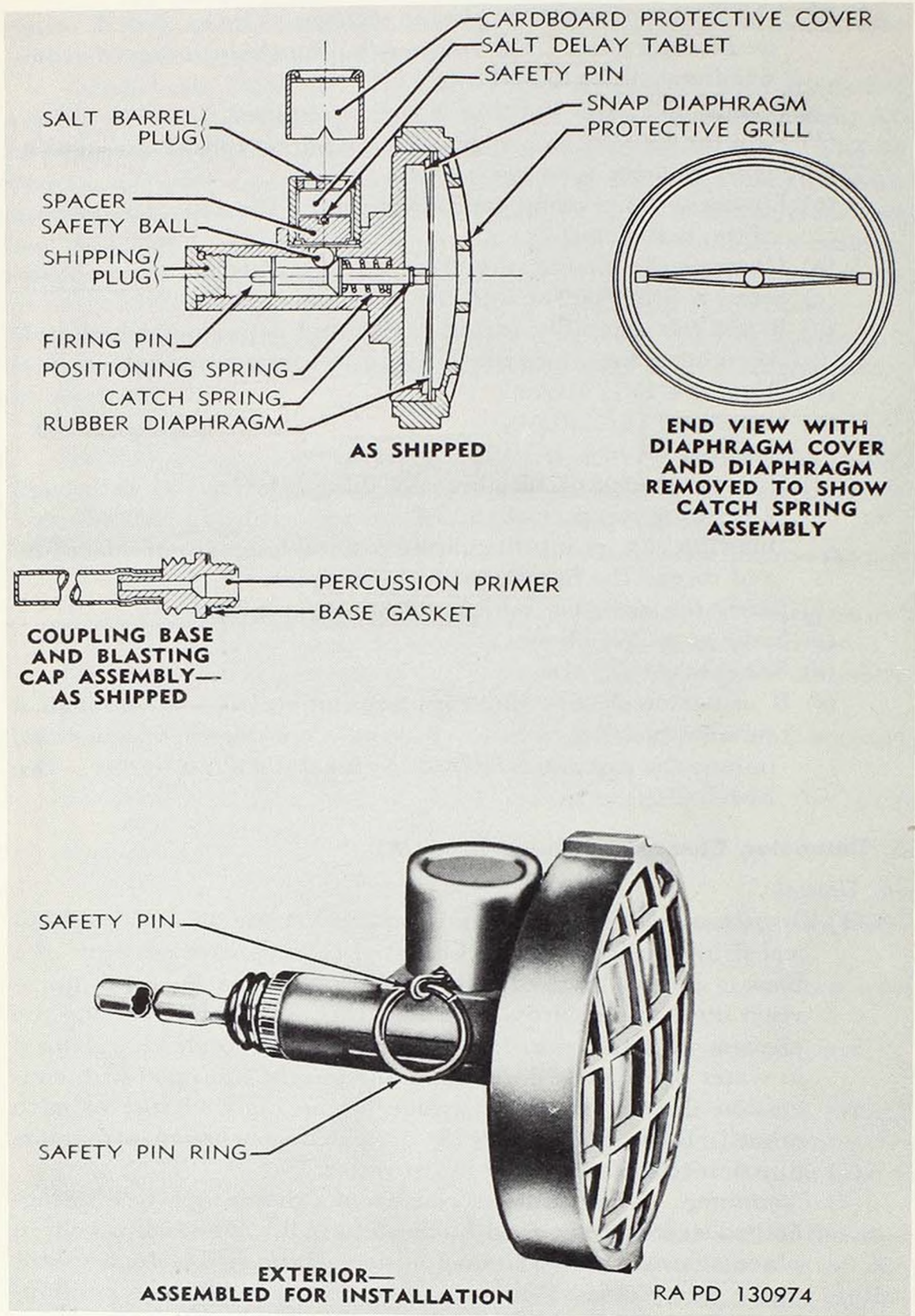

Figure 66. Detonator, concussion, delay type, M1.

b. *Preparation for Firing in Water.*

- (1) *Delay tablets.* To provide safety while arming the device in water, two water-soluble time-delay salt tablets are supplied with the detonator. The blue tablet gives a delay of approximately 3½ minutes and the yellow tablet approximately 7 minutes. However, since the dissolving time of the salt tablets varies with surf conditions and water temperature, tests should be made to determine the arming time before preparing and installing the charge. The test is made by submerging the device to the proper depth under conditions similar to those anticipated in the actual operation, and observing the dissolving time of the salt tablet.
- (2) *Arming time.* Since the salt tablets become soft before they are completely dissolved, detonators are dangerous after one-half of the dissolving time elapses. Personnel should be withdrawn from the danger area within half of the arming time, since a nearby concussion from enemy bombs or shells could fire the device. The initiating charge is not fired until the complete arming time of the delay tablet has elapsed.
- (3) *Cardboard protective cover.* A cardboard protective cover fits over the salt tablet well to prevent the tablet from dissolving while the activator is being installed underwater. The cover should not be removed until the last possible moment before pulling the safety pin.

Table I. *Operating Range of Concussion Detonator M1*

Initiating charge	In water		In air
	Depth of water	Recommended range	Recommended range
(Pounds)	(Feet)	(Feet)	(Feet)
0.5	2	10	
0.5	4	50	
0.5	6	80	
0.5	8	80	
2.5	-----		15
2.5	2	20	
2.5	4	80	
2.5	6	80	
2.5	8	150	
5	-----		20
10	-----		35
15	-----		35
20	-----		35
20	2	20	
20	4	80	
20	6	180	
20	8	260	

- (4) *Ranges and depth.* Detonators frequently function at ranges greater than those given in table I, but their reliability at those ranges is not assured. The device should not be used in surf at a greater depth than 15 feet. The snap diaphragm functions by hydrostatic pressure at a depth of 25 feet.
- (5) *Installing device in water.*
- (a) If long delay is necessary, remove blue tablet and install yellow tablet, taking care that spacer, safety pin, and cardboard protective cap are properly installed.
 - (b) Discard shipping plug from nipple of coupling base and carefully insert coupling base and blasting cap assembly with its associated gasket to form a tight waterproof fit.
 - (c) Screw the coupling base with blasting cap into threaded cap well of charge or connect blasting cap to charge with a short length of detonating cord.
 - (d) Wire or tie detonator to charge and make sure detonator diaphragm is free of obstructions and is clearly exposed.
 - (e) Place all charges in water where required.
 - (f) Remove cardboard protective covers from salt tablet wells.
 - (g) Remove safety pins.
 - (h) Evacuate danger area within one-half of the arming time of the delay tablets in use.
 - (i) Wait full interval of arming time of the delay tablet before firing initiating charge.

c. *Preparation for Firing in Air.*

- (1) *Checking and preparing.* When the detonator is used in air, remove and discard the salt delay tablet. Before fitting the coupling base and blasting cap assembly to the detonator, check to make sure that the catch spring restrains the firing pin when the safety pin is withdrawn and that the spacer releases. When the safety pin is withdrawn, the firing pin should move forward approximately one-sixteenth of an inch, but it should not fall or fly out of the barrel of the detonator. If it falls or flies out of the barrel, discard the detonator. Replace the spacer and safety pin.
- (2) *Range.* All charges equipped with concussion detonators should be placed reasonably equidistant and at least 15 feet from the initiating charge. When placed too close to another charge in air, the concussion wave frequently causes the diaphragm to be impaled on the firing pin, resulting in a misfire.
- (3) *Installing.*
- (a) Remove shipping plug and carefully screw the coupling base and blasting cap assembly with its associated gasket firmly into the detonator.
 - (b) Screw the other end of the coupling base into the threaded cap well of charge so that the blasting cap goes into the well, or

connect the blasting cap to the charge with a short length of detonating cord.

- (c) Wire or tie the detonator to charge, making sure that the detonator diaphragm is free of obstructions and is clearly exposed.
- (d) Place all charges with detonator diaphragms facing initiating charge.
- (e) Withdraw safety pins and evacuate area. *The detonators are immediately armed as soon as the safety pins are withdrawn.*
- (f) Fire initiating charge when personnel are clear of danger zone.

d. *Disarming.*

- (1) Depress spacer and force safety ball against shoulder of firing pin.
- (2) Insert 10d nail through holes in salt barrel.
- (3) Remove coupling base and blasting cap assembly from device.
- (4) Restore to original condition and packing.

e. *Packing.* The concussion detonator is packed one detonator, with one base and blasting cap assembly and one salt tablet of each delay, per metal container, 50 containers in a wooden box. The dimensions of the box are 21¼ x 19½ x 13 inches. The box with contents weighs 71 pounds (approx.).

56. Detonator, Friction Igniter—Delay Type

a. *General.* Delay detonators are devices for detonating explosive charges after a definite period of delay. The initiating mechanism, delay system, and detonator are all integral parts of the unit. Table II gives the time of delay of delay detonators which may be anticipated at any given temperature.

b. *8-Second Delay Detonator.*

- (1) *Description.* The 8-second delay detonator (fig. 67) consists of a cylindrical-shaped green 3412 (olive drab) plastic housing containing a pull wire coated with friction material. The pull wire is set in a flash compound. A tube set in the lower end of the housing contains an 8-second time fuse and a blasting cap. This igniter is used to delay the firing of demolition charges, particularly during assault demolitions. It is also used to fire underwater charges.

Table II. *Temperature—Delay for Delay Detonators*

Degree F.	Time delay		
	8-second delay detonator M2	15-second delay detonator M1	15-second delay detonator M1A1
	(Seconds)	(Seconds)	(Seconds)
140.....	7.8 to 9.1.....	13.1 to 14.0.....	13.1 to 14.0
100.....	8.6 to 9.6.....	14.2 to 15.0.....	14.2 to 15.0
60.....	9.5 to 10.2.....	15.3 to 17.1.....	15.3 to 17.1
20.....	10.4 to 11.2.....	16.0 to 18.0.....	16.0 to 18.0
-40.....	9.6 to 11.0.....	17.5 to 19.5.....	17.5 to 19.5

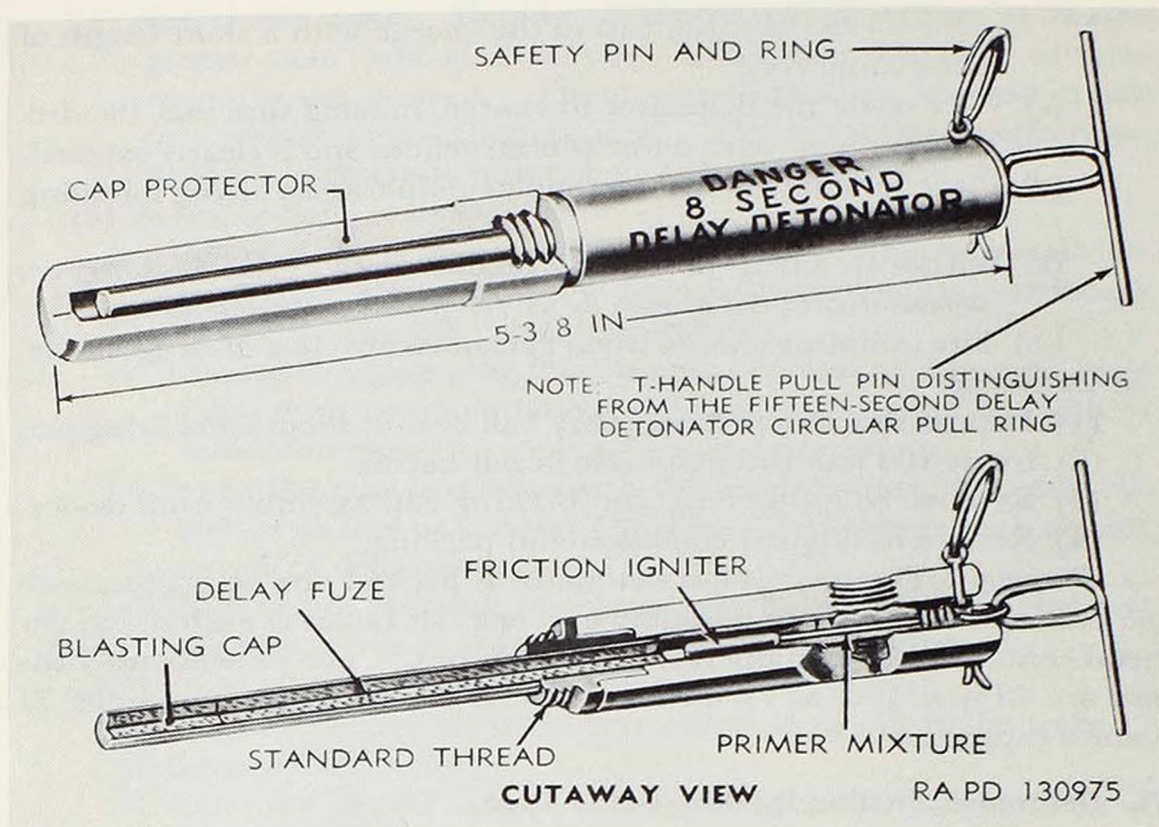

Figure 67. Detonator, 8-second delay, M2.

(2) *Functioning.*

- (a) With safety pin removed, a pull on T ring draws the coated wire through the flash compound.
- (b) Flash ignites powder-train delay.
- (c) Eight seconds later, the delay element explodes the attached blasting cap. Actual time delay of 8-second delay igniter varies with temperature from approximately 10.5 seconds at 0° F. to 7.8 seconds at 140° F.

(3) *Preparation for use.*

- (a) Remove protector cap from the blasting cap of the detonator.
- (b) Screw the detonator into threaded secondary fuze well or cap well in the appropriate mine or explosive charge.
- (c) Lay mine or charge.
- (d) Remove safety pin.
- (e) Pull T handle vigorously to fire and leave area immediately.

Do not stop to investigate installation.

Caution: Once safety pin is removed, any movement of T ring may ignite delay powder train, and fire the detonator in prescribed time. There is little warning as the powder train gives off practically no smoke and is practically noiseless in burning.

- (4) *Neutralizing.* The detonator cannot be neutralized once the T

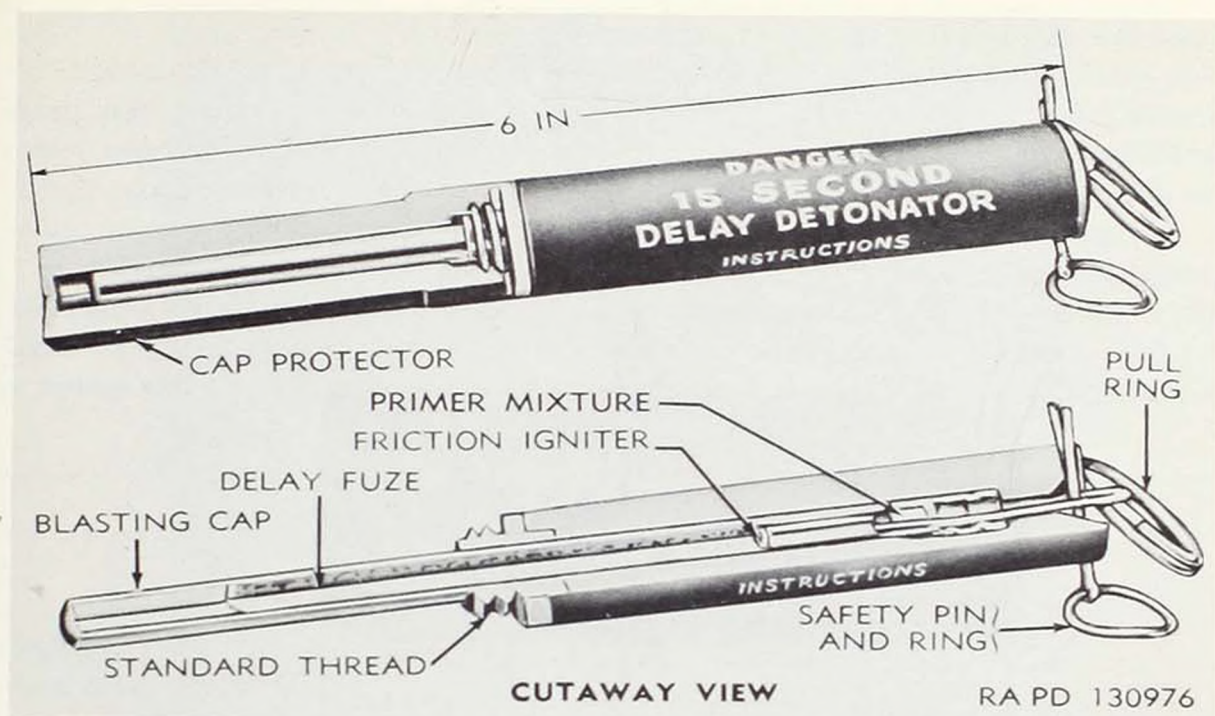

Figure 68. Detonator, 15-second delay, M1.

ring has been pulled. If T ring has not been pulled, proceed as follows:

- (a) Reinsert safety pin.
- (b) Unscrew the detonator from charge.
- (c) Replace protector cap.

Note. Once the T ring has been pulled, this delay detonator cannot be reused.

- (5) *Packing.* Ten detonators are packed in a cardboard box, five boxes in an inner packing, four inner packings (200 detonators) per wooden box; the complete packing weighs 56 pounds.

c. 15-Second Delay Detonator. The 15-second delay detonator (fig. 68) is almost identical to the 8-second delay detonator in overall appearance and functioning. However, the pull ring is circular, and the powder-delay train is of 15 seconds duration. The detonator is used for similar purposes as for the 8-second delay detonator. The 8-second delay has a T-type pull pin handle and the 15-second delay has a circular pull pin ring which can be identified even in darkness. Preparation for use, neutralizing, nonreuse, and method of packing are the same as for the 8-second delay detonator. The 15-second delay detonation M1A1 is a later model. (M1 and M1A1 are identical in construction and use.)

57. Firecracker, M80

This item is used to simulate explosive charges in land mine and boobytrap detection and deactivation training. It may be used to simu-

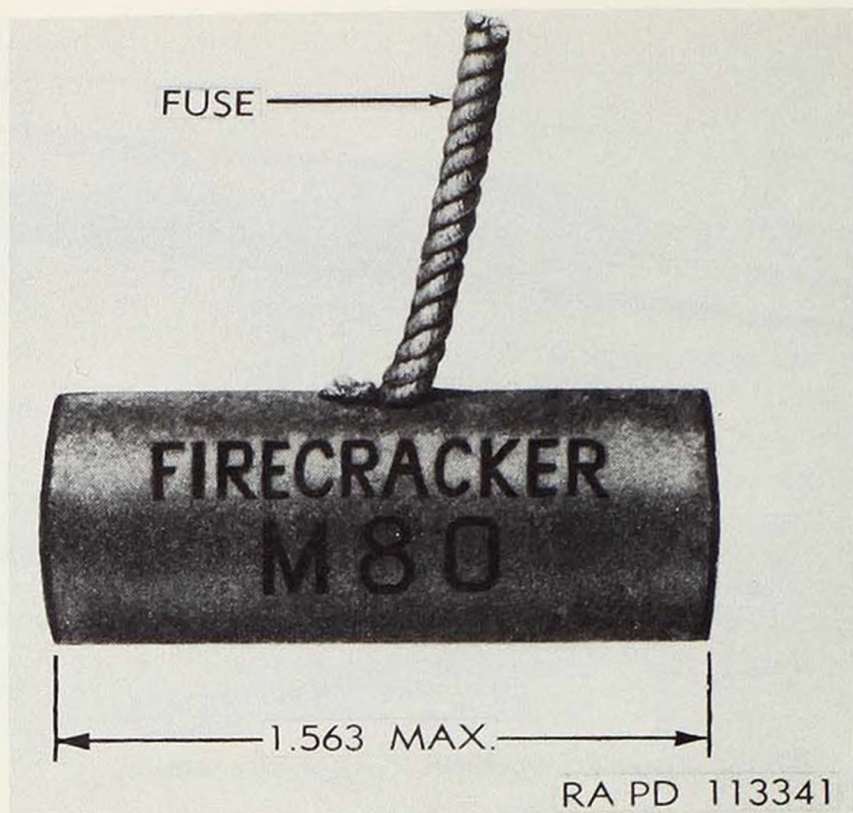

Figure 69. Firecracker, M80.

late hand grenades, boobytraps, land mines, and rifle or artillery fire. Firecracker M80 (fig. 69) consists of a compressed paper cylinder containing a 2-inch 3- to 7-second fuse and a charge of 3 grams of pyrotechnic composition. The fuse may be ignited with fuse lighter or an ordinary match. For use in simulating boobytraps or land mines, the fuse may be removed and any firing device (firing mechanism and primed coupling base) substituted. For further information on this item, refer to TM 9-1981.

58. Firing Devices, General

a. A firing device is a device designed to initiate a train of fire or a detonation of demolition charges, boobytraps, or mines, principally by action on a nonelectric blasting cap or activator. It is a separate item of issue and is packed in its own packing box. Firing devices (table III) are of two general types, the tubular-type and the box-type. The tubular-type firing devices, consisting of head, case, and coupling base, are arranged for actuation by pressure, pull, or release of pull according to the design of the particular model. The box-type firing devices consisting of a rectangular steel body and coupling base are arranged for release of pressure. The coupling base, fitted to all types, contains a percussion primer. Service firing devices are painted olive drab with marking in yellow.

b. All firing devices are physically interchangeable, as coupling bases

have the same thread (nine-sixteenths of an inch) for attachment to mine or explosive charge. The coupling bases of the *pull friction* type and the *delay type* firing devices are *not* removable. The coupling base of all other type firing devices *are* removable. Firing devices may be reprimed where appropriate (par. 66) and their firing mechanism recocked such as when used repeatedly in training with "practice" or "inert" mines.

c. Firing devices may be used with demolition blocks or explosive charges (fig. 70), with heavy antitank mines if fitted to activators, with light antitank mines, and with improvised mines or demolition. When a firing device is used with a service activator or a practice activator, a

Table III. Firing Device Data

Nomenclature	Means of initiation	Dimensions (Inches)		
		Length	Width	Height
FIRING DEVICE, M1, 9-minute delay, black.	Finger pinch.	6¼	⅜ diam.	⅜ diam.
FIRING DEVICE, M1, 15-minute delay, red.				
FIRING DEVICE, M1, 1-hour delay, white.				
FIRING DEVICE, M1, 2½-hour delay, green.				
FIRING DEVICE, M1, 5½-hour delay, yellow.				
FIRING DEVICE, M1, 11½-hour delay, blue.				
FIRING DEVICE, pressure-release type, M5.	Removal of 5-lb. load.	1¾	1⅝	1⅞
FIRING DEVICE, pressure type, M1A1.	20-lb. pressure.	4¼	½ diam.	½ diam.
FIRING DEVICE, pull-friction type, M2.	3-lb. pull.	1½	⅝ diam.	⅝ diam.
FIRING DEVICE, pull-release type, M3.	Release or 6-lb. pull.	4½	½ diam.	½ diam.
FIRING DEVICE, pull type, M1.	3-lb. pull.	4¾	⅝ diam.	⅝ diam.
FIRING DEVICE, release type, M1.	Removal of 2-lb. load.	3	2x2 cube.	2x2 cube.

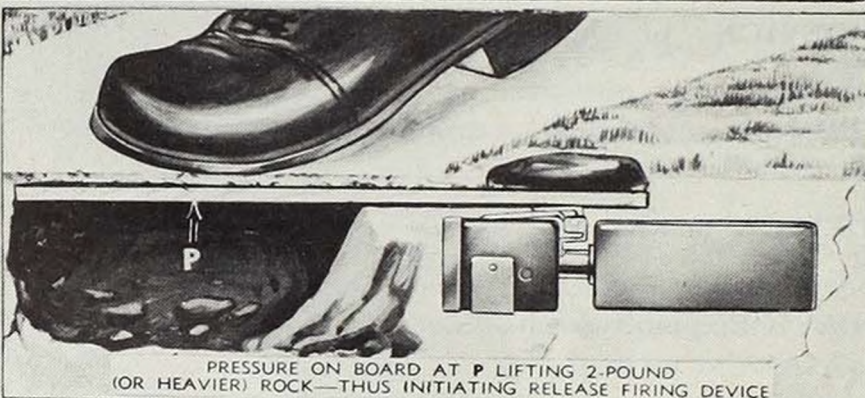
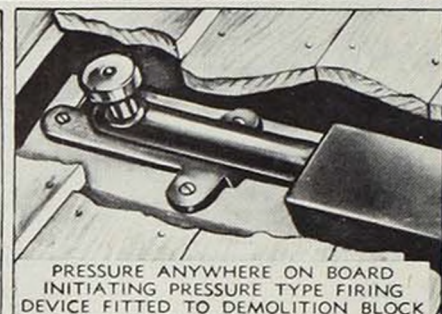
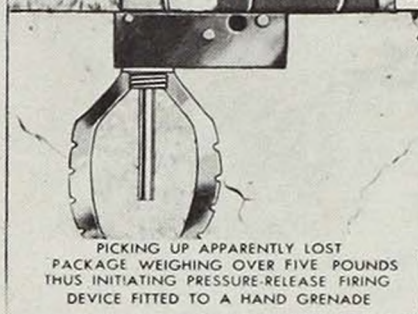
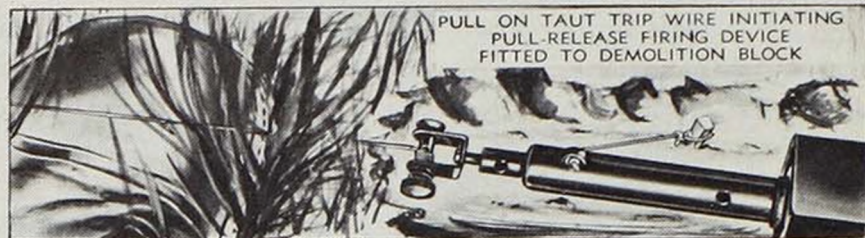
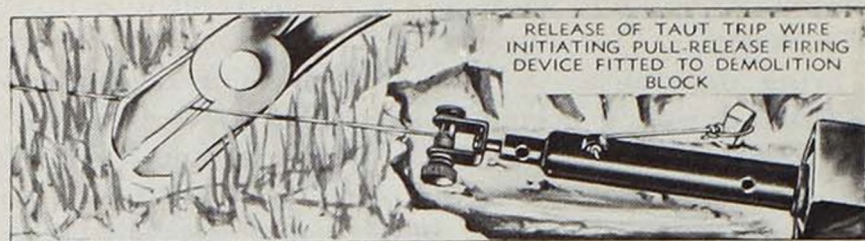

RA PD 116926

Figure 70. Representative methods of using firing devices fitted to demolition blocks for initiation by enemy troops—safety pins removed.

blasting cap or an igniter is not necessary and cannot be used. When used with light antitank service mines, with demolition blocks or charges, or with universal destructor M10 (par. 54), the firing device requires a crimped-on blasting cap.

d. Inert firing devices, which contain an inert percussion primer are provided for training in connection with inert mines. Inert firing devices used for training purposes are to be employed in exactly the same manner and *with the same care and precautions* as are the explosive items comprising the firing devices simulated, hence it is essential that personnel in training be fully conversant with all procedures and instructions given in this manual pertaining to the explosive firing devices. Inert firing devices, which are used for training, are painted black with marking in white.

59. Firing Device, Delay Type, M1

a. *General.* This is a chemical device (fig. 71) used for delay action firing of a mine, demolition block, or other explosive charge.

b. *Description.* The device consists of a two-part case or tube, the parts being joined near the center by a coupling. The tube is about $\frac{3}{8}$ inch in diameter and the device is $6\frac{1}{4}$ inches long including a primed coupling base having the same size thread and nipple as on all firing devices. The part of the case attached to the coupling base is brass and the other part

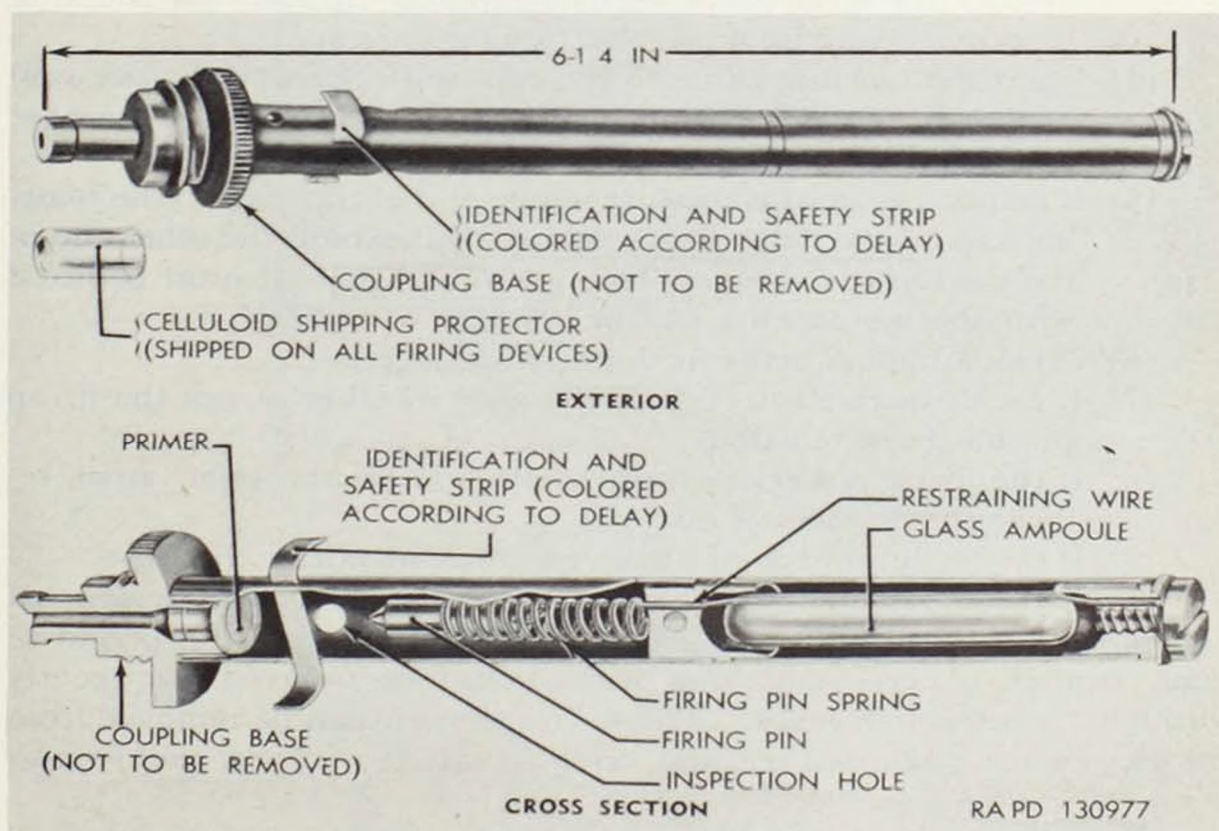

Figure 71. Firing device, delay type, M1—exterior and cross section.

is thin copper capable of being crushed between thumb and finger. The copper part contains a sealed glass ampoule of corrosive chemical and the brass part houses a firing pin and spring. An identification and safety strip, colored according to the length of delay in which the device functions, extends through slots opposite an inspection hole near the primer of the coupling base. Devices with black, red, white, green, yellow, and blue identification and safety strips, each having consecutively longer delay periods, are available. A restraining wire, extending from the end of the device where it is held by a screw, extends along the ampoule, through the firing pin spring, and to the firing pin to which it is attached.

c. Functioning. When the glass ampoule is crushed (fig. 72), the corrosive liquid is released. The liquid then eats through the restraining wire releasing the firing pin. The firing pin, driven by a spring, fires the primer in the coupling base. A temperature correction table (one in each box) showing the delay of a device having a strip of a particular color at various temperatures is shown in table IV.

d. Installation and Arming.

- (1) Select a device with identification strip of the appropriate color.
- (2) Look into, or insert a nail or wire into, the inspection hole to make sure that the firing pin has not been released. Examine the copper part of the tube of the device (this part contains the glass ampoule of corrosive chemical) to see that it is undented and that there is no evidence that the ampoule has been crushed.
- (3) Remove the celluloid protective shipping cap from the coupling base and crimp on a nonelectric blasting cap.
- (4) Insert the blasting cap into the cap well or secondary fuze well of the charge, demolition block, or mine, as the case may be, and screw the device into the threads of the well.
- (5) If detonating cord is used, tape one end of the cord to the blasting cap on the delay firing device, then extend the other end of the cord to the charge, block, or mine, where it must be fitted with another blasting cap for insertion or taping.
- (6) Crush ampoule between thumb and fingers.
- (7) Look through inspection hole to see whether or not the firing pin has been released.
- (8) If the firing pin rests on the identification and safety strip, remove the device and discard.
- (9) If the firing pin has not been released, withdraw the strip.

e. Neutralizing. There is *no safe way* to neutralize this firing device. If an *extreme necessity* arises to neutralize the device before the period of delay expires, a cotter pin or a wire should be inserted very gently through the inspection holes. The device should then be removed from the charge and discarded because, once actuated, *no attempt must be made to reuse it.*

f. Precautions in Use.

- (1) When screwing this device into an explosive item, it should be

Table IV. Effect of Temperature on Delays of Firing Device, Delay Type, M1

Degree F.	Black*		Red*		White		Green		Yellow		Blue		Degree C.
	OM	ST	OM	ST	OM	ST	OM	ST	OM	ST	OM	ST	
-25													-32
0	8hr	2.5hr	8.5hr	3.3hr	3day	1.3day	2.6day	1.2day	8.5day	3.8day	23day	10day	-18
+25	36min	16min	45min	20min	17.5hr	8hr	17hr	8hr	2.0day	20hr	5.0day	2.2day	-4
50	15min	7min	17min	8min	5.5hr	2.5hr	6hr	2.7hr	14hr	6.0hr	1.3day	14hr	+10
75	9min	4min	15min	7min	2hr	55min	2.5hr	70min	5.5hr	2.5hr	11.5hr	5hr	24
100	5min	2.0min	8min	3.5min	1hr	27min	70min	30min	2.5hr	65min	5.2hr	2.3hr	38
125	4min	1.5min	5min	2min	32min	14min	35min	15min	80min	36min	2.5hr	1.1hr	52
150	3min	1min	4min	1.5min	15min	6min	20min	9min	46min	21min	80min	36min	66

*The red pencils should not be used below 0° F., nor black pencils below 25° F.

OM—Most likely delay if two devices are used in the same charge. If only a single device is used, this value should be increased approximately 15 percent.

ST—Reasonably safe time. Delays of less than this value should not occur more often than one in a thousand.

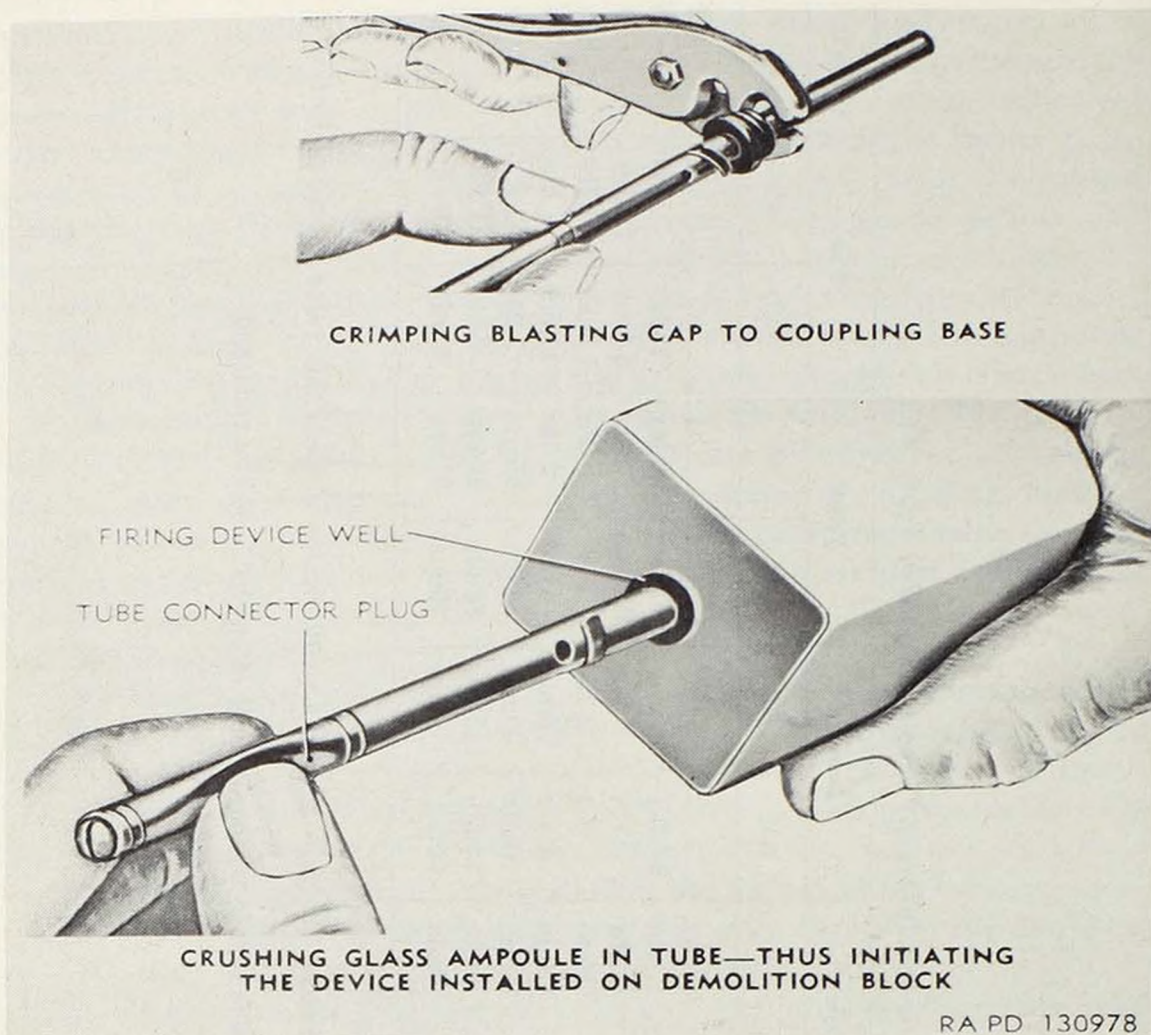

Figure 72. Firing device, delay type, M1—installation.

held with the thumb and fingers gripping the coupling which joins the two parts (copper and brass) of the tube.

- (2) The time delay starts when the ampoule is crushed—not when the colored identification and safety strip is withdrawn. Calculations must be made accordingly.
- (3) Areas where explosives fuzed with this type of device have been installed and actuated should be especially so marked and recorded. Troops must not approach installed charges employing this type of delay firing device.

g. Packing. Firing devices of each color (delay time) are packed separately. Each device except the black (9-minute delay) is packed 10 per carton, 12 cartons per waterproof-lined wooden box. The black (9-minute delay) device is packed 10 per paperboard box, ten boxes per wooden box. The devices are also issued as a set of 10, consisting of two red, three white, three green, one yellow, and one blue. One set is packed in a paperboard box, 10 paperboard boxes per fiberboard box, five fiberboard boxes (50 sets) in a wooden box.

60. Firing Device, Pressure Release Type, M5

a. *Description.* This device (fig. 73) consists of a rectangular pressed-steel case containing a spring-loaded firing pin (striker). The firing pin is restrained by a release plate which is held in place by a safety pin. A primed coupling base fits into the threaded hole in the bottom of the case. This device may be used to boobytrap antitank mines equipped with secondary fuze wells (cap wells) and for general boobytrap installations with charges having a threaded well.

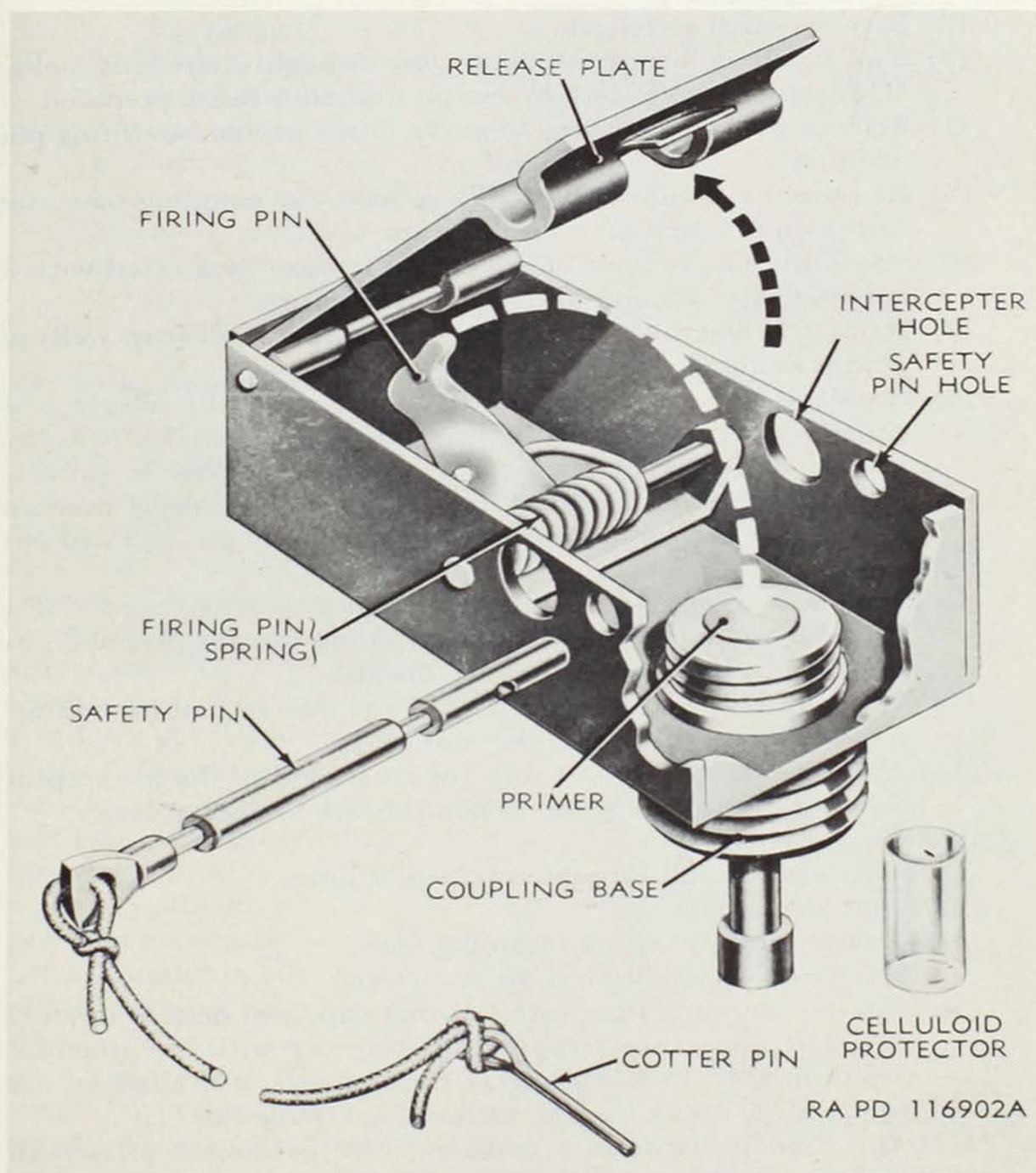

Figure 73. Firing device, pressure release type, M5.

b. Functioning.

- (1) When restraining load of at least 5 pounds is displaced more than five-eighths of an inch, the release plate releases the firing pin (striker).
- (2) The firing pin, impelled by spring, fires the percussion cap in the coupling base.

c. Installing and Arming.

- (1) Inspect the device to make sure that there are no obvious defects, that firing pin is cocked, and that the safety pin is in proper position.
- (2) Remove small cotter pin.
- (3) Slip a nail or length of stout wire through interceptor holes. This provides safety while the installation is being prepared.
- (4) Remove the coupling base from the firing mechanism (firing pin housing).
- (5) Remove the celluloid shipping cap from the coupling base and crimp on a nonelectric blasting cap.
- (6) Screw the primer end of the coupling base thus fitted with a blasting cap back into the firing mechanism.
- (7) Screw this assembly into the threaded fuze well (cap well) of charge or mine.
- (8) Install so that the release plate is held closed by weight of a mine, a charge, or a boobytrap bait. If the device is in the ground, use a small board issued with the device to provide solid foundation. See that the safety pin is in proper position and adjust the installation so that the safety pin will slip out easily.
- (9) Remove the safety pin gently by pulling attached cord. If it does not come out easily, the restraining force is probably insufficient or improperly placed—check.
- (10) If no clicking sound is heard, pull out wire or nail from interceptor holes. It should come out easily.
- (11) Save the safety pin and wire (or nail) used in the interceptor holes for possible later use in neutralizing the firing device.

d. Neutralizing.

- (1) Insert wire or nail through interceptor holes.
- (2) Insert safety pin.
- (3) Remove mine or other restraining load.
- (4) Remove the device from mine or charge.
- (5) Unscrew coupling base with blasting cap, and destroy or store in a safe place, protecting the blasting cap with the protector cap from used 15-second delay firing device, if available. *Do not attempt to remove blasting cap from the coupling base.*

e. Packing. Four firing devices, complete with percussion primers in the coupling bases, and four small plywood boards are packed in paperboard box; five paperboard boxes are packed in a fiberboard box which,

in turn, is packed 10 boxes (making a total of 200 devices) in a wooden box. The dimensions of the box are 19½ x 11¼ x 10 inches; complete packing weighs 55 pounds (approx).

f. Reuse. If the primer (percussion) has been fired and the device is to be used again, remove the coupling base from the device, remove the fired primer from the coupling base, and insert an M27 percussion primer into place (refer to paragraph 66 for discussion of repriming coupling base). To recock, proceed as follows:

- (1) Remove the coupling base.
- (2) Hold the firing mechanism in the left hand with release plate up, hinge of release plate toward you.
- (3) With a nail in right hand held perpendicular to long axis of firing mechanism, force the firing pin back toward you to cocked position.
- (4) Push down release plate with the left thumb and, while holding it down, withdraw nail.
- (5) Insert safety pin.
- (6) With release plate still held down firmly, withdraw safety pin to see that it slides out easily; replace safety pin.

Note. Other methods of recocking may be used if found satisfactory.

61. Firing Device, Pressure Type, M1A1

a. General. This firing device (figs. 74 and 75) is designed for actuation by pressure and intended for use in setting up boobytraps.

b. Description. The firing device consists of a head, case, and coupling base. The case which contains the firing mechanism has three lugs, each with a hole for use in anchoring the device. The firing mechanism consists of a spring-loaded firing pin held in the "cocked" position by a firing pin release pin which is attached to the pressure cap. This is accomplished by a keyhole-shaped opening in the trigger pin. The smaller part of this opening fits into a groove in the firing pin (cocked position), the larger part of the opening permits the free movement of the firing pin upon release. The head, an integral part of the case, contains the firing pin release pin mechanism which terminates in a pressure cap. A tapped hole in the center of the pressure cap is provided for use of an extension. The coupling base, which screws into the case, contains the primer. A removable fork, located under the pressure cap, prevents movement of the firing pin release pin. The safety pin, which passes through a hole in the case between the firing pin and the primer of the coupling base, prevents the firing pin from striking the primer should the firing pin be accidentally released.

c. Functioning. A pressure of 20 pounds on the pressure cap compresses the firing pin release pin spring and pushes the release pin inward. When the enlarged portion of the keyhole-shaped opening in the release pin is in line with the spindle, the firing pin is released. The spring-loaded firing pin then fires the primer.

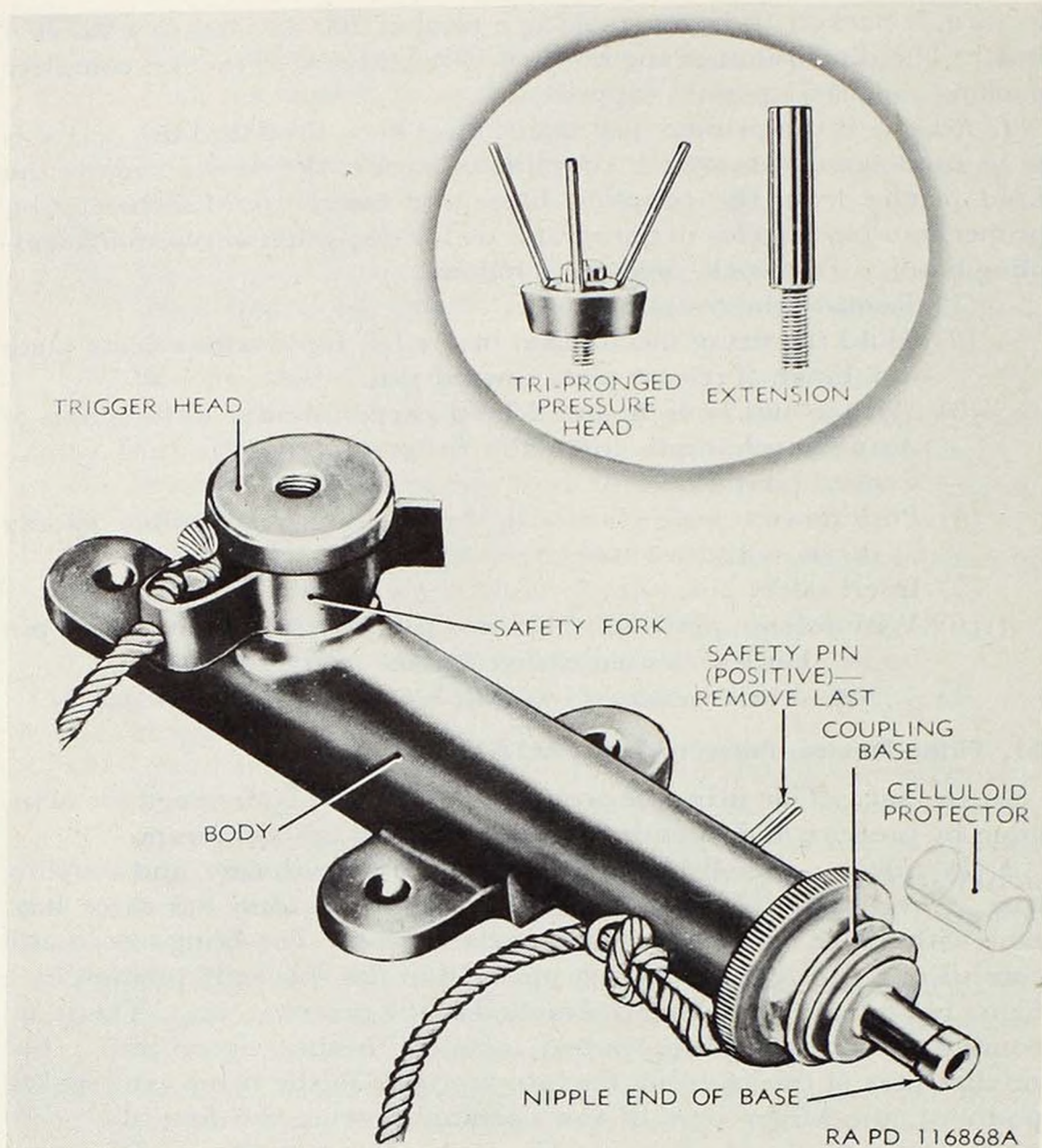

Figure 74. Firing device, pressure type, M1A1.

d. Preparation for Use.

- (1) *Inspection before use.* Check the firing mechanism as follows:
 - (a) Unscrew the coupling base from the firing mechanism and inspect the primer. Invert the coupling base and hold it against the firing mechanism with the nipple extending into the threaded end of the firing mechanism.
 - (b) Holding the coupling base firmly against the case, remove safety fork and safety pin. Depress the pressure cap. The firing pin should strike the nipple end of the coupling base

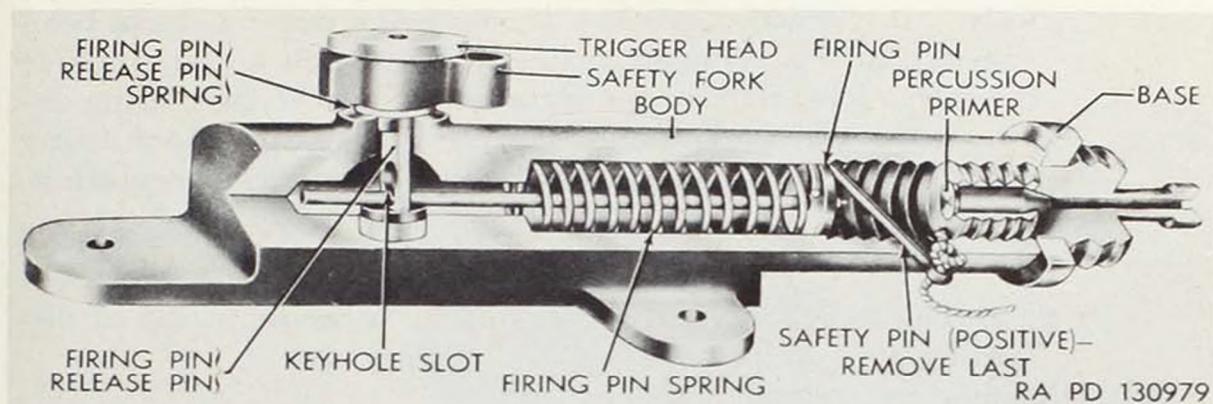

Figure 75. Firing device, pressure type, M1A1—sectioned.

sharply indicating proper functioning of the firing mechanism.

- (c) Recock the firing mechanism by pushing firing pin inward with unsharpened end of a pencil or a small blunt rod and at the same time pressing downward on the pressure cap so that the end of firing pin can pass through the enlarged portion of the keyhole in the firing pin release pin.
 - (d) Release pressure on pressure cap to allow the narrow part of the keyhole to engage the groove on the spindle.
 - (e) Replace safety pin and safety fork. The safety pin and the safety fork should be free enough for easy removal after the firing device has been installed.
 - (f) Screw the coupling base into the firing mechanism handtight. This restores firing device to original condition.
- (2) *Installation and arming.*
- (a) Remove protector tube from nipple and then screw firing device, with safety fork and safety pin in place, into a mine or other explosive charge.
 - (b) Bury and anchor the assembled mine and firing device on a firm flat foundation.
 - (c) Place or arrange some suitable object such as a pressure board in contact with, but not bearing on, the pressure cap. If the particular object does not touch the pressure cap, screw extension rod into pressure cap. Adjust by unscrewing the rod up snugly against object, then backing the rod away one-quarter turn to relieve any pressure on pressure cap. If the tripronged extension is to be used, screw it into the pressure cap and adjust in the same manner.
 - (d) Remove the safety fork. It should pull off easily. A sudden jerk may cause firing device to function. If the safety fork does not pull off easily, check the installation to make sure there is no pressure on pressure cap.
 - (e) Using the attached cord, pull out safety pin slowly and care-

fully. If it resists a gentle pull, the firing pin may have been released and is pressing against it. In such a case, replace the safety fork, remove the installation, and remove firing device from mine. Unscrew coupling base and check firing mechanism. If the firing mechanism is defective, replace it.

Note. Remove the safety pin from a safe distance, using a cord or length of wire for the purpose.

(f) Save the safety fork and safety pin for subsequent use in disarming.

(3) *Disarming and removal.*

(a) Carefully insert the safety pin into the case of the firing device. Then install safety fork.

(b) Take up assembled firing device and mine or other explosive charge.

(c) Remove firing device from mine or explosive charge or demolition block.

(d) Restore firing mechanism and coupling base to original condition and packing.

e. Reuse. To prepare this firing device for reuse, proceed as follows (fig. 75):

(1) Unscrew the coupling base from the end of the barrel (body) of the firing mechanism.

(2) Insert the end of a suitable blunt instrument such as a rod, stick, or unsharpened pencil into the open end of the barrel (body) and push the striker inward against the firing pin spring until the firing pin release pin slips into place and holds it, thus recocking the firing mechanism.

(3) Insert the positive safety pin through the positive safety pin holes, which are located near the coupling base end of the barrel (body).

(4) Insert the safety fork into place under the trigger head.

(5) Screw a new coupling base (or used base with new primer (par 66a)) into the end of the barrel (body).

f. Packing. Five devices are packed in a carton, 50 cartons (250 devices) per wooden box. Approximate dimensions of packing box are $27\frac{1}{4} \times 12\frac{3}{4} \times 10\frac{1}{4}$ inches; the weight of the complete packing is 80.0 pounds.

62. Firing Device, Pull Friction Type, M2

a. General. This firing device (fig. 76), which contains a friction initiated primer, is designed for actuation by a pull wire and intended for use in setting up boobytraps.

b. Description. The firing device consists of a body, a nonremovable base, and an assembly consisting of a pull ring, a spring, and a coated wire secured by a safety pin. The nipple on the nonremovable base is

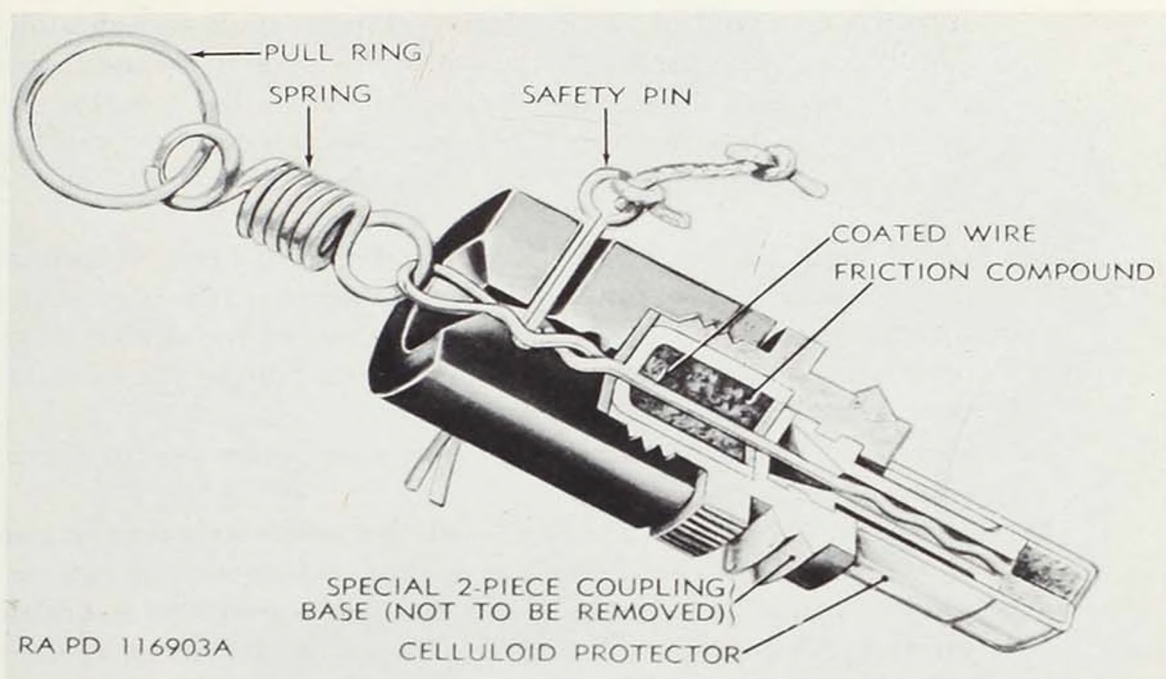

Figure 76. Firing device, pull friction type, M2—sectioned.

fitted with a celluloid protector which contains a dessicant to keep the friction compound dry. The outer end of the base is threaded to fit activators and secondary fuze wells, cap wells. The coated wire, to which the spring and pull ring is attached, passes through an axial hole in the body of the device, through the friction compound, and into the nipple.

c. Functioning. A direct pull of 3 to 9 pounds on the trip wire (pull wire) stretches the spring and draws the coated wire through the friction compound thereby igniting it.

d. Preparation for Use.

- (1) *Inspection before use.* Check the firing device as follows:
 - (a) Check for presence of safety pin. Loosen the safety pin. It should be free enough for easy removal after the firing device has been installed. *Do not attempt to remove the base.*
 - (b) Examine for position of coated wire. The loop of the wire should be in the body recess. If wire is partially withdrawn, discard the firing device and use a new one.
 - (c) Check for presence of celluloid protector. If the celluloid protector is missing and if friction compound has absorbed moisture, a dud may result.
- (2) *Installation and arming.*
 - (a) Remove celluloid protector from the nipple of the coupling base.
 - (b) If the firing device is to be used with a blasting cap (nonelectric), crimp the cap to the nipple of the firing device. Screw the firing device and blasting cap with safety pin in place,

into the cap well of the explosive charge, such as a demolition block, to be used. If the firing device is to be used with heavy antitank mines such as the M6A2 or M15, screw the firing device into activator M1 and then screw the assembly into the boobytrapping well (secondary fuze well) of the mine.

- (c) Install loose trip wire, attaching anchor end first. Unspool the trip wire to the mine. Before connecting trip wire to the firing device, step off to the side and inspect for detectability of trip wire and mine. If necessary, rearrange the installation to obtain adequate concealment.
- (d) Attach free end of trip wire to pull ring, drawing up excess wire through pull ring.
- (e) Using the attached cord, pull out the safety pin slowly and carefully. If undue force is required to remove the pin, examine spring to make sure it is not tensioned and examine safety pin for excessive spread of legs. If defective, replace firing device.

Note. Remove safety pin from a safe distance, using a cord or length of wire for the purpose.

- (f) Retain safety pin for future use in disarming the firing device.
- (3) *Disarming and removal.*
- (a) Carefully insert safety pin into body of safety device, making sure that the legs of safety pin are closed. After insertion, spread the legs enough to prevent accidental loss of pin during handling and shipment.
 - (b) Disconnect trip wire from the pull ring.
 - (c) Unscrew firing device from mine or charge, and destroy the device or store it in a safe place.

Caution: Do not attempt to remove the blasting cap from the firing device.

- (4) *Reuse.* An unfired "pull friction" firing device may be reinstalled provided it has been kept dry. Once fired, it cannot be reused.

e. Packing. Five devices with two 80-foot spools of trip wire are packed in a carton, five cartons per inner package, five packages (125 devices) per wooden box.

63. Firing Device, Pull Release Type, M3

a. General. This firing device (fig. 77) is a mechanical device containing a percussion cap. It is designed for actuation by either an increase (pull) or decrease (release) of the tension in a taut trip wire and is intended for use with antipersonnel mines, improvised antipersonnel mines, or, in setting up boobytraps.

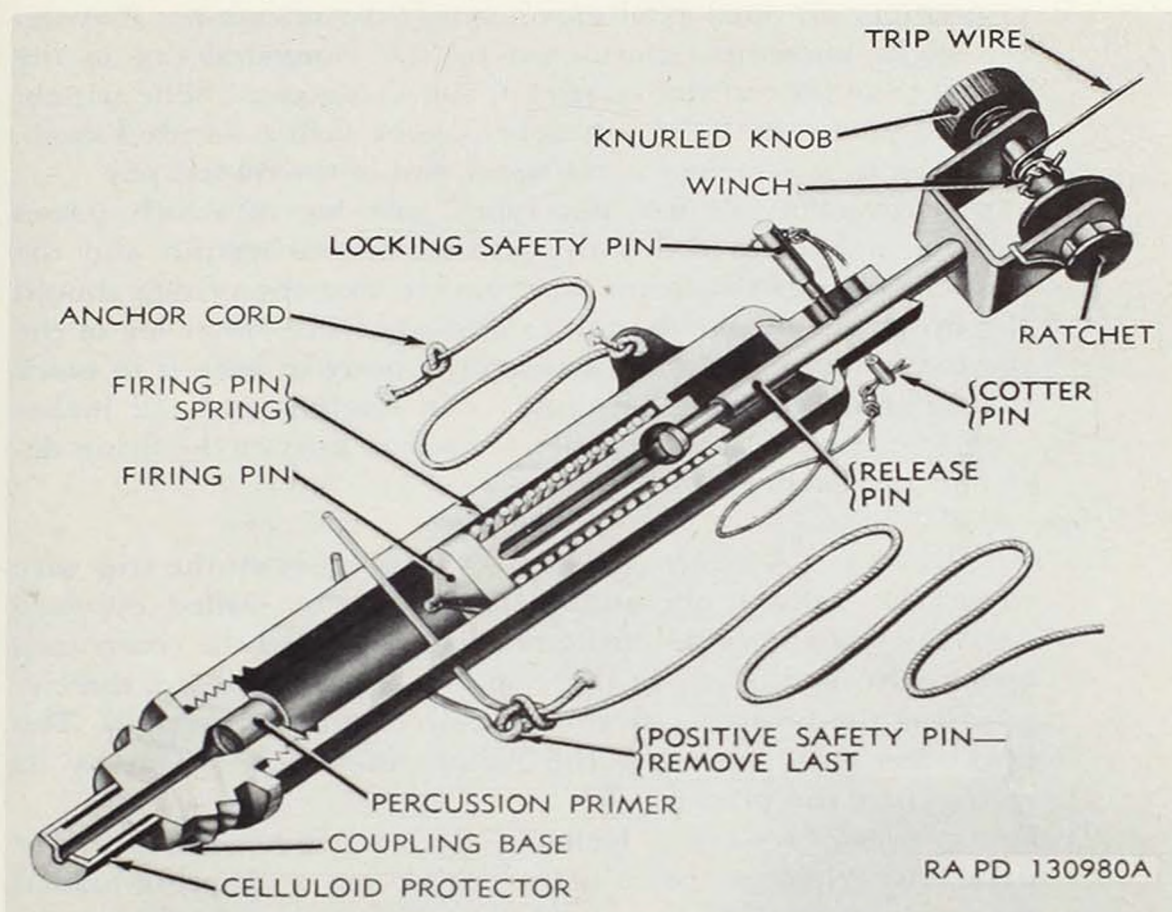

Figure 77. Firing device, pull release type, M3—sectioned.

b. Description.

- (1) The firing device consists of a head, body, coupling base, firing pin, release pin, winch assembly, locking safety pin and positive safety pin. The head, which is crimped to the body, acts as a guide for the release pin. The body contains a spring-loaded firing pin with recess for the knob end of the release pin. The coupling base, which screws into the body, contains the primer. The outer end of the coupling base is threaded to fit activators and secondary fuze wells (cap wells) and has a nipple to which a blasting cap may be crimped.
- (2) The outer end of the firing pin is slotted longitudinally to form four jaws and grooved internally to receive the knob end of the release pin. This slotted end passes through a cylindrical opening in the body in which position it is held by the knob of the release pin when the release pin is in its normal axial position and the locking safety pin in place. The locking safety pin passes through an elongated opening in the head and a hole in the release pin. A small cotter pin, which passes through a hole in the end of the locking safety pin, prevents its accidental movement during shipment. The safety pin when

in position, prevents axial movement of the release pin (beyond the slight movement permitted by the elongated slot in the head) thus preventing release of the firing pin. The winch, consisting essentially of a bracket, spool with a knurled knob, and a pawl, is attached to the outer end of the release pin.

- (3) A positive safety (cotter pin type), one leg of which passes through a hole in the body between the firing pin and the primer prevents the firing pin from striking the primer should the firing pin be accidentally released. The other leg of the positive safety pin is bent around the body to keep it in place during shipment and handling. An anchor cord, 12 inches long, in the eyelet on the body, is used to anchor the firing device firmly during installation.

c. Functioning.

- (1) *Pull operation.* A direct pull of 6 to 10 pounds on the trip wire causes the release pin and firing pin to be pulled outward until the jaw end of the firing pin passes beyond the constricted opening in the body. In this position, the jaws spread, thereby releasing the firing pin from the knob of the release pin. The jaws then close releasing the firing pin which driven by its spring, fires the primer.
- (2) *Tension-release operation.* Release of tension, such as cutting or detaching trip wire, permits the release pin and spring-loaded firing pin to move inward. When the end of the firing pin

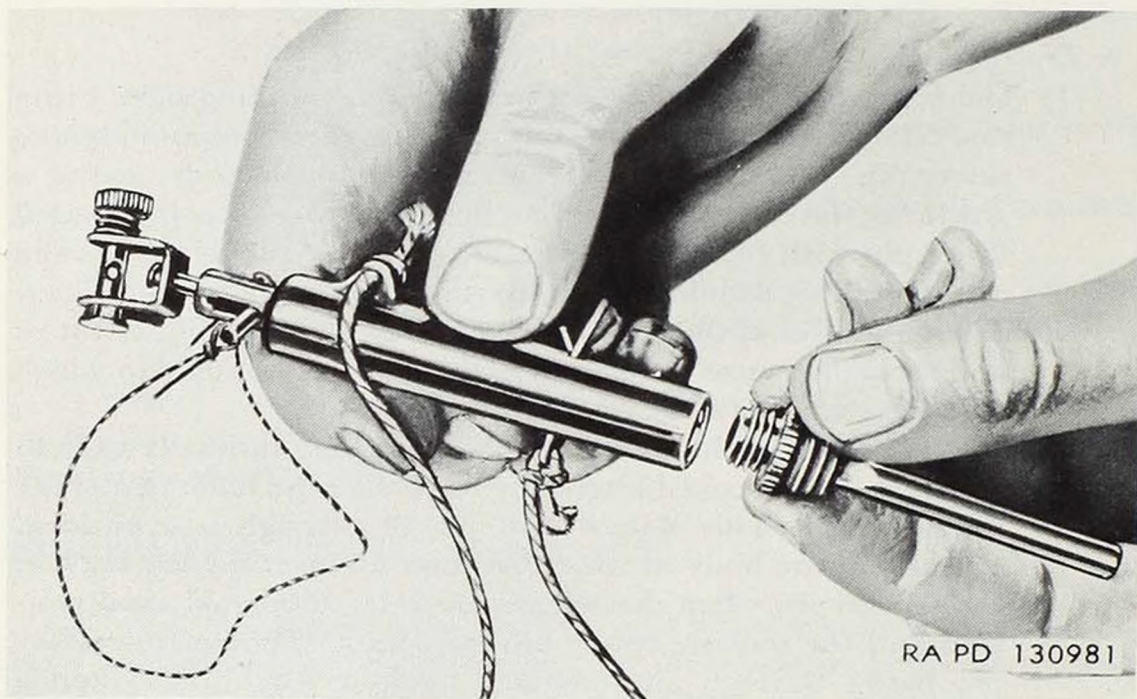

Figure 78. Assembling pull release type firing mechanism to primed coupling base with crimped-on blasting cap.

clears the constricted opening in the body, the jaws spread, thereby freeing the firing pin from the release pin. The release firing pin, driven by its spring, fires the primer.

d. *Preparation for Use.*

(1) *Inspection before use.* Check firing device as follows:

- (a) Unscrew the primed coupling base from the firing mechanism and inspect the primer.
- (b) Inspect cotter pin (for positive safety) and the safety pin to see that they are in place, yet free enough for easy removal after firing device has been installed.
- (c) Leaving the cotter pin (for positive safety) and safety pin in position, pull the winch assembly out with the fingers until it is stopped by the safety pin and then release gently. Repeat two or three times. The winch assembly should move smoothly approximately one-fourth of an inch and should require a force of 6 to 10 pounds. If the assembly hangs or moves jerkily or too easily, examine the firing device. If fault cannot be corrected, use another firing device.

(2) *Installation and arming.*

- (a) Remove the protector cap from the nipple of the primed coupling base and crimp on a blasting cap.
- (b) Screw the firing mechanism to the primed coupling base (fig. 78).
- (c) Screw the firing device, with cotter pin (for positive safety) and safety pin in place, into a mine or other explosive charge.
- (d) Secure the trip wire at the anchor end making certain that this tie will not slip. Unspool the trip wire to the mine or charge. Before connecting the trip wire to the firing device, step off to the side and inspect for detectability of the trip wire and mine. If necessary, rearrange the installation to obtain adequate concealment.
- (e) Attach loose end of trip wire to the winch by threading it through the hole in the winch spindle.

Note. The wire must be threaded through the hole in the winch spindle to prevent slippage and accidental functioning.

- (f) Draw up excess wire through hole in winch spindle. Take up the remaining slack by turning the knurled knob until the locking safety pin (near the winch end) is pulled *exactly* to the mid-position of its elongated hole in the head.
- (g) Remove small cotter pin from the locking safety pin and then gently remove the locking safety pin. If the locking safety pin does not slide out easily, adjust the winch winding slightly until the locking safety pin is loose enough to be withdrawn easily.
- (h) Using the attached cord, pull out the positive safety pin slowly and carefully. It should come out easily. If it resists

a gentle pull, replace the locking safety pin, remove trip wire from winch by depressing knurled knob and stripping off the wire. Remove the coupling base and check the mechanism. If defective, replace the whole firing device.

Note. When finally removing safety pins, remove them from a safe distance using a string or length of wire previously attached for the purpose.

- (i) Save the safety pins for subsequent use in disarming.
- (3) *Disarming and removal.*
 - (a) Carefully insert the positive safety pin into the body. The pin should enter freely.
 - (b) Insert the locking safety pin and replace cotter pin in end of locking safety pin.
 - (c) Release tension on trip wire by depressing knurled knob and stripping off wire.
 - (d) Unscrew firing device with blasting cap attached from the explosive charge or mine.
 - (e) Unscrew the primed coupling base from the firing mechanism. *Do not attempt to remove the blasting cap from the primed coupling base; either destroy it or store it in a safe position.*
 - (f) Restore firing mechanism to original condition and packing.
- e. *Reuse.* To prepare this firing device for reuse, proceed as follows (fig. 77):
 - (1) Unscrew the coupling base from the end of the barrel (body) of the firing mechanism.
 - (2) Insert the end of a suitable blunt instrument such as a rod, stick, or unsharpened pencil into the open end of the barrel (body) and push the striker inward against the firing pin spring until the release pin slips into place and holds it, thus recocking the firing mechanism.
 - (3) Insert the positive safety pin through the positive safety pin holes, which are located near the coupling base end of the barrel (body).
 - (4) Insert the locking safety pin through the locking safety pin slot and through the holes in the release pin and the head end of the firing mechanism.
 - (5) Screw a new coupling base (or used base with new primer (par. 66a)) into the end of the barrel (body).

f. *Packing.* Five devices with two 80-foot spools of trip wire are packed in a carton, five cartons per inner package, six packages (150 devices) per wooden box. Approximate dimensions of the box are $17\frac{3}{4}$ x 13 x $10\frac{1}{4}$; the weight of the complete packing is 52 pounds.

64. Firing Device, Pull Type, M1

a. *General.* This firing device (fig. 79) is designed for actuation only by a pull on a trip wire and intended for use with improvised antiper-

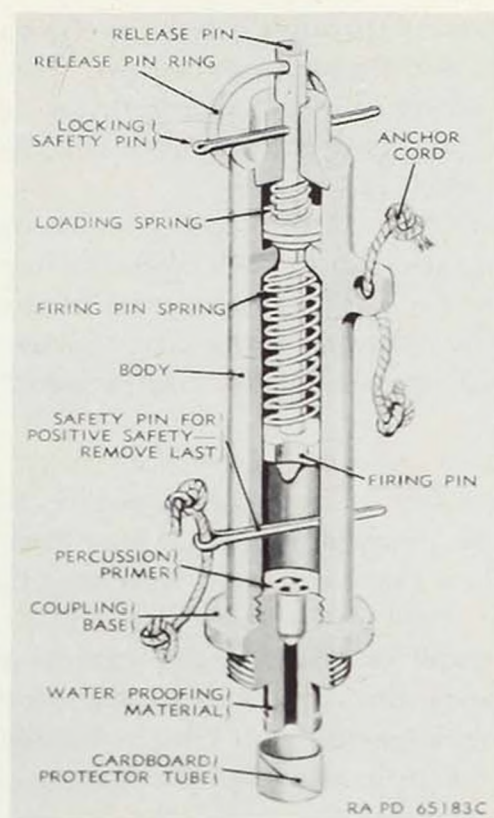

Figure 79. Firing device, pull type, M1—sectioned.

sonnel mines, for boobytrapping of antitank mines, and for setting up boobytraps.

b. Description.

- (1) This firing device consists of a cylindrical case (body), head, and coupling base. The head, which permanently joined to the case, contains a release pin, release-pin ring, a loading spring, and a locking safety pin. The case, which contains the firing mechanism consisting of the firing pin and compression spring, also contains a positive safety pin. The coupling base, which screws into the case, contains the primer. The outer end of the coupling base is threaded to fit activators and secondary fuze wells (cap wells). It has a nipple to which a blasting cap may be assembled.
- (2) The pull ring end of the firing pin, which is slotted axially to form four jaws, passes through a cylindrical opening in the case. The end of the release pin, fitting into an axial hole in the slotted end of the firing pin, causes it to engage on the upper surface of the opening, thereby restraining downward movement of the firing pin.
- (3) The safety pin, which passes through a hole in the head and a hole in the release pin, prevents accidental movement of the release pin during shipment and handling. The positive safety

pin, which passes through a hole in the case between firing pin and primer, prevents the firing pin from striking the primer should the firing pin be accidentally released. An anchor cord, on the case, is used to anchor the firing device firmly during installation.

c. Functioning. A direct pull of 3 to 8 pounds on the trip wire causes the release pin to be pulled outward, overcoming the resistance of the loaded release pin spring. The slotted end of the firing pin, being no longer restrained by the cylindrical opening, passes through the opening. The released firing pin, driven by the compression spring, then fires the percussion cap.

d. Preparation for Use.

(1) *Inspection before use.* Check firing device as follows:

- (a) Unscrew the primed coupling base and inspect primer. Invert coupling base and hold it so that the nipple end is inside the case.
- (b) Holding coupling base firmly against the case, remove the positive safety pin and the locking safety pin. Pull outward 3 to 8 pounds on the pull ring. Firing pin should strike the end of the nipple sharply, indicating proper functioning of assembly.
- (c) Recock by pushing firing pin inward with unsharpened pencil or blunt rod until release pin slips into place, thus expanding slotted head of firing pin.
- (d) Insert positive safety pin and locking safety pin, then screw the primed coupling base into the case, primer end inward. Safety pins should be free enough for easy removal after the firing device has been installed.

(2) *Installation and arming.*

- (a) Remove the primed coupling base.
- (b) Remove the protector cap from the nipple and crimp on a nonelectric blasting cap.
- (c) Screw the firing device, with safety pins in place, into a mine or other explosive charge.
- (d) Install loose trip wire, attaching anchor end first. Unspool the trip wire to the mine. Before connecting trip wire to the firing device, step off to the side and inspect for detectability of trip wire and mine. If necessary, rearrange the installation to obtain adequate concealment.
- (e) Attach free end of wire to pull ring, drawing up excess wire through pull ring just taut but without strain.
- (f) Remove the locking safety pin. If it does not pull out easily, trip wire may be too tight. Adjust trip wire if necessary. If the locking safety pin still binds, remove the coupling base and check mechanism. If defective, replace faulty firing device with a serviceable one.

- (g) Using the attached cord, pull out the positive safety pin slowly and carefully. If it resists a gentle pull, the firing pin may have been released and is pressing against it or spread of legs of the positive safety pin is excessive. If spread of legs is not excessive but the pin still resists gentle pull, install locking safety pin, unscrew coupling base, and check mechanism. If defective, replace faulty firing device with a serviceable one.

Note. Remove the positive safety pin, which is always removed last, from a safe distance using a cord or length of wire for the purpose.

- (h) Save safety pins for future use in disarming the firing device.

(3) *Disarming and removal.*

- (a) Carefully insert the positive safety pin first and then the locking safety pin into the firing device. After insertion, spread legs of safety pins just enough to prevent accidental loss of pins during handling and shipment.

- (b) Disconnect trip wire from the pull ring.

- (c) Unscrew firing device from mine or charge.

- (d) Restore firing device to original condition and packing.

e. Reuse. To prepare this firing device for reuse, proceed as follows (fig. 79):

- (1) Unscrew the coupling base from the end of the barrel (body) of the firing mechanism.

- (2) Insert the end of a suitable blunt instrument such as a rod, stick, or unsharpened pencil into the open end of the barrel (body) and push the striker inward against the firing pin spring until the release pin slips into place and holds it, thus recocking the firing mechanism.

- (3) Insert the positive safety pin through the positive safety pin holes which are located near the coupling base end of the barrel (body).

- (4) Insert the locking safety pin through the locking safety pin hole in head of the firing mechanism and in the release pin.

- (5) Screw a new coupling base (or used base with a new primer (par. 66a)) into the end of the barrel (body).

f. Packing. Five firing devices with two 80-foot spools of trip wire are packed in a carton, 30 cartons (150 devices) per wooden box or 50 cartons (250 devices) per wooden box.

65. Firing Device, Release Type, M1

a. General. This firing device (fig. 80) is designed to be actuated when a restraining weight is removed from it and is intended for use in setting up boobytraps. The restraining weight is applied at the time of installation. The firing device is restrained from firing as long as there is a load of at least 2 pounds on the top face of latch.

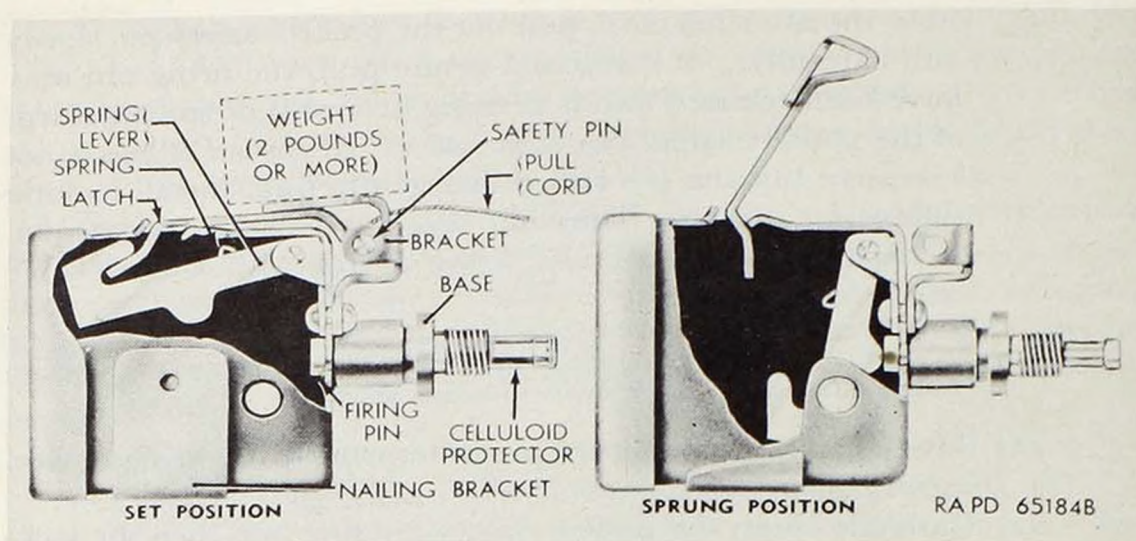

Figure 80. Firing device, release type, M1.

b. Description. The firing mechanism of this device is cube-shaped approximately 2-inches square by 3-inches long. It is fitted with a cover at one end and a threaded hole to receive a primed coupling base at the opposite end. The body houses a spring lever, a spring, and a firing pin. One end of a steel latch engages a lip on the lever, the remaining portion of the latch rests on top of the device and, as issued, is held in place by a safety pin. This arrangement holds the lever in the set position. Two holes (three-sixteenths of an inch) are provided in the sides of the body to permit the insertion of a nail or heavy gage wire to act as an additional safety device by intercepting the lever and preventing it from striking the firing pin should premature functioning occur during installation. A strip of metal $\frac{3}{4}$ -inch wide and 4 inches long spot welded to the base of the body serves as a nailing bracket.

c. Functioning. Upon removal of restraining weight from the firing device, the lever is unlatched and is driven through an arc of approximately 75 degrees to strike the firing pin which explodes the primer contained in the coupling base.

d. Preparation for Use.

- (1) *Inspection before use.* Check firing device for any obvious defects and to make sure that the safety pin is properly installed and that the lever is latched in the set position.
- (2) *Installation and arming.*
 - (a) Remove the cotter pin in the end of the safety pin.
 - (b) Slip a nail or stout wire through the interceptor holes.
 - (c) Remove coupling base. Remove its protector cap and crimp on a nonelectric blasting cap.
 - (d) Screw the coupling base into the firing mechanism.
 - (e) Screw the firing device thus assembled into secondary fuze well (cap well) of the mine or charge.

- (f) Provide a level surface at the base of the hole in which the mine or charge with firing device assembled is to be planted. A board may be used for this purpose.
- (g) Place the assembled mine (or charge) and firing device in the hole with the latch on the firing device uppermost.
- (h) Place the restraining weight on the exposed surface of the latch.

Caution: The weight placed on the latch must be greater than 2 pounds to prevent firing device from functioning when safety devices are withdrawn.

- (i) Make sure that the safety pin cord and interceptor wire is at ground level in position convenient for removal.
- (j) Conceal the installation.
- (k) Gently withdraw the safety pin by pulling on its cord. If it does not come out easily, the load on the mine is too light or improperly placed on the latch. If resistance is met, uncover and check the installation.
- (l) Withdraw the interceptor wire; it also should come out easily.

(3) *Disarming and removal.*

- (a) Carefully uncover installation.
- (b) Insert a nail or wire through interceptor holes.
- (c) Insert safety pin.
- (d) Remove restraining weight.
- (e) Remove mine (or charge) with its assembled firing device. Unscrew the firing device (firing mechanism and coupling base) from the mine or charge.
- (f) Unscrew the coupling base from the firing mechanism.
- (g) Destroy the coupling base with blasting cap attached or store in a safe place.

Caution: Do not attempt to remove the blasting cap from the primed coupling base.

- (h) Restore firing mechanism to original condition and packing.

e. *Reuse.* To prepare the firing device for reuse, proceed as follows (fig. 80):

- (1) Unscrew the coupling base (formerly called "base" or "standard-base") from the firing pin housing of the firing mechanism.
- (2) Remove the cover (lid) from the firing mechanism.
- (3) Pull the spring lever back from the spring (fired) position, catch the hook of the spring lever with the end of the latch and move the loop of the latch into the bracket.
- (4) When the loop of the latch aligns with the holes in the bracket, insert the safety pin.
- (5) Replace the cover (lid).
- (6) Screw a new coupling base (or used base with a new primer (par. 66a)) into firing pin housing of the firing mechanism.

f. *Packing.* This firing device is packed 4 per chipboard box and 20-

chipboard boxes—comprising a total of 80-firing devices—per wooden box.

66. Firing Device Coupling Bases and Percussion Primers

a. Repriming Coupling Bases. In the secondary fuzing of a practice mine installation, a firing device with no blasting cap attached to it is usually employed. The coupling base of a firing device contains an explosive percussion primer which is similar to a caliber .22 blank cartridge. After each practice firing of the firing device, the coupling base can be unscrewed from the firing mechanism, the fired primer removed, and a new primer inserted. The firing mechanism is then recocked, using a pencil or nail to compress the firing pin (striker) spring, and the coupling base with the new primer is inserted into the firing mechanism. The method of removing a *fired* primer from a coupling base and inserting a new one depends on local conditions and will be in accordance with precautions and instructions by local ordnance personnel. Coupling bases, except those in delay M1 and pull friction M2, can normally be used 6 to 8 times in this manner.

Caution: No attempt will be made to remove an unfired or misfired primer from a coupling base.

b. Primer, Percussion, M27. This primer (fig. 81) consists of a flanged gilding metal cup, about 0.2 inch in diameter by 0.3 inch long. This cup contains an inner inverted gilding metal cup with a 0.4 grain charge of styphnate-composition primer mixture, and a brass anvil. The primer produces a small but intense flame when struck by a firing pin. It is fitted to the coupling base of firing devices of newer manufacturers. Coupling bases of earlier manufacture were fitted with primer M2. Primers are also issued separately for repriming coupling bases of fired firing devices in the field under appropriate conditions (*a* above).

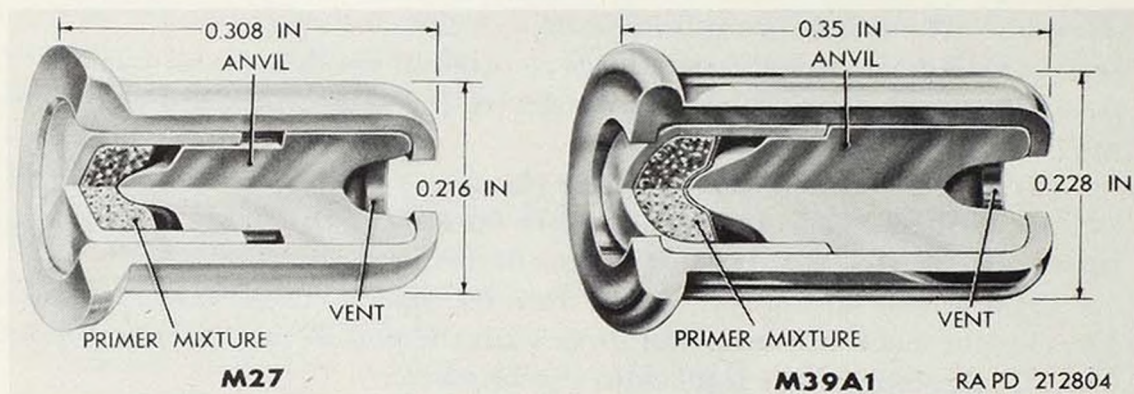

Figure 81. Percussion primers.

c. Primer, Percussion, M39A1. This primer (fig. 81), which is somewhat similar to the primer M27 (*b* above), is used in the antipersonnel mine fuze M10 or M10A1 (par. 28).

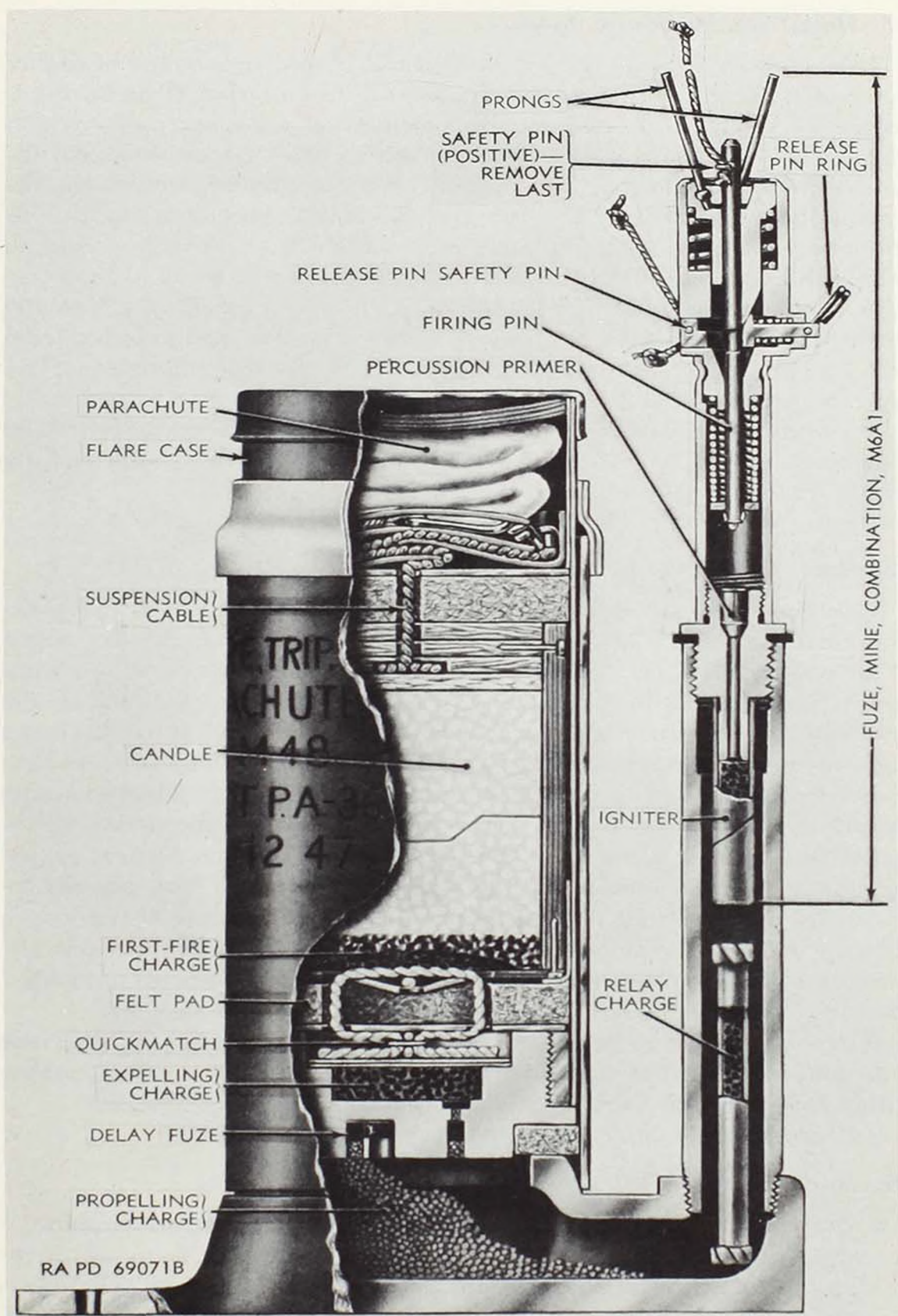

Figure 82. Flare, trip, parachute, M48.

67. Flare, Trip, Parachute, M48

This trip flare (fig. 82) is intended primarily to give warning of enemy marauders or infiltrating hostile troops and illumination of such troops. Its use for signalling is secondary. It is used as a boobytrap for which purpose it is left in the path of an advancing enemy and is thus dependent on enemy action for initiation. The flare, which is similar in outward appearance to the M2 series antipersonnel mines, contains a parachute-type magnesium illuminating element which burns with a white to yellowish light. In effect, the flare is a one-shot mortar, fired by a trip wire, projecting an illuminant candle vertically to a height of 250 to 400 feet where the parachute-supported candle is ignited and expelled from its flare case, illuminating a circular area of 600 yards diameter. The flare weighs 5 pounds.

Warning: Each trip flare used in training will be fenced, or otherwise guarded, in a manner which will prevent personnel from approaching within six feet of each installed flare.

For further information, refer to TM 9-1981.

68. Flare, Trip, M49

This trip flare (fig. 83) is intended for similar purposes as the parachute trip flare M48 (par. 67) except for candle projection. It consists of a cylindrical-shaped laminated paper case containing a magnesium candle and a grenade-type fuze. It resembles a hand grenade in size and shape except that it is provided with a trigger mechanism for firing and a bracket for attachment to a tree or post. The trip fuze M12 resembles hand grenade fuzes such as are used in offensive hand grenades but has no body tube or delay charge. The flare is intended to be installed with a taut trip wire which holds the trigger in a vertical armed position against the pressure of the trigger spring. The flare may be operated by pull of 2 to 9 pounds on the trip wire or release of tension on the trip wire such as the wire being cut. When the fuze functions, the illuminant is blown out and burns with a white to yellowish light for 1 minute. The flare weighs 1.4 pounds.

Warning: Each trip flare used in training will be fenced, or otherwise guarded, in a manner which will prevent personnel from approaching within 6 feet of each installed flare.

For further information, refer to TM 9-1981.

69. Fuse, Safety, M700, and Fuse, Blasting, Time

a. *Fuse, Safety, M700.* Safety fuse is a medium through which flame is conveyed at a continuous and uniform rate, for direct firing of an explosive charge as in the case the ignition of black blasting or pellet powder, or for indirect firing as in the case of the initiation of a blasting cap. The M700 fuse (fig. 84) is for general use in military demolitions and as required in improvised boobytrap installation. It is in the form of a cord, 0.20 inch in diameter. It is dark green in color, and smooth, with

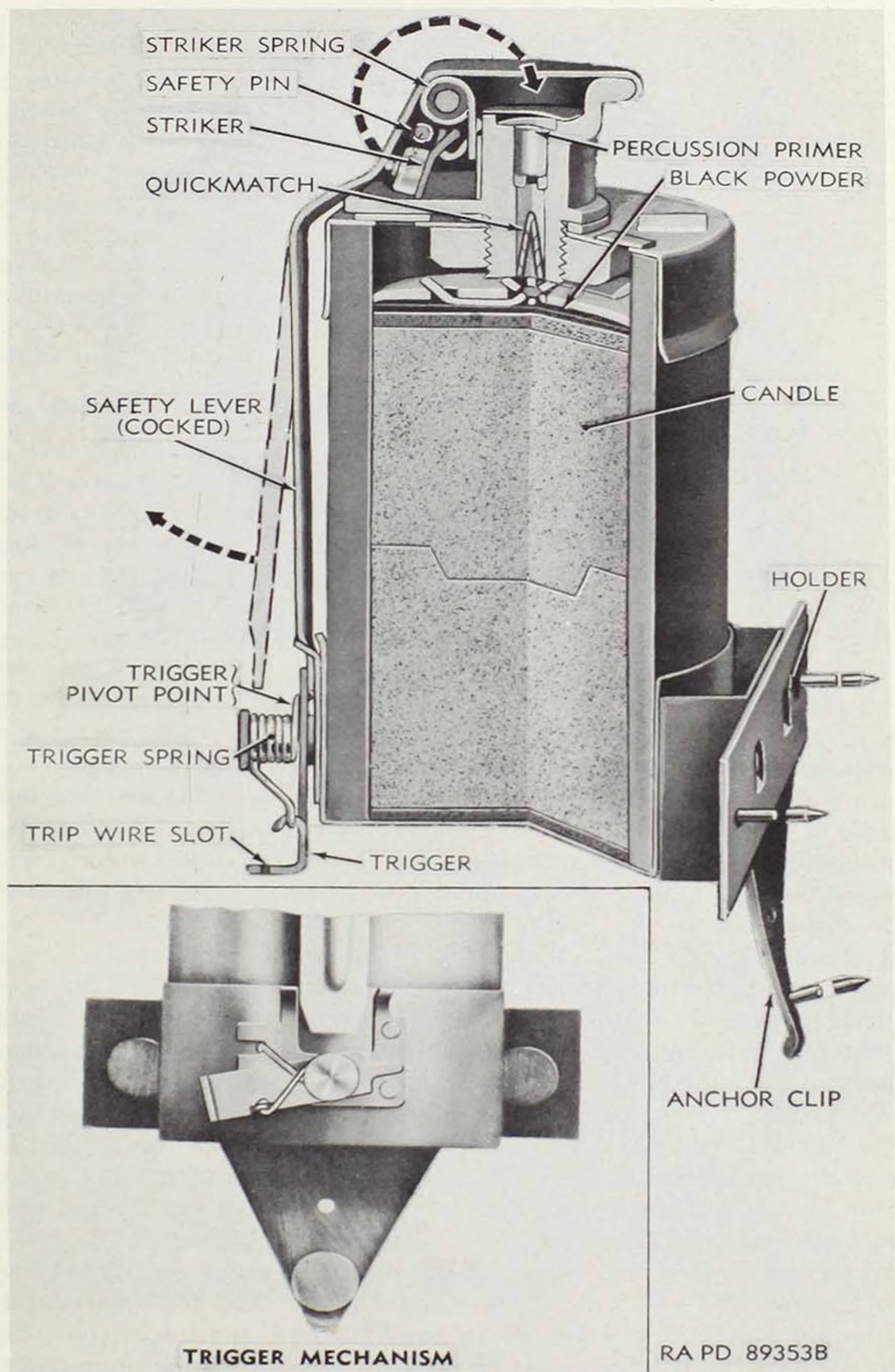

Figure 83. Flare, trip, M49.

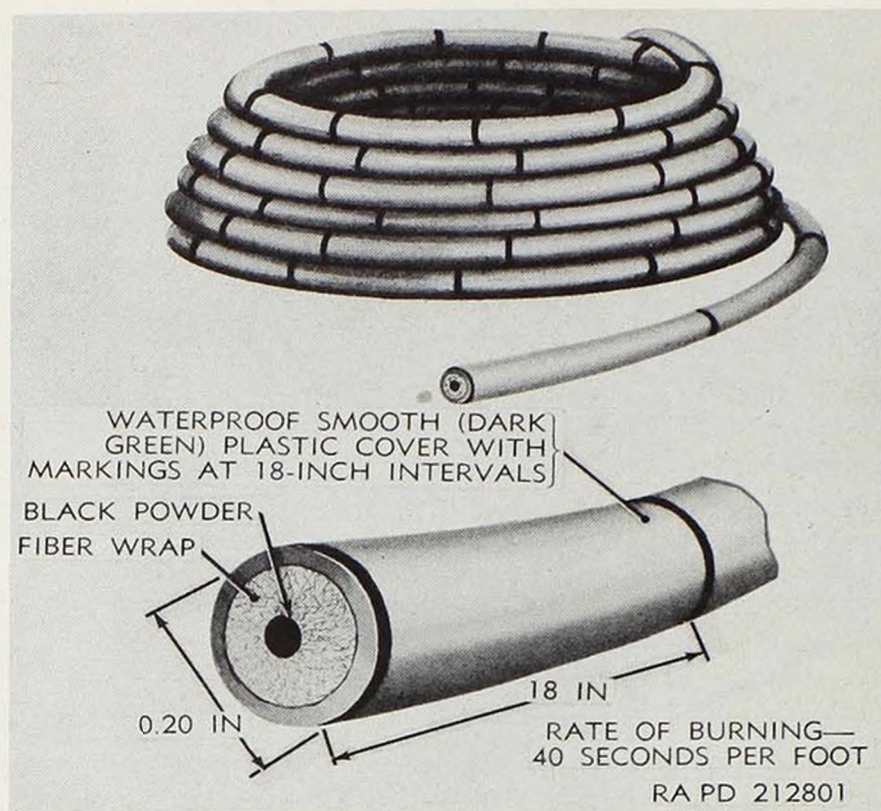

Figure 84. Fuse, safety, M700.

abrasive markings at 18-inch intervals. These intervals indicate one minute of burning time. When ignited by an ordinary match or a fuse lighter, it will transmit a flame to a nonelectric blasting cap which may be installed in a high-explosive charge either on land or under water. The fuse which has a black powder core, burns slowly at a uniform rate of 40 seconds per foot.

b. Fuse, Blasting, Time. This fuse, which is of older manufacture, is limited standard and is for use only in the continental United States in general demolitions. It is in the form of a cord approximately 0.22 inch in diameter and has a black powder core covered with several layers of fabric and waterproofing material. It may be identified by its corrugated surface. Since the burning rate of different rolls of this fuse may vary between 30 and 45 seconds per foot, *each* roll of fuse should be tested before use by timing the burning of a one-foot length. For preparation for use, precautions for use, and precautions in storage and handling, refer to paragraphs *c*, *d*, and *e* below.

c. Preparation for Use. In preparing to attach a nonelectric blasting cap, first cut off about 1 inch of fuse and discard. Cut the fuse squarely in the place provided in the jaws of the blasting cap crimper (par. 79). The fresh end of the fuse must be inserted firmly into the open end of the nonelectric blasting cap and then the cap crimped in the place provided in the jaws of the crimper.

d. *Precaution for Use.* Fuse should not be handled roughly during or after cutting. Instances involving misfires show that the trouble was due to loss of powder from the ends of the fuse before insertion into the blasting cap. The length of fuse cut should be sufficient to allow the personnel using it to reach a place of safety after lighting the fuse. Under no circumstances should less than 2 feet of fuse be used. Fuse should not be allowed to get wet.

e. *Precautions in Storage and Handling.* The fuse should be stored in a cool, dry place free from oils, paints, gasoline, kerosene, and similar distillates and solvents. In handling the fuse, avoid twists, kinks, or sharp bends which may crack the covering or cause breaks in the powder train of the fuse.

70. Grenade, Hand, Offensive, MK 3A2 (w/o Fuze)

This grenade (fig. 85), which is shipped unfuzed, consists of a cylindrical $\frac{1}{2}$ -pound charge of TNT with an axial fuze well (cap well). It is encased in a cardboard container with metal ends, $2\frac{1}{8}$ inches in diameter and $4\frac{1}{2}$ inches long. Used as a grenade, it is designed for detonation by straight-handle FUZE, grenade, hand, M6A4D, or FUZE, grenade, hand, M206A1. Used as an improvised antipersonnel mine, in booby-trap installations, or to detonate large high-explosive charges, it may be detonated by any firing device with blasting cap crimped thereto. Grenades of older manufacture are designated MK 3A1. The grenade is prepared as follows:

a. Screw the firing device with a nonelectric blasting cap crimped to the coupling base into the fuze well of the grenade, using a fiber or rubber washer to make a watertight joint.

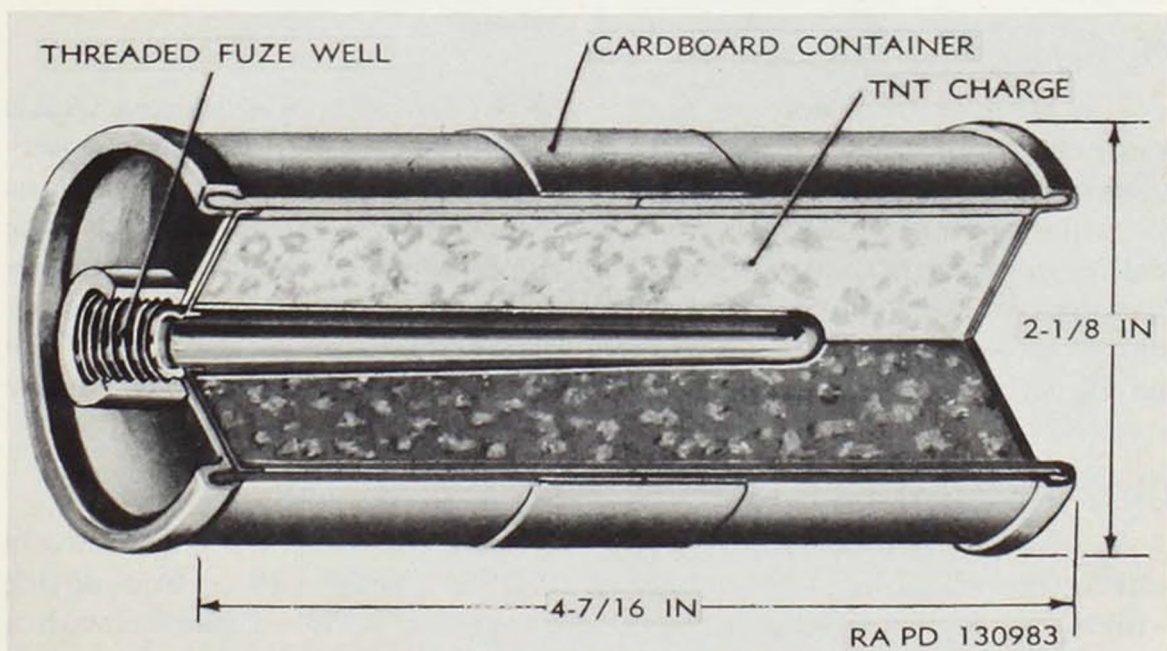

Figure 85. Grenade, hand, offensive, MK 3A2 (w/o fuze).

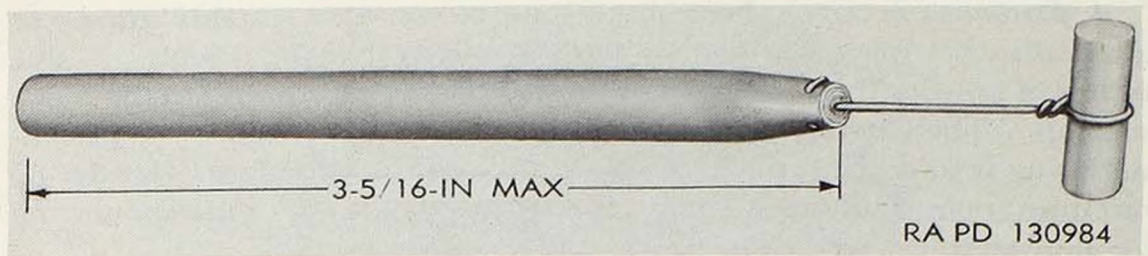

Figure 86. Lighter, fuse, friction type, M1.

- b. Install the grenade in position for the particular use desired and camouflage.
- c. Arm the firing device as required. Refer to paragraphs 59 through 65.

71. Lighter, Fuse, Friction Type, M1

This fuse lighter (fig. 86) is a device for initiating safety fuse (or time blasting fuse) (par. 69a and b). It consists of a paper tube containing friction compound which is mechanically ignited. The open end, when placed over the end of safety fuse or time blasting fuse, is held in place by the barbed surface inside the fuse lighter. The barbs are inclined so they permit the fuse to enter, but prevent its removal except by force. A pull on the loop, or handle at the closed end ignites the friction compound which in turn fires the powder train in the fuse. To prevent pulling the fuse lighter from the fuse and causing an air gap between the fuse end and the lighter, hold the body of the lighter in one hand and pull the igniter wire with the other. When the length of fuse will permit time, pull the fuse lighter off the fuse by force immediately after pulling the igniter wire to make certain that the fuse is burning.

72. Lighter, Fuse, Weatherproof, M2

The M2 weatherproof fuse lighter (fig. 87) consists of a housing which holds the firing mechanism and a coupling base which contains a percussion primer and has a pronged fuse retainer. The housing contains the firing pin spring and firing pin held locked by a release pin. Plastic sealing material is used to waterproof the joint of the safety fuse (or time blasting fuse) and fuse lighter. When the release pin is pulled, the firing pin strikes the percussion primer which in turn ignites the fuse. The lighter will ignite the fuse under all weather conditions, even under water.

73. Simulators—Boobytrap

- a. *General.* These simulators (fig. 88) are for use during maneuvers and in troop training where there is need for a small pyrotechnic device which can be installed as a "safe" boobytrap. They function with a loud report and flash when their "victims" unwittingly fire the simulators. These devices are intended to provide training in the installation

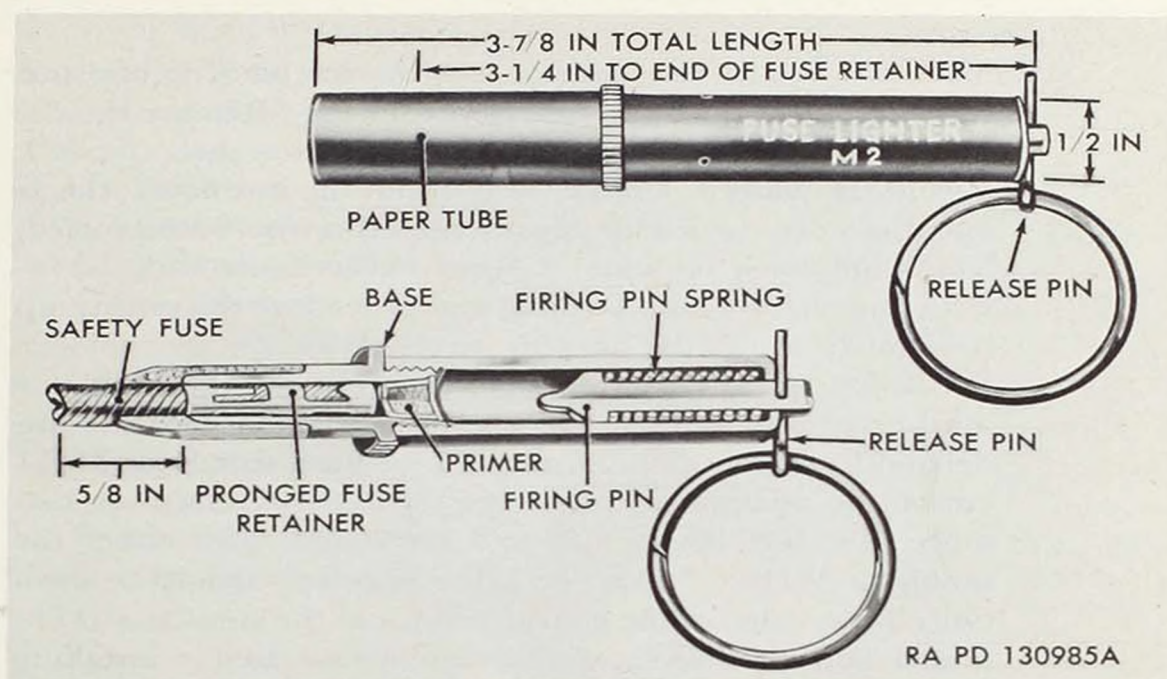

Figure 87. Lighter, fuse, weatherproof, M2—exterior and cross section.

and use of boobytraps as well as encourage the use of caution by troops exposed to traps set by the enemy. Included with each simulator, as issued, is a spool of wire (for use as trip wire), an extension spring, four staples, and two nails. Information pertaining to these simulators is also contained in TM 9-1981.

b. Simulator, Boobytrap, Flash, M117 (T80).

- (1) *Description.* The flash simulator M117 (fig. 88) consists of a cylindrical body (outer tube) and a flat, metal nailing bracket which extends from one end of the body. The body is 0.92 inch in diameter and, without nailing bracket, 2.25-inches long. The nailing bracket increases the length to 3.56 inches. An inner tube, of approximately half the body diameter, is located eccentrically within the body and houses the charge composition. The assembly used for initiating the charge is located in the space between the inner and outer tubes. This assembly consists of a strip of paper, coated with a friction-sensitive composition and folded into a pad so that the coated surfaces are face to face. The pad is glued to the inner tube. Over the top of the pad is a strip of felt held in place, under light pressure, by adhesive tape wrapped around the inner tube. A length of cotton cord runs between the coated surfaces of the pad. One end of the cord is covered with scratch composition; the other end is coiled and placed in the end of the body opposite the nailing bracket. A paper cap, held on by a strip of tape, covers this end of the simulator.

(2) *Operation.*

- (a) *Preparation for use.* Remove cover from the packing box and carefully break open the waterproof lining. Remove the desired number of simulators and the instruction sheet (fig. 89). Refold the waterproof liner and install the box cover; this is essential since the simulators are not otherwise waterproofed. The simulator is prepared for use in accordance with the instruction sheet which outlines the procedure for setting up the simulator and the hazards involved.

Caution 1: Do not attempt to set up or fire the simulator until procedure and hazards on the instruction sheet are understood. If the position selected for flash simulator M117 cannot be adequately protected to insure a minimum distance of 6 feet between it and personnel, then either the simulator M118 (*c* below) or M119 (*d* below) should be used. Once knowledge of the characteristics of the simulator is obtained, considerable ingenuity may be exercised in installing the simulator to best advantage dependent upon the specific object to be trapped. For example, if the simulator is installed to function upon the opening or closing of a door or window, it would not be necessary to use the spring or trip wire.

Caution 2: A condition may be encountered in which the cord adheres to the inside of the simulator cap; upon removal of the cap tape, if the cap pulls loose with the tape, the cap may pull the cord, igniting the simulator. To avoid injury to personnel, the following procedure should be used for removal of tape and cap, supplementing instruction 7 in figure 89: Hold cap in place and remove cap tape with extreme care. Remove cap carefully, taking care that no pull is exerted on cord.

- (b) *Removal.* If the simulator is not fired it should be disarmed and removed as follows:
1. Without touching trip wire or spring, cut pull cord close to trip wire.
 2. Coil cord and install in simulator.
 3. Install cap and seal it with tape.
 4. Remove nails from nailing bracket.
 5. Remove trip wire from spring being careful to slowly release the tension in the spring.
 6. Remove trip wire from anchored position and wind it onto the spool.
 7. Remove spring from its anchored position.
 8. Return simulator and equipment to original condition and packing.
- (c) *Functioning.* If, after the simulator is prepared for use as out-

lined in (a) above, the trip wire is pulled or cut, the pull cord will be drawn through the friction sensitive pad. The flame produced by this action ignites the charge composition which functions with a loud report and accompanying flash.

(3) *Precautions.* In addition to the general precautions cited in paragraph 11, the following should also be closely observed.

(a) Boxes should be opened only as needed. Any box in which only a portion of the simulators are used should be resealed as well as possible.

(b) Do not remove cap and extend pull cord of simulator until the simulator, spring, and trip wire have been set up. Before tying pull cord to trip wire, check the fastening of trip wire and spring to see that they are secure.

c. *Simulator, Boobytrap, Illuminating, M118 (T81).* This simulator (fig. 88) is a variation of the M117 (b above) and differs principally from that

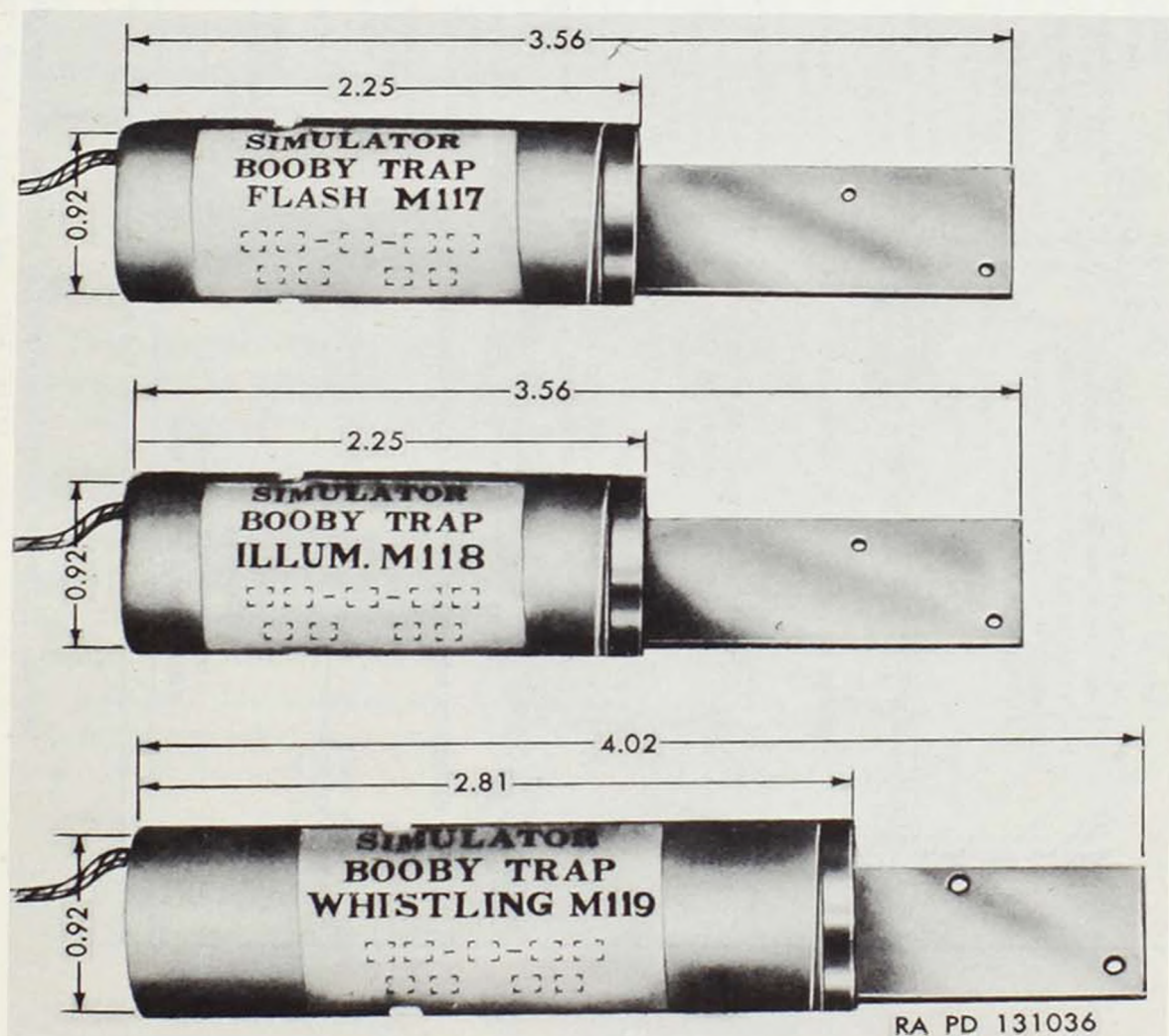
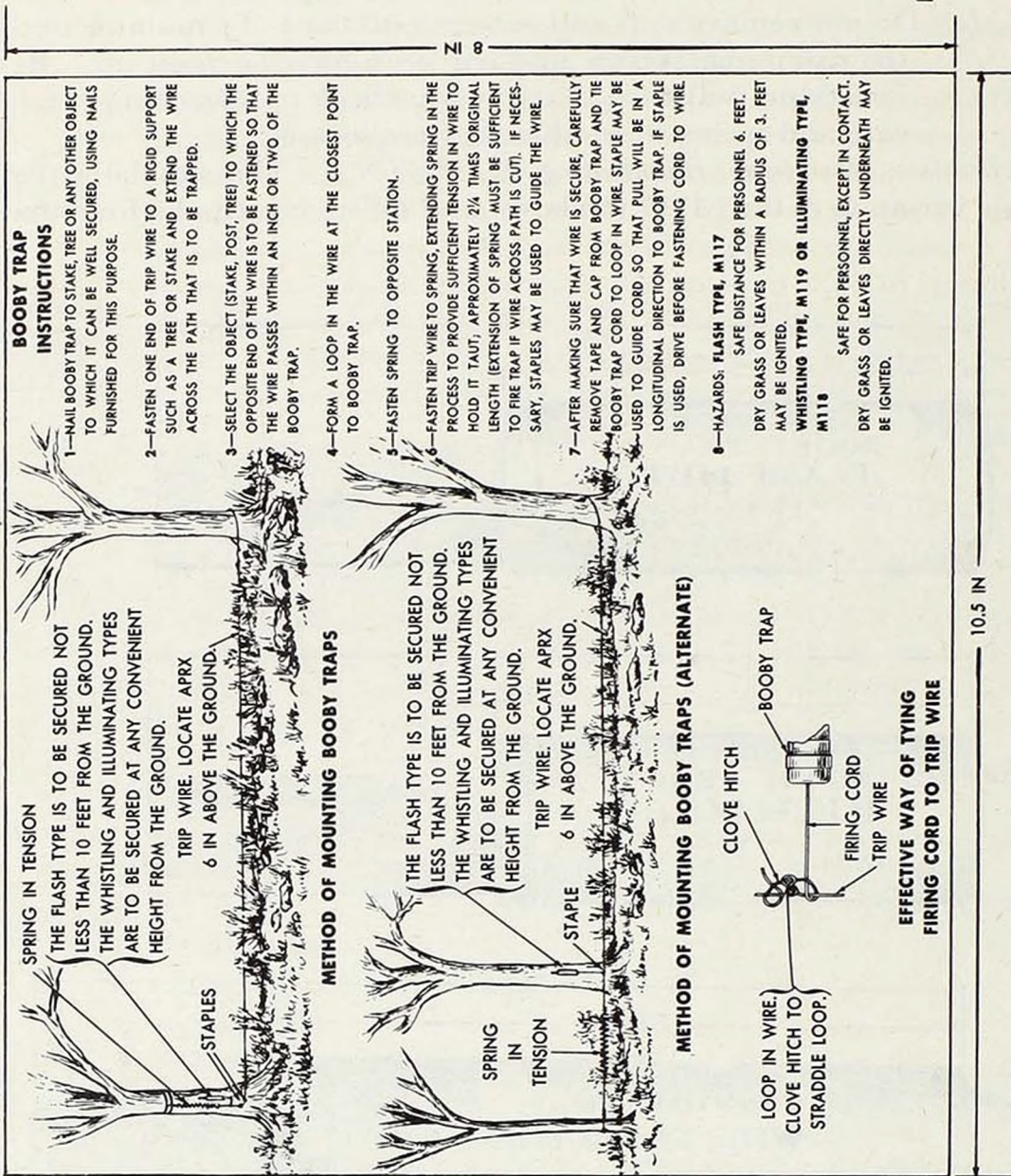

Figure 88. Simulator, boobytrap, flash, M117 (T80); illuminating, M118 (T81); and whistling, M119 (T82).



RA PD 131037

Figure 89. Instruction sheet for preparation of simulator, boobytrap, flash, M117 (T80); illuminating, M118 (T81); and whistling, M119 (T82).

item in the effect produced. The M118 contains a flare composition which, when ignited by the pull cord, produces a flame that burns for 30 seconds. The M118 is considered safe for personnel, that is, except for direct contact with the flame. Therefore, a danger area as specified for the M117 is not required for this simulator. Care should be exercised to see that the flame does not ignite the wooden support to which the simulator is attached. Otherwise, the description, instructions, and cautions contained in *b* above apply equally to the M118.

d. Simulator, Boobytrap, Whistling, M119 (T82). This simulator (fig. 88) is a variation of the M117 (*b* above) and differs principally from that item in overall length and effect produced. The body of the M119 is 2.81 inches long; overall length including nailing bracket is 4.02 inches. The M119 contains a slow burning composition which, when ignited by the pull cord, produces a whistle by liberating gas in the paper tube; the whistle lasts for 3 to 4 seconds. The M119 is considered safe for personnel, that is, except for direct contact with the simulator when functioning. Therefore, a danger area as specified for the M117 is not required for this simulator. Except for the above differences and packing dimensions and weight, the description, instructions, and cautions contained in *b* above apply equally to the M119.

Section II. NONEXPLOSIVE ITEMS

74. Adapter, Priming, M1A4

This adapter (fig. 90) is used to facilitate the priming of explosive items such as mines and boobytrapping explosive charges which have a $\frac{9}{16}$ -inch threaded opening, known variously as cap well, firing device well, or, in the case of some mines, secondary fuze well. The adapter is a small hollow plastic bushing, $\frac{13}{16}$ inch in length and having a hexagonal shape. One end of the adapter is threaded to fit $\frac{9}{16}$ -inch wells and the other end has a hole which accommodates safety fuse, detonating cord, or electric lead wires. The adapter has a longitudinal slot to permit easy insertion of lead wires. The M1A3 and earlier models of the adapter are similar except their external shape is cylindrical. The adapters are used as in *a* through *c* below.

a. With Electric Blasting Cap (A, fig. 90).

- (1) Pass lead wires of an electric blasting cap through slot of priming adapter.
- (2) Pull cap into adapter.
- (3) Insert the blasting cap into the well of explosive charge to be fired.
- (4) Screw the adapter into the well.

b. With Nonelectric Blasting Cap and Safety Fuse (or Time Blasting Fuse) (B, fig. 90).

- (1) Cut off squarely and discard 2 inches from end of fuse.

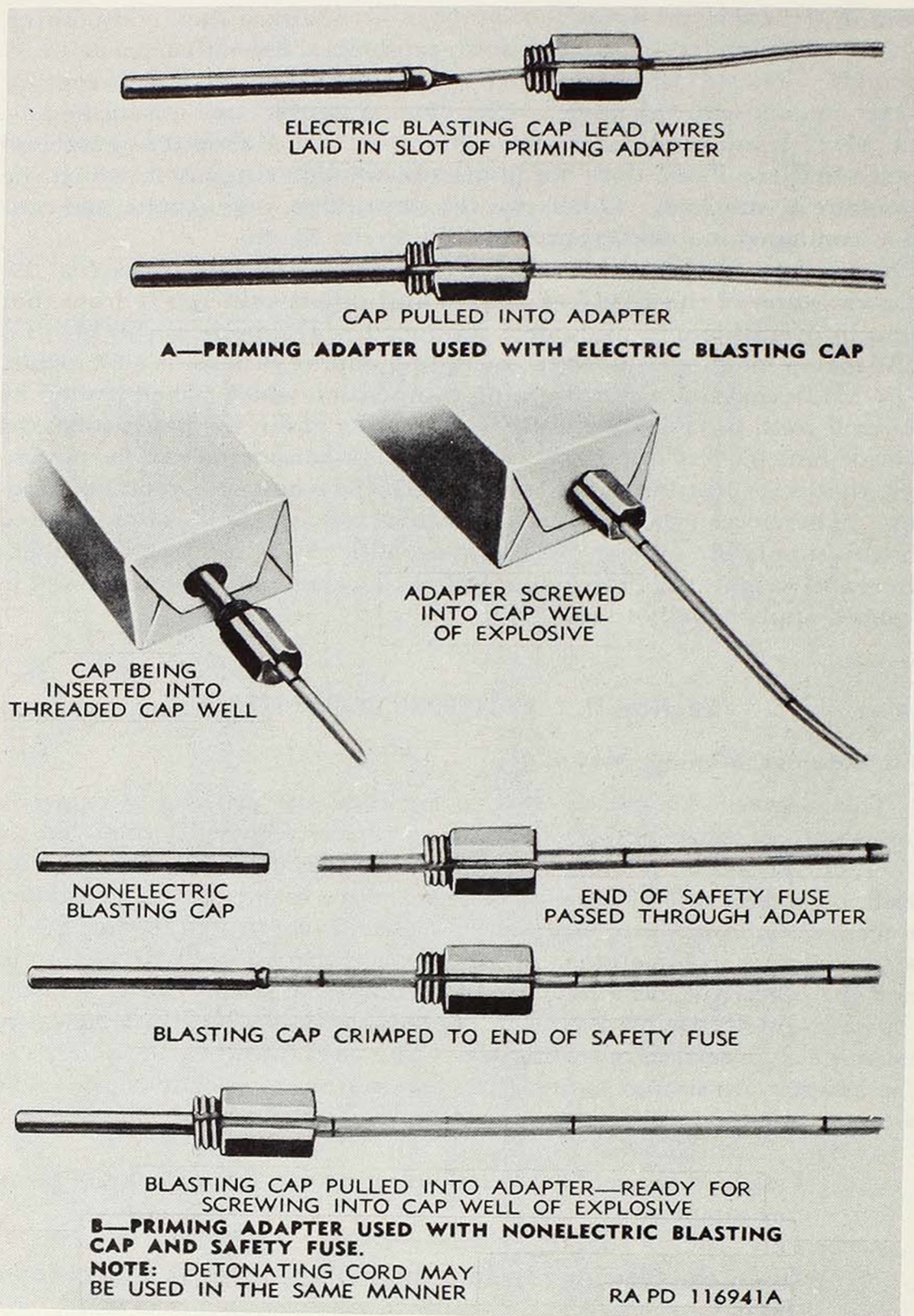

Figure 90. Use of adapter, priming, M1A4, with electric and nonelectric blasting caps, and with safety fuse or detonating cord.

- (2) Pass the end of the fuse through the adapter.
- (3) Crimp a nonelectric blasting cap to the fuse, using crimper.
- (4) Pull the cap into the adapter.
- (5) Insert cap into the well of the explosive item to be fired and screw adapter into place.

c. *With Detonating Cord.*

- (1) Cut off squarely and discard 6 inches from the end of detonating cord.
- (2) Pass the end of the detonating cord through the adapter.
- (3) Crimp a nonelectric blasting cap to the cord, using crimper.
- (4) Pull the cap into the adapter.
- (5) Insert the cap into the well of the explosive item to be fired and screw adapter into place.

Note. Detonating cord alone in the cap well of a TNT block is not sufficiently powerful to detonate the block with high order detonation. A special electric blasting cap (type II (J2 PETN)) or a special nonelectric blasting cap (type I (J1 PETN)) should be used, or, three full turns of detonating cord around the block should be made.

75. Clip, Cord, Detonating, M1

This is a metal device (fig. 64) used to connect detonating cord.

76. Compound, Sealing, Blasting Cap, Waterproof, 1/2-Pint Can

This compound is used to waterproof the connection between safety fuse (or time blasting fuse) and a nonelectric blasting cap and to moisture-proof dynamite primers. It does not make a permanent waterproof seal and must not be submerged in water unless the charge is to be fired immediately.

77. Tape, Friction, General Use, Black, 3/4-Inch, 8-Oz. Roll

Twine and friction tape are used to fasten blasting caps to detonating cord, tape knots where detonating cord is tied together, insulate electrical connections, fasten charges in place, tie or tape blocks of explosive together into a compact package, and miscellaneous uses.

78. Wire, Firing

Rubber-covered and vinyl-polymer-covered 2-conductor wire, Nos. 18 and 20, used in demolition firing system, are available (unit of issue is 1 ft).

Section III. INSTRUMENTS AND TOOLS (GENERAL SUPPLY)

79. Crimper, Cap (W/Fuse Cutter), M2

This crimper, shown crimping a blasting cap to a coupling base in figure 72, is designed to squeeze the neck of the thin metal case of the nonelectric cap tightly enough around safety fuse (or time blasting fuse) or detonating cord to prevent it from being pulled off easily and still not

interfere with the burning of the powder train in the fuse. The lower portion of the jaws of the crimper are shaped and sharpened for cutting safety fuse. One leg of the handle is pointed for punching holes for blasting caps in dynamite cartridges. The other leg has a screwdriver end. The cutting jaws must be kept clean and must be used only for cutting fuse or detonating cord. The crimper must not be used as pliers. The crimper M2 has a narrow jaw that crimps a water-resistant groove completely around the cap. Earlier model cap crimpers have wider crimping jaws which form a sleeve at the open end of the cap. Both crimpers are constructed so the jaws cannot be closed tightly enough to injure the blasting cap or fuse.

80. Galvanometer, Blasting (W/Leather Case and Carrying Strap)

a. The galvanometer (fig. 91) is used to test electrical firing-wire priming circuits used in priming explosives. It contains an electromagnet, a small special silver-chloride dry cell, and a scale and indicator needle. When the two external terminals are joined by a closed circuit, the flow of current from the dry cell causes the needle to move across the scale. The amount of deflection depends upon the amount of resistance in the closed circuit and on the strength of the cell.

b. The galvanometer must be handled with care and kept dry. Before using, it is tested by holding a piece of metal across its two terminals. If this does not cause a wide deflection of the needle, the cell is weak and must be replaced. Only the special cell (silver chloride dry cell battery, type BA 245/U) may be used in the galvanometer because other cells may be strong enough to detonate a cap. The galvanometer is delicate and must not be tampered with or opened except to replace a weak cell.

c. Dry cells tend to freeze and to cease functioning at temperatures below 0° F. When using the galvanometer in a cold climate, protect it from freezing by placing it under the clothing near the body.

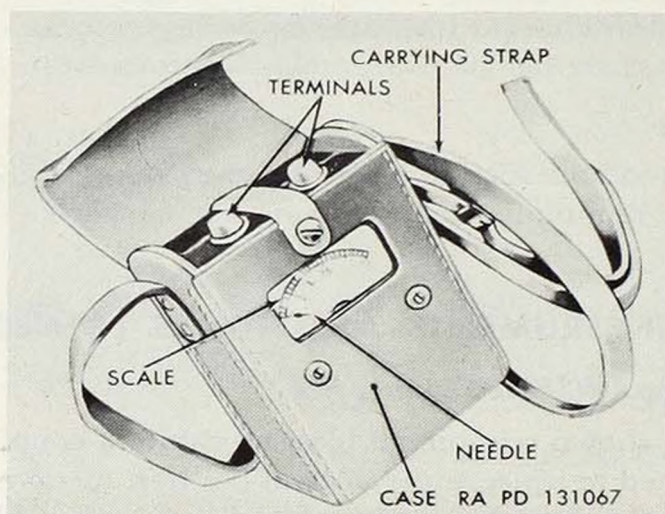

Figure 91. Galvanometer and carrying case.

d. A leather carrying case with carrying strap is issued with this instrument. The case may also be requisitioned separately as a replacement.

e. For use of the galvanometer to test firing circuits, refer to FM 5-25.

f. Two grades of batteries for GALVANOMETER, blasting, are now issued. Grade A standard has the usual 25 divisions of needle deflection reading and is for use under normal temperatures. Grade B has 10 divisions of needle deflection reading and is for use in subzero temperatures down to -40° F.

81. Knife, Pocket, General Purpose, 74-K-65 (Stored, Issued, and Reviewed by Quartermaster Corps)

This pocket knife is a nonexplosive item of Demolition Equipment Sets Nos. 1 and 2. It is also separately issuable.

82. Machine, Blasting

The blasting machine is a small electric generator that produces current for firing electric blasting caps. There are two types in Army use, the 10-cap twist type, and the 30-, 50-, and 100-cap push-down type (fig. 92).

a. *Ten-Cap Blasting Machine* (A, fig. 92). If operated correctly, the 10-cap blasting machine delivers 1.5 amperes and may be used to fire two standard electric blasting caps or electric squibs connected in parallel, the two parallel caps in turn connected in series with an external resistance with the total circuit resistance being 48 ohms. The binding posts are slotted in newer issue blasting machines, whereas old issues were clamped by thumb nuts. When using this machine, proceed as follows:

- (1) To be sure the machine is working properly and to loosen it up, operate it several times before attaching the firing wires.
- (2) Insert the T-shaped handle.
- (3) Insert the left hand through the strap and grasp the bottom of the machine very firmly as shown in (C), figure 92. With the back of the right hand toward you, grasp the handle and give it a very vigorous clockwise turn as far as it will go. It will fire 10 electric blasting caps properly connected in series.

b. *Thirty-Cap Blasting Machine* (B, fig. 92). The 30-cap capacity blasting machine Class B may be used to fire two series of two standard electric blasting caps or electric squibs each, each series being connected in parallel and these two parallel series in turn connected in series with an external resistance—the total resistance up to 144 ohms. The 30-cap blasting machine can deliver 1.5 amps through a total resistance of 96 ohms for 10 milliseconds. It is operated by raising the handle to the top of its stroke, then pushing it rapidly and very forcefully downward as far as it will go. It will fire 30 electric blasting caps properly connected in series.

c. *Fifty-Cap Blasting Machine*. The 50-cap blasting machine is similar

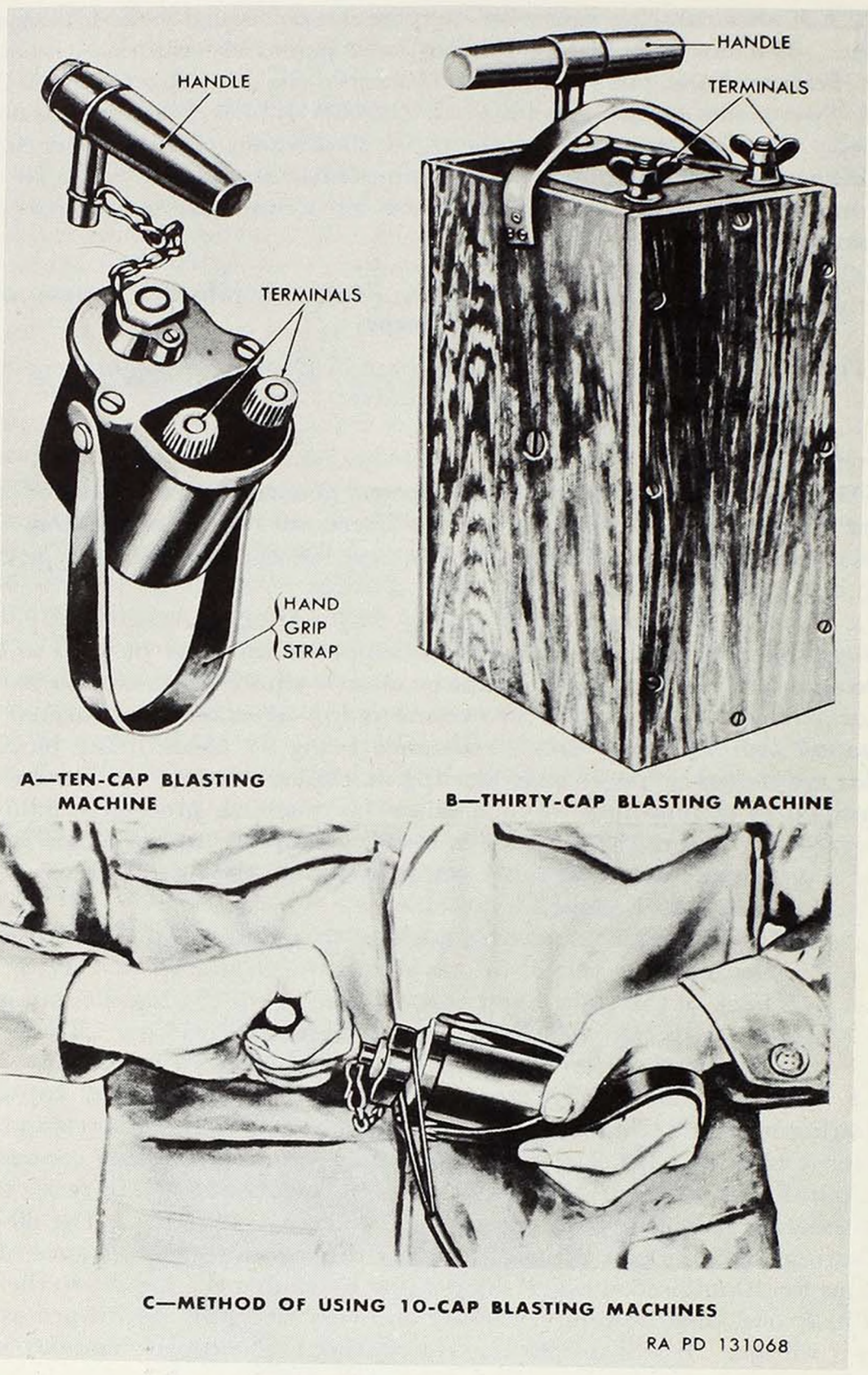

A—TEN-CAP BLASTING MACHINE

B—THIRTY-CAP BLASTING MACHINE

C—METHOD OF USING 10-CAP BLASTING MACHINES

RA PD 131068

Figure 92. Blasting machines.

to the 30-cap blasting machine except for size and weight and is operated in the same manner. The 50-cap capacity may be used in circuits similar to the 10- and 30-cap capacity. It also delivers a 1.5 amps current for 10 milliseconds but over a total resistance up to 240 ohms. It will fire 50 electric blasting caps properly connected in series.

d. One Hundred-Cap Blasting Machine. The 100-cap blasting machine is similar to the 50-cap machine except for size and weight and is operated in a similar manner. It will fire 100 caps properly connected in series.

e. Testing. Blasting machines should be frequently tested for capacity with a rheostat connected in series with the machine and with a circuit of electrically connected electric blasting caps. Refer to FM 5-25 for details of testing procedure.

f. Care and Preservation.

- (1) Blasting machines are of somewhat rugged construction but they house a relatively delicate, electrical mechanism, hence the machine should be treated with care.
- (2) No attempt will be made to disassemble or repair a blasting machine.
- (3) Cleaning and oiling will be done only by authorized personnel.
- (4) When not in use, machines will be stored in a clean, dry, and relatively cool place.
- (5) Directions for care and use on metal plates attached to each machine should be followed carefully.

83. Pliers, Lineman's, Side-Cutting, Length 8-Inches

The item, which is separately issuable, is a useful tool in many operations in connection with boobytrapping and allied work.

84. Rheostats

There are two types of rheostats used in the Army in connection with testing blasting machines (par. 82), the six-post and the nine-post (fig. 93).

a. Rheostat, Blasting Machine, Testing, 6-Post.

- (1) *Description.* This instrument is used to test blasting machines for blasting cap priming circuits. In use all but two or four caps in a testing circuit are replaced with the equivalent resistance in the rheostat thus making it possible to check the action of the blasting machine with the expenditure of only a few electric blasting caps. This rheostat consists of a series of coils of electrical resistance wire in a rectangular block-type case approximately 3½ inches in length. Six brass binding posts with circular nuts protrude from the top of the case. The terminals of the resistance coils inside the case are connected to the internal ends of the binding posts. Numbers on the side of the case between *adjacent* pairs of binding posts indicate the number of caps in series having the same resistance as the internal resist-

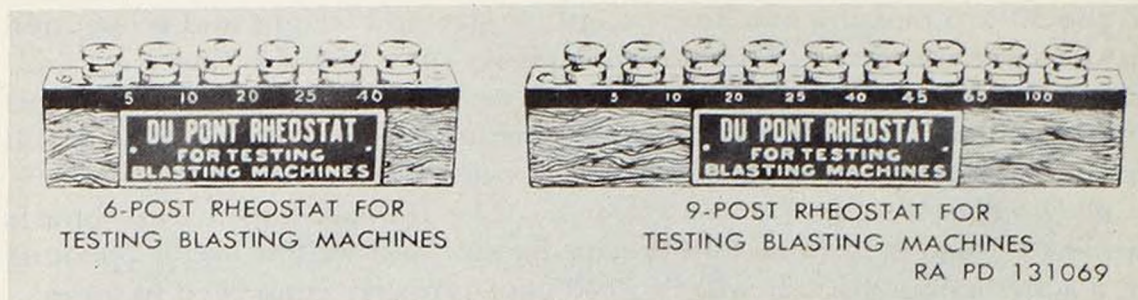

Figure 93. Rheostats for testing blasting cap firing circuits.

ance coil connected to that particular pair of posts. The number of caps in series having a resistance equal to that between *any* pair of posts is obtained by adding the figures between the pair selected.

- (2) *Use.* In order to test a blasting machine, connect the rheostat at any selected pair of binding posts, in series with the blasting machine and in series with a circuit of several blasting caps, themselves in series. Operate the blasting machine. If all the caps are successfully exploded, the number of caps plus the number stamped between the binding posts to which the circuit is attached will be the tested capacity of the machine. Many combinations of blasting cap circuits and pairs of rheostat binding posts may be used, thus testing the blasting machine from 5 to 100 cap capacity.

b. Rheostat, Blasting Machine, Testing, 9-Post. This rheostat is similar to that described in *a* above, except that it is longer. It has nine binding posts and correspondingly larger capacity than the 6-post rheostat.

85. Wrench, Arming Plug, Mine, M20

For employment of this wrench, which is used to arm M6-series, M12 practice, and M15 antitank mines, refer to paragraph 34*d*.

86. Wrench, Fuzing, Antipersonnel Mine, M25

For employment of this wrench, which is used for the shipping plug and fuze of antipersonnel mine M16, refer to paragraph 22*e*.

87. Wrench, Mine and Fuze, M22

For employment of this wrench, which is used with antipersonnel mine M14, refer to paragraph 21*d*.

CHAPTER 5

DESTRUCTION OF AMMUNITION TO PREVENT ENEMY USE

88. General

a. Destruction of land mines, when subject to capture or abandonment, will be undertaken by the using arm only when, in the judgment of the unit commander concerned, such action is necessary in accordance with orders of, or policy established by, the army or other appropriate commander.

b. The information which follows is for guidance only. The conditions under which destruction will be effected are command decisions and may vary in each case, dependent upon a number of factors such as the tactical situation, security classification of the land mines, their quantity and location, facilities for accomplishing destruction, and time. In general, destruction of land mines can be accomplished most effectively by burning or detonation, or a combination of these. However, selection of the particular method of destruction requires imagination and resourcefulness in the utilization of the facilities at hand under the existing conditions. Time is usually critical.

c. If destruction to prevent enemy use is resorted to, land mines and their components must be so badly damaged that they cannot be restored to a usable condition in the combat zone. Equally important, the same essential components of all land mines must be destroyed so that the enemy cannot assemble complete rounds from undamaged components of several damaged complete rounds.

d. If destruction of land mines is directed, due consideration should be given to:

- (1) Selection of a site (place for the destruction operation) that will cause greatest obstruction to enemy movement and also prevent hazard to friendly troops from fragments which may occur incidental to the destruction.
- (2) Observance of appropriate safety precautions.

89. Methods

Land mines can be most quickly destroyed by burning or detonation. The following methods, in order of preference, are considered the most satisfactory for destruction of mines to prevent enemy use.

a. *Method No. 1—by Detonation.*

- (1) *General.* Packed and unpacked high-explosive items such as high-explosive mines, blasting caps, firing devices, and similar

items may be destroyed by placing them in piles and detonating them with TNT, COMP C, or other explosives of equivalent potential.

(2) *Method of destruction.*

- (a) One hundred pounds of packed HE mines or packed explosive charges requires a 2-pound explosive charge to insure complete detonation of the pile. For unpacked mines or charges, a 1-pound explosive charge per pile is sufficient.
- (b) Prepare the charge of EXPLOSIVE, TNT (using two 1-lb. blocks or equivalent together with the necessary detonating cord per charge) and place the charge on the pile to be detonated.
- (c) Provide for dual priming to minimize the possibility of a misfire. For priming, either a nonelectric blasting cap crimped to at least 5 feet of safety fuse or time blasting fuse (safety fuse burns at the rate of 40 sec per ft and time blasting fuse burns at the rate of 30 to 45 sec per ft—test whichever is to be used before using) or an electric blasting cap and firing wire may be used. Safety fuse and time blasting fuse, both of which contain black powder, and blasting caps must be protected from moisture at all times. Safety fuse and time blasting fuse may be ignited by a fuse lighter or an ordinary match; the electric blasting cap requires a blasting machine or equivalent source of electricity.

Caution: Blasting caps, detonating cord, safety fuse, and time blasting fuse must be kept separated from the charges until required for use.

Note. For the successful execution of methods of destruction involving the use of demolition materials, all personnel concerned will be thoroughly familiar with the provisions of FM 5-25. Training and careful planning are essential.

- (d) Detonate the charges. If primed with nonelectric blasting cap and safety fuse or time blasting fuse, ignite and take cover; if primed with electric blasting cap, take cover before firing the charges. The danger area for piles detonated in the open is a circular area of a radius which varies according to the quantity of explosive items to be destroyed. Quantity-distance data for inhabited buildings as given in TM 9-1900 and ORDM 7-224 may be used as an approximate guide for such operations as are contemplated in this chapter.

b. *Method No. 2—by Burning.*

- (1) *General.* Packed and unpacked high-explosive items such as high-explosive mines, blasting caps, firing devices, and similar items may be destroyed quickly and effectively by burning.

(2) *Method of destruction.*

- (a) The ammunition should be stacked up in a pile if possible.
- (b) Pour gasoline and oil over the entire pile.
- (c) Ignite the pile by means of a paper or excelsior train and take cover. The danger area for piles being burned in the open is 600 yards.

Caution: Cover must be taken without delay since an early explosion of the explosive ammunition may be caused by the fire. Due consideration should be given to the highly flammable nature of gasoline and its vapor. Carelessness in its use may result in painful burns.

APPENDIX I.

REFERENCES

1. Publication Indexes

Consult Department of the Army pamphlets in the 310-series and DA Pam 108-1 frequently for latest changes or revisions of references given in this appendix and for new publications relating to materiel covered in this manual.

2. Supply Manuals

The following supply manuals of the Department of the Army Supply Manual pertain to this ammunition:

a. Supply Manuals Which Pertain to Ammunition Covered in This Manual.

Aircraft Bombs, Bomb Fuzes, Miscellaneous Explosive and Inert Components and Instruction Material.	SM 9-5-1325
Explosives, Bulk Propellants, Explosive Devices	SM 9-5-1375
Grenades, Hand and Rifle, and Related Components	SM 9-5-1330
Land Mine and Components	SM 9-5-1345

b. Explosive Materials Required for Destruction.

Explosives, Bulk Propellants, Explosive Devices	SM 9-5-1375
---	-------------

c. General.

Introduction and Index	ORD 1
----------------------------------	-------

d. Maintenance and Repair.

Cleaners, Preservatives, Lubricants, Recoil Fluids, Special Oils, and Related Maintenance Materials.	ORD 3 SNL K-1
General Tools and Supplies for Ordnance Ammunition Company . .	ORD 10 SNL N-17
Special Tools for Ordnance Explosive Disposal Munitions, Ammunition Renovating Tools, and Bomb Handling Tools.	ORD 3 SNL J-11 Section 2
Tool Set, Maintenance (Field), Explosive Ordnance Disposal Squad.	ORD 6 SNL J-8 Section 1
Tool Set, Maintenance (Field), Ammunition Renovation Platoon .	ORD 6 SNL J-8 Section 4

e. Training Aid.

Training Aid Catalog	TO 28-1-3 (USAF)
--------------------------------	------------------

f. USAF Supply.

USAF Supply Catalog	Class 28E (USAF)
-------------------------------	------------------

Ammunition Disposition Report AFR 65-19

3, 4. Other Publications

The following publications contain information pertinent to this ammunition and associated equipment.

<i>a. Ammunition, All Types.</i>	
Ammunition and Explosives Materiel—Surveillance and Safety . . .	AFR 136-6
Ammunition, General	TM 9-1900
Ammunition: Federal Stock Number and DOD Identification Code.	TB 9-AMM 5
Ammunition Renovation	TM 9-1905
Ammunition: Restricted or Suspended	TB 9-AMM 2
Ammunition Supply	AFR 67-28
Ammunition Supply and Preservation	ORDM 3-4
Ammunition Surveillance Manual	OFSB 3-20
Bombs for Aircraft	TM 9-1980 AFM 136-7
Carrying Live Bombs and Other Ammunition on Tactical Aircraft.	AFR 55-25
Characteristics and Employment of Ground Chemical Munitions . .	FM 3-5
Coordination with Armed Services Explosives Safety Board— Report of Hazardous Conditions Involving Military Explosives or Ammunition.	SR 385-15-1
Demolition Materials	TM 9-1946
Disposal by Dumping at Sea	SR 75-70-10
Disposal of Supplies and Equipment: Ammunition	SR 755-140-1
Distribution of Ammunition and Explosives for Training Pur- poses.	AR 710-1300-1
Employment of Land Mines	FM 20-32
Explosive Ordnance Disposal Policies and Responsibilities	AR 75-15
Explosives and Demolitions	FM 5-25
Identification of Inert Ammunition and Ammunition Components.	SR 385-410-1
Land Mine Warfare	TC 34
Military Explosives	TM 9-1910
Military Pyrotechnics	TM 9-1981
Ordnance Ammunition Service in the Field	FM 9-6
Ordnance Safety Manual	ORDM 7-224
Passage of Obstacles other than Mine Fields	TM 5-220
Pricing Guide—Ammunition	ORD 5-3-6
Processing Requisitions	SR 725-10-2
Qualification in Arms and Ammunition Training Allowances	AR 775-10
Quantity-Distance Standards for Storage of Mass-Detonating Military Explosives.	AFR 86-6
Regulations for Firing Ammunition for Training, Target Practice, and Combat.	AR 385-63
Reports	SB 9-AMM 8
Reports of Accidents, Fires, and Explosions	SR 385-10-series
Small-Arms Ammunition	TM 9-1990
Supply Bulletins	SB 9-series
Technical Bulletins	SB 9-AMM-series TB 9-AMM-series
Transportation by Water of Explosives, Flammables, and Chemi- cal Materials.	AR 55-470
Transportation of Public Property (Except Animals) and Remains.	AR 55-155
<i>b. Camouflage.</i>	
Camouflage, Basic Principles	FM 5-20
<i>c. Decontamination.</i>	
Decontamination	TM 3-220
Defense Against Chemical Attack	FM 21-40

<i>d. Destruction To Prevent Enemy Use.</i>	
Explosives and Demolitions	FM 5-25
<i>e. General.</i>	
Administration	AR 210-10
Administration, Operation, and Organization	AR 780-10
Department of the Army Supply Catalog System	SR 320-20-2
Dictionary of United States Army Terms	SR 320-5-1
Engineer Field Data	FM 5-34
Engineer Soldier's Handbook	FM 21-105
Inspection of Ordnance Materiel in Hands of Troops	TM 9-1100
Military Chemistry and Chemical Agents	TM 3-215
Numbering of Department of the Army Publications	SR 310-20-1
Ordnance Service in the Field	FM 9-5
Reference Data	FM 5-35
Report of Loss, Theft, and Recovery of Government Property	SR 210-10-10
Report of Malfunctions and Accidents Involving Ammunition and Explosives (During Training or Combat).	SR 700-45-6
Safeguarding Military Information	AR 380-5
	AFR 205-1
Safety: Accident Reporting	SR 385-10-40
<i>f. Maintenance and Repair.</i>	
Abrasive, Cleaning, Preserving, Sealing Adhesive, and Related Materials Issued for Ordnance Materiel.	TM 9-850
<i>g. Maintenance of Supplies and Equipment.</i>	
Inspection and Reports—Ordnance Corps Materiel	AR 750-412
<i>h. Shipment and Limited Storage.</i>	
Army Shipping Document	TM 38-705
Instruction Guide, Ordnance Packaging and Shipping (Posts, Camps, and Stations).	TM 9-2854
Marking of Oversea Supply	SR 746-30-5
Shipment of Supplies and Equipment: Report of Damaged or Improper Shipment.	SR 745-45-5

APPENDIX II.

COMPLETE ROUND DATA

LAND MINES, ANTIPERSONNEL

Mine and fuze	Firing device
Practice	
<p>MINE, antipersonnel, M2 (all mods), inert, and fuze, mine, combination, M6A1, inert.</p> <p>MINE, antipersonnel, practice, M8, and fuze, mine, combination, M10 or M10A1, practice: Consists of— Mine body. FUZE, mine, combination, M10 or M10A1 practice (less igniter and primer assembly). Mine cap (cover). Projectile (cardboard) (canister). Spotting charge. Igniter and Primer assembly consisting of primed coupling base with delay element and igniter charge.</p> <p>MINE, antipersonnel, NM, practice, T34.</p>	} None.
Service	
<p>MINE, antipersonnel, M2, and fuze, mine, combination, M6A1.</p> <p>MINE, antipersonnel, M2A1, and fuze, mine, combination, M6A1.</p> <p>MINE, antipersonnel, M2A3, and fuze, mine, combination, M6A1.</p> <p>MINE, antipersonnel, M2A3 or M2A3B1, and fuze, mine, combination, M6A1.</p> <p>MINE, antipersonnel, M2A4, and fuze, mine, combination, M6A1.</p> <p>MINE, antipersonnel, M3, and fuze, mine, combination, M7A1.</p> <p>MINE, antipersonnel, NM, M14, w/integral fuze (detonator holder containing detonator M46 is to be inserted in the field).</p> <p>MINE, antipersonnel, M16, and fuze, mine, combination, M605.</p>	} None. } FIRING DEVICE w/nonelectric blasting cap. } None.

LAND MINES, ANTITANK

Mine	Fuze	Activator	Firing device
Practice			
MINE, antitank, heavy, M6, empty, and inert fuze M603 and inert activator M1.*			} FIRING DEVICE, w/inert coupling base.
MINE, antitank, heavy, M6, inert (w/o fuze and w/o activator).*	FUZE, mine, AT, M603, inert.	ACTIVATOR M1, inert.	
MINE, antitank, heavy, practice, M12 (w/o fuze).	FUZE, mine, AT, practice, M604.	ACTIVATOR, practice, M1 (smoke (HC) puff charge).	} FIRING DEVICE, w/primed coupling base w/o blasting cap or igniter.
MINE, antitank, NM, practice, M9, and fuze mine, chemical, AT, NM, M12, practice.		} None.	
MINE, antitank, light, practice, M10 or M10A1, and fuze, mine, AT, practice, M604.			
MINE, antitank, light, practice, M10 (w/o fuze).	FUZE, mine, AT, practice, M604.		
MINE, antitank, light, M7, inert (w/o fuze).*	FUZE, mine, AT, M603 inert.	} None.	} FIRING DEVICE, w/inert coupling base.
MINE, antitank, light, M7, M7A1 or M7A2, inert, and fuze, mine, AT, M603, inert.*			

Refer to footnote at end of table.

LAND MINES, ANTITANK—Continued

Mine and fuze	Activator	Firing device
Service		
MINE, antitank, HE, heavy, M6A2, and fuze, mine, AT, M603.*	} ACTIVATOR, M1.	FIRING DEVICE, w/primed coupling base and w/o blasting cap or igniter charge.
MINE, antitank, HE, COMP B, heavy, M15 and fuze, mine, AT M603.		
MINE, antitank, HE, light, M7A2, and fuze, mine, AT, M603.*	None	FIRING DEVICE, w/primed coupling base and w/blasting cap.

*Those M6-series and M-series antitank mines which were formerly intended to be fuzeed with the now obsolete chemical mine fuzes M600 or M601 have been renovated by installing booster M120 with booster retainer in the bottom of the fuze well, thus adapting those mines for mechanical (belleville spring type) fuze M603.

INDEX

	<i>Paragraph</i>	<i>Page</i>
Accidents, field report of	3	3
Activator, M1:		
Description	50a	110
Precautions against misfires	50b	110
Packing	50c	111
Activator, M1, inert	40	93
Activator, practice, M1	51	112
Actuation (initiation)	4h	6
Adapter, priming, M1A4	74	163
Adapter, priming	7c	8
Ammunition Identification Code (AIC)	10g	18
Ammunition lot number	10b	17
Antilift device	7d	8
Antipersonnel mines:		
Bounding type	4a	3
Blast type	4a	3
Antipersonnel inert mine M2A3B2	26	54
Antipersonnel NM practice mine, T34, w/integral fuze	29	61
Antipersonnel practice mines	25	52
Antipersonnel practice mine M8 (T4)	27	54
Antipersonnel service mines	15	22
Antipersonnel service mine fuzes:		
Fuze M6A1	15b	22
Fuze M7A1	19	30
Fuze M605	15b	22
Antitank mines:		
Heavy type	4a	3
Light type	4a	3
Antitank practice mines:		
Mine, antitank, heavy, M6, empty	40	93
Mine, antitank, light, M7A1 or M7A2, inert	41	93
Mine, antitank, light, practice, M10A1	45	99
Mine, antitank, NM, practice, M9	42, 43	94, 97
Mine, antitank, practice, M12	47	101
Antitank practice mine fuzes:		
Fuze, mine, AT, M603, inert	40, 41	93
Fuze, mine, AT, practice, M604	45, 46, 47	99, 101
Fuze, mine, chemical, AT, NM, M12, practice	44	97
Antitank service mines:		
M6 series modification	33	69
Mine, antitank, HE, heavy, M6A2	34	69
M7 series modification	36	79
Mine, antitank, HE, light, M7A2	37	79
Mine, antitank, HE, heavy, M15 (T27)	38	85

	<i>Paragraph</i>	<i>Page</i>
Antitank service mine fuzes:		
Fuze, mine, AT, M603	34, 35, 37, 38	69, 77, 79, 85
Arming	7e	8
Arming plug	7f	9
Bangalore torpedo M1A1	31	68
Base, coupling	66	152
Blasting caps	52	112
Blasting machine	82	167
Block, demolition	7g	9
Bomb, fragmentation, 4-lb, M83:		
Assembly	24a	51
Fuze, bomb, M131	24b	51
Bomb fuze M131	24	51
Boobytrap	5, 7	7
Boobytrap installation	6	7
Boobytrap simulator:		
Flash boobytrap simulator M117 (T80)	73b	159
Illuminating boobytrap simulator M118 (T81)	73c	161
Whistling boobytrap simulator M119 (T82)	73d	163
Booster	7j	9
Cable, detonating, antipersonnel-mine-clearing, M1	30	66
Cap well	7k	9
Care, handling, and preservation	11	19
Chain, firing	7l	9
Classification of land mines	9	16
Clip, cord, detonating, M1	75	165
Combination inert mine fuze M6A1	26	54
Combination mine fuze M6A1	17, 18	23, 29
Combination mine fuze M605	22, 23	42, 48
Combination practice mine fuze M10 (T14) or M10A1	27, 28	54, 60
Complete round mine:		
Description	8a	13
Explosive train	8b	15
Compound, sealing, blasting cap	76	165
Concussion detonator, delay type, M1	55	121
Cord, detonating, waterproof	53	117
Coupling base	7n, 66	9, 152
Crimper, cap (w/fuze cutter), M2	7o, 79	9, 165
Danger area	7p	9
Data card	10f	18
Defuzing (removing the fuze)	7ay	12
Demolition material	7r	10
Demolition snake M2A1	48	108
Demolition snake M3	48	108
Department of Defense Identification Code	10g	18
Destruction of ammunition to prevent enemy use:		
General	88	171
Methods	89	171
Destructor, HE, universal, M10	7s, 54	10, 119
Detonating cord clip M1	75	165
Detonating waterproof cord	53	117
Detonation	7t	10

	<i>Paragraph</i>	<i>Page</i>
Detonator:		
Definition of	7u	10
Types of:		
Concussion	7v	10
Delay	7w	10
Detonator, concussion, delay type, M1:		
Operating range (table I)	55	117
Detonator, friction igniter—delay type:		
Temperature delay (table II)	56	125
Development-type mines	4c	4
Disarming	7x	10
Effect of temperature on delays of firing device M1 (table IV)	59	131
Electric blasting caps	52c	112
Explosives:		
High explosives	7z	10
Low explosives	7z	10
Explosive trains	8b	15
Federal Stock Number	10g	18
Field storage and preservation	12	20
Firecracker, M80	7aa, 57	11, 127
Firing devices:		
Definition of	7ac	11
Data (table III)	58	128
Delay type M1	59	131
Inert	58	128
Pressure release type M5	60	135
Pressure type M1A1	61	137
Pull friction type M2	62	140
Pull release type M3	63	142
Pull type M1	64	146
Release type M1	65	149
Firing device data (table III)	58	128
Firing mechanism	7ad	11
Firing pin	7ab	11
Flare, trip:		
Definition of	7ae	11
Flare, trip, M49	68	154
Flare, trip, parachute, M48	67	154
Fougasse:		
Ordinary type	7af	11
Flame type	7ag	11
Fragmentation bomb, 4-lb, M83	24	51
Fuze, blasting, time	69	154
Fuze lighter, friction type M1	71	158
Fuze lighter, weatherproof, M2	72	158
Fuze, safety, M700	69	154
Fuze, bomb, M131	24	51
Fuze, mine:		
Definition of	7ah	11
Fuze, mine, AT, M603	35	77
Fuze, mine, AT, practice, M604	46	101
Fuze, mine, chemical, AT, NM, M12, practice	44	97
Fuze, mine, combination, M605	22, 23	42, 48

	<i>Paragraph</i>	<i>Page</i>
Fuze, mine, combination, M6A1, inert	26	54
Fuze, mine, combination, practice, M10 (T14) or M10A1	27, 28	54, 60
Fuze, mine, combination, M6A1	18	29
Fuze, mine, combination, M7A1	20	34
Fuze well	<i>7ai</i>	11
Fuzing (installing)	<i>7am</i>	12
Galvanometer, blasting (w/leather case and carrying strap)	80	166
General purpose mines:		
Metallic	<i>4b</i>	4
Nonmetallic	<i>4b</i>	4
Grapnel	<i>7ak</i>	11
Grenade, band, offensive, Mk 3A2 (w/o fuze)	70	157
Identification (of land mines)	10	17
Igniter	<i>7al</i>	12
Improvised mines	<i>4d</i>	5
Inert firing devices	58	128
Inert issue mines	<i>4e, 4f</i>	5, 6
Initiating material:		
Detonators	49	110
Firing devices	49	110
Lighters	49	110
Initiation (actuation)	<i>4h</i>	6
Installing (fuzing)	<i>7am</i>	12
Instruments and tools	79-87	165
Knife, pocket	81	167
Lighter, fuze, friction type, M1	71	158
Lighter, fuze, weatherproof, M2	72	158
Live issue mines	<i>4e</i>	5
Lot number, ammunition	<i>10b</i>	17
Mine, antipersonnel:		
M2 series modification	16	22
M2A4	17	23
M3	19	30
M14, w/integral fuze	21	36
M16 (T6), and fuze, mine, combination, M605	22	42
Mine, antipersonnel, M2A3B2, inert	26	54
Mine, antipersonnel, NM, practice, T34, w/integral fuze	29	61
Mine, antipersonnel, practice, M8 (T4)	27	54
Mine, clearing	<i>7m, 7ap</i>	9, 12
Mine-clearing detonating cable M1	30	66
Mine-clearing devices	48	108
Minefield	<i>7aq</i>	12
Mine, practice	<i>7an</i>	12
Mine, service	<i>7ao</i>	12
Model designation	<i>10c</i>	17
Neutralizing	<i>7ar</i>	12
Nonelectric blasting caps	<i>52d</i>	112
Nonexplosive items	74	163
Nonmetallic mines	<i>4g</i>	6
Offensive hand grenade, MK 3A2 (w/o fuze)	70	157

	<i>Paragraph</i>	<i>Page</i>
Packing and marking for shipment	14	21
Painting of mines	10d	18
Percussion primers:		
Primer, percussion, M27	66b	152
Primer, percussion, M39A1	66c	152
Phony minefield	7y	10
Phony mines	4e	5
Planting	7as	12
Pliers, lineman's	83	169
Practice activator M1	51	112
Practice mines	4f	6
Primers:		
Percussion type	7at	12
Stab type	7at	12
Primers, percussion:		
M27	66	152
M39A1	66	152
Priming material:		
Blasting caps	49	110
Detonating cord	49	110
Safety fuze	49	110
Projector	7au	12
Protector, shipping	7av	12
Release	7ax	12
Removing the fuze (defuzing)	4ay	12
Repriming coupling bases	66a	152
Rheostats	84	169
Safeties	7az	12
Safety fuze M700	69	154
Sealing compound for blasting cap	76	165
Secondary (boobytrapping) mine fuzes	15b	22
Secondary fuze well	7ba	12
Shaped charge	7bb	13
Shipping Protector	7av	12
Simulators:		
Definition of	7bc	13
Simulator, boobytrap, flash, M117 (T80)	73b	159
Simulator, boobytrap, illuminating, M118 (T81)	73c	161
Simulator, boobytrap, whistling, M119 (T82)	73d	163
Snake, demolition, M2A1	48	108
Snake, demolition, M3	48	108
Sympathetic detonation	7bd	13
Tables:		
Operating range of concussion detonator M1 (table I)	55	121
Temperature-delay for delay detonators (table II)	56	125
Firing device data (table III)	58	128
Effect of temperature on delays of firing device, delay type, M1 (table IV)	59	131
Tape, friction	77	165
Time blasting fuze	69	154
Tools and instruments	79-87	165
Torpedo, bangalore, M1A1	31	68
Training mines	4f	6

	<i>Paragraph</i>	<i>Page</i>
Transportation	13	21
Trip flares	67, 68	154
Trip wire	<i>7aw</i>	12
Wire, firing	78	165
Wrench, arming plug, mine, M20	85	170
Wrench, fuzing, antipersonnel mine, M25	86	170
Wrench, mine and fuze, M22	87	170

[AG 476.1 (29 Feb 56)]

By Order of *Wilber M. Brucker*, Secretary of the Army:

MAXWELL D. TAYLOR,
General, United States Army,
Chief of Staff.

Official:

JOHN A. KLEIN,
Major General, United States Army,
The Adjutant General.

Distribution:

Active Army:

CNGB (1)	Engr Co (2)
Tec Svc, DA (1) except COFORD (25)	Ord Co (2)
Ord Bd (2)	Ft & Cp (2)
Hq CONARC (3)	Gen & Br Svc Sch (2) except Ord Sch (50)
Army AA Comd (2)	PMST Ord ROTC Units (1)
OS Maj Comd (5)	Gen Depots (2) except Atlanta Gen Depot (None)
OS Base Comd (2)	Ord Sec, Gen Depots (5)
Log Comd (3)	Ord Depots (10)
MDW (1)	Trans Terminal Comd (2)
Armies (3)	Army Terminal (2)
Corps (2)	OS Sup Agencies (2)
Div (2)	Ord PG (10)
Regt/Gp (1) except Ord Gp (2)	Ord Arsenal (5) except Raritan Ar- senal (5)
Engr Bn (2)	Mil Dist (1)
FA Bn (1)	Ord Proc Dist (5)
Inf Bn (1)	MAAG (1)
Ord Bn (2)	Mil Msn (1)
Armd Bn (1)	
AAA Bn (1)	

NG: State AG (6); units—same as Active Army except allowance is one copy to each unit.

USAR: None.

For explanation of abbreviations used, see SR 320-50-1.

NOTES

NOTES

NOTES

NOTES

NOTES

NOTES

NOTES

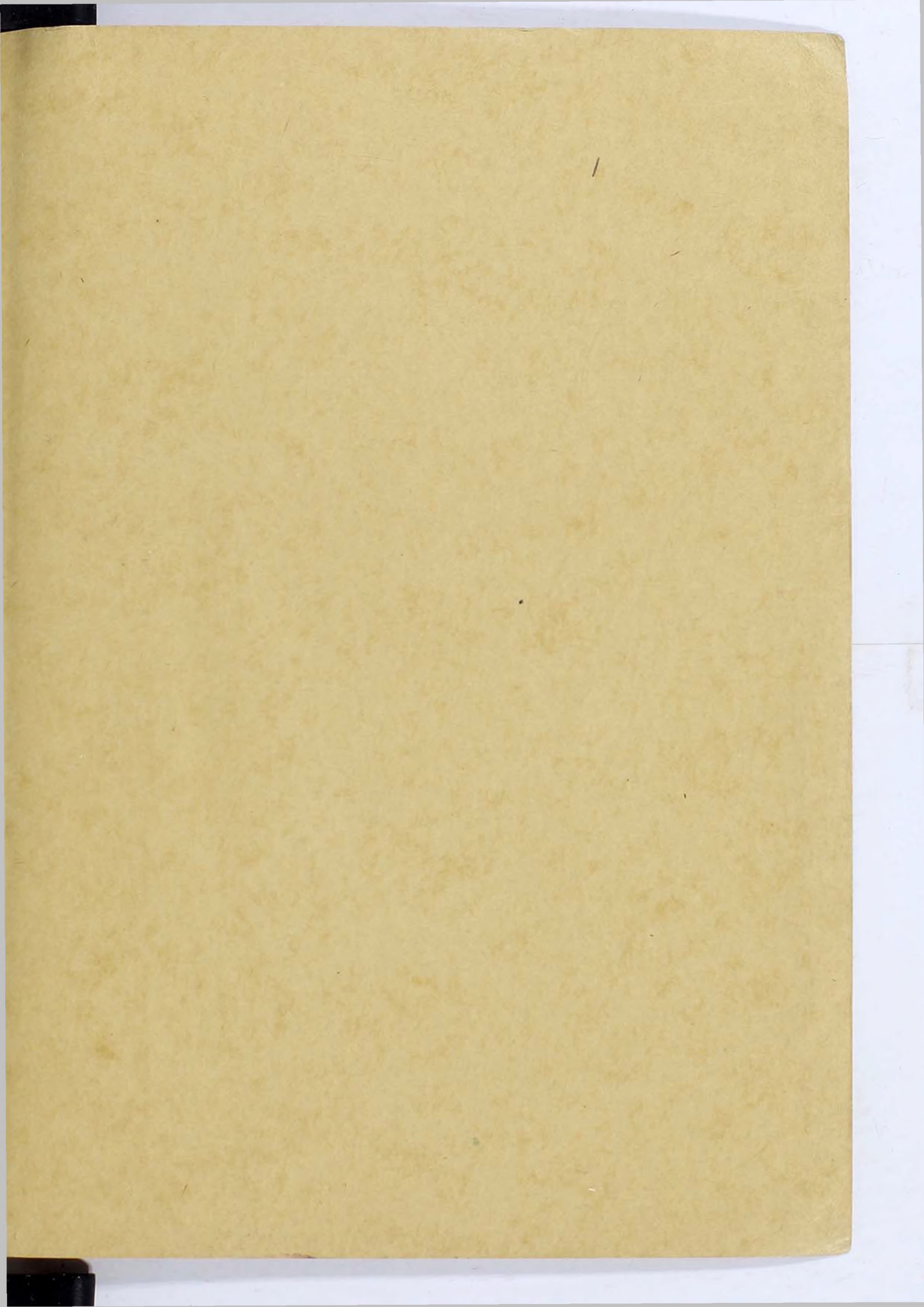

R 67700
d 16733

