

TM 11-2050

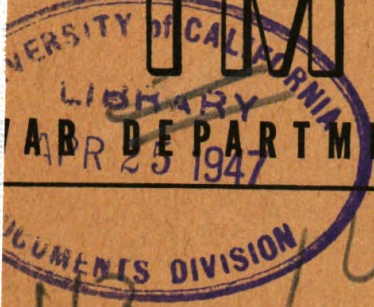

WAR DEPARTMENT TECHNICAL MANU

DOCUMENTS DIVISION

U.S. Dept. of Army

*113
12
TM
1944*

TEST SET I-48-B

RESTRICTED. DISSEMINATION OF RESTRICTED MATTER.
The information contained in restricted documents and the essential characteristics of restricted material may be given to any person known to be in the service of the United States and to persons of undoubted loyalty and discretion who are cooperating in Government work, but will not be communicated to the public or to the press except by authorized military public relations agencies. (See also par. 28, AR 380-5, 15 Mar 1944.)

WAR DEPARTMENT

14 OCTOBER 1944

WAR DEPARTMENT TECHNICAL MANUAL

TM 11-2050

TEST SET

I-48-B



WAR DEPARTMENT

14 OCTOBER 1944

RESTRICTED. DISSEMINATION OF RESTRICTED MATTER. The information contained in restricted documents and the essential characteristics of restricted materiel may be given to any person known to be in the service of the United States and to persons of undoubted loyalty and discretion who are cooperating in Government work, but will not be communicated to the public or to the press except by authorized military public relations agencies. (See also par. 28, AR 380-5, 15 Mar 1944.)

WAR DEPARTMENT,
WASHINGTON 25, D. C., 14 October 1944.

TM 11-2050, Test Set I-48-B, is published for the information and guidance of all concerned.

[A. G. 300.7 (15 Jul 44).]

BY ORDER OF THE SECRETARY OF WAR:

G. C. MARSHALL,
Chief of Staff.

OFFICIAL:

J. A. ULIO,
*Major General,
The Adjutant General.*

DISTRIBUTION:

*IC 11 (5) (2); IC 55(5);

As prescribed in paragraph 9a, FM 21-6.

Armies (Sig) (5); Sv C (Sig) (5); Depts (Sig) (5); Def C (Sig) (2); D (2); *Tech Sv (2); Arm & Sv Boards (2); Posts, Camps & Stas (2); ROTC (5); Sp Sv Schs (10); T of Opns (5); Base C (5); Sig C Dep (2); Gen Oversea, SOS Dep (Sig Sec) (2); Sig C Labs (2); Sig C Rep Shs (2); PE (Sig) (2).

IC 11; (5) T/OE 11-27, 11-57, 11-67, 11-97, 11-107, 11-127, 11-227, 11-287, 11-237, 11-277, 11-587, 11-592, 11-597.

IC 11; (2) T/OE 11-400 Hq (A), Radar Plot Plat (E), Wire Team (J), 11-500 40 Line Switchboard Team (GA), 1-Position Switchboard Team (GB), 2-Position Switchboard Team (GC), 200 Sta Automatic Switchboard Team (GE), Switchboard Instl Sec (GF), Cable Rep Sec (GL), Open Wire Rep Sec (GM), Telephone Carrier and Repeater Sec (GH), Telephone and Telegraph Sec (GO), Spiral 4 Cable Sec (GP), Wire Rep Sec (CQ), Submarine Cable Sec (GR),

IC 55; (5) T/OE 55-217TC.

(For explanation of symbols, see FM 21-6.)

TABLE OF CONTENTS

U 113
-3

TM 113030
1944

★
Paragraph

★
Page

SECTION I. Description.

General	1	1
List of components.....	2	1
Case assembly	3	3
End shield	4	3
Chassis	5	3
Carrying case	6	3
Test leads	7	3
Differences in models	8	5

II. Installation and operation.

Installation	9	7
Adjustments	10	7
Range of Test Set I-48-B.....	11	7
Precautions and test prior to operation	12	7
Calibration	13	8
Operation of Test Set I-48-B for insulation resistance measurements	14	8
Insulation resistance tests of motors	15	9
Insulation resistance tests of apparatus with high electrostatic capacitance	16	10
Measurement over 100 megohms..	17	11
Insulation resistance test of cable.	18	11
Operation of Test Set I-48-B as 500-volt d-c potential source...	19	12
Proper insulation resistance values of equipment under test.....	20	12

M558458

TABLE OF CONTENTS

	<i>Paragraph</i>	<i>Page</i>
III. Functioning of parts.		
Ohmmeter	21	14
Working circuit	22	15
Guard circuit	23	16
Generator	24	16
Resistance network	25	17
IV. Maintenance.		
Routine inspection	26	19
Periodic shop inspection.....	27	19
Maintenance test procedures....	28	19
Output voltage adjustment.....	29	21
Lubrication	30	21
Moistureproofing and fungiproof- ing	31	21
V. Supplementary data.		
Maintenance parts list for Test Set I-48-B	32	21

LIST OF ILLUSTRATIONS

<i>Fig. No.</i>	<i>Title</i>	<i>Page</i>
1	Test Set I-48-B with carrying case and test leads.....	VI
2	Test Set I-48-B, top view.....	2
3	Test Set I-48-B, case and shield removed.....	4
4	Terminal voltage for various resistances under test...	6
5	Test Set I-48-B connected to motor for measurement of insulation resistance	9
6	Test Set I-48-B connected to capacitor for measure- ment of insulation resistance.....	10
7	Test Set I-48-B connected to cable for measurement of insulation resistance	11
8	Ohmmeter movement of Test Set I-48-B.....	14
9	Test Set I-48-B, schematic diagram.....	15
10	Test Set I-48-B, wiring diagram.....	17
11	Test Set I-48-B, shield connections.....	18
12	Adjustment of output voltage.....	20

DESTRUCTION NOTICE

WHY —To prevent the enemy from using or salvaging this equipment for his benefit.

WHEN—When ordered by your commander.

- HOW** —1. Smash—Use sledges, axes, handaxes, pickaxes, hammers, crowbars, heavy tools.
2. Cut —Use axes, handaxes, machetes.
3. Burn —Use gasoline, kerosene, oil, flame throwers, incendiary grenades.
4. Explosives—Use firearms, grenades, TNT.
5. Disposal —Bury in slit trenches, fox holes, other holes. Throw in streams. Scatter.

USE ANYTHING IMMEDIATELY AVAILABLE FOR DESTRUCTION OF THIS EQUIPMENT.

- WHAT**—1. Smash—Entire instrument.
2. Burn—Technical manuals.
3. Bury or scatter—All pieces after breaking.

DESTROY EVERYTHING



Figure 1. Test Set I-48-B with carrying case and test leads.

RESTRICTED

SECTION I

DESCRIPTION

1. GENERAL.

a. Test Set I-48-B is a portable insulation resistance test set for testing electrical resistance. It has a range from 0 to 1,000 megohms and in addition a scale marking for infinite resistance. Test Set I-48-B consists of a high-range ohmmeter of special design mounted in the same case with a hand-operated direct-current generator. The generator delivers a potential of 500 volts at the test terminals.

b. Test Set I-48-B is designed to be used for checking insulation resistance of cables, between conductors of multiple cables, between windings and windings to ground in transformers, between windings and windings to frame in rotating equipment, and for other equipment where insulation resistance is an important factor. Figures 1 and 2 show different views of Test Set I-48-B.

c. As Test Set I-48-B applies a potential of 500 volts direct current to the apparatus under test, it will often show up low-insulation resistance which might read satisfactorily when tested with a conventional ohmmeter applying 3- to 6-volt potential.

2. LIST OF COMPONENTS.

a. Complete equipment for Test Set I-48-B includes the following:

<i>Quantity</i>	<i>Name of unit</i>	<i>Dimensions</i>	<i>Weight (lb)</i>
1	Test Set I-48-B	7 ³ / ₄ -in. x 6-in. x 7 ³ / ₄ -in.	10.7
1	Carrying case	9 ³ / ₄ -in. x 6 ¹ / ₂ -in. x 8 ¹ / ₂ -in.	2.7
2	Test leads with terminals	10 ft long	1.3

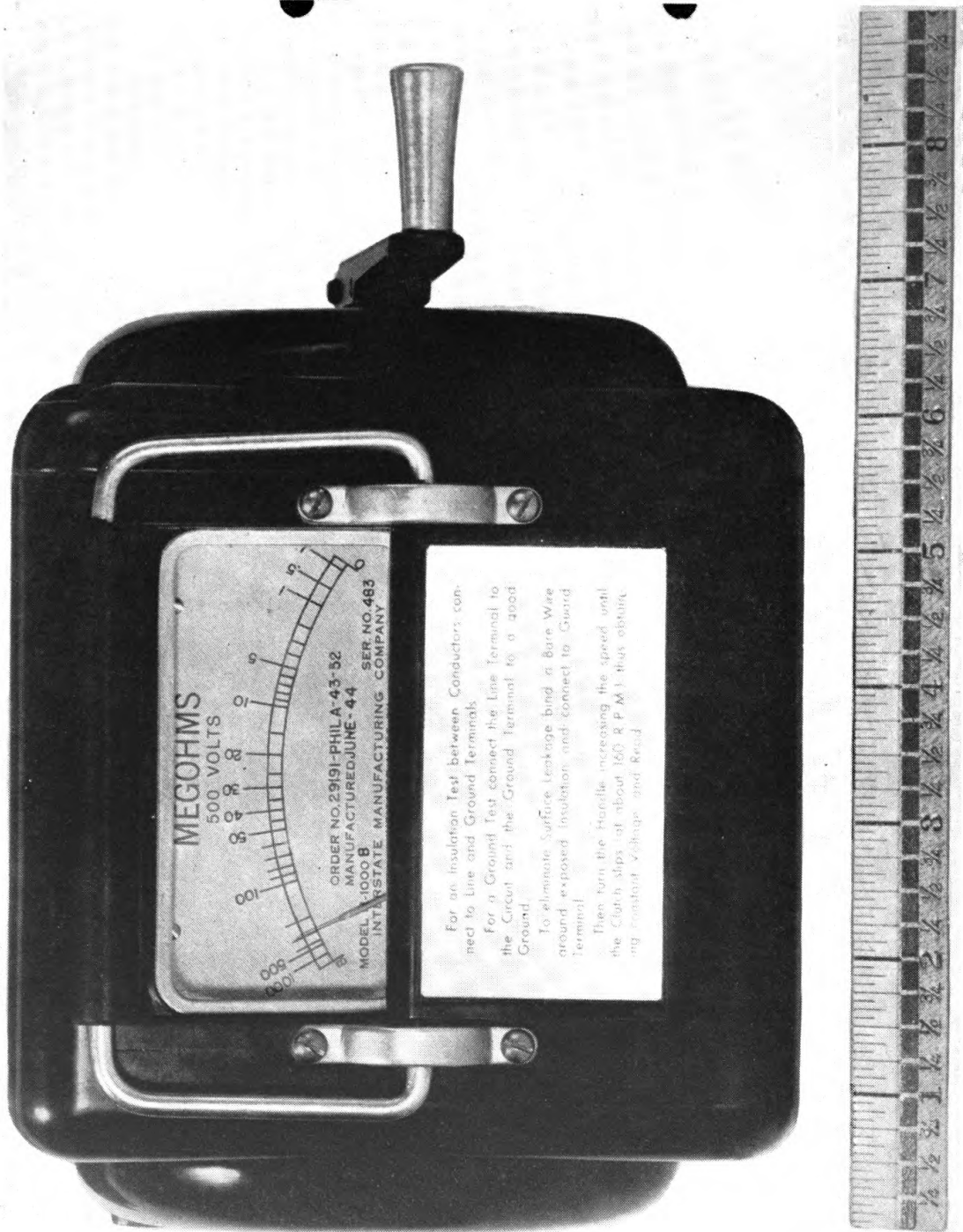

Figure 2. Test Set I-48-B, top view.

TL 52181

b. As Test Set I-48-B is a complete self-contained and self-powered unit, no other equipment is required.

3. CASE ASSEMBLY.

The case is made of molded bakelite and houses the entire test set assembly. The case supports the pillow blocks which act as bearings for both the handle assembly and the case cover. An instruction card is attached to the case cover. The opening in the case is covered by instrument glass held in place by a glass retainer. Three binding posts, marked LINE, GROUND, and GUARD, are attached to one end of the case. The LINE binding post is provided with a guard ring and guard bushing internally connected to the GUARD binding post and to a part of the guard circuit.

4. END SHIELD.

The end shield is made of molded bakelite and is provided with four inserts to which the chassis is attached. The crank drive is brought out through a hole in the end shield. This construction permits removal of the entire mechanism from the case in one piece.

5. CHASSIS.

The chassis supports the generator, indicator, resistance mounting strip, indicator scale plate, and gear plate. On this assembly there is also provided a shield which prevents air currents, caused by the rotating clutch assembly, from affecting the reading of the indicator.

6. CARRYING CASE.

The carrying case is sturdily constructed of wood and houses Test Set I-48-B and two test leads.

7. TEST LEADS.

The two test leads are made of finely stranded and insulated flexible cable, 10 feet in length. One lead is equipped with a positive battery clip protected by a red battery clip cover on one end and a spade terminal protected by 1½ inches of red insulated sleeving on the other end. The other lead is equipped with a negative battery clip protected by a black battery clip cover on one end and a spade terminal protected by 1½ inches of black insulated sleeving on the other end (fig. 1).

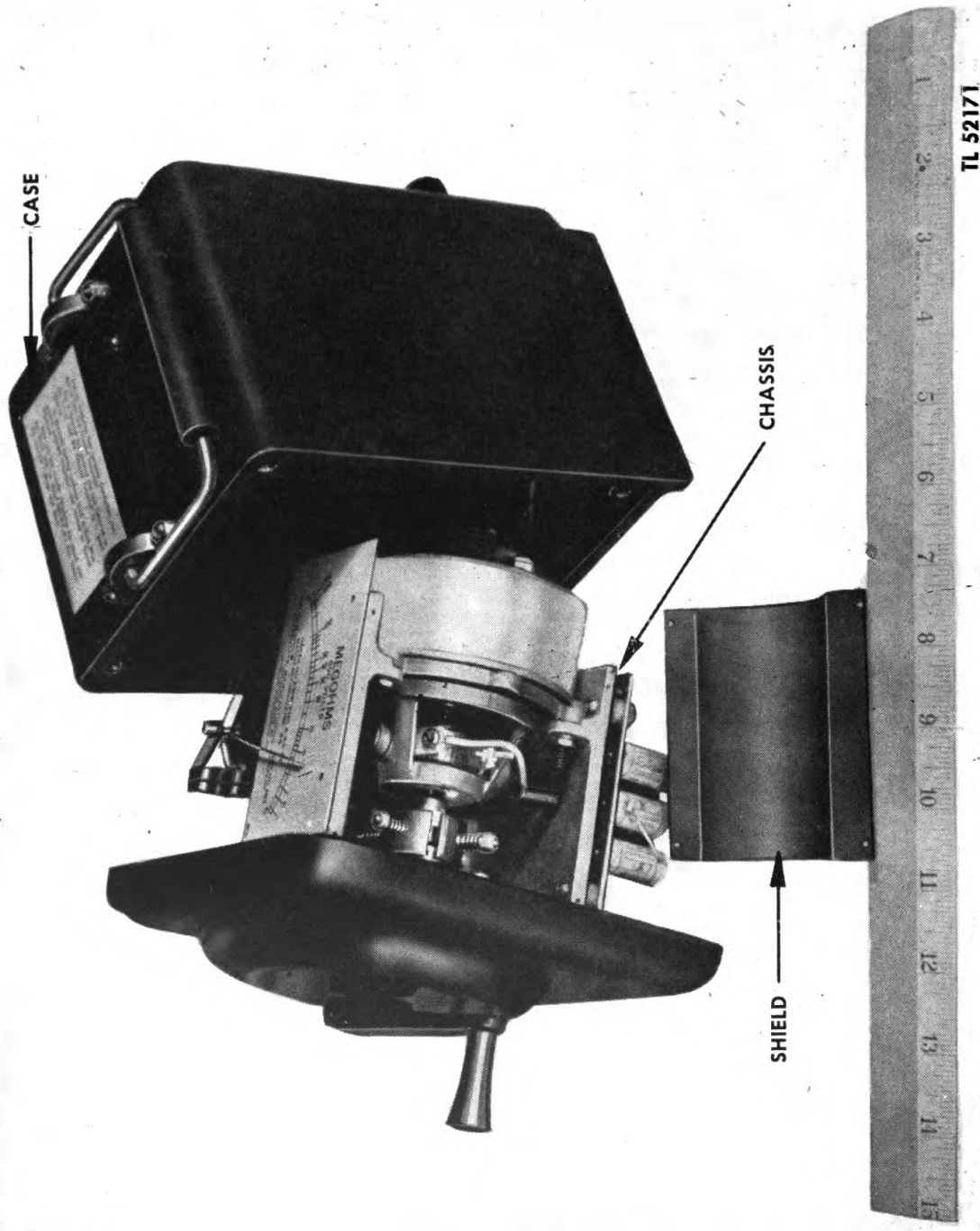

Figure 3. Test Set I-48-B, case and shield removed.

8. DIFFERENCES IN MODELS.

a. Test Set I-48. Test Set I-48 is a 500-volt, single-range, test set, similar to Test Set I-48-B described above except that Test Set I-48 is equipped with a scale calibrated for readings of insulation resistance from 2 to 1,000 megohms.

b. Test Set I-48-A. Test Set I-48-A is a 500-volt, 0- to 1,000-megohm, *double-range* test set. It is similar to Test Set I-48-B except that Test Set I-48-A is equipped with a 1 to 10 ratio switch. The reading on the scale, divided by the ratio in use—1 or 10—gives the value of the resistance under test. The ratio switch is used to bring the reading as near as possible to the middle of the scale for a closer scale reading.

c. Interchangeability. Insulation resistance tests may be made with Test Sets I-48 and I-48-A in the same manner as described for Test Set I-48-B in this technical manual. The parts of Test Set I-48-B are not interchangeable with those of Test Sets I-48 and I-48-A.

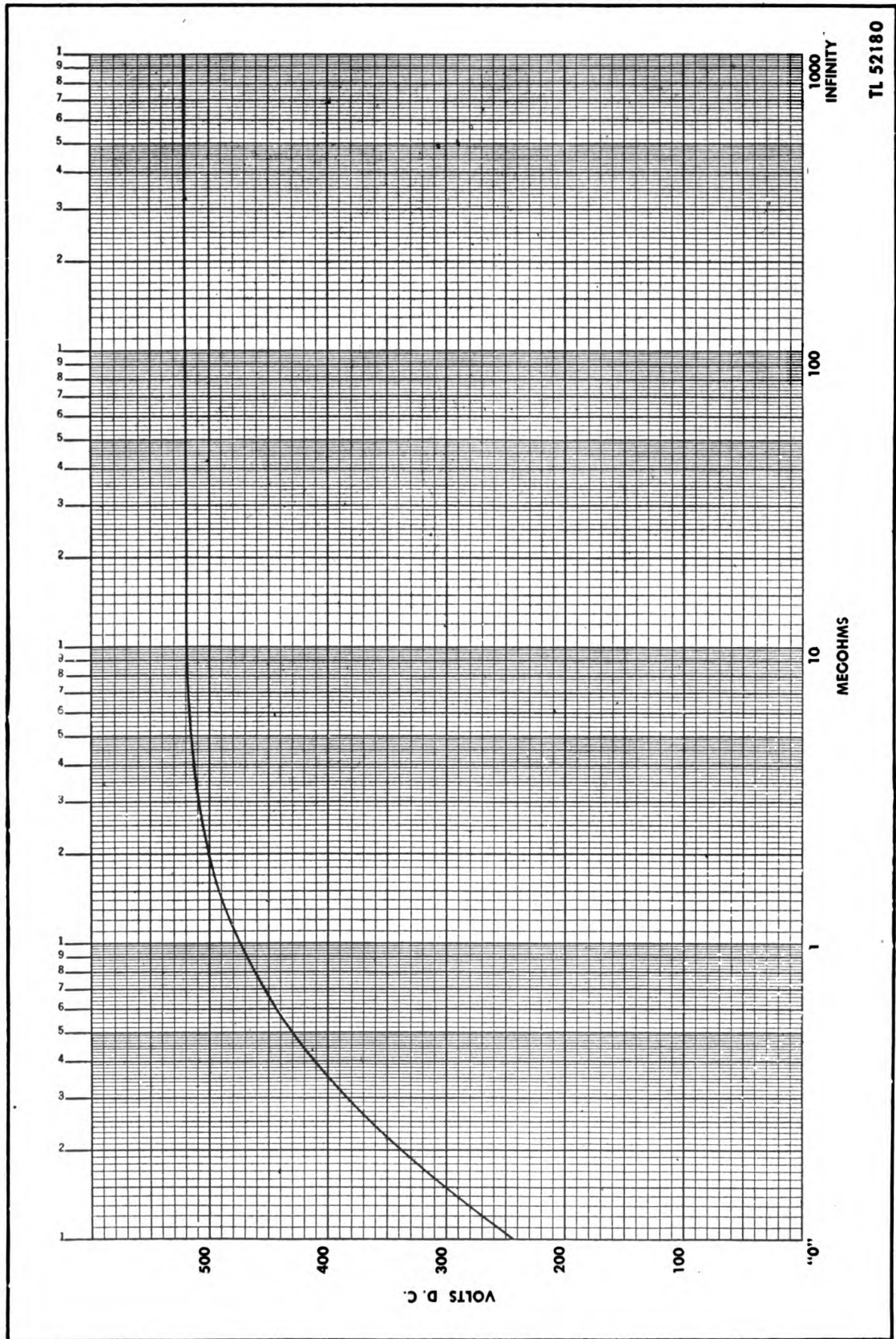

Figure 4. Terminal voltage for various resistances under test.

SECTION II

INSTALLATION AND OPERATION

9. INSTALLATION.

As Test Set I-48-B is a portable unit used only for testing purposes, no permanent installation is necessary.

10. ADJUSTMENTS.

It will be noted that there is no provision made on Test Set I-48-B for a zero adjustment of the indicating instrument. Do not attempt to make any zero adjustments.

11. RANGE OF TEST SET I-48-B.

Test Set I-48-B is designed to make insulation resistance checks between 0 and 1,000 megohms at a potential of 500 volts. While potential applied to the apparatus under test is normally rated at 500 volts, it will be noted from the curve in figure 4 that there will be an increased voltage drop as the apparatus under test decreases in resistance. This voltage drop is due to the protective resistance of 100,000 ohms which is at all times in series with the LINE binding post. Test Sets I-48-B and I-49 should not be used interchangeably since Test Set I-48-B is designed for measuring large insulation resistances and Test Set I-49 is designed for measuring smaller resistances more accurately.

12. PRECAUTIONS AND TEST PRIOR TO OPERATION.

a. Disconnect the apparatus under test from any live power supply before testing.

b. As Test Set I-48-B operates on a minimum of current drain (delivering a minimum torque to the indicating movement), make all checks with the instrument as near level as possible and with the indicator scale plate in a horizontal plane.

c. Always keep Test Set I-48-B as far as possible from strong external magnetic fields, such as those produced by transformers, chokes, or rotating electrical equipment.

d. If the combined insulation resistance of interconnected apparatus together with the interconnecting wires or cables is found to be sufficiently high, do not disconnect the apparatus for further test. If the combined resistance is not high enough, disconnect the apparatus and test the various pieces of equipment and the interconnecting wires and cables separately. Make sure that all connections opened for test purposes are reconnected after tests have been made. Particular attention is called to ground connections.

e. On equipment having appreciable capacitance, such as long cables or capacitors, discharge the residual charge both before and after making a test. This can be done easily and effectively by short-circuiting and grounding the leads from the equipment under test.

f. To make certain that there is no leakage between the test leads, check them before making tests of other apparatus.

(1) Connect the spade terminals of the test leads to the LINE and GROUND terminals of Test Set I-48-B. Leave the other ends of the test leads disconnected. When Test Set I-48-B is operated with leads in this position, the indicator should read infinity.

(2) With the spade terminals of the test leads connected to the LINE and GROUND terminals of Test Set I-48-B, short-circuit the clip ends of the test leads and operate the hand crank of the test set. The indicator scale readings should be zero.

13. CALIBRATION.

A simple calibration check may be made by following the procedure outlined in paragraph 12*f*. If a further calibration check is desired and a known resistance of the proper magnitude is available, it may be connected with the test leads and checked against the indicator by operating the test set.

14. OPERATION OF TEST SET I-48-B FOR INSULATION RESISTANCE MEASUREMENTS.

The following procedure applies for all tests of insulation resistance approximately 100 megohms or less. For tests of insulation resistance over 100 megohms, refer to paragraphs 17 and 18.

a. Connect the LINE and GROUND terminals of Test Set I-48-B to the apparatus under test (pars. 15 and 16), using the test leads furnished.

b. Turn the crank of Test Set I-48-B fast enough (approximately 160 rpm) to cause the centrifugal clutch to slip. The slipping of the clutch assures the operator that the proper voltage is being developed, and at the same time protects the instrument against overload due to excessive generator speed. Continue turning the crank until scale reading is obtained.

c. Note the position of the pointer over the indicator scale. The scale reads directly in megohms. Be sure to have the eye directly over the scale and pointer to avoid errors in reading due to parallax.

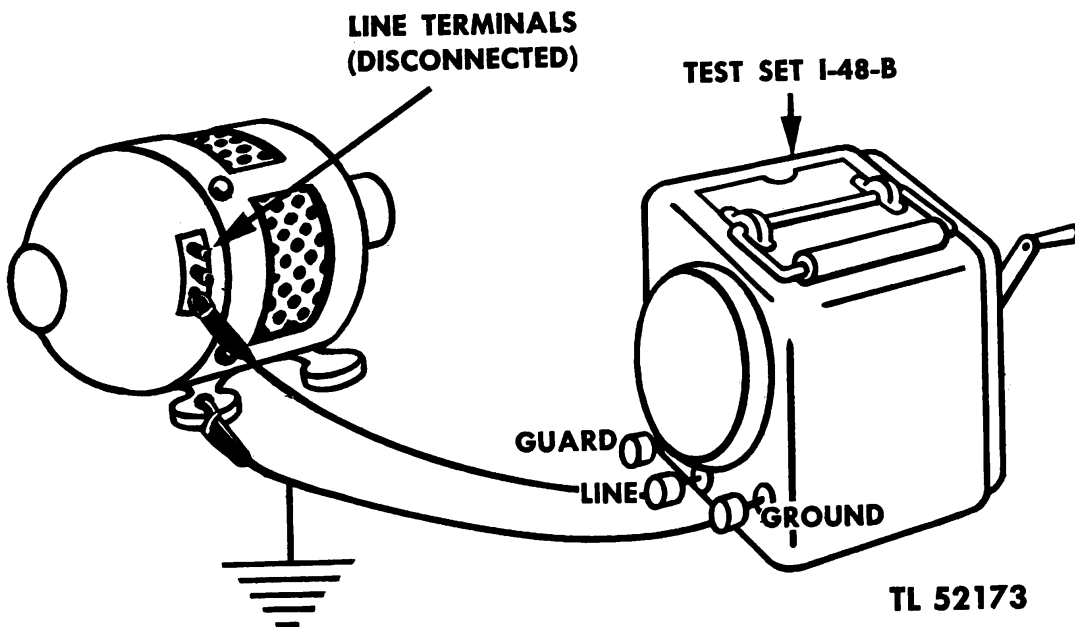

Figure 5. Test Set I-48-B connected to motor for measurement of insulation resistance.

15. INSULATION RESISTANCE TESTS OF MOTORS.

Figure 5 shows proper connections for testing insulation resistance of a motor.

a. Connect LINE binding post of Test Set I-48-B to line terminal of the motor.

b. Connect GROUND binding post of Test Set I-48-B to frame of the motor and to ground.

c. Proceed with test as described in paragraph 14b and c.

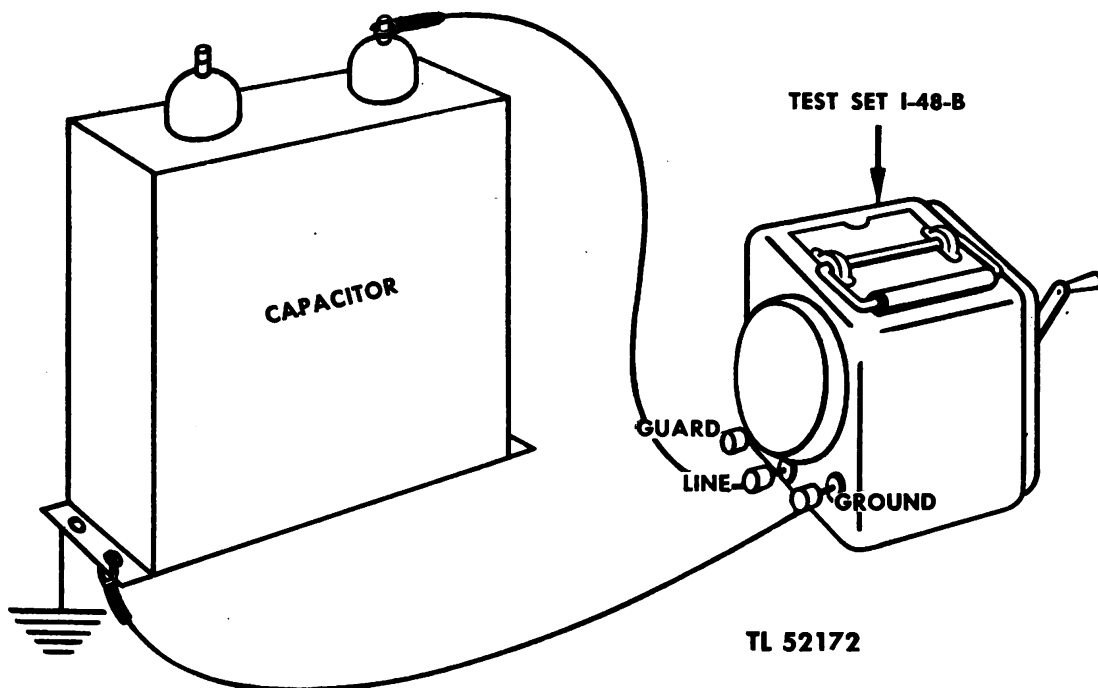

Figure 6. Test Set I-48-B connected to capacitor for measurement of insulation resistance.

16. INSULATION RESISTANCE TESTS OF APPARATUS WITH HIGH ELECTROSTATIC CAPACITANCE.

Figure 6 shows proper connections for testing a capacitor.

- a. Connect LINE binding post of Test Set I-48-B to terminal of the capacitor.
- b. Connect GROUND binding post of Test Set I-48-B to case of the capacitor and to ground.

NOTE: For test of insulation resistance between sections of the capacitors, connect the LINE binding post of Test Set I-48-B to one section of the capacitor and the GROUND binding post to the other section.

- c. Crank Test Set I-48-B until the capacitor is fully charged before taking a reading. (This applies also to testing long cables or rotating equipment having a high capacitance.) It will be necessary to turn the crank some length of time before the pointer comes to rest.

17. MEASUREMENTS OVER 100 MEGOHMS.

For measurements over 100 megohms it is often desirable to shield the circuit under test from parallel circuits which might cause errors due to leakage. In this case connect the parallel circuits to the GUARD terminal of Test Set I-48-B and proceed as described in paragraph 14.

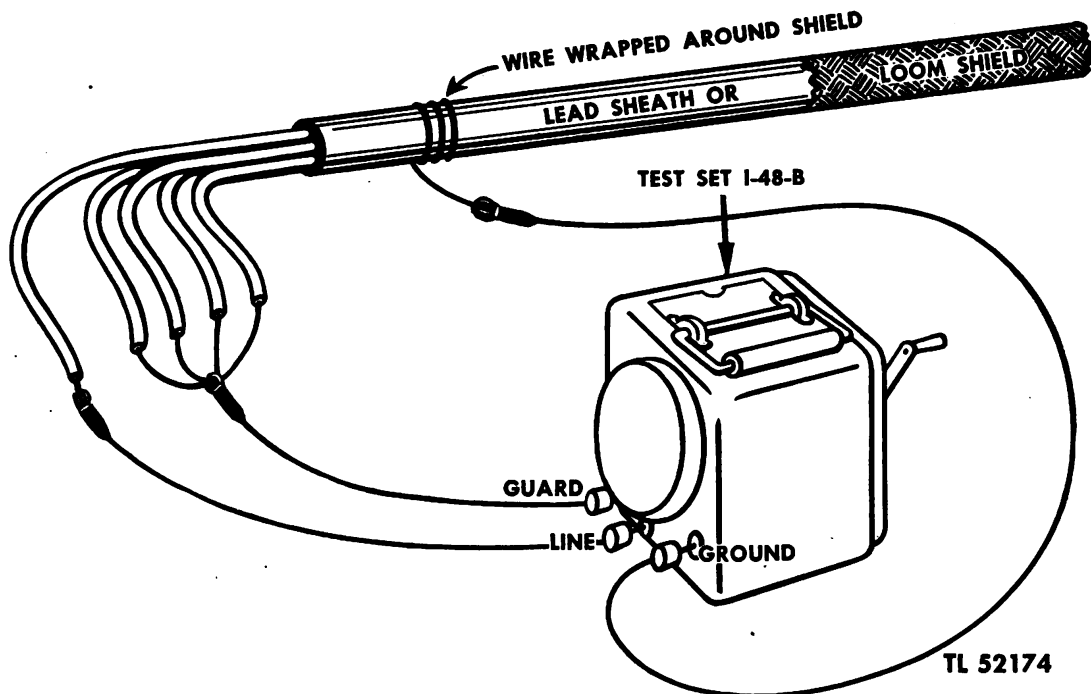

Figure 7. Test Set I-48-B connected to cable for measurement of insulation resistance.

18. INSULATION RESISTANCE TEST OF CABLE.

Figure 7 shows proper connections for testing insulation resistance of cable.

- a. Connect LINE terminal of Test Set I-48-B to one conductor of the cable.
- b. Connect GROUND terminal of Test Set I-48-B to shield of the cable.
- c. Tie all other conductors of the cable together and connect to the GUARD terminal of Test Set I-48-B. This prevents error due to leakage in the parallel circuits.

d. Operate Test Set I-48-B and take the scale reading as described in paragraph 14*b* and *c*.

NOTE: If test required is one conductor to all others, reverse GUARD and GROUND connections. Guard circuit will prevent error due to parallel ground leakage.

19. OPERATION OF TEST SET I-48-B AS 500-VOLT D-C POTENTIAL SOURCE.

Test Set I-48-B may be used as a potential source of approximately 500-volt direct current for operation of apparatus requiring a low-current power supply. The positive connection should be made to the GROUND terminal of Test Set I-48-B and the negative connection to the GUARD terminal. When the hand crank is turned fast enough to cause the clutch to slip, maximum voltage is being delivered.

20. PROPER INSULATION RESISTANCE VALUES OF EQUIPMENT UNDER TEST.

Whenever possible, take minimum insulation resistance values of equipment being tested from the specifications covering such equipment. However, if specifications are not available, the following table may be used as a guide. This table is not made up of arbitrary standards, but is a consensus of generally accepted minimum requirements.

<i>Type of Equipment</i>	<i>Type of Test</i>	<i>Insulation Resistance</i>
Multiple conductor cables, such as those used for inter-connecting various parts of radio equipment (tests to be made with plugs, jacks, and other fittings attached).	Between single conductor and shield.	100 to 1,000 megohms.
Complete power circuits.	Conductor to all other conductors.	100 to 500 megohms.
Rotating equipment.	Conductor to conductor, or conductor to ground.	Circuits carrying 5 to 50 amperes, 0.2 to 2 megohms; 100 amperes or over, 0.1 to 1 megohm.
Transformers, chokes, and similar apparatus.	Between ground and all circuits of equal potential above ground connected together.	Min. Ins. Res. = $\frac{\text{Rated voltage of equipment}}{\text{KVA (or KW) rating}} + 1,000$
Ammeters, voltmeters, wattmeters, etc.	Winding to winding or winding to frame.	Same limits as applied to rotating equipment.
	Between all circuits in case to ground.	At least 20 megohms.
	Between different circuits.	At least 5 megohms.

SECTION III

FUNCTIONING OF PARTS

21. OHMMETER.

a. Figure 8 illustrates the ohmmeter movement of Test Set I-48-B.

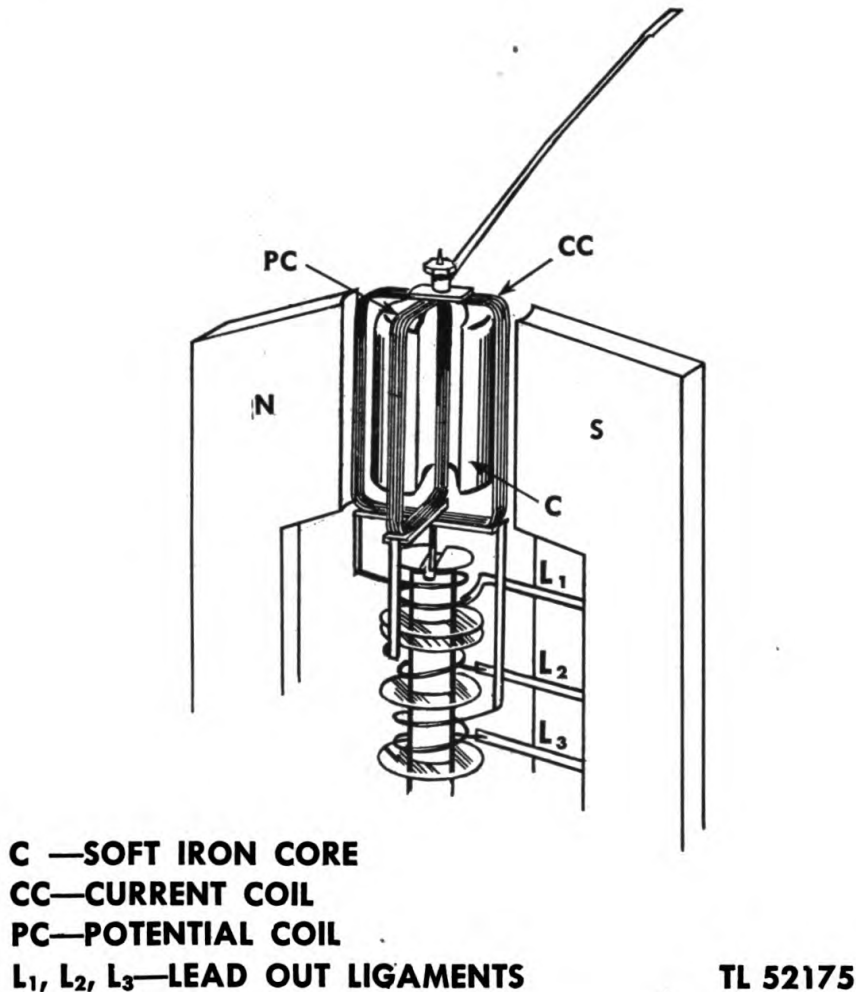

Figure 8. Ohmmeter movement of Test Set I-48-B.

b. The indicating instrument, a true ohmmeter, consists of two coils, PC and CC (fig. 8), designed and connected to oppose each other in a definite ratio. The indicating pointer is rigidly fixed to the coil assembly so that when the assembly is connected through a proper resistance network to the generator and test terminals, it will indicate the true resistance of the apparatus under test. The

coil and pointer assembly is supported on hardened steel pivots riding in jewel bearings. Current flows to the indicator through flexible ligaments L_1 , L_2 , and L_3 , having practically negligible torque, instead of through the conventional springs found on ordinary indicating instruments. This construction permits the moving system to move freely over the scale so that the indication shown will be as close as possible to a true representation of resistance without regard to fluctuation of voltage in the circuit. The moving system rotates between two pole pieces, N and S. These pole pieces together with an Alnico V magnet provide the field in which the indicator operates.

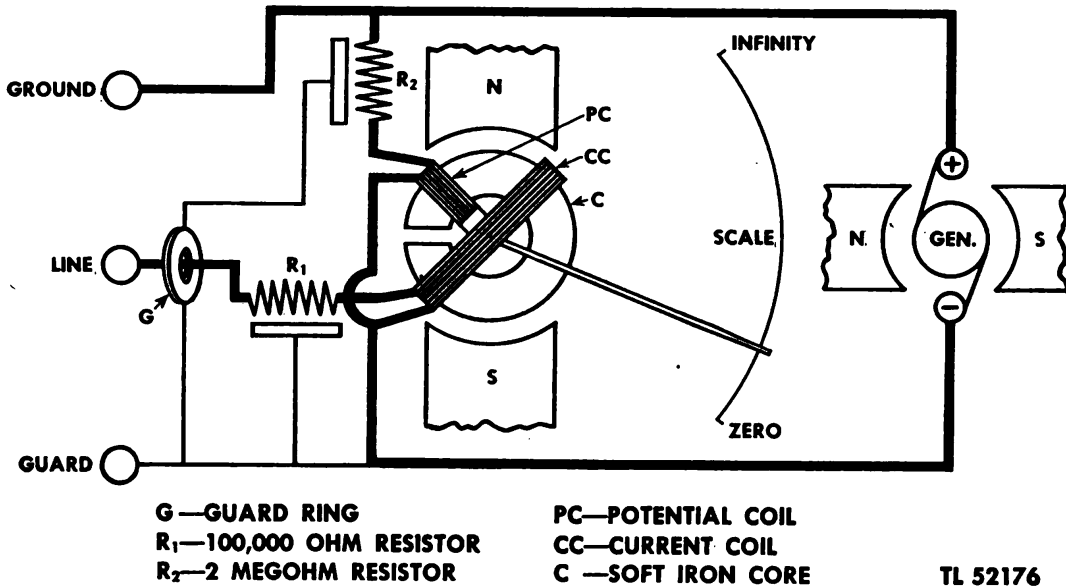

Figure 9. Test Set I-48-B, schematic diagram.

22. WORKING CIRCUIT.

In figure 9 the working circuit is shown by heavy lines. Part of the current flows from the generator to the GROUND terminal, through the unknown resistance to the LINE terminal, and through the 100,000-ohm resistor R_1 and current coil CC back to the generator. The current flowing through the current coil tends to rotate the coil and pointer assembly in a clockwise direction. The other part of the current flows from the generator through the 2-megohm resistor R_2 and the potential coil PC, and back to the generator. The current flowing through the potential coil tends to rotate the coil and pointer assembly in a counterclockwise direction.

It will be seen that with nothing connected across the LINE and GROUND terminals (infinite resistance) all of the current will flow through the potential coil and move the pointer to the infinity mark on the scale. With the GROUND and LINE terminals short-circuited (zero resistance) practically all of the current will flow through the current coil and move the pointer to the zero position of the scale. Therefore, it follows that as the resistance between the GROUND and LINE terminals increases from zero to infinity, the pointer will move from zero to infinity on the scale.

23. GUARD CIRCUIT.

The above explanation shows how the resistance between the GROUND and LINE terminals controls the position of the pointer on the scale. As there is always a certain amount of surface leakage across the bakelite case between the GROUND and LINE terminals, the current through this leakage path would obviously affect the readings of the instrument unless protection were provided. The guard circuit shown in light lines in figure 9 provides this protection. Any current that might flow from the GROUND terminal to the LINE terminal is picked up by the guard ring G (fig. 9) and led to the generator directly, as it will pick the path of low resistance rather than flow through the 100,000-ohm resistor and the current coil. The resistors are mounted on, but insulated from, metal plates which are connected to the guard ring. The metal plates perform the same function with regard to the resistors as the ring performs with regard to the LINE terminal. The entire guard system is connected to the GUARD terminal and can then be extended to apparatus under test. Figure 7 shows this connection being utilized.

24. GENERATOR.

a. General. The power for Test Set I-48-B is supplied by a self-excited direct-current generator of the permanent magnet type. The armature has a 26-segment commutator running between two carbon brushes. The brush retainers also act as terminals by which the current is led out from the generator.

b. Drive Assembly. The generator is driven by a hand crank through a gear train and clutch assembly. When the hand crank is rotated at approximately 160 revolutions per minute, the generator rotates at approximately 6,000 revolutions per minute. The mechanism is so designed that the crank handle operates the gear

train only when it is rotating in the proper direction. Centrifugal force disengages the clutch shoes from the clutch hub when the generator is being driven at the proper speed. This centrifugal clutch assures proper voltage being delivered from the generator even though the crank is rotating at greater than designed speed.

25. RESISTANCE NETWORK.

The resistance network consists of two 1-megohm resistors connected in series and one 100,000-ohm resistor, all mounted on a resistance mounting strip. Figures 10 and 11 show this assembly. The 2-megohm resistance is connected in series with the potential coil and the positive side of the generator. The 100,000-ohm resistor is connected between the line terminal and the current coil, and acts as a protective resistance to guard against damage to the current coil.

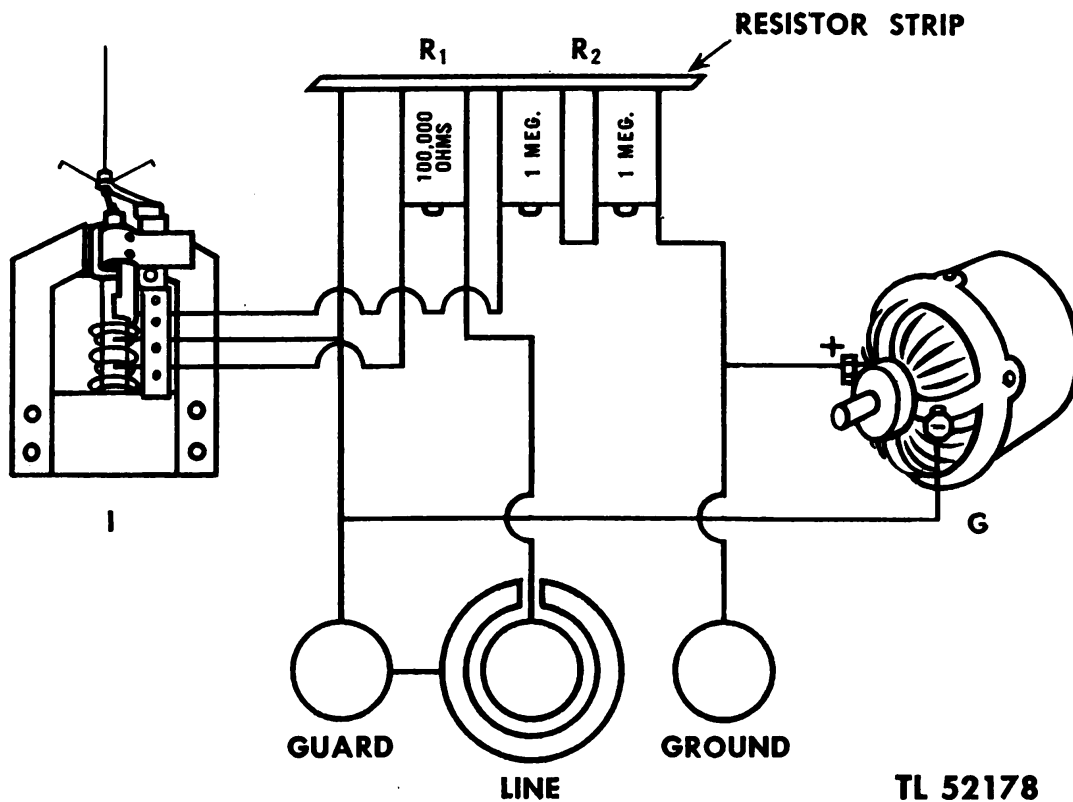

Figure 10. Test Set I-48-B, wiring diagram.

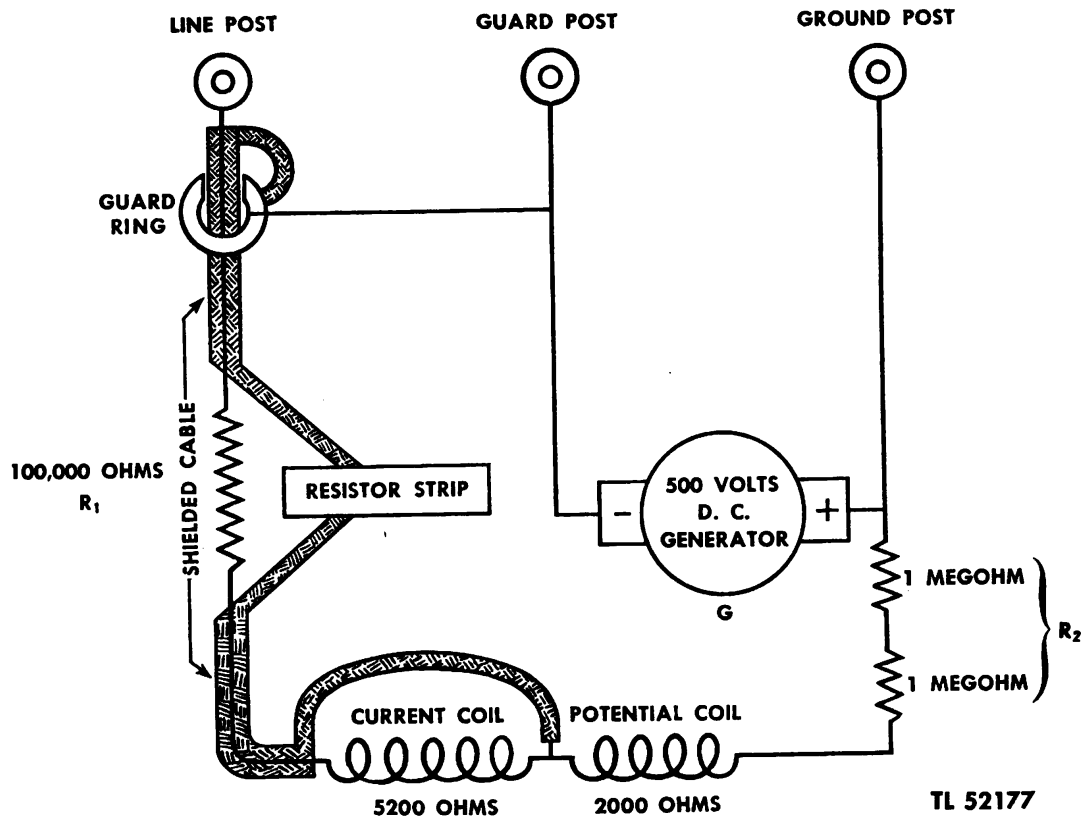

Figure 11. Test Set I-48-B, shield connections.

SECTION IV MAINTENANCE

NOTE: Failure or unsatisfactory performance of equipment will be reported on W.D., A.G.O. Form No. 468. If this form is not available, see TM 38-250.

26. ROUTINE INSPECTION.

Test Set I-48-B can be very easily checked by the operator before attempting to make any test or series of tests. Short-circuit the LINE and GROUND terminals. The test set should read zero when operated. With the LINE and GROUND terminals open-circuited, the test set indicator should read infinity. Even though infinity reading should not be exact, Test Set I-48-B can still be operated and the error in its readings will always be less than the error at the infinity position.

27. PERIODIC SHOP INSPECTION.

Test Set I-48-B should be given a periodic test and inspection at least once each 6 months. This test and inspection should be performed only by qualified personnel in a properly equipped laboratory or shop.

28. MAINTENANCE TEST PROCEDURES.

a. Indicator Scale Test. Connect the LINE and GROUND terminals to known resistances. Operate the hand crank of Test Set I-48-B and note any deviation between the known resistance values and the values shown on the indicator of the test set. The deviation at any marked point on the scale should not exceed $\frac{1}{32}$ inch.

b. Generator Output Voltage Test. Connect the LINE and GROUND terminals to either an electrostatic voltmeter or a vacuum-tube voltmeter. Operate the hand crank of Test Set I-48-B and note the voltmeter scale reading. The voltmeter should read 500 volts plus or minus 25 volts. If the voltage is found to be incorrect, adjust the output voltage as described in paragraph 29. A 20,000-ohm/volt instrument may be used for this test instead of the electrostatic voltmeter or the vacuum-tube voltmeter. However, allowance should be made for the voltage drop due to the internal resistance of the instrument used for checking.

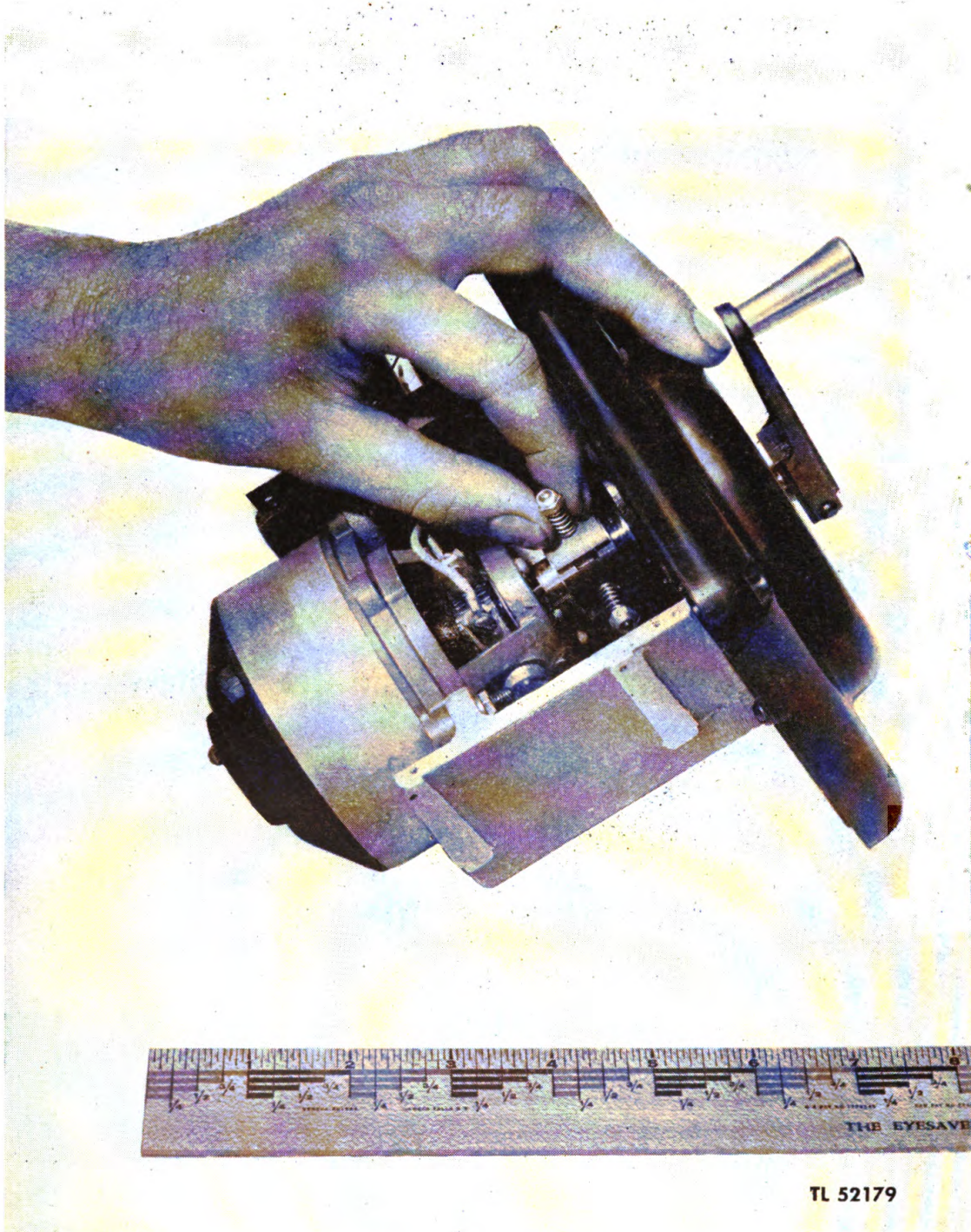

TL 52179

Figure 12. Adjustment of output voltage.

c. Resistance Network Test. Disconnect the three resistors and check each separately with Test Set I-49 (TM 11-2019) or other suitable resistance measuring apparatus. The resistors should check within one percent of marked value.

d. Continuity Test. Check continuity of the circuit point-to-point, using a low-voltage ohmmeter or other suitable circuit tester. Check possible short circuits in the same manner.

29. OUTPUT VOLTAGE ADJUSTMENT.

The only adjustment that can be made on Test Set I-48-B is that of the output voltage. If the test described in paragraph 28*b* indicates incorrect output voltage, remove the entire mechanism from the case.

CAUTION: Be careful not to break the flexible leads to the terminals when removing chassis from the case.

a. If the output voltage is low, slightly tighten the four elastic stop nuts on the clutch assembly as shown in figure 12 until the voltage is correct when the clutch slips.

b. If the output voltage is high, loosen the four elastic stop nuts.

NOTE: When making generator adjustments, turn all four stop nuts approximately the same amount.

30. LUBRICATION.

All bearings of Test Set I-48-B are packed with lubricant when assembled at the factory. No provision has been made for additional lubrication.

31. MOISTUREPROOFING AND FUNGIPROOFING.

Moistureproofing and fungiproofing of Test Set I-48-B is not recommended.

SECTION V SUPPLEMENTARY DATA

32. MAINTENANCE PARTS LIST FOR TEST SET I-48-B.

A maintenance parts list has not been authorized for this equipment.

Order Nos. 29191-Phila-43, 31080-Phila-43, 34909-Phila-43, 8724-Phila-44, 28629-Phila-44; 2366 copies, 14 October 44.

