

L W 113  
12  
TM  
1945

# TM 11-2400

WAR DEPARTMENT TECHNICAL MANUAL

U.S. Dept. of Army

## GENERATORS

ML-185-A and ML-185-B

(HYDROGEN)

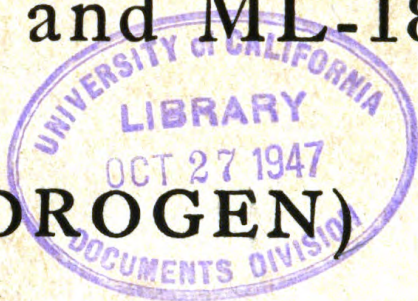

**WARNING:** This manual is the property of the United States Government, and is printed and distributed solely for the use of the military, naval, and civilian personnel of the War and Navy Departments, and may not be published or reproduced in whole or in part, or in any manner or form (except by lawful copyright holders who may reproduce their copyrighted material in its original form) unless specifically approved by authorized military public relations agencies.

WAR DEPARTMENT • MAY 1945



WAR DEPARTMENT TECHNICAL MANUAL  
TM 11-2400

*This manual supersedes TM 11-2400, 22 June 1943, and TB 11-2400-1,  
7 April 1944.*

GENERATORS  
ML-185-A and ML-185-B  
(HYDROGEN)

WARNING: This manual is the property of the United States Government, and is printed and distributed solely for the use of the military, naval, and civilian personnel of the War and Navy Departments, and may not be published or reproduced in whole or in part, or in any manner or form (except by lawful copyright holders who may reproduce their copyrighted material in its original form) unless specifically approved by authorized military public relations agencies.

---

WAR DEPARTMENT • MAY 1945

---

*United States Government Printing Office  
Washington: 1945*

WAR DEPARTMENT  
Washington 25, D. C., 31 May 1945.

TM 11-2400, War Department Technical Manual, is published for the information and guidance of all concerned.

[AG 300.7 (28 Sep 44)]

BY ORDER OF THE SECRETARY OF WAR:

OFFICIAL:

J. A. ULIO  
*Major General*  
*The Adjutant General*

G. C. MARSHALL  
*Chief of Staff*

DISTRIBUTION:

AAF (5); AGF (5); ASF (2); T of Opn (5); Dept (5); Base Comd (5);  
Island Comd (5); Gulf Comd (5); AAF Comds (2); Arm & Sv Bd (1);  
Def Comd (2); S Div ASF (1); Tech Sv (2); SvC (5); PC&S (2);  
PE (2); Dep 11 (2); Gen Oversea SOS Dep (2); Pro Dist 11 (2);  
Gen & Sp Sv Sch (5); USMA (10); ROTC (2); Lab 11 (2); Sig AS (2);  
WDGS Lib (5); Rep Shops 11 (2); A (5); CHQ (5); D (2); AF (2);  
T/O & E 1-627 (2); Three (3) copies to each of the following: T/O &  
E 3-267, 4-46, 4-112, 4-156, 6-10-1, 6-76, 6-110-1, 6-160-1, 6-270-1,  
11-107, 11-127, 11-587, 11-592, 11-597, 44-16, 44-116, 44-136.

Refer to FM 21-6 for explanation of distribution formula.

# CONTENTS

U113  
12  
TM 115240  
1945

	Paragraph	Page
<b>PART ONE. INTRODUCTION.</b>		
<i>Section</i> I. Description of Generator ML-185-(*) (Hydrogen).		
General .....	1	1 ★ ★
Application .....	2	1
Components parts list .....	3	2
Cylinder assembly.....	4	5
Cylinder safety device .....	5	6
Outlet valve assembly .....	6	6
Support assembly .....	7	8
Cleaning cap assembly .....	8	8
Large hardwood stick .....	9	8
Chest for accessories .....	10	9
Chemicals .....	11	9
Special equipment for aluminum process .....	12	11
Differences in Generators ML-185-(*) .....	13	12
II. Installation and assembly.		
Siting .....	14	15
Unpacking, uncrating, and checking .....	15	16
Assembly .....	16	16
Repacking Generator ML-185-(*) for transport .....	17	19
<b>PART TWO. OPERATING INSTRUCTIONS.</b>		
III. Preliminary procedure.		
Preparation of Generator ML-185-(*) for use .....	18	20
Precautions on handling Generator ML-185-(*) .....	19	20
Treatment of caustic burns .....	20	21
IV. Operation of equipment and use of accessories.		
Charging Generator ML-185-(*) using ferrosilicon process .....	21	23
Obtaining maximum hydrogen yield with ferrosilicon .....	22	25
Charging Generator ML-185-B using aluminum process .....	23	26
Release of hydrogen from Generator ML-185-(*) .....	24	28
Cleaning Generator ML-185-(*) .....	25	30
Special information on climatic conditions .....	26	32
<b>PART THREE. PREVENTIVE MAINTENANCE.</b>		
V. Preventive maintenance techniques.		
Meaning of preventive maintenance .....	27	34
Description of preventive maintenance techniques .....	28	34
Threads and openings .....	29	35
Brass fittings .....	30	35
VI. Preventive maintenance items.		
Common materials .....	31	37
Preventive maintenance check list .....	32	38
Maintenance of the cylinder .....	33	38
Maintenance of the outlet valve assembly .....	34	39
VII. Lubrication.....		39

**PART THREE. PREVENTIVE MAINTENANCE (Contd.)**

	<i>Paragraph</i>	<i>Page</i>
<i>VIII.</i> Moistureproofing and fungiproofing.		
Moistureproofing and fungiproofing .....	35	39

**PART FOUR. AUXILIARY EQUIPMENT.**

<i>IX.</i> Description and use of transfer hose.		
Transfer hose .....	36	40

**PART FIVE. REPAIR INSTRUCTIONS.**

<i>X.</i> Theory of equipment.		
Mechanical design and functioning of Generator		
ML-185-(*) .....	37	43
<i>XI.</i> Repair.		
Trouble shooting .....	38	45
General repair .....	39	46
Care of leaking generator .....	40	48
Painting and refinishing .....	41	48
Emergency replacement of used safety disks .....	42	48
Replacement of parts .....	43	49
<i>XII.</i> Adjustments.		
Adjustment of pressure gauge .....	44	50
War Department Unsatisfactory Equipment Report	45	50

<b>APPENDIX I. MAINTENANCE PARTS LIST FOR GENERATOR ML-185-(*).....</b>	<b>52</b>
---	-----------

<b>II. REFERENCES.....</b>	<b>53</b>
----------------------------	-----------

# DESTRUCTION NOTICE

---

**WHY** — To prevent the enemy from using or salvaging this equipment for his benefit.

**WHEN** — When ordered by your commander.

**HOW** — 1. Smash — Use sledges, axes, handaxes, pickaxes, hammers, crowbars, heavy tools.

2. Cut — Use axes, handaxes, machetes.

3. Burn — Use gasoline, kerosene, oil, flame throwers, incendiary grenades.

4. Explosives — Use firearms, grenades, TNT.

5. Disposal — Bury in slit trenches, fox holes, other holes. Throw in streams. Scatter.

## USE ANYTHING IMMEDIATELY AVAILABLE FOR DESTRUCTION OF THIS EQUIPMENT

**WHAT** — 1. Smash — Cylinder, large plug assembly, outlet valve assemblies, support assembly, cylinder safety device assemblies, all tools, running spare parts, and accessories.

2. Cut — Rubber gloves and apron, goggles, washers, corks, copper disks, hardwood sticks.

3. Burn — Hardwood sticks, rubber apron and gloves, washers, brush, Technical Manual, and all papers.

4. Bend — Support assembly, tools, cleaning cap assembly, buckets, scoop, funnel.

5. Bury or Scatter — Any or all of the above after destroying them.

## DESTROY EVERYTHING

v

## SAFETY NOTICE

---

The use of Generator ML-185-(\*) involves high pressures and explosive mixtures of air and hydrogen. The following precautions must be observed:

1. Never smoke near the generator shack. Sparks from shoe nails are dangerous. Do not drop or strike iron tools against a concrete floor because dangerous sparks may be produced. Remove *all* sources of flames and sparks.
2. Display conspicuous warning signs wherever hydrogen is used or stored.
3. Provide permanent louvered ventilators near the ceiling and floor to prevent the accumulation of hydrogen, and to allow the escape of hydrogen from any building in which it is used or stored.
4. Ground the generator to eliminate the possibility of sparks. (See par. 16b(1).)
5. Ground the personnel. (See par. 16b(4).)
6. Wear goggles, rubber apron, and rubber gloves when handling caustic soda.
7. Do not allow the cylinder to be heated by the sun.
8. Beware of working pressures of 2,800 pounds per square inch or over. If these pressures are reached, move away from the generator—*FAST*.
9. The same hazards and precautions discussed in the above paragraphs exist when using hydrogen cylinders in which the gas is stored. Ground a hydrogen cylinder as follows:
  - a. Attach a large battery clip to one end of a braided or flexible wire.
  - b. Attach the clip to the safety device cap on the cylinder valve.
  - c. Attach the other end of the wire to a well-grounded object such as a water pipe or metal stake driven into wet ground.
10. Avoid wearing heavy woolen or fur clothing which may create an electrostatic charge.

## FIRST AID NOTICE

---

Treat caustic burns immediately. Detailed first aid instructions for the treatment of caustic burns on the skin and in the eyes are given in paragraph 20 of this manual.



TL52835

*Figure 1. Generator ML-185-(\*)(Hydrogen) in use.*

# PART ONE

## INTRODUCTION

---

### Section I.

#### DESCRIPTION OF GENERATOR ML-185-(\*) (HYDROGEN)

##### 1. General

Generator ML-185-(\*) (Hydrogen) consists of complete, portable equipment to generate hydrogen for the inflation of meteorological balloons. The generator is packed in two crates, one containing the cylinder assembly, and the other the chest with all the accessories and running spare parts. The cylinder assembly weighs 275 pounds, uncrated, and has a gross weight of 340 pounds, crated. The chest weighs 225 pounds, uncrated, and has a gross weight of about 280 pounds, crated. Total weight of the equipment is 500 pounds, uncrated, and approximately 620 pounds, crated. Wherever used in this manual, Generator ML-185-(\*) refers to both models ML-185-A and ML-185-B. The differences in the two models are described in paragraph 13.

##### 2. Application

The hydrogen is generated in a steel generating cylinder and results from the reaction of sodium hydroxide (caustic soda), water, and either ferrosilicon or aluminum depending upon the process used.

*a.* FERROSILICON PROCESS. In the reaction of sodium hydroxide, water, and ferrosilicon, each unit charge yields approximately 85 to 90 cubic feet of hydrogen in about 2 hours.

*b.* ALUMINUM PROCESS. In the reaction of sodium hydroxide, water, and aluminum, each unit charge yields approximately 120 cubic feet of hydrogen in approximately 2 hours.

### 3. Components Parts List

Quan.	Component	Dimensions (in.)			Volume	Weight (lb)	
		Length	Width	Height		Crated	Uncrated
1	cylinder assembly						
	1 cylinder	56	9 $\frac{8}{16}$		10.6	275	340
	1 plug assembly						
	1 chest	61 $\frac{1}{4}$	20 $\frac{3}{4}$	11 $\frac{1}{2}$	12.0	225	280
	2 cylinder safety device assemblies						
	2 outlet valve assemblies						
	1 support assembly						
1	Group						
	Accessories included in chest:						
	1 pr safety goggles						
	1 pr long rubber gloves						
	1 rubberized apron						
	1 cleaning cap assembly						
	1 spanner wrench						
	1 funnel						
	1 adjustable wrench						
	1 wrench for large plug (Generator ML-185-B only)*						

Note. Signal Corps nomenclature and stock numbers for all running spares and organizational stock are shown in the illustrations in this technical manual.

3. Components Parts List (contd).

Quan.	Component	Dimensions (in.)			Volume	Weight (lb)	
		Length	Width	Height		Uncrated	Crated
	1 large bucket						
	1 small bucket						
	1 large stick assembly						
	1 small hardwood stick						
	1 brass wire brush for small openings (Generator ML-185-B only)*						
	1 brass wire brush						
	1 reamer assembly (Generator ML-185-B only)*						
	1 scoop						
	Corks						
	Washers						
	Copper disks						
	List of running spare parts included in chest:						
	1 cylinder safety device assembly						
	1 cylinder safety device adapter						
	1 outlet valve assembly						
	1 outlet valve adapter						

### 3. Components Parts List (contd).

Quan.	Component	Dimensions (in.)			Volume	Weight (lb)	
		Length	Width	Height		Uncrated	Crated
1	wrench for large plug (Generator ML-185-B only)						
1	spanner wrench						
1	large stick assembly						
1	small hardwood stick						
1	brass wire brush for small orifices (Generator ML-185-B only)						
1	brass wire brush						
1	pr. safety goggles						
1	pr. long rubber gloves						
1	apron						
	Copper disks						
	Washers						

*Note.* Running parts are for initial issue only and are not to be requisitioned as a kit or group as shown in this list.  
 \* If using hydrogen Generator ML-185-A, order these items from supply depot.

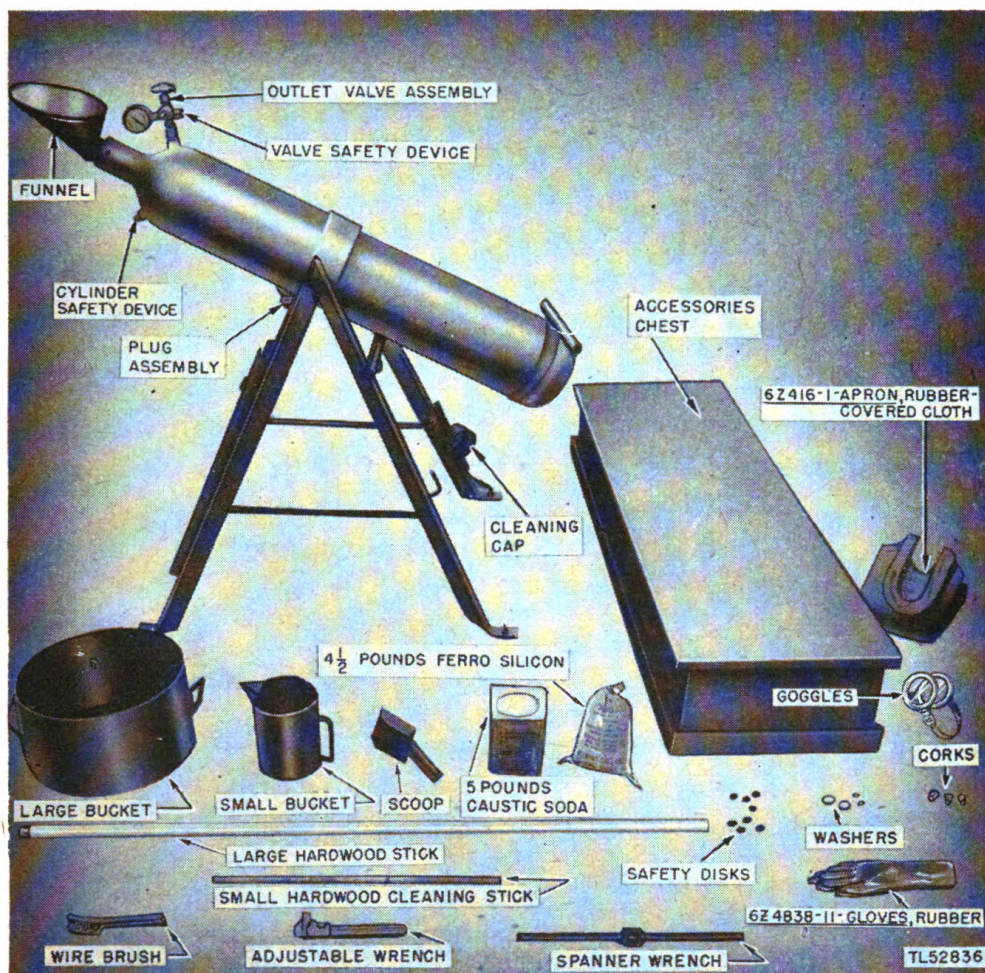

Figure 2. Generator ML-185-(\*) (Hydrogen) and accessories, assembled.

#### 4. Cylinder Assembly

The cylinder assembly consists of the cylinder and the large plug assembly.

a. **CYLINDER** (FIG. 2). The cylinder is of seamless steel construction and is 56 inches long and  $9\frac{9}{16}$  inches in outside diameter.

(1) *Neck of cylinder.* The neck has a large opening with a right-hand internal thread  $2\frac{3}{4}$  inches in diameter, through which the cylinder is charged. Two pins project from opposite sides of the neck.

(2) *Body of cylinder.* The body of the cylinder is tested to withstand a pressure of 5,000 pounds per square inch. It has a capacity of  $11\frac{1}{3}$  gallons. A cylinder safety device adapter and an outlet valve adapter are located on opposite sides of the cylinder near the top of the main body. Brass protector caps are provided to protect the screw threads of these adapters. Two trunnions project from the sides of the cylinder and form an axis on

which the cylinder can be turned. A metal handle is permanently attached to the lower end of the cylinder.

*b.* **PLUG ASSEMBLY.** The large plug assembly seals the cylinder opening. The assembly consists of a right-hand, threaded plug and a center screw. The center screw passes through the body of the plug assembly and controls a center screw seal.

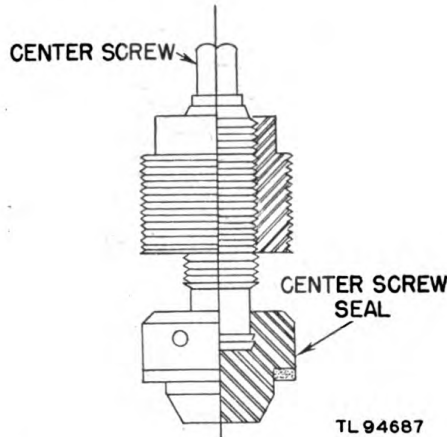

Figure 3. Large plug assembly, cross-section.

## 5. Cylinder Safety Device

The cylinder safety device screws onto the small cylinder safety device adapter. The function of the cylinder safety device is to release excessive pressure from the cylinder. (See par. 13a.)

## 6. Outlet Valve Assembly (figs. 3, 4, 5)

*a.* **GENERAL.** The outlet valve assembly consists of a regulating and discharge valve, a hose coupling, a pressure gauge, and a valve safety device. At one end of the assembly a left-hand, threaded coupling attaches the assembly to the large outlet valve adapter. At the other end, a handwheel is mounted on a stainless steel or brass valve stem.

*b.* **REGULATING AND DISCHARGE VALVE (FIG. 5).** The regulating and discharge valve is a corrosion-resistant, high-pressure needle valve which controls the rate of discharge of the hydrogen from the cylinder. The valve body is made of bronze. It has an outlet connection and provisions for attaching an inlet coupling, a pressure gauge, and a valve safety device.

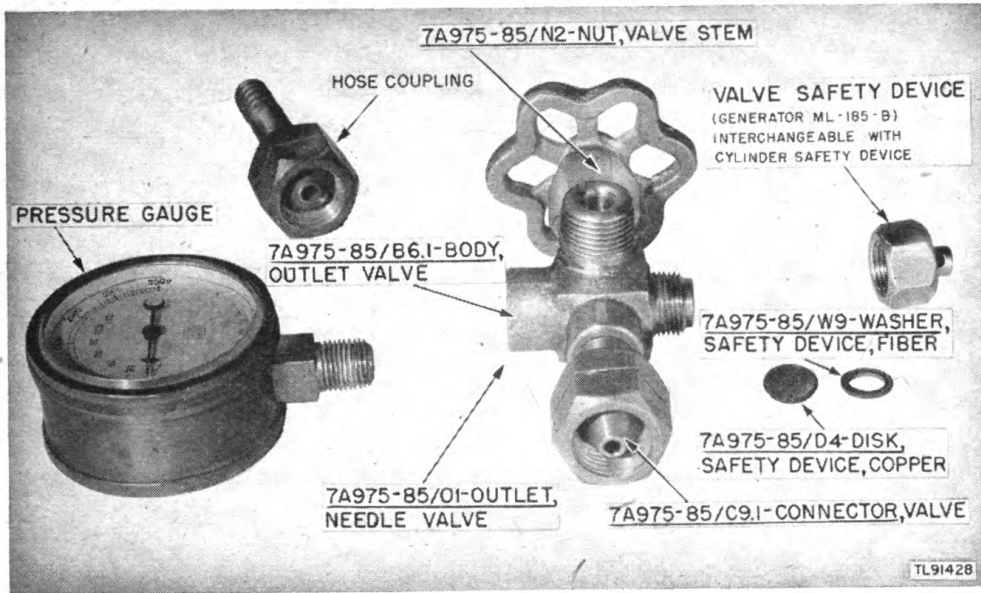
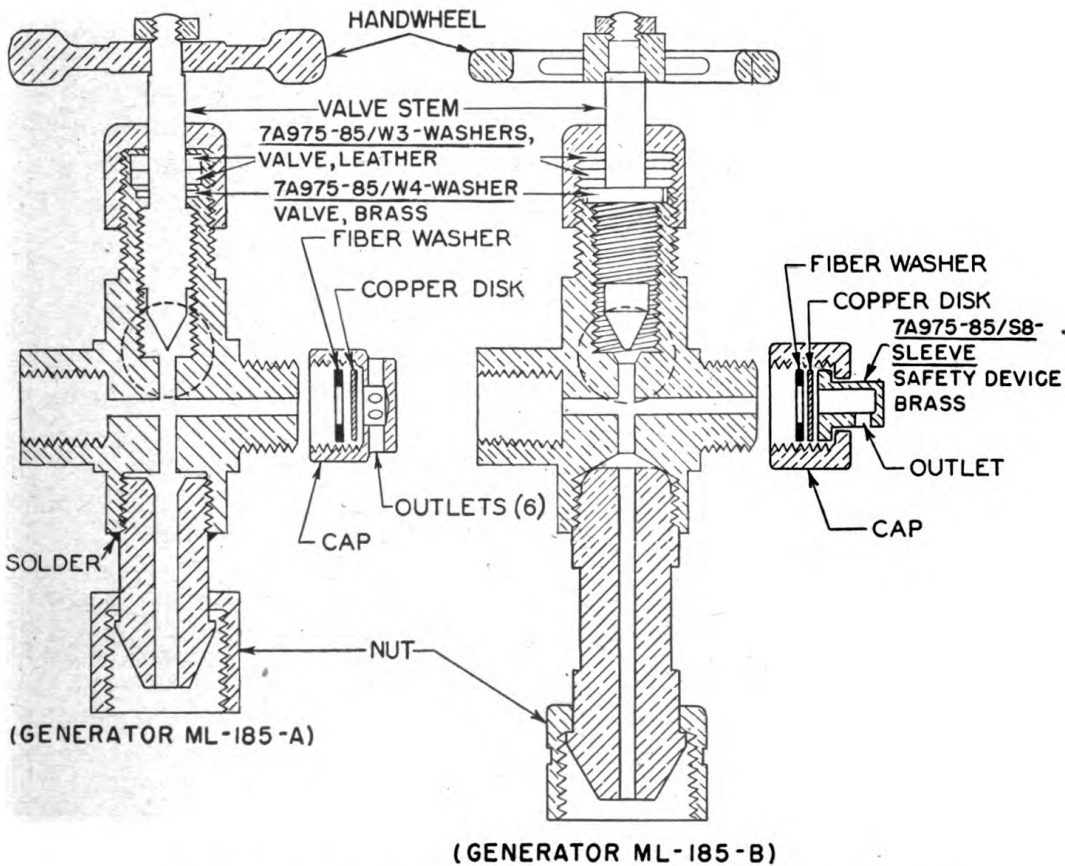

Figure 4. Outlet valve assembly.



REGULATING AND DISCHARGE VALVE

TL52840

Figure 5. Regulating and discharge valves with safety devices, cross-sections.

c. **PRESSURE GAUGE (FIG. 4).** The pressure gauge indicates the pressure and the volume of hydrogen within the reaction cylinder. The black scale on the gauge is calibrated in pounds per square inch over a range from 0 to 3,000 pounds. The red scale is not applicable to the generator.

d. **OUTLET HOSE COUPLING (FIG. 4).** The hose coupling provides a means of attaching Hose ML-81 to the outlet connection of the regulating and discharge valve assembly. One end of the coupling is secured to the valve assembly by a left-hand threaded union nut. The other end of the coupling is a serrated sleeve which receives Hose ML-81.

e. **VALVE SAFETY DEVICE (FIGS. 4 AND 5).** The valve safety device releases excessive pressure from the cylinder. It is secured on the valve assembly opposite the pressure gauge. The device differs in the two models, Generator ML-185-A and Generator ML-185-B. (See pars. 13b(1)(c), 13b(2)(c).)

## 7. Support Assembly (fig. 2)

The support assembly, which holds the cylinder during cleaning and charging operations, consists of two folding **A**-frames. The two legs of each **A**-frame are held apart by a rod hooked to the legs by means of eye hooks. With the rod in place, each frame forms the letter **A**. A socket to receive a cylinder trunnion is located at the junction of the legs of each **A**-frame. Holes are provided in the base of each leg so that the frame may be bolted to a platform for stability. One leg of each **A**-frame has a bar ( $\frac{1}{2}$ -inch metal pipe) mounted on a swivel connection and held in place at its free end by a bar hook. The bars hold the cylinder in the positions required by the various operations. Holders are provided on the **A**-frame legs for the plug assembly, funnel, cleaning cap assembly, and spanner wrench. (One leg of the **A**-frame for Generator ML-185-B is provided with a bolt, nut, and flat washers for attaching a ground wire. (See par. 13c.))

## 8. Cleaning Cap Assembly

The cleaning cap assembly is used in removing residue from the cylinder. The assembly is a cap with a metal bar welded to its top. A bolt and metal washer hold in place a rubber washer which seals the cap. On the sides of the cap are two L-shaped slots. The L-shaped slots are used for attaching the cap to the cylinder. A metal chain is fastened to one end of the metal handle. The chain is used to remove the cap from the cylinder.

## 9. Large Hardwood Stick

Hydrogen Generator ML-185-(\*) is provided with a large hardwood stick which is used to break the solidified residue resulting from the action

of the chemicals involved. The stick has a brass ring slipped over the tip and held in place by a pin. The improved hardwood stick supplied with Generator ML-185-B has a bronze tip with a chisel point (four faces) which is secured by a brass rivet. (See par. 13e.)

## 10. Chest for Accessories

a. GENERAL. The chest is a wooden box in which the support assembly, accessories, and running spare parts are stored and shipped. The chest is 61¼ inches long, 20¾ inches wide, and 11½ inches high. The top cover is hinged and is held upright, when open, by a chain at one end. The inside of the chest is divided into three main sections for the convenient storage of the various items. (See fig. 6.)

b. ACCESSORIES. The accessories included in the chest are listed in paragraph 3 (components parts list).

c. RUNNING SPARE PARTS. The running spare parts included in the chest are listed in paragraph 3 (components parts list).

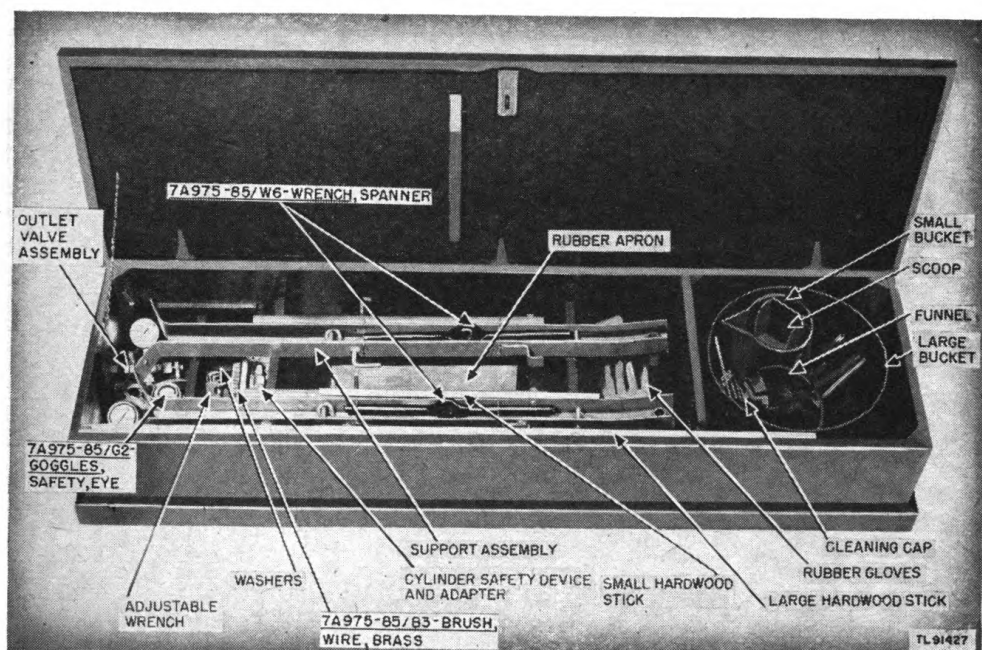

Figure 6. Chest for accessories, open.

## 11. Chemicals

The chemicals, caustic soda in flake form (Signal Corps stock No. 6G197) and ferrosilicon (Signal Corps stock No. 6G550) or Caustic Soda Charge ML-388/UM\* and Aluminum Charge ML-389/UM\*, are used with Hydrogen Generator ML-185-(\*) but are not components of the equip-

\* Signal Corps stock number not available at time of publishing this Technical Manual.

ment. The chemicals are procured as supplies, as allowed in Army Service Forces Catalog Sig 4-1.

a. FERROSILICON PROCESS. (1) Caustic soda (98% sodium hydroxide) is provided in flake form (known commercially as *technical flakes*) supplied in 5-pound cans. Five pounds are used for one unit charge. For export shipment, the caustic soda is boxed in cases of 24 cans.

(2) Ferrosilicon (90% silicon; grain size,  $\frac{1}{4}$  inch by down) is usually supplied in bags of  $4\frac{1}{2}$  pounds, which is the amount needed for one unit charge. If the ferrosilicon is provided in an airtight metal container, the container should have a small hole punched in it for the release of any gas formed by decomposition of impurities.

**Caution:** Ferrosilicon and caustic soda react violently in the presence of moisture, liberating hydrogen. They should never be stored together where there is any possibility of their coming in contact with one another.

(3) Four gallons of water are required for one unit charge. Either fresh or sea water may be used.

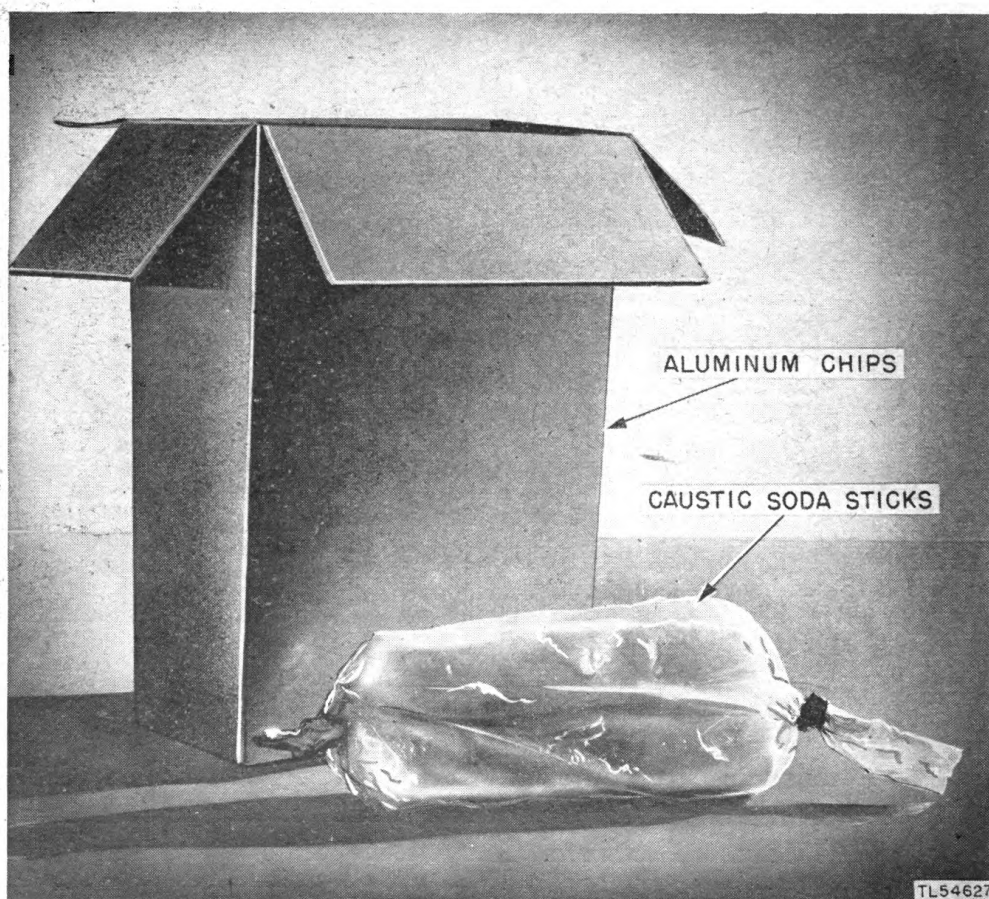

Figure 7. Aluminum Charge ML-389/UM and Caustic Soda Charge ML-388/UM.

*b.* ALUMINUM PROCESS. (1) Caustic Soda Charge ML-388/UM will be supplied in the form of two 1-pound sticks\*,  $1\frac{5}{8}$  inch in diameter by  $7\frac{1}{2}$  inches long sealed in plastic film. Two pounds are necessary for one unit charge.

(2) Aluminum Charge ML-389/UM\* will be provided in chip form (aluminum chips) packed in cardboard boxes containing one unit charge;  $6\frac{1}{4}$  pounds are used for one unit charge.

(3) Three gallons of water are required for one unit charge. Either fresh or sea water may be used. Sea water, however, gives lower hydrogen yield.

## 12. Special Equipment for Aluminum Process†

The equipment used for the aluminum process will be essentially the same as is used for the ferrosilicon process. The differences of the equipment used with the aluminum process are as follows:

**Caution:** Never use the aluminum process with Generator ML-185-(\*) unless the nickel safety disks and outlet valve assembly, manufacturers' part No. 200S, are used. The valve assembly supplied with Generator ML-185-A, and the copper safety disks, cannot withstand the increased pressures and temperatures reached with the aluminum process.

*a.* SAFETY DISKS. The safety disks will be made of nickel (Signal Corps stock No. 7A858), instead of copper. The nickel disks will be designed to rupture at pressures in the cylinder of 3,000 to 3,500 pounds per square inch.

*b.* WATER BUCKET. The water bucket for measuring the quantity of water for each charge will be altered to have angle markers (iron projections,  $\frac{1}{2}$  inch wide) placed  $1\frac{3}{8}$  inch below the existing markers. The new marker will indicate a 3-gallon capacity, as against a 4-gallon capacity for the ferrosilicon process.

*c.* FUNNEL. A new funnel (Signal Corps stock No. 7A891) will be provided for use when charging the generator in an upright position.

*d.* OUTLET VALVE ASSEMBLY. The outlet valve assembly, manufacturer's part No. 200S, must be used. This valve assembly is supplied with Generator ML-185-B. It is not soldered, as is the valve supplied with Generator ML-185-A, and is thus able to withstand the increased pressures and temperatures of the aluminum process.

\*Signal Corps stock number not available at time of publishing this Technical Manual.

†All material in this Technical Manual describing the use and equipment for generating hydrogen gas with aluminum and caustic soda is for information only. The necessary modifications and special equipment will be covered in a modification work order to be published at a later date.

### 13. Differences in Generators ML-185-(\*)

Both models of the generator are referred to in this manual as Generator ML-185-(\*). (See par. 1.) Items which differ in the two models, hydrogen Generator ML-185-A and hydrogen Generator ML-185-B, are described below.

a. CYLINDER SAFETY DEVICE. (1) *Generator ML-185-A*. The cylinder safety device for this model consists of a safety disk which bursts under excessive pressures, and of a right-hand threaded cap which holds the disk. The cap has hexagonal sides above which is a knob-like projection. In this projection are six holes through which the hydrogen escapes in all directions when the safety disk breaks. The copper safety disk is  $9/16$  inch in diameter and bursts at a pressure of 2,550 to 2,850 pounds per square inch. A fiber washer provides a seal for the disk.

(2) *Generator ML-185-B*. The safety disk for this model consists of a right-hand threaded cap, a sleeve, and a safety disk. The sleeve contains one outlet, and can be adjusted to assure a blow-off discharge in one direction when the disk blows. Always adjust the sleeve so that the discharge will be directed *down and away from the operator* and will not strike the cylinder. In this model, the copper safety disk is  $19/32$  inch in diameter and bursts at a pressure of 2,700 to 3,000 pounds per square inch. The nickel safety disk, used with the aluminum process, ruptures at a pressure of 3,000 to 3,500 pounds per square inch; the disk is  $19/32$  inch in diameter. The cylinder and valve safety devices (par. 13b(2)(c)) for Generator ML-185-B are interchangeable. (See fig. 5.)

b. OUTLET VALVE ASSEMBLY (FIG. 4). (1) *Generator ML-185-A*. (fig. 5). (a) The valve stem of this model is made of brass.

(b) The regulating and discharge valve is made of brass and there are no flats on the inlet coupling similar to those found in Generator ML-185-B. (See par. 13b(2)(b).)

(c) The valve safety device consists of a copper safety disk, sealed by two fiber washers, and of a hexagonal, right-hand threaded cap which holds the disk. Each of the hexagonal faces of the cap has a hole through it to provide an outlet for a blow-off discharge. The copper disk is  $19/32$  inch in diameter and bursts at a pressure of 2,550 to 2,850 pounds per square inch.

(2) *Generator ML-185-B*. (fig. 5). (a) The valve stem of this model is made of stainless steel.

(b) The inlet coupling on the regulating and discharge valve is constructed of hard bronze and is provided with flats so that it can be gripped and removed by a wrench. The inlet coupling is connected to the valve body by a ball and cone joint.

(c) The valve safety device for this model is identical to the cylinder safety device described above (par. 13a(2)), with which it is interchangeable.

c. SUPPORT ASSEMBLY. The support assembly for Generator ML-185-B is provided with a bolt,  $4\frac{1}{2}$  inches from the lower end of one of the legs, to which the ground wire is connected. (See par. 16b.) The bolt is held in place by two washers and a nut. Generator ML-185-A is not equipped with this bolt.

d. ACCESSORIES. Generator ML-185-B is equipped with the following items which are not furnished with Generator ML-185-A:

Wrench for large plug.

Brass wire brush for small openings.

Reamer assembly.

These items should be ordered from supply depot, if using Generator ML-185-A.

e. LARGE HARDWOOD STICK. (1) *Generator ML-185-A*. The large hardwood stick supplied with this model has a brass ring slipped over the tip and held in place by a pin.

(2) *Generator ML-185-B*. The improved hardwood stick supplied with this model has a bronze tip with a chisel point (four faces), secured by a brass rivet.

f. CHART SHOWING DIFFERENCES IN MODELS.

*Differences in Models*

Item	Generator ML-185-A	Generator ML-185-B
Cylinder safety device safety disk	9/16 inch diameter; bursts at 2,550-2,850 pounds per square inch.	1 1/2 inch diameter; bursts at 2,700-3,000 pounds per square inch.
safety device cap	right-hand threaded cap; six holes through which hydrogen discharges in all directions.	right-hand threaded cap and sleeve with one outlet adjustable for hydrogen discharge in one direction.
Outlet valve assembly valve stem	brass.	mfrs. part 200S.
regulating and discharge valve	no flats on inlet coupling; connected to valve body by threads, and soldered.	stainless steel.
safety device	copper safety disk 1 1/2 inch diameter, bursts at 2,550-2,850 pounds per square inch; six holes on cap holding disk.	flats on hard bronze inlet coupling connected to valve body by ball and cone joint.
Support assembly	no bolt for connection of ground wire.	interchangeable with cylinder safety device.
Large hardwood stick	brass ring over tip, held by pin.	bolt for connection of ground wire.
Accessories		bronze tip with chisel point (4 faces) secured by brass rivet. wrench for large plug brass wire brush (for small openings) reamer assembly.

## Section II. INSTALLATION AND ASSEMBLY

### 14. Siting

a. SHELTER. (1) Whenever possible, generate hydrogen in a building with permanent louvered ventilators near the floor and ceiling to allow the escape of hydrogen in case of leakage. The shelter\* should have sliding

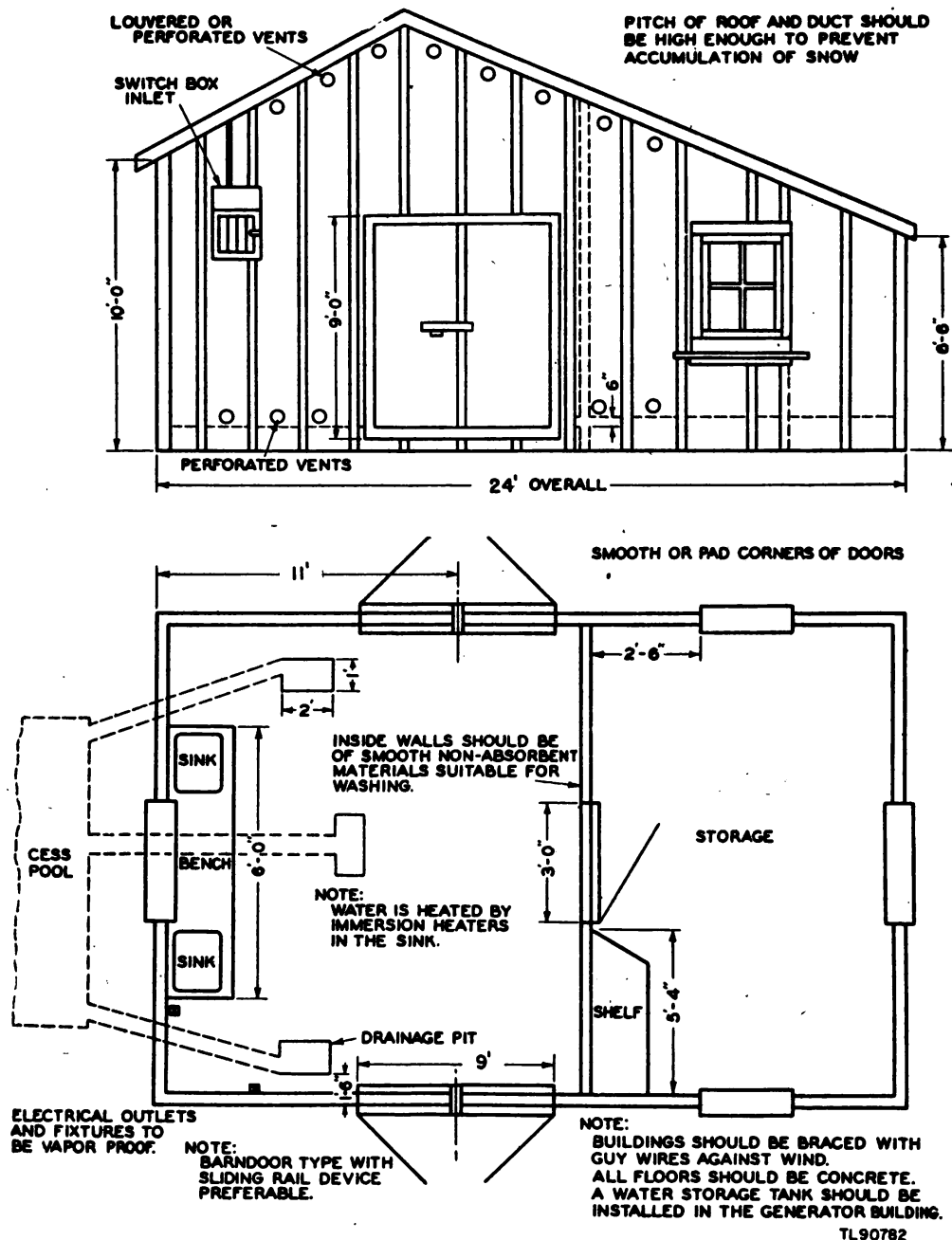

Figure 8. Shelter\* for hydrogen generator.

\*This shelter is a suggested plan only, and may be varied by using personnel to suit local conditions.

doors (or doors that open outward) that provide an exit at least 9 feet square to permit the passage of the largest balloon used. Doors should open on all four sides of the building, if practicable, so that the balloons may be taken out in the direction towards which the wind is blowing. Pad or smooth all door frames and all sharp corners in the shelter to reduce balloon breakage. The walls should be constructed of an easily scrubbed, caustic-resistant material such as concrete or brick. The floor should be concrete with suitable drainage pits (caustic soda eats away wood). A dirt floor is also satisfactory. As a safety measure, locate the shelter away from other buildings.

**Caution:** Make all electrical fixtures and switches explosion-proof.

(2) A storage room for the chemicals is desirable. Store the caustic soda and ferrosilicon, or caustic soda and aluminum, apart from each other so that the chemicals cannot mix if the containers break. Keep the chemicals dry. Punch a small hole in all small metal ferrosilicon containers to release any gas that may form from the decomposition of impurities in the ferrosilicon.

*b.* HEATED SHELTER FOR USE IN ARCTIC REGIONS (FIG. 9). In arctic regions, use Generator ML-185-(\*) in a heated shelter if possible. Use an indirect heating system, preferably a hot-air system, since steam or hot-water systems freeze in cold weather. Locate the heating unit in a separate building, or in a portion of the generator building, *completely separated by a fireproof partition*. All possibilities of fire, sparks, or explosion *must* be eliminated. The entrance to the heater room should be from the outside. Provide adequate ventilation for the immediate removal of hydrogen gas in case of leakage.

**Caution:** Never use an open heater to heat a shelter where hydrogen is stored or generated.

## 15. Unpacking, Uncrating, and Checking

*a.* Hydrogen Generator ML-185-(\*) is packed in two crates. One crate contains the cylinder assembly and its components. The other crate contains the chest with all the accessories and running spare parts.

*b.* Carry the crates to the shelter in which Generator ML-185-(\*) will be installed, and unpack them. Take care not to overlook or lose either the small parts or the accessories, when unpacking. Check the parts against the components parts list. (See par. 3.)

## 16. Assembly

*a.* MOUNTING CYLINDER ON SUPPORT ASSEMBLY. Two operators are required to mount the cylinder on its support assembly. The support assembly and all accessories are stored in the chest. (See fig. 6.)

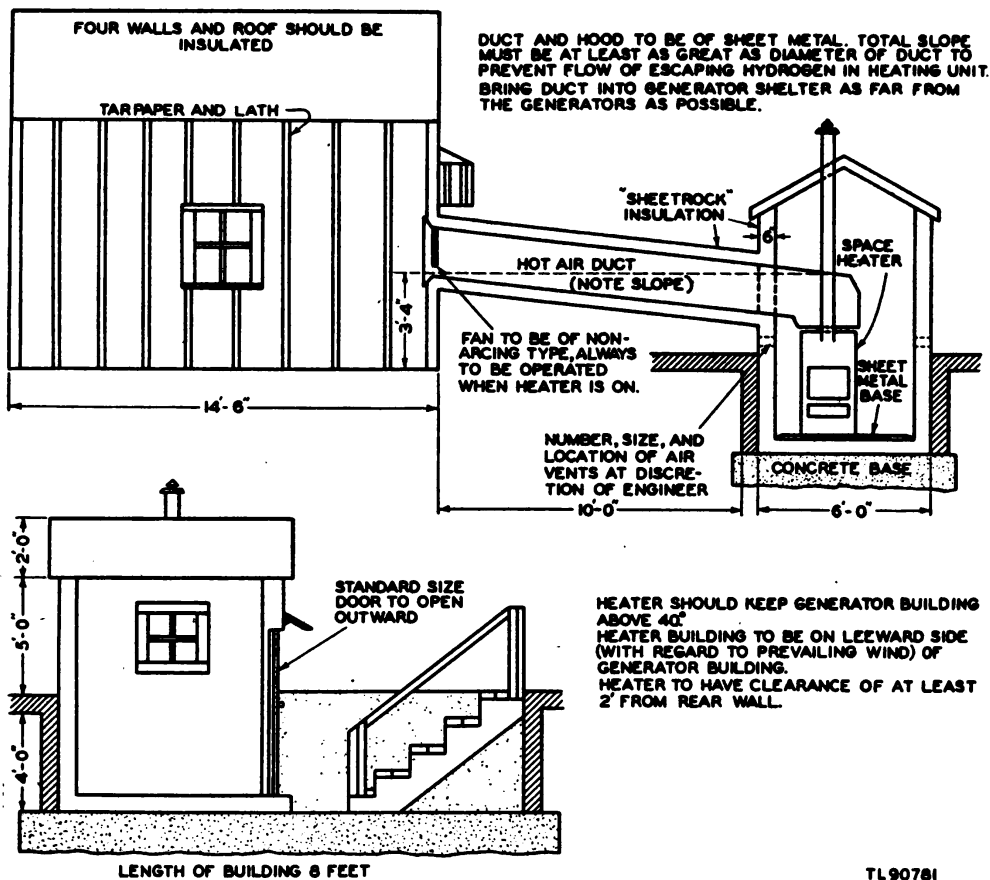

Figure 9. Heated generator shelter.

- (1) Unfold the support legs of both **A**-frames, and hook the rods into the eye hooks.
- (2) Stand the cylinder upright.
- (3) Operator 1 tilts the cylinder against his shoulder so that one trunnion points upward. Operator 2 places the socket of one support on the trunnion.
- (4) Operator 2 lowers the support to the ground. Operator 1 and Operator 2 pivot the cylinder on the support legs and push the cylinder upright (slightly past the vertical). Operator 1 leans against, and balances the cylinder on the one support.
- (5) Operator 2 fits the socket of the second **A**-frame on the remaining cylinder trunnion. Operator 1 releases the cylinder and allows it to rest on both supports.
- (6) To make the support assembly stable when it is resting on sand or on muddy ground, use the holes in the base of the frames, and bolt each **A**-frame to a 2 x 4. For installation on a truck or cart, bolt the assembly to the platform.

(7) Place the spanner wrench funnel, and cleaning cap assembly on the support hooks. Place all other accessories within convenient reach.

*b. GROUNDING PROCEDURE.* (1) The friction of hydrogen escaping at a high velocity may build up an electrostatic charge which could discharge to ground and ignite the hydrogen. To eliminate the possibility of fire when using Generator ML-185-(\*), attach a braided wire to the frame support of the generator, and then run the wire to a well-grounded object such as a pipe or metal stake driven into wet ground. When using Generator ML-185-B, attach the wire to the bolt provided for this purpose. (See par. 13c.) At the connection to the frame support, fasten a second braided wire between the frame support and the end of the trunnion shaft. This connection should be brazed or bolted to the trunnion shaft. A bolted connection can be made by drilling and tapping a hole in the trunnion shaft. This connection will eliminate the possibility of building up a charge on the generator when grease or foreign matter in the socket of the support offers a high resistance to the flow of electricity to ground. Provision should also be made for a periodic test of ground connections, using an ohmmeter connected from the cylinder to the ground rod.

(2) Hydrogen cylinders should be grounded by attaching a large battery clip to one end of a braided or flexible wire. Attach the clip to the safety disk cap on the cylinder valve. Attach the other end of the wire to a well-grounded object.

(3) Inflation cocks or nozzles should be grounded by attaching a large battery clip to one end of a braided or flexible wire. Attach the clip to a balloon cock or nozzle. Attach the other end of the wire to a well-grounded object.

(4) Personnel should be grounded. To do this, a wrist band of metal is attached to the operating personnel with a wire running from the wrist band to a well-grounded object. For convenience, the wire running from the wrist band may end in a telephone plug which can be inserted in a jack which in turn is permanently grounded.

(5) It is recommended that, wherever possible, a ground connection be made to a water pipe since this is one of the best possible grounds which can be obtained with a minimum expenditure of effort. In the event that it is impossible to use a water system for the ground, it is recommended that the following procedure be used to obtain a satisfactory ground:

(a) Space two ground rods approximately 20 feet apart and drive the rods into the ground to a depth of approximately 4 feet.

(b) Measure the resistance between these two rods with an ohmmeter.

(c) If the resistance is greater than 1,000 ohms, drive another pair

of ground rods into the ground to form two rows of rods. The distance between each rod in a row should be approximately 5 feet.

(*d*) Connect each row of rods electrically and measure the resistance between them with an ohmmeter.

(*e*) If the resistance is still greater than 1,000 ohms, drive additional rods into the ground until the resistance between the two rows of rods is less than 1,000 ohms.

(*f*) Connect all rods electrically and use the combination of all rods as the ground.

## 17. Repacking Generator ML-185-(\*) for Transport

To repack Generator ML-185-(\*) for transport, proceed as follows:

- a.* Thoroughly clean and completely empty the generator.
- b.* Grease the threaded steel parts.
- c.* Remove the outlet valve assembly and the cylinder safety device, and cover the adapters with the protection caps.
- d.* Attach the large plug assembly to the cylinder.
- e.* Remove the cylinder from the support and pack it.
- f.* Pack the accessories in the chest.

# PART TWO

## OPERATING INSTRUCTIONS

---

*Note.* For information on destroying this equipment to prevent enemy use, see the destruction notice at the front of this manual.

### Section III. PRELIMINARY PROCEDURE

#### 18. Preparation of Generator ML-185-(\*) for Use

*a.* Check the equipment thoroughly before attaching the outlet valve assembly to the cylinder.

(1) Examine the pressure gage and valve safety disk. Make sure that the openings in the outlet valve assembly are clean. Run a stiff wire through these openings to remove any obstructions.

(2) Run a stiff wire through the two adapters in the sides of the cylinder to remove any obstruction.

*b.* Assemble the outlet valve assembly by screwing the pressure gauge, the valve safety device, and the hose coupling in place. (See fig. 4.)

*c.* Remove the left-hand threaded protection cap from the outlet valve adapter and store it in the chest. Screw the left-hand threaded outlet valve assembly to the adapter.

*d.* Screw the cylinder safety device on its adapter.

**Caution:** Adjust the sleeve of the cylinder safety device on Generator ML-185-B so that the outlet directs the blow-off discharge downward. Adjust the outlet on the valve safety device so that the outlet points down and away from the operators and cylinder.

*e.* Replace defective or improperly seated disks (par. 42*b*) and washers.

**Caution:** Always be sure to check the washers and safety disks to see that they are properly in place before using the generator.

*f.* Make sure that main plug threads and threads on the inside of the neck of the cylinder are cleaned and lightly greased before assembling. (See par. 29*c*.)

#### 19. Precautions on Handling Generator ML-185-(\*)

Special attention is called to the safety notice in the front of this manual. Since the use of Generator ML-185-(\*) involves high pressures and explosive mixtures of air and hydrogen, the following precautions must be observed constantly:

a. Remove all possible sources of flames and sparks. (1) Never smoke near the generator shack.

(2) Sparks from shoe nails are dangerous.

(3) Do not strike or drop iron tools against a concrete floor or iron because dangerous sparks may be produced.

b. Display conspicuous warning signs wherever hydrogen is used or stored.

c. Provide permanent louvered ventilators near the ceiling and floor to prevent the accumulation of hydrogen and to allow its escape from any building in which it is stored.

d. Ground the generator. (See par. 16b(1).)

e. The personnel should be grounded. (See par. 16b(4).)

f. Wear goggles, rubber apron, and rubber gloves when handling caustic soda or caustic residue.

g. Do not allow the cylinder to be heated by the sun. If the cylinder is heated by the sun, excessive pressures may result.

h. Beware of working pressures in excess of 2,800 pounds per square inch, since they approach the pressure at which the safety disks blow. At pressures of 2,800 pounds per square inch or over, move away from the generator—*FAST*.

## 20. Treatment of Caustic Burns

a. GENERAL. Caustic soda causes serious, hard-to-heal burns. An itchy or slippery, soapy feeling indicates the presence of caustic soda on the skin. *Treat caustic burns immediately. Call a doctor immediately but proceed with treatment until the doctor arrives.*

*Note.* Before treating a burn, wash hands thoroughly. Use sterile water and sterile bandages.

b. EMERGENCY MEDICAL EQUIPMENT. Secure the following emergency medical equipment from the medical officer before using Generator ML-185-(\*):

Boric acid (2 percent).

Solution of butyn (2 percent).

Ointments:

boric acid in petrolatum, or nupercaine.

Acetic acid (4 percent) or vinegar.

**Eye pads and dressings.**

**Adhesive tape.**

**Vaseline.**

*c. TREATMENT OF EYE BURNS.* For caustic burns in the eyes, *call a doctor immediately* and proceed as follows until the doctor arrives:

(1) Have the patient lie on his back.

(2) Wash the eyes generously with a lukewarm saturated solution of boric acid (4-percent boric acid in water).

(3) Apply two drops of 2-percent butyn, an anaesthetic, to the affected eye. This will sting at first and then will gradually deaden the eye to pain.

(4) Apply a boric acid ointment between the lid and the eyeball. Use nupercaine, if boric acid ointment is not available. The ointment prevents adhesion of the lid to the eyeball.

(5) Bandage the eye with a sterile eye pad and with adhesive, to keep air from the burn.

(6) Get the patient to the hospital as soon as possible. The patient is likely to lose his eyesight if the eye is not treated at once.

*d. TREATMENT OF SKIN BURNS.* Treat caustic burns on the skin as follows:

(1) First wash the affected area plentifully with water. Then wash it several times with vinegar (4-percent acetic acid), and finally with water again.

(2) Apply vaseline or boric acid ointment to the burn. Cover the burn with a bandage so that the burn will be kept sterile, and get the patient to a doctor as soon as possible.

## Section IV.

## OPERATION OF EQUIPMENT AND USE OF ACCESSORIES

## 21. Charging Generator ML-185-(\*) Using Ferrosilicon Process

a. BE SURE TO PUT ON THE SAFETY GOGGLES. Also wear rubber apron, and rubber gloves.

b. Tilt the cylinder so that the outlet valve assembly is on the upper side. (See fig. 10.) Secure the support bar of the proper A-frame to the bar hook opposite it on the other A-frame. Lower the cylinder *gently* on the crossbar to prevent bending the bar. The bar now supports the cylinder at an angle of 45°.

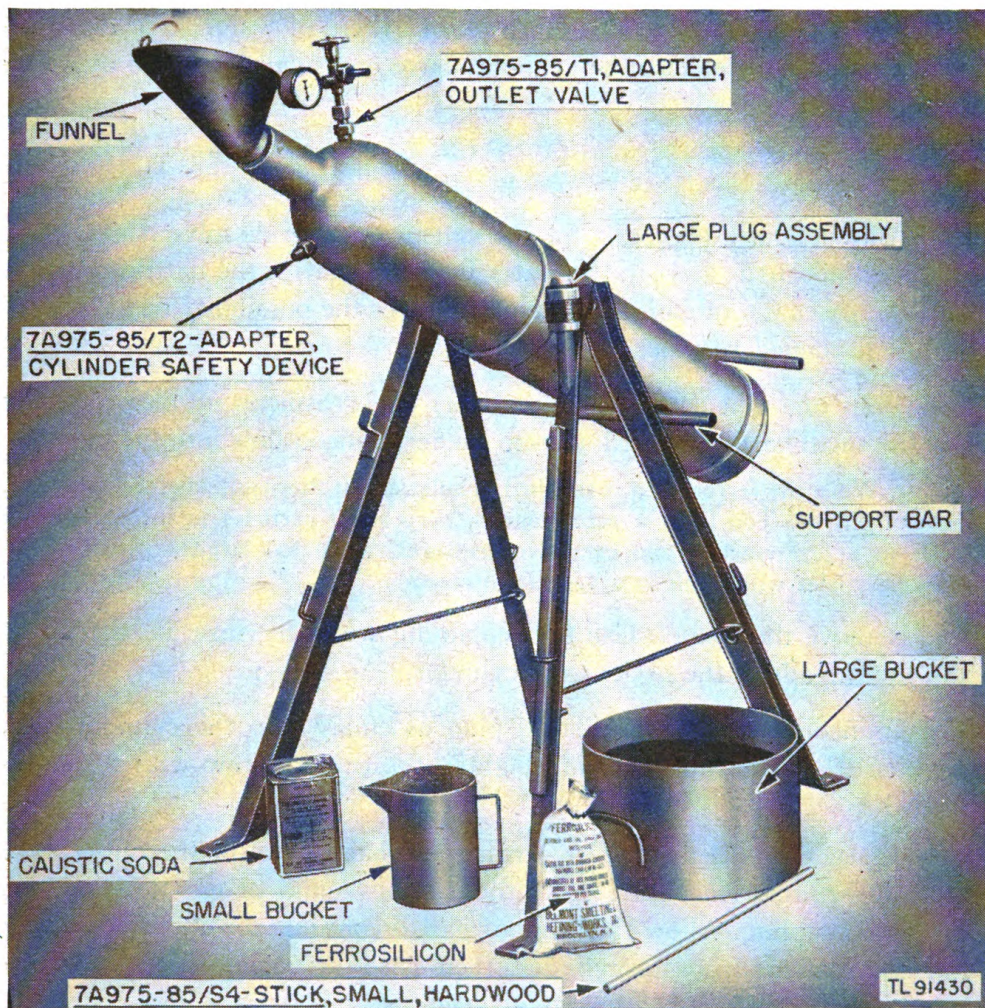

Figure 10. Generator ML-185-(\*), inclined charging position.

c. Make sure that the outlet valve is partly open.

d. Place the funnel into the opening of the neck of the cylinder. Be certain that the pin is in the slotted projection on the neck of the funnel.

c. Pour one unit charge (5 pounds or 2.3 kilograms) of caustic soda (sodium hydroxide) into the cylinder. Use the small hardwood stick to push all of the caustic soda through the funnel into the cylinder. An empty 5-pound sodium hydroxide can makes a convenient measure if later supplies come in bulk.

**Caution:** Sodium hydroxide can cause serious burns. When handling it, always stand so that the wind will blow any flakes or caustic soda dust *away* from the hands, face, and body. Avoid splashing solutions containing sodium hydroxide. Do not handle the residue.

For first aid treatment of caustic burns, see paragraph 20.

f. Fill the large bucket with water up to the inside projections. If the bucket is not available, use 16 quarts or 15 liters of water. Use the small bucket to pour water into the cylinder. Save one small bucketful of water. (See par. 21i.)

*Note.* The water should be at least 80° F (27° C), preferably warmer. In the arctic, the water should be hot. (See par. 26b.)

g. Allow about 30 seconds for the caustic soda to dissolve. *Completely* dissolve the caustic soda in the water by stirring with the hardwood stick. This increases the rate of reaction and reduces the possibility of the formation of hardened residues.

h. Pour one unit charge (4½ pounds) of ferrosilicon into the cylinder. Use the small hardwood stick to help the ferrosilicon flow into the cylinder.

*Note.* When the ferrosilicon is supplied in bulk, mix it thoroughly before measuring the unit charge. Too large a percentage of *very small* particles in the charge will result in a *fast* reaction and excessive pressures, while too large a percentage of *coarse* particles will result in a *very slow* reaction.

i. Remove the funnel. Use the remaining water to rinse out the funnel and the threads in the neck of the cylinder.

j. Immediately screw the large plug assembly into the cylinder neck. Tighten the large nut *by hand*. Tighten the center screw with a spanner wrench.

k. Open the outlet valve by turning the handwheel of the outlet valve assembly *counterclockwise*. Note the hissing sound of gas flowing from the hose coupling. Allow this flow of gas to continue for about 30 seconds to remove all air from the cylinder ; then close the valve.

**Caution:** Do not tighten the handwheel too much, as the valve may lock or freeze. Never use a wrench to tighten the handwheel.

l. The reaction of the chemicals causes wide temperature changes and causes stress in the valve. Relieve this stress at intervals by opening the valve slightly and then immediately closing it while the temperature is changing.

*m.* Lift the cylinder slightly, and unhook the support bar. Lower the cylinder until it is in an upright position. Secure the bar in the lower hook so that it will be out of the way when the cylinder is later swung on its axis.

*n.* Agitate the contents of the generator as follows:

(1) Tilt the cylinder to a  $45^\circ$  angle. Allow the cylinder to swing downward, and then stop it with a jerk at the bottom of the swing.

(2) Repeat until the reaction is well started. (See (1) above.) A pressure of over 200 pounds per square inch or a bubbling sound and heat coming from the generator, show that the reaction has started. In cold weather, it may be necessary to shake the cylinder for 15 minutes to be sure of a normal yield.

*Note.* In oscillating the generator, do not swing the generator so that it will approach within  $30^\circ$  of the horizontal position.

**Caution:** If the gauge indicates a rapid, instead of a gradual increase in pressure, move away quickly, and stand at a safe distance from the generator. **MOVE FAST.** The gauge dial is moving rapidly if, after reaching a pressure of 1,500 pounds per square inch, it moves at the rate of 100 pounds per minute.

*o.* Once the reaction has started, further action is automatic. See paragraph 22 for securing maximum yields of hydrogen.

## 22. Obtaining Maximum Hydrogen Yield with Ferrosilicon

*a.* When using the ferrosilicon process, the ratio of chemicals may be varied to obtain a maximum hydrogen yield with minimum difficulty in cleaning. In the field, this ratio may be found by experiment.

(1) The size of the charge is correct if the pressure attained is from 1,600 to 2,100 pounds per square inch while the generator is hot, or from 1,200 to 1,500 pounds per square inch when it is cold. If the resultant pressure is not within these limits, increase or decrease the size of the charge proportionately.

(2) The ratio of the chemicals is correct if the residue is a gray liquid sludge with no solids.

(a) The presence of much ferrosilicon and clinkers in the residue indicates too high a ratio of ferrosilicon in the charge.

(b) The presence of a brown, gummy, hard-to-clean sludge indicates too high a ratio of sodium hydroxide.

*b.* The hydrogen yield may be increased by additional vigorous shaking of the cylinder after the pressure has apparently reached a maximum. This occurs about 30 to 60 minutes after mixing the chemicals.

## 23. Charging Generator ML-185-B Using Aluminum Process

a. BE SURE TO PUT ON THE SAFETY GOGGLES. Also wear rubber apron, and rubber gloves.

b. Place the cylinder in an upright position. Secure the support bar of each A-frame to the bar hook opposite it on the other A-frame.

c. Make sure that the outlet valve is partly open.

d. Place the funnel into the opening of the neck of the cylinder, and see that the pin is in the slotted projection on the neck of the funnel.

e. Load the aluminum charge ( $6\frac{1}{4}$  pounds aluminum chips) into the generator, using the small hardwood stick to aid its descent.

f. Fill the large bucket with water to the markers indicating a 3-gallon capacity, or  $1\frac{1}{2}$  inches below the angular markings. Use the small bucket to pour the water into the cylinder. Save one small bucketful of water (*g* below).

*Note.* Never use water at a temperature above  $130^{\circ}$  F with the aluminum process.

g. With the remaining water in the small bucket, wash down the chips of aluminum which may be stuck in the threads in the neck of the cylinder.

h. Place two sticks of caustic soda into the generator by allowing them to drop freely through the neck of the cylinder.

**Caution:** Be extremely careful in handling the caustic. *Always use rubber gloves.*

i. Immediately screw the plug assembly completely into the neck of the cylinder. Tighten the large nut *by hand*. Tighten the center screw with a spanner wrench.

j. Unhook the crossbars to allow the cylinder to swing freely and oscillate until gas starts to issue from the outlet valve.

k. Open the outlet valve by turning the handwheel of the outlet valve assembly *counterclockwise*. Note the hissing sound of gas flowing from the hose coupling. Allow this flow of gas to continue for 30 seconds to remove all air from the cylinder; then close the valve. (This procedure is known as "purging".)

*Note.* Do not tighten the handwheel too much, as the valve may lock or freeze.

l. Continue oscillation for 3 minutes after purging. In temperate climates, it will take about 2 to 3 minutes from the time the plug assembly is sealed until the generator is purged.

*Note.* In oscillating the generator, do not swing the generator so that it will approach within  $30^{\circ}$  of the horizontal position.

m. It will take about 30 to 40 minutes for the pressure to reach 1,000



*Figure 11. Generator ML-185-B in upright charging position.*

pounds per square inch. At this point, oscillate the cylinder for about 5 minutes. The pressure will then begin to rise quite consistently, and in about 1 hour will reach the maximum pressure of approximately 2,300 pounds per square inch. Thereafter, as the cylinder cools, the pressure will decrease slowly.

u. Once the reaction has started, further action is automatic.

**Caution:** If the gauge indicates a rapid, instead of a gradual increase in pressure, move away quickly, and stand at a safe distance from the generator. MOVE FAST. The gauge dial is moving rapidly if, after reaching a pressure of 1,500 pounds per square inch, it moves at the rate of 100 pounds per minute.

## 24. Release of Hydrogen from Generator ML-185-(\* )

Hydrogen may be released from the generator while the generator is in an inclined or upright position. To hold the cylinder upright, secure the crossbars, one on each side of the cylinder.

a. **FERROSILICON PROCESS.** When using ferrosilicon in the chemical reaction, Generator ML-185-(\* ) produces about 85 to 90 cubic feet of hydrogen in about 2 hours. (However, 10 to 20 cubic feet of gas may be used about 15 minutes after charging, if the gauge indicates a pressure of 1,000 pounds per square inch or greater. This hydrogen is hot. If hydrogen is removed at lower pressures, it may be diluted with steam. That is why *only* 10 to 20 cubic feet may be removed, and *only* at pressures of 1,000 pounds per square inch or more). To release hydrogen and inflate balloon, proceed as follows:

(1) Attach the balloon to the hose cock, the cock to Hose ML-81, and Hose ML-81 to the hose coupling.

(2) Open the handwheel of the outlet valve assembly gently, *only a fraction of a turn at a time*, to release the gas *slowly*. The rate of release of hydrogen must not exceed 10 cubic feet per minute. Also, rapid discharge of hydrogen may build up an electrostatic charge, and possibly result in an explosion.

(a) If hydrogen is released too rapidly from a hot cylinder, the charge may foam and carry particles of ferrosilicon into the valve assembly. When the valve is closed, these particles score the valve seat and cause a leak.

(b) A balloon too rapidly inflated may be pierced by ferrosilicon particles. In addition, the hot gas carries steam into the balloon; this reduces the lift from a given volume of gas.

(c) Hot gas, escaping through the valve, may melt the solder in the joint of Generator ML-185-A connecting the valve to the adapter and may cause a leak.

(3) When the balloon has been inflated, close and tighten the wheel of the valve *by hand*. The rest of the gas remains in the cylinder, and the approximate volume is indicated on the pressure gauge.

*b.* ALUMINUM PROCESS. When using aluminum in the chemical reaction, about 120 cubic feet of hydrogen is produced in 2 hours. The hydrogen can be discharged from the generator at various times during the generation cycle. In 1 hour, the generation is not complete but 100 cubic feet of hydrogen are available. If generation is allowed to continue for 1½ hours, 110 cubic feet of hydrogen are produced, and in 2 hours time the maximum 120-cubic-foot yield is available. **Under normal operating conditions, do not attempt to use the hydrogen gas until the charge has been generating for approximately 2 hours.** To release hydrogen and inflate balloon, proceed as follows:

(1) Attach the balloon to the hose cock, the cock to Hose ML-81, and Hose ML-81- to the hose coupling.

(2) Open the handwheel of the outlet valve assembly gently, *only a fraction of a turn at a time*, to release the gas *slowly*. The rate of release of hydrogen must not exceed 10 cubic feet per minute. Also, rapid discharge of hydrogen may build up an electrostatic charge, and possibly result in an explosion.

(*a*) If hydrogen is released too rapidly from a hot cylinder, the charge may foam and carry particles of aluminum into the valve assembly. When the valve is closed, these particles score the valve seat and cause a leak.

(*b*) A balloon too rapidly inflated may be pierced by aluminum particles. In addition, the hot gas carries steam into the balloon. This reduces the lift from a given volume of gas.

*c.* HOT INFLATIONS. Do not inflate balloons while the generator is hot, if it can be avoided. A hot generator contains solutions, at temperatures ranging up to 500° F, which will boil as the pressure is reduced below 500 pounds per square inch. This results in the issuance of steam, which must not be allowed to enter the balloon.

(1) The issuance of steam can be evidenced by the distinct difference in the sound of the flow of gas. The flow of hydrogen is accompanied by a sharp hissing sound, the flow of steam by a dull hollow sound.

(2) If steam begins to issue, close the outlet valve *immediately*.

*d.* COLD CLIMATES. In cold climates, use the gas before the generator is entirely cool so that the cylinder may be cleaned before the residue hardens and solidifies. If hydrogen is left in the cylinder, transfer the hydrogen to an empty air-purged cylinder (par. 26a(2)) and clean the cylinder while it is still warm. A special high-pressure hose is used for the transfer. (See par. 36.) If not all of the hydrogen is to be used at one

time, some of it can be transferred to an empty or partially filled cylinder. The balloon can then be filled with the gas from the charged generator, and additional hydrogen can be taken from the storage cylinder if necessary. If hydrogen remains in the generator and there is no available cylinder to hold it, discharge it into the atmosphere. Clean the generator while it is still warm; otherwise the residue will freeze, and ice and hard clinkers will form, making cleaning very difficult.

## 25. Cleaning Generator ML-185-(\*)

The cylinder of Generator ML-185-(\* ) should be cleaned *immediately* after the generated hydrogen has been used. Proceed as follows:

a. Remove the hose and open the valve, allowing steam or any remaining gas to escape. Turn the handwheel of the outlet valve assembly *counterclockwise*. Make sure that all the gas is released by partially closing the valve and then opening it, several times. This usually permits the gas that is trapped by obstructions, such as water or dirt, to escape through the valve. *The room must be kept well-ventilated.*

b. After all gas and steam are released, remove the outlet valve assembly (left-hand threads). Do this *slowly*, as the valve may be clogged and may have retained some gas under pressure. Plug the outlet valve adapter either with the brass protection cap or with a cork.

c. Using the handle, spin the cylinder at least six times on the trunnions to mix and loosen the residue. Be sure that the crossbars are out of the way and are hooked flat against the support legs.

**Caution:** If a cork is used to close the outlet valve adapter, stand so as not to be splattered in case the cork is forced out.

d. Set the cylinder in the inclined charging position of 45°. (See fig. 10.) Be sure to lock the supporting crossbar in place.

e. Loosen the center screw of the large plug assembly by two or three turns with the spanner wrench. Unscrew the plug assembly with the wrench provided for that purpose. Remove the plug assembly, and place it in the support plug socket.

f. Cap the cylinder opening with the cleaning cap assembly by turning the cap slots on the cylinder pins. Do not fasten the cap too tightly because it will be difficult to remove when the chain is pulled. (Be sure that the cleaning cap contains a rubber washer.)

g. Place the large bucket under the cylinder to receive the residue.

h. Invert the cylinder so that the cylinder opening is directly over the bucket. (See fig. 12.) Hook the crossbars horizontally so that they hold the cylinder in the inverted position.

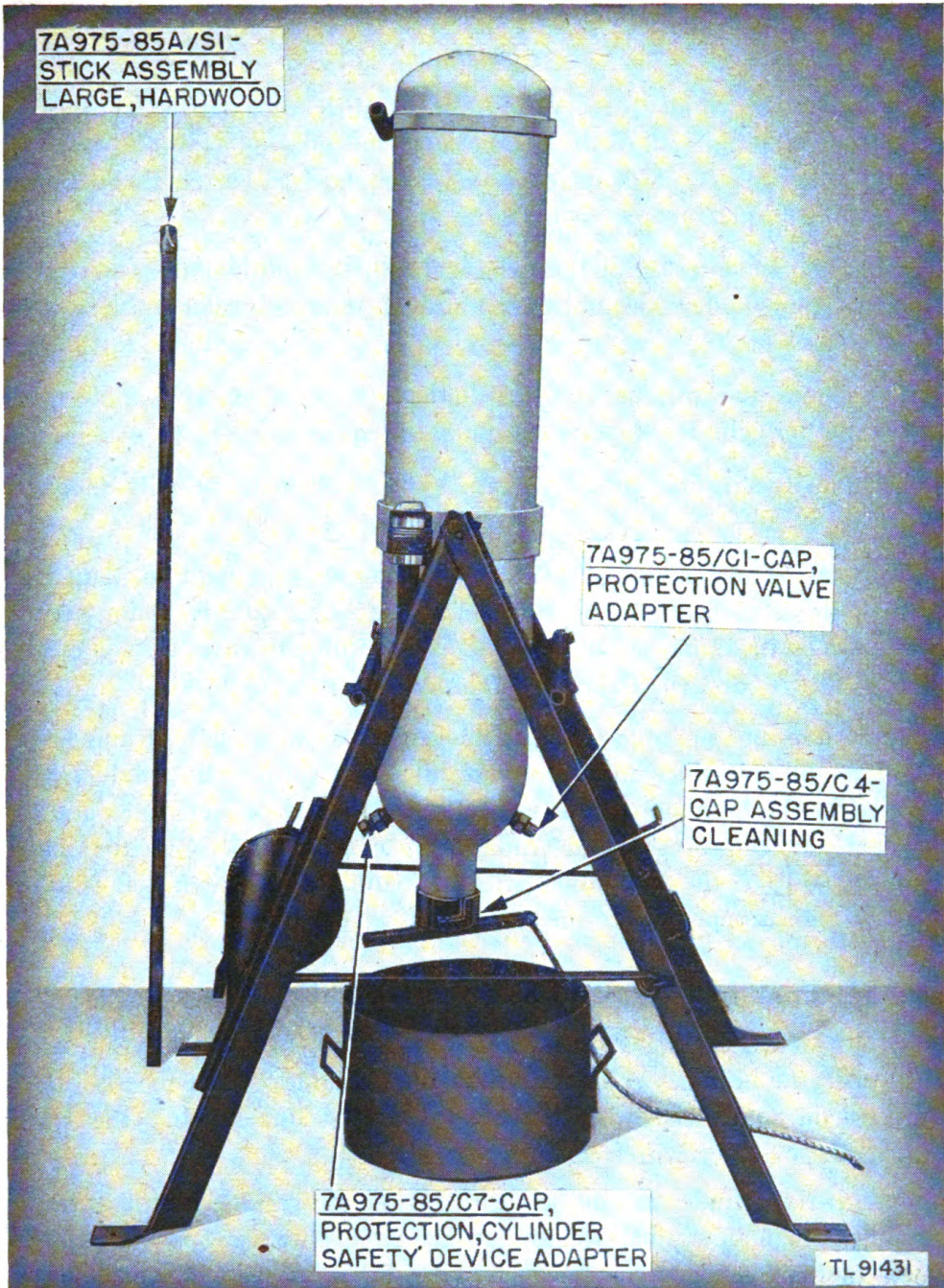

Figure 12. Generator ML-185-(\*), inverted position for emptying.

- i. Grasp the free end of the chain, and stand as far from the generator as possible. (The length of the chain can be increased, and the danger of being splashed lessened, by adding a brass wire extension to it.) Pull the chain, and allow the residue to pour into the bucket.
- j. Retrieve the cleaning cap, and rinse it in water to remove the caustic residue.

**Caution:** Do not handle the cap with bare hands until it has been rinsed.

*k.* Rinse the cylinder with water, and use the large hardwood stick to break the clinkers, if all of the residue does not fall out. Never use a steel rod for this purpose. Hot water may be required to loosen the residue. *The cylinder must be clean of all residue.*

(1) Feel the interior of the cylinder with the hardwood stick. If the inside of the cylinder does not feel clean, continue to break up the residue and rinse, as above.

(2) Check the volume of the cylinder. If less than  $11\frac{1}{3}$  gallons of water fill the cylinder, further cleaning is required.

*l.* Dump the residue into a covered pit or cesspool, specially reserved for this purpose.

**Caution:** The remaining residue is dangerous and fatal to plant and animal life. Never dump the residue close to or into any water supply used by men or animals. The residue may continue to react for some time and give off hydrogen. *Do not smoke near the residue dump.*

*m.* If it is not possible to clean the generator while hot, cleaning will be more difficult since more solid residue will form. The solid residue formed in the aluminum process has a consistency of wet ashes and, in the ferrosilicon process, hard clinkers are characteristic. In either case, vigorous use of the hardwood stick is required to loosen the residue. Follow the same procedure for cleaning as above.

## 26. Special Information on Climatic Conditions

*a.* CLEANING GENERATOR IN ARCTIC REGIONS. (1) Use the gas before the generator becomes cold, and clean the generator while the residue is still warm. Otherwise, the residue will form clinkers, and the water within the cylinder will freeze.

(2) If the cylinder cannot be cleaned while the residue is still warm, as in a pilot balloon (pibal) station, use a *high-pressure hose* to transfer some of the hydrogen to an empty, air-purged cylinder. (See par. 36.) About 60 percent of the gas may be transferred from a full generator to an empty cylinder of the same size. Use the gas in the generator, discharge the rest into the atmosphere, and then clean the generator without delay.

*b.* ABSENCE OF HEATED SHELTER. When in arctic regions, if it is not possible to use the generator in a heated shelter as advocated in paragraph 14*b*, observe the following precautions:

(1) In the ferrosilicon process use hot water to charge the generator. In subzero weather, use boiling water. Pour the water into the cylinder,

let it stand for several minutes and then empty the cylinder of water. Repeat if necessary. However, do not use hot or boiling water with the aluminum process. *Never heat a cylinder with a blow torch.*

(2) Generate the hydrogen immediately before it is to be used.

(3) Use hot water to clean the generator while the residue is still warm. The pointed, bronze-tipped hardwood stick gives better results than a wooden stick and will not produce sparks. *Never use a steel rod.* Clean all threads thoroughly, and *dry* them completely before reassembly.

(4) Frequently disassemble the outlet valve assembly, and clean it thoroughly with hot water. If the outlet valve freezes or sticks, thaw out the valve with hot water. *Do not use a wrench.* Store the assembly in a warm, dry place when it is not in use, otherwise an ice block may form in the valve openings. As a result, the gauge may indicate no pressure for a condition of high pressure.

(5) To soften clinkers and to make their removal easier, pour a few quarts of hot water into the generator and add a small amount of caustic soda. Allow this solution to act on the clinkers for about 30 minutes. This method of softening clinkers is of equal value in all climates.

c. SPECIAL INSTRUCTIONS FOR ALUMINUM PROCESS IN ARCTIC. When using the aluminum process at a temperature of 0° F or lower, it will be necessary to add an additional stick of caustic in order to obtain the best results. The heat of solution of this additional pound of caustic raises the temperature of the solution and permits the reaction to proceed at normal speed.

**Caution:** Do not use an additional stick of caustic when the outdoor temperature is above 0° F. Rapid rises in pressure will result, and the safety disks may blow.

# PART THREE

## PREVENTIVE MAINTENANCE

---

### Section V. PREVENTIVE MAINTENANCE TECHNIQUES

#### 27. Meaning of Preventive Maintenance

Preventive maintenance may be defined as a systematic series of operations performed periodically on equipment in order to maintain top efficiency in performance, to minimize unwanted interruptions in service, and to eliminate major break-downs. To appreciate the meaning of the term *preventive maintenance*, it is necessary to distinguish between preventive maintenance and trouble shooting and repair. The primary function of preventive maintenance is to prevent major break-downs and the consequent necessity of repair. In sharp contrast, the primary function of trouble shooting and repair is to locate and correct existing defects. The importance of preventive maintenance cannot be overemphasized. The usefulness of an entire meteorological system depends upon each piece of meteorological equipment in the system being ready to operate at peak efficiency when needed. Consequently, it is vitally important that operators and repairmen of meteorological equipment maintain their equipment properly.

*Note.* The operations in sections VI and VII are considered first and second echelon (organization operators and repairmen) maintenance.

#### 28. Description of Preventive Maintenance Techniques

a. Most of the parts of this meteorological equipment require routine preventive maintenance. Those requiring maintenance differ in the amount and kind required. Because maintenance techniques cannot be applied indiscriminately, definite and specific instructions are needed. This section of the manual contains this type of specific instructions and serves as a guide for personnel assigned to perform the six basic maintenance operations, namely: FEEL, INSPECT, TIGHTEN, CLEAN, ADJUST, and LUBRICATE. Throughout this manual the lettering system for the six operations will be as follows:

F—Feel

I—Inspect

T—Tighten

C—Clean

A—Adjust

L—Lubricate

The first two operations establish the need for the other four. The selection of operations is based on a general knowledge of field requirements. Field use without continuous inspection and the continuous performance of necessary, tightening, cleaning, and lubricating will result in most equipment becoming operationally erratic, undependable, and subject to break-down when it is most needed.

*b.* This section of the manual does not deal with individual parts of the equipment. Rather it combines all instructional material on the major *classes* of parts. Section VI treats the individual parts requiring maintenance.

## 29. Threads and Openings

Preventive maintenance work on the threads and openings of hydrogen Generator ML-185-(\*) consists of Inspect (I), Clean (C), and Lubricate (L).

*a.* INSPECT (I). Inspect the openings in the outlet valve assembly and cylinder adapters to make sure that they are clean and free of all residue. Inspect for obstructions by running a stiff wire through the openings, taking care not to damage the needle and seat in the axial channel of the valve. Inspect all the threads to see that stripping or abrasive action is not occurring.

*b.* CLEAN (C). Wash all the threads and openings with hot water to remove any chemical residue. If necessary, use the brass brushes. They do not produce sparks and will not notch or scratch the threads. Never use a steel or iron brush.

*c.* LUBRICATE (L). Lubricate all the steel threads in the plug and cylinder neck sparingly with low temperature grease or oil, to prevent the formation of rust.

(1) The lubricant recommended is Grease, General Purpose, No. O, U.S. Army Spec. No. 2-106. Axle grease is satisfactory, if the recommended lubricant is not available.

(2) If available, the use of Oil, Lubricating, Preservative, Medium (Ordnance Spec. No. AXS-674) or Oil, Lubricating, Preservative, Special, U.S. Army Spec. No. 2-120, is an effective rust preventive.

## 30. Brass Fittings

Preventive maintenance work on the brass fittings of hydrogen Generator ML-185-(\*) consists of Inspect (I), Tighten (T), and Clean (C).

*a.* INSPECT (I). Inspect all the fittings to see that they are clean, and that no residue has collected. Inspect to see that none of the parts are damaged or bent.

*b.* **TIGHTEN (T).** Tighten the brass fittings only when leaks develop (par. 38*c*), taking care not to use too much leverage on the wrench. Too much wrench pressure injures both the threads and the outside surfaces of the nuts. When an adjustable wrench is used, it must be fitted snugly to the *flats* before turning a nut.

**Caution:** The hose coupling and the outlet valve adapter are left-hand threaded. All other parts have right-hand threads.

*c.* **CLEAN (C).** Clean the brass fittings with a rag and hot water, and with a brass brush if necessary.

## Section VI. PREVENTIVE MAINTENANCE ITEMS

### 31. Common Materials

Have the following items on hand before beginning maintenance work :

- a. TOOLS. (1) Brush, brass wire.
- (2) Brush, brass wire (for small orifices).
- (3) Wrench, spanner.
- (4) Wrench, adjustable.
- (5) Wrench, for large plug assembly.
- (6) Stiff wire.
- b. MATERIALS. (1) Clean cloths.
- (2) Grease (General Purpose, USA 2-106).
- (3) Oil (Preservative, Medium, AXS-674) (if available).
- (4) Oil (Lubricating, Preservative, Special, USA 2-120) (if available).
- (5) Emery cloth.
- (6) Solvent, Dry Cleaning, Federal Spec. No. P-S-661a.

*Note.* Leaded gasoline will not be used as a cleaning fluid for any purpose. Solvent, Dry Cleaning, Federal Spec. No. P-S-661a, is available as a cleaning fluid, through established supply channels. Oil, Fuel, Diesel, U.S. Army Spec. No. 2-102B, may be used for cleaning purposes when dry-cleaning solvent is not at hand. Since unleaded gasoline is available only in limited quantities and in certain locations, it should be used for cleaning purposes only when no other agent is suitable. Carbon tetrachloride, or fire-extinguishing liquid (carbon tetrachloride base) should not be used on this equipment.

### 32. Preventive Maintenance Check List

Item No.	Description	Operation	When performed					Echelon	
			Immediately after use	Daily	Weekly	Monthly	Six months		Yearly
1	Exterior of cylinder	IC	X						1st
2	Interior of cylinder	FIC	X						1st
3	Plug assembly	IC	X						1st
4	Pressure gauge	I		X					1st
5	Regulating and discharge valve	ITC	X						1st
6	Valve safety device	IT	X						1st
7	Cylinder safety device	IT	X						1st
8	All the washers	FI		X	X				1st
9	Support assembly	IT							1st
10	Cleaning cap assembly	IC	X						1st
11	Gloves, goggles, apron	FIC	X						1st

### 33. Maintenance of the Cylinder

a. The cylinder of hydrogen Generator ML-185-(\*) should be cleaned *immediately* after the generated hydrogen has been used. For procedure of this operation see paragraph 25.

b. All residue must be removed from the cylinder. (1) Inspect and feel the interior of the cylinder with the hardwood stick.

(2) Check the volume of the cylinder. If less than  $11\frac{1}{3}$  gallons of water fills the cylinder, further cleaning is required.

c. Inspect the threads in the neck of the cylinder to see that they are clean. Clean with warm water and brass brush and apply grease. (See par. 29c(1)).

### 34. Maintenance of the Outlet Valve Assembly

a. The outlet valve assembly of Generator ML-185-(\*) must be stripped down to its component parts and cleaned after every 10 or 12 charges.

b. The cleaning procedure is described in detail in paragraph 39 as a repair-measure when the chemical residue clogs the outlet valve assembly.

c. Inspect the washers and disks, and replace if necessary.

## Section VII. LUBRICATION

*Note.* A War Department Lubrication Order has not been issued on hydrogen Generator ML-185-(\*). See section V, Preventive Maintenance Techniques, for the lubricating instructions for this equipment. (See pars. 29c, 31b, 32.)

## Section VIII. MOISTUREPROOFING AND FUNGIPROOFING

### 35. Moistureproofing and Fungiproofing

Moistureproofing and fungiproofing will not be required for this equipment.

## PART FOUR AUXILIARY EQUIPMENT

### Section IX. DESCRIPTION AND USE OF TRANSFER HOSE

#### 36. Transfer Hose

A high-pressure hose for use in transferring some of the hydrogen to a storage cylinder may be needed (par. 26a(2)), but is not supplied with Generator ML-185-(\*). Hose ML-216, Signal Corps stock No. 7A986-216, may be requested from the supply depot. The hose is 8 feet long, made of flexible braided copper with couplings at either end for attachment to the generator and to the storage cylinder.

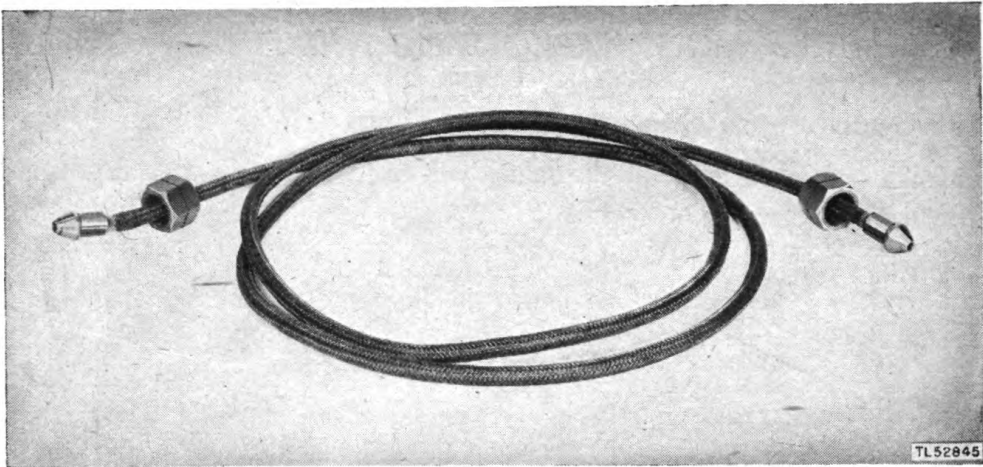

Figure 13. Hose ML-216.

a. CONNECTING HOSE TO GENERATOR. (1) Set up the generator and the hydrogen storage cylinder so that the transfer hose, when connected, will hang freely in one place between them without any sharp bends or twists.

*Note.* Be certain that the generator is grounded, in order to avoid the possibility of accumulating an electrostatic charge. (See par. 16b.)

(2) Remove the hose coupling from the outlet valve assembly of the generator, and connect one coupling of the transfer hose directly to the outlet valve body.

b. PURGING TRANSFER HOSE AND STORAGE CYLINDER. (1) Attach the free coupling of the transfer hose to the storage cylinder.

(a) If Generator ML-185-(\* ) is used as a storage cylinder, attach the outlet valve assembly, and remove the hose coupling from the outlet valve

assembly. Connect the free coupling of the transfer hose directly to the outlet valve body and tighten the coupling by hand.

(b) If a standard hydrogen cylinder is used, connect the free coupling of the transfer hose directly to the outlet valve on the cylinder, and tighten the coupling by hand.

(2) Open wide valve on the *storage cylinder*.

(3) Slowly open the outlet valve on the generator; hydrogen must flow *slowly* into the storage cylinder. When the pressure in the generator drops 15 to 20 pounds per square inch, close the outlet valve on the generator.

(4) *Loosen* the hose coupling on the storage cylinder, and permit the gas to escape slowly. *Do not remove the transfer hose coupling* from the storage cylinder.

(5) Tighten the transfer hose coupling on the storage cylinder.

(6) Repeat (b(3) and (4) above) until the escape of gas slows down. Then tighten the coupling with a wrench. The storage cylinder has now been purged of air and is ready for the transfer of hydrogen.

c. TRANSFERRING HYDROGEN TO STORAGE CYLINDER. (1) Open the valve on the storage cylinder wide, and then *slowly* open the valve on the generator. Hydrogen will flow from the generator to the storage cylinder. *Do not open the valve on the generator sufficiently to permit a rapid transfer of hydrogen.*

(2) Observe the pressure gauge. When the reading remains constant, close the outlet valves on the generator and on the storage cylinder. If a leak from the valve gland is apparent, ignore the leak until after the hydrogen is transferred. Fix it later. (See par 40.)

(3) Remove the transfer hose carefully. There is pressure within the hose.

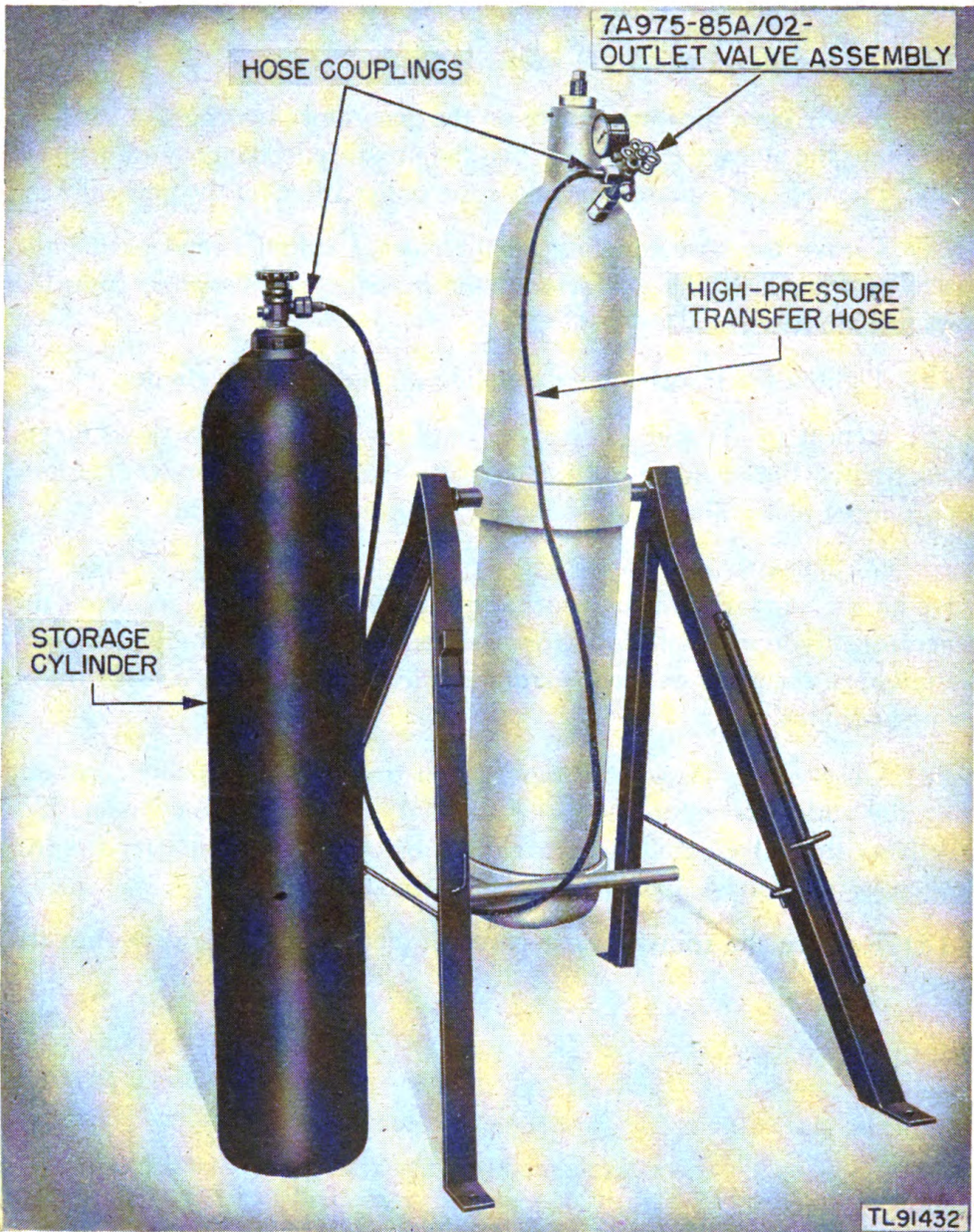

Figure 14. Transfer of hydrogen.

## PART FIVE

# REPAIR INSTRUCTIONS

---

*Note.* Failure or unsatisfactory performance of equipment used by Army Ground Forces and Army Service Forces will be reported on WD, AGO Form 468. For particulars see paragraph 45. If Form 468 is not available, see TM 38-250. Failure or unsatisfactory performance of equipment used by Army Air Forces will be reported on Army Air Forces Form 54.

### Section X. THEORY OF EQUIPMENT

#### 37. Mechanical Design and Functioning of Generator ML-185-(\* )

*a.* **CYLINDER.** The cylinder of hydrogen Generator ML-185-(\* ) is constructed of seamless steel with a  $1\frac{13}{16}$ -inch opening at the top through which the cylinder is charged and cleaned. This opening has internal threads and is sealed off with the large plug assembly when the generator is in operation. There are two adapter fittings on opposite sides of the cylinder near the top, for attachment of the outlet valve assembly and the cylinder safety device. The cylinder is fitted with trunnions near its center so that it can be mounted on a support frame for convenient handling. A handle is provided at the bottom for convenient agitation. Pins on the neck of the cylinder serve to hold the funnel when the generator is charging, and also the cleaning cap when the generator is being cleaned. The cylinder is designed to withstand pressures of 5,000 pounds per square inch, and weighs approximately 275 pounds.

*b.* **OUTLET VALVE ASSEMBLY.** The outlet valve provides a means of controlling the discharge of hydrogen. It is equipped with a pressure gauge by which the pressure within the cylinder is determined, a safety device for relieving excessive pressure, and an outlet nozzle for convenient attachment of Hose ML-81.

*c.* **SAFETY DEVICES.** The safety devices are designed to relieve the internal pressure when it exceeds a value of 2,850 pounds per square inch (copper disks) and 3,000 to 3,500 pounds per square inch (nickel disks). They consist of thin metal disks which rupture when the excessive pressures are reached. When the disk ruptures in the earlier type safety device, supplied with Generator ML-185-A, the discharge blows in all directions. On the improved model B type device, the discharge blows in one direction only, as set by the operator. Also, the earlier types of valve safety device and cylinder safety device provided with model A are not interchangeable as are those of model B. (See par. 13a(2).)

*d.* **SUPPORT ASSEMBLY.** The support assembly, composed of two folding A-frames, is designed to support the cylinder when it is assembled for oper-

ation. Suitable bars on the support assembly provide a means by which the cylinder can be swung on its trunnions and placed in various positions for cleaning and charging operations.

e. CHEST FOR ACCESSORIES. The function of the chest is to provide a convenient storage place and carry-all for accessories, safety apparel, spares, and all parts except the cylinder assembly.

f. SAFETY APPAREL AND ACCESSORIES. Safety apparel, tools, and various accessories are provided to simplify the operations and protect the operator from caustic soda and the caustic residue.

g. CHEMICAL REACTION. (1) *Ferrosilicon process*. Charges of ferrosilicon, sodium hydroxide (caustic soda), and water are proportioned and graded to produce a controlled reaction within the cylinder and yield about 85 to 90 cubic feet of hydrogen per charge. The time of reaction for maximum yield is about 2 hours with air temperatures of 70° to 90° F. If surrounding temperatures are lower, the rate of reaction is slowed up and the yields are usually lower.

(2) *Aluminum process*. Charges of aluminum, sodium hydroxide (caustic soda), and water are proportioned and graded to produce a controlled reaction and yield about 120 cubic feet of hydrogen per charge. The time of reaction for a maximum yield is about 2 hours at surrounding temperatures of 60° to 90°F. If temperatures are lower, the reaction rate is slowed up, but the yield remains unchanged. At below zero degrees Fahrenheit, performance is maintained by varying the charge. (See par. 26c.)

## Section XI. REPAIR

## 38. Trouble Shooting

a. If the pressure is consistently higher than normal, check the cylinder to see that all the chemical residue has been broken up and removed. (See par 25.)

b. If there is difficulty in meshing the threads, examine them to see that they are free of residue and rust.

c. If leaks develop (par. 40) perform the following to locate the trouble:

(1) Examine the joints to be sure that they are tight.

(2) Examine the condition of the washers.

(3) Check the safety disks to see that they are properly placed and in good condition.

(4) Examine the needle of the outlet valve assembly to see that it is not badly scored.

(5) Examine the outlet valve seat to determine the need of reseating.

d. A trouble-shooting chart follows:

*Trouble-shooting chart*

Trouble	What to do	Equipment	Corrective action	Performance check
Excess pressure (consistently in excess of normal).	Examine cylinder to see that all residue is removed.	Hardwood stick	Remove all residue.	Pressure returns to normal.
Threads will not mesh easily.	Examine threads to see that no residue has collected.	Solvent Cleaning cloth Brass brush	Clean threads.	Threads will mesh easily.
Leaks.	1. Check the joints. 2. Inspect washers. 3. Inspect safety disks. 4. Examine all equipment for leaks due to dirt.	Wrench   Solvent Cleaning cloth Brass brush	Tighten coupling joints. Replace washers if worn. Replace or reseat disks. Clean.	Leaks disappear. Leaks disappear. Leaks disappear. Leaks disappear.
Leaking outlet valve (due to scored valve seat).	Examine valve.	Reamer assembly	Ream the valve seat.	Leaks disappear.
(due to scored needle).	Examine needle.		Replace needle if badly scored.	Leaks disappear.

### 39. General Repair

a. When chemical residue clogs the outlet valve assembly, strip the assembly down to its component parts. Clean the parts with hot water and a brass brush.

b. A scored needle may be turned on a lathe. The valve seat should be reamed out if it has been scored. Proceed as follows:

(1) Loosen the valve gland nut, and remove the valve stem from the assembly.

(2) Insert the reseating tool, and screw up the reamer guide nut until it is just tight.

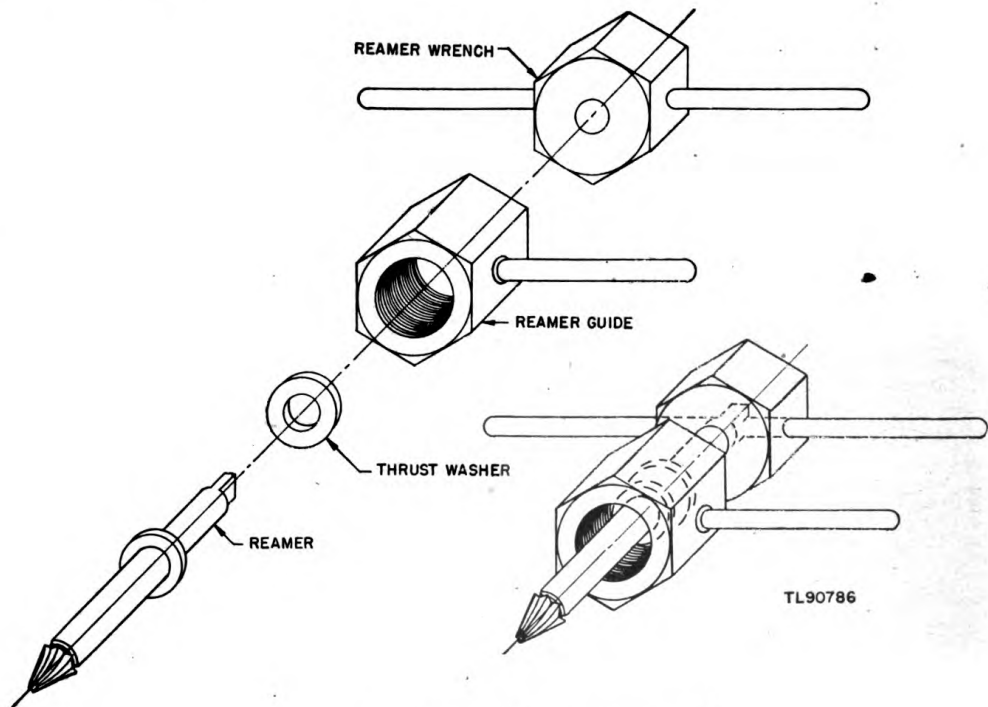

Figure 15. Valve seat reamer assembly.

(3) Turn the reseating tool wrench handle two complete revolutions.

(4) Retighten the reamer guide nut, and repeat as in (3) above.

(5) Remove the reseating tool, and clean out all openings thoroughly.

(6) Examine the valve seat. If it is not smooth, repeat the operation.

**Caution:** Do not reseat the valve seat unless it is necessary. Repeated use of this tool will gradually remove enough metal so that the valve will become inoperative.

c. See paragraph 26b(4) for instructions on the care of the outlet valve assembly in arctic regions.

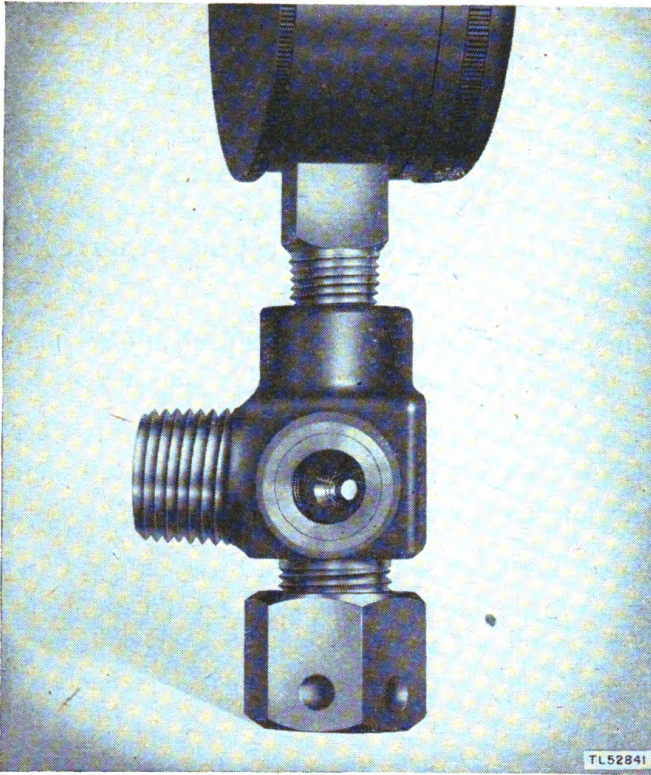

*Figure 16. Scored valve seat.*

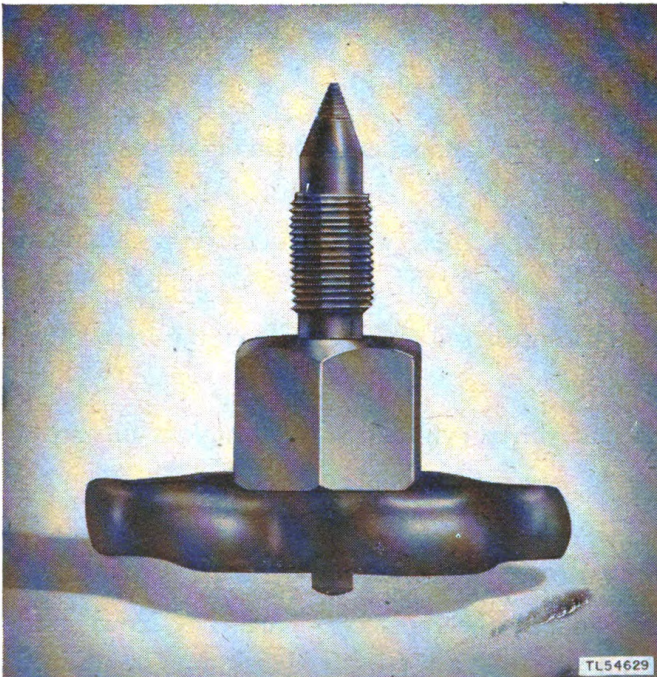

*Figure 17. Scored needle.*

## 40. Care of Leaking Generator

*a.* A hissing sound gives evidence of a leak in the generator. If a leak is noted while a generator is charging, *do not attempt to stop the leak*. This is particularly true if the safety devices leak due to improper seating of the disks or washers. Do not tighten the safety devices unless they are noticeably loose, otherwise the disks may be distorted and blow immediately. The operator is then in serious danger of being spattered. Observe the following procedure:

(1) Ignore the leak. Enough pressure will probably be retained to allow some of the gas to be used. Thus the charge is not entirely wasted.

(2) Allow the leak to continue until the pressure is down, and then clean the generator. Be certain that the generator is completely empty of gas before the center cap is removed.

(3) Never open the outlet valve wide in order to empty a leaking cylinder. If the gas is cold, the additional cold produced by the expanding gas can cause the valve to ice up. If the gas is very hot, it can carry enough heat to melt the soldered joint in the outlet valve assembly of Generator ML-185-A.

*b.* For causes of leaks, and their correction, see paragraph 38*c*.

## 41. Painting and Refinishing

*a.* Hydrogen-gas storage cylinders, which have become rusty where the paint has worn off through use, must be cleaned of rust and repainted.

*b.* Proceed as follows:

(1) Use emery cloth or sandpaper to clean off all rust spots until the bare metal is exposed and bright.

(2) Wash the cleaned areas with solvent or recommended oil. (See par 31*b*.)

(3) Apply a coating of red lead paint over the bare steel surfaces and let it dry overnight.

(4) Repaint the entire cylinder with semigloss olive drab air-drying enamel.

## 42. Emergency Replacement of Used Safety Disks

*a.* Safety disks should be replaced before they blow (par 43*b*), but if new disks are not available a used safety disk may be utilized as an emergency measure.

*b.* A used safety disk is bent into a slightly concave shape. If the safety disk is to be used again, replace it in the cap in the *exact* position it was in before removal. Be sure that the indentation in the disk faces away from the generator.

**Caution:** Never allow gas pressure to be applied to the convex side of the disk, because the pressure will flex the disk, weaken it greatly, and cause it to blow at less than its rated pressure.

### 43. Replacement of Parts

*a.* RUBBER WASHERS. Rubber washers should be replaced when they show roughness and evidence of hard use. Remove the washers if the generator is to be stored for any length of time.

*b.* SAFETY DISKS. (1) Safety disks should be replaced before they blow, generally after five or six charges or as determined by experience.

(2) To replace a disk, tilt the cylinder so that the adapter opening is downward. Seat a new disk horizontally in the cap. Place a new fiber washer on top of the disk; then screw up the cap tightly. This permits proper assembly and, therefore, prevents leaks caused by buckling or cross-threading of the disk in the assembly.

**Caution:** The safety disks are thin and may stick together. *Check carefully* to make sure that only *one disk* is being installed.

(3) If new disks are not available, used safety disks may be utilized. For procedure, see paragraph 42.

*Note.* Bad washers or improperly placed disks may cause leaks. Do not attempt to stop the leak by additional tightening of the cap, as the threads are too easily stripped. Replace the washer, or reseal the disks.

## Section XII. ADJUSTMENTS

### 44. Adjustment of Pressure Gauge

*a.* If excessive pressure moves the pointer against the stop so that the pointer does not return to zero when there is no pressure in the cylinder, remove the glass cover from the gauge, and move the pointer back to the zero position.

*b.* The gauge sometimes sticks at a high-pressure reading instead of returning to zero because the temperature is low enough for moisture in the gauge to freeze. Thaw the gauge by using hot water or steam; *do not use a torch.*

### 45. War Department Unsatisfactory Equipment Report

*a.* When trouble in equipment used by Army Ground Forces or Army Service Forces occurs more often than repair personnel consider normal, fill out War Department Unsatisfactory Equipment Report WD, AGO Form 468 (fig. 18) and forward through channels to the office of the Chief Signal Officer, Washington 25, D. C.

*b.* When trouble in equipment used by Army Air Forces occurs more often than repair personnel feel is normal, Army Air Forces Form 54 should be filled out and forwarded through channels.

*c.* If either form is not available, prepare the data according to the sample form reproduced in figure 18.

WAR DEPARTMENT UNSATISFACTORY EQUIPMENT REPORT											
FOR	TECHNICAL SERVICE <i>Signal Corps</i>	MATERIEL	DATE <i>15 Nov 1944</i>								
FROM	ORGANIZATION <i>Weather RCN. Squadron, Med.</i>	STATION <i>AFPO 000 San Francisco, Cal.</i>									
TO	NEXT SUPERIOR HEADQUARTERS <i>Signal Officer, 00th Air Force</i>	STATION _____			TECHNICAL SERVICE <i>Signal Corps</i>						
COMPLETE MAJOR ITEM											
NOMENCLATURE <i>Hydrogen Generator ML-185-B</i>		TYPE _____			MODEL _____						
MANUFACTURER <i>A. B. C Co.</i>		U. S. A. REG. NO.		SERIAL NO. <i>7A975</i>		DATE RECEIVED <i>27 Sept 1944</i>					
EQUIPMENT WITH WHICH USED (if applicable)											
DEFECTIVE COMPONENT—DESCRIPTION AND CAUSE OF TROUBLE											
PART NO. <i>7A975-85/W1</i>	TYPE <i>Rubber Washers</i>		MANUFACTURER <i>X. Y. Z. Co</i>			DATE INSTALLED <i>3 Oct 1944</i>					
DESCRIPTION OF FAILURE AND PROBABLE CAUSE (if additional space is required, see back of form) <i>Leaks occur due to quick wear of washers</i>											
DATE OF INITIAL TROUBLE <i>5 Oct 1944</i>		TOTAL TIME INSTALLED			TOTAL PERIOD OF OPERATION BEFORE FAILURE						
		YEARS	MONTHS	DAYS	YEARS	MONTHS	DAYS	HOURS	MILES	ROUNDS	
		-	-	<i>2</i>	-	-	-	<i>4</i>	-	-	
BRIEF DESCRIPTION OF UNUSUAL SERVICE CONDITIONS AND ANY REMEDIAL ACTION TAKEN											
TRAINING OR SKILL OF USING PERSONNEL											
POOR		FAIR		GOOD <input checked="" type="checkbox"/>						RECOMMENDATIONS (if additional space is required, see back of form) <i>Improve rubber quality</i>	
ORIGINATING OFFICER											
TYPED NAME, GRADE, AND ORGANIZATION <i>CHARLES T BROWN, CAPT, AIR FORCE 00th WEATHER RCN. SQUADRON, MED.</i>					SIGNATURE <i>Charles T. Brown</i>						
FIRST ENDORSEMENT											
TO CHIEF		TECHNICAL SERVICE			OFFICE						
NAME, GRADE, AND STATION					STATION		DATE				
Instructions											
<ol style="list-style-type: none"> <li>1. It is imperative that the chief of technical service concerned be advised at the earliest practical moment of any constructional, design, or operational defect in material. This form is designed to facilitate such reports and to provide a uniform method of submitting the required data.</li> <li>2. This form will be used for reporting manufacturing, design, or operational defects in material, petroleum fuels, lubricants, and preserving materials with a view to improving and correcting such defects, and for use in recommending modifications of material.</li> <li>3. This form will not be used for reporting failures, isolated material defects or malfunctions of material resulting from fat-wear-and-tear or accidental damage nor for the replacement, repair or the issue of parts and equipment. It does not replace currently authorized operational or performance records.</li> <li>4. Reports of malfunctions and accidents involving ammunition will continue to be submitted as directed in the manner described in AR 780-10 (change No. 8).</li> <li>5. It will not be practicable or desirable in all cases to fill all blank spaces of the report. However, the report should be as complete as possible in order to expedite necessary corrective action. Additional pertinent information not provided for in the blank spaces should be submitted as inclosures to the form. Photographs, sketches, or other illustrative material are highly desirable.</li> <li>6. When cases arise where it is necessary to communicate with a chief of service in order to assure safety to personnel, more expeditious means of communication are authorized. This form should be used to confirm reports made by more expeditious means.</li> <li>7. This form will be made out in triplicate by using or service organization. Two copies will be forwarded direct to the technical service; one copy will be forwarded through command channels.</li> <li>8. Necessity for using this form will be determined by the using or service troops.</li> </ol>											
W. D., A. G. O. Form No. 468 20 August 1944					This form supersedes W. D., A. G. O. Form No. 468, 1 December 1943, which may be used until existing stocks are exhausted. TL 53872						
U. S. GOVERNMENT PRINTING OFFICE 16-52640-1											

Figure 18. WD, AGO Form 468 with sample entries.

**APPENDIX I**  
**MAINTENANCE PARTS LIST FOR GENERATOR**  
**ML-185-\***

---

For maintenance parts information, see appropriate sections of Army Service Forces Signal Supply Catalog SIG 7 ML-185, Organizational Spare Parts, SIG 8 ML-185, Higher Echelon Spare Parts, and SIG 10-900 (Plant Engineering Agency maintenance information).

## APPENDIX II

### REFERENCES

---

#### 1. Army Regulations

AR 380-5, Restricted Documents.

#### 2. Parts List

Army Service Forces Catalog Sig V—Volume III.

#### 3. Technical Manuals on Auxiliary Equipment

TM 1-315 .....Hydrogen.

#### 4. Painting, Preserving, and Lubrication

TM 9-850 .....Cleaning, Preserving, Sealing, Lubricating, and Related Materials Issued for Ordnance Materiel.

#### 5. Other Technical Publications

FM 21-6 .....List and Index of War Department Publication.

FM 4-187 .....Barrage Balloon, Service of the Balloon and Balloon Equipment, Low Altitude.

FM 4-193 .....Barrage Balloon, Gas Generation, Use, Purification and Service of Hydrogen Generator.

TM 11-2405 .....Meteorological Balloons.

TM 8-285 .....Treatment of Casualties from Chemical Attack.

TM 3-250 .....Storage and Shipment of Dangerous Chemicals.

Technician's Manual .....Weather Equipment.

#### 6. Forms

WD AGO Form 468 .....Unsatisfactory Equipment Report.

Army Air Forces Form 54 .....Unsatisfactory Report.

## 7. List of Abbreviations

C	Centigrade
corp	corporation
cu ft	cubic feet
F	Fahrenheit
gal	gallon
in.	inch
lb	pounds
mfrs	manufacturer's
No.	number
pr	pair
quan	quantity
spec	specification
WD, AGO	War Department, Adjutant General's Office
x	by

U. S. Government Printing Office 1945: 628023 TM-131





