

TM 11-2531

WAR DEPARTMENT TECHNICAL MANUAL

PUBLIC ADDRESS SET AN/TIQ-3

SEMINATION OF RESTRICTED MATTER.

The information contained in restricted documents and the essential characteristics of restricted material may be given to any person known to be in the service of the United States and to persons of undoubted loyalty and discretion who are co-operating in Government work, but will not be communicated to the public or to the press except by authorized military public relations agencies. (See also par. 23b, AR 380-5, 15 Mar 1944.)

WAR DEPARTMENT · 27 NOVEMBER 1944

WAR DEPARTMENT TECHNICAL MANUAL

TM 11-2531

PUBLIC ADDRESS SET
AN/TIQ-3



WAR DEPARTMENT

27 NOVEMBER 1944

RESTRICTED. DISSEMINATION OF RESTRICTED MATTER.

The information contained in restricted documents and the essential characteristics of restricted material may be given to any persons known to be in the service of the United States and to persons of undoubted loyalty and discretion who are coöperating in Government work, but will not be communicated to the public or to the press except by authorized military public relations agencies. (See also par. 23*b*, AR 380-5, 15 Mar 1944.)

WAR DEPARTMENT,
WASHINGTON 25, D. C., 15 November 1944.

TM 11-2531, Public Address Set AN/TIQ-3, is published for the information and guidance of all concerned.

[A. G. 300.7 (8 July 44).]

BY ORDER OF THE SECRETARY OF WAR:

G. C. MARSHALL,
Chief of Staff.

OFFICIAL:

J. A. ULIO,
*Major General,
The Adjutant General.*

DISTRIBUTION:

AAF (5); AGF (5); ASF (5); AAF Comds (2); Arm & Sv Bd (2);
Def Comd (2); T of Opns (5); Base Comd (5); Dept (5); Tech
Sv (2); SVC (5); Area ASvC (2); PC&S (2); PE (2); Dep, 11 (2);
Gen Overseas SOS Dep (Sig Sec) (2); GH (2); M Cpnc C (2);
Air Base Hosp (2); Gen Sv Sch (5); Sp Sv Sch (10); USMA (2);
ROTC (5); Lab, 11 (2); Sig AS (2); Rep Shop, 11 (2); A (5);
D (2); AF (2).

3 copies to the following T/O & E's:

T/O & E 1-67, 1-117, 1-127, 1-167, 1-277S, 1-317, 1-457T,
1-637S, 11-15, 11-25, 11-95, 11-107, 11-127, 11-237,
11-287, 11-587, 11-597.

(For explanation of symbols see FM 21-6.)

U113
 .2
 TM11:
 2531
 1944

TABLE OF CONTENTS



SECTION	I. Description	<i>Paragraph</i>	<i>Page</i>
	General	1	1
	Technical characteristics	2	1
	List of components with weights and dimensions	3	2
	Description of components	4	5
	II. Installation and operation.		
	Initial procedure	5	17
	Interconnecting the components . .	6	20
	Operation with Handset TS-13-()	7	21
	Operation with constant-, intermit- tent-, or warble-tone signal	8	22
	Operation for intercommunication	9	22
	Unsatisfactory equipment report .	10	23
	Operator's trouble chart	11	23
	Operator maintenance	12	28
	III. Functioning of parts.		
	General	13	29
	Introduction to functioning of parts	14	29
	Voltage-amplifier stage using tube V-3	15	31
	Tone-generator channel	16	34
	Voltage-amplifier stage using tube V-1	17	36
	Voltage-amplifier stage using tube V-1 with booster input through jack J-5	18	36
	Phase-inverter stage	19	36
	Push-pull voltage-amplification stage	20	39
	Push-pull parallel power-amplifica- tion stage	21	39
	Power supply of Control Unit C-104/TIQ-3	22	41
	Power supply of Amplifier AM-34/TIQ-3	23	42

III

TABLE OF CONTENTS

	<i>Paragraph</i>	<i>Page</i>
SECTION III. Functioning of parts (contd).		
Loudspeakers LS-104/TIQ-3	24	43
Intercommunication feature	25	43
Booster amplifier	26	44
IV. Maintenance.		
Introduction	27	45
Voltage measurements	28	46
Resistance measurements	29	48
Capacitor tests	30	50
Current measurements	31	50
Tube checking	32	51
Replacing parts	33	51
Isolation of trouble and remedy of minor defects	34	52
Isolation of trouble and remedy of major defects	35	54
Voltage and resistance chart for Control Unit C-104/TIQ-3	36	56
Voltage and resistance chart for Amplifier AM-34/TIQ-3	37	57
V. Supplementary Data.		
Maintenance parts list for Control Unit C-104/TIQ-3	38	59
Maintenance parts list for Amplifier AM-34/TIQ-3	39	67
Maintenance parts list for Public Address Set AN/TIQ-3	40	74
Maintenance parts list for Handset TS-13-()	41	76

LIST OF ILLUSTRATIONS

<i>Fig. No.</i>	<i>Title</i>	<i>Page</i>
1	Public Address Set AN/TIQ-3	VII
2	Control Unit C-104/TIQ-3 and Case CY-38/TIQ-2	5
3	Amplifier AM-34/TIQ-3 and Case CY-38/TIQ-2	6
4	Spare parts Case CY-38/TIQ-2	7
5	Spare parts for Public Address Set AN/TIQ-3	8
6	Case CY-96/TIQ-3 and Loudspeakers LS-104/TIQ-3	9
7	Cords CX-49/TIQ-2, CX-51/TIQ-2, CX-53/TIQ-2, CX-54/TIQ-2, CX-55/TIQ-2, CX-164/TIQ-3, and CX-165/TIQ-3	10
8	Handset TS-13-()	13
9	Loudspeaker Stand MT-128/TIQ-2	14
10	Loudspeaker LS-104/TIQ-3	15
11	Public Address Set AN/TIQ-3, cording diagram facing	16
12	Loudspeaker LS-104/TIQ-3 with horn removed	18
13	Loudspeaker LS-104/TIQ-3 on Stand MT-128/TIQ-2	19
14	Public Address Set AN/TIQ-3, block diagram	30
15	Circuit switching, simplified schematic	31
16	Microphone input, simplified schematic	32
17	Tone generators, simplified schematic	33
18	Control Unit C-104/TIQ-3, top view of chassis	35
19	Control Unit C-104/TIQ-3, bottom view of chassis	37
20	Amplifier AM-34/TIQ-3, top view of chassis	38
21	Amplifier AM-34/TIQ-3, bottom view of chassis	40
22	Data chart for Loudspeaker LS-104/TIQ-3	79
23	Control Unit C-104/TIQ-3, schematic diagram	81
24	Amplifier AM-34/TIQ-3, schematic diagram	83
25	Outline dimensions of Loudspeaker LS-104/TIQ-3	85
26	Outline dimensions of Stand MT-128/TIQ-2	86
27	Outline dimensions of Case CY-38/TIQ-2	87
28	Outline dimensions of Case CY-96/TIQ-3	88

DESTRUCTION NOTICE

WHY — To prevent the enemy from using or salvaging this equipment for his benefit.

WHEN — When ordered by your commander.

HOW — 1. **Smash** — Use sledges, axes, handaxes, pickaxes, hammers, crowbars, heavy tools.
2. **Cut** — Use axes, handaxes, machetes.
3. **Burn** — Use gasoline, kerosene, oil, flame throwers, incendiary grenades.
4. **Explosives** — Use firearms, grenades, TNT.
5. **Disposal** — Bury in slit trenches, fox holes, other holes. Throw in streams. Scatter.

USE ANYTHING IMMEDIATELY AVAILABLE FOR DESTRUCTION OF THIS EQUIPMENT.

WHAT — 1. **Smash** — Cases, panels, controls, loudspeakers, connectors, handset, tubes, switches, relays, terminal boards, gas engine, generator, and every other electrical or mechanical part, moving or fixed.
2. **Cut** — All wiring, cables, and fuel lines.
3. **Burn** — All equipment cases and covers, cords, diagrams, and technical manuals.
4. **Bend** — All panels, cases, fuel tanks, controls, and metal parts.
5. **Bury or scatter**—All the remaining pieces after destruction.

DESTROY EVERYTHING

WARNING

HIGH VOLTAGE
is used in the operation of
this equipment.

DEATH OR INJURY ON CONTACT
may result if operating personnel
fail to observe safety precautions.

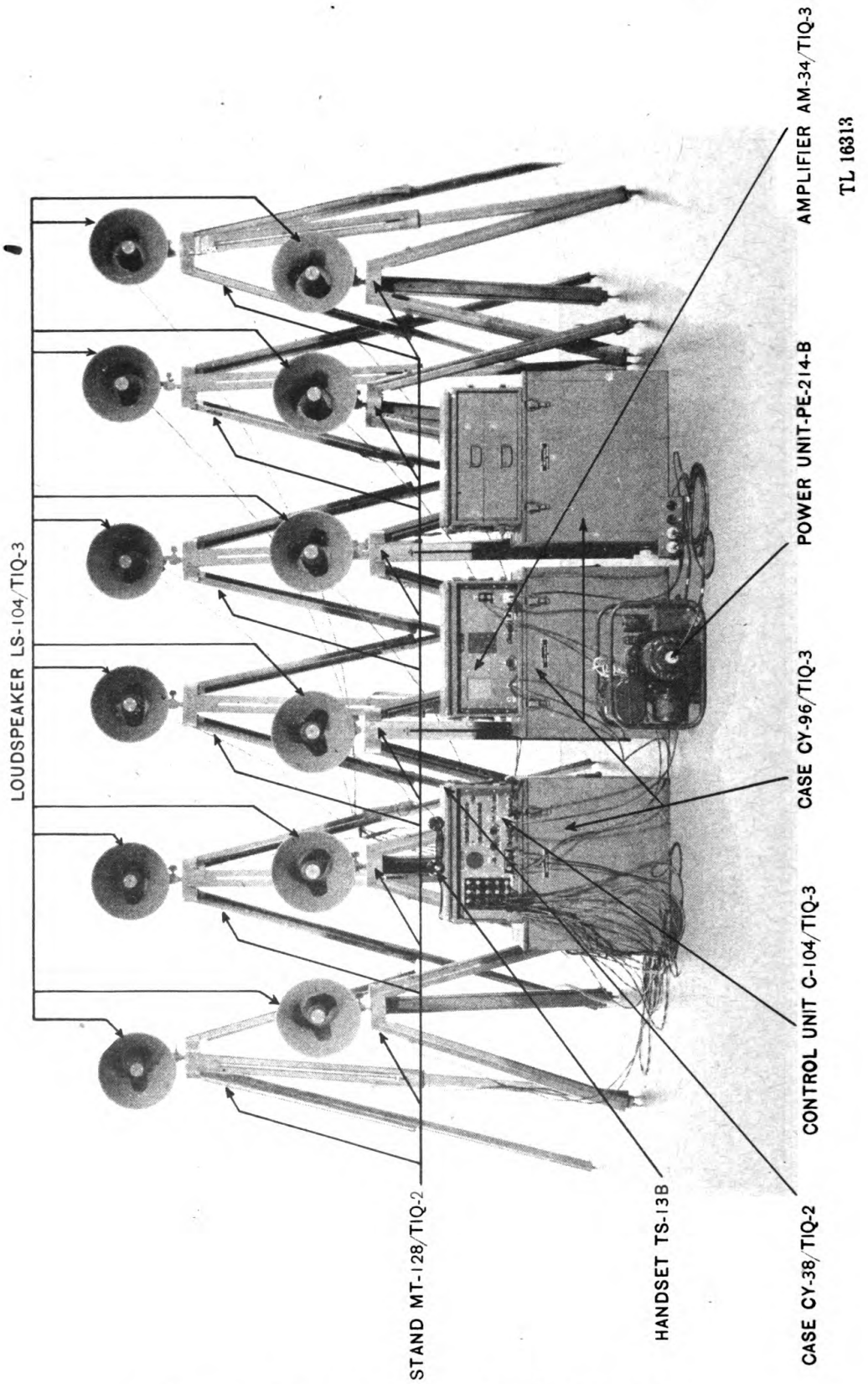

Figure 1. Public Address Set AN/TIQ-3.

RESTRICTED

SECTION I DESCRIPTION

1. GENERAL.

Public Address Set AN/TIQ-3 (fig. 1) is a portable public address system designed for fixed operation. This public address system is composed of Control Unit C-104/TIQ-3, Amplifier AM-34/TIQ-3, Power Supply Unit PE-214-B, Handset TS-13-(), and 12 Loudspeakers LS-104/TIQ-3. Handset TS-13-(), or a monitor speaker on the control unit, permits two-way communication with selected loudspeakers, or may be used to communicate over the whole system. A tone generator provides a constant, intermittent, or warble tone, which may be sent over the system for signaling.

2. TECHNICAL CHARACTERISTICS.

a. **Power Sources.** Public Address Set AN/TIQ-3 is powered by Power Unit PE-214-B, or any 115- or 230-volt, 50- to 60-cycle a-c (alternating-current) source.

b. **Power Input and Current Requirements.** With a power supply of either 115 or 230 volts at 60 cycles, the power input required by Amplifier AM-34/TIQ-3 is 255 watts, and the power input required by Control Unit C-104/TIQ-3 is 20 watts. The current required by Amplifier AM-34/TIQ-3 is $2\frac{1}{5}$ amperes; the current required by Control Unit C-104/TIQ-3 is $\frac{1}{5}$ ampere.

c. **Power Output.** With a power supply of 115- or 230-volt, 50- to 60-cycle a-c, the power output of Public Address Set AN/TIQ-3 is 50 watts, at less than 10 percent distortion.

d. **Frequency Range.** The frequency range of Public Address Set AN/TIQ-3 is 50 to 10,000 cycles.

3. LIST OF COMPONENTS WITH WEIGHTS AND DIMENSIONS.

a. Table of Packed Weights and Volumes.

<i>Component</i>	<i>Weight (lb) Contents only</i>	<i>Weight (lb) Packing only</i>	<i>Total weight (lb)</i>	<i>Volume (cu ft)</i>
Case CY-38/TIQ-2 and Amplifier AM-34/TIQ-3.	89.50	49.00	138.5	4.4
Case CY-38/TIQ-2 and Control Unit C-104/TIQ-3.	65.25	47.00	112.25	4.4
Case CY-38/TIQ-2, spare parts, cords, and telephone handset.	53.50	47.00	100.50	4.4
Case CY-96/TIQ-3 and Loudspeakers LS-104/TIQ-3.	127.50	73.00	200.50	9.2
Case CY-96/TIQ-3 and Loudspeakers LS-104/TIQ-3.	127.50	73.00	200.50	9.2
Case CY-96/TIQ-3 and Loudspeakers LS-104/TIQ-3.	127.50	73.00	200.50	9.2
Stand MT-128/TIQ-2.	114.00	72.00	186.00	13.3
Stand MT-128/TIQ-2.	114.00	72.00	186.00	13.3
Total	818.75	506.00	1,324.75	67.4

b. Individual Components Weights and Dimensions

Quan	Name of component	Dimensions (in.)				Unit weight (lb)
		Height	Width	Depth	Length	
1	Amplifier AM-34/TIQ-3.	8 ³ / ₄	19	13		65
1	Control Unit C-104/TIQ-3.	8 ³ / ₄	19	13		40 ³ / ₄
2	Cable assembly, a-c power Cord CX-49/TIQ-2 (W-1 and W-2).				120	3/4
1	Cable assembly, interconnecting Cord CX-51/TIQ-2 (W-3).				120	1/2
1	Cable assembly, a-c power Cord CX-53/TIQ-2 (W-4).				300	33/8
2	Cable assembly, a-c power extension Cord CX-54/TIQ-2 (W-5 and W-6).				300	2 1/2
1	Cable assembly, power adapter Cord CX-55/TIQ-2 (W-7).				36	1/2
2	Cable assembly, interconnecting extension Cord CX-164/TIQ-3 (W-8 and W-9).				300	1 1/4
1	Cord assembly, handset extension Cord CX-165/TIQ-3 (W-10).				300	1 1/2
1	Case CY-38/TIQ-2, marked AMPLIFIER	10 ³ / ₄	22	17		24 1/2
1	Case CY-38/TIQ-2, marked CONTROL UNIT	10 ³ / ₄	22	17		24 1/2
1	Case CY-38/TIQ-2, marked SPARE PARTS, containing the above cables, and running spare parts, as follows: 4 Lamp LM-27 (E-3) 4 Tube JAN-6SL7GT (V-1, 2, and 3) 8 Tube JAN-6L6GA (V-4, 5, and 7) 6 Tube JAN-5U4G (V-8, V-9, and V-10) 6 Fuse, 5-amp, 250-volt, type 3AG (F-1) 6 Fuse, 1-amp, 250-volt, (F-2)	10 ³ / ₄	22	17		32 1/2

b. Individual Components Weights and Dimensions (contd).

Quan	Name of component	Dimensions (in.)					Unit weight (lb)
		Height	Width	Depth	Length	Diam	
3	2 Tube JAN-OC3/VR-105 (V-11)						46½
	7 Neon lamp, ¼-w, 105- to 125-v (E-1 and E-2)						
	3 Air filters						
	1 Plug, male, 2-contact (P-16)						
	2 Connector, female, 9-contact (J-10)						
	4 Receptacle, female, 2-contact (J-12)						
	3 Connector, female, 2-contact (J-16)						
	5 Plug, male, 2-contact (P-11, 12, 13)						
	5 Plug PL-55						
	1 Plug PL-68						
	3 Jack JK-34A						
	1 Jack JK-33A						
	3 Junction box, small						
	1 Junction box, large						
3	Case CY-96/TIQ-3, containing loudspeakers.	12¾	27	17⅞			
2	Canvas cover for power unit.						
1	Handset TS-13-() complete with cord W-11.				15½	19⅝	1
12	Loudspeaker LS-104/TIQ-3.	12⅜	14⅞	17¾			20¼
1	Power Unit PE-214-B.	84½					60¾
12	Stand MT-128/TIQ-2 for loudspeaker.						19

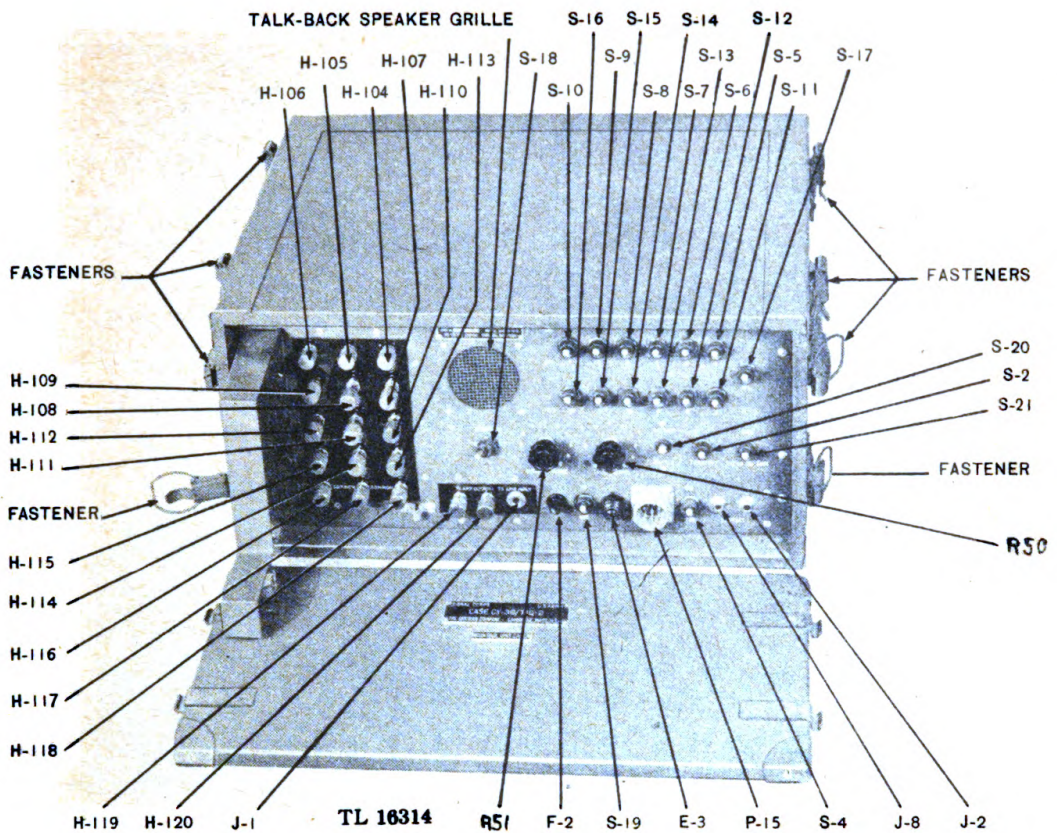

Figure 2. Control Unit C-104/TIQ-3 and Case CY-38/TIQ-2.

4. DESCRIPTION OF COMPONENTS.

a. **Control Unit C-104/TIQ-3 (fig. 2).** All control knobs, switches, power, input, and output connectors necessary for the operation of Control Unit C-104/TIQ-3 are mounted on its front panel. The control unit amplifies the signal from any one of three sources: the sound input of Handset TS-13-(); the signal from the constant-, intermittent-, or warble-tone generators; or the sound input of any one of the Loudspeakers LS-104/TIQ-3 when the intercommunication feature is used. It also receives and distributes the output of Amplifier AM-34/TIQ-3. The circuit of the control unit is described on a label mounted on the inside of the base plate. The unit is fastened by six screws in a Case CY-38/TIQ-2 marked CONTROL UNIT. This case is constructed of plywood, heavily reinforced with a steel frame and corners. The front cover of the case is secured with catch fasteners, and is removable. A neoprene weatherproof gasket is fastened to the removable front cover to protect the control unit against moisture. It does not protect the unit, however, in event of total immersion in water. Carrying handles are provided at each end of the case. Catch fasteners are attached to the sides of the case at both top and bottom to permit several cases to be fastened together during storage or transportation.

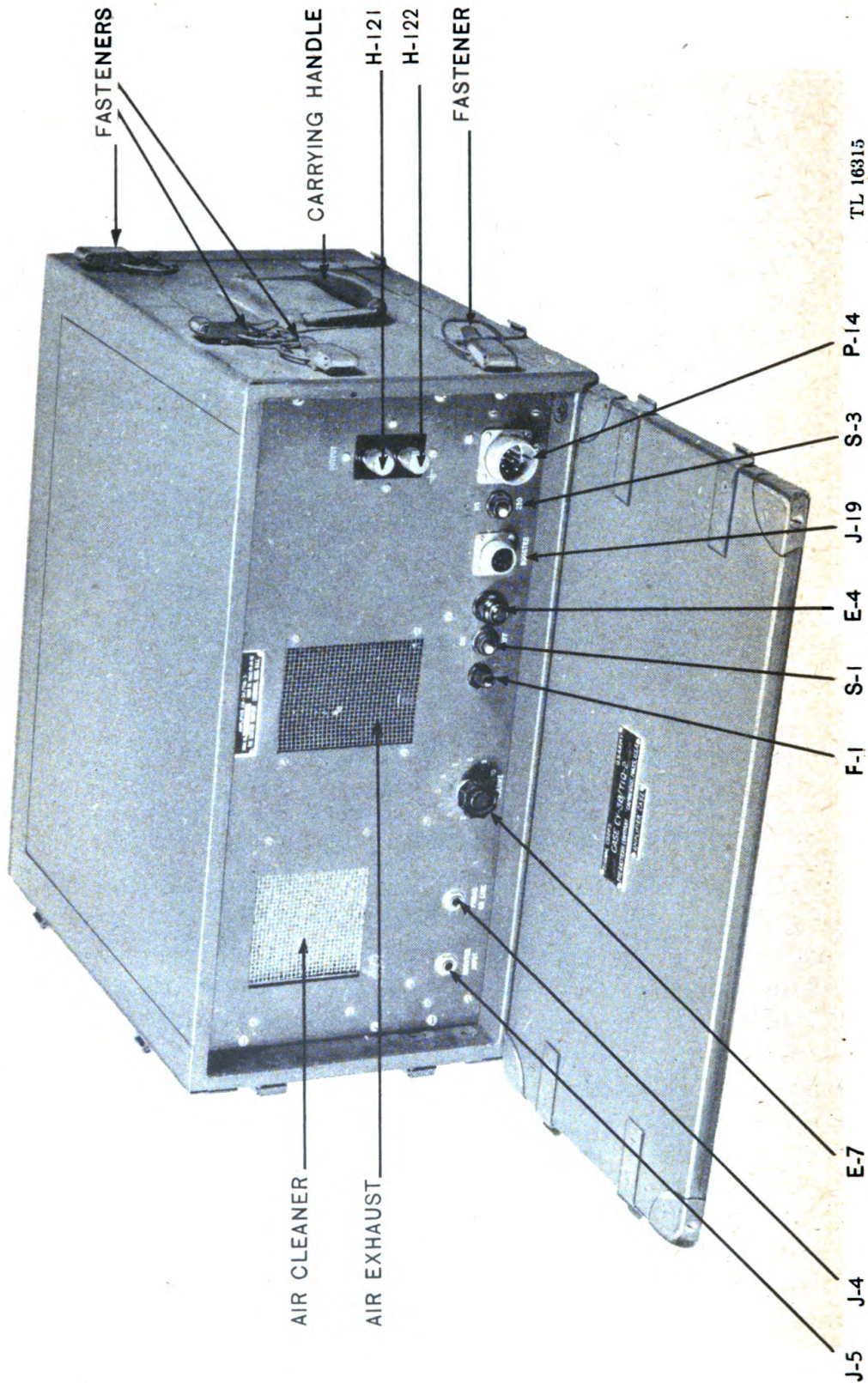

Figure 3. Amplifier AM-34/TIQ-3 and Case CY-38/TIQ-2.

b. Amplifier AM-34/TIQ-3 (fig. 3). The amplifier unit is fastened by six screws in a Case CY-38/TIQ-2 marked AMPLIFIER. This case is identical with the case containing the control unit (subpar. a above) except for the marking. All control knobs, switches, power, input, and output connectors necessary to the operation of the amplifier are mounted on the front panel. This unit amplifies the output voltage of the control unit. The output of the amplifier is connected back to the control unit for distribution. The tubes in the amplifier unit are cooled by an electrical blower unit. The circuit of the amplifier is described on a label mounted on the inside of the base plate of the amplifier unit.

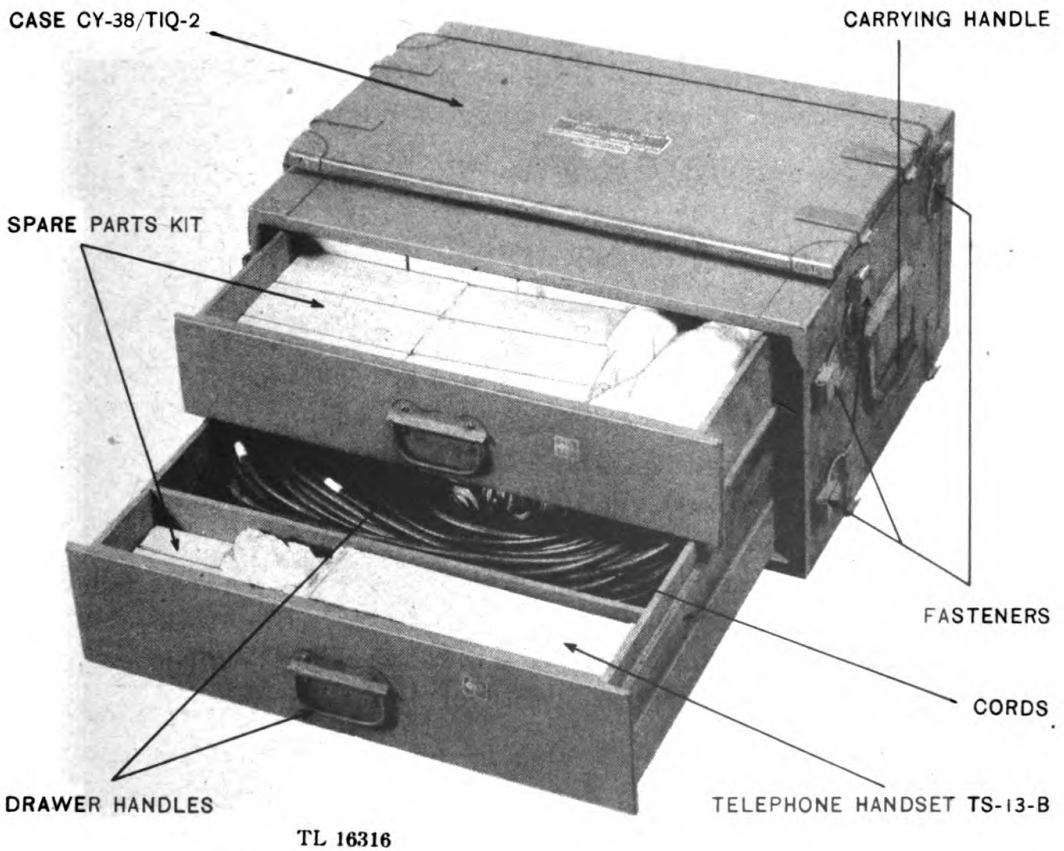
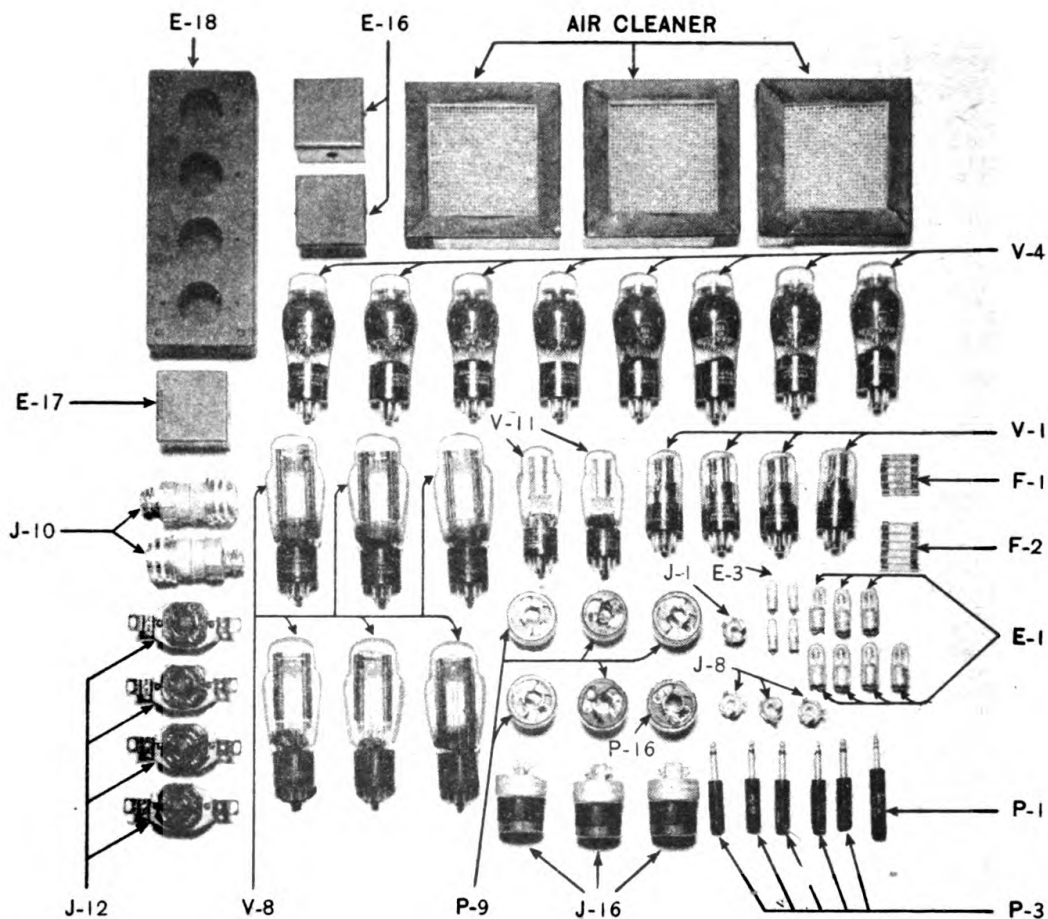

Figure 4. Spare parts Case CY-38/TIQ-2.



TL 16317

Figure 5. Spare parts for Public Address Set AN/TIQ-3.

c. SPARE PARTS Case CY-38/TIQ-2 (fig. 4). This case is identical in general design with the cases housing the control unit and the amplifier unit, except that it is marked SPARE PARTS, and contains two drawers. These two drawers are used to store the cable assemblies and cords used in the system, and the spare parts kit, the contents of which is listed in the list of components.

d. Loudspeaker Case CY-96/TIQ-3 (fig. 6). There are three cases of this type used with Public Address Set AN/TIQ-3, each containing four Loudspeakers LS-104/TIQ-3. The case is constructed of plywood, heavily reinforced with a steel frame and corners. A hinged lid secured by catch fasteners covers the case. A stay chain on each side of the lid protects the hinges. A folding casket-type handle is attached to each side of the case for carrying. The case contains four compartments

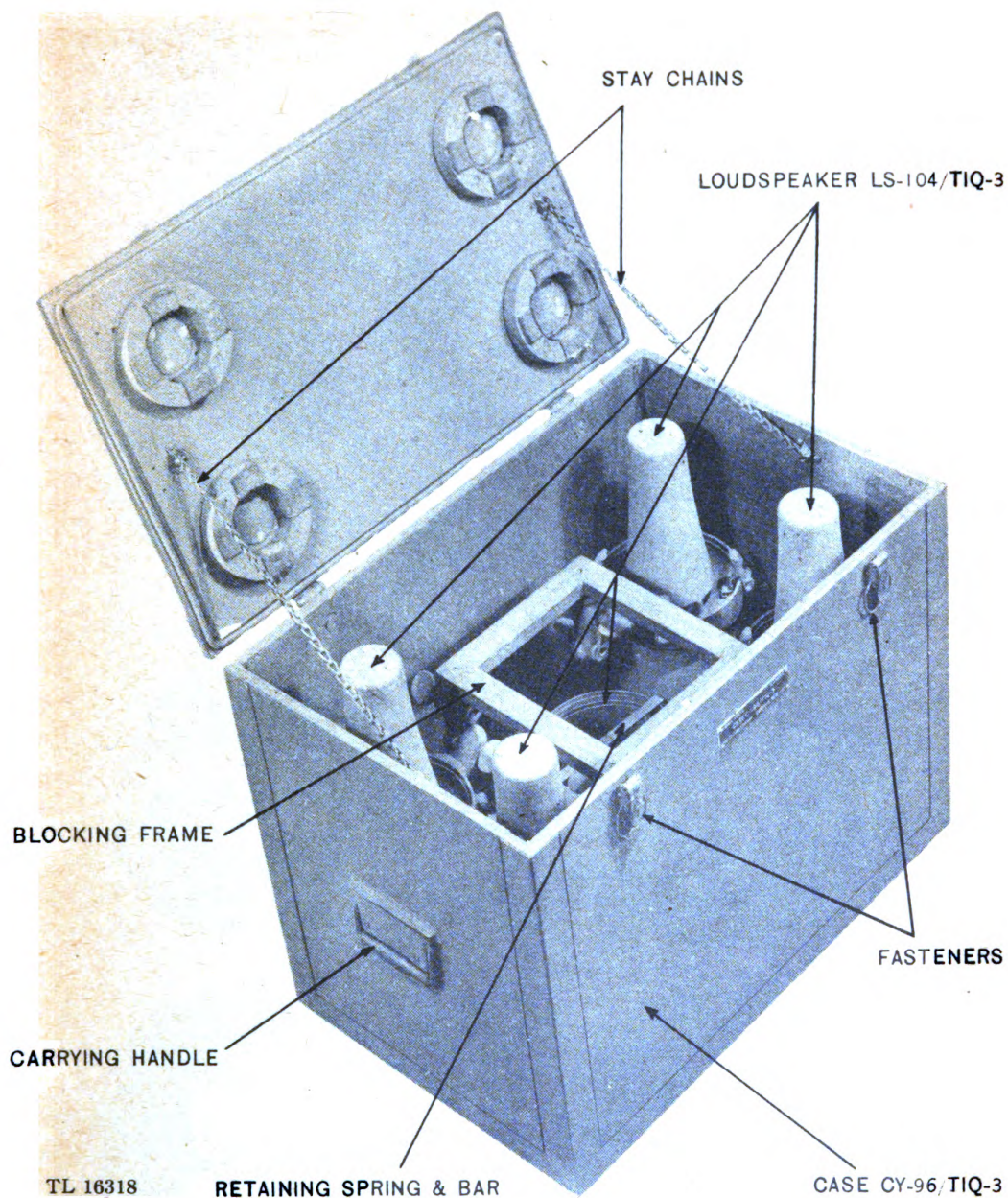
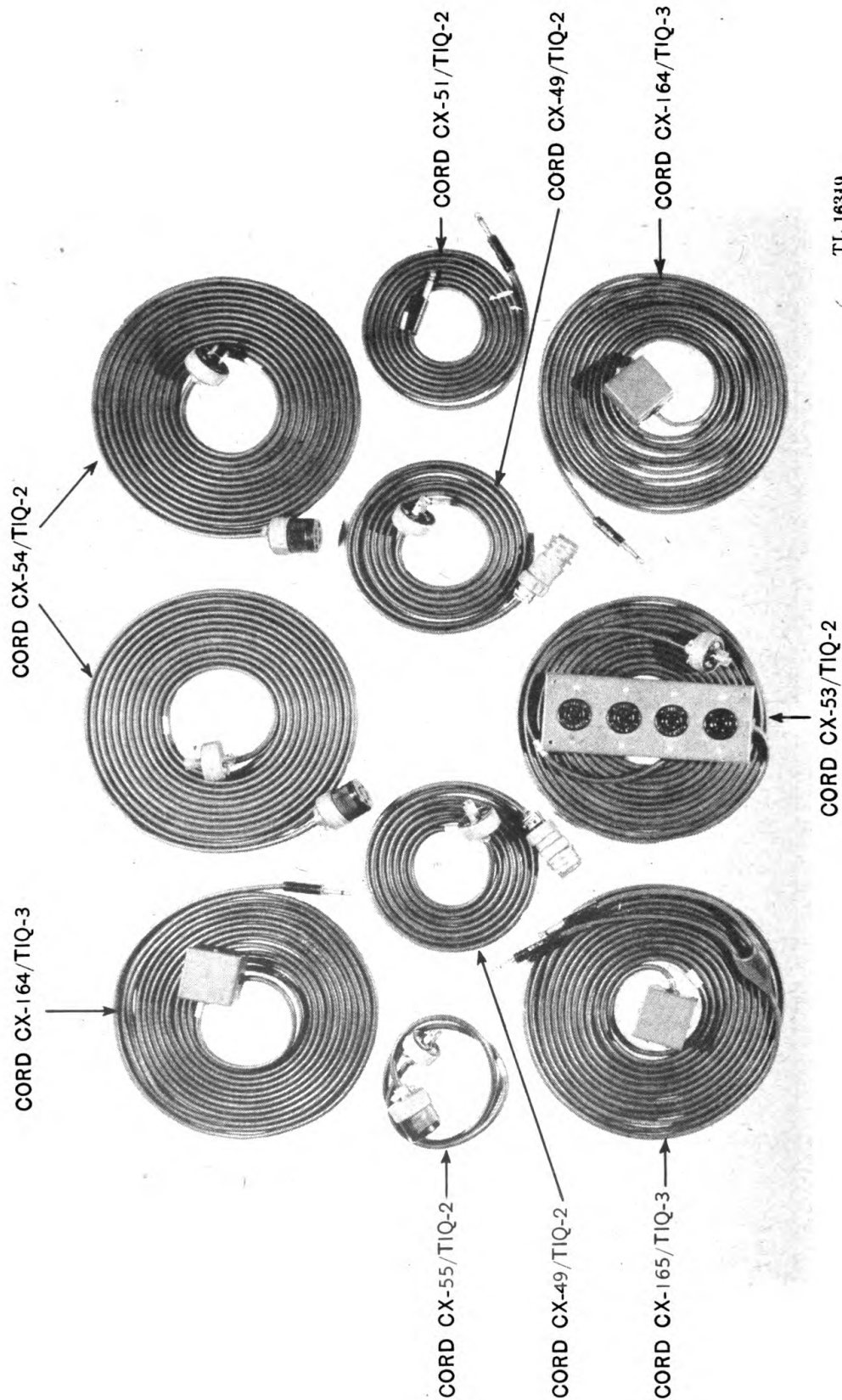

Figure 6. Case CY-96/TIQ-3 and Loudspeakers LS-104/TIQ-3.

which house the driver units of four loudspeakers, and one compartment which contains the horns of four loudspeakers. These horns are nested within one another. Four wooden rings on the inside of the lid hold the driver units in place. A spring attached to the bottom of the case is equipped with a crossbar which holds down the horns. A neoprene gasket is fastened around the inside of the lid to protect the equipment from moisture, but not from total immersion.



TL 16319

Figure 7. Cords CX-49/TIQ-2, CX-51/TIQ-2, CX-53/TIQ-2, CX-54/TIQ-2, CX-55/TIQ-2, CX-164/TIQ-3, and CX-165/TIQ-3.

e. Cord CX-49/TIQ-2, A-c Power Cords W-1 and W-2 (figs. 7 and 11). (1) Cord CX-49/TIQ-2 (W-1) is stored in the bottom drawer of the SPARE PARTS case. This cord consists of 10 feet of two-conductor cable, and is terminated at one end by female connector J-10 which is attached to male connector P-15 on the front panel of the control unit. The other end of this cord is terminated by plug P-10 which is inserted into receptacle J-12, J-13, J-14, or J-15 in the connector box on power extension Cord CX-53/TIQ-2 (W-4).

(2) Cord CX-49/TIQ-2 (W-2) is stored in the bottom drawer of the SPARE PARTS case. This cord consists of 10 feet of two-conductor cable, terminated at one end by female connector J-11 which is attached to connector P-14 on the front panel of the amplifier unit. The other end of this cord is terminated by plug P-9 which is inserted into receptacle J-12, J-13, J-14, or J-15 in the connector box on power extension Cord CX-53/TIQ-2 (W-4).

f. Cord CX-53/TIQ-2, Power Extension Cord W-4 (figs. 7 and 11). Cord W-4 is stored in the bottom drawer of the SPARE PARTS case. This cord is a 25-foot rubber-covered, two-conductor cable, terminated at one end by a connector box containing receptacles J-12, J-13, J-14, and J-15, to which are connected plug P-10 on control unit power cord W-1, and plug P-9 on amplifier power cord W-2. The two remaining receptacles are spares. The other end of cord W-4 is terminated by plug P-13 which may be connected directly to the power output connector on Power Unit PE-214-B, or to the female connector on one of the power extension cords W-5, W-6, or W-7.

g. Cords CX-54/TIQ-2, Power Extension Cords W-5 and W-6 (figs. 7 and 11). (1) Cord CX-54/TIQ-2 (W-5) is stored in the bottom drawer of the SPARE PARTS case. This is a 25-foot rubber-covered, two-conductor cable, terminated at one end by female connector J-18 which is connected to plug P-13 on power cord W-4. The other end of cord W-5 is terminated by plug P-12 which may be connected directly to the power unit, or to the female connector on power extension cord W-6.

(2) Cord CX-54/TIQ-2 (W-6) is stored in bottom drawer of the SPARE PARTS case. This is a 25-foot rubber-covered, two-conductor cable, terminated at one end by female connector J-17 which is connected to plug P-12 on power extension cord W-5. The other end of cord W-6 is terminated by plug P-11 which may connect directly to the power unit, or to the female connector on cord W-7.

h. Cord CX-55/TIQ-2, Power Connection Adapter Cord W-7 (figs. 7 and 11). Cord W-7 is stored in the bottom drawer of the SPARE PARTS case. This cord is a 3-foot, rubber-covered, two-conductor cable,

terminated at one end by female connector J-16 which is connected to plug P-13 on power cord W-4, or plug P-12 on power extension cord W-5, or to plug P-11 on power extension cord W-6. Cord W-7 is terminated at the other end by plug P-16 which is connected to a standard a-c outlet. The purpose of this cord is to provide a suitable connector for a standard a-c outlet when an external power source is used.

i. **Cord CX-51/TIQ-2, Interconnecting Cable W-3 (figs. 7 and 11).** Cord W-3 is stored in the bottom drawer of the SPARE PARTS case. This cord is a 10-foot rubber-covered, single-conductor, shielded cable, terminated at one end by Plug PL-55 (P-8) which is inserted into Jack JK-34A (J-1) on the control unit. The other end of cord W-3 is terminated by Plug PL-55 (P-5) which is connected to Jack JK-34A (J-4) on the amplifier front panel, or the jack on one of the interconnecting extension cords W-8 or W-9.

j. **Cords CX-164/TIQ-3, Interconnecting Extension Cords W-8 and W-9 (figs. 7 and 11).** (1) Cord W-8 is stored in the bottom drawer of the SPARE PARTS case. This cord is a 25-foot rubber-covered, single-conductor, shielded cable, terminated at one end by Plug PL-55 (P-6) which is connected to Jack JK-34A (J-4) on the amplifier front panel. The other end of cord W-8 is terminated by a connector box containing Jack JK-34A (J-6) which is connected to plug P-5 on cord W-3. (2) Cord W-9 is stored in the bottom drawer of the SPARE PARTS case. This cord is a 25-foot rubber-covered, two-conductor, shielded cable, terminated at one end by Plug PL-55 (P-7) which is connected to Jack JK-34A (J-4) on the front panel of the amplifier unit. The other end of cord W-9 is terminated by a connector box containing Jack JK-34A (J-7) which is connected to plug P-6 on power extension cord W-8. This cord provides additional extension for interconnecting cords W-3 and W-8.

k. **Cord CX-165/TIQ-3, Handset-cord Extension W-10 (figs. 7 and 11).** Cord W-10 is stored in the bottom drawer of the SPARE PARTS case. This cord is a 25-foot rubber-covered, 5-conductor, shielded cable, divided into a Y at one end. One cord of the Y contains two conductors and terminates in Plug PL-55 (P-4) which is connected to Jack JK-34A (J-2) on the control unit panel. The other cord of the Y contains three conductors terminating in Plug PL-68 (P-2) which connects to Jack JK-33A (J-8) on the control unit panel. The other end of cord W-10 is terminated by a connector box containing one Jack JK-34A (J-3) which connects to Plug PL-55 (P-3) on the handset cord W-11, and one Jack JK-33A (J-9) which connects to Plug PL-68 (P-1) on the handset cord W-11. This cord is used to extend the handset cord when necessary.

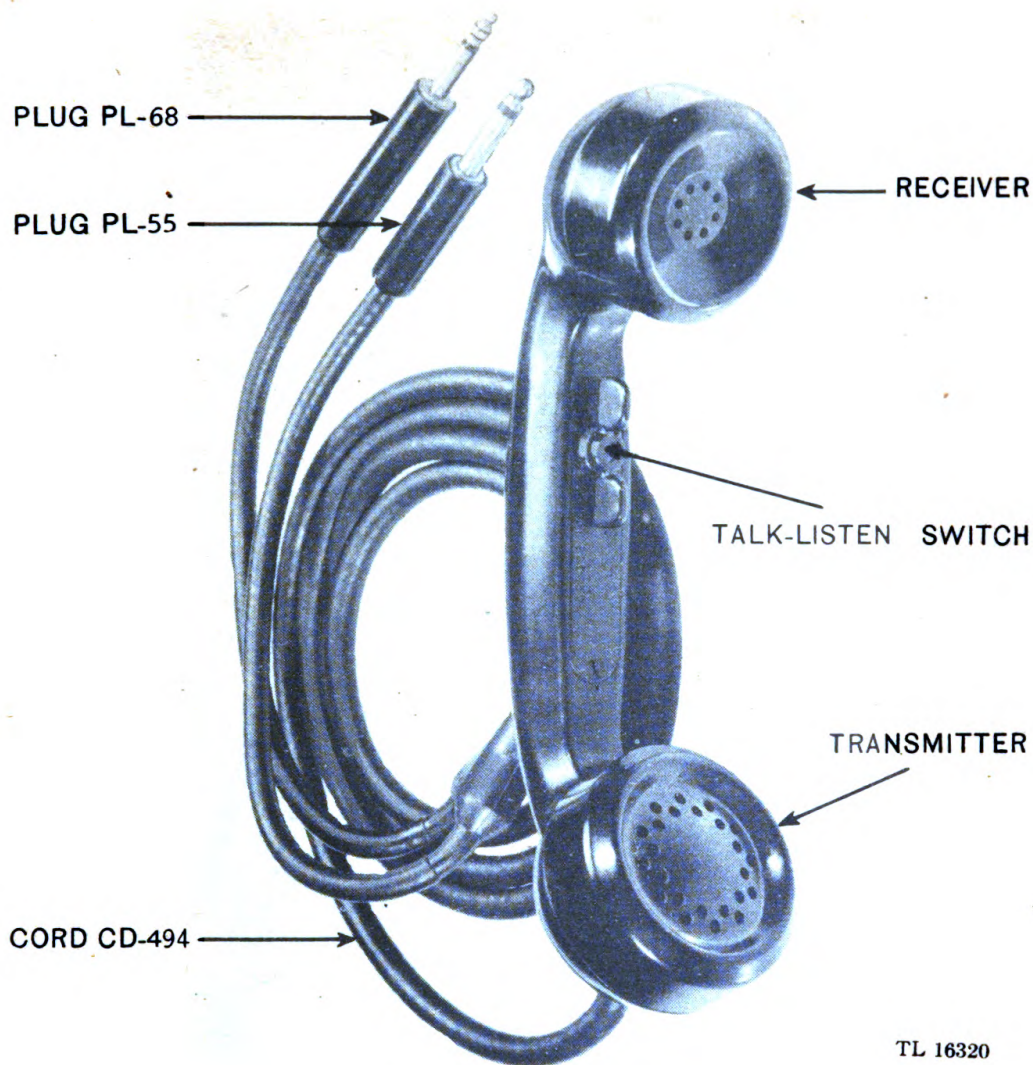

TL 16320

Figure 8. Handset TS-13-().

l. Handset TS-13-() (figs. 8 and 11). This handset consists of a microphone, which converts the acoustical power of the voice of the operator into electrical energy, and a receiver which converts the audio power output of the amplifier into audible sound. A butterfly press-to-talk switch is located on the handle to complete the microphone circuit. Cord W-11 is attached to the handset. This cord terminates in Plug PL-55 (P-3) which is connected to jack J-2 on the control unit panel, or to jack J-3 on extension cord W-10, and Plug PL-68 (P-1) which is connected to jack J-8 on the control unit panel or to jack J-9 on extension cord W-10.

m. Loudspeaker Stand MT-128/TIQ-2 (figs. 9 and 13). Stand MT-128/TIQ-2 is made of wood and painted olive drab. It consists of a round, flat top and three extensible legs, each fastened to the top by means of a hinge. The stand when closed measures 4 feet high by 7½

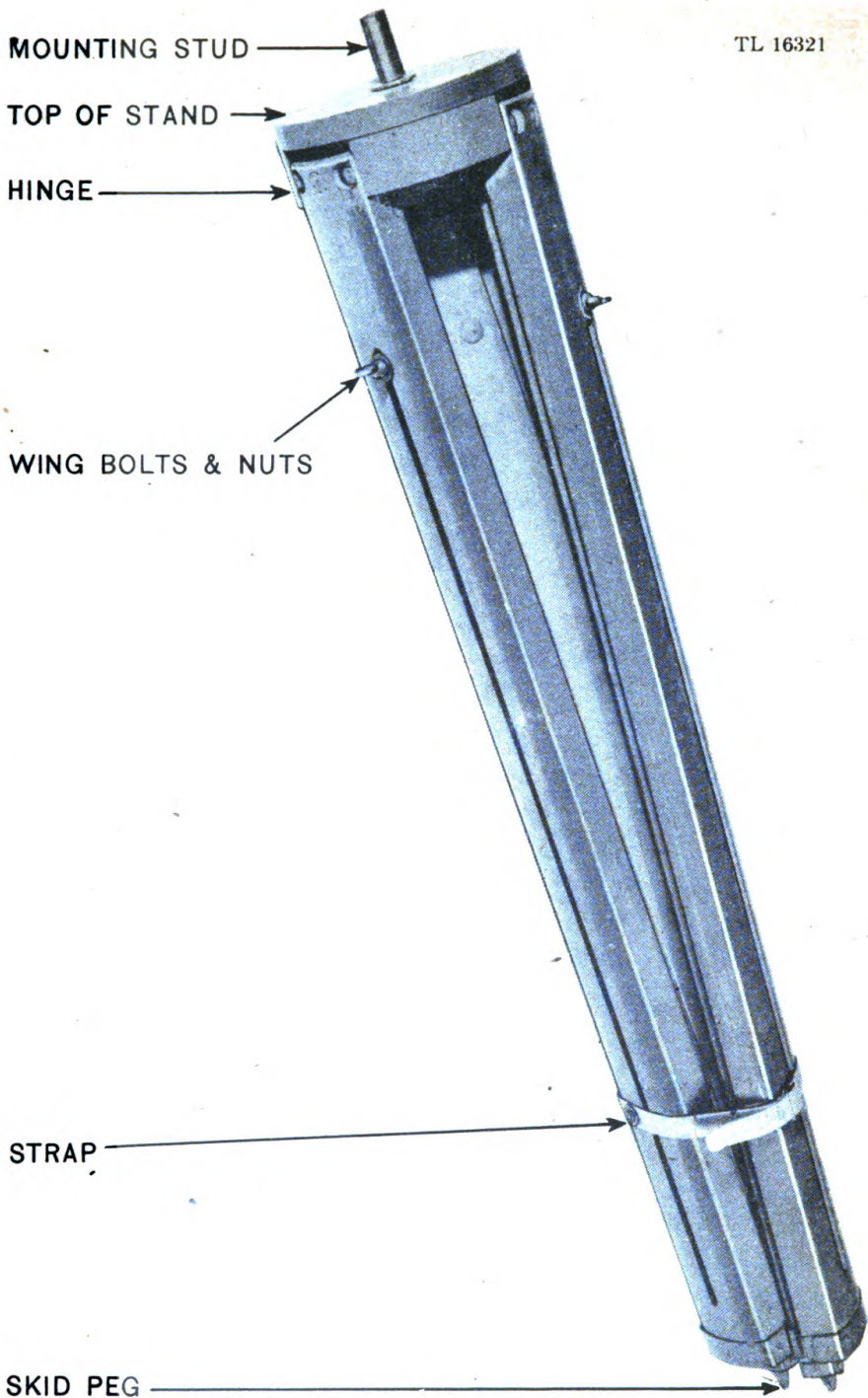

Figure 9. Loudspeaker Stand MT-128/TIQ-2.

inches in diameter. It is adjustable, when open, from a height of 3 feet, 7 inches to a height of 6 feet, 1 inch. The minimum height when closed for carrying purposes is 3 feet, 11 inches. The diameter of the top is $7\frac{1}{2}$ inches. The legs are individually adjustable to compensate for uneven ground and are locked in place by means of wingnuts and bolts. A mounting stud is provided on which the mounting-bracket socket of the loudspeaker is placed and locked by means of a wingbolt.

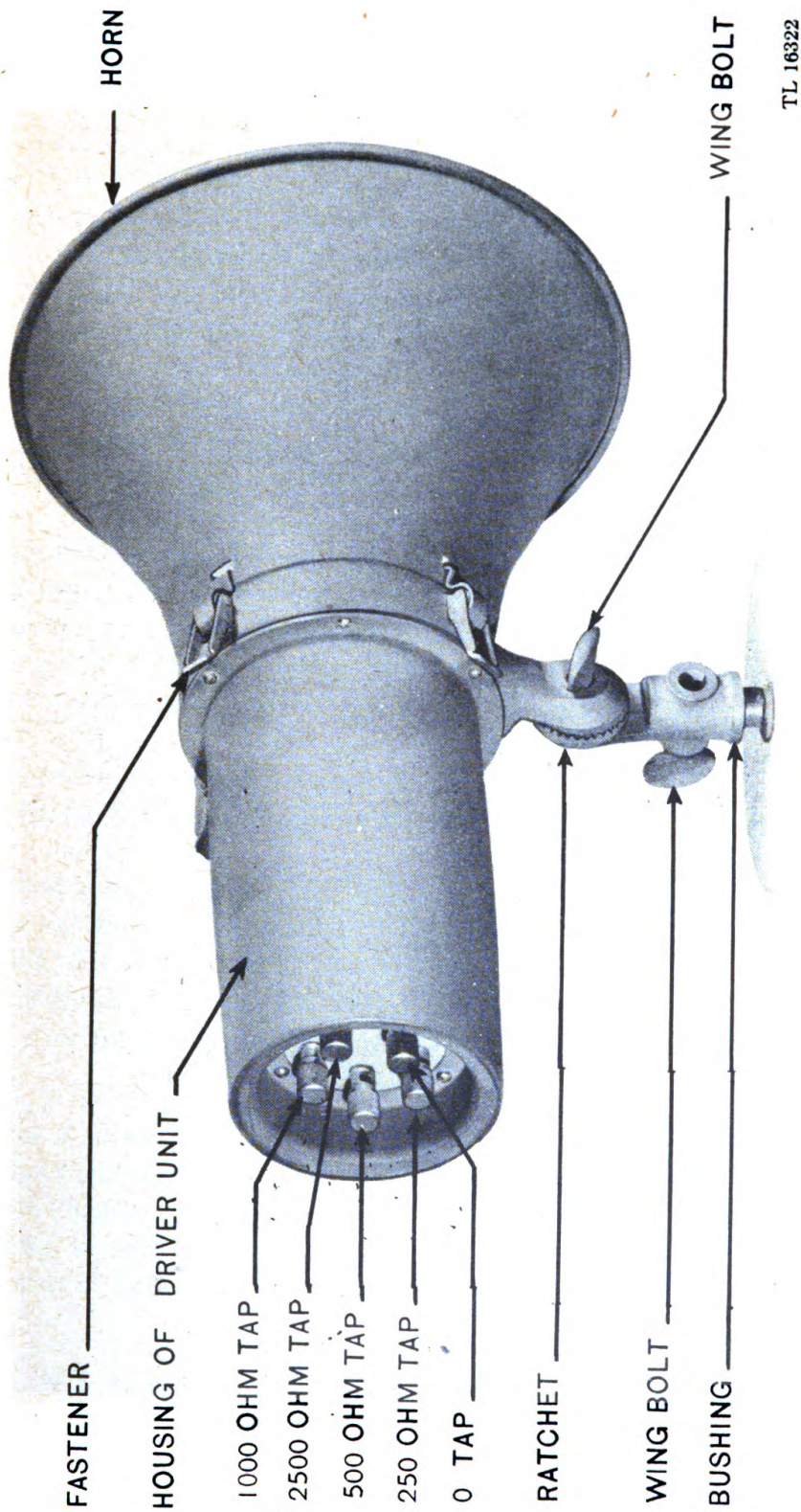

Figure 10. Loudspeaker LS-104/TIQ-3.

n. Loudspeakers LS-104/TIQ-3 (fig. 10). (1) **SPEAKER HORN.** The speaker horn is of the reflex type. In this type of horn, the sound travels back and forth three times before leaving the horn, thereby providing the same efficiency as a nonreflex type of horn several times its length. By means of four clasp fasteners, the bell of the horn is attached to the frame that holds the horn, the driver unit, the transformer box, and the terminal strip. The horn of the speaker is, therefore, removable and permits the nesting of four horns for storing in Case CY-96/TIQ-3. (2) **SPEAKER DRIVER UNIT.** The driver unit is the motive power of the loudspeaker. It converts the electrical energy received from the amplifier and control unit into audible sound. It also acts as a microphone and converts acoustical energy into electrical energy when the intercommunication feature of the system is used. The driver unit is blastproof. (3) **TRANSFORMER T-8 (fig. 22).** This unit transforms the electrical energy received from the amplifier and control unit to the proper value for the speaker driver unit. When the speaker is used as a microphone, this transformer converts the electrical energy received from the speaker driver unit voice coil into electrical energy of the proper value to energize the input of the control unit. (4) **TRANSFORMER BOX.** The transformer box contains transformer T-8, terminal board E-15, and its five binding posts for the loudspeaker cable. (5) **MOUNTING BRACKET AND BUSHING.** The bracket is equipped with an adjustable ratchet to permit elevation of the speaker, and with a bushing to fit the mounting stud on Stand MT-128/TIQ-2. A wingbolt on the bushing is used to lock the bushing on the mounting stud. A wingbolt on the ratchet is used to lock the speaker at any desired elevation.

o. Power Unit PE-214-B (fig.1). This power unit is a compact, light-weight, electric-generating set, consisting of a gasoline engine and an a-c generator and designed to deliver 300 watts at either 120 or 240 volts a-c. It is fully described in Technical Manual TM 11-945 which accompanies the equipment. A canvas cover is provided to protect the power unit when not in use.

p. Technical Manual TM 11-2531. Two copies of TM 11-2531 are stored in the bottom drawer of the SPARE PARTS case.

q. Wire W-110-B. Wire W-110-B (field wire) is used to connect both the output of the amplifier, and the loudspeakers to the control unit. This wire is not included in the equipment.

LEGEND

- W-1 CORD CX-49/TIQ-2
- W-2 CORD CX-49/TIQ-2
- W-3 CORD CX-51/TIQ-2
- W-4 CORD CX-53/TIQ-2
- W-5 CORD CX-54/TIQ-2
- W-6 CORD CX-54/TIQ-2
- W-7 CORD CX-55/TIQ-2
- W-8 CORD CX-164/TIQ-3
- W-9 CORD CX-164/TIQ-3
- W-10 CORD CX-165/TIQ-3
- W-11 CORD CD-494

- P-9 CONNECTOR - 2 MALE CONTACTS
- P-10 CONNECTOR - 2 MALE CONTACTS
- P-11 CONNECTOR - 2 MALE CONTACTS
- P-12 CONNECTOR - 2 MALE CONTACTS
- P-13 CONNECTOR - 2 MALE CONTACTS
- P-14 CONNECTOR - AN-3102-20S-7P
- P-15 CONNECTOR - AN-3102-20S-7P
- P-16 CONNECTOR - 2 MALE CONTACTS

- J-10 CONNECTOR - AN-3106-20-7S
- J-11 CONNECTOR - AN-3106-20-7S
- J-12 CONNECTOR - FEMALE CONTACT
- J-13 CONNECTOR - FEMALE CONTACT
- J-14 CONNECTOR - FEMALE CONTACT
- J-15 CONNECTOR - FEMALE CONTACT
- J-16 CONNECTOR - 2 FEMALE CONTACTS
- J-17 CONNECTOR - 2 FEMALE CONTACTS
- J-18 CONNECTOR - 2 FEMALE CONTACTS
- J-19 CONNECTOR - AN-3102-14S-5S

- J-1 JACK - JK-34 A
- J-2 JACK - JK-34 A
- J-3 JACK - JK-34 A
- J-4 JACK - JK-34 A
- J-5 JACK - JK-34 A
- J-6 JACK - JK-34 A
- J-7 JACK - JK-34 A
- J-8 JACK - JK-33 A
- J-9 JACK - JK-33 A

- P-1 PLUG-PL-68
- P-2 PLUG-PL-68
- P-3 PLUG-PL-55
- P-4 PLUG-PL-55
- P-5 PLUG-PL-55
- P-6 PLUG-PL-55
- P-7 PLUG-PL-55
- P-8 PLUG-PL-55

- H-119 POST-BINDING
- H-120 POST-BINDING
- H-121 POST-BINDING
- H-122 POST-BINDING
- H-104 TO H-118 INCLUSIVE - POST BINDING

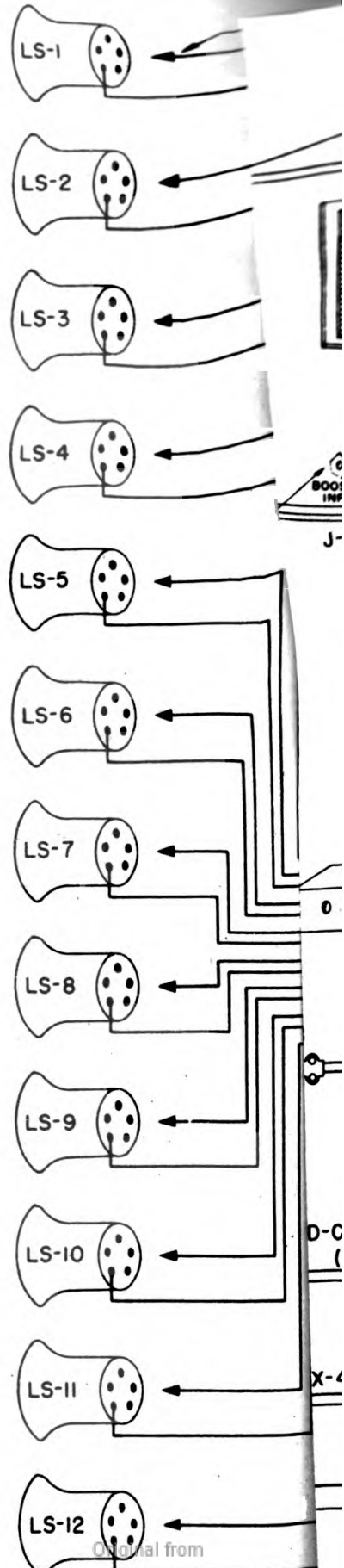

5
a
r

SECTION II

INSTALLATION AND OPERATION

5. INITIAL PROCEDURE (fig. 11).

a. Remove the equipment from its shipping containers and inspect it for any damage that may have occurred during shipment. If any items are found to be unserviceable, report this fact immediately and procure replacements.

b. Remove the front cover from Case CY-38/TIQ-2 marked **AMPLIFIER** by loosening the four catch fasteners securing this cover, and set up the case in the location selected (fig. 3).

c. Remove the front cover from Case CY-38/TIQ-2 marked **CONTROL UNIT** by loosening the four catch fasteners securing this cover, and set up the case in the location selected (fig. 2).

d. Remove the front cover from Case CY-38/TIQ-2 marked **SPARE PARTS** by loosening the four catch fasteners securing this cover, and set up the case in the location selected (fig. 4).

e. Open the lid of the three cases marked Case CY-96/TIQ-3 and remove the four Loudspeakers LS-104/TIQ-3 from each case (fig. 6). The four speaker horns are nested together and held down by a spring and crossbar which can readily be lifted to release the horns. Remove the horns from the case and separate them. Next remove the four loudspeaker driver units which are housed in four wooden compartments fastened to the bottom of the case.

CAUTION: The powerful magnets contained in the speaker driver units will magnetize the steel parts of watches, compasses, and instruments, making them useless. Remove such items from the vicinity of speaker driver units.

f. Remove the canvas cover from Power Unit PE-214-B, and prepare the unit for operation as described in TM 11-945, which accompanies the equipment.

g. Remove all cable assemblies, cords, and Handset TS-13-() from the bottom drawer of the SPARE PARTS case.

h. Remove loudspeaker Stands MT-128/TIQ-2 from their packing containers and unbuckle the retaining straps from the legs of the stands.

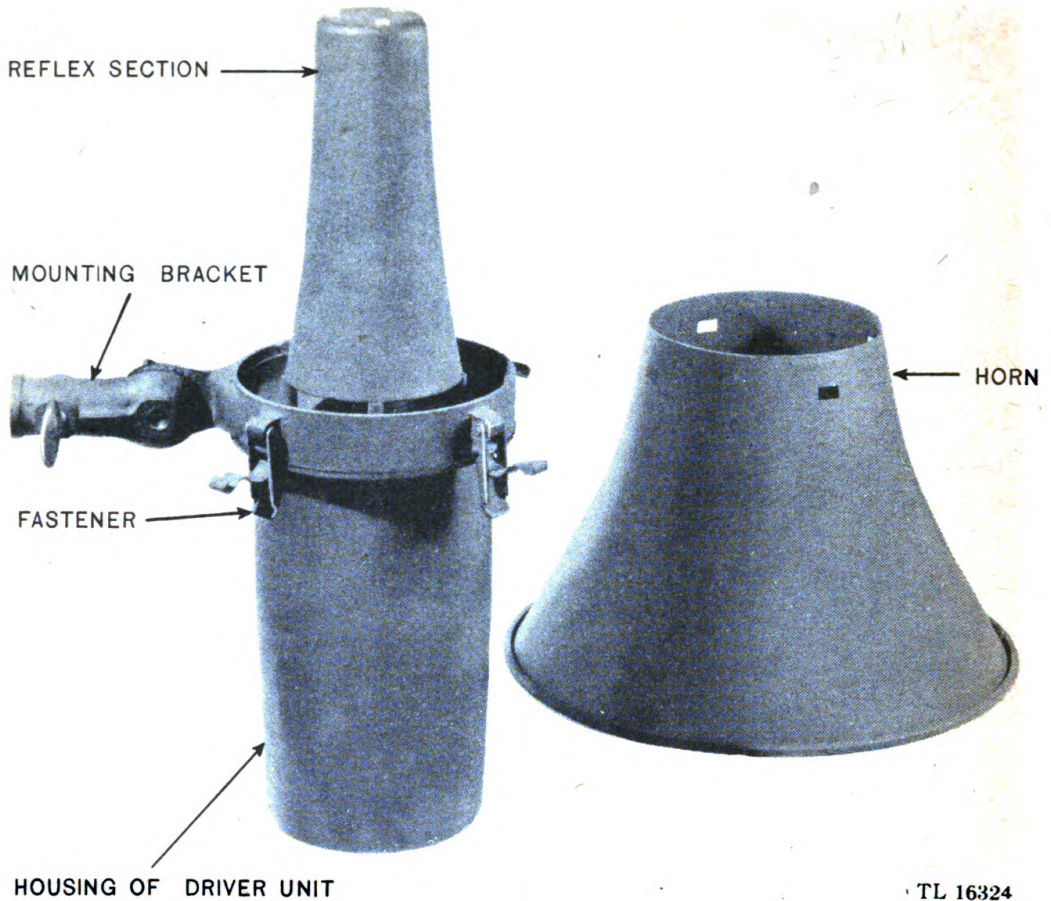

Figure 12. Loudspeaker LS-104/TIQ-3 with horn removed.

i. To assemble Loudspeaker LS-104/TIQ-3, insert the rim of the small end of the speaker horn into the throat of the speaker driver unit (figs. 10 and 12). Place the catches of the four catch-fasteners opposite the slots in the speaker horn rim. Insert all four catches before pressing down the fasteners. Loosen the wingbolt securing the ratchet on the frame of the speaker, and place the bushing at a right angle to the speaker body. Then, tighten the wingbolt.

j. Adjust the legs of Stand MT-128/TIQ-2 by loosening the wingnut and bolt on each leg and adjusting the legs to secure the desired elevation. Then, level the mounting (fig. 13).



Figure 13. Loudspeaker LS-104/TIQ-3 on Stand MT-128/TIQ-2.

k. Place Loudspeaker LS-104/TIQ-3 on Stand MT-128/TIQ-2 so that the bushing slides onto the mounting stud as far as it will go. Turn the speaker in the direction desired, then tighten the wingbolt securely on the bushing. Loosen the wingbolt on the speaker frame and elevate the speaker to the desired level. Tighten the wingbolt.

6. INTERCONNECTING THE COMPONENTS (fig. 11).

a. Loosen the screw on the back plate of Loudspeaker LS-104/TIQ-3 housing unit (fig. 10) and turn the plate to expose terminal board E-15.

b. Attach one wire of a speaker cable (field wire) to the binding post marked 0, and the other wire to the binding post marked 500, on speaker terminal board E-15.

c. Repeat the procedure described in subparagraphs a and b above for as many of the 12 loudspeakers as are to be used.

d. Attach one terminal of the other end of the speaker cable to one of the binding posts numbered 1 to 12 on terminal board E-10 on the front panel of Control Unit C-104/TIQ-3 (fig. 2).

NOTE: The locations of all loudspeakers used should be determined beforehand and marked on terminal board E-10, so that it is known which speaker is connected to each number binding post.

e. Attach the other terminal of the speaker cable to one of the binding posts marked COMMON on terminal board E-10. No more than four wires should be attached to any one of the COMMON binding posts.

f. Connect binding post H-122 on Amplifier AM-34/TIQ-3 to binding post H-119 on Control Unit C-104/TIQ-3 by means of a suitable cable or field wire.

g. Connect binding post H-121 on Amplifier AM-34/TIQ-3 to binding post H-120 on Control Unit C-104/TIQ-3 by means of a suitable cable or field wire.

h. Insert plug P-1 on cord W-11 of Handset TS-13-() into jack J-8 on the front panel of the control unit, and insert plug P-3 on cord W-11 of the handset into jack J-2 on the front panel of the control unit.

i. In case an extension of the handset cord is required, insert plug P-2 on Cord CX-165/TIQ-3 (W-10) into jack J-8 on the control unit, and insert plug P-4 on cord W-10 into jack J-2 on the control unit. Insert plug P-3 on the handset cord into jack J-3 in the terminal box on the other end of cord W-10, and insert plug P-1 on the handset cord into jack J-9 in the terminal box on W-11.

j. Insert plug P-8 on interconnecting Cord CX-51/TIQ-2 (W-3) into output jack J-1 on the control unit, and insert plug P-5 on the other end of the interconnecting cord W-3 into jack J-4 on the amplifier unit panel.

k. In case an extension of the interconnecting cord W-3 is required, insert plug P-5 on cord W-3 into jack J-6 in the terminal box on extension Cord CX-164/TIQ-3 (W-8), and insert plug P-6 on the extension

cord W-8 into jack J-4 on the amplifier panel. Cord W-9 may also be used in the same manner for an additional extension of cords W-3 and W-8.

l. Insert connector J-10 on power Cord CX-49/TIQ-2 (W-1) into receptacle P-15 on the control unit. Insert plug P-10 on the other end of power cord W-1 into receptacle J-12, J-13, J-14, or J-15 in the terminal box on power Cord CX-53/TIQ-2 (W-4). Insert plug P-13 on power cord W-4 into the output connector on Power Unit PE-214-B.

m. Insert connector J-11 on the amplifier power Cord CX-49/TIQ-2 (W-2) into receptacle P-14 on the amplifier panel, and plug P-9 on the other end of the amplifier power cord W-2 into one of the receptacles J-12, J-13, J-14, or J-15 in the terminal box on power cord W-4.

n. In case an extension for power cord W-4 is required, insert plug P-13 on power cord W-4 into connector J-18 on power extension Cord CX-54/TIQ-2 (W-5), and insert plug P-12 on the other end of power extension cord W-5 into the output connector on Power Unit PE-214-B.

o. In case a still longer extension of power cord W-4 is required, insert plug P-12 on cord W-5 into connector J-17 on power extension Cord CX-54/TIQ-2 (W-6), and insert plug P-11 on the other end of power extension cord W-6 into the output connector on Power Unit PE-214-B.

p. If connection is to be made to a standard a-c outlet for operation from an external power source, insert connector J-16 on the adapter Cord CX-55/TIQ-2 (W-7) onto plug P-13 on power cord W-4 (or plug P-12 on W-5, or plug P-11 on W-6), and insert plug P-16 on the other end of adapter cord W-7 into the standard a-c outlet.

7. OPERATION WITH HANDSET TS-13-() (fig. 11).

CAUTION: Before operating Public Address Set AN/TIQ-3, be sure that the source of power is either 115 or 230 volts ac, and that all switches on the amplifier unit and on the control unit are in the off position.

a. After checking the voltage of the supply source, place switch S-3 on the amplifier, and switch S-4 on the control unit, either in the position marked 115 or in the position marked 230, according to the voltage supplied, and lock both switches in place with switch bracket A-3.

b. Turn POWER switch S-19 on the control unit to the ON position, and turn POWER switch S-1 on the amplifier unit to the ON position.

c. Turn VOLUME control R-47 on the amplifier in a clockwise direction to position 5.

d. Turn **TALK VOLUME** control R-50 on the control unit in a clockwise direction to position 5.

e. To make an announcement over one or more of the 12 loudspeakers, place the switch or switches controlling the desired speakers in the **ON** position (switches S-5 to S-16 on the control unit panel).

f. Depress the switch on Handset TS-13-(), and speak directly into the microphone of the handset.

g. Adjust **VOLUME** control R-47 on the amplifier, and **TALK VOLUME** control R-50 on the control unit until the desired volume is reached at the speaker locations. Release the handset switch when the announcement has been completed.

h. To make an announcement over all 12 loudspeakers, place **ALL** switch S-17 on the control unit in the **ON** position and proceed as described in subparagraphs f and g above. The announcement will be heard over all the loudspeakers regardless of the position of the individual speaker selector switches.

NOTE: If **TALK VOLUME** control R-50 is turned too far clockwise, a howling, whistling sound is heard. This sound, known as acoustic feedback, is caused by the speaker output reflecting from surrounding walls, trees, or the ground, and reëntering the microphone and interfering with the successful operation of the system. This feedback may be reduced or eliminated by placing the speakers in front of the microphone and facing away from it. If feedback still occurs, decrease the microphone volume by turning **TALK VOLUME** control R-50 counterclockwise to a point just under where feedback occurs. Another aid is to turn the microphone at a right angle to the loudspeakers.

8. OPERATION WITH CONSTANT-, INTERMITTENT-, OR WARBLE-TONE SIGNAL (fig. 11).

a. Proceed as in paragraphs 7a through d.

b. To turn on the constant-tone signal, place **CONSTANT** switch S-2 in the **ON** position. A steady uninterrupted tone will be produced.

c. To turn on the intermittent-tone signal, place the **INTERMIT-WARBLE** switch S-20 in the **INTERMIT** position. A series of short tone dashes will be produced.

d. To turn on the warble-tone signal, place the **INTERMIT-WARBLE** switch S-20 in the **WARBLE** position. A rising and falling tone will be produced.

9. OPERATION FOR INTERCOMMUNICATION (fig. 11).

a. Proceed as in paragraphs 7a through d.

b. To start communication with any one of the loudspeaker locations, transmit a predetermined signal from the control unit, using any one of

the tone generators described in paragraph 8. Communicate with the remote location as described in paragraphs 7e, f, and g.

c. To receive a signal from the remote speaker location through the receiver of the handset, turn the LISTEN VOLUME control R-51 on the control unit in a clockwise direction until the signal is heard at the desired level.

d. To receive a signal from the remote speaker location through the monitor speaker LS-13 in the control unit, place SPEAKER switch S-18 in the ON position. Turn the LISTEN VOLUME control R-51 in a clockwise direction until the signal is heard at the desired level.

e. To use the monitor speaker to acknowledge communication from the remote speaker location, with SPEAKER switch S-18 ON, depress the PRESS TO TALK switch S-21 on the control unit panel and speak into the monitor speaker. Adjust the TALK VOLUME control R-50 until the desired sound level is reached at the remote speaker.

10. UNSATISFACTORY EQUIPMENT REPORT.

a. When trouble in equipment used by Army Ground Forces or Army Service Forces occurs more often than repair personnel feel is normal, War Department Unsatisfactory Equipment Report, W.D., A.G.O. Form No. 468 should be filled out and forwarded through channels to the Office of the Chief Signal Officer, Washington 25, D. C. Refer to TM 38-250 for complete instructions for the handling of this report.

b. When trouble in equipment used by Army Air Forces occurs more often than repair personnel feel is normal, Army Air Forces Form No. 54 should be filled out and forwarded through channels.

c. When reporting vacuum tube failures, the manufacturer's code name should be included. This code name appears between JAN and the commercial number on tubes that have been tested and approved according to JAN-1A specifications. Such a marking may be JAN-CHS-5U4G, which indicates that the 5U4G tube as manufactured by Sylvania (CHS) has been tested and approved. Tubes that have been manufactured according to JAN specifications, but have not been tested and approved, do not carry the manufacturer's code name after JAN, and are marked JAN-5U4G. In this case the manufacturer's name is printed below the tube number.

11. OPERATOR'S TROUBLE CHART.

When equipment failure is encountered, check the items in the trouble chart before making a detailed examination. Operating personnel should attempt only such replacements and repairs as are listed in the trouble chart. Other and more complicated maintenance should be made only by authorized personnel.

OPERATOR'S TROUBLE CHART

<i>Symptom</i>	<i>Possible cause</i>	<i>Remedy</i>	
1. Pilot lamp E-3 on control unit panel does not light when power ON-OFF switch is in ON position.	1. Fuse F-2 burned out.	1. Replace fuse.	
	Pilot lamp E-3 burned out.	Replace lamp.	
	Connector J-10 or plug P-10 on power Cord CX-49/TIQ-2 (W-1) disconnected.	Tighten loose connections.	
	Plug P-13 on power Cord CX-53/TIQ-2 (W-4) disconnected.	Tighten loose connections.	
	Plug P-12 on power extension Cord CX-54/TIQ-2 (W-5) disconnected.	Tighten loose connection.	
	Plug P-11 on power extension Cord CX-54/TIQ-2 (W-6) disconnected.	Tighten loose connection.	
	Plug P-16 on power adapter Cord CX-55/TIQ-2 (W-7) disconnected.	Tighten loose connection.	
	Any of the above cords damaged.	Replace damaged cord.	
	2. Pilot lamp E-4 on amplifier panel does not light when power ON-OFF switch S-1 is in ON position.	2. Fuse F-1 burned out.	2. Replace.
		Pilot lamp E-4 burned out.	Replace.
Connector J-11 or plug P-9 on power Cord CX-49/TIQ-2 (W-2) disconnected.		Tighten loose connection.	
3. Pilot lamps light but there is no output.	Connectors or plugs on power cords W-4, W-5, W-6, or W-7 disconnected as described in 1 above.	Tighten loose connection.	
	3. Volume control R-47 on the amplifier and/or the volume control R-50 on the control unit not turned up high enough.	3. Turn up R-47 or R-50.	
	Speaker switches S-5 through S-16 on the control unit panel not in ON position.	Place in ON position.	

OPERATOR'S TROUBLE CHART (contd).

<i>Symptom</i>	<i>Possible cause</i>	<i>Remedy</i>
	PRESS TO TALK switch S-21 on the control unit not depressed.	Depress switch S-21.
	Plugs P-2 and P-4, and jacks J-3 and J-9 on handset extension Cord CX-165/TIQ-3 (W-10) disconnected.	Tighten loose connection.
	Plugs P-1 and P-3, and jacks J-2 and J-8 on handset cord (W-11) disconnected.	Tighten loose connection.
	Loose connections at loudspeaker cable binding posts H-104 to H-118 on control unit terminal board E-10.	Tighten loose connection.
	Loose connections at binding posts H-119 and H-120 on the control unit, or binding posts H-121 and H-122 on the amplifier.	Tighten loose connections.
	Connections reversed at binding posts H-119, H-120, H-121, or H-122.	Connect H-119 to H-122, and connect H-120 to H-121.
	Loose connections at plugs P-8 or P-5 on interconnecting Cord CX-51/TIQ-2 (W-3), or at jack J-6 or plug P-6 on extension interconnecting Cord CX-164/TIQ-3 (W-8), or at jack J-7 or plug P-7 on extension interconnecting cord W-9.	Tighten loose connections.
	Loose connections at binding posts on terminal board E-15 on Loudspeakers L.S-104, TIQ-3.	Tighten loose connections.

OPERATOR'S TROUBLE CHART (contd).

<i>Symptom</i>	<i>Possible cause</i>	<i>Remedy</i>
	Defective Handset TS-13-().	Replace.
	Defective tubes in amplifier or control unit.	Replace.
	Defective loudspeakers.	Replace defective drive unit or transformer.
4. Weak output.	4. Improper voltage selection at switch S-4 on control unit panel, or switch S-3 on the amplifier panel.	4. Correct setting to correspond with voltage supplied.
	Low line voltage when Power Unit PE-214-B is used.	Proceed as directed in TM 11-945.
	Low line voltage when an external source of power is used.	Report to central station.
	Volume control R-50 on the control unit panel, or volume control R-47 on the amplifier panel not turned up.	Turn up controls.
	Improper impedance matching at Loudspeakers LS-104/TIQ-3.	Make connections at 500-ohm tap on loudspeaker transformer.
	Defective Handset TS-13-().	Replace.
	Defective tubes in amplifier or control unit.	Replace.
	One or more defective loudspeakers.	Replace defective drive unit or transformer.
5. Distorted output.	5. Defective tubes, incorrect control settings, poor connections, defective loudspeakers or handset.	5. If these items (symptom column) operate properly, the trouble is in the control unit or amplifier circuits. Return the defective unit to maintenance depot for repairs.
6. Strong but intermittent output.	6. Loose connections in cables or external wiring.	6. Tighten loose connections.
	Defective tubes.	Replace.
	Loose tube socket.	Tighten or replace.

OPERATOR'S TROUBLE CHART (contd).

<i>Symptom</i>	<i>Possible cause</i>	<i>Remedy</i>
	Defective wiring in amplifier or control unit.	Substitute good unit and return defective unit to repair depot.
	Defective handset.	Replace.
	Open wiring in transformer T-8 on Loudspeakers LS-104/TIQ-3.	Replace loudspeaker.
	Loose connections at binding posts on terminal board E-10 on control unit.	Tighten loose connections.
Hum in output.	7. Defective tubes.	7. Replace.
	Open circuit in microphone cord or plug, with volume control R-50 on control unit turned up fully.	Check all connections and cords.
	Loose connection or open circuit between control unit and amplifier, with volume controls on full.	Check and tighten all connections.
	Defective amplifier unit or control unit.	Return defective unit to repair depot.
8. Weak or no output, or strong intermittent output when tone-generators are used.	8. See causes listed above under these heads.	8. Apply remedies suggested above under these heads.
	Defective lamps E-1 and E-2.	Replace.
	Defective amplifier unit or control unit.	Return defective unit to repair depot.

12. OPERATOR MAINTENANCE.

a. Fuse Replacement. To remove fuse F-1 or F-2, turn the knurled fuse holder counterclockwise until the holder can be removed. Lift the holder out of the chassis and pull the defective fuse from the holder. Replace the fuse, reinsert the holder in the chassis, and turn clockwise until tight.

b. Pilot Lamp Replacement. To replace pilot lamps E-3 and E-4, remove the knurled holding-ring of the pilot lamp assembly by turning it counterclockwise. To remove the pilot lamp, push the bulb into the socket, turn it slightly to the left and remove. Install a new bulb and replace the knurled ring.

c. Vacuum Tube and Glow Lamp Replacement. To remove the tubes and glow lamps, it is necessary to take Amplifier AM-34/TIQ-3 and Control Unit C-104/TIQ-3 from their cases. This is accomplished by removing the three machine screws located on each side of the front panels of the amplifier and control unit. After these screws are removed, the units can be taken from the cases.

(1) To remove tubes V-4, V-5, V-6, V-7, V-8, V-9, V-10, and V-11, it is first necessary to release the springs on the tube clamps which secure these tubes. After the spring has been released, the tube is removed by lifting straight out of the socket.

(2) To remove tubes V-1, V-2, and V-3, lift the tubes out of the socket and replace.

CAUTION: Compare type numbers of replacement tubes with type numbers stamped on the tube sockets and/or the chassis, before inserting.

(3) To remove glow lamps E-1 and E-2, press down on the bulb, twist it to the left, and remove. To replace the bulb, press it down and twist to the right.

SECTION III

FUNCTIONING OF PARTS

13. GENERAL.

a. Public Address Set AN/TIQ-3 is an audio-amplifying system consisting of a Handset TS-13-(), Control Unit C-104/TIQ-3, Amplifier AM-34/TIQ-3, and 12 Loudspeakers LS-104/TIQ-3. Power is supplied to the system by Power Unit PE-214-B, or by an external 115- or 230-volt, 60-cycle, a-c source.

b. TM 11-945 contains functional information on Power Unit PE-214-B, which is mentioned in this manual but not covered in detail.

c. This public address set is arranged to communicate from the control location to a loudspeaker (or loudspeakers), and to receive a response from the loudspeaker location. These operations are illustrated in the block diagram, figure 14.

14. INTRODUCTION TO FUNCTIONING OF PARTS.

The public address system with its associated amplifier and 12 loudspeakers is controlled from the control unit. With the press-to-talk handset switch closed, relay K-1 (fig. 15) is energized, and closes the circuit between the amplifier (entering the remote control unit through binding posts H-119 and H-120) and the speaker switch panel. The speakers to which the signal is transmitted are set by the series of switches S-5 to S-16. The voice or tone originates at the control unit, passes through amplifier V-3 and output jack J-1, to the input of the amplifier unit. From the amplifier output binding posts H-121 and H-122, the signal returns to the control unit, and on to the loudspeakers. When relay K-1 is not energized and ALL switch S-17 is off or grounded through resistor R-46, an audio signal from any of the 12 speakers enters the control unit through the speaker selector switches S-5 to S-16. This signal passes through the contacts of relay K-1 to the input of the

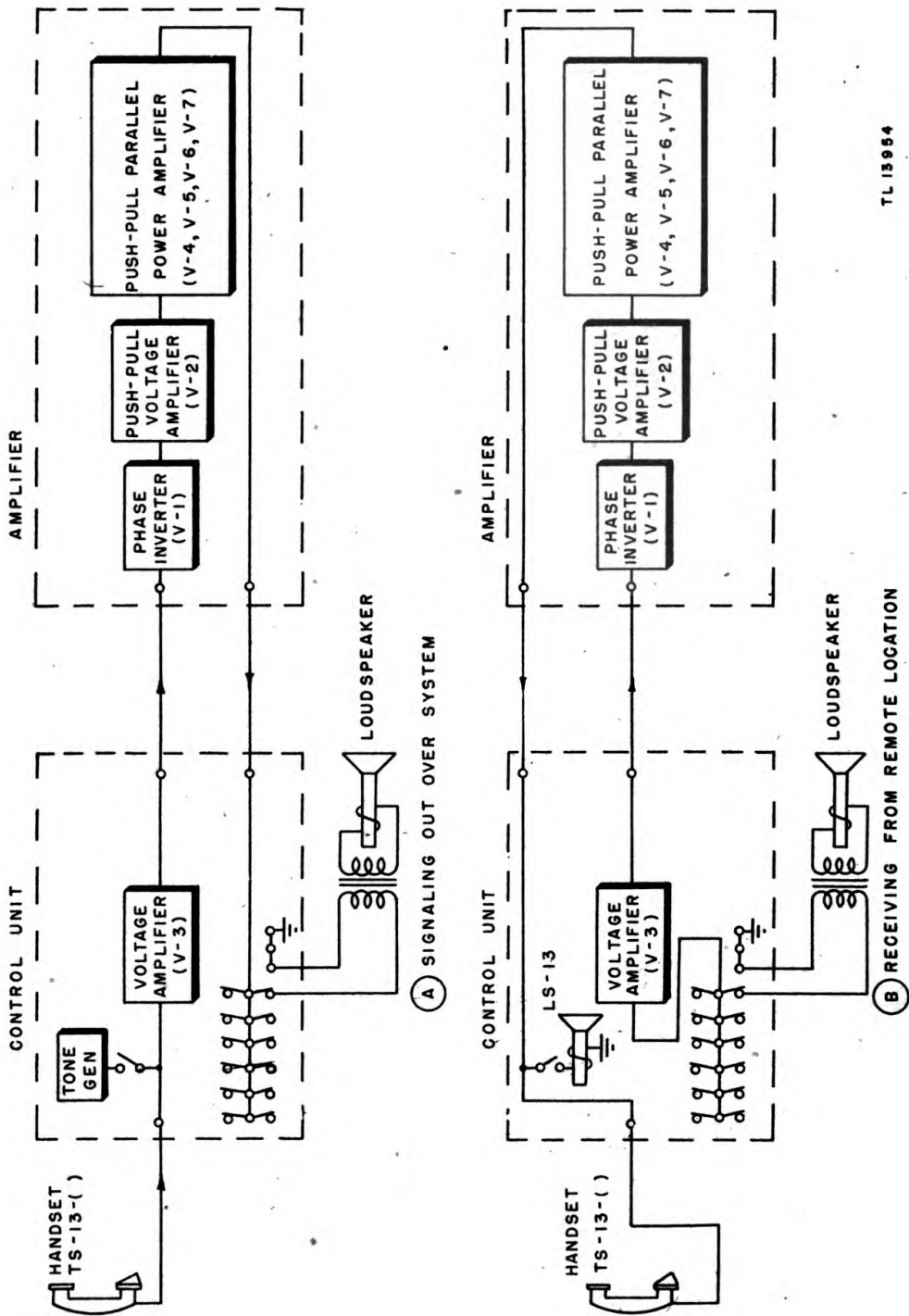

TL 15954

Figure 14. Public Address Set AN/TIQ-3, block diagram.

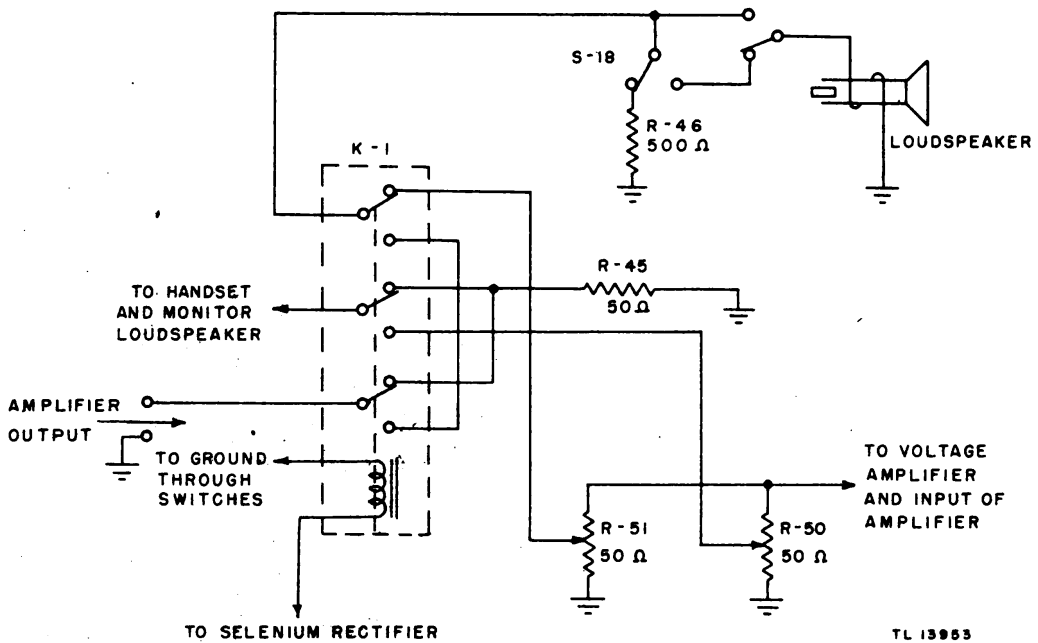

Figure 15. Circuit switching, simplified schematic.

control unit voltage amplifier. The talk-back signal can now be heard in the receiver of the handset, or in monitor speaker LS-13 when switch S-18 is placed in the ON position.

15. VOLTAGE-AMPLIFIER STAGE USING TUBE V-3 (figs. 16 and 23.)

When the butterfly switch on Handset TS-13-() is operated, relay K-1 is energized. When the diaphragm of the microphone is energized, a varying voltage appears across its terminals. This voltage is conducted through jack J-8, to capacitor C-8. Capacitor C-8 blocks dc (direct current) from entering the receiver of the handset and couples the audio voltage to the contacts of relay K-1 and to potentiometer R-50. When the monitor loudspeaker is used as a microphone, relay K-1 is energized by switch S-21 (PRESS TOTALK). Vibration of the speaker diaphragm causes the voice coil to move through the magnetic field of the loudspeaker's permanent magnet, and induces a voltage in the voice coil that varies at audio frequencies. This voltage is fed through switch S-18 and the contacts of relay K-1 to potentiometer R-50 (TALK VOLUME). Potentiometer R-50 controls the amount of voltage applied to the primary of transformer T-2. Transformer T-2 steps-up the audio voltage and presents the proper input impedance to Tube JAN-6SL7 (V-3). Resistor R-16 is used to stabilize the load on transformer T-2, and in combination with resistor R-7 sets the operating grid bias of tube V-3. The elements of tube V-3 are wired to connect the two triode sections of the tube in parallel. Resistor R-17 drops the d-c power supply voltage

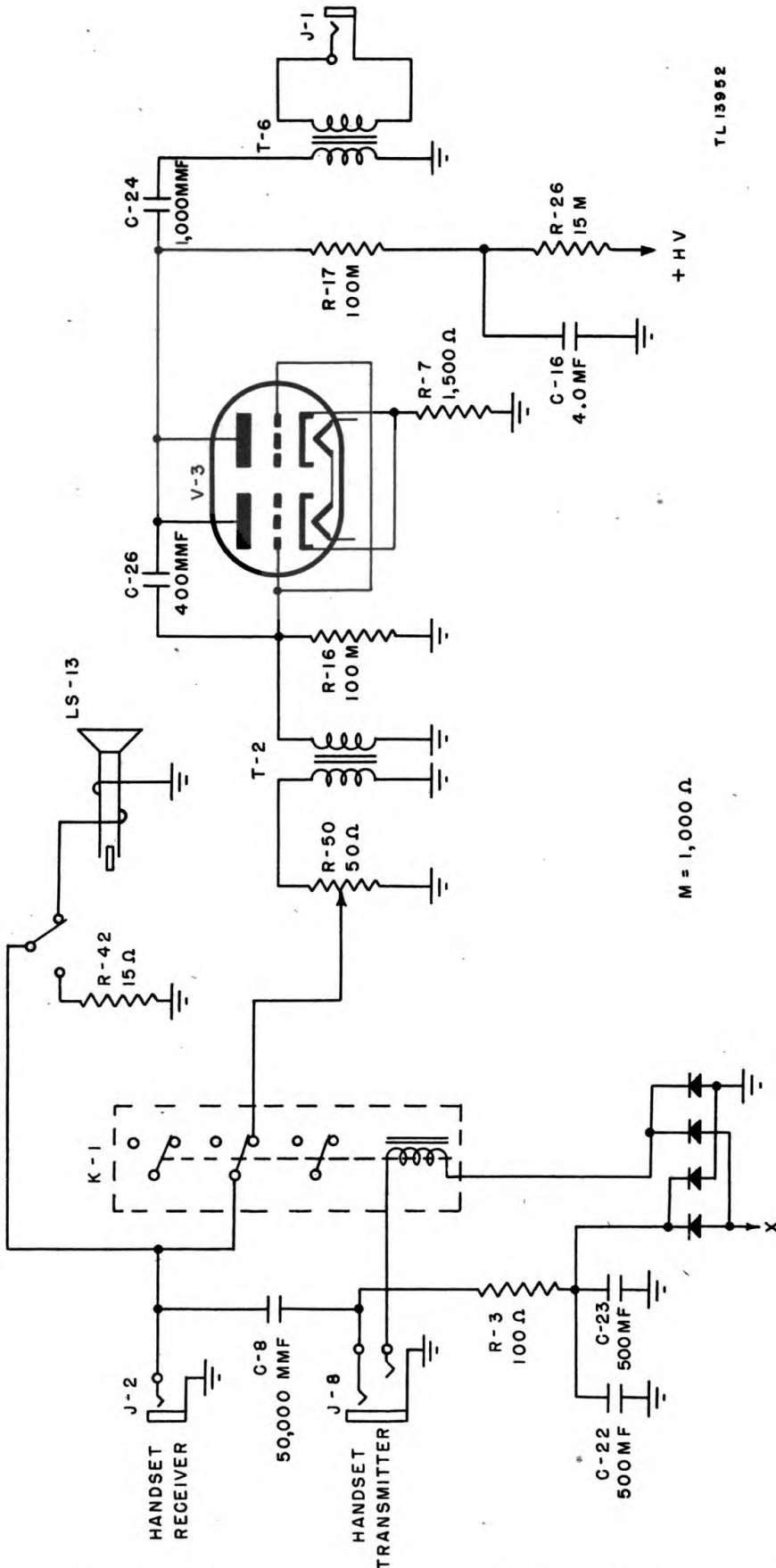
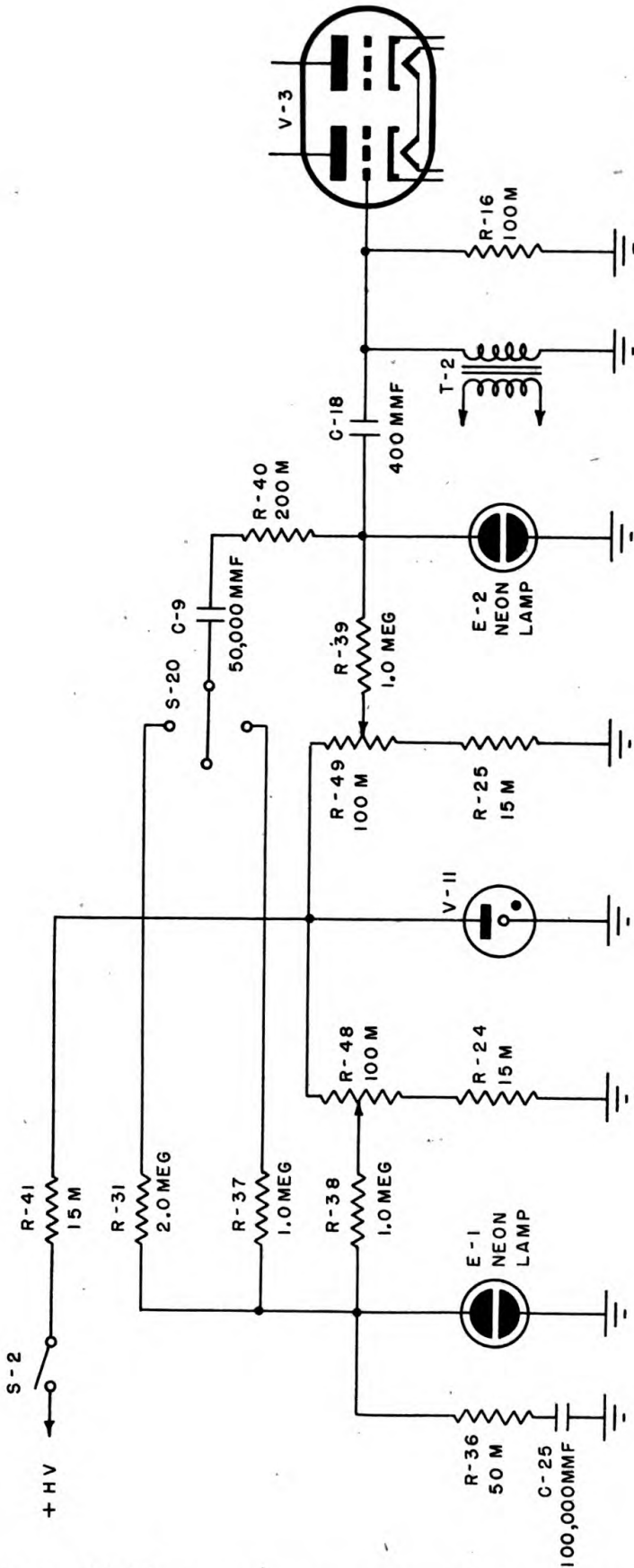

Figure 16. Microphone input, simplified schematic.



TL 13955

M = 1,000 Ω

Figure 17. Tone generators, simplified schematic.

to the correct value for plates 1 and 2 of tube V-3. This tube amplifies the input audio voltage received from transformer T-2. Capacitor C-26 prevents the tube from oscillating at high audio frequencies. Capacitor C-16 provides a low-impedance path to ground for any audio voltage present at the junction of resistors R-17 and R-26. This prevents audio voltages from being fed back to the power supply. Resistor R-26 is a decoupling resistor for tube V-3. Capacitor C-24 couples the audio output voltage from plates 1 and 2 of tube V-3 to the primary of line-coupling transformer T-6. The induced voltage in the secondary of T-6 is then fed to the input of Amplifier AM-34/TIQ-3 through Cord CX-51/TIQ-3 (W-3) and Cords CX-164/TIQ-3 (W-8 and W-9).

16. TONE-GENERATOR CHANNEL (fig. 17).

The voltage regulator Tube JAN-OC3/VR-105 (V-11) maintains a constant voltage from the power supply by varying the voltage drop across resistor R-41, which provides a fixed voltage for the operation of tone generator tubes E-1 and E-2. When CONSTANT switch S-2 is in the ON position, power is connected to tone-generator tube E-2. Variable resistor R-49 provides a means of obtaining a maximum-efficiency operating voltage for constant-tone generator E-2. The adjustment of this resistor, once set, need not be changed. Resistor R-25 limits the minimum voltage supplied to E-2. Resistor R-39 limits the initial voltage applied to E-2. Tube E-2, acting as a relaxation oscillator, generates an audio voltage, the frequency of which is largely determined by capacitor C-18, resistor R-16, and transformer secondary. When the INTERMIT-WARBLE switch S-20 is in the INTERMIT position, voltage is applied to both E-1 and E-2, and the audio output voltage of tube E-1 is coupled to tube E-2. Variable resistor R-48 provides a means of obtaining a maximum-efficiency operating voltage for tone-generator E-1. The adjustment of this resistor, once set, need not be changed. Resistor R-24 limits the minimum voltage supplied to E-1. Resistor R-38 limits the initial d-c voltage applied to E-1. Capacitor C-25 in conjunction with resistors R-36 and R-38 determines the frequency of the intermittent or warble signals. Resistor R-36 limits the discharge of current from capacitor C-25. When capacitor C-25 has charged up to a point sufficiently high to ionize tube E-1, the capacitor will discharge through resistor R-36 and tube E-1. While tube E-1 is ionized, its internal resistance is low, thus shorting the output terminal of tube E-2 to ground, causing no output for a very short time, and producing an intermittent signal. When switch S-20 is in WARBLE position, the components in the circuit function the same as for intermittent operation, except that a larger resistor R-31 is placed in the coupling lead between the tubes E-1 and E-2, which limits the effect of E-1 upon E-2, causing the output from E-2 to decrease when E-1 is ionized,

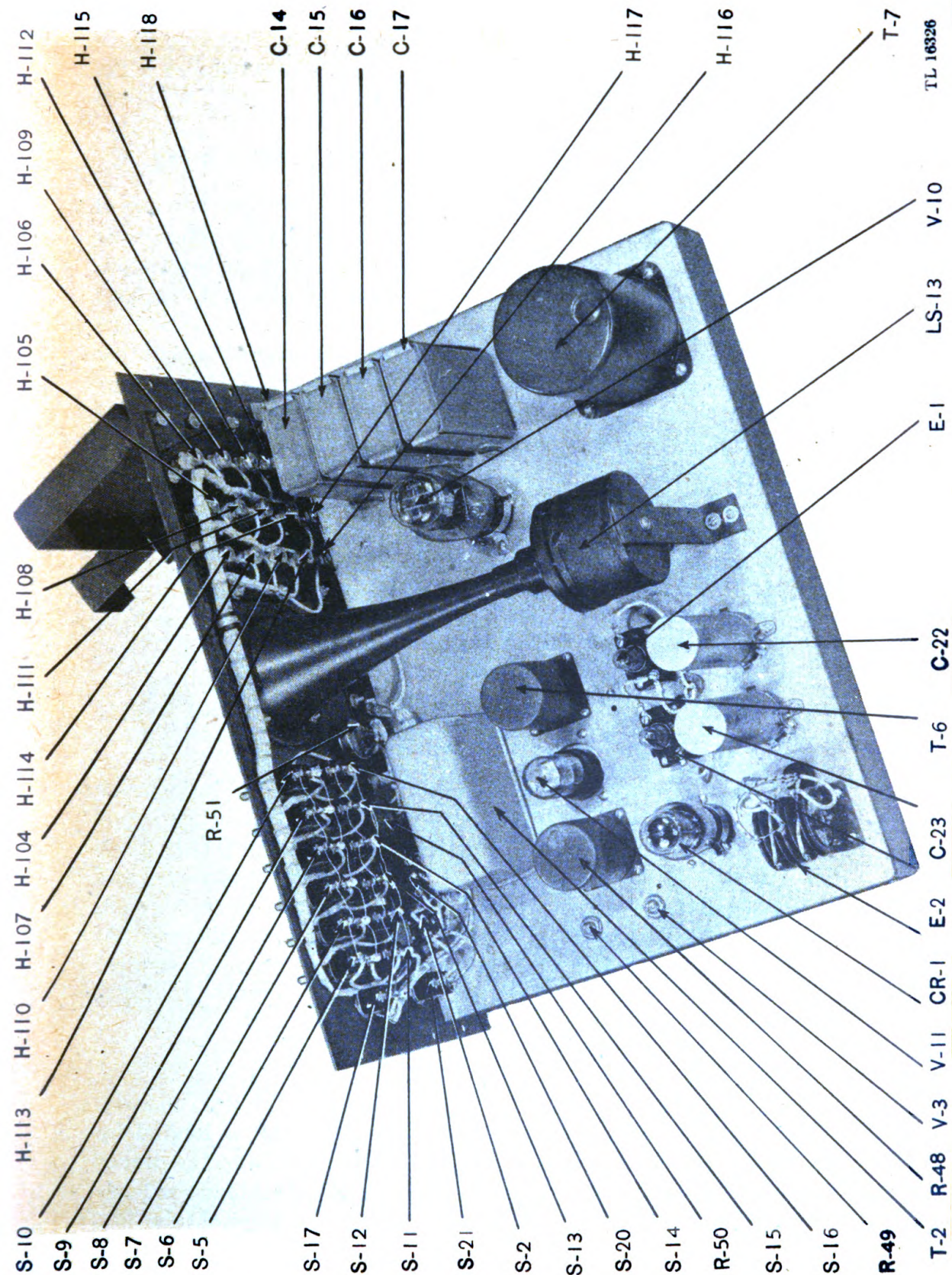

Figure 18. Control Unit C-104/TIQ-3, top view of chassis.

thereby producing a rising and falling signal. The signal is coupled to the control grid of V-3 by capacitor C-18. The operation of V-3 is the same as described in the preceding paragraph.

17. VOLTAGE-AMPLIFIER STAGE USING TUBE V-1 (fig. 24).

The audio output voltage from tube V-3 in the control unit is received through jack J-4 on the amplifier panel and is conducted to the primary of transformer T-1. Transformer T-1 properly matches the low-impedance of the interconnecting cable to the higher impedance of the grid circuit of Tube JAN-6SL7 (V-1). VOLUME control R-47 varies the input voltage to the control grid. Resistor R-35 reduces the shunting effect of R-47 and decouples the line-input circuit from the booster-input circuit. The voltage drop developed across resistor R-5 is used to bias the control grids of both sections of tube V-1. Capacitor C-1 provides a low-impedance path to ground for the audio voltages present on the cathodes. The first section of V-1 amplifies the audio input voltage received from transformer T-1. Resistor R-10 drops the d-c supply voltage to the proper operating value for the plate of the first section of tube V-1. Capacitor C-4 couples the audio output voltage of plate number one of tube V-1 to the number one control grid of tube V-2, and also to the phase inversion circuit.

18. VOLTAGE-AMPLIFIER STAGE USING TUBE V-1 WITH BOOSTER INPUT THROUGH JACK J-5.

When the booster input channel is used, resistor R-1 in conjunction with resistor R-4 provides a return circuit to ground for control grid one of tube V-1. Audio voltage across resistor R-1 is transferred to grid one through resistor R-4. R-4 limits the audio voltage fed to grid one, and decouples the booster input circuit from the line-input circuit through transformer T-1. Resistor R-1 also provides a fixed impedance of 100 ohms for the booster input. From this point on, the line-input channel and the booster-input channel are identical.

19. PHASE-INVERTER STAGE (fig. 24).

Section two of tube V-1 is used in a phase-inverter circuit. The audio input voltage to the control grid of the phase inverter is limited by resistor R-8. Resistor R-9 drops the d-c supply voltage to the proper operating value for the plate of section two. Capacitor C-13 in combination with resistor R-18 decouples the plates of both sections of tube V-1 from the power supply. Capacitor C-5 couples the audio output voltage of the phase inverter to the control grid of section two of tube V-2. Resistor R-27 in combination with resistor R-5 sets the operating bias for the control grid of the phase inverter.

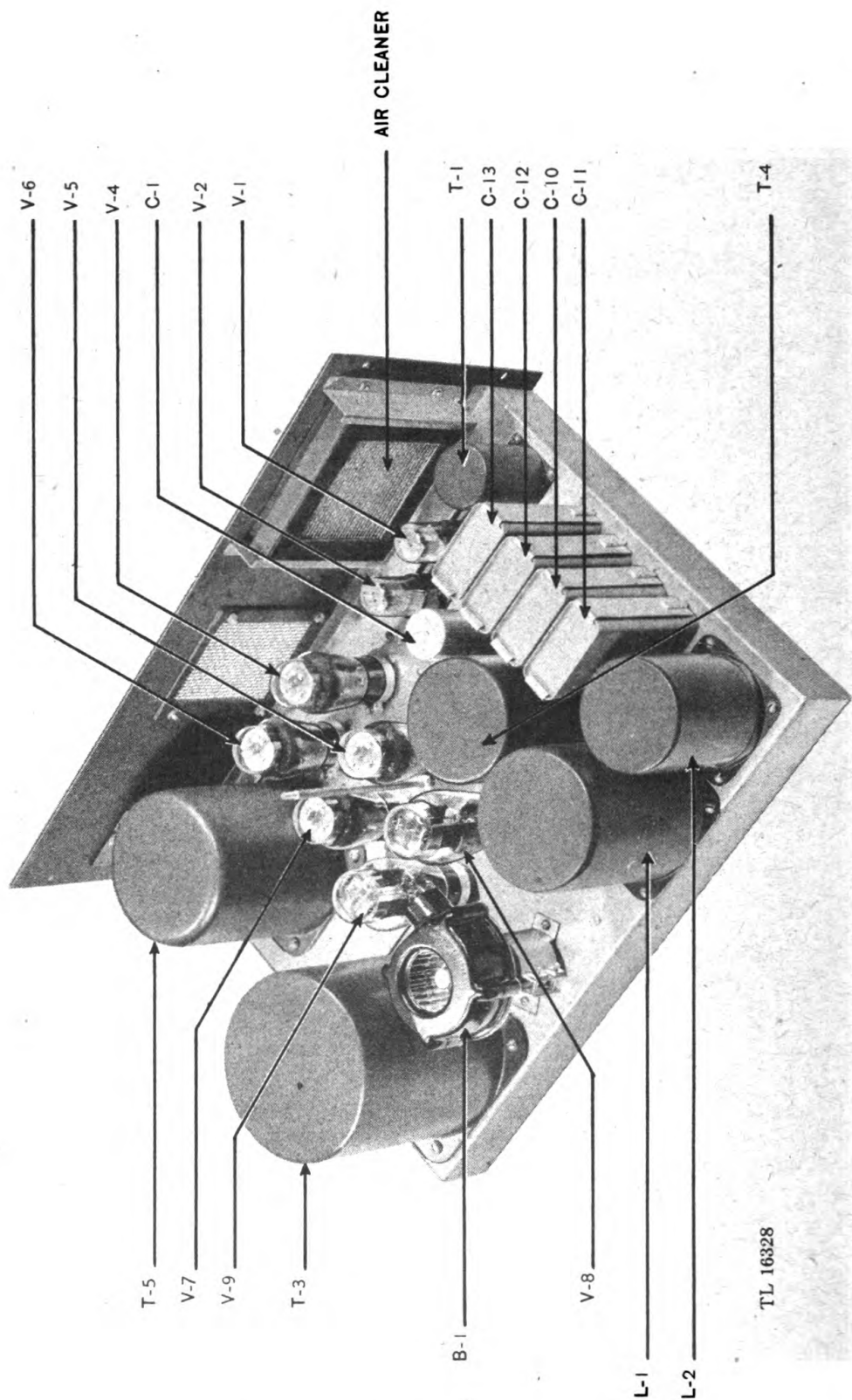

TL 16328

Figure 20. Amplifier AM-34/TIQ-3, top view of chassis.

20. PUSH-PULL VOLTAGE-AMPLIFICATION STAGE (fig. 24).

Resistors R-8 and R-27 in combination with resistor R-6 provide the operating bias for control grid one of Tube JAN-6SL7GT (V-2). Resistor R-15 in combination with resistor R-6 provides the operating bias for control grid two of tube V-2. Section one of tube V-2 amplifies the audio output voltage of section one of tube V-1. Section two of tube V-2 amplifies the audio output voltage of the phase-inverter section of tube V-1. Resistor R-12 drops the d-c supply voltage to the proper operating value for plate one to tube V-2. Resistor R-11 drops the d-c supply voltage to the proper operating value for plate two of tube V-2. Resistor R-19 decouples both plate circuits of tube V-2 from the power supply. Capacitor C-6 couples the audio output voltage of plate one of tube V-2 to the control grids of tubes V-4 and V-6. Capacitor C-7 couples the audio output voltage of plate two of tube V-2 to the control grids of tubes V-5 and V-7.

21. PUSH-PULL PARALLEL POWER-AMPLIFICATION STAGE (fig. 24).

Grid resistor R-14 in combination with cathode resistor R-28 provides operating bias for the control grid of Tube JAN-6L6GA (V-4). Resistor R-20 decouples the control grid of tube V-4 from the control grid of tube V-6. Grid resistor R-14 in combination with the cathode resistor R-29 provides operating bias for the control grid of Tube JAN-6L6GA (V-6). Resistor R-21 decouples the control grid of tube V-6 from the control grid of tube V-4. Grid resistor R-13 in combination with cathode resistor R-28 provides the operating bias for the control grid of Tube JAN-6L6GA (V-5). Resistor R-22 decouples the grid of tube V-5 from the grid of tube V-7. Resistor R-13 in combination with cathode resistor R-29 provides the operating bias for the control grid of Tube JAN-6L6GA (V-7). Resistor R-23 decouples the control grid of tube V-7 from the control grid of tube V-5. Cathode bypass capacitor C-2 provides a low-impedance path to ground for any audio voltages present on the cathodes of tubes V-4 and V-5. Cathode bypass capacitor C-3 provides a low-impedance path to ground for any audio voltages present on the cathodes of tubes V-6 and V-7. Tubes V-4 and V-6 in parallel amplify the audio output voltage of section one of tube V-2. Tubes V-5 and V-7 in parallel amplify the audio output voltage of section two of tube V-2. Resistors R-33 and R-34 form a voltage divider to supply a fixed voltage to the screen grids of tubes V-4, V-5, V-6, and V-7. Screen bypass capacitor C-20 provides a low-impedance path to ground for any audio voltages present on the screen grids of tubes V-4, V-5, V-6, and V-7. The full voltage output of the power supply is supplied to the plates of tubes V-4, V-5, V-6, and V-7 through the center-tapped primary winding of output transformer T-5. Transformer T-5 couples

the audio output voltage from the plates of the four tubes to the amplifier output terminals H-121 and H-122. Resistor R-30 drops the inverse-feedback voltage from the 4-ohm secondary tap on the output transformer T-5 to the proper value. Capacitor C-21 couples the inverse-feedback voltage to the plate of section one of tube V-1, and blocks the plate voltage of tube V-1 from the output transformer. When amplifier AM-34/TIQ-3 is used as a booster amplifier (par. 26), resistors R-2 and R-32 are used as a voltage divider to provide the proper voltage to operate one or more power amplifiers. The output voltage from terminals H-121 and H-122 on the amplifier is coupled to terminals H-119 and H-120 on the control unit by means of field wire (Wire W-110-B). This wire is not supplied with the equipment. When relay K-1 is energized by the microphone switch or the PRESS TO TALK switch on the control unit, the audio voltage is fed to the bank of switches (S-5 to S-6) on the control unit panel, and distributed to the loudspeakers from terminals H-104 to H-118, inclusive. The connections from the terminals on the control unit to the individual loudspeakers is made with field wire (Wire W-110-B).

22. POWER SUPPLY OF CONTROL UNIT C-104/TIQ-3 (fig. 23).

A-c voltage from Power Unit PE-214-B, or from an external source, is connected through Cord CX-49/TIQ-2 (W-1), Cord CX-53/TIQ-2 (W-4), Cords CX-54/TIQ-2 (W-5 and W-6), and Cord CX-55/TIQ-2 (W-7) to receptacle P-15 on the front panel of the control unit. From this receptacle the a-c voltage passes through fuse F-2, which protects the control unit against an overload or short circuits, to switch S-19 on the front panel of the control unit. When switch S-19 is in the ON position, and switch S-4 is in the proper voltage position, a-c voltage is applied to the two primary windings of transformer T-7. For 115-volt operation, the two primary windings are connected in parallel. For 230-volt operation, the two primary windings are connected in series. Transformer T-7 also steps down the a-c line voltage to the proper value for the filaments of tubes V-3 and V-10, pilot light E-3, and the selenium rectifier CR-1. Pilot light E-3 indicates when power is applied to the control unit. The high-voltage secondary winding of transformer T-7 is connected to the plates of full-wave rectifier tube V-10. This tube rectifies the high-voltage a-c and delivers a pulsating d-c voltage to filter capacitor C-17. Capacitors C-17, C-14, and C-15, in combination with resistors R-43 and R-44, form a ripple filter to deliver a constant d-c voltage to the load. Rectifier CR-1 is a metallic, two-section selenium rectifier. This device offers a high resistance to the flow of current through it in one direction, and comparatively low resistance to the flow of current through it in the opposite direction. Therefore, if an

alternating voltage is applied to the terminals of the rectifier, current flows only in one direction, producing d-c voltage. The a-c voltage input to rectifier CR-1 is supplied by the step-down winding of transformer T-7. One side of the voltage output of rectifier CR-1 is connected to relay coil K-1 when switch S-21 is in ON position. The other side of the voltage output of CR-1 is connected to jack J-8 through resistor R-3 for the operation of the microphone part of Handset TS-13-(). Resistor R-3 reduces the d-c output voltage of rectifier CR-1 to the proper value for the operation of the microphone. Capacitor C-22 and capacitor C-23 act as a ripple filter for the output voltage of rectifier CR-1.

23. POWER SUPPLY OF AMPLIFIER AM-34/TIQ-3 (fig. 24).

A-c voltage from Power Unit PE-214-B, or an external source, is conducted through Cord CX-49/TIQ-2 (W-2), Cord CX-53/TIQ-2 (W-4), Cords CX-54/TIQ-2 (W-5 and W-6), and Cord CX-55/TIQ-2 (W-7) to receptacle P-14 on the front panel of Amplifier AM-34/TIQ-3. From this receptacle the a-c voltage passes through fuse F-1, which protects the amplifier against shorts and overloads, to one side of switch S-1 on the front panel of the amplifier. When switch S-1 is in the ON position, and switch S-3 is in its proper voltage-selection position, a-c voltage is applied to the primary windings of transformers T-3 and T-4. Each of these two transformers has two primary windings. For 115-volt operation, the two primary windings are connected in parallel. For 230-volt operation, the two primary windings are connected in series. Filament transformer T-4 steps down the a-c line voltage to the proper value for the filaments of tubes V-1, V-2, V-4, V-5, V-6, V-7, V-8, and V-9, and pilot light E-4. The pilot light indicates when power is applied to the amplifier. High-voltage transformer T-3 steps up the a-c line voltage, and its secondary winding is connected to the plates of full-wave rectifier tubes V-8 and V-9 in parallel. These tubes rectify the a-c voltage, and deliver a pulsating d-c voltage through receptacle P-14 to filter capacitor C-10. Capacitors C-10, C-11, and C-12, in combination with filter chokes L-1 and L-2, smooth out the fluctuations in the d-c voltage output of rectifier tubes V-8 and V-9. Receptacle P-14 may be used with appropriate adapters and circuit modifications to permit operation of the amplifier from an auxiliary source of d-c power, external to the amplifier. In an emergency, the filament of the vacuum tubes may be supplied by an external source of 6 volts ac or dc. High voltage may be obtained for the set from an external source, and fed through the filter circuit to the amplifier tubes. In such applications, however, it may be necessary to reduce the power consumption of the set. This is accomplished by removing tubes V-6 and V-7 from their sockets, in which case the equipment operates as a 20-watt amplifier.

24. LOUDSPEAKERS LS-104/TIQ-3 (fig. 22).

This component converts the audio frequency output of Amplifier AM-34/TIQ-3 and Control Unit C-104/TIQ-3 into acoustical power or audible sound and projects this sound into a specified area. The loudspeaker cables (field wire) conduct the audio output from binding posts H-104 to H-118 on terminal board E-10 of Control Unit C-104/TIQ-3 to the binding posts on terminal board E-15 on Loudspeakers LS-104/TIQ-3. Transformer T-8 on Loudspeaker LS-104/TIQ-3 provides variable impedance connections to match the output of the amplifier and control unit. Taps are provided at 0, 250, 500, 1000 and 2500 ohms on terminal board E-15 on Loudspeaker LS-104/TIQ-3. The voice coils of Loudspeakers LS-104/TIQ-3 are immersed in a steady magnetic field produced by permanent magnets. When energized, the voice coil moves in accordance with the frequency of the audio output. The voice coil is attached to a diaphragm which vibrates as the voice coil moves and thus produces acoustical power resulting in audible sound. The horn of Loudspeaker LS-104/TIQ-3 couples the diaphragm efficiently to the surrounding air.

25. INTERCOMMUNICATION FEATURE.

When the equipment is used as an inter-communication system, the circuits function exactly as described above, except that Loudspeakers LS-104/TIQ-3 function as a microphone and the receiver of Handset TS-13-(), or the monitor speaker LS-13 on the control unit, functions as the loudspeaker. When any one of switches S-5 to S-16 is placed in the ON position and switch S-17 is placed in the OFF position, electrical energy generated by Loudspeaker LS-104/TIQ-3 is conducted to the primary of transformer T-2 through the contacts of changeover relay K-1 and across resistor R-51. Electrical energy is produced at Loudspeaker LS-104/TIQ-3 by the voice coil of the loudspeaker moving in a magnetic field supplied by a permanent magnet. The voltage thus produced is of low value and line matching transformer T-8 is used as a step-up transformer to increase the voltage. This transformer has a primary winding (short leads) of about 15 ohms and a secondary winding with variable impedances from 0 to 2500 ohms. From transformer T-8, electrical energy is conducted through the loudspeaker cables to the binding posts on terminal board E-10 of Control Unit C-104/TIQ-3. From here on, the parts function exactly as described in paragraphs 15 to 21 above. After being amplified, the electrical energy is converted into acoustical energy by the receiver of Handset TS-13-() or by monitor speaker LS-13. Variable resistor R-51 (TALK VOLUME) varies the input voltage received from Loudspeaker LS-104/TIQ-3 to the proper value for the operation of amplifier tube V-3. When switch S-18 is in the ON position, monitor loudspeaker LS-13 is connected to

Amplifier AM-34/TIQ-3 through the contacts of changeover relay K-1. When switch S-18 is in the OFF position, resistor R-42 is connected to the amplifier. Resistor R-42 reduces the audio voltage to the proper value for the receiver of Handset TS-13-(). Resistor R-42 also provides a constant load equivalent to that of the monitor speaker LS-13. Resistor R-45 provides a minimum load for the operation of monitor speaker LS-13, or of the receiver in Handset TS-13-(). Resistor R-46 provides a minimum load when Loudspeakers LS-104/TIQ-3 are not connected.

26. BOOSTER AMPLIFIER.

Provision has been made (J-5 and J-19 on the amplifier panel) for the connection of a booster amplifier to Amplifier AM-34/TIQ-3 for additional gain, to permit the operation of additional speakers, or to permit the operation of two or more Public Address Sets AN/TIQ-3 from a single control location.

SECTION IV

MAINTENANCE

NOTE: Failure or unsatisfactory performance of equipment used by Army Ground Forces and Army Service Forces will be reported on W.D., A.G.O. Form No. 468 (Unsatisfactory Equipment Report). For particulars see paragraph 10. If Form No. 468 is not available, see TM 38-250. Failure or unsatisfactory performance of equipment used by Army Air Forces will be reported on Army Air Forces Form No. 54 (unsatisfactory report).

27. INTRODUCTION.

No matter how well equipment is designed and manufactured, faults occur in service and the repairman must locate and correct them as rapidly as possible. This section contains information designed to aid those engaged in trouble shooting. (Remember, however, that preventive maintenance will minimize the necessity of trouble shooting.)

a. Trouble-shooting Data. Use the material in this manual to help in rapidly locating faults. Consult the following trouble-shooting data when necessary:

- (1) Block diagram of the set (fig. 14).
- (2) Complete schematic diagrams (figs. 23 and 24). These diagrams include all parts and show all the connections (power, input, and output) to other units.
- (3) Simplified and partial schematics (figs. 15, 16, and 17). These diagrams are particularly useful in trouble shooting, because the electrical functioning of the circuits is followed more clearly than on the regular schematics, thus speeding trouble location.
- (4) Voltage and resistance data at socket connections (pars. 36 and 37).
- (5) Illustrations of components (figs. 2, 3, 18, 19, 20, and 21). Front, top, and bottom views aid in locating and identifying parts.
- (6) Pin connections. Pin connections on the sockets, plugs, and receptacles are numbered or lettered on the various charts.

(a) Seen from the bottom, pin connections are numbered in a clockwise direction around the sockets. On octal sockets, the first pin clockwise from the keyway is pin No. 1.

(b) Plugs and receptacles are numbered on the side to which the associated connector is attached. To avoid confusion, some individual pins are identified by letters which appear directly on the connector.

b. Trouble-shooting Steps. The first step in servicing a defective radio set is to sectionalize the fault. *Sectionalization* means tracing the fault to the component responsible for the abnormal operation of the set. The second step is to localize the fault. *Localization* means tracing the fault to the defective part responsible for the abnormal condition. (1) Use of the equipment performance check list and the starting procedure aids in tracing the fault to the defective component. The procedures to be followed are explained in subparagraphs c and d below.

(2) Some troubles such as burned-out resistors, arcing, etc., can be located by sight, smell, and hearing. The majority of faults, however, must be located by checking voltages and resistances.

c. Starting-procedure Sectionalization. The starting procedure is the systematic method used to put the set on the air. This procedure is used in sectionalization when the cause of the set failure is not known. In most cases, it will trace the defect to a particular component. The steps of the starting procedure are performed in sequence until an abnormal result is obtained. As each step is performed, the visible and audible results of the action are noted.

d. Localization. Localization is the tracing of the fault to a particular part. Paragraphs 34 and 35 of this section describe the method of localizing faults within the individual components. These sections contain trouble-shooting charts which list symptoms and their causes. The charts also give the procedure for finding out which of the probable troubles is the exact one. Paragraphs 36 and 37 show the resistance and the voltage at every socket-pin connection. The method of using the voltage and resistance data in checking a circuit is described in detail in paragraphs 28 and 29.

28. VOLTAGE MEASUREMENTS.

a. General. Voltage measurements are an almost indispensable aid to the repairman, because most troubles either result from abnormal voltages or produce abnormal voltages. Voltage measurements are easily obtained, because they are always made between two points in a circuit and the circuit is not interrupted.

(1) Complete information on normal operating voltages is given in the voltage charts. Unless otherwise specified, these voltages are measured between the indicated points and ground.

(2) Always begin by setting the voltmeter on the highest range, so that the voltmeter will not be overloaded. Then, if it is necessary to obtain increased accuracy, set the voltmeter to a lower range.

(3) In checking cathode voltage, remember that a reading can be obtained when the cathode resistor is actually open. The resistance of the meter may act as a cathode resistor. Thus, the cathode voltage may be approximately normal only as long as the voltmeter is connected between cathode and ground. Before the cathode voltage is measured, a resistance check should be made with the circuit cold to determine whether the cathode resistor is normal.

b. Precautions Against High Voltage. Certain precautions must be followed when measuring voltages above a few hundred volts. High voltages are dangerous and can be fatal. When it is necessary to measure high voltages, observe the following rules:

- (1) Connect the ground lead to the voltmeter.
- (2) Place one hand in your pocket.
- (3) If the voltage is less than 300 volts, connect the test lead to the hot terminal (which may be either positive or negative with respect to ground).
- (4) If the voltage is greater than 300 volts, shut off the power, connect the hot test lead, step away from the voltmeter, turn on the power, and note the reading on the voltmeter. Do not touch any part of the voltmeter, particularly when it is necessary to measure the voltage between two points both of which are above ground.

c. Voltmeter Loading. It is essential that the voltmeter resistance be at least 10 times as large as the resistance of the circuit across which the voltage is measured. If the voltmeter resistance is comparable to the circuit resistance, the voltmeter will indicate a lower voltage than the actual voltage present with the voltmeter removed from the circuit.

(1) The resistance of the voltmeter on any range can always be calculated by the following simple rule: resistance of voltmeter equals the ohms-per-volt multiplied by the full-scale range in volts. Two examples are shown below:

(a) What is the resistance of a 1,000-ohm-per-volt voltmeter on the 300-volt range?

$$R = 1,000 \text{ ohms per volt} \times 300 \text{ volts} = 300,000 \text{ ohms.}$$

(b) What is the resistance of a 20,000-ohm-per-volt voltmeter on the 300-volt range?

$$R = 20,000 \text{ ohms per volt} \times 300 \text{ volts} = 6 \text{ megohms.}$$

(2) To minimize voltmeter loading in high-resistance circuits, use the highest voltmeter range. Although only a small deflection will be obtained (possibly only 5 divisions on a 100-division scale), the accuracy of the voltage measurement will be increased. The decreased loading of the voltmeter will more than compensate for the inaccuracy which results from reading only a small deflection on the scale of the voltmeter.

(3) When a voltmeter is loading a circuit, the effect can always be noted by comparing the voltage reading on two successive ranges. If the voltage readings on the two ranges do not agree, voltmeter loading is excessive. The reading (not the deflection) on the highest range will be greater than on the lowest range. If the voltmeter is loading the circuit heavily, the deflection of the pointer will remain nearly the same when the voltmeter is shifted from one range to another.

(4) The voltage and resistance charts used in this manual are based on readings taken with an actual meter. The ohm-per-volt sensitivity of the meter which was used is printed on the drawing. The trouble shooter should use a meter having the same ohm-per-volt sensitivity. Because the meter used in testing for the voltage will produce the same amount of loading as the meter used in measuring the voltage, it is unnecessary to consider the effect of loading.

29. RESISTANCE MEASUREMENTS.

a. Normal Resistance Values. When a fault develops in a circuit, its effect will very often show up as a change in the resistance values. To assist in the localization of such faults, trouble-shooting data includes the normal resistance values as measured at the tube sockets and at key terminal points. These values are measured between the indicated points and ground, unless otherwise stated. Often it is desirable to measure the resistance from other points in the circuit, in order to determine whether the particular points in the circuit are normal. The normal resistance values at any point can be determined by referring to the resistance values shown in the schematic diagram, or by use of a resistor color code.

b. Precautions. (1) Before making any resistance measurements, turn off the power. An ohmmeter is essentially a low-range voltmeter and battery. If the ohmmeter is connected to a circuit which already has voltages in it, the needle will be knocked off scale and the voltmeter movement may be burned out.

(2) Capacitors must always be discharged before resistance measurements are made. This is very important when checking power supplies that are disconnected from their load. The discharge of the capacitor through the meter will burn out its movement and in some cases may endanger life.

c. Correct Use of Low and High Ranges. It is important to know when to use the low-resistance range and when to use the high-resistance range of an ohmmeter. When checking the circuit continuity, the ohmmeter should be set on the lowest range. If a medium or high range is used, the pointer may indicate zero ohms, even if the resistance is as high as 500 ohms. When checking high resistances or measuring the

leakage resistance of capacitors or cables, the highest range should be used. If a low range is used, the pointer will indicate *infinite* ohms, even though the actual resistance is less than a megohm.

d. Parallel Resistance Connections. In a parallel circuit the total resistance is less than the smallest resistance in the circuit. This is important to remember when shooting trouble with the aid of a schematic diagram.

(1) When a resistance is measured and the value is found to be less than expected, make a careful study of the schematic to be certain that there are no resistances in parallel with the one that has been measured. Before replacing a resistor because its resistance measures too low, disconnect one terminal from the circuit and measure its resistance again, to make sure that the low reading does not occur because some part of the circuit is in parallel with the resistor.

(2) In some cases it will be impossible to check a resistor because it has a low-voltage transformer winding connected across it. If the resistor must be checked, disconnect one terminal from the circuit before measuring its resistance.

e. Checking Grid Resistance. When checking grid resistance, a false reading may be obtained if the tube is still warm and the cathode is emitting electrons. Allow the tube to cool, or reverse the ohmmeter test leads so that the negative ohmmeter test lead is applied to the grid.

f. Tolerance Values For Resistance Measurements. *Tolerance* means the normal difference that is expected between the rated value of the resistor and its actual value.

(1) Most resistors that are used in radio circuits have a tolerance of at least 20 per cent. For example, the grid resistor of a stage might have a rated value of 1 megohm. If the resistor were measured and found to have a value between 0.8 megohm and 1.2 megohms, it would be considered normal. As a rule, the ordinary resistors used in circuits are not replaced unless their values are off more than 20 percent. Some precision resistors and potentiometers are used. When a resistor is used whose value must be very close to its rated value, the tolerance is usually stated on the diagram or the MPL.

(2) The tolerance values for transformer windings are generally between 1 and 5 percent. As a rule, suspect a transformer which shows a resistance deviating more than 5 percent from its rated value. Allow the transformer to cool off before the resistance test is made.

g. High-resistance Measurements. Many leakages will not show up when measured at low voltages. Most ohmmeters use a maximum test voltage of 15 volts on the highest resistance range. Where it is necessary to measure resistance above a few megohms or the leakage resistance between conductors of a cable, the test should be made using an applied

voltage of 100 volts or more. Where it is possible to ground one end of the resistance being checked, one of the low-voltage power supplies in the equipment can be used to provide about 300 volts for making these high-resistance measurements. This method should be used only when the resistance being measured is very high. Be careful not to handle the meter after the circuit has been completed. The meter used should have an ohm-per-volt sensitivity of 1,000 ohms or more. The resistance of the meter is equal to the ohm-per-volt sensitivity multiplied by the range to which the meter is set. The derivation of the formula $R_x = 300 \frac{R_m}{V}$ is shown below. R_x is the unknown resistance, R_m is the meter resistance, and V is the voltmeter reading.

$$\frac{R_x}{R_m} = \frac{300V}{V}$$

If R_x is very large, V will be small in comparison to 300. Assuming that 300V can be replaced by 300, the formula $\frac{R_x}{R_m} = \frac{300}{V}$ is obtained. When solved for R_x this gives $R_x = \frac{300R_m}{V}$. When making the measurement, the meter should first be put on the 300-volt scale to protect it in case R_x is very low. If the voltage used is not 300 volts, the correct value should be inserted in the formula in place of 300.

30. CAPACITOR TESTS.

Capacitors which are leaky or shorted can be found by resistance checks of the stage. A capacitor which is suspected of being open can best be checked by shunting a good capacitor across it.

31. CURRENT MEASUREMENTS.

Current measurements, other than those indicated by panel meters, are not ordinarily required in trouble shooting in the radio set. Under special circumstances where the voltage and resistance measurements by themselves are not sufficient to localize the trouble, a current measurement can be made by opening the circuit and connecting an ammeter to measure the current. This procedure is not recommended except in very difficult cases.

a. When the meter is inserted in a circuit to measure current, it should always be inserted away from the tube end of the resistance. For example, when measuring *plate* current, do not insert the meter next to the plate of a tube, but insert it next to the end of the resistor which connects to the power.

CAUTION: A meter has least protection against damage when it is used to measure current. Always set the current range to the highest value. Then, if necessary, decrease the range to give a more accurate reading. Avoid working close to full-scale reading because this increases the danger of overload.

b. In most cases, the current to be measured flows through a resistance which is either known or can be measured with an ohmmeter. The current flowing in the circuit can be determined by dividing the voltage drop across the resistor by its resistance value. The drop across the cathode resistor is a convenient method of determining the cathode current.

32. TUBE CHECKING.

Tube checkers are used to check the emission of electrons from the cathode and to test for shorted elements. Tube checkers will not test the performance of high-voltage tubes or rectifiers or of some special tubes in the modulator and rectifier. Tube checkers are useful, however, for checking receiving-type tubes used in the various components.

a. Results obtained from a tube checker are not always conclusive, because the conditions are not the same as those under which the tube operates in the set. For this reason, the final test of a tube must be its replacement with a tube which is known to be good. In many cases it is quicker and more reliable to replace a suspected tube with a good one than to check it with the tube checker.

b. An operating chart and an instruction book or technical manual are provided with the tube checker. This chart indicates the setting of the tube checker for each tube type. The number of controls, their arrangement, and their settings vary with different types of tube checkers.

33. REPLACING PARTS.

Careless replacement of parts often makes new faults inevitable. Note the following points:

a. Before a part is unsoldered, note the position of the leads. If the part, such as a transformer, has a number of connections to it, tag each of the leads.

b. Be careful not to damage other leads by pulling or pushing them out of the way.

c. Do not allow drops of solder to fall into the set, since they may cause short circuits.

d. A carelessly soldered connection may create a new fault. It is very important to make well soldered joints, since a poorly soldered joint is one of the most difficult faults to find.

e. When a part is replaced it must be placed exactly as the original one was. A part which has the same electrical value but different physical size may cause trouble in high-frequency circuits. Give particular attention to proper grounding when replacing a part. Use the same ground point as in the original wiring. Failure to observe these precautions may result in decreased gain or possibly in oscillation of the circuit.

34. ISOLATION OF TROUBLE AND REMEDY OF MINOR DEFECTS.

a. General. In the event of failure of the system, first determine what part of the system has failed. Using Test Set I-56-K, or equal, localize the trouble in one of the following components:

(1) Source of power: Power Unit PE-214-B or an external source, power cable assemblies and interconnecting plugs, connectors, jacks, switches, and fuses.

(2) Loudspeakers LS-104/TIQ-3, loudspeaker cables and binding posts on speakers and on control unit terminal board.

(3) Handset TS-13-().

(4) Amplifier AM-34/TIQ-3.

(5) Control Unit C-104/TIQ-3.

(6) Cables, wiring, plugs, jacks, and connectors which interconnect the amplifier and the control unit.

b. Local Source of Power. If, when the system is set up to operate with Power Unit PE-214-B, no sound is produced, first determine by the following steps whether power is being supplied.

(1) Connect the system to an external source of alternating current. If it functions properly, the trouble is in the power unit. Consult TM 11-945.

(2) Check Cords CX-49/TIQ-2 (W-1 and W-2), CX-53/TIQ-2 (W-4), CX-54/TIQ-2 (W-5 and W-6).

(3) Check fuses F-1 and F-2.

(4) Check switches S-1 and S-19 to make certain that power is passing through them.

(5) Check vacuum tubes as previously described by replacing one at a time with a tested new tube.

c. External Source of Power. If, when the system is set up to operate on an outside source of alternating current, no sound is produced, determine whether power is being supplied by making the following checks.

(1) Check source of a-c power to make certain that current is being supplied.

(2) Check cords listed in subparagraph b (2) above, and also Cord CX-55/TIQ-2 (W-7).

(3) Proceed as described in subparagraphs b (3), (4), and (5), above.

d. Loudspeakers LS-1 to 12, Speaker Cables, and Connectors.

After making sure that power is supplied to the system, check the loudspeakers. If one or more loudspeakers operate, the trouble exists in the cables to the other speakers or in the other loudspeakers themselves. If, after checking loudspeaker cables and connections, the speaker is still dead, the difficulty is in the speaker or speakers. If no loudspeakers function and all connections are properly made, the trouble exists in another part of the system.

e. Handset TS-13-(). After making sure that power is being supplied to the system, and that loudspeakers and connections are in operating order, check the handset input. If no sound is produced by the system when the microphone of the handset is used, place switch S-2 in the ON position to operate the constant-tone signal. If a signal is produced, the difficulty is obviously in the handset. If no signal is produced, then the difficulty is not in the handset, but in some other part of the system.

f. Amplifier AM-34/TIQ-3 and Control Unit C-104/TIQ-3. If power input, loudspeakers, and sound input have been found to be in proper condition, the trouble in the system lies in Amplifier AM-34/TIQ-3 or Control Unit C-104/TIQ-3.

(1) Remove Amplifier AM-34/TIQ-3 from Case CY-38/TIQ-2, replace each tube with a tested tube, and test the system.

(2) Remove Control Unit C-104/TIQ-3 from Case CY-38/TIQ-2 and proceed as described in subparagraph (1) above.

(3) If replacement of tubes as described does not remedy the difficulty, a more obscure or major defect exists which cannot be isolated without the use of measuring instruments.

g. Interconnections of Amplifier and Control Unit. If the power input, loudspeakers, handset, amplifier, and control unit have been found to be in proper condition and no sound is produced, then the difficulty exists in the only part of the system now unchecked which is the interconnection of the amplifier and control unit.

(1) Check connection of plug P-8 to jack J-1; plug P-5 to jack J-4; plug P-5 to jack J-6; plug P-6 to jack J-4; plug P-6 to jack J-7; or plug P-7 to jack J-4.

(2) Check the cables connecting binding posts H-121 to H-120, and H-122 to H-119.

35. ISOLATION OF TROUBLE AND REMEDY OF MAJOR DEFECTS.

a. Loudspeaker LS-104/TIQ-3. In general, it will be found that if trouble does develop in a loudspeaker which is caused by the speaker itself, it will be necessary to replace the complete diaphragm head assembly. To test the loudspeaker proceed as follows:

- (1) Remove the four screws connecting the back cover.
- (2) Unsolder the two wires from the driver unit, noting the solder lug to which each wire is connected.
- (3) Using the low-resistance scale on an ohmmeter, check across the two terminal lugs for a continuity reading of approximately 15 ohms. While doing this, a click should be heard.
- (4) If no reading is obtained or no click is heard, then a new driver unit should be installed.
- (5) If a reading is obtained and a click is heard, the driver unit is in operating condition and the trouble is probably located in line-matching transformer T-8.
- (6) To test transformer T-8, apply a low-reading ohmmeter to the secondary terminals of the transformer. The reading should be approximately 3.3 ohms and a substantially higher reading should be obtained at the primary terminals. If no open circuit is found in either the primary or the secondary, the trouble does not lie in the transformer.
- (7) To replace the driver unit, remove it from the loudspeaker frame by turning the unit counterclockwise.
- (8) Screw on the replacement driver unit by turning it clockwise into the loudspeaker frame.
- (9) Solder the two wires back on the driver unit, observing proper polarity.
- (10) Replace the back cover by inserting and tightening the holding screws.
- (11) To replace a defective transformer, remove the two mounting screws holding the transformer to the terminal board E-15.
- (12) Unsolder the four wires connecting the transformer to the binding posts on terminal board E-15.
- (13) Replace with new transformer T-8 by resoldering connections and mounting the transformer on the terminal board.

b. Handset TS-13-(). (1) To test the microphone of the handset, apply an ohmmeter across plug P-1. A reading of 15 to 75 ohms should be obtained depending upon atmospheric conditions and the position of carbon granules in the transmitter. Readings should vary with the movement of handset; however, not more than 10- to 15-ohm variation should occur. If incorrect readings are obtained, the handset should be replaced and the defective set returned to the depot.

(2) To test the continuity of the receiver of the handset, check across plug P-3 with an ohmmeter. A continuity reading of approximately 3000 ohms should be obtained. If the readings are incorrect, return the handset to the depot.

c. Amplifier AM-34/TIQ-3. Determine whether the amplifier is functioning properly by checking the voltages at the tube sockets of tubes V-1, V-2, V-4, V-5, V-6, V-7, V-8, and V-9 with a d-c voltmeter. The correct voltages are shown in the voltage and resistance chart, paragraph 37. If proper voltages are not obtained at any tube, check the circuit of the tube and all its components individually with an ohmmeter for shorts or open circuits.

d. Control Unit C-104/TIQ-3. Determine whether the control unit is functioning properly by checking the voltages at the tube sockets of tubes V-3, V-10, and V-11 with a d-c voltmeter. The correct voltages are shown in the voltage and resistance chart, paragraph 36. If proper voltages are not obtained at any tube, check the circuit of the tube and all of its components individually with an ohmmeter for shorts or open circuits.

36. VOLTAGE AND RESISTANCE CHART FOR CONTROL UNIT C-104/TIQ-3.
 Meter sensitivity: 10,000 ohms per volt.

<i>Measured from</i>	<i>To</i>	<i>D-c operation voltage (volts)</i>	<i>A-c operation voltage (volts)</i>	<i>Resistance (ohms)</i>
V-3 Plate No. 1 & No. 2 Pin No. 2 & No. 5	Chassis ground	130		10 meg.
V-3 Grid No. 1 & No. 2 Pin No. 1 & No. 4	do.			3,500
V-3 Cathode No. 1 & No. 2 Pin No. 3 & No. 6	do.	1 $\frac{3}{4}$		1,500
V-10 Plate No. 1 Pin No. 4	do.		275	600
V-10 Plate No. 2 Pin No. 6	do.		275	600
V-10 Filament Pin No. 2	do.	390		10 meg.
K-1 Coil (closed circuit)	do.	1.5		
K-1 Coil (open circuit)	do.	2.5		4
V-11 Pin No. 2	do.			
V-11 Pin No. 5	do.	105		57,000

37. VOLTAGE AND RESISTANCE CHART FOR AMPLIFIER AM-34/TIQ-3.
Meter sensitivity: 10,000 ohms per volt.

<i>Measured from</i>	<i>To</i>	<i>D-c operation voltage (volts)</i>	<i>A-c operation voltage (volts)</i>	<i>Resistance (ohms)</i>
V-1 Pins No. 2 and 5, Plates No. 1 and 2	Chassis ground	220		160,000
V-1 Pin No. 1, Grid No. 1	do			50,000
V-1 Pin No. 4, Grid No. 2	do			4,000
V-1 Pins No. 3 and 6, Cathodes No. 1 and 2	do	2.5		1,500
V-2 Pins No. 2 and 5, Plates No. 1 and 2	do	260		150,000
V-2 Pin No. 1, Grid No. 1	do			104,000
V-2 Pin No. 4, Grid No. 2	do			90,000
V-2 Pins No. 3 and 6, Cathodes No. 1 and 2	do	3		1,500
V-4 Pin No. 3, Plate	do	400		10,000
V-4 Pin No. 4, Screen-grid	do	310		8,000
V-4 Pin No. 5, Control grid	do			115,000
V-4 Pin No. 8, Cathode	do	23		200
V-5 Pin No. 3, Plate	do	400		10,000
V-5 Pin No. 4, Screen-grid	do	310		8,000
V-5 Pin No. 5, Control grid	do			115,000
V-5 Pin No. 8, Cathode	do	23		200
V-6 Pin No. 3, Plate	do	400		10,000
V-6 Pin No. 4, Screen	do	310		8,000
V-6 Pin No. 5, Grid	do			115,000
V-6 Pin No. 8, Cathode	do	23		200

37. VOLTAGE AND RESISTANCE CHART FOR AMPLIFIER AM-34/TIQ-3 (contd).
Meter sensitivity: 10,000 ohms per volt.

<i>Measured from</i>	<i>To</i>	<i>D-c operation voltage (volts)</i>	<i>A-c operation voltage (volts)</i>	<i>Resistance (ohms)</i>
V-7 Pin No. 3, Plate	do	400		10,000
V-7 Pin No. 4, Screen	do	310		8,000
V-7 Pin No. 5, Grid	do			115,000
V-7 Pin No. 8, Cathode	do	23		200
V-8 Pin No. 8, Filament	do	420		10,000
V-8 #1 Pin No. 4, Plate No. 1	do		410	35
V-8 #2 Pin No. 6, Plate No. 2	do		410	35
V-9 Pin No. 8, Filament	do	420		10,000
V-9 #1 Pin No. 4, Plate No. 1	do		410	35
V-9 #2 Pin No. 6, Plate No. 2	do		410	35
A-F Choke coil L-1	Chassis ground to input side			120
A-F Choke coil L-2	Chassis ground to output side			200
A-F Choke coil L-1	Chassis ground to input side			10,000
A-F Choke coil L-1	Chassis ground to output side			10,100
A-F Choke coil L-2	Chassis ground to output side			10,100
T-3 Transformer	Total secondary			10,200
T-3 Transformer	One half of secondary			70
T-3 Transformer	Primary 0-115			35
T-3 Transformer	Primary 0-115			2.5
				2.5

SECTION V SUPPLEMENTARY DATA

38. MAINTENANCE PARTS LIST FOR CONTROL UNIT C-104/TIQ-3.

Ref symbol	Signal Corps stock No.	Name of part and description	Quan per unit	Run-ning spares	Orgn stock	3d ech	4th ech	5th ech	Depot stock
	2Z1240-13	BRACKET, switch; safety; Z shape; bonder-ized steel o-d enamel; $1\frac{3}{4}$ " x $1\frac{1}{8}$ " x $\frac{3}{4}$ "; 18-gauge; Eastern Codwg No. KS-14-AS-11; one $\frac{5}{16}$ " mtg hole.	1				*	*	*
C22	3DB500-5.2	CAPACITOR, fixed: electrolytic; 500 mf +20%	2			*	*	*	*
C23		-10%; 12 v dc working; Incco type 1B-189.							
C18	3D9400-40	CAPACITOR, fixed: paper; 400 mmf +20%	1			*	*	*	*
		-10%; 600 v dc working; Sprague part PX24B.							
C24	3DA1-111.2	CAPACITOR, fixed: paper; 1,000 mmf +20%	1			*	*	*	*
		-10%; 600 v dc working; Sprague type PX24B							
C8	3DA500-57.4	CAPACITOR, fixed: paper; 50,000 mmf +20%	2			*	*	*	*
C9		-10%; 600 v dc working; Sprague type PX24B.							
C25	3DA100-26.8	CAPACITOR, fixed: paper; 100,000 mmf +20% -10%; 600 v dc working; Sprague type PX24B.	1			*	*	*	*
C14, C15, C16, C17	3DB4-158	CAPACITOR, fixed: paper; 4 mf +20%; -10%; 600 v dc working; Incco type 8723.	4			*	*	*	*

* Indicates stock available.

38. MAINTENANCE PARTS LIST FOR CONTROL UNIT C-104/TIQ-3 (contd).

Ref symbol	Signal Corps stock No.	Name of part and description	Quan per unit	Run-ning spares	Orgn stock	Sd ech	4th ech	5th ech	Depot stock
P15	2Z3027-4	CONNECTOR, male-contact: seven round male contacts, polarized; straight-type; $1\frac{1}{2}$ " x $1\frac{1}{2}$ " x $1\frac{1}{4}$ ", $1\frac{1}{8}$ " diam body; Amphe-nol No. AN-3102-20S-7P (cylindrical alumi-num body with square mtg flange; molded bakelite insert; mounts in $1\frac{1}{8}$ " diam hole; $1\frac{5}{8}$ " mounting center.	1			*	*	*	*
	2Z3352.02	COVER, terminal board: sheet steel, 16 gauge; cadmium plated, o-d finish; $7\frac{1}{4}$ " long x $7\frac{3}{8}$ " wide x $1\frac{1}{4}$ " diam; Eastern Co dwg No. KS-4 and KS-5; (two openings in bottom for cable clearance when closed; self locking catch fas-tener; mounts to front panel with five 6-32 screws); protects terminal board on front panel.	1			*	*	*	*
F2	SZ1926	FUSE, cartridge: 1-amp, 250-v; one time; glass; $1\frac{1}{4}$ " long x $\frac{1}{4}$ " diam over-all; Littell-fuse No. 1040.	1	6		*	*	*	*
E6	SZ3275-9	HOLDER, fuse: extractor post; for single SAG fuse; bakelite; 8-amp, 125-v; $2\frac{1}{2}$ " long x $1\frac{1}{8}$ " diam; Littelfuse No. 1075F; (fits $\frac{1}{2}$ " mtg hole).	1			*	*	*	*

E8, E9	2Z5892-58	<p>KNOB, round; black plastic; for $\frac{1}{4}$" shaft, with 8-32 setscrew; indicator pointer; Kurz-Kasch No. S-308-64, cut No. 2 (brass insert; shaft hole $\frac{1}{8}$" diam; natural grip).</p>	2			*	*	*	*	*
E3	2Z5927	<p>LAMP LM-27: 6-8 v, 0.25 amp; T3-$\frac{1}{4}$" bulb; $1\frac{3}{8}$" long; miniature bayonet base; single-contact; GE No. 44.</p>	1	2		*	*	*	*	*
E1 E2	2Z5889-3	<p>LAMP, glow: 105-125 v; $\frac{1}{4}$ w; T-4-$\frac{1}{2}$" bulb; $1\frac{1}{8}$" long; bayonet base; double-contact; GE NE-48 (tone generator).</p>	2	6		*	*	*	*	*
J22	2Z5883-181	<p>LAMP HOLDER: bayonet base; single-contact; 17 ST aluminum; $2\frac{1}{2}$" x $\frac{3}{4}$" diam; Dialco No. DP90F; (mounts $\frac{1}{8}$" hole; adjustable shutter).</p>	1			*	*	*	*	*
J20 J21	2Z5885-18	<p>LAMP HOLDER: candelabra; dc; bayonet base; molded bakelite base, brass and copper socket; $1\frac{1}{2}$" x $1\frac{3}{8}$"; Dialco No. 9S4 634L; (mounts with two $\frac{5}{8}$" bolts on $\frac{5}{8}$" mounting centers).</p>	2			*	*	*	*	*
H104 to H120	3Z737-19	<p>POST, binding: screw-type; $1\frac{9}{16}$" long x $\frac{1}{2}$" diam; 12-24 x $\frac{3}{4}$" mtg stem; Eby 96 v telepost (brass nickel plated finish; wire slot adjustable 0.01" to 0.140"; knurled cap).</p>	17			*	*	*	*	*

* Indicates stock available.

38. MAINTENANCE PARTS LIST FOR CONTROL UNIT C-104/TIQ-3 (contd).

Ref symbol	Signal Corps stock No.	Name of part and description	Quan per unit	Run-ning spares	Orgn stock	3d ech	4th ech	5th ech	Depot stock
CRI	3H4857-4	RECTIFIER, metallic: selenium; two-section; input 9 v ac max, 60 c, each half transformer sec; output 6 v dc 0.35 amps max; rectangular, 2 1/4" x 1 3/4" x 2 1/2"; Fed Tele & Radio No. 10-DO-998; (normal convection cooling; mounting centers 1 7/8" x 1 5/8").	1			*	*	*	*
K1	2Z7597-3	RELAY, change-over: contact arrangement 4C; 4 3/8" x 2 1/4" x 3 1/8" over-all; Clare CP No. B-14694; dwg No. F.S.218 (code 4 contacts; special palladium alloy; 3 amp, 150 w; single-wound coil; 1.75 v dc, 0.6 amp; 2.75 ohm; fast acting; hermetically sealed; angle bracket mtg).	1			*	*	*	*
R7	3RC21BE152K	RESISTOR, fixed: composition; 1,500 ohms ± 10%; 1/2-w; IRC type BT-1/2.	1			*	*	*	*
R26	3RC21BE153K	RESISTOR, fixed: composition; 15,000 ohms ± 10%; 1/2-w; IRC type BT-1/2.	1			*	*	*	*
R17	3RC21BE104K	RESISTOR, fixed: composition; 100,000 ohms ± 10%; 1/2-w; IRC type BT-1/2.	1			*	*	*	*
R40	3Z6720-6	RESISTOR, fixed: composition; 200,000 ohms ± 10%; 1/2-w; IRC type BT-1/2.	1			*	*	*	*
R37	3RC21BE105K	RESISTOR, fixed: composition 1 meg ± 10%; 1/2-w; IRC type BT-1/2.	1			*	*	*	*

R31	3Z4542	RESISTOR, fixed: composition; 2 meg \pm 10%; $\frac{1}{2}$ -w; IRC type BT- $\frac{1}{2}$.	1	*	*	*	*	*
R43, R44	3RC41AE103K	RESISTOR, fixed: composition; 10,000 ohms \pm 10%; 2-w; RC41AE103K.	1	*	*	*	*	*
R41	3RC41AE153K	RESISTOR, fixed: composition; 15,000 ohms \pm 10%; 2-w; AWS type RC41AE153K.	1	*	*	*	*	*
R3	3Z6010-18	RESISTOR, fixed: wire-wound; 100 ohms \pm 10%; $\frac{1}{2}$ -w; IRC type BW- $\frac{1}{2}$.	1	*	*	*	*	*
R46	3ZK6050-78	RESISTOR, fixed: wire-wound; 500 ohms \pm 10%; 8-w; IRC type DG.	1	*	*	*	*	*
R42	3Z6001E5-43	RESISTOR, fixed: wire-wound; 15 ohms \pm 5%; 12-w; IRC type DJ.	1	*	*	*	*	*
R45	3Z6005-126	RESISTOR, fixed: wire-wound; 50 ohms \pm 5%; 20-w; IRC type EP.	1	*	*	*	*	*
R48 R49	2Z7271-142	RESISTOR, variable: carbon; 100,000 ohms; 2-w; Clarostat type W-37.	2	*	*	*	*	*
R50 R51	2Z7277.82	RESISTOR, variable: wire-wound; 50 ohms; 2-w; Clarostat type 37W; 3 terminals.	2	*	*	*	*	*
X3, 10 X11	2Z8678.122	SOCKET, tube: Navy No. 49380; octal; ceramic; Ucinite No. 115001-1.	3	*	*	*	*	*

* Indicates stock available.

38. MAINTENANCE PARTS LIST FOR CONTROL UNIT C-104/TIQ-3 (contd).

Ref symbol	Signal Corps stock No.	Name of part and description	Quan per unit	Run-ning spares	Orgn stock	3d ech	4th ech	5th ech	Depot stock
LS13	6C48-15	SPEAKER, dynamic; diaphragm type; PM; output 10 w; voice coil impedance 15 ohms; 4" diam x $1\frac{11}{16}$ " long over-all; Racon LS-13 (four $\frac{3}{32}$ " holes equally spaced on horn flange; "L" type mtg bracket).	1			*	*	*	*
S4	3Z9849.144	SWITCH, toggle: DPDT; bakelite; $1\frac{5}{16}$ " x $\frac{3}{4}$ " x $2\frac{3}{32}$ "; C-H No. 8825K-3 w/8916K615 (24 v, 20 amp; locking type $\frac{3}{32}$ " bushing w/ No. 32 thd; surface mtg; solder lug terminal; rubber boot; radio active indicating lever).	1			*	*	*	*
S2	3Z9849.143	SWITCH, toggle: DPST; bakelite; $1\frac{5}{16}$ " x $\frac{3}{4}$ " x $2\frac{3}{32}$ "; C-H No. 8823K-3 w/8916K615 (24 v, 20 amp; locking type; $\frac{3}{32}$ " bushing w/ No. 32 thd; surface mtg; solder lug terminals; rubber boot; radio active indicating lever).	1			*	*	*	*
S5 to S18	3Z9849.107	SWITCH, toggle: SPDT; bakelite $1\frac{1}{8}$ " x $\frac{5}{8}$ " x $2\frac{1}{32}$ "; C-H No. 8816K-3 w/8916K615 (24 v, 20 amp; locking type; $\frac{3}{32}$ " bushing w/ No. 32 thd; surface mtg; solder lug terminals, rubber boot; radio active indicating lever).	14			*	*	*	*
S21	3Z9849.142	SWITCH, toggle: SPDT; bakelite; $1\frac{1}{8}$ " x $\frac{5}{8}$ " x $2\frac{1}{32}$ "; C-H No. 8815K4 w/8916K615 (24 v, 20 amp; locking type; $\frac{3}{32}$ " bushing w/ No. 32 thd; one hole surface mtg; solder lug terminals; rubber boot; radio active indicating lever).	1			*	*	*	*

S19	3Z9849.141	SWITCH, toggle: SPST; bakelite; $1\frac{1}{8}$ " x $\frac{5}{8}$ " x $2\frac{3}{4}$ "; C-H No. 8803K-4 w/8916K615 (24 v, 20 amp; locking type; $\frac{1}{4}$ " bushing w/ No. 32 thd; surface mtg; solder lug terminals; rubber boot; radio active indicator lever).	1			*	*	*	*	*
S20	3Z9849.140	SWITCH, toggle: TPDT; bakelite; $2\frac{1}{8}$ " x $1\frac{3}{8}$ " x $2\frac{3}{4}$ "; C-H No. 8743K-4 w/8916K-16 (24 v, 20 amp; locking type; $\frac{1}{4}$ " bushing; four mtg holes; No. 6-32 tap on $1\frac{1}{8}$ " x $\frac{1}{2}$ " mounting centers; solder lug terminals; rubber boot; radio active lever; "off" center position).	1			*	*	*	*	*
T8	2Z9637.42	TRANSFORMER, a-f: impedance matching; pri 0-15 ohms; sec 0-250-500-1000-2500 ohms; steel fully shielded case; 3 " x $2\frac{1}{4}$ " x 3 "; UTC No. 89204, dwg No. SH-3559; (frequency response 50 to 10,000 c; 7 terminals, 5 binding posts, 2 solder lugs; fungus treated; impregnated).	12			*	*	*	*	*
T6	2Z9632.274	TRANSFORMER, a-f: output; pri 44,000 ohms; sec 100 ohms; steel fully shielded case; $2\frac{1}{2}$ " x $1\frac{1}{4}$ " x $1\frac{1}{4}$ "; UTC No. 89201, case No. RC-62, dwg No. ST-1051; (turns ratio 20:7; dual alloy internal shielding; 4 waterproof solder lug terminals on bottom; vertical mtg; $\frac{1}{8}$ " mtg holes on $1\frac{1}{2}$ " mounting centers; hermetically sealed, fungus treated; impregnated).	1			*	*	*	*	*

* Indicates stock available.

38. MAINTENANCE PARTS LIST FOR CONTROL UNIT C-104/TIQ-3 (contd).

Ref symbol	Signal Corps stock No.	Name of part and description	Quan per unit	Run-ning spares	Orgn stock	3d ech	4th ech	5th ech	Depot stock
T2	2Z9631.203	TRANSFORMER, a-f: input; pri 100 ohms; sec 3,500 ohms; steel fully shielded case; $2\frac{1}{2}$ " x $1\frac{1}{4}$ " x $1\frac{1}{8}$ " over-all; UTC No. 83197 case No. RC-62, dwg No. ST-1051; (turns ratio of pri approx 17:1; dual alloy internal shielding; 4 waterproof terminals protruding from bottom; vertical mtg; four $\frac{1}{8}$ " mtg holes on $1\frac{1}{2}$ " diam mtg centers; hermetically sealed; fungus treated; impregnated).	1			*	*	*	*
T7	2Z9608-38	TRANSFORMER, power: plate and fil; steel case fully shielded; $4\frac{1}{8}$ " x $3\frac{1}{2}$ " x $3\frac{1}{2}$ "; UTC No. 83202 case No. RC-112 dwg No. ST-1051, (pri No. 1, 115 v, 50/60 c, pri No. 2, 115 v 50/60 c, sec No. 1, 300-0-300 v 9 ma; sec No. 2, 5 v 3 amp; sec No. 3, 6.3 v, 1 amp; impregnated for tropical use, fungus treated, hermetically sealed; vertical mtg, four $\frac{1}{8}$ " mtg holes on $2\frac{1}{16}$ " mounting centers; 11 waterproof solder lugs on bottom).	1			*	*	*	*
V11	2JC3/VR105	TUBE JAN-OC3/VR-105: VT-200.	1					*	*
V3	2J6SL7GT	TUBE JAN-6SL7GT: VT-299.	1	2				*	*
V10	2J5U4G	TUBE JAN-5U4G: VT-244.	1	3				*	*

* Indicates stock available.

39. MAINTENANCE PARTS LIST FOR AMPLIFIER AM-34/TIQ-3.

Ref symbol	Signal Corps stock No.	Name of part and description	Quan per unit	Run-ning spares	Orgn stock	3d ech	4th ech	5th ech	Depot stock
B1	3HS88-14	BLOWER, centrifugal: elec ind motor; 24 metal fan blades, 1 $\frac{5}{8}$ " diam; nonportable; motor rated 1/250 hp, 3,100 rpm, single-phase, 60 c, 115 v ac; 4 $\frac{1}{8}$ " x 3 $\frac{1}{2}$ " x 3 $\frac{3}{4}$ "; Eastern Air Devices No. J-50 ac dwg No. 50B14-C; (10 cfm at 3,100 rpm; direct drive; vertical mtg with two $\frac{3}{16}$ " holes).	1			*	*	*	*
A3	2Z1240-13	BRACKET, switch: safety; Z shape; bonderized steel o-d enamel; 1 $\frac{3}{4}$ " x 1 $\frac{1}{8}$ " x $\frac{3}{4}$ ", 18 gauge; Eastern Co dwg No. KS-14-AS-11; (one $\frac{5}{8}$ " mtg hole).	1		*	*	*	*	*
C1, C2, C3	3DB50-33	CAPACITOR, fixed: electrolytic; 50 mf +65% -10%; 50 v dc (working); Incco type IB-188.	3			*	*	*	*
C21	3DA6-76.1	CAPACITOR, fixed: paper; 6,000 mmf +20% -10%; 600 v dc (working); Sprague type PX24B.	1			*	*	*	*
C4, C5, C6, C7	3DA500-57.4	CAPACITOR, fixed: paper; 50,000 mmf +20% -10%; 600 v dc (working); Sprague type PX24B.	4			*	*	*	*
C19, C20	3DB1.630-3	CAPACITOR, fixed: paper; 1 mf +20% -10%; 600 v dc (working); Aerovox type 630MT.	2			*	*	*	*
C10, C11, C12, C13	3DB4-158	CAPACITOR, fixed: paper; 4 mf +20% -10%; 600 v dc (working); Incco type 8723.	4			*	*	*	*

* Indicates stock available.

39. MAINTENANCE PARTS LIST FOR AMPLIFIER AM-34/TIQ-3 (contd).

Ref symbol	Signal Corps stock No.	Name of part and description	Quan per unit	Run-ning spares	Orgn stock	3d ech	4th ech	5th ech	Depot stock
	3H388-14/1	CASING, blower: bakelite; 2-piece; $3\frac{1}{2}$ " x $3\frac{1}{2}$ " wide x $1\frac{3}{8}$ " high over-all; outlet pipe $1\frac{1}{8}$ " OD protruding counterclockwise; (air intake opening $1\frac{5}{8}$ " diam located in top of casing; upper section contains 4 brass inserts tapped for 8-32 screws 1" long).	1			*	*	*	*
L1	3C573-6	COIL, choke, a-f: filter; single-winding; 10-h; 250-ma; 120-ohm; $3\frac{1}{2}$ " x $3\frac{1}{2}$ " x $4\frac{1}{2}$ "; UTC No. 83199 case RC125 (1,500 v dc insulation test; enclosed metal case dual; four $\frac{1}{8}$ diam mtg holes on 3" x 3" mtg centers; hermetically sealed, impregnated for tropical use, fungus treated; 2 solder terminal lugs on bottom).	1			*	*	*	*
L2	3C573-7	COIL, choke; a-f: filter; single-winding; 20-h; 50-ma; 200-ohm; 3" x 3" x $3\frac{3}{4}$ "; UTC No. 83200 case 100 (1,500 v dc insulation test; enclosed metal case dual alloy shielding; four $\frac{3}{8}$ " mtg holes on $2\frac{3}{8}$ " mtg centers hermetically sealed; impregnated for tropical use, fungus treated; two solder terminal lugs on bottom).	1			*	*	*	*
J19	2ZS066-7	CONNECTOR, female-contact: 5 round polarized contacts; straight-type; $\frac{1}{8}$ " x $\frac{1}{4}$ " x $1\frac{1}{8}$ " over-all; Amphenol No. AN-3102-14S-5S; (booster connector when used).	1			*	*	*	*

P14	2Z3027-4	CONNECTOR, male-contact: 7 round male contacts polarized; straight-type; $1\frac{1}{2}''$ x $1\frac{1}{2}''$ x $1\frac{1}{4}''$ over-all; $1\frac{1}{8}''$ diam body; Amphenol No. AN-3102-20S-7P; (cylindrical aluminum body with square mtg flange; molded bakelite insert; mounts in $1\frac{1}{8}''$ diam hole; 4 mtg holes; $1\frac{5}{16}''$ mtg centers.	1		*	*	*	*	*
F1	6Z3856-54	FILTER ELEMENT, air: 1" x 5" x 5" over-all; Fibre-glass No. 61-00-01-10-01; (sealed-type; no mtg, slides in channel; cardboard container).	1	*	*	*	*	*	*
	3Z2605.2	FUSE, cartridge: 5-amp; 250-v; one-time; glass; ferrule, $\frac{1}{4}''$ diam x $\frac{1}{4}''$ long; $1\frac{1}{4}''$ long x $\frac{3}{4}''$ diam over-all Littelfuse No. 1358.	1	6	*	*	*	*	*
E5	3Z3275-9	HOLDER, fuse: extractor post; for single 3 AG fuse; bakelite; 8-amp, 125-v; $2\frac{1}{2}''$ long x $1\frac{1}{16}''$ diam; Littelfuse No. 1075F.	1	*	*	*	*	*	*
E7	2Z5822-79	KNOB, round: black plastic; for $\frac{1}{4}''$ diam shaft with 8-32 setscrew; indicator pointer; $\frac{1}{8}''$ diam x $\frac{5}{8}''$ long; Kurz-Kasch No. S-308-64, cut No. 2 (brass insert; shaft hole $\frac{1}{16}''$ diam; natural grip).	1	*	*	*	*	*	*
E4	2Z5927	LAMP LM-27; 6-8-v; $\frac{1}{4}$ -amp; blue bead; miniature bayonet base; GE No. 44.	1	2	*	*	*	*	*
J23	2Z5883-181	LAMPHOLDER: bayonet-base; single-contact: 17 ST aluminum; $2\frac{1}{2}''$ x $\frac{3}{4}''$ diam; Dialco No. DP90F; (mounts $\frac{1}{16}''$ hole; adjustable shutter).	1	*	*	*	*	*	*

* Indicates stock available.

39. MAINTENANCE PARTS LIST FOR AMPLIFIER AM-34/TIQ-3 (contd).

Ref symbol	Signal Corps stock No.	Name of part and description	Quan per unit	Run-ning spares	Orgn stock	3d ech	4th ech	5th ech	Depot stock
H121, H122	3Z737-19	POST, binding: screw-type; $1\frac{9}{16}$ " x $\frac{3}{8}$ " diam; No. 12-24 x $\frac{3}{4}$ " mtg stem; Eby No. 96V telepost; brass nickel-plated finish; wire slot in neck adjustable 0.01" to 0.140"; knurled cap.	2			*	*	*	*
R5, R6	3RC21BE152K	RESISTOR, fixed: composition; 1,500 ohms \pm 10%; $\frac{1}{2}$ -w; IRC type BT $\frac{1}{2}$.	2			*	*	*	*
R18	3RC21BE504J	RESISTOR, fixed: composition; 50,000 ohms \pm 10%; $\frac{1}{2}$ -w; IRC type BT $\frac{1}{2}$.	1			*	*	*	*
R19, R20, R21, R22, R23	3RC21BE153K	RESISTOR, fixed: composition; 15,000 ohms \pm 10%; $\frac{1}{2}$ -w; IRC type BT $\frac{1}{2}$.	5			*	*	*	*
R8, R9, R10, R11, R12, R13, R14, R15	3RC21BE104K	RESISTOR, fixed: composition; 100,000 ohms \pm 10%; $\frac{1}{2}$ -w; IRC type BT $\frac{1}{2}$.	8			*	*	*	*
R28, R29	3Z6020-112	RESISTOR, fixed: wire-wound; 200 ohms \pm 5%; 8-w; IRC type DG.	2			*	*	*	*

R94	3Z6200-147	RESISTOR, fixed: wire-wound; 2,000 ohms $\pm 5\%$; 20-w; IRC type EP (C coating).	1				*	*	*	*
R92	3Z6500-141	RESISTOR, fixed: wire-wound; 5,000 ohms $\pm 5\%$; 8-w; IRC type DG.	1				*	*	*	*
R93	3Z6580-30	RESISTOR, fixed: wire-wound; 8,000 ohms $\pm 5\%$; 30-w; IRC type ES (C coating).	1				*	*	*	*
R47	2Z7271-141	RESISTOR, variable: carbon; 100,000-ohm; 2-w; Clarostat type W-37.	1				*	*	*	*
X1, X2, X4, X5, X6, X7, X8, X9	2Z8678.122	SOCKET, tube: Navy No. 49380; octal; ceramic; Ucinite No. 115001-1.	8				*	*	*	*
S3	3Z9849.144	SWITCH, toggle: DPDT; bakelite; $1\frac{1}{8}'' \times \frac{3}{4}'' \times 2\frac{3}{4}''$; C-H No. 8825K3 w/8916K615 (24-v; 20-amp; locking-type; $\frac{1}{16}''$ diam bushing watt No. 32 thd; 1-hole mtg; rubber boot, radio active indicating lever).	1				*	*	*	*
S1	3Z9849.143	SWITCH, toggle: DPST; bakelite; $1\frac{1}{8}'' \times \frac{3}{4}'' \times 2\frac{3}{4}''$; C-H No. 8823K3 w/8916 K615 (24-v; 20-amp; locking-type; $\frac{1}{16}''$ diam bushing watt No. 32 thd; 1-hole surface mtg; solder lug term; rubber boat, radio active indicating lever).	1				*	*	*	*

* Indicates stock available.

39. MAINTENANCE PARTS LIST FOR AMPLIFIER AM-34/TIQ-3 (contd).

Ref symbol	Signal Corps stock No.	Name of part and description	Quan per unit	Run-ning spares	Orgn stock	3d ech	4th ech	5th ech	Depot stock
T1	2Z9631.203	TRANSFORMER, a-f: input; pri 100 ohms, sec 25,000 ohms; steel fully shielded case $2\frac{1}{2}'' \times 1\frac{1}{4}'' \times 1\frac{1}{4}''$; UTC No. 83197 case RC-62 dwg No. ST-1051; (tums ratio of pri approx 17:1; dual alloy internal shielding; 4 waterproof term protruding from bottom; vertical mtg, four $\frac{1}{8}''$ mtg holes, $1\frac{1}{2}''$ mtg centers; hermetically sealed, fungus treated, impregnated).	1			*	*	*	*
T5	2Z9632.268	TRANSFORMER, a-f: output; pri 4,500 ohms ct; section No. 1; 4 ohms; sec No. 2; 250 ohms, tapped at 50 ohms and 125 ohms; steel case fully shielded; $5\frac{1}{2}'' \times 4\frac{1}{4}'' \times 4\frac{1}{4}''$; UTC No. 83196 case RC-150 dwg No. ST-1051; (50-w; complete pri to sec No. 2 ratio 4.2:1; frequency response 50:10,000 c=3SDB; dual alloy shielding; 11 waterproof term; vertical mtg, four $\frac{1}{8}''$ mtg holes on $3\frac{3}{16}''$ mtg centers).	1			*	*	*	*
T4	2Z9606-8	TRANSFORMER, power; filament; completely enclosed metal case; $4\frac{1}{8}'' \times 3\frac{1}{4}'' \times 3\frac{1}{4}''$; UTC No. 83205 dwg No. ST-1051; (pri No. 1; 115 v, 60 c; pri No. 2: 115 v, 60 c; sec No. 1; 5 v, 6 amp; sec No. 2; 6.3 v, $4\frac{1}{2}$ amp; hermetically sealed; dual alloy shielding; 8 waterproof term on bottom, fungus treated; impregnated; vertical mtg; four $\frac{1}{8}''$ mtg holes, $2\frac{1}{4}''$ mtg centers).	1			*	*	*	*

T3	2Z9607-19	<p>TRANSFORMER, power: plate; completely enclosed metal case; $5\frac{5}{8}''$ x $5\frac{5}{32}''$ x $5\frac{5}{32}''$; UTC No. 83198, case RC-152 dwg No. ST-1051; (pri No. 1: 115 v, 50/60 c; pri No. 2, 115 v, 50/60 c; sec 480-0-430 v, 300 ma dc; waterproof, on bottom, dual alloy shielding; hermetically sealed, fungus treated; impregnated; $\frac{1}{8}''$ mtg holes, $4\frac{1}{8}''$ mtg centers; 7 solder lugs).</p>	1					*
V8, V9	2J5U4G	TUBE JAN-5U4G: VT-244.	2	7	*	*	*	*
V4, V5, V6, V7	2J6L6GA	TUBE JAN-6L6GA.	4	13	*	*	*	*
V1, V2	2J6SL7GT	TUBE JAN-6SL7GT: VT-299.	2	5	*	*	*	*

* Indicates stock available.

40. MAINTENANCE PARTS LIST FOR PUBLIC ADDRESS SET AN/TIQ-3.

Ref symbol	Signal Corps stock No.	Name of part and description	Quan per unit	Run-ning spares	Orgn stock	3d ech	4th ech	5th ech	Depot stock
	2C449-34	AMPLIFIER AM-34/TIQ-3: a-f; 50 to 10,000 c; output 50 w; 19" x 13" x 8 $\frac{3}{4}$ " over-all; Eastern Co No. AM-34/TIQ-3: (power input 115/230 v, single-phase, 60 c, two low-impedance input channels; output impedance 50, 125 and 250 ohms; complete with 1 set tubes).	1				*	*	*
	2C684-104	CONTROL UNIT C-104/TIQ-3: a-f amplifier; frequency range 50 to 10,000 c; 19" x 13" x 8 $\frac{3}{4}$ " over-all; Eastern Co No. C-104/TIQ-3.	1					*	*
J16, J17, J18	6Z3149	CONNECTOR, female-contact: 2 curved contacts; straight-type; 2 $\frac{3}{32}$ " long x 1 $\frac{1}{2}$ " OD; Hubbell No. 7101; (20-amp 250-v; cylindrical bakelite shell; steel-covered; cadmium-plated; cable clamp; (part of Cords CX-55/TIQ-2 and CX-54/TIQ-2).	3			*	*	*	*
J12, J13, J14, J15	6Z7808.1	CONNECTOR, female-contact: 2 curved female contacts; straight-type; 3 $\frac{5}{8}$ " long x 1 $\frac{1}{2}$ " wide x 1 $\frac{5}{32}$ " diam over-all; Hubbell No. 7910 (modified); Eastern Co dwg No. PS-1; (20-amp 250-v; octagonal porcelain body with mounting brackets; mounts in 2 $\frac{1}{16}$ " diam hole).	4			*	*	*	*
J10, J11	2Z3069-8	CONNECTOR, female-contact: 8 polarized contacts; straight-type; 1 $\frac{1}{2}$ " OD x 2 $\frac{1}{8}$ " long; Amphenol No. AN-3106-20-7S; (cylindrical aluminum body; molded bakelite insert; cable clamp; locking ring)	2			*	*	*	*

P9, P10, P11, P12, P13	6C901C/P2	CONNECTOR, male-contact: 2 curved blades; straight-type; $1\frac{1}{8}$ " OD x $1\frac{1}{4}$ " long less contacts; Hubbel No. 7102; (part of Cords CX-49/TIQ-2, CX-54/TIQ-2, and CX-53/TIQ-2).	5		*	*	*	*	*
P16	6Z1727	CONNECTOR, male-contact: 2 parallel blades; straight-type; $1\frac{1}{2}$ " diam x $1\frac{3}{4}$ " long less blades; Hubbel No. 7057; (10-amp 250-v; cylindrical composition cap, steel-covered, cadmium-plated).	1		*	*	*	*	*
W3	3E6000-51	CORD CX-51/TIQ-2: single-conductor; shielded rubber jacket; 10 ft long; Plug PL-55 on each end; (connects C-104/TIQ-3 to AM-34/TIQ-3).	1		*	*	*	*	*
W8, W9	3E6000-164	CORD CX-164/TIQ-3: single-conductor, shielded; rubber jacket; 25 ft long; Plug PL-55 on one end; terminal box containing Jack JK-34 on other; (extension for Cord CX-51/TIQ-2).	2		*	*	*	*	*
W10	3E6000-165	CORD CX-165/TIQ-3: rubber jacket; 25 ft long; (extension cord for Handset TS-13).	1		*	*	*	*	*
H44	6Z1747-25.1	FASTENER, cover and case interlock: carbon steel parkerized; $2\frac{1}{8}$ " long x 1 " w x $\frac{5}{8}$ " thick; Corbin No. 15795-RC with case top; (fasteners for all chests).	18		*	*	*	*	*
TS-13-B	2B613	HANDSET TS-13.	1		*	*	*	*	*
J8, J9	2Z5533A	JACK JK-33-A: telephone; (part of Cord CX-165/TIQ-3).	1		*	*	*	*	*
LS1 to LS12	6C42-104	LOUDSPEAKER LS-104/TIQ-3: 25-w, re-entrant.	12		*	*	*	*	*
	3H4600-214	POWER UNIT PE-214.	1	*	*	*	*	*	*

* Indicates stock available.

41. MAINTENANCE PARTS LIST FOR HANDSET TS-13-() .

Ref symbol	Signal Corps stock No.	Name of part and description	Quan per unit	Run-ning spares	Orgn stock	3d ech	4th ech	5th ech	Depot stock
	SB1494	CORD CD-494.	1				*	*	*
	2Z7155	PLUG PL-55.	1				*	*	*
	2Z7168	PLUG PL-68.	1				*	*	*
	3Z6075-23	RESISTOR.	1				*	*	*
	6L6440-3.59	SCREW, machine: No. 4-40 x $1\frac{1}{8}$ "; flat binding head; black oxide.	2				*	*	*
	6L6448-3.9	SCREW, machine: No. 4-48 x $1\frac{1}{4}$ "; binding head; brass; nickeled.	2				*	*	*
	6L6540-3.8	SCREW, machine: No. 5-40 x $1\frac{1}{4}$ "; binding head; brass; nickeled.	2				*	*	*
	3Z9650	SWITCH ASSEMBLY. NOTE: No initial distribution of the following parts will be made on the basis of this list, as Handsets TS-13 are of four manufacturing types, parts of which are not interchangeable. Sufficient spare handsets are provided in depot and echelon stocks for six months replacement without repairs. To conserve stocks of repair parts, defective handsets should be allowed to accumulate, and parts requisitioned only as required for specific manufacturing types.	1				*	*	*

4B1109J/20	HANDBET TS-13-A (AUTOMATIC ELECTRIC)	1					*
4B1109J/19	CAP, receiver.						*
4B1109J/12	CAP, transmitter.	1					*
4B1109J/13	CONTACT SPRING: receiver; center.	1					*
4B1109J/14	CONTACT SPRING: receiver; outside.	1					*
4B1109J/15	CONTACT SPRING: transmitter; center.	1					*
2B613C/2	CONTACT SPRING: transmitter; outer.	1					*
2B611D/1	HANDLE, handset.						*
2B613A/25	RECEIVER, handset.						*
4B1109J/3	SCREW: cord fastening.						*
	TRANSMITTER UNIT: handset.						*
4B1109K/20	HANDBET TS-13-B (KELLOGG)						*
2B613B/9	CAP, receiver.						*
2B613B/2	CONNECTING RACK: black phenolic; linen.						*
2B613B/11	HANDLE, handset.						*
4B1109/	INSERT: brass; round.						*
2B611C/1	MOUTHPIECE: transmitter.						*
4B1109K/7	RECEIVER, handset.						*
2B611B/3	RING, clamping: transmitter.						*
	TRANSMITTER UNIT: handset.						*

* Indicates stock available.

41. MAINTENANCE PARTS LIST FOR HANDSET TS-13-() (contd).

Ref symbol	Signal Corps stock No.	Name of part and description	Quan per unit	Run-ning spares	Orgn stock	3d ech	4th ech	5th ech	Depot stock
		HANDSET TS-13-E (AMERICAN MICROPHONE CO.)							*
	4B407-103	CAP, receiver.							*
	4B408-102	CAP, transmitter.							*
	4B442-142A	CONTACT SPRING: receiver; center.							*
	4B442-604	CONTACT SPRING: receiver; outside.							*
	4B442-142	CONTACT SPRING: transmitter; center.							*
	4B443-141	CONTACT SPRING: transmitter; outside.							*
	4B1001	HANDLE, handset.							*
	4B3054	RECEIVER, handset.							*
	4B9854	TRANSMITTER UNIT.							*
		HANDSET TS-13-F (FEDERAL (FORMERLY INTERNATIONAL)).							*
	4B1109A.11/20	CAP, receiver.							*
	4B1109A.6/19	CAP, transmitter.							*
	4B1109A.11/12	CONTACT SPRING: receiver; center.							*
	4B1109A.6/13	CONTACT SPRING: receiver; outside.							*
	2B613F/7	CONTACT SPRING: transmitter; outside.							*
	2B613F/8	CONTACT SPRING: transmitter; center.							*
	2B613B/4	HANDLE, handset.							*
	4B3058	RECEIVER, handset.							*
	4B1109F/3	TRANSMITTER UNIT, handset.							*

* Indicates stock available.

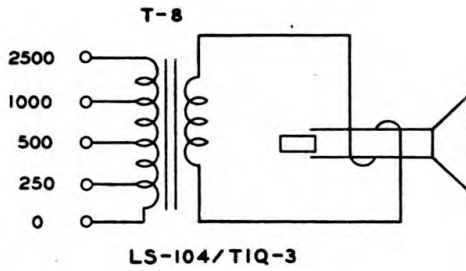

IF FEWER THAN EIGHT LOUDSPEAKERS LS-104/TIQ-3 ARE USED,
 CONNECT FIELD WIRE TO THE 0- AND 250-OHM TERMINALS.
 FOR EIGHT OR MORE LOUDSPEAKERS CONNECT THE FIELD
 WIRE TO 0- AND 500-OHM TERMINALS.

TL13965

Figure 22. Data chart for Loudspeaker LS-104/TIQ-3.

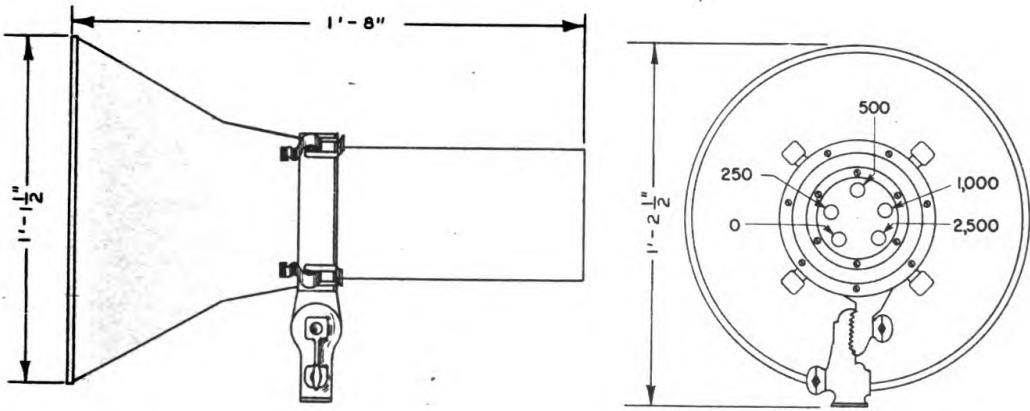

TL 16311

Figure 25. Outline dimensions of Loudspeaker LS-104/TIQ-3.

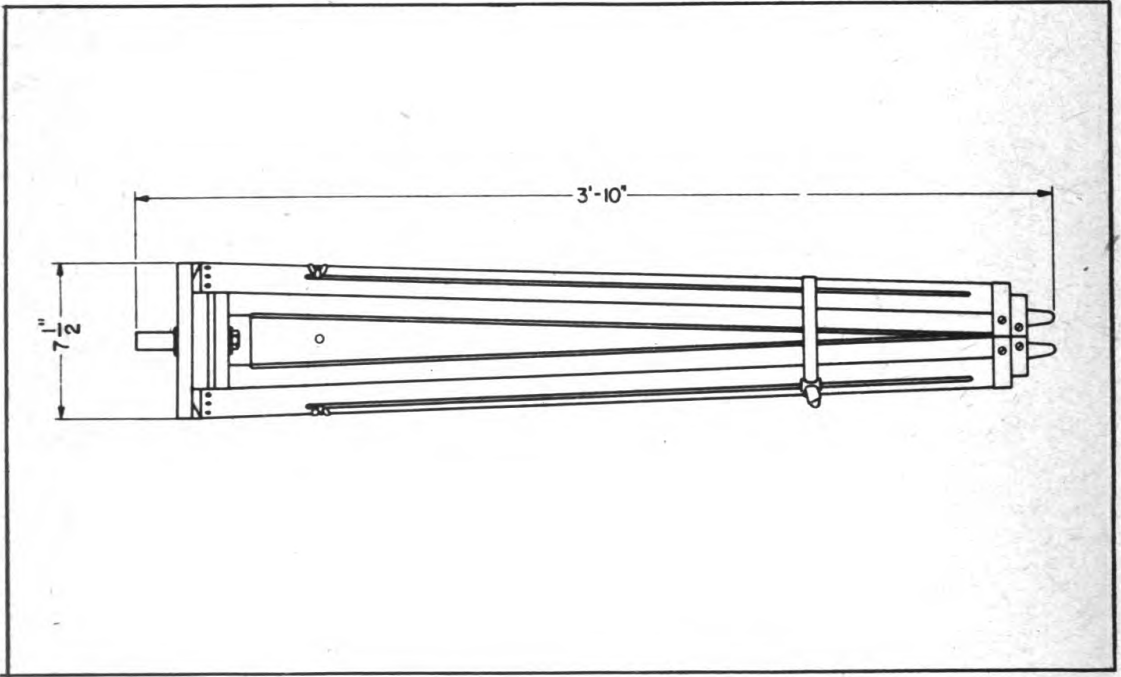

TL 16332

Figure 26. Outline dimensions of Stand MT-128/TIQ-2.

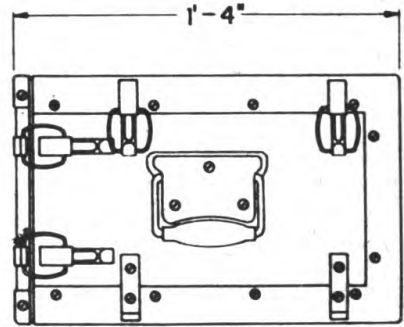
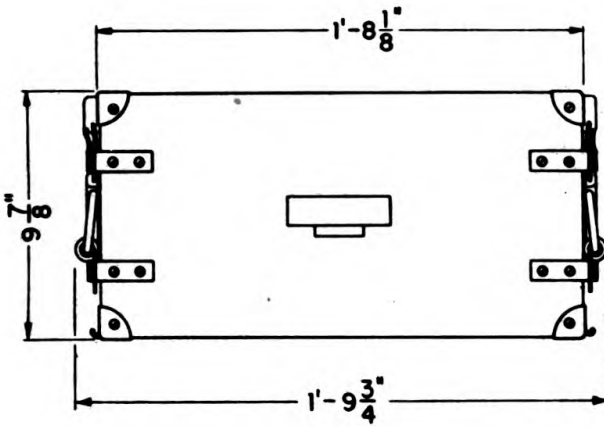

TL 16333

Figure 27. Outline dimensions of Case CY-38/TIQ-2.

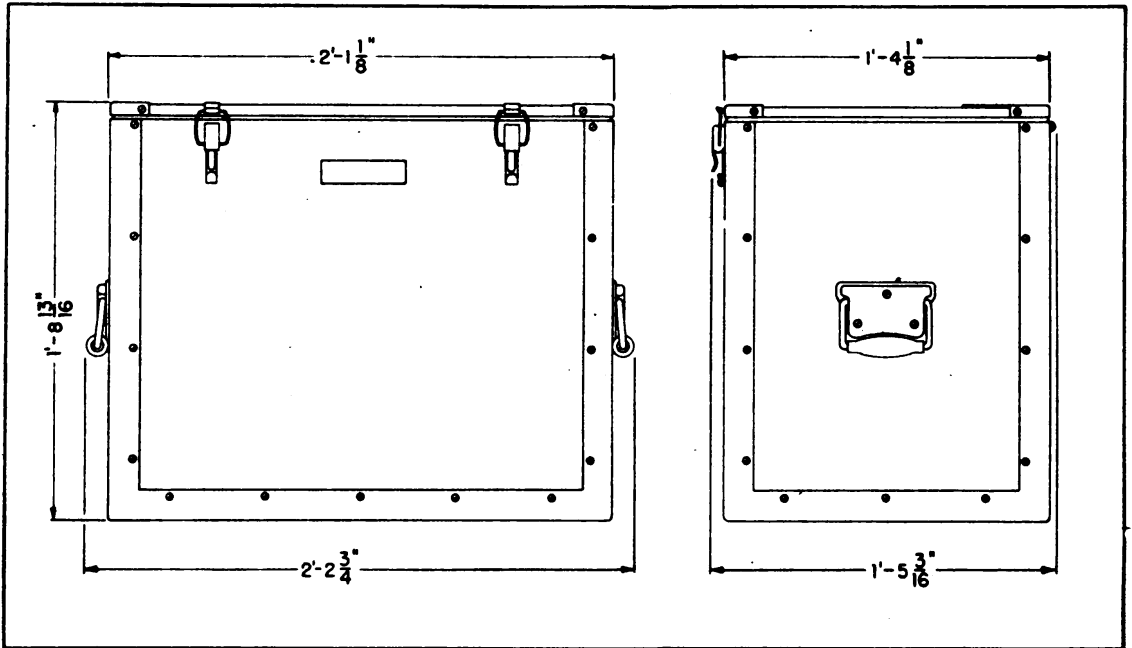

TL 16334

Figure 28. Outline dimensions of Case CY-96/TIQ-3.

LEGEND

C-8	CAPACITOR, 50000 MMF, 600 V-DC-(WORKING)	T-7	TRANSFORMER
C-9	CAPACITOR, SAME AS C-8		POWER, PLATE
C-14	CAPACITOR, 4.0 MF, 600 V-DC-(WORKING)		AND FILAMENT
C-15	CAPACITOR, SAME AS C-14	V-3	JAN, 6SL7GT
C-16	CAPACITOR, SAME AS C-14	V-10	JAN, 5U4G
C-17	CAPACITOR, SAME AS C-14	V-11	JAN, OC-3/VR-1C
C-18	CAPACITOR, 400 MMF, 600 V-DC-(WORKING)		
C-22	CAPACITOR, 500 MF, 12 V-DC-(WORKING)		
C-23	CAPACITOR, SAME AS C-22		
C-24	CAPACITOR, 1000 MMF, 600 V-DC-(WORKING)		
C-25	CAPACITOR, 100,000 MMF, 600 V-DC-(WORKING)		
C-26	CAPACITOR, SAME AS C-18		
P-15	CONNECTOR, MALE CONTACT		
F-2	FUSE, 1 AMP, 250 V		
J-1	JACK JK-34A		
J-2	JACK, SAME AS J-1		
J-8	JACK JK-33A		
E-1	LAMP, GLOW		
E-2	LAMP, SAME AS E-1		
E-3	LAMP, 1/4 AMP, 6-8V		
H-104 to	120 INC. POST, BINDING		
CR-1	RECTIFIER, 9-V-AC TO 6-V-DC		
K-1	RELAY, CHANGE-OVER		
R-3	RESISTOR, 100 OHMS 1/2 W		
R-7	RESISTOR, 1500 OHMS 1/2 W		
R-16	RESISTOR, 100,000 OHMS, 1/2 W		
R-17	RESISTOR, SAME AS R-16		
R-24	RESISTOR, 15,000 OHMS, 1/2 W		
R-25	RESISTOR, SAME AS R-24		
R-26	RESISTOR, SAME AS R-24		
R-31	RESISTOR, 2.0 MEG 1/2 W		
R-36	RESISTOR, 50,000 OHMS, 1/2 W		
R-37	RESISTOR, 1.0 MEG 1/2 W		
R-38	RESISTOR, SAME AS R-37		
R-39	RESISTOR, SAME AS R-37		
R-40	RESISTOR, 200,000 OHMS, 1/2 W		
R-41	RESISTOR, 15,000 OHMS, 2 W		
R-42	RESISTOR, 15.0 OHMS, 12 W		
R-43	RESISTOR, 10,000 OHMS, 2 W		
R-44	RESISTOR, SAME AS R-43		
R-45	RESISTOR, 50 OHMS, 20 W		
R-46	RESISTOR, 500 OHMS, 8 W		
R-48	RESISTOR, VARIABLE, 100,000 OHMS, 2 W		
R-49	RESISTOR, SAME AS R-48		
R-50	RESISTOR, VARIABLE, 50 OHMS, 2 W		
R-51	RESISTOR, SAME AS R-50		
LS-13	SPEAKER, TALKBACK		
S-2	SWITCH, DPST		
S-4	SWITCH, DPDT		
S-5 to 18	INC. SWITCH, DPDT		
S-19	SWITCH, SPST		
S-20	SWITCH, TPDT		
S-21	SWITCH, SPDT		
T-2	TRANSFORMER, A-F, INPUT		
T-6	TRANSFORMER, A-F, OUTPUT		

