

W113
12
TM
1945

TM 11-2674

WAR DEPARTMENT TECHNICAL MANUAL

U.S. Dept. of Army

CRYSTAL TEST SET TS-314/FSM-1 (RAY JEFFERSON MODEL AF-30)

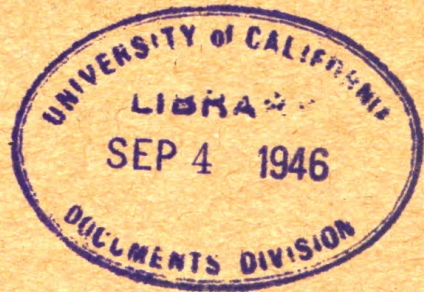

WARNING This manual is the property of the United States Government, and is printed and distributed solely for the use of the military, naval, and civilian personnel of the War and Navy Departments, and may not be published or reproduced in whole or in part, or in any manner or form (except by lawful copyright holders who may reproduce their copyrighted material in its original form) unless specifically approved by authorized military public relations agencies.

WAR DEPARTMENT

4 MAY 1945

WAR DEPARTMENT TECHNICAL MANUAL
TM 11-2674

CRYSTAL TEST SET TS-314/FSM-1
(RAY JEFFERSON MODEL AF-30)



WAR DEPARTMENT

4 MAY 1945

WARNING

This manual is the property of the United States Government, and is printed and distributed solely for the use of the military, naval, and civilian personnel of the War and Navy Departments, and may not be published or reproduced in whole or in part, or in any manner or form (except by lawful copyright holders who may reproduce their copyrighted material in its original form) unless specifically approved by authorized military public relations agencies.

WAR DEPARTMENT,
WASHINGTON 25, D. C., 4 MAY 1945.

TM 11-2674, Crystal Test Set TS-314/FSM-1 (Ray Jefferson Model AF-30), is published for the information and guidance of all concerned.

[A. G. 300.7 (9 Jan 45).]

BY ORDER OF THE SECRETARY OF WAR:

G. C. MARSHALL,
Chief of Staff.

OFFICIAL:

J. A. ULIO,

Major General,

The Adjutant General.

col
Adjt Gen
care

DISTRIBUTION:

AAF(5); AGF(5); ASF(2); S Div ASF (1); T/O & E 11-500
Teams (EA) (2); 11-587 (2); 11-597 (2).

(For explanation of symbols see FM 21-6.)

U113
12

TM11:2677
1945

TABLE OF CONTENTS

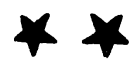

	<i>Paragraph</i>	<i>Page</i>
PART ONE. Introduction.		
Section I. Description of Crystal Test Set TS-314/FSM-1.		
General	1	1
Application	2	1
Technical characteristics of Crystal Test Set TS-314/FSM-1	3	3
Description of major components	4	3
List of components	5	3
Packaging	6	4
Differences in models	7	7
II. Installation and assembly of Crystal Test Set TS-314/FSM-1.		
Unpacking, uncrating, and checking	8	5
Installation	9	5
Assembly	10	5
Connections and interconnections	11	6
Removal from service	12	6
III. Initial adjustments.		
Meter zeroing	13	6
PART TWO. Operating instructions.		
Section IV. Preoperational procedures.		
Preparation for use	14	8
Starting procedure	15	10
V. Operation.		
Step-by-step operating procedure, part 1....	16	10
Step-by-step operating procedure, part 2....	17	11
		III

TABLE OF CONTENTS

	<i>Paragraph</i>	<i>Page</i>
PART THREE. Maintenance instructions.		
Section VI. Preventive maintenance techniques.		
Meaning of preventive maintenance	18	13
Description of preventive maintenance techniques	19	13
Vacuum tubes	20	15
Capacitors	21	16
Resistors	22	17
Switches	23	17
Coils	24	18
Potentiometers	25	18
Terminal blocks	26	18
Cords and cables	27	19
Meters	28	19
Pilot lamps	29	20
Jacks and plugs	30	20
Cabinets, chassis, and mountings	31	20
Headset	32	21
Coupling shafts and control knobs	33	21
Gears	34	21
Power transformers, filter chokes, and audio transformers	35	21
Batteries	36	22
VII. Itemized preventive maintenance.		
Introduction	37	22
Preventive maintenance tools and materials	38	23
Item 1, exterior of oscillator section	39	23
Item 2, interior of oscillator section	40	23
Item 3, exterior of frequency meter section	41	24
Item 4, interior of frequency meter section	42	24
Item 5, cords and headset	43	25
Preventive maintenance check list	44	25
VIII. Lubrication.		
Lubrication	45	27
IX. Moistureproofing and fungiproofing.		
General	46	27
Treatment	47	28
Step-by-step method	48	28
Moistureproofing and fungiproofing after repairs	49	31

TABLE OF CONTENTS

	<i>Paragraph</i>	<i>Page</i>
PART FOUR. Auxiliary equipment.		
PART FIVE. Repair instructions.		
Section X. Theory of equipment.		
General theory of oscillator section	50	32
General theory of frequency meter section ..	51	33
Crystal oscillator circuits	52	34
Diode detector circuit	53	35
Heterodyne detector circuit	54	36
Audio amplifier, oscillator section	55	36
Power Supply, oscillator section	56	37
Audio amplifier, frequency meter section ..	57	38
Electron-ray beat indicator	58	39
Pulse generator and rectifier	59	40
Power Supply, frequency meter section	60	42
XI. Trouble-shooting procedures.		
General trouble-shooting information	61	42
Trouble-shooting procedures	62	45
Start stop procedure analysis	63	46
XII. Test and analysis data.		
Voltage measurements	64	50
Resistance measurements	65	52
XIII. Repairs.		
Servicing	66	55
General repair	67	56
Mechanical repairs	68	56
Painting and refinishing	69	56
XIV. Calibration, alignment, and adjustment.		
Equipment needed	70	57
Preparation for correlation	71	58
Frequency correlation	72	58
Activity correlation	73	60
Unsatisfactory equipment report	74	60

TABLE OF CONTENTS

	<i>Paragraph</i>	<i>Page</i>
APPENDIX.		
Section XV. References.		
Army regulations	75	68
Supply publications	76	68
Painting, preserving, and lubrication	77	68
Camouflage	78	68
Shipping instructions	79	69
Decontamination	80	69
Demolition	81	69
Other publications	82	69
Forms	83	70
Abbreviations	84	70
Glossary	85	70
XVI. Maintenance parts.		
Maintenance parts for Crystal Test Set		
TS-314/FSM-1	86	71

LIST OF ILLUSTRATIONS

<i>Fig. No.</i>	<i>Title</i>	<i>Page</i>
1	Crystal Test Set TS-314/FSM-1, in two cabinets	X
2	Crystal Test Set TS-314/FSM-1, in one cabinet	2
3	Crystal Test Set TS-314/FSM-1, block diagram	6
4	Crystal Test Set TS-314/FSM-1, front view showing all controls	9
5	Crystal Test Set TS-314/FSM-1, front view showing parts requiring preventive maintenance	25
6	Bottom view of oscillator section, showing parts requiring preventive maintenance	26
7	Bottom view of frequency meter section, showing parts requiring preventive maintenance	27
8	Bottom view of frequency meter section, showing method of masking	29
9	Rear view of frequency meter section, showing method of masking	29
10	Rear view of oscillator section, showing method of masking	30
11	Bottom view of oscillator section, showing method of masking	30
12	Crystal Test Set TS-314/FSM-1, front view showing method of masking	31
13	Simplified schematic of crystal oscillators	35
14	Simplified schematic of diode detector	36
15	Simplified schematic of heterodyne oscillator	37
16	Simplified schematic of audio amplifier, oscillator section	38
17	Simplified schematic of power supply, oscillator section	38
18	Simplified schematic of audio amplifier, frequency meter section	39
19	Simplified schematic of electron-ray beat indicator	40
20	Simplified schematic of pulse generator and rectifier	41
21	Simplified schematic of power supply, frequency meter section	43
22	W.D., A.G.O. Form No. 468, sample form	61

LIST OF ILLUSTRATIONS

<i>Fig. No.</i>	<i>Title</i>	<i>Page</i>
23	Top view of oscillator section, showing location of parts	62
24	Bottom view of oscillator section, showing location of parts	62
25	Rear view of oscillator section, showing location of parts	63
26	Top view of frequency meter section, showing location of parts	63
27	Bottom view of frequency meter section, showing location of parts	64
28	Rear view of frequency meter section, showing location of parts	64
29	Resistor color codes	65
30	Capacitor color codes	66
31	Schematic diagram of oscillator section	79
32	Schematic diagram of frequency meter section	81

DESTRUCTION NOTICE

WHY —To prevent the enemy from using or salvaging this equipment for his benefit.

WHEN—When ordered by your commander.

HOW —1. Smash—Use sledges, axes, handaxes, pickaxes, hammers, crowbars, heavy tools.

2. Cut —Use axes, handaxes, machetes.

3. Burn —Use gasoline, kerosene, oil, flame throwers, incendiary grenades.

4. Explosives—Use firearms, grenades, TNT.

5. Disposal —Bury in slit trenches, fox holes, other holes. Throw in streams. Scatter.

USE ANYTHING IMMEDIATELY AVAILABLE FOR DESTRUCTION OF THIS EQUIPMENT.

WHAT—1. Smash—Tubes, meters, variable capacitors, control knobs, switches, coils, and other exposed parts.

2. Cut —All wiring and cords.

3. Burn —Technical manuals, calibration charts, and wiring.

4. Bend —Variable capacitor plates, panels, chassis, cabinets.

5. Bury or scatter—All of the pieces.

DESTROY EVERYTHING



Figure 1. Crystal Test Set TS-314/FSM-1, in two cabinets.

X

PART ONE

INTRODUCTION

SECTION I

DESCRIPTION OF CRYSTAL TEST SET TS-314/FSM-1

1. GENERAL.

Crystal Test Set TS-314/FSM-1 (Ray Jefferson Activity and Frequency Test Unit AF-30) is an instrument designed for checking the activity and frequency of quartz crystals either for duplication purposes or for final test. It is an alternating-current (a-c) operated instrument, mainly used in grinding crystal blanks to the frequency of a standard crystal and for checking the activity of these new crystals. Adjustments are provided for measuring the frequency of the crystals over the range of 2,000 to 10,000 kilocycles (kc). Activity is checked by means of a meter inserted in the grid circuit of the crystal oscillator while frequency is checked aurally by means of headphones, and visually by means of a frequency meter. These checks read the frequency difference between the crystal under test and a crystal of known frequency, and an electric eye tube which indicates the beat note at frequencies too low for accurate reading on the meter. The equipment is designed for testing mounted crystals in Crystal Holder FT-243 or Crystal Holder FT-171-B, although other crystals can be tested by the use of adapter sockets. Crystal blanks are tested by inserting them in holder RJ-4A which fits into the crystal sockets on the panel.

2. APPLICATION.

a. Crystal Test Set TS-314/FSM-1 is used to test the activity of crystals by measuring the grid current in the oscillator circuit of the crystal under test and comparing it with the grid current of a crystal known to meet the activity requirements for a particular radio set in which the crystals are eventually to be used, with the standard crystal operating in an identical oscillator circuit. Adjustments are provided in both crystal-oscillator stages for duplicating the conditions present in the oscillator circuits of the radio set in which the crystals will be used.



Figure 2. Crystal Test Set TS-314/FSM-1, in one cabinet.

b. Frequency duplication is obtained by first beating a crystal of known frequency against a variable heterodyne oscillator. At the zero-beat setting on the tuning dial of the heterodyne oscillator, the position is noted and the crystal being tested is also beat against the heterodyne oscillator. When, by means of successive polishings of the blank, the dial setting of the crystal blank approximates that of the standard crystal, the heterodyne oscillator is turned off and the signals from the two crystal oscillators are beat against each other. The difference frequency can then be noted either on the frequency meter or in the electric eye tube. Careful finishing of the crystal blank will then enable the operator to duplicate the frequency of the standard crystal.

3. TECHNICAL CHARACTERISTICS OF CRYSTAL TEST SET TS-314/FSM-1.

Frequency range of crystals to be tested:

- Low band 2,000 to 5,000 kc.
- High band 5,000 to 10,000 kc.

Frequency meter range:

- Band 1 0 to 1,000 cycles per second (cps).
- Band 2 0 to 2,000 cps.
- Band 3 0 to 10,000 cps.

Number of tubes:

- Oscillator section 6.
- Frequency meter section 8.
- Power source 110 volts, 50- to 60-cycles.
- Power consumption 110 watts.

4. DESCRIPTION OF MAJOR COMPONENTS.

The principal components of Crystal Test Set TS-314/FSM-1 are its oscillator section and its frequency meter section. These two sections are each on a separate chassis but both may be mounted in the same cabinet (fig. 2) or in separate cabinets (fig. 1). When both are mounted in the same cabinet the bottom unit is the oscillator section, and the upper unit the frequency meter section. All the cabinets are painted in a grey crackle finish.

5. LIST OF COMPONENTS.

The following table gives the weights and dimensions of the major components of Crystal Test Set TS-314/FSM-1.

Quantity	Name of component	Dimensions (in.)				Unit weight (lb)
		Height	Width	Depth	Length	
1	Frequency meter section without cabinet.	8	14½	7		
1	Frequency meter section with separate cabinet.	8	16¾	8¾		17
1	Oscillator section without cabinet.	8	14½	7		
1	Oscillator section with separate cabinet.	8	16¾	8¾		14
1	Frequency meter section and oscillator section in one cabinet.	16½	16¾	7¾		30
1	Test Crystal Holder RJ-4A.	2¼	1¾	1½		
1	Headset (Dependable No. 65).					
2	Tubes JAN-6SJ7.					
1	Tube JAN-6SQ7.					
1	Tube JAN-25L6GT/G.					
1	Tube JAN-25Z6GT/G.					
1	Tube JAN-OA3/VR-75.					
1	Tube JAN-6N7.					
1	Tube JAN-6E5.					
2	Tubes JAN-884.					
1	Tube JAN-6H6.					
1	Tube JAN-874.					
2	Tubes JAN-117Z6GT/G.					
2	TM 11-2674.	8½	5½	½		
3	Batteries BA-31.	2¼	2¼	1¼		

6. PACKAGING.

Crystal Test Set TS-314/FSM-1 is packed for domestic shipment in a packing case 18 inches wide, 22 inches high, 23 inches long, weighing 63 pounds. Packed for export shipment, the dimensions of the wooden box are the same but the weight is 81 pounds. For dimensions of the unpacked equipment see paragraph 5, list of components.

7. DIFFERENCES IN MODELS.

This equipment is supplied either in two separate cabinets, one containing the oscillator section and the other the frequency meter section; or in one cabinet containing both sections. All cabinets are metal with grey crackle finish.

SECTION II
INSTALLATION AND ASSEMBLY OF
CRYSTAL TEST SET TS-314/FSM-1

8. UNPACKING, UNCRATING, AND CHECKING.

Exercise particular care when unpacking or handling this equipment because it may be damaged easily when it is not protected by the packing case. In unpacking the equipment follow the steps outlined below:

- a. Place the packing case in a convenient location where it can be opened easily.
- b. Cut the steel straps.
- c. Remove the nails with a nail puller, and remove the top of the packing case. *Prying off the top may result in damage to the set.*
- d. Carefully lift the test set from the case and remove the waterproof material surrounding it.
- e. Thoroughly inspect all parts of the equipment for possible damage during shipment.
- f. Check the components against the packing list.
- g. Make sure the tubes are seated properly in the correct sockets.

CAUTION: If the chassis has received moistureproofing and fungiproofing treatment, do not remove any of the protective coating.

9. INSTALLATION.

a. This equipment is shipped with a set of tubes already installed in their respective sockets. A tube type number is stamped on each tube. Check to see that each tube is in its correct socket. Make sure it is firmly seated.

b. Check to see that each Battery BA-31 is properly installed as illustrated in figure 26, and that the clamp holding it in place is tight.

10. ASSEMBLY.

a. If the equipment has been shipped with the oscillator and frequency meter sections in separate chassis, the frequency meter section should be placed directly upon the oscillator section, if possible, in order

to insure short interconnecting leads. If space does not permit this, place the units side by side.

b. Since the headphones connect the B+ voltage to the plate of the audio amplifier of the oscillator section, it is necessary to install the headphones before the equipment will operate. Plug the headphones into jacks S18 and S19 at the rear of the oscillator section, being careful to observe correct polarity, that is, red tipped plug into red jack and black tipped plug into black jack.

CAUTION: Failure to observe correct polarity will reduce the sensitivity of the phones and may permanently damage them. With incorrect polarity the direct-current (d-c) component of the plate output will oppose the magnetism of the headphones and possibly demagnetize them.

11. CONNECTIONS AND INTERCONNECTIONS (fig. 3).

a. The only interconnection required for this equipment is the cord which carries the audio output of the oscillator section to the frequency meter section. This cord plugs into C.P.S. METER jacks S20 and S21 at the rear of the oscillator section, and the other end plugs into INPUT jacks S9 and S10 at the rear of the frequency meter section. Care must

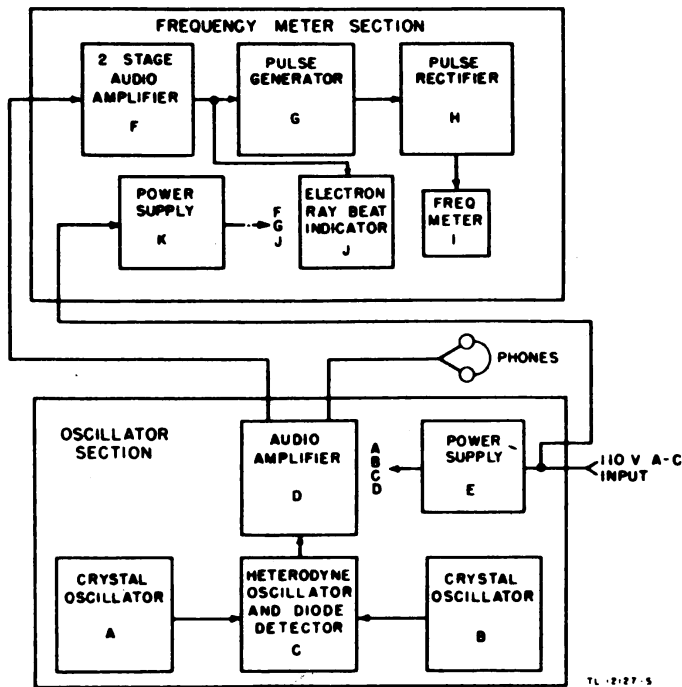

Figure 3. Crystal Test Set TS-314/FSM-1, block diagram.

be taken to observe correct polarity, that is red tipped plug into red jack and black tipped plug into black jack.

b. Instructions for connecting the power cord of the frequency meter section are given in paragraph 14b.

12. REMOVAL FROM SERVICE.

When this equipment is not in use, always be sure that the POWER ON OFF switch is OFF, and the ON LINE switch is in the LINE position. If the equipment is to be moved to another location it should be returned to the original box for shipment.

SECTION III

INITIAL ADJUSTMENTS

13. METER ZEROING.

Check to see that the meter needles rest on zero. If either needle is off the zero point when the set is level, adjust the needle to zero by turning the screw located at the bottom of the meter panel. Refer to paragraph 28d before doing this operation.

PART TWO

OPERATING INSTRUCTIONS

NOTE: For information on destroying the equipment to prevent enemy use, refer to the destruction notice at the front of the manual.

SECTION IV

PREOPERATIONAL PROCEDURES

14. PREPARATION FOR USE (fig. 4).

a. Before handling any of this equipment, carefully read the instructions covering its use. *Pay particular attention to all cautions.* They are inserted to guide the user and protect the equipment.

CAUTION: Whenever the equipment is not in use, certain controls should be returned to their neutral positions, as indicated below. This practice safeguards the instrument from damage.

The neutral positions for the various controls are as follows:

<i>Control</i>	<i>Neutral position</i>
POWER ON OFF switch	OFF
OSC. ON switch	OSC.
ON PLATE switch	PLATE
ON LINE switch	LINE

b. After setting the switches to the neutral positions, plug power cord plug P1 of the frequency meter section into socket S7 at the rear of the oscillator section chassis.

c. Connect oscillator power cord plug P1 into a 110-volt 50/60-cycle a-c source.

d. Check to see that the earphones and interconnecting cord are properly plugged in and that polarity has been observed.

CAUTION: In order to determine whether the chassis of both sections are at the same potential, connect a lead to

the chassis of either the oscillator or frequency meter section and touch the other chassis with the other end of the lead. If sparking occurs, reverse power cord plug P1 of the frequency meter section so that it connects the oscillator section. If this precaution is not observed, a shock will be received when touching the chassis.

15. STARTING PROCEDURE.

After the line cord from the oscillator section has been connected to a 110-volt source, it is only necessary to turn the POWER ON OFF switch to ON and the ON LINE switch to ON to put the equipment in operation.

SECTION V OPERATION

NOTE: Before this equipment can be used for testing and duplicating crystals, it must be correlated so that the crystal oscillator circuits duplicate the oscillator circuit of the radio set in which the crystals are to be used. For correlation procedure refer to section XIV.

16. STEP-BY-STEP OPERATING PROCEDURE, PART 1.

- a. Make certain that the equipment has been correlated to resemble the radio set in which the crystals are to be used.
- b. Turn the set on, following the instructions in paragraphs 14 and 15.
- c. Allow it to warm up for 1 minute.
- d. Plug a crystal, whose known frequency is to be duplicated, into the crystal jacks on the bottom left-hand side of the oscillator panel (fig. 4).

NOTE: For simplification, throughout this paragraph the crystal of known frequency will be designated as X1, and the crystal blank under test will be designated as X2.

- e. Turn the OSC. ON switch to ON.
- f. Flip the toggle TEST switch to the left. The activity meter on the oscillator section panel should now give a reading, indicating grid current in the oscillator circuit of crystal X1. This current should be above the minimum specifications for activity requirements of the crystals to be used in the particular radio set for which the crystals are being prepared.
- g. If crystal X1 is between 2,000 and 5,000 kc, turn BAND A B switch to A (fig. 4). If crystal X1 is between 5,000 and 10,000 kc, turn this switch to B.

h. Rotate the tuning knob on the oscillator section (fig. 4) until a beat note is heard, and then carefully adjust it so that zero beat is reached. Note the dial setting at this point.

NOTE: For convenience, and to eliminate the possibility of tuning the heterodyne oscillator to a harmonic of the crystal, a calibration chart should be made up for this dial. This chart should indicate the approximate frequency at certain regular divisions of the dial, for example, at every fifth point. This chart should then be kept at some convenient location near the equipment.

i. Remove crystal X1 and insert crystal X2 in the test crystal holder after plugging the holder into the jacks on the bottom right-hand side of the oscillator section panel.

j. Again rotate the oscillator tuning dial until a zero-beat point is reached. This point should be at a lower point on the dial than that recorded in step h above since further grinding of the blank will cause the frequency to rise.

k. If the two dial settings which have been noted are within approximately 8,000 cycles of each other, as determined by the calibration chart mentioned in the note above, turn the OSC. ON switch to OSC. and proceed as described in paragraph 17. If the difference frequency is greater than this, continue polishing and testing the blank as described in steps i and j above until the beat frequency is approximately 8,000 cycles.

17. STEP-BY-STEP OPERATING PROCEDURE, PART 2.

a. Set the CYCLES PER SECOND switch (fig. 4) at X10000.

b. Turn the ON PLATE switch to ON. Insert crystal X1. The frequency meter should now give an indication of the beat frequency between the two crystals. The reading on the meter multiplied by the switch position indicates frequency in cycles per second. If the indication is less than 2,000 cycles turn the CYCLES PER SECOND switch to X2000 where a more accurate reading can be obtained. Careful polishing of the crystal will now enable the operator to gradually bring the frequency of the blank to close proximity of that of crystal X1.

CAUTION: Turn the ON PLATE switch to PLATE whenever frequency measurements are not being made. Leaving this switch closed causes Tubes JAN-884 to reach a state of steady ionization. In this condition, these tubes will draw excessive current, resulting in overheating of the tubes and associated components. In case ionization does occur (gen-

erally indicated by lack of any reading on the meter when the CYCLES PER SECOND switch is in the X10000 position), push the deionizing button located slightly below and to the left of the frequency meter several times. This condition will ordinarily occur only with the switch in the X10000 position. However, it should be a standard practice to turn the ON PLATE switch ON only for readings, and to switch it off after the reading has been taken.

c. Each time the crystal blank is tested, flip the toggle TEST switch to the right. The meter on the oscillator section panel will then indicate the amount of grid current flowing in the oscillator circuit of crystal X2. Compare this activity reading with the activity of crystal X1.

d. As crystal X2 approaches zero beat with crystal X1, place your hand near the test crystal holder. The pitch of the beat note should rise indicating that the blank is still safe, that is, its frequency is still lower than that of crystal X1. (Placing your hand near the crystal holder adds to its capacity, thus decreasing the frequency and increasing the audible tone.)

e. After the meter indicates less than 50 cycles (while the CYCLES PER SECOND switch is in the X1000 position) meter readings will no longer be accurate. At this time, the difference in frequency between the two crystals can be noted by watching the electron-ray tube to the right of the frequency meter. The rate of blinking of the eye will indicate the difference in cycles. Adjust the sensitivity control on the left of the frequency meter to give the desired width of shadow on the tube.

PART THREE

MAINTENANCE INSTRUCTIONS

SECTION VI

PREVENTIVE MAINTENANCE TECHNIQUES

18. MEANING OF PREVENTIVE MAINTENANCE.

Preventive maintenance is a systematic series of operations performed at regular intervals on equipment, when turned off, to eliminate major break-downs, unwanted interruptions in service, and to keep equipment operating at top efficiency. To understand what is meant by preventive maintenance, it is necessary to distinguish between preventive maintenance, trouble shooting, and repair. The prime function of preventive maintenance is to *prevent break-downs* and, therefore, the need for repair. On the other hand, the prime function of trouble shooting and repair is to locate and correct *existing* defects. The importance of preventive maintenance cannot be overemphasized. A system of radio communication depends on the performance of every set. Therefore, it is vitally important that radio operators and repairmen maintain their equipment properly. See TB SIG 123, Preventive Maintenance Practices for Ground Signal Equipment.

NOTE: The operations in sections VI and VII are user maintenance operations. Some operations in section IX are higher echelon maintenance.

19. DESCRIPTION OF PREVENTIVE MAINTENANCE TECHNIQUES.

a. General. Most of the electrical parts used in Crystal Test Set TS-314/FSM-1 require routine preventive maintenance. This preventive maintenance varies. Some parts require a different kind of maintenance than others. Some require more, some less. Definite and specific instructions must be followed. Hit-or-miss techniques cannot be applied. This section of the manual contains these specific instructions to guide personnel assigned to perform the six basic maintenance operations:

Feel, Inspect, Tighten, Clean, Adjust, and Lubricate. Throughout this manual the lettering system for the six operations will be as follows:

F—Feel

I—Inspect

T—Tighten

C—Clean

A—Adjust

L—Lubricate*

The first two operations show if the other four are needed. Selection of operations is based on a knowledge of field needs. For example, dust filters into equipment no matter how much care is taken to prevent it. Rapid changes in weather (such as heavy rain followed by blistering heat), excessive dampness, snow, and ice tend to cause corrosion of exposed surfaces and parts. Without frequent inspections and the necessary tightening, cleaning, and lubricating operations, equipment becomes undependable and subject to break-down when it is needed most.

b. Feel. The feel operation is used most often to check rotating machinery, such as dynamotors, blower motors, and drive motors, also to determine whether electrical connections and bushings are overheated. Feeling will show the need for lubrication or the existence of other defects requiring correction. The maintenance man *must* become familiar with the normal operating temperatures of motors, transformers, and other parts, to recognize signs of overheating.

NOTE: It is important to perform the feel operation as soon as possible after shut-down and always before any other maintenance is done.

c. Inspect. Inspection is the most important operation in preventive maintenance. A careless observer will overlook evidences of minor trouble. Although these defects may not at the moment interfere with performance of the equipment, invaluable time and effort can be saved if they are corrected *before* they lead to major and costly break-downs. To be able to recognize the signs of a defective set, make every effort to become thoroughly familiar with indications of *normal* functioning. Inspection consists of *carefully* observing all parts of the equipment, noticing their color, placement, state of cleanliness, etc. Inspect for the following conditions:

(1) Overheating, as indicated by discoloration, blistering, or bulging of the parts or surface of the container; leakage of insulating compounds; and oxidation of metal contact surfaces.

(2) Placement, by observing that all leads and cabling are in their original positions.

(3) Cleanliness, by carefully examining all recesses in the units for accumulation of dust, especially between connecting terminals and binding posts. Parts, connections, and joints should be free of dust,

* The Lubricate operation is inapplicable to Crystal Test Set TS-314/FSM-1.

corrosion, and other foreign matter. In tropical and high-humidity areas, look for fungus growth and mildew.

(4) Tightness, by testing any connection or mounting which appears to be loose.

d. Tighten, Clean, and Adjust. These operations explain themselves. Specific procedures to be followed in performing them are given wherever necessary throughout part three.

CAUTION: Screws, bolts, and nuts should not be tightened carelessly. Fittings tightened beyond the pressure for which they are designed will be damaged or broken.

Whenever a loose connection is tightened, it should be moistureproofed and fungiproofed again by applying the varnish with a small brush. See section IX for details of moistureproofing and fungiproofing.

e. Lubricate. Lubrication refers to the application of grease or oil to the bearings of motors or rotating shafts. It may also mean the application of a light oil to door hinges or other sliding surfaces on the equipment.

20. VACUUM TUBES.

NOTE: Do not work on the tubes immediately after shut-down. Severe burns may result from contact with the envelopes of hot tubes.

a. Inspect (I).

(1) Inspect glass and metal tube envelopes. Tubes with loose envelopes should be replaced if possible.

(2) Inspect the firmness of tubes in their sockets. Make the inspection by pressing the tubes down in the sockets and testing them in that position, *not* by partially withdrawing the tubes and jiggling them from side to side. Movement of a tube tends to weaken the pins in the base and unnecessarily spread the contacts in the socket. Inspect the tube sockets at the time the tubes are removed.

(3) Be careful when removing a tube from its socket, especially if it is a high-power tube. Never jar a warm tube.

b. Tighten (T). Tighten all loose connections to the tube sockets or to the tubes. If the connections are dirty or corroded, clean them before tightening.

c. Clean (C).

(1) Clean the tubes, if necessary. Tubes operated at high voltages

and with exposed plate and grid connections must be kept free of dirt and dust because of possible leakage between grid and plate terminals. In contrast, tubes operating at low voltages and not having exposed grid and plate caps do not require frequent cleaning. However, do not permit dirt to accumulate on low-voltage tubes.

(2) Remove dust and dirt from the glass or metal envelopes with a clean, lint-free, dry cloth. If proper care is used, the grid and plate caps may be cleaned with a piece of #0000 sandpaper by wrapping the paper around the cap and *gently* rubbing the surface. Excessive pressure is not needed; nor is it necessary to grip the cap tightly. Wipe the cap with a clean dry cloth.

(3) When tube sockets are cleaned and the contacts are accessible, fine sandpaper may be used to remove corrosion, oxidation, and dirt.

21. CAPACITORS.

a. Inspect (I).

(1) Inspect the terminals of large fixed capacitors for corrosion and loose connections. Carefully inspect the mountings to discover loose mounting screws, studs, or brackets. Examine the leads for poor insulation, cracks, and evidences of dry rot. Cut away frayed strands on the insulation. If the wire is exposed, wrap it with friction tape. See that the terminals of the capacitors are not cracked or broken.

(2) Thoroughly inspect the case of each large fixed capacitor for leaks, bulges, and discoloration.

(3) Inspect the plates of variable capacitors for dirt, dust, or lint. Examine the movable set of plates for signs of damage or misalignment that would cause them to touch the fixed plates during tuning. Rotate the movable plates, using the panel tuning control, and thus check for proper operation of the capacitor.

b. Tighten (T). Tighten loose terminals, mountings, and connections on the capacitors, when necessary. Do not break the bushing or damage the gasket.

c. Clean (C).

(1) Clean the cases of fixed capacitors, the insulated bushings, and all connections that are dirty or corroded. The capacitor cases and bushings can usually be cleaned with a dry cloth. However, if the deposit of dirt is hard to remove, moisten the cloth in solvent, dry-cleaning.

(2) Clean the plates of variable capacitors with a small brush or pipe cleaner, removing all dust and lint. Dust, if present, may cause arcing.

22. RESISTORS.

a. General. Various types of resistors are used in Crystal Test Set TS-314/FSM-1. The connections to the various resistors are either of the pigtail or solder-lug type.

b. Inspect (I). Inspect the coating of the vitreous-enameled resistors for signs of cracks and chipping, especially at the ends. Examine the bodies of all types of resistors for blistering, discoloration, and other indications of overheating. Inspect leads and all other connections for corrosion, dirt, dust, looseness, and broken strands in the connecting wires. Check the security of all mountings. Do not attempt to move resistors with pigtail connections, because there is danger of breaking the connections at the point where they enter the body of the resistor. Such defects cannot be repaired.

c. Tighten (T). Tighten resistor connections and mounting whenever they are found loose. If a resistor is allowed to remain loose, vibration may break the connection or damage the body.

d. Clean (C).

(1) Clean all carbon resistors with a small brush.

(2) The vitreous-enameled resistors must be kept clean to avoid leakage between the terminals. Wipe them with a dry cloth. However, if the dirt deposit is unusually hard to remove, use dry-cleaning solvent (SD).

(3) Resistors with discolored bodies cannot be cleaned. Discoloration indicates that there has been overloading and overheating at some time prior to the inspection. The discoloration is probably due to circuit trouble which requires analysis and correction. Trouble-shooting procedures are described in part five.

23. SWITCHES.

a. Inspect (I).

(1) Inspect the mechanical action of each switch and, while so doing, look for signs of dirt or corrosion on all exposed elements. In some cases, it will be necessary to examine the elements of the switch visually; in others, the action of the switch is checked by flipping the control knob or toggle, or pressing the switch button and noting the freedom of movement and amount of spring tension.

(2) Examine switches SW2 on the frequency meter section and SW4 on the oscillator section to see that the contacts are clean. Inspection is visual. Do not pry the leaves of the switch apart. The rotary members should make good contact with the stationary members; and as the former slides into the latter, a spreading of the stationary contact leaves should be visible. Switch action should be free. Wiping action of contacts usually removes any dirt at the point of contact.

b. **Clean (C).** Clean the exterior surfaces of switches with a stiff brush, moistened with dry-cleaning solvent (SD).

24. COILS.

a. **Inspect (I).** Inspect the heterodyne detector coils L1 or L2 for cleanliness of coil form and secureness of mounting supports.

b. **Tighten (T).** Tighten any loose coil mounting or connections by resoldering wires or tightening screws.

c. **Clean (C).** Clean the coil form and coil with a soft brush.

25. POTENTIOMETERS.

a. **Inspect (I).**

(1) Inspect the mechanical condition of potentiometers R2 and R4 in the oscillator section and potentiometers R15, R16, and R17 in the frequency meter section. The arm should be keyed tightly to the shaft, and the shaft should turn easily in the bushing which supports it.

(2) Inspect the assembly and mounting screws, setscrews, and nuts.

(3) Examine all metallic parts for dust, dirt, and corrosion.

b. **Tighten (T).** Tighten loose assembly or mounting screws.

c. **Clean (C).** Clean the bodies of the potentiometers with a brush or cloth.

26. TERMINAL BLOCKS.

a. **Inspect (I).**

(1) Inspect terminal blocks for cracks, breakage, dirt, loose connections, and loose mounting screws.

(2) Carefully examine connections for mechanical defects, dirt, and corrosion.

b. **Tighten (T).** Tighten loose screws, lugs, and mounting bolts.

When tightening screws, be sure to select a screwdriver of correct size. Do not exert too much pressure. Tighten loose connections.

c. Clean (C). Clean terminal blocks, when they require it, with a dry brush. When necessary, use a cloth moistened with dry-cleaning solvent (SD). Thoroughly wipe the block with a cloth and then brush it to remove any lint.

27. CORDS AND CABLES.

The cables in Crystal Test Set TS-314/FSM-1 are the life lines of the equipment. Condition of the cabling must be closely observed. Operating equipment in all kinds of weather, and moving it on all kinds of roads, subjects cabling to a great deal of punishment.

a. Inspect (I). Inspect the cables for cracked or deteriorated insulation, frayed or cut insulation at the connecting and supporting points, and improper placement which places the cables or connections under strain. Also watch for kinks and improper supports.

b. Clean (C). Clean connections on cables when they are dirty or corroded. Clean corroded connectors with #0000 sandpaper. Clean the entire surface of the connector. Make no attempt to remove individual prongs from cable plugs.

28. METERS.

Meters are extremely delicate instruments and must be handled carefully. They require very little maintenance. They are precision instruments and ordinarily cannot be repaired in the field.

a. Inspect (I). Inspect the leads and connections of the meters. Look for loose, dirty, and corroded connections. Look for cracked or broken cover glasses. Since the movement of a meter is extremely delicate, its accuracy will be seriously affected if the glass is broken and dirt and water filter through.

b. Tighten (T). Tighten all connections found loose. Any loose meter wires should be inspected for dirt or corrosion before they are tightened. The tightening of meter connections requires a special technique because careless handling can easily crack the meter case.

c. Clean (C). Meter cases can usually be cleaned with a dry cloth. If cleaning is difficult, dampen the cloth with dry-cleaning solvent (SD). Clean dirty connections with a small brush dipped in dry-cleaning solvent (SD), or with a small piece of cloth dipped in the solvent.

d. Adjust (A). Normally, meters in Crystal Test Set TS-314/FSM-1 should indicate zero when the equipment is turned off. Before

deciding that a meter needs readjusting, tap the meter case *lightly* with the tip of one finger. This will help the needle to overcome the slight friction which sometimes exists at the bearings and prevents an otherwise normal unit from coming to rest at zero. If adjustment is needed, insert the tip of the thinnest screwdriver available into the slotted screw head located below the meter glass and *slowly* turn the adjusting screw until the pointer is at zero. Lightly tap the meter case again and view the meter face and pointer *full on* and not from either side. Avoid turning the screw too far, because the needle may be bent or the hairspring damaged.

29. PILOT LAMPS.

Pilot lamps are used to indicate when power has been applied to a circuit. They are easily removed and replaced.

a. Inspect (I). Inspect the pilot-lamp assemblies for loose lamps, loose mounting screws, and loose, dirty, or corroded connections.

b. Tighten (T).

(1) Tighten loose mounting screws and resolder any loose connections. If the connections are dirty or corroded, clean them before soldering.

(2) Screw loose lamps tightly into their sockets.

30. JACKS AND PLUGS.

Jacks require very little attention, and then only at infrequent intervals. Occasionally it will be necessary to tighten the mounting nut, clean the contacts, or increase the spring tension. Remove dirt with a brush and carbon tetrachloride; remove corrosion with a piece of crocus cloth followed by a clean cloth. Increase spring tension, when necessary. Try the action of the jack after each adjustment. Be sure to keep all soldered connections intact.

31. CABINETS, CHASSIS, AND MOUNTINGS.

The cabinets which house the various components of Crystal Test Set TS-314/FSM-1 are constructed of sheet steel, with a grey crackle finish.

a. Inspect (I). Inspect the outside and inside of each cabinet thoroughly, paying strict attention to every detail. Check the ventilator mountings, the panel screws, and the zero settings of the meters. Examine the pilot-lamp covers for cracks and breaks. Inspect the panels for loose knobs, switches, and jacks.

b. Clean (C). Clean each cabinet, outside and in, with a clean dry cloth. Repaint any surface that is found scratched, rusted, or chipped.

c. Tighten (T). Tighten all loose mounting bolts, panel screws, plugs, and control knobs.

32. HEADSET.

The headset is essential to the operation of the equipment. The operator must therefore give it the same care as the set.

a. Inspect (I). Inspect all external surfaces for dirt and corrosion. See that all cable connections are tight and that plugs and jacks fit together properly.

b. Clean (C). Clean all items of the equipment in accordance with the instructions outlined previously for cords, jacks, cabinets, etc.

33. COUPLING SHAFTS AND CONTROL KNOBS.

The control of various capacitors, switches, and resistors, found throughout the set is effected through coupling shafts that connect these items to control knobs located on the front panels. It is important that these shafts and control knobs be kept tight at all times. Use a small screwdriver to tighten these items whenever they are found loose.

34. GEARS.

a. Inspect (I). Inspect the teeth of the gears on variable capacitor C12, in the oscillator section of the equipment, for dirt or corrosion. Check the antibacklash gears for proper operation by varying the panel tuning control.

b. Clean (C). If the gears are dirty, clean them with a pipe cleaner or small brush dipped in dry-cleaning solvent (SD).

35. POWER TRANSFORMERS, FILTER CHOKES, AND AUDIO TRANSFORMERS.

Since power transformers, filter chokes, and audio transformers used in Crystal Test Set TS-314/FSM-1 are of similar potted construction, preventive maintenance for them is similar.

a. Feel (F). As soon as possible after shut-down, feel filter choke L5 for abnormal heating which may indicate an overloaded condition, or imminent failure due to moisture absorption or other causes. Likewise feel audio transformer T1 for abnormal heating. Power transformer T2 normally operates at a warm temperature. Feel for abnormal heating, but use care to avoid burns.

b. Inspect (I). Inspect power transformer T2, filter choke L5, and audio transformer T1, for signs of blistering, bulging, or leakage of tar

or insulating compounds. Inspect for external signs of electrolytic action or corrosion.

c. Tighten (T). Tighten all mounting bolts or screws, but not to the point that threads are destroyed. The securing of such heavy parts as transformers and chokes to the chassis is very important in preventive maintenance. Should a heavy filter choke or transformer break loose from its mounting in vehicular use or in transit, it may smash tubes, variable capacitors, coils, and resistors, and at the same time sever a large number of connections.

d. Clean (C). Clean power transformers, filter chokes, and audio transformers with a dry cloth. Be sure that no dirt, lint, threads, or foreign material is present between terminals. Dirt, lint, and thread absorb moisture which may provide a leakage path for high voltages between these terminals. Be sure that none are present.

36. BATTERIES.

a. Inspect (I). Inspect dry cells for signs of bulging, leakage of compound, or signs of electrolytic action. Moisture soon ruins improperly sealed dry cells, even those with waxed jackets. It enters cardboard through ends where waxing is incomplete. If the equipment is to be out of service for a considerable length of time, the dry cells should be removed and stored separately from the equipment. Store the dry cells in a cool dry place. Heat is ruinous to dry cells. It accelerates internal chemical action, greatly reducing shelf life.

b. Tighten (T). Tighten the strap holding the batteries in place. Check all leads connected to the batteries and if necessary tighten the nuts holding them to the batteries.

c. Clean (C). Remove any accumulations of dirt or lint with a dry cloth or brush.

SECTION VII

ITEMIZED PREVENTIVE MAINTENANCE

37. INTRODUCTION.

For ease and efficiency of performance, preventive maintenance on Crystal Test Set TS-314/FSM-1 will be broken down into operations that can be performed at different time intervals. In this section the preventive maintenance work to be performed on the radio set at the specific time intervals is broken down into units of work called items. The general techniques involved and the application of the FITCAL operations in performing preventive maintenance on individual parts are discussed in section VI. These general instructions are not repeated in this

section. When performing preventive maintenance, refer to section VI if more information is required for the following items. Perform all work with the power removed from the equipment. After preventive maintenance has been performed on a given day, put the equipment into operation and check it for satisfactory performance.

38. PREVENTIVE MAINTENANCE TOOLS AND MATERIALS.

The following preventive maintenance tools and materials will be needed:

- Common hand tools.
- Clean cloth.
- #0000 sandpaper.
- Crocus cloth.
- Contact burnishing tool.
- Paste metal polish (Signal Corps stock No. 6G1516).
- Dry-cleaning solvent (SD).
- Carbon tetrachloride.

NOTE: Gasoline will not be used as a cleaning fluid for any purpose. Dry-cleaning solvent (SD), is available as a cleaning fluid through established supply channels. Oil, Fuel, Diesel, may be used for cleaning purposes when dry-cleaning solvent (SD) is not at hand. Carbon tetrachloride will be used as a cleaning fluid only on electrical wiring and electrical mechanisms which cannot be cleaned with an inflammable solvent because of the fire hazard.

39. ITEM 1, EXTERIOR OF OSCILLATOR SECTION (fig. 5).

OPERATIONS.

ITC	Cabinet.
ITC	Jacks.
IT	Control knobs.
ICA	Meter.
I	• Connecting cords.
ITC	Switches.

REMARKS. With a small screwdriver, tighten all control knobs. Adjust the meter adjustment screw until the meter needle rests squarely over the zero point on the meter scale.

40. ITEM 2, INTERIOR OF OSCILLATOR SECTION (fig. 6).

PRELIMINARY STEPS. Remove the four screws from the front panel and the two screws from the bottom of the cabinet. Slide the chassis out of the cabinet.

OPERATIONS.

ITCA	Tubes and sockets.
ITC	Capacitors.
ITC	Resistors.
ITC	Potentiometers.
ITC	Switches.
ITC	Terminal blocks.

REMARKS. Check for any poor solder connections or loose wiring.

41. ITEM 3, EXTERIOR OF FREQUENCY

METER SECTION (fig. 5).

OPERATIONS.

ITC	Cabinet.
ITC	Jacks.
ITC	Pilot lamp.
IT	Control knobs.
ICA	Meter.
I	Connecting cords and plugs.

REMARKS. With a small screwdriver, tighten all control knobs. Adjust the meter adjustment screw until the meter needle rests squarely over the zero point on the meter scale.

42. ITEM 4, INTERIOR OF FREQUENCY

METER SECTION (fig. 7).

PRELIMINARY STEPS. Remove the four screws from the front panel and the two screws from the bottom of the cabinet. Slide the chassis out of the cabinet.

OPERATIONS.

ITCA	Tubes and sockets.
ITC	Capacitors.
ITC	Resistors.
ITC	Potentiometers.
ITC	Switches.
ITC	Terminal blocks.
FIC	Transformers.
IT	Batteries.

REMARKS. Tighten the clamp holding the batteries in place. Tighten the nuts on the batteries to make certain the battery leads are making good connection. Check for any poor solder connections or loose connections.

43. ITEM 5, CORDS AND HEADSET (fig. 1).

OPERATION.

IC

Cords and headset.

44. PREVENTIVE MAINTENANCE CHECK LIST.

The following check list is a summary of the preventive maintenance operations to be performed on Crystal Test Set TS-314/FSM-1. The time intervals shown on the check list may be reduced at any time by the local commander. For best performance of the equipment, perform operations at least as frequently as called for in the check list. The echelon column indicates which operations are first echelon maintenance and which operations are second echelon maintenance. Operations are indicated by the letters of the word FITCAL. For example, if the letters ITCA appear in the "Operations" column, the item to be treated must be inspected (I), tightened (T), cleaned (C), and adjusted (A).

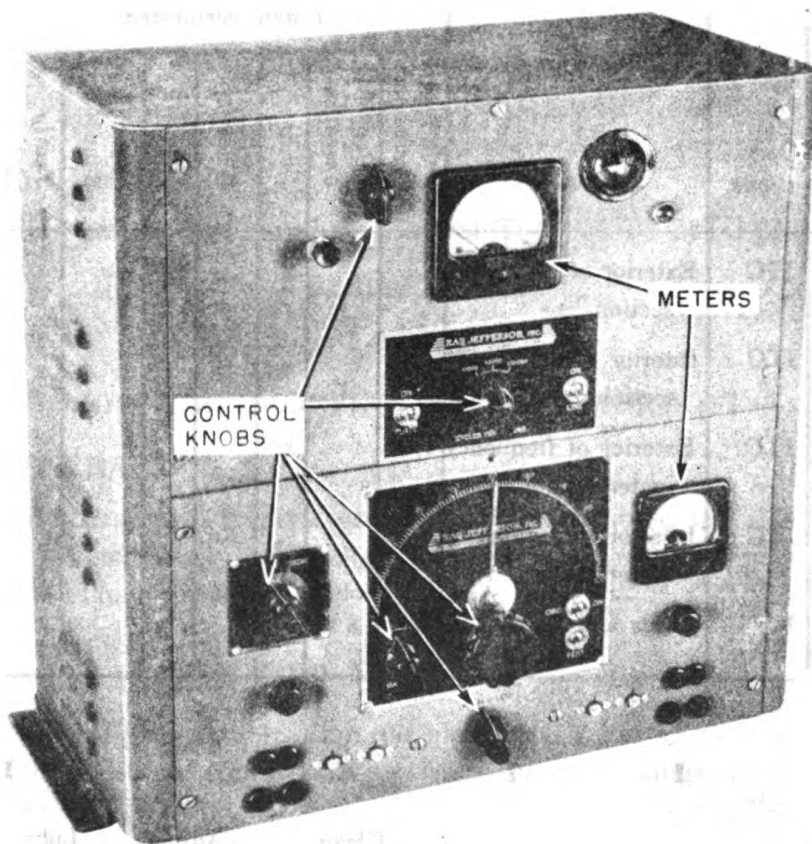

TL119515

Figure 5. Crystal Test Set TS-314/FSM-1, front view showing parts requiring preventive maintenance.

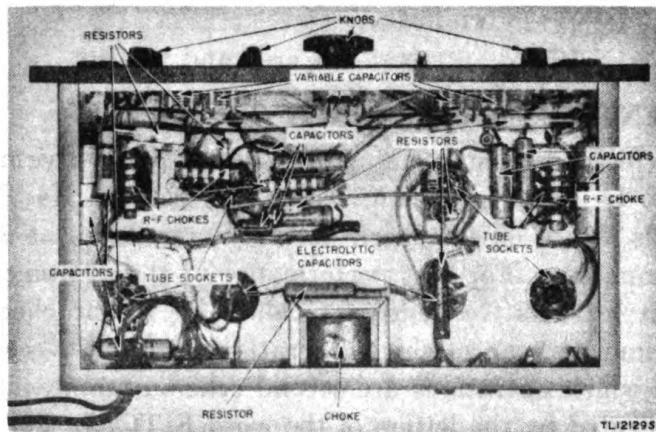

Figure 6. Bottom view of oscillator section, showing parts requiring preventive maintenance.

Item No.	Operations	Item	When performed							Echelon
			Before operation	After operation	Daily	Weekly	Monthly	Semi-annually	Yearly	
1	ITC	Exterior of oscillator section.			x					1st
2	ITC	Interior of oscillator section.				x				1st
3	ITC	Exterior of frequency meter section.			x					1st
4	ITC	Interior of frequency meter section.				x				1st
5	IC	Cords and headset.	x	x						1st

F **I** **T** **C** **A** **L**
 Feel Inspect Tighten Clean Adjust Lubricate*

* The Lubricate operation is inapplicable to Crystal Test Set TS-314/FSM-1.

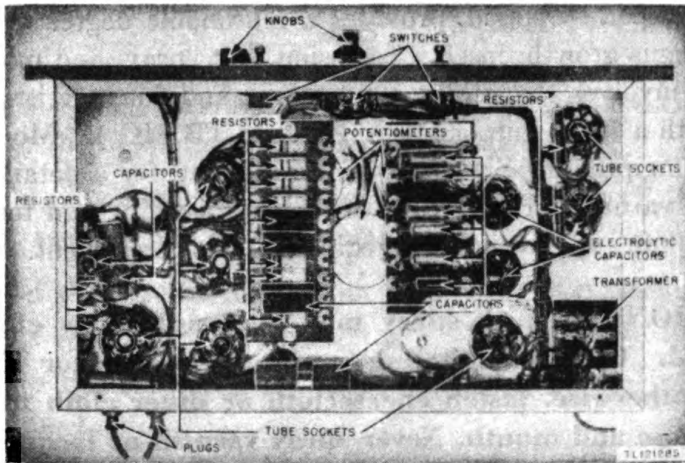

Figure 7. Bottom view of frequency meter section, showing parts requiring preventive maintenance.

SECTION VIII LUBRICATION

45. LUBRICATION.

No lubrication is required for Crystal Test Set TS-314/FSM-1.

SECTION IX MOISTUREPROOFING AND FUNGIPROOFING

46. GENERAL.

When operated in tropical areas where temperature and relative humidity are extremely high, Signal Corps equipment requires special attention. These are some of the problems met:

- a. Resistors, capacitors, coils, chokes, transformer windings, etc., fail because of the effects of fungus growth and excessive moisture.
- b. Electrolytic action, often visible in the form of corrosion, takes place in resistors, coils, chokes, transformer windings, etc., causing eventual break-down.
- c. Hook-up wire insulation and cable insulation break down. Fungus growth accelerates deterioration.
- d. Moisture provides leakage paths between battery terminals.

47. TREATMENT.

A moistureproofing and fungiproofing treatment has been devised which, if properly applied, provides a reasonable degree of protection against fungus growth, insects, corrosion, salt spray, and moisture. The treatment involves the use of a moisture- and fungi-resistant varnish applied with a spray gun or brush. Refer to TB SIG 13, Moistureproofing and Fungiproofing Signal Corps Equipment, for a detailed description of the varnish-spray method of moistureproofing and fungiproofing and the supplies and equipment required in this treatment.

CAUTION: Varnish spray may have poisonous effects if inhaled. To avoid inhaling spray, use respirator if available; otherwise, fasten cheesecloth or other cloth material over nose and mouth. Never spray varnish or lacquer near an open flame. Do not smoke in a room where varnish or lacquer is being sprayed. The spray may be highly explosive.

48. STEP-BY-STEP METHOD.

a. Preparation.

(1) Make a thorough maintenance check of the equipment to insure that it is operating properly.

(2) Make all repairs and adjustments necessary for proper operation of the equipment.

b. Disassembly.

(1) Remove the two-wire cable connecting the oscillator section to the frequency meter section.

(2) Disconnect the a-c cord of the frequency meter section from the female socket of the oscillator section.

(3) Remove the two chassis from their cases.

c. Cleaning. Clean all dirt, dust, rust, and fungus from the equipment to be processed. Clean all oil and grease from the surfaces to be varnished.

d. Masking.

(1) Either remove the tubes and cover the sockets with masking tape or, if the tubes are left in the set, be sure prongs are kept clean of varnish. Varnish on the base or envelope of the tube will not affect its operation.

(2) Cover the frequency meter range switch (A, fig. 8), the phone jacks (B, fig. 9), and the metal contacts of the push-button switch (A, fig. 9) of the frequency meter section with masking tape.

(3) Cover all jacks (A, fig. 10), the band switch (C, fig. 10), the four air-padder capacitors (C, fig. 11), and the HIGH-LOW switch (B, fig. 11) of the oscillator section with masking tape.

(4) Mold paper around the main tuning capacitor (B, fig. 10) of the oscillator section and fasten in place with masking tape.

(5) Cover the face of the two meters (A, fig. 12), located on the front panels, with paper and fasten in place with masking tape.

(6) Cover the crystal jacks of the oscillator section with masking tape (B, fig. 12).

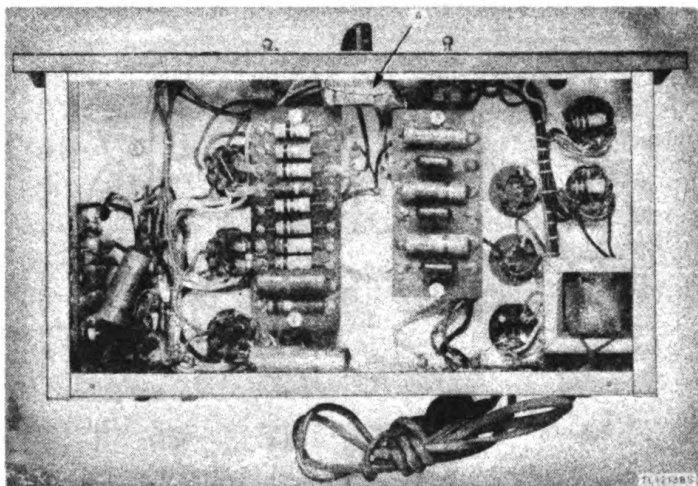

Figure 8. Bottom view of frequency meter section, showing method of masking.

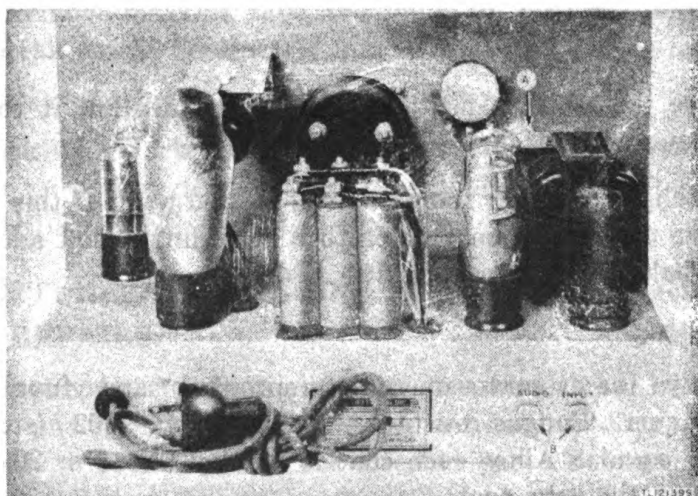

Figure 9. Rear view of frequency meter section, showing method of masking.

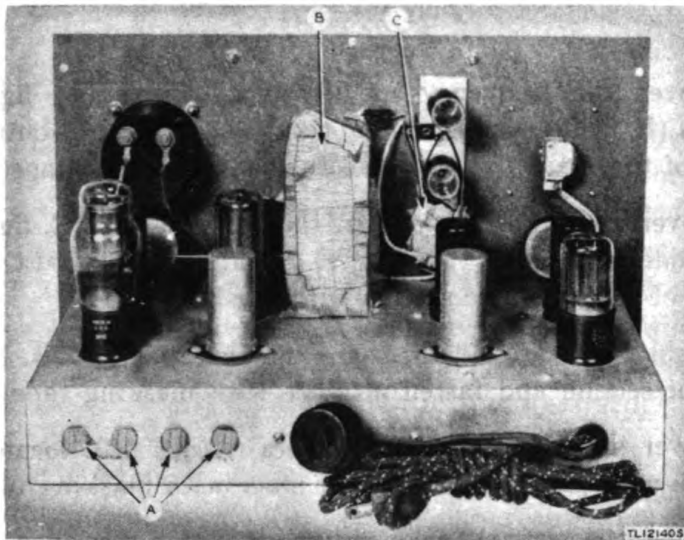

Figure 10. Rear view of oscillator section, showing method of masking.

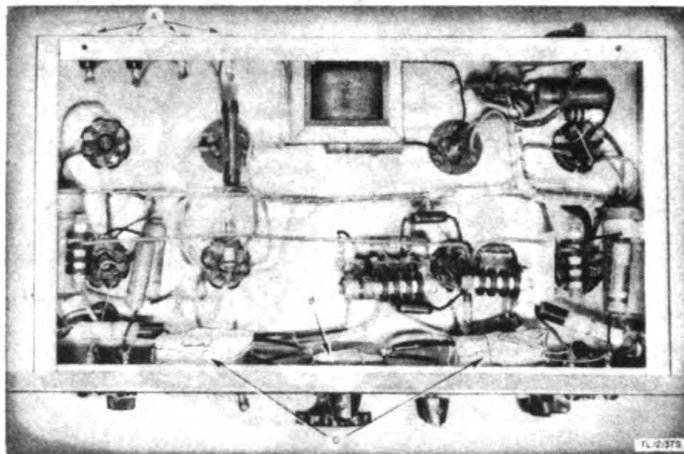

Figure 11. Bottom view of oscillator section, showing method of masking.

e. Drying.

(1) Place the set in a heating apparatus and allow it to remain there for 3 hours at 160° F.

(2) Watch all parts for indications of melted wax. If this becomes evident, lower the maximum temperature accordingly and add 1 hour to the total baking time for each 10° F drop.

f. Varnishing.

(1) Apply three coats of moistureproofing and fungiproofing varnish (Lacquer, Fungus-resistant, Spec. No. 71-2202 (stock No. 6G1005.3), or equal). Allow each coat to air-dry for 15 or 20 minutes before applying the next coat.

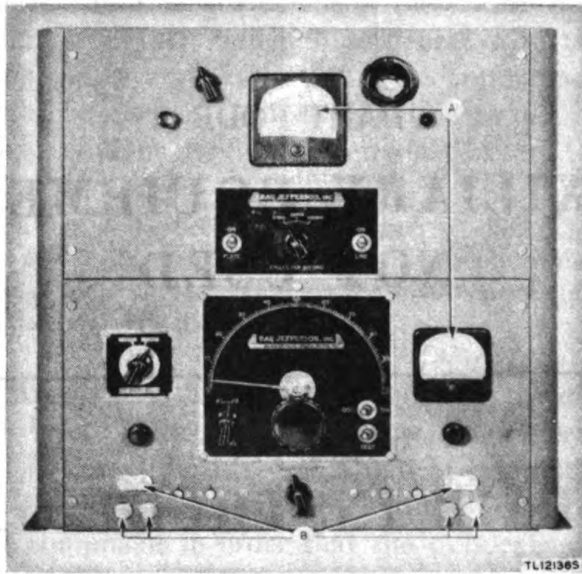

Figure 12. Crystal Test Set TS-314/FSM-1, front view showing method of masking.

(2) Apply varnish immediately after the equipment is dried. If varnish is not applied immediately, moisture condenses on the equipment. Varnish applied over the moisture peels off readily after the varnish has dried.

- (3) Spray all unmasked circuit elements.
- (4) Brush-paint all parts that cannot be reached by spraying.
- (5) The set may be handled when the varnish is no longer tacky.

g. Reassembly.

(1) Remove masking tape and touch up by brush any areas that show a break in the continuous film of varnish.

- (2) Reassemble the set and test its operation.

h. Marking. Mark the letters MFP and the date of treatment above the meter on both sections of the equipment.

EXAMPLE: MFP:—13 Apr 45.

49. MOISTUREPROOFING AND FUNGIPROOFING AFTER REPAIRS.

If, during repair, the coating of protective varnish has been punctured or broken, and if complete treatment is not needed to reseal the equipment, apply a brush coat to the affected part. Be sure the break is completely sealed.

PART FOUR

AUXILIARY EQUIPMENT NOT USED

PART FIVE

REPAIR INSTRUCTIONS

NOTE: Failure or unsatisfactory performance of the equipment used by Army Ground Forces and Army Service Forces will be reported on W.D., A.G.O. Form No. 468 (Unsatisfactory Equipment Report); by Army Air Forces on Army Air Forces Form No. 54 (unsatisfactory report). If either form is not available, prepare the data according to the sample form reproduced in figure 22.

SECTION X

THEORY OF EQUIPMENT

50. GENERAL THEORY OF OSCILLATOR SECTION (fig. 3).

The oscillator section consists of the following circuits:

a. Two Identical Crystal Oscillators. These circuits may be adjusted for frequency and activity correlation with respect to each other or with a variety of other oscillators.

b. Diode Detector. This circuit is used to mix the signals from the two crystal oscillators and make it possible to compare the frequency of the two signals by the zero-beat method.

c. Heterodyne Oscillator. This circuit generates a signal that may be varied over the range of approximately 2 to 10 megacycles (mc) in two bends and it also acts as a receiver in that it picks up the signals radiated by the two crystal oscillators. This allows the frequency of two crystals to be compared when the difference in their frequency is

out of the audible range. The heterodyne oscillator may be tuned until it produces a zero beat with one of the crystal oscillators using a standard crystal, and then tuned to zero beat with the other crystal oscillator using the crystal under test. The approximate difference in frequency of the two crystals can then be told by noting the points on the dial of the heterodyne oscillator where the two zero beats were found.

NOTE: The dial of the heterodyne oscillator is calibrated in equal divisions of 0 to 100. A calibration chart showing frequency versus dial divisions should be made in order to determine the approximate difference in frequency of the two crystal oscillators.

d. Audio Amplifier. The audio amplifier is used to amplify the beat notes produced in the diode detector or the heterodyne oscillator. The output of the amplifier is fed to a pair of headphones for listening to the beat produced by the oscillators and also to the frequency meter section of the equipment in order that the frequency of the beat produced by the oscillators may be measured.

e. Rectifier. The rectifier circuit operates from any 110-volt, 50- to 60-cycle source and supplies B+ voltage to the oscillator section of the equipment. All filaments of the oscillator section of the equipment are connected in series to a resistance cord from the 110-volt source.

51. GENERAL THEORY OF FREQUENCY

METER SECTION (fig. 3).

The frequency meter section consists of the following circuits:

a. Two-stage Audio Amplifier. This stage amplifies and clips the output of the oscillator section and applies it to the frequency measuring circuits.

b. Electron-ray Beat Indicator. The electron-ray circuit gives a visual indication of the beat note produced by the oscillators. The advantage of this circuit is that it will indicate a beat note that is too low in frequency to be heard in the headset or measured by the frequency measuring circuits.

c. Pulse Generator and Rectifier. The pulse generator circuit takes the output from the two-stage audio amplifier and applies to the pulse rectifier circuit a pulsating d-c voltage that is proportional to the frequency. The rectified current is then read as frequency on a 0 to 1 milliammeter.

d. Power Supply. The power supply circuit consists of two tubes connected in parallel to form a half-wave rectifier. This circuit operates

from any 110-volt source and provides B+ voltage for all of the frequency meter section. The voltage supplied to the pulse generator circuit is controlled by a voltage regulator tube. The filaments of the two rectifier tubes operate directly from the 110-volt source while the rest of the filaments of the frequency meter section operate from a 6.3-volt transformer.

52. CRYSTAL OSCILLATOR CIRCUITS (fig. 13).

Two identical crystal oscillator circuits, V1 and V2, are provided to compare a crystal under test to a standard crystal. Pentode Tubes JAN-6SJ7 are used in Pierce oscillator circuits that are designed to permit oscillations over a range greater than 2 to 10 mc without the need for manual tuning. Variable capacitors C4 and C6 in the plate circuits, and capacitors C3 and C5 in the grid circuits permit the oscillators to be correlated for frequency with respect to each other or with various other oscillators. By means of two-circuit double-throw switch SW5 grid capacitors C3 and C5 may be connected from the grid of each tube to ground, or in parallel with the crystals. With switch SW5 in the LOW position, capacitors C3 and C5 are connected from the grid to ground. This decreases the reactance of the grid circuit and increases the crystal current which will cause a slight change in crystal frequency. The dotted lines of figure 13 show capacitors C3 and C5 with switch SW5 in the HIGH position. When switch SW5 is in the HIGH position capacitors C3 and C5 are connected in parallel with the crystal thereby increasing the capacity across the crystal and lowering the frequency. The dashed lines of figure 13 show capacitors C3 and C5 with switch SW5 in the LOW position. Resistors R1 and R3 in series with potentiometers R2 and R4 make up the d-c grid return of the oscillators. The oscillators may be correlated for activity by varying the setting of potentiometers R2 and R4. With potentiometers R2 and R4 set at maximum clockwise rotation, a minimum of resistance will be present in the grid circuit. This decreases the grid bias developed by the rectified grid current and allows a maximum amount of grid current or activity. Conversely, with potentiometers R2 and R4 rotated to the maximum counterclockwise position, a maximum amount of resistance will be present in the grid circuit and the grid current or activity will be at a minimum. A 0 to 1 milliammeter M1 may be inserted in the grid circuit of either oscillator by means of double-pole, double-throw switch SW3. Capacitors C1 and C8 are bypass capacitors and prevent any radio frequency from entering the meter. Meter M1 indicates the grid current or activity and makes it possible to adjust potentiometers R2 and R4 for the desired activity correlation. Plate voltage is applied to the oscillators through the plate loads, radio-

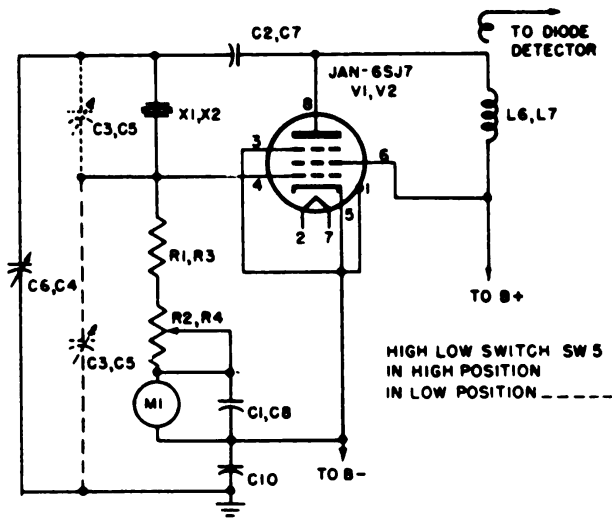

NOTE: CIRCUIT REFERENCE NUMBERS ARE SHOWN FOR BOTH OSCILLATORS

⊢ IS SYMBOL FOR FIXED CAPACITOR
 ⊢ IS SYMBOL FOR VARIABLE CAPACITOR

TL 1215-5

Figure 13. Simplified schematic of crystal oscillators.

frequency (r-f) chokes L6 and L7, while screen voltage is applied directly from the voltage regulator tube V5. The crystal is isolated from the d-c plate voltage by blocking capacitors C2 and C7. Output from the two oscillators is loosely coupled to one diode section of V6 by means of a pick-up coil consisting of one turn around r-f chokes L6 and L7. When using the heterodyne detector to compare the frequency of the oscillators the output from the oscillators is coupled to the heterodyne detector only by radiation or coupling through stray circuit capacitance.

53. DIODE DETECTOR CIRCUIT (fig. 14).

Diode detector V6 is a conventional diode detector using one diode section of Tube JAN-6SQ7. The detector load consists of resistors R11 and R5 and is bypassed by capacitor C13 in series with R10 and C16. By referring to figure 14 it can be seen that resistor R5 is common both to the detector and to audio amplifier V3. With the output of the two crystal oscillators loosely coupled to the plate, pin 4, of the diode detector, a beat note equal to the difference in frequency of the two oscillators will be developed across resistors R11 and R5. The portion of the detector voltage developed across resistor R5 is then amplified by audio-frequency (a-f) amplifier V3.

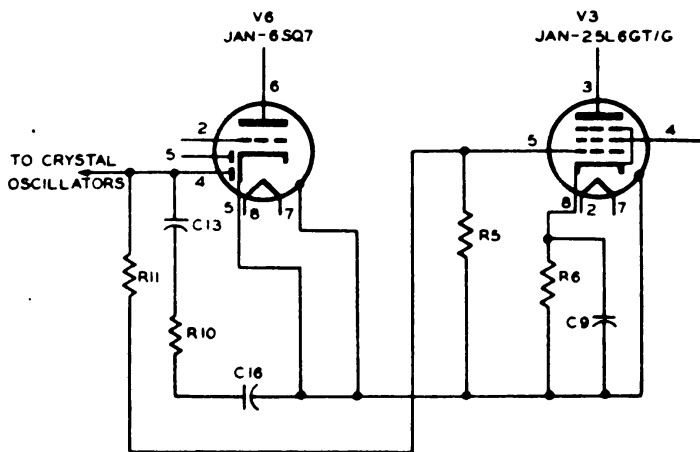

NOTE:

⊥ IS SYMBOL FOR FIXED CAPACITOR.

Figure 14. Simplified schematic of diode detector.

54. HETERODYNE OSCILLATOR CIRCUIT (fig. 15).

The heterodyne oscillator is connected in a series Hartley oscillator circuit using the triode section of tube V6. The frequency range is covered in two bands of from 2 to 4.6 mc (band A) and 4.6 to 10 mc (band B). The frequency range is covered by two coils which may be switched in or out of the circuit by two-circuit, double-throw switch SW4. Feedback from plate to grid is accomplished by plate current flowing through the lower half of coil L1 or L2 and inducing a voltage in the upper or grid section. This r-f voltage is applied to the grid through d-c blocking capacitor C11. Capacitor C12 through capacitor C18 is connected across a portion of coil L1 or L2 and is used to vary the frequency of the circuit over the complete frequency range of the detector. Capacitor C15 is a trimmer capacitor connected in parallel with capacitor C12. The grid load is composed of r-f choke L3 and resistor R12. Grid bias is developed across resistor R12 by the rectified grid current flowing through it. Plate voltage is applied through plate load resistor R10, plate choke L4, and the lower half of L1 or L2. R-f choke L4 and bypass capacitors C18 and C16 form a filter circuit that prevents radio frequency from entering the power supply. When a signal from the crystal oscillator beats with the heterodyne oscillator to form an audible beat note the audio note will be developed across resistor R10 and applied to the grid of the a-f amplifier V3 through coupling capacitor C17.

55. AUDIO AMPLIFIER, OSCILLATOR SECTION (fig. 16).

Audio amplifier V3 uses a beam power pentode Tube JAN-25L6 GT/G to amplify the beat note produced in the diode detector or the beat

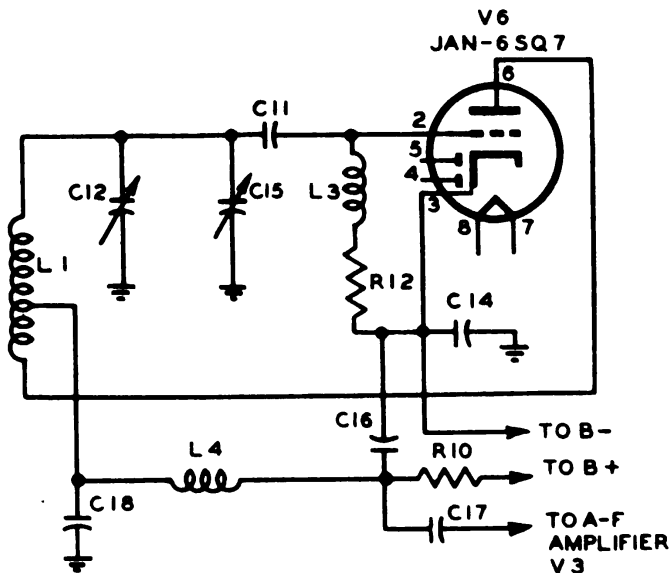

NOTE: $\text{—}|$ IS SYMBOL FOR FIXED CAPACITOR.

$\text{—}|$ IS SYMBOL FOR VARIABLE CAPACITOR.

TL12117-5

Figure 15. Simplified schematic of heterodyne oscillator.

note produced in the heterodyne detector. With switch SW2 in the OSC. position, voltage is developed across the grid load resistor R5 which also forms part of the diode detector circuit. With switch SW2 in the ON position the output from the heterodyne detector is applied to the grid through coupling capacitor C17. Screen voltage is applied directly from the output of the rectifier while plate voltage is applied through the externally connected headset. The headset provides an audible indication of the amplifier output while the frequency meter section indicates the audio output in cycles per second.

56. POWER SUPPLY, OSCILLATOR SECTION (fig. 17).

The power supply circuit consists of rectifier tube V4 and voltage regulator tube V5. Rectifier tube V4 is a duo-diode Tube JAN-25Z6GT/G in which the two sections are connected in parallel to form a half-wave rectifier designed to operate from a 110-volt line. This circuit is as follows: from one side of the line through the load and voltage regulator Tube JAN-OA3/VR-75 in parallel, and then through current limiting resistor R9, filter choke L5, rectifier tube V4, and current limiting resistor R7 back to the other side of the line. Capacitors C19, C20, and C21 are filter capacitors. All filaments in the oscillator section of the equipment are connected in series and through a resistance cord to the 110-volt source. Capacitors C22 and C23 provide an a-c ground path from the chassis to the ground of the power source.

output from the oscillator section of the equipment is coupled through blocking capacitors C1 and C2 to the voltage-divider circuit consisting of resistors R1 and R2. The portion of the voltage developed across R2 is applied to the grid, pin 5 of the first section of V1. When the voltage applied to the grid is larger than the bias developed by cathode resistor R4 and capacitor C4, grid current will flow through resistor R2 and produce a self bias. The stronger the signal applied to the grid the greater will be this bias. This controls the output of the amplifier to a practically constant value with input voltages from approximately 0.25 volt to 200 volts. Stability of the amplifier is increased by applying a negative feedback from plate to grid through capacitor C3. The output of the first section of V1 is developed across plate load resistor R6 and applied to the grid, pin 4, of the second section of V1 through blocking capacitor C5. The output voltage of the second section of V1 is developed across plate load resistor R7, capacitor C7, and transformer T1. Transformer T1 is necessary to supply the two pulse generator tubes with voltages that are 180° out of phase with each other. Capacitor C7 is a d-c blocking resistor.

58. ELECTRON-RAY BEAT INDICATOR (fig. 19).

Electron-ray circuit V2 uses an electron-ray Tube JAN-6E5. Output voltage from the first section of audio amplifier tube V1 is developed across potentiometer R3 and applied to the grid, pin 3, through resistor R22. Grid bias is supplied partly by cathode resistor R23 and partly by the 9 volts supplied by the batteries in series with potentiometer R3. The voltage developed across potentiometer R3 opposes the battery

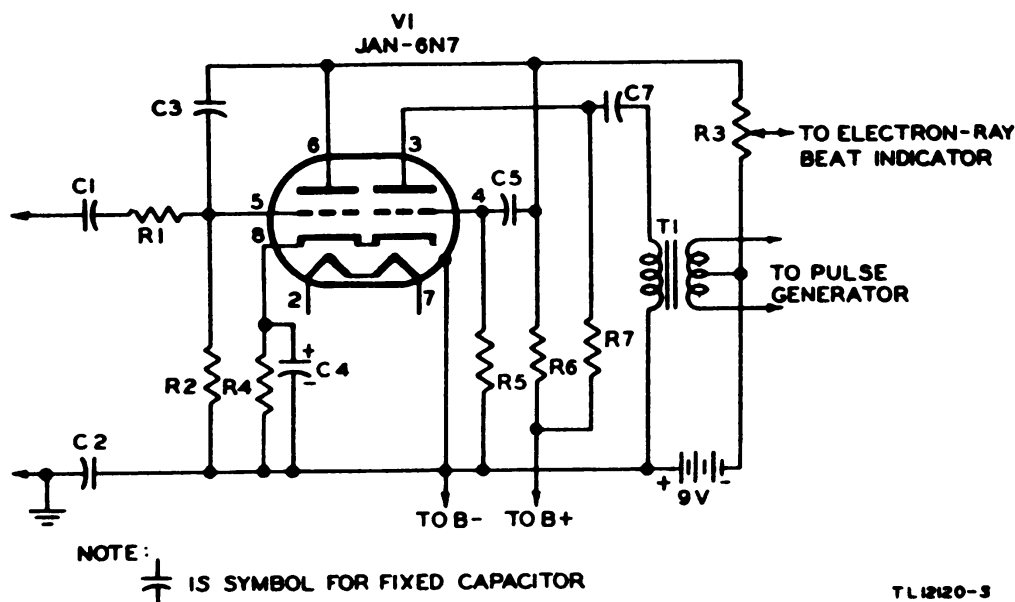

Figure 18. Simplified schematic of audio amplifier, frequency meter section.

voltage. Therefore, by varying the setting of R3 the bias of the electron-ray tube may be regulated. When the electrons emitted by the cathode strike the target, pin 4, they produce a glow on the fluorescent coating of the target and cause it to appear as a ring of light. The ray-control electrode is mounted between the target and the cathode, therefore when the ray-control electrode is made less positive than the target, the portion of the target behind the ray-control electrode is shielded and does not glow. Resistor R21 is connected between the ray-control electrode and the target. Therefore, any current flowing in the ray-control circuit will produce a voltage drop across R21 and will make the ray-control electrode less positive than the target. With potentiometer R3 adjusted to apply a minimum bias to the control grid, the ray-control electrode will draw a maximum amount of current and produce a maximum voltage drop across R21. This causes the ray-control electrode to be less positive than the target and increases the angle of the target that is shielded and does not glow. With the grid bias adjusted so that a small portion of the target does not glow and a signal below 50 cycles per second applied to the grid from the audio amplifier the angle of that portion of the target not glowing will vary at the same rate as the signal.

59. PULSE GENERATOR AND RECTIFIER (fig. 20).

Pulse generator circuits V3 and V4 consist of two gas-triode Tubes JAN-884 connected in an inverter circuit. The grids return to a bias battery through resistors R9 and R11 and the secondary of transformer T1. Resistors R9 and R11 prevent the secondary of T1 from being effectively shorted when ionization of tubes V3 and V4 occurs. Plate supply

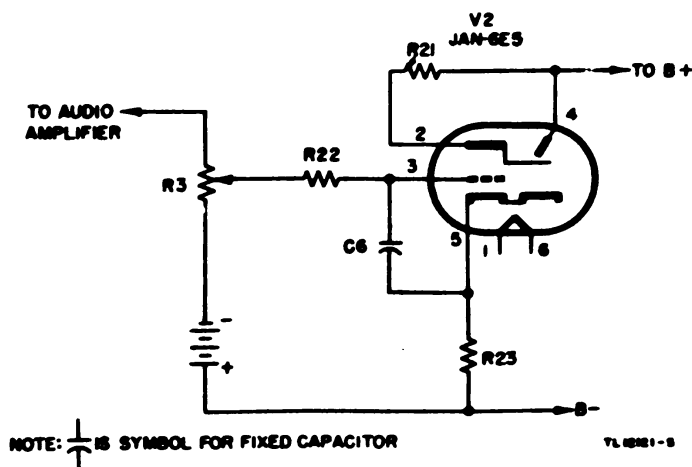
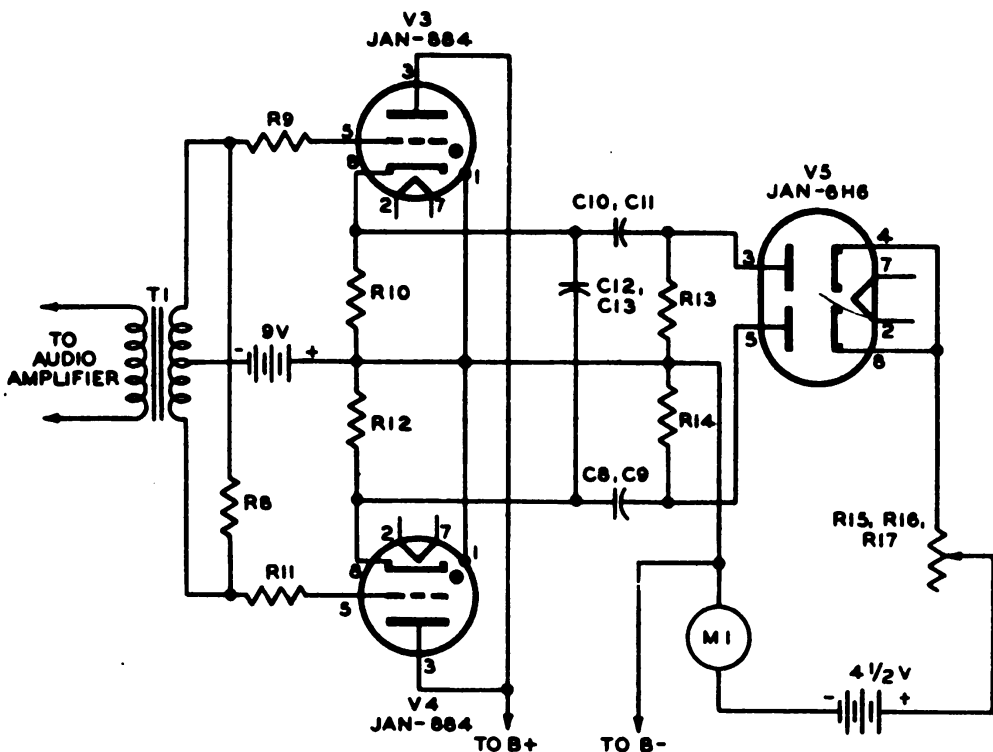

Figure 19. Simplified schematic of electron-ray beat indicator.

voltage is controlled by switch SW3 (fig. 32) which is turned ON only when taking frequency readings. Push-button switch SW4 (fig. 32) is also in series with the plate supply and must be pushed to de-ionize the tubes should ionization occur. Resistor R8, connected across the secondary of transformer T1 improves the frequency response of the transformer. The useful output voltage of the circuit appears across the two cathode load resistors R10 and R12. A considerable bias voltage is also developed across these resistors. The entire function of the frequency measuring section of the equipment depends upon the function of the pulse generator circuit. This circuit operates as follows: capacitor C8 or C9 and capacitor C10 or C12 are alternately charged from the plate supply voltage drop occurring across resistors R10 and R12 as first one tube and then the other ionizes. The plate supply voltage is held constant by voltage regulator tube V6. The capacitors discharge through resistors R10 and R13 on one half of the cycle, and through resistors R12 and R14 on the other half. The average current flowing into capacitors C8, C9, C10, and C11 is proportional to the number



NOTES:

WHERE CAPACITORS ARE LABELED WITH TWO CIRCUIT REFERENCES THE CAPACITOR IN THE CIRCUIT DEPENDS UPON THE POSITION OF SWITCH SW2.

* IS SYMBOL FOR FIXED CAPACITOR.

TL 12122-8

Figure 20. Simplified schematic of pulse generator and rectifier.

of charges per second, which depends upon the frequency of the voltage applied to the circuit. The voltage developed across resistors R13 and R14 is applied to the plates of V5, full-wave rectifier Tube JAN-6H6. The cathode of the rectifier returns through a 0 to 1 milliammeter, a 4½-volt bias battery, and multiplier resistor R15, R16, or R17. The resulting current read by meter M1 will be proportional to the frequency of the applied voltage. Calibration of meter M1 is accomplished by varying the setting of potentiometer R15, R16, or R17, depending upon the range in use. Capacitor C12 or C13 is necessary to prevent the tubes from remaining ionized at all times and functions in the following manner: When one tube fires (ionizes), the voltage developed across its cathode resistor charges capacitor C12 or C13. This voltage being in series with the cathode of the other tube places a bias on it, causing it to de-ionize. In this manner each time one tube fires it places a bias on the other tube and returns the control of the tube to the grid.

60. POWER SUPPLY, FREQUENCY METER SECTION (fig. 21).

The power supply consists of two rectifier Tubes JAN-117Z6GT/G (V7 and V8) connected in a half-wave rectifier circuit. The circuit operates from any 110-volt source and is connected to the source through double-pole, single-throw switch SW1. The filaments of V7 and V8 operate directly from the 110-volt source while the rest of the filaments of the frequency meter section operate from the 6.3-volt transformer T2. Resistors R19 and R20 are connected in series with the plates of V7 and V8 to limit the current through the tubes. The output from the rectifier is filtered by filter capacitors C14, C15, C16, and C17. The output of the rectifier is maintained at a constant value of 90 volts by voltage regulator Tube JAN-874, V6.

SECTION XI

TROUBLE-SHOOTING PROCEDURES

61. GENERAL TROUBLE-SHOOTING INFORMATION.

No matter how well equipment is designed and manufactured, faults occur in service. When such faults occur, the repairman must locate and correct them as rapidly as possible. This section contains general information to aid personnel engaged in the important duty of trouble shooting.

a. Trouble-shooting Data. Take advantage of the material supplied in this manual to help in the rapid location of faults. Consult the following trouble-shooting data when necessary:

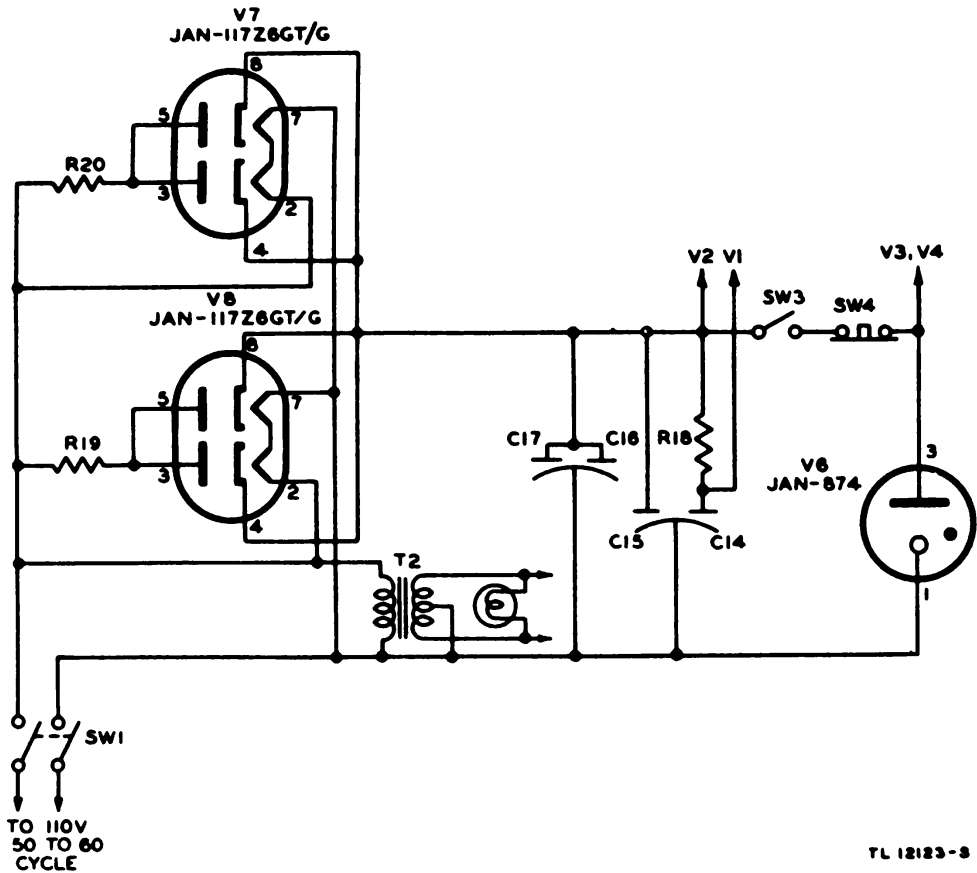

Figure 21. Simplified schematic of power supply, frequency meter section.

- (1) Block diagram of Crystal Test Set TS-314/FSM-1 (fig. 3).
 - (2) Complete schematic diagrams (figs. 31 and 32).
 - (3) Simplified and partial schematic diagrams. These diagrams are particularly useful in trouble shooting, because the repairman can follow the electrical functioning of the circuits more easily than on the regular schematics, thus speeding trouble location.
 - (4) Voltage and resistance data for all socket connections.
 - (5) Illustrations of components. Top, bottom, and rear views which aid in locating and identifying parts (figs. 23 through 28).
 - (6) Pin connections. Seen from the bottom, pin connections are numbered in a clockwise direction around the sockets. On octal sockets the first pin clockwise from the keyway is the No. 1 pin.
- b. Trouble-shooting Steps.** The first step in servicing a defective test set is to sectionalize the fault. Sectionalization means tracing the

fault to the component or circuit responsible for the abnormal operation of the set. The second step is to localize the fault. Localization means tracing the fault to the defective part responsible for the abnormal condition. Some faults such as burned-out resistors, r-f arcing, and shorted transformers can be located by sight, smell, and hearing. The majority of faults, however, must be located by checking voltage and resistance.

c. Sectionalization. Careful observation of the performance of the test set while turning the equipment on often sectionalizes the fault to the oscillator or frequency meter section, and careful observation of the meters on the front panels often determines the stage or circuit at fault.

d. Localization. After sectionalizing the trouble by following the start-stop procedure outlined in paragraph 63, the exact component causing the trouble may be located by making voltage and resistance measurements of the defective stage and checking the readings against the voltage and resistance charts in paragraphs 64 and 65.

e. Voltage Measurements. Voltage measurements are an almost indispensable aid to the repairman, because most troubles either result from abnormal voltages or produce abnormal voltages. Voltage measurements are taken easily, because they are always made between two points in a circuit and the circuit need not be interrupted.

(1) Unless otherwise specified, the voltages listed on the voltage charts are measured between the indicated points and ground.

(2) Always begin by setting the voltmeter on the highest range so that the voltmeter will not be overloaded. Then, if it is necessary to obtain increased accuracy, set the voltmeter to a lower range.

(3) In checking cathode voltage, remember that a reading can be obtained when the cathode resistor is actually open. The resistance of the meter may act as a cathode resistor. Thus, the cathode voltage may be approximately normal only as long as the voltmeter is connected between cathode and ground. Before the cathode voltage is measured, make a resistance check with a cold circuit to determine whether the cathode resistor is normal.

f. Voltmeter Loading. It is essential that the voltmeter resistance be at least 10 times as large as the resistance of the circuit across which the voltage is measured. If the voltmeter resistance is comparable to the circuit resistance, the voltmeter will indicate a voltage lower than the actual voltage present when the voltmeter is removed from the circuit.

(1) The resistance of the voltmeter on any range can always be calculated by the following simple rule: resistance of the voltmeter

equals the ohms per volt multiplied by the full-scale range in volts. For example: the resistance of a 1,000-ohm-per-volt meter on the 300-volt range is 300,000 ohms ($R = 1,000 \text{ ohms per volt times } 300 \text{ volts} = 300,000 \text{ ohms}$).

(2) To minimize the voltmeter loading in high-resistance circuits, use the highest voltmeter range. Although only a small deflection will be obtained (possibly only 5 divisions on a 100-division scale), the accuracy of the voltage measurement will be increased. The decreased loading of the voltmeter will more than compensate for the inaccuracy which results from reading only a small deflection on the scale of the voltmeter.

(3) When a voltmeter is loading a circuit, the effect can always be noted by comparing the voltage reading on two successive ranges. If the voltage readings on the two ranges do not agree, voltmeter loading is excessive. The reading (not the deflection) on the highest range will be greater than that on the lowest range. If the voltmeter is loading the circuit heavily, the deflection of the pointer will remain nearly the same when the voltmeter is shifted from one range to another.

(4) The ohm-per-volt sensitivity of the voltmeter used to obtain the readings recorded on the voltage and resistance charts in this manual is printed on each chart. Use a meter having the same ohm-per-volt sensitivity; otherwise it will be necessary to consider the effect of loading.

62. TROUBLE-SHOOTING PROCEDURES.

a. When Crystal Test Set TS-314/FSM-1 becomes defective or inoperative the trouble can quickly be isolated to the oscillator section or the frequency meter section by following the start-stop procedure analysis in paragraph 63.

b. After the trouble has been isolated to one section or stage the trouble-shooting chart and the voltage and resistance charts will be a great help in isolating the trouble in the exact component that is causing the trouble.

c. To analyze and inspect the trouble without the aid of test equipment, proceed as follows:

(1) Remove the chassis from the case and examine the wiring for poorly soldered connections, damaged wiring, parts shorting against each other or against the chassis case, and bad sockets or socket connections. Make certain tubes are not cracked or broken and that they are plugged all the way into their proper sockets.

(2) Examine for component parts which appear abnormal, such as swollen capacitors, charred or broken resistors, broken sockets, tubes, controls, etc.

(3) Replace the tubes one at a time.

(4) Feel the various components for signs of excessive heating.

(5) Shorted parts or any part through which excessive current is passing usually gives off a strong odor. Examine for the presence of unusual odors.

63. START-STOP PROCEDURE ANALYSIS.

a. Preparation. Connect the set as described in paragraphs 10, 11, and 14. Obtain two crystals of approximately the same frequency that are known to be in good condition and that operate within the frequency range of the equipment.

b. Analysis. Plug one of the crystals into the crystal jacks of one of the oscillators. Set all switches to the OFF position. The step-by-step procedure of the start-stop operation is as follows:

STEP 1.

Set the POWER switch at ON. Check its operation against the following table for indications of normal or abnormal operation.

Normal indication	
A rushing sound is heard in the headset.	
Abnormal indications	Probable causes of trouble
1. No rushing sound in headset.	1. Defective POWER switch. Defective line cord. Defective phone jacks. Defective headset. Defective audio tube V3. Defective rectifier tube V6.
2. 60-cycle hum heard in headset.	2. Line cord connecting the two sections plugged in backwards giving a difference of potential between the two chassis.

STEP 2.

Set the TEST meter switch to the left position if the crystal is plugged into the jacks on the left side of the front panel, or to the right if the crystal is plugged into the jacks on the right side of the panel. Rotate the

BIAS control to the maximum clockwise position. Watch the activity meter for an indication of grid current while rotating the plate and grid capacity controls with the capacity switch in first the LOW and then the HIGH position.

Normal indication	
A maximum amount of grid current will be indicated by the activity meter at some point as the capacity controls are rotated.	
Abnormal indication	Probable causes of trouble
No meter reading.	Defective METER switch. Defective capacity HIGH LOW switch. Defective oscillator tube V1 or V2. Defective crystal jacks.

STEP 3.

Repeat step 1 with the crystal plugged into the other crystal oscillator, using the appropriate controls for the oscillator in use.

STEP 4.

Set the oscillator OSC. ON switch at ON. With the crystal plugged into one of the oscillators and the oscillator operating properly, tune the heterodyne oscillator while listening for a beat note in the headset. Try both bands of the heterodyne detector. Check against the following chart for indications of normal or abnormal operation.

Normal indication	
A beat note between the crystal oscillator and the heterodyne detector will be heard at some point as the heterodyne detector is tuned.	
Abnormal indication	Probable causes of trouble
No beat note is heard.	Defective heterodyne. Defective tube V6. Defective headset. Defective OSC. ON switch. Defective audio tube V3.

STEP 5.

Repeat step 4 using the other oscillator.

Set the OSC. ON switch to the OSC. position. Plug the two crystals into the two oscillators.

NOTE: The two crystals must be approximately the same frequency in order to produce a beat note within the audible range.

Normal indication	
The output from the two crystals will beat in the diode detector and produce a beat note that will be heard in the headset.	
Abnormal indication	Probable causes of trouble
No beat note heard in the headset.	<ul style="list-style-type: none"> Defective detector tube V6. Defective audio tube V3. Defective headset. Defective OSC. ON switch.

STEP 7.

Set the ON LINE switch of the frequency meter section of the equipment at ON. Check against the following table for indications of normal or abnormal operation.

Normal indication	
The pilot lamp and the electron-ray beat indicator tube will both glow.	
Abnormal indications	Probable causes of trouble
<ul style="list-style-type: none"> 1. Pilot lamp does not glow. 2. Electron-ray beat indicator tube does not glow. 	<ul style="list-style-type: none"> 1. Defective pilot lamp. Defective ON LINE switch. Defective line cord. Defective transformer T2. 2. Defective line cord. Defective ON LINE switch. Defective rectifier V7 or V8. Defective electron-ray tube V2.

STEP 8.

Adjust the sensitivity control for the electron-ray beat indicator until only a small portion of the target is not glowing. With an audio note from the oscillator section coupled to the frequency meter section, switch the oscillator section off and on. Check against the following table for indications of normal or abnormal operation.

Normal indication	
The angle of that portion of the target not glowing will increase when the oscillator section is operating.	
Abnormal indication	Probable causes of trouble
The angle of the target not glowing does not change.	The cord coupling the two sections is open or connected backwards. Defective audio tube V1 in frequency meter section.

STEP 9.

Set the ON PLATE switch at ON. Observe the frequency meter as the CYCLES PER SECOND switch is switched from one position to another. Check against the following table for indications of normal or abnormal operation.

Normal indication	
An approximate indication of the frequency will be indicated on one position of the CYCLES PER SECOND switch.	
Abnormal indication	Probable causes of trouble
No reading indicated on frequency meter.	Defective audio tube V1. Defective ON PLATE switch. Defective CYCLES PER SECOND switch. Defective pulse generator tube V3 or V4. Defective pulse rectifier tube V5. Defective meter M1.

STEP 10.

Press the push-button switch on the frequency meter section while a reading is indicated on the frequency meter. Check against the following table for indications of normal or abnormal operation.

Normal indication	
No reading will be observed on the frequency meter.	
Abnormal indication	Probable cause of trouble
A reading is still observed on the frequency meter.	Defective push-button switch.

STEP 11.

Set the ON LINE switch at LINE. Check against the following table for indications of normal or abnormal operation.

Normal indication	
Neither the pilot lamp nor the electron-ray tube glows.	
Abnormal indication	Probable cause of trouble
The pilot lamp and the electron-ray tube still glow.	Defective ON LINE switch.

STEP 12.

Set the POWER switch on the oscillator section at OFF. Check against the following table for indications of normal or abnormal operation.

Normal indication	
A click is heard in the headset and the beat note is no longer heard.	
Abnormal indication	Probable cause of trouble
No click is heard in headset and the beat is still heard.	Defective POWER switch.

SECTION XII

TEST AND ANALYSIS DATA

64. VOLTAGE MEASUREMENTS.

An a-c and d-c 1,000-ohm-per-volt voltmeter with ranges from 0 to 12 volts to 0 to 300 volts is necessary to make the following voltage measurements on this equipment.

a. Oscillator Section. The voltages listed below were made under the following conditions: the oscillator section connected to a 110-volt source; headset connected to S18 and S19; POWER switch at ON; heterodyne detector switch at ON; heterodyne detector tuning dial set at 100; and no crystals in the crystal sockets.

50

CAUTION: Connect a jumper wire in shunt with the activity meter M1 to prevent its damage while making voltage measurements.

50

<i>Tube</i>	<i>Voltmeter range</i>	<i>Test leads connected to points designated</i>	<i>Voltage</i>
V1	0-12 volts ac	Pin 2 to Pin 7	5.6
	0-300 volts dc	Pins 1, 3, 5 to V5 Pin 2	0.0
	0-12 volts dc	Pin 4 to V5 Pin 2	-0.2
	0-300 volts dc	Pin 6 to V5 Pin 2	75.0
	0-300 volts dc	Pin 8 to V5 Pin 2	75.0
V2	0-12 volts ac	Pin 2 to Pin 7	5.6
	0-300 volts dc	Pins 1, 3, 5 to V5 Pin 2	0.0
	0-12 volts dc	Pin 4 to V5 Pin 2	-0.2
	0-300 volts dc	Pin 6 to V5 Pin 2	75.0
	0-300 volts dc	Pin 8 to V5 Pin 2	75.0
V3	0-60 volts ac	Pin 2 to Pin 7	22.0
	0-300 volts dc	Pin 1 to V5 Pin 2	0.0
	0-300 volts dc	Pin 3 to V5 Pin 2	90.0
	0-300 volts dc	Pin 4 to V5 Pin 2	100.0
	0-300 volts dc	Pin 5 to Pin 8	-10.0
	0-60 volts dc	Pin 8 to V5 Pin 2	-12.0
	0-300 volts dc	Pin 2 to Pin 7	21.0
V4	0-60 volts ac	Pins 3, 5 to V5 Pin 2	110.0
	0-300 volts ac	Pins 4, 8 to V5 Pin 2	115.0
	0-300 volts dc	Pin 5 to Pin 2	75.0
V5	0-12 volts ac	Pin 7 to Pin 8	5.6
V6	0-300 volts dc	Pins 1, 3 to V5 Pin 2	0.0
	0-12 volts dc	Pin 2 to V5 Pin 2	-0.2
	0-300 volts dc	Pin 5 to V5 Pin 2	0.0
	0-300 volts dc	Pin 4 to V5 Pin 2	-0.1
	0-300 volts dc	Pin 6 to V5 Pin 2	60.0

b. Frequency Meter Section. The voltages listed below were made under the following conditions: frequency meter section connected to a 110-volt source; LINE ON switch in the ON position; ON PLATE switch in the PLATE position unless otherwise indicated; and no input signal applied.

CAUTION: Connect a jumper wire in shunt with frequency meter M1 to prevent its damage while making voltage measurements.

<i>Tube</i>	<i>Voltmeter range</i>	<i>Test leads connected to points designated</i>	<i>Voltage</i>
V1	0-12 volts ac	Pin 2 to Pin 7	6.3
	0-300 volts dc	Pin 1 to V6 Pin 1	0.0
	0-300 volts dc	Pin 3 to V6 Pin 1	90.0
	0-12 volts dc	Pin 4 to V6 Pin 1	0.0
	0-12 volts dc	Pin 5 to V6 Pin 1	0.0

<i>Tube</i>	<i>Voltmeter range</i>	<i>Test leads connected to points designated</i>	<i>Voltage</i>
V2 (tube removed from socket)	0-300 volts dc	Pin 6 to V6 Pin 1	60.0
	0-12 volts dc	Pin 8 to V6 Pin 1	1.2
	0-12 volts dc	Pin 8 to Pin 4	0.4
	0-12 volts dc	Pin 8 to Pin 5	0.3
	0-12 volts ac	Pin 1 to Pin 6	6.3
	0-300 volts dc	Pin 2 to Pin 5	35.0
	0-60 volts dc	Pin 3 to Pin 5 (R22 full clockwise)	-3.5
	0-300 volts dc	Pin 3 to Pin 5 (R22 full counter-clockwise)	55.0
V3 and V4	0-300 volts dc	Pin 4 to Pin 5	150.0
	0-12 volts ac	Pin 3 to Pin 7	6.3
	0-300 volts dc	Pin 1 to V6 Pin 1	0.0
	0-300 volts dc	Pin 3 to V6 Pin 1 (SW3 ON)	90.0
	0-12 volts dc	Pin 5 to V6 Pin 1 (SW3 OFF)	-0.8
V5	0-300 volts dc	Pin 8 to V6 Pin 1 (SW3 ON)	75.0
	0-12 volts ac	Pin 2 to Pin 7	6.3
	0-12 volts dc	Pin 3 to V6 Pin 1	0.0
	0-12 volts dc	Pin 4, 8 to Pin 3 or 5 (SW2 at X 1000)	3.5
		(SW2 at X 2000)	3.4
		(SW2 at X 10000)	3.5
V6	0-300 volts dc	Pin 3 to Pin 1	90.0
V7, V8	0-300 volts ac	Pin 2 to Pin 7	110.0
	0-200 volts ac	Pin 7 to Pin 3, 5	110.0
	0-300 volts dc	Pin 7 to Pin 4, 8	150.0

65. RESISTANCE MEASUREMENTS.

An ohmmeter with ranges from 0 to 1,000 ohms to 0 to 1 megohm is necessary to make the following resistance measurements.

a. Conditions of Measurements. The resistance measurements listed below were made under the following conditions:

- (1) The equipment disconnected from the 110-volt source.
- (2) The cord connecting the two sections together disconnected.
- (3) The bias batteries disconnected in the frequency meter section.

CAUTION: Connect a jumper wire in shunt with the activity meter in the oscillator section and with the frequency meter in the frequency meter section of the equipment while making resistance measurements.

b. Significance of Measurements. Resistance measurements should be within ± 20 percent of the measurements listed below. When other values than these are obtained, isolate the parts concerned and check the resistance of each to determine the cause for the abnormal reading. In cases where abnormal readings occur in a circuit with resistors and capacitors connected in parallel, disconnect one side of the capacitor and check its resistance for leakage.

c. Oscillator Section.

<i>Test leads connected to points designated</i>	<i>Resistance</i>
P1 Contact 1 to P1 contact 2 (SW1 ON and tubes in sockets)	220.0
P1 Contacts 1, 2 to Chassis (SW1 ON)	Infinity
V1 Pins 1, 3, 5 to V5 Pin 2	0.0
V1 Pin 4 to V1 Pin 5 (SW3 to right side and R2 full counterclockwise)	59,000.0
(R2 full clockwise)	9,000.0
V1 Pin 6 to V1 Pin 8	26.0
V1 Pin 6 to V5 Pin 5	0.0
V1 Pin 8 to S9, S10	Infinity
S9, S10 to Chassis	Infinity
V2 Pins 1, 3, 5 to V5 Pin 2	0.0
V2 Pin 2 to Junction R7 and R8	180.0
V2 Pin 4 to V1 Pin 5 (SW3 to left side and R4 full counterclockwise)	59,000.0
(R4 full clockwise)	9,000.0
V2 Pin 6 to V2 Pin 8	26.0
V2 Pin 6 to V5 Pin 5	0.0
V2 Pin 8 to S13, S16, S17	Infinity
S13, S16, S17 to Chassis	Infinity
V3 Pin 1 to V5 Pin 2	0.0
V3 Pin 3 to V3 Pin 4 (Headset connected to S18 and S19)	2,000.0
V3 Pin 4 to V5 Pin 5	750.0
V3 Pin 5 to V5 Pin 2	500,000.0
V3 Pin 5 to V6 Pin 4 (SW2 at OSC. position)	25,000.0
V3 Pin 8 to V5 Pin 2	2,000.0
V4 Pins 4, 8 to V3 Pin 4	360.0
V4 Pins 4, 8 to V5 Pin 5	1,110.0
V4 Pin 3, 5 to Junction R7, R8	50.0
V4 Pin 7 to V5 Pin 2	0.0
V5 Pin 5 to V5 Pin 2 (Positive lead to Pin 5. Use 0-1 meg range.)	0.0
V6 Pin 1 to V5 Pin 2	0.0
V6 Pin 2 to Junction L3, R12	26.0
V6 Pin 2 to V6 Pin 3	10,000.0

<i>Test leads connected to points designated</i>	<i>Resistance</i>
V6 Pin 3 to V5 Pin 2	0.0
V6 Pin 4 to V6 Pin 3 (SW2 ON)	Infinity
V6 Pin 4 to V6 Pin 5	Infinity
V6 Pin 6 to Junction IA, R10	26.0
V6 Pin 6 to V5 Pin 5 (SW2 OFF)	Infinity
V6 Pin 6 to V5 Pin 5 (SW2 ON)	25,000.0
V6 Pin 6 to Junction C11, C12 (SW4 at A)	0.5
V6 Pin 6 to Junction C11, C12 (SW4 at B)	0.25
Chassis to Junction C11, C12	Infinity
S8, 9, 10, 11, 12, 13, 14, 15, 16, 17 to Chassis	Infinity
S18, 20 to V3 Pin 3	0.0
S19 to V3 Pin 4	0.0
S21 to Chassis	0.0

d. Frequency Meter Section.

<i>Test leads connected to points designated</i>	<i>Resistance</i>
P1 Contact 1 to P1 Contact 2 (SW1 ON and tubes in sockets)	20.0
V1 Pin 1 to V6 Pin 1	0.0
V1 Pin 1 to Chassis	Infinity
V1 Pin 2 to V1 Pin 7	0.225
V1 Pin 3 to Junction R7, R18	25,000.0
Junction R7, R18 to V7, V8 Pin 4, 8	3,000.0
Junction R7, R18 to V1 Pin 6 (SW3 OFF)	50,000.0
Junction R7, R18 to V6 Pin 1 (Negative lead to V6 Pin 1. Use 0-1 megacycle range.)	100,000.0+
V1 Pin 4 to V1 Pin 6 (Negative lead to V1 Pin 4. Use 0-1 megacycle range.)	100,000.0+
V1 Pin 4 to V6 Pin 1	50,000.0
V1 Pin 5 to Junction R1, C1	100,000.0
V1 Pin 5 to V6 Pin 1	1,000,000.0
V1 Pin 6 to T1 Center tap of secondary winding	500,000.0
V1 Pin 6 to V1 Pin 5 (Negative lead to V1 Pin 5)	1,000,000.0+
V1 Pin 6 to V2 Pin 3 (R22 full counterclockwise.)	100,000.0
V1 Pin 8 to V6 Pin 1	500.0
V2 Pin 2 to V2 Pin 4	100,000.0
V2 Pin 5 to V6 Pin 1	2,000.0
Junction C7, T1 to V6 Pin 1	850.0

<i>Test leads connected to points designated</i>	<i>Resistance</i>
Junction R8, R9 to Junction R8, R11	4,000.0
V3 Pin 1 to V6 Pin 1	0.0
V3 Pin 3 to V7, V8 Pin 4, 8 (SW3 ON)	0.0
V3 Pin 3 to V7, V8 Pin 4, 8 (SW3 OFF)	Infinity
V3 Pin 5 to V4 Pin 5	300,000.0
V3 Pin 8 to V6 Pin 1	3,000.0
V4 Pin 1 to V6 Pin 1	0.0
V4 Pin 3 to V6 Pin 1 (SW3 OFF)	Infinity
V4 Pin 3 to V6 Pin 1 (SW3 ON. Use negative lead to V6 Pin 1.)	100,000.0+
V4 Pin 3 to V3 Pin 3	0.0
V4 Pin 8 to V6 Pin 1	3,000.0
V4 Pin 8 to V3 Pin 8	6,000.0
V5 Pin 4, 8 to Junction R15, R16, R17 (SW2 at x 1000)	600.0
(SW2 at x 2000)	3,600.0
(SW2 at x 10000)	1,100.0
V5 Pin 3 to V5 Pin 5	6,000.0
V5 Pin 3 to V6 Pin 1	3,000.0
V5 Pin 5 to V6 Pin 1	3,000.0
V6 Pin 3 to V4, V5 Pin 3	0.0
V6 Pin 3 to V6 Pin 1 (SW3 OFF)	Infinity
V7 Pin 3, 5 to V7 Pin 2	50.0
V7 Pin 4, 8 to V6 Pin 3 (SW3 ON)	0.0
V8 Pin 3, 5 to V8 Pin 2	50.0
Chassis to S10	0.0

SECTION XIII

REPAIRS

66. SERVICING.

Crystal Test Set TS-314/FSM-1 is constructed to withstand the shocks and strains which may be expected in fixed or mobile service. Nevertheless, this equipment is accurate and sensitive, and should be handled with care. Servicing and repair other than the replacement of tubes and batteries should be performed only by competent personnel supplied with adequate tools and instruments. An inexperienced operator attempting to locate and repair troubles may damage the equipment to such an extent that shipment to a higher repair echelon will be necessary.

67. GENERAL REPAIR.

Removal and replacement of defective parts or circuit elements in this equipment are very difficult, and great care must be taken to avoid further damage to the equipment or to the part being replaced. Before attempting repairs make every effort to obtain the proper tools for the job.

a. Identification of Leads. Often it may be necessary to remove other circuit elements to gain access to the defective part. To insure proper reinstallation, make a record of the connections to each removed element and of the position of the elements on the equipment.

b. Electrical Connections. When replacing leads clip them as short as possible for satisfactory connection and avoid using more solder than necessary to make a secure connection. A very slight amount of excess solder dropped accidentally inside the equipment may cause other circuits or circuit elements to be short-circuited. Some clearances are very small, and extreme care must be exercised in soldering. Do not heat the lug or connection more than is absolutely necessary because of possible damage to near-by elements such as chokes, capacitors, coil forms, resistors, and wiring. When a wire is connected to a tube socket, the connecting wire should be long enough to prevent pull on the socket. Save time and trouble by making a thorough electrical check of any part that appears to be defective *before* removing it from the equipment.

CAUTION: Never change the location of parts or wiring leads. Such a change may make it difficult to correlate the oscillators at some frequencies.

68. MECHANICAL REPAIRS.

When replacing mechanical parts in the equipment, use extreme care in disassembling and reassembling any mechanical units. Use screwdrivers and other tools that fit the job at hand. Secure bolts snugly, but do not overtighten them. All parts of this equipment are readily accessible and need no special instructions for removal.

69. PAINTING AND REFINISHING.

If the finish on the case has been badly scarred or damaged, the repairman should touch up the bared surface of the case to prevent rust and corrosion. When painting and refinishing are necessary, proceed as follows:

a. Clean the scarred surface down to the bare metal. Use #00 or #000 sandpaper to obtain a bright, smooth finish. To remove rust, first clean the corroded metal with dry-cleaning solvent (SD).

CAUTION: The use of steel wool instead of sandpaper is not recommended. Minute particles of the metal frequently enter the case and cause harmful internal electrical shorting or grounding of circuits.

b. When a touch-up job is necessary, apply paint with a small brush. When numerous scars and scratches warrant a complete repainting job, remove the chassis from the case and spray-paint the entire case. Use authorized paint consistent with existing regulations.

SECTION XIV

CALIBRATION, ALIGNMENT, AND ADJUSTMENT

70. EQUIPMENT NEEDED.

For accurate production finishing or testing of crystals it is necessary to adjust Crystal Test Set TS-314/FSM-1 to match as closely as possible the oscillator in which the crystals are actually to be used. To accomplish this correlation the following equipment is necessary:

a. A communications receiver.

b. A primary reference oscillator that is accurately adjusted for activity and frequency to match the equipment in which the crystals are intended to be used, or the actual transmitter or receiver in which the crystals are to be used.

NOTE: The phrase, primary reference oscillator, will be used hereafter in the text to designate any primary test oscillator that contains the same crystal circuit and component parts as contained in the oscillator in which the crystals being tested (or produced) will be used.

c. A standard crystal (S) known to have correct frequency and normal activity, when measured in the primary reference oscillator.

d. A crystal (T) that has good activity and a frequency at the specification tolerance limit for the particular type of crystal, when measured in the primary reference oscillator.

e. A crystal (A) with correct frequency, the same as the S crystal, but with the minimum passing activity allowed by specifications when measured in the primary reference oscillator.

NOTE: Test crystals S and T are employed for correlating for frequency. Since the frequency deviation between these crystals is (or should be, for correlating purposes) in the audible range, use of the frequency meter section of the equipment greatly simplifies the procedure and aids in obtaining accurate results.

71. PREPARATION FOR CORRELATION.

a. Connect the frequency meter section of the equipment to a communications receiver that is fitted with a meter for indicating carrier signal strength (an S meter). To do this remove the RED plug (P3) of the connecting cord from the RED jack (S9) at the rear of the frequency meter chassis. Insert a single wire in the RED jack (S9) and run this wire to the plate pin of the audio-amplifier output tube socket of the receiver.

b. Set the capacity switch (SW5), of the oscillator section of the equipment to the LOW position.

NOTE: In case it is impossible to obtain the following frequency correlation with switch SW5 in the LOW position, switch to the HIGH position and repeat the correlation procedure. For some crystals, usually those that are intended for use in oscillator circuits containing very high crystal capacity, and operating in the range of 2,000 to 4,000 kc, it may be necessary, when the capacity switch is in the HIGH position, to increase grid to ground capacity to maintain regeneration and to obtain normal activity reading. To accomplish this in the standard crystal oscillator (the oscillator on the left side of the equipment), connect a 0.00005 microfarad mica capacitor externally between an unused crystal socket (either S8, S11, or S12) and the adjacent panel screw (ground). The test oscillator (the oscillator on the right side of the equipment) may be treated in the same manner. In this case make certain the capacitor is connected from one of the spare crystal sockets associated with its circuit.

c. Place the equipment in operation as explained in paragraphs 14 and 15. Connect the communications receiver to its power source and place it in operation.

72. FREQUENCY CORRELATION.

a. Plug the standard frequency crystal (S) into a primary reference oscillator.

b. Plug the standard tolerance frequency crystal (T) into the crystal jacks of the standard crystal (left hand) oscillator of Crystal Test Set TS-314/FSM-1.

c. Switch the activity test meter switch, SW3, to the left-hand position.

d. Adjust the left-hand grid BIAS control, R2, to obtain a reading of 0.6 milliamperes on activity meter M1.

e. Tune in the signal emitted by standard crystal S, operating in the primary reference oscillator, on the communications receiver to maximum signal strength as shown on the S meter. This reading should be S-9 minimum. If the signal strength is below this level, closer coupling between the receiver and primary reference oscillator will be required to raise the level of the signal to S-9 or higher.

f. Remove the standard crystal (S) from the primary reference oscillator, and note the signal strength of the tolerance frequency crystal (T) operating in the standard crystal oscillator. The carrier level (signal strength) of both crystals should be made equal by adjustment of the coupling between the crystal test oscillators and the receiver.

NOTE: Coupling can be increased by running a short lead of wire from the antenna binding post of the receiver to the proximity of the test oscillators.

g. Replace the standard frequency crystal (S) in the primary reference oscillator, and with the tolerance crystal (T) operating in the standard crystal oscillator an audio tone will be heard in the receiver, thus indicating that both crystals are oscillating.

h. Set CYCLES PER SECOND switch SW2, on the frequency meter section at X2000.

i. Set ON PLATE switch SW3, of the frequency meter section, at ON. Make accurate note of the frequency (cps) deviation on the frequency meter. It may be necessary to switch to another scale if the reading on the X2000 is too high or too low.

j. Interchange the S and T crystals and again read the frequency deviation between them. This second reading will undoubtedly differ from the first, thus indicating that the capacity in the two oscillator circuits differ.

k. Vary the two capacity adjustments, C3 and C4, at the lower left of the oscillator section panel, until the frequency deviation reading is the same as that previously obtained with the S crystal operating in the primary reference oscillator. Interchange the S and T crystals between oscillators several times and make fine adjustments, if necessary, to obtain the identical deviation reading with the S and T crystals operating in either oscillator (primary reference oscillator or standard crystal oscillator). During this procedure adjust grid BIAS control R2, of the standard oscillator, so that only normal activity is maintained.

l. Repeat the procedure outlined in par. 68 a through m, this time substituting the test (right-hand) oscillator for the standard crystal (left-hand) oscillator in each case. Adjust capacitors C5 and C6 in place of C3 and C4, and BIAS control R4 instead of R2.

m. The deviation in frequency between the two test crystals S and T should read the same on the frequency meter, with the crystals operating in any two of the three oscillators concerned.

NOTE: Proper correlation between the standard crystal (left-hand) oscillator and the test (right-hand) oscillator requires an equal amount of capacity in the circuit of each. Check this by observing the position of capacity adjusting screws C3, C4, C5, and C6 on the front panel. If the capacity is not approximately equal in the two oscillators, re-correlate the test oscillator to use the same amount of capacity as the standard crystal oscillator.

73. ACTIVITY CORRELATION.

a. Plug the activity (A) crystal into the primary reference oscillator and observe the activity reading. Now remove crystal A from the primary reference oscillator and plug it into the standard crystal oscillator. Adjust grid BIAS control R2 until the same activity is indicated as when the crystal was operating in the primary reference oscillator.

b. When possible, obtain 5 or 6 crystals of the same frequency as crystal S and note the activity of each crystal in the primary reference oscillator. Now operate each crystal in the standard crystal oscillator and the test oscillator. The activity of all crystals should now be in direct proportion to the activity obtained in the primary reference oscillator. If this is not the case, adjust grid and plate capacitors C3, C4, C5, and C6 of the standard crystal oscillator and the test oscillator until the activity varies in direct proportion to the activity obtained in the primary reference oscillator.

NOTE: Frequency correlation in the above operation must be maintained by varying the ratio of plate and grid capacity so that the total capacity applied to the oscillator circuits remains approximately constant.

74. UNSATISFACTORY EQUIPMENT REPORT.

a. When trouble in equipment used by Army Ground Forces or Army Service Forces occurs more often than repair personnel feel is normal, War Department Unsatisfactory Equipment Report, W.D., A.G.O. Form No. 468 should be filled out and forwarded through channels to the Office of the Chief Signal Officer, Washington 25, D. C.

b. When trouble in equipment used by Army Air Forces occurs more often than repair personnel feel is normal, Army Air Forces Form No. 54 should be filled out and forwarded through channels.

c. If either form is not available, prepare the data according to the sample form reproduced in figure 22.

WAR DEPARTMENT UNSATISFACTORY EQUIPMENT REPORT									
FOR	TECHNICAL SERVICE Signal Corps	DATE 1 Feb 45							
FROM	ORGANIZATION 175 Signal Repair Co.	MATÉRIEL							
TO	NEXT SUPERIOR HEADQUARTERS Supply Sec. Hq Fourth Army Sig Sv.	STATION APO 110							
		TECHNICAL SERVICE Signal Corps							
COMPLETE MAJOR ITEM									
NOMENCLATURE Radio Transmitter BC-123-A	TYPE Ground, vehicular	MODEL A							
MANUFACTURER American Radio Corp	U. S. A. REG. NO 1234-Phila-45	ORDER NO. 12345							
		DATE RECEIVED 5 Jan 45							
EQUIPMENT WITH WHICH USED (if applicable) Radio Set SCR-45G-A Tank, Medium, M4									
DEFECTIVE COMPONENT—DESCRIPTION AND CAUSE OF TROUBLE									
PART NO. Sig C	TYPE Capacitor C20:fixed;	MANUFACTURER American Radio Corp							
STK. NO. 3E47-3	DESCRIPTION 1-mf; 500 vdcw	DATE INSTALLED when manufactured							
DESCRIPTION OF FAILURE AND PROBABLE CAUSE (If additional space is required, see back of form) Capacitor C20 shorts out due to humid operating conditions									
DATE OF INITIAL TROUBLE 15 Jan 45	TOTAL TIME INSTALLED	TOTAL PERIOD OF OPERATION BEFORE FAILURE							
	YEARS MONTHS DAYS	YEARS MONTHS DAYS HOURS MILES ROUNDS							
	- - -	0 0 5 - -							
BRIEF DESCRIPTION OF UNUSUAL SERVICE CONDITIONS AND ANY REMEDIAL ACTION TAKEN Operation in tropics; heavy rainfall. Was replaced and set given moistureproofing and fungiproofing treatment, 20 Jan 45.									
TRAINING OR SKILL OF USING PERSONNEL	RECOMMENDATIONS (If additional space is required, see back of form)								
POOR FAIR GOOD	I Substitute capacitor designed for tropical operation								
ORIGINATING OFFICER									
TYPED NAME, GRADE, AND ORGANIZATION E. A. WILSON, 1st Lt., Sig C. 175 Sig Repair Co.		SIGNATURE <i>E. A. Wilson</i>							
FIRST ENDORSEMENT									
TO CHIEF	TECHNICAL SERVICE	OFFICE							
NAME, GRADE, AND STATION	STATION	DATE							
Instructions									
<ol style="list-style-type: none"> It is imperative that the chief of technical service concerned be advised at the earliest practical moment of any constructional, design, or operational defect in matériel. This form is designed to facilitate such reports and to provide a uniform method of submitting the required data. This form will be used for reporting manufacturing, design, or operational defects in matériel, petroleum fuels, lubricants, and preserving materials with a view to improving and correcting such defects, and for use in recommending modifications of matériel. This form will not be used for reporting failures, isolated material defects or malfunctions of matériel resulting from fair-wear-and-tear or accidental damage nor for the replacement, repair or the issue of parts and equipment. It does not replace currently authorized operational or performance records. Reports of malfunctions and accidents involving ammunition will continue to be submitted as directed in the manner described in AR 750-10 (change No. 3). It will not be practicable or desirable in all cases to fill all blank spaces of the report. However, the report should be as complete as possible in order to expedite necessary corrective action. Additional pertinent information not provided for in the blank spaces should be submitted as inclosures to the form. Photographs, sketches, or other illustrative material are highly desirable. When cases arise where it is necessary to communicate with a chief of service in order to assure safety to personnel, more expeditious means of communication are authorized. This form should be used to confirm reports made by more expeditious means. This form will be made out in triplicate by using or service organization. Two copies will be forwarded direct to the technical service; one copy will be forwarded through command channels. Necessity for using this form will be determined by the using or service troops. 									
W. D., A. G. O. Form No. 488 30 August 1944		This form supersedes W. D., A. G. O. Form No. 488, 1 December 1943, which may be used until existing stocks are exhausted.							

TL 19569

Figure 22. W.D., A.G.O. Form No. 488, sample form.

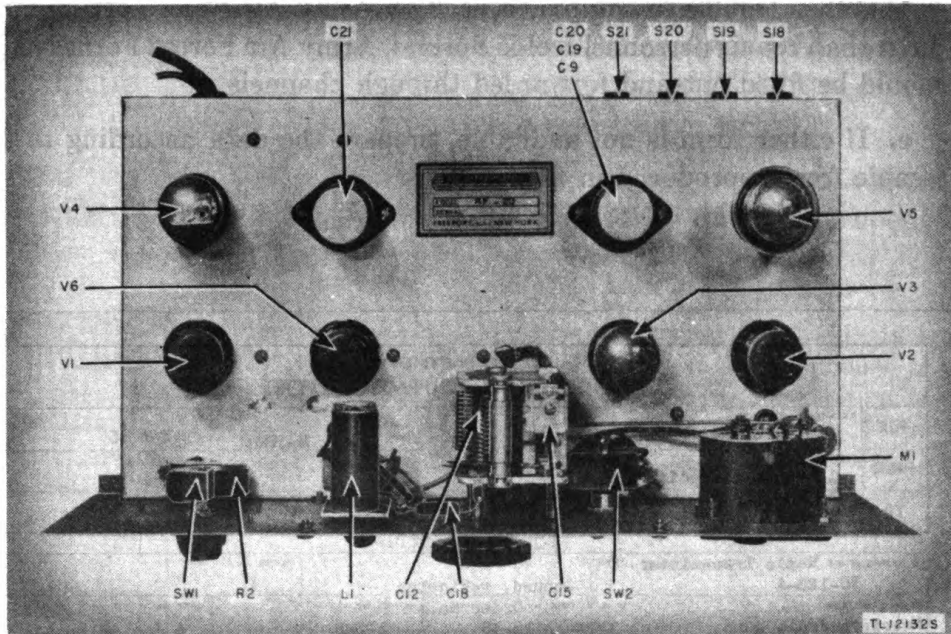

Figure 23. Top view of oscillator section, showing location of parts.

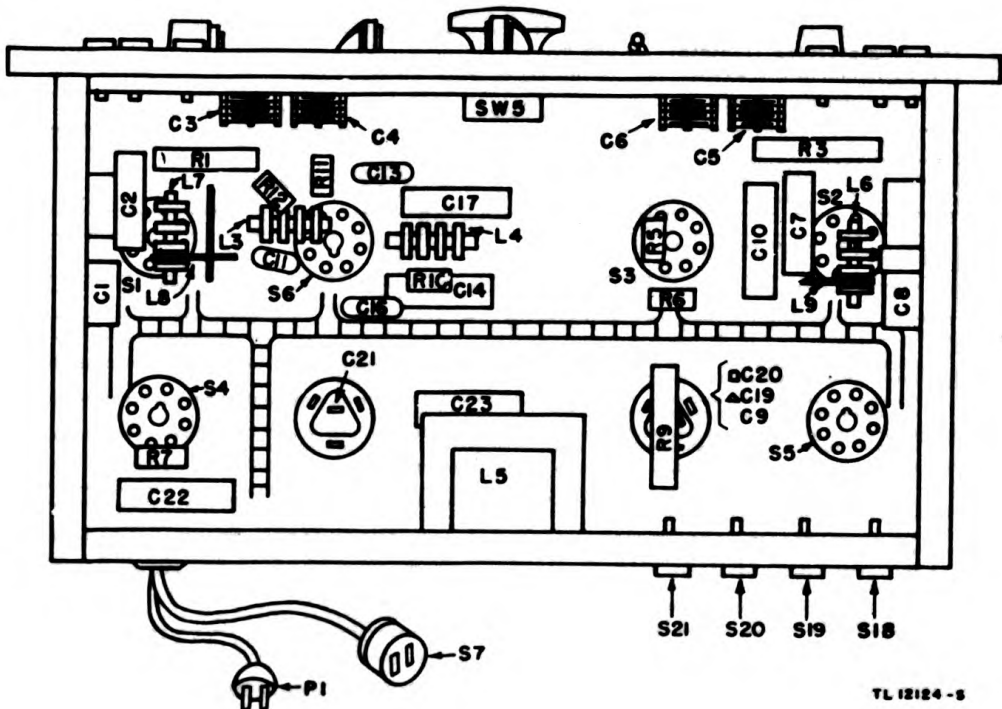

Figure 24. Bottom view of oscillator section, showing location of parts.

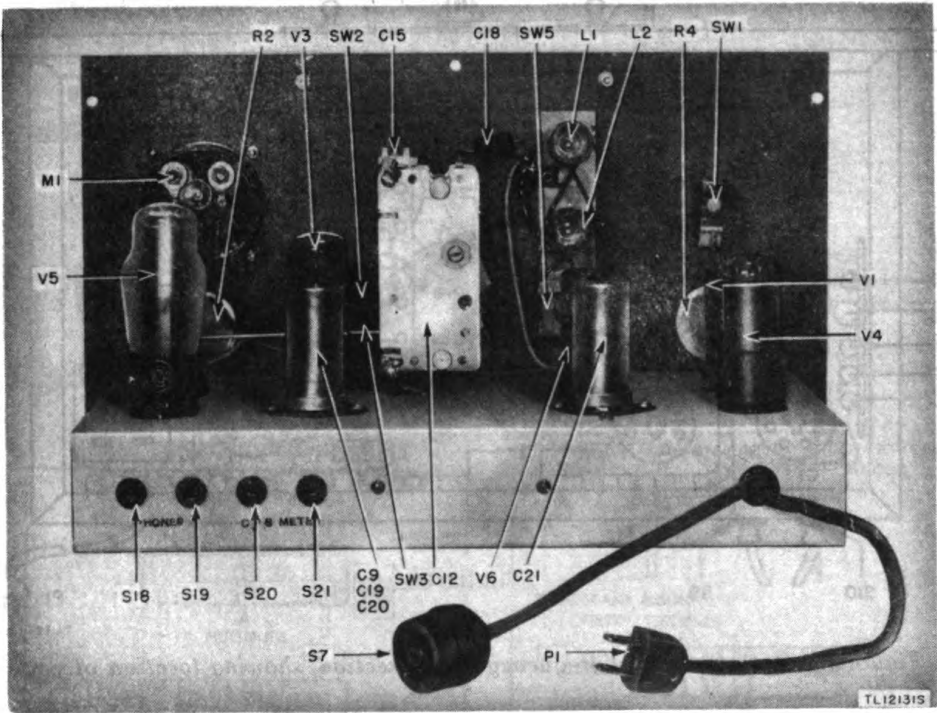

Figure 25. Rear view of oscillator section, showing location of parts.

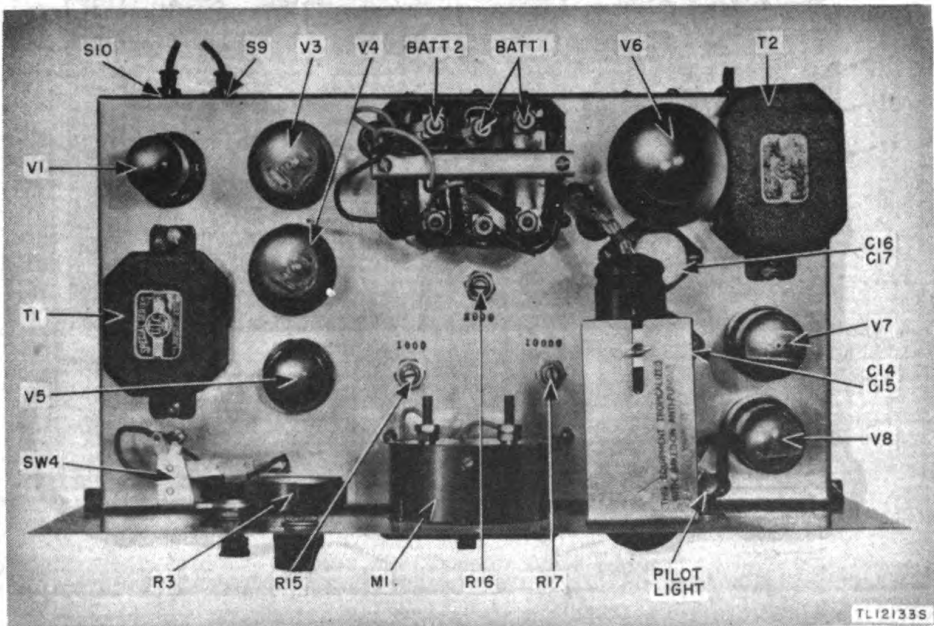

Figure 26. Top view of frequency meter section, showing location of parts.

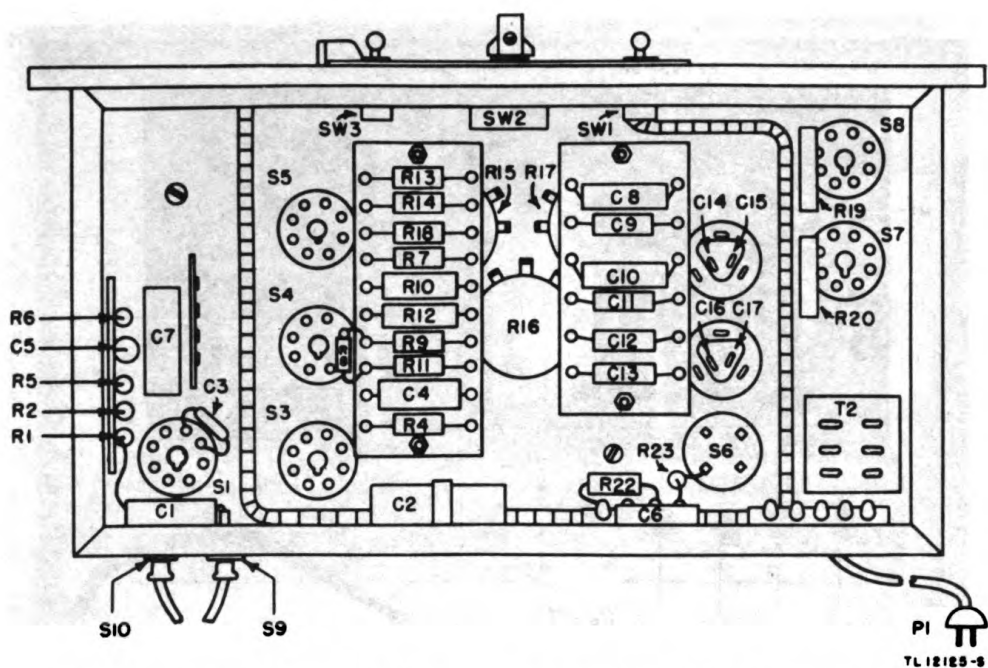

Figure 27. Bottom view of frequency meter section, showing location of parts.

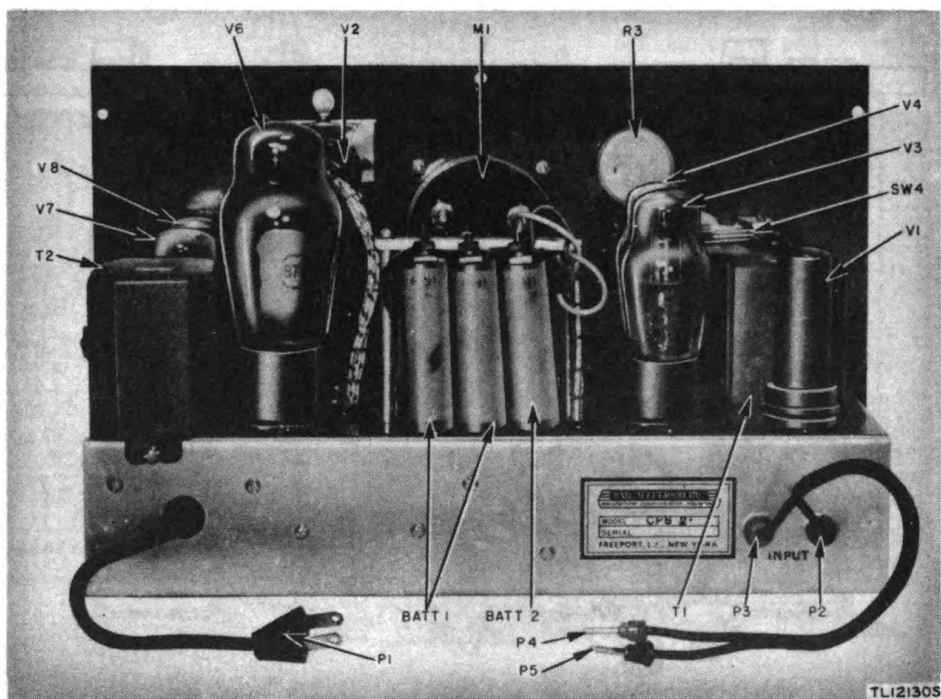
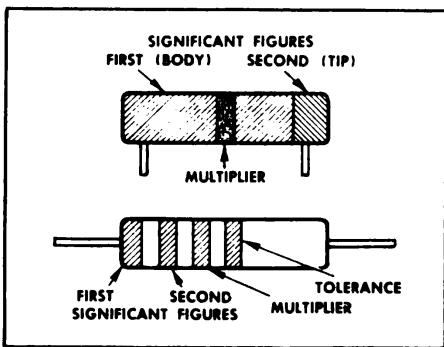

Figure 28. Rear view of frequency meter section, showing location of parts.

RESISTOR COLOR CODES

RMA COLOR CODE FOR FIXED COMPOSITION RESISTORS



Insulated fixed composition resistors with axial leads are designated by a natural tan background color. Non-insulated fixed composition resistors with axial leads are designated by a black background color.

AWS COLOR CODE FOR FIXED COMPOSITION RESISTORS

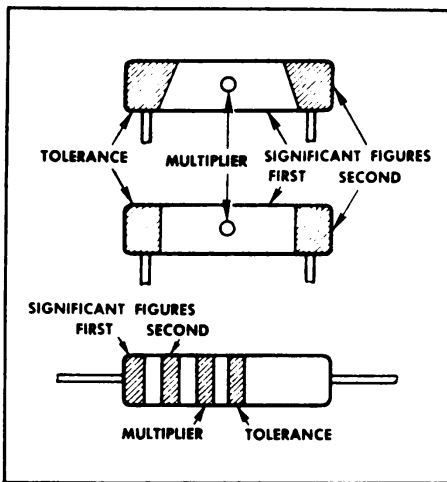

The exterior body color of insulated resistors may be any color except black. The usual color is natural tan. The exterior body color of uninsulated resistors with axial leads may be either black or white. The exterior body color of uninsulated resistors with radial leads may be black or it may be the color of the first significant figure of the resistance value.

COLOR	SIGNIFICANT FIGURE	MULTIPLIER	TOLERANCE (PERCENT)
BLACK	0	1	
BROWN	1	10	
RED	2	100	
ORANGE	3	1000	
YELLOW	4	10,000	
GREEN	5	100,000	
BLUE	6	1,000,000	
VIOLET	7	10,000,000	
GRAY	8	100,000,000	
WHITE	9	1,000,000,000	
GOLD		0.1	5
SILVER		0.01	10
NO COLOR			20

RMA: Radio Manufacturers Association
 AWS: American War Standard
 (American Standards Association)

TL 13418

Figure 29. Resistor color codes.

CAPACITOR COLOR CODES

RMA 6-DOT COLOR CODE FOR MICA-DIELECTRIC CAPACITORS

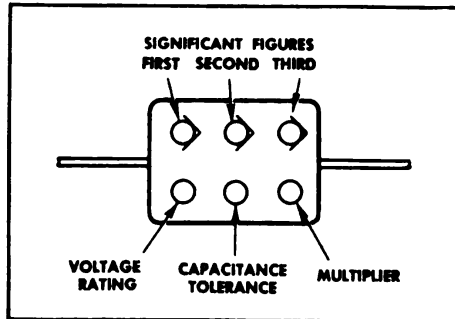

RMA 3-DOT COLOR CODE FOR MICA-DIELECTRIC CAPACITORS

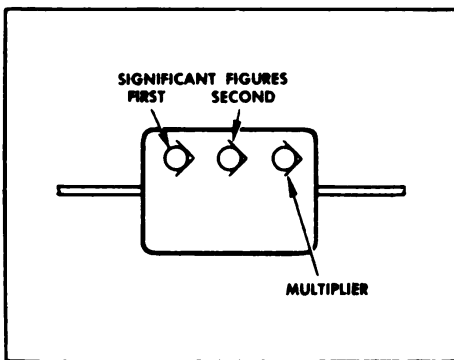

Capacitors marked with this code have a voltage rating of 500 volts.

AWS 6-DOT COLOR CODE FOR PAPER-DIELECTRIC CAPACITORS

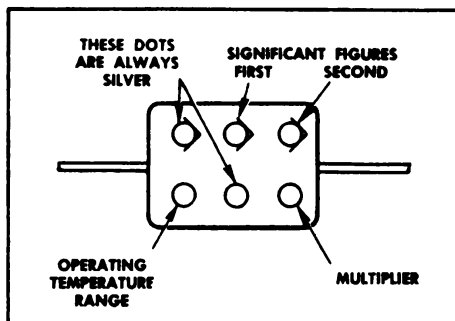

The silver dots serve to identify this marking. The sixth dot shows whether the capacitor has a maximum operating temperature of 167°F (black) or 185°F (brown).

COLOR	SIGNIFICANT FIGURE	MULTIPLIER		VOLTAGE RATING (VOLTS)	CHARACTERISTIC (AWS MICA-DIELECTRIC)
		RMA MICA- AND CERAMIC-DIELECTRIC AWS MICA- AND PAPER-DIELECTRIC	AWS CERAMIC-DIELECTRIC		
BLACK	0	1	1		A
BROWN	1	10	10	100	B
RED	2	100	100	200	C
ORANGE	3	1000	1000	300	D
YELLOW	4	10,000		400	E
GREEN	5	100,000		500	F
BLUE	6	1,000,000		600	G
VIOLET	7	10,000,000		700	
GRAY	8	100,000,000	0.01	800	
WHITE	9	1,000,000,000	0.1	900	
GOLD		0.1		1000	
SILVER		0.01		2000	
NO COLOR				500	TL13417

Figure 30. Capacitor color codes.

AWS 6-DOT COLOR CODE FOR MICA-DIELECTRIC CAPACITORS

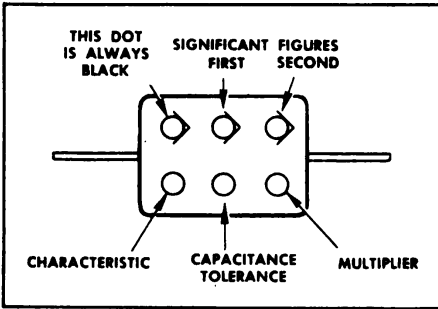

The black dot serves to identify the AWS marking. Capacitors marked with this code are rated at 500 volts, except the following. AWS type CM35 capacitors with capacitances of 6,800, 7,500, and 8,200 micromicrofarads, and AWS type CM40 capacitors with capacitances of 9,100 and 10,000 micromicrofarads are rated at 300 volts.

AWS COLOR CODE FOR TUBULAR CERAMIC-DIELECTRIC CAPACITORS

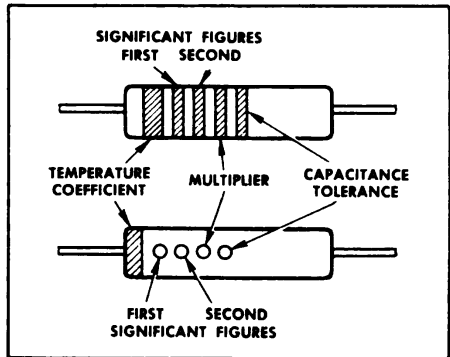

Capacitors marked with this code have a voltage rating of 500 volts.

RMA COLOR CODE FOR TUBULAR CERAMIC-DIELECTRIC CAPACITORS

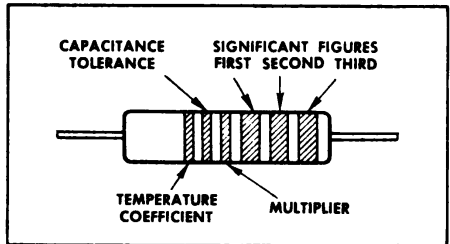

Capacitors marked with this code have a voltage rating of 500 volts.

RMA: Radio Manufacturers Association
AWS: American Wor Standard (American Standards Association)

NOTE: These color codes give all capacitances in micromicrofarads.

CAPACITANCE TOLERANCE				TEMPERATURE COEFFICIENT OF CAPACITANCE $\times 10^{-6}$ MMF/MMF/°C
RMA & AWS MICA- AND PAPER-DIELECTRIC (PERCENT)	RMA CERAMIC-DIELECTRIC (PERCENT)	AWS CERAMIC-DIELECTRIC GREATER THAN 10 MMF (PERCENT)	AWS CERAMIC-DIELECTRIC LESS THAN 10 MMF (MMF)	
20	20	20	2.0	0
1	1	1		- 30
2	2	2		- 80
3	3	2.5	0.25	- 150
4	4			- 220
5	5	5	0.5	- 330
6	6			- 470
7	7			- 750
8	2.5			+ 30
9	10	10	1.0	Not specified
5				
10				
20				

TL 13417

Figure 30. Continued.

APPENDIX

SECTION XV

REFERENCES

75. ARMY REGULATIONS.

AR 380-5 Safeguarding Military Information.

76. SUPPLY PUBLICATIONS.

SIG 1 Introduction to ASF Signal Supply Catalog.
SIG 2 Complete Index to ASF Signal Supply Catalog.
SIG 3 List of Items for Troop Issue.
SIG 4-1 Allowances of Expendable Supplies.
SIG 4-2 Allowances of Expendable Supplies for Schools,
 Training Centers, and Boards.
SIG 5 Stock List of All Items.
SB 11-6 Dry Battery Supply Data.
SB 11-8 Chests for Running Spares.
SB 11-10 Signal Corps Kit and Materials for Moisture and
 Fungi-Resistant Treatment.
SB 11-17 Electron Tube Supply Data.

77. PAINTING, PRESERVING, AND LUBRICATION.

TB SIG 6 A Method of Prolonging the Life of Dry Batteries.
TB SIG 13 Moistureproofing and Fungiproofing Signal Corps
 Equipment.
TB SIG 69 Lubrication of Ground Signal Equipment.

78. CAMOUFLAGE.

FM 5-20 Camouflage, Basic Principles.

79. SHIPPING INSTRUCTIONS.

U.S. Army Spec No. 100-14A. Army-Navy General Specification for Packaging and Packing for Overseas Shipment.

80. DECONTAMINATION.

TM 3-220 Decontamination.

81. DEMOLITION.

FM 5-25 Explosives and Demolitions.

82. OTHER PUBLICATIONS.

FM 21-6*	List of Publications for Training.
W.D. Pamphlet 12-6†	List of Administrative and Supply Publications.
FM 24-18	Radio Communication.
TB SIG 5	Defense Against Radio Jamming.
TB SIG 25	Preventive Maintenance of Power Cords.
TB SIG 66	Winter Maintenance of Ground Signal Equipment.
TB SIG 72	Tropical Maintenance of Ground Signal Equipment.
TB SIG 75	Desert Maintenance of Ground Signal Equipment.
TB SIG 123	Preventive Maintenance Practices for Ground Signal Equipment.
TM 1-455	Electrical Fundamentals.
TM 11-227	Signal Communication Equipment Directory. Radio Communication Equipment.
TM 11-453	Shop Work.
TM 11-455	Radio Fundamentals.
TM 11-462	Reference Data.
TM 11-483	Suppression of Radio Noises.
TM 37-250	Basic Maintenance Manual. Signal Equipment.

* Refer to for applicable technical bulletins.

† Refer to for applicable modification work orders.

83. FORMS.

W.D., A.G.O. Form No. 468 (Unsatisfactory Equipment Report).
Army Air Forces Form No. 54 (unsatisfactory report).

84. ABBREVIATIONS.

a-c	alternating-current
a-f	audio-frequency
cps	cycles per second
d-c	direct-current
h	henry (s)
JAN	Prefix designation for radio electron tubes procured under Joint Army Navy speci- fication JAN-1A
kc	kilocycles
M	1,000 ohms
ma	milliamperes
mc	megacycles
mh	millihenrys
r-f	radio-frequency
XTAL	crystal
Ω	ohms
~	cycles per second

85. GLOSSARY.

Refer to glossary in TM 11-455.

- Activity correlation Process of adjusting two or more crystal oscillator circuits so that the crystal activity of a crystal used in one circuit will be duplicated when the same crystal is used in the other circuit or circuits.
- Calibration Process of determining the values of graduations of dials or meters.
- Crystal activity Relative measurement of the output of a crystal, usually expressed in terms of the grid current in a crystal oscillator.
- Frequency correlation Process of adjusting two or more crystal oscillator circuits so that the frequency of output of any crystal in one circuit will be duplicated when the same crystal is used in the other circuit or circuits.

SECTION XVI

MAINTENANCE PARTS

86. MAINTENANCE PARTS FOR CRYSTAL TEST SET TS-314/FSM-1.

The following information was compiled on 10 April 1945. The appropriate section of the ASF Signal Supply Catalog for Crystal Test Set TS-314/FSM-1 is:

Higher Echelon Spare Parts

SIG 8-TS-314/FSM-1

when published

For the latest index of available catalog sections, see ASF Signal Supply Catalog SIG 2.

<i>Ref symbol</i>	<i>Signal Corps stock No.</i>	<i>Name of part and description</i>
	3F4325-314	CRYSTAL TEST SET TS-314/FSM-1: 110 v ac. 60 c; range 0 to 10 mc; metal case; 16½" wd x 16½" h x 8½" d; (used to test activity and frequency by comparison method); (formerly Ray Jefferson Model AF-30).
		FREQUENCY METER SECTION
	3A31	BATTERY BA-31: dry; 4½ v; rectangular; 13/16" x 2-13/16" x 2-11/16".
	3F3852J/C8	CABLE ASSEMBLY, power: RC; oval shape; 6 ft lg; two No. 18 AWG flexible cond; Belden No. 1725 (with molded rubber plug on one end).
C14 C17	3DKB10-43	CAPACITOR, fixed: electrolytic; 2-sect; 10-10 mf +50% -10%; 450 vdcw; 1" diam x 2" lg; Mallory No. FPD-231.
C4	3DB20-9.1	CAPACITOR, fixed: electrolytic; 20-mf +60% -10%; 25 vdcw; 2¼" lg x ¾" diam; Aerovox No. PRSV25-20.
C3	3K2551042	CAPACITOR, fixed: mica; 51-mmf ±5%; 500 vdcw; max dimen 1-7/64" lg x 15/32" wd x 7/32" thk; CM25D510J.
C9, C11	3K2510242	CAPACITOR, fixed: mica; 1,000-mmf ±5%; 500 vdcw; max dimen 1-7/64" lg x 15/32" wd x 7/32" thk; CM25D102J.

86. Maintenance Parts for Crystal Test Set TS-314/FSM-1 (contd).

<i>Ref symbol</i>	<i>Signal Corps stock No.</i>	<i>Name of part and description</i>
C13	3K3030212	CAPACITOR, fixed: mica; 3,000-mmf $\pm 5\%$; 500 vdcw; max dimen 53/64" lg x 53/64" wd x 9/32" thk; CM30A302J.
C12	3K3562222	CAPACITOR, fixed: mica; 6,200-mmf $\pm 5\%$; 500 vdcw; max dimen 53/64" lg x 53/64" wd x 11/32" thk; CM35B622J.
C1, C5, C8, C10	3DA10-153	CAPACITOR, fixed: paper; 10,000-mmf $\pm 10\%$; 600 vdcw; 7/16" diam x 1 1/8" lg; Dubilier No. DT-6S1.
C6	3DA50-12	CAPACITOR, fixed: paper; 50,000-mmf $\pm 5\%$; 400 vdcw; 15/32" diam x 1 1/8" lg; Dubilier No. DT-4S5.
C7	3DA100-16	CAPACITOR, fixed: paper; 100,000-mmf $\pm 5\%$; 400 vdcw; 10/32" diam x 1 1/8" lg; Dubilier type No. DT-4P1.
C2	3DA500-162	CAPACITOR, fixed: paper; 500,000-mmf $\pm 20\%$; 400 vdcw; 2" lg x 7/8" diam; Aerovox type No. 484.
S9	2Z5531.6	CONNECTOR, female contact: banana type, red; insulated; 3/4" lg x 1/2" diam; Amer Rad Hdwe No. 136.
S10	2Z5531.9	CONNECTOR, female contact: banana type; single-ckt; black brass, insulated; 1" lg x 1/2" OD x 9/32" ID; Amer Rad Hdwe No. 136.
P2, P5	2Z3021-103	CONNECTOR, male contact: banana; black; insulated; 3/8" diam x 1 1/2" lg over-all; ICA type No. 883B.
P3, P4	2Z3021-102	CONNECTOR, male contact: banana; red; insulated; 3/8" diam x 1 1/2" lg over-all; ICA type No. 883R.
	2Z5821-7	KNOB, bar: black bakelite; for 1/4" diam shaft; 1-3/16" lg x 5/8" h x 3/4"; Davies Molding Co No. 2300.
	2Z5848.14	KNOB, round: black bakelite; for 1/4" diam shaft; 11/16" diam x 3/8" thk; John M Forshay No. 1450; (part of switch).
	2Z5927	LAMP LM-27: incandescent; 6- to 8-v, 0.25 amp; bulb T 3 1/4 clear; miniature bayonet base; Mazda No. 44 (pilot).
	2Z5883-58	LAMPHOLDER: miniature bayonet base; brass, nickel pl; with 1/2" red jewel; 1 1/8" x 1" x 5/8"; Mallory No. B-310-R (pilot light).

86. Maintenance Parts for Crystal Test Set TS-314/FSM-1 (contd).

<i>Ref symbol</i>	<i>Signal Corps stock No.</i>	<i>Name of part and description</i>
M1	3F891-61	METER, ammeter: d-c; 0- to 1-ma; sq black bakelite case; 3" sq flange x 2¼" diam body x 2" d; ½" panel; Hoyt No. 597.
R19, R20	3RC30BE470J	RESISTOR, fixed: composition; 47 ohms ±5%; 1-w; max dimen 0.718" lg x 0.280" diam; RC30BE470J.
R4	3RC30BE511J	RESISTOR, fixed: composition; 510 ohms ±5%; 1-w; max dimen 0.718" lg x 0.280" diam; RC30BE511J.
R13, R14, R18	3RC30BE302J	RESISTOR, fixed: composition; 3,000 ohms ±5%; 1-w; max dimen 0.718" lg x 0.280" diam; RC30BE302J.
R7	3RC30BF243J	RESISTOR, fixed: composition; 24,000 ohms ±5%; 1-w; max dimen 0.718" lg x 0.280" diam; RC30BF243J.
R5, R6	3RC21BF513J	RESISTOR, fixed: composition; 51,000 ohms ±5%; ½-w; max dimen 0.655" lg x 0.249" diam; RC21BF513J.
R1, R8, R22	3RC30BF104K	RESISTOR, fixed: composition; 100,000 ohms ±10%; 1-w; max dimen 0.718" lg x 0.280" diam; RC30BF104K.
R9, R11	3RC30BF154K	RESISTOR, fixed: composition; 150,000 ohms ±10%; 1-w; max dimen 0.718" lg x 0.280" diam; RC30BF154K.
R2, R21	3RC30BE105J	RESISTOR, fixed: composition; 1-meg ±5%; 1-w; max dimen 0.718" lg x 0.280" diam; RC30BE105J.
R10, R12	3Z6300-62	RESISTOR, fixed: wire-wound; 3,000 ohms ±5%; 5-w; 1" lg x 5/16" diam; Utahrad No. X-10070.
R15, R17	2Z7279-35	RESISTOR, variable (potentiometer): wire-wound; 2,000 ohms; 4-w; body 1½" diam x 9/16" d, shaft ¼" diam x ½" lg; Mallory No. M2MP.
R16	2Z7280-16	RESISTOR, variable (potentiometer): wire-wound; 5,000 ohms; 4-w; body 1½" diam x 9/16" d, shaft ¼" diam x ¾" lg; Mallory No. M5MP.
R3	2Z7272-41	RESISTOR, variable (potentiometer): carbon; 500,000 ohms; 2-w; body 1¾" diam x 9/16" d, shaft ¼" diam x 3¾"; Centralab No. A-128.
S6	2Z8674.8	SOCKET, tube: 4-prong female; black bakelite; 1½" diam x 13/16" h; Amphenol type No. S4 (with No. 4 retainer ring).

86. Maintenance Parts for Crystal Test Set TS-314/FSM-1 (contd).

<i>Ref symbol</i>	<i>Signal Corps stock No.</i>	<i>Name of part and description</i>
S1, S2, S3, S4, S5, S7, S8	2Z8799-137	SOCKET SO-137: tube; octal; 1¼" diam x 13/16" h; Amphenol type No. S8 (with No. 4 retainer ring).
SW4	3Z9824-27.4	SWITCH, push button: non-locking; single-ckt; cont normally closed; bakelite; 1-11/16" wd x ¼" thk x 1-5/16" d; Mallory No. 2002 (deionizing switch).
SW2	3Z9825-55.3	SWITCH, rotary: 4-pole; 3-position; single-sect; bakelite; 1¼" diam x 13/16" d over-all; Mallory No. 3243J (multiplier).
SW1	3Z8116	SWITCH SW-116: toggle; DPST; bakelite body; 1-9/16" lg x 17/32" d x ⅝" wd; Sig C dwg No. SC-A-1042 (3-amp, 250-v).
SW3	3Z8131	SWITCH SW-131: toggle; SPST; bakelite body; 1⅝" lg x ½" wd x ½" thk; Sig C dwg No. SC-A-1042 (3-amp, 250-v) (plate supply on 884 tube).
T1	2Z9636.88	TRANSFORMER, AF: interstage; pri 10,000 ohms, sec 40,000 ohms impedance; fully inclosed metal case; 2-5/16" h x 2⅝" wd x 1-15/16" d over-all; UTC No. S2 (audio input).
T2	2Z9611.345	TRANSFORMER, power: fil; pri 117-v, 15-amp; sec 6.3-v, 3-amp, ct; completely inclosed metal case; 2½" h x 2¾" wd x 2⅝" d over-all; UTC No. S55.
V2	2J6E5	TUBE, electron: JAN-6E5.
V1	2J6N7	TUBE, electron: JAN-6N7 (VT-96-B).
V7, V8	2J117Z6GT/G	TUBE, electron: JAN-117Z6GT.
V6	2J874	TUBE, electron: JAN-874.
V3, V4	2J884	TUBE, electron: JAN-884.
	3E7276	OSCILLATOR SECTION CABLE ASSEMBLY, power: fabric covered; ¼" diam; 60" lg; two No. 20 AWG flexible copper cond, and one 180-ohm resistor Clarostat No. PC-180 (line cord).
C9, C19, C20	3DB40-56	CAPACITOR, fixed: electrolytic; 3-sect; 40-20-20 mf +50% -10%; 150-150-25 vdcw; 2" lg x 1" diam; Mallory No. FPT-306.
C21	3DB50-48	CAPACITOR, fixed: electrolytic; 50-mf +40% -10%; 150 vdcw; 2" lg x 1" diam; Mallory No. FPS-115.

86. Maintenance Parts for Crystal Test Set TS-314/FSM-1 (contd).

<i>Ref symbol</i>	<i>Signal Corps stock No.</i>	<i>Name of part and description</i>
C11	3K2510114	CAPACITOR, fixed: mica; 100-mmf $\pm 20\%$; 500 vdcw; max dimen 1-7/64" lg x 15/32" wd x 7/32" thk; CM25A101M.
C18	3K2551112	CAPACITOR, fixed: mica; 510-mmf $\pm 5\%$; 500 vdcw; max dimen 1-7/64" lg x 15/32" wd x 7/32" thk; CM25A511J.
C13, C16	3K2510242	CAPACITOR, fixed: mica; 1,000-mmf $\pm 5\%$; 500 vdcw; max dimen 1-7/64" lg x 15/32" wd x 7/32" thk; CM25D102J.
C2, C7	3DA10-153	CAPACITOR, fixed: paper; 10,000-mmf $\pm 20\%$; 600 vdcw; 1 3/8" lg x 7/16" diam; Dubilier type No. DT-6S1.
C10, C14, C17, C22, C23	3DA50-1.2	CAPACITOR, fixed: paper; 50,000-mmf $\pm 5\%$; 400 vdcw; 15/32" diam x 1 3/8" lg; Dubilier type No. DT-4S5.
C1, C8	3DA500-162	CAPACITOR, fixed: paper; 500,000-mmf $\pm 20\%$; 400 vdcw; 2" lg x 3/8" diam; Aero-vox type No. 484.
C15	3D9003-1	CAPACITOR, variable: air; 3- to 30-mmf; 2 plates; 13/16" x 9/16" x 1/2" over-all; Natl Co type No. M30.
C3, C4, C5, C6	3D9035V-27	CAPACITOR, variable: air; 4- to 35-mmf; 0.015" air gap; 5 rotor and 5 stator plates; 1-17/64" lg x 15/16" wd x 1-7/32" h; Hammarlund No. APC-35.
C12	3D9442VE6	CAPACITOR, variable: air; 442-mmf; 25 plates; 1-27/32" x 3-9/16" x 2-15/16" over-all; RCC No. 23 series 123 (heterodyne detector).
L5	3C323-6W	COIL, AF: filter; 10-h; 65-ma, 360 ohms resistance; 2" h x 1 1/2" wd x 2 3/8" lg; Freed No. 404.
L3, L4, L6, L7	3CK342-1	COIL, RF: choke; unshielded; 2.5-mh, 200-ma, 26 ohms; 1 1/2" lg x 5/8" diam over-all; Miller JW No. 4537.
L2	3C323-154B	COIL, RF: oscillator; single-layer wound; unshielded; 37- μ h; 9/16" lg x 3/4" diam; Ray Jefferson No. AF30-L2 (4,500 kc-10,000 kc).
L1	3C323-154A	COIL, RF: oscillator; single-layer wound; unshielded; 12- μ h; 9/16" lg x 3/4" diam; Ray Jefferson No. AF-30-L1 (2,000 kc-4,700 kc).

86. Maintenance Parts for Crystal Test Set TS-314/FSM-1 (contd).

<i>Ref symbol</i>	<i>Signal Corps stock No.</i>	<i>Name of part and description</i>
S8, S9, S12, S13, S14, S17, S20, S21 S18, S19	2Z5573.b 2Z5581-11	CONNECTOR, female contact: one cont; straight; 7/8" x 1/2" diam over-all; Amphe-nol No. 78-1M (banana jacks). CONNECTOR, female contact: one cont; straight; 1-1/16" x 1/2" diam; Amphenol No. 78-1P (banana jacks).
S10, S11, S15, S16	2Z5573.9	CONNECTOR, female contact: one cont; straight; 31/32" x 1/2" diam; Amphenol No. 78-1S (banana jack).
S7	6Z7567-4 4F49070 2Z5821-7 2Z5848.14 2Z5850-64	CONNECTOR, female contact: 2-cont; straight; spring action; 1-3/16" x 1-3/16" diam; Amphenol No. 61-F4 (a-c outlet). HOLDER ASSEMBLY, crystal: test; quartz; 2-cont; bakelite body; spring ac-tion clip; 2-13/16" x 1 1/8" x 1 1/2"; Ray Jefferson No. RJ4A. KNOB, bar: black bakelite; for 1/4" diam shaft; 1-3/16" lg x 5/8" wd; Davies Mold-ing Co No. 2300. KNOB, round: black bakelite; for 1/4" diam shaft; single No. 8-32 setscrew; 3/8" x 11/16" diam; John M Forshay No. 1450 (grid leak, adjustment). KNOB, round: black bakelite; for 1/4" diam shaft; single No. 8-32 setscrew; 15/16" x 1-11/16" diam; John M Forshay No. 3000 (tuning knob).
M1	3F891-63	METER, ammeter: dc; 0 to 1 ma; sq, black bakelite case; 2 3/8" sq x 1 3/4" d; Marion Instrument Co model No. 545; Hoyt No. 17.
R7	3RC30BE510J	RESISTOR, fixed: composition; 51 ohms ±5%; 1-w; max dimen 0.750" lg x 0.280" diam; RC30BE510J.
R8	3RC30BE202J	RESISTOR, fixed: composition; 2,000 ohms ±5%; 1-w; max dimen 0.750" lg x 0.280" diam; RC30BE202J.
R1, R3	3RC20BE912J	RESISTOR, fixed: composition; 9,100 ohms ±5%; 1/2-w; max dimen 0.468" lg x 0.249" diam; RC20BE912J.
R12	3RC20BE103J	RESISTOR, fixed: composition; 10,000 ohms ±5%; 1/2-w; max dimen 0.468" lg x 0.249" diam; RC20BE103J.

86. Maintenance Parts for Crystal Test Set TS-314/FSM-1 (contd).

<i>Ref symbol</i>	<i>Signal Corps stock No.</i>	<i>Name of part and description</i>
R10, R11	3RC20BE243J	RESISTOR, fixed; composition; 24,000 ohms $\pm 5\%$; $\frac{1}{2}$ -w; max dimen 0.468" lg x 0.249" diam; RC20BE243J.
R5	3RC20BE514J	RESISTOR, fixed: composition; 510,000 ohms $\pm 5\%$; $\frac{1}{2}$ -w; max dimen 0.468" lg x 0.249" diam; RC20BE514J.
R9	3Z6075-31	RESISTOR, fixed: wire-wound; 750 ohms $\pm 10\%$; 10-w; $1\frac{3}{4}$ " lg x $5/16$ " diam; Ohmite type Brown Devil.
R2, R4	2Z7270.43	RESISTOR, variable (potentiometer): carbon; 50,000 ohms; 1-w; 3-term; $1\frac{3}{8}$ " diam x $9/16$ " d, shaft $\frac{1}{4}$ " diam x $\frac{1}{2}$ " lg; Centralab No. 1010098.
S1 to S6	2Z8799-137	SOCKET SO-137: tube; octal; black bakelite; $1\frac{1}{4}$ " x $13/16$ "; Amphenol type No. 1S-8.
SW1	3Z9826-7.4	SWITCH, rotary: SPST; bakelite body; $1-9/32$ " lg x $1-3/16$ " wd x $\frac{3}{4}$ " thk; Bud Rad No. 499 (off-on).
SW4, SW5	3Z8314.7	SWITCH, rotary: 2-pole; 2-position; single-act; metal covered bakelite wafer; $1\frac{1}{4}$ " diam x $13/16$ " over-all; Mallory No. 3122-J (heterodyne oscillator selector and trimmer capacitor switch).
SW2, SW3	3Z8157	SWITCH SW-157: toggle; DPDT; bakelite; $1-5/16$ " lg x $\frac{3}{4}$ " wd x $25/32$ " d; Sig C dwg No. SC-A-1042 (heterodyne oscillator, meter switch).
V1, V2	2J6SJ7	TUBE, electron: JAN-6SJ7 (VT-116).
V6	2J6SQ7	TUBE, electron: JAN-6SQ7 (VT-103).
V3	2J25L6GT	TUBE, electron: JAN-25L6GT (VT-201C).
V4	2J25Z6GT	TUBE, electron: JAN-25Z6GT.
V5	2J0A3/VR-75	TUBE, electron: JAN-0A3/VR-75 (VT-260).

Order No. 29081-Phila-45-10; 1204 copies, May 1945.

HETERODYNE
OSCILLATOR
AND DETECTOR
V6
JAN-6SQ7

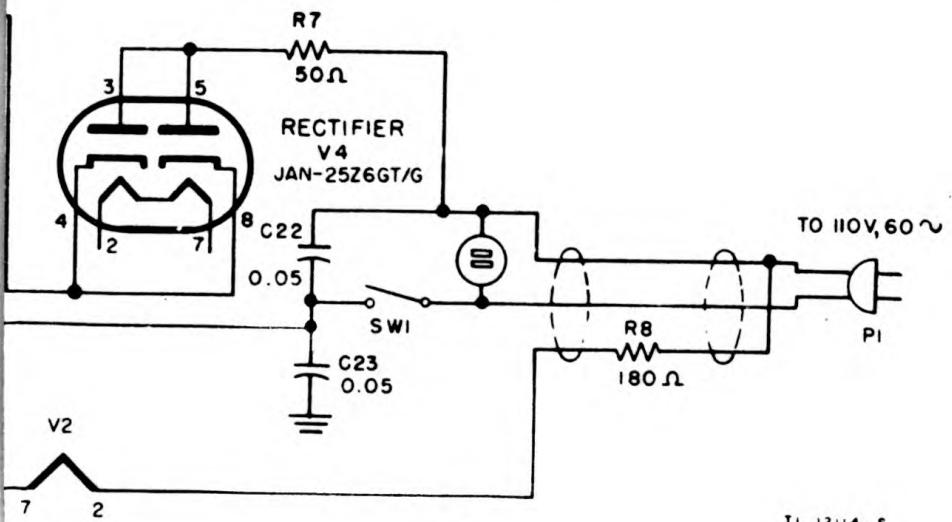
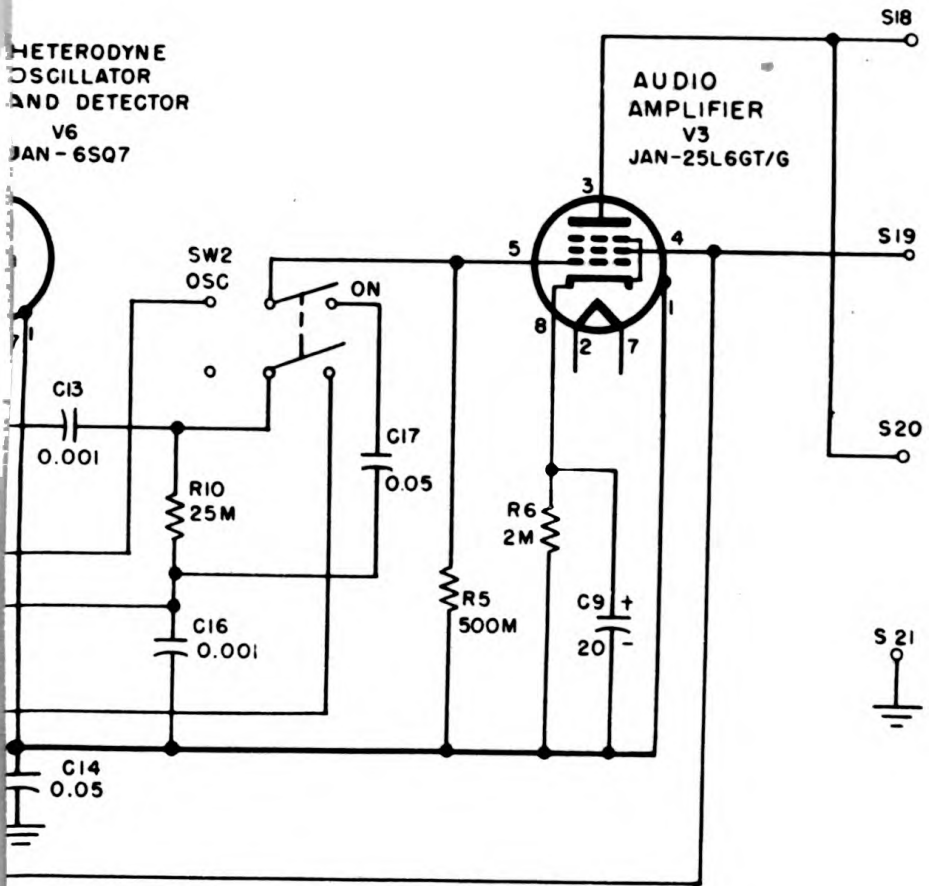

TL 12114.5

Figure 31. Schematic diagram of oscillator section.

41
31
11
14
1

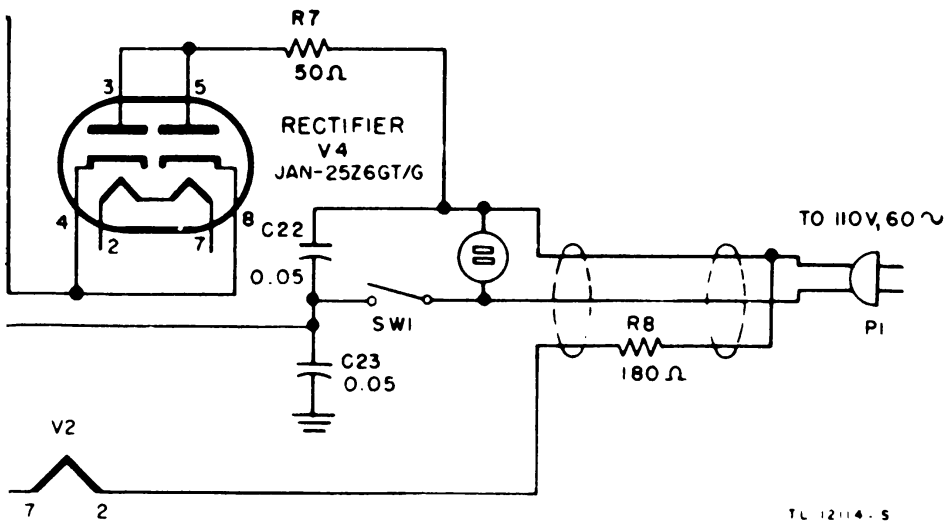
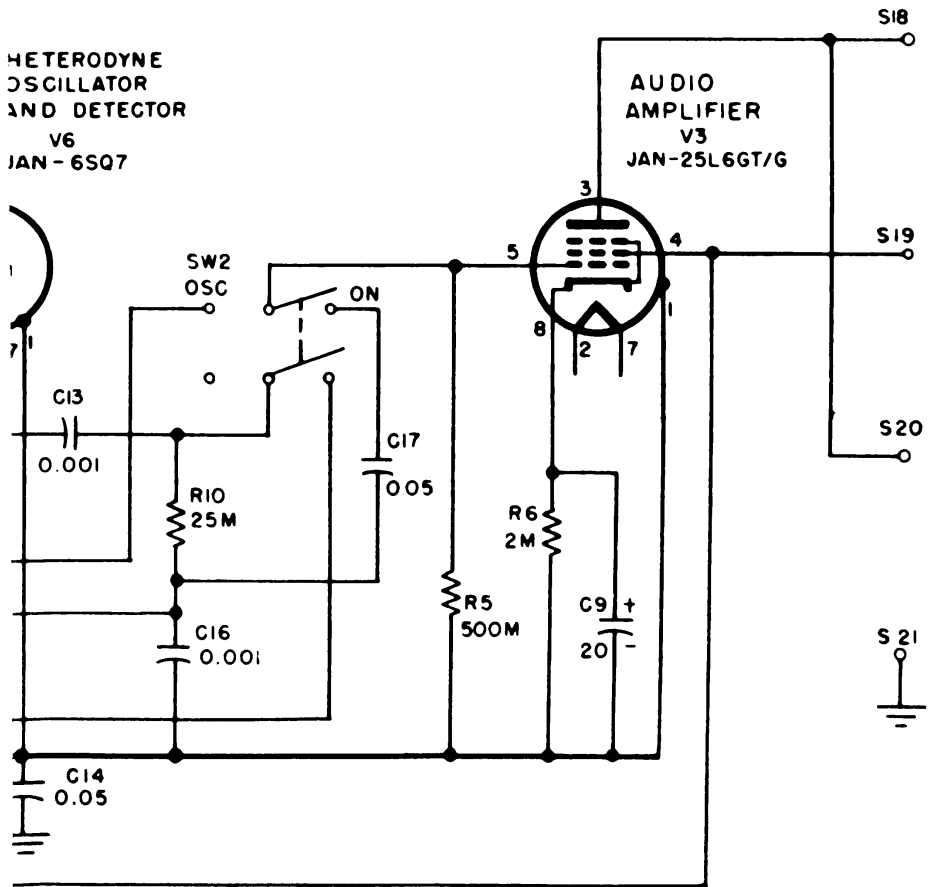

Figure 31. Schematic diagram of oscillator section.

