

11113
7463

RESTRICTED

TM 11-317

UNIVERSITY OF CALIFORNIA
LIBRARY
APR 25 1947
DOCUMENTS DIVISION

WAR DEPARTMENT
U.S. Dept of Army

TECHNICAL MANUAL

SIGNAL GENERATOR I-208

28 Aug 1943

WAR DEPARTMENT

Washington 25, D. C. 28 Aug 1943

This Technical Manual is furnished for the information and guidance of all concerned.

RESTRICTED

Dissemination of restricted matter.—The information contained in restricted documents and the essential characteristics of restricted materiel may be given to any person known to be in the service of the United States and to persons of undoubted loyalty and discretion who are cooperating in Government work, but will not be communicated to the public or to the press except by authorized military public relations agencies. (See also par 18b, AR 380-5, 28 Sep 1942.)

61-12

TM 11-317

1943
★ ★

RESTRICTED

TECHNICAL MANUAL
No. 11-317

WAR DEPARTMENT
WASHINGTON 25, D.C. 28 AUG 1943

SIGNAL GENERATOR I-208

Prepared under direction of the
Chief Signal Officer

TABLE OF CONTENTS

SECTION I—DESCRIPTION

	<i>Paragraph</i>
General	1
Characteristics	2
Source of power	3
List of components	4

SECTION II—INSTALLATION AND OPERATION

Installation	5
Operation	6

SECTION III—DETAILED FUNCTIONING OF PARTS

Audio oscillator unit	7
Radio-frequency unit	8
Calibrator unit	9
Main power supply	10
Dynamotor assembly	11

SECTION IV—MAINTENANCE

Procedure in case of equipment failure	12
Removal of tubes for testing	13
Removal of units	14
Adjustments	15

SECTION V—SUPPLEMENTARY DATA

Table of replaceable parts	16
List of manufacturers	17

LIST OF ILLUSTRATIONS

<i>Figure</i>	<i>Page</i>
1. Signal Generator I-208 on Mounting FT-237-A	4
2. Signal Generator I-208, rear view	6
3. RMA Standard Phantom Antenna	9
4. Signal Generator I-208, front view	10
5. Signal Generator I-208, top view showing tube locations	12
6. Signal Generator I-208, bottom view	16
7. Signal Generator I-208, rear view, dust cover removed	18
8. Cords	20
9. Signal Generator I-208, schematic diagram	25
10. Dial mechanism	28
11. Dial film, preparation for installation	30
12. Block diagram showing methods of connecting Signal Generator I-208 to a radio spectroscop.	34
13. Panoramic pattern, unmodulated signal	36
14. Panoramic pattern, first null point	36
15. Connection diagram for determination of modulation voltage (d-c method)	38
16. Practical wiring diagram, audio oscillator unit	41
17. Practical wiring diagram, main power supply	42
18. Practical wiring diagram, r-f unit	43
19. Practical wiring diagram, dynamotor assembly	44
20. Practical wiring diagram, calibrator unit	45
21. Socket voltage and resistance measurements, r-f unit	46
22. Socket voltage and resistance measurements, calibrator unit	47
23. Socket voltage and resistance measurements, main power supply	48
24. Socket voltage and resistance measurements, audio oscillator	49

DESTRUCTION NOTICE

WHY—To prevent the enemy from using or salvaging this equipment for his benefit.

WHEN—When ordered by your commander, or when you are in immediate danger of capture.

HOW—1. Smash—Use sledges, axes, hand-axes, pick-axes, hammers, crowbars, heavy tools, etc.

2. Cut—Use axes, hand-axes, machete, etc.

3. Burn—Use gasoline, kerosene, oil, flame-throwers, incendiary grenades, etc.

4. Explosives—Use firearms, grenades, TNT, etc.

5. Disposal—Bury in slit trenches, fox-holes, other holes. Throw in streams. Scatter.

6. **USE ANYTHING IMMEDIATELY AVAILABLE FOR DESTRUCTION OF THIS EQUIPMENT.**

WHAT—1. Smash—Meter, crystal, controls, tubes, switches, plugs, sockets, dials, capacitors, transformers, and dynamotor.

2. Cut—Cables, wiring, and cords.

3. Bend and/or break—Panel, chassis, and cabinet.

4. Burn—Diagrams, charts, cables, cords, capacitors, transformer, and dynamotor.

5. Bury or scatter—Any or all of the above pieces after breaking or burning.

DESTROY EVERYTHING

SAFETY NOTICE

THIS EQUIPMENT USES DANGEROUSLY HIGH VOLTAGES. DO NOT CHANGE VACUUM TUBES OR MAKE ADJUSTMENTS WITHIN ANY UNIT OF THE EQUIPMENT WITH THE DYNAMOTOR RUNNING OR WITH THE A-C POWER SUPPLY IN OPERATION, EXCEPT AS SPECIFICALLY DIRECTED IN THIS MANUAL.

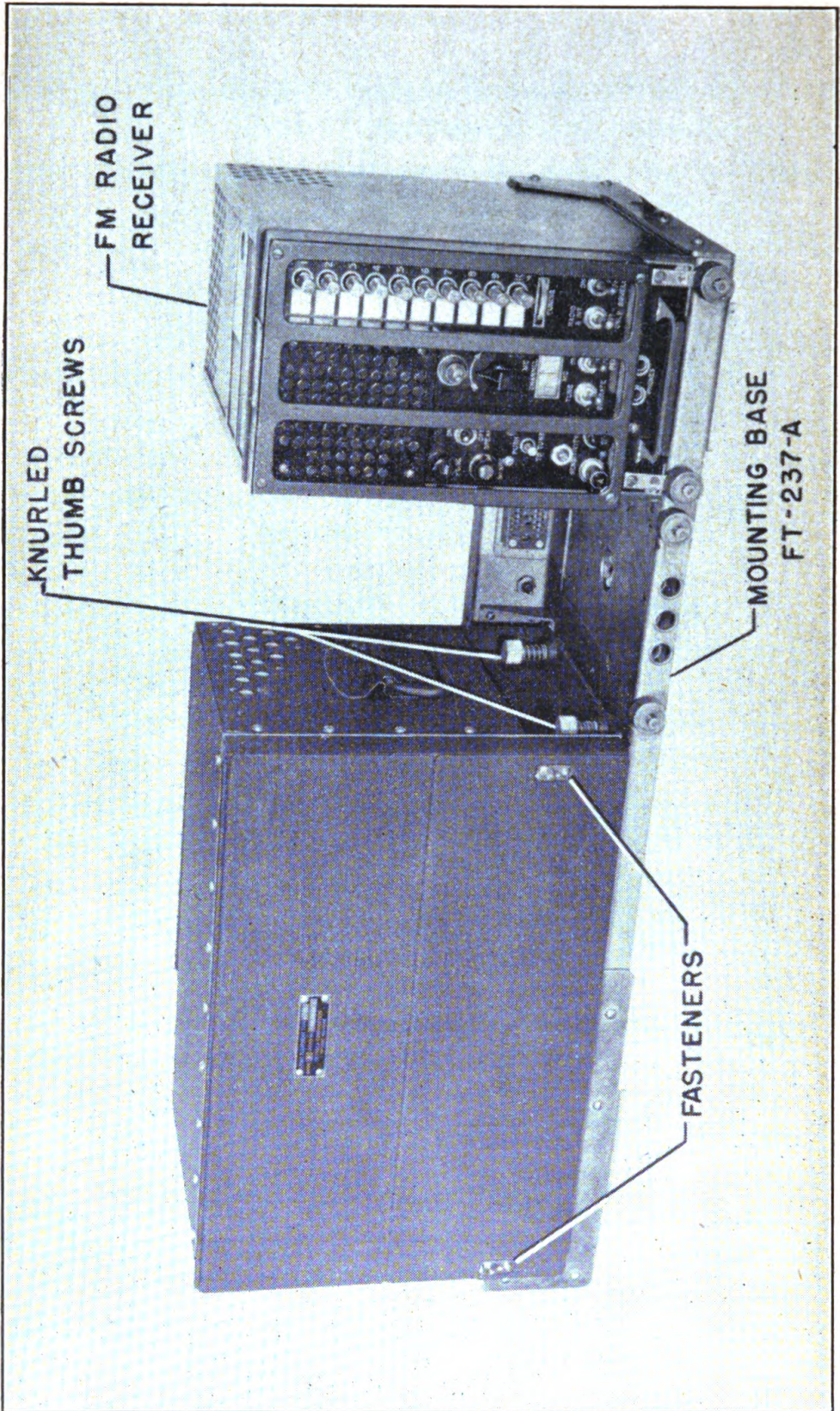

Figure 1—Signal Generator I-208 on Mounting FT-237-A

SECTION I

DESCRIPTION

	<i>Paragraph</i>
General	1
Characteristics	2
Source of power	3
Main components	4

1. General

Signal Generator I-208 is a frequency and voltage standard for testing frequency modulation radio equipment. It is used in the calibration, alignment, and determination of sensitivity of frequency modulation radio receivers. The signal generator may be installed on Mounting FT-237-(*) for use in mobile units or for field use (figure 1).

2. Characteristics

a. Range: The signal generator covers two frequency ranges. These are 1.9 to 4.5 megacycles and 19 to 45 megacycles.

b. Frequency deviation: The frequency deviation can be adjusted from 0 to 5 kilocycles each side of center frequency for the 1.9 to 4.5 megacycle band, and from 0 to 50 kilocycles each side of center frequency for the 19 to 45 megacycle band. Frequency deviation is controlled by a calibrated control marked K. C. DEVIATION.

c. Modulation: Five modulation frequencies are provided by an internal audio oscillator. They are 150, 400, 1000, 2500, and 5000 cycles per second. Terminals on the front panel provide for external modulation.

d. Output: Output voltage up to 100,000 microvolts is developed at the termination of a 30-ohm line. This output is controlled and measured by a calibrated attenuator, multiplier, and vacuum tube voltmeter. Output signal voltage, up to .84 volt, is delivered through the high output terminal and the high output cable which is stored in a compartment at the rear of the signal generator (figure 2). This output is controlled by a potentiometer and measured by the vacuum tube voltmeter.

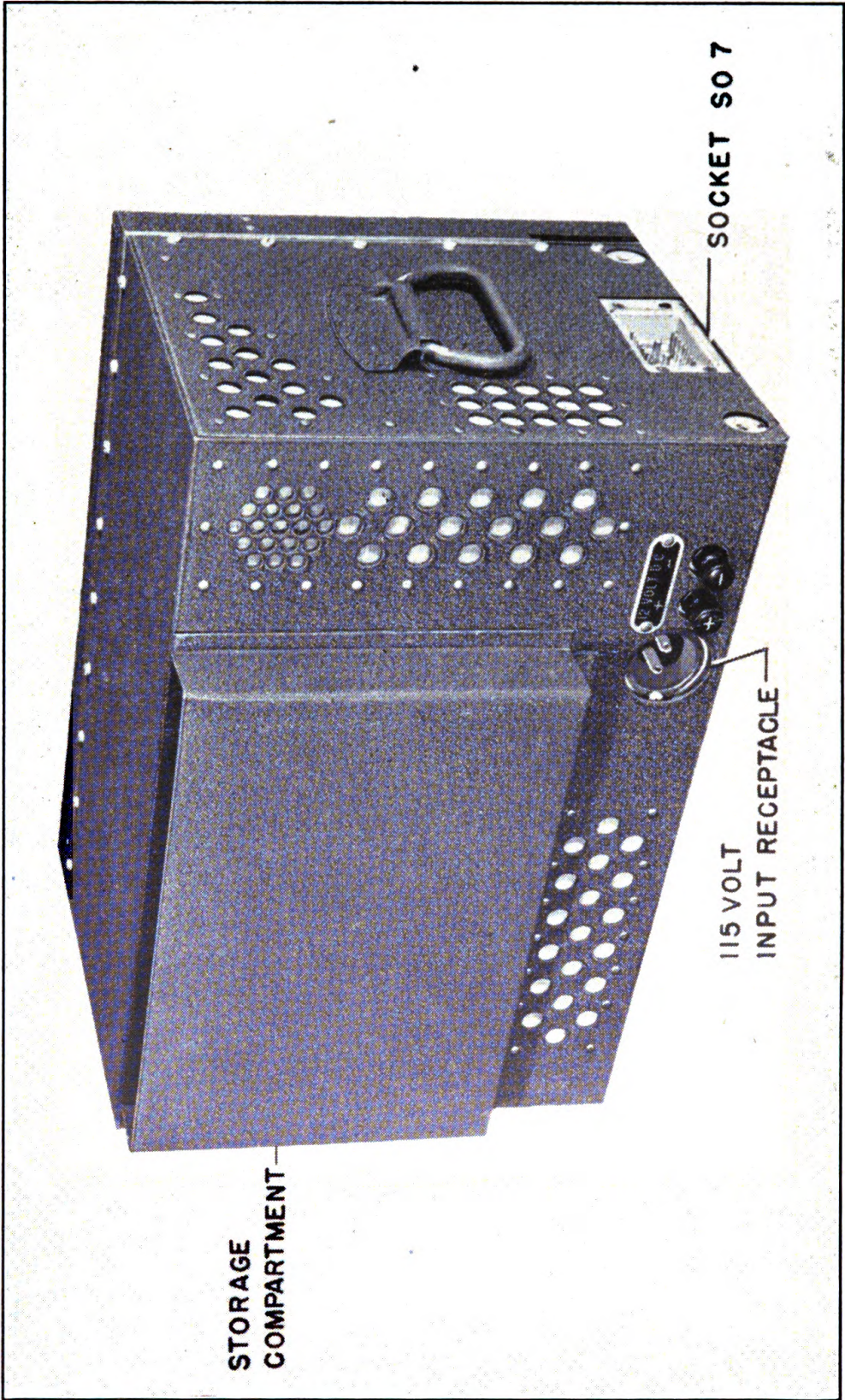

Figure 2—Signal Generator I-208, rear view

e. Output signal: The frequency of the output signal is maintained within .03 per cent of the dial indication over a temperature range from 0° to 60° C through the use of a crystal calibrator unit included in the signal generator.

3. Source of Power

- a. 12-volt direct current (11 to 14 volts).
- b. 115-volt 60-cycle, alternating current (105 to 130 volts).

4. List of Components

Signal Generator I-208 105 lbs 19" x 12 $\frac{1}{8}$ " x 11 $\frac{1}{2}$ "
with the following installed:

- a. Cord CD-778, 115-volt power cord 8 oz 8 feet long
- b. Cord CD-749, high output cable 4 oz 40 inches long
- c. Cord CD-984, service extension cord 6 oz 36 inches long
- d. Crystal Unit DC-23-A (1 in use, 1 spare) 1/2 oz ea. 1 $\frac{1}{8}$ " x 1 $\frac{1}{8}$ " x 7/16"
- e. Dynamotor DM-64-A 5 $\frac{1}{2}$ lbs 6 $\frac{9}{16}$ " x 4 $\frac{1}{4}$ " x 3 $\frac{3}{8}$ "
- f. Fuse FU-53 (1 in use, 9 spare) 1/4 oz ea. 1 $\frac{1}{4}$ " x 1/4" dia.
- g. Fuse FU-54 (1 in use, 9 spare) 1/4 oz ea. 1 $\frac{1}{4}$ " x 1/4" dia.
- h. Lamp LM-27 (3 in use, 6 spare) 1/4 oz ea. 1 $\frac{1}{8}$ " x 7/16" dia.
- i. Spare dial film 2 oz 1 $\frac{3}{8}$ " x 1 $\frac{7}{8}$ " dia.
- j. 3 sets of tubes (1 set in use, 2 spare) 1 lb 14 oz Two sets in carton
ea. set 5 $\frac{3}{4}$ " x 9" x 12 $\frac{3}{4}$ "
- k. Technical Manual TM 11-317 (2 supplied) 3 $\frac{1}{2}$ oz ea. 5 $\frac{1}{2}$ " x 8 $\frac{1}{2}$ "

SECTION II

INSTALLATION AND OPERATION

	<i>Paragraph</i>
Installation	5
Operation	6

5. Installation

a. When the signal generator is installed on Mounting FT-237-(*), make the 12-volt, d-c input connections to the power receptacle by sliding the signal generator to the left as far as it will go and tightening the knurled thumb screws at the lower right of the signal generator (figure 1). Some Mountings FT-237-(*) have plug covers installed on the left side of the rear rail. These covers must be removed before placing the signal generator on the mounting base.

b. For other d-c installations, two binding posts are provided on the rear of the signal generator for the 12-volt, d-c input leads.

CAUTION: MAKE SURE THE POSITIVE POST OF THE POWER SOURCE IS CONNECTED TO THE POSITIVE BINDING POST MARKED (+) AND THAT THE NEGATIVE POST IS CONNECTED TO THE BINDING POST MARKED (-).

c. For operation from a 115-volt, 60-cycle source, one end of Cord CD-778 is plugged into the receptacle at the rear of the signal generator and the other end connected to any 115-volt, 60 cycle, a-c source.

NOTE: NEVER TRY TO OPERATE THE SIGNAL GENERATOR FROM A SOURCE OTHER THAN 115-VOLT, 50 TO 70-CYCLE, A-C.

6. Operation

a. Initial procedure

(1) See that the POWER switch is at OFF. Throw power selector switch to correspond with available power source (12 DC or 115 AC).

(2) Check the meter reading. The pointer must be at 0. If it does not read 0, very carefully adjust the meter adjusting screw (figure 4) so that the meter needle is at zero.

(3) After you have installed the signal generator as outlined in paragraph 5a, b, or c, and made the adjustments outlined in paragraphs 6a(1) and 6a(2), throw the POWER, PLATE VOLTAGE, and CALIBRATOR switches to ON and allow the signal generator to warm up for about 15 minutes.

(4) While waiting for the signal generator to warm up, determine from the radio receiver alignment procedure the type of coupling (phantom antenna) required between the signal generator and the radio receiver. A network as shown in figure 3 may be used if a specific phantom antenna is not recommended in the receiver alignment procedure.

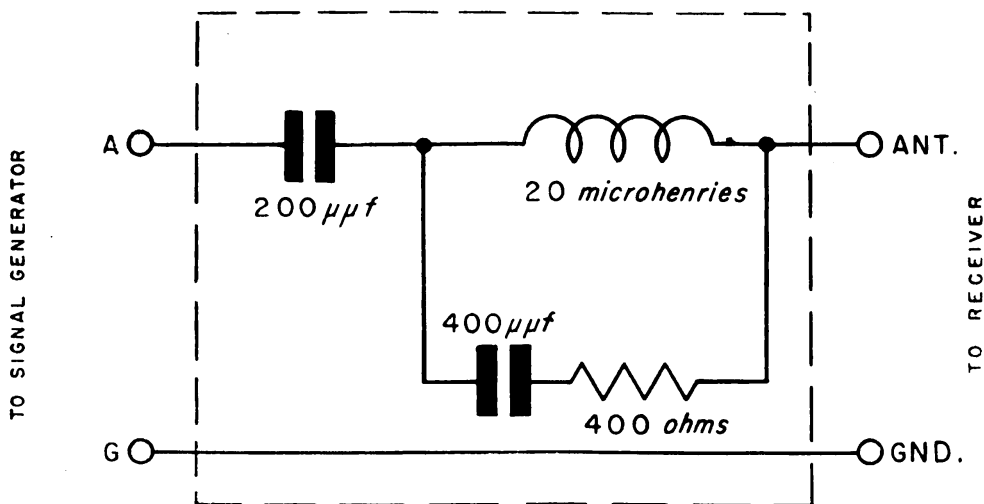

Figure 3—RMA Standard Phantom Antenna

(5) Remove the 30-ohm line from the clips around the edge of the front panel of the signal generator (figure 4).

(6) Make connections between the terminals of the 30-ohm line and the radio receiver according to the instructions in the alignment procedure for the radio receiver. Terminal G is ground. In some installations, if leakage is encountered, it may be necessary to connect the ground binding post of the receiver and the output terminal box of the signal generator directly to the receiver chassis with the shortest possible length of copper braid. The best grounding condition must

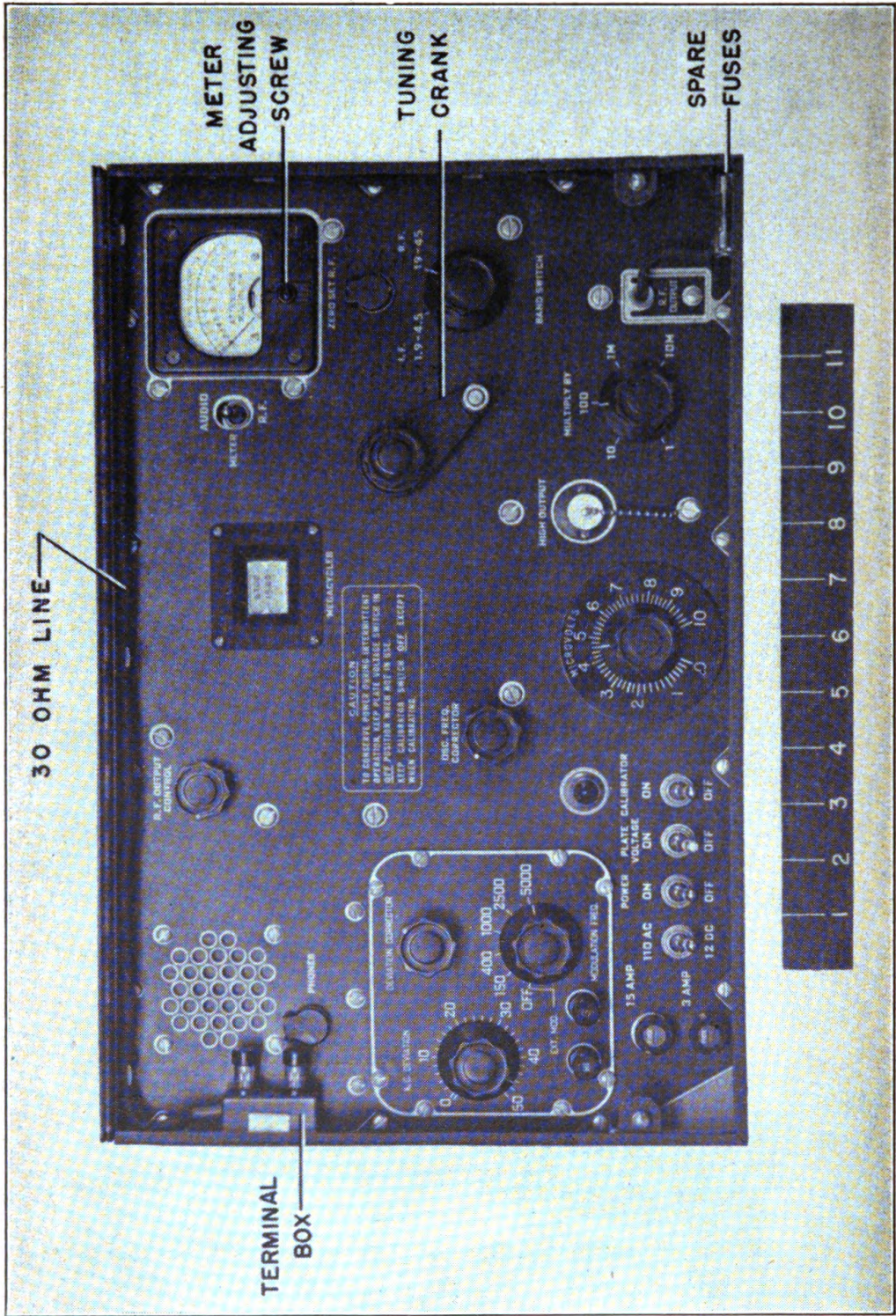

Figure 4—Signal Generator I-208, front view

be determined for the particular installation by trying various means of grounding until the leakage is eliminated.

b. Voltmeter adjustment (r-f)

When the operations outlined in sub-paragraphs 6a (1), (2), and (3) are completed:

(1) Turn the R.F. OUTPUT CONTROL to the left as far as it will go.

(2) Throw the METER switch to R.F.

(3) The meter must now read 0. If it does not read 0, lift the spring cover over the ZERO SET R.F. control (figure 4) and adjust the screw under the cover with a small screwdriver until the reading is zero.

(4) Turn the R.F. OUTPUT CONTROL to the right until the meter pointer is set to the red line (1.0) on the scale. The pointer will move as the signal generator is tuned over the frequency range. Always set it back to the red line on the meter scale by adjusting the R.F. OUTPUT CONTROL when the desired frequency has been reached.

c. Frequency checking

When the operations outlined in sub-paragraphs 6a (1), (2), and (3) are completed:

(1) Set the BAND SWITCH to R.F. 19-45 MC. Always calibrate the dial on the 19-45 MC band.

(2) Turn the dial crank until the frequency you want is indicated on the dial film. If the desired frequency is between 1.9 and 4.5 megacycles, multiply the frequency by 10 to determine the dial setting at which the calibration is made. NOTE: While turning the tuning crank a beat note (whistle) is heard in the loudspeaker for each $\frac{1}{2}$ megacycle as indicated on the dial film. The beat notes may be heard through headsets inserted into the PHONES jack. Inserting a headset automatically disconnects the speaker.

(3) Turn the vernier control knob of the signal generator so that the dial indicates the multiple of .5 megacycles nearest the frequency you want. For example, if the desired frequency is 31.30 megacycles, tune the signal generator to 31.50 megacycles.

(4) Adjust the OSC. FREQ. CORRECTOR control for zero beat in the speaker or phones. This is the point between the two lowest frequencies which can be heard. As the OSC. FREQ. CONTROL is turned in either direction from the zero beat position, a tone of increasing frequency is heard.

(5) Turn the dial crank to the desired frequency as indicated on the tuning dial.

(6) Throw the CALIBRATOR switch to OFF. When the calibrator is in use, the audio oscillator is automatically disconnected. As a result, a clean beat note is obtained. Keep the CALIBRATOR switch at OFF except when checking the dial calibration of the signal generator. UNLESS THE CALIBRATOR SWITCH IS AT OFF, IT WILL NOT BE POSSIBLE TO MODULATE THE SIGNAL GENERATOR.

(7) If the desired operating frequency is between 1.9 and 4.5 megacycles, set the BAND SWITCH to I.F. 1.9-4.5 MC.

d. Attenuator adjustment (100,000 microvolts maximum)

(1) Adjust the R.F. OUTPUT control so that the meter indicates 1.0. If the meter pointer cannot be set to 1.0, set the pointer to a lower scale division and multiply the attenuator settings by the factor indicated on the meter.

(2) Set the MICROVOLTS control and the MULTIPLY BY switch for the desired output voltage. The output voltage in microvolts is the numerical product of the meter indication, the MICROVOLTS dial reading and the MULTIPLY BY switch reading. For example, if you want an output of 5000 microvolts, set the meter pointer to 1.0, set the MICROVOLTS dial to 5.0 and the MULTIPLY BY switch to 1000. If the meter pointer cannot be set to 1.0, set it to .5, set the MICROVOLTS dial to 10, and the MULTIPLY BY switch to 1000. The output voltage is across the terminals at the end of the 30-ohm line.

e. Attenuator adjustment (output greater than 100,000 microvolts)

For an output greater than 100,000 microvolts:

(1) Remove the high output cable (Cord CD-749) from the compartment at the rear of the signal generator (figure 2).

(2) Unscrew the knurled cap from the HIGH OUTPUT terminal.

(3) Connect the cord and tighten the knurled fitting of the 100-ohm line to the HIGH OUTPUT terminal.

(4) Connect the other end of the 100-ohm line to the radio receiver to be checked, using the phantom antenna recommended in the alignment procedure of the radio receiver. See paragraph 6a(6).

(5) Adjust the R.F. OUTPUT CONTROL for the output voltage wanted. The output voltage is approximately .7 volt when the meter pointer is at 1.0. For example, if an output of 350,000 microvolts is wanted, set the meter pointer to .5 by means of the R.F. OUTPUT CONTROL. THE MICROVOLTS CONTROL AND THE MULTIPLY BY SWITCH MUST NOT BE USED WITH THE HIGH OUTPUT CABLE.

f. Internal modulation

To modulate the output voltage of the signal generator:

(1) Set the MODULATION FREQ. selector switch to the desired audio frequency: 150, 400, 1000, 2500, or 5000. Be sure the calibrator ON-OFF switch is at OFF.

(2) Set the K.C. DEVIATION control to 50.

(3) Throw the METER switch to AUDIO.

(4) Turn the BAND SWITCH to R.F. 19-45 MC.

(5) Adjust the DEVIATION CORRECTOR control so that the meter needle is at the red line on the meter scale. DON'T DISTURB THIS ADJUSTMENT WHILE USING THIS MODULATION FREQUENCY.

(6) Adjust the K.C. DEVIATION control for the desired frequency deviation. The scale is direct reading for the 19 to 45 megacycle range. Divide the scale reading by 10 to obtain the frequency deviation for the 1.9 to 4.5 megacycle range.

(7) Throw the METER switch to R.F. NOTE: THE PROCEDURE OUTLINED IN PARAGRAPH 6f(1) THROUGH (7) MUST BE FOLLOWED FOR EACH MODULATION FREQUENCY USED.

g. External modulation

To modulate the output voltage of the signal generator with an external audio source:

(1) Set the MODULATION FREQ. selector switch to EXT. MOD. (OFF).

(2) Adjust the audio source voltage to approximately 5 volts rms.

(3) Connect the external audio source to the EXT. MOD. terminals. The G terminal is ground.

(4) Proceed as outlined in paragraph 6f(2) through (7).

h. Final instructions

(1) *If the signal generator is to be used intermittently, throw PLATE VOLTAGE switch to OFF when the signal generator is not in use. This will conserve power and keep the signal generator warmed up for instant use.*

(2) To turn the signal generator off completely, throw the POWER switch to OFF.

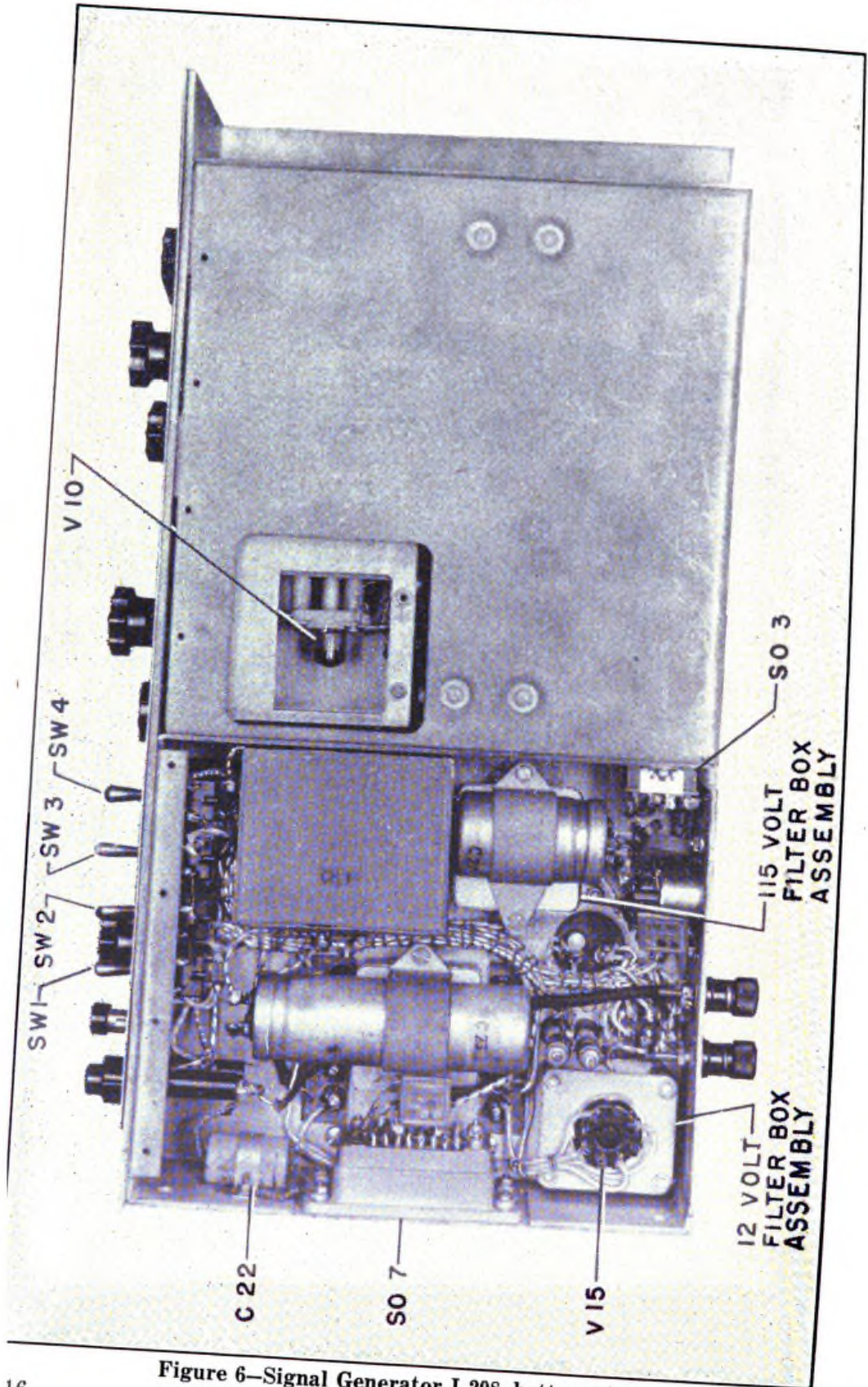

Figure 6—Signal Generator I-208, bottom view

SECTION III

DETAILED FUNCTIONING OF PARTS

	<i>Paragraph</i>
Audio oscillator unit	7
Radio-frequency unit	8
Calibrator unit	9
Main power supply	10
Dynamotor assembly	11

7. Audio oscillator unit

a. The audio oscillator unit is on the left side of the front panel of the signal generator (figure 4). It contains the MODULATION FREQ. selector switch, the K.C. DEVIATION control, the DEVIATION CORRECTOR control, and the EXT. MOD. (external modulation) terminals.

b. The audio oscillator unit employs tube V_1 (commercial type 12SN7-GT) (figure 9). One triode section is used in a Hartley oscillator circuit. The frequency is determined by the amount of inductance selected from tapped choke CH-2 and by the arrangement of capacitors C-13, C-14, C-15, and C-16.

c. The oscillator output voltages are maintained nearly constant for all frequencies by switch SW_5 which connects resistors R_{16} , R_{17} , R_{18} , R_{19} , and R_{20} into the oscillator plate voltage supply circuit. Capacitor C_{17} by-passes the audio voltage from the oscillator plate to ground. Grid bias for the oscillator is provided by the voltage drop across resistor R_{30} in the oscillator cathode circuit. The audio output voltage is impressed across resistor R_{21} and potentiometer R_{23} , the manual deviation control. The frequency deviation is controlled by setting potentiometer R_{23} to the desired deviation as indicated on the K.C. DEVIATION dial. This regulates the audio voltage impressed upon the grid of the second triode section of tube V_1 . Variations in the audio oscillator output voltages are compensated by adjusting variable resistor R_{22} , the DEVIATION CORRECTOR control.

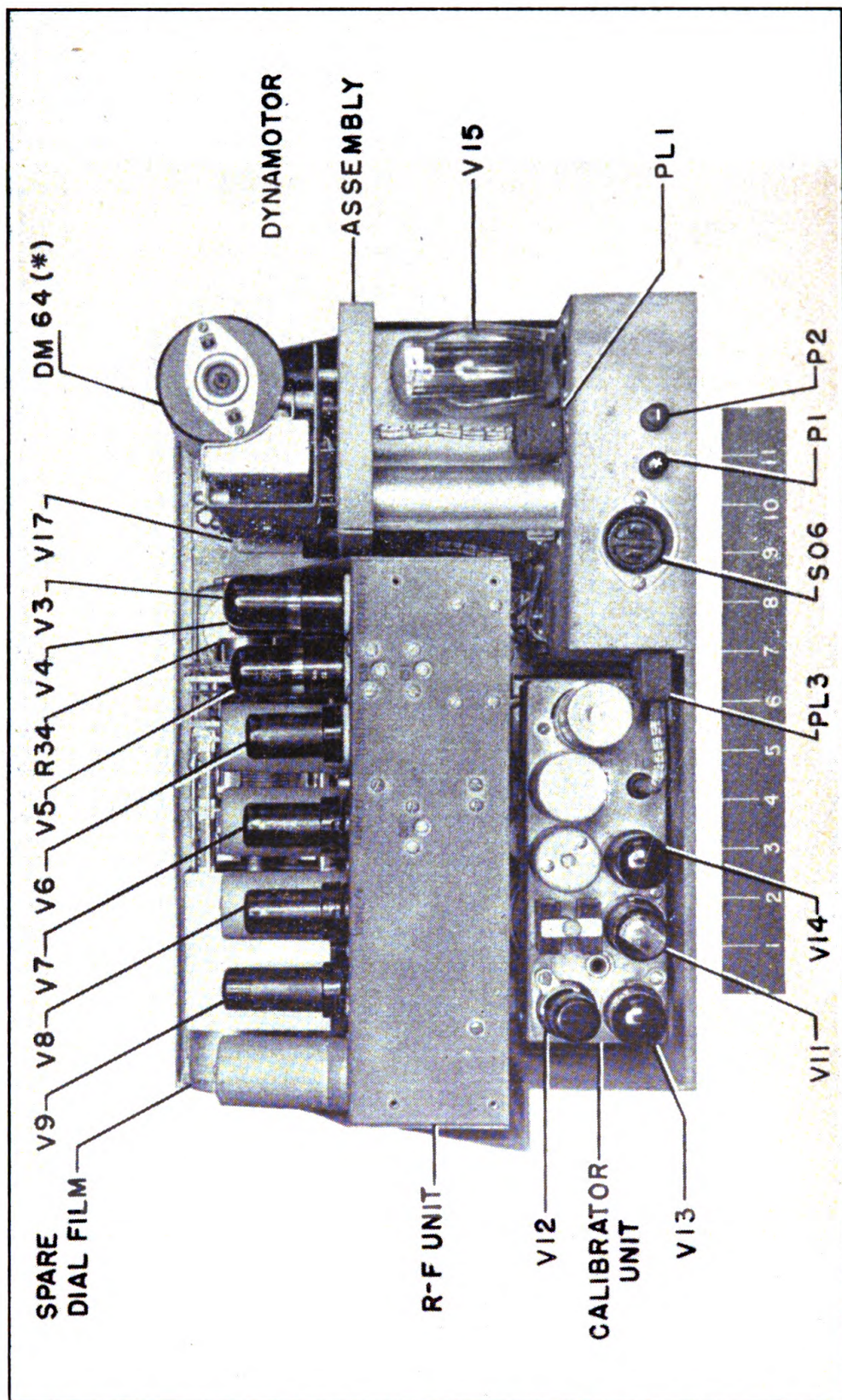

Figure 7—Signal Generator I-208, rear view, dust cover removed

8. Radio-frequency unit

a. The r-f unit is located beside the dynamotor assembly and the power supply (figure 7). It contains the frequency modulator, the r-f oscillator, the frequency multipliers, the output stage, the attenuator, and the dial mechanism. The r-f unit is mounted to the front panel. All electrical connections are made through a plug and receptacle to facilitate removal of this unit.

b. The signal from the audio oscillator is impressed across a series circuit consisting of resistor R_{33} , potentiometer R_{34} , and resistor R_{35} . The voltage across this circuit is measured by a vacuum tube voltmeter and is set to the correct value for modulation by adjusting variable resistor R_{22} which is located in the audio oscillator. The vacuum tube voltmeter circuit employs tube V_2 (commercial type 6SQ7GT). The voltmeter sensitivity is controlled by variable resistor R_{29} . Tube V_2 is biased beyond cut-off, and no zero adjusting control is necessary.

c. Potentiometer R_{34} is connected to the tuning capacitor through a special cam arrangement to maintain a constant frequency deviation over the entire r-f range.

d. The voltage from potentiometer R_{34} is applied through capacitor C_{31} to the signal grid of tube V_3 [Tube VT-161-()] and also to one side of choke CH_3 . The other side of choke CH_3 feeds an out-of-phase voltage to the signal grid of tube V_4 [Tube VT-161-()].

e. Tubes V_3 and V_4 are used in a push-pull reactance circuit utilizing resistors R_{40} , R_{41} , and R_{42} , and variable capacitors C_{36} and C_{38} . Tubes V_3 and V_4 bias voltage is provided by the voltage drop across cathode resistor R_{36} which is by-passed to ground by capacitor C_{34} . The plates of tubes V_3 and V_4 are coupled to the oscillator coil L_{10} by capacitor C_{37} . Coil L_{10} is tuned by the following capacitors:

- (1) Tuning capacitor TC_1
- (2) Capacitor C_{51} (trimmer capacitor)
- (3) Capacitor C_{50} (frequency corrector capacitor)
- (4) Capacitor C_{52} (temperature compensating capacitor)

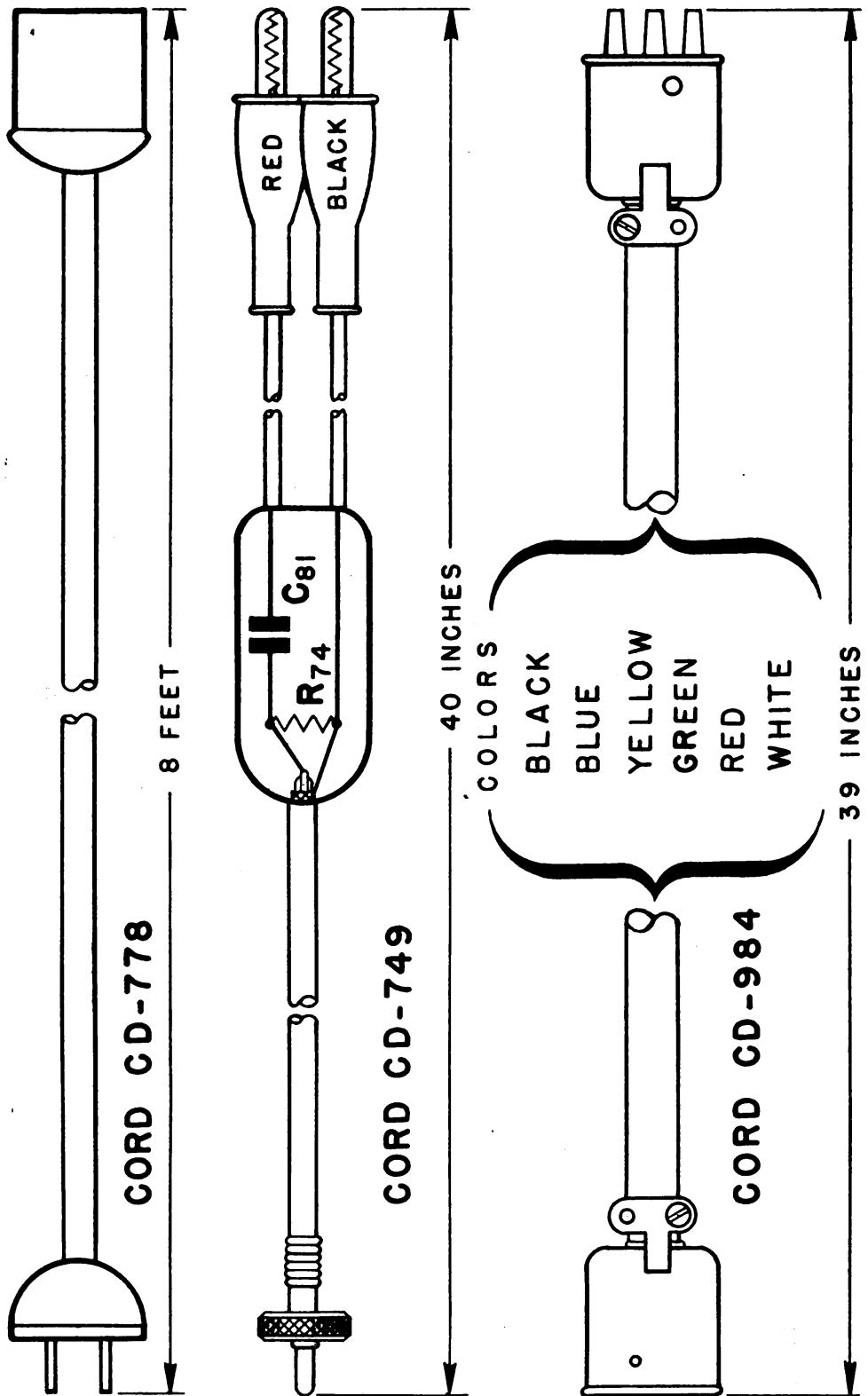

Figure 8—Cords

f. The oscillator tunes from 1.9 to 4.5 megacycles. The r-f voltage from the oscillator is applied to the grid of tube V_6 (Tube VT-288), which is employed as a buffer-limiter stage.

g. When band switch SW_6 is turned to 1.9-4.5 MC, the r-f voltage from the buffer-limiter (tube V_6) stage is fed to the grid of V_9 (Tube VT-247), and the plate of tube V_9 is connected to output coil L_{14} . This coil is tuned by tuning capacitor TC_4 to the same frequency as that of the oscillator. The secondary winding of coil L_{14} is connected by means of a 100-ohm line to the variable attenuator. In the 1.9-4.5 MC position, meter M_1 is inoperative when the METER switch is at AUDIO.

h. When band switch SW_6 is turned to 19-45 MC, the frequency multiplier stages are connected in the circuit. The output voltage of tube V_6 is fed to the grid of V_7 (Tube VT-288), which is employed as a frequency quintupler stage. Coil L_{11} and tuning capacitor TC_3 tune its plate circuit to the fifth harmonic of the oscillator frequency. The output voltage of V_7 is fed to the grid of V_8 (Tube VT-288), which is used as a frequency doubler stage. Coil L_{12} and tuning capacitor TC_2 tune its plate circuit to the second harmonic of the voltage developed in the quintupler stage, which is the tenth harmonic of the oscillator frequency. The output voltage of tube V_8 is fed to the grid of tube V_9 (Tube VT-247). Output coil L_{15} and tuning capacitor TC_4 tune its plate circuit to the tenth harmonic of the oscillator frequency. The secondary winding of coil L_{15} is connected to the variable attenuator through the transmission line.

i. The attenuator consists of a slide-wire inductance for continuous variation of the output voltage and a fixed voltage divider arrangement used as a step attenuator (R_{59} through R_{67}).

j. A vacuum tube voltmeter employing tube V_{10} (Tube VT-121) is used to indicate the voltage across the attenuator.

k. The output voltage is developed across resistor R_{68} , located in a shielded terminal box at the end of a line having a characteristic impedance of 30 ohms.

l. Cord CD-749, which has a characteristic impedance of 100 ohms, connects to input circuit of the attenuator through the high output terminal (figure 8).

m. The output voltage of the signal generator is controlled by potentiometer R_{37} which regulates the screen voltages of tubes V_6 , V_7 , and V_9 .

n. The signal generator output frequency is checked by the calibrator unit which is connected to the input circuit of the attenuator through receptacle SO_9 and resistor R_{56} .

9. The calibrator unit

a. The calibrator unit is located at the rear of the signal generator beneath the r-f unit (figure 7). The calibrator unit contains two Crystal Units DC-23-A (one as a spare) and the components required for frequency checking. The signal generator will operate with the calibrator unit removed, but its frequency must then be checked by some external means.

b. One triode section of tube V_{11} is employed in a crystal controlled oscillator circuit. Coil L_4 and capacitor C_1 comprise the oscillator tank circuit. The output of the oscillator is coupled by capacitor C_2 to the crystal frequency doubling stage employing tube V_{12} . Coil L_{16} and capacitor C_{82} comprise the tank circuit, which is tuned to 1000 KC.

c. The frequency of the crystal oscillator is 500 kilocycles per second.

d. The output voltages of the frequency doubler and the r-f unit are combined in tube V_{13} [Tube VT-161-()] operating as a harmonic generator resulting in an audio beat frequency signal for each multiple of .5 megacycle of the r-f output frequency.

e. The audio beat frequency voltage is amplified by a triode section of tube V_{11} and power amplifier tube V_{14} (Tube VT-134). Transformer T_2 couples the plate of tube V_{14} to the voice coil of the permanent magnet dynamic loudspeaker LS_1 , located on the front panel.

f. Capacitor C_{12} couples the plate of tube V_{14} to headset jack J_1 also located on the front panel. The loudspeaker voice coil circuit opens when a plug is inserted into jack J_1 .

10. Main power supply

a. The main power supply assembly is shown in figure 7. Its chassis supports all the other units and contains all of the power supply components except the voltage regulator tube, the current regulator tube and the dynamotor. A speaker and headset jack (used in frequency checking) are mounted to the upper left corner of the front panel. A metal guard folds down over the front panel for protection during transit or while in storage (figure 1). A metal dust cover houses the components located behind the front panel and provides storage compartments for cords and connectors (figure 2).

b. Receptacle SO_7 automatically makes connection to the 12-volt, d-c source of power when the signal generator is installed on Mounting FT-237-(*). Terminals P_1 and P_2 are wired in parallel with receptacle SO_7 for connecting the signal generator to a d-c power source when not installed on this mounting base.

c. A line filter consisting of r-f choke L_3 and capacitors C_{22} through C_{26} prevents r-f signal voltages from entering the line. A similar filter consisting of r-f chokes L_1 and L_2 , and capacitors C_{18} , C_{19} , C_{20} , and C_{21} is wired in series with the 115-volt receptacle SO_6 .

d. Switch SW_2 (POWER) is in series with both the 12-volt and the 115-volt input circuits. When switch SW_2 is closed, the heaters and filaments of all the tubes are turned on.

e. Switch SW_3 (PLATE VOLTAGE) is in series with both the input circuit of the dynamotor and the center tap of the high voltage winding of power transformer T_1 .

f. Switch SW_1 (power selector) performs two functions. When this switch is thrown to 12 DC, the heaters of the tubes and the dial lamps are connected to the d-c source of power, and the plate supply filter is connected to the output circuit of the dynamotor. When switch SW_1 is thrown to 115 AC, the heaters of the tubes and the dial lamps are connected to the 12-volt winding of transformer T_1 , and the plate supply filter is connected to the filament of rectifier tube V_{15} , Tube VT-244.

g. Switch SW_4 (calibrator) at ON grounds terminal No. 2 of CH_2 (audio oscillator choke) stopping the audio oscillator and connects the unregulated plate supply voltage to the calibrator. At OFF switch SW_4 disconnects the unregulated plate supply voltage from the calibrator and connects load resistor R_{78} to the unregulated plate supply and disconnects terminal No. 2 of CH_2 from ground.

h. The plate supply filter consists of capacitors C_{28} and C_{29} , and filter choke CH_1 . Resistor R_{24} reduces the plate supply voltage to a safe value for the voltage regulator tube V_{16} (Tube VT-139) located on the dynamotor chassis. Capacitor C_{27} bypasses the regulated plate supply voltage. Resistor R_{25} limits the surge current from capacitor C_{27} through tube V_{16} .

11. Dynamotor assembly

a. The dynamotor assembly is located at the upper left corner of the signal generator (figure 7). It contains the dynamotor, the voltage regulator tube, and the current regulator tube.

b. Dynamotor DM-64-A contains a noise filter consisting of r-f chokes and capacitors.

c. Tube V_{16} (Tube VT-139) commercial type VR150-30, regulates the voltage for the oscillator and modulator tubes.

d. Tube V_{17} , commercial type 1H-20, limits the current drawn from the power supply when the voltage of the power source rises.

SIGNAL GENERATOR I-208

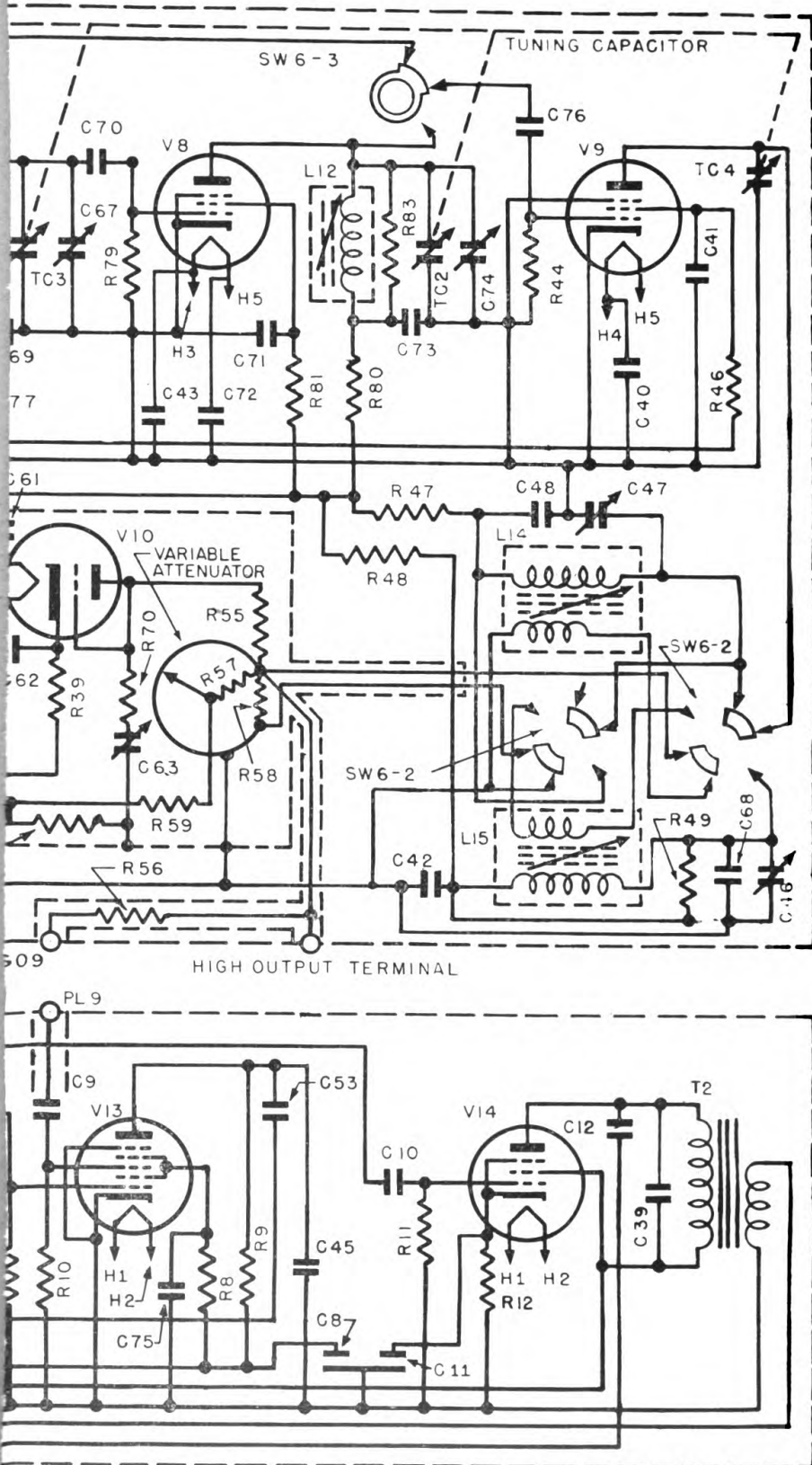

Figure 9—Signal Generator I-208, schematic diagram

SECTION IV MAINTENANCE

	<i>Paragraph</i>
Procedure in case of equipment failure	12
Removal of tubes for testing	13
Removal of units	14
Adjustments	15

12. Procedure in case of equipment failure

Don't make any adjustments before reading this section thoroughly. Time will be saved in locating the source of trouble if you follow a systematic procedure. Special testing equipment is necessary for some of the adjustments, and if these adjustments are tampered with, the signal generator may be made entirely useless.

Make the following preliminary tests first.

a. Check cords, connectors, and fuses for open circuits. If the dial lights when the POWER switch is at ON, it is practical to assume that the power connections and fuses are working properly.

b. If a fuse is burned out, install a new one. Look elsewhere for the trouble if the new fuse burns out.

13. Removal of tubes for testing

a. Remove all the screws from the front edges of the dust cover.

b. Tilt the signal generator slightly forward and remove the dust cover by pushing it backward.

c. Remove both the outer and the inner shield from the r-f unit

d. The r-f VTVM tube V_{10} can be reached through a removable panel at the bottom of the signal generator (figure 6).

e. If a tube tester is available, test the tubes one at a time, and as each tube is found to be good, place it in the socket from which it came. For tube locations see figures 5 and 7. Replace tubes which are found to be defective.

f. If a tube tester is not available, substitute new tubes of the proper type one at a time. Check the signal generator after each substitution. If installing a new tube does not restore the signal generator to normal operation, replace the old tube before substituting another.

14. Removal of units

a. The audio oscillator unit

(1) Remove the screws from the front edge of the audio oscillator panel.

(2) Pull the audio oscillator unit forward as far as it will go without disconnecting its power cord. Check socket voltages and resistances in accordance with figures 21, 22, 23 and 24.

b. Calibrator unit

(1) Remove the four screws which hold the calibrator unit to the bottom of the signal generator.

(2) Disconnect plug PL₃ from receptacle SO₃.

(3) Pull the calibrator unit out and to the left, and disconnect PL₉ from receptacle SO₉.

(4) Connect plug PL₃ back to receptacle SO₃ and check voltages and resistances in accordance with figure 22.

c. Radio-frequency unit

(1) Remove calibrator unit as outlined in sub-paragraphs 14b(1) through (3).

(2) Remove all knobs from r-f unit controls.

(3) Remove cap from HIGH OUTPUT terminal.

(4) Remove the 30-ohm line from its mounting clips.

(5) Remove the 11 large binding-head screws which hold the r-f unit to the front panel.

(6) Remove the r-f unit by pulling it away from the front panel.

(7) Connect Cord CD-984 to plug PL₂ and receptacle SO₂.

(8) Check socket voltages and resistances in accordance with figure 21.

d. Dynamotor assembly

(1) Remove the three large screws located below the speaker on the front panel.

(2) Remove the three flathead screws which hold the dynamotor chassis to the side of the main chassis.

(3) Remove the screw which holds the dynamotor chassis to the supporting rod at the rear of the main chassis.

(4) Disconnect plug PL_1 from receptacle SO_1 and remove dynamotor assembly.

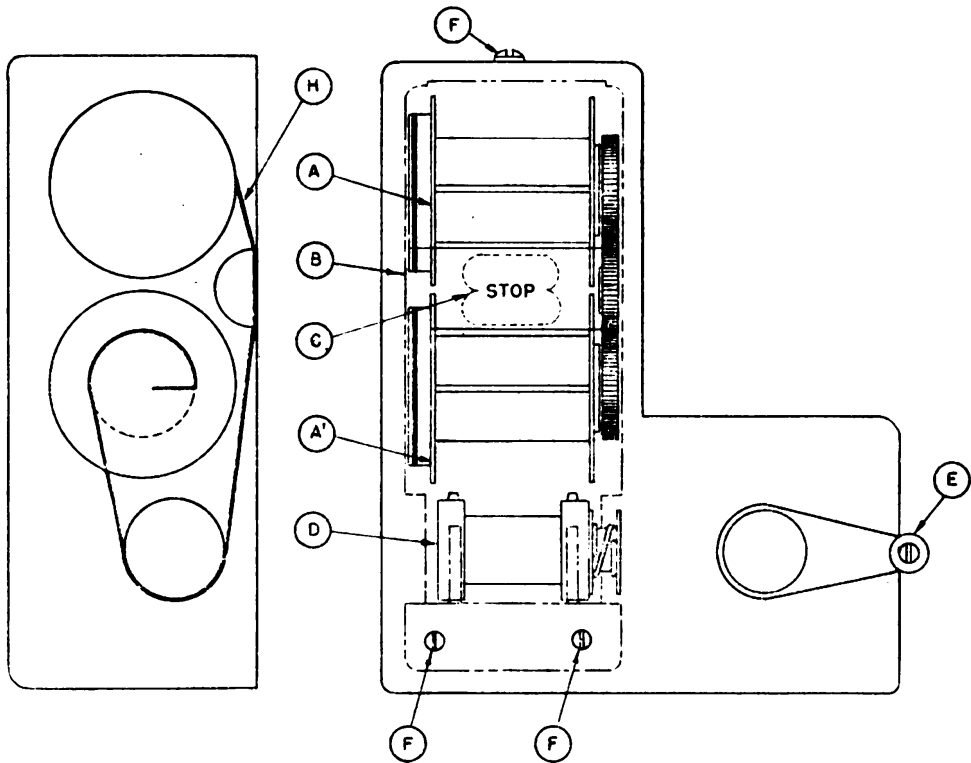

Figure 10—Dial mechanism

e. Power supply components

(1) Power transformer removal.

(a) Remove dynamotor assembly as outlined in subparagraph 14d.

(b) Remove capacitor C_{29} .

(c) Unsolder leads on transformer terminals.

(d) Remove transformer mounting screws.

(2) Removal of POWER, PLATE VOLTAGE, or CALIBRATOR switch.

(a) Unsolder leads at terminals of filter choke CH₁.

(b) Remove the filter choke by removing the four screws which hold it to the main chassis. Unsolder and remove switch.

f. To replace dial film.

(1) Remove r-f unit as outlined in sub-paragraph 14c.

(2) Remove three screws F (figure 10) and pull out film coverplate.

(3) Remove old film, including any scotch tape used to fasten film to spool.

(4) Turn crank E (figure 10) to the left until the word STOP is reached.

(5) Remove spare film from round can on tuning capacitor shield and check leader length. There should be 10 inches of blank film on each end of the dial as measured from the word START on the high frequency end, and STOP on the low end. If there is more than 10 inches, cut it off.

(6) Make a sharp right angle bend in the low frequency (19mc) end of the film and attach a piece of scotch tape as shown in figure 11.

(7) Insert low frequency end of film in slot in lower spool, fasten with scotch tape, and wind the film on the spool.

(8) Thread the film around the sprocket as shown in figure 10 placing the word STOP at the center of the dial. Make sure the crank E is turned against the stop.

(9) Prepare this end of dial by cutting to 10" from word STOP, bend, and use scotch tape (see figure 11).

(10) Double the film in a large loop and insert it between the sprocket and the end of case to prevent the film from slipping off the sprocket.

(11) Moving the thumbs alternately towards the sprocket, wind the lower spool to tighten the film, then, hold upper spool to prevent lower one from unwinding.

(12) When the lower spool is wound tight, again moving the thumbs in the same direction, wind the upper spool *exactly* 15 turns.

(13) Secure end of film in upper spool as described before. Allow spool to take up surplus film. It is important that the film be held firmly on the sprocket and that the crank is

turned to the left (counter-clockwise) against the stop during the winding of the upper spool. The 15 turns applied to the upper spool gives the *proper* tension to the film and assures

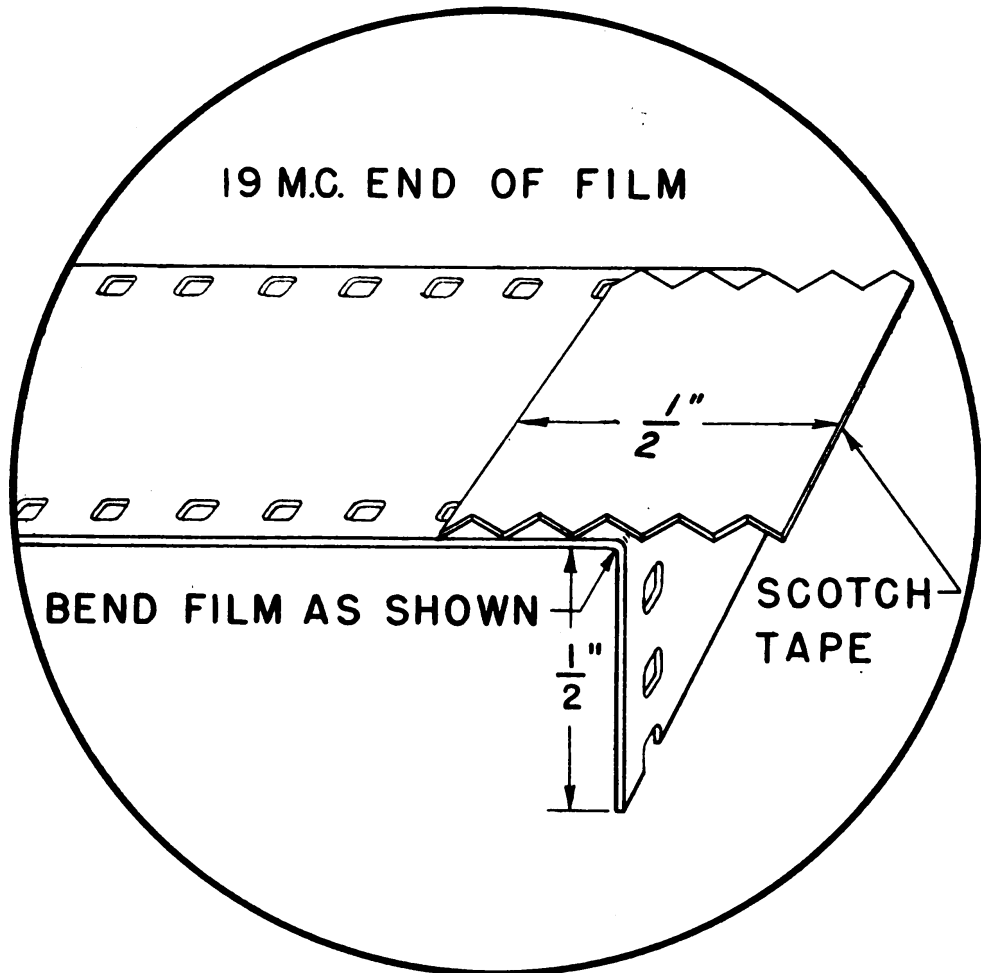

Figure 11—Dial film, preparation for installation

long life. Too much tension wears the film sprocket holes and too little does not permit proper operation.

(14) The film should now be on the spools and sprocket as shown in sketch H (figure 10).

(15) Replace film cover plate and hold in place without screws. Wind film to upper reel, rewind slowly to lower reel, and check STOP point. "STOP" should be in the center of the dial on one end and "START" at the other. Correct if necessary by shifting film on sprocket and fasten cover plate in place with three screws F (figure 10).

(16) Make final check after cover has been replaced. If STOP point is not lined up properly, remove cover plate and advance film on drive sprocket teeth until proper alignment is reached.

g. Tuning unit

The tuning unit consists of the dial tuning mechanism, the tuning capacitor, potentiometer R_{34} , and the spare dial film. **DO NOT REMOVE THE TUNING CAPACITOR FROM THE DIAL TUNING MECHANISM UNDER ANY CIRCUMSTANCES.** If any part of the tuning unit fails, replace the entire tuning unit as follows:

- (1) Remove r-f unit as outlined in sub-paragraph 14c.
- (2) Remove all wires connected to the tuning capacitor and potentiometer R_{34} .
- (3) Remove the five screws which hold the tuning unit to the r-f chassis.
- (4) Remove the four screws which hold the tuning unit to the front panel of the r-f unit.
- (5) Remove the METER switch SW_7 and associated bypass condensers.
- (6) Remove the dial lamp bracket and assembly.
- (7) Lift tuning unit upward and remove from r-f unit.

h. Replacement of Crystal Unit DC-23-A

If Crystal Unit DC-23-A is to be replaced with the spare crystal, proceed as follows:

- (1) Loosen the thumb screw and turn crystal hold-down clamp.
- (2) Remove both crystals and insert crystal from SPARE socket into ACTIVE socket.
- (3) Insert a microammeter (0-200 microamperes) equipped with Plug PL-55 into jack J_2 on crystal calibrator unit. The leads connecting the plug to the microammeter should not be over six inches long.
- (4) Turn on the POWER and throw CALIBRATOR switch to ON.
- (5) Adjust capacitor C_1 located on top of coil L_4 shield can for maximum meter reading.
- (6) Tune the signal generator to 40.00 MC on the dial.

The 40.00 megacycle beat frequency of the crystal calibrator should be heard in the phones or speaker. Tune for zero beat.

(7) Adjust capacitor C_1 so that as C_1 is changed it is necessary to tune the signal generator to a slightly higher frequency (toward 40.02 MC) to maintain zero beat. As this adjustment is made the meter will indicate a lower value of grid current. When approximately 70% of the maximum meter reading is obtained, C_1 is properly adjusted.

(8) Remove meter plug from jack J_2 .

(9) Install new spare crystal in SPARE socket and fasten hold-down clamp.

15. Adjustments

It is not generally necessary to make the adjustments outlined in this paragraph, as the corrector controls on the front panel will compensate for frequency drift and variations in modulation voltages. However, when a new tube or part has been installed, some further adjustments may be necessary. Try another tube if a new tube seriously alters the frequency or the voltage of the circuit into which it is installed. *It is much better to select a tube which will not change the circuit operation than to install one which will make necessary these adjustments.*

a. Oscillator frequency adjustment

(1) Throw band-switch to I.F. 1.9–4.5 MC.

(2) Connect output terminals of signal generator to Frequency Meter BC-221-(*).

(3) Set MICROVOLTS dial to 10 and multiplier switch to 10,000.

(4) Set OSC. FREQ. CORRECTOR control so that the white dot on the knob is at the top.

(5) Turn R.F. OUTPUT control to the right.

(6) Turn tuning crank so that dial film indicates 45 MC.

(7) Set the frequency meter to 4500 kilocycles.

(8) Adjust the oscillator trimmer capacitor C_{51} at rear of r-f chassis for zero beat at the frequency meter.

(9) Turn tuning crank so that the dial film indicates 19 MC.

(10) Set frequency meter to 1900 kilocycles.

(11) Turn the iron core adjusting screw of oscillator coil L_{10} for zero beat at the frequency meter.

(12) Repeat adjustments outlined in sub-paragraphs 15a (6) through (11) until you get a zero beat at both 19 and 45 without further adjustments.

b. Low frequency (1.9–4.5 mc) output coil adjustments

(1) See that the METER switch is at R.F.

(2) Tune the signal generator to 4.5 MC.

(3) Set the frequency meter to 4500 kilocycles.

(4) Adjust the low frequency output trimmer capacitor C_{47} for maximum output as indicated on the meter. If the meter indicator goes off scale, turn the R.F. OUTPUT control to the left until pointer is approximately in the center of the scale.

(5) Tune the signal generator to 1.9 MC.

(6) Set the frequency meter to 1900 kilocycles.

(7) Turn adjusting screw for the iron core of the low frequency output coil L_{14} so that the meter indicates maximum output.

(8) Repeat adjustment outlined in sub-paragraphs 15b (2) through (7) until maximum output is obtained at both 19 and 45.

c. Adjustment of reactance tubes

If tube V_2 , V_3 , V_4 , or V_5 is replaced, it is necessary to check and readjust the KC deviation. This is accomplished by either of two methods. The first method is outlined in sub-paragraph 15 d(1) through (21) and the second method is outlined in sub-paragraph 15 e(1) through (18).

Always check the KC deviation before making any adjustments since *it will not always be necessary to make adjustments when tubes are replaced.*

CAUTION: DO NOT ADJUST REACTANCE TRIMMERS C_{36} AND C_{38} . THESE TRIMMERS ARE ADJUSTED AND SEALED AT THE FACTORY. ANY ADJUSTMENT OF THESE TRIMMERS WILL AFFECT DIAL CALIBRATION ACCURACY.

d. Modulation voltage adjustment (panoramic method)

(1) Refer to figure 12 for the equipment necessary. Two setups are shown.

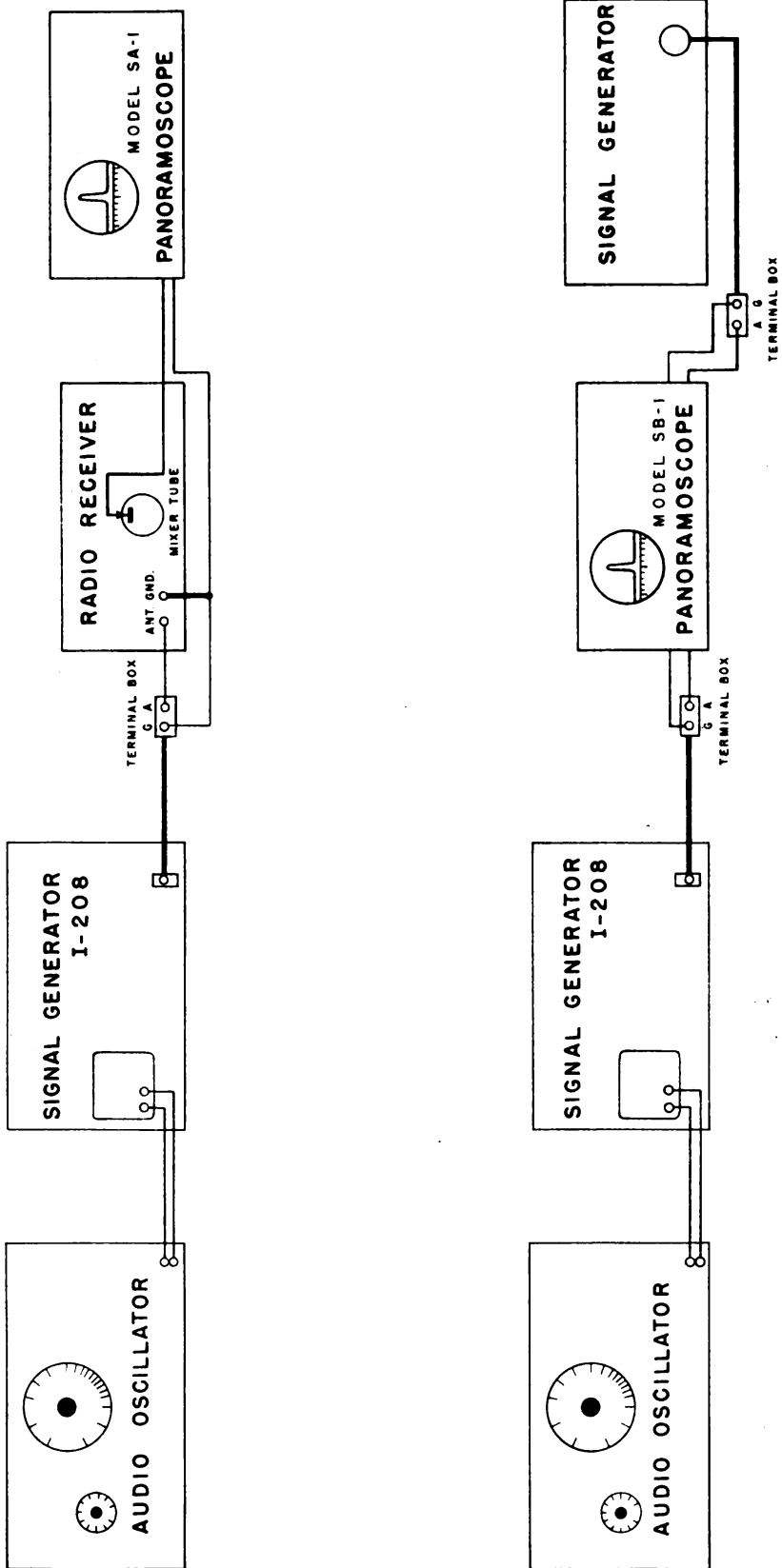

Figure 12—Block diagram showing methods of connecting Signal Generator I-208 to a radio spectroscope

- (2) Connect the signal generator as shown in figure 12.
- (3) Set the MICROVOLTS control to 10.
- (4) Turn the multiplier switch to 10M.
- (5) Adjust the R.F. OUTPUT control so that the meter indicates approximately 1.
- (6) Turn the band switch to R.F. 19–45 MC.
- (7) Turn the signal generator to 19 MC.
- (8) See that the MODULATION FREQ. switch is at EXT. MOD. (OFF).
- (9) Turn the output gain control of the external audio oscillator to zero. Since the accuracy of this adjustment depends upon the frequency accuracy of the audio source, the external audio oscillator should be highly accurate. If such an oscillator is not available, the 5000-cycle modulation frequency of the internal audio oscillator may be used. In this case, however, the error in deviation accuracy introduced will then be a maximum of 5 per cent.
- (10) Throw the METER switch to AUDIO.
- (11) Turn the K.C. DEVIATION control to 43.
- (12) Tune the radio receiver to the frequency of the signal generator. At this point a pattern as shown in figure 13 should appear on the panoramic screen.
- (13) Set the frequency of the external audio oscillator to 5000 cycles per second.
- (14) Turn the gain control of the external audio oscillator slowly to the right until the center frequency peak reaches the horizontal axis. This is a center frequency null point (figure 14). Continue to turn the audio gain control until the third consecutive null point has been reached and leave the control in this position.
- (15) Turn the K.C. DEVIATION control to 50.
- (16) Adjust variable resistor R_{29} so that the meter indicator is coincident with the red line.
- (17) Turn the tuning dial counterclockwise (left) to 45 MC.
- (18) Audio meter reading at 50 KC should be 1.0. If it is not, adjust DEVIATION CORRECTOR until the audio meter reads 1.0.

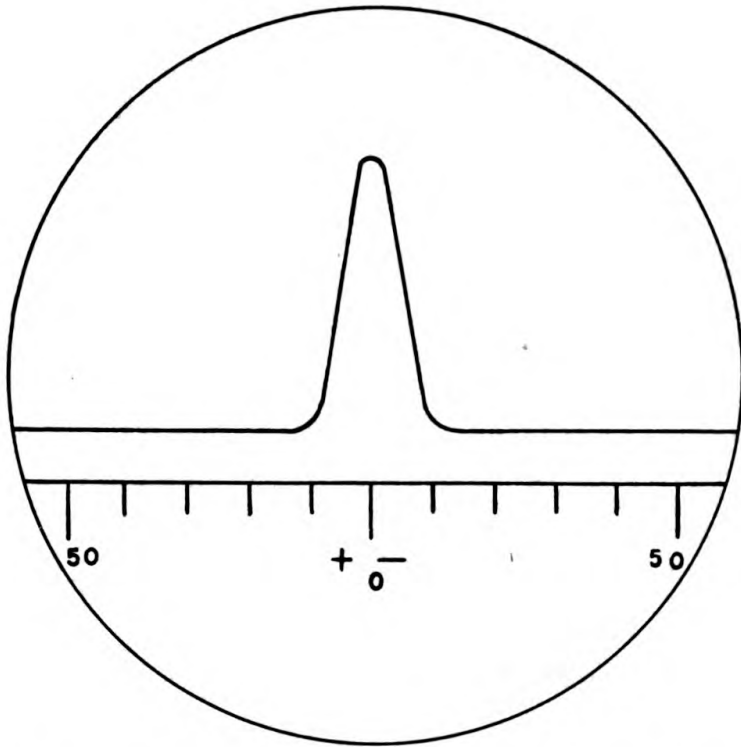

Figure 13—Panoramic pattern, unmodulated signal

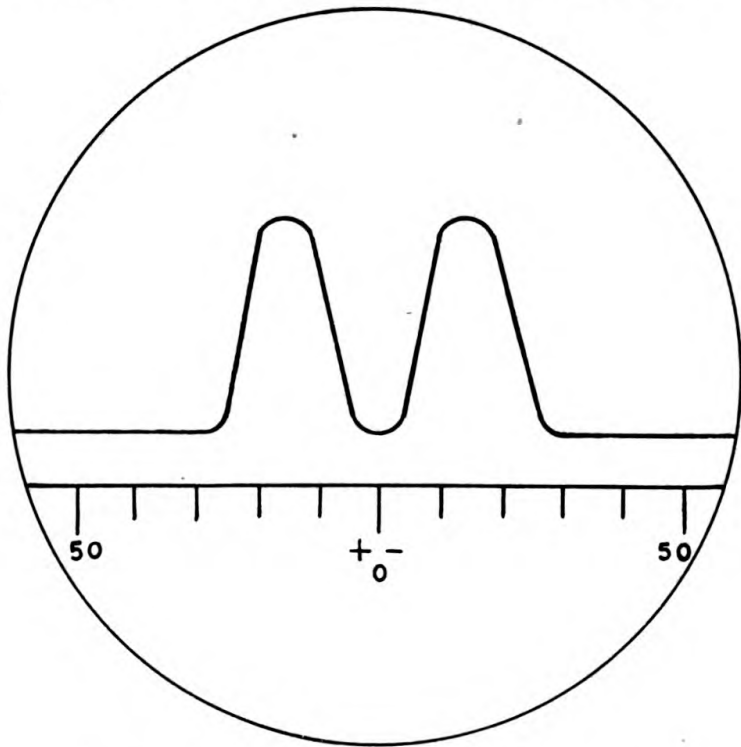

Figure 14—Panoramic pattern, first null point

(19) Turn K.C. DEVIATION control counterclockwise (left) to 0, and then advance the K.C. DEVIATION control until the third null point is obtained. This should occur at 43 KC. If it does not occur, loosen lock nut of R_{34} (located on the gang condenser) and adjust, by turning the body of the control a small amount at a time, until third null point is obtained at 43 KC. Then lock R_{34} in place by tightening the lock nut.

(20) Turn dial crank to 19 MC and check third null point. Reset R_{29} , if necessary.

(21) Check deviation accuracy at line voltages of 107 and 126.5 volts a-c. If a difference of more than 2 or 3 percent exists, adjust R_{87} until the same reading is obtained at both line voltages.

(22) If it is necessary to replace R_{34} , proceed as follows:

(a) With a screwdriver, remove the two binding head screws and lockwashers holding the control mounting plate to the tuning unit end plate.

(b) Pull slightly on the control so that the locating pins are disengaged from the end plate.

(c) Holding the control in position by hand, turn the dial tuning crank until the cam drive pin on the tuning condenser drive gear appears in the opening of the tuning unit end plate.

(d) Give the control a slight twist to disengage the cam and cam spring from the drive pin.

(e) With the Bristol set screw wrench mounted on side of tuning unit end plate, remove cam from the control.

(f) Replace cam on new control (be sure to align the set screw on the cam with the flat on the control shaft), and tighten the Bristol set screw with wrench.

(g) Replace Bristol wrench in holder on tuning unit end plate.

(h) Turn cam and control shaft so that it is in approximately the same position as when removed with defective control.

(i) Insert cam through the opening in the tuning unit end plate and adjust until the pin on the tuning condenser drive gear is between the cam and the cam spring.

(j) Holding the control in position by hand, turn the dial tuning crank to 45 megacycles.

(k) Line up the locating pins on the control mounting plate with the holes in the tuning condenser end plate and push in place.

(l) Replace the two binding head screws and lock-washers holding the control mounting plate to the tuning unit end plate and tighten securely.

(m) Adjust modulation voltage as outlined in paragraphs 15e (1) through (20).

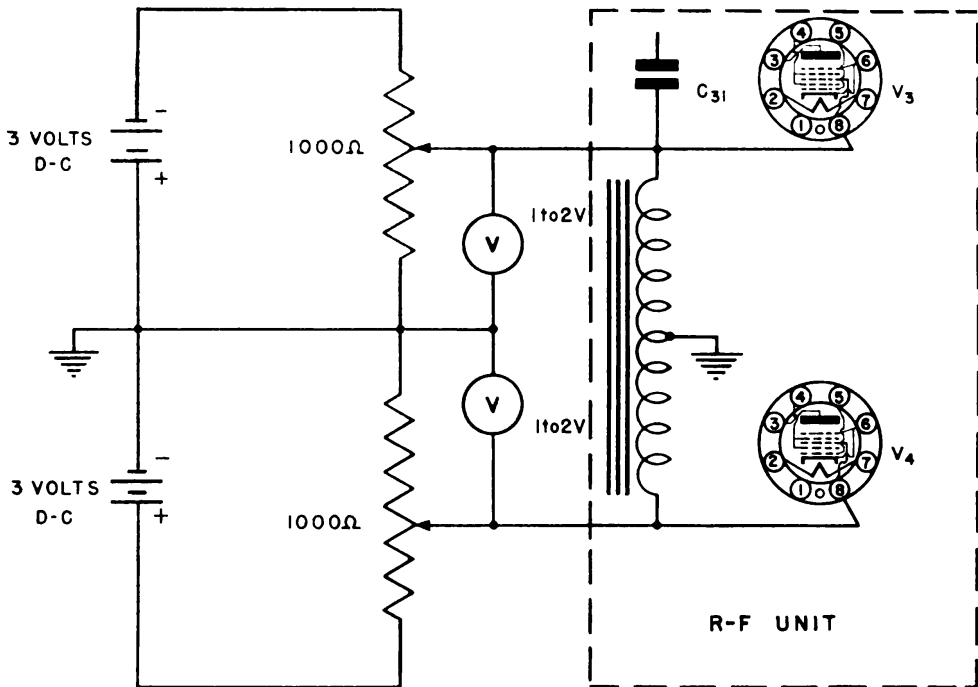

Figure 15—Connection diagram for determination of modulation voltage (d-c method)

e. Modulation voltage adjustment (d-c method)

This method of adjustment can be used in an emergency when the panoramic equipment is not available, if tube V_2 , V_3 , or V_4 is replaced. If any other component part associated with the reactance tubes is replaced, use the method described in sub-paragraph 15d.

(1) Follow procedure outlined in sub-paragraphs 15c(1) through (8).

(2) Connect batteries, potentiometers, and voltmeters to audio input grids of tubes V_3 and V_4 as shown in figure 15.

(3) Set potentiometers so the voltmeters read zero.

- (4) Connect the output terminals of the signal generator to Frequency Meter BC-221-(*).
- (5) Tune the frequency meter to 1900 kilocycles.
- (6) Turn the band switch to I.F. 1.9-4.5 MC.
- (7) Tune the signal generator to 19.
- (8) Adjust the OSC. FREQ. CORRECTOR control until zero beat is obtained as heard in the headsets of the frequency meter.
- (9) Tune the frequency meter to 1905 kilocycles.
- (10) Increase the voltages on the grids of tubes V_3 and V_4 by adjusting the potentiometers, keeping the voltages equal, until zero beat is obtained.
- (11) Record the voltage indicated on the voltmeters.
- (12) Disconnect the batteries, potentiometers, and voltmeters.
- (13) Connect an a-c vacuum tube voltmeter to the audio input grid of tube V_3 . Make the connection by winding a wire around the No. 8 pin of the tube. Connect the low side of the vacuum tube voltmeter to the chassis.
- (14) Turn the MODULATION FREQ. control to 1000.
- (15) Turn the KC DEVIATION control to 50.
- (16) Turn the band switch to R.F. 19-45 MC.
- (17) Adjust the DEVIATION CORRECTOR control so that the externally connected vacuum tube voltmeter reads .707 of the voltage recorded in sub-paragraph 15d(11).
- (18) Adjust potentiometer R_{29} so that the indicator of the meter on the signal generator is coincident with the red line.

f. Adjustment of the amplifier stages

After having performed the operations outlined in paragraphs 15d or 15c:

- (1) Turn the band switch to R.F. 19-45 MC.
- (2) Turn the R.F. OUTPUT CONTROL to the right.
- (3) Throw the METER switch to R.F.
- (4) Tune the signal generator to 45 MC.
- (5) Adjust capacitors C_{67} , C_{74} , and C_{46} , for maximum output as indicated on the meter. If the indicator goes off scale turn the R.F. OUTPUT CONTROL to the left so that the meter indicator is approximately in the center.

(6) Tune the signal generator to 19.

(7) Adjust the iron core adjusting screws of coils L_{11} , L_{12} , and L_{15} for maximum output as indicated on the meter. If the meter indicator goes off scale, turn the R.F. OUTPUT CONTROL so that the meter indicator is approximately in the center.

(8) Repeat operations outlined in sub-paragraphs 15e(4) through (7) until maximum output is obtained at 19 and 45 megacycles without further adjustment.

g. R-f VTVM sensitivity control adjustment

This adjustment should be made only if tube V_{10} is replaced. If this tube is replaced without making the following adjustment, an error of not more than 5 per cent will be introduced.

(1) Connect a vacuum tube voltmeter, capable of measuring radio-frequency voltages as low as 0.1 volt, to binding posts A and G of the R.F. OUTPUT transmission line terminal box.

(2) Set the MICROVOLTS control to 10.

(3) Turn the multiplier switch to 10M.

(4) Turn BAND SWITCH to I.F. 1.9–4.5 MC, and turn dial to 4.5 MC.

(5) Adjust the R.F. OUTPUT control so that the externally connected vacuum tube voltmeter indicates 0.1 volt.

(6) Adjust variable resistor R_{75} (located on the chassis directly below the spare dial film can) until the meter in the signal generator indicates 1.0.

(7) Turn R.F. OUTPUT control counterclockwise until the stop is reached, and check the zero setting of the meter. If an adjustment of R_{73} , the zero set control, is necessary, it will also be necessary to readjust R_{75} .

h. Adjustment of VTVM frequency compensator

This adjustment is made at the factory, and readjustment is never necessary unless the setting of C_{63} is disturbed. If this setting has been changed, first make the adjustments as described in sub-paragraph 15g. Then proceed as follows:

(1) Turn BAND SWITCH to R.F. 19–45 MC.

(2) Turn dial crank counterclockwise (left) to 45 MC.

(3) Advance R.F. OUTPUT control to the right until the external VTVM reads 0.1 volt.

(4) Adjust C_{63} (located adjacent to tube V_{10}) until the meter on the signal generator reads 1.0.

SIGNAL GENERATOR I-208

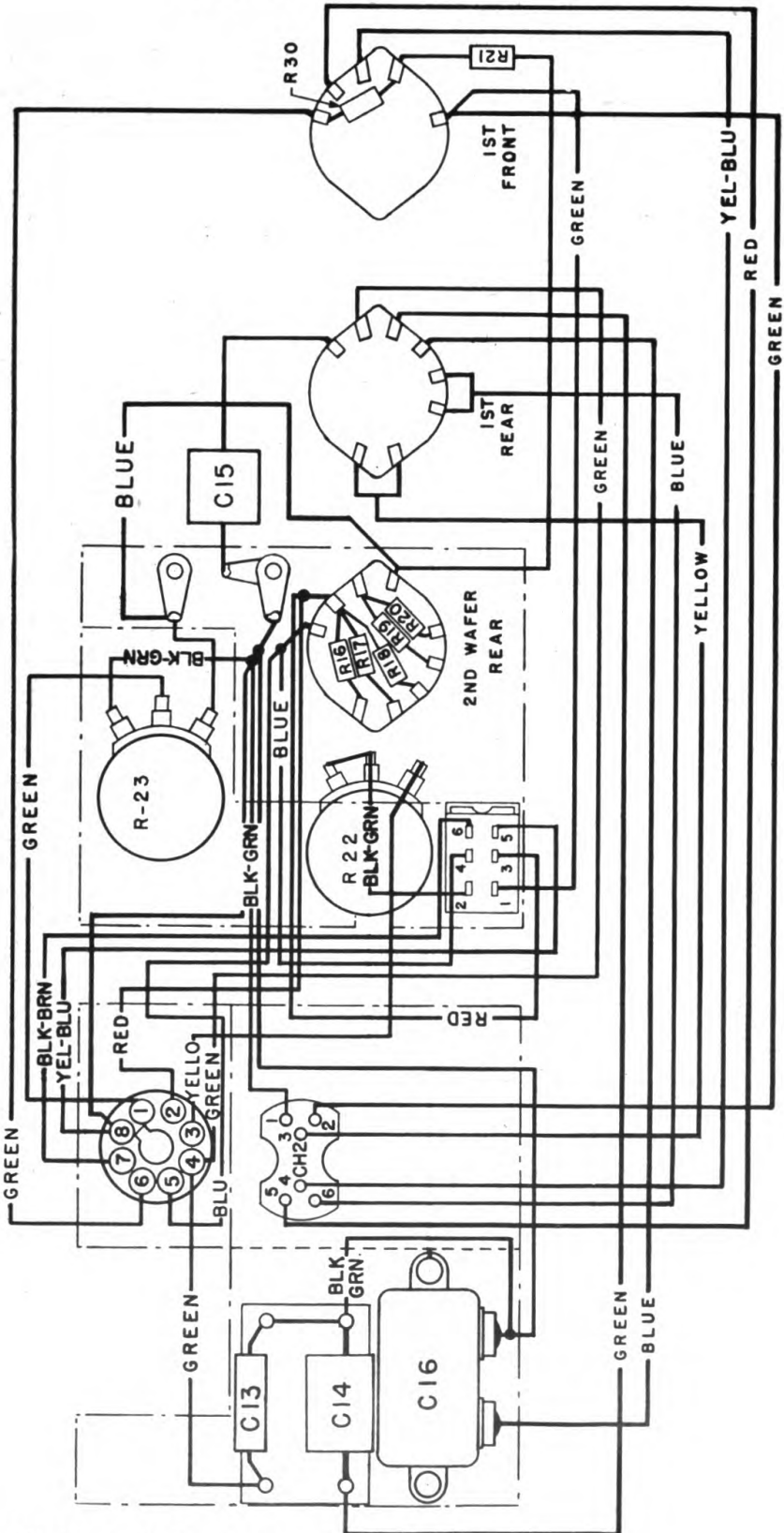

All designated colors are tracer colors.

Figure 16—Practical wiring diagram, audio oscillator unit

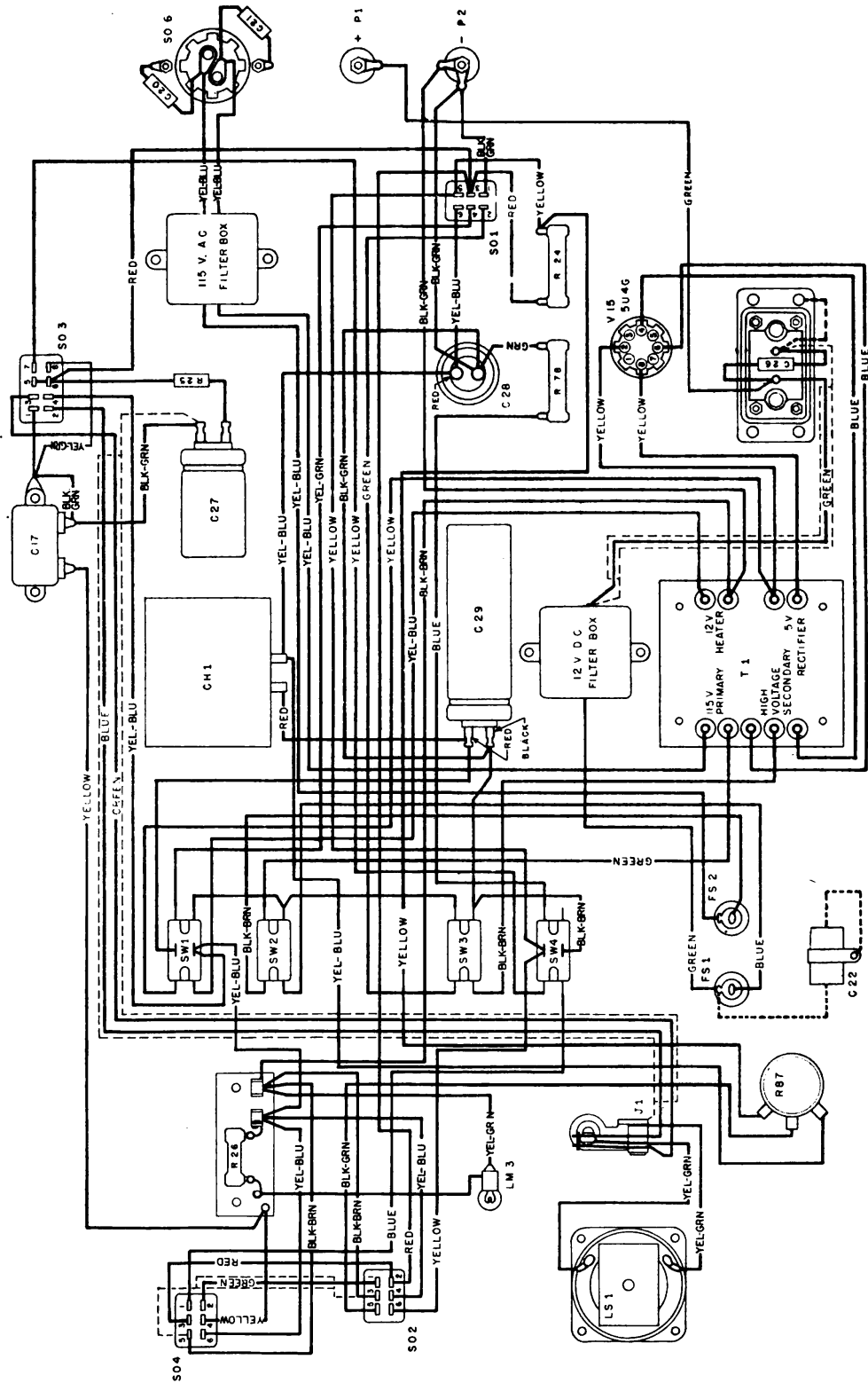

All designated colors are tracer colors.

Figure 17—Practical wiring diagram, main power supply

SIGNAL GENERATOR I-208

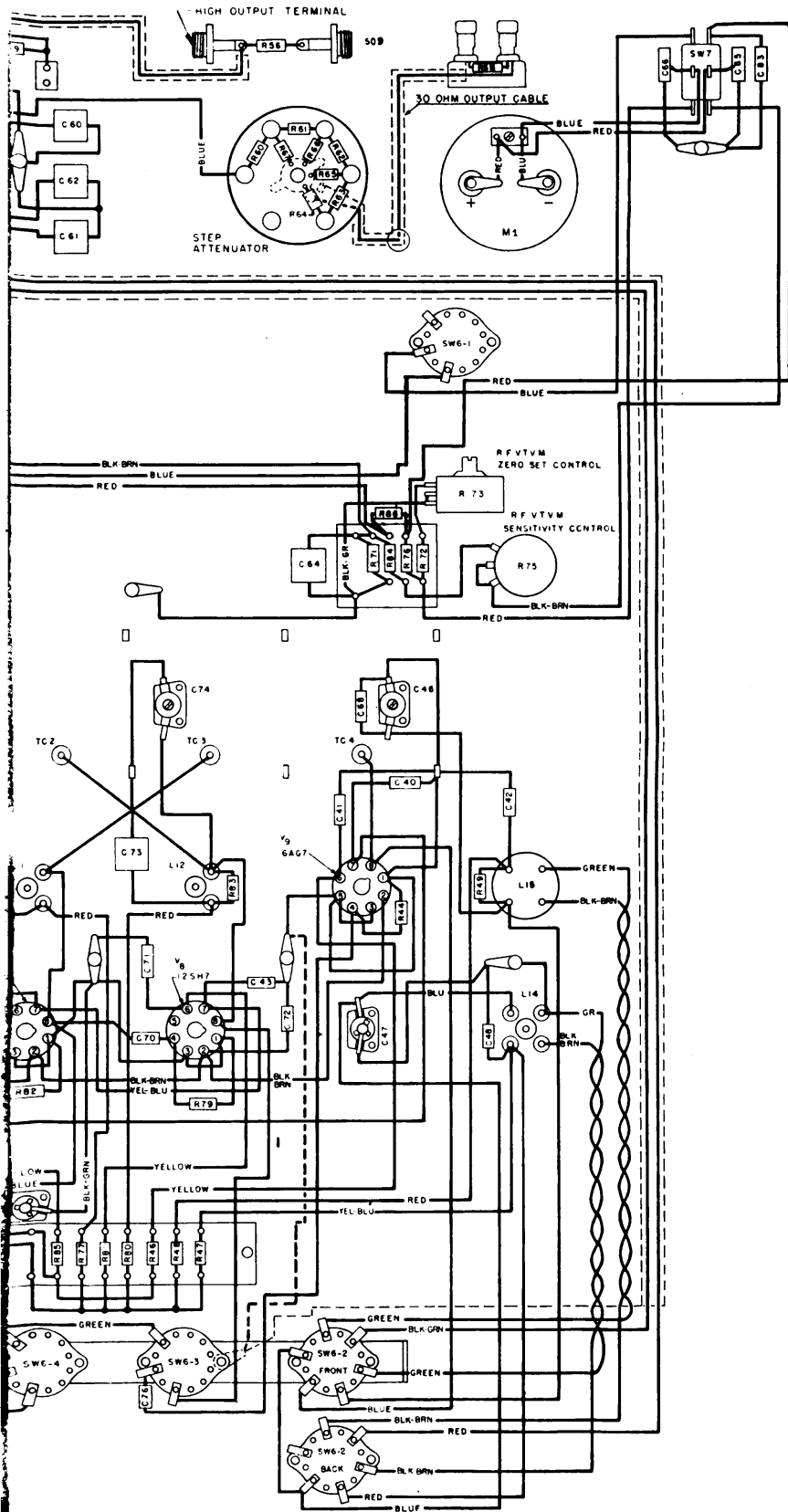

Designated colors are tracer colors.

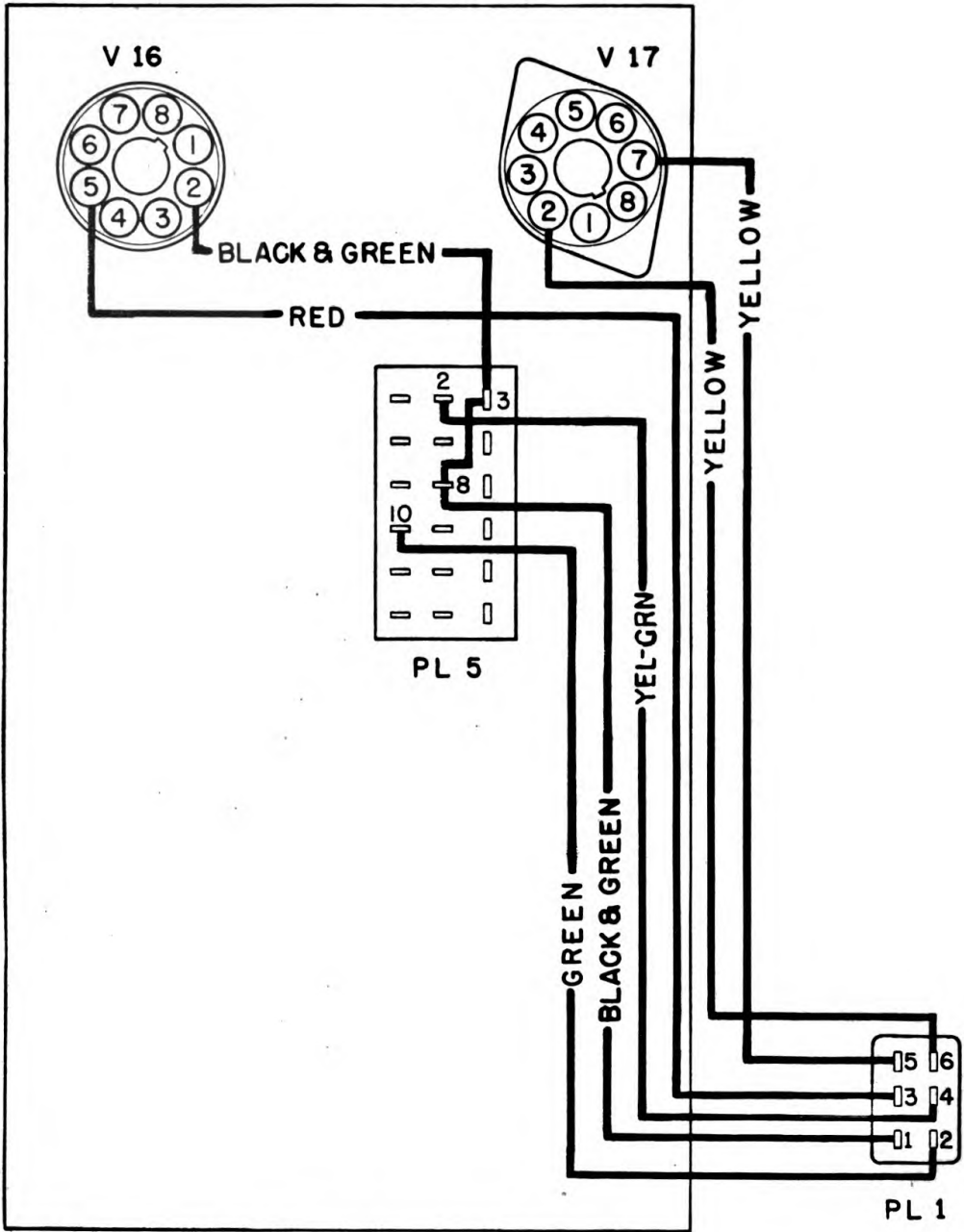

All designated colors are tracer colors.

Figure 19—Practical wiring diagram, dynamotor assembly

SIGNAL CORPS

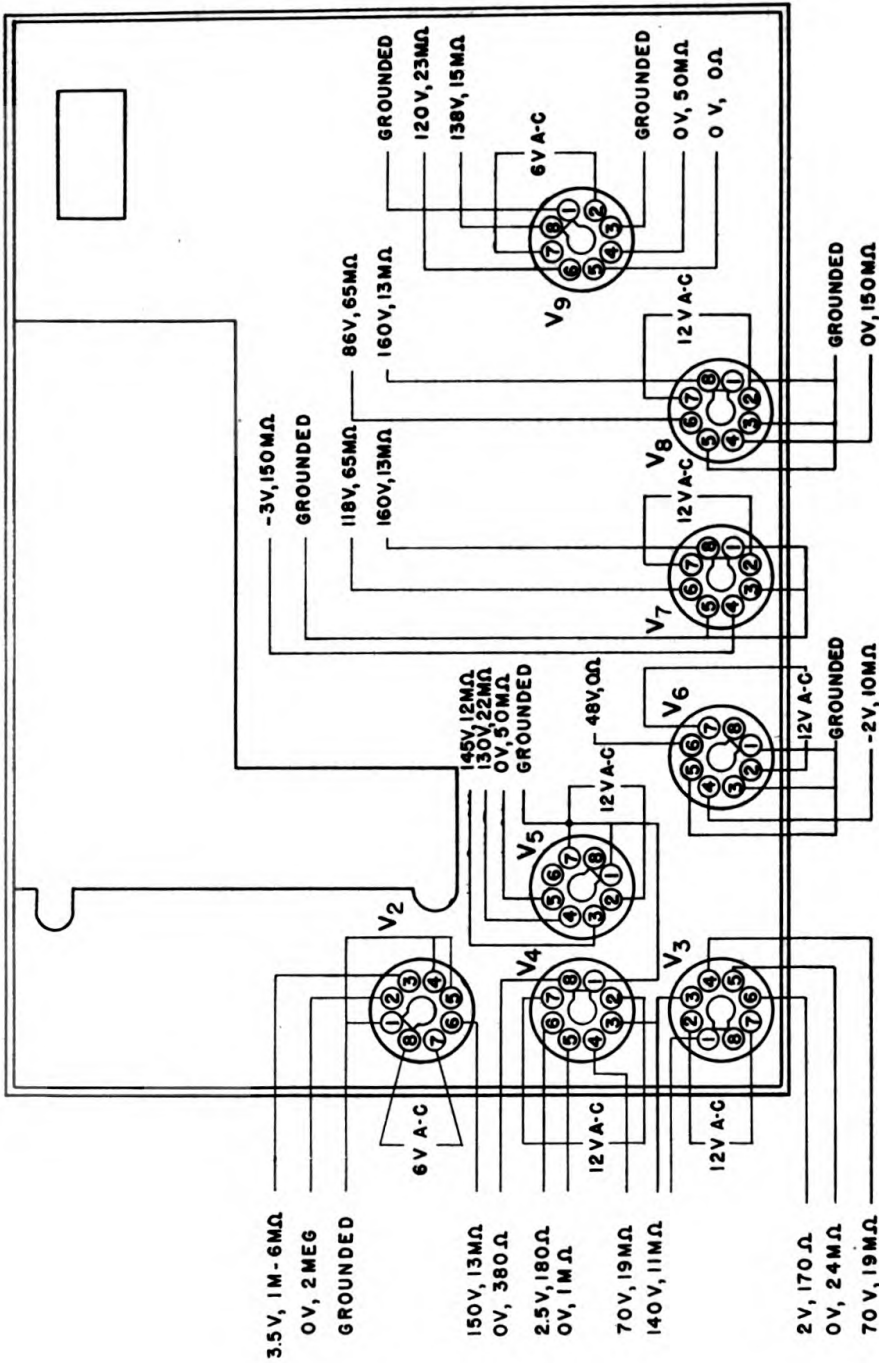
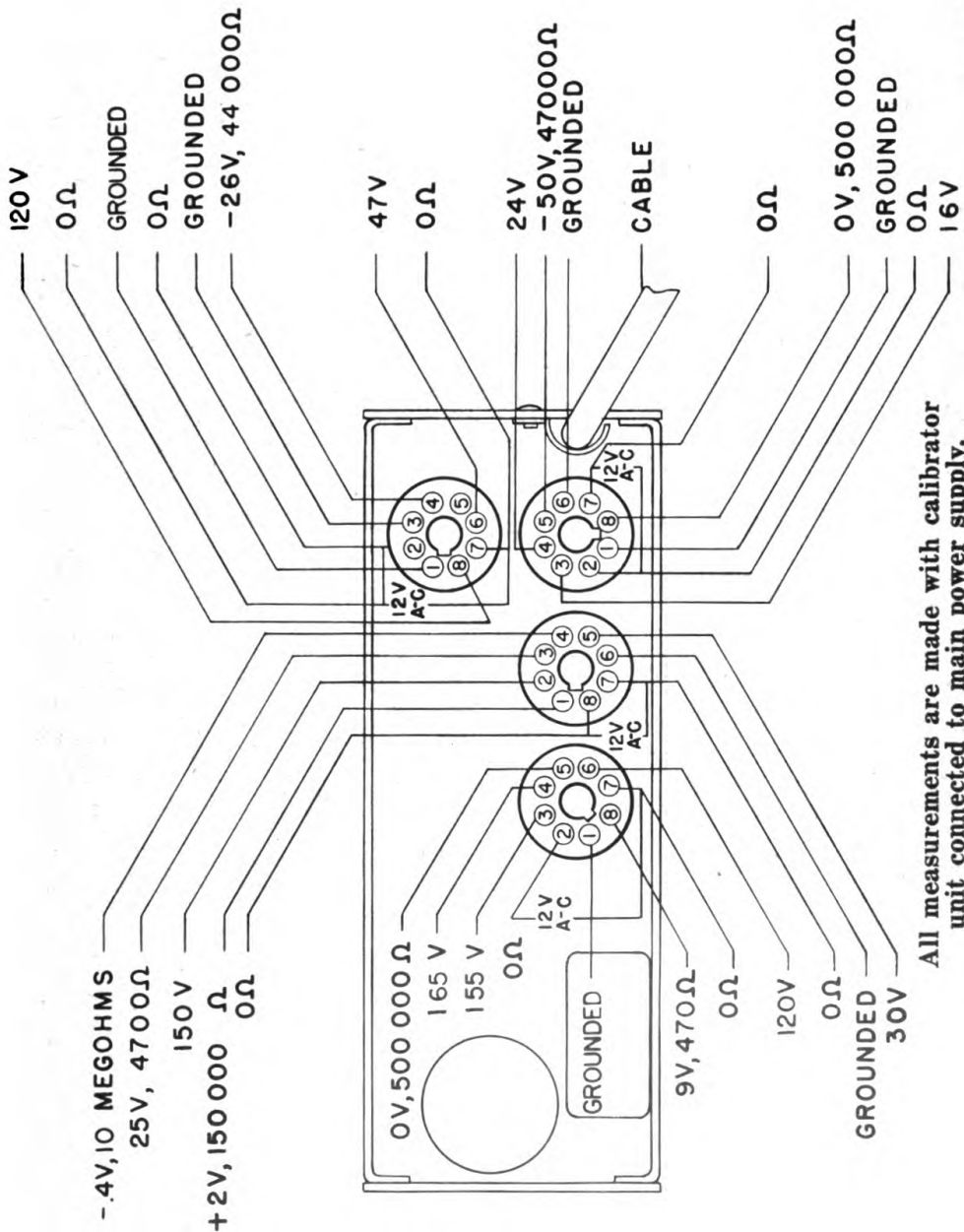

Figure 21—Socket voltage and resistance measurements, r-f unit



All measurements are made with calibrator unit connected to main power supply.

All designated colors are tracer colors.

Figure 22—Socket voltage and resistance measurements, calibrator unit

SIGNAL CORPS

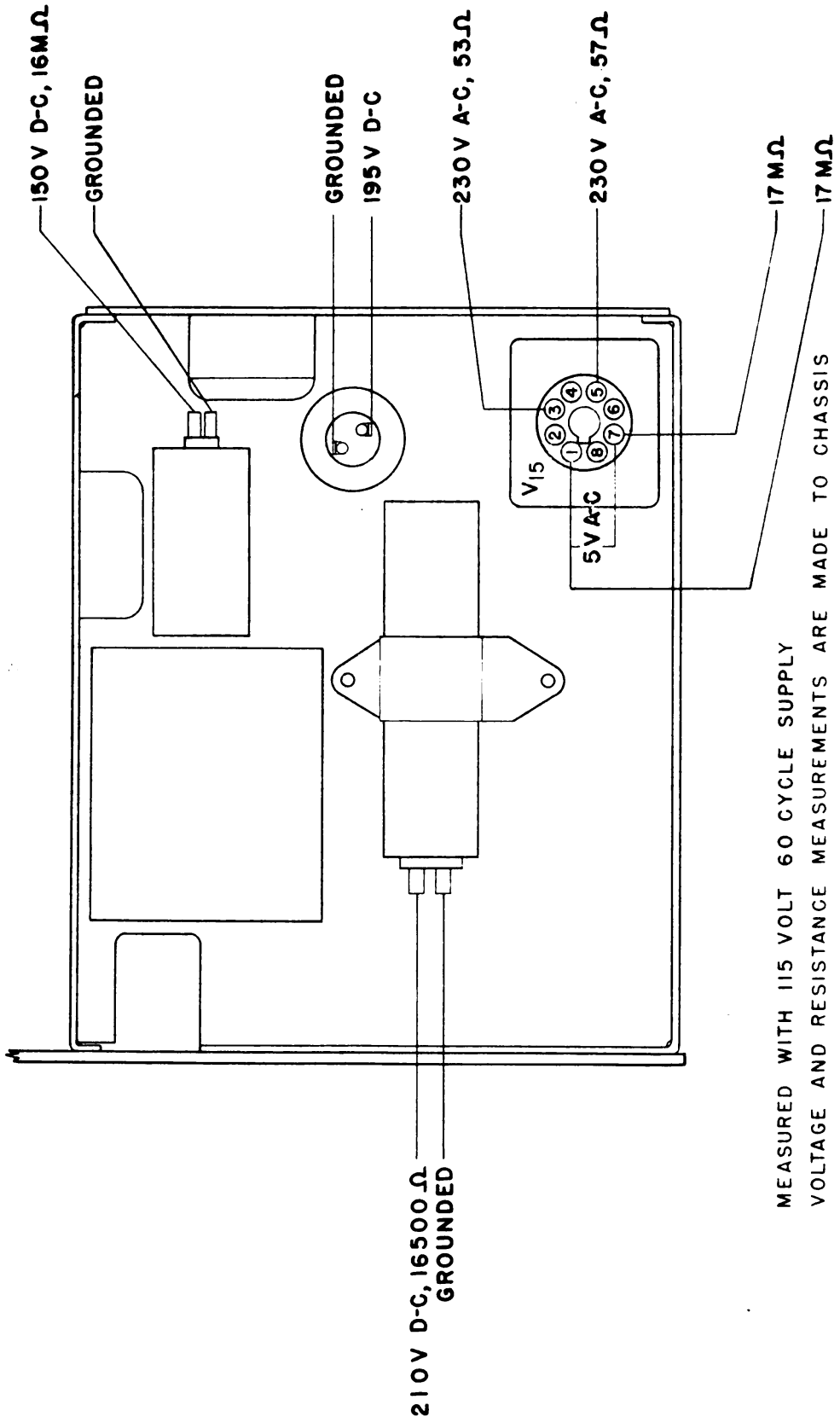

Figure 23—Socket voltage and resistance measurements, main power supply

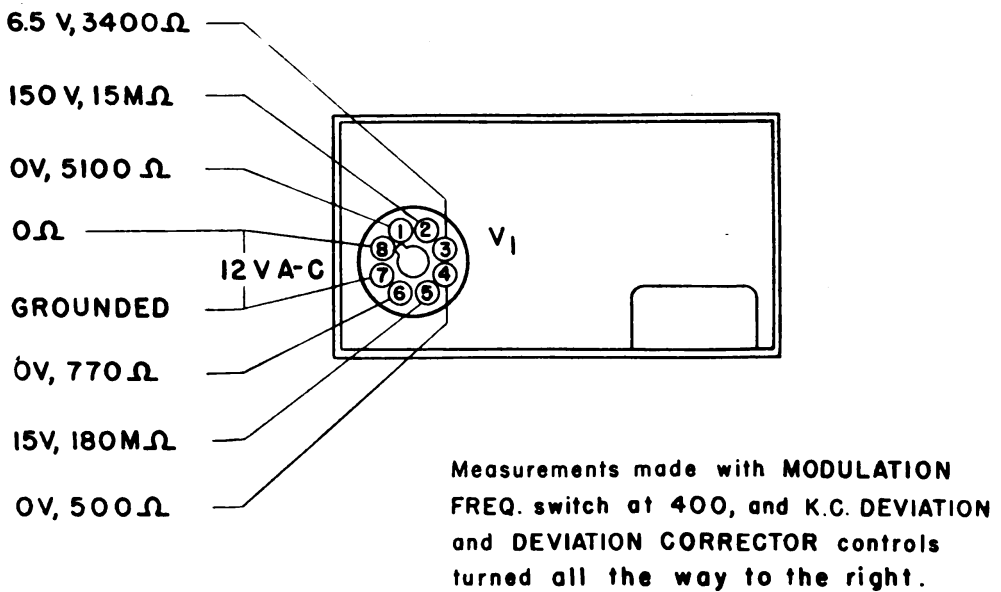

Figure 24—Socket voltage and resistance measurements, audio oscillator

SECTION V
SUPPLEMENTARY DATA

Table of replaceable parts	<i>Paragaph</i> 16
List of manufacturers	17

16. Table of replaceable parts

a. R-F unit

Ref. No.	Sig. C. Stock No.	Name of Part	Description	Function	Mfr. Code	Detrola Part No.
R ₂₇	3RC20AE688M	Resistor	68,000-ohm, 20%, 1/2-watt, insulated carbon.	Tube V ₂ bias supply.	2	G-44529
R ₂₉		Resistor	Variable, 5,000-ohm, 10%, wire wound, linear.	Tube V ₂ sensitivity control.	10	G-44557
R ₃₁	3RC20AE102M	Resistor	1,000-ohm, 20%, 1/2-watt, insulated carbon.	Tube V ₂ minimum bias limiter.	2	G-15083
R ₃₂	3RC20AE225M	Resistor	2.2 megohm, 20%, 1/2-watt, insulated carbon.	Tube V ₂ grid bias.	2	G-44517
R ₃₃	3RC20AE102M	Resistor	Same as R ₃₁ .	Audio voltage droppng.	2	G-15083
R ₃₄		Resistor	Variable, 2,000-ohm, 10%, wire wound, linear.	Frequency deviation regulator.	10	G-44536
R ₃₅	3RC20AE181K	Resistor	180-ohm, 10%, 1/2-watt, insulated carbon.	Minimum audio voltage limiter.	2	G-44542
R ₃₆	3RC20AE181K	Resistor	Same as R ₃₅ .	Tubes V ₃ and V ₄ cathode bias.	2	G-44542

R ₃₇	Resistor	Variable, 25,000-ohm, 10%, wire wound, linear.	Screen voltage control.	28	G-44553
R ₃₈	Resistor	30-ohm, 10%, 5-watt, wire wound.	Tubes V ₂ and V ₁₀ heater shunt.	38	G-44552
R ₃₉	Resistor	500-ohm, 10%, 1/2-watt, insulated carbon.	VTVM cathode.	36	G-17365
R ₄₀	Resistor	24,000-ohm, 5%, 1/2-watt, insulated carbon.	Tube V ₃ reactance network.	2	G-44512
R ₄₁	Resistor	500,000-ohm, 10%, 1/2-watt, insulated carbon.	Tube V ₃ grid bias.	2	G-15914
R ₄₂	Resistor	1,000-ohm, 5%, 1/2-watt, insulated carbon.	Tube V ₄ reactance network.	2	G-44531
R ₄₃	Resistor	7,500-ohm, 5%, 1/2-watt, insulated carbon.	Tubes V ₃ and V ₄ screen voltage dropping.	2	G-44504
R ₄₄	Resistor	47,000-ohm, 20%, 1/2-watt, insulated carbon.	Tube V ₉ grid bias.	2	G-44508
R ₄₆	Resistor	Same as R ₄₃ .	Tube V ₉ screen voltage dropping.	2	G-44504
R ₄₇	Resistor	Same as R ₃₁ .	Tube V ₉ plate voltage supply filter.	2	G-15083
R ₄₈	Resistor	Same as R ₃₁ .	Same as R ₄₇ .	2	G-15083
R ₄₉	Resistor	10,000-ohm, 10%, 1/2-watt, insulated carbon.	Coil L ₁₅ shunting resistor.	2	G-23249
R ₅₀	Resistor	Same as R ₄₄ .	Tube V ₅ grid bias.	2	G-44508
R ₅₁	Resistor	Same as R ₄₉ .	Tube V ₅ screen voltage dropping.	2	G-23249
R ₅₂	Resistor	Same as R ₄₉ .	Tube V ₆ grid bias.	2	G-23249
R ₅₃	Resistor	Same as R ₄₄ .	Tube V ₆ screen voltage bleeder.	2	G-44508
R ₅₄	Resistor	Same as R ₄₄ .	Tube V ₆ screen voltage dropping.	2	G-44508
R ₅₅	Resistor	150-ohm, 5%, 1/2-watt, insulated carbon.	VTVM isolation resistor.	36	G-44544
R ₅₆	Resistor	Same as R ₃₁ .	Calibrator isolation resistor.	36	G-15083

16. Table of replaceable parts
a. R-F unit (Continued)

Ref. No.	Sig. C. Stock No.	Name of Part	Description	Function	Mfr. Code	Detrola Part No.
R ₅₇	3RC20AE201J	Resistor	200-ohm, 5%, 1/2-watt, insulated carbon.	Attenuator network.	36	G-44546
R ₅₈	3RC20AE101J	Resistor	100-ohm, 5%, 1/2-watt, insulated carbon.	Same as R ₅₇ .	36	G-44543
R ₅₉	3RC20AE101J	Resistor	Same as R ₅₈ .	Same as R ₅₇ .	36	G-44543
R ₆₀	3RC20AE271J	Resistor	270-ohm, 5%, 1/2-watt, insulated carbon.	Multiplier network.	36	G-44549
R ₆₁	3RC20AE271J	Resistor	Same as R ₆₀ .	Same as R ₆₀ .	36	G-44549
R ₆₂	3RC20AE271J	Resistor	Same as R ₆₀ .	Same as R ₆₀ .	36	G-44549
R ₆₃	3RC20AE271J	Resistor	Same as R ₆₀ .	Same as R ₆₀ .	36	G-44549
R ₆₄	3RC20AE300J	Resistor	30-ohm, 10%, 1/2-watt, insulated carbon.	Same as R ₆₀ .	36	G-44551
R ₆₅	3RC20AE330J	Resistor	33-ohm, 5%, 1/2-watt, insulated carbon.	Same as R ₆₀ .	36	G-44548
R ₆₆	3RC20AE330J	Resistor	Same as R ₆₅ .	Same as R ₆₀ .	36	G-44548
R ₆₇	3RC20AE330J	Resistor	Same as R ₆₅ .	Same as R ₆₀ .	36	G-44548
R ₆₈	3RC20AE300J	Resistor	Same as R ₆₄ .	Line impedance termination.	36	G-44551
R ₆₉	3RC20AE430J	Resistor	43-ohm, 5%, 1/2-watt, insulated carbon.	Same as R ₆₀ .	36	G-44547
R ₇₀	3Z6050-65	Resistor	Same as R ₃₉ .	VTVM frequency compensation network.	36	G-17365
R ₇₁	3RC20AE103K	Resistor	10,000-ohm, 10%, 1/2-watt, insulated carbon.	VTVM sensitivity network.	2	G-23249
R ₇₂	3RC20AE390K	Resistor	39-ohm, 10%, 1/2-watt, insulated carbon.	VTVM zero set network.	2	G-44538
R ₇₃	Resistor	Resistor	Variable, 200-ohm, 10%, wire wound, linear.	Same as R ₇₂	10	G-44558

SIGNAL GENERATOR I-208

TM 11-317
Par. 16

R ₇₄	3RC20AE101J	Resistor	Same as R ₅₈ .		Hi output cable line impedance termination.	2	G-44543
R ₇₅		Resistor	Variable, 10,000-ohm, 10%, wire wound, linear.		VTVM sensitivity control.	10	G-44561
R ₇₆	{ 3RC20AE473M 3RC21BE473M	Resistor	Same as R ₄₄ .		Same as R ₇₂ .	2	G-44508
R ₇₇	3RC20AE102M	Resistor	Same as R ₃₁ .		Tube V ₇ plate voltage supply filter.	2	G-15083
R ₇₉	{ 3RC20AE154K 3RC21BE154K	Resistor	150,000-ohm, 10%, 1/2-watt, insul. carbon.		Tube V ₈ grid bias.	2	G-31357
R ₈₀	3RC20AE102M	Resistor	Same as R ₃₁ .		Tube V ₈ plate voltage supply filter.	2	G-15083
R ₈₁	{ 3RC20AE473M 3RC21BE473M	Resistor	Same as R ₄₄ .		Tube V ₈ screen voltage dropping.	2	G-44508
R ₈₂	{ 3RC20AE154K 3RC21BE154K	Resistor	Same as R ₇₉ .		Tube V ₇ grid bias.	2	G-31357
R ₈₃	3RC20AE103K	Resistor	Same as R ₄₉ .		Coil L ₁₂ shunting resistor.	2	G-23249
R ₈₄	3RC20AE332M	Resistor	3,300-ohm, 20%, 1/2-watt, insulated carbon.		Same as R ₇₁ .	2	G-44526
R ₈₅	{ 3RC20AE473M 3RC21BE473M	Resistor	Same as R ₄₄ .		Tube V ₇ screen dropping.	2	G-44508
R ₈₆		Resistor	500-ohm, 10%, 1/2-watt, insulated carbon.		Isolation resistor.	36	G-17365
R ₈₇		Resistor	Variable, 20,000-ohm, 10%, wire wound linear.		Line voltage compensator.	10	G-44534
C ₃₀		Capacitor	.01 μf, -20% +40%, 400 volts d.c., oil impregnated moulded paper.		Audio VTVM input capacitor.	29	G-44581
C ₃₁		Capacitor	.25 μf, ±20%, 400 volts d.c., oil filled paper.		Choke CH ₃ coupling.	22, 24	G-44568
C ₃₂	3D9500-24	Capacitor	500 μf, ±10%, 250 volts d.c., mica.		Tube V ₃ grid by-pass.	29, 35	G-3131
C ₃₃	3D9500-24	Capacitor	Same as C ₃₂ .		Tube V ₄ grid by-pass.	29, 35	G-3131
C ₃₄	3DA3-35.2	Capacitor	.003μf, ±20%, 400 volts d.c., mica.		Tubes V ₃ and V ₄ cathode by-pass.	29, 35	G-44583

16. Table of replaceable parts

a. R-F unit (Continued)

Ref. No.	Sig. C. Stock No.	Name of Part	Description	Function	Mfr. Code	Detrola Part No.
C ₃₅	3DA3-35.2	Capacitor	Same as C ₃₄ .	Tubes V ₃ and V ₄ screen by-pass.	29, 35	G-44583
C ₃₆	3D9007V-4	Capacitor	1.5-7 μf trimmer ceramic, Erie NPO-TS2B.	Tube V ₃ reactance network.	17	G-44592
C ₃₇	3D9500-42	Capacitor	500 μf , $\pm 10\%$, 250 volts d.c., silver mica.	Tubes V ₈ and V ₉ coupling.	29	G-44574
C ₃₈	3D9007V-4	Capacitor	Same as C ₃₆ .	Tube V ₄ reactance network.	17	G-44592
C ₄₀	3D9500-24	Capacitor	Same as C ₃₂ .	Tube V ₉ heater by-pass.	29, 35	G-3131
C ₄₁	3DA3-35.2	Capacitor	Same as C ₃₄ .	Tube V ₉ screen by-pass.	29, 35	G-44583
C ₄₂	3DA10-117	Capacitor	.01 μf , $\pm 20\%$, 400 volts d.c., mica.	Tube V ₉ plate voltage supply by-pass	29, 35	G-44578
C ₄₃	3D9500-24	Capacitor	Same as C ₃₂ .	Tube V ₈ heater by-pass.	29, 35	G-3131
C ₄₆	3D9030V-6.1	Capacitor	4-30 μf trimmer ceramic, Erie N 500-TS2B.	Coil L ₁₅ trimmer capacitor.	17	G-44593
C ₄₇	3D9012V-6	Capacitor	3-12 μf trimmer ceramic, Erie NPO-TS2B.	Coil L ₁₄ trimmer capacitor.	17	G-44571
C ₄₈	3DA10-117	Capacitor	Same as C ₄₃ .	Tube V ₉ plate voltage supply by-pass.	29, 35	G-44578
C ₄₉	3DA3-35.2	Capacitor	Same as C ₃₄ .	Tube V ₉ plate by-pass.	29, 35	G-44583
C ₅₀	Capacitor	3.0 μf , $\pm .25 \mu\text{f}$, trimmer.		Coil L ₁₀ frequency corrector.	37	G-43423
C ₅₁	3D9030V-6.1	Capacitor	Same as C ₄₆ .	Coil L ₁₀ trimmer capacitor.	17	G-44593
C ₅₂	3D9010-26.1	Capacitor	10 μf , $\pm 5\%$, ceramic, Erie type N750K.	Compensation capacitor.	17	G-44579
C ₅₄	3K2010131	Capacitor	100 μf , $\pm 10\%$, 250 volts d.c., silver mica.	Tube V ₆ grid coupling capacitor.	29	G-44576
C ₅₅	3DA3-35.2	Capacitor	Same as C ₃₄ .	Tube V ₆ screen by-pass.	29, 35	G-44583

C ₅₆	3K2010021	Capacitor 10 μf , $\pm 10\%$, 250 volts d.c., silver mica.	Tube V ₆ grid coupling capacitor.	29	G-44572
C ₅₇		Capacitor Same as C ₃₀ .	Tube V ₆ screen by-pass.	29	G-44581
C ₅₈	3D9025-29	Capacitor 25 μf , $\pm 10\%$, 250 volts d.c., mica.	Tube V ₇ grid coupling capacitor.	29, 35	G-2925
C ₅₉		Capacitor Same as C ₃₀ .	Tube V ₇ screen by-pass.	29	G-44581
C ₆₀	3D9500-24	Capacitor Same as C ₃₂ .	Tube V ₁₀ heater by-pass.	29, 35	G-3131
C ₆₁	3D9500-24	Capacitor Same as C ₃₂ .	Same as C ₆₀ .	29, 35	G-3131
C ₆₂	3D9500-24	Capacitor Same as C ₃₂ .	Tube V ₁₀ cathode by-pass.	29, 35	G-3131
C ₆₃	3D9007V-4	Capacitor Same as C ₃₆ .	VTVM frequency compensator.	17	G-44592
C ₆₄		Capacitor Same as C ₃₀ .	Same as C ₆₂ .	29	G-44581
C ₆₅	3DA3-35.2	Capacitor Same as C ₃₄ .	Meter by-pass.	29, 35	G-44583
C ₆₆	3DA3-35.2	Capacitor Same as C ₃₄ .	Same as C ₆₅ .	29, 35	G-44583
C ₆₇	3D9030V-6.1	Capacitor Same as C ₄₆ .	Coil L ₁₁ trimmer capacitor.	17	G-44593
C ₆₈	3K2010021	Capacitor 10 μf , $\pm 10\%$, 250 volts d.c., silver mica.	Coil L ₁₆ shunt.	29	G-44572
C ₆₉	3DA10-117	Capacitor Same as C ₄₂ .	Tube V ₇ plate voltage supply by-pass.	29, 35	G-44578
C ₇₀	3D9025-29	Capacitor Same as C ₅₈ .	Tube V ₈ grid coupling capacitor.	29, 35	G-2925
C ₇₁		Capacitor Same as C ₃₀ .	Tube V ₈ screen by-pass.	29	G-44581
C ₇₂	3D9500-24	Capacitor Same as C ₃₂ .	Tube V ₈ heater by-pass.	29, 35	G-3131
C ₇₃	3DA10-117	Capacitor Same as C ₄₂ .	Tube V ₈ plate voltage supply by-pass.	29, 35	G-44578
C ₇₄	3D9030V-6.1	Capacitor Same as C ₄₆ .	Coil L ₁₂ trimmer capacitor.	17	G-44593
C ₇₆	3D9050-32	Capacitor 50 μf , $\pm 10\%$, 250 volts d.c., mica.	Tube V ₉ grid coupling.	29, 35	G-44577
C ₇₇	3DA3-35.2	Capacitor Same as C ₃₄ .	Regulated plate voltage supply by-pass.	29, 35	G-44583
C ₇₈	3DA3-35.2	Capacitor Same as C ₃₄ .	Heater voltage supply by-pass.	29, 35	G-44583

16. Table of replaceable parts
a. R-F unit (Continued)

Ref. No.	Sig. C. Stock No.	Name Part	Description	Function	Mfr. Code	Detrola Part No.
C ₇₉	3DA3-35.2	Capacitor	Same as C ₃₄ .	Same as C ₇₈ .	29, 35	G-44583
C ₈₀	3DA3-35.2	Capacitor	Same as C ₃₄ .	Plate voltage supply by-pass.	29, 35	G-44583
C ₈₁	3DA3-35.2	Capacitor	Same as C ₃₄ .	Hi output cable isolation capacitor.	29, 35	G-44583
C ₈₃		Capacitor	Same as C ₃₀ .	B + by-pass.	29	G-14581
L ₅	3C323-37B	Choke	R-f, 1 mh.	Regulated plate supply r-f filter.	25	G-43395
L ₆	3C323-37D	Choke	R-f, 5 μ h.	Heater supply r-f filter.	25	G-43415
L ₇	3C343-37D	Choke	R-f, same as L ₆ .	Same as L ₆ .	25	G-43415
L ₈	3C323-37B	Choke	R-f, same as L ₆ .	Unregulated plate supply r-f filter.	25	G-43395
L ₉	3C323-37B	Choke	R-f, same as L ₆ .	Tubes V ₃ and V ₄ plate choke.	25	G-43395
L ₁₀	3C1084F-6	Coil	Tapped, variable, iron core.	Tube V ₅ oscillator coil.	25	G-43250
L ₁₁	3C1084F-8	Coil	Variable, iron core.	Tube V ₇ plate coil.	25	G-43230
L ₁₂	3C1084F-7	Coil	Variable, iron core.	Tube V ₈ plate coil.	25	G-43280
L ₁₃	3C323-37C	Choke	R-f, 2.5 mh.	Tube V ₆ plate choke.	30	G-43626
L ₁₄	3C1084F-5	Coil	Variable, iron core.	Tube V ₉ low frequency output.	25	G-43260
L ₁₅	3C1084F-4	Coil	Variable, iron core.	Tube V ₉ high frequency output.	25	G-43310
L ₁₇		Choke	R-f, 1 mh.	Regulated plate supply r-f filter.	25	G-43395
CH ₃	3C323-37A	Choke	Audio, tapped, special.	Tubes V ₃ and V ₄ modulation choke.	19	G-43106
SW _{a-1}	3Z9825-95.2	Switch	Rotary, special.	Meter circuit closing.	31	G-43104
SW _{a-2}	3Z9903E-14.1	Switch	Rotary, special.	Coil L ₁₄ and L ₁₆ switching.	31	G-43442

16. Table of replaceable parts

a. R-F unit (Continued)

Ref. No.	Sig. C. Stock No.	Name of Part	Description	Function	Mfr. Code	Detrola Part No.
			Tuning unit assembly.	Tuning capacitors and dial tuning mechanism.	23	G-43330
	3Z737-25.2	Binding post "A"		30-ohm line terminal.	15	G-43713
	3Z737-25	Binding post "G"		30 ohm line terminal.	15	G-42812
		Slide wire assembly		Variable attenuator.	12	G-43885
		Step at-tenuator assy.		R-f attenuator.	12	G-43510
		Dial film			12	G-43271

b. Audio oscillator unit

R ₁₆	Resistor	100,000-ohm, 10%, 1/2-watt, insul. carbon.	Tube V ₁ oscillator plate voltage dropping.	2	G-23252
R ₁₇	Resistor	150,000-ohm, 10%, 1/2-watt, insul. carbon.	Same as R ₁₆ .	2	G-31357
R ₁₈	Resistor	8,200-ohm, 10%, 1/2-watt, insulated carbon.	Same as R ₁₆ .	2	G-44502
R ₁₉	Resistor	22,000-ohm, 10%, 1/2-watt, insul. carbon.	Same as R ₁₆ .	2	G-15080
R ₂₀	Resistor	33,000-ohm, 10%, 1/2-watt, insul. carbon.	Same as R ₁₆ .	2	G-23251

R ₂₁	3RC20AE103K	Resistor	10,000-ohm, 10%, ½-watt, insul. carbon.	Tube V ₁ oscillator cathode circuit.	2	G-23249
R ₂₂		Resistor	Variable 10,000-ohm, 10%, wire wound, linear.	Deviation corrector.	10	G-44559
R ₂₃		Resistor	Variable 10,000-ohm, 10%, wire wound, linear.	Amplifier grid input voltage control.	10	G-44556
R ₃₀	3RC20AE331K	Resistor	330-ohm, 10%, ½-watt, insulated carbon.	Tube V ₁ oscillator cathode bias.	2	G-23259
C ₁₃		Capacitor	.01 μf, = 5%, 300 volts d.c., mica.	Tube V ₁ oscillator tuning.	29, 35	G-44586
C ₁₄	3K4010322	Capacitor	.03 μf, = 5%, 400 volts d.c., oil filled, paper.	Same as C ₁₃ .	17	G-44597
C ₁₅	3DKA7-6	Capacitor	.007 μf, = 5%, 500 volts d.c., mica.	Same as C ₁₃ .	29, 35	G-44598
C ₁₆		Capacitor	.25 μf, = 5%, 400 volts d.c., oil filled paper.	Same as C ₁₃ .	25	G-42820
CH ₂	3C323-36B	Choke	Audio, tapped, special.	Audio oscillator.	19	G-42801
SW ₅	3Z9825-95.3	Switch	Rotary, 6 position, special.	MODULATION FREQ. selector switch.	31	G-42861
PL ₄	2Z7116.36	Plug	6 terminal, male, type P-306-AB modified.	Power connector to SO ₄ .	25	G-42880
V ₁		Tube	Commercial type 12SN7-GT.	Audio oscillator and amplifier.	34	G-42818
P ₃	3Z737-25	Binding post	"G" type 60 MB.	Ground connection for external modulation.	15	G-42812
P ₄	3Z737-25.1	Binding post	"H1" type 60 MB.	Signal input connection for external modulation.	15	G-42813
		Socket	Octal, bakelite, type S8-T.	Socket for tube V ₁ .	4	G-42311
c. Calibrator unit						
R ₁	3RC20AE154M	Resistor	150,000-ohm, 20%, ½-watt, insul. carbon.	Tube V ₁₁ oscillator grid bias.	2	G-44501
R ₂	{ 3RC20AE472M 3RC21BE472M	Resistor	4,700-ohm, 20%, ½-watt, insulated carbon.	Tube V ₁₁ oscillator cathode bias.	2	G-44509
R ₃	3RC31AE472K	Resistor	4,700-ohm, 20%, 1-watt, insulated carbon.	Plate supply decoupling filter.	2	G-44521

16. Table of replaceable parts
c. Calibrator unit (Continued)

Ref. No.	Sig. C. Stock No.	Name of Part	Description	Function	Mfr. Code	Detroit Part No.
R ₄	3RC20AE106M	Resistor	10 megohm, 1/2-watt, insulated carbon.	Tube V ₁₁ audio grid bias.	2	G-15087
R ₅	3RC20AE223M	Resistor	22,000-ohm, 20%, 1/2-watt, insulated carbon.	Tube V ₁₂ grid bias.	2	G-44511
	3RC21BE223M					
R ₆	3RC20AE223M	Resistor	Same as R ₅ .	Tube V ₁₂ screen voltage dropping.	2	G-44511
	3RC21BE223M					
R ₇	3RC20AE473M	Resistor	47,000-ohm, 20%, 1/2-watt, insul. carbon.	Tube V ₁₃ grid bias.	2	G-44508
	3RC21BE473M					
R ₈	3RC20AE473M	Resistor	Same as R ₇ .	Tube V ₁₃ screen voltage dropping.	2	G-44508
	3RC21BE473M					
R ₉	3ZK6750-39	Resistor	500,000-ohm, 20%, 1/2-watt, insul. carbon.	Tube V ₁₃ plate load.	2	G-15914
R ₁₀	3ZK6750-39	Resistor	Same as R ₉ .	Tube V ₁₃ mixer grid bias.	2	G-15914
R ₁₁	3ZK6750-39	Resistor	Same as R ₉ .	Tube V ₁₄ grid leak.	2	G-15914
R ₁₂	3RC20AE471M	Resistor	470-ohm, 20%, 1/2-watt, insulated carbon.	Tube V ₁₄ cathode bias.	2	G-44532
R ₁₃	3RC20AE224M	Resistor	220,000-ohm, 20%, 1/2-watt, insulated carbon.	Tube V ₁₁ plate load.	2	G-44514
R ₁₄	3RC20AE223M	Resistor	Same as R ₅ .	Tube V ₁₂ grid isolation resistor.	2	G-44511
	3RC21BE223M					
C ₁	3D9045.V-1.1	Capacitor	7-45 μmf, trimmer ceramic.	Tube V ₁₁ oscillator tank tuning.	17	G-44599
C ₂	3D9050-32	Capacitor	50 μmf, ±10%, 250 volts d.c., mica.	Tube V ₁₁ oscillator plate to V ₁₂ grid.	29, 35	G-44577

C ₃	Capacitor .01 μ f, -20% +40%, 400 volts d.c., oil impregnated moulded paper.	Tube V ₁₂ screen by-pass.	29	G-44581
C ₄	Capacitor 250 μ f, 250 volts d.c., mica.	Tube V ₁₁ oscillator cathode by-pass.	29, 35	G-44596
C ₅	Capacitor Same as C ₃ .	Tube V ₁₁ oscillator plate voltage supply by-pass.	29	G-44581
C ₆	Capacitor Same as C ₃ .	Tube V ₁₂ plate voltage supply by-pass.	29	G-44581
C ₇	Capacitor 250 μ f, \pm 10%, 250 volts d.c., mica.	Tubes V ₁₂ and V ₁₃ coupling.	29, 35	G-44596
C ₈	Capacitor Dual electrolytic. 10 μ f, 350 volts d.c., non-polarized, Aerovox N 12.	Tubes V ₁₂ and V ₁₃ plate supply filter.	1	G-44588
C ₉	Capacitor 500 μ f \pm 10%, 250 volts d.c., mica.	Tube V ₁₃ input coupling.	29, 35	G-3131
C ₁₀	Capacitor Same as C ₃ .	Tubes V ₁₁ and V ₁₄ coupling.	29	G-44581
C ₁₁	Capacitor Dual electrolytic. 20 μ f, 25 volts d.c., polarized, Aerovox N 12.	Tube V ₁₁ cathode by-pass.	1	G-44588
C ₁₂	Capacitor .25 μ f, \pm 20%, 600 volts d.c., oil filled.	Output capacitor to headsets.	21, 24	G-44582
C ₃₉	Capacitor .003 μ f, -20% +40%, 400 volts d.c., oil impregnated.	Tube V ₁₄ plate by-pass.	29	G-44587
C ₄₅	Capacitor 100 μ f, \pm 10%, 250 volts d.c., mica.	Tube V ₁₃ plate by-pass.	29, 35	G-44573
C ₅₃	Capacitor Same as C ₉ .	Audio coupling capacitor.	29, 35	G-3131
C ₇₅	Capacitor Same as C ₃ .	Tube V ₁₃ screen by-pass.	29	G-44581
C ₈₂	Capacitor Same as C ₁ .	Tube V ₁₂ tank tuning.	17	G-44599
L ₄	Coil Crystal oscillator.	Tube V ₁₁ oscillator coil.	9	G-42950
L ₁₆	Coil Frequency doubler.	Tube V ₁₂ plate coil.	9	G-42975
T ₂	Transformer Output primary 10,000 ohms, secondary 3.5 ohms, special.	Tube V ₁₄ output transformer.	19	G-42901

SIGNAL CORPS

16. Table of replaceable parts
c. Calibrator unit (Continued)

Ref. No.	Sig. C. Stock No.	Name of Part	Description	Function	Mfr. Code	Detroit Part No.
PL ₃	2ZK7118.17	Plug	8 terminal, male, type P-308-FHT.	Connection for socket SO ₃ .	26	G-42941
PL ₉	2Z7226-238	Plug	2 circuit.	Connection for socket SO ₉ .	26	G-23389
V ₁₁		Tube	Commercial type 12SN7-GT.	Crystal oscillator and audio amplifier.	34	G-42818
V ₁₂	2T288	Tube	Commercial type 12SH7.	Frequency doubler.	34	G-43141
V ₁₃	2T161	Tube	Commercial type 12SA7-GT.	R-f mixer.	34	G-6963
V ₁₄	2T134	Tube	Commercial type 12A6-GT.	Power amplifier.	33	G-42908
J ₂		Jack	Meter jack for test purposes.	Crystal oscillator grid current.	28	G-42922
	2Z3501-23A	Crystal	Crystal and holder assy.	Tube V ₁₁ 500 kc. crystal.	39	G-42912
		Unit DC-23-A				
	2Z8762.2	Socket	Octal, steatite, type SS-8.	Socket for tube V ₁₁ .	4	G-16111
		Socket	Octal, bakelite, type S8-T.	Socket for tubes V ₁₂ , V ₁₃ , and V ₁₄ .	4	G-42311
	2Z8672.28	Socket	2 prong.	Sockets for crystals.	12	G-42902

d. Main power supply

R ₂₄	3Z6015-30	Resistor	150-ohm, 10%, 10-watt, wire wound, vitreous enamelled.	Regulated voltage dropping resistor.	28	G-44524
R ₂₅	3RC20AE560K	Resistor	56-ohm, 10%, 1/2-watt, insulated carbon.	Tube V ₁₆ initial current limiter.	2	G-44537
R ₂₆	3Z6003-35	Resistor	30-ohm, 10%, 5-watt, wire wound, vitreous enamelled.	Lamp LM, voltage dropping resistor.	28	G-44552

SIGNAL GENERATOR I-208

TM 11-317
Par. 16

R ₇₈	3Z6500-139	Resistor	5000-ohm, 10%, 10-watt, wire wound, vitreous enamelled.	Plate power supply shunt.	28	G-44523
C ₁₇		Capacitor	.25 μ f, \pm 20%, 600 volts d.c., oil filled.	Tube V ₁ , plate by-pass.	25	G-42540
C ₁₈	3DA10-117	Capacitor	.01 μ f, \pm 20%, 400 volts d.c., mica.	Part of 115-volt line filter assembly.	29, 35	G-44578
C ₁₉	3DA10-117	Capacitor	Same as C ₁₈ .	Same as C ₁₈ .	29, 35	G-44578
C ₂₀	3DA3-35.2	Capacitor	.003 μ f, \pm 20%, 400 volts d.c., mica.	Receptacle SO ₆ r-f by-pass.	29, 35	G-44583
C ₂₁	3DA3-35.2	Capacitor	Same as C ₂₀ .	Same as C ₂₀ .	29, 35	G-44583
C ₂₂	3DA500-147	Capacitor	.5 μ f, \pm 20%, 100 volts d.c., paper.	12-volt filter capacitor.	19	G-42193
C ₂₃	3DA500-147.1	Capacitor	Same as C ₂₂ .	Part of 12-volt filter assembly.	19	G-42344
C ₂₄		Capacitor	400 μ f, 100 volts d.c., paper, special type.	Same as C ₂₃ .	25	G-42385
C ₂₅	3DA3-35.2	Capacitor	.003 μ f, \pm 20%, 400 volts d.c., paper.	Same as C ₂₃ .	29, 35	G-44583
C ₂₆	3DA3-35.2	Capacitor	Same as C ₂₀ .	Same as C ₂₀ .	29, 35	G-44583
C ₂₇		Capacitor	20 μ f, -0% +50%, 250 volts d.c., electrolytic, non-polarized.	Regulated plate supply filter.	1	G-44591
C ₂₈		Capacitor	40 μ f, -0% +50%, 400 volts d.c., electrolytic, non-polarized.	Plate supply filter.	1	G-44589
C ₂₉		Capacitor	Same as C ₂₃ .	Same as C ₂₃ .	1	G-44589
T ₁		Transformer	Power, primary 117 volts a.c. Secondary (1) 465 volt C.T. at 150 ma. (2) 12 volt at 3 amps. (3) 5 volt at 3 amps, special.	Power transformer.	19	G-42101
CH ₁	3C323-36H	Choke	Filter, 5 hy. 150 ma. special.	Plate supply filter choke.	19	G-42102
L ₁		Choke	R-f, 10 μ h, special.	Part of 115-volt line filter assembly.	25	G-42365
L ₂		Choke	R-f, same as L ₁ .	Same as L ₁ .	25	G-42365

16. Table of replaceable parts
d. Main power supply (Continued)

Ref. No.	Sig. C. Stock No.	Name of Part	Description	Function	Mfr. Code	Detrola Part No.
L ₃	3C1084F-9	Choke	R-f, 5 μ h, special.	Part of 12-volt filter assembly.	25	G-42395
SW ₁	3Z9858-3	Switch	DPDT, toggle.	Power selector switch.	6	G-42413
SW ₂	3Z9858-8.66	Switch	DPST, toggle.	POWER switch.	6	G-42418
SW ₃	3Z9858-8	Switch	DPST, toggle.	PLATE VOLTAGE switch.	6	G-42414
SW ₄	3Z9858-3	Switch	Same as SW ₁ .	CALIBRATOR switch.	6	G-42413
LS ₁		Loudspeaker	Permanent magnet dynamic, type RM2.	Calibrator output.	25	G-42550
J ₁		Jack	Headset, special.	Calibrator output.	28	G-42118
FS ₁	3Z2015-1	Fuse	15 amp.	12-volt line fuse.	7	G-40002
FS ₂	3Z1950	Fuse	3 amp.	115-volt line fuse.	7	G-40001
LM ₃	2Z5927	Lamp	6.3 volt, 250 ma, bayonet base, type 44.	Calibrator power indicator.	20	G-18013
SO ₁		Socket	6 terminal, female, type S-306-AB.	Connection to plug PL ₁	25	G-42465
SO ₂	2Z8639-16	Socket	6 terminal, female, type S-306-AB, special.	Connection to plug PL ₂ on r-f unit.	26	G-42412
SO ₃		Socket	8 terminal, female, type S-308-AB.	Connection to plug PL ₃ on cali- brator unit.	25	G-42440
SO ₄	2Z7116.19	Socket	6 terminal, female, type S-306-FHT.	Connection to plug PL ₄ on audio oscillator unit.	26	G-42471
SO ₆		Socket	2 terminal, male, type 7868-K7.	115-volt power connection.	25	G-42530
SO ₇	2Z7112.32	Socket	2 terminal, male, type DP-D2-34P-1.	12-volt power connection.	8	G-42108
P ₁	3Z737-24	Binding post	Type 44 Admiral.	12-volt power terminal.	15	G-42129

SIGNAL GENERATOR I-208

TM 11-317

Par. 16

P ₂	3Z737-24.1	Binding post	Same as P ₁ .	15	G-42104
V ₁₅	2T244	Tube	VT-244, commercial type 5U4G.	34	G-42131
		115-volt filter assembly		25	G-42320
		12-volt filter assembly		25	G-42340
		Socket	Octal, bakelite, type S8-T.	4	G-42311
	2Z5991	Panel lamp assembly	Jeweled.	14	G-42116
	2Z3285-2	Fuse holder	Type HKM.	7	G-42111

e. Dynamotor assembly

V ₁₆	2T139	Tube	VT-139, commercial type VR150-30.	34	G-42601
V ₁₇		Tube	Commercial type 1H-20, ballast resistor tube.	5	G-42607
PL ₁	2Z7228-21	Plug	6 contact, male, type P-306-FHT.	26	G-42676
SO ₅	2Z7228	Socket	18-terminal, male.	26	G-42614
	2Z8659-6	Socket	Octal, bakelite, MIP8.	4	G-42628
		Socket	Octal, bakelite, type S8-T.	4	G-42311
	3H1664A	Dynamotor		3	G-42603
		DM-64-(*)			

f. Cords

	Cord CD-778	115-volt power cord, 8 ft. long.	25	G-44000
	Cord CD-749	High output cable, 40 inches long.	25	G-45000
	Cord CD-984	Service extension cord, 36 inches long.	25	G-46000

17. List of Manufacturers

1. Aerovox Corporation, New Bedford, Massachusetts
2. Allen Bradley Company, Milwaukee, Wisconsin
- International Resistance Company, 401 North Broad Street,
Philadelphia, Pennsylvania
- Speer Resistor Corporation, St. Marys, Pennsylvania
- Stackpole Carbon Company, St. Marys, Pennsylvania
3. Alliance Manufacturing Company, Alliance, Ohio
4. American Phenolic Corporation, Chicago, Illinois
5. Amperite Company, 561 Broad Street, New York, New York
6. Arrow-Hart & Hegeman Electric Company, 103 Hawthorne
Street, Hartford, Connecticut
7. Bussman Manufacturing Company, St. Louis, Missouri
8. Cannon Electric Development Company, 3209 Humboldt
Street, Los Angeles, California
9. Carron Mfg. Co., 415 S. Aberdeen St., Chicago, Illinois
10. Chicago Telephone Supply Company, Elkhart, Indiana
11. Cinaudagraph Speakers, Inc., 3911 South Michigan Avenue,
Chicago, Illinois
12. Cinch Manufacturing Corporation, 2335 West Van Buren
Street, Chicago, Illinois
13. De Jur-Amsco Corporation, 6 Bridge Street, Shelton, Con-
necticut
- General Electric Company, West Lynn, Massachusetts
- O. B. McClintock Company, Minneapolis, Minnesota
- Simpson Electric Company, 5208 W. Kinzie Street, Chicago,
Illinois
14. Drake Manufacturing Company, 1713 West Hubbard Avenue,
Chicago, Ill.
15. Hugh H. Eby, Inc., 18 West Chelton Avenue, Philadelphia,
Pennsylvania
16. Electrical Utilities Company, LaSalle, Illinois
17. Erie Resistor Corporation, Erie, Pennsylvania

18. John E. Fast Company, Crawford & Berry Street, Chicago, Illinois
19. A. P. Foster Company, 719 Wyoming Avenue, Lockland, Ohio
20. General Electric Company, Cleveland, Ohio
21. Gudeman Company, 361 W. Superior Street, Chicago, Illinois
22. Hammarlund Mfg. Company, 424 W. 33rd Street, New York, New York
23. Hedman Manufacturing Company, 1158 Armitage Street, Chicago, Illinois
24. Industrial Condenser, 1725 W. North Street, Chicago, Illinois
25. International Detrola Corporation, 1501 Beard Avenue, Detroit, Michigan
26. Howard B. Jones, 2300 Wabansia Avenue, Chicago, Illinois
27. Kenrad Tube & Lamp Corporation, Owensboro, Kentucky
28. P. R. Mallory & Company, Inc., Indianapolis, Indiana
29. Micamold Radio Corporation, Brooklyn, New York
30. National Company, Inc., 61 Sherman Street, Malden, Massachusetts
31. Oak Manufacturing Company, 1260 Clybourn Avenue, Chicago, Illinois
32. Power Equipment Company, 51 Antoinette Avenue, Detroit, Michigan
33. Raytheon Production Corporation, 420 Lexington Avenue, New York, New York
34. RCA Manufacturing Company, Inc., Camden, New Jersey
35. Solar Manufacturing Company, Bayonne, New Jersey
36. Stackpole Carbon Company, St. Marys, Pennsylvania
37. Underwood Electric Company, 3120 West Grand Avenue, Chicago, Illinois
38. Utah Radio Products Company, 848 Orleans Street, Chicago, Illinois
39. Western Electric Company, Hawthorne Plant, Chicago, Illinois

[A. G. 300.7 (30 JULY '43)]

BY ORDER OF THE SECRETARY OF WAR:

G. C. MARSHALL

Chief of Staff.

Official:

J. A. ULIO,

Major General,

The Adjutant General.

Distribution:

IR 2, 6, 17(2); IBn 6, 17, 18(3); IC 2, 6, 11, 17, 18(5)

(For explanation of symbols see FM 21-6.)

RESTRICTED

SUPPLEMENT
15 December 1944
TM 11-317

SUPPLEMENT

to

TECHNICAL MANUAL
TM 11-317

SIGNAL GENERATOR I-208A

28 August 1943

The following information, published on Order Nos. 2398-Phila-44-52, 9238-Phila-44-52, and 11884-Phila-45-52, supplements TM 11-317, 28 August 1943. Personnel using the equipment and having custody of this Technical Manual will attach this supplement securely inside the front cover of the TM and will enter suitable notations beside each changed paragraph in the TM to indicate the presence of this supplementary information.

RESTRICTED

RESTRICTED

SUPPLEMENT
30 August 1943
TM 11-317

SUPPLEMENT
to
TECHNICAL MANUAL
TM 11-317

SIGNAL GENERATOR I-208A
28 August 1943

Corrections in Text

- Fig. 2 See new photograph I-208A, rear view,
Page 6: Figure 2A.
- Fig. 4 See new photograph I-208A, front view,
Page 10: Figure 4A.
- Page 11: **b. Voltmeter adjustment (r-f) should**
Par. 6 read:

b. Voltmeter adjustment (r-f and audio)
Continue after (4):
“(5) Throw METER switch to AUDIO
“(6) Turn the KC DEVIATION control to
the left as far as it will go.
“(7) The meter must now read zero. If it
does not read zero, lift the spring cover
over the ZERO SET AUDIO control and
adjust the screw under the cover with a
small screw-driver until the meter read-
ing is zero.”
- Page 12: See new photograph I-208A, R.F. unit
Fig. 5 showing tube locations, Fig 5A.
- Page 14: (7) Should read:
Par. 6 “Throw the METER switch to R.F.

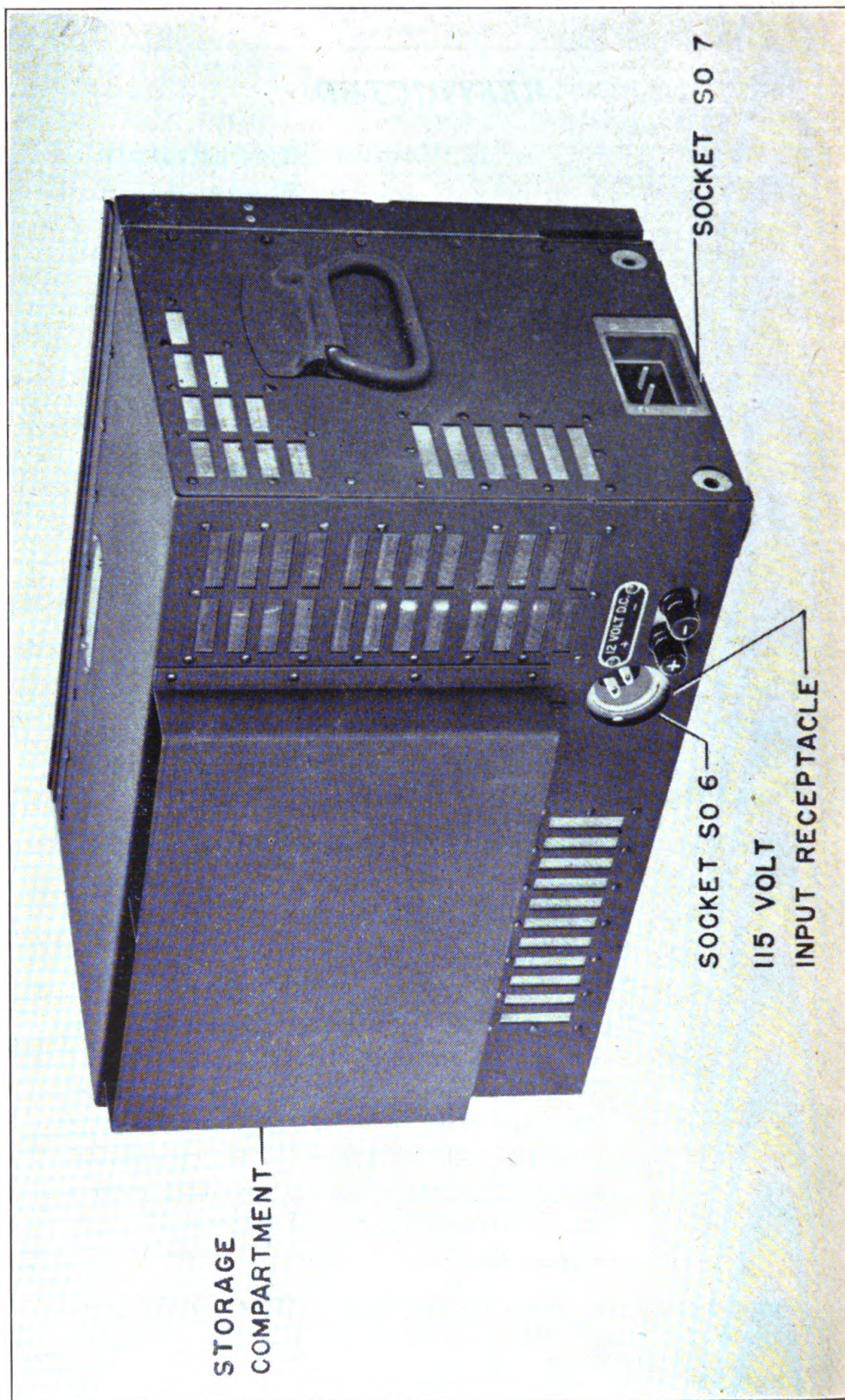

Figure 2A—Revised Signal Generator I-208A, rear view

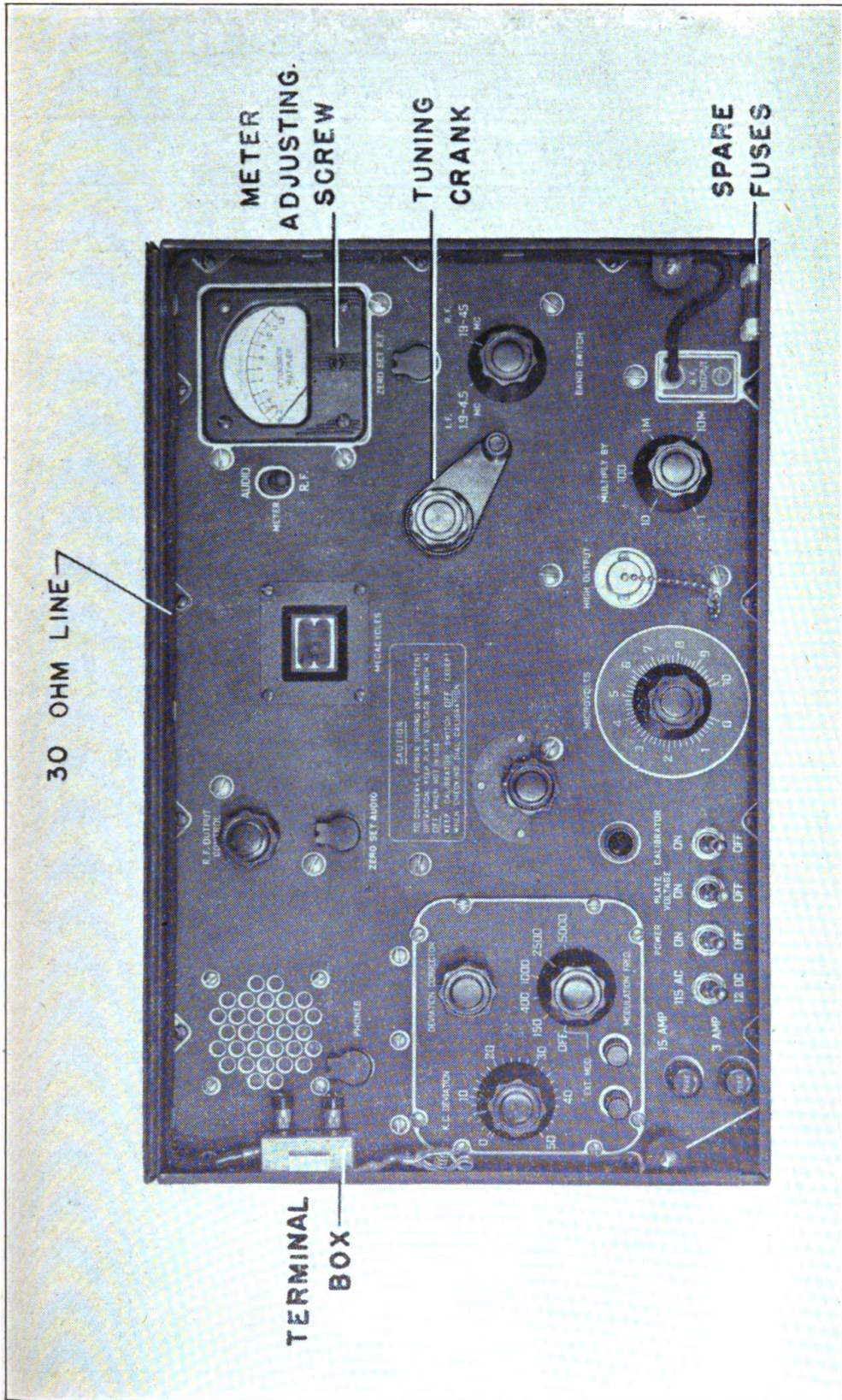

Figure 4A—Revised Signal Generator I-208A, front view

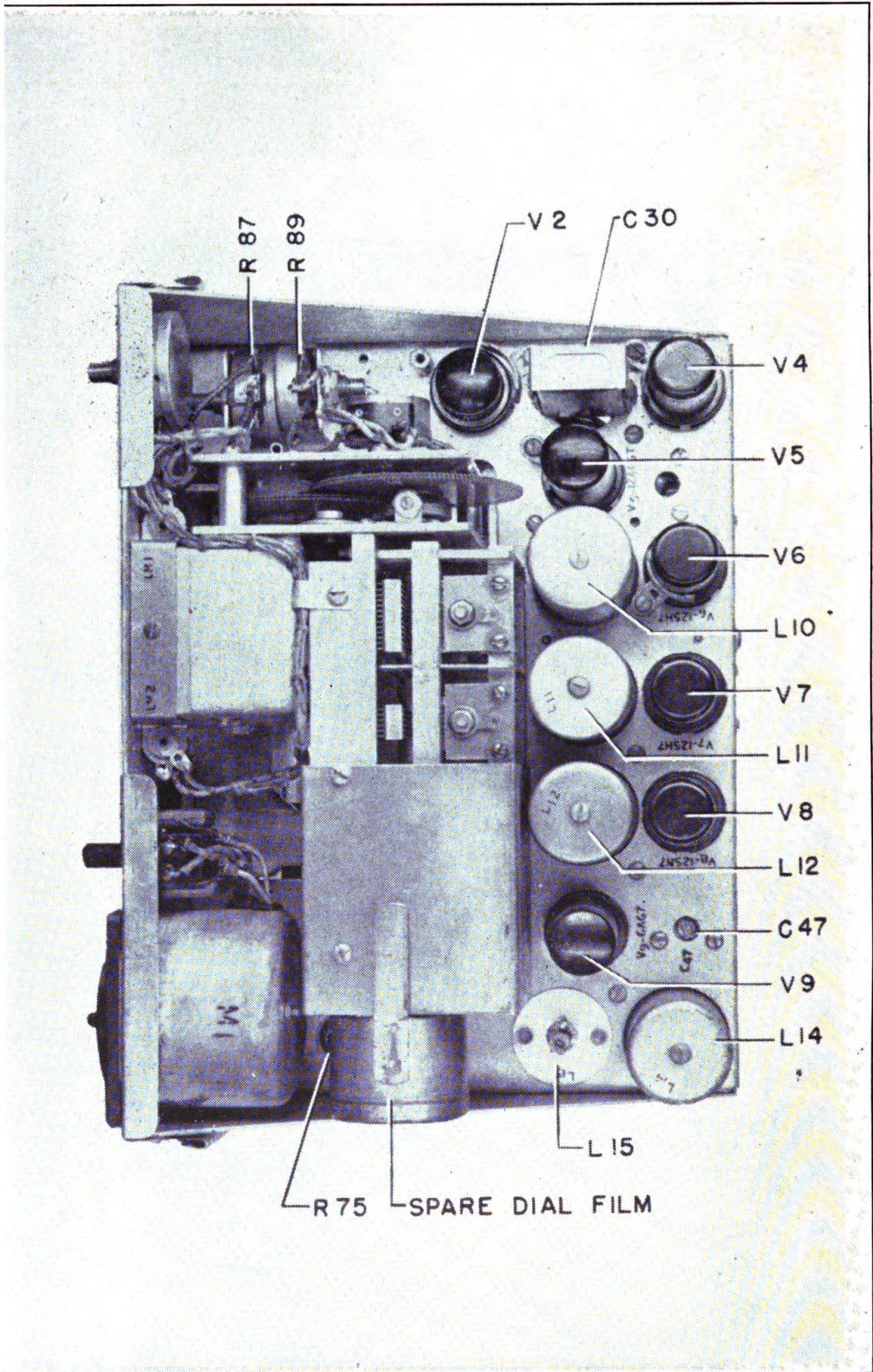

Figure 5A—Revised Signal Generator I-208A, R.F. unit showing tube locations

NOTE:

ALWAYS KEEP THE METER SWITCH IN RF POSITION EXCEPT WHEN SETTING THE MODULATION VOLTAGE. THE PROCEDURE OUTLINED IN PARAGRAPH 6f (1) THROUGH (7) MUST BE FOLLOWED FOR EACH MODULATION FREQUENCY USED."

Page 15: h. Final Instructions should read:
Par. 6

"(1) Always be sure the zero set adjustments have been made in both METER switch positions, AUDIO and R.F. and are checked periodically during the time the Signal Generator is in use.

"(2) If the Signal Generator is to be used intermittently throw PLATE VOLTAGE switch to OFF when the Signal Generator is not in use. This will conserve power and keep the Signal Generator warmed up for instant use.

"(3) To turn the Signal Generator off completely, throw the POWER switch to OFF."

Page 18: See new photograph, Signal Generator
Fig. 7 I-208A, rear view, Fig. 7A.

Page 19: Radio-frequency unit
Par. 8 b. should read:

"The signal from the audio oscillator is impressed across a series circuit consisting of resistor R_{33} , potentiometer R_{34} , variable resistor R_{89} , and resistor R_{35} . The audio frequency voltage across this circuit is measured by a vacuum tube voltmeter and is set to the correct value for modula-

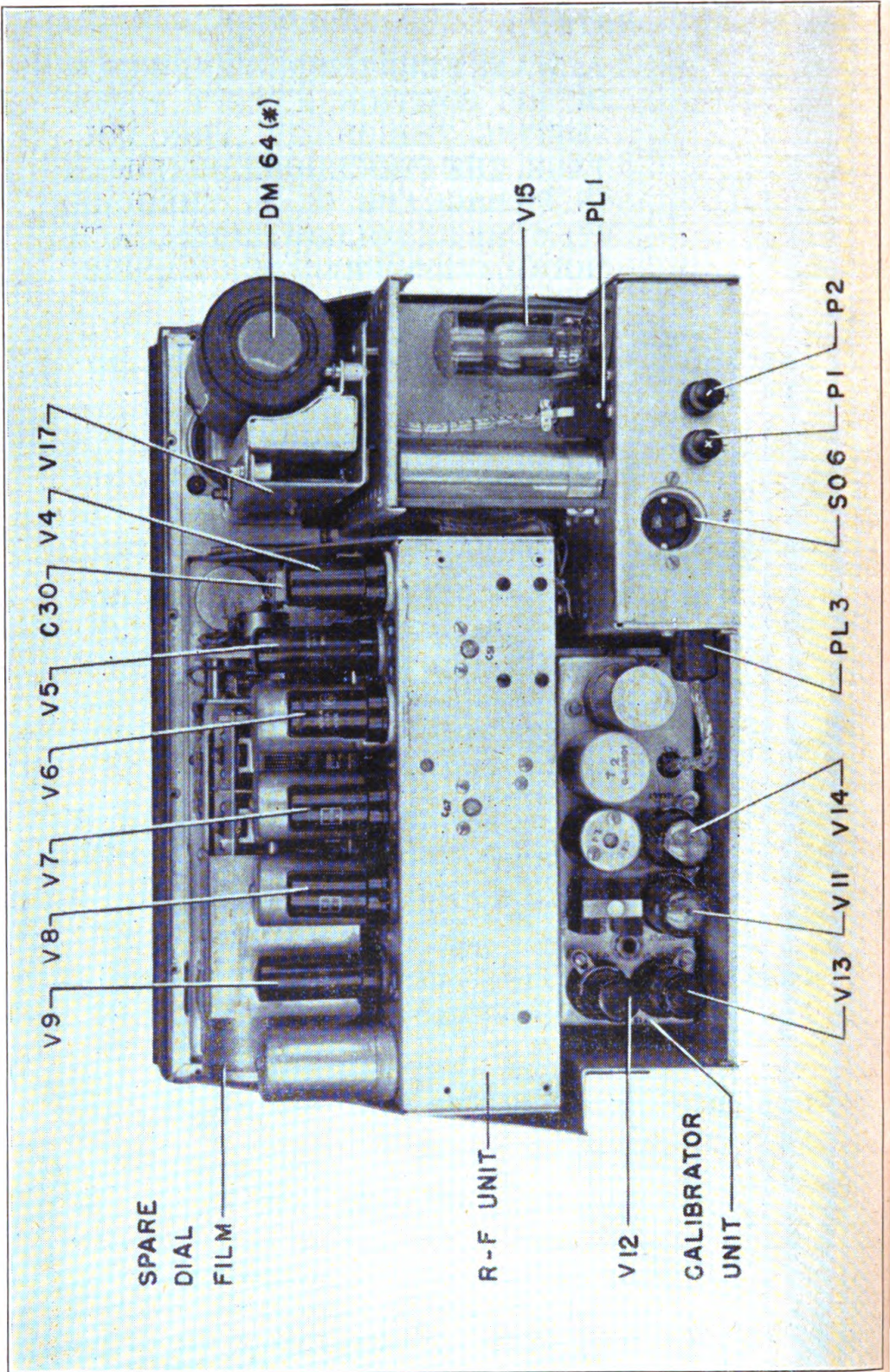

Figure 7A—Revised Signal Generator I-208A, rear view,
dust cover removed

Page 19:
Par. 8
Cont'd

tion by adjusting variable resistor R_{22} which is located in the audio oscillator unit. The vacuum tube voltmeter circuit employs tube V_2 (commercial type 6H6) VT-90 double diode as full wave rectifiers. By using this arrangement, the voltmeter loads the circuit equally on each half of the cycle when the METER switch is in R.F. position. The voltmeter sensitivity is controlled by variable resistor R_{45} . Potentiometer R_{87} is the zero set adjustment."

c. should read:

"Potentiometer R_{34} is connected to the tuning capacitor through a special cam arrangement designed to select the correct value of audio voltage necessary to maintain a constant frequency deviation over the entire r-f tuning range. The audio frequency voltage is set by variable resistor R_{89} to the correct value for 50 KC deviation when the signal generator is tuned to 45 megacycles."

d. should read:

"The audio frequency voltage from potentiometer R_{34} is applied through capacitor C_{31} and R.F. choke L_9 to the signal grid of tube V_4 (commercial type 6SG7) VT-211."

e. should read:

"Tube V_4 functions as a reactance tube in parallel with the r-f oscillator tank. The signal grid is fed r-f voltage 90° out of phase with the oscillator tank voltage by the RC network of R_{40} and C_{32} . Bias voltage for tube V_4 is provided by the voltage drop across cathode resistor R_{36} , which is by-passed to ground by capacitor C_{34} . The plate of tube V_4 is directly connected to

Page 19: the oscillator tank and plate voltage is applied through the tank coil L_{10} . Coil L_{10} is
Par. 8 tuned by the following capacitors:
Cont'd

- (1) Tuning Capacitor TC_1
- (2) Capacitor C_{51} (trimmer capacitor)
- (3) Capacitor C_{50} (frequency corrector capacitor)
- (4) Capacitor C_{52} (temperature compensating capacitor)
- (5) Capacitor C_{83} (fixed, silver mica capacitor)"

Page 24: g. should read:
Par. 10

"Switch SW_4 (calibrator) at ON grounds terminal No. 2 of SO_4 and terminal No. 1 of SO_2 thereby removing the modulation voltage from the RF unit and connects the unregulated plate supply voltage to the calibrator. At OFF switch SW_4 disconnects the unregulated plate voltage from the calibrator and connects load resistor R_{78} to the unregulated supply and disconnects terminal No. 2 of SO_4 and terminal No. 1 of SO_2 from ground, allowing modulation voltage to be applied to the signal grid of tube V_4 ."

Page 25: See Signal Generator I-208A, schematic
Fig. 9 diagram, Figure 9A.

Page 33: c. Adjustment of reactance tubes should
Par. 15 read:

"c. Adjustment of the frequency deviation.

If tube V_2 , V_4 , or V_5 is replaced, it is necessary to check the KC Deviation accuracy. This can be accomplished by either of two methods. The preferable method is outlined in sub-paragraph 15 d. (1) through

- Page 33: (21). Another method is outlined in sub-
Par. 15 paragraph 15 e. (1) through (8).
Cont'd Always check the KC deviation accuracy
before making any adjustments since *It
Will Not Always be Necessary to Make Ad-
justments when Tubes are Replaced.*"
- Page 33: d. (10) Modulation Voltage Adjustment
Par. 15 (Panoramic Method) should read:
"Throw the METER switch to AUDIO and
check the meter zero setting. Adjust ZERO
SET AUDIO control R₈₇ if necessary."
- Page 35: (16) should read:
Par. 15 "Adjust variable resistor R₄₅ so that the
meter indicator is coincident with the red
line."
- Page 37: (19) should read:
Par. 15 "Turn KC DEVIATION counterclockwise
(left) to 0, and then advance the KC De-
VIATION control until the third null point
is obtained. This should occur at 43 KC. If
it does not occur, adjust R₈₉ (located on
mounting bracket behind the ZERO SET
AUDIO control).
(20) Turn dial crank to 19 MC and check
third null point. Reset R₄₅ if necessary.
(21) Turn dial crank to 45 MC and re-
check third null point. Reset R₈₉ if neces-
sary."
- Page 38: (m) should read:
Par. 15 "Measure the resistance between the arm
of the control and the terminal connected
to R₈₉. This resistance should be approxi-
mately 100 ohms. If the measured resist-
ance is not approximately 100 ohms, loosen
lock nut of R₃₄ and adjust by turning the
body of the control, then lock R₃₄ in place
by tightening the lock nut.
(n) Adjust modulation voltage as out-
lined in paragraphs 15 d. (1) through
(20)."

Page 38: See new connection diagram for determination of modulation voltage (d-c method)
 Fig. 15 Figure 15A.

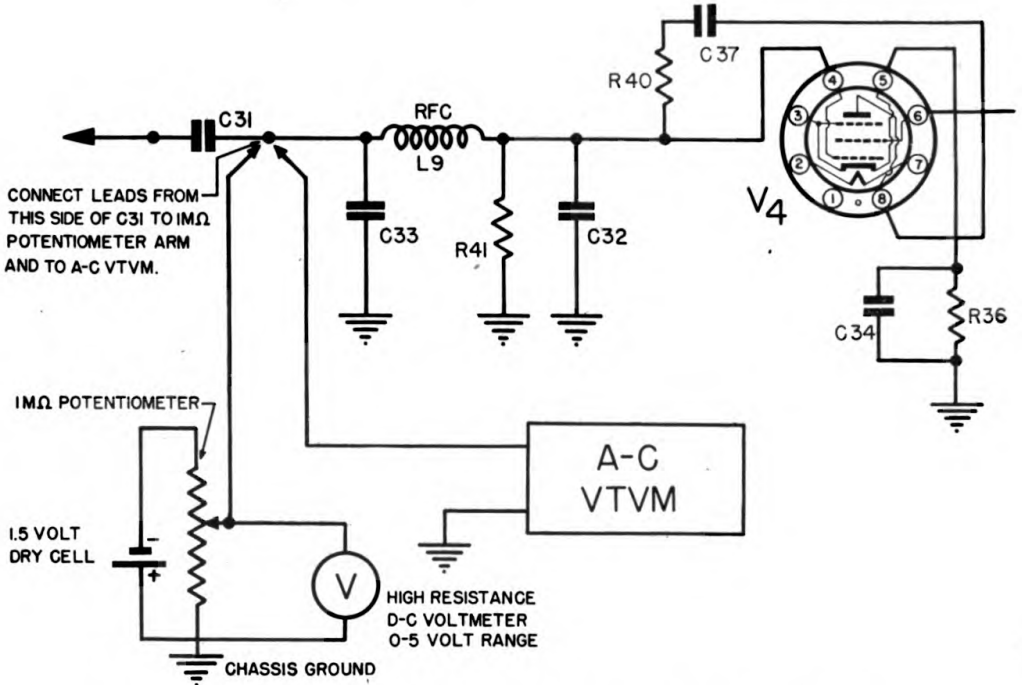

Figure 15A—Revised connection diagram for determination of modulation voltage (D-C method)

Page 38: e. Modulation Voltage Adjustment (d-c
 Par. 15 Method) should read:

“This method of adjustment can be used in an emergency when the Panoramic equipment is not available and tube V_2 or V_4 is replaced. If any other component part associated with the reactance tube V_4 is replaced, it is preferable to use the method outlined in sub-paragraph 15 d.

- (1) Connect battery, 1000 ohm potentiometer, and voltmeter to grid side of C_{31} as shown in Figure 15A.
- (2) Set potentiometer so that the voltmeter reads zero.

Page 38:
Par. 15
Cont'd

- (3) Connect the output terminals of the signal generator to Frequency Meter BC-221-(*).
- (4) Set MODULATION FREQUENCY selector switch to OFF.
- (5) Turn on signal generator and allow to "warm up" for 15 minutes.
- (6) Tune the frequency meter to 1900 kilocycles.
- (7) Turn the band switch to IF 1.9-4.5 MC.
- (8) Tune the signal generator to 19.00 on the dial.
- (9) Adjust the OSC. FREQ. CORRECTOR control until zero beat is obtained as heard in the headsets of the frequency meter.
- (10) Tune the frequency meter to 1905 kilocycles.
- (11) Increase the d-c voltage applied to the grid of V_4 by adjusting the 1000 ohm potentiometer across the battery until zero beat is again heard in the headset of the frequency meter.
- (12) Record the d-c voltage indicated on the voltmeter.
- (13) Disconnect the battery, potentiometer, and voltmeter.
- (14) Connect the high side of an a-c vacuum tube voltmeter to the same terminal of C_{31} as the 1000 ohm potentiometer was connected, indicated in Figure 15A. Connect the low side of the vacuum tube voltmeter to the chassis.
- (15) Turn the band switch to R.F. 19-45 MC.
- (16) Throw METER switch to R.F.

- Page 38: (17) Turn R.F. OUTPUT CONTROL to
Par. 15 the left as far as it will go and check
Cont'd meter zero setting. Adjust R_{73} if neces-
sary.
- (18) Turn R.F. OUTPUT CONTROL to
the right until the meter indicator is set
to the red line.
- (19) Throw meter switch to AUDIO.
- (20) Check meter zero setting. Adjust
 R_{87} if necessary.
- (21) Turn the MODULATION FREQ. se-
lector switch to 1000.
- (22) Turn the KC DEVIATION control
to 50 KC.
- (23) Adjust the DEVIATION CORREC-
TOR control so that the externally con-
nected vacuum tube voltmeter reads .707
of the voltage recorded in sub-paragraph
15 d. (12).
- (24) Adjust potentiometer R_{45} so that the
indicator of the meter on the signal gen-
erator is set to the red line.
- (25) Disconnect the external vacuum tube
voltmeter.”
- Page 42: See revised Figure 17A—Practical wiring
Fig. 17 diagram, main power supply.
- Page 43: See revised Figure 18A—Practical wiring
Fig. 18 diagram, r-f unit.
- Page 46: See revised Figure 21A—Socket voltage
Fig. 21 and resistance measurements, r-f unit.
- Page 50: Supplementary Data—Revised, see page
Section V 22, this supplement.

Page 67: Add to List of Manufacturers:

- Par. 17 40. General Film Lab., Inc., 66 Sibley, Detroit, Michigan
41. Scientific Industries, 5320 N. Broadway, Chicago, Illinois
42. Sonotone Co., Elmesford, New York
43. Tilton Electric Co., 23 E. 26th, New York, New York
44. Tobe Deutschman Corp., Canton, Massachusetts

Legend for Figure 9A

R ₁ 150M ohm	R ₃₃ 1000 ohm	R ₆₁ 270 ohm
R ₂ 4700 ohm	R ₃₄ 2000 ohm	R ₆₂ 270 ohm
R ₃ 4700 ohm	variable	R ₆₃ 270 ohm
R ₄ 10 megohm	R ₃₅ 500 ohm	R ₆₄ 30 ohm
R ₅ 22M ohm	R ₃₆ 400 ohm	R ₆₅ 33 ohm
R ₆ 22M ohm	R ₃₇ 25M ohm	R ₆₆ 33 ohm
R ₇ 47M ohm	variable	R ₆₇ 33 ohm
R ₈ 47M ohm	R ₃₈ 30 ohm	R ₆₈ 30 ohm
R ₉ 500M ohm	R ₃₉ 500 ohm	R ₆₉ 43 ohm
R ₁₀ 500M ohm	R ₄₀ 50M ohm	R ₇₀ 500 ohm
R ₁₁ 500M ohm	R ₄₁ 500M ohm	R ₇₁ 10M ohm
R ₁₂ 470 ohm	R ₄₂ 17.5 ohm	R ₇₂ 39 ohm
R ₁₃ 220M ohm	R ₄₃ 7500 ohm	R ₇₃ 200 ohm
R ₁₄ 22M ohm	R ₄₄ 47M ohm	variable
R ₁₆ 100M ohm	R ₄₅ 20M ohm	R ₇₄ 100 ohm
R ₁₇ 150M ohm	variable	R ₇₅ 10M ohm
R ₁₈ 8200 ohm	R ₄₆ 7500 ohm	variable
R ₁₉ 22M ohm	R ₄₇ 1000 ohm	R ₇₆ 47M ohm
R ₂₀ 33M ohm	R ₄₈ 1000 ohm	R ₇₇ 1000 ohm
R ₂₁ 10M ohm	R ₄₉ 10M ohm	R ₇₈ 5M ohm
R ₂₂ 10M ohm	R ₅₀ 47M ohm	R ₇₉ 150M ohm
variable	R ₅₁ 10M ohm	R ₈₀ 1000 ohm
R ₂₃ 10M ohm	R ₅₂ 10M ohm	R ₈₁ 47M ohm
variable	R ₅₃ 47M ohm	R ₈₂ 150 ohm
R ₂₄ 150 ohm	R ₅₄ 47M ohm	R ₈₃ 10M ohm
R ₂₅ 56 ohm	R ₅₅ 150 ohm	R ₈₄ 3300 ohm
R ₂₆ 30 ohm	R ₅₆ 1000 ohm	R ₈₅ 47M ohm
R ₂₇ 68M ohm	R ₅₇ 200 ohm	R ₈₆ 10M ohm
R ₃₀ 330 ohm	R ₅₈ 100 ohm	R ₈₇ 20M ohm
R ₃₁ 270 ohm	R ₅₉ 100 ohm	variable
R ₃₂ 150M ohm	R ₆₀ 270 ohm	R ₈₈ 10M ohm

Legend for Figure 9A (Continued)

R ₈₉	1000 ohm variable	C ₃₉	.003 mfd	C ₈₂	7-45 mmfd
C ₁	7-45 mmfd	C ₄₀	500 mmfd	C ₈₃	25 mmfd
C ₂	50 mmfd	C ₄₁	.003 mfd	TC1	} Ganged tuning condenser (special)
C ₃	.01 mfd	C ₄₂₋₁	.01 mfd	TC2	
C ₄	250 mmfd	C ₄₂₋₂	.01 mfd	TC3	
C ₅	.01 mfd	C ₄₃	500 mmfd	TC4	
C ₆	.01 mfd	C ₄₅	100 mmfd	L1	Choke, r-f
C ₇	250 mmfd	C ₄₆	4-30 mmfd	L2	Choke, r-f
C ₈	Dual electrolyt- ic, 10 mfd sec- tion	C ₄₇	3-13 or 1.5-7 mmfd	L3	Choke, r-f
C ₉	500 mmfd	C ₄₈	.01 mfd	L4	Coil, Crystal Oscillator
C ₁₀	.01 mfd	C ₄₉	.003 mfd	L5	Choke, r-f
C ₁₁	Dual electrolyt- ic, 20 mfd sec- tion	C ₅₀	6.0 mmfd	L6	Choke, r-f
C ₁₂	.25 mfd	C ₅₁	4-30 mmfd	L7	Choke, r-f
C ₁₃	.01 mfd	C ₅₂	10 mmfd	L8	Choke, r-f
C ₁₄	.03 mfd	C ₅₃	500 mmfd	L9	Choke, r-f
C ₁₅	.007 mfd	C ₅₄	100 mmfd	L10	Coil, Osc.
C ₁₆	.25 mfd	C ₅₅	.003 mfd	L11	Coil, Freq. Multiplier
C ₁₇	.25 mfd	C ₅₆	10 mmfd	L12	Coil, Freq. Multiplier
C ₁₈	.01 mfd	C ₅₇	.01 mfd	L13	Choke, r-f
C ₁₉	.01 mfd	C ₅₈	25 mmfd	L14	Coil, L. F. Output
C ₂₀	.003 mfd	C ₅₉	.01 mfd	L15	Coil, H. F. Output
C ₂₁	.003 mfd	C ₆₀	500 mmfd	L16	Coil, Freq. Doubler 1000 kc.
C ₂₂	.5 mfd	C ₆₁	500 mmfd	L17	Choke, r-f
C ₂₃	.5 mfd	C ₆₂	500 mmfd	CH1	Choke, filter
C ₂₄	400 mmfd	C ₆₃	1.5-7 mmfd	CH2	Choke, Audio Osc.
C ₂₅	.003 mfd	C ₆₄	.01 mfd	CH3	Choke, Modulation
C ₂₆	.003 mfd	C ₆₅	.003 mfd	T1	Power trans- former (special)
C ₂₇	20 mfd	C ₆₆	.003 mfd	T2	Output trans- former (special)
C ₂₈	40 mfd	C ₆₇	4-30 mmfd	V1	12SN7GT
C ₂₉	40 mfd	C ₆₈	10 mmfd	V2	6H6
C ₃₀	1.0 mfd	C ₆₉	.01 mfd	V4	6SG7
C ₃₁	.25 mfd	C ₇₀	25 mmfd	V5	12A6GT
C ₃₂	25 mmfd	C ₇₁	.01 mfd		
C ₃₃	500 mmfd	C ₇₂	500 mmfd		
C ₃₄	.003 mfd	C ₇₃₋₁	.01 mfd		
C ₃₅	.003 mfd	C ₇₃₋₂	.01 mfd		
C ₃₇	500 mmfd	C ₇₄	4-30 mmfd		
C ₃₈₋₁	.01 mfd	C ₇₅	.01 mfd		
C ₃₈₋₂	.01 mfd	C ₇₆	50 mmfd		
		C ₇₇	.003 mfd		
		C ₇₈	.003 mfd		
		C ₇₉	.003 mfd		
		C ₈₀	.003 mfd		
		C ₈₁	.003 mfd		

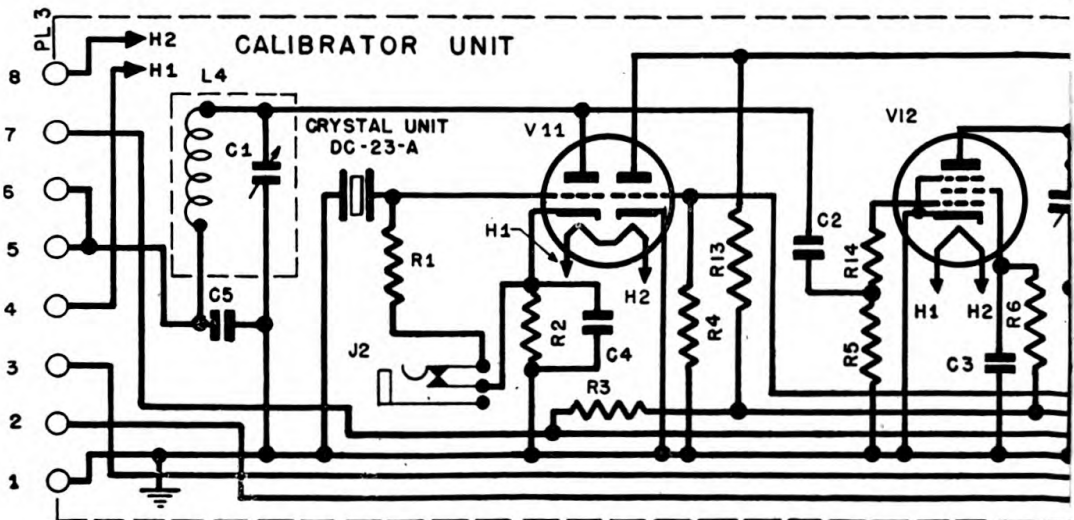
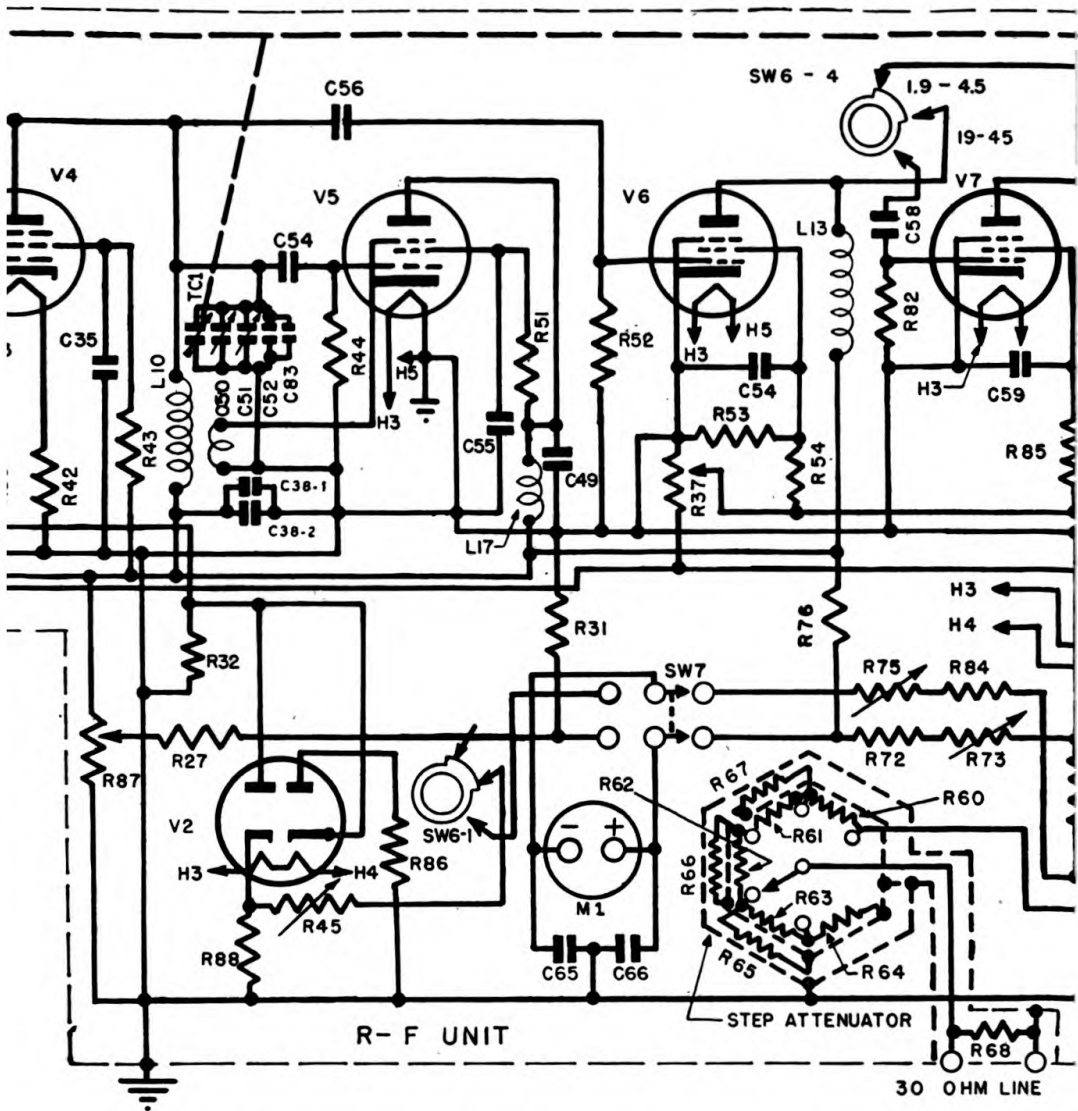

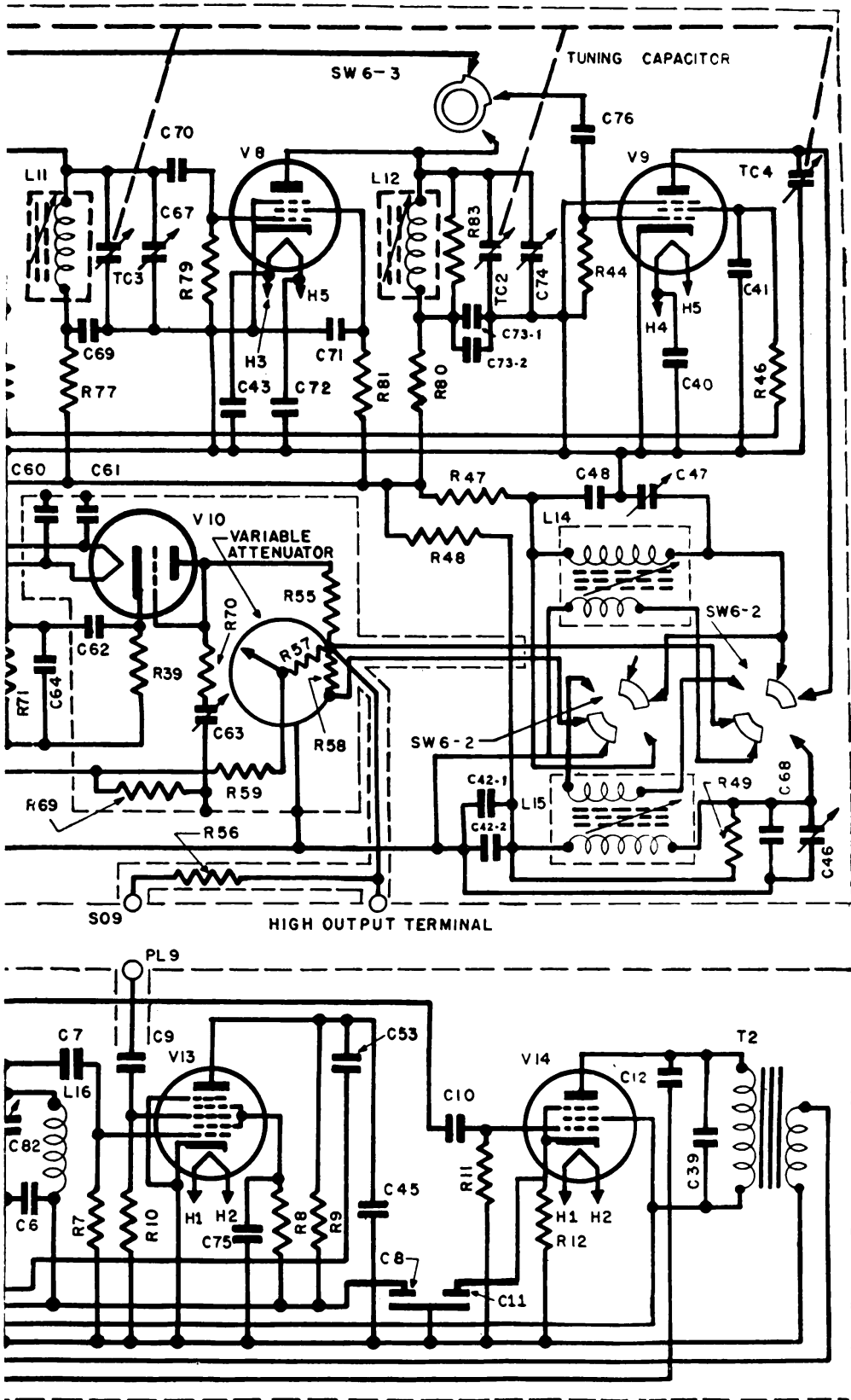

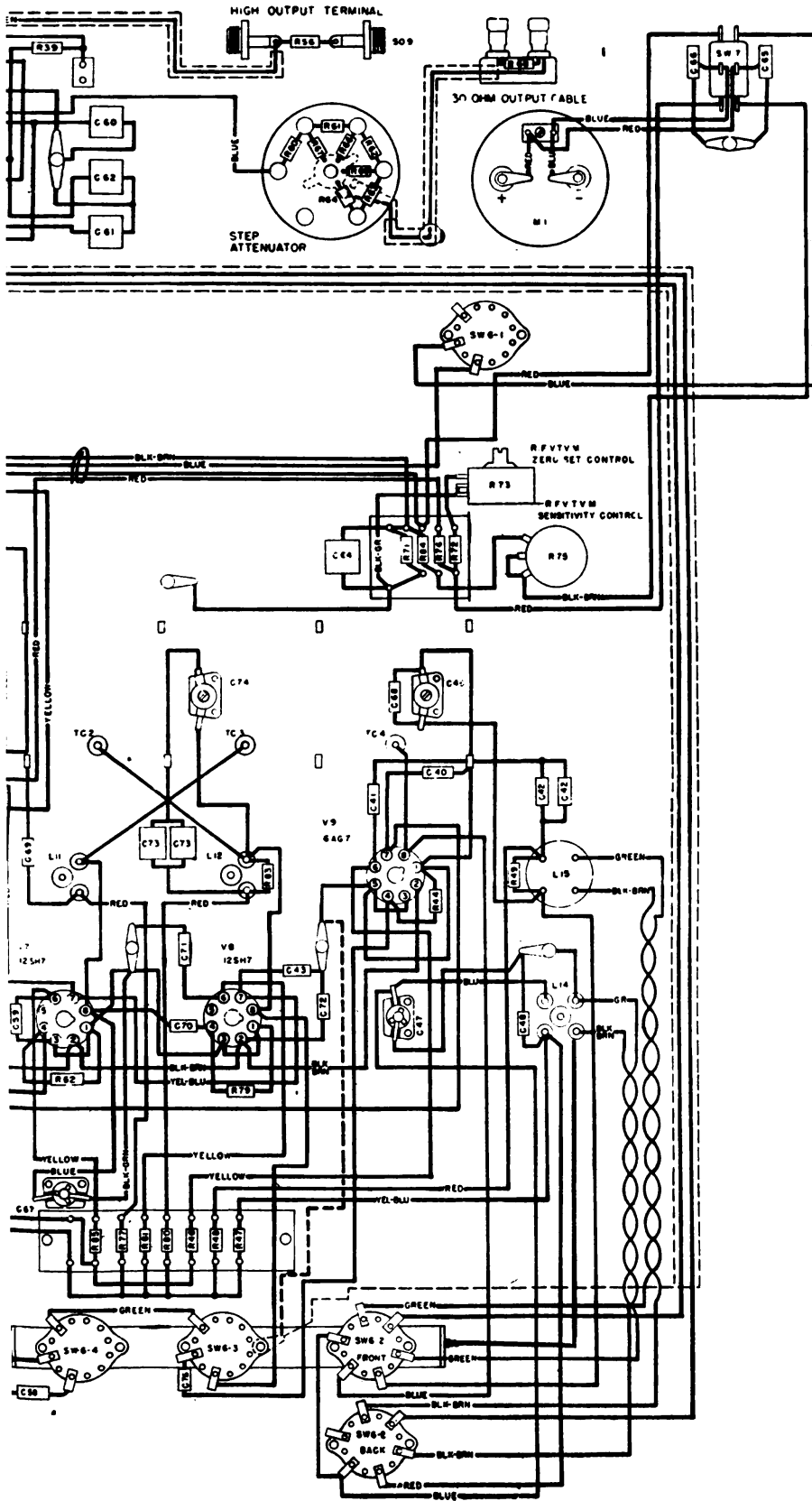

ing diagram, R.F. unit

Handwritten text in a vertical column on the left side of the page, possibly bleed-through from the reverse side. The text is partially obscured and difficult to decipher, but appears to contain several lines of characters and symbols.

Legend for Figure 9A (continued)

V6	12SH7 (VT-288)	IH-20 Current Regulator	SW5	6-position, 2-wafer Rotary Switch
V7	12SH7 (VT-288)	FS1 Fuse, 15 amp (FU54)		(special)
V8	12SH7 (VT-288)	FS2 Fuse, 3 amp (FU50)	SW6	2-position, 4-wafer Rotary Switch
V9	6AG7 (VT-247)	M1 0-50 Micro- amperes D.C.		(special)
V10	955 (VT-121)	J1 Phone Jack	SW7	DPDT Toggle switch
V11	12SN7GT	J2 Meter Jack		
V12	12SH7 (VT-288)	SW1 DPDT Toggle Switch	LM1	6V Dial Light (LM-27)
V13	12SA7GT	SW2 DPST Toggle Switch	LM2	6V Dial Light (LM-27)
V14	12A6GT	SW3 DPST Toggle Switch	LM3	6V Dial Light (LM-27)
V15	5U4G (VT-244)	SW4 DPDT Toggle Switch		
V16	VR-150-30 (VT-139)		LS1	P.M. Speaker
V17	Amperite			

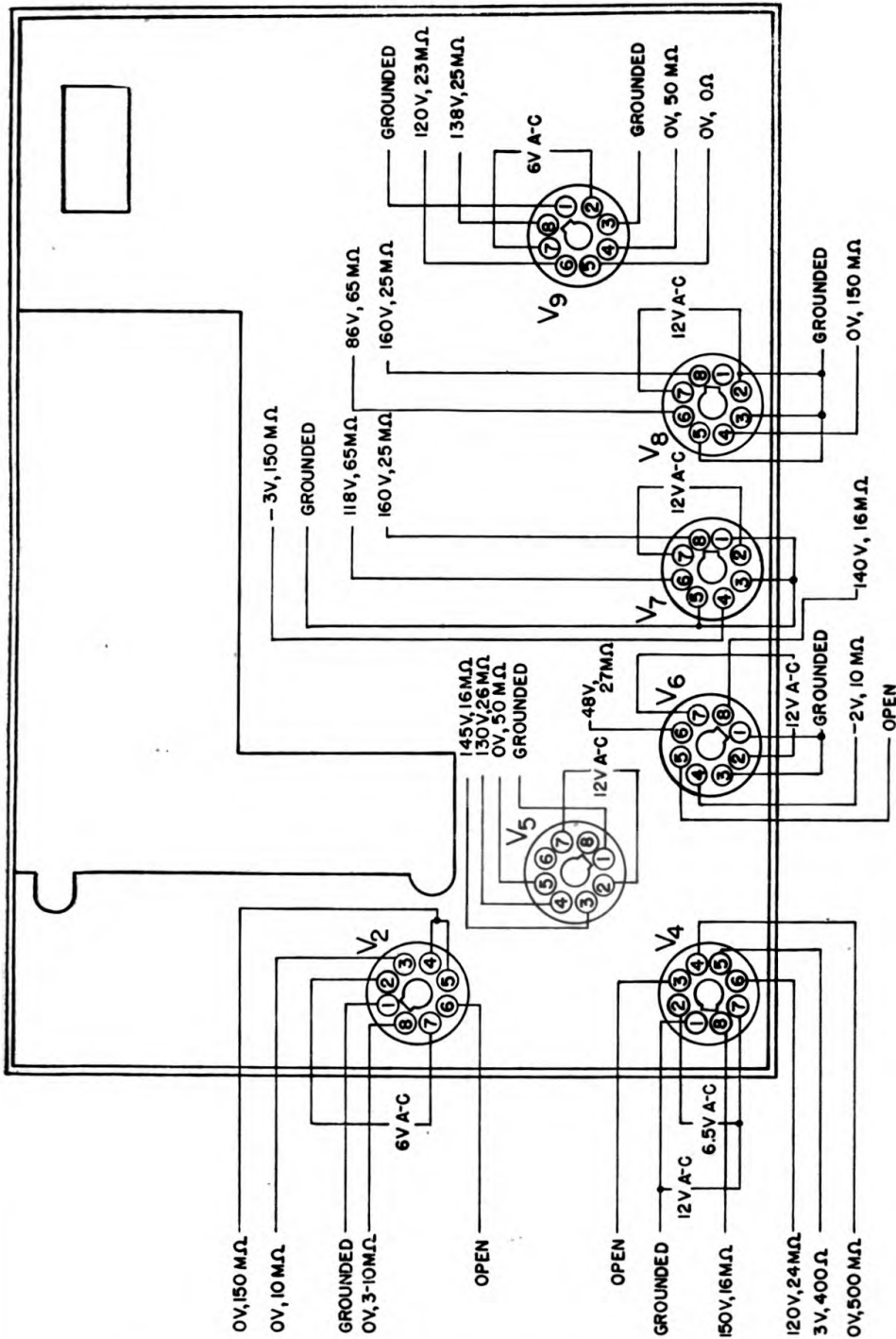

Figure 21A—Revised socket voltage and resistance measurements, R.F. unit

SECTION V
SUPPLEMENTARY DATA

Page 50, Par. 16. Delete table of replaceable parts and add the following:
16. Maintenance Parts List for Signal Generators I-208 and I-208-A.

Ref. Symbol	Signal Corps Stock No.	Name of Part and Description	Quan. per Unit	Run-ning Spares	Orgn Stock	3d Ech.	4th Ech.	5th Ech.	Depot Stock
	3F3900-208/1	ARM, crank: bakelite; moulded; Detrola No. 41502.	1			*		*	*
	2Z395.38	ATTENUATOR, variable: slide wire; Detrola No. G43885.	1			*	*	*	*
	2Z395.39	ATTENUATOR ASSEMBLY: less input line; Detrola No. G34510.	1			*		*	*
	3F3900-208/U1	OSCILLATOR, AF: completely wired and assembled with chassis and marked panel; Detrola No. 42800; less tubes, tube clamp, and knobs.	1			*		*	*
	3E4040-3	CABLE, RF: output; 36" lg.; Cornish Wire Co. No. 18-16/30; Detrola No. G43735.	36"			*	*	*	*

3F3900-208/C1		1				*
C ₆₂	3D9010-26.1		CALIBRATOR, crystal: completely wired and assembled; Detrola No. 42900; less tubes, clamps, and crystals.		*	*
C _{8, 11}	3DB20-39	1	CAPACITOR, fixed: ceramic; 10-mmf = 5%; 500 v dc (working); Erie No. N750K.	*	*	*
C ₂₇	3DB20-38	1	CAPACITOR, fixed: electrolytic; 2-section; 10-20-mf +50%, -0%; 25-350 v dc (working); Aerovox type N-12.	*	*	*
C _{28, 29}	3DB40-32	2	CAPACITOR, fixed: electrolytic; 20-mf +50%, -10%; 250 v dc (working); Aerovox type N-12.	*	*	*
C _{56, 68}	3K2010021	2	CAPACITOR, fixed: electrolytic; 40-mf +50%, -0%; 450 v dc (working); Aerovox type N-12.	*	*	*
C _{58, 70}	3K2024022	2	CAPACITOR, fixed: silver mica; 10-mmf = 10%; 500 v dc (working); CM20B100K.	*	*	*
C ₃₂	3K2024022	3	CAPACITOR, fixed: mica; 25-mmf = 5%; 500 v dc (working); CM20B240J.	*	*	*
C _{2, 76}	3K2051022	2	CAPACITOR, fixed: mica; 25-mmf = 5%; 500 v dc (working); CM20B240J; for I-208-A only.	*	*	*
			CAPACITOR, fixed: mica; 50-mmf = 5%; 500 v dc (working); 1,000 v dc (test); CM20B-510J.	*	*	*

*Indicates stock available.

16. Maintenance Parts List for Signal Generators I-208 and I-208-A (contd).

Ref. Symbol	Signal Corps Stock No.	Name of Part and Description	Quan. per Unit	Run-ning Spares	Orgn Stock	3d Ech.	4th Ech.	5th Ech.	Depot Stock
C _{45, 54}	3K2010131	CAPACITOR, fixed: mica; 100-mmf = 10%; 500 v dc (working); CM20C101K.	2			*	*	*	*
C _{4, 7}	3K2024122	CAPACITOR, fixed: mica; 240-mmf = 5%; 500 v dc (working); 1,000 v dc (test); CM20B241J.	2			*	*	*	*
C _{9, 33, 37, 40, 43, 53, 60, 61, 62, 72}	3K2051122	CAPACITOR, fixed: mica; 510-mmf = 5%; 500 v dc (working); CM20B511J.	10			*	*	*	*
C ₃₂	3K2051122	CAPACITOR, fixed: mica; 510-mmf = 5%; 500 v dc (working); CM20B511J; for I-208 only.	1			*	*	*	*
C _{20, 21, 25, 26, 34, 35, 39, 41, 49, 55, 65, 66, 77, 78, 79, 80, 81}	3K3533221	CAPACITOR, fixed: mica; 3,000-mmf = 5%; 500 v dc (working); CM35B203J.	17			*	*	*	*
C ₁₅	3DKA7-6	CAPACITOR, fixed: mica; 7,000-mmf = 5%; 300 v dc (working); RCA No. 720538-35.	1			*	*	*	*

C ₁₃	3DA10-21	CAPACITOR, fixed: mica; 10,000-mmf \pm 5%; 300 v dc (working); CM35A103J.	1	*	*	*	*	*
C ₁₈ , 19, 38 ⁻¹ , 38 ⁻² , 42 ⁻¹ , 42 ⁻² , 48, 69, 73 ⁻¹ , 73 ⁻²	3K3510324	CAPACITOR, fixed: mica; 10,000-mmf \pm 20%; 500 v dc (working); CM35B103M.	10	*	*	*	*	*
C ₁₄	3DA250-116	CAPACITOR, fixed: mica; 30,000-mmf \pm 5%; 600 v dc (working); CM55B303J.	1	*	*	*	*	*
C ₁₂ , 16, 17, 31	3DKA10-226	CAPACITOR, fixed: oil-filled; paper; 250,000- mmf \pm 20%; 600 v dc (working); Gudeman No. 7502.	3	*	*	*	*	*
C ₃ , 5, 6, 10, 71, 75, 57, 59, 64	3DKA10-226	CAPACITOR, fixed: paper; 10,000-mmf +30%, -20%; 400 v dc (working); Micamold No. 340-21.	9	*	*	*	*	*
C ₃₀ , 83	3DA500-147	CAPACITOR, fixed: paper; 500,000-mmf \pm 20%; 100 v dc (working); Detrola No. G42193.	2	*	*	*	*	*
C ₂₂ , 23	3DB1.601-1	CAPACITOR, fixed: oil filled; paper; 1-mf \pm 20%; 600 v dc (working); Tobe Deutsch- man Type OM601 (for I-208A only).	2	*	*	*	*	*
C ₃₀	3DB1.601-1	CAPACITOR, fixed: oil filled; paper; 1-mf \pm 20%; 600 v dc (working); Tobe Deutsch- man Type OM601 (for I-208A only).	1	*	*	*	*	*

*Indicates stock available.

16. Maintenance Parts List for Signal Generators I-208 and I-208-A (contd).

Ref. Symbol	Signal Corps Stock No.	Name of Part and Description	Quant. per Unit	Run-ning Spares	Orgn Stock	3d Ech.	4th Ech.	5th Ech.	Depot Stock
C ₅₀	3D9003VE25	CAPACITOR, variable: ceramic; 3-mmf =0.25-mmf; zero temp coef; Detrola No. 4323 for I-208 only.	1			*	*	*	*
C _{36, 35}	3D9007V-4	CAPACITOR, variable: ceramic; 1.5-7-mmf; 500 + v dc (working); Erie No. NPO-TS2B for I-208 only.	2			*	*	*	*
C ₄₇	3D9007V-4	CAPACITOR, variable: ceramic; 1.5-7-mmf; 500 v dc (working); Erie No. NPO-TS2B (for I-208A only).	1			*	*	*	*
C ₆₃	3D9007V-4	CAPACITOR, variable: ceramic; 1.5-7-mmf; 500 v dc (working); Erie No. NPO-TS2B.	1			*	*	*	*
C ₅₀	3D9006V-10	CAPACITOR, variable: ceramic; 6-mmf; Erie No. N500 (for I-208-A only).	1			*	*	*	*
C ₄₇	3D9012V-6	CAPACITOR, variable: ceramic; 3-12-mmf; zero temp coef; Erie NPO-TS2B (for I-208 only).	1			*	*	*	*
C _{46, 51, 67}	3D9030V-6.1	CAPACITOR, variable: ceramic; 4-30-mmf; 500 v dc (working); zero temp coef; Erie No. N500-TS2B.	4			*	*	*	*
74									
C _{1, 32}	3D9045V-1.1	CAPACITOR, variable: ceramic; 7-45-mmf; 500 v dc (working); neg temp coef 0.000500 mmf/mmf/°C; Erie No. N500-TS2B.	2			*	*	*	*

CH ₃	3C323-37A	COIL, radio, AF: choke; input; 268 ohms between terminals 1 & 2, 353 ohms between terminals 2 & 3; shielded metal can; Detrola No. G43106; 3-terminal.	1	*	*	*	*	*
CH ₂	3C323-36B	COIL, radio, AF: choke; 509 ohms total resistance; Detrola No. G42801; audio osc choke.	1	*	*	*	*	*
CH ₁	3C323-36A	COIL, radio, AF: filter; 5-h; 150-ma; 98 ohms dc resistance; AP Foster No. AA-5079; Detrola No. G42102.	1	*	*	*	*	*
L _{5, 8, 9, 17}	3C323-37B	COIL, radio, RF: choke; Detrola No. G43395; plate r-f filter.	4	*	*	*	*	*
L ₁₃	3C323-37C	COIL, radio, RF: choke; 125-ma; 500 ohms resistance; Detrola No. G43626; 1 1/4" axial leads.	1	*	*	*	*	*
L ₁₆	3C1084F-10	COIL, radio, RF: frequency doubler; Detrola No. G42975; radial leads.	1	*	*	*	*	*
L ₁₁	3C1084F-8	COIL, radio, RF: frequency multiplier; Detrola No. G43230; iron-core; adjustable, 9,500-22,500-kc.	1	*	*	*	*	*
L ₁₂	3C1084F-7	COIL, radio, RF: frequency multiplier; Detrola No. G43280; iron-core; adjustable, 19,000-45,000-kc.	1	*	*	*	*	*
L _{6, 7}	3C323-37D	COIL, radio, RF: choke; Detrola No. G43415; heater supply filter.	2	*	*	*	*	*

*Indicates stock available.

16. Maintenance Parts List for Signal Generators I-208 and I-208-A (contd).

Ref. Symbol	Signal Corps Stock No.	Name of Part and Description	Quan. per Unit	Run-ning Spares	Orgn Stock	3d Ech.	4th Ech.	5th Ech.	Depot Stock
L ₄	3F3900-208/C2	COIL ASSEMBLY, radio, RF: crystal oscillator; Detrola No. G42950; complete with trimmer; Erie Ceramicon No. N500-TS2B; 3-wire leads out bottom.	1			*	*	*	*
L ₁₄	3C1084F-5	COIL, radio, RF: output; Detrola No. G43260; iron-core; adjustable, 1,900-4,500-kc.	1			*	*	*	*
L ₁₅	3C1084F-4	COIL, radio, RF: output; Detrola No. G43310; ceramic form.	1			*	*	*	*
L ₁₀	3C1084F-6	COIL, radio, RF: oscillator, Detrola No. G43250; iron-core; adjustable, 1,900-4,500-kc.	1			*	*	*	*
SO ₉	3G8839-26	COLLAR, crank: moulded bakelite; 1 1/8" OD x 1 1/2" d over-all; Detrola No. G41501; insulates crank handle and bearing.	1			*	*	*	*
SO ₄	2Z8671.30	CONNECTOR, female contact: single brass contact; Jones HB No. S-101-D.	2			*	*	*	*
SO ₄	2Z7116.19	CONNECTOR, female contact: 6-cont; Jones HB No. P-306-FHT.	1			*	*	*	*
SO ₃	2Z8639-15	CONNECTOR, female contact: 8-cont; Jones HB No. S-308-AB.	1			*	*	*	*

SO ₇	2Z7112.32	CONNECTOR, male contact: 2-straight cont; Cannon No. DP-D2-34P-1 (12 v power connection).	1	*	*	*	*	*
SO ₈	6Z7816-1	CONNECTOR, male contact: 2-rectangular cont; Detrola No. 42530; 115-v power connector.	1	*	*	*	*	*
PL ₁	2Z7116.43	CONNECTOR, male contact (plug): 6-cont; Jones No. P-306-FHT; connects to SO-1.	1	*	*	*	*	*
PL ₄	2Z7227-2	CONNECTOR, male contact (plug): 6-cont; Jones No. P-306-AB modified; connects to SO-4.	1	*	*	*	*	*
PL ₂	2Z7227-2	CONNECTOR, male contact (plug): 6-cont; Jones No. P-306-AB; connects to SO-2.	1	*	*	*	*	*
PL ₃	2ZK7118.17	CONNECTOR, male contact (plug): 8-cont; Jones No. P-308-FHT; connects to SO-3.	1	*	*	*	*	*
PL ₅	2Z7228	CONNECTOR, male contact: 18-cont; Jones HB P-318-AB; dynamotor connection.	1	*	*	*	*	*
PL ₉	2Z7226-238	CONNECTOR, male contact: Plug PL-238; single-contact; Jones No. P-101.	1	*	*	*	*	*
	3E1749	CABLE, RF: Cord CD-749; coaxial; 40" lg; high output.	1	*	*	*	*	*
	3E1778	CABLE ASSEMBLY, power: Cord CD-778; 8-ft; 2-cond.	1	*	*	*	*	*
	3E1984	CABLE ASSEMBLY, power: Cord CD-984; 36" lg; service extension cord.	1	*	*	*	*	*

*Indicates stock available.

16. Maintenance Parts List for Signal Generators I-208 and I-208-A (contd).

Ref. Symbol	Signal Corps Stock No.	Name of Part and Description	Quan. per Unit	Run-ning Spares	Orgn Stock	3d Ech.	4th Ech.	5th Ech.	Depot Stock
L ₃ , C ₂₃ , 24, 25	2Z3400-167	COVER, generator: Cover BG-167; canvas.	1			*	*	*	*
	2 X9-500	CRYSTAL UNIT: Crystal DC-23; 500-kc.	1			*	*	*	*
	3H1664A	DYNAMOTOR UNIT DM-64-A; 12-v input.	1			*	*	*	*
	3Z1894-12.1	FILTER ASSEMBLY: A hermetically sealed metal case; Detrola No. 42340; mounts under capacitor C-29; marked with item ref No. 0.	1			*	*	*	*
L ₁ , L ₂ , C ₁₈ , C ₁₉	3Z1894-12	FILTER ASSEMBLY: 110-v; hermetically sealed metal case; Detrola No. 42320 mounts under C-27; marked with ref No. S.	1			*	*	*	*
	3Z1894-12.2	FILTER UNIT, input, RF: completely wired and assembled; Detrola No. 43350; complete with coils L5, 6, 7, 8 and capacitors C77, 78, 79, 80.	1			*	*	*	*
FS ₂	3Z1950	FUSE, cartridge: Fuse FU-50; 3-amp, 250-v; glass body; nickel plated ends; Littelfuse 3AC No. 1043.	1	9	*	*	*	*	*
FS ₁	3Z2015-1	FUSE, cartridge: 15-amp, 25-v; nonrenewable; glass body with metal ends; Littelfuse 3AG No. 1082.	1	9	*	*	*	*	*

3Z3285-2	HOLDER, fuse: extractor post; cylindrical moulded black bakelite; Buss type HKM.	2	*	*	*	*	*
2Z5534A.3	JACK, telephone: junior; 3-cont; normally closed circuit; Mallory No. 702; test jack.	1	*	*	*	*	*
2Z5850-5	KNOB, crank: metal; Detrola No. G41506.	1	*	*	*	*	*
2Z5822-68	KNOB, skirted: black bakelite; Detrola No. G42001.	3	*	*	*	*	*
2Z5822-68	KNOB, skirted: black bakelite; K&K No. S-380-3L; Detrola No. G42008.	1	*	*	*	*	*
2Z5822-66	KNOB, skirted: black bakelite; Detrola No. 42003; similar to K&K No. S-380-3L except center shaft hole.	1	*	*	*	*	*
2Z5822-65	KNOB, skirted: black bakelite; Detrola No. G41504.	1	*	*	*	*	*
2ZKS822-38	KNOB, plain: black bakelite; Detrola No. G42002; similar to K&K No. S-308-3	3	*	*	*	*	*
2Z5883-68	LAMP BRACKET ASSEMBLY: includes bracket, Socket assembly, 4 flat solder lugs, 4 insulating washers, 2 rivets, and 2 sockets; Detrola No. G41605, single bayonet base for pilot lamps.	1	*	*	*	*	*
2Z5991	LAMP HOLDER ASSEMBLY: miniature bayonet base; with 1/2" red jewel; Drake No. 50; horizontal mtg.	1	*	*	*	*	*

*Indicates stock available.

16. Maintenance Parts List for Signal Generators I-208 and I-208-A (contd).

Ref. Symbol	Signal Corps Stock No.	Name of Part and Description	Quan. per Unit	Run-ning Spares	Orgn Stock	3d Ech.	4th Ech.	5th Ech.	Depot Stock
LM-1, 2, 3	2Z5927	LAMP, incandescent: Lamp LM27; 6-8-v; miniature bayonet base; blue head; Mazda No. 44.	3	6		*	*	*	*
M ₁	3F865-7	METER, microammeter: 0-1.2-kc deviation scale; special; Detrola No. G43107. NOTE: Supply in following order of Priority: Detrola No. G-A3107-3, GE; Detrola No. G43107-1, De Jur; Detrola No. G43107-2, McClintock.	1			*	*	*	*
	3Z737-24	POST, binding: screw-type; Eby No. 44 Admiral.	2			*	*	*	*
	3Z737-25	POST, binding: push-type; engraved G, Eby No. 60 MB.	2			*	*	*	*
	3Z737-25.1	POST, binding; push-type; engraved HI; Eby No. 60 MB.	1			*	*	*	*
	3Z737-25.2	POST, binding: push-type; engraved A; Eby No. 60 MB.	1			*	*	*	*
R ₆₄ , 66	3RC20AE300J	RESISTOR, fixed: carbon; 30-ohm ±5%; ½-w; RC20AE300J.	2			*	*	*	*

R ₆₅ , 66, 67	3RC20AE330J	RESISTOR, fixed: carbon; 33-ohm ±5%; ½-w; RC20AE330J.	3	*	*	*	*	*
R ₇₂	3RC20AE390K	RESISTOR, fixed: carbon; 39-ohm ±10%; ½-w; RC20AE390K.	1	*	*	*	*	*
R ₆₉	3RC20AE430J	RESISTOR, fixed: carbon; 43-ohm ±5%; ½-w; RC20AE430J.	1	*	*	*	*	*
R ₂₅	3RC20AE560K	RESISTOR, fixed: carbon; 56-ohm ±10%; ½-w; RC20AE560K.	1	*	*	*	*	*
R ₆₈ , 59, 74	3RC20AE101J	RESISTOR, fixed: carbon; 100-ohm ±5%; ½-w; RC20AE101J.	3	*	*	*	*	*
R ₆₅	3RC20AE151J	RESISTOR, fixed: carbon; 150-ohm ±5%; ½-w; RC20AE151J.	1	*	*	*	*	*
R ₃₅ , 36	3RC20AE181K	RESISTOR, fixed: carbon; 180-ohm ±10%; ½-w; RC20AE181K (for I-208 only).	2	*	*	*	*	*
R ₄₇	3RC20AE201J	RESISTOR, fixed: carbon; 200-ohm ±5%; ½-w; RC20AE201J.	1	*	*	*	*	*
R ₃₁	3RC20AE271J	RESISTOR, fixed: carbon; 270-ohm ±5%; ½-w; RC20AE271J (for I-208-A only).	1	*	*	*	*	*
R ₆₀ , 61, 62, 63	3RC20AE271J	RESISTOR, fixed: carbon; 270-ohm ±5%; ½-w; RC20AE271J.	4	*	*	*	*	*
R ₃₀	3RC20AE331K	RESISTOR, fixed: carbon; 330-ohm ±10%; ½-w; RC20AE331K.	1	*	*	*	*	*

*Indicates stock available.

16. Maintenance Parts List for Signal Generators I-208 and I-208-A (contd).

Ref. Symbol	Signal Corps Stock No.	Name of Part and Description	Quan. per Unit	Run-ning Spares	Orgn Stock	3d Ech.	4th Ech.	5th Ech.	Depot Stock
R ₃₈	3ZK6039-11	RESISTOR, fixed: carbon; 390-ohm \pm 5%; $\frac{1}{2}$ -w; RC20AE390J (for I-208-A only).	1			*	*	*	*
R ₁₂	3RC20AE471M	RESISTOR, fixed: carbon; 470-ohm \pm 20%; $\frac{1}{2}$ -w; RC20AE471M.	1			*	*	*	*
R _{39, 70}	3RC21AE511J	RESISTOR, fixed: carbon; 510-ohm \pm 5%; $\frac{1}{2}$ -w; RC21AE511J.	2			*	*	*	*
R ₃₅	3RC21AE511J	RESISTOR, fixed: carbon; 510-ohm \pm 5%; $\frac{1}{2}$ -w; RC21AE511J (for I-208-A only).	1			*	*	*	*
R ₆₆	3RC21AE511J	RESISTOR, fixed: carbon; 510-ohm \pm 5%; $\frac{1}{2}$ -w; RC21AE511J (for I-208 only).	1			*	*	*	*
R _{33, 47, 48, 56, 77, 80}	3RC20AE102M	RESISTOR, fixed: carbon; 1,000-ohm \pm 20%; $\frac{1}{2}$ -w; RC20AE102M.	6			*	*	*	*
R ₃₁	3RC20AE102M	RESISTOR, fixed: carbon; 1,000-ohm \pm 5%; $\frac{1}{2}$ -w; RC20AE102M. (For I-208 only).	1			*	*	*	*
R ₄₂	3RC20AE102K	RESISTOR, fixed: carbon; 1,000-ohm \pm 10%; $\frac{1}{2}$ -w.	1			*	*	*	*
R ₆₄	3RC20AE332M	RESISTOR, fixed: carbon; 3,300-ohm \pm 20%; $\frac{1}{2}$ -w; RC20AE332M.	1			*	*	*	*
R ₂	3RC20AE472M	RESISTOR, fixed: carbon; 4,700-ohm \pm 20%; $\frac{1}{2}$ -w; RC20AE472M.	1			*	*	*	*
R ₃	3RC31AE472M	RESISTOR, fixed: carbon; 4,700-ohm \pm 20%; 1-w; RC31AE472M.	1			*	*	*	*

R ₄₃ , 46	3RC20AE752J	RESISTOR, fixed: carbon; 7,500-ohm \pm 5%; $\frac{1}{2}$ -w; RC20AE752J.	2	*	*	*	*
R ₁₈	3RC20AE822K	RESISTOR, fixed: carbon; 8,200-ohm \pm 10%; $\frac{1}{2}$ -w; RC20AE822K.	1	*	*	*	*
R ₈₃ , 21, 49, 51, 52, 71	3RC20AE103K	RESISTOR, fixed: carbon; 10,000-ohms \pm 10%; $\frac{1}{2}$ -w; RC20AE103K.	6	*	*	*	*
R ₉₆ , 88	3RC20AE103K	RESISTOR, fixed: carbon; 10,000-ohms \pm 10%; $\frac{1}{2}$ -w; RC20AE103K (for I-208-A only).	2	*	*	*	*
R ₅ , 6, 14,	3RC20AE223M	RESISTOR, fixed: carbon; 22,000-ohm \pm 20%; $\frac{1}{2}$ -w; RC20AE223M.	3	*	*	*	*
R ₁₉	3RC20AE223K	RESISTOR, fixed: carbon; 22,000-ohm; \pm 10%; $\frac{1}{2}$ -w.	1	*	*	*	*
R ₄₀	3RC20AE243J	RESISTOR, fixed: carbon; 24,000-ohm \pm 5%; $\frac{1}{2}$ -w; RC20AE243J; (for I-208 only).	1	*	*	*	*
R ₂₀	3RC20AE333K	RESISTOR, fixed: carbon; 33,000-ohm \pm 10%; $\frac{1}{2}$ -w; RC20AE333K.	1	*	*	*	*
R ₇ , 8, 44, 50, 53, 54, 76, 81, 85	3RC20AE473M	RESISTOR, fixed: carbon; 47,000-ohm \pm 20%; $\frac{1}{2}$ -w; RC20AE473M.	9	*	*	*	*
R ₄₀	3RC21BE153J	RESISTOR, fixed: carbon; 50,000-ohm \pm 10%; $\frac{1}{2}$ -w; IRC BT $\frac{1}{2}$ (for I-208-A only).	1	*	*	*	*
R ₂₇	3RC20AE683M	RESISTOR, fixed: carbon; 68,000-ohm \pm 20%; $\frac{1}{2}$ -w; RC20AE683M.	1	*	*	*	*

*Indicates stock available.

16. Maintenance Parts List for Signal Generators I-208 and I-208-A (contd).

Ref. Symbol	Signal Corps Stock No.	Name of Part and Description	Quan. per Unit	Run-ning Spares	Orgn Stock	3d Ech.	4th Ech.	5th Ech.	Depot Stock
R ₁₆	3RC20AE104K	RESISTOR, fixed: carbon; 100,000-ohm ±10%; ½-w; RC20AE104K.	1			*	*	*	*
R _{1, 17, 79, 82}	3RC20AE154K	RESISTOR, fixed: carbon; 150,000-ohm ±10%; ½-w; RC20AE154K.	4			*	*	*	*
R ₃₂	3RC20AE154K	RESISTOR, fixed: carbon; 150,000-ohm ±10%; ½-w; RC20AE154K (for I-208-A only).	1			*	*	*	*
R ₁₃	3RC20AE224M	RESISTOR, fixed: carbon; 220,000-ohm ±20%; ½-w; RC20AE224M.	1			*	*	*	*
R _{9, 10, 11, 41}	3RC21AE514J	RESISTOR, fixed: carbon; 510,000-ohm ±5%; ½-w; RC21AE510J.	4			*	*	*	*
R ₃₂	3RC20AE225M	RESISTOR, fixed: carbon; 2.2-meg ±20%; ½-w; RC20AE225M (for I-208 only).	1			*	*	*	*
R ₄	3RC20AE106M	RESISTOR, fixed: carbon; 10-meg ±20%; ½-w; RC20AE106M.	1			*	*	*	*
R ₄₂	3Z6001.G7-9	RESISTOR, fixed: wire-wound; 17.5-ohm ±5%; 5-w; Detrola No. 44401 (for I-208-A only).	1			*	*	*	*
R _{28, 38}	3Z6003-35	RESISTOR, fixed: wire-wound; 30-ohm ±10%; 5-w; Utah No. 5VWQ30.	2			*	*	*	*

R ₂₄	3Z6015-30.1	RESISTOR, fixed: wire-wound; 150-ohm ±10%; 10-w; Ohmite Brown Devil.	1		*	*	*	*	*
R ₇₈	3Z6500-139	RESISTOR, fixed: wire-wound; 5,000-ohm ±10%; 10-w; Utah No. CC.	1		*	*	*	*	*
R ₇₂	2Z7278-50	RESISTOR, variable (potentiometer): wire-wound; 200-ohm ±10%; 1-w; 3-term; Detrola No. 44558 part of r-f unit; zero set control.	1		*	*	*	*	*
R ₃₄	2Z7279-62	RESISTOR, variable (potentiometer): wire-wound; 2,000-ohm ±10%; 1-w; 3-term; CTS No. 3215; Detrola No. G44536; (part of r-f unit); frequency deviation regulator.	1		*	*	*	*	*
R ₈₉	2Z7279-98	RESISTOR, variable (potentiometer): wire-wound; 1,000-ohm ±10%; 1-w; 3-term; CTS No. 4264 (for I-208-A only).	1		*	*	*	*	*
R ₂₉	2Z7280-81	RESISTOR, variable (potentiometer): wire-wound; 5,000-ohm; 1-w; 3-term; CTS No. 4265; part of r-f unit, audio VTVM sensitivity control (for I-208 only).	1		*	*	*	*	*
R ₂₂	2Z7280-80	RESISTOR, variable (potentiometer): wire-wound; 10,000-ohm ±10%; 1-w; 3-term; CTS No. 3180; Detrola No. 44559; part of audio osc unit; deviation corrector.	1		*	*	*	*	*

*Indicates stock available.

16. Maintenance Parts List for Signal Generators I-208 and I-208-A (contd).

Ref. Symbol	Signal Corps Stock No.	Name of Part and Description	Quan. per Unit	Run-ning Spares	Orgn Stock	3d Ech.	4th Ech.	5th Ech.	Depot Stock
R ₃₃	2Z7280-149	RESISTOR, variable (potentiometer): wire-wound; 10,000-ohm \pm 10%; 1-w; 3-term; CTS No. 3201; Detrola No. G44556; part of audio osc unit; kc deviation control.	1			*	*	*	*
R ₇₅	2Z7280-96	RESISTOR, variable (potentiometer): wire-wound; 10,000-ohm \pm 10%; 1-w; 3-term; CTS No. 3207; Detrola No. G44561; part of r-f unit; r-f VTVM sensitivity control.	1			*	*	*	*
R ₄₅	2Z7281-120	RESISTOR, variable (potentiometer): wire-wound; 20,000-ohm \pm 10%; 1-w; 3-term; CTS No. 4265.	1			*	*	*	*
R ₉₇	2Z7281.121	RESISTOR, variable (potentiometer): wire-wound; 20,000-ohm \pm 10%; 1-w; 3-term; CTS No. 4221.	1			*	*	*	*
R ₃₇	2Z7281.45	RESISTOR, variable (potentiometer): wire-wound; 25,000-ohm; 1-w; 3-term; Mallory No. M25MP; part of r-f unit; r-f output control.	1			*	*	*	*

2Z8672.8	SOCKET, crystal: 2-cont; Cinch No. 9816.	1	*	*	*	*	*
2Z8675.44	SOCKET, tube: acorn; 5-cont; Detrola No. G19027.	1	*	*	*	*	*
2Z8659-6	SOCKET, tube: 8-prong; bakelite; Amphenol M1P-8.	1	*	*	*	*	*
2Z8762.2	SOCKET, tube: 8-prong; Amphenol No. SS-8.	2	*	*	*	*	*
2C4452A/S6	SOCKET, tube: 8-prong; steatite; Amphenol No. S8T.	5	*	*	*	*	*
6C34	SPEAKER, dynamic: 2" cone; permanent-magnet; 3.5-ohm voice coil; Cinaudagraph No. 2ZMP.	1	*	*	*	*	*
3Z9825-95.2	SWITCH, rotary: SPST; single-sect; bakelite insulation; Oak type No. H; Detrola No. G43104.	3	*	*	*	*	*
3Z9903E-14.1	SWITCH, rotary: SPST; single-sect; ceramic insulation; Detrola No. G43442.	1	*	*	*	*	*
3Z9825-95.3	SWITCH, rotary: 6-position, 2-sect; Oak type H; Detrola No. G42861; modulation selector.	1	*	*	*	*	*
3Z9858-3	SWITCH, toggle: DPDT; bakelite body; AH & H No. 81012.	2	*	*	*	*	*
3Z9858-8.66	SWITCH, toggle: DPST; bakelite insulation; AH & H No. 81009; power.	1	*	*	*	*	*

*Indicates stock available.

16. Maintenance Parts List for Signal Generators I-208 and I-208-A (contd).

Ref. Symbol	Signal Corps Stock No.	Name of Part and Description	Quan. per Unit	Run-ning Spares	Orgn Stock	3d Ech.	4th Ech.	5th Ech.	Depot Stock
SW ₃	3Z9858-8	SWITCH, toggle: DPST; AH & H No. 81009; plate voltage.	1			*	*	*	*
T ₁		TRANSFORMER, power: plate and fil; Foster AP No. AA-5014-1; Detrola No. G42101.	1			*	*	*	*
T ₂	2Z9632-119	TRANSFORMER, AF: output; Foster AP No. AA-5005; Detrola No. G42901.	1			*	*	*	*
V ₁₇	3Z6925-3.3	TUBE, ballast: Amperite 1H-20. . . TUNING UNIT: complete with drive gears, dial mechanism, and tuning capacitors; Detrola No. 43330.	1			*	*	*	*
	3F3900-208.1	VACUUM TUBE VOLTMETER ASSEMBLY: completely wired and assembled, less tube; Detrola No. 43730.	1					*	*
V ₁₅	2J5U4	TUBE, electron: JAN-5U4; VT-244.	1	1		*	*	*	*
V ₉	2J6AG7	TUBE, electron: JAN-6AG7; VT-247.	1	1		*	*	*	*
V ₂	2J6H6	TUBE, electron: JAN-6H6 (for I-208A only)	1	1		*	*	*	*
V ₄	2J6SG7	TUBE, electron: JAN-6SG7 (for I-208A only)	1	1		*	*	*	*
V ₂	2J6SQ7GT	TUBE, electron: JAN-6SQ7GT (for I-208A only).	1	1		*	*	*	*

V ^{5, 14}	2J12A6GT	TUBE, electron: JAN-12A6GT.	2	1	*	*	*	*
V ^{3, 4}	2J12SA7GT	TUBE, electron: JAN-12SA7GT; VT-161 (for I-208 only).	2	1	*	*	*	*
V ¹³	2J12SA7GT	TUBE, electron: JAN-12SA7GT; VT-161	1	1	*	*	*	*
V ^{6, 7, 8, 12}	2J12SH7	TUBE, electron: JAN-12SH7; VT-288 Reference Nos. V ^{6, 7, 8, 12} .	4	1	*	*	*	*
V ^{1, 11}	2J125N7GT	TUBE, electron: JAN-12SN7GT.	2	1	*	*	*	*
V ¹⁰	2J955	TUBE, electron: JAN-955; VT-121.	1	1	*	*	*	*
V ¹⁶	2JOD3/VR-150	TUBE, electron: JAN-OD3/VR-150; VT-139.	1	1	*	*	*	*

*Indicates stock available.

X-40809A TYPO 12-44