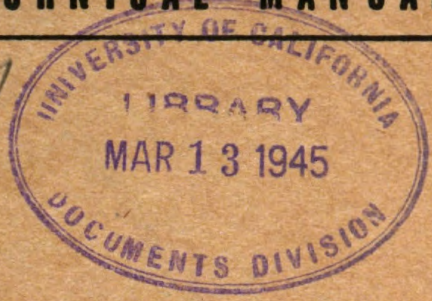


✓
#460 U113
12
TM
1944

TM 11-338

WAR DEPARTMENT TECHNICAL MANUAL

U.S. Dept. of Army



TELEPHONE CENTRAL OFFICE SET TC-10

WAR DEPARTMENT

28 JULY 1944

WAR DEPARTMENT TECHNICAL MANUAL

TM 11-338

This manual supersedes TM 11-338, 26 February 1943.

TELEPHONE CENTRAL
OFFICE
SET TC-10



WAR DEPARTMENT

28 JULY 1944

WAR DEPARTMENT,

WASHINGTON 25, D. C., 28 JULY 1944.

TM 11-338, Telephone Central Office Set TC-10, is published for the information and guidance of all concerned.

[A. G. 300.7 (22 June 44).]

BY ORDER OF THE SECRETARY OF WAR:

G. C. MARSHALL,
Chief of Staff.

OFFICIAL:

J. A. ULIO,
Major General,
The Adjutant General.

DISTRIBUTION:

As prescribed in paragraph 9a, FM 21-6:

Armies (10); Corps (10); SvC (10); Depts (10); Def Comds (2); D (2); IBn 11 (2); IC 11 (5) ¹(2); C of Tech Sv (2); Arm & Sv Boards (2); PC & S (1); PE (Sig Sec) (5); Sig C Deps (15); AGF Repl Deps (Sig Sec) (10); Sig C Labs (10); Sig C Rep Sh (10); Sig C Inspec Zones (2); Sig C Proc Dists (2).

IBn 11: T/O 11-95.

IC 11: T/O 11-97; 11-107; 11-127; 11-237; 11-587; 11-592; 11-597; ¹T/O 11-500, Sig Sv Orgn-2 Position Switchboard Team (GC), 3 Position Switchboard Team (GD); Switchboard Instl Sec (GF).

(For explanation of symbols, see FM 21-6.)

U113

. 2

TM 11:335

1944

TABLE OF CONTENTS

★ ★

SECTION	I. Description.	<i>Paragraph</i>	<i>Page</i>
	General.....	1	1
	Component parts.....	2	1
	Switchboard BD-110-().....	3	7
	Frame FM-19.....	4	10
	Power equipment.....	5	11
	Test and power distribution equipment.....	6	15
	II. Installation and operation.		
	General.....	7	17
	Setting up equipment.....	8	17
	Connecting equipment.....	9	23
	Preparation for use.....	10	28
	Operation of power equipment....	11	29
	Switchboard operation.....	12	29
	III. Functioning of parts.		
	General.....	13	33
	Tracing line and trunk circuits...	14	40
	Line protection and cross- connection circuit.....	15	42
	Line circuit, common battery.....	16	47
	Line circuit, magneto.....	17	63
	Trunk circuit, universal two-way to dial or manual offices.....	18	63
	Universal cord circuit.....	19	66
	Ringling circuit.....	20	69
	Operator's telephone circuit.....	21	70
	Auxiliary operator's telephone circuit.....	22	71
	Conference circuit.....	23	75
	Dial cord circuit.....	24	76

TABLE OF CONTENTS

SECTION III	<i>Paragraph</i>	<i>Page</i>
Functioning of parts (contd.)		
Cabinet BE-72 test circuits	25	76
Night alarm circuit	26	77
Fuse alarm circuit	27	79
No-voltage alarm circuit	28	79
Panel BD-90 power and ringing circuits	29	79
IV. Maintenance.		
General	30	82
Testing with Cabinet BE-72	31	83
Moistureproofing and fungi- proofing	32	92
Wiring diagrams	33	98
Storage batteries	34	98
Switchboard plugs, cleaning	35	99
Switchboard cord repairs	36	99
Cleaning contacts	37	100
Cleaning relay parts	38	101
Drop and relay adjustments	39	101
Circuit requirements of relays	40	105
Telering 20-cycle power ringer	41	111
Battery-driven ringing interrupter	42	111
V. Supplementary data.		
Packing for transportation	43	112
Maintenance parts lists	44	116

LIST OF ILLUSTRATIONS

<i>Fig. No.</i>	<i>Title</i>	<i>Page</i>
1	Telephone Central Office Set TC-10, assembled.....	x
2	Switchboard BD-110-(), front view.....	4
3	Switchboard BD-110-(), rear view, terminal panel raised	5
4	Switchboard BD-110-() packed for transportation.....	6
5	Line side of main distributing frame consisting of three Frames FM-19 bolted together.....	8
6	Switchboard side of main distributing frame consisting of three Frames FM-19 bolted together.....	9
7	Rectifier RA-36-J mounted on Rack FM-30, front view . . .	10
8	Panel BD-90, front view.....	11
9	Panel BD-90, rear view.....	12
10	Cabinet BE-75 mounted on Rack FM-30.....	13
11	Cabinet BE-72, front view.....	14
12	Test Cabinet BE-70-(), front view.....	16
13	Cording diagram for Telephone Central Office Set TC-10..	18
14	Suggested floor plan for Telephone Central Office Set TC-10 in one room.....	19
15	Suggested floor plan for Telephone Central Office Set TC-10 in two rooms.....	20
16	Distributing frame, assembly diagram.....	21
17	Switchboard BD-110-(), rear view.....	22
18	Cabinet BE-72, showing method of connecting spade terminals to binding posts.....	24
19	Three-conductor plug and jack.....	33
20	Switchboard BD-110-(), front equipment.....	34
21	Switchboard BD-110-(), keyshelf equipment.....	35

LIST OF ILLUSTRATIONS

<i>Fig. No.</i>	<i>Title</i>	<i>Page</i>
22	Multiple scheme, one- and two-position installations, Switchboard BD-110-().....	37
23	Multiple scheme, three-position installations, Switchboard BD-110-().....	38
24	Switchboard BD-110-(), cabling scheme for one- and two-position installations.....	39
25	Switchboard BD-110-(), cabling scheme for three-position installations.....	41
26	Switchboard BD-110-(), cabling scheme for four-, five-, and six-position installations.....	42
27	Switchboard BD-110-(), answering jack and multiple numbering; one-, two-, and three-position installations... ..	43
28	Switchboard BD-110-(), answering jack and multiple numbering; four-, five-, and six-position installations. . . .	44
29	Switchboard BD-110-(), binding posts on terminal panel	45
30	Multiple cable terminal strips at top of Switchboard BD-110-().....	46
31	Switchboard BD-110-(), spade terminal strip designations.....	47
32	Frame FM-19, line circuit, wiring diagram.....	48
33	Common-battery line circuit, wiring diagram, Switchboard BD-110-().....	49
34	Magneto line circuit, wiring diagram, Switchboard BD-110-().....	62
35	Universal trunk circuit, schematic diagram, Switchboard BD-110-().....	64
36	Universal cord circuit, schematic diagram, Switchboard BD-110-().....	67
37	Ringing circuit, schematic diagram, Switchboard BD-110-().....	70
38	Operator's telephone circuit, schematic diagram, Switchboard BD-110-().....	72
39	Grouping circuit, functional diagram, Switchboard BD-110-().....	73

LIST OF ILLUSTRATIONS

<i>Fig. No.</i>	<i>Title</i>	<i>Page</i>
40	Auxiliary operator's telephone circuit, wiring diagram, Switchboard BD-110-().....	74
41	Conference circuit, wiring diagram, Switchboard BD-110-().....	75
42	Switchboard BD-110-(), dial cord circuit, schematic diagram.....	76
43	Night alarm circuit, schematic diagram, Panel BD-90.....	78
44	Fuse alarm circuit, schematic diagram, Panel BD-90.....	79
45	No-voltage alarm circuit, schematic diagram, Panel BD-90.....	79
46	Panel BD-90, power and ringing supply circuits, schematic diagram.....	80
47	Cabinet BE-72, voltmeter test circuit, schematic diagram..	83
48	Cabinet BE-72, switchboard test circuit, schematic diagram.....	86
49	Test of contacts of common-battery line jacks, Switchboard BD-110-(), functional diagram.....	88
50	Test of magneto line circuit drops, Switchboard BD-110-(), functional diagram.....	88
51	Test of supervisory relay, Switchboard BD-110-(), functional diagram.....	89
52	Test of sleeve and supervisory relays, Switchboard BD-110-(), functional diagram.....	90
53	Operate test of sleeve relay, Switchboard BD-110-(), functional diagram.....	90
54	Ringing key test, Switchboard BD-110-(), functional diagram.....	91
55	Nonclick test of TALK-RING key, Switchboard BD-110-(), functional diagram.....	91
56	Method of adjusting spring tang of an E- or R-type relay...	102
57	Front contact make adjustment of a G-type relay.....	103
58	Racks FM-34, FM-35, FM-36, and FM-37 in Case CS-61.	112
59	Frames FM-19 in Cases CS-59, covers removed, showing two stages of packing.....	113
60	Cabinet BE-72 in Case CS-66, cover removed.....	114

LIST OF ILLUSTRATIONS

<i>Fig. No.</i>	<i>Title</i>	<i>Page</i>
61	Switchboard BD-110-(), front panel removed, showing cords secured for transportation.....	115
62	Power distribution circuits, wiring diagram, Cabinet BE-72	138
63	Voltmeter test circuit, wiring diagram, Cabinet BE-72.....	139
64	Switchboard test circuit, wiring diagram, Cabinet BE-72..	140
65	Cabinet BE-75, wiring diagram.....	141
66	No-voltage alarm circuit, wiring diagram, Panel BD-90....	142
67	Power and ringing circuits and interrupter contact protection circuit, wiring diagram, Panel BD-90.....	143
68	Night alarm and fuse alarm circuits, wiring diagram, Panel BD-90.....	144
69	Power cable connector circuit, wiring diagram, Switchboard BD-110-().....	145
70	Dial cord circuit, wiring diagram, Switchboard BD-110-().....	146
71	Power and heating circuit, wiring diagram, Switchboard BD-110-().....	146
72	Universal cord circuit and ringing circuit, wiring diagram, Switchboard BD-110-().....	147
73	Operator's telephone circuit, wiring diagram, Switchboard BD-110-().....	148
74	Universal two-way trunk circuit, wiring diagram, Switchboard BD-110-().....	149

DESTRUCTION NOTICE

WHY —To prevent the enemy from using or salvaging this equipment for his benefit.

WHEN—When ordered by your commander.

- HOW** —1. Smash—Use sledges, axes, handaxes, pickaxes, hammers, crowbars, heavy tools.
2. Cut —Use axes, handaxes, machetes.
3. Burn —Use gasoline, kerosene, oil, flame throwers, incendiary grenades.
4. Explosives—Use firearms, grenades, TNT.
5. Disposal —Bury in slit trenches, fox holes, other holes. Throw in streams. Scatter.

USE ANYTHING IMMEDIATELY AVAILABLE FOR DESTRUCTION OF THIS EQUIPMENT.

- WHAT**—1. Smash—Jack field, switchboard plugs, storage battery, battery charger, power generator, ringing generators, keys, relays, meters, receptacles, dial, etc.
2. Cut —All cables and wires.
3. Burn —Wood cases and cabinets, cables, wire, technical manual, blueprints.
4. Bury or scatter—Any or all of the above pieces after breaking.

DESTROY EVERYTHING

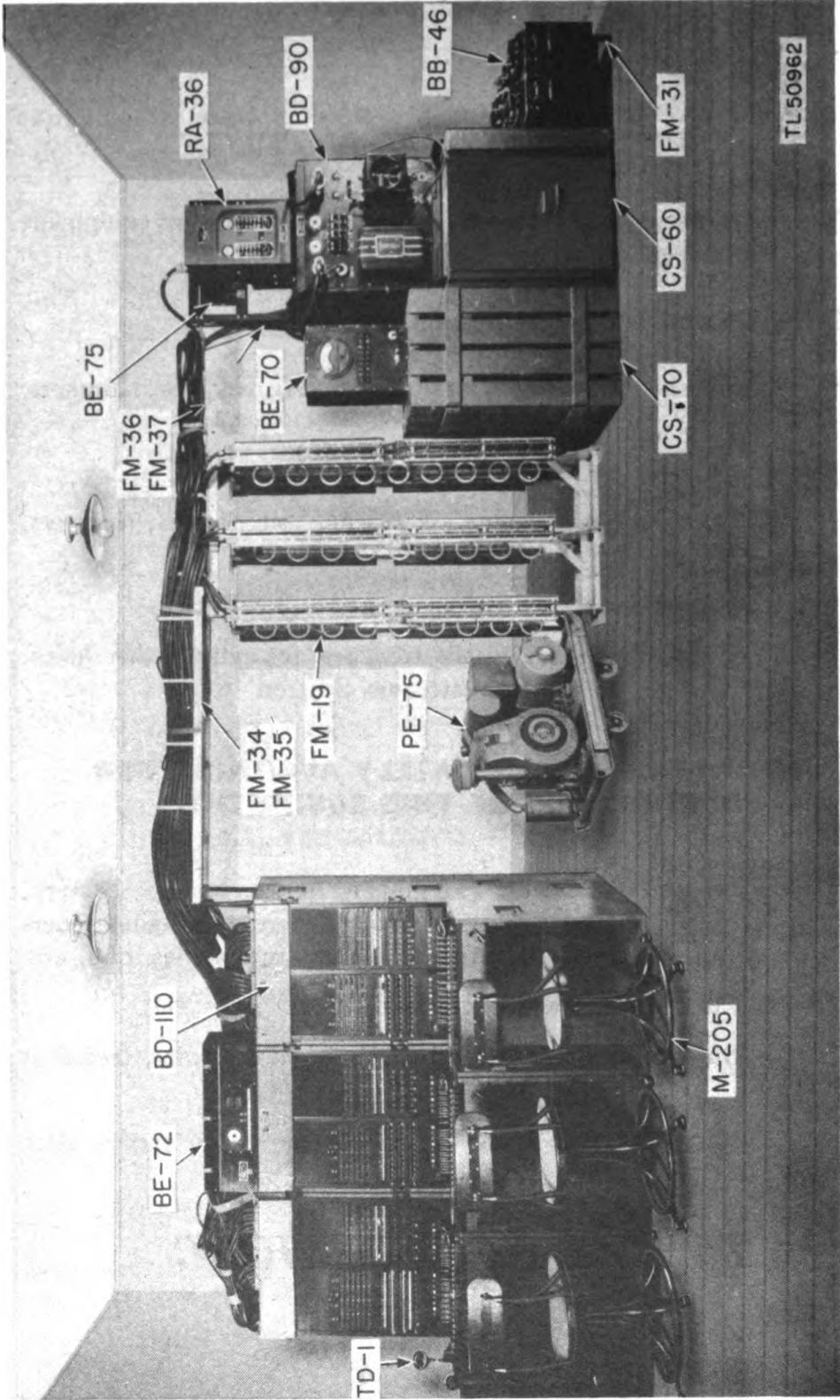


Figure 1. Telephone Central Office Set TC-10, assembled.

SECTION I

DESCRIPTION

1. GENERAL.

a. Telephone Central Office Set TC-10 is a complete transportable telephone central office for use at any army headquarters or other headquarters requiring a telephone switchboard of the capacity of one to six Switchboards BD-110-(). The number of switchboards to be used in an installation is determined by the number of lines to be served and by the expected maximum calling rate. For *each* Switchboard BD-110-() used, a maximum of 60 common-battery lines, 30 local-battery (magneto) lines, and 4 two-way trunks may be connected, and a maximum of 15 conversations can be handled at one time. The magneto line circuits can be used for magneto lines, toll lines, or inter-office, two-way, ring-down trunks. The trunk circuits may be used for trunks to manual or automatic (dial) exchanges. The anticipated normal installation is three Switchboards BD-110-(), and this number will normally be furnished with Telephone Central Office Set TC-10. The normal working ranges of lines and trunks connected to this board are shown on the circuit diagrams (figs. 33, 34, 35, 36, and 43).

NOTE: The use of parentheses () with an equipment code indicates that any existing model of the equipment may be used.

b. The equipment (fig. 1) may be installed any place under cover (par. 7). A complete installation, up to the point of connecting incoming lines, can be made in 6 hours or less by a crew of 12 men.

2. COMPONENT PARTS. The total weight of a complete Telephone Central Office Set TC-10 with three Switchboards BD-110-() is approximately 7,000 pounds. Each additional Switchboard BD-110-(), with Frame FM-19 and Chair M-205, plus their associated Cases CS-59 and CS-70, has a total weight of approximately 1,330 pounds. The weight and dimensions of the separate units are listed in table I.

TABLE I
LIST OF COMPONENT PARTS

Quantity	Article	Use	Approximate size (in.)	Approx. weight ea. (lb.)
20	Battery BA-23.	For Cabinet BE-70-().	2½ diam x 6½	2
1	Battery BA-26.	For Cabinet BE-72.	8¼ x 4½ x 7 ¹⁵ / ₁₆	13
4	Battery BB-46.	D-c power.	15½ x 6½ x 14 ⁹ / ₁₆	119
1	Cabinet BE-70-().	Wire chief's set.	12 x 9 x 18	32
1	Cabinet BE-72.	Test and power distribution.	26½ x 7 x 9 ⁹ / ₁₆	61
1	Cabinet BE-75.	A-c power distribution.	13½ x 4 ⁵ / ₈ x 9 ³ / ₄	25
1	Case CS-57.	For Cabinet BE-70-().	15¼ x 15¼ x 22 ³ / ₄	36
3	Case CS-59.	For Frame FM-19.	85¼ x 30 ³ / ₄ x 13¼	254
1	Case CS-60.	For Panel BD-90 and cords.	28¼ x 39 ¹ / ₈ x 29 ¹ / ₈	130
1	Case CS-61.	For cable racks.	70¼ x 31 ³ / ₄ x 12 ⁹ / ₁₆	156
4	Case CS-63.	For Battery BB-46.	8 ⁵ / ₈ x 18 ³ / ₁₆ x 19 ⁷ / ₈	19
1	Case CS-66.	For Cabinet BE-72.	14½ x 35 x 12	44
1	Case CS-69.	For 12 Cords CD-334.	19¼ x 42½ x 12	57
3	Case CS-70.	For Chair M-205.	23 ¹ / ₈ x 22 ³ / ₈ x 36	25
1	Case CS-72.	For 2 Racks FM-31 and Hammer HM-5, and 3 Ground Rods GP-29.	19½ x 10 ¹ / ₈ x 40 ⁹ / ₁₆	49
1	Case CS-73.	For Rectifier RA-36-(), Cabinet BE-75, and Rack FM-30.	28 ³ / ₈ x 26 ³ / ₈ x 25 ¹ / ₈	63
3	Chair M-205.	Operator's.		24
6	Chest Set TD-1.	Operator's chest set.		³ / ₄
12	Cord CD-334.	Multiple splicing with 4 or more Switchboards BD-110-().	86 long	6.5
1	Cord CD-335.	Battery cable.	374 long	13

1	Cord CD-393.	A-c power to Cabinet BE-75.	614 long	21
1	Cord CD-409.	Power Unit PE-75-() to Cabinet BE-75.	608 long	20
3	Cord CD-413.	A-c power, Switchboard BD-110-() to Switchboard BD-110-().	36 long	1
1	Cord CD-414.	A-c power, Cabinet BE-75 to Switchboard BD-110-().	576 long	6
3	Cord CO-38.	Battery BB-46 to Battery BB-46.	13 long	¼ for 3
1	Cord CO-258.	Frame FM-19 to Ground Rods GP-29.	600 long	4
3	Frame FM-19.	Main distributing frame.	17¼ x 23 x 80	180
3	Ground Rod GP-29.	Ground.	36 x 2¼ diam	8
1	Hammer HM-5.	Drive ground rods.	12 pound sledge	12
6	Headset HS-30-().	Operator's headset.	1" x 7½" x 7½"	¾
1	Maintenance Equipment ME-4 (CH-64).	Maintenance parts and tools.	44 x 21 x 20	250
1	Panel BD-90.	Power panel.	35½ x 25 x 26¼	230
6	Paulin, duck.	Cover equipment.	147 x 192	65
2	Power Unit PE-75-().	Emergency a-c power.	40 x 19 x 27½	324
1	Rack FM-30.	For Rectifier RA-36-() and Cabinet BE-75.	16¾ x 25 x 22½	50
2	Rack FM-31.	For Battery BB-46.	16 x 15½ x 31¾	7
3	Rack FM-34.	For Cords CD-333.	66¼ x 12½ x 9¼	27
2	Rack FM-35.	For Cords CD-333.	16 x 12¼ x 8¾	5
3	Rack FM-36.	For power cable.	63¼ x 5½ x 5¾	12½
2	Rack FM-37.	For power cable.	13½ x 5¾ x 5/8	2
1	Rectifier RA-36-().	D-c power.	11½ x 11½ x 19¾	82
3	Switchboard BD-110-().	Operator position.	36¾ x 26½ x 72	850
1	Tool Equipment TE-44 (CH-58).	Installation.	24¼ x 18¾ x 26¾	50
3	Truck.	Moving equipment into place.	22 x 15½	26

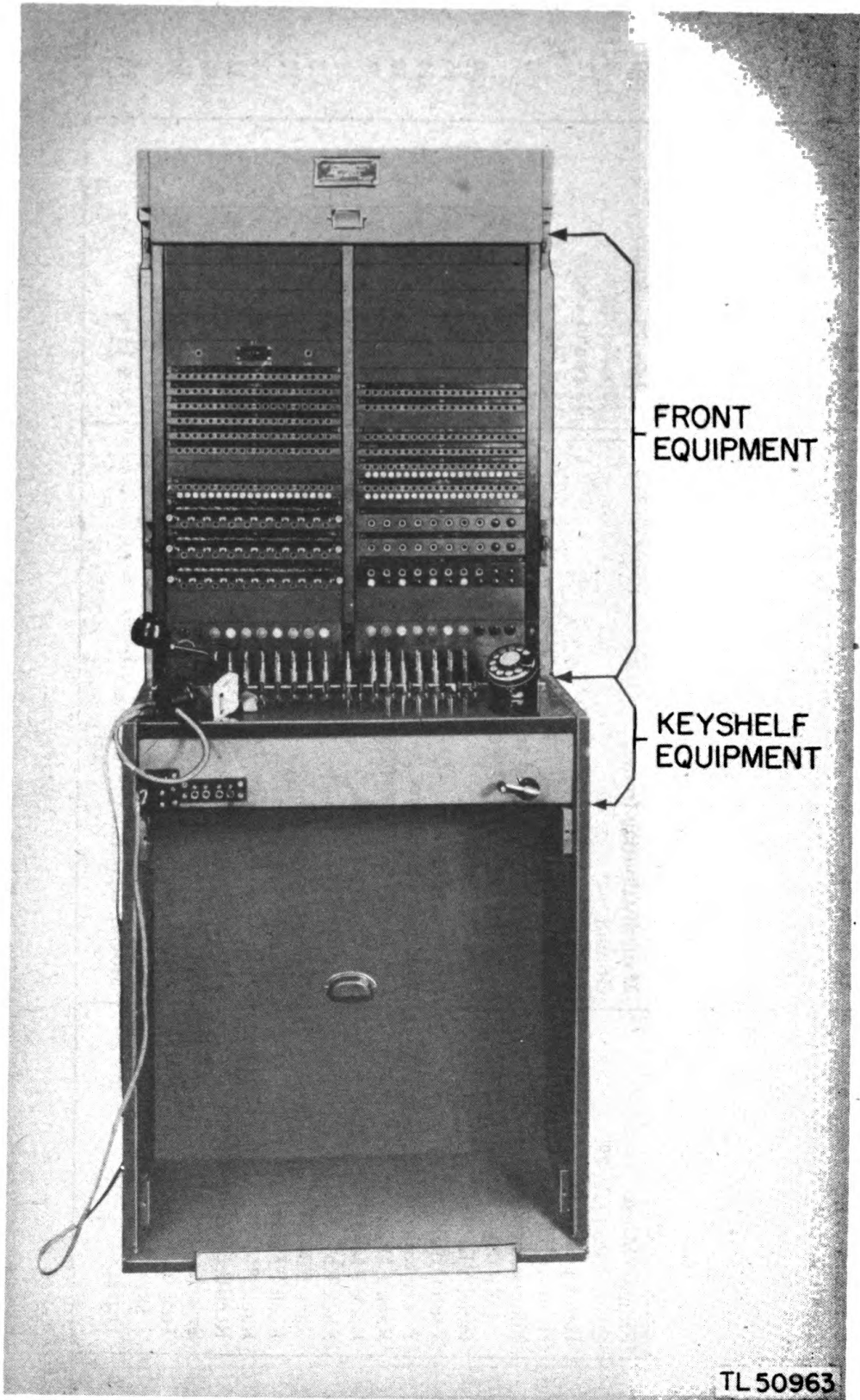


Figure 2. Switchboard BD-110-(), front view.

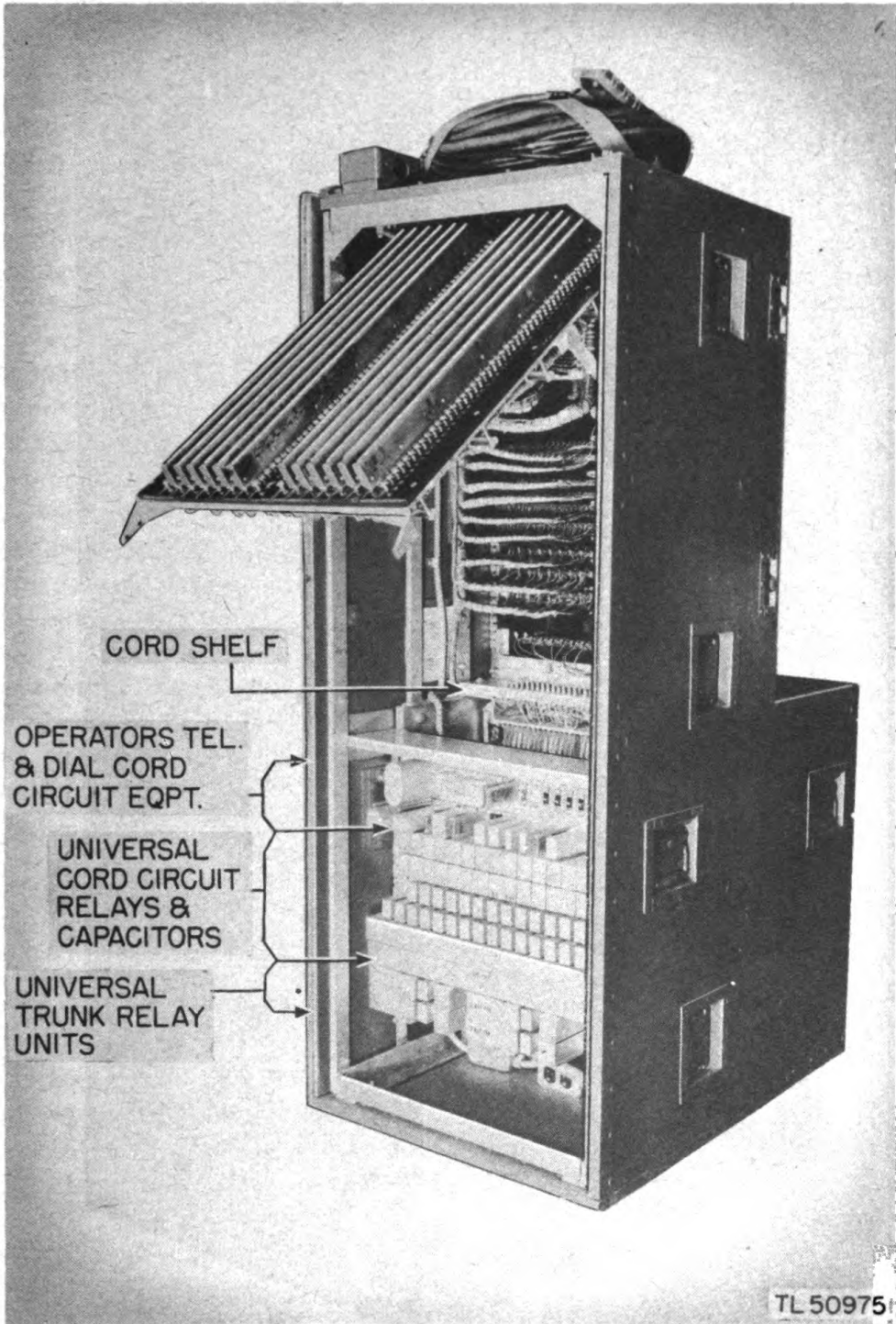
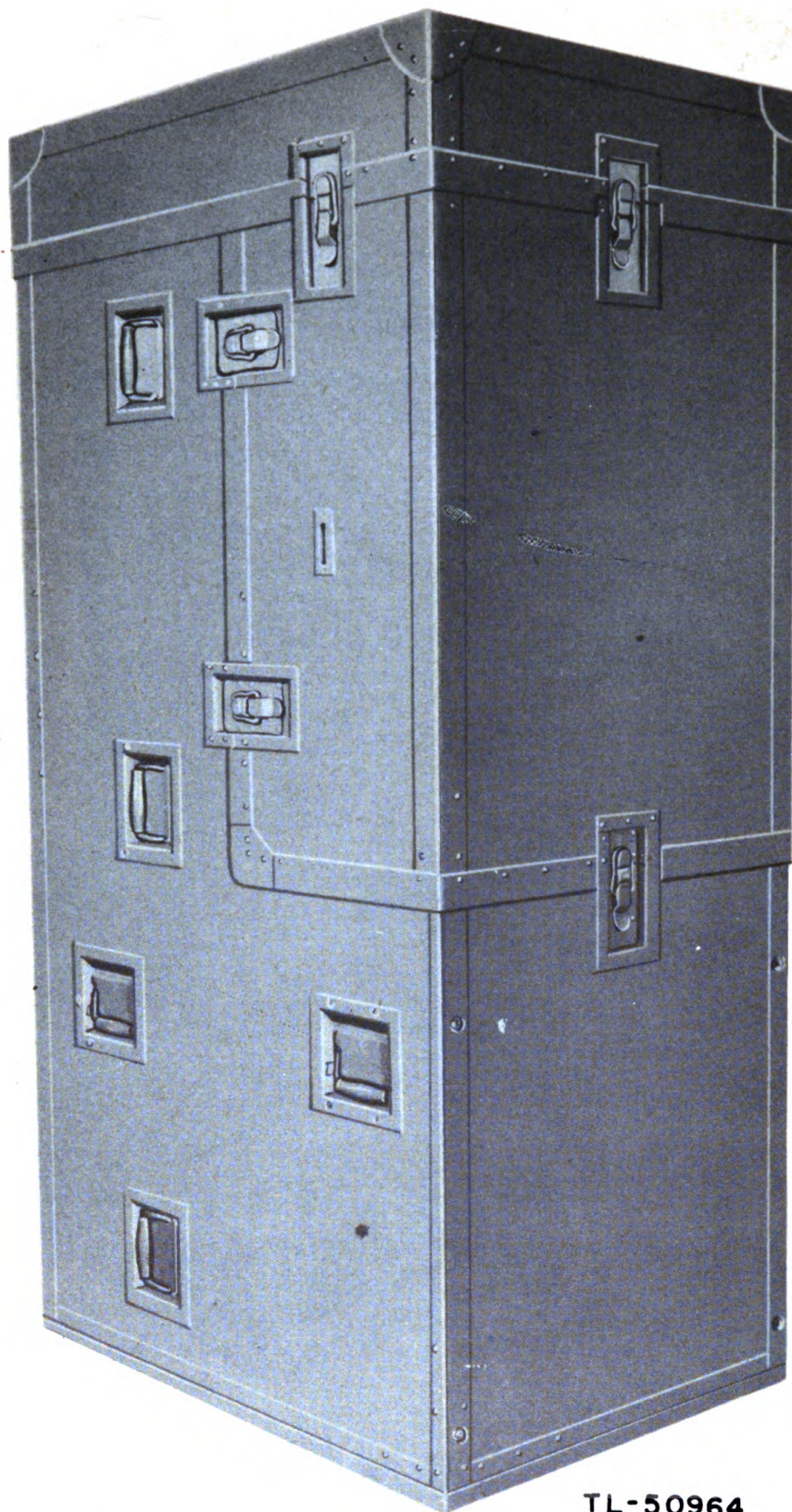


Figure 3. Switchboard BD-110—(), rear view, terminal panel raised.



TL-50964

Figure 4. Switchboard BD-110-(), packed for transportation.

3. SWITCHBOARD BD-110-().

a. Switchboard BD-110-() (figs. 2, 3, 20, and 21) is a single-position, two-panel, manually operated telephone switchboard. It has a steel frame inclosed in a trunk-type case with removable front, back, and top covers, and it does not require any additional covering for transportation. The lower section of the switchboard contains the cords and a rack upon which are mounted the cord circuit relays, operator's telephone circuit apparatus, universal trunk circuit apparatus, and switchboard fuses. The upper section of the switchboard is occupied by the jack and signal equipment, the cabling therefrom, and the terminal panel. The terminal panel is formed by one section which, supported by top bolts, can be swung out for access to the jack and signal equipment and wiring (fig. 3). The terminal panel provides 800 binding posts in 16 vertical rows of 50 binding posts per row. Lamp signals are provided for signaling on common-battery lines and trunks, and for magneto and common-battery supervision on cord circuits. Drop signals are provided for signaling on magneto lines. Multiple jacks are provided for use when two or more switchboards are used. The answering and multiple jacks are wired to binding posts on the terminal panel in the rear of the board. The multiple jacks are also wired to flexible cables which are equipped with spade terminal strips. These strips are arranged for connection to the binding posts on the terminal panel of the same or another switchboard. This arrangement permits making rapid multiple jack connections between switchboards. A smaller spade terminal strip with four flexible cables permits connections to battery, ringing, alarm, and grouping circuits. The cord circuits are fully universal, and can be used to interconnect all lines and trunks.

b. Each switchboard contains the following circuits:

<i>Quantity</i>	<i>Circuit</i>
1	Operator's telephone circuit.
1	Auxiliary operator's telephone circuit.
1	Dial-cord circuit.
30	Local-battery (magneto) line circuits.
60	Common-battery line circuits.
4	Universal trunk circuits.
15	Cord circuits (fully universal).
1	Power and heating circuit.
1	Conference circuit (10 jacks).
1	Grouping key circuit.
1	Emergency-ringing circuit.
1	Keyshelf and framework ground circuit.

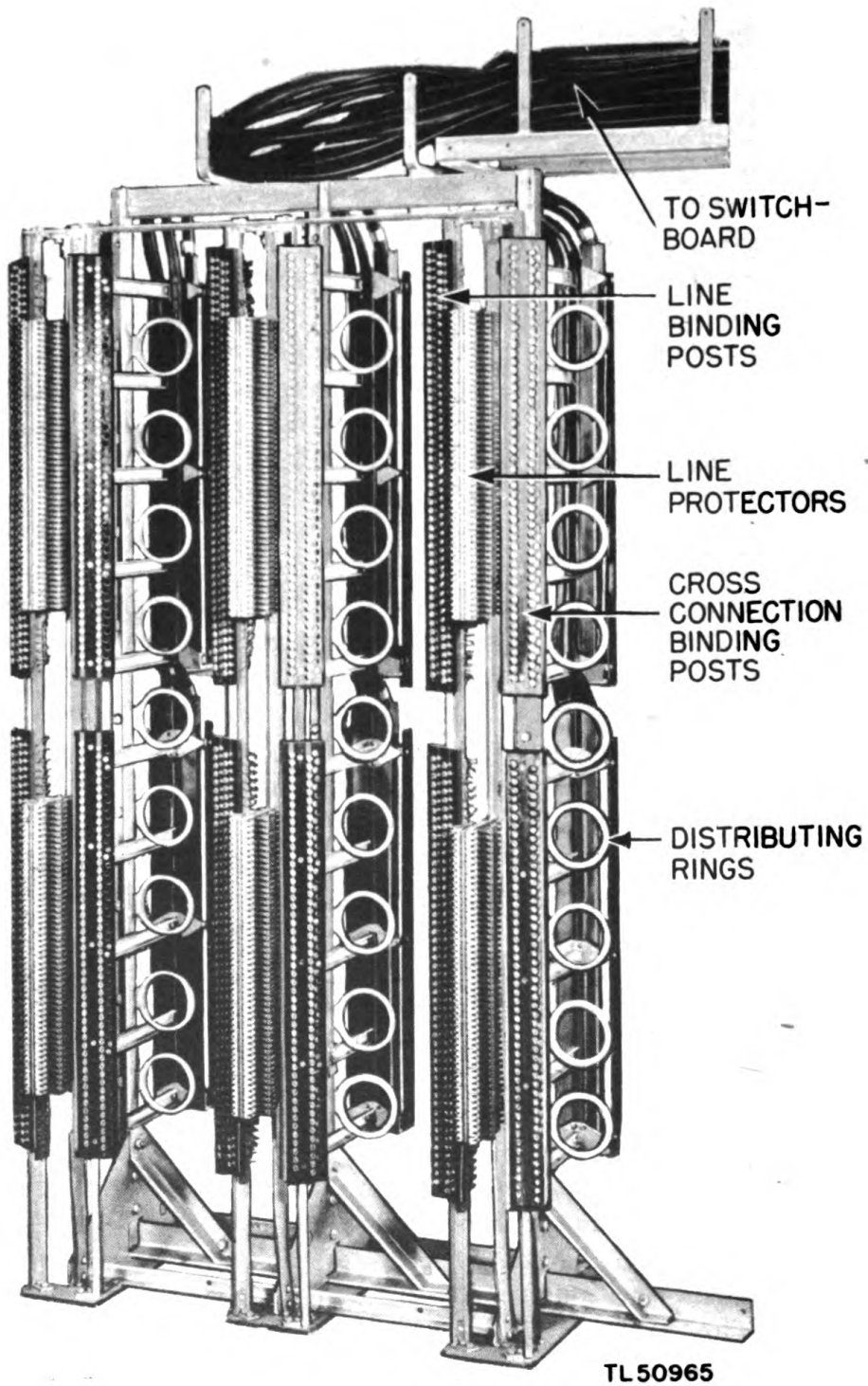
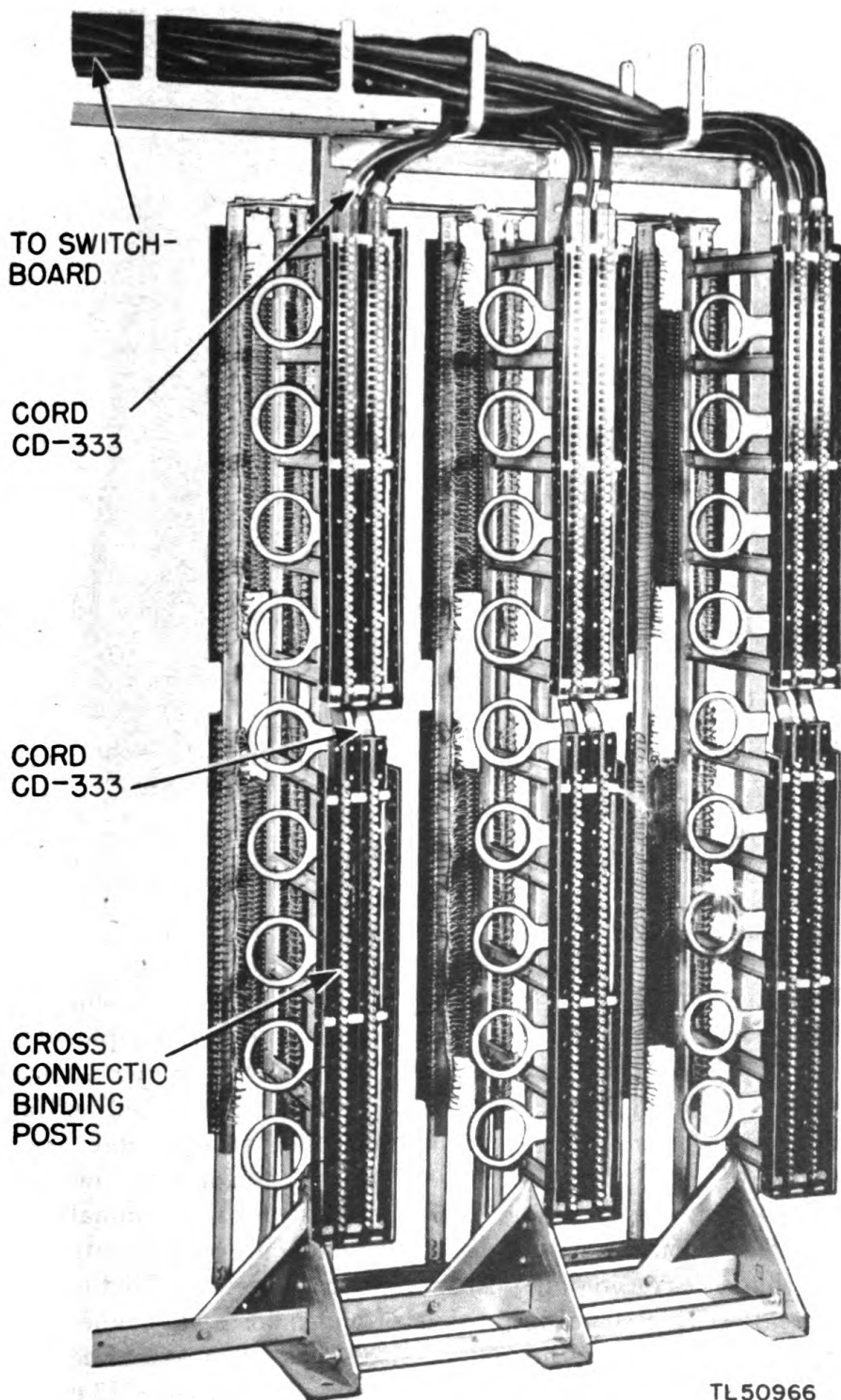


Figure 5. Line side of main distributing frame consisting of three Frames FM-19 bolted together.



TL 50966

Figure 6. Switchboard side of main distributing frame consisting of three Frames FM-19 bolted together.

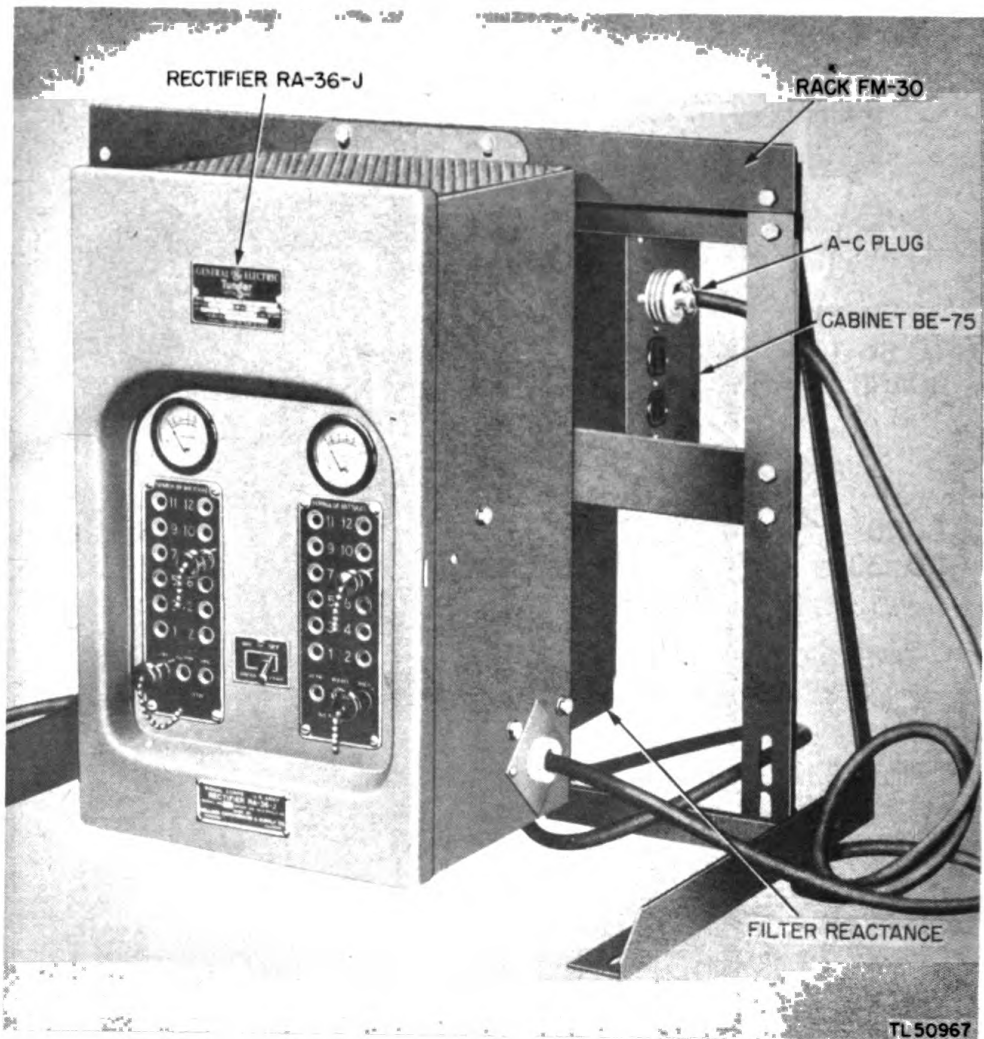


Figure 7. Rectifier RA-36-J mounted on Rack FM-30, front view.

4. FRAME FM-19 (figs. 5 and 6). Frame FM-19 is a 100-line main distributing frame unit used to mount the line protection equipment and to furnish a cross-connecting frame between the field or line wires and the switchboard equipment. One Frame FM-19 is furnished and used with each Switchboard BD-110-(), and when two or more Frames FM-19 are installed, they are bolted together to form the main distributing frame. A series of binding posts is provided for terminating the field lines. Heat-coil and carbon-block protectors are permanently wired between this series of binding posts and a second series of binding posts. This second series of binding posts is provided for cross-connecting to the binding post strips on the switchboard side of the frame. Each binding post strip on the switchboard side is part of Cord CD-333 clamped to Frame FM-19 by small lugs. The binding posts connect through the 35-foot rubber-jacketed cord to a spade terminal strip which engages with the binding posts on the switchboard terminal panel.



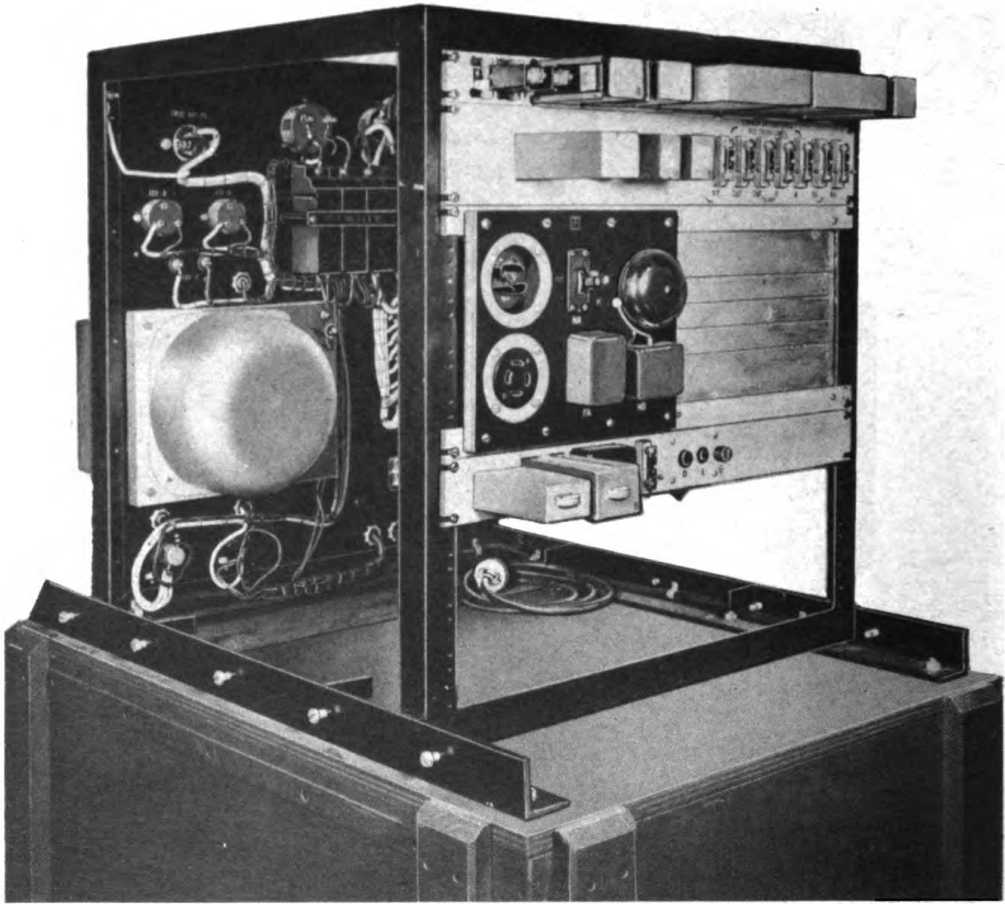
TL50969

Figure 8. Panel BD-90, front view.

5. POWER EQUIPMENT.

a. Batteries. Four storage Batteries BB-46, connected in series by Cords CO-38, provide the 48-volt battery required for relay operation, talking battery, etc. Battery BB-46 is a 12-volt, 75 ampere-hour sealed type battery. The batteries are packed in four Cases CS-63 for transporting and when in use are mounted, two batteries per rack, on two Racks FM-31. One 45-volt dry-cell Battery BA-26 is required for the voltmeter test circuit of Cabinet BE-72, and twenty 1.5-volt dry-cell Batteries BA-23, connected in series, are required to furnish 30 volts for the test Cabinet BE-70-().

b. Rectifier RA-36-() (fig. 7). This rectifier is used to charge the 48-volt storage battery. It is a full-wave rectifier designed to mount on Rack FM-30 and to operate from a 105- to 125-volt, 60-cycle a-c power source. When used to charge a 48-volt (24-cell) battery, it can be adjusted to charge at a rate of 2-12 amperes. To insure that the charging



TL50968

Figure 9. Panel BD-90, rear view.

current does not cause noise in the telephone circuits, an external filter reactance, mounted on the rear of Rack FM-30, is connected in the + (positive) charging lead. For additional information, refer to TM 11-951 covering Rectifier RA-36.

c. Panel BD-90 (figs. 8 and 9). This panel serves as a control and connecting point for the 48-volt battery circuits, as a source of ringing power for the switchboard, and as an alarm panel. It is a steel-frame box structure with front and rear panels. The front panel is equipped with receptacles and binding posts for connection to the battery and rectifier and to the switchboard or other equipment requiring 48-volts direct current. Circuit breaker switches on the panel control the power supply to the switchboard or other equipment and, in addition, protect these circuits against overload. The lower part of the front panel is equipped with a telering (vibrator-type) power ringer to obtain 90-volt, 20-cycle ringing power from a 110-volt, 60-cycle supply. It is also equipped with a vibrating interrupter which has a ringing transformer to obtain ringing

power from the 48-volt storage battery. Equipment is mounted on the rear panel for the following circuits:

<i>Quantity</i>	<i>Circuit</i>
1	Contact protection circuit for the ringing interrupter.
1	Night alarm circuit (including the battery supply fuses for the line lamps on the switchboard).
1	No-voltage alarm circuit (ringing voltage alarm).
1	Fuse alarm circuit.
1	Voltage supply circuit for Cabinet BE-72 voltmeter test circuit.

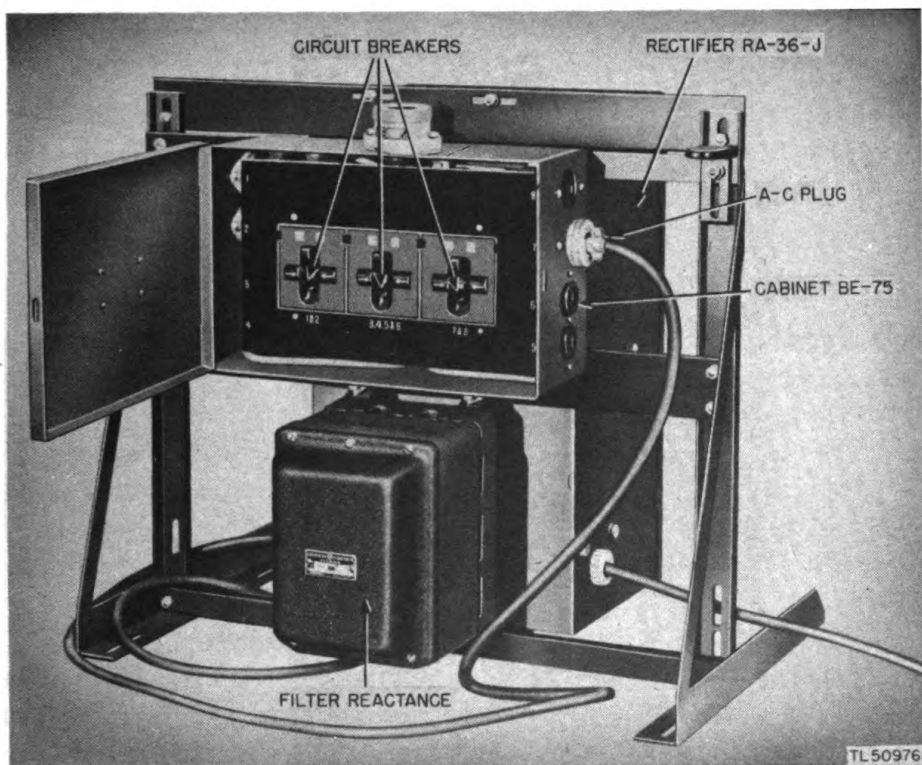


Figure 10. Cabinet BE-75, mounted on Rack FM-30.

d. Power Supply. Telephone Central Office Set TC-10 is designed to operate on a commercial source of 110- to 120-volt, 60-cycle alternating current. A 50-foot Cord CD-393 is provided to connect a 110-volt outlet to the a-c distribution Cabinet BE-75. When commercial power is not available, two Power Units PE-75-(), included with the set, can be used to furnish the power. Each of these units consists of a gasoline-engine coupled to an a-c generator. This generator will deliver 2,500 watts at 120 volts and 60 cycles. A 50-foot Cord CD-409 is provided to connect Power Unit PE-75-() to the a-c distribution Cabinet BE-75. For additional information on Power Unit PE-75-(), refer to TM 11-900 on this unit.

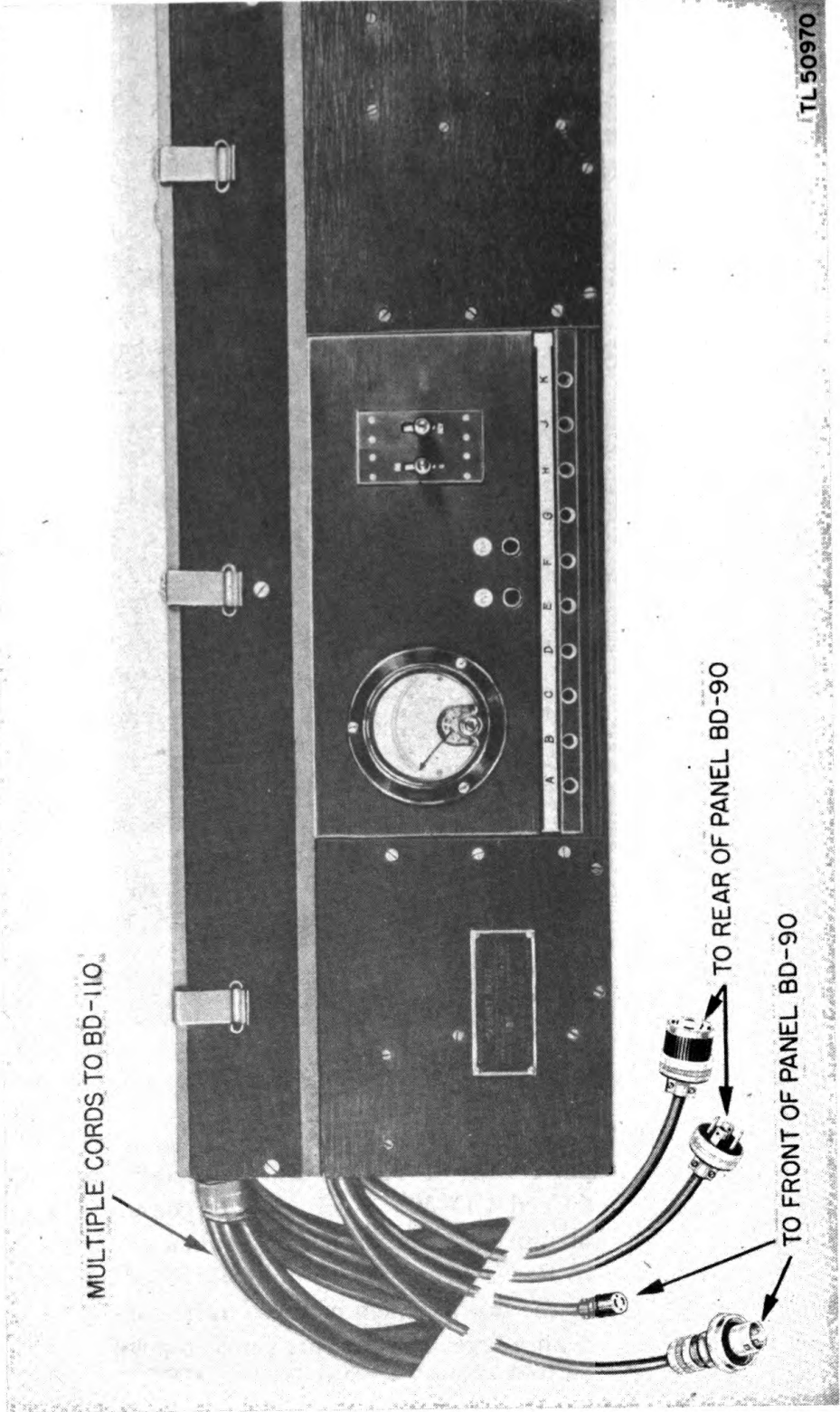


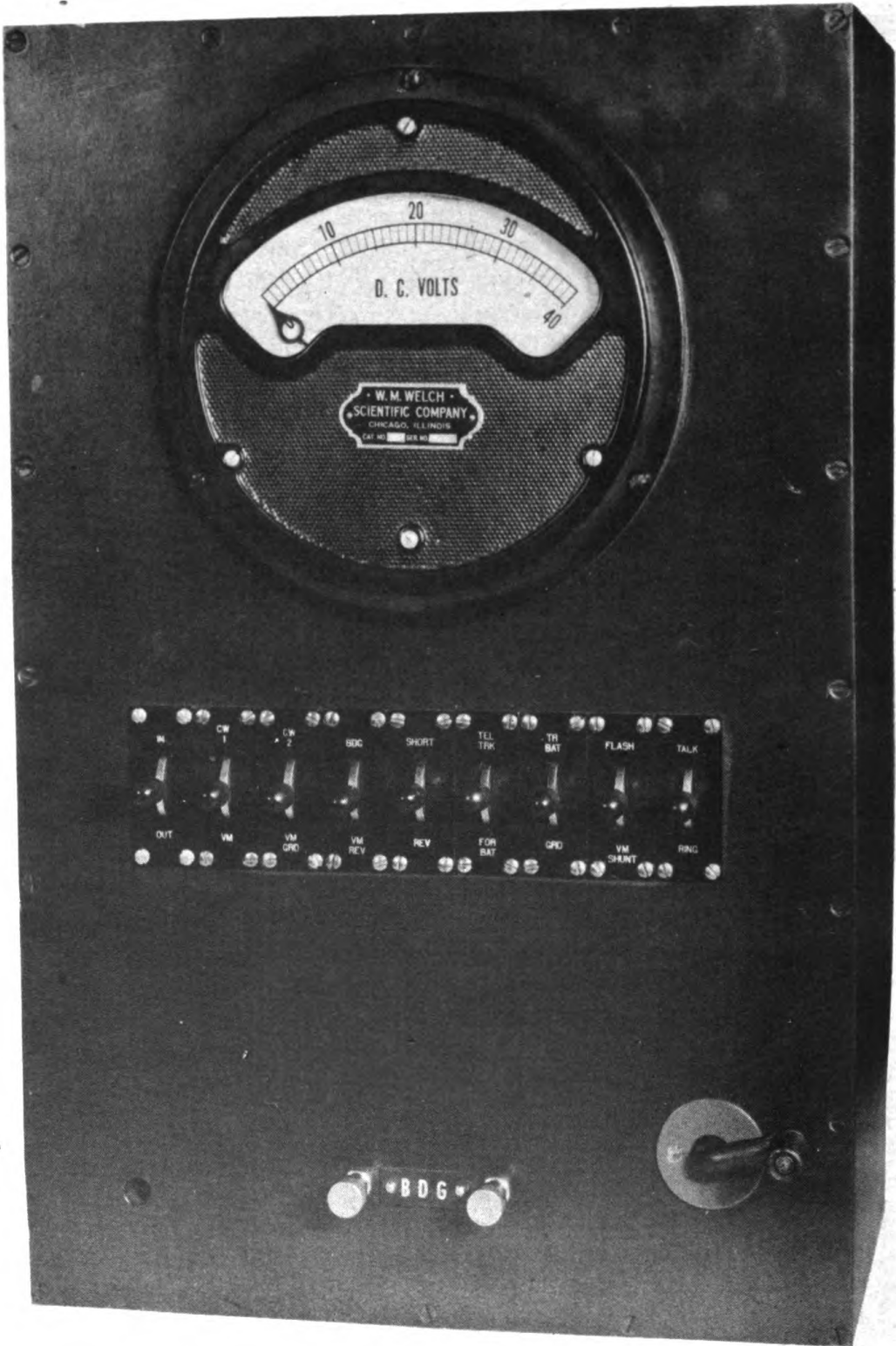
Figure 11. Cabinet BE-72, front view.

e. Cabinet BE-75. The a-c power connections to the telering, Rectifier RA-36-(), Switchboard BD-110-(), and other equipment are made through the a-c distribution Cabinet BE-75 (fig. 10). This cabinet is a small metal case with a hinged cover. The cabinet has one duplex and two twist-lock receptacles mounted on each end, and a two-pole plug receptacle mounted on top of the cabinet. Three circuit-breaker switches are mounted on the front panel inside the front cover. Each circuit-breaker switch is a double-pole type rated at 25 amperes. Numbers stamped beneath each switch indicate the receptacles controlled by that switch. In use, the cabinet is fastened to Frame FM-30, directly behind Rectifier RA-36-().

6. TEST AND POWER DISTRIBUTION EQUIPMENT.

a. Cabinet BE-72 (fig. 11). In use, Cabinet BE-72 is mounted on top of a centrally located Switchboard BD-110-(). In this position, it serves as a distribution point for the power and alarm leads and as a test panel for the cord circuits and line circuits of Switchboard BD-110-(). Four cables attached to Cabinet BE-72 are connected by plugs and receptacles to the power and alarm circuits at Panel BD-90. These cables are connected in Cabinet BE-72 to a series of binding posts located in the top of the cabinet. Spade terminal strips attached to cables from each Switchboard BD-110-(), when connected to these binding posts (fig. 18), extend the power and alarm leads to the switchboard, and interconnect the telephone circuit grouping leads between switchboards. On the face of the cabinet is mounted equipment associated with the switchboard test circuit and the voltmeter test circuit. The switchboard circuits may be given routine tests by using jacks A to J. These tests are covered in detail in paragraph 31. The equipment located above these jacks is associated with the voltmeter test circuit. The lines and trunks connected to Switchboard BD-110-() may be tested by using this circuit. An additional feature permits ringing the bells on a line having a receiver off the hook if the bells are connected between either side of the line and ground. These tests are covered in detail in paragraph 31.

b. Cabinet BE-70-() (fig. 12). The wire chief's Test Cabinet BE-70-() contains a 100,000-ohm, d-c voltmeter having a range of 0-40 volts with keys and connections which enable the testman to test for and locate practically all line faults. Provision is made for connecting a Wheatstone bridge to the line under test, for talking and ringing on the line under test, and for talking on call wires or trunks to operators, testmen, etc. In use, the cabinet is placed on top of packing Case CS-70, for ease of operation. For additional information, refer to TM 11-345 covering Cabinet BE-70-().



TL-50972

Figure 12. Test Cabinet BE-70-(), front view.

SECTION II

INSTALLATION AND OPERATION

7. GENERAL.

a. Telephone Central Office Set TC-10 may be installed any place under cover. In humid climate, choose as dry a location as possible. In dry desert country or where the ground is frozen to considerable depth, choose a location near a good source of ground if possible (par. **8h**). The equipment may be located as desired, with the following limitations:

(1) The maximum distance between Switchboard BD-110-() and Frame FM-19 is approximately 15 feet (limited by the lengths of cable Racks FM-34).

(2) The maximum distance between Frame FM-19 and Panel BD-90 is approximately 15 feet (limited by the lengths of cable Racks FM-36).

(3) The maximum distance between other items of equipment is limited by the lengths of the connecting cables. These lengths are shown on the cording diagram (fig. 13).

(4) The batteries and Power Units PE-75-() should be installed in an inclosure separate from the switchboard to keep the switchboard room reasonably quiet and free from battery fumes and exhaust fumes.

b. Figures 14 and 15 illustrate two arrangements of Telephone Central Office Set TC-10. Figure 14 shows a suggested floor plan where space is limited. Figure 15 illustrates a preferred arrangement using two rooms. Where a large room is available, the set may be arranged in a manner similar to the set-up in figure 1. The room shown is approximately 25 feet long. Space between the different components and between the equipment and the walls is essential to good maintenance.

c. When choosing a location for the switchboard, consider the switchboard operator. Best operator performance can be obtained in a well-ventilated room which is not brightly lighted. Bright light on the face of the switchboard makes the signal lights hard to see. Keep noise down so that the operator can easily hear.

8. SETTING UP EQUIPMENT.

a. Remove the equipment from cases and crates with extreme care. Save the permanent cases for future transportation. Use care at all times when handling the equipment.

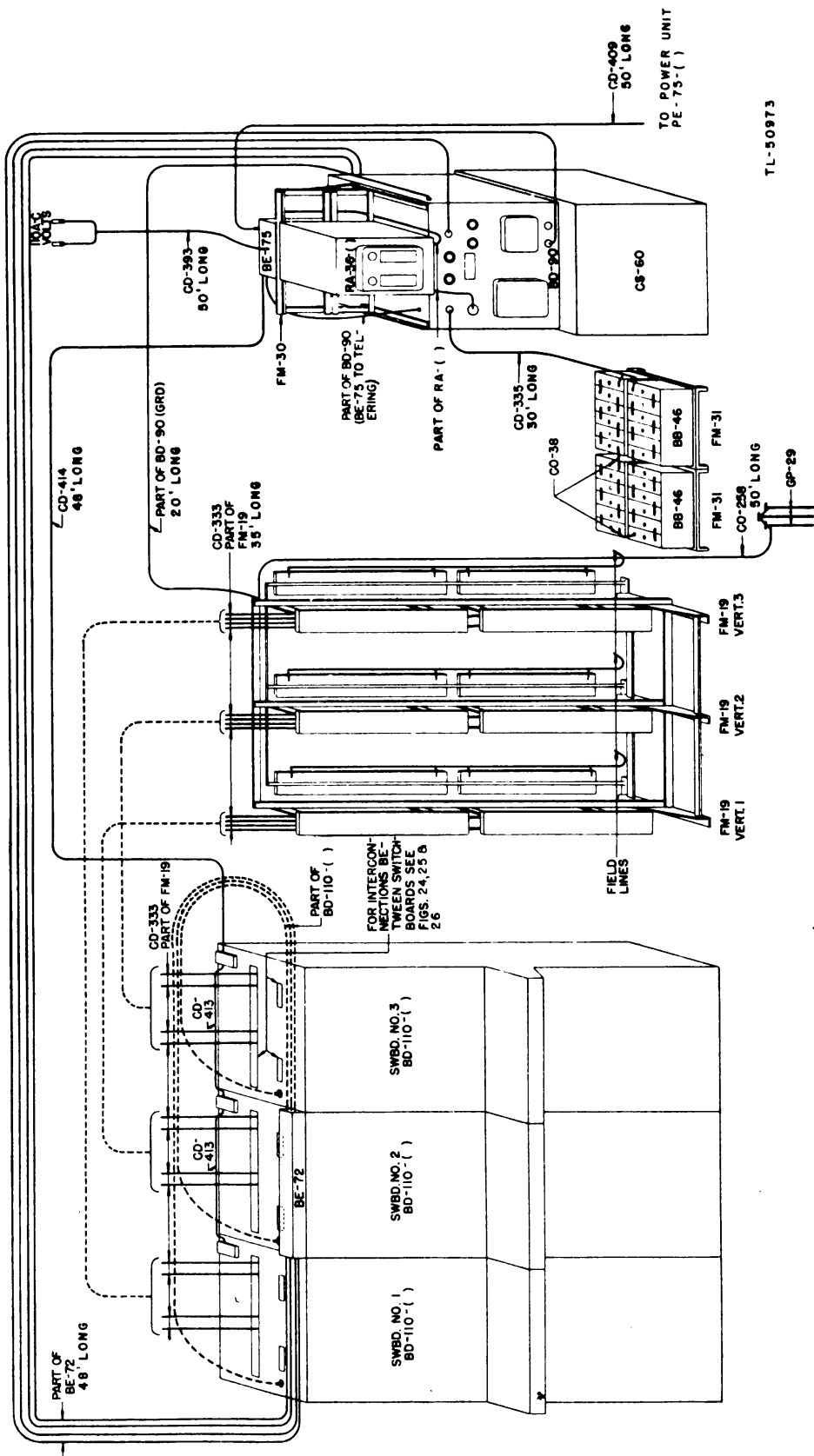


Figure 13. Cording diagram of Telephone Central Office Set TC-10.

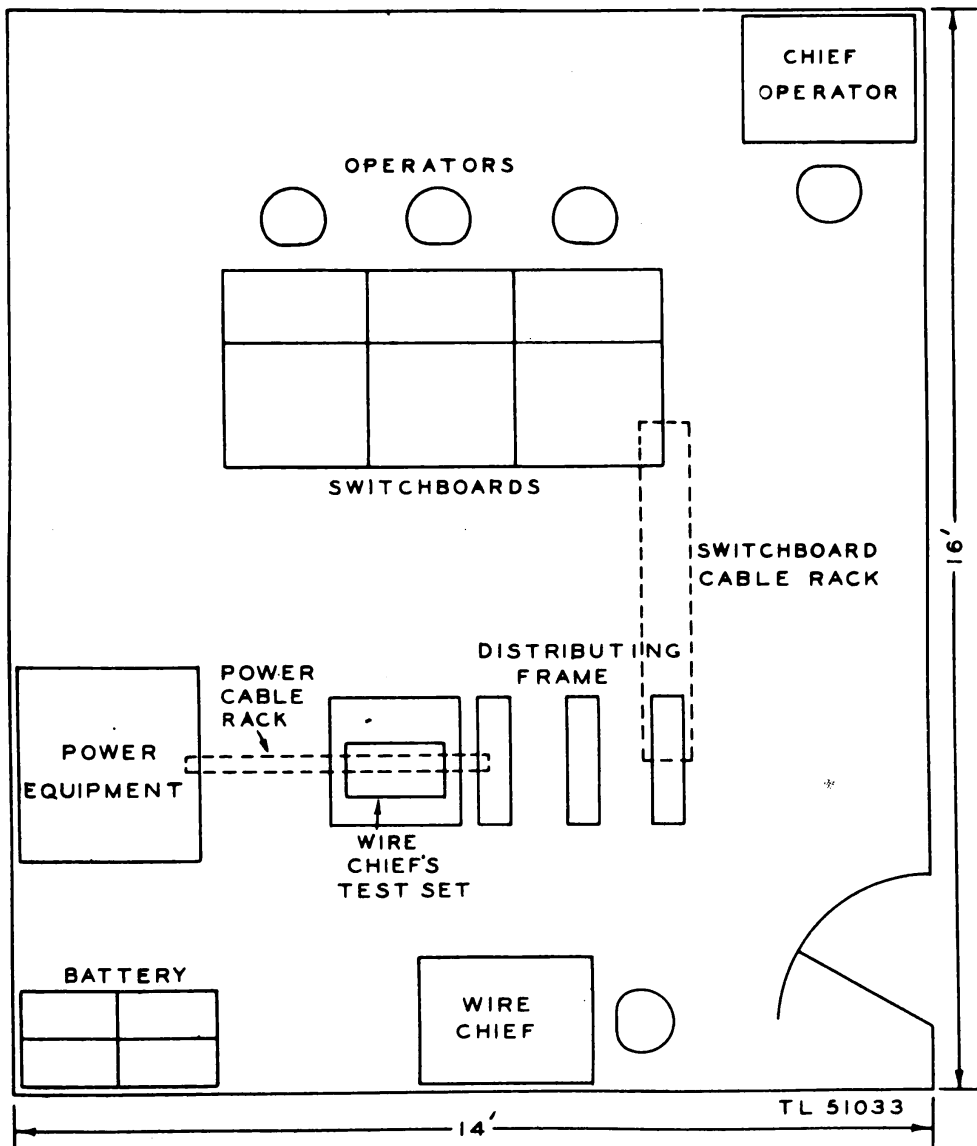


Figure 14. Suggested floor plan for Telephone Central Office Set TC-10 in one room.

b. Set the required number of switchboards in place. Remove the covers and unfasten the straps holding the switchboard cords. Replace the cover panel in front of the cords. Remove the drop guards and store them inside the keyshelf. Remove spare parts box from kneewell of switchboard and store for future use. Set up operator's head and chest set.

c. Erect the main distributing frame. Use as many Frames FM-19 as the number of Switchboards BD-110-() installed. Stand in place the Frame FM-19 which will be nearest the switchboard. Assemble the small parts and adjacent Frames FM-19 in the order shown by the numbers in figure 16. The piece which is installed as designated by figure 16 ② is identified by two small tapped holes in its top flange. If

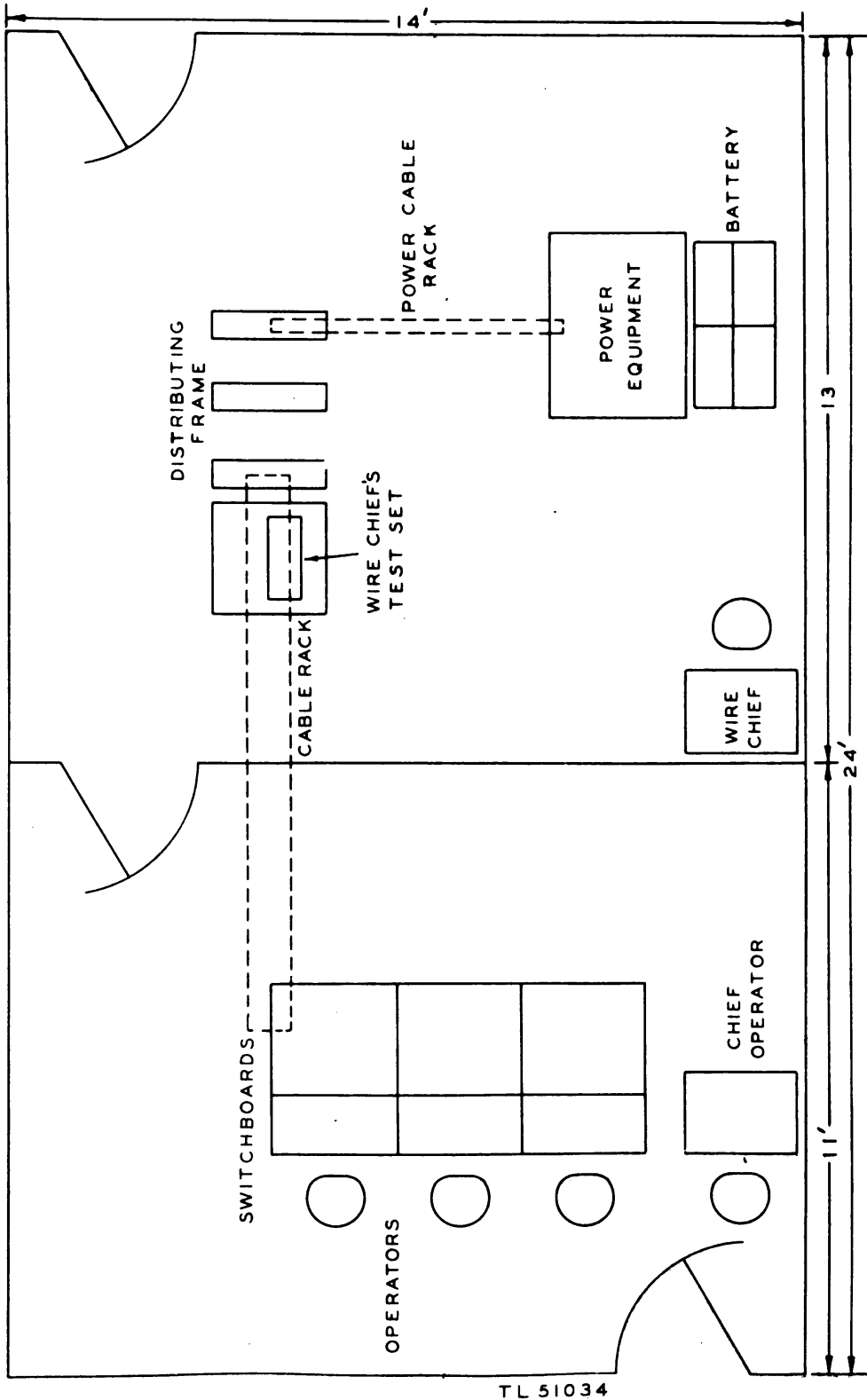
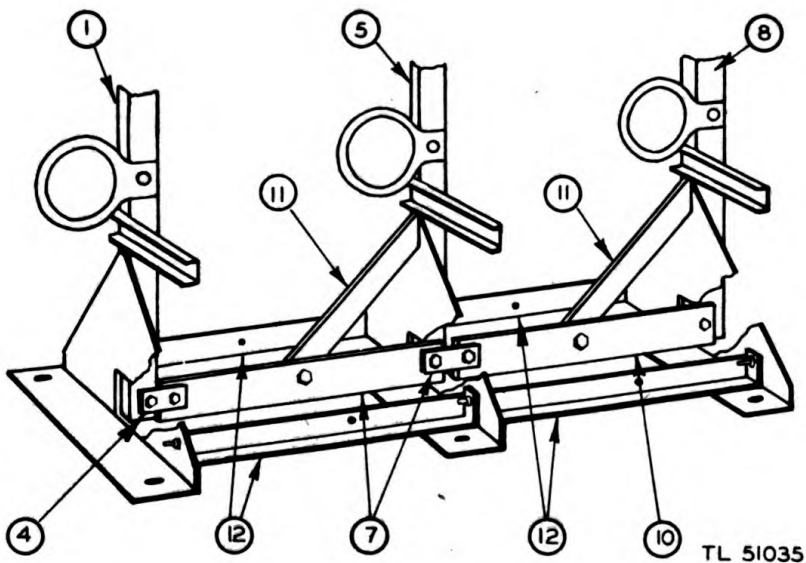
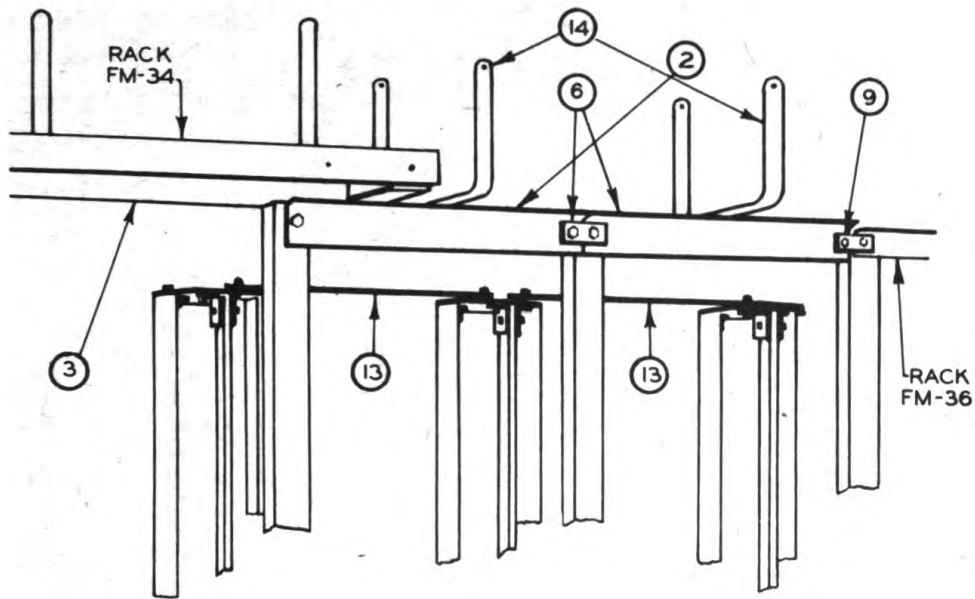


Figure 15. Suggested floor plan for Telephone Central Office Set TC-10 in two rooms.



TL 51035

Figure 16. Distributing frame, assembly diagram.

only one vertical is being used, install Rack FM-36 at the top of the vertical instead of the piece shown as ② in figure 16. Other parts shown to the right of vertical ① would not be used. Where feasible, bolt the frame to the floor.

d. Install Racks FM-34 and FM-35 as needed between Switchboard BD-110-() and main distributing Frame FM-19. Bolt the rack support to the top of Switchboard BD-110-() when required. This

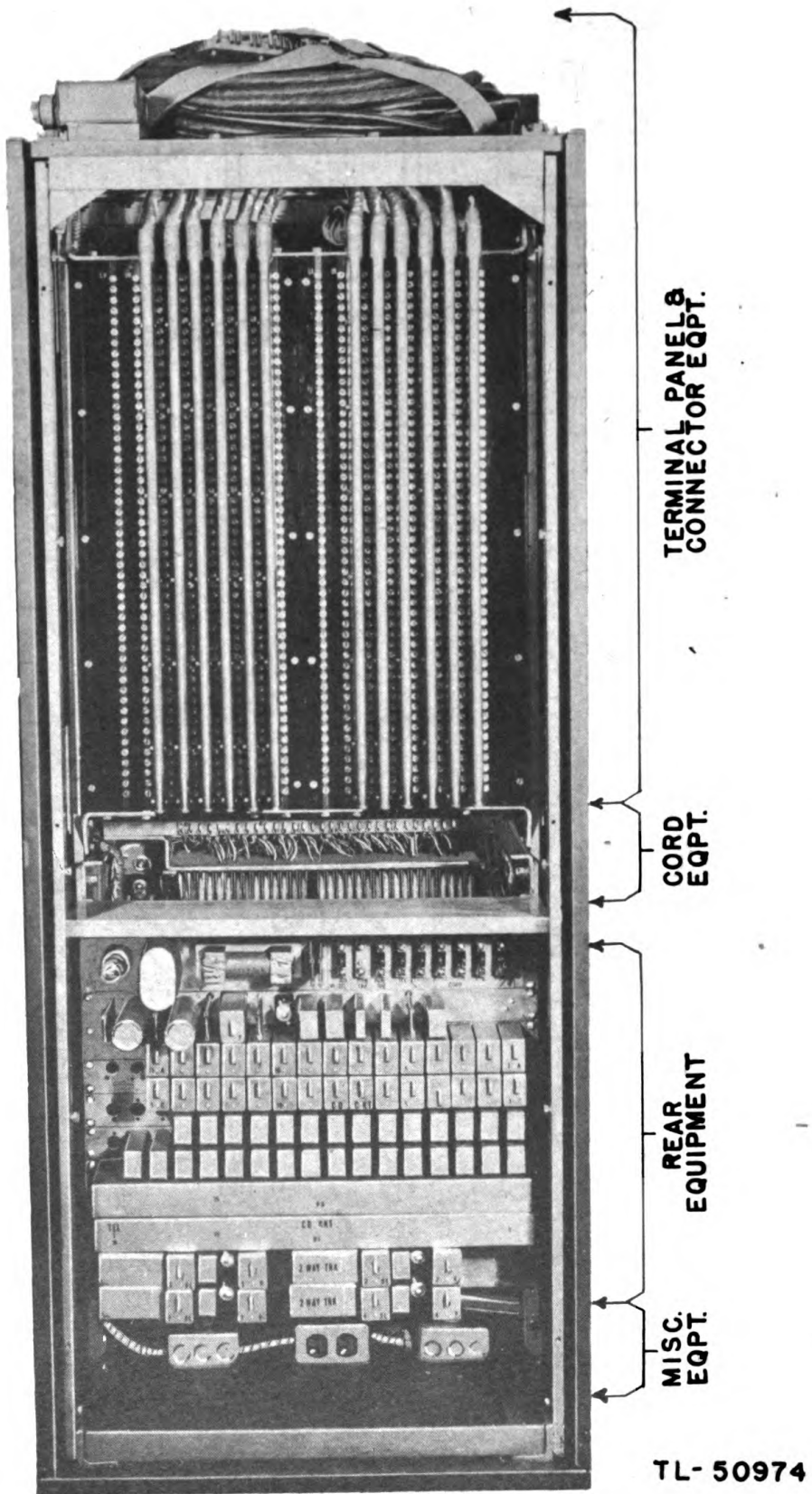


Figure 17. Switchboard BD-110-(), rear view.

support raises Rack FM-34 about 11 inches above the top of the switchboard and makes it level with the top of Frame FM-19.

e. Place Cabinet BE-72 on top of a centrally located Switchboard BD-110-() and bolt the angle irons to the frame of the switchboard.

f. Place the power supply equipment in the selected locations. Place Batteries BB-46 on Racks FM-31. Place Panel BD-90 on Case CS-60. Place Rack FM-30 equipped with Rectifier RA-36-() and Cabinet BE-75, on top of Panel BD-90.

g. Install Racks FM-36 and FM-37, as needed, between the main distributing frame and Rack FM-30.

h. If possible, locate a good ground source such as a water pipe or other buried metallic object of good conductivity having a large area of earth contact. If this is not possible, drive three Ground Rods GP-29 at a low damp spot. Place the ground rods at least 10 feet apart. Drive the rods deeply using light strokes to prevent the whipping of the rods from destroying the earth contact. Moisten the surrounding ground with salt water if additional conductivity is needed.

i. Set Cabinet BE-70-() on top of packing Case CS-70.

9. CONNECTING EQUIPMENT. All connections between units of equipment, except the connections to Cabinet BE-70, are shown on the cording diagram (fig. 13), and are covered in the following subparagraphs. Before making any connections be sure the switches on Panel BD-90, Rectifier RA-36-(), and Cabinet BE-75 are in the OFF position.

a. Disconnect and remove the spade terminal strips stored during transportation on the terminal panels of Switchboards BD-110-() (fig. 17). Terminal strips which are to be connected back into the same boards need not be removed. Table II indicates these terminal strips. Tighten and loosen binding posts with a screwdriver.

b. Four flexible Cords CD-333 are attached to each Frame FM-19 (fig. 6). Connect the spade terminal strips of these cords to the corresponding rows of binding posts of the proper Switchboard BD-110-(). Table II indicates the proper switchboard.

c. Connect the multiple cables between Switchboards BD-110-() by connecting the spade terminal strips (attached to each switchboard) to the terminal panel of the same or another switchboard as covered by table II. When this scheme is followed a spade terminal always connects to a row of binding posts having the same number.

EXAMPLE: To determine connections for multiple cable spade terminal strip No. 7 of switchboard No. 1 when two switchboards are being installed, proceed as follows: Find the switch-

board number in column (1) of table II. In the group of terminal strip numbers (in column (2)) opposite the switchboard No. 1, find 7. Under the heading "Size of installation," in column (3), find column 2. In this column, find switchboard No. 2 in line with the 7 already selected. This means that switchboard No. 1 is connected through spade terminal 7 to the terminal panel of switchboard No. 2. By the same procedure, when four switchboards are installed (column (3)), spade terminal strip No. 9 (column (2)) from switchboard No. 3 (column (1)) is connected to switchboard No. 1.

d. Connect the power distributing (small) terminal strips, which are a part of Switchboards BD-110-(), to the proper row of binding posts of Cabinet BE-72 as indicated in table III. (See fig. 18).

e. Connect the cables which are a part of Cabinet BE-72 to the receptacles of Panel BD-90. Two of the cables connect to SWBD BAT CA and TELER outlets. The other two connect to the alarm receptacles on the rear of the panel (fig. 9).

f. Connect Cord CD-413 between the outlets on the top of adjacent switchboards. Connect Cord CD-414 from the outlet on an end switchboard to Cabinet BE-75.

g. Connect the four storage Batteries BB-46 in series, using Cords CO-38, to form a 48-volt group. Connect the battery to the BAT CABLE outlet of Panel BD-90 using Cord CD-335.

CAUTION: *Poor connections at the battery, liable to arcing, are a fire hazard.*

h. Connect the a-c cord of Rectifier RA-36-() to an outlet of Cabinet BE-75. Connect the other cord to the BAT CHG receptacle of Panel BD-90. *If the rectifier and the external filter reactance were not previously connected on Frame FM-30, it will be necessary, in addition to the above connections, to splice one wire of the filter reactance to the positive (+) output lead of the rectifier and the other wire to the positive (white) wire of the cord which goes to Panel BD-90.*

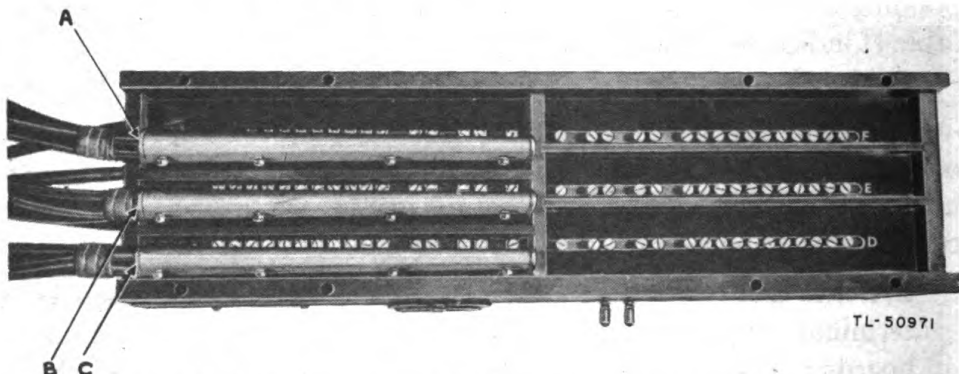


Figure 18. Cabinet BE-72, showing method of connecting spade terminals to binding posts.

TABLE II
MULTIPLE CONNECTIONS FOR SWITCHBOARDS
BD-110-() AND FRAMES FM-19

(1) Switch-board No.	(2) Multiple cable spade terminal strip No.	(3) Size of installation (Quantity of switchboards installed)					
		1	2	3	4	5	6
		Numbers below are switchboard Nos.					
1	1, 2, 3	1	2	2	3	3	3
	4, 5, 6	1	1	2	1	3	3
	7, 8, 9	1	2	2	3	3	3
	10, 11, 12	1	1	2	1	3	3
2	1, 2, 3		1	3	4	4	4
	4, 5, 6		2	3	2	2	4
	7, 8, 9		1	3	4	4	4
	10, 11, 12		2	3	2	2	4
3	1, 2, 3			1	1	5	5
	4, 5, 6			1	3	5	5
	7, 8, 9			1	1	5	5
	10, 11, 12			1	3	5	5
4	1, 2, 3				2	2	6
	4, 5, 6				4	4	6
	7, 8, 9				2	2	6
	10, 11, 12				4	4	6
5	1, 2, 3					1	1
	4, 5, 6					1	1
	7, 8, 9					1	1
	10, 11, 12					1	1
6	1, 2, 3						2
	4, 5, 6						2
	7, 8, 9						2
	10, 11, 12						2
Frames FM-19 vertical No.	Cord CD-333 spade terminal strip designation	Size of installation (Quantity of switchboards installed)					
		1	2	3	4	5	6
		Numbers below are switchboard Nos.					
1	UL, UR, LL, LR	1	2	2	3	3	3
2	UL, UR, LL, LR		1	3	4	4	4
3	UL, UR, LL, LR			1	1	5	5
4	UL, UR, LL, LR				2	2	6
5	UL, UR, LL, LR					1	1
6	UL, UR, LL, LR						2

TABLE III
CONNECTIONS BETWEEN SWITCHBOARDS
AND CABINET BE-72

<i>Cables from switchboard No.</i>	<i>Connect to binding post row</i>	<i>Operator's circuit can be transferred to switchboard No.</i>
<i>For an office using other than four switchboards—</i>		
1	A	2
2	B	1
3	C	2
4	D	5
5	E	4
6	F	5
<i>For an office using four switchboards—</i>		
1	A	2
2	B	1
3	D	4
4	E	3

i. Plug the cable from the telering ringer on Panel BD-90 into an outlet on Cabinet BE-75.

j. Connect the ground wire attached to Panel BD-90 to the frame ground stud near the top of one Frame FM-19. Connect ground Cord CO-258 between this stud and Ground Rods GP-29 or another source of ground.

k. Connect Cord CD-393 between Cabinet BE-75 and the 110- to 120-volt, 60-cycle a-c power supply. Check the voltage and frequency of the power source before connecting it to commercial power. When a commercial source of power is not available, connect Cord CD-409 from Power Unit PE-75-() to Cabinet BE-75.

l. Insert fuses in the fuse blocks on the relay panel at the rear of Switchboards BD-110-() and the rear of Panel BD-90.

m. Connect the line wires to binding posts on the line side of the main distributing frame. These binding posts are on the left-hand panel as the operator faces the line side of the frame (fig. 5). Connect the jumper wires from the right-hand panel to the binding posts on the switchboard side of the frame.

n. Prepare and insert designation strips above the jacks. With multiple connections made according to table II, the designation strips may be prepared by replacing the alphabetical designations shown on figure 20 with numbers, in accordance with table IV. For example, jack A20 in figure 20 will become 020, and jack D10 will become 110.

TABLE IV
JACK DESIGNATIONS

No. of switchboards installed	Switchboard No.	CHANGE THE ALPHABETICAL DESIGNATIONS A TO F SHOWN ON FIGURE 20 TO NUMBERS AS FOLLOWS:					
		A	B	C	D	E	F
1	1	0	0	0	1	1	1
2	1	0	2	2	1	3	3
	2	2	0	0	3	1	1
3	1	0	2	4	1	3	5
	2	2	4	0	3	5	1
	3	4	0	2	5	1	3
4	1	0	4	4	1	5	5
	2	2	6	6	3	7	7
	3	4	0	0	5	1	1
	4	6	2	2	7	3	3
5	1	0	4	8	1	5	9
	2	2	6	6	3	7	7
	3	4	8	0	5	9	1
	4	6	2	2	7	3	3
	5	8	0	4	9	1	5
6	1	0	4	8	1	5	9
	2	2	6	10	3	7	11
	3	4	8	0	5	9	1
	4	6	10	2	7	11	3
	5	8	0	4	9	1	5
	6	10	2	6	11	3	7

o. Connect Battery BA-26 to the binding posts on the rear panel of Panel BD-90. This furnishes battery for the voltmeter test circuit of Cabinet BE-72.

p. Make the connections to Cabinet BE-70-() as covered in TM 11-345.

q. Connect the operator's telephone sets to the proper jacks in the front of the keyshelf as required (fig. 2).

r. Mark the switchboard side of Frames FM-19 to show the line numbers. This can be done by attaching a tag at the top of each terminal strip showing the number of the upper line, and another tag at the bottom of each strip showing the number of the lower line. These strips are designated UL, LL, UR, and LR on each frame to indicate the upper-

left, lower-left, upper-right, and lower-right terminals as viewed from the switchboard side of the frame. These designations are also marked on each cable immediately above the terminal strip. These strips should be designated as shown in table V. The markings for a three-position installation are shown in figure 25. The line side of the main frame should be marked to identify the connected field wires or cables.

TABLE V
MAIN FRAME DESIGNATIONS

<i>Frames FM-19 vertical No.</i>	<i>Lines appearing on terminal strip</i>			
	<i>UL</i>	<i>LL</i>	<i>UR</i>	<i>LR</i>
1	00-24	25-49	100-124	125-149
2	200-224	225-249	300-324	325-349
3	400-424	425-449	500-524	525-549
4	600-624	625-649	700-724	725-749
5	800-824	825-849	900-924	925-949
6	1000-1024	1025-1049	1100-1124	1125-1149

10. PREPARATION FOR USE.

a. Operate the MAIN circuit breaker switch of Panel BD-90 to the ON position. The voltmeter must read approximately 50 volts. A reading much different than this indicates wrong battery connections and must be corrected before proceeding.

b. Operate the switch of Cabinet BE-75 to connect power to Rectifier RA-36-(). Set the rectifier coarse adjustment plugs to holes No. 8. Make sure that neither fine adjustment (lower) plug is inserted, and operate the switch on the rectifier to the ON position. If both bulbs light, insert the fine adjustment plugs into the holes marked LOW. The ammeter on Panel BD-90 should show a small current in the charge direction. Operation of the rectifier is explained in TM 11-951.

c. Operate the G key on the rear of Panel BD-90 to the TEL position. The no-voltage alarm buzzer will sound. Operate the switch of Cabinet BE-75 which controls the telering ringer. The alarm buzzer should stop, indicating proper operation of the telering.

d. Check the fuse alarm circuit by temporarily connecting the alarm stud of a fuse block to the battery. The fuse alarm buzzer should sound. Test fuse blocks on the rear of Panel BD-90 and of Switchboard BD-110-().

e. When possible, test the cord, line, and trunk circuits as explained in paragraph 31.

11. OPERATION OF POWER EQUIPMENT.

a. Charging Batteries. To charge storage Batteries BB-46, operate charging Rectifier RA-36-() in accordance with TM 11-951. Refer to paragraph 34 and TM 11-430 for the proper charging rate for the various types of storage batteries and for other information concerning their care and use.

b. Changing Ringing Generators. (1) Due to the failure of the 110-volt, 60-cycle power supply, or for maintenance, or for other reasons, it may be necessary to use the battery-driven ringing interrupter on Panel BD-90 to furnish ringing power. To do this, proceed as follows:

(a) Operate the a-c line key, near the upper right-hand corner of the ringing interrupter, to the OFF position (fig. 8). This opens the a-c line, avoids operating the circuit breaker, and avoids possible damage to the interrupter contacts.

(b) Operate the circuit breaker switch INT on Panel BD-90 to the ON position. The interrupter armature should vibrate.

(c) Turn the a-c line key back to the ON position.

(d) Turn the no-voltage alarm key G on the rear lower subpanel, to the INT position (fig. 9). Lighting of the lamp E and operation of the buzzer C indicates failure of the interrupter to deliver ringing power.

(e) Remove the plug from receptacle TELER on the front panel of Panel BD-90, and insert it in the INT receptacle.

(f) Turn the proper switch of Cabinet BE-75 to the OFF position disconnecting the telering.

(2) To transfer the ringing circuits back to the telering, start the telering as in paragraph 10c and transfer the plug from INT to the TELER receptacle. Turn the INT circuit breaker switch to the OFF position.

c. Operation of Power Unit PE-75-(). Refer to TM 11-900 for information on the operation of this engine-driven power unit.

d. Power Supply. (1) Operation of the MAIN circuit breaker switch of Panel BD-90 supplies 48-volt, d-c power to the switchboard and alarm circuits. With the MAIN circuit breaker operated, operate circuit breaker switches A&B and C to supply 48-volt, d-c power to the A, B, and C receptacles and binding posts on Panel BD-90.

(2) To supply 110-volt, a-c power to the switchboards for lights, heaters, soldering iron, etc., operate the switch on Cabinet BE-75 corresponding to the outlet to which Cord CD-414 is connected.

12. SWITCHBOARD OPERATION. The keys, cords, jacks, etc., referred to below can be located on figures 20 and 21.

a. Calls between Common Battery Lines. The general procedure of answering and completing a call can be summarized by describing

in detail the handling of a call from one common battery line to another. When the receiver is lifted on a common battery line, a lamp lights on the face of the board. Answer the call by inserting the plug of any answering (rear) cord into the answering jack of the line. The lamp will be extinguished. Operate the associated talk-ring key to the TALK position (toward the switchboard) and talk to the calling party. To complete the call, as requested by the calling party, pick up the associated calling (front) cord. Test the called line to see if it is busy by touching the tip of the calling plug to the jack sleeve of the line to be called (fig. 19). If there is a click in the operator's receiver when this test is made, the line is busy on one of the other positions. If no click is received, insert the plug of the calling cord in the jack of the called line. The calling supervisory lamp (subpar. **d** below) in the keyshelf (fig. 21) will light. Operate the talk-ring key to the RING position to ring the called party. When the called party answers, the calling supervisory lamp will go out. When the receivers are returned to the hooks by the two parties, both the called and the calling supervisory lamps will light. Then disconnect both cords, restoring equipment to normal. Calls to and from trunks and magneto lines are handled in the same manner. Differences in supervision, etc. are explained in the following paragraphs.

b. Answering Calls. (1) An incoming call on a magneto line is indicated by the operation of a drop signal on the face of the board. Insert an answering plug in the jack directly beneath the drop signal and operate the associated talk-ring key to the TALK position. Push the drop shutter back to its unoperated position.

(2) An incoming call on a universal trunk is indicated by a lighted lamp. Insert the answering plug in the associated L (line) jack and operate the talk-ring key to the TALK position.

c. Outgoing Calls. (1) A call to a magneto line is handled the same as a call to a common battery line. The cord supervisory lamp will not light when the calling cord is connected. Cord supervision on magneto lines is explained in subparagraph **d** below.

(2) On a call over a universal trunk to a manual common battery exchange, it is not necessary to ring on the trunk. Insert the calling cord in the L jack of the trunk and operate the talk-ring key to TALK. The distant operator will answer and required information can be passed.

(3) On a call over a trunk to a dial exchange, insert the calling cord in the L jack and leave talk-ring key in the TALK position. When the dial tone is heard, insert the dial cord in the associated D (dial) jack and dial the required number. Remove the dial cord and listen for the busy or ringing tone.

d. Supervision. The cord supervision on common battery lines is indicated by the answering lamps and calling lamps on the keyshelf (fig. 21). A lighted answering lamp indicates that the calling party

connected to the answering cord has hung up. A lighted calling lamp indicates that the called party connected to the calling cord has not answered or has hung up after the conversation. Do not take down the cords used in establishing a connection until both lamps are lighted. If only one lamp is lighted, challenge the connection. To assist in disconnecting the right cords, the lamp caps of each pair are the same color as the associated cords.

(2) No supervision is received on cords connected to universal trunks. The operator may disconnect cords on calls to or from these trunks when only one supervisory lamp is lighted.

(3) Supervision on magneto lines is provided by recall lamps located on the face of the switchboard directly above the associated plugs. Ringing in on a magneto line connected to either the answering or calling cords will cause the recall lamp to light. This lamp will light or flicker only while the station is ringing and will not remain lighted. These lamps should be given close attention when magneto lines are connected. To determine whether this signal is for ring off or recall, challenge the connection.

e. Monitoring. To listen in on a connection without interfering with those using the line, operate the monitoring MR key and then operate the proper talk-ring key to the TALK position.

f. Ringing on Party Lines. Two stations connected to one line may be signalled independently if the bell of one is connected between the ring side of the line (par. 13b below) and ground, and the bell of the other is connected between the tip side of the line and ground. Signal the ring station in the usual manner. Signal the tip station with the master ringing MR key operated.

g. Conference Calls. The conference circuit, consisting of ten jacks (fig. 20), is used to connect a number of lines together as follows:

(1) With an answering plug in the jack of the party originating the conference, insert the associated calling plug in a conference circuit jack.

(2) Complete the conference circuit by inserting answering plugs in other jacks of the conference circuit, and using the associated calling cords to call the desired parties.

h. Emergency Ringing. If ringing power fails, the hand generator on each Switchboard BD-110-() can be used as an emergency source of ringing power. To use this, operate the emergency ringing EMG key on the face of the switchboard to the HAND position. Crank the hand generator while the cord circuit ringing key is operated.

i. Position Grouping. The cord circuits of an unattended switchboard may be operated from an adjacent switchboard by operating the grouping GR key of the unattended switchboard. The possible grouping combinations are listed in table III. The cords of the unattended position

are operated the same as the cords of the position with which it is grouped except when ringing with the hand generator. The hand generator of the unattended position must be used with cords of that position.

J. Night Alarm. To connect the night alarm bell to ring on incoming calls, operate the night alarm NA key on the rear of Panel BD-90 to the ON position. For calls on trunks and common battery lines, after each operation of the night alarm bell, operate the night alarm release RLS key provided on the keyshelf of each Switchboard BD-110-(). This silences the alarm and prepares the circuit for the next signal. Make sure that no unanswered calls remain on the board.

k. Auxiliary Operator's Circuit. An auxiliary operator's telephone circuit enables an auxiliary operator to handle other than routine calls during heavy traffic, thus relieving the pressure on the regular operator. To use this circuit, connect a field telephone (set to local battery) to the TEL jack using cord 125^a (fig. 40). Operate the circuit as follows:

(1) Answer a call by connecting an answering cord to the calling line and the associated calling cord to the LINE jack of this circuit. The call can be completed by moving the calling cord from the LINE jack to a jack of the called line or trunk and completing the call in the usual manner. The regular operator must supervise the connection.

(2) A call from a trunk or magneto line circuit can be answered by connecting from the LINE jack to the jack of the trunk or line with a 3-wire patching cord (3-conductor cord with a plug on each end). A cord circuit must be used to complete these calls.

(3) Calls can be placed by connecting an answering cord to the LINE jack and completing the call in the usual manner with the associated calling cord. Calls to trunks and magneto lines can be placed with a 3-wire patching cord. To ring magneto lines through the patching cord, use the generator in the field telephone set.

(4) Make a busy test before connecting to any called line. Use a patching cord connected to the LINE jack. Have the busy test BT key operated to CB when testing common battery lines and to MAG when testing trunks or magneto lines. With the key operated, touch the tip of the patching cord to the jack sleeve of the line or trunk to be tested. A click in the receiver of the field telephone set indicates a busy line. Release the BT key after testing for busy.

l. Switchboard Heaters. Where a high humidity condition is liable to cause cross talk or corrosion troubles, the two heater resistors furnished with each Switchboard BD-110-() should be screwed into the sockets in the bottom of the switchboard. Operate the switch in Cabinet BE-75 to energize these sockets.

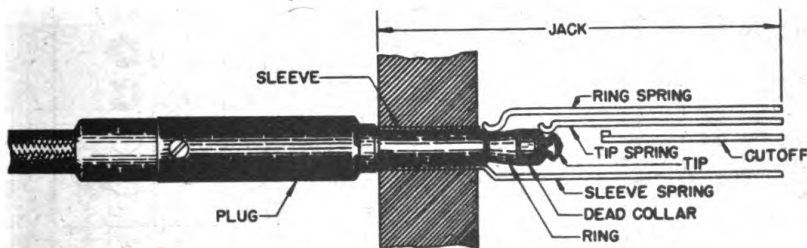
^a Reference numbers refer to numbers on the illustrations and in Table VI.

SECTION III

FUNCTIONING OF PARTS

13. GENERAL.

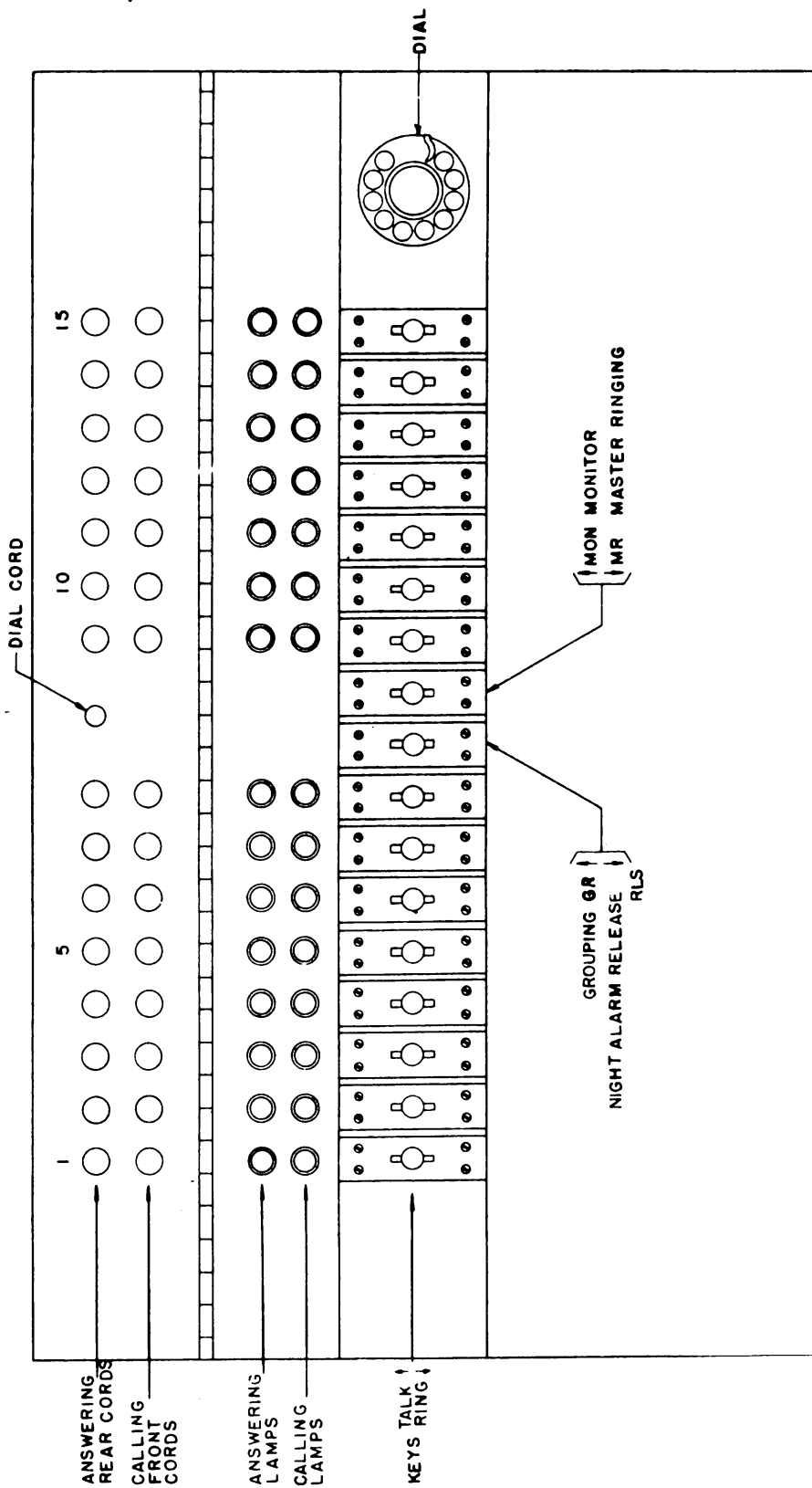
a. The operation of circuits used with Telephone Central Office Set TC-10 is explained in the following paragraphs. The relays, capacitors, etc., used in these circuits can be identified by the functional designation associated with each. These designations are shown in parentheses on the schematic diagrams and are stamped on or adjacent to the apparatus. The numbers in bold-face lettering, near each apparatus symbol, appear in the reference symbol column of table VI where a description of the part and its function is given. Relay springs are conventionally numbered from left to right facing the front (apparatus side) of the relay. Exceptions in this set are the (A) and (C) relays of the cord circuit where the center contact (armature) is designated A; and the (AU) relay of the night alarm circuit where the contacts from left to right are designated 2, 5 (armature), and 3 on the schematic drawings. Unnumbered terminals can be located by referring to the wiring diagram (par. 33). Circuits consisting only of plugs, receptacles, binding posts, or terminal strips with connecting wires are utilized only to extend circuits from one piece of equipment to another and are not discussed in this section.



TL-50977

Figure 19. Three-conductor plug and jack.

b. In subsequent discussions and in manufacturers' drawings furnished with Telephone Central Office Set TC-10, frequent reference is made to the terms *tip*, *ring*, and *sleeve*. A brief explanation of these may be helpful. This method of designating the three conductions (two line



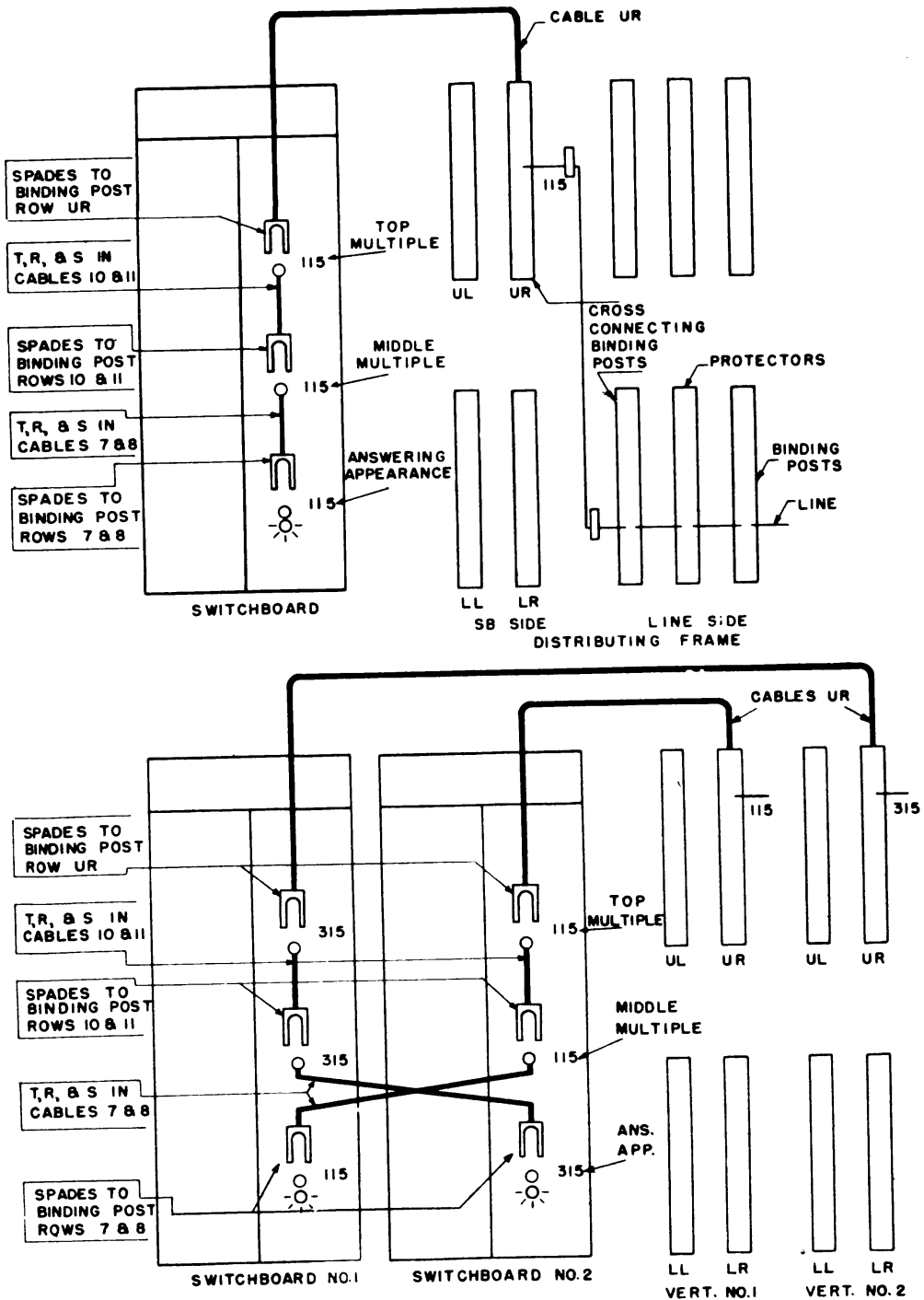
TL-50979

Figure 21. Switchboard BD-110-(), keyshelf equipment.

wires, and one control wire) is derived from the plug used on a manual switchboard. One cord conductor is connected to the *tip* of the plug, a second conductor is connected to the *ring* of the plug, and the third conductor (control wire) is connected to the *sleeve* of the plug. This method of distinguishing between the various cord conductors is applied to the line circuit. The tip of the plug makes contact with the short spring of the jack (fig. 19). This jack spring is designated as the tip-spring and the side of the line connected to the tip-spring is designated as the tip side of the line, or tip-conductor. The ring of the plug makes contact with a longer jack-spring. The longer jack-spring is designated as the ring-spring and the side of the line connected to the ring-spring is known as the ring side of the line or ring-conductor. The sleeve of the plug makes contact with the sleeve of the jack. The control wire connected to the sleeve of the jack is designated as the sleeve wire, and is used only to assist in controlling the supervisory relays in the cord circuit.

c. The circuit diagrams, figures 33, 34, 35, 36, and 43 for cord, line, trunk, and night alarm circuits list limits, called *working limits*, which are based on the length and condition of lines connected to the switchboard to insure the proper operation of the switchboard circuits. The *maximum external circuit loop* is the value of loop resistance of line wires and connected equipment which should not be exceeded if the connected switchboard circuit is to function properly. For example, the maximum external circuit loop of the common battery line circuit (fig. 33) is 600 ohms. The resistance of the common battery holding coil in Telephone EE-8-A is 100 ohms. Therefore, the maximum resistance of the line connecting the telephone to Switchboard BD-110-() should not exceed 500 ohms. The maximum external common battery circuit loop for the universal cord circuit (fig. 36) is 1,000 ohms. In an emergency, the cord circuit can be used on some external circuit loops which are too long to allow proper lighting of the line circuit signal lamps. The *minimum insulation resistance* is the minimum allowable resistance between either line wire and ground with the other wire grounded. On the night alarm circuit (fig. 43) the *minimum combined line insulation resistance* is the minimum resistance allowed across the (AU) relay. This resistance is the parallel combination of the line-to-ground resistances of all connected lines.

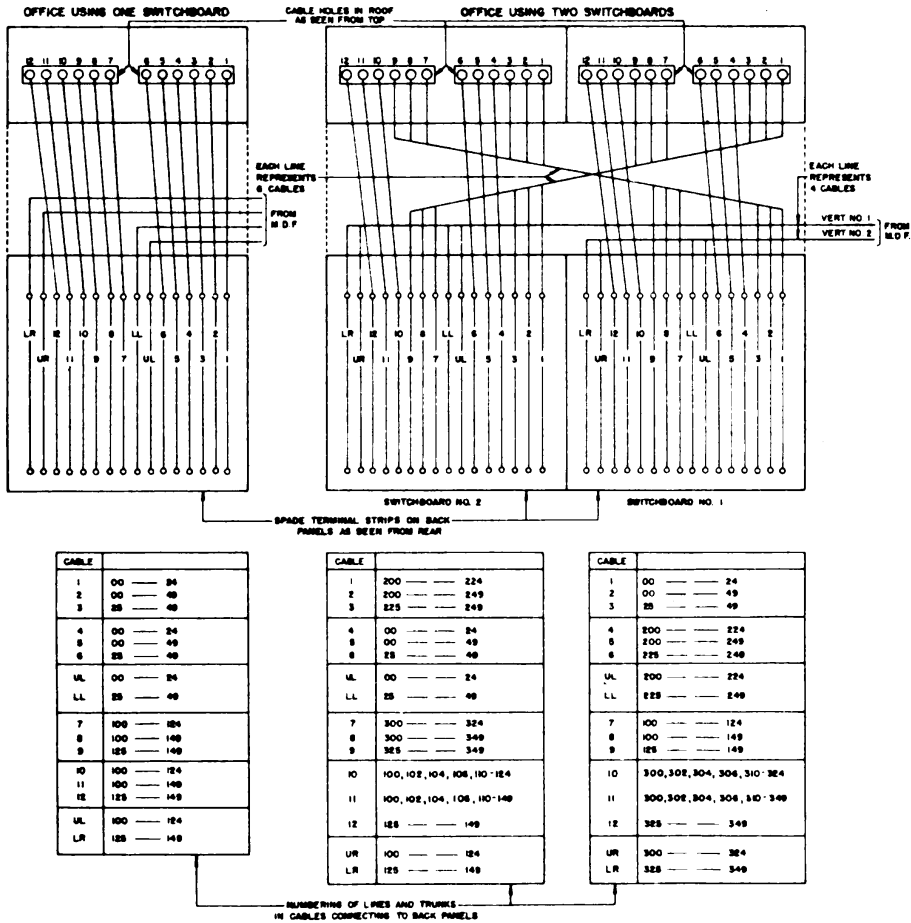
d. In installations of Telephone Central Office Set TC-10, using three switchboards or less, the interconnection of the lines and trunks between the switchboards is such that all lines and trunks coming into the central office are connected to a jack on each switchboard. The function of this arrangement is to enable either operator to answer a share of the incoming calls and complete them on any line or trunk connected into the central office. The jacks at which cord connections can be made to a



TL 50980

Figure 22. Multiple scheme, one- and two-position installations, Switchboard BD-110-().

line or trunk are called appearances. The lower jacks on the switchboard face have associated signal lamps and are the answering appearances (fig. 20). There are two other appearances to provide for interconnection between the switchboards. These are called multiple appearances. For convenience in referring to the multiple appearances, they are designated middle and top multiples because of their position on the switchboard face. The general multiple scheme is illustrated in figures 22 and 23. For example follow line number 115. In the one-switchboard set-up, all appearances are connected together. In the two-switchboard set-up, line 115 appears in the top and middle multiples on switchboard No. 2 but crosses over to switchboard No. 1 to its answering appearance. In the three-switchboard set-up, line 115 appears in the top multiple on switchboard No. 2, in the middle multiple on switchboard No. 3, and in the answering appearance on switchboard No. 1. Where more than three switchboards are installed, they are treated as two sets. The switchboards of one set are placed alternately between the switchboards of the other set (fig. 26).



TL-50982

Figure 24. Switchboard BD-110-(), cabling scheme for one- and two-position installations.

14. TRACING LINE AND TRUNK CIRCUITS.

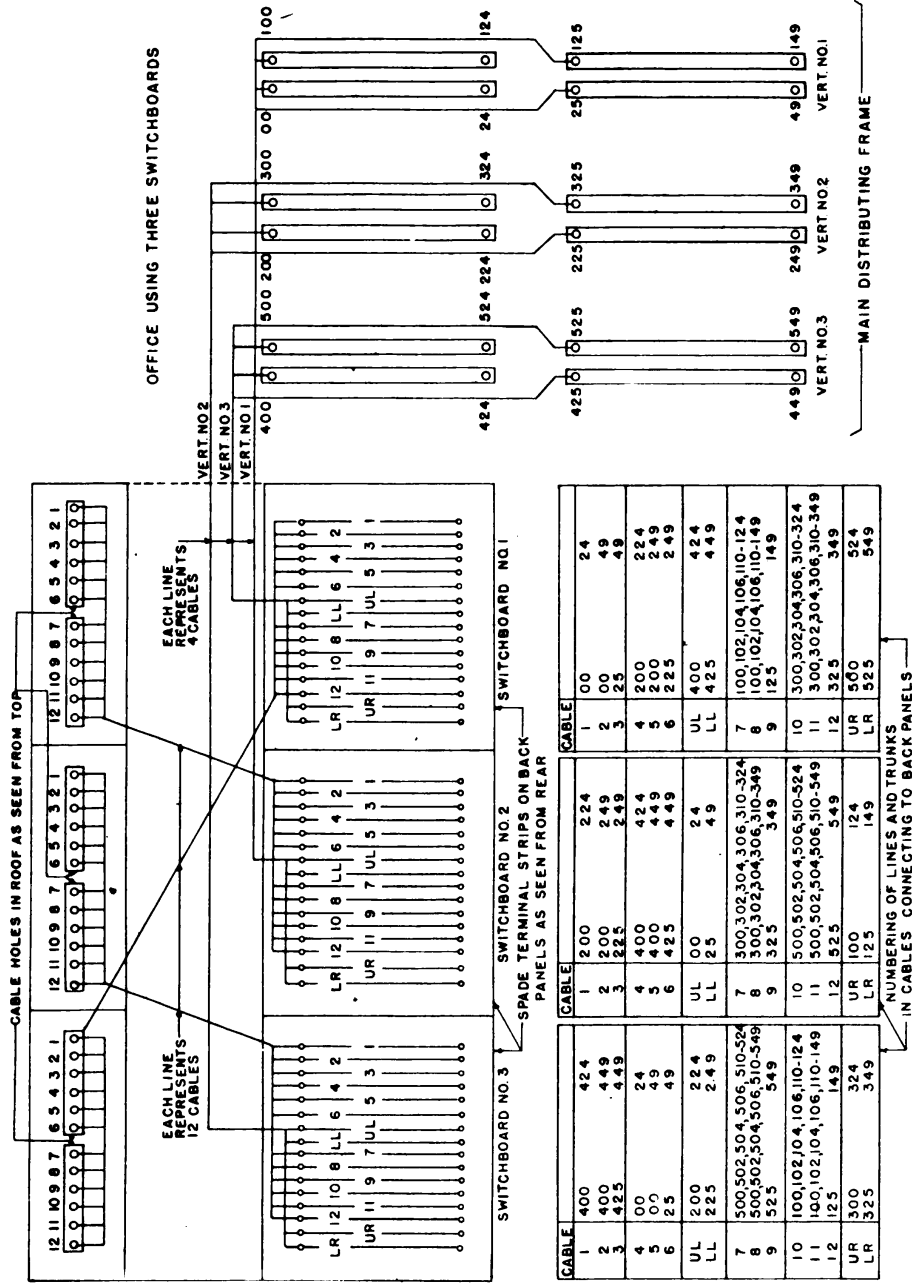
a. Note that in tracing through any specific line or trunk (on the wiring diagrams) the magneto lines, common battery lines, and universal trunks from the main distributing frame are connected in Switchboards BD-110-() first to the top multiple appearance, then to the middle multiple appearance, and finally to the answering appearance.

b. For example, in the anticipated normal installation of three switchboards, first trace through the group of common battery lines numbered 110-149, inclusive. Assuming that the three switchboards are connected in accordance with figure 25; then, as shown in figure 27, lines 110-149 have their top multiple appearance in switchboard No. 2, their middle multiple appearance in No. 3, and their answering appearance in No. 1. (Particular attention should be paid to the notes on figure 27 relating to the numbering of the lines.)

c. In tracing the lines through each individual switchboard, alphabetical designations are used to supplement the line numbers (table IV). For example, in figure 20, note that the jacks are designated A00-A49, B00-B49, C00-C49, D00-D49, E00-E49, and F00-F49. The alphabetical designations A, B, and C refer to even-numbered hundred groups; D, E, and F refer to odd-numbered hundred groups. The letters C and F refer to the top multiple, B and E to the middle multiple, and A and D to the answering appearance. In the example given, lines 110-149 are in the top multiple appearance of an odd-numbered hundred group, so these lines appear on jacks F10 to F49 (figs. 20 and 23).

d. Inspection of the common battery line circuit wiring diagram (fig. 33) shows that in the top multiple appearance, lines 110-149 appear as F--. The lines coming in from the main distributing frame connect to the binding posts on the rear terminal panel. In figure 29, lines F10-F49 appear in rows of binding posts designated as UR and LR (upper-right and lower-right, referring to the location of these lines on the main distributing frame). The lines then connect to the jacks, and in figure 20 lines F10-F49 appear in the top multiple on the right. The wiring diagram (fig. 33) shows the lines connecting to punchings on the terminal strips, and in figure 30 lines F10-F49 appear on terminal strip IV. Finally the lines connect to spade terminals, and in figure 31 lines F10-F49 appear in spade terminal strips 10, 11, and 12.

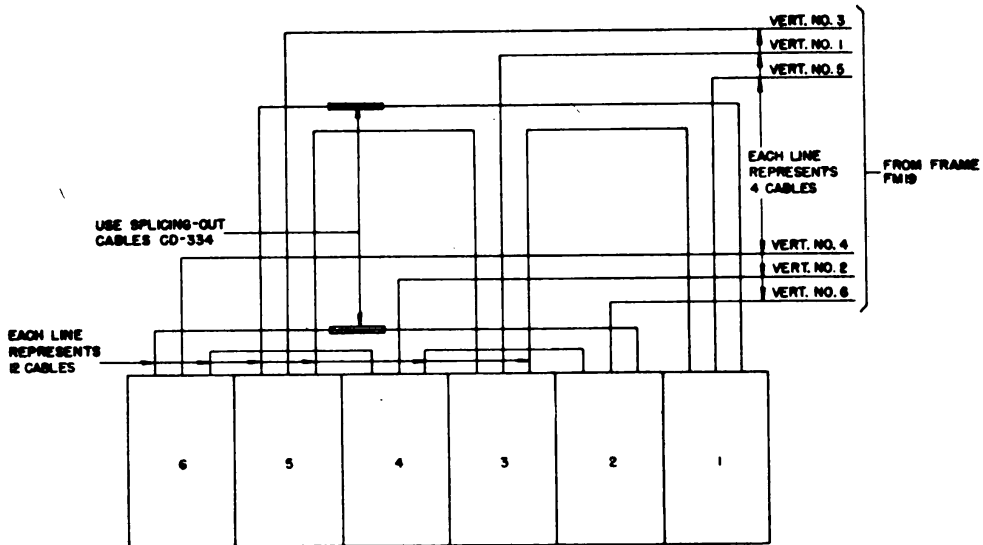
e. For the middle multiple appearance, figure 27 shows that lines 110-149 appear in switchboards No. 3, and figure 20 shows that they become lines E10-E49 for the middle multiple. As shown in figures 23 and 25, spade terminal strips 10, 11, and 12 coming from the top multiple in switchboard No. 2 connect to binding post rows 10, 11, and 12 on the rear terminal panel of switchboard No. 3. Following this procedure, lines 110-149 can be traced through the middle multiple appearance as



SWITCHBOARD NO. 3		SWITCHBOARD NO. 2		SWITCHBOARD NO. 1	
CABLE	TERMINALS	CABLE	TERMINALS	CABLE	TERMINALS
1	400	1	200	1	00
2	400	2	200	2	00
3	425	3	225	3	25
4	00	4	400	4	200
5	00	5	400	5	200
6	25	6	425	6	225
UL	200	UL	00	UL	400
LL	249	LL	25	LL	425
7	500,502,504,506,510,524	7	300,302,304,306,310,324	7	100,102,104,106,110,124
8	500,502,504,506,510,549	8	300,302,304,306,310,349	8	100,102,104,106,110,149
9	549	9	325	9	125
10	100,102,104,106,110,124	10	500,502,504,506,510,524	10	300,302,304,306,310,324
11	100,102,104,106,110,149	11	500,502,504,506,510,549	11	300,302,304,306,310,349
12	125	12	525	12	325
UR	300	UR	100	UR	500
LR	325	LR	125	LR	525

TL-50983

Figure 25. Switchboard BD-110-(), cabling scheme for three-position installations.



IN AN OFFICE USING FOUR SWITCHBOARDS NO. 1 AND NO. 3 ARE CONNECTED AS AN OFFICE USING TWO SWITCHBOARDS. SWITCHBOARDS NO. 2 AND NO. 4 ARE CONNECTED IN THE SAME WAY.

IN AN OFFICE USING FIVE SWITCHBOARDS NO. 1, NO. 3 AND NO. 5 ARE CONNECTED AS AN OFFICE USING THREE SWITCHBOARDS, BUT SWITCHBOARDS NO. 2 AND NO. 4 ARE CONNECTED AS AN OFFICE USING TWO SWITCHBOARDS. USE SPLICING-OUT CABLES WHERE NEEDED.

IN AN OFFICE USING SIX SWITCHBOARDS NO. 1, NO. 3 AND NO. 5 ARE CONNECTED AS AN OFFICE USING THREE SWITCHBOARDS. SWITCHBOARDS NO. 2, NO. 4 AND NO. 6 ARE CONNECTED IN THE SAME WAY.

TL-50984

Figure 26. Switchboard BD-110-(), cabling scheme for four-, five-, and six-position installations.

lines E10-E49, connecting to jacks in the middle multiple on the right, to punchings on terminal strip III, and to spade terminal strips 7, 8, and 9 which, in turn, connect to binding post rows 7, 8, and 9 on switchboard No. 1. Lines 110-149 can then be traced as lines D10-D49 to the jacks and lamps of the answering appearance, where they terminate, as shown on the wiring diagram (fig. 33).

f. The magneto lines and universal trunks can be traced through in the same general manner as the common battery lines with the use of figures 34 and 74 respectively in place of figure 33.

g. Any group of lines and trunks may be traced through an installation of three switchboards as outlined above. For a complete picture of multiple cabling arrangements of any switchboard installation of from 1 to 6 switchboards, see figures 24 to 26.

15. LINE PROTECTION AND CROSS-CONNECTION CIRCUIT (fig. 32). Line wires connected to the binding post panel of Frame FM-19 are wired through carbon-block and heat-coil protectors to protect the switchboard circuits from excessive line voltages and currents.

SWITCHBOARD NO. 1		SWITCHBOARD NO. 1		SWITCHBOARD NO.2	
		230-249		30-49	
		220-229	330-349	20-29	130-149
		200-219	310-329	00-19	110-129
	130-149		130-149		330-349
30-49	110-129	30-49	110-129	230-249	310-329
20-29		20-29		220-229	
10-19		10-19	300,302,304,306	210-219	100,102,104,106
00-09	100,102,104,106	00-09	100,102,104,106	200-209	300,302,304,306

SWITCHBOARD NO. 1		SWITCHBOARD NO. 2		SWITCHBOARD NO. 3	
430-449		30-49		230-249	
420-429	530-549	20-29	130-149	220-229	330-349
400-419	510-529	00-19	110-129	200-219	310-329
230-249		430-449		30-49	
220-229	330-349	420-429	530-549	20-29	130-149
200-219	310-329	400-419	510-529	00-19	110-129
	130-149		330-349		530-549
30-49	110-129	230-249	310-329	430-449	510-529
20-29	500,502,504,506	220-229	100,102,104,106	420-429	300,302,304,306
10-19	300,302,304,306	210-219	500,502,504,506	410-419	100,102,104,106
00-09	100,102,104,106	200-209	300,302,304,306	400-409	500,502,504,506

NOTES:

1. IN EVEN-NUMBERED HUNDRED GROUPS
 NOS. -00 TO -29 INCLUSIVE ARE FOR MAGNETO LINES,
 NOS. -30 TO -49 INCLUSIVE ARE FOR COMMON BATTERY LINES.
2. IN ODD-NUMBERED HUNDRED GROUP
 NOS. -00,-02,-04 AND -06 ARE FOR UNIVERSAL DIAL OR MANUAL TRUNKS,
 NOS. -10 TO -49 INCLUSIVE ARE FOR COMMON BATTERY LINES.

TL-50985

Figure 27. Switchboard BD-110-(), answering jack and multiple numbering; one-, two-, and three-position installations.

SWBD. NO. 1		SWBD. NO. 2		SWBD. NO. 3		SWBD. NO. 4		SWBD. NO. 1		SWBD. NO. 2		SWBD. NO. 3		SWBD. NO. 4		SWBD. NO. 5	
								8	9			0	1			4	5
4	5	6	7	0	1	2	3	4	5	6	7	8	9	2	3	0	1
	1		3		5		7		1		3		5		7		9
0		2		4		6		0	9	2		4	1	6		8	5
	5		7		1		3		5		7		9		3		1
	1		3		5		7		1		3		5		7		9

TWO UNITS, SWBDS. 1 & 3 AND SWBDS. 2 & 4
 0 REPRESENTS 00-49 INCLUSIVE,
 1 REPRESENTS 100, 102, 104 OR 107, 108, 109 OR
 110-149 INCLUSIVE, ETC.

TWO UNITS, SWBDS. 1, 3 & 5 AND SWBDS. 2 & 4

SWBD. NO. 1		SWBD. NO. 2		SWBD. NO. 3		SWBD. NO. 4		SWBD. NO. 5		SWBD. NO. 6	
8	9	10	11	0	1	2	3	4	5	6	7
4	5	6	7	8	9	10	11	0	1	2	3
	1		3		5		7		9		11
0	9	2	11	4	1	6	3	8	5	10	7
	5		7		9		11		1		3
	1		3		5		7		9		11

TWO UNITS, SWBDS. 1, 3 & 5 AND SWBDS. 2, 4 & 6

NOTES:

1. IN EVEN-NUMBERED HUNDRED GROUPS

NOS. -00 TO -29 INCLUSIVE ARE FOR MAGNETO LINES,
 NOS. -30 TO -49 INCLUSIVE ARE FOR COMMON BATTERY LINES.

2. IN ODD-NUMBERED HUNDRED GROUPS

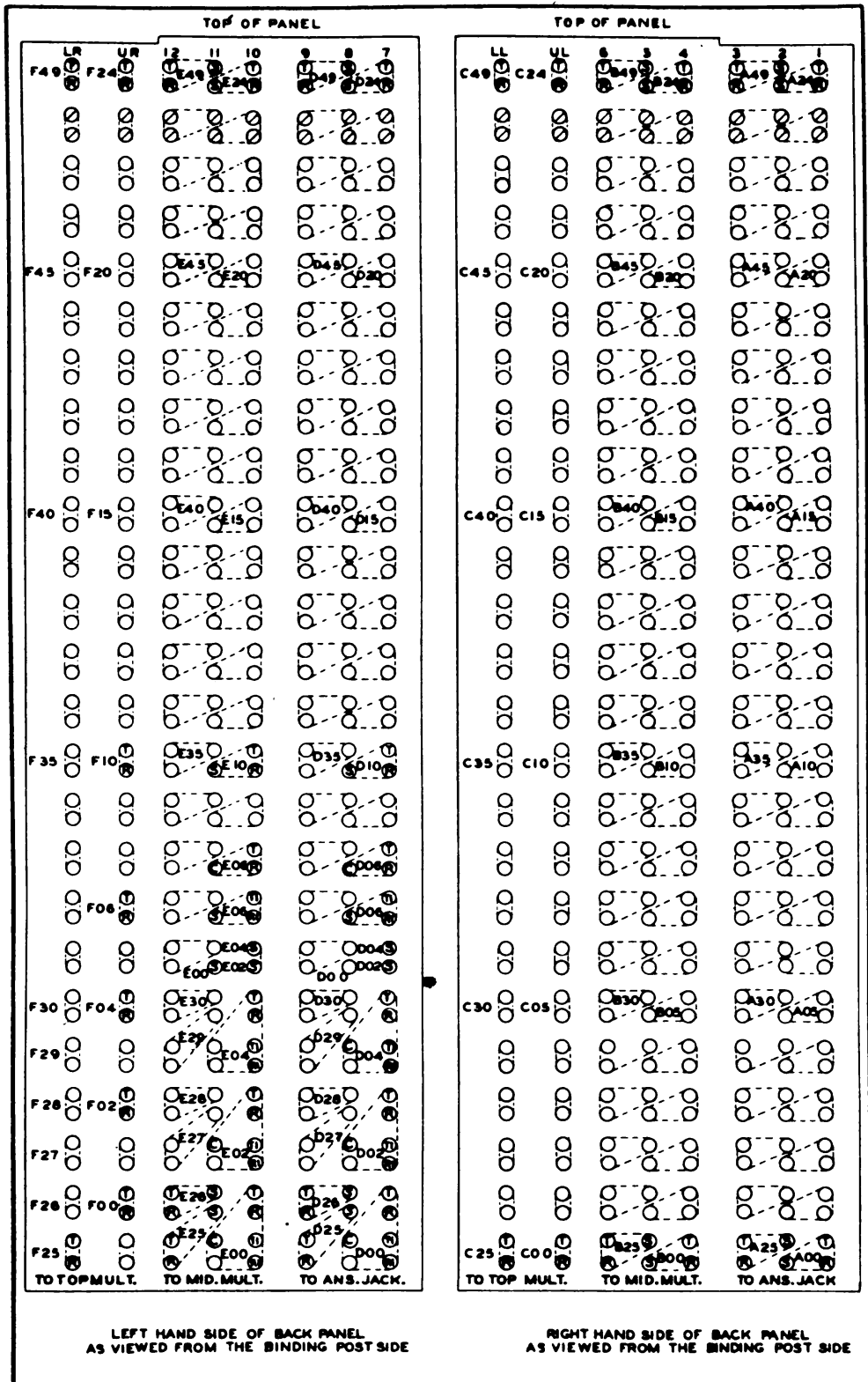
NOS. -00, -02, -04 AND -06 ARE FOR UNIVERSAL
 DIAL OR MANUAL TRUNKS,
 NOS. -10 TO -49 INCLUSIVE ARE FOR COMMON
 BATTERY LINES.

TL-50987

Figure 28. Switchboard BD-110-(), answering jack and multiple numbering; four-, five-, and six-position installations.

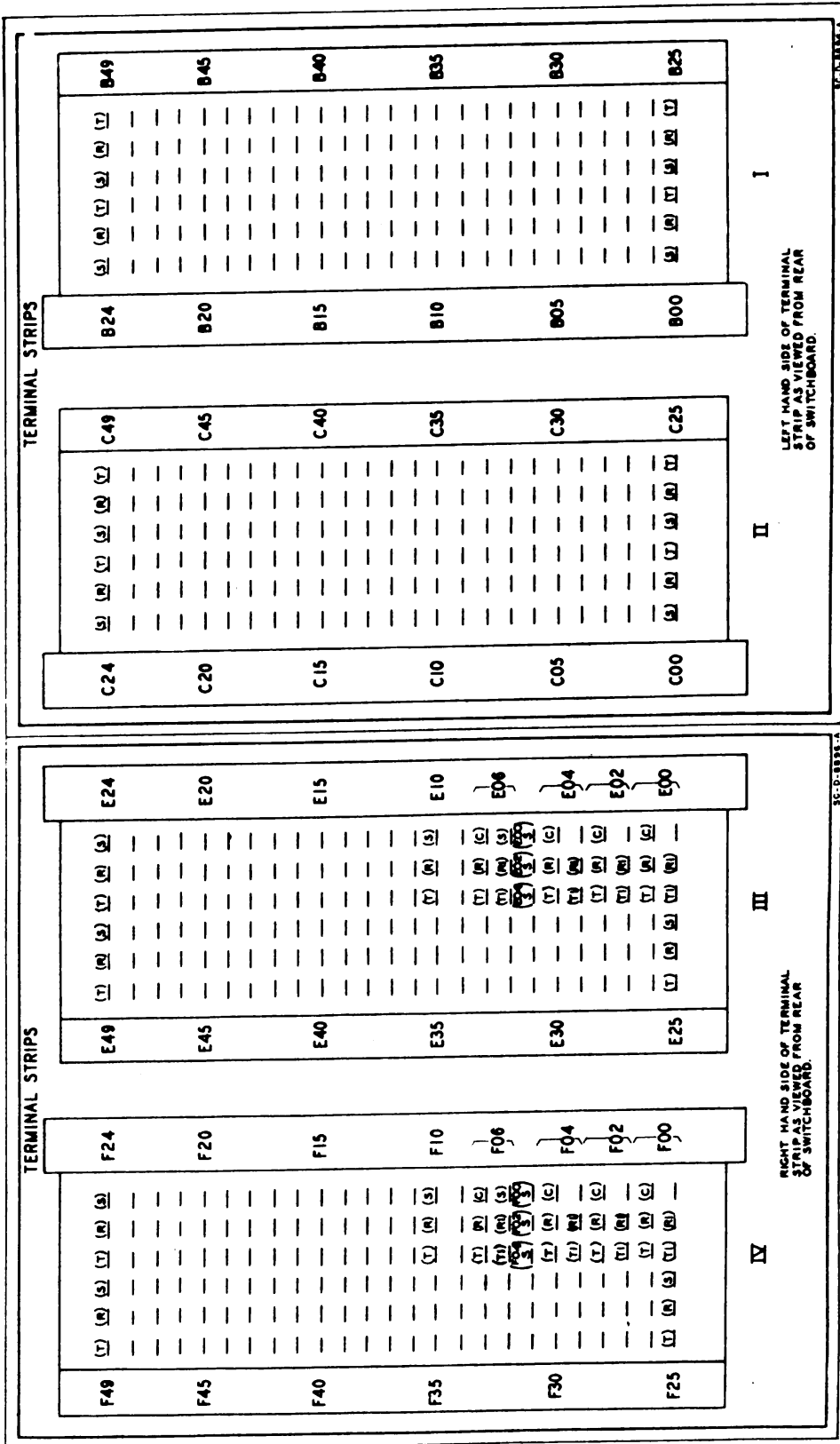
a. The carbon-block protector consists of two carbon blocks, one of which is cemented into a porcelain block to separate it from the other block by a few thousandths of an inch. One block is connected to a line wire and the other is connected to ground. At voltages above about 350 volts, the line wire will be grounded by arcing across the air gap between the blocks. Continued arcing will soften the fusible cement on the porcelain block and will allow the protector mounting springs to force the carbon blocks together, grounding the line wire.

b. The heat-coil protector consists of a small coil of wire wound around a copper tube and connected in series with the line wire. A metal pin inside the copper tube is held in place by solder having a low melting point. Current in the line wire of the order of $\frac{1}{3}$ ampere or above will melt the solder and allow the protector mounting spring to move the pin and ground the line wire. From the protectors, the line is wired to the right-hand binding post panel, and is extended by temporary cross-connection wires to the switchboard side of the frames.



TL-50986

Figure 29. Switchboard BD-110-(), binding posts on terminal panel.



TL-50988

Figure 30. Multiple cable terminal strips at top of Switchboard BD-110-().

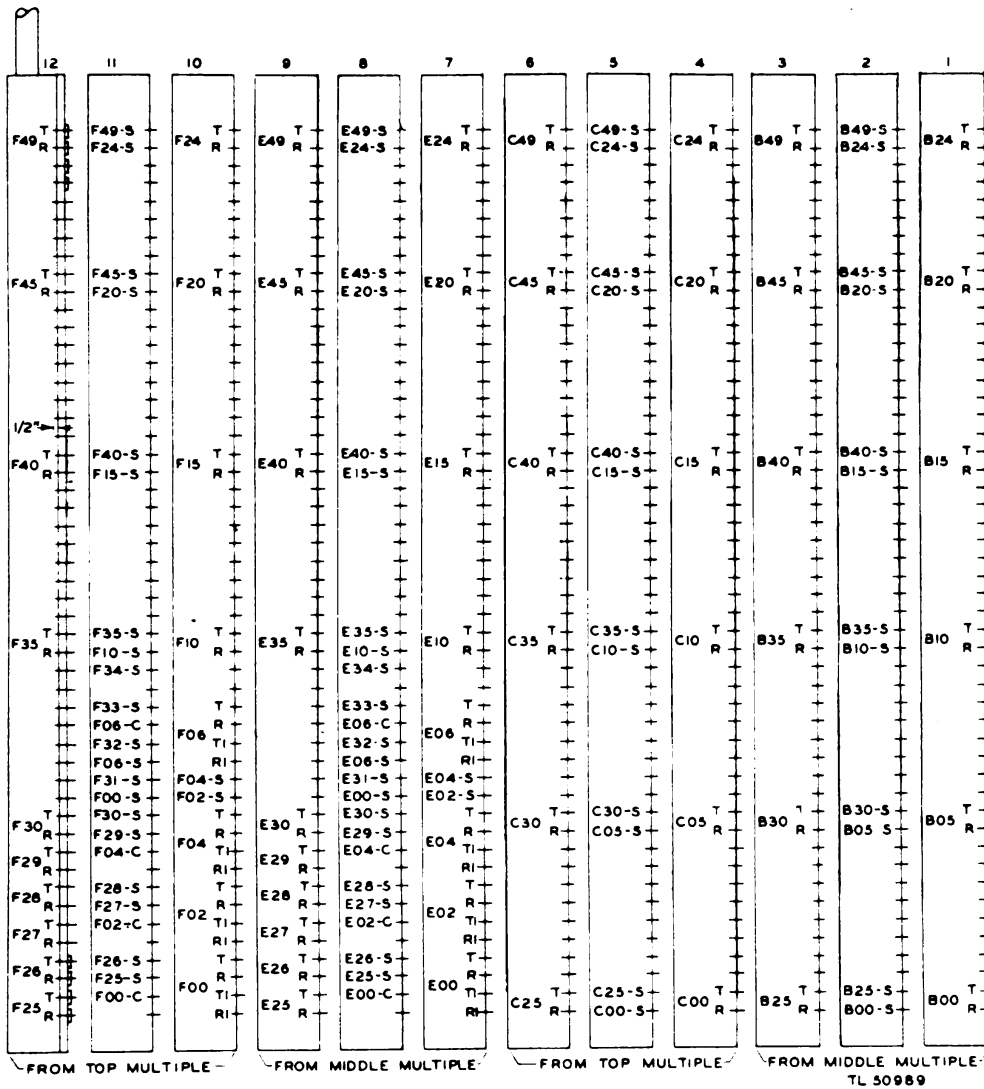


Figure 31. Switchboard BD-110-(), spade terminal strip designations.

16. LINE CIRCUIT, COMMON BATTERY (fig. 33).

a. This circuit is suitable for use with telephones and circuits which require an external source of transmitter current and those which signal Switchboard BD-110-() by closing a d-c path. The d-c path is completed through a common battery telephone by removing the handset from the switch. This permits the current to flow through the line lamp (which is in series with the line and the telephone) and causes it to glow, thereby signaling the operator. The lamp receives its battery supply through the night alarm circuit which provides an audible signal. The lamp and ground are disconnected from the line when an answering (rear) plug is inserted in jack 14 (fig. 33). Transmitter battery is supplied from the cord circuit to the distant telephone. When the plug is removed, the line lamp and ground are again connected to the line and other calls may be received.

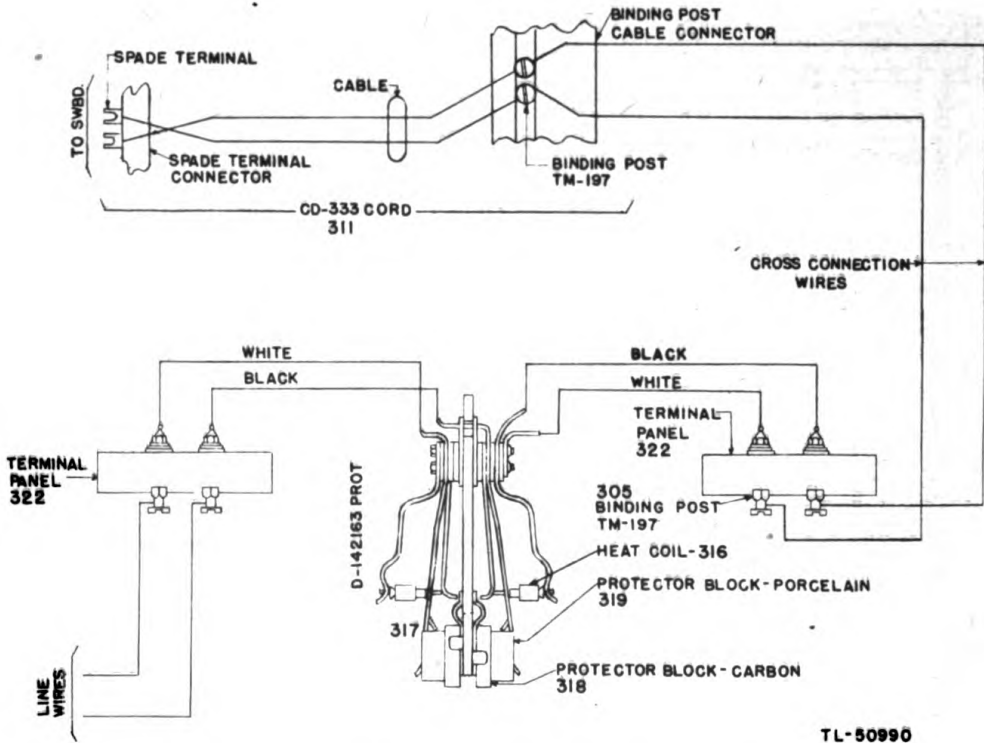


Figure 32. Frame FM-19, line circuit, wiring diagram.

b. Outgoing calls can be made by inserting the calling (front) plug in the jack. This disconnects the line lamp and ground from the line. The alternating ringing current applied from the cord circuit operates the distant equipment. When the cord plug is inserted in the line or multiple jacks of this circuit, a busy condition is set up by closing through a ground circuit from the jack frame to the sleeves of associated multiple jacks. This circuit may be connected to the following types of equipment or circuits:

- (1) Telephone EE-8-(), with screw switch turned to CB.
- (2) Commercial common battery telephones.
- (3) Trunk circuits which are arranged at the distant switchboard for incoming a-c ringing signals and outgoing d-c signaling.

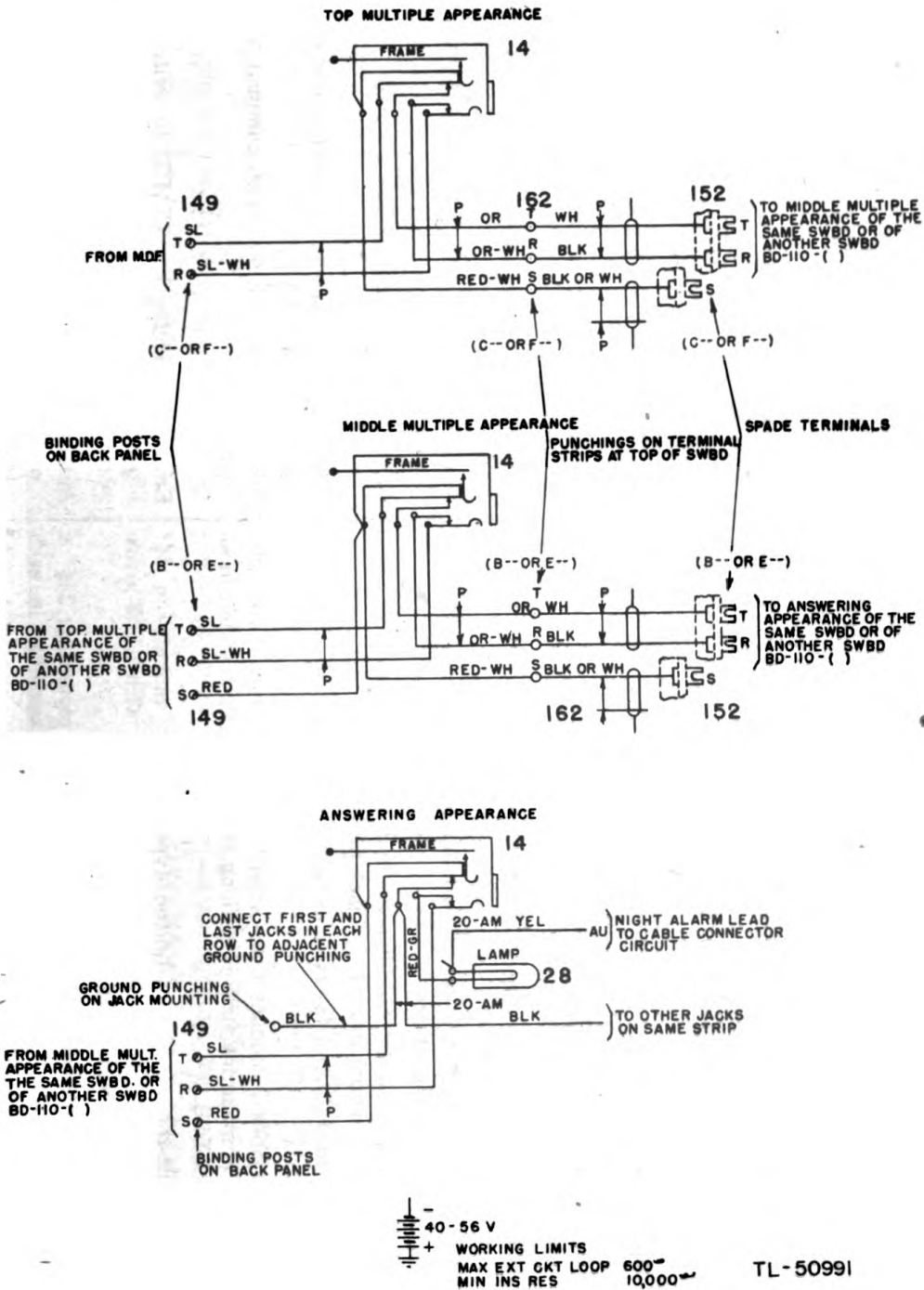


Figure 33. Common-battery line circuit, wiring diagram, Switchboard BD-110-().

TABLE VI
PARTS REFERENCE TABLE

NOTE: Reference symbols appear in schematic diagrams or in the text.

<i>Ref. symbol</i>	<i>Name of part and description</i>	<i>Function</i>	<i>Fig. No.</i>
6	DROP: magneto; shutter-type; manual restoring; $3\frac{1}{2}$ " long, $\frac{1}{8}$ " diam; 670-ohm d-c coil resistance.	Line signal (L.); magneto line circuit.	34
9	JACK: for single-screw mounting on $\frac{5}{8}$ " panel; $3\frac{3}{8}$ " long; 3-conductor cut-off; 1 make contact.	Dial jack (DIAL); trunk circuit.	35
10	JACK: same as ref. No. 9, except 3-conductor with no cut-off contacts and with 1 make contact.	Line (LINE) and telephone (TEL) jacks; auxiliary telephone circuit.	40
11	JACK: same as ref. No. 9, except 3-conductor with no cut-off contacts and with 2 make contacts.	Answering (ANS) jack or multiple (MULT) jack; trunk circuit.	35
12	JACKS: ten 3-conductor cut-off jacks in a mounting strip $11\frac{1}{8}$ " long, $\frac{1}{2}$ " thick; to mount in an $11\frac{1}{4}$ " jack field.	Answering jacks; magneto line circuit.	34
13	JACKS: in mounting strip; same as ref. No. 12 except with 20 jacks per strip.	Multiple jacks, magneto line circuit; and conference jacks, conference circuit.	34, 41
14	JACKS: 20 jacks; 3-conductor cut-off with sleeve circuit make contacts; jacks set in mounting strip $11\frac{1}{8}$ " long and $\frac{1}{2}$ " thick; to mount in an $11\frac{1}{4}$ " jack field.	Answering and multiple jacks; common battery line circuit.	33
24	KEY: single-throw, rotating-button type; locking; mounts on $\frac{1}{8}$ " panel; $3\frac{13}{16}$ " long, $\frac{1}{2}$ " diam; black phenol button with white arrow engraved; one break-make contact assembly.	Emergency ringing key (EMG) to switch to hand generator, ringing circuit.	37
25	KEY: lever-type; double-throw; nonlocking panel mounting; $2\frac{1}{4}$ " x $\frac{1}{16}$ " top, approx $4\frac{1}{2}$ " long; 1 make contact assembly in each position.	Auxiliary operator's busy test key (BT); auxiliary operator's circuit.	40

1 1/4" diam

Magneto recall lamp (R); cord circuit.

27	LAMP: switchboard-type, 36-v; 0.032- to 0.044-amp; long.	36
28	LAMP: same as ref. No. 27.	33
29	LAMP: same as ref. No. 27.	35
45	COIL C-281: Signal Corps type; base mounting; core-type; iron core; 2 windings each 10 ohms $\pm 10\%$; $2\frac{3}{8}$ " x $1\frac{1}{16}$ " x $1\frac{1}{8}$ " over-all.	38
46	DIAL: telephone dial; impulse sender with break-make off-normal contact assembly; approximately 10 pulses per second and 60% break; 3" diam.	42
53	GENERATOR: hand-driven; 5-bar, 80-v into 1,500-ohm noninductive load at 1,025 rpm armature speed; 4 No. 12-24 x 1" mounting screws furnished.	37
57	JACK: 2-conductor; for W. E. Co. No. 289 and similar plugs; 3" x $1\frac{1}{16}$ " x $\frac{1}{16}$ ", mounts on a $\frac{1}{4}$ " panel with 1 No. 6-32 machine screw.	38
58	JACK JK-37: 3-conductor; 2" x 2" x $\frac{3}{16}$ " phenol block with springs and mounting brackets.	38
61	KEY: lever-type, double-throw; $2\frac{3}{4}$ " x $\frac{7}{16}$ " top; approximately $4\frac{1}{2}$ " long; mounts on keyshelf bars spaced for single-unit keys; locking; 2 sets of transfer contacts in each position.	37, 38
62	KEY: same as ref. No. 61, except has a locking position with 2 sets of transfer contacts and a nonlocking position with 2 make-before-break contact assemblies; equipped with a red handle.	38, 43
63	KEY: same as ref. No. 61, except has a locking position with 2 make and 1 break contact assemblies and a non-locking position with 2 sets of transfer contacts.	36
68	LAMP: same as ref. No. 27, except 6-v, 0.033- to 0.045-amp.	36
79	CAPACITOR: fixed; 2.0-mf; tolerance 2.0- to 2.5-mf; 180-v at 0°-55° C; paper; hermetically-sealed; $5\frac{1}{2}$ " x 1" x $1\frac{1}{2}$ " over-all; stud mounting.	42
	Signaling lamp (LINE) for trunk circuit.	
	For Signal Corps type head and chest sets, operator's telephone circuit.	
	To complete calls over trunks to a dial office; dial cord circuit.	
	Emergency-ringing generator; ringing circuit.	
	Headset jacks (A), (B), (C), and (D); operator's telephone circuit.	
	For Plug PL-58 used on headsets and chest sets.	
	Monitoring key (MON), operator's telephone circuit; and master ringing key (MR), cord circuit.	
	Night alarm release (RLS), alarm circuit; and switch-board grouping (GR), operator's telephone circuit.	
	Operator's talking (TALK) and ringing (RING) key; operator's telephone circuit.	
	Supervisory lamps (A) and (C); cord circuit.	
	Dial contact protection capacitor (B); dial cord circuit.	

TABLE VI (continued)
PARTS REFERENCE TABLE

NOTE: Reference symbols appear in schematic diagrams or in the text.

<i>Ref. symbol</i>	<i>Name of part and description</i>	<i>Function</i>	<i>Fig. No.</i>
80	CAPACITOR: same as ref. No. 79.	Signaling operator (A); trunk circuit.	35
81	CAPACITOR: same as ref. No. 79, except 2.14- to 2.18-mf.	D-c blocking, capacitors (T) and (R); operator's telephone circuit.	38
82	CAPACITOR: same as ref. No. 79, except 2.16- to 2.28-mf.	D-c blocking capacitors (T) and (R); cord circuit.	36
83	CAPACITOR: fixed; 1.0-mf; tolerance 1.0-1.25-mf; 180-v at 0°-55° C; paper; hermetically-sealed; $5\frac{1}{2}$ " x $1\frac{1}{8}$ " x $1\frac{1}{2}$ " over-all; stud mounting.	A-c by-pass capacitor (P); operator's telephone circuit.	38
84	CAPACITOR: same as ref. No. 83, except 0.5-mf; tolerance 0.5- to 0.625-mf.	Busy test capacitor (A); operator's telephone circuit.	38
85	COIL: retardation; 165-ohm d-c; straight iron core, $5\frac{1}{2}$ " long over-all; $1\frac{1}{2}$ " diam, metal case; panel mounting.	Transmitter battery supply coil (A); operator's telephone circuit.	38
86	COIL: retardation; same as ref. No. 85, except with 2 windings; parallel wound; each 100-ohm d-c.	Busy test coil (BT); operator's telephone circuit.	38
87	COIL: induction; straight iron core, 3 windings: 10-ohm, 500 ohm, and 5.9-ohm d-c; $4\frac{1}{4}$ " x $1\frac{1}{8}$ " x $1\frac{1}{8}$ " ; base mounting.	Allows operator to talk and listen on line; operator's telephone circuit.	38
88	COIL: repeating, shell-type iron core; 2 windings: 9-ohm and 400-ohm d-c; 5 " x $3\frac{1}{8}$ " x $1\frac{1}{8}$ " over-all; metal case; stud mounting.	Monitoring coil; operator's telephone circuit.	38
89	COIL: repeating; toroidal permalloy core; 4 windings: 2 parallel-wound 35.5-ohm each, and 2 separately-wound 51-ohm each; $4\frac{1}{8}$ " x $3\frac{3}{8}$ " x $1\frac{1}{8}$ " over-all; metal case; stud mounting.	Trunk repeating coil; trunk circuit.	35

90	FUSE: indicating alarm-type; rated $1\frac{1}{2}$ amp; $1\frac{1}{16}$ " long, $\frac{1}{16}$ " wide; fits under No. 10 screws on $\frac{1}{16}$ " centers; white bead.	Battery fuse for cords 1-15, trunks 1-4, telephone and auxiliary telephone circuits.	40
91	FUSE BLOCK: insulating block $2" \times \frac{3}{4}" \times \frac{7}{16}"$; equipped with 2 fuse posts and an alarm stud; panel mounting.	Holds battery fuse.	40
92	LAMP: resistance; tungsten filament, medium screw base; $3"$ long, $1\frac{1}{16}"$ max diam; approx 0.046-amp, 10-v; and 0.176-amp, 90-v.	Resistance lamp for ringing supply lead; ringing circuit.	37
101	RELAY: flat-type; 2 sets of transfer contacts and 2 make-before-break contact assemblies; winding 1,000-ohm d-c; panel mounting; approx $4" \text{ long} \times 1" \text{ wide} \times 1\frac{3}{8}" \text{ high}$.	Relay (M) to switch monitoring coil; operator's telephone circuit.	38
102	RELAY: flat-type; 1 make contact assembly; windings: primary 250-ohm d-c; secondary 270-ohm d-c; panel mounting, approx $4" \text{ long} \times 1" \text{ wide} \times 1\frac{3}{8}" \text{ high}$.	Relay (T) to complete busy test circuit; operator's telephone circuit.	38
103	RELAY: flat-type; 2 transfer and 1 break contact assemblies; winding 1,000-ohm d-c; (1,975-ohm inductive and 2,030-ohm noninductive windings in parallel); panel mounting, approx $4" \text{ long} \times 1" \text{ wide} \times 1\frac{3}{8}" \text{ high}$.	Relays (FS) and (BS) for front and back cord battery control; cord circuit.	36
104	RELAY: flat-type, individual cover with removeable cap, 1 set of transfer contacts; windings: primary 155-ohm d-c, secondary 2,230-ohm d-c each; panel mounting, $4\frac{1}{16}" \text{ long} \times 1\frac{1}{16}" \text{ wide} \times 1\frac{1}{16}" \text{ high}$.	RELAYS (A) and (C) for cord supervision; cord circuit.	36
105	RELAY: flat-type; 4 make contact assemblies; windings: primary 475-ohm d-c, secondary 3,200-ohm d-c; panel mounting, $4\frac{7}{16}" \text{ long} \times 1\frac{1}{16}" \text{ high}$; approx $1" \text{ wide}$.	Signaling relay (R) trunk circuit.	35
106	RELAY: flat-type; 1 make and 2 break contact assemblies; windings: primary 1,500-ohm d-c, secondary 700-ohm noninductive, tertiary 300-ohm noninductive; panel mounting, $4\frac{1}{2}" \text{ long} \times 1\frac{1}{16}" \text{ high}$; approx $1" \text{ wide}$.	Sleeve-operated relay (SL); trunk circuit.	35
112	RESISTOR: fixed; wire-wound; flat-type; noninductive; wound on a core of heat-resisting material; panel mounting $4\frac{7}{16}" \text{ long} \times 1\frac{1}{2}" \text{ high} \times \frac{1}{4}" \text{ wide}$; 5-w, 1,000-ohm $\pm 5\%$.	Battery supply resistance (A); auxiliary telephone circuit.	40

TABLE VI (continued)
PARTS REFERENCE TABLE

NOTE. Reference symbols appear in schematic diagrams or in the text.

<i>Ref. symbol</i>	<i>Name of part and description</i>	<i>Function</i>	<i>Fig. No.</i>
113	RESISTOR: same as ref. No. 112, except 5,000-ohm $\pm 5\%$.	Busy test ground resistance (B); auxiliary telephone circuit.	40
114	RESISTOR: same as ref. No. 112, except 600-ohm $\pm 5\%$.	Contact protection resistor (E); dial cord circuit.	42
115	RESISTOR: same as ref. No. 112, except 9,000-ohm $\pm 5\%$.	Resistor (A) and (B) of busy test network; operator's telephone circuit.	38
116	RESISTOR: same as ref. No. 112, except 6,000-ohm $\pm 5\%$.	Resistor (C) of busy test network; operator's telephone circuit.	38
117	RESISTOR: same as ref. No. 112, except 8,080-ohm $\pm 5\%$.	By-pass resistor (D) for busy test; operator's telephone circuit.	38
118	TERMINAL PUNCHING: U-shaped solder terminal; $\frac{3}{8}$ " high x $\frac{3}{8}$ " x $\frac{5}{16}$ ".	Terminations for ground wires at location of battery fuses.	40
119	TERMINAL STRIP: insulating strips clamped to a steel base strip to hold 4 rows of 5 terminals each; $1\frac{11}{32}$ " high x $1\frac{3}{4}$ " wide x $2\frac{1}{2}$ " thick.	Connecting strip for trunk relay unit.	35
121	THERMISTOR: in a nitrogen-filled glass tube enclosed in a fiber tube with metal ends; $1\frac{1}{16}$ " long, $\frac{1}{4}$ " diam; 50,000-ohm, 0-amp; 250-ohm, 0.025-amp.	Signaling time delay element (C); trunk circuit.	35
122	VARISTOR: half-wave; 22 disks; panel mounting; $3\frac{3}{16}$ " long x $1\frac{11}{16}$ " wide x $\frac{7}{8}$ " high.	Rectifier (B) for signaling circuit; trunk circuit.	35
123	VARISTOR: conducts current in both directions; 0.5-w; resistance is approx 2,000-ohm, 0.1-v; 15-ohm, 1.5-v; 6 disks; panel mounting, $2\frac{1}{8}$ " long x $1\frac{1}{16}$ " high x $\frac{1}{16}$ " wide.	Nonlinear element (E) for click reduction; operator's telephone circuit.	38

125	CORD ASSEMBLY: patching; 2-conductor, rubber-insulated with green cotton covering; 9'6" long, 3-conductor plug on one end and phone tips on the other.	Connects field telephone set to auxiliary telephone circuit.	40
126	CORD ASSEMBLY: patching; 3-conductor; low-resistance (0.24-ohm) rubber-insulated with black cotton covering; 6 ft long with 3-conductor plug on each end.	Connects line or trunk jacks to auxiliary telephone circuit.	40
127	CORD ASSEMBLY: switchboard; 3-conductor rubber-insulated with red cotton covering; 8 ft long with 3-conductor plug on one end and spade tips on the other.	Line and trunk connecting cords (ANS) and (CALL); cord circuit.	36
130	CORD ASSEMBLY: same as ref. No. 127, except with slate cotton covering.	Dial cord.	42
149	BINDING POST TM-197: brass, compression type, slotted top; approx 1 $\frac{1}{16}$ " long over-all; No. 10-32 thread mounting stud.	Connection to lines and trunks through the spade terminals of connectors.	33, 34
152	CABLE AND CONNECTOR ASSEMBLY: metal-covered phenol-insulated connector, 29" x 2 $\frac{1}{4}$ " x 1" over-all; with 50 angle terminals connected to 26-pair cable; 6' 4" free cable length when connected in place.	Multiple connections between switchboards.	33, 34
162	TERMINAL STRIP: insulating strips clamped to fanning strip and steel base strip to hold 6 rows of 25 terminals each; 7 $\frac{7}{16}$ " long x 2 $\frac{5}{8}$ " high x 3 $\frac{13}{16}$ " wide; with 4 roundhead machine screws No. 8-32 x $\frac{5}{8}$ " for mounting in switchboard.	Multiple cable terminal strips at top of switchboard.	33, 34
163*	CABLE: steel-armored; flexible; 2-conductor; 14 AWG copper; approx 10 ft required per switchboard; 600-v insulation.	Cable for heater units and light outlets.	71
181*	RECEPTACLE: porcelain; female; twist-lock type; 2-conductor; 20-amp, 250-v; mounts in outlet box.	110-v power connection at top of switchboard.	71
182*	RECEPTACLE: flush base; male; twist-lock type; polarized; 2-conductor; metal shell; composition base; 20-amp, 250-v; mounts on outlet box cover.	110-v power connection at top of switchboard.	71

* These reference symbols appear only on figure 71.

TABLE VI (continued)
PARTS REFERENCE TABLE

NOTE: Reference symbols appear in schematic diagrams or in the text.

<i>Ref. Symbol</i>	<i>Name of part and description</i>	<i>Function</i>	<i>Fig. No.</i>
183*	RECEPTACLE: composition; female; duplex; 2-conductor; 10-amp, 250-v; or 15-amp, 125-v; mounts in outlet box.	Outlet for soldering iron, lights, etc.	71
184*	RESISTOR: vitreous enamel; 60-w, 250-ohm $\pm 10\%$ medium screw base, $5\frac{1}{16}$ " long and $\frac{3}{16}$ " diam over-all.	Heater element.	71
311	CORD CD-333: rubber-insulated and covered 26-pair cable; 35' free length with a 50-terminal spade connector on one end and a binding post terminal strip connector on the other end.	Cords (UL), (UR), (LL), and (LR) to connect lines and trunks from frame to switch board.	32
316	HEAT COIL: black; insulating shell; $\frac{5}{16}$ " diam, $\frac{7}{16}$ " long; 3.45-ohm resistance; will carry 0.35 amp for 3 hours.	Protects office equipment from sneak currents on lines.	32
317	PROTECTOR MOUNTING: 19" x 6" x $\frac{1}{8}$ " steel support provided with springs equipped with heat coils and protector blocks (ref. Nos. 316, 318, and 319) to protect 50 pairs of wires.	High potential and sneak current arrestor.	32
318	PROTECTOR BLOCK: plain hard carbon block; 1" x $\frac{1}{2}$ " x $\frac{1}{4}$ ".	Used with porcelain block (ref. No. 319).	32
319	PROTECTOR BLOCK: groved porcelain block; $\frac{7}{8}$ " x $\frac{3}{16}$ " x $\frac{3}{8}$ " with a carbon insert held in place by fusible cement.	Used with carbon block (ref. No. 318) to provide an air gap cut-out for protection from high potentials.	32
322	STRIP: black phenolic terminal mounting strip; $27\frac{3}{4}$ " x $2\frac{13}{16}$ " x $\frac{3}{8}$ "; drilled to mount 100 binding posts in two equal rows, with 50 holes drilled along one edge for fanning wires.	Terminal strip for line wires and for cross-connection from protectors.	32
407	CORD: gray; 6-ft; 3-conductor, with 1 switchboard plug and 1 special test plug, rubber-insulated.	Test cord.	48

* These reference symbols appear only on figure 71.

408	CORD: black; 8-ft; 2-conductor, with 3-conductor switchboard plug and push-button key; rubber-insulated.	Test cord.	48
409	CORD: green; 10-ft; 2-conductor, with 3-conductor switchboard plug and 2 suspender clips; rubber-insulated.	Test cord.	48
410	CORD: green; 3-ft; 2-conductor, with 3-conductor switchboard plug on each end; rubber-insulated.	Test cord.	48
411	CORD: low-resistance; black; 6-ft; 3-conductor, with 3-conductor switchboard plug on each end.	Test cord.	48
413	JACK: 3-conductor; used with W. E. Co. 310 plug; mounted 10 per strip on mounting of insulating material; $1\frac{1}{16}$ " x $2\frac{1}{16}$ " x $\frac{1}{16}$ "; fits $1\frac{1}{16}$ " jack field.	Test jacks (A) to (J) for switchboard tests.	48
414	JACK: singly-mounted; 3-conductor; 1 independent make contact; $3\frac{3}{8}$ " long, for $\frac{1}{8}$ " mounting hole in panels up to $\frac{5}{8}$ " thick.	Test jack (TST) for voltmeter tests.	47
415	JACK: singly-mounted; 3-conductor, with cut-off contacts on tip and ring springs, 1 independent break contact; $3\frac{3}{8}$ " long, for $\frac{1}{8}$ " mounting hole in panels up to $\frac{5}{8}$ " thick.	(TLK) jack for ringing and talking on lines under test.	47
416	KEY: keyshelf mounting; lever-type; single-throw; locking, staggered insulation; 2 sets of break-before-make contact assemblies; key top engraved REV.	Reverses connections to line under test.	47
417	KEY: keyshelf mounting, lever-type, double-throw; locking; staggered insulation; key top engraved G and RG, 1 make contact in G position; 1 break contact in RG position.	(G) position grounds line; (RG) position opens t p side of ringing circuit.	47
423	RESISTOR: fixed; noninductive; 400-ohm $\pm 1\%$; 5-w; panel mounting, $4\frac{5}{8}$ " x $1\frac{1}{2}$ " x $\frac{1}{2}$ ".	Switchboard test circuit (A1).	48
424	RESISTOR: same as ref. No. 423, except 1,000-ohm $\pm 1\%$.	Switchboard test circuit (F) and (G).	48
425	RESISTOR: same as ref. No. 423, except 750-ohm $\pm 1\%$.	Switchboard test circuit (B).	48
426	RESISTOR: same as ref. No. 423, except 1,800-ohm $\pm 5\%$.	Switchboard test circuit (H).	48
427	RESISTOR: fixed; noninductive; 2-section; 380- and 900-ohm $\pm 1\%$; 5-w panel mounting, $4\frac{5}{8}$ " x $1\frac{1}{2}$ " x $\frac{1}{2}$ ".	Switchboard test circuit (E).	48

TABLE VI (continued)
PARTS REFERENCE TABLE

NOTE: Reference symbols appear in schematic diagrams or in the text.

Ref. symbol	Name of part and description	Function	Fig. No.
428	RESISTOR: same as ref. No. 427, except 20- and 5,590-ohm $\pm 1\%$.	Switchboard test circuit (C).	48
429	RESISTOR: same as ref. No. 427, except 44- and 3,480-ohm $\pm 1\%$.	Switchboard test circuit (A).	48
430	RESISTOR: same as ref. No. 427, except 69.6- and 5,245-ohm $\pm 1\%$.	Switchboard test circuit (D).	48
432	TERMINAL PUNCHING: U-shaped; for solder connections; $\frac{1}{8}$ " x $\frac{3}{16}$ " x $\frac{3}{16}$ "; single-screw mounting.	For connecting a field set to the test circuit.	47
433	VOLTMETER: d-c; 0- to 100-v; 2% accuracy; 100,000-ohm D'Arsonval movement; flange $3\frac{1}{2}$ " diam; self-contained.	Testing meter.	47
501	AMMETER: d-c; 20-0-20 amp; zero center; 2% accuracy; 0.00125-ohm; D'Arsonval movement; $3\frac{1}{2}$ " flush mounting; self-contained; calibrated for 0.09" steel panel.	Battery charge and discharge meter.	46
502	BELL: a-c or d-c type; 680-ohm d-c resistance; 24- to 60-v; $5\frac{1}{2}$ " x $3\frac{1}{2}$ " x $1\frac{1}{2}$ ".	Audible night alarm bell.	43
503	BINDING POST TM-109: screw-type insulated top; $\frac{5}{8}$ " diam; $1\frac{3}{4}$ " long (open); No. 10-32 thread $\frac{3}{4}$ " long.	D-c power supply terminals (C).	46
507	BUZZER: a-c or d-c type; 680-ohm d-c resistance; 20- to 60-v; $2\frac{3}{4}$ " x 2" x $1\frac{1}{8}$ ".	Audible fuse alarm buzzer (FA).	44
508	BUZZER: same as ref. No. 507.	Audible no-voltage alarm buzzer (C).	45
510	CAPACITOR: fixed; paper; 4.0-mf; tolerance 4.0- to 5.0-mf; 200-v d-c; $4\frac{1}{4}$ " x $1\frac{5}{8}$ " x $1\frac{1}{2}$ " over-all; stud mounting.	To provide a slight time delay for night alarm circuit; capacitors (A) and (A1).	43
511	CAPACITOR: fixed; paper; oil-filled; hermetically-sealed; max 2.3-mf; min 1.7-mf; 2,500-v d-c (working); $4\frac{3}{4}$ " x $1\frac{1}{2}$ " x $1\frac{1}{8}$ "; stud mounting.	Interruption contact protection; capacitors (C) and (D).	46

512	CAPACITOR: fixed; paper; oil-filled; hermetically-sealed; max 9.2-mf; min 6.8-mf; 2,500-v d-c (working); $5\frac{5}{8}$ " x 5" x $1\frac{1}{2}$ "; stud mounting.	Interrupter contact protection; capacitors (A) and (B).	46
513	CIRCUIT BREAKER: magnetic; 2 poles; 15-amp; toggle action; manual reset; time delay curve D; black bakelite case.	Control and overload protection for battery main discharge leads.	46
514	CIRCUIT BREAKER: magnetic; 1-pole; 10-amp; toggle action; manual reset; time delay curve D; black bakelite case.	Control and overload protection for leads to (A) and (B) receptacles.	46
515	CIRCUIT BREAKER: same as ref. No. 514.	Control and overload protection for leads to (C) binding posts.	46
516	CIRCUIT BREAKER: same as ref. No. 514.	Control and overload protection for battery leads to interrupter (INT).	46
517	COIL: repeating; toroidal core; 2 primary windings each 2.35-ohm d-c; 27.8-ohm secondary tapped to give ratios of 1.9 to 1, 3.02 to 1, and 3.18 to 1; $8\frac{5}{8}$ " x 11 " x $5\frac{1}{8}$ ".	Ring transformer used with the interrupter (ref. No. 526).	46
518	COIL: retardation; toroidal core; 2 windings each 3-ohm $\pm 1\%$; $8\frac{5}{8}$ " x 11 " x $5\frac{1}{8}$ ".	Coil (A) of bridge network for night alarm circuit.	43
520	CORD: 7-ft; two No. 18 AWG conductors; rubber-covered; black; plug on one end.	Telering 110-v a-c supply cord.	46
522	FUSE: alarm-type; $1\frac{1}{8}$ -amp, 90-v; white glass indicating bead; interchangeable with fuse (ref. No. 90) of Switchboard BD-110; $1\frac{1}{16}$ " x $\frac{13}{16}$ ".	Battery fuse for voltmeter test and night alarm circuit.	43
526	INTERRUPTER: ringing; vibrating pole-changer type; 1,300-ohm operating coil; $9\frac{1}{4}$ " x $1\frac{15}{16}$ " x $5\frac{1}{2}$ ".	To furnish ringing current from 48-v d-c.	46
527	KEY: lever-type; single-throw; locking; panel mounting; top $2\frac{1}{4}$ " x $\frac{15}{16}$ "; approx $4\frac{1}{2}$ " long; 2 sets of transfer contacts in each position.	Night alarm key (NA).	43
528	KEY: push-button type; nonlocking; 2 make contacts; $\frac{3}{16}$ " diam; approx $3\frac{1}{2}$ " long.	No-voltage alarm audible cut-off key (D).	45
529	KEY SW-178: rotating-button type; double-throw; locking; 3 make contacts in each position; $\frac{1}{2}$ " diam; $3\frac{19}{32}$ " long.	No-voltage alarm control key (G).	45
532	LAMP: telephone switchboard; 36-v, 0.032-amp; tungsten filament.	No-voltage alarm lamp (E).	45

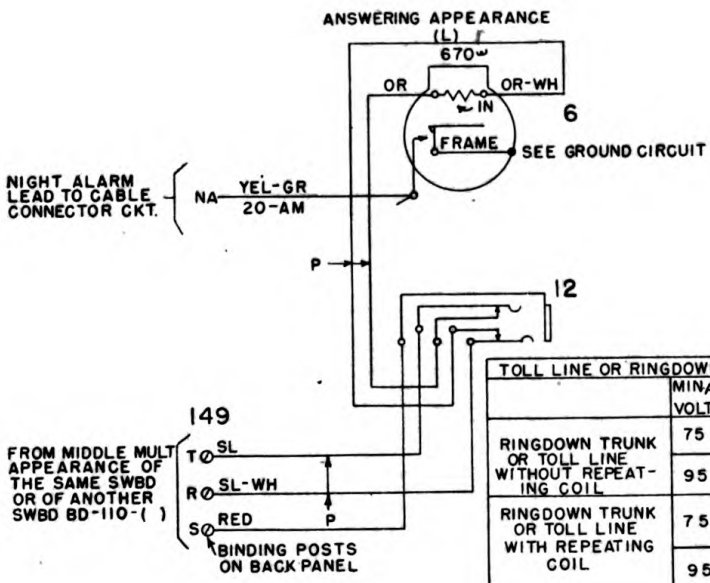
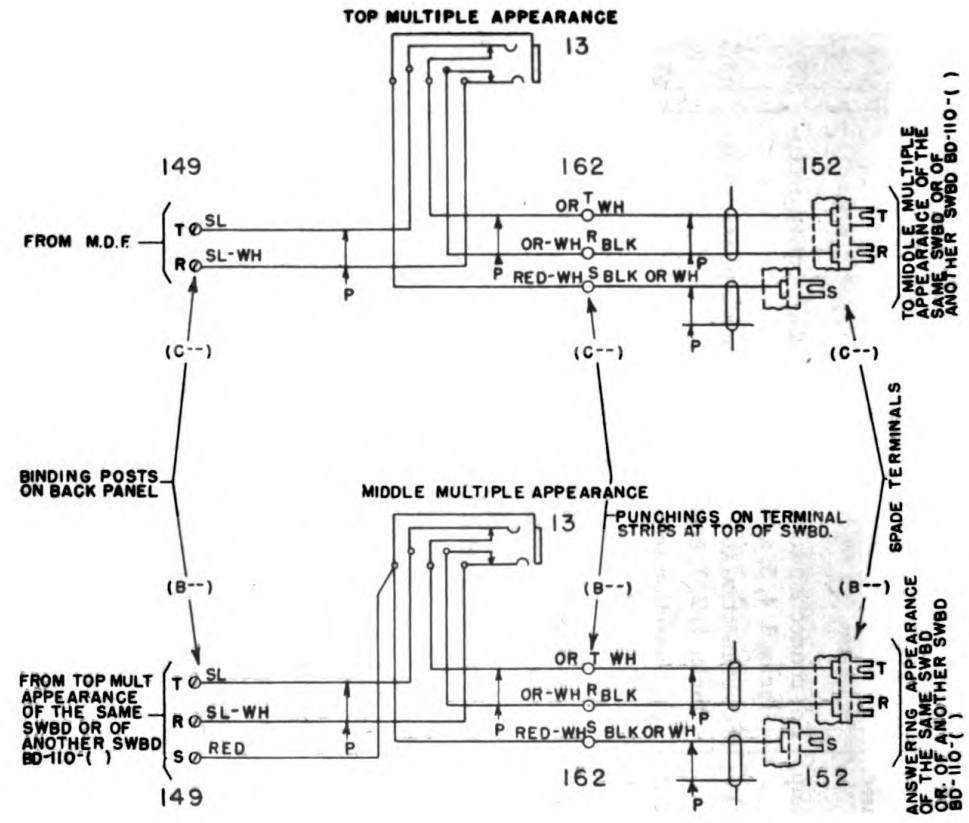
TABLE VI (continued)
PARTS REFERENCE TABLE

NOTE: Reference symbols appear in schematic diagrams or in the text.

<i>Ref symbol</i>	<i>Name of part and description</i>	<i>Function</i>	<i>Fig. No.</i>
536	RECEPTACLE: twist-lock; midget motor base; male; flush mounting; polarized; 2-conductor; 10-amp, 250-v.	Ringing power outlet (TELER).	46
537	RECEPTACLE: same as ref. No. 536.	Ringing power outlet (INT).	46
538	RECEPTACLE: twist-lock; motor plug; flush base in casing; male; polarized; 3-conductor; 20-amp, 250-v.	For connection to battery charger (BAT CHG).	46
539	RECEPTACLE: motor plug; flush base; male; polarized; 3-conductor; 10-amp, 250-v; or 15-amp, 125-v.	D-c power outlets (A) and (B).	46
542	RECEPTACLE: metal housing equipped with 2-conductor, round-prong, female, polarized receptacle; 30-amp, 250-v.	For connection to battery and to switchboard.	46
543	RELAY: flat-type; 3,500-ohm winding; 1 break contact; equipped with individual cover.	Night alarm release relay (AR).	43
544	RELAY: flat-type; 750-ohm winding; 2 make contacts; equipped with individual cover.	Night alarm lock-in relay (NA).	43
545	RELAY: polarized; 25-ohm winding; 1 set of transfer contacts.	Night alarm relay (AU).	43
546	RELAY: a-c operated; 3,000-ohm winding; 1 set of transfer contacts; equipped with individual cover.	No-voltage alarm control relay (A).	45
547	RELAY: general purpose; 3,300-ohm winding; 1 set of transfer contacts.	No-voltage alarm audible cut-off relay (B).	45
548	RESISTOR: fixed; wire-wound; flat-type noninductive; 5-w; 5,000-ohm $\pm 5\%$.	Resistor (C) to delay operation of night alarm relay (NA).	43
549	RESISTOR: same as ref. No. 548, except 5-ohm $\pm 5\%$.	Interrupter contact protection resistor (A).	46
550	RESISTOR: fixed; wire-wound; noninductive; flat; punched; iron core; 3-ohm.	Resistors (A) and (B) of night alarm bridge network.	43

552	TELERING: vibrator-type ringing generator; operates on 110-v, 60-cycle; delivers 95-v, 20-cycle current.	Ringing power generator.	46
562	VOLTMETER: d-c; 0- to 75-v, 2% accuracy; 75,000 ohms, D'Arsonval-type; 3½" flush mounting; self-contained; calibrated for 0.09" steel panel.	Indicates the battery voltage.	46
603**	RECEPTACLE: composition; duplex; female; 2-conductor; 10-amp, 250-v; or 15-amp, 125-v.	For connection to circuits requiring a-c power, receptacles 3, 4, 5, and 6.	65
604**	RECEPTACLE: female; twist-lock; 2-conductor; 20-amp, 250-v; composition body 1⅞" diam and 1¼" long, flush mounting.	For connection to circuits requiring a-c power; receptacles 1, 2, 7, and 8.	65
605**	RECEPTACLE: metal housing 2¼" diam and 1⅜" long, base mounting; equipped with 2-pole, round-prong plug receptacle; female; polarized; 30-amp, 250-v a-c (same as ref. No. 542).	For connection to a-c power supply.	65
606**	CIRCUIT BREAKER: magnetic; 2-pole; 230-v a-c, 25-amp; toggle action, manual reset; time delay curve D; black bakelite case; 5⅝" x 3½" x 3" over-all.	Control and overload protection for circuits connected to receptacles (ref. Nos. 603 and 604).	65
701	CHEST UNIT T-26: carbon transmitter fastened to metal chest plate with special hinged fastening; includes 2 straps and 1 switch.	Operator's transmitter unit.	38
709	PLUG PL-58: 3-conductor; 3 brass prongs molded in phenol mounting.	For connecting head and chest set to switchboard.	38
710	RECEIVER R-22: telephone receiver in metal case with phenol cap; 2⅝" diam; 1½" long.	Operator's receiver.	38
722	RECEIVER R-30: magnetic receiver unit in small metal case.	Operator's receiver.	38
731	CHEST SET TD-1.	Operator's transmitter unit.	38
741	CORD: 4-conductor; rubber-insulated; 6 ft long.	Connects plug to transmitter and receiver.	38
742	PLUG: two 2-conductor plugs loosely mounted in a phenol shell.	For connecting telephone set to switchboard.	38
743	RECEIVER: magnetic-type receiver unit in a phenol case; 135-ohm, 1,000-cycle.	Operator's receiver.	38
744	TRANSMITTER: carbon transmitter unit in metal case which is mounted on a metal chest plate; curved phenol transmitter horn.	Operator's transmitter.	38

** These references appear only on figure 65.



	TOLL LINE OR RINGDOWN TRUNKS SIGNALING RANGE			
	MIN. AC VOLTS	FREQUENCY	MAX. EXT. CABLE	COND. LOOP OPEN WIRE
RINGDOWN TRUNK OR TOLL LINE WITHOUT REPEATING COIL	75	16-2/3 OR 20 \sim	5000 ω	5000 ω
RINGDOWN TRUNK OR TOLL LINE WITH REPEATING COIL	95	16-2/3 OR 20 \sim	5000 ω	5000 ω
		75	16-2/3 OR 20 \sim	4000 ω
	95	16-2/3 OR 20 \sim	4500 ω	3900 ω
		20 \sim	5200 ω	4500 ω
MIN. INSULATION RES. 30,000 ω				

TL-50992

Figure 34. Magneto line circuit, wiring diagram, Switchboard BD-110-().

17. LINE CIRCUIT, MAGNETO (fig. 34). This circuit can be used with equipment employing 16- to 20-cycle ringing current for signaling. It cannot be used with telephones or circuits which require direct current for supervisory or transmission purposes, since no direct current is applied to the line through this circuit. Ringing current applied to the circuit from the line causes the drop to fall. Contacts on the drop close a night alarm circuit and give an audible signal when the drop falls. When a line is in use, a busy signal is provided through the sleeve of the plug in the multiple jacks from battery in the associated cord circuit. The magneto line circuit may be connected to the following types of equipment or circuits:

a. Military local battery (magneto) telephones such as Telephone EE-3-(), EE-4-(), EE-5, and EE-8-().

b. Commercial local battery (magneto) telephones.

c. Switchboards as follows:

(1) Magneto line circuits in Switchboard BD-14, BD-71, BD-72-(), BD-80-(), BD-89-(), BD-91-(), BD-96, other BD-110-(), and commercial switchboards.

(2) Line circuits equipped with ring-down relays and arranged for two-way ringing in Switchboards BD-74 and BD-78 and in commercial switchboards.

18. TRUNK CIRCUIT, UNIVERSAL TWO-WAY TO DIAL OR MANUAL OFFICES (fig. 35). This is a universal trunk circuit with its associated dial circuit providing for two-way service between Switchboard BD-110-() and a dial (automatic) or a common battery telephone central office. This circuit can be connected to a telephone line circuit or a trunk circuit of a dial or manual common battery telephone central office. The trunk can be connected in place of any dial or manual common battery telephone.

a. Functions. The functions of the trunk circuit are as follows:

(1) To provide means for establishing incoming or outgoing connections to dial (automatic) or common-battery telephone central office.

(2) To provide a locked-in line lamp on incoming ringing signals.

(3) To make the jack-sleeve test busy when the line lamp is lighted.

(4) To provide an operating path for the night alarm circuit when the line lamp is lighted.

(5) To extinguish the line lamp when the call is answered.

(6) To close the loop toward the telephone central office when a plug is in the answering jack or in a multiple jack.

(7) To provide a through-ringing path for operating the cord-ringing relay when a plug is in the answering jack or in a multiple jack.

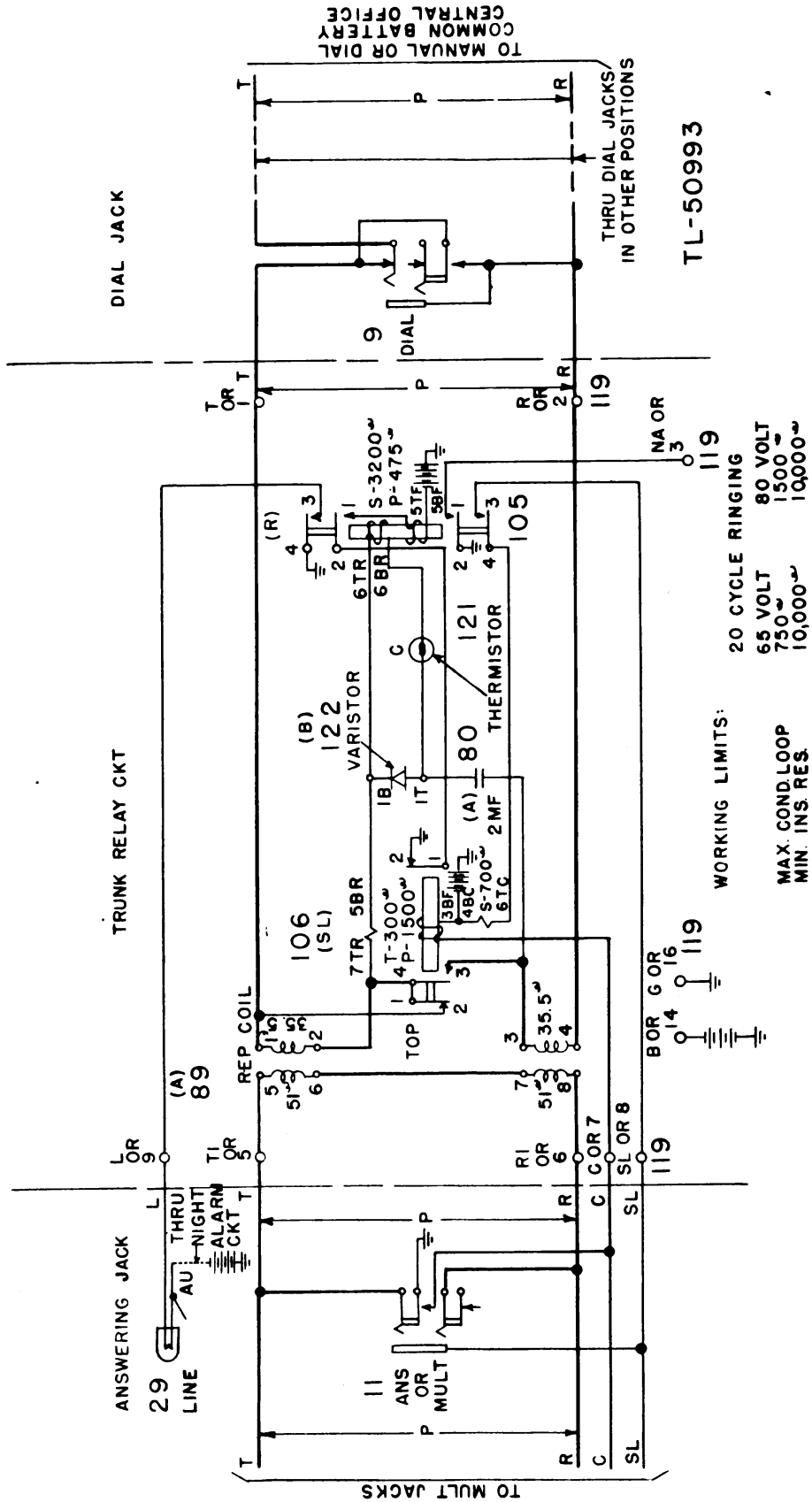


Figure 35. Universal trunk circuit, schematic diagram, Switchboard BD-110-().

- (8) To prevent a false line-lamp signal upon disconnection.
- (9) To provide a dialing path in the trunk which is free from series or bridged apparatus when the dial cord plug is in the dial jack.
- (10) To prevent a false pulse when the dial cord plug is inserted in the dial jack.
- (11) To provide a talking path when a cord plug is in the answering jack or in a multiple jack.
- (12) To provide for dial cord dialing.

b. Detailed Description of Outgoing Calls. (1) TO MANUAL COMMON BATTERY CENTRAL OFFICE. A cord-circuit plug inserted in the answering jack or in a multiple jack causes ground to be connected to the C lead which, in turn, operates relay SL. Relay SL closes the bridge on the inside of the repeating coil which signals the called central office.

(2) TO DIAL CENTRAL OFFICE. A cord-circuit plug inserted in the answering jack or a multiple jack causes ground to be connected to the C lead which, in turn, operates relay SL. Relay SL closes the bridge on the inside of the repeating coil to the central office. This operates the equipment at the called central office and dial tone can be heard in the operator's receiver. When the dial cord plug is inserted in the dial jack, the trunk circuit is disconnected from the line and short-circuited, and the dial is connected to the line. The short circuit in the repeating coil (in the trunk circuit) at this time prevents a dial pulse from being transmitted back through the switchboard to the calling party. When dialing is completed, the dial cord plug must be removed from this dial jack to permit listening for the ringing or busy back tones.

c. Detailed Description of Incoming Calls. (1) GENERAL. When ringing current is applied on the trunk circuit at the associated central office, relay R operates on its secondary winding and locks on its primary winding under the control of relay SL. Relay R does not operate immediately on the ringing current, because thermistor C is in series with the secondary winding. The thermistor is a thermal device which ordinarily has a very high resistance, approximately 100,000 ohms. During the ringing period, the thermistor heats up (in about $\frac{1}{2}$ second) and its resistance drops to approximately 1,000 ohms. This permits relay R to operate on the half-cycles of ringing current which are blocked by varistor B. In addition to locking up, relay R, operated, lights the lamp associated with the answering jack, connects ground to the night alarm circuit, connects battery through the 700-ohm winding of relay SL to the jack sleeve, and serves as a busy test in multiple switchboards.

(2) ANSWERING ON INCOMING CALLS. The insertion of the answering plug of a cord circuit in the answering jack extends ground over the C lead, through the contacts of the jack, and operates relay SL.

Relay SL, operated, removes the short circuit from one winding of the repeating coil, closes the repeating coil across the line, and opens the ground to the contacts of relay R. This releases relay R which extinguishes the lamp and opens the circuit to the night alarm circuit. When the circuit on the inside of the repeating coil is closed, it also discharges capacitor A through the varistor B and the 300-ohm winding of relay SL. Although this winding prevents the possibility of heavy surges of current from the capacitor which would result in welding or pitting of relay contacts, it does not interfere with the operation of relay R or ringing current. The closing of two windings of the repeating coil across the trunk trips machine ringing in the central office and provides a holding bridge for the central office connection.

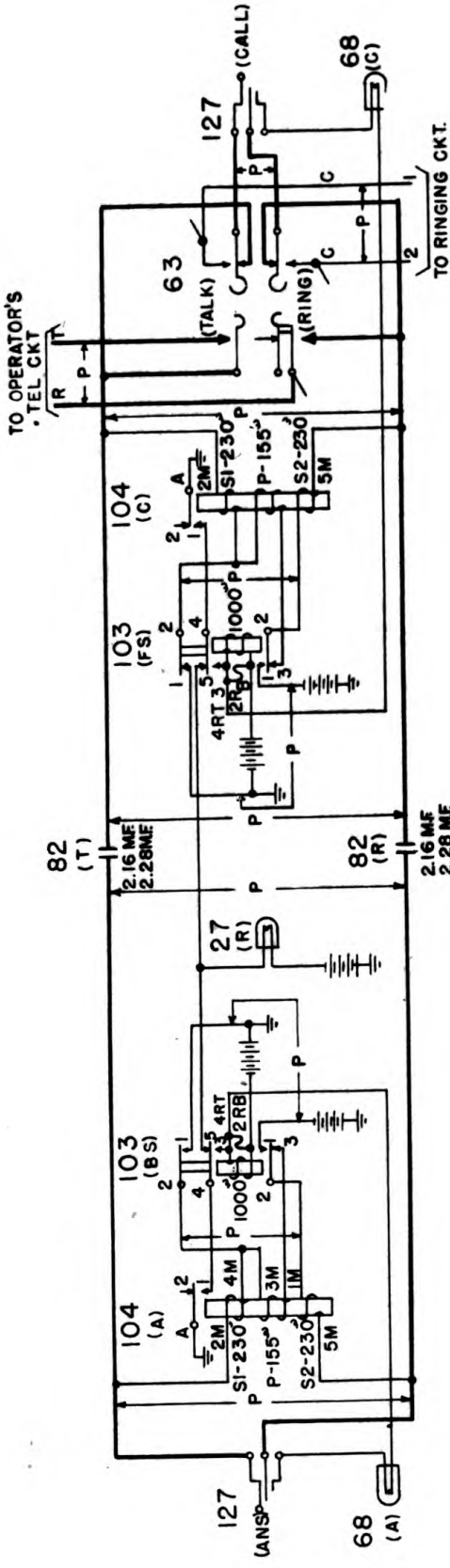
19. UNIVERSAL CORD CIRCUIT (fig. 36). These cord circuits are of the universal type. They provide for connections between common battery lines, between magneto lines, from common battery to magneto lines, and from magneto to common battery lines or trunks. Signal lamps located on the keyshelf (fig. 21) between the key and plug provide for supervision on common battery lines. Signal lamps located in the face of the switchboards behind the plugs and below the magneto line drops (fig. 20) provide for recall and disconnect signals on magneto lines.

a. Functions. The functions of the universal cord circuit are as follows:

- (1) To provide means for supervising common battery connections.
- (2) To provide means for making busy tests.
- (3) To provide means for connecting the operator's telephone set to the cord circuit.
- (4) To provide means for ringing on either the tip or ring of the calling cord.
- (5) To provide means for establishing talking connections.
- (6) To provide a nonlocking lamp ring-off signal on magneto line connections.

b. Connection to Magneto Lines. (1) **INCOMING CALLS.** The insertion of the plug of the answering cord into the jack of a magneto line in response to a call prevents the BS relay from operating, and the A lamp from lighting, since the sleeve circuit of the line jack is open (fig. 34). Under this condition, the three windings of the A relay are connected-series aiding, and remain bridged across the tip and ring of the answering cord for ring-off supervision. Answer the call with the talk-ring key in the TALK position.

(2) **OUTGOING CALLS.** The insertion of the plug of the calling cord into a multiple jack of the magneto line prevents FS relay from operating since the sleeve circuit of the line jack is open. Under this condition, the



WORKING LIMITS:

COMMERCIAL TOLL LINES OR RINGDOWN TRUNKS		MAGNETO LINES		COMMON BATTERY LINES
16-2/3~		20~		
75 V.	95 V.	75 V.	95 V.	20 PARTY LINES USING 5 BAR HAND GENERATORS & 1000 RINGERS
CABLE WIRE	OPEN WIRE	CABLE WIRE	OPEN WIRE	
4000 ^m	4000 ^m	4000 ^m	4000 ^m	2500 PARTY LINES USING 5 BAR HAND GENERATORS & 2500 RINGERS
1700 ^m	2400 ^m	2900 ^m	3200 ^m	
30,000 ^m	30,000 ^m	30,000 ^m	30,000 ^m	800 ^m
				10,000 ^m
				10,000 ^m
				10,000 ^m

MAX. EXT. CONDUCT. LOOP WITHOUT REP. COIL IN TOLL LINE OR TRUNK
 MAX. EXT. CONDUCT. LOOP WITH REP. COIL IN TOLL LINE OR TRUNK
 MAX. EXT. CIRCUIT LOOP
 MIN. INSULATION RES.

TL-50994

Figure 36. Universal cord circuit, schematic diagram, Switchboard BD-110-().

windings of the C relay are connected-series aiding, and remain bridged across the tip and ring of the calling cord for the ring-down supervision. Operating the ringing key supplies ringing current to the line and rings the called party. The talk-ring key should be in the TALK position while not ringing so that the operator may know when a call is answered at the distant end of the line, since no supervision is obtained when the call is answered.

(3) **COMPLETION OF CONVERSATION.** When the magneto telephone user disconnects, ringing current is applied to the line through the operation of a hand generator at the magneto station, operating either the A or C relay, depending upon which cord is connected to the magneto line. The operation of the A or C relay lights the R lamp during the time that ringing current is applied, thus providing a non-locked-in disconnect signal.

c. Connection to Conference Circuit. The insertion of the plug of a cord into a conference circuit jack prevents the BS or FS relay from operating because the jack circuit is open at the sleeve. The three windings of the A or C relay are connected series-aiding, and remain bridged across the tip and ring of the cord. In the normal use of the conference circuit, the relays associated with the half of the cord circuit connected to the conference jack do not function.

d. Connection to Common Battery Lines. (1) **INCOMING CALLS.** When the plug of the answering cord is inserted into the jack of the common battery line in response to a call, the ground on the line jack sleeve causes the BS relay to operate and light the A lamp. The operation of the BS relay connects ground and battery to the tip and ring of the cord through the S1 and S2 windings of the A relay, operating the A relay which short circuits the A lamp, thus extinguishing the answering supervisory lamp. Now, with the talk-ring key in the TALK position, the call can be answered.

(2) **OUTGOING CALLS.** The insertion of the plug of the calling cord into a multiple jack of a common battery line causes the FS relay to operate and the C lamp, in series with the FS relay, to light. The operation of FS relay connects ground and battery, respectively, to the tip and ring of the calling cord through the S1 and S2 windings of the C relay. Operating the ringing key applies ringing current to the line and rings the called party. When the called party answers, the C relay operates and short circuits the C calling supervisory lamp, thus extinguishing the lamp.

(3) **COMPLETION OF CONVERSATION.** When a conversation is completed and the parties hang up, the circuit is broken at each telephone hook switch or lever switch. This releases the A and C relays and lights the A and C supervisory lamps. The associated cords may now be

disconnected from the jacks. This releases the BS and FS relays, and extinguishes the A and C lamps, thereby restoring the circuit to normal. The noninductive windings of relays FS and BS act to slow down the collapse of the magnetic flux of these relays on disconnection.

e. Connection to Universal Trunk Circuits. (1) **INCOMING CALLS.** In response to an incoming call signal, the plug of an answering cord is inserted into the line jack of a trunk. The supervising lamp A will not light as it does when the plug is connected to a common battery line, since the sleeve of the trunk jack is not grounded. Supervision of the connection depends upon the lamp associated with the cord connected to a local line. Should the local operator fail to disconnect the cords at the completion of a call, the distant operator can light the A supervisory lamp by placing ringing current on the line thus causing the recall lamp to light through the operation of the A relay.

(2) **OUTGOING CALLS.** The insertion of the plug of a calling cord into the line jack of an answering or multiple jack of a trunk circuit prevents the FS relay from operating, since the sleeve of the trunk jack is not grounded. Therefore, lamp C associated with the calling cord will not light and will not provide calling cord supervision.

(3) **COMPLETION OF CONVERSATION.** When the conversation is completed and the parties hang up, the A or C relays associated with the cord connected to the line in Switchboard BD-110-() are released. This lights the A or C supervisory lamp and serves as a disconnect signal. The cords are taken down, releasing BS or FS relays, extinguishing the A or C lamp, and restoring the circuit to normal.

f. Busy Test. When making a busy test, the TALK-RING key is operated to TALK. The tip of the plug of the calling cord is touched to the sleeve of the multiple jack of the called line. A click of the receiver of the associated operator's telephone circuit indicates a busy line. If there is no click, the line is idle, and the plug of the calling cord may be inserted into the multiple jack of the called line. (See par. **21b** (2) for a detailed description.)

20. RINGING CIRCUIT (fig. 37).

a. With the keys of the ringing circuit in the normal position, ringing current passes through the resistance lamp and over the No. 2 lead; through the talk-ring key of the cord circuit, when operated to the ring position; and out on the ring side of the line to ring bells connected from the ring side of the line to ground. With the master ringing MR key operated, the ringing leads to the cord circuit are reversed, and ringing current goes out on the tip of the line to ring bells connected from the tip to ground. Bells connected across the line will ring with the MR key in either position from ringing current on one side of the line through the bells to generator ground on the other side of the line. The resistance

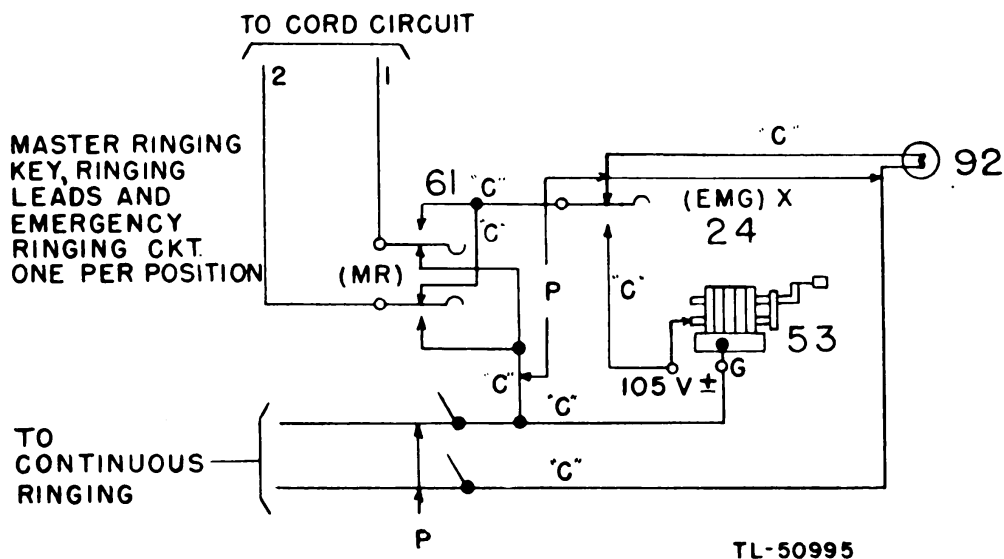


Figure 37. Ringing circuit, schematic diagram, Switchboard BD-110-().

lamp protects against overload by the increase in resistance of the tungsten filament as the current through the lamp increases.

b. Operation of the emergency ringing EMG key opens the continuous ringing lead and places the hand generator across the ringing leads. Turning the crank of the hand generator provides the ringing power.

21. OPERATOR'S TELEPHONE CIRCUIT (fig. 38). This circuit is used by the operator for talking, monitoring, and making busy tests.

a. Functions. The functions of the ringing circuit are as follows:

- (1) To permit the operator to talk over cord circuits.
- (2) To permit the operator to monitor.
- (3) To permit the making of busy tests.
- (4) To permit the operator to use cords of adjacent switchboards.

b. Detailed Description. (1) TALKING AND MONITORING. The operation of the talk-ring key of the associated cord circuit connects the telephone circuit to the cord circuit for talking, monitoring, or for making busy tests. The operation of first the MON key and then the talk-ring key to TALK allows monitoring of a connection. The MON key operates the M relay; the M relay disconnects the tip and ring leads and the operator's receiver from the induction coil, and connects them to the monitoring repeating coil. This permits the operator to listen in on the connection and renders the transmitter ineffective. The repeating coil bridged across the tip and ring of the cord circuit causes very little transmission loss. Restoring the MON key to normal position causes M relay to release, and restores the circuit to normal.

(2) **BUSY TEST.** By means of the A, B, C, and D resistors, the A capacitor, and the BT retardation coil, tests may be made on the sleeves of lines which are connected either to battery or to ground when busy. The insertion of the plug of the operator's telephone in the telephone jack operates the T relay, and connects ground to the C resistor which, with the A and B resistors, forms a potentiometer. Current flowing through this potentiometer sets up a potential at the junction of resistors B and C. This junction is connected with the A capacitor and the tip and ring of the telephone circuit through the windings of the BT retardation coil. When the tip of the cord touches the busy-line sleeve (which may be connected to either battery or ground), the difference between the potential of the junction of the B and C resistors and the potential of the sleeve of the line causes a surge through the winding of the induction coil and causes a click in the listening operator's receiver. This click re-occurs when the tip of the cord is removed from the busy-line sleeve of the jack. If the line is not busy, no click occurs when the tip of the plug is touched to the sleeve of the jack.

(3) **GROUPING** (figs. 36, 38, and 39). Operation of the GR key of Switchboard BD-110-() opens the T and R connections between the talk-ring keys of the cord circuits and the telephone circuit. The T and R leads from the cord circuits are connected through the make contacts of the GR key to the telephone circuit of an adjacent position. With the GR key operated, operating the talk-ring key of any cord circuit to TALK on a position will allow the operator on the *adjacent* position to talk to or monitor on parties connected to this cord circuit and to test for busy with the calling plug of this circuit.

(4) **ALTERNATE OPERATOR'S SET.** To permit the use of a standard Headset HS-30 and Chest Set TD-1 instead of the conventional 4-wire operator's set, a 3-wire jack and associated repeat coil are provided.

22. AUXILIARY OPERATOR'S TELEPHONE CIRCUIT (fig. 40).

This circuit is used to permit a second operator on the switchboard when traffic conditions warrant.

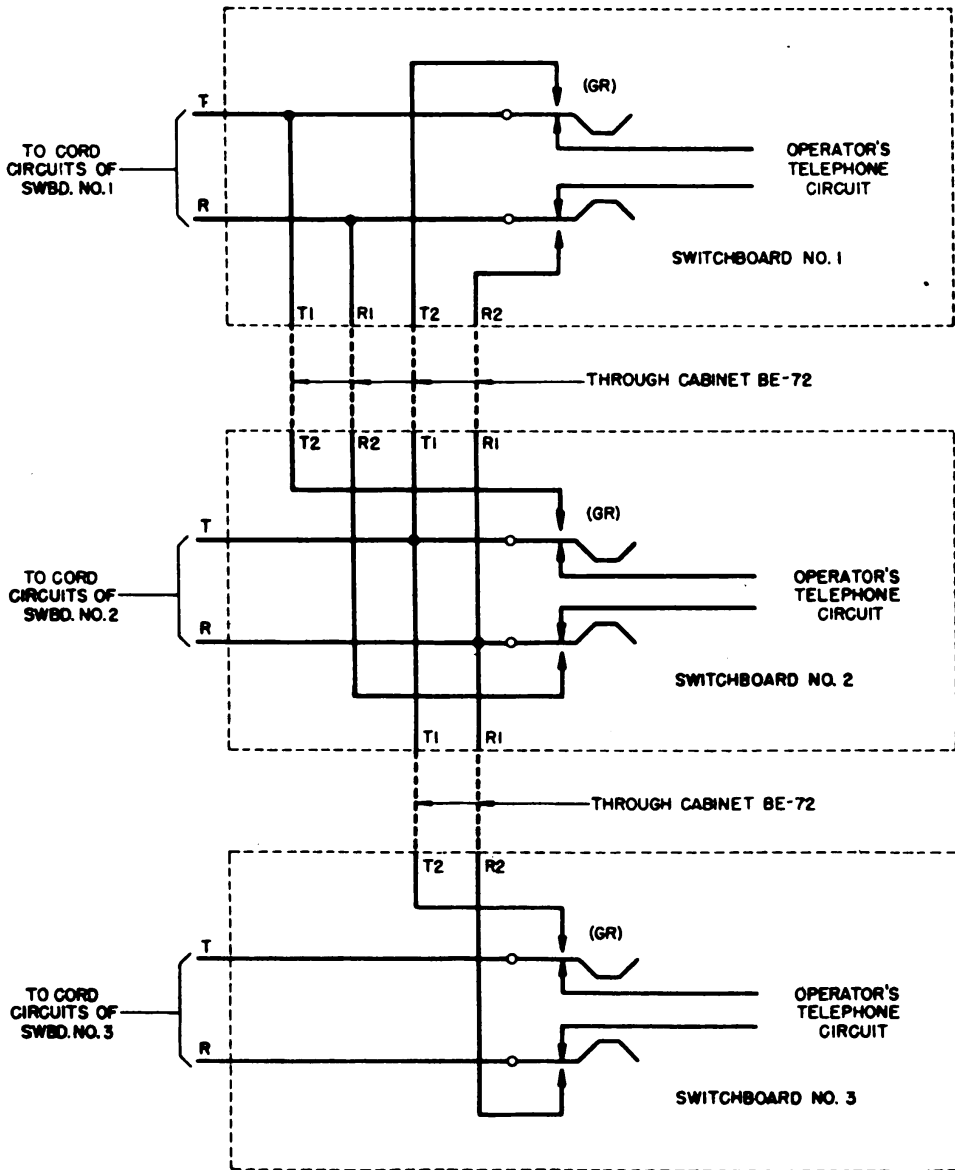
a. Functions. The functions of the auxiliary operator's telephone circuit are as follows:

- (1) To permit the operator to talk over magneto lines and universal trunks from field telephone used as an operator's telephone by means of a patching cord or the universal cord circuit.
- (2) To permit the operator to talk over common battery lines by means of the universal cord circuit.
- (3) To permit the making of busy test.
- (4) To provide busy signals on magneto lines when a patching cord is used.

b. Detailed Description. The location of front and keyshelf equipment is shown in figures 20 and 21.

(1) **AUXILIARY OPERATOR'S CIRCUIT.** The auxiliary operator's telephone circuit is completed by patching from the TEL jack to a field telephone by means of a two-wire, plug-ended cord (fig. 40).

(2) **ANSWERING CALL.** When the answering plug of a universal cord circuit is inserted into the jack of the calling line or trunk, and the calling plug is inserted into the LINE jack, the line is connected to the field telephone. With magneto lines and trunks, a patching cord with



TL-50977

Figure 39. Grouping circuit, functional diagram, Switchboard BD-110-().

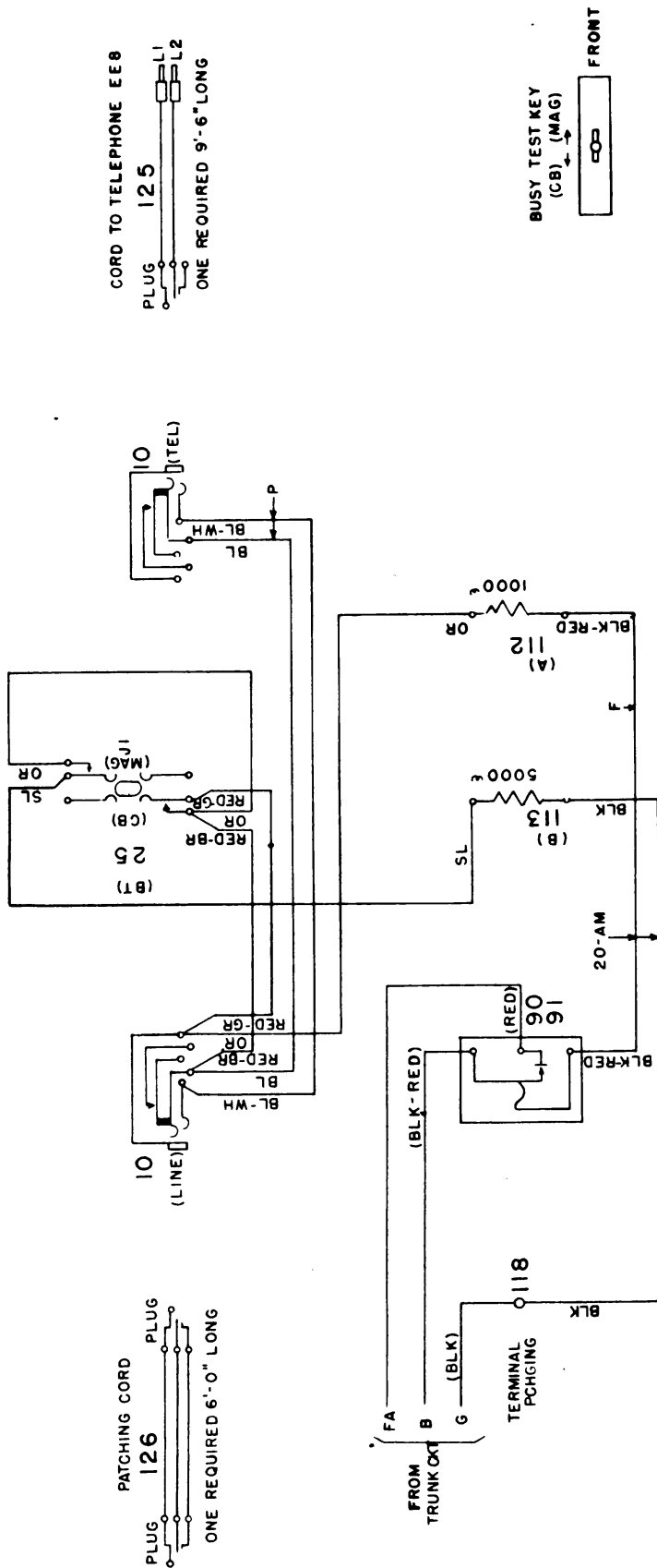


Figure 40. Auxiliary operator's telephone circuit, wiring diagram, Switchboard BD-110-().

TL-50998

plugs on each end can be used instead of a cord circuit.

(3) **MAKING CALL.** When the answering plug of a cord circuit is inserted into the LINE jack, and the calling plug is inserted into the jack of the desired line or trunk, ringing current is supplied through the talk-ring key of the cord circuit. Magneto lines are connected with a patching cord instead of a cord circuit. In this instance, ringing current is supplied from the field telephone.

(4) **BUSY TEST ON MAGNETO LINE OR TRUNK.** A circuit is prepared for testing on a magneto line or a universal trunk by operation of the BT key to MAG which grounds one side of the circuit through the busy test circuit. When the sleeve of the jack being tested is touched with the tip of the plug of the patching cord, a circuit is completed through the field telephone. If the line or trunk is busy, battery is connected (from the cord circuit causing the busy condition) to the sleeve. The test completes a circuit through the capacitors of the field telephone and the B resistor to ground. The surge of current in the charging of the capacitors in the field telephone causes a click in the receiver. When the circuit is broken, the discharge of the capacitors causes another click.

(5) **BUSY TEST ON COMMON BATTERY LINE.** A circuit is prepared for testing on a common battery line, by operation of the BT key to CB. In this instance, ground is connected to the jack sleeve of a busy line. The test completes a circuit to battery through the field telephone and the A resistor.

(6) **BUSY SIGNAL.** When the patching cord is used in connection with magneto lines instead of a cord circuit, a busy signal is provided by the extension of battery through the A resistor to the sleeve of the line jack.

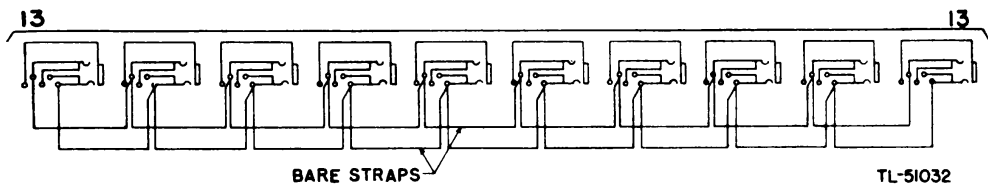


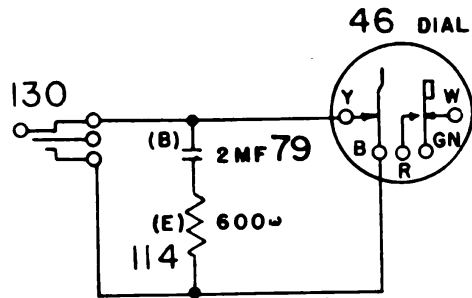
Figure 41. Conference circuit, wiring diagram, Switchboard BD-110-().

23. CONFERENCE CIRCUIT (fig. 41). This circuit consists of ten jacks wired in parallel to connect a number of lines for conference purposes. All lines connected to the conference circuit by switchboard cords (par. 12g) are connected together by straps between the conference jacks. A person talking at any station can then be heard by all connected stations.

24. DIAL CORD CIRCUIT

(fig. 42). With the plug of the dial cord circuit inserted in the DIAL jack of the trunk circuit, the equipment in the dial office is held through the pulse contacts of the dial. When the dial returns to normal from any operated position, the pulse contacts

are momentarily opened a number of times, corresponding to the operated position. Thus if the dial is pulled to 9 and released, the dial contacts will be momentarily opened nine times while the dial is returning to normal. Capacitor B and resistor E protect the dial contact from excessive arcing.



TL-50999

Figure 42. Switchboard BD-110-(), dial cord circuit, schematic diagram.

25. CABINET BE-72 TEST CIRCUITS. The test circuits in Cabinet BE-72 provide a convenient means of setting up connections for testing various circuits in the switchboard, and for testing on lines. For use and detailed function of test circuits see paragraph 31.

a. Voltmeter Test Circuit. The voltmeter test circuit can be used to perform the following functions:

- (1) To ring on magneto or common-battery lines.
- (2) To provide a talking connection to magneto or common-battery telephone users with the operator's telephone set in a switchboard position, or with a subset connected to the test set.
- (3) To provide for disconnecting the voltmeter and test battery when ringing or talking on a line.
- (4) To reverse the connections from the tip and ring of the line to the voltmeter and test battery.
- (5) To connect ground to one side of the line for the purpose of making tests for crosses and insulation resistance.

b. Switchboard Test Circuit. The switchboard test circuit is used for making routine tests and for locating trouble in the switchboard circuits. It can be used to perform the following functions:

- (1) To check the continuity of lamps in common-battery line circuits.
- (2) To check the make-and-break contacts of the common-battery multiple line jacks.
- (3) To apply a d-c operate test to the line drops of the magneto lines and trunk circuits.
- (4) To check the operation and to provide means for readjusting the night alarm relays.

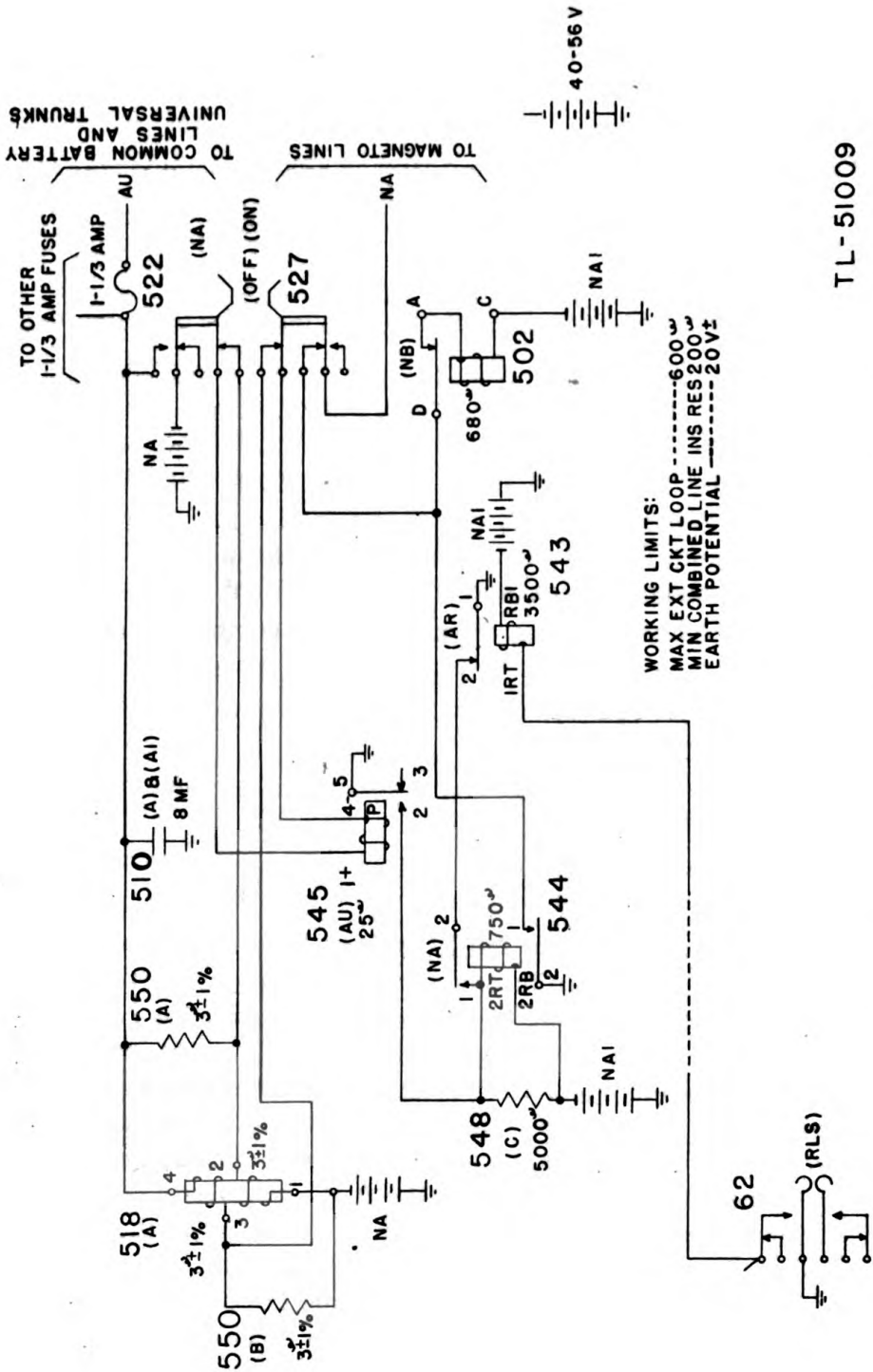
- (5) To provide means for testing for defective cords, plugs, and keys.
- (6) To apply an operate-and-release test to the supervisory relay.
- (7) To apply a nonoperate test to the sleeve relay.
- (8) To apply an operate test to the sleeve relay.
- (9) To provide means for testing the ringing contact of the ringing keys.
- (10) To provide means for testing for non-click on the TALK-RING keys.
- (11) To provide operate test on a-c ringing relays in universal trunk circuits:
 - (a) To apply a ringing current operate test to the a-c ringing relay of the universal trunk circuits.
 - (b) To apply a d-c operating test to the bridging relay of the universal trunk circuit.

26. NIGHT ALARM CIRCUIT (fig. 43).

a. Functions. The night alarm circuit can be operated to perform the following functions:

- (1) To give an audible signal on incoming calls from common-battery subscriber lines, magneto lines, and trunk lines.
- (2) To silence the audible night alarm signal for common-battery lines when the RLS key is operated.
- (3) To remove the night alarm circuit from service when the night alarm signal is not required.
- (4) To open both sides of the winding of the AU relay when the NA key is operated.
- (5) To connect the battery directly to the AU lead for the purpose of lighting the line lamp without giving an audible signal.

b. Detailed Description of Night Alarm Circuit. When the NA key is normal and there is an incoming call from any magneto line, the drop shutter closes the circuit to ground. This causes the NB bell to operate, providing an audible signal to the operator. Restoration of the drop shutter to normal opens the circuit and silences the bell. When a call originates on any of the common-battery lines, common-battery manual trunks, or dial trunks, a circuit is closed from battery through the Wheatstone net which consists of the A retardation coil and the A and B resistors through the line lamp to the ground. When the circuit is first closed, a surge of current flows from the battery through the B resistor, the AU relay, the A resistor, the line lamp, and the line to ground, and operates the AU relay. This current flows through the relay since the inductance in the windings of the A retardation coil prevents the current from building up rapidly in these windings. When the build-up is complete in the windings of the A retardation coil, the current no



TL-51009

Figure 43. Night alarm circuit, schematic diagram, Panel BD-90.

longer flows through the AU relay, and the relay releases. By operating the AU relay, ground is connected to the NA relay which operates and holds through the back contact of the AR relay. The NA relay, when energized, operates the NB bell as an audible signal. Operating the RLS key energizes the AR relay and releases the NA relay which, in turn, silences the NB bell. When the night alarm is not required, the NA key is operated. This opens the operating path of the NB bell from the magneto line, connects battery directly to the AU lead, and disconnects the winding of the AU relay from the Wheatstone net circuit.

27. FUSE ALARM CIRCUIT (fig. 44). When a grasshopper battery fuse blows, its spring makes contact with the alarm stud of its fuse block. Battery on the spring connects through the FA buzzer to ground, and operates the FA buzzer as a warning signal that a fuse has blown. When the fuse is removed from the fuse block, the FA buzzer is silenced.

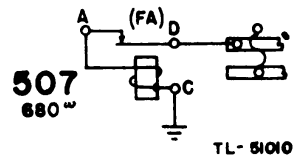


Figure 44. Fuse alarm circuit, schematic diagram, Panel BD-90.

28. NO-VOLTAGE ALARM CIRCUIT (fig. 45). This circuit provides an alarm when the ringing voltage decreases below a given value. The A relay is connected directly across the output leads from the ringing supply and is normally held operated by the ringing voltage. When the ringing voltage decreases below a predetermined value, the A relay releases, lighting the E lamp and operating the C buzzer. The buzzer is silenced by the operation of the (nonlocking) D key which operates the B relay. The B relay, operated under the control of the A relay, locks itself and silences the buzzer by opening the buzzer circuit. When the ringing voltage has been restored to normal, the A relay operates, removing ground from the rest of the circuit. This extinguishes the E lamp and returns the circuit to its normal condition.

29. PANEL BD-90 POWER AND RINGING CIRCUITS (fig 46).

a. The meters, receptacles, and circuit breaker switches on the upper front panel of Panel BD-90 provide for control, interconnection, and

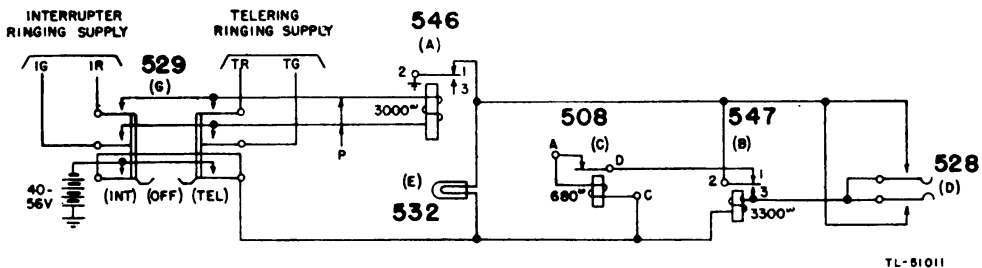
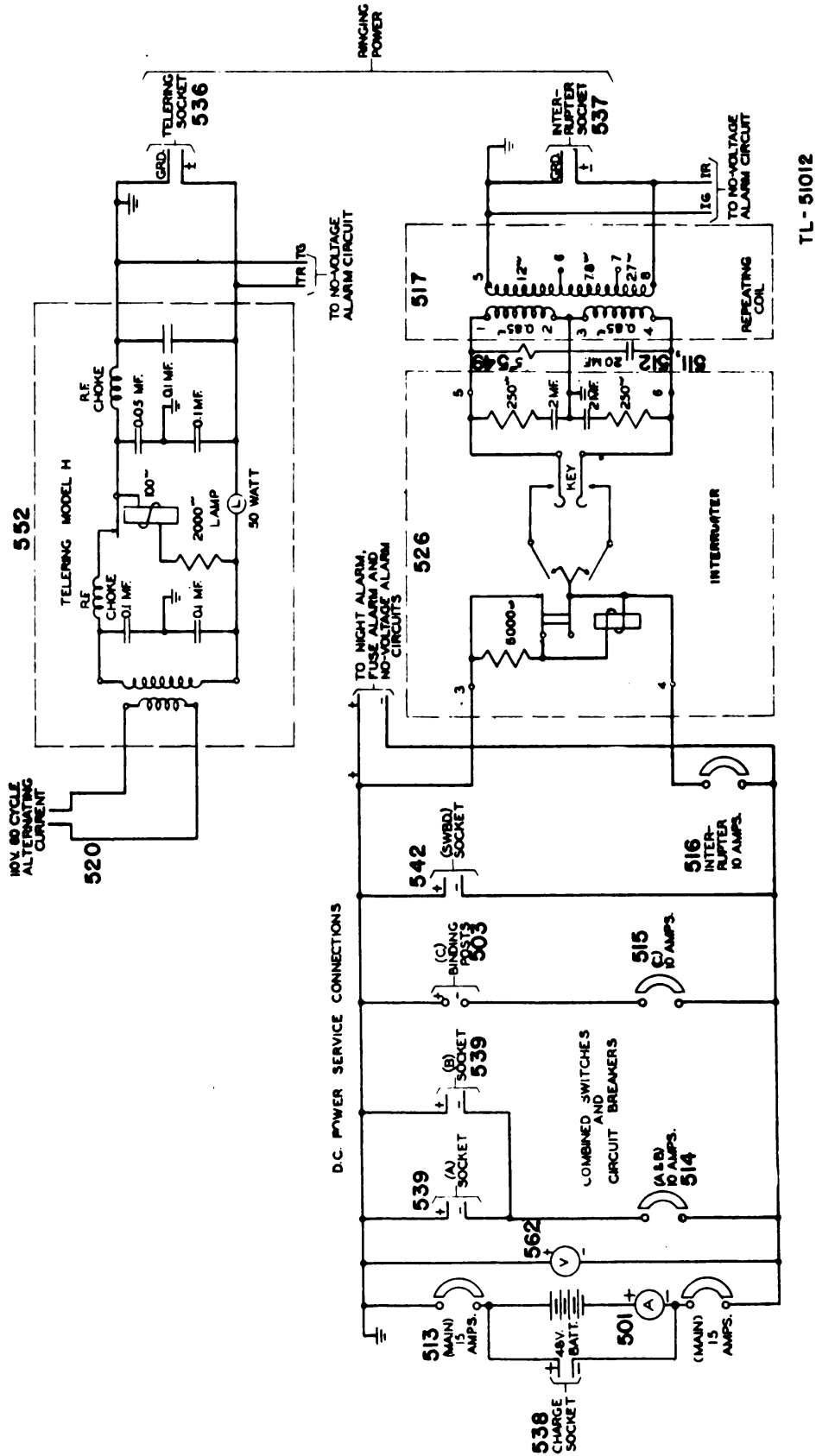


Figure 45. No-voltage alarm circuit, schematic diagram, Panel BD-90.



TL-51012

Figure 46. Panel BD-90, power and ringing supply circuits, schematic diagram.

protection of the 48-volt, d-c power circuits (fig. 8). The ammeter is connected to show the *difference* between the charge and discharge currents. Deflection in the charge or discharge direction will indicate which current is the greater. With the MAIN circuit breaker switch in the ON position, 48-volt, d-c power is connected to the switchboard and the alarm circuits. Power is connected to the A and B receptacles, the C binding posts, or the ringing interrupter when, with the MAIN circuit breaker operated, the respective circuit breaker switch is thrown to the ON position.

b. In the telering ringing generator, 60-cycle commercial power through the transformer drives a vibrating reed by buzzer action. The reed is tuned by a small weight and makes contact at proper intervals to allow 20-cycle current to be delivered at the TELER socket. Capacitors and radio-frequency chokes are used to avoid interference with radio circuits.

c. In the Western Electric Company's No. 84G ringing interrupter, a tuned vibrating reed is driven by 48-volt direct current through a buzzer contact. The reed vibrates at 16 to 20 cycles per second. Contact arms attached to the reed make a contact at each end of the stroke. Alternate make and break of the two contacts allows current to flow alternately through opposite transformer (repeating coil) primary windings to ground at the center tap. The secondary of the transformer is adjustable to provide the ringing voltage required. Capacitor and resistors are provided to prevent excessive burning of the contacts. The a-c line key is provided to prevent damage to the contacts; should the armature stick when the interrupter is started. Another key, not shown on the schematic, is provided but is not used in this circuit. This key reverses the d-c supply leads when the circuit is designed to connect these leads to terminals 1 and 2 of the interrupter.

SECTION IV

MAINTENANCE

NOTE: Unsatisfactory performance of this equipment will be reported immediately on W.D., A.G.O. Form No. 468. If Form No. 468 is not available see TM 38-250.

30. GENERAL.

a. Major sources of trouble in telephone equipment are:

- (1) Wires broken off.
- (2) Relay and keys out of adjustment.
- (3) Dirty key and relay contacts.

Trouble can be reduced to a minimum by careful handling while transporting, installing, and maintaining the equipment. This is particularly true of the cords attached to Frames FM-19 and to Switchboards BD-110-(). Reduce contact troubles by keeping the relay covers in place and the rear and cordpit doors of the switchboard closed when not working on the equipment. Move the wires as little as possible when locating trouble and repairing equipment, and do *not* move the wires to perform routine testing or cleaning.

b. Routine tests using the switchboard test circuit of Cabinet BE-72 are explained in paragraph 31 below. Make these tests immediately after installing the set; after a general cleaning of equipment; and, periodically, about once each month or as required. At frequent intervals, the switchboard cords and plugs should be inspected for worn cords and bent or worn plugs. Make an occasional inspection for tightness of the screws holding the fuses, cord tips, and terminal strips. Tests on a line should be made when the line is connected to the switchboard. These will ordinarily be made using Cabinet BE-70-(), but the voltmeter test circuit of Cabinet BE-72 can be used as explained in paragraph 31 below. Insulation resistance tests made on lines, especially if made during wet weather, are a good indication of the condition of the lines, and can be used as a guide in routine line maintenance. Refer to paragraph 13 for the working limits of connected lines.

c. Dirty key, relay, and jack contacts are the most common causes of central office trouble. Other common causes are open lamps, broken wires, and relays sticking due to dirt. Less common causes are crosses between apparatus terminals, lamps turned in their jacks to short the

lamp jack springs, and foreign material in the line and trunk jacks. If previous experience does not give a clue to the location of the trouble, set up the circuit, using the test circuits of Cabinet BE-72 or other switchboard circuits to simulate the conditions under which the trouble occurred. Examine the action of the circuit under these conditions. It is sometimes helpful to examine the position of the associated relays. If there is a question whether the trouble is in the line, cord, operator's telephone, or other circuit, substitute other circuits of the same type, one at a time, to associate the trouble with the proper circuit. Using a test receiver or a volt-ohmmeter, test for open contacts, wires, or parts, or for crosses or grounds which could cause the observed trouble. The repairman should be thoroughly familiar with the functioning of the circuits before attempting to locate trouble.

d. Start the emergency power equipment at regularly scheduled intervals and transfer the central office load to it. Make sure that the equipment is in good condition. Run it long enough for it to heat up and show signs of defects, if any. Transfer the ringing load from the inter-rupter to the telering or vice versa to insure the proper operation of both.

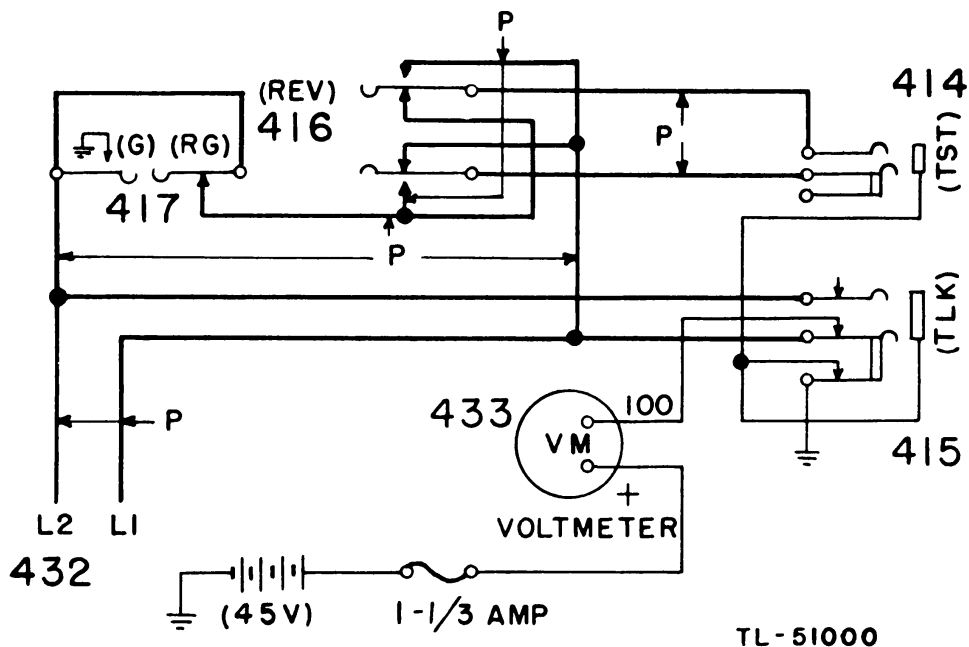


Figure 47. Cabinet BE-72, voltmeter test circuit, schematic diagram.

31. TESTING WITH CABINET BE-72.

a. **Voltmeter Test Circuit (fig. 47).** This circuit is used for routine testing of magneto and common-battery lines, and for making tests on out-of-order lines as follows:

(1) **VOLTMETER TEST.** (a) *Test for Grounds and Crosses.* To test for grounds on the ring side of the line, patch the line under test to the

TST jack and operate all keys to the normal position. This connects the voltmeter in series with the test battery to the ring side of the line. If the line is clear, the voltmeter will show no deflection or, at most, only slight deflection. However, in a magneto line with a bell connected directly from either the tip or ring lead to ground with no capacitor in series with the bell, a deflection will show. To test the tip side of the line for grounds, operate the reversing key REV. If, on the above tests, the voltmeter shows a reading in excess of the test battery voltage, it indicates a cross to battery on the line, probably a cross with another line. In this instance, the voltmeter reading will be the sum of the test battery voltage and the voltage of the battery cross.

(b) *Test for Short Circuits.* To test for short circuits, patch the line under test to the TST jack, and operate key G which on its contact, connects ground, in series with the voltmeter. Operate and restore the reversing key REV. If the line is short-circuited, the voltmeter will deflect to the approximate test-battery voltage reading, and will read the same when REV key is operated and restored.

(c) *Test for Continuity.* Conduct tests for continuity in a manner similar to that of the test for a short circuit (subpar. (b) above). Patch the line under test to the TST jack and operate the G key. Then operate and restore the REV keys several times. This will cause momentary deflections of the voltmeter needle as a result of charge and discharge of the capacitance on the line. If the needle does not return to zero after both operation and restoration of the REV key, it indicates trouble or line leak. Tests for grounds should always precede tests for continuity.

(d) *Insulation Resistance Tests.* These tests can be made only on lines on which the ringers are in series with capacitors. Patch the line under test to TST jack and operate the G key. If the line is free from faults or grounds, the deflection of the voltmeter before the calling party removes the receiver from the switchhook is a measure of the insulation resistance of the line. The insulation resistance may be calculated by the use of the following formula:

$$X = R \frac{E - V}{V}$$

Where X = unknown insulation resistance

R = resistance of voltmeter (100,000 ohms)

V = voltmeter reading

E = test battery voltage.

(e) *Testing Voltage of Test Battery.* Check the voltage of the test battery by first connecting a plug with tip and ring short-circuited to the TST jack and then operating the G key.

(f) *Ballistic Capacitance Tests.* Capacitance tests are made as described in subparagraph (c) above. The momentary deflection is a measure of the line capacity.

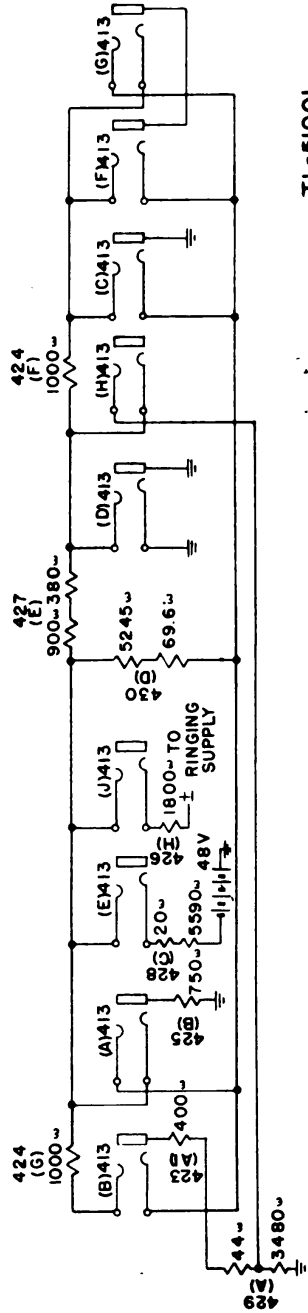
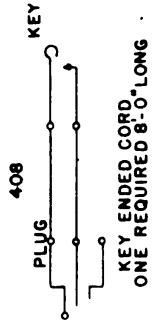
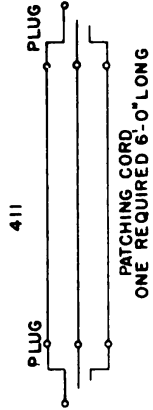
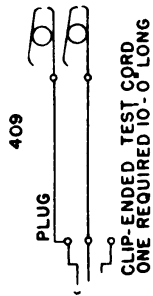
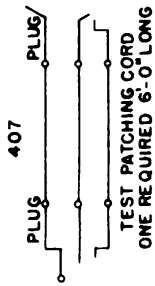
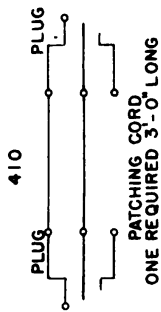
(2) TALKING AND RINGING. (a) *Talking to Telephone Users by Using Calling Cord.* When necessary to talk with the user of a magneto or common-battery telephone, patch the telephone user's line to the TST jack. Insert a calling-cord plug into the TLK jack, thus furnishing a transmitter battery supply from the cord circuit for a common-battery telephone, and disconnecting the voltmeter from the ring of the line. To ring the called party, operate the cord circuit talk-ring key in the regular manner. The talking connection from the operator's headset may be established by operating the cord circuit talk-ring key.

(b) *Talking to Telephone User by Using Subset.* When it is necessary to talk over a common-battery line using a subset wired to L1 and L2 terminal punchings, patch the line to the TST jack, and insert a calling cord plug into the TLK jack. Ring over the cord circuit in the regular manner. For a magneto line, use a magneto subset connected to L1 and L2. Patch the line to the TST jack, and insert a plug with tip, ring, and sleeve open into the TLK jack. Ring with the hand generator of the subset.

(c) *Ringng on Line with Receiver-off-hook Condition.* When a telephone user on a common-battery party line (bell circuits connected between either side of the line and ground) has left the receiver off the switchhook, the bell cannot be rung from the switchboard. To ring the parties on that line, operate the talk-ring key of the cord circuit connected to the TLK jack, and operate the RG key to open the ringing generator ground from the line. With the generator ground removed, ringing current passes through the bells to ground and rings the bells. The bells on both sides of the line usually ring at the same time because of the connection between the tip and ring through the station having a receiver off the hook; however, to be sure that all bells are rung, the REV key should be operated to ring on the tip side of the line.

b. Switchboard Test Circuit (fig. 48). This circuit is used in making routine tests and in locating trouble on the cord sleeve relays, supervisory relays, line lamps, line circuit drops, and night alarm relays. The tests are made from the front of the switchboard. Connect the circuit under test to the jacks in the switchboard test circuit, on the front of Cabinet BE-72, either with a cord circuit or by means of patching cords. Provision is made for giving the testman a visual or audible indication of the performance of the equipment under test. Before making any of the following tests, the testman should be familiar with the switchboard operation as outlined in paragraph 12. The tests are made as follows:

(1) CHECK OF CONTINUITY OF LINE LAMPS. First connect a test plug, with the tip and ring shorted, to the D jack. Connect one end of the two-conductor 3-foot, double-ended test cord 410 (fig. 48) to the C jack and insert the other end in a jack of the line under test until the



TL-51001

Figure 48. Cabinet BE-72, switchboard test circuit, schematic diagram.

tip of the plug makes contact with the ring-spring of a jack. This completes the circuit for lighting the associated line lamp through the 1,000-ohm resistor. The line lamp should light and thus indicate continuity of the filament.

(2) CHECK OF MAKE-AND-BREAK CONTACTS OF COMMON-BATTERY LINE MULTIPLE JACKS (fig. 49). With the associated talk-ring key operated to TALK, connect a spare cord circuit to the F jack. Then connect one end of the three-conductor, double-ended test cord 411 (fig. 48) to the G jack, and the other end to the jack under test. The supervisory lamp of the spare cord should light, due to ground on the sleeve of the line jack, and remain lighted as an indication of no trouble. If the tip or ring break contacts of a jack do not break, the supervisory relay of the spare cord will operate and extinguish the associated supervisory lamp as a trouble indication. In the event that the ring break contacts do not break, the line lamp will light as an additional trouble indication. In case the auxiliary make contacts of the jack do not make, the supervisory lamp of the spare cord will not light. This indicates trouble. A momentary make of the tip- or ring-contacts of the jack while rotating the plug in the jack under test causes a click in the operator's telephone receiver and indicates trouble in the jack.

(3) TESTING MAGNETO LINE CIRCUIT DROPS (fig. 50). To apply an operate test to the line drop of the magneto lines, connect the key-ended cord 408 (fig. 48) to the D jack and patch a jack of the line under test to the E jack by means of the test cord 407 (fig. 48), equipped with a test plug. First connect the test plug to the line circuit jack. The white line marked on the shell of the test plug shall be on the underside of the plug shell when inserting the plug in the jack. Remove the heat coils associated with the line under test. Then operate the key on the end of cord 408. This completes the testing path and applies the operate test current to the line circuit drop.

(4) TESTING AND READJUSTING NIGHT ALARM RELAYS.

(a) *Testing.* To test the operation of the night alarm relays, connect the key-ended cord 408 to the D jack, and connect a three-conductor patching cord 411 equipped with three-conductor plugs at both ends to the C jack. Hold the key on the end of the cord operated, and slowly insert the free end of the patching cord into a common-battery line jack until the tip of the plug makes contact with the ring-spring of the jack. This test is made with the night alarm key normal. The connection of the tip of the plug to the ring of the line jack should cause the night alarm to function and light the line lamp.

(b) *Readjusting.* If it is necessary to readjust the night alarm relays, select any common-battery line jack which has been checked as described in subparagraphs (1) and (2) above. The key-ended cord should be connected to the D jack, and one end of the three-conductor patching

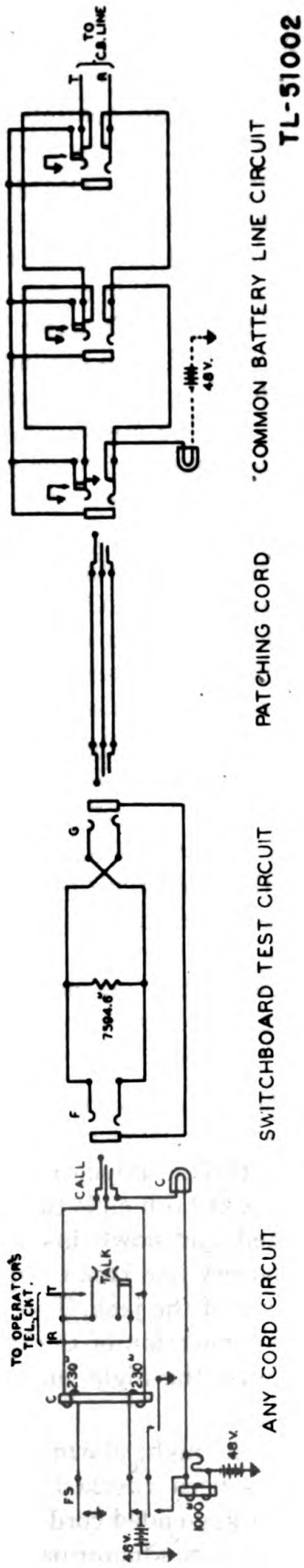


Figure 49. Test of contacts of common-battery line jacks, Switchboard BD-110-(), functional diagram.

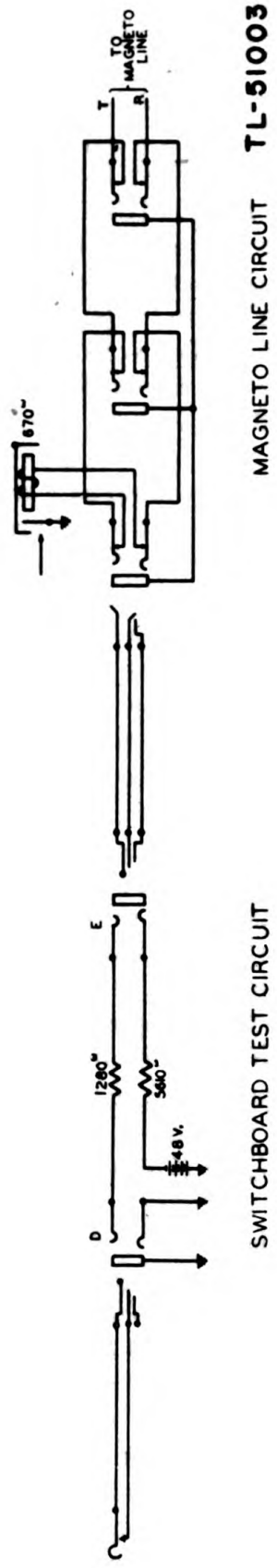


Figure 50. Test of magneto line circuit drops, Switchboard BD-110-(), functional diagram.

cord equipped with plugs should be connected to the C jack. With the key (on the end of the cord) operated, and with the night alarm key in normal position, insert the free end of the patching cord slowly into the common-battery line jack until the tip of the plug makes contact with the ring-spring of the jack. This will cause a surge through the winding of the polarized (AU) relay in the night alarm circuit. Adjust the relay to operate momentarily from this surge. Failure of the night alarm circuit to operate when the battery line lamp lights indicates faulty operation of the night alarm circuit.

(5) TEST FOR DEFECTIVE CORDS, PLUGS, AND KEYS. Connect a test plug with the tip and ring shorted to the A jack. With the talk-ring key of the cord circuit under test operated to TALK, connect the plug of the cord circuit under test to the C jack. Under this condition, a defective cord, plug, or key causes a click in the operator's telephone receiver.

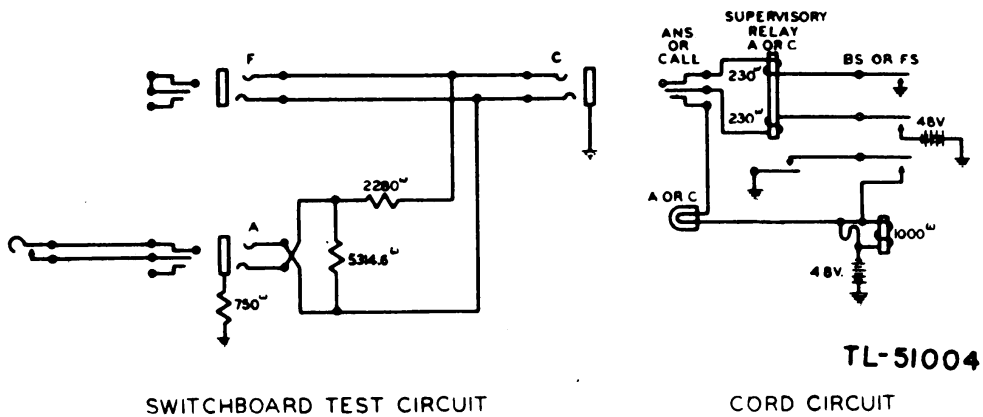


Figure 51. Test of supervisory relay, Switchboard BD-110-(), functional diagram.

(6) OPERATE AND RELEASE TEST OF SUPERVISORY RELAY (fig. 51). Connect the plug of the cord under test to the C jack, and connect the key-ended cord to the A jack. The supervisory lamp associated with the cord under test lights and remains lighted until the key on the end of the cord is operated. The operation of the key applies an operate test current to the supervisory relay. Release the key. This applies the release test current to the supervisory relay. Apply a soak current to the supervisory relay by momentarily connecting a test plug with the tip and ring shorted to the F jack. Continued lighting of the lamp after the operation of the key indicates a failure of the supervisory relay to operate on the operate test value. Failure of the supervisory lamp to relight upon release of the key or upon removal of the test plug indicates failure of the supervisory relay to meet its release test value.

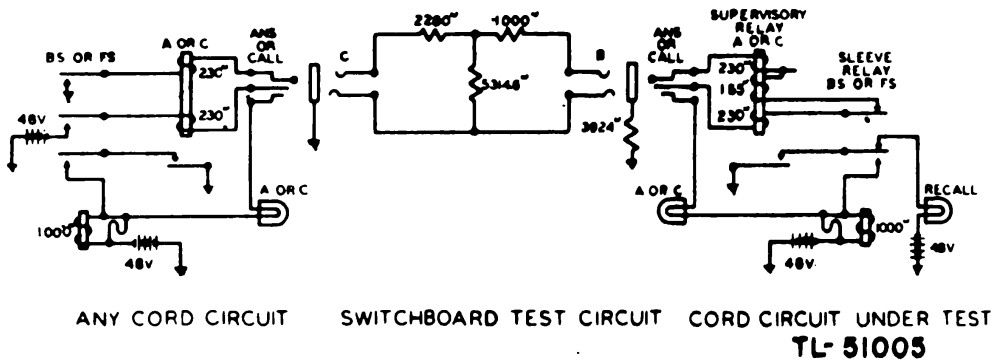


Figure 52. Test of sleeve and supervisory relays, Switchboard BD-110-(), functional diagram.

(7) NONOPERATE TEST OF SLEEVE RELAY AND CHECK TEST FOR CONTINUITY OF THREE WINDINGS OF SUPERVISORY RELAY (fig. 52). Connect the plug of the cord under test to the B jack, and connect the plug of any other cord to the C jack. This operates the supervisory relay, but not the sleeve relay. If the recall lamp of the cord under test lights, there is no trouble. This test, then, also performs a continuity test on the three windings of the supervisory relay. Failure of the recall lamp to light indicates that the sleeve relay fails to meet its nonoperate requirements, or that the supervisory relay fails to meet its operate requirements on the three windings.

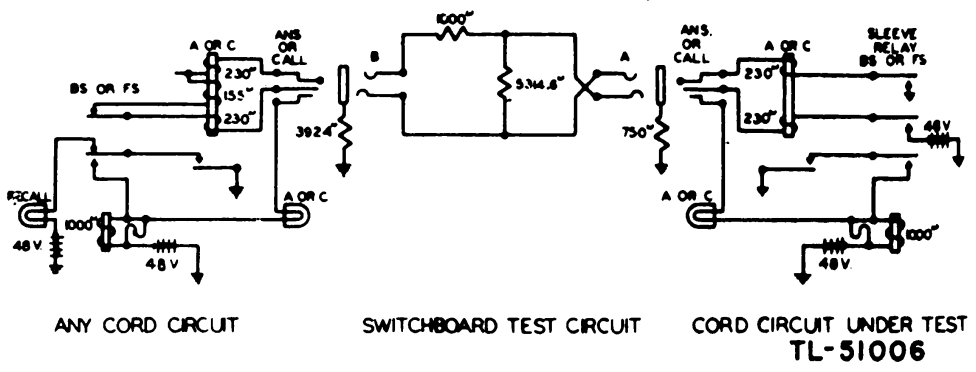


Figure 53. Operate test of sleeve relay, Switchboard BD-110-(), functional diagram.

(8) OPERATE TEST OF SLEEVE RELAY (fig. 53). Connect the plug of the cord under test to the A jack and connect the plug of any other cord to the B jack. If both the sleeve relay of the cord circuit under test and the supervisory relay of the cord circuit associated with the B jack operate satisfactorily, the recall lamp of the latter cord circuit will light, and the associated sleeve relay should remain inoperative. If the recall lamp associated with the B jack lights, there is no trouble.

(9) TALK-RINGING KEY TEST (fig. 54). Insert the plug of a spare cord in the F jack, and insert the plug of the cord under test into

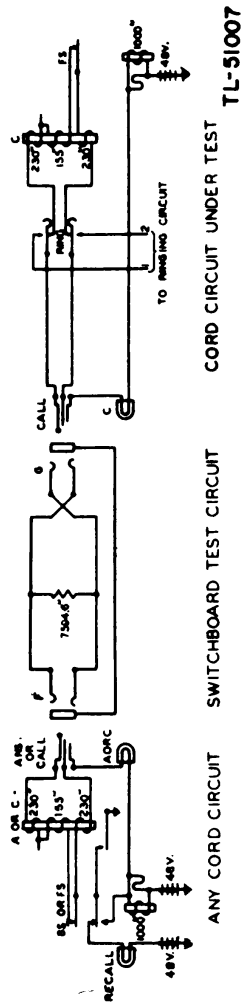


Figure 54. Ringing key test, Switchboard BD-110-(), functional diagram.

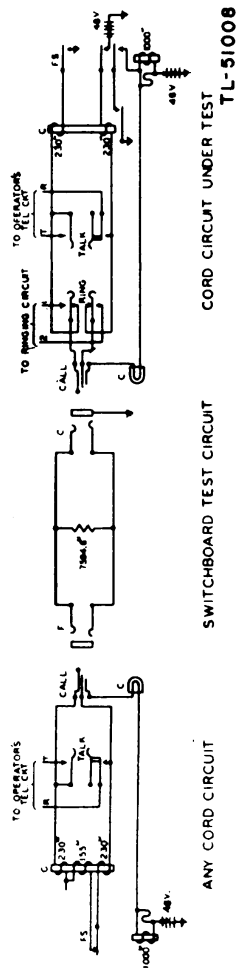


Figure 55. Nonclick test of talk-ring key, Switchboard BD-110-(), functional diagram.

the G jack. Then operate the talk-ring key of the cord under test to the RING position. If the recall lamp of the spare cord lights while the ringing key is operated, there is no trouble.

(10) **NONCLICK TEST OF TALK-RING KEYS** (fig. 55). Insert the plug of any calling (front) cord into the F jack and operate its associated talk-ring key to TALK. Then insert the plug of the calling cord under test into the C jack, operate its associated talk-ring key to TALK and allow it to release unrestrained. As the talk-ring key returns to normal, faulty operation of the key under test is indicated if there is a click in the operator's telephone receiver. This may be caused by a momentary opening of the break-contact on the RING position of the key as it releases from the TALK position.

(11) **TESTING A-C RINGING AND BRIDGING RELAYS OF UNIVERSAL TRUNK CIRCUITS.** To make an operate test on the ringing relays of the trunk circuits, connect the key-ended cord to the D jack. Patch from the M.D.F. terminals (fig. 74) of the trunk under test to the J jack by means of the clip-ended test cord 409 (fig. 48). Be sure to remove the heat coils associated with the trunk under test. The operation of the key completes the testing path, applies the test current to the ringing relay, and should cause the line lamp to light. The lamp should remain lighted when the key is released. To extinguish the line lamp, connect the plug of a spare cord circuit to the line jack of the trunk circuit under test. If the light goes out, it indicates that the bridging relay is operating.

32. MOISTUREPROOFING AND FUNGIPROOFING.

a. Problems Encountered. Communication failures commonly occur when Signal Corps equipment is operated in tropical areas where temperature and relative humidity are extremely high. The following problems are typical:

- (1) Resistors, capacitors, coils, transformer windings, etc. fail.
- (2) Electrolytic action takes place in resistors, coils, transformer windings, etc., causing eventual break-down.
- (3) Hook-up wire and cable insulations break down. Fungus growth accelerates deterioration.
- (4) Moisture forms electrical leakage paths on terminal boards and insulating strips, causing flash-overs and crosstalk.
- (5) Moisture provides leakage paths between battery terminals.

b. Treatment. A moistureproofing and fungiproofing treatment has been devised which, if properly applied, provides a reasonable degree of protection against fungus, insects, corrosion, salt spray, and moisture. The treatment involves the use of a moisture- and fungi-resistant varnish applied with a spray gun or brush. Refer to TB SIG 13, Moisture-

proofing and Fungiproofing Signal Corps Equipment, for a detailed description of the varnish-spray method of moistureproofing and fungi-proofing.

CAUTION: *Varnish spray may have toxic effects if inhaled. Use respirator if available; otherwise, fasten cheesecloth or other cloth over nose and mouth.*

c. Step-by-step Instructions.

(1) SWITCHBOARD BD-110-().

(a) Disassembly.

1. Release the catches and remove the front, rear, and top panels of the switchboard.
2. Release the four screws and remove the knee panel and canvas cord-weight protector (panel and canvas not to be treated).
3. On the rear of the switchboard remove the cable connector from the binding posts by loosening the screws (cable connectors to be treated).
4. Remove the eight screws from each cable connector and remove the metal covers (covers not to be treated).
5. Remove the four screws from the cable connector for power cables; remove the metal cover (cover and cables not to be treated).
6. Loosen the two thumbscrews and raise the binding post panel; lock it in place with side brackets.
7. Remove the four screws from the bottom of the generator shaft, and remove the hand generator; disconnect the wires (generator to be treated).
8. Raise the keyshelf, loosen the key retaining screws, and turn the clamp so that it will slide by the key mounting bars.
9. Remove the shells from the plugs (plug shell and cord not to be treated).
10. Remove the fuses from the rear equipment (fuses not to be treated).

(b) Masking.

1. Screw down the binding-post screws on the connecting panel.
2. Mask the spade-clip contact on the cable connectors.
3. Mask the key-spring contacts and cam mechanism, after raising the keys above the keyshelf. When they are masked, replace the keys.
4. Cover the local cable and jack equipment in the face of the switchboard with cloth, and hold it in place with masking tape.
5. Mask the spring contacts of the operator's jacks in the piling rail.

6. Mask the cord pulleys on the underside of the cord shelf. Use a strip of cloth or paper and hold in place with masking tape.
7. Mask the fuse blocks on the rear equipment.
8. Mask the openings in the plug receptacles in the base of the switchboard.

(c) *Drying.*

1. Dry the equipment from 4 to 6 hours at 140° F for the switchboard, and from 2 to 3 hours at 160° F for the generator.

(d) *Varnishing.*

CAUTION: *Varnish spray may have toxic effects. Use a respirator if available. Otherwise, fasten cheesecloth or other cloth over nose and mouth.*

1. Apply three coats of moisture- and fungi-resistant varnish.
2. Use a brush to varnish the spring pile-up and armature winding of the hand generator. Remove the armature to reach both sides of the coil.
3. Use a brush to varnish the terminal screws and conductors inside the plug body.
4. When spraying the terminal side of the relay rack equipment, slant the spray gun up and down so varnish will not penetrate into the holes in the mounting plates.
5. After the varnish is dry, remove the cover from the local cable and jack equipment in the face of the switchboard, and brush three coats of varnish on the local cable and on soldered connections.
6. Do not varnish the rubber jacket, the textile jacket cables, nor the cords.

(e) *Reassembly and Testing.* Reassemble the equipment and test it for proper operation.

(f) *Marking.* Mark the equipment MFP, followed by the date of treatment.

(2) DISTRIBUTING FRAME FM-19.

(a) *Disassembly.*

1. Remove Frame FM-19 from Case CS-59.
2. Loosen the six straps and uncoil the cable (jacketed cable not to be treated).
3. Remove the screws from the cable connectors, and remove the metal cover (cover not to be treated).

(b) *Masking.*

1. Screw down the binding-post screws.
2. Mask the protector springs, including carbon blocks, and the heat coils.
3. Mask the spade-clip contacts on the cable connectors.

(c) *Drying.* Dry the equipment from 2 to 3 hours at 160° F.

(d) *Varnishing.*

1. Apply three coats of moisture- and fungi-resistant varnish.
2. Do not varnish the metal framework.

(e) *Reassembly and Testing.* Reassemble the equipment and test it for proper operation.

(f) *Marking.* Mark the equipment MFP, followed by the date of treatment.

(3) CABINET BE-72.

(a) *Disassembly.*

1. Remove Cabinet BE-72 from Case CS-66.
2. Remove the clip-spring cover.
3. Remove the eight screws from the top edge of the binding-post compartment; screw down the binding-post screws.
4. Lift off the binding-post compartment to expose the underside. Do not disconnect the wires.
5. Remove the six screws holding the key panel; pull the panel forward. Do not disconnect the wires.

(b) *Masking.*

1. Mask the jack spring contacts and sleeve.
2. Mask the key-spring contacts and cam mechanism.

(c) *Drying.* Dry the equipment from 4 to 6 hours at 140° F.

(d) *Varnishing.* Apply three coats of moisture- and fungi-resistant varnish.

(e) *Reassembly and Testing.* Reassemble the equipment and test it for proper operation.

(f) *Marking.* Mark the equipment MFP, followed by the date of treatment.

(4) TEST SET BE-70-().

(a) *Disassembly.*

1. Remove the rear panel.
2. Remove the generator crank and the four screws from the bottom of the generator. Remove the generator and disconnect the wires (generator to be treated).
3. Remove the fuses and screw down the connecting screws.
4. Loosen the screw and remove the shell from the retardation coil (shell not to be treated).
5. Screw down the connecting screws on the terminal strip.
6. Remove the escutcheon plates, if any, from the front of the board around the keys.
7. Remove the two screws from each key, and pull the keys forward.

(b) *Masking.*

1. Mask the armature, pivot screws, pole pieces, and adjusting screw of the buzzer.
2. Mask the key-spring contacts and lever mechanism; push the keys back in place after masking.

(c) *Drying.* Dry the equipment from 2 to 3 hours at 160° F.

(d) *Varnishing.*

1. Apply three coats of moisture- and fungi-resistant varnish.
2. Apply varnish around the edges of the voltmeter glass window, adjustable arrow, and resetting screw.
3. Apply varnish, using a brush, to the generator spring pile-up and armature coil; revolve the armature to reach both sides of the coil.

(e) *Reassembly and Testing.* Reassemble the equipment and test it for proper operation.

(f) *Marking.* Mark the equipment MFP, followed by the date of treatment.

(5) POWER PANEL BD-90.

(a) *Disassembly.*

1. Loosen the four screws and remove the telering from the panel (telering to be treated).
2. Remove the covers from the buzzers and bell (covers not to be treated).
3. Loosen the screw and open the interrupter glass-panel door.

(b) *Masking.*

1. Mask the fuse blocks.
2. Mask the spring contacts on the keys and lamp sockets.
3. Mask the plug receptacles on the rear panel.
4. Mask the key tops on the rear panel.
5. Mask the gong, clapper, armature, and pole pieces of the bell.
6. Mask the pole pieces, vibrator spring, and spring contacts of buzzers.

(c) *Drying.* Dry the equipment from 2 to 3 hours at 160° F.

(d) *Varnishing.*

1. Apply three coats of moisture- and fungi-resistant varnish.
2. Brush the varnish around the edges of the meter glass windows and over the adjusting screws.
3. Brush the varnish on to the interrupter coil.

(e) *Reassembly and Testing.* Reassemble the equipment and test it for proper operation.

(f) *Marking.* Mark the equipment MFP, followed by the date of treatment.

(6) TELERING.

(a) *Disassembly.*

1. Loosen the four screws and remove the bottom cover plate (plate not to be treated).
2. Loosen the four knurled screws and remove the face plate (plate not to be treated).
3. Loosen one bolt and remove the bracket holding the plug receptacle (bracket not to be treated).
4. Remove the four screws and raise the transformer to expose the underside of the coil.

(b) *Masking.*

1. Mask the fuse clips.
2. Mask the vibrator reed and adjusting screw.

(c) *Drying.* Dry the equipment from 2 to 3 hours at 160° F.

(d) *Varnishing.* Apply three coats of moisture- and fungi-resistant varnish.

(e) *Reassembly and Testing.*

1. Reassemble the equipment and test it for proper operation.
2. Replace the telering on Power Panel BD-90.

(f) *Marking.* Mark the equipment MFP, followed by the date of treatment.

(7) TOOL EQUIPMENT: VOLT-OHMMETER, MODEL NO. 564.

(a) *Disassembly.*

1. Loosen the four screws and remove the case (case not to be treated).
2. Disconnect the battery leads and remove the battery (battery not to be treated).

(b) *Masking.*

1. Mask the terminal ends of the pin jacks.
2. Mask the battery-adjusting rheostat.
3. Mask the ends of the battery leads.

(c) *Drying.* Dry the equipment from 2 to 3 hours at 160° F.

(d) *Varnishing.*

1. Apply three coats of moisture- and fungi-resistant varnish.
2. Apply the varnish, with a brush, around the edges of the meter glass window and over the adjusting screw.

(e) *Reassembly and Testing.* Reassemble the equipment and test it for proper operation.

(f) *Marking.* Mark the equipment MFP, followed by the date of treatment.

33. WIRING DIAGRAMS.

a. Schematic diagrams are drawn in simplified form to show how the circuit operates. Wiring diagrams show the exact circuit wiring, the wire colors, the manufacturer's code of each piece of apparatus, and the functional designations (in parentheses). The functional designations are the same as those shown on the schematic diagrams. These functional designations are also stamped on the apparatus or on the mounting plate adjacent to the apparatus and are referred to in table VI. The wiring diagram shows, in addition to the above, the relative location of apparatus terminals as viewed from the wiring side of the apparatus. The wiring diagrams are shown in figures 62 to 74.

b. The wiring diagrams for universal trunk and universal cord circuits use the *airline* system of showing connections (figs. 72 and 74). With this system each piece of apparatus is arbitrarily numbered and lines called feed lines, representing the individual wires, are carried a short distance and are terminated at a common or base line running at right angles to the feed lines. The feed lines representing the individual wires are marked with the color of the wire (if color-coded); they also have a number near the base line which is the same as the number of the piece of apparatus to which the other end of the wire connects. It is not necessary to trace a connection through the common or base line and no provision is made for doing so. By observing the color and identification number (or number only if the wire is not color-coded), it is possible to move directly to the other end of the wire. For example, in figure 74, the D-161985-58 relay SL has been arbitrarily assigned the number 7. Connected to terminal 2 of the top assembly are 2 red-orange-white wires. One of these wires runs to apparatus 12 which is the D-162081-C terminal strip, and examination of the feed lines of 12 shows that the R-O-W wire from 7 connects to terminal T. The other wire is connected to apparatus 9 which is the D-162038 repeat coil A, and examination shows that the R-O-W wire from 7 connects to terminal 1 of this coil. The other wires may be traced in the same manner.

34. STORAGE BATTERIES. Maintain the electrolyte in the storage batteries at the proper level. The voltage of the battery should be as follows:

- a. Not less than 44 volts.
- b. Not more than 56 volts if the batteries are being charged during use.
- c. Between 50.4 and 52.8 volts if the batteries are trickle-charged or floated.

CAUTION: *Violent gassing and a rise in temperature of the electrolyte are two indications of too high a charging current. Open flames, lighted cigarettes, and other burning articles should be kept*

away from the batteries. Poor connections cause sparking and are therefore very dangerous fire hazards. Do not change connections without turning off the MAIN circuit breaker on Panel BD-90 and the control switch on Rectifier RA-36-(). The instructions for the care and use of the battery, outlined in TM 11-430, should be carefully followed.

35. SWITCHBOARD PLUGS, CLEANING. In order to maintain high grade transmission through the cord circuits, clean all plugs as often as required to maintain brightness. Use a light oil and cake (jeweler's) rouge or a paste-type metal polish (Signal Corps stock No. 6G1516). The use of light oil and cake rouge is preferred, as there is less tendency to use too much polishing material and it is easier to remove the unused portion of the polishing material from the plug. Pour a few drops of light oil on the cake to soften the rouge, so that a small portion of the rouge is transferred to the rag when rubbed across the cake. Polish the plug to brightness. Remove *all* polishing material with a clean portion of the polishing cloth.

36. SWITCHBOARD CORD REPAIRS.

a. General. The cords and plugs furnished with Switchboard BD-110-() are wax-treated, after assembly, to be moisture-resistant, and it is not recommended that frayed cords be repaired nor defective plugs replaced in the field. If it is necessary to do so, either of the methods explained in subparagraphs **b** and **c** below may be used. If possible, after repair and before the plug shell is replaced, dip the plug from the base to shoulder in melted paraffin or beeswax. The cord repair tools referred to by number are the 312B cord-cutting tool, the 316 plug vise, and the 444A crimping tool, all manufactured by the Western Electric Co. These tools are a part of Tool Equipment TE-44.

b. Solderless-cord-tip Method. (1) Remove the shell from the plug. Remove the two contact screws. Place the plug in the 316 plug vise. Tighten the chuck of the 316 tool by turning the crank counterclockwise with the handwheel held. Release the handwheel, hold the cord, and turn the crank counterclockwise to remove the cord.

(2) If the cord is frayed directly behind the plug, place the cord in the 312B cutting tool. Close and latch down the upper part of the tool. Turn the handle so that the L side faces the front. Close down the handle to cut off the end of the cord. With the handle down, rotate the cord to cut the two outer braids. Release the handle. Release the catch to open the tool. Slide off the outer braid of the cord by pulling and twisting in the direction of the twist of the conductors. Untwist the conductors and cut off the filler cords. Serve the butt of the cord with thread, if available.

(3) Place the cord on the gauge block of the 444A crimping tool with the

butt in the recess at the left of the block. Cut the blue (ring) and red (sleeve) conductors accurately to the length of the RS slot. Cut the white (tip) conductor to the length of the T slot. With diagonal cutting pliers, strip the rubber insulation from the red conductor. Place a 133 (long) cord-tip in the T slot in the jaw of the 444A tool, eyelet down, and insert the end of the white (tip) conductor in the open shank of the cord-tip. Rotate the crank of the 444A tool once in a clockwise direction to crimp the tip. Remove the tip conductor. Insert a 132 (short) cord-tip and the blue (ring) conductor in the R slot of the 444A tool and crimp as before. Remove the cord from the 444A tool.

(4) Bend the stripped sleeve conductor back over the butt of the cord. Insert the cord in the plug (in the 316 tool) and crank the cord into the plug to about three turns before its final position. If necessary, press the end of the cord with pliers to aid in starting the cord into the plug. Cut off the sleeve conductor flush with the base of the plug. Turn the cord in until tip and ring-cord tips line up with the tapped holes in the plug. Place and tighten the contact screws to fasten first the ring and then the tip conductors to the terminal plates. Replace the plug shell. Test the cord before returning it to service.

c. Punched-hole Method. If tools or material are not available for repairing frayed cords by the method described in subparagraph **b** above, the following method can be used:

(1) Remove the plug from the cord as described in subparagraph **b** (1) above. If a plug vise is not available, use pliers to remove the plug (grasp the plug behind the shoulder to avoid scoring the part which is inserted in the jack).

(2) Cut off the end of the cord and remove the outer braid as described in subparagraph **b** (2) above. If a cord cutting tool is not available, use the diagonal cutting pliers. Serve the butt of the cord with thread, if available. Remove the rubber insulation from the sleeve conductor. Turn the sleeve conductor back over the butt of the cord and place the plug on the cord as described in subparagraph **b** (4) above.

(3) Opposite each contact screw terminal plate, strip $\frac{1}{4}$ inch of the rubber insulation from the proper conductor. Leave the insulation on the end of each conductor to prevent the tinsel wires from fraying out. Do not cut the tinsel wires while stripping the insulation. With a suitable needle or awl applied directly above the associated screw hole, pierce the *center* of each conductor. Run the awl through until the hole is large enough to take the contact screw. Place and tighten the contact screws. Cut off the ends of the conductors, leaving enough rubber insulation on the end of each conductor to hold the tinsel wires together. Replace the plug shell. Test the cord before returning it to service.

37. CLEANING CONTACTS. Contacts which fail on test or in serv-

ice should be burnished to remove any foreign material. Before burnishing any contact, wipe the burnisher blade with a clean, dry cloth. Place the flat blade of the burnisher between the contacts to be burnished. Press the contacts together to give a *slight* pressure on the blade of the burnisher, at the same time moving the blade back and forth two or three times. For pitted contacts, burnish the pit by using the ball point of the wire burnisher blade. Separate the contacts and place the ball point in the pit. Rotate the barrel between thumb and finger or move it in a circular motion to burnish the entire pit. On very dirty contacts, if carbon tetrachloride is available, flush the contact with carbon tetrachloride taken up on a toothpick and wipe out with the flat end of a clean, dry toothpick. Burnish the contact after cleaning. If the contacts of a relay or key have large buildups or are pitted to the base metal of the spring, replace the key or relay or refer the trouble to a higher repair echelon for repair or replacement.

38. CLEANING RELAY PARTS.

a. In service, especially during humid weather, dirt deposits on the cores, backstop nuts, etc., of relays or drops will cause relays to stick in the operated or nonoperated position.

b. To clean a relay or drop armature where it touched the core, backstop nut, etc., cut a strip of good bond paper and insert it between the core or backstop nut and armature. Hold the armature to exert pressure on the paper and withdraw the paper. Repeat the operation if necessary.

c. Clean drop shutters and the more accessible parts of relays with a clean, lint-free cloth. Dampen the cloth with carbon tetrachloride, alcohol, or other cleaning fluid, if available. *Do not use an inflammable fluid where sparks from relay contacts, loose connections, etc., might ignite the vapor.* Do not use any fluid, such as kerosene, which leaves an oily residue.

d. Clean pivot- and pin-type bearings by flushing them with carbon tetrachloride or other cleaning fluid. Apply the fluid above or adjacent to the bearing surface, using a toothpick or a small bare wire.

39. DROP AND RELAY ADJUSTMENTS.

a. General. The drop and relay adjusting information covered below is only a bare outline of the proper adjusting procedure to be used when more complete information or experienced personnel is not available. Before adjusting any relay, clean it in accordance with paragraphs 37 and 38 above, and check the parts for tightness. Special cleaning procedures for the polarized AU relay of the night alarm circuit are covered in subparagraph **e** below. With a clean, dry, and lint-free cloth, wipe the blades of any thickness gauges inserted between contacts while adjust-

ing. Unless roughly handled, relays will operate for long periods without adjustment and with only an occasional cleaning.

b. Magneto Drop Adjustment. (1) If the armature binds with side play taken up in either direction or if it has no side play, adjust the pivot screws to provide slight (0.005 inch maximum) side play.

(2) If the tripping latch binds on the shutter or mounting plate, bend the latch with duck-bill pliers sufficiently to clear both parts.

(3) If the shutter binds, check for a bent bearing pin or bent shutter and hinge plate bearing tangs. Straighten or replace as required.

(4) With the shutter raised, the night alarm spring should be bent to clear the contact wire by at least 0.005 inch. The spring should touch the contact wire and then have perceptible follow as the shutter descends. If necessary, remove the shutter hinge plate to make this adjustment.

(5) Apply the electrical operate test current, using the test circuit of Cabinet BE-72 (par. 25). If the drop fails to operate, reduce the unoperated armature air gap by bending the tripping latch. This can sometimes be done without removing the drop from the board by holding the tripping latch against the bottom of the slot and forcing the armature towards the core. If, after this adjustment is made, the latch does not clear the shutter when the drop operates, turn the armature adjusting screw out to increase the travel, or bend up the *tip* of the tripping latch to clear the shutter. The armature adjusting screw should *not* be turned out enough to allow the armature to touch the shell of the coil; this causes the armature to stick in the operated position.

c. Flat-type Relays. (1) These relays include the Western Electric Co. E-, R-, and UA-type relays used with this board. These are the R and SL relays of the trunk circuit, the FS and BS relays of the cord circuit, the T and M relays of the operator's telephone circuit, and the AR and NA relays of the night alarm circuit.

(2) Contact points should strike within the opposing disk, and bar contacts should strike wholly within the length of the opposing bar when

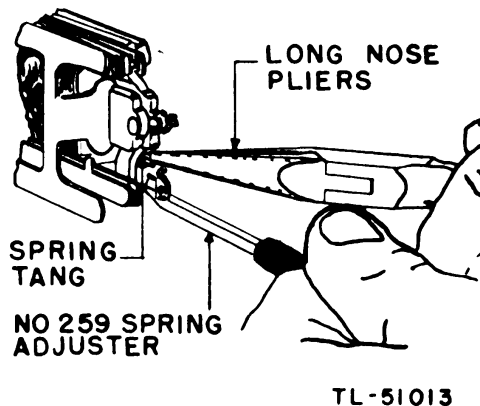
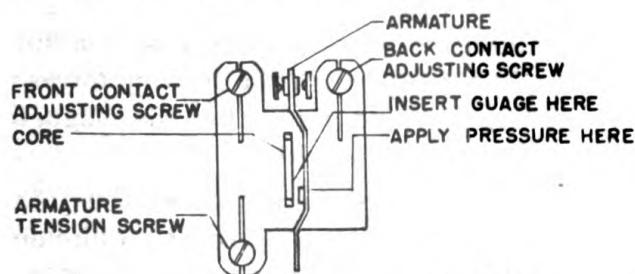


Figure 56. Method of adjusting a spring tang of an E- or R-type relay.

the contact is made. Armature studs which pass through contact springs must not rub on those springs. Spring tangs should overlap the spoolhead on which they rest by at least 1/32 inch but should not rub on the spoolhead when the spring is moved (fig. 56). Move the springs up or down as required to meet these requirements. Loosen the spring assembly screws if necessary. Adjusting to meet one of the above requirements may throw another out of limits. Check all of the above requirements after making any of the above adjustments.

(3) Adjust the armature travel to the value shown on the circuit requirement tables VII to XI. If the special gauges used with this relay are not available, use the Western Electric Co. 74D gauge nest furnished with each switchboard. Insert the proper blade or combination of blades of the 74D nest between the armature and the adjusting nut with the armature against the core.

(4) On relays having break (normally closed) contacts, *except* contacts 4-6 top and bottom of relay M (operator's telephone circuit), there should be a slight clearance between the armature stud and the spring when the relay is unoperated. The separation between any pair of contacts, normally open or opened when the relay is operated, should be at least 0.005 inch. The follow on make (normally open) contacts when the relay is operated shall be perceptible. Adjust the armature stud clearance and the contact separation, and follow by bending the spring tangs as required (fig. 56). Spoolhead springs should be tensioned firmly against the spoolhead when the relay is unoperated. On bifurcated (double) contacts on the UA-type relays, both contacts on a spring should make at approximately the same time. All springs should be adjusted so that the tension is consistent with meeting the electrical requirements (par. 40) to give good contact pressure between made contacts, either normally made or normally open. Adjusting to meet one of the above requirements may throw another out of limits. Check all of these requirements after adjustments have been made.



TL-51014

Figure 57. Front contact make adjustment of a G-type relay.

d. Relays A and C of the Cord Circuit. These are Western Electric Co. G101 relays.

(1) Place the 0.015-inch blade of the gauge nest between the core and

the armature stop pin. Touching the armature near the stop pin, press the armature lightly against the gauge and turn the front contact adjusting screw in until the front contact just makes (fig. 57). Remove the gauge. Adjust the back contact adjusting screw until the contact separation is near but not less than 0.005 inch.

(2) Tension the armature until the relay just fails to operate on the readjust operate current. Decrease the tension slightly until the relay operates. If the relay fails to release on the readjust release current, readjust the relay as above but increase the 0.015-inch front contact make adjustment.

(3) If no current-flow test set is available, the relay may be temporarily adjusted using the test circuit of Cabinet BE-72 (par. 25).

e. Relay AU of the Night Alarm Circuit. (1) This is a Western Electric Co. 239GB polarized relay. Before readjusting mechanically, adjust the relay biasing spring as covered in paragraph 40. If the relay fails to meet this adjustment or fails in operation a short time after this adjustment, readjust the relay.

(2) Before readjusting, clean the pole pieces. To do this, loosen the clamping screws and back off the pole pieces as far as they will go. Fold a small piece of friction tape over the end of a thin strip of metal with the sticky side in. *Press*, do not rub, the tape against each pole piece. This will remove small filings which cling to the pole pieces and which are a common source of trouble in polarized relays.

(3) With the pole pieces backed off and the biasing spring disengaged, adjust the contact screws so that the armature stands approximately midway between the two, and, with the armature held against one contact, the space between the armature and the other contact is a minimum of 0.003 inch and a maximum of 0.005 inch. Connect a relay test set as explained in paragraph 40. Advance the pole pieces until, with the soak current applied in either direction for 1 second, the armature will stick to the associated contact with a minimum force of 1 gram and with a difference in sticking force between the two contacts of not over 3 grams. Best results are usually obtained with the sticking forces near the minimum. Clamp the pole pieces and check that the magnetic balance adjustment is still within the specified limits.

(4) Disconnect the relay test set and adjust the biasing spring in accordance with paragraph 40. If the readjust requirements cannot be met, readjust the sticking pressure up or down as required.

f. Relays A and B of the No-voltage Alarm Circuit. These relays are Automatic Electric Co. relays ZR-3012-2381 and R-2444-A8. Connect the test set for either relay in accordance with paragraph 40.

(1) If relay A fails to meet its operate requirements, reduce the unoperated armature air gap by bending the back contact spring, or reduce

the spring tension in the armature spring. If the relay fails to meet its release requirements, increase the follow in the front (normally open) contact spring or increase the spring tension in the armature spring. If the armature chatters excessively in service, reduce the follow on the front contact and the tension on the armature spring consistent with meeting the electrical requirements. Keep as much tension in the armature spring as possible, consistent with meeting the above requirements.

(2) With relay B electrically operated, adjust the armature adjusting screw (in the center of the armature) so that the space between the armature and the core is approximately 0.002 inch to 0.005 inch. Adjust the armature arm so that, with a gauge of approximately 0.013-inch thickness between the armature (not the armature adjusting screw) and the core, the back (break) contact just breaks. Adjust the front (make) contact spring so that, with a 0.009-inch gauge between armature and core, the front contact just makes. Adjust the backstop spring to provide clearance between the armature stud and the armature spring when the relay is unoperated. Adjust the tension of the armature spring as required to meet the electrical requirements.

40. CIRCUIT REQUIREMENTS OF RELAYS. Information on the electrical and mechanical adjustments of the various relays is given in the following circuit requirement tables. Under *Circuit preparation*, in the column headed *Block*, the letters in parentheses are the functional designation of the relays to be blocked O (operated) or NO (non-operated). The *Connect battery* and *Connect ground* columns list the terminal and the relay (in parentheses) to which the cords from the relay test set should be connected. The *Test set* column lists the test set connections to be used. The letter G denotes that ground is to be connected through the test set to the terminal listed in the *Connect ground* column, B/G denotes that both battery and ground are to be supplied through the test set, and M denotes that the test set is connected across the terminals listed and does not supply either battery or ground. In the *Test for* column, O denotes that the relay shall operate on the specified test or readjust current after the soak current (if specified) has been applied for about 1 second. The letters NO denote that the relay will not operate, and RLS (release) denotes that when the current is *reduced* from the specified soak value to the release value, the relay will release.

TABLE VII

CIRCUIT REQUIREMENTS FOR UNIVERSAL CORD CIRCUIT

Functional designation	Armature travel (in.)	Circuit preparation				D-c flow required						Note
		Block	Test clip data			Test set	Test winding	Test for	After soak (amp)	Test (amp)	Readjust (amp)	
			Connect battery	Connect ground								
A	0.040	(BS)O	2M(A)	5M(A)	M	S1/S2	O	0.069	0.0133	0.0126	1	
		(BS)O	2M(A)	5M(A)	M	S1/S2	RLS	0.069	0.0068	0.0072	1	
		(BS)NO	2M(A)	5M(A)	B/G	P/S1/S2	O		0.0069			1
BS	0.020			RT(BS)	G		O		0.023	0.0215		
				RT(BS)	G			NO		0.0126	0.0133	
C	0.040	(FS)O	2M(C)	5M(C)	M	S1/S2	O	0.069	0.0133	0.0126	1	
		(FS)O	2M(C)	5M(C)	M	S1/S2	RLS	0.069	0.0068	0.0072	1	
		(FS)NO	2M(C)	5M(C)	B/G	P/S1/S2	O		0.0069			1
FS	0.020			RT(FS)	G		O		0.023	0.0215		
				RT(FS)	G			NO		0.0126	0.0133	

NOTE: 1. This test can be made by connecting the test set between the tip and ring of the front (A) or back (C) cord in place of the terminals of the A or C relay.

TABLE VIII
CIRCUIT REQUIREMENTS FOR OPERATOR'S TELEPHONE CIRCUIT

<i>Functional designation</i>	<i>Armature travel (in.)</i>	<i>Circuit preparation</i>		<i>D-c flow required</i>					
		<i>Test clip data</i>	<i>Test set</i>	<i>Test winding</i>	<i>Test for</i>	<i>After soak (amp)</i>	<i>Test (amp)</i>	<i>Readjust (amp)</i>	
		<i>Connect ground</i>							
M	0.025	RT(M)	G		O			0.036	0.031
T	0.015	2RT(T)	G	P	O			0.048	0.020

TABLE IX
CIRCUIT REQUIREMENTS FOR 2-WAY TRUNK RELAY CIRCUITS

Func- tional desig- nation	Armature travel (in.)	Block	Circuit preparation				D-c flow required					Note
			Test clip data		Test set	Test winding	Test for	After soak (ma)	Test (ma)	Readjust (ma)		
			Connect battery	Connect ground								
R	0.023	(SL)O (SL)O		STF(R) STF(R)	GRD GRD	P P S	O NO O		18 11.4 a-c	17 12 a-c		
SL	0.035			T(SL)	GRD	P	O		9.4	8.9		1

NOTE: 1. Test and readjust the (R) relay for operation on a-c by ringing on the trunk from the central office, or by connecting 95- to 110-volt, 16½ to 20 CPS ringing supply through a 6,000-ohm noninductive resistance to the tip-line terminal, and the ringing ground to the ring-line terminal, with the line disconnected. The relay will also operate and lock with the same ringing supply, similarly connected, without the noninductive resistance in the circuit. These requirements are based on the use of a Western Electric 12D resistance lamp, or equivalent, in series with the ringing supply. During testing or readjustment, the lock-in winding should be connected.

TABLE X
CIRCUIT REQUIREMENTS FOR NIGHT ALARM AND FUSE ALARM CIRCUITS

Func- tional desig- nation	Armature travel (in.)	Circuit preparation				D-c flow required				Note
		Block	Connect ground	Test set	Test for	After soak (amp)	Test (amp)	Readjust (amp)		
AR	0.015		RT(AR) RT(AR)	G G	O O		0.006 0.0126	0.005 0.0105	2 3	
AU					O RLS	-0.038 0.038	0.038		1, 4 1, 4	
NA	0.015				O NO O		0.010 0.0055 0.0117	0.0095 0.0058 0.0111	5 5 6	
FA		(AR)O	RT(NA)	G	NO		0.0062	0.0066	6	
NB		(AR)O	RT(NA)	G	NO				6	

These magnets shall be adjusted to function properly on exchange battery voltages of 40-56 volts.

- NOTES: 1. A negative sign (-) preceding a current value indicates this current shall flow in a direction opposite to the circuit operating current.
2. Adjust for relay alone.
3. Adjust with two relays in multiple.
4. Test and readjust relay using the test circuit of Cabinet BE-72 (par. 25). When readjusting, turn the biasing screw in a clockwise direction until the relay just fails to operate on this test. Then turn the biasing screw in a counterclockwise direction only enough to make the relay operate satisfactorily. Soak value is for use in meeting the magnetic balance required when applying the mechanical requirements.
5. Required for relay winding only.
6. Required for parallel combination of NA relay and C resistance.

TABLE XI
CIRCUIT REQUIREMENTS FOR NO-VOLTAGE ALARM CIRCUIT

Functional designation	Armature travel (in.)	Circuit preparation			D-c flow required				Note
		Block	Connect ground	Test set	Test for	After soak	Test (amp)	Readjust (amp)	
A		(B)O			O			60V	1, 2
B		(A)NO	See note	G	RLS O		0.0061	20V 0.0058 (amp)	1, 2 3

NOTES: 1. Operate the G key to the OFF position. Connect an a-c voltmeter across the relay winding. Connect the output terminals of a potentiometer to the winding. Connect 20-cycle ringing current to the input of the potentiometer.

2. The readjust values refer to the drop in volts across the relay winding.

3. Connect the test set to the inner end of the winding (IN terminal).

41. TELERING 20-CYCLE POWER RINGER. The telering 20-cycle power ringer is a vibrating-reed type of frequency converter. It is designed to supply 20-cycle ringing current from a 110-volt, 60-cycle, a-c power supply. The reed vibrates between a contact screw and an electromagnet. The contact screw adjustment is set at the factory, and it is suggested that no change be made in the adjustment unless the reed vibrates in a surging manner, or there is sparking at the contact. If sparking occurs, turn the contact screw slightly, either inward or outward, to correct it. However, it is seldom that any change will be necessary. The adjustment of the telering contact is practically opposite to that of other types of vibrating-type power ringers, in that the contact gap in the telering must be kept *as wide as possible*. Closing the contact gap does not increase the output but instead upsets the adjustment, causes sparking, interferes with radio reception, and may prevent starting.

42. BATTERY-DRIVEN RINGING INTERRUPTER.

a. The Western Electric Company No. 84G interrupter is a vibrating pole-changer type of ringer for converting direct current into alternating current for ringing. When the interrupter is properly adjusted, it is sparkless and noiseless in operation. When the machine is in constant use, inspect it daily and check for the following:

- (1) Sparking at the contacts.
- (2) Noisy operation.
- (3) Tendency of the armature to stick to the magneto (operating coils).
- (4) Short circuits.

b. Inspect the condition of the contacts weekly. If sparking occurs at the contacts in the magneto, the contacts should be polished. Operate the ringing key, in the upper right-hand corner of the interrupter, to the OFF position while adjusting the interrupter. If polishing does not eliminate the sparking, readjust the ringing springs. If the armature can be made to lock by pushing it toward the magnets while the interrupter is in operation, unscrew the setscrew slightly. If readjustment of the setscrew affects the adjustment of the ringing springs, make a complete readjustment of the ringing springs. The position of the weighting nut on the threaded screw at the end of the armature governs the frequency of vibrations of the armature. The nut should be approximately at the center of the threaded portion of the screw. If the vibrating arm strikes the magnet, the operation of the interrupter will be noisy. To eliminate noise from this source, move all ringing springs in such a manner that the vibrating arm will be farther away from the magnet. Then completely readjust the interrupter.

NOTE: If necessary to replace the strip of jacks on Cabinet BE-72 with a thicker strip, pry loose and remove the white holly strip from the top of the designation strip. This will allow space for the thicker jack strip.

SECTION V

SUPPLEMENTARY DATA

43. PACKING FOR TRANSPORTATION.

a. Be careful at all times when packing and transporting the equipment in order to minimize maintenance troubles in the operation of the equipment.

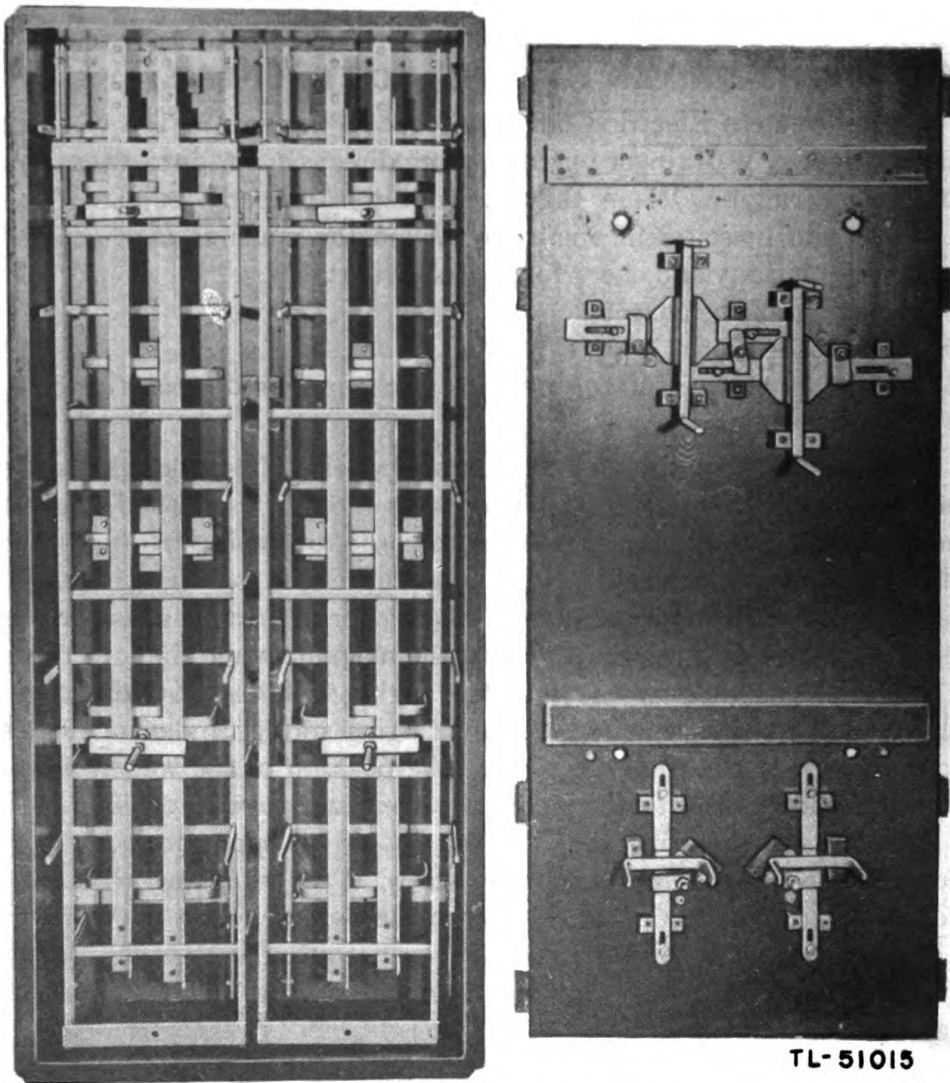
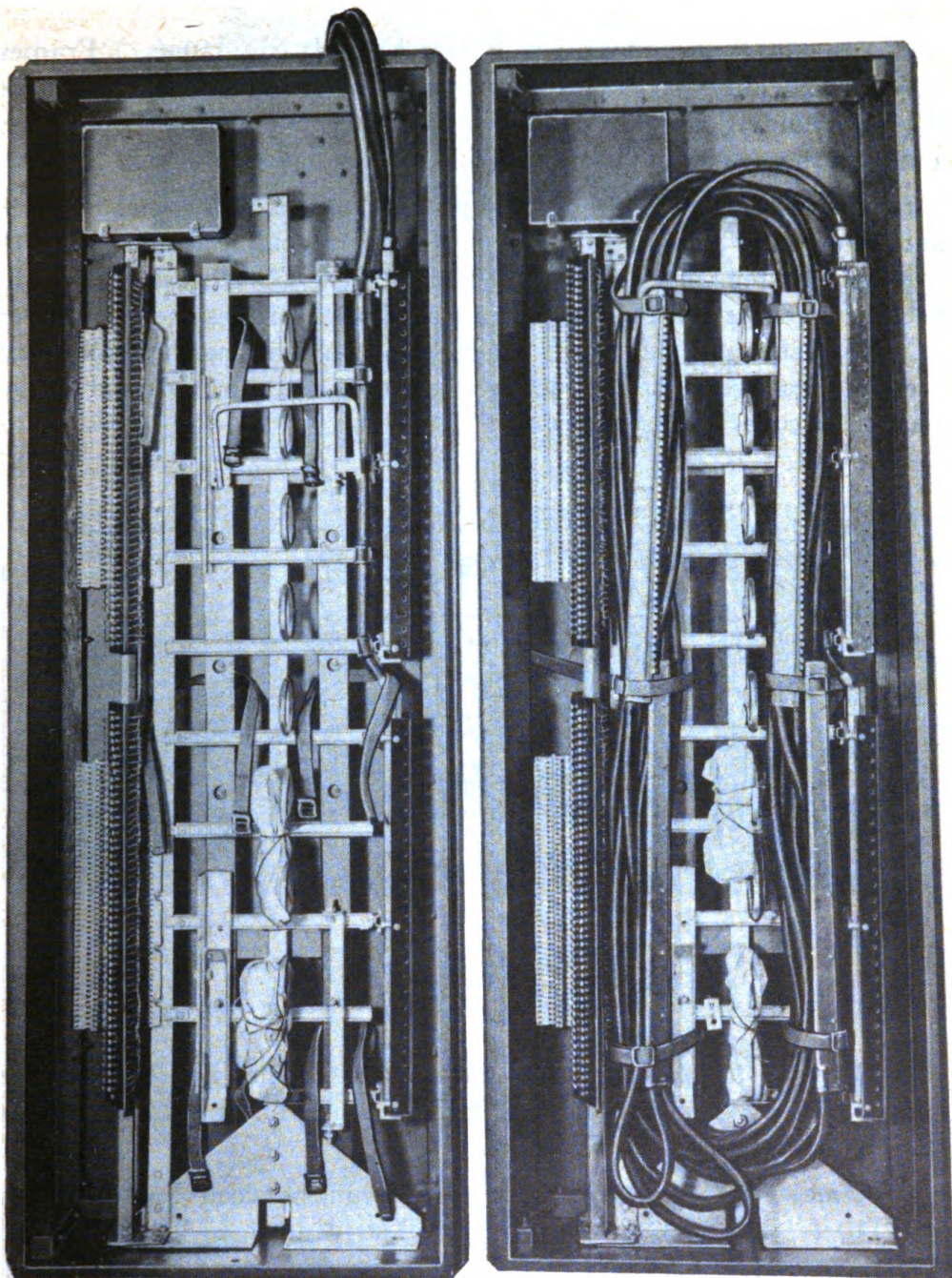


Figure 58. Racks FM-34, FM-35, FM-36, and FM-37 in Case CS-61.



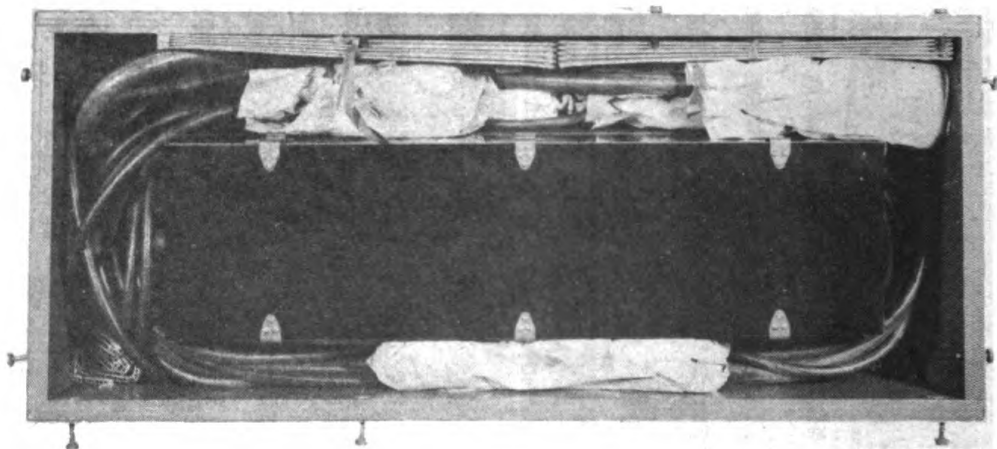
TL-51016

Figure 59. Frames FM-19 in Cases CS-59, covers removed, showing two stages of packing.

b. Turn the switch on Rectifier RA-36-() to the OFF position. Turn all circuit breaker switches on Cabinet BE-75 and Panel BD-90 to the OFF position. Shut off Power Unit PE-75-() if in operation. Remove all connections at the storage Battery BB-46 and at the dry-cell batteries connected to Panel BD-90 and Cabinet BE-70-(). Remove the connection to the commercial power supply by disconnecting Cord CD-393.

c. Disconnect all cables between Switchboards BD-110-(), Frames FM-19, and Panel BD-90, and remove from the cable racks. Remove the bolts holding Racks FM-34, FM-35, FM-36, and FM-37 in place, and pack these racks in Case CS-61 as shown in figure 58.

d. Disconnect the field lines and ground cords from Frames FM-19, and remove the bolts and connecting members holding Frames FM-19 together. Fasten each Frame FM-19 in a Case CS-59, using the connecting members as clamps as in figure 59. Coil the cables and strap them in place as shown in this figure. Exercise care in handling these cables to prevent breakage of the conductors where they enter the terminal strips. Fasten the cover to Case CS-59.

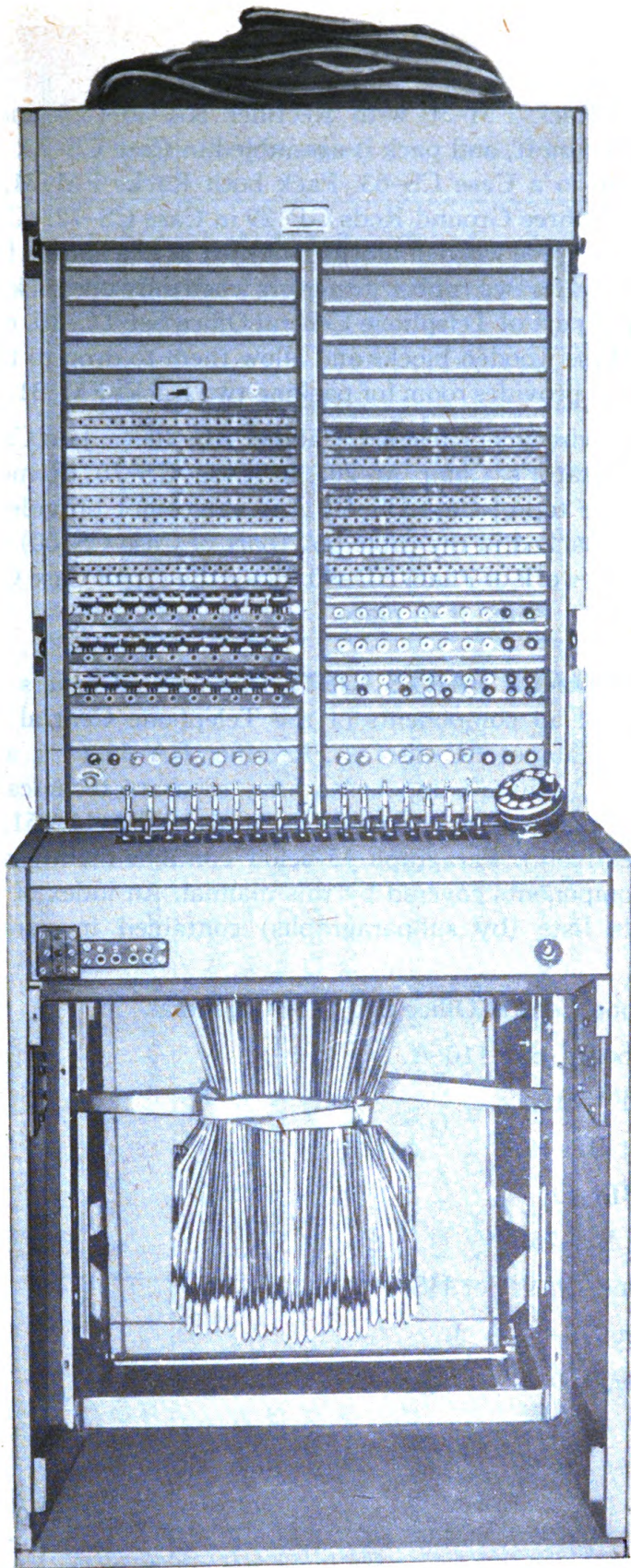


TL-51017

Figure 60. Cabinet BE-72 in Case CS-66, cover removed.

e. Remove the spade terminal strips from Cabinet BE-72. Remove Cabinet BE-72 from Switchboard BD-110-(), and pack the cabinet in Case CS-66 as shown in figure 60.

f. Remove the spade terminal strips run between Switchboards BD-110-(). Fasten the spade terminal strips from each switchboard to the corresponding binding post row on its own rear terminal panel. Coil the cables before fastening as shown in figure 17. Pack the operator's Headsets HS-30, Chest Sets TD-1, and the miscellaneous operator's supplies in the spare parts box in Case CS-58. Fasten the magneto drops in place with the drop guards. Fasten the cords in place with straps as shown in figure 61. Tie the relay covers in place with a suitable lacing twine. Fasten the knee panel, the lower front panel, and the rear panel in place with the bolts provided for the purpose. Place the front cover over the keyshelf and jack field, and lock it in place with the trunk catches. Put the top cover in place and secure it with the trunk catches (fig. 4).



TL-51018

Figure 61. Switchboard BD-110-(), front panel removed, showing cords secured for transportation.

g. Remove Rack FM-30 with Rectifier RA-36-() and Cabinet BE-75 mounted on it, and pack it assembled in Case CS-73. Pack each Battery BB-46 in a Case CS-63. Pack both Racks FM-31, Hammer HM-5, and the three Ground Rods GP-29 in Case CS-72. (Case CS-72 is provided with three wooden blocks mounted at the middle for holding Rack FM-31 and its two rubber insulators when only one rack is packed. When used as a part of Telephone Central Office Set TC-10, remove the screws from these wooden blocks and allow them to drop to the bottom of the case. This provides room for packing two Racks FM-31.)

h. Pack the wire chief's test set, Cabinet BE-70-(), in Case CS-57. Pack each operator's Chair M-205 in Case CS-70. Remove Panel BD-90 from the top of Case CS-60. Any cables not provided for elsewhere shall be packed in the cable box (part of Case CS-60) which sets in the iron framework of Panel BD-90. Place the top of Case CS-60 over Panel BD-90 and fasten it in place.

44. MAINTENANCE PARTS LIST. This manual covers the maintenance parts of all components of the Telephone Central Office Set TC-10 except Cabinet BE-70-(), Rectifier RA-36-(), and Power Unit PE-75-(); these components have separate technical manuals which list the maintenance parts (TM 11-345, TM 11-951, and TM 11-900, respectively). Paragraph 45 below contains maintenance parts list for the components covered by this manual. An index of the maintenance parts lists (by subparagraphs) contained in paragraph 45 follows:

- a.** Telephone Central Office Set TC-10, general.
- b.** Switchboard BD-110-A.
- c.** Frame FM-19.
- d.** Cabinet BE-72.
- e.** Panel BD-90.
- f.** Cabinet BE-75.
- g.** Head and Chest Set HS-19.
- h.** Headset HS-30-().
- i.** Chest Set TD-1.

45. MAINTENANCE PARTS LIST FOR TELEPHONE CENTRAL OFFICE SET TC-10.

NOTE Order maintenance parts by stock number, name, and description.
Only maintenance parts listed can be requisitioned.

a. Telephone Central Office Set TC-10, General.

Ref symbol	Signal Corps Stock No.	Name of part and description	Running spares	Orgn stock	3d ech	4th ech	5th ech	Depot stock	Quan per unit
731	4B417	CHEST SET TD-1: component.				*	*	*	6
	3E1334	CORD CD-334: multiple splicing.						*	12
	3E1335	CORD CD-335: connects Battery BB-46 to Panel BD-90.						*	1
	3E1393	CORD CD-393: connects Cabinet BE-75 to a-c power.						*	1
	3E1409	CORD CD-409: connects Power Unit PE-75 to Cabinet BE-75.						*	1
	3E1413	CORD CD-413: a-c power; connects Switchboard BD-110-A to BD-110-A.						*	3
	3E1414	CORD CD-414: a-c power; connects Cabinet BE-75 to Switchboard BD-110-A.						*	1
	3E2038	CORD CO-38: connects Battery BB-46 to BB-46.				*	*	*	3
	3E2258	CORD CO-258: connects Frame FM-19 to Ground Rod GP-29.					*	*	1
	3Z3329	GROUND ROD GP-29.					*	*	3
6Q49005	HAMMER HM-5.					*	*	1	
4B1279A	HEAD AND CHEST SET HS-19: equipped with #716A receiver and #396A transmitter: W.E.Co.					*	*	3	

45. MAINTENANCE PARTS LIST FOR TELEPHONE CENTRAL OFFICE SET TC-10.

NOTE: Order maintenance parts by stock number, name, and description.
Only maintenance parts listed can be requisitioned.

a. Telephone Central Office Set TC-10, General (continued).

Ref symbol	Signal Corps Stock No.	Name of part and description	Running spares	3d ech	4th ech	5th ech	Depot stock	Quan per unit
	2B830 ()	HEADSET HS-30-() .			*	*	*	6
	6Z7510-1	PAULIN; duck; 12.3 ft x 16 ft.			*	*	*	6
	3H4676 ()	RECTIFIER RA-36-() ; component.			*	*	*	1
	4C2905/1	SEAT; cane; for Chair M-205.			*	*	*	3
	6D13151	TM 11-430.			*	*	*	1
	3A23	TM 11-345.			*	*	*	2
	3A26	BATTERY BA-23; for Cabinet BE-70-() ; test battery.			*	*	*	20
	3B46	BATTERY BA-26;** for Cabinet BE-72; test battery.			*	*	*	1
	3H606	BATTERY BB-46.			*	*	*	4
	4C5498D	BULB; rectifier; 6-amp; #189049 (for Rectifier RA-36-()) G.E.Co.	4		*	*	*	2
	4C5491-E	LAMP; switchboard; resistance; (for Switchboard BD-110-A), W.E.Co. #12D.			*	*	*	3
68	4C5492-C	LAMP; switchboard; 6-v; 0.033- to 0.045-amp; W.E.Co. #E-1 (cord supervisory Switchboard BD-110-A).	30		*	*	*	90
27	4C5492-C	LAMP; switchboard; 36-v; 0.032- to 0.044-amp; (recall and common-battery station line and trunk, Switchboard BD-110-A); W.E.Co. #C-2.	117		*	*	*	237

45. MAINTENANCE PARTS LIST FOR TELEPHONE CENTRAL OFFICE SET TC-10.

NOTE: Order maintenance parts by stock number, name, and description.
Only maintenance parts listed can be requisitioned.

b. Switchboard BD-110-A (continued).

Ref symbol	Signal Corps Stock No.	Name of part and description	Running spares	Orgn stock	3d ech	4th ech	5th ech	Depot stock	Quan per unit
82	3DB2.39QF	CAPACITOR: paper; 2.16-mf min to 2.28-mf max; 500v dc (test); moistureproofed; (cord circuits (T) and (R)).	2					*	30
87	3C1072A	COIL: induction; moistureproofed; (operator's telephone circuit).	1					*	1
89	3C1399-175A	COIL: repeating; moistureproofed; (trunk circuit (A)).	2					*	4
85	3C1764R	COIL: retardation; moistureproofed; (operator's telephone circuit (A)).	1					*	1
86	3C1754W	COIL: retardation; moistureproofed; (operator's telephone circuit (BT)).	1					*	1
127	4C10110A/P1	CORD PULLEY: moistureproofed.	5			*	*	*	31
127	4E4036-96-3	CORD: switchboard; 8-ft; 3-conductor; green; equipped with #310 plug; moistureproofed.	5			*	*	*	10
127	3E4036-96-1	CORD: switchboard; 8-ft; 3-conductor; red; equipped with #310 plug; moistureproofed.	5			*	*	*	11
127	3E4036-96-2	CORD: switchboard; 8-ft; 3-conductor; slate; equipped with #310 plug; moistureproofed.	5			*	*	*	10
46	4C3287	CRANK: generator; switchboard.	1			*	*	*	1
	4B794.7	DIAL: telephone; moistureproofed.	1			*	*	*	1

6	4C9914.5/16	DROP: line; moistureproofed; (line circuit (L)).	10	*	*	30
	4C3709	FASTENER: cord; switchboard; moistureproofed.			*	93
90	322135A.1	FUSE: 1½-amp moistureproofed; (circuit protection).	20	*	*	9
	4C5072C/2	HANDLE: hard-rubber; black (universal keys).		*	*	17
58	2Z5537	JACK JK-37: (operator's telephone circuit).		*	*	1
12	4C4741.7	JACK: switchboard; mounted 10 per strip on W.E.Co. #136 mounting; jack moistureproofed per #D-161794; mounting moistureproofed per #D-161800; (magneto line jacks); W.E.Co. #141.	1	*	*	3
13	4C4741.6	JACK: switchboard; mounted 20 per strip on W.E.Co. #217A mounting; jack moistureproofed per #D-161794; mounting moistureproofed per #D-164087; (magneto line multiple jacks); W.E.Co. #141.	1	*	*	4
14	4C4875.1	JACK: switchboard; mounted 20 per strip on W.E.Co. #217A mounting; jack moistureproofed per #D-164086; mounting moistureproofed per #D-164087; (CB answering and multiple jacks); W.E.Co. #275.	1	*	*	9
11	4C4885A	JACK: switchboard; moistureproofed per #D-161891-285; (universal trunk answering and multiple jack); W.E.Co. #285A.	2	*	*	12
57	4C4864	JACK: switchboard; moistureproofed; (operator's telephone circuit).		*	*	4
24	4C5104.98Y	KEY: switchboard; moistureproofed; (ringing transfer).		*	*	1
62	4C5073DB	KEY: switchboard; moistureproofed; (grouping and night alarm release).		*	*	1
63	4C5073MG	KEY: switchboard; moistureproofed; (talk and ring).	1	*	*	15
	4C5646D	MOUNTING: dial; moistureproofed; per #D-166182; W.E.Co. #6000-D.		*	*	1

* Indicates stock available.

45. MAINTENANCE PARTS LIST FOR TELEPHONE CENTRAL OFFICE SET TC-10.

NOTE: Order maintenance parts by stock number, name, and description.
Only maintenance parts listed can be requisitioned.

b. Switchboard BD-110-A (continued).

Ref symbol	Signal Corps Stock No.	Name of part and description	Running spares	Orgn stock	3d ech	4th ech	5th ech	Depot stock	Quan per unit
152	4C10110A/C1	MULTIPLE CABLE ASSEMBLY: includes 25-pair connector; (interposition connection); Sig C dwg SC-D-4599-D.						*	12
	6Z7813	PLUG: 2-wire; flush base; male; twistlock, polarized; (terminates 110-v ac from Cabinet BE-75); Hubbell #9105.						*	1
183	4C7410 6Z7809-1.1	PLUG: switchboard; W.E.Co. #310 CR. RECEPTACLE: duplex; female; (trouble lamp and soldering iron outlet).			*			*	31 1
181	4C9980.7C/R11	RECEPTACLE: porcelain; screw base; female; (heater unit mounting).						*	2
101	6Z7808 4C8749.1073	RECEPTACLE: 2-wire; flush base; porcelain; female; (multiples 110-v a-c). RELAY: switchboard; telephone; moistureproofed; (operator's telephone circuit (M)).						*	1 1
104	4C8761.101.1	RELAY: switchboard; telephone; moistureproofed; (cord circuits (A) and (C)).	2					*	30
103	4C8827.2007	RELAY: switchboard; telephone; moistureproofed; (cord circuits (FS) and (BS)).	2					*	30

105	4C892057	RELAY: switchboard; telephone; moistureproofed; (trunk circuit (R)).	2	*	*	4
106	4C8920.58	RELAY: switchboard; telephone; moistureproofed; (trunk circuit (SL)).	2	*	*	4
184	3Z6025	RESISTOR: 250-ohm; Edison base; (heater element).	2	*	*	2
115	3Z5818EA	RESISTOR: wire-wound; flat-type, 9,000-ohm, moisture-proofed; (operator's telephone circuits (A) and (B)).	2	*	*	1
116	3Z5818EC	RESISTOR: wire-wound; flat-type; 6,000-ohm; moisture-proofed; (operator's telephone circuit (C)).	1	*	*	1
	4C7310/1	SCREW: plug shell.		*	*	31
	4C7310/2	SCREW: plug terminal.		*	*	62
	6L-31132-3	SCREW: stud; (dial mounting retainer).		*	*	1
	4C9781.2-37	SOCKET: lamp; switchboard, mounted 20 per strip on W.E.Co. #137 mounting; socket moistureproofed per #D-161949; mounting moistureproofed per #D-162342; (CB station line circuit).	1	*	*	3
	3Z7846A	SOCKET: lamp; female; screw base; porcelain; panel-mounted; moistureproofed; (ringing resistance lamp receptacle); W.E.Co. #46A.		*	*	1
	4C9783.4	SOCKET: lamp; switchboard moistureproofed; (cord circuit (R)).		*	*	15
	4C9784.9A	SOCKET: lamp; switchboard; moistureproofed; (cord supervisory (A) and (C)).		*	*	30
	3Z12048-23	TERMINAL: ring-type; solderless; (ring conductor; cord repair).	15	*	*	31
	3Z12048-27	TERMINAL: ring-type; solderless; (tip conductor; cord repair).	15	*	*	31

* Indicates stock available.

45. MAINTENANCE PARTS LIST FOR TELEPHONE CENTRAL OFFICE SET TC-10.

NOTE: Order maintenance parts by stock number, name, and description.
Only maintenance parts listed can be requisitioned.

b. Switchboard BD-110-A (continued).

Ref symbol	Signal Corps Stock No.	Name of part and description	Running spares	Orgn stock	3d ech	4th ech	5th ech	Depot stock	Quan per unit
121	3Z6926-2	THERMISTOR: moistureproofed per #D-162181 (trunk circuit (C)); W.E.Co. #1C.	2					*	4
122	4Z9730.1	VARISTOR: moistureproofed per #D-161871-A (trunk circuit (D)); W.E.Co. #27A.	2					*	4
123	4Z9730	VARISTOR: moistureproofed per #D-162708-A (operator's telephone circuit (E)); W.E.Co. #33A.	1					*	1
	4C10110A/W1	WEIGHT: cord; switchboard; double-pulley; 22½ oz; moistureproofed.						*	31
	6L4904-12P	GENERAL HARDWARE SCREW: cap; ¼" - 20 x ¾" hexagonal head; steel; (terminal panel mounting).						*	16
	6L6436-3.5	SCREW: machine; #4-36 x ¾" roundhead; (dial mounting).				*	*	*	3
	6L6632-6.1Z	SCREW: machine; #6-32 x ¾" roundhead; (trunk jack and lamp socket mounting).				*	*	*	28
	6L6632-7.7B	SCREW: machine; #6-32 x ¾" flathead; (operator's telephone jack mounting).						*	6
	6L7032-4.5	SCREW: machine; #10-32 x ¼" roundhead; (fuse mounting).				*	*	*	18

6L7224-7.8P	SCREW: machine; #12-24 x $\frac{1}{8}$ " binding head; steel; bonderized; (rear equipment units mounting).	*	*	*	40
6L7224-16.1	SCREW: machine; #12-24 x 1" roundhead; (generator mounting).	*	*	*	4
6L8104-4	SCREW: wood; brass; roundhead, $\frac{1}{2}$ ", #4; (recall and supervisory lamp socket mounting).	*	*	*	45
6L8106-16	SCREW: wood; brass; roundhead; 2", #6; (#72 induction coil mounting).	*	*	*	2
6L52005-12	WASHER: iron; for $\frac{1}{4}$ " screw; zinc finish; (terminal panel frame mounting).	*	*	*	16
6L58012N	WASHER: steel; #12 screw; standard nicked; (generator mounting).	*	*	*	4
6L75039-1	WASHER: split-spring; steel; #12; electro-galvanized; (generator mounting).	*	*	*	4
6L58025-2P	WASHER: split-spring; steel; $\frac{5}{16}$ " OD x $\frac{1}{16}$ " ID x $\frac{1}{16}$ " thick; bonderized; (terminal panel frame mounting).	*	*	*	16
<i>c. Frame FM-19.</i>					
149	BINDING POST TM-197.	*	*	*	400
318	BLOCK: protector; carbon; W.E.Co. #28.	*	*	*	200
319	BLOCK: protector; porcelain; W.E.Co. #29.	*	*	*	200
316	COIL: heat; W.E.Co. #76A.	*	*	*	200
311	CORD CD-333: includes 25-pair connector, Frame FM-19 to Switchboard BD-110.	*	*	*	4
3E4036-252	CORD: test; 4-conductor tinsel; 19'6" long; W.E.Co. #D-166001.	*	*	*	1
317	PROTECTOR: (strip of 50); W.E.Co. #C50A.	*	*	*	2 strips

* Indicates stock available.

45. MAINTENANCE PARTS LIST FOR TELEPHONE CENTRAL OFFICE SET TC-10.

NOTE: Order maintenance parts by stock number, name, and description.
Only maintenance parts listed can be requisitioned.

c. Frame FM-19 (continued).

Ref symbol	Signal Corps Stock No.	Name of part and description	Running spares	Orgn stock	3d ech	4th ech	5th ech	Depot stock	Quan per unit
	6L7928-4-20.3S	SCREW: machine; special; $\frac{1}{4}$ "-28 threads x $1\frac{1}{2}$ " fillister head; item #21, Sig C dwg SC-D-4637C.						*	24
	6Z8449	STRAP ST-32: secures cords for transportation.						*	6
	6Z8815	TWINE RP-15: secures cords to racks and frames.						*	1 lb
	1B122-1	WIRE: #22; 2-conductor; black and red; solid; tinned; insulated; (cross-connection).			*			*	2000 ft.
		GENERAL HARDWARE						*	
	6L3504-28E-A7	NUT: steel; hexagonal; $\frac{1}{4}$ "-28 threads; standard; parkerized; (frame assembly).						*	16
	6L3506-16P	NUT: steel; hexagonal; $\frac{3}{8}$ "-16 threads; standard; (frame assembly).						*	8
	6L4904-6.28P	SCREW: cap; hexagonal; $\frac{1}{4}$ " x $\frac{3}{8}$ "; 28 threads; parkerized; (frame assembly).						*	10
	6L4904-12.28	SCREW: cap; hexagonal; $\frac{1}{4}$ " x $\frac{3}{4}$ "; 28 threads; parkerized; (frame assembly).						*	6
	6L4906-12P	SCREW: cap; hexagonal; $\frac{3}{8}$ " x $\frac{3}{4}$ "; 16 threads; parkerized; (frame assembly).						*	3
	6L4906-20P	SCREW: cap; hexagonal; $\frac{3}{8}$ " x $1\frac{1}{4}$ "; 16 threads; (frame assembly).						*	4

45. MAINTENANCE PARTS LIST FOR TELEPHONE CENTRAL OFFICE SET TC-10.

NOTE: Order maintenance parts by stock number, name, and description.
Only maintenance parts listed can be requisitioned.

d. Cabinet BE-72.

Ref symbol	Signal Corps Stock No.	Name of part and description	Running spares	Orgn stock	3d ech	4th ech	5th ech	Depot stock	Quan per unit
427	3Z5819CC	RESISTOR: wire-wound; flat-type; 1,280-ohm; tapped at 380 ohms; (resistor (E)); W.E.Co. #19CC.						*	1
426	3Z5818EY	RESISTOR: wire-wound; flat-type; 1,800-ohm; (resistor (H)); W.E.Co. #18EY.						*	1
429	3Z5819MK	RESISTOR: wire-wound; flat-type; 3,480-ohm; tapped at 44 ohms; (resistor (A)); W.E.Co. #19MK.						*	1
430	3Z5819MS	RESISTOR: wire-wound; flat-type; 5,245-ohm; tapped at 69.6 ohms; (resistor (D)); W.E.Co. #19MS.						*	1
428	3Z5819MG	RESISTOR: wire-wound; flat-type; 5,610-ohm; tapped at 20 ohms; (resistor (C)); W.E.Co. #19MG.						*	1
433	3H672/V1	VOLTMETER: d-c; 0- to 100-v; $3\frac{3}{16}$ " flange diam.; $2\frac{3}{4}$ " body diam; flush mounting; W.E.Co. #D-55067.						*	1
<i>e. Panel BD-90.</i>									
501	3F1020-14	AMMETER: d-c; 20-0-20-amp; $2\frac{3}{4}$ " round case; flush mounting.						*	1
502	6Z816	BASE: midget; flush; male; (power-ringing receptacle).	1			*	*	*	1
503	4C307F	BELL: switchboard; night alarm (NB alarm).	1			*	*	*	1
	3Z209	BINDING POST TM-109; except engraved (+).						*	1

45. MAINTENANCE PARTS LIST FOR TELEPHONE CENTRAL OFFICE SET TC-10.

NOTE: Order maintenance parts by stock number, name, and description.
Only maintenance parts listed can be requisitioned.

e. Panel BD-90 (cont'd).

Ref symbol	Signal Corps Stock No.	Name of part and description	Running spares	Orgn stock	3d ech	4th ech	5th ech	Depot stock	Quan per unit
529	4C4908	KEY SW-178: rotating button key for no-voltage alarm control (G).						*	1
528	4G5092Y	KEY: switchboard; (push-button key; no-voltage alarm guard; audible cut-off (D)).						*	1
527	4C5104.79	KEY: switchboard; (night alarm key (NA)).	1		*	*		*	1
538	6Z8366	PLUG: 3-wire motor; flush base; male; (for connection to battery charger).						*	1
539	6Z8367	PLUG: 3-wire motor; flush base; male; (d-c power outlet (A) and (B)).	1		*	*		*	2
542	6Z6021	RECEPTACLE: 2-contact; female; in #BRM-7307; metal housing; (for connecting to battery and to switchboard).	1					*	2
546	3H4090/R3	RELAY: switchboard; telephone; with cover; (no-voltage alarm control (A)).						*	1
547	3H4090/R4	RELAY: switchboard; telephone; with cover; (no-voltage alarm guard; audible cut-off (B)).						*	1
543	4C8827	RELAY: switchboard; telephone with cover; (night alarm release (AR)).	1					*	1
544	4C8749.931	RELAY: switchboard; telephone with cover; (night alarm lock-in (NA)).	1					*	1

545	4C9139GB	RELAY: switchboard; telephone; with cover; (night alarm control (AU)).	1	*	1
549	3Z5818CJ	RESISTOR: wire-wound; flat-type; 5-ohm; (interrupter contact protection).		*	1
550	3Z5840BS	RESISTOR: 3-ohm $\pm 1\%$, noninductive; flat punched iron core; (part of NA bridge network (A) and (B)).		*	2
548	3Z6500-79	RESISTOR: wire-wound; flat-type; 5,000-ohm; (to delay operation of NA relay (C)).		*	1
	6Z8366-1	SOCKET: 4-wire motor plug; flush base in casing; male; (alarm circuit connectors).		*	1
	6Z8367-1	SOCKET: 4-wire motor plug; flush base; female; (alarm circuit connectors).		*	1
552	4F2425.1	TELERING: model H; (converts 60-cycle power to 20-cycle ringing current); Sig C dwg SC-D-4329.		*	1
	3Z12004	TERMINAL: U-shaped; solder terminal; $\frac{1}{2}$ " x $\frac{3}{8}$ "; (for connection to ringing power outlets); Cinch Mfg. Co. #CM1477.		*	4
	3Z10122	TERMINAL TM-122: main circuit breaker terminals.		*	6
	3Z10126	TERMINAL TM-126: (48-v, A&B, C, and INT circuit breaker terminals).		*	7
	3Z10130	TERMINAL TM-130: d-c bus bar terminals.		*	20
	3Z12045	TERMINAL: lug; (BAT CA, SWBD BAT CA outlets, ammeter and voltmeter terminals).		*	11
562	3F8075-2	VOLTMETER: 0-75 volts; d-c; $2\frac{3}{4}$ " round case; flush mounting.		*	1
	6L3104-40 S. P.	<i>GENERAL HARDWARE</i> NUT: steel; hexagonal; #4-40; (meters and NA key mounting).		*	10

* Indicates stock available.

45. MAINTENANCE PARTS LIST FOR TELEPHONE CENTRAL OFFICE SET TC-10.

NOTE: Order maintenance parts by stock number, name, and description.
 Only maintenance parts listed can be requisitioned.

e. Panel BD-90 (cont'd).

Ref symbol	Signal Corps Stock No.	Name of part and description	Running spares	3d ech	4th ech	5th ech	Depot stock	Quan per unit
	6L3106-32 S. G.	NUT: steel; hexagonal; #6-32; (power ringing receptacle mounting).			*	*	*	4
	6L610-32 S. P.	NUT: steel; hexagonal #10-32; (repeating coil; retardation coil, and 4-pole socket mounting).			*	*	*	16
	6L3612-24.1Z	NUT: iron; hexagonal; #12-24; (battery termination receptacle mounting).			*	*	*	4
	6L6440-8.1S	SCREW: machine; #4-40 x 1/2" roundhead; (mounts meters).			*	*	*	6
	6L6440-12.2S	SCREW: machine; #4-40 x 3/4" ovalhead; (mounts NA key).			*	*	*	4
	6L6632-6.87	SCREW: machine; #6-32 x 3/8" roundhead; (mounts power ringing receptacles).			*	*	*	6
	6L6832-6.1P	SCREW: machine; #8-32 x 3/8" roundhead; (mounts circuit breakers and BAT CHG, 48-v A&B receptacles).			*	*	*	17
	6L6832-10.45Z	SCREW: machine; #8-32 x 5/8" roundhead; (interrupter mounting).			*	*	*	4
	6L6832-14.1	SCREW: machine; #8-32 x 7/8" roundhead; (mounts FA buzzer and NB bell).			*	*	*	4
	6L7032-6.1M	SCREW: machines; #10-32 x 3/8" roundhead; brass; silver-plated; (connect TM-130 to bus bar).			*	*	*	20

6L7032-8.8P	SCREW: machines; #10-32 x 1/2"; binding head; steel; parkrized; (mounts support for circuit breakers, front panel, and rear equipment mounting plates).	*	*	*	*	30
6L7032-16.1	SCREW: machine; #10-32 x 1"; roundhead; steel; electro-galvanized; (mounts telering and 4-pole sockets).	*	*	*	*	12
6L7032-24Z	SCREW: machine; #10-32 x 1/2"; flathead; (mounts repeating coil).	*	*	*	*	4
6L7032-25.1P	SCREW: machine; #10-32 x 3/16"; roundhead; steel; bonderized; (mounts retardation coil).	*	*	*	*	4
6L7224-14.8E	SCREW: machine; #12-24 x 7/8"; binding-head; steel; electro-galvanized; (battery termination receptacle mounting).	*	*	*	*	4
6L7918-5-20.81E	SCREW: machine; 1/16" x 1 1/4"; 18-thread; hexagonal head; steel; electro-galvanized; (CS-60 cover fastening).	*	*	*	*	10
6L7928-47.81E	SCREW: Semo Fastener, 44"-28 x 1/16"; hexagonal slotted head, electro-galvanized; shakeproof-type #62 (mounts front panel).	*	*	*	*	10
6L73010-1E	WASHER: flat; steel; standard for #10 screw; (mounts repeating and retardation coils, telering, and 4-pole sockets).	*	*	*	*	20
6L75004N.1	WASHER: lock; split-spring; steel; standard for #4 screw (mounts meters and NA key).	*	*	*	*	10
6L75006N.1	WASHER: lock; split-spring; steel; standard for #6 screw; (power ringing receptacle mounting).	*	*	*	*	4
6L73008	WASHER: split-spring; steel; standard for #8 screw; (circuit breakers interrupter, keys, and audible signal equipment mounting).	*	*	*	*	27

* Indicates stock available.

45. MAINTENANCE PARTS LIST FOR TELEPHONE CENTRAL OFFICE SET TC-10.

NOTE: Order maintenance parts by stock number, name, and description.
Only maintenance parts listed can be requisitioned.

e. Panel BD-90 (cont'd).

<i>Ref symbol</i>	<i>Signal Corps Stock No.</i>	<i>Name of part and description</i>	<i>Running spares</i>	<i>Orgn stock</i>	<i>3d ech</i>	<i>4th ech</i>	<i>5th ech</i>	<i>Depot stock</i>	<i>Quan per unit</i>
	6L73010	WASHER: lock; split-spring; steel; standard for #10 screw; (bus bar, circuit breakers, 4-pole sockets, telering, retardation and repeating coil mounting).			*	*	*	*	36
	6L72212-13	WASHER: lock; split-spring; steel; standard for #12 screw, electro-galvanized; (battery termination receptacle mounting).			*	*	*	*	4
<i>f. Cabinet BE-75.</i>									
606	3H900-15-4	CIRCUIT BREAKER: 15-amp; double-pole; time delay curve D; (a-c overload protection); Heinemann #0322-15.			*	*	*	*	3
603	6Z7809-1.1	OUTLET. duplex; female; 2-conductor; bakelite; (low-current receptacle); Hubbell #9575.	1		*	*	*	*	2
604	6Z7588.1	PLUG: 2-conductor; flush base; female; (high-current receptacle); Hubbell #8809.	1		*	*	*	*	4
605	6Z6021	RECEPTACLE: 2-contact; female; (a-c feeder receptacle); Crouse-Hinds #BR-2302 in BRM-7302 metal housing.	1		*	*	*	*	1
	6L3606-32P	GENERAL HARDWARE NUT: iron; hexagonal; #6-32; (low-current receptacle mounting).			*	*	*	*	4

6L3610-32SP	NUT: iron, hexagonal; #10-32; (circuit breaker and high-current receptacle mounting).	*	*	*	17
6L3612-24.1Z	NUT: iron; hexagonal; #12-24; (a-c feeder receptacle mounting).	*	*	*	2
6L6632-5.8S	SCREW: machine; #6-32 x $\frac{5}{16}$ "; roundhead (low-current receptacle mounting).	*	*	*	6
6L6832-4.13	SCREW: machine; #8-32 x $\frac{1}{4}$ "; roundhead (phenolic designation plate mounting).	*	*	*	4
6L7032-6.5S	SCREW: machine; #10-32 x $\frac{5}{16}$ "; roundhead (high-current receptacle mounting).	*	*	*	8
6L7032-8.1SE	SCREW: machine; #10-32 x $\frac{1}{2}$ "; roundhead (circuit breaker mounting).	*	*	*	9
6L75006N.1	WASHER: lock; split-spring; steel; standard for #6 screw; (low-current receptacle mounting).	*	*	*	4
6L73010	WASHER: lock; split-spring; steel; standard for #10 screw; (circuit breaker and high-current receptacle mounting).	*	*	*	17
<i>g. Head and Chest Set HS-19.</i>					
4C28234/1	TRANSMITTER ATTACHMENT: webbing; with buckles; (neck strap); W.E.Co. #3 type.	*	*	*	1
2B2116D/1	CAP: receiver; W.E.Co. (part of W.E.Co. #716A receiver).	*	*	*	1
2B192	CASE: receiver; W.E.Co.; (part of W.E.Co. #716A receiver).	*	*	*	1
3EL4R	CORD: 6-ft; 4-conductor; moistureproofed W.E.Co. #L4R per #D-161085 (part of head and chest set, W.E.Co.).	*	*	*	1
4C4153BA	HEADBAND ASSEMBLY: wire-type; single-receiver; with pad; moistureproofed per #D-142091; W.E.Co. #11A.	*	*	*	1

* Indicates stock available.

45. MAINTENANCE PARTS LIST FOR TELEPHONE CENTRAL OFFICE SET TC-10.

NOTE: Order maintenance parts by stock number, name, and description.
Only maintenance parts listed can be requisitioned.

g. Head and Chest Set HS-19 (cont'd).

Ref symbol	Signal Corps Stock No.	Name of part and description	Running spares	Orgn stock	3d ech	4th ech	5th ech	Depot stock	Quan per unit
	4C28396/1	MOUTHPIECE: W.E.Co. #P-209279; (for W.E.Co. #396A transmitter).				*	*	*	1
742	4C7337A.1	PLUG: moistureproofed per #D-161821 (part of head and chest set, W.E.Co.) W.E.Co. #289A.				*	*	*	1
743	481109F/1	RECEIVER UNIT: headset; W.E.Co. #HA1.				*	*	*	1
	6L6256-7.545	SCREW: machine; special; W.E.Co. #P-209560 (W.E.Co. #396A transmitter case assembly).				*	*	*	3
	4C27010/S1	SPRING: contact; coil; W.E.Co. #P-209266 (part of W.E.Co. #396A transmitter).				*	*	*	1
744	4C28396	TRANSMITTER: operator's; W.E.Co. #396A.				*	*	*	1
	4C28396/8	TRANSMITTER UNIT. W.E.Co. #A-1; (part of W.E.Co. #396A transmitter).				*	*	*	1
<i>h. Headset HS-30-().</i>									
	2B1300	†INSERT M-300.				*	*	*	2
	3Z10161	†TERMINAL TM-161: ring tip; solderless.				*	*	*	4
	3Z10163	†TERMINAL TM-163: spade tip; solderless.				*	*	*	2

i. Chest Set TD-1.

701	4B418	CHEST UNIT T-26.	*	*	*	*	1
	2Z2637-13	CLAMP: band; (for stay cord).	*	*	*	*	1
	2Z2637-12	CLAMP: hook; (for stay cord).	*	*	*	*	1
	3E333	CORD CC-333.	*	*	*	*	1
	4Z3785	CORDAGE: (stay cord).	*	*	*	*	1
709	4B2358	PLUG PL-58.	*	*	*	*	3
	6L7032-4.4	SCREW: machine; #10-32 x 1/4"; fillister head; (for Plug PL-58).	*	*	*	*	3
	3Z10163	TERMINAL TM-163: small.	*	*	*	*	3
	3Z10182	TERMINAL TM-182: large.	*	*	*	*	3

*Indicates stock available.

†Owing to the large number of manufacturing types of Headset HS-30, parts of which are not interchangeable, no repair parts other than those shown above will be furnished. Repairs should be made as far as possible through cannibalization.

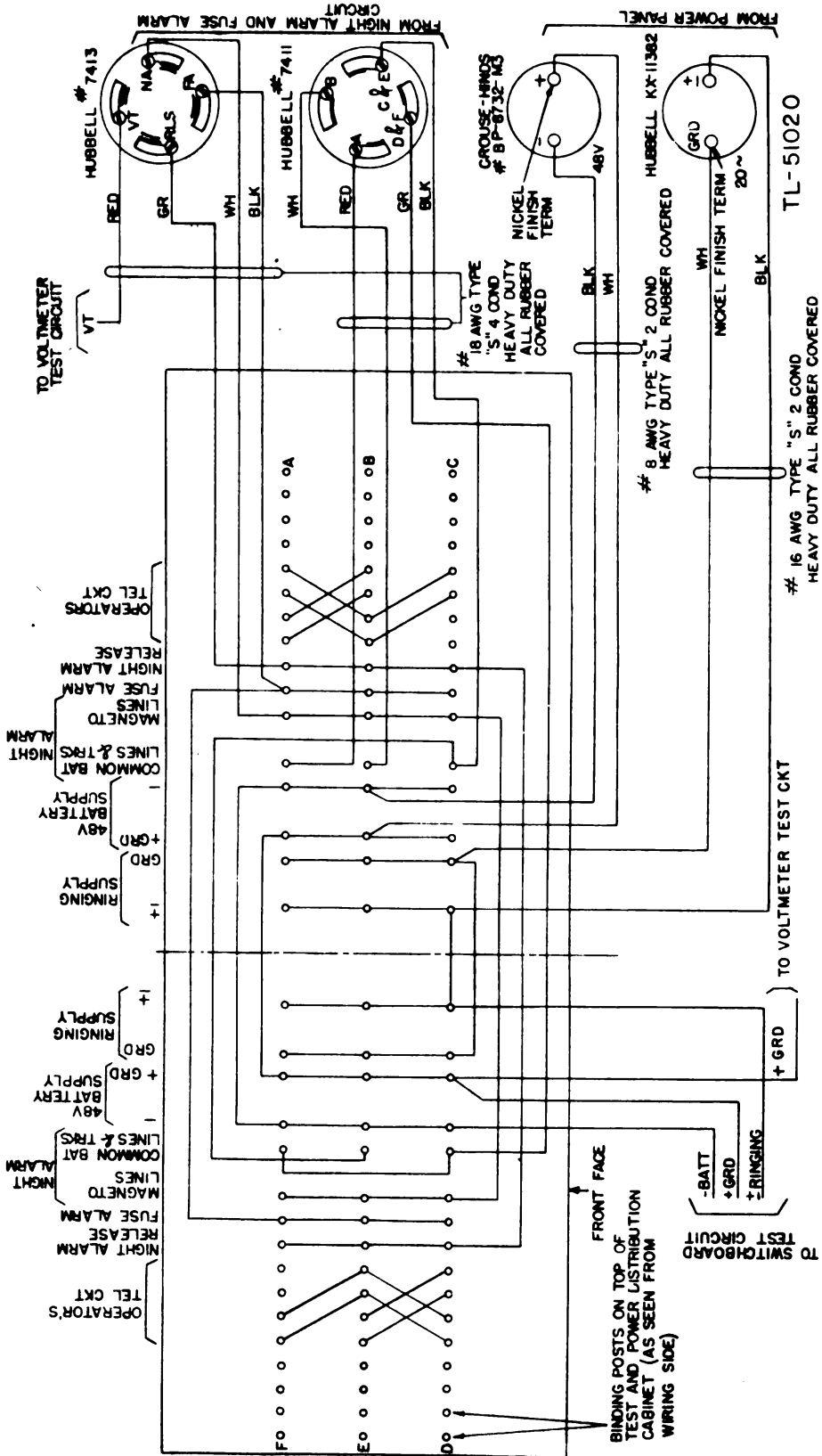
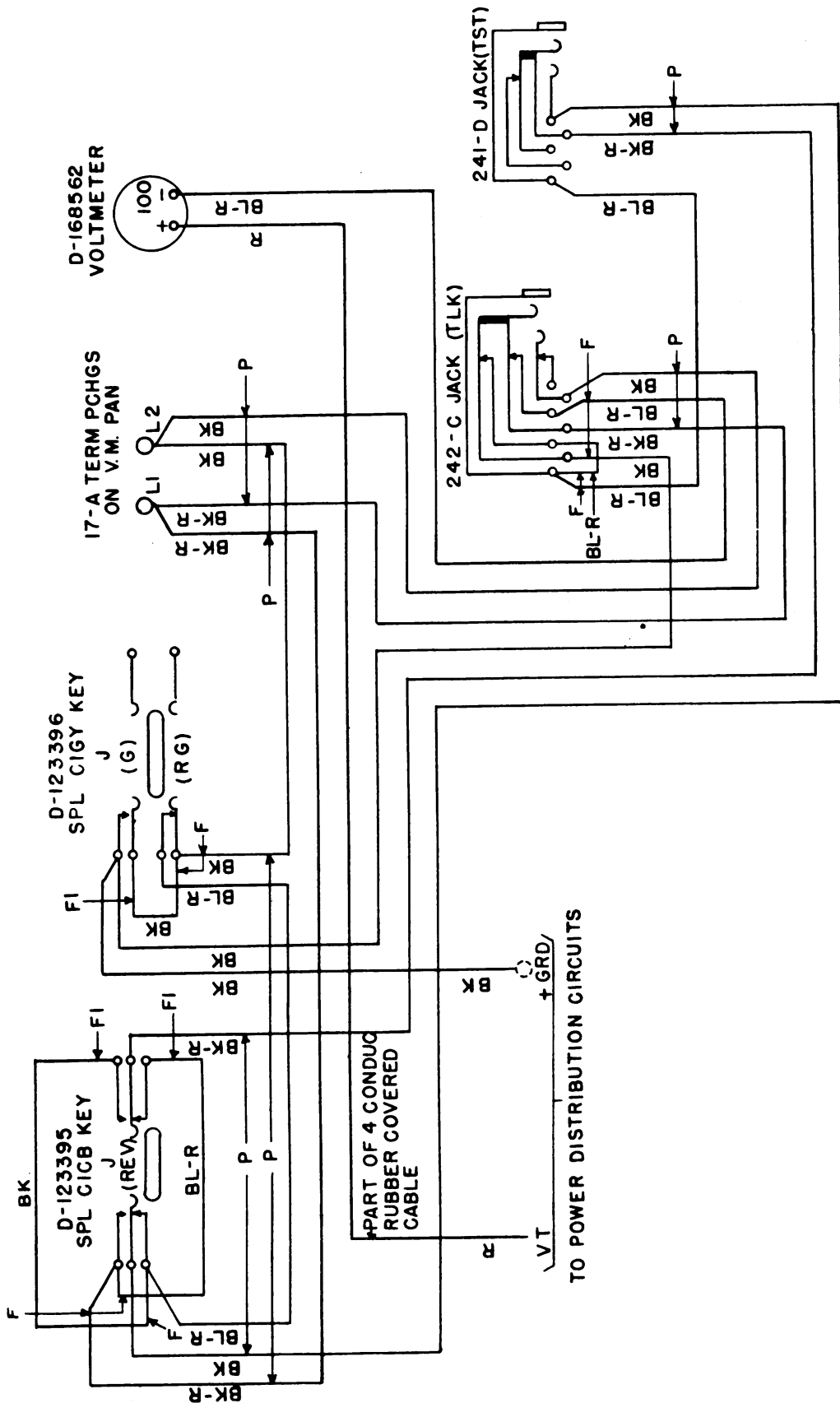


Figure 62. Power distribution circuits, wiring diagram, Cabinet BE-72.



TL-51021

Figure 63. Voltmeter test circuit, wiring diagram, Cabinet BE-72.

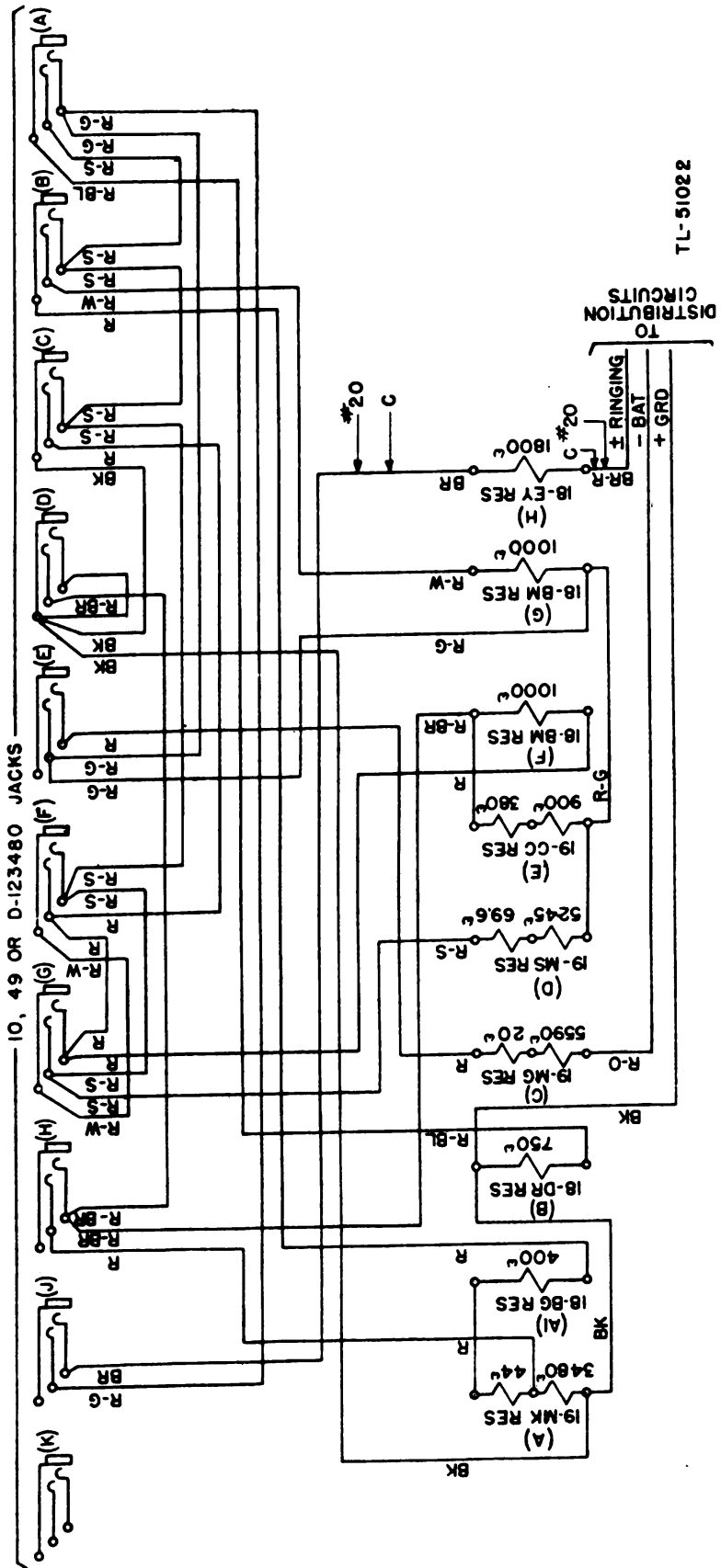
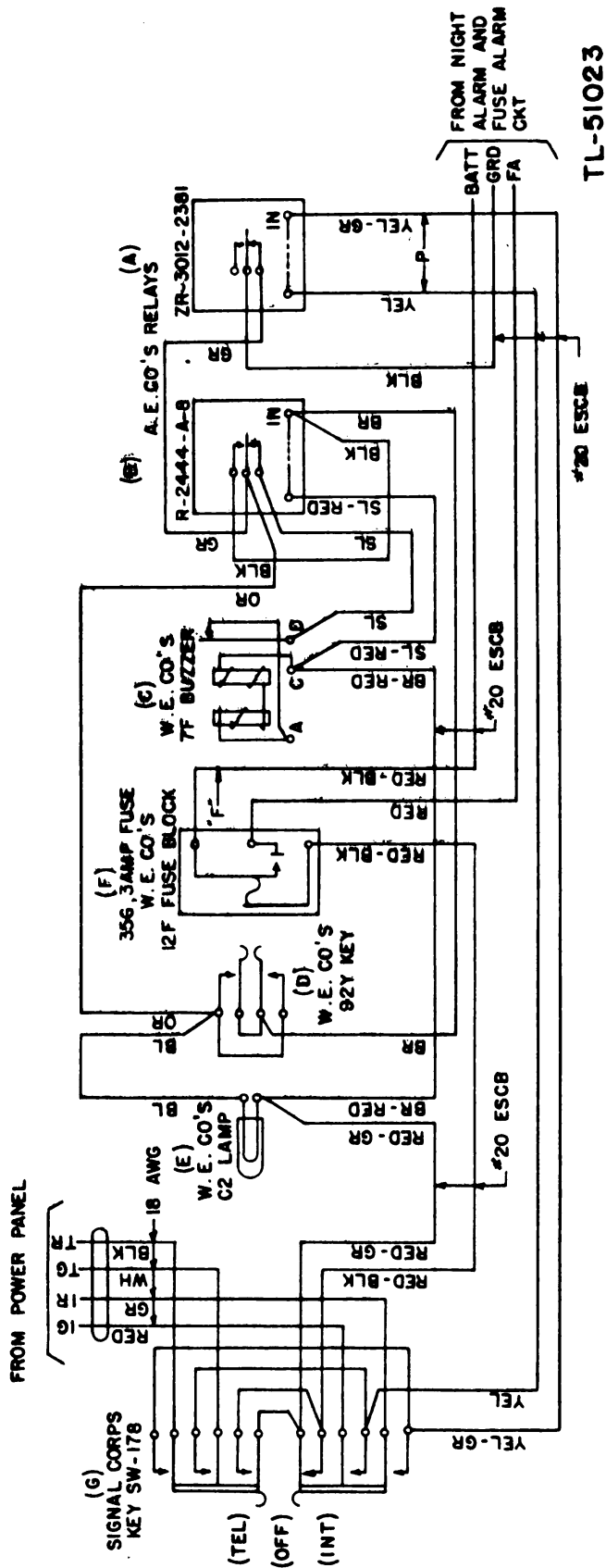


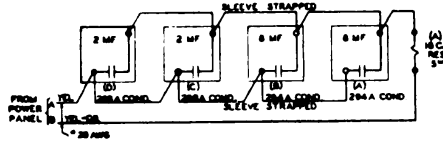
Figure 64. Switchboard test circuit, wiring diagram, Cabinet BE-72.



TL-51023

Figure 66. No-voltage alarm circuit, wiring diagram, Panel BD-90.

CODE NUMBERS REFER TO APPARATUS AS MADE BY WESTERN ELECTRIC CO.
INC., NEW YORK, N.Y.



INTERRUPTER CONTACT PROTECTION CIRCUIT
WIRING DIAGRAM

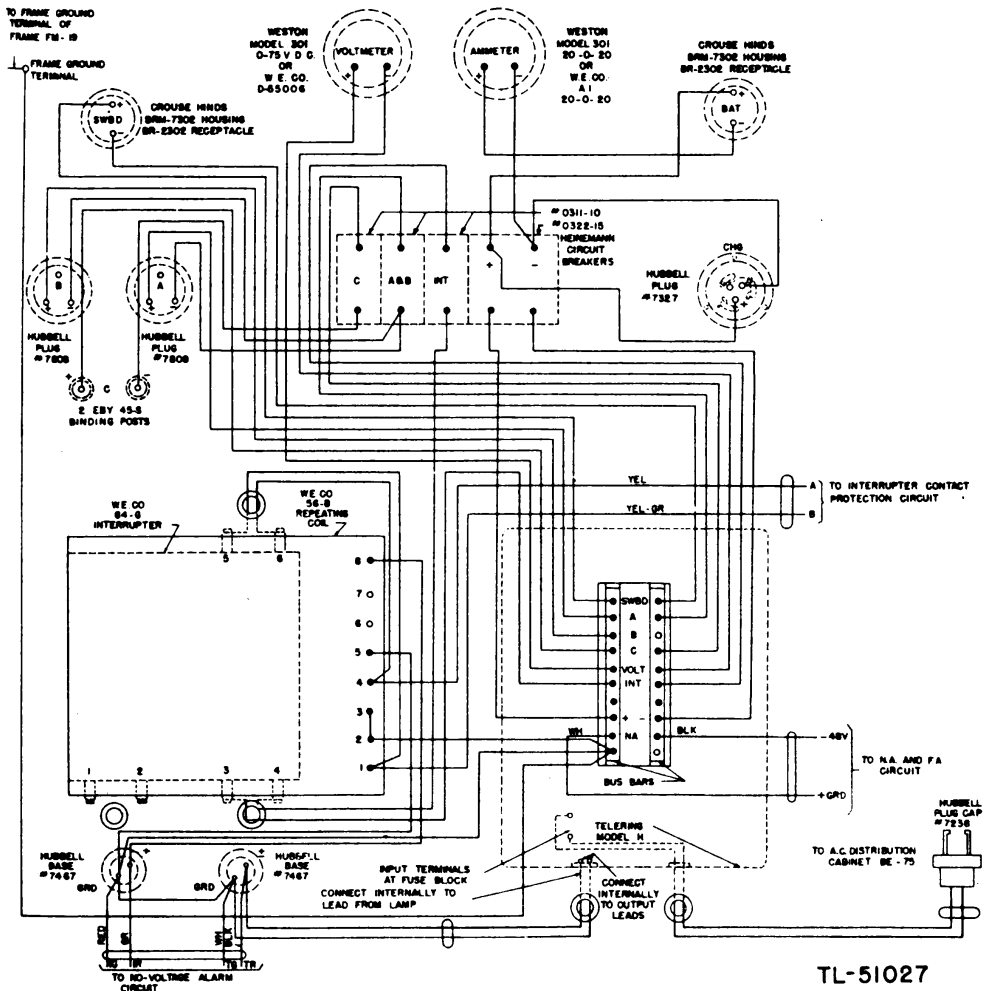


Figure 67. Power and ringing circuits and interrupter contact protection circuit, wiring diagram, Panel BD-90.

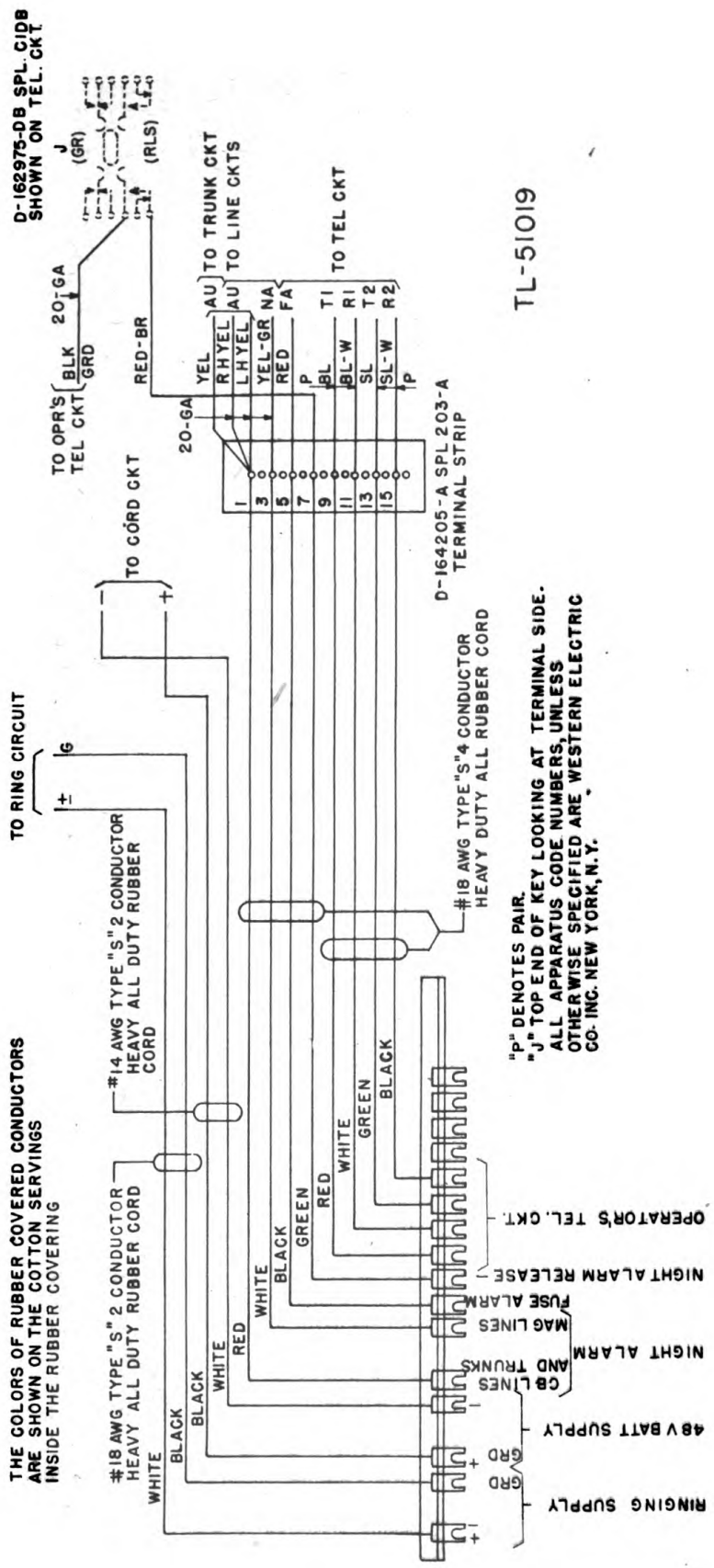


Figure 69. Power cable connector circuit, wiring diagram, Switchboard BD-110-().

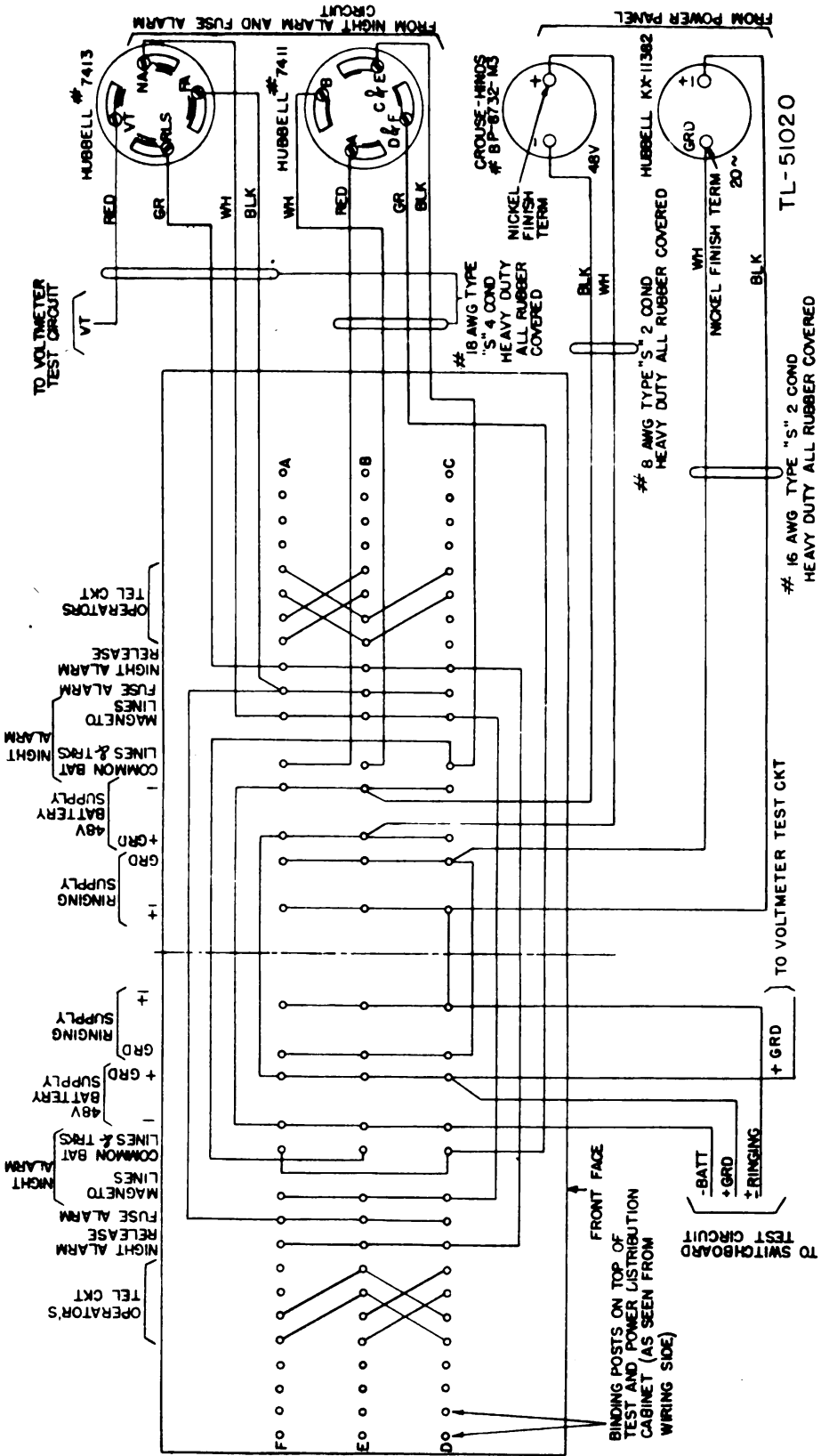
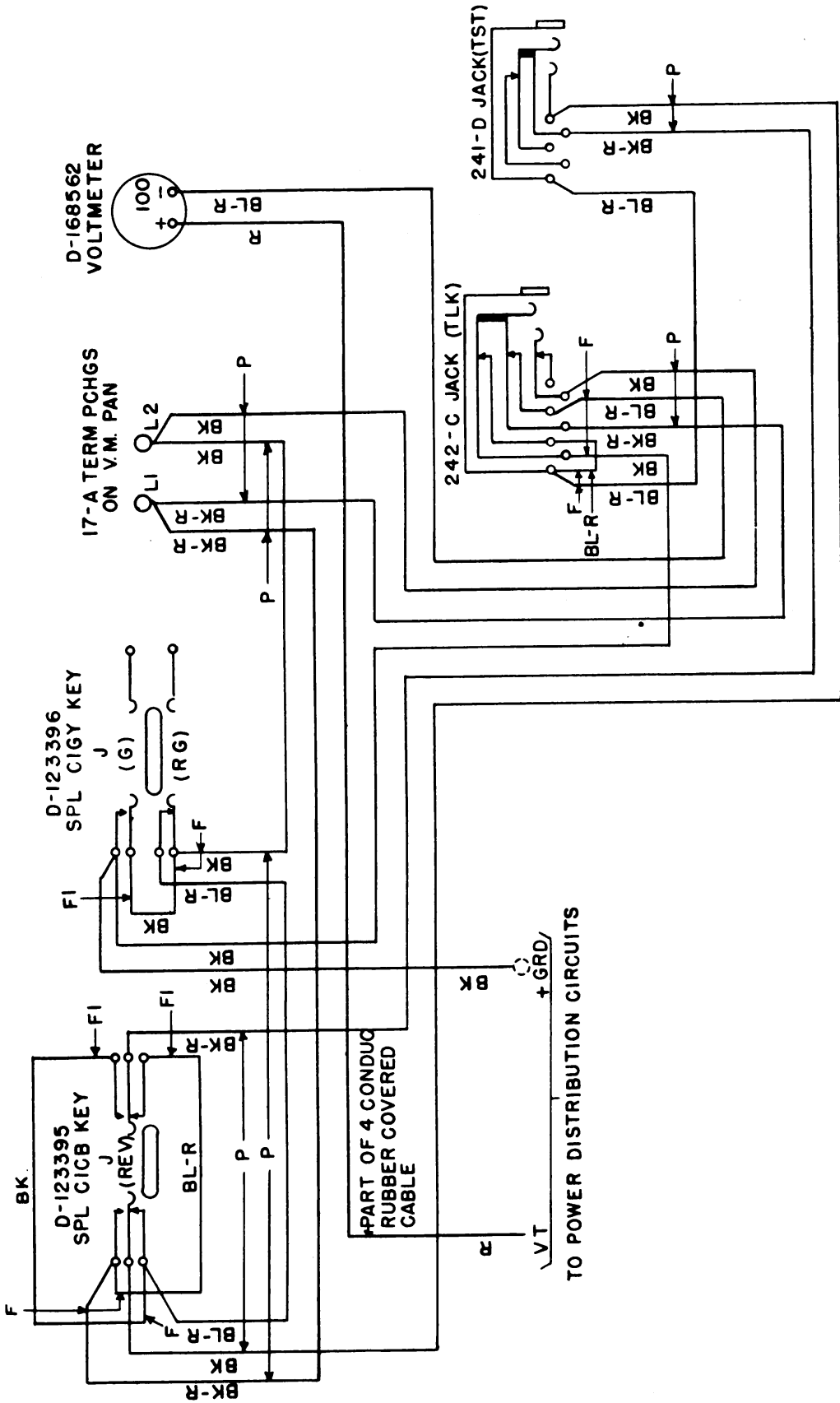
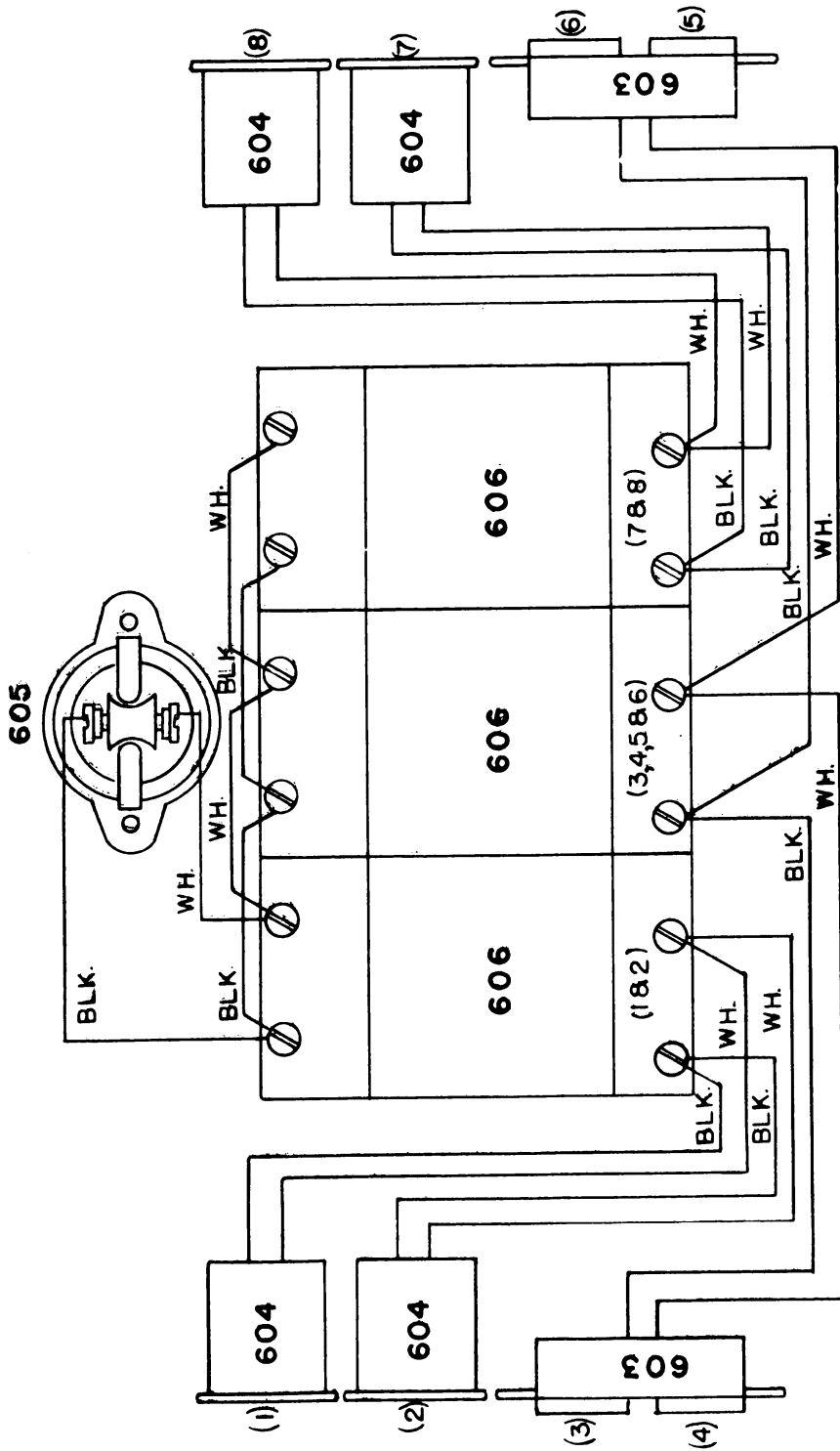


Figure 62. Power distribution circuits, wiring diagram, Cabinet BE-72.



TL-51021

Figure 63. Voltmeter test circuit, wiring diagram, Cabinet BE-72.



TL-51026

Figure 65. Cabinet BE-75, wiring diagram.

NOTE: The bold-face numbers refer to reference symbols in table VI.

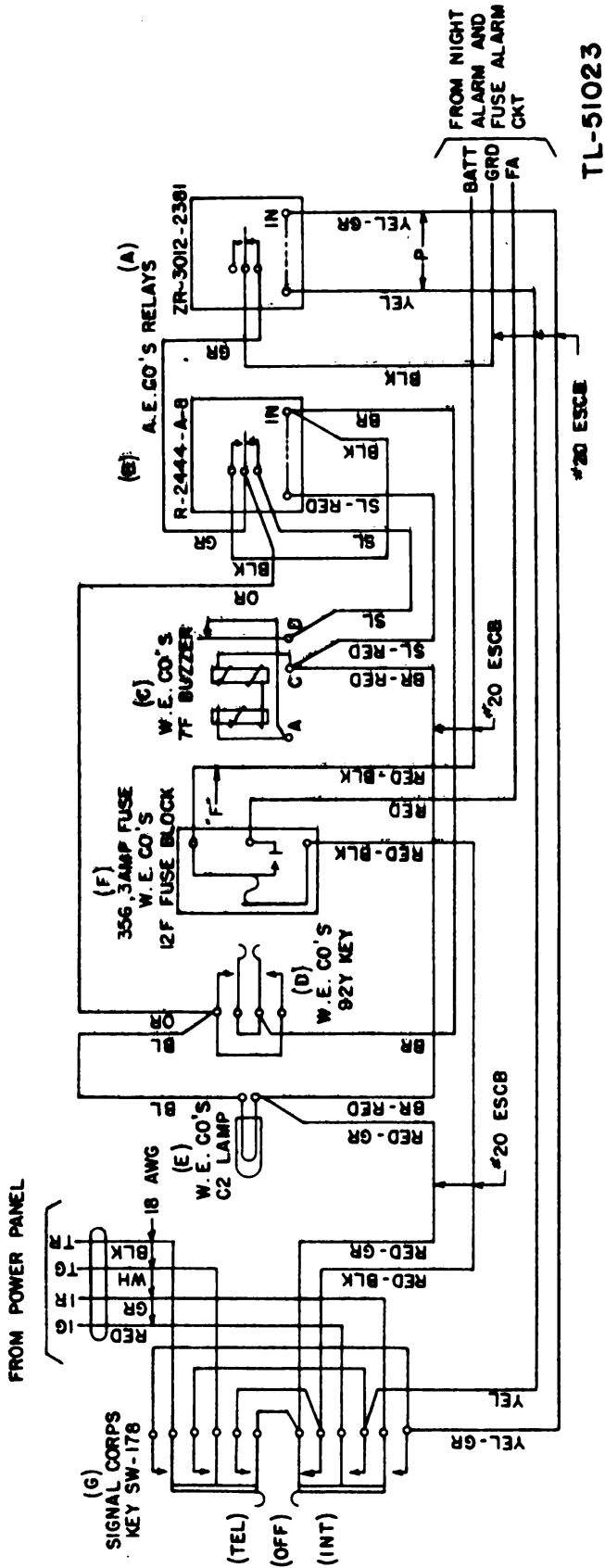
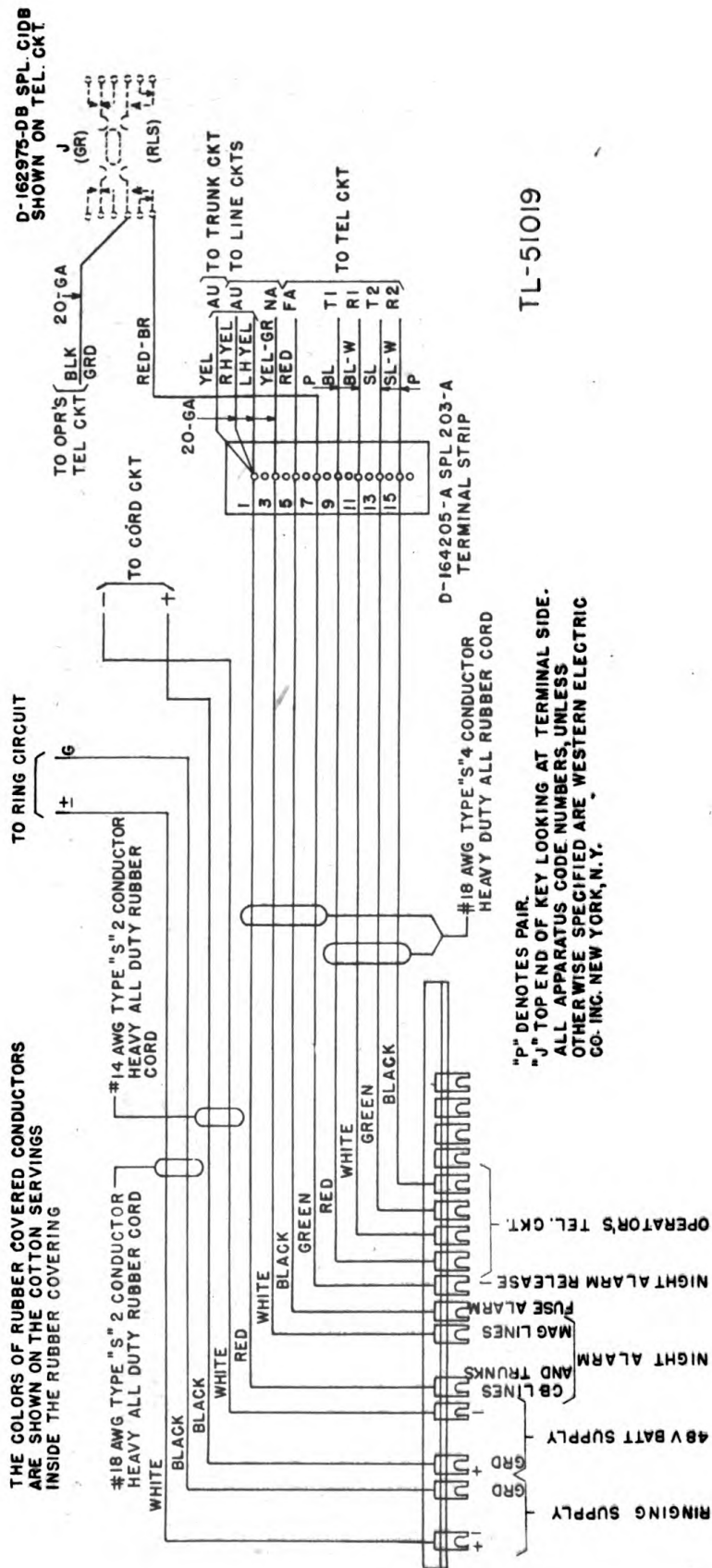


Figure 66. No-voltage alarm circuit, wiring diagram, Panel BD-90.



TL-51019

Figure 69. Power cable connector circuit, wiring diagram, Switchboard BD-110-().

"P" DENOTES PAIR.
 "J" TOP END OF KEY LOOKING AT TERMINAL SIDE.
 ALL APPARATUS CODE NUMBERS, UNLESS
 OTHERWISE SPECIFIED ARE WESTERN ELECTRIC
 CO. INC. NEW YORK, N. Y.

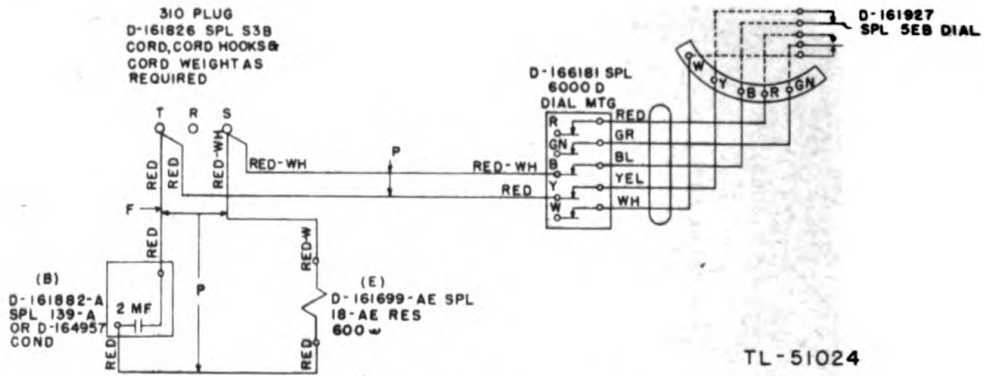


Figure 70. Dial cord circuit, wiring diagram, Switchboard BD-110-().

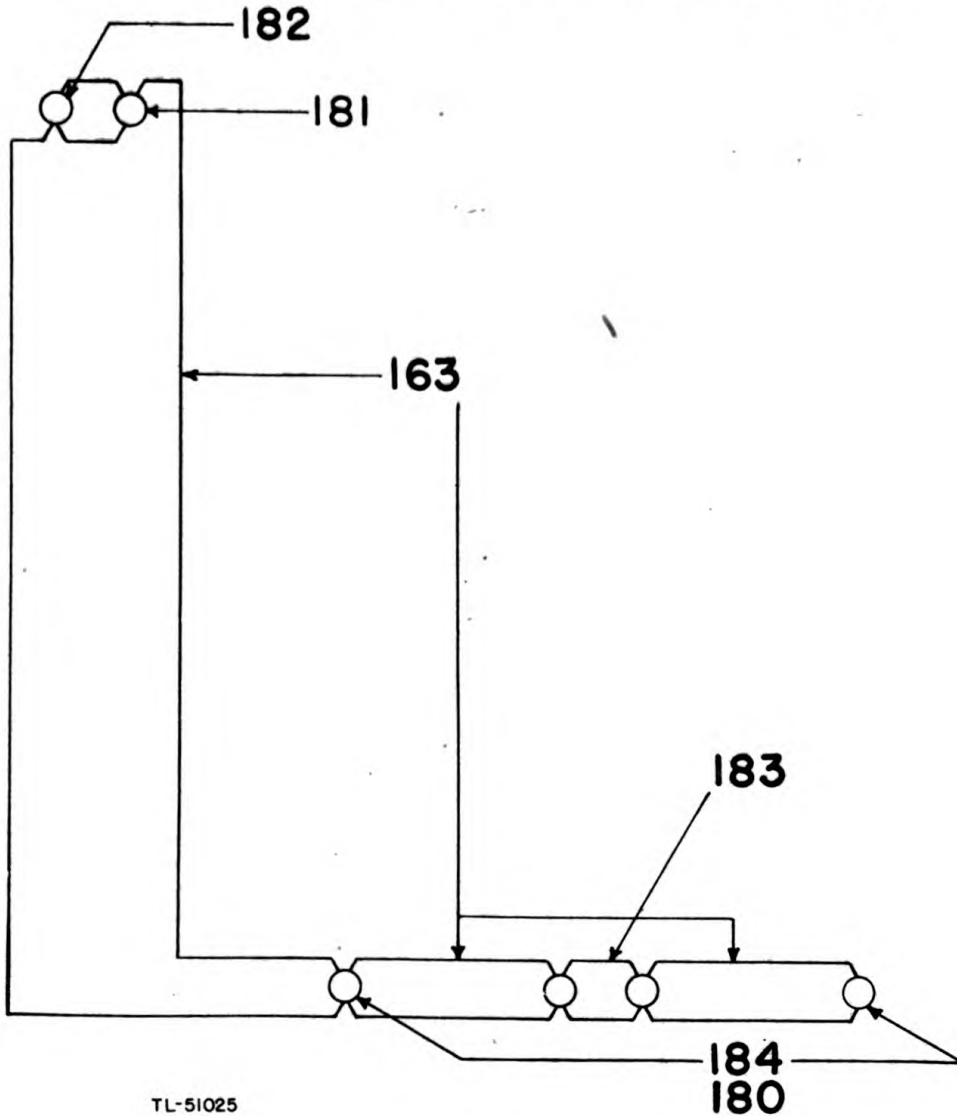


Figure 71. Power and heating circuit, wiring diagram, Switchboard BD-110-().

NOTE: The numbers refer to reference symbols in table VI.

20
 30 PLUGS SPL 3 B CORD LENGTH AS REQ
 D-161826 SPL 3 B CORDWEIGHTS AS REQ
 2 - CORD PASTENERS AS REQ

19

(A) EI LAMP
 ANS (REAR)
 OT OR OS
 P

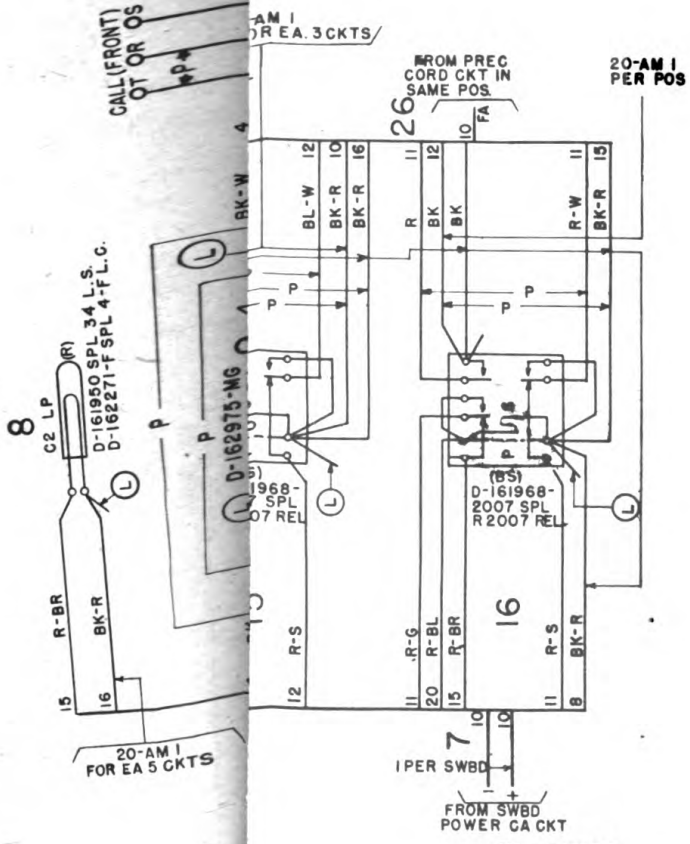
D-161946 SPL 49 A.L.S.
 D-162270-H SPL 2-HOR
 D-162270-AY SPL 2AY OR
 D-162270-L SPL 2-L LAMP

(C) EI LAMP
 CALL (FRONT)
 OT OR OS
 P

D-161946 SPL 49 A.L.S.
 D-162270-H SPL 2-HOR
 D-162270-AY SPL 2AY OR
 D-162270-L SPL 2-L LAMP

OTHERWISE SPECIFIED CODE
 TO APPARATUS AS MADE BY
 ELECTRIC CO. INC., NEW YORK, N.Y.

LEADS TO BE INSULATED
 CONNECTED
 BLE FORM AT SEPARATE SWITCH
 Y LOOKING AT TERMINAL
 OPEN
 DE OF KEY LOOKING AT
 SEPARATE CABLE SEWED TO
 GULAR CABLE



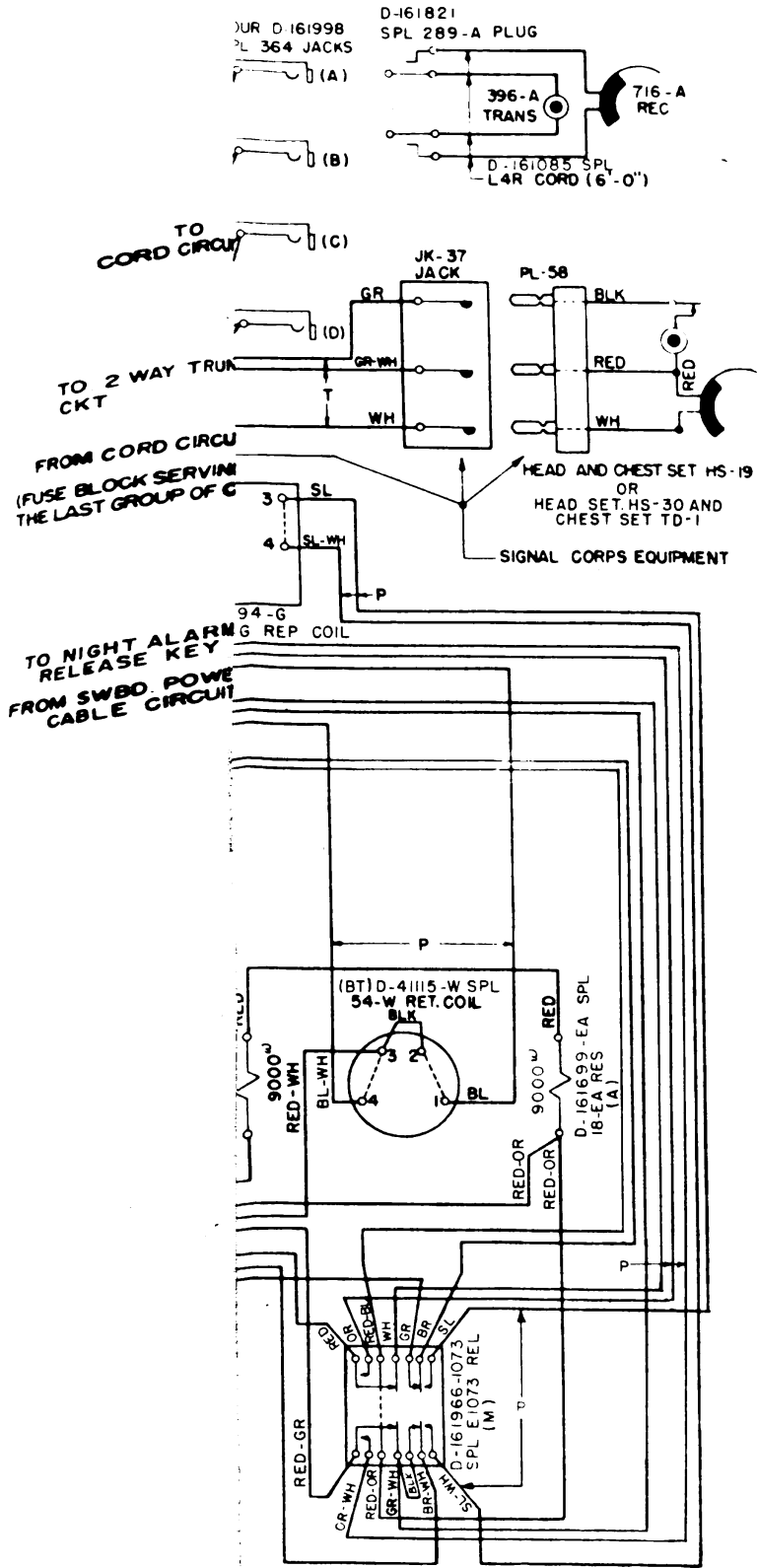
(B)
D-161882-A
SPL 139-A
OR D-164957
COND

RE
C
O
R
D

Figt

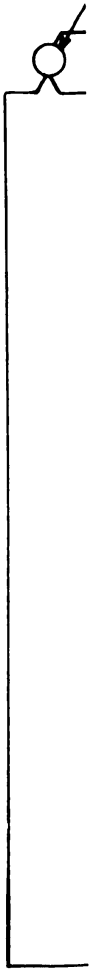


Figure 7



(8)
D-161882-1
SPL 139-A
OR D-16495
COND

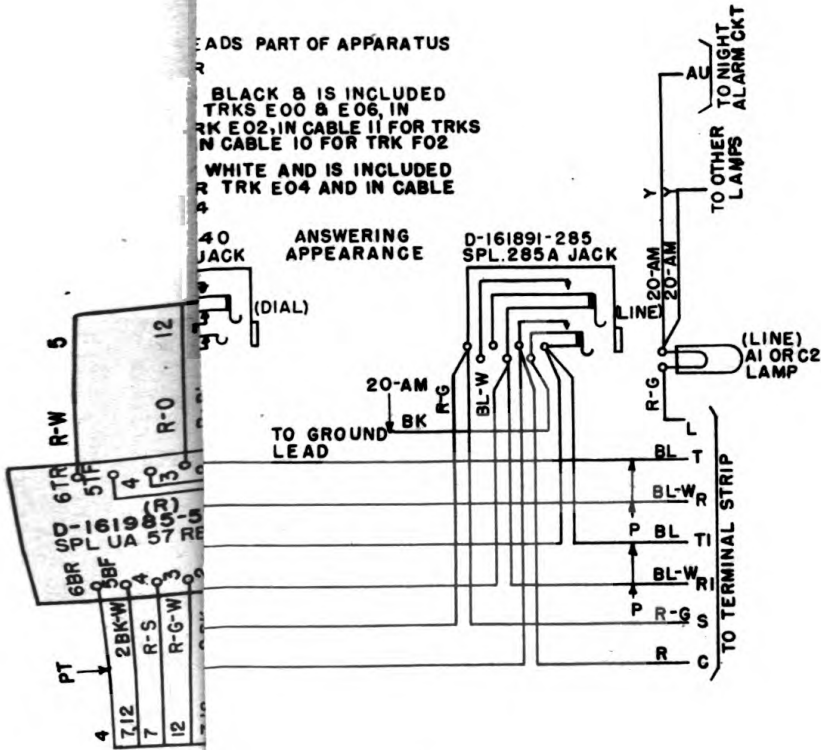
Fi



Figure

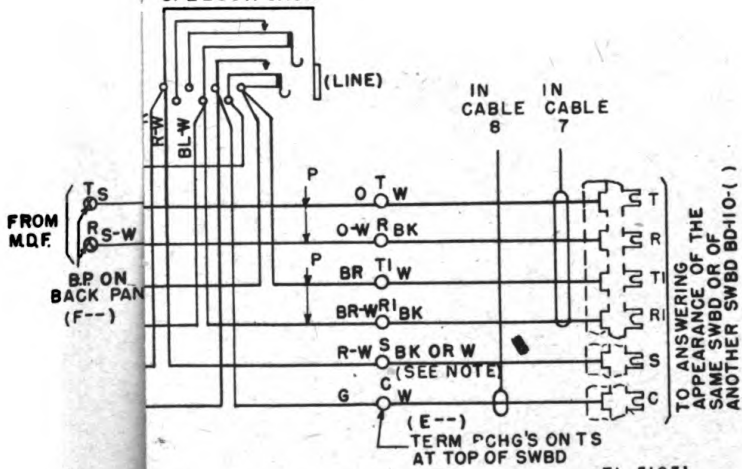
LEADS PART OF APPARATUS

BLACK IS INCLUDED
TRKS E00 & E06, IN
TRK E02, IN CABLE 11 FOR TRKS
IN CABLE 10 FOR TRK F02
WHITE AND IS INCLUDED
FOR TRK E04 AND IN CABLE



PEARANCE

D-161891-285
SPL 285A JACK



TL-51031

(8)
D-1011
SPL I
OR D-1
COND



Fig

