

464
4113
TM
1945

TM 11-636

WAR DEPARTMENT TECHNICAL MANUAL

U.S. Dept. of Army

UNIVERSITY OF CALIF.
LIBRARY
APR 25 1947
DOCUMENTS DIVISION

RADIO SET AN/TRC-10

RESTRICTED. DISSEMINATION OF RESTRICTED MATTER.
No person is entitled solely by virtue of his grade or position to knowledge or possession of classified matter. Such matter is entrusted only to those individuals whose official duties require such knowledge or possession. (See also paragraph 23b, AR 380-5, 15 March 1944.)

WAR DEPARTMENT

14 MARCH 1945

RADIO SET
AN/TRC-10



WAR DEPARTMENT

14 MARCH 1945

RESTRICTED. DISSEMINATION OF RESTRICTED MATTER.
No person is entitled solely by virtue of his grade or position to knowledge or possession of classified matter. Such matter is entrusted only to those individuals whose official duties require such knowledge or possession. (See also paragraph 23b, AR 380-5, 15 March 1944.)

WAR DEPARTMENT,
WASHINGTON 25, D. C., 14 MARCH 1945.

TM 11-636, Radio Set AN/TRC-10, is published for the information and guidance of all concerned.

[A. G. 800.7 (14 Aug. 44).]

BY ORDER OF THE SECRETARY OF WAR:

G. C. MARSHALL,
Chief of Staff.

OFFICIAL:

J. A. ULIO,
Major General,
The Adjutant General.

DISTRIBUTION:

AAF(2) ; AGF(2) ; ASF(2) ; T of Opns(2) ; Arm & Sv Bd(2) Def Comd(2) ; S Div ASF(1) Tech Sv(2) ; Sv C(2) ; PE(2) ; Gen Overseas SOS Dep (Sig Sec) (2) ; Dep 11(2) ; Gen & Sp Sv Sch (2) ; USMA(2) ; WDGS Lib(5) ; Lab 11(2) ; A(2). T/O & E: 11-107(3) ; 11-127(3) ; 11-587(3) ; 11-592(3) ; 11-597(3).

(For explanation of symbols see FM 21-6.)

U113

12

TM11:636

1945

✱ ✱

TABLE OF CONTENTS

	<i>Paragraph</i>	<i>Page</i>
PART ONE. Introduction.		
SECTION I. Description of Radio Set AN/TRC-10.		
General	1	1
Application	2	1
Technical characteristics	3	3
Table of components	4	5
Receiver-Transmitter RT-46/TRC-10 ..	5	7
Rectifier Power Unit PP-74/TRC-10...	6	7
Vibrator Power Unit PP-84/TRC-10...	7	7
Hand Generator G-4/TRC-10	8	7
Key Mount MT-147/TRC-10	9	10
Headset HS-30-U	10	10
Antenna	11	11
Counterpoises CP-12 and CP-13.....	12	11
Packaging data	13	11
II. Installation of Radio Set AN/TRC-10.		
Siting	14	15
Unpacking, uncrating, and checking...	15	17
Installation	16	17
PART TWO. Operating instructions.		
III. Controls and their use.		
Receiver section	17	21
Transmitter section	18	23
Rectifier Power Unit PP-74/TRC-10...	19	25
Vibrator Power Unit PP-84/TRC-10...	20	25
IV. Operation.		
Preparation for use	21	26
Transmitter operation	22	27
Receiver operation	23	28

TABLE OF CONTENTS

	<i>Paragraph</i>	<i>Page</i>
V. Equipment performance check list.		
Purpose and use of check list.....	24	30
Equipment performance check list.....	25	32

PART THREE. Preventive maintenance.

VI. Preventive maintenance techniques.		
Meaning of preventive maintenance....	26	36
Description of preventive maintenance techniques	27	36
Vacuum tubes	28	38
Capacitors	29	39
Resistors	30	40
Fuses	31	41
Switches	32	41
Coils	33	42
Meter	34	42
Antenna insulator	35	43
Relays	36	43
Cords and cables	37	45
Cabinets and chassis	38	45
Headset and key.....	39	45
Jacks	40	45
Gears	41	46
Hand generator	42	46
VII. Itemized preventive maintenance.		
Introduction	43	46
Common materials needed.....	44	47
Item 1, exterior of Radio Set		
AN/TRC-10	45	47
Item 2, cables.....	46	47
Item 3, headset and key.....	47	47
Item 4, Hand Generator G-4/TRC-10...	48	48
Item 5, Receiver-Transmitter		
RT-46/TRC-10	49	48
Item 6, Rectifier Power Unit		
PP-74/TRC-10	50	48
Item 7, Vibrator Power Unit		
PP-84/TRC-10	51	48

TABLE OF CONTENTS

	<i>Paragraph</i>	<i>Page</i>
VII. Itemized preventive maintenance (contd).		
Item 8, antenna	52	48
Preventive maintenance check list.	53	49
VIII. Lubrication.		
Lubrication of Hand Generator		
G-4/TRC-10	54	50
PART FOUR. Auxiliary equipment.		
IX. Power Unit PE-214-B and Maintenance Kit MK-24/TRC-10.		
Power Unit PE-214-B	55	51
Maintenance Kit MK-24/TRC-10	56	52
PART FIVE. Repair instructions.		
X. Theory of receiver section.		
General	57	54
Block diagram of receiver section.	58	54
Radio-frequency amplifier	59	55
Converter	60	57
Intermediate-frequency amplifier	61	58
Detector	62	59
Audio amplifier	63	60
Audio oscillator	64	60
Beat-frequency oscillator	65	61
Plate and filament power circuits.	66	62
XI. Theory of transmitter section.		
General	67	66
Block diagram of transmitter section.	68	66
Master oscillator	69	66
Power amplifier	70	69
Transmitter keying circuit.	71	70
XII. Theory of Rectifier Power Unit PP-74/TRC-10.		
General	72	73
Rectifier circuit	73	73

TABLE OF CONTENTS

	<i>Paragraph</i>	<i>Page</i>
XIII. Theory of Vibrator Power Unit PP-84/TRC-10.		
General	74	75
Vibrator circuit	75	75
Vibrator supply circuit	76	75
XIV. Theory of Hand Generator G-4/TRC-10.		
General	77	78
Circuit analysis	78	78
XV. Trouble shooting.		
Trouble-shooting data	79	81
Trouble-shooting steps	80	81
Precautions against high voltage.....	81	82
Voltmeter loading	82	83
Test equipment	83	84
Trouble-shooting procedures	84	84
Sectionalizing trouble in		
Radio Set AN/TRC-10	85	85
Sectionalizing trouble in receiver		
section	86	87
Localizing trouble in receiver section...	87	89
Sectionalizing trouble in transmitter		
section	88	93
Localizing trouble in transmitter		
section	89	94
Receiver section voltage chart.....	90	96
Receiver section resistance chart.....	91	97
Transmitter section voltage chart.....	92	97
Transmitter section resistance chart...	93	98
XVI. Repairs.		
Emergency repair of receiver.....	94	107
Emergency repair of transmitter.....	95	108
Rustproofing and repainting	96	109
Unsatisfactory equipment report	97	109
XVII. Alignment and adjustment of receiver section.		
General	98	111
Intermediate-frequency alignment	99	111
Beat-frequency oscillator adjustment...100		112
High-frequency oscillator adjustment..101		112

TABLE OF CONTENTS

	<i>Paragraph</i>	<i>Page</i>
XVII. Alignment and adjustment of receiver section (contd).		
Radio-frequency amplifier and antenna adjustments	102	113
Minimum test requirements for receiver	103	113
Test instruments required	104	114

APPENDIX

XVIII. References.

Maintenance parts	105	115
Technical manuals on auxiliary equipment and test equipment.....	106	115
Preventive maintenance	107	116
Painting, preserving, and lubrication...	108	116
Shipping instructions	109	116
Decontamination	110	116
Demolition	111	116
Camouflage	112	116
Other technical publications.....	113	116
Forms	114	117
List of abbreviations.....	115	117

XIX. Maintenance parts.

Maintenance parts for Radio Set AN/TRC-10	116	125
Maintenance parts for Receiver-Transmitter RT-46/TRC-10	117	132
Maintenance parts for Vibrator Power Unit PP-84/TRC-10	118	141
Maintenance parts for Rectifier Power Unit PP-74/TRC-10	119	143
Maintenance parts for Hand Generator G-4/TRC-10	120	145

DESTRUCTION NOTICE

WHY — To prevent the enemy from using or salvaging this equipment for his benefit.

WHEN — When ordered by your commander.

- HOW** —
1. Smash — Use sledges, axes, handaxes, pickaxes, hammers, crowbars, heavy tools.
 2. Cut — Use axes, handaxes, machetes.
 3. Burn — Use gasoline, kerosene, oil, flame throwers, incendiary grenades.
 4. Explosives — Use firearms, grenades, TNT.
 5. Disposal — Bury in slit trenches, fox holes, other holes. Throw in streams. Scatter.

USE ANYTHING IMMEDIATELY AVAILABLE FOR DESTRUCTION OF THIS EQUIPMENT.

- WHAT** —
1. Smash — Crystals, meter, tubes, capacitors, switches, relays, vibrator, headset, key, generators.
 2. Cut — Wires, cables, cords.
 3. Burn — Technical manual, wiring, resistors, capacitors, generators.
 4. Bend — Switches, capacitors, cases, panels, generators.
 5. Bury or scatter — All of the above pieces after breaking.

DESTROY EVERYTHING

FIRST AID FOR ELECTRIC SHOCK

RESCUE.

In case of electric shock, shut off the high voltage at once and ground the circuits. If the high voltage cannot be turned off without delay, free the victim from contact with the live conductor as promptly as possible. Avoid direct contact with either the live conductor or the victim's body. Use a dry board, dry clothing, or other nonconductor to free the victim. An ax may be used to cut the high-voltage wire; however, be watchful of electric flashes which may result disastrously.

SYMPTOMS.

a. Breathing stops abruptly in electric shock if the current passes through the breathing center at the base of the brain. If the shock has not been too severe, the breathing center recovers after a while and normal breathing is resumed, provided that a sufficient supply of air has been furnished meanwhile by artificial respiration.

b. The victim is usually very white or blue. The pulse is very weak or entirely absent and unconsciousness is complete. Burns are usually present. The victim's body may become rigid or stiff in a very few minutes. This condition is due to the action of electricity and is not to be considered rigor mortis. Artificial respiration must still be given, as several such cases are reported to have recovered. The ordinary and general tests for death should never be accepted.

TREATMENT.

a. Start artificial respiration immediately. At the same time send for a doctor, if assistance is available. Do not leave the victim unattended. Perform artificial respiration at the scene of the accident, unless the victim's or operator's life is endangered from such action. *In this case only*, remove the victim to another location, but no farther than is necessary for safety. If the new location is more than a few feet away, artificial respiration should be given while the victim is being moved. During transportation, other methods of resuscitation may be used, if

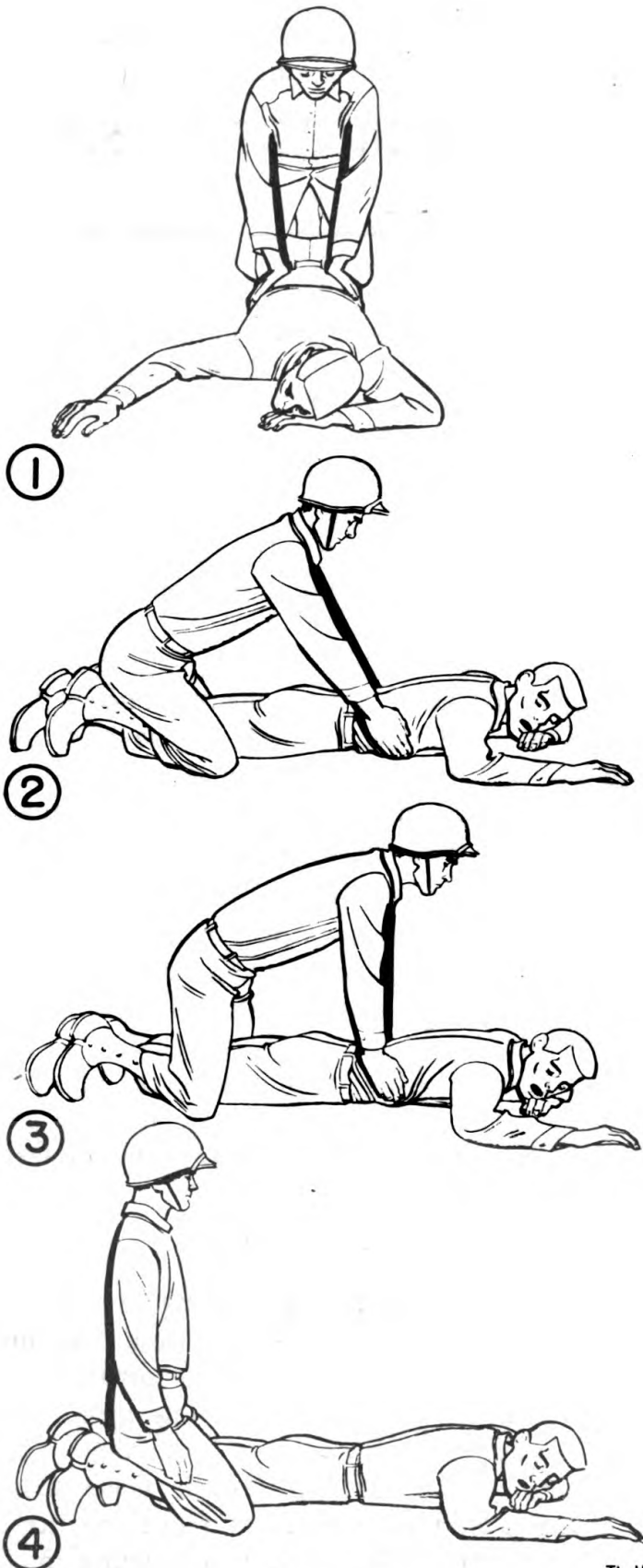

TL 15338

Figure A

the method of transportation prohibits the use of the Shaeffer prone pressure method. Pressure may be exerted on the front of the victim's diaphragm, or the direct mouth to mouth method may be used. Artificial respiration, once started, must be continued, without loss of rhythm.

b. Lay the victim in a prone position, one arm extended directly overhead, and the other arm bent at the elbow so that the back of the hand supports the head. The face should be turned away from the bent elbow so that the nose and mouth are free for breathing (fig. A ① and ②).

c. Open the victim's mouth and remove any foreign bodies, such as false teeth, chewing gum, or tobacco. The mouth should remain open, with the tongue extended. Do not permit the victim to draw his tongue back into his mouth or throat.

d. If an assistant is available during resuscitation, he should loosen any tight clothing to permit free circulation of blood and to prevent restriction of breathing. He should see that the victim is kept warm, by applying blankets or other covering, or by applying hot rocks or bricks wrapped in cloth or paper to prevent injury to the victim. The assistant should also be ever watchful to see that the victim does not swallow his tongue. He should continually wipe from the victim's mouth any frothy mucus or saliva that may collect and interfere with respiration.

e. The resuscitating operator should straddle the victim's thighs, or one leg, in such a manner that:

(1) The operator's arms and thighs will be vertical while applying pressure on the small of the victim's back (fig. A ③).

(2) The operator's fingers are in a natural position on the victim's back with the little finger lying on the last rib.

(3) The heels of the hands rest on either side of the spine as far apart as convenient without allowing the hands to slip off the victim (fig. A ①).

(4) The operator's elbows are straight and locked.

f. The resuscitation procedure is as follows:

(1) Exert downward pressure, not exceeding 60 pounds, for 1 second.

(2) Swing back, suddenly releasing pressure, and sit on the heels (fig. A ①).

(3) After 2 seconds' rest, swing forward again positioning the hands, and apply pressure for another second (fig. A ② and ③).

g. The forward swing, positioning of the hands, and the down-pressure should be accomplished in one continuous motion, which requires 1 second. The release and backward swing require 1 second. The addition of the 2 second rest makes a total of 4 seconds for a complete cycle. Until the operator is thoroughly familiar with the correct cadence of the cycle, he should count the seconds aloud, speaking distinctly and counting evenly in thousands. Example: one thousand and one, one thousand and two, one thousand and three, one thousand and four, etc. This method of counting insures accurate timing. The exact frequency of the operating cycle of resuscitation is of utmost importance.

h. Artificial respiration should be continued without interruption until the victim regains normal breathing or until pronounced dead by a medical officer. It may be necessary to continue resuscitation for several hours. For this reason relief operators should be used if available.

METHOD OF RELIEVING OPERATOR.

The relief operator kneels beside the operator, assuming the same position on an imaginary victim, and follows the operator through three or four complete cycles. When he is sure that he has the correct rhythm, on the next forward swing of the operator the relief operator places his hands on the top of the operator's hands without applying pressure. This indicates to the operator that the relief operator is ready to take over. On the backward swing, the operator moves off the victim, to the side, and the relief operator takes the position of the operator. On the next forward swing, the operator being relieved assumes the position on an imaginary victim beside the new operator, and follows through two or three complete cycles of the new operator, or until he is sure that the new operator has the correct rhythm. The operator being relieved remains alert to take over instantly if the new operator should falter or hesitate on the cycle. During the process of relief, the original operator should count aloud, by thousands, to give the relief operator the correct timing.

INHALANT STIMULANTS.

If an inhalant stimulant is used, such as aromatic spirits of ammonia, the individual administering the stimulant should first test it himself to see how close he can hold the inhalant to his own nostrils for comfortable breathing. Be sure that the inhalant is not held closer to the victim's nostrils and then only for short duration, 1 or 2 seconds every minute.

LIQUID STIMULANTS.

After the victim has regained consciousness, he may be given a glass of water with $\frac{1}{2}$ teaspoon of aromatic spirits of ammonia added, or he may be offered hot coffee or hot tea as a stimulant. **DO NOT GIVE AN UNCONSCIOUS VICTIM ANY LIQUIDS.**

CAUTIONS.

a. After the victim revives, keep him lying quietly. Do not allow him to get up and walk even though he may feel that he is strong enough. Any injury which a person might have received, including electric shock, may bring about a condition of shock or fainting. This condition should be guarded against at all times. Shock is present if the victim is pale and has a cold sweat. His pulse is weak and rapid and his breathing is short and gasping.

b. Keep the victim lying flat on his back, with his head lower than the rest of his body, and his hips elevated. Be sure that there is no tight clothing to restrict the free circulation of blood or hinder natural breathing. Keep him warm and quiet.

c. A resuscitated victim may suddenly stop breathing and require additional artificial respiration. For this reason, he must be carefully watched. **NEVER LEAVE A RESUSCITATED PERSON ALONE UNTIL IT IS CERTAIN THAT HE IS FULLY CONSCIOUS AND BREATHING NORMALLY.**

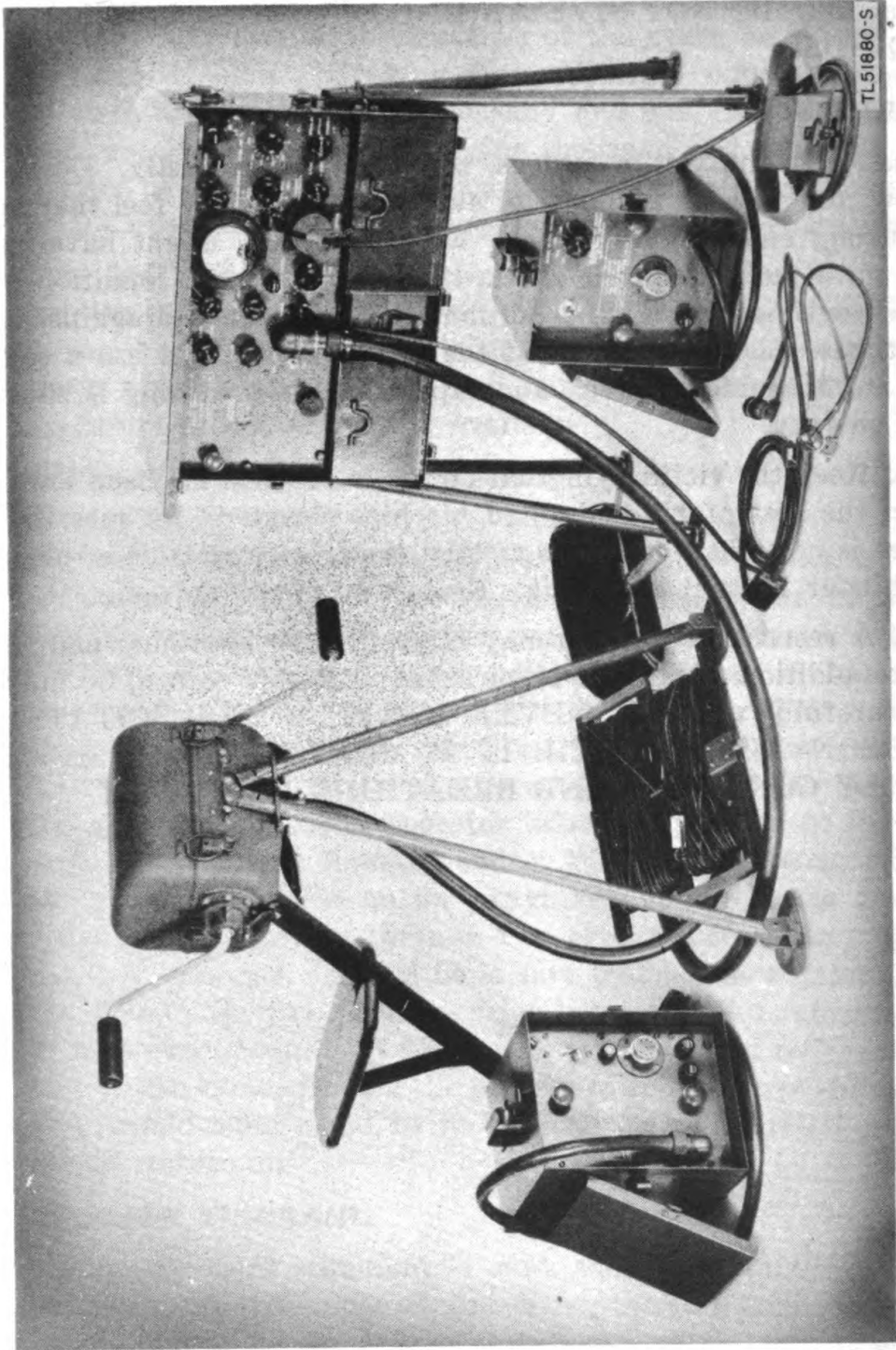

Figure 1. Radio Set AN/TRC-10.

RESTRICTED

PART ONE

INTRODUCTION

SECTION I. DESCRIPTION OF RADIO SET AN/TRC-10

1. GENERAL.

a. Radio Set AN/TRC-10 (fig. 1) is a low-power, c-w (continuous-wave) ground transportable communications set consisting of Receiver-Transmitter RT-46/TRC-10, a rectifier power supply, a vibrator power supply, a hand generator, and a number of associated items (par. 5). The radio set is designed for general field use and is supplied with a 50-foot and a 100-foot wire antenna.

b. The transmitter section of Receiver-Transmitter RT-46/TRC-10 covers a frequency range of from 2,000 to 12,000 kc (kilocycles) (2.0 to 12.0 mc (megacycles)) which is divided into crystal-controlled channels. The transmitter has a c-w output of 20 watts.

c. The receiver section of Receiver-Transmitter RT-46/TRC-10 is designed for the reception of amplitude-modulated voice and tone signals or c-w signals, and covers the frequency range of 2.0 to 12.0 mc in two bands: 2.0 to 5.0 mc, and 5.0 to 12.0 mc. Provision is made for checking the calibration of the receiver section by using the crystal-controlled oscillator in the transmitter section.

d. The average distance range of the transmitter is 20 miles; however, this range will vary with the operating frequency, time of day, antenna length, and operating conditions.

2. APPLICATION.

a. A simplified block diagram of the radio set is given in figure 2 and shows the inter-relation of the various components. Any one of three power supply units may be used with the receiver-transmitter; the unit used will depend on the primary power source that is available.

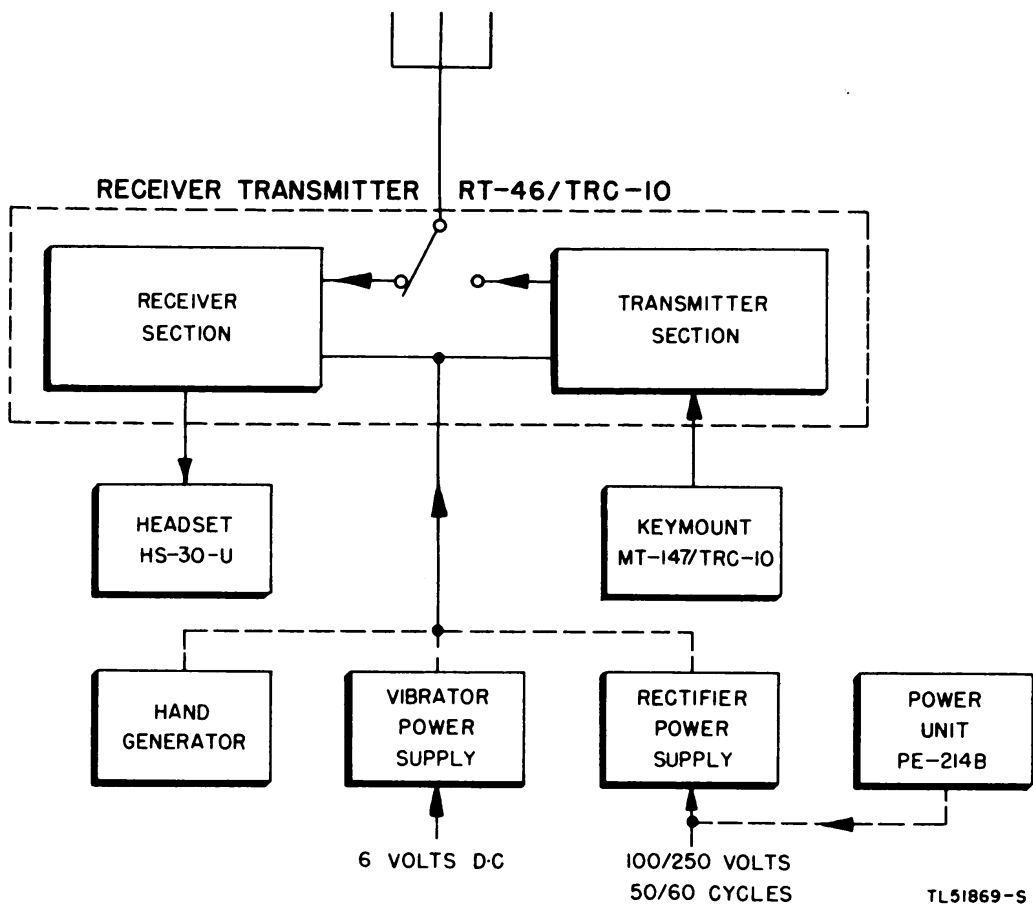

Figure 2. Radio Set AN/TRC-10, simplified block diagram.

b. The transmitter section of the receiver-transmitter develops a continuous r-f (radio-frequency) carrier which is applied to a common antenna through a manual switch on the front panel of the receiver-transmitter. The r-f carrier is keyed by a telegraph key plugged into the KEY jack on the transmitter section front panel.

c. The receiver section is a five-tube superheterodyne receiver designed to receive tone-modulated, voice-modulated, and c-w signals. The receiver uses the common antenna and is so designed that when the antenna is connected to the receiver, the transmitter section will not operate. When transmitting, the receiver audio-output stage is converted into an audio oscillator which is keyed along with the transmitter for monitoring purposes. A headset is provided with the radio set; however, sufficient audio power is available to operate a small speaker.

d. The common antenna consists of a 50-foot and a 100-foot length of wire equipped with insulators for fastening to near-by trees, buildings, or similar objects. Either antenna may be used

separately, or the two sections may be connected in series to give a total length of 150 feet.

3. TECHNICAL CHARACTERISTICS.

a. Transmitter Section of Receiver-Transmitter RT-46/TRC-10.

Frequency range2.0 to 12.0 mc
Transmitter typecrystal-controlled oscillator,
power amplifier
Type of signals transmitted.....c-w
Distance range20 mi*
Number of tubes2
Power input:
115-volt, 50- to 60-cycle.....160 watts
6-volt d-c120 watts
Power output20 to 30 watts
Antenna50- to 150-foot wire

b. Receiver Section of Receiver-Transmitter RT-46/TRC-10.

Frequency range:
Band 12.0 to 5.0 mc
Band 25.0 to 12.0 mc
Receiver typesuperheterodyne
Type of signal received.....c-w, tone, and voice (a-m)
Number of tubes.....5
Intermediate frequency454 kc
Method of calibration.....transmitter crystal-controlled
oscillator
Power input:
115-volt, 50- to 60-cycle.....75 watts
6-volt d-c62 watts
Antennasame as transmitter

*This value is only approximate since the range will vary considerably according to terrain and atmospheric conditions.

c. Power Sources for Radio Set AN/TRC-10.

- (1) When using Rectifier Power Unit PP-74/TRC-10, 115
- (2) When using Vibrator Power Unit PP-84/TRC-10, 6-
to 250 volts, 50 to 60 cycles.
volt direct current.
- (3) Hand power when using Hand Generator G-4/TRC-10.

FREQUENCY SPECTRUM: Megacycles

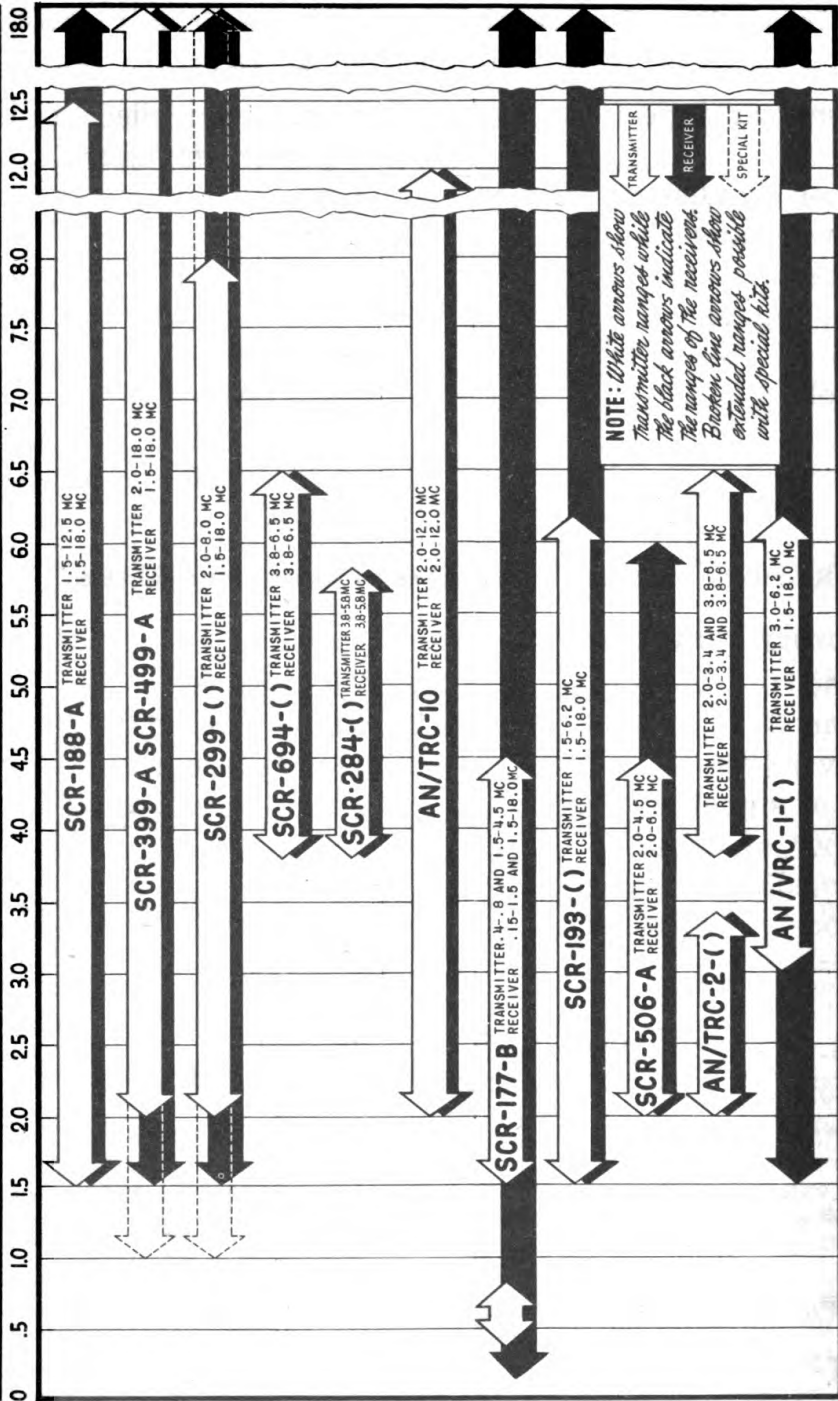

TL51679-5

Figure 3. Frequency spectrum chart.

4. TABLE OF COMPONENTS.

Component	Required number	Height (in.)	Depth (in.)	Length (in.)	Weight (lb)
Bag BG-175 (hand generator)	1	—	—	—	2
Bag CW-6/TRC-10 (miscellaneous)	1	—	—	—	2¾
Bag CW-7/TRC-10 (receiver-transmitter)	1	—	—	—	6¼
Bag CW-134/TRC-10 (rectifier and vibrator power units)	2	—	—	—	3¼
Case CY-49/TRC-10 (receiver-transmitter)	1	7¼	13½	18	9½
Case CY-50/TRC-10 (rectifier and vibrator units)	2	8½	11¼	9½	3½
Case CY-277/TRC-10 (crystals)	2	3	4	5½	¾
Cord CD-201-A (telegraph key)	1	—	—	61	—
Cord CD-605 (headset)	1	—	—	82	—
Cord CX-83/TRC-10 (power)	1	—	—	96	3
Cord CX-350/TRC-10 (power)	1	—	—	50 ft	4½
Counterpoise CP-12	1	—	—	—	2
Counterpoise CP-13	1	—	—	—	2
Hand Generator G-4/TRC-10	1	8	8	10	26
Headset HS-30-U	1	—	—	—	—
Key J-37	1	7⁄8	27⁄8	5¼	—
Key Mount MT-147/TRC-10	1	2	3¾	4½	—
Rectifier Power Unit PP-74/TRC-10	1	8¾	8½	6¾	18
Vibrator Power Unit PP-84/TRC-10	1	8¾	9¾	6¾	18
Power Unit PE-214-B	1	12¾	14	17½	40
Receiver-Transmitter RT-46/TRC-10	1	7½	6¾	17	14¼
Reel RL-102/TRC-10 (antenna)	1	9½	5⁄8	12	½
Reel RL-29	1	8	¾	11¾	½

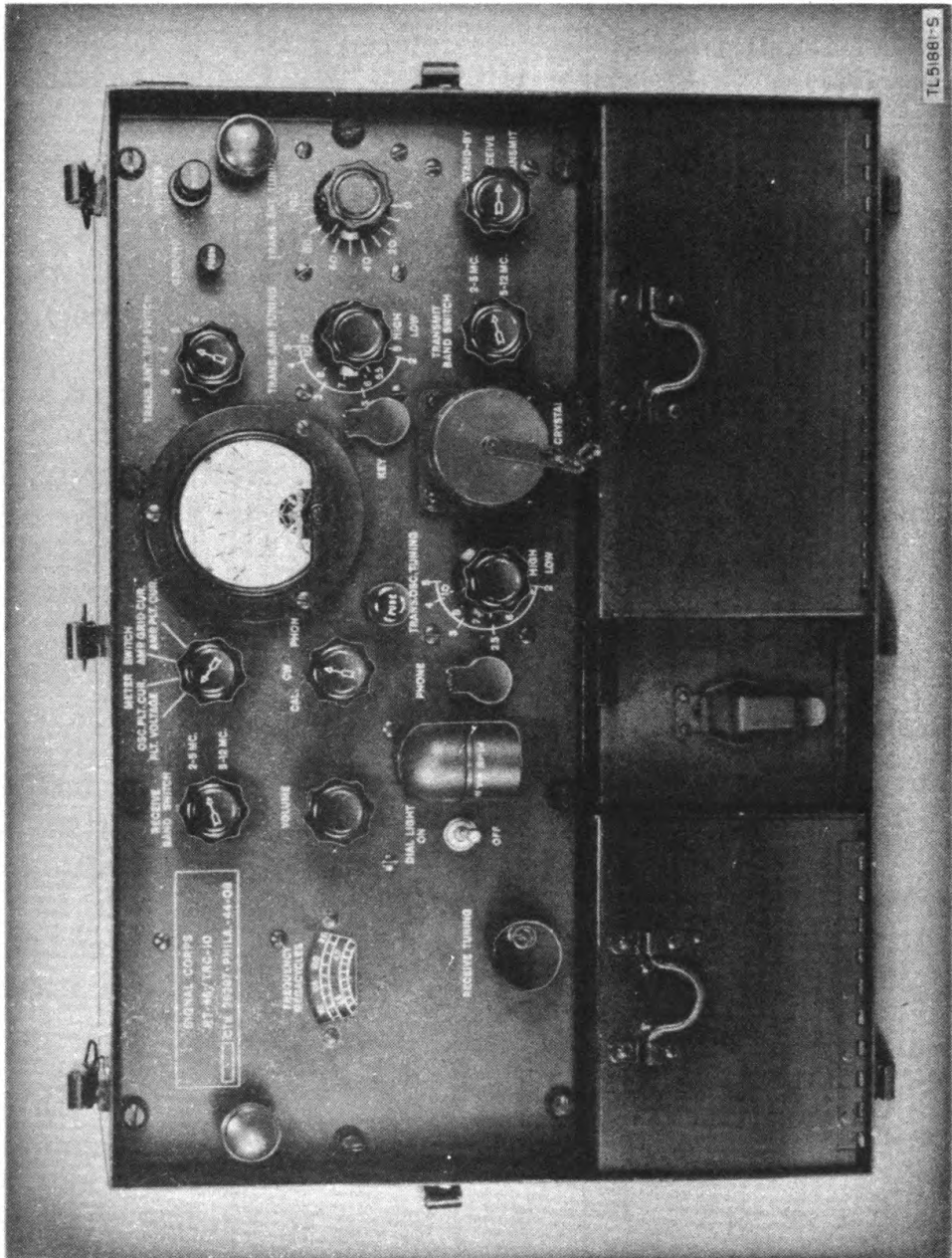

Figure 4. Receiver-Transmitter RT-46/TRC-10.

5. RECEIVER-TRANSMITTER RT-46/TRC-10.

The receiver-transmitter (fig. 4) is a single unit installed in Case CY-49/TRC-10 and contains the receiver and transmitter circuits. These circuits are physically and electrically divided into separate sections fastened to the common front panel upon which are mounted the adjustment controls. This panel also contains a meter for use in tuning the transmitter circuit. The filament and plate power for the receiver-transmitter unit may be obtained from any one of three power units depending on the available primary power source.

6. RECTIFIER POWER UNIT PP-74/TRC-10.*

This unit, encased in Case CY-50/TRC-10 (fig. 5), is a rectifier power supply for converting 115- to 250-volt, 50- to 60-cycle primary power into 6.3-volt a-c (alternating-current) filament power and approximately 600-volt d-c (direct-current) plate power. The rectifier power unit is used with the receiver-transmitter when commercial power or an alternator such as Power Unit PE-214-B is available. The primary winding of the power transformer is tapped for connection to 115-, 150-, 200-, or 250-volt, 50- to 60-cycle power. A five-position switch is mounted on the front panel to permit selection of the proper tap.

7. VIBRATOR POWER UNIT PP-84/TRC-10.**

This unit, encased in Case CY-50/TRC-10 (fig. 6), is a vibrator power supply for converting 6-volt d-c power into approximately 600-volt d-c plate power for operation of the receiver and transmitter circuits. Connections are also provided to supply 6-volt direct current to the filaments of the tubes. The vibrator power unit is used with the receiver-transmitter when operation from a 6-volt storage battery is desired.

8. HAND GENERATOR G-4/TRC-10.

A hand-operated generator (fig. 7) is also supplied with the radio set and provides 6-volt d-c filament power and approximately 550-volt d-c plate power. Crank handles and legs for mounting the unit are included with the equipment. The hand generator may be used for supplying power to the radio set when either of the above power sources is not available, or when the equipment must be hand-carried for considerable distances.

*Labeled Power Supply PP-74/TRC-10 on unit front panel.

**Labeled Power Supply PP-84/TRC-10 on unit front panel.

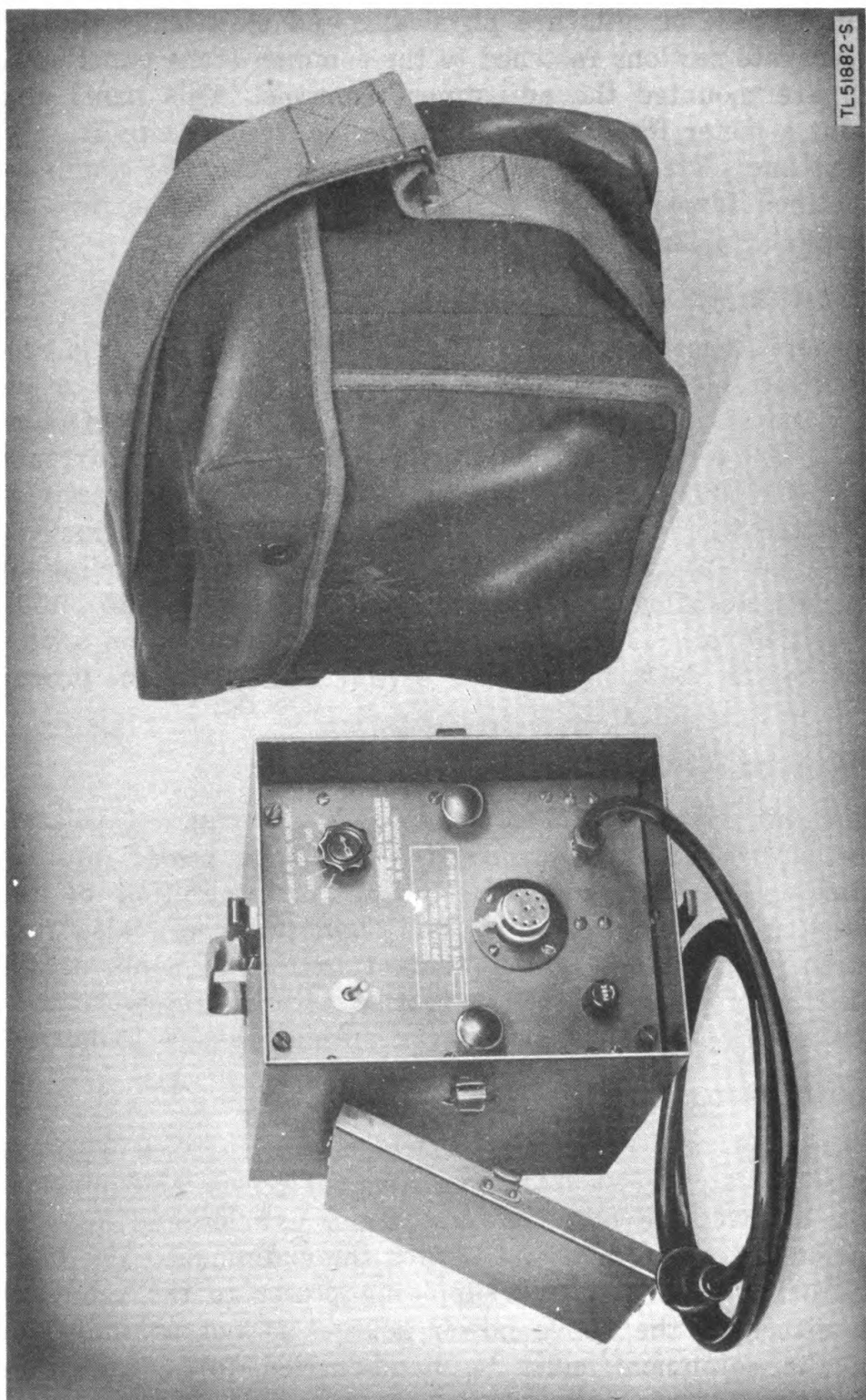
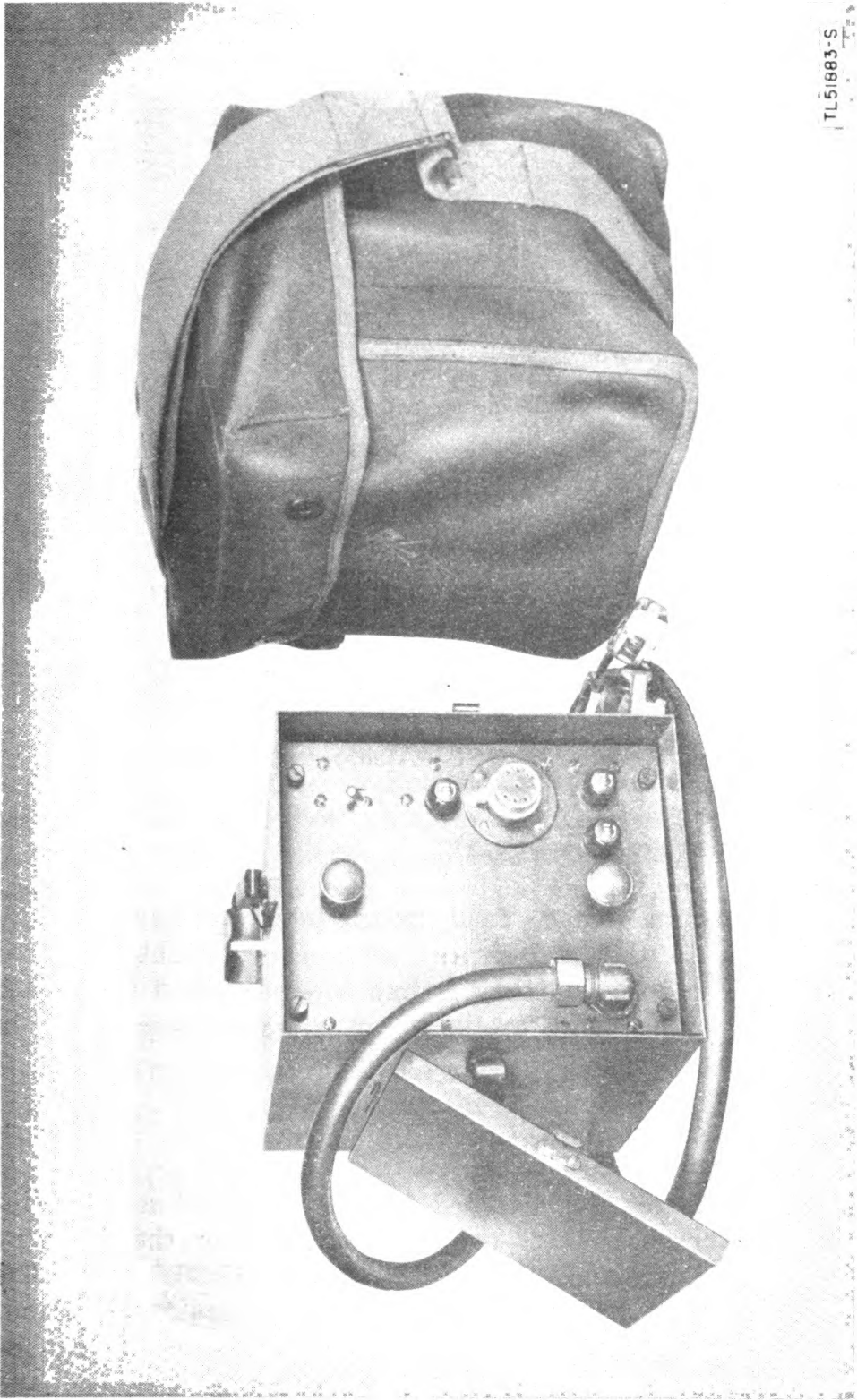

Figure 5. Rectifier Power Unit PP-74/TRC-10, with carrying bag.



TL51883-S

Figure 6. Vibrator Power Unit PP-84/TRC-10, with carrying bag.



Figure 7. Hand Generator G-4/TRC-10, equipped with legs and cranks.

9. KEY MOUNT MT-147/TRC-10.

The key mount (fig. 8) contains the telegraph key and may be connected to the transmitter section by means of Cord CD-201-A. The telegraph key is hand-operated and is used to operate the keying relay in the receiver-transmitter which in turn keys the r-f output.

10. HEADSET HS-30-U.

This headset (fig. 8) is issued for use with Helmet M1 (infantry) and crash helmets used by personnel of the Infantry and Armored Command. Soft rubber Inserts M-300 fit into the wearer's ears and are attached to two Receivers R-30. Headband HB-30 is a thin band of relatively soft steel that can be bent to fit the contour of the wearer's head. When the headband is properly shaped, the helmet exerts no additional pressure on Inserts M-30 in the wearer's ears.

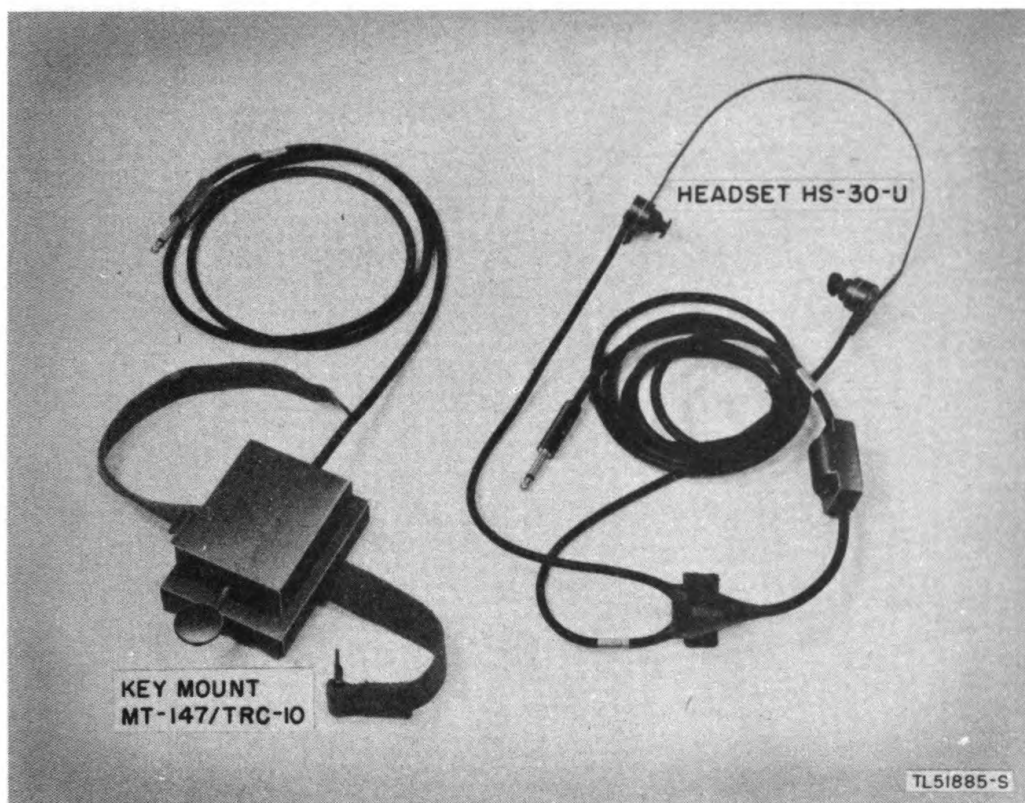

Figure 8. Key Mount MT-147/TRC-10 and Headset HS-30-U.

11. ANTENNA.

The antenna consists of a 50-foot and a 100-foot length of insulated wire contained on Reel RL-102/TRC-10 (fig. 9). Either antenna section, or both, may be used and is connected to the ANTENNA binding post on the receiver-transmitter. Insulators are provided for fastening the ends of the antenna wire to trees, buildings, or similar objects.

12. COUNTERPOISE CP-12 and CP-13.

Two counterpoise wires are supplied with the radio set for use as a simulated ground. The counterpoise wires are contained on Reel RL-29 (fig. 9). In use, the counterpoise wires are spread out at 45° angles to each other with the lead-in wire connected to the GROUND binding post on the receiver-transmitter front panel.

13. PACKAGING DATA.

a. For transporting the equipment in the field, five carrying bags are provided. With the exception of Bag CW-7/TRC-10, the carrying bags are made of heavy canvas and are provided with carrying straps. Bag CW-7/TRC-10 is made of heavy rubber and is waterproof to protect the receiver-transmitter unit.

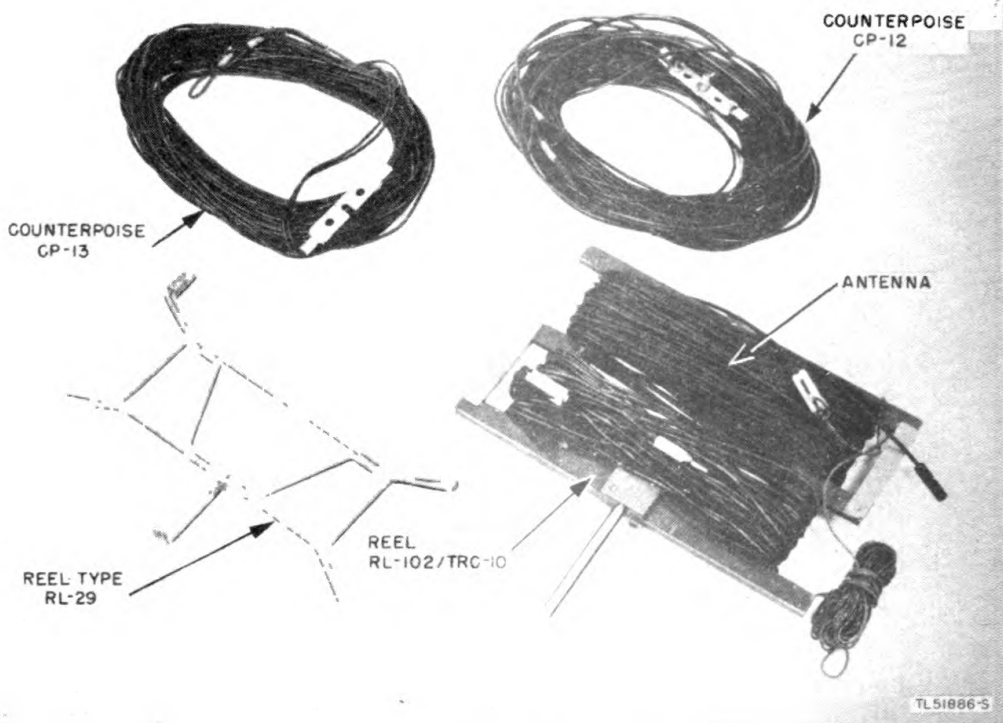

Figure 9. Antenna and counterpoise.

The carrying bags and contents are listed in the following subparagraphs.

(1) Bag CW-7/TRC-10 (fig. 10).

(a) Case CY-49/TRC-10 (receiver-transmitter).

- (1) Receiver-Transmitter RT-46/TRC-10.
- (2) Case CY-277/TRC-10.
- (3) Spare tubes.
- (4) Key Mount MT-147/TRC-10 with key and cord.
- (5) Headset HS-30-U and cord.
- (6) Four legs for Case CY-49/TRC-10.

(b) Reel RL-102/TRC-10.

- (1) 100-foot antenna wire.
- (2) 50-foot antenna wire.

(2) Bag CW-134/TRC-10 (fig. 5).

- (a) Case CY-50/TRC-10.
- (b) Rectifier Power Unit PP-74/TRC-10.

(3) Bag CW-134/TRC-10 (fig. 6).

- (a) Case CY-50/TRC-10.
- (b) Vibrator Power Unit PP-84/TRC-10.

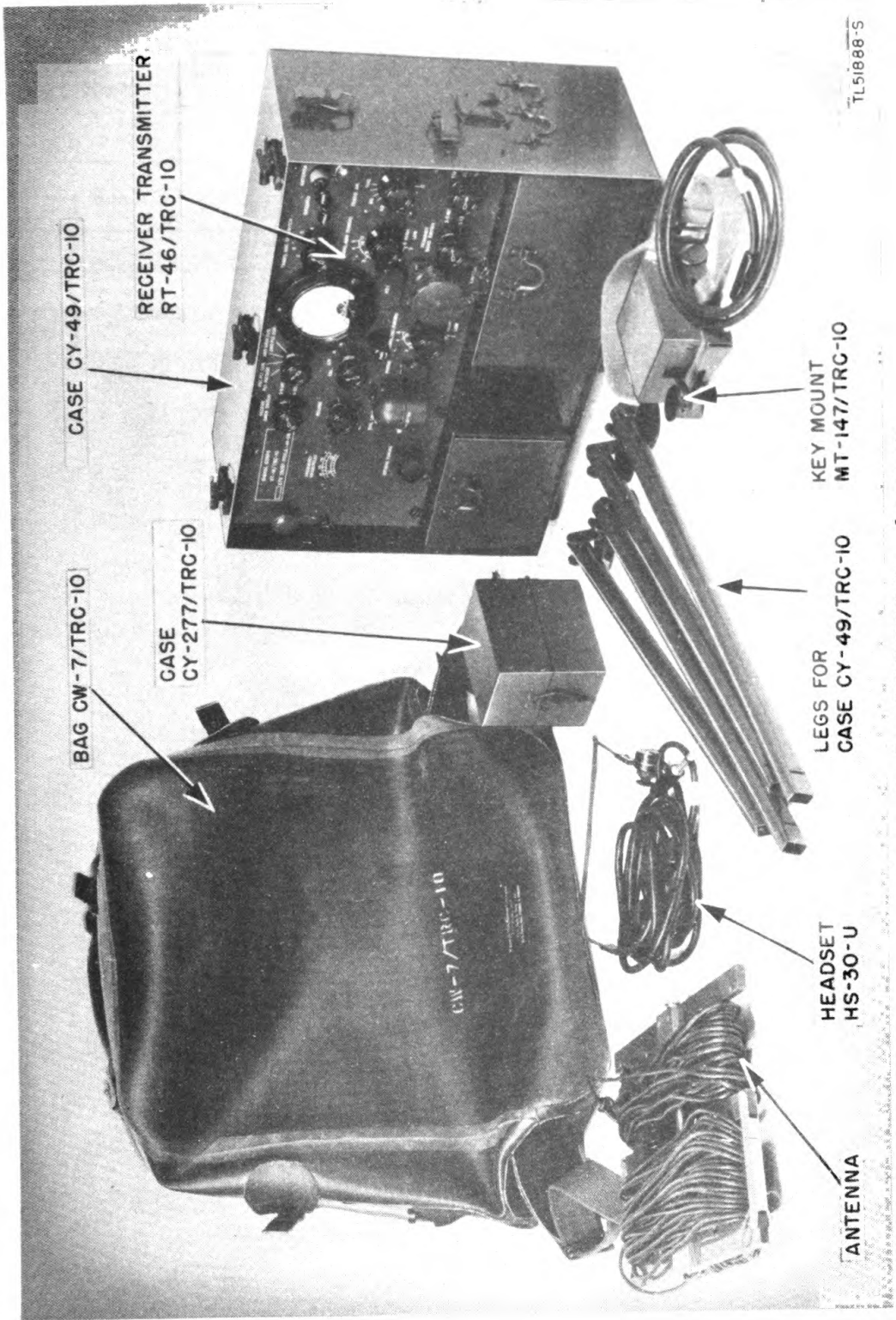

TL51886-5

Figure 10. Bag CW-7/TRC-10 and contents.

(4) Bag-175 (fig. 11), Hand Generator G-4/TRC-10.

(5) Bag CW-6/TRC-10 (fig. 12).

(a) Crank GC-7 (two).

(b) Leg LG-3 (two).

(c) Leg LG-2A.

(d) Cord CX-83/TRC-10.

(e) Cord CX-350/TRC-10.

(f) Reel, Type RL-29.

(1) Counterpoise CP-12.

(2) Counterpoise CP-13.



TL51890-S

Figure 11. Hand Generator G-4/TRC-10 and Bag BG-175.

b. When packaged for export (par. 15), Radio Set AN/TRC-10 is contained in four boxes, excluding Power Unit PE-214-B. The weight and dimensions of the export packaging boxes are given in the following table.

Box No.	Dimensions (inches)			Weight (lb)
	Length	Width	Depth	
1	19	15 $\frac{3}{4}$	12 $\frac{7}{8}$	50
2	21 $\frac{1}{4}$	18 $\frac{1}{2}$	14 $\frac{3}{8}$	55
3	24 $\frac{7}{8}$	24	18 $\frac{5}{8}$	40
4	37 $\frac{1}{2}$	16 $\frac{1}{8}$	14 $\frac{1}{4}$	40

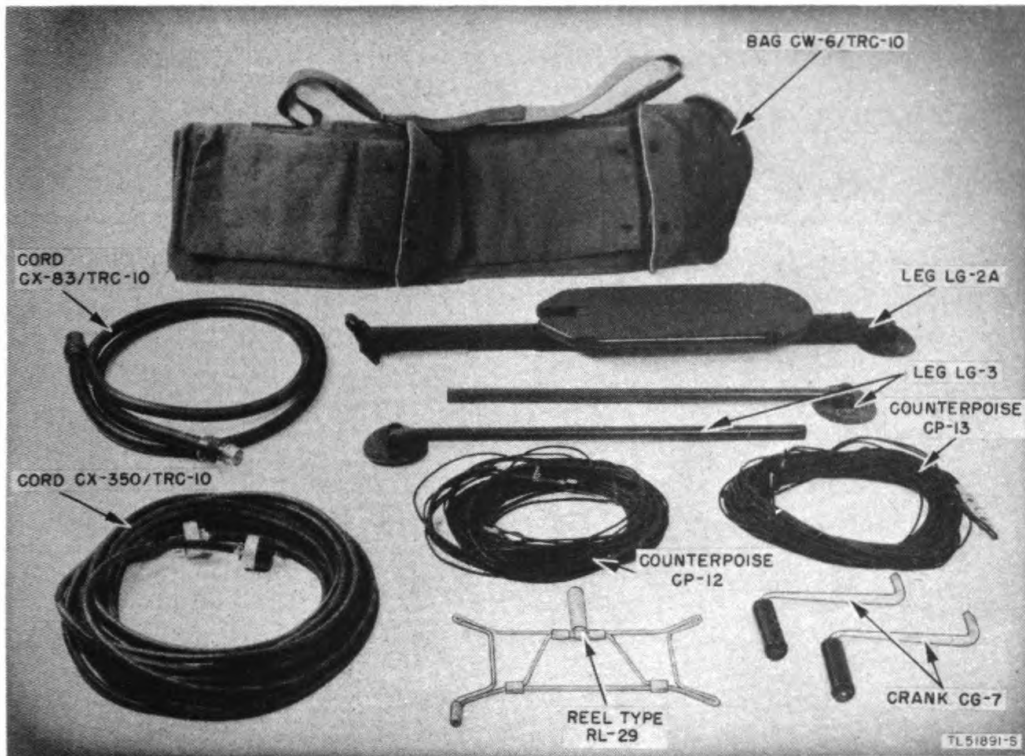

Figure 12. Bag CW-6/TRC-10 and contents.

SECTION II. INSTALLATION OF RADIO SET AN/TRC-10

14. SITING.

a. The signals put out by the transmitter section of Receiver-Transmitter RT-46/TRC-10 have a greater range if the antenna is high and clear of hills, buildings, cliffs, densely wooded areas, and other obstructions. Dips, depressions, valleys, and low places are poor for radio transmission and reception because the surrounding high terrain absorbs r-f energy. Weak signals may be

SITING

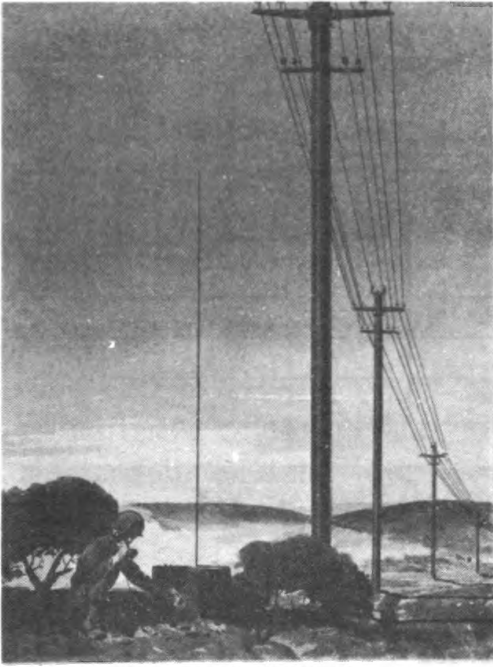

UNDER OR NEAR HIGH TENSION LINES—BAD

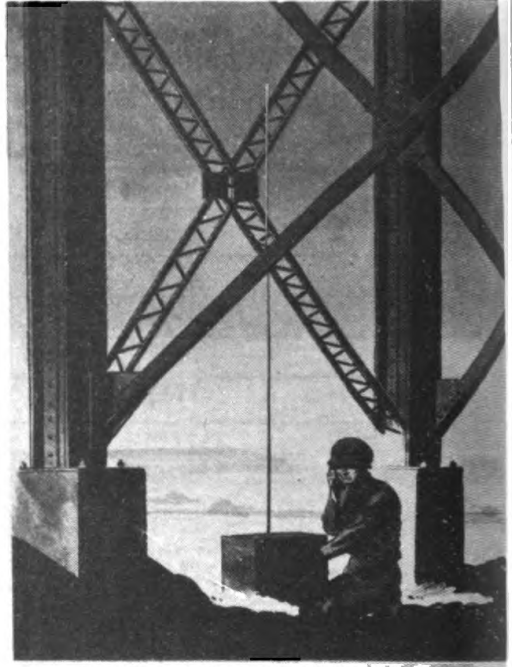

UNDER OR NEAR STEEL GIRDER CONSTRUCTION—BAD

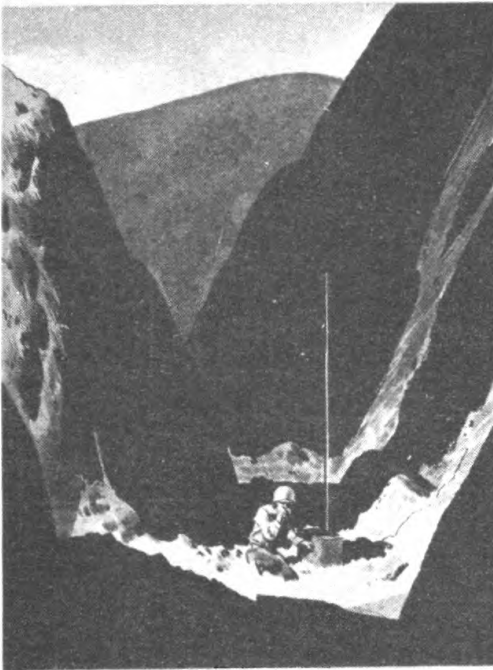

IN VALLEYS—BAD



ON HILLS OR RISES—GOOD

expected if the radio set is operated close to steel bridges, underpasses, or near power lines or power circuits.

b. The most desirable locations for transmission and reception are hilltops, elevations, and slight rises in the ground. Flat terrain is also good. Normally, transmission over water is better than that over land. When selecting a flat site remember that an object such as a tree or building must be available to which the antenna may be fastened.

15. UNPACKING, UNCRATING, AND CHECKING.

a. General. Radio Set AN/TRC-10 is packaged for export in four wooden cases, excluding the power unit. A packing slip in a moistureproof inclosure is stapled to each box and lists the contents of the box. Export packing is labeled: "Packed with dehydrating agent. DO NOT OPEN UNTIL READY FOR USE." The boxes should be as close as possible to their final destination before unpacking. Proceed with the unpacking of boxes in the following order.

b. Box No. 3. To unpack box No. 3, first clip the metal straps binding the box. Remove the top of the box, using a nailpuller if available. Open the bag liner and lift out the smaller carton containing the carrying bags. Leave this carton sealed until the carrying bags are required. Remove the larger carton containing the receiver-transmitter. Open the corrugated fiberboard carton and the moistureproof and vaporproof barrier. (Cut off the heat-sealed edge so that the barrier can be used again should the occasion arise.) Remove and open the inner fiberboard box and take out silica-gel bags and cardboard cushions. Remove Case CY-49/TRC-10 containing the receiver-transmitter, telegraph key, headset and cord, crystal case with crystals, and spare tubes. Check components against the packing slip.

c. Box No. 4. Since the legs of the receiver-transmitter case are packed in box No. 4, it will be necessary to open this box next. Clip the metal straps binding the box and remove the cover. Remove cartons and unpack the legs for the receiver-transmitter and the antenna reel. Check contents of cartons against packing list.

d. Box No. 2. Box No. 2 contains the rectifier and vibrator power units. Unpack this box next, unless the receiver-transmitter is to be powered by the hand generator. In that case, open box No. 1 leaving box No. 2 crated until required. To unpack box No. 2 proceed as for box No. 3 (subpar. b above).

e. Box No. 1. If the receiver-transmitter is to be powered by the hand generator, unpack this box in place of box No. 2 above. To unpack box No. 1, proceed as for box No. 3 (subpar. b above). The legs for the hand generator are included in box No. 4, already unpacked.

16. INSTALLATION.

Radio Set AN/TRC-10 is designed for field use and as such

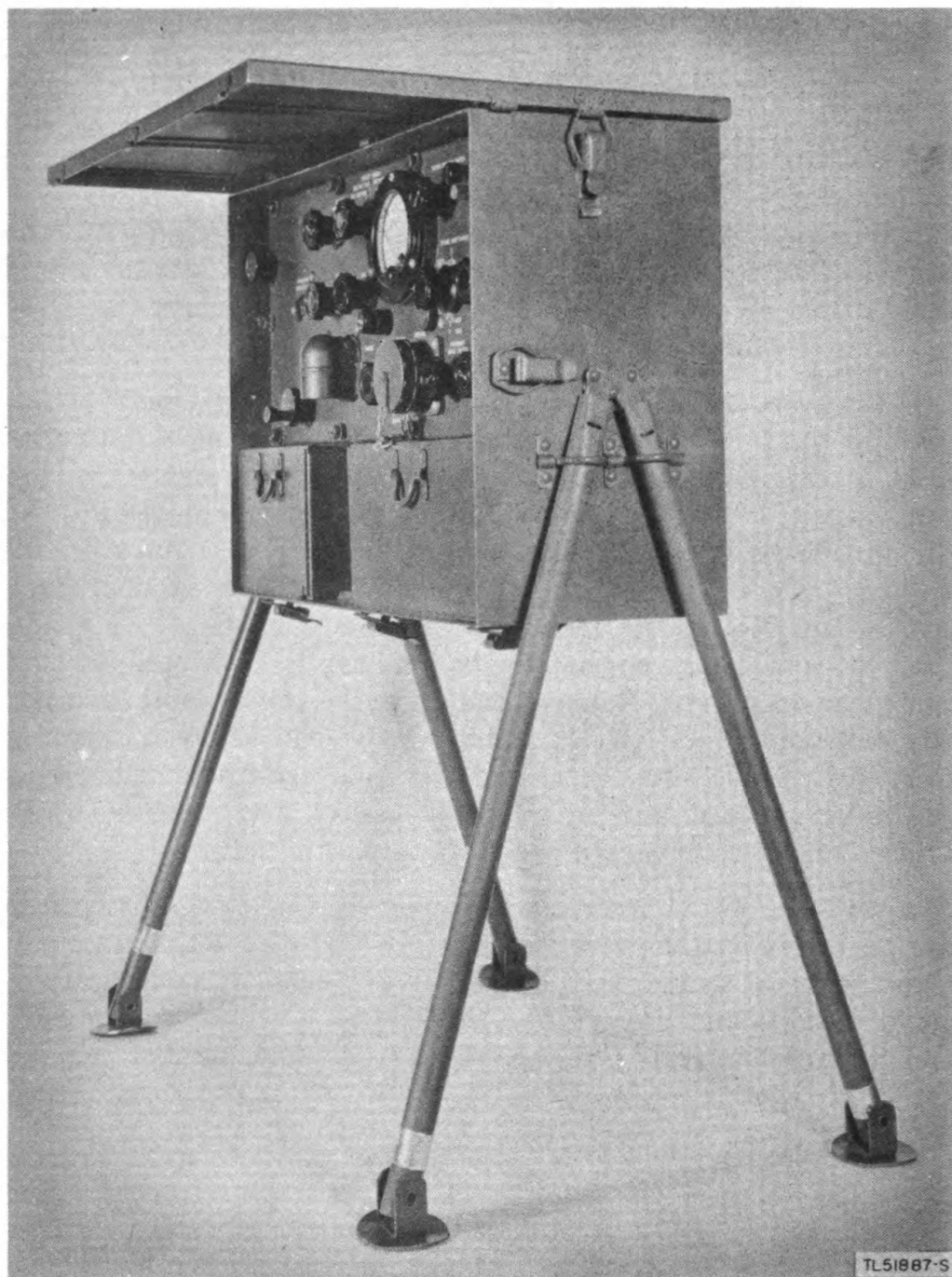

Figure 13. Method of fastening legs and cover to receiver-transmitter.

the set is complete with mounting legs, cables, and power supplies as shown in figure 1.

a. Receiver-transmitter.

(1) Remove Case CY-49/TRC-10, containing the receiver-transmitter, from its rubber container and slip the four supporting legs in place (fig. 13) with the hinged feet down.

(2) Remove the cover from Case CY-49/TRC-10 and place it in position on top of the case (fig. 13) with the three projections on the inside of the cover to the rear. Hold in place by securing the two side fasteners.

b. Antenna.

(1) Unwind either the 50-foot or the 100-foot antenna wire and attach one end of the ANTENNA binding post on the receiver-transmitter front panel. The long antenna should be used for operation on the low frequencies and the short antenna for operation on the high frequencies. If necessary, on the lower frequencies the two antenna wires may be connected together (fig. 14) to form a 150-foot antenna.

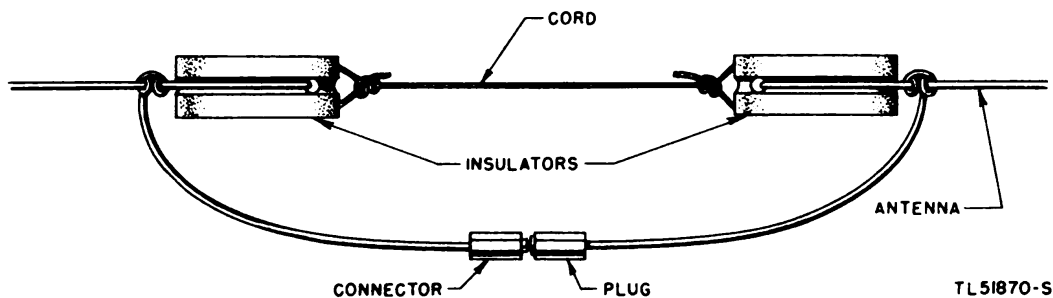

Figure 14. Connection of 50-foot and 100-foot antennas.

(2) For efficient operation the antenna should be supported as high as possible above the ground. Do not fasten antenna wire directly to supporting object. Use the insulators provided and a length of cord or additional wire as shown in figure 15.

c. Counterpoise.

(1) Unwind the two counterpoise wires and connect the

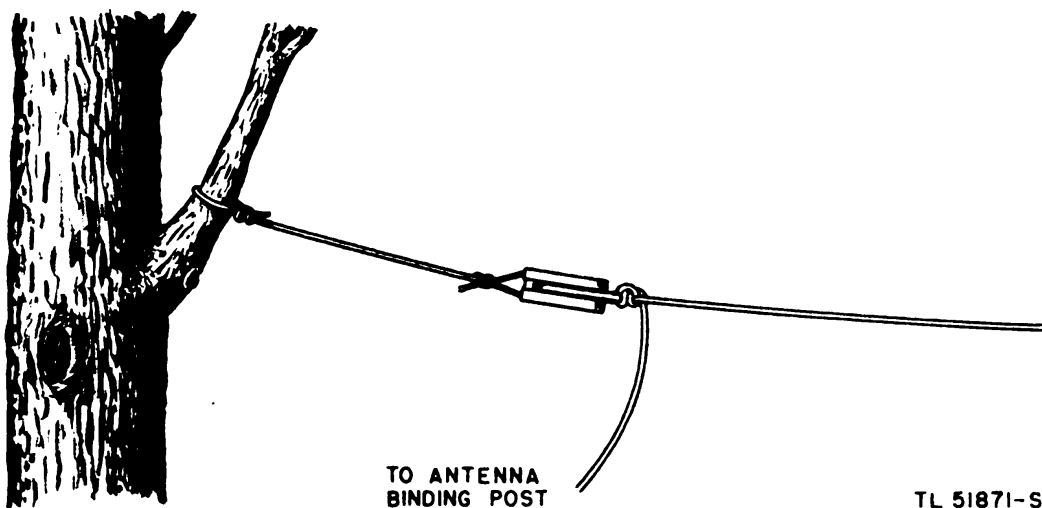

Figure 15. Method of supporting antenna wire.

center plates at right angles by means of the thumbnut provided. Connect the short, heavy, central conductor to the GROUND binding post on the receiver-transmitter front panel.

(2) Spread out the eight long leads radially over the ground, displaced about 45° with respect to each other.

NOTE: For transmission over short distances the counterpoise wires are not required.

d. Headset and Telegraph Key.

(1) Insert plug of Headset HS-30-U into PHONE jack on front panel of receiver-transmitter.

(2) Insert plug of Key Mount MT-147/TRC-10 into KEY jack on front panel of receiver-transmitter.

e. Power Connections.

(1) Determine what primary power source is available and unpack the corresponding power unit.

(2) Connect one end of Cord CX-83/TRC-10 to the power input socket on the receiver-transmitter, and connect the other end to the output receptacle on the power source to be used. *Make certain that the OFF-ON switch on the power unit is in the OFF position.*

PART TWO

OPERATING INSTRUCTIONS

NOTE: For information on destroying the equipment to prevent enemy use, refer to the destruction notice at the front of the manual.

SECTION III. CONTROLS AND THEIR USE

17. RECEIVER SECTION (fig. 16).

a. RECEIVE TUNING. This knob tunes the radio receiver circuits and controls the operation of the calibrated dial which is viewed through the window marked **FREQUENCY MEGACYCLES**.

(1) The lower scale on the dial covers the frequency range of 2.0 to 5.0 mc, with dial marks every 50 kc between 2.0 and 2.5 mc and every 100 kc between 2.5 and 5.0 mc.

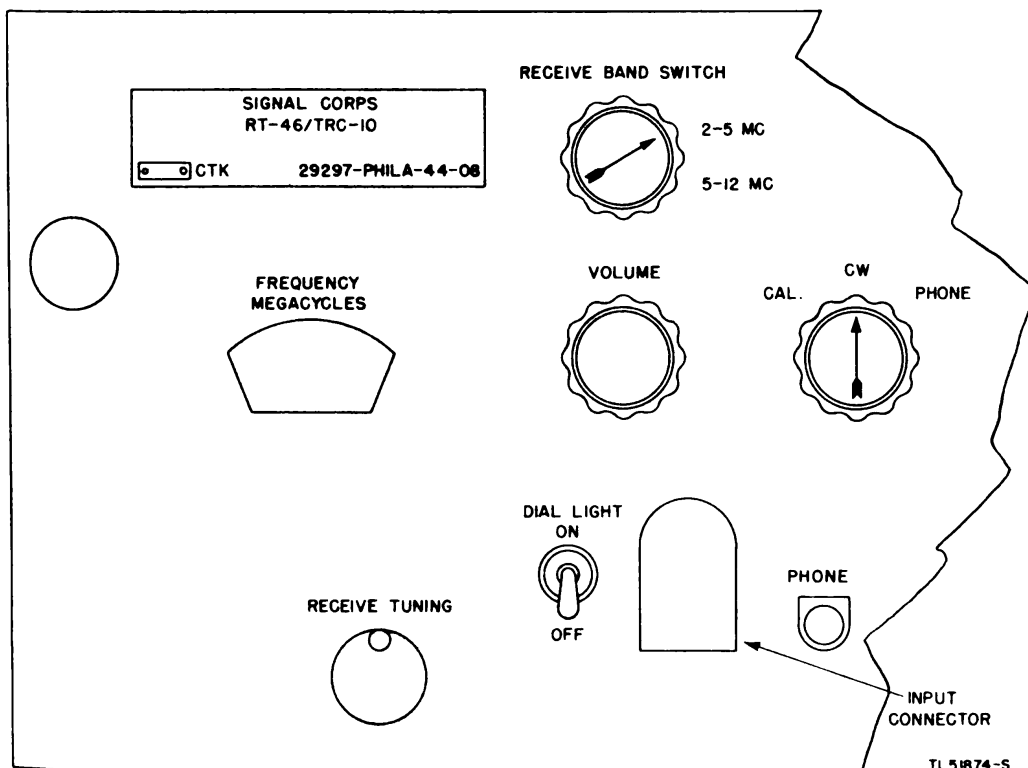

Figure 16. Receiver section, identification of controls.

(2) The upper scale covers the frequency range of 5.0 to 12.0 mc, with dial marks every 100 kc between 5.0 and 6.5 mc and every 250 kc between 6.5 and 12.0 mc.

b. RECEIVE BAND SWITCH. This switch permits the selection of either the low-frequency or high-frequency band.

c. VOLUME. The volume control, located directly beneath the RECEIVE BAND SWITCH, adjusts the strength of the output signals delivered to Headset HS-30-U.

d. DIAL LIGHT. This toggle switch controls the operation of the dial light located behind the front panel and adjacent to the receiver tuning dial. The dial light provides illumination of the dial for night operation.

e. CAL, CW, PHONE. This three-position switch performs the following functions:

(1) When placed in the CAL. position, the frequency calibration of the receiver dial may be checked.

(2) When placed in the CW position, c-w signals may be received.

(3) When placed in the PHONE position, voice- or tone-modulated signals may be received.

f. PHONE. The phone jack provides the means for connecting the audio output of the receiver to the headphone.

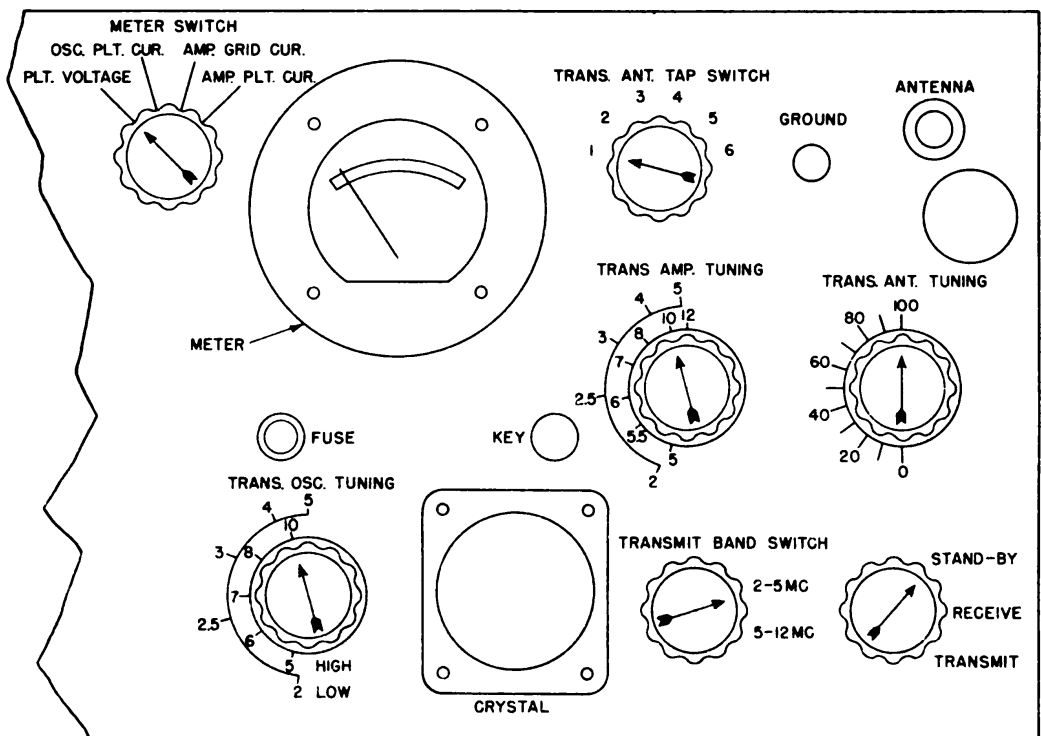

TL51872-S

Figure 17. Transmitter section, identification of controls.

18. TRANSMITTER SECTION (fig. 17).

a. METER SWITCH. This switch connects the meter on the front panel to the following circuits for adjusting and tuning purposes.

(1) With the switch in the PLT. VOLTAGE position, the meter indicates the value of the plate supply voltage delivered by the power supply. The value is read on the lower scale which must be used with a multiplying factor of 100. The scale therefore reads 0 to 1,200 volts.

(2) With the switch in the OSC. PLT. CUR. position, the current flowing in the plate circuit of the oscillator tube is measured. The upper scale on the meter is used and is calibrated for 50 ma (milliamperes) (full-scale reading). The multiplying factor is 1.

(3) With the meter switch in the AMP. GRID CUR. position, the rectified current flowing in the grid circuit of the amplifier tube is measured. The lower scale of the meter is used and is calibrated 0 to 12.0 ma.

(4) With the switch in the AMP. PLT. CUR. position, the total plate current of the amplifier tube is measured. The lower scale is used with a multiplying factor of 10, thereby indicating plate current between 0 and 120 ma.

b. TRANS. OSC. TUNING. This control tunes the tank circuit in the oscillator plate circuit. Two scales are provided: the outer scale covers the low-frequency range of 2.0 to 5.0 mc and the inner scale covers the high-frequency range 5.0 to 12.0 mc.

c. KEY. The key jack provides the means for connecting the telegraph key to the keying circuit in the transmitter.

d. CRYSTAL. The crystal receptacle houses the operating crystal. The receptacle is covered with a waterproof screw-type cover.

e. TRANSMIT BAND SWITCH. This switch provides the means of connecting the transmitter circuits for operation on either the low-frequency or high-frequency band.

f. TRANS. AMP. TUNING. This control tunes the tank circuit in the amplifier plate circuit.

g. TRANS. ANT. TAP SWITCH. This six-position switch provides the means for matching the antenna to the transmitter output circuits. Six positions are provided on the switch to compensate for different antenna lengths at various operating frequencies.

h. TRANS. ANT. TUNING. This control tunes the transmitting antenna circuit and is used in conjunction with the TRANS. ANT. TAP SWITCH to obtain maximum output power to the antenna.

i. STAND-BY, RECEIVE, TRANSMIT. This three-position switch performs the following functions:

(1) With the switch in the STAND-BY position, only the receiver section of the receiver-transmitter is energized. The common antenna is connected to the receiver.

(2) With the switch in the RECEIVE position, the receiver section is energized as is the filament of the crystal-controlled oscillator tube in the transmitter section. The common antenna is connected to the receiver.

(3) With the switch in the TRANSMIT position, the plate voltage is removed from the receiver section and is applied to the transmitter section. The common antenna is transferred from the receiver to the transmitter.

j. FUSE. The fuse receptacle contains a 1-ampere fuse connected in the plate-voltage supply.

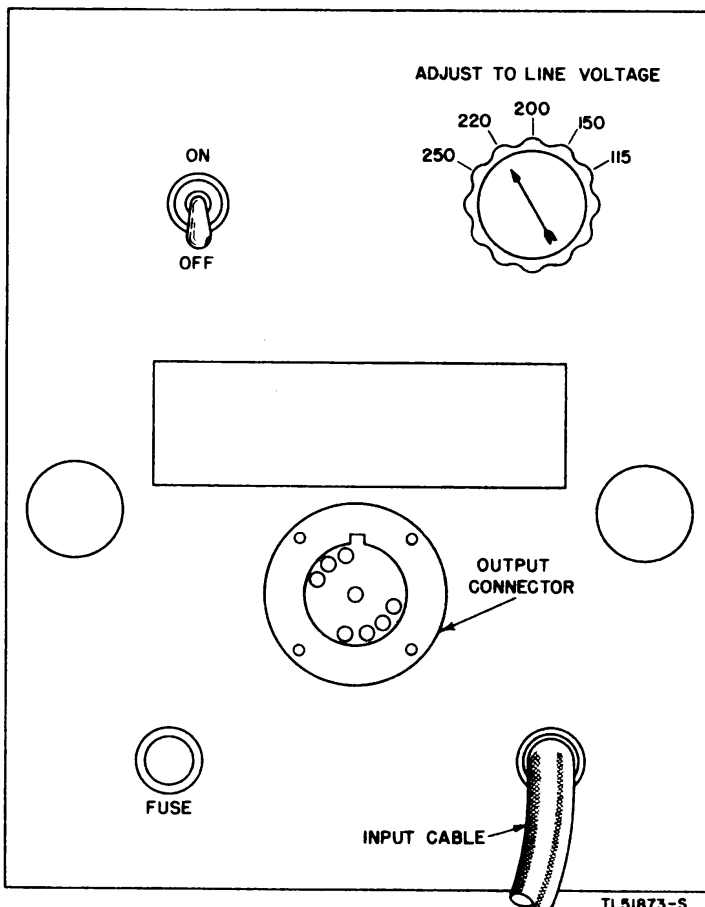

Figure 18. Rectifier power unit, identification of controls.

19. RECTIFIER POWER UNIT PP-74/TRC-10 (fig. 18).

a. Power is applied to the rectifier power supply through the ON-OFF toggle switch mounted on the front panel.

b. A five-position rotary switch is also mounted on the front panel and serves to adjust the tap on the primary of the power transformer to connect to a 50- to 60-cycle source of 115 volts to 250 volts.

c. A fuse is mounted in a fuse receptacle on the front panel and is connected in the primary side of the power transformer.

20. VIBRATOR POWER UNIT PP-84/TRC-10 (fig. 19).

a. Power is applied to the vibrator power supply through the ON-OFF toggle switch mounted on the front panel.

b. A fuse is mounted in a fuse receptacle on the front panel and is connected in the 6-volt input lead to the vibrator supply.

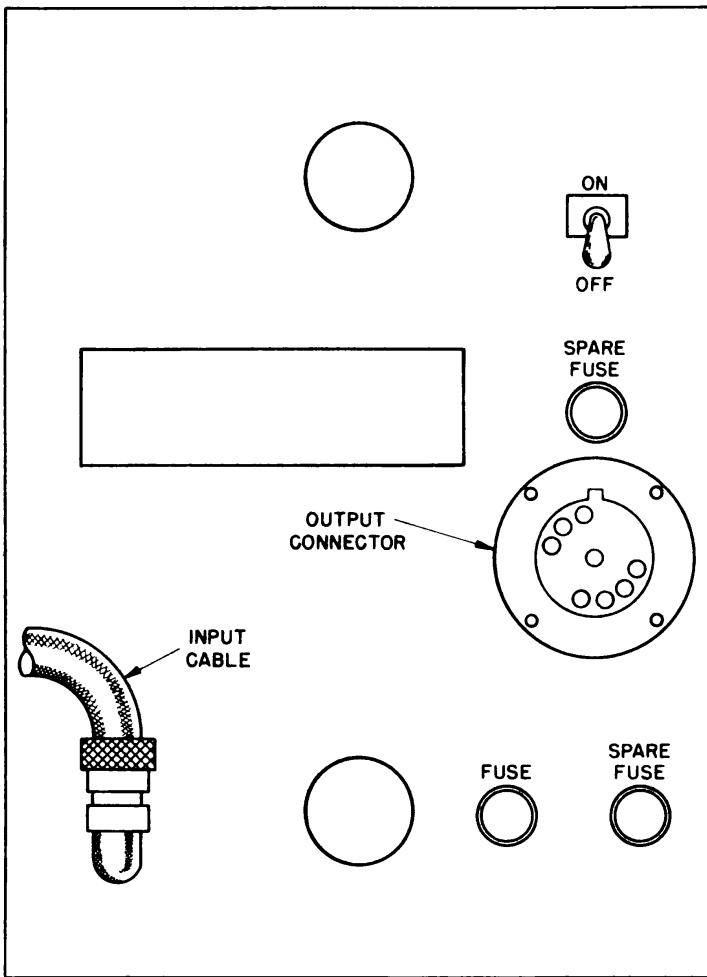

TL51875-S

Figure 19. Vibrator power unit, identification of controls.

c. Two spare fuse receptacles are also mounted on the panel of the vibrator power supply.

SECTION IV. OPERATION

21. PREPARATION FOR USE.

a. Use with Rectifier Power Unit PP-74/TRC-10.

(1) Place the ON-OFF toggle switch on the rectifier power unit in the OFF position.

(2) Make certain that the primary power source is 50- to 60-cycles alternating current, and connect the power unit to this source. *Do not connect equipment to 25-cycle or d-c power sources.* Connect the power unit to the receiver-transmitter by means of Cord CX-83/TRC-10.

(3) Measure the line voltage by means of an a-c voltmeter, if available, and set ADJUST TO LINE VOLTAGE switch in the position corresponding nearest to the measured line voltage.

(4) If a suitable a-c voltmeter is not available and the line voltage is not known, set the ADJUST TO LINE VOLTAGE switch in the following manner (telegraph key open).

(a) Turn the top switch to the 250-volt position.

(b) Turn the METER SWITCH on the front panel of the receiver-transmitter to the PLT. VOLTAGE position.

(c) Turn the STAND-BY, RECEIVE, TRANSMIT switch on the front panel of the receiver-transmitter to the TRANSMIT POSITION.

(d) Throw the toggle switch on the rectifier power unit to ON, and read the meter on the front panel of the receiver-transmitter. This meter should read approximately 800 volts.

(e) A meter reading of appreciably less than 500 volts indicates that the supply voltage is less than 250 volts. Reduce the setting of the ADJUST TO LINE VOLTAGE switch in steps until the meter reads approximately 800 volts.

b. Use with Vibrator Power Unit PP-84/TRC-10.

(1) Place the ON-OFF toggle switch on the vibrator power unit in the OFF position.

(2) Measure the terminal voltage of the storage battery with a d-c voltmeter if available. Satisfactory operation of the vibrator requires a terminal voltage between 5.5 and 7.5 volts. *Do not attempt to operate the vibrator from a battery having greater than a 6-volt rating.*

(3) Connect the power input cable to the battery terminals,

observing the correct polarity of the leads, and connect the power unit to the receiver-transmitter using Cord CX-83/TRC-10.

c. Use with Hand Generator G-4/TRC-10.

(1) Assemble the legs and handles on the hand generator as shown in figure 7.

(2) Connect Cord CX-83/TRC-10 to the receptacle on the generator and to the socket on the front panel of the receiver-transmitter.

(3) The generator operator sits astride the leg-seat and rotates the generator armature at the rate of approximately one revolution per second in the direction indicated by the arrow on the generator housing. Do not attempt to rotate the generator armature in the reverse direction to that indicated by the arrow.

22. TRANSMITTER OPERATION.

a. Preliminary.

(1) Remove the cover marked CRYSTAL on the receiver-transmitter front panel by unscrewing it in a counterclockwise direction.

(2) Remove a crystal of the desired operating frequency from the crystal box and insert it into the crystal holder.

(3) Replace the crystal compartment cover.

(4) Place the STAND-BY, RECEIVE, TRANSMIT switch in the TRANSMIT position.

(5) Place the CAL, CW, PHONE switch in either the CW or PHONE position.

(6) Place the METER switch in the PLT. VOLTAGE position. This will enable the operator to check the operation of the power supply.

(7) Place the TRANSMIT BAND SWITCH in the position covering the transmission frequency.

(8) Rotate the TRANS. OSC. TUNING and TRANS. AMP. TUNING controls so that the reference lines are opposite the operating frequency on the tuning scales marked on the panel. This setting is important as it is possible to operate at the second harmonic frequency of the crystal.

(9) Apply power to the receiver-transmitter. If the rectifier or vibrator power unit is used, the ON-OFF switch on the power unit panel should be placed in the ON position. If the hand generator is used, the generator operator should rotate the crank shaft at approximately one revolution per second. With no load (telegraph key not depressed) the meter on the receiver-transmitter front panel should read about 800 volts.

b. Transmitter Tuning.

(1) Rotate the METER switch knob to the AMP. GRID CUR. position.

(2) Depress the telegraph key and tune the TRANS. OSC. TUNING knob for a maximum meter reading. This reading will vary between 3.0 and 4.0 ma on the l-f (low-frequency) range and between 2.0 and 3.0 ma on the h-f (high-frequency) range. The reading is also dependent upon the tuning of the plate circuit; the reading is higher when the plate circuit is properly tuned.

(3) Rotate the METER switch knob to the AMP. PLT. CUR. position and tune the AMP. TUNING knob for a minimum meter reading. This reading will be affected by the position of the TRANS. ANT. TAP SWITCH and the TRANS. ANT. TUNING control.

(4) Remove the small $\frac{1}{4}$ -watt neon lamp from the tube compartment and hold it against the antenna binding post. This lamp will glow brightest when maximum power is being delivered to the antenna.

(5) Adjust the TRANS. ANT. TAP SWITCH for maximum lamp glow.

(6) Adjust the TRANS. ANT. TUNING control for maximum lamp glow.

(7) Retune the TRANS. AMP. TUNING for a minimum plate current. (Minimum plate current will always produce maximum lamp glow.)

(8) Repeat steps (5), (6), and (7) to insure optimum tuning of the output circuits.

(9) Retune the TRANS. OSC. TUNING control to insure that maximum power is being delivered to the antenna circuit, as indicated by the brightness of the neon lamp. The transmitter is now properly adjusted and ready for use.

NOTE: When operation is desired at a frequency above 6.0 mc, a crystal having a fundamental frequency of one-half the operating frequency is used and the transmitter circuits are tuned to the operating frequency. As an example: if the transmitter is to be operated at 7.5 mc, a 3.75 mc crystal must be used; however, the band switch will be set for operation on the h-f band and the circuit will be tuned to 7.5 mc.

23. RECEIVER OPERATION.

a. Preliminary.

(1) Place the STAND-BY, RECEIVE TRANSMIT switch in the RECEIVE position.

(2) Place the CAL, CW, PHONE switch in the CW position if CW signals are to be received, or in the PHONE position if voice or tone signals are to be received.

NOTE: When tuning in weak voice- or tone-modulated signals, increased sensitivity may be obtained during tuning by placing the CAL, CW, PHONE switch in the CW position.

(3) Place the RECEIVE BAND SWITCH in the proper range position.

(4) Turn volume control to the extreme clockwise position for maximum sensitivity.

b. Receiver Tuning.

(1) Tune the receiver to the incoming signal by means of the REC. TUNING control.

(2) If the receiver is operated at night, the DIAL LIGHT switch should be placed in the ON position. This will provide dim illumination for the dial and assist the operator in tuning to the proper frequency.

(3) If only receiver operation is contemplated, place the STAND-BY, RECEIVE, TRANSMIT switch in the STAND-BY position. When the switch is in this position the filament circuit of the oscillator tube is open and the power requirements are reduced. This is particularly helpful when the hand generator is being used as a power source.

c. Receiver Calibration.

(1) Determine the frequency that the receiver is to be calibrated at, and select a transmitter crystal at this frequency. If the frequency is above 6.0 mc, it will be necessary to select a crystal of half this frequency and tune for the second harmonic.

(2) Remove the CRYSTAL cover from the front panel of the receiver-transmitter, insert the crystal, and replace the cover.

(3) Set the CAL, CW, PHONE switch to the CAL position.

(4) Set the STAND-BY, RECEIVE, TRANSMIT switch to the TRANSMIT position.

(5) Set the METER switch to the AMP. GRID CUR. position.

(6) Apply power to the receiver-transmitter by throwing the OFF-ON switch on the power supply unit to ON, or by rotating the hand generator.

(7) Depress the telegraph key and tune the TRANS. OSC. TUNING control for a maximum meter reading. This indicates

that the crystal-controlled oscillator is tuned to the crystal frequency.

(8) Set the STAND-BY, RECEIVE, TRANSMIT switch to the RECEIVE position.

(9) With the telegraph key depressed, tune the RECEIVE TUNING control until the beat tone is heard in the headset. This beat tone should be heard at approximately the correct receiver dial setting.

NOTE: If the frequency is above 6.0 mc, make certain that the TRANS. OSC. TUNING and RECEIVE TUNING controls are tuned to the second harmonic of the crystal frequency.

(10) The receiver is now calibrated to the selected crystal frequency. *Return the CAL, CW, PHONE switch to either the CW or the PHONE position before operating the radio set and retune the transmitter to the desired operating frequency.*

SECTION V. EQUIPMENT PERFORMANCE CHECK LIST

24. PURPOSE AND USE OF CHECK LIST.

a. General. The equipment performance check list (par. 25) will help the operator to determine whether Radio Set AN/TRC-10 is functioning properly. The check list gives the items to be checked, the normal indications and tolerances of correct operation, and the corrective measures that the operator can take. Items 1 to 5 are checked before starting, items 6 and 7 are checked while starting, items 8 to 16 are checked during operation, and item 17 when stopping. Items 8 to 16 on this check list should be checked at least once during a normal operating period or at least four times a day during continuous operation.

b. Normal Indications. The normal indications listed include the visible and audible signs that the operator will perceive when he checks the items. In the case of meter readings, the allowable tolerances of the readings are given. The actual meter reading will depend on the frequency operated on; however, if the meter reads between the limits specified, operation can be considered satisfactory. If the meter reads outside the limits given, it is a sign of impending trouble. If the indications are not normal, the operator should apply the corrective measures given in the next column.

c. Corrective Measures. The corrective measures listed are those that the operator can make without turning the set in for repairs. Reference to part five indicates that the correction of trouble cannot be effected during operation and that trouble shooting by an experienced repairman is called for. If the set is completely inoperative or if the corrective measures do not yield the desired results, trouble shooting is necessary. However, if the tactical situation requires that communication be maintained and the set is not completely inoperative, the operator must maintain the set in operation as long as it is possible to do so.

d. Items 1 to 7. Items 1 to 7 should be checked each time for the transmitter section of Receiver-Transmitter RT-46/ the equipment is put into operation.

e. Item 8 to 12. Items 8 to 12 show correct meter readings for the transmitter section of Receiver-Transmitter RT-46/ TRC-10 when the transmitter is properly tuned and in operation. The meter readings are read with the STAND-BY, RECEIVE, TRANSMIT switch in the TRANSMIT position, with the telegraph key plugged into the KEY jack on the front panel of the receiver-transmitter, and with the key closed for all items except item 8.

f. Items 13 to 15. These items represent general operating characteristics of the radio set. The operator must become familiar with the characteristics of the set during normal operation and use that knowledge as a basis for judging the change in audible and visual indications, such as the relay clicks, keying tone in the headset, etc., when the set is not operating as it should.

g. Item 16. This item need only be performed when it is desired to check the calibration of the receiver, or when it is necessary to set the receiver to an exact predetermined frequency.

h. Item 17. This item is performed when the set is taken out of operation. Any abnormal indications noted during operation that were not remedied should be corrected before the next expected period of operation.

25. EQUIPMENT PERFORMANCE CHECK LIST.
Receiver-Transmitter RT-46/TRC-10.

	Item No.	Item	Action or condition	Normal indications	Corrective measures
PREPARATORY	1	Key Mount MT-147/TRC-10.	Plug key in KEY jack.		
	2	Headset HS-30-U.	Plug headset in PHONE jack.		
	3	Antenna.	Connect lead-in wire to ANTENNA binding post. Check that insulator is clean and not cracked.		
	4	Counterpoise.	Connect lead-in wire to GROUND binding post.		
	5	METER switch.	Turn to PLT. VOLT-AGE position.		

Rectifier or Vibrator Power Supply.

Item No.	Item	Action or condition	Normal indications	Corrective measures
START	6 ADJUST TO LINE VOLTAGE switch on rectifier power unit.	Set to proper line voltage position (par. 21a).		
	7 OFF-ON switch.	Throw to ON position.	Meter on receiver-transmitter should read approximately 800 volts.	Check primary power supply voltage.

Receiver-Transmitter RT-46/TRC-10.

	Item No.	Item	Action or condition	Normal indications	Corrective measures
EQUIPMENT PERFORMANCE	8	Plate voltage (STANDBY, RECEIVER, TRANSMIT switch in TRANSMIT position, operated).	Set METER switch to PLT. VOLTAGE position.	Meter should read approximately 800 volts.	If rectifier power unit is used, increase or decrease setting of ADJUST TO LINE VOLTAGE SWITCH.
	9	Oscillator plate current. (Key operated.)	Set METER SWITCH to OSC. PLT. CUR. position.	Meter should read approximately 10.0 to 20.0 ma.	Refer to par. 88, part five.
	10	Amplifier grid current. (Key operated.)	Set METER SWITCH to AMP. GRID CUR. position.	Meter should read approximately 1.0 to 4.0 ma.	Retune oscillator, (par. 22b). Refer to par. 88, part five.
	11	Amplifier plate current. (Key operated.)	Set METER SWITCH to AMP. PLT. CUR. position.	Meter should read approximately 60.0 to 110 ma.	Check tuning of TRANS. ANT. TAP switch, TRANS. ANT. TUNING, and TRANS. AMP. TUNING.
	12	Antenna current. (Key operated.)	Hold neon lamp against ANTENNA binding post.	Lamp should glow brightly.	Check TRANS. AMP. TUNING control.

Receiver-Transmitter RT-46/TRC-10.

	Item No.	Item	Action or condition	Normal indications	Corrective measures
EQUIPMENT PERFORMANCE	13	Key (c-w operation).	Key transmitter.	Keying clicks are heard. Keying tone is heard in headset.	Refer to par. 88, part five.
	14	VOLUME control.	Rotate volume control in a clockwise direction.	Increased output is heard in headset.	Refer to par. 86, part five.
	15	Headset.	Set STAND-BY, RECEIVE, TRANSMIT switch to STAND-BY OR RECEIVE position.	Signal is heard in headset.	Check headset cable. Tune receiver.
	16	Calibration.	Check receiver calibration as outlined in par. 23c.	Dial calibration correct.	

Rectifier or Vibrator Power Supply.

	Item No.	Item	Action or condition	Normal indications	Corrective measures
STOP	17	OFF-ON switch.	Throw to OFF position.		

PART THREE

PREVENTIVE MAINTENANCE

SECTION VI.

PREVENTIVE MAINTENANCE TECHNIQUES

26. MEANING OF PREVENTIVE MAINTENANCE.

Preventive maintenance is a systematic series of operations performed at regular intervals on equipment, when turned off, to eliminate major break-downs, unwanted interruptions in service, and to keep the equipment at top operating efficiency. To understand what is meant by preventive maintenance, it is necessary to distinguish between preventive maintenance, trouble shooting, and repair. The prime function of preventive maintenance is to *prevent* break-downs and, therefore, the need for repair. On the other hand, the prime function of trouble shooting and repair is to locate and correct *existing* defects. The importance of preventive maintenance cannot be overemphasized. The entire system of radio communication depends upon each set's being *on the air* when it is needed and upon its *operating efficiency*. It is vitally important that radio operators and repairmen maintain their radio sets properly. See TB SIG 123, Preventive Maintenance Practices for Ground Signal Equipment.

NOTE: The operations in sections VI and VII are first and second echelon (organization operators and repairmen) maintenance. Some operations in sections VIII and X are higher echelon maintenance.

27. DESCRIPTION OF PREVENTIVE MAINTENANCE TECHNIQUES.

a. General. Most of the electrical parts used in Radio Set AN/TRC-10 require routine preventive maintenance. Those requiring maintenance differ in the amount and kind required. Because hit-or-miss maintenance techniques cannot be applied, definite and specific instructions are needed. This section of the manual contains these specific instructions and serves as a guide for personnel assigned to perform the six basic maintenance operations namely: Feel, Inspect, Tighten, Clean, Adjust, and

Lubricate. Throughout this manual the lettering system for the six operations will be as follows:

- F — Feel.
- I — Inspect.
- T — Tighten.
- C — Clean.
- A — Adjust.
- L — Lubricate.

The first two operations establish the need for the other four. The selection of operations is based on a general knowledge of field needs. For example, the dust encountered on dirt roads during cross-country travel filters into the equipment no matter how much care is taken to prevent it. Rapid changes in weather (such as heavy rain followed by blistering heat), excessive dampness, snow, and ice tend to cause corrosion of exposed surfaces and parts. Without frequent inspections and the necessary performance of tightening, cleaning, and lubricating operations, equipment becomes undependable and subject to break-down when the equipment is most needed.

b. Feel. The feel operation is used most often to check rotating machinery, such as blower motors, drive motors, etc., and to determine if electrical connections, bushings, etc., are overheated. Feeling indicates the need for lubrication or the existence of similar types of defects requiring correction. The maintenance man must become familiar with the normal operating temperatures of motors, etc., in order to recognize signs of overheating.

NOTE: It is important that the feel operation be performed as soon as possible after shut-down and always before any other maintenance is done.

c. Inspect. Inspection is the most important operation in the preventive maintenance program. A careless observer will overlook the evidences of minor trouble. Although these defects may not interfere with the performance of the equipment, valuable time and effort can be saved if they are corrected before they lead to major break-downs. Make every effort to become thoroughly familiar with the indications of normal functioning in order to be able to recognize the signs of a defective set. Inspection consists of carefully observing all parts of the equipment, noticing their color, placement, state of cleanliness, etc. Inspect for the following conditions:

(1) Overheating, as indicated by discoloration, blistering, or bulging of the parts or surface of the container; leakage of

insulating compounds; and oxidation of metal contact surfaces.

(2) Placement, by observing that all leads and cabling are in their original positions.

(3) Cleanliness, by carefully examining all recesses in the units for accumulation of dust, especially between connecting terminals. Parts, connections, and joints should be free of dust, corrosion, and other foreign matter. In tropical and high-humidity locations, look for fungus growth and mildew.

(4) Tightness, by testing any connection or mounting which appears to be loose. Whenever a loose connection is tightened, it should be moistureproofed and fungiproofed again by applying the varnish with a small brush.

d. Tighten, Clean, and Adjust. These operations are self-explanatory. Specific procedures to be followed in performing them are given wherever necessary throughout part three.

CAUTION: Screws, bolts, and nuts should not be tightened carelessly. Fittings tightened beyond the pressure for which they are designed will be damaged or broken.

Whenever a loose connection is tightened, it should be moistureproofed and fungiproofed again by applying the varnish with a small brush. See section X for details of moistureproofing and fungiproofing.

e. Lubricate. Lubrication refers to the application of grease or oil to the bearings of motors or other rotating shafts. It may also mean the application of a light oil to door hinges or other sliding surfaces on the equipment.

28. VACUUM TUBES.

a. Inspect (I).

(1) Inspect glass and metal tube envelopes, tube caps, and tube connector clips for accumulation of dirt and for corrosion. When tubes with loose plate or grid caps or envelopes are found, replace the tubes if possible.

(2) The spring clips that make contact with the grid caps must be examined for corrosion and for loss of tension with resulting looseness. Also, check the condition of the wires soldered to the spring clips. The wires should be free of frayed insulation or broken strands.

(3) Inspect the firmness of tubes in their sockets. This is accomplished by pressing the tubes down in the sockets and testing them in that position, and *not* by partially withdrawing the

tubes and jiggling them from side to side. Movement of a tube tends to weaken the pins in the base and unnecessarily spread the contacts in the socket. It is desirable to inspect the sockets of the tubes at the time the tubes are removed.

(4) When it is necessary to remove a tube from its socket, especially if it is a high-power tube, great care must be used. Never jar a warm tube. Connections to the grid and plate caps must always be removed.

b. Tighten (T). If the connections to the tube sockets are dirty or corroded, clean before tightening.

c. Adjust (A). Adjust loose tube connector clips. Do not flatten tube connector clips adjustments. Flattened clips do not make adequate contact with the surface of the tube cap. If the clip is made of thin metal, it can be adjusted by gently compressing it with the fingers. If it is made of heavy-gauge metal, suitable pressure can be applied with a pair of long-nose pliers.

d. Clean (C).

(1) Clean the tubes, but only if inspection shows cleaning to be necessary. Tubes operated with high voltages and with exposed plate and grid connections must be kept free of dirt and dust because of possible leakage between grid and plate terminals. In contrast, tubes operating at low voltages and not having exposed grid and plate caps do not require frequent cleaning. However, do not permit dirt to accumulate on low-voltage tubes.

(2) Remove dust and dirt from the glass or metal envelopes with a clean, lint-free, dry cloth. If proper care is exercised, the grid and plate caps may be cleaned with a piece of #0000 sandpaper. Wrap the paper around the cap and *gently* run along the surface. Excessive pressure is not needed; neither is it necessary to grip the cap tightly. Wipe with a clean dry cloth.

(3) When tube sockets are cleaned and the contacts are accessible, fine sandpaper may be used to remove corrosion, oxidation, and dirt.

29. CAPACITORS.

a. Inspect (I).

(1) Inspect the terminals of large, fixed capacitors for corrosion and loose connections. Carefully inspect the mountings to discover loose mounting screws, studs, or brackets. Examine the leads for poor insulation, cracks, and evidences of dry rot.

Frayed strands on the insulation should be cut away. If the wire is exposed, wrap it with friction tape. The terminals of the capacitors should not be cracked or broken.

(2) Thoroughly inspect the case of each large fixed capacitor for leaks, bulges, and discoloration.

(3) Inspect the plates of variable capacitors for dirt, dust, or lint. Examine the movable set of plates for signs of damage or misalignment that would cause them to touch the fixed plates during tuning. Rotate the movable plates, using the panel tuning control, and thus check for proper operation of the capacitors.

CAUTION: Do not bend any plates of the tunable capacitors.

b. Tighten (T). Tighten loose terminals, mountings, and connections on the capacitors, whenever they are observed. Do not break the bushing or damage the gasket.

c. Clean (C).

(1) Clean the case of fixed capacitors, the insulating bushings, and connections that are dirty or corroded. The capacitor cases and bushings can usually be cleaned with a dry cloth, but if the deposit of dirt is hard to remove, moisten the cloth in a dry-cleaning solvent.

(2) Clean the plates of variable capacitors with a soft brush, removing all dust and lint.

d. Lubricate (L). The bearings of variable capacitors are usually of the ball-bearing type, lubricated and sealed at the factory. These bearings will not need relubrication during the life of the equipment.

30. RESISTORS.

a. General. Various types of resistors are used in Radio Set AN/TRC-10. The connections to the various resistors are either of the pigtail or solder-lug type.

b. Inspect (I). Inspect the coating of the cement coated resistors for signs of cracks and chipping, especially at the ends. Examine the bodies of all types of resistors for blistering, discoloration, and other indications of overheating. Inspect leads and all other connections for corrosion, dirt, dust, looseness, and broken strands in the connecting wires. Check the security of all mountings. Do not attempt to move resistors with pigtail connections; there is danger of breaking the connections at the

point where they enter the body of the resistor. Such defects cannot be repaired.

c. Clean (C).

(1) Clean all carbon resistors with a small brush.

(2) Resistors with discolored bodies cannot be cleaned. Discoloration indicates that there has been overloading and overheating at some time prior to the inspection. The discoloration is probably due to circuit trouble which requires analysis and correction. Trouble-shooting procedures are described in part five.

NOTE: When fungiproofed resistors are heated, a harmless brown stain may appear.

31. FUSES.

a. General. The fuses used in Radio Set AN/TRC-10 are of the glass type, and are held in place by fuse caps.

b. Inspect (I). Inspect the fuse caps for evidence of burning, charring, and corrosion.

c. Clean (C). Clean fuse ends and fuse holder with emery cloth; then wipe them with a clean cloth.

32. SWITCHES.

a. Inspect (I).

(1) Inspect the mechanical action of each switch and, while so doing, look for signs of dirt or corrosion on all exposed elements. In some cases, it will be necessary to examine the elements of the switch visually, in others, the action of the switch is checked by flipping the control knob or toggle and noting the freedom of the movement and the amount of spring tension.

(2) Examine the ganged switches to see if they are properly lubricated and if the contacts are clean. The inspection is visual. Do not pry the leaves of the switch apart. The rotary members should make good contact with the stationary members, and as the former slides into the latter, a spreading of the stationary contact leaves should be noticeable. The switch action should be free. The wiping action of the contacts usually removes any dirt at the point of contact.

b. Clean (C). Clean the exterior surfaces of switches with a stiff brush moistened with dry-cleaning solvent.

c. Lubricate (L). If necessary, lubricate the wiping contacts with a light oil.

33. COILS.

a. Inspect (I). Inspect all coils for cleanliness of the ceramic coil form.

b. Tighten (T). Tighten any loose coil mountings or connections by resoldering wires or tightening screws.

c. Clean (C). Clean the coil form and coil with a soft brush.

34. METER.

Meters are extremely delicate instruments and must be handled very carefully. They require little maintenance. They are precision instruments and ordinarily cannot be repaired in the field.

a. Inspect (I). Inspect the leads and connections to the meter. Look for loose, dirty, and corroded connections. Look for a cracked or broken cover glass. Since the movement of a meter is extremely delicate, its accuracy will be seriously affected if the glass is broken and dirt and water filter through.

b. Tighten (T). Tighten all connections found loose. Any loose meter wires should be inspected for dirt or corrosion before they are tightened. The tightening of meter connections requires a special technique because careless handling can easily crack the meter case.

c. Clean (C). Meter cases can usually be cleaned with a dry cloth. If cleaning is difficult, the cloth should be dampened with a dry-cleaning solvent. Dirty connections may be cleaned with a small brush dipped in dry-cleaning solvent, or with a small piece of cloth dipped in the solvent.

d. Adjust (A). Normally, the meter in Radio Set AN/TRC-10 should indicate zero when the equipment is turned off. The procedure for setting a meter to zero is not difficult. The tool required is the thinnest screwdriver. Before deciding that a meter needs readjusting, tap the meter case lightly with the tip of one finger. This will help the needle to overcome the slight friction which sometimes exists at the bearings and prevents an otherwise normal unit from coming to rest at zero. If adjustment is needed, insert the tip of the screwdriver in the slotted screw head located below the meter glass and slowly turn the adjusting screw until the pointer is at zero. Lightly tap the meter case again and view the meter face and pointer *full on*, and not from the side. Avoid turning the screw too far, because the needle may be bent or the hairspring damaged.

35. ANTENNA INSULATOR.

The antenna insulator is constructed of ceramic material with a glazed surface. Any deposit of foreign substance on the surface of this insulator will materially reduce its insulating value. Therefore it is necessary to inspect this insulator frequently.

a. Inspect (I). Inspect the physical condition of the insulator. It should be clean without cracks or chips. It is possible for a highly glazed insulator to develop fine-line surface cracks where moisture and dust will accumulate and eventually form a leakage path.

b. Tighten (T). The procedure to be used in tightening the insulator is self-evident. However, observe one precaution. Avoid forcing the screws down too tight. If excessive pressure is exerted on the insulator, damage is almost certain.

c. Clean (C). The insulator is very easily cleaned. Never use abrasive materials because the glazed finish will be destroyed. A clean cloth is usually satisfactory. If deposits of grime or dirt on the surface of the insulator are hard to remove, use dry-cleaning solvent. After the surface has been cleaned with a solvent, polish it with a dry cloth. Otherwise, a thin film of the solvent will be left which will impair the effectiveness of the insulator.

36. RELAYS.

Relay K101 in the receiver-transmitter and the regulator and protective relays in the hand generator are considered normal if: the exterior is free from dirt or dust; the contacts are not burned, pitted, or corroded; the contacts are lined up and correctly spaced; the moving parts travel freely and function properly; the connections to the relay are tight; the wire insulation is not frayed or torn; the relay assembly is securely mounted; the field coil shows no signs of overheating.

a. Inspect (I).

(1) Inspect the relay to detect defects. Examine the contacts with the aid of a flashlight.

(2) The mechanical action of the relay should be checked to make certain that when the moving and stationary contacts come together they make positive contact and are in line with each other.

b. Tighten (T). Tighten all loose connections and mounting screws, but do not apply enough force to damage the screw or to break the parts it holds.

c. Clean (C).

(1) *Relay Exterior.* Brush the exterior of the relay with a soft brush. If it is very dirty, clean it with a brush dipped in dry-cleaning solvent.

(2) *Relay Contacts.* The hard-alloy contacts are cleaned by drawing a strip of clean bond paper between them while holding them together. In some cases, it may be necessary to moisten the paper with dry-cleaning solvent. Use a dry paper strip for polishing. Corroded, burned, or pitted contacts must be cleaned with a point file or burnishing tool and crocus cloth.

d. Adjust (A). If it is necessary to adjust the regulator relay in the hand generator, proceed as follows:

(1) Adjust setscrew A (fig. 20) so that distance between the vibrator and stop is $1/64$ inch. This distance can be determined by inserting the body of Gauge TL-127 (fastened to cover of hand generator) between the contacts.

(2) Adjust setscrew B (fig. 20) so that distance between the vibrator and stop is 0.0006 inch. This distance can be determined by inserting the thin leaf of Gauge TL-127 between the contacts.

(3) Adjust setscrew C (fig. 20) to obtain required output voltage.

NOTE: Do not attempt adjustment of the regulator relay unless absolutely necessary.

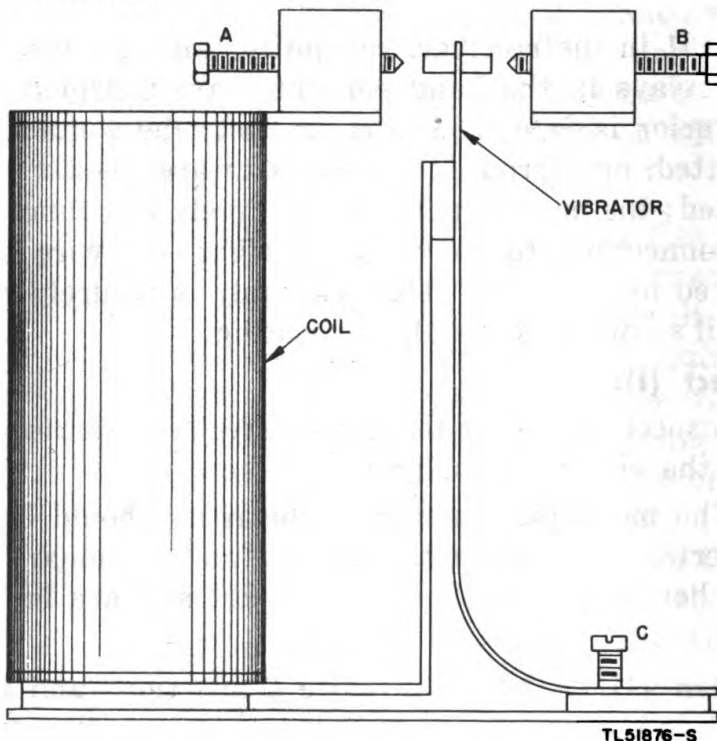

Figure 20. Adjustment of regulator relay.

37. CORDS AND CABLES.

The cables in Radio set AN/TRC-10 can be regarded as the life lines of the equipment. The condition of the cabling must be closely observed. Equipment operated in all kinds of weather and moved on all kinds of roads subjects cabling to a great deal of punishment.

a. Inspect (I). Inspect the cables for cracked or deteriorated insulation, frayed or cut insulation at the connecting and supporting points, and improper placement which places the cables or connections under strain. Also watch for kinks and improper supports.

b. Tighten (T). Tighten loose cable clamps, coupling rings, and cable connections.

c. Clean (C). Clean connections on cables when they are dirty or corroded. Clean corroded connectors with #0000 sandpaper. It is important that the entire surface of the connector be cleaned. Do not make any attempt to remove individual prongs from cable plugs.

38. CABINETS AND CHASSIS.

a. Inspect (I). Inspect the outside and inside of each cabinet thoroughly, paying strict attention to every detail. Check the panel screws and the zero setting of the meter. Inspect the panels for loose knobs, switches, and jacks.

b. Clean (C). Clean each cabinet, outside and in, with a clean dry cloth. Repaint any surface that is found scratched, rusted, or chipped.

c. Tighten (T). Tighten all mounting bolts, panel screws, plugs, and control knobs found loose.

39. HEADSET AND KEY.

a. Inspect (I). Inspect all external surfaces for dirt and corrosion. See that all external surfaces are tight and that plugs and jacks fit together properly. Inspect the key for proper operation.

b. Clean (C). Clean all items of the equipment in accordance with the instructions outlined previously for relays, cords, jacks, cabinets, etc.

40. JACKS.

Jacks require very little attention, and then only at infrequent intervals. Occasionally it will be necessary to tighten the mount-

ing nut, clean the contacts, or increase the spring tension. Remove dirt with a brush and dry-cleaning solvent; remove corrosion with a piece of crocus cloth followed by a clean cloth. Increase spring tension when necessary. Try the action of the jack after each adjustment. Be careful to keep all soldered connections intact.

41. GEARS.

a. Inspect (I). Inspect the teeth of the gears in the variable capacitor and hand generator for dirt or corrosion.

b. Clean (C). If the gears are dirty, clean them with a pipe cleaner or small brush dipped in dry-cleaning solvent.

42. HAND GENERATOR.

a. Inspect (I). Inspect the brushes and the commutator at regular intervals. The brush springs must have adequate tension and be in firm contact with the brushes.

b. Clean (C). The commutator may be cleaned with a cloth moistened in dry-cleaning solvent. If the commutator has been burned or pitted, hold a piece of #0000 sandpaper against the commutator and turn it slowly.

c. Lubricate (L). Apply a few drops of Oil, Engine, SAE-10 U.S. Army Spec No. 2-104B, or Oil, Lubricating, Preservative, Special, U.S. Army Spec No. 2-120, to bearings at both ends of case at three-month intervals.

SECTION VII. ITEMIZED PREVENTIVE MAINTENANCE

43. INTRODUCTION.

For ease and efficiency of performance, preventive maintenance on Radio Set AN/TRC-10 will be broken down into operations that can be performed at different time intervals. In this section the preventive maintenance work to be performed on the radio set at specified time intervals is broken down into units of work called items. The general techniques involved and the application of the FITCAL operations in performing preventive maintenance on individual parts are discussed in section VI. These general instructions are not repeated in this section. When performing preventive maintenance, refer to section VI if more information is required for the following items. All work is to be performed with the power removed from the equipment. After preventive maintenance has been performed on a

given day, the equipment should be put into operation and checked for satisfactory performance (par. 25).

44. COMMON MATERIALS NEEDED.

The following materials will be needed in performing preventive maintenance:

Common hand tools.

Clean cloth.

#0000 sandpaper.

Crocus cloth.

Fine file or relay burnishing tool.

Oil, Lubricating, Preservative, Special, U.S. Army Specification No. 2-120, Symbol PS.

Solvent, Dry-cleaning, Federal Specification P-S-661a.

NOTE: Gasoline will not be used as a cleaning fluid for any purpose. Solvent, Dry-cleaning, Federal Specification P-S-661a, a cleaning fluid, is available through established supply channels. Oil, Fuel, Diesel, U. S. Army Specification 2-102B, may be used for cleaning purposes when dry-cleaning solvent is not at hand. Carbon tetrachloride, or fire-extinguishing liquid (carbon tetrachloride base), will be used, if necessary, only on contact parts of electronic equipment.

45. ITEM 1, EXTERIOR OF RADIO SET AN/TRC-10.

OPERATIONS.

ITC Cabinets.

ITC Jacks.

IT Pilot lights.

IT Control knobs.

IC Meter.

REMARKS. With an Allen wrench, tighten all the control knobs found loose.

46. ITEM 2, CABLES.

OPERATIONS.

IC Cables and connections.

47. ITEM 3, HEADSET AND KEY.

OPERATIONS.

ITC Cords and plugs.

REMARKS. Clean the key contacts according to the method prescribed for cleaning relays.

48. ITEM 4, HAND GENERATOR G-4/TRC-10.

OPERATIONS.

- IC Generator housing.
- IC Commutator and brushes.
- IC Power receptacle.
- L Generator bearings (once every 3 months).

49. ITEM 5, RECEIVER-TRANSMITTER RT-46/TRC-10.

PRELIMINARY STEPS. Remove the receiver-transmitter unit from Case CY-49/TRC-10.

OPERATIONS.

- ITC Tubes and sockets.
- IC Power receptacle.
- ITC Capacitors.
- ITC Resistors.
- ITC Insulator.
- ICL Switches.
- I Cables.
- ITC Relay.
- IC Gears.
- IC Coils.

50. ITEM 6, RECTIFIER POWER UNIT PP-74/TRC-10.

OPERATIONS.

- ITC Tube and socket.
- ITC Capacitors.
- IC Power receptacle.
- ITC Resistors.
- IC Transformer.
- IC Switch.

51. ITEM 7, VIBRATOR POWER UNIT PP-84/TRC-10.

OPERATIONS.

- ITC Tube and socket.
- IC Power receptacle.
- ITC Capacitors.
- IC Vibrator.
- ITC Resistors.
- IC Switch.

52. ITEM 8, ANTENNA.

OPERATIONS.

- IC Supporting insulators.
- I Condition of antenna wire.

53. PREVENTIVE MAINTENANCE CHECK LIST.

a. General. The following check list is a summary of the preventive maintenance operations to be performed on Radio Set AN/TRC-10. The time intervals shown on the check list may be reduced at any time by the local commander. For best performance of the equipment, perform the operations at least as frequently as called for in the check list. The echelon column indicates which operations are first echelon maintenance and which operations are second echelon maintenance. Operations are indicated by the letters of the word FITCAL. For example, if the letters ITCA appear in the "Operations" column, the item to be treated must be inspected (I), tightened (T), cleaned (C), and adjusted (A).

b. Check List.

Item No.	Operations	Item	When performed							Echelon
			Before operation	After operation	Daily	Weekly	Monthly	Semi-annually	Yearly	
1	ITC	Exterior of Radio Set AN/TRC-10.			X					1st
2	I	Cables.	X	X						1st
3	ITC	Headset and key.			X					1st
4	IC	Hand Generator G-4/TRC-10.						X		1st
5	ITCA	Receiver-Transmitter RT-46/TRC-10.						X		2d
6	ITC	Rectifier Power Unit PP-74/TRC-10.						X		1st
7	ITC	Vibrator Power Unit PP-84/TRC-10.						X		1st
8	I	Antenna.	X	X						1st

F
Feel

I
Inspect

T
Tighten

C
Clean

A
Adjust

L
Lubricate

SECTION VIII. LUBRICATION

NOTE: There is no lubrication order for this equipment. All lubrication instructions are included in section VII under preventive maintenance of the various parts discussed there.

54. LUBRICATION OF HAND GENERATOR G-4/TRC-10.

The hand generator is inclosed in an immersionproof case which entails removal of the specially sealed machine screws or bolts which hold the generator to the case in order to lubricate the equipment. Operating personnel should not attempt lubrication other than a few drops of oil on the hand crank bearings (par. 42c). The following lubricating instructions apply only to a third or higher echelon station and should be performed when the generator is taken in for general overhaul or repair.

a. Remove the outer half of the chain housing and wipe off accessible old grease. Coat chain and gear teeth, and pack chain recesses with Grease, Special, High-temperature (GM). Spread lubricant evenly and avoid piling up an excess of grease at points where it cannot be expected to adhere to the mechanism. Pack a small amount of grease around exposed bearing surfaces.

b. Remove diamond-shaped plate covering armature bearings at other end of generator. Clean out any of the old grease that is accessible. Knead Grease, Special, High-temperature (GM) into recess between races. Avoid an excess of lubricant.

c. If Solvent, Dry-cleaning, Federal Specification, P-S-661a, or Oil, Fuel, Diesel, U. S. Army Specification 2-102B is used for the removal of the old lubricant, be sure to invert the generator to prevent flow of fluid onto commutator of armature windings.

d. Apply a sealing compound around heads of machine screws on outer case when the unit is reassembled.

PART FOUR

AUXILIARY EQUIPMENT

SECTION IX. POWER UNIT PE-214-B AND MAINTENANCE KIT MK-24/TRC-10

55. POWER UNIT PE-214-B.

Power Unit PE-214-B (fig. 21) is a compact, light-weight, voltage generating set that may be used with Radio Set

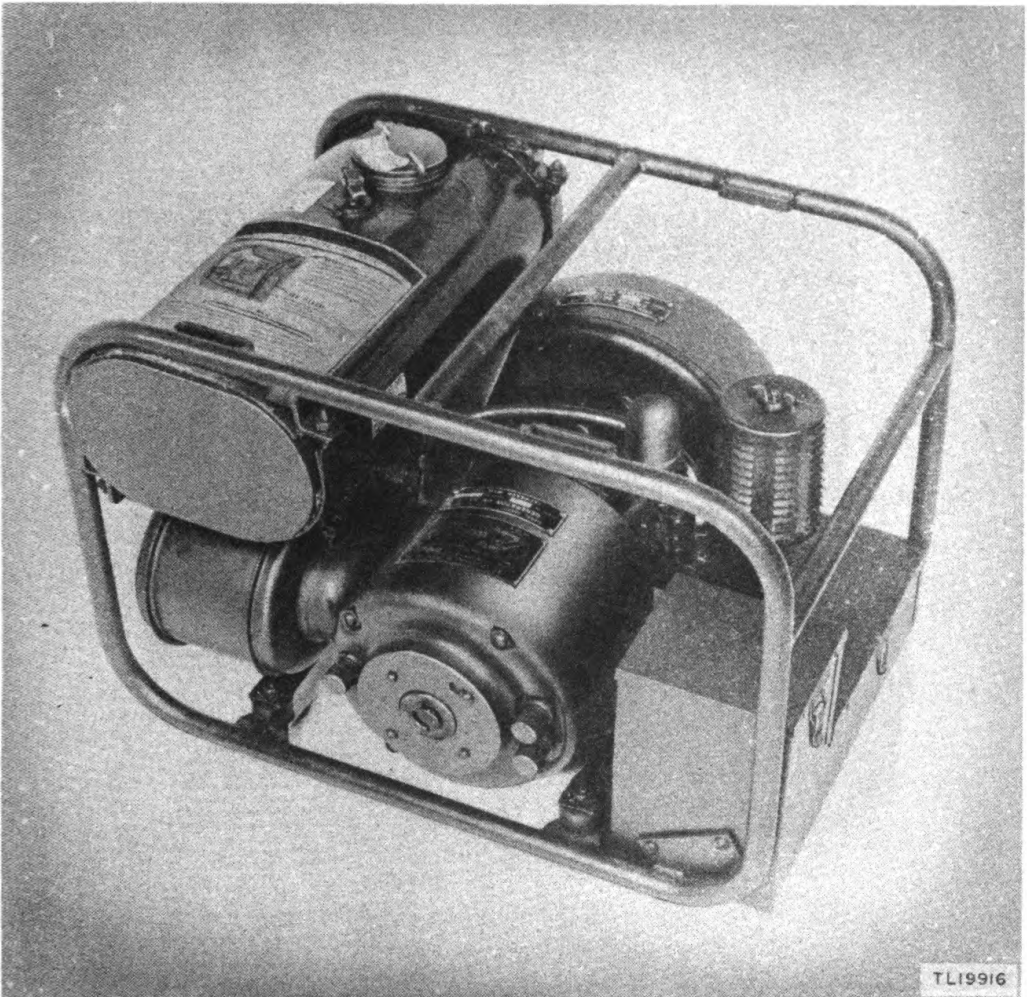

Figure 21. Power Unit PE-214-B.

AN/TRC-10 to supply 120 or 240 volts alternating current. The unit is designed to deliver 300 watts of power, and when used, it is connected to Rectifier Power Unit PP-74/TRC-10 by means of Cord CX-350/TRC-10. Complete installation, operation, and maintenance instructions for Power Unit PE-214-B are given in TM 11-945.

56. MAINTENANCE KIT MK-24/TRC-10.

One Maintenance Kit MK-24/TRC-10 (fig. 22) is provided

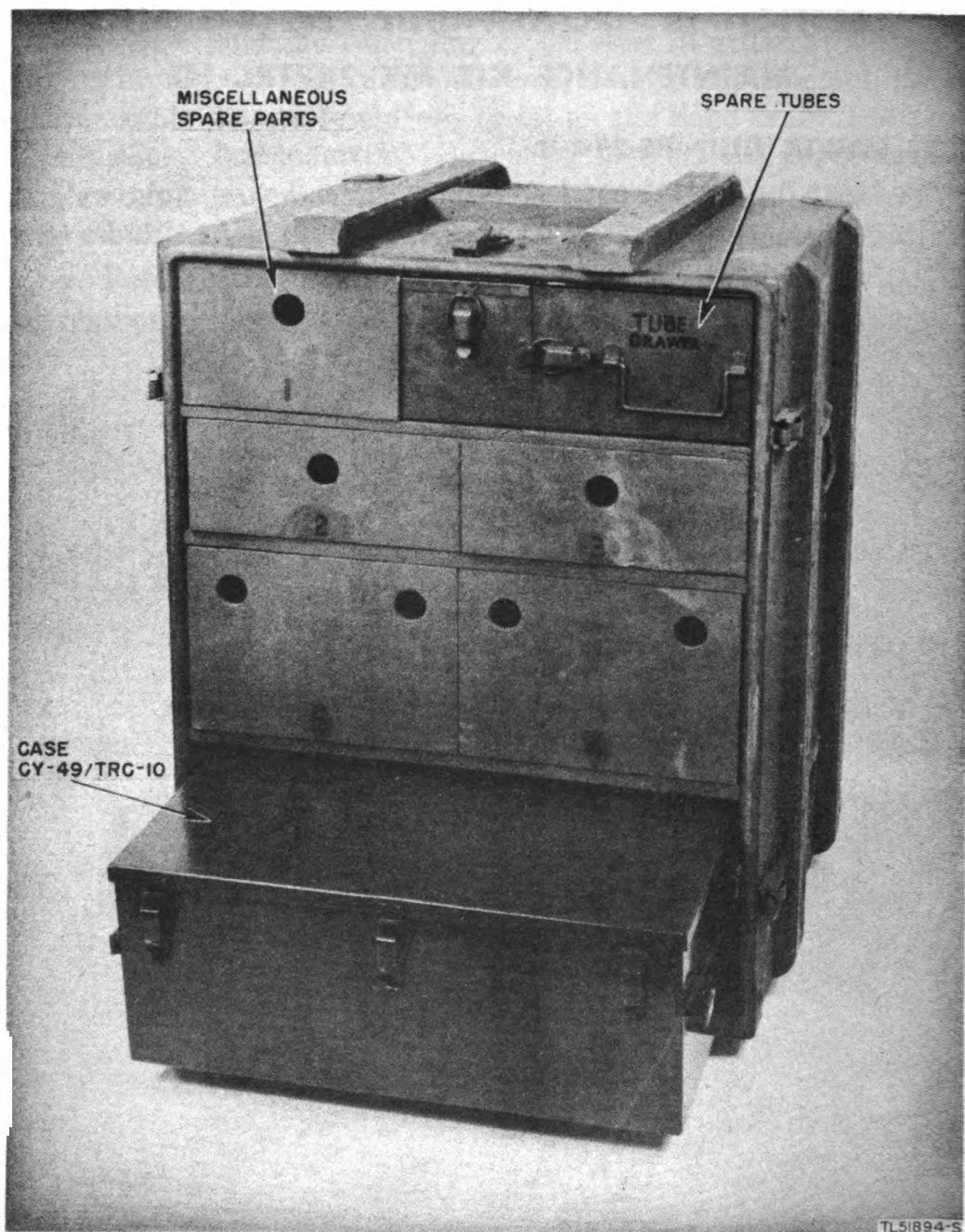

Figure 22. Maintenance Kit MK-24/TRC-10.

for shipment with five radio sets and contains the following spare equipment:

a. Case CY-49/TRC-10 with Legs.

- (1) Receiver-Transmitter RT-46/TRC-10.
- (2) Case CY-277/TRC-10 with crystals.
- (3) Key Mount MT-147/TRC-10 with key and cord.
- (4) Headset HS-30-U with cord and Inserts M-300.
- (5) Spare tubes in compartment.

b. Spare Tube Carrying Case.

- (1) JAN-6V6GT/G (5 each).
- (2) JAN-2E22 (8 each).
- (4) JAN-6SK7 (10 each).
- (4) JAN-6SL7GT (5 each).
- (5) JAN-6SA7 (5 each).
- (6) JAN-6J5GT (5 each).
- (7) JAN-5R4GY (4 each).

c. Five Miscellaneous Parts Drawers.

- (1) Antenna insulators (10 each).
- (2) Cord CX-83/TRC-10.
- (3) Cord CX-350/TRC-10.
- (4) Plugs No. 110 (5 each).
- (5) Plug PL-55.
- (6) Neon lamps, $\frac{1}{4}$ -watt (10 each).
- (7) Mazda lamps (10 each).
- (8) Antenna wire, 50-foot (2 each).
- (9) Antenna wire, 100-foot (2 each).
- (10) Cord, 12-foot length.
- (11) Miscellaneous maintenance parts.

PART FIVE

REPAIR INSTRUCTIONS

NOTE: Failure or unsatisfactory performance of equipment used by Army Ground Forces and Army Service Forces will be reported on W.D., A.G.O. Form No. 468 (Unsatisfactory Equipment Report) (fig. 54); by Army Air Forces, on Army Air Forces Form No. 54 (Unsatisfactory Equipment Report).

SECTION X. THEORY OF RECEIVER SECTION

57. GENERAL.

The receiver section of Receiver-Transmitter RT-46/TRC-10 consists of a five-tube superheterodyne receiver designed to receive a-m (amplitude-modulated) signals or keyed c-w signals over a frequency range of 2.0 to 12.0 mc. Two bands are used to cover this range: band 1 covers 2.0 to 5.0 mc and band 2 covers 5.0 to 12.0 mc. The audio-output stage of the receiver is converted into a keyed audio oscillator during operation of the transmitter to monitor the keying of the transmitter. To calibrate the receiver, a portion of the output of the crystal-controlled oscillator in the transmitter section is fed through to the receiver. When transmitting, the plate voltage is removed from the receiver section, and the receiver antenna coil is shorted to ground.

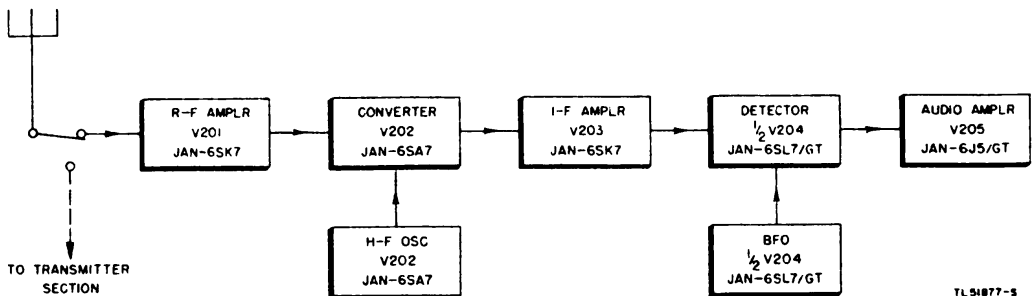

Figure 23. Receiver section, block diagram.

58. BLOCK DIAGRAM OF RECEIVER SECTION.

a. The receiver section of Receiver-Transmitter RT-46/TRC-10 is shown in the block diagram in figure 23. The same antenna is used for both receiving and transmitting, and switching between

the two sections is accomplished by the manual STAND-BY, RECEIVE, TRANSMIT switch on the receiver-transmitter front panel.

b. The signal is picked up by the antenna and is fed through the antenna switch to the r-f amplifier stage. After amplification the r-f signal is fed to the converter tube where it is mixed with the signal from the h-f oscillator. The combination of the h-f oscillator signal and the r-f received signal produces an i-f (intermediate-frequency) signal. This signal is fed from the converter to the i-f amplifier stage where it is further amplified before detection.

c. For voice reception, the amplified i-f signal is fed to the detector stage where the signal is demodulated and applied to the following audio-output stage. The output stage amplifies the voice signal and feeds it to the headset, plugged into the PHONE jack.

d. For c-w reception, a BFO (beat-frequency oscillator) generates a signal which is mixed with the amplified i-f signal fed to the detector. The detector, in this case, demodulates the combined signal leaving the audible beat note which is amplified by the audio-output stage and is applied to the headset.

59. RADIO-FREQUENCY AMPLIFIER (fig. 24).

a. The first stage of the receiver section is an r-f amplifier and uses a Tube JAN-6SK7 (V201). The signal picked up by the antenna is fed through the antenna switch (not shown on simplified diagram) to the primary winding of antenna transformer T201. Figure 24 is a simplified diagram of the r-f stage showing a single secondary coil for clarity. The frequency range of the receiver is covered in two bands and a second tuned secondary coil is included which may be switched into the circuit by operation of the RECEIVE BAND SWITCH on the front panel of the receiver-transmitter. For operation on the h-f band, the l-f secondary coil is short circuited to prevent it from affecting the operation of the stage. The h-f secondary winding of T201 is tuned to resonance by main tuning capacitor C201A and by parallel trimmer capacitor C204. Additional capacitive coupling is provided between the primary and the h-f secondary by a single open turn wrapped around the secondary winding and connected to the antenna side of the primary winding. The selected r-f signal in the resonant secondary circuit is applied to the grid (pin 4) of r-f amplifier tube V201.

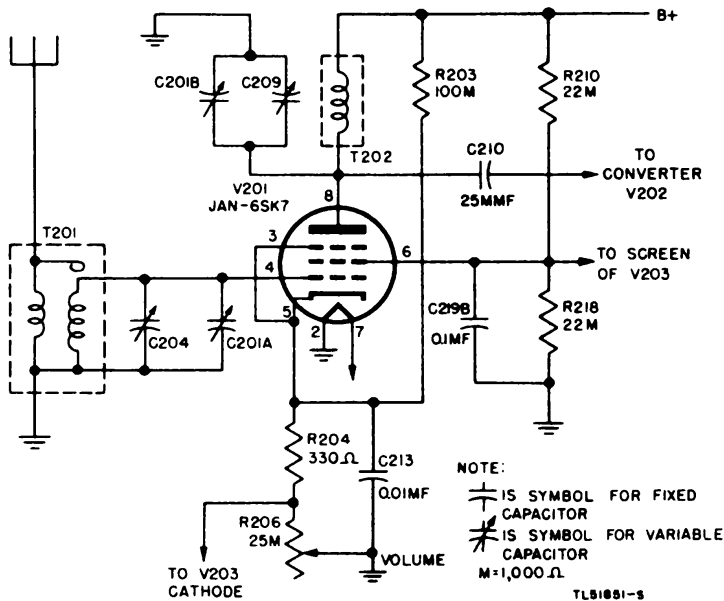

Figure 24. R-f amplifier V201, simplified diagram.

b. Grid bias for tube V201 is obtained by the voltage drop across resistor R204 and variable resistor R206 in the cathode circuit. The voltage drop is developed both by the plate current flowing through the tube and by the bleeder current from the B+ supply flowing through resistor R203. As the value of variable resistor R206 is increased, the bias voltage is also increased which in turn reduces the gain of the stage. The voltage developed across R206 is also applied as bias to i-f amplifier stage V203 and serves to control the gain of this tube. Variable resistor R206 is labelled VOLUME and is mounted on the front panel of the receiver-transmitter. The resistors in the cathode of V201 are bypassed to ground for the r-f signal by capacitor C213.

c. The plate load of tube V201 consists of coil T202 tuned to resonance at the received signal frequency by tuning capacitor C201B and trimmer C209. Only one winding of T202 is shown in figure 24, the other winding is used when tuning the l-f band. Tuning capacitor C201B is a part of a three-section variable capacitor which includes capacitor C201A in the grid circuit of the r-f amplifier and capacitor C201C in the h-f oscillator circuit.

d. Resistors R210 and R218 form a voltage divider across the B+ supply to drop the screen voltage on tubes V201 and V203 to approximately 100 volts. The screen is bypassed to ground for r-f signals by capacitor C219B. The amplified r-f output of V201 is applied through silver-mica coupling capacitor C210 to the signal grid of the following converter stage.

60. CONVERTER (fig. 25).

a. The converter stage uses a Tube JAN-6SA7 (V202) for frequency conversion. V202 is a pentagrid converter tube combining an h-f oscillator and a mixer in a single envelope. The h-f oscillator is of the cathode feedback type and uses the first two grids and the cathode of V202. Only half of transformer T206 is shown in figure 25; the other windings are used for the l-f band.

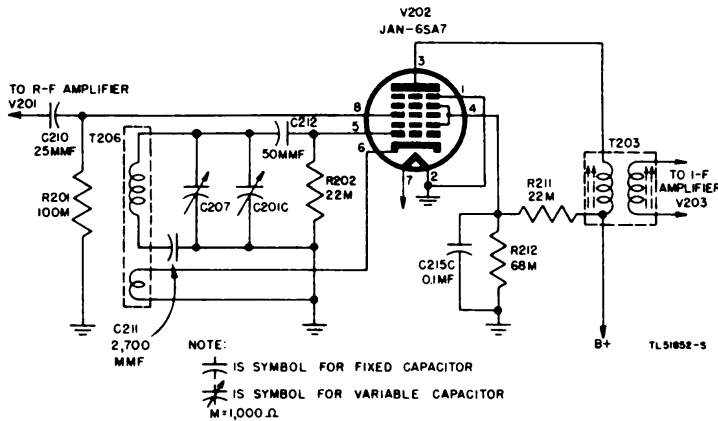

Figure 25. Converter V202, simplified diagram.

b. The resonant circuit in the oscillator grid of V202 is formed by one coil of T206 which is tuned by tuning capacitor C201C, trimmer C207, and padder C211. The tuning capacitor is ganged to capacitors C201A and C201B in the grid and plate circuits, respectively, of V201. The r-f energy in the resonant circuit is applied to the grid of the oscillator section of V202 through coupling capacitor C212. A portion of the energy in the cathode circuit is fed back through a second coil in the correct phase to sustain oscillations. Grid 2, the acting oscillator plate, obtains its positive potential from the voltage divider circuit consisting of R211 and R212 connected across the B+ supply. The acting plate is bypassed to ground for radio frequency by capacitor C215C. Resistor R202 is the grid return resistor for the oscillator grid.

c. The h-f oscillator is tuned by C201C so that it is always 454 kc above the incoming signal frequency. Thus when the received signal from the r-f amplifier is applied to grid 3 of V202, the two frequencies will beat together forming a sum and a difference frequency. The tuned primary of i-f transformer T203 in the plate of the mixer section is resonant at the difference frequency of 454 kc and therefore provides maximum amplifi-

cation at this frequency. Both the primary and secondary windings of the i-f transformer are shunted by fixed capacitors and are tuned to resonance by adjustable powdered iron cores inserted in the coils. Resistor R201 is the grid return resistor for the grid of the mixer section of tube V202.

61. INTERMEDIATE-FREQUENCY AMPLIFIER (fig. 26).

a. The single i-f amplifier stage uses a Tube JAN-6SK7 (V203) in a fixed-frequency amplifier stage. The 454-kc signal induced in the tuned secondary of T203 is applied to the grid (pin 4) of V203. The cathode of V203 is grounded through resistor R205 and VOLUME control resistor R206 previously described for the r-f amplifier stage (par. 59). The variable bias developed across R206 serves to control the gain of this stage simultaneously with the gain of the r-f amplifier stage.

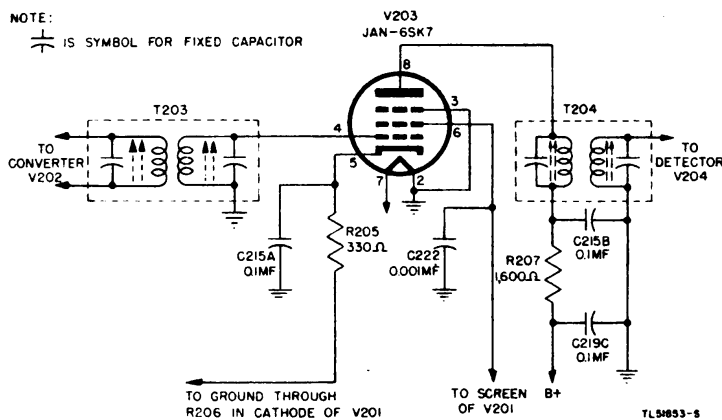

Figure 26. I-f amplifier V203, simplified diagram.

b. The primary of i-f transformer T204 in the plate circuit of V203 is also tuned to resonance at 454 kc and therefore provides maximum stage gain at the intermediate frequency. Both the primary and secondary windings of T204 are shunted by fixed capacitors and are tuned to resonance by adjustable powdered iron cores inserted in the coils. Resistor R207 and capacitors C215 and C219C form a decoupling network which prevents intermediate frequencies from entering the power circuits.

c. The screen supply for tube V203 is obtained from the same voltage divider R210 and R218 used for the screen of r-f amplifier tube V201. An additional screen-bypass capacitor C222 is provided between the screen and ground.

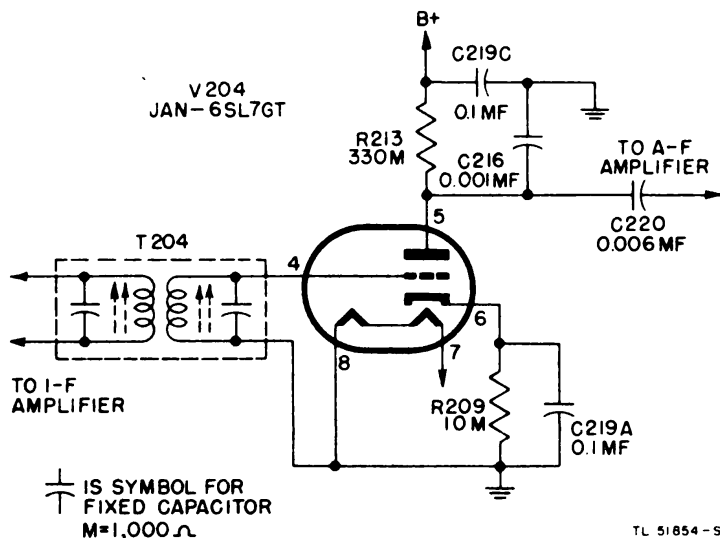

Figure 27. Detector V204, simplified diagram.

62. DETECTOR (fig. 27).

a. The detector stage uses one section of Tube JAN-6SL7GT (V204), a double-triode tube, in a plate, or bias detector circuit. The other section of the double triode is used as the BFO tube (par. 65).

b. The detector section of V204 (fig. 27) is self-biased nearly to cut-off by the voltage drop developed across 10,000-ohm resistor R209 in the cathode circuit. Thus the i-f output of transformer T204 applied to the grid of the plate detector is rectified, producing an average current fluctuation in the detector plate load proportional to the audio modulation. The rectified i-f component in the plate circuit of the detector is bypassed to ground through capacitor C216 which also functions to improve the a-f (audio-frequency) response of the receiver. The demodulated signal voltage is applied through coupling capacitor C220 to the following audio-amplifier stage. Capacitor C219A bypasses the cathode resistor for the i-f and a-f signal voltages.

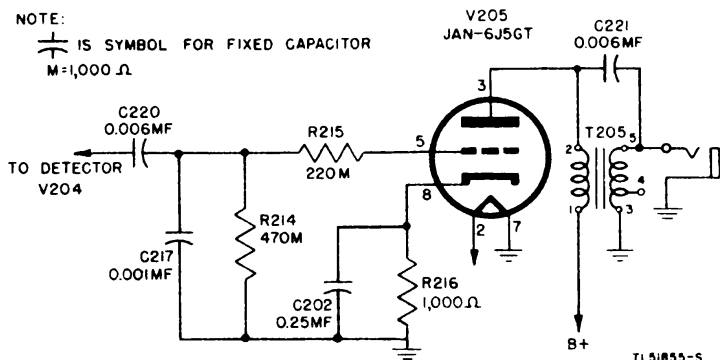

Figure 28. Audio amplifier V205, simplified diagram.

63. AUDIO AMPLIFIER (fig. 28).

a. The audio-output stage uses a Tube JAN-6J5GT (V205) as a triode output amplifier which may be transformed into a keyed audio oscillator during transmission, to monitor the keying (par. 64). The circuit is shown in figure 28 as an audio amplifier.

b. The detected audio signal from V204 is applied through coupling capacitor C220 and resistor R215 to the grid of V205. Grid return resistor R214 is shunted by capacitor C217 to bypass the h-f components of the audio band, resulting in reduced noise in the receiver output. V205 is self-biased by cathode resistor R216 and capacitor C202, producing Class A operation. The plate load of audio amplifier V205 is the audio-output transformer T205 which provides a 10,000-ohm output impedance. The secondary winding of T205 is also tapped to provide a 250-ohm output if required. Capacitor C221 is connected across the primary and secondary of T205 to improve the wide-band a-f response and to improve the operation of the circuit as an audio oscillator.

c. Headset HS-30-U, included with the radio set, is a low-impedance device equipped with a built-in transformer resulting in a 10,000-ohm input impedance which matches the output impedance of the audio-amplifier stage.

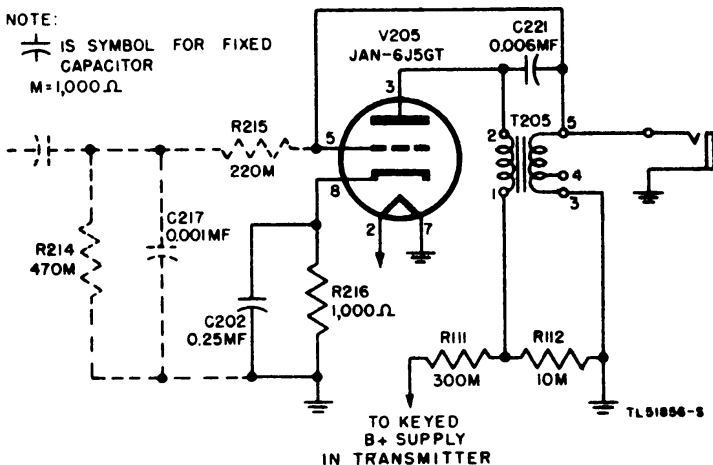

Figure 29. Audio oscillator V205, simplified diagram.

64. AUDIO OSCILLATOR (fig. 29).

a. In order to monitor the keying of the transmitter, the audio amplifier is converted into an audio oscillator when the STANDBY, RECEIVE, TRANSMIT switch is in the TRANSMIT position. The oscillator circuit is shown in figure 29.

b. When connected as an audio oscillator, the output from the secondary of T205 is fed back to the grid of V205, resulting in sufficient feedback to sustain oscillations. The secondary winding of T205 is also connected to the output PHONE jack for headset monitoring.

c. Resistors R111 and R112, connected across the keyed 600-volt supply, drop the plate voltage applied to the audio oscillator to approximately 13 volts to provide an output signal that will not overload the headset.

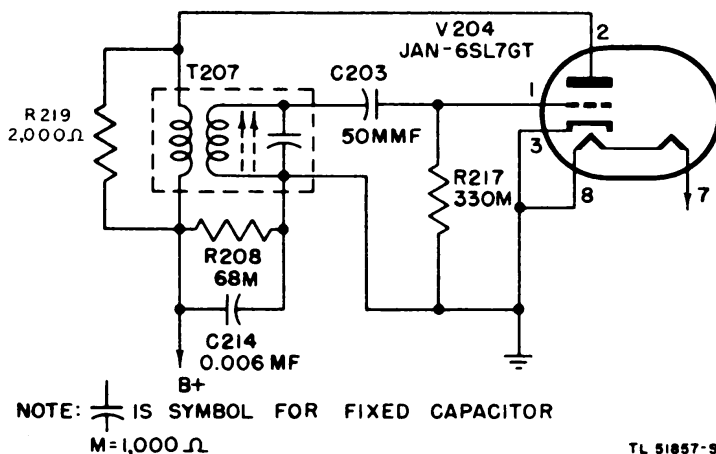

Figure 30. Beat-frequency oscillator V204, simplified diagram.

65. BEAT-FREQUENCY OSCILLATOR (fig. 30).

a. The BFO is a circuit designed to produce a signal which when beat against the amplified c-w i-f signal produces an audible note in the headset. This will enable the operator to hear c-w signals. The BFO utilizes the other section of double-triode Tube JAN-6SL7GT (V204), one section of which was used in the detector circuit (par. 62).

b. The BFO is a conventional oscillator with a tuned circuit in the grid consisting of one winding of T207 shunted by a fixed capacitor and tuned to resonance by an adjustable, powdered iron core inserted in the coil. Feedback from the plate circuit through the untuned primary of T207 has the proper phase and amplitude to sustain oscillations. Resistor R219 is shunted across the feedback coil to reduce the amount of feedback voltage applied to the grid. Resistor R108 in the transmitter section and resistor R208 form a voltage divider to drop the plate voltage for the BFO to approximately 40 volts. Capacitor C214 in conjunction with R108 serves as a decoupling network to prevent the BFO signal from getting back into the power circuits.

AUDIO AMPLIFIER

V205
JAN-6J5GT

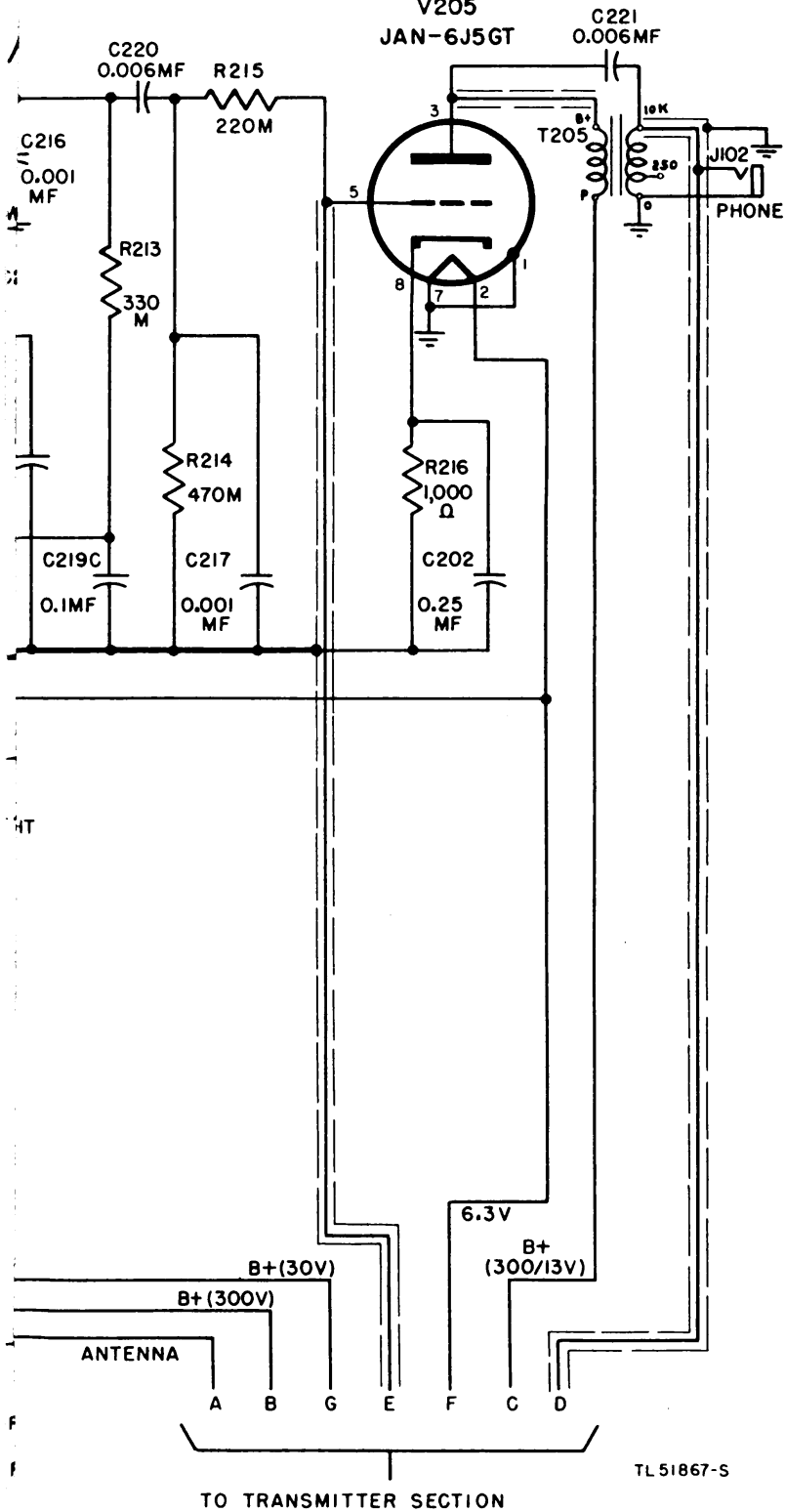

tubes, serve with capacitors C110 and C111 as a pi-section filter to provide additional filtering to the receiver plate voltage supply.

(2) With the CAL, CW, PHONE switch SW105 in the CAL or CW position, the plate voltage is further dropped by resistor R108 to supply a lower voltage for operation of the BFO stage. With switch SW105 in the PHONE position, no voltage is applied to the BFO circuit.

(3) With switch SW103 in the TRANSMIT position, plate voltage for the audio-amplifier stage which now functions as an audio oscillator is obtained through contacts 1 and 2 of keying relay K101 through either the CW or PHONE position of switch SW105. This voltage is developed across resistor R112 of voltage divider R111 and R112, and is applied through a second TRANSMIT contact of switch SW103. In this way a keyed low-voltage plate supply is connected to the audio oscillator in the receiver section during transmission.

b. Filament voltage from the power supply is connected through pins 4 and 5 of power connector P101 direct to the filament of all receiver tubes.

SECTION XI. THEORY OF TRANSMITTER SECTION

67. GENERAL.

The transmitter section of Receiver-Transmitter RT-46/TRC-10 consists of a crystal-controlled m-o (master-oscillator) stage and a p-a (power-amplifier) stage. The frequency range of the transmitter is from 2.0 to 12.0 mc. There is no provision for voice modulation of the carrier frequency as the transmitter is designed only for c-w operation. When receiving, the plate voltage is removed from the transmitter section and the common antenna is transferred to the receiver section.

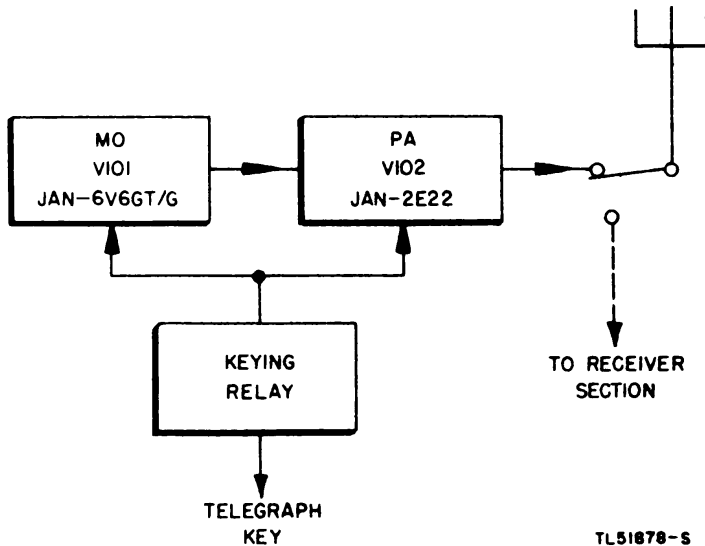

Figure 33. Transmitter section, block diagram.

68. BLOCK DIAGRAM OF TRANSMITTER SECTION.

The crystal-controlled master oscillator (fig. 33) establishes the r-f signal frequency on which the transmitter operates. This signal is fed to the p-a stage where the signal is amplified and is then applied through the antenna switch to the antenna. A keying relay is provided under control of a telegraph key inserted in the KEY jack on the receiver-transmitter front panel. When operated, this relay applies plate and screen voltage to the oscillator stage, and applies screen voltage to the power amplifier. Therefore, operation of the telegraph key causes the transmitter to function and the c-w carrier to be radiated.

69. MASTER OSCILLATOR.

The m-o circuit consists of Tube JAN-6V6GT/G (V101), a beam-power tetrode whose oscillating frequency is determined by crystal Y101 in the grid circuit. The crystal is provided with

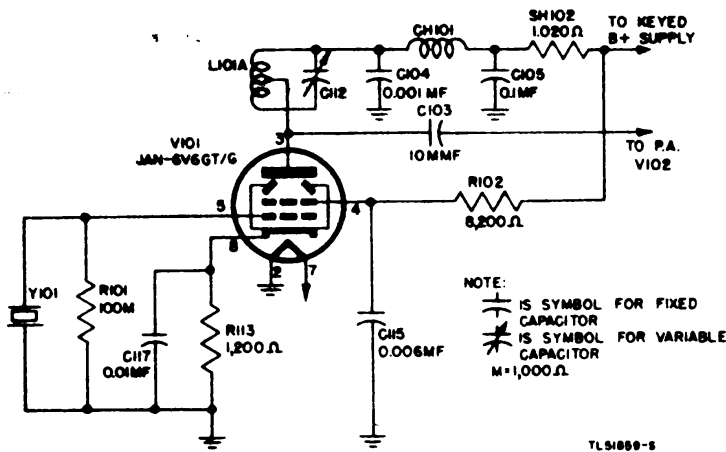

Figure 34. Master oscillator, l-f band, simplified diagram.

a plug-in base and socket, and sufficient crystals are provided with the radio set to cover the specified frequency band. The plate coils are provided, one for covering the l-f band, and one for covering the h-f band. As the circuit arrangements for the two bands are slightly different, both circuits will be explained.

a. Low-frequency Band Operation (fig. 34).

(1) When the TRANSMIT BAND SWITCH is in the l-f position, one terminal of crystal Y101 is grounded and the low-potential side of plate coil L101A is bypassed to ground through capacitor C104. With L101A tuned slightly above the resonant frequency by C112, a high voltage at the crystal frequency is developed across the tuned plate circuits. A portion of this voltage is applied back to the grid through the grid-plate capacitance of the tube. This voltage is in the correct phase to sustain oscillations.

(2) It is necessary that the resonant frequency of the plate circuit be slightly higher than the crystal frequency to produce oscillations. By decreasing the value of C112, the resonant frequency of the plate circuit is increased, therefore, the impedance offered to the crystal-frequency voltage is reduced and oscillations become weaker. As the resonant frequency is further increased, oscillations will cease as there will be insufficient voltage applied back to the grid. The l-f oscillator circuit is therefore suitable only for operation at the fundamental frequency of the crystal.

(3) Cathode resistor R113 develops sufficient bias to limit the plate current flow, and thereby protects the tube if oscillations cease. Resistor R113 is bypassed for radio frequency by capacitor C117. Resistor R101, across the crystal, serves as a

grid return resistor for the oscillator and develops additional self-bias when the circuit is oscillating.

(4) The crystal-controlled r-f output of V101 is fed through coupling capacitor C103 to the following p-a circuit.

(5) When the meter is in the OSC. PLT. CUR. position the voltage developed across shunt resistor SH102 enables the operator to determine the oscillator plate current.

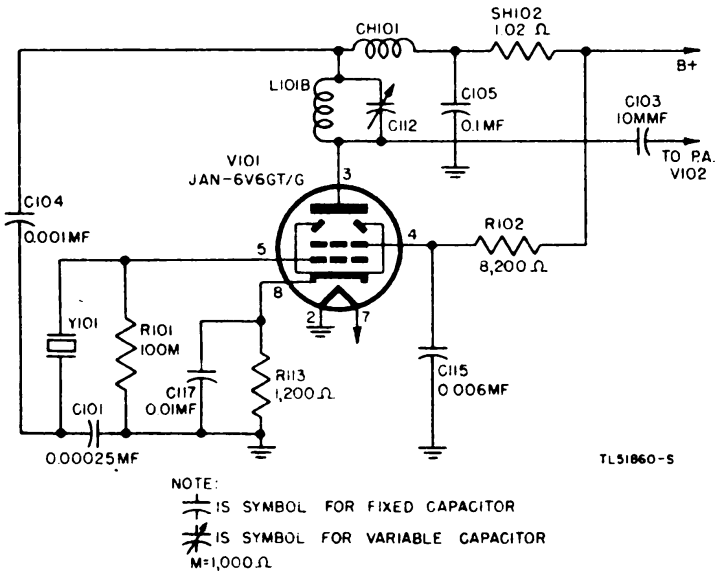

Figure 35. Master oscillator, h-f band, simplified diagram.

b. High-frequency Band Operation (fig. 35).

(1) When the TRANSMIT BAND SWITCH is in the h-f position, crystal Y101 and capacitor C104 are no longer connected direct to ground but are connected to ground through capacitor C101 (fig. 35). Thus the plate circuit conditions are modified and the plate load now consists of tuned circuit L101B and C112 in addition to r-f choke CH101.

(2) The r-f feedback voltage is now developed across choke CH101, and the amount applied to the grid circuit is controlled by capacitors C101 and C104. By properly selecting the value of these capacitors, sufficient feedback may be obtained to sustain oscillations over the frequency range of the transmitter. Since the grid-plate capacitance of the tube is no longer the factor controlling oscillations, the impedance of the tuned circuit is not critical, and L101B and C112 may be tuned either to the fundamental crystal frequency or to a higher harmonic without materially affecting the efficiency of the tube as an oscillator.

(3) The remainder of the oscillator circuit functions in a manner similar to that previously described for the l-f band.

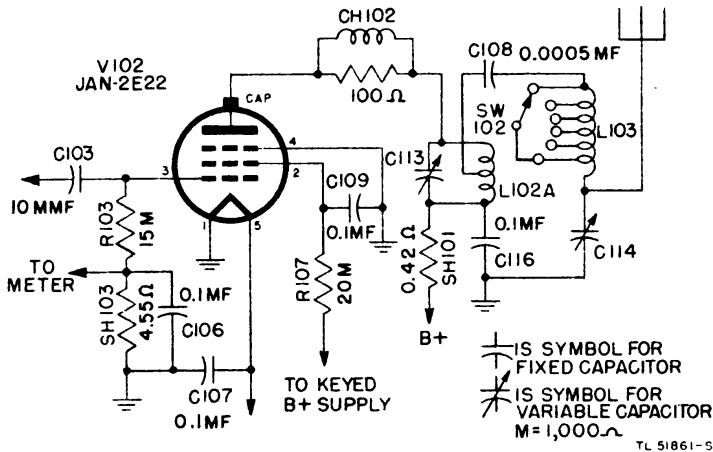

Figure 36. Power amplifier V102, simplified diagram.

70. POWER AMPLIFIER (fig. 36).

a. The p-a circuit consists of Tube JAN-2E22 (V102), a filament-type pentode power amplifier. The r-f output of the crystal-controlled master oscillator is applied to the grid of V102 through coupling capacitor C103. Since the grid and filament of tube V102 are initially at the same potential, the positive half cycles of the r-f voltage are rectified, producing a d-c voltage across grid return resistor R103 and shunt resistor SH103. The d-c voltage serves as an operating bias, and since it will be a maximum when the plate circuit of the master oscillator is tuned to resonance, it can also be used to indicate proper tuning of the master oscillator. The d-c voltage across shunt resistor SH103 is applied to the panel meter to indicate resonance of the master oscillator when the METER SWITCH is in the AMP. GRID CUR. position. Capacitor C106 bypasses the meter circuit for r-f.

b. The plate-tank circuit of the power amplifier consists of coil L102A tuned by capacitor C113 (l-f band) or coil L102B tuned by capacitor C113 (h-f band). When the tank circuit is tuned to resonance, the plate current through the amplifier tube will be a minimum. Shunt resistor SH101 is provided in the B+ lead across which the meter is connected with the METER SWITCH in the AMP. PLT. CUR. position.

c. The r-f output from the plate-tank circuit is coupled through capacitor C108 to the antenna matching network consisting of tapped coil L103 and variable capacitor C114 (fig. 36). By adjusting TRANS. ANT. TAP SWITCH SW102 and the variable capacitor, the antenna impedance may be matched to

the output impedance of the oscillator for maximum transfer of energy.

d. Resistor R107 is the screen-dropping resistor and capacitor C109 is the screen bypass capacitor. Choke CH102 wound about a 100-ohm resistor serves to prevent parasitic oscillations in the oscillator plate circuit.

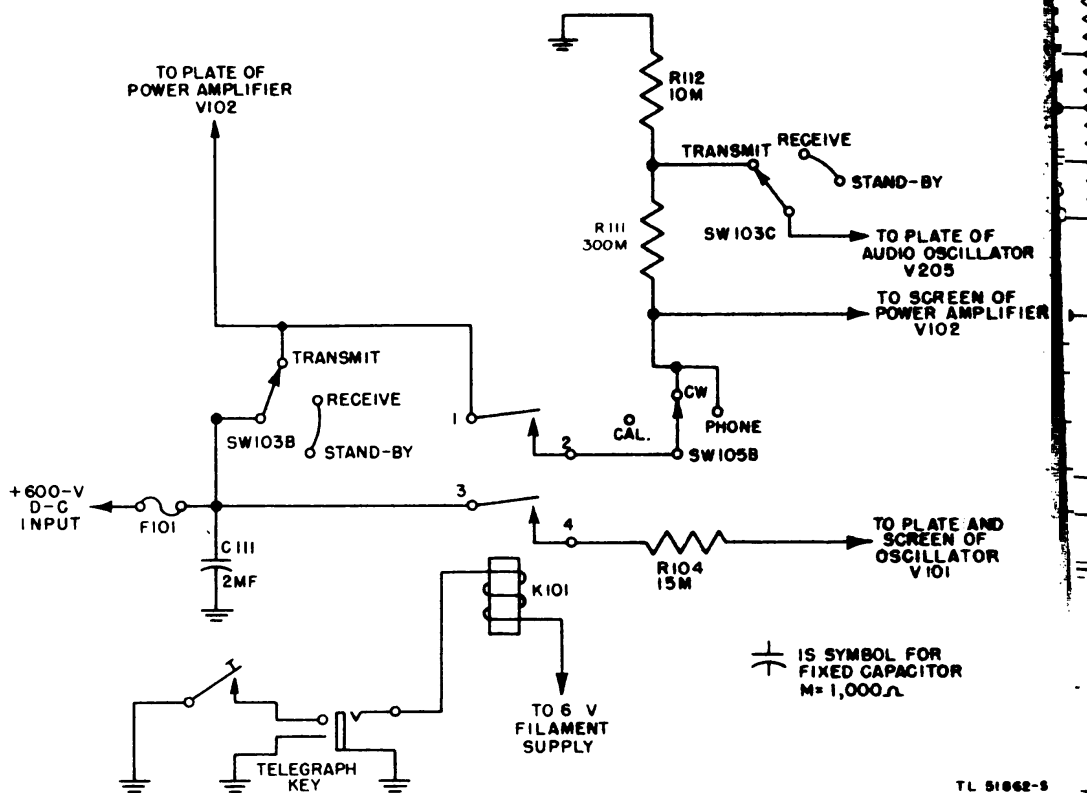

Figure 37. Transmitter keying circuit.

71. TRANSMITTER KEYING CIRCUIT.

The transmitter keying relay circuit is shown in figure 37. When the telegraph key inserted in the KEY jack is operated, the 6-volt winding of relay K101 is energized and the two relay contacts are closed. These contacts connect +600 volts direct current from the power supply through fuse F101 to the following circuits:

a. Contacts 3 and 4 of relay K101 connect the B+ through resistor R104 to the plate and screen grid of the crystal-controlled master oscillator in the transmitter.

b. The +600 volts is applied to contacts 1 and 2 of relay K101 through the TRANSMIT position of switch SW103B (fig. 37) and thus to the rotor of switch SW105B. With switch SW105

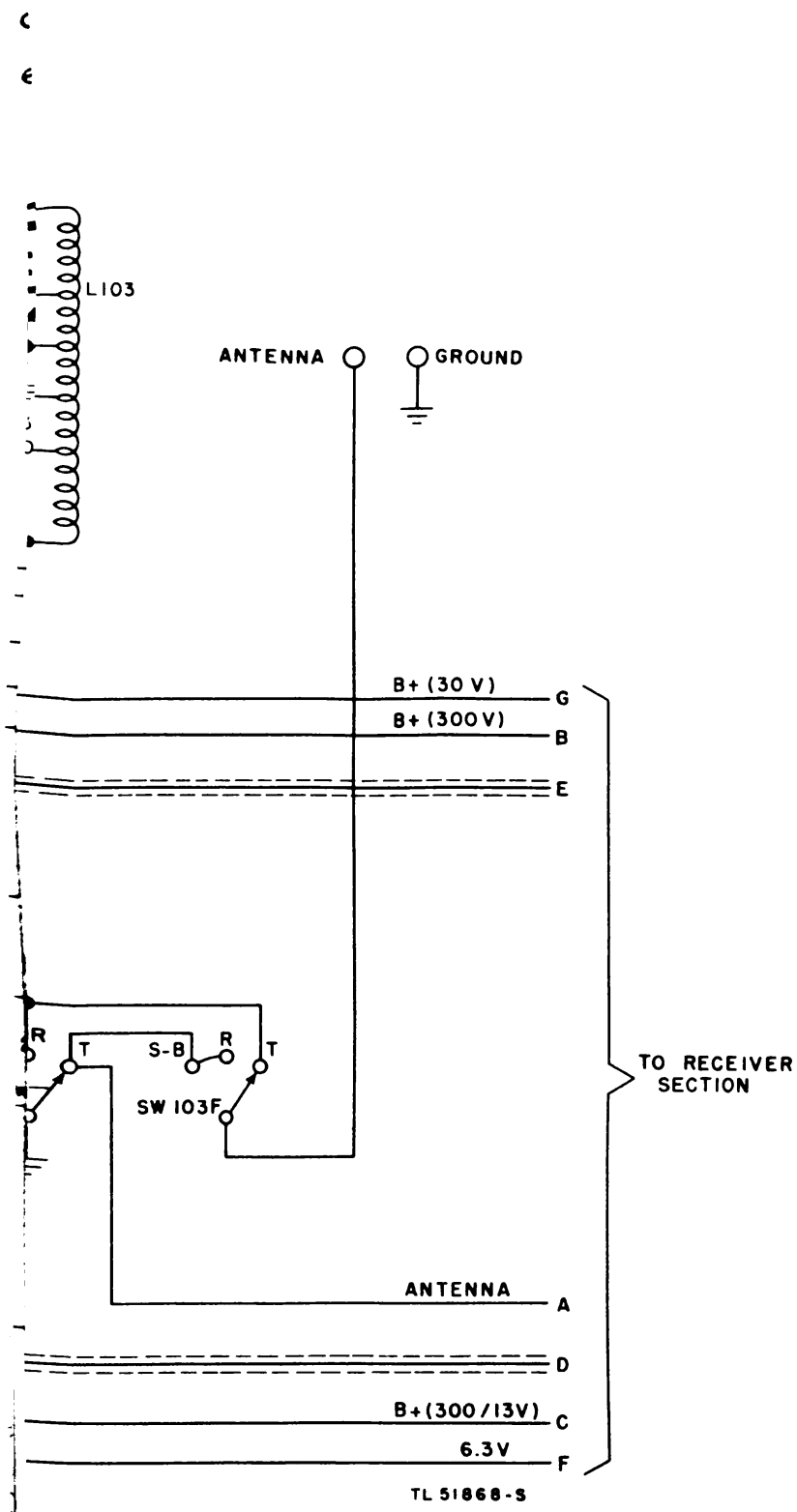

TL 51868-S

in the CW or PHONE position, the +600 volts is applied direct to the screen circuit of the p-a tube and to a voltage divider circuit consisting of R111 and R112.

c. When switch SW103C is in the TRANSMIT position, approximately 13 volts from the voltage divider is applied to the plate circuit of audio oscillator tube V205 in the receiver section. Thus when the telegraph key is operated, the transmitter circuits are energized and the audio oscillator in the receiver is energized, producing a monitoring keying tone in the headset.

SECTION XII. THEORY OF RECTIFIER POWER UNIT PP-74/TRC-10

72. GENERAL.

Three power units are included with the radio set: A rectifier power unit for operation from a 115- to 250-volt, 50- to 60-cycle power source; a vibrator power unit for operation from a 6-volt d-c power source; and a hand generator for manual operation. Rectifier Power Unit PP-74/TRC-10 is designed to convert a 115- to 250-volts, 50- to 60-cycle power source to approximately 650 volts direct current and 6.3 volts alternating current for operation of the receiver-transmitter unit. The input power and d-c output voltage for the different receive-transmit conditions of Receiver-Transmitter RT-46/TRC-10 are shown below.

Condition	A-c input (volts)	Input (watts)	*D-c output (volts)
Receive (min gain)	115.0	71.0	655
Receive (max gain)	115.0	75.0	640
Transmit (key up)	115.0	61.0	825
Transmit (key down)	115.0	160.0	515

* Measured on receiver-transmitter panel meter.

73. RECTIFIER CIRCUIT.

a. The rectifier circuit (fig. 39) uses a Tube JAN-5R4GY (V401) in a conventional full-wave rectifier circuit. One side

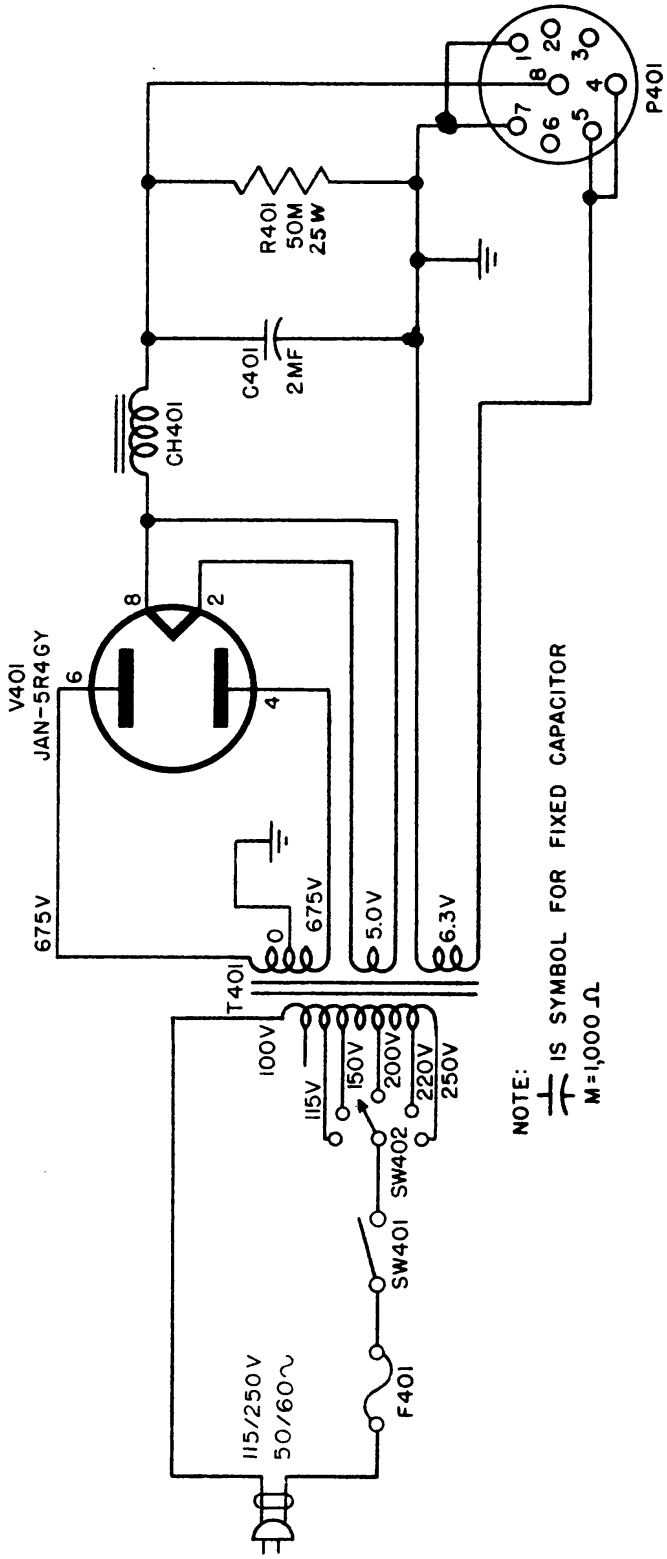

TL51863-S

NOTE:
 IS SYMBOL FOR FIXED CAPACITOR
 M=1,000 Ω

Figure 39. Rectifier Power Unit PP-74/TRC-10, schematic diagram.

of the input line is connected directly to the primary winding of power transformer T401, while the other side of the line is brought in through fuse F401 and OFF-ON switch SD401 to the rotor of ADJUST TO LINE VOLTAGE switch SW402. This switch is a five-position rotary switch whose five contacts are connected to taps on the primary of the power transformer. The switch should be set at the position corresponding nearest to the value of the line voltage.

b. The high-voltage secondary winding of T401 is connected to the two plates of V401 with the center tap grounded. The heater of V401 is energized by a 5-volt heater winding on transformer T401.

c. The rectified output from the heater circuit of V401 is applied through choke CH401 to pin 8 of socket P401 and through the connecting cable to the receiver-transmitter. Choke CH401 and capacitor C401 form a choke input filter to smooth the rectified direct current. Additional filtering is obtained in the receiver-transmitter unit. Resistor R401 across the d-c output serves as a bleeder to discharge the filter capacitor when the power supply is turned off, and to provide a load when the power supply is not connected to the receiver-transmitter, thereby keeping the no-load output voltage from rising excessively.

d. A third secondary winding on transformer T401 provides 6.3 volts alternating current for operation of the tube filaments in the receiver-transmitter. One side of the filament supply is grounded, the other side is connected to pins 4 and 5 on output socket P401.

SECTION XIII. THEORY OF VIBRATOR POWER UNIT PP-84/TRC-10

74. GENERAL.

Vibrator Power Unit PP-84/TRC-10 is designed to convert a 6-volt d-c power source into approximately 550 volts direct current for operation of the receiver-transmitter unit. The vibrator unit consists of a vibrator, a power transformer, and a vacuum-tube rectifier. The input power and d-c output voltage for the

different receive-transmit conditions of Receiver-Transmitter RT-46/TRC-10 are shown below.

Condition	D-c input (volts)	D-c input (amp)	Calculated input (watts)	*D-c output (volts)
Receive (min gain)	6.2	9.0	56.0	550
Receive (max gain)	6.2	10.0	62.0	550
Transmit (key up)	6.2	7.5	46.5	670
Transmit (key down)	6.2	19.0	118.0	400

* Measured on receiver-transmitter panel meter.

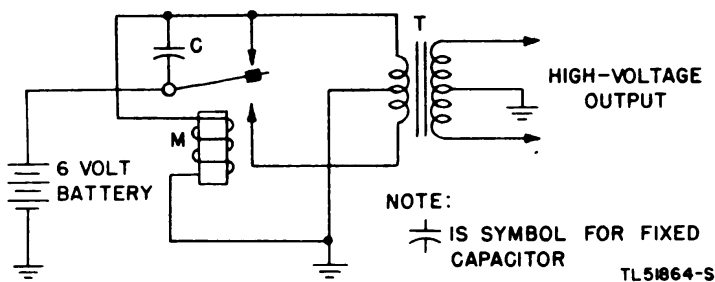

Figure 40. Vibrator simplified diagram.

75. VIBRATOR CIRCUIT.

The vibrator circuit (fig. 40) changes the direct current delivered by the battery into 120 cycles alternating current that can be stepped up by the power transformer and rectified in the normal manner. A vibrating reed is provided with contacts connected in such a manner that the battery voltage is first applied across half of the primary winding of transformer T, and then in the opposite direction across the other half of the winding. This induces an alternating voltage in the secondary of transformer T. The value of this alternating voltage is determined by the battery voltage and by the transformer ratio. The reed is kept in vibration at its frequency of mechanical resonance by magnet M (fig. 40) the magnet is so arranged that when the reed is drawn to the magnet, the magnet is no longer energized and the reed is allowed to spring back. Capacitor C is connected across the contacts of the vibrator to minimize sparking.

76. VIBRATOR SUPPLY CIRCUIT.

a. The complete schematic diagram of the vibrator supply is shown in figure 41. The vibrator unit includes a capacitor across the points and is equipped with multiple contacts to carry the heavy primary current. The negative battery lead is grounded

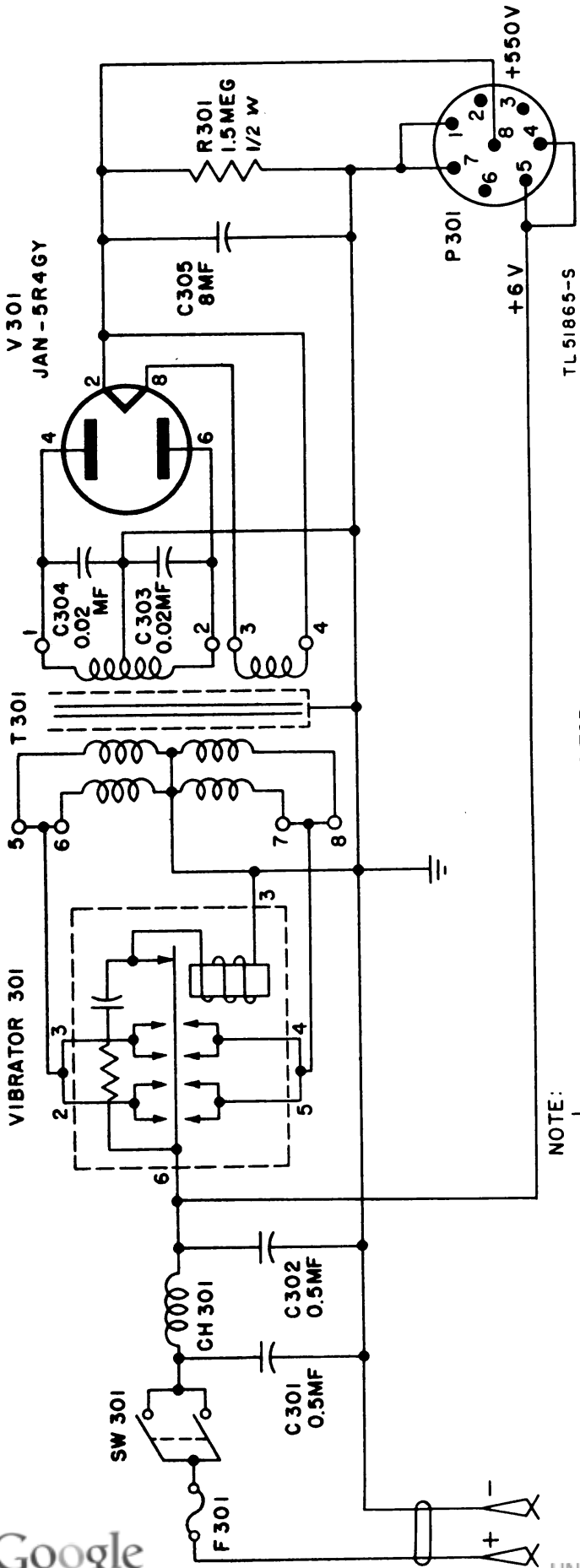

Figure 41. Vibrator Power Unit PP-84/TRC-10, schematic diagram.

in the unit and the positive voltage is applied through fuse F301, OFF-ON switch SW301, and choke CH301 to the vibrator reed. Choke CH301 and capacitors C301 and C302 form a pi-section filter to prevent noise developed by the vibrator contacts from going out over the power cable to the receiver. A 6-volt filament lead is connected to one side of the choke, and is connected to pins 4 and 5 of power connector P301.

b. A Tube JAN-5R4GY (V301) is used in a conventional full-wave rectifier circuit to supply approximately 550 volts direct current to the receiver-transmitter through pin 8 of power connector P301. Buffer capacitors C303 and C304 across the secondary windings of transformer T301 are essential to control transient voltages and to prevent radio interference.

c. Capacitor C305, an 8-mf (microfarad) electrolytic, provides a degree of filtering to the output voltage. Additional filtering is provided in the receiver-transmitter unit. Resistor R301 serves as a bleeder to discharge the filter capacitor when the vibrator unit is turned off.

SECTION XIV

THEORY OF HAND GENERATOR G-4/TRC-10

77. GENERAL.

The hand generator is a dual-voltage unit driven through a step-up gear train from a pair of hand cranks. A voltage regulator circuit inside the generator housing keeps the generated voltage constant. Filters are provided to eliminate commutator ripple and r-f interference in both the 500-volt and 6-volt d-c circuits. When used, the hand generator may be connected directly to the receiver-transmitter by means of Cord CX-83/TRC-10.

78. CIRCUIT ANALYSIS.

a. The generator consists of an armature having two independent windings connected in series (fig. 42). The low-voltage winding provides 6 volts direct current, and the high-voltage winding provides approximately 500 volts direct current. The armature rotates between the two field coils shown in the circuit diagram. The field coils are in series with a 3-ohm resistor and are connected across the low-voltage armature.

b. A voltage regulator relay is also connected across the low-voltage supply in series with a 25-ohm resistor and a 15-ohm

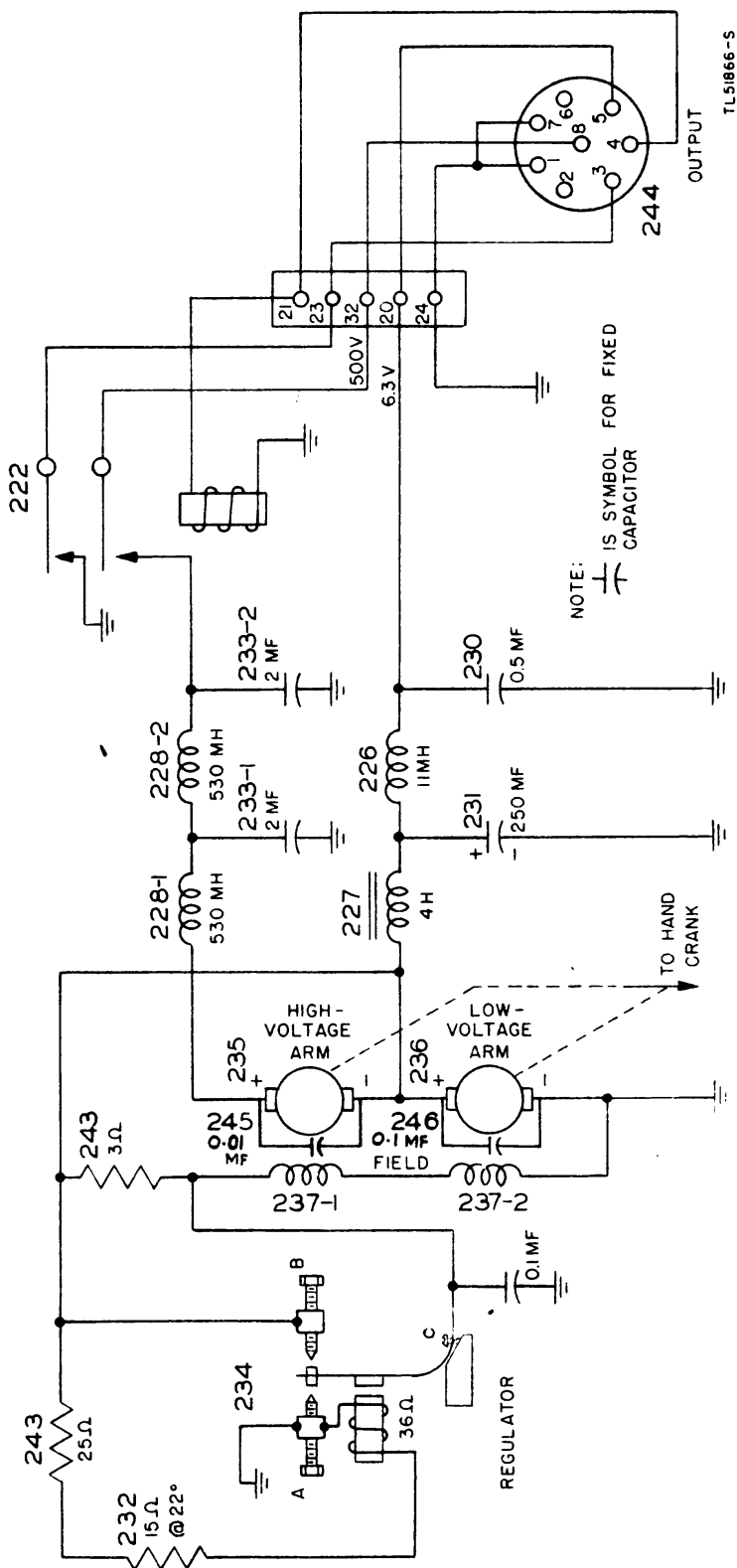

Figure 42. Hand Generator G-4/TRC-10, schematic diagram.

temperature-compensated resistor. The voltage regulator circuit operates on the voltage applied to the field to maintain a constant output in the following manner:

(1) When the armature is rotated the low-voltage output operates the regulator relay pulling the vibrator reed over against the ground contact, thereby short circuiting the generator field.

(2) With the field short-circuited, the generator output voltage drops, thereby releasing the vibrator which springs back against the opposite contact. In this position the 3-ohm resistor in the generator field circuit is shorted, thereby increasing the field current and consequently the output voltage.

(3) In operation the above sequence is repeated so rapidly that the field voltage never actually falls to zero but is regulated at a value between zero and the value obtained with the 3-ohm resistor shorted. If the low-voltage output increases, the vibrator reed is pulled harder against the ground contact, thereby reducing the field voltage, and consequently the output voltage. If the low-voltage output decreases, the reverse is true.

(4) The tension of the vibrator spring is adjusted by screw C (fig. 42) to obtain the required output voltage. Since both the high- and low-voltage armature windings revolve in the same field, controlling the voltage on the low-voltage commutator also maintains the voltage constant on the high-voltage commutator.

(5) The 25-ohm resistor in series with the regulator coil establishes the approximate operating point of the voltage regulator. The 15-ohm series resistor is a temperature compensating resistor to offset the effect of temperature on the resistance of the regulator coil. The 0.1-mf capacitor is connected from the vibrator to ground to absorb the spark at the regulator contacts and to suppress part of the r-f interference produced by the spark.

c. The high-voltage output is filtered by two 2-mf capacitors connected to ground, and r-f interference from the commutator is removed by the combination of 350-mh (millihenry) chokes and 2-mf capacitors. The filtered output voltage is applied through a contact of the protective relay (fig. 42) to pin 8 on the power-output connector. The protective relay coil is connected between ground and pin 4 of the output connector and is energized, when the armature is turned, only if the connecting cable to the receiver-transmitter is in place. When in place, pins 4 and 5 are connected at the receiver-transmitter. In this

way the +500-volt output is present at the output socket only if the cable is in place.

d. The output of the 6-volt commutator is filtered for ripple by the 4-h choke and 250-mf capacitor (fig. 42), and for r-f interference by the 11-mh choke and 0.5-mf capacitor. The 6-volt filament output is applied through pin 5 to the power cable.

SECTION XV. TROUBLE SHOOTING

79. TROUBLE-SHOOTING DATA.

Use the material listed below to help in the rapid location of faults.

- a. Block diagram of the receiver (fig. 23).
- b. Block diagram of the transmitter (fig. 33).
- c. Complete schematic diagrams (figs. 32 and 38).
- d. Simplified and partial schematic diagrams. These diagrams are particularly useful in trouble shooting as the circuits can be followed more clearly on the regular schematics, thus speeding trouble location.
- e. Voltage and resistor data at all socket connections (pars. 90, 91, 92 and 93).
- f. Illustrations of components. Front, top, and bottom views aid in locating and identifying parts.
- g. Pin connections. Pin connections on sockets, plugs, and receptacles are numbered or lettered on the various diagrams.

(1) Seen from the bottom, pin connections are numbered in a clockwise direction around the sockets. On octal sockets the first pin clockwise from the keyway is pin No. 1. Pin numbers appear on the schematic diagrams so that any tube element can be readily located.

(2) Plugs and receptacles are numbered on the side to which the associated connector is attached. To avoid confusion, some individual pins are identified by letters which appear directly on the connector.

80. TROUBLE-SHOOTING STEPS.

The first step in servicing a defective radio set is to sectionalize the fault. The second step is to localize the fault. Some faults, such as burned-out resistors, r-f arcing, and shorted transformers can be located by sight, smell, and hearing. The majority of faults, however, must be located by checking voltages and resistances.

a. Sectionalization. Sectionalization is the tracing of a fault to the component or circuit responsible for the abnormal operation of the set. By carefully observing the performance of the receiver and transmitter when the equipment is on, the fault is often sectionalized immediately as a transmitter or receiver fault. A careful observation of the meters on the receiver-transmitter front panel often determines which stage or circuit in the transmitter is at fault. Additional sectionalizing of the fault is discussed in paragraphs 86 and 88.

b. Localization. Localization is the tracing of the fault to a particular part. Paragraphs 87 and 89 of this section describe the method of localizing faults within the individual components. These paragraphs are accompanied by trouble-shooting charts which list trouble symptoms and their probable causes. The charts also give the procedure for finding out which of the probable locations of the fault is the exact one. In addition, charts are included which show the resistance and the voltage values at every socket pin connection.

c. Voltage Measurements. Voltage measurements are an almost indispensable aid to the repairman, because most troubles either result from abnormal voltages or produce abnormal voltages. Voltage measurements are made easily because they are always made between two points in a circuit and the circuit need not be interrupted.

(1) Unless otherwise specified, voltages listed in the voltage charts are measured between the indicated points and ground.

(2) Always begin by setting the voltmeter on the highest range, so that the voltmeter will not be damaged. Then, if it is necessary to obtain increased accuracy, set the voltmeter to a lower range.

(3) In checking cathode voltage, remember that a reading can be obtained when the cathode resistor is actually open. The resistance of the meter may act as a cathode resistor. Thus, the cathode voltage may be approximately normal only as long as the voltmeter is connected between cathode and ground. Before the cathode voltage is measured, make a resistance check with no voltage applied to the circuit to determine if the cathode resistor is normal.

81. PRECAUTIONS AGAINST HIGH VOLTAGE.

Certain precautions must be followed when measuring voltages above a few hundred volts. High voltages are dangerous

and can be fatal. When it is necessary to measure high voltages, observe the following rules:

- a. Connect the ground lead to the voltmeter.
- b. Place one hand in your pocket. This will eliminate the possibility of making accidental contact with either ground or another part of the circuit and causing the electricity to travel from one hand to the other.
- c. If the voltage is less than 300 volts, connect the test lead to the hot terminal (which may be either positive or negative with respect to ground).
- d. If the voltage is greater than 300 volts, shut off the power, temporarily ground the terminal, remove ground from the terminal, connect the hot test lead, step away from the voltmeter, turn on the power, and note the reading on the voltmeter. Do not touch any part of the voltmeter, particularly when it is necessary to measure the voltage between two points which are both above ground.

82. VOLTMETER LOADING.

It is essential that the voltmeter resistance be at least 10 times as large as the resistance of the circuit across which the voltage is measured. If the voltmeter resistance is comparable to the circuit resistance, the voltmeter will indicate a lower voltage than the actual voltage present with the voltmeter removed from the circuit.

a. The resistance of the voltmeter on any range can always be calculated by the following simple rule: Resistance of voltmeter equals the ohms-per-volt value of the meter multiplied by the full-scale range in volts.

Example: The resistance of a 1,000-ohm-per-volt voltmeter on the 300-volt range is 300,000 ohms ($R = 1,000 \text{ ohms per volt} \times 300 \text{ volts} = 300,000 \text{ ohms}$).

b. To minimize voltmeter loading in high-resistance circuits, use the highest voltmeter range. Although only a small deflection will be obtained (possibly only 5 divisions on a 100-division scale), the accuracy of the voltage measurement will be increased. The decreased loading of the voltmeter will more than compensate for the inaccuracy which results from reading only a small deflection on the scale of the voltmeter.

c. When a voltmeter is loading a circuit, the effect can always be noted by comparing the voltage reading on two suc-

cessive ranges. If the voltage readings on the two ranges do not agree, voltmeter loading is excessive. The reading (not the deflection) on the highest range will be greater than on the lowest range. If the voltmeter is loading the circuit heavily, the deflection of the pointer will remain nearly the same when the voltmeter is shifted from one range to another.

d. The ohm-per-volt sensitivity of the voltmeter used to obtain the readings recorded on the voltage and resistance charts in this manual is printed on each chart. Use a meter having the same ohm-per-volt sensitivity, otherwise it will be necessary to consider the effects of loading.

83. TEST EQUIPMENT.

Radio Set AN/TRC-10 does not require the use of special test equipment other than that which is commonly issued and used with other equipments in the field.

84. TROUBLE-SHOOTING PROCEDURES.

The accompanying trouble-shooting charts, if properly used, simplify trouble shooting. The charts are divided into five groups.

a. The first chart (par. 85) covers sectionalizing trouble in Radio Set AN/TRC-10. This chart lists the various symptoms which may be easily recognized, and gives the probable location of the existing trouble as well as the recommended correction. This chart tells the operator whether the trouble is in the transmitter section, receiver section, power supply, or antenna. By proper use of the charts, the operator can readily recognize troubles that may occur in the components of the equipment.

b. The second chart (par. 86) covers sectionalizing trouble in the receiver section of Receiver-Transmitter RT-46/TRC-10. This chart will aid in determining which *stage* in the receiver is at fault.

c. The third chart (par. 87) is to be used to localize trouble in the receiver to an individual *part* within the faulty stage.

d. The fourth chart (par. 88) is similar to the second, except that it deals with sectionalizing trouble in the transmitter section of Receiver-Transmitter RT-46/TRC-10.

e. The fifth chart (par. 89) localizes the trouble in the transmitter to an individual *part* within the faulty stage.

85. SECTIONALIZING TROUBLE IN RADIO SET AN/TRC-10.

Symptoms	Probable trouble	Correction
<p>1. All controls in correct position for operation of receiver and transmitter sections but neither operate; meter does not read with METER SWITCH in PLT. VOLTAGE position.</p>	<p>1. Fuse F101 in receiver-transmitter blown. Fuse F301 or F401 in vibrator or rectifier power unit, respectively, blown. Safety relay in hand generator not operating properly. Poor connection between plug P101 on front of receiver-transmitter and Cord CX-83/TRC-10 to power unit. Poor connection between plug P301 on vibrator unit, plug P401 on rectifier unit, or output socket on hand generator, and Cord CX-83/TRC-10 to receiver-transmitter.</p>	<p>1. Replace defective fuse. Replace defective fuse. Clean relay contacts. Clean contacts or repair open circuit in plug or receptacle. Clean contacts or repair open circuit in cable, plug, or receptacle.</p>
<p>2. Receiver section dead; pilot lamp on receiver dial lighted; transmitter operative.</p>	<p>2. Contacts of STAND-BY, RECEIVE, TRANSMIT switch dirty or open. Defective tubes in receiver. Open connection in Headset HS-30-U or connection to PHONE jack. Major defect in receiver section.</p>	<p>2. Clean STAND-BY and RECEIVE contacts of switch SW103. Replace defective tubes. Replace defective headset, repair any open circuits. Refer to paragraphs 86 and 90.</p>

85. SECTIONALIZING TROUBLE IN RADIO SET AN/TRC-10 (contd).

Symptoms	Probable trouble	Correction
<p>3. Transmitter inoperative; receiver normal; transmitter filament lighted.</p>	<p>3. Contacts of STAND-BY, RECEIVE, TRANSMIT switch dirty or open. Contacts of CAL, CW, PHONE switch dirty or open. Keying relay K101 inoperative. Major defect in transmitter section.</p>	<p>3. Clean TRANSMIT contacts of switch SW103. Clean CW and PHONE contacts on switch SW105. Clean relay contacts. Repair any open connections. Refer to paragraphs 88 and 89. Turn switch to PHONE or CW position.</p>
<p>4. Receiver weak; transmitter apparently normal.</p>	<p>4. Antenna shielded because of poor section of location. Weak tubes. Receiver misaligned. Major trouble in receiver.</p>	<p>4. Increase antenna height or relocate (par. 14). Replace defective tubes. Align receiver (sec. XVII). Refer to paragraphs 86 and 87.</p>
<p>5. Receiver normal; transmitter meter readings not normal.</p>	<p>5. Transmitter not properly tuned. Defective transmitter. Major trouble in transmitter.</p>	<p>5. Retune transmitter (par. 22). Replace defective tubes. Refer to paragraphs 88 and 89.</p>

86. SECTIONALIZING TROUBLE IN RECEIVER SECTION.

Symptoms	Probable trouble	Correction
<p>1. Weak reception and weak signal in headset with Signal Generator I-72-() connected to antenna post; strong signal with signal generator connected to grid (pin 4) of tube V201.</p>	<p>1. Antenna stage misaligned. Antenna stage defective.</p>	<p>1. Align stage (par. 102). Refer to paragraph 87.</p>
<p>2. Weak reception; 454-kc signal from Signal Generator I-72-() fed to pin 8 (grid) of tube V202 is heard very strong in headset.</p>	<p>2. R-f amplifier tube V201. R-f amplifier stage. Poor contact at switch 201A.</p>	<p>2. Replace tube. Refer to paragraph 87. Clean switch contacts.</p>
<p>3. No reception; 454-kc signal from Signal Generator I-72-() fed to grid (pin 8) of tube V202 is heard very strong in headset.</p>	<p>3. H-f oscillator circuit. Converter tube V202.</p>	<p>3. Refer to paragraph 87. Replace tube.</p>
<p>4. Signal heard in headset when 454-kc signal from Signal Generator I-72-() is fed to grid (pin 4) of tube V203, but not when signal is fed to grid (pin 8) of V202.</p>	<p>4. Input stage to i-f amplifier. Converter tube V202. Converter stage.</p>	<p>4. Refer to paragraph 87. Replace tube. Refer to paragraph 87.</p>

86. SECTIONALIZING TROUBLE IN RECEIVER SECTION (contd).

Symptoms	Probable trouble	Correction
<p>5. Signal heard in headset when signal from Signal Generator I-72-() is fed to grid (pin 4) of V204, but not when 454-kc signal is fed to grid (pin 4) of tube V203.</p>	<p>5. I-f amplifier tube V203. I-f amplifier output stage. Input stage to detector.</p>	<p>5. Replace tube. Refer to paragraph 87. Refer to paragraph 87.</p>
<p>6. Signal heard in headset when audio signal from Signal Generator I-72-() is fed to grid (pin 5) of output tube V205, but not when fed to grid (pin 4) of tube V204.</p>	<p>6. Detector tube V204. Input stage to output tube V205.</p>	<p>6. Replace tube. Refer to paragraph 87.</p>
<p>7. Reception heard in headset with headset connected between grid (pin 5) of output tube V205 and ground, but not with headset connected to PHONE jack.</p>	<p>7. Audio amplifier tube V205. Output stage.</p>	<p>7. Replace tube. Refer to paragraph 87.</p>
<p>8. Carrier signal only heard in headset when operating on CW; no beat note.</p>	<p>8. BFO tube V204. BFO circuit.</p>	<p>8. Replace tube. Refer to paragraph 87.</p>

87. LOCALIZING TROUBLE IN RECEIVER SECTION.

Symptoms	Probable trouble	Correction
<p>1. Voltages at all pins of tube V201 normal except:</p> <p>a. No voltage on pin 8.</p> <p>b. No voltage on pin 6.</p> <p>c. Excessive voltage at pins 3 and 5. and 5.</p> <p>d. No voltage at pins 3 and 5.</p> <p>e. No voltage at pin 7.</p>	<p>a. Open switch S201B. Open winding of transformer T202. Shorted capacitor C208 or C209. Short in capacitor C201B.</p> <p>b. Open resistor R210. Shorted capacitor C219B.</p> <p>c. Open resistor R204. Open resistor R206.</p> <p>d. Shorted capacitor C213.</p> <p>e. Poor connection between Cord CX-83/TRC-10 and connecting sockets.</p>	<p>a. Replace or repair switch. Replace or repair transformer T202. Replace capacitor. Remove short in capacitor.</p> <p>b. Replace resistor. Replace capacitor.</p> <p>c. Replace resistor. Replace resistor.</p> <p>d. Replace capacitor.</p> <p>e. Clean plug connections; repair open circuits.</p>
<p>2. Voltages at all pins of tube V202 normal except:</p> <p>a. No voltage at pin 3.</p> <p>b. No voltage on pin 4.</p>	<p>a. Open primary winding on T203.</p> <p>b. Open resistor R211. Shorted capacitor C215C.</p>	<p>a. Replace transformer T203.</p> <p>b. Replace resistor. Replace capacitor C215.</p>

87. LOCALIZING TROUBLE IN RECEIVER SECTION (contd).

Symptoms	Probable trouble	Correction
<p>c. No voltage on pin 7.</p> <p>d. High positive voltage on pin 8.</p> <p>3. Voltages on all pins of tube V203 normal except:</p> <p>a. No voltage on pin 8.</p> <p>b. No voltage on pin 6.</p> <p>c. No voltage on pin 5.</p> <p>d. Excessive voltage on pin 5.</p> <p>e. No voltage on pin 7.</p> <p>4. Voltages on all pins of V204 normal except (CAL, CW, PHONE switch in CW position):</p>	<p>c. Same as 1d above.</p> <p>d. Shorted capacitor C210.</p> <p>a. Open primary winding on transformer T204. Shorted capacitor C215B. Open resistor R207.</p> <p>b. Shorted capacitor C222. Shorted capacitor C219B. Open resistor R210.</p> <p>c. Shorted capacitor C215A. Open resistor R205.</p> <p>d. Open resistor R206.</p> <p>e. Same as 1d above.</p>	<p>c. Same as 1d above.</p> <p>d. Replace capacitor.</p> <p>a. Replace transformer T204. Replace capacitor C215. Replace resistor.</p> <p>b. Replace capacitor. Replace capacitor C219. Replace resistor.</p> <p>c. Replace capacitor C215. Replace resistor.</p> <p>d. Replace resistor.</p> <p>e. Same as 1d above.</p>

87. LOCALIZING TROUBLE IN RECEIVER SECTION (contd).

Symptoms	Probable trouble	Correction
<p>a. No voltage on pin 5.</p> <p>b. No voltage on pin 6.</p> <p>c. No voltage on pin 2.</p> <p>d. No voltage on pin 7.</p>	<p>a. Open resistor R213. Shorted capacitor C216.</p> <p>b. Open resistor R209. Shorted capacitor C219A.</p> <p>c. Switch SW105 in PHONE position.</p> <p>d. Same as 1d above.</p>	<p>a. Replace resistor. Replace capacitor.</p> <p>b. Replace resistor. Replace capacitor C219.</p> <p>c. Turn switch SW105 to CW position. Replace capacitor.</p> <p>d. Same as 1d above.</p>
<p>5. Voltages at all pins of audio amplifier V205 normal except (SW103 in RE-CEIVE or STAND-BY position):</p> <p>a. No voltage at pin 3.</p> <p>b. No voltage on pin 8.</p> <p>c. High positive voltage at pin 5.</p> <p>d. No voltage on pin 2.</p>	<p>a. Open primary of transformer T205. Open switch SW103C.</p> <p>b. Open resistor R216. Shorted capacitor C202.</p> <p>c. Shorted capacitor C220.</p> <p>d. Same as 1d above.</p>	<p>a. Replace transformer. Replace or repair switch.</p> <p>b. Replace resistor. Replace capacitor.</p> <p>c. Replace capacitor.</p> <p>d. Same as 1d above.</p>

87. LOCALIZING TROUBLE IN RECEIVER SECTION (contd).

Symptoms	Probable trouble	Correction
<p>6. Voltages at all pins of audio oscillator V205 normal except (SW103 in TRANSMIT position, telegraph key closed):</p> <p>a. No voltage on pin 3.</p> <p>b. No voltage on pin 8.</p>	<p>a. Open resistor R111. Open switch SW103C. Switch SW105 in CAL position. Shorted capacitor C221. Open primary of transformer T205.</p> <p>b. Open resistor R216. Shorted capacitor C202.</p>	<p>a. Replace resistor. Replace or repair switch. Turn to CW or PHONE position. Replace capacitor. Replace transformer.</p> <p>b. Replace resistor. Replace capacitor.</p>

88. SECTIONALIZING TROUBLE IN TRANSMITTER SECTION.

Symptoms	Probable trouble	Correction
1. Transmitter inoperative; no AMP. PLT. CUR. reading; oscillator meter readings normal; receiver normal.	1. CAL, CW, PHONE switch SW105 in CAL position. Defective p-a tube V102. Defective stage. Defective antenna coupling stage.	1. Turn switch SW105 to CW or PHONE position. Replace tube. Refer to paragraph 89. Check continuity of coil L103 and contacts of switch SW102.
2. Transmitter inoperative; abnormal oscillator and amplifier meter readings; receiver normal.	2. Defective m-o tube V101. Defect in keying relay circuit. Defect in m-o stage.	2. Replace tube. Refer to paragraph 89. Refer to paragraph 89.
3. Transmitter operative; high AMP. PLT. CUR.	3. P-a stage not properly tuned. Defective p-a tube V102. Defective p-a stage.	3. Retune p-a stage. Replace tube. Refer to paragraph 89.
4. Transmitter operative; low AMP. PLT. CUR.	4. Defective p-a tube V102. Faulty power supply. Defective p-a stage.	4. Replace tube. Check PLT. VOLTAGE and repair power supply if necessary. Refer to paragraph 89.
5. Transmitter operative on only one band.	5. Switch SW101 defective. One section of coil L101 or L102 defective.	5. Clean contacts or repair switch. Check continuity of windings, and replace coil if necessary.

89. LOCALIZING TROUBLE IN TRANSMITTER SECTION.

Symptoms	Probable trouble	Correction
<p>1. Keying relay circuit inoperative.</p>	<p>1. Dirty relay contacts. Open winding of keying relay K101. Open circuit in telegraph key.</p>	<p>1. Clean contacts. Replace relay. Check continuity and repair open circuit.</p>
<p>2. No PLT. VOLTAGE reading; receiver normal.</p>	<p>2. Open resistor SH101. Open resistor R105.</p>	<p>2. Replace resistor. Replace resistor.</p>
<p>3. Voltage at all pins of tube V101 normal except:</p>	<p>a. Open coil L101A or L101B. Open contacts on switch SW101A. Open plate choke CH101. Shorted capacitor C104 (h-f band).</p>	<p>a. Repair open circuit. Repair or replace switch. Replace choke. Replace capacitor.</p>
<p>b. No voltage at pin 4.</p>	<p>b. Shorted capacitor C115.</p>	<p>b. Replace capacitor.</p>
<p>c. No filament voltage at pin 7.</p>	<p>c. Open contact in switch SW103A. Shorted capacitor C102.</p>	<p>c. Repair or replace switch. Replace capacitor.</p>
<p>d. No voltage at pin 8.</p>	<p>d. Open resistor R113. Shorted capacitor C117.</p>	<p>d. Replace resistor. Replace capacitor.</p>

89. LOCALIZING TROUBLE IN TRANSMITTER SECTION (contd).

Symptoms	Probable trouble	Correction
<p>4. Voltage at all pins of tube V102 normal except:</p> <ul style="list-style-type: none"> a. No voltage at pin 2. b. Excessive voltage at pin 3. c. No filament voltage at pin 5. d. No voltage at top cap. 	<ul style="list-style-type: none"> a. Open contact of keying relay K101. CAL, CW, PHONE switch in CAL position. Open contact of switch SW105. Open resistor R107. Shorted capacitor C1-09. b. Leaky or shorted capacitor C103. Shorted contacts 3 and 4 of switch SW104A. c. Open contact in switch SW103A. Shorted capacitor C107. d. Plate choke CH102 open. Open contact in switch SW101B. Open coil L102A or L102B. 	<ul style="list-style-type: none"> a. Repair or replace relay. Turn switch SW105 to CW or PHONE position. Repair or replace switch. Replace resistor. Replace capacitor. b. Replace capacitor. Remove short. c. Repair or replace switch. Replace capacitor. d. Replace choke. Repair or replace switch. Repair or replace coil.

90. RECEIVER SECTION VOLTAGE CHART.

The d-c voltage values given in the following charts were made with a 20,000-ohm-per-volt meter under the following conditions:

- a. STAND-BY, RECEIVE, TRANSMIT switch in the RECEIVE position.
- b. PHONE, CW, CAL switch in PHONE position.
- c. OFF-ON switch on power unit in ON position.

Tube	*Voltage to ground (volts)							
	Pin number							
	1	2	3	4	5	6	7	8
V201	0	0	63	0	63	160	6.3**	310
V202	0	0	310	100	-7.0	0	6.3**	-0.4
V203	0	0	0	0	63	160	6.3**	310
V204	-1.0	45	0	0	200	2.9	6.3**	0
V205	0	6.3**	310	0	0	0	0	9.2

*VOLUME control set at minimum gain.

**Reading may be ac or dc.

Tube	*Voltage to ground (volts)							
	Pin number							
	1	2	3	4	5	6	7	8
V201	0	0	30	0	3.0	88	6.3**	240
V202	0	0	240	80	-7.0	0	6.3**	0
V203	0	0	0	0	2.4	88	6.3**	240
V204	-0.8	35	0	0	160	2.4	6.3**	0
V205	0	6.3*	240 vdc	0	0	0	0	7.0

*VOLUME control set at minimum gain.

**Reading may be ac or dc.

91. RECEIVER SECTION RESISTANCE CHART.

The resistance values given in the following chart were measured with an ohmmeter under the following conditions:

- a. OFF-ON switch on power unit in OFF position.
- b. All receiver tubes removed from sockets.
- c. All cables disconnected.
- d. PHONE, CW, CAL switch in PHONE position.
- e. VOLUME control set at maximum gain.
- f. STAND-BY, RECEIVE, TRANSMIT switch in STAND-BY position.

Tube	Resistance to ground (ohms)							
	Pin number							
	1	2	3	4	5	6	7	8
V201	0	0	330	0	330	17,000	—	23,000
V202	0	0	23,000	30,000	22,000	0	—	100,000
V203	0	0	0	25	330	17,000	—	25,000
V204	300,000	68,000	0	25	350,000	10,000	—	0
V205	0	—	23,000	0	690,000	500,000	0	1,000

92. TRANSMITTER SECTION VOLTAGE CHART.

The d-c voltage values given in the following charts were made with a 20,000-ohm-per-volt meter under the following conditions

- a. STAND-BY, RECEIVE, TRANSMIT switch in TRANSMIT position.
- b. PHONE, CW, CAL switch in PHONE position.
- c. OFF-ON switch on power unit in ON position.

Tube	*Voltage to ground (volts)								
	Pin number								
	1	2	3	4	5	6	7	8	Top cap
V101	0	0	360	300	—85	0	6.3**	27	—
V102	6.3**	160	—70	0	0	—	—	—	600

*Telegraph key closed.

**Reading may be ac or dc.

Tube	*Voltage to ground (volts)								
	Pin number								
	1	2	3	4	5	6	7	8	Top cap
V101	0	1.2	1.2	0	0	0	6.3**	0	—
V102	0	0	—2.5	0	6.3**	—	—	—	880

*Telegraph key open.

**Reading may be ac or dc.

93. TRANSMITTER SECTION RESISTANCE CHART.

The resistance values given in the following chart were measured with an ohmmeter under the following conditions:

- a. OFF-ON switch on power unit in OFF position.
- b. All transmitter tubes removed from sockets.
- c. All cables disconnected.
- d. PHONE, CW, CAL switch in PHONE position.
- e. STAND-BY, RECEIVE, TRANSMIT switch in TRANSMIT position.

Tube	Resistance to ground (ohms)								
	Pin number								
	1	2	3	4	5	6	7	8	Top cap
V101	0	0	—	—	100,000	15,000	—	1,200	—
V102	0	—	15,000	0	—	—	—	—	*1.2 meg

*METER switch in PLT. VOLTAGE position.

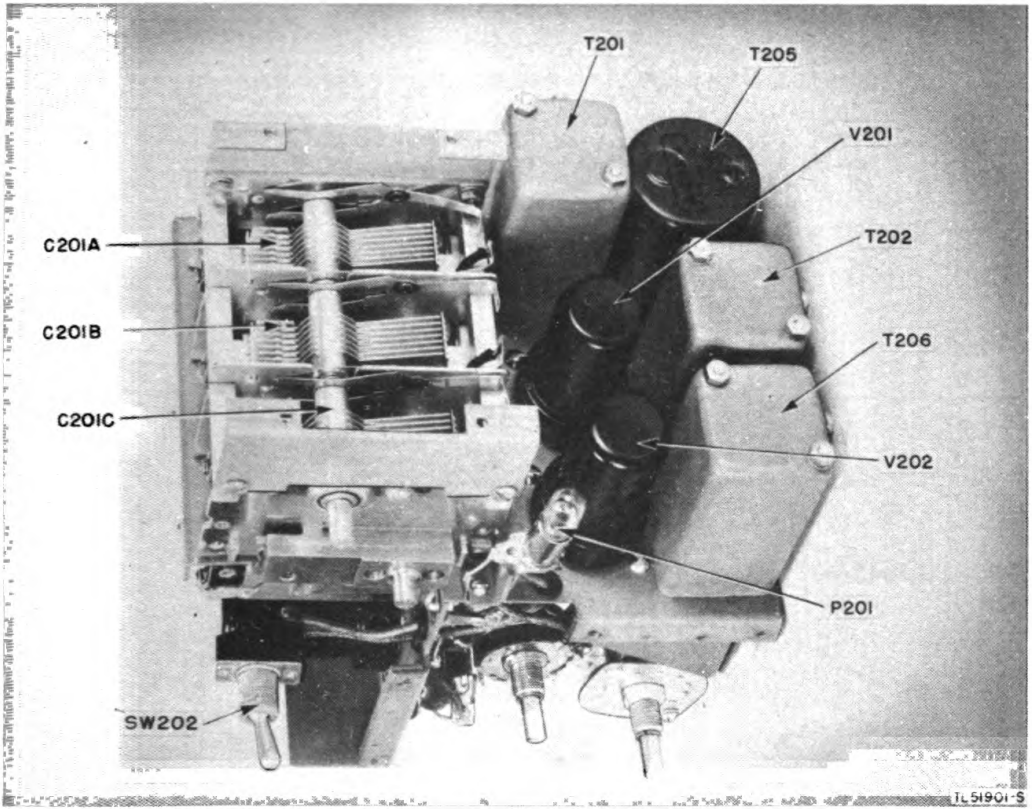

Figure 43. Receiver section, right side view.

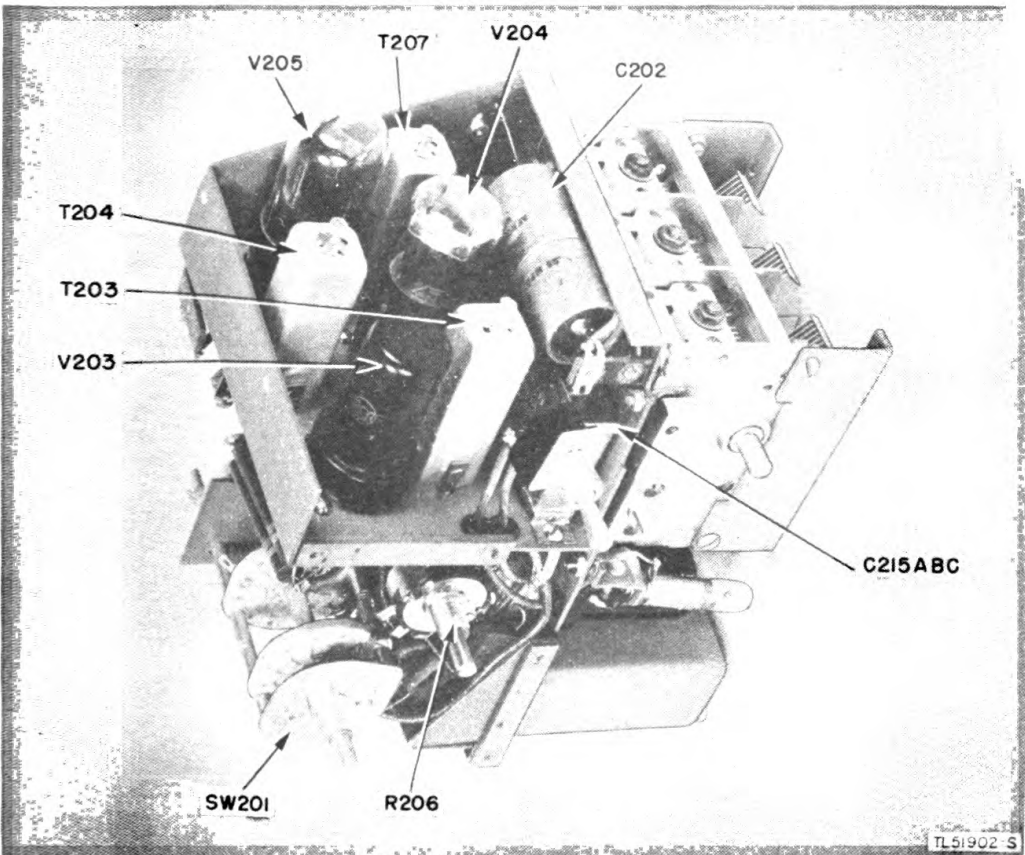

Figure 44. Receiver section, bottom view.

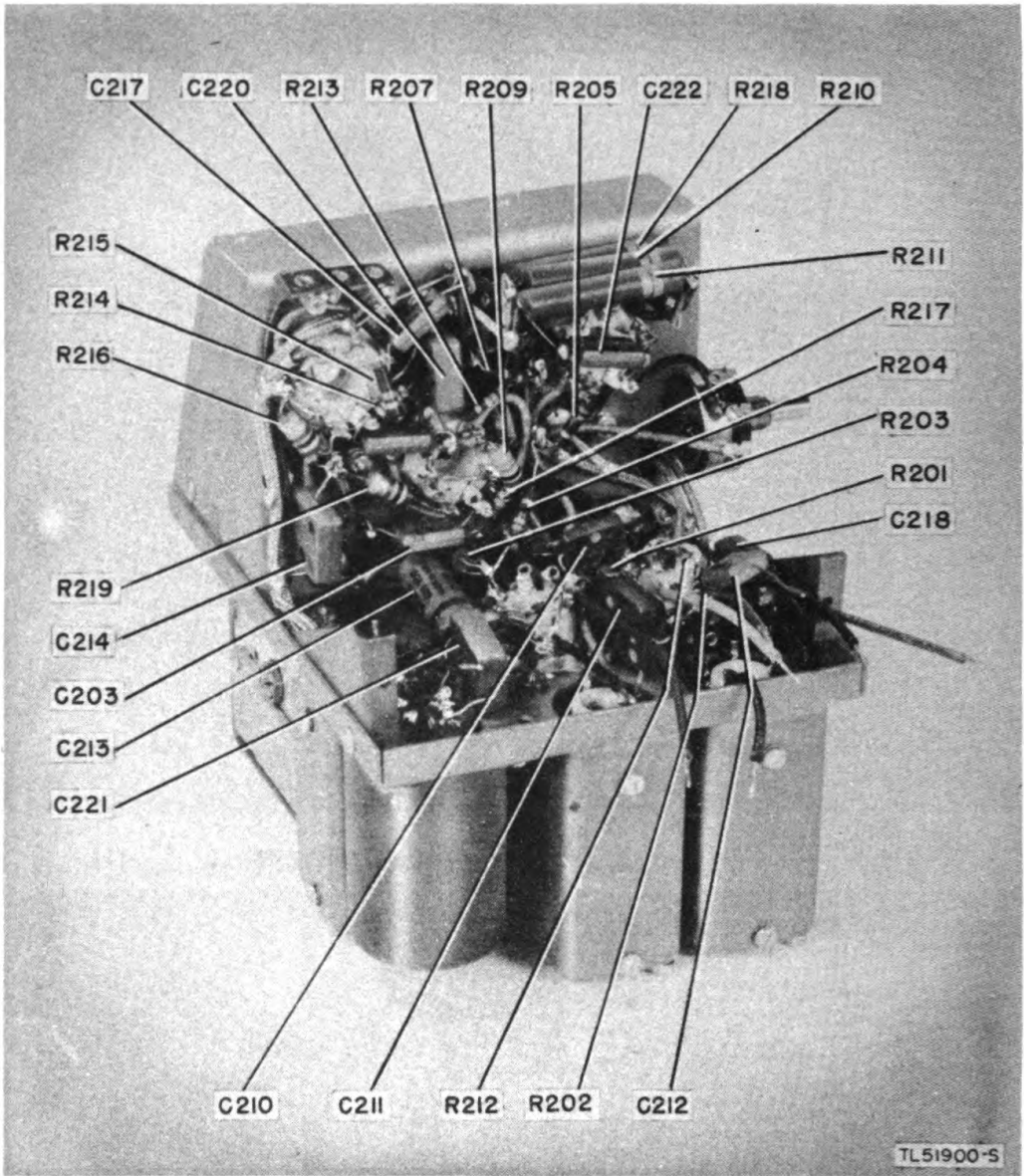

Figure 45. Receiver section, left side view with band switch removed.

TL51895-S

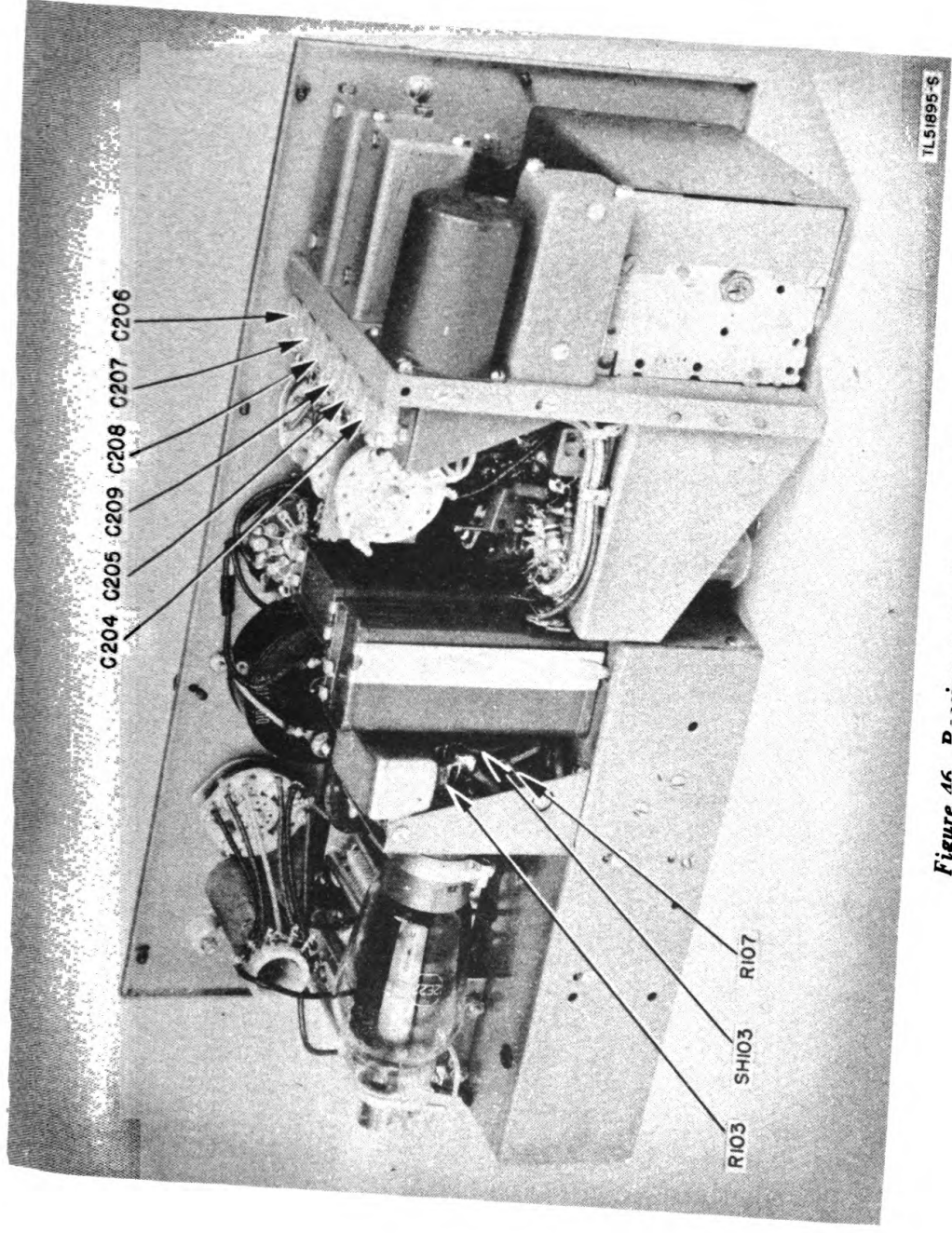

Figure 46 Diver-transmitter, rear view.

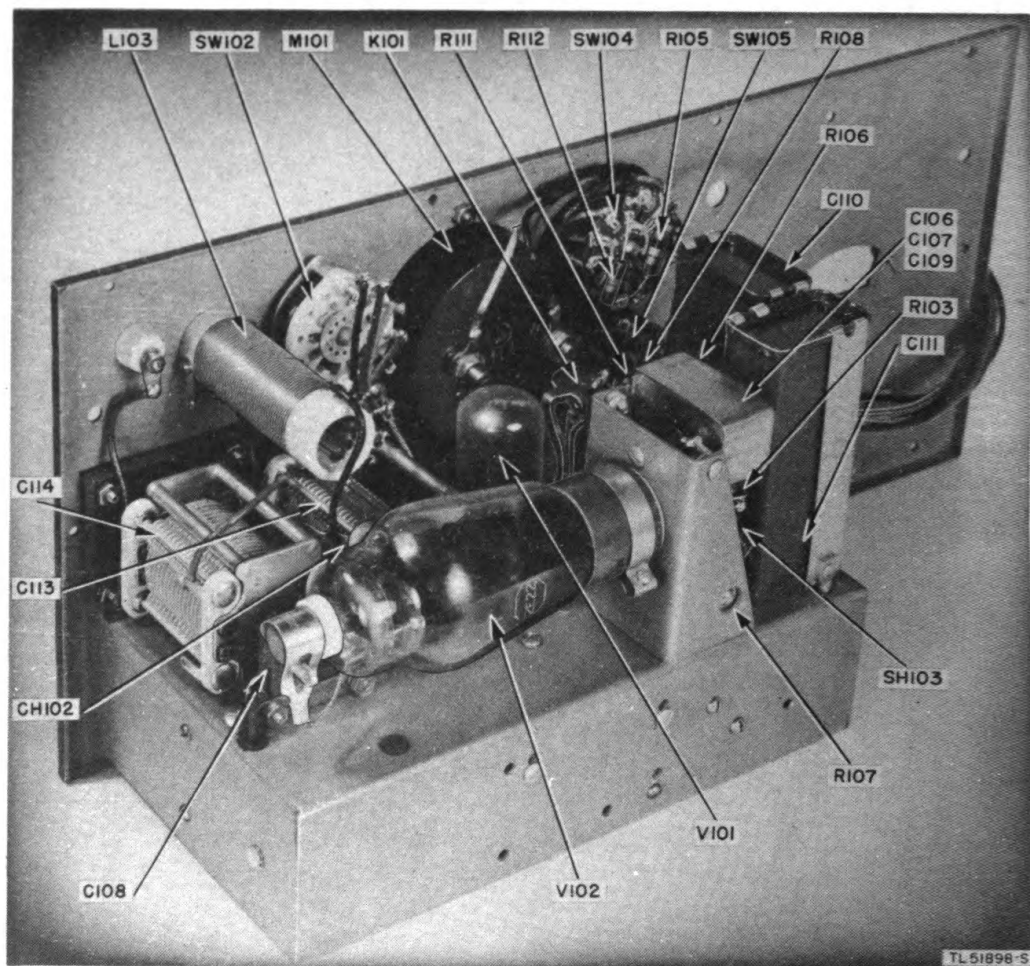

Figure 47. Transmitter section, rear view.

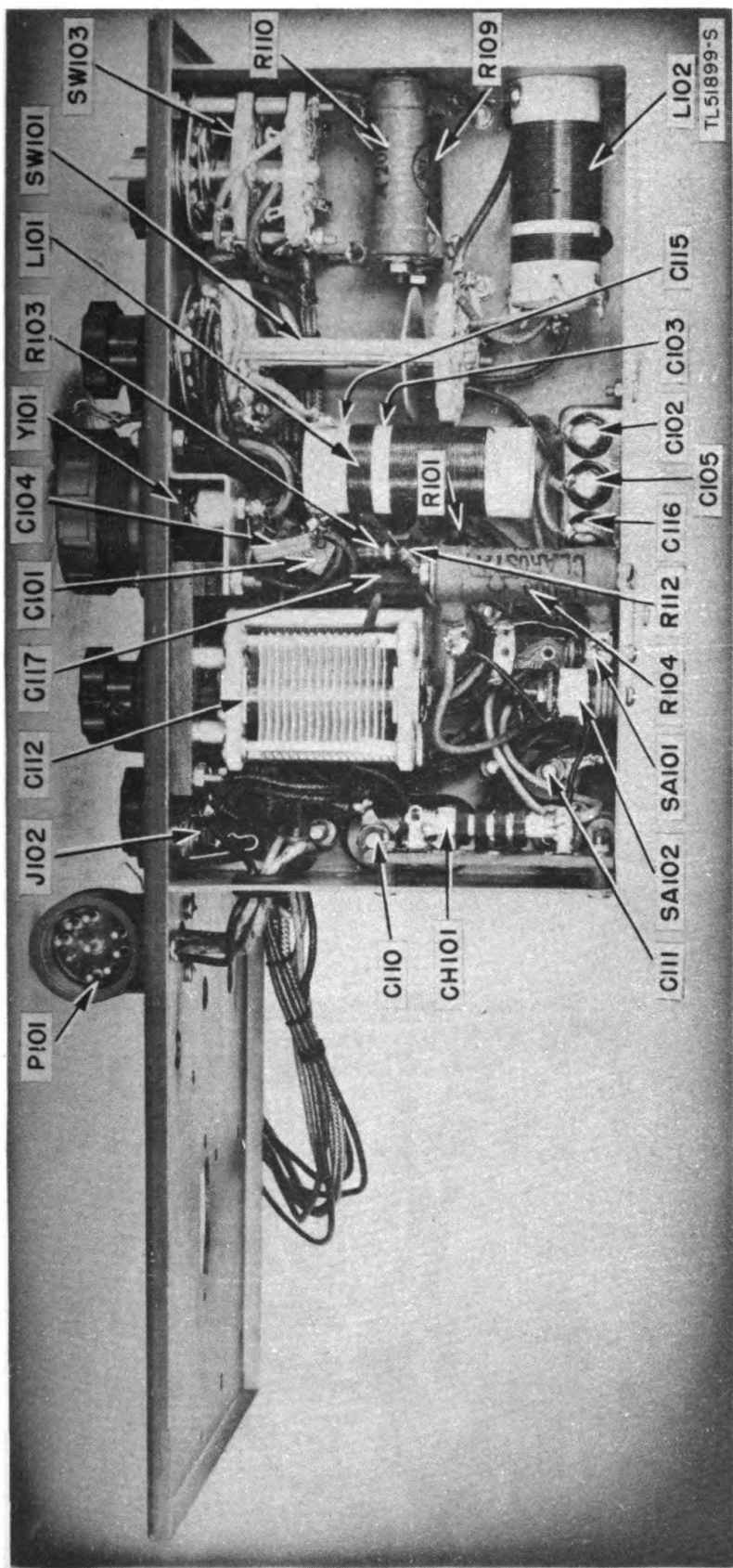

Figure 48. Transmitter section, bottom view.

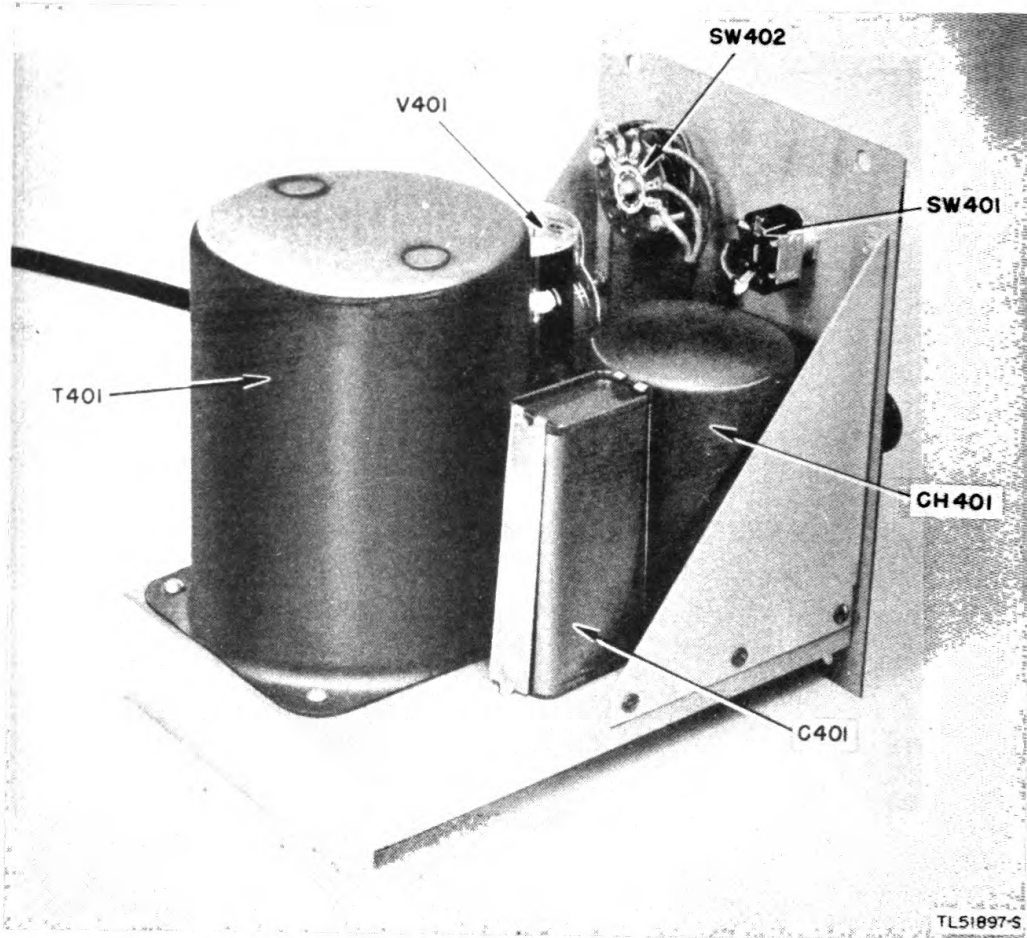

Figure 49. Rectifier power unit, rear oblique view.

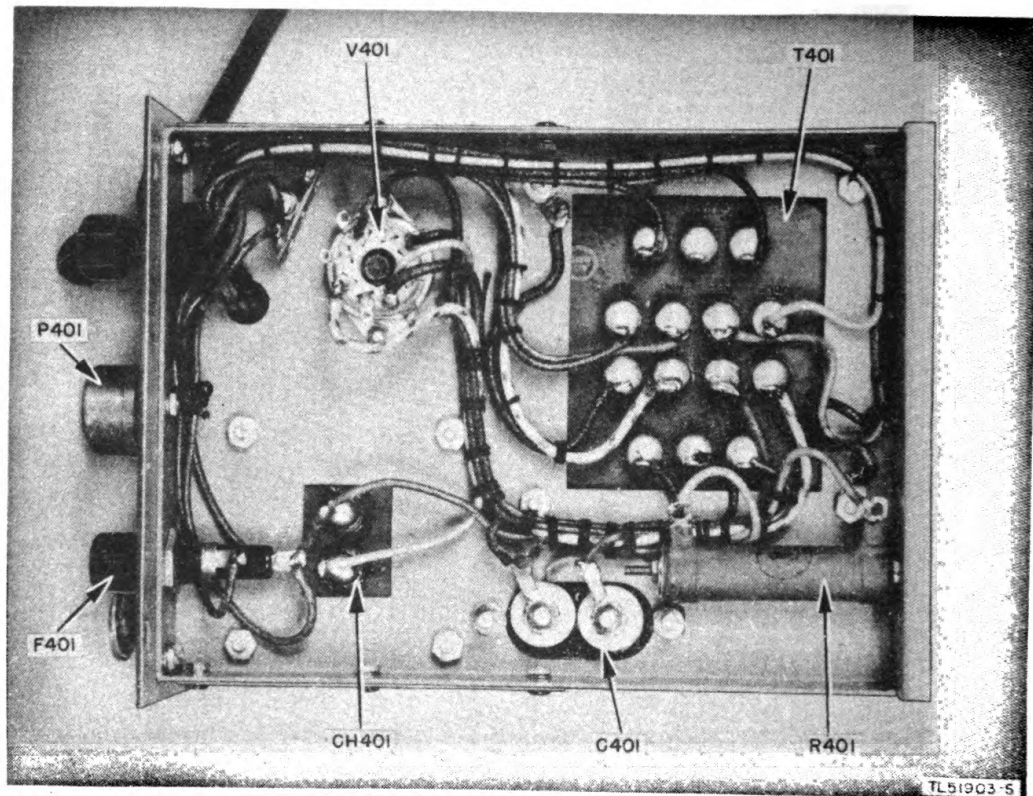

Figure 50. Rectifier power unit, bottom view.

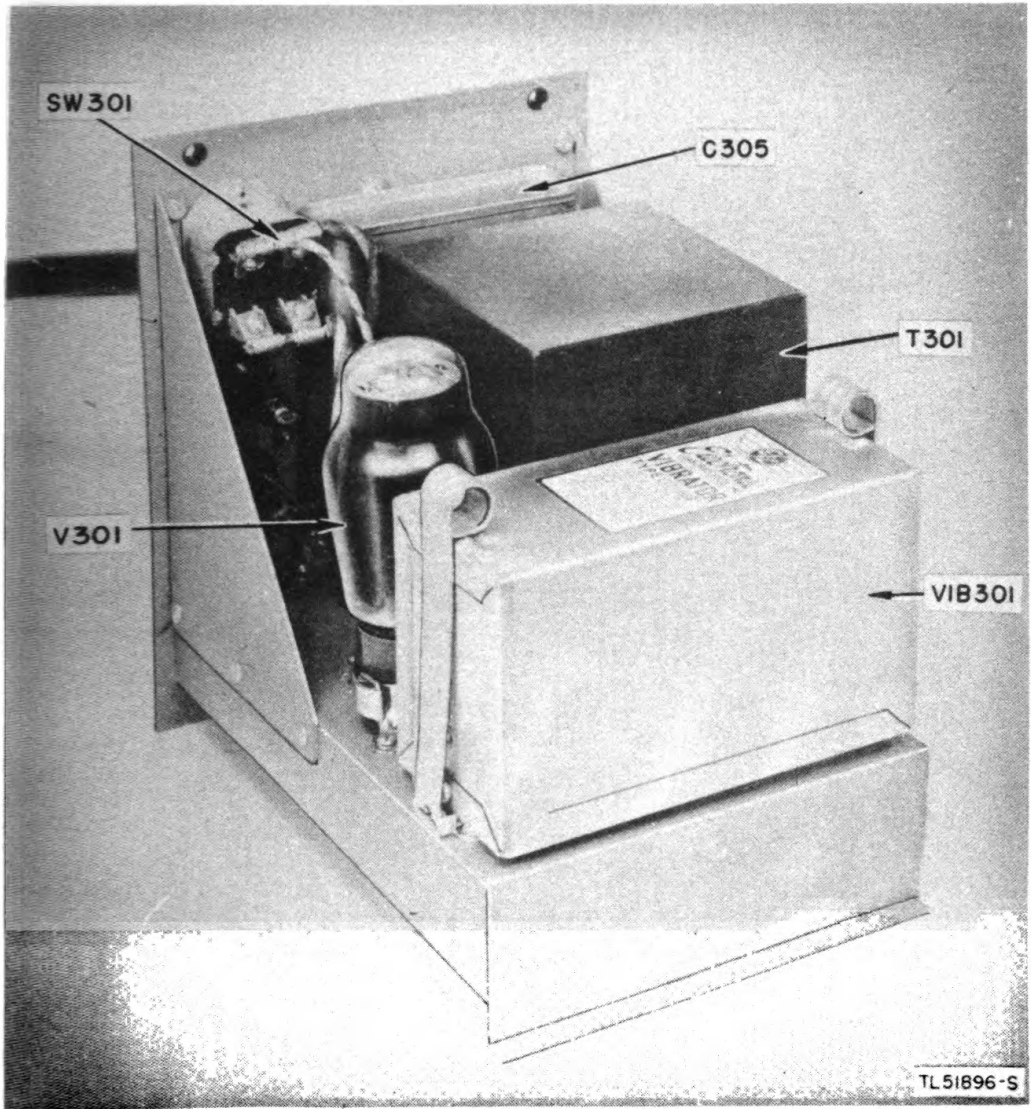

Figure 51. Vibrator power unit, rear oblique view.

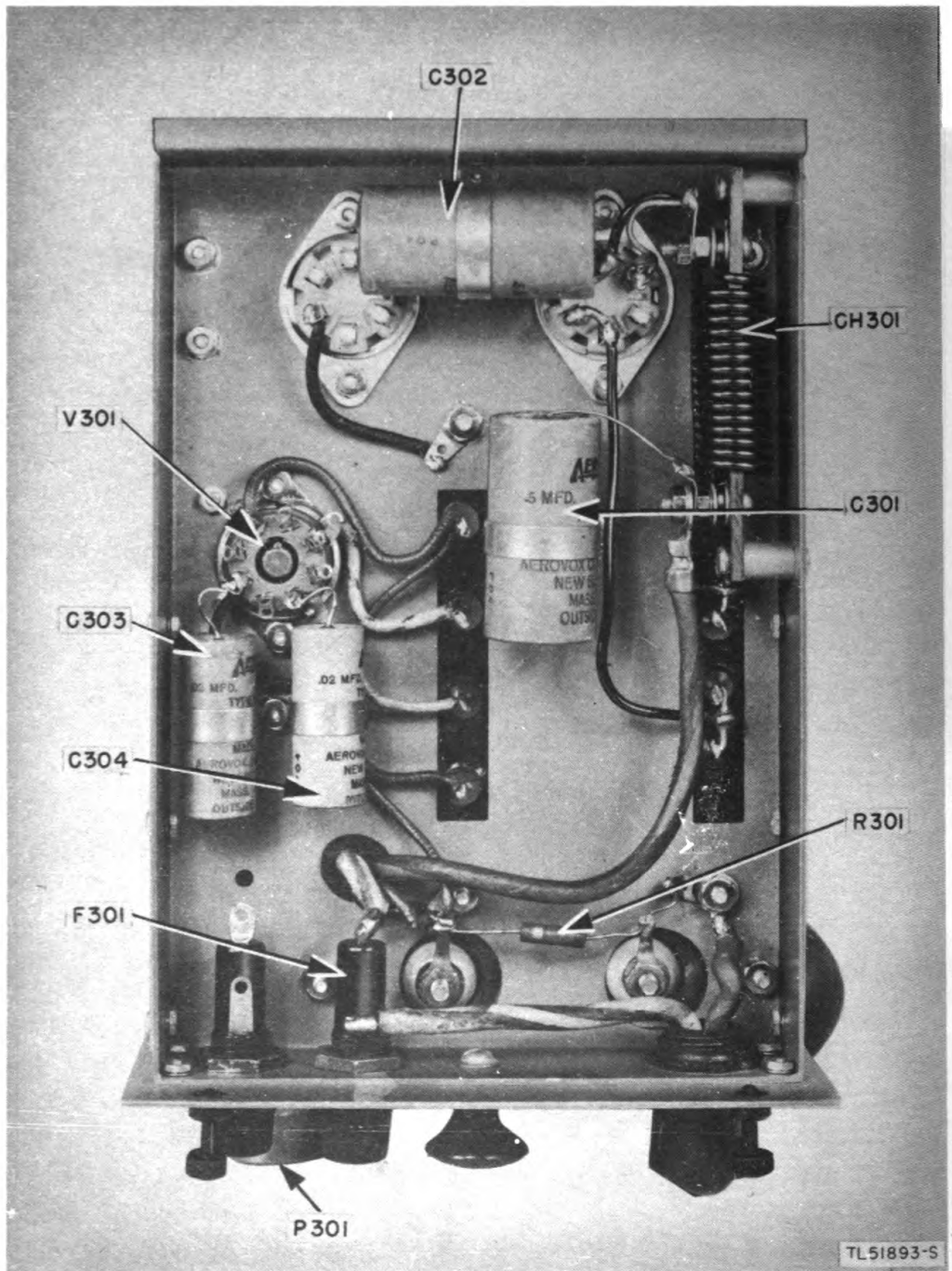

Figure 52. Vibrator power unit, bottom view.

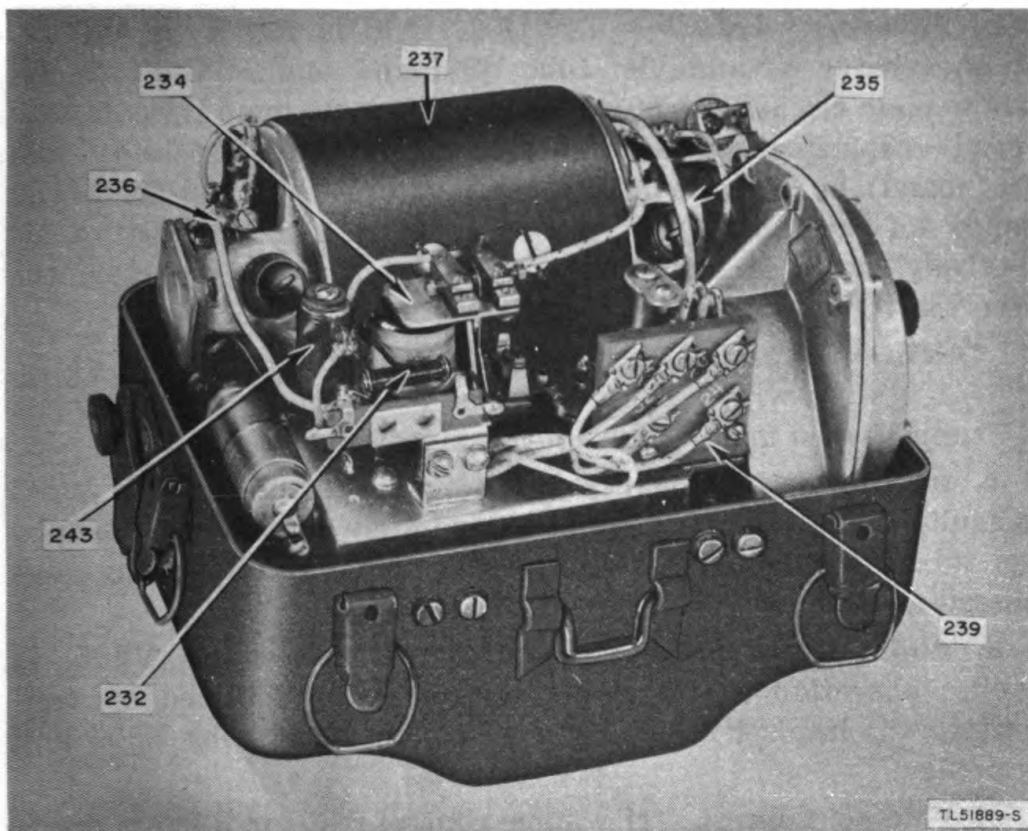

Figure 53. Hand generator, cover removed.

SECTION XVI. REPAIRS

94. EMERGENCY REPAIR OF RECEIVER.

Trouble may exist in a component of the equipment at a time when the equipment is most vitally needed. By becoming familiar with the trouble-shooting charts in section XV of this manual, the operator may be able to sectionalize the fault to a specific circuit; that circuit may then be isolated and the equipment kept in operation during the period of emergency. The following emergency repairs may be made *only* as temporary repairs until such time as the equipment may be serviced properly.

a. Antenna Stage. If the antenna coil in the receiver is open-circuited, connect a jumper wire from the ANTENNA binding post to the grid of r-f amplifier tube V201. The connection to the grid is conveniently made to trimmer capacitor C204 (h-f band) or to trimmer capacitor C205 (l-f band) at the top of the receiver section. This connection effectively bypasses the faulty antenna coil, however the receiver selectivity is reduced.

b. Radio-frequency Stage. If trouble is found in the r-f stage, remove r-f amplifier tube V201 and connect the antenna to the plate circuit of V201 by connecting a 25-mmf (micromicrofarad) capacitor between trimmer capacitors C204 and C209 (h-f band) or between trimmer capacitors C205 and C208 (l-f band) on the top of the receiver section. This connection effectively bypasses the faulty r-f amplifier stage, however, the receiver volume, sensitivity, and selectivity are reduced.

CAUTION: Trimmer capacitors C208 and C209 are at +300 volts with respect to ground. Turn off the power supply when making the above connections.

c. Intermediate-frequency Stage. If i-f amplifier tube V203 is faulty and a good tube is not immediately available, r-f amplifier tube V201 may be substituted and the r-f amplifier stage bypassed as outlined in subparagraph b above.

d. Audio-output Stage. If audio-amplifier stage V205 is faulty, operation at reduced volume may be obtained by connecting the headset between the grid (pin 5) of tube V205 and ground.

e. Volume Control. If volume control resistor R206 is open-circuited, a high positive voltage is applied to the cathodes of tubes V201 and V203 making these circuits inoperative. If a new volume control is not available, the faulty volume control resistor may be shorted out of the circuit to provide emergency operation.

f. Headset HS-30-U. If the step-down transformer in the headset cord is faulty and a replacement cord is not immediately available, satisfactory emergency operation can be obtained by connecting the two Receivers R-30 directly to the 250-ohm tap on output transformer T205.

95. EMERGENCY REPAIR OF TRANSMITTER.

Emergency repair of the transmitter section of Receiver-Transmitter RT-46/TRC-10 is impractical and difficult; however the following may be used if absolutely necessary:

a. Antenna Coil. If the antenna coil is smashed beyond repair and a replacement coil is not available, the coil may be short-circuited. To properly match to the antenna when operating with antenna coil L103 shorted, it may be necessary to change the antenna length, or increase the frequency of the transmitter.

b. Keying Relay. If the keying relay becomes inoperative and a replacement is not immediately available, hold the keying

relay in the transmitter section in the operated position and key the transmitter by connecting the telegraph key in series with resistor R113 in the cathode circuit of master oscillator tube V101. When connected in this manner, be sure that the key is in the ground side of the cathode resistor.

96. RUSTPROOFING AND REPAINTING.

a. If the finish on the receiver-transmitter case or on the power supply cases is badly scarred or damaged, touch up the exposed surfaces in order to prevent rust and corrosion. Using #00 or #000 sandpaper, clean the surface down to the base metal until the finish is bright and smooth. Apply paint with a small brush.

CAUTION: The use of steel wool is not recommended because small particles of the metal may fall into the case and cause internal electrical shorting or grounding of circuits.

b. If a complete repainting job is necessary, proceed as follows:

(1) Remove the receiver-transmitter from the case.

(2) Clean corroded metal on the case and cover with dry-cleaning solvent.

(3) If the dry-cleaning solvent does not remove the rust, use sandpaper to complete the rust removal.

(4) Spray-paint the entire case and cover using a paint which is authorized by existing regulations.

97. UNSATISFACTORY EQUIPMENT REPORT.

a. When trouble in equipment used by Army Ground Forces or Army Service Forces occurs more often than repair personnel feel is normal, War Department Unsatisfactory Equipment Report, W.D., A.G.O. Form No. 468 should be filled out and forwarded through channels to the Office of the Chief Signal Officer, Washington 25, D. C.

b. When trouble in equipment used by Army Air Forces occurs more often than repair personnel feel is normal, Army Air Forces Form No. 54 should be filled out and forwarded through channels.

c. If either form is not available, Form No. 468 (fig. 54) may be reproduced, filled out, and forwarded through channels. When Army Air Forces Form No. 54 is required but unavailable, reproduce Form No. 468 and forward it through channels in accordance with directions on Form No. 468.

SECTION XVII

ALIGNMENT AND ADJUSTMENT OF RECEIVER SECTION

98. GENERAL.

During manufacture, the receiver section of Receiver-Transmitter RT-46/TRC-10 is carefully adjusted and should not require realignment. However, if unusually severe use has resulted in lack of sensitivity, it may be necessary to realign the set. The complete alignment procedure includes, in the order listed, the adjustment of the i-f amplifier, BFO, h-f oscillator, r-f amplifier, and antenna trimmers. Do not make just one adjustment, but follow the entire alignment and adjustment procedure. Use a visual indicating output meter, Signal Generator I-72-(), a 100-mmf capacitor, an alignment tool, and a headset.

99. INTERMEDIATE-FREQUENCY ALIGNMENT.

a. Remove the receiver-transmitter from its case by loosening the 10 screws on the front panel.

b. Turn on the signal generator and the receiver (STAND-BY, RECEIVE, TRANSMIT switch in STAND-BY position) and allow them to warm up for at least 15 minutes.

c. Connect the output meter to a phone plug and insert the plug into the PHONE jack.

d. Set the signal generator for modulated output (400 cycles, 30 percent) and tune it for 454 kc, the intermediate frequency of the receiver.

e. Connect the output lead from the signal generator through a 100-mmf capacitor to the control grid (pin 4) of i-f amplifier tube V203.

f. Set the VOLUME control to *maximum*. During alignment, keep the signal generator attenuator adjusted for a *minimum* reading on the output meter.

g. Adjust the cores of output i-f transformer T204 to give a *maximum* reading on the output meter. One of the adjustments is below the chassis, on top of the i-f transformer; the other is above the chassis.

h. Transfer the signal generator leads to the grid (pin 8) of converter tube V202, and reduce the signal input to avoid overloading.

i. Adjust the cores of input i-f transformer T203 for *maximum* reading on the output meter.

j. After i-f transformer T203 has been adjusted, leave the signal generator connected to the converter grid and slightly readjust i-f output transformer T204 for maximum indication on the output meter.

100. BEAT-FREQUENCY OSCILLATOR ADJUSTMENT.

a. Without changing the setting of the signal generator from 454 kc, feed the output to the grid (pin 8) of converter tube V202.

b. Switch the signal generator to give an *unmodulated* output.

c. Remove the output meter and plug the headset into the PHONE jack.

d. Turn the CAL, CW, PHONE switch to the CW position.

e. Adjust the core of the BFO transformer, on top of transformer T207, until zero beat is heard in the headset. During c-w operation the RECEIVE TUNING dial must be slightly detuned to obtain a suitable audio signal.

101. HIGH-FREQUENCY OSCILLATOR ADJUSTMENT.

The h-f oscillator requires alignment whenever the tuning dial reading is not correct for either band.

a. Low-frequency Band.

(1) Set the RECEIVE BAND SWITCH to the l-f position.

(2) Tune the receiver to a quiet place on the dial between 4.5 and 5.0 mc, and connect an output meter to the PHONE jack.

(3) Connect the signal generator to the ANTENNA binding post through a 100-mmf capacitor, and set the signal generator to the same frequency reading as the receiver.

(4) Turn the attenuator on the signal generator for a low reading on the output meter.

(5) Adjust trimmer capacitor C206 for a maximum deflection on the output meter.

b. High-frequency Band. Follow the procedure used for the l-f frequency band with the following exceptions:

(1) Set the RECEIVE BAND SWITCH in the h-f position.

(2) Set the receiver and signal generator tuning dials between 11.0 and 12.0 mc.

(3) Adjust trimmer capacitor C207 for a maximum deflection on the output meter.

102. RADIO-FREQUENCY AMPLIFIER AND ANTENNA ADJUSTMENTS.

a. Low-frequency Band.

(1) With the signal generator and receiver controls set as described in paragraph 101a, adjust the r-f trimmer, C208, for *maximum* deflection.

(2) Adjust antenna trimmer capacitor C205 for *maximum* deflection.

b. High-frequency Band.

(1) With the signal generator and receiver control set as described in paragraph 101b above, adjust r-f trimmer capacitor C209 for *maximum* deflection.

(2) Adjust antenna trimmer capacitor C204 for maximum deflection. This completes the alignment procedure.

(3) Remove the output meter and signal generator.

(4) Replace receiver-transmitter in its case.

103. MINIMUM TEST REQUIREMENTS FOR RECEIVER.

a. General. This paragraph is to be used as a guide in determining the quality of a repaired receiver. If the receiver passes the tests outlined below, it is suitable for field operation. If each repaired radio set is subjected to the tests described in this paragraph, uniform high-quality operation of each set is assured.

b. Electrical Check on Receiver. Check the receiver electrically using the chart shown in table I of the appendix as a guide.

c. Moving Parts and Finish. In addition to the electrical tests described in the test chart, the receiver should be checked for smoothness of operation in moving or rotating parts, and for condition of the finish.

(1) Check the radio set for cleanliness inside and outside.

(2) Rotate all tuning and volume control. These should be smooth in operation across the arc of rotation. There should be no appreciable backlash or slipping of controls.

(3) Try all switches, both rotary and toggle. They should snap firmly into each contact position.

(4) Insert the appropriate plugs into the proper jacks. They should seat firmly and make good contact.

(5) Check fuse holders to see that fuses may be removed easily, yet lock tightly when inserted.

(6) Observe the condition of the finish and plating. Both paint and plating should be free from corrosion, blisters, flaking, bare or worn spots, or deep scratches.

104. TEST INSTRUMENTS REQUIRED.

The following instruments are required to make the tests outlined in the chart of table I.

a. R-f Signal Generator with Metered Output. The signal generator should cover the range of frequencies from 400 to 12,000 kc. It should have provisions for modulating the output signal at audio frequencies ranging from 200 to 3,000 cycles. (If the r-f generator does not have internal modulation capabilities, a separate a-f generator may be used to modulate the r-f signal externally.)

b. Voltohmmeter or Multimeter. The meter must have an a-c sensitivity of 1,000 ohms per volt or greater, and ranges covering from 0 to 10 volts and from 0 to 100 volts. Use Test Unit I-176, or its equivalent.

c. Dummy Antenna Consisting of 100-Micromicrofarad Mica Capacitor.

d. Output Load Resistor. One 10,000-ohm resistor is required.

e. Plug PL-55. The plug should be equipped with two 6-inch wires terminated in alligator clips.

APPENDIX

SECTION XVIII. REFERENCES

105. SUPPLY PUBLICATIONS.

- *SIG 1 Introduction to ASF Signal Supply Catalogue.
- *SIG 2 Complete Index to ASF Signal Supply Catalogue.
- SIG 3 List of Items for Troop Issue.
- SIG 4 - 1 Allowances of Expendable Supplies.
- SIG 4 - 2 Allowances of Expendable Supplies for Schools, Training Centers, and Boards.
- SIG 5 Stock List of All Items.
- *SIG 6 Sets (a listing of tool sets, equipment sets, other similar assemblies grouped for issue, showing component items of each set).
- *SIG 7 Organizational Spare Parts.
- *SIG 8 Higher Echelon Spare Parts.
- SB 11 - 8 Chests for Running Spares.

106. TECHNICAL MANUALS ON AUXILIARY EQUIPMENT AND TEST EQUIPMENT.

- TM 11 - 300 Frequency Meter Sets SCR-211-().
- TM 11 - 303 Test Sets I-56-C, I-56-D, I-56-H and I-56-J.
- TM 11 - 307 Signal Generator I-72-().
- TM 11 - 321 Test Set I-56-E.
- TM 11 - 472 Repair and Calibration of Electrical Measuring Instruments.
- TM 11 - 945 Power Unit PE-214-B.
- TM 11 - 2613 Voltohmmeter I-166.
- TM 11 - 2626 Test Unit I-176.
- TM 11 - 2627 Tube Tester I-177.

*When published.

107. PREVENTIVE MAINTENANCE.

- TB SIG 25 Preventive Maintenance of Power Cords.
TB SIG 66 Winter Maintenance of Ground Signal Equipment.
TB SIG 72 Tropical Maintenance of Ground Signal Equipment.
TB SIG 75 Desert Maintenance of Ground Signal Equipment.
TB SIG 123 Preventive Maintenance Practice for Ground Signal Equipment.

108. PAINTING, PRESERVING, AND LUBRICATION.

- TB SIG 13 Moistureproofing and Fungiproofing Signal Corps Equipment.
TB SIG 69 Lubrication of Ground Signal Equipment.
SB 11 - 10 Signal Corps Kit and Materials for Moisture and Fungi-Resistant Treatment.

109. SHIPPING INSTRUCTIONS.

- U. S. Army Spec. Army-Navy General Specification for
No. 100-14A Packaging and Packing for Overseas Shipment.

110. DECONTAMINATION.

- TM 3 - 220 Decontamination Materials.

111. DEMOLITION.

- FM 5 - 25 Explosives and Demolition.

112. CAMOUFLAGE.

- FM 5 - 20 Camouflage, Basic Principles.

113. OTHER TECHNICAL PUBLICATIONS.

- FM 21 - 6 List of Publications for Training.
FM 21 - 7 List of Training Films, Film Strips, and Film Bulletins.
FM 21 - 8 Military Training Aids.
FM 21 - 40 Defense Against Chemical Attack.
FM 24 - 5 Signal Communication.
FM 24 - 6 Radio Operator's Manual, Army Ground Forces.
FM 24 - 9 Combined United States-British Radio-Telephone (R/T) Procedure.

FM 24 - 10	Combined Radiotelegraph (W/T) Procedure.
FM 24 - 11	Combined Operating Signals.
FM 24 - 12	Army Extract of Combined Operating Signals.
FM 24 - 18	Radio Communication.
TM 1 - 455	Electrical Fundamentals.
TM 11 - 227	Signal Communication Equipment Directory, Radio Communication Equipment.
TM 11 - 310	Schematic Diagrams for Maintenance of Ground Radio Communication Sets.
TM 11 - 314	Antennas and Antenna Systems.
TM 11 - 453	Shop Work.
TM 11 - 454	The Radio Operator.
TM 11 - 455	Radio Fundamentals.
TM 11 - 462	Reference Data.
TM 11 - 483	Suppression of Radio Noises.
TM 11 - 499	Radio Propagation.
TM 3 - 250	Basic Maintenance Manual.
TB SIG 5	Defense Against Radio Jamming.

114. FORMS.

Refer to Unsatisfactory Equipment Report (W.D., A.G.O. Form No. 468). If this form is not available, see TM 3-250, Basic Maintenance Manual.

115. LIST OF ABBREVIATIONS.

a-c	alternating-current
a-f	audio-frequency
a-m	amplitude-modulated
amp	amperes
BFO	beat-frequency oscillator
c-w	continuous-wave
d-c	direct-current
h-f	high-frequency
i-f	intermediate-frequency
kc	kilocycles
l-f	low-frequency
ma	milliamperes
mc	megacycles
mcw	modulated continuous wave
mf	microfarad
mh	millihenry

mmf	micromicrofarad
m-o	master-oscillator
p-a	power-amplifier
r-f	radio-frequency
μ v	microvolts

NOTE: Refer to appendix I of TM 11-455, 22 May 1944, for additional abbreviations of radio terms.

RESISTOR COLOR CODES

RMA COLOR CODE FOR FIXED COMPOSITION RESISTORS

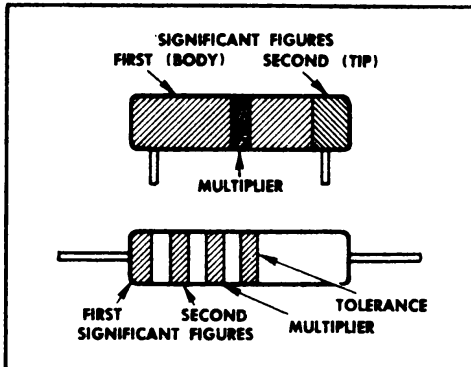

Insulated fixed composition resistors with axial leads are designated by a natural tan background color. Non-insulated fixed composition resistors with axial leads are designated by a black background color.

AWS COLOR CODE FOR FIXED COMPOSITION RESISTORS

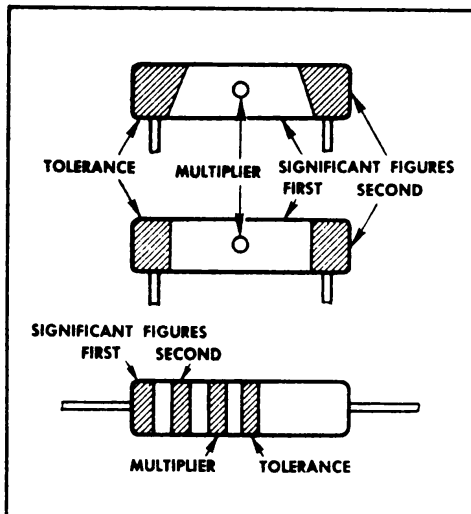

The exterior body color of insulated resistors may be any color except black. The usual color is natural tan. The exterior body color of uninsulated resistors with axial leads may be either black or white. The exterior body color of uninsulated resistors with radial leads may be black or it may be the color of the first significant figure of the resistance value.

COLOR	SIGNIFICANT FIGURE	MULTIPLIER	TOLERANCE (PERCENT)
BLACK	0	1	
BROWN	1	10	
RED	2	100	
ORANGE	3	1000	
YELLOW	4	10,000	
GREEN	5	100,000	
BLUE	6	1,000,000	
VIOLET	7	10,000,000	
GRAY	8	100,000,000	
WHITE	9	1,000,000,000	
GOLD		0.1	5
SILVER		0.01	10
NO COLOR			20

RMA: Radio Manufacturers Association
 AWS: American War Standard
 (American Standards Association)

7L 13418

Figure 55. Resistor color code.

CAPACITOR COLOR CODES

RMA 6-DOT COLOR CODE FOR MICA-DIELECTRIC CAPACITORS

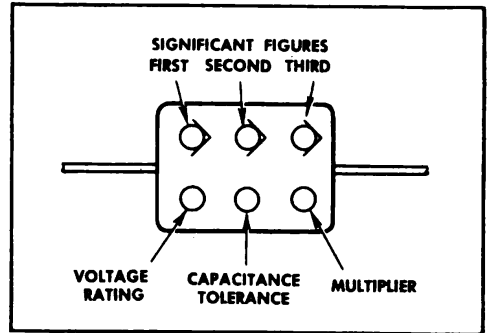

RMA 3-DOT COLOR CODE FOR MICA-DIELECTRIC CAPACITORS

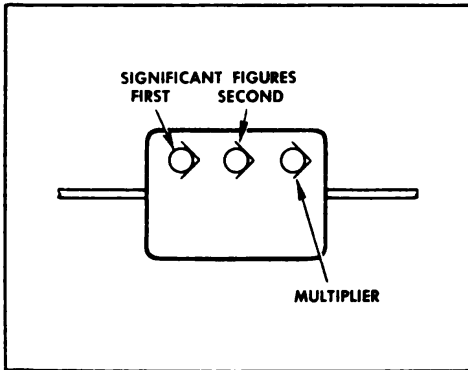

Capacitors marked with this code have a voltage rating of 500 volts.

AWS 6-DOT COLOR CODE FOR PAPER-DIELECTRIC CAPACITORS

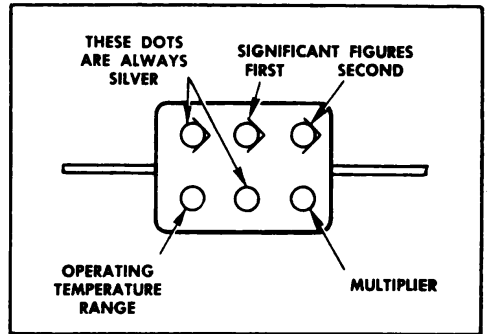

The silver dots serve to identify this marking. The sixth dot shows whether the capacitor has a maximum operating temperature of 167°F (black) or 185°F (brown).

COLOR	SIGNIFICANT FIGURE	MULTIPLIER		VOLTAGE RATING (VOLTS)	CHARACTERISTIC (AWS MICA-DIELECTRIC)
		RMA MICA- AND CERAMIC-DIELECTRIC AWS MICA- AND PAPER-DIELECTRIC	AWS CERAMIC-DIELECTRIC		
BLACK	0	1	1		A
BROWN	1	10	10	100	B
RED	2	100	100	200	C
ORANGE	3	1000	1000	300	D
YELLOW	4	10,000		400	E
GREEN	5	100,000		500	F
BLUE	6	1,000,000		600	G
VIOLET	7	10,000,000		700	
GRAY	8	100,000,000	0.01	800	
WHITE	9	1,000,000,000	0.1	900	
GOLD		0.1		1000	
SILVER		0.01		2000	
NO COLOR				500	

Figure 56. Capacitor color code.

AWS 6-DOT COLOR CODE FOR MICA-DIELECTRIC CAPACITORS

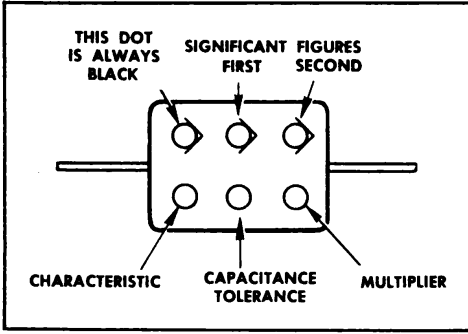

The black dot serves to identify the AWS marking. Capacitors marked with this code are rated at 500 volts, except the following. AWS type CM35 capacitors with capacitances of 6,800, 7,500, and 8,200 micromicrofarads, and AWS type CM40 capacitors with capacitances of 9,100 and 10,000 micromicrofarads are rated at 300 volts.

AWS COLOR CODE FOR TUBULAR CERAMIC-DIELECTRIC CAPACITORS

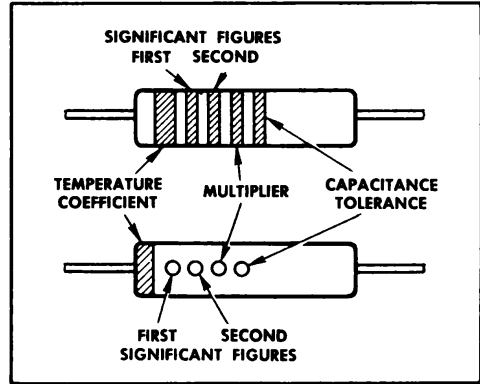

Capacitors marked with this code have a voltage rating of 500 volts.

RMA COLOR CODE FOR TUBULAR CERAMIC-DIELECTRIC CAPACITORS

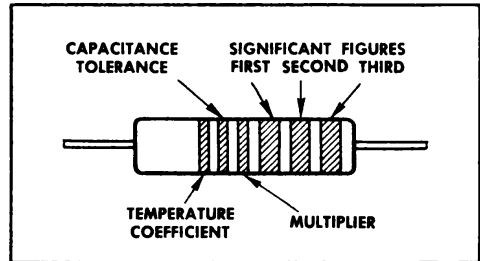

Capacitors marked with this code have a voltage rating of 500 volts.

RMA: Radio Manufacturers Association
AWS: American War Standard (American Standards Association)

NOTE: These color codes give all capacitances in micromicrofarads.

CAPACITANCE TOLERANCE				TEMPERATURE COEFFICIENT OF CAPACITANCE $\times 10^{-4}$ MMF/MMF/°C
RMA & AWS MICA- AND PAPER-DIELECTRIC (PERCENT)	RMA CERAMIC-DIELECTRIC (PERCENT)	AWS CERAMIC-DIELECTRIC GREATER THAN 10 MMF (PERCENT)	AWS CERAMIC-DIELECTRIC LESS THAN 10 MMF (MMF)	
20	20	20	2.0	0
1	1	1		- 30
2	2	2		- 80
3	3	2.5	0.25	-150
4	4			-220
5	5	5	0.5	-330
6	6			-470
7	7			-750
8	2.5			+ 30
9	10	10	1.0	Not specified
5				
10				
20				

TL 13417

Figure 56. Capacitor color code (contd).

LE LIT

VTS sa

r

lt

NTR

o

EQUH

(CP)

a

I

3

40

1

Nox

1

1

1

1

1

1

1

1

1

1

1

1

1

1

1

1

1

1

1

1

1

1

1

1

1

1

1

1

1

1

LITY.

same conditions as for MCW sensitivity test (par. 1a).
receiver VOLUME control for 10-volt output with 100
volts input from signal generator. This corresponds to
the step in the test chart. Proceed in accordance with fidel-
ity chart.

MCHANICAL NOISE.

Place the receiver-transmitter on a soft rubber or felt pad,
padded bench.

Use the same conditions as in output test (par. 4), except
the output meter and load resistor are replaced by headset.

Tap receiver repeatedly in various places with a padded
stick listening for extraneous noise indicative of loose contacts
or phonic conditions. (Tapping is to simulate a vibration.
Do not strike receiver hard enough to damage it.)

M

M

M

M

M

M

M

M

M

M

M

M

M

M

116. MAINTENANCE PARTS FOR RADIO SET AN/TRC-10 (contd).

Signal Corps stock No.	Name of part and description
2A1660-1	ANTENNA ASSEMBLY: consisting of 100 ft lg No. 16 AWG tinned copper wire, comprising 26 strands No. 30, jack with 18" lg No. 16 AWG stranded tinned copper wire, 2 insulators and two 20 ft lg No. 9 woven cotton cords; Tedeco dwg No. TU-1316-3A, part No. 2.
2Z553-6	BAG CW-6/TRC-10: accessory; canvas; 8" lg x 1-1/2" wd x 36" h; Sig C Spec No. 271-3047; (holds leg LG-2-A, leg LG-3, and cords).
2Z553-7	BAG CW-7/TRC-10: transmitter; canvas, rubberized; with four 3" straps; 13" lg x 8" wd x 18-1/2" h; Sig C Spec No. 271-3047; (holds Receiver-Transmitter RT-46/TRC-10 and spare accessories).
2Z553-134	BAG CW-134/TRC-10: power units; canvas; (holds Vibrator Power Unit PP-84/TRC-10 and Rectifier Power Unit PP-74/TRC-10).
3H160-175	BAG BG-175: generator; waterproof canvas; 6" x 8" x 13" with 2" web strap; Sig C Spec No. 71-1606; (for Generator G-4/TRC-10).
1B3018-2.8	CABLE, power: copper; 2 No. 18 AWG stranded copper cond each comprising 41 No. 34 AWG strands; 0.39" OD; rubber insulated; in 100-ft rolls.
3E6000-83	CABLE ASSEMBLY, power: Army-Navy Cord CX-83/TRC-10; Buna S jacket over metal loom; round, 0.725" diam; 8 ft lg; 4 No. 18 AWG stranded copper cond and 4 No. 15 AWG stranded copper cond; Tedeco dwg No. TU-1333-3; (Cannon No. P8-24 one end, Cannon No. P8-23 other end).
3E6000-350	CABLE ASSEMBLY, power: Army-Navy Cord CX-350/TRC-10; Buna S jacketed; round; 0.410" OD; 50 ft lg; 2 No. 16 AWG copper cond, ea comprising 65 No. 34 AWG copper cond; Tedeco dwg No. TU-1308-2; (Hubbell No. 7102 one end, Hubbell No. 7084 other end); (connects AC generator to Rectifier Power Unit PP-74/TRC-10).

116. MAINTENANCE PARTS FOR RADIO SET AN/TRC-10 (contd).

Signal Corps stock No.	Name of part and description
3E4059-31	CABLE ASSEMBLY, power: battery; RC; rubber jacketed; round; 0.705" OD; 6 ft lg; 2 No. 10 AWG stranded cond; 105 strands of No. 30 AWG copper cond; Belden type S; Tedeco dwg No. TU-1333-3; (2 battery clamps attached to one end, other end stripped and tinned); (for Vibrator Power Unit PP-84/TRC-10).
2Z3062-88	CONNECTOR, female contact: single banana jack; straight; black cast phenolic resin; 1-1/4" lg x 3/8" diam; Birnback No. 605; (for antenna).
6Z3150-5	CONNECTOR, female contact: 2-wire connector; T slots; with cord grip; Hubbell No. 7084; (for Cord CX-350/TRC-10).
2Z8734.3	CONNECTOR, female contact: 8-numbered cont; keyed and polarized; 2-1/2" lg x 1-3/8" diam; Cannonelec No. P8-23; (with cord grip for 9/16" cable); (for Cord CX-83/TRC-10).
2Z7111.1	CONNECTOR, male contact: single banana plug; black cast phenolic resin; 1" lg x 3/8" diam; Birnback No. 404; (for antenna).
6Z1735.4	CONNECTOR, male contact: 2 twist lock cont each 3/4" lg; 1-1/2" diam x 9/16" d less cont; Hubbell No. 7102; (with 1/2" lg cord grip); (for Cord CX-350/TRC-10).
2Z7118	CONNECTOR, male contact: 8-numbered cont; keyed and polarized; 2-1/8" lg x 1-3/16" diam; Cannonelec No. P8-24; (with cord grip for 3/4" cable); (for Cord CX-83/TRC-10).
3E1201A	CORD CD-201-A: key; tinsel rubber jacketed cordage; 5 ft lg; 2 cond No. 18 AWG each comprising 41 strands No. 34 or 65 strands No. 36 AWG; Sig C Spec No. 71-571-C; (Plug PL-55 one end; 2 Terminals TM-29 on other end); (for Key Mount MT-147/TRC-10).
3E1605-6.5	CORD CD-605: headset; RC; round; 0.270" diam, 6 ft 6" lg; consisting of 2 tinsel rubber insulated cond; Sig C Spec No. 71-1525; (with Transformer C-410 on one end and Plug PL-55 on other end); (extension cord for Headset HS-30).

116. MAINTENANCE PARTS FOR RADIO SET AN/TRC-10 (contd).

Signal Corps stock No.	Name of part and description
2A712	COUNTERPOISE CP-12: multiple wire; consisting of four 25 ft lg No. 16 AWG tinned copper wire each comprising 26 strands No. 30, with 4" lg No. 16 AWG; stranded tinned copper wire leads; Sig C dwg No. SC-D-1038, group 1.
2A713	COUNTERPOISE CP-13: multiple wire; consisting of four 25 ft lg No. 16 AWG tinned copper wire each comprising 26 strands No. 30, with 4" lg No. 16 AWG stranded tinned copper wire leads; Sig C dwg No. SC-D-1038, group 2.
3HL407	CRANK GC-7: hand generator; steel; arm 6" lg; socket end 3/8" sq x 1-3/32" lg; handle end 1/4" diam x 3-1/8" lg; Maple handle 1-1/8" OD x 5/16" ID x 3" lg; Sig C dwg No. RL-D-6213, group 2.
	CRYSTAL UNITS CR-5B/U: each consisting of a quartz crystal mtd in a Sig C Crystal Holder FT-243; over-all dimen 1-19/32" h x 13/16" wd x 13/32" thk; (reference symbol No. X-101).
2X178-2030	CRYSTAL UNIT CR-5B/U: 2030 kc; channel 2030 kc
2X178-2220	CRYSTAL UNIT CR-5B/U: 2220 kc; channel 2220 kc
2X178-2258	CRYSTAL UNIT CR-5B/U: 2258 kc; channel 2258 kc
2X178-2300	CRYSTAL UNIT CR-5B/U: 2300 kc; channel 2300 kc
2X178-2360	CRYSTAL UNIT CR-5B/U: 2360 kc; channel 2360 kc
2X178-2390	CRYSTAL UNIT CR-5B/U: 2390 kc; channel 2390 kc
2X178-3050	CRYSTAL UNIT CR-5B/U: 3050 kc; channel 3050 kc
2X178-3510	CRYSTAL UNIT CR-5B/U: 3510 kc; channel 3510 kc
2X178-3520	CRYSTAL UNIT CR-5B/U: 3520 kc; channel 3520 kc
2X178-3550	CRYSTAL UNIT CR-5B/U: 3550 kc; channel 3550 kc
2X178-3570	CRYSTAL UNIT CR-5B/U: 3570 kc; channel 3570 kc

116. MAINTENANCE PARTS FOR RADIO SET AN/TRC-10 (contd).

Signal Corps stock No.	Name of part and description
2X178-3580	CRYSTAL UNIT CR-5B/U: 3580 kc; channel 3580 kc
2X178-3945	CRYSTAL UNIT CR-5B/U: 3945 kc; channel 3945 kc
2X178-3955	CRYSTAL UNIT CR-5B/U: 3955 kc; channel 3955 kc
2X178-3995	CRYSTAL UNIT CR-5B/U: 3995 kc; channel 3995 kc
2X178-4090	CRYSTAL UNIT CR-5B/U: 4090 kc; channel 4090 kc
2X178-4130	CRYSTAL UNIT CR-5B/U: 4130 kc; channel 4130 kc
2X178-4210	CRYSTAL UNIT CR-5B/U: 4210 kc; channel 4210 kc
2X178-4250	CRYSTAL UNIT CR-5B/U: 4250 kc; channel 4250 kc
2X178-4290	CRYSTAL UNIT CR-5B/U: 4290 kc; channel 4290 kc
2X178-4310	CRYSTAL UNIT CR-5B/U: 4310 kc; channel 4310 kc
2X178-4520	CRYSTAL UNIT CR-5B/U: 4520 kc; channel 4520 kc
2X178-4565	CRYSTAL UNIT CR-5B/U: 4565 kc; channel 4565 kc
2X178-4580	CRYSTAL UNIT CR-5B/U: 4580 kc; channel 4580 kc
2X178-4610	CRYSTAL UNIT CR-5B/U: 4610 kc; channel 4610 kc
2X178-4640	CRYSTAL UNIT CR-5B/U: 4640 kc; channel 4640 kc
2X178-4830	CRYSTAL UNIT CR-5B/U: 4830 kc; channel 4830 kc
2X178-4870	CRYSTAL UNIT CR-5B/U: 4870 kc; channel 4870 kc
2X178-4885	CRYSTAL UNIT CR-5B/U: 4885 kc; channel 4885 kc
2X178-4920	CRYSTAL UNIT CR-5B/U: 4920 kc; channel 4920 kc
2X178-5065	CRYSTAL UNIT CR-5B/U: 5065 kc; channel 5065 kc
2X178-5090	CRYSTAL UNIT CR-5B/U: 5090 kc; channel 5090 kc
2X178-5115	CRYSTAL UNIT CR-5B/U: 5115 kc; channel 5115 kc

116. MAINTENANCE PARTS FOR RADIO SET AN/TRC-10 (contd).

Signal Corps stock No.	Name of part and description
2X178-5570	CRYSTAL UNIT CR-5B/U: 5570 kc; channel 5570 kc
2X178-5790	CRYSTAL UNIT CR-5B/U: 5790 kc; channel 5790 kc
2X178-6405	CRYSTAL UNIT CR-5B/U: 3202.5 kc; channel 6405 kc
2X178-6430	CRYSTAL UNIT CR-5B/U: 3215 kc; channel 6430 kc
2X178-6475	CRYSTAL UNIT CR-5B/U: 3237.5 kc; channel 6475 kc
2X178-6500	CRYSTAL UNIT CR-5B/U: 3250 kc; channel 6500 kc
2X178-6645	CRYSTAL UNIT CR-5B/U: 3322.5 kc; channel 6645 kc
2X178-7170	CRYSTAL UNIT CR-5B/U: 3585 kc; channel 7170 kc
2X178-8860	CRYSTAL UNIT CR-5B/U: 4430 kc; channel 8860 kc
2X178-8920	CRYSTAL UNIT CR-5B/U: 4460 kc; channel 8920 kc
2X178-9990	CRYSTAL UNIT CR-5B/U: 4995 kc; channel 9990 kc
2X178-10960	CRYSTAL UNIT CR-5B/U: 5480 kc; channel 10960 kc
2X178-11080	CRYSTAL UNIT CR-5B/U: 5540 kc; channel 11080 kc
2X178-11260	CRYSTAL UNIT CR-5B/U: 5630 kc; channel 11260 kc
3H2320-4	HAND GENERATOR G-4/TRC-10: 500-v, 0.11-amp; 6.3-v, 3.3-amp; 11" lg x 7-5/8" wd x 8" h; Sig C Spec No. 271-3108.
2B830	HEADSET HS-30: radio; magnetic; approx 250 ohms; 2 receivers 0.895" diam x 0.68" h; headband 6-1/8" max; with cord and 2 Insert M-300; Sig C Spec No. 271-1518-B.
3G1250-24.13	INSULATOR, strain: glazed steatite, white; 1-1/2" lg x 1/2" diam; Birnbach No. 463; (for antenna).
3Z3437	KEY J-37: radio; open ckt; special; molded bakelite base with phosphor bronze lever; Sig C dwg No. RL-D-59325.

116. MAINTENANCE PARTS FOR RADIO SET AN/TRC-10 (contd).

Signal Corps stock No.	Name of part and description
3Z4010-147	KEY MOUNT MT-147/TRC-10: metal mtg with strap; used to fasten Key J-37 to operator's leg; mtg 4-1/2" lg x 3-3/8" wd; cover 3-5/8" lg x 2-7/8" wd x 1-1/8" thk; Sig C Spec No. 271-3047.
2Z6102A	LEG LG-2-A: tripod; rectangular shape; hollow aluminum alloy tube; 31-7/16" lg x 1-3/8" wd x 3/4" thk; Sig C Spec No. 71-512; (for Generator G-4).
2Z6103	LEG LG-3: metal tube 22-3/8" lg with cir shoe-plate on one end and other end tapered to fit generator; Sig C Spec No. 71-513.
3H4600-214	POWER UNIT PE-214: gasoline; 300 w at 1.0 pf full load; 120/240 v, 2.5 amp, 60 c single-phase, 2-wire (Elec Mtrs & Spec alternator; Jacobsen Model J-100 engine, one hp).
3H4698-74	RECTIFIER POWER UNIT PP-74/TRC-10: electron tube rectifier; output No. 1, 550 v dc, 0.14 amp; No. 2, 6.3 v ac, 3 amp; input 100 to 250 v ac; 7-1/2" lg x 6-1/2" h x 5-1/2" wd; Sig C Spec No. 271-3047.
2C5130-46	RECEIVER-TRANSMITTER RT-46/TRC-10: portable; cw; transmitter output 20 w; 18" lg x 5-1/2" wd x 12" h; Sig C Spec No. 271-3047.
2A3129	REEL RL-29: antenna or counterpoise; flat rectangular frame 11-3/4" lg x 10" wd, formed of 3/16" iron wire; with 1/2" std iron pipe handle 4-9/16" lg; Sig C dwg No. SC-D-1040.
6H6302-2	REEL RL-102/TRC-10: antenna; phenolic; for reeling and carrying a 150-ft antenna or counterpoise; frame 10" lg x 8" wd x 1/4" thk; Sig C Spec No. 271-3047.
3H6699-84	VIBRATOR POWER UNIT PP-84/TRC-10: non-synchronous vibrator; output No. 1, 500 to 600 v dc, 50 to 60 w; No. 2, 250 to 300 v dc, 15 w; No. 3, 6 v, 12 to 15 w; No. 4, 6 v, 10 w; input 5.5 v to 7.5 v dc; Tedeco spec No. 271-3047; Sig C Spec No. 71-3106.

117. MAINTENANCE PARTS FOR RECEIVER-TRANSMITTER RT-46/TRC-10.

The following information was compiled on 28 February 1945. The appropriate sections of the ASF Signal Supply Catalog for Receiver-Transmitter RT-46/TRC-10 are:

Higher Echelon Spare Parts

SIG 8-RT-46/TRC-10

when published

For the latest index of available catalog sections, see ASF Signal Supply Catalog SIG 2.

Ref symbol	Signal Corps stock No.	Name of part and description
	2C5130-46	RECEIVER-TRANSMITTER RT-46/TRC-10: c-w; transmitter output 20 w; portable; Sig C Spec No. 271-3047.
	2Z3351-54	CAP, connector: die cast aluminum shell; with chain; 1-15/16" OD x 1/2" h; Amphenol No. 9760-28; (for crystal cover receptacle).
	2Z3351-55	CAP, jack: hinged spring type; 1" lg x 3/4" diam; Crowe No. A-23559.
C103	3K2010021	CAPACITOR, fixed: mica; 10- mmf $\pm 10\%$; 500 vdcw; max dimen 51/64" lg x 15/32" wd x 7/32" thk; CM20BLOOK.
C210	3K2024032	CAPACITOR, fixed: mica; 24- mmf $\pm 5\%$; 500 vdcw; max dimen 51/64" lg x 15/32" wd x 7/32" thk; Aerovox type 1469S.
C203, C212	3K2051022	CAPACITOR, fixed: mica; 51- mmf $\pm 5\%$; 500 vdcw; max dimen 51/64" lg x 15/32" wd x 7/32" thk; CM20B510J.
C101	3K2024132	CAPACITOR, fixed: mica; 240- mmf $\pm 5\%$; 500 vdcw; max dimen 51/64" lg x 15/32" wd x 7/32" thk; CM20C241J.

117. MAINTENANCE PARTS FOR RECEIVER-TRANSMITTER RT-46/TRC-10 (contd).

Ref symbol	Signal Corps stock No.	Name of part and description
C108	3K4551122	CAPACITOR, fixed: mica; 510-mm ² $\pm 5\%$; 2,500 vdcw; max dimen 2-9/32" lg x 1-1/8" wd x 29/64" thk; CM45B511J.
C104, C216, C217, C222	3K2510224	CAPACITOR, fixed: mica; 1,000-mm ² $\pm 20\%$; 500 vdcw; approx dimen 1-1/16" lg x 15/32" wd x 7/32" thk; CM25B102M.
C218	3K3013242	CAPACITOR, fixed: mica; 1,300-mm ² $\pm 5\%$; 500 vdcw; max dimen 53/64" lg x 53/64" wd x 9/32" thk; CM30D132J.
C211	3K3027232	CAPACITOR, fixed: mica; 2,700-mm ² $\pm 5\%$; 500 vdcw; max dimen 53/64" lg x 53/64" wd x 9/32" thk; CM30C272J.
C115, C214, C221, C220	3K3562222	CAPACITOR, fixed: mica; 6,200-mm ² $\pm 5\%$; 500 vdcw; max dimen 53/64" lg x 53/64" wd x 11/32" thk; CM35B622J.
C213, C117	3DA10-146.3	CAPACITOR, fixed: paper, oil-filled; 10,000-mm ² $+40\% - 10\%$; 600 vdcw; 15/32" diam x 1-1/4" lg; Aerovox No. 638T.
C215 ABC C219 ABC	3DA100-450	CAPACITOR, fixed: paper, oil-filled; 3-sect; 100,000 - 100,000 - 100,000 mm ² $+20\% - 10\%$; 400 vdcw; 1-3/4" lg x 1-1/2" wd x 9/16" thk; Aerovox No. 418B; Sig Corps No. 255.
C106, C107, C109	3DA100-385	CAPACITOR, fixed: paper, oil-filled; 3-sect; 100,000 - 100,000 - 100,000 mm ² $\pm 20\%$; 600 vdcw; 1-3/4" lg x 1" wd x 15/16" thk; Aerovox No. 630.
C102, C105, C116	3DA100-469	CAPACITOR, fixed: paper, oil-filled; 3-sect; 100,000 - 100,000 - 100,000 mm ² $+20\% - 10\%$; 1000 vdcw; 1-3/4" lg x 1-1/4" wd x 3/4" thk; Aerovox No. 1030.

117. MAINTENANCE PARTS FOR RECEIVER-TRANSMITTER RT-46/TRC-10 (contd).

Ref symbol	Signal Corps stock No.	Name of part and description
C202	3DA250-39	CAPACITOR, fixed: paper, oil-filled; 250,000-mmf $\pm 20\%$; 600 vdcw; 2-3/16" lg x 15/16" diam; Aerovox No. 689.
C110, C111	3DB2.1009-6	CAPACITOR, fixed: paper, oil-filled; 2-mf $\pm 20\%$; 1,000 vdcw; 3-7/8" lg x 1-13/16" wd x 1-1/16" thk; Aerovox No. 1009MB.
C112, C113, C114	3D9252V	CAPACITOR, variable: air; 14.5- to 252-mmf; 0.0225" air gap; 29/16" lg x 1-1/2" wd x 1-13/16" h; Oak type MT.
C201A, B, C	3D9261V-1	CAPACITOR, variable: air; 3-sect; 14- to 261-mmf; 0.0185" air gap; 3-13/16" lg x 3-3/16" wd x 1-7/8" h; Oak type No. 50.
C204 to C209	3D9045V-10	CAPACITOR, variable: ceramic; 7.5- to 45-mmf; 3/4" lg x 1/2" wd x 1/4" h; Centralab type No. 822-040.
	2Z2712.44	CLIP, tube contact: spring bronze, cadmium pl; 9/16" diam cap; National No. ST-12; (for 2R22 plate cap).
L102	3C1084Z11-13	COIL, RF: amplifier pl; 2 single-layer windings; unshielded; 2-1/2" lg x 1" diam; Tedeco No. TU-1383-1.
T202	3C1084Z11-14	COIL, RF: amplifier; 2 windings; shielded; 2-7/8" lg x 1-1/4" wd x 1-1/4" thk; Tedeco dwg No. TU-1386-1.
L103	3C1084Z11-12	COIL, RF: antenna; single-layer wound; unshielded; 3" lg x 1" diam; Tedeco No. TU-1384-1; (antenna coupling).
T201	3C1084Z11-15	COIL, RF: antenna; 3 windings; shielded; 2-7/8" lg x 1-1/4" wd x 1-1/4" thk; Tedeco dwg No. TU-1385-1.

117. MAINTENANCE PARTS FOR RECEIVER-TRANSMITTER RT-46/TRC-10 (contd).

Ref symbol	Signal Corps stock No.	Name of part and description
T207	229641.208	COIL, RF: BFO; rectangular aluminum shield can; 2-1/8" lg x 3/4" wd x 3/4" thk; Sickles No. G-8-230-18.
CH101	3C341-12	COIL, RF: choke; 4 pi wound; unshielded; 2.5 mh, 250 ma max, 40 ohm; 2" lg x 1/2" OD; Miller No. 3401.
CH102	3Z1891A-1	COIL, RF: choke; single-layer winding; unshielded; 13 turns No. 26 wire on 200-ohm resistor; 1/2" lg x 1/8" OD; Tedeco No. TU-1379-1.
L101	3C1084Z11-11	COIL, RF: oscillator; 2 single-layer windings; unshielded; 2-1/2" lg x 1" diam; Tedeco No. TU-1382-1.
T206	3C1084Z11-10	COIL, RF: oscillator; 4 windings, one interwound; shielded; 3" lg x 1-1/4" wd x 1-1/4" thk; Tedeco dwg No. TU-1387-1.
P101	2Z7118.1	CONNECTOR, male contact: 8-numbered cont, keyed and polarized; 90° mtg; 1-3/4" lg x 1-1/4" wd x 1-1/2" h; Cannon No. P-8-42.
F101	3Z1926	FUSE FU-26: cartridge; 1-amp, 250-v; one-time; glass body, ferrule ends; 1-1/4" x 1/4" diam; Littelfuse type 3AG.
	2Z4868.150	GASKET: synthetic rubber; 3-1/2" OD x 2-3/4" ID x 1/16" thk; Tedeco dwg No. TP-1247-1A; (meter sealing).
	2Z4868.146	GASKET: synthetic rubber; 1/2" OD x 7/64" ID x 1/16" thk; Tedeco dwg No. TP-1245-1-3; (for antenna insulator).
	2Z4868.145	GASKET: synthetic rubber; 5/8" OD x 3/8" ID x 1/16" thk; Tedeco dwg No. TP-1245-1-2; (for antenna insulator).
	2Z4868.149	GASKET: synthetic rubber; 1-13/16" lg x 1-1/4" wd x 1/16" thk; Tedeco dwg No. TP-1250-1; (for connector P101).

117. MAINTENANCE PARTS FOR RECEIVER-TRANSMITTER RT-46/TRC-10 (contd).

Ref symbol	Signal Corps stock No.	Name of part and description
	2Z4868.148	GASKET: synthetic rubber; 2" sq x 1/16" thk; Tedeco dwg No. TP-1248-1A; (for crystal holder assembly).
	2Z4868.151	GASKET: synthetic rubber; 4-1/4" lg x 1-7/8" wd x 1/16" thk; Tedeco dwg No. TP-1258-1A; (for double transmitting capacitors).
	2Z4868.147	GASKET: synthetic rubber; 2-5/8" lg x 2" wd x 1/16" thk; Tedeco dwg No. TP-1257-1A; (for transmitting capacitor).
	3Z3285-2	HOLDER, fuse: extractor post; for 3AG cartridge fuse; molded bakelite case; 2" lg x 7/16" diam; Buss No. HKW.
	3G1050-36.1	INSULATOR, feed-through: conical; white ceramic, glazed outside; 3/4" lg x 5/8" diam; Natl Co type No. X3-7.
J101, J102	2Z5534	JACK JK-34-A: telephone; used with Sig C Plug PL-55, single ckt; 1-1/4" lg x 1" wd x 3/4" h.
	2Z5790-24	KNOB, round: black bakelite; for 1/4" diam shaft; setscrew; white indicator mark; 1-7/32" diam x 13/16" h; Crowe No. 6607; Tedeco No. TP-1251-1C.
	2Z5753-28	KNOB, round: black bakelite; for 1/4" diam shaft; setscrew; white indicator arrow; 1-1/8" diam x 5/8" h; Crowe No. 6606; Tedeco No. TP-1252-1.
E201	2Z5952	LAMP LM-52: incandescent; 6- to 8-v, 0.15-amp; T3-1/4; miniature bayonet; Mazda No. 47; (brown bead).
	2Z5889-13	LAMP, glow: 105- to 125-v, 1/4-w; T4-1/2 clear; 1-1/2" lg over-all; candelabra screw base; GE No. T4-1/2.
X206	2Z5883-65	LAMPHOLDER: miniature bayonet, single-cont; Dialco No. 708.

117. MAINTENANCE PARTS FOR RECEIVER-TRANSMITTER RT-46/TRC-10 (contd).

Ref symbol	Signal Corps stock No.	Name of part and description
M101	3F6326-1	METER, voltammeter: dc; 0 to 12-50-120 ma, 0- to 1,200-v; round, bakelite flush mtg case; 3-1/2" diam flange, 2-3/4" diam x 1-7/8" d body; Simpson Electric Co No. 25; (dual scale).
EP101	3Z737-33	POST, binding: push type; engraved push; 1/2" d x 5/8" h; Eby type No. 62-M; (antenna).
EP102	3Z737-34	POST, binding: push type; 3/8" diam x 1/2" h; Eby type No. 60-M; (ground).
K101	2Z7598-29	RELAY, keying: contact arrangement 2A, DPST; 1-17/32" lg x 1-3/4" h x 1-1/4" wd; Clare CP type GAC.
R204, R205	3RC21BF331K	RESISTOR, fixed: composition; 330-ohm $\pm 10\%$; 1/2-w; max dimen 0.655 lg x 0.249" diam; RC21BF331K.
R216	3RC21BF102K	RESISTOR, fixed: composition; 1,000-ohm $\pm 10\%$; 1/2-w; max dimen 0.655" lg x 0.249" diam; RC21BF102K.
R113	3RC31BF122K	RESISTOR, fixed: composition; 1,200-ohm $\pm 10\%$; 1-w; max dimen 1.28" lg x 0.310" diam; RC31BF122K.
R207	3RC21BF162J	RESISTOR, fixed: composition; 1,600-ohm $\pm 5\%$; 1/2-w; max dimen 0.655" lg x 0.249" diam; RC21BF162J.
R102	3RC31BF822K	RESISTOR, fixed: composition; 8,200-ohm $\pm 10\%$; 1-w; max dimen 1.28" lg x 0.310" diam; RC31BF822K.
R209, R112	3RC21BF103K	RESISTOR, fixed: composition; 10,000-ohm $\pm 10\%$; 1/2-w; max dimen 0.655" lg x 0.249" diam; RC21BF103K.
R103	3RC31BF153K	RESISTOR, fixed: composition; 15,000-ohm $\pm 10\%$; 1-w; max dimen 1.28" lg x 0.310" diam; RC31BF153K.
R202	3RC21BF223K	RESISTOR, fixed: composition; 22,000-ohm $\pm 10\%$; 1/2-w; max dimen 0.655" lg x 0.249" diam; RC21BF223K.
R210, R211, R218	3RC41BF223K	RESISTOR, fixed: composition; 22,000-ohm $\pm 10\%$; 2-w; max dimen 1.78" lg x 0.405" diam; RC41BF223K.

117. MAINTENANCE PARTS FOR RECEIVER-TRANSMITTER RT-46/TRC-10 (contd).

Ref symbol	Signal Corps stock No.	Name of part and description
R208, R212	3RC21BF683K	RESISTOR, fixed: composition; 68,000-ohm $\pm 10\%$; 1/2-w; max dimen 0.655" lg x 0.249" diam; RC21BF683K.
R201	3RC21BF104K	RESISTOR, fixed: composition; 100,000-ohm $\pm 10\%$; 1/2-w; max dimen 0.655" lg x 0.249" diam; RC21BF104K.
R101, R203	3RC31BF104K	RESISTOR, fixed: composition; 100,000-ohm $\pm 10\%$; 1-w; max dimen 1.28" lg x 0.310" diam; RC31BF104K.
R215	3RC21BF224K	RESISTOR, fixed: composition; 220,000-ohm $\pm 10\%$; 1/2-w; max dimen 0.655" lg x 0.249" diam; RC21BF224K.
R108	3RC21BF304J	RESISTOR, fixed: composition; 300,000-ohm $\pm 5\%$; 1/2-w; max dimen 0.655" lg x 0.249" diam; RC21BF304J.
R111	3RC41BF304J	RESISTOR, fixed: composition; 300,000-ohm $\pm 5\%$; 2-w; max dimen 1.78" lg x 0.405" diam; RC41BF304J.
R213, R217	3RC21BF334K	RESISTOR, fixed: composition; 330,000-ohm $\pm 10\%$; 1/2-w; max dimen 0.655" lg x 0.249" diam; RC21BF334K.
R214	3RC21BF474K	RESISTOR, fixed: composition; 470,000-ohm $\pm 10\%$; 1/2-w; max dimen 0.655" lg x 0.249" diam; RC21BF474K.
R105	3Z6960-18.2	RESISTOR, fixed: composition; 1.2-meg $\pm 1\%$; 1-w; 2 resistors in series, each 1.28" lg x 0.310" diam; Tedeco R-105.
R106	3Z5995-57	RESISTOR, fixed: wire-wound; 5-ohm $\pm 10\%$; 10-w; 1-3/4" lg x 3/8" diam; Clarostat type No. A-10F.
R109, R110	3Z6500-219	RESISTOR, fixed: wire-wound; 5000 ohms $\pm 10\%$; 20-w; 1-3/4" lg x 5/8" diam; Clarostat type No. A-20F.

117. MAINTENANCE PARTS FOR RECEIVER-TRANSMITTER RT-46/TRC-10 (contd).

Ref symbol	Signal Corps stock No.	Name of part and description
R104	3Z6640-61	RESISTOR, fixed: wire-wound; 15,000-ohm $\pm 10\%$; 20-w; 1-3/4" lg x 5/8" diam; Clarostat type No. A-20F.
R107	3Z6620-157	RESISTOR, fixed: wire-wound; 20,000-ohm $\pm 10\%$; 10-w; 1-3/4" lg x 3/8" diam; Clarostat type No. A-10F.
R206	2Z7270-29	RESISTOR, variable: carbon; 25,000-ohm; 1-w; 3-term; 1-1/8" diam x 9/16" d; Clarostat No. 37; (sensitivity control).
SH101	3F3802-1500	SHUNT, meter: fixed; 0.4201-ohm $\pm 1\%$; 1-w; 1/2" lg x 1/2" diam; Elco Resistor Co type No. A-1.
SH102	3F3802-700	SHUNT, meter: fixed; 1.0204-ohm $\pm 1\%$; 1/2-w; 1/2" lg x 1/2" diam; Elco Resistor Co type No. A-1.
SH103	3F3802-332	SHUNT, meter: fixed; 4.55-ohm $\pm 1\%$; 1/2-w; 1/2" lg x 1/2" diam; Elco Resistor Co type No. A-1.
X101	2Z8761-22	SOCKET, crystal: 2-cont; steatite ceramic; 13/16" x 9/16" x 5/16" thk; Millen No. 33002.
X103	2Z8763.4	SOCKET, tube: std 5 cont; steatite; 7/8" h x 1-1/4" diam; Amphenol type No. RSS5; (for 2E22).
X201 to X205	2ZK8678.19	SOCKET, tube: std octal; steatite; 7/8" h x 1-1/4" diam; Ucinite No. 8019.
SW104	3Z9825-62.184	SWITCH, rotary: 1-position; 1-sect; 2-ckt; 2" lg x 2" diam; Oak No. 28306-H; Tedeco dwg No. TU-1196-1; (meter selector).
SW101	3Z9825-62.185	SWITCH, rotary: 2-position; 2-sect; 7-ckt; 4-13/32" lg x 2" diam; Oak No. 28308-H2C; Tedeco dwg No. TU-1198-1B; (transmit band switch).
SW201	3Z9825-62.187	SWITCH, rotary: 2-position; 3-sect; 4-ckt; 4-5/32" lg x 2" diam; Oak No. 28302-H3C; Tedeco dwg No. TU-1194-1B; (receiver band selector).
R219	3RC21BF202K	RESISTOR, fixed: composition; 2,000-ohm $\pm 10\%$; 1/2-w; max dimen 0.655" lg x 0.249" diam; RC21BF202K.

117. MAINTENANCE PARTS FOR RECEIVER-TRANSMITTER RT-46/TRC-10 (contd).

Ref symbol	Signal Corps stock No.	Name of part and description
SW105	3Z9825-62.182	SWITCH, rotary: 3-position; 1-sect; 3-ckt; bakelite body; 2" lg x 2" diam; Oak No. 28307-H; Tedeco dwg No. TU-1197-1; (cw-calibrate-phone selector).
SW103	3Z9825-62.183	SWITCH, rotary: 3-position; 2-sect; 7-ckt; steatite body; 2-11/16" lg x 2" diam; Oak No. 28305-HC; Tedeco dwg No. TU-1195-1C; (stand-by, receive-transmit).
SW102	3Z9825-62.186	SWITCH, rotary: 6-position; 1-sect; 1-ckt; 1-3/4" lg x 2" diam; Oak No. 28300HC; Tedeco dwg No. TU-1200-1B; (antenna switch).
SW202	3Z9845	SWITCH, toggle: SPST; bakelite case; 1" lg x 3/4" wd x 5/8" d; C-H No. 8280; (dial light).
T205	2Z9632.332	TRANSFORMER, AF: output; pri 10,000 ohms; sec 10,000 ohms, tapped at 250 ohms; upright shielded steel case; 2-1/4" h x 1-9/16" wd x 1-9/16" d; UTC No. 85307.
T203	2Z9641.210	TRANSFORMER, IF: 454-kc; input; shielded; 2-1/8" lg x 3/4" wd x 3/4" thk; Sickles FW No. G-8-230-19.
T204	2Z9641.209	TRANSFORMER, IF: 454-kc; output; shielded; 2-1/8" lg x 3/4" wd x 3/4" thk; Sickles FW No. G-8-230-20.
V102	2J2E22	TUBE, electron: JAN-2E22.
V205	2J6J5GT/G	TUBE, electron: JAN-6J5GT/G.
V202	2J6SA7	TUBE, electron: JAN-6SA7.
V201, V203	2J6SK7	TUBE, electron: JAN-6SK7.
V204	2J6SL7GT	TUBE, electron: JAN-6SL7GT.
V101	2J6V6GT/G	TUBE, electron: JAN-6V6GT/G.

118. MAINTENANCE PARTS FOR VIBRATOR POWER UNIT PP-84/TRC-10.

The following information was compiled on 28 February 1945. The appropriate sections of the ASF Signal Supply Catalog for Vibrator Unit PP-84/TRC-10 are:

Higher Echelon Spare Parts

SIG 8-PP-84/TRC-10

when published

For the latest index of available catalog sections, see ASF Signal Supply Catalog SIG 2.

Ref symbol	Signal Corps stock No.	Name of part and description
	3H4497-84	VIBRATOR POWER UNIT PP-84/TRC-10: nonsynchronous vibrator; output 500-600 v dc, 50 to 60 w; 250-300 v dc, 15 w; 6 v, 12 to 15 w; 6 v, 10 w; input 5.5 v to 7.5 v; Sig C Spec No. 271-3047.
C303, C304	3DA20-52	CAPACITOR, fixed: paper, oil-filled; 20,000-mmf $\pm 20\%$; 1,000 vdcw; 1-5/16" lg x 11/16" diam; Solar No. XT-1MW10-62; (buffer capacitor).
C301, C302	3DA500-56.1	CAPACITOR, fixed: paper, oil-filled; 500,000-mmf $\pm 20\%$; 400 vdcw; 2-3/16" lg x 1-1/16" diam; Aerovox No. 489.
C305	3DB8-162	CAPACITOR, fixed: paper, oil-filled; 8-mf $\pm 20\%$; 1,000 vdcw; 4-3/4" lg x 3-3/4" wd x 1-1/4" thk; Aerovox No. 1009 MB.
	3B925	CLIP, battery: steel, lead coated; 4" lg x 1-9/32" h x 3/4" wd; Muller No. 21A (stamped "positive"; pr insulating clamping ears).
	3B921	CLIP TL-110: battery; steel, lead coated; 4-1/32" lg x 1-19/32" h x 3/4" wd; Muller No. 21A; (stamped "negative"; pr insulating clamping ears)
P301	227118.7	CONNECTOR, female contact: 8-numbered cont; keyed and polarized; straight; 1-1/4" thk x 2" diam; Cannon No. P8-17.

118. MAINTENANCE PARTS FOR VIBRATOR POWER UNIT PP-84/TRC-10 (contd).

Ref symbol	Signal Corps stock No.	Name of part and description
F301	3Z1940	FUSE FU-40: cartridge; 30-amp, 25-v; glass body; ferrule ends; 1-1/4" lg x 9/32" diam; Littelfuse type 4AG, No. 1099.
F301-A	3Z2876-6.1	HOLDER, fuse: extractor post; for single No. 4AG cartridge fuse; molded bakelite with brass inserts; 20 amp max; 2-9/32" lg x 25/32" diam over-all; Buss No. HCM.
R301	3RC21BF155K	RESISTOR, fixed: composition; 1.5-meg $\pm 10\%$; 1/2-w; max dimen 0.655" lg x 0.249" diam; RC21BF155K.
X301	2ZK8666-13	SOCKET, tube: std octal; mica-filled; 7/8" h x 1-1/4" diam; Cinch No. 115001-2; (rectifier tube).
X302, X303	2Z8676.10	SOCKET, tube: std 6 prong; steatite; 7/8" h x 1-1/4" diam; Amphenol type No. RSS6; (vibrator).
SW301	3Z9849.163	SWITCH, toggle: DPST; bakelite body; 2-1/8" lg x 49/64" wd x 1-1/8" h; No. ST25H; (off-on).
T301	2Z9625-40	TRANSFORMER, power: fil and plate; pri 5.5 to 6.75 v, ct, 120 c; sec No. 1, 1,320 v, 100 ma, ct; sec No. 2, 5 v, 2 amp; hermetically sealed; 4-3/4" h x 4-1/8" wd x 3-7/8" d; Electronic Labs No. TA-2730A.
V301	2J5R4GY	TUBE, electron: JAN-5R4GY.
V1b- 301	3H6691-19	VIBRATOR, non-synchronous: input 5 to 7.5 v dc; 5-5/8" lg x 3-5/16" wd x 2-5/8" thk; two 6-prong male plug-in term; Electronic No. LTD-1633.

119. MAINTENANCE PARTS FOR RECTIFIER POWER UNIT PP-74/TRC-10.

The following information was compiled on 28 February 1945. The appropriate sections of the ASF Signal Supply Catalog for Rectifier Power Unit PP-74/TRC-10 are:

Higher Echelon Spare Parts

SIG 8-PP-74/TRC-10

when published

For the latest index of available catalog sections, see ASF Signal Supply Catalog SIG 2.

Ref symbol	Signal Corps stock No.	Name of part and description
	3H4698-74	RECTIFIER POWER UNIT PP-74/TRC-10: electron tube rectifier; output 550 v dc, 0.14 amp; 6.3 v ac, 3 amp; input 100 to 250 v ac; approx dimen 7-1/2" lg x 6-1/2" h x 5-1/2" wd.
C401	3DB2.1009-6	CAPACITOR, fixed: paper, oil-filled; 2-mf +20%; 1,000 vdcw; 3-7/8" lg x 1-13/16" wd x 1-1/16" thk; Aerovox type No. 1009MB.
CH401	3C573-15	COIL, AF: filter choke; single-winding; 6-h; 150-ma; 75-ohm d-c resistance; 3" lg x 3" wd x 3-5/8" h; UTC No. 85309.
	6Z1736-5	CONNECTOR, male contact: 2 parallel blade cont, spring action type; straight; 2-1/4" lg x 1-3/8" diam; Allied No. 110; (for a-c cord).
P401	2Z7118.7	CONNECTOR, female contact: 8-numbered cont; keyed and polarized; straight; 1-1/4" thk x 2" diam; Cannon No. P8-17; (connector for CX-83/TRC-10).
F401	3Z2605.2	FUSE, cartridge: 5-amp; 250-v; glass body; ferrule ends; 1-1/4" lg x 1/4" diam; Buss type No. MTH.
F401-A	3Z3285-2	HOLDER, fuse: extractor post; for single 3AG cartridge fuse; molded bakelite with 3/8" term; 2" lg x 7/16" diam; Buss type No. NKM.

119. MAINTENANCE PARTS FOR RECTIFIER POWER UNIT PP-74/TRC-10 (contd).

Ref symbol	Signal Corps stock No.	Name of part and description
	225753.28	KNOB, round: black bakelite; for 1/4" diam shaft; No. 8-32 setscrew; white indicator arrow; 1-1/8" diam x 5/8" h; Crowe No. 6606; Tedeco No. TP-1252-1.
R401	326650-162	RESISTOR, fixed: wire-wound; 50,000-ohm $\pm 10\%$; 25-w; 2-1/2" lg x 9/16" diam; Clarostat Type No. A-25K.
X401	228678.56	SOCKET, tube: std octal; steatite; over-all dimen 7/8" h x 1-1/4" diam; Ucinite type No. 8019; (for rectifier).
SW402	329825-62.181	SWITCH, rotary: selector; 5-position; 1-sect; 1-ckt; non-shorting type cont; 1-3/4" lg x 2" diam; Oak No. 28309-H; Tedeco dwg No. TU-1199-1; (primary voltage).
SW401	329849.39-1	SWITCH, toggle: SPST; bakelite body; 1-1/8" lg x 5/8" wd x 21/32" d; No. ST12A; (on-off).
T401	229602-32	TRANSFORMER, power: fil and plate; pri 0-100-115-150-200-220-250 v, 60 c; sec No. 1, 1350 v, 150 ma, ct; sec No. 2, 5 v, 2 amp; sec No. 3, 6.3 v, 5 amp; completely enclosed metal case 4-7/16" sq x 5-1/2" h; VTC No. 85308.
V401	2J5R4GY	TUBE, electron: JAN-5R4GY; (rectifier).

120. MAINTENANCE PARTS FOR HAND GENERATOR G-4/TRC-10.

The following information was compiled 28 February 1945. The appropriate sections of the ASF Signal Supply Catalog for Hand Generator G-4/TRC-10 are:

Higher Echelon Spare Parts

SIG 8-G-4/TRC-10

when published

For the latest index of available catalog sections, see ASF Catalog SIG 2.

Ref symbol	Signal Corps stock No.	Name of part and description
235	3H2320-4	HAND GENERATOR G-4/TRC-10: d-c; output 500 v, 110 ma; 6.3 v, 3.3 amp; 11" lg x 8" h x 7-5/8" wd; Sig C Spec No. 271-3108.
	3H2358/P8	BEARING ASSEMBLY, sleeve: coupling; left; includes pin, spring, bearing bell, felt gasket, bearing seal, oilite bearing, retainer, stud and thumb nut; over-all dimen, with bearing seal assembly open, 4-3/4" lg x 2-5/16" wd x 1-5/32" thk; Warwick part dwg No. US-84134.
	3H2358/P7	BEARING ASSEMBLY, sleeve: coupling; right; includes pin, spring, bearing ball, felt gasket, bearing seal, oilite bearing, retainer, stud and thumb nut; over-all dimen, with bearing seal assembly open, 4-1/8" lg x 2-7/8" wd x 1-7/16" thk; Warwick part dwg No. US-84133.
	3H525-97	BRUSH, electrical contact: h-v; Morganite grade HM-6782; complete with spring, pigtail and cap; 1-9/64" lg x 0.089" thk x 0.275" wd over-all; Pioneer No. AS-B-6008, AS-B-6008-1.

120. MAINTENANCE PARTS FOR HAND GENERATOR G-4/TRC-10 (contd).

Ref symbol	Signal Corps stock No.	Name of part and description
236	3H525-99	BRUSH, electrical contact: lv; Morganite grade CM-6210; complete with spring, pigtail and cap; 1-18/32" lg x 0.188" thk x 0.262" wd over-all; Pioneer No. AS-B-6017, AS-B-6017-1.
	3H2358/C1	CAP, contact brush: bakelite; with brass insert; tapped 7/16"-27 thd; screwdriver slot; 11/16" diam x 5/8" thk; Pioneer No. A-5009; Warwick dwg No. US-6317.
231	3DB250-3	CAPACITOR, fixed: electrolytic; 250-mf +100% -0%; 10 vdcw; 2" lg x 3/4" diam; Dubilier No. BRG; Warwick dwg No. US-18280.
245	3DA10-326	CAPACITOR, fixed: paper, oil-filled; 10,000-mmf $\pm 20\%$; 2,000 vdcw; 1-5/8" lg x 5/8" diam; Fast No. A8246H; Warwick dwg No. US-16178.
241	3DA100-329	CAPACITOR, fixed: paper; 100,000-mmf $\pm 10\%$; 200 vdcw; 1-7/16" x 3/4" x 3/8"; Micamold No. 345-21.
246	3DA100-471	CAPACITOR, fixed: paper; 100,000-mmf $\pm 20\%$; 600 vdcw; max dimen 1-3/4" lg x 11/16" diam; CP29A1DF104MM.
230	3DA500-346	CAPACITOR, fixed: paper; 500,000-mmf $\pm 20\%$ -10%; 600 vdcw; max dimen 2-1/2" lg x 1-3/4" wd x 7/8" thk; CP50E1DF504MK.
233-1, 233-2	3DE2-48	CAPACITOR, fixed: paper; 2-mf $\pm 10\%$; 600 vdcw; max dimen 2-3/4" lg x 2-3/4" wd x 1-1/8" thk; CP50E1DF205KK.
	3C575K	COIL, AF: choke; single-winding; 3.45 mh; 2-1/2 amp; 0.210 ohms d-c resistance; 4" lg x 1-1/2" h x 1" wd; Radionic Control per Warwick dwg No. US-33232.

120. MAINTENANCE PARTS FOR HAND GENERATOR G-4/TRC-10 (contd).

Ref symbol	Signal Corps stock No.	Name of part and description
228-1, 228-2	3C323-34Y	COIL, RF: choke; 4 pie wound; 530 uh $\pm 5\%$, 150-ma, 7 ohms d-c resistance; 2" lg x 11/16" diam; Guthman per Warwick dwg No. US-84128.
244	2Z3069-22	CONNECTOR, female contact: 8 polarized cont; straight; 1.895" OD x 1-1/4" d; Cannonelec No. P8-13 modified per Warwick dwg No. US-6840; (connector for power cable).
	3H2690.1-3	COUPLING, rigid: machine steel, isolated by Acadia synthetic No. N-187-15 neoprene; dull nickel finish; 1-5/8" diam x 1-9/16" lg with 3/8" sq broached hole in driver bearing shank; Warwick part dwg No. US-84157.
	3H1500.1	DRIVE, generator: gear and chain; magnesium, dow metal alloy R; Dow No. 7 dichromate finish; 6-1/8" h x 5-7/8" d x 7-33/64" wd; Warwick part dwg No. US-84140; (less items Nos. 20, 21, 23, 35, 36).
	6Z3810-26	FASTENER, latch: cover; bonderized steel, olive drab; 1-5/16" wd x 2-3/8" lg x 9/16" thk; Amer Cabinet Lock Co No. WX-6889; Warwick dwg No. US-83341; (holds down top to bottom cover).
	3H2358/G7	GASKET: asbestos; No. 231 BT compressed sheet packing; 2-5/16" OD x 1-3/8" ID x 3/64" thk; Warwick part dwg No. US-2819; (6 holes; 2 parallel sides between holes cut flat 1" from center, for left bell).
	3H2358/G9	GASKET: asbestos; No. 231 BT compressed sheet packing; 2-7/8" OD x 1-3/4" ID x 3/64" thk; Warwick part dwg No. US-2816; (7 holes; flat 1-1/16" from center, for right bell).
	2Z4867.233	GASKET: asbestos; No. 231 BT compressed sheet packing; 1-29/32" OD x 1-33/64" ID x 0.015" thk; Warwick No. US-2823; (5 holes; 7/16" cutout opposite one hole, for connector ref No. 244).

120. MAINTENANCE PARTS FOR HAND GENERATOR G-4/TRC-10 (contd).

Ref symbol	Signal Corps stock No.	Name of part and description
	3H2358/G1	GASKET: rubber; tubular, vulcanized endless; 27-7/8" lg x 1/8" OD x 1/16" ID; Warwick part dwg No. US-288; (cover seal).
	2Z4867.234	GASKET: synthetic rubber; channeled; 26" lg continuous x 1/8" thk x 3/16" wd; Warwick part dwg No. US-2822; (cover seal).
	3H2358/G10	GASKET: synthetic rubber; black, freeze resistant; 2-1/4" OD x 1-1/2" ID x 13/64" thk, with 1/16" thk web; Warwick part dwg No. US-83351; (seal for connector).
	3H2358/G11	GASKET: synthetic rubber; freeze resistant; 1-1/16" OD x 7/8" ID x 9/64" thk; Warwick part dwg No. US-83350; (for left and right seal assembly).
	3H2358/G5	GASKET: vellumoid or victorite; 1-1/2" sq x 1/64" thk x 7/8" ID; Warwick part dwg No. US-289; (2 holes 0.156" diam on 1-3/8" mtg center); (seal between generator and chain drive).
	6Q45127	GAUGE TL-127: thickness; one end 0.0006" - 0.0007", stainless steel type No. 438; other end 0.0156", stainless steel type No. 302; 1-1/4" lg x 3/4" wd; Sig C Spec No. SC-A-931.
	3H2358/S18	GEAR: pinion sprocket; 3d stage; X-1335 steel; 16 teeth for 7/32" 3-4 link, side guide; 0.961" diam x 0.375" wd x 5/16" diam, broached hole with 2 flats 1/4" across; Warwick part dwg No. US-7813.
235 236	3H2403.1	GENERATOR, DC: "A", 6.7-v, 3.45-amp; "B", 78-w, 500-v, 110-ma; 4" diam x 6-17/32" lg; Pioneer No. SF-20, SS-3143 per Warwick dwg No. US-385.
	6G609.1	GREASE: 1-lb can; Andoc C; (for gear case).

120. MAINTENANCE PARTS FOR HAND GENERATOR G-4/TRC-10 (contd).

Ref symbol	Signal Corps stock No.	Name of part and description
	3H2358/M10	MOUNT, vibration: round; 9/16" diam x 1/2" thk; Warwick part dwg No. US-83349; (No. 8-32 x 9/32" stud one end, No. 8-32 x 13/32" stud other); (for generator).
234	3H4990-6	REGULATOR, voltage: 6-v, 3-amp; 13/16" wd x 2" h x 1-1/2" base; Warwick No. US-84132.
222	227590.2	RELAY, armature: DPST normally open; 2-5/16" lg x 1-9/16" wd x 1-3/4" h over-all; Radionic Control No. G-189; Warwick No. US-83377; (switches high voltage on-off).
232	3Z6001E5-27	RESISTOR, fixed: composition; 15-ohm $\pm 15\%$; 3-w; 1" lg x 1/4" diam; Keystone Carbon Co. type LC-061; Warwick No. US-60709.
243	3Z6002E5-63	RESISTOR, fixed: wire-wound; 28-ohm $\pm 5\%$; 10-w; tapped at 25 ohms; 2" lg x 9/16" diam; Warwick part dwg No. US-60711.
	3H2358/R15	SEAL ASSEMBLY, bearing: left; aluminum; retainer with neoprene seal; 2-27/64" lg x 1-3/8" wd x 9/32" thk; Warwick part dwg No. US-84130; (for left coupling bearing assembly).
	3H2358/R16	SEAL ASSEMBLY, bearing: right; aluminum retainer with neoprene seal; 2-1/8" lg x 1-3/8" wd x 5/16" thk; Warwick part dwg No. US-84129; (for right coupling bearing assembly).
	3H2358/S15	SPRING, torsion: spring nickel alloy 0.025" diam; 0.225" lg x 5/32" ID with 3/8" lg leads at ends; Warwick part dwg No. US-70135; (for bearing seal assemblies).
	6L35032-2	WASHER, flat: No. 231 BT compressed asbestos sheet packing; 3/8" OD, 0.133" ID, 1/32" thk; Warwick part dwg No. US-2818; (for mounting screws).

120. MAINTENANCE PARTS FOR HAND GENERATOR G-4/TRC-10 (contd).

Ref symbol	Signal Corps stock No.	Name of part and description
	6L53014-1	WASHER, flat: thrust; bearing bronze; 9/16" OD, 1/4" ID, 0.091" thk; Warwick No. US-83345; (for pinion wheel and sprocket assembly).
	6L53013-4	WASHER, flat: thrust; bearing bronze; 11/16" OD, 0.377" ID, 0.072" thk; Warwick No. US-83344; (for pinion gear).
	6L53016-1	WASHER, flat: thrust; bearing bronze; 0.377" ID, 11/16" OD, 0.91" thk; Warwick No. US-83342; (for 2d stage sprocket wheel).
	6L53018-1	WASHER, flat: thrust; bearing bronze; 13/16" OD, 0.502" ID, 0.91" thk; Warwick No. US-83343; (for drive shaft).

NOTES

NOTES

ORDER No. 29297-PHILA-44-08

7250

26 MARCH 1945

Digitized by Google

Original from
UNIVERSITY OF CALIFORNIA

