

WAR DEPARTMENT
TECHNICAL MANUAL

TM 11 - 903

U.S. Army

§ SUPP.

POWER UNIT PE-77-(*)

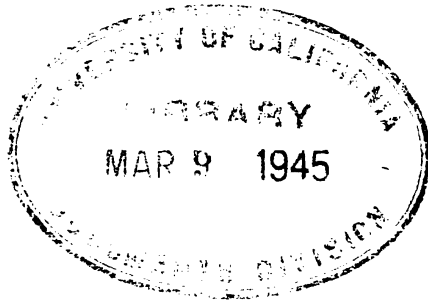

WAR DEPARTMENT 14 OCTOBER 1943

War Department Technical Manual

TM 11-903

POWER UNIT PE-77-(*)

War Department,

14 October, 1943

POWER UNIT PE-77-(*)

WAR DEPARTMENT
WASHINGTON 25, D. C. 14 October 1943.

TM 11-903, Power Unit PE-77-(*), is published for the information and guidance of all concerned.

(A. G. 300.7 (14 October 1943).)

BY ORDER OF THE SECRETARY OF WAR:

G. C. MARSHALL,
Chief of Staff.

OFFICIAL:

J. A. ULIO,
Major General
The Adjutant General.

DISTRIBUTION:

R and H 1 (5); IBn 1, 11 (6); IC 11 (10).

(For explanation of symbols see FM 21-6.)

U 113

, 2

TM 11:903

1943

TABLE OF CONTENTS

SECTION I. Description	★ ★	1
Paragraph 1. General		1
2. Component parts, weights, dimensions, and ratings		1
II. Installation and Operation		4
3. Unpacking		4
4. Installation		4
5. Ventilation		4
6. Preparation for use		4
7. Operation		5
III. Functioning of parts		7
8. Engine		7
9. Carburetor		7
10. Magneto		7
11. Speed regulation		7
IV. Maintenance		8
12. General maintenance		8
13. Lubrication		9
14. Carburetor adjustment		9
15. To clean fuel system		10
16. Removing and cleaning carburetor		11
17. Governor and governor speed adjustment		12
18. Ignition system		15
19. To remove and replace flywheel		16
20. To remove magneto assembly		17
21. To replace magneto		17
22. Magneto timing		17
23. To adjust and clean magneto contact points		18
24. To replace magneto condenser		18
25. To replace and adjust magneto armature		18
26. Cylinder head		20
27. Compression		20
28. Valve adjustment		22
29. Breather valve		23
30. Pistons		23
31. Piston rings		24
32. Piston pins		25
33. Connecting rod		25
34. Oil pump		25
35. To remove crankshaft		26
36. Oil leaks		27
37. Carbon		27
38. Air cleaner		28

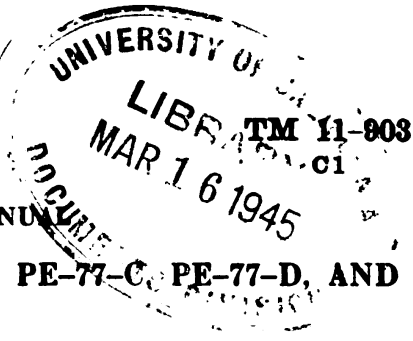

TECHNICAL MANUAL

POWER UNITS PE-77-A, PE-77-B, PE-77-C, PE-77-D, AND PE-77-E

CHANGES |
No. 1 |

WAR DEPARTMENT,
WASHINGTON 25, D. C., 3 October 1944.

TM 11-903, 14 October 1943, is changed as follows:

The title of this manual is changed to read: **POWER UNITS PE-77-A, PE-77-B, PE-77-C, PE-77-D, AND PE-77-E.**

5. VENTILATION.

* * * * *

c. If the unit * * * excessive back pressure A 1-inch tube may be used where the length of the exhaust tube is less than 10 feet; a 1½-inch I. D. (inside diameter) tube should be used if the exhaust tube exceeds 10 feet. Make sure that * * * entrance of water.

7. OPERATION.

* * * * *

b. *Stopping.*—On PE-77-C, D, and * * * engine stops turning. Do not disconnect any external load until the unit has come to a dead stop. If the load is disconnected from the unit before the unit stops, it may cause a reversal of the polarity of the unit. When the engine * * * formation of gum.

c. *Operator's maintenance schedule* (Superseded.)—Follow instructions contained in War Department Lubrication Order No. 3018.

WAR DEPARTMENT LUBRICATION ORDER No. 3018
SIGNAL CORPS



POWER UNIT PE-77

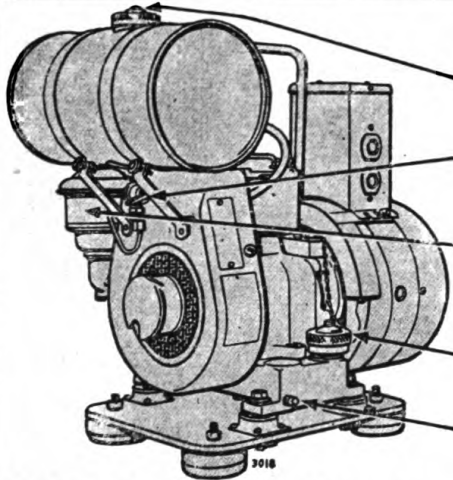

Operating Hours • Lubricant

1024 Fuel Tank

Clean inside of tank and fuel line. Keep fuel clean and vent in cap open. Cap. 1/2 or 1 gal.

64 Fuel Tank Shut-Off Valve

Drain water and sediment. Also, remove fuel strainer sediment bowl, located next to carburetor, clean bowl and strainer screen.

8 OE Air Cleaner

Check level and refill to level mark. Every 24 hours, remove, drain, clean and refill. Every 256 hours, remove and wash all parts.

4 OE Crankcase Fill and Level Gage

Check level.

48 Crankcase Drain Plug

Drain and refill. Cap. approx. 3/4 qt. Drain only when hot

COLD WEATHER—Below 0°F., drain Crankcase daily. Refill Crankcase with 75% OE SAE 10 and 25% gasoline thoroughly mixed. Check level more often. Maintain at FULL mark by adding undiluted OE SAE 10 only.
HOURS—Reduce hours under severe operating conditions.

CLEAN parts with SOLVENT, dry-cleaning, or OIL, fuel, Diesel. Allow parts to dry thoroughly before lubricating.
OIL CAN POINTS—Every 64 hours, lubricate Throttle and Governor Control Linkage with OE.
DO NOT LUBRICATE—Magneto, Engine Governor.
REFERENCE—Technical Manual TM 11-903.

*By Order of the Secretary of War:
G. C. Marshall, Chief of Staff.*

KEY

LUBRICANTS	LOWEST EXPECTED AIR TEMPERATURE		
	above +32°F.	+32°F. to 0°F.	below 0°F.
OE—OIL, engine			
Crankcase	OE SAE 30	OE SAE 10	See Cold Weather Note
Except Crankcase	OE SAE 30	OE SAE 10	PS
PS—OIL, lubricating, preservative, special			

Requisition LUBRICATION ORDER from Philadelphia Signal Depot, or Utah ASF Depot, Ogden, Utah, by Signal Corps Stock No. 6D 10 113-18

-3018

25 Mar 1944
Supersedes all previous lubrication instructions.

Data based on inspection of Production Model.

TL92080

Figure 3.—War Department Lubrication Order No. 3018.

13. LUBRICATION.

* * * * *

b. Crankcase.

* * * * *

(2) Drain and supply * * * crankcase is 1 1/2 pints. Follow instructions contained in War Department Lubrication Order No. 3018.

(3) Rescinded.

* * * * *

c. *Air cleaner*.—Before using the * * * at all times. Follow lubricating instructions contained in War Department Lubrication Order No. 3018.

18. IGNITION SYSTEM.

* * * * *

c. *Spark plug adjustment*.—The cap of * * * plug and gasket. Apply a little *graphite* grease on thread when replacing; do not get the grease on the points. Replace the shield as it reduces radio interference.

* * * * *

38. **AIR CLEANER**.—Clean the air * * * (Federal Specification P-S-661A). Clean the bowl by submerging in **cleaning solvent** or fuel oil, Diesel. Fill cleaner bowl * * * the cleaner bowl. (See War Department Lubrication Order No. 3018.) Make sure filter is dry before replacing it.

40. GENERATOR.

* * * * *

g. *Generator line condenser*.—A condenser is * * * not immediately available. The large capacity of this electrolytic condenser permits the storage of considerable energy during operation of the unit. When the unit is stopped, this energy is bled off through the armature and series field of the generator and through any load connected to the unit at that time. This discharge energy has a polarity opposite to that being produced by the generator. If, at any point during the period of deceleration, the discharge voltage of the condenser is greater than the generator voltage, the direction of current flow in the generator will be reversed. This may cause a reversal in polarity of the residual magnetism of the generator poles, and the polarity of the generator leads will be reversed.

* * * * *

i. *Polarity reversal* (Added).—In case of polarity reversal, remove the outlet box cover and interchange the two generator leads at the condenser terminals. Although the polarity of the generator will now be reversed, the polarity of the condenser will coincide with that of the generator and the unit will operate normally

43.1. **MOISTUREPROOFING AND FUNGIPROOFING** (Added).—a. *Treatment*.—A moistureproofing treatment has been devised which, if properly applied, provides a reasonable degree of protection against fungus growth, insects, salt spray and moisture. The treat-

ment involves the use of a moisture- and fungi-resistant varnish applied with a spray gun or brush. Refer to TB SIG 13 for detailed description of the varnish-spray method of moistureproofing and fungiproofing.

b. Step-by-step instructions.—(1) *Disassembly.*—(a) Remove the four screws that hold the filter box to the top of the generator.

(b) Lift the filter box from the generator. Remove the cover of the filter box and disconnect all leads from the capacitor.

(c) Remove the capacitor from the filter box.

(2) *Masking.*—(a) Mask the two terminals of the capacitor with tape.

(b) Cover the openings in the duplex receptacle with masking tape.

(c) Cover the two connecting lugs on the leads from the duplex receptacle with masking tape.

(d) Cover the lugs on the leads coming from the generator to the capacitor with masking tape.

(3) *Drying.*—Dry all parts to be treated for 2 to 3 hours at 160° F.

(4) *Varnishing.*—Apply three coats of moisture- and fungi-resistant varnish as follows:

(a) Spray both the inside and the outside of the filter box and the filter box cover.

(b) Spray the capacitor thoroughly on all sides.

(c) Hand brush the leads from the generator. Do not get any varnish on the connecting lugs.

(d) Hand brush the duplex receptacle and leads. Do not get any varnish on the connecting lugs.

(5) *Reassembly.*—Reassemble and check the operation of the unit.

(6) *Marking.*—Mark the letters MFP and the date of treatment on the unit. EXAMPLE: MFP 21 June 1944.

44. (Superseded.) MAINTENANCE PARTS LIST FOR POWER UNITS PE-77-A, PE-77-B, PE-77-C
PE-77-D, and PE-77-E.

Note.—Only maintenance parts listed can be requisitioned.

Ref. symbol	Signal Corps stock No.	Name of part and description	Quan per unit	Run-ning spares	Orgn stock	3d ech	4th ech	5th ech	Depot stock
	3H1901-J.1	ENGINE: complete; used in Power Unit PE-77-A, B, C, D, or E; Briggs & Stratton model I.	1			(*)	(*)		(*)
		AIR CLEANER GROUP							
Fig. 27	3H4577A/C19	AIR CLEANER ASSEMBLY; Briggs & Stratton No. 290184.	1				(*)	(*)	(*)
Do	3H4577A/G15	GASKET; air cleaner; Briggs & Stratton No. 68957.	1		(*)	(*)	(*)	(*)	(*)
		CRANKSHAFT AND CONNECTING ROD GROUP							
Do	3H4577A/B3	BEARING ball; crankshaft; Briggs & Stratton No. 99158.	1			(*)	(*)	(*)	(*)
Do	3H4577A/C9	CAP ASSEMBLY; oil filler; Briggs & Stratton No. 89636.	1		(*)	(*)	(*)	(*)	(*)
Do	3H4577A/G12	GASKET; base; Briggs & Stratton No. 68337	1		(*)	(*)	(*)	(*)	(*)
Do	3H4577A/P33	PLUG oil drain; Briggs & Stratton No. 91488	1		(*)	(*)	(*)	(*)	(*)
	3H4577A/P48	PUMP; oil assembly; Briggs & Stratton No. 290304.	1			(*)	(*)	(*)	(*)
Do	3H4577A/R32	CONNECTING ROD; aluminum; (assembly including connecting rod, screws, lock-washers); Briggs & Stratton No. 99640.	1		(*)	(*)	(*)	(*)	(*)
Do	3H4577A/S19	SEAL; oil; (ball bearing); Briggs & Stratton No. 99176.	1			(*)	(*)	(*)	(*)

*Indicates stock available.

Ref. symbol	Signal Corps stock No.	Name of part and description	Quan per unit	Run-ning spares	Orgn stock	3d ech	4th ech	5th ech	Depot stock
		CYLINDER GROUP							
Fig. 27	3H4577A/C43	CYLINDER ASSEMBLY: complete with valve guides and governor; (for PE-77-D only); Briggs & Stratton No. 290179.	1				(*)	(*)	(*)
Do	3H4577A/G9	GASKET: carburetor elbow; Briggs & Stratton No. 68997.	1		(*)	(*)	(*)	(*)	(*)
Do	3H1901-A/G3	GASKET: carburetor to intake elbow; Briggs & Stratton No. 68987.	1		(*)	(*)	(*)	(*)	(*)
Do	3H4577A/G11	GASKET: cylinder head; Briggs & Stratton No. 67537.	1		(*)	(*)	(*)	(*)	(*)
Do	3H4577A/G1	GASKET: valve cover plate; Briggs & Stratton No. 67527.	1		(*)	(*)	(*)	(*)	(*)
Do	3H4577A/P10	PIN: valve spring retainer; Briggs & Stratton No. 23187.	2		(*)	(*)	(*)	(*)	(*)
Do	3H4577A/P34	SPARK PLUG: Champion No. J-8 (14 mm); Briggs & Stratton No. 29693.	1		(*)	(*)	(*)	(*)	(*)
Lo	3H4577A/R13	RETAINER: valve spring; Briggs & Stratton No. 23184.	2		(*)	(*)	(*)	(*)	(*)
Do	3H4577A/R37	ROPE: starter; 1/16-inch; Friggs & Stratton No. 290282.	1		(*)	(*)	(*)	(*)	(*)
Do	3H1901-J/S15	SHIELD: spark plug; Briggs & Stratton No. 89742.	1				(*)	(*)	(*)
Do	3H4577A/S53	SPRING: exhaust valve; Briggs & Stratton No. 26478.	1		(*)	(*)	(*)	(*)	(*)
Do	3H4577A/S57	SPRING: intake valve; Briggs & Stratton No. 26021.	1		(*)	(*)	(*)	(*)	(*)
Do	3H4577A/V1	VALVE: exhaust; Briggs & Stratton No. 23612.	1		(*)	(*)	(*)	(*)	(*)
Do	3H4577A/V2	VALVE: intake; Briggs & Stratton No. 63782.	1		(*)	(*)	(*)	(*)	(*)
		EXHAUST GROUP							
Do	3H4577A/E8	ELBOW: exhaust line; Briggs & Stratton No. 92478.	1		(*)	(*)	(*)	(*)	(*)

Do-----	3H4577A/M17	MUFFLER: Briggs & Stratton No. 89945.	1	(*)	(*)	(*)	(*)
Do-----	3H4577A/N10	NIPPLE: exhaust pipe; steel: 1/2" x 3"; Briggs & Stratton No. 91961.	1	(*)	(*)	(*)	(*)
Do-----	3H4577A/C1	FLYWHEEL GROUP INCLUDING MAGNETO CABLE: shielded ignition; Briggs & Stratton No. 99391.	1	(*)	(*)	(*)	(*)
Do-----	3H4577A/C15	CONDENSER: magneto; Briggs & Stratton No. 29861.	1	(*)	(*)	(*)	(*)
Do-----	3H4577A/G35	GASKET: magneto plate; 0.005" thick; Briggs & Stratton No. 67597.	1	(*)	(*)	(*)	(*)
Do-----	3H4577A/G4	GASKET: magneto plate; 0.009" thick; Briggs & Stratton No. 67607.	1	(*)	(*)	(*)	(*)
Do-----	3H4577A/G3	GASKET: magneto plate; 0.015" thick; Briggs & Stratton No. 67307.	1	(*)	(*)	(*)	(*)
Do-----	3H4577A/M4	MAGNETO ASSEMBLY: (replaces Briggs & Stratton Nos. 89616 and 290238; remove airvane governor) Briggs & Stratton No. 290174.	1	(*)	(*)	(*)	(*)
Do-----	3H4577A/P50	POINT ASSEMBLY: magneto; Briggs & Stratton No. 290307.	1	(*)	(*)	(*)	(*)
Do-----	3H1901-AP/B8	FUEL SUPPLY GROUP BOWL: fuel filter; Briggs & Stratton No. 68487.	1	(*)	(*)	(*)	(*)
Do-----	3H4577A/C10	CAP ASSEMBLY: fuel tank; Briggs & Stratton No. 89769.	1	(*)	(*)	(*)	(*)
Do-----	3H4577A/C16	CARBURETOR ASSEMBLY: Briggs & Stratton No. 89641.	1	(*)	(*)	(*)	(*)
Do-----	3H4577A/F7	FILTER ASSEMBLY: fuel; Briggs & Stratton No. 99714.	1	(*)	(*)	(*)	(*)
Do-----	3H1901-AP/F1	FLOAT: carburetor; Briggs & Stratton No. 99622.	1	(*)	(*)	(*)	(*)
Do-----	3H4577A/G5	GASKET: carburetor; Briggs & Stratton No. 27112.	1	(*)	(*)	(*)	(*)

*Indicates stock available.

Ref. symbol	Signal Corps stock No.	Name of part and description	Quan per unit	Run-ning spares	Orgn stock	3d ech	4th ech	5th ech	Depot stock
Fig. 27	3H1901-AP/G9	GASKET: fuel filter; Briggs & Stratton No. 68477.	1	---	(*)	(*)	(*)	(*)	(*)
Do	3H1901-A/G5	GASKET: inlet valve seat (carburetor); Briggs & Stratton No. 68877.	1	---	---	(*)	(*)	(*)	(*)
Do	3H4577A/G7	GASKET: venturi (carburetor); Briggs & Stratton No. 27113.	1	---	---	(*)	(*)	(*)	(*)
Do	3H4577A/L10	LINE: fuel; copper; 1/8" pipe, 13" long; Briggs & Stratton No. 89190.	1	---	(*)	(*)	(*)	(*)	(*)
Do	3H1901-AP/H1	PIN: float hinge, (carburetor); Briggs & Stratton No. 23114.	1	---	---	(*)	(*)	(*)	(*)
Do	3H4577A/S2	SCREW: choke lever (carburetor); Briggs & Stratton No. 23270.	1	---	---	(*)	(*)	(*)	(*)
Do	3H1901-AP/S2	SCREEN: fuel filter; Briggs & Stratton No. 62876.	1	---	(*)	(*)	(*)	(*)	(*)
∞	3H4577A/S54	SPRING: choke lever (carburetor); Briggs & Stratton No. 26229.	1	---	---	(*)	(*)	(*)	(*)
Do	3H1901-AP/S88	SPRING: idler valve (carburetor); Briggs & Stratton No. 26157.	1	---	---	(*)	(*)	(*)	(*)
Do	3H4577A/T4	TANK ASSEMBLY: fuel; Briggs & Stratton No. 89640.	1	---	---	(*)	(*)	(*)	(*)
Do	3H1901-AP, V4	VALVE: idler needle; Briggs & Stratton No. 23228.	1	---	---	(*)	(*)	(*)	(*)
Do	3H1901-A/V7	VALVE ASSEMBLY: needle (carburetor); Briggs & Stratton No. 290284.	1	---	(*)	(*)	(*)	(*)	(*)
Do	3H1901-A/V1	VALVE AND SEAT: inlet (carburetor); Briggs & Stratton No. 99636.	1	---	(*)	(*)	(*)	(*)	(*)
Do	3H4575T/Y1	YOKE: fuel filter; Briggs & Stratton No. 99665.	1	---	---	---	(*)	(*)	(*)
		GOVERNOR GROUP (Mechanical)							
Do	3H4577A/C48	CONTROL ASSEMBLY: governor; Briggs & Stratton No. 290212.	1	---	---	(*)	(*)	(*)	(*)

Do-----	3H4577A/G53	GASKET: governor housing; Briggs & Stratton No. 27140.	(*)	(*)	(*)	(*)	(*)
	3H1901-J/G10	GOVERNOR ASSEMBLY; (mechanical); Briggs & Stratton No. 290300.	(*)	(*)	(*)	(*)	(*)
		PISTON GROUP					
Do-----	3H4577A/L19	LOCK: piston pin; Briggs & Stratton No. 26026.	(*)	(*)	(*)	(*)	(*)
Do-----	3H4577A/P7	PISTON PIN: standard; Briggs & Stratton No. 63773.	(*)	(*)	(*)	(*)	(*)
Do-----	3H4577A/P12	PISTON ASSEMBLY: standard; (includes piston, three rings; two piston pin locks); Briggs & Stratton No. 29739.	(*)	(*)	(*)	(*)	(*)
	3H4577A/P13	PISTON ASSEMBLY: 0.010" oversize; (includes piston, three rings, two piston pin locks); Briggs & Stratton No. 29778.	(*)	(*)	(*)	(*)	(*)
Do-----	3H4577A/R17	PISTON RING: compression; center; standard; Briggs & Stratton No. 61756.	(*)	(*)	(*)	(*)	(*)
	3H4577A/R14	PISTON RING: compression; center; 0.010" oversize; Briggs & Stratton No. 61768.	(*)	(*)	(*)	(*)	(*)
Do-----	3H4577A/R21	PISTON RING: compression; top; standard; Briggs & Stratton No. 21283.	(*)	(*)	(*)	(*)	(*)
	3H4577A/R22	PISTON RING: compression; top; 0.010" oversize; Briggs & Stratton No. 21367.	(*)	(*)	(*)	(*)	(*)
Do-----	3H4577A/R15	PISTON RING: oil; standard; Briggs & Stratton No. 61757.	(*)	(*)	(*)	(*)	(*)
	3H4577A/R25	PISTON RING: oil; 0.010" oversize; Briggs & Stratton No. 61771.	(*)	(*)	(*)	(*)	(*)
		MISCELLANEOUS GROUP					
	6G245.2	COMPOUND: valve grinding	(*)	(*)	(*)	(*)	(*)
	3H1901-J/III	HARDWARE KIT: (nuts, bolts, screws, washers); Briggs & Stratton No. 290288.	(*)	(*)	(*)	(*)	(*)

*Indicates stock available.

Ref. symbol	Signal Corps stock No.	Name of part and description	Quan per unit	Run-ning spares	Orgn stock	3d ech	4th ech	5th ech	Depot stock
		GENERATOR GROUP							
	3H4577A/B44	BRUSH ASSEMBLY: d-c; National Carbon No. G-2964.	2	---	(*)	(*)	(*)	(*)	(*)
	3DB500-5	CONDENSER; electrolytic; 500 mf; 200 v, d-c; Aerovox No. EPLO5.	1	---	(*)	(*)	(*)	(*)	(*)
	3H4577A/C14	CONDENSER; generator; Pioneer Gen-E-Motor Corp. No. P-4241.	1	---	---	(*)	(*)	(*)	(*)
	3H2450-1	GENERATOR: 250 watt; 115 volt, d-c; Pioneer Gen-E-Motor Corp. model No. 77; Climax No. 28CX-160.	1	---	---	(*)	(*)	(*)	(*)
	3H4577A/M8	MOUNTING; truck; Pioneer Gen-E-Motor Corp. No. 613.	4	---	---	---	(*)	(*)	(*)
	3H4577A/S67	STAPLE; brush; Pioneer Gen-E-Motor Corp. No. P-1886.	2	---	(*)	(*)	(*)	(*)	(*)
	3H4577A/R6	RECEPTACLE; Hubbell No. 9200	1	---	(*)	(*)	(*)	(*)	(*)

*Indicates stock available.

[A. G. 300.7 (20 Jul 44).]

BY ORDER OF THE SECRETARY OF WAR:

G. C. MARSHALL,
Chief of Staff.

OFFICIAL:

J. A. ULIO,
Major General,
The Adjutant General.

DISTRIBUTION:

As prescribed in paragraph 9a, FM 21-6: Armies (10); Corps (10); SvC (10); Dept (10); Def C (2); D (2); R & H 1 (5); I Bn 1 (5); I Bn 11 (5); IC 11 (10); C of Tech Sv (2); Arm & Sv Boards (2); P, C and Sta (1); Gen & Sp Sv Sch (10).

I Bn 1: T/O & E 1-27; 1-37; 1-47; 1-67; 1-117; 1-127; 1-130-1; 1-137; 1-147; 1-167; 1-252; 1-267; 1-312; 1-469S; 1-487S; 1-547; 1-637; 1-758; 1-767; 1-777S; 1-779; 1-757.

I Bn 11: T/O & E 11-15; 11-85S; 11-95.

I C 11: T/O & E 11-97; 11-7; 11-18; 11-57; 11-217; 11-237; 11-247; 11-257; 11-287; 11-460-1S; 11-510; 11-267; 11-517S; 11-537S; 11-107; 11-127; 11-587; 11-592; 11-597.

For explanation of symbols, see FM 21-6.

DESTRUCTION NOTICE

WHY—To prevent the enemy from using or salvaging this equipment for his benefit.

WHEN—When ordered by your commander, or when you are in immediate danger of capture.

HOW—1. **Smash**—Use sledges, axes, handaxes, pickaxes, hammers, crow-bars, heavy tools, etc.

2. **Cut**—Use axes, handaxes, machetes, etc.

3. **Burn**—Use gasoline, oil, flame-throwers, incendiary grenades, etc.

4. **Explosives**—Use firearms, grenades, TNT, etc.

5. **Disposal**—Bury in slit trenches, fox holes, other holes. Throw in streams, scatter.

USE ANYTHING IMMEDIATELY AVAILABLE FOR THE DESTRUCTION OF THIS EQUIPMENT

WHAT—1. **Smash**—Power plant, generator, carburetor, governor, and cable connectors.

2. **Cut**—All connecting wires, cables, etc.

3. **Burn**—all the above equipment, technical manuals, etc.

4. **Bury or scatter**—Any or all of above pieces after smashing or burning.

DESTROY EVERYTHING

SAFETY NOTICE

Power Unit PE-77-(*) Generates High Voltages which are dangerous to life. Observe every safety precaution at all times. Do not make or change any connections while the unit is in operation. The exhaust fumes from this unit are deadly poisonous. Sufficient ventilation is imperative when the unit is operated in a closed room.

Do not fill gasoline tank while engine is running. Avoid spilling gasoline on hot engines

POWER UNIT PE-77-(*)

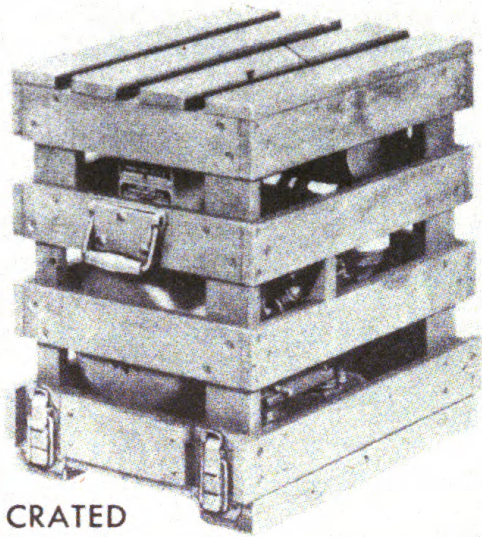

CRATED

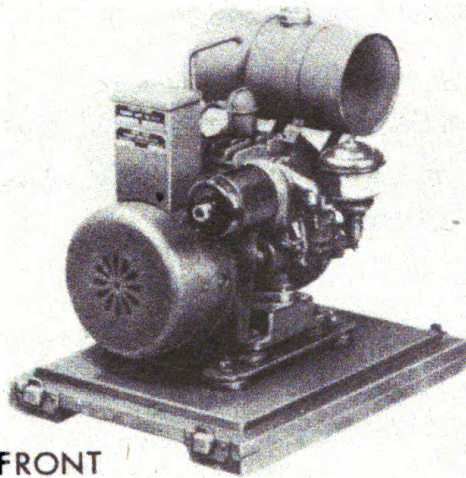

FRONT

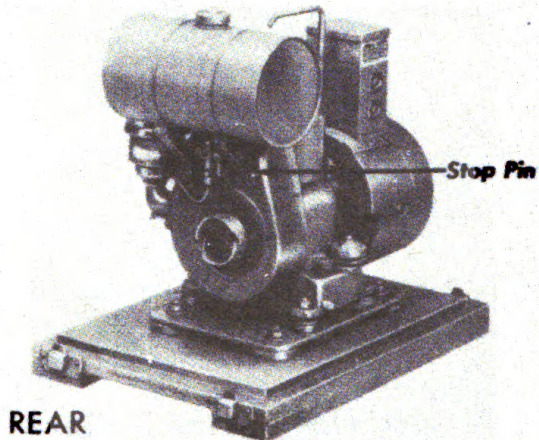

REAR

Figure 1.—Power Unit PE-77-E.

SECTION I—DESCRIPTION

	<i>Paragraph</i>
General.....	1
Component parts, weights, dimensions, and ratings.....	2

1. **GENERAL.**—*a.* Power Unit PE-77-A through E (fig. 1) is a compact, portable, gasoline-engine-driven, 110-volt, direct current, generating set. Minor variations between the different models are explained herein, and the term “PE-77-E” is used to indicate all procurements.

b. The entire unit is protected against rust and corrosion by a lusterless olive-drab finish.

2. **COMPONENT PARTS, WEIGHTS, DIMENSIONS, AND RATINGS.**—*a.* *Over-all dimensions and weights.*—

	Height (inches)	Width (inches)	Length (inches)	Weight (pounds)
(1) PE-77-A through D	22	16	20	72
(2) PE-77-E	22	12	22	86

NOTE: The weight given is the total weight of the unit ready to operate with the crankcase filled, but with the gas tank empty, and without tool kit, extra apparatus, or carrying case.

b. Case.—A wooden case is provided for handling and transportation. The power unit is mounted on a sub-base which rests on the base of this case.

Handles are provided on the case for convenience in handling.

c. Engine.—The engine is a single-cylinder, four-cycle, L-head, air-cooled, rope-starting gasoline engine (fig. 2).

*This manual supersedes chapter 2, TM 11-354, 28 Dec 42.

d. Fuel.—The power unit will operate efficiently on any commercial grade of low test gasoline.

e. Temperature.—The power unit is designed to operate in all temperature ranging from -22° to $+122^{\circ}$ F.

f. Gasoline tank.—The tank on PE-77-A, B, C and D is designed to hold $\frac{1}{2}$ gallon of gasoline which is sufficient to run the unit for 5 hours at one-half load, or 3 hours at full load. On Power Unit PE-77-E the tank holds 1 gallon of gasoline which is sufficient to run the unit for 7 hours at one-half load.

g. Generator.—The generator, mounted directly on the gasoline engine and driven by the engine crank shaft without any intermediate coupling, develops a 250-watt, 110-volt direct current at 2,600 to 3,000 rpm, 40° C.

h. Outlet box.—The outlet box mounted on top of the generator is weatherproof containing a filter unit and output receptacles.

POWER UNIT PE-77-(*)

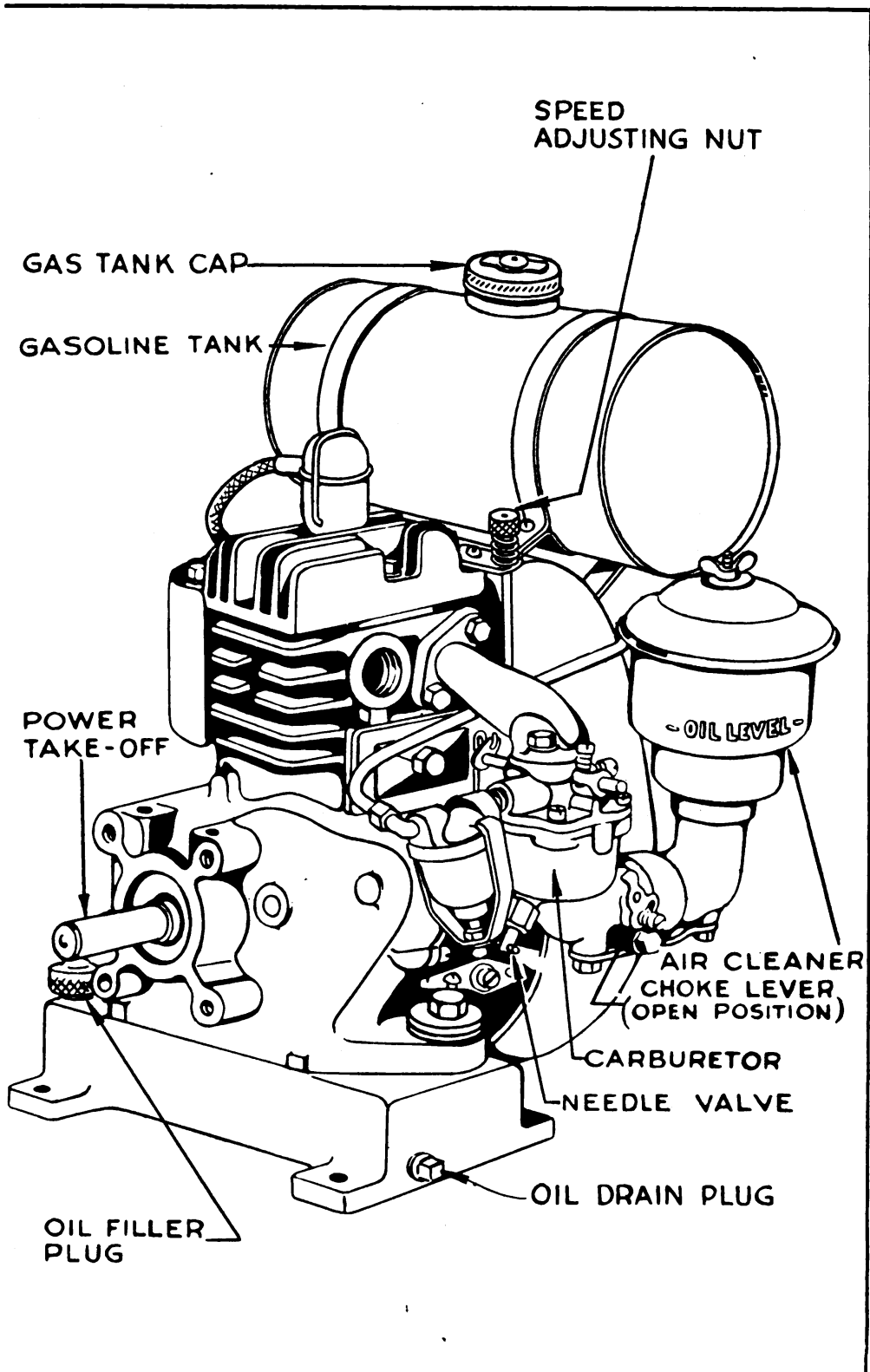

Figure 2.—Engine for Power Unit PE-77-E

SECTION I

i. Ignition.—The ignition spark is produced by a high-tension magneto built into the flywheel. It consists of an armature, condenser, contact points and rotating magnets. The spark plug is a 14 mm Champion J-8, or equal.

j. Lubrication.—A mechanically-operated pump built into the base of the engine, furnishes positive lubrication to all moving parts of the engine (fig. 22).

k. Governor.—(1) *Power Units PE-77-D and E.*—An automatic, mechanical built-in governor is provided. It is fully enclosed to protect it against climatic conditions. It operates through a gear driven by the cam gear. The speed regulation holds the generator output between +5 and —1 volts at all constant load levels. A governor speed-adjustment nut is located on the end of the control rod which extends above the cylinder head (fig. 8).

(2) *Power Units PE-77-A, B, C and some early models PE-77-D.*—A fully-enclosed, automatic, air-vane blade, built-in governor is used. It is constructed so that wind and external weather conditions have no effect on engine speed.

The speed regulation holds the generator output within 5 volts at all constant load levels. A speed adjustment is located beneath the carburetor, on the back of the magneto plate (fig. 9).

REMEMBER THESE POINTS

1. Don't attempt repairs or adjustments to this unit unless you are sure what you're doing.
2. Watch your lubrication; check the oil level every 4 hours.
3. Don't take chances with carbon monoxide; keep your exhaust line gas tight and be sure you have proper ventilation.
4. Be sure there is no dirt in your oil and gasoline.
5. Keep your air filter clean. Watch this closely in dusty locations.
6. Keep the unit as clean as possible. Dirt on the cooling fins and in the air passages will cause overheating.
7. Don't expose your unit to rain or dampness. Electrical equipment and water don't mix.
8. Look out for shock. Don't touch exposed wires.
9. Go over your unit daily and tighten all screws and nuts.
10. Don't spill gas on your unit when filling the tank. It may catch fire.
11. Always warm up your unit before applying a load.
12. Study this book. Keep it handy. It'll save you plenty of headaches.

POWER UNIT PE-77-(*) .

SECTION II—INSTALLATION AND OPERATION

	<i>Paragraph</i>
Unpacking	3
Installation	4
Ventilation	5
Preparation for use	6
Operation	7

3. UNPACKING.—Power Unit PE-77-(*) is shipped in a wooden, steel-banded box. The steel bands should be cut, the box opened, and then discarded. The unit is enclosed in a permanent wooden carrying case which may be removed by unlatching the four clamps at the base and lifting the cover straight up until the unit is clear.

4. INSTALLATION.—Power Unit PE-77-(*) is designed primarily for portable service. In setting up the unit for operation, it is important to select a level surface so that the wooden skids rest firmly.

5. VENTILATION.—*a.* Proper ventilation must be provided for indoor operation. Deadly poisonous carbon monoxide contained in the exhaust fumes is odorless, and tasteless. Therefore, in addition to piping the exhaust from the engine to the outside of the building, make sure the room is well ventilated to carry away any leaking fumes while the engine is in operation. In a relatively small engine room forced air circulation by means of a suitable fan may be necessary to provide proper ventilation, to prevent the engine from overheating, and to support combustion.

b. Ventilation is necessary to insure proper cooling of the engine. The minimum requirement is 2 feet clearance around the entire unit.

c. If the unit is operated *indoors*, remove the muffler and attach the exhaust tube to the exhaust outlet. Extend the tube to the outside of the building and attach the muffler to the outer end. Keep the exhaust line as short as possible to avoid excessive back pressure. A 1-inch tube may be used where the length of the exhaust tube is less than 10 feet; a 1½-inch I. D. tube should be used if the exhaust tube exceeds 10 feet. Make sure that all exhaust connections are gas tight. It is important that the exhaust line pitch downward toward its outer end and the that muffler outlet point downward to prevent the entrance of water.

6. PREPARATION FOR USE.—*a.* Remove the oil filler cap which is painted blue and located on the top of the engine base (fig. 2). and fill the crankcase of the engine with a high-grade lubricating oil (fig. 3 for proper oil).

b. The capacity of the crankcase is 1½ pints. Oil should be added until it reaches the level of the filler plug opening.

c. Remove the filler cap of the gasoline tank, blow through the vent hole to make sure it is open (figs. 1 or 2), and fill the tank with ½ gallon (1 gallon for PE-77-E) of clean, fresh gasoline. Make sure gasoline is free from

SECTION II

water and other foreign substances. *Do not add lubricating oil to gasoline in the fuel tank.*

d. Fill the air cleaner with light oil to the indicated level and in accordance with the directions on its label. Do not add any kerosene or gasoline.

7. **OPERATION.**—*a. Starting.*—(1) Open gasoline shut-off valve (fig. 2) on top of the gasoline tank (at the bottom of the gasoline tank on PE-77-E) by turning valve to the left and allowing the carburetor float chamber to fill up. Completely close carburetor choke by turning choke lever to the left (fig. 2). If engine is hot it may be necessary to close choke.

(2) Insert the knotted end of the starter rope in the notch of the starter pulley and wind the rope clockwise around the pulley. Crank the engine a few times to prime it. After the engine has been primed, open choke about half-way and repeat the cranking operation to start the engine. As the engine warms up gradually, open choke by turning the choke lever (fig. 2) toward the right until the engine operates smoothly with the choke wide open.

(3) If it is necessary to keep the choke partially closed for several minutes before the engine runs smoothly, the carburetor is set too lean and the needle valve located in the lower part of the carburetor (fig. 2, 8 or 9) should be opened slightly by turning to the left (counter clockwise). **CAUTION: Except in cases of extreme emergency, under low temperature conditions operate the unit for a period of not less than ten minutes before applying load.**

b. Stopping.—On PE-77-C, D and E, push in the stop pin (painted red) located on the blower case below the gasoline tank (fig. 1) and hold it in until the engine stops turning. On PE-77-A and B push the stop pin (painted red) in the spark plug shield and hold it in until the engine stops turning. When the engine is not to be operated for a period of 4 hours or longer, stop the engine by turning off the fuel shut-off valve and not using the stop pin. This method will drain the carburetor and avoid the formation of gums and deposits from the gasoline and decrease the fire hazard. Keep the fuel tank filled to prevent the formation of gum.

c. Operator's maintenance schedule.—(1) At the beginning of operation and every 4 hours of service, check oil level in crankcase. Keep to top of plug level at all times.

(2) Every 8 hours of service, check oil level in air cleaner. Maintain level to bead. Lubricate throttle bearing points and linkage.

(3) Every 48 hours of service, drain crankcase. *Drain while oil is warm.* Drain air filter, clean in gasoline, and refill with new oil.

(4) Every 256 hours of service, drain fuel tank, fuel lines, and clean fuel bowl screen.

POWER UNIT PE-77-(*)

(5) Every 512 hours of service, arrange for general inspection of power unit, removal of crankcase, and cleaning of sludge from pan and pump screen by appropriate maintenance echelon.

NOTE: The detailed methods of doing the above work is covered in section IV.

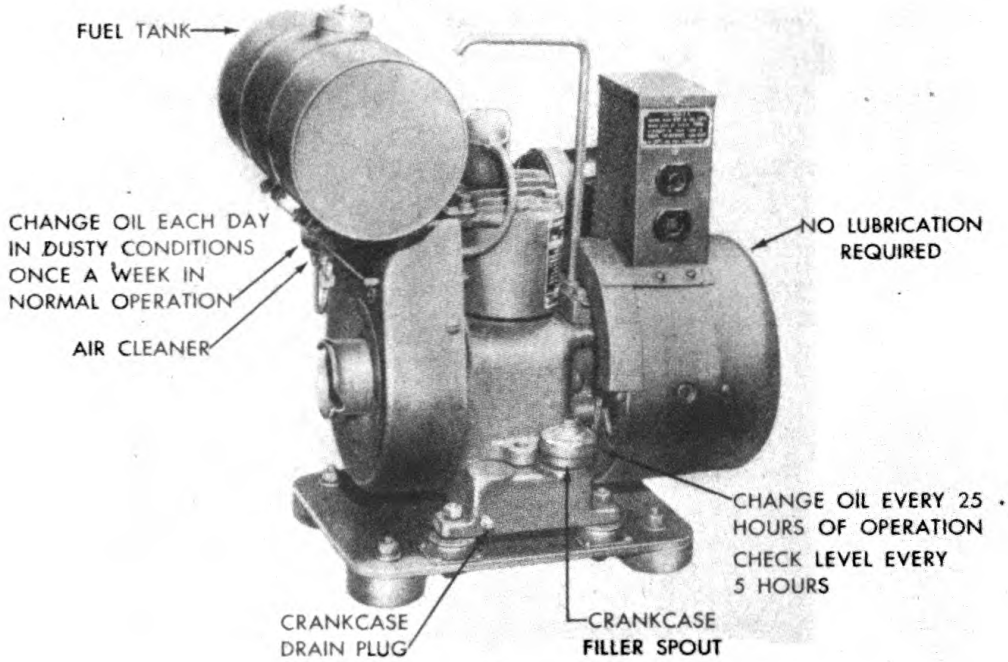

Figure 3.—Lubrication

TABLE OF CAPACITIES AND RECOMMENDATIONS
Lowest expected atmospheric temperatures

	Capacity	Above			Below		
		90° F.	32° F.	10° F.	-10° F.	-30° F.	-30° F.
Engine oil crankcase	1½ pts.	U.S. Army spec. 2-104B SAE 10 SAE 10 SAE 10			with with with		
		SAE 30	SAE 30	SAE 10	10%	25%	40%
		gasoline gasoline gasoline					
Engine fuel tank	½ gal. 1 gal.	U. S. Army spec. 2-103A Motor fuel (all purpose) 80 octane (See par. 6, c. page 4)					
Oil bath air cleaner	Keep level up to the beading	Use same SAE grade oil as in crankcase				No oil	
Generator	No lubrication required						

SECTION III—FUNCTIONING OF PARTS

	<i>Paragraph</i>
Engine.....	8
Carburetor.....	9
Magneto.....	10
Speed regulation.....	11

8. ENGINE.—Power Unit PE-77-(*) has a portable, compact, single-cylinder, air-cooled, 4-cycle, L-head gasoline engine. The design and functioning of gasoline engines are all similar and fully explained in TM 10-570.

9. CARBURETORS.—Gasoline flows by gravity from the gas tank mounted on the top of the unit, through a fuel filter to a float-feed carburetor. The gasoline supply is regulated by a needle valve, and the throttle is automatically controlled by the governor. The functions of carburetion are fully explained in TM 10-550.

10. MAGNETO.—The spark is produced by a high tension magneto, consisting of armature, condenser, contact points, and rotating magnets cast in a flywheel. See TM 10-580 for full explanation of the magneto function.

11. SPEED REGULATION.—*a.* The speed is automatically maintained under varying loads by a pneumatic governor in PE-77-A, B, and C, and some early PE-77-D's. Later PE-77-D's, PE-77-E and later procurements use a mechanical governor.

b. The pneumatic, or air-vane blade, governor is located inside the blower housing and is fastened to the magneto plate (fig. 9). The governor blade is actuated by air currents caused by the turning of the fan-type flywheel. The governor is attached by a link to the carburetor throttle shaft, which in turn controls the throttle valve. As the engine picks up speed, after starting, the governor blade is immediately affected by the air currents, and in turn acts upon the throttle shaft through the governor link. Any movement of the governor blade caused by a rise or drop in load affecting the engine speed, is immediately transmitted to the carburetor, thereby increasing or decreasing the throttle valve opening. A spring for regulating and controlling the action of the governor is attached to the carburetor throttle arm. This spring is adjustable by means of a thumbscrew, the speed adjusting nut. The speed of the engine varies between 2,600 and 3,000 rpm. for normal operation.

c. The mechanical governor is a flyball or counterweight type. This maintains a constant output voltage. The governor flyballs consist of two counterweights fastened to the governor pinion-gear shaft inside the governor housing. The pinion gear is driven by the cam gear. As the engine picks up speed after starting, these weights are driven away from the shaft by centrifugal force and forced against the governor cup facing the pinion

POWER UNIT PE-77-(*)

gear (fig. 7). The cup is moved outward by action of the weights and in turn acts upon the crank and lever which are connected to the carburetor throttle. The governor lever is connected to the carburetor throttle by a link. Any movement of the governor weights, caused by a rise or drop in load affecting the engine speed, is immediately transmitted to the carburetor throttle, thereby increasing or decreasing the throttle valve opening. A spring for regulating and controlling action of the governor (fig. 8) is incorporated in the governor lever. This spring is adjustable by means of a thumbscrew, the speed-regulating nut. Recommended operating speed is 2,700 rpm at no load.

SECTION IV—MAINTENANCE

	<i>Paragraph</i>
General maintenance.....	12
Lubrication.....	13
Carburetor adjustment.....	14
To clean fuel system.....	15
Removing and cleaning carburetor.....	16
Governor and governor speed adjustment.....	17
Ignition system.....	18
To remove and replace flywheel.....	19
To remove magneto assembly.....	20
To replace magneto.....	21
Magneto timing.....	22
To adjust and clean magneto contact points.....	23
To replace magneto condenser.....	24
To replace and adjust magneto armature.....	25
Cylinder head.....	26
Compression.....	27
Valve adjustment.....	28
Breather valve.....	29
Pistons.....	30
Piston rings.....	31
Piston pins.....	32
Connecting rod.....	33
Oil pump.....	34
To remove crankshaft.....	35
Oil leaks.....	36
Carbon.....	37
Air cleaner.....	38
Muffler.....	39
Generator.....	40
To remove generator.....	41
Engine trouble and remedy chart.....	42
Generator trouble and remedy chart.....	43

12. GENERAL.—*a.* Dirt or sand in the generator will cause trouble and often serious damage. The engine is air cooled and the cylinder fins

SECTION IV

and air intake must be kept free of dirt, grease, or other obstruction to allow proper air circulation and cooling. *Keep the engine clean.*

13. LUBRICATION.—*a. General.*—Correct lubrication of the engine is important. Lubrication data must be observed. The chart shown in figure 3 gives the proper oil to use at various temperatures and lubrication points. Lubrication of the generator is not required.

b. Crankcase.—(1) Check the oil level in the crankcase every 4 hours of service or every gasoline refill period. Add sufficient oil to bring the level up even with the top of the (blue) oil filler cap opening.

(2) Drain and supply new oil every 48 hours of operation. The oil should be drained right after the engine has been run and while it is still hot. To drain, remove the yellow oil drain plugs, located at either end of the motor base. Always allow the crankcase to drain completely. *Do not flush the crankcase with kerosene or other solvents.* Replace the (yellow) drain plugs and make sure they are securely tightened. Refill with the proper grade oil and replace (blue) oil filler cap. Capacity of the crankcase is 1½ pints.

(3) Water will collect in the crankcase due to moisture in the gasoline condensing as it passes the rings. This mixture of moisture, particles of carbon, dirt, and crankcase oil will form a gummy substance or sludge. This sludge will in time clog up the oil pump and oil passages. This condition is particularly bad in cold weather.

(4) Every 512 hours of operation, clean the crankcase by removing the screws that hold it to the base and remove the crankcase. Wash the oil pump, using a good brush and Diesel oil or cleaning solvent (Federal Specification P-S-661A). Wash the crankcase carefully with brush and Diesel oil, making sure all sludge has been removed. Replace the crankcase, using a new gasket if the old one is damaged, and fill with new oil before starting the engine.

NOTE: If a brush is not available and a cloth must be used it should be free of all lint.

c. Air Cleaner.—Before using the engine, fill the air cleaner with light engine oil to the indicated oil level. Keep oil to that level at all times.

14. CARBURETOR ADJUSTMENT.—The carburetor is a gravity type. The gasoline supply is regulated by a needle valve and float. The throttle is automatically controlled by the governor.

NOTE: Carburetor adjustments should be made only when the engine is warmed up and under full load. Too rich a mixture should be avoided to prevent injury to the engine.

To adjust carburetor, completely close needle valve (figs. 8 and 9) by turning to the right or clockwise as far as possible. Do not screw valve

POWER UNIT PE-77-(*)

too tightly, as damage to the valve might result. From the closed position, first open the needle valve one to one and one-half turns. After the engine has been started and warmed up, make final adjustment with the choke wide open by turning the needle valve to a point at which engine operates most smoothly at a full load. This setting will also take care of starting when using the choke. When starting a cold engine, if it is necessary to keep choke partially closed several minutes before engine runs smoothly, carburetor setting is too lean and needle valve should be opened slightly by turning to the left (counter-clockwise). The idle adjusting screw setting is about half to three-quarters of a turn open. Do not force screw against seat or you will damage both.

15. TO CLEAN FUEL SYSTEM.—*a.* Every 256 hours of operation—clean the fuel system as follows:

- (1) Close the fuel shut-off valve on the fuel tank.
- (2) Remove the fuel line and clean by blowing through it.
- (3) Take the gasoline filter apart by loosening the thumb nut below the filter bowl and remove the bowl, gasket, and screen (fig. 4).

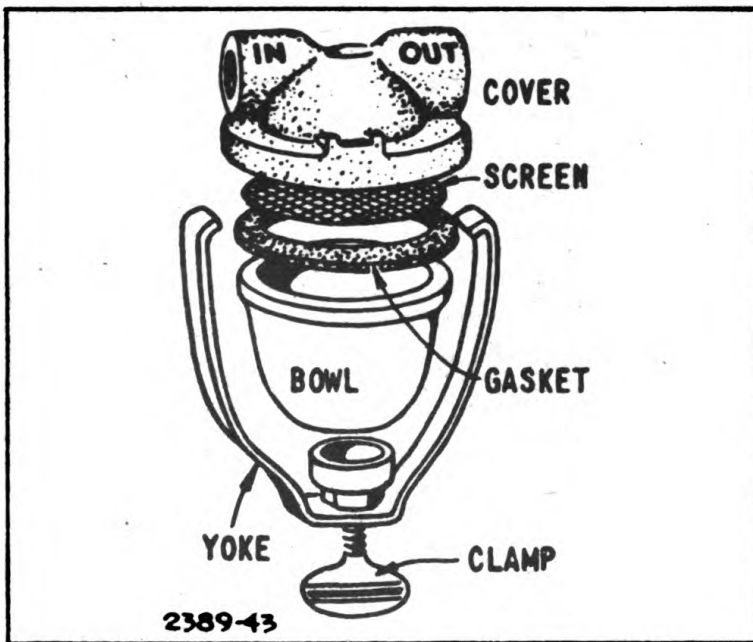

Figure 4.—Gasoline filter

- (4) Clean the bowl and screen. Blow through all passages to make sure they are open.
- (5) Inspect the gasket and replace if necessary.
- (6) Open the gas shut-off valve on the gasoline tank for a moment to see if gasoline flows freely from the tank.
- (7) Replace the bowl, gasket, and screen.
- (8) Open gas shut-off valve and make certain there are no leaks.

SECTION IV

b. If a gummy, varnish-like substance is found while cleaning the fuel system it can be dissolved by acetone or alcohol. Most gum formations are caused by the evaporation of stale gasoline. When the unit is temporarily out of use, keep the gasoline tank and filter bowl full to prevent the formation of gummy substance. If the unit is to be out of service for an extended period, drain the gas tank completely. Start the unit and allow it to run until the carburetor is pumped dry.

16. REMOVING AND CLEANING CARBURETOR.—a. Close gasoline shut-off valve at the gasoline tank. Disconnect gasoline line from gas filter, loosen carburetor brace screw at base, remove brace screw from carburetor and air cleaner elbow. Remove air cleaner and elbow, unhook throttle and control return spring, loosen carburetor and unhook throttle link.

b. Remove gasoline line-connector elbow. To disassemble carburetor, remove needle valve, stuffing-box nut, packing-nut gland, and nozzle. Then remove screws and lock washers from upper carburetor body.

CAUTION: The upper and lower bodies are interlocked by the nozzle and failure to disassemble in above order will result in damaged parts (fig. 5).

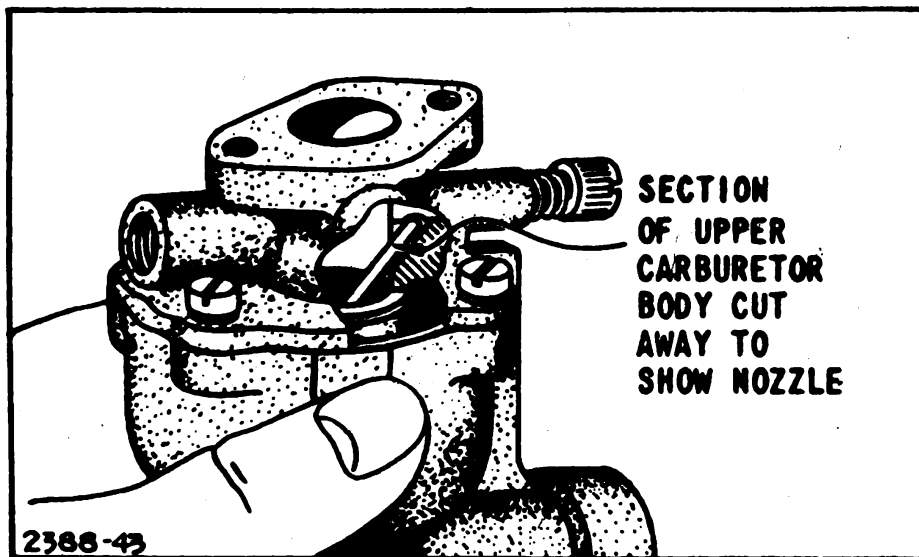

Figure 5.—Carburetor nozzle position

c. To check inlet valve and seat, pull out brass pin holding carburetor float. A worn or dirty inlet valve and seat or incorrect float level will cause carburetor to leak. In reassembling, float should be in a horizontal position when it closes inlet valve in seat.

d. To check float, invert upper carburetor body and place a scale or a flat straight piece of steel across carburetor float and see that distance from top of float to carburetor body flange is equal at both sides of the float

POWER UNIT PE-77-(*)

(fig. 6). The float hinge tang can be bent to adjust the position of the float.

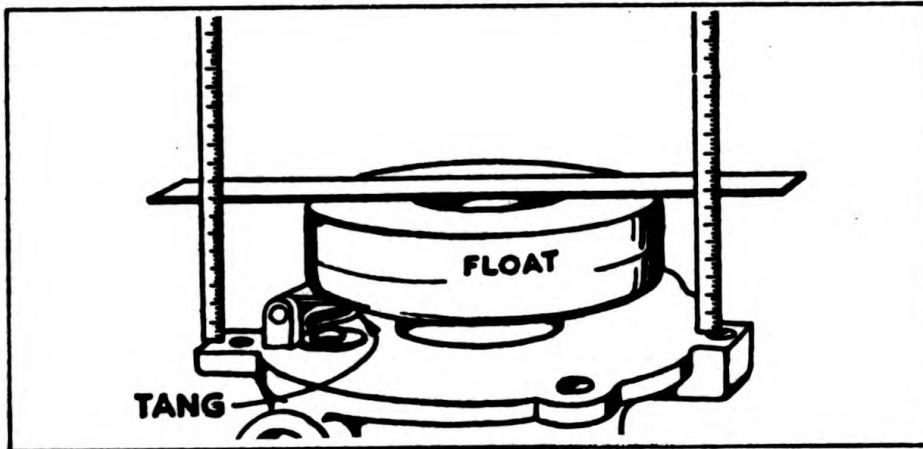

Figure 6.—Carburetor float position

a. If any parts are gummy, clean them in alcohol or acetone. Blow through all passages and openings. Do not use wire to clean out small holes. Replace worn or damaged parts.

17. GOVERNOR AND GOVERNOR SPEED ADJUSTMENT.—a. The speed of the engine is automatically maintained under varying loads by the governor. The governor was carefully adjusted to maintain normal speed under load. Do not readjust unless absolutely necessary. Adjust carburetor for best performance before touching the governor.

b. On PE-77-D and E a speed regulator is located on top of the cylinder above the carburetor (fig. 8). Turn the regulator to the right to increase speed and voltage; to the left to reduce engine speed and voltage. Adjust so that the voltage reads 115 volts at full load.

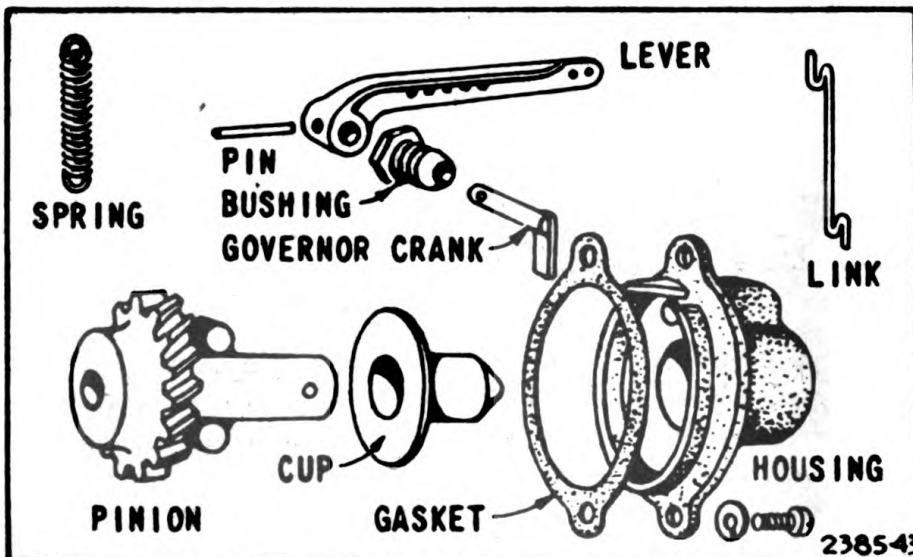

Figure 7.—Governor parts

SECTION IV

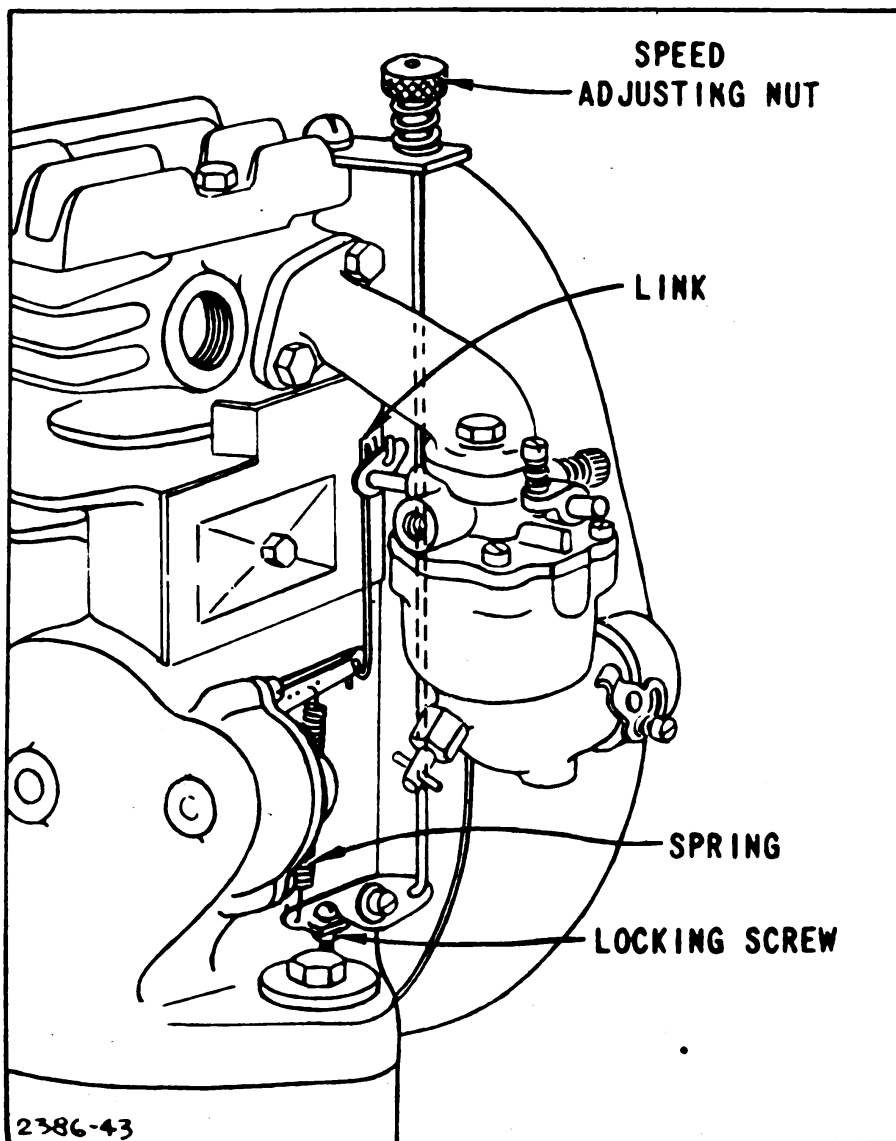

Figure 8.—Carburetor and governor (mechanical) hook-up

c. To inspect and clean governor parts (PE-77-D and PE-77-E):—(1) Remove carburetor by disconnecting fuel line and removing two screws at top and one at bottom.

(2) Unhook throttle link (fig. 7).

(3) Unhook spring.

(4) Remove two screws which fasten governor housing to crankcase and lift off housing.

(5) Remove cup and pinion

(6) Clean parts in Diesel oil or cleaning solvent (Federal Specification P-S-661A) and inspect them carefully.

(7) Replace worn parts with new ones and assemble with new lubricant.

POWER UNIT PE-77-(*)

d. On models PE-77-A, B, and C, and some early PE-77-D's (air-vane blade governor) the speed adjustment is located beneath the carburetor on the magneto plate (fig. 9). The speed adjuster should be set so that the voltage reads 115 volts at full load. Turn the speed adjuster nut (fig. 9) to the *left* to increase engine speed and voltage; to the *right* and decrease engine speed and voltage.

SCL-1193

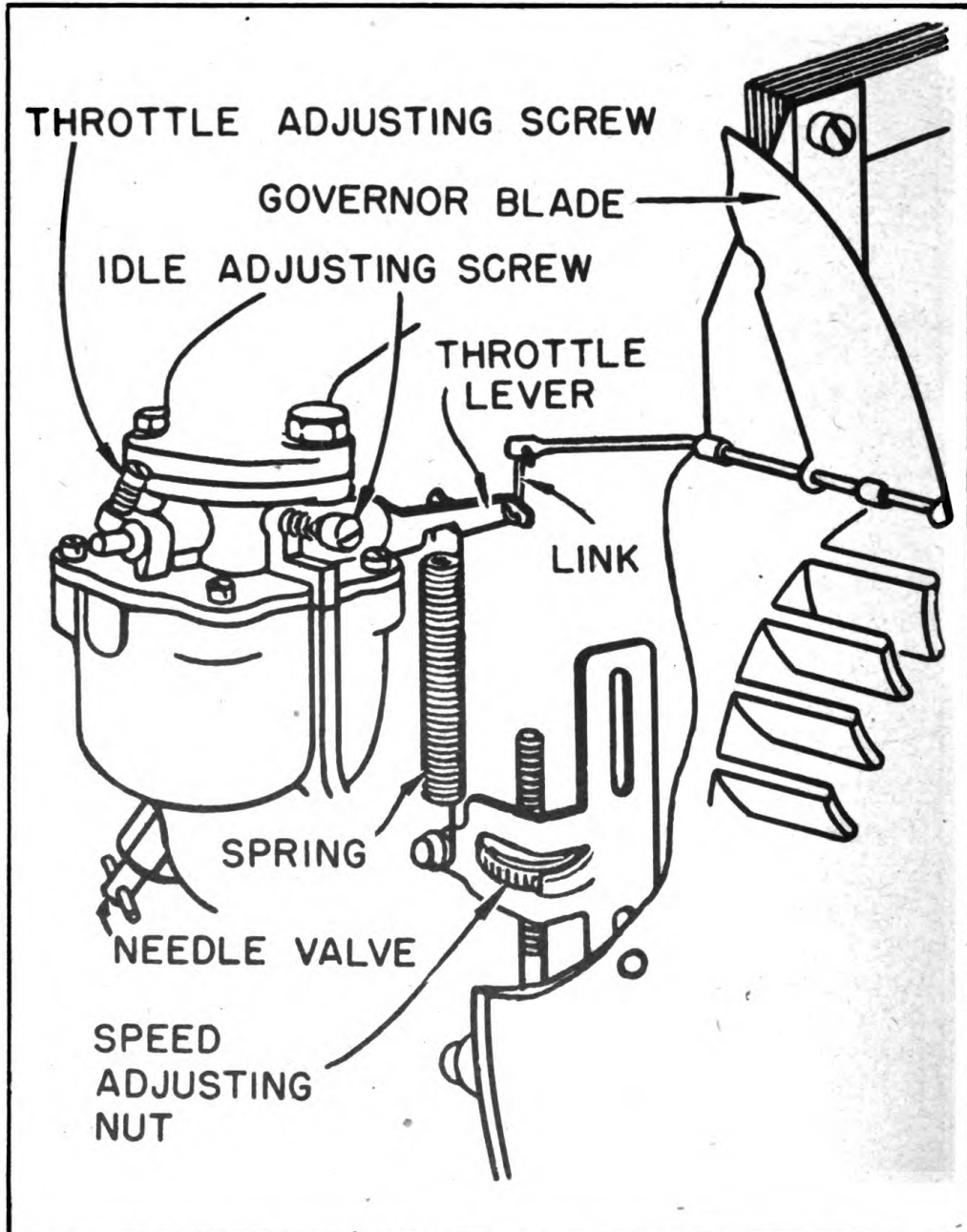

Figure 9.—Carburetor and governor (air-vane blade) hook-up

SECTION IV

18. IGNITION SYSTEM.—*a. Magneto.*—The spark is produced by a high-tension magneto, consisting of armature, condenser, contact points, and a rotating magnet cast in the flywheel. The magneto, spark plug cable, and spark plug must all be in proper condition and adjustment to insure efficient engine operation.

b. Check for spark.—To see if a satisfactory spark is being delivered by the magneto, remove the ignition cable from the plug. Hold the ignition cable terminal about $\frac{1}{8}$ inch from any part of cylinder head (fig. 10). (Keep hand on insulated part of cable to avoid shock.) Turn the engine with the starter cord. If the spark jumps this gap the entire ignition system with the exception of the spark plug, is in good working order. If no spark occurs, check the spark plug cable, contact points, and condenser in the order named.

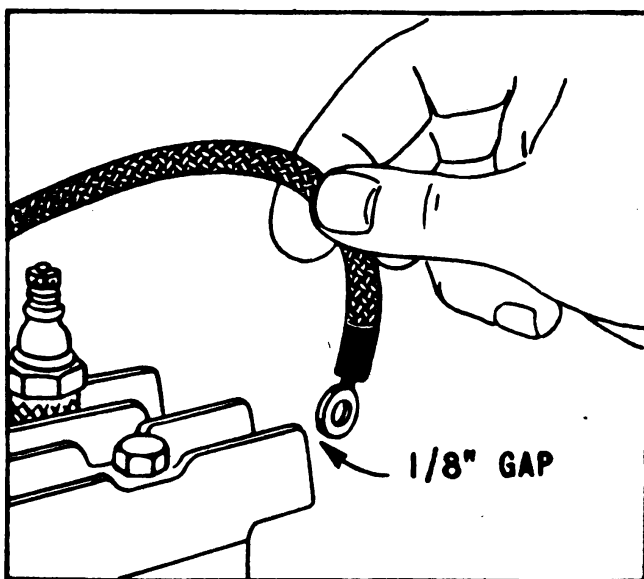

Figure 10.—Checking for spark

c. Spark plug adjustment.—The cap of the spark plug shield on PE-77-C, D, and E must first be removed by raising the lock lever on the top of the shield, or on PE-77-A and B by slipping the coil spring off. The spark plug should then be removed with the spark plug wrench supplied with the unit. Spark plugs should be cleaned and points reset to .025 inch after each 50 hours of operation, and replaced after 100 hours. (Fig. 11.) The spark plugs may be cleaned by scraping off the carbon and washing with cleaning solvent (Federal Specification P-S-661A). The points should be dressed with a fine file or emery cloth. When points become burned through service or the porcelain of the plug becomes cracked, replace with a new plug and gasket. Use Champion No. J-8 (14 mm) spark plug or its exact equivalent. Apply a little graphite grease on thread when replacing;

POWER UNIT PE-77—(*)

do not get the grease on the points. Be sure to replace or install a new spark plug gasket. Replace the shield carefully as it reduces radio interference.

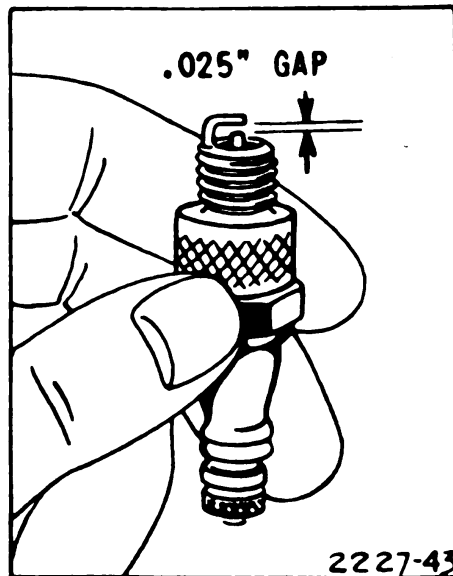

Figure 11.—Adjusting spark plug

d. Ignition cable.—The cable is shielded to prevent radio interference. The insulation must be kept free of oil or water, and must not be broken. Any of these conditions may cause ground connection to the engine and will interfere with good ignition. To check cable all the way to the magneto it is necessary to remove blower case. Ignition cable should be securely bound to the secondary terminal loop of the coil (fig. 15).

19. TO REMOVE AND REPLACE FLYWHEEL.—*a.* The flywheel is securely fastened to the crankshaft by means of a taper fit, a key, a left-hand nut and spring washer.

b. Remove the blower housing. Bolt or clamp engine to work bench. Place a wood block under flywheel fin on right side of flywheel to hold it rigid and prevent turning as you loosen nut (fig. 12). To loosen and start nut to the *right*, tap end of wrench handle lightly with hammer. Remember that this is a left-hand thread and nut must be turned to the right. Tap carefully or a broken fin may result which will throw the flywheel out of balance. After the nut is removed, loosen flywheel by placing a wooden block against end of crankshaft and striking with a hammer. Pull off flywheel.

c. To replace flywheel, rotate crankshaft so that keyway is at the top. Place the key in the keyway and install the flywheel and spring washer with the hollow or concave side of washer next to the flywheel. Start the flywheel nut and turn to *left* until tight. Then place block under fin on left

SECTION IV

side of flywheel to hold flywheel rigid and draw nut very tight by tapping with a hammer.

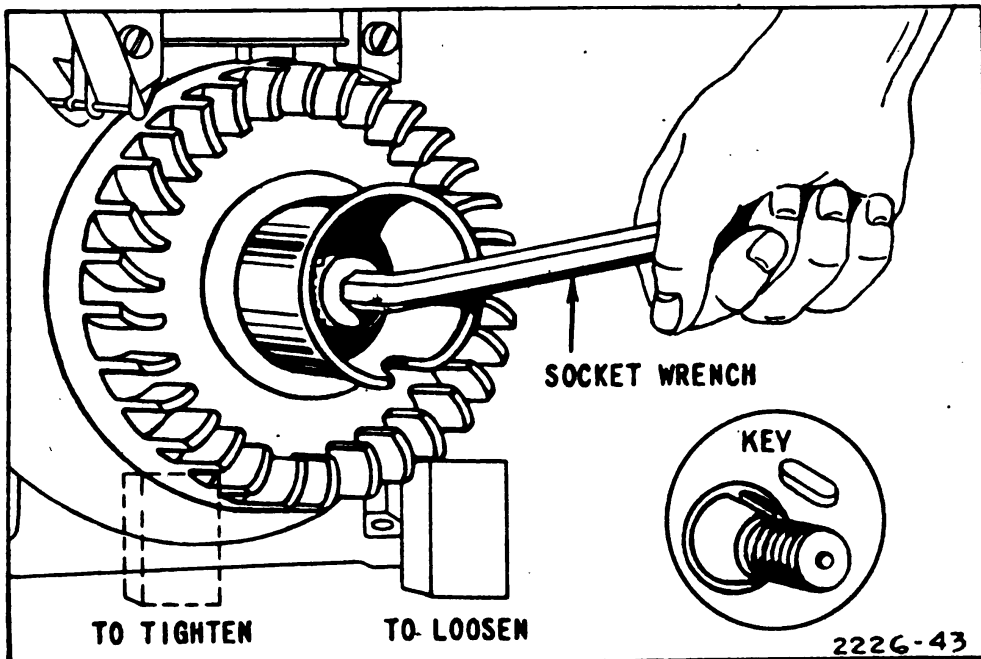

Figure 12.—Removing flywheel

20. TO REMOVE MAGNETO ASSEMBLY.—*a.* On models using the mechanical governor, after removing flywheel (par. 19) remove magneto point dust cover. If carburetor has not been removed, leave it alone. Remove the four magneto plate mounting screws and lift off the complete magneto assembly.

b. On models using the air-vane governor blade after removing the flywheel, remove magneto point dust cover. Remove governor air vane from armature. Unhook governor spring from the throttle lever. Remove four magneto plate mounting screws.

21. TO REPLACE MAGNETO.—Use same gasket between plate and crankcase or if damaged a new gasket, see parts #67307, #67597, or 67607# for proper thickness to get correct end play of .002 to .008 inch between magneto bearing and crankshaft thrust faces (fig. 13). Use lock washers when mounting screws.

22. MAGNETO TIMING.—The magneto is always correctly timed when the flywheel is assembled to the tapered crankshaft with the key and securely held in place with the left hand threaded nut. Do not attempt to change the timing by relocating any parts or filing crankshaft timing plate. Always use soft key, stock number 3H4577A/K1. If a steel key is used and the flywheel becomes loose, it will damage the keyway in the crankshaft.

POWER UNIT PE-77-(*)

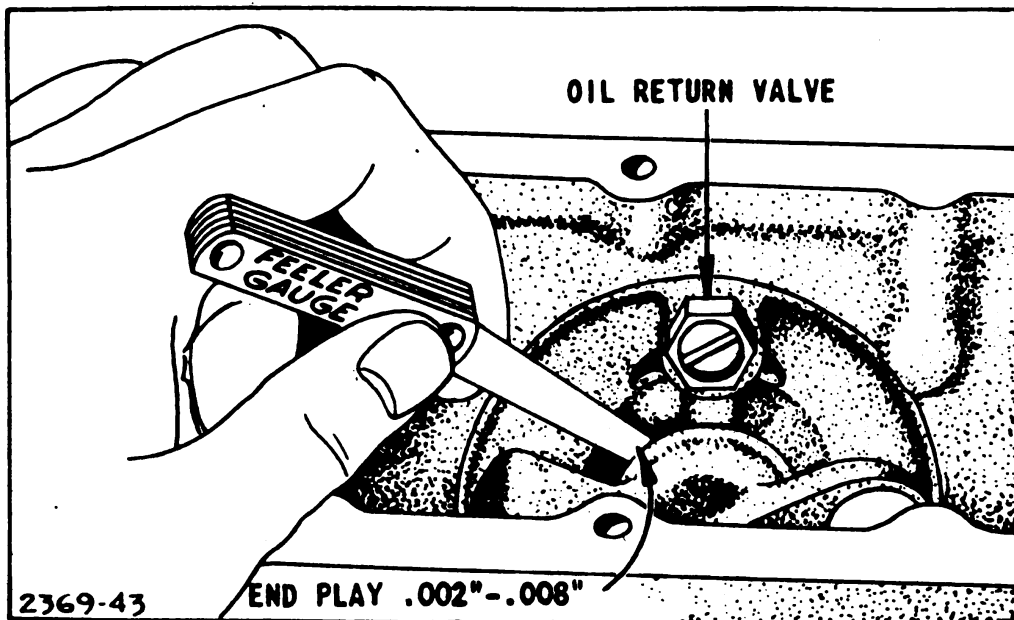

Figure 13.—Checking end play

23. TO ADJUST AND CLEAN MAGNETO CONTACT POINTS.—Remove blower housing, flywheel and magneto point dust cover. Turn crankshaft by hand to see if contact points open and close properly. Points must be clean and lined up squarely to make good electrical contact. Do not use a steel file, but use fine sandpaper or fine grit hone to clean points. Adjust gap to .020 inch by loosening the adjusting lock screw and moving contact point bracket up or down (fig. 14). When proper gap is obtained, tighten lock screws securely. Recheck the gap after tightening lock screw to make sure adjustment has not shifted. If either or both points become badly pitted or burned and need replacement, always replace complete assembly, stock number 3H4577A/P30.

24. TO REPLACE MAGNETO CONDENSER.—A leaky or weak magneto condenser may cause the engine to start hard, to sputter or misfire under load. If engine misfires after you have checked gasoline line, carburetor, spark plug, cable and contact points, install a new condenser. Both the condenser lead and armature lead must be soldered to the brass arm (fig. 15). Be sure to push condenser lead down between condenser and hub of magneto plate so it cannot rub against flywheel. If, after new condenser has been installed, the ignition system still does not deliver a satisfactory spark, replace the complete magneto unit.

25. TO REPLACE AND ADJUST MAGNETO ARMATURE.—a. Remove primary armature lead wire of coil from brass arm on contact bracket. Remove high tension ignition cable from secondary terminal loop in coil. Unscrew four armature mounting screws. After installing new armature, be sure that the condenser lead wire and armature lead wire

SECTION IV

from coil are soldered to brass arm on contact bracket (fig. 15) Replace mounting screws, insert the loop of the ground wire under screw and draw screws up tight.

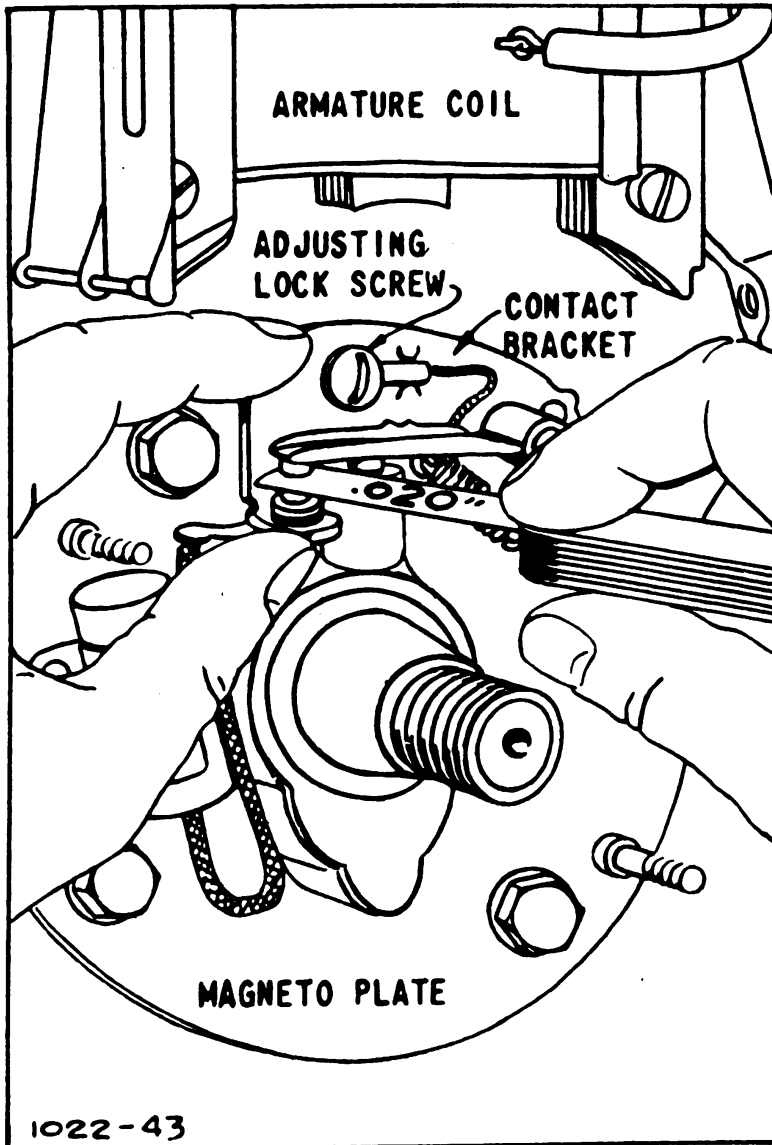

Figure 14.—Adjusting contact points

b. Air gap of .008 to .012 inch must be maintained between armature core ends and flywheel (fig. 16). Gap must only be sufficient to prevent rubbing and must not exceed .012 inch. To adjust gap to proper clearance, loosen the four armature-mounting screws, slide armature assembly up, and place correct feeler gauge or three thicknesses of newspaper between rim of flywheel and armature core end. Lower armature assembly until core ends rest on gauge and tighten mounting screws securely (fig. 13).

POWER UNIT PE-77-(*)

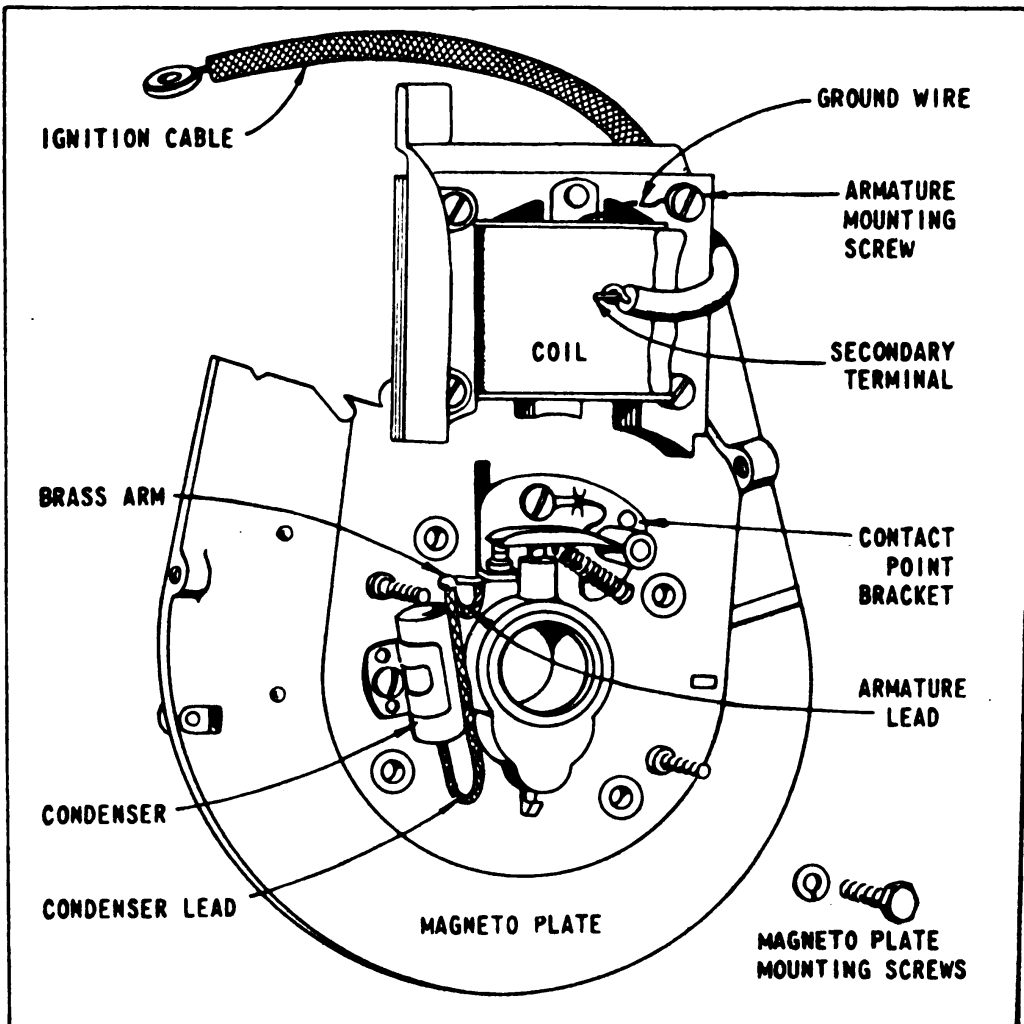

Figure 15.—Complete Magneto assembly

26. **CYLINDER HEAD.**—The cylinder head (fig. 17) is held on with six cap screws. When the cylinder head has been removed for the purpose of cleaning carbon, or grinding valves, care should be used in replacing it. Use a new gasket if possible. Otherwise, clean the old one and coat both sides with cup grease. *Do not use shellac on cylinder head gaskets.* Tighten each cap screw *a little at a time*, in the order shown in figure 17, so that cylinder head is pulled down evenly. Screws need be only moderately tight.

27. **COMPRESSION.**—Proper compression is obtained when valves seat properly, gaskets do not leak, and pistons and rings fit properly. When tuning up the engine it is always well to check compression. This is done by turning the engine over quickly by hand. If turned slowly, sticky valves may not be detected. If a point of resistance is offered every other revolution, compression should be satisfactory. If engine turns over

SECTION IV

without compression resistance for a full cycle, it is possible that a worn piston, or piston rings, leaky valves, or leaky gaskets, are present. See that spark plug has a gasket under it and is drawn up tight. Check cylinder head gasket and tighten cylinder head cap screws

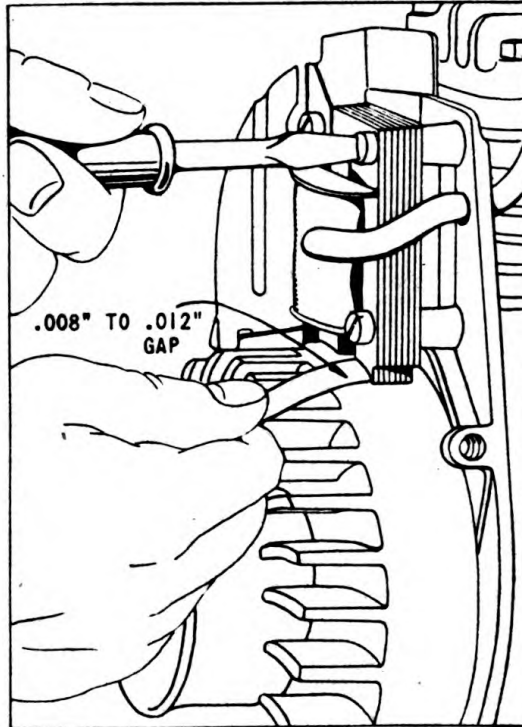
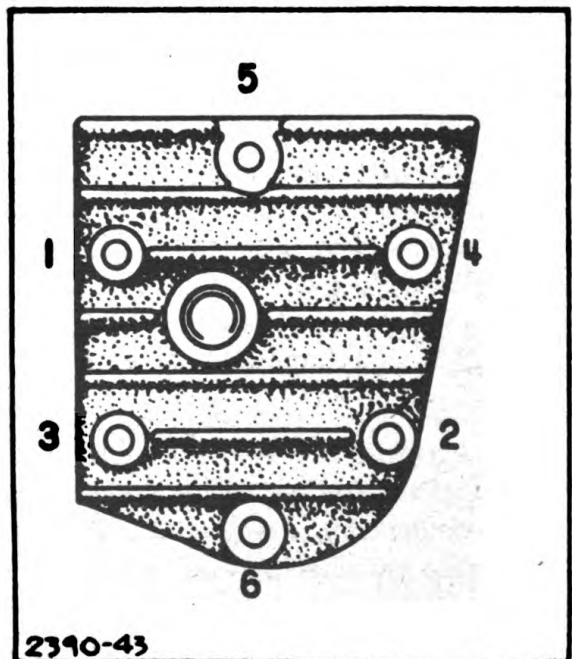

Figure 16.—Checking air gap

Figure 17.—Cylinder head



POWER UNIT PE-77-(*)

28. VALVE ADJUSTMENT.—*a.* To check valve clearance, remove valve cover plate. The correct clearance on the exhaust valve is .007 to .009 inch and on the intake valve .005 to .007 inch when engine is cold (fig. 18). Tappet clearance is adjusted by grinding the ends of the valve stems. End of stem must be square with stem proper. Be careful to grind off only a little at a time.

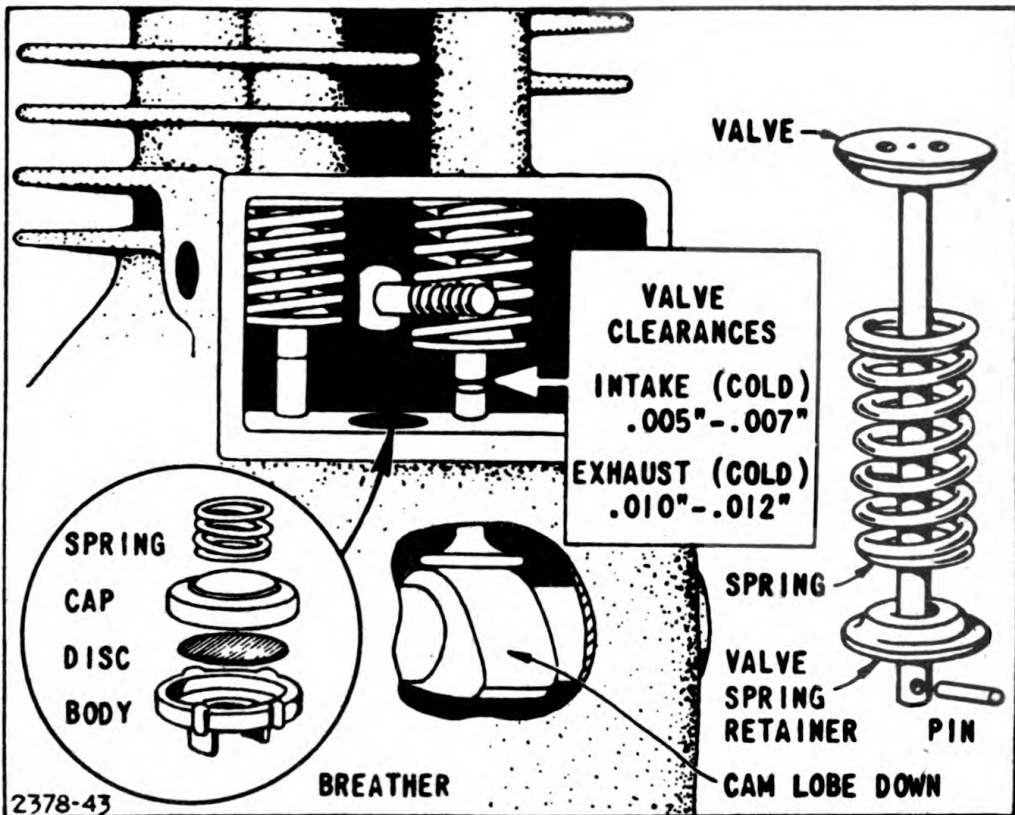

Figure 18.—Valve adjustments

b. To remove valve, remove cylinder head and if engine is not dismantled, drain oil from crankcase. Invert cylinder. Compress the valve spring with a screw driver and pull out valve retainer pin with long-nosed pliers. Tilt cylinder back far enough to allow valve to drop, permitting its stem to clear the spring. Pry the spring out with a screw driver. To replace, reverse the operations as performed above.

c. If valves or valve seats are badly pitted, burned, or warped, reface them with a cutter. When refacing, bolt the cylinder to a bench or a heavy block. Do not clamp the cylinder in a vise as heavy-vise-clamping will distort a cylinder. Use valve compound to grind the valves. Place a small amount of compound on the face of the valve, place a light coil spring on the valve stem, under the head of the valve, and place the valve in its seat in the cylinder and rotate it back and forth with a screw driver

SECTION IV

or valve grinding tool. Lift the valve after every rotation. Rotate to the right several times, then to the left. Heavy pressure should not be applied because it will cause rings on the valve and on the valve seats. After rotating, and the valves and seat look to be ground in thoroughly, wash all compound off the valve and seat with Diesel oil or cleaning solvent (Federal Specification P-S-661A). Be sure to replace the valves in the seats to which they have been ground.

d. The valves are timed by the meshing of the cam shaft gear with the gear on the crankshaft. These gears are properly meshed when the mark on the cam shaft gear is in line with the mark on the crankshaft collar (fig. 19).

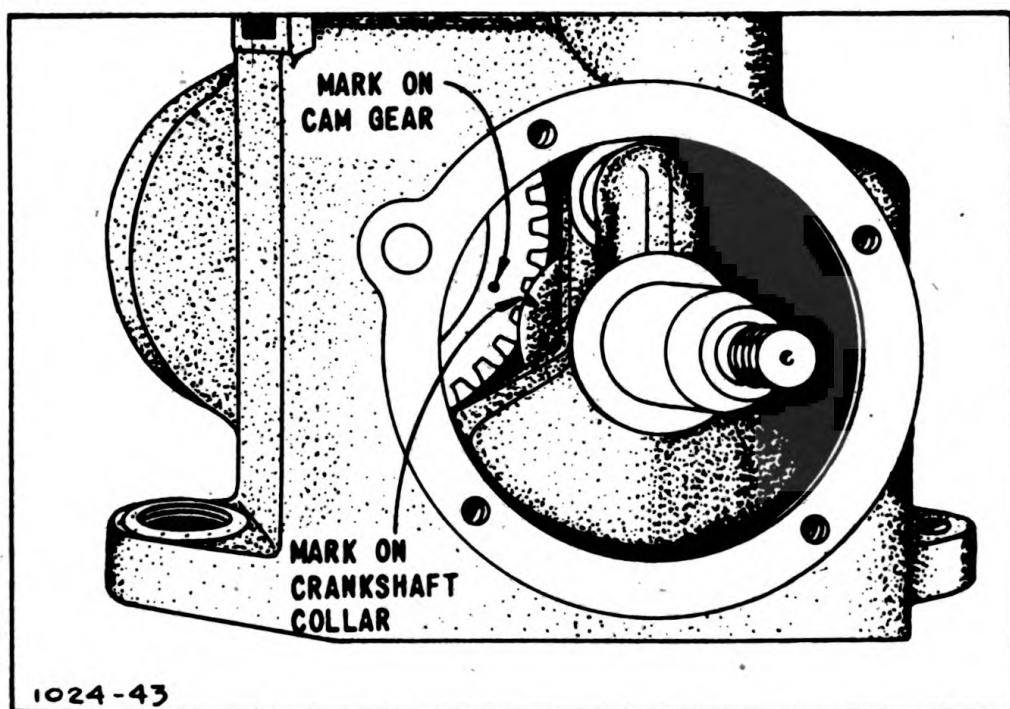

Figure 19.—Valve timing

29. BREATHER VALVE.—This engine is equipped with a breather valve to prevent pressure from forming in the crankcase (fig. 18). If this becomes clogged, it will cause oil leaks. Therefore, it is well to check and clean this valve whenever engine is taken apart for service. Wash parts in Diesel oil or cleaning solvent (Federal Specification P-S 661A) and re-assemble the parts in the order illustrated (fig. 18).

30. PISTONS.—*a.* The piston in the engine is made of special aluminum alloy which is very light in weight. The standard clearance between the piston skirts and cylinder wall is .003 to .0045 inch. This clearance is to compensate for the considerable expansion of aluminum when hot. The top and second lands of the piston are smaller than the skirt to allow

POWER UNIT PE-77-(*)

for greater expansion at the piston head. When piston is removed, be sure you thoroughly clean carbon from head of piston and ring grooves. If piston is out of round or scored, it should be replaced.

NOTE: Do not attempt to install a new piston without checking the cylinder bore. If the cylinder is out of round, it should also be replaced.

b. When fitting a new piston in the engine, assemble it with the free side pin hole, with an X on the boss, toward the magneto side (fig. 20).

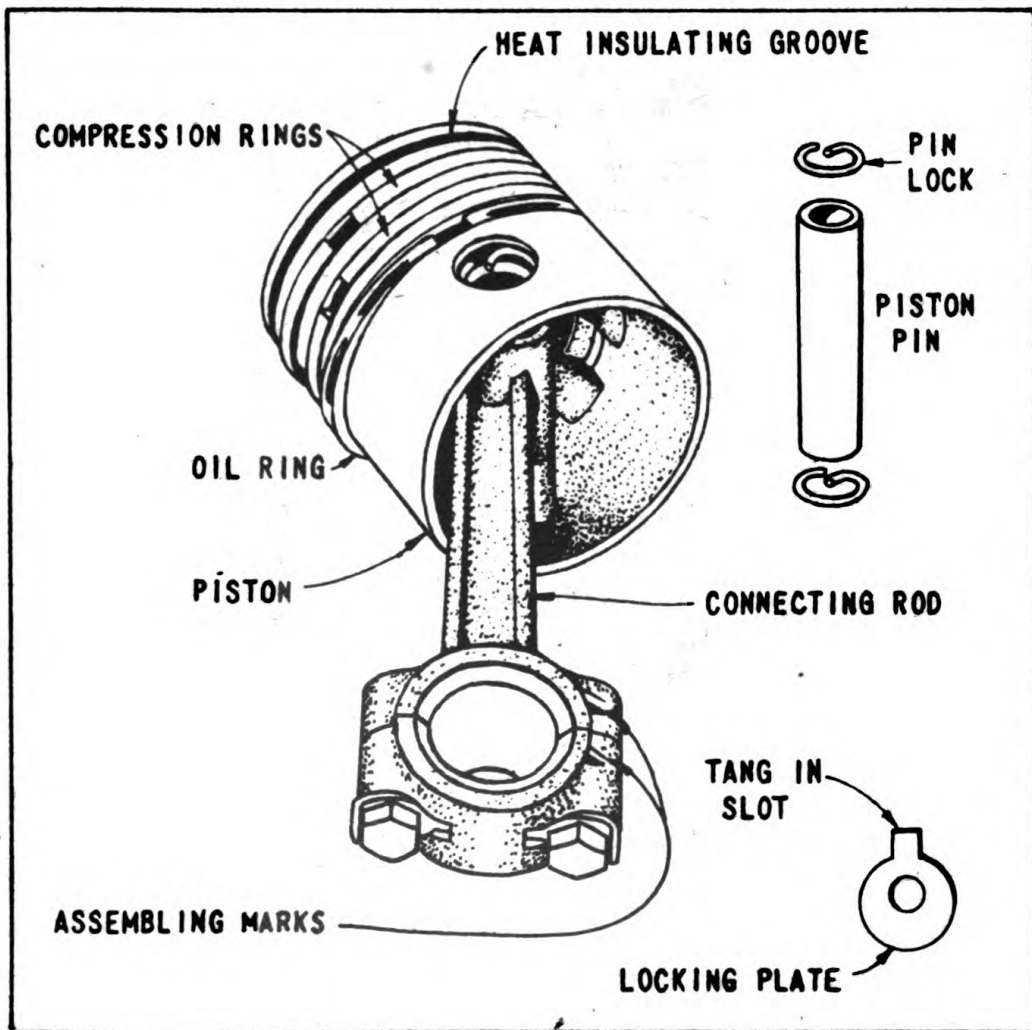

Figure 20.—Piston assembly

31. **PISTON RINGS.**—The piston rings when fitted in the cylinder should have a gap of .007 to .017 inch. The rings should be fitted in the cylinder below the piston ring travel. Before assembling new rings to piston, be sure that piston ring grooves are thoroughly clean and rings move in grooves freely.

SECTION IV

32. PISTON PINS.—*a.* The piston pin is a slip fit in the piston (free fit in one side of the piston and a tight fit in the other). In some cases, it can be removed from the piston by removing the lock rings, then slip the pin out of the piston. If the pin does not come out easily and necessary equipment is not available, an improvised method can be used. First heat the piston in boiling water, expanding the aluminum alloy piston. Cut a wooden pin a little smaller than the size of the piston pin and use this and a hammer to drive the pin out. Drive the pin out through the free fit hole. This hole is toward the magneto side and is indicated with an X on the pinhole boss. Drive the pin out while the piston is hot. The piston may have to be heated in the same manner to replace the pin.

b. There is no fitting on piston pins. They are machined to proper sizes. However, allow .0015 inch total wear before replacing with new pins.

33. CONNECTING ROD.—*a.* The connecting rod is assembled to crankshaft with the marks on the cap and rod on the same side. These marks must also be toward the magneto side of the engine. Bend locking plates against hexagon head of cap screws (fig. 21).

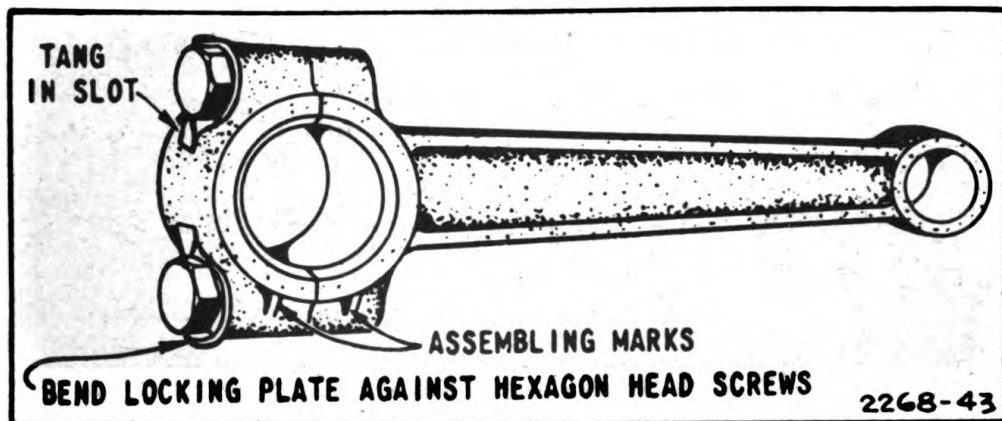

Figure 21.—Connecting rod

b. The bearing is an integral part of the rod and is not replaceable.

34. OIL PUMP.—*a.* The oil pump is mounted in the crankcase with two bolts and lockwashers and is operated by an eccentric on the cam shaft (fig. 22). A defective pump will result in insufficient lubrication; this may score cylinder and piston assembly. To check oil pump, remove from base. Place the bottom of the pump in a pan of oil about $\frac{1}{2}$ inch deep. Work plunger up and down. A stream of oil will be forced out of the hole in the oil tube if the pump is in good operating condition. If clogged, remove plunger and plunger spring and submerge complete unit in gasoline for 3 to 4 hours to loosen accumulated sludge or gum. In assembling, be sure that spring and plunger are in place.

POWER UNIT PE-77-(*)

b. A pump that has been washed or soaked in kerosene must first be primed or lubricated before it is operated again, so that it will start pumping the instant the gear begins to turn. This is done by running oil into the inlet tube opening. A dry pump will not function immediately. An inoperative pump must be replaced.

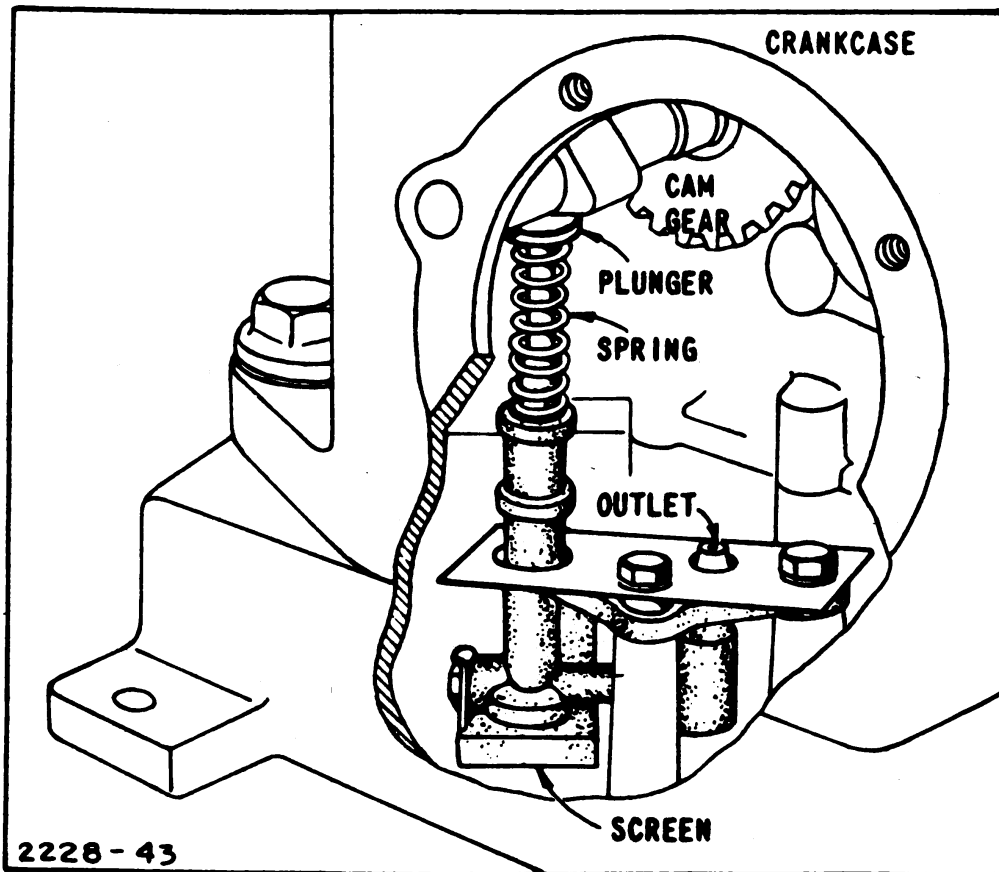

Figure 22.—Oil pump

- 35. TO REMOVE CRANKSHAFT.**—*a.* Drain oil from crankcase.
b. Remove blower housing.
c. Remove flywheel.
d. Remove magneto.
e. Remove engine from base.
f. Turn engine upside down.
g. Disconnect connecting rod and push piston down in cylinder bore so that it clears the crankshaft. Do not push too far as the top ring may become detached.
h. Remove cam shaft by driving it out of crankcase with a $\frac{5}{16}$ -inch rod or punch from drive side (fig. 23). Be careful not to lose the camshaft plug (part #68122).

SECTION IV

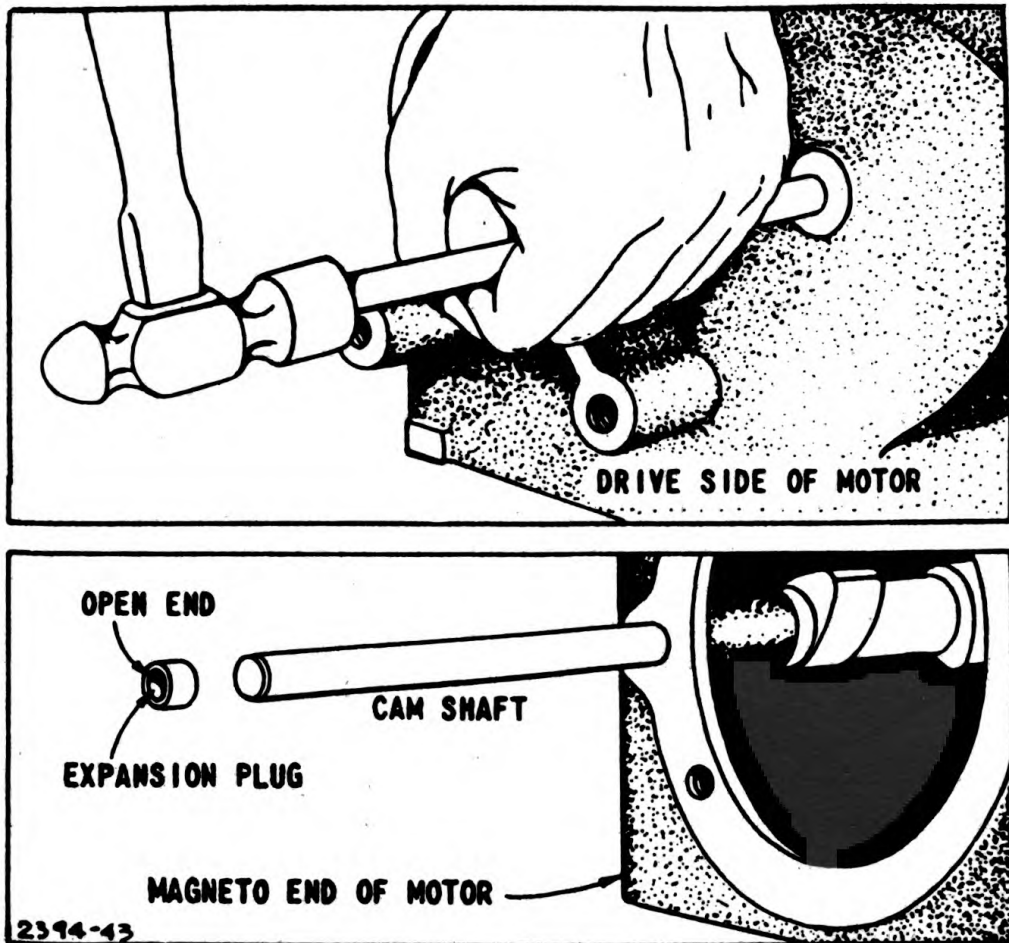

Figure 23.—Removing and replacing cam shaft

- i. Remove bearing nut on end of the crankshaft.
- j. Slide cam gear over to allow ball bearing on crankshaft to clear. Slide crankshaft out toward magneto side of the engine.
- k. To reassemble, reverse above operations. Be sure to install camshaft expansion plug in the hole on the magneto side with the open end out (fig. 23).

NOTE: It is assumed that the generator has been removed as instructed in paragraph 41, before attempting the above operations.

36. OIL LEAKS.—If oil leaks from either end of crankshaft main bearings, remove base from engine. Oil return valves are screwed into crankcase and magneto back plate below main bearings. Remove oil return valve and clean or flush with gasoline and blow out any dirt lodged under the small disc. Replace if necessary (fig. 13).

37. CARBON.—Excessive carbon is caused by an improper grade of oil, too much oil, piston rings not seating properly or sticking, carburetor set too rich, or oil leaking past the piston caused by natural wear through

POWER UNIT PE-77-(*)

long service. An unusual amount of carbon is noticeable by engine knocking or loss of power, or by engine continuing to run after the spark has been cut off. About every 300 operating hours, remove carbon from valves, valve parts, piston head, piston rings and ring grooves, cylinder head and top of cylinder bore.

38. AIR CLEANER.—Clean the air cleaner every 32 hours, or daily under very dusty conditions, by removing it and washing it in Diesel oil or cleaning solvent (Federal Specification P-S-661A). Clean the bowl by submerging in gasoline or kerosene. Fill cleaner bowl with light oil to the level marked on the cleaner bow. *Do not use diluted oil.* (See instructions on air cleaner.) Make sure filter is dry before replacing it.

39. MUFFLER.—After long periods of service it is possible that the muffler will become clogged to the point where it will affect engine operation. To check the muffler, unscrew it from the engine and run water into the intake end of the muffler. If water runs out of the outlet end of the muffler freely you will know that it is not clogged. If the water runs through very slowly, however, the muffler is probably clogged and should be replaced.

40. GENERATOR.—*a.* The generator of Power Unit PE-77-(*) will require very little attention, with the exception of replacement of brushes and a regular examination of the commutator to make sure there is good electrical contact between it and the brushes. Oil, grease, or dirt will affect the output of the generator and cause sparking at the brushes. The generator must be inspected regularly by removing the end cover, which is fastened to the generator frame by three machine screws. Figure 25 shows the circuit diagram and figure 28 the parts of the generator. No lubrication is required.

b. Overload.—Always be sure that the load the unit is expected to carry is within the range of the unit, namely 250 watts, 115 volts, direct current. Overloading may cause the engine to overheat, lose power or stop. If the generator is overloaded, it will cause overheating, excessive brush wear, sparking at the brushes, and low voltage output.

c. Brushes.—Check brushes after every 300 hours of operation. When worn to a point where the brush holder arm nearly touches the brush holder, replace with new brushes. The brushes can be taken out by removing the lock wire holding brush and spring in brush holder. Disconnect brush pigtail from brush holder. To install brushes, reverse the procedure. Fit the brushes to the commutator and slip rings, by putting a piece of fine sandpaper (fig. 24) the width of the brushes on the commutator or slip ring (from the side of the commutator or slip ring). Shape the brush by pulling sandpaper in the direction of rotation of the generator while pressing on the brush. Release the pressure on the brush and pull the

SECTION IV

sandpaper back and repeat the shaping operation until at least 75 percent brush fit is obtained by testing in proper position for operation, with the brush spring in place.

d. Commutator.—The commutator is probably the most frequent source of trouble. Keep the commutator clean by rubbing with a clean, coarse cloth while the unit is operating, or if necessary with 000 (fine) sandpaper. Do not use sandpaper more than necessary. Do not use emery cloth or paper as they are electrical conductors and may short circuit the armature. If the commutator is rough, badly pitted, or out of round, place it in a lathe and turn it down until smooth. After turning down the commutator, undercut the mica insulation about $\frac{1}{32}$ inch below the level of the commutator bars so the brushes can ride on the copper without interference (fig. 24). Check carefully to see that no metal particles are lodged between the bars. The armature winding may be damaged if the plant is operated with the commutator shortcircuited in this manner.

e. Testing d-c winding.—To test the d-c winding of the armature raise the brushes from the commutator. Place one end of a test lamp lead (series hook-up using a 3 or 4 candlepower bulb with a 6- or 12-volt battery) on the commutator and the other lead on the end of the armature stud (fig. 24). If the bulb lights, the commutator is grounded and the plant will not generate current. Replace the generator.

f. To test field coils.—To test the coil circuit, first disconnect the brush rig leads. Using a test lamp as described for commutator testing, touch one lead of the test lamp to a field lead and the other to the generator frame. A grounded coil is indicated if the lamp lights. If the coil is grounded, replace the generator. Test for an open field circuit by connecting the test lamp across both field leads. If the lamp does not light, the field circuit is open. If the field circuit is open, replace the generator.

g. Generator line condenser.—A condenser is connected across the generator output line which acts as a filter to minimize radio interference and prevent excessive brush arcing. If this condenser is shortcircuited, no current will flow in the line, and the armature or fields will burn open. Disconnect the condenser; if current flows, the condenser is defective and must be replaced. An open condenser will be indicated by an increase in radio interference and excessive brush arcing. Test the condenser and if defective replace it. The plant can be run without the condenser for a short time if one is not immediately available.

h. Low voltage.—If the generator output is low, check the brushes and see if they are seating on the commutator properly. Check field coils for a defective coil by holding a screw driver or a piece of iron near the pole-shoe bolts and compare the magnetic attraction of the poles. If one has little or no attraction, it may be shortcircuited. To correct this, replace the gen-

POWER UNIT PE-77-(*)

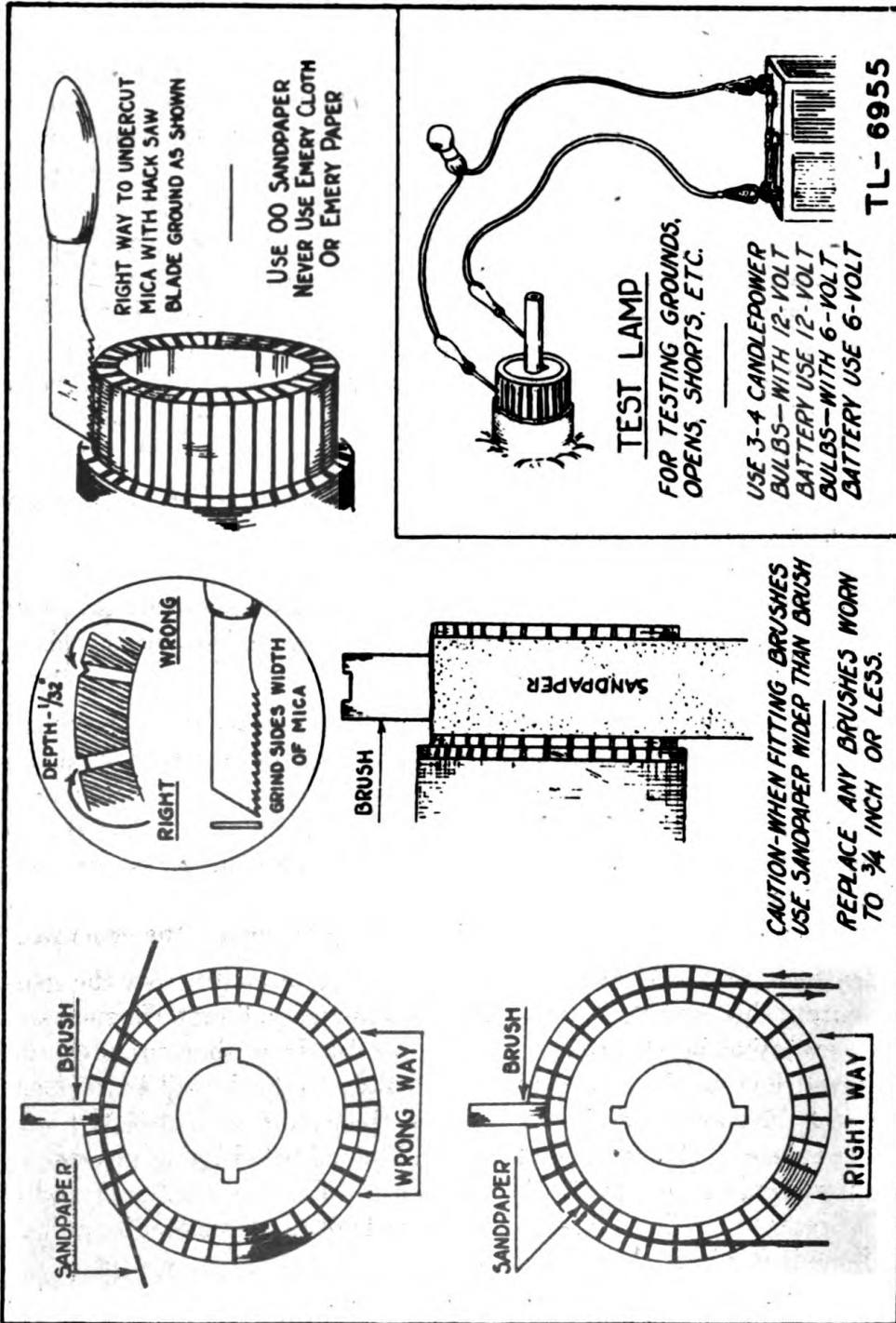

Figure 24.—Fitting brushes; undercutting and testing commutators.

SECTION IV

erator. Check the speed of the engine with a tachometer, if available. Correct engine speed is approximately 3,000 rpm generating 250 watts, 115 volts, direct current.

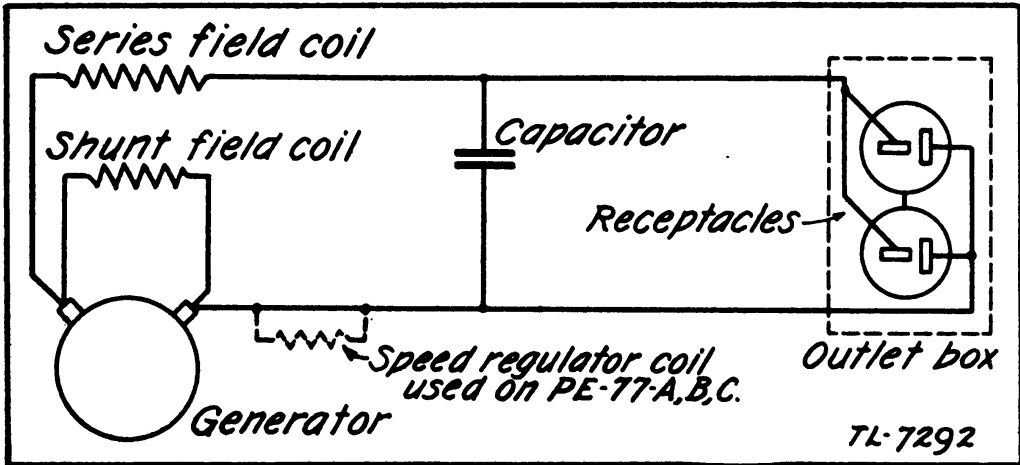

Figure 25.—Power Unit PE-77-E, connection diagram

41. **TO REMOVE GENERATOR.**—Remove the capscrew at the center of the fan and remove fan. Remove the field frame by removing the four nuts on the inner surface of the generator adapter ring. Studs in the field frame project through the adapter. The armature may now be removed by tapping on the end of the crankshaft with a hammer, and pulling off at the same time. After the armature has been removed from the crankshaft and reassembled, the alignment should be checked by using a dial indicator on the commutator surface. Misalignment must not exceed ± 0.0015 inch.

42. **ENGINE TROUBLE AND REMEDY CHART.**

a. *Engine will not start.*—

Possible cause	Check	Remedy
(1) Gasoline tank empty.	Check fuel supply.	Fill gasoline tank.
(2) Gasoline line clogged.	Check screen and gasoline line. Check carburetor float.	Clean filter screen, blow out fuel lines.
(3) Poor grade of fuel or water in gasoline.	Check filter and carburetor and fuel in tank.	Replace with fresh fuel.
(4) Loose or defective wiring.	Check wire connections.	Tighten connections.
(5) Spark plug dirty or cracked.	Check for excessive carbon or cracks.	Clean plugs or replace.
(6) Spark plug gap not adjusted properly.	Check with feeler gauge for .025".	Bend contact points to .025" gap.
(7) Improper gasoline mixture.	Check float level and needle valve adj.	Adjust level of float and adjust needle valve.
(8) Throttle rod loose.	Check rod from governor to carburetor.	Tighten rod.

POWER UNIT PE-77-(*)

42. ENGINE TROUBLE AND REMEDY CHART.—

a. Engine will not start.—

<i>Possible cause</i>	<i>Check</i>	<i>Remedy</i>
(9) Throttle valve out of adjustment or stuck.	Check throttle valve and governor.	Remove and clean valve.
(10) Valve seats pitted.	Check for loss of compression.	Return unit to depot for regrinding or replacement.
(11) Valves sticking.	Check valve springs and valve stems for excessive carbon. Check for bent valve stems.	Clean springs and clean valve stem.
(12) Valve adjusted too tightly.	Check valve clearance with feeler gauge.	Adjust to proper clearance.
(13) Improper timing.	Check magneto point opening.	Clean or replace points and set gap to .020". Check valve timing.
(14) Defective magneto.	(a) Check to see if magneto coil is burned out.	(a) Replace coil.
	(b) Breaker points pitted or worn.	(b) Clean points with fine grit hone or, if badly pitted, replace.
	(c) Breaker points out of adjustment.	(c) Adjust to proper gap.
	(d) Check condenser for leaks or weakness.	(d) Replace condenser.
	(e) Check to see if high-tension wire is shorted.	(e) Replace if wire is broken or insulation damaged.
(15) Air or compression leaks from loose bolts or defective gaskets.	Check for oil or air leaks.	Tighten bolts or replace gaskets if damaged or broken.

b. Engine misfiring.—

<i>Possible cause</i>	<i>Check</i>	<i>Remedy</i>
(16) Loose electrical connection.	Check connections.	Tighten connections.
(17) Spark plug dirty or cracked.	Check for excessive carbon or crack.	Clean plug. Replace plug if cracked.
(18) Spark plug gap adjusted incorrectly.	Check with feeler gauge for .025".	Bend contact points to .025" gap.
(19) Magneto high-tension coil burned out or weak.	Check by trying another coil.	Replace coil.
(20) Ignition breaker points sticking or out of adjustment.	Check distance of gap.	Clean points. Adjust gap to .020".
(21) Defective wiring.	Check for broken wires or damaged insulation.	Replace or repair wire.
(22) Valves warped or broken.	Check by removing valves and inspecting them.	Replace with new valves. This should be done at Signal Corps repair depot.

SECTION IV

42. ENGINE TROUBLE AND REMEDY CHART.—(Cont.)

<i>Possible cause</i>	<i>Check</i>	<i>Remedy</i>
(23) Valve tappets sticking.	Check by turning motor over by hand to see how valves function.	Clean carbon from tappets. This should be done at Signal Corps repair depot.

c. Engine overheated.—

<i>Possible cause</i>	<i>Check</i>	<i>Remedy</i>
(24) Valve tappets improperly adjusted.	Check clearance with feeler gauge.	Adjust to proper clearance.
(25) Oil level too low.	Check oil level by removing oil filler cap.	Add oil to top of filler plug opening.
(26) Improper gasoline mixture.	Check float level and needle valve adjustment.	Adjust level of the float and adjust needle valve.
(27) Carburetor choke valve partly closed.	Check valve.	Adjust valve to open completely and close completely.
(28) Piston rings sticking.	Check by removing piston and examining rings.	Clean carbon from ring grooves. This should be done at Signal Corps repair depot.
(29) Insufficient ventilation of motor.	Check to see if there is 2-foot clearance on all sides of unit.	Provide more space.
(30) Improper timing.	Check magneto point opening.	Adjust so that points break when piston is on firing stroke.
(31) Muffler clogged.	Check to see if explosions from exhaust are continuous or alternating. They should be alternating.	Replace muffler.
(32) Air cleaner dirty.	Check for dirt in bowl or on screen by removing filter.	Clean out bowl and screen.
(33) Air fins clogged.	Check for dirt or grass in fins.	Clean out dirt or other obstructions.
(34) Governor or throttle loose.	Check to see if rod from governor to carburetor is disconnected.	Connect and tighten rod.

d. Engine knocks.—

<i>Possible cause</i>	<i>Check</i>	<i>Remedy</i>
(35) Poor gasoline.	Check source and grade of fuel.	Replace with fresh leaded gasoline.
(36) Sticking valves.	Check valve springs and valve stems for excessive carbon. Check for bent valve stems.	Replace springs or clean carbon from valve stems. This should be done at Signal Corps repair depot.

POWER UNIT PE—77—(*)

42. ENGINE TROUBLE AND REMEDY CHART.—(Cont.)

<i>Possible cause</i>	<i>Check</i>	<i>Remedy</i>
(37) Broken valve spring.	Check by removing valve cap cover and observing.	Replace valve spring.
(38) Carbon in cylinder.	Check by removing spark plug and observing through spark plug hole.	Remove cylinder head and clean out carbon.
(39) Loose main bearings.	Check for oil leaks in front and rear of engine.	Replace bearings. This should be done at Signal Corps repair depot.
(40) Loose rod bearings.	Short plug while engine is running to see if noise disappears.	Tighten rod if possible, otherwise replace.
(41) Improper adjustment of carburetor.	Check float valve and needle valve adjustment.	Adjust level of float and adjust needle valve. Drain out dirt and water in carburetor bowl.
(42) Loose valve tappets.	Check valve clearance with feeler gauge.	Adjust to proper clearance.
(43) Tight pistons.	Check engine for seizing under full load.	Remove check ring and piston clearance. Renew if necessary.
(44) Lack of oil or insufficient oil.	Check oil level by removing oil filler cap.	Add oil to top of filler plug opening.
(45) Loose flywheel.	Check by stopping motor and determining play of flywheel by rocking against compression.	Remove flywheel. Examine Woodruff key. Key may need replacement.
(46) Improper timing.	Check to see if flywheel key is sheared. See <i>c</i> .	Replace flywheel key. See <i>c</i> .
(47) Engine overheated.	See <i>c</i> .	See <i>c</i> .
(48) Worn piston and cylinder.	Check by turning engine over by hand to see if compression is satisfactory, after determining that valves are in good condition.	Replace piston. Send engine to depot for repairs.
(49) Loose piston pin.	Check by shorting spark plug to see if noise disappears.	Replace piston pin or connecting rod. This should be done at Signal Corps repair depot.

e. Faulty carburetion.—

<i>Possible cause</i>	<i>Check</i>	<i>Remedy</i>
(50) Carburetor improperly adjusted.	Check float level and needle valve adjustment.	Adjust level of float and adjust needle valve.
(51) Sediment in fuel tank.	Check sediment in fuel filter.	Flush tank with gasoline line and refill with fresh fuel.

SECTION IV

42. ENGINE TROUBLE AND REMEDY CHART.—(Cont.)

<i>Possible cause</i>	<i>Check</i>	<i>Remedy</i>
(52) Screen on filter bowl clogged.	Check by removing filter bowl and examining screen.	Clean screen with gasoline. Clean out fuel tank.
(53) Shut-off valve closed	Check by turning valve to see if gasoline flows to filter bowl.	Open valve.
(54) Vent hole on cap of gasoline tank clogged.	Check by removing gasoline tank cap and blowing through vent hole.	Clean vent hole on cap.
(55) Valves leaking.	Check by removing valves and inspecting them.	Send to depot for repairs.

f. Explosions in carburetor.—

<i>Possible cause</i>	<i>Check</i>	<i>Remedy</i>
(56) Improper timing.	Check magneto point opening.	Set opening to .020".
(57) Gasoline mixture too lean.	Check by opening needle valve slightly while engine is running.	Open needle valve to best adjustment.
(58) Intake tappets sticking.	Check by turning motor over by hand to see how valves function.	Clean carbon from tappets or replace springs if weak. Return to depot if necessary.
(59) Intake valve springs weak.	Check by turning motor over by hand to see how valves function.	Replace springs. Return to depot if necessary.
(60) Intake valves warped or broken.	Check by removing valves and inspecting them.	Return to depot.
(61) Intake tappets set too close.	Check valve clearance with feeler gauge.	Return to depot.
(62) Intake valve sticking.	Check valve stems for excessive carbon and valve spring. Check for bent valve stems.	Replace spring or clean carbon from valve stem. Return to depot if necessary.

g. Excessive smoke from exhaust.—

<i>Possible cause</i>	<i>Check</i>	<i>Remedy</i>
(63) Carburetor needle valve open too far.	Check by closing needle valve slightly.	Close needle valve to best adjustment.
(64) Poor fuel.	Check source and grade of fuel.	Replace with fresh gasoline.
(65) Worn piston and piston rings.	Check by turning engine over by hand to see if compression is satisfactory, after determining that valves are in good condition.	Replace rings and piston if necessary. This should be done at Signal Corps repair depot.

POWER UNIT PE—77—(*)

42. ENGINE TROUBLE AND REMEDY CHART.—(Cont.)

<i>Possible cause</i>	<i>Check</i>	<i>Remedy</i>
(66) Carburetor float sticking or leaking.	Check float level and remove float and examine for leaks.	Adjust level of the float. Replace with new float if necessary.
(67) Worn connecting rod bearing.	See <i>d</i> (40).	See <i>d</i> (40).
(68) Too light oil.	Drain small quantity and check.	Drain and refill with heavier oil.

h. Poor compression.—

<i>Possible cause</i>	<i>Check</i>	<i>Remedy</i>
(69) Defective or missing spark plug gasket.	Check by removing plug and examining gasket.	Replace with new gasket.
(70) Loose spark plug.	Check plug for tightness.	Tighten plug.
(71) Cracked spark plug.	Check by removing and examining plug.	Replace plug.
(72) Cylinder head gaskets blown.	Check gasket for air leaks.	Replace gasket.
(73) Valves sticking.	Check valve stems for excessive carbon, also valve springs. Check for bent valve stems.	Replace springs or clean carbon from valve stems. Return to depot if necessary.
(74) Valves not seating.	Check by removing valve to see if warped, or if excessive carbon around valve seat.	Replace valve or return to depot for grinding.
(75) Valve tappets sticking.	Check by turning motor over by hand to see how valves function.	Clean carbon from tappets or replace springs if weak. Return to depot if necessary.
(76) Valve tappets set too close.	Check valve clearance with feeler gauge.	Adjust to proper clearance. Return to depot.
(77) Piston rings sticking.	Check by removing piston and examining rings.	Clean carbon from ring grooves. This should be done at Signal Corps repair depot.
(78) Piston rings broken.	Check by removing piston and examining rings.	Replace with new rings.
(79) Worn piston and cylinder.	Check by turning engine over by hand to see if compression is satisfactory, after determining that valves are in good condition.	Replace piston. Send engine to depot for repair.

SECTION IV

43. GENERATOR TROUBLE AND REMEDY CHART.—

a. Sparking at the brushes.—

<i>Possible cause</i>	<i>Check</i>	<i>Remedy</i>
(1) Too much load.	Check voltmeter and ammeter readings to make sure they indicate voltage and current as marked on the nameplate.	Reduce the load.
(2) Brushes not seated properly. Dirty brushes and commutator.	Remove brushes and check for uneven wear or dirt on brushes or commutator.	Adjust brushes with fine sandpaper.
(3) Rough or eccentric commutator.	Check for uneven wear on commutator and brushes.	If only slightly rough, use coarse cloth or very fine sandpaper; if rough, send unit to depot.
(4) Open armature.	Check to see if coil lead is disconnected or coil open.	Solder coil lead back on or return to depot.
(5) Grounded or open or shorted field winding.	Check for breaks or shorts in the field.	Open or shorted fields should be replaced. A grounded field may be repaired by insulating at the point where ground occurs. Return to depot for repairs.
(6) Brushes sticking in the holders.	Check to see that brushes move freely in holders.	Readjust brushes or replace with new ones.

b. Voltage too low.—

<i>Possible cause</i>	<i>Check</i>	<i>Remedy</i>
(7) Engine speed low.	Check speed with tachometer.	Increase speed of engine by adjusting speed regulator.
(8) Brushes not set properly.	Remove brushes and check for uneven wear.	Adjust brushes with fine sandpaper.

c. Voltage too high.—

<i>Possible cause</i>	<i>Check</i>	<i>Remedy</i>
(9) Speed of engine too high.	Check engine speed with tachometer.	Adjust speed by means of speed regulator.

d. Armature too hot.—

<i>Possible cause</i>	<i>Check</i>	<i>Remedy</i>
(10) Armature overloaded	Check voltmeter and ammeter readings to make sure they indicate voltage and current as marked on the nameplate.	Reduce the load.

POWER UNIT PE-77-(*)

43. GENERATOR TROUBLE AND REMEDY CHART.—(Cont.)

<i>Possible cause</i>	<i>Check</i>	<i>Remedy</i>
(11) Armature coil short-circuited.	Check for breaks.	Replace armature. This should be done at Signal Corps repair depot.
(12) Armature striking on pole pieces.	Check the bearings to make sure they are not worn out and also the line-up of the brackets.	Replace bearings and re-line bracket if necessary. Return unit to Signal Corps repair depot.
(13) Poor ventilation.	Check air space around generator.	Make sure there is at least a 2-foot clearance on all sides of generator.

e. Commutator too hot.—

<i>Possible cause</i>	<i>Check</i>	<i>Remedy</i>
(14) Sparking of brushes.	See a.	See a.
(15) Too much pressure on brushes.	Pressure should be approximately $2\frac{1}{2}$ to 5 pounds per square inch.	Replace springs with weaker springs.
(16) Too much load.	Check voltmeter and ammeter reading to make sure they indicate voltage and current as marked on the nameplates.	Reduce the load.
(17) Poor ventilation.	Check air space around generator.	Make sure there is at least a 2-foot clearance on all sides of generator.

f. Field coils too hot.—

<i>Possible cause</i>	<i>Check</i>	<i>Remedy</i>
(18) Short circuit in field coils.	Check for breaks in the field.	Open or shorted fields should be replaced. A grounded field may be repaired by insulating at the point where the ground occurs.
(19) Poor ventilation.	Check air space around generator.	Make sure there is at least a 2-foot clearance around all sides of generator.

g. Noisy generator.—

<i>Possible cause</i>	<i>Check</i>	<i>Remedy</i>
(20) Armature striking pole.	Check for loose wires.	Replace armature if necessary. Return unit to depot.

SECTION IV

43. GENERATOR TROUBLE AND REMEDY CHART.—(Cont.)

h. Generator fails to generate.—

<i>Possible cause</i>	<i>Check</i>	<i>Remedy</i>
(21) Short circuit in line.	Check for short circuits.	Replace armature or field coils if necessary. Return unit to depot.
(22) Too weak residual magnetism.	Check by passing current from battery through field coils.	Pass current from battery through field coils, making sure positive pole of battery is connected to positive lead of shunt field.
(23) Short-circuited armature.	Check for breaks in armature or dirt on commutator bars.	Remove dirt, etc. Replace armature. If necessary, return to depot.
(24) Grounded field.	Check for breaks in field	Open or shorted fields should be replaced. A grounded field may be repaired by insulating at the point where the ground occurs. Return to depot.
(25) Reversed field coils.	Pass current through field coil and check to see that coils are alternate north and south.	Change position of coils. Return to depot if necessary.
(26) Brushes not making contact.	Check to see if brushes are stuck.	Make sure that brushes move freely in holders. Replace with new brushes if necessary.
(27) Condenser short-circuited.	Disconnect condenser and see if current flows in the line.	Replace condenser.

POWER UNIT PE-77-(*)

SECTION V - SUPPLEMENTARY DATA

44. TABLE OF REPLACEABLE PARTS.—
a. Gasoline engine (figs. 30 and 31).

Mfg. stock No. (ref. No.)	Signal Corps stock No.	Name and description	Function	Used in PE-77-	Remarks ¹
Model I	3H4577(*) 3H1901-J.1	Power Unit PE-77-(*) Engine, complete, with mechanical governor	Complete power unit Replacement engine for PE-77-(*)	
21090	*3H4577A/P26	Plate, generator end, aluminum	End plate	A	Replaced by 21458
21110	*3H4577A/V6	Venturi, carburetor (for replacement use complete carburetor)	Mixer throat	ABCD&E	Order assy. 89641
21119	*3H4577A/E6	Elbow, air cleaner	Guides air from air cleaner to carburetor	ABCD&E	
21130	*3H4577A/E5	Elbow, carburetor intake	Guides flow of vapor	ABCD&E	
21277	*3H4577A/G27	Gear, cam	Operates valves	ABCD&E	
21283	3H4577A/R21	Ring, piston, top compression, standard	Seals power	ABCD&E	
21310	*3H4577A/B8	Breather body	Breather, ventilate crankcase	ABCD&E	
21362	*3H4577A/H5	Head, cylinder	Combustion chamber	CD&E	Replaces 61991
21376	3H4577A/R22	Ring, piston, top compression, .010" oversize	Seals power	ABCD&E	
21377	*3H4577A/R19	Ring, piston, top compression, .020" oversize	do	ABCD&E	

*Not issued as replaceable part. Not stocked. Do not order.

¹Complete assemblies (instead of individual parts) should be ordered by No. in "Remarks" column.

SECTION V

Mfg. stock No. (ref. No.)	Signal Corps stock No.	Name and description	Function	Used in PE-77-	Remarks ¹
21378	*3H4577A/R20	Ring, piston, top compression, .030" oversize	do	ABCD&E	
21458	*3H4577A/P31	Plate, generator end, cast iron	End plate	BCD&E	Replaces 21090
21468	*3H4575A/F15	Flywheel, magneto	To equalize torque, build up magnetic flux, and create air currents to cool motor	AB&C	Replaced by 29835
21470	*3H4577A/B11	Body, carburetor, lower	Maintain constant gasoline level	ABCD&E	Order assy. 89641
21589	*3H4577A/L23	Lever, governor	Actuate carburetor throttle	D&E	
21590	*3H4577A/H14	Housing, governor	Governor housing	D&E	Order assy. 290300
21596	*3H4577A/K1	Key, flywheel	Locate flywheel	C	Replaced by 61760
22011	*3H4577A/P24	Plate, valve cover	Encloses valve adjustment parts	ABCD&E	
22025	*3H4577A/P25	Plate, oil baffle	Retain oil in base	ABCD&E	
22032	*3H1901-AP/W4	Washer, needle-valve packing	Hold packing in place	ABCD&E	Order assy. 290284
22036	*3H1901-AP/V2	Valve, carburetor throttle	Controls flow of fuel to intake post	ABCD&E	
22050	*3H1901-AP/V1	Valve, carburetor choke	Choke motor for starting	ABCD&E	
22062	*3H4577A/W1	Washer, choke lever, carburetor	Produces friction to control position of choke lever	ABCD&E	
22082	*3H1901-AP/L7	Lock, connecting-rod screw-head	To lock screw	ABCD&E	
22206	*3H4577A/S26	Shield, cylinder	Directs flow of air	CD&E	Replaces 62853
22216	*3H4577A/C30	Cover, breather	Seals breather body	ABCD&E	

*Not issued as replaceable part. Not stocked. Do not order.

¹Complete assemblies (instead of individual parts) should be ordered by No. in "Remarks" column.

POWER UNIT PE-77-(*)

Mfg. stock No. (ref. No.)	Signal Corps stock No.	Name and description	Function	Used in PE-77-	Remarks ¹
22217	*3H4577A/S28	Shield, oil spray	Prevent oil escaping	ABCD&E	
22233	*3H4577A/P22	Plate, spark plug shield support	Spark plug shield support	A&B	
22279	*3H4577A/B30	Brace, air cleaner	Fastens air cleaner to carburetor	ABCD&E	
22353	*3H1901-AP/W12	Washer, Valve cover, fibre, hard	Seal between valve cover plate and cylinder	ABCD&E	
22386	*3H4577A/P23	Plate, speed adjuster, governor	Encloses governor speed adjuster	AB&C	
22389	*3H4577A/W16	Washer, flywheel	Spacer between flywheel and flywheel nut	AB&C	Replaced by 62577
22436	*3H4577A/C31	Cover, magneto dust	Enclose magneto	AB&C	Replaced by 62835
22531	*3H4577A/L24	Lever, governor control	Governor control	D&E	
22533	*3H4577A/C44	Cup, governor	Hold governor gear	D&E	Order assy. 290300
22620	*3H4577A/B31	Brace, carburetor	To brace carburetor	D&E	
23059	*3H4577A/L6	Lever, gasoline shut-off	To shut off gasoline	ABCD&E	
23114	3H1901-AP/H1	Pin, carburetor float hinge	To mount carburetor float	ABCD&E	
23125	3H1901-AP/P4	Pin, carburetor throttle leve	Throttle lever to shaft	ABCD&E	
23184	3H4577A/R13	Retainer, valve spring	Retains valve springs	ABCD&E	
23187	3H4577A/P10	Pin, valve spring retainer	Hold valve spring retainer in place	ABCD&E	
23215	*3H4577A/S48	Spacer, oil baffle plate	Baffle plate spacer	ABCD&E	
23222	*3H4577A/N15	Nozzle, carburetor	Meters fuel at high speeds	ABCD&E	Order assy. 290284
23227	*3H1901-AP/N8	Nut, needle valve packing, brass	Retains carburetor needle valve packing	ABCD&E	Order assy. 290284
23228	3H1901-AP/V4	Valve, carburetor idler needle	Meters fuel at idling speeds	ABCD&E	

*Not issued as replaceable part. Not stocked. Do not order.

¹Complete assemblies (instead of individual parts) should be ordered by No. in "Remarks" column.

SECTION V

Mfg. stock No. (ref. No.)	Signal Corps stock No.	Name and description	Function	Used in PE-77	Remarks ¹
23230	*3H1901-AP/B15	Bushing, carburetor throttle shaft	Throttle shaft bushing	A&B	No longer used.
23270	3H4577A/S2	Screw, choke lever, steel, 6-32 x 5/8"	Produces friction to control position of choke lever	ABCD&E	Do not order.
23292	*3H4577A/B16	Bolt, air cleaner, steel, 10-32 thread	To fasten air cleaner	ABCD&E	
23444	*3H4577A/S62	Stud, valve cover, steel	Secures valve cover	ABD&E	
23612	3H4577A/V1	Valve, exhaust	Controls exhaust gases	ABCD&E	
23688	*3H4577A/B48	Bushing, 3/8" diam.	For mounting governor control lever	D&E	
23690	*3H1901-J/S10	Crank, governor	Operates governor lever	D&E	
23691	*3H4577A/B49	Bushing, governor crank	Governor crank bushing	D&E	Order assy. 290300
23692	*3H4577A/R33	Rod, stop switch push	To shut engine off	CD&E	
23698	*3H4577A/S62	Stud, valve cover	Valve cover fastens to stud	C	Replaced by 23444
26018	*3H4577A/S56	Spring, contact bracket	Tension for contact bracket	AB&C	Order assy. 290307
26021	3H4577A/S57	Spring, intake valve	Seat valves	ABCD&E	
26026	3H4577A/L19	Lock, piston pin	Lock piston pin	ABCD&E	
26115	*3H4577A/C37	Crankshaft	Transmits power	BCD&E	Replaces 26482
26157	3H1901-AP/S38	Spring, idler valve, carburetor	Retains carburetor idler valve	ABCD&E	
26172	*3H4577A/S55	Spring, pump plunger	Returns plunger and pump rod to driving eccentric	ABCD&E	Order assy. 290304
26229	3H4577A/S54	Spring, carburetor choke lever	Produces friction to control position of choke lever	ABCD&E	
26235	*3H4577A/L12	Link, governor	Fastens air-vane shaft to carburetor throttle shaft	AB&C	

*Not issued as replaceable part. Not stocked. Do not order.

¹Complete assemblies (instead of individual parts) should be ordered by No. in "Remarks" column.

POWER UNIT PE-77-(*)

Mfg. stock No. (ref. No.)	Signal Corps stock No.	Name and description	Function	Used in PE-77-	Remarks ¹
26265	*3H4577A/S51	Spring, governor (air vane governor only)	Fastens to speed adjuster assembly	AB&C	
26330	*3H4577A/S52	Spring, breather	Controls breather	ABCD&E	
26404	*3H4575T/W14	Washer, stop switch, 1/2" x .170	For magneto short-circuiting stop button screw	CD&E	
26478	3H4577A/S53	Spring, exhaust valve	Seat valves	ABCD&E	
26482	*3H4577A/C37	Crankshaft	Transmit power	A	Replaced by 26115
26483	*3H4575T/S26	Spring, stop switch	Returns stop-switch push rod	CD&E	
26502	*3H4577A/S58	Spring, governor, (flyball type only)	Tension on speed adjuster	D&E	
26558	3H4577A/L25	Link, governor (models using mechanical governor)	Fastens governor lever to carburetor throttle shaft	D&E	
27113	3H4577A/G5	Gasket, carburetor body	Seals upper and lower carburetor body	ABCD&E	
27115	3H4577A/G7	Gasket, venturi, carburetor	Seals lower carburetor body to venturi	ABCD&E	
27140	3H4577A/G53	Gasket, governor housing	Seals governor housing to engine	D&E	
29667	*3H4577A/P30	Magneto point assembly	To interrupt primary circuit	D&E	Replaced by 290307
29668	*3H4577A/A1	Contact breaker, arm, magneto	To interrupt primary circuit	ABCD&E	Order assy. 290307
29671	*3H4577A/A6	Armature, magneto	Induce high voltage spark	D&E	Replaces 89618 Order assy. 89616
29693	3H4577A/P34	Spark plug with gasket-champion 8	Fires spark that ignites fuel	ABCD&E	
29739	3H4577A/P12	Piston assembly, standard	Transmit power	ABCD&E	
29778	3H4577A/P13	Piston assembly, .010" oversize	do	ABCD&E	
29779	*3H4577A/P14	Piston assembly, .020" oversize	do	ABCD&E	

*Not issued as replaceable part. Not stocked. Do not order.

¹Complete assemblies (instead of individual parts) should be ordered by No. in "Remarks" column.

SECTION V

Mfg. stock No. (ref. No.)	Signal Corps stock No.	Name and description	Function	Used in PE-77-	Remarks ¹
29780	*3H4577A/P15	Piston assembly, .030" oversize	Transmit power	ABCD&E	
29781	*3H4577A/P17	Piston, .010" oversize	do	ABCD&E	
29782	*3H4577A/P18	Piston, .020" oversize	do	ABCD&E	
29783	*3H4577A/P19	Piston, .030" oversize	do	ABCD&E	
29806	3H4577A/G21	Gasket, spark plug	Seals plug	ABCD&E	
29835	*3H4577A/F15	Flywheel, magneto	To equalize torque, build up magnetic flux and create air currents to cool motor	D&E	Replaces 21468
29861	3H4577A/C15	Capacitor, magneto	Reduce breaker point arcing	ABCD&E	
29878	*3H4577A/R37	Rope, starter	Start motor	ABCD&E	Replaced by 290282
37346	*3H4577A/R27	Rivet, 1/8" x 1/4"	Used in air-vane governor speed adjuster	AB&C	
38852	*3H4577A/W12	Washer, 5/16 x 1/4 x .020" thick	For magneto contact breaker arm	ABCD&E	
46133	*3H1901-AP/P17	Spring, spark plug shield	Shield spring holds cover together	A&B	
61735	*3H4577A/C11	Cap, oil filler, with gasket	Cover for filler opening	ABCD&E	
61756	3H4577A/R17	Ring, center compression, standard	Seals power	ABCD&E	
61757	3H4577A/R15	Ring, oil, standard	Seals power	ABCD&E	
61760	*3H4577A/K1	Key, flywheel	Locate flywheel	ABD&E	Replaces 21596
61768	3H4577A/R14	Ring, center compression .010" oversize	Seals power	ABCD&E	
61769	*3H4577A/R23	Ring, center compression .020" oversize	do	ABCD&E	
61770	*3H4577A/R24	Ring, center compression .030" oversize	do	ABCD&E	
61771	3H4577A/R25	Ring, oil .010" oversize	do	ABCD&E	
61772	*3H4577A/R16	Ring, oil .020" oversize	do	ABCD&E	
61773	*3H4577A/R18	Ring, oil .030" oversize	do	ABCD&E	

¹Not issued as replaceable part. Not stocked. Do not order.

²Complete assemblies (instead of individual parts) should be ordered by No. in "Remarks" column.

POWER UNIT PE-77-(*)

Mfg. stock No. (ref. No.)	Signal Corps stock No.	Name and description	Function	Used in PE-77-	Remarks ¹
61967	*3H1901-AP/S42	Stop, throttle	Throttle stop	ABCD&E	
61991	*3H4577A/H5	Head, cylinder, aluminum	Combustion chamber	A&B	Replaced by 21362
62473	*3H4577A/S45	Shim, .005" thick	Generator mounting	ABCD&E	
62474	*3H4577A/S44	Shim, .005" thick	do	ABCD&E	
62577	*3H4577A/W16	Washer, flywheel	Spacer between flywheel and flywheel nut	CD&E	Replaces 22389
62598	*3H4577A/G56	Guide, Air	Direct flow of air around magneto armature	D&E	
62693	*3H4577A/P40	Pulley, robe starter	Start motor	ABCD&E	
62835	*3H4577A/C31	Cover, magneto dust	Encloses magneto	D&E	
62842	*3H4577A/S38	Spacer, dust cover	Spacer for magneto dust cover	ABCD&E	
62851	*3H4577A/S72	Strap, gas tank	Clamp gas tank to bracket	ABCD&E	
62853	*3H4577A/S26	Shield, cylinder	Directs flow of air	ABCD&E	Replaced by 22206
62863	*3H4577A/S39	Spacer cylinder head .05" thick	Spacer used with aluminum heads	A&B	
62876	3H1901-AP/S2	Screen, gasoline filter	To filter gasoline	ABCD&E	
62891	*3H4577A/W32	Wrench, spark plug	Wrench to remove and replace, spark plug	A&B	Replaced by 89838
63773	3H4577A/P7	Pin, piston, standard	Connect piston and connecting rod	ABCD&E	
63782	3H4577A/V2	Valve, intake	Controls flow of fuel to combustion chamber	CD&E	Replaces 63807
63785	*3H4577A/C7	Shaft, cam	Supports cam and gears	ABCD&E	
63788	*3H4577A/T1	Tappet, valve	Transmits motion from cam to valve	ABCD&E	

*Not issued as replaceable part. Not stocked. Do not order.

¹Complete assemblies (instead of individual parts) should be ordered by No. in "Remarks" column.

SECTION V

Mfg. stock No. (ref. No.)	Signal Corps stock No.	Name and description	Function	Used in PE-77-	Remarks ¹
63807	*3H4577A/V2	Valve, intake	Controls flow of fuel to combustion chamber	A&B	Replaced by 63782
63816	*3H4577A/P8	Pin, piston, .005" oversize	Connects piston and connecting rod	ABCD&E	
63965	*3H4577A/P36	Plunger, oil pump	Pumps the oil	ABCD&E	Order assy. 290304
65534	*3H4577A/W4	Washer, oil filler cap	Seals cap	ABCD&E	
65704	*3H4577A/P37	Plunger, contact point	Actuates breaker points	ABCD&E	Order assy. 290307
65777	*3H4577A/G52	Gasket, gas tank cap	Seals gas cap	ABCD&E	
65794	*3H4577A/W25	Wrapper, magneto armature coil	Keeps armature clean	ABCD&E	
65938	*3H1909C/G7	Gasket, oil filler cap	Seals oil filler cap	ABCD&E	
65968	*3H4577A/D5	Disc, breather	Breather valve or baffle plate	ABCD&E	
66154	*3H4575T/W13	Washer, fibre	For magneto short-circuiting stop-button screw	CD&E	
66164	*3H4575T/W16	Washer, fibre	do	CD&E	
66432	*3H4577A/W11	Washer, $\frac{5}{16}$ " x $\frac{13}{64}$ " x $\frac{1}{16}$ "	For governor lever	D&E	
66432	*3H4577A/W11	Washer, $\frac{5}{16}$ " x $\frac{13}{64}$ " x $\frac{1}{16}$ "	For gas tank strap belt	AB&C	
66432	*3H4577A/W11	Washer, $\frac{5}{16}$ " x $\frac{13}{64}$ " x $\frac{1}{16}$ "	For magneto plate mounting screw	AB&C	Replaces 67072
67072	*3H4577A/W11	Washer, tank strap, $\frac{1}{2}$ x No. 9 drill x $\frac{1}{8}$ " thick	For gas tank strap bolt	D&E	Replaced by 66432
67307	3H4577A/G3	Gasket, .015" thick, magneto plate	Seal to prevent oil leak between magneto plate and crankcase	ABCD&E	
67527	3H4577A/G1	Gasket, valve cover plate	Seals cover plate to crankcase	ABCD&E	

¹Not issued as replaceable part. Not stocked. Do not order.

²Complete assemblies (instead of individual parts) should be ordered by No. in "Remarks" column.

POWER UNIT PE-77-(*)

Mfg. stock No. (ref. No.)	Signal Corps stock No.	Name and description	Function	Used in PE-77-	Remarks ¹
67537	3H4577A/G11	Gasket, cylinder head	Seals compression chamber between head and cylinder	ABCD&E	
67597	3H4577A/G35	Gasket, .005" thick, magneto plate	Seal to prevent oil leak between magneto plate and crankcase	ABCD&E	
67607	3H4577A/G4	Gasket, .009" thick, magneto plate	Seal to prevent oil leak between magneto plate and crankcase	ABCD&E	
68122	*3H1901-AP/P15	Plug, cam shaft	Prevent oil leaks	ABCD&E	
68337	3H4577A/G12	Gasket, base (used on all motors equipped with 8 screws for mounting to cylinder)	Seals crankcase to base	ABCD&E	
68477	3H1901-AP/G9	Gasket, gasoline filter	Seal gasoline filter bowl	ABCD&E	
68487	3H1901-AP/B8	Bowl, gasoline filter	Gasoline receptacle for straining	ABCD&E	
68507	*3H4577A/W5	Washer, felt	For gas shut-off lever	ABCD&E	
68877	3H1901-A/G5	Gasket, inlet valve seat, carburetor	Seals inlet valve and seat	ABCD&E	
68887	*3H1901-A/P1	Packing, carburetor, needle valve	Seals carburetor needle valve	ABCD&E	
68957	3H4577A/G15	Gasket, air cleaner	Seals air cleaner to air cleaner pipe	ABCD&E	
68987	3H1901-A/G3	Gasket, carburetor to intake elbow	Seals carburetor to intake elbow	ABCD&E	
68997	3H4577A/G9	Gasket, carburetor elbow	Seals elbow to cylinder	ABCD&E	
69817	*3H1901-A/V6	Valve, oil return	A	
69221	*3H4577A/C10	Cap, gasoline tank with gasket	Cover for gas tank filler opening	A	Replaced by 89769
89190	3H4577A/L10	Line, gas, 13" long	Gasoline fuel line from gas tank to fuel filter	ABCD&E	

*Not issued as replaceable part. Not stocked. Do not order.

¹Complete assemblies (instead of individual parts) should be ordered by No. in "Remarks" column.

SECTION V

Mfg. stock No. (ref. No.)	Signal Corps stock No.	Name and description	Function	Used in PE-77-	Remarks ¹
89494	*3H4577A/S16	Shaft assembly, throttle	Locates and operates throttle valve	A	Replaced by 99868
89616	*3H4577A/M1	Magneto assembly	Supports component parts of magneto. Provides spark to set off fuel charge	A&B	See note 2
89617	*3H4577A/A3	Adjuster, speed, governor	Regulates governor speed	AB&C	Replaced by 29671
89618	*3H4577A/A6	Armature, magneto	Induce high-voltage spark	AB&C	Order assy. 89616
89619	*3H4577A/P30	Point assembly, magneto	Controls magneto spark	AB&C	Order assy. 290307
89620	*3H4577A/P32	Plate and bearing, magneto	Mount parts for magneto ignition assembly, cover for crankcase. Gearing surface for crankshaft retainer	A&B	See note 2
89622	*3H4577A/R36	Bracket, contact, magneto	Part of point assembly to control spark	AB&C	Order assy. 290307
89636	3H4577A/C9	Cap, assembly, oil filler, with chain	Cover for oil filler opening	ABCD&E	
89640	3H4577A/T4	Tank, assembly, gas-(order 1 gal. size for PE-77-E)	Hold fuel supply	ABCD&E	
89641	3H4577A/C16	Carburetor assembly	Fuel mixing chamber and regulator	AD&E	Replaces 89749
89644	*3H4577A/B9	Body, upper carburetor assembly	House throttle assembly	ACD&E	Replaces 89751
89645	*3H4577A/B10	Body, upper carburetor	House throttle	ABCD&E	
89660	*3H4577A/S11	Seal, oil, magneto end	Prevent oil leak	ABCD&E	
89661	*3H4577A/B1	Base, engine, aluminum	Oil reservoir and supports motor	A	Replaced by 89874

*Not issued as replaceable part. Not stocked. Do not order.

¹Compete assemblies (instead of individual parts) should be ordered by No. in "Remarks" column.

POWER UNIT PE-77-(*)

Mfg. stock No. (ref. No.)	Signal Corps stock No.	Name and description	Function	Used in PE-77-	Remarks ¹
89677	*3H4577A/B4	Bearing assembly, crankshaft with No. 89660 oil seal	Bearing surface for crankshaft retainer	ABCD&E	Order assy. 89616
89687	*3H4577A/C39	Cylinder assembly	Compression chamber	A	Replaced by 99727
89697	*3H4577A/H1	Handle, carrying	For carrying unit	ABCD&E	
89713	*3H4577A/M15	Muffler assembly	Silence exhaust	A	Replaced by 89945
89736	*3H4577A/S16	Shaft, throttle assembly	Locates and operates throttle valve	B	Replaced by 99868
89742	3H1901-J/S15	Shield, spark plug	Shield to eliminate radio interference	CD&E	Order assy. 89641
89749	*3H4577A/C23	Carburetor assembly	Fuel mixing chamber and regulator	B&C	Replaced by 89641
89751	*3H4577A/B9	Body, upper carburetor assembly	House throttle assembly	B	Replaced by 89644
89769	3H4577A/C10	Cap, gasoline tank with gasket 65777	Cover for gas tank filler opening	BCD&E	Replaces 69221
89838	3H4577A/W32	Wrench, spark plug, 14 MM plug in shielding	Wrench to remove and replace spark plug	CD&E	Replaces 62891
89874	*3H4577A/B5	Base, engine, cast iron	Oil reservoir and supports motor	BCD&E	Replaces 89661
89903	*3H4577A/M16	Muffler, assembly	Silence exhaust	B&C	Replaced by 89945
89945	3H4577A/M17	Muffler	do	BCD&E	Replaces 89713
90029	*6L6436-4.15	Screw, machine, 4-36 x 1/4" round head	Holds choke and valve in place	ABCD&E	
90066	*6L6832-4.15	Screw, machine, 8-32 x 1/4" round head	Used in magneto capacitor mounting	ABCD&E	
90067	*6L6832-5.15	Screw, machine, 8-32 x 5/16" round head	Used in magneto contact arm breaker mounting	ABCD&E	

*Not issued as replaceable part. Not stocked. Do not order.

¹Complete assemblies (instead of individual parts) should be ordered by No. in "Remarks" column.

SECTION V

Mfg. stock No. (ref. No.)	Signal Corps stock No.	Name and description	Function	Used in PE-77-	Remarks ¹
90079	*6L7032-6.1	Screw, machine, 10-32 x 3/8" round head	Used in blower housing mounting	ABCD&E	
90083	6L7032-10.1	Screw, machine, steel, 10-32 x 5/8" round head	Gas tank strap screw	ABCD&E	
90200	*6L6832-8.35	Screw, machine, 8-32 x 1/2", fillster head	Used in carburetor body mounting	ABCD&E	
90202	*6L7032-8.38	Screw, machine, 10-32 x 1/2", fillster head	Used in magneto plate mounting	AB&C	
90310	*6L3610-32	Nut, Hex, 6-32 x 5/16" x 1/4"	Used on governor lever stop screw	D&E	
90313	*3H1901-AP/N15	Nut, hex, 8-32 x 1 1/8" x .102"	Used on magneto dust cover	ABCD&E	
90337	6L3108-325	Nut, brass, 8-32 x 5/8" x 1/4", hex	For magnetic short-circuit stop button screw	CD&E	
90366	*6L71005-1	Washer, lock, 5/16 x 1/8 x 1/8" thick	Used on mounting generator end plate	ABCD&E	
90369	*6L71002	Washer, lock #4 1/8 x 3/4 x 1/8" thick	Used in carburetor assembly	ABCD&E	
90699	*3H4577A/W14	Washer, lock, 1/4 x 5/4 x 1/16" thick	Used on oil pump screw 22025	ABCD&E	
90832	*6L71004-1	Washer, lock, 1/4 x 5/8 x 5/4" thick	Used on blower housing, carburetor elbow, and other mountings throughout the engine	ABCD&E	
90847	*6L3504-285	Nut, hex, 1/4"-28 x 1/8" x 1/8"	Used to mount valve cover plate	ABCD&E	
90877	*3H4575T/S24	Screw, brass, 8-32 x 1/8" round head	Used on magnetic short-circuit stop button	CD&E	

*Not issued as replaceable part. Not stocked. Do not order.

¹Complete assemblies (instead of individual parts) should be ordered by No. in "Remarks" column.

POWER UNIT PE-77-(*)

Mfg. stock No. (ref. No.)	Signal Corps stock No.	Name and description	Function	Used in PE-77-	Remarks ¹
90916	*6L7920-4-8.15	Screw, machine, 1/4-20 x 1/2" round head	Used on blower housing mounting strap	ABCD&E	
90950	*6L4905-12.24	Screw, cap, hex head, heat treated, 5/16-24 x 3/4" SAE	Attaches generator end plate	ABD&E	
91199	*3H4577A/W17	Washer, lock #8 standard, 1/4 x 3/4 x 3/4" thick	Used for magneto armature assembly mounting	A	Use 91661
91287	*6L72914	Washer, lock #8 3/4 x 1/8" thick	For magneto short circuit stop button screw	CD&E	
91324	*3H4577A/W9	Spacer, 3/4" x 5/16" x 1/16" thick	For cylinder head bolt	ABCD&E	
91407	*3H4577A/W19	Washer, lock #10	For gas tank strap screw	ABCD&E	
91427	*6L70010	Washer, lock #10 1/4 x 3/4 x 3/4" thick	For governor housing bolt	D&E	
91456	*6L4904-16.20	Screw, cap, hex head, 1/4-20 x 1" USS	Used on air cleaner elbow	ABCD&E	
91488	3H4577A/P33	Plug, oil drain 1/8" standard pipe plug, square head	Drain oil	ABCD&E	
91661	*3H4577A/W17	Washer, lock, #8 1/4 x 3/4 x 3/4" thick	Used for magneto armature assembly mounting	BCD&E	
91708	*3H4577A/N23	Nut, flywheel, left-hand thread, 3/4" hex x 7/16" thick 1/2-20 SAE thread	Secures flywheel in place	D&E	Replaces 92318
91711	*3H4577A/S3	Screw, cap, hex head, 5/16-18 x 1" USS cylinder head, short	Attaches cylinder head	ABD&E	
91712	*3H4577A/S5	Screw, cap, hex head, 5/16-18 x 1 1/4" USS cylinder head, long	do	ABD&E	
91753	*6L6832-16.35	Screw, machine, 8-32 x 1" fillister head	Fastens magneto armature to magneto plate	ABCD&E	

*Not issued as replaceable part. Not stocked. Do not order.

¹Complete assemblies (instead of individual parts) should be ordered by No. in "Remarks" column.

SECTION V

Mfg. stock No. (ref. No.)	Signal Corps stock No.	Name and description	Function	Used in PE-77-	Remarks ¹
91787	*6L4904-32.28	Screw, cap, hex head, heat treated 1/4-28 x 2" SAE	Used to attach engine to base	ABD&E	
91811	*3H4577A/N24	Nut, lock, 1/2", exhaust elbow locknut	Locks nipple and elbow in place	ABCD&E	
91833	*3H4577A/S75	Stud, dust cover, 8-32 x 3/16, 1/8 x 45° chamber on both ends	Holds magneto dust cover in place	ABCD&E	
91838	*3H4577A/E9	Elbow, exhaust, street	Exhaust connector between nipple and muffler	A&B	Replaced by 92478
91920	*6L6832-10.32	Screw, machine	Used in upper carburetor assembly.	ABCD&E	
91961	3H4577A/W10	Nipple, pipe, exhaust, 1/2" x 3"	Exhaust connector between cylinder and elbow	ABCD&E	
91984	*3H4575C/P48	Pin, cotter, 1/8 x 1/2" long	Secures stop button on blower housing	CD&E	
92000	*6L4904-20.28	Screw, cap, hex head, 1/4-28 x 1 1/4" SAE	Attaches oil pump to base	ABCD&E	
92067	*3H4577A/N25	Nut, wing, 10-32 thread	Secures air cleaner to elbow	ABCD&E	
92084	*3H4577A/S8	Screw, heat treated, 1/4-28 x 1 1/8" connecting rod	Attaches connecting rod bearing to connecting rod	ABCD&E	
92089	*3H4577A/S9	Screw, machine, 1/4-20 x 3/4" fillister head	Attach elbow to carburetor	ABCD&E	
92125	*6L58020	Screw, cap, hex head, 1/4-20 x 1/2" USS	Used on carburetor brace	ABCD&E	
92134	*6L4904-12.28	Screw, cap, hex head, 1/4-28 x 3/4" SAE magneto	Attach magneto plate assembly	ABCD&E	

POWER UNIT PE-77-(*)

Mfg. stock No. (ref. No.)	Signal Corps stock No.	Name and description	Function	Used in PE-77-	Remarks ¹
92151	*6L71104-52	Washer, lock, 1/4 x 3/8 x 3/4" thick	Used on magneto assembly and cylinder shield	ABCD&E	
92291	*3H4577A/N22	Nut, #61F x 3/8, brass	Retaining nut for gas shut-off lever	ABCD&E	
92307	*6L7032-4.12S	Screw, machine, 10-32 x 1/8" fillister head	Used on governor control lever	D&E	
92317	*3H4577A/W15	Washer, lock, #8 shakeproof	Used on magneto point assembly screw	ABCD&E	
92318	*3H4577A/N23	Nut, flywheel, left-hand thread, 1/2-20 x 1/8" thick	Secures flywheel in place	AB&C	Replaced by 91708
92387	*6L4905-22.242	Screw, cap, hex head, heat treated, 5/16-24 x 1 1/4" USS	Attaches generator end plate	C	Use 90950
92388	*6L71005-1	Washer, lock, 5/16 x 1/8 x 1/8" SAE	Generator and plate	C	Use 90366
92389	*6L3504-28S	Nut, 1/8" hex, 1/4-28 x 1/8" thick	Used on generator end plate mounting	C	Use 92161
92390	*6L7928-4-32.81S	Screw, hex head, 1/4-28 x 2"	Used to attach engine to base	C	Use 91787
92393	*6L4905-16.18	Screw, cap, hex head, heat treated, 5/16-18 x 1" USS	Attaches cylinder head	C	Use 91711
90950	*6L4905-12.24	Screw, cap, hex head, heat treated, 5/16-24 x 3/4" SAE	Attaches generator end plate	ABD&E	
92394	*6L7920-4-8.1P	Screw, machine, 1/4-20 x 1/2" round head	Used on blower housing mounting strap	C	Use 90916
92395	*6L4905-20.18	Screw, ca., hex head, heat treated, 5/16-18 x 1 1/4" USS	Attaches cylinder head	C	Use 91712

*Not issued as replaceable part. Not stocked. Do not order.

¹Complete assemblies (instead of individual parts) should be ordered by No. in "Remarks" column.

SECTION V

Mfg. Stock No. (ref. No.)	Signal Corps Stock No.	Name and description	Function	Used in PE-77-	Remarks ¹
92396	*6L7032-6.1S	Screw, machine, 10-32 x 3/8" round head		C	Use 90079
92451	*3H4577A/S4	Screw, cap, hex head, has 1/16 x 3/8" screw driver slot	For mounting carburetor intake elbow	ABCD&E	
92478	3H4577A/E8	Elbow, exhaust, 90°	Exhaust connector between nipple and muffler	CD&E	Replaces 91838
92506	*3H4577A/S80	Screw, machine, 6-32 x 1" round head	Governor level stop screw	D&E	
99158	3H4577A/B3	Bearing, ball, crankshaft	Crankshaft bearing	ABCD&E	
99176	3H4575C/S19	Seal, oil	Seals oil in crankcase	ABCD&E	
99179	*3H4577A/H13	Housing, blower	Blower housing	A&B	
99390	*3H4577A/S25	Shield, spark plug	Shield to eliminate radio interference	A&B	
99391	*3H4577A/C1	Cable, ignition	Conducts electrical energy from armature to spark plug	ABCD&E	
99621	*3H1901-AP/V5	Valve, needle adjusting carburetor	Controls flow of fuel to carburetor	ABCD&E	Order assy. 290284
99622	3H1901-AP/F1	Float, carburetor	Controls gasoline level in carburetor bowl	ABCD&E	
99630	*3H4577A/C19	Air cleaner assembly	Filters air entering carburetor	AB&C	Replaced by 290184
99636	3H1901-A/V1	Valve and seat, inlet, carburetor	Controls gasoline level in carburetor bowl	ABCD&E	
99640	3H4577A/R32	Rod, connecting, aluminum	Transmits power, connects piston to crankshaft	ABCD&E	

*Not issued as replaceable part. Not stocked. Do not order.

¹Complete assemblies (instead of individual parts) should be ordered by No. in "Remarks" column.

POWER UNIT PE-77-(*)

Mfg. Stock No. (ref. No.)	Signal Corps stock No.	Name and description	Function	Used in PE-77-	Remarks ¹
99665	3H1901-AP/Y1	Yoke, gasoline filter	Clamps gasoline filter bowl to cover	ABCD&E	
99700	*3H4577A/S15	Shaft and lever, choke	Controls and locates carburetor choke valve	ABCD&E	
99714	3H4577A/F7	Filter assembly, gas	To strain fuel	ABCD&E	
99727	3H4577A/C39	Cylinder assembly	Compression chamber	B&C	Replaces 89687
99732	*3H4577A/B6	Blade, governor	Speed regulator blade	AB&C	
99748	*3H4577A/P16	Piston, standard	Transmits power	ABCD&E	Order assy. 29739
99868	*3H4577A/S16	Shaft, assembly, throttle	Locates and operates throttle valve	CD&E	Order assy. 89641
99879	*3H4577A/C32	Cover, assembly, gas filter	Provides necessary passages and cover for gas cover	ABCD&E	Order assy. 99714
99955	*3H4577A/B18	Pump assembly, oil pump body	Pump oil to working parts		Replaced by 290304
290017	*3H4577A/C46	Governor crank assembly	Operates governor elver	D&E	Order assy. 290300
290020	*3H4577A/W34	Wire, ground	Ground ignition to stop motor	CD&E	
290027	*3H4577A/H15	Housing, blower	Blower housing	CD&E	
290053	*3H4577A/P32	Magneto plate and bearing	Mount parts for magneto ignition assembly, cover for crankcase, bearing surface for crankshaft retainer.	CD&E	Order assy. 920174
290166	*3H4577A/G28	Gear, governor	Controls motor speed	D&E	
290171	*3H4577A/C25	Control assembly, governor	Manual motor speed adjustment	C	

*Not issued as replaceable part. Not stocked. Do not order.

¹Complete assemblies (instead of individual parts) should be ordered by No. in "Remarks" column.

SECTION V

Mfg. stock No. (ref. No.)	Signal Corps stock No.	Name and description	Function	Used in PE-77-	Remarks ¹
290174	3H4577A/M4	Magneto assembly	Supports component parts of magneto, provides spark to set off fuel charge	C	See note 1
290179	3H4577A/C43	Cylinder assembly complete with valve guides and valve inserts	Compression chamber	D&E	
290184	3H4577A/C19	Air cleaner assembly	Filters air entering carburetor	D&E	Replaces 99630
290212	*3H4577A/C48	Control assembly, governor	Manual motor speed adjustment	D&E	
290238	*3H4577A/M5	Magneto assembly	Supports component parts of magneto, provides spark for ignition.	D&E	See note 1
290282	3H4577A/R37	Rope starter	To start motor	ABCD&E	Replaces 29878
290284	3H1901-A/V7	Valve, carburetor needle valve assembly used on carburetor assembly 89641	Meters fuel at high speeds	AD&E	
290288	3H1901-J/H1	Group assembly, hardware for servicing PE-77-(*)	Necessary nuts, bolts, screws, washers, etc.	ABCD&E	
290300	3H1901-J/G10	Governor parts assembly		D&E	
290304	3H4577A/P48	Oil pump assembly	Pumps oil	ABCD&E	Replaces 99955
290307	3H4577A/P30	Point assembly, magneto, with mounting hardware	Controls magneto spark	ABCD&E	Replaces 29667 and 89619

*Not issued as replaceable part. Not stocked. Do not order.

¹Complete assemblies (instead of individual parts) should be ordered by No. in "Remarks" column.

NOTE—Order 290174 and remove governor air-vane blade.

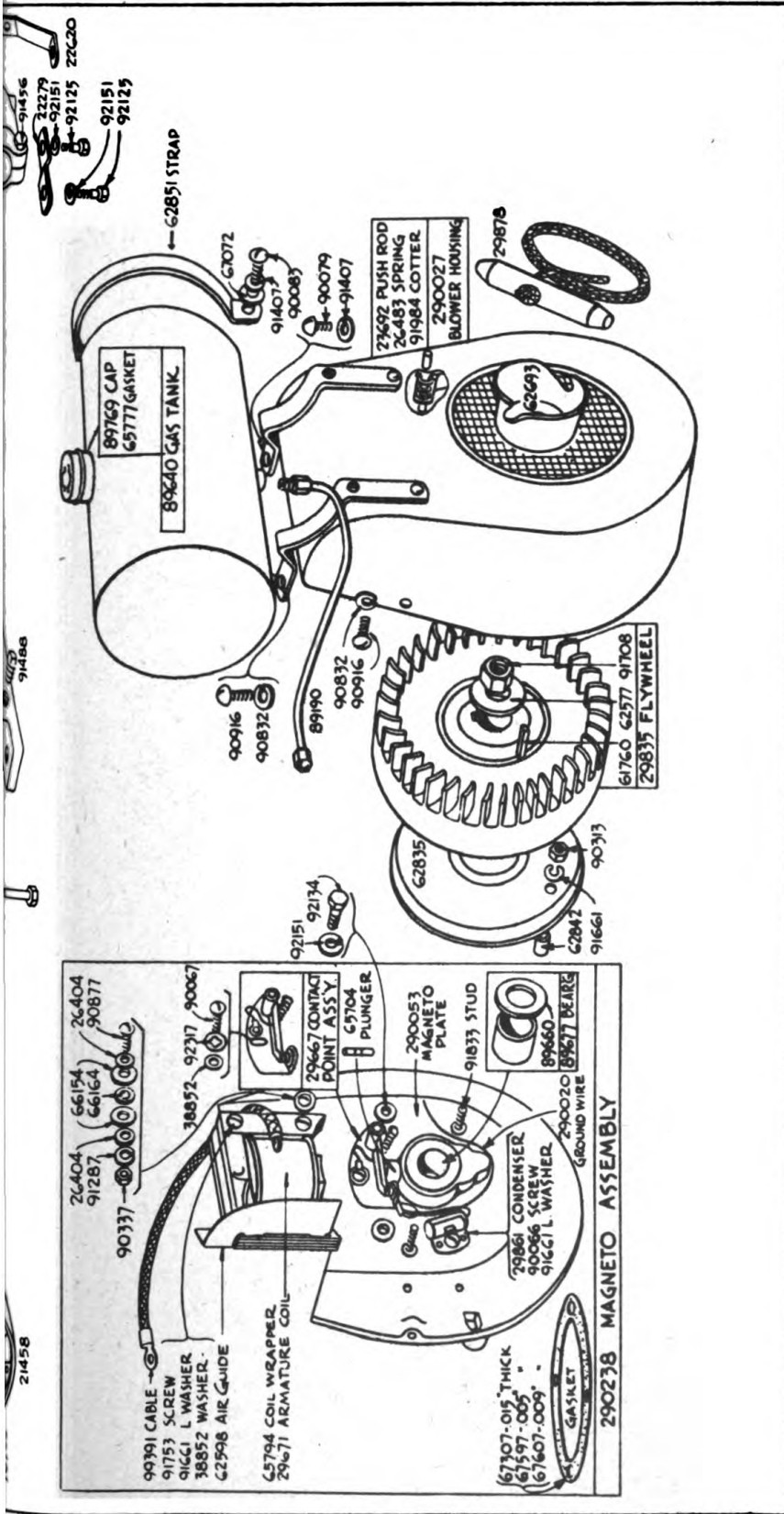

Figure 27.—Power Unit 77-D and E, engine parts

POWER UNIT PE-77-(*)

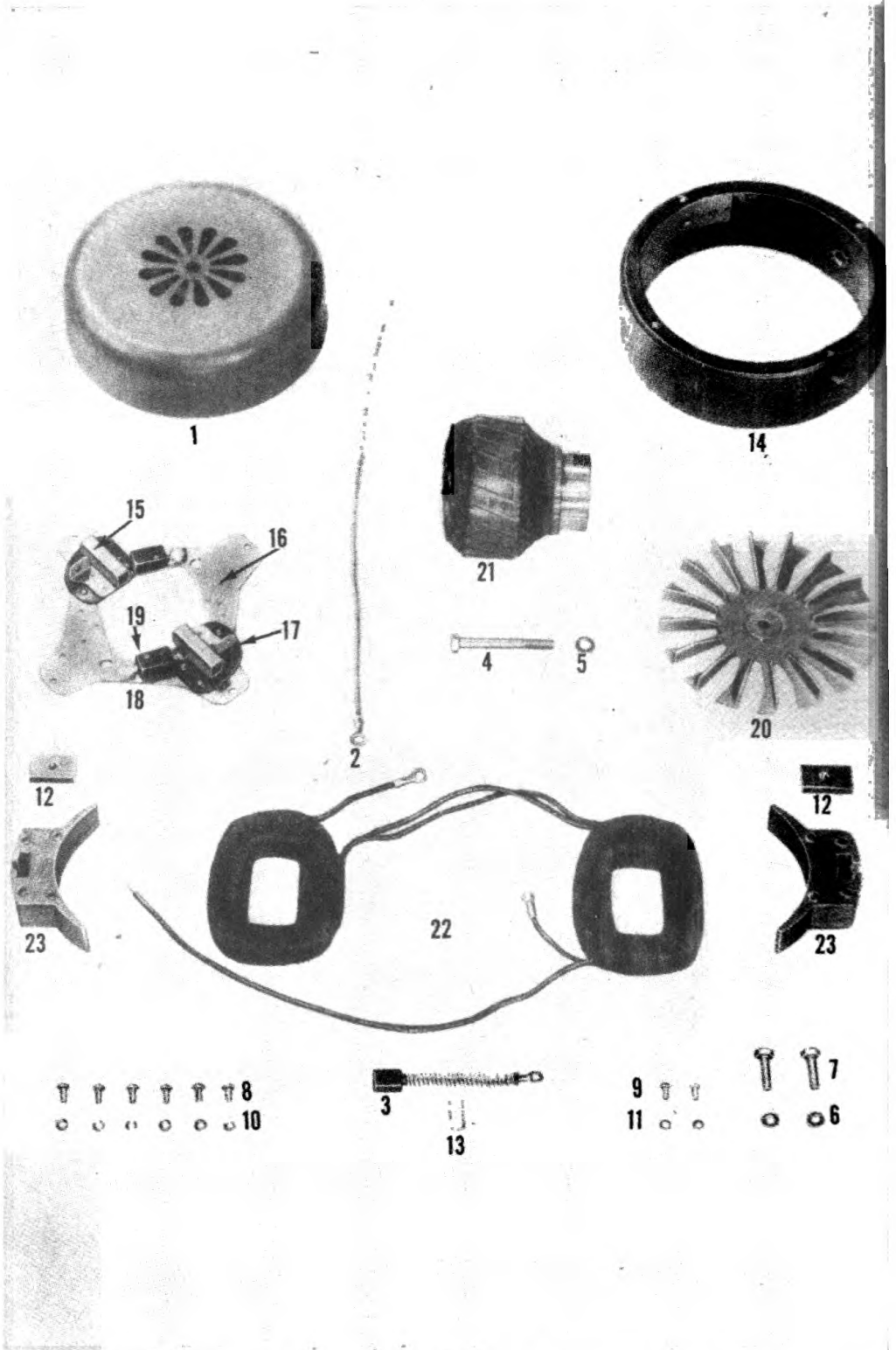

Figure 28.—Power Unit PE-77-E, generator parts

SECTION V

44. TABLE OF REPLACEABLE PARTS.—(Cont.)

b. Generator.

Ref. No.	Mfg. stock No.	Signal Corps stock No.	Name and description	Function	Used in PE-77-
		*3H2450-1	Generator, complete, 250 watt, 115 volt d-c, mfd by Pioneer Gen-E-Motor Corp., Chicago, Ill. Model 77, climax No. 28CX-160		
1	P-4049-1	*3H4577A/C33	Cover	Generator end cover	ABCD&E
2	G-5857	*3H4577A/L1	Lead and lug assembly	Carry current to outlet	ABCD&E
2	AS-B-10116-118	*	Lead and lug assembly	do	E
3	G-2964	3H4577A/B44	Brush assembly d-c	do	ABCD&E
4	P-5114	*3H4577A/B14	$\frac{5}{16}$ -24 x $2\frac{3}{4}$ hex. hd. bolt	do	ABCD&E
5	P-1590	*3H4577A/W24	$\frac{5}{16}$ split lock washer	do	ABCD&E
6	P-1295	*3H4577A/W23	$\frac{1}{4}$ split lock washer	do	ABCD&E
7	P-2685	*3H4577A/B15	$\frac{1}{4}$ -28 x $\frac{3}{4}$ hex. hd. bolt	do	ABCD&E
8	P-3851	*6L7032-6.1S	No. 10-32 x $\frac{5}{8}$ R.H.M.	do	ABCD&E
9	P-1037	*6L6832-4.1S	8-32 x $\frac{1}{4}$ R.H.M. screw	do	ABCD&E
10	P-3852	*3H4577A/W22	No. 10 split lock washer	do	ABCD&E
11	P-1715	*3H4577A/W21	No. 8 split lock washer	do	ABCD&E
11	3743	*	No. 4 split lock washer	do	E
12	P-5148	*3H4577A/R12	Pole shoe retainer	Secure pole shoe	ABCD&E
12	AS-A-11089	*	Pole shoe retainer	do	E
13	P-1886	3H4577A/S67	Staple	Holds brush in holder	ABCD&E
14	P-5639	*3H4577A/S20	Shell	Holds generator parts	ABCD&E
15	P-5748	*3H4577A/H12	Brush holder	Holds brushes	QBCD&E
16	P-5747	*3H4577A/B37	Brush holder mounting bracket	do	ABCD&E
17	P-3986	*3H4577A/J1	Brush holder insulator	Insulator	ABCD&E
18	G-5648	*3H4577A/B38	Brush holder and mounting bracket assembly	Holds brush assembly	ABCD&E

*Not issued as replace- Not stocked. Do not order.

POWER UNIT PE-77-(*)

Ref. No.	Mfg. stock No.	Signal Corps stock No.	Name and description	Function	Used in PE-77-
15	AS-C-5648	*	Brush holder assembly	Holds brushes	E
19	P-4241	3H4577A/C14	Capacitor	Filtering	ABCD&E
20	G-2836-2	*3H4577A/F1	Fan	Cool generator	ABCD&E
20	AS-B-10949	*	Fan and bushing assembly	do	E
21	AR-B4562	*3H4577A/A5	Armature	Generate current	ABCD&E
21	AS-B-5643	*	Armature assembly	Generate current	E
22	W-6316	*3H4577A/C21	Field coil assembly	do	ABCD&E
22	AS-C-5645	*	Field coil assembly	do	E
23	G-3545	*3H4577A/S32	Pole shoe assembly	Holds field coil	ABCD&E
23	AS-A-11089	*	Pole shoe assembly	do	E

c. Mounting base assembly (generator).

Mfg. stock No. (ref. No.)	Signal Corps stock No.	Name and description	Function	Used in PE-77-
C-576H	*3H4577A/B2	Mounting base	Holds generator	ABCD&E
613	3H4577A/M8	Rubber truck mounting	do	ABCD&E
SK-5327	*3H4577A/M9	Vibration mountings	Cut down vibration	ABCD&E
C-554E	*3H4577A/S77	Stud		ABCD&E
	*3H4577A/W6	1½ O.D. x 0.257 I.D. x ½ steel washer		ABCD&E
	*3H4577A/S14	¾-18 NC x 1 hex. hd. cap screw		ABCD&E
	*6L6832-5.1S	¾ x ½ rd. hd. mach. screw		ABCD&E
	*6L3505-18	¾-18 NC hex. nut		ABCD&E
	*6L3504-205	¼-20 NC hex. nut		ABCD&E
	*3H4577A/W26	¾ plain washer		ABCD&E
	*6L71005-2	¾ lock washer		ABCD&E
	*6L71104	¼ lock washer		ABCD&E

*Not issued as replaceable part. Not stocked. Do not order.

SECTION V

d. Outlet box assembly.

Mfg. stock No. (ref. No.)	Signal Corps stock No.	Name and description	Function	Used in PE-77-
C-393AA	*3H4577A/B21	Outlet box		ABCD&E
	*3H4577A/S7	No. 2 x 1/4 sheet metal screw		ABCD&E
1210	*6L7024-6.1S	No. 10-24 x 3/8 rd. hd. mach. screw		ABCD&E
EPL05	*3H4577A/W7	Shakeproof lock washer		ABCD&E
	3DB500-5	Aerovox 200-v d-c, 500 uf electrolytic capacitor		ABCD&E
	*6L6632-5.1S	No. 6-32 x 5/8 rd. hd. mach. screw		ABCD&E
	*6L3606-32	No. 6-32 hex. nut		ABCD&E
1106	*3H4577A/W8	Shakeproof lock washer		ABCD&E
	3H4577A/R6	Hubbell Duplex Twist-tite receptacle		ABCD&E
	*6L6632-5.1S	No. 6-32 x 5/8 rd. hd. mach. screw		ABCD&E
	*6L3606-32	No. 6-32 hex. nut		ABCD&E
1106	*3H4577A/W8	Shakeproof lock washer		ABCD&E
B71	*3H4577A/T7	Sta-Kon terminal		ABCD&E
B36	*3H4577A/T8	Sta-Kon terminal		ABCD&E

e. Name plates.

Mfg. stock No. (ref. No.)	Signal Corps stock No.	Name and description	Function	Used in PE-77-
C-401W	*3H4577A/N1	Case name plate		ABCD&E
C-401AB	*3H4577A/N3	Outlet box name plate		ABCD&E
C-401AC	*3H4577A/N2	Power unit name plate		ABCD&E

POWER UNIT PE-77-(*)

Mfg. stock No. (ref. No.)	Signal Corps stock No.	Name and description	Function	Used in PE-77-
C-401AD	*3H4577A/N4 *3H4577A/N7	Generator name plate No. 2 x 1/4 sheet metal screw		ABCD&E ABCD&E

f. Carrying case and tool box assembly.

Mfg. stock No. (ref. No.)	Signal Corps stock No.	Name and description	Function	Used in PE-77-
1216	*3H4577A/H2	Handle	Carrying case and tool box assembly	ABCD&E
313	*3H4577A/C17	Brass flush ring catch		ABCD&E
C-567D	*3H4577A/P27	Strike plate		ABCD&E
BN-1060	*3H4577A/P8	Brass hinge, dull nickel, finish		ABCD&E
49110	*3H4577A/C18	Steel catch		ABCD&E

g. Spare parts.

Mfg. stock No. (ref. No.)	Signal Corps stock No.	Name and description	Function	Used in PE-77-
29693	3H4577A/P34	Champion spark plug No. J-8, 14 mm		ABCD&E
67537	3H4577A/G11	Cylinder head gasket		ABCD&E
68337	3H4577A/G12	Base gasket		ABCD&E
65534	3H4577A/W4	Oil filler cap washer		ABCD&E
67527	3H4577A/G1	Valve cover gasket		ABCD&E

*Not issued as replaceable part. Not stocked. Do not order.

SECTION V

Mfg. stock No. (ref. No.)	Signal Corps stock No.	Name and description	Function	Used in PE-77-
67307	3H4577A/G3	Magneto plate gasket, 0.015"		ABCD&E
67597	3H4577A/G35	Magneto plate gasket, 0.005"		ABCD&E
67607	3H4577A/G4	Magneto plate gasket, 0.009"		ABCD&E
27112	3H4577A/G5	Carburetor gasket		ABCD&E
68877	3H1901-A/G5	Inlet valve seat gasket		ABCD&E
68887	3H1901-A/P1	Needle valve packing		ABCD&E
27113	3H4577A/G7	Venturi gasket		ABCD&E
68957	3H4577A/G15	Air cleaner gasket		ABCD&E
68477	3H1901-AP/G9	Gas filter gasket		ABCD&E
68997	3H4577A/G9	Carburetor elbow gasket		ABCD&E
68507	3H4577A/W5	Felt washer		ABCD&E
290307	3H4577A/P30	Magneto point assembly		ABCD&E
23612	3H4577A/V1	Exhaust valve		ABCD&E
290282	3H4577A/R37	Starter rope		ABCD&E
68987	3H1901-A/G3	Carburetor gasket (between carburetor and elbow)		ABCD&E
65777	3H4577A/G52	Tank cap gasket		ABCD&E
G-2964	3H4577A/B44	Set of brushes for generator		ABCD&E

*Not issued as replaceable part. Not stocked. Do not order.

POWER UNIT PE-77-(*)

h. Tools.

Mfg. stock No. (ref. No.)	Signal Corps stock No.	Name and description	Function	Used in PE-77-
.....	3H4577A/F20	Funnel, No. 10 standard	General use	ABCD&E
.....	3H4577A/P28	Thin-nose pliers, 6½" slip joint		ABCD&E
.....	3H4577A/S13	Screw driver, wood handle, 8¾" over-all		ABCD&E
CTK646	3H4577A/H3	"LT" handle		ABCD&E
CTK6614	3H4577A/S49	¼ socket		ABCD&E
CTKH2701	3H4577A/S47	½ Husky socket		ABCD&E
CTK6624	3H4577A/S46	¾ socket		ABCD&E
M.W.	3H4577A/G25	Feeler gage, 20B		ABCD&E
89838	3H4577A/W32	Spark plug wrench 5½ x 9" cloth bag 5 x 9", envelope, waterproof	Remove spark plug Hold tools Hold spare gaskets	ABCD&E ABCD&E ABCD&E

*Not issued as replaceable part. Not stocked. Do not order.

Order No. 28723—Phila—43—9700 copies—Nov. 43.

