

dot 1113  
12  
TM  
1943

# TM 11-923F

WAR DEPARTMENT TECHNICAL MANUAL

U.S. Dept. of Army

## POWER UNIT

### PE-99-F

WAR DEPARTMENT • 28 DECEMBER 1943

1888

1888

WAR DEPARTMENT TECHNICAL MANUAL  
TM 11-923F

---

POWER UNIT  
PE-99-F



WAR DEPARTMENT • 28 DECEMBER 1943

---

*United States Government Printing Office  
Washington : 1945*

**POWER UNIT PE-99-F**

**WAR DEPARTMENT**

**WASHINGTON 25, D. C., 28 December 1943**

**TM 11-923F, Power Unit PE-99-F, is published for the information and guidance of all concerned.**

[A. G. 300.7 (28 December 1943).]

**BY ORDER OF THE SECRETARY OF WAR**

**G. C. MARSHALL,**  
*Chief of Staff.*

**OFFICIAL:**

**J. A. ULIO,**  
*Major General,*  
*The Adjutant General.*

**DISTRIBUTION: X**

(For explanation of symbols see FM 21-6.)

U113  
 2  
 TM 11:923F  
 1943

**TABLE OF CONTENTS**



**SECTION I—DESCRIPTION**

**PAR. PAGE**

General .....	1.	1
Components .....	2.	1
Weights and Dimensions .....	3.	7

**II —INSTALLATION and OPERATION**

Initial Procedure .....	4.	7
Installation .....	5.	7
Preparation for Use .....	6.	8
Operation .....	7.	11
Voltage Regulation .....	8	13

**III —FUNCTIONING of PARTS**

Automatic Choke .....	9.	14
Impulse Coupling .....	10.	15
Automatic Voltage Regulator .....	11.	15
Remote Control .....	12.	17

**IV —MAINTENANCE**

General .....	13.	18
Lubrication .....	14.	18
Fuel .....	15.	20
Carburetor .....	16.	20
Fuel Pump .....	17.	22
Automatic Choke .....	18.	25
Governor .....	19.	27
Ignition System .....	20.	27
Firing Order .....	21.	32
Magneto Timing .....	22.	32
Spark Plug Adjustment .....	23.	32
Ignition Cable .....	24.	33
Electric Starter .....	25.	33
Battery Charging Generator .....	26.	33

# TABLE OF CONTENTS

(CONTINUED)

	PAR.	PAGE
Removing and Replacing Flywheel .....	27.	34
Cylinder Assembly .....	28.	34
Compression .....	29.	34
Valve Adjustment .....	30.	35
Piston .....	31.	36
Connecting Rod .....	32.	37
Crankshaft .....	33.	37
Camshaft .....	34.	37
Oil Pump .....	35.	37
Carbon .....	36.	37
Air Cleaner .....	37.	37
Muffler .....	38.	38
Overhauling .....	39.	38
Dis-Assembly and Assembly of Connecting Rod, Piston, Etc. ....	40.	38
Dis-Assembly and Assembly of Oil Pump ..	41.	39
Dis-Assembly and Assembly of Cylinders ..	42.	40
Dis-Assembly and Assembly of Camshaft ..	43.	41
Dis-Assembly and Assembly of Governor ...	44.	41
Dis-Assembly and Assembly of Crankshaft ..	45.	41
Adjusting A-C Generator Belt Tension ....	46.	42
A-C Generator .....	47.	43
General Description .....	48.	43
Care and Maintenance .....	49.	45
Automatic Regulator Maintenance .....	50.	53
Trouble Chart - Engine .....	51.	54
Trouble Chart - Generator .....	52.	57
 <b>V — SUPPLEMENTARY DATA</b>		
Table of Replaceable Parts .....	53.	62
 <b>VI —</b>		
Nuts, Bolts, Screws and Washers .....	54.	106
 <b>VII —</b>		
Names and Addresses of Manufacturers ..	55.	115

## LIST OF ILLUSTRATIONS

	<b>Figure</b>
Power Unit PE-99-F Complete With Accessories .....	1
Engine, Right Side, With Covers Removed .....	2
Generator and Exciter .....	3
Control Panel .....	4
Remote Control Assembly .....	5
Contents of Tool Box .....	6
Checking Oil in Crankcase .....	7
Adding Oil .....	8
Putting Oil in Air Cleaner .....	9
Battery Connections .....	10
Engine, Showing Fuel Line .....	11
Cranking by Hand .....	12
Automatic Choke .....	13
Automatic Voltage Regulator, Details .....	14
Operation Diagram of Voltage Regulator .....	14 a
Lubrication Diagram .....	15
Carburetor, Cross Section .....	16
Fuel Pump-Details .....	17
Adjustment of Automatic Choke .....	18
Testing Ignition Spark .....	19
Magneto Point Adjustment .....	20
Drive Gear Marking and Assembly .....	21
Timing Diagram .....	22
Adjusting Spark Plug .....	23
Valve Tapper Adjustment .....	24
Removing Valves .....	25
Inserting Piston in Cylinder .....	26
Removal of Oil Pump Assembly .....	27

**LIST OF ILLUSTRATIONS**

(CONTINUED)

	<b>Figure</b>
Adjusting Drive Belts .....	28
Cross Section of Generator and Exciter .....	29
Removing the Exciter Armature .....	30
Removing Ball Bearing With Typical Bearing Puller .....	31
Practical Wiring Diagram .....	32
A. C. and Exciter Circuit Diagram .....	33
Start and Stop Circuit Diagram .....	34
Main Engine Parts .....	35
Cylinder Block Assembly .....	36
Oil Pump Assembly .....	37
Fuel Pump and Camshaft Parts .....	38
Gear Cover Magneto and Governor .....	39
Crankshaft, Piston and Connecting Rod .....	40
Air Shrouding .....	41
Spark Plug Shield .....	42
Carburetor Assembly .....	43
Fuel Pump Assembly .....	44
Oil Filter Assembly .....	45
Fuel Strainer Asssembly .....	46
Air Cleaner Assembly .....	47
Magneto Impulse Coupling .....	48
Magneto Rotor and Breaking .....	49
Magneto End Cap Distribution Block and Rotor .....	50
Automatic Choke Assembly .....	51
Exploded View of Generator - Exciter Unit .....	52
Battery Charging Generator .....	53
Starting Motor .....	54

## DESTRUCTION NOTICE

**WHY**—To prevent the enemy from using or salvaging this equipment for his benefit.

**WHEN**—When ordered by your commander.

**HOW**—1. **Smash**—Use sledges, axes, hand-axes, pick-axes, hammers, crowbars, heavy tools, etc.

2. **Cut**—Use axes, hand-axes, machete, etc.

3. **Burn**—Use gasoline, kerosene, oil, flame-throwers, incendiary grenades, etc.

4. **Explosives**—Use firearms, grenades, TNT, etc.

5. **Disposal**—Bury in slit trenches, fox-holes, other holes.  
Throw in streams. Scatter.

6. **USE ANYTHING IMMEDIATELY AVAILABLE FOR DESTRUCTION OF THIS EQUIPMENT.**

**WHAT**—1. **Smash**—Engine cylinder head, manifolds, carburetor, cylinder blocks, crankcase, generator frame, control panel instruments, magneto, fuel filter, oil filter and air filter.

2. **Cut**—Generator drive belts, remote fuel pipe, exhaust tube, power cable, remote control cable, and all other wires and cables in or on the unit. Cut armature and field windings.

3. **Bend and/or Break**—Gas tank, engine housing, control cabinet, tool box, mounting frame and control panel.

4. **Burn**—All manuals, wire, oil and fuel.

5. **Bury or scatter**—Any or all of the above pieces after breaking.

## DESTROY EVERYTHING

---

## SAFETY NOTICE

This unit generates voltage which may cause severe and possibly fatal shocks. Always trip the main circuit breaker before attempting to change load connections. Disconnect the remote control and battery connection before working on the unit.

Provide proper ventilation when operating the unit in a confined space. Locate the exhaust, when operating the unit out of doors, so that the wind will carry exhaust gases away from personnel. Exhaust gases contain carbon monoxide which is odorless and deadly poison.

Do not service with gasoline while the unit is in operation or in close proximity to an operating radio transmitter. Avoid spilling gasoline when filling the fuel tank.

## POWER UNIT PE-99-F



Figure 1.—Power Unit PE-99-F Complete with Accessories

## SECTION I

### DESCRIPTION

1. **General.**—*a.* Power Unit PE-99-F is a complete gasoline-engine driven electric generator with an integral control cabinet. A power cable, remote control cable and a tool and spare parts box are furnished with the unit. The unit generates  $7\frac{1}{2}$  kw, 3 phase, 60 cycle, 120 volt alternating current at 100% power factor. It will safely carry 25 percent overload for two hours and will carry 5 kw, 100% power factor on a single phase with no load on the other two phases.

*b.* The unit is suppressed to effectively eliminate radiated and conducted radio interference within the range of 0.5 to 150 megacycles at a distance of 25 feet from the unit.

*c.* The unit will start and operate continuously at all temperatures ranging from  $-30^{\circ}$  to  $+130^{\circ}$  Fahrenheit, at any altitude up to 5,000 feet above sea level and under all climatic conditions that may be encountered within these ranges.

*d.* The engine, belt driven generator, and control cabinet are mounted on a welded steel skid base.

2. **Components.**—*a. Engine (fig. 2).*— The engine is a 4-cycle, air cooled, 4 cylinder, V type and has a 3 in. bore  $3\frac{1}{4}$  in. stroke, 91.9 cubic inches piston displacement and is equipped with a high-tension magneto and impulse coupling. It develops 20.5 brake horse power at 2,200 rpm and operates on commercial 80 octane leaded gasoline or gasoline to U. S. Army specification No. 2-103. It will operate on approximately 2 gallons of gasoline per hour at full load. The unit is equipped with a  $9\frac{3}{4}$  gallon fuel tank, diaphragm type fuel pump and a 3-way gasoline valve to which the 20 foot auxiliary fuel line may be attached for pumping fuel from a remote supply tank. A muffler and a 10 ft. flexible exhaust hose are provided to enable carrying the exhaust away from the unit.

## POWER UNIT PE-99-F

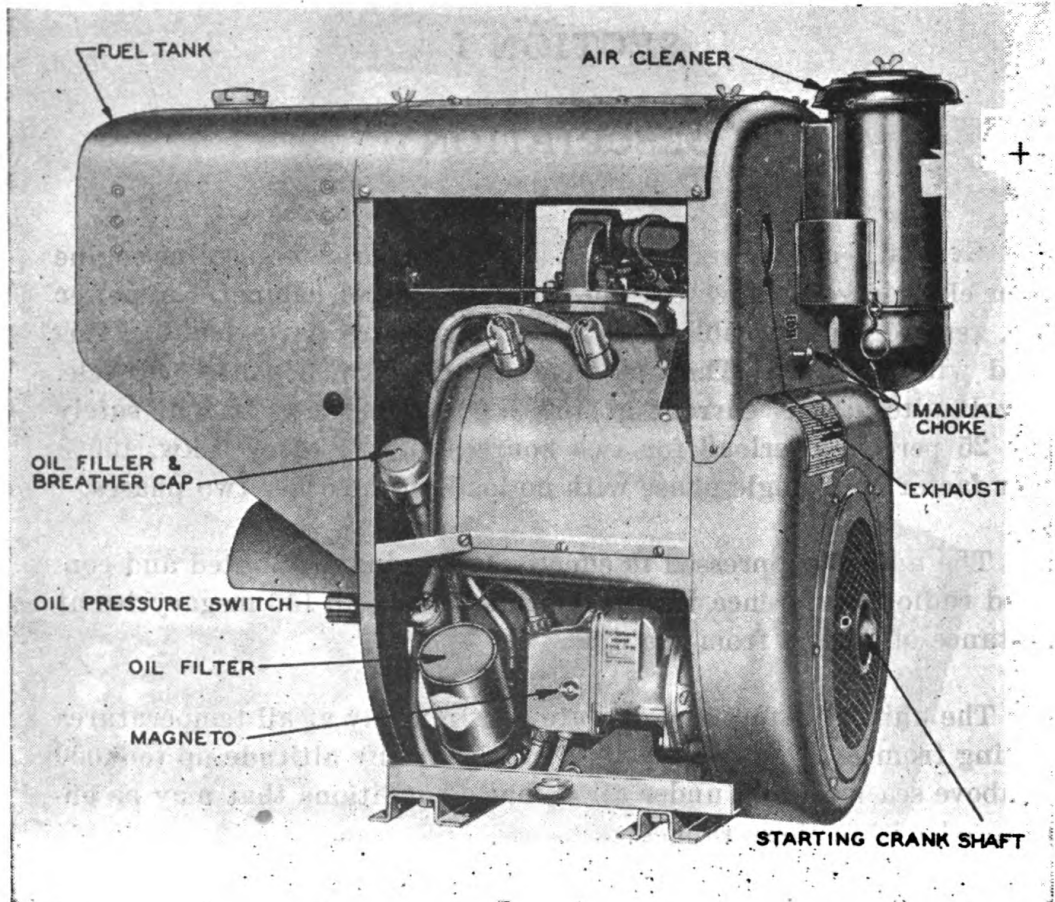

Figure 2.—Engine, Right Side, With Covers Removed

*b. Electrical starting system.*— (1) Power Unit PE-99-F is provided with both electrical and manual starting equipment. The starting motor is of conventional automotive type with Bendix drive and is mounted to the flywheel housing at the side of the crankcase. Two buttons, one marked START the other marked STOP are provided on the control panel for starting and stopping the unit. An AUTOMATIC-MANUAL STARTING switch is provided on the control panel which when thrown to MANUAL enables starting the unit by means of the hand crank mounted on the engine next to the air-cleaner.

(2) A Start-Stop switch attached to one end of the remote control cable enables starting and stopping the unit from a remote point.

## SECTION I

*c. Batteries.*—Two 6-volt storage batteries are mounted on the skid base, one on each side of the engine. The batteries are furnished dry charged. Electrolyte is provided in separate containers packed in a wooden box. A battery charging generator and a battery charging regulator maintain the battery charge.

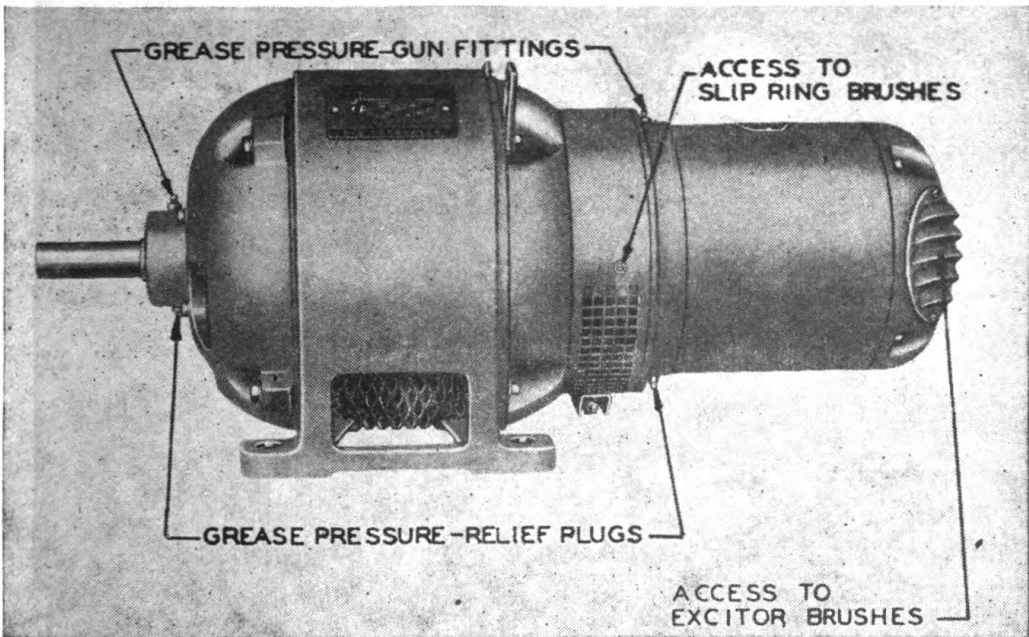

Figure 3.—Generator and Exciter

*d. Generator.*—The semi-enclosed drip-proof generator has a revolving field and a direct connected exciter, and generates  $7\frac{1}{2}$  kw at 1800 rpm. Generator voltage is regulated at the control panel either manually by a hand rheostat or automatically by a voltage regulator. The voltage regulator will provide 3% plus or minus regulation.

*e. Control cabinet.*—(1) A control panel, shock mounted to the upper frame of the skid base, and enclosed in a removable steel housing, is accessible through two doors in the housing. Wiring diagrams and a lubrication diagram are mounted on the inside surface of the doors.

## POWER UNIT PE-99-F



Figure 4.— Control Panel

The following instruments and controls are mounted on the panel:

- 1- AC Voltmeter 0-150 Volts
- 1- Phase Selector Switch
- 3- AC Ammeters, 0-50 Amperes
- 1- Elapsed Time Meter
- 1- Frequency Meter
- 1- Battery Ammeter 30-0-30 amperes
- 1- 3-Phase Main Circuit Breaker

## SECTION I

- 1- Duplex Convenience Receptacle
- 1- Automatic Voltage Regulator
- 1- Regulator Voltage Adjustment Rheostat
- 1- Automatic-Manual Voltage Control Switch
- 1- Exciter Field Rheostat
- 3- Push Buttons, Start- Stop
- 1- Remote Control Receptacle
- 1- Automatic-Manual Starting Switch
- 2- Panel Lights

Located below the panel and mounted to the frame are the following:

- 1- 3-Phase Power Receptacle
- 1- Terminal Block with Power Studs
- 1- Terminal Block with Remote Control Studs

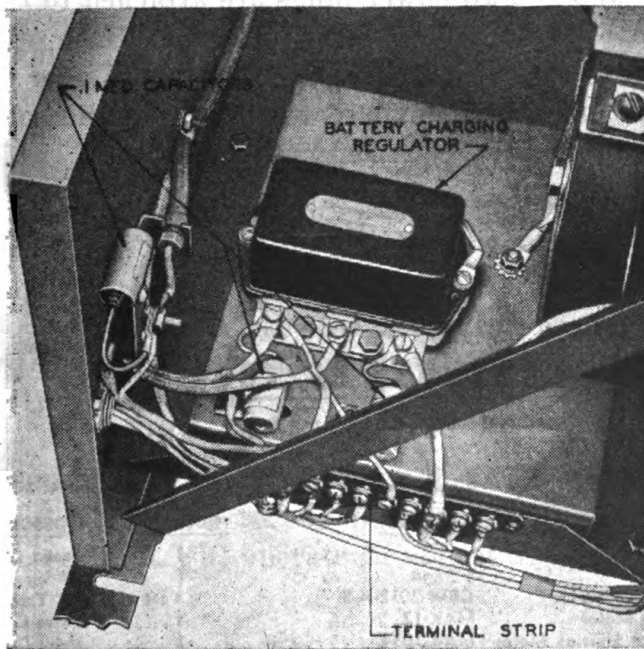

Figure 5.—Remote Control Assembly

(2) Remote Control Assembly.—The remote control assembly serves as the bottom of the control cabinet. Four relays are mounted to a bottom pan and are wired to a terminal strip at which leads from the engine and control panel are connected. A cover pan encloses the relays.

*f. Skid Base.*—A welded steel skid base supports all the other components of the engine-generator assembly. A generator platform which is separable from the main frame is hinged by a long bolt to one side of the skid base and may be raised and lowered at the other side by means of two bolts, facilitating adjustment and replacement of V-belts. Skids are made of standard steel angle and are rounded at the ends.

Cross members near each end are of 1½" pipe into which lifting bars may be inserted for easy handling. Two frames are welded across the skids, one to support the engine, the other to support the control cabinet.

*g. Remote Control Cable.*—(1) The 150-foot flexible, weatherproof, 3-conductor, No. 18 Remote Control cable is terminated at one end by a 3-pole twist-lock plug and at the other end by a weatherproof Start-Stop switch. Each of the 3 conductors has an identifying colored, cotton stranding. One conductor has green, another has white, another has black. These colors indicate the proper connection of the cable to the remote control studs, should this be necessary.

(2) A cable reel is furnished on which the cable should be mounted when not in use.

*h. Power Cable.*—Two power plugs are attached to the 150 foot, 3-conductor, No. 6 power cable, one at each end. Each of these 3-phase plugs will fit into the receptacle located below the door of the control cabinet. This cable is also flexible, weather proof and color coded, and should be mounted on its reel when not in use.

*i. Tool and Spare Parts Box.*—Mounted to the undersurface of the tool and spare parts box cover is a packing list as shown below. The tools are in the upper tray, gaskets in the lower tray, spare parts and 20-foot gasoline hose in the box beneath both trays.

**CONTENTS OF TOOL BOX**  
**FOR PE-99-F POWER UNIT**

S P A R E P A R T S

T O O L S a n d M I S C E L L A N E O U S

QUAN.	DESCRIPTION	PART NO.	QUAN.	DESCRIPTION
4	Brushes for Alternator		1	Feeler Gage Set
2	Brushes for Exciter		1	6" Slip Pliers
2	Brushes for Battery Generator	GBW-2012-A-S	1 set of 2	½" Tappet Wrenches
2	Brushes for Starting Motor	MAK-12	1	Valve Lifter
2	Brushes (ground) for Starting Motor	MAK-1034	1	Valve Grinding Tool
20	Spark Plugs	YD-47	1 Can	Valve Grinding Compound
4	Exhaust Valve Springs	AF-49-A	1	8" Screw Driver
4	Valves	AE-75-B	1	3" Screw Driver
4	Valve Spring Seats	AG-26	1	8" Crescent Wrench
4 poly	Valve Spring Seat Bushings	AH-9	1	Hammer, 1lb. Machinists
8	Valve Seat Inserts	HG-201-B	1	Open End Wrench ¾"-7/16"
5	Oil Filter Cartridges	RV-27-S	1	Open End Wrench ½"-9/16"
2 sets	Engine Gaskets	Q-10-A	1	Open End Wrench ¾"-¾"
2 sets	Carburetor Gaskets	382391	1	Open End Wrench ¾"-15/16"
2 sets	Magneto Gaskets	CK-16	1	Open End Wrench 1 1/16"
3 sets	Cylinder Head Gaskets	QD-613-B	1	Allen Wrench for Pulleys
1 set	Magneto Breaker Points	T-2437	1	Spark Plug Wrench
1 set	Replacements for Fuel Strainer		1 box	Assorted Cotter Pins
1	Connecting Rod-Piston Assy. with rings		1 spool	Soft Iron Wire
8	Piston Rings - Compression	DC-163	2 sheets	#00 Sandpaper
4	Piston Rings - Scraper	DC-163-1	1 bottle	Gasket Seal with Brush
4	Piston Rings - Oil	DC-109	2	Technical Manuals
1 set	V - Belts - Main Drive (5 to a set)	4713	1 20' lgth.	Gasoline Hose with fittings
1	V - Belt	4714	1	* Oil Can
2	Knobs - for Rheostat and Switch	4775	1	* Starting Crank
2	Capacitors - .1 Mfd.	4760		
2	Capacitors - .01 Mfd.	4779		
1	Fuel Pump Diaphragm Kit			

\* Mounted on Power Unit

Figure 6.—Contents of Tool Box

## SECTION II

## 3. Weights and Dimensions.—

Component	Length (inches)	Width (inches)	Height (inches)	Weight (pounds)
Battery, each	10½	7	9	37.5
Control Cabinet	17	22	23	79
Engine Assembly (crankcase empty)	36¼	22½	32	413
A.C. Generator Assembly	30	15	13	218
Power Cable & Reel	20	20	14	131
Remote Control Cable & Reel	20	20	7	27
Skid Base Assembly	60	28	36½	140
Tools & Spare Parts Box				
Power Unit PE-99-F (crankcase filled, fuel tank empty)	19 60	16 28	9 42	54.5 1015

## SECTION II

## INSTALLATION and OPERATION

4. **Initial Procedure.**—Inspect the equipment for damage and for conformity with packing sheet. Should the equipment be incomplete or damaged, report this fact immediately.

5. **Installation.**—*a.* Choose a general location that will be consistent with the assignment to be carried out and the length of the cables. The power unit will operate in almost any place outdoors or indoors.

*b.* If the power unit is to be located outdoors, select a dry and reasonably level spot preferably on grass or soft ground. Avoid low spots that a sudden rain storm may flood. Locate the unit so that the wind carries exhaust gases away from operating personnel.

*c.* If the power unit is to be located indoors, proceed as follows:

**CAUTION**

**THE EXHAUST GASES FROM THE ENGINE  
CONTAIN CARBON MONOXIDE, AN ODOR-  
LESS AND DEADLY POISONOUS GAS.**

(1) Adequate ventilation is necessary while engine operates in order to carry away fumes from exhaust leaks and to replenish the supply of oxygen.

**POWER UNIT PE-99-F**

(2) Locate the unit so that the exhaust end is near to and facing an opening to the outdoors. The muffler should be attached to the exhaust hose and the unattached end of the exhaust hose should be attached to the engine exhaust. Make all connections gas tight. Locate the unit so that the exhaust hose is as free of bends as possible to prevent excessive back pressure and so that the length of hose indoors is as short as possible.

d. At least 2 feet of space must be provided around all sides of the unit at all times.

e. When fuel is to be taken from a remote supply tank connect the 20-foot flexible fuel line supplied with the unit to the 3-way valve below the fuel tank (see figure 11) and carry the other end to the remote fuel supply. The remote fuel supply should be so located that the total fuel lift by the fuel pump will not be more than 6 feet.

6. **Preparation for Use.**— a. Inspect unit thoroughly to see that it is complete and in proper working order. Adjust all V-belts to proper tension. Give engine a few slow turns with hand crank to be sure all parts move freely. Check to see that all wiring connections are tight. If the unit has not been previously used, or has just been removed from storage, remove sealing paper from air cleaner, exhaust, oil filler pipe and both sides of magneto.

b. **BEFORE** filling the fuel tank with gasoline make the following preparations:



**Figure 7. Checking Oil in Crankcase**



**Figure 8. Adding Oil**

(1) Remove the oil gauge to see that the oil is up to the full mark.

## SECTION II

Replenish or if empty, fill with 4 quarts of oil through the oil filler in accordance with instructions under paragraph 14.

(2) Fill the air cleaner to the indicated level with same grade of oil as used in the crankcase. Check hose connecting air cleaner to carburetor. See that connections are tight to prevent entrance of dust.

(3) Originally the equipment is furnished with dry charged batteries and with electrolyte separately packaged. If the batteries have not been previously used, remove the stoppers from holes in the filler plugs, remove the filler plugs and fill all cells with battery grade electrolyte to a level of  $\frac{1}{2}$ " above the separators. Use 1.285 (32° Baume) specific gravity [for tropical countries 1.225 (26.6° Baume) specific gravity].

(4) After filling, allow battery to stand until the temperature of the electrolyte has dropped to 90° F. (32° C.) or lower [for tropics 110° F. (43.3° C.) or lower] before using. In emergencies, dry charged batteries may be put into service immediately but under no condition should a period of more than 12 hours elapse before giving them a freshening charge. Batteries should be charged at approximately a 7 ampere charging rate and should be kept on charge until the gravity reading of each cell is 1.285 (or 1.225 in tropics) or until there is no further rise in gravity readings during a 3 hour charging period. While charging, the temperature of the electrolyte should not be permitted to rise above 110° F (43.3° C) [125° F (51.6° C) in tropical countries]. Should the temperature rise above the maximum, reduce the charging rate or stop charging until the solution has cooled.

(5) If the batteries have been previously used, check the specific gravity of the electrolyte with a hydrometer. A hydrometer reading of not less than 1.225 (1.175 in tropics) should be obtained. Add distilled water so that the level of the electrolyte within the cells is  $\frac{1}{2}$ " above the tops of the separators.

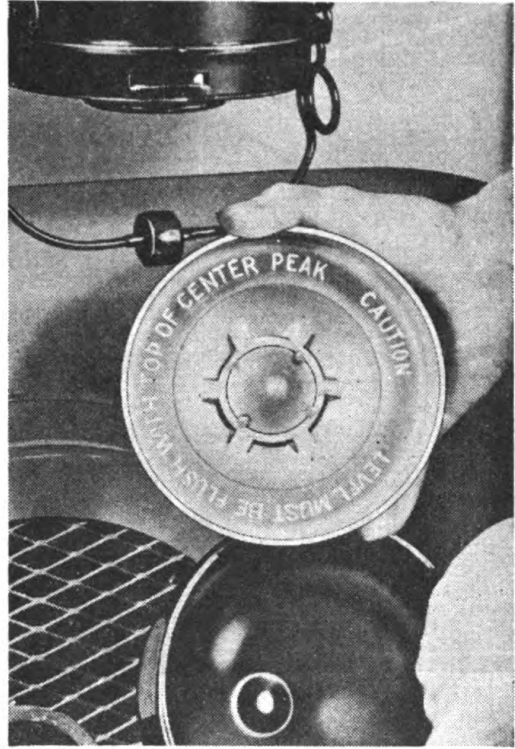
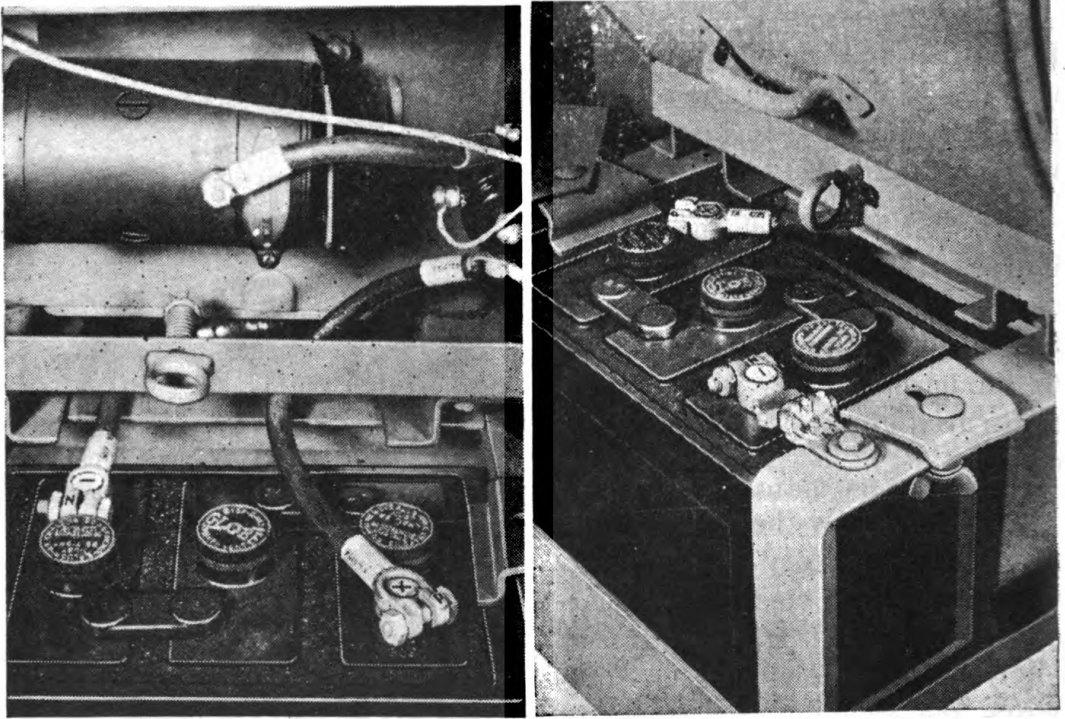

Figure 9. Putting Oil in Air Cleaner



Left Side

Right Side

Figure 10.—Battery Connections

(6) Be sure battery connections are clean and tight. The minus (—) post of the battery connects by ground strap to frame of skid base. The plus (+) post connects by cable to lower terminal of solenoid start switch. Connect the batteries by means of the connecting cable. Replace battery covers and tighten wing nuts to securely fasten battery covers and battery clamps.

(7) Fill the fuel tank with  $9\frac{3}{4}$  gallons of clean gasoline. Blow through the vent hole in the filler cap to make sure it is clear. Set the pointer of the 3-way gasoline valve so it points toward the fuel strainer.

(8) If a remote fuel supply is to be used connect the flexible fuel line from the remote tank to the 3-way gasoline valve and set the pointer of the 3-way gasoline valve to point down. Make sure shut-off valve on the gasoline strainer is open. Check all fuel lines for any possible leaks.

(9) Assemble electric plugs of cables or equipment to be used to proper receptacles in control cabinet and make any other necessary load connection. Press circuit breaker to RESET position and release.

(10) All ventilating openings in generator, exciter and engine fly wheel screen must be kept free from leaves, grass or other debris, to insure proper ventilation and prevent overheating of the components.

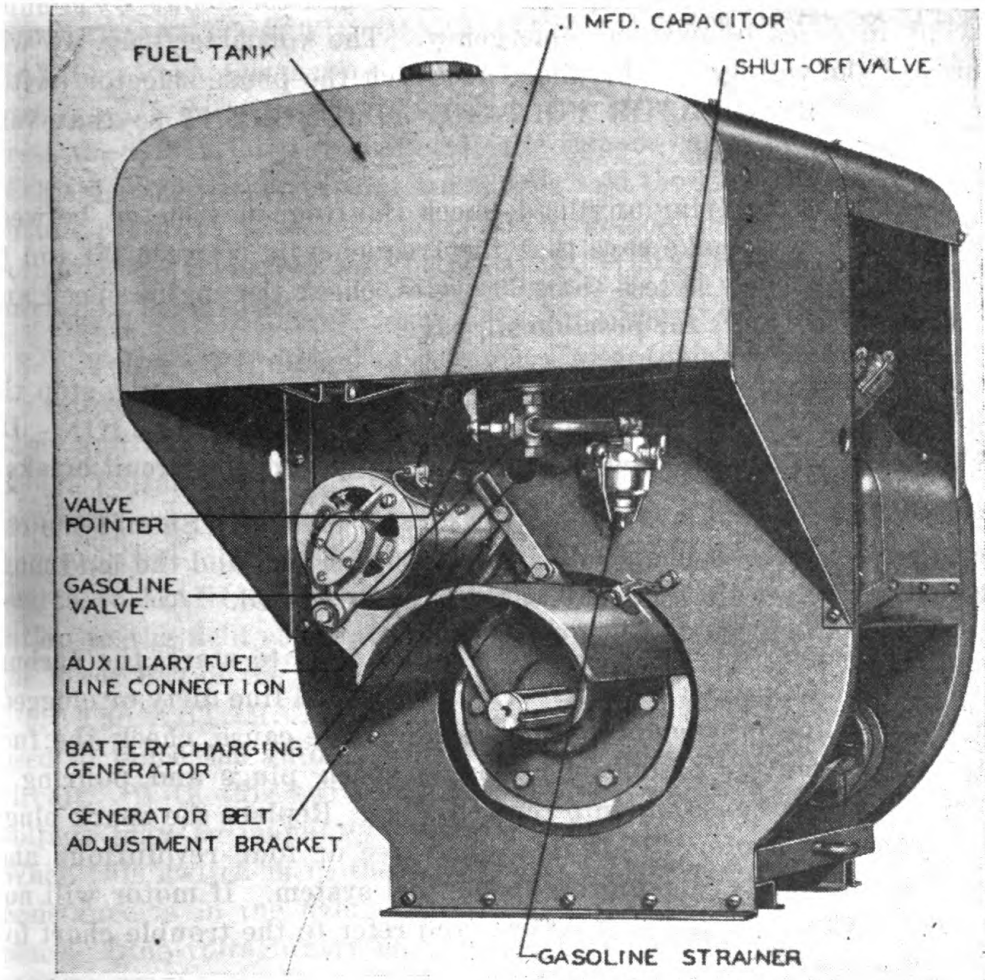

Figure 11.—Engine, Showing Fuel Line

**7. Operation.—a. Caution.**—Refer to paragraphs 5 and 6, check to see that unit is ready for operation.

**b. To Start the Engine.**— (1) Check AUTOMATIC-MANUAL STARTING switch and AUTOMATIC-MANUAL VOLTAGE CONTROL switch and see that both switches are thrown to the left hand, (AUTOMATIC) position

(2) Press START button or operate the remote control switch to the ON position. The engine will normally start within a few seconds. If the engine does not start within about 30 seconds refer to the trouble chart (par. 51a.) and check for possible cause.

(3) Check battery charging ammeter to make sure that battery charging equipment is functioning properly. The needle of this meter will swing to the right to indicate the rate of charge and to the left to indicate discharge. Normally there should be no discharge indicated while the unit is in operation or standing idle, except during electric starting.

(4) Permit the unit to operate without load for about 15 minutes except in cases of extreme emergency. The voltmeter (fig. 4) will indicate the voltage on the phase at which the phase selector switch is set. Set **REGULATOR VOLTAGE ADJUSTMENT** so that voltmeter reads 120 volts.

(5) Before applying any load, check the frequency meter, between panel lights, and make sure that the frequency is between 60 and 62 cycles. If frequency is less than 60 cycles, check the engine speed and check the drive belts for possible slippage.

(6) If the load connections have not been previously made, stop the unit by pressing the **STOP** button and make them. **CAUTION - Do not make or change load connections without opening the circuit breaker.**

(7) Restart the unit and close the circuit breaker. Should the circuit breaker **TRIP** it is an indication of an overload and the load must be checked before the circuit breaker is again closed.

*c. To Prime the Engine.*—If the motor fails to start, the carburetor may be incorrectly adjusted or dirty, the fuel line dirty or clogged, or the gasoline tank empty. To determine the cause, check the fuel supply. Prime the motor by removing spark plugs and pouring a small quantity of gasoline into the cylinders. Replace the spark plugs and crank the motor. If it fires for three or four revolutions and stops, the difficulty is definitely in the fuel system. If motor will not fire at all, check the ignition system, and refer to the trouble chart for possible cause.

*d. Starting with Dead Battery.*—When necessary to start the engine with a dead battery, remove the starting crank, and insert it in the hole in the center of the air shroud. Push the crank in until it contacts the end of the crankshaft and rotate it clock-wise until it engages the starting pin. Pull out the manual choke button located on the flywheel end of the unit. Next, set the **AUTO-MATIC - M A N U A L STARTING** switch, at **MANUAL**. Crank the engine by pulling up quickly on the starting crank. Never attempt to push down on the crank as serious injury may result if the engine

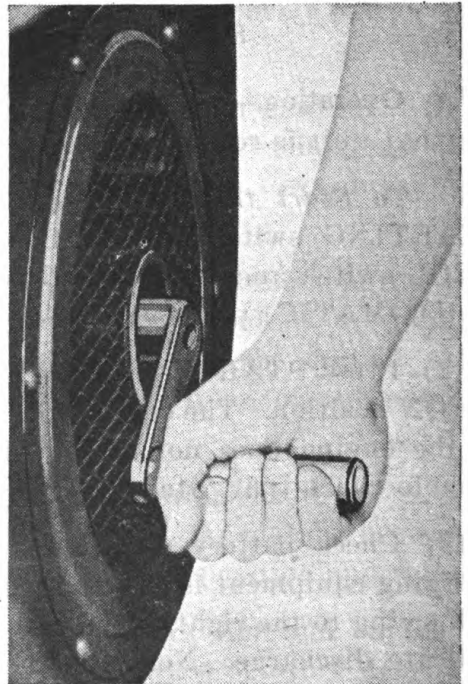

Figure 12.—Cranking By Hand

## SECTION III

should backfire. When the unit starts press the START button and throw the AUTOMATIC-MANUAL STARTING switch to AUTOMATIC. Push the manual choke button in gradually as the engine warms up. To stop the unit, when operating with a dead battery, press the STOP button or operate the remote control switch to OFF. If this does not stop the unit, press and hold the EMERGENCY STOP button. *Always be sure to press STOP button when leaving the unit inoperative.* Switch should be set at AUTOMATIC when the electric starter is being used.

8. **Voltage Regulator.**—*a.* Voltage is automatically regulated by the automatic voltage regulator mounted on the back of the control panel and adjusted by the REGULATOR VOLTAGE ADJUSTMENT knob. Voltage may be adjusted by means of this knob while the unit is in operation. The automatic voltage regulator may be disconnected by throwing the AUTOMATIC-MANUAL VOLTAGE CONTROL switch to MANUAL. This automatically transfers the voltage regulation to the field rheostat which is adjusted by means of the knob at the lower left of the panel.

*b.* The AUTOMATIC-MANUAL VOLTAGE CONTROL switch is used to place the automatic voltage regulator either in or out of the circuit. With this switch in the MANUAL position, the generator voltage may be manually regulated by means of the field rheostat. When this switch is in the AUTOMATIC position, voltage regulator resistance is in the field circuit and automatic regulation will take place. Line voltage may be adjusted by means of the REGULATOR VOLTAGE ADJUSTMENT which adjusts the automatic voltage regulator rheostat. It is not necessary to change the regulator adjustment when the unit is shut down as the regulator will function normally as soon as the unit is again started.

*c.* When the unit is first started, set the REGULATOR VOLTAGE ADJUSTMENT in the maximum resistance position with knob pointing to the left (extreme counter clockwise rotation) and gradually reduce the resistance until the a-c voltmeter reads between 100 and 140 volts. Automatic voltage regulation should begin between 100 and 140 volts and failure of the automatic regulator to function at this voltage is an indication of faulty wiring and the connections should be checked.

### SECTION III FUNCTIONING OF PARTS

#### References.

The functioning of internal combustion engines, carburetion and ignition systems is completely covered in the following technical manuals: TM 10-570 The Internal Combustion Engine; TM 10-550 Fuels and Carburetion; and TM 10-580 Automotive Electricity.

POWER UNIT PE-99-F

9. **Automatic Choke.**—*a. Description.*—(1) The Automatic Choke Control is a unit operating independently of the carburetor unit. While the function of the choke control unit is to furnish the proper amount of choke valve opening during the cranking and warming up period of the engine, its operation depends entirely upon manifold vacuum and heat on the Thermostat Spring.

(2) The vacuum piston, link and lever assembly, opens the choke valve when the engine begins to fire. This is accomplished by means of a rod hook-up from a lever on the automatic choke control unit to a choke lever attached to the choke valve stem of the carburetor unit.

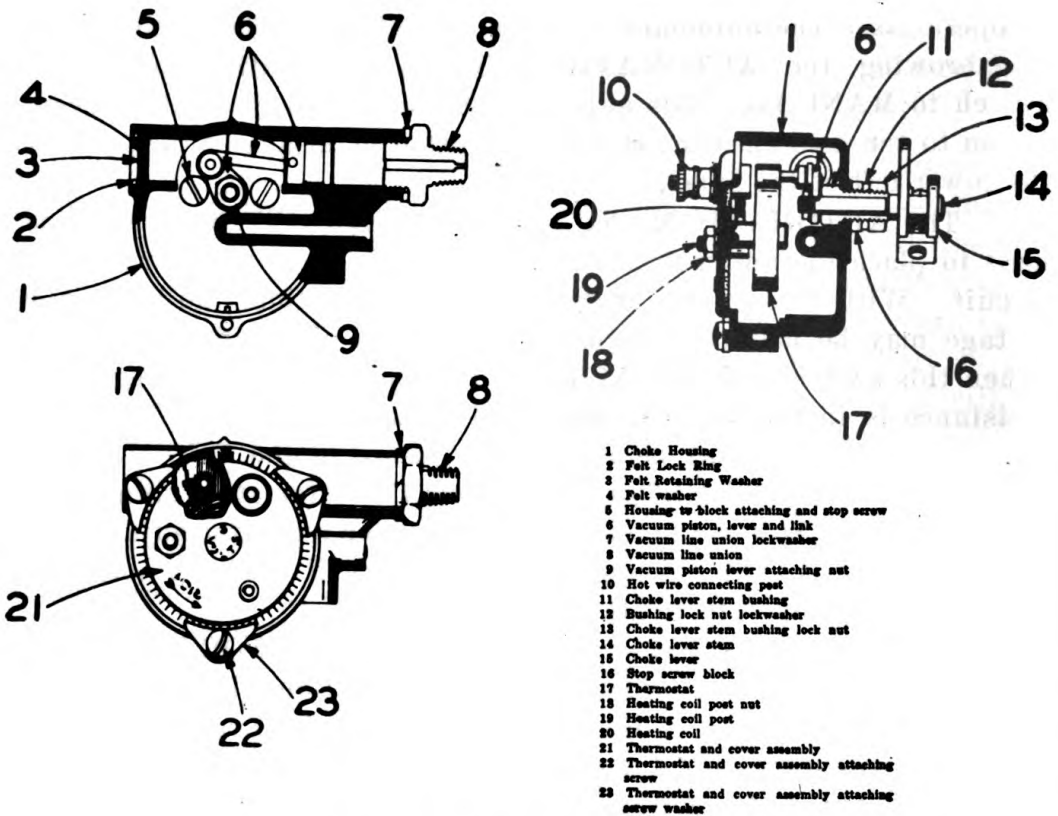

Figure 13.—Automatic Choke

*b. Functioning.*—(1) When the engine is stopped and allowed to stand, the heating coil in the thermostat assembly cools, since its source of heat, derived from the charging generator, is no longer present.

(2) As the heating coil cools, the thermostat spring also cools and gradually rotates the choke lever, closing the choke valve in the car-

## SECTION III

buretor. The automatic choke control and choke valve remain in this position while the engine is not in operation and during the cranking period.

(3) The thermostat assembly is directly connected, at the hot wire post, by a wire to the charging circuit of the engine. When the engine starts, the thermostat heating coil is heated by the passage of current through it derived from the charging generator.

(4) When the engine is started, a vacuum is created in the manifold. The automatic choke unit, connected by means of a tube from the vacuum line union to the intake manifold, is now subjected to the manifold vacuum which actuates the vacuum piston, link and lever assembly. As the heating coil heats up, the thermostat spring tends to heat and lose its tension. This enables the vacuum piston, through its link and lever assembly, to pull in a direction opposite to the spring tension and actuate the choke lever so as to open the choke and permit normal operation of the engine.

10. **Impulse Coupling.**—The impulse coupling facilitates starting the engine and at the same time automatically retards the ignition spark while starting. Through this device, the rotor of the magneto is held back while the engine is turned over to its firing position, at which instant the pawls of the coupling release and the rotor is snapped forward at high speed, thereby producing an intense spark, automatically retarded to prevent backfiring. Since the ignition spark must occur each 90° of its rotation, two stop pins are required to engage the coupling pawls at proper intervals. To provide positive pawl action over the cranking speed range, individual torsion-type pawl springs have been provided, with the result that a certain amount of impulse action may be expected up to 500 rpm.

11. **Automatic Voltage Regulator.**—*a. General.*—(1) The voltage regulator is an instrument which performs the function of an automatic field rheostat to provide a simple, effective and automatic means for obtaining almost constant voltage for all normal load conditions.

(2) The regulator consists mainly of solenoid, a commutator, and two resistor plaques.

(3) The solenoid coil is connected to the a.c. generator and is affected by voltage changes. These changes actuate the solenoid plunger, and the crossarm which moves the carbon contact across the silver commutator, thereby adjusting the resistance of the plaques to a which maintains the generator voltage.

(4) The regulator has two electrical circuits; the one consisting of the solenoid coil, the voltage dropping resistor and the external control rheostat; the other consisting of the voltage regulating resistor, which is actually the exciter field rheostat.

(5) Both the voltage dropping resistor, which limits the impressed voltage on the solenoid coil, and the regulator resistance, which adjusts the exciter field current, are embedded in and equally divided between the two plaques. The external control rheostat is not located in the regulator but is mounted separately on the switch board panel.

(6) The commutator consists of a stack of insulated silver segments, each segment connected to a tap on the regulator resistor. The commutator is of a "V" shape and the carbon contact roller rests on the commutator at two points, thereby short-circuiting all of the resistance included between these two points. By moving the contact roller transversely across the commutator, the distance between these two points of contact is changed and thus the effective resistance of the voltage regulating resistor is adjusted.

(7) The solenoid is of the a.c. quick acting type and allows the regulator momentarily to over-correct and then find a new steady-state position. The contact roller is not in constant motion, moving only when regulating action is demanded.

- 1 Contact Roller Assembly
- 2 Silver Commutator
- 3 Solenoid Spring
- 4 Contact Pressure Spring
- 5 Adjustable Spring Holder
- 6 Regulator Crossarm Plunger Assembly
- 7 Solenoid Coil
- 8 Solenoid Magnetic Structure
- 9 Adjustable Magnetic Core
- 10 Locknut
- 11 Solenoid Stop
- 12 Left Resistor Plaque
- 13 Right Resistor Plaque
- 14 Regulator Base
- 15 Solenoid Spring Adjusting Nut
- 16 Lock Spring
- 17 Cover

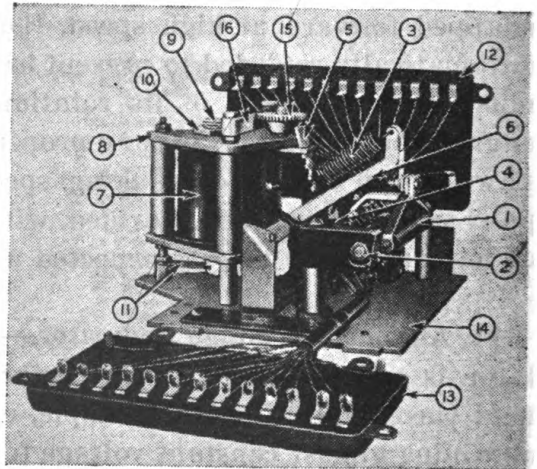

Figure 14.—Automatic Voltage Regulator, details

*b. Theory of operation.*—(1) Reference to wiring diagrams, (figs. 14a and 34) will assist in understanding the operation of the regulator.

(2) Since the solenoid is energized from the a.c. generator, any change in a.c. voltage will cause motion of the solenoid plunger. The resulting motion of the arm and contact roller changes the resistance in the exciter-shunt field circuit so as to restore the a.c. voltage to its original value.

## SECTION IV

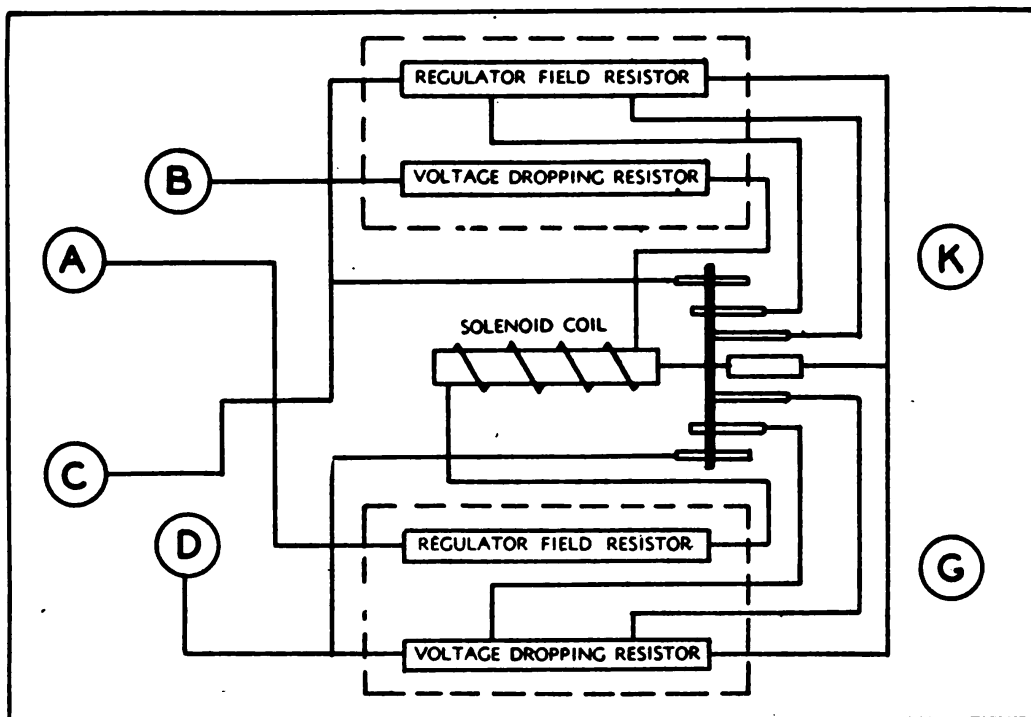

Figure 14a. Operation Diagram of Voltage Regulator

(3) Assume that the load on the generator increases. The regulating cycle then is:

- (a) - The a.c. voltage decreases.
- (b) - The current in the solenoid coil like wise decreases, causing the plunger and the contact roller to move, short-circuiting segments of the comutator.
- (c) - As the number of segments short-circuited increases, the resistance of the exciter-shunt field circuit decreases.
- (d) - The exciter-shunt field current, therefore, increases resulting in an increased exciter-armature voltage and generator field current, restoring the a.c. voltage.

12. **Remote Control** (fig. 35).—*a.* Pressing the START switch operates relay RA, closes contacts RA 1 and RA 2 and opens RA 3. RA 1 operates relay RB, closing RB4, locking relay RB and opening RB 5.

When contacts RA 3 and RB 5 are open, the magneto is ungrounded.

RA 2 feeds current from the battery through RC 6 which operates the solenoid starting switch. This switch closes the starting motor circuit supplying current to the starting motor which cranks the engine.

When the engine starts, current from the charging generator operates relay RC which opens RC 6. This prevents operation of the starter while the unit is running.

Releasing the START button when the engine starts, releases relay RA. Contacts RA 1 and RA 2 return to open position and RA 3 returns to closed position. When the unit is running, pressure in the lubricating

system opens the oil pressure safety switch which is in series with RA 3. Therefore closing RA 3 does not ground the magneto.

*b. Oil Pressure Protection.*—Failure of the oil pressure causes the oil pressure safety switch to close, grounding the magneto and stopping the unit. In this case relay RB will remain locked until the STOP button is pushed to release it.

*c. Stopping.*—Pressing the STOP button operates relay RD and opens RD 7, breaking the circuit that locks RB and thus releasing it. RB 5 returns to close position which grounds the magneto.

## SECTION IV MAINTENANCE

13. **General.**—*a.* Keep the unit clean and free from sand dust. Dirt or sand in any part of the unit will cause trouble and often serious damage. Keep the cooling fan intake free from obstructions and the cooling fins and air passages free from dirt and grease.

*b.* In reassembling any part or parts of the unit be sure to replace all star washers, bonding, shielding and capacitors to insure radio noise suppression.

14. **Lubrication.**—*a. General Instructions* (1) High grade, highly refined oils corresponding in body to the SAE (Society of Automotive Engineers) Viscosity. Numbers listed below will prove economical and assure long engine life: Summer - Above 32° F - SAE 30 (intermittent full load or sustained partial load.)

Winter (32° F. to 0° F.) SAE No. 10

Below - 0° F. dilute SAE 10 with one percent gasoline for each degree of temperature below 0. Dilution must never exceed 40 per cent. NOTE: Follow summer recommendation in winter if engine is housed in a building where average temperature is over 50° F:

(2) A motor which is run without oil will be ruined within a few minutes. Always fill the oil reservoir to the full mark on the oil level gauge after each 25 hours of motor operation. Capacity of oil reservoir is 4 quarts. See figures 7 and 8.

*b. Change Oil Frequently.*—THE OIL SHOULD BE DRAINED AND FRESH OIL ADDED AFTER EVERY 300 HOURS OF OPERATION. Open the crankcase drain, located underneath the engine, and let the oil flow into a pan or other receptacle. This should be done while the engine is warm. Close the crankcase drain, refill with fresh oil and replace the breather cap. Note the condition of the drained oil and change the oil filter element when the oil becomes discolored.

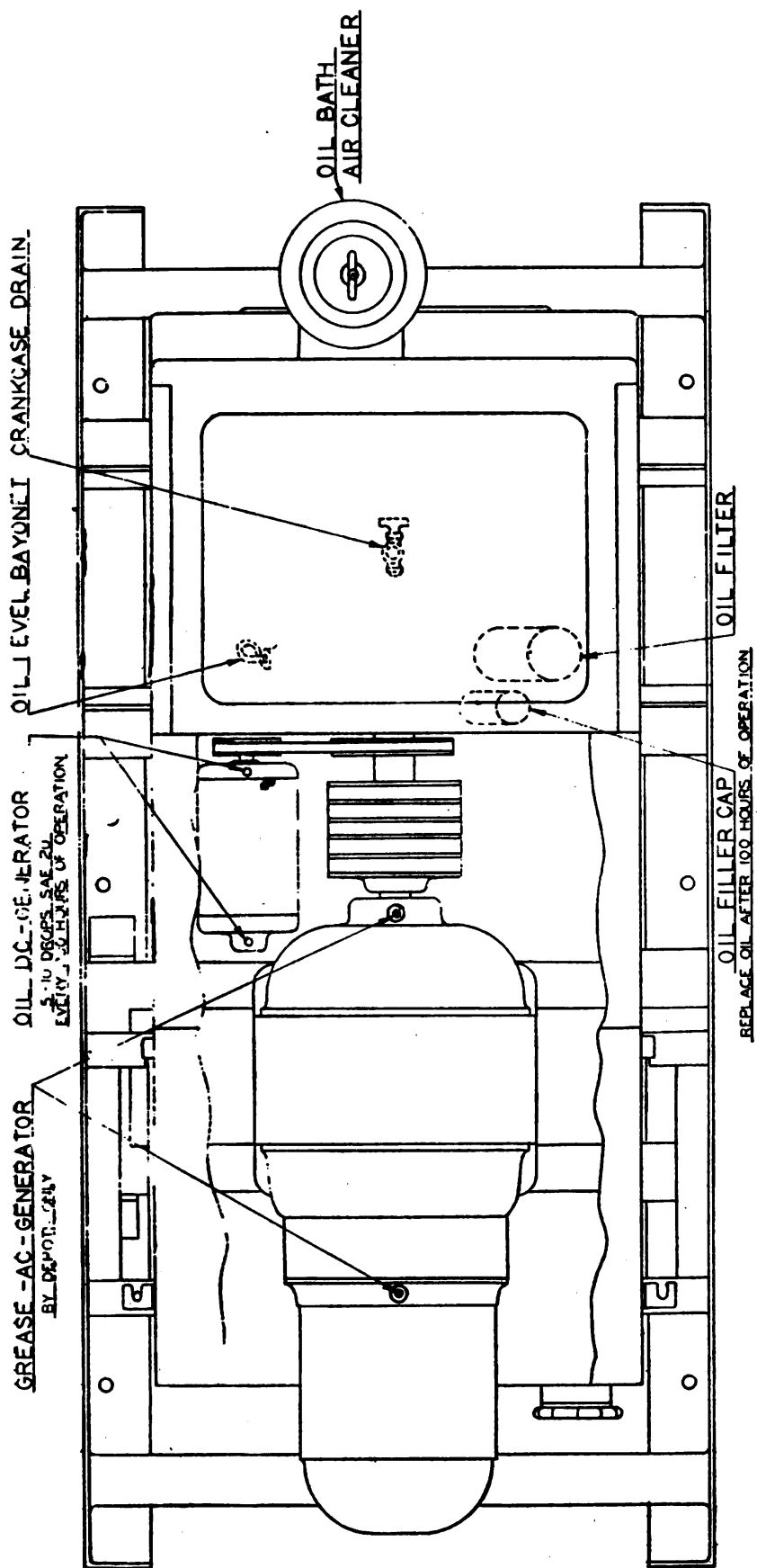

## LUBRICATION DIAGRAM

Figure 15.—Lubrication Diagram.

**POWER UNIT PE-99-F**

**15. Fuel.—a.** A good grade of fresh clean gasoline is recommended. Be sure that the small vent hole in the gasoline tank cap is not clogged up; air must enter the tank to allow the gasoline to flow to the carburetor. Test by blowing through the vent hole in the top of cap. Fuel pump line connections must be tight to prevent air-lock in the line.

**b. Avoid Gummy Gasoline.—TO AVOID TROUBLE FROM GUM FORMATION, KEEP THE TANK FULL WHEN NOT USING THE MOTOR.** If used only occasionally, drain tank completely and refill when motor is used again.

**c. Storage.—**Drain gasoline from tank and fuel filter bowl. Drain carburetor by removing plug, at bottom of bowl. Remove spark plugs and pour small quantity of oil into each cylinder through spark plug holes. Crank motor slowly by hand to spread oil. Replace spark plugs. Seal openings at oil filler pipe, exhaust, air cleaner and both sides of magneto.

**d. To Clean The Fuel Lines.—**Disconnect the gasoline line at the carburetor and also at the gas filter and fuel pump. Blow through the gas line to clear it. To clean the gas filter, first close the shut-off valve and loosen thumb screw. Remove and clean glass bowl, gasket and screen. Reassemble the gasoline filter using a new gasket if any leakage is noticed. Open shut-off valve to see if gasoline flows freely from the tank. **IMPORTANT:** If you find a gummy varnish-like substance, alcohol or acetone will dissolve it.

**16. Carburetor.—a. Description.—**The carburetor is of conventional float feed type. The float chamber is built concentric to the main discharge jet, and thus practically surrounds the main metering system with fuel. This permits a supply of gasoline to be present at the main discharge jet even though the motor is set at an angle. The float used is so constructed that two halves of the float operate on either side of the float chamber, and are connected by means of one and the same lever to the float needle valve. The float mechanism is of the hinge type which assures positive shut-off under all conditions. The carburetor is entirely sealed and all air for venting and bleeders is taken through the air horn.

**b. Adjustments.—**The engine is governor controlled. The mixture for normal speeds is controlled by a fixed metering jet and no adjustments are necessary.

(1) Fuel level—The gasoline level in the float chamber is properly preadjusted and should not be readjusted unless carburetor has been

SECTION IV

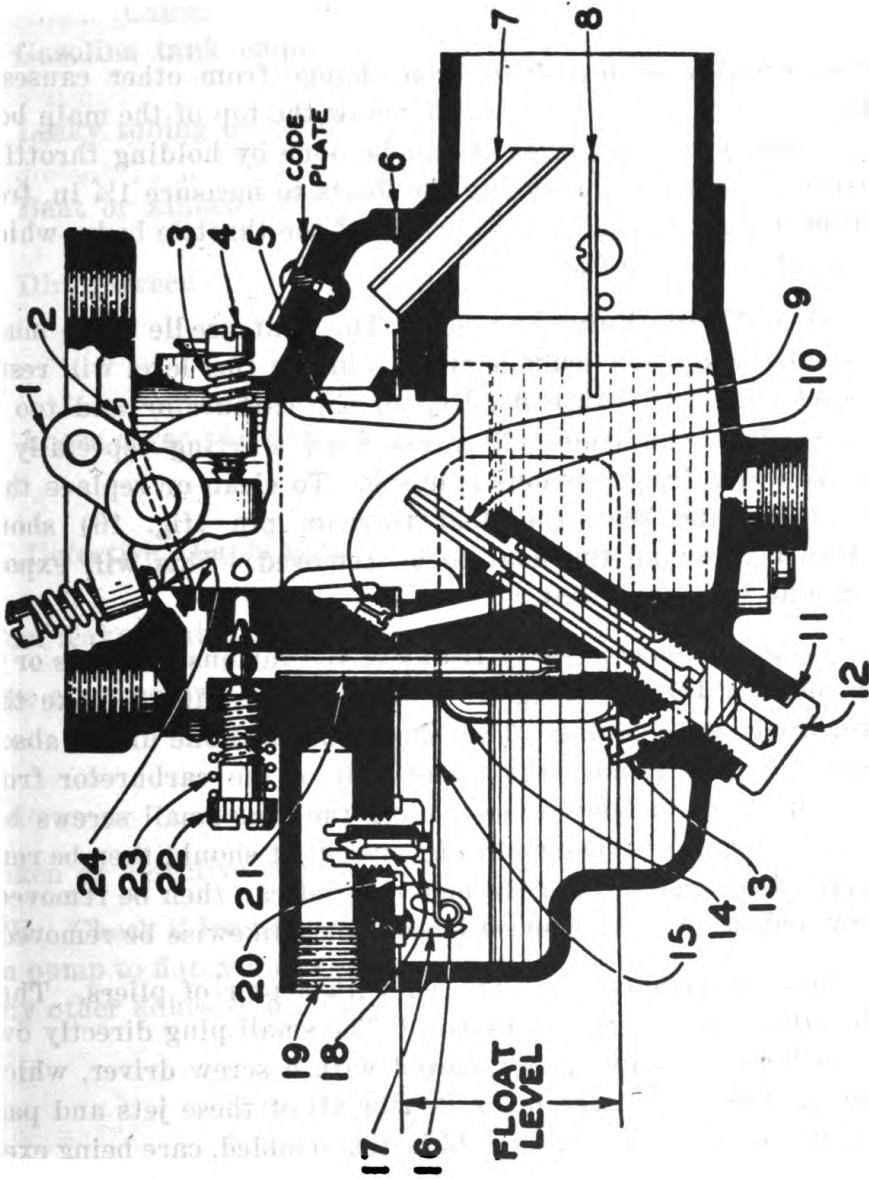

**PARTS  
ILLUSTRATED**

1. Throttle Lever
2. Throttle Valve Stop
3. Throttle Lever Stop Screw
4. Throttle Lever Stop Screw
5. Venturi
6. Main Body Gasket
7. Vent Tube
8. Choke Valve
9. High Speed Bleeder
10. Main Discharge Jet
11. Main Jet Plug Gasket
12. Main Jet Plug
13. Metering Jet
14. Float
15. Float Leve:
16. Float Fulcrum Pin
17. Float Hanger
18. Float Needle Valve & Seat
19. Gas Inlet
20. Float Needle Valve and Seat Gasket
21. Idle Tube
22. Idle Needle Valve
23. Idle Needle Valve Spring
24. Idle Discharge Holes

Figure 16.—Carburetor, Cross Section

**POWER UNIT PE-99-F**

handled roughly or level has been change from other causes. The level is set at  $15/32$  in. to  $17/32$  in. below the top of the main body. If it is necessary to reset level, it can be done by holding throttle body in inverted position and setting the floats to measure  $1\frac{1}{4}$  in. from the top of each float to the gasket surface of the throttle body, which will give the approximate fuel level.

(2) **Float Needle Valve and Seat** The float needle valve must seat needle-valve will cause leakage and too high a fuel level will result. A high fuel level will cause flooding of the carburetor and too rich a mixture. This condition will cause hard starting especially if the engine is warm from previous running. To clean or replace the float needle valve and seat, the float fulcrum pin (fig. 16) should be withdrawn, allowing the float to be removed. This will expose the float needle valve and seat.

*c. Cleaning Carburetor.*—(1) If any of the various passages or jets in the carburetor become clogged, it may be necessary to take the carburetor apart for cleaning. This should not be done unless absolutely necessary. First remove the upper half of the carburetor from the lower half, or main body, by removing the four small screws holding these parts together. The main high-speed jet should then be removed. The main discharge jet and the metering jet can then be removed with a screw driver. The high-speed bleeder may likewise be removed.

(2) The idler tube can be removed with a pair of pliers. The idler needle valve can be removed by hand. The small plug directly over the idler needle valve, should be removed with a screw driver, which will expose the idler discharge holes. After all of these jets and passages have been cleaned, the parts should be reassembled, care being exercised that all gaskets are replaced and if necessary new gaskets used. Unless personel doing this work are thoroughly familiar with carburetor construction, it is advisable to replace the various jets as they are removed and cleaned. This will prevent mistakes in reassembly.

**17. Fuel Pump.**—Fuel pump repairs are divided into two classifications: Repairs which can be made without disturbing the pump installation and repairs which necessitate removal and dis-assembly of the pump.

*a. Repairs made without disturbing pump installation:*

(1) **Lack of Fuel at the Carburetor.**

Check as follows:

Cause	Remedy
Gasoline tank empty	Refill
Leaky tubing or connections	Replace tubing & tighten all pipe connections at the fuel pump and gasoline tank.
Bent or kinked tubing	Replace tubing.
Dirty screen	Clean the screen. Make certain that cork gasket, S, is properly seated when reassembling.
Loose cover plate cap screw.	Tighten cover plate cap screw, Q, securely, replacing cover plate cap screw gasket, R, if necessary.
Defective Diaphragm.	Replace diaphragm or fuel pump.

(2) Fuel leakage at edge of diaphragm

Loose cover screws.	Tighten cover screw, G, alternately and securely, also check inlet and outlet connections.
Broken or defective gasket.	Replace gasket.

NOTE: Check if leak occurs at pipe fittings thus allowing fuel to run down pump to flange and appear to originate there. Do not use shellac or any other adhesive on diaphragm.

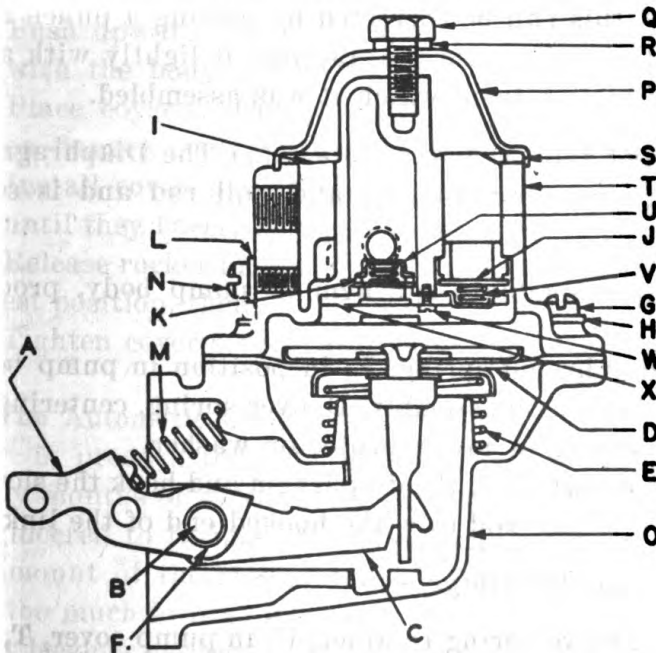

Figure 17.—Fuel Pump - Details

*b. Repairs which necessitate removal and dis-assembly of the pump:*

## (1) Fuel Pump Trouble Chart

Trouble	Evidenced by	Remedy
Broken rocker arm.	Visible	Replace rocker arm, A.
Broken rocker arm spring	Visible	Replace rocker arm spring, M.
Defective or worn links	Pump does not supply sufficient fuel.	Replace links, C.
Broken diaphragm return spring	Does not supply to carburetor.	Replace spring, E.
Punctured or worn out fuel pump diaphragm	Fuel leaking through hole in body.	Replace diaphragm assembly, D.

Important: Mark the cover T and body O with a file before dis-assembly so that in re-assembling they are placed back in the same relative position.

*c. Procedure in Assembling.*—Body, rocker arm and link Assembly.—Assemble link, C, rocker arm, A, and rocker arm spring, M, in body O. Insert rocker arm pin, B, through hole in body, engaging link and rocker arm. Use a punch and “stake” die cast metal of body over end of pin in one place on each end, to retain in place.

Note: It has been found that the assembly of the rocker arm pin can be simplified by first assembling a piece of .240” drill rod through the rocker arm pin hole in one side of the body far enough to engage the rocker arm and link, then insert rocker arm from the opposite side, pushing out the drill rod until the pin is in proper position. If after assembling the rocker arm pin it is found that the rocker arm or link does not work freely, this can be corrected by placing a punch against the opposite end of the rocker arm pin, tapping it lightly with a small hammer in reverse direction from which it was assembled.

*d. Diaphragm and Pull Rod Assembly.*—(1) The Diaphragm is an assembly including protector washers and pull rod and is serviced as a unit.

(2) To correctly assemble diaphragm in pump body, proceed as follows:

- (a) Place diaphragm spring, E, in position in pump body, O.
- (b) Place diaphragm assembly, D, over spring, centering upper end of spring in lower protector washer.
- (c) Press downward on the diaphragm and hook the slot in the diaphragm pull rod over the hooked end of the link.

*e. Valve and Cover Assembly.*—

- (1) Place outlet valve spring retainer, U, in pump cover, T, taking care not to bend or distort legs of retainer.

## SECTION IV

- (2) Place valve plate gasket, K, in position.
- (3) Place outlet valve spring, V, in position in spring retainer.
- (4) Place outlet valve, J, on spring.
- (5) Place inlet valve, J, on valve seat.
- (6) Place valve spring, V, on center of inlet valve.
- (7) Assemble inlet valve retainer, U, in valve plate, X, taking care that shoulder of retainer fits down flush in depression in plate.
- (8) Place valve plate, X, in position and secure with 3 screws, W. Inlet valve spring, V, must be centered properly in spring seat in valve plate and outlet valve must be seated properly against valve seat in valve plate.
- (9) Place strainer screen, I, in position on top of cover, making certain that it fits snugly around the gasoline inlet and edges of cover.
- (10) Assemble cork gasket, S, in cover plate and install cover plate on top of cover assembly. Make certain that gasket seats properly and strainer screen is not wrinkled or distorted.
- (11) Place fibre washer, R, on cover plate cap screw, Q, then insert and tighten screw securely.

*f. Cover Assembly.—*

- (1) Push upward on rocker arm, A, until diaphragm, D, is level with the body flange.
- (2) Place cover assembly in proper position designated by mark on flanges made before dis-assembling the pump.
- (3) Install cover screws, G, and lockwashers, H, tightening only until they barely engage lockwashers.
- (4) Release rocker arm which will place the diaphragm in its highest position, then - -
- (5) Tighten cover screws alternately and securely.

18. **The Automatic Choke.**—*a.* The Automatic Choke thermostat assembly is preadjusted and under ordinary circumstances it will give many months of satisfactory service. The heating elements have been engineered to furnish the proper amount of heat to provide the proper amount of thermostat tension for choking and, likewise, not produce too much heat so as to cause the choke valve to open too fast. Should it become necessary to replace the thermostat unit, the whole

## POWER UNIT PE-99-F

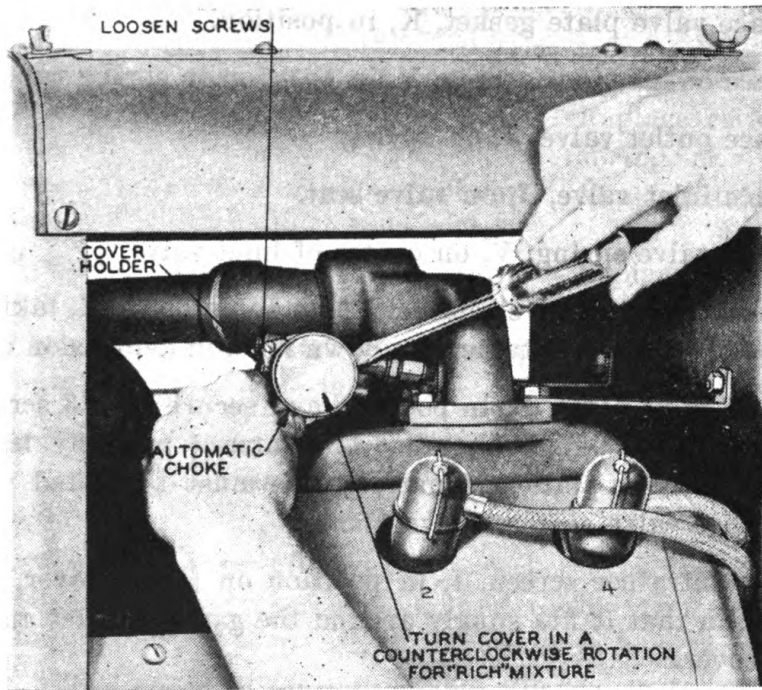

Figure 18.—Adjustment of Automatic Choke

assembly should be renewed since thermostat spring is included in thermostat assembly as a single unit and replacement of the thermostat spring alone is not recommended.

*b. Thermostat Setting.*—When replacing the thermostat unit the loop of the thermostat spring must be placed over the pin of the vacuum piston, link and lever assembly. (THIS OPERATION IS VERY IMPORTANT, SINCE IT IS NECESSARY THAT THE LOOP OF THE THERMOSTAT BE INSTALLED PROPERLY IN RELATION TO THE PIN OF THE VACUUM PISTON LINK AND LEVER TO OBTAIN THE CORRECT AUTOMATIC CHOKE PERFORMANCE.) After the thermostat assembly has been assembled to the automatic choke housing, the thermostat cover should be rotated in the right direction or counter-clockwise until the marking (\*) coincides with the projection at the top of the thermostat housing.

*c. Disassembly.*

- (1) Disconnect the vacuum line from the automatic choke.
- (2) Remove thermostat cover screws and "lug" washers. Thermostat cover assembly can then be taken off the choke housing.
- (3) Loosen locknut and remove lock washer.

## SECTION IV

- (4) Remove vacuum piston assembly from housing.
- (5) With a clean rag saturated with acetone or alcohol, thoroughly clean the cylinder walls, removing any foreign material which may have accumulated. Blow out all of the channels with compressed air.

*d. Reassembly.—*

- (1) Place vacuum piston in cylinder with slot on piston assembly down. **THIS IS IMPORTANT. DO NOT USE ANY TYPE OF LUBRICANT ON PISTON OR IN CYLINDER.** Place lever on choke stem and put on the lockwasher and locknut, fasten the nut securely.
- (2) Adjust as instructed in subparagraph b.

19. **Governor.**—*a.* The motor speed is automatically maintained at about 2,200 rpm under varying loads by a centrifugal governor, operated from the cam gear. This centrifugal flyball governor, which is bolted to the timing gear case, automatically controls the engine speed varying the throttle opening through suitable linkage to suit the load.

*b.* The linkage between the governor and the carburaetor must be properly connected. The governor level has just sufficient travel to give full movement to the carburetor throttle lever from open to closed position. When engine is stopped, the governor level position corresponds to wide open throttle position.

*c.* The governor was carefully preadjusted to maintain normal speed under load. Do not re-adjust unless absolutely necessary. It can be changed by reducing or increasing the tension of the governor spring. Turn inner governor spring rod adjustment nut to the right or clockwise to increase engine speed and voltage; to left or counter clockwise to reduce engine speed and voltage.

*d.* Be sure to tighten outer nut after making adjustment.

20. **The Ignition System.**—*a. Application.*—The magneto is designed and built for use with these engines, which have a firing interval of 180° cylinder 1 to 3, -270° cylinder 3 to 4, -180° cylinder 4 to 2, -90° 2 to 1. To provide this timing, the magneto has a four-pole magnetic rotor with a four-lobe cam. Four sparks are produced per revolution of the rotor, which runs at crank-shaft speed. In a complete cycle (two

**POWER UNIT PE-99-F**

revolutions), four sparks are used for ignition and four occur on the exhaust stroke. The magneto has a standard SAE flange mounting, but a special coupling and gear drive arrangement which requires an extended rotor shaft.

*b. Service Procedure.*—Do not dismantle the magneto unless it has been positively ascertained that the ignition spark produced is unsatisfactory. This condition may be determined through ignition spark tests which are easily made on the field. See sub-paragraphs c and d.

*c. Testing the Ignition Spark.*—To check if a satisfactory spark is being delivered by the magneto, remove the ignition cable from the plug. Hold ignition cable terminal about  $\frac{1}{8}$ " from any metal part of the cylinder head (keep hand on insulated part of the cable to avoid a shock). Turn motor with starter and if the spark jumps this gap, the entire ignition system with the exception of the spark plug is o.k. Check spark plug and replace if necessary. If no spark occurs, check cable, and refer to magneto adjustments. Ignition tests made while any part of the system is wet are useless.

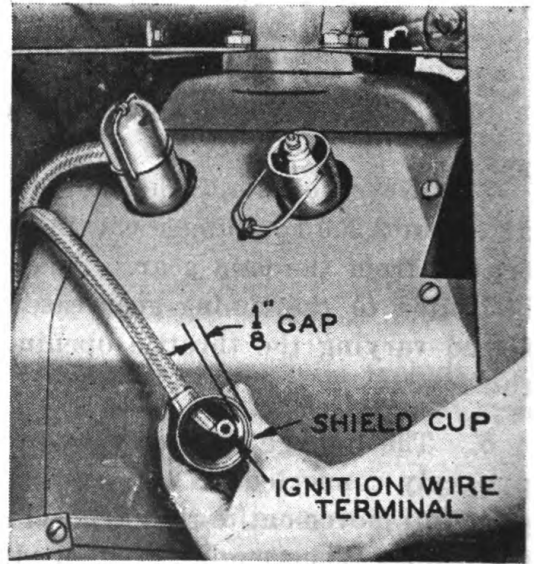

Figure 19.—Testing Ignition Spark

*d. Testing the Magneto.*—Pull the ignition cables out of the magneto end cap sockets and insert a short, stiff wire in one of the sockets. Bend this wire to within  $\frac{1}{8}$ " of the engine block. Turn the engine over slowly and watch carefully for the spark discharge which should occur at the instant the impulse coupling releases. The test should then be repeated for each of the remaining terminals. It is highly recommended that, when a strong spark is observed, no dismantling of the magneto takes place and that cables, terminals and spark plugs be thoroughly inspected. If no spark is observed the AUTOMATIC-MANUAL STARTING switch should be first carefully examined to be certain it has not become accidentally closed (the magneto shorted).

*e. Distributor Cover Removal.*—In removing the distributor housing cover, care must be taken not to damage the gasket attached to the

## SECTION IV

cover side of the joint. The distributor compartment should be thoroughly cleaned and the air inlet and outlet passages cleared. Examine the high tension lead brush and replace, if noticeably worn or damaged. This brush should move freely in its holder and should have a slight spring pressure.

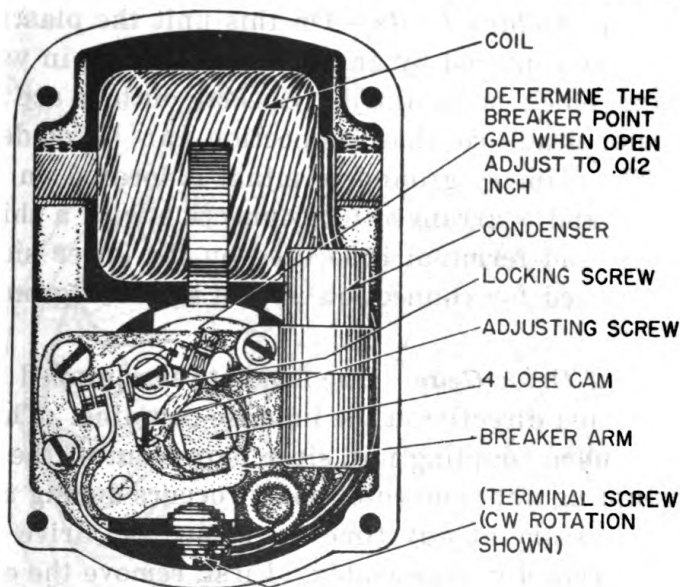

Figure 20.—Magneto Point Adjustment

*f. Service of Breaker Contact Points.*—Contact point adjustment necessitates removal of the distributor housing which has a sealed gasket joint with the metal housing. The contact points should be examined for evidence of pitting or pyramiding. A small tungsten file or fine stone may be used to resurface the points. If the points are worn or badly pitted, they should be replaced. Points should be adjusted to have a .012 inch gap at full separation. Adjustment is made by loosening the round-head locking screw at the upper end of the stationary point bracket (figure 20) then turning the eccentric head adjusting screw until the proper gap is obtained, and locking the assembly by tightening the round head screw.

*g. Precautions.*—Do not oil or grease the bearings or cam of the magneto as the design eliminates the necessity of field lubrication. The cam felt wick should be replaced by a new impregnated wick if dry or hard. Coil and condenser replacements, while simple, are not recommended unless test equipment is available. Under no circumstance should any attempt be made to remove the magnetic rotor from the housing as it is locked in a special drive and thrust bearing and specific instructions must be carefully followed in releasing the shaft.

## POWER UNIT PE-99-F

When replacing the distributor housing a new gasket should be provided, the joint cleaned thoroughly and the new seal coated with sealing varnish.

*h. Radio Shielded Units.*—On this unit the plastic distributor cap and cover are replaced by an all metal housing in which an insulated distributor block is mounted. Special outlets are provided for the high tension leads so that connection can be made to the shielded cables. The primary ground terminal is located on the lower side of the end cap and is arranged for connection with a shielded cable. The primary ground terminal is located on the lower side of the end cap and is arranged for connection with a shielded ground cable.

*i. Special Drive Gear.*—The magneto is equipped with special drive gears, mounted directly on the impulse coupling. The gear is a slip fit on the extended coupling nut, since movement of the gear with respect to the coupling nut (and rotor shaft) occurs during the impulse period. If it is necessary at any time to remove the drive gear, special care must be exercised in reassembly. First, remove the entire end cap and turn the rotor until the contact segment is in firing position for No. 1 cylinder (fig. 21). With the rotor in this position, fit the gear to the coupling lugs so that the prick punch mark on the rim of the gear is in the position shown (fig. 21).

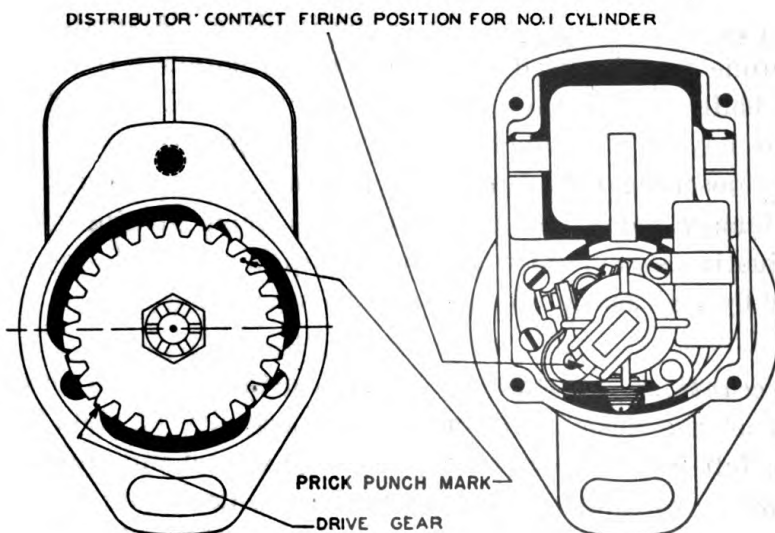

Figure 21.—Drive Gear Marking and Assembly

SECTION IV

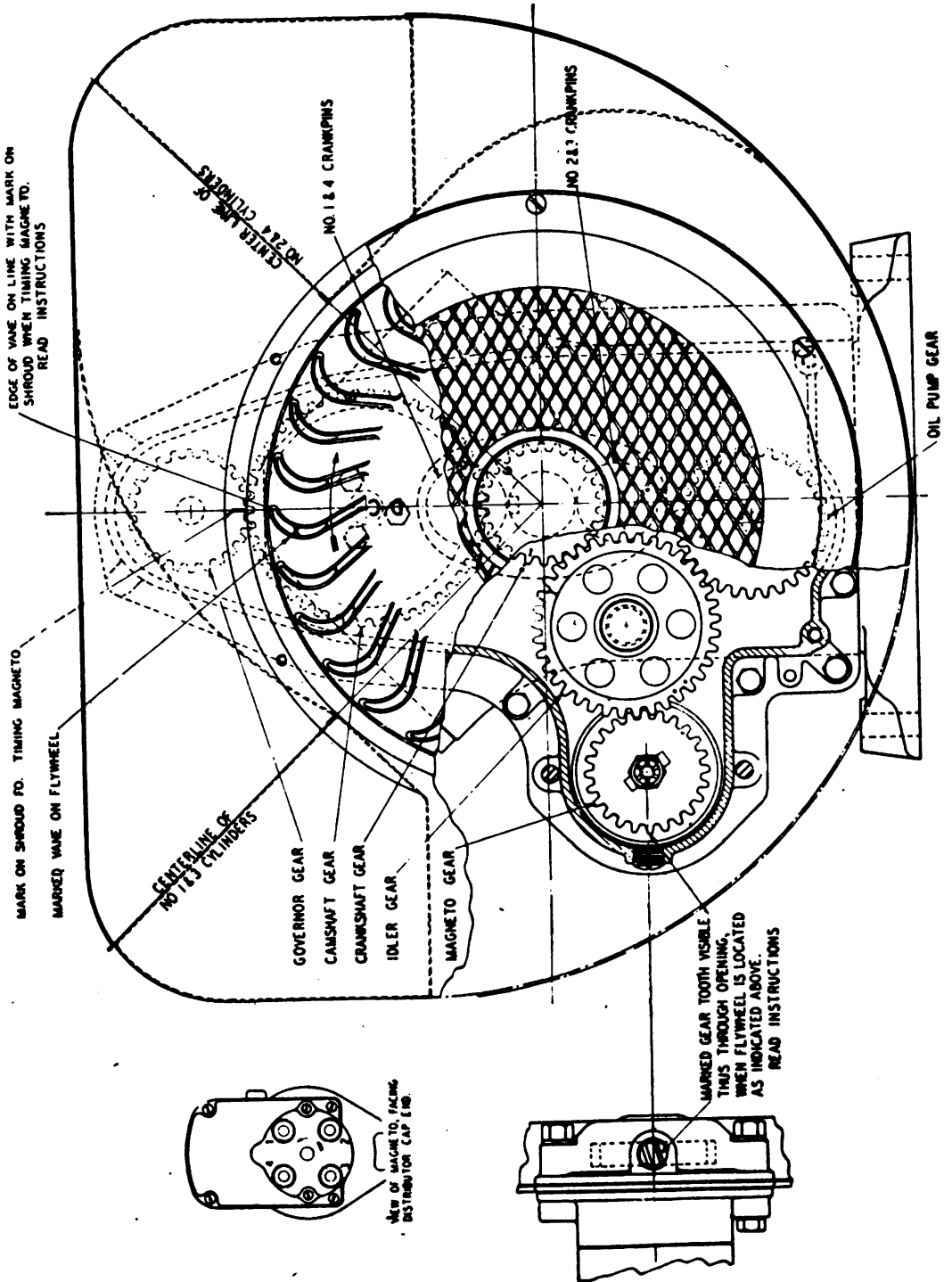

Figure 22.—Timing Diagram

**POWER UNIT PE-99-F**

**21. Firing Order.**—*a.* The firing order of the cylinders is 1—3—4—2. Number 1 cylinder is the one nearest to the flywheel in the left bank of cylinders, when viewed from the flywheel end of the engine. Number 3 cylinder is the other cylinder in the left bank. Number 2 cylinder is the one nearest to the flywheel in the right bank of cylinders and Number 4 is the other cylinder in the right bank. The cylinders are numbered 1 to 4 on the air shroud near the spark plugs. The flywheel end of the engine is designated the front end, and the power take-off end, the rear end of the engines.

*b.* As these engines are of the V type, the interval between firing of cylinders is as follows: Crankshaft rotation between firing of the cylinders No. 1 and No. 3 is  $180^{\circ}$ ; between No. 3 and No. 4 is  $270^{\circ}$ ; between No. 4 and No. 2 is  $180^{\circ}$  and between No. 2 and No. 1 is  $90^{\circ}$ .

**22. Magneto Timing.**—If it is necessary to retime the magneto, the following instructions will be helpful:

*a.* First, remove the screen over the flywheel air intake opening by taking out the six screws holding the screen in place. This will expose the mark on shroud for timing magneto. See timing diagram, figure 22.

*b.* Next remove the spark plugs from the cylinders. Then turn engine over slowly with the starting crank until the compression in Number 1 cylinder blows the air out of the spark plug hole.

*c.* The flywheel is marked with the letters "DC" near one of the air circulating vanes. This vane is further identified by a mark cast on the end. (See figure 22). When the air blows out of No. 1 spark plug hole, continue turning the starting crank until the edge of the marked vane on the flywheel is on line with the top center. The keyway at take-off end of the crankshaft is also on top.

*d.* The magneto should then be fitted to the engine so that the marked tooth on the magneto gear is visible through the opening in timing gear housing as shown on timing diagram (figure 22). The distributor cap on the magneto is numbered from 1 to 4. The leads from the magneto should be connected to spark plugs of like numbers, according to the engine fire number.

**23. Spark Plug Adjustment.**—Spark plugs should be cleaned and points reset to .025 in. after each 50 hours of operation. The porcelain is to prevent the spark from jumping anywhere except at the gap, and if cracked or broken, it will prevent the plug firing. Water on the outside of the spark plug may permit the high voltage current to leak

## SECTION IV

over the surface of the porcelain. Dirt or carbon on it will do the same thing. Clean the spark plug by washing off the carbon with gasoline or use fine sandpaper. Points should be scraped or sand papered. Always keep spare plugs on hand. When re-assembling spark plugs to cylinder heads, put a little mica grease on the threads. Do not get grease on points. The spark plug is shielded to prevent radio interference.

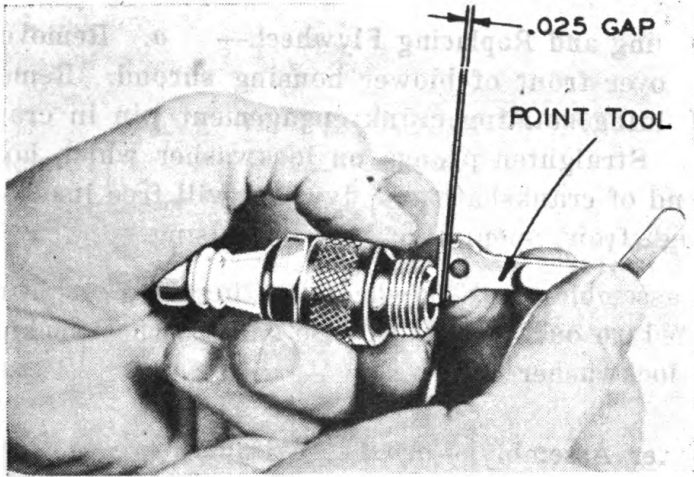

Figure 23.—Adjusting Spark Plug

**24. Ignition Cable.**—The spark plug cable insulation must not be broken, or soaked with oil or water, grounded in any way where it touches the motor, or it will interfere with good ignition. The cable is shielded to prevent radio interference.

**25. Electric Starter.**—The starter should be checked over at regular intervals. A thorough inspection will include the removal of the starter from bellhousing, removal of commutator cover band and removal of brushes. When the brushes are removed, the commutator should be cleaned.

**26. Battery Charging Generator.**—*a. General.*—The battery charging generator is of the ordinary 12 volt automotive type. The generator has a hinge-type mounting and the belt tension is adjusted by loosening the screw which holds it to the adjusting bracket and pulling the generator outward. To replace the battery-charging generator belt, remove the main generator drive belts and place new belt over engine drive pulley and then replace the main generator drive belts.

*b. 300 Hour Complete Overhaul.*—To completely overhaul the generator it should be removed from the engine and taken to the bench.

- (1) Remove the head band.
- (2) Remove the drive pulley and nut. To remove the pulley

**POWER UNIT PE-99-F**

use a press or puller. Be careful not to damage the pulley or end head.

- (3) Remove the two frame screws at the commutator end and slide the commutator end plate off of the armature shaft. Disconnect the leads at the brush.
- (4) Lift the drive end and armature out of the frame and field.
- (5) Press the armature shaft out of the drive end head.

**27. Removing and Replacing Flywheel.**— *a.* Remove expanded metal cover over front of blower housing shroud. Remove headless set screw holding starting crank engagement pin in crankshaft and remove pin. Straighten prongs on lockwasher which holds flywheel nut. Tap end of crankshaft and flywheel will free itself. Remove flywheel through front opening of blower housing.

*b.* To reassemble place flywheel key in place on crankshaft and reverse procedure outlined above. Be sure flywheel locknut is locked in place by lockwasher.

**28. Cylinder Assembly.**— *a.* The cylinders are cast in pairs of a special alloy iron. Two cylinder heads are fitted. The heads are made of an aluminum alloy especially suited to this kind of service. Both heads and cylinders are provided with ample cooling fins so that the engine will not overheat when operating at full load in the hottest weather.

*b.* When the cylinder heads have been removed for the purpose of cleaning carbon or grinding valves, care should be used in replacing them. Use new gaskets if possible. Otherwise clean the old ones and coat both sides with cup grease. The use of shellac on cylinder head gaskets is not recommended. Tighten each cap screw a little at a time so that the cylinder heads are pulled down evenly. Screws need be only moderately tight.

**29. Compression.**— Proper compression is obtained when valves seat properly, gaskets do not leak and piston and rings are properly fitted. When tuning up a motor, it is always well to check compression. This is done by turning the motor over quickly by hand. If turned slowly sticky valves may not be detected. If a point of resistance is offered every half revolution, compression should be satisfactory. If motor turns over without compression resistance for a full cycle, it is possible that a worn piston or piston rings, leaky valves or leaky gaskets are present. See that spark plugs have a gasket under them and are drawn up tight. Also check cylinder head gaskets and tighten cylinder head bolts.

## SECTION IV

30. **Valve Adjustment.**— *a.* To check valve clearance remove valve cover plate. The correct clearance on the exhaust valve is .012". The clearance of the intake valve is .010". These clearances to be adjusted when motor is cold. Tappet clearance is adjusted by means of adjusting screws on the mushroom type tappets. End of stem must be square with stem proper.

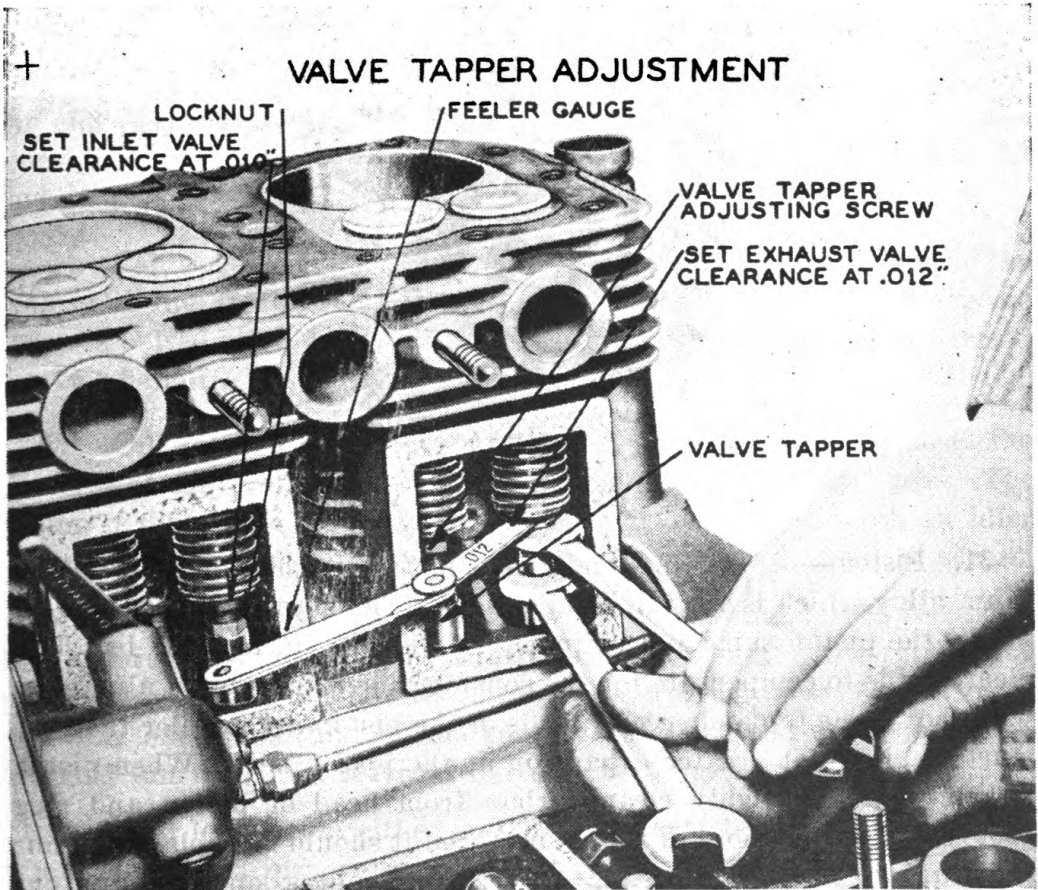

Figure 24.—Valve Tapper Adjustment

*b.* To reset valves, grind in the same manner as automobile valves. If valves stick, remove gum, lead, or carbon with alcohol or acetone and clean valve stems thoroughly with wire brush or emery cloth. Also scrape all carbon from other valve parts.

*c.* Valve timing is accomplished through the camshaft gear train, driven off the crankshaft. These gears are properly meshed when the

**POWER UNIT PE-99-F**

marks on the gears line up with the marks as shown on timing diagram, (figure 22).

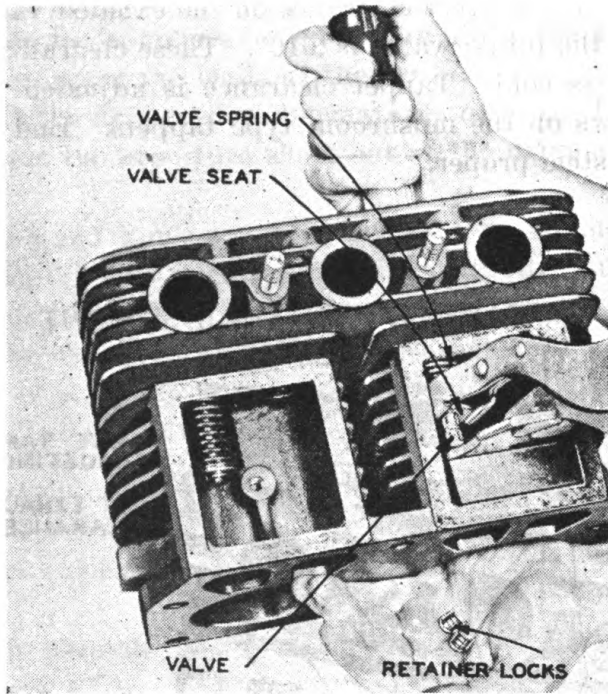

Figure 25.—Removing Valves

31. **Piston.**—*a.* The piston in this motor is made of lynite aluminum alloy which is very light in weight. The standard clearance between the piston skirt and cylinder wall is .003 in. to .0035 in. This clearance is to compensate for the considerable expansion of aluminum when hot. The top and second lands of the piston are smaller than the skirt to allow for greater expansion at the piston head. When piston is removed, thoroughly clean carbon from head of piston and ring grooves. If piston is out of round or scored it should be replaced. Four rings are fitted to each piston. Three are compression rings and one is an oil regulating ring. Note: If piston is badly worn or out of round, check the cylinder bore and if it also shows excessive wear, have it rebored or install a new cylinder before fitting a new piston.

*b. Piston Rings.*—The piston rings, when fitted in the cylinder, should have a gap of .007 in. The rings should be fitted in the cylinder within the piston ring travel. Before assembling new rings to piston be sure that piston ring grooves are thoroughly cleaned and rings move in grooves freely.

*c. Piston Pin.*—The piston pin is a slip fit in the piston. To remove it from the piston, first remove the lock rings, then slip pin out of piston.

## SECTION IV

**32. Connecting Rod.**—The connecting rods, on the crankshaft ends, are direct babitted and fitted with laminated shims. The upper end of the rods are fitted with hard bronze bushings. The oil streams from the oil spray nozzles must strike the fins on the connecting rod caps about 3/16 in. from the low end. If these oil streams strike the fins or connecting rods higher up, the cylinder will receive too much oil.

**33. Crankshaft.**—The crankshaft is carried on two roller bearings. The cones are a tight press fit on the crankshaft. The outer race or cup of the bearings at the power take-off end of the engine is carried in a plate bolted to the crankcase. Under this plate several shims are fitted for adjusting the bearings. The bearings properly fitted have no end play when engine is cold. It is seldom necessary to readjust these bearings for wear, and then the work should be done only by qualified personnel.

**34. Camshaft.**—The camshaft is made of a special alloy with the cams and fuel pump eccentric an integral part of the shaft. The driving gear is bolted to a flange by three bolts, and the camshaft is carried on two babbitted bearings.

**35. Oil Pump.**—*a.* The oil pump is of the gear type located in the bottom of the crankcase and extending down into the oil pan. The pump is driven by helical gears from the crankshaft through an idler gear. The suction opening in the oil pump is protected by an oil screen.

*b.* Lubrication is by a combination of splash and forced feed. The oil is forced by the oil pump into a header extending the full length of the crankcase. Four nozzles in this header direct oil streams against the fins on the bottom of the connecting rods, and the spray thus formed lubricates all internal parts of the engine.

*c.* If oil leaks from either end of crankshaft bearings, remove base from motor and inspect the oil seals. Replace the seals if necessary.

**36. Carbon.**—Excessive carbon is caused by too much oil, usually the result of piston rings not seating properly or sticking, carburetor set too rich, or wear from long service. An unusual amount of carbon is indicated by motor knocking or loss of power. Occasionally, remove carbon from valves, valve ports, piston head, piston rings and ring grooves, cylinder head and top of cylinder bore.

**37. Air Cleaner.**—Clean the air cleaner occasionally by removing it and washing it in Diesel oil. Test it to see if it is clogged by blowing through it or noting if motor performs better with it off. If clogged, it should be replaced. Keep the oil level up to the beading. See instructions on air cleaner label.

38. **Muffler.**—After long periods of service it is possible that the muffler will become clogged to the point where it will affect the motor's power. To check the muffler, unscrew it from the motor and run water into the open end of the muffler. If full streams of water come out of the other end of the muffler, you will know that it is not clogged up and need not be replaced.

39. **Overhauling.**—*a.* Power Unit PE-99-F should be overhauled about every 1000 hours of operation. Follow previous instructions given as to proper methods of assembly.

*b. Clearances:*

Connecting Rod Clearance	.001 - .002
Piston Pin Clearance	.0005 - .001
Camshaft	
Small Bearing Clearance	.002 - .004
Large Bearing Clearance	.002 - .0035
Valve Stem Diameter	.003 - .005
Tappet Stem Diameter	.0005 - .0025
Tappet Clearance	
Cold Inlet	.010
Cold Exhaust	.012
Idler Gear	.0005 - .002
Spark Plug Gap	.025
Magneto Breaker Point Opening	.012
Piston Clearance	.003 - .0035
Firing Order:	1—3—4—2
Interval of Firing:	
No. 1 to No. 3 cylinder	- 180°
No. 3 to No. 4 cylinder	- 270°
No. 4 to No. 2 cylinder	- 180°
No. 2 to No. 1 cylinder	- 90°

40. **Dis-Assembly and Assembly of Connecting Rod, Piston, Etc.—**

*a.* Remove the top and rear panels before attempting to work on the engine.

*b.* Remove bottom cover.

*c.* Remove cylinder shroud cover and cylinder heads.

*d.* Through the bottom opening of the crankcase, the connecting rod bolt nuts can be removed which will permit the removal of connecting rod caps. The piston and connecting rod assembly can be pushed out through the top of the cylinder bore. This can be done without removing engine from base.

- e. To remove the piston from the rod, remove piston pin snap rings and drive out piston pin.
- f. Re-assemble in the reverse manner.
- g. Observe the following clearances for correct assembly:
 

Piston clearance in the bore for cast iron pistons (This is measured at the bottom of the skirt)	.003	.0035
Crank Pin	.001	.002
Connecting rod, piston end	.0005	.001
Connecting rod side clearance	.004	.011

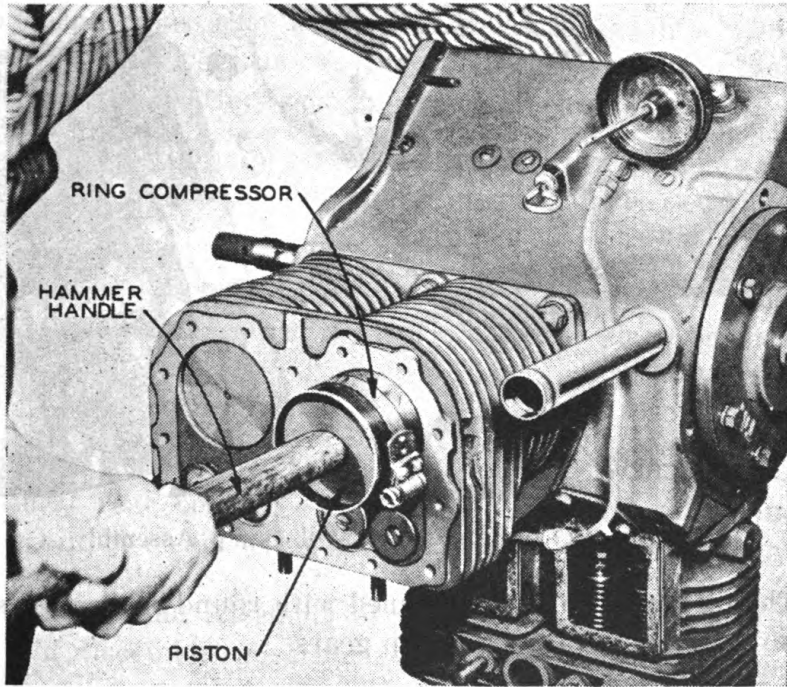

Figure 26.—Inserting Piston in Cylinder

- 41. Dis-Assembly and Assembly of Oil Pump.—a. Remove flywheel.
  - (1) Remove set screw and drive out crank pin.
  - (2) Remove flywheel nut.
  - (3) With a babbitt hammer or brass bar, hit the crankshaft a sharp blow to loosen the flywheel which fits on a taper. An ordinary hammer may be used with a hardwood block held against the shaft to receive the blow.
- b. Remove flywheel shroud and gear cover.
 

Before the gear cover is pulled off the shaft, be sure to remove flywheel key.
- c. Remove oil pump gear by loosening nut which is locked in place with a cotter pin. The oil pump gear drives the oil pump shaft by means of a woodruff key. After the nut is removed, the gear can be pulled off.

**POWER UNIT PE-99-F**

*d.* To remove the oil pump from the crankcase, remove screw through hole in engine support and withdraw the oil pump assembly through the crankcase opening. The oil pump is fitted into a bored opening in the crankcase and is held in proper location by set screw.

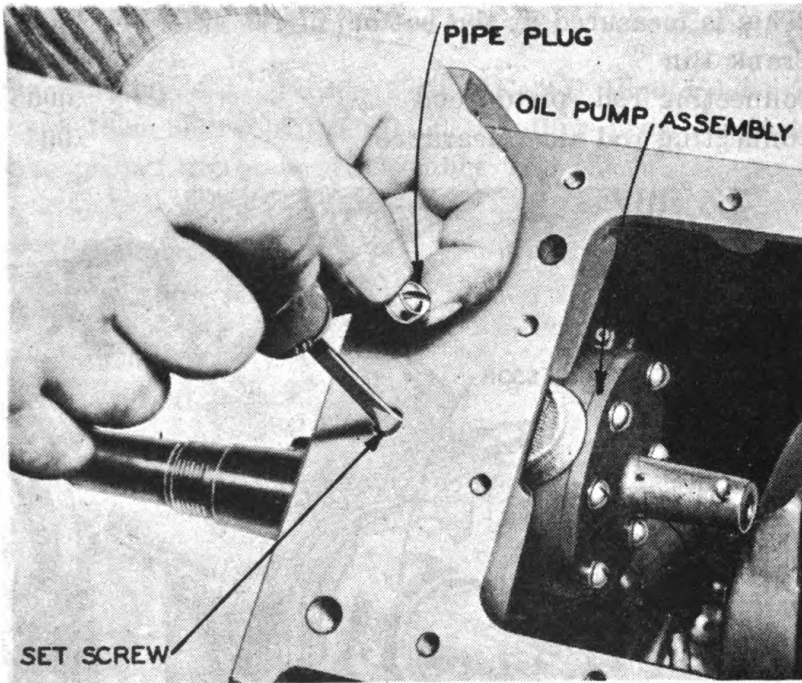

Figure 27.—Removal of Oil Pump Assembly

*e.* The oil pump cover is fastened with round-head screws that can be removed to expose the oil pump gears.

*f.* The idler gear fits over the idler gear pin.

*g.* A relief valve is built into the oil pump cover. The relief valve ball is held in position and holds pressure by means of spring.

Be sure in re-assembly that this relief valve functions.

*h.* To re-assemble, follow the reverse procedure.

*i.* The oil pump gears should have .002-.0035 in. clearance in the bore.

**42. Dis-Assembly and Assembly of Cylinders.**— *a.* Remove governor rod, gasoline connection and choke connection to carburetor.

*b.* Remove nuts on studs and lift off manifold assembly with carburetor.

*c.* Remove nuts on studs and remove manifold to cylinder block.

*d.* Remove cylinder hold-down stud nuts and remove the entire cylinder block and valve assembly.

## SECTION IV

e. The valve can be removed by removing wedge keys and spring retainer after valve chamber cover plate has been removed.

f. Re-assemble in the reverse order.

g. Observe the following clearances for correct assembly:

Valve stem clearance	.003 - .005 in.
Tappet clearance cold exhaust	.012 in.
Tappet clearance cold inlet	.010 in.

43. Dis-Assembly and Assembly of Camshaft.— a. The tappets will have to be held up so they will clear the camshaft lobes. The camshaft, and camshaft drive gear can then be withdrawn from the gear cover end of the engine after removing the fuel pump.

b. To remove the fuel pump, remove the two hollow-head cap screws holding the fuel pump adapter and fuel plunger in place and lift same out.

c. Re-assemble in the reverse order, being sure that the camshaft thrust pin and camshaft thrust pin spring are in place before gear cover is re-assembled.

d. The following clearances should be observed for correct assembly:

Camshaft front bearing	.002 - .0035 in.
Camshaft rear bearing	.002 - .0035 in.
Valve tappet clearance in crankcase	.0005 - .0025 in.

44. Dis-Assembly and Assembly of Governor.—a. Remove oil line to governor and disconnect governor rod and governor spring.

b. Remove governor housing cap screws to withdraw housing and cross-shaft assembly.

c. The governor gear and assembly can be withdrawn after the housing is removed.

d. The governor thrust bearing and thrust sleeve is an assembly and if replacement is required, it is to be handled as such.

e. Do not attempt to re-assemble parts in the field as this is very important for proper governor regulation.

f. To re-assemble, follow reverse procedure. Be sure that spring is connected exactly as before dis-assembly.

45. Dis-Assembly and Assembly of Crankshaft.—a. Bearing plate must be removed and, with flywheel and gear cover off and connecting rod dis-assembled, the entire crankshaft can be withdrawn through the bearing plate opening on the take-off end of the engine.

b. The roller bearing inner race is pressed on the crankshaft and the outer race into the bearing plate on the take-off end.

c. The outer race of the bearing on the cranking end is pressed directly into the crankcase and held in place by retainer ring.

d. If necessity requires replacement of bearings, the complete bearing should be changed and not only the inner or outer race.

e. To re-assemble, follow reverse procedure.

f. The crankshaft bearing should be fitted so the bearings have an end play of approximately .006 in.

(1) The amount of end clearance is governed by shims.

(2) By driving the crankshaft from one side to another, the end play can be easily felt.

**46. Adjusting A-C Generator Belt Tension.**—*a.* Adjust the main generator drive belts by means of the two adjustment bolts on the right side of the skid base. (The side to your right when facing the panel) Loosen the two jam-nuts below the adjustment support arms and turn the adjustment nuts (above the support arms) counter-clockwise (moving the wrench from left to right) to tighten the belts. Turn the adjustment nuts in the opposite direction to loosen the belts. Be sure to tighten the jam-nuts after the belt adjustment has been made, and be sure the engine and generator pulleys are in correct alignment.

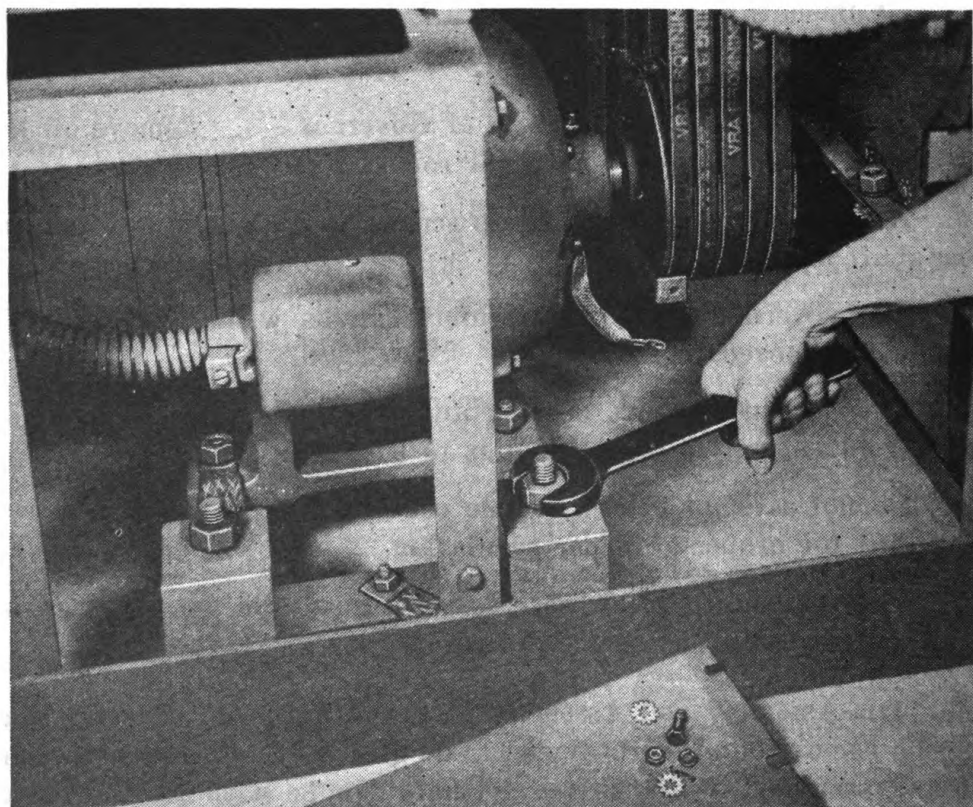

Figure 28.—Adjusting Drive Belts

## SECTION IV

b. When removing the drive belts or installing new belts, turn the jam-nuts all the way down and take up on the adjustment nuts (moving the wrench from right to left) as far as they will go. After installing the new belts, slack off on these nuts until the belt tension is such as to permit a half inch deflection when pressed with the thumb. This is the correct belt tension which should be maintained at all times.

47. **A-C Generator.**— *a.* To obtain maximum efficiency from the generator, attention must be given to the generator bearings, commutator and brushes.

b. The generator bearings must be greased with a semi-fluid grease at least once every 700 hours of service. Pressure lubricating-gun fittings are provided for filling the reservoirs. Where the plant is is being operated for long periods, as in continuous service, these points must be checked more frequently.

**KEEP THE UNIT CLEAN AND FREE FROM OIL AND DIRT TO AVOID THE POSSIBILITY OF FIRE.**

48. **General Description.**— *a.* *Power Generator* (figure 29)

(1) The alternating-current generator is a revolving field, semi-enclosed, drip-proof unit with two ball bearings and a direct-connected exciter. Full line voltage (120 volts) is on stationary winding.

(2) The four revolving generator field coils are not removable. Should it become necessary to replace them, a complete rotor assembly (632) which includes shaft, punchings, windings, fan and slip rings, should be installed as a unit. Generator stator coils are not easily rewound. When necessary to repair any major damage, a complete generator stator (601) (frame, punchings and windings) should be replaced. An approximate range of d-c excitation voltage on slip rings varies from 25 volts (generator cold and unloaded) to 125 volts (generator hot and carrying 25 per cent overload).

(3) Each generator bearing has an Alemite hydraulic pressure-gun grease fitting (608) and a grease pressure-relief plug on the under-side of machine (609).

*b. Exciter.*—The exciter is shunt wound and self-excited. The exciter frame (660) is bolted to the generator end shield (619), and its armature (668) is mounted on an extension of the generator shaft. Polarity (+ or -) of exciter brushes (671) is unimportant since the a-c generator does not operate in parallel with other generators. The exciter field coils were impregnated in position, are not removable.

Direction of rotation is counter-clockwise (CCW) facing commutator end of exciter.



## SECTION IV

**49. Care and Maintenance.**— Satisfactory performance of the generator-exciter unit depends upon the care and maintenance given to it.

*a. General.*— (1) Dust and dirt, particularly carbon dust, should be blown out of the windings, commutator, and especially the ventilating passages in the punchings at least once a week. Screened openings should be clear of debris that would hinder free passage of air. Remove grease and oil with carbon tetrachloride. In an emergency, a rag dampened with solvent can be used on the commutator or slip rings. Free liquid solvent should not be used as it is injurious to the impregnating varnish.

(2) If the generator gets wet with salt water or filled with mud, it should be flushed thoroughly with clean, fresh water. Be sure that the ventilating passages are open. After such washing, the unit should be dried out, preferably with warm air even though the operating voltage is relatively low and the windings are moisture resistant.

*b. Generator Slip Rings and Brushes.*— (1) It is important that the slip-ring brushes (649) are kept in good condition and seated properly on collector rings (640) with approximately a 2-lb. pressure. Pressure can be changed by moving the tension clip on the spring to a new slot in the holder. Brushes should move freely in their holders and leads should be securely fastened to the terminals on the brush-holder body. Collector rings should be concentric with the shaft, and should be clean and free of uneven wear, grooves, nicks, or any other roughness.

(2) Routine cleaning and simple smoothing up can be done with fine 000 or 00 sandpaper held against the rings while the unit is running. Use a flat wood stick and a narrow strip of sandpaper that is long enough to reach around the end of stick and be held securely at both ends with the fingers. The point of contact with the ring should be back slightly from the end of stick. If rings are excessively rough, place the entire rotor assembly in a lathe, and true up and polish the rings. This operation should be done only by experienced personnel. Brushes should be replaced when they become worn down enough to permit the pressure arm to come close to the holder.

*c. To Seat New Brushes.*— (1) Place new brushes in holders so that the taper conforms to ring contour. Be sure that they are free to move in their holders and that the spring pressure is normal.

(2) Seat the brush to at least 50 per cent initial contact by drawing a narrow flexible strip of fine 000 or 00 sandpaper under it in the di-

rection of rotation. Hold sandpaper snugly against the slip ring with sanded surface against the brush to insure proper contour. Final fit and polish will come with operation.

(3) The brush rigging assembly includes two cast bronze brush holders mounted on a porcelain-enameled insulated stud. Be sure that the stud is screwed tightly into position and that the enamel is not damaged. The brush holders should be so positioned on the stud that the space between the brush holders and the collector rings is equal on both sides of the stud and that the brushes are centered on the rings. The screws holding the brush holders should be tightened securely.

*d. Exciter Commutator.*—(1) The commutator should be concentric with the shaft and should be free of cuts, deep scratches, or other roughness. If such injury cannot be removed with sandpaper or a commutator stone, the rotor should be placed in a lathe and trued by an experienced mechanic.

(2) The exciter commutator is built of copper bars spaced and insulated from each other with mica which should be undercut to a depth equal to the width of the mica. When it is necessary to undercut mica, use a commutator undercutting saw or a special commutator file. In an emergency, a hacksaw blade with teeth ground to the width of the mica is a satisfactory tool.

(3) The commutator, and particularly the spaces between the bars, should be kept clean. Use carbon-tetrachloride to remove oil and grease. Do not use solvent except in an emergency and then use it very sparingly on a damp rag.

(4) Commutators become polished and darkened with use. If commutator becomes blackened, rough, or dirty, it should be cleaned and polished with fine sandpaper. Use the same procedure as in polishing the generator slip rings. The position of the end of stick should be so that the end points in the direction of rotation to avoid grabbing.

*e. Exciter Brushes.*—(1) For best performance, exciter brushes (671) should make 100 per cent contact and be well polished and free from appreciable chips on their edges. Brushes that become badly chipped or worn sufficiently to permit the pressure spring to come close to the holder, should be replaced with new brushes of the same type.

(2) To seat a new brush, first, place it in holder with the spring in position, making sure that it fits free in holder. Second, sand the brush with a narrow strip of fine sandpaper held snugly against the commutator contour, and manually draw it under the brush in the direction of rotation. Do not draw the sandpaper back and forth as

## SECTION IV

it will round the edges of the brush. Do not use emery cloth or emery paper.

(3) This should give approximately a 90 per cent contact in the direction of rotation over a considerable portion of the brush surface. Run the machine to polish brushes. Initial sparking of new brushes can be reduced by filing a 1/16 in. bevel on both long edges of the brushes.

(4) The brush-holder yoke (670) is held in place by a set screw on each side. The yoke should be set so that the chisel marks on the right-hand side (facing commutator) of the yoke and frame (near clamping screw) match up.

*f. Radio Noise, Shaft Ground.*—Shaft grounding for radio-noise suppression is provided by special metal-graphite brushes riding on a slip ring at the end of the exciter armature. Keep the ring free of dirt, grease, nicks, etc. and replace brushes when necessary. Very little, if any, brush sanding should be required.

*g. Radio Noise-suppression Capacitors, Shielding, and Grounding.*— (1) There are five capacitors (653 and 672) on the generator exciter unit; two being on the generator slip rings, two on exciter brushes and one on the exciter field lead inside the exciter housing. Be sure that their terminals are connected when brushes are changed. Should it become necessary to replace a capacitor, be sure to use one of the same rating as the unit replaced, making sure that the leads are no longer than the original ones. Replace the shakeproof washers under the mounting brackets, and the plain washer under the screw or bolt head.

(2) Exciter field leads are shielded and the shields are grounded. After any changes have been made, be sure to replace the shielding braid and reconnect the ground connections with shakeproof washers, between the shield terminal and the ground, and with plain washers under the holding screw or bolt head.

(3) The generator slip-ring-opening cover (630) has two grounding screws in addition to the holding screws (631). If removed, be sure that the cover and the grounded screws with shakeproof washers under their heads, are replaced. Likewise, replace the shakeproof washers under the heads of the exciter hand-hole-cover screws (664).

*h. Exciter Armature (Removal and Replacement).*—The exciter armature core is machined to a light-pressure sliding fit on the generator-shaft extension. It is driven home and held tightly against the tapered driving fit on the shaft by bolt (643) in the commutator end of armature.

*(1) To remove armature:*

- (a) Disconnect the exciter main and field leads.
- (b) Remove brushes from their holders.
- (c) Remove stator frame (660) by taking off the nuts and washers and pulling the frame off the four holding bolts (665).
- (d) Straighten the locking clip on washer (644) and remove the armature holding bolt (643).
- (e) Screw the 7/16 in. armature bolt (in depot spares kit) into the armature shaft (commutator end) until the bolt butts against the end of shaft.
- (f) Turn the bolt with a wrench, as shown in Fig. 30 to loosen the armature (1 turn is sufficient) so that it can be pulled off by hand.

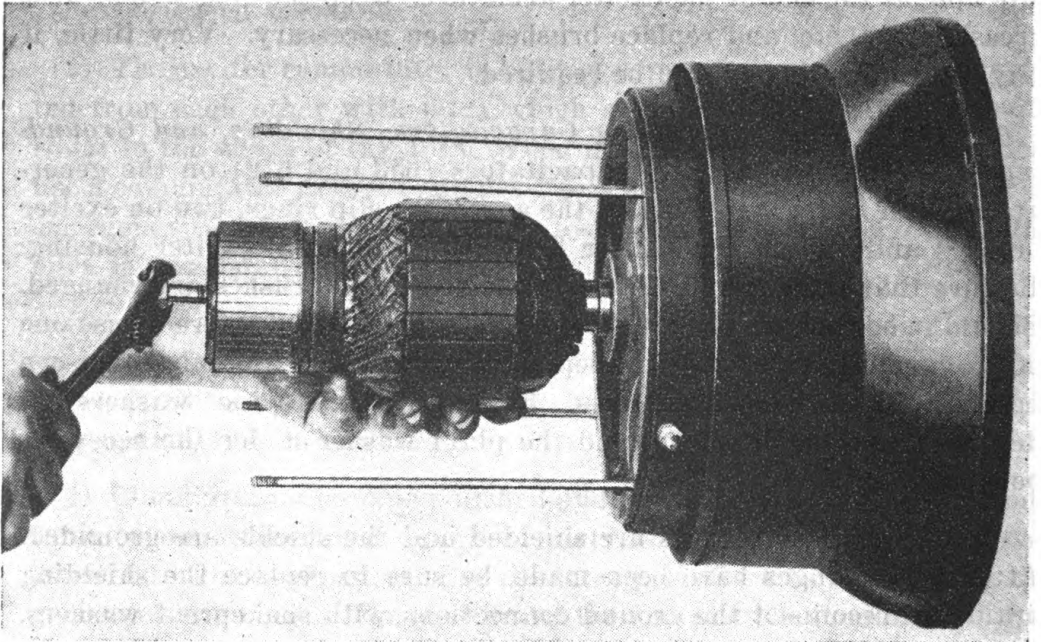

Figure 30.—Removing the Exciter Armature

*(2) To replace the armature:*

- (a) Remove all sand, scale, and dirt from the shaft and from inside armature bore.
- (b) Slide the armature on shaft. **Do not lubricate.**
- (c) Insert and tighten the armature holding bolt (643) and bend up the locking clip on lockwasher (644).
- (d) Replace the frame and reconnect the main and field leads. Make sure that the radio shields are in position and grounded.
- (e) Replace brushes in holders.

## SECTION IV

*i. To replace Exciter Field Coils.*—The exciter field coils cannot be removed and replaced with new coils in the field, therefore if necessary to replace them:—

(1) Remove brushes from holders, disconnect armature and field leads and remove end shield.

(2) Remove generator slip ring opening cover and disconnect exciter armature leads from terminals on brush holders.

(3) Partially remove exciter frame, disconnect exciter field lead from binding post on generator end shield and finish removing frame.

(4) Remove armature leads for use with new assembly.

(5) Slide new frame (with nameplate on top) partially into position on holding bolts, connect field lead (F.) to binding post on generator end shield, replace armature leads and reconnect them to slip rings and push frame into position against generator end shield. Be sure that all leads are secured out of the way of rotating parts. Be sure capacitors and grounding terminals are properly connected.

(6) Replace end shield and tighten nuts on holding bolts securely taking care that generator frame fits squarely over rabbets on exciter and generator end shields.

(7) Connect armature lead (A2) and field lead, (paragraph 5), plus brush and capacitor leads, to terminal screw of brush holder on left side facing commutator. Reconnect the armature lead (A1), together with the brush and capacitor leads, to the brush holder terminal screw on the right side facing the commutator. Replace brushes.

(8) Be careful not to interchange brushes. The fit may be disturbed slightly but should wear in again quickly.

(9) It should not be necessary to change the brush setting as determined by the chisel marks on end shield and brush holder yoke.

(10) If the machine voltage refuses to build up after installation of new field coils, the trouble may be due to reversal of the field leads.

*j. To remove and replace Slip-Ring Brush Holder.*—

(1) Remove the exciter and generator brushes from their holders and disconnect leads.

- (2) Remove exciter frame (660), armature (668), generator collector-ring, end-shield holding bolts and washers (628-629) bearing-housing cap screws (626-627), generator end shield (619), baffle plate (622), and capacitors (653-672). Remove end shield entirely from shaft to avoid any possibility of damaging the shaft.
- (3) Loosen the brush-holder clamping screws and slide the brush holders (646) and insulation washer (650) from the stud (651). Use a wrench on the hexagonal base to remove the insulated stud (651). **DO NOT USE A PIPE WRENCH OR OTHER TOOLS ON THE ENAMELED PORTION OF STUDS.**

*k. Ball Bearings, (Removal and Replacement).—*

- (1) To remove engine-end ball bearings (612).
  - (a) Remove pulley.
  - (b) Remove the generator end - shield holding bolts and washers (616-617), the bearing-housing cap screws and washers (614-615), and end shield (607).
  - (c) Remove ball bearing (612) and inside portion of housing (613) with a bearing puller attached to the bearing housing as shown in Fig. 31. **IF A PULLER IS USED DIRECTLY ON THE BEARING AFTER REMOVING IT ENOUGH TO CLEAR THE HOUSING, IT SHOULD BE ATTACHED TO THE INNER RACE ONLY.**
- (2) To Remove Exciter End Ball Bearing (624):
  - (a) Remove the exciter and slip-ring brushes (649-671) from their holders and disconnect leads.
  - (b) Remove the complete exciter, the generator end- shield holding bolts and washers (628-629) the bearing-housing cap screws and washers (626-627) and the generator end shield (619).
  - (c) Use a bearing puller attached to bearing housing cover plate (625) in the same manner as used on the engine end. **WHEN THE PULLER IS USED DIRECTLY ON THE BEARING, ATTACH IT TO THE INNER RACE ONLY.**

## SECTION IV

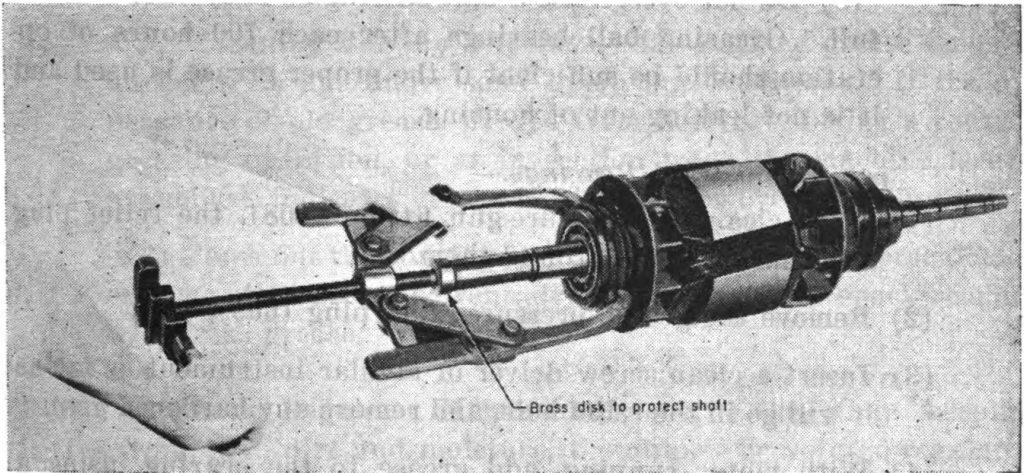

Figure 31.—Removing Ball Bearing with Typical Bearing Puller

(3) To Replace Ball Bearing (Engine or Exciter End):

- (a) Remove all old grease from the housing and from the pressure-relief openings.
- (b) Be sure that there is no dirt on the new bearings.
- (c) Replace rear portion of the bearing housing, and press the bearing on shaft. Be sure that it goes on squarely. If the bearing becomes skewed and stuck, do not use force to straighten; instead, remove the bearing with a puller ATTACHED TO THE INNER RACE and try again.
- (d) Pack the bearing and housing with fresh grease one-third full and replace parts removed.

l. *Greasing Ball Bearings.*—(1) An important factor in determining the type of grease for ball bearings is the total operating temperature which varies with an ambient (surrounding air) temperature (tropical, temperate, arctic) in which the set operates.

(2) Generator ball bearings are packed at the factory with a grease suitable for use in any ambient temperature in which the set will be used. When regreasing, use a high-quality, neutral, soap base (sodium, sodium-calcium, lithium) grease suitable for use in any ambient temperature (high-low). If a grease of this description is not available, use a high-or low temperature grease to suit the total temperature expected.

**POWER UNIT PE-99-F**

(3) Do not overgrease a ball bearing as it overheats if too full. Greasing ball bearings after each 700 hours of operation should be sufficient if the proper grease is used and it is not leaking out of housing.

*m. Engine-End Bearings.—*

- (1) Wipe clean the pressure-gun fitting (608), the relief plug (9), and the areas around them.
- (2) Remove the grease pressure-relief plug (609).
- (3) Insert a clean screw driver or similar instrument as far as it will go in the relief hole, and remove any hardened grease.
- (4) With motor running, add grease to the bearing, using a hand-operated pressure gun (do not use an air or pedal operated gun because it will feed grease to the housing faster than the excess grease can pass through the relief hole). Purge housing of used grease by continuing to add grease until the fresh grease comes out of the relief hole.
- (5) Let motor run after adding grease until excess grease stops coming out of relief hole. **THIS IS IMPORTANT.**
- (6) Replace the relief plug.

*n. Exciter End Bearing.—*

- (1) Wipe clean the pressure-gun fitting, the relief plug and the areas around them.
- (2) Remove the relief plug.
- (3) Remove old grease from the full length of the pressure-relief passage with a wire or long-handled scoop.
- (4) With motor running, add a small quantity of grease with a hand-operated pressure gun.
- (5) Use a cleaning instrument between shots of grease to remove grease discharged into the relief passage. Because of friction, any excess old or new grease expelled from the bearing will travel only a short distance down the pressure-relief passage. To properly purge the bearing of old grease, continue to alternately add new grease, and remove purged grease from the relief opening until fresh grease appears.
- (6) Let motor run and continue removing grease from the relief opening until no more grease comes out of the bearing.
- (7) Replace relief plug.

## SECTION IV

*o. Cleaning Bearing Housings.*—(1) Bearing grease tends to harden with age under some operating conditions. If the appearance of old grease, purged from bearings during a routine greasing operation, or at inspection when the machine is disassembled, indicates grease hardening, remove all old grease.

(2) Flush out the housing and bearing with carbon tetrachloride or some other grease solvent, dry off solvent, and repack bearing with fresh grease.

**50. Automatic Regulator Maintenance.**— *a.* Other than keeping it free from dust, dirt and moisture, the automatic voltage regulator requires very little attention. Don't attempt to oil or otherwise lubricate any part of the regulator.

*b.* The contact roller presses on the silver commutator with a pressure of 100 grams. This value is carefully preadjusted and should not require further adjustment. Do not lift the contact roller from the commutator, as the contact pressure spring may be over-stressed, thereby reducing the contact pressure. Never touch the contact roller while the regulator is operating as arcing will occur at the point of contact causing the commutator surface to become roughened. Polish the surface lightly with jeweler's rouge cloth or crocus cloth. After polishing, be sure to remove all traces of rouge from the surface of the commutator. After the regulator has been operating a short time a fine black line will appear along the point of contact on the commutator. This is a normal condition.

*c.* The regulator is preadjusted and should require no adjustment after installation. If for any reason adjustment is necessary, do not attempt to adjust the magnetic core. Any necessary adjustment should be made by means of the solenoid spring. For greater regulator sensitivity, the spring is moved to a lower position on the holder. Raising it to a higher position decreases the sensitivity and increases the stability of the regulator.

*d.* After any spring adjustment, the coil current should be checked and the spring reset if the current is more or less than its normal value of 0.4 amps. To reset spring, loosen the spring holder adjusting screw and slide the holder forward or backward, decreasing or increasing spring tension.

*e.* In making any necessary readjustments to the regulator, an a-c ammeter must be used, connecting it in series with either terminal "A" or "B" to measure the solenoid coil current.

**POWER UNIT PE-99-F**

**51. Trouble Chart.—Engine**

**a. Engine will not start.**

CAUSE	REMEDY
(1) AUTOMATIC-MANUAL Start switch in wrong position.	Correct switch setting
(2) Lack of fuel.	Refill fuel tank.
(3) Fuel line clogged.	Remove and clean fuel line and filter.
(4) Foreign matter in fuel.	Clean out fuel system and refill with clean fuel.
(5) Magneto defective.	See paragraph 19.
(6) Automatic choke defective.	See paragraph 17.
(7) Ignition short circuited.	Check for wiring short.
(8) Ignition wire broken.	Check wiring for break.
(9) Defective fuel pump.	See paragraph 16.
(10) Governor not working.	See paragraph 18.
(11) No oil pressure.	Check lubrication system.

**b. Engine difficult to start.**

(1) See 3,4,6 and 10 above.	
(2) Carburetor clogged.	See paragraph 15.
(3) Air leak in intake manifold.	Check for leak. Replace gasket and tighten.
(4) Loose cylinder head.	Tighten head.
(5) Cylinder head gasket defective.	Replace Gasket.
(6) Fouled or defective spark plugs.	Clean or replace plugs.
(7) Air intake filter clogged.	Clean air filter.
(8) Muffler clogged.	Replace muffler.
(9) Valves not seating properly.	See paragraph 29.
(10) Worn piston and/or rings.	See paragraph 28, 29 and 30.
(11) Faulty lubrication.	See paragraph 34 and 40, check lubrication.
(12) Fuel tank vent clogged.	Remove fuel filler cap and blow through vent.

**c. Engine stops.**

(1) Out of fuel.	Fill fuel tank.
(2) Foreign matter in fuel.	See a, 4 above.
(3) Ignition wire broken or short circuited.	Check ignition wiring.
(4) Lack of oil.	Check oil supply.
(5) Fuel tank vent clogged.	See b, 12 above.
(6) Fuel pump defective.	See paragraph 16.
(7) Fuel line clogged.	See a, 3 above.

## SECTION IV

## 51. TROUBLE CHART.—Engine (Cont.)

*d.* Engine lacks power.

CAUSE	REMEDY
(1) Overload on generator.	Check and reduce load.
(2) Engine overheated.	Check oil and air passages.
(3) Improper lubrication.	Check oil and make sure oil pump is working.
(4) One or more spark plugs fouled or defective.	Clean or replace faulty spark plugs.
(5) Faulty carburetion.	See paragraph 15.
(6) Muffler clogged.	Replace muffler.
(7) Poor compression.	Check for cause. See paragraph 28.
(8) Improper timing.	See paragraph 21.
(9) Air cleaner clogged.	Remove and clean air cleaner.

*e.* Engine misfiring.

(1) One or more spark plugs fouled or defective.	Clean or replace faulty spark plugs.
(2) Magneto breaker points pitted or out of adjustment.	See paragraph 19.
(3) Defective ignition wiring.	Check wiring and correct fault.
(4) Valves sticking or not seating properly.	See paragraph 29.

*f.* Explosions in carburetor.

(1) Carburetor float level too low.	See paragraph 15.
(2) Fuel line obstructed.	Check fuel line and filter. Remove and clean both.
(3) Intake valve sticking or not seating properly.	Check valves and correct fault.
(4) Air leak in intake manifold.	Check for leak and remedy fault.
(5) Engine out of time.	See paragraph 21 and 29.

*g.* Excessive smoke from exhaust.

(1) Lubricating oil too light.	See lubrication chart. Drain and refill with correct oil.
(2) Choke stuck in closed position.	Check choke and correct fault.
(3) Carburetor float level too high.	See paragraph 15.
(4) Worn cylinder, piston or piston rings.	Check compression and return unit to higher echelon if compression is poor.
(5) Excessive oil in base.	Check oil and drain any excess.

**POWER UNIT PE-99-F**

**51. TROUBLE CHART.—Engine (Cont.)**

CAUSE	REMEDY
(6) Worn connecting rod bearings.	Rock against compression with hand crank and feel for play. Return to higher echelon if bearings seem at fault.
(7) Carburetor float or float valve sticking.	See paragraph 15.
<b>h. Engine knocks.</b>	
(1) Lack of oil.	See paragraph 6. b. (1). Check oil supply. Replenish with correct oil.
(2) Engine overheated.	Check generator load, cooling passages, oil supply and ventilation. Correct fault.
(3) Excessive carbon in cylinders.	See paragraph 35.
(4) Worn wrist-pin or connecting rod bearings.	See G. 6, above.
(5) Cylinders and/or pistons and rings worn.	See G 4, above.
(6) Loose flyweel.	Remove air shroud and rock flywheel by hand. Play will be apparent. Tighten nut. If fault is not corrected, return to higher echelon.
(7) Ignition timing too early.	See paragraph 19.
(8) Low octane fuel.	Drain fuel and refill with higher octane.
<b>i. Engine overheats.</b>	
(1) Cooling air intake obstructed.	Clear any obstruction.
(2) Lack of ventilation.	Provide better ventilation.
(3) Cooling fins or air passages clogged or dirty.	Clean fins and air passages.
(4) Overload on unit.	Check and reduce load.
(5) Ignition timing late.	See paragraph 21.
(6) Muffler clogged.	Replace muffler.
(7) Improper lubrication.	Check lubrication. If unable to detect fault, return to higher echelon.
(8) Valve tappets not properly adjusted.	See paragraph 29.
(9) Choke not opening properly.	Check choke and correct fault.

SECTION IV

52. Trouble Chart.— Generator

a. No a. c. output.

CAUSE

- (1) Commutator dirty.
- (2) Brushes not making contact.
- (3) Open field coil.
- (4) Open or shorted armature.
- (5) Burned out rheostat.
- (6) Circuit breaker OFF or defective.
- (7) Broken or loose wires.
- (8) Field wire to resistance unit open or shorted.

REMEDY

- See paragraph 47 b.
- See paragraph 47 b, and e.
- Check with test lamp.
- Check with test lamp for open.
- Use ammeter to check for short.
- Check circuit breaker.
- Check wiring and correct fault.
- Check wiring and correct fault.
- Check with test lamp.

b. Low a. c. output.

- (1) Unit not up to speed.
- (2) Commutator dirty.
- (3) Commutator mica high.
- (4) Short circuit in power line.
- (5) Brushes not seating.
- (6) Field coil grounded.
- (7) Rheostat not properly adjusted.
- (8) Defective filter condenser.
- (9) Generator drive belts slipping.
- (10) Defective filter capacitors.

- Check speed of unit and correct.
- See paragraph 47 b.
- See paragraph 47 d.
- Check power line and correct.
- See paragraph 48 b. and e.
- Check with test lamp.
- Correct adjustment.
- Check filter and correct fault.
- Check belt tension and adjust.
- Check all capacitors.

c. Arcing at brushes.

- (1) Commutators dirty.
- (2) High mica on commutator.
- (3) Brushes not seating properly.

- See paragraph 47 b.
- See paragraph 47 d.
- See paragraph 48 b, and e.

d. Interference with radio reception.

- (1) Defective filter.
- (2) Loose electrical connections.
- (3) Loose ignition shielding.

- Check condensers in filter. Make necessary replacement.
- Check and tighten all electrical connections.
- Check and tighten all shields.

e. Frequency low.

- (1) Engine not up to speed.
- (2) Generator drive belts slipping.

- Check speed of engine and correct cause.
- Adjust drive belts. See paragraph 45.

POWER UNIT PE-90-F

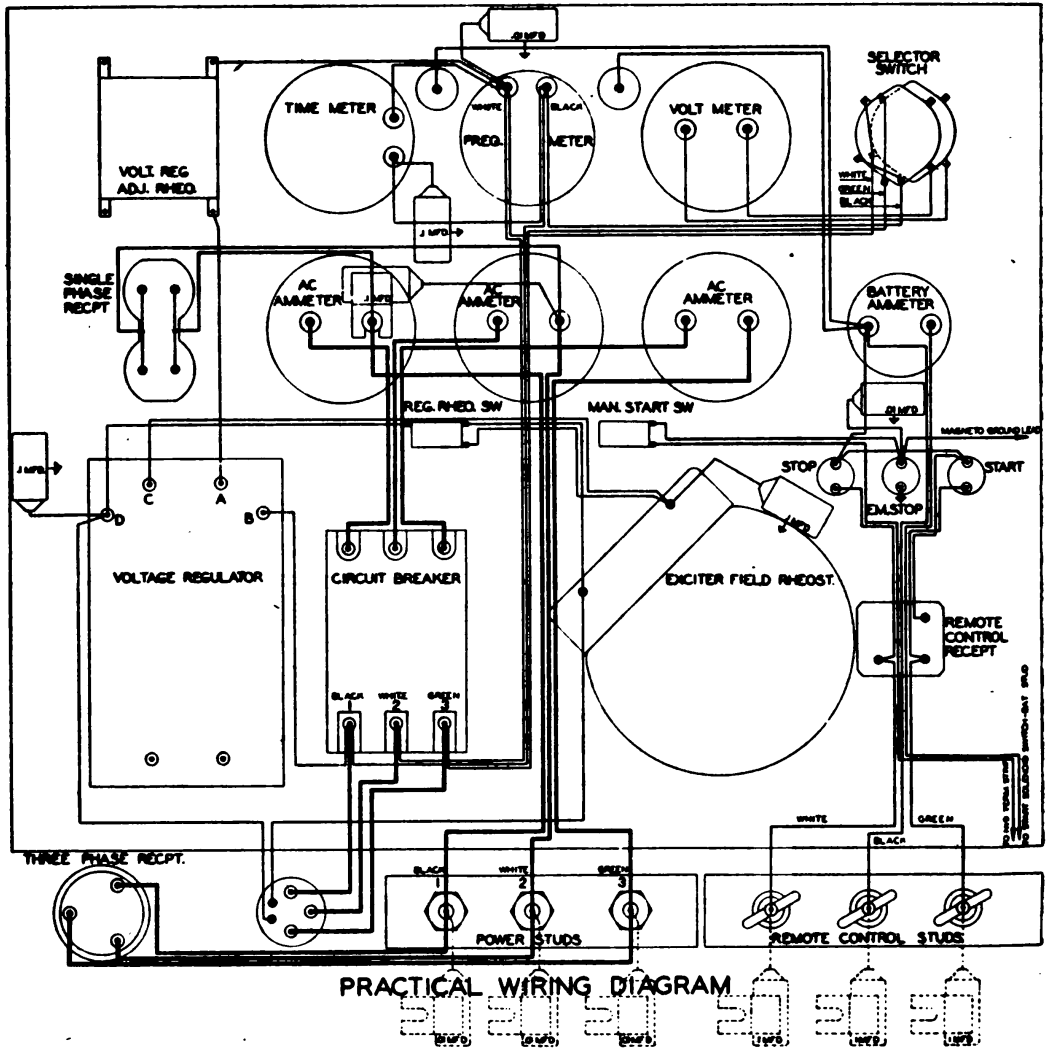
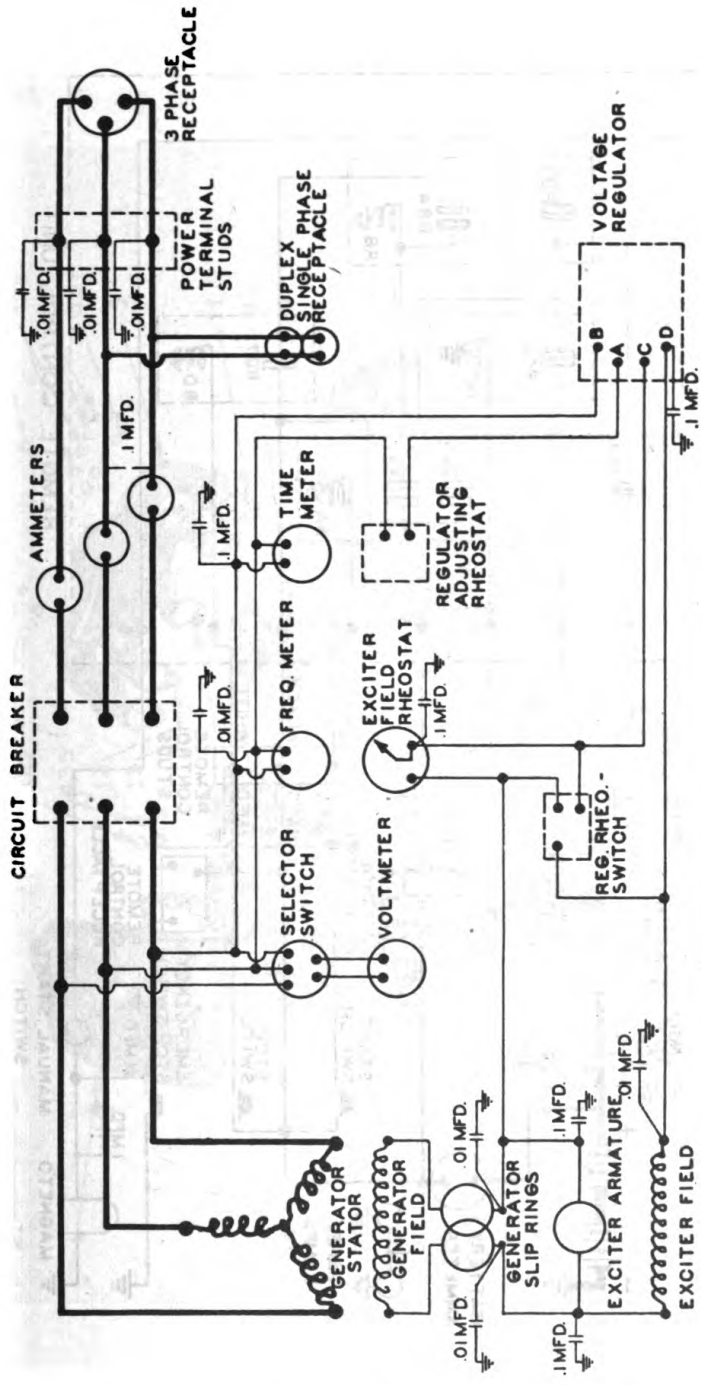

Figure 32.—Practical Wiring Diagram.

SECTION IV



AC. AND EXCITER CIRCUITS

Figure 33.—A. C. and Exciter Circuit Diagram.

POWER UNIT PE-99-F

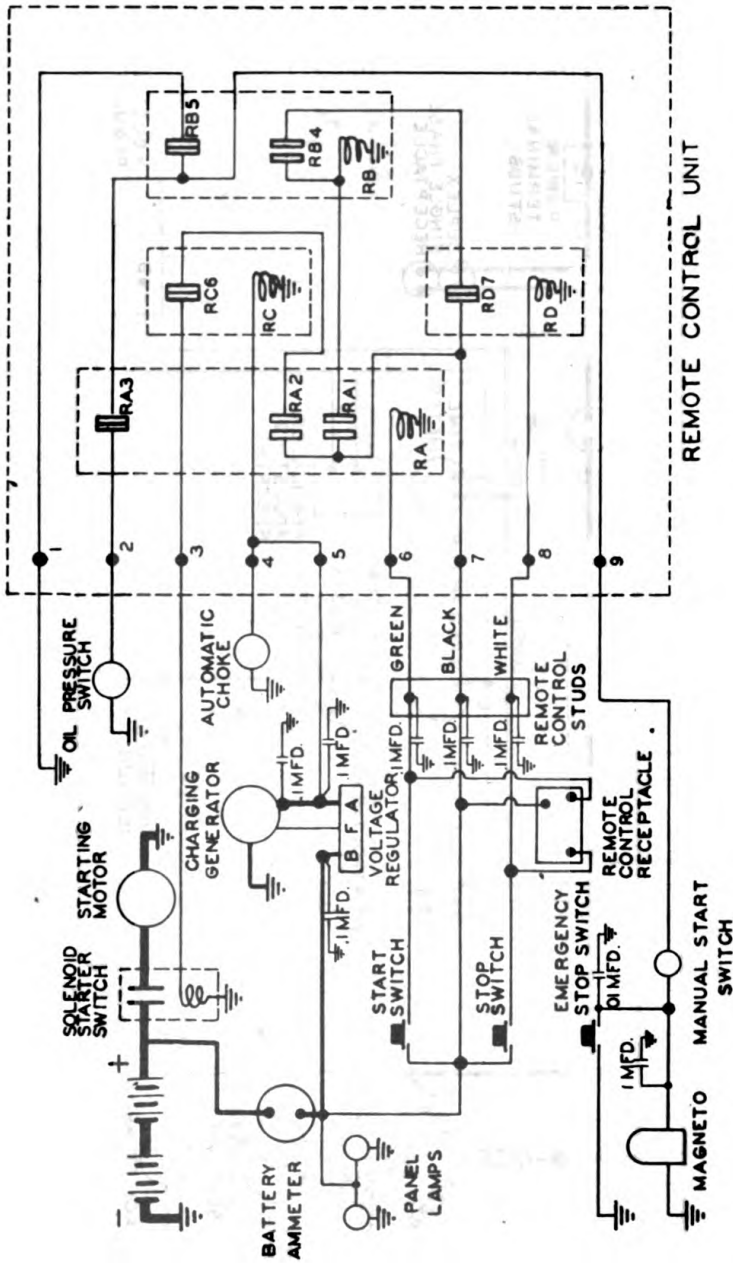

START AND STOP CIRCUITS

Figure 34.—Start and Stop Circuit Diagram.

SECTION V

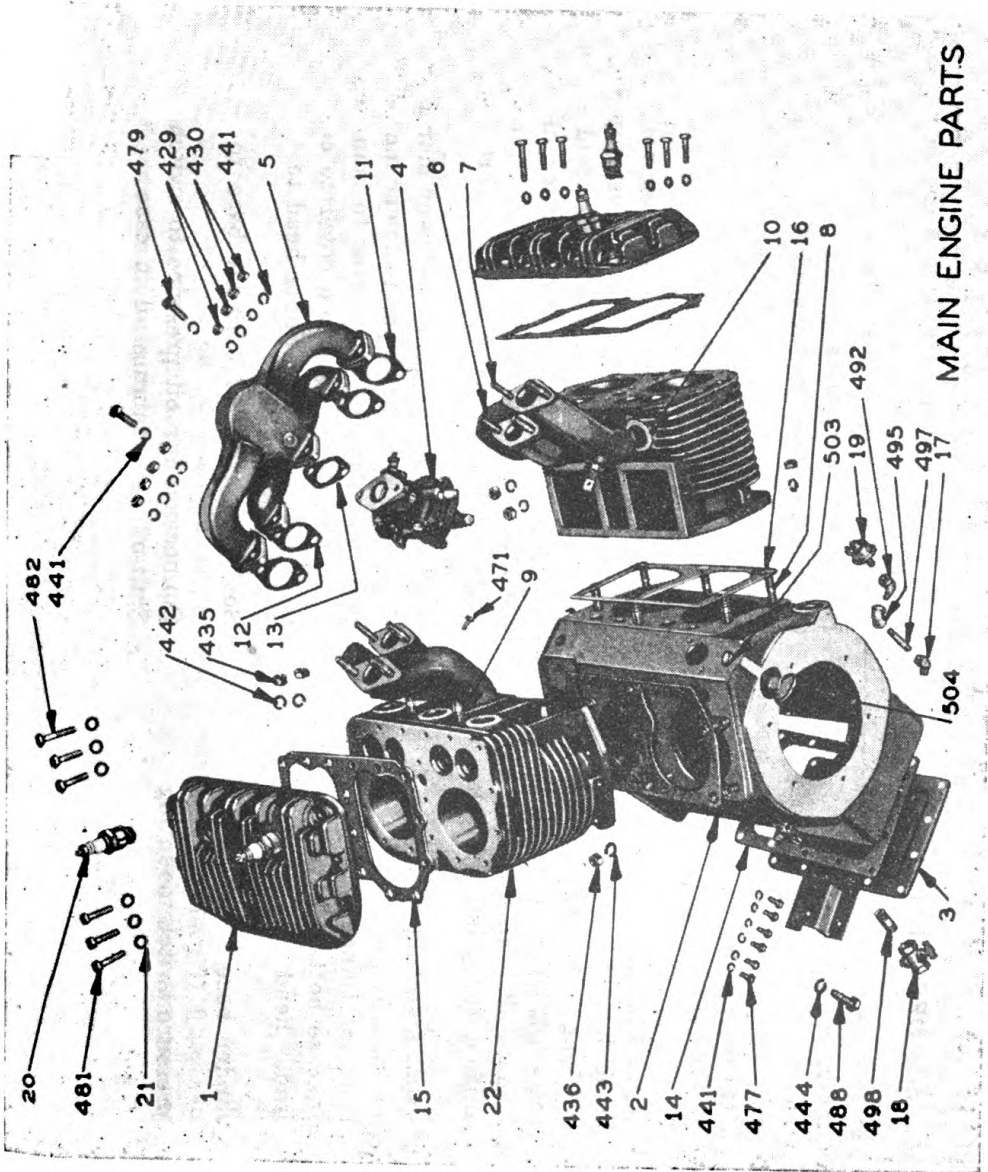

Figure 35.—Main Engine Parts

POWER UNIT PE-22-F

SECTION V—SUPPLEMENTARY DATA

53. Table of Replaceable Parts.— a. Engine group.—

Ref. No.	NAME and DESCRIPTION	FUNCTION	Mfg. Part No.	MFG.
1	Engine assembly, complete	Drives A.C. generator	VE-41	A
2	Cylinder head	Compressed gas vapor chamber	AB-80-G	A
2	Crankcase with studs, oil filler tube, screen, plugs & oil spray nozzles	Main body	BA-48-A-19	A
3	Bottom cover for crankcase	Covers bottom of case	BH-141-B	A
4	Carburetor	Mixes gasoline and air	L-45-24	A
5	Manifold - upper branch	Passage duct for inlet and exhaust vapors	LD-227-C-1	A
6	Manifold - lower branch	Passage duct for inlet and exhaust vapors	LD-228	A
7	Stud - 1-5/16" long 5/16-18x5/16-24 thread	For mounting upper to lower manifold	PC-171	A
8	Stud - 1 1/8 long - 7/16-14 x 7/16-20 thread	For mounting cylinder block to crankcase	PC-337	A
9	Stud - 1-7/8 long-3/8-16x3/8-24 thread	For mounting manifold to cylinder block	PC-369	A
10	Gasket - manifold to cylinder block	Seals manifold against cylinder port openings	QB-75	A
11	Gasket - exhaust manifold	Seals mounting of upper to lower manifold	QB-78	A
12	Gasket - inlet manifold	Seals mounting of upper to lower manifold	QB-79	A
13	Gasket - carburetor flange	Seals mounting of carburetor to manifold	QC-58	A
14	Gasket - crankcase bottom cover	Seals mounting of bottom cover to case	QD-610-A	A
15	Gasket - cylinder head	Seals mounting of cylinder head to cylinder block	QD-613-B	A
16	Gasket - cylinder base	Seals mounting of cylinder base to crankcase	QD-617	A
17	Elbow - oil pressure switch mounting	Connection for oil pressure to switch	RF-1096	A
18	Shut-off cock for oil drain	Shut-off for draining oil in case	RG-28	A
19	Switch - oil pressure	Signals if engine oil pressure is or is not maintained	YC-11-A	A

\* Supplied in Spare Parts Kit

SECTION V

Ref. No.	NAME and DESCRIPTION	FUNCTION	Mfg. Part No.	MFG.
* 20	4 Spark plug	Furnishes spark to ignite gas vapor	#7-18mm.	O
21	34 Specialwashers for cylinder head	For mounting cylinder head	PH-77-A	A
22	2 Cylinder block with HG-201-B inserts	Guide for piston and valves	AA-85	A
* 23	8 Valve spring	Returns valve to closed position	AF-49-A	A
* 24	8 Valve spring seat	Retains valve spring	AG-26	A
* 25	8 Valve spring retainer lock	Locks seat on valve	AH-9	A
* 26	8 Valve - inlet & exhaust	Regulates intake and exhaust of head	AE-75-B	A
27	8 Valve tappet	Opens valves	FA-40-B	A
* 28	8 Valve seat insert	Hardened seat for valve	HG-201-B	A
29	8 Valve tappet adjusting screw	Adjustment for valve tapper clearance	PB-147	A
* 30	4 Gasket for valve tapper plates	Seals plate against oil leaks	QD-612-A	A
31	4 Valve inspection cover plate	Cover for valve spring chamber	SA-68	A
32	1 Oil pump drive gear	Drives oil pump	GD-94-C	A
33	1 Oil pump body	Main body for oil pump	KA-61-A	A
34	1 Oil pump gear - driver	Creates oil pressure	KC-54-1	A
35	1 Oil pump gear - driven	Creates oil pressure	KC-55-1	A
36	1 Oil pump drive shaft	Drives oil pump drivegear	KD-121	A
37	1 Oil pump stub shaft	Drives oil pump driven gear	KD-122	A
38	1 Covers for oil pump gears	Covers gear chamber	KB-39	A
39	1 Oil pump lockscrew	Retains oil pump in place	PI-143-A	A
40	1 Nut for mounting oil pump gear	Retains oil pump drive gear	PD-100-1	A
40	1 Spring for oil pump relief valve	Retains check ball	PM-111	A
* 42	1 Gasket for oil pump cover	Seals cover against body	QD-535	A
43	1 Oil pump screen	Strains oil before it enters pump	RD-119	A
44	2 Oil spray nozzles - long	Guides oil spray to connecting rod bearing	RF-1121	A
45	1 Oil stand pipe	Outlet of oil from filter	RF-1128	A
46	2 Oil spray nozzles - short	Guides oil spray to connecting rod bearings	RF-1143	A

\* Supplied in Spare Parts Kit

POWER UNIT PE-99-F

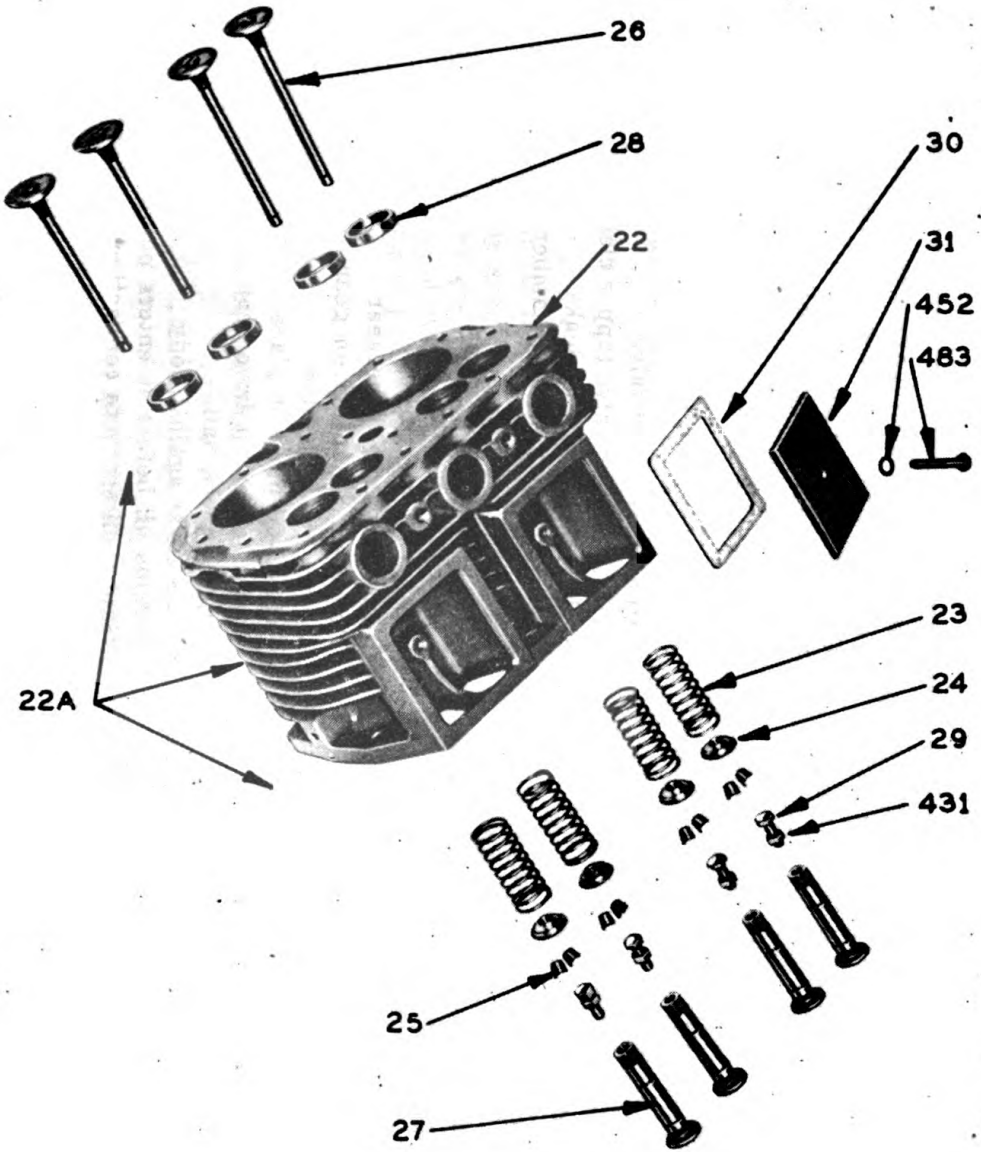

CYLINDER BLOCK ASSEMBLY

Figure 36.—Cylinder Block Assembly

SECTION V

70505C

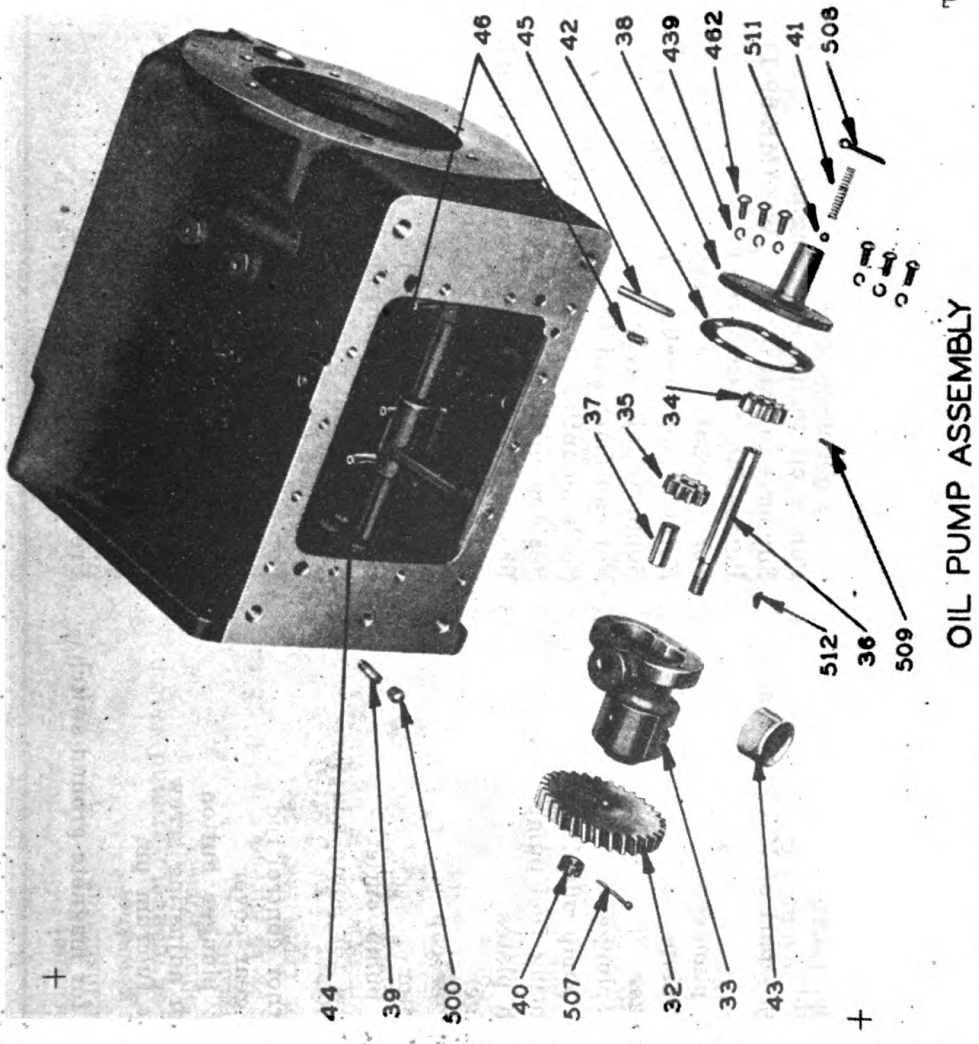

Figure 37.—Oil Pump Assembly

SECTION V

Ref. No.	No. Req.	NAME and DESCRIPTION	FUNCTION	Mfg. Part No.	MFG.
47	1	Camshaft	Regulates valve opening and closing	EA-102	A
48	1	Camshaft gear	Drives camshaft	GB-45-A	A
49	1	Idle gear	Drives oil pump and magneto gear	GC-27-B-1	A
50	1	Oil pump assembly	Pumps oil to lubricate engine	K-95-A	A
51	1	Main bearing cup - part of ME-71 assembly	Supports to crankshaft Wis.(ME-69-1)	No. 414	C
52	1	Fuel Pump	Pumps fuel to carburetor	LP-38-1	A
53	1	Camshaft thrust plunger	For camshaft end thrust	PF-101	A
54	1	Bearing retainer plate	Retains main bearing cup	BG-209	A
55	1	Stud for idler gear	Supports idler gear	PJ-105	A
56	1	Camshaft thrust plunger	For camshaft end thrust	PM-108	A
57	1	Gasket for fuel pump adaptor	Seals mounting against oil leaks	QD-67	A
58	1	Gasket for mounting fuel pump	Seals mounting against oil leaks	QD-538-A	A
59	2	Crankcase splash plates	Prevents excessive oil from going to cyl.	RK-167	A
60	1	Fuel pump plunger	Operates fuel pump	TA-111-1	A
61	1	Fuel pump plunger cap	Cap for plunger	TA-116	A
62	1	Fuel pump adaptor	Adaptor for mounting fuel pump	TB-105-B	A
63	1	Elbow for fuel pump outlet	Connection for mounting fuel line	RF-270	A
64	2	Socket head screw for pump adaptor	To mount fuel pump adaptor	XB-75	A
65	1	Gear cover	Cover for gear train	BD-100-C-2	A
66	1	Spacer for governor control rod	For mounting rod for carburetor	HF-381	A
67	2	Dowel pins for gear cover	To line up gear cover to case	PA-291	A
68	1	Camshaft thrust plunger button	For camshaft end thrust	PF-52	A
69	1	Nut for governor adjusting screw	To adjust governor spring tension	PD-173-A	A
70	2	Governor weight fulcrum pin	Axis for flywheel weights	PA-265	A
71	1	Governor gear	To manipulate governor	GD-100-A	A
72	1	Shield assembly for magneto ground switch complete	Prevent radio interference .	YD-89-A	A

\* Supplied in Spare Parts Kit

SECTION V

Ref. No.	No. Req.	NAME and DESCRIPTION	FUNCTION	Mfg. Part No.	MFG.
73	1	Ground cable terminal	Makes contact to ground strip	A3969	D
74	1	Ground terminal insulator	Insulates ground terminal	A1166	D
75	1	Ground insulating washer	Insulates terminal from shields	B6018	D
76	1	Loom assembly for magneto ground switch	Part of YD-89-A complete assembly	YD-89-A-1	A
77	1	Terminal for ground wire	For making connection at ground switch	YA-87	A
78	1	Oil seal for crankshaft	Prevents oil leaks around crankshaft	PH-299	A
79	1	Stud - 2 1/4" long 3/8-16 thread x 3/8-24" thread	For mounting the magneto	PC-110	A
80	1	Cup for governor cross shaft seal	Retains oil seal in governor housing	PF-118	A
81	1	Oil seal for governor cross shaft	Prevents oil leaks around cross shaft	PH-318-A	A
82	1	Shim for governor drive gear bushing	Prevents bushing from wearing	PH-313-A	A
83	1	Adjusting screw for governor	For adjusting governor speed	PI-115-F	A
84	1	Governor spring	Regulates governor speed	PM-76	A
85	1	Gasket for gear cover spacer	Seals spacer to crankcase	QD-614	A
86	1	Gasket for gear cover	Seals gear cover to spacer	QD-611	A
87	1	Gasket for governor housing	Seals governor housing to spacer	QD-615-A	A
88	1	Gasket for mounting magneto	Seals magneto flange to spacer	QD-616	A
89	1	Fitting in governor housing	For mounting oil line to governor	RF-1165	A
90	1	Governor flyweight assembly - consisting of following parts which are illustrated separately 2TC-322-A flyweights, 2PA-265 pins, 4X-I-83 cotter pins, 1GD-100-A gear, 1TC-389-1 sleeve, 2TC-328 thrust pin	Governs engine speed	TC-405	A
91	2	Governor flyweight	Governs bearing sleeve travel	TC-322-A	A
92	1	Special washer for magneto mounting	For mounting magneto	PH-22-A	A
93	2	Governor flyweight thrust pin	Moves governor thrust bearing sleeve	TC-328	A
94	1	Governor drive shaft	Governor weight assembly support	TC-388-1	A
95	1	Governor drive gear bushing	Bushing for gear and thrust bearing	TC-389-1	A



SECTION V

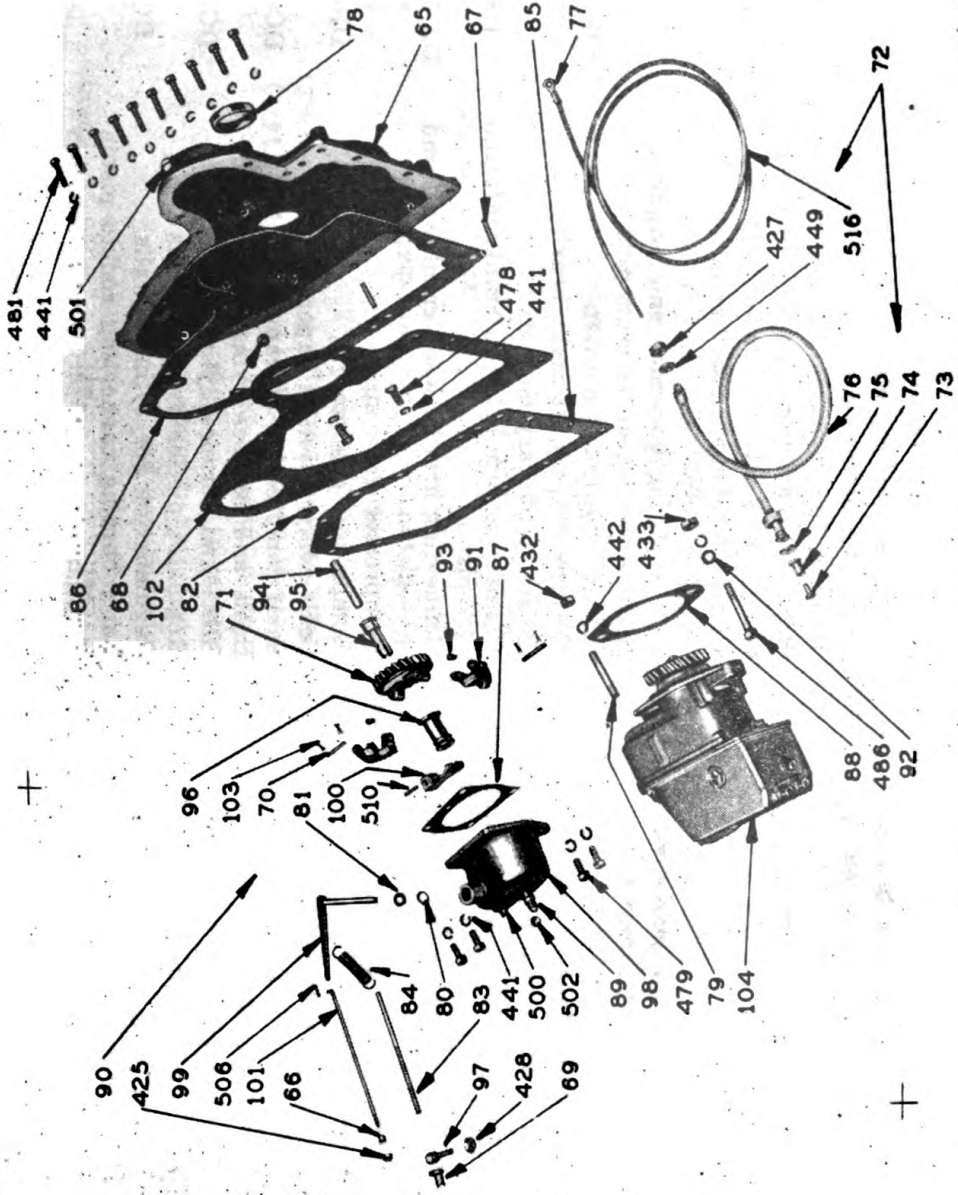

GEAR COVER, MAGNETO & GOVERNOR

Figure 39.—Gear Cover Magneto and Governor

SECTION V

Ref. No.	No. Req.	NAME and DESCRIPTION	FUNCTION	Mfg. Part No.	MFG.
96	1	Governor thrust sleeve and bearing	Moves governor yoke	TC-391	A
97	1	Pin for governor adjusting screw	Supports adjusting screw	TC-367	A
98	1	Governor housing	Housing for governor	TC-395	A
99	1	Governor cross shaft and lever	Regulates carburetor throttle opening	TC-398	A
100	1	Governor yoke	Moves cross shaft and lever	VB-151	A
101	1	Governor control rod	Connection between governor lever and carburetor	VE-464	A
102	1	Spacer between case and gear cover	For mounting governor and magneto	WE-182-A	A
103	4	Cotter pins for governor weight	Retains weights on fulcrum pins	XI-33	A
104	1	Magneto (Wis. No. Y-41-B-1)	Creates spark for ignition	FM-JVE4B7A	D
105	1	Main bearing plate - Take-off end	Returns crankshaft main bearing	BG-210	A
106	1	Crankshaft, with main bearings, gear and key	To convert rotary motion	CA-55	A
* 107	4	Connecting rod with bolts, nuts, shims and bushing	Connecting arm between crankshaft and piston	DA-51-A-S-1	A
107		.010" undersize connecting rod assembly	Connecting arm between crankshaft and piston	DA-51-A-S-10	A
* 108	4	Piston - standard - cast iron	Compresses gas vapor	DB-199	A
108		.010" oversize piston	Compresses gas vapor	DR-199-S-10	A
* 109	8	Piston ring - compression - standard	Seals compression of vapor	DC-163	A
109		.010" oversize compression ring	Seals compression of vapor	DC-163-1-S10	A
* 110	4	Piston ring - scraper standard	Seals and scrapes cylinder walls	DC-163-1	A
110		.010" oversize scraper ring	Seals and scrapes cylinder walls	DC-163-1-S10	A
* 111	4	Piston ring - oil regulator - standard	Regulates oil for cylinder walls	DC-109	A
111		.010" oversize oil ring	Regulates oil for cylinder walls	DC-109-S10	A
* 112	4	Piston pin - standard	For mounting connecting rod to piston	DE-65	A
112		.010" oversize piston pin	For mounting connecting rod to piston	DE-65-S10	A
113	1	Crankshaft gear	Drives idler and camshaft gear	GA-36-A	A

\* Supplied in Spare Parts Kit

SECTION V

Ref. No.	NAME and DESCRIPTION	FUNCTION	Mfg. Part No.	MFG.
114	1 Crankshaft oil seal - Take off end	Prevents oil leaks around crankshaft main bearing	HF-261	A
115	4 Piston pin bushing	Bushing for pin	HG-157-A	A
116	1 Oil filler tube	For filling crankcase with oil	LJ-300-A	A
117	1 Oil filler and breather cap	Breather and oil filler tube cap	LO-60-1	A
118	1 Main bearing cone - flywheel end	Part of main bearing (Wis. No. ME-71-1)	No. 420	C
119	1 Main bearing cone - take off end	Part of main bearing (Wis. No. ME-114-1)	No. 3382	C
120	1 Main bearing cup - take off end	Part of main bearing (Wis. No. ME-114-2)	No. 3328	C
121	1 Pin for starting crank	For hand cranking	PA-239	A
122	2 Stud - 1 5/16" long 5/16-18 & 5/16-24 thrd.	For mounting oil filter	PC-171	A
123	8 Bolt for connecting rod	For mounting rod to crankshaft	PB-148	A
124	1 Nut for crankshaft	Retains flywheel on shaft	PD-123	A
125	8 Connecting rod bolt nut	For mounting connecting rod to crankshaft	PD-148	A
* 126	8 Retaining ring for piston pin	Retains piston pin in place	PK-52	A
127	8 Shim for connecting rod	To secure proper connecting rod fitting on crankshaft pin	QA-108-A	A
* 128	2 Gasket for main bearing plate - take-off end	Seals bearing plate against oil leaks	QD-527-A	A
* 129	2 Gasket for mounting oil filter	Seals oil filter mounting against oil leaks	QD-595-A	A
130	2 Shim for bearing plate .006" thick	To secure proper shaft end play	QF-33	A
131	2 Shim for bearing plate .013" thick	To secure proper shaft end play	QF-33-A	A
132	1 Oil filler screen	Strains oil when added to case	RC-91	A
133	1 Oil saber with PH-245 cork washer	For measuring case oil level	RJ-143	A
134	1 Washer for oil saber	Seals saber mounting	PH-245	A
135	1 Oil filter	Filter engine oil - (Wis No. RV-27-A)	No. 18667	E
136	1 Spacer for oil filter	To allow clearance for oil switch	SA-65-A-2	A
137	1 Elbow for oil line to governor	For mounting oil line to crankcase	RF-270	A
138	1 Oil seal retainer for crankshaft	Retains crankshaft oil seal - take off end	SD-43	A
139	1 Lockwasher for flywheel nut	Locks flywheel nut in place	PE-66	A

\* Supplied in Spare Parts Kit



SECTION V

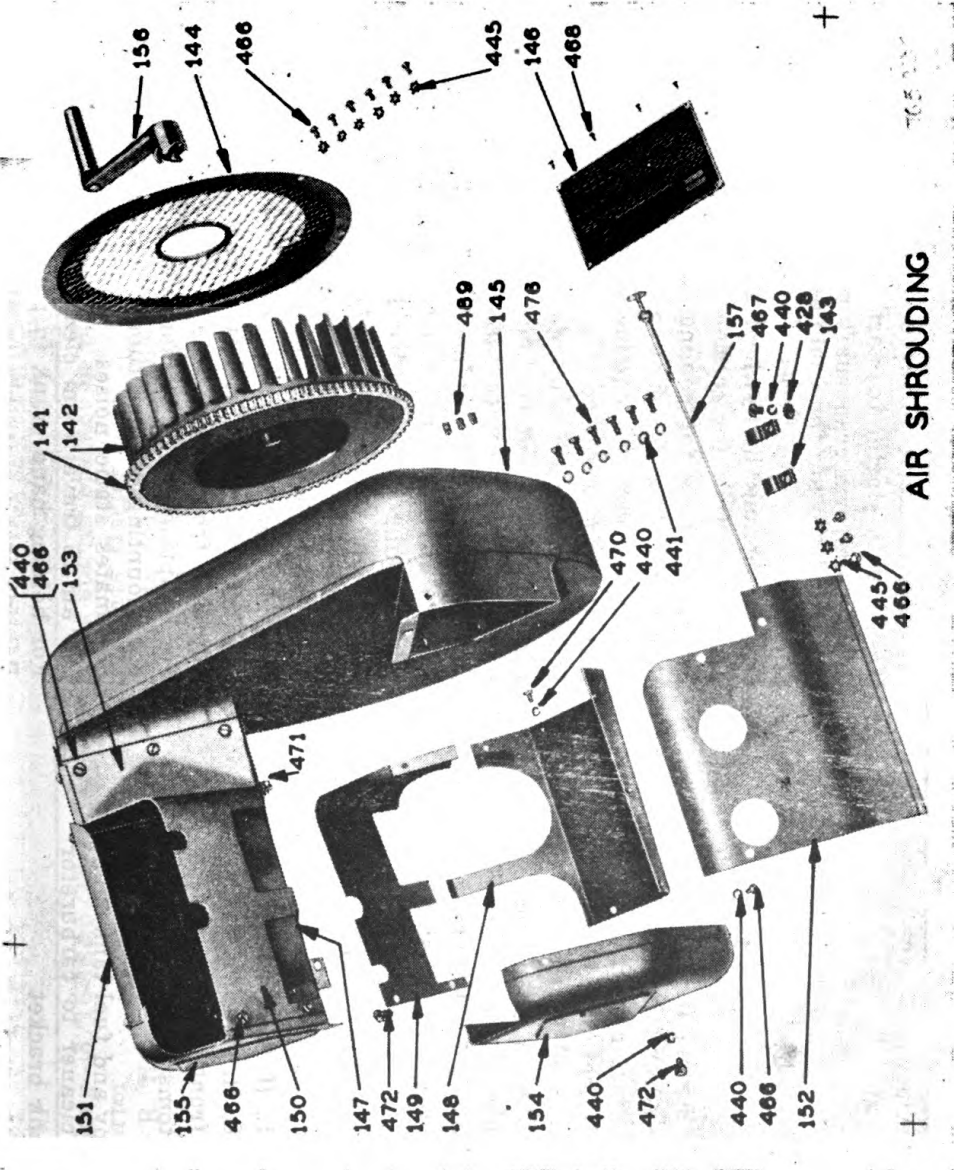

Figure 41.—Air Shrouding

Ref. No.	No. Req.	NAME and DESCRIPTION	FUNCTION	Mfg. Part No.	MFG.
140	1	Crankshaft oil sling	Prevents excessive oil around seal	RK-170	A
141	1	Flywheel ring gear	Meshes with starter to start engine	GH-44	A
142	1	Flywheel with ring gear	Creates uniform crankshaft motion and circulates air for cooling	NC-140-1	A
143	2	Clips for ignition wires	Supports magneto wires	PG-429	A
144	1	Flywheel screen	Covers opening in flywheel shroud	SE-20-B-3	A
145	1	Flywheel shroud	Directs air flow for cooling	SE-74-A-5	A
147	1	Lower cylinder shroud R. H. side	Directs air flow for cooling	SE-75-B	A
148	1	Lower cylinder shroud L. H. side	Directs air flow for cooling	SE-76-B	A
149	1	Cylinder heat deflector L. H. side	Directs air flow for cooling	SE-77-A	A
150	1	Cylinder heat deflector R. H. side	Directs air flow for cooling	SE-77-B	A
151	1	Cylinder head shroud R. H. side	Directs air flow for cooling	SE-78-A	A
152	1	Cylinder head shroud L. H. side	Directs air flow for cooling	SE-79-A	A
153	1	Side cover for air shroud	Directs air flow for cooling	SE-80	A
154	1	Rear shroud cover - L. H. Side	Directs air flow for cooling	SE-82-B	A
155	1	Rear shroud cover - R. H. side	Directs air flow for cooling	SE-83-A-5	A
156	1	Starting crank	For cranking engine by hand	U-212	A
157	1	Choke control	For choking carburetor manually	VE-435-1	A
158	1	Hose clamp	For mounting air cleaner hose to cleaner	LK-8	A
160	1	Fuel line	Line from pump to carburetor	RM-1049-A	A
163	1	House brace - L. H. side	Supports rear panel and fuel tank	PG-394	A
164	1	House brace - R. H. side	Supports rear panel and fuel tank	PG-395	A
165	1	House brace - front panel	Supports front house panel	PG-421	A
166	1	Fitting for automatic choke	For adapting choke to manifold	VE-461	A
167	1	Hose clamp	For mounting cleaner tube to carburetor	LK-11	A
168	4	Felts for canopy and fuel tank support	Eliminates static noises	PH-244-A	A
169	1	Hose for air cleaner to carburetor	For air to travel from cleaner to carburetor	LL-64	A
170	1	Spacer for crank bracket	For holding hand crank in place	HF-387	A
171	1	Spring clip for crank	Retains crank assembly in place	PK-87	A

SECTION V

Ref. No.	NAME and DESCRIPTION	FUNCTION	Mfg. Part No.	MFG.
172	2 Stud - 13/16" long - 5/16-18&5/16-24 thread	Holds starter bracket in place	PC-396	A
173	1 Bracket for starter	Supports starter	PG-331	A
174	1 House brace - R. H. side	Supports rear house panel	PG-425	A
175	1 Air cleaner	Filter air before entering carburetor (LO-66)	No.CT50-10505	F
176	1 Fuel tank cap	Covers opening in tank	RC-77-3	A
177	1 Fuel tank with supports and cap	Holds gasoline to feed carburetor	WE-192-D-6	A
178	1 Engine support - T.O. end	Supports engine	WE-193-A	A
179	1 Engine support - fly-wheel end	Supports engine	WE-194-A	A
180	2 Side rails	Adaptor for mounting doors	WE-195	A
181	2 Doors	Inclodes unit	WE-196-1	A
182	1 Canopy	Top cover	WE-198-A-5	A
183	1 Automatic choke rod	Connection between choke and carburetor	VE-446	A
184	1 Spacer for air cleaner	For mounting air cleaner to panel	PH-77-A	A
185	1 Bracket for mounting generator	Supports generator	BI-273	A
186	1 Spacer - for rear panel L. H. side	Supports rear panel	HF-380	A
187	1 Generator adjusting strap	For adjusting generator belt tension	PG-391	A
188	1 Fuel strainer	Strains gasoline	OW-418	G
189	1 Elbow in fuel strainer	For mounting fuel line	RF-270	A
190	1 Shut-off cock	To shut off fuel supply	RG-36	A
191	1 Fuel line - strainer to shut-off cock	Line for gasoline from tank	RM-1049-A	A
192	1 Rear house panel	Encloses engine	WE-199-A-17	A
193	2 Generator bracket ground wire	To eliminate radio interference	YL-117	A
194	4 Straps for inspection cover canopy	Retains inspection cover in place	PG-128	A
195	1 House brace - rear panel L. H. side	Supports rear house panel	PG-424	A
196	2 Door clips	Retains door in closed position	PG-323	A
197	4 Wing nut for inspection cover	Retains inspection cover in place	PI-148	A
198	2 Fenderwelt between canopy and panel	To eliminate radio interference	PH-238	A

POWER UNIT PE-99-F

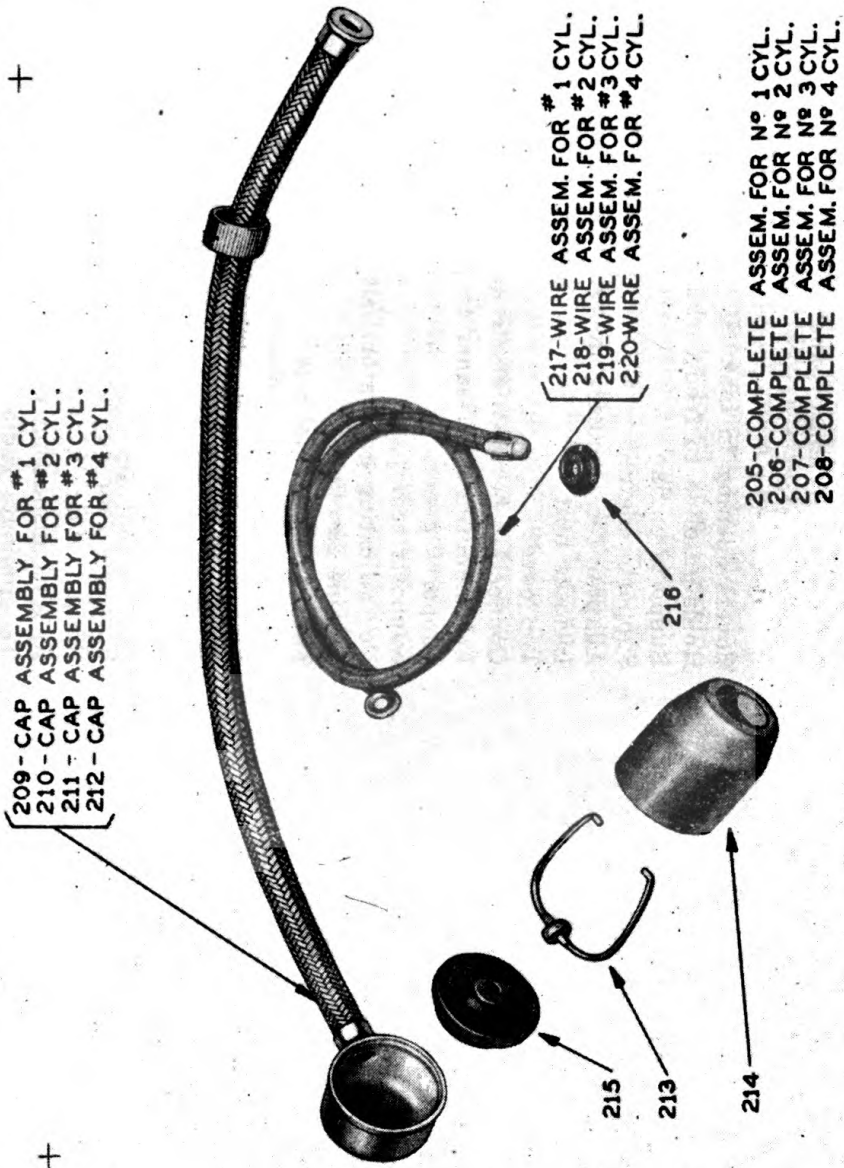

SPARK PLUG SHIELD ASSEMBLIES

76557K

Figure 42.—Spark Plug Shield

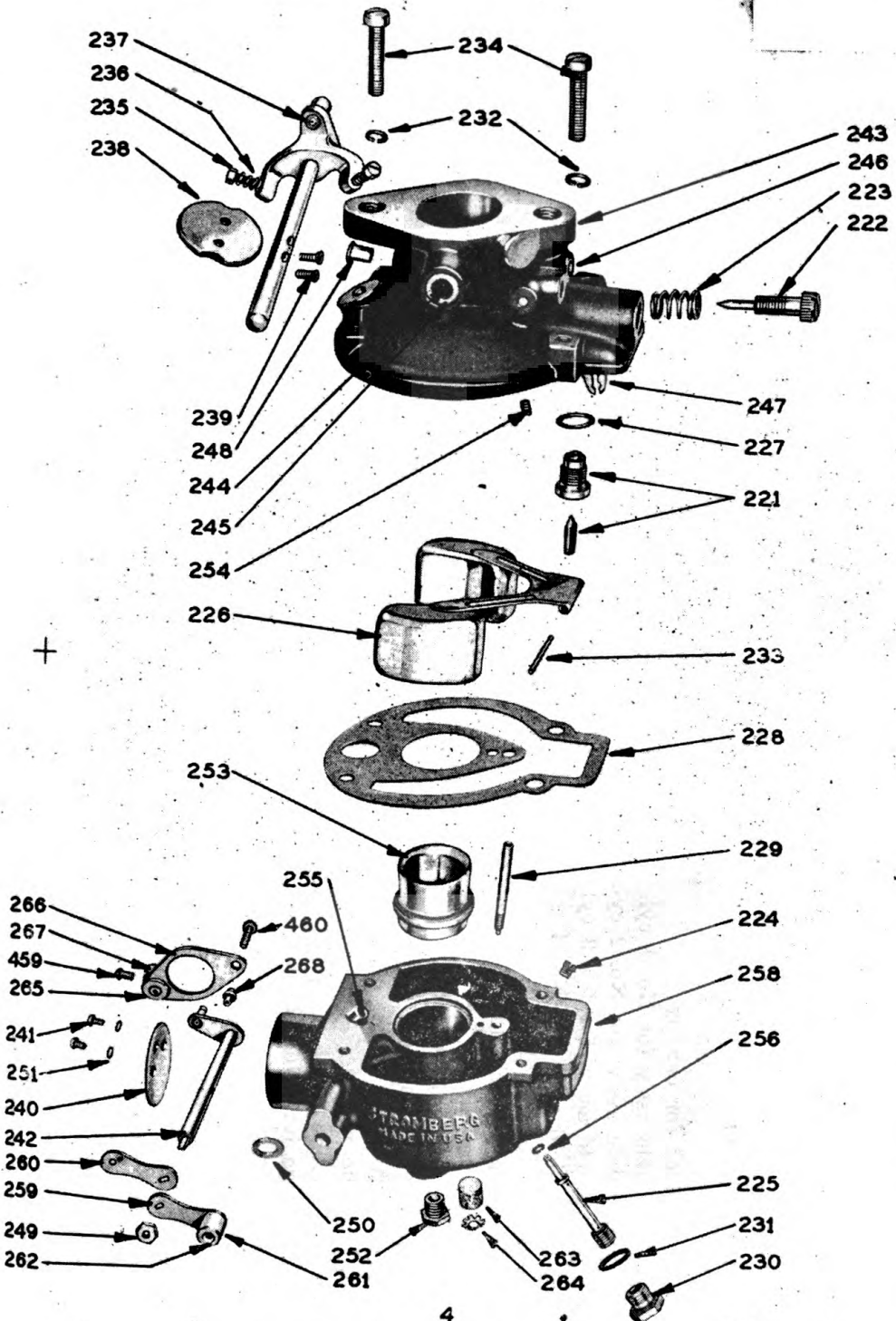

CARBURETOR ASSEMBLY

76555C  
11-14

Figure 43.—Carburetor Assembly

POWER UNIT PE-99-F

Ref. No.	No. Req.	NAME and DESCRIPTION	FUNCTION	Mfg. Part No.	MFG.
199	2	Spring for door clips	Retains clip in position	PM-137	A
200	1	Oil line - case to governor	Line for oil to governor	RM-1049-E	A
201	1	Choke instruction plate	Instruction for operating manual choke	SD-133	A
202	1	Front house panel	For inclosing engine	WE-197-29	A
203	1	Partition plate	Directs hot air out of unit	WE-218-A	A
204	1	Inspection cover for canopy	For inspection of top of engine	WE-227-A	A
205	1	Spark plug shield ass'y for No. 1 cyl.	Eliminates radio interference noises	YD-69-C	A
206	1	Spark plug shield ass'y. for No. 2 cyl.	Eliminates radio interference noises	YD-69-D	A
207	1	Spark plug shield ass'y, for No. 3 cyl.	Eliminates radio interference noises	YD-69-E	A
208	1	Spark plug shield ass'y for No. 4 cyl	Eliminates radio interference noises	YD-69-F	A
213	1	Bail assembly for shield	Retains body to cap	PK-88	A
214	1	Body for spark plug shield	Lower half of shield assembly	YD-70	A
215	1	Terminal tension cap	Retains terminal to plug	YD-73	A
216	1	Packing ring for ignition cable	Retains wire in shield	YD-78	A
221	1	Float needle valve and seat	Regulates fuel flow in carburetor	425173	H
222	1	Idle needle valve	Idle adjustment	P-15396	H
223	1	Spring for idle needle	Retains valve adjustment	P-12530	H
224	1	Metered jet - .053	Meters fuel into main jet	P-16362	H
225	1	Main discharge jet - No. 52	Discharges gasoline to manifold	P-18340	H
226	1	Float assembly	Regulates needle valve	425106	H
* 227	1	Gasket for float needle valve & seat	Secures proper mounting	425176	H
* 228	1	Gasket for main body	Seals mounting of the body to the throttle body	425122	H
229	1	Idle tube - No. 74	Determines amount of gas for idling	425123	H
230	1	Main discharge jet plug	Plugs jet mounting hole	P-11571	H
* 231	1	Gasket for main discharge plug	Seals plug against body	P-11572	H
232	1	Lockwashers for main body mounting	Locks body mounting screws in place	40-S-49	H
233	1	Fulcrum pin for float	Float axis	425162	H
234	4	Screws for main body mounting	Mounts main body to throttle body	177S-44	H

\* Supplied in Spare Parts Kit

SECTION V

Ref. No.	No. Req.	NAME and DESCRIPTION	FUNCTION	Mfg. Part No.	MFG.
235	2	Screws for throttle stop	Regulates throttle opening	P-23474	H
236	2	Spring for throttle stop screw	Retains screw position	P-15301	H
237	1	Throttle lever and shaft	For mounting throttle valve	425393	H
238	1	Throttle valve	Regulates gasoline to manifold	425111	H
239	2	Screw for throttle valve	For mounting valve to shaft	425161	H
240	1	Choke valve	Regulates air flow into carburetor	425112	H
241	2	Screws for choke valve	For mounting valve to shaft	425201	H
242	1	Choke stem and lever	For mounting choke valve	425156	H
243	1	Throttle body (complete with idle holes, throttle stem & valve)	Upper half of main body	425419	H
244	1	Felt packing	For throttle cross shaft	425157	H
245	1	Retainer for felt packing	Retains felt in place	425158	H
246	1	Channel plug	Plug idle hole opening	P-15459	H
247	1	Float hanger	For mounting float	42159	H
248	1	Channel plug	Plug idle hole opening	425160	H
249	1	Nut for choke lever	For mounting choke lever to shaft	P-2290	H
250	1	Lockwasher for choke lever	For mounting choke lever to shaft	40-S-49	H
251	2	Lockwasher for mounting choke valve	For mounting choke valve to shaft	425202	H
252	1	Pipe plug	For draining carburetor bowl	P-3292	H
253	1	Venturi - 3/4"	Determines volume of mixture of gas and air which goes to manifold	425104	H
254	1	High speed bleeder	Allows extra gas for higher speeds	P-20242	H
255	1	Vent tube	Air intake when choke valve is closed	425163	H
* 256	1	Main discharge jet gasket	Seals main jet to main body	P-9600	H
257	1	Complete set of gaskets (not illustrated)	Main housing	382391	H
258	1	Carburetor main body lower half	For mounting choke weight	LQ-12	A
259	1	Choke lever	For mounting control rod to choke	VB-147	A
260	1	Choke lever		VB-147-1	A

\* Supplied in Spare Parts Kit

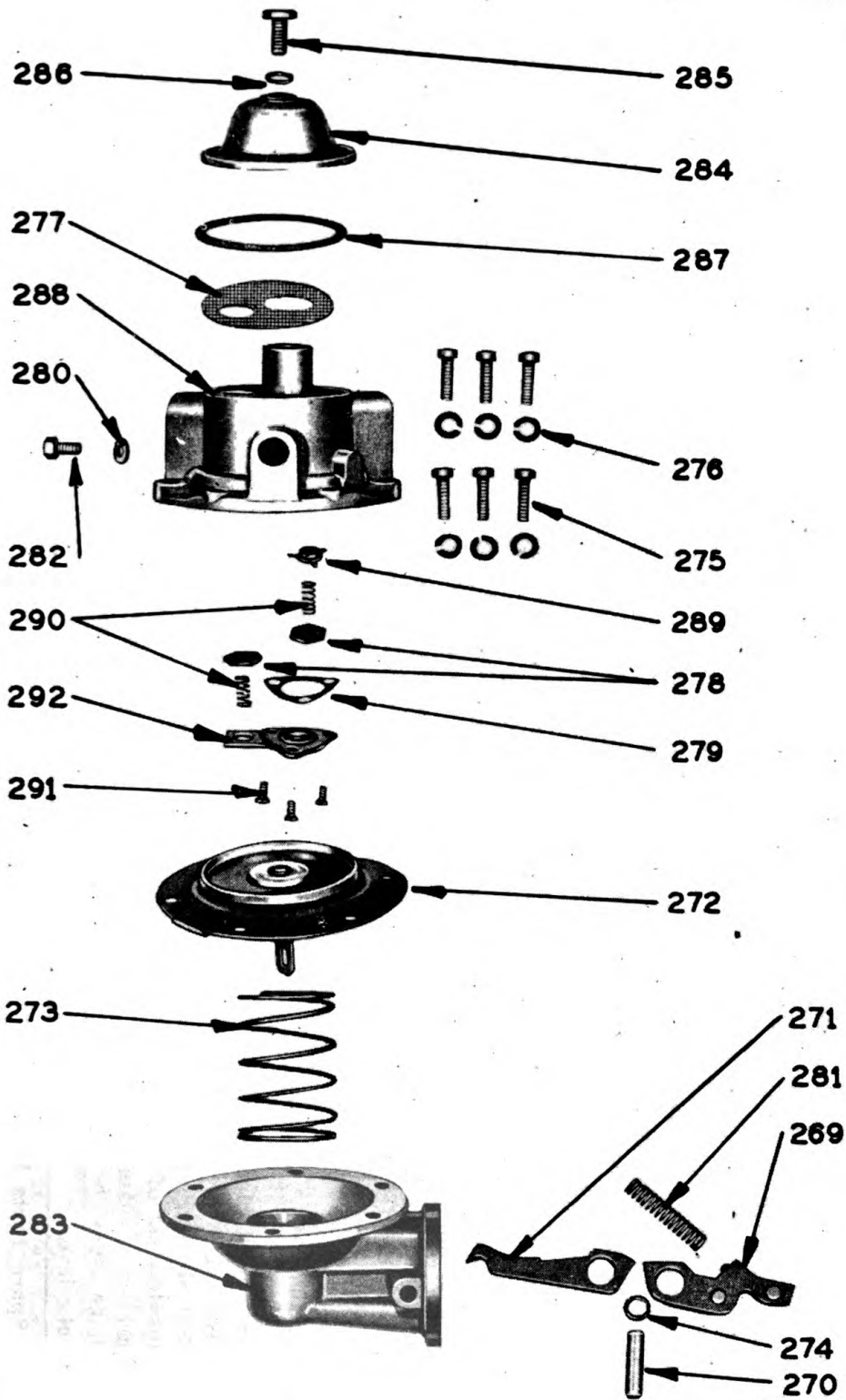

52  
**FUEL PUMP ASSEMBLY**

Figure 44.—Fuel Pump Assembly

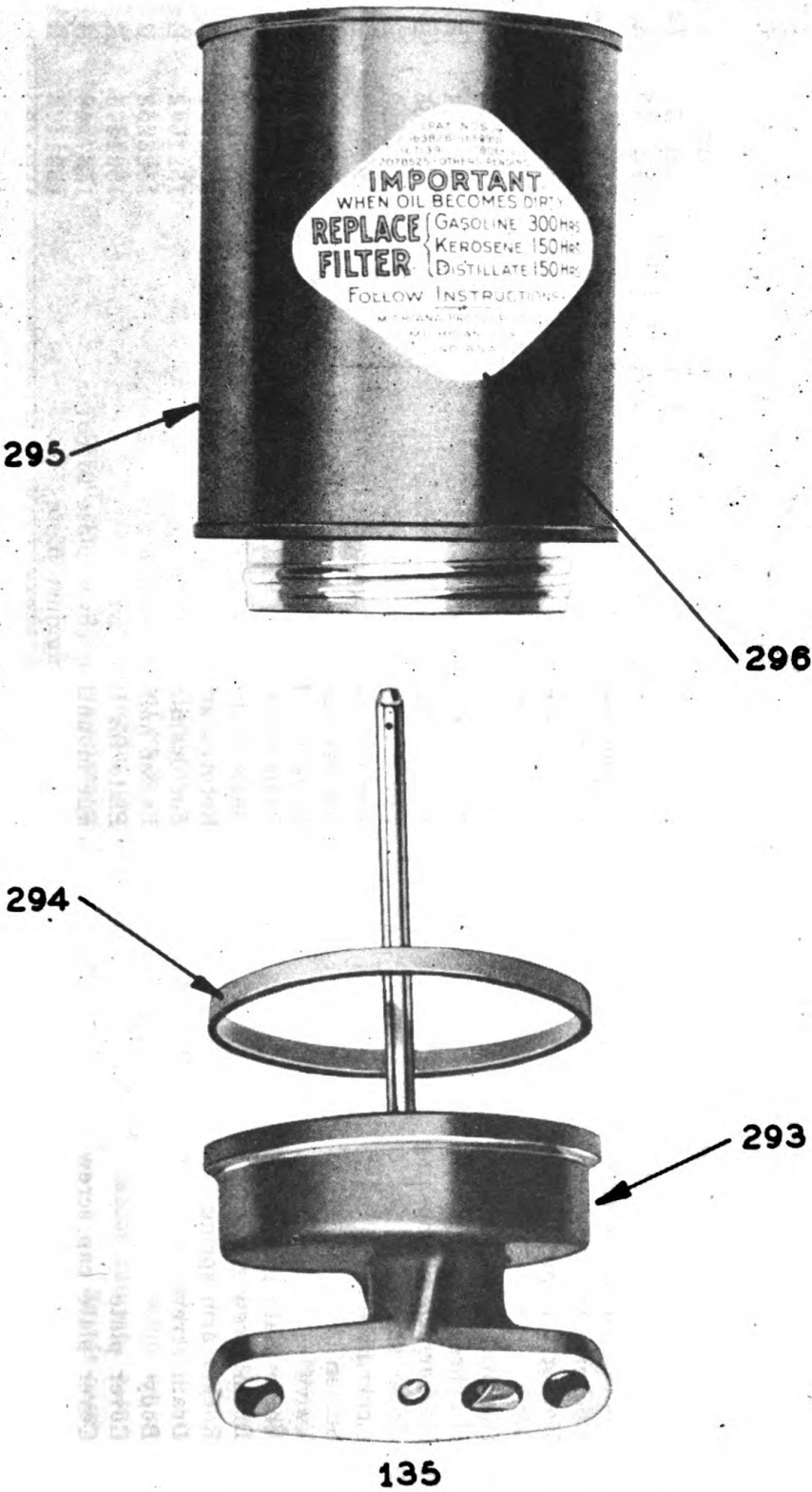

# OIL FILTER ASSEMBLY

Figure 45.—Oil Filter Assembly

Ref. No.	No. Req.	NAME and DESCRIPTION	FUNCTION	Mfg. Part No.	MFG.
261	1	Weight for choke lever	Counterbalance choke lever	PH-316	A
262	1	Rivet for choke lever weight	For mounting choke weight to lever	XJ-34	A
263	1	Carburetor drain felt	Absorbs gasoline overflow in bowl	PH-267-1	A
264	1	Washer for drain felt	Retains drain felt in place	PE-44	A
265	1	Washer for swivel block	Allows block to swivel freely	PH-236	A
266	1	Choke lever	For mounting manual choke control	VB-158	A
267	1	Swivel block for choke lever	For mounting choke control to lever	VE-509	A
268	1	Spacer for choke lever	For mounting manual choke lever	VE-510	A
269	1	Rocker arm	Dries the pump	1521862	B
270	1	Rocker arm pin	Connects arm to link	1521640	B
271	1	Link	Connection between arm and diaphragm	1521868	B
272	1	Diaphragm assembly	Causes diaphragm to pump	1523714	B
273	1	Diaphragm spring	Sucks and pumps fuel	1523301	R
274	1	Rocker arm pin bushing	For mounting arm to link pin	1521865	B
275	6	Cover screw	For mounting cover to body	855493	B
276	6	Lockwashers	For locking cover screws in place	855064	B
277	1	Screen	Strains fuel	1521479	B
278	2	Valve	Regulates fuel inlet and outlet	855279	B
279	1	Valve plate gasket	Seals mounting of valve plate to cover	1521472	B
280	1	Drain screw gasket	Seals drain screw against cover	851297	B
281	1	Rocker arm spring	Returns arm to normal position	1522091	B
282	1	Drain screw	For draining fuel pump	1521612	B
283	1	Body	Lower half of main body	1523258	B
284	1	Cover plate	Plate for top cover	1521475	B
285	1	Cover plate cap screw	For mounting cover plate to cover	1537148	B
* 286	1	Gasket for plate screw	Seals screw against plate	1521476	B
287	1	Cover plate gasket	Seals plate to cover	1521480	B
288	1	Cover and valve seat assembly	Upper half of main body	1521641	B

\* Supplied in Spare Parts Kit

SECTION V

Ref. No.	NAME and DESCRIPTION	FUNCTION	Mfg. Part No.	MFG.
289	1 Outlet valve spring retainer	Retains spring in position	1521473	B
290	2 Valve spring	Returns valves to closed position	856270	B
291	3 Valve retainer screw	For mounting valve plate	856374	B
292	1 Valve plate	Retains valves in cover	1521471	B
293	1 Oil filter base with tube and restriction	Main body	18201	E
* 294	1 Gasket	Seals element to base	18404	E
* 295	1 Filtering element	Filters oil	SA-18667	E
* 297	1 Fuel strainer gasket	Seals glass to cover	OW-222	G
* 298	1 Screen	Strains gasoline	OW-352	G
299	1 Cover	Main body	OW-355	G
* 300	1 Glass bowl	Traps impurities in fuel	OW-363	G
301	1 Valve	Opens and closes fuel supply	OW-432	G
302	1 Wire and stud	Retains glass bowl in position	OW-446	G
303	1 Nut and cup	Retains glass bowl in position	OW-462	G
304	1 Air cleaner wing nut	Retains cover in place	A-1317	F
305	1 Cap	Covers top of cleaner	A-10579	F
307	1 Screen	Screens air intake	A-10581	F
308	1 Filter screen	Screens air outlet	A-9981	F
309	1 Screw	For supporting air cleaner	A-10962	F
310	1 Air cleaner body	Main body	A-10724	F
311	1 Filter unit	Cleans air going to carburetor	A-10068	F
312	1 Oil cup gasket	For sealing oil cup to body	A-9986	F
313	1 Filter retainer	Retains filtering unit in place	B-9947	F
314	1 Oil cup baffle	Baffles air to element	10139	F
315	1 Oil cup	Retains oil for filtering	B-9948	F
316	1 Oil cup and baffle	Assembly	10141	F
317	1 Roller and bail	Retains oil cup assembly to body	B-9982	F

\* Supplied in Spare Parts Kit

POWER UNIT PE-99-F

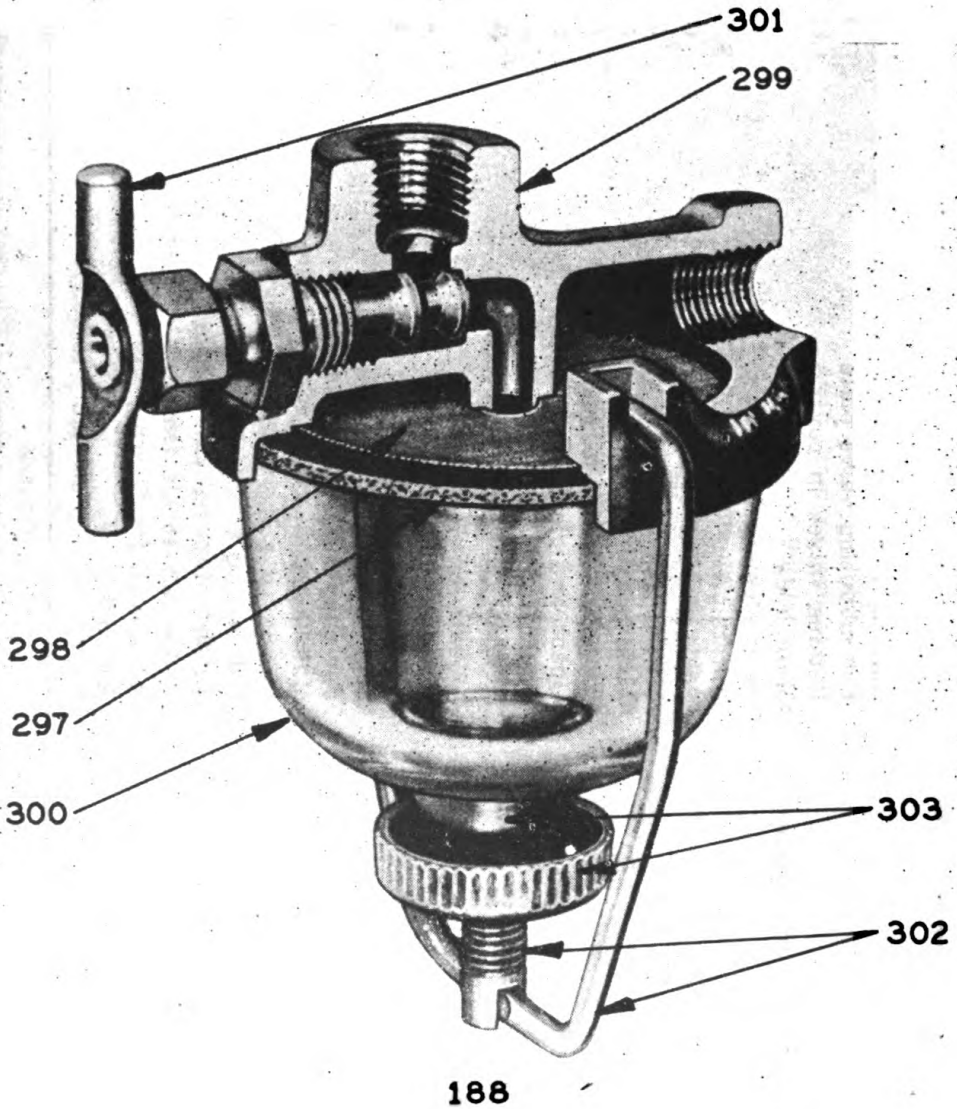

FUEL STRAINER ASSEMBLY

Figure 46.—Fuel Strainer Assembly

SECTION V

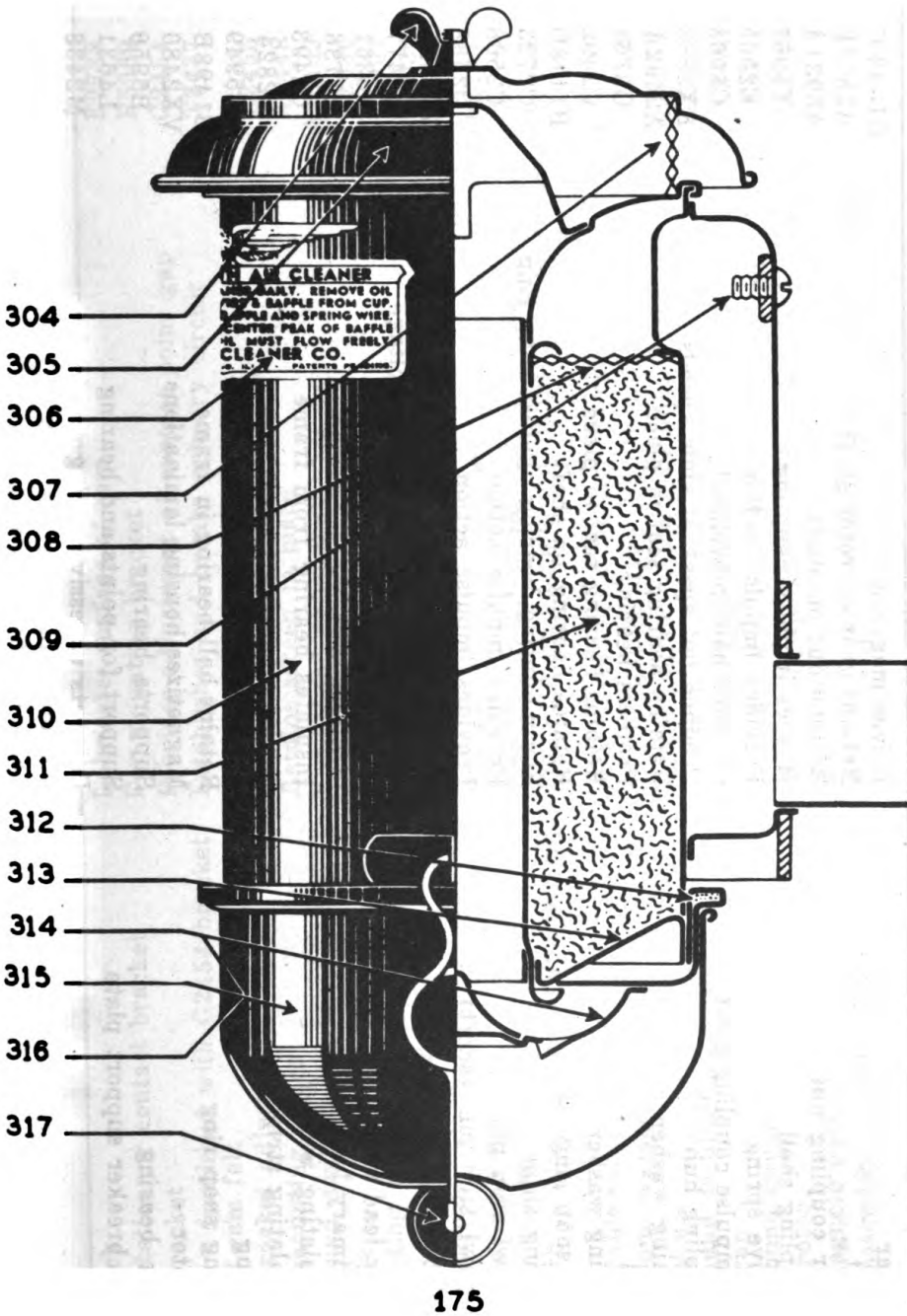

AIR CLEANER ASSEMBLY

Figure 47.—Air Cleaner Assembly

POWER UNIT PE-88-F

Ref. No.	No. Req.	NAME and DESCRIPTION	FUNCTION	Mfg. Part No.	MFG.
318	1	Magneto gear	Drives magneto	GD-93-C	A
319	1	Coupling nut	Retains gear on rotor shaft	A2570B	D
320	1	Lockwire for coupling nut	Retains nut on shaft	A5931A	D
321	1	Impulse coupling shell	Houses impulse coupling	Y5957	D
322	1	Coupling drive spring	Provides impulse action	E2565	D
323	2	Spring for impulse coupling pawl	Controls pawl movement	C5963	D
324	1	Impulse coupling hub	Produce hot spark at slow speeds	EX2563	D
325	1	Outer retaining washer	Retains bearing seal in place	A2492A	D
326	1	Bearing seal	Protects bearing	G3861	D
327	1	Inner retaining washer	Retains bearing seal in place	C2492	D
328	1	Rotor shaft snap ring	Retains bearing on shaft	B1498D	D
329	1	Thrust bearing shim	For mounting bearing against snap ring	C2723	D
330	1	Coupling pawl stop pin	Provides impulse action	C2568	D
331	1	Coupling pawl stop pin (short)	Provides impulse action	Q2568	D
332	1	Magneto housing	Main body	GX2425	D
333	1	Coil	Transfers low voltage to high voltage	H-2477	D
334	1	Terminal for lead wire	For connecting coil wire	A4361	D
335	1	Tube for primary lead	Insulates wire	E2736	D
336	2	Bearing insulating washer	Insulates bearing from frame	C2493	D
337	1	Bearing insulating strip	Insulates bearing from frame	B2824	D
338	1	Rotor bearing	Supports rotor	C5949	D
339	1	Rotor bearing snap ring	Retains ball bearing in frame	B1498B	D
340	1	Magnetic rotor	Magnetizes housing laminations	VX2480	D
341	1	Rotor sleeve bearing	Supports bearing	B5950	D
342	1	Bearing and breaker support plate	Support for points and bearing	L4631	D
343	1	Condensor	Prevents excessive arcing	M2433	D
344	1	Cam felt wick washer	For mounting cam felt wick	C6503	D
345	1	Cam felt wick spacer	For mounting cam felt wick	A2982	D

SECTION V

Ref. No.	No. Req.	NAME and DESCRIPTION	FUNCTION	Mfg. Part No.	MFG.
346	1	Cam felt wick	Lubricates surface of cam	E2788	D
347	1	Washer for stationary contact bracket	For mounting bracket	B5969	D
* 348	1	Stationary bracket	Provides adjustment of contact point gap	G2454	D
* 349	1	Breaker arm - furnished with G2454 bracket and E2788 cam felt	Establishes and breaks primary circuit	T2437	D
350	1	Stationary bracket adjusting screw	For adjusting contact point gap	C2455	D
351	2	Washer for mounting screen	Retains screen in place	A2448	D
352	1	Primary ground switch assembly	For grounding magneto	A2514J	D
353	1	End cap plate	For mounting end cap	A2636	D
354	2	Screen mounting rivets	For mounting screen	A5961	D
355	4	Washer for ventilating screen	For mounting screen	A6030	D
356	2	Ventilating screen	For ventilation of magneto	A6032A	D
357	2	Ventilating screen assembly	For ventilation of magneto	A6032AC	D
358	1	Guide for ground switch strip	Insulates switch strip against housing	B1355	D
359	1	End cap - with ventilating screens and end cap plate	Part of main housing and mounts ignition cables	C2430A	D
360	1	Distributor cable outlet block	Main terminal of ignition wires	C2474E	D
361	1	Primary ground washer	For insulating screw from housing	D2458	D
362	1	Coil lead brush	Makes contact to the distributor rotor	E2460B	D
363	1	Primary ground insulating bushing	Insulates screw from housing	H2489	D
* 364	1	Gasket for cap	Seals cap against housing	H2489	D
365	1	Strip for ground switch	Connection from breaker arm to ground	J2514	D
366	1	Distributor rotor	Distributes spark to ignition cables	M2765	D
* 367	1	Complete magneto gasket kit	not illustrated	GK-16	D
368	1	Suppressor assembly (10,000 OHM)	Suppress radio interference and makes contact from coil to distributor block	A983B	D
369	1	.1 MFD Capacitor	Suppress radio interference	A1184	D
372	1	Automatic choke assembly - without shielded plate	Automatically opens and closes carburetor wire assembly	VF-51-A-4	A

POWER UNIT PE-99-F

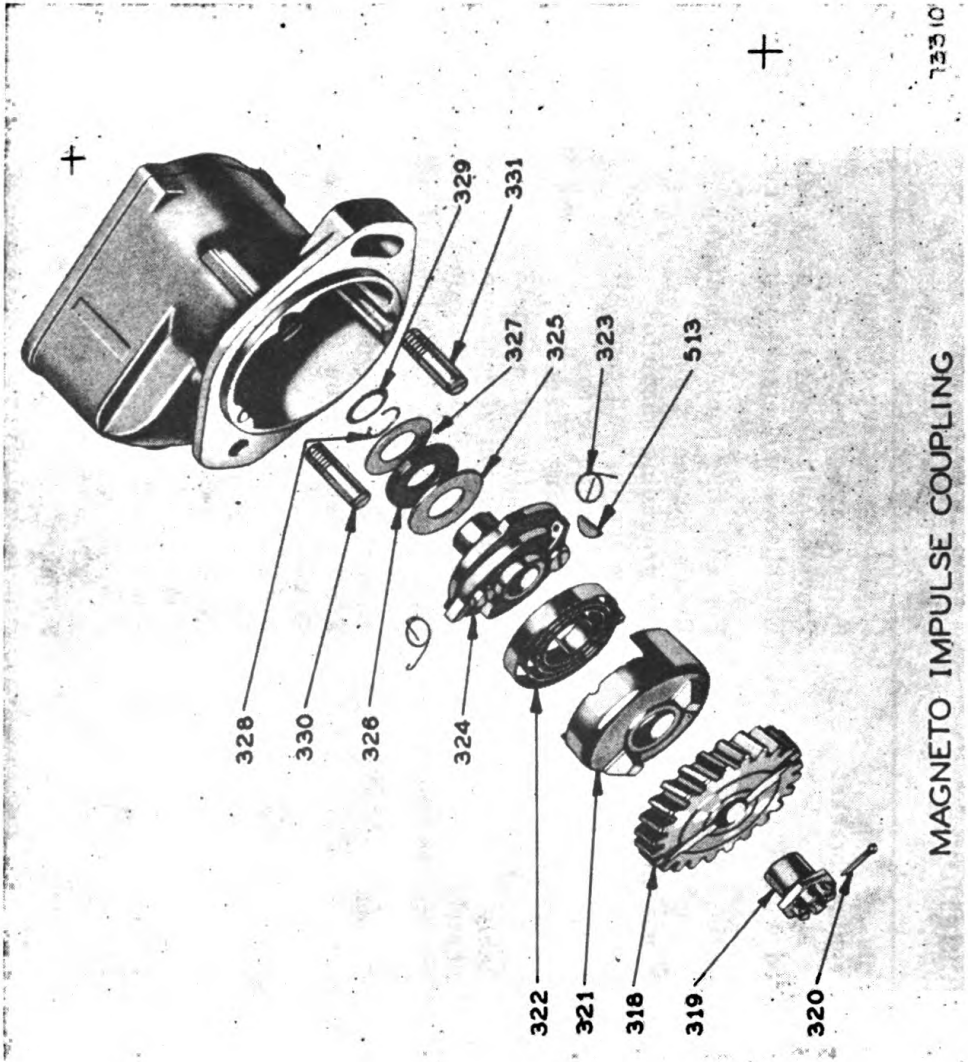

Figure 48.—Magneto Impulse Coupling



POWER UNIT PE-88-F

Ref. No.	No. Req.	NAME and DESCRIPTION	FUNCTION	Mfg. Part No.	MFG.
373	1	Shielded wire assembly for automatic choke	Prevents radio interference	YD-52-A	A
374	1	Wire shield	Part of YD-52-A assembly	YD-52-A-1	A
375	2	Terminals for choke wire	Part of YD-52-A assembly	YD-87	A
376	2	Insulating washers for choke	Insulates cover from terminals	PH-323	A
377	1	Cover for choke terminal shield	Cover for shield cup	SA-28	A
378	1	Cup for choke terminal shield	Housing for terminal shield	SA-73	A
379	1	Choke housing	Choke main body	382770	H
380	1	Felt strainer and washer clip	Retains washer and felt in place	382777	H
381	1	Felt strainer washer	Retains felt in place	P-20744	H
382	1	Felt strainer	Breather for choke housing	382776	H
383	2	Piston lever stop screw	Limits piston travel	382774	H
384	1	Piston and link	Piston vacuum moves choke lever	P-24133	H
385	1	Union lockwasher	Locks union in place	382779	H
386	1	Vacuum line union	Fitting for mounting choke	382778	H
387	1	Vacuum piston lever nut	For mounting lever to stem	P-16571	H
388	1	Lever nut lockwasher	Locks nut in place	P-15875	H
389	1	Choke lever stem bushing	Guide for choke stem	382772	H
390	1	Bushing lockwasher	Retains bushing nut in place	P-8838	H
391	1	Choke stem bushing nut	Retains bushing in place	382773	H
392	1	Choke stem	Connection from link to lever	382771	H
393	1	Choke lever with screw and nut	For connecting to carburetor lever	P-20229	H
394	1	Choke lever	Part of P-20229 assembly	P-16955	H
395	1	Screw for choke lever	Part of P-20229 assembly	P-18300	H
396	1	Nut for choke lever	Part of P-20229 assembly	P-18299	H
397	1	Stop screw plate	Adaptor for mounting stop screws	382775	H
398	2	Stop screw lockwasher	Locks screws in place	40-S-19	H
399	1	Thermostat unit complete	Contraction of spring operates piston and choke lever	382780	H
400	1	Thermostat unit cover	Part of 382780 assembly	P-23165	H

SECTION V

Ref. No.	No. Req.	NAME and DESCRIPTION	FUNCTION	Mfg. Part No.	MFG.
401	1	Thermostat unit gasket	Part of 382780 assembly	23285	H
402	1	Thermostat unit spring	Part of 382780 assembly	P-21507	H
403	1	Thermostat unit cotter pin	Part of 382780 assembly	P-4	H
404	3	Thermostat unit mounting screws	For mounting unit to body	P-21596	H
405	3	Thermostat unit mounting screw washers	Retains cover in place	P-24179	H
406	2	Terminal insulating washers	Insulates cover from terminals	P-21033	H
407	3	Star lockwashers for terminal post	For locking terminal nut in place	76-S-2	H
408	3	Nut for terminal post mounting	For mounting terminal post in place	901818	H
409	1	Nut for terminal post	For mounting terminal to post	P-21030	H
410	1	Exhaust hose, 10 foot length		4705	L
411	1	Muffler	To reduce noise of engine	4812	S
412	1	Gasoline valve fitting	For connecting 20 foot fuel line	5225	L
413	1	Fuel line, 20 foot length	For taking fuel from a remote tank	4759	L
414	1	Starting motor	.Starts engine	MBE-4003-A	K
415	1	Solenoid start switch	Closes battery circuit to starting motor	SS-4023	K
416	2	Cable, starting	Connects motor to switch, grounds motor to frame	4704	L
417	1	Choke lead support strap	Supports shielded choke lead	4762	L
<i>b. Battery Group.—</i>					
418	2	Battery, 6 volt storage	Furnishes 12 volt D.C. current for starting etc.	2HRSC	L
419	1	Cable, battery ground		4727	L
420	1	Cable, inter-battery		4725	L
421	1	Cable, battery-switch		4726	L
422	4	Battery clamp		4746	L
423	2	Battery cover		4767	L
424	1	Battery charging voltage regulator	Regulates battery charging rate	VRS-4004F	K

POWER UNIT PE-99-F

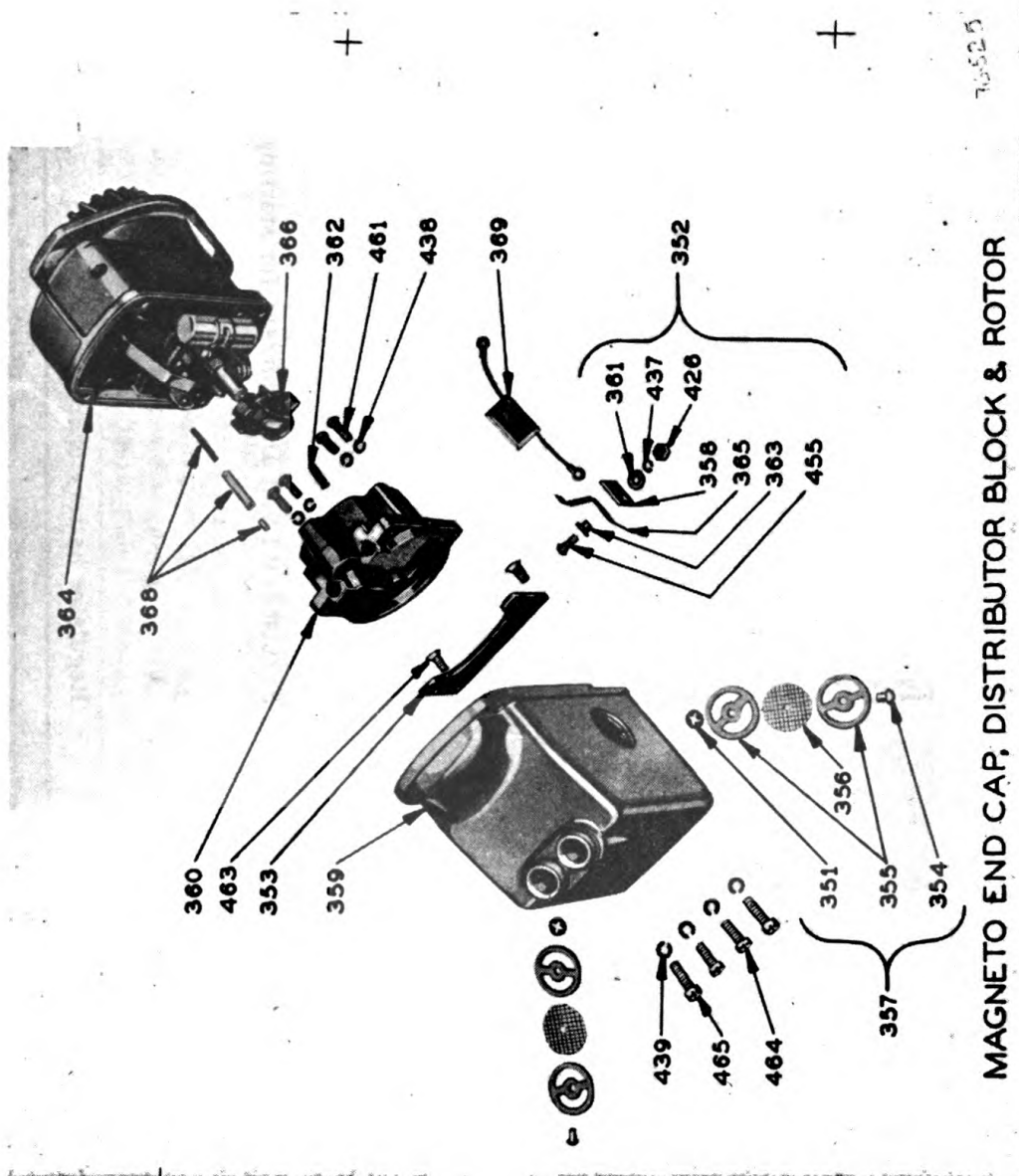

Figure 50.—Magneto End Cap Distribution Block and Rotor

SECTION V

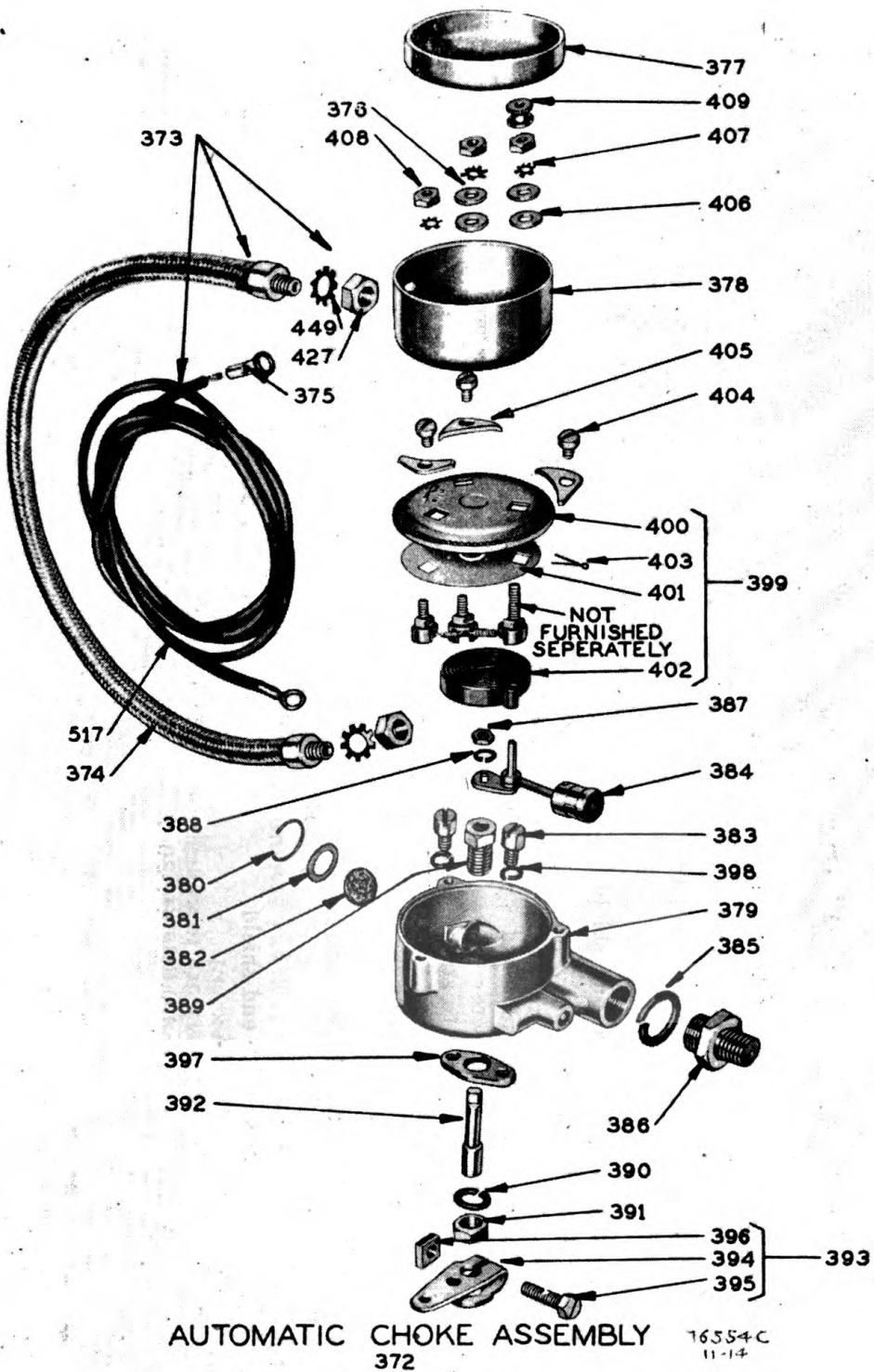

Figure 51.—Automatic Choke Assembly

POWER UNIT PE-3-F

Ref. No.	NAME and DESCRIPTION	FUNCTION	Mfg. Part No.	MFG.
c. A. C. Generator Group.—				
601	1 Stator complete with windings and leads	Generates 120 volt, A.C. power	8421167G1	I
605	1 Conduit box	Encloses generator leads	6614061G2	I
606	2 Screw fastening conduit box to plate		6613465	I
607	1 End shield, engine end	Holds bearing	8421205G1	I
608	1 Grease fitting (alemite No. 1610)	For attaching grease gun	71X766	I
609	1 Pipe plug (1/8 in. std.)	Stopper for opening to relieve excess grease pressure	203852	I
610	1 Baffle	Directs cooling air against windings	8421176	I
611	4 Screw fastening baffle to end shield		1287	I
612	1 Ball bearing, engine end	Supports generator shaft	3666784P8	I
613	1 Cap for ball bearing	Retains grease in bearing housing	6614032P1	I
614	4 Screw fastening cap to end shield		206882	I
615	4 Lockwasher for 5/16 in. screw		304X57	I
616	4 Bolt fastening end shield to stator frame (3/8-16 2 1/2 in hex. h.)		IX753	I
617	4 Lockwasher for 3/8 in. screw		87X532	I
618	2 Lifting lug		8429407	I
619	1 End shield, exciter end	Holds bearing, supports slip ring brush rigging and exciter frame	8433701G1	I
622	1 Baffle	See reference No. 10	8420753	I
623	4 Screw fastening baffle to end shield	See reference No. 10	1287	I
624	1 Ball bearing, exciter end	Supports generator shaft	2892334P7	I
625	1 Cap for ball bearing	See Reference No. 13	8449P1	I
626	3 Screw fastening cap to end shield (1/4-20, 2 in. fill hd.)	See reference No.13	50X19	I
627	3 Lockwasher for 1/4 in. screw	See reference No. 13	66X131	I
628	4 Bolt fastening end shield to stator (3/8-16, 1 3/4 in. hex. h.)	See reference No. 13	235405	I
629	4 Lockwasher for 3/8 in. screw	See reference No. 13	87X532	I
630	1 Cover for end shield	See reference No. 13	8433704G1	I

SECTION V

Ref. No.	No. Req.	NAME and DESCRIPTION	FUNCTION	Mfg. Part No.	MFG.
631	1	Clamping screw for cover (10-32, 1 3/4 in. fill hd.)	See reference No. 13	61X530	I
632	1	Rotor with coils, shaft, keys, punchings fans, collector, insulation washers, and end plates	Provides rotating magnetic flux for generating current in stator windings	8421243G1	I
643	1	Bolt fastening exciter armature to alternator shaft (5/16-18, in. hex. h.)		155559	I
644	1	Lockwasher for bolt		8429495	I
646	2	Brushholder with pressure arm, and pressure spring	Supports brushes and exerts pressure on brushes	6634853G1	I
649	4	Carbon brush with pigtail and terminal	Carries current to rotor windings	1334358	I
650	1	Insulation washer		5530276	I
651	1	Brushholder stud	Insulated support for brush holder	8429381	I
652	1	Lockwasher for stud		64X92	I
653	3	Capacitor .01 Mfd.	Radio noise suppressor	304X58	I
654	1	Grounding plate	Provides shaft grounding for radio noise suppression	8424597P1	I
655	2	Set screw for plate (10-32, 1/2 in. headless cup point)		61X519	I
656	2	Brushholder		8430379	I
657	2	Carbon brush	Sliding contact for grounding plate	8430374	I
658	2	Spring for carbon brush	Press brush against grounding plate	8424568	I
660	1	Magnet frame and field coil assembly	Provides magnetic flux for generating current in	S-6529	J
662	1	End shield without covers	Supports exciter brush holder yoke	50150	J
663	2	Cover for end shield		5324	J
664	4	Screw fastening cover to end shield		5057	J
666	4	Nut for stud		5972	J
667	4	Lockwasher for nut (shakeproof No. 1414)			
668	1	Armature with winding, core and commutator	Generates D.C. current for rotating field of A.C. generator	S-50149	J
670	1	Brushholder with pressure springs, and ring insulation plates		S-6469	J

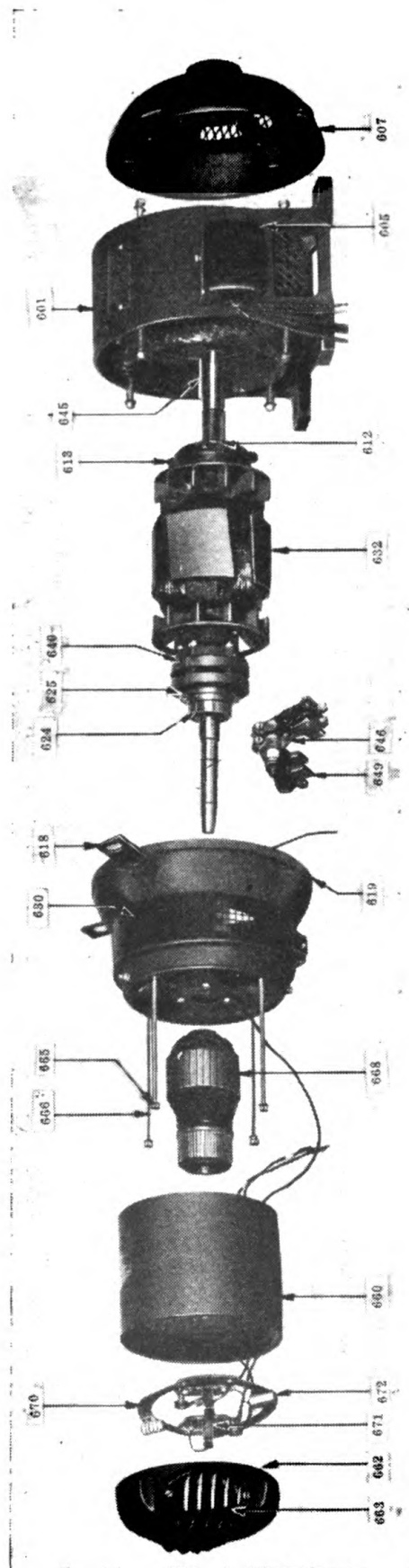

Figure 52.—Exploded View of Generator Exciter Unit

SECTION V

Ref. No.	NAME and DESCRIPTION	FUNCTION	Mfg. Part No.	MFG.
671	2 Carbon brush		S-50211	J
672	2 Capacitor for brushholder ring, .1 Mfd.	Radio noise suppressor		
<i>d. Skid Base Group.—</i>				
1	Skid Base complete		5224	L
1	Frame, skid base	Supports engine, control cabinet and generator platform	4739-A	L
1	Platform, generator	Pivot support for generator platform	4747	L
1	Pivot bolt 1/2-13x11"	Adjustable support for A.C. generator	4737-A	L
1	Nut, hex 1/2-13		NI-213R	L
1	Lockwasher, split 1/2"		SW-7	L
2	Bolt, hex 5/8-11 x 4" threaded full length	Provides adjustment of main belt drive	H5-811-6416	L
2	Lockwasher 5/8 I.T.		EW5-81	L
4	Nut, hex 5/8-11 light jam		N-5811J	L
2	Nut, hex 5/8-11		N-5811R	L
<i>c. V-Belt Drive Group.—</i>				
1	Main engine pulley, 5 groove		5B54B	R
1	Main generator pulley, 5 groove		5B66B	R
1	Matched set of 5 non spark v-belts		B-35	R
1	Engine-charging generator pulley		ILA30	R
1	Charging generator v-belt		FHP-122	R
1	Key for engine shaft, 3/8 x 3/8 x 4 1/2"		4708	L
1	Key for A.C. generator shaft 1/4 x 1/4 x 3 1/4"		4709	L
1	Belt guard - left	Protection against injury from belts	47486	L
1	Belt guard - right	Protection against injury from belts	4748R	L
1	Belt guard brace	Reduce vibration of belt guards	4948	L

POWER UNIT PE-93-F

Ref. No.	Name and Description	FUNCTION	Mfg. Part No.	MFG.
<i>g.</i> Control Panel Group				
1	Cabinet housing	Encloses control panel and remote control assembly	5226	L
1	Remote control assembly	Provides means of starting and stopping engine from a remote location	4873A	L
1	Cover pan	Encloses relays in remote control assembly	4810	L
1	Terminal block, power, 3 phase	Connects power leads	4758	L
1	Terminal block, remote, 3 wire	Connect remote control leads	4757	L
1	Receptacle, power, 3 phase	Connect power plug	AR-637	T
1	16" length of 1" flex conduit	Protective enclosure for generator leads	4788	L
1	Connector, 1 inch	Connect 1" flex conduit	5227	L
1	Connector, right angle 1 inch	Connect 1" flex conduit	4789	L
1	Back pan	Encloses back of control cabinet	4808	L
1	Oil can holder		5228	L
1	Oil can		4825	L
1	Terminal block, magneto		5229	L
1	Magneto lead support	Provides terminal post for connecting condenser	4882	L
2	15" length of 1/2" flex conduit	Protective enclosure for engine wire leads	4806	L
4	Connector, 1/2 inch	Connect 1/2" flex. conduit	4807	L
<i>f.</i> Control Cabinet Group				
1	Control panel complete	Provides instruments, switch receptacles, etc.	5222	L
1	Panel board, 1/8" steel		4752B	L
1	A.C. voltmeter, 0-150 volts	Measures A.C. voltage	8A022VAX26M	I
1	Frequency meter	Measures A.C. cycles	31-F	P
1	Elapsed time meter	Measure total time unit has operated since mfg.	8KT8Y18	I
3	A.C. ammeter 0-50 amps.	Measures A.C. amperes	8A022ACY18	I
1	Battery charging ammeter	Measures charging rate	4706	L
1	Phase selector switch, A.C. volts		4774	L
1	Rheostat, Exciter field	Regulates voltage manually	51003.2-1	M

SECTION V

Ref. No.	No. Req.	NAME and DESCRIPTION	FUNCTION	Mfg. Part No.	MFG.
1		Rheostat regulator voltage adjustment		16718-1	M
1		Voltage regulator	Regulates voltage automatically	No. 5660	M
1		Sub-base, voltage regulator	Quick disconnect shock mtg. for voltage regulator	4781	L
1		Circuit breaker	Makes or breaks load circuits	SK-117786	Q
1		Automatic manual voltage control switch		4734	L
1		Automatic manual starting switch		4733	L
3		Push buttons, start-stop		XA-456	K
1		Duplex convenience receptacle	Provides single phase 120 volts A.C. current	3860	L
1		Remote control receptacle	For remote control cable	4787	L
2		Panel lights		4715	L
4		Shock mounts		4732	L
<i>h. Charging Generator Group</i>					
1		Battery charging generator		GEF-4805A	K
1		Frame & field assembly		(GEF-2001)	K
1		Washer, ins., arm. term.		GAA-32	K
1		Ins., terminal post, inner		GAL-44	K
1		Washer, ins., field term.		GBW-34	K
1		Bushing, ins. arm term.		GCT-25	K
1		Bushing, ins., field term.		GCY-25	K
2		Pole piece		GDZ-29	K
1		Ins., Term. Post, inner		GEA-34	K
1		Coil assy., field comp.		GEF-1005	K
1		Post, terminal, field No. 10-32		GBW-58	K
1		Post, arm. term., No. 14-24		GEA-27	K
1		Lead assembly		GEA-30	K
1		Terminal		X-847	K
1		Coil, field, left		GEF-1007	K
1		Coil, field, right		GEF-1008	K

POWER UNIT PE-99-F

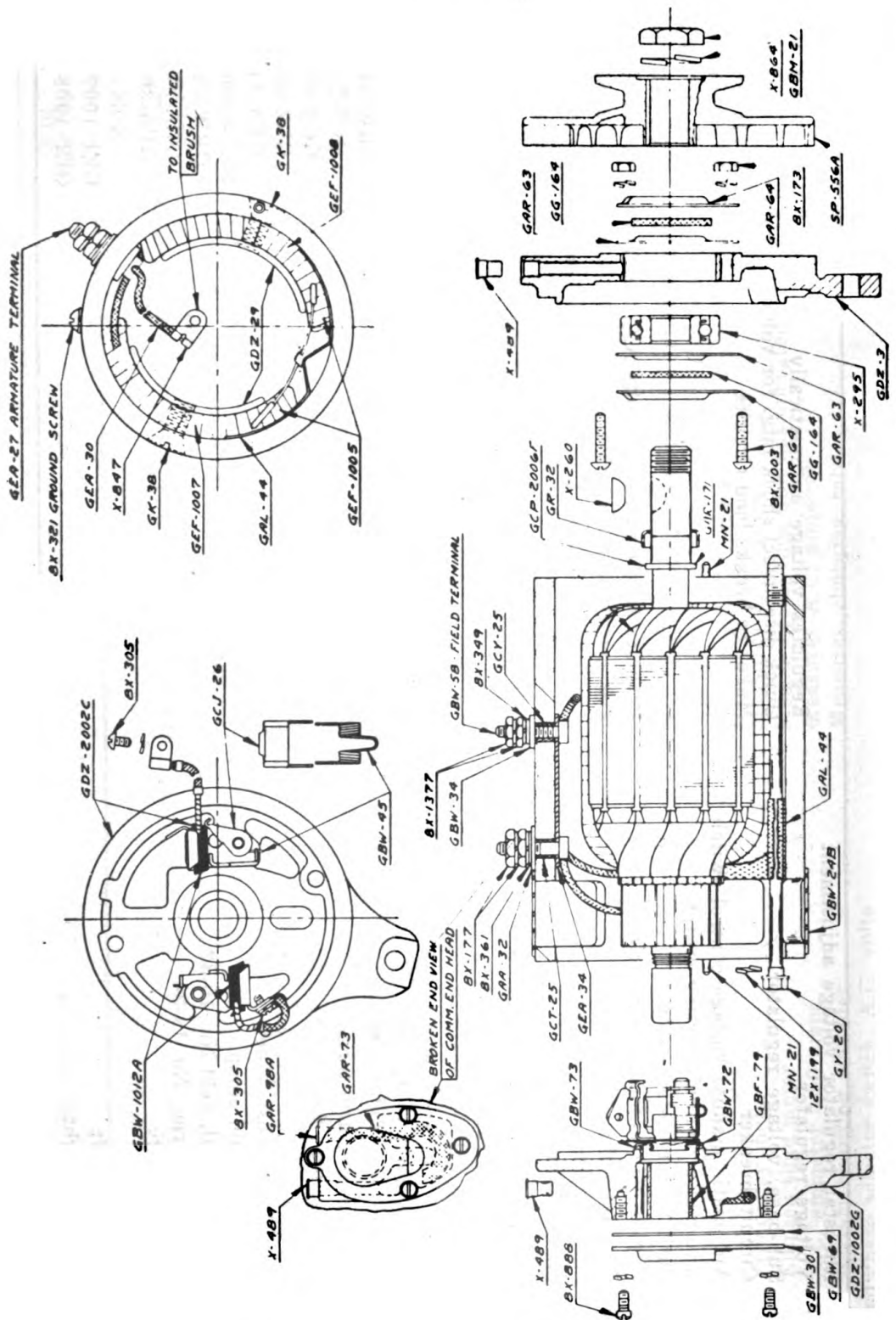

Figure 53.—Battery Charging Generator

SECTION V

No. Req.	NAME and DESCRIPTION	Mfg. Part No.	MFG.
2	Screw, pole piece	GK-38	K
2	Pin, dowel, 1/8 x 7/16	MN-21	K
1	Nut, hex. No. 14-24	8X-177	K
1	Washer, lock, No. 14	12X-193	K
1	Washer, lock, No. 10	12X-196	K
1	Washer, Plain, No. 10	8X-361	K
1	Washer, plain, 1/4	8X-321	K
1	Nut, hex., No. 10-32	8X-1377	K
2	Screw, frame	GY-20	K
1	Nut, hex., No. 14-24	8X-177	K
1	Washer, lock, No. 14	12X-193	K
2	Washer, lock, No. 10	12X-196	K
2	Washer, lock, 1/4	12X-199	K
1	Screw, rd. hd., No. 10-32 x 5/16	8X321	K
1	Nut, hex., No. 10-32	8X-1377	K
1	Head assy., comm. end	(GDZ-2002C)	K
1	Wick, felt (1/4 x 2 1/4)	GAR-73	K
1	Cover, wick	GAR-98A	K
1	Cover, ocomm. end	GBW-30B	K
1	Oil Guard	GBW-72	K
1	Gasket, oil retaining	GBW-73	K
2	Brush	GBW-2012AS	K
1	Head assy., partial. comm. end	GDZ-1002G	K
2	Spring, brush	GBW-45	K
1	Brg., Absorbent bronze	GBF-79	K
2	Arm, brush	GCJ-26	K
5	Washer, lock, No. 8	X-195	K
1	Screw, rd. hd. No. 8-32 x 1/4	8X-305	K
1	Oiler, press-in type, 1/4	X-489	K

POWER UNIT PE-8-F

Ref. No.	No.	NAME and DESCRIPTION	FUNCTION	Mfg. Part No.	MFG.
4		Screw, fill. hd. No. 8-32 x 5/16		8X-888	K
1		Washer, lock, No. 8		X-195	K
1		Screw, rd. hd., No. 8-32 x 1/4		8X-305	K
1		Nut, armature shaft (hex. .699-20)		GBM-21	K
1		Armature assembly		GCP-2006F	K
1		Snap ring		GAR-171	K
1		Retainer, felt washer		GR-32	K
1		Pulley, drive		SP-556A	K
1		Key, woodruff, No. 5		X-260	K
1		Washer, lock, .669		X-864	K
1		Head assy., drive end		GDZ-1003	K
2		Retainer, felt washer		GAR-63	K
2		Retainer, bearing		GAR-64	K
1		Head		GDZ-3	K
2		Washer, felt (7/8 x 1 5/16 x 1/8)		GG-164	K
3		Nut, hexagon, No. 10-32		8X-173	K
3		Washer, lock, No. 10		X-196	K
1		Bearing, ball, S.A.E. No. 203		X-295	K
1		Oiler, press-in type, 1/4		X-489	K
3		Screw, rd. hd., No. 10-32 x 7/8		8X-1003	K
1		Band, head		GBW-24B	K
1		Screw, rd. hd., No. 10-32 x 1/4		8X-715	K
1		Nut, square, No. 10-32		8X-794	K
<b>Radio Noise Suppression (Group)</b>					
11		Condensers .1 Mfd.	Suppress radio noise	4760	L
5		Condensers .01 Mfd.	Suppress radio noise	4779	L
2		Bond strap 1" x 6"	Bonds generator platform to skid base	4883	L

SECTION V

Ref. No. No. Req.	NAME and DESCRIPTION	FUNCTION	Mfg. Part No.	MFG.
2	Bond strap 1" x 6"	Bonds generator to generator platform	4884	L
2	Bond strap 1/2" x 4 1/4"	Bonds battery generator to cast pulley guard	4932	L
1	Bond strap 1/4" x 4 3/4"	Bonds cover pan to exciter field rheostat	4933	L
5	Bond strap 1/2" x 3"	Bonds charging regulator to cover pan	4934	L
1	Bond strap 1/2" x 3"	Bonds control panel to frame	4935	L
3	Bond strap 1/2" x 4 1/2"	Bonds battery generator to cast pulley guard	4936	L
		Bonds voltage regulator to frame		
		Bonds battery generator to back pan		
		Bonds belt guards to A.C. generator.		
<i>j.</i> Cable Group				
1	Power cable		IGC6Z210	I
1	Power cable reel		4754-I	L
1	Remote control cable		IGC2C5	I
1	Remote control cable reel		4754-2	L
<i>k.</i> Starting Motor Group				
1	Brush - Grounded		MAK-1034	
2	No. 10 Lock Washer		X-196	
3	Frame Screw		MAK-79	
4	Brush Spring		MAK-19	
5	Tubular Rivet		X-521	
6	Brush Holder		MAK-16A	
7	Felt Pad		MAK-59	
8	Thrust Washer		MAK-55	
9	Connector and Brush Assembly		MBE-1044	
10	Brush		MAK-12	

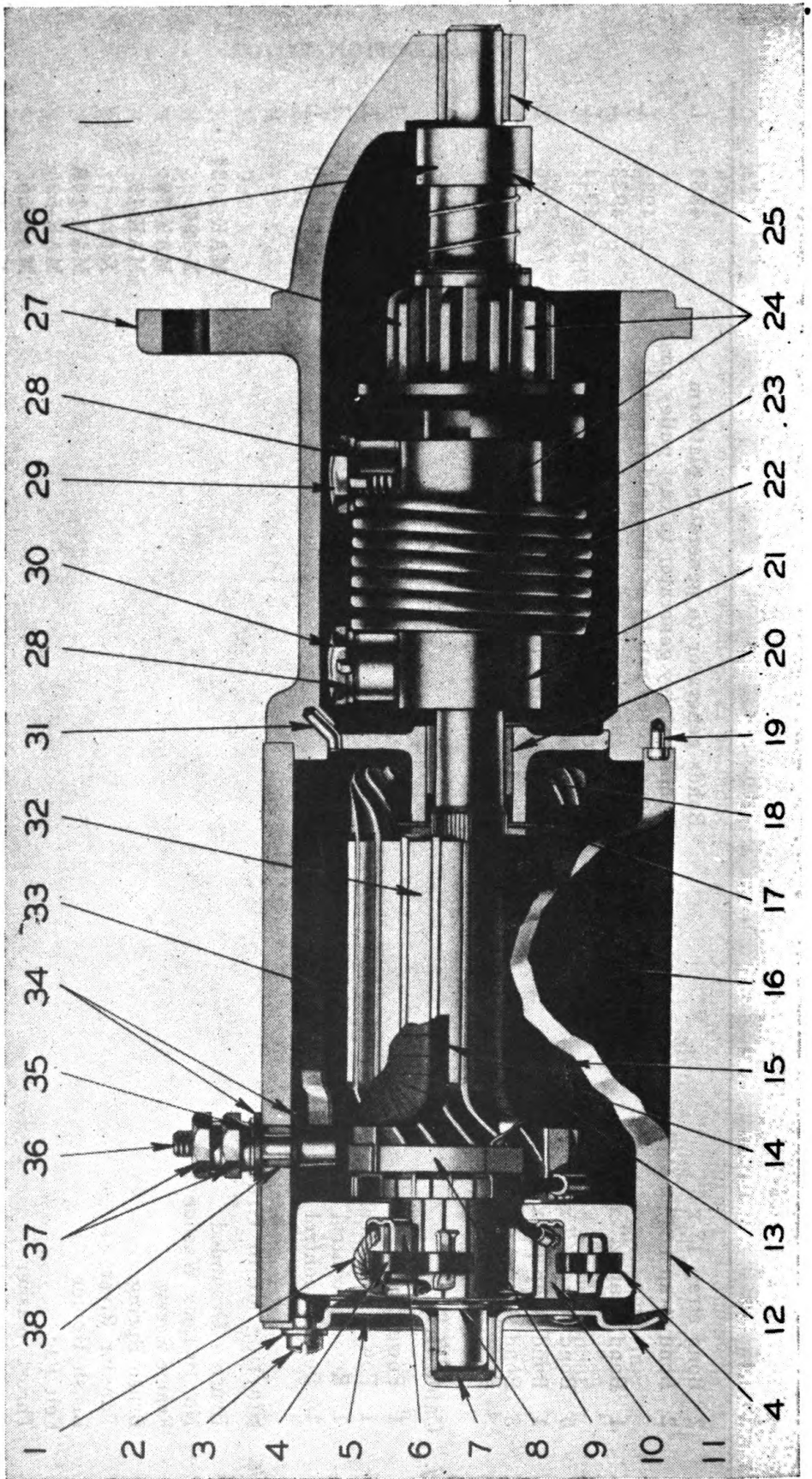

Figure 54.— Starting Motor

## SECTION VI

Ref. No.	NAME and DESCRIPTION	Part No.
11	Comm. End Head Assembly	MAK-3002
12	Head Band	GAS-1024C
13	Field Coil - L.R.	MBE-1008
14	Field Coil - U.R.	MBE-1007
15	Pole Piece	MAK-29
16	Pole Piece Screw	MZ-38
17	Thrust Washer	MU-54
18	Intermediate Brg. Assembly	MAK-2092
19	Dowel Pin	GBF-95
20	Absorbent Bronze Bearing	MZ-44-A
21	Driving Head	EB-8503
22	Compression Sleeve	EB-7819S
23	Drive Spring	EB-7805
24	Bendix Drive Assembly	EBA-56
25	Absorbent Bronze Bearing	MP-41A
26	S-A Assmebly	EBA-3611
27	Pinion Housing Assembly	PS-115C
28	Lock Washer	EB-108
29	Shaft Spring Screw	EB-7807
30	Head Spring Screw	EB-7806
31	Dowel Pin	MAB-88
32	Armature Assembly	MAK-2088
33	Field Coil - U.L.	MBE-1010
34	Insulating Washer	MAK-49
35	Plain Washer	MAK-50
36	Terminal Post	MBC-28
37	1/4-20 Hexagon Nut	5X-146
38	Insulating Bushing	MAK-51

POWER UNIT PE-99-F

SECTION VI  
54. Nuts, Bolts, Screws and Washers.—

Quan.	Size	Lgth.	Thrd.	Description	Where Used
1	No. 5		.40	Hexagon nut - Steel	For carburetor control rod
1	No. 6		32	Hexagon nut - Steel	Magneto ground screw
3	¼		28	Hexagon nut - Steel	For magnet ground wire Mounting partition plate For choke wire shield
22	¼		20	Hexagon nut - Steel	For mtg. air cleaner For mounting house brace For mounting crank clip For crank spacer For mounting tank to panel For governor adjusting screw pin For ignition wire clip
8	5/16		24	Hexagon nut - Steel	For upper to lower manifold For starter bracket For mounting oil filter
4	5/16		24	Hexagon nut - brass	For lower to upper manifold
8	5/16		24	Hexagon jam nut - steel	For valve tapper adj. screws
1	¾		24	Hexagon nut - Steel	For mounting magneto-stud
1	¾		16	Hexagon jam nut steel	For mounting magneto-screw
4	¾		16	Hexagon nut - Steel	For mounting engine side rails
4	¾		24	Hexagon nut - brass	Manifold to cyl. studs
12	7/16		20	Hexagon nut - Steel	Cyl. block to case studs
2	No.6			Standard lockwasher	Magneto ground screws Cam felt wick screw
9	No. 8			Standard lockwasher	Distributor block Magneto condenser mtg Breaker arm terminal Stationary bracket Support plate
	No.10			Standard lockwasher	For oil pump cover Magneto end cap

SECTION VI

Quan.	Size	Lgth.	Thrd.	Description	Where Used
50		1/4		Standard lockwasher	Crankcase splash plates Fuel pump adaptor Partition plate Air cleaner mounting House braces Crank support clip Crank support spacer Mounting tank to house spacer Ignition wire clip Cylinder heat deflectors Lower cylinder shroud Cylinder end covers
57	5/16			Standard lockwasher	Crankcase bottom cover Mounting carburetor Lower to upper manifold Mounting fuel pump Starter support bracket Mounting oil filter Air shroud to gear cover Gear cover mounting Gear cover spacer Governor housing mounting
10	3/8			Standard lockwasher	Manifold to cylinder mounting Magneto mounting Side rail mounting
12	7/16			Standard lockwasher	Cylinder block mounting Engine support mounting
4	1/2			Standard lockwasher	Flywheel screen mounting
42	1/4			"Everlock" internal-external lockwasher	Air shroud cover House braces House canopy House end panel Fuel tank to panel Rear panel to engine support

**POWER UNIT FE-30-F**

Quan.	Size	Lgth.	Thrd.	Description	Where Used
1	5/16			"Everlock" internal-external lockwasher	Gen. adjusting st
6	3/8			"Everlock" internal-external lockwasher	Main bearing plate
2	7/16			"Everlock" internal-external lockwasher	Generator bracket mounting
3	1/4			"Everlock" internal-external lockwasher	Ground wire shield
3	5/16			Everlock external lockwasher	Choke wire shield
4	5/16			"Everlock" counter-sunk lockwasher	For mounting camshaft
4	5/16			Plain washer - lead	For mtg. bearing retainer plate
2	29/64			Plain washer - 13/16 O.D.	Valve inspection cover
1	No. 6	3/8	32	Fillister head screw	Unit door clips
1	No. 6	1/2	32	Round head screw	Magneto cam felt wick
3	No. 8	5/16	32	Round head screw	Primary ground
					Condenser mounting
					Breaker arm terminal
					Stationary bracket
2	8	3/8	32	Round head screw	Bearing and breaker support plate
2	8	3/8	32	Flat head screw	Bearing and breaker support plate
1	8	5/8	32	Round head screw	Wire connector on carburetor
1	8	5/8	32	Round head screw	Manual choke lever
4	8	9/16	32	Round head screw	Distributor block mounting
6	10	1/2	24	Round head screw	Oil pump cover
2	10	3/8	24	Flat head screw	Magneto extension plate
2	10	1/2	24	Fillister head screw	Magneto end cap
2	10	5/8	24	Fillister head screw	Magneto end cap
38	1/4	3/8	20	Round head screw	Cylinder heat deflector R. side
					Lower cylinder shroud
					Cylinder side cover
					Flywheel screen
					Cylinder shroud covers.
					Canopy
					Rear panel to support

## SECTION VI

Quan.	Size	Lgth.	Thrd.	Description	Where Used
17	¼	½	20	Round head screw	Ignition wire clip House braces Crank mounting clip Fuel tank to panel Partition plate Instruction plate Choke plate Front house panel
13	No. 4	¼		Parker Kalon self-tapping screw	Bearing retainer plate
4	5/16	¾	18	Flat head machine screw	Lower cyl. shroud R. and L. sides
4	¼	⅜	20	Hexagon head cap screw	Exhaust manifold tap
11	¼	½	20	Hexagon head cap screw	Splash plates
8	¼	¾	20	Hexagon head cap screw	Cyl. heat deflector R. and L. sides Cylinder heat deflector L.H. side Rear shroud cover Air cleaner mounting
1	¼	1	20	Hexagon head cap screw	Rear panel R.H. side
1	¼	2	20	Hexagon head cap screw	Crank spacer mounting
1	¼	3¼	20	Hexagon head cap screw	Rear panel L.H. side
6	5/16	½	18	Hexagon head cap screw	Air shroud to gear cover
16	5/16	⅝	18	Hexagon head cap screw	Fuel pump mounting Crankcase bottom cover Mounting spacer to gear cover and crankcase generator strap
8	5/16	¾	18	Hexagon head cap screw	Carburetor mounting
6	5/16	⅞	18	Hexagon head cap screw	Governor housing
3	5/16	1	18	Hexagon head cap screw	Camshaft gear mounting Cylinder head mounting
40	5/16	1¼	18	Hexagon head cap screw	Gear cover mounting
4	5/16	1½	18	Hexagon head cap screw	Cylinder head mounting
4	5/16	1¾	18	Hexagon head cap screw	Valve inspection cover
4	¾	¾	16	Hexagon head cap screw	Side rail mounting

POWER UNIT PE-89-F

Quan.	Size	Lgth.	Thrd.	Description	Where Used
6	3/8	1 1/4	16	Hexagon head cap screw	Main bearing retainer plate
1	3/8	2 1/4	16	Hexagon head cap screw	Magneto mounting, lower hole
2	7/16	1 1/4	14	Hexagon head cap screw	Generator bracket mounting
4	1/2	1	13	Hexagon head cap screw	Engine support mounting
4	1/4	3/8	20	Headless set screw	Starting crank pin Flywheel ring gear
2	1/4	3/4	20	Headless set screw	Magneto coil bridge
1	5/16	3/8	18	Allen head set screw	Idler gear mounting
2	1/8			900 street ell	Oil switch mounting For fuel pump inlet
1	1/8			450 street ell	For fuel line, in carburetor
2	1 1/4			450 street ell	For exhaust outlet
1	1/8			900 elbow	For oil switch mounting
2	1/8	3/4		W. I. pipe nipple	Fuel strainer to pump Shut-off cock
1	1/8	2		W. I. pipe nipple	Oil pressure switch mounting
1	3/8			W. I. pipe nipple	Oil drain
1	1 1/4	5 1/2		W. I. pipe nipple	Exhaust mounting
6	1/8	3/8		Slotted pipe plug	Oil pump lock screw hole Governor housing Oil spray nozzle holes
1	3/8	3/8		Slotted pipe plug	Gear cover
1	1/2			Expansion plug	Governor housing
2	5/8			Expansion plug	Camshaft oil hole
1	1 3/8			Expansion plug	Camshaft end hole
8	1/16	1/2		Cotter pin	Connecting rod
5	3/64	3/8		Cotter pin	Carburetor control rod Choke control rod Door clips
1	3/82	1		Cotter pin	Oil pump drive gear

SECTION VI

Quan.	Size	Lgth.	Thrd.	Description	Where Used
1	1/8	1		Cotter pin	Oil pump relief valve
1	1/8	3/4		Straight pin-steel	Oil pump gear
1	No. 0	3/4		Taper pin	Governor yoke
1	1/4			Steel ball	Oil pump relief valve
1	No. 1			Woodruff key	Oil pump gear
1	No. 3			Woodruff key	Magneto coupling hub
1	No. 8			Woodruff key	Crankshaft gear
1	No. 23			Woodruff key	Flywheel mounting
1	No. 50			No. 50 packard cable 68" long for magneto ground switch	On YD-89-A ground wire shield assembly
1	No. 50			No. 50 packard cable 48" long for automatic choke	On YD-52-A wire shield for automatic choke
20	No. 6		32	Hexagon nut steel	Mount meters
10	No. 8		32	Hexagon nut steel	Mount duplex receptacles
6	No. 10		32	Hexagon nut steel N.P.	Mount circuit breaker
46	1/4		20	Hexagon nut steel	Fasten magneto leads
					Fasten harness at rheostat leg
					Mount magneto terminal block
					Mount solenoid start switch
					Magneto terminal block post
					Mount condensers
					Mount terminal blocks
					Mount control cabinet
					Mount exciter field rheostat
					Mount charging regulator
					Fasten bonds
					Fasten motor ground
					Fasten battery ground
9	1/4		20	Hexagon nut brass	Remote terminal block
3	1/4		20	Wing nut brass	Remote terminal block
11	5/16		18	Hexagon nut steel	Mount 3 phase receptacle
					Mount charging generator
					Fasten 1" bonds

POWER UNIT PE-88-F

Quan.	Size	Legth.	Thrd.	Description	Where Used
4	3/8		16	Wing nut - steel	Battery clamps and covers
12	3/8		16	Hexagon nut brass	Power terminal block
12	1/2		13	Hexagon nut steel	Mount engine Mount A.C. generator
22	No. 6			Standard lockwasher - steel	Mount meters Mount duplex receptacles Mount remote receptacles
10	No. 8			Standard lockwasher - steel	Fasten magneto leads Mount circuit breakers Fasten wiring harness to rheostat leg
4	No. 10			Standard lockwasher - steel	Mount magneto terminal block Magneto terminal block post
61	1/4			Standard lockwasher - steel	Magneto terminal block post Mount terminal blocks Mount condensers Mount bonds Mount control cabinet Mount charging regulator Mount exciter field rheostat
21	5/16			Standard lockwasher - steel	Mount 3 phase receptacle Mount charging generator Mount 1" bond Mount control panel
19	3/8			Standard lockwasher - steel	Mount starting motor Fasten battery clamps and covers
12	1/2			Standard lockwasher - steel	Mount engine Mount A.C. generator
4	No. 8			Everlock - Internal lockwasher - steel	Fasten magneto lead

SECTION VI

Quan.	Size	Lgth.	Thrd.	Description	Where Used
6	No. 10			Everlock - Internal External lockwasher - steel	Mount solenoid start switch Ground condenser case and shielding terminal at magneto terminal block mounting
54	¼			Everlock - Internal External lockwasher - steel	Mount condensers Mount bonds Mount control cabinet Mount charging regulator Mount belt guards Mount exciter field rheostat
18	5/16			Everlock - Internal External lockwasher - steel	Panel bonds Charging generator bonds 1" bonds Belt guard to A.C. generator Motor ground
1	¾			Everlock - Internal External lockwasher - steel	Belt guards to frame 1" generator bonds
4	½			Everlock - Internal External	Toggle switches to panel Push switches to panel
2	½			Everlock internal washer steel	Mount circuit breaker
3	¾			Everlock internal washer steel	Mount condensers Mount belt guards
4	No. 8			Plain washer - steel	Mount exciter field rheostat Motor ground
24	¼			Plain washer - steel	Battery ground
18	¼			Plain washer - brass	Remote terminal block
7	5/16			Plain washer - steel	1" Bonds Adjust charging generator
4	¾			Plain washer - steel	Fasten battery clamps and covers
15	¾			Plain washer - brass	Power Terminal block

Quan.	Size	Lgth.	Thrd.	Description	Where Used
22	No. 6	5/8	32	Screw, round head - steel	Mount meters
					Mount duplex receptacle
					Mount remote receptacle
6	No.	5/8	32	Screw, round head - steel	Fasten magneto leads
					Fasten harness at rheostat leg
4	No. 8	3"	32	Screw, round head - steel	Mount circuit breaker
2	No. 10	1/2"	32	Screw, round head - steel	Mount solenoid start switch
3	No. 10	1"	32	Screw, round head - steel	Mount magneto terminal block
					Magneto terminal block post
8	1/4	1/2	20	Cap screw, hex. head - steel	Mount charging regulator
					Mount Condensers
9	1/4	5/8	20	Cap screw, hex. head - steel	Mount condensers
					Mount belt guards
					Mount charging regulator
9	1/4	3/4	20	Cap screw, hex. head - steel	Mount bonds to pulley guard
					Mount condensers
					Mount remote terminal block
					Motor ground
17	1/4	1	20	Cap screw, hex. head - steel	Bond at belt guard
					Bond at cover pan
					Mount control cabinet
					Motor ground
					Battery ground
3	1/4	1 1/4	20	Screw, round head - steel	Mount exciter field rheostat
3	1/4	2 1/4	20	Stud, brass	Remote terminal block
8	5/16	1/2	18	Cap screw, hex. head - steel	Mount panel to frame
9	5/16	1	18	Cap screw, hex. head - steel	Mount charging generator
					Mount 1" bonds
3	3/8	1 1/8	24	Cap screw, hex. head - steel	Mount starting motor
4	3/8	1 1/2	16	Carriage bolt, steel	Fasten battery clamps and covers
3	3/8	3/4	16	Stud, brass	Power terminal block
8	1/2	1 1/4	13	Cap screw, hex. head - steel	Mount engine
4	1/2	1 3/4	13	Cap screw, hex. head - steel	Mount generator

## SECTION VII

## SECTION VII

## 55. List of Manufacturers.—

Key Letter	MANUFACTURER	ADDRESS
A	Wisconsin Motor Corp.	Milwaukee, Wisconsin
B	A. C. Spark Plug Company	Flint, Michigan
C	Timken Bearing Company	Canton, Ohio
D	Fairbanks-Morse Company	Beloit, Wisconsin
E	Michiana Products Company	Michigan City, Indiana
F	United Specialities Co.	Chicago, Illinois
G	Tillotson Manufacturing Co.	Toledo, Ohio
H	Bendix-Stromberg	South Bend, Indiana
I	General Electric Co.	Schenectady, N. Y.
J	Marathon Electric Mfg. Corp.	Wassau, Wis.
K	Electric Auto-Lite Co.	Toledo, Ohio
L	E. A. Laboratories, Inc.	Brooklyn, N. Y.
M	Ward Leonard Electric Co.	Mt. Vernon, N. Y.
N	Globe Union, Inc.	Milwaukee, Wisconsin
O	Champion Spark Plug Co.	Toledo, Ohio
P	J. B. T. Instruments, Inc.	New Haven, Connecticut
Q	Square D Company	Detroit, Michigan
R	Browning Mfg. Co. Inc.	Maysville, Kentucky
S	Nelson Muffler Corp.	Stoughton, Wisconsin
T	Crouse-Hinds Co.	Syracuse, N. Y.



