

End U113
12
TM
1943

TM 11-923G

WAR DEPARTMENT TECHNICAL MANUAL

U.S. Dept. of Army

POWER UNIT

PE-99-G

WAR DEPARTMENT • 27 DECEMBER 1943

POWER UNIT

PE - 99 - G



WAR DEPARTMENT • 27 DECEMBER 1943

United States Government Printing Office

Washington : 1945

WAR DEPARTMENT
WASHINGTON 25, D. C., 27 December, 1943

TM 11-923G, Power Unit PE-99-G, is published for the information and guidance of all concerned.

[A. G. 300.7 (27 Dec. 43)]

BY ORDER OF THE SECRETARY OF WAR:

G. C. MARSHALL,
Chief of Staff

OFFICIAL:

J. A. ULIO,
Major General
The Adjutant General.

DISTRIBUTION: X

(For explanation of symbols see FM 21-6)

U113
 12
 TM11:923G
 1943
 ☆ ☆

TABLE OF CONTENTS

	Par.	Page
SECTION I. Description		
Description	1	1
SECTION II. Installation and Operation		
Initial Procedure	2	7
Installation	3	7
Preparation for Use	4	9
Operation	5	13
Operation After Starting	6	13
SECTION III. Functioning of Parts		
Fuel Pump	7	16
Automatic Choke	8	16
Starting Motor	9	18
Magneto	10	18
Main Voltage Regulator	11	19
SECTION IV. Maintenance		
Lubrication	12	21
Battery Charging Generator	13	21
Disassembly of Connecting Rod, Piston, etc.....	14	23
Disassembly of Oil Pump	15	23
Disassembly of Cylinders	16	24
Disassembly of Camshaft	17	25
Disassembly of Governor	18	25
Disassembly of Crankshaft	19	25
Carburetor	20	26
Magneto	21	30
Fuel Pump Service	22	32
Charging Generator	23	37
Battery Charging Regulator	24	42
Main Generator	25	44
Main Voltage Regulator	26	46
Automatic Choke	27	47
Spark Plugs	28	48
Trouble Chart	29	49
SECTION V. Supplementary Data		
Table of Replaceable Parts	30	53
Table of Nuts, Bolts and Washers	31	97
Names and Addresses of Manufacturers	32	109

LIST OF ILLUSTRATIONS

Fig. No.	TITLE	Page
1	Power Unit PE-99-G, right quarter view	VI
2	Power Unit PE-99-G, right side view	5
3	Power Unit PE-99-G, left side view	5
4	Power Unit PE-99-G, rear view	6
5	Cable Reels, tool box	6
6	Lubrication diagram	8
7	Instrument panel, front view	11
8	Instrument panel, rear view	12
9	Fuel pump, cross section	15
10	Automatic choke	17
11	Main A.C. generator	22
12	Carburetor	27
13	Timing diagram	28
14	Magneto details	33
15	Battery voltage regulator	34
16	Engine, sectional view	52
17	Engine magneto, side view	55
18	Engine starter, side view	56
19	Spark Plug Shielding	63
20	Starting motor	64
21	Battery voltage regulator parts	67
22	Automatic choke parts	68
23	Carburetor parts	73
24	Fuel pump parts	74
25	Air filter	77
26	Fuel strainer	78
27	Charging generator parts	81
28	Magneto parts	82
29	Exciter and Field coils, main A.C. generator	89
30	Frame assembly, main A.C. generator	90
31	Voltage regulator, inside view	94
32	Voltage regulator, main generator	95
33	Installation diagram	106
34	Power unit PE-99-G wiring diagram	107
35	Power unit PE-99-G schematic diagram a.c. and d.c. circuit	108

DESTRUCTION NOTICE

WHY—To prevent the enemy from using or salvaging this equipment for his benefit.

WHEN—When ordered by your commander.

HOW—1. Smash—Use sledges, axes, handaxes, pickaxes, hammers, crowbars, heavy tools, etc.

2. Cut—Use axes, handaxes, machets, etc.

3. Burn—Use gasoline, kerosene, oil, flame throwers, incendiary grenades, etc.

4. Explosives—Use firearms, grenades, TNT, etc.

5. Disposal—Bury in slit trenches, foxholes, other holes. Throw in streams. Scatter.

6. USE ANYTHING IMMEDIATELY AVAILABLE FOR DESTRUCTION OF THIS EQUIPMENT.

WHAT—1. Smash—Engine cylinder head, manifolds, carburetor, cylinder blocks, crankcase, generator frame, control panel instruments, magneto, fuel filter, oil filter, and air filter.

2. Cut—Generator drive belts, remote fuel pipe, exhaust tube, power cable, remote control cable, and all other wires and cables in or on the unit. Cut armature and field windings.

3. Bend and/or break—Gas tank, engine housing, control cabinet, tool box, mounting frame and control panel.

4. Burn—All manuals, wire, oil and fuel.

5. Bury or Scatter—Any or all of the above pieces after breaking.

Destroy Everything

SAFETY NOTICE

This unit generates voltage which may cause severe and possibly fatal shocks. Always trip the main circuit breaker before attempting to change load connections. Disconnect the remote control before working on the unit.

Provide proper ventilation when operating the unit in confined space. Locate the exhaust, when operating the unit out of doors, so that the wind will carry exhaust gases away from personnel. Exhaust gases contain carbon monoxide which is odorless and deadly poison.

Do not service with gasoline while the unit is in operation or in close proximity to an operating radio transmitter. Avoid spilling gasoline when filling the fuel tank.

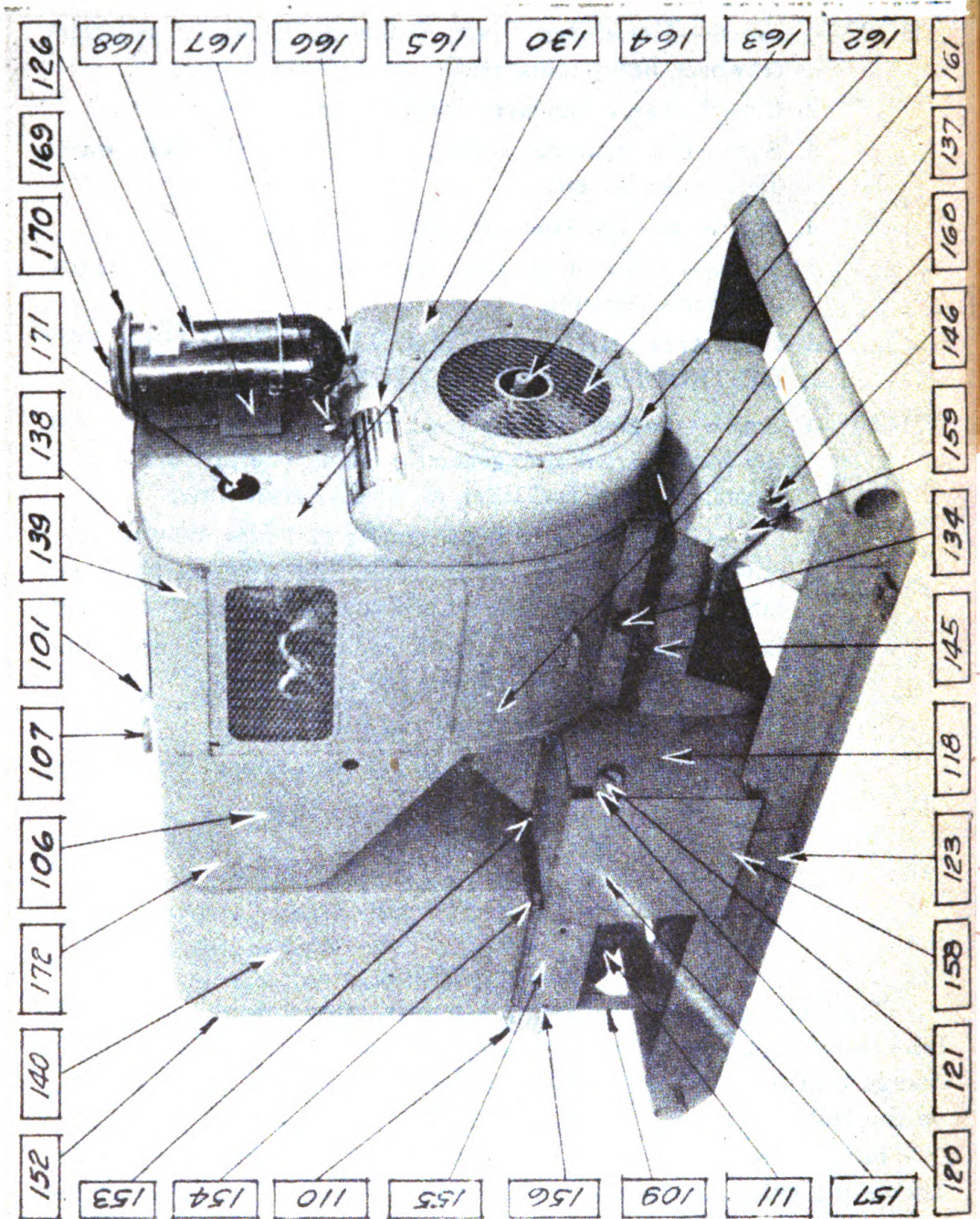

FIGURE 1.—Power Unit PE-99-G, right quarter view.

SECTION I

DESCRIPTION

1. **Description.** Power Unit PE-99-G is a complete gasoline-engine driven electric generating set, designed to generate alternating current of $7\frac{1}{2}$ KVA capacity, 120 volts, 3 phase, 60 cycle. It consists primarily of three main component parts:

- a. **Engine.** The engine is a four cylinder, four cycle, V-type air cooled unit, $3'' \times 3\frac{1}{4}''$ bore and stroke, with a piston displacement of 91.9 cu. in. Its operating speed is approximately 2200 r.p.m. at which it develops 20.5 h.p.
- b. **Generator.** The generator is a semi-enclosed drip-proof machine, rated at $7\frac{1}{2}$ KVA, 100% power factor, 120 volts, 60 cycles, 3 phase, 1800 r.p.m., and is driven by means of 5 V-belts of 36.5" pitch-length.
- c. **Control Cabinet Assembly.** This assembly consists of a $\frac{1}{8}''$ steel instrument panel mounted on rubber supports in a steel frame-work and fitted with a removable steel cover. Two doors are provided which swing outward to permit access to the controls and instruments mounted on the panel. On this panel are mounted all instruments and controls for the operation of the unit. This entire control cabinet assembly can be removed from the unit with a minimum of disturbance in connection with the other main component parts. The instrument panel controls, etc., consist of the following:

- 1—AC Voltmeter
- 1—Phase Selector Switch
- 1—AC Ammeter
- 1—Elapsed Time Meter
- 1—Exciter Field Rheostat
- 1—Frequency Meter
- 1—Start-Stop Push Button Station
- 1—Main Circuit Breaker

- 1—Automatic Voltage Regulator
- 1—Voltage Regulator Control Rheostat
- 1—Voltage Regulator OFF-ON Switch
- 1—Battery Charging Ammeter
- 2—Panel Lights
- 1—Manual Reset Control
- 1—Duplex Convenience Receptacle

- d. The above three main components of Power Unit PE-99-G are securely mounted on a structural steel skid base. Cross members at each end of the base are made of pipe to facilitate the insertion of lifting bars for easy handling.
- e. **Fuel:** Fuel for this unit is gasoline and is normally supplied from the 9¾ gallon tank attached to the unit. Provision is also made to permit drawing fuel from a remote tank by means of the flexible fuel line provided with the tool equipment. Fuel consumption is approximately two gallons per hour at full load.
- f. **Operating Temperatures:** Power Unit PE-99-G will operate in any temperatures ranging from —30°F. to 120°F. and care should be taken to see that the proper grade lubricating oil is used in accordance with lubricating instructions for various temperatures.
- g. **Frequency:** Power Unit PE-99-G will deliver current at a frequency of 60 cycles with a variation of 4 cycles when operated between no load and full load at the designated power factor.
- h. **Voltage:** The automatic voltage regulator will maintain terminal voltage within plus or minus 3% from no load to full load.
- i. **Dimensions and Weights of Main Components:**

	Length	Width	Height	Weight Lbs.
Engine	36"	22½"	30"	500
Generator	30½"	13"	13"	300
Control Cabinet				
Assembly	15"	22⅝"	38½"	75
Complete Unit	60"	28"	41"	1080

j. **Panel Board.** (Figures 7 and 8)

- (1) The panel board mounted inside the control cabinet is for the purpose of concentrating at one point all of the controls and instruments used in connection with the operation of this unit. All such functions as starting, stopping, applying load, etc., originate at this control panel.
- (2) The instruments and controls mounted on this panel, as indicated on Figure 7, and their functions are as follows:
 - (a) Voltmeter (77) is for measuring the electrical pressure being developed by the A.C. Generator. This is normally 120 volts.
 - (b) The Frequency Meter (78) is for measuring the frequency in cycles of the A.C. Generator. This is normally 60 cycles.
 - (c) The Elapsed Time Meter (79) indicates the total hours the unit has been in actual operation.
 - (d) Panel Lights (72) are for lighting the panel in darkness.
 - (e) Voltmeter Selector Switch (73) is for transferring the reading of the Voltmeter (77) from one phase to another of the A.C. Generator.
 - (f) Battery Charging Ammeter (81) measures the charging current being supplied by the battery generator.
 - (g) Start-Stop Switch (80) is for starting and stopping the unit.
 - (h) Exciter Field Rheostat (75) is for manually controlling the terminal voltage of the A.C. Generator. Turning to right increases voltage; turning to left decreases voltage.
 - (i) Voltage Regulator Switch (74) is for placing the automatic voltage regulator in operation. When this switch is on, the voltage is automatically controlled; when this switch is off, the voltage is controlled manually by the Field Rheostat (75).
 - (j) Main Circuit Breaker (82) is for connecting and disconnecting the generator to and from the main output receptacle or terminal block.

- (k) Voltage Regulator Control Rheostat (76) is for adjusting the automatic voltage regulator to maintain the desired voltage.
- (l) Manual Reset Control (83) is used for tripping the stopping relay in case it is desired to crank the unit manually.
- (m) Duplex Convenience Receptacle (84) is for convenience in taking comparatively light loads from the unit without using the main power cable.
- (n) A.C. Ammeter (71) is for the purpose of measuring the current flow in each phase of the A.C. Generator. Full load on this unit is 36 amperes, and it should not be operated under any circumstances when these meters read in excess of this value.

k. Cabinet Structure.

- (1) This structure is of welded steel construction and may be removed in its entirety from the unit proper by disconnecting the wires from the terminal blocks and removing the four bolts by which it is attached to the base assembly.
- (2) The following parts are attached to this structure and their descriptions and functions are as follows:
 - (a) Main Power Receptacle (No. 110, Fig. 2) is for the purpose of delivering the full power developed by this unit. The Plug (No. 10, Fig. 5) which is attached to the end of the main power cable fits this receptacle and should be used at all times, except when using a cable not fitted with this type plug. Then it is permissible to take full power from the unit from the output terminal studs (No. 143, Fig. 2) located on the right-hand under side of this structure.
 - (b) Remote Control Receptacle (No. 113, Fig. 3) is for connecting the remote control power cable (No. 3, Fig. 5) to the unit. This cable has a plug attached which fits this receptacle. This connection should always be used, except in cases where a remote power cable is used not incorporating the proper plug. Under these conditions, the cable may be attached directly to the remote control terminal block located on the left lower side of the main control cabinet structure.

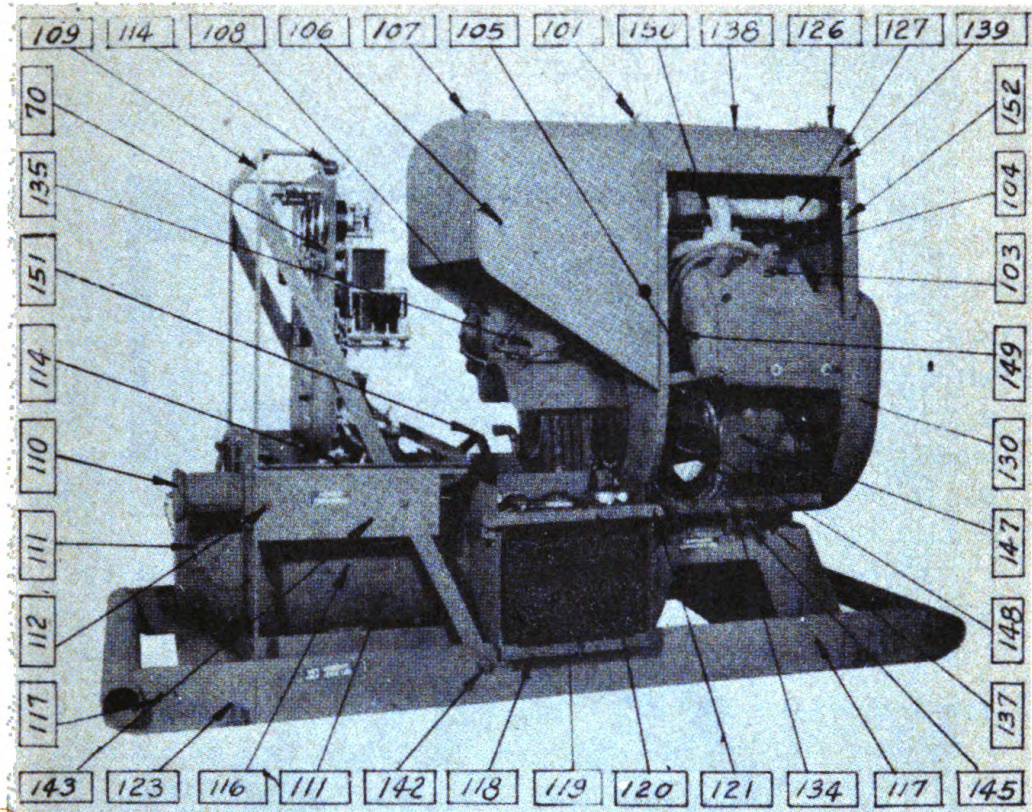

FIGURE 2.—Power Unit PE-99-G, right side view.

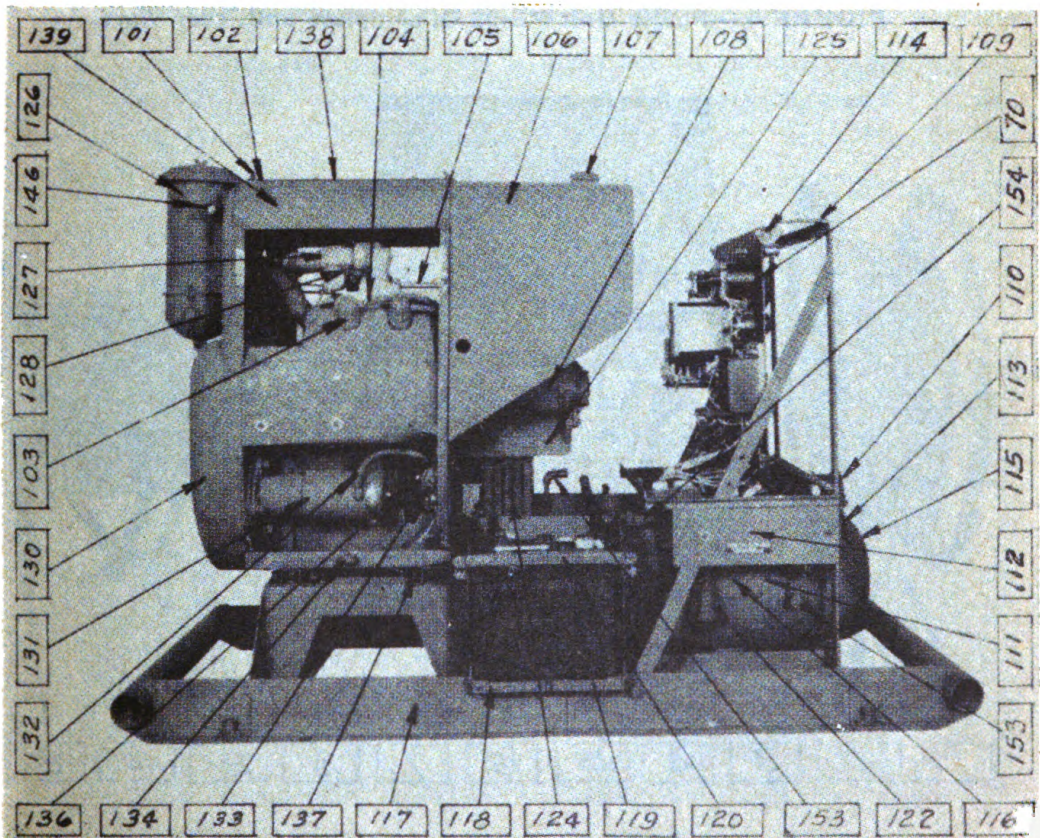

FIGURE 3.—Power Unit PE-99-G, left side view.

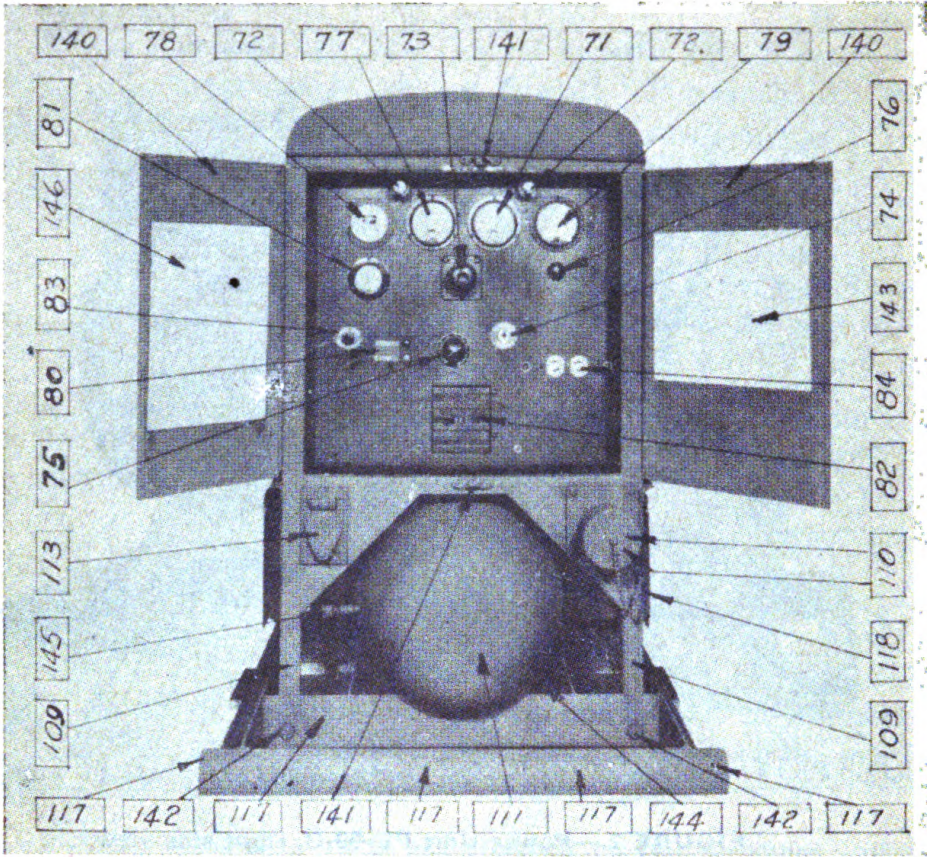

FIGURE 4.—Power Unit PE-99-G, complete unit, rear view.

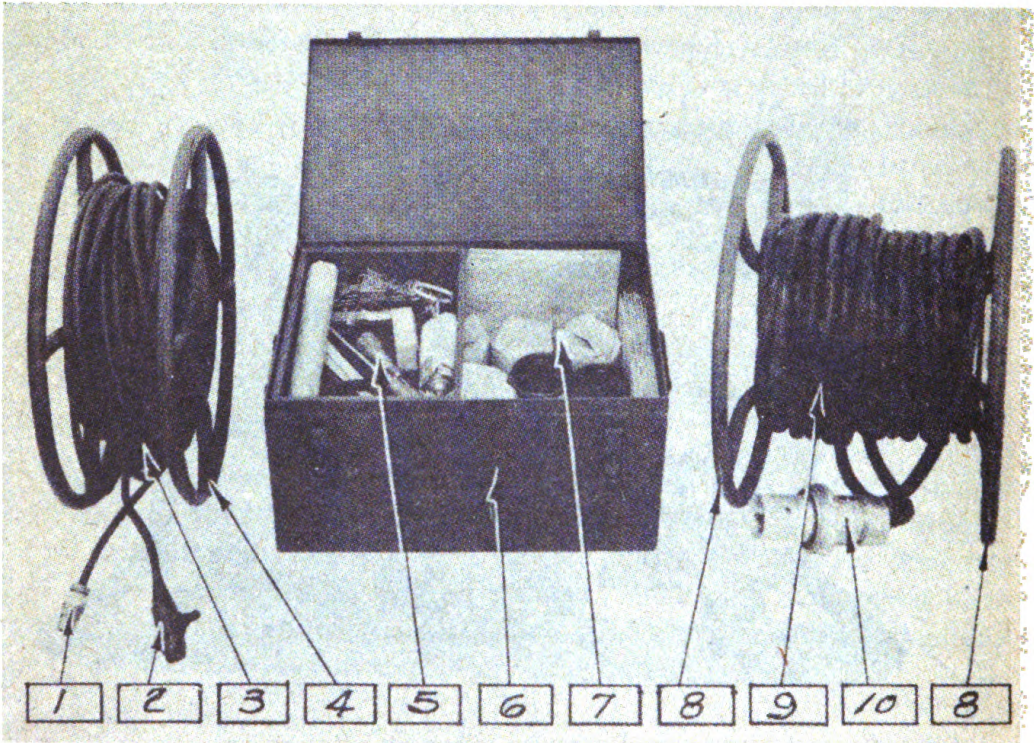

FIGURE 5.—Cable reels, tool box.

SECTION II

INSTALLATION AND OPERATION

2. **Initial Procedure.** Before uncrating the equipment, first inspect the equipment to be sure it is not damaged in any way and that it is complete as to the items listed on the packing list. If the shipment is found to be complete and in good order, it may be uncrated preparatory to mounting on foundation. Care should be exercised in uncrating to avoid damage to any of the parts.
3. **Installation.** Free circulation of air is necessary. This is very important for two reasons:
 - a. First, exhaust fumes from any gasoline engine are very poisonous if discharged in a closed space, but they are harmless if mixed with plenty of outside air. Therefore, in addition to piping the exhaust away from the engine, make sure that the compartment is amply ventilated to carry away any leaking exhaust fumes while the engine is in operation.
 - b. Secondly, free ventilation is necessary to avoid overheating of the engine. Provide suitable openings for ventilator to admit air from the outside.
 - c. **Exhaust Warning.** Observe carefully the instructions in regard to piping the exhaust to the outside. Keep the exhaust line as short as possible and as free of bends as possible to prevent excessive back-pressure. Be sure that it is free from leaks.
 - d. **Muffler.** A muffler is furnished with the unit and should be located as near the engine as possible. There is furnished with the unit a 10' length of flexible exhaust tubing, and provision is made for attaching the muffler directly to the engine or at the end of the flexible tubing.
 - e. **Accessibility.** Locate the engine foundation to allow ample space between the engine and any wall or surrounding objects. It is well to allow about three feet of space all around the engine for oil changing, cleaning, and general accessibility.

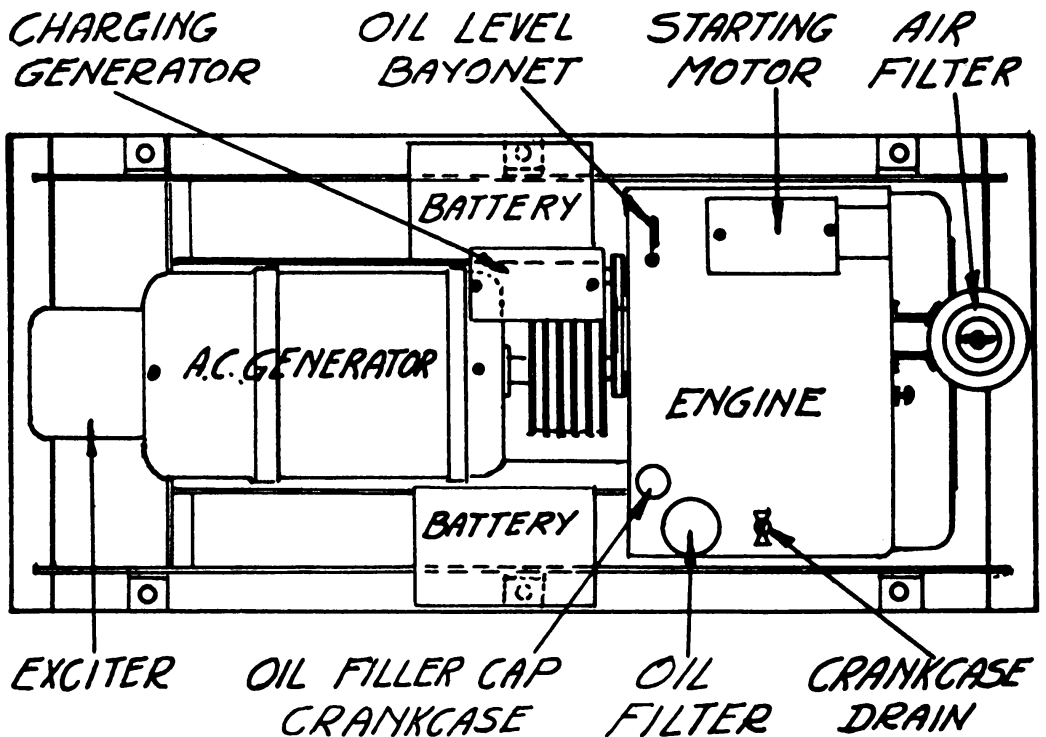

FIGURE 6.—Lubrication diagram.

4. **Preparation for Use.** Before starting for the first time, inspect the engine thoroughly and see that it is complete and in proper working order. Next, give the engine a few slow turns with the hand crank to be sure that all parts move freely. Make sure that the following preparations are made in the order named:
- a. Fill the crankcase with oil, approximately 4 quarts are required. See lubrication instructions paragraph 12a.
 - b. Place a few drops of oil in the oilers on the charging generator and starting motor. See paragraph 12a.
 - c. The generator bearings should be lubricated with a high grade ball bearing grease. See instructions paragraph 25. h.
 - d. Check Fuel. Be sure the fuel tank is full. In breaking in a new engine, mix about a pint of light cylinder oil to every three to five gallons of fuel during the first fifty hours of service. Blow through the vent in the fuel tank filler cap to be sure it is free of obstructions. Be sure the 3-way fuel valve is in the correct position to draw fuel from the supply to be used.
 - e. Check all wires to make sure they have not become loose in shipping.
 - f. Check the air cleaner. Be sure the connection to the carburetor is tight. Fill to indicated level with light lubricating oil.
 - g. Operate the switches, controls, etc., to make certain that they function properly.
 - h. To prepare batteries for use, the following instructions are to be followed:
 - (1) Remove sealing discs located on top or under vent plugs and make certain vent holes in all plugs are open.
 - (2) Fill cells to $\frac{3}{8}$ " above separators with electrolyte of not warmer than room temperature.
 - (3) Place the battery on charge at a 7 ampere rate. Continue charging at this rate until the gravity reading of each cell is between 1280 and 1290 or until there is no further rise in the gravity readings during a 3 hour charging period. While charging, the temperature of the electrolyte should not be permitted to rise above 110° F. Should the temperature of any cell exceed this maximum, reduce the charg-

ing rate or stop charging until the electrolyte solution in the cell or cells has cooled.

- (4) After permitting the electrolyte solution to cool all of the battery cells should be equalized by the addition or removal of electrolyte. If the reading of a cell is found to be high, remove electrolyte and add distilled water to equalize the solution with that in the other cells. If the reading of any cell is found to be low, remove some of the solution and add 1300 electrolyte until that cell has been equalized with the other cells of the battery. Place the battery back on charge for a few hours after equalizing the cells to thoroughly mix the solution. After allowing the battery to cool, it may be placed in service.
- i. If engine has been in storage for any length of time, remove the spark plugs and squirt two teaspoonsful of light cylinder oil in each cylinder to insure lubrication of the piston and cylinders when the engine first starts.
 - j. **Caution:** Always open the circuit breaker switch while connecting or disconnecting wires at the load terminals if the unit is in operation. This will remove the danger of being shocked.
 - k. After the load is applied, check the voltmeter again to be sure the desired voltage is being delivered by the unit. If not, adjust the automatic voltage regulator rheostat.
 - l. Should it become desirable to control the voltage manually, the automatic voltage regulator can be rendered inoperative by switching the voltage regulator switch to OFF. This will make it possible to entirely control the voltage by means of the exciter field rheostat Fig. 7 (75). Turning the rheostat to the right will increase the voltage while turning it to the left will decrease the voltage.
 - m. **Carburetor.** The carburetor on the engine has been carefully pre-adjusted for smooth and efficient operation. It should normally require no adjustment in the field. If the engine seems to miss occasionally, on the initial idling run, do not immediately adjust the carburetor. Usually it will smooth out after a few minutes of idling operating and the operation should be found to be satisfactory.
 - n. Condensed operating instructions will be found attached to the inside of the left-hand door of the control panel housing.

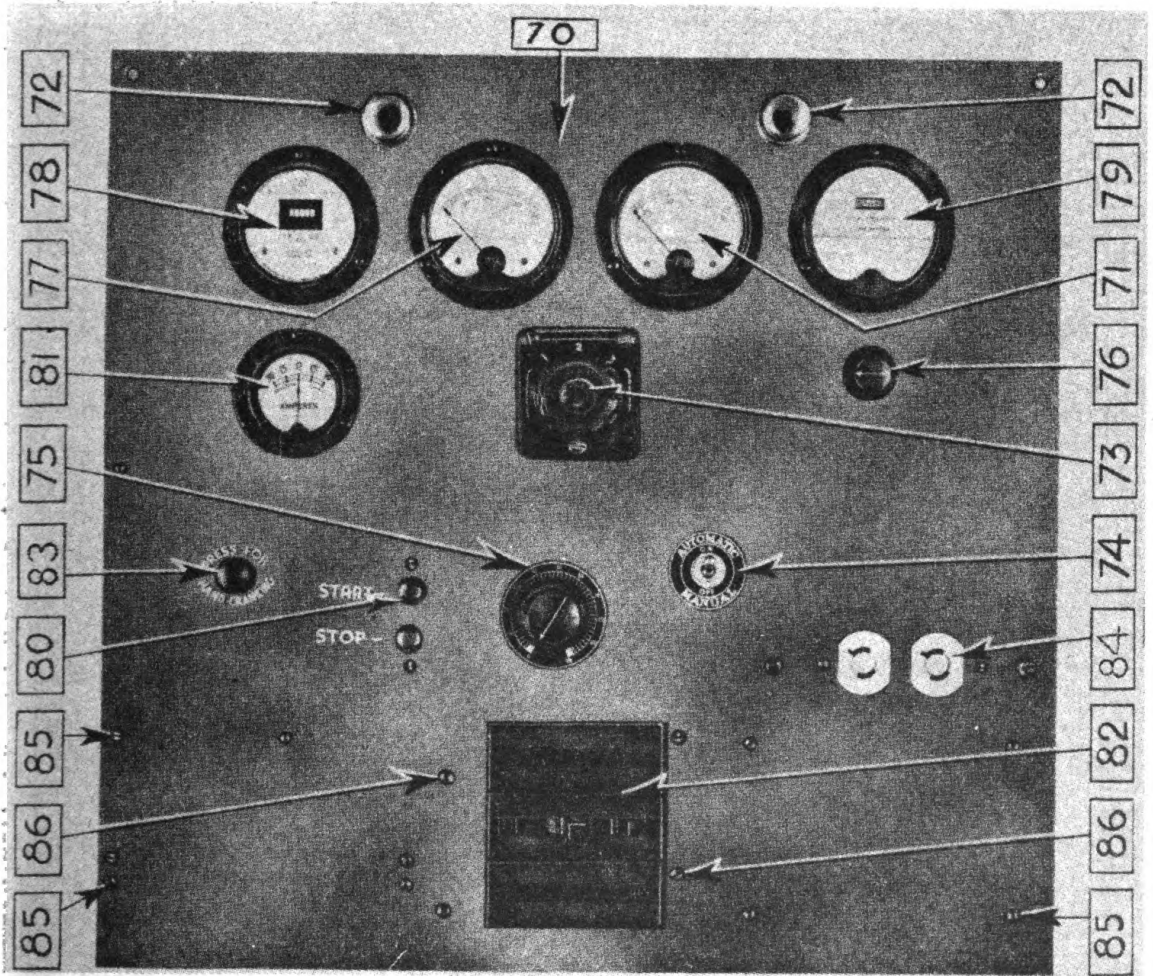

FIGURE 7.—Instrument panel, front view.

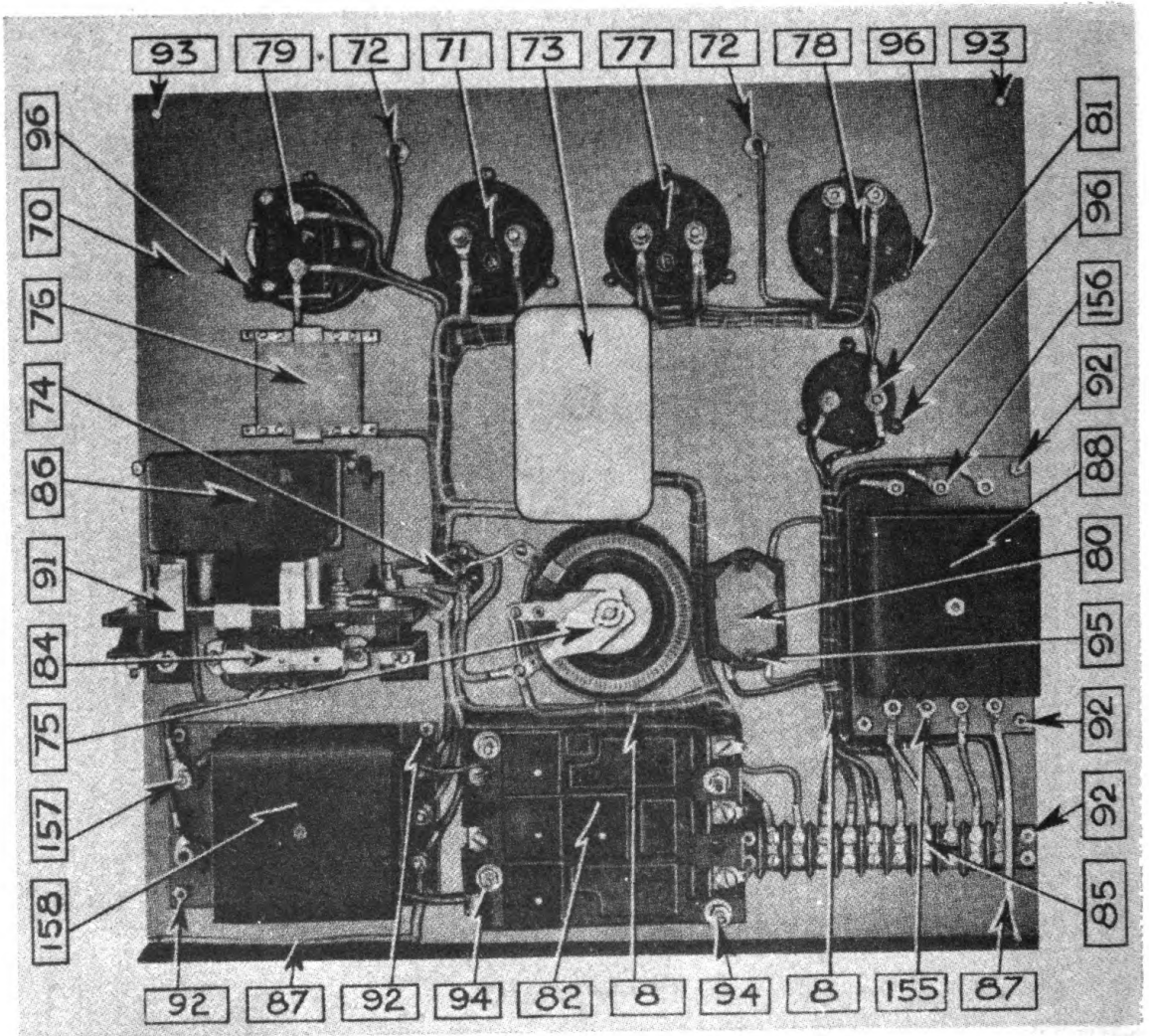

FIGURE 8.—Instrument panel, rear view.

- b. As quickly as the unit indicates that it is functioning properly, the load can be applied either by plugging into the side convenience receptacle, or by connecting directly to the a.c. output terminals Fig. 2, (143) on the right side of the unit and moving the circuit breaker handle to ON.
- c. The first time that the automatic voltage regulator is put into service it may be advisable to leave the field rheostat set for maximum resistance. After starting the motor-generator, set the control rheostat to mid-position, and slowly turn the exciter field rheostat to the "all-resistance-out" position and at the same time watch the a.c. voltmeter to make sure that the voltage does not rise to an abnormally high value. The regulator should begin to control the voltage at some value between 100 and 140 volts, as the rheostat resistance is reduced. If the voltage is not controlled in this manner an error in the external wiring of the regulator circuit is indicated and all wiring should be checked and the fault eliminated.

It is not necessary to take the regulator out of service in order to shut down the generator. Without touching the regulator, the generator may be shut down and later re-started as often as desired. The regulator automatically starts and stops with the generator.

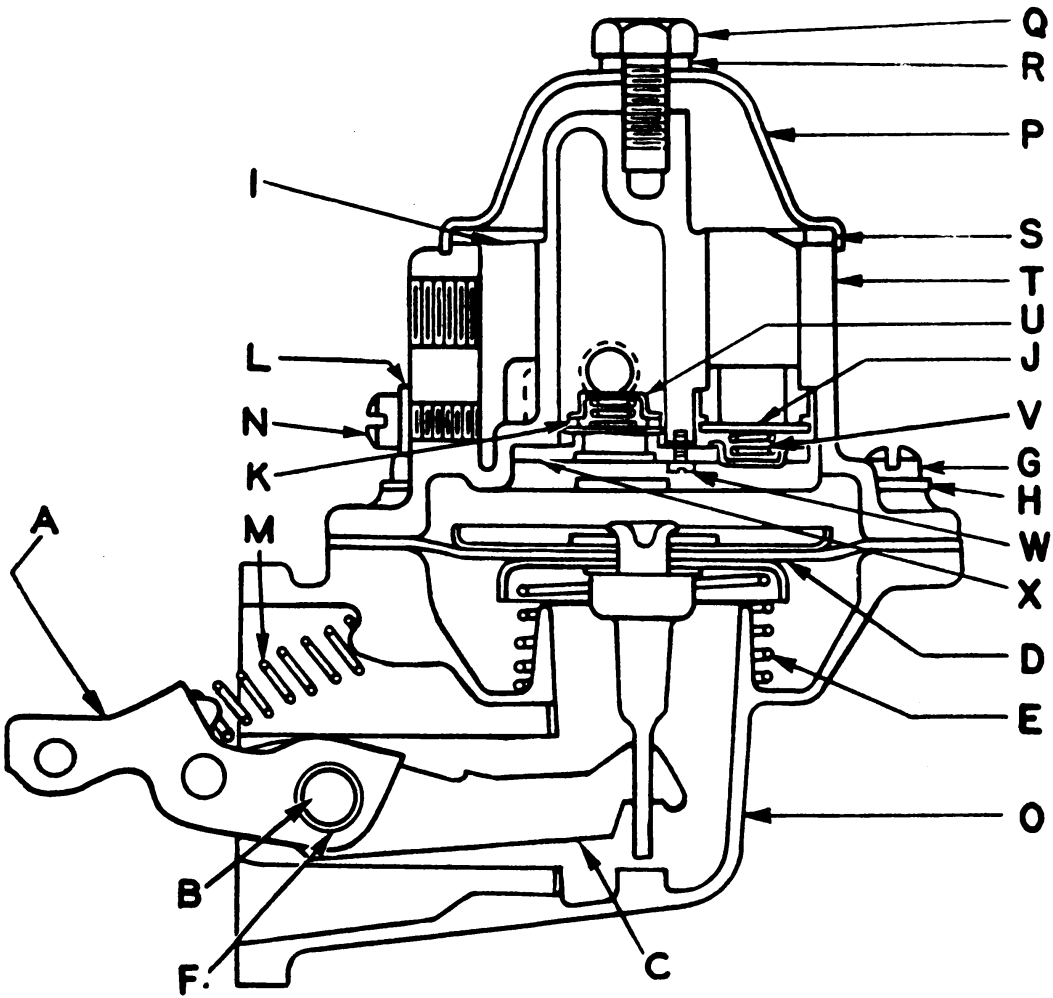

FIGURE 9.—Fuel pump, cross section.

SECTION III

FUNCTIONING OF PARTS

7. Fuel Pump. (Figure 9)

- a. The fuel pump mounts to the engine and is operated through a push rod which, in turn, is operated off of an eccentric on the engine camshaft. The fuel pump is of the diaphragm type. The sequence of operations is as follows: As the push rod on the engine deflects lever A, this in turn, operates lever C which pulls the diaphragm assembly, D, against the spring tension, E, and fills the fuel pump body, T, with gasoline. The outlet and inlet check valves, K, control the pumping action of the pump and as the pressure is built up in the gasoline line, the pressure will also be built up in the pump which will hold diaphragm B against the spring E and prevent the pump from operating. Spring E maintains the proper pressure in the fuel system.
- b. There is a screen S in the top dome of the fuel pump which will take out any solid matter that might be in the gasoline. The bowl also has a drain screw which will permit draining off any water that might accumulate in the body.

8. Automatic Choke (Figure 10)

- a. The Automatic Choke Control is built as a unit operating independently of the carburetor unit. While the function for the choke control unit is to furnish the proper amount of choke valve opening during the cranking and warming-up-period of the engine, its principles of operation depend entirely upon manifold vacuum and heat on the thermostat spring.
- b. The vacuum piston, link and lever assembly #6 is used to open the choke valve when the engine begins to fire. This operation is accomplished by means of a rod hook-up made from a lever on the automatic choke control unit to a choke lever attached to the choke stem and valve of the carburetor unit.
- c. The following paragraphs will describe the automatic choke control during its various stages of operation:

- (1) When the engine ignition is turned off and the engine allowed to stop, the heating coil (20) in the thermostat assembly (21) cools, since its source of heat, being derived from the current supplied by the charging generator is no longer present.
- (2) As the heating coil cools, the thermostat spring (17) also cools and gradually gains sufficient tension to rotate choke lever (15) closing the choke valve in the carburetor. The automatic choke control and choke valve remain in this position during the time when the engine is not in use and, also, during the cranking period.
- (3) The Thermostat Assembly (21) is directly connected at the hot wire post (10) by a wire to the charging circuit of the engine. Thusly, when the charging generator begins to deliver current, the thermostat heating coil (20) receives a charge of electricity which in turn produces heat.

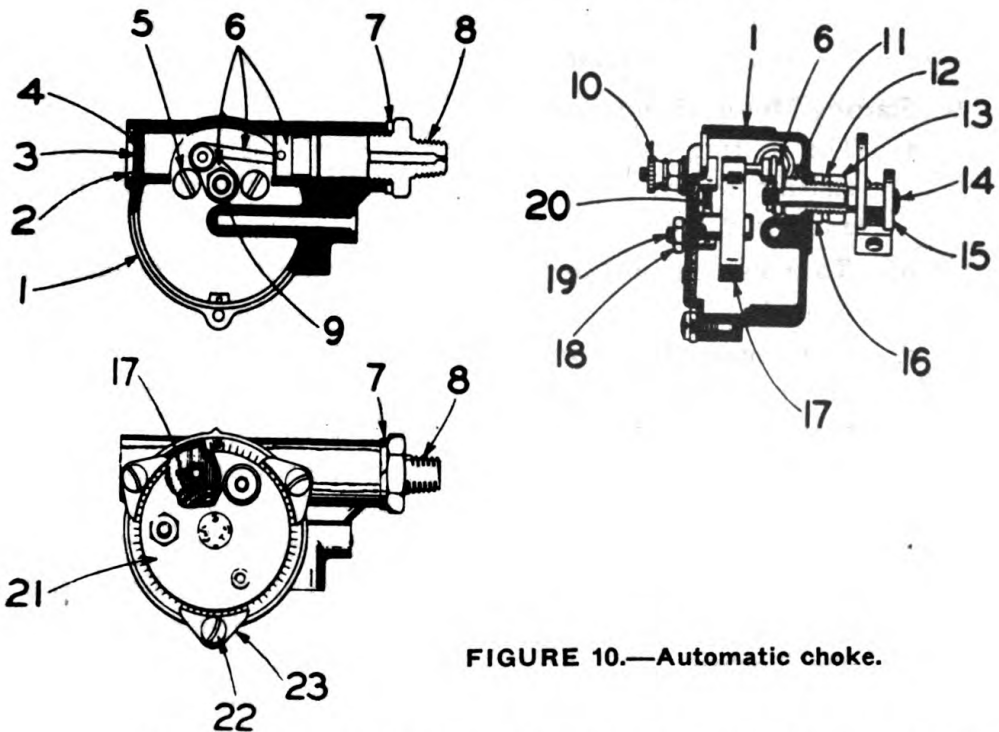

FIGURE 10.—Automatic choke.

- (4) After the engine is cranked and begins to fire, a manifold vacuum is created. The automatic choke unit, being connected by means of a tube running from the vacuum line union (8) to the intake manifold, is now subject to the manifold vacuum which is applied to the vacuum piston, link and

lever assembly (6). As mentioned above, the heating coil of the thermostat assembly starts to produce heat at the time charging generator starts and tends to heat the thermostat spring (17), which after a time will no longer furnish resistance and with the assistance of the vacuum piston, link and lever which is now being pulled in the opposite direction by the manifold vacuum, will allow the choke lever (15) also to rotate in the opposite direction from that which was necessary to choke the carburetor and allow the choke valve in the carburetor to open permitting the engine to operate normally.

The vacuum piston, link and lever (6), being subject to the manifold vacuum being created, tends to force the choke lever (15) in the opposite direction, as already explained in the preceding paragraph.

This action tends to operate the choke lever (15), opening the choke valve in the carburetor at the proper time that is required, since the thermostat spring when cooling does not release as readily as may be demanded.

9. Starting Motor (Figure 20)

- a. The starting motor is designed to crank the engine when the starting switch closes the circuit between the storage battery and the motor.
- b. To transmit power to the flywheel of the engine a Bendix drive is used.
- c. The Bendix drive consists of a threaded sleeve fastened to the armature shaft through a drive spring and a pinion mounted on the threads of the sleeve. When the starting circuit is closed the armature revolves, turning the sleeve within the pinion forcing the gear forward meshing it with the flywheel gear. The sudden shock of meshing is absorbed by the spring. When the engine starts the pinion is driven faster than the sleeve and is forced back along the threads automatically de-meshing it from the flywheel.

10. Magneto (Figure 14)

- a. The magneto is of the rotating magnet design, the basic principle of which consists in reversing the magnetic flux lines through the induction coil by revolving the permanent magnet which forms the basis of the magnetic circuit. While most magnetos of this design use rotors with two magnetic poles,

these units have four pole rotors, with the result that the magnetic field through the coil is completely reversed four times per revolution of the rotor.

- b. A four lobe cam on the rotor shaft actuates the breaker point assembly four times per revolution of the rotor and, since the distributor-rotor is mounted directly on the magnetic rotor shaft and therefore rotates at the same speed, an ignition spark is produced at each of the four terminals during one complete revolution. These ignition sparks occur at intervals of 90° , necessary in the case of these engines, which have a firing interval of 180-270-180- 90° . In a complete engine cycle (two revolutions) four sparks are used for ignition and four fire in the exhaust.
- c. **Impulse Coupling.** The impulse coupling facilitates starting the engine and at the same time automatically retards the ignition spark while starting. Through this device the rotor of the magneto is held back while the engine is turned over to its firing position at which instant the pawls of the coupling release and the rotor is snapped forward at high speed, thereby producing an intense spark, automatically retarded to prevent backfiring. Since the ignition spark must occur each 90° of its rotation, two stop pins are required to engage the coupling pawls at proper intervals. To provide positive pawl action over the cranking speed range, individual torsion type pawl springs have been provided, with the result that a certain amount of impulse action may be expected up to 500 r.p.m.

11. Main Function Voltage Regulator. (Figures 29 and 30)

a. General:

This voltage regulator is an instrument which performs the functions of an automatic field rheostat to provide a simple, effective and automatic means for obtaining almost constant voltage for all normal load conditions.

The regulator consists mainly of a solenoid, a commutator, and two resistor plaques.

The solenoid coil is connected to the a-c generator and is affected by voltage changes which actuate the solenoid plunger and likewise the crossarm moving the carbon contact across the silver commutator, thereby, adjusting the resistance of the plaques to a value which maintains the generator voltage.

The regulator has two electrical circuits: the one consisting of the solenoid coil, the voltage dropping resistor and the external control rheostat; the other consisting of the voltage regulating resistor, which is actually the exciter field rheostat.

Both the voltage dropping resistor, which limits the impressed voltage on the solenoid coil, and the regulator resistance, which adjusts the exciter field current, are embedded in, and equally divided between the two plaques. The external control rheostat is not located in the regulator but is mounted separately on the switch board panel.

The commutator consists of a stack of insulated silver segments, each segment connected to a tap on the regulator resistor. The commutator is of a "V" shape and the carbon contact roller rests on the commutator at two points, thereby short-circuiting all of the resistance included between these two points. By moving the contact roller transversely across the commutator, the distance between these two points of contact is changed and thus the effective resistance of the voltage regulating resistor is adjusted.

The solenoid is of the a-c quick acting type and allows the regulator momentarily to over-correct and then find a new steady-state position. The contact roller is not in constant motion, moving only when regulating action is demanded.

b. Theory of operation:

Since the solenoid is energized from the a-c generator, any change in a-c voltage will cause motion of the solenoid plunger. The resulting motion of the arm and contact roller changes the resistance in the exciter-shunt field circuit so as to restore the a-c voltage to its original value.

Assume that the load on the generator increases. The regulating cycle then is:

- (1) The a-c voltage decreases.
- (2) The current in the solenoid coil likewise decreases, causing the plunger and the contact roller to move, short-circuiting segments of the commutator.
- (3) As the number of segments short-circuited increases, the resistance of the exciter-shunt field circuit decreases.
- (4) The exciter-shunt field current, therefore, increases resulting in an increased exciter-armature voltage and generator field current, restoring the a-c voltage.

SECTION IV
MAINTENANCE

CAUTION: ALWAYS DISCONNECT THE REMOTE CONTROL CABLE BEFORE ATTEMPTING ANY REPAIRS OR ADJUSTMENTS OF THIS UNIT.

12. Lubrication.

- a. Use oil in engine in accordance with the following:
- | Temperature | Oil |
|----------------------|--------|
| Above 32° F. | SAE 30 |
| 32° F. to 0° F. | SAE 10 |
- Below 0° F.—Dilute SAE 10 with 1% gasoline for each degree below 0° F. Total dilution must never exceed 40%.

13. Battery Charging Generator. (Figure 27)

- a. A periodic maintenance inspection should be made of the charging circuit. The interval between these checks will vary depending on the type of service. Dirt, dust and high speed operating are factors which contribute to increased wear of the bearings, brushes, etc. Under normal conditions, an inspection of the generator should be made every 200 hours of operation.
- b. If the commutator is dirty or discolored it can be cleaned by holding a piece of 00 sandpaper against it while running the armature slowly. Never use emery paper or cloth. If the commutator is rough or worn, the generator should be removed and the commutator turned down. This should be attempted only by authorized personnel.
- c. The brushes should slide freely in their holders and if worn to less than half the original length, they should be replaced. The spring tension on the brushes should be 53 oz. maximum.
- d. Add 5 to 10 drops of medium engine oil (a good grade of SAE-20 oil) to the oilers about every 200 hours of operation.

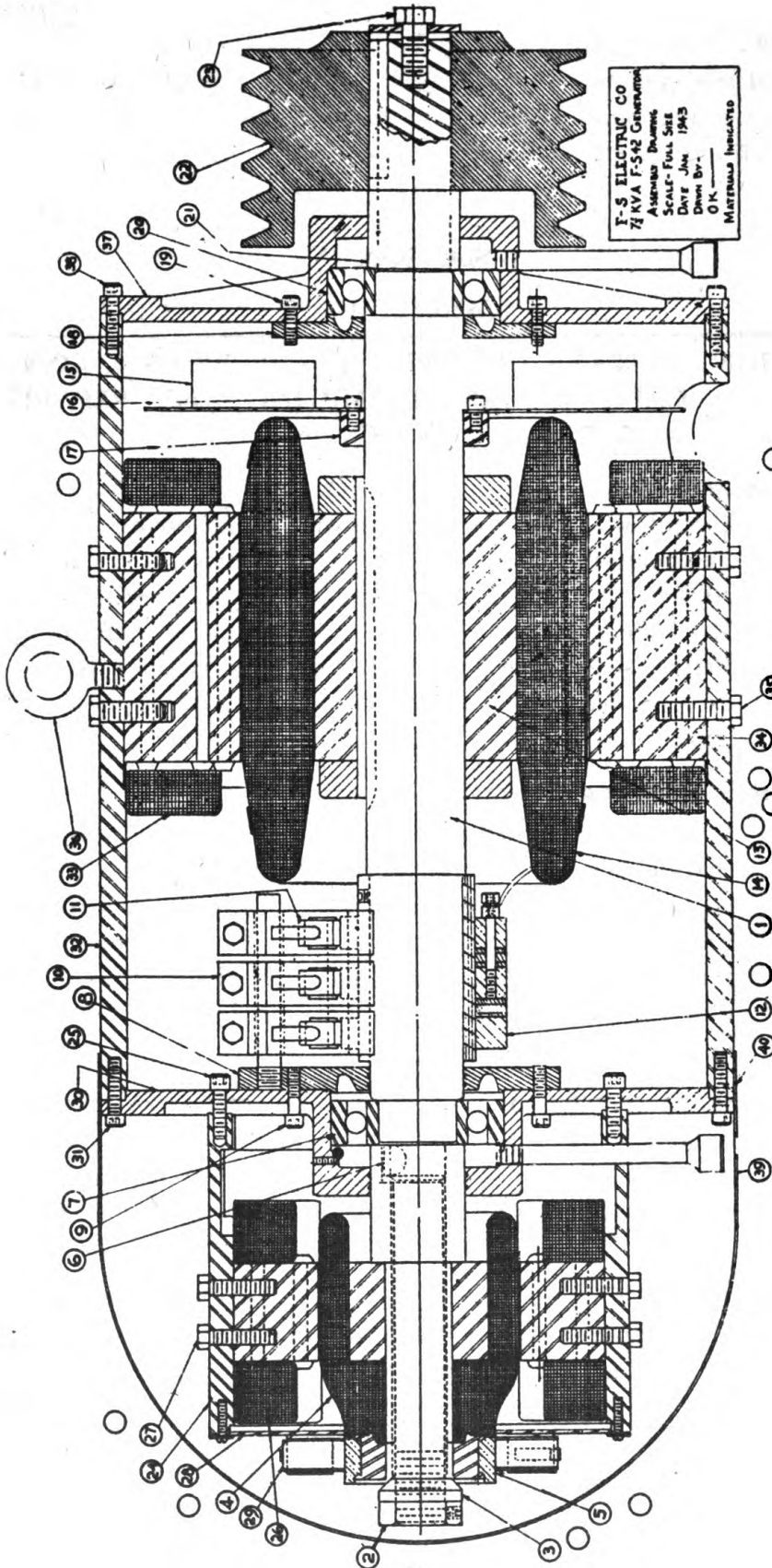

FIGURE 11.—Main A-C generator.

- e. The generator is belt driven from the engine crankshaft and the belt tension should be adjusted so that the belt can be deflected approximately $\frac{1}{2}$ " by pressing against one side of the belt. A belt which is too tight should be avoided because undue belt and bearing wear will result. On the other hand, a belt which is too loose will also wear the belt excessively.

14. Dis-Assembly and Assembly of Connecting Rod, Piston, Etc.

- a. The engine is in a unit house—for identifying numbers refer to Figure 16—it is desirable to remove the top and rear panels before attempting to work on the engine.
 - (1) Remove #117 bottom cover.
 - (2) Remove cylinder shroud cover 252, 253, 255, 256 and cylinder heads 102. See Fig. 15 and 16.
 - (3) Through the bottom opening of the crankcase, the connecting rod bolt nuts 186 can be removed which will permit the removal of connecting rod caps, the piston and connecting rod assembly can be pushed out through the top of the cylinder bore.
 - (4) To remove the piston from the rod, remove piston pin snap rings and drive out piston pin 128.
 - (5) Re-assemble in the reverse manner.
- b. Observe the following clearances for correct assembly:
 - (1) Piston clearance in the bore for cast iron pistons—.003—.0035.
 - (2) (This is measured at the bottom of the skirt.)
 - (3) Crank pin—.001—.002.
 - (4) Connecting rod piston end—.0005—.001.
 - (5) Connecting rod side clearance—.004—.011.

15. Dis-Assembly and Assembly of Oil Pump.

- a. Remove flywheel 170.
 - (1) Remove set screw 282 and drive out crank pin 174.
 - (2) Remove flywheel nut 185.
 - (3) With a babbit hammer or brass bar hit the crankshaft a sharp blow to loosen the flywheel which fits on a taper.
- b. Remove flywheel shroud 247 and gear cover 112.
 - (1) Before the gear cover is pulled off the shaft, be sure to remove flywheel key 202.
Remove oil pump gear 137 by loosening nut 184 which is locked in place with a cotter pin.

- (2) The oil pump gear drives the oil pump shaft by means of a Woodruff key. After the nut is removed, the gear can be pulled off.

To remove the oil pump from the crankcase, remove engine supports 279B and set screw 197 and withdraw the oil pump assembly through the crankcase opening.

- (3) The oil pump is fitted into a bored opening in the crankcase which is held in proper location by set screw 197.
- (4) The oil pump cover is fastened with round-head screws which can be removed to expose the oil pump gears.
- (5) The idler gear fits over the idler gear pin and the oil pump driving gear is pinned to the main oil pump drive shaft.
- (6) A relief valve is built into the oil pump cover. The relief valve ball 164 is held in position and holds pressure by means of spring 208.

- (a) Be sure in re-assembling that this relief valve functions. To re-assemble follow the reverse procedure.

The oil pump gears should have .002—.0035 clearance in the bore.

16. Dis-Assembly and Assembly of Cylinders.

- a. Remove governor rod 278-A, gasoline connection and choke connection to carburetor.
- b. Remove nuts on 180-A studs and lift off manifold assembly 156 with carburetor 155.
- c. Remove nuts on studs 182 and remove manifolds to cylinder block 157. Remove cylinder hold-down stud nuts and remove the entire cylinder block valve assembly.
- d. The valves 104 and 105 can be removed by removing wedge keys 108 and spring retainer 107 after valve chamber cover plate 242 has been removed.

Re-assemble in the reverse order. Be sure governor rod is replaced.

Observe the following clearances for correct assembly exactly as it was before removal:

Valve stem clearance	— .003—.005
Tapper clearance	— .012 exhaust
Tapper clearance	— .010 inlet

17. Dis-Assembly and Assembly of Camshaft.

- a. Remove the engine from the unit.
- b. Turn the crankcase upside down so tappers will clear the camshaft cams, the camshaft and camshaft drive gear can then be withdrawn from the gear cover end of the engine.
- c. The fuel pump and fuel pump bracket must be removed, before removing camshaft, by loosening the two screws which secure it to the crankcase.

Re-assemble in the reverse order, being sure that the camshaft thrust pin 191 and camshaft thrust pin spring 207 are in place before gear cover is re-assembled.

The following fittings should be observed for correct assembly:

Camshaft front bearing.....002—.0035

Camshaft rear bearing.....002—.0035

Valve tappet clearance in crankcase.....0005—.0025

18. Dis-Assembly and Assembly of Governor.

- a. Remove oil line to governor 236-A and disconnect governor rod 278-A and governor spring 206.
- b. Remove governor mounting cap screws to withdraw housing and cross shaft assembly.
- c. The governor gear and assembly 138 and 264 can be withdrawn after the housing is removed.
- d. The governor thrust bearing and thrust sleeve 269 is an assembly and if replacement is required, it is to be handled as such.

(1) Do not attempt to assemble parts in the field as this is very important for proper governor regulation.

To re-assemble follow reverse procedure. Be sure to replace all parts exactly as they were before removal.

19. Dis-Assembly and Assembly of Crankshaft.

Bearing plate 115 must be removed and with flywheel and gear cover off and connecting rod dis-assembled, the entire crankshaft can be withdrawn through the bearing plate opening on the take-off end of the engine.

The roller bearing inner race is pressed on the crankshaft and the outer race into the bearing plate on the take-off end.

- a. The outer race of the bearing on the cranking end is pressed directly into the crankcase and held in place by retainer ring 114.

- b. If necessity requires replacement of bearings the complete bearing should be changed and not only the inner or outer race.
- c. To re-assemble follow reverse procedure.
- d. The crankshaft bearing should be fitted so the bearings have an end play of approximately .006".
 - (1) The amount of end clearance is governed by shims 226 and 227.
 - (2) By driving the crankshaft from one side to another, the end play can be easily felt.

20. **Carburetor. (Figure 12)**

- a. **Adjustments—Idle or Low Speed—**Have the engine well warmed up so that the intake manifold is at least warm to the hand. Close the hand throttle until minimum steady idling speed is reached. Turn low speed adjustment No. 22 gradually to right or left until the engine runs steady and fast as this throttle position will permit. This adjustment operates on air so that screwing it IN gives a richer mixture; OUT a leaner one. If after adjusting, the engine idles too fast or too slow, the desired speed can be obtained by turning throttle stop screw No. 4. If a satisfactory adjustment cannot be obtained, see that idle discharge holes No. 24 and idle tube No. 21 are open and allow a free flow of gas.
- b. **Intermediate and High Speed—**The mixture for intermediate and high speeds is controlled by a fixed metering jet which requires no adjustment.
- c. **Fuel Level—**The gasoline level in the float chamber is pre-set, and should not be adjusted unless carburetor has been handled roughly or level has been changed from some other cause. The level is set at $15/32$ " to $17/32$ " below the top of the main body. If it is necessary to reset level, it can be done by holding body in an inverted position and setting the floats to measure $1\frac{1}{4}$ " from the top of each float to the gasket surface of the throttle body, which will give the approximate fuel level.
- d. **Float Needle Valve and Seat—**The float needle valve No. 18 must seat tightly and must be free from wear. A poorly seated float needle valve will cause leakage and too high a fuel level will result. A high fuel level will cause too rich a mixture, and flooding of carburetor. This condition will also cause hard starting, especially if the engine is warm from previous

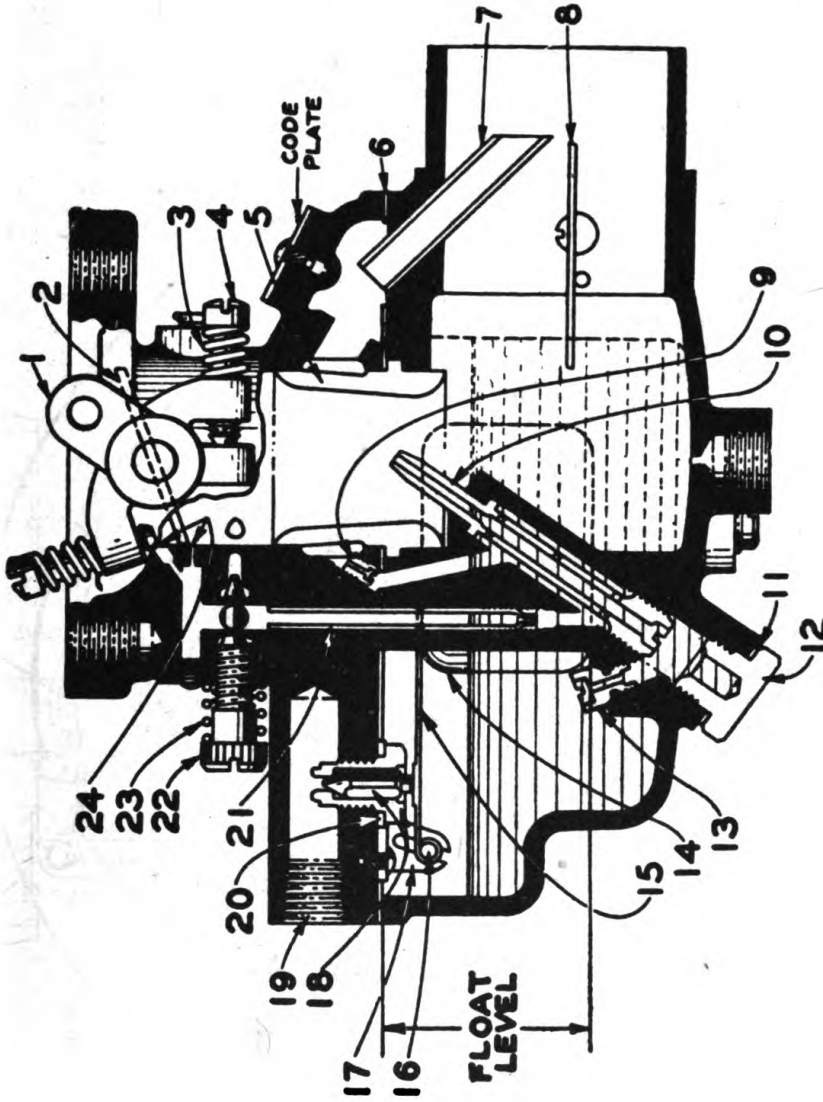

FIGURE 12.—Carburetor.

PARTS ILLUSTRATED

1. Throttle Lever
2. Throttle Valve
3. Throttle Lever Stop Screw Spring
4. Throttle Lever Stop Screw
5. Venturi
6. Main Body Gasket
7. Vent Tube
8. Choke Valve
9. High Speed Bleeder
10. Main Discharge Jet
11. Main Jet Plug Gasket
12. Main Jet Plug
13. Metering Jet
14. Float
15. Float Lever
16. Float Fulcrum Pin
17. Float Hanger
18. Float Needle Valve & Seat
19. Gas Inlet
20. Float Needle Valve and Seat Gasket
21. Idle Tube
22. Idle Needle Valve
23. Idle Needle Valve Spring
24. Idle Discharge Holes

643711 O - 45 - 3

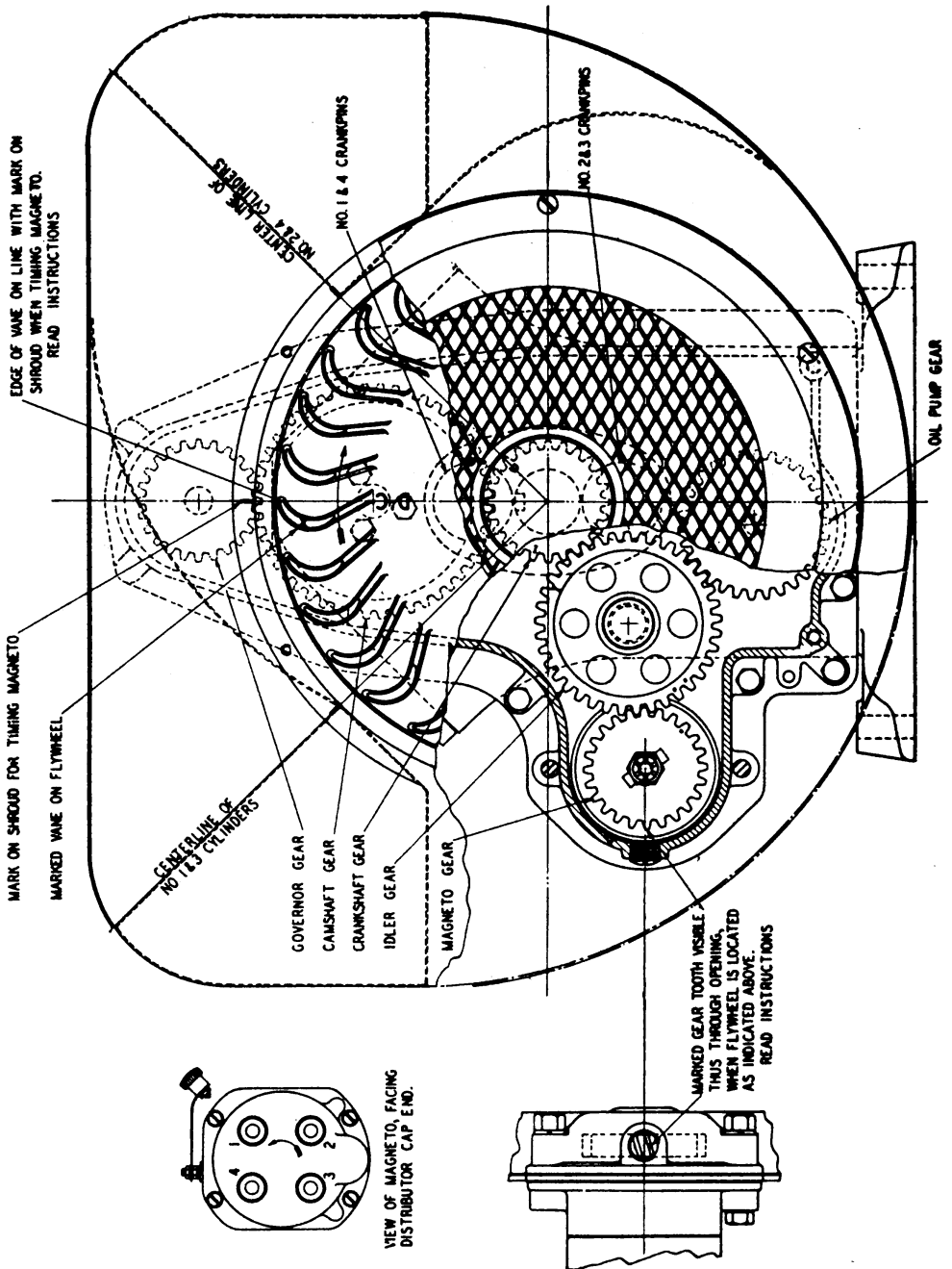

FIGURE 13.—Power Unit PE-99-G, timing diagram.

running. To clean or replace the float needle valve and seat, the float fulcrum pin No. 16 should be withdrawn, allowing the float to be removed. This will expose the float needle valve and seat, No. 18.

- e. **Cleaning Carburetor**—If at any time any of the various passages or jets in the carburetor become clogged with dirt or gum from the fuel, it may be necessary to take the carburetor apart for cleaning. This should not be done unless absolutely necessary and then only by authorized personnel. First the upper half or throttle body should be removed from the lower half or main body by removing the four small screws holding these parts together. The main jet plug No. 12 should then be removed. The main discharge jet No. 10 and the metering jet No. 13 can then be removed with a screw driver. The high speed bleeder No. 9 likewise.

The idle tube No. 21 can be removed with a pair of pliers. The idle needle valve No. 22 can be removed by hand. The small plug directly over the idle needle valve should be removed with a screw driver, which will expose the idle discharge holes No. 24. After all of these jets and passages have been cleaned the parts should be re-assembled, care being exercised that all gaskets are replaced and if necessary new gaskets should be used. Unless the operator is very familiar with carburetor construction it is advisable to replace the various jets as they are removed and cleaned. This will prevent mistakes in re-assembly.

- f. Air cleaner (Fig. No. 25) must be cleaned frequently depending on the dust conditions in the air. The oil in the cup together with the collected dust should be emptied and the cup then refilled with oil to the level indicated on the cup.

NOTE: Never operate the engine with any part of the air shroud removed as this will allow the engine to overheat and score. The air shroud is absolutely necessary to direct the air flow so the engine may be properly cooled. **Keep Entire Engine Clean.**

21. **Magneto.** (Figure No. 13.) If for any reason it is necessary to re-time the magneto, proceed as follows:
 - a. First remove the screen over the flywheel air intake opening by taking out the six screws holding the screen in place. This will expose the mark on shroud for timing magneto. See Timing Diagram, Figure No. 13.

- b. Next remove the spark plug from No. 1 cylinder. Then turn engine over slowly with the starting crank until the compression in this cylinder blows the air out of spark plug hole.
- c. The flywheel is marked with the letters DC near one of the air circulating vanes. This vane is further identified by a mark cast on the end. When the air blows out of the No. 1 spark plug hole, continue turning the starting crank until the edge of the marked vane on flywheel is in line with the mark on the shroud. See Diagram, Figure No. 13. Then leave flywheel in this position.
- d. The keyway at take-off end of crankshaft is on top. The magneto should then be fitted to the engine so that the marked tooth on the magneto gear is visible through the opening in timing gear on housing as shown on Timing Diagram, Fig. No. 13. The distributor cap on the magneto is numbered from 1 to 4. The leads from the magneto should be connected to spark plugs of like number.
- e. **Service Procedure.** Do not dismantle the magneto unless it has been positively ascertained that the ignition spark produced is unsatisfactory. This condition may be determined through ignition spark tests which are easily made in the field. See f. and g. following.
- f. **Testing the Ignition Spark.** With properly adjusted spark plugs in good condition, the ignition spark should be strong enough to bridge a short gap in addition to the actual spark plug discharge; this may be determined by holding the ignition cable end not more than 1/16" away from the spark plug terminal. The engine should not miss fire when this is done. Ignition tests made while any part of the system is wet are useless.
- g. **Testing the Magneto Spark.** Pull the ignition cables out of the magneto end cap sockets and insert a short, stiff wire in one of the sockets. Bend this wire to within 1/8" of the engine block. Turn the engine over slowly and watch carefully for the spark discharge which should occur at the instant the impulse coupling releases. The tests should then be repeated for each of the remaining terminals. It is highly recommended that, when a strong spark is observed, no dismantling of the magneto takes place and that cables, terminals and spark plugs be thoroughly inspected. If no spark is observed the ignition switch should be first carefully examined to be certain it has not become accidentally closed (the magneto shorted.)

- h. Distributor Cover Removal.** In removing the distributor housing cover, care must be taken not to damage the gasket attached to the cover side of the joint. The distributor compartment should be thoroughly cleaned and the air inlet and outlet passages cleared. Examine the high tension lead brush and replace, if noticeably worn or damaged. This brush should move freely in its holder and should have a slight spring pressure.
- i. Service of Breaker Contact Points.** Contact point adjustment necessitates removal of the distributor housing which has a sealed gasket joint with the metal housing. The contact points should be examined for evidence of pitting or pyramiding. A small tungsten file or fine stone may be used to resurface the points. If the points are worn or badly pitted, they should be replaced. Points should be adjusted to have a .012 inch gap at full separation. Adjustment is made by loosening the round head locking screw at the upper end of the stationary point bracket (figures 13 or 14 or both) then turning the eccentric head adjusting screw until the proper gap is obtained, and locking the assembly by tightening the round head screw.
- j. Reassembly of Magneto.** Do not oil or grease the bearings or cam of the magneto as the design eliminates the necessity of field lubrication. The cam felt wick should be replaced by a new impregnated wick if dry or hard. Coil and condenser replacements, while simple, are not recommended unless test equipment is available. Under no circumstances should any attempt be made to remove the magnetic rotor from the housing as it is locked in a special drive and thrust bearing and specific instructions must be carefully followed in releasing the shaft. When replacing the distributor housing a new gasket should be provided, the joint cleaned thoroughly and the new seal coated with sealing varnish.
- k. Impulse Coupling.** The impulse coupling facilitates starting the engine and at the same time automatically retards the ignition spark while starting. Through this device the rotor of the magneto is held back while the engine is turned over to its firing position at which instant the pawls of the coupling release and the rotor is snapped forward at high speed, thereby producing an intense spark, automatically retarded to prevent backfiring. Since the ignition spark must occur each 90° of its rotation, two stop pins are required to engage the coupling pawls at proper intervals. To provide positive pawl action

over the cranking speed range, individual torsion type pawl springs have been provided, with the result that a certain amount of impulse action may be expected up to 500 r.p.m.

- l. **Radio Shielded Units.** On this unit the plastic distributor cap and cover are replaced by an all metal housing in which an insulated distributor block is mounted. Special outlets are provided for the high tension leads so that connection can be made to the shielded cables. The primary ground terminal is located on the lower side of the end cap and is arranged for connection with a shielded ground cable.
- m. **Special Drive Gear.** The magneto is equipped with special drive gears, mounted directly on the impulse coupling. The gear is a slip fit on the extended coupling nut, since movement of the gear with respect to the coupling nut (and rotor shaft) occurs during the impulse period. If it is necessary at any time to remove the drive gear, special care must be exercised in reassembly. First, remove the entire end cap and turn the rotor until the contact segment is in firing position for #1 cylinder (figure 13). With the rotor in this position, fit the gear to the coupling lugs so that the prick punch mark on the rim of the gear is in the position shown (figure 13).

22. **Fuel Pump Service.** (Figure 9)

Fuel pump repairs are divided into two classifications:

Repairs made without disturbing pump installation.

Repairs which necessitate removal and dis-assembly of fuel pump.

a. **Repairs made without disturbing pump installation.**

(1) **Lack of Fuel at the Carburetor.**

Check as follows:

Cause	Remedy
Gasoline tank empty.	Refill.
Leaky tubing or connections.	Replace tubing & tighten all pipe connections at the fuel pump and gasoline tank.
Bent or kinked tubing	Replace tubing.
Dirty screen.	Clean the screen, I. Make certain that cork gasket, S, is properly seated when reassembling.
Loose cover plate cap screw.	Tighten cover plate cap screw, Q, securely, replacing cover plate cap screw gasket, R, if necessary.
Defective Diaphragm	Replace diaphragm or fuel pump.

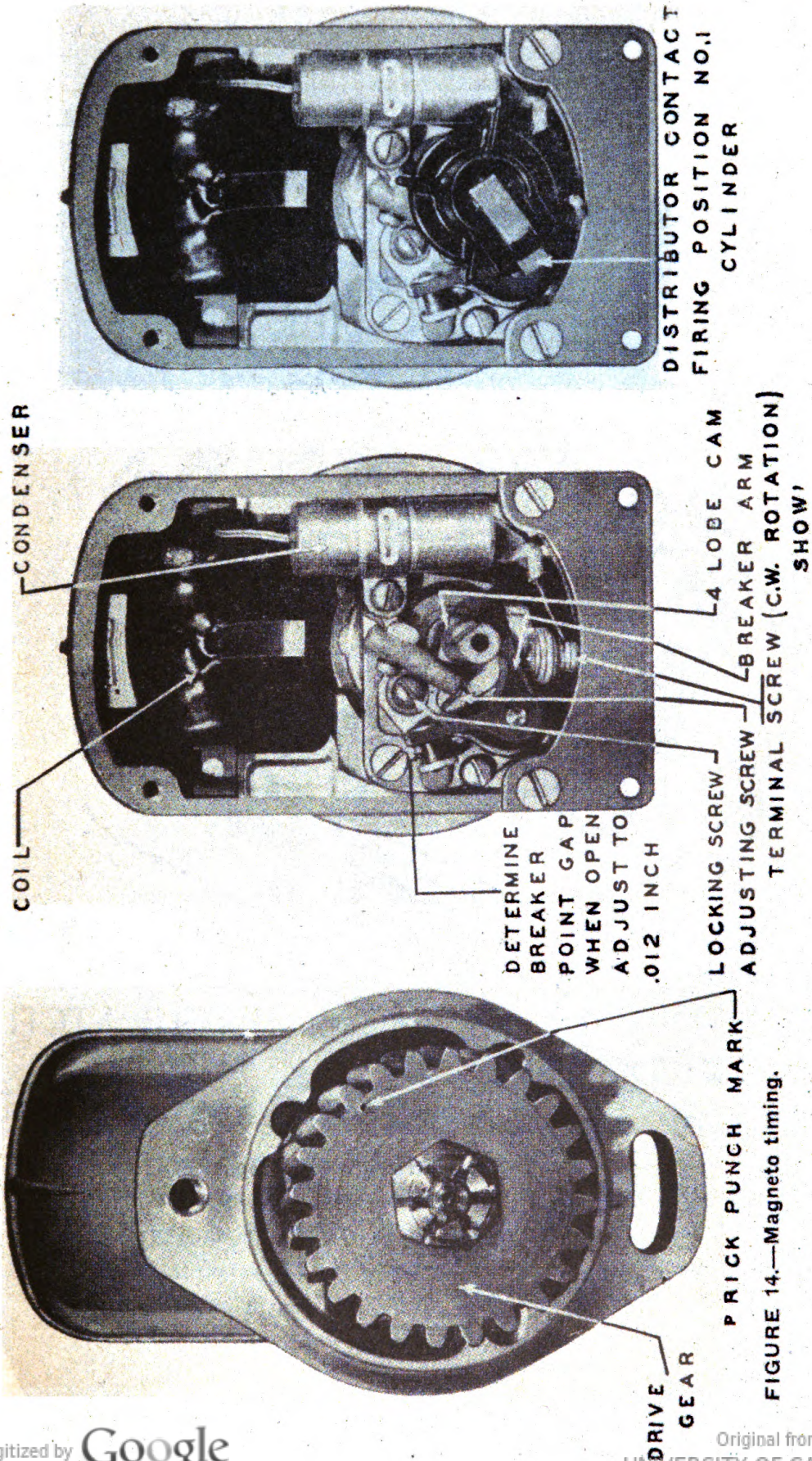

FIGURE 14.—Magneto timing.

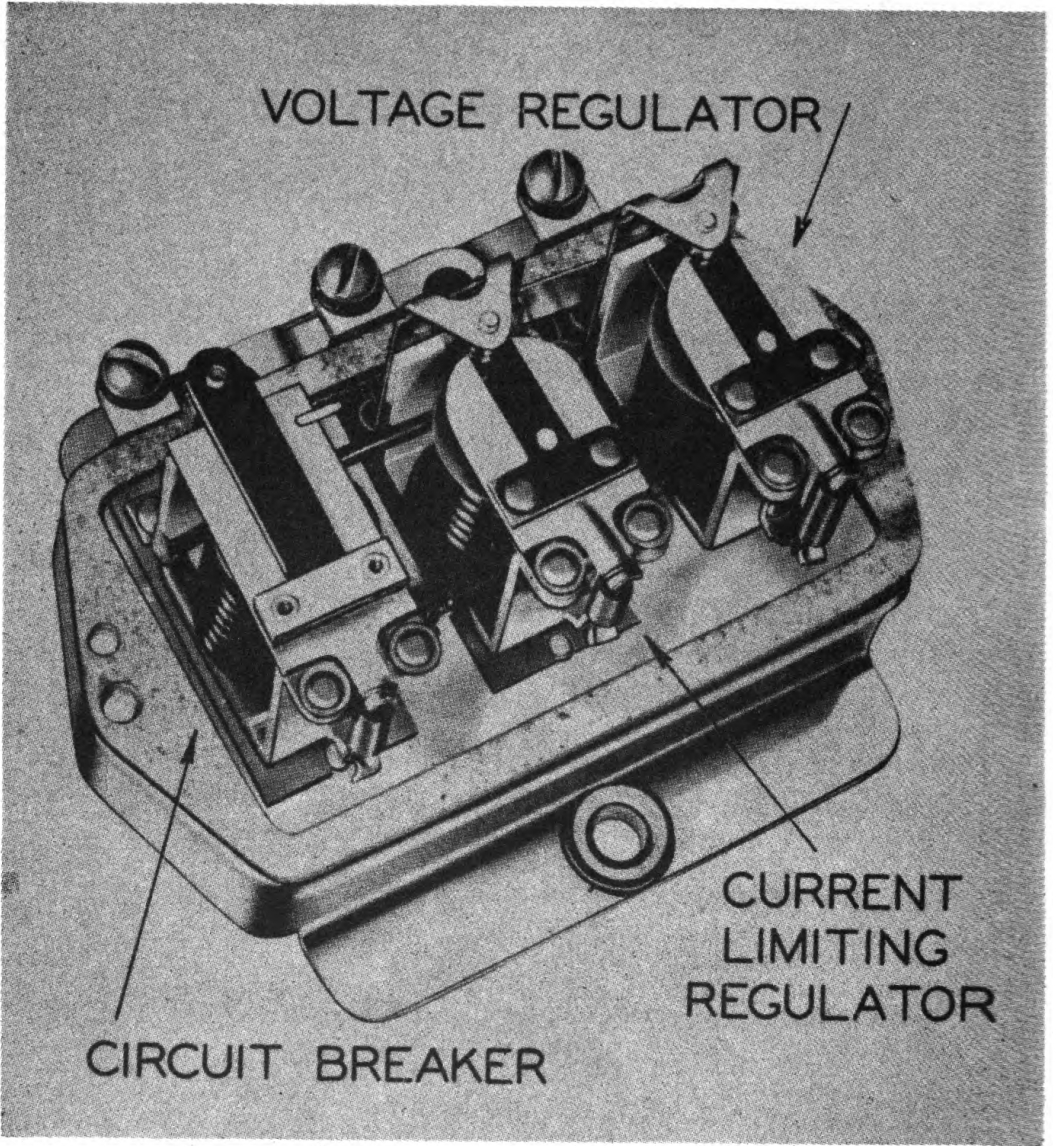

FIGURE 15.—Battery voltage regulator.

(2) Fuel leakage at edge of diaphragm

Check as follows:

Cause	Remedy
Loose cover screws.	Tighten cover screw, G, alternately and securely. Also check inlet and outlet connections.
Broken or defective gasket.	Replace gasket.

Note: Check if leak occurs at pipe fittings thus allowing fuel to run down pump to flange and appear to originate there. Do not use shellac or any other adhesive on diaphragm.

b. Repairs which necessitate removal and dis-assembly of the pump.**(1) Fuel Pump Trouble Chart.**

Trouble	Evidenced by	Remedy
Broken rocker arm.	Visible	Replace rocker arm, A.
Broken rocker arm spring.	Visible	Replace rocker arm spring, M.
Defective or worn links.	Pump does not supply sufficient fuel.	Replace links, C.
Broken diaphragm return spring.	Does not supply fuel to carburetor.	Replace spring, E.
Punctured or worn out fuel pump diaphragm	Fuel leaking through hole in body.	Replace diaphragm assembly, D.

Important: Mark the top cover, T, and body O, with a file before dis-assembly so that in re-assembling they are placed back in the same relative position.

- c. Procedure in Assembling; Body, Rocker Arm and Link Assembly:** Assemble link, C, rocker arm, A, and rocker arm spring, M, in body O. Insert rocker arm pin, B, through hole in body, engaging link and rocker arm. Use a punch and "stake" die cast metal of body over end of pin in one place on each end, to retain in place.

Note: It has been found that the assembly of the rocker arm pin can be simplified by first assembling a piece of .240" drill rod through the rocker arm pin hole in one side of the body far enough to engage the rocker arm and link, then insert rocker arm pin from the opposite side, pushing out the drill rod until the pin is in proper position. If after assembling the rocker arm pin it is found that the rocker arm or link does not work freely, this can be corrected by placing a punch against the opposite end of the rocker arm pin, tapping it lightly with a small hammer in reverse direction from which it was assembled.

- d. **Diaphragm and Pull Rod Assembly.** (Figure 9). The diaphragm is an assembly including protector washers and pull rod and is serviced as a unit.

To correctly assemble diaphragm in pump body, proceed as follows:

- (1) Place diaphragm spring, E, in position in pump body, O.
- (2) Place diaphragm assembly, D, over spring, centering upper end of spring in lower protector washer.
- (3) Press downward on the diaphragm and hook the slot in the diaphragm pull rod over the hooked end of the link.

- e. **Valve and Cover Assembly.**

- (1) Place outlet valve spring retainer, U, in pump cover, T, taking care not to bend or distort legs of retainer.
- (2) Place valve plate gasket, K, in position.
- (3) Place outlet valve spring, V, in position in spring retainer.
- (4) Place outlet valve, J, on spring.
- (5) Place inlet valve, J, on valve seat.
- (6) Place valve spring, V, on center of inlet valve.
- (7) Assemble inlet valve retainer, U, in valve plate, X, taking care that shoulder of retainer fits down flush in depression in plate.
- (8) Place valve plate, X, in position and secure with 3 screws, W. Inlet valve spring, V, must be centered properly in spring seat in valve plate and outlet valve must be seated properly against valve seat in valve plate.

- (9) Place strainer screen, I, in position on top of cover, making certain that it fits snugly around the gasoline inlet and edges of cover.
- (10) Assemble cork gasket, S, in cover plate and install cover plate on top of cover assembly. Make certain that gasket seats properly and strainer screen is not wrinkled or distorted.
- (11) Place fibre washer, R, on cover plate cap screw, Q, then insert and tighten screw securely.

t. **Cover Assembly.**

- (1) Push upward on rocker arm, A, until diaphragm, D, is level with the body flange.
- (2) Place cover assembly in proper position designated by mark on flanges made before dis-assembling the pump.
- (3) Install cover screws, G, and lockwashers, H, tightening only until they barely engage lockwashers.
- (4) Release rocker arm, which will place the diaphragm in its highest position, then—
- (5) Tighten cover screws alternately and securely.

23. **Charging Generator.** (Figure No. 27.)

a. **Description:**

Volts—12

Rotation—Clockwise at the drive end

Ventilated—Yes

Control—Vibrating type current-voltage regulator

Poles—2

Brushes—2

b. **Inspection.** The following attention is required at the end of each 100 hours operation:

- (1) Remove the head band.
- (2) Inspect the commutator. If the commutator is dirty or discolored it can be cleaned by holding a piece of 00 sandpaper against it while turning the armature slowly. Do not use emery paper as emery is a conductor. Blow the sand out of the generator after cleaning the commutator. If the commutator is rough or worn the generator should

be removed and completely overhauled. This work should be done only by authorized personnel.

- (3) Inspect the brushes. The brushes should slide freely in their holders. If the brushes are oil soaked or if they are worn to less than one-half of their original length replace them.

c. Lubrication:

Commutator end. Add 5 to 10 drops of medium engine oil to the oilers in the commutator end plate and in the drive end head.

d. Wiring:

- (1) Visual inspection: Inspect all wiring from the generator to the regulator, from the regulator to the battery and from the battery to ground for worn or frayed insulation, broken wires and for loose or corroded connections. Repair or replace any defective wiring.
- (2) Voltage drop test: Run the generator and apply an 8 to 10 ampere load so that the battery charging ammeter reads about 10 amperes. With an accurate reading voltmeter measure the voltage from the generator "A" terminal to the regulator "A" terminal from the generator "F" terminal to the regulator "F" terminal and from the regulator "B" terminal to the battery post. The voltage reading for any of these tests should not be more than .1 volt at the 10 ampere charging rate. At the same charging rate the voltmeter should show no reading when measured from the generator frame to the regulator base, the generator frame to the battery ground post or to the regulator base and the battery ground post. If larger readings are obtained the high resistance should be eliminated.

e. Operation:

Run the generator at about 10 to 15 amperes and note the commutator action. If there is excessive arcing between the brushes and commutator remove the generator and return it to the repair depot for overhauling. Replace the generator head band.

f. 200 Hour Tune-up Inspection.

- (1) Remove the generator from the engine and take off the head band.

(2) Inspect the commutator as in Paragraph 23-b.

(3) Brushes :

(a) Inspection: Each brush should slide freely in its holder and should be free from oil and dirt. Brushes that are oil soaked or are worn to less than one-half of their original length should be replaced.

To install new brushes remove the brush lead screw and lift the brush arm. Replace the old brushes and securely fasten the brush lead. Make sure the brush is turned so the beveled face fits the commutator. Check the brush alignment to make sure the brush edge is parallel with the commutator segments. If the alignment is off or if the brushes do not slide freely the commutator end plate should be inspected as described in Paragraph 23 (2).

(b) Check brush spring tension: Measure with a spring scale hooked in the hole in the end of the brush arm. Pull the scale on a line parallel with the face of the brush and take the reading just as the arm leaves the brush. Brush spring tension should not be more than 53 ounces maximum.

If the pressure is too great the brushes and commutator will wear excessively while if the tension is too little there will be a tendency to arc at the commutator.

(c) Run in new brushes: New brushes should be run in to make sure of a perfect brush fit before output tests are made on a generator. To run in new brushes the generator should be run under load long enough to secure a perfect brush fit.

(2) Check Armature end play: Armature end play should be held between .003" to .010". If the end play is too great it can be reduced by installing thrust washers on the armature shaft just inside of either end head. Make sure when installing thrust washers that the brushes are correctly centered on the commutator.

g. Bench test:

(1) Field Coil Draw:

1.40 to 1.58 amperes at 13.0 volts.

- (2) **Motorizing Draw :**
3100 to 3.35 amperes at 13.0 volts.
This test is made with the field terminal grounded to the frame.
- (3) **Output Test :**
4.0 Amps., 14.2 volts at 1100 Max. R.P.M.
18.0 Amps., 14.6 volts at 1650 Max. R.P.M.
18.0 Amps., 15.0 volts at 1650 Max. R.P.M.
- h. **Re-assembly:** Re-mount the generator on the engine and follow the 100-hour lubrication instructions.
- i. **300 Hour Overhaul:** To completely overhaul the generator it should be removed from the engine and taken to the bench. This work should be done only by authorized personnel.
 - (1) **Dis-assembly :**
 - (a) Remove the head band.
 - (b) Remove the drive pulley and nut. To remove the pulley use a press or puller. Be careful not to damage the pulley or end head.
 - (c) Remove the two frame screws at the commutator end and slide the commutator end-plate off of the armature shaft. Disconnect the leads at the brush.
 - (d) Lift the drive end and armature out of the frame and field.
 - (e) Press the armature shaft out of the drive end head.
 - (2) **Inspection :**
 - (a) **Armature:** Inspect the armature and commutator for evidence of wear. Inspect the insulation and the soldering to make sure all coils are in proper working order. Check the windings for grounds, shorts and open circuits. If the commutator is rough or worn it should be turned down in a lathe. **When turning, mount the shaft on the bearing seats and not on the shaft centers.** After turning undercut the mica clean and squarely to a depth of $1/32$ ". If the solder has been thrown it should be resoldered and any other visible fault should be repaired. It is recommended that armatures with internal faults be replaced.
 - (b) **Frame and Field:** Inspect the insulation on the field coils and terminal posts and replace any faulty part. Check the field coils for grounds and for open circuits.

Inspect the leads for broken wires and for frayed insulation. Check the armature terminal for grounds.

If the field coils are faulty and must be replaced remove the pole piece screws. Assemble the new coils on the pole pieces and tighten securely with pole piece screws that have been dipped in boiled linseed oil. As the screws are tightened the frame should be struck with a rawhide hammer a few times to properly settle the pole pieces.

- (c) Commutator end-plate: Inspect the brush holders to see that they are not bent or corroded. Check the insulated brush holder for grounds.

Clean the commutator end-plate making sure the oil pocket and bearing are thoroughly clean. Inspect the bearing for wear and replace if badly worn.

When replacing the bearing use only the proper arbor to insure the correct bearing fit and to prevent damage to the bearing.

Do not re-assemble the felt wick and the commutator end cap cover until after the armature and commutator end-plate are assembled.

- (d) Drive end head: Dis-assemble and clean the bearing and retainers. Inspect each part for wear or failures. Pack the ball bearings $\frac{1}{2}$ full with a high melting point grease and re-assemble the drive end head.

(3) Assembly:

- (a) Assemble the drive end head on the armature shaft.
- (b) Assemble the drive end head and armature to the frame and field making sure the dowel pin is in place.
- (c) Soak the commutator end bearing in oil and remove the excess oil. Place the commutator end plate on the armature shaft and make sure the dowel pin is in its proper place.
- (d) Fasten the end heads with the frame screws.
- (e) Install the felt wick in the commutator end-plate and assemble the cover and gasket.
- (f) Assemble the drive pulley and shaft nut making sure the Woodruff key is in place.
- (g) Fill the oiler in the commutator end head to overflow hole with medium engine oil.

24. Battery Charging Regulators. (Figure 21)

a. Test:

NOTE: BEFORE ANY WORK IS DONE ON THE REGULATOR THE FOLLOWING CONDITIONS SHOULD BE CAREFULLY CHECKED AND CORRECTED IF AT FAULT:

- (1) Wiring from generator to regulator properly connected.
- (2) High resistance connections in the charging circuit. This should be checked with an accurate reading voltmeter and inspected mechanically for poorly soldered terminals and loose or corroded connections.
- (3) Generator performance without the regulator in the circuit operating properly.
- (4) That the regulator is the one designed for the generator with which it is operating. These regulators will function satisfactorily only when installed with the generator designed to operate it. Also battery condition affects regulator operation. An old battery, one partially charged or one subjected to excessive cold, hard plates, high resistance separators and sulphation will cause low charging rate. The open circuit terminal voltage of the battery as well as its specific gravity should be checked. The condition of the battery as to capacity, leakage, etc., should be checked by separate test.

b. Adjustment:

NOTE: THE COVER MUST BE ON THE REGULATOR WHEN TAKING READINGS OR WHEN THE UNIT IS BEING HEATED BY OPERATION PRIOR TO TAKING READINGS. THIS IS NECESSARY DUE TO THE FACT THAT THE COVER FORMS PART OF THE MAGNETIC CIRCUIT AND ALSO HELPS RETAIN THE HEAT.

Heat the regulator by operating it for 15 minutes with the generator charging 10 amperes. While heating the regulator have the cover on the unit.

- (1) Check circuit breaker operation: To test, connect the ammeter in series between the battery and the "B" terminal. The voltmeter should be connected to the "A" terminal of the regulator and to ground. Be sure that the voltmeter connections are on the regulator side of the ammeter connections to avoid losses due to poor connections.

To adjust the contact opening voltage, adjust the armature spring tension by bending the bracket which holds the lower end of the spring.

To adjust the contact opening amperage, adjust the contact gap by raising or lowering the stationary contact.

After each adjustment, replace the regulator cover and again test the circuit breaker operation.

There should always be at least .5 volts less voltage at which the circuit breaker closes than the voltage at which the voltage regulator operates.

- (2) Check voltage regulator unit: In making this test an accurate voltmeter must be used. It is to be connected to the regulator "B" terminal and to ground.

To adjust its operation, increase or decrease the armature spring tension. Increasing the spring tension increases the voltage at which the unit will operate, decreasing the tension decreases its operating voltage. This is done by bending the bracket which holds the lower end of the spring.

Replace the cover after making each adjustment. Take a flash voltage reading by stopping the generator and noting the maximum voltage reading when the generator is re-started.

- (3) Check current limiting regulator unit: Connect the test ammeter in series between the regulator "B" terminal and the battery.

By increasing the generator output with a lamp bank or other suitable resistance connected across the battery on the battery side of the ammeter, the ampere output should be as noted on the name plate of the regulator under test with an allowable variation of 5%.

Its operation is adjusted by varying the armature spring tension. This is done by bending the bracket which holds the lower end of the spring.

It is necessary that after all adjustments are made, a final flash test be made of all three units.

c. **Battery Charging Regulator Specifications:**

Volts	12
Ground Polarity	Positive
Carbon Resistors	Two used—R1 marked 80, resistance 76 to 84 ohms. R2 marked 30, resistance 28 to 32 ohms.
Circuit Breaker	Contact point gap .015" minimum Contacts close 13.0 to 13.75 volts Contacts open 1.0 to 5.0 amperes discharge
Voltage Regulator	Operating Voltage—Allowable variation .30 volts

Temp. F.

50°	60°	70°	80°	90°	100°	110°	120°
14.59	14.54	14.50	14.46	14.42	14.37	14.33	14.29

Current Regulator Operating amperage 17 to 19 amperes

25. **Main Generator.**

a. **Care of the Generator:** The generator is a high-grade electrical machine and with just ordinary care, will give good service and last a long time. To get the best service out of the generator, however, it should be given a periodical inspection at intervals of from 30 to 60 days, depending upon the number of hours per day the generator is in operation. The following points should be carefully followed at each inspection and the necessary adjustments or corrections made:

Remove inspection covers from generator and check:

- (1) Wear on collector ring brushes.
- (2) See that the brushes are free in their holders.
- (3) Check the brush spring tension and brush contact.
- (4) Check slip rings and commutator for roughness and uneven wear.

b. The slip rings should be checked periodically to see that they are running true and if necessary, use a piece of No. 00 sandpaper to polish them, applying even pressure around the entire circumference of the ring. Polishing in one spot may make that spot low and start arcing and wear. Do not attempt to tighten set screws holding slip ring assembly to the shaft. This may cause an eccentric condition of the ring.

c. It is advisable to apply a little lubricating oil occasionally by means of a cloth or chamois skin to keep the slip rings in the best of condition.

- d. The exciter brushes should be checked occasionally for sparking and wear. See that proper and equal spring tension is maintained in all of the exciter brushholders and that the brushes move freely in their holders.
- e. Replace an exciter brush whenever the top of the brush falls more than $\frac{1}{4}$ " below the top of the brush holder. Check appearance and general condition of the commutator. Ordinarily the use of fine sandpaper or commutator stone will put the commutator in first class condition if roughness or sparking under the brushes should occur. If the commutator becomes worn or grooved, it will be necessary to take the exciter armature to a repair shop to turn it and to undercut the mica.
- f. Under no circumstances should emery cloth be used for taking rough spots off commutator. Unless the commutator is very rough, it may be ground with a piece of sandstone. After turning or grinding, it should be polished with No. 00 sandpaper. After sanding, the commutator should be wiped clean with a piece of canvas lubricated with a very small amount of oil or vaseline. An excess of lubrication is injurious to the insulation between segments and may result in the breaking down of insulation. If the commutator is kept clean and smooth there will be no sparking under the exciter brushes and the commutator will take on a dark brown polish after a few weeks of operation. The commutator is then in good condition.
- g. Sometimes high mica will develop as a result of turning the commutator down. This condition will cause sparking and burning away of the copper segments. In such cases the mica should be cut away to a depth of $\frac{1}{32}$ " below the copper. Care being taken to remove all loose flakes and fins between segments. The mica may be cut away with a hack saw blade, held between suitable guides, or with a three-cornered file. After cutting, the sharp edges of the commutator bars should be removed.
- h. **Ball Bearings:** The proper lubricant for ball bearings should be free of grit, moisture, acid, and alkali, in order to prevent corrosion or cutting of the highly polished surface of balls and races. There should be a constant supply of lubricant.
- i. Attention to ball bearings is necessary about twice a year. The bearing reservoir should be at least one-half full. Too much grease will cause overheating of bearing.

26. **Main Voltage Regulator.** (Figures 29 and 30)

a. **Maintenance:**

The regulator requires very little attention. The regulator must be out of service during any maintenance. The apparatus should be kept free from dust, dirt and moisture. Do not oil, or otherwise lubricate any part of the regulator.

The contact roller presses on the silver commutator with a pressure of 100 grams. This value is carefully set at the factory and should require no further adjustment. Do not lift the contact roller from the commutator, as the contact pressure spring may be over-stressed, thereby reducing the contact pressure. Never touch the contact roller while the regulator is operating as arcing will occur at the point of contact causing the commutator surface to become pitted and rough. If through any accident the commutator should become roughened, polish the surface lightly with jeweler's rouge cloth or crocus cloth. After polishing, be sure to remove all traces of rouge from the surface of the commutator. After the regulator has been operating a short time a fine black line will appear along the point of contact on the commutator. This is a normal condition.

The regulator is pre-set and should require no adjustment after installation. If for any reason adjustment is necessary, do not attempt to adjust the magnetic core. Any necessary adjustment should be made by means of the solenoid spring. For greater regulator sensitivity the spring is moved to a lower position on the holder. Raising it to a higher position decreases the sensitivity and increases the stability of the regulator.

After any spring adjustment the coil current should be checked and the spring reset if the current is more or less than its normal value of 0.4 amps. To reset spring, loosen the spring holder adjusting screw and slide the holder forward or backward, decreasing or increasing spring tension.

In making any necessary re-adjustments to the regulator an a-c ammeter must be used, connecting it in series with either terminal "A" or "B" to measure the solenoid coil current.

27. **Automatic Choke.** (Figure 10)

- a. The object of the automatic choke is to close the carburetor choke on the engine when the engine is cold and needs a rich charge of gasoline and gradually open the choke as the engine warms up and runs at higher speed.

- b. There is a thermostat in the cover of the automatic choke which is heated by an electric heating coil which operates off the battery circuit and will heat the coil sufficiently so the thermostat will open the choke after a short period of operation. In conjunction with this, there is a piston which operates off of the intake manifold vacuum which will also open the carburetor choke when the engine is accelerated. Between the thermostat spring tension and the vacuum forces on the piston, the correct choking is obtained.
- c. If, for any reason, the engine choke does not function properly, the cover can be rotated by loosening the three clamp screws (Figure 10) and the choking can be increased as required.

The automatic choke cover is graduated for adjustment which is set to a line cast on the automatic choke housing. The graduated cover has a (0) and an (*) on the dial and for normal engine operation the (*) should be 12 notches in the rich direction and in line with the cast mark on the housing. Do not attempt to adjust the choke before the idle and high speed jets have been adjusted properly on the carburetor for smooth engine operation and do not attempt to adjust more than two notches at a time.

- d. The Thermostat Assembly (21) is properly pre-set and under ordinary circumstances it will give many months of satisfactory service. The heating elements, as shown by (20), have been engineered to furnish the proper amount of heat to offer the proper amount of thermostat tension for choking and, likewise, will not produce too much heat to allow the choke valve to open too fast.
- e. Should it become necessary to replace the thermostat unit, the whole assembly should be renewed.
- f. **Thermostat Setting.** When replacing thermostat unit (21), the loop of the thermostat spring (17) must be placed over the pin of the vacuum piston, link and lever assembly shown as (6). (This operation is very important, since it is necessary that the loop of the thermostat be installed properly in relation to the pin of the vacuum piston, link and lever to obtain the correct automatic choke performance.) After the thermostat assembly has been assembled to the automatic choke housing,

the thermostat cover should be rotated in the RICH direction or counter-clockwise (left) until the marking (*) coincides with the projection at the top of the thermostat housing.

g. **Disassembly.**

- (1) Disconnect the vacuum tube from the automatic choke.
- (2) Remove thermostat cover screws and lug washers.
- (3) Loosen locknut, remove lock washer.
- (4) Remove vacuum piston assembly from housing.
- (5) With a clean rag saturated with acetone or alcohol, thoroughly clean the cylinder walls of any dirt or other foreign material which may have accumulated in regular service. Use compressed air to blow out all of the channels. The surface of the piston should also be thoroughly cleaned. Do not use any abrasive materials for cleaning piston or cylinder.

h. **Reassembly.**

- (1) Place vacuum piston in cylinder with slot on piston assembled down. **THIS IS VERY IMPORTANT. ALSO DO NOT USE ANY TYPE OF LUBRICANT ON PISTON OR IN CYLINDER.** Assemble lever onto choke stem. Next assemble lockwasher and locknut, fastening the nut securely.
- (2) Follow setting procedure as outlined above.

28. **Spark Plugs.** (Figure 19)

- a. To prevent ignition noise and radio interference the ignition system is radio shielded. The spark plugs and ignition wires are covered entirely with metal which, when grounded to the engine, grounds out radio interference.
- b. When replacing spark plugs the radio shielding knurled nut must be unscrewed which will permit the removal of the top cap of the shielding and with a spark plug wrench the spark plug can then be removed from the cylinder head.
- c. When re-assembling the spark plug and shielding, a gasket must be placed between the spark plug and the shielding or between the shielding and the cylinder head to prevent leaks at this point.

29. Trouble Chart.**a. Engine Difficult to Start:**

1. No gasoline in tank
2. Gasoline flow obstructed
3. Loose or defective wiring
4. Spark plug cracked
5. Spark plug fouled
6. Improper gas mixture
7. Throttle valve stuck
8. Throttle rod loose
9. Valve seats pitted
10. Valves sticking
11. Improper timing
12. Defective Magneto
 - (a) Breaker points worn or pitted
 - (b) Breaker points out of adjustment
 - (c) Breaker cam out of time
 - (d) Switch shorted
 - (e) High tension wires shorted
13. Automatic choke not functioning
14. Defective fuel pump

b. Engine Missing

1. Spark plug fouled
2. Spark plug cracked
3. Spark plug gap wrong
4. Defective wiring
5. Magneto breaker points sticking
6. Valves warped or broken
7. Valve tappets sticking
8. Valve tappets improperly adjusted
9. Breaker points worn
10. Breaker points out of adjustment
11. Carburetor out of adjustment
12. Leaky intake manifold
13. Loose spark plug

- c. **Engine Overheating**
 - 1. Carburetor choke valve partly closed
 - 2. Improper fuel mixture
 - 3. Piston rings sticking
 - 4. Improper timing
 - 5. Muffler clogged
 - 6. Air cleaner dirty
 - 7. Insufficient ventilation
 - 8. Faulty or insufficient lubrication
 - 9. Cooling passages obstructed
 - 10. Unit overloaded

- d. **Engine Knocks**
 - 1. Carbon in cylinders
 - 2. Loose main bearings
 - 3. Loose rod bearings
 - 4. Worn pistons
 - 5. Loose valve tappets
 - 6. Motor overheated
 - 7. Tight pistons
 - 8. Loose flywheel
 - 9. Lack of oil
 - 10. Improper fuel
 - 11. Improper fuel mixture
 - 12. Improper timing

- e. **Faulty Carburetion**
 - 1. Carburetor improperly adjusted
 - 2. Float valve leaking
 - 3. Float valve stuck
 - 4. Fuel valve partially closed
 - 5. Sediment in fuel tank
 - 6. Leaky manifold
 - 7. Faulty choke

- f. **Excessive Smoke in Exhaust**
 - 1. Carburetor needle valve open too far
 - 2. Carburetor float sticking or leaking
 - 3. Worn piston or piston rings
 - 4. Too much oil in crankcase
 - 5. Using too light grade oil
 - 6. Fuel mixture too rich
 - 7. Faulty choke

- g. Explosion in Carburetor
 - 1. Gas mixture too lean
 - 2. Intake valves sticking
 - 3. Intake tappets sticking
 - 4. Intake valve springs weak
 - 5. Intake valves warped or broken
 - 6. Intake tappets set too close
 - 7. Leaky manifold
 - 8. Improper timing
- h. Poor Compression
 - 1. Valves not seating
 - 2. Valves sticking
 - 3. Valve tappets sticking
 - 4. Valve tappets set too close
 - 5. Piston rings worn or weak
 - 6. Piston rings broken
 - 7. Piston rings sticking
 - 8. Loose spark plugs
 - 9. Cylinder head loose
 - 10. Scored cylinder
 - 11. Worn pistons and cylinders
 - 12. Improper lubrication
- i. Battery Generator Not Charging
 - 1. Defective brushes
 - 2. Burned commutator
 - 3. High mica
 - 4. Grounded circuit
 - 5. Open circuit
 - 6. Burned out windings
- j. Main Generator Inoperative
 - 1. Exciter brushes not seating
 - 2. Burned exciter commutator
 - 3. High mica
 - 4. Defective collector ring brushes
 - 5. Worn collector rings
 - 6. Voltmeter switch out of position
 - 7. Open field circuit
 - 8. Shorted terminals
 - 9. Grounded terminals
 - 10. Insufficient speed
 - 11. Burned out windings

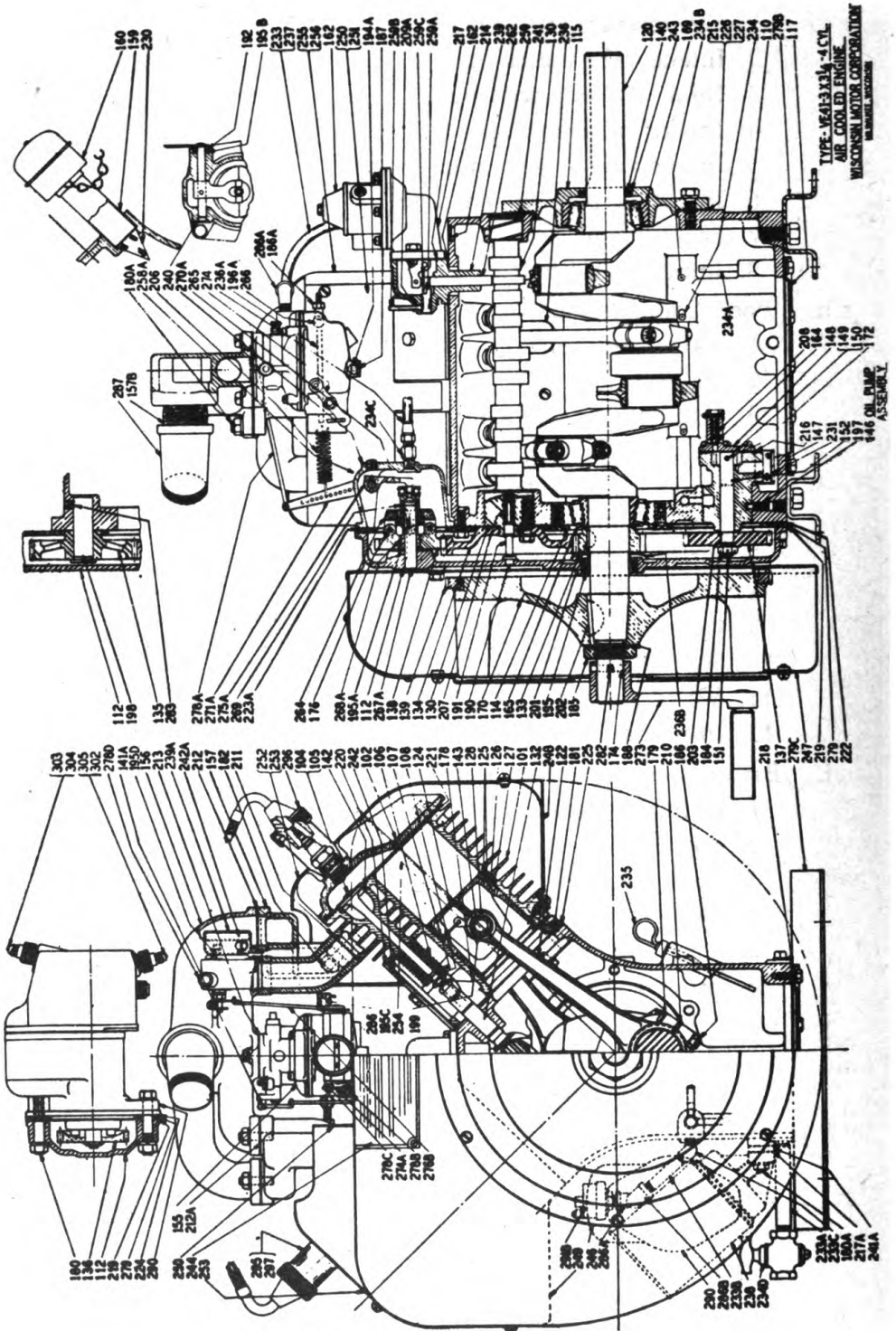

FIGURE 16.—Engine, sectional view.

SECTION V.
SUPPLEMENTARY DATA
30. TABLE OF REPLACEABLE PARTS

NOTE. Order parts by Signal Corps Stock No., name, and description.

* Reference numbers are given only when referred to in text or illustration.

*** See List of Manufacturers—paragraph 32, page 52.

<i>Ref. No.</i>	<i>S. C. Stock No.</i>	<i>No. Req.</i>	<i>Name, Description and Function</i>	<i>Mfg'r. Pt. No.</i>	<i>M/Gr.</i>

					M/Gr.
FLYWHEEL AND HOUSING GROUP (Figures 16, 17 and 18)					
170		1	Engine Assembly Complete	VE-4I	B
139		1	Flywheel and Fan	NC-140-1	B
202		1	Flywheel Ring Gear	GH-AA	B
247		1	Woodruff Key for Flywheel	PL-83	B
246		1	Shroud for Flywheel	SE-74-A	B
248		1	Air Intake Screen	SE-20-B-3	B
249		1	Shroud, Lower Cyl, Right Side	SE-75-B	B
252		1	Shroud, Lower Cyl, Left Side	SE-76-B-1	B
253		1	Shroud, Cyl Head, Right Side	SE-78-A	B
255		1	Shroud, Cyl Head, Left Side	SE-79-A	B
256		1	Rear Shroud Cover, Left Side	SE-82-B	B
250		1	Rear Shroud Cover, Right Side	SE-83-B	B
251		1	Cyl Heat Deflector, Left Side	SE-77-A	B
192B		4	Cyl Heat Deflector, Right Side	SE-77-B	B
281		1	Inspection Cover Strap	PG-128	B
281C		1	Canopy	WE-198A-4	B
197A		4	Inspection Cover	WE-227-A	B
281A		1	Inspection Cover Wing Nut	PI-148	B
281B		1	Rear Panel	WE-199A-10	B
280		2	Partition Plate	WE-218A	B
			Side Rails	WE-195	B

TABLE OF REPLACEABLE PARTS—(Continued)

Ref. No.	S. C. Stock No.	No. Req.	Name, Description and Function	Mfg'r's.		*** Mfg'r.
				Pt. No.		
194D		1	Housing Brace, Left Rear	PG-394		B
194E		1	Housing Brace, Right Rear	PG-395		B
194F		1	Housing Brace, Front Panel	PG-421		B
193		2	Door Clips	PG-323		B
209		2	Door Clip Springs	PM-137		B
194G		6	Canopy and Tank Support Felts	PH-244A		B
280A		2	Side Panel, Left and Right	WE-196		B
280B		1	End Panel, Flywheel End	WE-197-16		B
254		1	Side Cover, Air Shroud	SE-80		B
141B		1	Spacer, Rear Panel to Eng. Sup.	HF-380		B
EXHAUST GROUP (Figures 16, 17 and 18)						
156		1	Exhaust Manifold, Upper	LD-227C-1		B
157B		1	Exhaust Nipple	LJ-324		B
287		2	Street Ell for Muffler	XK-94		B
		1	Exhaust Muffler	WD-40		B
		1	Exhaust Tube, 10' Flexible	LJ-318A		B
211		6	Gasket, Exhaust Manifold Port	QB-75		B
MISCELLANEOUS GROUP (Figures 16 and 17)						
273		1	Starting Crank Assembly	U-212		B
279B		1	Engine Support, T. O. End	WE-193-A		B
279C		1	Engine Support, Flywheel End	WE-194-A		B
117		1	Skid Base Assembly	99-101		A
			Supports Comp. Assembly			

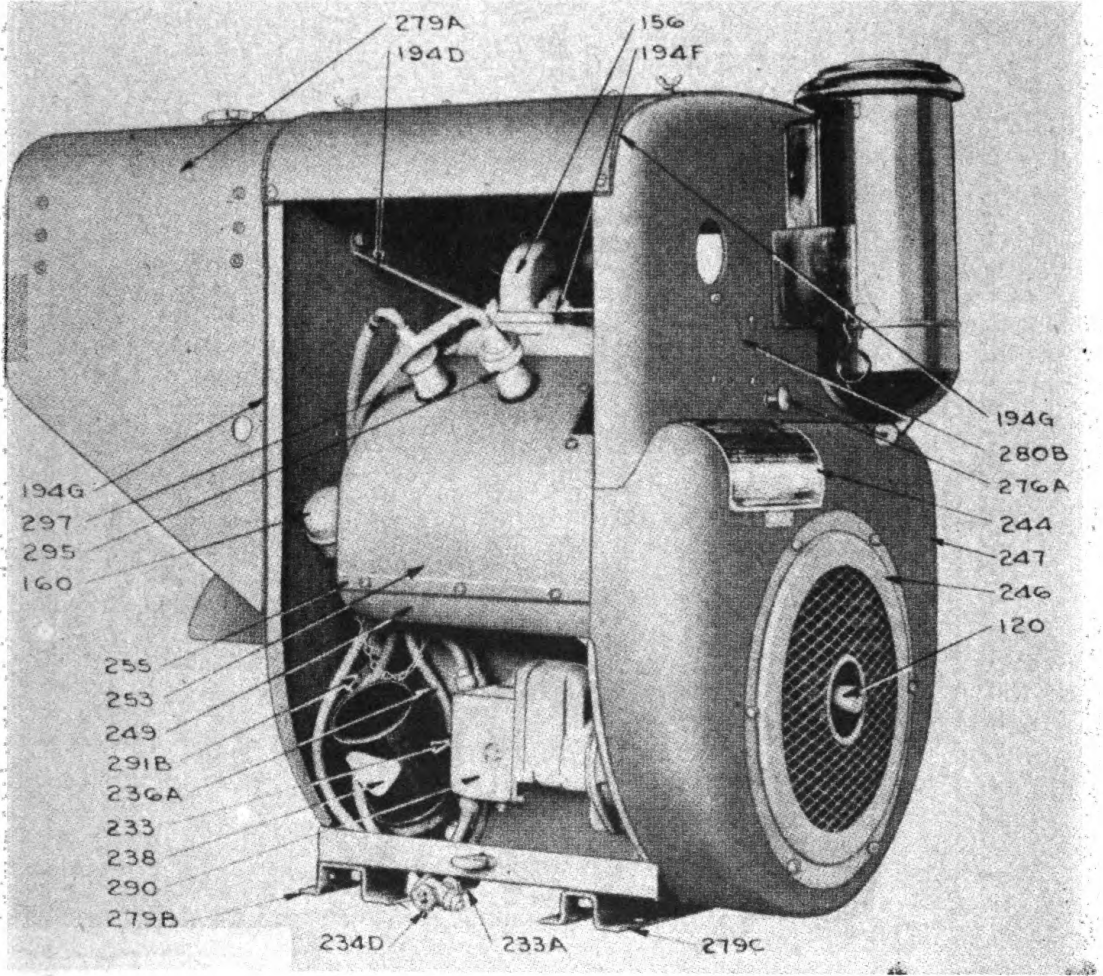

FIGURE 17.—Engine magneto, side view.

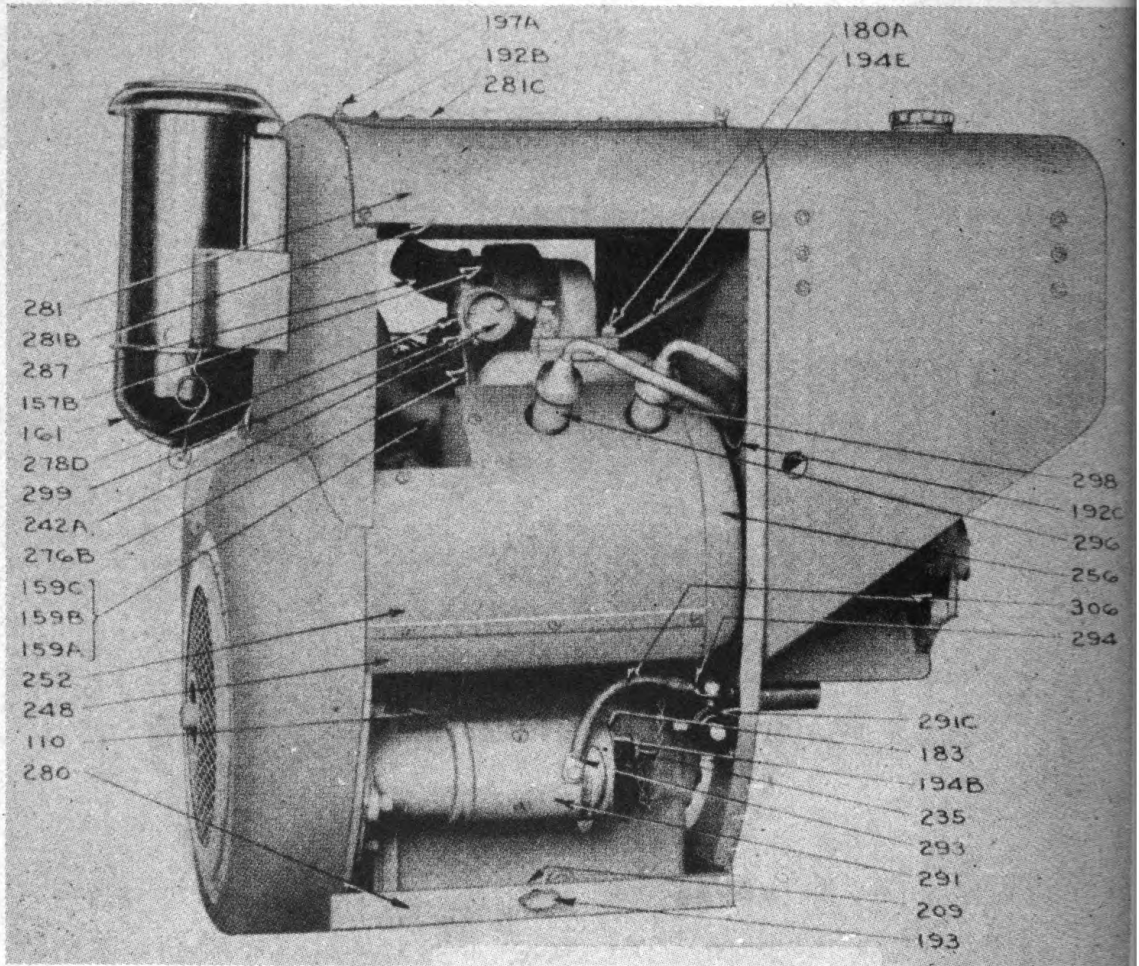

FIGURE 18.—Engine starter, side view.

TABLE OF REPLACEABLE PARTS—(Continued)

Ref. No.	S. C. Stock No.	No. Req.	Name, Description and Function	Mfg'r's Pt. No.	*** Mfg.
CYLINDER GROUP (Figure 16)					
101		2	Cylinder Block with Inserts	AA-85-A	B
101		2	Cyl Block w/studs, inserts, valves, springs, seats and insp. covers	AA-85-B	B
102		2	Cylinder Head	AB-80-G	B
221		2	Cylinder Head Gasket	QD-613-B	B
225		2	Cylinder Base Gasket	QD-617	B
CRANKCASE GROUP (Figure 16)					
110		1	Crankcase	BA-48-A-19	B
117		1	Crankcase Bottom Cover Plate	BH-141	B
218		1	Crankcase Bottom Cover Plate Gasket	QD-610-A	B
112		1	Gear Cover	BD-100-C-2	B
177		2	Gear Cover Dowel Pin	PA-291	B
222		1	Gear Cover Spacer Gasket	QD-614	B
219		1	Gear Cover Gasket	QD-111	B
114		1	Bearing Retainer Plate, Fan End	BG-209	B
115		1	Main Bearing Plate, T. O. End	BG-210	B
140		1	Cork Oil Seal, Crankshaft T. O. End	HF-261	B
195		1	Oil Seal, Crankshaft Fan End	PH-299	B
236B		1	Crankshaft Oil Sling	RK-170	B
242		4	Valve Inspection Cover	SA-68	B
220		4	Valve Inspection Cover Gasket	QD-612-A	B
215		2	Main Bearing Plate Gasket, T. O. End	QD-527-A	B
226		2	Main Bearing Plate Shim, T. O. End .006"	QF-33	B
227		2	Main Bearing Plate Shim, T. O. End .003"	QF-33-A	B

TABLE OF REPLACEABLE PARTS—(Continued)

Ref. No.	S. C. Stock No.	No. Req.	Name, Description and Function	M/gr's.		*** M/gr.
				Pt. No.		
234D		1	Oil Drain Cock	RG-28-A		B
233A		1	Oil Drain Nipple	RF-1139		B
235		1	Oil Level Gauge	RJ-143		B
230		1	Oil Filler Screen	RC-91		B
159		1	Oil Filler Tube	LJ-300-A		B
160		1	Oil Filler and Cap	LO-60-1		B
236		2	Splash Plate, Crankcase	RK-167		B
239		2	Welch Plug	SA-26		B
241		1	Welch Plug	SA-58		B
243		1	Oil Seal Retainer	SD-43		B
279		1	Spacer	WE-182-A		B
PISTON AND CONNECTING ROD GROUP (Figure 16)						
122		4	Connecting Rod Assembly	DA-51-A		B
210		8	Shim for Connecting Rod	QA-108-A		B
143		4	Piston Pin Bushing	HG-157-A-S		B
124		4	Piston, Standard	DB-199-A		B
124		4	Piston, Semi-Finished	DB-199-B		B
125		8	Piston Ring, Std. Compression	DC-163		B
126		4	Piston Ring, Std. Scraper	DC-163-1		B
127		4	Piston Ring, Std. Oil Regulator	DC-109		B
128		4	Piston Pin	DE-65		B
199		8	Piston Pin Retainer Ring	PK-52		B

TABLE OF REPLACEABLE PARTS—(Continued)

Ref. No.	S. C. Stock No.	No. Req.	Name, Description and Function	M/gr's. Pt. No.	*** M/gr.
CAMSHAFT & VALVE GROUP (Figure 16)					
104		8	Valve, Intake and Exhaust	AE-75-B	B
106		8	Valve Spring, Intake and Exhaust	AF-46	B
107		8	Valve Spring Seat	AG-26	B
108		8 pr.	Valve Spring Retainer Lock	AH-9	B
142		8	Valve Seat Insert	HG-201-B	B
132		8	Valve Tappet	FA-40-B	B
178		8	Valve Tappet Adjusting Screw	PB-147	B
130		1	Camshaft	EA-102	B
134		1	Camshaft Gear	GB-45-A	B
135		1	Idler Gear	GC-27-B-1	B
198		1	Idler Gear Stud	PJ-105	B
283		1	Idler Gear Stud Set Screw	XE-55	B
190		1	Camshaft Thrust Plunger Gear Cover Button	PF-52	B
191		1	Thrust Plunger	PF-101	B
207		1	Thrust Plunger Spring	PM-108	B
CRANKSHAFT GROUP (Figure 16)					
120		1	Crankshaft Assembly	CA-55	B
133		1	Crankshaft Gear	GA-36-A	B
201		1	Woodruff Key for Crankshaft Gear	PL-53	B
169		1	Main Bearing Assembly, T. O. End	ME-114	B
165		1	Main Bearing Assembly, Fan End	ME-71	B
185		1	Crankshaft Nut	PD-123	B
188		1	Crankshaft Nut Lock Washer	PE-66	B
174		1	Starting Crank Pin	PA-239	B
282		1	Starting Crank Pin Set Screw	XE-17	P

TABLE OF REPLACEABLE PARTS—(Continued)

Ref. No.	S. C. Stock No.	No. Req.	Name, Description and Function	Mfg'r's.		*** Mfg.
				Pt. No.		
LUBRICATION GROUP (Figure 16)						
146		1	Oil Pump Assembly	K-95-A		B
147		1	Oil Pump Body	KA-61-A		B
148		1	Oil Pump Cover	KB-39		B
216		1	Oil Pump Cover Gasket	QD-535		B
149		1	Oil Pump Gear, Driver	KC-54-1		B
150		1	Oil Pump Gear, Driven	KC-55-1		B
172		1	Oil Pump Cover Pin	PA-64		B
151		1	Oil Pump Drive Shaft	KD-121		B
152		1	Oil Pump Stub Shaft	KD-122		B
137		1	Oil Pump Drive Gear	GD-94-A		B
203		1	Woodruff Key for Oil Pump Gear	PL-137		B
184		1	Oil Pump Gear Nut	PD-100-1		B
197		1	Oil Pump Lock Screw	PI-143-A		B
208		1	Oil Pump Relief Valve Spring	PM-111		B
164		1	Oil Pump Relief Valve Ball	ME-60		B
231		1	Oil Pump Screen	RD-119		B
238		1	Oil Filter Assembly	RV-27-A		B
217A		2	Oil Filter Gasket	QD-595-A		B
241A		1	Oil Filter Spacer	SA-65A-2		B
234A		1	Standpipe, Oil Filter Drain	RF-1128		B
233B		1	Oil Pressure Gauge Nipple	RF-902		B
233C		1	45° St. Ell for Pressure Gauge	RF-1096		B
286B		1	Elbow for Oil Pressure Gauge	XK-44		B
286A		3	1/8" St. Ell for Oil Pressure Gauge	XK-38		B
291B		1	Oil Pressure Switch	YC-11A		B
234		2	Oil Nozzle, Long	RF-1121		B
234B		2	Oil Nozzle, Short	RF-1143		B

TABLE OF REPLACEABLE PARTS—(Continued)

Ref. No.	S. C. Stock No.	No. Req.	Name, Description and Function	Mfg's. Pl. No.	*** Mfg.
FUEL TANK GROUP (Figure 17)					
279A		1	Fuel Tank with Supports	WE-192D-3	B
107		1	Fuel Tank Cap and Chain	RC-92-1	B
232		2	1/8" Pipe Nipple	RF-794	B
234E		1	3-way Fuel Valve	RG-36	B
237		2	Fuel Line	RM-1049A	B
GOVERNOR GROUP (Figure 16)					
258A		1	Governor Assembly	T-89-2	B
138		1	Governor Gear	GD-100-A	B
141A		1	Governor Control Rod Spacer, Carb. End	HF-381	B
176		2	Governor Weight Fulcrum Pin	PA-265	B
186A		1	Special Governor Adjusting Screw Nut	PD-173A	B
192		1	Governor Cross Shaft Seal Cup	PF-118	B
195A		1	Governor Drive Gear Bushing Washer	PH-313-A	B
195B		1	Governor Cross Shaft Oil Seal	PH-318-A	B
196A		1	Governor Adjusting Screw	PI-115-F	B
206		1	Governor Spring	PM-76	B
223A		1	Governor Housing Gasket	QD-615-A	B
234C		1	Governor Housing Oil Line Fitting	RF-1165	B
236A		1	Oil Line to Governor	RM-1049E	B
240		1	Welch Plug—Governor Housing	SA-52	B
264		2	Governor Fly Weight	TC-322A	B
265		2	Governor Fly Weight Thrust Pin	TC-328	B
266		1	Governor Adjusting Screw Pin	TC-367	B
267A		1	Governor Drive Shaft	TC-388-1	B

TABLE OF REPLACEABLE PARTS—(Continued)

Ref. No.	S. C. Stock No.	No. Req.	Name, Description and Function	Mjgr's. Pt. No.	*** Mjgr.
268A		1	Governor Drive Gear Bushing	TC-389-1	B
269		1	Governor Thrust Sleeve & Brg. Assy.	TC-391	B
270A		1	Governor Housing	TC-395	B
271A		1	Governor Cross Shaft & Lever Assembly	TC-398	B
275A		1	Governor Yoke	VB-151	B
278A		1	Governor Control Rod	VE-464	B
SPARK PLUG & CABLE GROUP (Figures 16, 17, 18 and 19)					
192C		2	Clips to hold Ignition Cable	PG-206	B
295		1	No. 1 Cyl. Spark Plug Shielding	YD-69C	B
296		1	No. 2 Cyl. Spark Plug Shielding	YD-69D	B
297		1	No. 3 Cyl. Spark Plug Shielding	YD-69E	B
298		1	No. 4 Cyl. Spark Plug Shielding	YD-69F	B
302		1	No. 1 Cyl. Spark Plug Cable	YL-84C	B
303		1	No. 2 Cyl. Spark Plug Cable	YL-84D	B
304		1	No. 3 Cyl. Spark Plug Cable	YL-84E	B
305		1	No. 4 Cyl. Spark Plug Cable	YL-84F	B
		4	Spark Plug	C-7	O
8		4	Ferrule Nut	YD-76	B
9		4	Ferrule	YD-77	B
2		4	Cap	YD-71	B
1		4	Main Body	YD-70	B
6		4	Ferrule	YD-72	B
3		4	Cap Spring	PN-88	B
4		4	Neoprene Bushing	YD-73	B

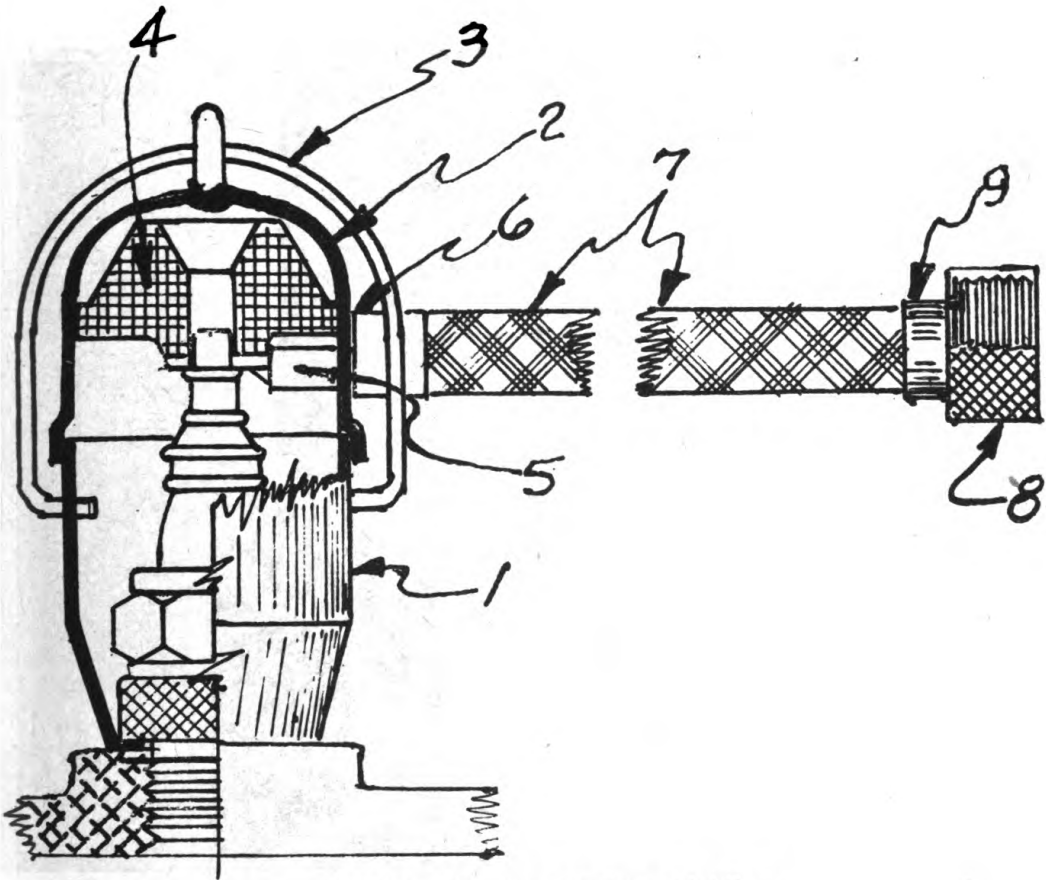

FIGURE 19.—Spark plug shielding.

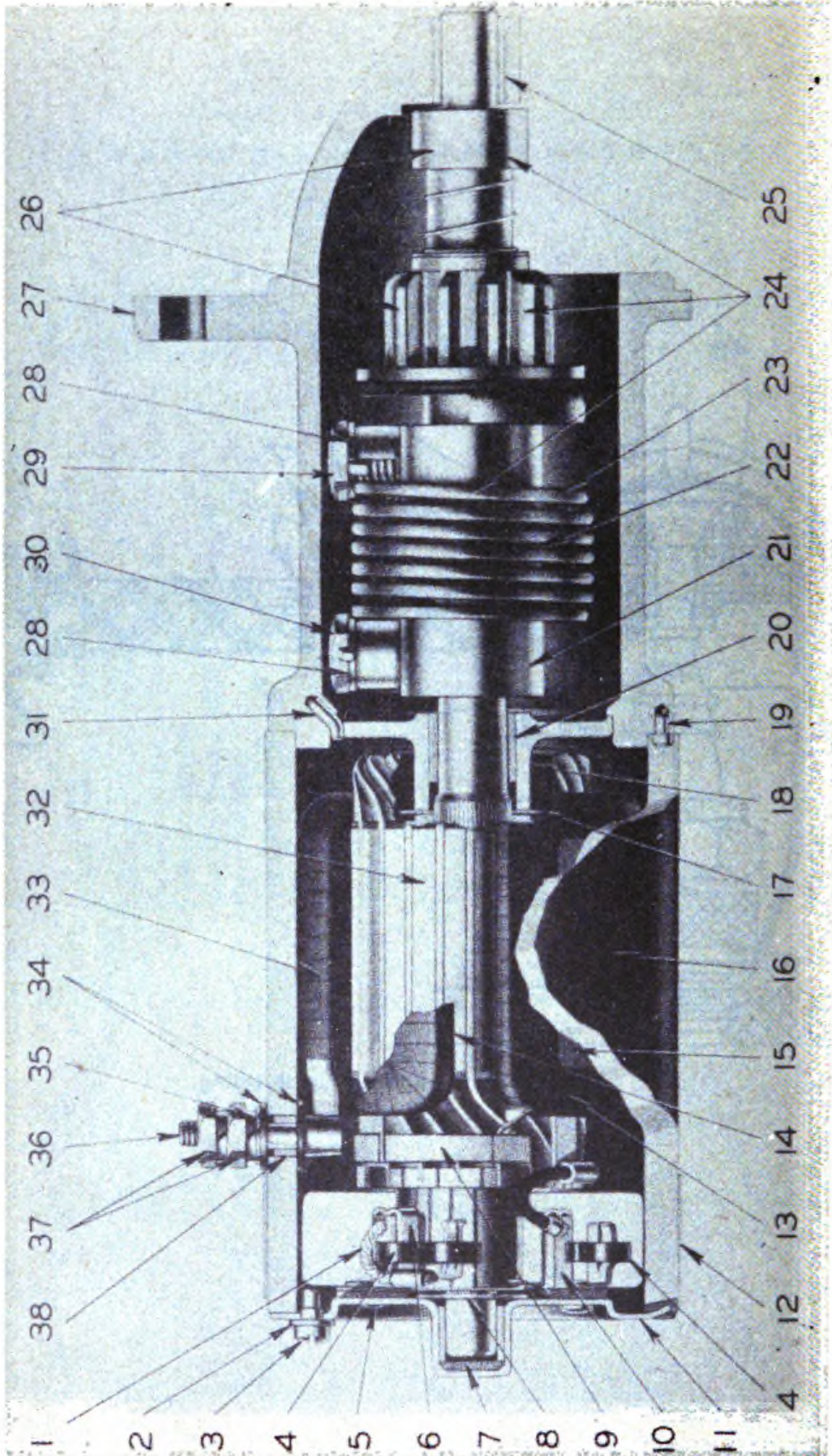

FIGURE 20.—Starting motor.

TABLE OF REPLACEABLE PARTS—(Continued)

Ref. No.	S. C. Stock No.	No. Req.	Name, Description and Function	Mfg's. Pt. No.	Mjgr. ***
STARTING MOTOR GROUP (Figures 18 and 20)					
		1	Starting Motor Assembly	MBE-4003A	G
194B		1	Starter Support Bracket	PG-331	B
291C		1	Solenoid Starting Switch	YC-20	B
294		1	Solenoid Starting Switch Terminal	YD-26B	B
293		1	Starting Motor Terminal	YD-26A	B
306		1	6" of #4 AWB Cable, Switch to Starter		B
1		1	Brush—Grounded	MAK-7034	G
2		1	#10 Lock Washer	X-196	G
3		1	Frame Screw	MAK-79	G
4		2	Brush Spring	MAK-19	G
5		2	Tubular Rivet	X-521	G
6		2	Brush Holder	MAK-16A	G
7		1	Felt Pad	MAK-59	G
8		1	Thrust Washer	MAK-55	G
9		1	Connector & Brush Assembly	MBE-1044	G
10		1	Brush	MAK-12	G
11		1	Comm. End Head Assembly	MAK-3002	G
12		1	Head Band	GAS-1024C	G
13		1	Field Coil, L.R.	MBE-1008	G
14		1	Field Coil, U.R.	MBE-1007	G
15		3	Pole Piece	MAK-29	G
16		3	Pole Piece Screw	MZ-38	G
17		1	Thrust Washer	MU-54	G
18		1	Intermediate Bearing Assembly	MAK-2092	G
19		1	Dowel Pin	GBF-95	G

TABLE OF REPLACEABLE PARTS—(Continued)

Ref. No.	S. C. Stock No.	No. Req.	Name, Description and Function	M/gr's.		*** M/gr.
				Pt. No.		
20		1	Absorbent Bronze Bearing	MZ-44-A		G
21		1	Driving Head	EB-8503		G
22		1	Compression Sleeve	EB-7819S		G
23		1	Drive Spring	EB-7805		G
24		1	Bendix Drive Assembly	EBA-56		G
25		1	Absorbent Bronze Bearing	MP-41A		G
26		1	S-A Assembly	EBA-3611		G
27		1	Pinion Housing Assembly	PS-1153		G
28		2	Lock Washer	EB-108		G
29		1	Shaft Spring Screw	EB-7807		G
30		1	Head Spring Screw	EB-7806		G
31		1	Dowel Pin	MAB-88		G
32		1	Armature Assembly	MAK-2088		G
33		1	Field Coil, U.L.	MBE-1010		G
34		2	Insulating Washer	MAK-49		G
35		1	Plain Washer	MAK-50		G
36		1	Terminal Post	MBC-28		G
37		2	1/4-20 Hex Nut	5X-146		G
38		1	Insulating Bushing	MAK-51		G
CHARGING VOLTAGE REGULATOR GROUP (Figure 21)						
VRS-4004F		1	Voltage Regulator Assembly compt	VRS-4004F		G
TC-51L		1	Carbon Resistance (Marked 30)	TC-51L		G
TC-51M		1	Carbon Resistance (Marked 60)	TC-51M		G
CBH-3001S		1	C. B. Coil Assembly	CBH-3001S		G
VRP-35		1	Armature Spring	VRP-35		G

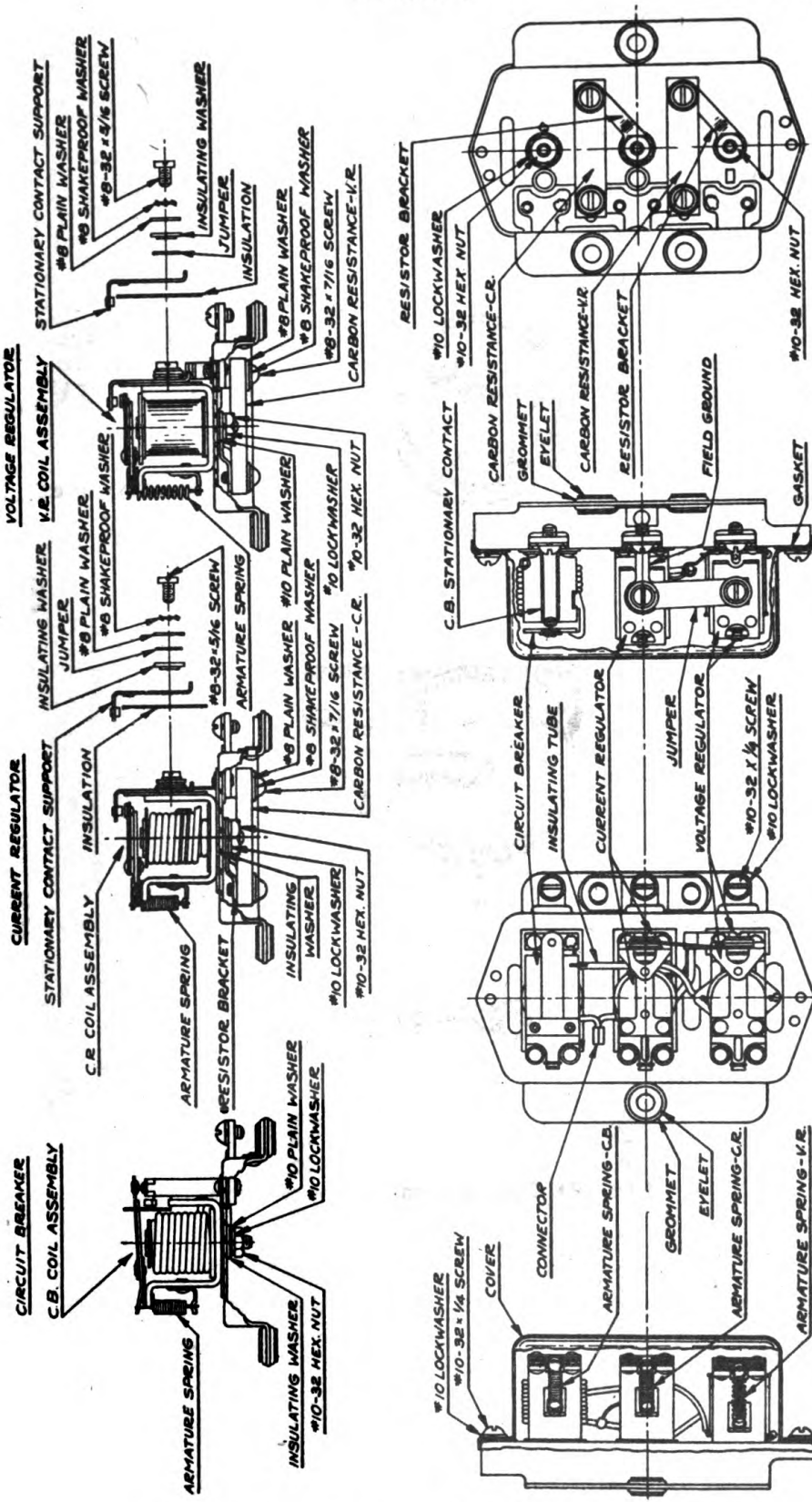

FIGURE 21.—Battery voltage regulator parts.

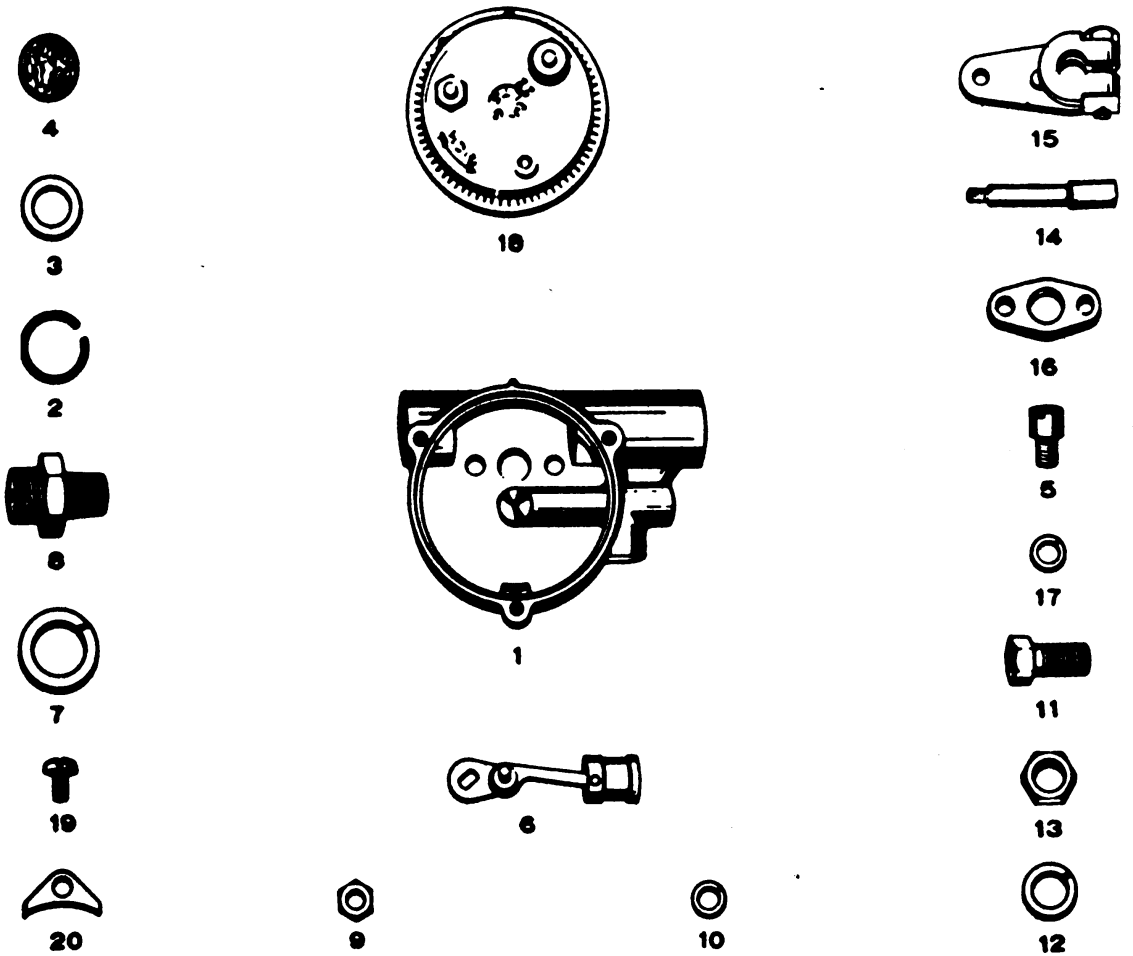

FIGURE 22.—Automatic choke parts.

TABLE OF REPLACEABLE PARTS—(Continued)

Ref. No.	S. C. Stock No.	No. Req.	Name, Description and Function	Mfg's. Pt. No.	*** Mfg.
8X-173		1	Hex Nut	8X-173	G
IGB-55		1	Insulating Washer	IGB-55	G
12X-196		1	Lock Washer	12X-196	G
8X-183A		1	Plain Washer	8X-183A	G
VRP-1034		1	C. B. Stationary Contact	VRP-1034	G
X-702		2	C. B. Stationary Contact Screw	X-702	G
VRS-1002A		1	Cover	VRS-1002A	G
VRP-50		1	Cover Gasket	VRP-50	G
12X-196		2	Cover Lock Washer	12X-196	G
8X-312		2	Cover Screw	8X-312	G
VRS-1003S		1	C. R. Coil Assembly	VRS-1003S	G
CB-123		1	Armature Spring	CB-123	G
8X-173		1	Hex Nut	8X-173	G
IGB-55		1	Insulating Washer	IGB-55	G
12X-196		1	Lock Washer	12X-196	G
VRB-36		3	Eyelet	VRB-36	G
VRB-37		3	Grommet—Rubber	VRB-37	G
VRP-58		1	Ground Terminal	VRP-58	G
X-1268		1	Ground Terminal Rivet	X-1268	G
TC-115D		1	Insulating Tube	TC-115D	G
VRB-28		1	Jumper	VRB-28	G
X-1316		1	Lead Seal	X-1316	G
VRP-36		2	Resistor Bracket	VRP-36	G
X-1275		4	Resistor Lock Washer	X-1275	G
8X-1503		4	Resistor Plain Washer	8X-1503	G
8X-56		4	Resistor Screw	8X-56	G

TABLE OF REPLACEABLE PARTS—(Continued)

Ref. No.	S. C. Stock No.	No. Req.	Name, Description and Function	Mfg'r's. Pt. No.	Mfg.
VRS-4		1	Series Coil Connector	VRS-4	G
X-196		3	Terminal Lock Washer	X-196	G
8X-312		3	Terminal Screw	8X-312	G
VRS-3008S		1	V. R. Coil Assembly	VRS-3008S	G
VRP-56		1	Armature Spring	VRP-56	G
8X-173		1	Hex Nut	8X-173	G
12X-196		1	Lock Washer	12X-196	G
8X-183A		1	Plain Washer	8X-183A	G
AUTOMATIC CHOKE GROUP (Figures 10 and 22)					
278D		1	12-volt Automatic Choke Assembly	VE-511A	B
Chokes Carburetor					
299		1	Choke Shielding Cup Loom Connector	YD-51	B
195D		2	Special Washer for Automatic Choke	PH-323	B
239A		1	Cover for Automatic Choke Shielding	SA-28	B
242A		1	Cup for Automatic Choke Shielding	SA-73	B
274A		1	Manual Lever for Automatic Choke	VB-158	B
276B		1	Automatic Choke Control Rod	VE-446	B
278B		1	Wire Connector on Automatic Choke	VE-509	B
278C		1	Choke Lever Spacer	VE-510	B
1		1	Choke Housing	382770	M
2		1	Felt Strainer and Washer Clip	382777	M
3		1	Felt Strainer Washer	P-20744	M
4		1	Felt Strainer	382776	M
5		1	Vacuum Piston Lever Stop Screw	382774	M
6		1	Vacuum Piston and Link	P-24133	M

TABLE OF REPLACEABLE PARTS—(Continued)

Ref. No.	S. C. Stock No.	No. Req.	Name, Description and Function	Mfg'r's Pt. No.	Mfg'r.
7		1	Vacuum Line Union Lock Washer	382779	M
8		1	Vacuum Line Union	382778	M
9		1	Vacuum Piston Lever Nut	P-16571	M
10		1	Vacuum Piston Lever Nut Lock Washer	P-15875	M
11		1	Choke Lever Stem Bushing	382772	M
12		1	Choke Lever Stem Bshg Lock Nut Lock Washer	P-8838	M
13		1	Choke Stem Bushing Nut	382773	M
14		1	Choke Stem	382771	M
15		1	Choke Lever	P-20229	M
16		1	Stop Screw Plate	382775	M
17		1	Stop Screw Lock Washer	40-S-19	M
18		1	Assembly Thermostat Unit	382780	M
19		1	Thermostat Unit Attach. Screw	P-21596	M
20		1	Thermostat Unit Attach. Screw Washer	P-24179	M
CARBURETOR GROUP (Figures 16 and 23)					
			Carburetor Assembly	426073	M
			Mixes Fuel and Air		
286A		1	1/8" Street Ell	XK-38	B
157		2	Manifold, Intake	LD-228	B
211		6	Intake Manifold Port Gasket	QB-75	B
212		2	Intake Manifold Port Gasket	QB-78	B
212A		2	Intake Manifold Port Gasket	QB-79	B
194A		1	Felt Washer, Carburetor Air Horn	PH-267-1	B
187		1	Everlock Washer, Carb. Air Horn	PE-44	B
195C		1	Carburetor Choke Lever Weight	PH-216	B

TABLE OF REPLACEABLE PARTS—(Continued)

Ref. No.	S. C. Stock No.	No. Req.	Name, Description and Function	Mfg'r's.		*** Mfg'r.
				Pt. No.		
213		1	Carburetor Mounting Gasket	QC-58		B
276A		1	Manual Choke Control	VE-435-1		B
274		1	Choke Lever	VB-147		B
286		1	Choke Weight Rivet	XJ-34		B
1		1	Float Needle Valve & Seat	425173		M
2		1	Complete set of Gaskets	382391		M
10		1	Idle Needle Valve	P-15396		M
11		1	Spring, Idle Needle Valve	P-12530		M
12		1	Metering Jet	P-18921		M
13		1	Main Discharge Jet	P-18340		M
14		1	Float Assembly	425106		M
15		1	Gasket, Float Needle Valve Seat	425176		M
17		1	Gasket, Main Body	425122		M
18		1	Idle Tube	425123		M
20		1	Gasket, Main Discharge Plug	P-11572		M
21		1	Lock Washer, Main Body Attach. Screw	40-S-49		M
23		1	Fulcrum Pin, Float	425162		M
27		2	Screw, Main Body Attach. (short)	177S-44		M
28		1	Screw, Throttle Stop	P-23474		M
29		1	Spring, Throttle Stop Screw	P-15301		M
30		1	Throttle Lever and Shaft	425120		M
31		1	Throttle Valve	425111		M
32		1	Screw, Throttle Valve Attach.	425161		M
40		1	Choke Valve	425112		M
41		1	Screw, Choke Valve Attach.	425201		M
42		1	Choke Stem and Lever	425156		M

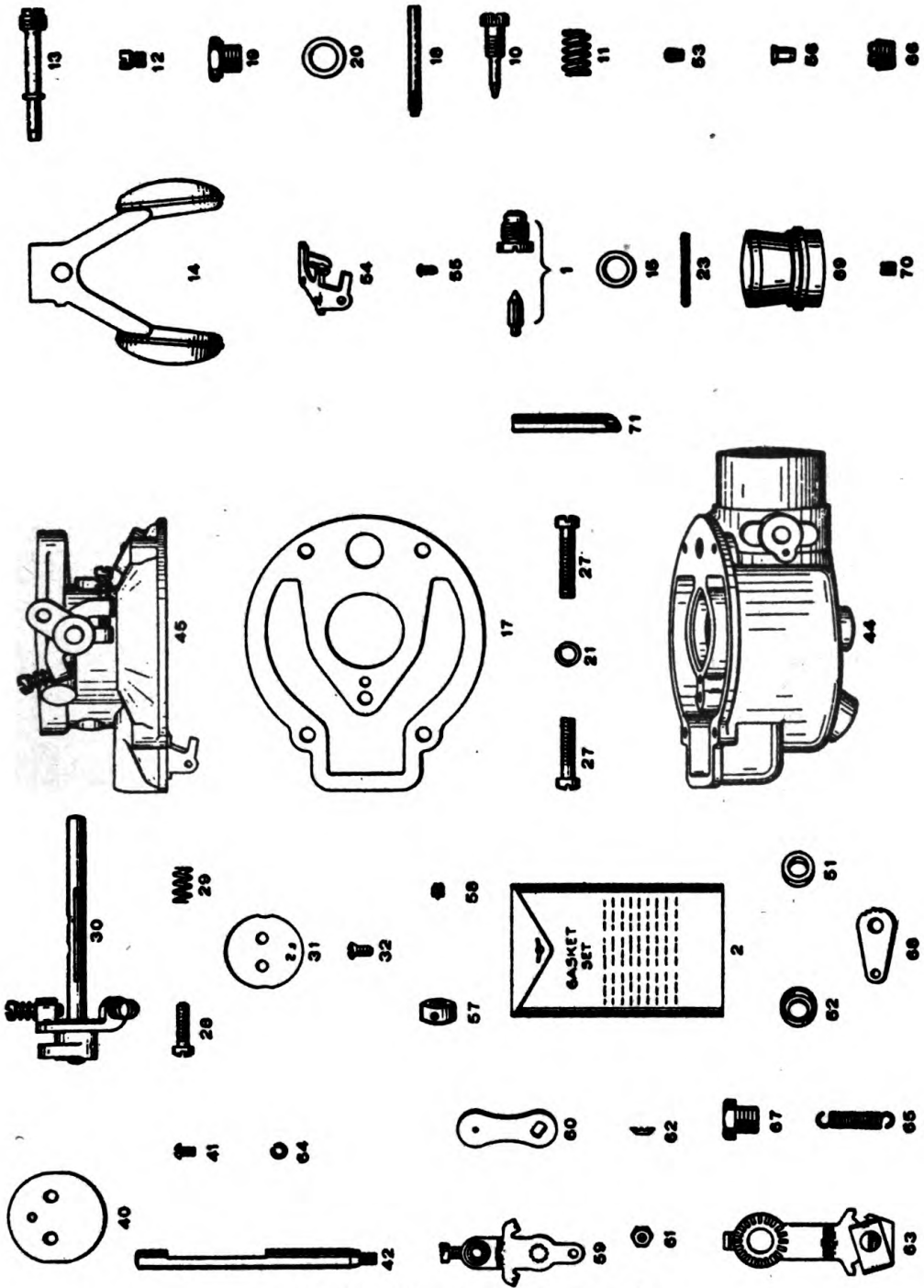
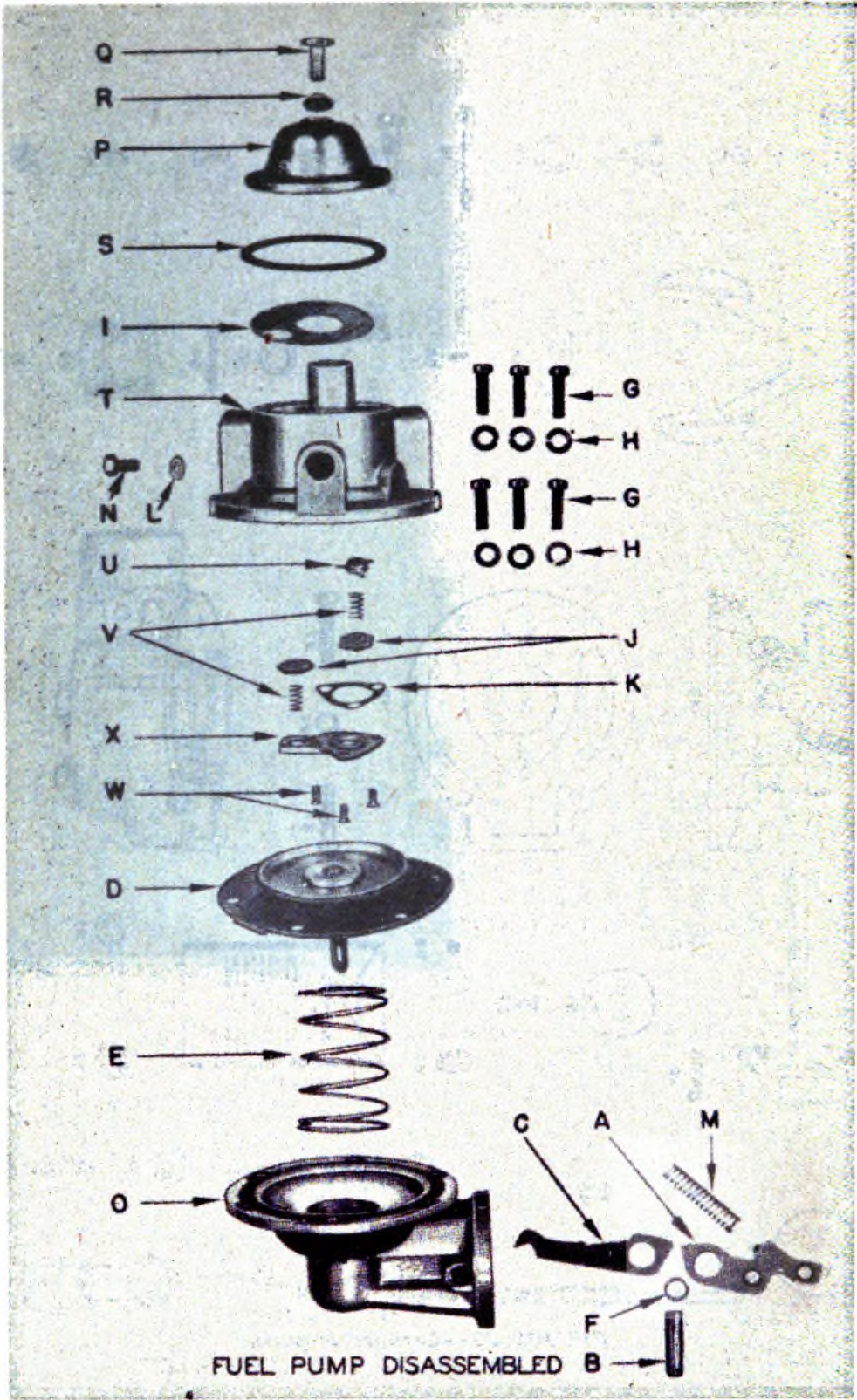

FIGURE 23.—Carburetor parts.



FUEL PUMP DISASSEMBLED

FIGURE 24.—Fuel pump parts.

TABLE OF REPLACEABLE PARTS—(Continued)

Ref. No.	S. C. Stock No.	No. Req.	Name, Description and Function	Mfg'r. Pt. No.	Mfg'r. ***
44		1	Main Body	425178	M
45		1	Throttle Body	425260	M
51		1	Felt Packing	425157	M
52		1	Retainer, Felt Packing	425158	M
53		1	Channel Plug	425160	M
54		1	Float Hanger	425159	M
55		1	Drive Screw, Float Hanger	253-S-22	M
56		1	Channel Plug	P-15459	M
57		1	Collar, Throttle Stem	P-17081	M
58		1	Set Screw, Throttle Stem Collar	P-16161	M
60		1	Choke Lever	425130	M
61		1	Nut, Choke Lever Attach.	P-2290	M
62		1	Lock Washer, Choke Lever Attach. Nut	40-S-49	M
64		1	Lock Washer, Choke Valve Attach. Screw	425202	M
66		1	Pipe Plug	P-3292	M
69		1	Venturi 13/16"	425104	M
70		1	High Speed Bleeder	P-20242	M
71		1	Vent Tube	425163	M
72		1	Main Discharge Jet Gasket	P-9600	M
FUEL STRAINER GROUP (Figure 26)					
161A		1	Fuel Strainer Assembly	LP-19	
			Cleans Fuel		
OW-462		1	Thumb Nut & Clamp Cup Assembly	OW-462	N
OW-460		1	Thumb Nut	OW-460	N
OW-461		1	Clamp Cup	OW-461	N

TABLE OF REPLACEABLE PARTS—(Continued)

Ref. No.	S. C. Stock No.	No. Req.	Name, Description and Function	M/gr's. Pt. No.	M/gr. ***
OW-446		1	Clamp Cup Stud & Clamp Wire Assy	OW-446	N
OW-317		1	Clamp Cup Stud	OW-317	N
OW-364		1	Clamp Wire	OW-364	N
OW-432		1	Shut-Off Cock	OW-432	N
OW-361		1	Strainer Cover (Main Body)	OW-361	N
OW-222		1	Gasket	OW-222	N
OW-352		1	Strainer Screen	OW-352	N
OW-363		1	Strainer Bowl	OW-363	N
AIR FILTER GROUP (Figures 18 and 25)					
		1	Air Filter Assembly	CT50-10505	L
			Cleans Air		
159C		1	Air Filter Connection, Rubber Elbow	LL-64	B
159A		1	Air Filter Conn, 2 1/8" ID Hose Clamp	LK-8	B
159B		1	Air Filter Conn, 1 7/8" ID Hose Clamp	LK-11	B
A1317		1	Wing Nut	A-1317	L
A10579		1	Top Cap	A-10579	L
A10089		1	Decalomania	A-10089	L
A10581		1	Intake Screen	A-10581	L
A9981		1	Filter Screen	A-9981	L
A10962		1	5/16" Machine Screw	A-10962	L
A10724		1	Body Assembly with Filter	A-10724	L
A10068		1	Filter Unit (4 balls)	A-10068	L
A9986		1	Oil Cup Gasket	A-9986	L
10128		1	Retainer Spider	10128	L
10139		1	Baffle Assembly	10139	L
B-9948		1	Oil Cup	B-9948	L
10141		1	Oil Cup & Baffle Assembly	10141	L
B-9982		1	Roller & Bail Assembly	B-9982	L

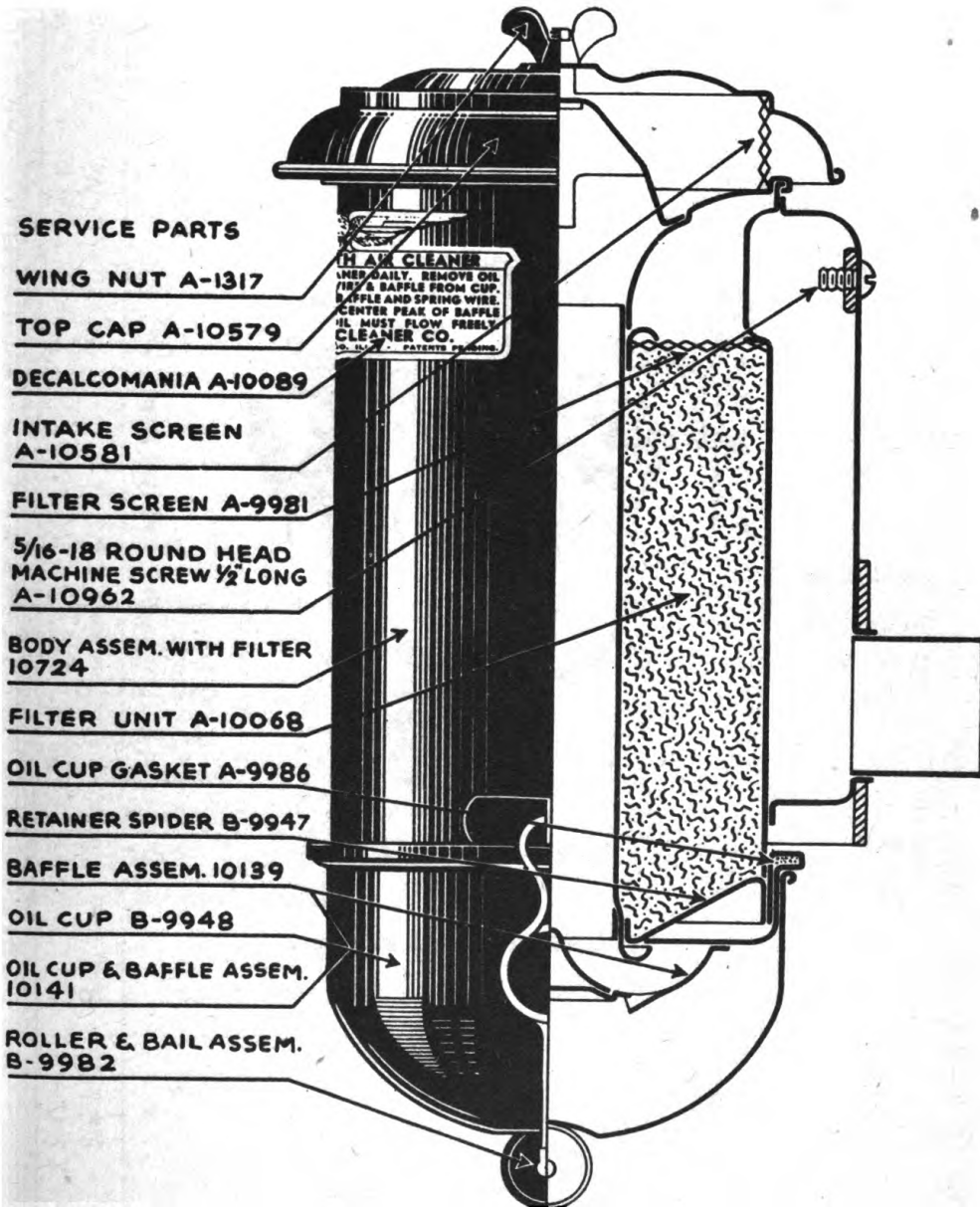

FIGURE 25.—Air filter.

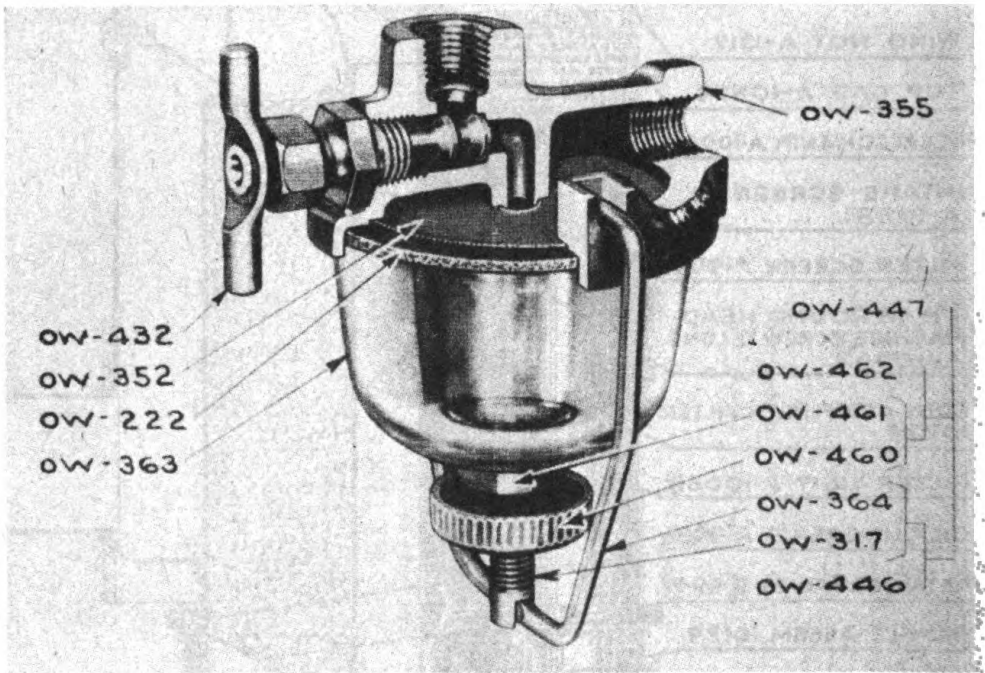

FIGURE 26.—Fuel strainer.

TABLE OF REPLACEABLE PARTS—(Continued)

Ref. No.	S. C. Stock No.	No. Req.	Name, Description and Function	Mfg's. Pt. No.	Mfg.
			FUEL PUMP GROUP (Figures 9 and 16)		
		1	Fuel Pump Assembly	1537421	K
			Supplies Fuel		
214		1	Fuel Pump Adapter Gasket	QD-67	B
217		1	Fuel Pump Mounting Gasket	QD-538-A	B
259		1	Fuel Pump Plunger	TA-111-1	B
259A		1	Fuel Pump Primer Shaft	TA-114	B
259B		1	Fuel Pump Primer Handle	TA-115	B
259C		1	Fuel Pump Plunger Cap	TA-116	B
262		1	Fuel Pump Adapter	TB-105-B	B
209A		1	Fuel Pump Primer Handle Spring	PM-145	B
286A		1	1/8" Street Ell	XK-38	B
A		1	Rocker Arm	1521862	K
B		1	Rocker Arm Pin	1521640	K
C		1	Link	1521863	K
D		1	Diaphragm Assembly	1523301	K
E		1	Diaphragm Spring	1523714	K
F		1	Rocker Arm Pin Bushing	1521864	K
G		6	Cover Screw	855493	K
H		6	Cover Screw Lock Washer	855064	K
I		1	Screen	1521479	K
J		2	Valve	855279	K
K		1	Valve Plate Gasket	1521472	K
L		1	Drain Screw Gasket	851297	K
M		1	Rocker Arm Spring	1522091	K
N		1	Drain Screw	1521612	K

TABLE OF REPLACEABLE PARTS—(Continued)

Ref. No.	S. C. Stock No.	No. Req.	Name, Description and Function	Mfgr's. Pt. No.	*** Mfgr.
O		1	Body	1523258	K
P		1	Cover Plate	1521475	K
Q		1	Cover Plate Cap Screw	1537148	K
R		1	Cover Plate Cap Screw Gasket	1521476	K
S		1	Cover Plate Gasket	1521480	K
T		1	Cover & Valve Seat Assembly	1521641	K
U		1	Outlet Valve Spring Retainer	1521473	K
V		2	Valve Spring	856270	K
W		3	Valve Retainer Screw	856374	K
X		1	Valve Plate (Outlet)	1521471	K
CHARGING GENERATOR GROUP (Figure 27)					
		1	Charging Generator Assembly	GEF-4805A	G
			Charges Battery		
169A		1	Charging Generator Drive Belt	MH-133	B
194C		1	Charging Generator Adjust. Strap	PG-391	B
GEF-2001		1	Frame & Field Assembly	GEF-2001	G
GAA-32		1	Washer, Ins., Arm Terminal	GAA-32	G
GAL-44		1	Ins., Field, Connection	GAL-44	G
GBW-34		1	Washer, Ins., Field Term.	GBW-34	G
GCT-25		1	Bushing, Ins., Arm Term.	GCT-25	G
GCY-25		1	Bushing. Ins., Field Term.	GCY-25	G
GDZ-29		2	Pole Piece	GDZ-29	G
GEA-34		1	Ins., Term. Post, Inner	GEA-34	G
GEF-1005		1	Coil Assembly, Field, Comp.	GEF-1005	G
GBW-58		1	Post, Terminal, Field	GBW-58	G

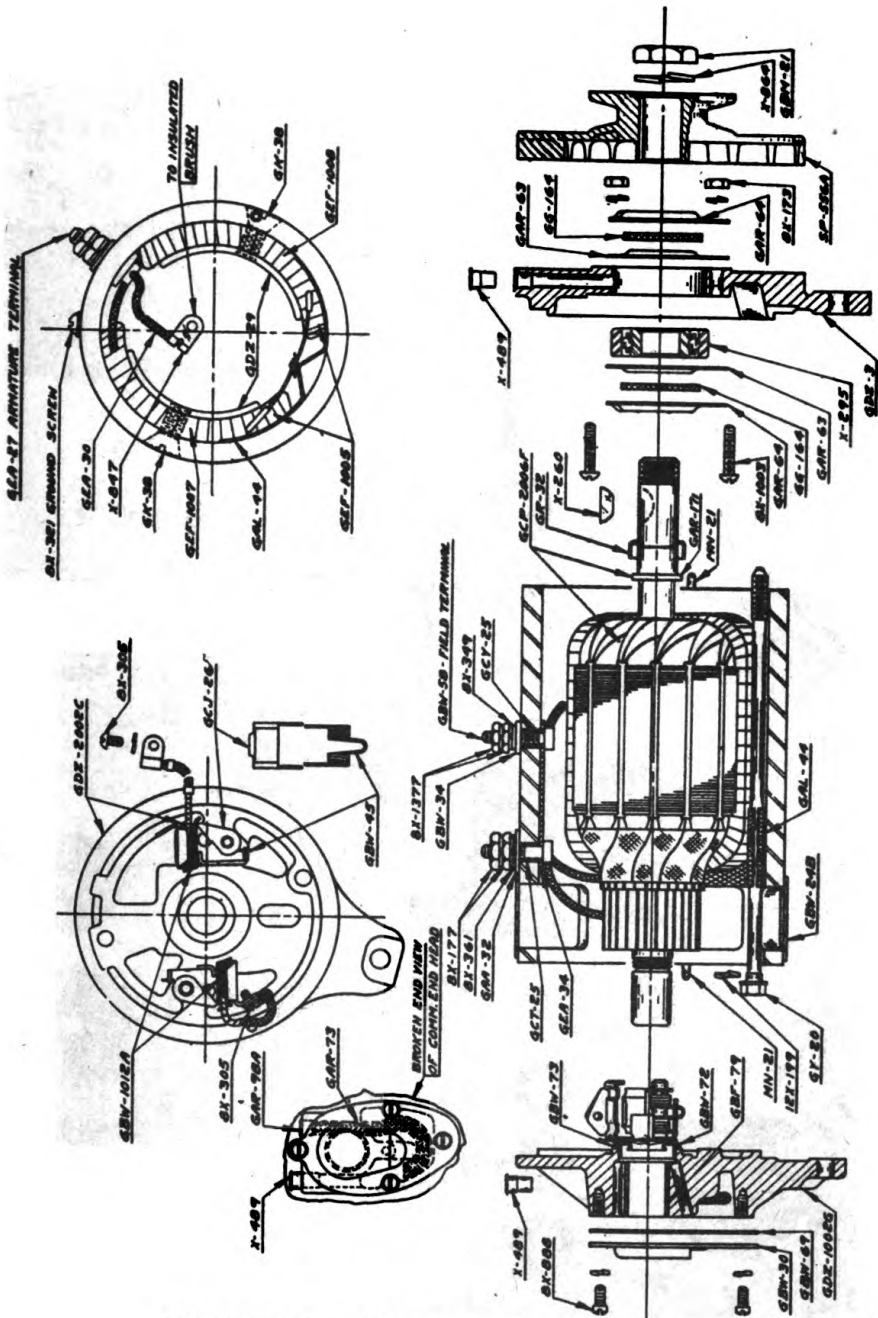

FIGURE 27.—Charging generator parts.

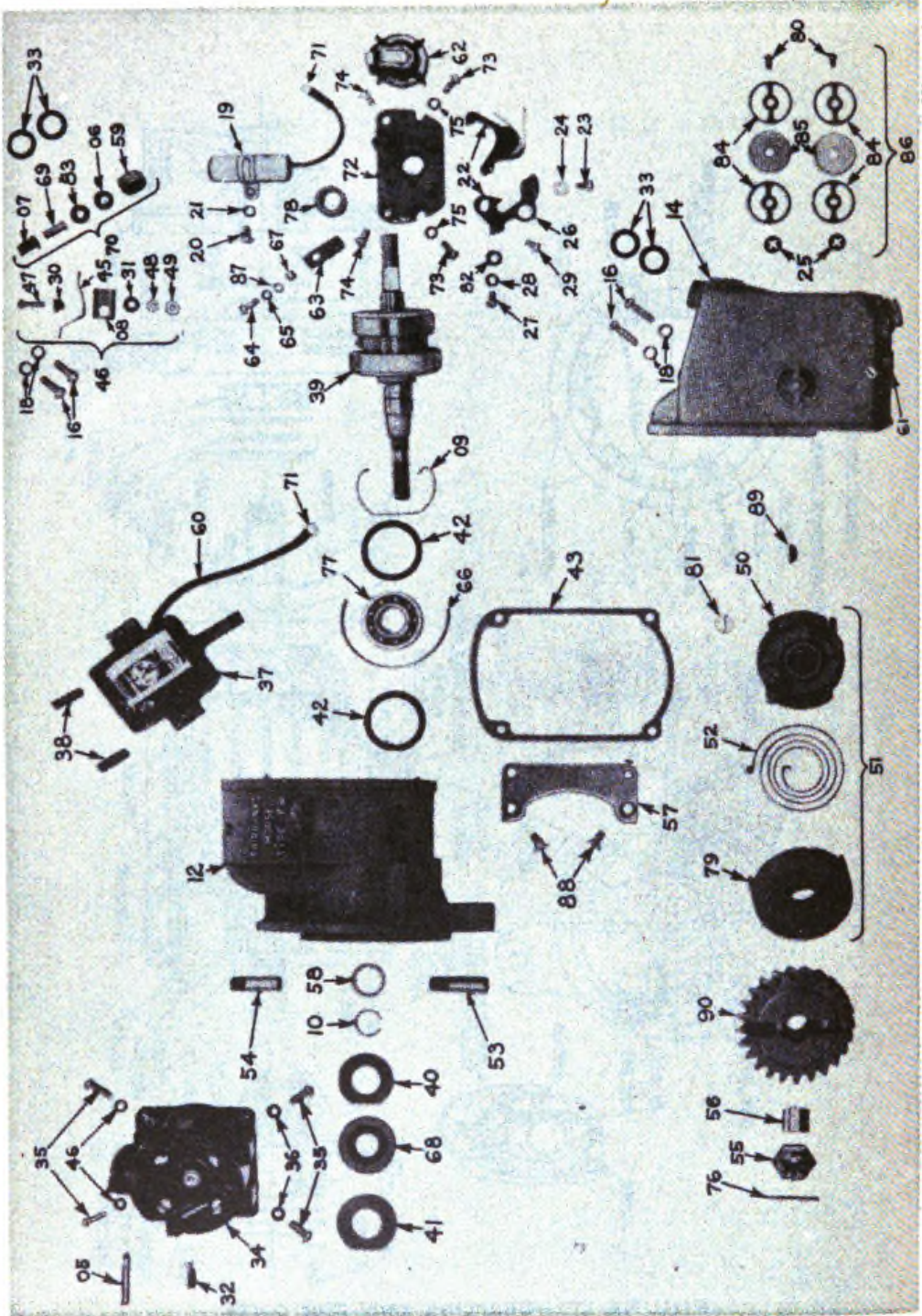

FIGURE 28.—Magneto parts.

TABLE OF REPLACEABLE PARTS—(Continued)

Ref. No.	S. C. Stock No.	No. Req.	Name, Description and Function	Mfg'r's. Pt. No.	Mfg'r. ***
GEA-27		1	Post, Arm Terminal	GEA-27	G
GEA-30		1	Lead Assembly	GEA-30	G
X-847		1	Terminal	X-847	G
GEF-1007		1	Coil, Field, Left	GEF-1007	G
GEF-1008		1	Coil, Field, Right	GEF-1008	G
GK-38		2	Screw, Pole Piece	GK-38	G
MN-21		2	Pin, Dowel	MN-21	G
8X-177		1	Nut, Hex	8X-177	G
12X-193		1	Washer, Lock	12X-193	G
12X-196		1	Washer, Lock	12X-196	G
8X-349		1	Washer, Plain	8X-349	G
8X-361		1	Washer, Plain	8X-361	G
8X-1377		1	Nut, Hex	8X-1377	G
GY-20		2	Screw, Frame	GY-20	G
8X-177		1	Nut, Hex	8X-177	G
12X-193		1	Washer, Lock	12X-193	G
12X-196		2	Washer, Lock	12X-196	G
12X-199		2	Washer, Lock	12X-199	G
8X-321		1	Screw, Round Head	8X-321	G
8X-1377		1	Nut, Hex	8X-1377	G
GDZ-2002C		1	Head Assembly, Comm. End	GDZ-2002C	G
GAR-73		1	Wick, Felt	GAR-73	G
GAR-98A		1	Cover, Wick	GAR-98A	G
GBW-30B		1	Cover, Comm. End	GBW-30B	G
GBW-69		1	Gasket, Comm. End Cover	GBW-69	G
GBW-72		1	Oil Guard	GBW-72	G

TABLE OF REPLACEABLE PARTS—(Continued)

Ref. No.	S. C. Stock No.	No. Req.	Name, Description and Function	Mfg's.		*** Mfg.
				Pt. No.	Mfg.	
GBW-73		1	Gasket, Oil Retaining	GBW-73		G
GBW-1012A		2	Brush	GBW-1012A		G
GDZ-1002G		1	Head Assy., Partial. Comm. End	GDZ-1002G		G
GBW-45		2	Spring, Brush	GBW-45		G
GBF-79		1	Bearing, Absorbent Bronze	GBF-79		G
GCJ-26		1	Arm, Brush	GCJ-26		G
X-195		5	Washer, Lock	X-195		G
8X-305		1	Screw, Round Head	8X-305		G
X-489		1	Oiler, Press-in Type	X-489		G
8X-888		4	Screw, Fill. Head	8X-888		G
X-195		1	Washer, Lock	X-195		G
8X-305		1	Screw, Round Head	8X-305		G
GBM-21		1	Nut, Armature Shaft	GBM-21		G
GCP-2006F		1	Armature Assembly	GCP-2006F		G
GAR-171		1	Snap Ring	GAR-171		G
GR-32		1	Retainer, Felt Washer	GR-32		G
SP-556A		1	Pulley, Drive	SP-556A		G
X-260		1	Key, Woodruff	X-260		G
X-864		1	Washer, Lock	X-864		G
GDZ-1003		1	Head Assembly, Drive End	GDZ-1003		G
GAR-63		2	Retainer, Felt Washer	GAR-63		G
GAR-64		2	Retainer, Bearing	GAR-64		G
GDZ-3		1	Head	GDZ-3		G
GG-164		2	Washer, Felt	GG-164		G
8X-173		3	Nut, Hex	8X-173		G
X-196		3	Washer, Lock	X-196		G

TABLE OF REPLACEABLE PARTS—(Continued)

Ref. No.	S. C. Stock No.	No. Req.	Name, Description and Function	Mfg's. Pt. No.	*** Mfgr.
X-295		1	Bearing, Ball	X-295	G
X-489		1	Oiler, Press-in Type	X-489	G
8X-1003		3	Screw, Round Head	8X-1003	G
GBW-24B		1	Band, Head	GBW-24B	G
8X-715		1	Screw, Round Head	8X-715	G
8X-794		1	Nut, Square	8X-794	G
MAGNETO GROUP (Figures 16, 17 and 28)					
290		1	Magneto Assembly	FM-JVE-4	P
136		1	Supplies Eng. Spark Magneto Drive Gear	GD-93C	B
224		1	Drives Magneto Gasket, Magneto Drive End Oil Seal	QD-616	B
05		1	Distributor High Tension Lead Rod	D-983A	P
06		1	Ground Cable Ferrule	A1077	P
07		1	Ground Cable Terminal Insulator	A1166	P
08		1	Ground Switch Strip Guide	B1355	P
09		1	Rotor Bearing Snap Ring	B1498B	P
10		1	Rotor Shaft Snap Ring	B1498D	P
12		1	Frame (or housing)	GX2425	P
14		1	End Cap, Radio Shielded, compt.	C2430A	P
19		1	Condenser complete	M2433	P
22		1	Breaker Assembly	T2437	P
25		2	Ventilating Screen Locking Washer	A2448	P
26		1	Stationary Support Bracket	G2454	P

TABLE OF REPLACEABLE PARTS—(Continued)

Ref. No.	S. C. Stock No.	No. Req.	Name, Description and Function	Mfg's. Pt. No.	*** M/gr.
29		1	Stationary Bracket Adj. Screw	C2455	P
30		1	Primary Ground Insulating Bushing	G2457A	P
31		1	Primary Ground Flat Washer	D2458	P
32		1	Coil Lead Brush	E2460B	P
33		4	High Tension Cable Socket Rubber Seal	B2473	P
34		1	Distributor Block Cable Outlet	C2474E	P
37		1	Coil, complete	H2477	P
39		1	Magnetic Rotor complete	VX2480	P
40		1	Inner Retaining Washer	C2492	P
41		1	Outer Retaining Washer	A2492A	P
42		2	Bearing Insulating Washer	C2493	P
43		1	End Cap Gasket	H2498	P
45		1	Ground Switch Strip	J2414	P
46		1	Primary Ground Switch	A2414J	P
50		1	Impulse Coupling Hub Assembly	EX2463	P
51		1	Impulse Coupling	GX2563C	P
52		1	Coupling Drive Spring	E2565	P
53		1	Coupling Pawl Stop Pin (15/16")	C2568	P
54		1	Coupling Pawl Stop Pin (1 1/8")	Q2568	P
55		1	Coupling Nut	M2570	P
56		1	Coupling Gear Bushing	A2572	P
57		1	End Cap Extension Plate	A2636	P
58		1	Thrust Bearing Shim	C2723	P
59		1	Ground Cable Outlet Nut	B2735A	P
60		1	Primary Lead Wire Tube	E2736	P
61		1	Ground Cable Outlet Bushing	B2744A	P

TABLE OF REPLACEABLE PARTS—(Continued)

Ref. No.	S. C. Stock No.	No. Req.	Name, Description and Function	Mfg's. Pt. No.	*** Mfg.
62		1	Distributor Rotor	M2765	P
63		1	Cam Felt Wick	E2788	P
66		1	Rotor Bearing Insulating Strip	B2824	P
67		1	Cam Felt Wick Spacer	A2982	P
68		1	Bearing Seal Rubber Washer	G3861	P
69		1	Ground Cable Terminal	A3969	P
70		1	Ground Cable Terminal complete	A3969C	P
71		2	Lead Wire Terminal	A4631	P
72		1	Bearing and Breaker Support Plate	L4631	P
76		1	Impulse Coupling Nut Lockwire	A5931A	P
77		1	Rotor Ball Bearing	C5949	P
78		1	Rotor Sleeve Bearing	B5950A	P
79		1	Impulse Coupling Shell	Y5957	P
80		2	Ventilating Screen Rivet	A5961	P
81		2	Impulse Coupling Pawl Spring	C5963	P
82		1	Stationary Contact Support Washer	B5969	P
83		1	Primary Ground Insulating Washer	B6018	P
84		4	Ventilating Screen Washer	A6030	P
85		2	Ventilating Screen	A6032A	P
86		2	Ventilating Screen complete	A6032AC	P
87		1	Cam Felt Wick Holding Washer	C6503	P
		1	Complete Gasket Kit	GK16	P
		1	Complete Gasket Kit	GK17	P
89		1	Coupling Hub Key	3K1	P

TABLE OF REPLACEABLE PARTS—(Continued)

No. Ref.	S. C. Stock No.	No. Req.	Name, Description and Function	Mfgs. Pt. No.	Mjgr. ***
BATTERY GROUP					
119		2	Battery	TSR-2-15	G
118		1	Battery Box, Right Hand	99-102	A
118		1	Battery Box, Left Hand	99-103	A
157		1	Battery Box Cover, Right Hand	99-104	A
157		1	Battery Box Cover, Left Hand	99-105	A
		1	Cable, Battery to Ground	99-106	A
151		1	Cable, Battery Jumper	99-107	A
		1	Cable, Battery to Magnetic Switch	99-108	A
120		2	Battery Hold-down Bar	99-109	A
DRIVE GROUP					
		1	Pulley, Engine	5B5.4	F
		1	Key, Engine Pulley	99-110	A
		1	Pulley, Generator	5B6.6	F
		1	Key, Generator Pulley	99-111	A
124		5	Belt, Drive	35B	F
A.C. GENERATOR GROUP (Figures 11, 29 and 30)					
1		1	Alternator shaft	JC-1	C
2		1	Exciter Armature Locknut $\frac{3}{8}$ " SAE	JC-2	C
3		1	Exciter Armature Aligning Collar	JC-3	C
4		1	Exciter Armature Assembly	JC-4	C
5		1	Exciter Armature Commutator	JC-5	C
6		1	Exciter Quill Key (Woodruff No. 8)	JC-6	C
7		1	Alternator Bearing No. 308 Exciter End	JC-20	C
8		1	Bearing Housing Cap Driving End	JC-8	C

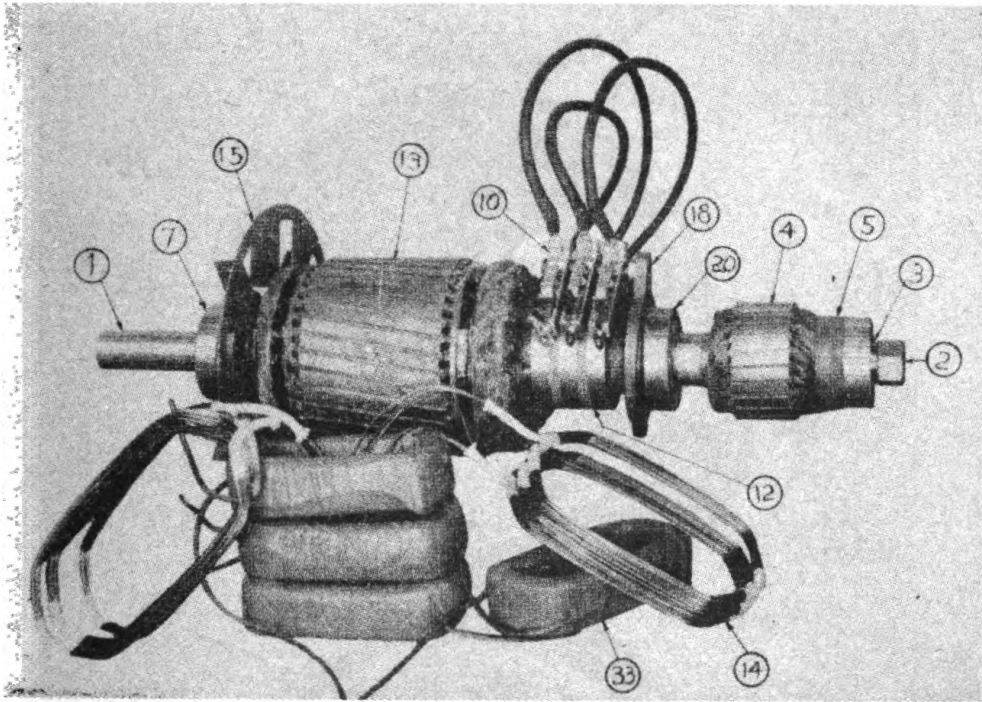

FIGURE 29.—Exciter and field coils, main A.C. generator.

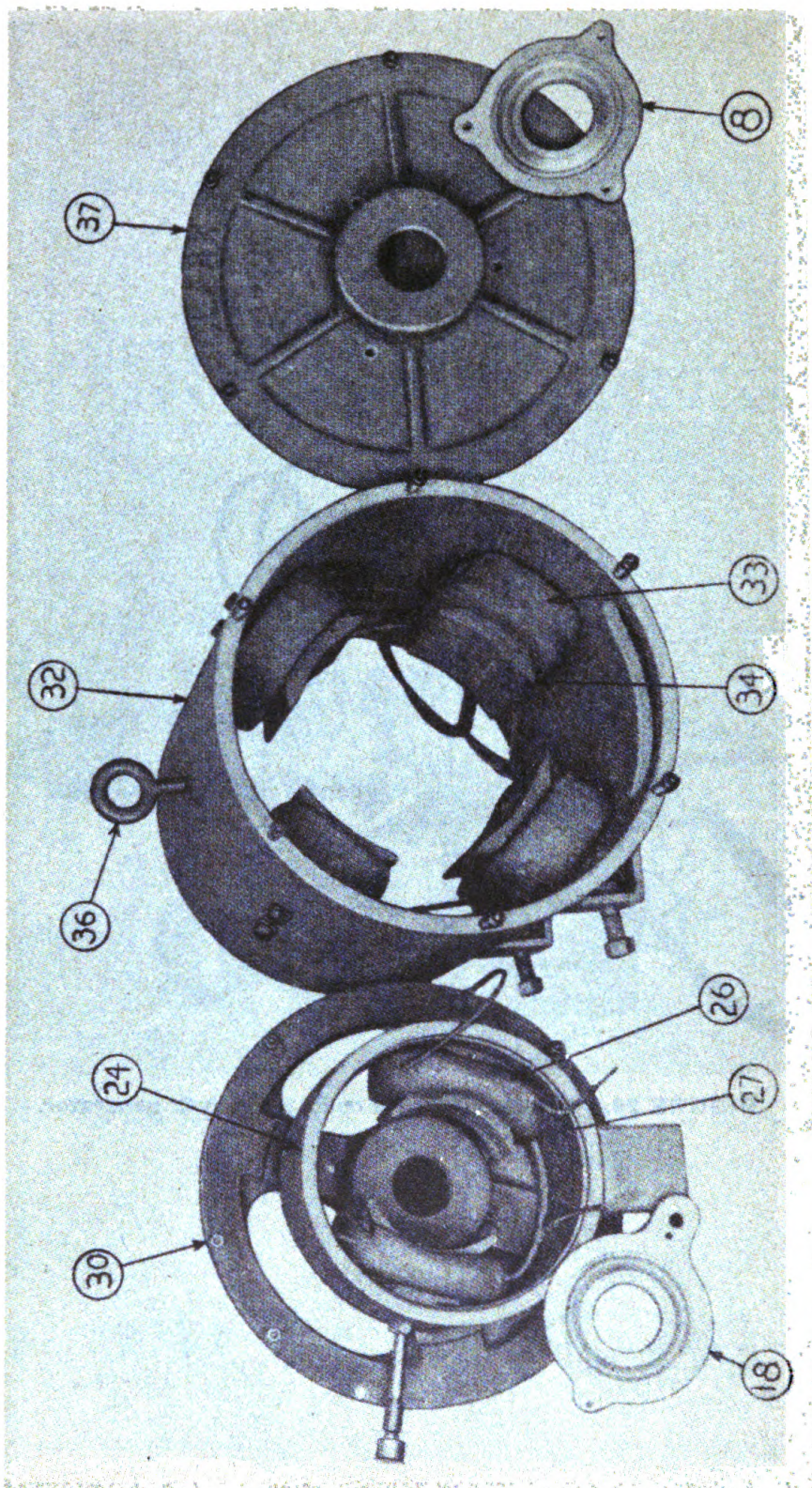

FIGURE 30.—Frame assembly, main A.C. generator.

TABLE OF REPLACEABLE PARTS—(Continued)

Ref. No.	S. C. Stock No.	No. Req.	Name, Description and Function	Mfg's. Pt. No.	Mfg.
10		1	Alternator Brushholder Assembly	JC-10	C
11		6	Alternator Brush	JC-11	C
12		1	Alternator Collector Rings	JC-12	C
13		1	Alternator Rotor Assembly	JC-13	C
14		36	Alternator Rotor Coils	JC-14	C
15		1	Ventilating Fan	JC-15	C
17		1	Fan Hub	JC-17	C
18		1	Bearing Housing Cap Exciter End	JC-18	C
20		1	Alternator Bearing No. 308 Drive End	JC-7	C
21		1	Sheave-Bearing Locking Collar	JC-21	C
22		1	V-Belt Sheave	JC-22	C
24		1	Exciter Frame	JC-24	C
26		2	Exciter Field Coils	JC-26	C
28		1	Exciter Brushholder Assembly	JC-28	C
29		2	Exciter Brush	JC-29	C
30		1	Exciter End Bearing Bracket	JC-30	C
32		1	Alternator Main Housing	JC-32	C
33		4	Alternator Field Coils	JC-33	C
34		4	Alternator Field Pole Pieces	JC-34	C
36		1	Lifting Eye Bolt 1/2x1 USS	JC-36	C
37		1	Drive End Bearing Bracket	JC-37	C
39		1	Exciter Cover	JC-39	C

TABLE OF REPLACEABLE PARTS—(Continued)

Ref. No.	S. C. Stock No.	No. Req.	Name, Description and Function	Mfg's.		*** Mfg.
				Pt. No.		
CONTROL CABINET GROUP (Figure 4)						
109		1	Substructure Assembly	99-112		A
155		1	Cover Plate, Right Side	99-113		A
		1	Cover Plate, Left Side	99-114		A
140		1	Cover, Main Control, with Doors	99-115		A
144		1	Terminal Block 60-amp, 3-wire	99-116		A
110		1	Receptacle, Main Power, 60-amp	AR-637		H
113		1	Receptacle, Remote Control	99-117		A
112		1	Terminal Block, Remote Control	99-118		A
		1	Conduit, Control Cabinet to Engine	99-119		A
		1	Conduit, Control Cabinet to Generator	99-120		A
122		1	Nameplate	99-121		A
PANEL BOARD GROUP (Figures 4, 7 and 8)						
70		1	Panel Board, 1/8" Steel, Drilled	99-122		A
77		1	Voltmeter	8A022VAX26M		D
78		1	Frequency Meter	31F		I
79		1	Elapsed Time Meter	KT94X922		D
72		2	Panel Light	99-123		A
76		1	Switch AC Voltmeter-Ammeter Selector	SB-1-6304871G1		D
81		1	Ammeter, Battery Charging	4001-2		U
80		1	Switch, Start-Stop	617-393		J
75		1	Rheostat, Exciter Field	99-125		A
74		1	Switch, Voltage Regulator	8810K2		J
82		1	Switch, Main Circuit Breaker	999026		W
73		1	Rheostat, Voltage Regulator	1106-13		E
83		1	Relay, Latching Type	CS		Q
88		1	Relay, By-Pass	CS-1		Q
84		1	Receptacle, Duplex Convenience	9200		R
71		1	Ammeter, AC	8A022ABS21M		D

Ref. No.	S. C. Stock No.	No. Req.	Name, Description and Function	Mfg's. Pt. No.	Mfg.
91		1	Base, Voltage Regulator	24554	S
8		1	Harness, Control Wire	99-127	A
114		4	Rubber Mounting, Anti-Vibration	99-128	A
158		1	AC Current Transformer Assy.	CS-2	Q
MAIN GENERATOR VOLTAGE REGULATOR GROUP (Figures 31 and 32)					
5660		1	Voltage Regulator Assembly	5660	E
1		1	Contact Roller Assembly	16631.21-1	E
2		1	Silver Commutator	16631.3-1	E
3		1	Solenoid Spring	69-444	E
4		1	Contact Pressure Spring	2.54-10	E
5		1	Adjustable Spring Holder	16631.19-1	E
6		1	Regulator Cross Arm & Plunger Assembly	16631.11-1	E
7		1	Solenoid Coil	16606.30-1	E
8		1	Solenoid Magnetic Structure	16606.6-7	E
9		1	Adjustable Magnetic Core	16606.6-4	E
10		1	Lock Nut	16606.6-3	E
11		1	Solenoid Strap	16606.14-2	E
12		1	Right Resistor Plaque	16606.21-1	E
13		1	Left Resistor Plaque	16606.21-2	E
14		1	Regulator Base	16631.13-1	E
17		1	Cover	16631.8-1	E
CABLE AND CABLE REEL GROUP (Figure 5)					
8		1	Reel, Power Cable	99-129	A
			Holds Power Cable		
4		1	Reel, Remote Control Cable	99-130	A
			Holds Remote Control Cable		
3		1	Cable, Remote Control	99-131	A
			Remote Starting		
9		1	Cable, Power	99-132	A
			Main Power Output		

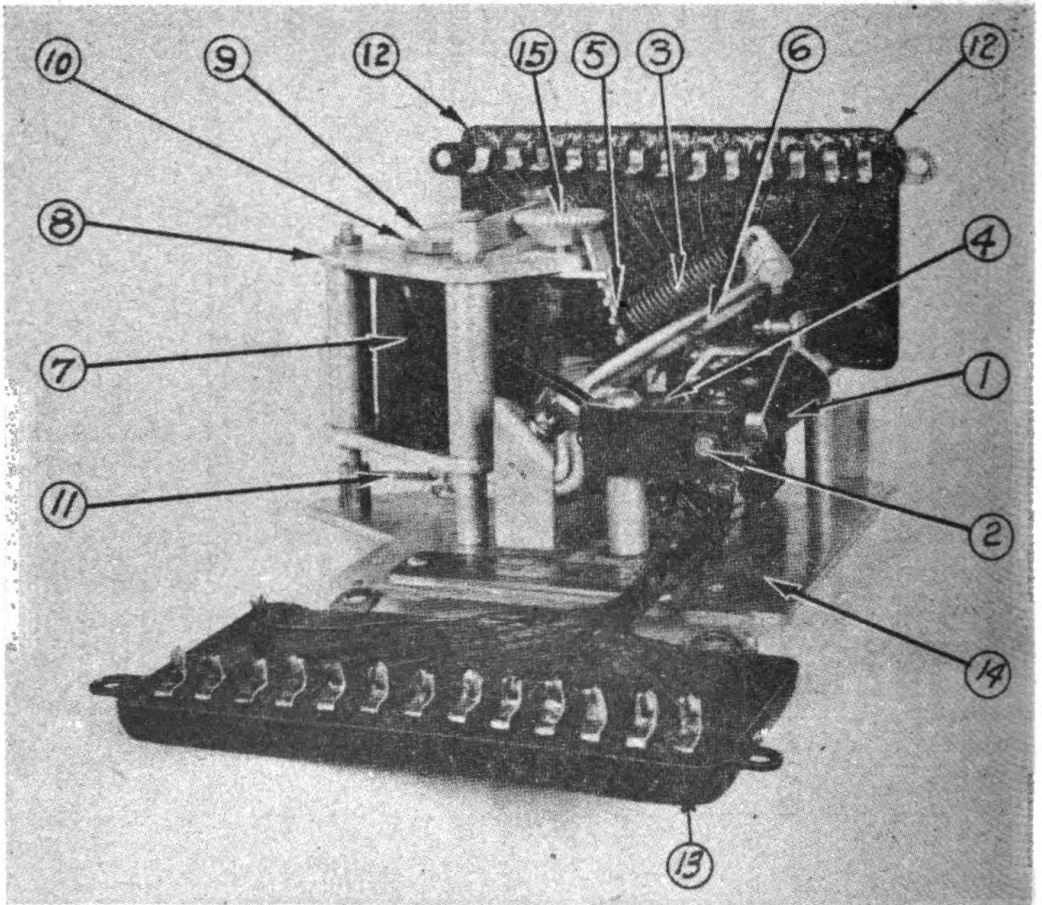

FIGURE 31.—Voltage regulator, inside view.

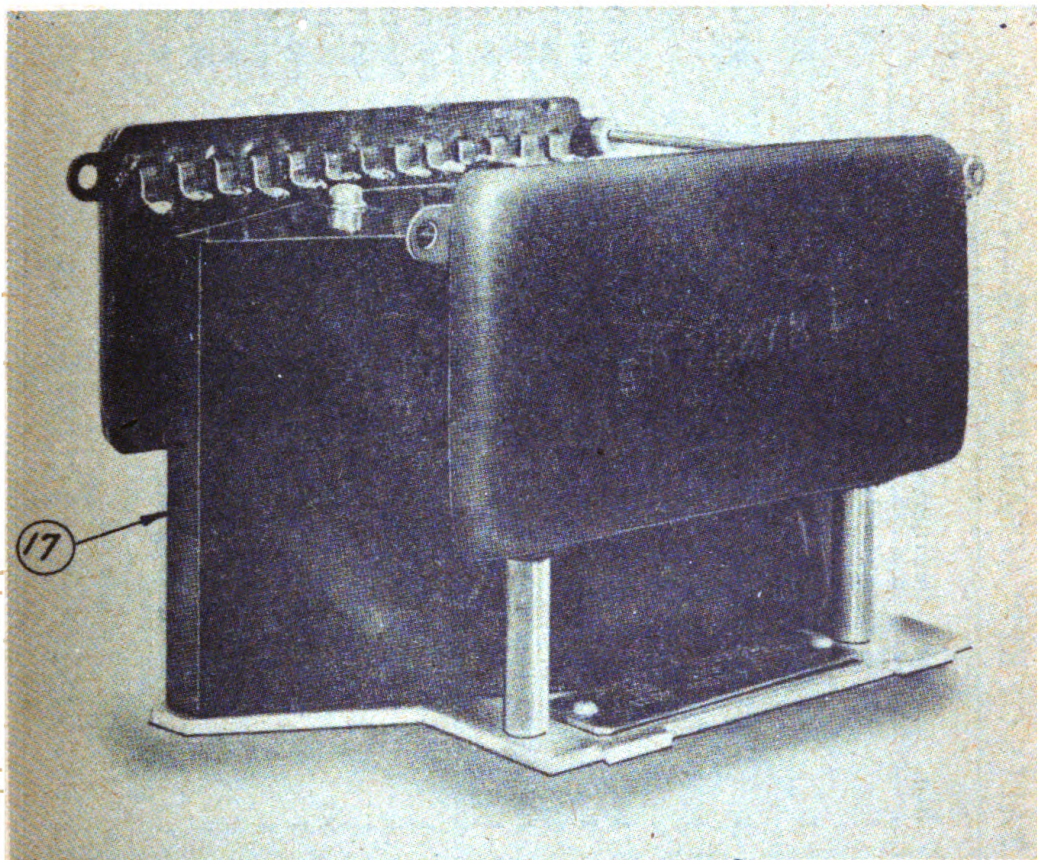

FIGURE 32.—Voltage regulator, main generator.

TABLE OF REPLACEABLE PARTS—(Continued)

Ref. No.	S. C. Stock No.	No. Req.	Name, Description and Function	Mfg's. Pt. No.	*** M/gr.
10		1	Plug, Power Cable	APJ-6375	H
			Power Cable Fitting		
1		1	Plug, Remote Control	99-133	A
			Remote Cable Fitting		
2		1	Switch, Remote Control	99-134	A
			Remote Start-Stop		
TOOL GROUP (Figure 5)					
6		1	Tool Box Assembly, Contains Tools	99-135	A
5		1	Spark Plug Wrench, Repairs and Maintenance	99-136	A
5		1	Gas Pliers	99-138	A
5		2	Tappet Wrenches	99-139	A
5		1	Small Screwdriver	99-141	A
5		1	Large Screwdriver	99-142	A
5		1	8" Crescent Wrench	99-143	A
5		1	1-lb. Machinist's Hammer	99-144	A
5		1	Box Assorted Cotter Keys	99-145	A
5		Set	Open End Wrenches	99-146	A
5		2	Sheets No. 00 Sandpaper	99-147	A
5		1	Gasket Seal	99-150	A
7		1	1/4"x20' Aux. Gasoline Line	99-151	A
5		1	Valve Lifter	99-137	A
5		1	Valve Grinding Kit	99-140	A

TABLE OF STANDARD NUTS, BOLTS AND WASHERS

Size	Length	Thread	Description	Quant.	Where Used
No. 6	1/2"	32	Round head screw	2	Mounting Rheostat to Panel
				2	Light studs
				2	Mounting Convenience Outlet to Panel
				9	Mounting Ammeters to Panel
				3	Mounting Voltmeter to Panel
				3	Mounting Frequency Meter to Panel
				3	Mounting Time Meter to Panel
				2	Mounting Regulator Rheostat to Panel
				3	Mounting Wires to Regulator Rheostat
				3	Mounting Wires to Field Rheostat
No. 6	3/4"	32	Round head screw	4	Mounting Terminal Strip to Panel
				4	Mounting Terminal Strip to Substructure
				2	Mounting Bypass Relay to Panel
No. 6	1-1/2"	32	Round head screw	4	Mounting Start-Stop Relay to Panel
				2	Mounting Start-Stop Switch to Panel
No. 8	3/8"	32	Round head screw	1	Wire Connection on Carburetor
				8	Brush Holder Mounting
No. 8	5/8"	32	Round head screw	1	Manual Choke Lever
No. 8	2-1/2"	32	Round head screw	8	Mounting Sealing Ring
No. 10	3/8"	32	Round head screw	2	Mounting Solenoid Starter Switch
No. 10	1/2"	32	Round head screw	6	Oil Pump Cover
No. 10	3/4"	24	Round head screw	6	Exciter Mounting Screw
No. 10	4"	32	Round head screw	4	Mounting Circuit Breaker to Panel
3/16"	1"	24	Hex head screw	1	Mounting Crank Holders
3/16"	5/8"	24	Round head screw	7	Switch Board Cabinet

TABLE OF STANDARD NUTS, BOLTS AND WASHERS—(Continued)

Size	Length	Thread	Description	Quant.	Where Used
3/16"	1/2"	24	Flat head screw	1	Switch Board Cabinet
3/16"	1"	24	Flat head screw	2	Mounting Field Rheostat to Panel
3/16"	1-1/2"	24	Round head screw	2	Air Filter Hose Clamp
1/4"	3/8"	20	Round head screw	6	Mounting Flywheel Screen
				23	Mounting Cylinder Cover to Side Cover
				5	Mounting Rear Panel to Engine Support
				6	Mounting Canopy to End Panels
				2	Upper Holes in Cylinder to End
				8	Mounting Tank Support to Rear Panel
				2	Mounting House Brace to Panel
				4	Mounting Partition Plate to Inspection Cover
				1	Mounting Support Strap
				4	Mounting Terminal Cover Plates
1/4"	3/8"	20	Hex head screw	4	Mounting Lower Cylinder Shroud, R&L
1/4"	1/2"	20	Hex head screw	1	Mounting Exhaust Manifold, LH Side
				6	Mounting Splash Plate
				4	Mounting Cylinder Head Deflector
				1	Ground Cable
1/4"	1/2"	20	Round head screw	2	Mounting Battery Box Cover
				2	Mounting Remote Control Receptacle
				4	Mounting Panel Cabinet to Substructure
1/4"	1/2"	20	Flat head screw	3	Battery Voltage Regulator
1/4"	3/4"	20	Socket head screw	2	Mounting Fuel Pump Adapter
1/4"	3/4"	20	Hex head screw	6	Mounting Cylinders
1/4"	1"	20	Round head screw	1	Support Rear Panel

TABLE OF STANDARD NUTS, BOLTS AND WASHERS—(Continued)

Size	Length	Thread	Description	Quant.	Where Used
1/4"	1"	20	Flat head screw	8	Mounting Battery Box to Base
1/4"	1"	20	Hex head screw	1	Ground Stud
1/4"	1"	20	All thread stud	4	Mounting Battery Box Cover
1/4"	1-1/2"	20	Round head screw	4	Mounting Battery Holddown
				8	Mounting Field Holding Plate
1/4"	3-1/4"	20	Round head screw	1	Mounting Read Panel to Cylinder Block
5/16"	1/2"	18	Hex head screw	6	Mounting Shroud to Gear Cover
5/16"	5/8"	18	Hex head screw	14	Mounting Crankcase Bottom Cover
				2	Mounting Fuel Pump
5/16"	3/4"	18	Hex head screw	5	Mounting Spacer to Crankcase
				2	Mounting Spacer to Gear Cover
				2	Mounting Generator
5/16"	1/8"	18	Hex head screw	2	Mounting Carburetor
				4	Mounting Governor Housing
5/16"	1"	18	Hex head screw	3	Mounting Camshaft Gear
				2	Mounting Generator
5/16"	1"	18	Round head screw	4	Mounting Arkkite Receptacle
5/16"	1-1/4"	18	Hex head screw	10	Mounting Gear Cover
				30	Mounting Cylinder Heads
5/16"	1-1/2"	18	Hex head screw	4	Mounting Cylinder Heads
5/16"	1-3/4"	18	Hex head screw	4	Mounting Tappet Inspection Plate
5/16"		32	Screw	1	Bolt for Starter
3/8"	3/4"	16	Hex head screw	4	Mounting Side Rails to Engine Support
3/8"	1-1/4"	16	Hex head screw	6	Mounting Main Bearing Plate to End

TABLE OF REPLACEABLE PARTS—(Continued)

Ref. No.	S. C. Stock No.	No. Req.	Name, Description and Function	Mfg's. Pt. No.	*** Mfg.
10		1	Alternator Brushholder Assembly	JC-10	C
11		6	Alternator Brush	JC-11	C
12		1	Alternator Collector Rings	JC-12	C
13		1	Alternator Rotor Assembly	JC-13	C
14		36	Alternator Rotor Coils	JC-14	C
15		1	Ventilating Fan	JC-15	C
17		1	Fan Hub	JC-17	C
18		1	Bearing Housing Cap Exciter End	JC-18	C
20		1	Alternator Bearing No. 308 Drive End	JC-7	C
21		1	Sheave-Bearing Locking Collar	JC-21	C
22		1	V-Belt Sheave	JC-22	C
24		1	Exciter Frame	JC-24	C
26		2	Exciter Field Coils	JC-26	C
28		1	Exciter Brushholder Assembly	JC-28	C
29		2	Exciter Brush	JC-29	C
30		1	Exciter End Bearing Bracket	JC-30	C
32		1	Alternator Main Housing	JC-32	C
33		4	Alternator Field Coils	JC-33	C
34		4	Alternator Field Pole Pieces	JC-34	C
36		1	Lifting Eye Bolt 1/2x1 USS	JC-36	C
37		1	Drive End Bearing Bracket	JC-37	C
39		1	Exciter Cover	JC-39	C

TABLE OF REPLACEABLE PARTS—(Continued)

Ref. No.	S. C. Stock No.	No. Req.	Name, Description and Function	Mfg's. Pt. No.	Mjgr.
CONTROL CABINET GROUP (Figure 4)					
109		1	Substructure Assembly	99-112	A
155		1	Cover Plate, Right Side	99-113	A
		1	Cover Plate, Left Side	99-114	A
140		1	Cover, Main Control, with Doors	99-115	A
144		1	Terminal Block 60-amp, 3-wire	99-116	A
110		1	Receptacle, Main Power, 60-amp	AR-637	H
113		1	Receptacle, Remote Control	99-117	A
112		1	Terminal Block, Remote Control	99-118	A
		1	Conduit, Control Cabinet to Engine	99-119	A
		1	Conduit, Control Cabinet to Generator	99-120	A
122		1	Nameplate	99-121	A
PANEL BOARD GROUP (Figures 4, 7 and 8)					
70		1	Panel Board, 1/8" Steel, Drilled	99-122	A
77		1	Voltmeter	8A022VAX26M	D
78		1	Frequency Meter	31F	I
79		1	Elapsed Time Meter	KT94X922	D
72		2	Panel Light	99-123	A
76		1	Switch-AC Voltmeter-Ammeter Selector	SB-1-6304871G1	D
81		1	Ammeter, Battery Charging	4001-2	U
80		1	Switch, Start-Stop	617-393	J
75		1	Rheostat, Exciter Field	99-125	A
74		1	Switch, Voltage Regulator	8810K2	J
82		1	Switch, Main Circuit Breaker	999026	W
73		1	Rheostat, Voltage Regulator	1106-13	E
83		1	Relay, Latching Type	CS	Q
88		1	Relay, By-Pass	CS-1	Q
84		1	Receptacle, Duplex Convenience	9200	R
71		1	Ammeter, AC	8A022ABS21M	D

Ref. No.	S. C. Stock No.	No. Req.	Name, Description and Function	Mfg's. Pt. No.	Mjgr.
91		1	Base, Voltage Regulator	2454	S
8		1	Harness, Control Wire	99-127	A
114		4	Rubber Mounting, Anti-Vibration	99-128	A
158		1	AC Current Transformer Assy.	CS-2	Q
MAIN GENERATOR VOLTAGE REGULATOR GROUP (Figures 31 and 32)					
5660		1	Voltage Regulator Assembly	5660	E
1		1	Contact Roller Assembly	16631.21-1	E
2		1	Silver Commutator	16631.3-1	E
3		1	Solenoid Spring	69-444	E
4		1	Contact Pressure Spring	2.54-10	E
5		1	Adjustable Spring Holder	16631.19-1	E
6		1	Regulator Cross Arm & Plunger Assembly	16631.11-1	E
7		1	Solenoid Coil	16606.30-1	E
8		1	Solenoid Magnetic Structure	16606.6-7	E
9		1	Adjustable Magnetic Core	16606.6-4	E
10		1	Lock Nut	16606.6-3	E
11		1	Solenoid Strap	16606.14-2	E
12		1	Right Resistor Plaque	16606.21-1	E
13		1	Left Resistor Plaque	16606.21-2	E
14		1	Regulator Base	16631.13-1	E
17		1	Cover	16631.8-1	E
CABLE AND CABLE REEL GROUP (Figure 5)					
8		1	Reel, Power Cable	99-129	A
			Holds Power Cable		
4		1	Reel, Remote Control Cable	99-130	A
			Holds Remote Cable		
3		1	Cable, Remote Control	99-131	A
			Remote Starting		
9		1	Cable, Power	99-132	A
			Main Power Output		

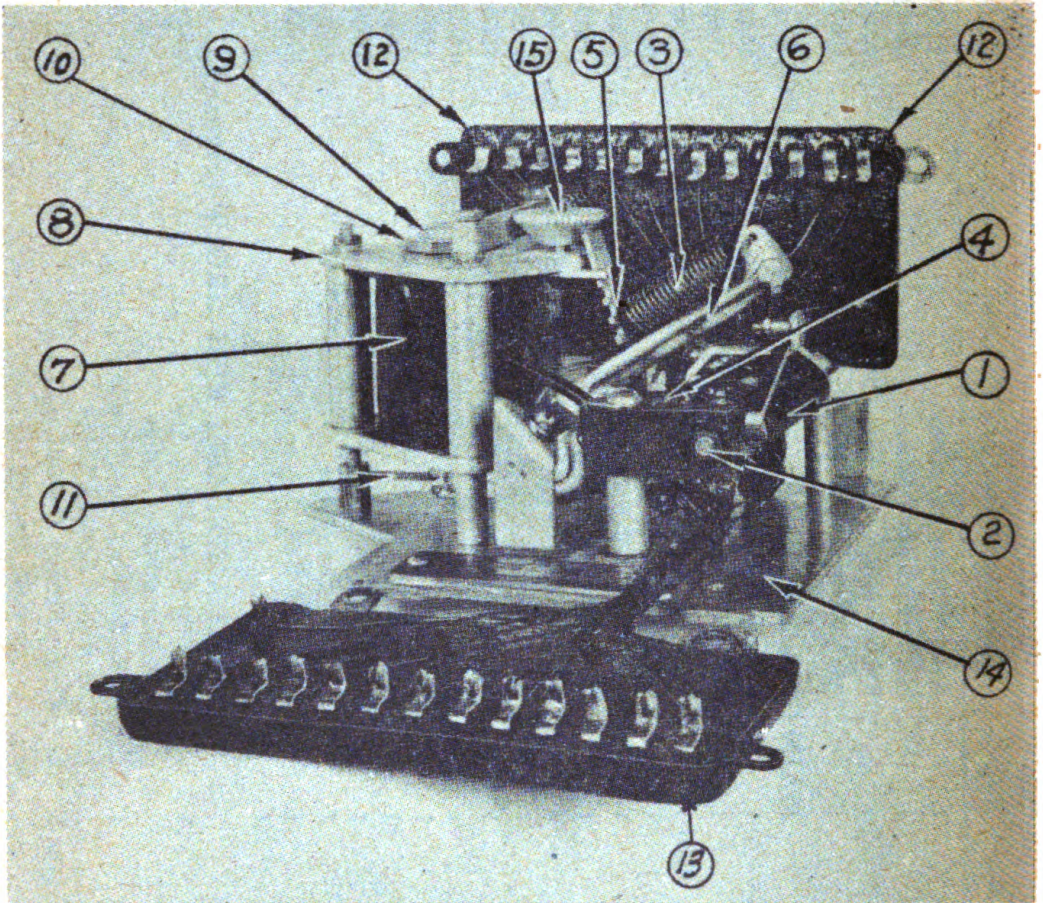

FIGURE 31.—Voltage regulator, inside view.

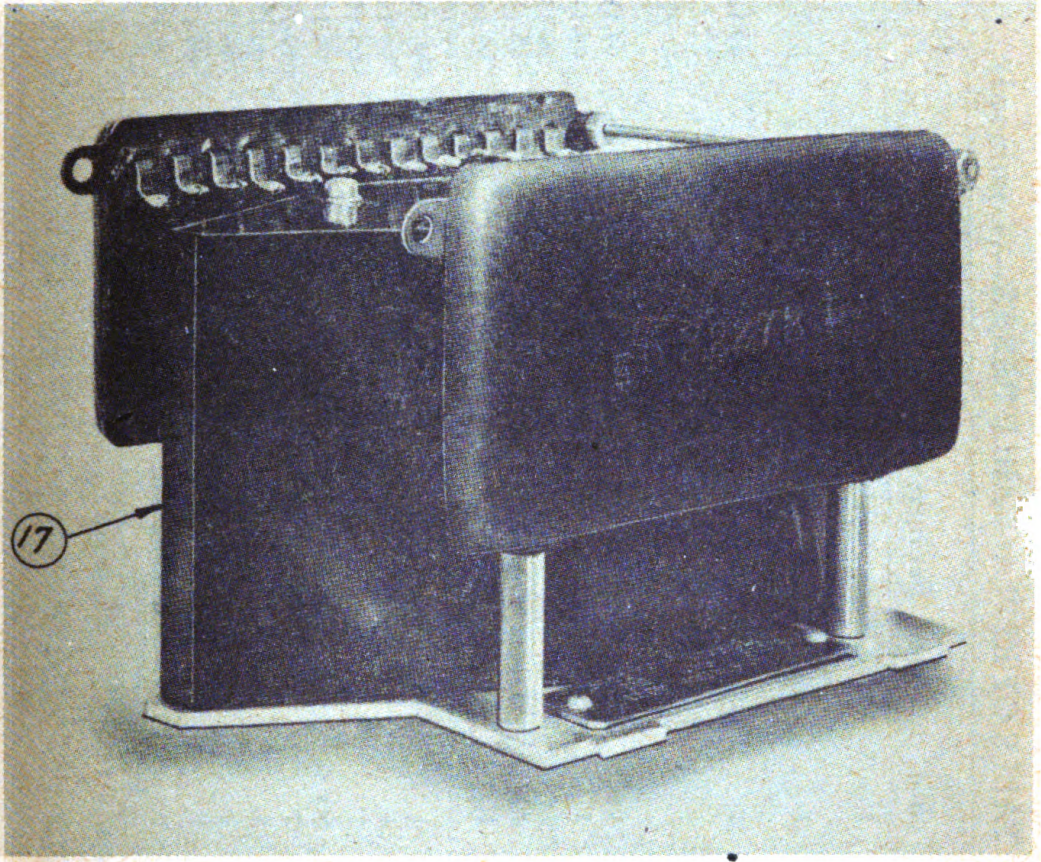

FIGURE 32.—Voltage regulator, main generator.

TABLE OF REPLACEABLE PARTS—(Continued)

Ref. No.	S. C. Stock No.	No. Req.	Name, Description and Function	Mfg. Pt. No.	*** Mfg.
10		1	Plug, Power Cable	APJ-6375	H
			Power Cable Fitting		
1		1	Plug, Remote Control	99-133	A
			Remote Cable Fitting		
2		1	Switch, Remote Control	99-134	A
			Remote Start-Stop		
TOOL GROUP (Figure 5)					
6		1	Tool Box Assembly, Contains Tools	99-135	A
5		1	Spark Plug Wrench, Repairs and Maintenance	99-136	A
5		1	Gas Pliers	99-138	A
5		2	Tappet Wrenches	99-139	A
5		1	Small Screwdriver	99-141	A
5		1	Large Screwdriver	99-142	A
5		1	8" Crescent Wrench	99-143	A
5		1	1-lb. Machinist's Hammer	99-144	A
5		1	Box Assorted Cotter Keys	99-145	A
5		Set	Open End Wrenches	99-146	A
5		2	Sheets No. 00 Sandpaper	99-147	A
5		1	Gasket Seal	99-150	A
7		1	1/4" x 20' Aux. Gasoline Line	99-151	A
5		1	Valve Lifter	99-137	A
5		1	Valve Grinding Kit	99-140	A

TABLE OF STANDARD NUTS, BOLTS AND WASHERS

Size	Length	Thread	Description	Quant.	Where Used
No. 6	1/2"	32	Round head screw	2	Mounting Rheostat to Panel
			Light studs	2	
			Mounting Convenience Outlet to Panel	2	
			Mounting Ammeters to Panel	9	
			Mounting Voltmeter to Panel	3	
			Mounting Frequency Meter to Panel	3	
			Mounting Time Meter to Panel	3	
			Mounting Regulator Rheostat to Panel	2	
			Mounting Wires to Regulator Rheostat	3	
			Mounting Wires to Field Rheostat	3	
No. 6	3/4"	32	Round head screw	4	Mounting Terminal Strip to Panel
			Mounting Terminal Strip to Substructure	4	
			Mounting Bypass Relay to Panel	2	
No. 6	1-1/2"	32	Round head screw	4	Mounting Start-Stop Relay to Panel
No. 8	3/8"	32	Round head screw	2	Mounting Start-Stop Switch to Panel
			Wire Connection on Carburetor	1	
			Brush Holder Mounting	8	
No. 8	5/8"	32	Round head screw	1	Manual Choke Lever
No. 8	2-1/2"	32	Round head screw	8	Mounting Sealing Ring
No. 10	3/8"	32	Round head screw	2	Mounting Solenoid Starter Switch
No. 10	1/2"	32	Round head screw	6	Oil Pump Cover
No. 10	3/4"	24	Round head screw	6	Exciter Mounting Screw
No. 10	4"	32	Round head screw	4	Mounting Circuit Breaker to Panel
3/16"	1"	24	Hex head screw	1	Mounting Crank Holders
3/16"	5/8"	24	Round head screw	7	Switch Board Cabinet

TABLE OF STANDARD NUTS, BOLTS AND WASHERS—(Continued)

Size	Length	Thread	Description	Quant.	Where Used
3/16"	1/2"	24	Flat head screw	1	Switch Board Cabinet
3/16"	1"	24	Flat head screw	2	Mounting Field Rheostat to Panel
3/16"	1-1/2"	24	Round head screw	2	Air Filter Hose Clamp
1/4"	3/8"	20	Round head screw	6	Mounting Flywheel Screen
				23	Mounting Cylinder Cover to Side Cover
				5	Mounting Rear Panel to Engine Support
				6	Mounting Canopy to End Panels
				2	Upper Holes in Cylinder to End
				8	Mounting Tank Support to Rear Panel
				2	Mounting House Brace to Panel
				4	Mounting Partition Plate to Inspection Cover
				1	Mounting Support Strap
				4	Mounting Terminal Cover Plates
1/4"	3/8"	20	Hex head screw	4	Mounting Lower Cylinder Shroud, R&L
1/4"	1/2"	20	Hex head screw	1	Mounting Exhaust Manifold, LH Side
				6	Mounting Splash Plate
				4	Mounting Cylinder Head Deflector
				1	Ground Cable
1/4"	1/2"	20	Round head screw	2	Mounting Battery Box Cover
				2	Mounting Remote Control Receptacle
				4	Mounting Panel Cabinet to Substructure
1/4"	1/2"	20	Flat head screw	3	Battery Voltage Regulator
1/4"	3/4"	20	Socket head screw	2	Mounting Fuel Pump Adapter
1/4"	3/4"	20	Hex head screw	6	Mounting Cylinders
1/4"	1"	20	Round head screw	1	Support Rear Panel

TABLE OF STANDARD NUTS, BOLTS AND WASHERS—(Continued)

Size	Length	Thread	Description	Quant.	Where Used
1/4"	1"	20	Flat head screw	8	Mounting Battery Box to Base
1/4"	1"	20	Hex head screw	1	Ground Stud
1/4"	1"	20	All thread stud	4	Mounting Battery Box Cover
1/4"	1-1/2"	20	Round head screw	4	Mounting Battery Holddown
				8	Mounting Field Holding Plate
1/4"	3-1/4"	20	Round head screw	1	Mounting Read Panel to Cylinder Block
5/16"	1/2"	18	Hex head screw	6	Mounting Shroud to Gear Cover
5/16"	5/8"	18	Hex head screw	14	Mounting Crankcase Bottom Cover
				2	Mounting Fuel Pump
5/16"	3/4"	18	Hex head screw	5	Mounting Spacer to Crankcase
				2	Mounting Spacer to Gear Cover
				2	Mounting Generator
5/16"	1/8"	18	Hex head screw	2	Mounting Carburetor
				4	Mounting Governor Housing
5/16"	1"	18	Hex head screw	3	Mounting Camshaft Gear
				2	Mounting Generator
5/16"	1"	18	Round head screw	4	Mounting Arkrite Receptacle
5/16"	1-1/4"	18	Hex head screw	10	Mounting Gear Cover
				30	Mounting Cylinder Heads
5/16"	1-1/2"	18	Hex head screw	4	Mounting Cylinder Heads
5/16"	1-3/4"	18	Hex head screw	4	Mounting Tappet Inspection Plate
5/16"		32	Screw	1	Bolt for Starter
3/8"	3/4"	16	Hex head screw	4	Mounting Side Rails to Engine Support
3/8"	1-1/4"	16	Hex head screw	6	Mounting Main Bearing Plate to End

TABLE OF STANDARD NUTS, BOLTS AND WASHERS—(Continued)

<i>Size</i>	<i>Length</i>	<i>Thread</i>	<i>Description</i>	<i>Quant.</i>	<i>Where Used</i>
3/8"	2-1/4"	16	Hex head screw	1	Mounting Magneto Lower Hole
3/8"	3"	16	Copper All thread stud	3	AC Output Terminals
7/16"	1-1/4"	14	Hex head screw	2	Mounting Generator Support Bracket
1/2"	3/8"	13	Hex head screw	4	Mounting Engine Support to Case
1/2"	1"	13	Hex head screw	8	Mounting Engine to Base
				4	Mounting Panel Substructure to Base
1/2"	1-3/4"	13	Hex head screw	4	Mounting Generator to Base
1/4"	3/8"	20	Set screw	3	Mounting Starter Ring Gear
No. 0	3/4"		Taper pin	1	Governor Yoke
1/8"	1"		Cotter pin	1	Relief Valve Spring
1/16"	1/2"		Cotter pin	8	Connecting Rod Bolts
1/8"	3/4"		Cotter pin	2	Door Clips
				1	Governor Control Rod
				2	Choke Control Rod
			Pipe plug	1	Inlet Manifold
			Pipe plug	1	Oil Strain Hole
No. 5		40	Hex nut	1	Governor Control Rod Carburetor End
No. 6		32	Hex nut	4	Mounting Terminal Strip to Panel
				2	Mounting Start-Stop Switch to Panel
				9	Mounting Ammeters to Panel
				3	Mounting Voltmeter to Panel
				3	Mounting Frequency Meter to Panel
				3	Mounting Elapsed Time Meter to Panel
				4	Mounting Light Terminal Stud to Panel
				2	Mounting Convenience Receptacle to Panel

TABLE OF STANDARD NUTS, BOLTS AND WASHERS—(Continued)

Size	Length	Thread	Description	Quant.	Where Used
No. 6		32	Hex nut	4	Mounting Start-Stop Relay to Panel
				2	Mounting Bypass Relay to Panel
				2	Mounting Regulator Rheostat to Panel
				3	Mounting Wire to Regulator Rheostat
				3	Mounting Wire to Field Rheostat
				4	Mounting Terminal Strip to Substructure
No. 8		32	Hex nut	1	Wire Connection on Carburetor
No. 10		32	Hex nut	2	Mounting Solenoid Starter Switch
				4	Mounting Battery Ammeter
				2	Mounting Wire to Frequency Meter
				4	Mounting Circuit Breaker to Panel
				6	Mounting Studs Voltage Regulator
No. 10		32	Hex elastic lock nut	8	Mounting Voltage Regulator Dampers
				6	Studs Voltage Regulator
3/16"		24	Hex nut	1	Mounting Crank Holder
				8	Switchboard Cabinet
1/4"		20	Square nut	2	Mounting Remote Control Receptacle
1/4"		20	Hex nut	4	Mounting Panel Cabinet to Substructure
				8	Mounting Battery Box to Frame
				1	Governor Spring Adjusting Screw
				7	Mounting Tank Support to Panel
				2	Mounting House Brace to Panel
1/4"		20	Hex nut	4	Mounting Partition Plate to Inspection Cover
				1	Mounting Support Strap
				4	Mounting Air Filter
				4	Mounting Battery Tie Down

TABLE OF STANDARD NUTS, BOLTS AND WASHERS—(Continued)

Size	Length	Thread	Description	Quant.	Where Used
3/8"	2-1/4"	16	Hex head screw	1	Mounting Magneto Lower Hole
3/8"	3"	16	Copper All thread stud	3	AC Output Terminals
7/16"	1-1/4"	14	Hex head screw	2	Mounting Generator Support Bracket
1/2"	3/8"	13	Hex head screw	4	Mounting Engine Support to Case
1/2"	1"	13	Hex head screw	8	Mounting Engine to Base
				4	Mounting Panel Substructure to Base
1/2"	1-3/4"	13	Hex head screw	4	Mounting Generator to Base
1/4"	3/8"	20	Set screw	3	Mounting Starter Ring Gear
No. 0	3/4"		Taper pin	1	Governor Yoke
1/8"	1"		Cotter pin	1	Relief Valve Spring
1/16"	1/2"		Cotter pin	8	Connecting Rod Bolts
1/8"	3/4"		Cotter pin	2	Door Clips
				1	Governor Control Rod
				2	Choke Control Rod
	1/8"		Pipe plug	1	Inlet Manifold
	1/4"		Pipe plug	1	Oil Strain Hole
No. 5		40	Hex nut	1	Governor Control Rod Carburetor End
No. 6		32	Hex nut	4	Mounting Terminal Strip to Panel
				2	Mounting Start-Stop Switch to Panel
				9	Mounting Ammeters to Panel
				3	Mounting Voltmeter to Panel
				3	Mounting Frequency Meter to Panel
				3	Mounting Elapsed Time Meter to Panel
				4	Mounting Light Terminal Stud to Panel
				2	Mounting Convenience Receptacle to Panel

TABLE OF STANDARD NUTS, BOLTS AND WASHERS—(Continued)

Size	Length	Thread	Description	Quant.	Where Used
No. 6	32		Hex nut	4	Mounting Start-Stop Relay to Panel
				2	Mounting Bypass Relay to Panel
				2	Mounting Regulator Rheostat to Panel
				3	Mounting Wire to Regulator Rheostat
				3	Mounting Wire to Field Rheostat
				4	Mounting Terminal Strip to Substructure
No. 8	32		Hex nut	1	Wire Connection on Carburetor
No. 10	32		Hex nut	2	Mounting Solenoid Starter Switch
				4	Mounting Battery Ammeter
				2	Mounting Wire to Frequency Meter
				4	Mounting Circuit Breaker to Panel
				6	Mounting Studs Voltage Regulator
No. 10	32		Hex elastic lock nut	8	Mounting Voltage Regulator Dampers
				6	Studs Voltage Regulator
3/16"	24		Hex nut	1	Mounting Crank Holder
				8	Switchboard Cabinet
1/4"	20		Square nut	2	Mounting Remote Control Receptacle
1/4"	20		Hex nut	4	Mounting Panel Cabinet to Substructure
				8	Mounting Battery Box to Frame
				1	Governor Spring Adjusting Screw
				7	Mounting Tank Support to Panel
				2	Mounting House Brace to Panel
1/4"	20		Hex nut	4	Mounting Partition Plate to Inspection Cover
				1	Mounting Support Strap
				4	Mounting Air Filter
				4	Mounting Battery Tie Down

TABLE OF STANDARD NUTS, BOLTS AND WASHERS—(Continued)

Size	Length	Thread	Description	Quant.	Where Used
1/4"	20		Hex nut	2	Mounting Ground Cable
				8	Mounting Panel Vibration Damper
				1	Battery Generator Regulator
				8	Mounting Gas Canopy to Engine Canopy
				2	Mounting Exhaust Braces to Engine Canopy
					Rear
				1	Mounting Exhaust Braces to Engine Canopy
					Front
1/4"	28		Hex nut	3	Connecting on Choke Cap
5/16"	24		Hex nut	2	Mounting Oil Filter
				4	Lower to Upper Manifold
				2	Mounting Starter Support Bracket
			(Brass)	4	Lower to Upper Manifold
				8	Valve Tappet Adjusting Screws
				2	Mounting Arkite Receptacle
3/8"	16		Hex nut	9	AC Output Terminals
				1	Mounting Magneto Screw
				4	Side Rail to Engine Support
3/8"	24		Hex nut	1	Magneto Mounting Stud
				4	Manifold to Cylinder Mounting Stud
7/16"	20		Hex nut	12	Mounting Cylinder Block to Crankcase
1/2"			Hex nut	8	Mounting Engine on Base
				4	Mounting Panel Substructure on Base
				4	Mounting Generator on Base
1/4"	20		Wing nut	6	Mounting Battery Box Cover
3/8"	16		Wing nut	3	AC Output Terminals

TABLE OF STANDARD NUTS, BOLTS AND WASHERS—(Continued)

Size	Length	Thread	Description	Quant.	Where Used
29/64"			Flat washer	2	Door Clips
5/8"			Flat washer	12	Generator Spacer Shim
3/8"			Flat washer	1	Magneto Mounting Screw
				34	Mounting Cylinder Heads
				1	Air Cleaner Spacer
5/16"			Flat washer	6	Mounting Wires to Ammeters
				4	For Valve Tappet Plates
1/2"			Flat washer	18	AC Output Terminals
1/2"			Lock washer	8	Mounting Engine to Base
				4	Mounting Panel Substructure to Base
				4	Mounting Generator to Base
7/16"			Lock washer	12	Mounting Cylinder Block
				2	Mounting Generator Bracket
				4	Mounting Engine Support
3/8"			Lock washer	4	Mounting Manifold to Cylinder
				6	Mounting Main Bearing Plate, to End
				1	Mounting Magneto Upper Stud
				1	Mounting Magneto Lower Stud
				3	Mounting Starter
				4	Mounting Side Rails to Engine Support
				6	AC Output Terminals
				2	Mounting Arkrite Receptacle
5/16"			Lock washer	14	Mounting Fuel Pump Adapter
				6	Mounting Shroud to Gear Cover
				20	Mounting Gear Cover Spacer and Govern- or Housing to Case

TABLE OF STANDARD NUTS, BOLTS AND WASHERS—(Continued)

Size	Length	Thread	Description	Quant.	Where Used	
5/16"			Lock washer	2	Mounting Fuel Pump	
				2	Mounting Carburetor	
				2	Mounting Oil Filter	
				8	Lower to Upper Manifold	
				2	Mounting Starter Support Bracket	
				4	Mounting Side Rail to Engine Support	
				12	Mounting Wires to Ammeters	
	1/4"			Lock washer	2	Mounting Fuel Pump Adapter
					6	Mounting Splash Plates to Case
					6	Mounting Air Shroud Screen
					33	Mounting Air Shroud
					8	Mounting Tank Support to Rear Panel
				2	Mounting House Brace to Panel	
				5	Mounting Rear Panel to Engine Support	
				6	Mounting Canopy to End Panels	
				4	Mounting Partition Plate to Inspection Cover	
				1	Mounting Support Strap	
				4	Mounting Air Filter	
				4	Mounting Battery to Base	
				8	Mounting Battery Box to Base	
				6	Mounting Battery Box Cover	
				2	Mounting Remote Control	
				3	Mounting Battery Voltage Regulator	
				4	Mounting Terminal Cover Plate	
				1	Battery Cable Bolt	
				1	Ground Stud	
				4	Mounting Circuit Breaker to Panel	
			2	Mounting Wires to Voltmeter		

TABLE OF STANDARD NUTS, BOLTS AND WASHERS—(Continued)

Size	Length	Thread	Description	Quant.	Where Used
3/16"			Lock washer	2	Mounting Wires to Frequency Meter
				2	Mounting Wires to Ammeter
				2	Mounting Ammeter
				4	Mounting Wires to Voltage Regulator
No. 6			Lock washer	9	Mounting Ammeters to Panel
				3	Mounting Voltmeter to Panel
				3	Mounting Frequency Meter to Panel
				3	Mounting Time Meter to Panel
				2	Mounting Terminal Studs to Panel
				2	Mounting Regulator Rheostat to Panel
				3	Mounting Wires to Regulator Rheostat
				3	Mounting Wires to Field Rheostat
				4	Mounting Start-Stop Relay to Panel
				6	Mounting Wires to Start-Stop Relay
				2	Mounting Bypass Relay to Panel
				6	Mounting Wires to Bypass Relay
No. 6			Lock washer	2	Mounting Convenience Receptacle to Panel
				2	Mounting Start-Stop Switch to Panel
				4	Mounting Terminal Strip to Panel
No. 10			Lock washer	4	Mounting Battery Ammeter to Panel
				8	Mounting Voltage Regulator Base to Panel
				2	Mounting Solenoid Starter Switch
				6	Mounting Oil Pump Cover
5/16"			External lock washer	3	Mounting Cam Gear
5/16"			Countersunk lock washer	4	Mounting Bearing Retainer Plate

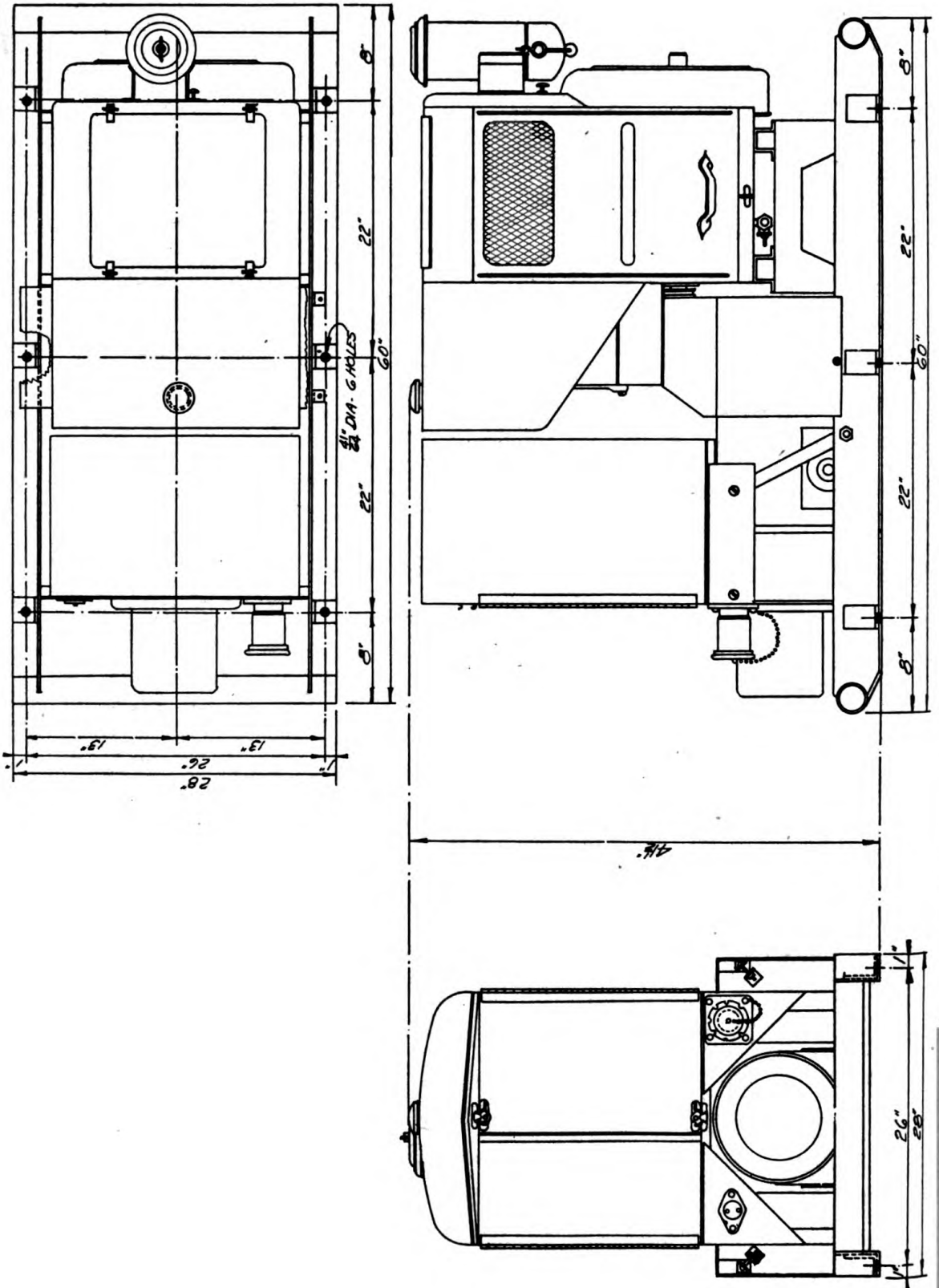
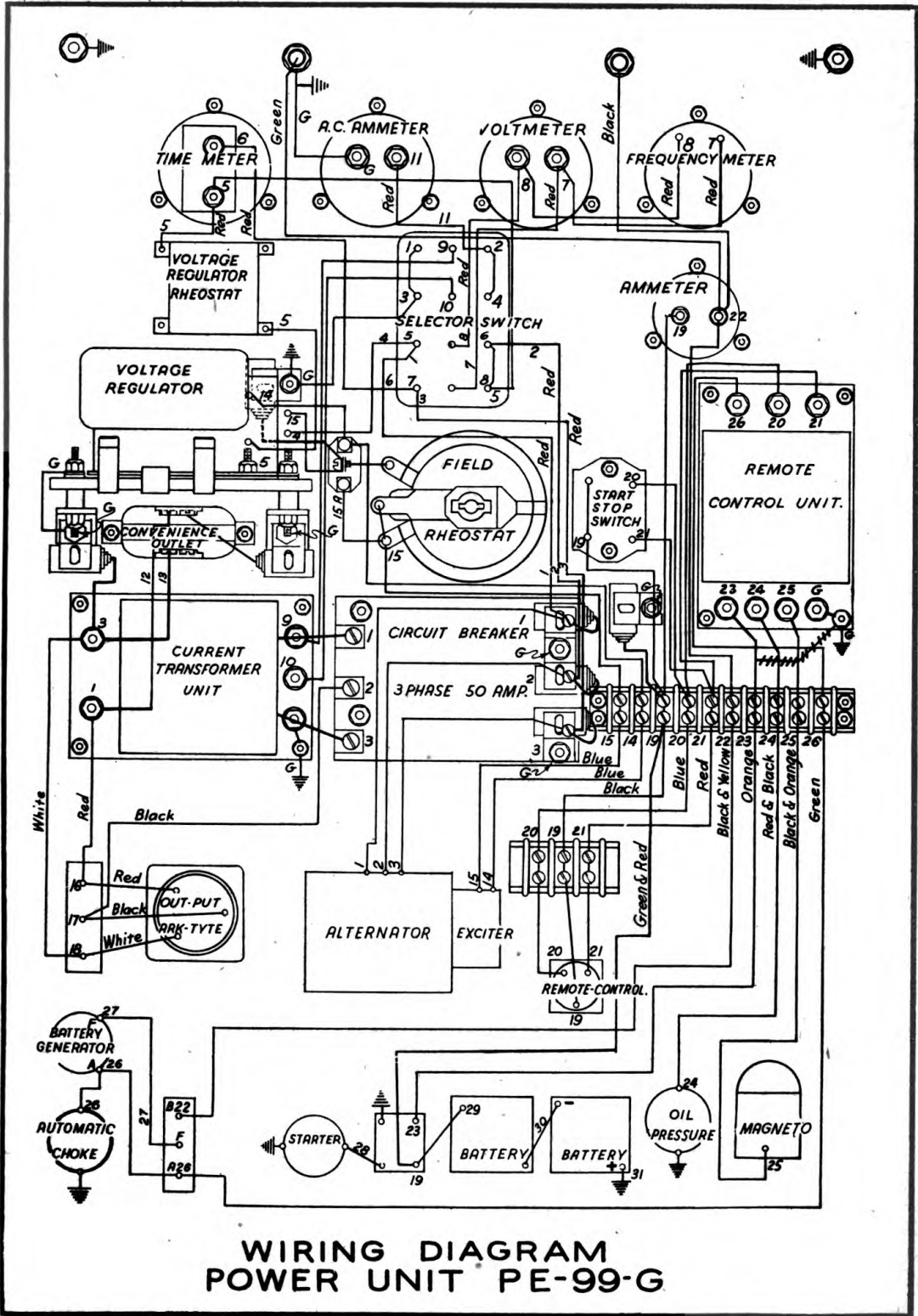
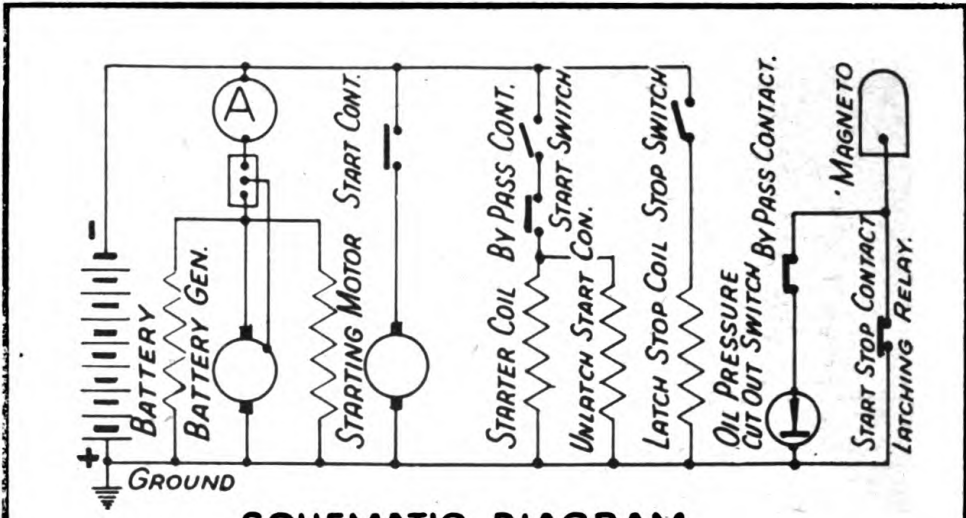

FIGURE 33.—Installation diagram.



**WIRING DIAGRAM
POWER UNIT PE-99-G**

FIGURE 34.—Power Unit PE-99-G, wiring diagram.



**SCHEMATIC DIAGRAM
START-STOP & SAFETY SHUT DOWN CIRCUITS**

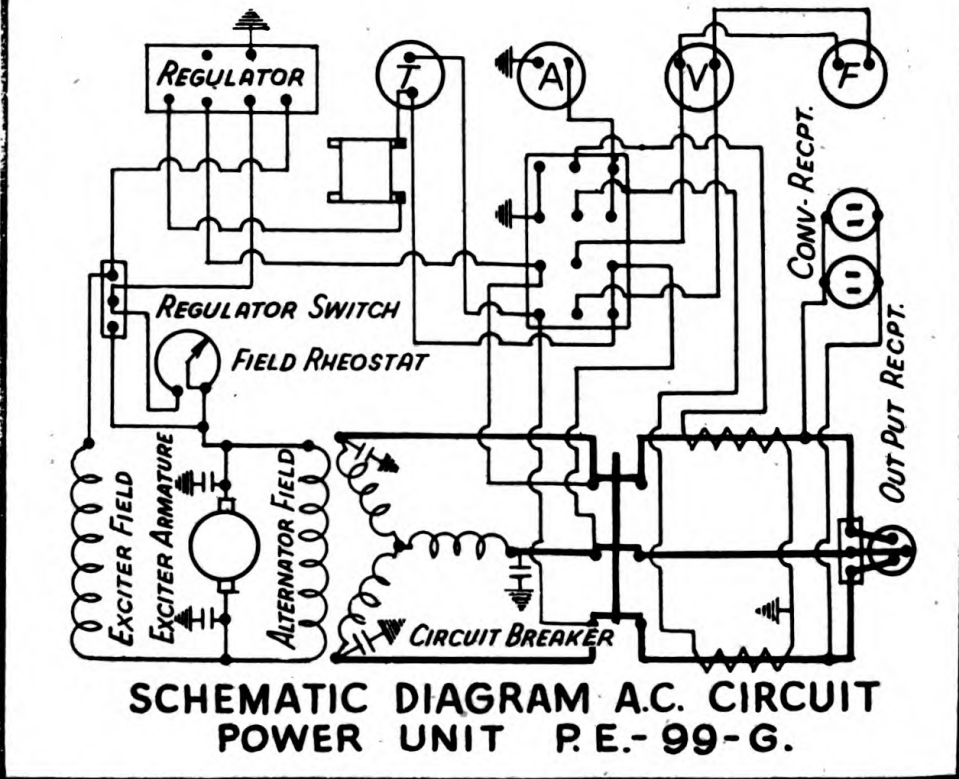

**SCHEMATIC DIAGRAM A.C. CIRCUIT
POWER UNIT P.E.-99-G.**

FIGURE 35.—Power Unit PE-99-G, Schematic diagram, A-C and D-C circuit.

32. NAMES AND ADDRESSES OF MANUFACTURERS

A—Carson Machine & Supply Co.
202 Southeast 29th Street
Oklahoma City, Oklahoma

B—Wisconsin Motor Corporation
Milwaukee, Wisconsin

C—F-S Electric Company
903 South Third Street
Memphis, Tenn.

D—General Electric Company
Schnectady, New York

E—Ward Leonard Electric Company
31 South Street
Mt. Vernon, New York

F—Gates Rubber Company
607 West Grand
Oklahoma City, Oklahoma

G—The Electric Auto-Lite Co.
Toledo, Ohio

H—Crouse Hinds Company
Hills & Clary Streets
Syracuse, New York

I—J-B-T Instruments, Inc.
441 Chapel Street
New Haven, Connecticut

J—Cutler-Hammer, Inc.
1333 West St. Paul Avenue
Milwaukee, Wisconsin

K—A-C Spark Plug Division
General Motors Corporation
1941 McGinnis Street
Flint, Michigan

L—United Specialties Company
Air Cleaner Division
9705 Cottage Grove Avenue
Chicago, Illinois

- M—Bendix Aviation Corporation
Bendix Products Division
South Bend, Indiana
- N—Tillotson Manufacturing Co.
Toledo, Ohio
- O—Champion Spark Plug Company
Toledo, Ohio
- P—Fairbanks, Morse & Company
Beloit, Wisconsin
- Q—Quick Charge
1750 N. E. 10th St.
Oklahoma City, Okla.
- R—Harvey Hubbell, Inc.
1930 Thomas Street
Bridgeport, Connecticut
- S—Leece-Neville Company
5363 Hamilton Avenue
Cleveland, Ohio
- T—Westinghouse Elec. & Mfg. Co.
East Pittsburgh, Pa.
- U—Rochester Mfg. Co.
Rochester, New York

