

68 U113  
12  
TM  
1943

# TM 11-923E

WAR DEPARTMENT TECHNICAL MANUAL

U.S. Dept. of Army

## POWER UNITS

///

## PE-99-E

WAR DEPARTMENT • 27 DECEMBER 1943



WAR DEPARTMENT TECHNICAL MANUAL  
TM 11-923 E

---

# POWER UNITS

## PE-99-E

---



WAR DEPARTMENT • 27 DECEMBER 1943

---

United States Government Printing Office  
Washington • 1945

WAR DEPARTMENT  
WASHINGTON 25, D. C., 27 DECEMBER 1943

TM 11-923E is published for the information and guidance of all concerned.

[A. G. 300.7 (27 December 1943).]

*By order of the Secretary of War:*

G. C. MARSHALL,  
*Chief of Staff.*

OFFICIAL:

J. A. ULIO,  
*Major General,*  
*The Adjutant General.*

DISTRIBUTION: X

(For explanation of symbols see FM 21-6.)

U113  
 12  
 TM11:923E  
 1943

## TABLE OF CONTENTS

Section	Paragraph	Page
<b>I. DESCRIPTION</b>		
General .....	1	1
Detailed description .....	2	1
Table of weights and dimensions .....	3	5
<b>II. INSTALLATION AND OPERATION</b>		
Installation .....	4	6
Initial procedure .....	5	6
Preparation for use .....	6	7
Starting procedure .....	7	8
Alternator voltage regulator adjustment' .....	8	10
<b>III. FUNCTIONING OF PARTS</b>		
Engine .....	9	12
Start and stop circuits .....	10	12
Automatic voltage regulator .....	11	13
<b>IV. MAINTENANCE</b>		
General construction (engine) .....	12	16
Lubrication .....	13	17
Timing of magneto .....	14	20
Governor .....	15	20
Fuel pump .....	16	22
Carburetor .....	17	26
Spark plug radio shielding .....	18	28
Automatic choke .....	19	29
Remote control unit .....	20	30
Disassembly and assembly of connecting rod, piston, etc. ....	21	34
Disassembly and assembly of oil pump .....	22	34
Disassembly and assembly of cylinders .....	23	35
Disassembly and assembly of camshaft .....	24	36

Section	Paragraph	Page
Disassembly and assembly of governor .....	25	36
Disassembly and assembly of crankshaft .....	26	37
Cylinder firing sequence .....	27	37
Low voltage generator .....	28	38
Low voltage regulator .....	29	38
Starting motor .....	30	38
Engine trouble chart .....	31	39
Alternator .....	32	41
Alternator voltage regulator .....	33	44
 <b>V. SUPPLEMENTARY DATA</b>		
Table of replaceable parts .....	34	48
Table of nuts, bolts and washers .....	35	105
Names and addresses of manufacturers .....	36	112

## LIST OF ILLUSTRATIONS

Figure	Title	Page
1.	Left side of Power Unit PE-99-E	x
2.	Right side of Power Unit PE-99-E	2
3.	Accessories for Power Unit PE-99-E	4
4.	Control panel front, Power Unit PE-99-E	9
5.	Wiring diagram, Power Unit PE-99-E	14
6.	Power Unit PE-99-E timing diagram	18
7.	Magneto timing	19
8.	Fuel pump cross section	21
9.	Carburetor cross section	25
10.	Automatic choke	29
11.	Engine, drive shaft end	31
12.	Engine, starter side view	32
13.	Engine magneto side view	33
14.	Exploded view of engine for Power Unit PE-99-E	46
14a.	Power Unit PE-99-E engine cross section	47
15.	Fuel pump disassembled	59
16.	Air cleaner cross section	61
17.	Carburetor disassembled	63
18.	Fuel filter	66
19.	Automatic choke—disassembled	68
20.	Battery charging generator	70
21.	Circuit breaker, current regulator, voltage regulator	74
22.	Starting motor—sectionalized view	77
23.	Magneto parts group	80
24.	Spark plug shielding	89
25.	Alternator, exciter and field coils	91
26.	Alternator frame assemblies	92
27.	Alternator cross section	93
28.	Schematic control panel diagram	94
29.	Alternator voltage regulator	99
30.	A.C. power circuits	113

## **DESTRUCTION NOTICE**

### **WHY—**

To prevent the enemy from using or salvaging this equipment for his benefit.

### **WHEN—**

When ordered by your commander.

### **HOW—**

1. Smash—Use sledges, axes, handaxes, pickaxes, hammers, crowbars, heavy tools, etc.
2. Cut—Use axes, handaxes, machete, etc.
3. Burn—Use gasoline, kerosene, oil, flame throwers, incendiary grenades, etc.
4. Explosives—Use firearms, grenades, TNT, etc.
5. Disposal—Bury in slit trenches, foxholes, other holes. Throw in streams. Scatter.
6. **USE ANYTHING IMMEDIATELY AVAILABLE FOR DESTRUCTION OF THIS EQUIPMENT.**

### **WHAT—**

1. Smash—Engine cylinder head, manifolds, carburetor, cylinder blocks, crankcase, generator frame, control panel instruments, magneto, fuel filter, oil filter and air filter.
2. Cut—Generator drive belts, remote fuel pipe, exhaust tube, power cable, remote control cable, and all other wires and cables in or on the unit. Cut armature and field windings.
3. Bend and/or Break—Gas tank, engine housing, control cabinet, tool box, mounting frame, and control panel.
4. Burn—All manuals, wire, oil and fuel.
5. Bury or scatter—Any or all of the above pieces after breaking.

**DESTROY EVERYTHING**

## **SAFETY NOTICE**

Operation of this equipment involves the use of voltages dangerous to human life.

**OBSERVE ALL PRECAUTIONS AND SAFETY REGULATIONS.** If Power Unit PE-99-E is operated within a building, make certain that all exhaust connections are gas tight and that room is properly ventilated.

Carbon monoxide, contained in exhaust gases, is tasteless, odorless, and a deadly poison!

Do not attempt to make mechanical adjustments while equipment is in operation.

When making mechanical adjustments, remove the remote control cable.

Do not service with gas while the unit is operating or in proximity to an operating transmitter. ●

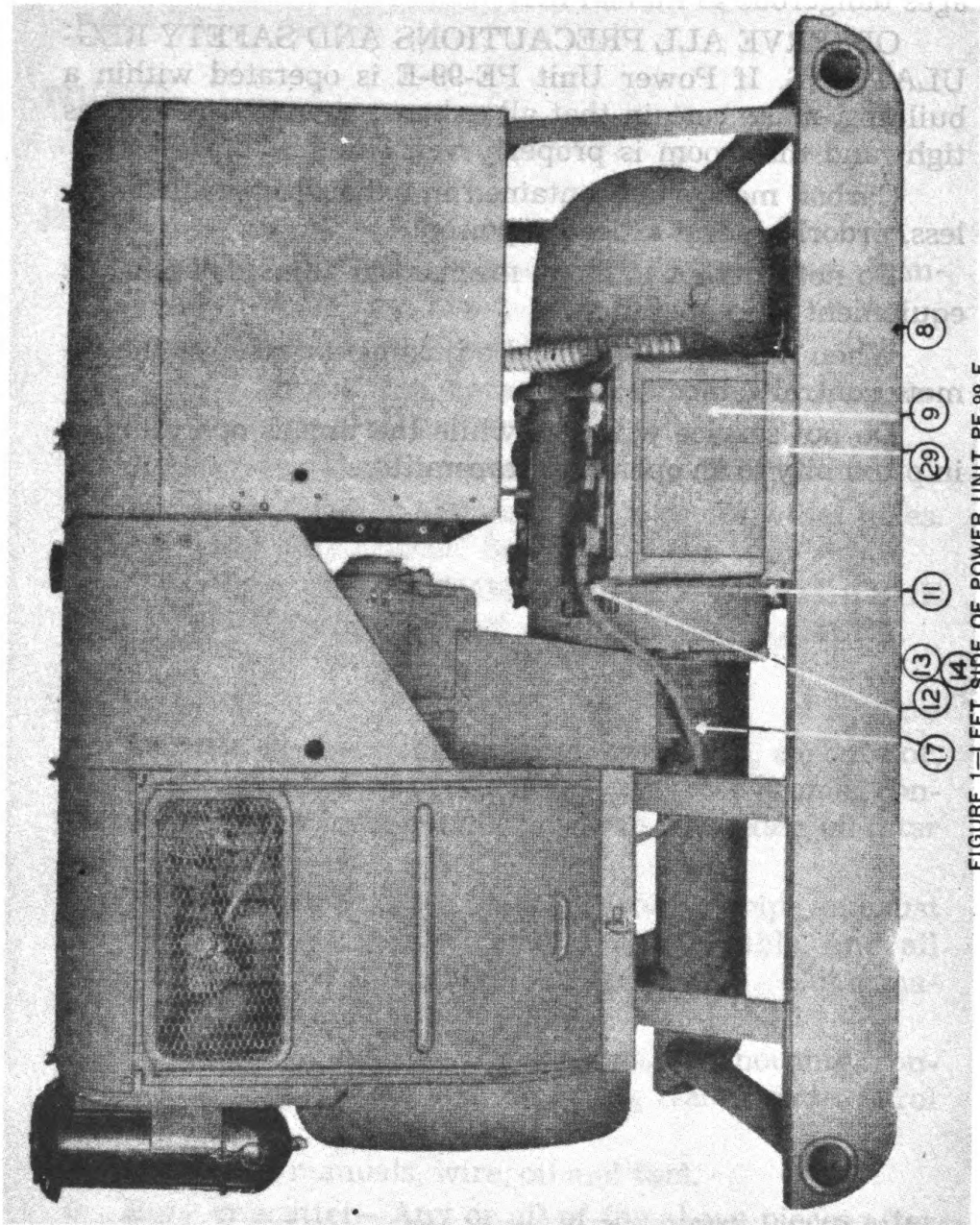

FIGURE 1—LEFT SIDE OF POWER UNIT PE-99-E

## SECTION I DESCRIPTION

### 1. General

a. Power unit PE-99-E is a complete self-contained, portable, gasoline-engine driven, self-excited generator. The unit develops 7.5 kva, 120 volt, 3-phase, 60 cycle, alternating current. The engine is mounted forward of and above the generator, and the drive is by means of five parallel V-belts.

b. The unit is designed for operation at all temperature ranges from  $-30^{\circ}$  to  $120^{\circ}$  F., and for operation under all climatic conditions that may be encountered in the above temperature ranges.

### 2. Detailed description

a. *Engine.* (1) The engine is a 4-cycle, air-cooled, four-cylinder V-type developing 20 BHP at 2200 RPM. It is of 3-inch bore and  $3\frac{1}{4}$ -inch stroke and 91.9 cubic inch displacement. It is designed for operating on commercial 80 octane, leaded gasoline. The fuel tank capacity is  $9\frac{3}{4}$  gallons, which is sufficient for six hours of operation at full load. The engine is equipped with a mechanical diaphragm fuel pump so that fuel may be drawn from either the self-contained fuel tank or a remote supply tank. The self-contained fuel tank is provided with a sediment bulb and a shut-off valve.

(2) Cooling is accomplished by a flow of air circulated over the cylinders and cylinder heads by a combination fan-flywheel, encased in a sheet metal shroud with air being directed by ducts and baffle plates to insure cooling of all parts.

(3) The side doors of the hood enclosure are removable but need not be removed while the engine is running.

b. *Power generator.* The generator is of the revolving armature semi-enclosed drip-proof type having a direct connected exciter and a temperature rise not exceeding

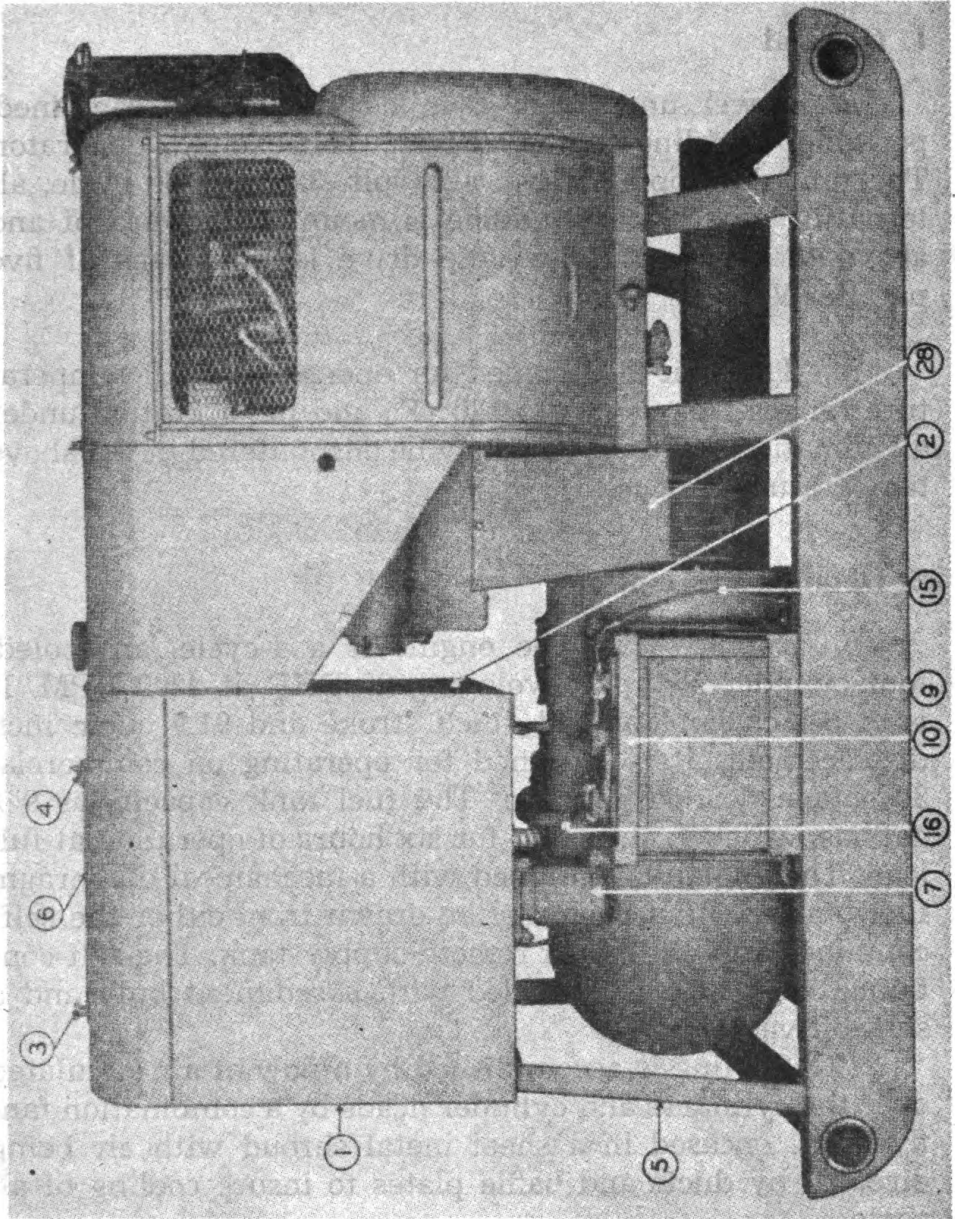

FIGURE 2—RIGHT SIDE OF POWER UNIT PE-99-E

50° C. Lubrication of the bearings is provided by means of compression cups through which soft grease is forced to the bearings.

c. *Base and drive.* The engine is mounted on a structural steel base and power is transmitted to the generator through five parallel V-belts and sheaves.

d. *Ignition and starting.* Magneto ignition with impulse coupling is provided and is completely radio shielded. The engine is started by means of an electric starter of the mechanical type with remote control starting equipment also provided. In case of emergency the unit can be manually started.

e. *Carburetor.* The carburetor is of the fixed jet, float feed type, provided with a thermo-electric automatic choke. A mechanical flyball governor maintains a constant speed and regulates the fuel consumption according to the load.

f. *Control panel.* The control panel is made of steel and is contained in a cabinet which is mounted on one end of the portable skid base level with the gasoline tank. This panel contains the lights, meters, switches, etc., necessary for efficient operation of the unit.

g. *Cables.* On individual reels, there is supplied one 3-conductor power cable 150 feet long, and one 3-conductor control cable 150 feet long. The cables are equipped with the necessary plugs, switches, etc.

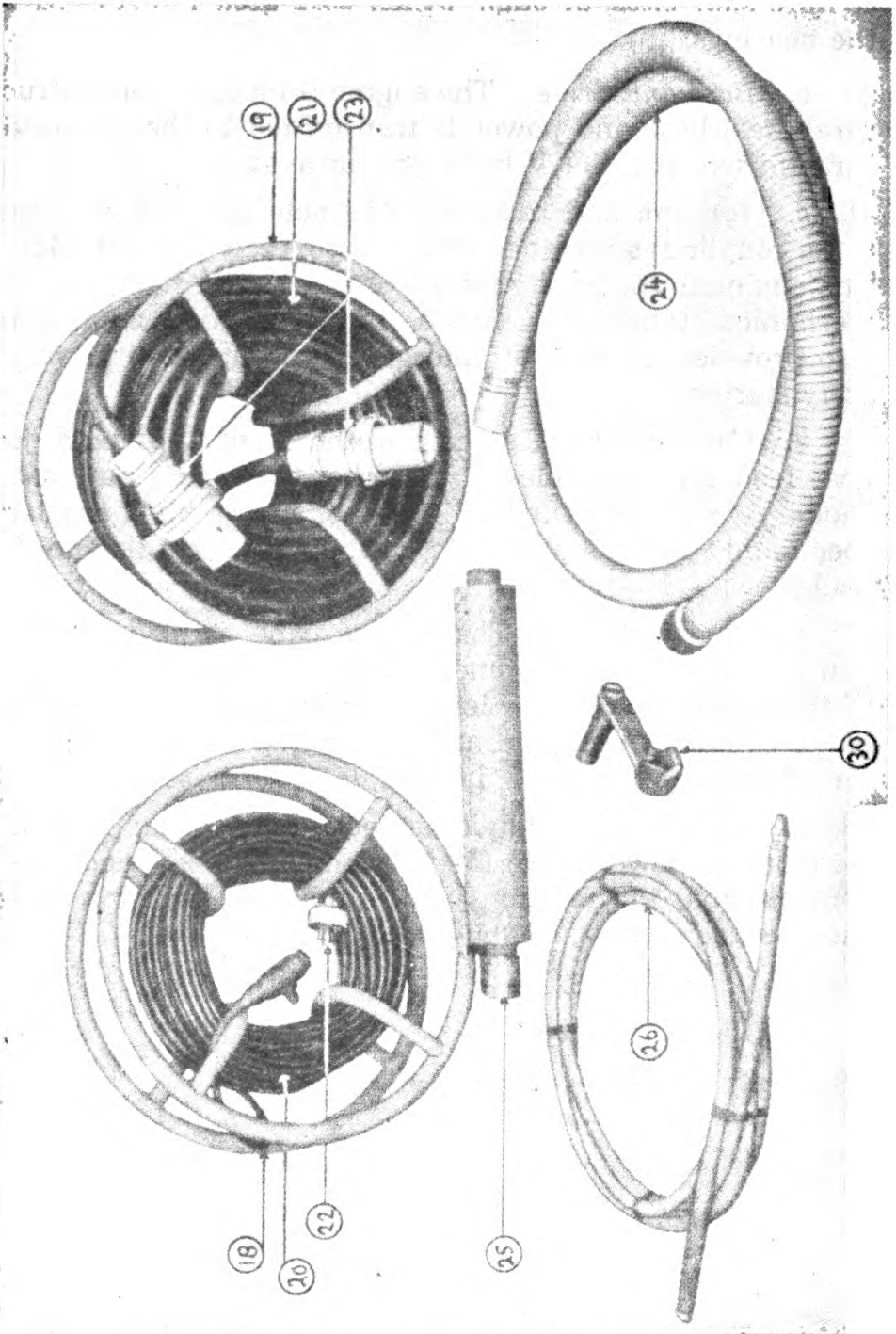

FIGURE 3—ACCESSORIES FOR POWER UNIT PE-99-E

## 3. Table of weights and dimensions

Component	Length	Width	Height	Weight lbs.
Power Unit PE-99-E	59"	28"	39 $\frac{1}{4}$ "	1085.0
Engine, only	36 $\frac{1}{4}$ "	22 $\frac{1}{2}$ "	28 $\frac{3}{4}$ "	445.0
A.C. Generator	30 $\frac{1}{8}$ "	13" Dia.	13" Dia.	323.0
Frame	56"	28"	10 $\frac{7}{8}$ "	115.0
Control Cabinet	20 $\frac{1}{4}$ "	21 $\frac{5}{8}$ "	21 $\frac{1}{4}$ "	61.0
Control Panel	$\frac{1}{8}$ "	21"	16 $\frac{1}{4}$ "	26.0
Batteries—2 6-volt with boxes, wires, etc.	10 $\frac{3}{8}$ "	7 $\frac{1}{8}$ "	9 $\frac{3}{8}$ "	107.0
Muffler, Exhaust Hose and Fuel Line	Exhaust Hose 10 ft. Fuel Line 20 ft.	1 $\frac{1}{2}$ " Dia. $\frac{1}{4}$ " Dia.		18.5
Remote Power Cable and Reel	150 ft. No. 6-3 AWG	Reel 20" Dia.		109.0
Remote Control Cable and Reel	150 ft. No. 16-3 AWG	Reel 20" Dia.		30.0
Tools	(Tool Compartment in Cabinet)			8.0

## SECTION II.

**INSTALLATION AND OPERATION****4. Installation**

a. *General Power Unit PE-99-E* may be used for either field work or indoor installation. The unit should be installed in as clean, dry, level, and accessible a location as possible. Choose a general location that will be consistent with the assignment to be carried out and the length of the cables. Avoid low spots that may be flooded by sudden rain. Locate the unit so that exhaust gases are carried away from personnel.

b. *Installing indoors.* (1) When installing indoors, ample provision for ventilation and cooling must be made. At least two feet of space must be provided around all sides of the unit.

(2) The muffler can be attached either between the engine exhaust and the flexible exhaust pipe, or on the end of the flexible exhaust pipe, whichever setup is indicated or desired. When fuel is to be taken from a remote supply tank, the 25-foot flexible fuel line must be connected from the remote tank to the 3-way valve in the fuel line, and the valve placed in the proper position for taking fuel from this tank.

(3) The remote fuel supply must be so located that the total fuel lift by the fuel pump will not be more than six feet.

**5. Initial procedure**

Clean off any cinders, dirt, oil or other foreign matter that might have accumulated from shipping. Crank the unit with the hand crank to make sure everything is free. Drain the rust-proofing oil from the crankcase and throw it away.

(NOTE: When reference is made to Left or Right, it is presumed that the operator is standing at the generator end of the unit facing the control cabinet. Front End refers to the generator end and Rear End refers to the flywheel end.)

## 6. Preparation for use

a. Fill the crankcase with four quarts of oil as recommended in the table following. The oil filler is located on the right side of the engine and the oil filler cap is painted blue. Wipe off any accumulated dirt, remove the cap and pour oil in slowly. Check the oil level with the sabre gauge located on the left side of the engine in front of the starter. The oil level should show FULL on the sabre gauge.

Temperature above 32° F.	SAE 30
32° to 0° F.	SAE 10
Below 0° F.—dilute SAE 10 with 1 percent gasoline for each degree F. below 0°. Never dilute in excess of 40 percent.	

b. Fill the fuel tank with G.I. gasoline through the tank cap which is painted red and located in the center of the tank on top of the unit.

c. Check the grease cups on each end of the power generator and fill them with soft grease.

d. Put 5 to 10 drops of light motor oil in each of the oil cups on the battery-charging generator which is located under the fuel tank on the left side of the unit. Oil cups are located on either end of this generator.

e. Check the air cleaner by removing the cup from the bottom. If any dirt or dirty oil is found, empty the cup and refill it to the indicated level with SAE-30 oil.

f. Check the flow of fuel to the carburetor. Turn the 3-way cock handle to the horizontal position with the long part of the handle pointing toward the front of the unit. Make sure that the shut-off cock on the sediment bulb is open by screwing it out as far as possible with the fingers. (Do not use pliers or a wrench on this cock.)

g. Before placing battery in service, remove wooden stoppers from filler plugs. Remove filler plugs and immediately fill all cells with battery grade electrolyte. Use 1.285 (32° Baume), specific gravity (for tropical countries 1.225 (26.6° Baume) specific gravity). 1.285 (32° Baume) specific gravity electrolyte may be obtained by mixing one volume of 1.835 (66° Baume) specific gravity concentrated sulphuric acid (battery grade) to  $2\frac{3}{4}$  volumes of distilled water.

(1.225 (26.6° Baume) specific gravity for tropical countries—one volume acid to 3¾ volumes water.) Use glass, earthenware, or lead container for mixing and handling electrolyte and water. Add sulphuric acid to water very slowly. Stir while adding acid to water and allow mixture to **Cool** to 90° F. or lower before using. **Never add water to concentrated acid.** Replace vent plugs. After battery has been filled and allowed to stand one hour it may be placed in service. If not placed in service within 12 hours after filling, charge battery on charging line until specific gravity becomes constant.

*h.* Connect the muffler and flexible exhaust line to the engine exhaust at the back end of the unit above the flywheel. The muffler can be placed next to the engine or at the end of exhaust line as conditions warrant.

## 7. Starting procedure

*a.* Open the control cabinet doors (figure 4). Be sure that the Main Circuit Breaker (No. 15) is open by pulling the handle down. Set the REGULATOR switch (No. 19) to the ON position. Set the MANUAL START switch (No. 18) to the ON position. To start the unit, push the START button (No. 7) on the control panel or throw the Remote Control cable switch to the ON position. As soon as the engine starts, release the start button. Do not crank continuously for more than 30-second intervals. If the engine does not start promptly, refer to the Trouble Chart on Page 39. To stop, momentarily push the STOP button (No. 6) or throw the Remote Control switch to the OFF position.

*b.* To put the unit into operation:

- (1) Be sure the Main Circuit Breaker is in the OFF or down position.
- (2) Move the "A.C. VOLTS" switch (No. 13) to the 1, 2, or 3 position, to be able to read the A.C. Voltmeter (No. 12) in the upper right of the control panel.
- (3) Move the REGULATOR ON-OFF Switch (No. 19) to the ON position.
- (4) Turn the Shunt Field Rheostat knob (No. 10), in the center of the control panel, in a clockwise direction all the way.

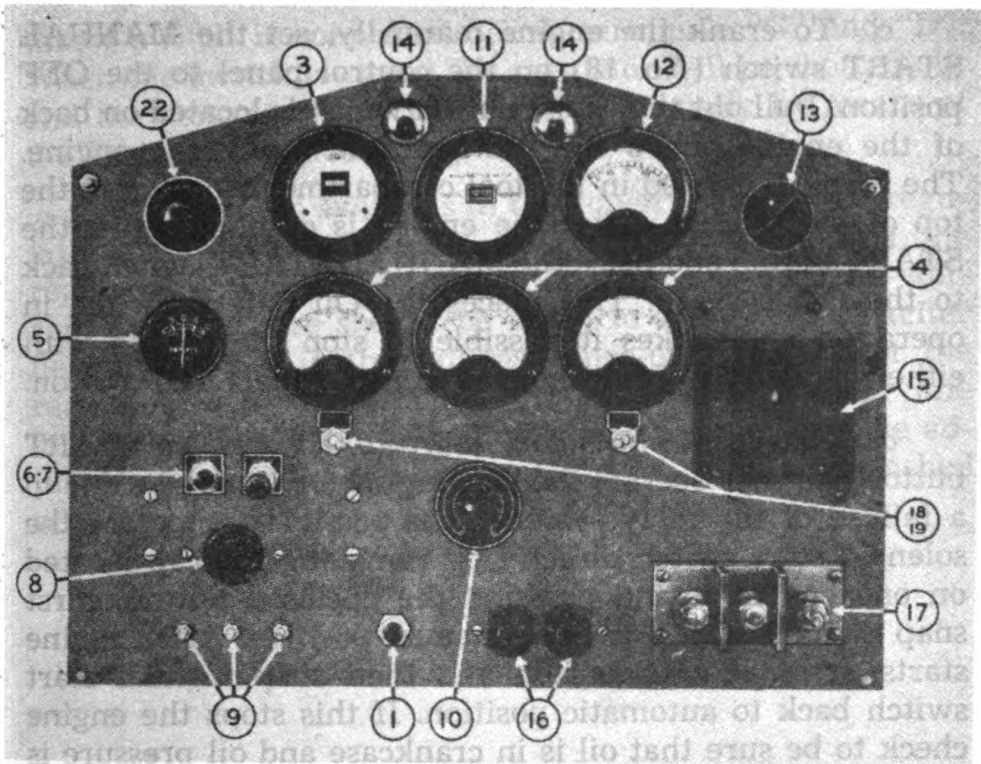

FIGURE 4—CONTROL PANEL. FRONT, POWER UNIT PE-99-E

- (5) Check all phases for proper voltage on the volt-meter by putting the "A.C. VOLTS" switch in the 1, 2, or 3 position.
- (6) Check the speed of the alternator by seeing that the vibrating reed of the frequency meter (No. 3) is on 60.
- (7) Put the Main Circuit Breaker in the ON or up position. This energizes all outlets and power studs (No. 17).
- (8) The entire output load can be determined by the three A.C. Ammeters (No. 4).
- (9) The unit can be started and stopped by the START-STOP push buttons in the lower left of panel, by the remote control cable plugged into the Remote Control Receptacle. (No. 8), or by the cable attached to the Remote Control studs (No. 9).
- (10) *Emergency stop switch.* If engine does not stop when STOP button is pressed momentarily, press and hold down the EMERGENCY STOP button, which provides a direct ground for the magneto.

c. To crank the engine manually, set the MANUAL START switch (No. 18) on the control panel to the OFF position. Pull out the choke button which is located on back of the engine above the flywheel and crank the engine. The crank is carried in the tool compartment located in the top of the cabinet. After the engine is cranked, press the START button and place the MANUAL START switch back to the ON position. This places the Oil Safety Switch in operation and makes it possible to stop the engine with either the Remote Control or the control panel STOP button.

d. *Emergency automatic starting.* If pressing START button does not operate the starting motor it may be due to a failure of the relay system. It is possible to operate the solenoid start switch directly by removing the cap located on one end of it and pressing the enclosed button. First snap manual start switch to manual position. After engine starts press START button and then snap manual start switch back to automatic position. If this stops the engine check to be sure that oil is in crankcase and oil pressure is satisfactory.

## **8. Alternator voltage regulator adjustment**

a. The first time that the regulator is put into service it may be advisable to leave the field rheostat set for maximum resistance. After starting the motor-generator, set the control rheostat to mid-position, and slowly turn the exciter field rheostat to the "all-resistance-out" position and at the same time watch the A.C. voltmeter to make sure that the voltage does not rise to an abnormally high value. The regulator should begin to control the voltage at some value between 100 and 140 volts, as the rheostat resistance is reduced. If the voltage is not controlled in this manner, an error in the external wiring of the regulator circuit is indicated and all wiring should be checked and the fault eliminated.

b. It is not necessary to take the regulator out of service in order to shut down the generator. Without touching the regulator, the generator may be shut down and later restarted as often as desired. The regulator automatically starts and stops with the generator. A single-pole, single-

throw switch is connected across terminals "C" and "D". When the switch is closed the regulator will be shorted-out and the generator may be operated manually by means of the exciter field rheostat.

c. When the switch is in the "open" position the regulator resistance is inserted in the field circuit, and the regulator will take over the automatic control of the voltage. Extreme care should be taken to see that the exciter field rheostat is in the "all-resistance-out" position or the regulator will not function properly. The nominal line voltage at which the generator should operate may be adjusted by means of the external control rheostat furnished with the regulator.

### SECTION III

## FUNCTIONING OF PARTS

### 9. Engine

Complete information on the functioning of internal combustion engines, and on carburetion and ignition systems may be found in the following technical manuals:

TM 10-570. The Internal Combustion Engines.

TM 10-550. Fuels and Carburetion.

TM 10-580. Automotive Electricity.

### 10. Start and stop circuits (Figure 5)

*a. To start the engine.* (1) Pressure on the START switch operates relay *RA*, closing contacts *RA1* and *RA2* and opening *RA3*. *RA1* operates relay *RB*, closing *RB4* to lock in relay *RB*, opening *RB5*.

(2) With contacts *RA3* and *RA5* open, the magneto is ungrounded.

(3) *RA2* feeds battery through *RC6* to operate the solenoid starter switch. The solenoid switch closes the battery circuit to the starting motor which cranks the engine.

(4) When the engine starts, the battery-charging generator operates relay *RC* to open *RC6*. This prevents the starting motor from being operated by the START button while the battery charging generator is running.

(5) After the engine starts, removing the finger from the START button releases relay *RA*. Contacts *RA1* and *RA2* return to the open position and *RA3* returns to closed position. *RA3* is in series with the oil pressure switch, which is open while the engine is running and the oil pressure is up. Therefore, closing *RA3* does not ground the magneto.

*b. Oil pressure protection.* If oil pressure drops below a safe minimum, the oil pressure switch will close to ground the magneto and stop the engine. In this case relay *RB* remains locked in until STOP button is pushed to unlock it.

*c. To stop the engine.* Pressing the STOP button operates relay *RD*. *RD7* opens and breaks the circuit by which relay *RB* locks itself in. *RB5* resumes closed position, grounding the magneto.

d. *Manual cranking.* Snapping the MANUAL START toggle switch to the manual position opens the circuit by which the magneto is grounded. After the engine has started, pressing the START button, with the battery-charging generator running, operates relay *RA* which in turn operates and locks in relay *RB* so that *RB5* remains open.

## 11. Automatic voltage regulator

a. *General.* (1) The voltage regulator is an instrument which performs the function of an automatic field rheostat to provide a simple, effective and automatic means for obtaining almost constant voltage for all normal load conditions.

(2) The regulator consists mainly of a solenoid, a commutator and two resistor plaques. The solenoid coil is connected to the A.C. generator and is affected by voltage changes which actuate the solenoid plunger and likewise the cross arm which moves the carbon contact across the silver commutator, thereby adjusting the resistance of the plaques to a value which maintains the generator voltage.

(3) The regulator has two electrical circuits; one consisting of the solenoid coil, the voltage dropping resistor and the external control rheostat; the other consisting of the voltage regulating resistor which is actually the exciter field rheostat.

(4) Both the voltage-dropping resistor, which limits the impressed voltage on the solenoid coil, and the regulator resistance, which adjusts the exciter field current, are embedded in and equally divided between the two plaques. The external control rheostat is not located in the regulator but is mounted separately on the control panel.

(5) The commutator consists of a stack of insulated silver segments, each segment connected to a tap on the regulator resistor. The commutator is of a V shape and the carbon contact roller rests on the commutator at two points. By moving the contact roller transversely across the commutator, the distance between these two points of contact is changed, and thus the effective resistance of the voltage regulating resistor is adjusted.

(6) The solenoid is of the A.C., quick-acting type and allows the regulator momentarily to over-correct and

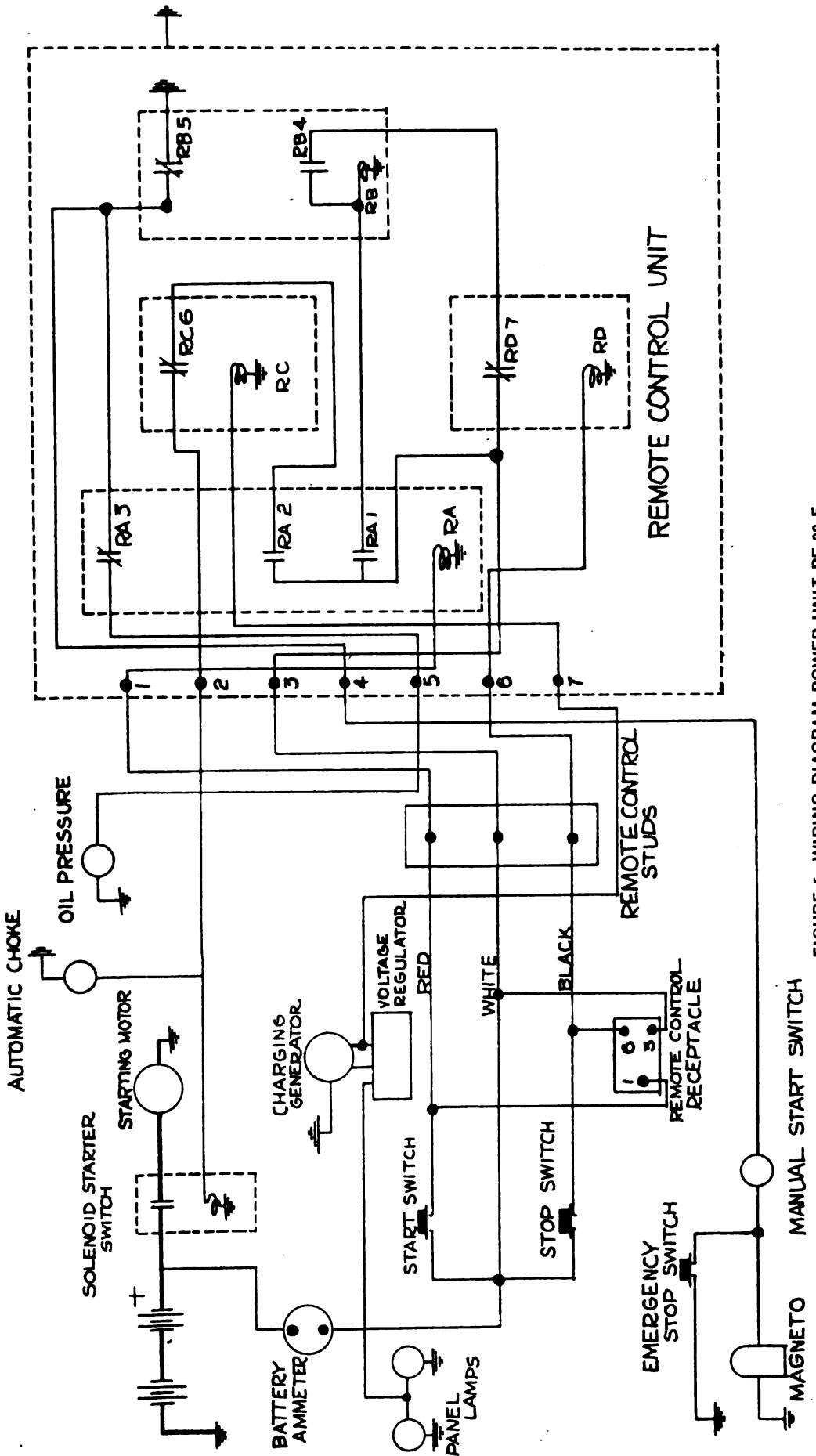

FIGURE 5—WIRING DIAGRAM POWER UNIT PE-99-E

then find a new steady-state position. The contact roller is not in constant motion, moving only when regulating action is demanded.

*b. Theory of operation.* (1) Reference to the wiring diagram, Figure 30, may assist in understanding the operation of the regulator. Since the solenoid is energized from the A.C. generator, any change in A.C. voltage will cause motion of the solenoid plunger. The resulting motion of the arm and contact roller changes the resistance in the exciter-shunt field circuit so as to restore the A.C. voltage to its original value.

(2) Assume that the load on the generator increases. The regulating cycle then is:

- (a) The AC voltage decreases.
- (b) The current in the solenoid coil like-wise decreases, causing the plunger and the contact roller to move and short-circuit segments of the commutator.
- (c) As the number of segments short-circuited increases, the resistance of the exciter-shunt field circuit decreases.
- (d) The exciter-shunt field current, therefore, increases, resulting in an increased exciter-armature voltage and generator field current, thus restoring the A.C. voltage.

## SECTION IV

### MAINTENANCE

#### 12. General construction (Engine)

a. The crankshaft is carried on two roller bearings. The cones are a tight press fit on the crankshaft. The outer race or cup of the bearings at the power take-off end of the engine is carried in a plate bolted to the crankcase. Under this plate several shims are fitted for adjusting the bearings. The bearings are properly fitted at the factory. It is very seldom necessary to change this adjustment for wear, and then the work should be done only by authorized personnel.

b. The connecting rods are direct babbitted at the large ends and are fitted with laminated shims. The upper ends of the rods are fitted with hard bronze bushings. The oil streams from the oil nozzles strike the fins on the connecting rod caps about 3/16 inch from the end. If these oil streams strike the fins or connecting rods higher up, the cylinders will receive too much oil.

c. The pistons are cast iron. Four rings are fitted to each piston, three compression and one oil regulating ring.

d. The piston pin is a light press fit in the piston, and steel wire snap rings in the piston bosses prevent end movement of the pin.

e. The camshaft is made of a special metal known as Gunite. The cams and fuel pump eccentric are formed integral with the shaft. The cam drive gear is bolted to a flange by three bolts.

f. The valves are located in side pockets in the cylinders. Special hardened valve seat insert rings are pressed into the cylinders. The valves are operated through mushroom type tappets. Adjusting screws are provided in the tappets, and these should be adjusted to give a clearance of ten thousandths (.010) of an inch at the inlet valve stems, and twelve thousandths (.012) of an inch at the exhaust valve stems when the engine is cold.

g. The oil pump which is of the gear type, is located in the crankcase and extends down into the oil pan. The

pump is driven by helical gears from the crankshaft through an idler gear. The suction opening in the oil pump is protected by an oil screen.

*h.* The crankcase is made of iron. The cylinders are cast in pairs of a special alloy iron. The cylinder heads are also cast in pairs. Both heads and cylinders are provided with ample cooling fins so the engine will not overheat when operating at full speed, full load, in the hottest weather. Cooling is accomplished by a flow of air circulated over the cylinders and heads by a combination fan-flywheel, which is encased in a sheet metal shroud. The air is directed by ducts and baffle plates to insure uniform cooling of all parts.

*i.* Never operate the engine with any part of the air shroud removed as this will allow the engine to overheat and score the cylinders. The air shroud is absolutely necessary to direct the air flow so the engine may be properly cooled.

NOTE: KEEP ENTIRE ENGINE CLEAN

### 13. Lubrication

*a.* Check the lubricating oil daily before operating the unit. High grade, highly refined oils corresponding in body to the S.A.E. (Society of Automotive Engineers) Viscosity Numbers listed below will prove economical and assure long engine life.

Temperature above 32° F. ....	SAE 30
32° to 0° F. ....	SAE 10
Below 0° F.—dilute SAE 10 with 1 percent gasoline for each degree F. below 0°. Never dilute in excess of 40 percent.	

The standard oil reservoir holds approximately four quarts of oil. THE OIL (old oil) SHOULD BE DRAINED AND FRESH OIL ADDED AFTER EVERY 100 HOURS OF OPERATION.

*b.* Lubrication is by a combination of splash and force feed. The oil is forced by a gear-type pump into a header extending the full length of the crankcase. Four nozzles in this header direct oil streams against the fins on the connecting rods, and the spray thus formed lubricates all internal parts of the engine.

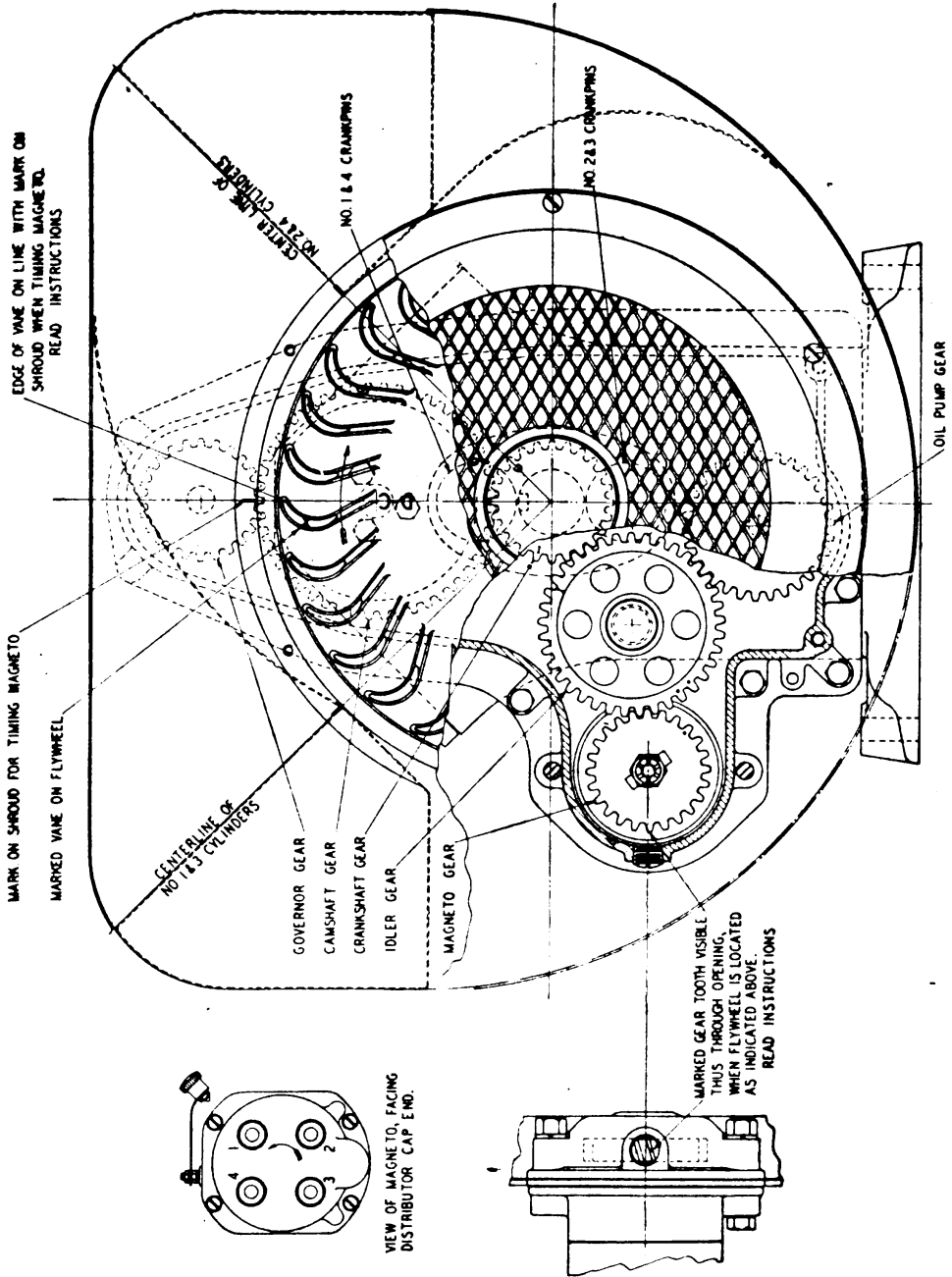
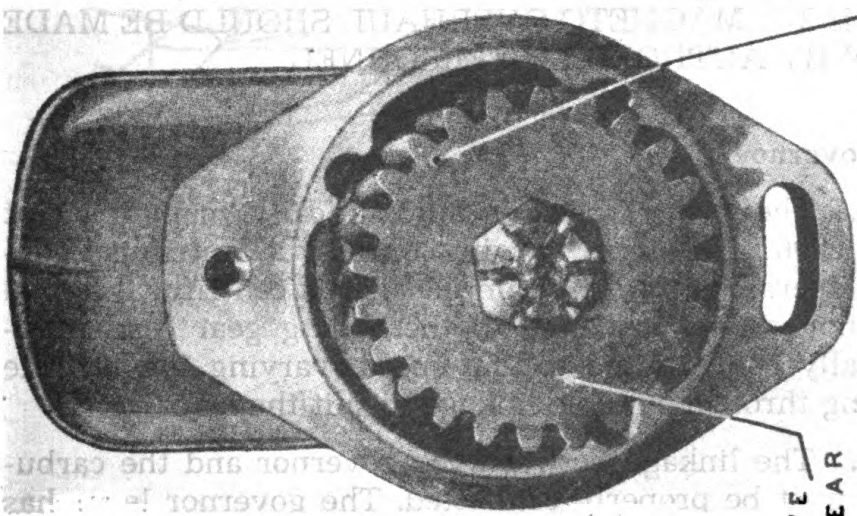

FIGURE 6—POWER UNIT PE-99-E TIMING DIAGRAM

COIL

CONDENSER



DRIVE GEAR

PRICK PUNCH MARK

DETERMINE  
BREAKER  
POINT GAP  
WHEN OPEN  
ADJUST TO  
.012 INCH

LOCKING SCREW

ADJUSTING SCREW

TERMINAL SCREW (C.W. ROTATION) SHOWN

L4 LOBE CAM

L BREAKER ARM

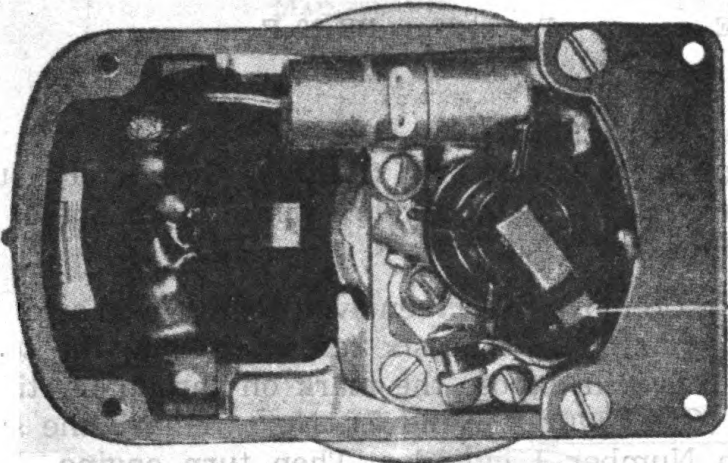

DISTRIBUTOR CONTACT  
FIRING POSITION NO.1  
CYLINDER

FIGURE 7—MAGNETO TIMING

#### 14. Timing of magneto

The magneto is properly timed at the factory but if for any reason it is necessary to retime the magneto, proceed as follows:

a. First remove the screen over the flywheel air intake opening by taking out the six screws holding the screen in place. This will expose the mark on shroud for timing magneto. (See Figures 6 and 7). Next remove the spark plug from Number 1 cylinder. Then turn engine slowly over with the starting crank until the compression in this cylinder blows the air out of spark plug hole.

b. The flywheel is marked with the letters DC near one of the air circulating vanes. This vane is further identified by a mark cast on one end. (See Figure 6.) When the air blows out of the Number 1 spark plug hole, continue turning the starting crank until the edge of the marked vane on flywheel is in line with the mark on shroud as shown in Figure 6. Leave flywheel in this position. The keyway at take-off end of crankshaft will be on top. The magneto should then be fitted to the engine so that the marked tooth on the magneto gear is visible through the opening in timing gear housing as shown on Figures 6 and 7. The distributor cap on the magneto is numbered from 1 to 4. The leads from the magneto should be connected to spark plugs of like number. The magneto breaker point opening should be from .015 to .018 of an inch and these points should be kept smooth and clean. The proper spark advance for these engines is 27°. **MAGNETO OVERHAUL SHOULD BE MADE ONLY BY AUTHORIZED PERSONNEL.**

#### 15. Governor

a. The motor speed is automatically maintained at about 2200 RPM under varying loads by a centrifugal governor operated from the cam gear. This centrifugal flyball governor, which is bolted to the timing gear case, automatically controls the engine speed, varying the throttle opening through suitable linkage to suit the load.

b. The linkage between the governor and the carburetor must be properly connected. The governor lever has just sufficient travel to give full movement to the carburetor

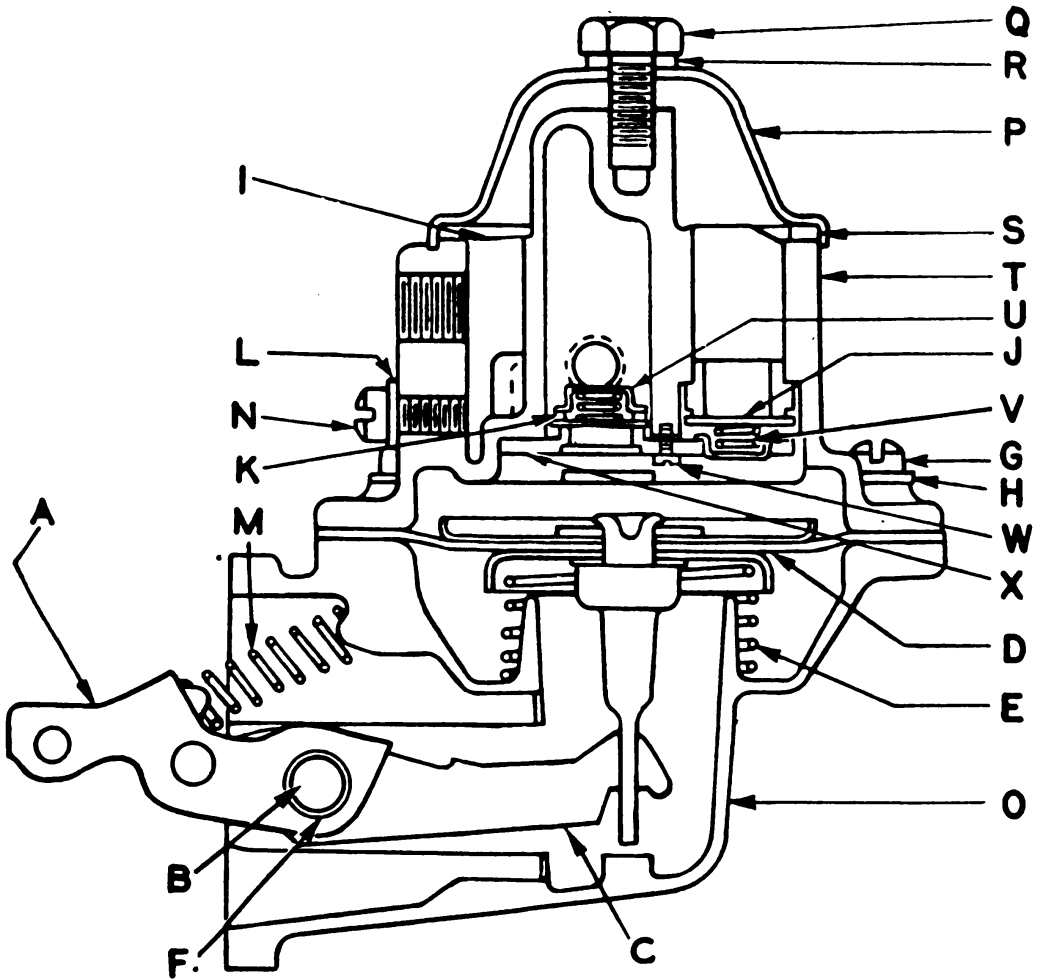

FIGURE 8—FUEL PUMP—CROSS SECTION

throttle lever from open to closed position. When engine is stopped, the governor lever position corresponds to wide open throttle position. The governor was carefully pre-adjusted to maintain normal speed under load. Do not re-adjust unless absolutely necessary. It can be changed by reducing or increasing the tension of the governor spring. Turn governor spring rod adjustment nuts to the right or clockwise to increase engine speed and frequency; to left or counter-clockwise to reduce engine speed and frequency.

## 16. Fuel pump

a. *Description.* (1) The fuel pump is mounted on the engine and is operated through a push rod which, in turn, is operated off an eccentric on the engine camshaft. The fuel pump is of the diaphragm type. The sequence of operations is as follows: As the push rod on the engine deflects the rocker arm, this in turn operates the link which pulls the diaphragm assembly against the spring tension and fills the fuel pump body with gasoline. The outlet and inlet check valves control the pumping action of the pump. As the pressure is built up in the gasoline line, it will also be built up in the pump and will hold the diaphragm against the spring and prevent the pump from operating. The spring maintains the proper pressure in the fuel system.

(2) There is a screen in the top dome of the fuel pump which prevents any solid matter that might be in the gasoline from entering the fuel line to the carburetor. The bowl also has a drain screw to permit the draining off of any water that might accumulate in the body.

b. *Repairs.* Fuel pump repairs are divided into two classifications:

- (1) Repairs made without disturbing pump installation.
- (2) Repairs which necessitate removal and disassembly of fuel pump. (Refer to Figure 8.)

c. *Fuel pump trouble chart.*

**REPAIRS MADE WITHOUT DISTURBING PUMP INSTALLATION.  
LACK OF FUEL AT THE CARBURETOR.**

<b>Cause</b>	<b>Remedy</b>
Gasoline tank empty.	Refill.
Leaky tubing or connections.	Replace tubing and tighten all pipe connections at the fuel pump and gasoline tank.
Bent or kinked tubing.	Replace tubing.
Dirty screen.	Clean the screen, <i>I</i> . Make certain that cork gasket, <i>S</i> , is properly seated when reassembling.
Loose cover plate cap screw.	Tighten cover plate cap screw, <i>Q</i> , securely, replacing cover plate cap screw gasket, <i>R</i> , if necessary.

**FUEL LEAKAGE AT EDGE OF DIAPHRAGM.**

<b>Cause</b>	<b>Remedy</b>
Loose cover screws.	Tighten cover screw, <i>G</i> , alternately and securely. Also check inlet and outlet connections.

**REPAIRS WHICH NECESSITATE REMOVAL AND DISASSEMBLY OF THE PUMP.**

<b>Trouble</b>	<b>Evidenced by</b>	<b>Remedy</b>
Broken rocker arm.	Visible.	Replace rocker arm, <i>A</i> .
Broken rocker arm spring.	Visible.	Replace rocker arm spring, <i>M</i> .
Defective or worn links.	Pump does not supply sufficient fuel.	Replace links, <i>C</i> .
Broken diaphragm return spring.	Does not supply fuel to carburetor.	Replace spring, <i>E</i> .
Punctured or worn-out fuel pump.	Fuel leaking through vent hole in body.	Replace diaphragm assembly, <i>D</i> .

**IMPORTANT:** *Mark* the top cover, *T*, and body *O*, with a file before disassembly so that in reassembling they are placed back in the same relative position.

*d. Procedure in assembling (Figure 8).*

(1) *Body, Rocker Arm and Link Assembly.* Assemble link, *C*, rocker arm *A*, and rocker arm spring, *M*, in body, *O*. Insert rocker arm pin, *B*, through hole in body, engaging link and rocker arm. Use a punch, and stake the die-cast metal of the body over the end of the pin in one place on each end, to retain in place.

(2) *Diaphragm and Pull Rod Assembly.* The diaphragm for Series "R" pump is an assembly including protector washers and pull rod, and is serviced as a unit. To correctly assemble diaphragm in pump body, proceed as follows:

- (a) Place diaphragm spring, *E*, in position in pump body, *O*.
- (b) Place diaphragm assembly, *D*, over spring, centering upper end of spring in lower protector washer.
- (c) Press downward on the diaphragm and hook the slot in the diaphragm pull rod over the hooked end of the link.

(3) *Valve and Cover Assembly.*

- (a) Place outlet valve spring retainer, *U*, in pump cover, *T*, taking care not to bend or distort legs of retainer.
- (b) Place valve plate gasket, *K*, in position.
- (c) Place outlet valve spring, *V*, in position in spring retainer.
- (d) Place outlet valve, *J*, on spring.
- (e) Place inlet valve, *J*, on valve seat.
- (f) Place valve spring, *V*, on center of inlet valve.
- (g) Assemble inlet valve retainer, *U*, in valve plate, *X*, taking care that shoulder of retainer fits down flush in depression in plate.
- (h) Place valve plate, *X*, in position and secure with three screws, *W*; inlet valve springs, *V*, must be centered properly in spring seat in valve plate, and outlet valve must be seated properly against valve seat in valve plate.
- (i) Place strainer screen, *I*, in position on top of cover, making certain that it fits snugly around the gasoline inlet and edges of the cover.
- (j) Assemble cork gasket, *S*, in cover plate and install cover plate on top of cover assembly. Make certain that gasket seats properly and strainer screen is not wrinkled or distorted.
- (k) Place fiber washer, *R*, on cover plate cap screw, *Q*, then insert and tighten screw securely.

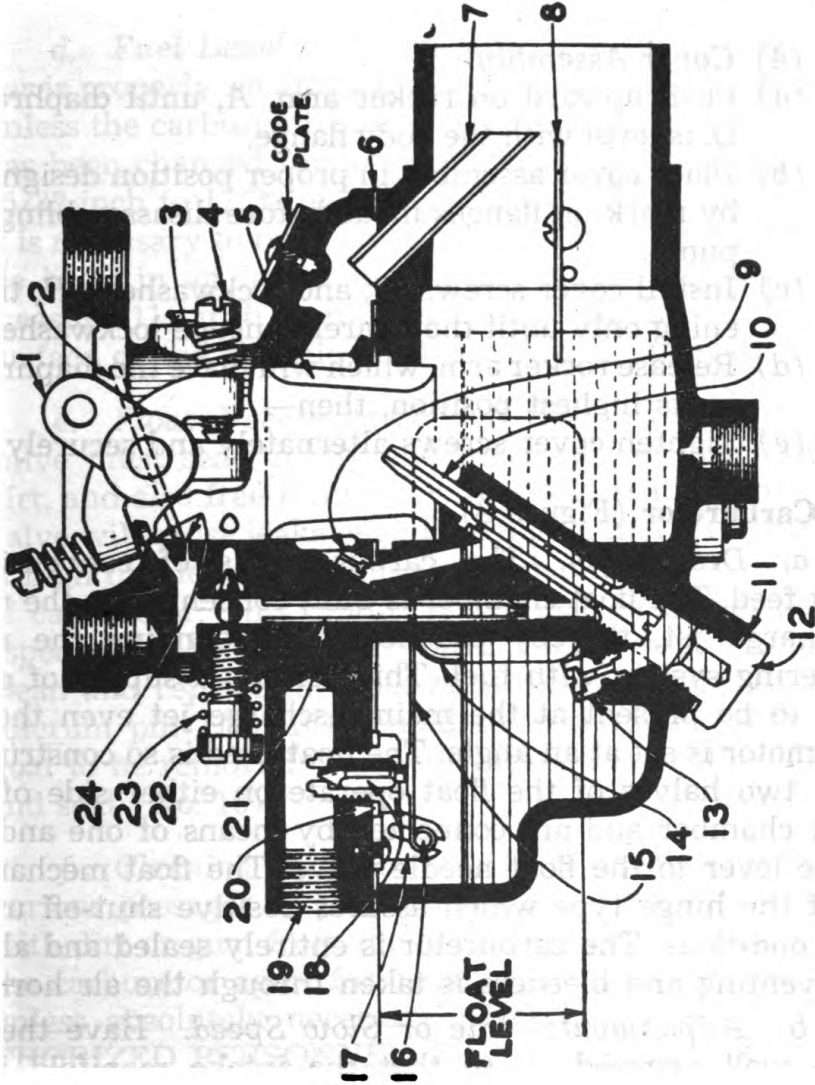

FIGURE 9—CARBURETOR, CROSS SECTION

**PARTS  
ILLUSTRATED**

- 1. Throttle Lever
- 2. Throttle Valve
- 3. Throttle Lever Stop Screw
- 4. Throttle Lever Stop Screw
- 5. Venturi
- 6. Main Body Gasket
- 7. Vent Tube
- 8. Choke Valve
- 9. High Speed Bleeder
- 10. Main Discharge Jet
- 11. Main Jet Plug Gasket
- 12. Main Jet Plug
- 13. Metering Jet
- 14. Float
- 15. Float Lever
- 16. Float Fulcrum Pin
- 17. Float Hanger
- 18. Float Needle Valve & Seat
- 19. Gas Inlet
- 20. Float Needle Valve and Seat Gasket
- 21. Idle Tube
- 22. Idle Needle Valve
- 23. Idle Needle Valve Spring
- 24. Idle Discharge Holes

28

- (4) *Cover Assembly.*
  - (a) Push upward on rocker arm, *A*, until diaphragm, *D*, is level with the body flange.
  - (b) Place cover assembly in proper position designated by mark on flanges made before disassembling the pump.
  - (c) Install cover screws, *G*, and lockwashers, *H*, tightening only until they barely engage lockwashers.
  - (d) Release rocker arm, which will place the diaphragm in its highest position, then—
  - (e) Tighten cover screws alternately and securely.

## 17. Carburetor (Figure 9)

a. *Description.* The carburetor is of conventional float feed. The float chamber is built concentric to the main discharge jet, thereby practically surrounding the main metering system with fuel. This permits a supply of gasoline to be present at the main discharge jet even though the motor is set at an angle. The float used is so constructed that two halves of the float operate on either side of the float chamber and are connected by means of one and the same lever to the float needle valve. The float mechanism is of the hinge type which assures positive shut-off under all conditions. The carburetor is entirely sealed and all air for venting and bleeders is taken through the air horn.

b. *Adjustments—Idle or Slow Speed.* Have the engine well warmed up so that the intake manifold is at least warm to the hand. Close the hand throttle until minimum steady idling speed is reached. Turn low speed adjustment (No. 22) gradually to right or left until the engine runs as steadily and fast as this throttle position will permit. This adjustment operates on air so that screwing it IN gives a richer mixture, OUT a leaner one. If, after adjusting, the engine idles too fast or too slowly, the desired speed can be obtained by turning throttle stop screw (No. 4). If a satisfactory adjustment cannot be obtained, see that idle discharge holes (No. 24) and idle tube (No. 21) are open and allow a free flow of gas.

c. *Intermediate and High Speed.* The engine is governor controlled. The mixture for normal speeds is controlled by a fixed metering jet and no adjustments are necessary.

d. *Fuel Level.* The gasoline level in the float chamber is properly set at the factory, and should not be adjusted unless the carburetor has been handled roughly or the level has been changed for some other cause. The level is set at  $15/32$  inch to  $17/32$  inch below the top of the main body. If it is necessary to reset level, it can be done by holding throttle body in an inverted position and setting the floats to measure  $1\frac{1}{4}$  inch from the top of each float to the gasket surface of the throttle body, marked float level.

e. *Float Needle-Valve and Seat.* The float needle-valve must seat tightly and must be free from specks of dirt, and also free from wear. A poorly seating float needle-valve will cause leakage and too high a fuel level will result. A high fuel level will cause too rich a mixture, and flooding of carburetor. This condition will also cause hard starting, especially if the engine is warm from previous running. To clean and replace the float needle-valve and seat, the float fulcrum pin (No. 16) should be withdrawn, allowing the float to be removed. This will expose the float needle-valve and seat (No. 18).

f. *Cleaning Carburetor.* (1) If at any time any of the various passages or jets in the carburetor become clogged with dirt or gum from the fuel, it may be necessary to take the carburetor apart for cleaning. This should not be done unless absolutely necessary AND THEN ONLY BY AUTHORIZED PERSONNEL. First, the upper half of throttle body should be removed from the lower half, or main body, by removing the four small screws holding these parts together. The main jet plug (No. 12) should then be removed. The main discharge jet (No. 10) and the metering jet (No. 13) can then be removed with a screw driver as can also the high speed bleeder (No. 9). The idle tube (No. 21) can be removed with a pair of pliers. The idle needle-valve (No. 22) can be removed by hand. The small plug directly over the idle needle valve should be removed with a screw driver, which will expose the idle discharge holes (No. 24).

(2) After all of these jets and passages have been cleaned, the parts should be reassembled, care being exercised that all gaskets are replaced and if necessary, new gaskets should be used. Unless the operator is very familiar

with carburetor construction, it is advisable to replace the various jets as they are removed and cleaned. This will prevent mistakes in reassembly.

g. *Air Cleaner.* An oil bath type of air cleaner is furnished. Air cleaners must be cleaned frequently depending on the dust conditions in the air. The oil in the cup together with the collected dust should be emptied and the cup then refilled with the same grade of oil as used in the crankcase to the level indicated on the cup.

## 18. Spark plug radio shielding

a. To prevent ignition noise and radio interference, the ignition system is radio shielded. The spark plugs and ignition wires are covered entirely with metal braiding which, when grounded to the engine, will ground out radio interference. To replace a spark plug, the radio shielding cap must be removed. This will permit the removal of the top cap of the shielding and the spark plug can then be removed from the cylinder head with a spark plug wrench. When re-assembling the spark plug and shielding, a gasket must be placed between the spark plug and the shielding or between the shielding and the cylinder head to prevent leaks at this point.

b. The spark plugs are located in the cylinder heads. The spark plug gaps should be held at .025 inch. The spark for ignition of the mixture is furnished by a high tension magneto fitted with an impulse coupling. The firing order of the cylinders is 1-3-4-2. Number 1 cylinder is the one nearest to the flywheel in the right bank of cylinders, when viewed from the power end of the engine. Number 3 cylinder is the other cylinder in this bank. Number 2 cylinder is the one nearest the flywheel in the left bank of cylinders and number 4 is the other cylinder in this bank. The cylinders are numbered from 1 to 4 on the air shroud near the spark plugs. The flywheel end of the engine is designated the rear end, and the power take-off end the front end of the engine. As these engines are of the V-type, the interval between firing of the cylinders is as follows: Crankshaft rotation between firing of cylinders number 1 and number 3 is 180°; between number 3 and number 4 is 270°; between number 4 and number 2 is 180°; between number 2 and number 1 is 90°.

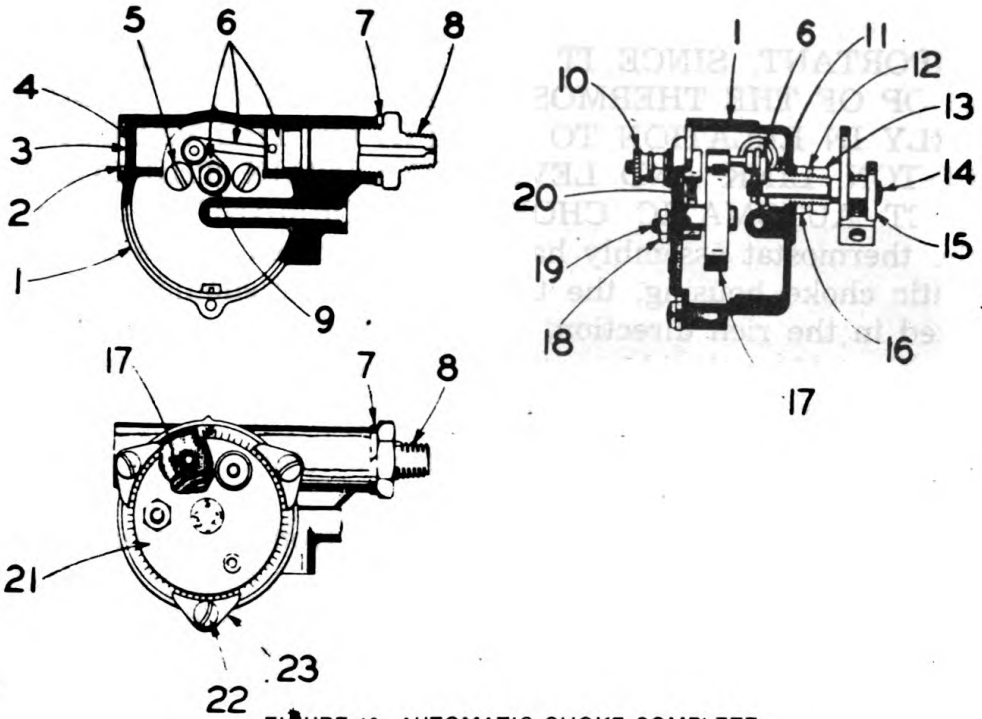

FIGURE 10—AUTOMATIC CHOKE COMPLETE

**19. Automatic choke (Figure 10)**

a. *General.* The object of the automatic choke is to close the carburetor choke on the engine when the engine is cold and needs a rich charge of gasoline, and gradually open the choke as the engine warms up and runs at higher speeds. There is a thermostat in the cover of the automatic choke which is heated by an electric heating coil which operates off the charging circuit. The current will heat the coil sufficiently so that the thermostat will open the choke after a short period of operation. In conjunction with this, there is a piston which operates off the intake manifold vacuum. This will also open the carburetor choke when the engine is accelerated. Between the thermostat spring tension and the vacuum force on the piston, the correct choking is obtained. If, for any reason, the engine choke does not function properly, the cover can be rotated by loosening the three clamp screws so that the choking can be increased or decreased.

b. *Thermostat Setting.* When replacing the thermostat unit (No. 21), the loop of thermostat spring (No. 17) must be placed over the pin of the vacuum piston, link and lever assembly (No. 6). (THIS OPERATION IS VERY

IMPORTANT, SINCE IT IS NECESSARY THAT THE LOOP OF THE THERMOSTAT BE INSTALLED PROPERLY IN RELATION TO THE PIN OF THE VACUUM PISTON, LINK AND LEVER TO OBTAIN THE CORRECT AUTOMATIC CHOKE PERFORMANCE.) After the thermostat assembly has been assembled to the automatic choke housing, the thermostat cover should be rotated in the rich direction, or counter-clockwise, until the marking (\*) coincides with the projection at the top of the thermostat housing.

c. *Servicing the Automatic Choke Unit.*

(1) Disassembly.

- (a) Disconnect the vacuum line from the automatic choke.
- (b) Remove thermostat cover screws and "lug" washers. Thermostat cover assembly can then be taken off the choke housing.
- (c) Loosen locknut and remove lockwasher.
- (d) Remove vacuum piston assembly from housing.
- (e) With a clean rag saturated with acetone or alcohol, thoroughly clean the cylinder walls, removing any foreign material which may have accumulated. Blow out all of the channels with compressed air.

(2) Reassembly.

- (a) Place vacuum piston in cylinder with slot on piston assembly down. This is very *important*. DO NOT USE ANY TYPE OF LUBRICANT ON PISTON OR IN CYLINDER. Place lever on choke stem and put on the lockwasher and locknut, fastening the nut securely.
- (b) Adjust as instructed in "Thermostat Setting" above.

## 20. Remote control unit

The remote control unit consists of a special latch type relay. The only adjustment practical in the field is the adjustment of the latch. This is accomplished by increasing or decreasing tension as necessary to hold the rocker bar in ground position and still allow coils to actuate the latch properly.

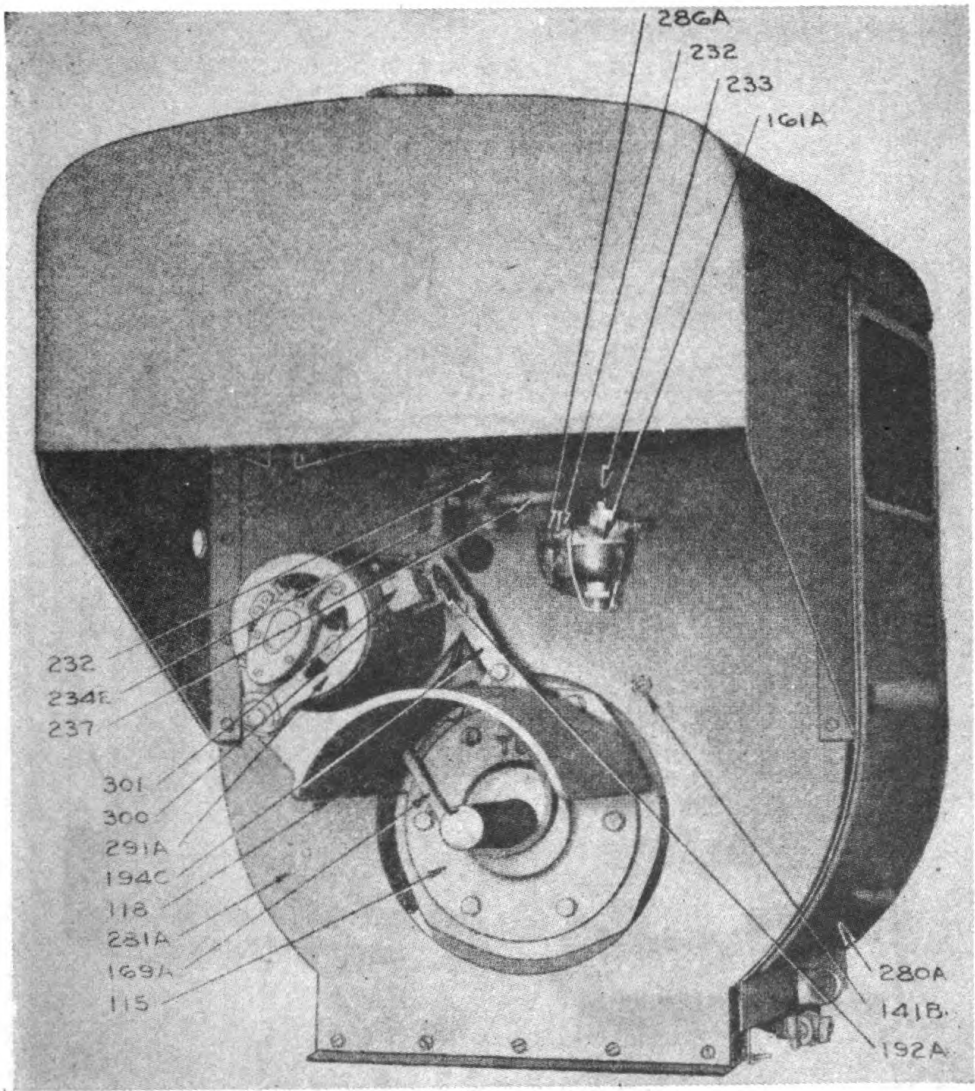

FIGURE 11—ENGINE, DRIVE SHAFT END

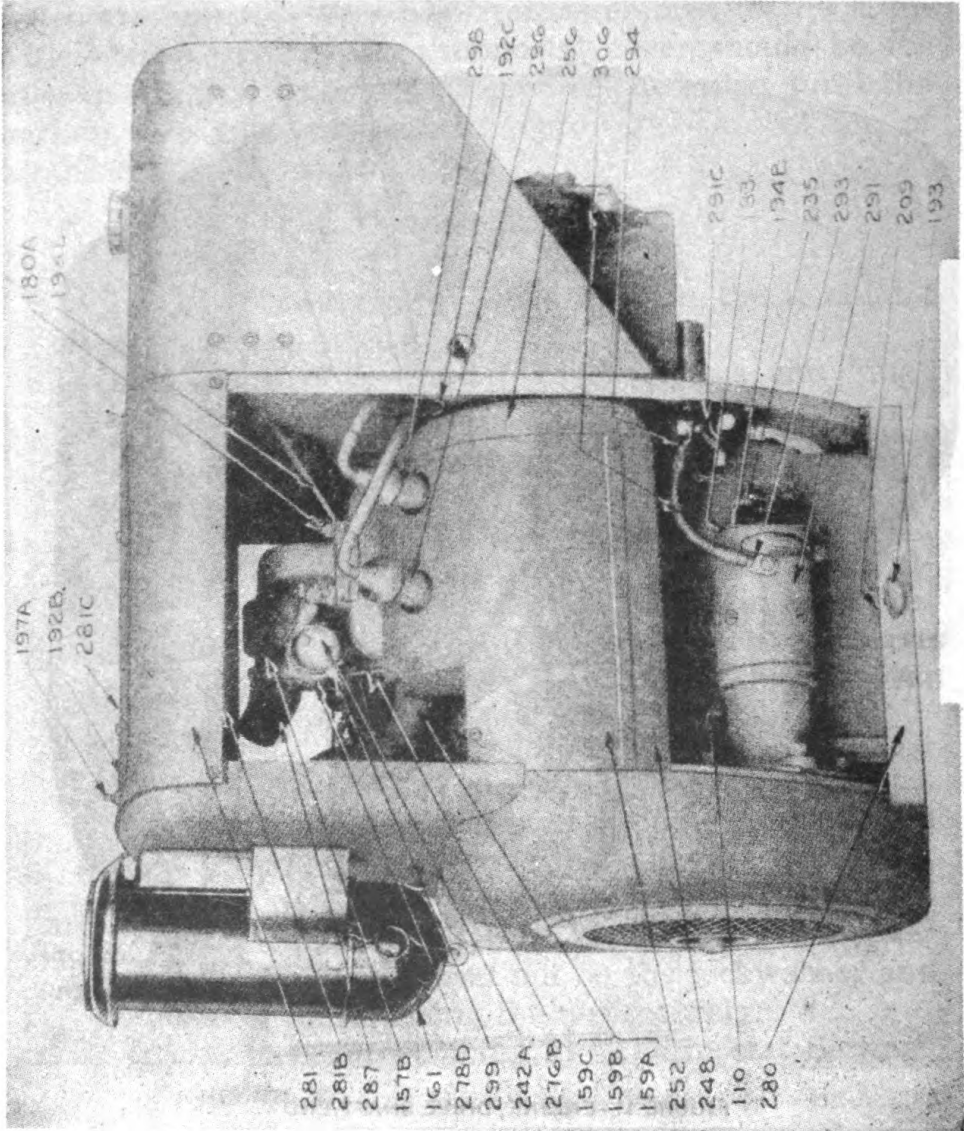

FIGURE 12—ENGINE, STARTER SIDE VIEW

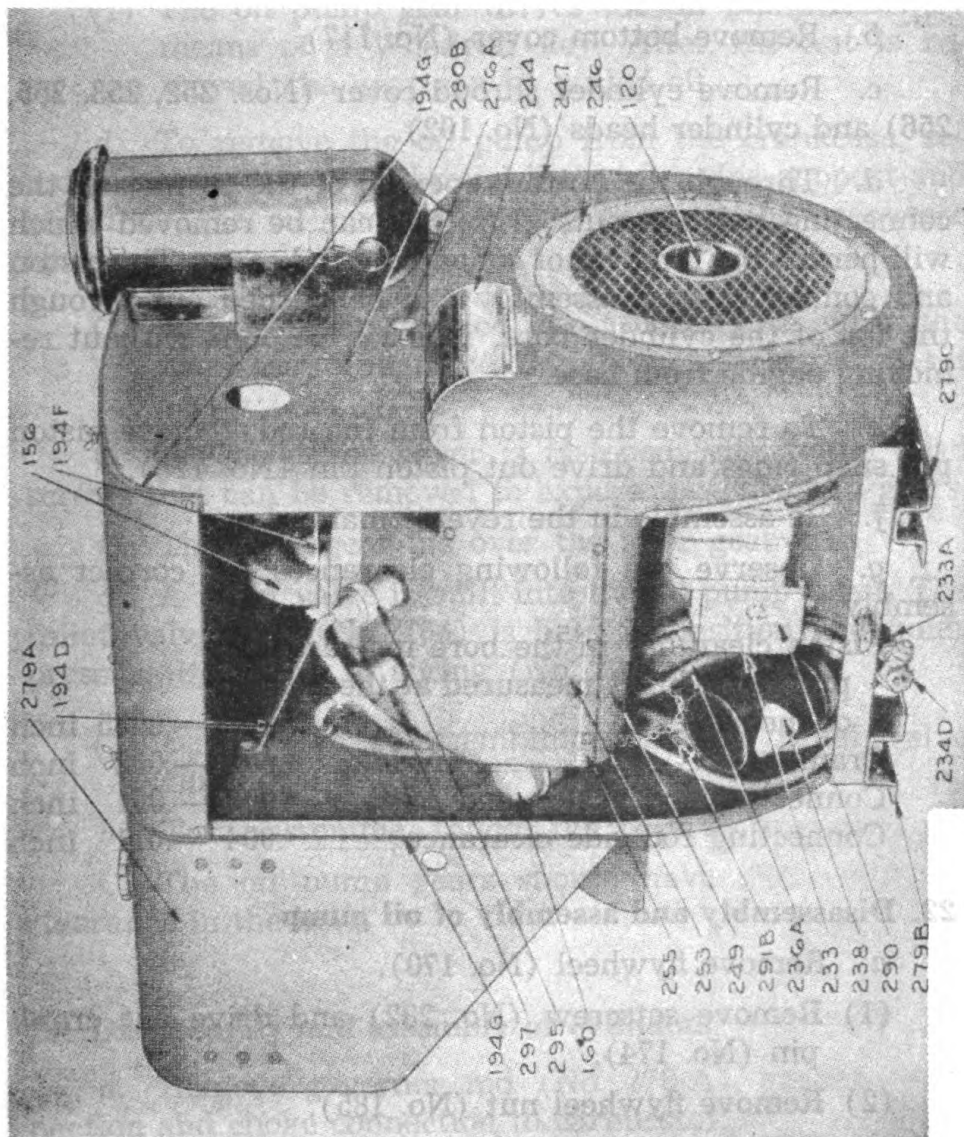

FIGURE 13—ENGINE, MAGNETO, SIDE VIEW

**21. Disassembly and assembly of connecting rod, piston, etc.**  
(Figures 14 and 14a)

a. If the engine is in a unit housing, it is desirable to remove the top and rear panels before attempting to work on the engine.

b. Remove bottom cover (No. 117).

c. Remove cylinder shroud cover (Nos. 252, 253, 255, 256) and cylinder heads (No. 102).

d. Through the bottom opening of the crankcase, the connecting rod bolt nuts (No. 186) can be removed which will permit the removal of connecting rod caps. The piston and connecting rod assembly can be pushed out through the top of the cylinder bore. This can be done without removing engine from base.

e. To remove the piston from the rod, remove piston pin snap rings and drive out piston pin (No. 128).

f. Re-assemble in the reverse manner.

g. Observe the following clearances for correct assembly:

Piston clearance in the bore for cast iron pistons (This is measured at the bottom of the skirt) .....	.003 —.0035	inch
Crank pin .....	.001 —.002	inch
Connecting rod, piston end .....	.0005—.001	inch
Connecting rod side clearance .....	.004 —.011	inch

**22. Disassembly and assembly of oil pump**

a. Remove flywheel (No. 170).

(1) Remove setscrew (No. 282) and drive out crank pin (No. 174).

(2) Remove flywheel nut (No. 185).

(3) With a babbitt hammer or brass bar, hit the crankshaft a sharp blow to loosen the flywheel which fits on a taper. An ordinary hammer may be used with a hardwood block held against the shaft to receive the blow.

b. Remove flywheel shroud (No. 247) and gear cover (No. 112).

(1) Before the gear cover is pulled off the shaft, be sure to remove flywheel key (No. 202).

c. Remove oil pump gear (No. 137) by loosening nut (No. 184) which is locked in place with a cotter pin.

(1) The oil pump gear drives the oil pump shaft by means of a Woodruff key. After the nut is removed, the gear can be pulled off.

d. To remove the oil pump from the crankcase, remove screw (No. 197) through hole in engine support and withdraw the oil pump assembly through the crankcase opening.

(1) The oil pump is fitted into a bored opening in the crankcase and is held in proper location by set screw (No. 197).

e. The oil pump cover is fastened with round head screws that can be removed to expose the oil pump gears.

f. The idler gear fits over the idler gear pin.

g. A relief valve is built into the oil pump cover. The relief valve ball (No. 164) is held in position and holds pressure by means of spring (No. 208).

(1) Be sure in re-assembling that this relief valve functions.

h. To re-assemble, follow the reverse procedure.

i. The oil pump gears should have .002—.0035 in. clearance in the bore.

### **23. Disassembly and assembly of cylinders**

a. Remove governor rod (No. 278-A), gasoline connection and choke connection to carburetor.

b. Remove nuts on studs (No. 180-A) and lift off manifold assembly (No. 156) with carburetor (No. 155).

c. Remove nuts on studs (No. 182) and remove manifolds to cylinder block (No. 157).

d. Remove cylinder hold-down stud nuts (No. 181) and remove the entire cylinder block and valve assembly.

(1) The valves (Nos. 104 and 105) can be removed by removing wedge keys (No. 108) and spring retainer (No. 107) after valve chamber cover plate (No. 242) has been removed.

e. Re-assemble in the reverse order.

f. Observe the following clearances for correct assembly:

Valve stem clearance .....	.003—.005 inch
Tappet clearance, cold .....	<i>exhaust</i> .012 inch
Tappet clearance, cold .....	<i>inlet</i> .010 inch

#### 24. Disassembly and assembly of camshaft

a. The tappets will have to be held up so they will clear the camshaft cams. The camshaft and camshaft drive gear can then be withdrawn from the gear cover end of the engine after removing the fuel pump.

(1) To remove the fuel pump, remove the two hollow-head cap screws holding the fuel pump adapter (No. 262) and fuel plunger (No. 259) in place and lift same out.

b. Re-assemble in the reverse order, being sure that the camshaft thrust pin (No. 191) and camshaft thrust pin spring (No. 207) are in place before gear cover is re-assembled.

c. The following clearances should be observed for correct assembly:

Camshaft front bearing .....	.002 —.0035 inch
Camshaft rear bearing .....	.002 —.0035 inch
Valve tappet clearance in crankcase	.0005—.0025 inch

#### 25. Disassembly and assembly of governor

a. Remove oil line to governor (No. 236-A) and disconnect governor rod (No. 278-A) and governor spring (No. 206).

b. Remove governor housing cap screws to withdraw housing and cross-shaft assembly.

c. The governor gear and assembly (No. 138 and No. 264) can be withdrawn after the housing is removed.

d. The governor thrust bearing and thrust sleeve (No. 269) is an assembly and, if replacement is required, it is to be handled as such.

(1) Do not attempt to assemble parts in the field as this is very important for proper governor regulation.

e. To re-assemble, follow reverse procedure. Be sure that spring is connected exactly as before dis-assembly.

## 26. Disassembly and assembly of crankshaft

a. Bearing plate (No. 115) must be removed and, with flywheel and gear cover off and connecting rod disassembled, the entire crankshaft can be withdrawn through the bearing plate opening on the take-off end of the engine.

b. The roller bearing inner race is pressed on the crankshaft and the outer race into the bearing plate on the take-off end.

(1) The outer race of the bearing on the cranking end is pressed directly into the crankcase and held in place by retainer ring (No. 114).

c. If necessity requires replacement of bearings, the complete bearing should be changed and not only the inner or outer race.

d. To re-assemble, follow reverse procedure.

e. The crankshaft bearing should be fitted so the bearings have an end play of approximately .006 inch.

(1) The amount of end clearance is governed by shims (No. 226 and No. 227).

(2) By driving the crankshaft from one side to another, the end play can be easily felt.

## 27. Cylinder firing sequence

Firing Order: 1—3—4—2.

Interval of Firing:

No. 1 to No. 3 cylinder—180°.

No. 3 to No. 4 cylinder—270°.

No. 4 to No. 2 cylinder—180°.

No. 2 to No. 1 cylinder— 90°.

## 28. Low voltage generator

This is a shunt wound type using a current and voltage limiting regulator to control its output, depending on the load requirements of the battery circuit. If the commutator is dirty or discolored, it can be cleaned by holding a piece of No. 00 sandpaper against it while running the armature slowly. **Do not use emery.** If the commutator is rough or worn, the generator should be removed and the commutator turned down. This work should be attempted only by authorized personnel. The brushes should slide freely in their holders and if worn to less than half the original length, they should be replaced. The spring tension on the brushes should be 53 oz. maximum. Add 5 to 10 drops of medium engine oil to the oilers about every 200 hours of operation. The generator belt tension should be adjusted so that the belt can be deflected approximately  $\frac{1}{2}$  inch by pressing against the loose side of the belt.

## 29. Low voltage regulator

The regulator used with the shunt generator has three units: First, the circuit breaker to close and open the circuit between the generator and battery; second, the voltage regulator to hold the system voltage at a predetermined value; and third, the current-limiting regulator to control the maximum output of the generator. Since the regulator is a very sensitive mechanism and requires special tools and meters to obtain the proper adjustments, these adjustments should not be attempted in the field, but should be done in a shop where the equipment is available. For field servicing, it is recommended to change the regulator with a complete new service element when such service is required.

## 30. Starting motor

The starting motor is designed to crank the engine when the starting switch closes the circuit between the storage battery and the motor. The starting motor uses a Bendix drive which consists of a threaded sleeve, fastened to the armature shaft through a drive spring, and a pinion, mounted on the threads of the sleeve. The pinion transmits the power to the flywheel of the engine.

When the starting circuit is closed, the armature revolves, turning the sleeve within the pinion and forcing the pinion forward until it meshes with the flywheel gear. The sudden shock of meshing is absorbed by the spring. When the engine starts, the pinion is driven faster than the sleeve and hence is forced back along the sleeve threads, automatically disengaging from the flywheel. Major repairs should only be made by authorized personnel.

### 31. Engine trouble chart

#### a. Engine difficult to start:

- (1) No gasoline in tank.
- (2) Gasoline flow obstructed.
- (3) Loose or defective wiring.
- (4) Spark plug cracked.
- (5) Spark plug fouled.
- (6) Improper gas mixture.
- (7) Throttle rod loose.
- (8) Throttle valve stuck or out of adjustment.
- (9) Valve seats bad.
- (10) Valves sticking.
- (11) Timing improper.
- (12) Defective magneto.
  - (a) Breaker points worn or pitted.
  - (b) Breaker points out of adjustment.
  - (c) Breaker cam out of time.
  - (d) Switch wire shorted.
  - (e) High tension wire shorted.
- (13) Faulty fuel pump.
- (14) Choke not operating.

#### b. Engine missing:

- (1) Spark plug fouled.
- (2) Spark plug cracked.
- (3) Spark plug gap wrong.
- (4) Breaker points out of adjustment.
- (5) Breaker points worn or pitted.
- (6) Defective wiring.
- (7) Ignition breaker points sticking.
- (8) Valves warped, broken, or sticking.

## c. Engine overheating:

- (1) Carburetor choke valve partly closed.
- (2) Improper gas mixture.
- (3) Piston rings sticking.
- (4) Improper timing.
- (5) Muffler clogged.
- (6) Faulty lubrication.
- (7) Fan obstructed.
- (8) Dirty cooling flanges.
- (9) Obstruction in gasoline passages.
- (10) Governor or throttle loose.
- (11) Air cleaner requires cleaning.
- (12) Generator overloaded.

## d. Engine knocks:

- (1) Carbon in cylinder.
- (2) Loose main bearings.
- (3) Loose rod bearings.
- (4) Worn piston or cylinder.
- (5) Motor overheated.
- (6) Tight pistons.
- (7) Loose flywheel.
- (8) Lack of oil.
- (9) Incorrect timing of ignition.

## e. Faulty carburetion:

- (1) Carburetor improperly adjusted.
- (2) Float valve leaking.
- (3) Shut-off valve closed or obstructed.
- (4) Gasoline strainer clogged.
- (5) Sediment in fuel tank.
- (6) Choke not operating properly.
- (7) Faulty fuel pump.
- (8) Air leaks at manifold.

## f. Excessive smoke from exhaust:

- (1) Carburetor needle valve open too far.
- (2) Carburetor float sticking or leaking.
- (3) Worn piston, piston rings, or cylinder.
- (4) Using too light oil.
- (5) Oil level too high.

*g.* Explosion in carburetor:

- (1) Gas mixture too lean.
- (2) Intake valve sticking.
- (3) Intake tappets sticking.
- (4) Intake valve spring weak.
- (5) Intake valve warped or broken.
- (6) Intake tappets set too close.
- (7) Improper timing.
- (8) Air leaks at manifold.

*h.* Poor compression:

- (1) Valves not seating.
- (2) Valves sticking.
- (3) Piston rings worn or weak.
- (4) Piston rings broken.
- (5) Piston rings sticking.
- (6) Loose spark plug.
- (7) Cylinder head loose.
- (8) Scored cylinder.
- (9) Worn piston or cylinder.
- (10) Using too light oil.
- (11) Defective oil pump.
- (12) Low oil supply.

## 32. Alternator

*a.* The alternator is of the revolving armature type, **WITH FULL LINE VOLTAGE ON COLLECTOR RINGS AND ALTERNATOR BRUSHES.** The exciter is separate but direct connected to and mounted on the alternator shaft. **Never touch or work on alternator brushes or holders when unit is in operation.** Since full voltage and current are passed through the alternator brushes, it is very important that the brushes are in good condition and seat properly on the collector rings with approximately two pounds pressure. Make sure they are free in brush holders and brush shunts are securely connected to terminals on ends of brush holders. To insure good contact, collector rings must be concentric with shaft, must be clean and free of uneven wear, grooves, nicks or any roughness. Rough or dirty collector rings will prevent efficient passage of current and cause undue wear on both rings and brushes. To maintain the collector rings, they should be kept clean at all times. At intervals, they

may be touched up lightly with fine sandpaper, *BUT ONLY WHEN THE ALTERNATOR IS BEING CRANKED*. If necessary, the entire rotor assembly may be placed between centers in a lathe, and the rings machined and polished. **This operation should not be attempted in the field, and only by authorized personnel.**

b. The direct connected exciter, which supplies direct current to the alternator field coils, has an armature with commutator and brushes similar to alternator rings and brushes. The same care must be taken of the exciter armature, commutator, and brushes as with the alternator. The exciter commutator can be machined and trued when alternator rings are machined. The exciter commutator is made of copper bars which have mica insulation between them. After the commutator has been machined, the mica must be undercut to a depth equal to its width. This must be carefully done with commutator undercutting saw, or special commutator file. In an emergency, a hacksaw blade with the teeth ground to the width of the mica is a satisfactory tool.

c. The alternator is equipped with two ball bearings, which are packed at the factory with sufficient grease to last for a limited period of operation. The bearing housings should be about one-half full of a good quality neutral ball bearing grease and such grease should be added when necessary to bring the quantity up to this point about once every 200 hours. This is done by filling compression type grease cups (filling twice should be sufficient each time). The old grease should be entirely removed and replaced with fresh grease once every 500 hours, using extreme care not to allow any dirt or grit to enter the bearing housing.

d. Removing Alternator Armature:

- (1) Remove  $\frac{1}{2}$  inch cap screw in pulley end of shaft, which will permit removal of V-belt pulley and spacing collar which secures ball bearing to shaft.
- (2) Remove three cap screws close to the bearing housing that holds bearing cap which eliminates end or lateral play in shaft.
- (3) Drive-end bearing bracket is held in place by six socket head cap screws, two of which can be used to help remove the bracket by placing them in drilled and tapped holes in sides of bracket.

- (4) Remove fan blade from hub.
- (5) Remove six 5/16 inch socket-head cap screws in exciter-end bearing bracket which permits removal of alternator rotor and exciter assembly. Alternator brushes can be checked or removed by removing rotor and exciter assembly enough for accessibility.
- (6) Remove the exciter brush holder after, first disconnecting the exciter leads. Then remove the 3/4 inch SAE nut and centering collar from end of shaft, which will permit exciter armature to be slipped off shaft.
- (7) Remove two 1/4 inch cap screws close to bearing housing that holds bearing cap, on which are mounted alternator brush holders.

e. The revolving armature type of alternator permits emergency field repairs without the need of an experienced armature winder, since main 3-phase alternator winding is on replaceable armature, and field coils can easily be replaced. Exciter armature and field coils can likewise be replaced.

f. Always keep the unit as clean and dry as possible. Maintain the proper brush tension on both the alternator rings and the exciter commutator. Keep clean grease in the bearing housings, but never have them more than one-half full. Be sure 1/2 inch cap screw in drive end and 3/4 inch nut on exciter end are tight. The 1/2 inch cap screw holds the V-pulley on the shaft and locks the ball bearing on the shaft, thus eliminating end play. The 3/4 inch nut holds exciter armature on shaft and locks rear-end ball bearing on shaft.

g. Generator trouble—unit runs, but no current available:

- (1) Short or open circuit in line outside of unit.
- (2) Dirty commutator.
- (3) Brushes sticking in holders.
- (4) Brushes worn and failing to contact.
- (5) Brush spring weak or broken, or tension not set up sufficiently.
- (6) Field wire to resistance unit broken.
- (7) Open circuit in field coil.

- (8) Winding of armature open or shorted.
- (9) Wires disconnected at control box.
- (10) High mica on commutator.
- (11) Circuit breakers in "OFF" position.
- (12) Generator not coming up to speed due to low engine speed.
- (13) Burned out rheostat.

### 33. Alternator voltage regulator

a. The regulator requires very little attention. The regulator must be out of service during any maintenance. The apparatus should be kept free from dust, dirt and moisture. Do not oil, or otherwise lubricate any part of the regulator.

b. The contact roller presses on the silver commutator with a pressure of 100 grams. This value is carefully set at the factory and should require no further adjustment. Do not lift the contact roller from the commutator, as the contact pressure spring may be overstressed, thereby reducing the contact pressure. Never touch the contact roller while the regulator is operating as arcing will occur at the point of contact, causing the commutator surface to become pitted and rough. If through any accident the commutator should become roughened, polish the surface lightly with jeweler's rouge cloth or crocus cloth. After polishing, be sure to remove all traces of rouge from the surface of the commutator. After the regulator has been operating a short time, a fine black line will appear along the point of contact on the commutator. This is a normal condition.

c. The regulator is set at the factory to have the proper sensitivity for the average generator. If greater sensitivity is required, the regulator can be made more sensitive by adjusting the regulator solenoid as follows: With the regulator in operation, carefully loosen the locknut No. 10 and turn the adjustable magnetic core No. 9 in about  $\frac{1}{4}$  turn. This will cause the generator voltage to be reduced. Restore the voltage to the normal value by increasing the tension on spring No. 3. Care should be taken to adjust the voltage to near its previous value, so that the regulator solenoid-coil current will be held constant.

d. The coil current should be within the limits of 0.35 to 0.4 amperes. If still greater sensitivity is required, repeat the above procedure until the desired result is obtained. When attempting to increase regulator sensitivity, be careful not to increase the sensitivity to a point where instability or hunting is established. The tendency toward instability is usually greatest when the generator is operated at no load. An unstable regulator may be made more stable by reducing the sensitivity of the regulator. This is done by reversing the procedure used to increase sensitivity.

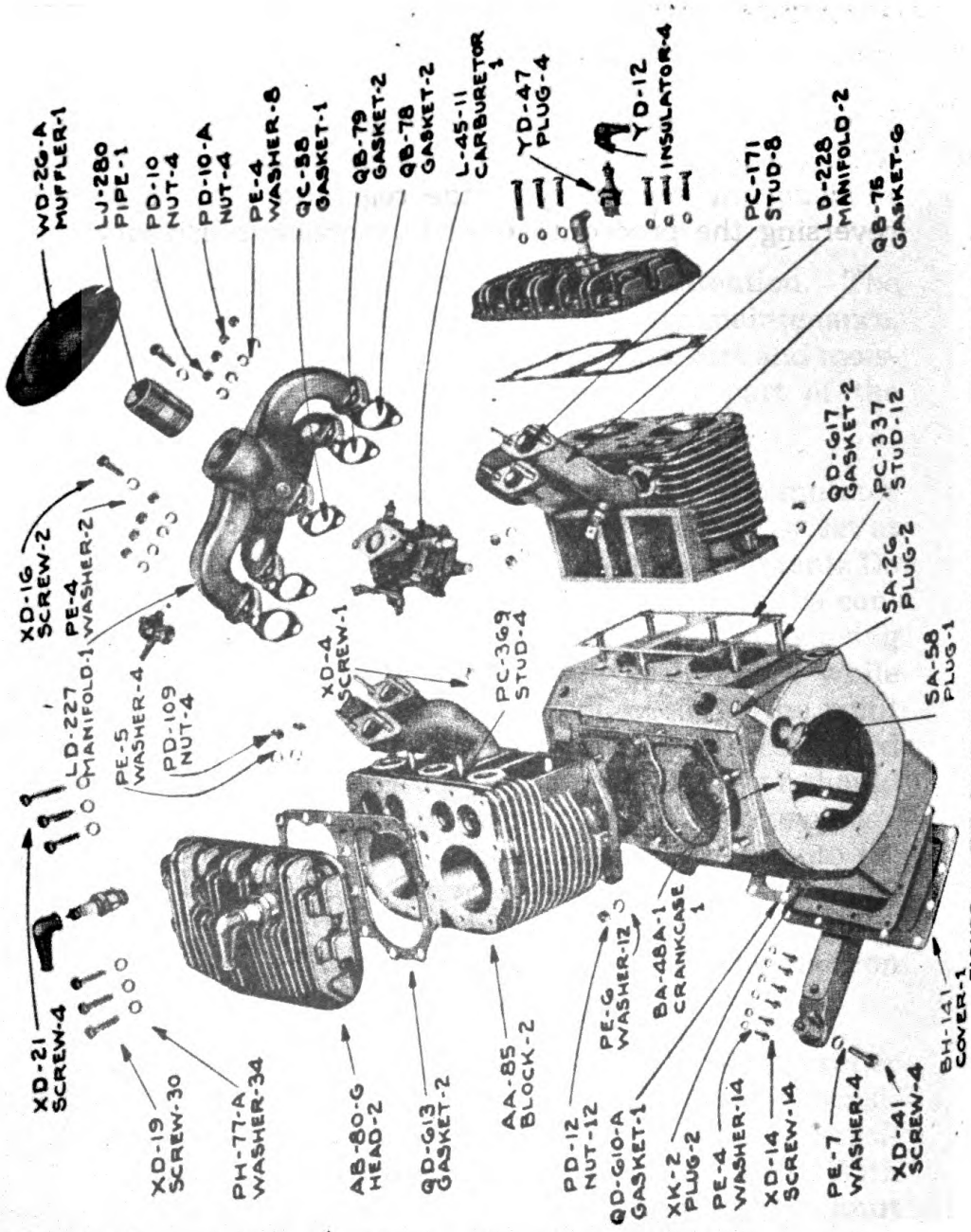

FIGURE 14—EXPLODED VIEW OF ENGINE FOR POWER UNIT PE-99-E

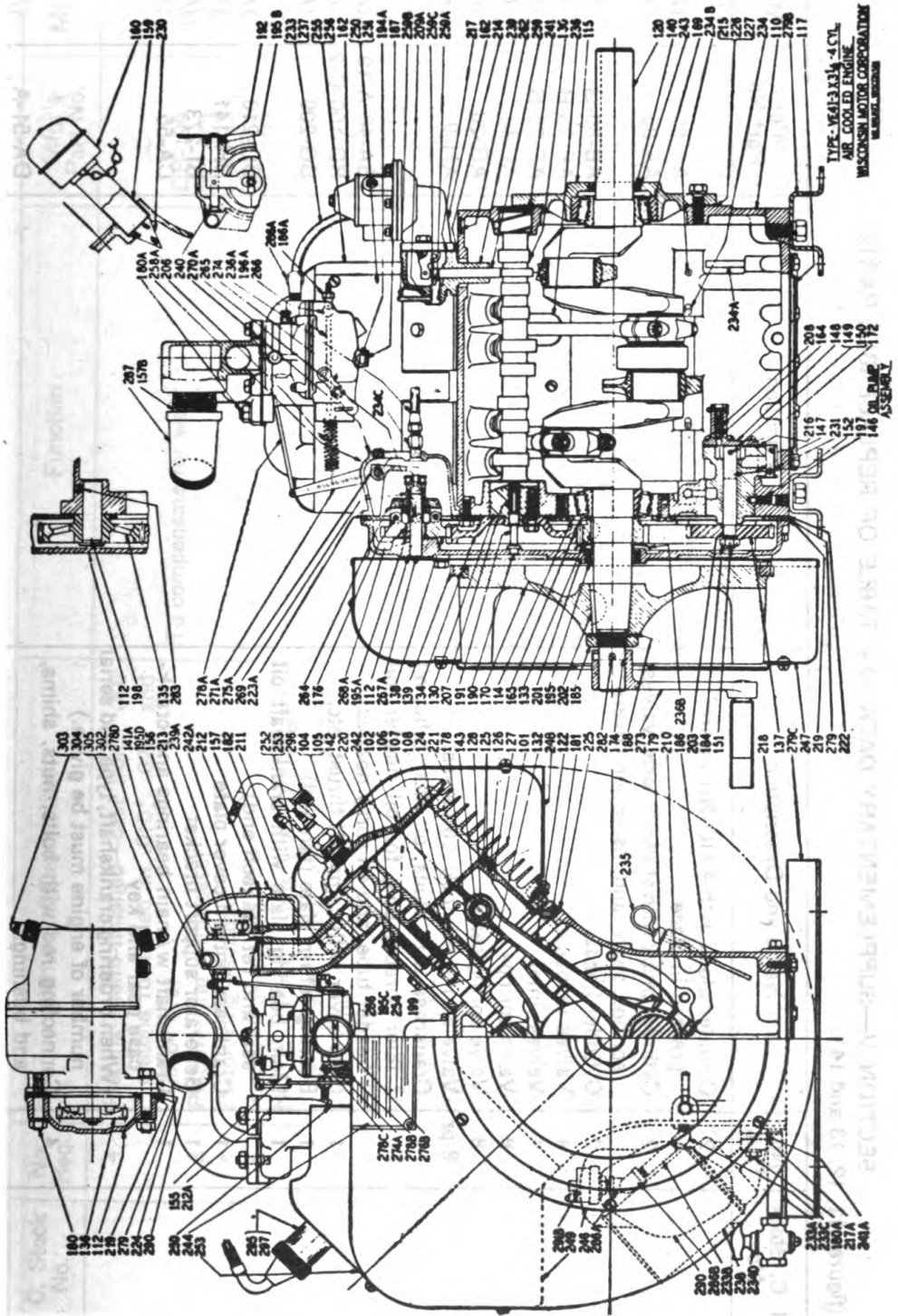

FIGURE 14A—POWER UNIT PE-99-E ENGINE CROSS SECTION

SECTION V—SUPPLEMENTARY DATA—34. TABLE OF REPLACEABLE PARTS.  
 a. Engine (figures 11, 12, 13 and 14).

Ref. No.	S. C. Stock No.	No. Req.	Name and Description	Function	Mfg'r's Part No.	Mfr.
101		2	Cylinder block with 4 HG-201 inserts pressed in place		AA-85	(A)
101		2	Cylinder block with studs, inserts, valves, springs, seats, and inspection covers		AA-85	(A)
102		2	Cylinder heads		AB-80-G	(A)
104		4	Valves (exhaust)		AE-75-B	(A)
105		4	Valves (inlet)		AE-75-B	(A)
106		8	Valve springs		AF-46	(A)
107		8	Valve spring seats		AG-26	(A)
108		8 pr.	Valve spring ret. lock (16 halves)		AH-9	(A)
110		1	Crankcase with studs, oil filler tube, oil filler screen, plug for oil header, oil header tube, and oil spray nozzles		BA-48-A-19	(A)
112		1	Gear cover with camshaft thrust, etc.		BD-100-C-2	(A)
114		1	Bearing return plate (fan end)		BG-209	(A)
115		1	Main bearing plate with crankshaft oil seal and ret. (takeoff end)		BG-210	(A)
117		1	Crankcase bottom cover plate		BH-141	(A)
118		1	Generator support bracket		BI-273	(A)
120		1	Crankshaft w/main bearings and crankcase gear and key (When ordering crankshaft, type and serial number of engine must be given.)		CA-55	(A)
122		4	Connecting rod with bolts, nuts, shims, and bushings		DA-51-A	(A)
124		4	Pistons—standard—cast iron		DB-199	(A)

Ref. No.	S. C. Stock No.	No. Req.	Name and Description	Function	Mfgr's Part No.	Mfr.
124		4	Pistons—semi-finished—cast iron. (All pistons furnished in .010", .020" and .030" O/s)	To compensate for wear	DB-199	(A)
125		8	Piston—ring compressor		DC-163	(A)
126		4	Piston ring—scraper		DC-163-1	(A)
127		4	Piston ring—oil reg.		DC-109	(A)
128		4	NOTE: Piston rings also furnished in .005", .910", .020" and .030" oversize.			
130		1	Piston pins		DE-65	(A)
132		8	Camshaft		EA-102	(A)
133		1	Valve tapper		FA-40-B	(A)
134		1	Crankshaft gear		GA-36-A	(A)
135		1	Camshaft gear		GB-45-A	(A)
136		1	Idle gear		GC-27-B-1	(A)
137		1	Magneto gear	Driver for magneto	GD-93-C	(A)
138		1	Oil pump gear	Driver for oil pump	GD-94-A	(A)
139		1	Governor gear	Driver for governor	GD-100-A	(A)
140		1	Flywheel gear	To transit starting power from starter to engine	GH-AA	(A)
141a		1	Oil seal cork for crankshaft—T. O. end		HF-261	(A)
141b		1	Spacer for gov. control rod—carb. end			
142		8	Spacer for supp. rear panel to end		HF-381	(A)
143		4	Valve seat insert		HF-380	(A)
146		1	Piston pin bushing		HG-201-B	(A)
147		1	Oil pump assembly		HG-157-A-S	(A)
		1	Oil pump body	To circulate oil and maintain pressure	K-95-A	(A)
					KA-61-A	(A)

Ref. No.	S. C. Stock No.	No. Req.	Name and Description	Function	Mfg.'s Part No.	Mfr.
148		1	Oil Pump cover		KB-39	(A)
149		1	Oil pump gear—driver		KC-54-1	(A)
150		1	Oil pump gear—driven		KC-55-1	(A)
151		1	Oil pump drive shaft		KD-121	(A)
152		1	Oil pump stub shaft		KD-122	(A)
155		1	Carburetor	Provides proper mixture of air and fuel for engine	L-45-24	(A)
156		1	Manifold—upper branch	Conducts exhaust gases (exhaust manifold)	LD-227C-1	(A)
157		2	Manifold—lower branch	Conducts fuel gases from carburetor to engine (intake manifold)	LD-228	(A)
157b		1	Nipple for exhaust		LJ-166	(A)
159		1	Oil filler tube in crankcase		LJ-300-A	(A)
159a		1	2 1/8 I.D. hose clamp for air filter connection	For filling engine with lubricating oil	LK-8	(A)
159b		1	1 1/8 I.D. hose clamp for air filter connection		LK-11	(A)
159c		1	Rubber elbow for air filter connection	To connect air filter to carburetor	LL-64	(A)
160		1	Oil filler and cap		LO-60-1	(A)
161		1	United oil bath air filter	To clean air used by engine	LO-66	(A)
161a		1	Fuel strainer	To prevent dirt, etc., from entering carburetor	LP-19	(A)
162		1	Fuel pump	To transfer fuel from fuel tank to carburetor	LP-38-1	(A)
164		1	Steel ball for oil pump relief valve		ME-60	(A)
165		1	Main brg. assembly—fan end		ME-71	(A)
169		1	Main brg. assembly—T.O. end		ME-114	(A)

Ref. No.	S. C. Stock No.	No. Req.	Name and Description	Function	Mfg'r's Part No.	Mfr.
169a		1	Gen. drive belt	Drives battery-charging generator	MH-133	(A)
170		1	Flywheel		NC-140-1	(A)
174		1	Pin for starting crank assembly		PA-239	(A)
172		1	Pin for oil pump gear—driven		PA-64	(A)
176		2	Gov. weight fulcrum pin		PA-265	(A)
177		2	Dowel pin for gear cov. to case		PA-291	(A)
178		8	Valve tapper adj. screw		PB-147	(A)
180		1	Stud for mag. upper mtg. hole		PC-110	(A)
180a		10	8 studs for mtg. lower to upper manifold 2 studs for mtg. oil filter		PC-171	(A)
179		8	Bolt for conn. rod		PB-148	(A)
181		12	Stud for mtg. block to crankcase		PC-337	(A)
182		2	Stud for mtg. block to crankcase		PC-369	(A)
183		2	Stud for mtg. starter bracket		PC-396	(A)
184		1	Special nut for mounting oil pump gear		PD-100-1	(A)
185		1	Special nut for crankshaft		PD-123	(A)
186		8	Conn. rod bolt nut		PD-148	(A)
186a		1	Special nut for gov. adj. screw		PD-173a	(A)
187		1	Everlock washer for carb. air horn drain hole		PE-44	(A)
188		1	Lockwasher for flywheel	PE-66	(A)	
190		1	Camshaft thrust plunger button—in gear cover	PF-52	(A)	
191		1	Camshaft and thrust plunger	PF-101	(A)	
192		1	Cup for gov. cross shaft seal	PF-118	(A)	
192a		2	Cap for gen. terminal housing	PF-121	(A)	
192b		4	Straps for holding insp. cover to canopy	PG-128	(A)	

Ref. No.	S. C. Stock No.	No. Req.	Name and Description	Function	Mfg'r's Part No.	Mfr.
192c		2	Clips for holding ignition cables		PG-206	(A)
193		2	Clips for doors		PG-323	(A)
194a		1	Felt washer for carb. air horn drain hole	To support starter	PH-267-1	(A)
194b		1	Starter support bracket	Provides belt adjustment	PG-331	(A)
194c		1	Generator adjusting strap		PG-391	(A)
194d		1	House brace—L. H. Rear		PG-394	(A)
194e		1	House brace—R. H. Rear		PG-395	(A)
194f		1	House brace to front panel		PG-421	(A)
194g		6	Felts for canopy and fuel tank support		PH-244a	(A)
195		1	Oil seal for crankshaft—Fan end		PH-299	(A)
195a		1	Gov. dr. gear bush, washer	To hold lever in operating position	PH-313-a	(A)
195b		1	Oil seal for gov. cross shaft		PH-318-a	(A)
195c		1	Weight on carb. for choke lever		PH-216	(A)
195d		2	Special washers for automatic choke		PH-323	(A)
196a		1	Adjusting screw for gov.		PI-115-f	(A)
197		1	Lockscrew for oil pump		PI-143-a	(A)
197a		4	Wing nuts for insp. cover to canopy		PI-148	(A)
198		1	Stud for idler gear		PJ-105	(A)
199		8	Ret. ring for piston pin		PK-52	(A)
201		1	Woodruff key for crankshaft gear		PL-53	(A)
202		1	Woodruff key for flywheel		PL-33	(A)
203		1	Woodruff key for oil pump gear		P-137	(A)
206		1	Governor spring		PM-76	(A)
207		1	Camshaft thrust plunger spring		PM-108	(A)
208		1	Relief valve spring for oil pump		PM-111	(A)
209		2	Spring for door clip		PM-137	(A)
209a		1	Spring for fuel pump primer handle		PM-145	(A)

Ref. No.	S. C. Stock No.	No. Req.	Name and Description	Function	Mfg'r's Part No.	Mfr.
210		8	Conn. rod shim		PM-145	(A)
211		6	Gasket for inlet and ex. man. port		QB-75	(A)
212		2	Gasket for inlet man. upper to lower branch		QB-78	(A)
212a		2	Gasket for man. upper to lower branch		QB-79	(A)
213		1	Gasket for mounting carb.		QC-58	(A)
214		1	Gasket for fuel pump adaptor		QD-67	(A)
215		2	Gasket for main bearing plate—T. O. end		QD-527a	(A)
216		1	Gasket for oil pump cover		QD-535	(A)
217		1	Gasket for mounting fuel pump		QD-538-a	(A)
217a		2	Gasket for oil filter		QD-595-a	(A)
218		1	Gasket for crankcase bottom cover plate		QD-610-a	(A)
219		1	Gasket for gear cover		QD-111	(A)
220		4	Gasket for valve inspection cover		QD-612-a	(A)
221		2	Gasket for cylinder head		QD-613-B	(A)
222		1	Gasket for gear cover spacer		QD-614	(A)
223a		1	Gasket for governor housing		QD-615-A	(A)
224		1	Gasket for magneto		QD-616	(A)
225		2	Gasket for cylinder base		QD-617	(A)
226		2	Shim for main brg. plate—T. O. end—.006" thick	Provides proper clearance of bearing	QF-33	(A)
227		2	Shim for main brg. plate—T. O. end—.003" thick	Provides proper clearance of bearing	QF-33-a	(A)
230		1	Oil filler screen	Prevents foreign matter from entering crankcase	RC-91	(A)
231		1	Oil pump screen	Strains crankcase oil before entering pump	RD-119	(A)

Ref. No.	S. C. Stock No.	No. Req.	Name and Description	Function	Mfg.'s Part No.	Mfr.
232		2	1/8" pipe nipple 1—in street ell at pump inlet 1—in fuel tank		RF-794	(A)
233a		1	Nipple for oil drain		RF-1139	(A)
233b		1	Nipple for oil pressure gauge		RF-902	(A)
233c		1	45" street ell in case for oil pressure gauge		RF-1096	(A)
234		2	Long nozzle		RF-1121	(A)
234a		1	Stand pipe for oil filter drain hole		RF-1128	(A)
234b		2	Short nozzle		RF-1143	(A)
234c		1	Oil line fitting in gov. housing		RF-1165	(A)
234d		1	Oil drain cock		RG-28a	(A)
234e		1	3-way cock for fuel line	For draining crankcase oil To switch fuel supply from engine tank to emergency supply		
235		1	Oil level gauge with PH-245 cork	For checking amount of oil in crankcase	RG-36	(A)
236		2	Crankcase splash plate		RJ-143	(A)
236a		1	Oil line case to gov.		RK-167	(A)
236b		1	Crankshaft oil sling		RM-1049e	(A)
237		2	Fuel line pump to carb. filter to pump		PK-170	(A)
238		1	Oil filter		RM-1049a	(A)
239		2	Welch plug in crankcase for camshaft bearing oil holes	For filtering oil in engine	RV-27-a	(A)
239a		1	Cover for automatic choke shielding		SA-26	(A)
240		1	Welch plug in gov. housing		SA-28	(A)
241		1	Welch plug for camshaft end hole		SA-52	(A)
241a		1	Spacer for oil filter		SA-58	(A)
242a		1	Cup for automatic choke shielding		SA-65a-2	(A)
242		4	Valve insp. cover plate		SA-73	(A)
					SA-68	(A)

Ref. No.	S. C. Stock No.	No. Req.	Name and Description	Function	Mfg'r's Part No.	Mfr.
243		1	Oil seat ret. for crankshaft—T. O. end	Provides proper cooling air circulation	SD-43	(A)
244		1	Name and instruction plate		SD-115-C	(A)
246		1	Flywheel screen		SE-20-G-3	(A)
247		1	Flywheel shroud		SE-74-E	(A)
248		1	Lower cyl. shroud—R.H. side		SE-75-B	(A)
249		1	Lower cyl. shroud—L.H. side		SE-76-b-1	(A)
250		1	Cyl. head deflector—L.H. side		SE-77-A	(A)
251		1	Cyl. head deflector—R.H. side		SE-77-B	(A)
252		1	Cyl. head shroud—R.H. side		SE-78-A	(A)
253		1	Cyl. head shroud—L.H. side		SE-79-A	(A)
254		1	Side cover for air shroud		SE-80	(A)
255		1	Rear shroud cover—L.H. side		SE-82-B	(A)
256		1	Rear shroud cover—R.H. side		SE-83-B	(A)
258a		1	Governor assembly		T-89-2	(A)
259		1	Fuel pump plunger		TA-111-1	(A)
259a		1	Fuel pump primer shaft		TA-114	(A)
259b		1	Handle for fuel pump primer		TA-115	(A)
259c		1	Fuel pump plunger cap		TA-116	(A)
262		1	Fuel pump adaptor		TB-105-B	(A)
264		2	Gov. flyweight		TC-322-A	(A)
265		2	Gov. flyweight thrust pin		TC-328	(A)
266		1	Pin for gov. adj. screw		TC-367	(A)A
267a		1	Gov. drive shaft		TC-388-1	(A)
268a		1	Gov. drive gear bushing		TC-389-1	(A)
269		1	Gov. thrust sleeve and bearing assembly		TC-391	(A)
270a		1	Gov. housing		TC-395	(A)
271a		1	Gov. cross shaft and lever assembly	TC-398	(A)	

Ref. No.	S. C. Stock No.	No. Req.	Name and Description	Function	Mfgr's Part No.	Mfr.
273		1	Starting crank assembly	For manually starting engine Control fuel mixture while cranking Control fuel mixture while hand-cranking	U-212	(A)
274		1	Choke lever		VB-147	(A)
274a		1	Manual lever for automatic choke		VB-158	(A)
275a		1	Governor yoke	Automatically chokes engine when cranking with starter	VB-151	(A)
276a		1	Carb. choke control		VE-435-1	(A)
276b		1	Automatic choke control rod		VE-446	(A)
278a		1	Governor control rod		VE-464	(A)
278b		1	Wire connector on choke lever		VE-509	(A)
278c		1	Spacer for choke lever		VE-510	(A)
278d		1	12-volt automatic choke		VE-511A	(A)
279		1	Spacer between crankcase and gear cover		WE-182-a	(A)
279a		1	Fuel tank with supports	Provides operating fuel supply	WE-192D-3	(A)
279b		1	Fuel tank cap		RC-92	(A)
279c		1	Engine support—rear	WE-193-A	(A)	
280		2	Engine support—front	WE-194-A	(A)	
280a		2	Side rails	WE-195	(A)	
280b		1	Side panels removable	WE-196	(A)	
281a		1	Front panel	WE-197-16	(A)	
281		1	Rear panel	WE-199A-10	(A)	
281b		1	Canopy	WE-198A-4	(A)	
281c		1	Partition plate	WE-218A	(A)	
282		1	Inspection cover for canopy	WE-227-A	(A)	
283		1	Headless set screw for starting pin	XE-17	(A)	
		1	Set screw for mounting idler stud in case	XE-55	(A)	

Ref. No.	S. C. Stock No.	No. Req.	Name and Description	Function	Mfgr's Part No.	Mfr.
286a		3	1/8" street ell 1—for fuel pump inlet 1—in carburetor 1—for oil pressure gauge		XK-38	(A)
286		1	Rivet for choke weight		XJ-34	(A)
286b		1	Elbow for oil pressure gauge		XK-44	(A)
287		1	Street ell for exhaust muffler		XK-94	(A)
290		1	Fairbanks-Morse mag. w/gear and bushing			
291		1	Autolite 12-volt starter	Provides spark for ignition	Y-41-B	(A)
291a		1	Autolite 12-volt generator	For normally cranking engine	YA-7	(A)
291b		1	Oil pressure switch	Maintains battery charge	YB-19A	(A)
291c		1	Solenoid starting switch	Prevents damage in event of too low oil pressure	YC-11A	(A)
293		1	Terminal for starter	Transmits battery current to starter	YC-20	(A)
294		1	Terminal for solenoid switch		YD-26A	(A)
295		1	Titeflex spark plug shielding for No. 1 cylinder		YD-26B	(A)
296		1	Titeflex spark plug shielding for No. 2 cylinder	Provide suppression from radio interference	YD-49A	(A)
297		1	Titeflex spark plug shielding for No. 2 cylinder	Provide suppression from radio interference	YD-49D	(A)
298		1	Titeflex spark plug shielding for No. 2 cylinder	Provide suppression from radio interference	YD-49A	(A)
299		1	Connector for loom on choke shielding cup		YD-49F	(A)
300		2	Grommet for gen. term. housing		YD-51	(A)
301		2	Generator for term. hous. assby.		YD-C1-1 YD-64	(A) (A)

Ref. No.	S. C. Stock No.	No. Req.	Name and Description	Function	Mfr's Part No.	Mfr.
302		1	Spark plug cable for No. 1 cyl.	Transmits magneto current to spark plugs	YL-64	(A)
303			Spark plug cable for No. 2 cyl.		YL-65	(A)
304			Spark plug cable for No. 3 cyl.		YL-66	(A)
305			Spark plug cable for No. 4 cyl.		YL-67	(A)
306		1	No. 4 A.W.G. cable 6" long, starter to switch	Controls rate and amount of current from generator to battery	1 piece	(A)
		1	12 volt voltage regulator		YJ-13	(C)
		1	Spark plug wrench		DF-48	(A)

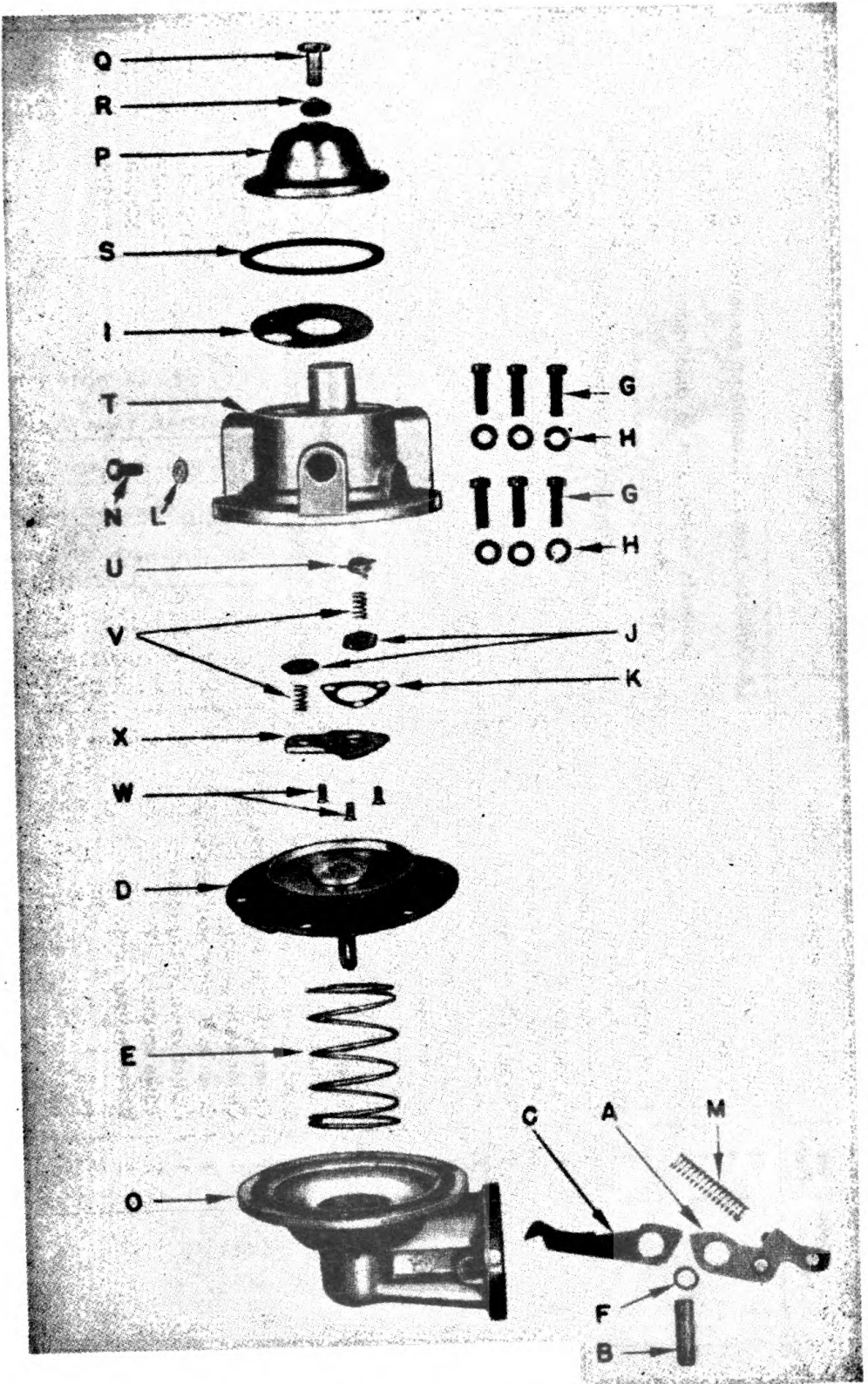

FIGURE 15—FUEL PUMP DISASSEMBLED

b. Fuel Pump (Figure 15)

Ret. No.	S. C. Stock No.	No. Req.	Name and Description	Function	Mfr's Part No.	Mfr.		
A		1	Rocker arm	Operates link and diaphragm assembly	A 1521862	(K)		
B		1	Rocker arm pin			Connects rocker arm to diaphragm assembly	B 1521640	(K)
C		1	Link					(K)
D		1	Diaphragm assembly	Returns diaphragm to normal position	1521863			(K)
E		1	Diaphragm spring		1523301	(K)		
F		1	Rocker arm pin bushing		1523714	(K)		
G		6	Cover screws	Cover screw lockwasher	1541864	(K)		
H		6	Cover screw lockwasher		855493	(K)		
I		1	Screen		855064	(K)		
J		2	Valves	Valve plate gasket	1521479	(K)		
K		1	Valve plate gasket		855279	(K)		
L		1	Drain screw gasket		1521472	(K)		
M		1	Rocker arm spring	Rocker arm spring	851297	(K)		
N		1	Drain screw		1522091	(K)		
O		1	Body		1521612	(K)		
P		1	Cover plate	For draining fuel pump	1523258	(K)		
Q		1	Cover plate cap screw		1521475	(K)		
R		1	Cover plate cap screw gasket		1537148	(K)		
S		1	Cover plate gasket	Cover plate cap screw gasket	1521476	(K)		
T		1	Cover and valve seat assembly		1521480	(K)		
U		1	Outlet valve spring retainer		1521641	(K)		
V		2	Valve spring	Valve spring retainer	1521473	(K)		
W		3	Valve retainer screw		856270	(K)		
					856374	(K)		

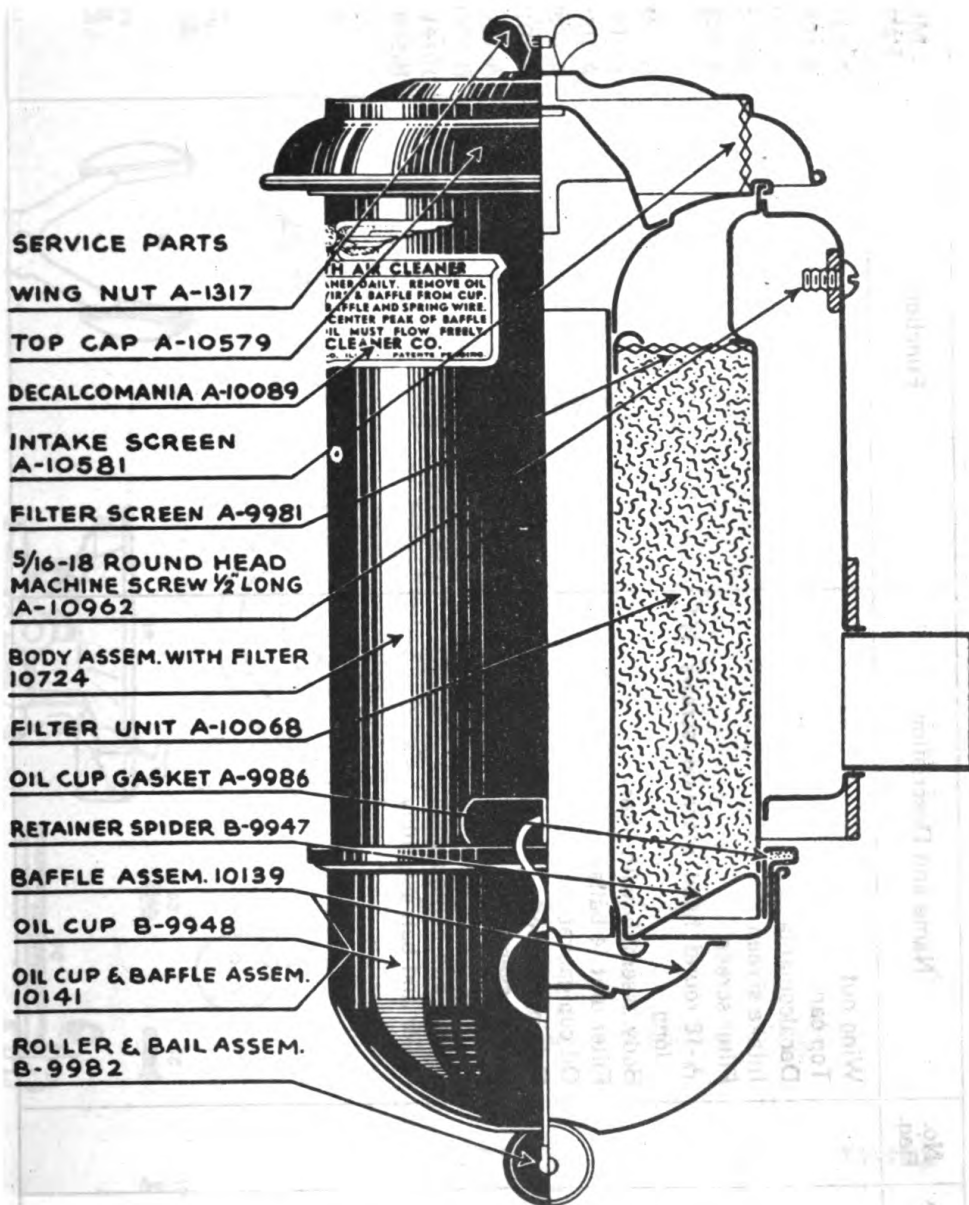

FIGURE 16—AIR CLEANER—CROSS SECTION

c. Air Cleaner (Figure 16)

Ref. No.	S. C. Stock No.	No. Req.	Name and Description	Function	Mfg.'s Part No.	Mfr.
			Wing nut		A-1317	(A)
			Top can		A-10579	(A)
			Decalcomania		A-10089	(A)
			Intake screen		A-10581	(A)
			Filter screen		A-9981	(A)
			$\frac{1}{8}$ "-18 round head machine screws $\frac{1}{4}$ " long			
			Body assembly with filter		A-10962	(A)
			Filter unit (4 balls)		A-10724	(A)
			Oil cup gasket		A-10068	(A)
			Retainer spider		A-9986	(A)
			Baffle assembly		A-10128	(A)
			Oil cup		A-10139	(A)
			Oil cup and baffle assembly		B-9948	(A)
			Roller and bail assembly		10141	(A)
					B-9982	(A)

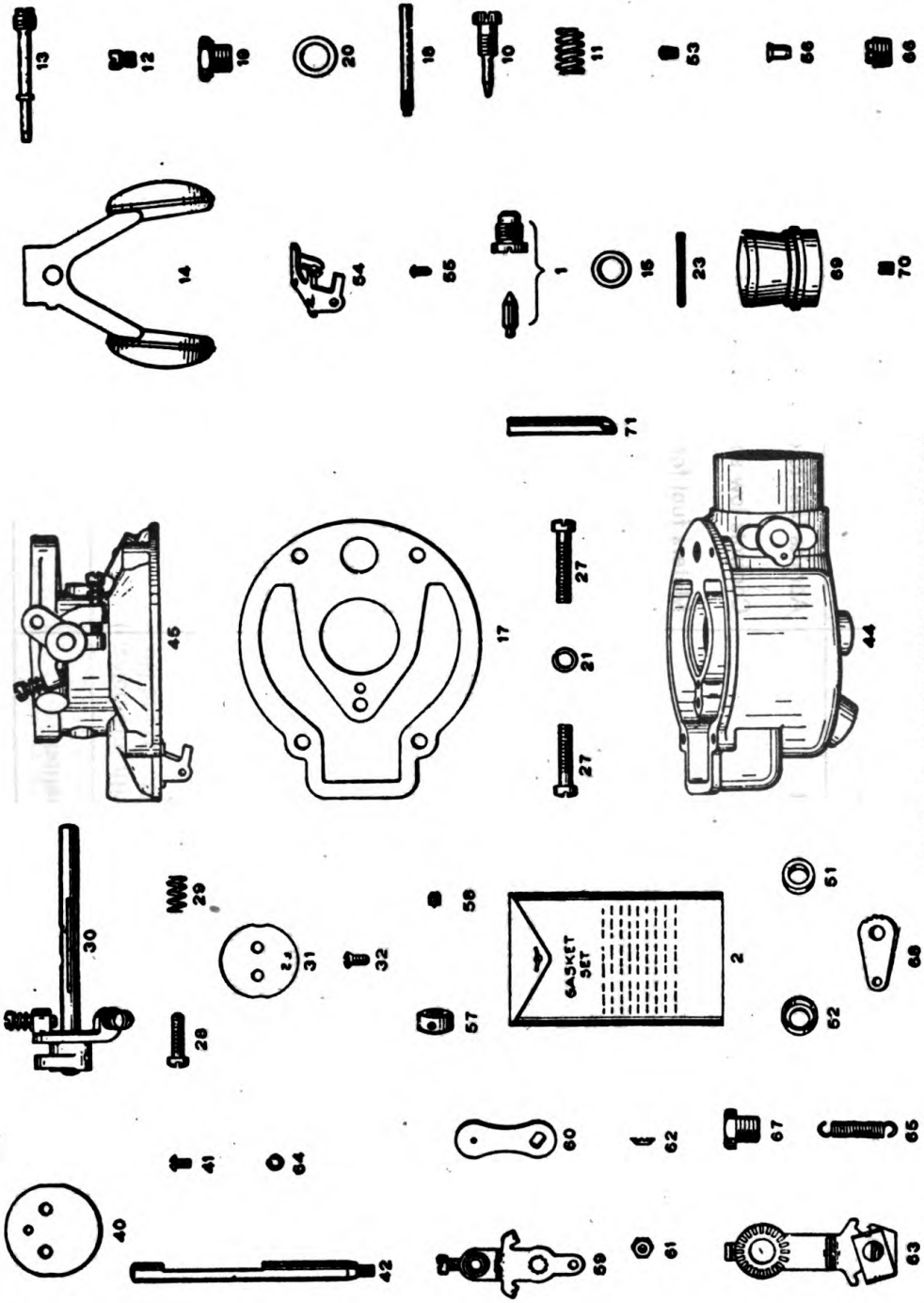

FIGURE 17—CARBURETOR DISASSEMBLED

d. Carburetor (Figure 17).

Ref. No.	S. C. Stock No.	No. Req.	Name and Description	Function	Mfr's Part No.	Mfr.
1			Float needle valve and seat	Admits fuel to carburetor	425173	(E)
2			Complete set of gaskets	Controls low speed adjustment	382391	(E)
10			Idle needle valve	Meters fuel for carburetion	P-15396	(E)
11			Spring—Idle needle valve	Meters fuel for carburetion	P-12530	(E)
12			Metering jet	Controls level of fuel in carburetor bowl	P-18921	(E)
13			Main discharge jet No. 48		P-18340	(E)
14			Float assembly		425106	(E)
15			Gasket—float needle valve seat		425176	(E)
17			Gasket—main body		425122	(E)
18			Idle tube, No. 74		425123	(E)
20			Gasket—main discharge plug		P-11572	(E)
21			Lockwasher—main body attach. screw		40-S-49	(E)
23			Fulcrum pin—float		425162	(E)
27			Screw—main body attach. (short)		177S-44	(E)
28			Screw—throttle stop	Prevents throttle from closing beyond a predetermined point	P-23474	(E)
29			Spring—throttle stop screw		P-15301	(E)
30			Throttle lever and shaft	Regulates amount of fuel going to engine	425120	(E)
31			Throttle valve	Regulates amount of fuel going to engine	425111	(E)
32			Screw—throttle valve attach.		425161	(E)
40			Choke valve	Controls mixture while starting	425112	(E)
41			Screw—choke valve attach.		425201	(E)
42			Choke stem and lever		425156	(E)
44			Main body		425178	(E)

Ref. No.	S. C. Stock No.	No. Req.	Name and Description	Function	Mfr's Part No.	Mfr.
45			Throttle body (complete with idle holes, throttle stem and valve) No. 60 and No. 68 idle holes		425260	(E)
51			Felt packing		425157	(E)
52			Retainer—felt packing		425158	(E)
53			Channel plug		425160	(E)
54			Float hanger		425159	(E)
55			Drive screw—float hanger		253-S-22	(E)
56			Channel plug		P-15459	(E)
57			Collar—throttle stem		P-17081	(E)
58			Set screw—throttle stem collar		P-16161	(E)
60			Choke lever		425130	(E)
61			Nut—choke lever attach. 40-S-49 lock-washer—choke lever attach. nut		40-S-49	(E)
64			Lockwasher—choke valve attach. screw		425202	(E)
66			Pipe plug		P-3292	(E)
69			Venturi $\frac{1}{8}$		425104	(E)
70			High speed bleeder No. 70		P-20242	(E)
71			Vent tube		425163	(E)
72			Main discharge jet gasket		P-9600	(E)

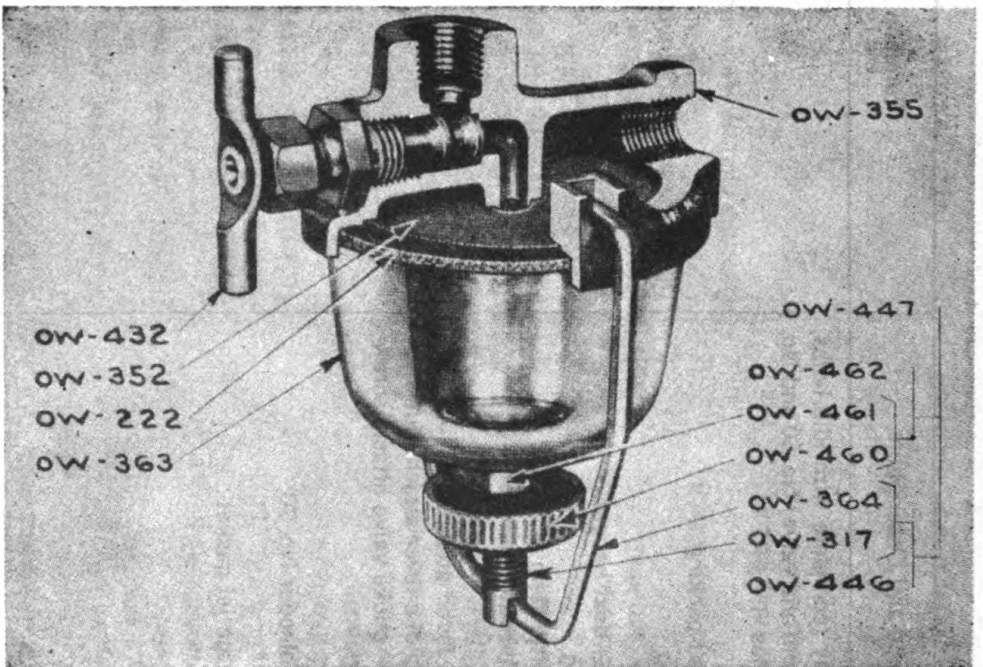

FIG. 18—FUEL FILTER

e. Fuel Filter (Figure 18).

Ref. No.	S. C. Stock No.	No. Req.	Name and Description	Function	Mfg.'s Part No.	Mfr.
			Thumb nut and clamp cup assembly consisting of: Thumb nut Clamp cup Clamp cup stud and clamp wire assembly consisting of: Clamp cup stud Clamp wire Shut-off cock Strainer cover (main body) Gasket Strainer screen Strainer bowl		OW-462 OW-460 OW-461  OW-446 OW-317 OW-364 OW-432 OW-361 OW-222 OW-352 OW-352	(A)  (A) (A) (A) (A) (A) (A)

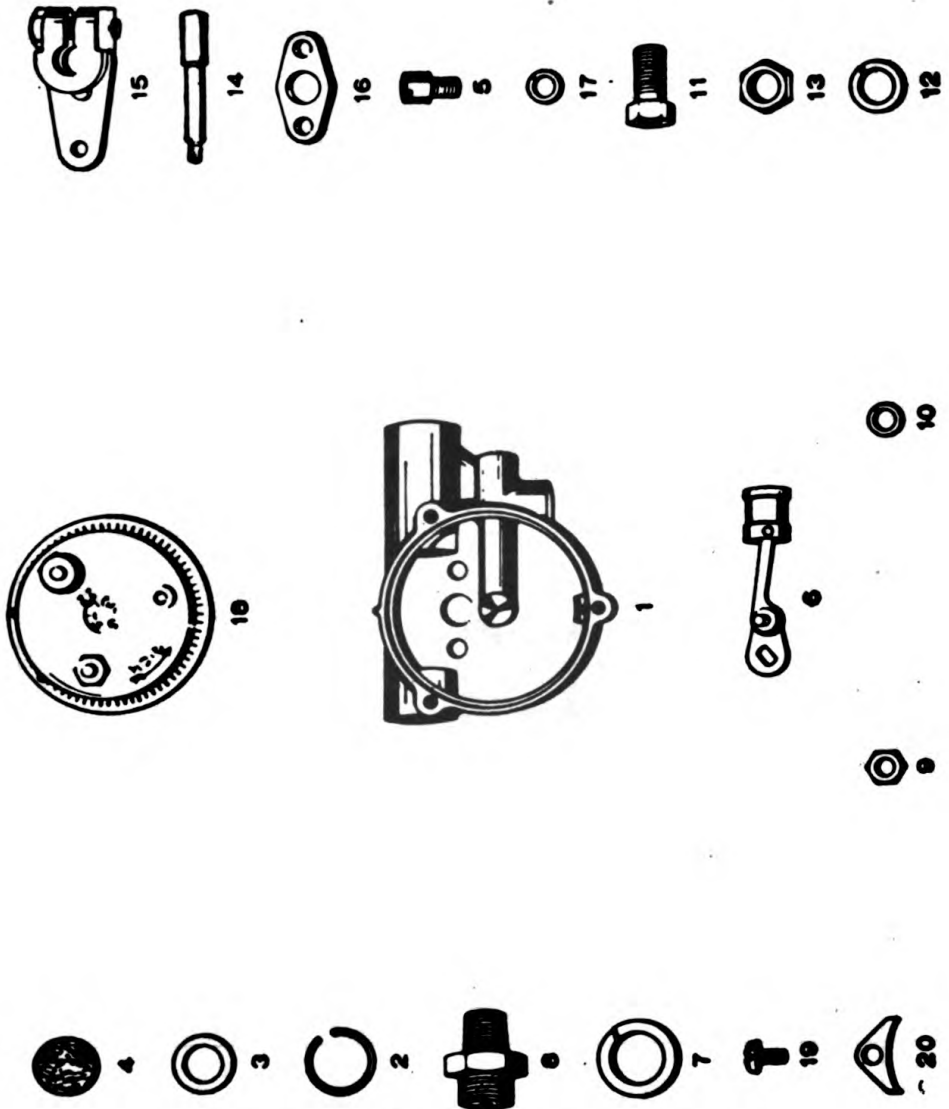

FIGURE 19—AUTOMATIC CHOKE—DISASSEMBLED

f. Automatic Choke (Figure 19).

Ref. No.	S. C. Stock No.	No. Req.	Name and Description	Function	Mfgr's Part No.	Mfr.
1			Choke housing		382770	(A)
2			Felt strainer and washer clip		382777	(A)
3			Felt strainer washer		P-207444	(A)
4			Felt strainer		382776	(A)
5			Vacuum piston lever stop screw		382774	(A)
6			Vacuum piston and link		P-24133	(A)
7			Vacuum line union lockwasher		382779	(A)
8			Vacuum line union		382778	(A)
9			Vacuum piston lever nut		P-16571	(A)
10			Vacuum piston lever nut lockwasher		P-15875	(A)
11			Choke lever stem bushing		382772	(A)
12			Choke lever stem bushing lock nut lock-washer			
13			Choke stem bushing nut		P-8838	(A)
14			Choke stem		382773	(A)
15			Choke lever		382771	(A)
16			Stop screw plate		P-20229	(A)
17			Stop screw lockwasher		382775	(A)
18			Assembly thermostat unit		40-S-19	(A)
19			Thermostat unit attach. screw		382780	(A)
20			Thermostat unit attach. screw washer		P-21596 P-24179	(A) (A)



g. Charging Generator (Figure 20).

Ref. No.	S. C. Stock No.	No. Req.	Name and Description	Function	Mfgr's Part No.	Mfr.
		1	Frame and field assembly		GEF-2001	(C)
		1	Washers, ins., arm. term. ( $\frac{11}{16}$ x $\frac{1}{4}$ x .062)		GAA-32	(C)
		1	Ins., field, connection		GAL-44	(C)
		1	Washer, ins., field term. ( $\frac{11}{16}$ x $\frac{1}{8}$ x $\frac{1}{8}$ )		GBW-34	(C)
		1	Bushing, ins., arm. term. (.250 x .3125 x $\frac{1}{8}$ )			
		1	Bushing, ins., field term. (.203 x .305 x $\frac{1}{8}$ )		GCT-25	(C)
		2	Pole piece		GCY-25	(C)
		1	Ins., term. post, inner		GDZ-29	(C)
		1	Coil assy., field, comp.		GEA-34	(C)
		1	Post, terminal, field No. 10-32		GEF-1005	(C)
		1	Post, arm. term., No. 14-24		GEW-58	(C)
		1	Lead Assembly		GEA-27	(C)
		1	Terminal		GEA-30	(C)
		1	Coil, field, left		X-847	(C)
		1	Coil, field, right		GEF-1007	(C)
		2	Screw, pole piece		GEF-1008	(C)
		2	Pin, dowel, $\frac{1}{8}$ x $\frac{1}{8}$		GK-38	(C)
		1	Nut, hex., No. 14-24		MN-21	(C)
		1	Washer, lock, No. 14		8X-177	(C)
		1	Washer, lock, No. 10		12X-193	(C)
		1	Washer, plain, No. 10		12X-196	(C)
		1	Washer, plain $\frac{1}{4}$		8Y349	(C)
		1	Nut, hex., No. 10-32		8X-361	(C)
		2	Screws, frame		8X-1377	(C)
		1	Nut, hex., No. 14-24		GY-20	(C)
		1	Washer, lock, No. 14		8X-177	(C)
					12X-193	(C)

Ref. No.	S. C. Stock No.	No. Req.	Name and Description	Function	Mfg's Part No.	Mfr.
		2	Washer, lock, No. 10		12X-196	(C)
		2	Washer, lock $\frac{3}{4}$		12X-199	(C)
		1	Screw, rd. hd., No. 10-32 x $\frac{1}{8}$		8X-321	(C)
		1	Nut, hex., No. 10-32		8X-1377	(C)
			<b>Comm. End Head Assembly &amp; Parts Used</b>			
			With			
		1	Head assembly, comm. end		GDZ-2002C	(C)
		1	Wick, felt, ( $\frac{1}{4}$ x $2\frac{1}{4}$ )		GAR-73	(C)
		1	Cover, wick		GAR-98A	(C)
		1	Cover, comm. end		GBW-30B	(C)
		1	Gasket, comm. end cover		GBW-69	(C)
		1	Oil guard		GBW-72	(C)
		1	Gasket, oil retaining		GBW-73	(C)
		2	Brushes		GBW-1012A	(C)
		1	Head assembly, partial comm. end		GDZ-1002G	(C)
		2	Springs, brush		GBW-45	(C)
		1	Brg., absorbent bronze		GBF-79	(C)
		2	Arm., brush		GCJ-26	(C)
		5	Washer, lock, No. 8		X-195	(C)
		1	Screw, rd. hd., No. 8-32 x $\frac{1}{4}$		8X-305	(C)
		1	Oiler, press-in type, $\frac{1}{4}$		X-289	(C)
		4	Screws, fill, hd., No. 8-32 x $\frac{1}{8}$		8X-888	(C)
		1	Washer, lock, No. 8		X-195	(C)
		1	Screw, rd. hd., No. 8-32 x $\frac{1}{4}$		8X-305	(C)
			<b>Armature Assembly &amp; Parts Used With</b>			
		1	Nut, armature shaft (hex., .699-20)		GBM-21	(C)
		1	Armature assembly		GCP-2006F	(C)

Ref. No.	S. C. Stock No.	No. Req.	Name and Description	Function	Mfr's Part No.	Mfr.
		1	Snap ring		GAR-171	(C)
		1	Retainer, felt washer		GR-32	(C)
		1	Pulley, drive		SP-556A	(C)
		1	Key, Woodruff, No. 5		X-260	(C)
		1	Washer, lock, .669		X-884	(C)
			Drive End Head Assembly & Parts Used With			
		1	Head assy., drive end		GDZ-1003	(C)
		2	Retainers, felt washer		GAR-63	(C)
		2	Retainers, bearing		GAR-64	(C)
		1	Head		GDZ-3	(C)
		2	Washer, felt ( $\frac{7}{8}$ — $1\frac{3}{8}$ x $\frac{1}{8}$ )		GG-164	(C)
		3	Nuts, hex., No. 10-32		8X-173	(C)
		3	Washers, lock, No. 10		X-196	(C)
		1	Brg. ball, S.A.E., No. 203		X-295	(C)
		1	Oiler, press-in type, $\frac{1}{4}$		X-489	(C)
		3	Sc., rd. hd., No. 10-32 x $\frac{7}{8}$		8X-1003	(C)
			Miscellaneous Parts			
		1	Band head		GBW-24B	(C)
		1	Screw, rd. hd., No. 10-32 x $1\frac{1}{4}$		8X-715	(C)
		1	Nut, square, No. 10-32		8X-794	(C)

USE MANUFACTURER'S PART NUMBER

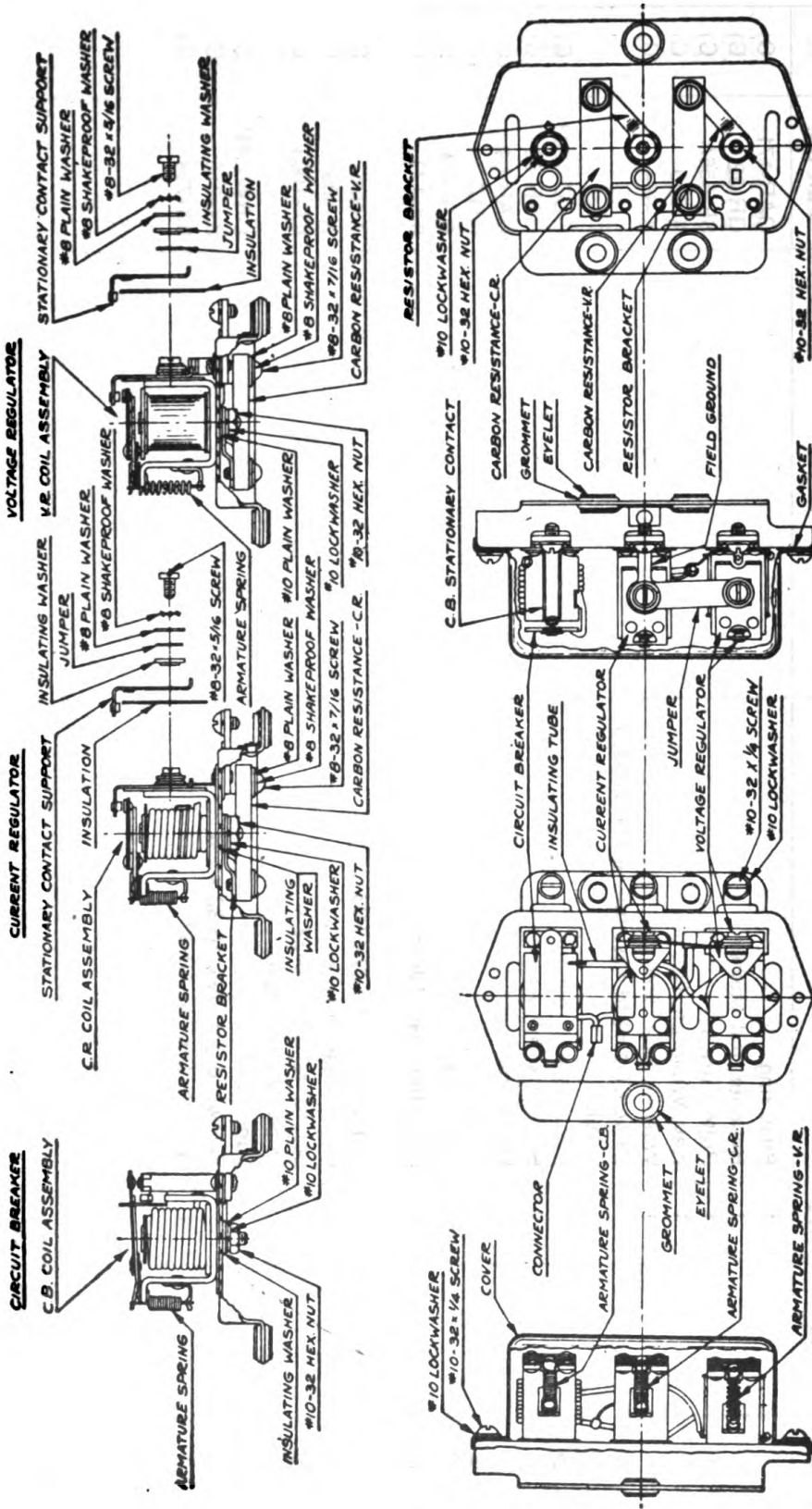

FIGURE 21—CIRCUIT BREAKER, CURRENT REGULATOR, VOLTAGE REGULATOR

h. Low Voltage Regulator (Figure 21).

Ref. No.	S. C. Stock No.	No. Req.	Name and Description	Function	Mfgr's Part No.	Mfr.
		1	Carbon resistance (Marked 30)		TC-516	(C)
		1	Carbon resistance (Marked 60)		TC-51M	(C)
		1	C. B. coil assembly		CBH-3001S	(C)
		1	Armature spring—13 turns		VRP-35	(C)
		1	Hex. nut—No. 10-32		SX-173	(C)
		1	Insulating washer		IGB-55	(C)
		1	Lock washer—No. 10		12X-196	(C)
		1	Plain washer—No. 10		8X-183A	(C)
		1	C. B. stationary contact		VRP-1034	(C)
		2	C. B. stat. contact sc. No. 8-32 x 1/4		X-702	(C)
		1	Cover		VRS-1002A	(C)
		1	Cover gasket		VRP-50	(C)
		2	Cover lock washer—No. 10		12X-196	(C)
		2	Cover screw—No. 10-32 x 1/4		8X-312	(C)
		1	C. R. coil assembly		VRS-1003S	(C)
		1	Armature spring—11 turns		CB-123	(C)
		1	Hex. nut—No. 10-32		8X-173	(C)
		1	Insulating washer		IGB-55	(C)
		1	Lock washer—No. 10		12X-196	(C)
		3	Eyelets		VRB-36	(C)
		3	Grommets—rubber		VRB-37	(C)
		1	Ground terminal		VRP-58	(C)
		1	Ground terminal rivet		X-1268	(C)
		1	Insulating tube		TC-115D	(C)
		1	Jumper		VRB-28	(C)
		1	Lead seal		X-1316	(C)
		2	Resistor bracket		VRP-36	(C)

Ref. No.	S. C. Stock No.	No. Req.	Name and Description	Function	Mfg's Part No.	Mfr.
		4	Resistor lock washer—No. 8		X-1275	(C)
		4	Resistor plain washer—No. 8		8X-1503	(C)
		4	Resistor screw—No. 8-32 x $\frac{1}{8}$		8X-56	(C)
		1	Series coil connector		VRS-4	(C)
		3	Terminal lock washers—No. 10		X-196	(C)
		3	Terminal screws—No. 10-32		8X-312	(C)
		1	V. R. coil assembly		VRS-3008S	(C)
		1	Armature spring—14 turns		VRP-56	(C)
		1	Hex. nut—No. 10-32		8X-173	(C)
		1	Lock washer—No. 10		12X-196	(C)
		1	Plain washer—No. 10		8X-183A	(C)

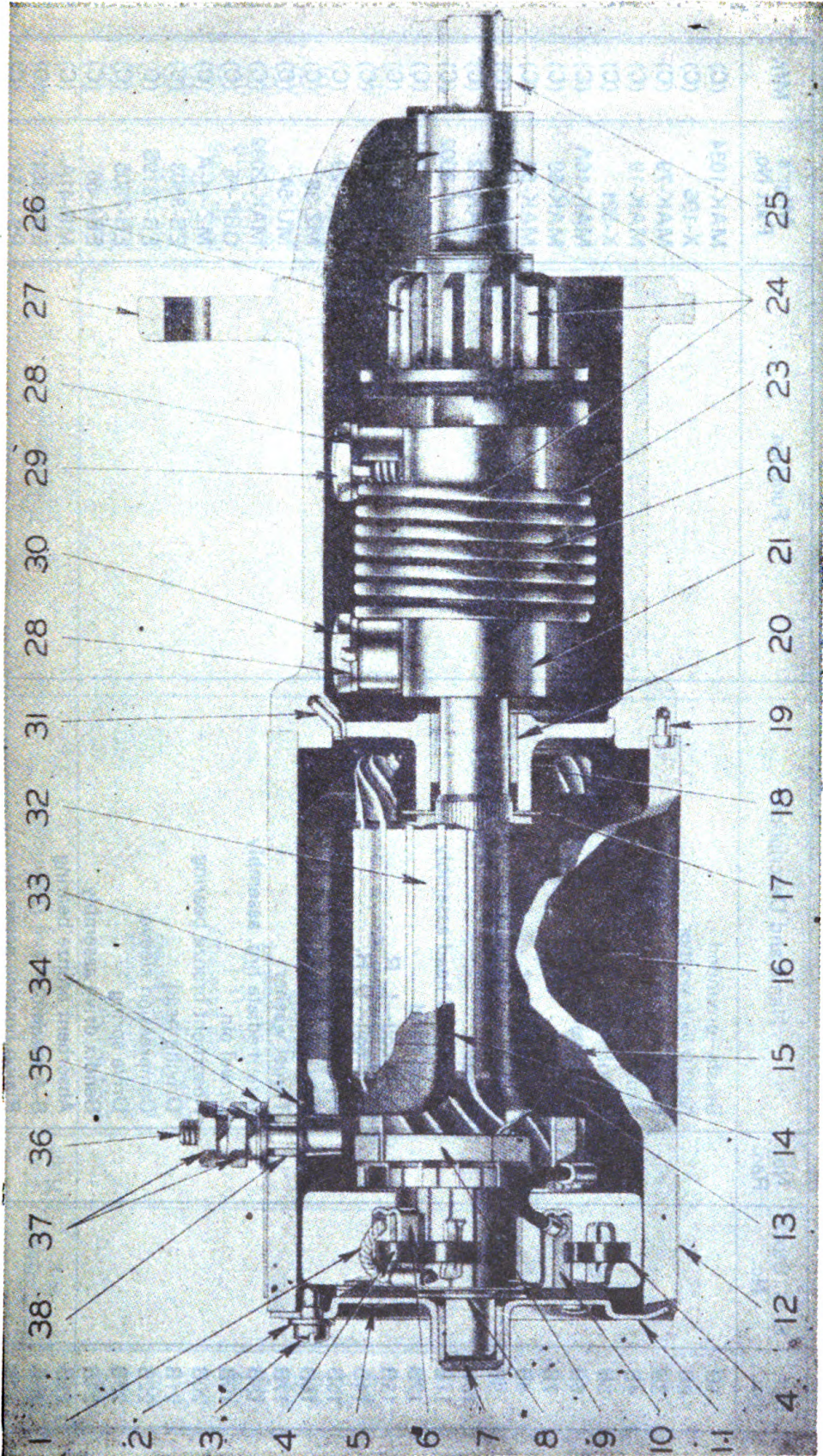

FIGURE 22—STARTING MOTOR—SECTIONALIZED VIEW

i. Starting Motor (Figure 22).

Ref. No.	S. C. Stock No.	No. Req.	Name and Description	Function	Mfr's Part No.	Mfr.
1B			Brush—grounded		MAK-1034	(C)
2B			No. 10 lock washer		X-196	(C)
3B			Frame screw		MAK-79	(C)
4B			Brush spring		MAK-19	(C)
5B			Tubular rivet		X-521	(C)
6B			Brush holder		MAK-16A	(C)
7B			Felt pad		MAK-59	(C)
8B			Thrust washer		MAK-55	(C)
9B			Connector and brush assy.		MBE-1044	(C)
10B			Brush		MAK-12	(C)
11B			Comm. end head assembly		MAK-3002	(C)
12B			Head band		GAS-1024C	(C)
13B			Field coil—L. R.		MBE-1008	(C)
14B			Field coil—U. R.		MBE-1007	(C)
15B			Pole piece		MAK-29	(C)
16B			Pole piece screw		MZ-38	(C)
17B			Thrust washer		MU-54	(C)
18B			Intermediate brg. assembly		MAK-2092	(C)
19B			Dowel pin		GBF-95	(C)
20B			Absorbent bronze bearing		MZ-44-A	(C)
21B			Driving head		EB-8503	(C)
22B			Compression sleeve		EB-7819S	(C)
23B			Drive spring		EB-7805	(C)
24B			Bendix drive assembly		EBA-56	(C)
25B			Absorbent bronze bearing		MP-41A	(C)
26B			S-A assembly		EBA-3611	(C)
27B			Pinion housing assembly		PS-1153	(C)

Ref. No.	S. C. Stock No.	No. Req.	Name and Description	Function	Mfr's Part No.	Mfr.
28B			Lock washer		EB-108	(C)
29B			Shaft spring screw		EB-7807	(C)
30B			Head spring screw		EB-7806	(C)
31B			Dowel pin		MAB-88	(C)
32B			Armature assembly		MAK-2088	(C)
33B			Field coil—U. L.		MBE-1010	(C)
34B			Insulating washer		MAK-49	(C)
35B			Plain washer		MAK-50	(C)
36B			Terminal post		MBC-28	(C)
37B			¼-20 hex. nut		5X-146	(C)
38B			Insulating bushing		MAK-51	(C)

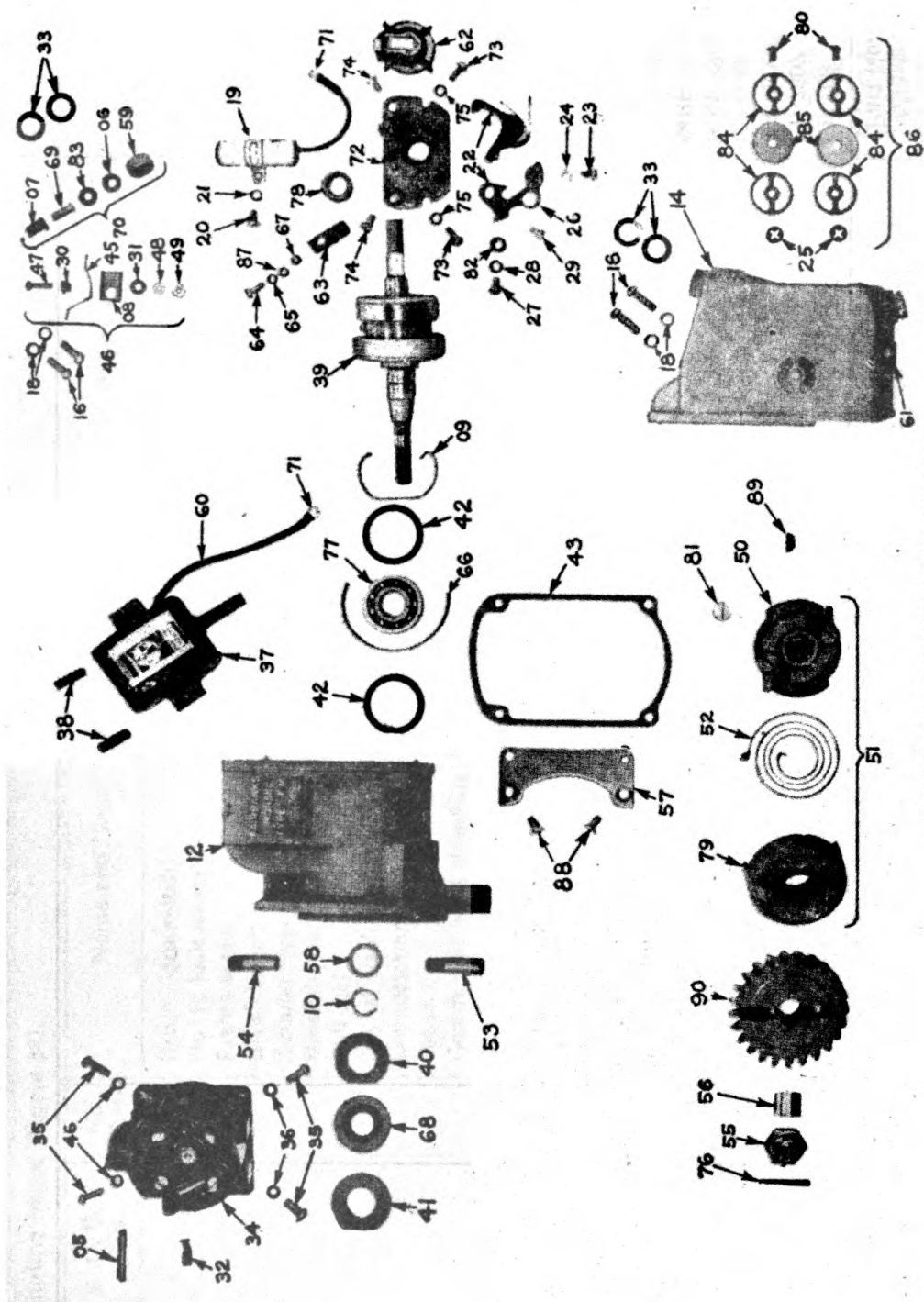

FIGURE 23—MAGNETO PARTS GROUP

j. Magneto (Figure 23).

Ref. No.	S. C. Stock No.	No. Req.	Name and Description	Function	Mfg.'s Part No.	Mfr.
05		1	Distributor high tension lead rod.		D983A	(D)
06		1	Ground cable ferrule		A1077	(D)
07		1	Ground cable terminal insulator		A1166	(D)
08		1	Ground switch strip guide		B1355	(D)
09		1	Rotor bearing snap ring		B1496B	(D)
10		1	Rotor shaft snap ring		B1498D	(D)
12		1	Frame (or housing)—complete GX2425 always includes: Frame field lamination		GX2425	(D)
14		2	Assembly—(not furn. sep.)		C2430A	(D)
		1	End cap-radio-shielded—comp.			
		4	C2430A always includes: Cable outlet bushing (not furnished separately)			
		1	Ground cable outlet bushing (See B2744A)			
		2	Ventilat. screens (See A6032A)			
		4	Vent. screen wash. (See A6030)			
		2	Vent. screen rivets (See A5961)			
		2	Vent. screen locking wash. (See A2448)			
15		2	End cap screws (No. 10-24 x 1/2")		10S8A	(D)
16		2	End cap screws (No. 10-24 x 5/8")		10S10A	(D)
18		1	End cap screws lockwashers (No. 10)		10LW2	(D)
19		1	Condenser—complete M2433 always includes:		M2433	(D)

Ref. No.	S. C. Stock No.	No. Req.	Name and Description	Function	Mfgr's Part No.	Mfr.
20		1	Condenser lead wire and tube (not furnished separately)			(D)
21		1	Cond. lead wire term. (See A4361)		8S5N	(D)
22		1	Cond. mtg. screw (No. 8-32 x $\frac{3}{16}$ "') Cond. mtg. screw lockwash. (No. 8) Break. arm, stationary bracket, and contact points T2437 always includes: Breaker arm (not furn. sep.) Breaker arm spring (not furn. sep.) Breaker arm contact point—Tungsten (Not furnished separately) Breaker arm lead (not furn. sep.) Breaker arm cont. point washer (not furnished separately)		T2437	(D)
23		1	Stat. supp. bracket and contact point (See G2454)			(D)
24		1	Cam felt wick (See No. 2788)		8S5N	(D)
25		1	Break. arm term. screw (No. 8-32x $\frac{1}{8}$ "')		8LW3	(D)
26		1	Break. arm term. screw lockwasher (No. 8) Ventilating screen locking washer Stationary supp. bracket and cont. point G2454 always includes: Stat. cont. supp. brack. (not furn. sep.) Primary insulating bush. (not furn. sep.) Prim. insulat. wash (not furn. sep.)		A2448 G2454	(D) (D)

Ref. No.	S. C. Stock No.	No. Req.	Name and Description	Function	Mfr's Part No.	Mfr.
27		1	Prim. cont. screw bush. (not furn. sep.)			
28		1	Prim. cont. screw insulator (not furn. sep.)		8S5N	(D)
29		1	Prim. cont. point Tungsten (not furn. sep.)		8LW3	(D)
30		1	Prim. cont. screw wash. (not furn. sep.)		C2455	(D)
31		1	Stationary brack. screw (No. 8-32 x $\frac{1}{8}$ " )		G2457A	(D)
32		1	Stationary brack. screw lockwasher (No. 8)		D2458	(D)
33		1	Stationary brack. adj. screw		E2460B	(D)
34		4	Prim. ground insulat. bushing			
34		1	Prim. ground flat washer			
33		1	Coil lead brush			
34		1	E2460B always includes:			
33		1	Coil lead brush spring (not furn. sep.)			
34		4	High tension cable sock, rubber seal			
34		1	Distributor block cable outlet			
34		1	C2474E always includes:			
34		2	Cable outlet insert (not furn. sep.)			
34		1	High tension lead insert (not furn. sep.)			
34		1	High ten. brush hold. ins't (not furn. sep.)			
34		1	High ten. lead conn. ins't (not furn. sep.)			
35		4	Distributor block cable outlet screw (No. 8-32 x $\frac{1}{8}$ " )		8S9N	(D)

Ref. No.	S. C. Stock No.	No. Req.	Name and Description	Function	Mfg's Part No.	Mfr.
36		4	Distributor outlet screw lockwasher (No. 8)			
37		1	Coil—complete H2477 always includes:		8LW3	(D)
		1	Coil winding (not furn. sep.)		H2477	(D)
		1	Coil second, lead (not furn. sep.)			
		1	Coil second, lead shield (not furn. sep.)			
		5	Coil tape—wide (not furn. sep.)			
		3	Coil tape—narrow (not furn. sep.)			
		1	Coil sticking tape (not furn. sep.)			
		1	Coil bridge lamination assembly (not furnished separately)			
		1	Coil prim. lead wire (not furn. sep.)			
		1	Coil prim. lead wire tube (see E2736)			
		1	Coil prim. lead wire term (see A4361)			
38		2	Coil bridge set screw (1/4-20 x 1/2)		25SS12A	(D)
39		1	Magnetic Rotor—complete VX2480 always includes:		VX2480	(D)
		1	Rotor shaft (not furn. sep.)			
		1	Rotor magnet (not furn. sep.)			
		2	Rotor lam. assbly. (not furn. sep.)			
		1	Rotor die casting (not furn. sep.)			
		1	Inner retaining washer			
40		1	Outer retaining washer		C2492	(D)
41		1	Bearing insulating washer		A2492A	(D)
42		2	Bearing insulating washer		C2493	(D)
43		1	End cap gasket		H2498	(D)
45		1	Ground switch strip		J2514	(D)

Ref. No.	S. C. Stock No.	No. Req.	Name and Description	Function	Mfgr's Part No.	Mfr.
46		1	Primary ground switch group—radio-shielded A2514J includes: Ground switch strip (See J2514) Ground screw bush. (See G24574A) Ground switch strip guide (See B1355) Ground screw washer (See D2458) Ground screw (See 6S8N) Ground screw lockwasher (See 6LW1) Ground screw nut (See 6N1)		A2514J	(D)
47		1	Primary ground screw (No. 6-32 x 1/2")		6S8N	(D)
48		1	Primary ground screw lockwasher (6LW1)		6LW1	(D)
49		1	Primary ground screw nut (6N1)		6N1	(D)
50		1	Impulse coupling hub assembly—Type UB9 EX2563 always includes: Hub plate (not furn. sep.) Hub shaft member (not furn. sep.) Hub pawls (not furn. sep.) Hub pawl rivets (not furn. sep.) Hub pawl washers (not furn. sep.) Hub pawl springs (See C5693)		EX2563	(D)
51		1	Impulse coupling—complete—Type UB9 GX2563C includes: Coupling hub assembly (See EX2563) Coupling drive spring (See E2565) Coupling shell (See Y5957)		GX2563C	(D)

Ref. No.	S. C. Stock No.	No. Req.	Name and Description	Function	Mfr's Part No.	Mfr.
52		1	Coupling drive spring		E2565	(D)
53		1	Coupling pawl stop pin (1 $\frac{1}{8}$ " long)		C2568	(D)
54		1	Coupling pawl stop pin (1 $\frac{1}{8}$ " long)		Q2568	(D)
55		1	Coupling nut		M2570	(D)
56		1	Coupling gear bushing		A2572	(D)
57		1	End cap extension plate		A2636	(D)
58		1	Thrust bearing shim		C2723	(D)
59		1	Ground cable outlet nut		B2735A	(D)
60		1	Primary lead wire tube		E2736	(D)
61		1	Ground cable outlet bushing		B2744A	(D)
62		1	Distributor rotor		M2765	(D)
			M2765 always includes:			
		1	Distributor rotor insert (not furn. sep.)			
63		1	Cam felt wick		E2788	(D)
64		1	Cam wick screw (No. 6-32 x $\frac{3}{8}$ " )		6S6A	(D)
65		1	Cam felt wick screw lockwasher (No. 6)		6LW2	(D)
66		1	Rotor bearing insulating strips		B2824	(D)
67		1	Cam felt wick spacer		A2982	(D)
68		1	Bearing seal rubber washer		G3861	(D)
69		1	Ground cable terminal		A3969	(D)
70		1	Ground cable terminal group		A3969C	(D)
			A3969C includes:			
		1	Ground cable ferrule (See A1077)			
		1	Ground cable term. insulat. (See A1166)			
		1	Ground cable nut (See B2735A)			
		1	Ground cable terminal (See A3969)			
		1	Terminal insulating washer (See B6018)			

Ref. No.	S. C. Stock No.	No. Req.	Name and Description	Function	Mfg'r's Part No.	Mfr.
71		1	Outlet bushing (See B2744A)			(D)
72		2	Lead wire terminal (for No. 8 screw)		A4631	(D)
		1	Bearing & breaker support plate L4631 always includes:		L4631	(D)
		1	Bearing plate (not furn. sep.)			
		1	Bearing plate ful. pin (not furn. sep.)			
		1	Rotor sleeve bearing (See B5950A)			
		1	Cam felt wick (See E2788)			
		1	Cam felt wick spacer (See A2982)			
		1	Cam felt wick screw (See 6S6A)			
		1	Cam felt wick screw lockwasher (See 6LW2)			
		1	Cam felt wick washer (See C6503)			
73		2	Bearing and breaker support plate screw —(No. 8-32 x 3/8")		8S6A	(D)
74		2	Bearing and breaker support plate screw —(No. 8-32 x 3/8")		8S6G	(D)
75		2	Supp. plate screw lockwasher (No. 8)		8LW3	(D)
76		1	Impulse coupling nut lockwire		A5931A	(D)
77		1	Rotor ball bearing		C5949	(D)
78		1	Rotor sleeve bearing		B5950A	(D)
79		1	Impulse coupling shield		Y5957	(D)
80		2	Ventilating screen rivet		A5961	(D)
81		2	Impulse coupling pawl spring		C5963	(D)
82		1	Stationary contact support washer		B5969	(D)
83		1	Primary ground insulating washer		B6018	(D)
84		4	Ventilating screen washer		A6030	(D)

Ref. No.	S. C. Stock No.	No. Req.	Name and Description	Function	Mfr's Part No.	Mfr.
85		2	Ventilating screen		A6032A	(D)
86		2	Ventilating screen group		A6032AC	(D)
			A6032AC group includes:			
		2	Ventilating screens (See A6032A)			
		4	Ventilating screen washer (See A6030)			
		2	Ventilating screen rivet (See A5961)			
		2	Ventilating screen locking washer (See A2448)			
87		1	Cam felt wick holding washer		C6503	(D)
		1	Complete gasket kit		GK16	(D)
		1	Complete gasket kit		GK17	(D)
			GK16 and GK17 always include:			
		1	Outer retaining washer (See A2492A)			
		1	End cap to frame gasket (See HS498)			
		1	Rotor bearing sealing wash. (See G3861)			
88		2	End cap extension plate screw (No. 10-24 x $\frac{3}{8}$ " )		10S6G	(D)
89		1	Coupling hub key		3K1	(D)
90			Drive gear (Order from Wisconsin Motor Corporation)			

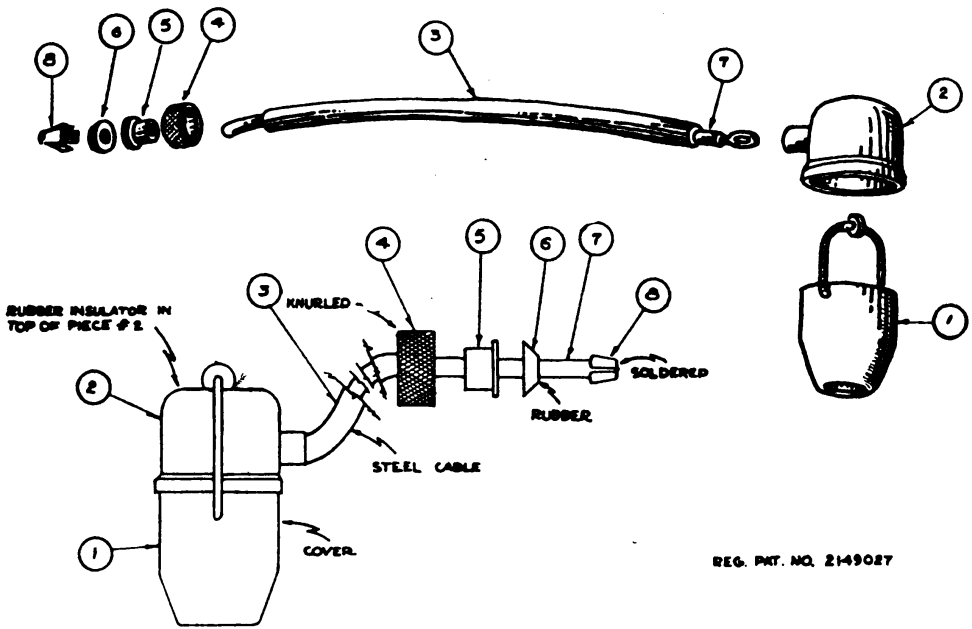

FIGURE 24—SPARK PLUG SHIELDING

k. Ignition Shielding (Figure 24).

Ref. No.	S. C. Stock No.	No. Req.	Name and Description	Function	Mfgr's Part No.	Mfr.
4			Ferrule nut	Provides suppression from radio interference	U2164-2A	(A)
5			Ferrule		U-2164-23A	(A)
3			Flexible tubing		152-21	(A)
2			Cap		A-26643	(A)
6			Insulator		A-27487	(A)
1			Main body		A-22061	(A)
9			Washer		A-22065	(A)
8			Terminal		A-22064	(A)
7			Wire		A-22706	(A)

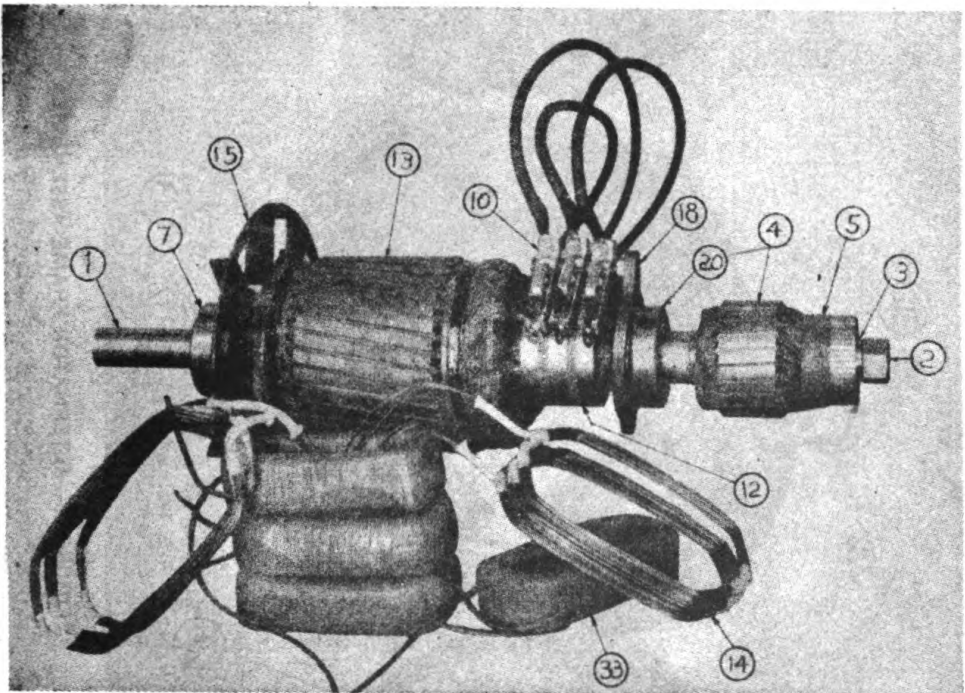

FIGURE 25--ALTERNATOR, EXCITER AND FIELD COILS

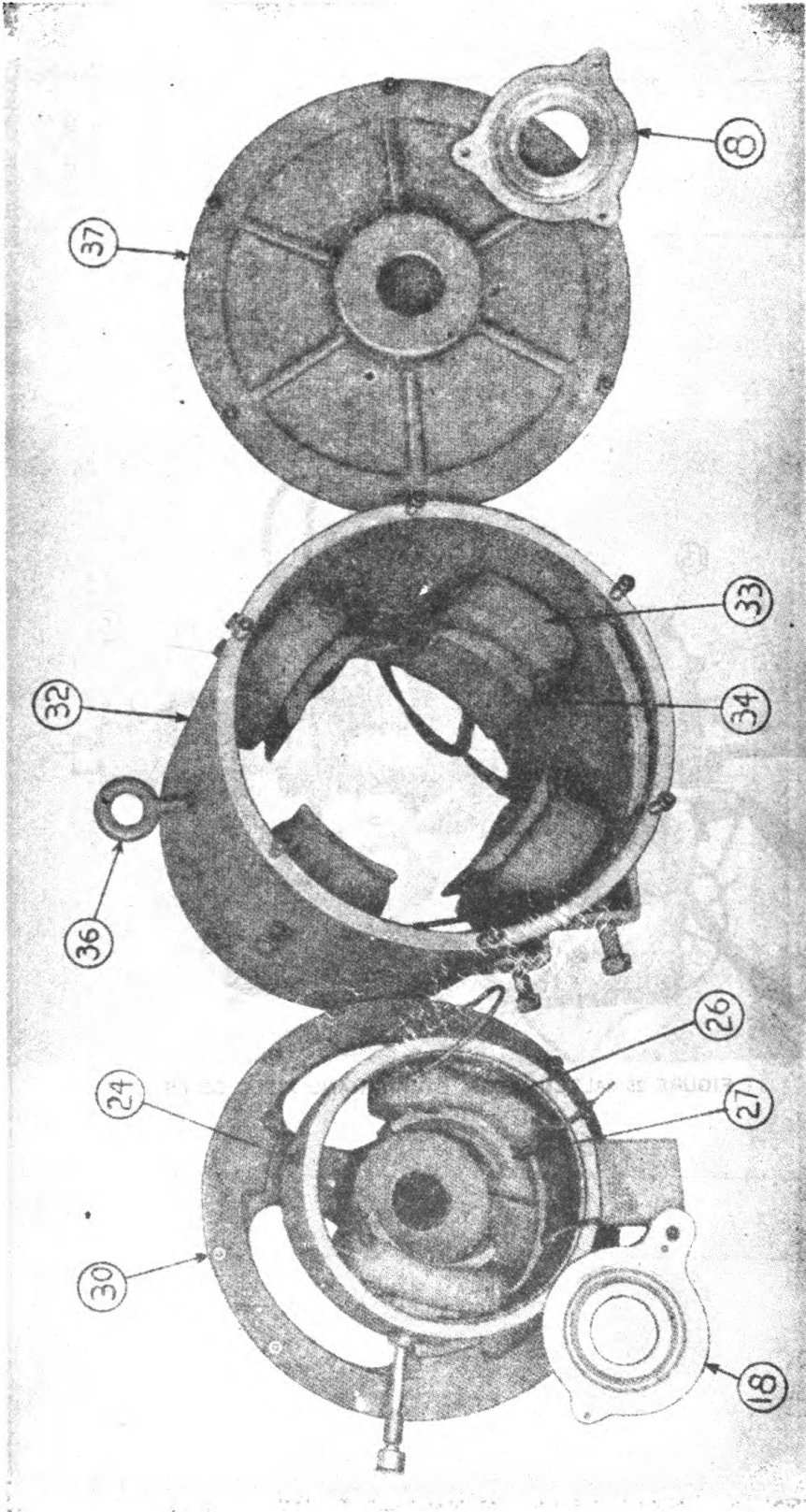

FIGURE 26—ALTERNATOR FRAME ASSEMBLIES

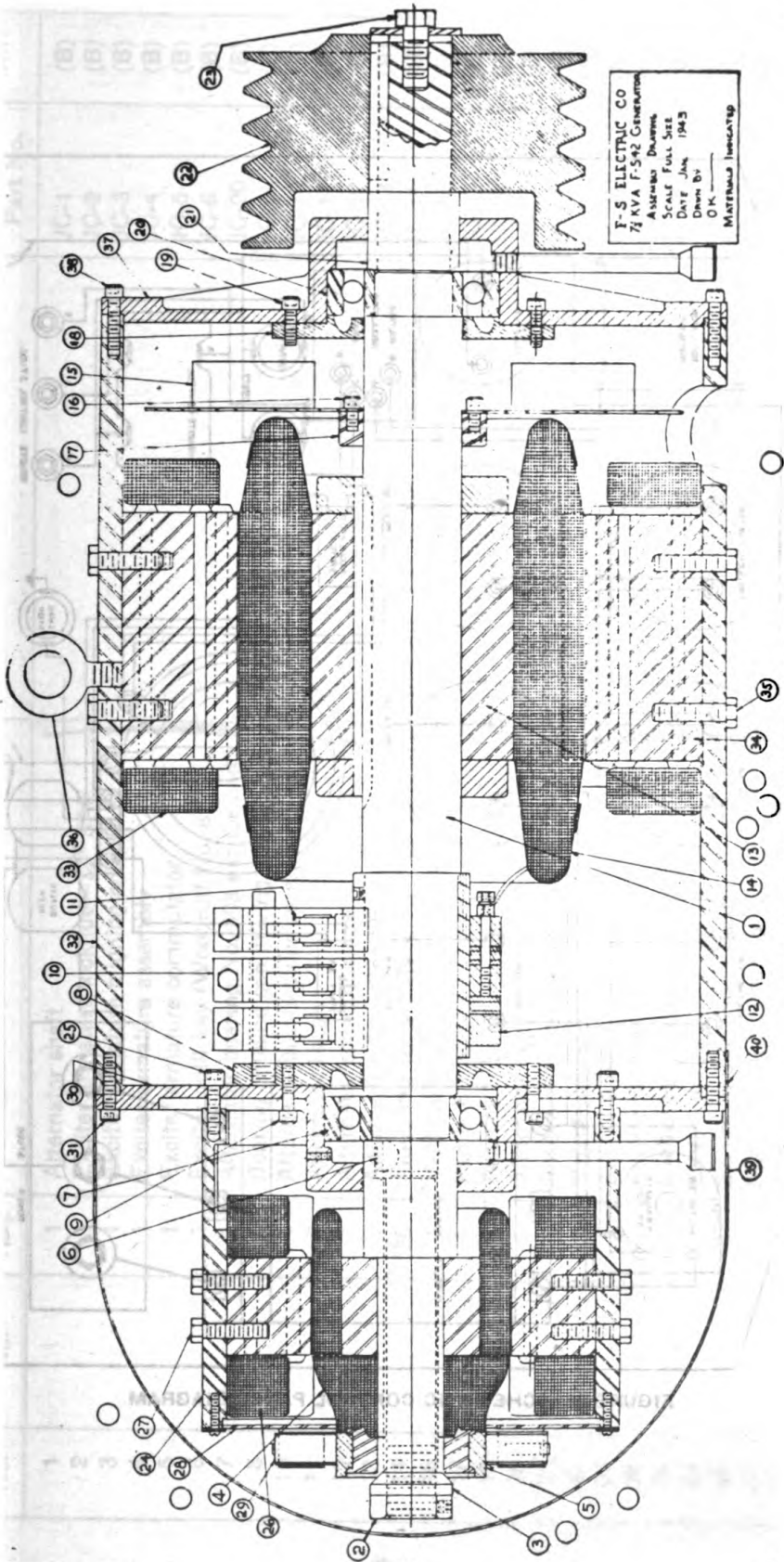

FIGURE 27—ALTERNATOR CROSS SECTION



I. Alternator (Figures 25, 26 and 27).

Ref. No.	S. C. Stock No.	No. Req.	Name and Description	Function	Mfgr's Part No.	Mfr.
1		1	Alternator shaft	Generates alternating current	JC-1	(B)
2		1	Exciter armature locknut— $\frac{3}{4}$ " SAE		JC-2	(B)
3		1	Exciter armature aligning collar		JC-3	(B)
4		1	Exciter armature assembly		JC-4	(B)
5		1	Exciter armature commutator		JC-5	(B)
6		1	Exciter quill key (Woodruff No. 8)		JC-6	(B)
7		1	Alternator bearing No. 308 exciter end		JC-20	(B)
8		1	Bearing housing cap driving end		JC-8	(B)
10		1	Alternator brushholder assembly		JC-10	(B)
11		6	Alternator brush		JC-11	(B)
12		1	Alternator collector rings		JC-12	(B)
13		1	Alternator rotor assembly		JC-13	(B)
14		36	Alternator rotor coils		JC-14	(B)
15		1	Ventilating fan		JC-15	(B)
17		1	Fan hub		JC-17	(B)
18		1	Bearing housing cap exciter end		JC-18	(B)
20		1	Alternator bearing No. 303 drive end		JC-7	(B)
21		1	Sheave-bearing locking collar		JC-21	(B)
22		1	V-belt sheave		JC-22	(B)
24		1	Exciter frame		JC-24	(B)
26		2	Exciter field coils		JC-26	(B)
28		1	Exciter brushholder assembly		JC-28	(B)
29		2	Exciter brush		JC-29	(B)
30		1	Exciter end bearing bracket		JC-30	(B)
32		1	Alternator main housing		JC-32	(B)
33		4	Alternator field coils		JC-33	(B)
34		4	Alternator field pole pieces		JC-34	(B)

Ref. No.	S. C. Stock No.	No. Req.	Name and Description	Function	Mfr's Part No.	Mfr.
36		1	Lifting eye bolt 1/2 x 1 USS Drive end bearing bracket Exciter cover	Generates alternating current	JC-36	(B)
37		1			JC-37	(B)
39		1			JC-39	(B)

m. Control Panel (Figures 4 and 28).

Ref. No.	S. C. Stock No.	No. Req.	Name and Description	Function	Mfgr's Part No.	Mfr.
1		1	Voltage regulator	Maintains constant voltage at various loads	Avr.	(N)
2		1	Voltage regulator base assy.	Used with voltage regulator	24554	(R)
3		1	Frequency meter	Indicates speed and cycle frequency	Model 31-F	(S)
4		3	Ammeters	Indicates amperage or load	NA-35 Sim. S1159118	(N)
5		1	D.C. battery charging ammeter	Indicates rate of charge or discharge of battery	4000-5-9	(T)
6		1	Stop push button		2A5570A	(U)
7		1	Start push button		2A5570A	(U)
8		1	Remote control receptacle (twist lock)	Permits use of remote control cable	TL-7310	(V)
9		3	Remote control terminal studs $\frac{1}{8}$ x 1 Brass	For emergency use of remote control cable		(B)
10		1	Exciter shunt field rheostat	For manually controlling output voltage	Model L-0542	(W)
11		1	Total time meter	To record hours operated	NH-35 Sim. S120585	(N)
12		1	A.C. voltmeter	To indicate voltage developed	NA-35 Sim. S1159010	(N)
13		1	Voltmeter transfer switch A.C.	To check voltage on selected phase or leg	Cat. No. III T-2-4	(W)
14		2	Dash lamps	Provides light for control cabinet	2932	(X)
15		1	Mainlines circuit breaker (3-pole)	For cutting electric power on and off at unit	28350F	(N)
16		1	Duplex convenience outlet (twist tite)	Provides service for light cords or electric tools		(Y)
17		3	Power terminal studs $\frac{3}{8}$ x 3 brass	Emergency connection for power cable	9200	(B)

Ref. No.	S. C. Stock No.	No. Req.	Name and Description	Function	Mfgr's Part No.	Mfr.
18		1	Manual, start switch	For emergency or manual cranking engine	8280-K-10	(Z)
19		1	Voltage regulator switch	Permits regulator to be cut out for manual regulation	8280-K-10	(Z)
20		1	Blank panel 1/8" steel with rubber grommets			(B)
21		1	Voltage regulator receptacle		AVR	(N)
22		1	Voltage regulator rheostat	Permits "trimmer" or close regulation of voltage	AVR	(N)

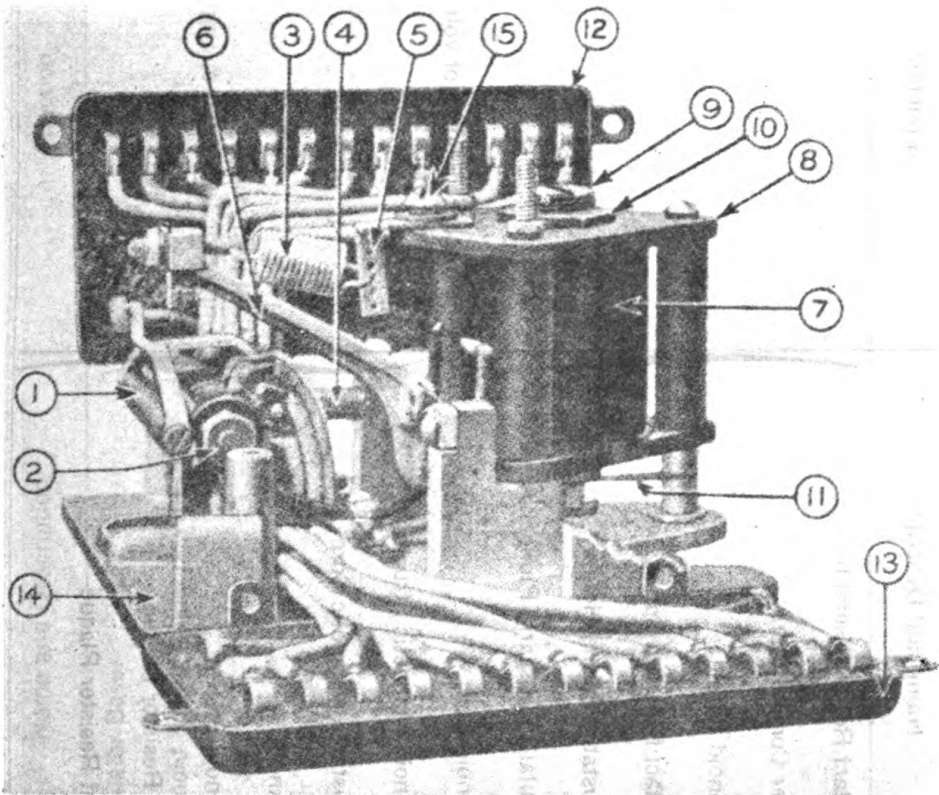

FIGURE 29—ALTERNATOR VOLTAGE REGULATOR.

n. Alternator Voltage Regulator (Figure 29).

Ref. No.	S. C. Stock No.	No. Req.	Name and Description	Function	Mfr's Part No.	Mfr.
1			Contact Roller Assembly	Automatic regulation of voltage through all load ranges	16631.21-1	(AA)
2			Silver Commutators			
3			Solenoid Spring			
4			Contact Pressure Spring			
5			Adjustable Spring Holder			
6			Regulator Crossarm Plunger Assembly			
7			Solenoid Coil			
8			Solenoid Magnetic Structure			
9			Adjustable Magnetic Core			
10			Locknut			
11			Solenoid Stop			
12			Left Resistor Plaque			
13			Right Resistor Plaque			

Ref. No.	S. C. Stock No.	No. Req.	Name and Description	Function.	Mfr's Part No.	Mfr.
14			Regulator Base	Automatic regulation of voltage through all load ranges	16631.13-1	
15			Solenoid Spring Adjusting Nut		16631.19-8	
16			Lock Spring		16631.19-4	
17			Cover (See Page 1)		16631.8-1	

o. Control Cabinet (Figures 1 and 2).

Ref. No.	S. C. Stock No.	No. Req.	Name and Description	Function	Mfg.'s Part No.	Mfr.
1		1	Control cabinet, complete with doors	Houses switch board, instruments, tools, etc.		(I)
2		1	Cabinet, back removable			(I)
3		4	$\frac{5}{16}$ " 18-thread wing nuts			(I)
4		4	Tool compartment cover fasteners			(I)
5		1	Support, angle iron cabinet			(I)
6		1	Tool compartment cover			(I)
7		1	Crouse Hinds receptacle No. AR-637	Provides service connection for power cable		(I)

p. Battery Equipment (Figures 1 and 2).

Ref. No.	S. C. Stock No.	No. Req.	Name and Description	Function	Mfg.'s Part No.	Mfr.	
9		2	No. 2H 6-volt batteries	Provide power for starter, lights, and relays  Provides positive connection to batteries Connects the two batteries in series  Connects batteries to starter switch		(H)	
10		2	No. 2H 6-volt battery holddown				
11		4	Holddown bolts $\frac{1}{8}$ x $10\frac{1}{2}$ 18-thread				
12		4	$\frac{1}{8}$ x 18-thread wing nuts				
13		4	$\frac{1}{8}$ flat washer				
14		4	$\frac{1}{8}$ locks				
15		1	No. 45-13-58 4-gauge ground strap				
16		1	No. 24 4-gauge connector with terminals				
17		1	No. 21-50-41 4-gauge connector with terminal				
28		2	Belt guards				
29		2	Battery boxes				
							(I)
							(I)
							(G)
						(G)	
						(I)	
						(I)	

q. Miscellaneous Parts (Figure 3).

Ref. No.	S. C. Stock No.	No. Req.	Name and Description	Function	Mfgr's Part No.	Mfr.
18		1	20" x 5" cable reel	Control cable		(I)
19		1	20" x 12" cable reel	Power cable		(I)
20		1	150' No. 16-3 Conductor type "S" cord w' switch	Remote control		(M)
21		1	150' No. 6-3 conductor type "S" cord	Remote power		(L)
22		1	Plug	Remote cable		(N)
23		2	Plugs	Power cable		(J)
24		1	Metal hose	Exhaust pipe		(O)
25		1	Muffler			(P)
26		1	Gatex hose	Gas line		(Q)
27		1	Remote control unit			(I)
8		1	Frame—structural steel	Unit base		(I)
5		1	Support—angle iron	Cabinet support		(I)
30		1	Crank		TL-7311 APJ-6375	(A)

35—TABLE OF NUTS, BOLTS, AND WASHERS:

Quantity	Size	Length	Thread	Description	Where Used
1	$\frac{3}{16}$ "	$1\frac{1}{2}$ "	32	Round head machine screws	Starter brush cover band
16	$\frac{5}{16}$ "		24	Hex. nuts	2—for mtg. oil filter 4—for lower and upper manifold 2—for mtg. starter support bracket 8—for valve tappet adjusting screws
4	$\frac{5}{16}$ "		24	Brass hex. nuts	Lower to upper manifold
1	$\frac{3}{8}$ "		24	Hex. nuts	For magneto mounting stud
12	$\frac{7}{16}$ "		20	Hex. nuts	For mounting cylinder block to crankcase
13	$\frac{3}{8}$ "		16	Hex. nuts	1—for lower magneto mounting screw 4—for mounting side rails to engine support 4—power receptacle to cabinet 4—switch panel to cabinet
4	$\frac{3}{8}$ "		24	Brass nuts	For manifold to cylinder mounting studs
19	$\frac{1}{4}$ "		20	Hex. nuts	1—for governor spring adjustment screw 7—for mounting tank support to rear panel 2—for mounting house brace to panel 4—for mounting partition panel to inspection cover 1—for mounting support strap 4—for mounting air filter
2	No. 10		32	Hex. nuts	For mounting solenoid starter switch
1	No. 5		40	Hex nuts	For governor control rod, carb. end
94	$\frac{1}{4}$ "			Lock washers	2—for mounting fuel pump adaptor 6—for mounting splash plate to case 6—for mounting air shroud screen 33—for mounting air shroud 8—for mounting tank support to rear panel 2—for mounting house brace to panel

Quantity	Size	Length	Thread	Description	Where Used
(94)	$\frac{1}{4}$ "			(Lock washers)	5—for mounting rear panel to engine 6—for mounting canopy to end panels 4—for mounting partition plate to inspection cover 1—for mounting support strap 4—for mounting air filter 4—for mounting control cabinet to tank support 4—for mounting remote control unit in cabinet 3—for mounting 12V-voltage regulator 6—for mounting belt guard to generator bracket
67	$\frac{5}{16}$ "			Lock washers	2—for mounting fuel pump 6—for mounting shroud to gear cover 14—for mounting crankcase to bottom cover plate 20—for mounting gear cover spacer and governor housing case 2—for mounting carburetor 2—for mounting oil filter 8—for mounting lower to upper manifold 2—for mounting starter support bracket 4—for mounting side rails to engine supports 3—for mounting cabinet to support 4—for mounting battery hold down
27	$\frac{3}{8}$ "			Lock washers	4—for mounting manifold to cylinder 6—for mounting main bearing plate T.O. end 1—for mounting magneto upper stud 1—for mounting magneto lower screw 3—for mounting starter 4—for mounting side rails to engine supports 4—for mounting switch panel to cabinet 4—for mounting power receptacle to cabinet

Quantity	Size	Length	Thread	Description	Where Used
14	$\frac{7}{16}$ "			Lock washers	12—for mounting cylinder block 2—for mounting generator bracket
10	$\frac{1}{2}$ "			Lock washers	4—for mounting engine to engine supports 2—for mounting cabinet support to skid base 4—for mounting alternator to skid base
23	No. 10			Lock washers	2—for mounting solenoid starter switch 6—for mounting oil pump cover 11—for mounting cabinet back panel 4—for mounting cabinet door-latch
3	$\frac{5}{16}$ "			External lock washers	For mounting cam gear
4	$\frac{5}{16}$ "			Counter-sunk lock washers	For mounting bearing retainer plate
6	$\frac{1}{8}$ "			Slotted pipe plugs	1—for oil hole to pump 1—for oil header 2—for oil spray nozzle holes 1—for governor housing 1—for oil pump lock screw
1	$\frac{1}{2}$ "			Slotted pipe plug	Slotted pipe plug for gear cover
2	$\frac{29}{64}$ "			Washers	Washers for door clips
4	$\frac{5}{16}$ "			Copper washers	Washers for valve taper plates
40	$\frac{3}{8}$ "			Plain washers	1—for lower mag. mounting screw 4—for mounting switch panel to cabinet 34—for mounting cylinder heads 1—for air cleaner spacer
1	No. 8	$\frac{3}{8}$ "	32	Round head screws	For wire conn. on carburetor
1	No. 8	$\frac{5}{8}$ "	32	Round head screws	For manual choke lever
2	No. 10	$\frac{3}{8}$ "	32	Round head screws	For mounting starter solenoid switch
6	No. 10	$\frac{1}{2}$ "	32	Round head screws	For oil pump cover

Quantity	Size	Length	Thread	Description	Where Used
40	1/4"		20 std.	Round head screws	6—for flywheel screen 23—for mounting cylinder cover and side covers 5—for mounting rear panel to engine support 6—for mounting canopy to end panels
17	1/4"	3/4"	20 std.	Round head screws	4—for mounting cabinet to engine 3—for mounting low voltage regulator 4—for mounting remote control unit 6—for mounting belt guard to generator bracket
2	1/4"		20 std.	Round head screws	Upper hole in cylinder—T.O. end
15	1/4"	3/8"	20 std.	Round head screws	8—for mounting tank support to rear panel 2—for mounting house brace to panels 4—for mounting partition plate to inspection cover
1	1/4"	1"	20 std.	Round head screws	1—for mounting support strap
1	1/4"	3 1/4"	20 std.	Round head screws	For support rear panel
5				Parker-Kalon screws	For mounting rear panel to cylinder block
2	1/4"	3/4"	20 std.	Socket head screws	Front panel to shroud
4				Flat head screws	For mounting fuel pump adaptor
4	1/4"	3/8"	20 std.	Hex. head screws	For mounting bearing retainer plate—fan end
11	1/4"	1/2"	20 std.	Hex. head screws	For mounting lower cylinder shroud—R and L sides
6	1/4"	3/4"	20 std.	Hex. head screws	1—for exhaust manifold R.H. side 6—for mounting splash plate 4—for mounting cylinder head deflector
6	5/16"	1/2"	18 std.	Hex. head screws	For mounting shroud to gear cover
16	5/16"	5/8"	18 std.	Hex. head screws	14—for mounting crankcase bottom cover 2—for mounting fuel pump

Quantity	Size	Length	Thread	Description	Where Used
1	1/8"	1"		Cotter pin	For relief valve spring
2	1/8"	3/4"		Cotter pins	For door clips
3				Cotter pins	1—for governor control rod 2—for choke control rod
1	1/8"			Pipe plug	For inlet manifold
1	1/4"			Pipe plug	For oil drain hole
16	1/4"		20	Square nuts	5—for mounting motor panel to motor support 4—for mounting cabinet to fuel tank support 3—for mounting low voltage regulator 4—for mounting remote control unit
15	3/16"	5/8"	24	Round head screws	11—for mounting cabinet back panel 4—for mounting cabinet door latch
15	3/16"		24	Square nuts	11—for mounting cabinet back panel 4—for mounting cabinet door latch
3	1/8"		18	Square nuts	For mounting cabinet to support
6	1/2"			Lock washers	2—for mounting cabinet support to base 4—for mounting alternator to base
6	1/2"		20 SAE	Hex. head nuts	2—for mounting cabinet support to base 4—for mounting alternator to base
4	1/2"			Flat washers	For mounting alternator to base
2	1/4"	1"	20 std.	Filister head screws	For mounting bearing housing exciter end
3	1/4"	1/2"	20 std.	Filister head screws	For mounting ventilator fan
3	1/4"	5/8"	20 std.	Filister head screws	For mounting bearing housing drive end
1	1/2"	1"	20 SAE	Hex. head screws	For mounting drive pulley

Quantity	Size	Length	Thread	Description	Where Used
9	$\frac{5}{16}$ "	$3\frac{1}{4}$ "	18 std.	Hex. head screws	5—for mounting spacer to crankcase 2—for mounting spacer to gear cover 2—for mounting generator
3	$\frac{1}{8}$ "	$3\frac{1}{4}$ "	18 std.	Round head screws	Cabinet to support
6	$\frac{5}{16}$ "	$7\frac{3}{8}$ "	18 std.	Hex. head screws	2—for mounting carburetors 4—for mounting governor housing
5	$\frac{5}{16}$ "	1"	18	Head screws—hex.	3—for mounting camshaft gear 2—for mounting generator
40	$\frac{5}{16}$ "	$1\frac{1}{4}$ "	18	Hex. head screws	10—for mounting gear cover 30—for mounting cylinder heads
4	$\frac{5}{16}$ "	$1\frac{1}{2}$ "	18	Hex. head screws	For mounting cylinder head
4	$\frac{5}{16}$ "	$1\frac{3}{4}$ "	18	Hex. head screws	For mounting valve taper covers
4	$\frac{3}{8}$ "	$3\frac{1}{4}$ "	16	Hex. head screws	For mounting side rails to engine support
6	$\frac{3}{8}$ "	$2\frac{1}{4}$ "	16	Hex. head screws	For mounting main bearing plate—T.O. end
8	$\frac{3}{8}$ "	$1\frac{1}{4}$ "	16	Hex. head screws	4—for mounting switch panel to cabinet 4—for mounting lower receptacle to bottom of cabinet
1	$\frac{3}{8}$ "	$2\frac{1}{4}$ "	16	Hex. head screws	For mounting magneto—lower hole
2	$\frac{1}{4}$ "	$1\frac{1}{4}$ "	14	Hex. head screws	For mounting generator support bracket
4	$\frac{1}{2}$ "	1"	13	Hex. head screws	For mounting engine support to case
2	$\frac{1}{2}$ "	$1\frac{1}{4}$ "	20 SAE	Hex. head screws	For mounting cabinet support to base
3	$\frac{1}{4}$ "	$\frac{3}{8}$ "	20	Set screws	For mounting starter ring gear
1	No. 0	$\frac{3}{4}$ "		Taper pin	For mounting governor yoke
8	$\frac{1}{8}$ "	$\frac{1}{2}$ "		Cotter pins	For connecting rod bolts
1	$\frac{3}{16}$ "	1"		Cotter pin	For mounting oil pump gear nut

Quantity	Size	Length	Thread	Description	Where Used
15	$\frac{1}{8}$ "	1"	18 std.	Hollow head screws	3—for mounting exciter frame 6—for mounting exciter end bearing bracket 6—for mounting drive end bearing bracket
4	$\frac{5}{16}$ "	1 $\frac{1}{4}$ "	18 std.	Hex. head screws	For mounting exciter pole pieces
8	$\frac{3}{8}$ "	1 $\frac{1}{2}$ "	16 std.	Hex. head screws	For mounting alternator pole pieces
3	$\frac{1}{8}$ "	$\frac{3}{4}$ "		Round head screws	For mounting exciter cover
2	No. 8-	$\frac{1}{2}$ "	32	Round head screws	For mounting exciter brush holder
5	$\frac{3}{4}$ "	$\frac{1}{4}$ "	20	Hollow head set screws	1—for locking exciter lock nut 2—for mounting alternator slip rings on shaft 2—for mounting fan hub to shaft
8	$\frac{3}{4}$ "			Lock washers	2—for mounting bearing housing exciter end 3—for mounting ventilating fan 3—for mounting bearing housing drive end
1	$\frac{1}{2}$ "			Lock washer	For mounting drive pulley
19	$\frac{1}{16}$ "			Lock washers	3—for mounting exciter frame 6—for mounting exciter end bearing bracket 6—for mounting drive end bearing bracket 4—for mounting exciter pole pieces
8	$\frac{3}{8}$ "			Lock washers	For mounting alternator pole pieces
3	$\frac{1}{8}$ "			Lock washers	For mounting exciter cover
2	No. 8			Lock washers	For mounting exciter brush holder

**36. Names and addresses of manufacturers**

Wisconsin Motor Corporation, Milwaukee, Wisconsin	(A)
F-S Electric Company, Memphis, Tennessee	(B)
Electric Auto-Lite Company, Toledo, Ohio	(C)
Fairbanks-Morse Company, Beloit, Wisconsin	(D)
Bendix-Stromberg Company, South Bend, Indiana	(E)
United Specialties Company, Chicago, Illinois	(F)
Whitaker Battery Supply Company, Kansas City, Missouri	(G)
Globe Union, Inc., Memphis, Tennessee	(H)
Lewis Supply Company, Memphis, Tennessee	(I)
Crouse Hinds Electric Company, Syracuse, New York	(J)
United Motors Service Corporation, Detroit, Michigan	(K)
Essex Wire Corporation, Detroit, Michigan	(L)
Mines Equipment Company, St. Louis, Missouri	(M)
Westinghouse Elec. & Mfg. Co., Newark, New Jersey	(N)
Chicago Metal Hose, Chicago, Illinois	(O)
Buffalo Muffler Company, Buffalo, New York	(P)
Gates Rubber Company, Denver, Colorado	(Q)
Leece-Neville, Cleveland, Ohio	(R)
J-B-T Instruments, Hartford, Connecticut	(S)
Rochester Mfg. Company, Rochester, New York	(T)
Soreng-Manegold, Chicago, Illinois	(U)
Bryant Electric Company, Bridgeport, Connecticut	(V)
Ohmite Mfg. Company, Chicago, Illinois	(W)
H. A. Douglas, Bronson, Michigan	(X)
Hart & Hegeman, Hartford, Connecticut	(Y)
Cutler-Hemmer, Milwaukee, Wisconsin	(Z)

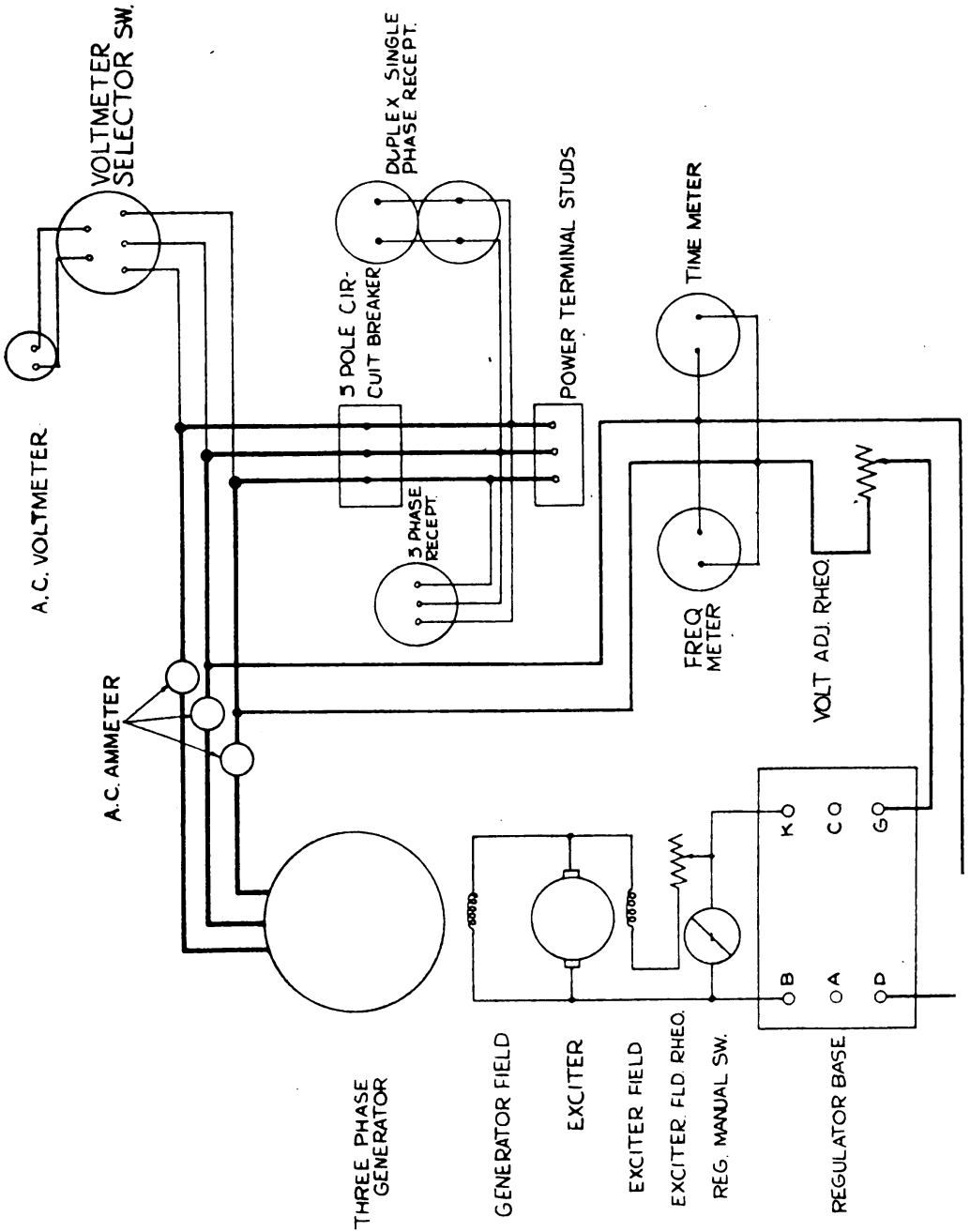

FIGURE 30—AC POWER CIRCUITS







