

160 U113
12
TM
1944

TM 11-935

WAR DEPARTMENT TECHNICAL MANUAL

U.S. Dept. of Army

1½-KVA

KOHLER POWER UNIT

MODEL 1M21-A

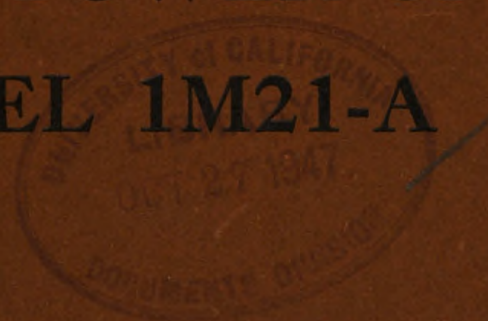

WAR DEPARTMENT

31 MARCH 1944

WAR DEPARTMENT TECHNICAL MANUAL

TM 11-935

**1½-KVA
KOHLER POWER UNIT
MODEL 1M21-A**



WAR DEPARTMENT

31 MARCH 1944

WAR DEPARTMENT,
WASHINGTON 25, D. C., 31 March 1944.

TM 11-935, War Department Technical Manual, 1 ½-KVA Kohler Power Unit Model 1M21-A, is published for the information and guidance of all concerned.

[A. G. 300.7 (14 Feb 44).]

BY ORDER OF THE SECRETARY OF WAR:

G. C. MARSHALL,
Chief of Staff.

OFFICIAL:

J. A. ULIO,
Major General,
The Adjutant General.

DISTRIBUTION: 1C 11 (10).

(For explanation of symbols see FM 21-6.)

TABLE OF CONTENTS

U113
111115
111115
★ ★

	<i>Paragraph</i>	<i>Page</i>
PART ONE. Description.		
General.....	1	1
Component parts.....	2	1
Dimensions and weights.....	3	5
PART TWO. Installation.		
For use with Radio Set SCR-291-(&).....	4	5
For general use.....	5	6
Ventilation.....	6	6
Wiring system requirements.....	7	6
PART THREE. Operation.		
Preparation for use.....	8	8
Starting the unit.....	9	10
Stopping the unit.....	10	11
PART FOUR. Preventive maintenance.		
Routine servicing.....	11	12
Engine.....	12	14
Generator.....	13	21
Lubrication.....	14	21
Engine trouble chart.....	15	23
Generator trouble chart.....	16	29
PART FIVE. Functioning of parts.		
Engine.....	17	31
Generator.....	18	34
PART SIX. Corrective maintenance.		
SECTION I. Engine.		
Specifications, tolerances, and clearances.....	19	37
Removing cylinder head.....	20	39
Grinding valves.....	21	41
Adjusting valve clearance.....	22	42
Magneto disassembly and timing.....	23	42

	<i>Paragraph</i>	<i>Page</i>
Installing new fan belt	24	45
Splitting the engine: removing engine from oil base	25	46
Cylinders and pistons	26	48
Connecting rods and bearings	27	49
Oil baffle plate and oil pump	28	53
Fitting main bearing	29	54
Crankshaft and camshaft gear timing	30	54
Replacing engine on oil base	31	55
 SECTION II. Generator and flywheel.		
Removing brush holder bracket	32	55
Removing collector rings and armature	33	55
Removing field coils	34	58
Testing the generator	35	60
Removing flywheel	36	60
 PART SEVEN. Supplementary data.		
Table of replaceable parts	37	69
List of manufacturers	38	86

LIST OF ILLUSTRATIONS

<i>Fig. No.</i>	<i>Title</i>	<i>Page</i>
1	1 ½-KVA Kohler Power Unit, magneto side	2
2	1 ½-KVA Kohler Power Unit, exhaust side	3
3	Outline dimensional sketch	4
4	Typical installation of unit in building	7
5	Filling the crankcase	10
6	Testing oil level with bayonet gauge	10
7	Draining the crankcase	13
8	Checking spark gap	13
9	Carburetor assembly	16
10	Fuel pump and strainer assembly	17
11	Air cleaner and cylinder head assembly	18
12	Governor assembly	19
13	Generator with end cover removed	20
14	Fan assemblies	22
15	Radiator assembly	32
16	Generator outline sketch, side view	33

<i>Fig. No.</i>	<i>Title</i>	<i>Page</i>
17	Generator outline sketch, end view	34
18	Wiring diagram, with ignition ground switch on switch box. .	35
19	Wiring diagram, with ground button on magneto.	36
20	Rocker arm assembly, with push rods	38
21	Removing cylinder head	39
22	Cylinder head and exhaust manifold	40
23	Grinding valves	41
24	Adjusting valve clearance	43
25	Magneto, cross section view	44
26	Installing new fan belt	45
27	Splitting the engine: removing engine from oil base	47
28	Fitting new piston with shim	49
29	Fitting piston pin	50
30	Fitting connecting rod bearings	51
31	Measuring oil dip of connecting rod	52
32	Checking baffle plate height in crankcase	53
33	Correct meshing of camshaft and crankshaft gears	54
34	Generator, with brush holder bracket and switchbox removed from generator frame	56
35	Removing collector rings from armature shaft	57
36	Removing armature from shaft	58
37	Removing field coils	59
38	Removing flywheel	61
39	Flywheel removed, showing split covers	62
40	Oil base assembly	63
41	Piston and connecting rod assembly	64
42	Cylinder block assembly	65
43	Cylinder block assembly	66
44	Crankshaft assembly	67
45	Camshaft assembly and starting crank	68

DESTRUCTION NOTICE

WHY —To prevent the enemy from using or salvaging this equipment for his benefit.

WHEN—When ordered by your commander.

HOW —1. Smash—Use sledges, axes, handaxes, pickaxes, hammers, crowbars, heavy tools.

2. Cut—Use axes, handaxes, machetes.

3. Burn—Use gasoline, kerosene, oil, flame throwers, incendiary grenades.

4. Explosives—Use firearms, grenades, TNT.

5. Disposal—Bury in slit trenches, fox holes, other holes. Throw in streams. Scatter.

USE ANYTHING IMMEDIATELY AVAILABLE FOR DESTRUCTION OF THIS EQUIPMENT

WHAT—1. Smash—Cylinder head, radiator, fuel pump, carburetor, governor, magneto, generator, switchbox, muffler, commutator, fuel tank, armature and other parts.

2. Cut—Ignition cables, wires, fan belt, leads.

3. Burn—Technical manual.

4. Bend—Fuel lines.

5. Bury or scatter—All parts after destroying their usefulness.

DESTROY EVERYTHING

SAFETY NOTICE

This equipment generates high voltage currents that are dangerous to life. Always turn OFF-ON switch to OFF position before opening switchbox, or before changing fuses. Ground unit when working on it. Provide adequate ventilation at all times when operating unit in a closed room. Exhaust gases are deadly poison.

PART ONE

DESCRIPTION

1. GENERAL.

The 1½-KVA Kohler Power Unit, model 1M21-A, is a manual-starting, 1,500-watt, gasoline-engine-driven direct-connected, a-c generating set. It is designed to generate 110-volt, 60-cycle current for operating radio transmitters of 75- to 300-watt output. It is employed as a power source for Radio Sets SCR-291-($\&$) and SCR-502-($\&$), and can also be used to run a small lighting system, or any other a-c equipment having power requirements within the rated capacity of this unit. The complete unit, less exhaust fittings and fuel tank, is shown in figures 1 and 2. Weight, excluding fittings and tank, is 497 pounds. In this manual Radio Sets SCR-291-($\&$) and Radio Sets SCR-502-($\&$) refer to all models of Radio Set SCR-291 and Radio Set SCR-502.

2. COMPONENT PARTS.

Kohler power unit 1M21-A consists of the following major components:

a. Engine. The gasoline engine is a 4-cylinder, 4-cycle, valve-in-head, water-cooled model. It has a 2-inch bore and a 3-inch stroke, and develops 3.2 horse-power at 1,200 revolutions per minute. It is radiator cooled and equipped with a high tension magneto, oil filter, air cleaner, and fixed-jet carburetor.

b. Radiator and Fan Assembly. The radiator in the cooling system has an 8½-quart capacity. The cooling system is of the gravity type, and includes a belt-driven cooling fan.

c. Fuel Tank and Exhaust Fittings. A 10-gallon fuel tank with suction assembly and copper tube fuel line holds sufficient fuel to run the unit for approximately 23 hours at full load. The exhaust fittings, including exhaust pipe, muffler, flexible manifold connection, fuel tank and line, and accessory equipment for inside installation, are shown in figure 4. (Numbers are Kohler part numbers.)

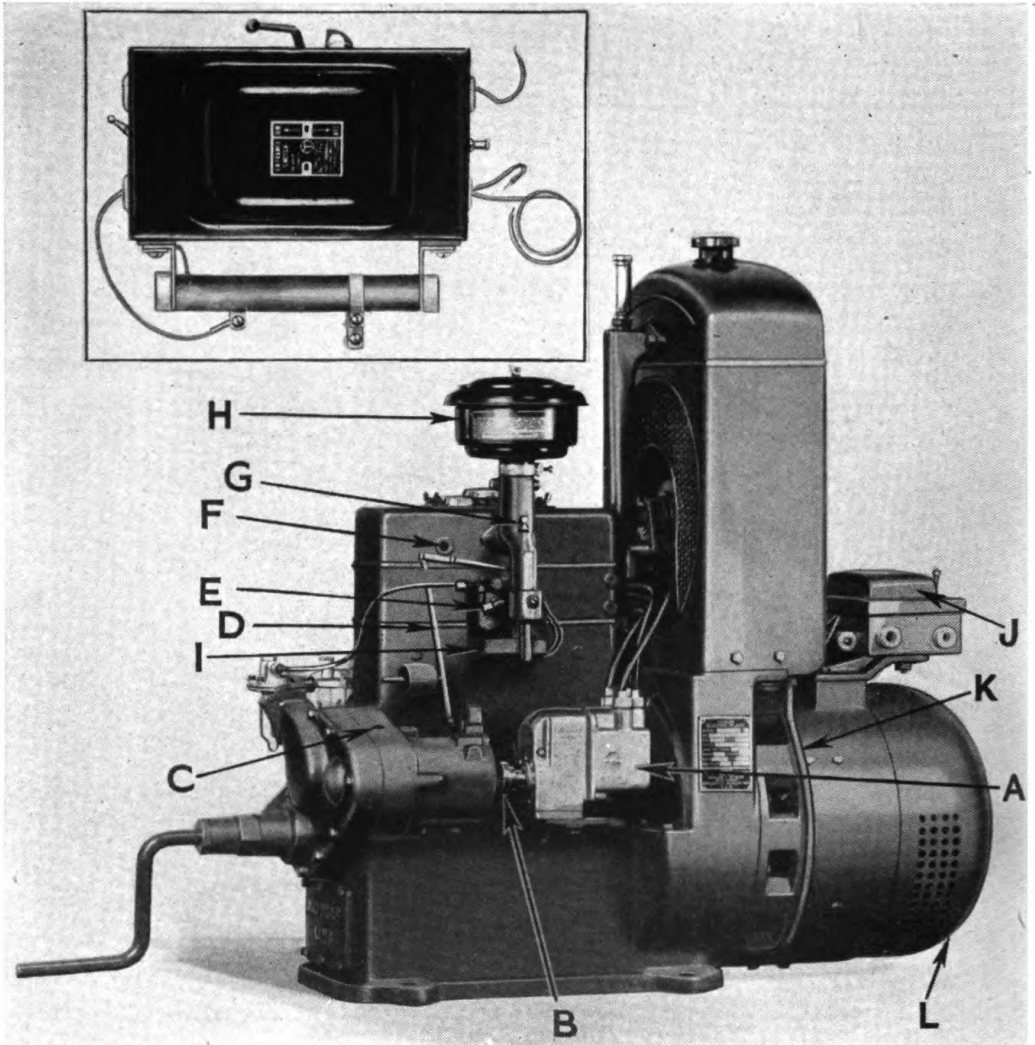

TL-90701

- | | |
|-------------------------------|----------------------------|
| A. Magneto. | G. Choke button. |
| B. Magneto coupling. | H. Air cleaner. |
| C. Governor bearing oil hole. | I. Carburetor drip pan. |
| D. Governor operating lever. | J. Switch box. |
| E. Carburetor. | K. Radiator overflow tube. |
| F. Oil sight hole. | L. Generator end cover. |

*Figure 1. 1½-KVA Kohler Power Unit, magneto side.
(Inset shows switch box when equipped with ignition
ground switch and exciter switch).*

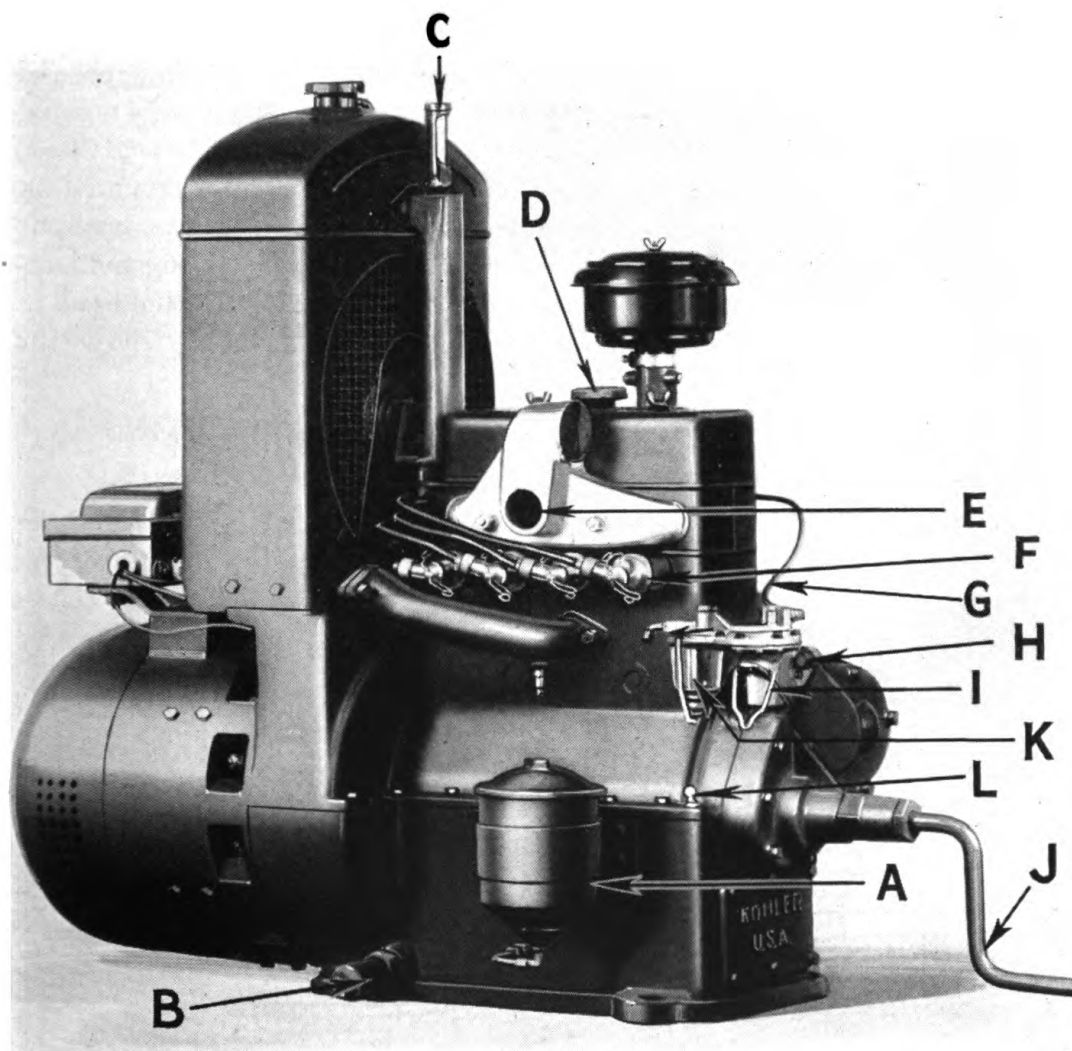

TL-90702

- | | |
|------------------------|-----------------------------|
| A. Oil filter. | G. Fuel line. |
| B. Oil drain plug. | H. Fuel pump. |
| C. Thermometer. | I. Fuel pump priming lever. |
| D. Oil fill plug. | J. Starting crank. |
| E. Exhaust outlet. | K. Fuel strainer. |
| F. Spark plug shields. | L. Bayonet gauge. |

Figure 2. 1 1/2-KVA Kohler Power Unit, exhaust side.

d. Generator. The generator is a shunt-wound, self-excited, 110-volt, 60-cycle, single-phase a-c type, with a 1,500-watt output. The generator armature shaft is directly connected to the engine crankshaft. The generator is equipped with capacitors to reduce radio interference.

e. Switchbox. On units equipped with magnetos having ground button, the switch-box (mounted on the generator end) contains a manual OFF-ON knife switch for controlling the output to the external load, plus two 30-ampere plug-type fuses. A field resistance coil is mounted on the outside of the box. Kohler units equipped with magnetos without ground buttons have, in addition to knife switch, fuses, and field resistance, an ignition ground switch, and an exciter switch mounted in the switchbox. The wiring diagrams in figures 18 and 19 show the

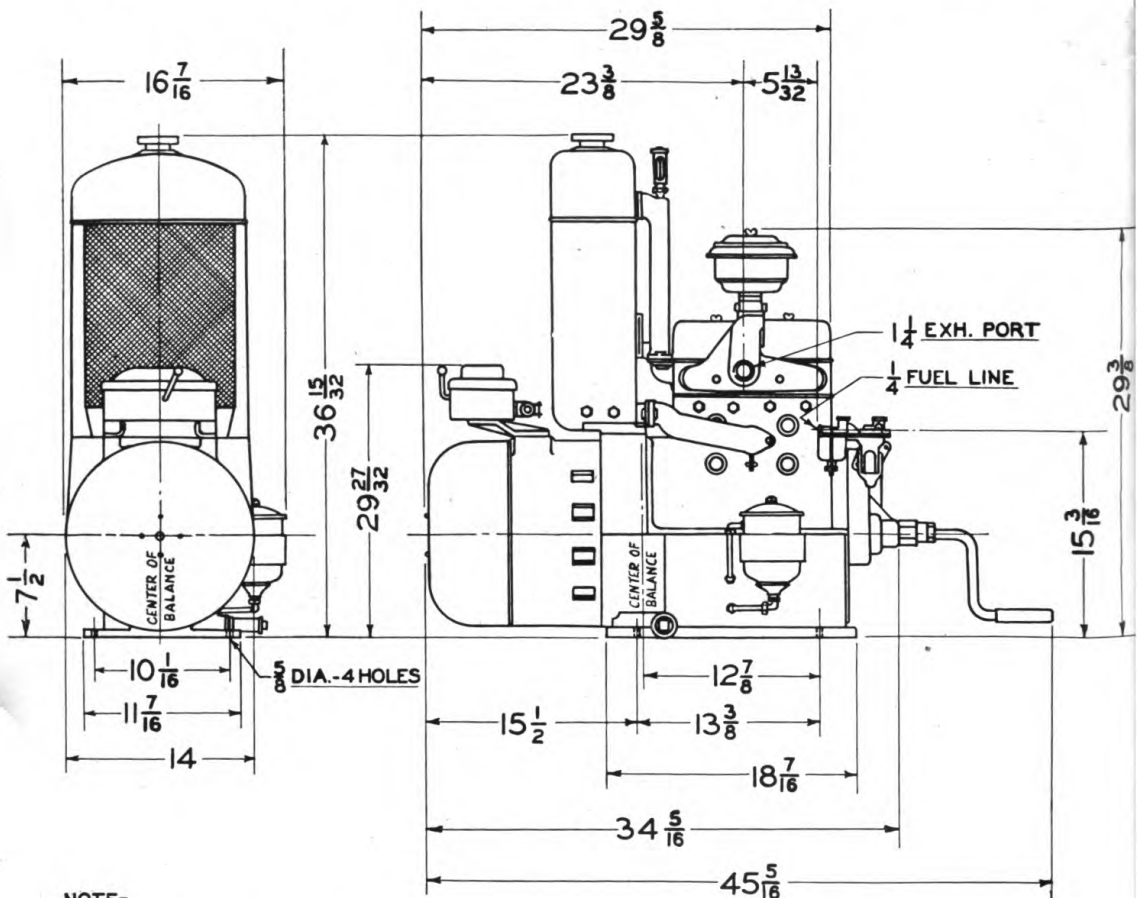

NOTE-

TOTAL WEIGHT - 497 LBS.

WT. AT EACH FRONT MOUNTING HOLE - 10.5 LBS.

WT. AT EACH REAR MOUNTING HOLE - 238 LBS.

DIMENSIONS FOR MODEL

IM2I PLANT - DWG. D-850-M

TL-90703

Figure 3. Outline Dimensional sketch.

difference between the switchboxes. The switchbox used with the ground-button-equipped magneto is shown mounted on the unit in figure 1. The inset shows the switchbox used when equipped with ignition ground switch and exciter switch.

f. Tools. A complete listing of tools furnished with the 1½-KVA Kohler unit follows: (numbers are Kohler part numbers):

Ball-peen hammer (151194).	6-inch pliers (151195).
Carburetor jet wrench (SS-213).	Feeler-gauge (B-913).
Screwdriver (151196).	Valve-feeler gauge case (D-914).
Two "S" wrenches (A-838, B-909).	Double-end wrench (A-849).
Spark plug wrench (D-831).	Socket wrench (A-827).
Socket wrench with six sockets (½ to 1-inch size) (151193).	
Magneto point gauge (153904).	

3. DIMENSIONS AND WEIGHTS.

The over-all dimensions and weight of the unit, less exhaust fittings and fuel tank, are shown in figure 3. Export weight is 880 lbs. Export volume is 28 cubic feet.

PART TWO

INSTALLATION

4. FOR USE WITH RADIO SET SCR-291-(&).

a. General. Shelter HO-19 is provided for housing the 1½-KVA Kohler unit when it is used with various models of Radio Set SCR-291. This shelter is constructed of wood, with removable sides and ends to permit access to the unit for servicing. The shelter is designed to hold two Kohler units, side by side, one of which can be kept in reserve. The removable side panels of Shelter HO-19 are fitted with rain-proof ventilation ports opposite the radiator end of each of the two power unit locations in the shelter. Wooden air chutes included with the shelter can be installed around each of these ventilating ports to conduct fresh air direct to the radiator of each unit for proper ventilation.

b. Installation in Shelter HO-19. To install the Kohler unit in Shelter HO-19, remove the sides of the shipping crate, leaving the crate base bolted to the engine base. The unit can then be slid onto the floor of the shelter. Four wooden planks bolted to the floor of the shelter hold the planks of the crate base in place to prevent the unit from sliding laterally due to engine vibration.

NOTE: Before installing the unit, be sure you have located the shelter in a dry, level, readily accessible spot, whenever possible. Locate it so the exhaust pipe openings in the sides of the shelter will face away from radio operating personnel. The 10-gallon fuel tank can be placed outside the shelter and connected to the fuel pump with copper tube fuel line furnished.

5. FOR GENERAL USE.

Where Shelter HO-19 is not provided, install the Kohler unit in a shed or building, located on dry, level ground. Remove the crate entirely and mount the unit on wooden stringers or on a concrete foundation. The engine base has four holes bored in it to accommodate foundation bolts for the installation. Figure 4 shows a typical installation in a building with the exhaust and fuel tank fittings in place. Locate the unit near the wall of the building so the exhaust pipe will be short and straight. A long exhaust pipe, or one with a number of elbows in it, frequently becomes clogged with carbon and decreases operating efficiency. Pitch the exhaust pipe slightly downward from the exhaust manifold connection, so moisture condensing in the pipe will not run back into the engine cylinders.

6. VENTILATION.

For the most efficient operation this equipment must have adequate ventilation. This is especially important in climates where temperatures exceed 80° F. If possible use only a building in which ventilation can be controlled by doors and windows.

CAUTION: Exhaust fumes are poisonous. Be sure that all joints in the exhaust fittings are tight. Plug the opening around the exhaust pipe where it passes through the wall of the building. Avoid contact between wood and tank.

7. WIRING SYSTEM REQUIREMENTS.

If this equipment is used to operate a lighting system the wiring installed should be adequate to handle future load requirements as well as current needs. Serious damage may result from overloading wires by forcing them to carry more current than they were designed to carry. A table of recommended wire sizes is furnished below as a guide in selecting the proper wire for a small lighting system.

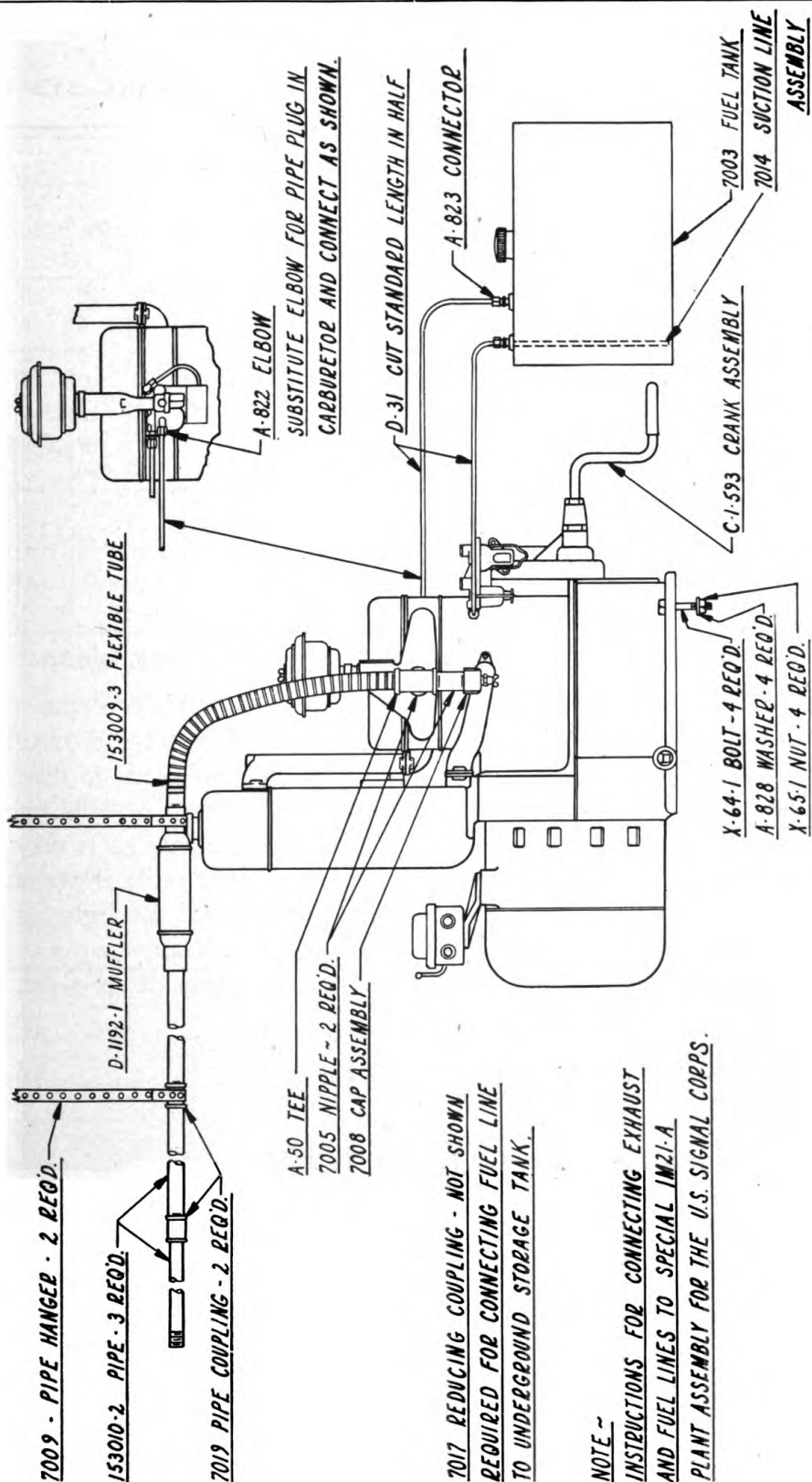

TL-90704

Figure 4. Typical installation of unit in building.

TABLE I
RECOMMENDED WIRE SIZES FOR 110-VOLT LIGHTING SYSTEM

Load in watts at end of circuit	Wire size versus circuit length in (ft.) *															
	100	200	300	400	500	600	700	800	900	1000	1200	1500	2000	2500	3000	4000
100	10	10	10	10	10	10	10	10	10	10	10	10	10	10	10	8
250	10	10	10	10	10	10	10	10	10	10	10	8	8	6	6	4
500	10	10	10	10	10	10	8	8	8	8	6	6	4	4	2	2
750	10	10	10	10	8	8	8	8	6	6	6	4	4	2	2	1-0
1000	10	10	10	8	8	6	6	6	6	6	4	4	2	2	1-0	2-0
1500	10	8	6	6	6	4	4	4	4	2	2	1	1-0	2-0	3-0	4-0
2000	10	8	6	4	4	2	2	2	2	1	1-0	2-0	3-0	4-0		
4000	8	6	6	4	2	2	1	1-0	1-0	2-0	2-0	3-0	4-0			
5000	8	4	2	2	1	1-0	2-0	2-0	3-0	3-0	4-0					
6000	6	4	2	1	1-0	2-0	2-0	3-0	3-0	4-0						
8000	4	2	1	1-0	2-0	3-0	4-0									
10000	4	2	1-0	2-0	3-0	4-0										

* Distance between generator and lead is ½ of circuit length.

NOTE: No. 4-0 wire is the largest size commercially practicable. Above wire sizes are based on maximum voltage drop of 5 percent. Wire smaller than No. 10, supported every 75 feet, should not be used for outside leads, as it does not have sufficient strength to withstand bad weather conditions although it may be large enough to carry the electrical load. The table above is based on commercial copper wire commonly used for lighting circuits. If hard drawn wire is used, a larger voltage drop may be encountered. For best results use the next larger size of wire.

PART THREE

OPERATION

8. PREPARATION FOR USE.

Do the following before attempting to put this unit into operation:

a. Fill the Crankcase. The crankcase holds seven quarts of oil, and is filled through an opening in the cylinder head cover, after removing the plug marked FILL OIL HERE. Use only the grade of oil shown in table below for temperature indicated. The oil level can be checked with the bayonet gauge (fig. 6). *Oil level should not be above the "H" mark on the gauge.*

TABLE II
PROPER OIL GRADES

Lowest expected temperature	Oil
+ 32° F.	SAE No. 30.
+ 10° F.	SAE No. 10.
— 10° F.	SAE No. 10, with 20 % gasoline.
— 30° F.	SAE No. 10, with 20 % gasoline.
Below — 30° F.	SAE No. 10, with 20 % gasoline.

b. Fill Air Cleaner. For temperatures above -10° F, fill air cleaner with oil of same SAE grade as that used in crankcase. For temperatures of -10° F, or below, do not use any oil in the air cleaner.

c. Fill Radiator. Use only pure soft water. If power unit is operated in cold climate, anti-freeze solution must be used. The solution recommended is compound, anti-freeze (ethylene glycol), Ordnance Spec. AXS-864. The table below shows correct percentage of solution to add according to the temperature. The cooling system holds 8½ quarts.

TABLE III
ANTI-FREEZE SOLUTIONS

Type of anti-freeze			Percent by volume to add, at temperatures shown
Ethylene glycol	Alcohol	Glycerine	
.....	27° F.	29° F.	10%
16° F.	19° F.	21° F.	20%
3° F.	10° F.	12° F.	30%
—11° F.	—2° F.	0° F.	40%
—31° F.	—18° F.	—15° F.	50%

NOTE: Check anti-freeze with a hydrometer daily. Add anti-freeze as needed.

d. Fill Fuel Tank. Use only 80-octane gasoline in this unit, which is U. S. Army Spec. 2-103A motor fuel (general purpose). Make sure gasoline is free from water and other foreign substances. *Do not over-fill the tank until the gasoline appears in the filler cap opening.* Examine the tank and fuel line for signs of leakage as soon as you have added fuel.

e. Inspect Exhaust Line. See that all joints are tight. *Remember, exhaust fumes are deadly.*

f. Crank Unit. Before starting, turn the unit with the hand crank, with the ignition grounded to be sure that all parts move freely.



TL-90705

Figure 5. Filling the crankcase.

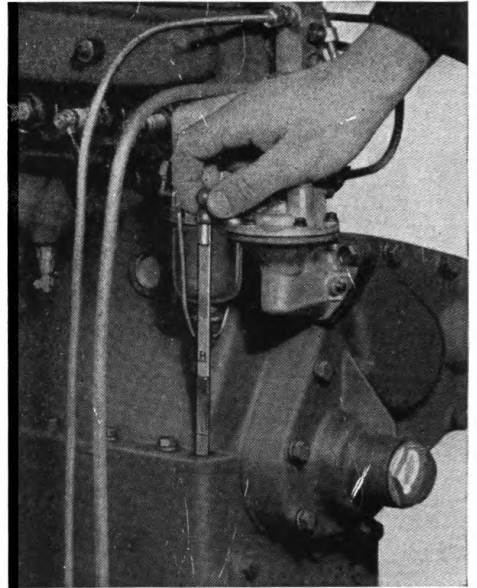

TL-90706

Figure 6. Testing oil level with bayonet gauge.

9. STARTING THE UNIT.

To start the engine, proceed as follows:

- a.* Throw the manual knife-switch to the OFF position.
- b.* Operate the priming lever (fig. 2) on the fuel pump until the bowl is filled.
- c.* On units equipped with ignition ground switch on the switchbox push ignition switch all the way in. Hold the choke button up and crank the engine.

d. On units with ground button on magneto, pull the choke button up, and crank the engine.

e. Check oil circulation after the engine has been started. Look through the small hole in the cylinder head cover (fig. 1), to see if the oil pump is delivering oil from the copper tubing which is visible there. If oil is not being pumped, hold the butterfly valve on the carburetor almost closed. This is done by manually operating the governor lever so that the engine operates at very low speed until oil flows. *If oil is not circulating, do not operate the unit.*

f. Allow the engine to warm up for a few minutes.

CAUTION: Do not put any load on this unit until the engine has warmed up to approximately 125° F. Check the thermometer on the radiator to see when the proper engine operating temperature has been reached.

10. STOPPING THE UNIT.

Throw the OFF-ON knife switch OFF, and stop the engine by pulling out the ignition ground switch located on the switchbox or by holding in the ground button on the magneto, as the case may be. If the unit is to be out of service for some time, drain fuel tank, crankcase, and radiator. When the unit is to be kept out of operation for a period of time where the surrounding temperature is below 0° F, use either of the following methods to keep crankcase oil fluid:

a. When the engine is stopped, drain the oil while still hot into a clean container, which can be covered to keep out dirt and water. When the engine is to be restarted, heat the oil to the point where the bare hand can be held in it for a few seconds without burning, fill the crankcase with the hot oil and start the engine immediately.

b. If the above procedure cannot be followed, drain the crankcase and dilute the drain oil with 20 percent gasoline by volume (5½ quarts oil, 1½ quarts gasoline). When preparing to restart the engine, fill the crankcase with the mixture, start the engine and allow it to run for 10 minutes to circulate the lubricant thoroughly.

NOTE: In sub-zero temperatures, add one quart of anti-freeze solution to radiator, after draining cooling system.

PART FOUR

PREVENTIVE MAINTENANCE

11. ROUTINE SERVICING.

a. Before Starting. Inspect the unit each time before starting it. Check for the following:

- (1) GENERAL CLEANLINESS. Unit must be free of dust, sand, and grease.
- (2) ELECTRICAL CONNECTIONS. Electrical connections must be clean and tight. Replace all defective cables immediately.
- (3) EXHAUST FITTINGS. Check to see that they are tight.
- (4) FUEL TANK AND CRANKCASE FILLED. See paragraph 8*a* for correct fuel and lubricant to use in the 1½-KVA Kohler power unit.
- (5) FUEL LINE AND OIL LEAKS. Tighten all connections and bolts.
- (6) RADIATOR FILLED. This is very important during periods of extreme heat or cold. Check for leaks at hose connections.

b. Weekly or After 48 Hours Operation. Inspect the equipment after every 48 hours of operation, as follows:

- (1) CHECK RADIATOR. Add water or anti-freeze as necessary. See paragraph 8*c* for instructions on anti-freeze.
- (2) DRAIN CRANKCASE. Refill with correct grade of lubricant. In below-zero temperatures be sure to heat oil before refilling crankcase. Drain crankcase while engine is still warm. Do not flush out crankcase with kerosene.
- (3) EXAMINE FAN BELT. Belt should be tight. Before starting unit again, make all checks indicated in paragraph 11*a* above.

c. Monthly or After 200 Hours Operation. Make the following inspections after every 200 hours of operation, in addition to those in the 48-hour check listed above:

- (1) CHECK OIL LEVEL IN CRANKCASE.

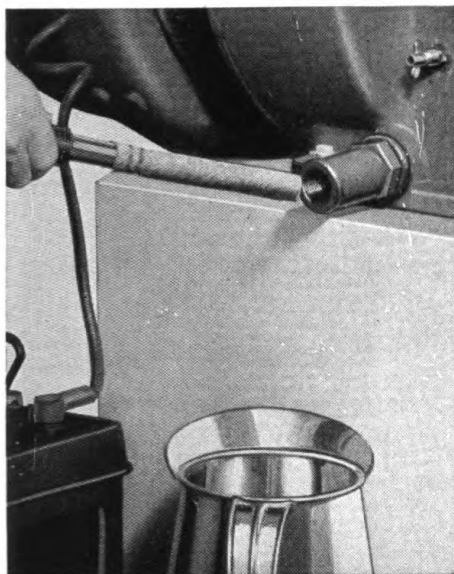

TL-90707

Figure 7. Draining the crankcase.

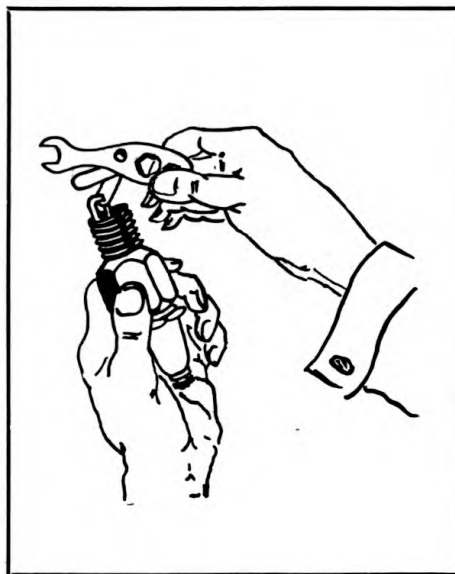

TL-90708

Figure 8. Checking spark gap.

(2) CHECK OIL FILTER. Examine condition of drained oil. Badly discolored or sludgy drainage indicates oil filter element may need replacing. Check condition of element. If it is clogged, replace it with a new element after flushing out the filter case. Oil filter must be cleaned thoroughly every 256 operating hours.

NOTE: After installing a new element and refilling oil base, be sure to check oil level with the bayonet gauge after engine has run a few minutes. Add oil, if necessary.

(3) INSPECT MUFFLER. If it is clogged, remove, and replace it. A clogged muffler means loss of power and less efficient operation.

(4) SERVICE THE SPARK PLUGS. Remove, clean, and adjust spark plugs. Use the feeler gauge in the tool kit to check spark gap, as shown in figure 8. Proper spark gap is 0.025 inches (1/32 inches). Examine porcelain on plug for chipping or cracking. Wipe each plug clean and replace, after checking condition of spark plug gasket.

(5) CHECK GENERATOR BEARING LUBRICANT. If bearing is packed, lubricant must be checked. Remove dynamotor end cover to inspect grease. Use only the correct grade of lubricant given in paragraph 14.

(6) CHECK ENGINE COMPRESSION. To do this, crank engine. If compression is good, there will be a noticeable resistance to the cranking action every half revolution, and crankshaft will tend to kick back.

Ease of cranking indicates lack of compression in one or more cylinders. Check for leaky valves or rings by removing exhaust fitting at engine. Listen to exhaust while cranking the engine. A hissing noise indicates that air is escaping or that valves or rings need checking. Above tests indicate poor compression. Consult Engine Trouble Chart, paragraph 15, for causes and remedies.

(7) CHECK VALVE CLEARANCE. Procedure for checking and adjusting valve clearance is explained in paragraph 22. Be sure to make adjustments while engine is still hot. Proper clearance is 0.006 inches to 0.008 inches on intake and exhaust valves.

(8) CHECK FUEL STRAINER. Clean or replace filter bowl screen, if clogged.

(9) INSPECT COMMUTATOR AND COLLECTOR RINGS. If cleaned and properly adjusted, these parts should have a polished mahogany appearance. Wipe them with a clean, dry cloth, or if necessary with No. 00 sandpaper. If commutator becomes gummy or sticky, clean it with a rag dipped in dry cleaning solvent. If commutator bars wear down to the mica, undercut the mica 1/32 inch below surface of bars, so brushes can ride on bars without interference.

CAUTION: Never use emery cloth or paper to dress the commutator.

(10) CHECK MAGNETO AND IGNITION SYSTEM. Follow instructions in paragraph 12*a* below. Inspect cables and replace any that are oil soaked or have broken insulation.

(11) CHECK COOLING SYSTEM. Drain radiator, flush with clear water, and refill. Examine all fittings and hose connections. Replace worn hose. Lubricate fan assembly bearing according to instructions in paragraph 14.

(12) INSPECT AIR CLEANER. Clean thoroughly every 256 operating hours. Change oil every 64 hours.

d. Moistureproofing and Fungiproofing. See Moistureproofing and Fungiproofing of Signal Corps Equipment, TB SIG 13, for general instructions applicable to this equipment.

12. ENGINE.

a. Ignition System. Test ignition system in the following manner:

(1) TEST IGNITION SPARK. Remove top half of spark plug shield and hold ignition cable about 1/8 inch away from spark plug terminal. Crank engine. Spark should jump gap.

(2) TEST MAGNETO SPARK. To test magneto spark, proceed as follows:

(a) Remove ignition cables from distributor block sockets.

(b) Insert a short piece of insulated wire into one of the sockets.

Be sure wire touches brass insert at bottom of socket.

(c) Bend this wire to within $\frac{1}{8}$ inch of engine or magneto frame.

(d) Crank engine. Spark should jump the gap.

(e) Test each of the remaining three sockets in the distributor block in the same manner.

(3) CHECK DISTRIBUTOR. Remove the ignition cables from the distributor block and remove distributor end cap assembly from generator frame (held on by four cap screws).

(a) Examine carbon brush for wear or damage. It should move freely in its socket and have light spring pressure when depressed.

(b) Clean screens covering ventilating ports.

(c) Inspect breaker points for pitting. Resurface points with a small tungsten file. Points can be replaced by removing locking and terminal screws. Use dry cleaning solvent to remove oil film from points.

(d) On the Fairbanks-Morse magneto, adjust breaker points after resurfacing or replacement, by loosening locking screw and turning the eccentric head adjustment screw until 0.018-0.020-inch gap is obtained at full separation. Use feeler gauge in tool kit to check gap.

(4) MAGNETO DISASSEMBLY AND TIMING. See paragraph 23 for instructions on disassembling magneto and timing magneto to engine.

b. Fuel System.

(1) DEFECTIVE CARBURETION. Dirt in gasoline will clog the carburetor jet aperture and cause defective carburetion. This will result in sluggish engine operation. The carburetor is not adjustable, and jet must be changed to change gasoline mixture.

(2) DIRTY CARBURETOR. If engine speed is unsteady, and causes change in output voltage, particularly on light loads, the carburetor jets need cleaning. To remove jets, take out the brass hexagonal nuts under the carburetor. Wash carburetor in gasoline and clean jets with an air hose. If carburetor still fails to operate, replace it. Carburetor parts are illustrated in figure 9.

(3) FUEL PUMP AND FUEL STRAINER. If fuel pump fails to operate, disassemble it and replace worn parts after installing a new pump on the engine. Fuel pump is shown completely disassembled in figure 10.

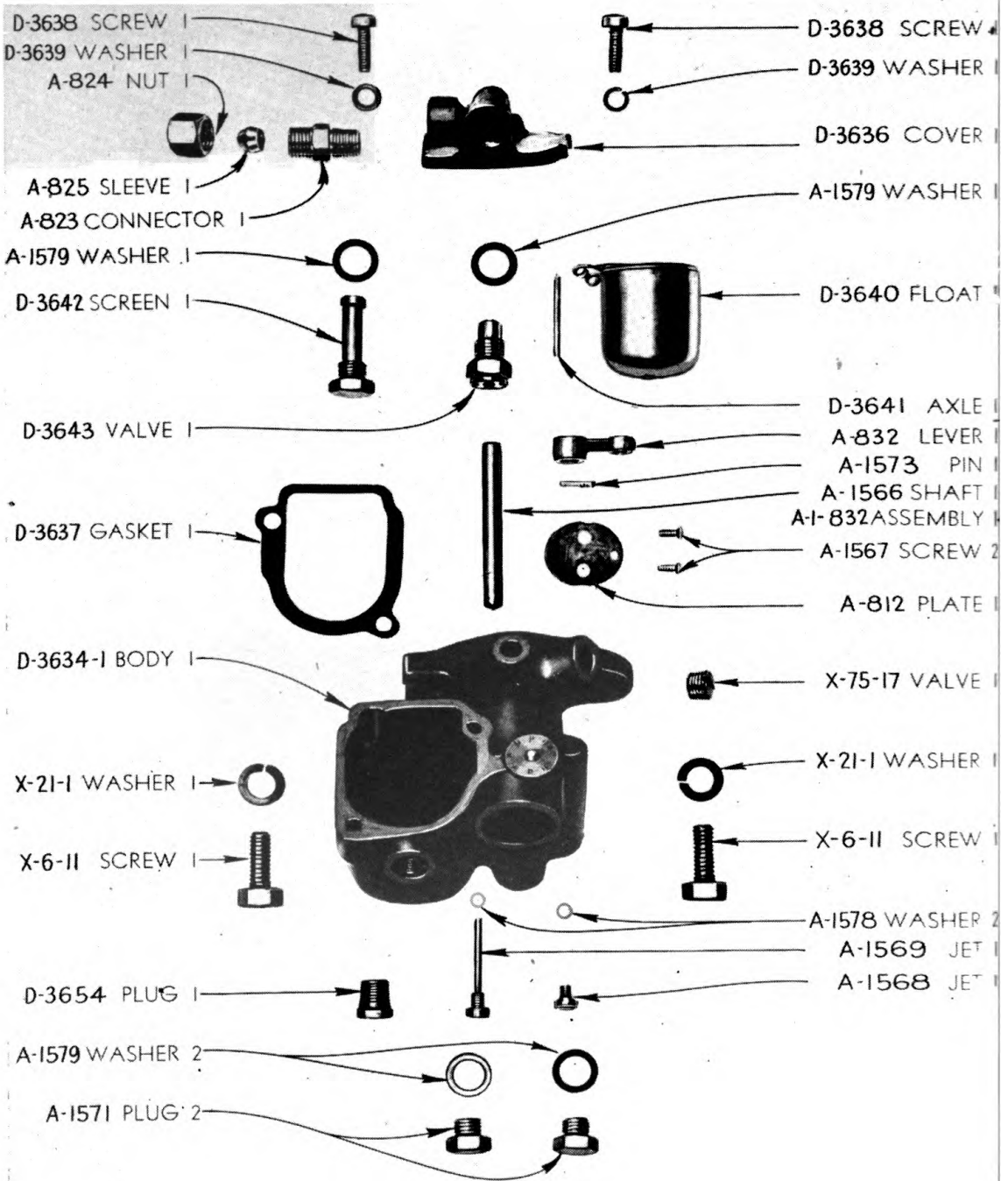

TL-90709

Figure 9. Carburetor assembly.

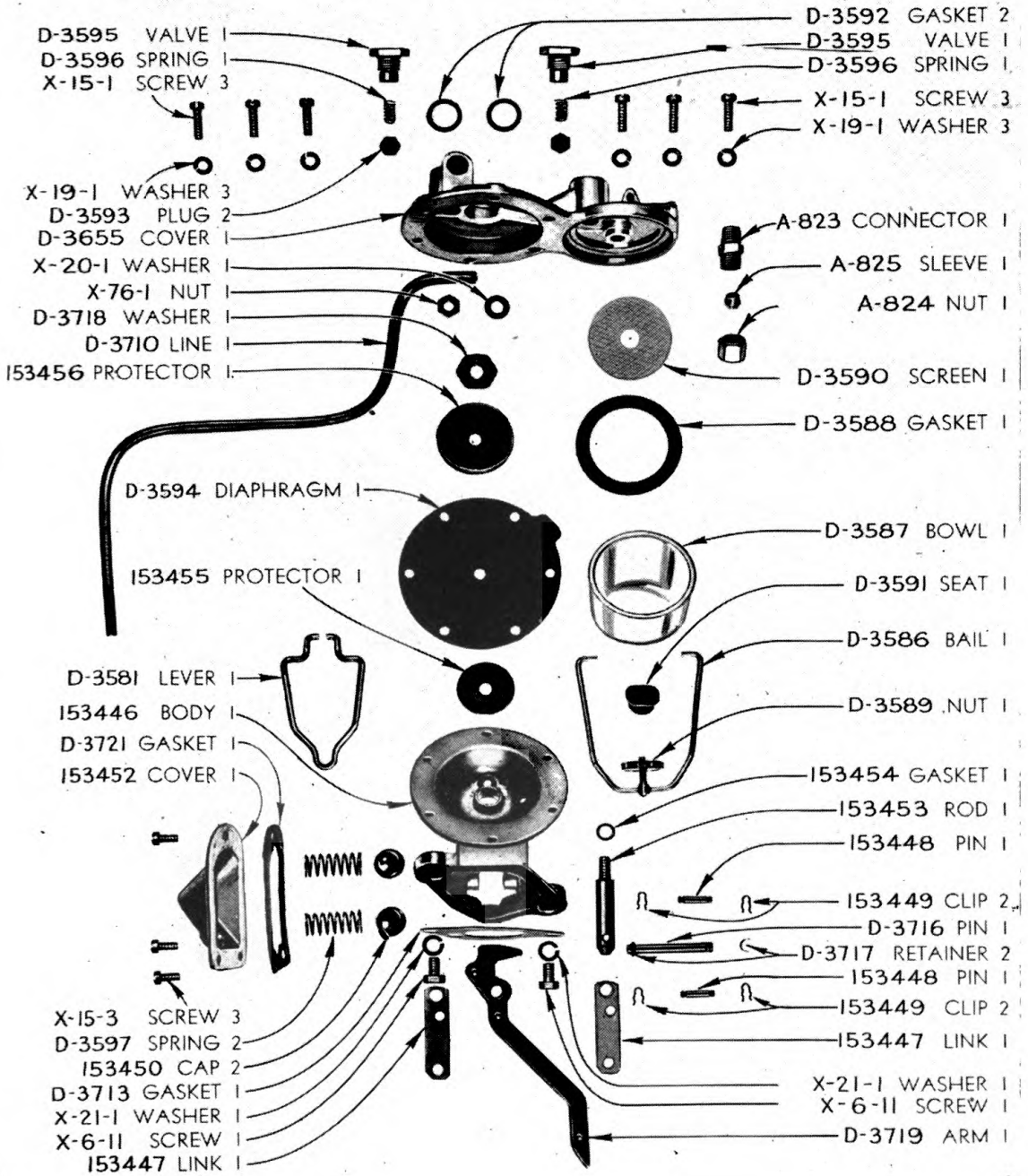

TL-90710

Figure 10. Fuel pump and strainer assembly.

c. Air Cleaner. The air cleaner (fig. 11) which protects the motor from dust and dirt, should be cleaned thoroughly every 256 operating hours, or more often if the power unit is operated under extremely dusty conditions. To clean, remove air cleaner wing nut, cover, and lift out filter and bowl. Wash outside of filter element with rag or brush dipped in gasoline. *Do not submerge.* Pour dirty oil out of bowl and wipe it with a clean rag before replacing. Refill air cleaner every 64 operating hours with oil according to instructions in paragraph 8*b*.

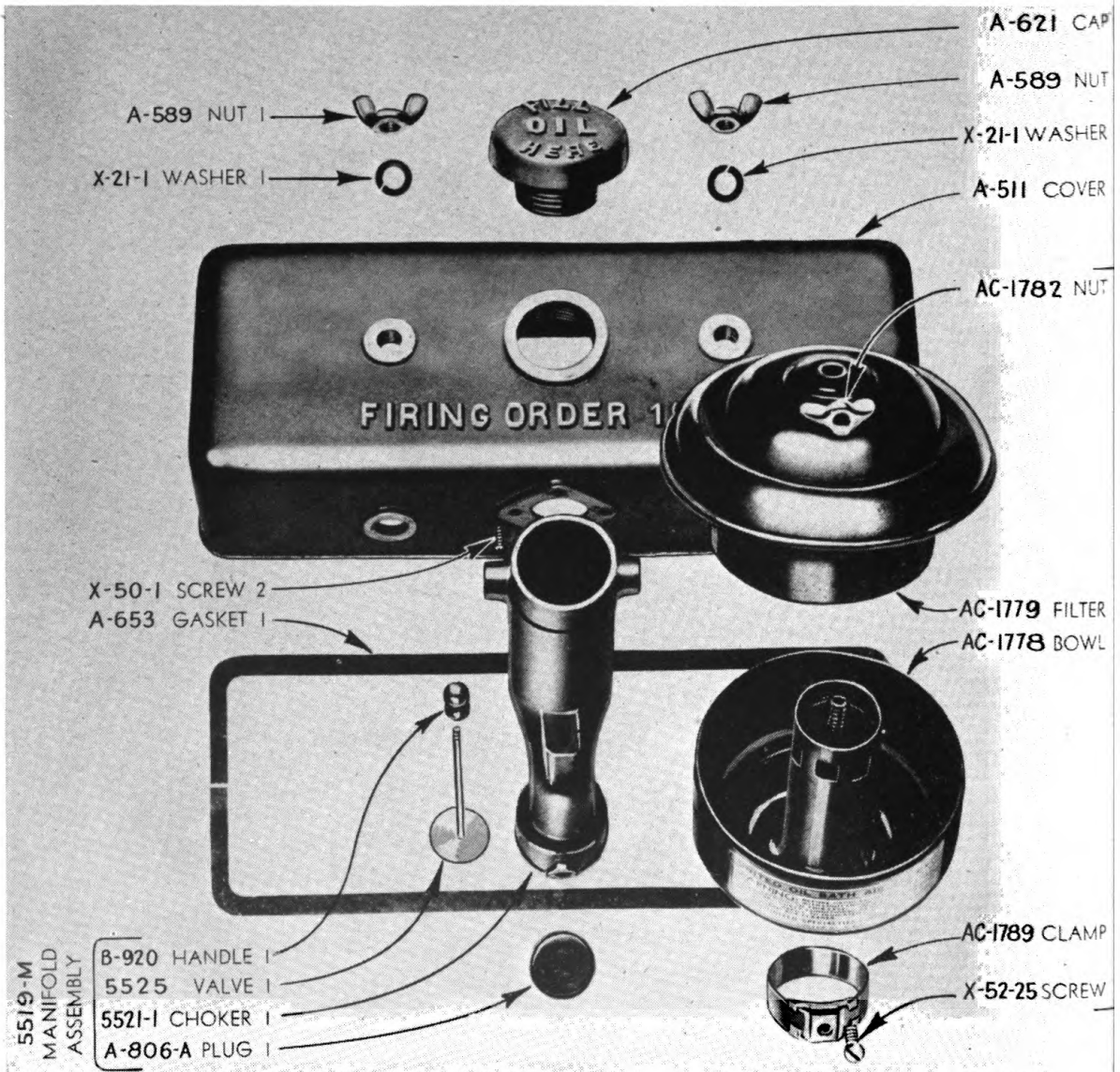

TL-90711

Figure 11. Air cleaner and cylinder head assembly.

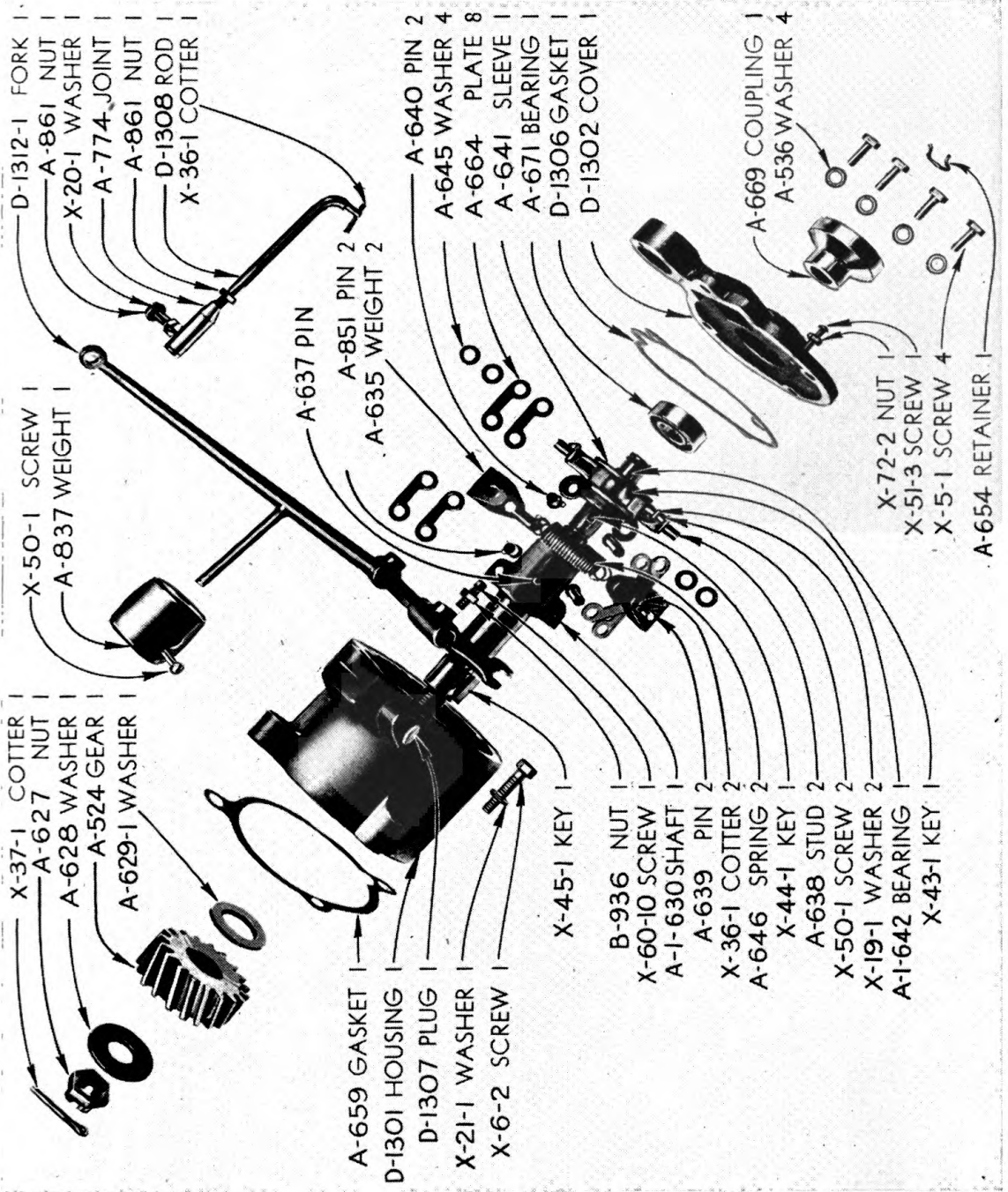

TL-90712

Figure 12. Governor assembly.

d. Governor. Engine speed on the 1½-KVA Kohler power unit is automatically maintained by a centrifugal governor, operated from the camshaft gear. The governor has been carefully adjusted to maintain normal speed of 1,200 revolutions per minute under load. Do not change adjustment unless absolutely necessary. If necessary loosen the screw holding the governor weight, to the governor operating fork (fig. 12) and slide the weight on the fork arm. To test for accuracy of setting, measure engine speed with a tachometer or the frequency at the output terminals with a frequency meter. The engine can be idled by manually operating the governor arm. See paragraph 14 for correct grade of oil to use in lubricating governor shaft bearing.

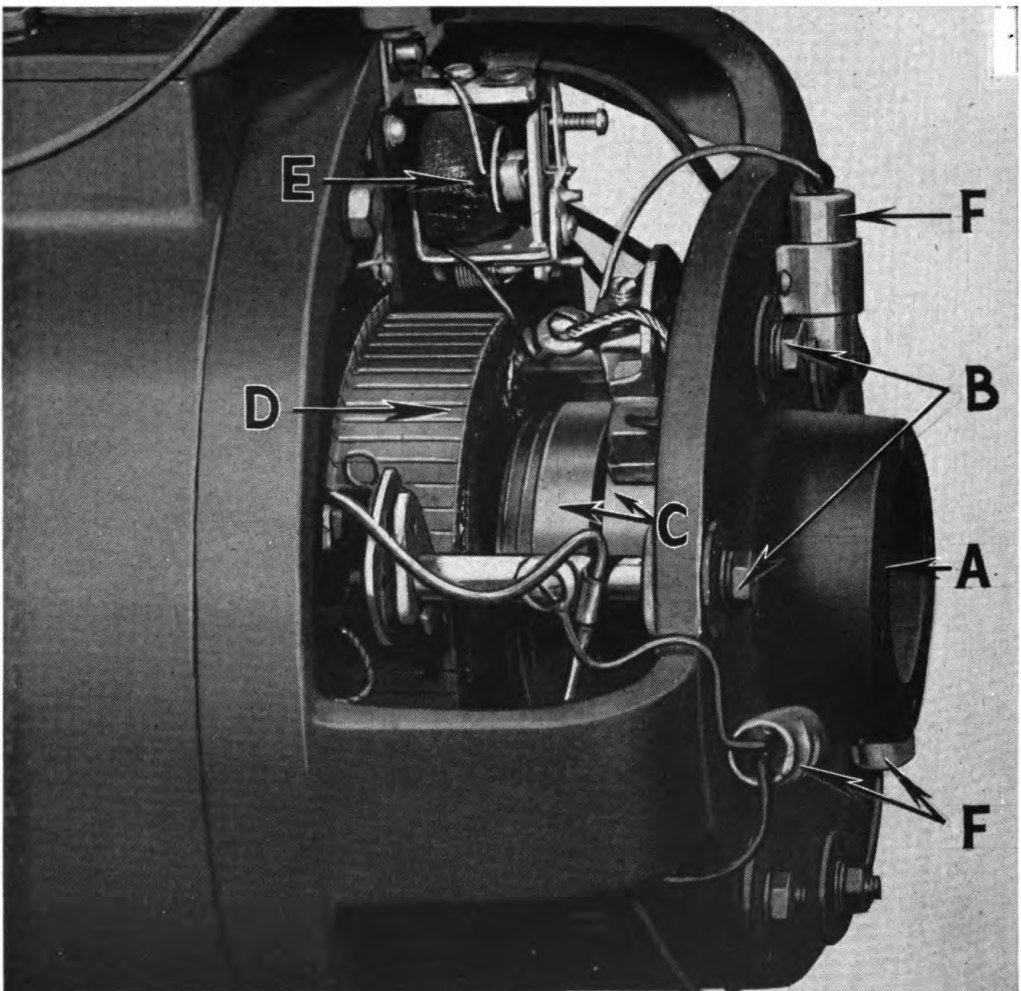

TL-90713

- | | |
|-------------------------------|------------------------------|
| A. Generator bearing housing. | D. Commutator. |
| B. Brush holder studs. | E. Voltage regulating relay. |
| C. Collector rings. | F. Capacitors. |

Figure 13. Generator with end cover removed.

13. GENERATOR.

a. General. The following preventive maintenance measures can be performed by removing the generator end cover (fig. 1). This cover is held to the brush holder bracket by four screws. Figure 13 shows view of generator with end cover removed. Additional disassembly is required to replace bearings, collector rings, armature, field coils, and flywheel. Detailed instructions for this are in part six, Corrective Maintenance.

b. Care of Commutator and Collector Rings. The monthly, or 200-hour operating check, outlined in paragraph 11*b* includes steps to follow in keeping the commutator and collector rings in good condition. Be sure to clean carbon dust out of commutator slots regularly.

c. Brush Care and Replacement.

(1) GENERAL. Brushes must fit easily in brush holders and be held against commutator or rings with uniform pressure. Brushes that are too loose will chatter or get out of alignment. Check condition of the brushes in the Kohler power unit at least once every 300 operating hours.

(2) REPLACEMENT AND CLEANING. When replacing new brushes, sand the ends which ride on the commutator to the proper shape. To do this wrap a piece of No. 00 sandpaper on the commutator. Insert brushes into holders and turn armature shaft with starting crank. Continue this shaping operation until at least 75 percent fit is obtained by testing brushes in proper position with brush holder springs in place. Follow the same procedure in sanding collector ring brushes. After a period of use, a gummy substance will collect on the brushes. Remove brushes from holders when this occurs and clean them with dry cleaning solvent.

d. Generator Bearing. Check the generator ball bearing on the armature shaft for smooth operation. Noisy operation indicates the bearing should be replaced. It is necessary to check the bearing lubricant every 200 hours (monthly). See next paragraph for correct grade of lubricant.

14. LUBRICATION.

a. Crankcase. Use only the grade of oil specified in table in paragraph 8*a* in the engine crankcase. The lubrication system of this engine is not designed for heavier oils which might be satisfactory for use in a truck. Drain the crankcase, as demonstrated in figure 7, while the engine is still warm. Replace drain plug before filling with correct grade of fresh oil. *Do not flush out the crankcase with kerosene.* If drained oil is badly discolored or sludgy, check the oil filter according to instructions given for 200-hour check.

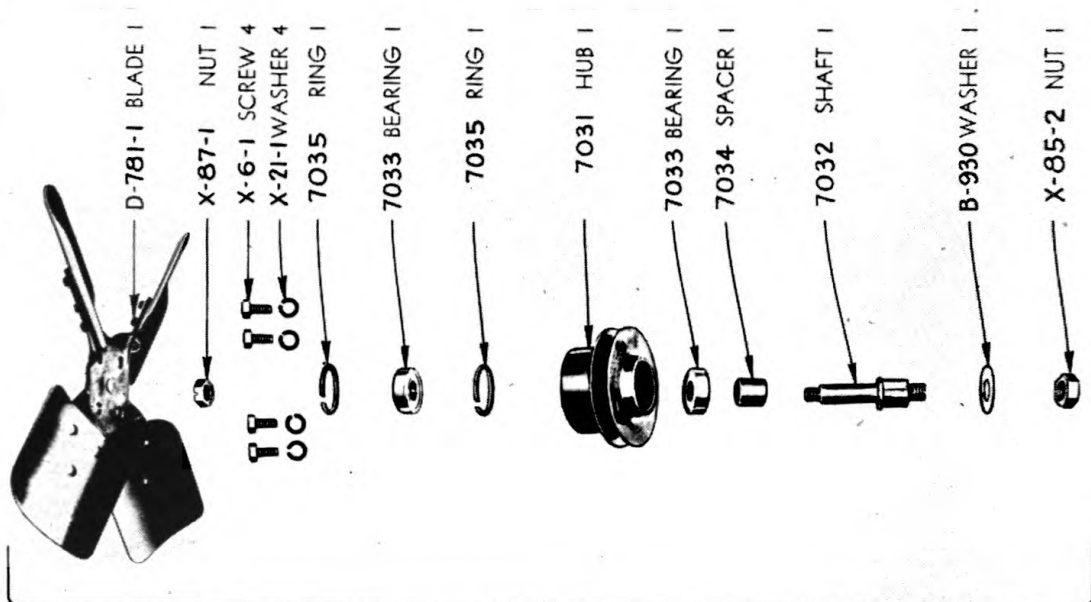

7004 ASSEMBLY

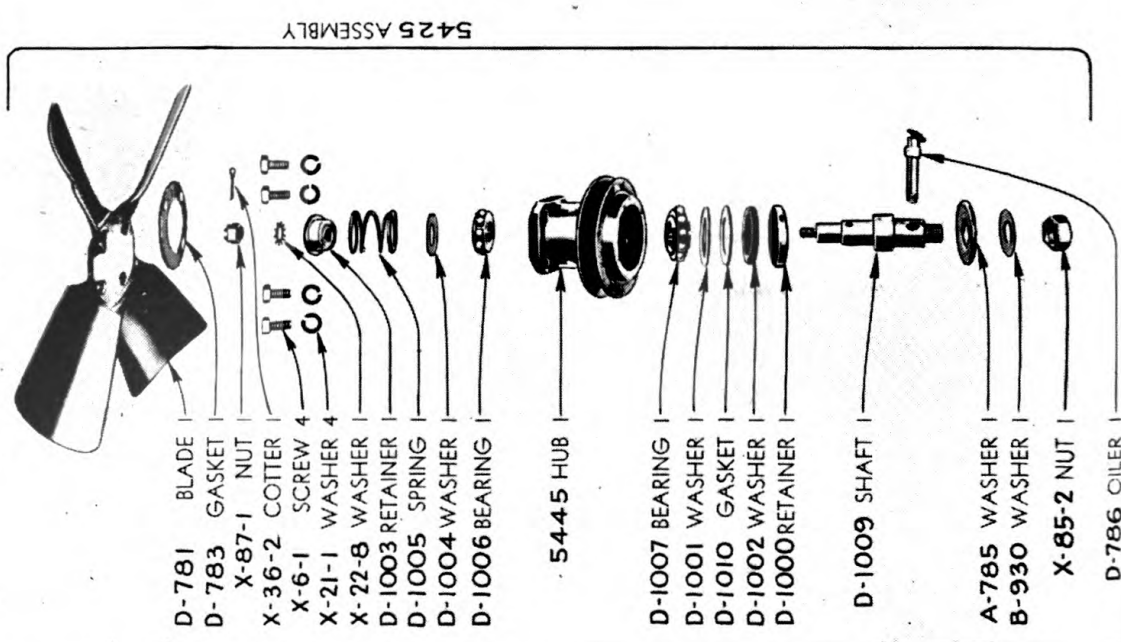

5425 ASSEMBLY

TL-90714

Figure 14. Fan assemblies.

b. Governor Shaft Bearing. Lubricate the governor shaft bearing daily. To do so, remove the threaded plug in the top of the gear box, and add a few drops of engine oil No. 10.

c. Fan Assembly Bearing. Fan assemblies equipped with oil cup should be lubricated daily with engine oil No. 50. Assemblies having no oil cup require no lubrication. The two fan assemblies are shown in figure 14.

d. Magneto Coupling. The magneto coupling should be lubricated each time the magneto is removed for overhaul. For this use general purpose grease, No. 2.

e. Generator Ball Bearing. The bearing housing should be lubricated every 1,064 hours of operation. Pack it with general purpose grease, No. 2.

CAUTION: Be sure not to get any grease on commutator or armature!

15. ENGINE TROUBLE CHART.

a. Engine Will Not Start.

<i>Possible Cause</i>	<i>Check</i>	<i>Remedy</i>
(1) Fuel tank empty.	Check fuel supply.	Add fuel.
(2) Fuel line clogged.	Check fuel strainer.	Clean or replace strainer screen if dirty. Remove and clean fuel line.
(3) Fuel not drawn freely from tank.	Check fuel tank filler cap vent. Check fuel line for air leaks.	Clean out vent. Tighten joints in fuel line.
(4) Improper or dirty fuel.	Check condition and grade of fuel.	Use fresh fuel.
(5) Carburetor clogged.	Check carburetor jet and float valve.	Clean or replace.
(6) Excessive choking.	Check for bent choke valve stem.	Replace defective parts.
(7) Defective fuel pump.	Try spare fuel pump.	Replace pump.
(8) Dirty or cracked spark plug.	Check for spark at spark plug.	Clean plugs or replace.
(9) Improper spark gap.	Check with gauge.	Adjust points.
(10) Improper timing.	Check timing.	Correct timing.

<i>Possible Cause</i>	<i>Check</i>	<i>Remedy</i>
(11) Incorrect valve adjustment.	Check valve clearance.	Adjust clearance.
(12) Defective magneto.	(Par. 23 for disassembly instructions.)	
(a) Burnt out armature.	Check armature.	Replace armature.
(b) Breaker points pitted or worn.	Inspect points.	Clean breaker points or replace.
(c) Breaker points improperly adjusted.	Check breaker point gap.	Adjust gap to 0.018 to 0.020 in.
(d) Loose or defective cables.	Examine cables.	Replace if worn or oil-soaked.
(e) Burnt out capacitor.	Test capacitor.	Replace capacitor.
(f) Dirty rotating disc, collector rings, or brushes.	Inspect parts.	Clean or replace defective parts.
(g) High tension wire shorted.	Check for short.	Replace if broken, or insulation damaged.
(13) Water in cylinder.	Check cylinder head gasket. Check head and block for cracks. Check exhaust pipe for water.	Tighten head bolts or replace gasket. Adjust downward pitch of exhaust pipe.
(14) Air or compression leaks from loose bolts or defective gaskets.	Check for oil or air leaks.	Tighten bolts or replace gaskets.

b. Engine Kicks Back When Being Cranked.

<i>Possible Cause</i>	<i>Check</i>	<i>Remedy</i>
(1) Magneto advanced too far.	Check magneto timing.	Adjust timing.
(2) Crankshaft and camshaft gears improperly meshed.	Check timing.	Correct timing.

c. Engine Starts But Misfires.

<i>Possible Cause</i>	<i>Check</i>	<i>Remedy</i>
(1) Loose electrical connections.	Check connections.	Tighten connections.

Preventive Maintenance

<i>Possible Cause</i>	<i>Check</i>	<i>Remedy</i>
(2) Defective spark plugs.	Check plugs for cracked insulation, cleanliness, and correct gap.	Clean, or replace. Adjust spark gap.
(3) Defective ignition cables.	Examine cables.	Replace worn cables.
(4) Defective magneto	See subparagraph a(12) above.	
(5) Improper timing.	See subparagraph a(10) above.	
(6) Poor compression.		
(a) Leaky valves	Check valve condition	See part six. Corrective Maintenance, for proper action.
(b) Improper valve clearance.	Check clearance.	
(c) Leaky spark plug gasket.	Check plug gasket.	
(d) Loose head, and gasket.	Check head bolts. Check for air leaks.	
(e) Valves not seating properly.	Check valves for warp and valve seat for carbon.	
(f) Worn or sticking piston rings.	Check compression.	
(g) Scored cylinders, worn pistons.	Check engine compression.	
(h) Broken valve springs, bent stems.	Inspect valve springs and stems.	
(7) Mixture too lean.	Check compensating jet.	Set jet in center of venturi tube.
(8) Mixture too rich.	Check choker rod position.	Push choker down.

d. Engine Backfires Through Carburetor.

<i>Possible Cause</i>	<i>Check</i>	<i>Remedy</i>
(1) Fuel contains water or dirt.	Check fuel and strainer.	Use fresh fuel. Replace strainer screen.
(2) Air leak between carburetor and cylinder head.	Check intake manifold gasket.	Replace worn gasket.

<i>Possible Cause</i>	<i>Check</i>	<i>Remedy</i>
(3) Improper mixture.	Check cleanliness and position of compensating jet in carburetor.	Clean out jet. Correct position. (Should be in center of venturi tube).
(4) Leaky, or improperly adjusted valves.	See subparagraph c(7)(a) above.	
(5) Improper timing.	See subparagraph a(10) above.	
(6) Defective choker.	Check choker rod operation.	Replace choker rod.
(7) Float level too low.	Check position of float level.	Adjust position.

e. Engine Knocks.

<i>Possible Cause</i>	<i>Check</i>	<i>Remedy</i>
(1) Improper fuel.	Check grade of fuel.	Replace with correct fuel.
(2) Carbon in cylinders.	Remove plugs and check for carbon.	Clean out carbon.
(3) Loose piston pins or flushings.	Remove and examine pistons.	Replace defective parts.
(4) Lack of oil.	Check oil level.	Add oil if necessary.
(5) Magneto timing advanced too far.	Check magneto timing to engine.	Correct timing.
(6) Loose main bearing.	Check for oil leaks.	Fit new bearing.
(7) Worn rod bearing.	Short plug to see if noise disappears.	Replace bearing.
(8) Loose generator bearing.	Check alignment and fit in housing.	Replace defective bearing. Correct alignment.
(9) Broken piston ring.	Check compression, remove piston.	Replace broken ring.
(10) Weak or broken valve, springs.	Remove cylinder head cover and inspect.	Replace faulty springs.
(11) Engine overheated.	See subparagraph g below.	

f. Engine Lacks Power.

<i>Possible Cause</i>	<i>Check</i>	<i>Remedy</i>
(1) Cold motor.	Check engine temperature with thermometer.	Remove load and allow engine to warm up.
(2) Mixture too rich.	See subparagraph c(9) above.	
(3) Mixture too lean.	See subparagraph c(8) above.	
(4) Improper fuel.	See subparagraph e(1) above.	
(5) Poor compression.	See subparagraph c(7) above.	
(6) Excessive carbon.	See subparagraph e(2) above.	
(7) Obstruction in exhaust or muffler.	See subparagraph g(11) below.	
(8) Lack of lubrication.	Check oil supply, lines oil pressure.	Add oil, repair oil pump.
(9) Defective magneto.	See subparagraph a(12) above.	
(10) Defective spark plugs.	See subparagraph c(2) above.	
(11) Improper valve adjustment.	See subparagraph a(11) above.	
(12) Valve tappets sticking.	Turn engine with crank to check operation.	Clean carbon from tappets or replace springs, if weak.
(13) Tight bearings.	Turn engine over with crank. Observe sticking.	Replace bearing.
(14) Improper governor adjustment.	Check engine rpm with tachometer.	Adjust governor fork weight to increase speed.

g. Engine Overheats.

<i>Possible Cause</i>	<i>Check</i>	<i>Remedy</i>
(1) Radiator empty.	Check radiator.	Add water.
(2) Radiator clogged.	Check amount of scale in radiator.	Flush out radiator.
(3) Lack of lubrication.		
(a) Insufficient oil.	Check oil level.	Add oil.

<i>Possible Cause</i>	<i>Check</i>	<i>Remedy</i>
(b) Oil pressure low.	Check through observation hole.	Check condition of oil pump.
(c) Oil too light.	Check grade of oil.	Drain and refill with oil of proper grade.
(4) Fan belt loose or slipping.	Test belt tension.	Replace fan belt.
(5) Air cleaner clogged.	Inspect air cleaner.	Clean out element.
(6) Excessive carbon.	See subparagraph e(2) above.	
(7) Improper timing.	See subparagraph a(10) above.	
(8) Cooling air passages obstructed.	Check radiator grille, and generator vents.	Remove dirt or obstruction.
(9) Lack of ventilation in shelter.	Check ventilation openings.	Open windows; provide more air vents.
(10) Overload on generator.	Check load.	Reduce load.
(11) Exhaust obstructed.	Check exhaust pipe and muffler.	Remove obstructions. Replace muffler if necessary.

b. Excessive Smoking at Exhaust.

<i>Possible Cause</i>	<i>Check</i>	<i>Remedy</i>
(1) Improper fuel.	Check grade of fuel.	Replace with correct fuel.
(2) Mixture too rich.	Check choker.	Adjust choker.
(3) Pistons pumping oil.		
(a) Loose or worn rings.	Check compression. Examine rings.	Replace rings.
(b) Scored cylinder walls.	Remove pistons and inspect cylinders.	Regrind cylinders.
(c) Oil too light.	Check grade of oil.	Replace with heavier oil.
(d) Oil level too high.	Check oil level (Should not be above "H" mark on gauge).	Drain excess oil.
(4) Worn rod bearings.	See subparagraph e(7) above.	

- (5) Worn cylinders, pistons. Check engine compression. Replace worn parts.

1. Engine Operates with Varying Speed.

<i>Possible Cause</i>	<i>Check</i>	<i>Remedy</i>
(1) Clogged fuel line, dirty fuel.	See subparagraph a(2) above.	
(2) Governor stuck.	Check governor operation.	Correct alignment. Replace faulty parts.
(3) Faulty choke operation.	Check choker button.	Replace defective or bent rod.
(4) Motor cold.	Check engine temperature.	Remove load, allow engine to warm up.

16. GENERATOR TROUBLE CHART.

a. Failure to Generate.

<i>Possible Cause</i>	<i>Check</i>	<i>Remedy</i>
(1) Short or open in wiring system.	Check leads in generator.	Solder connections. Replace defective wires.
(2) Ground or open in armature or coils.	Test armature and coils.	Replace defective parts.
(3) Residual magnetism weak.	Pass current from battery through field coils.	Connect positive battery pole to positive lead of field.
(4) Brushes not contacting.	Check to see if stuck or unevenly worn.	Adjust or replace brushes.
(5) Shorted armature.	Check commutator bars for dirt and material in slots.	Clean bars and slots.
(6) Reversed field coils.	Check to see that coils are alternate north and south.	Change position of coils if necessary.
(7) Capacitor shorted.	Disconnect capacitor and see if current flows.	Replace capacitor.
(8) Defective voltage regulator relay.	Test relay.	Replace relay.

<i>Possible Cause</i>	<i>Check</i>	<i>Remedy</i>
(9) Shorted commutator bars.	Check for rim fire indicating high mica. Inspect slots for dirt.	Undercut mica. Clean out slots.

b. Sparking at Brushes.

<i>Possible Cause</i>	<i>Check</i>	<i>Remedy</i>
(1) Dirty brushes or commutator.	Check condition of each.	Clean brushes and commutator with dry cleaning solvent.
(2) Improper brush contact.	Check to see if brushes are stuck. Check spring tension.	Correct spring tension. Replace brush, if necessary.
(3) Loose armature lead.	Check leads.	Connect lead properly.
(4) Commutator rough.	Inspect for uneven places.	Dress with No. 00 sandpaper.
(5) Load too heavy.	Check load.	Reduce load.
(6) Grounded, open or shorted field coils.	Test as directed in paragraph 35.	Replace defective coils.
(7) High mica between commutator bars.	Check for rim fire.	Undercut mica.

c. Voltage Too High or Too Low.

<i>Possible Cause</i>	<i>Check</i>	<i>Remedy</i>
(1) Engine speed incorrect.	Check engine rpm with tachometer.	Adjust governor. Proper engine speed (1,200 rpm).
(2) Load shorted.	Check external wiring.	Correct deficiencies.

d. Armature Too Hot.

<i>Possible Cause</i>	<i>Check</i>	<i>Remedy</i>
(1) Armature coil shorted.	Check for breaks.	Replace coil.
(2) Poor ventilation.	Check air space around generator.	Provide 2-ft. clearance all around unit.
(3) Excessive load.	Check load.	Reduce load.
(4) Foreign matter in air passages.	Check.	Remove obstructions.

PART FIVE

FUNCTIONING OF PARTS

17. ENGINE.

a. General. The engine is a 4-cycle, internal-combustion type, with radiator cooling. The theory of operation is explained in The Internal Combustion Engine, TM 10-570. The cylinder firing order is 1, 3, 4, 2.

b. Ignition System. The voltage required for the spark ignition is supplied by a high tension magneto. The magneto contains an interrupter, distributor and capacitor. The only other parts necessary to complete the system are the spark plugs. The interrupter opens the primary circuit of the armature when it has reached its peak voltage position. The distributor completes the circuit from the magneto to the individual spark plugs at the correct instant to ignite the fuel mixture during the compression stroke of the piston. The spark plugs in the ignition system are shielded to prevent radio interference (fig. 1).

c. Fuel System. The fuel is contained in a 10-gallon tank. The fuel passes through a fuel line and fuel pump to the fixed jet carburetor. From there it is drawn through the intake manifold to the intake valves and the cylinders.

d. Governor. A centrifugal governor controls the engine speed of the Kohler power unit. The governor is adjusted at the factory for 1,200 revolutions per minute. The method of readjusting is explained in paragraph 12d.

e. Cooling System. The cooling system uses the gravity method of circulation. This type of system requires no water pump. The water jacket is cast integrally with the cylinders and has two openings; one for the water to enter, and the other for the water to escape through. Pipes connect the water jacket openings to the radiator. The radiator is shown in figure 15.

f. Lubricating System. The lubrication system provides for forced oiling to the main bearings and rocker arms, and splash oiling to connecting rods, pistons, and piston pins. The oil pump is a plunger type, operated by a cam on the camshaft. An oil filter is mounted on the crankcase on the muffler side of the engine.

g. Exhaust System. The exhaust, consisting of flexible tubing, a muffler, and exhaust pipe, conducts the exhaust fumes from the manifold away from the unit. The muffler in the system is designed to reduce engine noise.

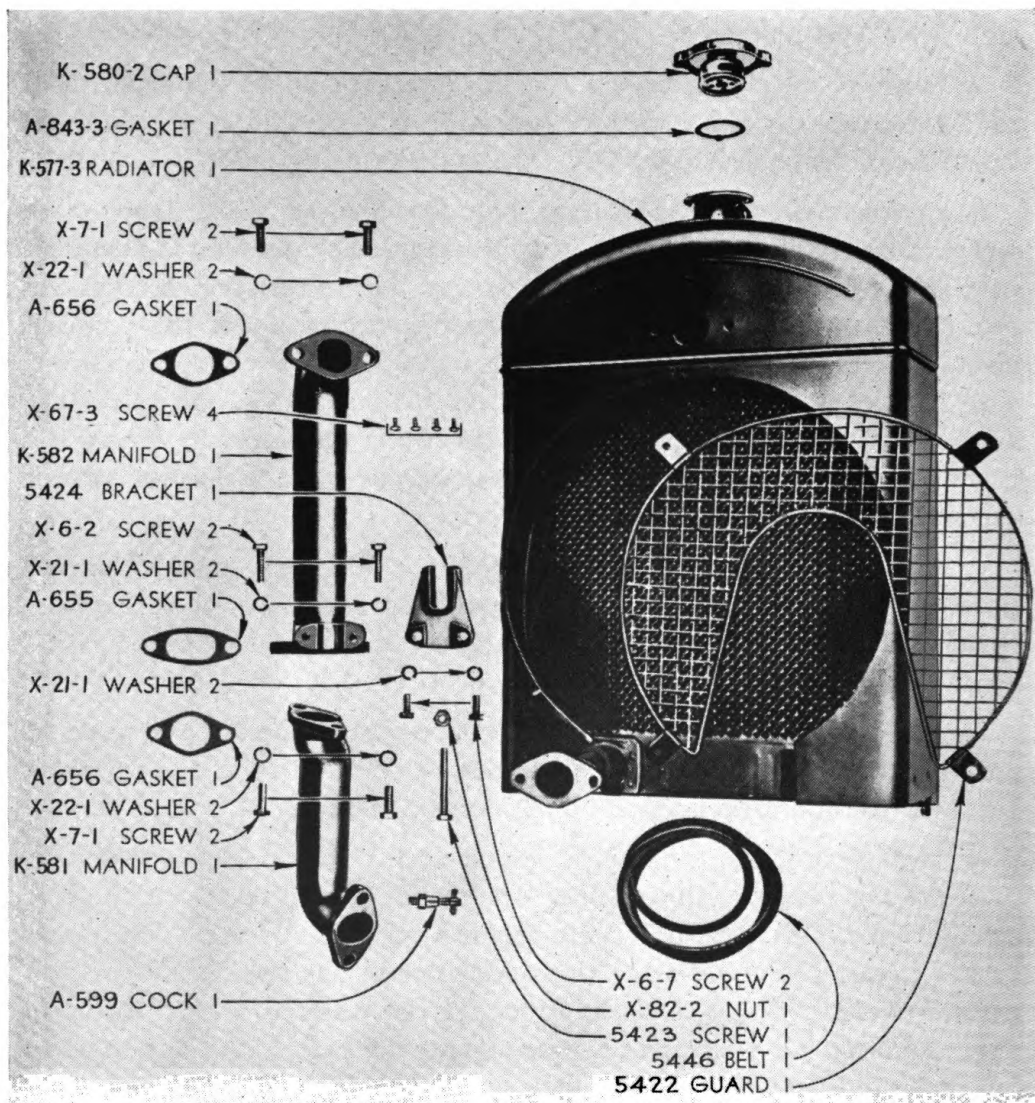

TL-90715

Figure 15. Radiator assembly.

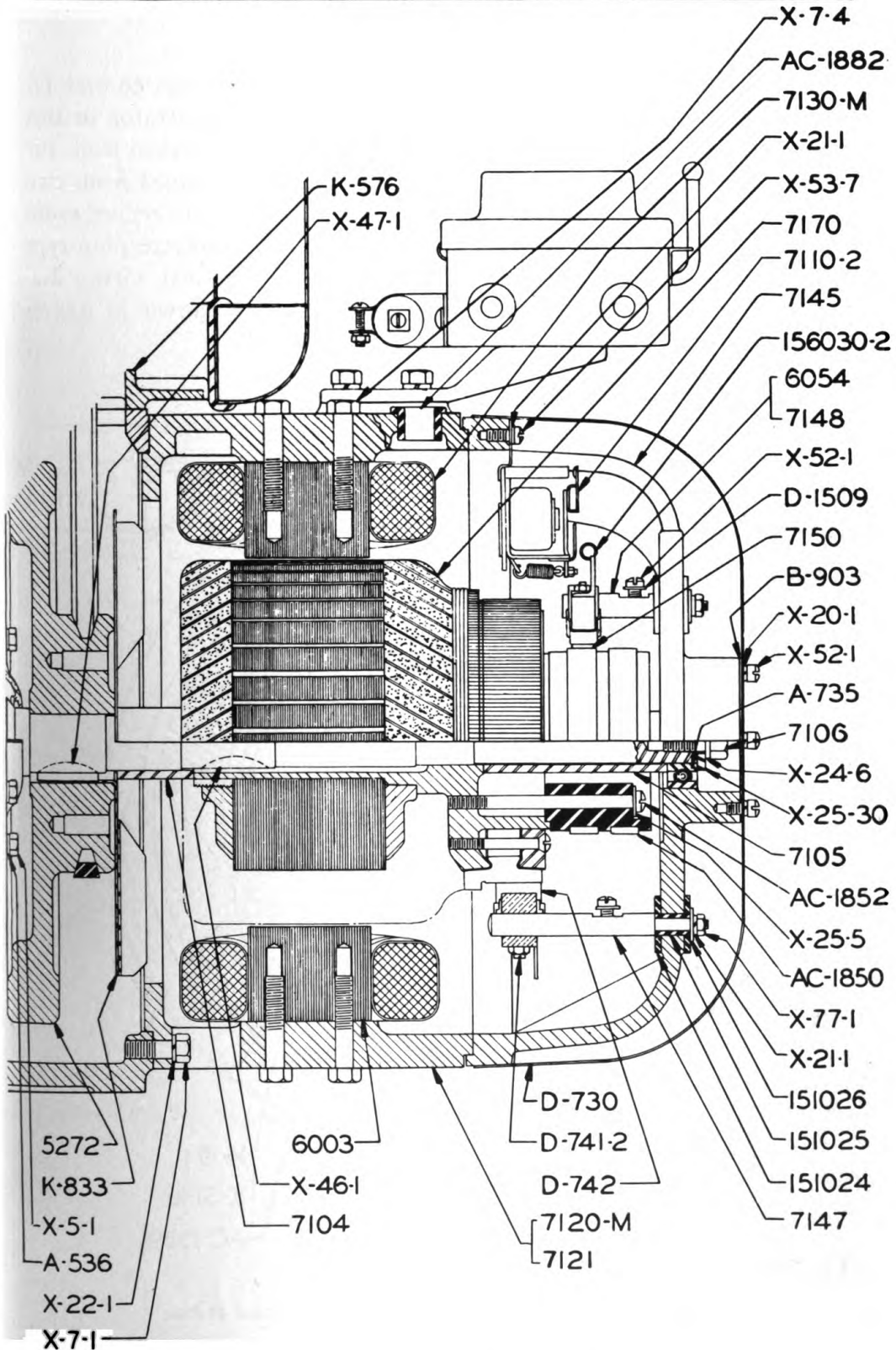

TL-90716

Figure 16. Generator outline sketch, side view.

18. GENERATOR.

Outline sketches of the generator are shown in figures 16 and 17. The d-c exciter winding and the a-c windings of the generator in this power unit are on the same shaft. The exciter current is taken from the commutator by four d-c brushes. The a-c output is obtained from two a-c collector rings. The unit is equipped with capacitors to reduce radio interference, and a voltage regulating relay. Two 30-ampere plug-type fuses in the switchbox protect the external load. Practical wiring diagrams of the unit with each type of switchbox are shown in figures 18 and 19.

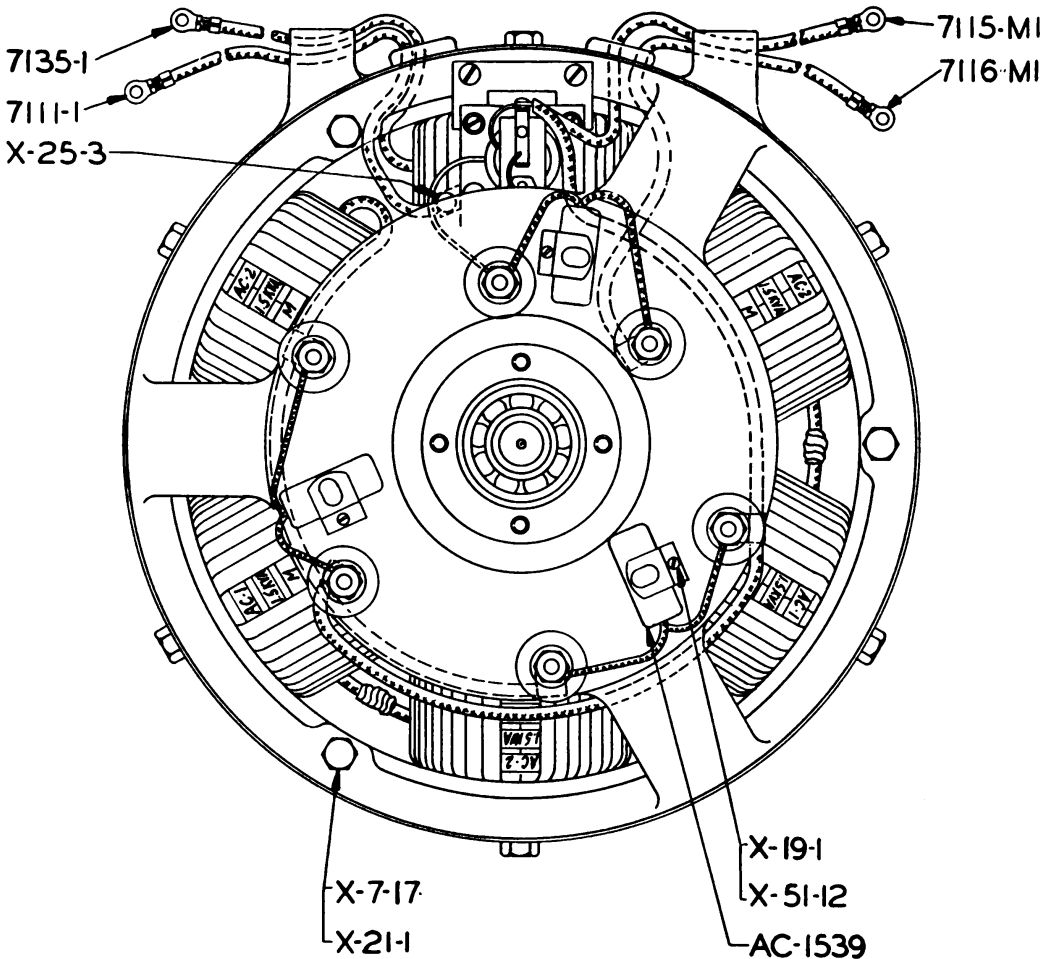

TL-90717

Figure 17. Generator outline sketch, end view.

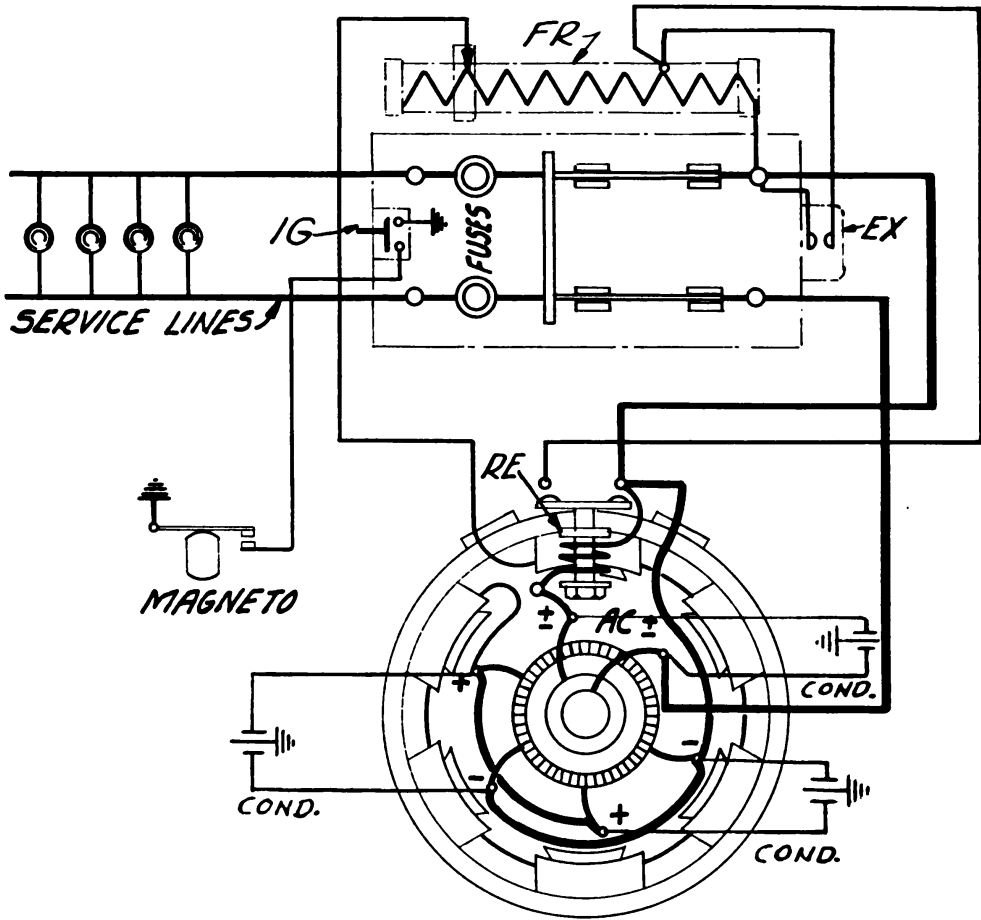

TL-90718

Figure 18. Wiring diagram, with ignition ground switch on switch box.

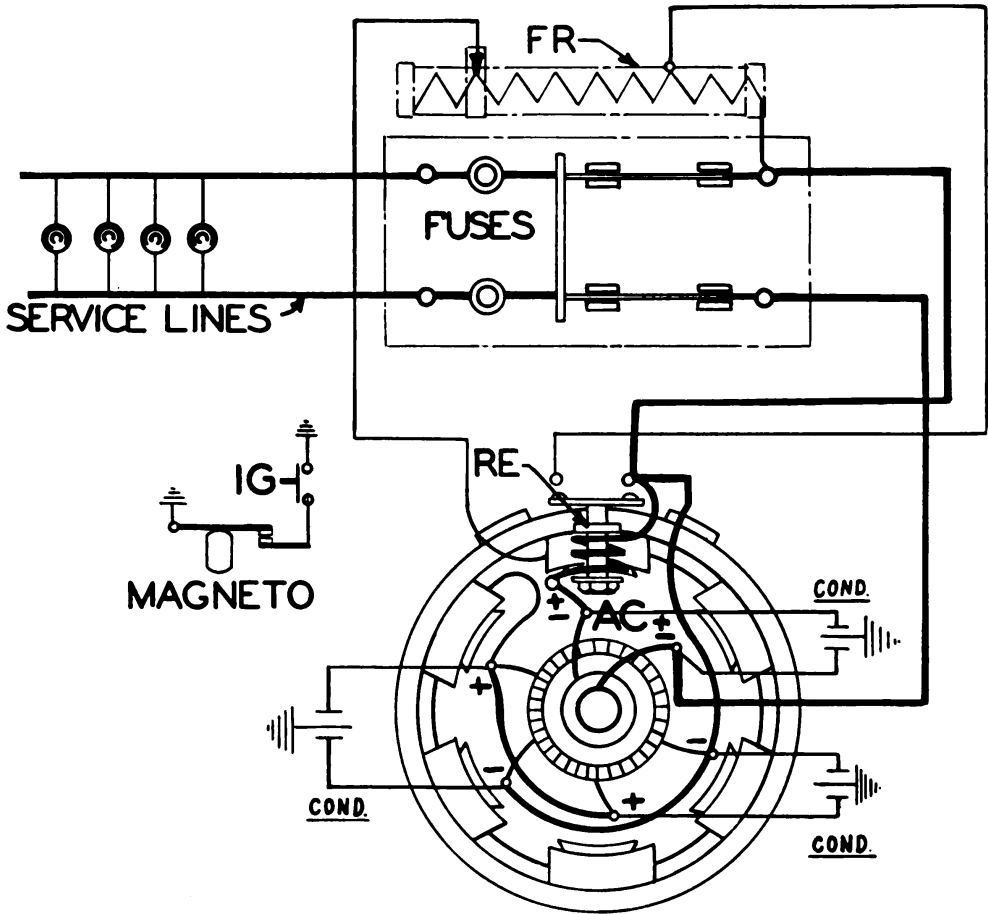

TL-90719

Figure 19. Wiring diagram, with ground button on magneto.

PART SIX

CORRECTIVE MAINTENANCE

Section I—ENGINE

19. SPECIFICATIONS, TOLERANCES, AND CLEARANCES.

The table below gives information on specifications, tolerances, and clearances of engine parts in the 1½ KVA Kohler unit:

TABLE IV—Specifications, Tolerances, and Clearances

Intake valve seat.....	1/32 in. x 45° chamfer x 25/32 in. diam.
Exhaust valve seat.....	1/32 in. x 45° chamfer x 25/32 in. diam.
Intake valve guide side clearance.....	0.002 in.
Exhaust valve guide side clearance.....	0.002 in.
Intake valve tappet clearance.....	0.006 in. hot.
Exhaust valve tappet clearance.....	0.006 in. hot.
Valve timing.....	40° before low dead center.
Main bearing diameters.....	Rear bearing, 1.251 in. Front bearing, 1.3125 in.
Main bearing diametral clearance.....	Rear bearing, 0.00125 in. Front bearing, 0.00125 in.
Main bearing thrust clearance.....	0.004 in.
Connecting-rod bearing diameter.....	1.249 in.
Connecting-rod bearing diametral clearance.....	0.00075 in.
Connecting-rod bearing side clearance..	0.0085 in.
Camshaft bearing diameters.....	Rear, 1.4375 in. Front, 1.500 in.
Camshaft bearing clearances.....	Rear, 0.00145 in. Front, 0.00195 in.
Cylinder bore.....	2.000 in.
Piston clearance.....	0.00175 in.
Number and type of piston rings per piston.....	4 Rings (3 plain, 1 oil ring).
Piston ring side and bottom clearance..	Bottom 0.007 in. Side, 0.00125 in.
Piston pin diametral clearance.....	0.001 in.
Ignition timing-maximum degrees ad- vance.....	Approximately 30°.

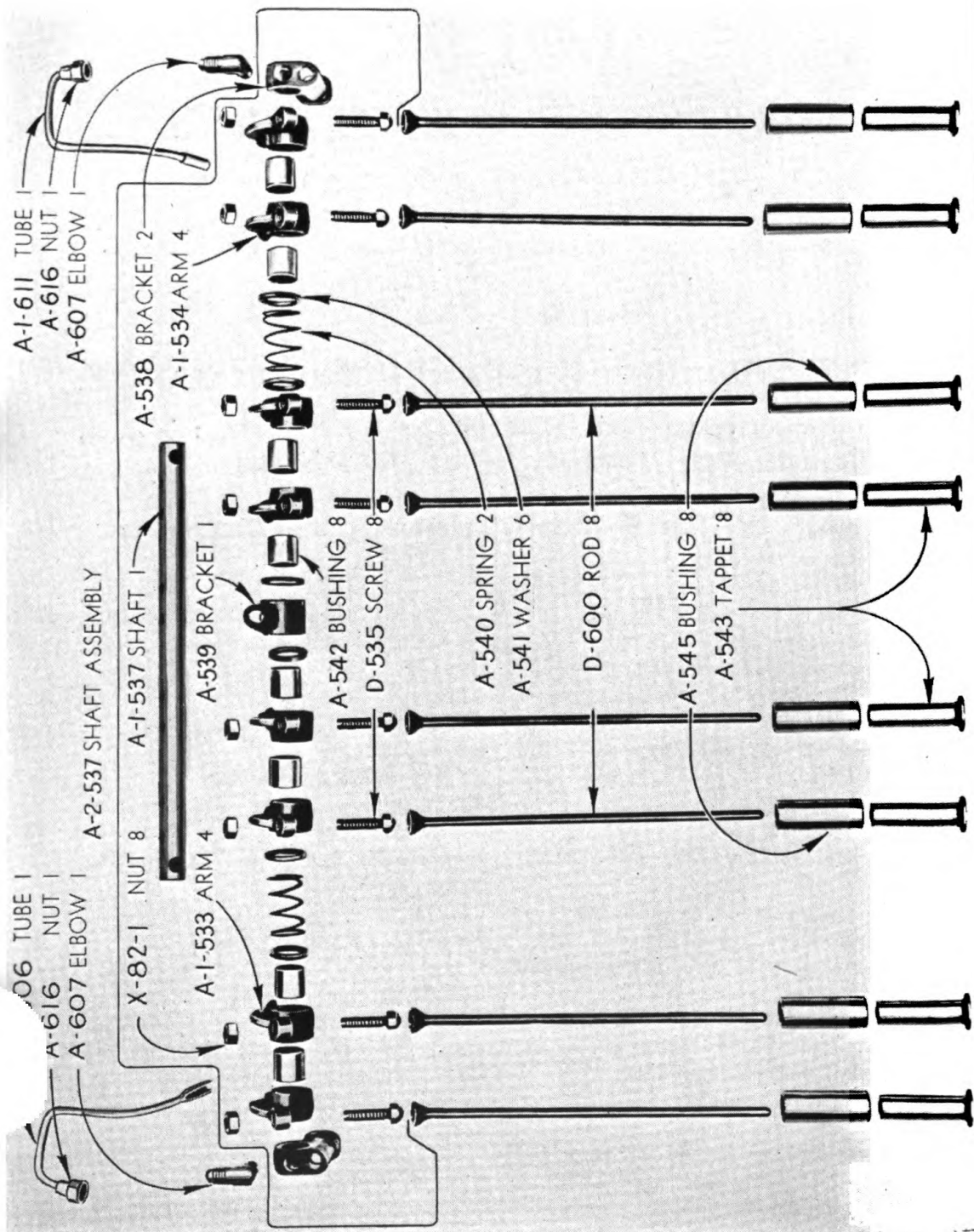

TL-90720

Figure 20. Rocker arm assembly with push rods.

20. REMOVING CYLINDER HEAD.

a. To remove the cylinder head from the engine in this unit, proceed as instructed below:

- (1) Drain all water from the cooling system, and then drain gasoline from fuel line. Remove water and gasoline connections.
- (2) Pull cotter pin connecting governor arm to carburetor butterfly valve, and unscrew ignition cable bracket mounted on end of cylinder block.
- (3) Remove air cleaner and intake manifold assembly from cylinder head cover, by unscrewing the two retaining bolts.
- (4) Unscrew the two wingnuts holding the cylinder head cover in place. Lift off cover, and remove gasket from head.
- (5) Remove rocker arm assembly by unscrewing the nuts on the three cylinder head studs. Lift entire rocker arm assembly off the studs (fig. 20).
- (6) Remove the eight push rods. Lay them aside so they can be replaced in their original positions.
- (7) Unscrew the nine cylinder head retaining nuts and lift the cylinder head and carburetor assembly off the engine (fig. 21). The complete cylinder head assembly with exhaust manifold is shown in figure 22.

CAUTION: Do not pry the head up with a screwdriver, as this may injure the copper asbestos cylinder head gasket. Tap the head gently with a block of wood until it is loose.

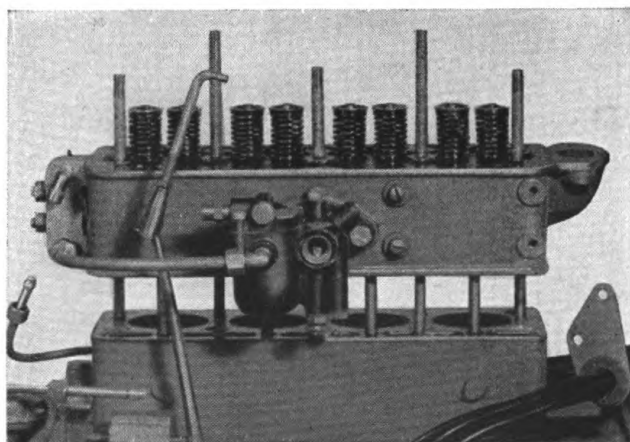

TL-90721

Figure 21. Removing cylinder head.

b. To replace cylinder head and cover, reverse the above procedure. Be sure to clean the cylinder head and engine surfaces. Coat the cylinder head and cover gaskets with grease for watertight and airtight connections. When replacing the cylinder head nuts, tighten them down evenly to prevent wrinkling the gasket.

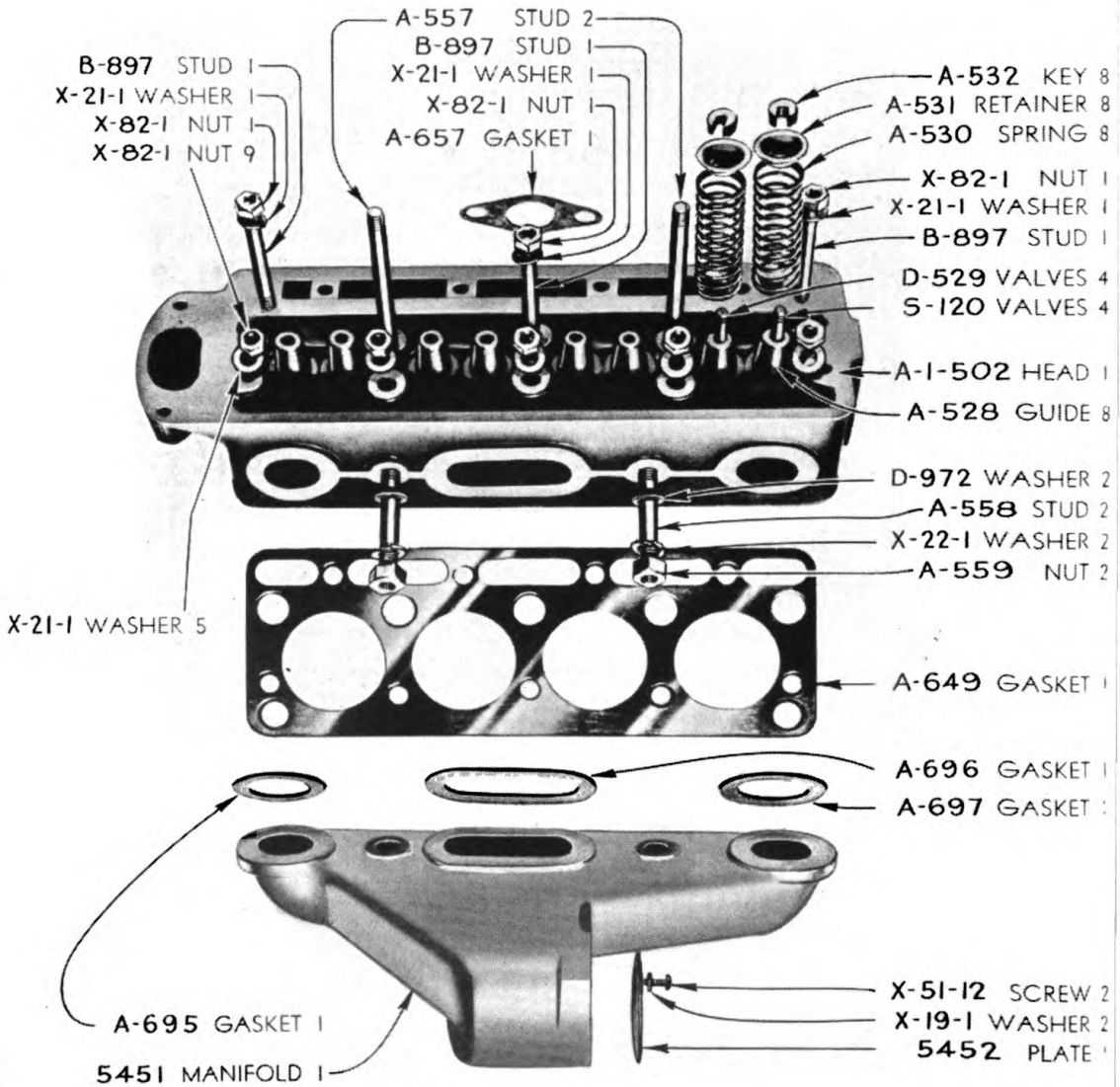

TL-90722

Figure 22. Cylinder head and exhaust manifold.

21. GRINDING VALVES.

a. General. To grind valves, remove the cylinder head as explained in paragraph 20 *a* and set it upside down on wooden blocks. Remove the valves by depressing the valve springs and removing the keepers from the slots on the end of each valve stem. Wash the valves and valve seats with gasoline and see whether they are pitted.

NOTE: Be sure to replace valves in original position in cylinder head. Note marks on both valve and head for proper replacement.

b. Grinding. Grind each of the valves in the engine as follows:

- (1) Apply the valve grinding compound around the entire valve seat.
- (2) Lubricate the valve stem, slip a light coil spring over the end of the stem, and drop the valve back into its place in the cylinder head. The spring should hold the valve just barely off the seat.
- (3) Place a valve grinding tool in the valve head and press the valve down with a screwdriver or handbrace until it is seated.
- (4) Rotate the valve on the seat $\frac{1}{4}$ turn, first in one direction and then in the other (fig. 23). Do this three or four times, then release the pressure on the valve and allow the coil spring to lift the valve from its seat.

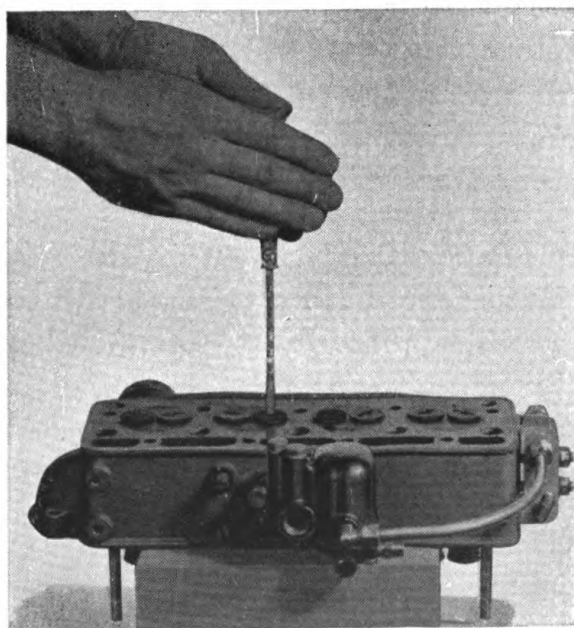

TL-90723

Figure 23. Grinding valves.

- (5) Now turn the valve about 10° or 15° and repeat the grinding operation. Continue until all the compound is rubbed off the valve seat.
- (6) Add fresh compound as necessary and continue grinding until the valve head and seat are free of pits and grooves, and until a uniform light gray band about 1/32" wide is visible around the valve and seat.
- (7) When grinding is completed, clean the grinding compound out of the valve chamber. Oil the valve stem and replace the valve in its original position.

22. ADJUSTING VALVE CLEARANCE (fig. 24).

a. General. Proper clearance must be maintained between the top of the valve stem and the face of the rocker arm in this engine. Correct clearance is 0.006 to 0.008 in. for intake and exhaust valves. If valve clearance is too great, the valves will open late and close early. If clearance is too small, the valves will not close at all, causing a considerable loss of power. Valve clearances should be adjusted only when the engine is hot. If made when the engine is cold, they will not be accurate because of the change in temperature when the engine warms up.

b. Procedure. Tighten the cylinder head and rocker arm retaining-bolts securely, and proceed as follows to adjust the valve clearance, (use the feeler gauge in the tool kit to measure clearance):

- (1) Turn the starting crank until the cylinder you are working on is in the firing center, and both valves are completely closed. Check to see that the valves are not being held open by carbon deposits or by a sticking valve stem.
- (2) To check clearance, insert the feeler gauge between the face of the rocker arm and the top of the valve stem. Clearance is correct when the gauge can be just moved.
- (3) If adjustment is necessary, loosen the upper locknut on the rocker arm. Turn the adjusting screw to the right to decrease the clearance and to the left to increase the clearance (fig. 24).
- (4) After checking clearance with the gauge, lock the nut by holding the adjusting screw tight with a screwdriver and tighten the top nut.

23. MAGNETO DISASSEMBLY AND TIMING.

a. General. For access to the interior of the magneto for testing the coil or capacitor (fig. 25), remove the end cap. The magneto should be returned to a depot for major repairs. In an emergency, however, the high tension coil or capacitor can be replaced in the field without using

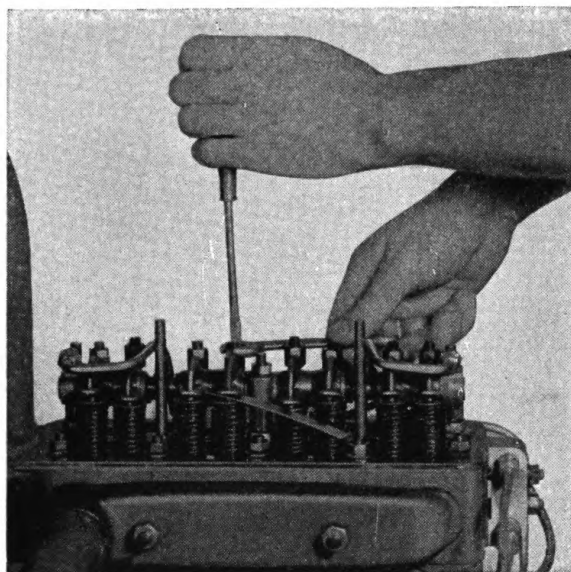

TL-90724

Figure 24. Adjusting valve clearance.

special equipment. To replace the coil, remove the rotor pinion from the rotor shaft, then unscrew the bearing plate. After loosening the set-screws which hold the coil lamination in place, pull the coil out of the frame. If the rotor pinion is removed, it must be properly meshed with the distributor gear when reassembled. Correct meshing for clockwise (to the right) rotation is obtained by meshing the single marked tooth on the rotor pinion between the two teeth marked C on the distributor gear.

b. Timing Magneto to Engine. When properly timed to the engine, the magneto provides the ignition spark at the plug at the precise instant the fuel in the cylinder should be ignited. To time the magneto proceed as follows:

- (1) Remove cylinder head cover, and tighten all cylinder head and rocker arm retaining nuts. Adjust valve clearance.
- (2) Crank the engine until piston in No. 1 cylinder (next to crank) is in top dead center position on the firing stroke. To check this, turn crank until No. 8 valve, next to radiator, has opened and almost closed. Then take hold of No. 7 rocker arm and continue to turn crank slowly until the arm just clears the valve stem and lost motion is felt. The No. 1 piston should be at top dead center. Verify by removing the spark plug from the No. 1 cylinder and inserting a stiff wire through the hole.

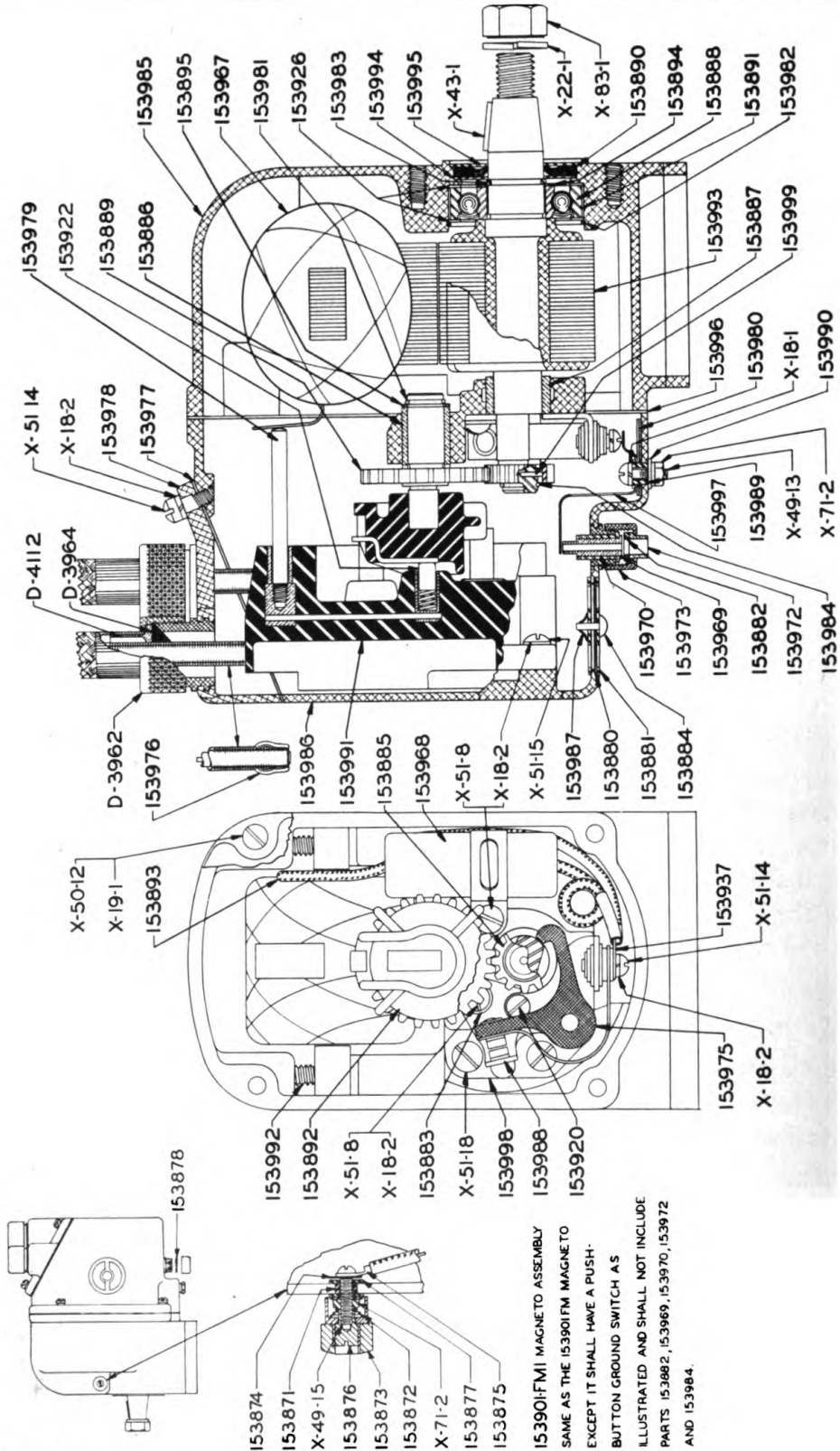

TL-90725

Figure 25. Fairbanks-Morse magneto, cross section.

(3) Turn the magneto until a spark is obtained from the No. 1 socket. Couple the magneto to the engine without changing the position of the rotor.

NOTE: Best results are obtained by advancing the timing until the engine begins to kick back, and retarding the magneto one or two teeth.

(4) Be sure the magneto and governor shafts are in line and the coupling does not bind.

NOTE: The magneto may be removed and replaced without re-timing it to the engine, if timing marks are placed on the coupling teeth before removing magneto. When replacing the magneto, turn the magneto coupling until the marks are lined up, and mesh the coupling teeth.

24. INSTALLING NEW FAN BELT

a. Disassembly to Remove Old Belt. To remove the fan belt from the

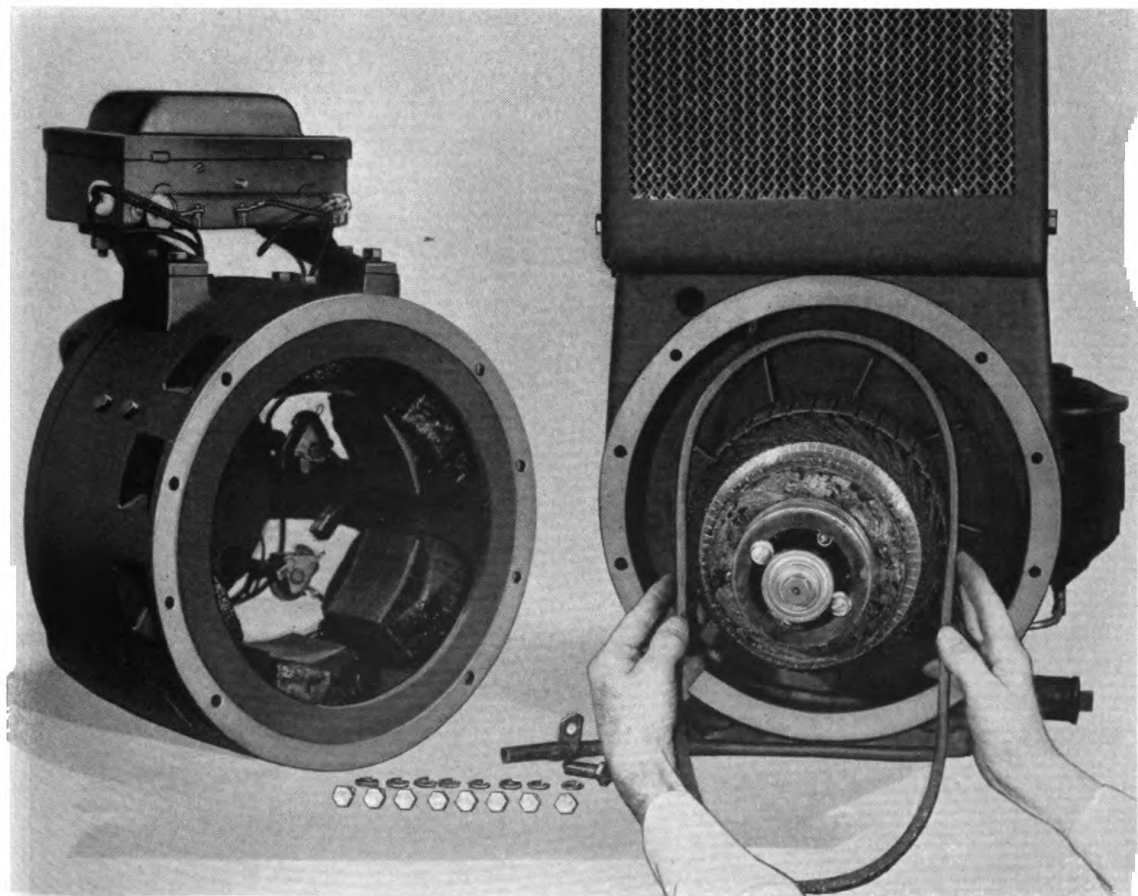

TL-90726

Figure 26. Installing new fan belt.

1½ KVA Kohler unit proceed as follows:

- (1) Remove generator end cover by taking out the four retaining screws.
- (2) Remove generator brushes from brush holders.
- (3) Remove the eight cap screws, which hold the generator frame to the flywheel housing after inserting a block of wood under each side of the generator frame to prevent it from toppling.
- (4) Remove the radiator overflow tube from the magneto side of the unit.
- (5) Pull off the generator assembly and set it to one side (fig. 26). If necessary, use a bar to pry the bracket away from the frame.
- (6) Remove engine cooling fan from bracket, and take off the old belt.

b. Installing New Belt and Reassembling Unit.

- (1) Slip new belt over armature and onto generator flywheel pulley (fig. 26).
- (2) Pull belt onto fan pulley, and tighten fan into place after checking belt tension.
- (3) Replace generator assembly. Be sure the outer race of generator ball bearing enters the bearing housing of the brush holder bracket squarely.
- (4) Replace the eight cap screws. Before tightening them, tap the brush holder bracket lightly with a hammer and block of wood above and below the generator bearing housing. When the bearing is properly aligned, tightening the cap screws forces the generator assembly tightly against the engine bell housing.
- (5) Replace the generator brushes. Be sure the generator brushes are put back in their original positions.
- (6) Start the unit after assembling it. Listen for noise in the generator bearing. Noise indicates improper alignment. To correct alignment, tap the bracket above and below the bearing until it runs quietly.
- (7) If the ball bearing is not sealed, repack the housing with correct grade of grease, and replace the generator end cover.

25. SPLITTING THE ENGINE: REMOVING ENGINE FROM OIL BASE.

a. General. When it is necessary to fit new main bearings, connecting rod bearings, pistons, piston rings and pins, or to repair the oil pump in this unit, the cylinder block must be removed from the oil base (crankcase). Before splitting the unit remove the generator assembly

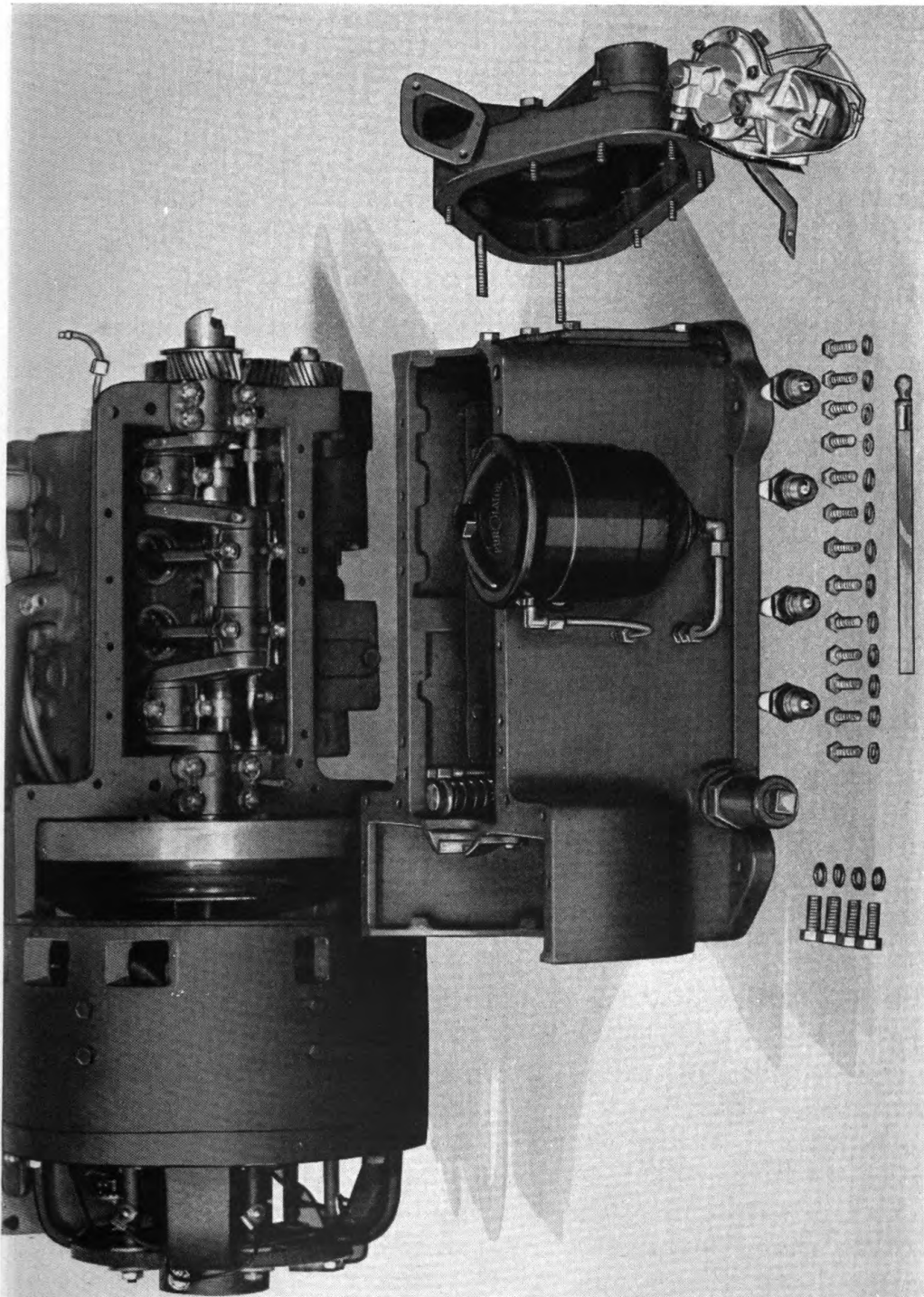

TL-90727

Figure 27. Splitting the engine: removing engine from oil base.

from the engine according to instructions for replacing the fan belt or, leave the generator bolted to the upper part of the cylinder block and split the engine according to the instructions below:

b. Detailed Instructions. To split the engine proceed as follows:

(1) Drain water from radiator, oil from crankcase, and gasoline from fuel pump and carburetor. Disconnect and remove fuel lines and radiator overflow pipe. Disconnect output leads at switchbox. Remove air cleaner and spark plugs.

(2) Remove fuel pump from gear cover (two cap screws hold it in place).

(3) Remove the ten cap screws holding gear cover in place, and pull off gear cover. When the cover is off, remove the crankshaft gear, camshaft gear and governor (or magneto) drive gear.

NOTE: When removing gear cover, be sure not to lose fiber cam thrust plug when it is forced out.

(4) Remove the thirteen cap screws holding the cylinder block to the oil base.

(5) Remove the four cap screws holding the lower half of the generator assembly to the flywheel housing.

(6) Remove the oil gauge so it will not be bent when the block is lifted off the oil base.

(7) Lift the engine and generator from the oil base and lay it on a suitable platform about 12 inches high, magneto side down (fig. 27). Tie a string around the oil pump tappet to prevent it from falling into the case.

NOTE: Do not withdraw the camshaft while the engine is in an upright position, or the tappets will drop into the oil base.

26. CYLINDERS AND PISTONS.

a. Inspection. After splitting the engine, disconnect the connecting rod bearings and withdraw the pistons from the cylinders. Examine the cylinder walls. If they are scored or worn excessively, they will have to be reground, and new pistons will have to be fitted. Clean the pistons and rings with gasoline and examine them. If the rings are properly fitted they will have a bright, highly polished surface. Any dark colored or rusty spots or tool marks on rings indicate that the rings are worn and do not fit the cylinder walls tightly. Improperly fitted rings should be replaced, or they may cause pistons to pump oil.

b. Fitting Pistons in Cylinders. Proper clearance between piston and cylinder wall is 0.002 inches. With rings removed, a piston of correct

size should just fall through the cylinder. Be sure to replace pistons in same cylinders from which they were removed. The cylinders are numbered consecutively 1, 2, 3, 4 from crank end to radiator end, and each connecting rod is marked with a number corresponding to the cylinder to which it is fitted. When fitting a piston, check the clearance with a 0.002 inches shim (fig. 28). New pistons should not wedge when being fitted with this size shim, but a noticeable drag will be felt.

c. Replacing Piston Pins. The piston pins in the engine are full-floating and are held in the piston by means of spring steel retainers (fig. 41). The steel pin is fitted to the bronze bushing in the upper end of the connecting rod with a snug hand-press fit, and to the piston itself with a tight hand-press fit (should be snug enough to require considerable force to insert the pin). To test fit of pin in rod bushing, clamp pin in a vise, after attaching the connecting rod. The weight of the rod should be sufficient to allow the rod to drop gradually. Use the same test when fitting pin in piston (fig. 29). Use a shim to test pin fit. Replace piston pins that are worn, or are loose in bushing or piston. If connecting rod bushing is worn, replace it.

27. CONNECTING RODS AND BEARINGS.

a. General. Each connecting rod bearing is numbered to correspond to the cylinder to which it belongs. When properly adjusted, the bearing clearance should be 0.002 inches for smooth operation. Examine the condition of the bearings after removing the connecting rods from the crankshaft. If they are scored, scrape or fit the rods with new bearings.

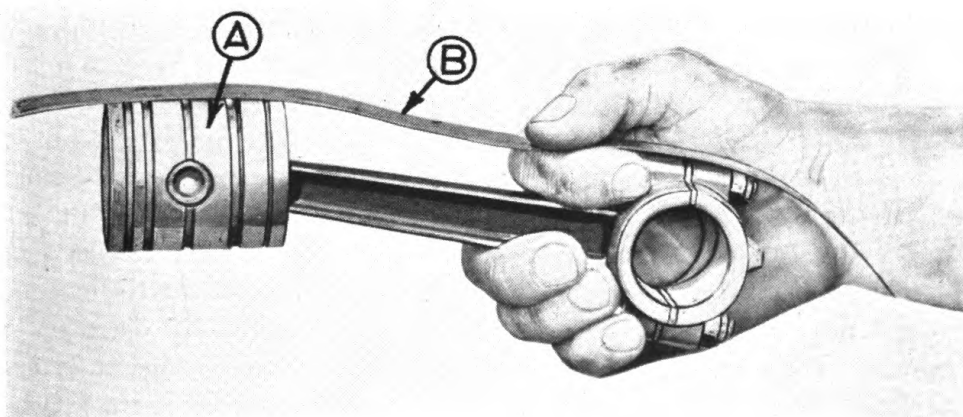

TL-90728

A. Piston. B. 0.002-inch shim.

Figure 28. Fitting new piston with shim.

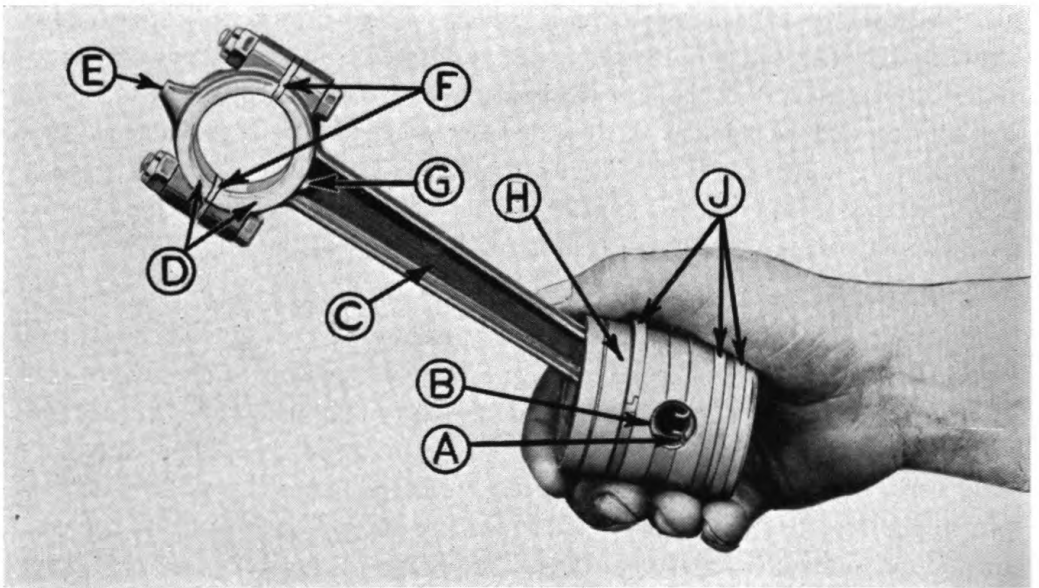

TL-90729

- | | |
|-----------------------------|-------------------|
| A. Piston pin retainer. | E. Oil dip. |
| B. Piston pin. | F. Bearing shims. |
| C. Connecting rod. | G. Oil hole. |
| D. Connecting rod bearings. | H. Piston. |
| J. Piston rings. | |

Figure 29. Fitting piston pin.

b. Fitting New Connecting Rod Bearings. New rod bearings must be fitted properly to the crankshaft. To do so, wipe the shaft and bearing clean and then apply a little Persian red or blue, mixed in oil, to the shaft. Place the bearing half on the shaft, and slide it back and forth around the pin. Remove the bearing and note the impression on it. Cut down the high spots on the bearing with a bearing scraper, and repeat the rubbing test. At least 80 percent of the bearing should touch the shaft. After fitting the bearings, adjust the bearing clearance of each connecting rod on the crankshaft individually. Connect each rod to the shaft, putting in sufficient shims to secure proper clearance. If the rods are attached so that they are left out of the cylinders when bearing clearance is adjusted (fig. 30) the clearance can be tested by raising the rod to a horizontal position after the bolts have been tightened. If the rod gradually drops, due to its own weight, the fit is approximately correct. The bearings should not bind, and should be able to be moved laterally slightly. Be sure to replace all cotter pins on bearing studs after tightening nuts.

c. Oil Dip of Connecting Rod. When the cranks are in the bottom center position, the top of the oil dips on the connecting rods should be

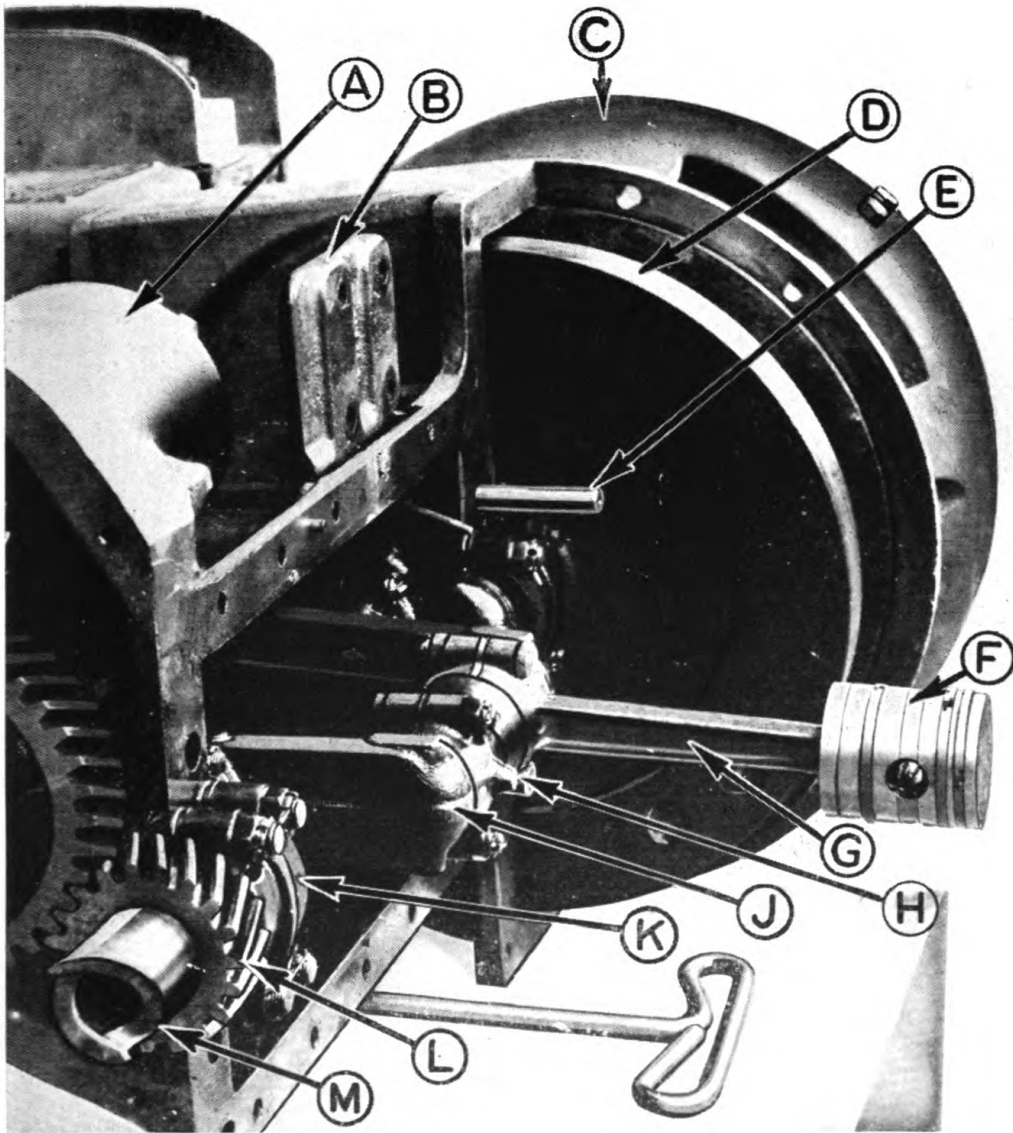

TL-90730

- | | |
|----------------------|---------------------|
| A. Governor housing. | G. Connecting rod. |
| B. Magneto bracket. | H. Oil dip. |
| C. Generator frame. | I. Crankshaft. |
| D. Flywheel. | K. Main bearing. |
| E. Oil pump tappet. | L. Crankshaft gear. |
| F. Piston. | M. Starting jaw. |

Figure 30. Fitting connecting rod bearings.

2 23/32 inches below the level of the cylinder block base. This will give a dip of 1/32 inches when the plant is assembled, as the oil baffle plate is bolted inside the oil base so that the drain slots on ends of plate are 2 11/16 inches below the top of the oil base. The method of measuring the oil dip is shown in figure 31. When replacing connecting rod bearing caps attach them so the hole in the oil dip faces to the exhaust side when viewed from the crank end of the engine; otherwise the bearing will not

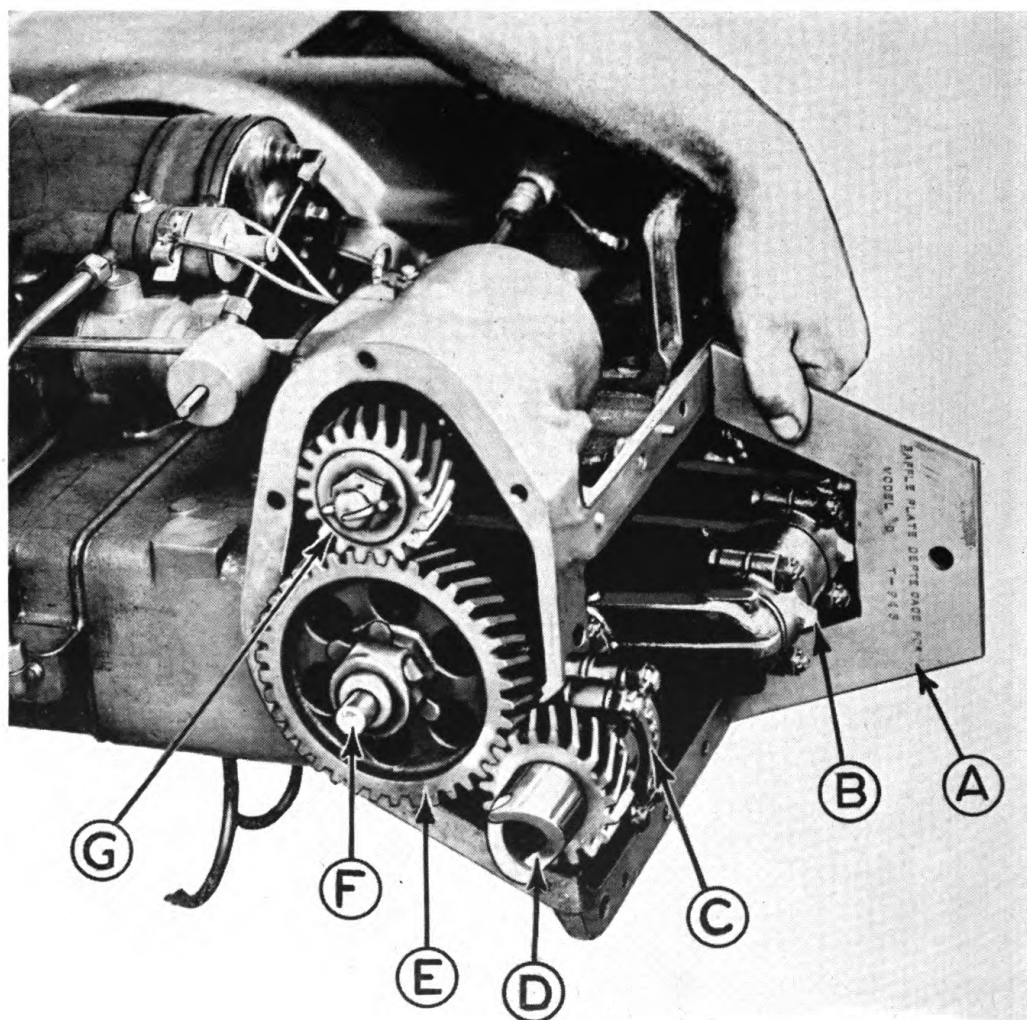

TL-90731

- | | |
|------------------------------|--------------------------|
| A. Measuring gauge. | D. Starting jaw. |
| B. Connecting rod oil dip. | E. Camshaft gear. |
| C. Front main bearing. | F. Camshaft thrust plug. |
| G. Magneto drive shaft gear. | |

Figure 31. Measuring oil dip of connecting rod.

be lubricated and will burn out. See next paragraph for instructions on checking height of oil baffle plate. This is very important to assure proper lubrication.

28. OIL BAFFLE PLATE AND OIL PUMP.

a. Height of Baffle Plate. Figure 32 shows the correct way to check the height of the oil baffle plate in the oil base. The baffle plate is in correct position when the drain slots in the end of the plate are 2 11/16 inches from the top of the oil base. If the baffle plate is too high, the engine may pump oil because too much oil is splashed on the cylinder walls. If the plate is too low, the connecting rod bearing will not receive enough lubrication and may burn out. To adjust position of plate for correct dip, loosen the capscrews holding it to the oil base. Raise or lower plate to correct position and tighten the screws.

b. Oil Pump. When the engine has been disassembled, remove the oil pump to clean it out, if necessary. Operate the plunger by hand to see that connections are tight. Examine all bolts and nuts to see that they are properly tightened.

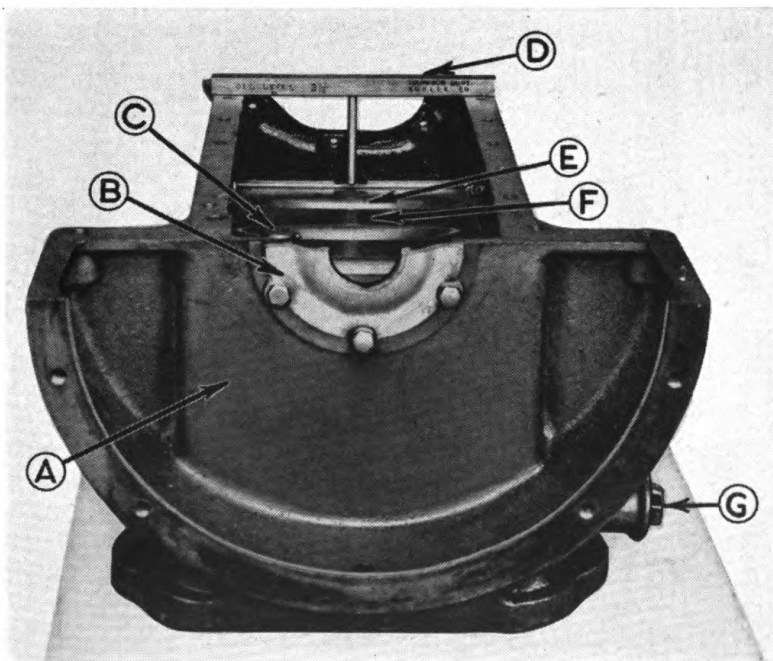

TL-90732

- | | |
|---|------------------|
| A. Oil base. | D. Gauge. |
| B. Split cover
(oil retaining ring). | E. Oil troughs. |
| C. Oil pump plunger. | F. Baffle plate. |
| | G. Drain plug. |

Figure 32. Checking baffle plate height in crankcase.

29. FITTING MAIN BEARINGS.

To fit new main bearings on the engine crankshaft (fig. 30) split the engine and remove the generator assembly, as described previously in this section. Remove the bearing caps and after lifting out the crankshaft, examine the bearings. If the bearings are scored or cut, scrape them to fit, if practicable, or fit new bearings. Follow the same procedure for fitting main bearings as described in paragraph 27*b* for connecting rod bearings. Adjust bearings for clearance of 0.002 inches after replacing crankshaft. When bearings are properly adjusted, the shaft can be turned easily by pulling on the flywheel. There should be no binding. Replace cotter pins in main bearing bolts after tightening nuts.

30. CRANKSHAFT AND CAMSHAFT GEAR TIMING.

The crankshaft and camshaft gears in the 1½ KVA Kohler unit are marked S O S. For proper timing they must be meshed so that the O on the crankshaft gear matches the O on the camshaft gear (fig. 33).

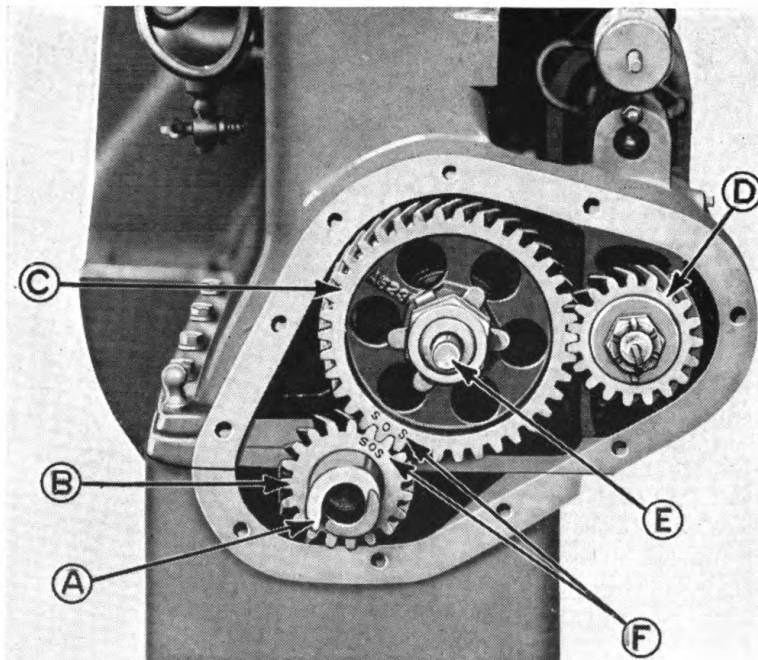

TL-90733

- | | |
|---------------------|--------------------------|
| A. Starting jaw. | D. Magneto drive gear. |
| B. Crankshaft gear. | E. Camshaft thrust plug. |
| C. Camshaft gear. | F. Timing marks. |

Figure 33. Correct meshing of camshaft and crankshaft gears.

31. REPLACING ENGINE ON OIL BASE.

After making internal repairs on the engine in the Kohler unit, clean off the flange joints and examine condition of gaskets. Coat the face of the cylinder block joint with shellac and press gasket firmly into place. Be sure not to blind any of the holes. After gasket has stuck fast apply a little oil to it. Remove the string or rubber band from the oil pump tappet, and replace the engine on the oil base. Set it in place squarely. Be sure not to displace gasket. To replace the remainder of the engine components, reverse the disassembly procedure given in paragraph 25.

Section II GENERATOR AND FLYWHEEL

32. REMOVING BRUSH HOLDER BRACKET.

a. General. The commutator or collector rings in the a-c generator may require servicing when the Kohler unit has been operated for a long period. For access to the commutator to dress the bars or undercut the mica, or for access to collector rings for sanding, remove the brush holder bracket from the generator assembly.

b. Procedure. To remove the brush holder bracket, proceed as follows:

- (1) Remove generator end cover. Four retaining screws hold it in place.
- (2) Remove brushes from brush holders and disconnect leads connected to voltage regulating relay and switchbox.
- (3) Remove the cap screws holding the brush holder bracket to the generator frame, and pull the bracket off (fig. 34).

33. REMOVING COLLECTOR RINGS AND ARMATURE.

a. Collector Rings (fig. 35). Collector rings may wear excessively due to brush sparking, excessive brush holder spring tension, or a stuck or binding brush. If they do, replace them. To remove collector rings:

- (1) Remove generator brush holder bracket according to instructions in paragraph 32*b*.
- (2) Remove armature leads which fasten to terminals inside the collector rings.
- (3) Remove the two bolts from the collector rings.
- (4) Withdraw collector rings from armature shaft over the ball bearing.
- (5) New collector rings may be installed by reversing the above disassembly procedure.

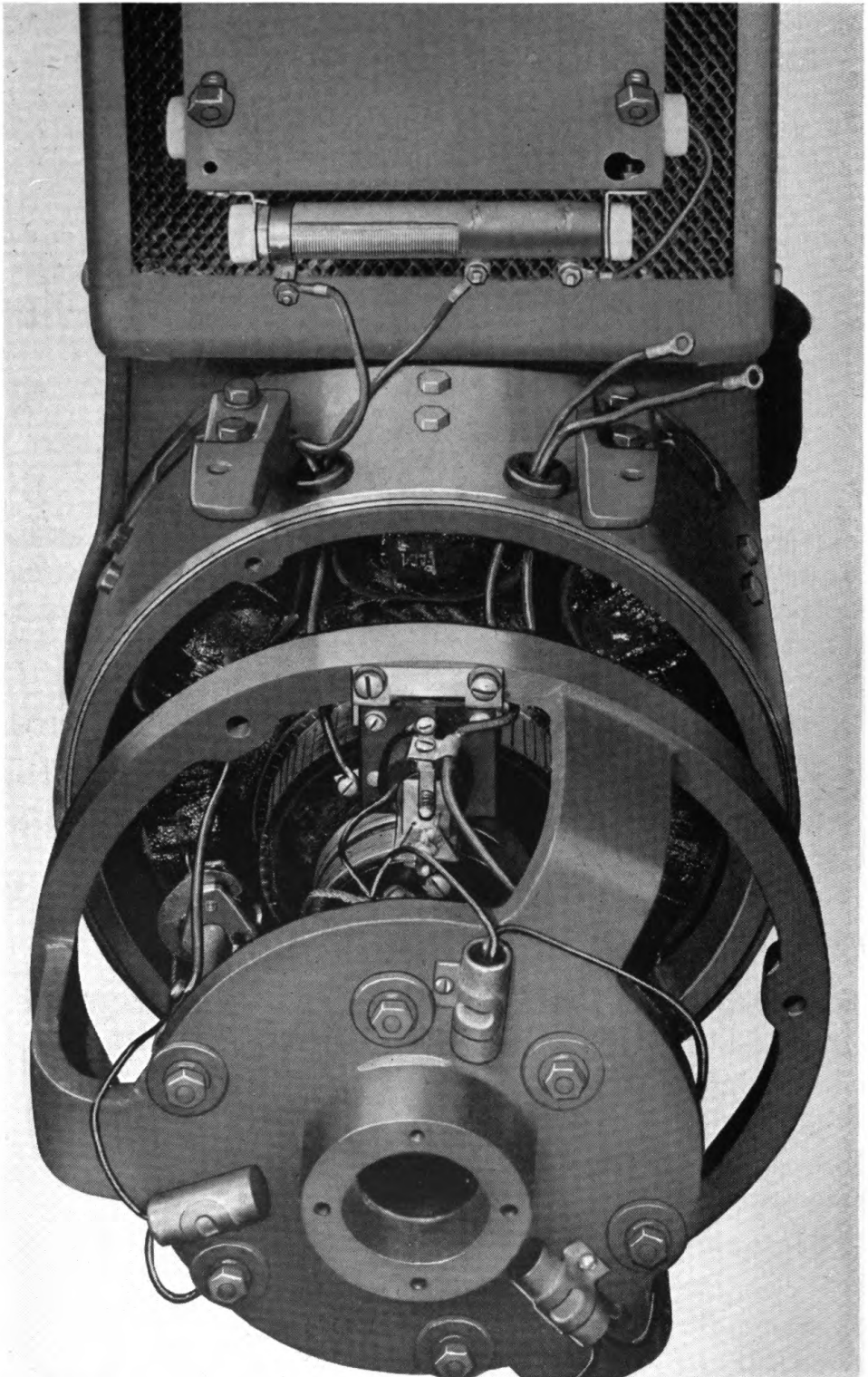

TL-90734

Figure 34. Generator, with brush holder bracket and switch box removed from generator frame.

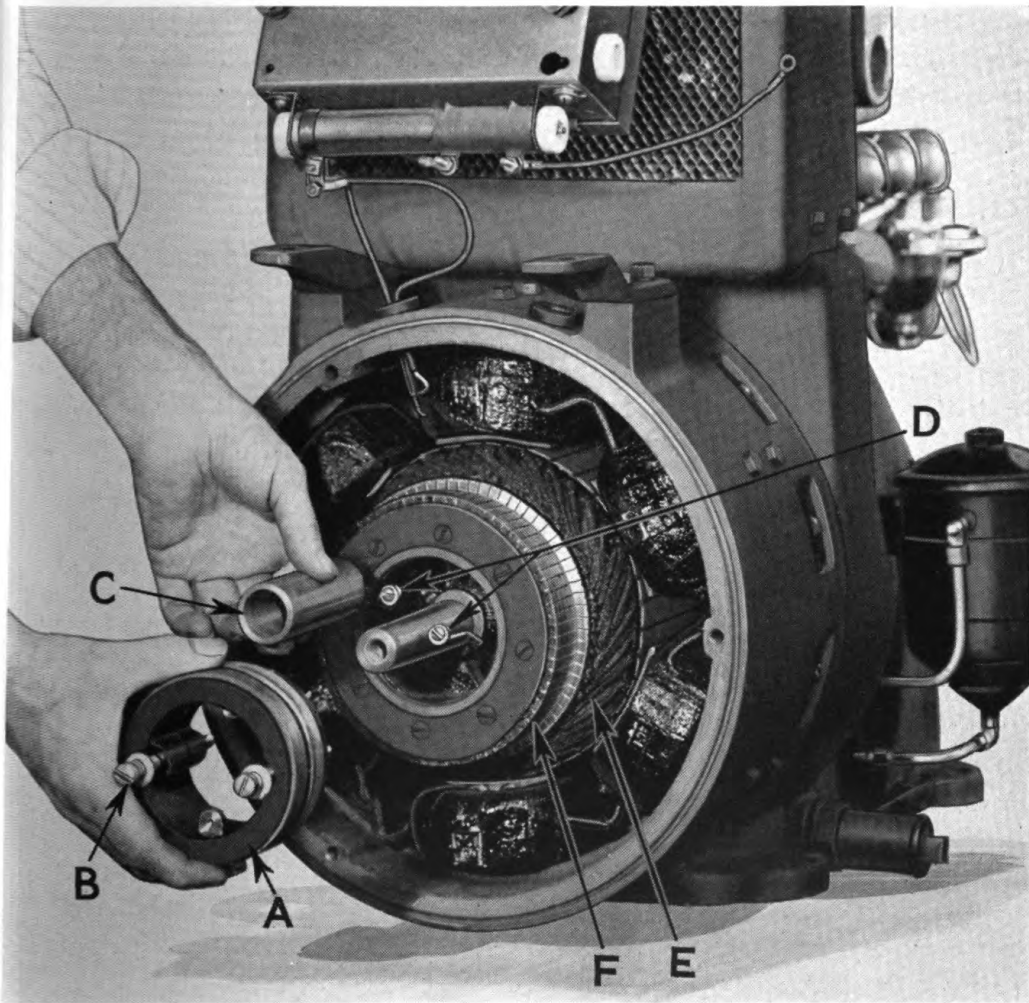

TL-90735

- | | |
|--------------------------|-------------------------|
| A. Collector rings. | D. Armature lead wires. |
| B. Collector ring bolts. | E. Armature. |
| C. Armature spacer. | F. Commutator. |

Figure 35. Removing collector rings from armature shaft.

b. Armature. To remove the armature from this unit, follow the same procedure described in subparagraph *a* above for taking off collector rings, and do the following in addition:

- (1) Remove the cap screw and two washers holding generator ball bearing on end of armature shaft. Remove ball bearing.
- (2) Slide armature spacer off shaft.
- (3) Remove armature from shaft with armature tool (fig. 36). To replace armature, reverse the above procedure. Insert driving screw of armature tool in armature shaft, slip armature onto shaft. After align-

ing the armature keyway with the shaft key press the armature into position. After the armature has been started, the armature spacer can be used to push the armature further onto the shaft. Hold the armature with a belt to prevent it from turning when being replaced on shaft.

34. REMOVING FIELD COILS.

The field coils can be removed from the generator frame after removing the armature, as described in paragraph 31*b*; or they can be removed after disassembling the entire generator frame from the engine flywheel housing as explained in instructions for replacing a fan belt (par. 24). Each field pole is held in place by two bolts through the

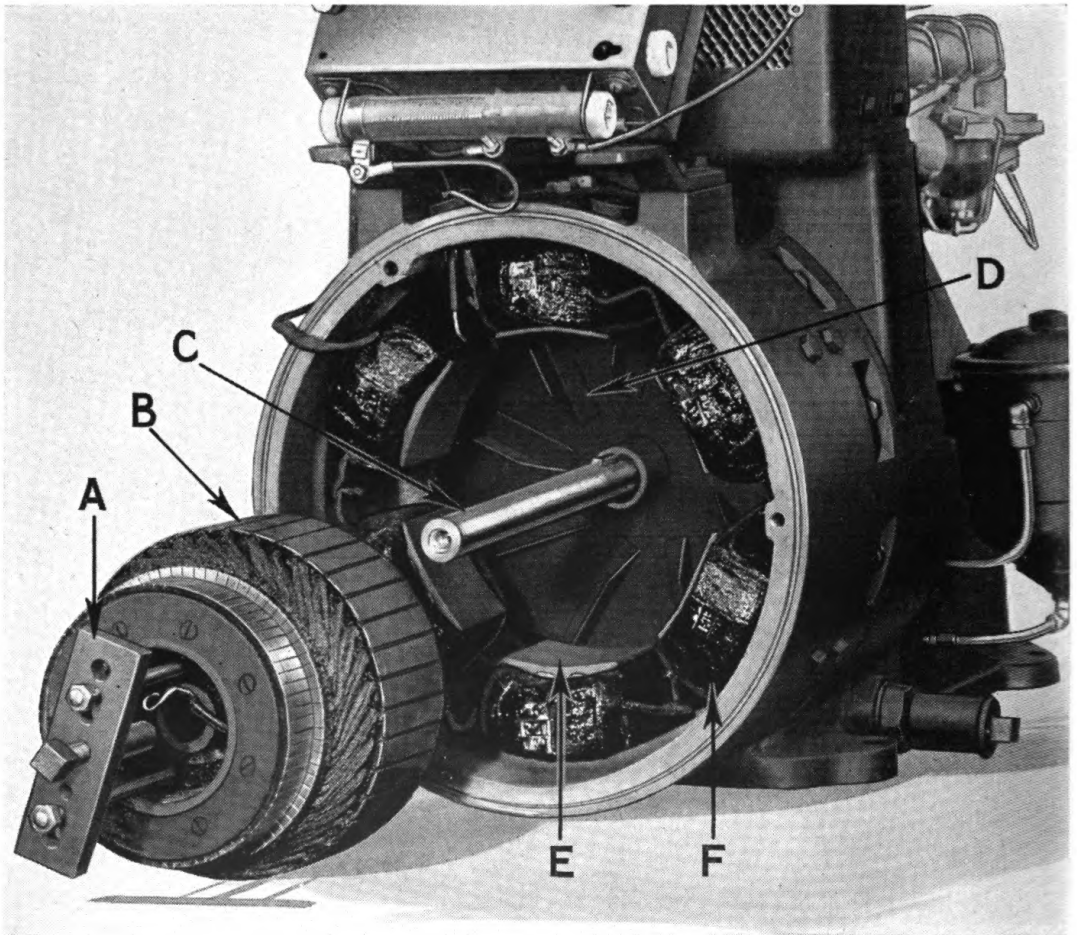

TL-90736

- | | |
|--------------------|-------------------|
| A. Armature tool. | D. Generator fan. |
| B. Armature. | E. Field pole. |
| C. Armature shaft. | F. Field coil. |

Figure 36. Removing armature from shaft.

generator frame. The poles are built up of thin, soft, iron sheets with threads which are stripped easily if too much pressure is used to tighten bolts when replacing them. Figure 37 shows interior of generator frame with field coil detached.

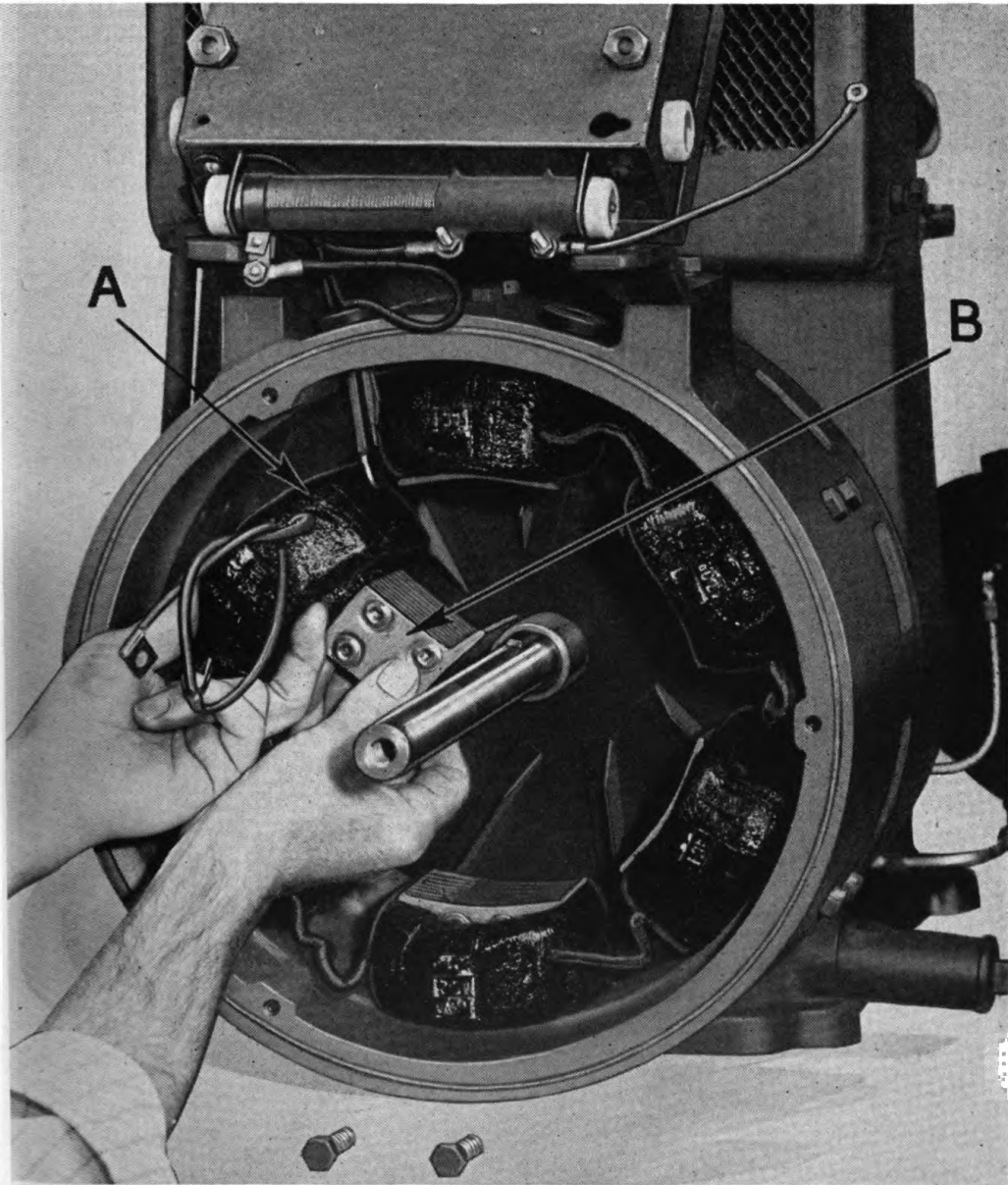

TL-90737

A. Field coil. B. Field pole.

Figure 37. Removing field coils.

35. TESTING THE GENERATOR.

a. Testing for Grounds in Armature. The armature circuits can be tested for grounds with the brush holder bracket removed, or with the entire generator assembled.

(1) If brush holder bracket has been removed, test the rings and then the commutator (each is insulated from the other). One ground will show trouble on both rings.

(2) To test for grounds in armature with generator completely assembled, isolate the commutator from the rings by placing a strip of paper under the brushes on the rings and commutator. Use a magneto ringer, field phone, or other test device.

b. Testing for Grounds in Field Coils. Field coils can be tested either after removing the entire generator frame from the engine flywheel housing, or after removing the armature from the generator frame. To test coils, remove all wiring from coil terminals and ground one end of a test wire equipped with battery and bell, light, or voltmeter in the circuit. Attach the other lead of the test circuit to one of the coils. If current flows, one or more of the coils is grounded. To determine which one, disconnect the coils from each other and test separately.

NOTE: When coils are hot they will often show grounds which will not show after the coils have cooled.

c. Testing for Open Circuits in Coils. Each field coil consists of two insulated coils taped as a single coil. Before testing coils, place a strip of paper under each brush, in the same manner as for testing the armature with the generator completely assembled (subparagraph *a* above). Remove cable S-1 from the terminal at the back of the voltage regulating relay, and remove cable F from its terminal. Attach one wire of the test circuit to cable S-1 terminal. Test for a complete circuit from a positive d-c brush to the S-1 terminal, using the same test as previously described for locating grounds (subparagraph *b* above.) Test the d-c shunt field circuit by attaching one test wire to a positive d-c brush stud, and touching the other to the cable F terminal. Absence of current flow indicates an open. To locate an open in the alternator field, disconnect one of the field leads from either of the two a-c brush studs, and test the circuit (fig. 17).

36. REMOVING FLYWHEEL.

a. General. After the armature has been removed, (paragraph 33*b*), the flywheel can be removed as shown in figure 38.

b. Procedure for Removal.

- (1) Remove Woodruff key from armature shaft. In removing this key, do not burr or cut edges of grooves that the key fits.
- (2) Remove armature spacer.
- (3) Remove generator fan.
- (4) Remove engine fan belt. To do so, loosen engine-fan holding nut and drop fan in housing to permit lifting belt over fan.
- (5) Clean the two holes specially drilled for the flywheel puller.
- (6) Attach flywheel puller and remove flywheel.

c. Split Covers (oil retainers). The split covers, which hold oil in engine oil base, are visible after flywheel has been removed (fig. 39). The split covers are held in place by six cap screws, and are fitted with copper asbestos packing washers. Clearance between crankshaft and

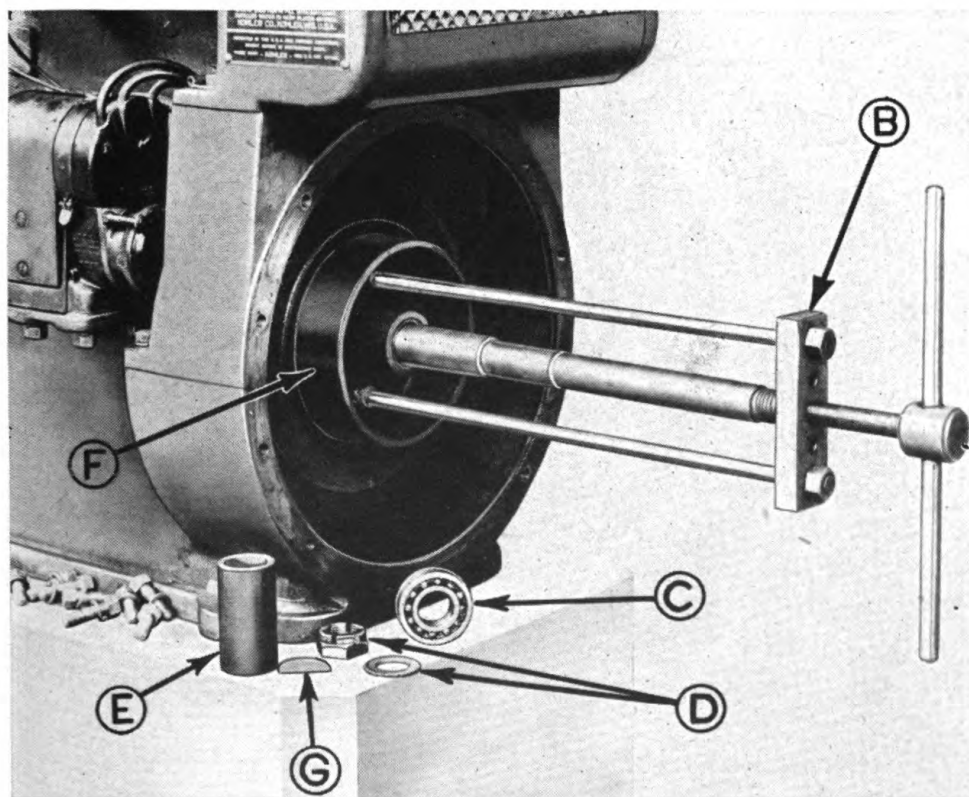

TL-90738

- | | |
|--------------------------------------|---------------------|
| B. Flywheel puller. | E. Armature spacer. |
| C. Generator ball bearing. | F. Flywheel. |
| D. Generator bearing nut and washer. | G. Woodruff key. |

Figure 38. Removing flywheel.

split covers should be 0.004 to 0.006 inches. If an oil leak develops through the split covers, drain the crankcase, and remove the upper half of the split cover. Replace the gasket and washers if worn. An oil leak through the cap screws can be checked by removing each of the screws and coating the threads with shellac.

NOTE: Do not attempt to repair an oil leak at the split covers by splitting the plant. The leak may be through the cap screw holes in the upper split cover. These are inaccessible unless the flywheel is removed.

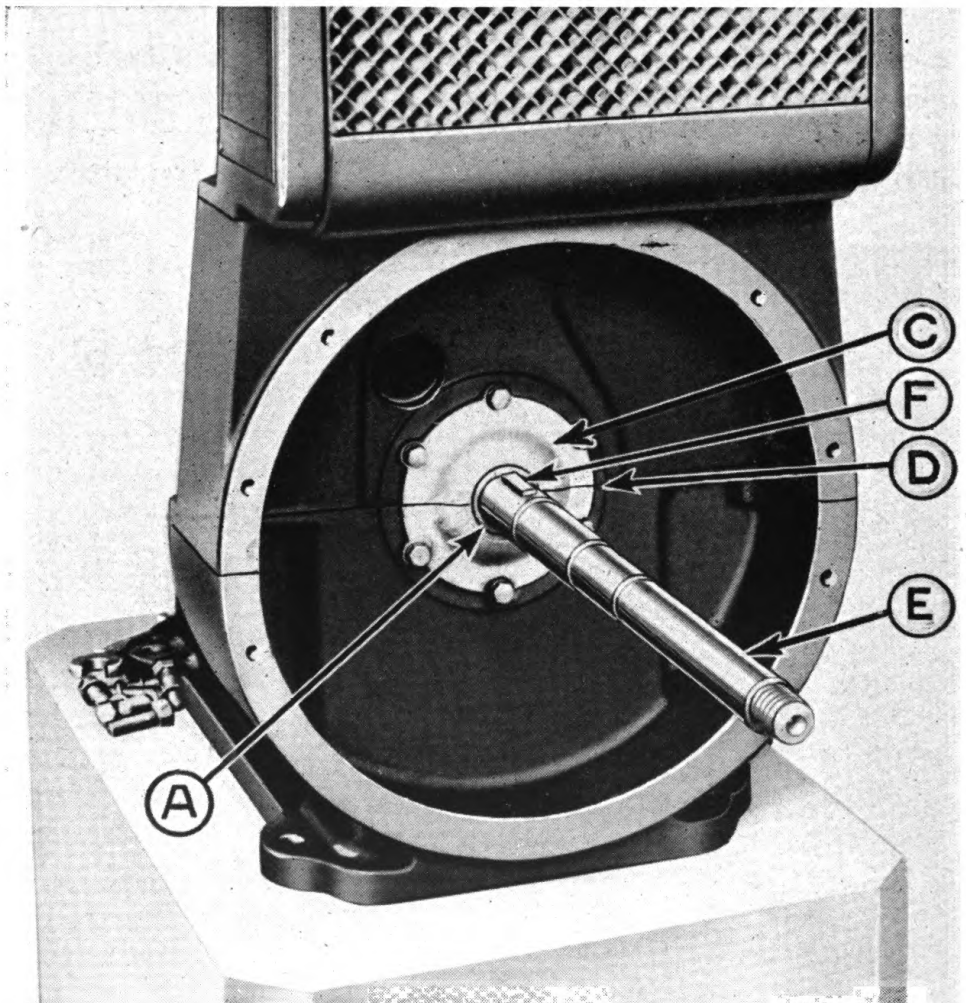

TL-90739

- | | |
|---|-----------------------|
| A. Clearance between split covers and crankshaft. | D. Split cover joint. |
| C. Split cover. | E. Armature shaft. |
| | F. Woodruff key. |

Figure 39. Flywheel removed, showing split covers.

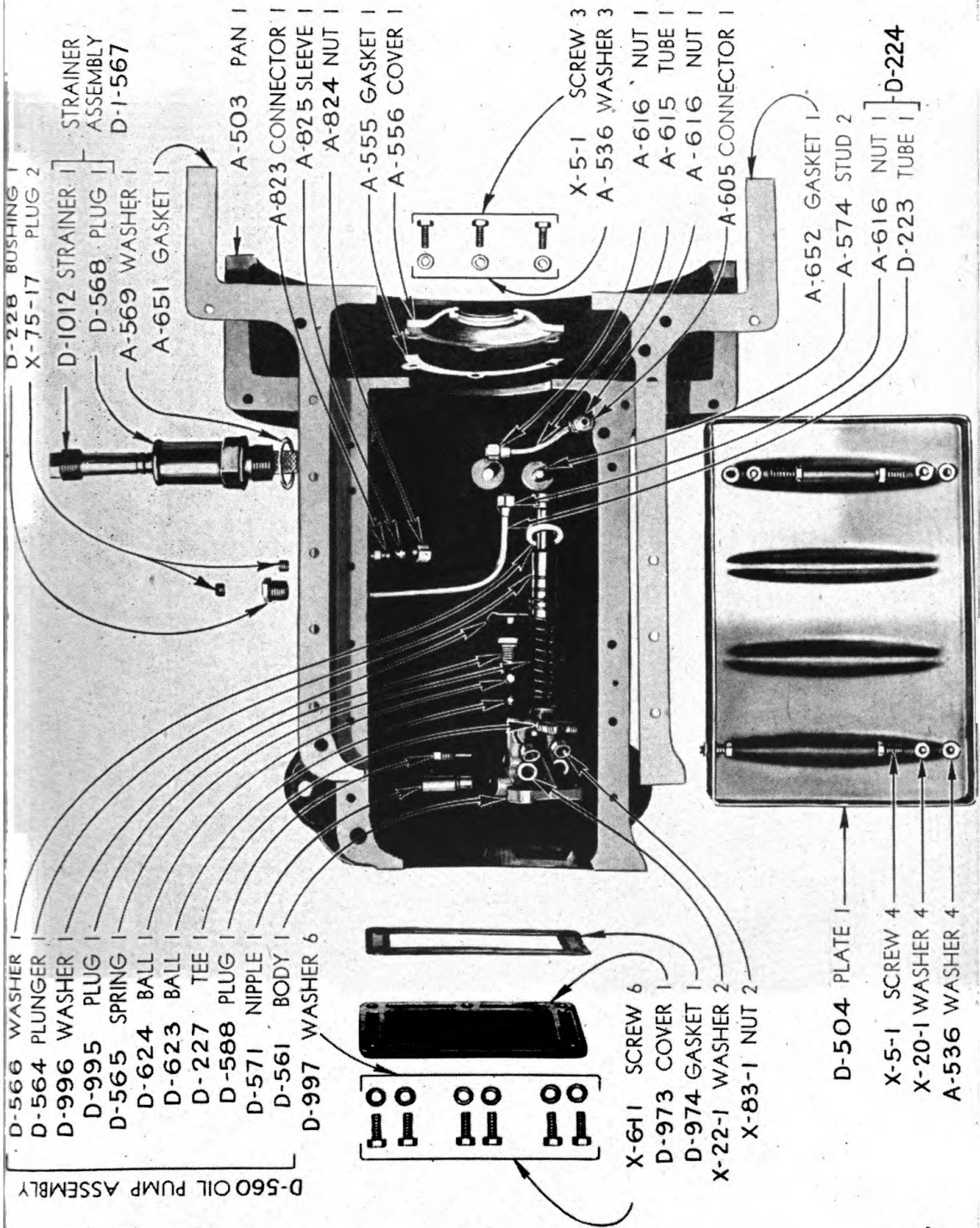

TL-90740

Figure 40. Oil base assembly.

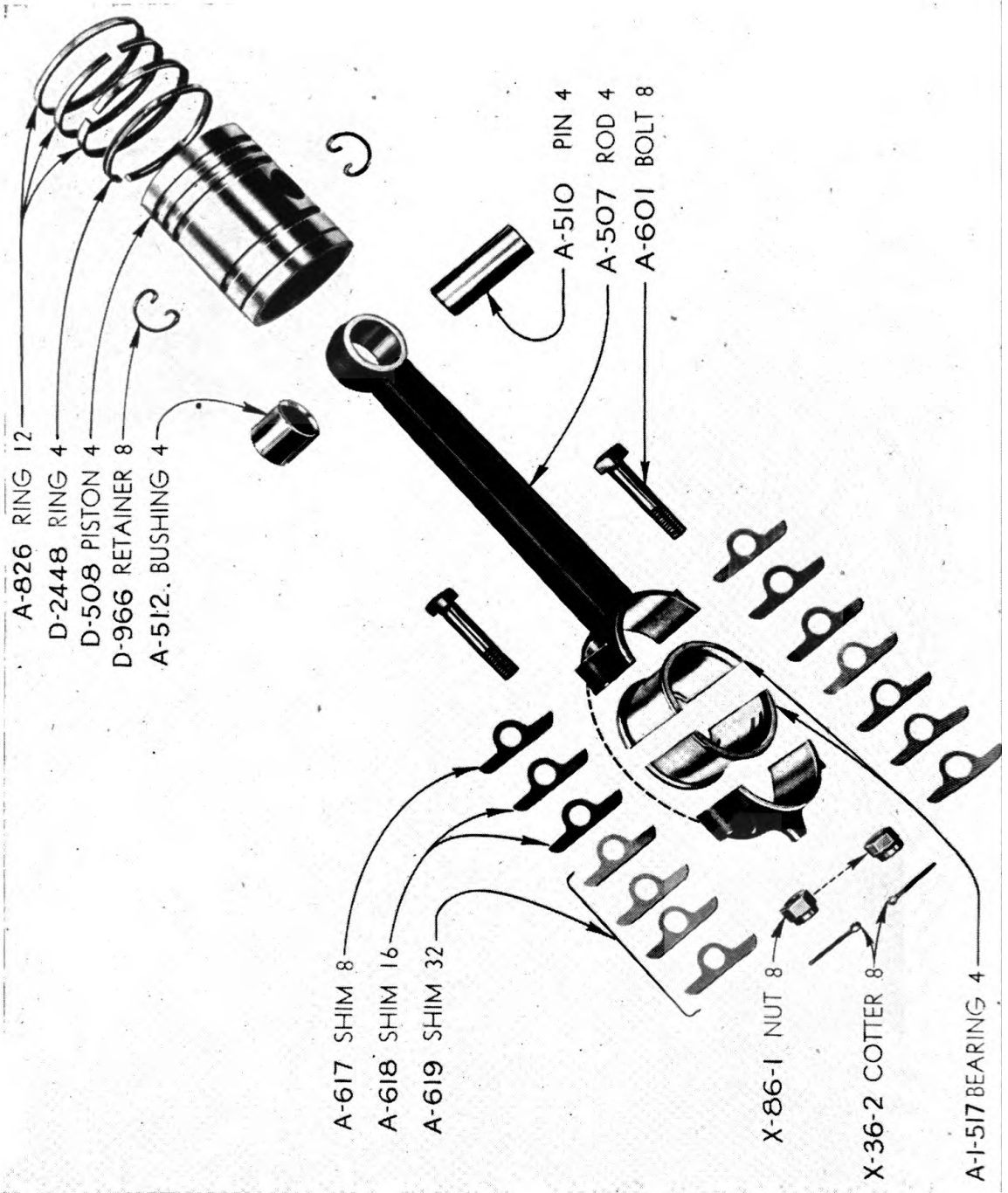

TL-90741

Figure 41. Piston and connecting rod assembly.

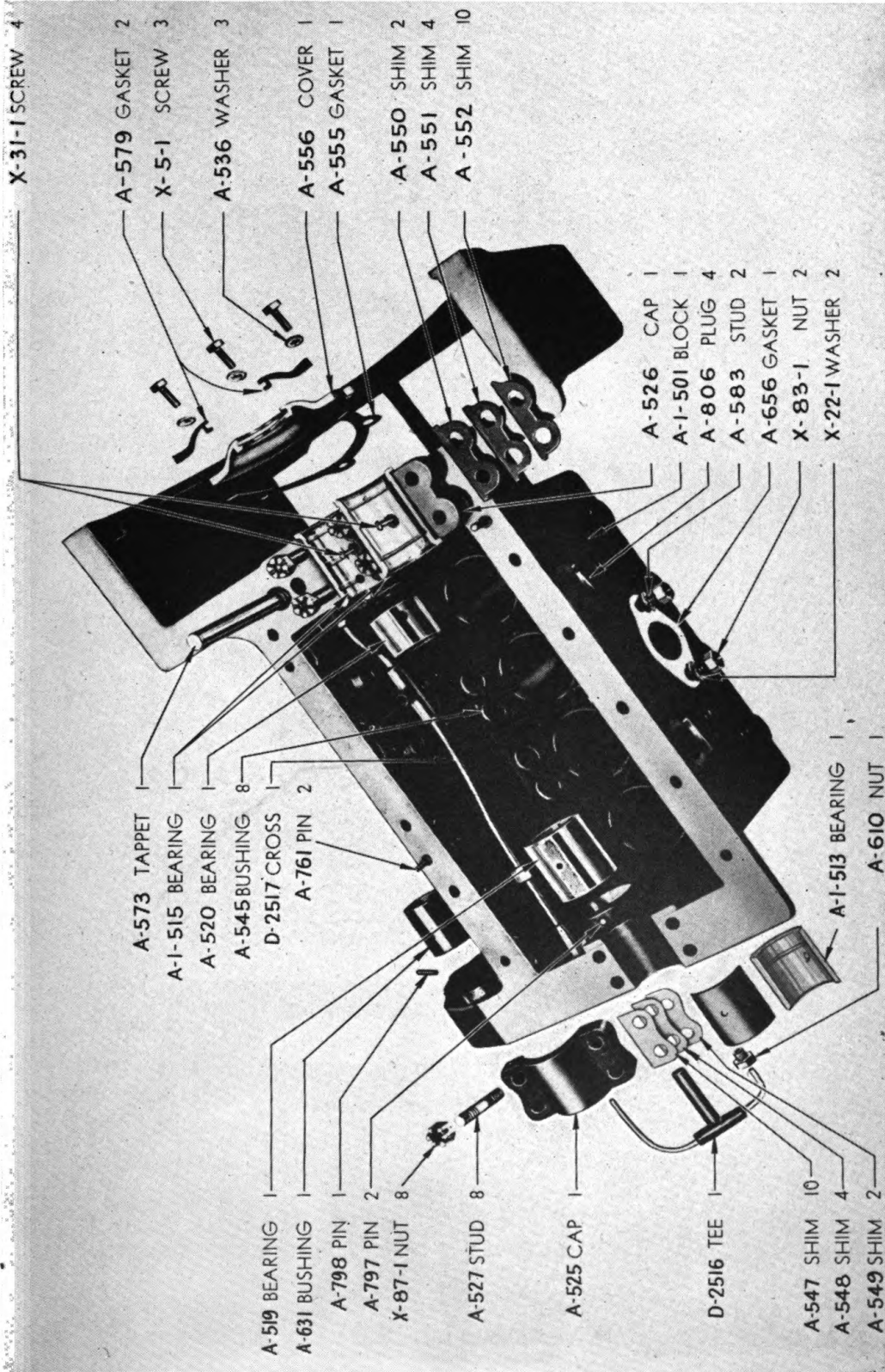

TL-90742

Figure 42. Cylinder block assembly.

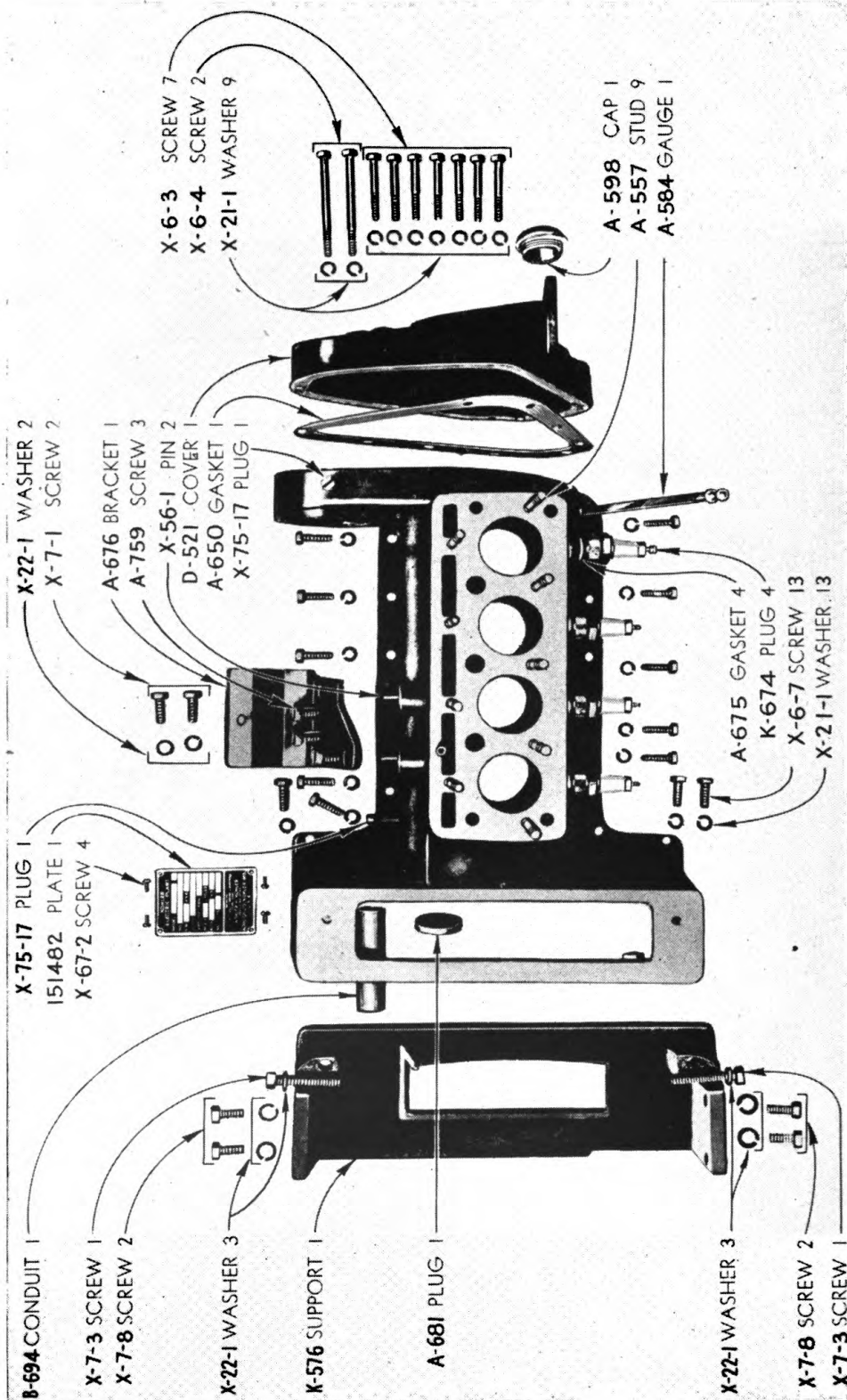

TL-90743

Figure 43. Cylinder block assembly.

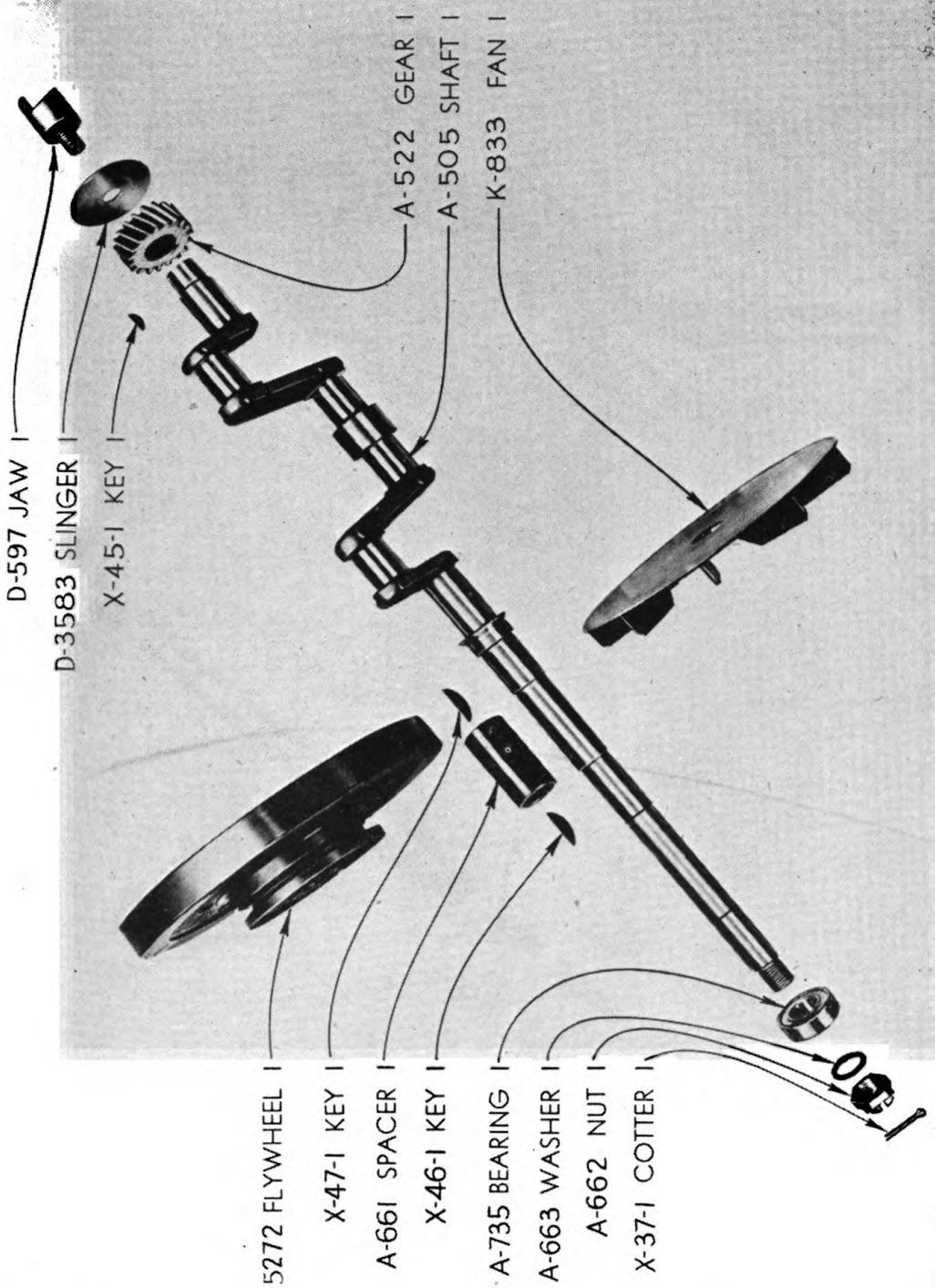

TL-90744

Figure 44. Crankshaft assembly.

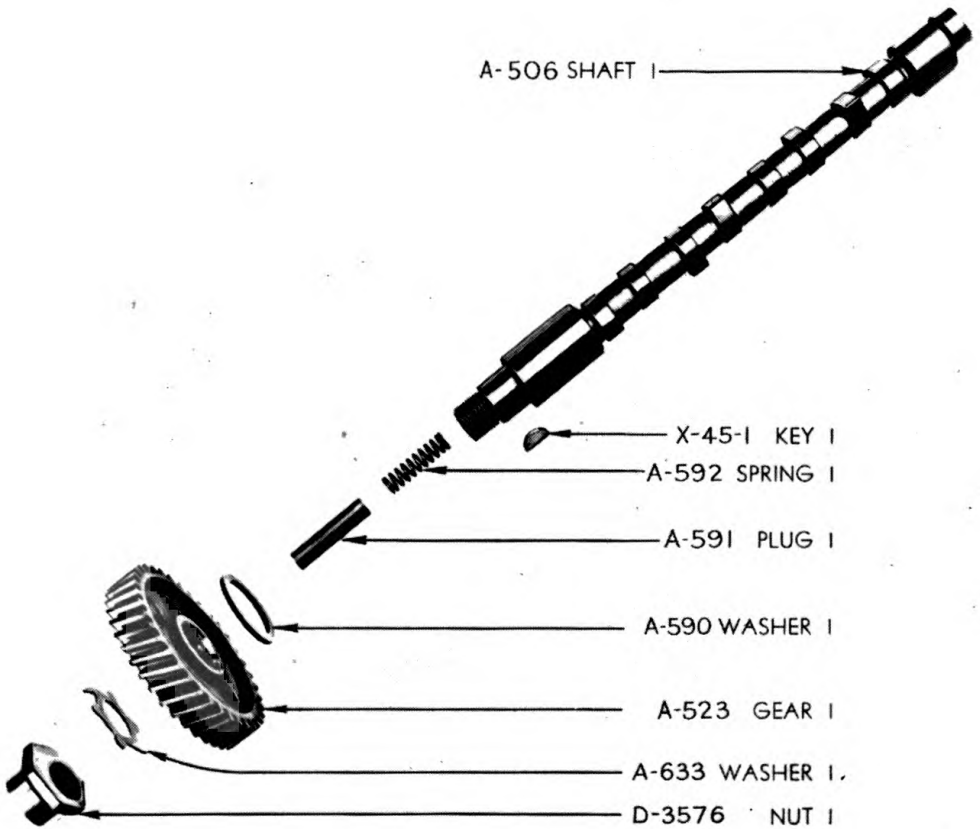
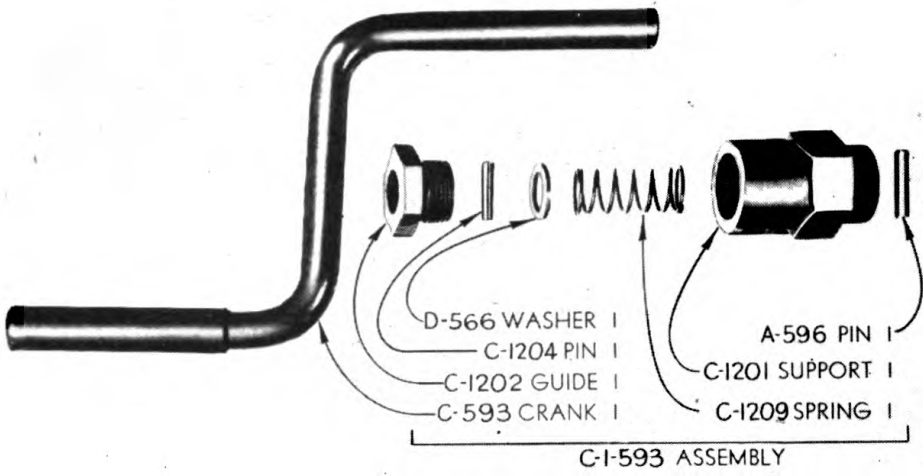

TL-90745

Figure 45. Camshaft assembly and starting crank assembly.

Supplementary Data

PART SEVEN
SUPPLEMENTARY DATA

37. TABLE OF REPLACEABLE PARTS.

NOTE—Order replacement parts by stock number, name of part, and description. Parts marked with an asterisk in the following table have been designated as maintenance parts. Illustrations showing each assembly listed in this table are identified below. *Standard nuts, bolts, screws, and washers (identified in each illustration by the prefix letter "X") are not listed in this table.*

a. Carburetor Group (fig. 9).

Ref. No.	Quan. in equip.	Signal Corps stock number	Name of part and description	Function	Mfr.	Kohler part No.
A-812	1	3H748-1	*Carburetor complete. Zenith model HK-3-12.	Regulates fuel mixture.	Z	5456
	1	3H1921/G28	*Gasket, carburetor flange.	For cylinder head intake.	K	A-657
	1	Plate, carburetor butterfly valve.	Controls opening in intake manifold.	Z	A-812
A-823	1	*Elbow, complete, 1/4 I. D.	For fuel line connection.	K	A-822
A-824	1	*Connector, complete, 1/4 I. D.	Connection for fuel line.	K	A-823
A-825	1	*Nut, compression, 1/4 I. D.	For connector.	K	A-824
A-832	1	*Sleeve, compression, 1/4 I. D.	For connector.	K	A-825
A-1-832	1	Lever, butterfly valve control.	Opens and closes valve.	Z	A-832
	1	Assembly, butterfly valve lever.	Z	A-1-832
	1	*Nut, compression, 5/16 I. D.	Same as A-824.	K	B-885
	1	*Sleeve, compression, 5/16 I. D.	Same as A-825.	K	B-886
	1	*Nipple.	K	B-887
	1	*Connector, complete.	Same as A-823.	K	B-890
	1	*Elbow, complete, 5/16 I. D.	Same as A-822.	K	B-892

a. Carburetor Group (fig. 9) (contd).

Ref. No.	Quan. in equip.	Signal Corps stock number	Name of part and description	Function	Mfr.	Kohler part No.
A-1566	1	Shaft, butterfly valve.	Holds butterfly valve.	Z	A-1566
A-1567	2	Screw, butterfly valve retainer.	Secures valve to shaft.	Z	A-1567
A-1568	1	*Jet, main. No. 9.	Controls fuel mixture.	Z	A-1568
A-1569	1	*Jet, compensating.	Controls fuel mixture.	Z	A-1569
A-1571	2	Plug, lower.	Holds jet in place.	Z	A-1571
A-1573	1	Pin, butterfly valve shaft.	Holds lever to shaft.	Z	A-1573
A-1578	2	*Washer, jet.	For carburetor jets.	Z	A-1578
A-1579	2	Washer, lower plug.	For lower plugs.	Z	A-1579
	1	*Nut, compression, ⅜ I. D.	Same as A-824.	K	BA-2035
	1	*Sleeve, compression, ⅜ I. D.	Same as A-825	K	BA-2036
D-3634-1	1	Body, carburetor.	Houses carburetor parts.	Z	D-3634-1
D-3636	1	Cover, carburetor.	Z	D-3636
D-3637	1	*Gasket, carburetor cover.	Z	D-3637
D-3638	2	Screw, cover.	Holds cover to body.	Z	D-3638
D-3639	2	Washer, cover screw.	For cover screws.	Z	D-3639
D-3640	1	*Float, carburetor.	Z	D-3640
D-3641	1	*Axle, carburetor float.	For float.	Z	D-3641
D-3642	1	3H4601/S2	*Filter screen.	Filters fuel.	Z	D-3642
D-3643	1	*Valve, fuel.	Controls fuel supply.	Z	D-3643
D-3654	1	Plug.	Z	D-3654

b. Fuel Pump Group (fig. 10).

Ref. No.	Quan. in equip.	Signal Corps stock number	Name of part and description	Function	Mfr.	Kohler part No.
D-3581	1	*Fuel pump complete, AC model 1521799.	Pumps fuel to carburetor.	A	3575
	1	Lever, priming.	For priming fuel pump.	A	3581

b. Fuel Pump Group (fig. 10) (contd).

Ref. No.	Quan. in equip.	Signal Corps stock number	Name of part and description	Function	Mfr.	Kohler part No.
D-3586	1	*Screw, fuel pump cover.	Holds fuel pump cover.	A	D-3584
D-3587	1	Bail, fuel strainer, with screw.	Holds sediment bowl.	A	D-3586
D-3588	1	*Bowl, sediment.	Collects sediment in fuel.	A	D-3587
D-3589	1	*Gasket, sediment bowl.	D-3588
D-3590	1	3H1921/S1	*Nut, fuel strainer bail.	Holds bowl seat secure.	A	D-3589
D-3591	1	*Screen, strainer.	Strains fuel.	A	D-3590
D-3592	2	*Seat, sediment bowl.	Holds sediment bowl.	A	D-3591
D-3593	2	*Gasket, valve plug.	For inlet and outlet valves.	A	D-3592
D-3594	1	Plug, valve.	For inlet and outlet valves.	A	D-3593
D-3595	2	*Diaphragm, fuel pump.	Creates vacuum in pump.	A	D-3594
D-3596	2	3H4601-7/S4	*Valve, fuel pump.	Inlet and outlet valves.	A	D-3595
D-3597	2	*Spring, valve.	Operate fuel pump valves.	A	D-3596
	1	*Spring, large.	For fuel pump.	A	D-3597
	1	*Spring, small.	For fuel pump.	A	D-3598
D-3655	1	Cover, fuel pump.	A	D-3655
D-3710	1	*Line, fuel 1/4-in.	Fuel line to carburetor.	K	D-3710
	1	*Line, fuel, 1/4-in.	Fuel line from pump to block.	K	D-3711
D-3713	1	*Gasket.	For gear case opening.	K	D-3713
D-3716	1	Pin, rocker arm.	A	D-3716
D-3717	2	Retainer, rocker arm pin.	For rocker arm pin.	A	D-3717
D-3718	1	Washer, alignment.	For diaphragm protector.	A	D-3718
D-3719	1	Arm, rocker.	Operates fuel pump.	A	D-3719
D-3721	1	Gasket, cover.	A	D-3721
153446	1	Body, fuel pump.	Houses fuel pump parts.	A	153446
153447	1	Link, fuel pump.	A	153447
153448	1	Pin, fuel pump link.	For fuel pump link.	A	153448
153449	2	Clip, fuel pump link pin.	A	153449

b. Fuel Pump Group (fig. 10) (contd).

Ref. No.	Quan. in equip.	Signal Corps stock number	Name of part and description	Function	Mfr.	Kohler part No.
153450	2	Cap, spring.	For large springs.	A	153450
153452	1	Cover, fuel pump side.	For side of pump.	A	153452
153453	1	Rod, fuel pump pull.	A	153453
153454	1	Gasket, fuel pump pull rod.	A	153454
153455	1	Protector.	Lower diaphragm protector.	A	153455
153456	1	Protector.	Upper diaphragm protector.	A	153456

c. Governor Group (fig. 12).

Ref. No.	Quan. in equip.	Signal Corps stock number	Name of part and description	Function	Mfr.	Kohler part No.
A-524	1	3H1921/G65	*Governor assembly.	Controls engine rpm.	K	5680
A-536	1	*Gear, governor (magneto).	Operates magneto drive shaft.	K	A-524
A-627	4	Washer, packing.	For magneto coupling (female).	K	A-536
A-628	1	Nut, magneto drive shaft.	K	A-627
A-629	1	Washer, magneto drive shaft.	Fits on shaft between nut and gear.	K	A-628
A-1-630	1	Drive shaft assembly.	K	A-629
A-635	2	Weight.	Drives magneto and operates governor.	K	A-1-630
A-637	1	Pin, governor flyweight hub.	K	A-635
A-638	2	Stud, governor sliding sleeve.	K	A-637
A-639	2	Pin, governor flyweight.	Supports governor fork.	K	A-638
A-640	2	Link pin, governor sliding sleeve.	K	A-639
A-641	1	Sleeve, governor sliding.	Pushes against governor fork to regulate engine rpm.	K	A-640
A-1-642	1	Collar assembly, governor sliding sleeve.	K	A-641
				K	A-1-642

c. Governor Group (fig. 12) (contd).

Ref. No.	Quan. in equip.	Signal Corps stock number	Name of part and description	Function	Mfr.	Kohler part No.
A-645	4	Washer, governor link plate.	K	A-645
A-646	2	Spring, governor flyweight.	Actuates flyweights.	K	A-646
A-654	1	*Retainer (lock ring), magneto coupling.	Locks magneto coupling.	K	A-654
A-659	1	3H1921/G29	*Gasket, governor housing.	Seals governor housing.	K	A-659
A-664	8	Link plate, governor.	Links flyweights to sliding collar and sleeve.	K	A-664
A-669	1	*Coupling, magneto (female).	Coupling on drive shaft to operate magneto.	K	A-669
A-671	1	Bearing, drive shaft.	Permits free rotation of governor (magneto) drive shaft.	K	A-671
A-774	1	*Ball joint, governor rod.	Connects ball joint rod to governor operating fork.	K	A-774
A-837	1	Weight, governor fork.	Counterbalances governor fork.	K	A-837
A-851	2	Link pin, governor flywheel hub.	Secures flywheel hub link.	K	A-851
A-861	2	Nut, ball joint rod.	Connects ball joint to rod.	K	A-861
B-936	1	Locknut.	For governor adjusting screw.	K	B-936
D-1301	1	Housing, governor.	Houses governor assembly.	K	D-1301
D-1302	1	Cover, governor housing.	K	D-1302
D-1306	1	*Gasket, governor housing cover.	Seals cover to housing.	K	D-1306
D-1307	1	Plug, governor housing.	K	D-1307
D-1308	1	*Rod, ball joint.	Controls fuel entering carburetor.	K	D-1308
D-1312-1	1	Fork assembly, governor.	Transmits governor action to carburetor.	K	D-1312-1

d. Fan Group (fig. 14). Components of each assembly are grouped together.

Ref. No.	Quan. in equip.	Signal Corps stock number	Name of part and description	Function	Mfr.	Kohler part No.
5425	1	Fan assembly, with oil cup.	Cooling.	S	5425
D-781	1	Blade, fan.	Circulates air.	S	D-781
D-783	1	Gasket, hub.	Seals fan hub.	S	D-783
A-785	1	Washer, hub.	S	A-785
D-786	1	Oiler, fan.	Holds lubricant.	S	D-786
B-930	1	Washer, shaft.	S	B-930
D-1000	1	Retainer, bearing.	Holds bearing in place.	S	D-1000
D-1001	1	Washer, bearing.	S	D-1001
D-1002	1	Washer, bearing.	S	D-1002
D-1003	1	Retainer.	Holds hub parts in place.	S	D-1003
D-1004	1	Washer, bearing.	S	D-1004
D-1005	1	Spring, retaining.	Used with D-1003.	S	D-1005
D-1006	1	Ball bearing.	Permits easy turning of fan shaft.	S	D-1006
D-1007	1	Ball bearing.	As above.	S	D-1007
D-1009	1	Shaft, fan.	Holds fan blade.	S	D-1009
D-1010	1	Gasket, hub.	Seals fan hub.	S	D-1010
5445	1	Hub, fan.	Houses shaft and hub parts.	S	5445
5446	1	3H1921/B40	*Fan belt, V-type.	Drives fan.	K	5446
7004	1	*Fan assembly, without oil cup.	Same as 5425.	S	7004
D-781-1	1	Blade, fan.	Same as D-781.	S	D-781-1
7031	1	Hub, fan.	Same as 5445.	S	7031
7032	1	Shaft, fan.	Same as D-1009.	S	7032
7033	2	Bearing.	Same as D-1006, 1007.	S	7033
7034	1	Spacer.	S	7034
7035	2	Ring, retainer.	Holds bearings.	S	7035

e. Radiator Group (fig. 15).

Ref. No.	Quan. in equip.	Signal Corps stock number	Name of part and description	Function	Mfr.	Kohler part No.
K-577-3	1	3H1921/R8	*Radiator.	Holds coolant supply.	K	K-577-3
K-580-2	1	*Cap, radiator.	K	K-580-2
K-581	1	Manifold, inlet.	Carries water to engine.	K	K-581
K-582	1	Manifold, outlet.	Carries water to radiator from engine.	K	K-582
K-599	1	*Petcock.	For draining radiator.	K	K-599
A-655	1	3H1921/G26	*Gasket, outlet.	Prevents leakage.	K	A-655
A-656	2	3H1921/G27	*Gasket, inlet and outlet.	Prevents leakage.	K	A-656
A-843-3	1	Gasket, radiator cap.	Prevents leakage.	K	A-843-3
5422	1	Guard, fan.	Protects operator.	K	5422
5423	1	Screw.	K	5423
5424	1	Bracket, fan.	Supports fan assembly.	K	5424
153657	1	*Thermometer.	Shows engine temperature.	K	153657

f. Magneto and Ignition Group (fig. 25). (See subpar. H for spark plugs.)

Ref. No.	Quan. in equip.	Signal Corps stock number	Name of part and description	Function	Mfr.	Kohler part No.
D-3962	1	*Coupling, magneto, male.	Couples magneto to drive shaft.	K	A-670
D-3964	4	Nut, cable outlet.	Shields cable.	K	D-3962
	4	Glands, rubber.	Seals cable outlets.	K	D-3964
	4	*Cables, ignition.	Transmit ignition voltage to plugs.	K	7029
153880	3	Screen, ventilator.	Keeps out dirt.	F	153880
153881	6	Washer, ventilator screen.	For screen rivets.	F	153881
153882	1	Insulating, washer, primary ground.	F	153882
153883	1	Washer, stationary contact bracket.	F	153883
153884	3	Rivet, ventilator screen.	Holds ventilator screens.	F	153884
153885	1	Pinion, rotor.	Operates distributor rotor.	F	153885

f. Magneto and Ignition Group (fig. 25) (contd).

Ref. No.	Quan. in equip	Signal Corps stock number	Name of part and description	Function	Mfr.	Kohler part No.
153886	1		Bearing, distributor sleeve.	Permits distributor shaft to turn easily.	F	153886
153887	1		Bearing, rotor sleeve.	Permits rotor shaft to turn easily.	F	153887
153888	1		Ball bearing, rotor.	As above.	F	153888
153889	1		Distributor shaft and gear assembly.		F	153889
153890	1		Rubber washer, bearing seal.		F	153890
153891	1		Insulating strip, rotor bearing.		F	153891
153892	1		Rotor, distributor.		F	153892
153893	1		Primary lead wire tube.		F	153893
153894	2		Shim, rotor shaft thrust bearing.		F	153894
153895	2		Flat washer, distributor shaft.		F	153895
	1		*Magneto, complete.	Provides ignition spark.	F	153901-FM-1
153920	1		Gauge, magneto point.		F	153909
	1		Stationary contact point adjusting screw.			
153922	1 pr		Brush, coil lead		F	153920
153926	1		Washer, bearing insulating.		F	153922
153937	3		Terminal, coil lead wire.	For ball bearing.	F	153926
153967	1		Coil assembly.		F	153937
153968	1		*Capacitor, magneto.	High tension coil.	F	153967
153969	1		Terminal, ground cable.		F	153968
153970	1		Insulation, ground terminal.		F	153969
153972	1		Ferrule, ground cable.		F	153970
153973	1		Outlet nut, ground cable.		F	153972
153975	1	3H2699/P82	*Breaker point set.	Contact points.	F	153973
153976	4		Retainer clips, high tension cable.		F	153975
153977	1		Gaskets, end cap cover.	Seals end cap.	F	153976

f. Magneto and Ignition Group (fig. 25) (contd).

Ref. No.	Quan. in equip.	Signal Corps stock number	Name of part and description	Function	Mfr.	Kohler part No.
153978	1	Cover, end cap.	For end cap.	F	153978
153979	1	Lead rod, distributor high tension.	F	153979
153980	1	Strip guide, ground cable switch.	F	153980
153981	1	Snap ring, distributor shaft.	Retains sleeve bearing.	F	153981
153982	1	Snap ring, rotor shaft.	Retains ball bearing.	F	153982
153983	1	Snap ring, rotor shaft.	Retains bearing shim.	F	153983
153984	1	Snap ring, rotor shaft pinion.	Holds pinion.	F	153984
153985	1	Frame, magneto.	Houses magneto parts.	F	153985
153986	1	End cap.	Houses distributor.	F	153986
153987	3	Lockwasher, ventilating screw.	F	153987
153988	1	Stationary bracket with contact point.	F	153988
153989	1	Bushing, primary ground screw.	F	153989
153990	1	Flat washer.	F	153990
153991	1	Cable outlet, distributor block.	F	153991
153992	2	Set screw, coil bridge.	Holds coil laminations.	F	153992
153993	1	Magneto rotor.	Armature.	F	153993
153994	1	Retaining washer, inner.	For ball bearing.	F	153994
153995	1	Retaining washer, outer.	For ball bearing.	F	153995
153996	1	Gasket, end cap to frame.	Seals joint.	F	153996
153997	1	Primary ground switch strip.	F	153997
153998	1	Plate, bearing and breaker support.	F	153998
153999	1	Pin, rotor pinion.	F	153999
	4	Cap assembly, spark plug shield.	Shields spark plug.	F	168551
	4	Bottom assembly, spark plug shield.	Shields spark plug.	F	168552

g. Cylinder Head, Manifold, and Muffler Group (figs. 11, 20, 22). Exhaust and installation fittings are shown in figure 4. (Numbers in figure 4 are Kohler part numbers.)

Ref. No.	Quan. in equip.	Signal Corps stock number	Name of part and description	Function	Mfr.	Kohler part No.
S-120	4	3H1921/V1	*Valve, exhaust.	Controls flow of exhaust gases.	K	S-120
A-1-502	1	Head, cylinder (less valves).	Holds valves.	K	A-1-502
	1	3H1921/H1	*Head, cylinder, complete.	As above.	K	K-2-502
A-511	1	*Cover, cylinder head.	K	A-511
A-528	8	3H1921/G80	*Guides, valve stem.	K	A-528
D-529	4	Valve, intake.	K	D-529
A-530	8	3H1921/S30	*Spring, valve.	Actuates valve.	K	A-530
A-531	8	*Retainer, valve spring.	Holds spring on valve.	K	A-531
A-532	8	*Key, valve spring retainer.	Locks spring retainer on stem.	K	A-532
A-1-533	4	Rocker arm with bushing (right).	Opens valve.	K	A-1-533
A-1-534	4	Rocker arm with bushing (left).	As above.	K	A-1-534
D-535	8	Screw, rocker arm.	For adjusting valve clearance.	K	D-535
A-1-537	1	Shaft, rocker arm.	Holds assembly.	K	A-1-537
A-2-537	1	3H1921/S15	*Shaft assembly, complete.	Rocker arm.	K	A-2-537
A-538	2	Bracket, shaft.	Supports ends of shaft.	K	A-538
A-539	1	Bracket, shaft.	Supports center of shaft.	K	A-539
A-540	2	3H1921/S32	*Spring, rocker arm spacer.	Holds rocker arm supports in place.	K	A-540
A-541	6	Washer, spacing.	Holds spring in place.	K	A-541
A-542	8	3H1921/B81	*Bushing, rocker.	Provides bearing surface.	K	A-542
A-543	8	Tappet, valve.	Operates rocker arm.	K	A-543
A-545	8	Bushing, valve tappet.	Guides tappet.	K	A-545
A-557	2	*Stud, cylinder head cover.	Anchors cover.	K	A-557
A-558	2	Stud, exhaust manifold.	Anchors exhaust manifold.	K	A-558
A-559	2	*Nut, exhaust manifold stud.	Secures exhaust manifold.	K	A-559
A-589	2	Nut, wing.	Holds cylinder head cover in place.	K	A-589
D-600	8	3H1921/R40	*Push rod.	Transmits tappet motion to rocker arms.	K	D-600

g. Cylinder Head, Manifold, and Muffler Group (figs. 11, 20, 22) (contd).

Ref. No.	Quan. in equip.	Signal Corps stock number	Name of part and description	Function	Mfr.	Kohler part No.
A-1-606	1	*Tube assembly, oil return.	Returns oil to oil base.	K	A-1-606
A-607	2	*Elbow, oil line.	Oil line fitting.	K	A-607
A-1-611	1	*Tube assembly.	Carries oil to rocker arm assembly.	K	A-1-611
A-616	2	Nut, oil line.	K	A-616
A-621	1	Cap, oil filler...	Covers oil-fill hole.	K	A-621
A-649	1	3H1921/G21	*Gasket, cylinder head.	Seals head to block.	K	A-649
A-653	1	3H1921/G25	*Gasket, cylinder head cover.	Seals cover to head.	K	A-653
A-657	1	Gasket, carburetor flange.	Prevents fuel leakage.	K	A-657
A-695	1	3H1921/G30	*Gasket, exhaust manifold, front.	Seals exhaust manifold.	K	A-695
A-696	1	3H1921/G31	*Gasket, exhaust manifold, center.	As above.	K	A-696
A-697	1	3H1921/G32	*Gasket, exhaust manifold, rear.	As above.	K	A-697
A-806-A	1	Plug.	For intake manifold.	K	A-806-A
B-897	3	Stud, cylinder head.	For rocker arm assembly.	K	B-897
B-920	1	Handle, choke valve.	For operating choke.	K	B-920
D-972	2	Flat washer.	For exhaust manifold stud.	K	D-972
	1	3H1921/M1	Muffler.	Reduces engine noise.	K	D-1192
	1	3H1921/G34	Gasket set.	K	D-1199
AC-1778	1	Bowl, air cleaner.	Holds oil.	U	AC-1778
AC-1779	1	Filter, air cleaner.	Filters air.	U	AC-1779
AC-1782	1	Wing nut, air cleaner.	Holds air cleaner filter on bowl.	U	AC-1782
AC-1788	1	Assembly, air cleaner.	Filters air.	U	AC-1788
AC-1789	1	Clamp, air cleaner.	Holds air cleaner on manifold.	U	AC-1789
5451	1	*Manifold, exhaust.	Draws out exhaust fumes.	K	5451
5452	1	Plate, exhaust manifold.	K	5452
5519-M	1	Manifold, intake.	Air intake.	K	5519-M
5521-1	1	Choker.	Holds choker valve.	K	5521-1
5525	1	Valve, choker.	Controls mixture.	K	5525

h. Cylinder Block and Piston Group (figs. 41, 42, 43).

Ref. No.	Quan. in equip.	Signal Corps stock number	Name of part and description	Function	Mfr.	Kohler part No.
A-1-501	1	Assembly, cylinder block.	K	A-1-501
A-507	4	3H1921/R40	*Rod, connecting.	Connects piston to crankshaft.	K	A-507
A-508	4	3H1921/P35	*Piston.	K	A-508
A-510	4	3H1921/P18	*Piston pin.	Connects piston to rod.	K	A-510
A-512	4	3H1921/B80	*Bushing, connecting rod bearing.	Provides bearing surface.	K	A-512
A-1-513	1	3H1921/B22	*Bearing, crankshaft (bearing).	Permits easy turning.	K	A-1-513
A-1-515	1	3H1921/B23	*Bearing, crankshaft (rear).	Permits easy turning.	K	A-1-515
A-1-517	4	3H1921/B24	*Bearing, connecting rod.	Provides bearing surface for rod.	K	A-1-517
A-519	1	3H1921/B25	*Bearing, camshaft (front).	Permits easy turning.	K	A-519
A-520	1	3H1921/B26	*Bearing, camshaft (rear).	Permits easy turning.	K	A-520
D-521	1	Cover, gear.	Houses gears.	K	D-521
A-525	1	Cap, crankshaft bearing cap (front).	Holds front bearing.	K	A-525
A-526	1	Cap, crankshaft bearing cap (rear).	Holds rear bearing.	K	A-526
A-527	1	*Stud, crankshaft bearing.	Holds bearing cap.	K	A-527
A-536	1	Packing washer.	For split cover screws.	K	A-536
A-545	8	Bushing, valve tappet.	Guide valve tappet.	K	A-545
A-547	10	Shim, front main bearing (0.094 in.).	Allow clearance.	K	A-547
A-548	4	Shim, front main bearing (0.008 in.).	As above.	K	A-548
A-549	2	Shim, front main bearing (0.002 in.).	As above.	K	A-549
A-550	2	Shim, rear main bearing (0.094 in.).	As above.	K	A-550
A-551	4	Shim, rear main bearing (0.008 in.).	As above.	K	A-551
A-552	10	Shim, rear main bearing (0.002 in.).	As above.	K	A-552
A-555	1	Gasket, split cover.	Prevents oil leakage.	K	A-555
A-556	1	Split covers.	Seal oil base.	K	A-556
A-557	9	Stud, cylinder head.	For securing head.	K	A-557
A-573	1	Tappet, oil pump.	Operates oil pump.	K	A-573
K-576	1	Base, radiator.	Supports radiator.	K	K-576
A-579	2	*Gasket, split cover.	Prevents oil leakage.	K	A-579

Supplementary Data

h. Cylinder Block and Piston Group (figs. 41, 42, 43) (contd.)

Ref. No.	Quan. in equip.	Signal Corps stock number	Name of part and description	Function	Mfr.	Kohler part No.
A-583	2		Stud, water inlet manifold.	Secures manifold.	K	A-583
A-584	1		Gauge, bayonet.	Shows oil level.	K	A-584
A-598	1		Cap, starting crank.	K	A-598
A-601	8		Bolt, connecting rod.	Holds rod bearings.	K	A-601
A-610	1		*Nut, oil line.	For oil line tee.	K	A-610
A-617	8		Shim, rod bearing (0.063 in.).	Adjust bearing clearance.	K	A-617
A-618	16		Shim, rod bearing (0.008 in.).	As above.	K	A-618
A-619	32		Shim, rod bearing (0.002 in.).	As above.	K	A-619
A-631	1		Bushing, magneto drive shaft.	Permits easy turning.	K	A-631
A-650	1	3H1921/G22	*Gasket, gear cover.	Seals gear cover.	K	A-650
A-656	1		Gasket, water inlet manifold.	Prevents leakage.	K	A-656
K-674	4	3H4410-7	*Spark plug, 18. mm.	Ignites fuel in cylinder. CHAMP.	K	K-674
A-675	4		Gasket, spark plug.	Prevent leakage.	K	A-675
A-676	1		Bracket, magneto.	Magneto support.	K	A-676
A-681	1		Plug, cylinder casting.	K	A-681
B-694	1		Bushing, magneto ground wire.	Ground wire conduit.	K	B-694
A-759	3		Screw, magneto bracket.	Secures bracket.	K	A-759
A-761	2		Pin, bearing.	K	A-761
A-797	2		Pin, camshaft bearing.	K	A-797
A-798	1		Pin, magneto drive shaft bearing.	K	A-798
A-806	4		Plug, cylinder casting.	Safety valve if water freezes in jacket.	K	A-806
A-826	12	3H1921/R30	*Ring, piston (compression).	Seals compression.	K	A-826
D-966	8	3H1921/R20	*Retainer, piston pin.	Secures pin.	K	D-966
D-2448	4		*Ring, piston (oil).	Distributes cylinder oil.	K	D-2448
D-2516	1		*Tee assembly.	Oil line assembly.	K	D-2516
D-2517	1		Cross assembly.	Oil line assembly.	K	D-2517
151482	1		Nameplate.	K	151482

i. Oil Base and Oil Pump Group (fig. 40).

Ref. No.	Quan. in equip.	Signal Corps stock number	Name of part and description	Function	Mfr.	Kohler part No.
D-223	1	Tube, oil line.	Part of oil line assembly.	K	D-223
D-224	1	Assembly, oil line tube.	Connects pump to filter.	K	D-224
D-227	1	Tee, oil line.	Connects pump to oil line.	K	D-227
D-228-1	1	Bushing, reducing.	Coupling for filter line.	K	D-228-1
A-503	1	Oil base.	Holds lubricant.	K	A-503
D-504	1	Baffle plate.	Retains oil for splash lubrication.	K	D-504
A-536	7	Washer, packing.	For split covers.	K	A-536
A-555	1	3H1921/G20	*Gasket, split cover.	Prevents oil leak.	K	A-555
A-556	1	Split cover.	Seals oil base.	K	A-556
D-560	1	*Oil pump assembly.	Provides forced lubrication.	K	D-560
D-561	1	Body, oil pump.	Houses pump parts.	K	D-561
D-564	1	Plunger, oil pump.	Pumps oil.	K	D-564
D-565	1	*Spring, oil pump.	Actuates plunger.	K	D-565
D-566	1	Washer, oil pump.	Retains oil pump spring.	K	D-566
D-1-567	1	Strainer assembly.	Plug and strainer.	K	D-1-567
D-568	1	Plug, oil drain.	Plugs oil drain.	K	D-568
A-569	1	Washer, drain plug.	Seals oil drain hole.	K	A-569
D-571	1	Nipple, oil pump.	Oil drain outlet extension.	K	D-571
A-574	2	Stud, oil pump.	For mounting pump.	K	A-574
D-588	1	Plug, oil pump.	Seals lead opening in pump.	K	D-588
A-605	1	*Connector, oil pump.	Connects oil pump to cylinder head oil duct.	K	A-605
A-1-615	1	*Assembly, oil pump tube.	Connects pump to oil line.	K	A-1-615
A-615	1	Oil line.	For A-1-615.	K	A-615
A-616	3	*Nut, oil line.	For assembly A-1-615.	K	A-616
D-623	1	Ball, oil pump inlet.	Valve for pump inlet.	K	D-623
D-624	1	Ball, oil pump outlet.	Valve for pump outlet.	K	D-624
A-651	1	3H1921/G23	*Gasket, oil base (right).	Seals oil base joint.	K	A-651

i. Oil Base and Oil Pump Group (fig. 40) (contd).

Ref. No.	Quan. in equip.	Signal Corps stock number	Name of part and description	Function	Mfr.	Kohler part No.
A-652	1	3H1921/G24	Gasket, oil base (left).	Seals oil base joint.	K	A-652
A-823	1	*Connector.	For oil line assembly.	K	A-823
A-824	1	Nut, compression.	For above connector.	K	A-824
A-825	1	Sleeve, compression.	For above connector.	K	A-825
D-973	1	Cover, oil base end.	For clean out.	K	D-973
D-974	1	3H1921/G33	*Gasket, oil base end cover.	Prevents oil leak.	K	D-974
D-995	1	Plug, oil pump passage.	K	D-995
D-996	1	Washer.	K	D-996
D-997	6	Washer.	Secures oil pump plug.	K	D-997
D-1012	1	Strainer.	For oil base end cover.	K	D-1012
D-1350	1	3H1921/F15	*Oil filter.	Part of D-1-567.	K	D-1350
D-1352	1	3H1921/E10	*Element, oil filter.	Filters oil.	P	D-1350
				Part of D-1350.	P	D-1352

j. Crankshaft, Camshaft, and Crank Group (figs. 44, 45).

Ref. No.	Quan. in equip.	Signal Corps stock number	Name of part and description	Function	Mfr.	Kohler part No.
A-505	1	Crankshaft.	Operates connecting rods.	K	A-505
A-506	1	Camshaft.	Carries cams and gear.	K	A-506
A-522	1	3H1921/G50	*Gear, crankshaft.	Meshes with cam gear.	K	A-522
A-523	1	3H1921/G51	*Gear, camshaft.	Operates camshaft	K	A-523
D-566	1	Washer.	In crank assembly.	K	D-566
A-590	1	Washer, camshaft thrust.	Fits between gear and block.	K	A-590
A-591	1	Plug, camshaft thrust.	Transfers thrust from spring to gear cover.	K	A-591
A-592	1	Spring, camshaft thrust plug.	Maintains end pressure on camshaft.	K	A-592
C-593	1	Crank, starting.	Part of C-1-593.	K	C-593

j. Crankshaft, Camshaft, and Crank Group (figs. 44, 45) (contd).

Ref. No.	Quan. in equip.	Signal Corps stock number	Name of part and description	Function	Mfr.	Kohler part No.
C-1-593	1	3H1921/C35	Crank assembly.	For manual starting.	K	C-1-593
A-596	1		Pin, starting crank.	Engages starting jaw.	K	A-596
A-597	1		Jaw, starting crank.	For engaging crank.	K	A-597
A-633	1		Lockwasher.	Secures camshaft nut.	K	A-633
A-661	1		Spacer.	Spaces flywheel from armature.	K	A-661
A-662	1		Nut, ball bearing.	Retains ball bearing on armature end.	K	A-662
A-663	1		Washer.	For ball bearing nut.	K	A-663
A-735	1	3H2425/B1	Ball bearing.	Supports armature shaft.	ND	A-735
K-833	1		Fan, generator.	Cools generator.	K	K-833
C-1201	1		Support, starting crank.	Holds crank in place.	K	C-1201
C-1202	1		Guide, starting crank.	Guides crank into place.	K	C-1202
C-1204	1		Pin, starting crank.	Rest for crank spring.	K	C-1204
C-1209	1		Spring, starting crank.	K	C-1209
D-3576	1		Nut, camshaft.	Holds shaft in place.	K	D-3576
D-3583	1		Thrower, oil.	Splashes oil on crankshaft bearing, gear.	K	D-3583
5272	1		Flywheel.	Equalizes torque.	K	5272

k. Generator Group (figs. 16, 17).

Ref. No.	Quan. in equip.	Signal Corps stock number	Name of part and description	Function	Mfr.	Kohler part No.
D-730	1		Cover, generator end.	Covers brush holder bracket.	K	D-730
A-735	1	3H2425/B1	*Ball bearing.	Supports armature shaft.	K	A-735
D-741	4	3H2452/H1	*D-C brush holder.	Holds d-c brush.	K	D-741
D-742	4		*Brush, d-c.	Collects current from commutator.	K	D-742
A-804	2		*Fuse, 30-amp.	Protects load.	K	A-804

k. Generator Group (figs. 16, 17) (contd).

Ref. No.	Quan. in equip.	Signal Corps stock number	Name of part and description	Function	Mfr.	Kohler part No.
D-903	1	3H2452/G1	*Gasket, bearing housing.	Keeps out dirt.	K	D-903
AC-1539	1	Condenser assembly.	Minimizes radio interference.	K	AC-1539
AC-1850	1	Collector ring assembly.	For A-C output.	K	AC-1850
AC-1852	2	Bolt, collector ring.	Holds ring to armature.	K	AC-1852
5272	1	Flywheel.	Equalizes torque.	K	5272
5446	1	Belt, V-belt.	Drives engine fan.	K	5446
5955	1	*Coil, resistance.	Varies field current.	K	5955
5956	1	*Exciter switch.	For use with resistance coil.	K	5956
6003	6	Poles, field.	Provide magnetic flux.	K	6003
6054	1	Stud, brush holder.	Fastens holder to bracket.	K	6054
7104	1	Spacer, bearing.	Spaces fan and armature.	K	7104
7105	1	Spacer, bearing.	Spaces armature and bracket.	K	7105
7110	1	2Z7599-2	*Voltage regulator relay.	Regulates voltage.	K	7110
7111	1	Lead, voltage control (No. 6).	Connects relay to resistance.	K	7111
7115	1	Lead, d-c brush (No. N).	Connection for d-c brush.	K	7115
7116	1	Lead, a-c brush (No. A).	Connects a-c brush to output.	K	7116
7121	1	Frame, generator.	Houses generator.	K	7121
7131-1	3	Field coil.	Provide flux.	K	7131-1
7131-2	3	Field coil.	Provide flux.	K	7131-1
7146	1	Bracket, brush holder.	Holds brushes—supports armature shaft.	K	7131-2
7148	1	Stud, brush holder (a-c).	Fastens a-c brush to bracket.	K	7146
7150	2	*A-C brush.	Collects a-c from rings.	K	7148
7171	1	Armature, complete.	Generates voltage.	K	7150
151024	12	Washer, insulating.	For brushholder stud.	K	7171
151025	6	Bushing, insulating.	Insulates studs.	K	151024
151026	6	Washer.	For stud screws.	K	151025
156030	2	Brush holder (a-c).	Holds brushes.	K	151026
						156030

1. Complete unit.

Ref. No.	Quan. in equip.	Signal Corps stock number	Name of part and description	Function	Mfr.	Kohler part No.
	1	3H4524-1M21A	1½-KVA Kohler Power Unit, model 1M21A.	A-C power source.	K	1M21A

38. LIST OF MANUFACTURERS.

Abbreviation	Name	Address
A	AC Spark Plug Co.	Flint, Mich.
F	Fairbanks-Morse Co.	Beloit, Wis.
K	Kohler Co.	Kohler, Wis.
ND	New Departure.	230 N. Michigan Ave., Chicago
P	Purolator Products, Inc.	Newark, N. J.
S	Switzer-Cummins Co.	1125 Mass. Ave., Indianapolis, Ind.
U	United Air Cleaner Co.	9705 Cottage Grove, Chicago.
Z	Zenith Carburetor Co.	Detroit, Mich.

Order Nos. 930—MPD—43 4097 copies March 1944
 1580—MPD—44
 12646—Phila.—44

