

✓  
bd  
U113  
12  
JM  
1944

# TM 5-1000

WAR DEPARTMENT TECHNICAL MANUAL

*U.S. Dept of Army*

**SPREADER, AGGREGATE,**

**TOWED-TYPE,** FEB 5 1946

**TRACTION-POWERED,**

**8-FT. WIDTH, GOOD ROADS,**

**BERNA MODEL 8**

**MAINTENANCE INSTRUCTIONS**

WAR DEPARTMENT • 20 MARCH 1944



SPREADER, AGGREGATE,  
TOWED-TYPE,  
TRACTION-POWERED,  
8-FT. WIDTH, GOOD ROADS,  
BERNA MODEL 8

MAINTENANCE INSTRUCTIONS

---



WAR DEPARTMENT • 20 MARCH 1944

---

*United States Government Printing Office*

*Washington : 1945*

WAR DEPARTMENT,  
WASHINGTON 25, D. C., 1 December 1944.

TM 5-1000, Spreader, Aggregate, Towed-Type, Traction-Powered, 8-ft. Width, Good Roads, Model 8, is published for the information and guidance of all concerned.

[AG 300.7 (11 Nov 44).]

BY ORDER OF THE SECRETARY OF WAR:

G. C. MARSHALL,  
*Chief of Staff.*

OFFICIAL:

J. A. ULIO,  
*Major General,  
The Adjutant General.*

DISTRIBUTION:

AAF (10); AGF (10); ASF (10); T of Opns (C of Engrs) (2); Dept (10); Base C (C of Engrs) (2); Arm & Sv Bd (2) except the Engr Bd (10); Def C (1); Tech Sv (2); except C of Engrs (20); SvC (10); PE (Port Engr) (2); ASF Dep (Engr Sec) (2); Dep 5 (2); except Albany (Pub Off) (7) & Granite City Engr Dep (25); Dist O 5 (2) except Seattle Dist Engr (4); Div Engr (2); Gen & Sp Sv Sch (2); USMA (2); Library of Congress (2); ROTC (1); ASF Tng Ctr (Engr Sec) (2); A (10); CHQ (10); D (2); T/O & E 5-247 (6); 2 copies to following: T/O & E 5-47; 5-157; 5-267; 5-357; 5-377; 5-567; 5-592; 1 copy to following: T/O & E 5-16; 5-17; 5-22; 5-26; 5-27; 5-36; 5-37; 5-52; 5-56; 5-57; 5-59; 5-66; 5-67; 5-72; 5-76; 5-77; 5-87; 5-88; 5-96; 5-97; 5-116; 5-136; 5-137; 5-138; 5-167; 5-172; 5-176; 5-186; 5-187; 5-188; 5-189; 5-192; 5-216; 5-217; 5-226; 5-227; 5-228; 5-236; 5-237; 5-238; 5-252; 5-256; 5-257; 5-276; 5-277; 5-283; 5-297; 5-317; 5-327; 5-337; 5-367; 5-386; 5-387; 5-412; 5-416; 5-417; 5-447; 5-456; 5-457; 5-466; 5-467; 5-476T; 5-477T; 5-500 SV Orgn, Comp Co, Map Dep Det, CA; Util Det Co, EA; Gas Generating Unit, GA; Model Making Team (Det) MA, Dredge Crew, Floating Power Plant Det, NE; Port Rep Ship Crew, NE; Survey Liaison Det, CA; Foundry Team (Det), PA; Avn Fire Fighting Plat; Util Plat, Util Tng Co, Mine Detection Co (DOG), Det; 5-510-1S; 5-512S; 5-516S; 5-517S; 5-526S; 5-527S; 5-536S; 5-537S; 5-538S; 5-539S; 5-547S; 5-556S; 5-557S; 5-587; 5-600-1; 5-601-1; 5-627; 5-652S; 5-656S; 5-657S; 5-658S; 5-659S; 5-666S; 5-667S; 5-669S; 5-677S; 5-800-2.

For explanation of symbols see FH 21-6.

LL113  
12  
TM5:1000  
L944  
★

# ALPHABETICAL INDEX

## OPERATION SECTION

General Description.....	1
Installation of Truck Attachment.....	14
Instructions for Mounting Spreader Upon Caisson Transport.....	11
Lubrication Instructions.....	17
Preparation of Spreader for Initial Operation.....	14
Preparation of Spreader for Storage.....	17
Safety Precautions and Proper Operating Procedure.....	2
Specifications.....	13

## MAINTENANCE SECTION

Assembling Transmission.....	21
Disassembling Transmission.....	20
Installing Transmission.....	21
Installing Wheels.....	19
Removing Transmission.....	20
Removing Wheels.....	19

M558573



## **SECTION I**

### **OPERATION SECTION**

#### **INTRODUCTION**

1. **PURPOSE and SCOPE**—These instructions are published for the information and guidance of the using arms charged with the operation, maintenance and repair of this material. They contain descriptions of the major units and their function in relation to other components of the **SPREADER, Aggregate, Towed-Type, Traction-Powered, Good Roads, Berna Model 8** as well as instructions for operation, inspection and maintenance.

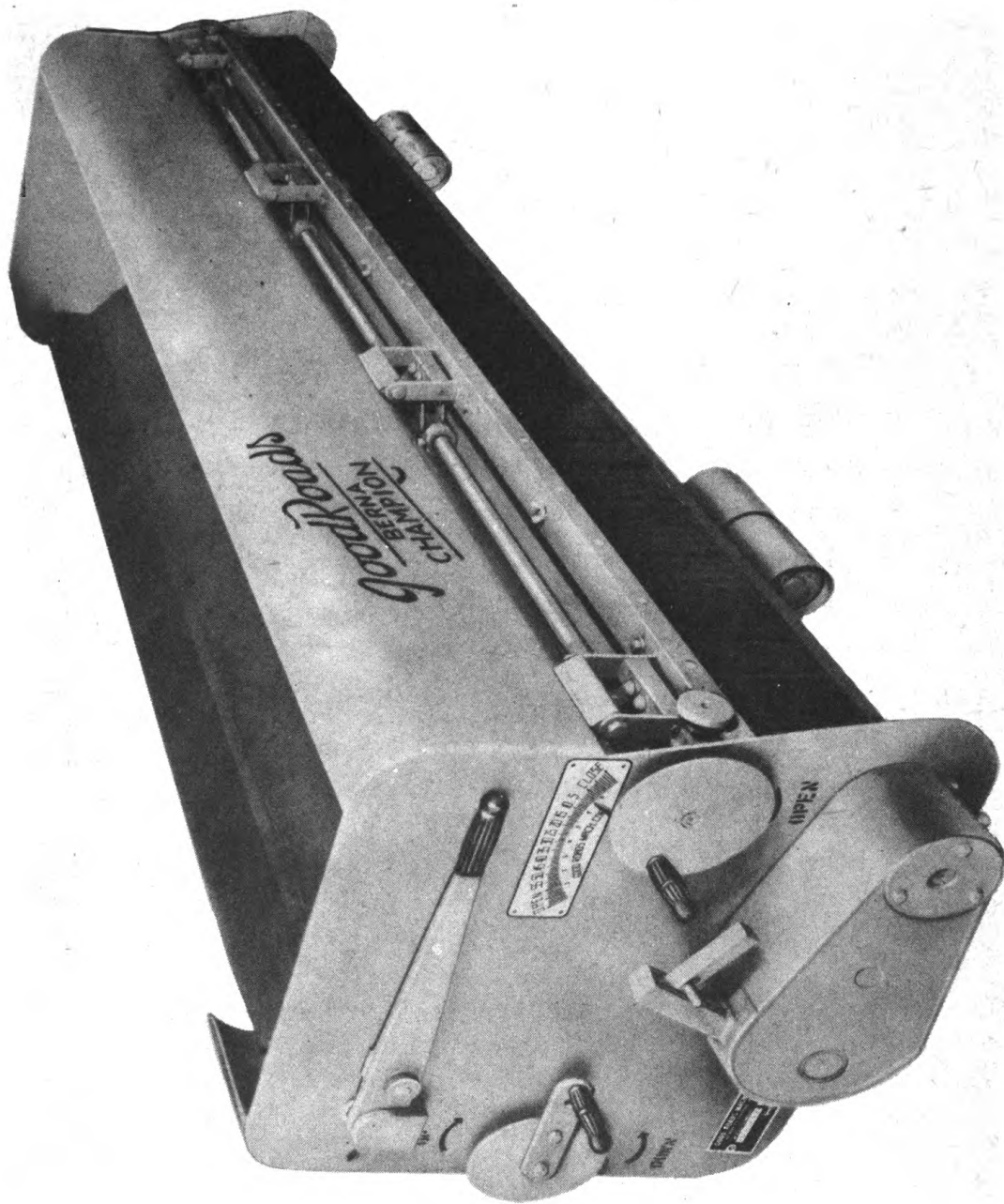

Plate No. 1— $\frac{3}{4}$  View of Spreader, Aggregate, Towed-Type Traction Powered, Model 8

## GENERAL DESCRIPTION

### MODEL 8

#### SPREADER, Aggregate, Towed-Type, Traction-Powered (with Transport)

This manual covers the Good Roads Spreader, Towed-Type Traction-Powered Aggregate, Berna Model 8, also the transport wheel equipment for hauling the spreader rapidly over the highway from one job location to another.

The Spreader is capable of spreading any material equally well, from sand to 1" stone, in any desired volume with accuracy and economy throughout its entire width. The feed of the material is smooth and uniform regardless of the speed of the truck.

The **KEYBOARD** (feed control gate,) has a maximum opening of  $3\frac{1}{4}$  inches. The continual vibration of the series of individual spring steel blades provides constant agitation of the material—eliminating the use of a mechanical agitator. Because of the flexibility of the spring steel blades, over-size material will pass through without clogging. It is impossible for the keyboard to sag, distort, or bend out of shape because of the supporting links of the adjustment shafts. The adjustment shafts extend the full length of the spreader and float on needle bearings.

The opening of the keyboard is controlled by a synchronized micrometer positive screw adjustment. The control handles are located on each end of the spreader, and indicators point out the exact location of the keyboard or the width of the opening. A taper spread attachment for changing road crown or increasing banks on curves is also provided. The adjustment for this attachment is independent of the keyboard adjustment and can also be operated from either end.

The entire drive—steel gears, sprockets, chain, and the automatic clutch are completely enclosed for the operator's safety and for long life of the mechanism. The location is on the left hand (truck driver's side) making it easy to signal the operator.

The feed roll is under absolute control, it can be stopped instantly or set in forward position or in reverse or held in neutral. An automatic safety clutch is provided to insure against reverse of the feed roll—without disturbing the transmission gear setting. The coupler vertical adjustment is an improved screw type, much faster than any ratchet type now in common use. It is simple in design, has a 7 in. vertical adjustment making it readily adaptable to any standard truck and has a swivel movement to permit the spreader to follow the road contour. The position of the release lever remains unchanged regardless of the angle of the coupler.

Two duplicate sets of castors (pony wheels) are employed to safeguard and protect the feed roll from damage. They also permit the spreader to rest at level when not in use. In backing up the pony wheels roll over irregularities without disturbing or marring the spreaded surface.

Long sturdy handles for moving the machine, located—one at each end, swing up and over—and lock out of the way when not in use. One man can handle the spreader without assistance.

## SAFETY PRECAUTIONS AND PROPER OPERATING PROCEDURE

### ATTACHING SPREADER TO THE TRUCK

The spreader coupler is simple in design, sure in action, has a 7 in. vertical adjustment making it readily adaptable to any standard truck, and has ample swivel movement *to permit the spreader to follow road contour.*

The position of the release lever (O) for the spreader coupler remains unchanged regardless of the angle of the coupler—pushing the release lever forward disengages the coupler from the truck.

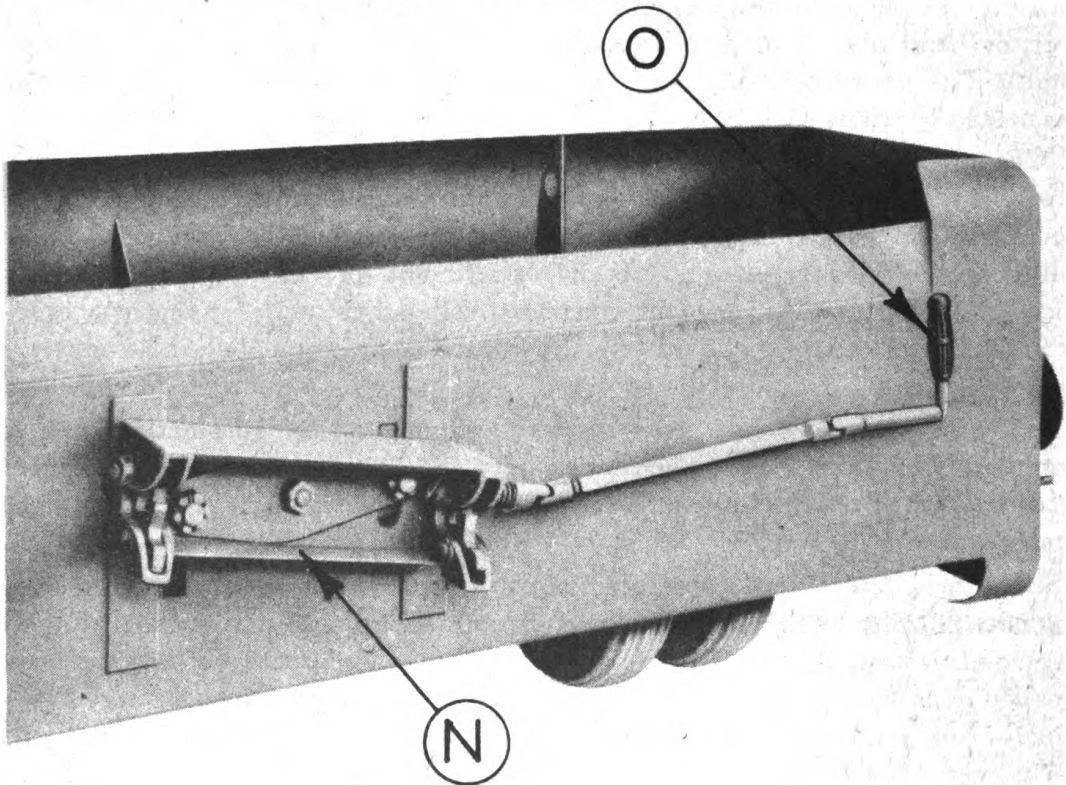
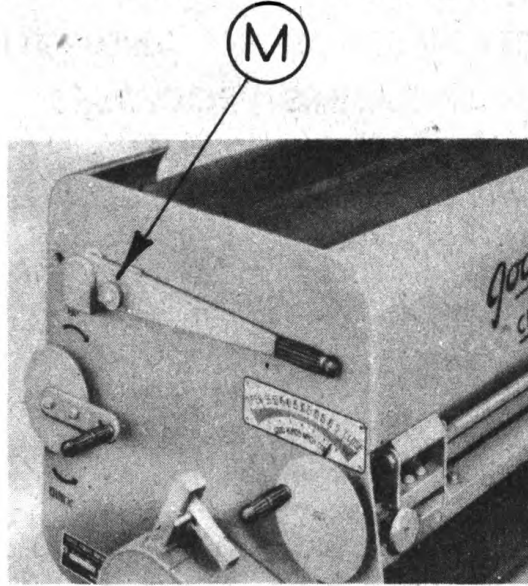

**Plate No. 2—Coupler Attachment**

(N) Spreader Coupler.      (O) Coupler release handle.

**CONNECTING TO TRUCK**

1. Adjust the coupler (N, Plate No. 2) on the spreader so that the spreader box is level when attached to the loaded truck. The coupler vertical adjustment is made by control (E, Plate No. 4). To raise, turn to the right, and to lower, turn to the left.
2. Remove all obstacles which will prevent proper clearance such as tail-lights, etc.



**Plate No. 3—Handle Bar Release**

3. In making the connection, line up the truck and spreader so that in backing up the truck, the truck attachment centers with the coupler (N, Plate No. 2) on the spreader.
4. After the connection is made, raise the body of the truck and make sure that the tail gate clears the spreader and that the truck body does not exert any load on the spreader box.

**DISCONNECTING FROM TRUCK**

To disconnect or release the spreader from truck, simply push the coupler release lever (O, Plate No. 2) forward, then back the spreader away. The long levers for moving the spreader can be put in place, first by unlocking them—turn the lock plug (M, Plate No. 3) right or left until the plug releases and the lever is free, then swing the lever up and over and lock in place in the same manner. This applies to both levers on either side of the hopper box.

OPERATION INSTRUCTIONS

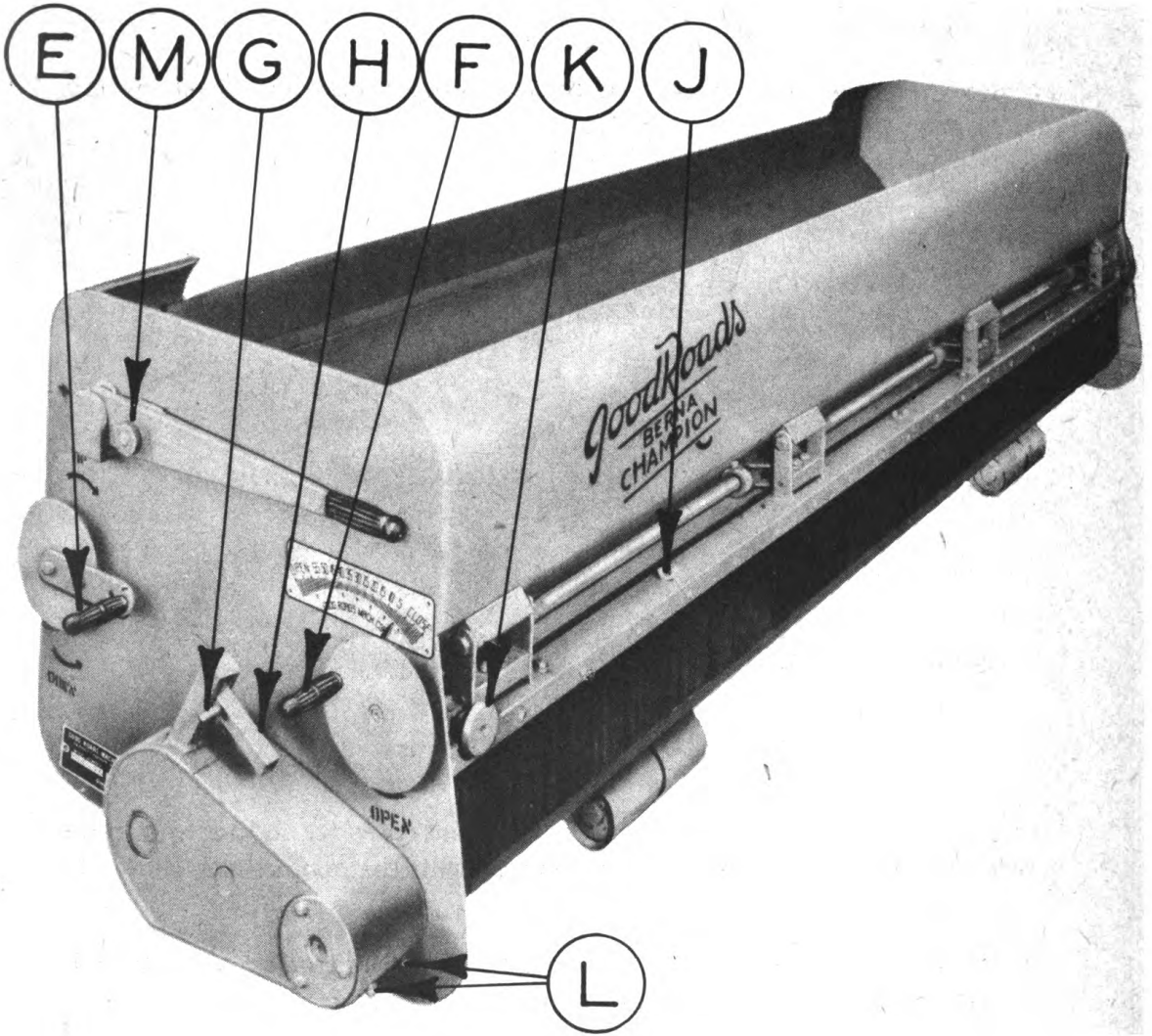

Plate No. 4—Operating Controls

- (E) Coupler Vertical Adjustment
- (F) Keyboard Feed Adjustment
- (G) Shift Lever Lock Stud
- (H) Transmission Shift Lever

- (J) Taper Attachment Lock Nuis
- (K) Taper Attachment Adjustment
- (L) Transmission Cover Bolts
- (M) Handle Bar Release Lock Plug

**OPERATION OF THE CONTROLS.**

With the spreader in position to attach to the truck, all important controls are located on the left hand (truck driver's) side.

**(E) COUPLER VERTICAL ADJUSTMENT.**

This control moves the coupler up or down so as to bring the spreader in line with the truck attachment. To raise, turn handle (E, Plate No. 4) to the right, and to lower, turn to the left.

**(F) MICROMETER POSITIVE SCREW ADJUSTMENT FOR KEYBOARD FEED CONTROL GATE—ONE ON EACH END OF THE SPREADER.**

This control opens and closes the feed gate—regulates the tension of the keyboard against the feed roll and measures out the quantity or thickness of the material application. When operating from the left side of the spreader, to OPEN, turn handle (F) to the left or counter-clockwise, and to CLOSE, turn to the opposite direction or clockwise.

**(G) LOCK STUD FOR SHIFT LEVER.**

This lock stud provides a positive lock for the gear setting and holds it in the intended position.

**(H) SHIFT LEVER FOR CHANGING TRANSMISSION GEAR SETTING.**

This is provided so that the feed roll will revolve in the same direction regardless of the forward or backward movement of the spreader. For forward movement of the spreader, set the lever (H) in the top position. For backward movement of the spreader, set the lever (H) in the bottom position. When the lever (H) is set in the center position, the transmission gears are in neutral and the feed roll will not revolve.

**(J) WING LOCK NUTS (3 SPACED EQUALLY APART) FOR TAPER ATTACHMENT.**

Three wing nuts (J) lock the taper attachment in position and must be loosened before attempting to make a taper adjustment.

**(K) MICROMETER ADJUSTMENT FOR TAPER ATTACHMENT—OPERATES AT EITHER END.**

After the wing lock nuts (J) mentioned above are loosened, the desired taper spread can be gained by operating the attachment (K) at either end to suit the requirements.

**(L) RETAINING BOLTS FOR TRANSMISSION GEAR BOX COVER.**

By removing the bolts (L), the gear box cover can be taken off for lubrication or inspection of the drive mechanism. Care should be taken not to distort or damage the cover cork gasket.

**(M) LOCK PLUG FOR THE HANDLE BAR USED IN MOVING THE MACHINE, ONE ON EACH END OF THE SPREADER.**

The lock plug (M) holds the handle bar in the desired location. To unlock turn the plug (M) right or left until it releases the handle bar so that the handle bar can be swung up and over, and then lock the plug (M) in place in the same manner.

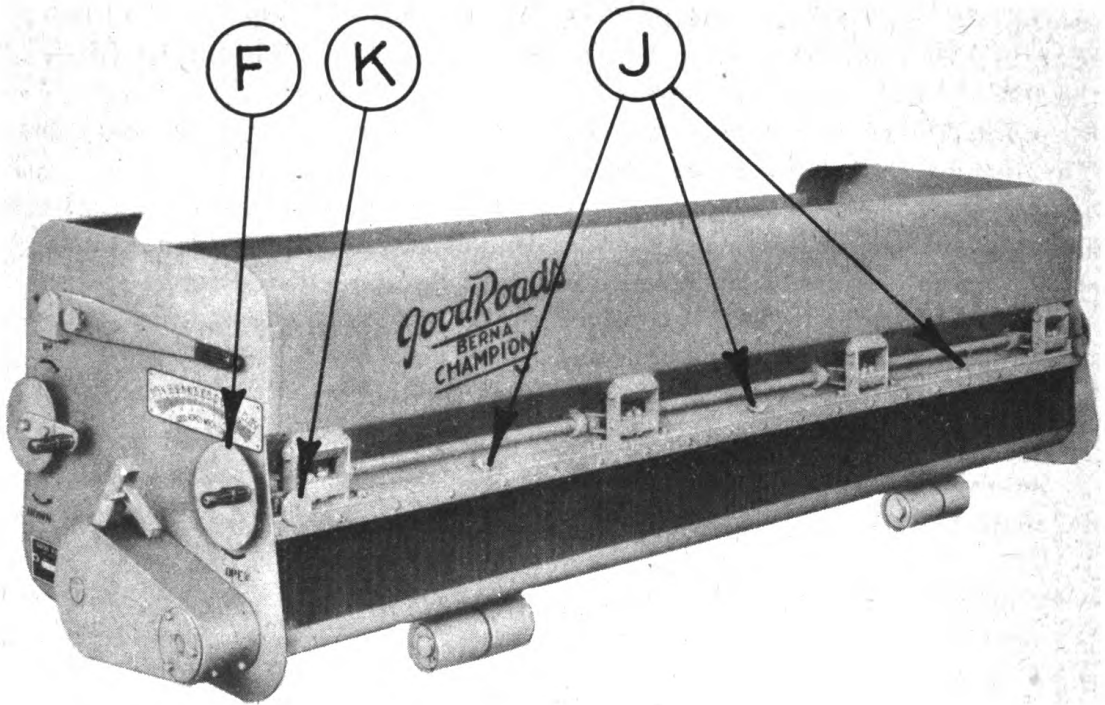

**Plate No. 5—Rear View to Show Keyboard Feed**

- (F) Keyboard Feed Adjustment (J) Taper Attachment Lock Nuts  
(K) Taper Attachment Adjustment

### KEYBOARD FEED AGITATION

The spring steel blades which control the thickness or quantity of spread, also serve as an agitator. The continual vibration of the series of individual spring steel blades provides constant agitation of the material, giving a steady uniform flow. Oversize material will pass through without clogging because of the flexibility of the spring steel blades.

**OPERATING KEYBOARD FEED CONTROL GATE (See Plate No. 5.)**

Two controls (F) independent of each other and located on each end of the spreader, regulate the thickness or quantity of the material application. They control the opening and tension of the keyboard against the feed roll. When operating from the left side to OPEN the keyboard feed control gate, turn to the left or counter-clockwise and to CLOSE, turn in the opposite direction or to the right. These instructions are reversed when operating from the right side. The opening can be either uniform or tapered as conditions require. To make a taper adjustment—for changing road crown or increasing bank on curves—loosen the three wing nuts (J) then open the taper attachment control (K) at either end as desired. When properly set, lock the three wing nuts (J) in place again. The micrometer adjustment for the taper attachment is independent of the keyboard micrometer adjustment.

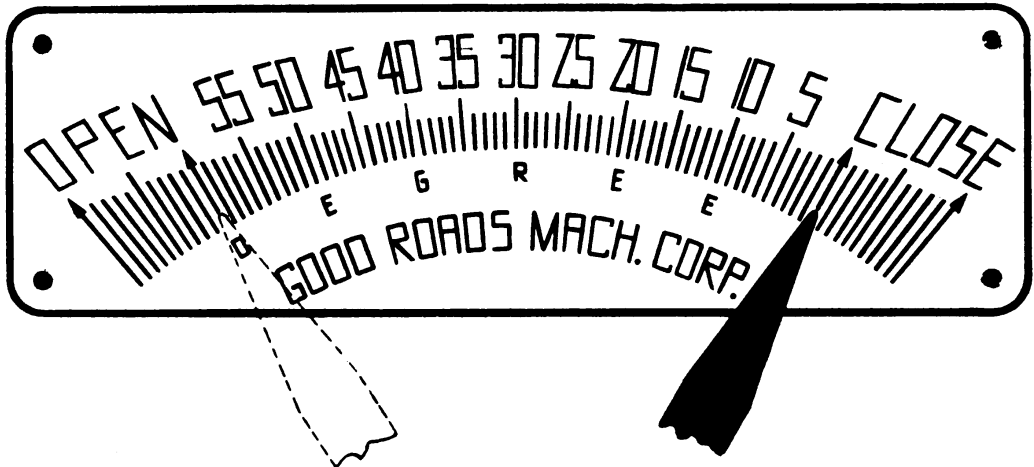
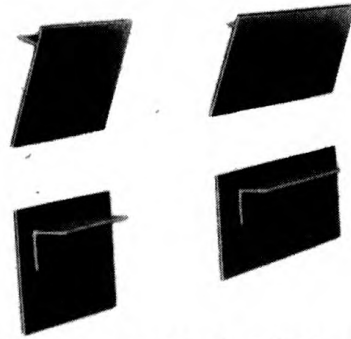

**Plate No. 6—Indicator Plate**

*Indicators* point out the exact position of the keyboard or the width of the opening so it is possible to close the opening entirely and then return to the original setting and be assured of spreading the same amount of material.

**PARTIAL SPREADING WIDTHS**

Steel block-off plates can be furnished to block either or both ends to limit the spread to less than maximum width. A set consists of four plates, 2—6 inch and 2—12 inch giving multiples of 6 inches up to 3 feet. There is a slight extra charge for the set.



**Plate No. 7—Block-Off Plates**

**SAFETY CLUTCH**

The safety clutch located between the drive sprocket and the feed roll—a *ratchet type*—is equipped with a tension spring which allows the jaws of the clutch to disengage when the direction of the spreader is reversed—this action does not disturb the transmission gear setting. The safety clutch is lubricated from the transmission gear box, is fool-proof and requires no adjustment.

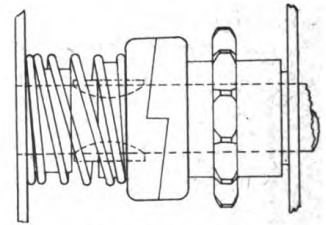

**Plate No. 8  
Safety Clutch**

**TRANSMISSION**

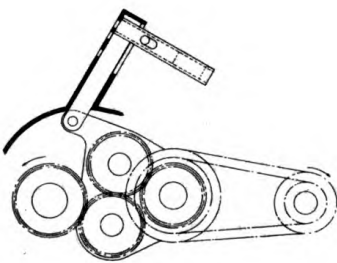

**Plate No. 9—Forward**

Position of the transmission gears when set in *top position* for the forward movement of the spreader.

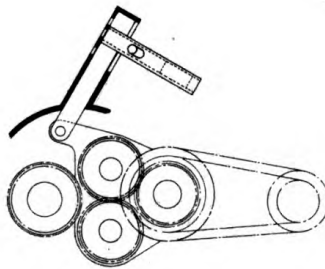

**Plate No. 10—Neutral**

Position of the transmission gears when held in the center or *neutral position*, the feed roll remaining stationary.

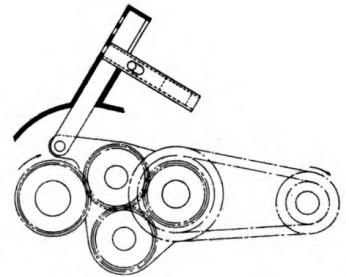

**Plate No. 11—Reverse**

Position of the transmission gears when set in the *bottom position* for the reverse movement of the spreader.

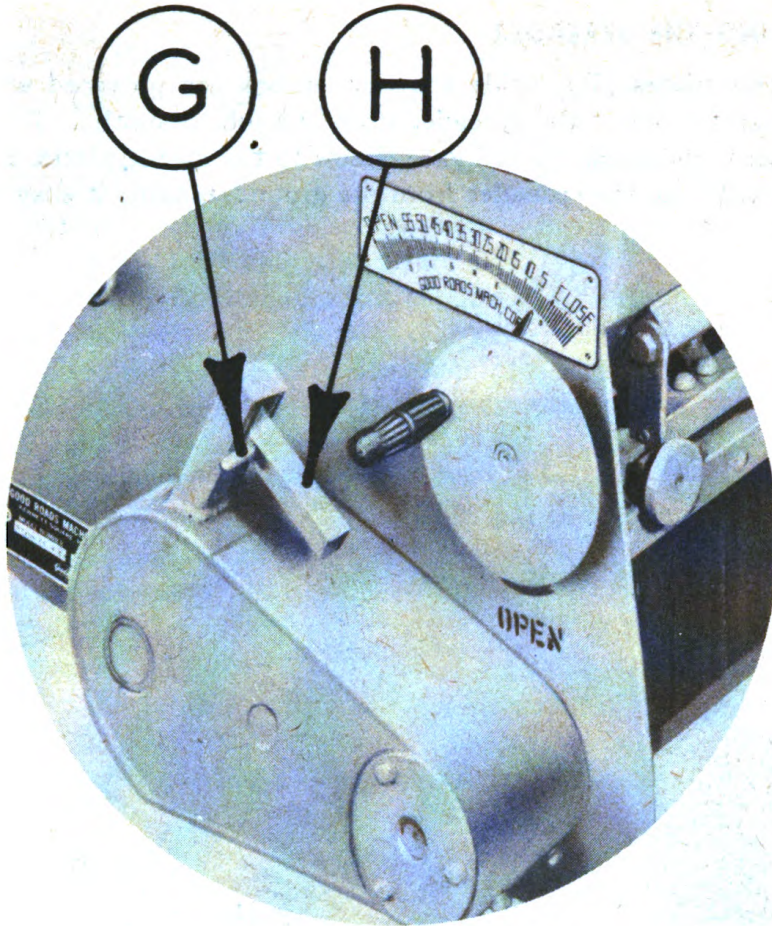

**Plate No. 12—Transmission Shift Lever and Lock**

The entire driving mechanism, even though completely enclosed, *extends no further out*, away from the spreader, than other exposed types.

#### **TRANSMISSION AND SAFETY CLUTCH**

The entire drive mechanism, transmission steel gears, driving sprockets, chain and the safety clutch are completely enclosed in a dust proof, oil tight housing, for the operator's safety and for the long life of the mechanism. When changing the direction of the drive, pull out and hold out the lock stud (G) while shifting the lever (H). The feed roll may be stopped instantly or set in forward at the top (Plate No. 9) or set in reverse at the bottom (Plate No. 11) or held in neutral in the center (Plate No. 10). See opposite page.

**TRANSPORTING THE SPREADER**

The gusset plates (P) inside the hopper box are provided with holes for attaching chains to move the spreader from one job to another. To attach, raise the dump body and hook the tail gate chains to the gusset plates. Lowering the truck body will raise the spreader from the ground, making it easy to transport.

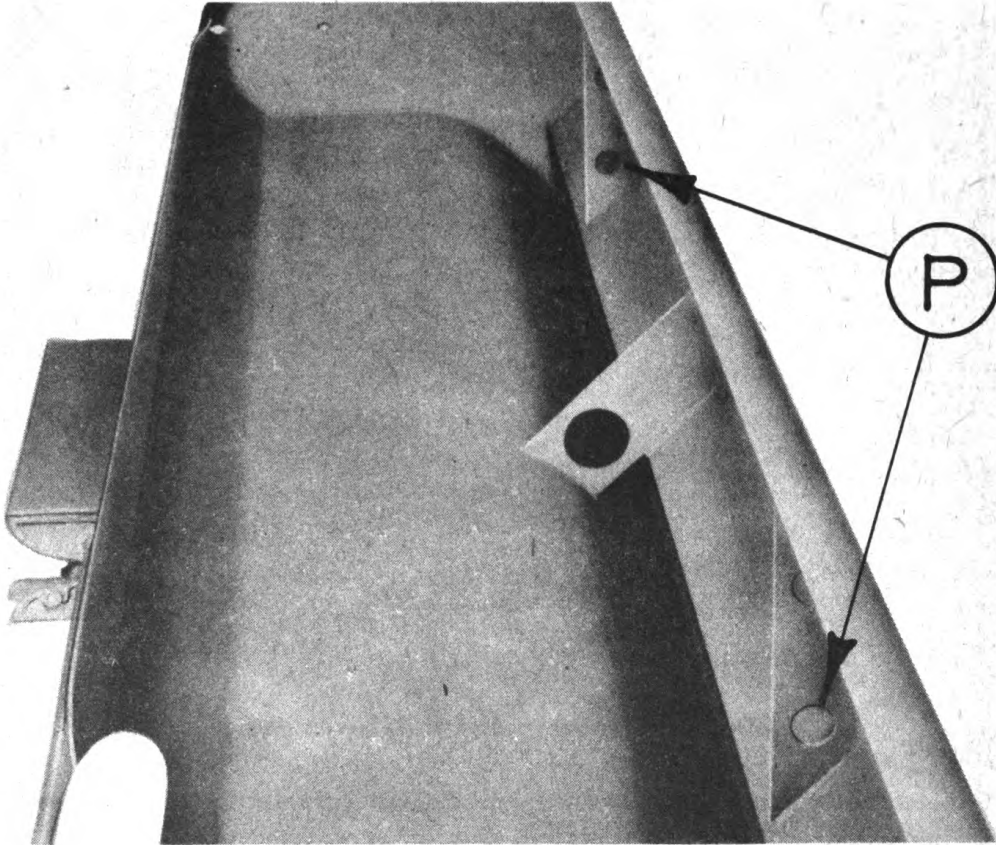

**Plate No. 13—Hopper Box Interior**

Showing the hopper box—a scientific weight supporting design—At least 98% of the material load weight, be it chips, sand, or other material, is supported within the box itself, and held off the feed roll and keyboard.

The load (entire weight of material) remains undisturbed—is not lifted or raised up when the amount of feed is changed or regulated.

## INSTRUCTIONS FOR MOUNTING THE SPREADER UPON THE TRANSPORT CAISSON

1. Assemble the connecting bar attachment (1, Plate No. 15) to the right end of the spreader.
2. Tilt the spreader forward until the hopper box rests upon the ground.
3. Slip right mounting bracket (14, Plate No. 15) on to the anchor studs located underneath the spreader just ahead of the feed roll.
4. Place clamp assembly (15, Plate No. 15) over the top rolled edge of the hopper box and tighten clamp locking bolt. (16, Plate No. 15)
5. Insert hook of the hydraulic jack chain into the holder provided at the left front corner of the spreader. Take up the slack and lock the chain in the fork at top of the jack. Insert the handle in the jack and operate pump-wise to full length of the stroke. Then place a block under raised end of the spreader. Lower jack, shorten chain, and repeat jacking operation until the spreader is at the desired height.
6. Engage the left mounting bracket (22, Plate No. 15) into the coupler and raise the coupler until the left mounting bracket swings into position under the spreader. Be sure the lugs on the left mounting bracket are in position so that they will lock in back of the bottom flange of the front hopper plate. Tighten the left mounting bracket by raising the spreader coupler.
7. Remove the jack.
8. Before using the transport, be sure to align the wheels for camber. This can be done by removing the upper adjusting cam bolt in the top of the right mounting bracket and moving the adjusting cam (19, Plate No. 15) in either direction until wheels are in proper alignment. Replace and tighten the adjusting cam bolt.



**Plate No. 14—Safety Platform for Shoveler**

*The entire platform is built of steel—sufficiently rigid and strong to permit the operator to work on the back of the spreader in absolute safety.*

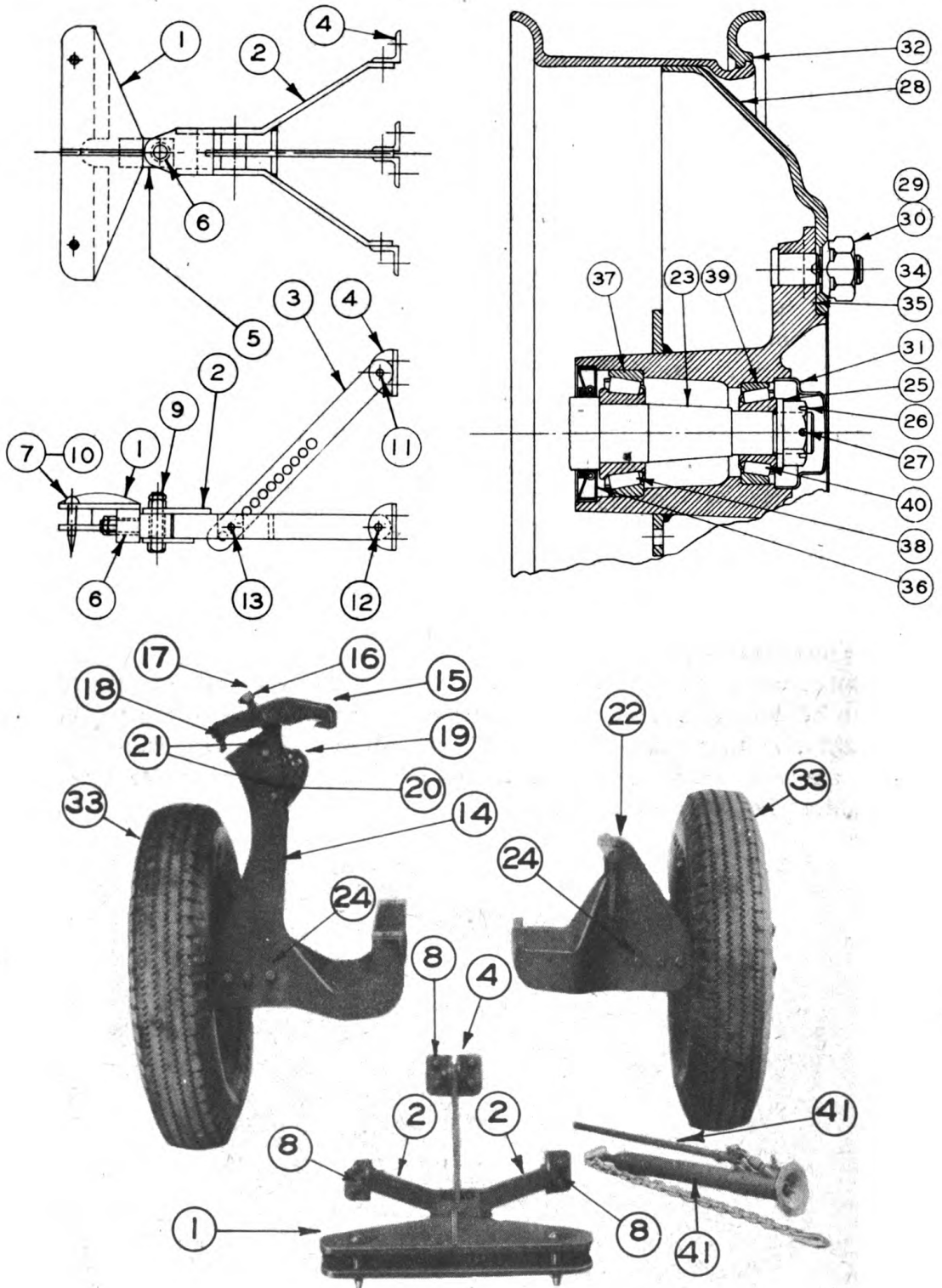

Plate No. 15—Connecting Bar and Caisson



Plate No. 16

**SPECIAL EQUIPMENT  
AND DELUXE FEATURES**

(Plate No. 16 above) The **SPREADER TRANSPORT CAISSON** on which is mounted the Spreader, Aggregate, Good Roads, Model 8. The **TRANSPORT CAISSON** is designed for all similar Models Spreaders as well as the Model 8.

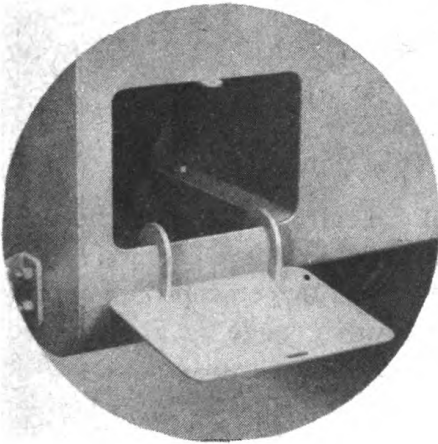

Plate No. 17

(Plate No. 17 left) The spacious 1.12 cubic yard **TOOL BOX** (special equipment) weather-proofed and provided with a master padlock.

(Plate No. 18) Hydraulic jack chain hook inserted in the **HOLDER** (special equipment) described under (5) opposite page.

(Plate No. 19) The spare tire and wheel fitted to the **CARRIER** (special equipment).

Note the two anchor studs at the bottom of photograph and mentioned under (3) previous page.

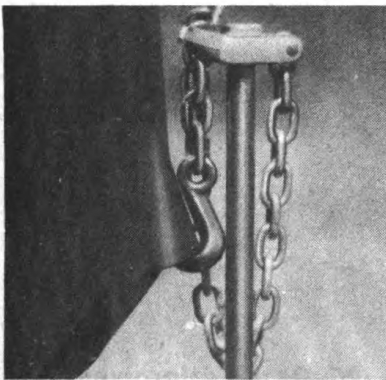

Plate No. 18

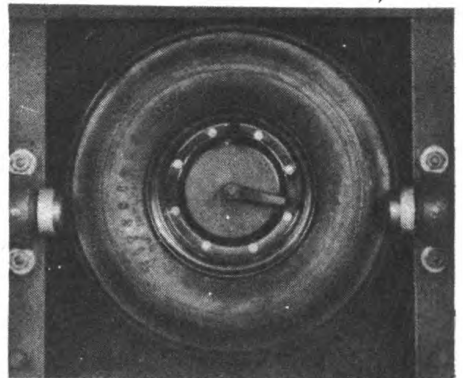

Plate No. 19

## PREPARATION OF THE SPREADER FOR INITIAL OPERATION

When preparing the Model 8 Spreader for operation the following precautions should be taken:

1. Check the axle shaft bearings, four in number, located on each end of the dual wheel drive and lubricate with oil, Engine, SAE 10, U. S. Army 2-104A Amend. 1).
2. Check the level of the transmission gear box by removing the two cap screws and raising the cover. Fill to proper level with SAE 80-90 (Gear Oil SAE 80-90) Federal VV-L-761 or AXS-825 (Rev. 1).
3. Lubricate the feed roll bearings with Oil, Engine, SAE 10, U. S. Army 2-104A (Amend. 1).
4. Check tire pressures and inflate to sixty-five (65) pounds.

To be certain there is no drag or mechanical difficulty, use the handle bars and roll the Spreader a few feet. Observe if it functions as a free running mechanism. As this is done note if the feed roll rotates freely. If feed roll does not revolve, check to make sure transmission gears are in mesh (page 9). Should feed roll fail to rotate, check transmission gearing by removing transmission cover (see Maintenance Instructions).

### INSTALLATION OF THE TRUCK ATTACHMENT

The attachment consists of the following parts:

- (A) Two structural Angles.
- (B) One Cross Bar with Collars.
- (C) Two "U" Bolts.
- (D) Two Brace Rods.

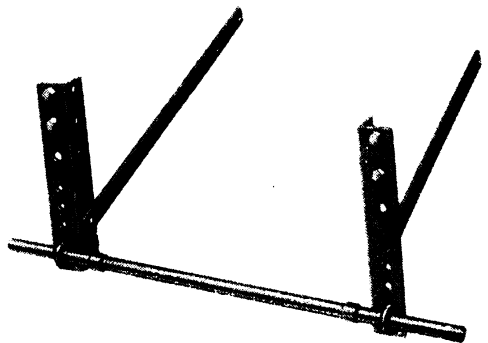
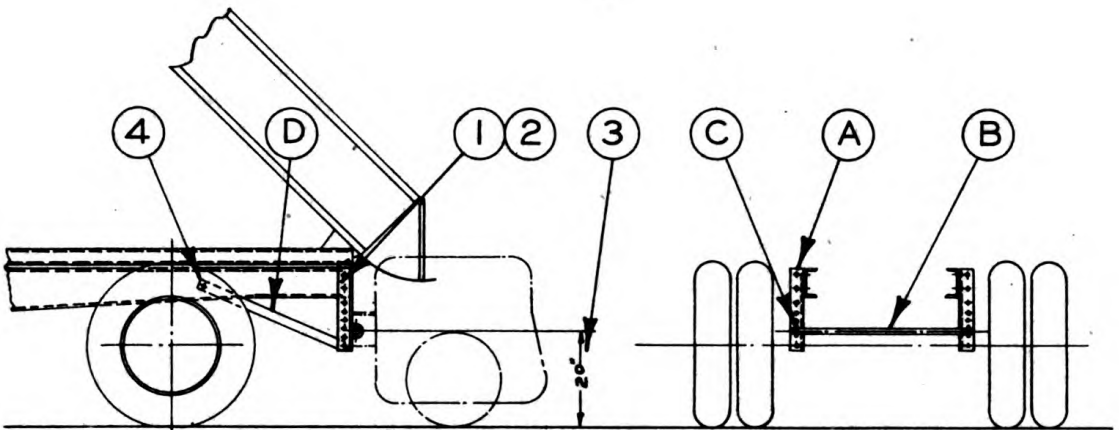
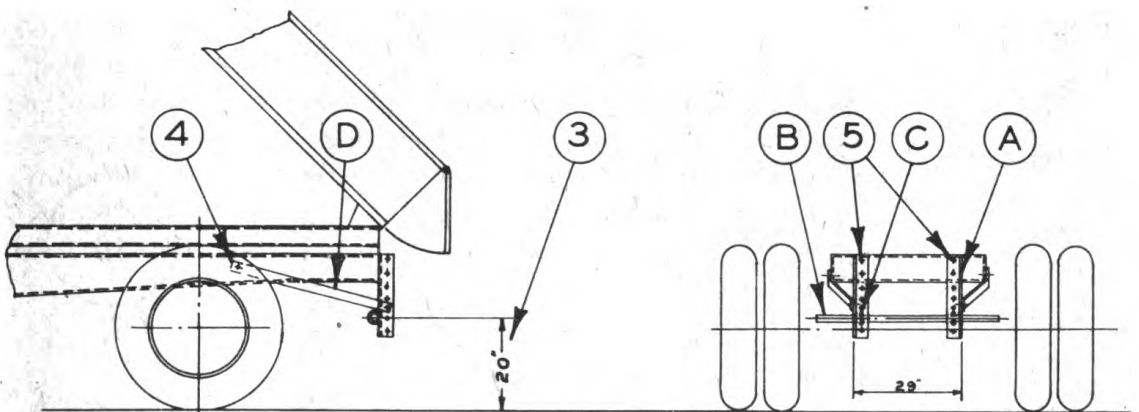

Plate No. 20—Truck Attachment



**Plate No. 21—Using Rear End of Truck Frame**



**Plate No. 22—Using Rear Cross Member**

### HOW TO INSTALL TRUCK ATTACHMENT

1. Remove tow hooks if truck is so equipped.
2. If truck is not equipped with tow hooks, drill a hole in each frame segment near rear as shown on Plate No. 21 above.
3. Load truck with normal load and bolt the attachment to the frame of the truck so that the cross bar (B) is approximately 20 in. from the ground.

**Note:** If truck cannot be loaded, allow for spring deflection as close as possible.

4. Install brace rods (D) by drilling frame for  $\frac{1}{2}$  in. bolt and bending rods to suit.
5. Drill Rear Cross Member for  $\frac{3}{4}$  in. bolts.

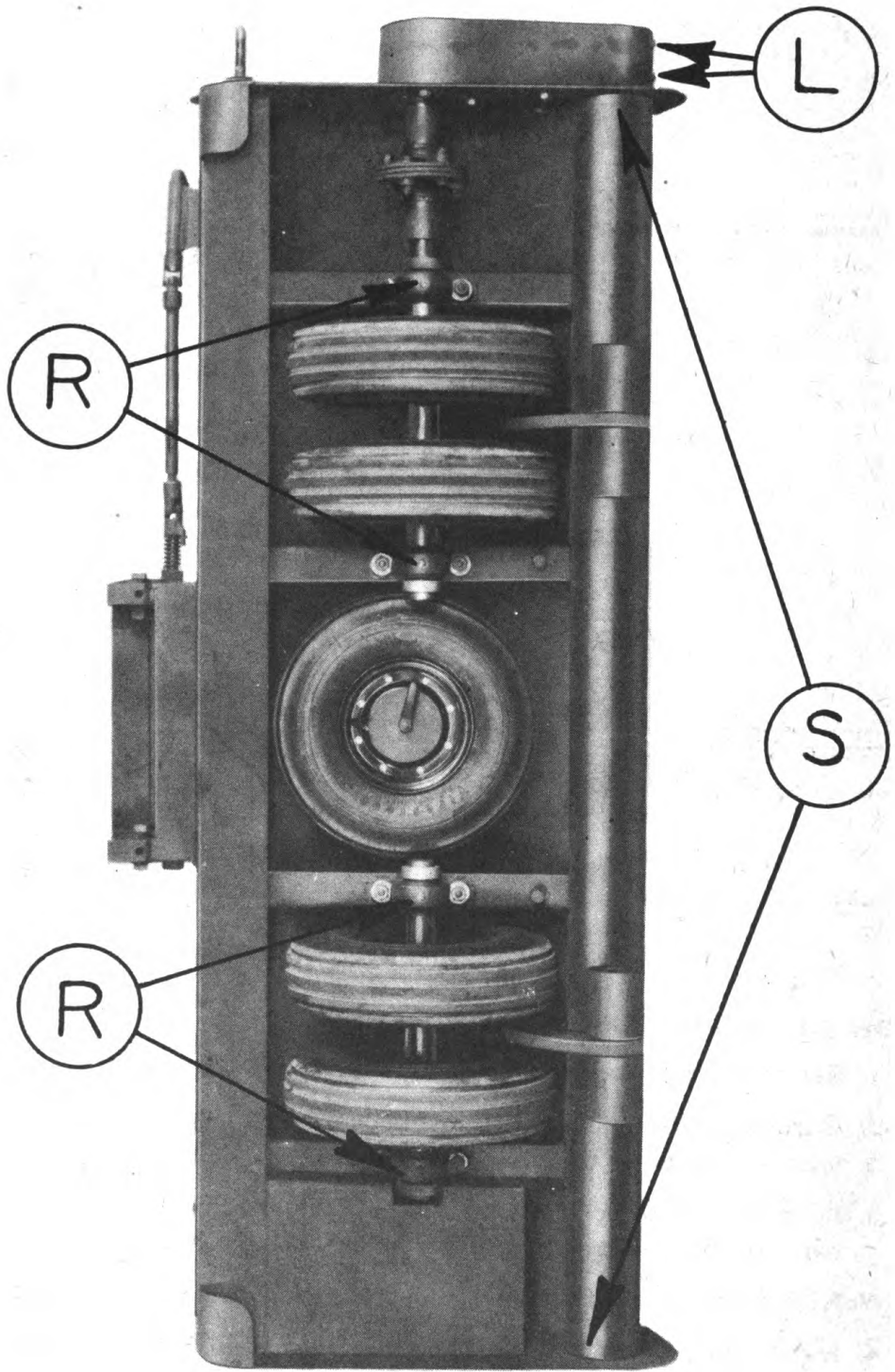

Plate No. 23—Lubrication Chart

## LUBRICATION INSTRUCTIONS

There are only four (4) points on the Spreader that require regular lubrication attention, namely:

1. **The Transmission Case (Gear Box).** The lubricant level should be checked when placing the machine in operation and every 64 hours of operation thereafter. Drain and replace lubricant every six (6) months. To check the lubricant level, remove the two screws (L) and lift the transmission case cover, being careful not to damage the cork gasket. The lubricant capacity is three (3) quarts. Use only LUBRICANT, Gear Universal: SAE 80-90 (Gear Oil SAE 80-90) Federal VV-L-761 or AXS-825 (Rev. 1).

2. **The Axle Shaft Bearings.** There are four (4) bearings located on each end of the dual wheel drive. These are provided with removable plugs (R) to add oil as required—six-month intervals is usually sufficient. Use only:

**Oil, Engine, SAE 10, U. S. Army 2-104A (Amend. 1).**

3. **The Feed Roll Bearings (S).** These are located on each end of the feed roll and are lubricated with a long spout oil can every 64 hours of operation. Remove plug and use only:

**Oil, Engine, SAE 10, U. S. Army 2-104A (Amend. 1).**

**ALWAYS KEEP TIRES INFLATED TO SIXTY-FIVE (65) POUNDS.** If tire pressure is not maintained at the same level in all tires this is apt to cause the Spreader to weave from side to side. Therefore care should be exercised when checking pressures and inflating tires to be certain pressures are equal in all four tires.

## PREPARATION OF THE SPREADER FOR STORAGE

Thoroughly clean the unit and lubricate it. It should be stored in a clean, dry place. Tires should be deflated and the unit blocked up so that no weight is imposed on the tires. Coat exposed unpainted and machined surfaces with U. S. Army Ordnance Department AXS-673 Rust Preventive Compound. For periods of 30 days or less regular Army lubricants may be substituted for AXS-673.

## SPECIFICATIONS

### BERNA MODEL 8

#### SPREADER, Aggregate, Towed-Type, Traction-Powered

Length over-all.....	8'-11 in.
Width over-all.....	44½ in.
Height .....	37 in.
Wheel tire size.....	6.00x9
Width of tread—inside.....	37 in.
Width of tread—outside.....	55 in.
Weight complete.....	1550 lbs.
Capacity of Hopper (struck measure).....	1.12 cu.yd.

#### PREPARATION FOR EXPORT SHIPMENT:

To prepare for Export shipment refer to **EXPORT MANUAL EM-172**, issued by Engineer Field Maintenance Office, P. O. Box 1679, Columbus, Ohio.

## **SECTION II**

### **MAINTENANCE SECTION**



## MAINTENANCE AND REPAIR INSTRUCTIONS

### REMOVING THE WHEELS

When a tire has been punctured, it is necessary to dismount the axle in order to install the spare wheel and tire. This operation can best be performed by turning the Spreader upside down.

**NOTE:** To turn Spreader upside down proceed as follows:

- (a) Block up each end of the Spreader using 4 x 4's at least 100 in. in length.
- (b) Tilt the Spreader on its front face by attaching chains to gusset plates (P, Plate No. 13) and pull forward by means of a wrecking truck equipped with hoist.
- (c) Chains should next be hooked to the pony wheel brackets or axles and the hoist used to pull the Spreader on over into an inverted position.

1. To remove and replace a tire and wheel assembly on the driver or traction —powered side, it will be necessary to disconnect the universal joint (33 Plate No. 23A). This is accomplished by removal of the cotter pins, nuts, washers and bolts (38).
2. Next, disassemble the self-aligning axle bearing retainers (8) by removing the two nuts, washers and bolts (39) which secure the two retainers in place.
3. Dismount the dual wheels and axle from the Spreader.
4. On the end of the axle it is desired to replace the wheel, loosen the axle shaft collar set screw (7) and slide the collar off the shaft (10). Remove the fibre thrust washer (4), and the self-aligning bearing (8). Slide the outside wheel spacer (6) off of the axle.
5. The wheel may now be dismounted from the hub by loosening the hub bolts which secure it in position.
6. Removal of a wheel on the idler axle is accomplished as outlined above except the operation outlined in paragraph one (1) is omitted.

### INSTALLING THE WHEELS

1. Mount the wheel to the hub and secure in place by installing the hub bolts and drawing them down flush. When drawing the bolts down tight, first draw one bolt down and next draw the bolt down that is diametrically opposite it. This will insure the wheel is evenly mounted and result in maximum tire life.
2. Next, install the outside wheel spacer (6, Plate No. 24) followed by the self-aligning bearing (8) and the fibre thrust washer (4). Then install the

axle shaft collar, lining up the set screw hole with that in the axle. Insert the collar set screw and draw it down tight.

3. The axle and wheels can now be mounted in position on the Spreader
4. Install the axle bearing retainers. Assemble the two which hold each retainer in position, followed by the lock washers and nuts. Draw the nuts down tight by turning the bolts with a socket or end wrench.
5. If performing the above operation on the traction-powered or driver side of the machine, reconnect the universal joint. To do this, insert the bolts (38), special washers, nuts and cotter pins.

### REMOVING THE TRANSMISSION

Should any repair operations or replacements be required on the transmission, these can be easily and quickly accomplished since the transmission is removable as an assembly from the Spreader.

To remove the transmission gear box, proceed as follows:

1. Remove the three feed roll bearing plate bolts (48, Plate No. 24) and lockwashers. This will permit removal of the transmission tension spring (59). Next, tilt the Spreader to drain the lubricant from the gear box.
2. The transmission clutch, left half may now be removed by tapping the shaft with a lead or rawhide hammer. When sliding the part off the shaft, be careful to remove the two woodruff keys.
3. Next, remove the three cover bolts (145, Plate No. 27). This will permit the transmission cover to be removed and provide access to the drive chain which is to be removed. Disassemble the drive chain (56, Plate No 23) by taking the master link apart and remove the chain from the transmission.
4. Turn the Spreader upside down. Then remove the set screw (44) from the universal spider adjacent to the transmission.
5. The five transmission attaching bolt nuts (51) should be removed next.
6. The transmission assembly can now be removed from the Spreader as a unit.

### DISASSEMBLING THE TRANSMISSION

1. The transmission drive shaft (43, Plate No. 24) can be disassembled from the case by removing the drive shaft set screw (44). This will permit the drive shaft (43) to be pulled out of the transmission case, after which the drive gear (41) and the drive bearings (42) may be removed.

2. The transmission gear plate assembly (52) is readily removed for disassembly by taking off the two idler gear bolt nuts (47) and lifting the gear plate assembly out of the transmission case.

**Note:** To facilitate ease of servicing, the transmission is designed so that no adjustments are required when assembling the component parts. Replacement of any damaged or worn parts is readily accomplished.

### ASSEMBLING THE TRANSMISSION

1. Install the transmission gear plate assembly (52, Plate No. 24) and secure in place by assembling the two idler gear bolt nuts (47), drawing them down tight.
2. Next, place the two drive shaft bearings (42) in place and then set the drive gear in position. The drive shaft (43) should now be installed. Be careful to line up the set screw hole with that in the drive gear (41) so the set screw may be installed and tightened with a socket wrench.
3. As a precautionary measure, rotate the gears by hand to determine they turn freely and there is no binding action. The transmission is now ready for reinstallation on the Spreader.

### INSTALLING THE TRANSMISSION

1. Mount the transmission on the Spreader, lining up the set screw hole in the drive shaft with the one located in the universal joint spider. Next, secure the transmission in place by installing the five mounting bolts, nuts (51, Plate No. 24) and washers. The set screw (44) should now be installed.
2. Install the drive chain (56) and connect the ends by assembling the master link.
3. Insert the two feed roll clutch woodruff keys (83) in the feed roll shaft and install the transmission clutch (58), tapping it into position with a lead or rawhide hammer.
4. The transmission tension spring (59) and feed roll bearing retainer (82) are then installed and secured in place with the three bolts (48) and lock washers.
5. Turn the Spreader right side up and fill the gear box with three quarts of the proper grade lubricant. (Refer to lubrication instructions.)
6. Finally inspect the transmission case cover gasket, replacing it if necessary, and install the cover securing it in position with the three bolts (145).

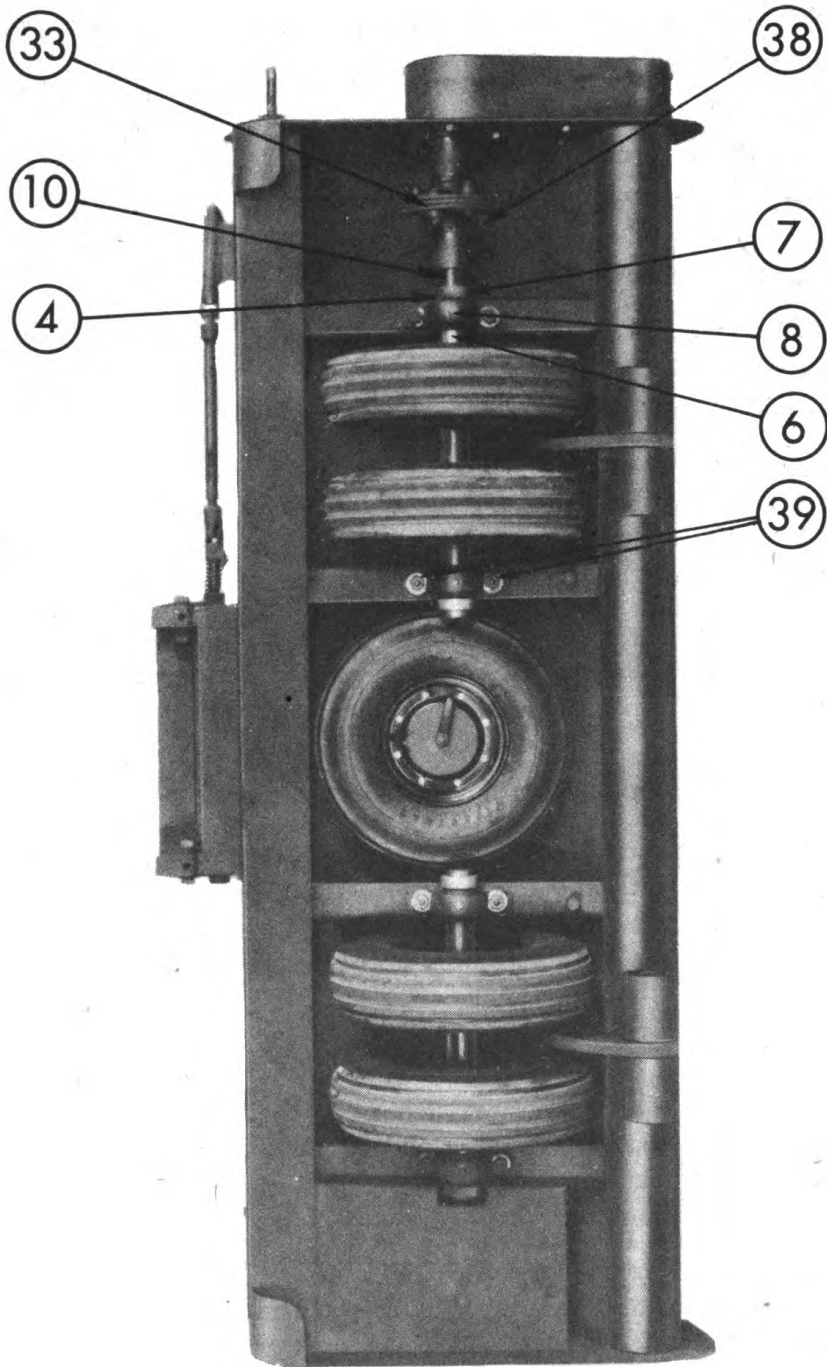

Plate No. 23A—Bottom View

**SECTION III**

**PARTS SECTION**



## PREPARATION OF REQUISITIONS

### Sample Copy for Use in the Preparation of Requisitions

On this page is shown a sample spare parts requisition on QMC Form No. 400 which conforms to the latest revisions. The marginal notes give instructions for preparing a requisition for spare parts for Engineer equipment.

The revised QMC Form 400 has new column headings. Until new forms are available use the present form and type or write in corrections in column headings as shown below.

Under revised heading "Nomenclature" and "Unit" list the article and the unit (ea for each; lb for pound; etc.). Under heading "Maximum or Authorized Level" list the authorized organizational allowances or depot stock levels given in ENG 7 and ENG 8 of the ASF

Engineer Supply Catalog (superseding Part III, Corps of Engineers Supply Catalog). The total number on hand for each item is listed under "On Hand". In column headed "Due In" enter the total quantity previously requisitioned but not delivered. Column headed "Required" is to be changed to read "Quantity Desired" and column headed "Approved" is to read "Remarks." For "Initial" and "Replenishment" requisitions, the sum of "Quantity Desired", "Due In", and "On Hand" should equal "Maximum or Authorized Level."

(Additional details on this subject are covered in ENG 1 of the ASF Engineer Supply Catalog which incorporates information formerly contained in Section AA-1, Part III, Engineer Supply Catalog.)

State PERIOD designation by use of one of the following terms:

- (1) "INITIAL"—first requisition of authorized allowances.
- (2) "REPLENISHMENT"—subsequent requisitions to maintain authorized allowances.
- (3) "SPECIAL"—requisitions for necessary repairs not covered by allowances.

Type "SPARE PARTS" in upper right hand corner of requisition.

Address requisitions to Engineer Field Maintenance Office, P. O. Box 1679, Columbus, Ohio (except for spare parts for searchlights and barrage balloons which are addressed to Schenectady, N. Y. or Ogden, Utah ASF depots).

Give complete shipping instructions. Special instructions for packing, marking, routing, etc., should be given at bottom of requisition.

State proper nomenclature of machine, also make, model, machine serial number and U. S. A. registration number.

Prepare a separate requisition for each different machine.

State basis or authority and date delivery is required, immediately below description of machine.

Double space between items.

Group parts required under group headings as shown in manufacturers' parts catalogs (Technical Manuals).

State OCE stock numbers, manufacturers' parts numbers and nomenclature accurately and completely. Do not use abbreviations.

**SPARE PARTS**

REQUISITION

(SAMPLE)

TO: ENGINEER FIELD MAINTENANCE OFFICE, P. O. Box 1679, Columbus, Ohio  
 Regulation No. L-511-3-44 Date: 6 June 1944 Period: Replenishment

SHIP TO: Engineer Property Officer, FORT LEWIS, WASHINGTON

MARKED FOR: SUPPLY OFFICER, 150th Engr. Regiment, FORT LEWIS, WASHINGTON

Requisitions by show Signature, Rank, Organization, Destination. If different from "ship to" include address:

Officer: *John Doe*  
 John Doe  
 Colonel, C. E.  
 Executive Officer

MFG. NO.	NOMENCLATURE AND UNIT	AUTH. or MAX. LEVEL	ON HAND	DUE IN	QUANTITY DESIRED	REMARKS
	PARTS FOR SPREADER, AGGREGATE, TOAD-TYPE, TRACTION-POWERED, 8-FT. WIDTH, GOOD ROADS, HEARMA MODEL 8, MACHINE SERIAL NUMBER -0000					
	Basis: to replenish second echelon set					
	DELIVERY: by 6 July 1944					
	<u>HITCH RELEASE</u>					
	HANDLE, HITCH RELEASE	4	3	0	1	
	SPRING, HITCH RELEASE	6	4	0	2	
	<u>KEYBOARD HANGAR</u>					
	SCRFH, KEYBOARD CONTROL	2	1	0	1	
	<u>MISCELLANEOUS PARTS</u>					
	WHEEL HUB	2	1	0	1	
	BEARING, AXLE, SELF ALIGNING TYPE	1	0	0	1	

\*Nonexpendable items such as tools must be accounted for, when requisitioned, by a statement that they have been placed on REPORT OF SURVEY or STATEMENT OF CHARGES.

Emergency requisitions sent by telephone, teletype, cablegram, telegraph or radio must be confirmed immediately with requisition marked: "Confirming (state identifying data)."

## PREPARATION OF REQUISITIONS

A sample requisition in the correct form for submission by the Engineer Property Officer is shown on the previous page.

### THIS SHALL BE FOLLOWED IN MAKING OUT REQUISITIONS

In order to eliminate duplication of work, Property Officers may authorize organizations to prepare requisitions in final form, leaving requisition number space blank for completion by Property Officer.

### THE FOLLOWING RULES WILL BE OBSERVED CAREFULLY IN PREPARING REQUISITIONS FOR SPARE PARTS:

- a. Prepare a separate requisition for each different machine.
- b. Type "SPARE PARTS" in upper right hand corner of requisition form.
- c. State PERIOD designation by use of one of the following terms:
  - (1) "INITIAL"—first requisition of authorized allowances.
  - (2) "REPLENISHMENT"—subsequent requisitions to maintain authorized allowances.
  - (3) "SPECIAL"—requisitions for necessary repairs not covered by allowances.
- d. Give complete shipping instructions.
- e. State proper nomenclature of machine, and make, model, serial number and registration number.
- f. State basis of authority, and date delivery is required, immediately below description of machine.
- g. Group parts required under group headings as shown in manufacturer's parts catalogs.
- h. State manufacturers' parts numbers and nomenclature descriptions accurately and completely. Do not use abbreviations.
- i. Double space between items.
- j. Emergency requisitions sent by telephone, telegraph, or radio must always be confirmed immediately with requisition marked: "Confirming (state identifying data)."
- k. Nonexpendable items must be accounted for.

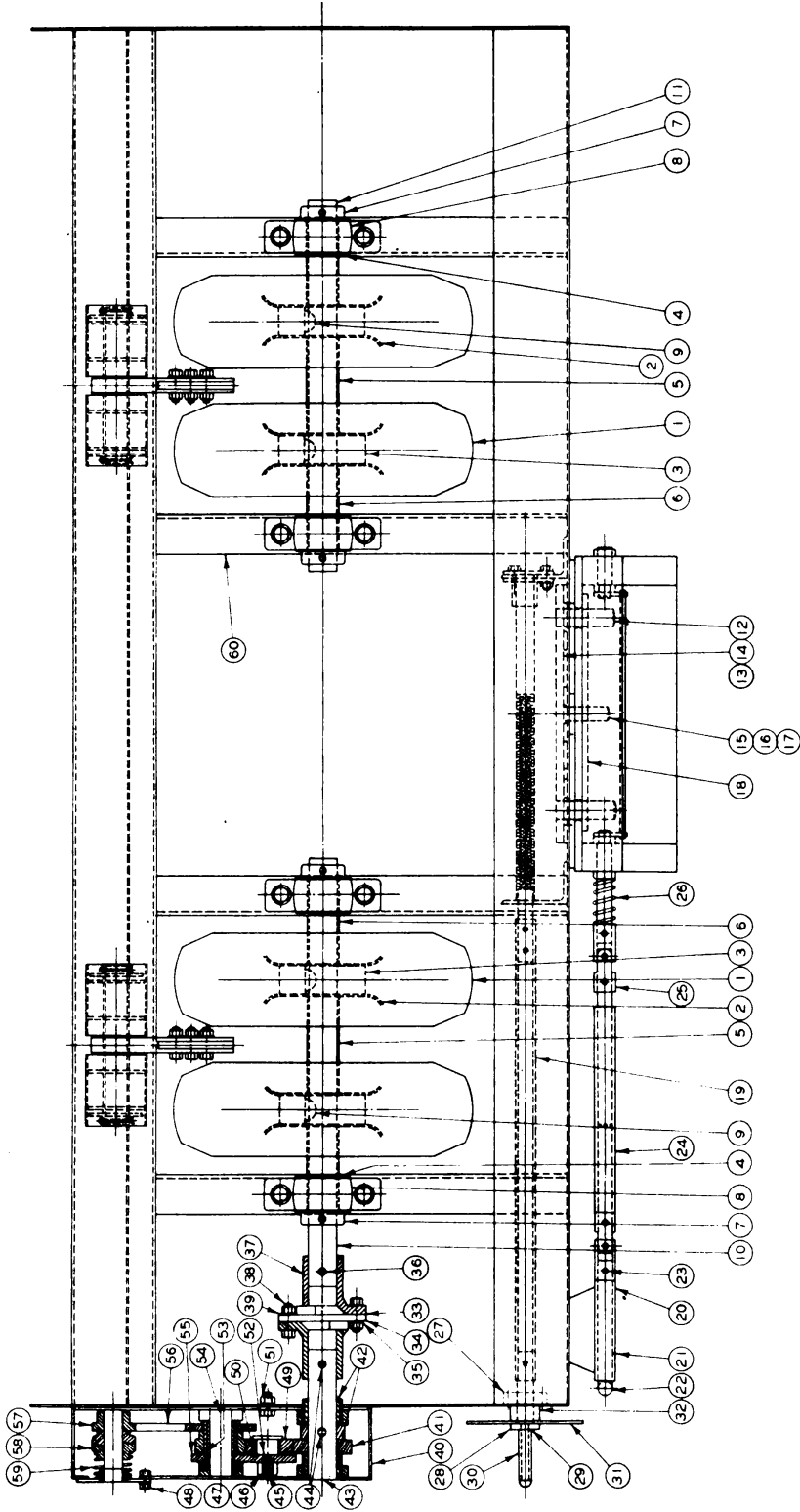

Plate No. 24—Bottom View of Spreader

**CHAPTER VI  
SPARE PARTS LIST  
BOTTOM PLAN LL-1070**

Cut No.	Part No.	Description	No. Reqd.
1	AA-1425	Tire Size 600-9, 6 ply and Tube with TR-50 valve . . .	4
2	CC-1391	Wheel, with bolts, less hub . . . . .	4
3	CC-1245	Wheel Hub . . . . .	4
4	AA-1252	Wheel Thrust Washer, Fibre . . . . .	4
5	AA-1250	Wheel Spacer, Center . . . . .	2
6	AA-1249	Wheel Spacer, Outside . . . . .	4
7	AA-1251	Axle Shaft Collar with Set Screw . . . . .	4
8	CC-1021	Axle Bearing, Self Aligning Type . . . . .	4
9	AA-1426	Wheel Hub Key, No. 25 Woodruff . . . . .	4
10	CC-1246	Axle Shaft, Driver . . . . .	1
11	BB-1247	Axle Shaft, Idler . . . . .	1
12 } 13 } 14 }	CC-1289	Hitch Support Plate Assembly . . . . .	1
15	AA-1269	Swivel Plate Bolt . . . . .	1
16	AA-1398	Swivel Plate Bolt Castle Nut, 1"—8. . . . .	1
17	AA-1399	Swivel Plate Bolt Cotter Pin, 3/16" x 2" . . . . .	1
18	CC-1263	Hitch Front Plate . . . . .	1
19	BB-1283-8	Hitch Control Screw Pipe . . . . .	1
20	DD-1375	Hitch Release Assembly, consisting of: (1) No. AA-1357 Hitch Release Handle, (1) No. AA-1230 Hitch Release Handle Rubber Grip, (1) No. AA-1396 Hollow Head Set Screw, (1) No. BB-1389 Hitch Release Universal and Pipe Assembly and (1) No. BB-1390 Hitch Release Universal and Shaft Assembly.	1
21	AA-1357	Hitch Release Handle . . . . .	1
22	AA-1230	Hitch Release Handle Rubber Grip . . . . .	1
23	AA-1396	Hitch Release Handle Set Screw, 3/8"—16 x 1/2" Hollow Head . . . . .	1
24	BB-1389	Hitch Release Universal and Pipe Assembly . . . . .	1
25	BB-1390	Hitch Release Universal and Shaft Assembly . . . . .	1
26	AA-1264	Hitch Release Spring . . . . .	1
27	AA-1066	Hitch Handle Shaft Retainer . . . . .	1
28	CC-1240	Hitch Vertical Adjustment Handle Assembly, consisting of: (1) No. AA-1243 Hitch Control Handle, (1) No. AA-1230 Hitch Control Handle Rubber Grip, (1) No. BB-1231 Hitch Control Handle Disc and (1) No. AA-1237 Hitch Control Handle Spacer and Shaft Assembly.	1
29	AA-1243	Hitch Control Handle . . . . .	1
30	AA-1230	Hitch Control Rubber Grip . . . . .	1
31	BB-1231	Hitch Control Handle Disc . . . . .	1
32	AA-1237	Hitch Control Handle Spacer and Shaft Assembly . . . . .	1

## BOTTOM PLAN LL-1070 (Continued)

Cut No.	Part No.	Description	No. Reqd.
33	DD-1378	<b>Universal Joint Assembly, consisting of:</b> (3) No. AA-1379 Universal Joint Discs, (6) No. AA-1428 Universal Joint Washers, (4) No. AA-1430 Universal Joint Set Screws, (2) No. CC-1393 Universal Joint Spiders, (6) No. AA-1431 Universal Joint Bolts and (18) No. AA-1429 Universal Joint Bolt Washers.	1
34	AA-1379	Universal Joint Disc	3
35	AA-1428	Universal Joint Washer, $\frac{1}{2}$ " Standard	6
36	AA-1430	Universal Joint Set Screw, $\frac{1}{2}$ " x $\frac{3}{4}$ " Hex. Head	4
37	CC-1393	Universal Joint Spider	2
38	AA-1431	Universal Joint Bolt, $\frac{1}{2}$ " x $2\frac{1}{2}$ " N.F. Hex. Head	6
	AA-1467	Universal Joint Bolt Castle Nut, $\frac{1}{2}$ " N.F.	6
	AA-1466	Universal Joint Bolt Cotter, $\frac{3}{32}$ " x 1"	6
39	AA-1429	Universal Joint Bolt Beaded Washer, Special	18
40	LL-1200	Transmission Case (Gear Box)	1
41	AA-1171	Transmission Drive Gear, 40 Teeth	1
42	AA-1164	Transmission Drive Bearing	2
43	BB-1157	Transmission Drive Shaft	1
44	AA-1430	Transmission Drive Shaft Set Screw, $\frac{1}{2}$ " x $\frac{3}{4}$ " Hex. Head	2
45	AA-1177	Idler Gear Bolt, Special	2
46	AA-1433	Idler Gear Bolt Lock Washer, $\frac{3}{4}$ " Standard	2
47	AA-1434	Idler Gear Bolt Nut, $\frac{3}{4}$ "-16 Hex.	2
48	AA-1402	Feed Roll Bearing Plate Bolt, $\frac{3}{8}$ "-16 x 1" Hex. Head	3
	AA-1458	Feed Roll Bearing Plate Bolt Lock Washer, $\frac{3}{8}$ "	3
49	AA-1172	Idler Gear, 35 Teeth	2
50	AA-1167	Idler Bearing, Oilite	2
51	AA-1420	Transmission Attaching Bolt Nut, $\frac{1}{2}$ " Hex.	5
	AA-1459	Transmission Attaching Bolt Lock Washer, $\frac{1}{2}$ "	5
52	CC-1199	<b>Transmission Gear Plate Assembly, consisting of:</b> (2) No. AA-1172 Idler Gears, (2) No. AA-1167 Idler Bearings, (1) No. AA-1165 Thrust Bearing, (2) No. AA-1177 Idler Gear Bolts, (2) No. AA-1433 Lock Washers, (2) No. AA-1434 Hex. Nuts, (1) No. BB-1195 Gear Plate and Spacer and (1) No. BB-1198 Intermediate Gear, 35 Teeth and Sprocket, 20 Teeth —All Assembled.	1
	BB-1198	Intermediate Gear, 35 Teeth, and Sprocket, 20 Teeth —All Assembled	1
53	AA-1165	Thrust Bearing	1
54	AA-1176	Transmission Intermediate Shaft	1
55	BB-1195	Transmission Gear Plate and Spacer	1
56	AA-1202	Transmission Drive Chain, No. 60 American	1
57	BB-1197	Driven Clutch Sprocket, 12 Teeth	1

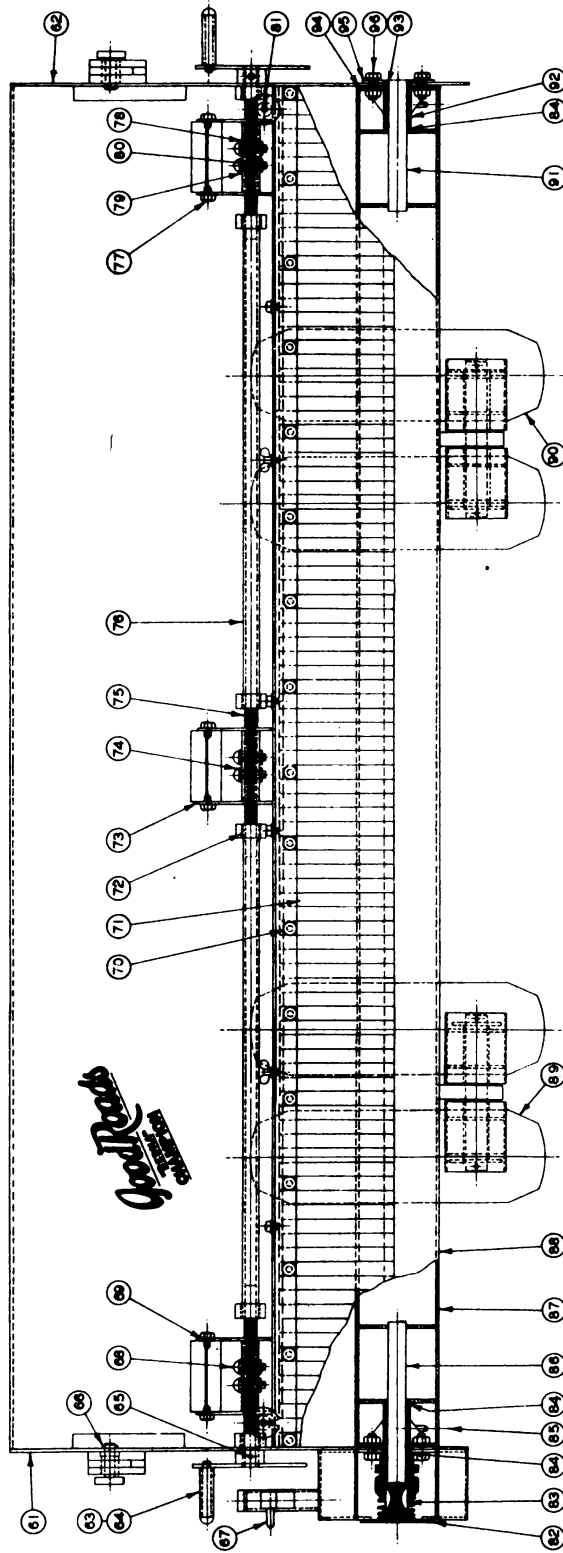

Plate No. 25—Rear View of Spreader

## BOTTOM PLAN LL-1070 (Continued)

Cut No.	Part No.	Description	No. Reqd.
58	BB-1156	Transmission Clutch, Left Half	1
59	AA-1187	Transmission Tension Spring	1
60	DD-1011	Wheel Support, Right	2
	DD-1012	Wheel Support, Left	2

## REAR ELEVATION LL-1070

61	LL-1058	End Plate, Left	1
62	LL-1057	End Plate, Right	1
63	AA-1230	Keyboard Control Handle Rubber Grip	2
64	CC-1239	Keyboard Control Handle	2
65	AA-1418	Keyboard Control Handle Set Screw, $\frac{5}{16}$ "-18 x $\frac{7}{8}$ ", Hollow Head Cup Point	2
66	AA-1144	Handle Bar Lock Pin	2
67	AA-1188	Gear Shift Handle Trigger	1
68	AA-1091	Connecting Link Rivet Pin	6
69	AA-1354	Keyboard Hanger Link Screw Bushing	6
70	AA-1437	Keyboard Retainer Bolt, $\frac{5}{16}$ "-18 x $2\frac{1}{4}$ "	17
	AA-1460	Keyboard Retainer Bolt Square Nut, $\frac{5}{16}$ "-18	17
	AA-1461	Keyboard Retainer Bolt Lock Washer, $\frac{5}{16}$ "	17
71	CC-1131	Keyboard Keys and Retainer Assembly	1
	AA-1082	Keyboard Key, Plain, 1" x $7\frac{7}{8}$ "	79
	AA-1083-A	Keyboard Key, with Hole, 1" x $8\frac{3}{8}$ "	17
72	AA-1090	Needle Bearing	6
73	DD-1125-8	Keyboard Hanger Assembly, consisting of: (6) No. AA-1080 Links, (1) No. DD-1100-8 Reinforce- ment Strip, (4) No. AA-1088 Taper Attachment Screw Retainers, (2) No. AA-1086 Taper Attach- ment Control Nuts, (2) No. AA-1085 Taper At- tachment Control Screws—All Assembled.	1
74	AA-1078	Keyboard Control Connecting Link, Plain	6
	AA-1078-T	Keyboard Control Connecting Link, Tapped	6
75	BB-1075	Keyboard Control Screw	3
76	BB-1099	Keyboard Control	2
77	AA-1403	Keyboard Hanger Link Cap Screw, $\frac{3}{8}$ "-16 x $\frac{5}{8}$ "	6
78	AA-1076	Keyboard Control Nut, Right	3
79	AA-1077	Keyboard Control Nut, Left	3
80	AA-1415	Connecting Link Rivet Pin Cotter, $\frac{1}{8}$ " x $\frac{3}{4}$ "	6
81	AA-1409	Taper Attachment Control Screw Cup Point Set Screw, $\frac{1}{4}$ "-20 x $\frac{3}{8}$ "	2
82	AA-1169	Feed Roll Support Bearing and Retainer-outer	1
83	AA-1427	Feed Roll Clutch Key, No. 21 Woodruff	2
84	AA-1225	Feed Roll Thrust Bearing	3

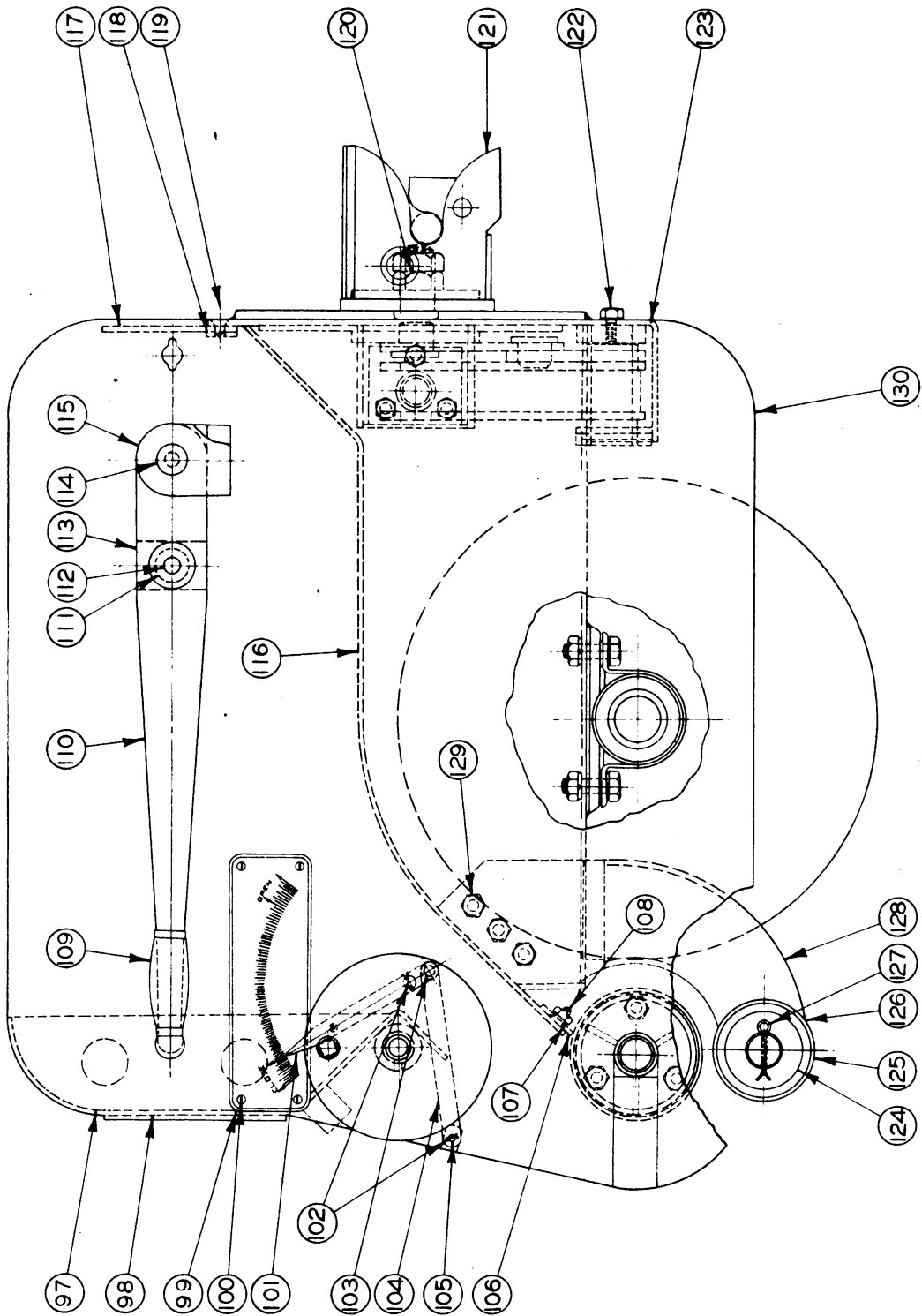

Plate No. 26—Right End Elevation of Spreader

## REAR ELEVATION LL-1070 (Continued)

Cut No.	Part No.	Description	No. Reqd.
85	AA-1432	Feed Roll Oil Plug, $\frac{1}{8}$ " Ctsk. Pipe Plug.....	2
86	DD-1213-8	Feed Roll Assembly, Complete.....	1
87			
88			
91			
89	AA-1425	Tire, Size 600-9, 6 Ply and Tube with TR-50 Valve..	4
90	CC-1227	Feed Roll Bearing Support, consisting of: (3) No. AA-1220 Gussets, (1) No. AA-1218 Bearing Retainer, (1) No. AA-1222 Oil Pipe, (1) No. BB-1226 Support Plate, (2) No. AA-1224 Bearings—All Assembled.	2
92			
93	AA-1224	Feed Roll Bearing.....	4
94	AA-1223	Feed Roll Bearing Support Seal.....	2
95	BB-1228	Feed Roll Cover Plate.....	1
96	AA-1436	Feed Roll Bearing Support Machine Bolt, $\frac{1}{2}$ "-13 x $1\frac{1}{4}$ "	6
	AA-1462	Feed Roll Bearing Support Machine Bolt Lock Washer, $\frac{1}{2}$ ", Standard.....	6

## RIGHT HAND ELEVATION LL-1070

97	CC-1032	Lift Plate, No. 7 Ga. x 4" x $16\frac{1}{8}$ ".....	1
98	CC-1027-8	Back Plate, No. 7 Ga. x $23\frac{3}{4}$ " x 96".....	1
99	BB-1318	Indicator Plate, Right.....	1
100	AA-1417	Indicator Plate Screw, No. 8 Parker-Kalon $\frac{1}{4}$ " Rd. Hd.	8
101	AA-1314	Indicator Pointer.....	2
102	AA-1415	Indicator Connecting Link Cotter, $\frac{1}{8}$ " x $\frac{3}{4}$ ".....	4
103	AA-1315	Indicator Pin.....	2
104	AA-1316	Indicator Connecting Link.....	2
105	AA-1320	Indicator Connecting Pin.....	2
106	AA-1360-8	Hopper Plate Belt, 96" x 2"—4 Ply.....	2
107	AA-1428	Hopper Plate Belt Flat Washer, $\frac{1}{2}$ " Standard.....	13
108	AA-1438	Hopper Plate Belt Bolt, $\frac{5}{16}$ "-18 x $\frac{3}{4}$ " Flat Hd.....	13
	AA-1463	Hopper Plate Belt Bolt Nut, $\frac{5}{16}$ " Hex.....	13
109	AA-1230	Handle Bar Rubber Grip.....	2
110	DD-1137	Handle Bar Only.....	2
111	AA-1146	Handle Bar Spring.....	2
112	AA-1148	Handle Bar Lock Assembly.....	2
113	DD-1056	Handle Bar Assembly, consisting of: (1) No. AA-1230 Rubber Grip, (1) No. DD-1137 Handle Bar, (1) No. AA-1146 Spring, (1) No. AA-1148 Lock Assembly, (1) No. AA-1142 Pin and (1) No. AA-1149 Pin Retainer.	2

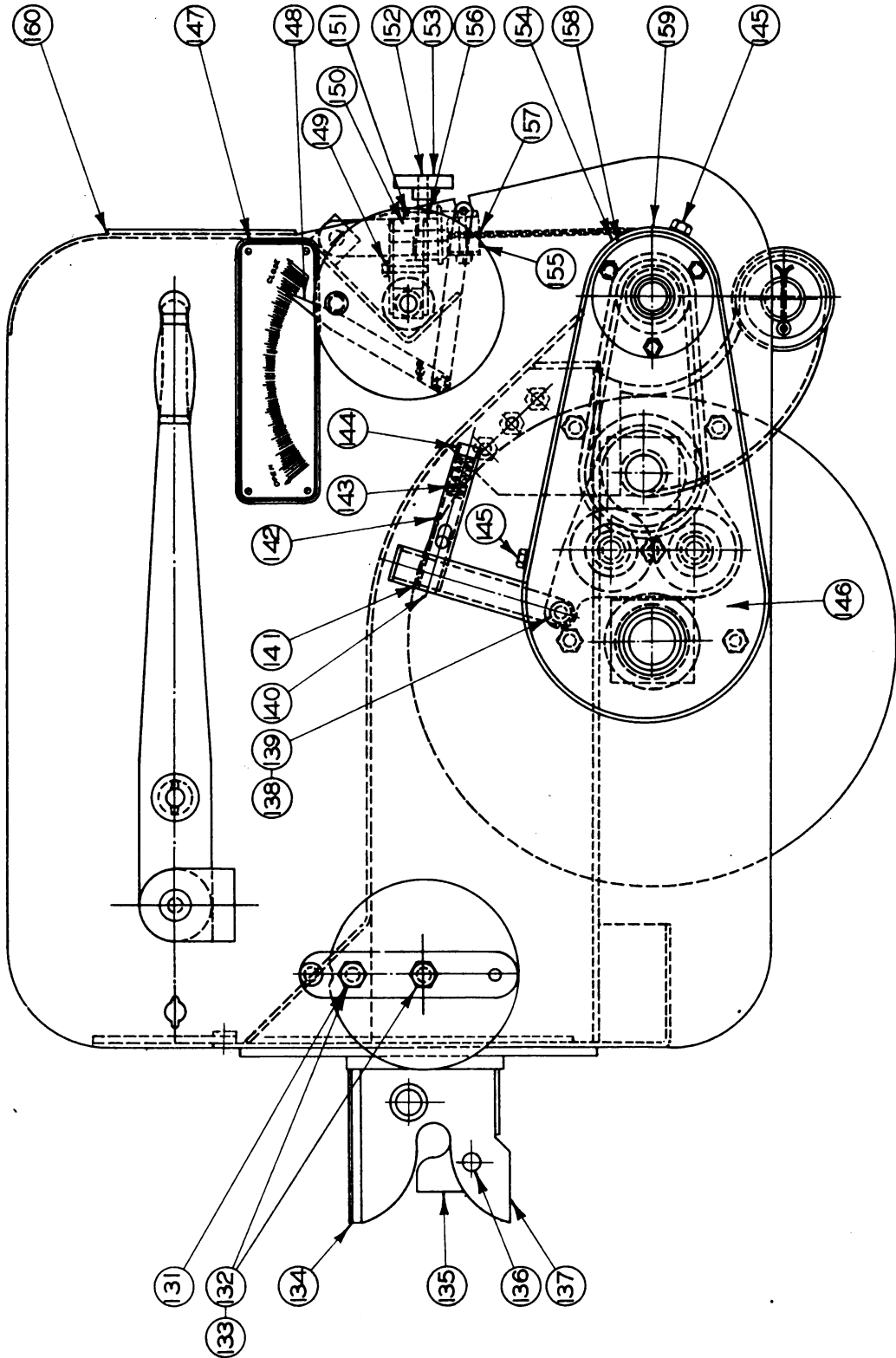

Plate No. 27—Left End Elevation of Spreader

## RIGHT HAND ELEVATION LL-1070 (Continued)

Cut No.	Part No.	Description	No. Reqd.
114	AA-1142	Handle Bar Pin.....	2
115	AA-1149	Handle Bar Retainer.....	2
116	DD-1000-8	Hopper Plate, No. 7 Ga., 35 $\frac{5}{8}$ " x 96".....	1
117	AA-1370	Flexible Apron, 96" x 6"—5 Ply.....	1
118	AA-1372	Apron Reinforcing Plate.....	1
119	AA-1439	Apron Reinforcing Plate Bolt, $\frac{5}{16}$ "-18 x $\frac{5}{8}$ " Flat Hd..	11
120	AA-1397	Hitch Swivel Bolt Jam Nut, 1 $\frac{1}{4}$ ".....	4
121	LL-1248	Hitch Assembly, Complete.....	1
122	AA-1402	Hitch Lift Shaft Bolt, $\frac{3}{8}$ "-16 x 1" Hex. Hd.....	1
	AA-1458	Hitch Lift Shaft Bolt Lock Washer, $\frac{3}{8}$ ".....	1
123	LL-1035-8	Lower Front Plate, No. 7 Ga. 24" x 96".....	1
124	AA-1305	Castor Roll Thrust Washer.....	4
125	BB-1307	Castor Roll (Pony Wheel).....	4
126	DD-1308	Castor, Pony Wheel Assembly, consisting of: (1) No. DD-1392 Castor Roll Support, (2) No. BB-1307 Castor Rolls (Pony Wheels), (2) No. AA-1305 Thrust Washers and (2) No. AA-1423 Cotter Pins.	2
127	AA-1423	Castor Roll Support Cotter Pin, $\frac{1}{4}$ " x 2 $\frac{1}{4}$ ".....	4
128	DD-1392	Castor Roll Support with Axles.....	2
129	AA-1424	Castor Roll Support Bolt, $\frac{1}{2}$ "-13 x 1 $\frac{3}{4}$ ", 24 x 1 $\frac{1}{4}$ " Hex. Hd.....	6
	AA-1420	Castor Roll Support Nut, $\frac{1}{2}$ " Hex.....	6
	AA-1459	Castor Roll Support Lock Washer, $\frac{1}{2}$ ".....	6
130	LL-3112	Hopper Assembly, Complete.....	1

## LEFT HAND ELEVATION LL-1070

131	AA-1420	Hitch Control Handle Nut, $\frac{1}{2}$ " Hex.....	1
132	AA-1419	Hitch Control Handle Bolt, $\frac{1}{2}$ "-13 x 1" Hex. Hd.....	1
133	AA-1421	Hitch Control Handle Bolt Lock Washer, $\frac{1}{2}$ ".....	2
134	DD-1290	Hitch Coupler Assembly, consisting of (2) No. AA-1386 Tumblers, (2) No. AA-1387 Triggers, (1 pr.) No. CC-1385 Couplers, (1) No. DD-1262 Swivel Plate, (2) No. AA-1406 Bolts, (2) No. AA-1434 Bolt Nuts and (2) No. AA-1433 Bolt Lock Washers.	1
135	AA-1386	Hitch Coupler Tumbler.....	2
136	AA-1406	Hitch Coupler Bolt, $\frac{3}{4}$ " x 3 $\frac{1}{4}$ " Hex. Hd.....	2
	AA-1434	Hitch Coupler Bolt Nut, $\frac{3}{4}$ " Hex.....	2
	AA-1433	Hitch Coupler Bolt Lock Washer, $\frac{3}{4}$ ".....	2
138	AA-1442	Gear Shift Handle Pin Cotter, $\frac{1}{8}$ " x 1".....	1
139	AA-1184	Gear Shift Handle Pin.....	1
140	AA-1181	Gear Shift Handle Plunger.....	1

LEFT HAND ELEVATION LL-1070 (Continued)

Cut No.	Part No.	Description	No. Reqd.
141 } 142 }	CC-1192	Gear Shift Handle Assembly . . . . .	1
143	AA-1183	Gear Shift Handle Plunger Spring . . . . .	1
144	AA-1186	Gear Shift Handle Plug . . . . .	1
145	AA-1441	Transmission Cover Bolt, $\frac{3}{8}$ "-24 x $\frac{3}{4}$ " . . . . .	3
	AA-1403	Transmission Cover Bolt Lock Washer, $\frac{3}{8}$ " . . . . .	3
146	LL-1200	Transmission Case (Gear Box) . . . . .	1
147	BB-1319	Indicator Plate, Left . . . . .	1
148	AA-1314	Indicator Pointer . . . . .	2
149	AA-1407	Connecting Link Bolt, $\frac{1}{4}$ "-20 x $1\frac{3}{4}$ " . . . . .	6
	AA-1465	Connecting Link Bolt Lock Washer, $\frac{1}{4}$ " . . . . .	6
150	AA-1079	Keyboard Connecting Link Retainer . . . . .	3
151	DD-1132-8	Keyboard Assembly, Complete . . . . .	1
152	AA-1085	Taper Attachment Control Screw . . . . .	2
153	AA-1087	Taper Attachment Handle . . . . .	2
154	CC-1299	Transmission Case Cover . . . . .	1
155	LL-1115-8	Keyboard Spacer, Wood . . . . .	2
156	AA-1086	Taper Attachment Control Nut . . . . .	2
157	CC-1379-8	Keyboard Key and Spacer Assembly . . . . .	1
	AA-1082	Keyboard Key, Plain, 1" x $7\frac{5}{8}$ " . . . . .	79
	AA-1082-A	Keyboard Key, with Hole, 1" x $7\frac{5}{8}$ " . . . . .	17
	AA-1083	Keyboard Key, Plain, 1" x $8\frac{3}{8}$ " . . . . .	79
	AA-1083-A	Keyboard Key, with Hole, 1" x $8\frac{3}{8}$ " . . . . .	17
158	AA-1440	Transmission Cover Plate Gasket, Cork . . . . .	1
159	LL-1201	Transmission Assembly, Complete . . . . .	1
160	LL-3112	Hopper Assembly, Complete . . . . .	1

HITCH LIFT ASSEMBLY LL-1070

161	AA-1401	Hitch Control Screw Bearing Bolt, $\frac{3}{8}$ "-24 x $1\frac{1}{4}$ " Hex. Hd. . . . .	3
	AA-1464	Hitch Control Screw Bearing Bolt Nut, $\frac{3}{8}$ " Hex. . . . .	3
	AA-1458	Hitch Control Screw Bearing Lock Washer, $\frac{3}{8}$ " . . . . .	3
162	AA-1291	Hitch Screw Control Thrust Washer . . . . .	1
163	AA-1396	Hitch Control Screw Retainer Set Screw, $\frac{3}{8}$ "-16 x $\frac{1}{2}$ " Hollow Head . . . . .	2
164	AA-1280	Hitch Control Screw Retainer . . . . .	1
165	DD-1274	Hitch Control Screw . . . . .	1
166	AA-1293	Hitch Lower Front Lift Shaft . . . . .	1
167	DD-1298	Lift Control Lever Assembly, Complete . . . . .	1
168	AA-1275	Hitch Control Nut . . . . .	1
169	CC-1292	Hitch Control Lift Link . . . . .	1
170	BB-1296	Hitch Control Screw Bearing . . . . .	1
171	AA-1278	Hitch Control Thrust Plate . . . . .	1

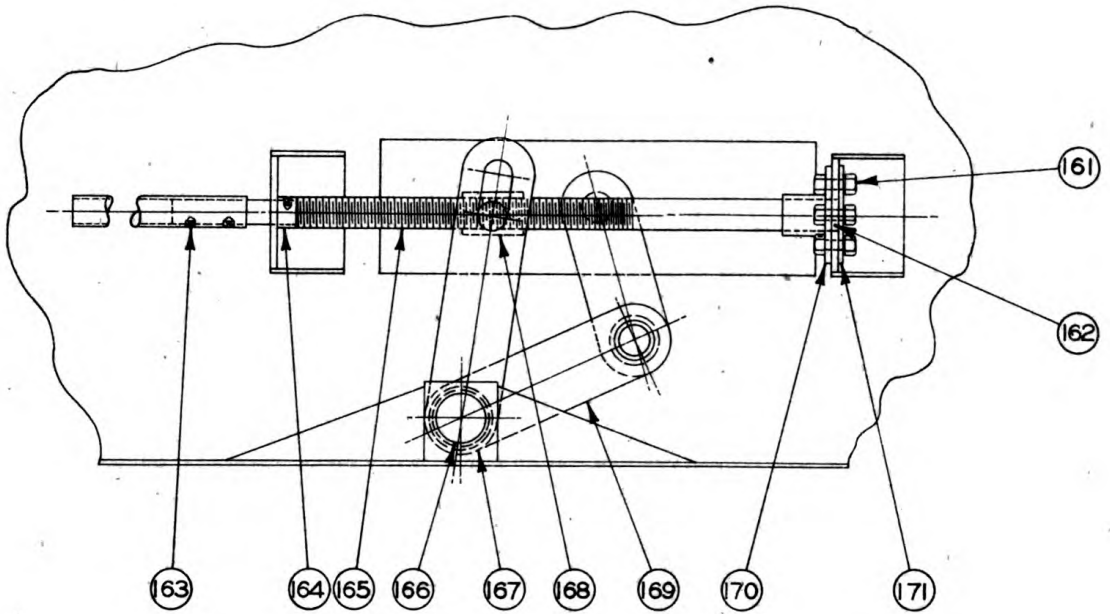

Plate No. 28—Hitch Lift Assembly

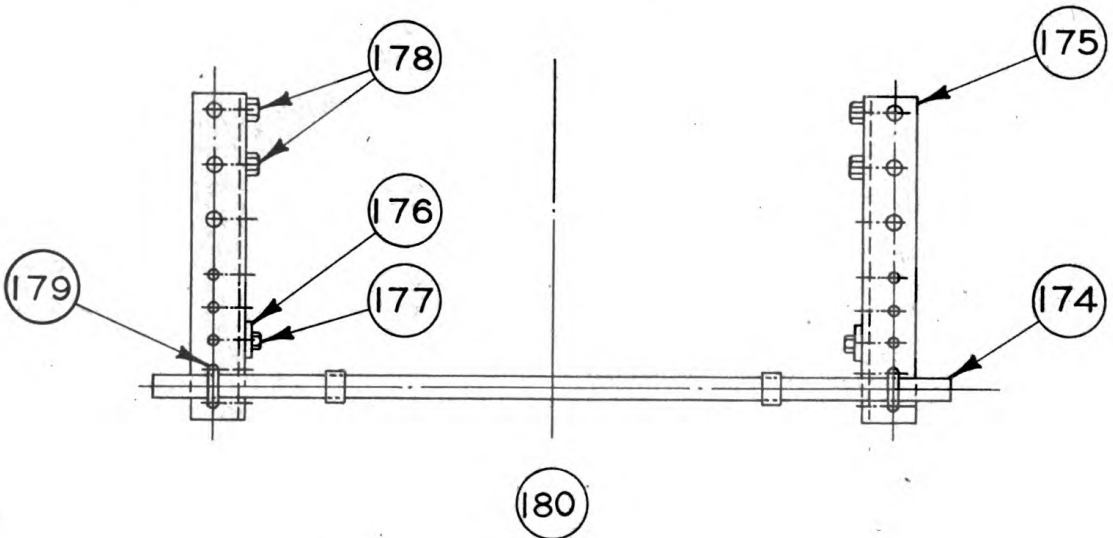

Plate No. 29—Truck Attachment

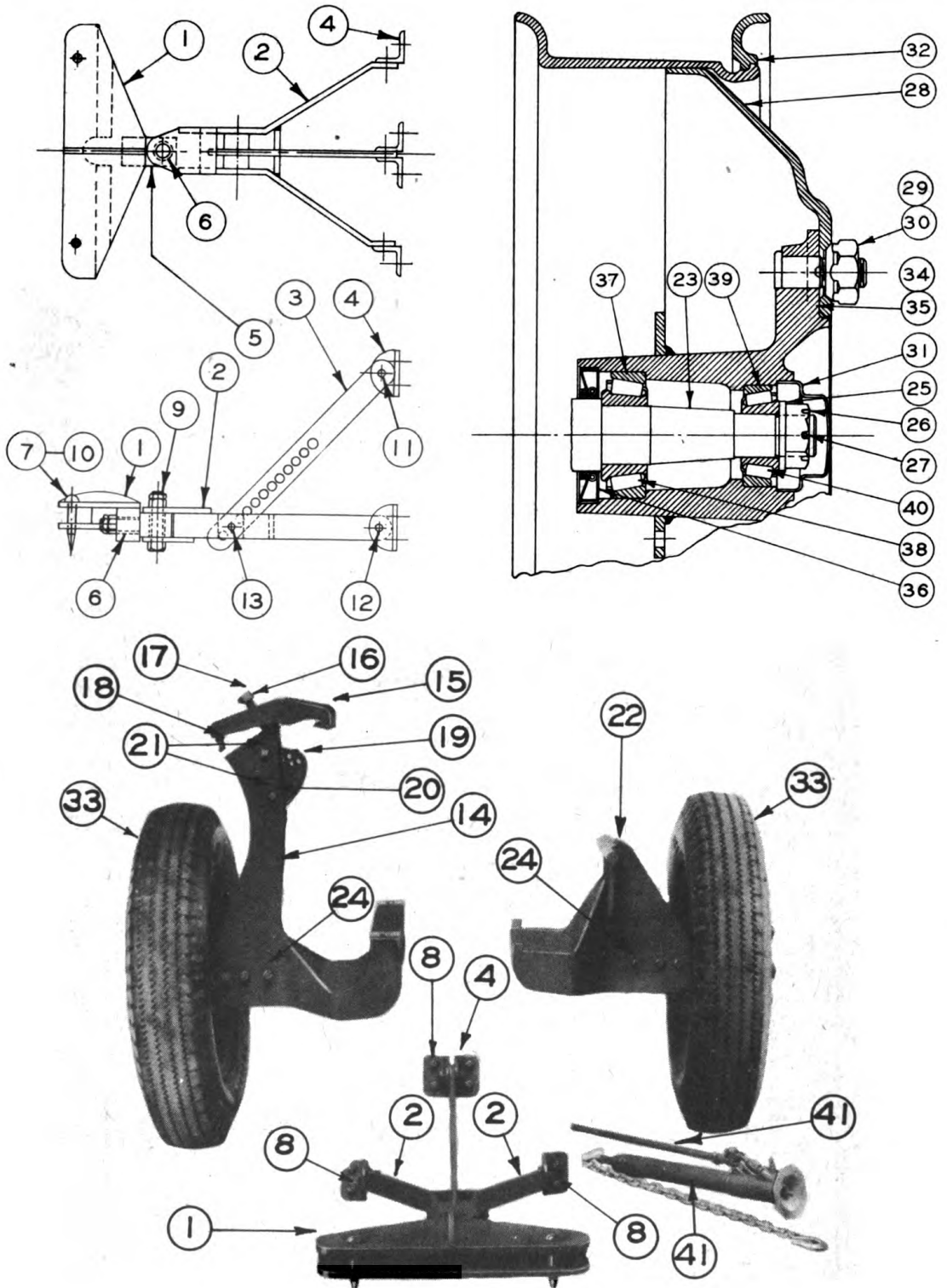

Plate No. 30—Connecting Bar and Caisson Parts

## BLOCK-OFF PLATES

Cut No.	Part No.	Description	No. Reqd.
	CC-1067	Block Off Plates—6" long.....	
	CC-1068	Block Off Plates—12" Long.....	

## TRUCK ATTACHMENT

174	W-2978-A	Cross Bar with Collars.....	1
175	W-2978-B	Side Angle.....	2
176	W-2978-C	Brace Rod.....	2
177	W-2978-D	Machine Bolt, $\frac{1}{2}$ " x $1\frac{1}{2}$ ".....	4
	W-2978-L	Machine Bolt Nuts, $\frac{1}{2}$ " Hex.....	4
	W-2978-M	Machine Bolt Lock Washer, $\frac{1}{2}$ ".....	4
178	W-2978-E	Machine Bolt, $\frac{3}{4}$ " x $1\frac{3}{4}$ ".....	4
	W-2978-F	Hex. Nut, $\frac{3}{4}$ ".....	4
	W-2978-G	Lock Washer, $\frac{3}{4}$ ".....	4
179	W-2978-H	U Bolt.....	2
	W-2978-J	U Bolt Nut, $\frac{1}{2}$ ".....	8
	W-2978-K	U Bolt Lock Washer, $\frac{1}{2}$ ".....	4
180	W-2978	Truck Attachment Assembly, Complete.....	1

## DRAW BAR ATTACHMENT

1	CC-1516	Connecting Bar Attachment.....	1
2	CC-1517	Tripod Side Leg Assembly.....	1
3	CC-1517-2	Tripod Center Brace.....	1
4	CC-1517-7	Tripod Assembly Bracket.....	4
5	CC-1516-6	Swivel Bolt Block.....	1
	CC-1516-8	Hex. Nut, 1".....	1
	CC-1516-12	Lock Washer, 1".....	1
	CC-1516-9	Hex. Jam Nut, 1".....	1
6	CC-1516-7	Swivel Bolt Block Spacer.....	2
7	AA-1519	Connecting Bar Attachment Pin, Special.....	2
8	CC-1517-11	Tripod Assembly Bracket Attaching $\frac{5}{8}$ " x $1\frac{1}{2}$ ", Hex. Hd.....	8
9	CC-1517-8	Tripod and Swivel Connecting Bolt.....	1
	CC-1516-8	Hex. Nut, 1".....	1
	CC-1516-9	Hex. Jam Nut, 1".....	1
10	CC-1516-11	Connecting Bar Attachment Pin Cotter, $\frac{3}{16}$ x $1\frac{1}{4}$ ".....	2
11	CC-1517-10	Tripod Center Brace Bolt, $\frac{5}{8}$ " x 2" Hex. Hd.....	1
12	CC-1517-12	Tripod Side Leg Bolt, $\frac{5}{8}$ " x $1\frac{3}{4}$ " Hex. Hd.....	2
	CC-1517-13	Lock Washer, $\frac{5}{8}$ ".....	3

**DRAW BAR ATTACHMENT (Continued)**

Cut No.	Part No.	Description	No. Reqd.
13	CC-1517-14	Hex. Nut, 5/8".....	3
	CC-1517-9	Tripod Center Brace to Side Leg Bolt, 3/4" x 5" Hex. Hd.....	
	CC-1517-15	Lock Washer, 3/4".....	1
	CC-1517-16	Hex. Nut, 3/4".....	1

**MOUNTING BRACKETS**

14	DD-1508-18	<p><b>Mounting Bracket, Right, consisting of:</b>                      (2) DD-1507-1 Side Plates, (2) DD-1507-2 Cross Angle, (2) DD-1507-3 Top Plate, (2) DD-1507-4 Center Spacer, (2) DD-1507-5 Spacer Strip, (2) DD-1507-6 Axle Guide, (2) DD-1507-7 Axle Guide, (2) DD-1507-8 Gusset, (2) DD-1507-9 Gusset, (2) DD-1507-11 Gusset, (2) DD-1507-12 Gusset, (1) CC-1503 Clamp Assembly, (1) AA-1508 Washer, (1) DD-1502-16 Clamp Locking Bolt, (1) DD-1502-24 Clamp Lock Bolt Nut, (2) CC-1503-6 Clamp Steady Bolts, (1) BB-1509 Adjusting Cam with Anti-Friction Pad, (2) DD-1502-15 Bolts, (2) DD-1502-22 Lock, (2) DD-1502-23 Nut, (1) DD-1502-14 Spacer, (1) BB-1511 Spindle, (3) DD-1502-17 Bolt, (3) DD-1502-20 Lock Washer and (3) DD-1502-21 Nut.</p>	
15	CC-1503	Clamp Assembly.....	1
	AA-1508	Clamp Washer, Special.....	1
16	DD-1502-16	Clamp Locking Bolt, 1" x 5" Hex. Hd.....	1
17	DD-1502-24	Clamp Locking Bolt Nut, 1" Hex.....	1
18	CC-1503-6	Clamp Steady Bolt, 1/2" x 3" Hex. Hd.....	2
19	BB-1509	Adjusting Cam with Anti-Friction Pad.....	1
20	DD-1502-14	Adjusting Cam Spacer.....	1
21	DD-1502-15	Adjusting Cam Bolt, 1/2" x 3 3/4" Hex. Hd.....	2
	DD-1502-22	Adjusting Cam Bolt Lock Washer, 1/2".....	2
	DD-1502-23	Adjusting Cam Bolt Nut, 1/2" Hex.....	2
22	DD-1513	<p><b>Mounting Bracket, Left, consisting of:</b>                      (1) DD-1514-1 Side Plate, (1) CC-1513-6 Spacer Angle, (1) DD-1514-2 Gusset, (1) DD-1514-3 Axle Guide, (1) DD-1514-4 Axle Guide, (1) DD-1514-5 Spacer Strip, (1) DD-1514-7 Bar, (2) DD-1514-8 Spacer, (2) DD-1514-9 Gusset, (1) BB-1511 Spindle, (3) DD-1502-17 Bolt, (3) DD-1502-20 Lock Washer and (3) DD-1502-21 Nut.</p>	1
23	BB-1511	Spindle.....	2

## (MOUNTING BRACKETS Continued)

Cut No.	Part No.	Description	No. Reqd.
24	DD-1502-17	Spindle Retaining Bolt, $\frac{5}{8}$ " x 4" Hex. Hd.	6
	DD-1502-20	Spindle Retaining Bolt Lock Washer, $\frac{5}{8}$ "	6
	DD-1502-21	Spindle Retaining Bolt Nut, $\frac{5}{8}$ " Hex.	6
25	AA-1506	Spindle Nut Washer, Special	2
26	CC-1505-12	Spindle Castle Nut, $1\frac{1}{8}$ " N.F.—12	2
27	CC-1505-13	Spindle Castle Nut Cotter Pin, $\frac{3}{16}$ " x 2"	2

## WHEELS, HUBS AND BEARINGS

28	CC-1505-1	Wheel Only, 20 x 7, 6 Hole—Spoke Hole Type	2
29	CC-1505-4	Wheel Cap Nut, Right	6
30	CC-1524-4	Wheel Cap Nut, Left	6
31	CC-1505-5	Hub Cap	2
32	CC-1505-2	Locking Ring	2
33	CC-1525	Tire, Tube with TR-50 Valve and Flap, Heavy Duty 750-20—8 Ply	2
34	CC-1505-3	Wheel Hub and Studs, Right	1
35	CC-1524-3	Wheel Hub and Studs, Left	1
36	CC-1505-10	Grease Retainer, Complete	2
37	CC-1505-15	Inner Bearing Cup, Timken No. 3525	2
38	CC-1505-9	Inner Bearing Cone, Timken No. 3576	2
39	CC-1505-14	Outer Bearing Cup, Timken No. 2523	2
40	CC-1505-8	Outer Bearing Cone, Timken No. 2582	2
25	AA-1506	Spindle Nut Washer, Special	2
26	CC-1505-12	Spindle Castle Nut, $1\frac{1}{8}$ " N.F.—12	2
27	CC-1505-13	Spindle Castle Nut Cotter Pin, $\frac{3}{16}$ " x 2"	2

## HYDRAULIC LIFTING JACK

41	CC-1521	Jack, Hydraulic type, with 19" Lift and Chain Adjustment, Complete with Handle	1
		Wrench, Crescent, 6-inch	1
		Wrench, Crescent, 8-inch	1
		Screwdriver, 8-inch	1
		Pliers, 8-inch	1
		Hammer, Ball Peen, $1\frac{1}{2}$ pounds	1
		Wrench, Wheel lug, Chrome-Vanadium	1

## CHAPTER VII

### NUMERICAL PARTS PRICE LIST

Part No.	Description	No. Reqd.	Price	Page No.
DD-1000-8	Hopper Plate, No. 7 Ga., 35 <sup>5</sup> / <sub>8</sub> " x 96"	1	\$24.70	33
DD-1011	Wheel Support, Right	2	4.56	29
DD-1012	Wheel Support, Left	2	4.56	29
CC-1021	Bearing, Axle, Self Aligning Type	4	5.20	26
CC-1027-8	Back Plate, No. 7 Ga., 23 <sup>3</sup> / <sub>4</sub> " x 96"	1	21.85	31
CC-1032	Lift Plate, No. 7 Ga., 4" x 16 <sup>1</sup> / <sub>8</sub> "	1	1.14	31
LL-1035-8	Lower Front Plate, No. 7 Ga., 24" x 96"	1	23.75	33
DD-1056	Handle Bar Assembly, consisting of:	2	13.85	31
	1 AA-1230 Rubber Grip			
	1 DD-1137 Handle Bar			
	1 AA-1146 Spring			
	1 AA-1148 Lock Assembly			
	1 AA-1142 Pin			
	1 AA-1149 Pin Retainer			
LL-1057	End Plate, Right	1	9.95	29
LL-1058	End Plate, Left	1	9.95	29
AA-1066	Retainer, Hitch Handle Shaft	1	1.45	26
CC-1067	Block Off Plates—6" Long		2.00	37
CC-1068	Block Off Plates—12" Long		4.00	37
BB-1075	Screw, Keyboard Control	3	2.25	29
AA-1076	Nut, Keyboard Control, Right	3	.65	29
AA-1077	Nut, Keyboard Control, Left	3	.65	29
AA-1078	Link, Keyboard Control Connecting, Plain	6	.20	29
AA-1078-T	Link, Keyboard Control Connecting, Tapped	6	.25	29
AA-1079	Retainer, Keyboard Connecting Link	3	1.10	34
AA-1082	Key, Plain, Keyboard 1" x 7 <sup>5</sup> / <sub>8</sub> "	79	.15	34
AA-1082-A	Key, with Hole, Keyboard, 1" x 7 <sup>5</sup> / <sub>8</sub> "	17	.20	34
AA-1083	Key, Plain, Keyboard, 1" x 8 <sup>3</sup> / <sub>8</sub> "	79	.20	34
AA-1083-A	Key, with Hole, Keyboard, 1" x 8 <sup>3</sup> / <sub>8</sub> "	17	.20	34
AA-1085	Screw, Taper Attachment Control	2	.65	34
AA-1086	Nut, Taper Attachment Control	2	2.55	34
AA-1087	Handle, Taper Attachment	2	2.20	34
AA-1090	Needle Bearing	6	.80	29
AA-1091	Rivet Pin, Connecting Link	6	.10	29
BB-1099	Keyboard Control	2	2.90	29
LL-1115-8	Spacer, Wood, Keyboard	2	.95	34
DD-1125-8	Keyboard Hangar Assembly	1	8.40	29
CC-1131	Keyboard Keys and Retainer Assembly	1	52.50	29
DD-1132-8	Keyboard Assembly Complete	1	95.10	34
DD-1137	Handle Bar, only	2	5.75	31
AA-1142	Pin, Handle Bar	2	.15	33
AA-1144	Lock Pin, Handle Bar	2	.15	29

## NUMERICAL PARTS PRICE LIST (Continued)

Part No.	Description	No. Reqd.	Price	Page No.
AA-1146	Spring, Handle Bar . . . . .	2	.25	31
AA-1148	Lock Assembly, Handle Bar . . . . .	2	2.50	31
AA-1149	Retainer, Handle Bar . . . . .	2	3.40	33
BB-1156	Clutch, Transmission, Left Half . . . . .	1	5.30	29
BB-1157	Shaft, Transmission Drive . . . . .	1	2.20	27
AA-1164	Bearing, Transmission Drive . . . . .	2	1.05	27
AA-1165	Thrust Bearing . . . . .	1	.70	27
AA-1167	Idler Bearing, Oilite . . . . .	2	.60	27
AA-1169	Bearing, Feed Roll Support and Outer Retainer . . . . .	1	1.95	29
AA-1171	Gear, Transmission Drive, 40 Teeth . . . . .	1	15.50	27
AA-1172	Gear, Idler, 35 Teeth . . . . .	2	10.90	27
AA-1176	Shaft, Transmission; Intermediate . . . . .	1	.85	27
AA-1177	Bolt, Idler Gear (special) . . . . .	2	2.60	27
AA-1181	Plunger, Gear Shift Handle . . . . .	1	.25	33
AA-1183	Spring, Gear Shift Handle Plunger . . . . .	1	.35	34
AA-1184	Pin, Gear Shift Handle . . . . .	1	.15	33
AA-1186	Plug, Gear Shift Handle . . . . .	1	.25	34
AA-1187	Spring, Transmission Tension . . . . .	1	.35	29
AA-1188	Trigger, Gear Shift Handle . . . . .	1	.25	29
CC-1192	Gear Shift Handle Assembly . . . . .	1	6.45	34
BB-1195	Transmission Gear Plate and Spacer . . . . .	1	4.10	27
BB-1197	Sprocket, Driven Clutch, 12 Teeth . . . . .	1	4.90	27
BB-1198	Intermediate Gear (35T) and Sprocket Assembly . . . . .	1	18.45	27
CC-1199	Transmission Gear Plate Assembly . . . . .	1	51.60	27
LL-1200	Transmission Case (Gear Box) . . . . .	1	25.15	34
LL-1201	Transmission Assembly Complete . . . . .	1	122.95	34
AA-1202	Chain, Transmission Drive (Am. No. 60) . . . . .	1	4.85	27
DD-1213-8	Feed Roll Assembly Complete . . . . .	1	31.60	31
AA-1223	Seal, Feed Roll Bearing Support . . . . .	2	.25	31
AA-1224	Bearing, Feed Roll . . . . .	4	.40	31
AA-1225	Thrust Bearing, Feed Roll . . . . .	3	.30	29
CC-1227	Feed Roll Bearing Support Assembly . . . . .	2	6.90	31
BB-1228	Cover Plate, Feed Roll . . . . .	1	.30	31
AA-1230	Rubber Grip, Keyboard Control Handle . . . . .	2	.30	26
AA-1230	Rubber Grip, Hitch Control Handle . . . . .	1	.30	26
BB-1231	Disc, Hitch Control Handle . . . . .	1	.90	26
AA-1237	Hitch Control Handle, Spacer and Shaft Assembly . . . . .	1	.84	26
CC-1239	Handle, Keyboard Control . . . . .	2	3.45	29
CC-1240	Hitch Vertical Adj. Handle Assembly . . . . .	1	3.70	26
AA-1243	Handle, Hitch Control . . . . .	1	1.40	26
CC-1245	Wheel Hub . . . . .	4	3.40	26
CC-1246	Driver, Axle Shaft . . . . .	1	6.90	26
BB-1247	Idler, Axle Shaft . . . . .	1	6.70	26
LL-1248	Hitch Assembly Complete . . . . .	1	73.50	33
AA-1249	Wheel Spacer, Outside . . . . .	4	1.10	26

NUMERICAL PARTS PRICE LIST (Continued)

Part No.	Description	No. Reqd.	Price	Page No.
AA-1250	Wheel Spacer, Center.....	2	1.25	26
AA-1251	Collar, Axle Shaft (with Set Screw).....	4	1.40	26
AA-1252	Wheel Thrust Washer, Fibre.....	4	.08	26
CC-1263	Hitch Front Plate.....	1	2.60	26
AA-1264	Hitch Release Spring.....	1	.25	26
AA-1269	Bolt, Swivel Plate.....	1	.45	26
DD-1274	Screw, Hitch Control.....	1	6.85	34
AA-1275	Nut, Hitch Control.....	1	10.55	34
AA-1278	Thrust Plate, Hitch Control.....	1	.45	34
AA-1280	Retainer, Hitch Control Screw.....	1	.40	34
BB-1283-8	Screw, Hitch Control.....	1	6.30	26
CC-1289	Plate, Hitch Support Assembly.....	1	6.10	26
DD-1290	Hitch Coupler Assembly.....	1	24.90	33
AA-1291	Thrust Washer, Hitch Control Screw.....	1	.45	34
CC-1292	Lift Link, Hitch Control.....	1	15.30	34
AA-1293	Lift Shaft, Hitch Lower Front.....	1	1.70	34
BB-1296	Bearing, Hitch Control Screw.....	1	1.55	34
DD-1298	Lever, Lift Control Assembly Complete.....	1	32.70	34
CC-1299	Cover, Transmission Case.....	1	6.30	34
AA-1305	Thrust Washer, Castor Roll.....	4	.05	33
BB-1307	Castor Roll (Pony Wheel).....	4	3.70	33
DD-1308	Castor, Pony Wheel Assembly.....	2	23.40	33
AA-1314	Indicator Pointer.....	2	.35	34
AA-1315	Indicator Pin.....	2	.05	31
AA-1316	Indicator Connecting Link.....	2	.20	31
BB-1318	Indicator Plate, Right.....	1	.50	31
BB-1319	Indicator Plate, Left.....	1	.50	34
AA-1320	Indicator Connecting Pin.....	2	.05	31
AA-1354	Bushing, Keyboard Hanger Link Screw.....	6	.25	29
AA-1357	Handle, Hitch Release.....	1	1.25	26
AA-1360-8	Belt, Hopper Plate, 96" x 2"—4 Ply.....	2	3.25	31
AA-1370	Flexible Apron, 96" x 6"—5 ply.....	1	7.35	33
AA-1372	Plate, Apron Reinforcing.....	1	2.05	33
DD-1375	Hitch Release Assembly.....	1	11.85	26
DD-1378	Universal Joint Assembly.....	1	21.40	27
AA-1379	Disc, Universal Joint.....	3	1.50	27
CC-1379-8	Keyboard Key and Spacer Assembly.....	1	48.70	34
AA-1386	Tumbler, Hitch Coupler.....	2	2.00	33
BB-1389	Hitch Release Universal and Pipe Assembly.....	1	2.60	26
BB-1390	Hitch Release Universal and Shaft Assembly.....	1	7.50	26
CC-1391	Wheel, with Bolts, less Hub.....	4	4.50	26
DD-1392	Support, Castor Roll, with Axles.....	2	8.40	33
CC-1393	Spider, Universal Joint.....	2	10.80	27
AA-1396	Set Screw, Hitch Control Screw Retainer.....	2	.15	34
AA-1397	Jam Nut, Hitch Swivel Bolt, 1¼".....	4	.18	33

## NUMERICAL PARTS PRICE LIST (Continued)

Part No.	Description	No. Reqd.	Price	Page No.
AA-1398	Castle Nut, Swivel Plate Bolt, 1"-8. ....	1	.16	26
AA-1399	Cotter Pin, Swivel Plate Bolt, 3/16" x 2" .....	1	.01	26
AA-1401	Bolt, Hitch Control Screw Bearing, 3/8" x 24 x 1/4" .....	3	.02	34
AA-1402	Bolt, Feed Roll Bearing Plate, Hex. Hd. 3/8" x 1"-16. ....	3	.02	33
AA-1403	Lockwasher, Transmission Cover Bolt, 3/8" .....	3	.01	34
AA-1406	Bolt, Hitch Coupler, Hex. Hd., 3/4" x 3 1/4" .....	2	.14	33
AA-1407	Bolt, Connecting Link, 1/4" x 1 3/4"-24. ....	6	.02	34
AA-1408	Cap Screw, Keyboard Hanger Link, 3/8" x 5/8"-16. ....	6	.02	29
AA-1409	Set Screw, Taper Att. Control Screw Point Cup, 1/4" x 3/8"-20. ....	2	.02	29
AA-1415	Cotter Pin, 1/8" x 3/4" .....	4	.01	29
AA-1417	Screw, Indicator Plate, No. 8 Rd. Hd. Parker Kalon. . .	8	.01	31
AA-1418	Set Screw, Keyboard Control Handle, 5/16" x 1/8"-18, Hollow Head Cup Point. ....	2	.06	29
AA-1419	Bolt, Hitch Control Handle, 1/2" x 1"-13, Hex. Hd. ....	1	.05	33
AA-1420	Nut, Transmission Attaching Bolt, 1/2" Hex. ....	5	.02	33
AA-1421	Washer, 1/2" .....	2	.01	33
AA-1423	Cotter Pin, 1/4" x 2 1/4" .....	4	.01	33
AA-1424	Bolt, Castor Roll Supp., 1/2" x 1 3/4" Hex. Hd. ....	6	.05	33
AA-1425	Tire, 6.00-9, 6 Ply and Tube with TR-50 Valve. ....	4	P.O.A.	26
AA-1426	Key, Woodruff, Wheel Hub, No. 25. ....	4	.04	26
AA-1427	Key, Woodruff, Feed Roll Clutch, No. 21. ....	2	.06	29
AA-1428	Washer, Flat, Hopper Plate Belt, 1/2" Std. ....	13	.01	27
AA-1429	Beaded Washer, Universal Joint Bolt, Special. ....	18	.06	27
AA-1430	Set Screw, Transmission Drive Shaft, 1/2" x 3/4" Hex. Hd. ....	2	.15	27
AA-1431	Bolt, Universal Joint, 1/2" x 2 1/2", NF, Hex. Hd. ....	6	.13	27
AA-1432	Plug, Feed Roll Oil, 1/8" Cast Pipe Plug. ....	2	.04	31
AA-1433	Lock Washer, Idler Gear Bolt, 3/4" Std. ....	2	.02	33
AA-1434	Nut, Idler Gear Bolt, 3/4"-16 Hex. ....	2	.05	33
AA-1436	Machine Bolt, Feed Roll Bearing Support, 1/2" x 1 1/4"-13. ....	6	.06	31
AA-1437	Bolt, Keyboard Retainer, 5/16" x 2 1/4"-18. ....	17	.03	29
AA-1438	Bolt, Hopper Place Belt, 5/16" x 3/4"-18. ....	13	.02	31
AA-1439	Bolt, Apron Reinforcing Plate, 5/16" x 5/8"-18, Flat Head. ....	11	.02	33
AA-1440	Gasket, Transmission Plate Cover (cork) .....	1	.75	34
AA-1441	Bolt, Transmission Cover, 3/8" x 3/4"-24. ....	3	.02	34
AA-1442	Cotter Pin, Gear Shift Handle Pin, 1/8" x 1" .....	1	.01	33
AA-1458	Lock Washer, Feed Roll Bearing Plate Bolt, 3/8" .....	3	.01	33
AA-1459	Lockwasher, Transmission Attaching Bolt, 1/2" .....	5	.01	33
AA-1460	Square Nut, Keyboard Retainer Bolt, 5/16"-18. ....	17	.01	29
AA-1461	Lock Washer, Keyboard Retainer Bolt, 5/16" .....	17	.01	29
AA-1462	Lock Washer, 1/2" Std. ....	6	.01	31
AA-1463	Nut, Hopper Plate Belt Bolt, 5/16" Hex. ....	13	.01	31
AA-1464	Nut, Hitch Control Screw Bearing Bolt, 3/8" Hex. ....	3	.01	34
AA-1465	Lock Washer, Connecting Link Bolt, 1/4" .....	6	.01	34
AA-1466	Cotter Pin, Universal Joint Bolt, 3/32" x 1" .....	6	.01	27

## NUMERICAL PARTS PRICE LIST (Continued)

Part No.	Description	No. Reqd.	Price	Page No.
AA-1467	Castle Nut, Universal Joint Bolt, $\frac{1}{2}$ " NF	6	.03	27
DD-1502-14	Spacer, Adjusting Cam	1	.25	38
DD-1502-15	Bolt, Adjusting Cam, $\frac{1}{2}$ " x $3\frac{3}{4}$ " Hex. Hd.	2	.07	38
DD-1502-16	Bolt, Clamp Locking, 1" x 5" Hex. Hd.	1	.31	38
DD-1502-17	Bolt, Spindle Retaining, $\frac{5}{8}$ " x 4" Hex. Hd.	6	.11	39
DD-1502-20	Lock Washer, Spindle Retaining Bolt, $\frac{5}{8}$ "	6	.01	39
DD-1502-21	Nut, Spindle Retaining Bolt, $\frac{5}{8}$ " Hex.	6	.03	39
DD-1502-22	Lock Washer, Adjusting Cam Bolt, $\frac{1}{2}$ "	2	.01	38
DD-1502-23	Nut, Adjusting Cam Bolt, $\frac{1}{2}$ " Hex.	2	.02	38
DD-1502-24	Nut, Clamp Locking Bolt, 1" Hex.	1	.09	38
CC-1503	Clamp Assembly	1	8.75	38
CC-1503-6	Bolt, Clamp Steady, $\frac{1}{2}$ " x 3" Hex. Hd.	2	.06	38
CC-1505-1	Wheel only, 20" x 7", 6 Hole—Spoke Hole Type	2	15.00	39
CC-1505-2	Locking Ring	2	2.30	39
CC-1505-3	Wheel Hub and Studs, Right	1	20.00	39
CC-1505-4	Nut, Wheel Cap, Right	6	.20	39
CC-1505-5	Hub Cap	2	.40	39
CC-1505-8	Bearing Cone, Outer, Timken No. 2582	2	3.09	39
CC-1505-9	Bearing Cone, Inner, Timken No. 3576	2	4.68	39
CC-1505-10	Grease Retainer, Complete	2	1.25	39
CC-1505-12	Castle Nut, Spindle, $1\frac{1}{8}$ " NF-12	2	.40	39
CC-1505-13	Cotter Pin, Spindle Castle Nut, $\frac{3}{16}$ " x 2"	2	.01	39
CC-1505-14	Bearing Cup, Outer, Timken No. 2523	2	1.79	39
CC-1505-15	Bearing Cup, Inner, Timken No. 3525	2	2.44	39
AA-1506	Washer, Spindle Nut, Special	2	.08	39
AA-1508	Washer, Clamp, Special	1	.09	38
DD-1508-18	Mounting Bracket, Right	1	78.30	38
BB-1509	Adjusting Cam with Anti-Friction Pad	1	8.25	38
BB-1511	Spindle	2	21.50	38
DD-1513	Mounting Bracket, Left	1	39.45	38
CC-1516	Attachment, Connecting Bar	1	16.90	37
CC-1516-6	Block, Swivel Bolt	1	12.15	37
CC-1516-7	Spacer, Swivel Bolt Block	2	.25	37
CC-1516-8	Nut, Hex. 1"	1	.09	37
CC-1516-9	Jam Nut, Hex. 1"	1	.08	37
CC-1516-11	Cotter Pin, Connecting Bar Attachment Pin	2	.01	37
CC-1516-12	Lock Washer, 1"	1	.03	37
CC-1517	Tripod Side Leg Assembly	1	21.00	37
CC-1517-2	Tripod Center Brace	1	2.75	37
CC-1517-7	Tripod Assembly Bracket	4	.90	37
CC-1517-8	Bolt, Tripod Swivel Connecting	1	.15	37
CC-1517-9	Bolt, Tripod Center Brace to Side Leg, $\frac{3}{4}$ " x 5" Hex. Hd.	1	.15	38
CC-1517-10	Bolt, Tripod Center Brace, $\frac{5}{8}$ " x 2" Hex. Hd.	1	.09	37
CC-1517-11	Bolt, Tripod Assembly, Bracket Attaching, $\frac{5}{8}$ " x $1\frac{1}{2}$ " Hex. Hd.	8	.08	37

## NUMERICAL PARTS PRICE LIST (Continued)

Part No.	Description	No. Reqd.	Price	Page No.
CC-1517-12	Bolt, Tripod Side Leg, $\frac{5}{8}$ " x 1" Hex. Hd.	2	.08	37
CC-1517-13	Lock Washer, $\frac{5}{8}$ "	3	.01	37
CC-1517-14	Nut, $\frac{5}{8}$ " Hex.	3	.03	38
CC-1517-15	Lock Washer, $\frac{3}{4}$ "	1	.01	38
CC-1517-16	Nut, $\frac{3}{4}$ " Hex.	1	.04	38
AA-1519	Pin, Connecting Bar Attachment, Special	2	1.30	37
CC-1521	Jack, Hydraulic Type with 19" Lift and Chain Adj., Complete with Handle.	1	8.85	39
CC-1524-3	Wheel Hub and Studs, Left	1	20.00	39
CC-1524-4	Nut, Wheel Cap, Left	6	.20	39
CC-1525	Tire, Tube, with TR-50 Valve and Flap, Heavy Duty 7.50-20, 8 Ply	2	P.O.A.	39
W-2978	Truck Attachment Assembly Complete	1	8.00	37
W-2978-A	Cross Bar with Collars	1	4.40	37
W-2978-B	Side Angle	2	2.90	37
W-2978-C	Brace Rod	2	1.65	37
W-2978-D	Machine Bolt, $\frac{1}{2}$ " x $1\frac{1}{2}$ "	4	.05	37
W-2978-E	Machine Bolt, $\frac{3}{4}$ " x $1\frac{3}{4}$ "	4	.12	37
W-2978-F	Nut, $\frac{3}{4}$ " Hex.	4	.05	37
W-2978-G	Lock Washer, $\frac{3}{4}$ "	4	.03	37
W-2978-H	U-Bolt	2	.40	37
W-2978-J	Nut, U-Bolt, $\frac{1}{2}$ "	8	.02	37
W-2978-K	Lock Washer, U-Bolt, $\frac{1}{2}$ "	4	.01	37
W-2978-L	Nut, Machine Bolt, $\frac{1}{2}$ " Hex.	4	.02	37
W-2978-M	Lock Washer, Machine Bolt, $\frac{1}{2}$ "	4	.01	37
LL-3112	Hopper Assembly, Complete	1	112.00	33
	Wrench, Crescent, 6-inch	1	1.95	
	Wrench, Crescent, 8-inch	1	3.30	
	Screwdriver, 8-inch	1	1.40	
	Pliers, 8-inch	1	3.80	
	Hammer, Ball Peen, $1\frac{1}{2}$ pounds	1	2.75	
	Wrench, Wheel lug, Chrome-Vanadium	1	7.55	



