



This is a digital copy of a book that was preserved for generations on library shelves before it was carefully scanned by Google as part of a project to make the world's books discoverable online.

It has survived long enough for the copyright to expire and the book to enter the public domain. A public domain book is one that was never subject to copyright or whose legal copyright term has expired. Whether a book is in the public domain may vary country to country. Public domain books are our gateways to the past, representing a wealth of history, culture and knowledge that's often difficult to discover.

Marks, notations and other marginalia present in the original volume will appear in this file - a reminder of this book's long journey from the publisher to a library and finally to you.

Usage guidelines

Google is proud to partner with libraries to digitize public domain materials and make them widely accessible. Public domain books belong to the public and we are merely their custodians. Nevertheless, this work is expensive, so in order to keep providing this resource, we have taken steps to prevent abuse by commercial parties, including placing technical restrictions on automated querying.

We also ask that you:

- + *Make non-commercial use of the files* We designed Google Book Search for use by individuals, and we request that you use these files for personal, non-commercial purposes.
- + *Refrain from automated querying* Do not send automated queries of any sort to Google's system: If you are conducting research on machine translation, optical character recognition or other areas where access to a large amount of text is helpful, please contact us. We encourage the use of public domain materials for these purposes and may be able to help.
- + *Maintain attribution* The Google "watermark" you see on each file is essential for informing people about this project and helping them find additional materials through Google Book Search. Please do not remove it.
- + *Keep it legal* Whatever your use, remember that you are responsible for ensuring that what you are doing is legal. Do not assume that just because we believe a book is in the public domain for users in the United States, that the work is also in the public domain for users in other countries. Whether a book is still in copyright varies from country to country, and we can't offer guidance on whether any specific use of any specific book is allowed. Please do not assume that a book's appearance in Google Book Search means it can be used in any manner anywhere in the world. Copyright infringement liability can be quite severe.

About Google Book Search

Google's mission is to organize the world's information and to make it universally accessible and useful. Google Book Search helps readers discover the world's books while helping authors and publishers reach new audiences. You can search through the full text of this book on the web at <http://books.google.com/>

DI 01,11:
5-248

TM 5-248

DEPARTMENT OF THE ARMY TECHNICAL MANUAL

FOREIGN MAPS

1365

UNIVERSITY OF VIRGINIA LIBRARY



X004788974

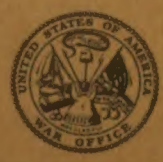

DEPARTMENT OF THE ARMY

JUNE 1956

Digitized by



FOREIGN MAPS

	Paragraphs	Page
CHAPTER 1. INTRODUCTION TO FOREIGN MAPS		
Section I. General.....	1-3	3
II. How topographic maps are evaluated.....	4-7	4
III. How foreign maps are adapted to U. S. Army use.....	8-10	10
CHAPTER 2. NORTHWEST AFRICA		
Section I. Spanish Morocco.....	11, 12	12
II. French Morocco.....	13, 14	15
III. Algeria and Tunisia.....	15, 16	20
CHAPTER 3. NORTHEAST AFRICA		
Section I. Libya.....	17, 18	27, 29
II. Egypt.....	19, 21	31
III. Ethiopia (Including Eritrea).....	22, 23	39
IV. British Somaliland.....	24, 25	40
V. French Somaliland.....	26, 27	41, 42
CHAPTER 4. WESTERN HEMISPHERE		
Section I. Greenland.....	28-31	44
II. Iceland.....	32-35	46
CHAPTER 5. EASTERN ASIA		
Section I. East China and Hong Kong.....	36-40	48
II. Indochina.....	41-45	63
III. Japan.....	46-50	68
IV. Korea.....	51-55	77
V. Karafuto (Sakhalin Island South of 50° N).....	56-60	87
VI. Sakhalin Island, North of 50° N.....	61-64	92
VII. Taiwan and the P'eng-Hu Islands.....	65-69	92
CHAPTER 6. SOUTHERN ASIA		
Section I. Arabian Peninsula.....	70-72	95
II. Burma.....	73-75	99
III. Iran.....	76-79	102
IV. Iraq.....	80-82	110
V. Israel and Jordan.....	83-85	116
VI. Lebanon and Syria.....	86-88	125
VII. Malaya and Singapore.....	89-91	130
VIII. The Philippines.....	92-94	133
IX. Thailand.....	95-97	136
X. Turkey.....	98-100	139
CHAPTER 7. WESTERN EUROPE		
Section I. Belgium.....	101-103	147
II. British Isles.....	104-106	151
III. France.....	107-109	157
IV. Gibraltar.....	110-112	162
V. Luxembourg.....	113-115	163
VI. Netherlands.....	116-120	166
VII. Portugal.....	121-124	169
VIII. Spain and the Balearic Islands.....	125-127	173
CHAPTER 8. NORTHERN EUROPE AND THE BALTIC STATES		
Section I. Denmark and the Faeroe Islands.....	128-131	178
II. Estonia, Latvia, and Lithuania.....	132-135	180
III. East Prussia.....	136-138	186
IV. Finland.....	139-143	187
V. Norway.....	144-147	192
VI. Sweden.....	148-151	195

*This manual supersedes TM 5-248, 1 July 1946.

	Paragraphs	Page
CHAPTER 9. CENTRAL EUROPE		
Section I. Austria.....	152-154	199
II. Czechoslovakia.....	155-158	200
III. Germany.....	159, 160	206, 207
IV. Hungary.....	161-164	215
V. Poland.....	165-168	217
VI. Switzerland.....	169-171	223
CHAPTER 10. SOUTHEASTERN EUROPE		
Section I. Albania.....	172-175	225
II. Bulgaria.....	176-179	226
III. Greece.....	180-182	230
IV. Italy and the Free Territory of Trieste.....	183-186	235
V. Rumania.....	187-190	240
VI. Yugoslavia.....	191-194	241
CHAPTER 11. U. S. S. R.	195-199	246
APPENDIX I. REFERENCES		251
II. REFERENCE DATA.....		253
GLOSSARY OF MAPPING TERMS		261
INDEX		266

UV

THE WORLD

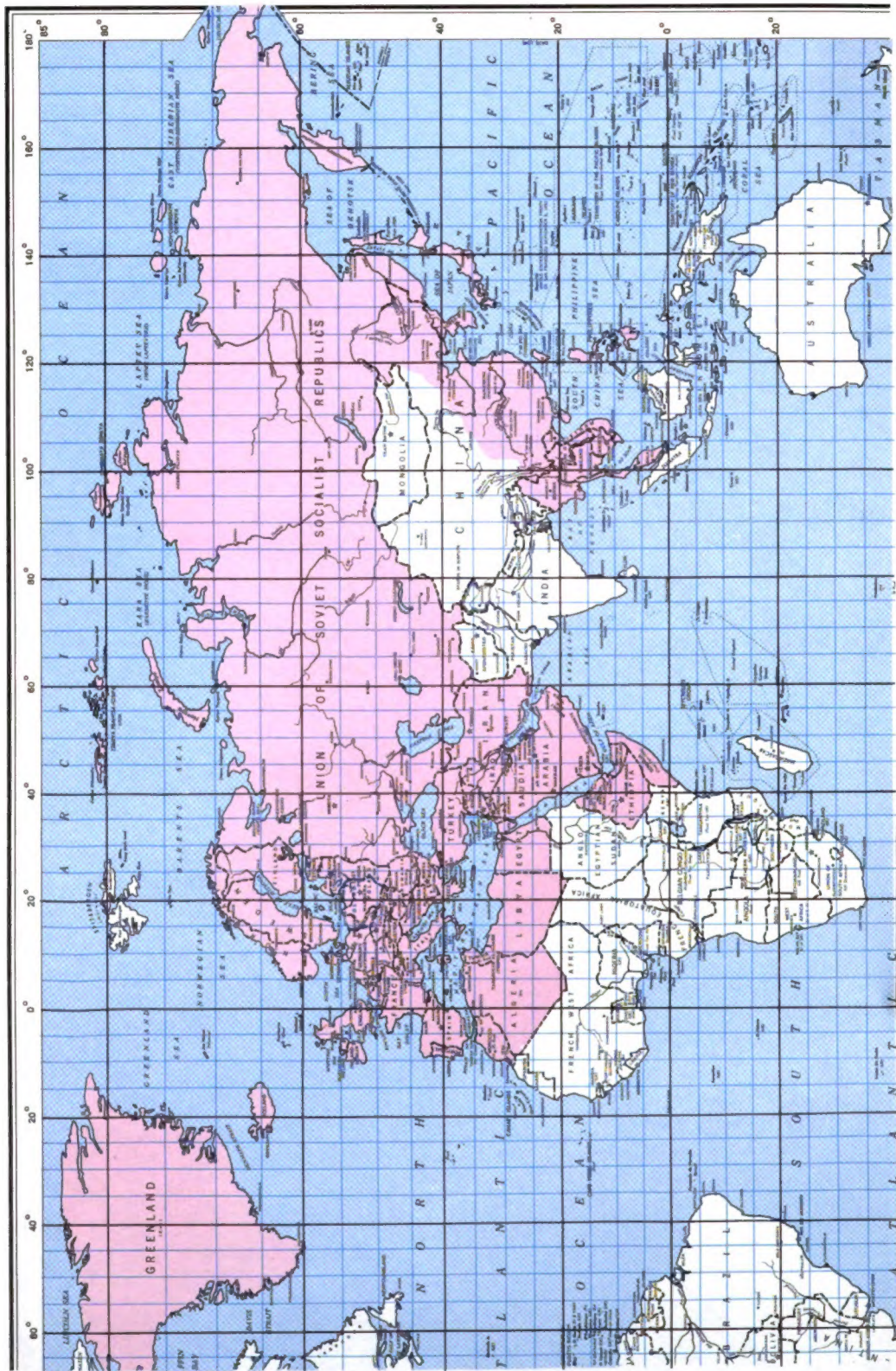

Figure 1. Key to areas for which maps are discussed in this manual.

THESE MAPS ARE THE PROPERTY OF THE U.S. GOVERNMENT AND ARE NOT TO BE REPRODUCED OR TRANSMITTED IN ANY FORM OR BY ANY MEANS, ELECTRONIC OR MECHANICAL, INCLUDING PHOTOCOPYING, RECORDING, OR BY ANY INFORMATION STORAGE AND RETRIEVAL SYSTEM.

CHAPTER 1

INTRODUCTION TO FOREIGN MAPS

Section I. GENERAL

1. Purpose

The purpose of this manual is to provide a reference for users of foreign maps. More specifically, it is intended to familiarize the map user with maps of foreign countries and to assist him in the analysis and evaluation of such maps.

2. Scope

a. This manual contains information on topographic maps and town plans for selected foreign countries. Areas for which coverage is discussed are indicated on figure 1. Major topographic maps of these areas are identified, and information on their areal coverage, compilation sources, relief representation, planimetric features, and marginal data is given. Series described as "major maps" do not necessarily constitute the best available coverage. Series that were compiled or reprinted from "native" and "official" maps (see par. 3*d*) comprise the latest and best coverage for many countries; in these instances, only the original sources on which these series are based are described under "major maps." Further coverage may also exist in classified series, which are not discussed in this manual. In addition to the descriptions of specific topographic map series, general information is included for each selected country on mapping activities, grid- and geographic-coordinate systems, and town plans. Hydrographic and aeronautical charts and special-purpose maps such as trafficability, communications, special armed-forces maps, and target charts are not discussed in this manual.

b. Criteria by which maps are evaluated and ways in which foreign maps are adapted to U. S. Army use are discussed. Reference aids such as definitions of mapping terms, glossaries of foreign map expressions, conversion tables, and illustrations of maps and marginal data are included. Many of the maps illustrated in black and white are available in color.

3. Organization

a. In the first chapter of this manual the evaluation criteria for large-, medium-, and small-scale topographic maps are discussed. Also included in this chapter is a resume of the ways in which foreign maps are adapted to U. S. Army use.

b. Each of the succeeding 10 chapters deals with a specific geographical area. Each section of a chapter includes a discussion of the mapping activities for a single country and descriptions of the major maps covering that country. Additional information on marginal data, map characteristics, and coordinate systems and a glossary of foreign map expressions are included in many of the sections. In a few cases the cartographic history of two or more countries is so interwoven that it is discussed in a single section, as for example, paragraphs 15 and 16.

c. Appendix I is a bibliography of publications and films concerning information on surveying, aerial photography, projections and grids, foreign military terms, allied mapping data, etc.; references are grouped according to publishing agency. Appendix II includes reference data such as foreign units of measure, conversion factors and tables, and prime meridian values. A glossary of mapping terms follows appendix II.

d. For purposes of this manual, mapping is discussed as "native," "official," and "other."

- (1) "*Native*" maps of a country are those produced by indigenous governmental or private agencies; for example, maps of Italy by the Italian Istituto Geografico Militare (Military Geographic Institute).
- (2) "*Official*" maps of protectorates, colonies, mandates, etc., are those produced by governmental agencies of the country

having administrative control; for example, maps of Greenland by the Danish Geodaetisk Institut (Geodetic Institute). Maps produced by nonindigenous agencies that have been authorized by the government are also considered as "official"; for example, Italian Istituto Geografico Militare mapping of Albania.

- (3) "Other" maps are those that are not produced by native agencies or by governmental agencies of the country having administrative control.

e. Citations of "Major Maps" are written in telegraphic style and include the map title, scale, authority, date, and grid name. The citation is followed by a description of the map. Map titles are always italicized. An English-language or foreign-language map title that is italicized but

not inclosed in either brackets or parentheses, is the title in the exact form in which it appears on the map. Brackets inclosing a title indicate that this title has been arbitrarily supplied to facilitate identification. Such treatment is necessary because some maps do not have a title, some have titles that duplicate those of other maps, and some maps have titles that lack significance. When an exact foreign-language title is cited, it is followed by a translation in parentheses. For languages that are not readily romanized, however, the exact form is not given. Only the translation is given and it is inclosed in parentheses. These non-roman languages include Chinese, Japanese, Korean, Thai, Persian (for native maps of Iran), Hebrew (for native maps of Israel), and Arabic (for native maps of Egypt, the Arabian Peninsula, Iraq, Jordan, Lebanon, and Syria).

Section II. HOW TOPOGRAPHIC MAPS ARE EVALUATED

4. General

a. One of the first questions asked by a map user is, "How reliable is this map?" Occasionally the answer may be derived by referring to information contained in the margin of the map. Such information may include a credit note, dates of survey and revision, dates and coverage of aerial photography used in compiling or revising the map, reliability diagram or note, and occasionally a note referring to method of preparation. These items should indicate whether the map is excellent, good, fair, or poor.

b. Marginal information is often inadequate and the user must evaluate the map himself. Too often, maps are evaluated by the inexperienced on the basis of such relatively minor aspects as expertness in design and drafting, or the use of pleasing colors, rather than on the more important merits of completeness of detail, accuracy of positioning, and currentness of data—the basic requirements of a military map.

c. Evaluations are influenced by knowledge of the purpose for which the map was designed, the surveys and other source material from which it was compiled, and the circumstances under which it was made. It should be obvious that maps designed for such specific needs as orientation, presentation of land use, geological or climatic data may or may not meet specific requirements for other military uses. The fact that

most maps do *not* meet rigid military standards does not preclude their use in cases of emergency.

d. Evaluation procedures discussed in this section refer specifically to topographic maps used by the military for firecontrol, tactical, logistical, armor, strategic, and planning purposes. Maps suitable for fire control are usually at scales larger than 1:75,000, preferably at the scale of 1:25,000, although 1:50,000 is frequently substituted; tactical maps generally include maps at scales larger than 1:126,720; armor maps are preferably at 1:50,000, but may range in scale from 1:25,000 to 1:250,000; logistical maps are usually confined to scales of 1:200,000 to 1:600,000; and maps for strategic or other planning purposes are usually at 1:600,000 and smaller scales. Thus, the scope and emphasis of the criteria used in map evaluation vary according to scale and purpose. The rigid criteria used in the evaluation of fire-control maps should not be applied to a map designed for strategic planning.

e. Map evaluation may be undertaken for a single map of a series or for an entire series of maps. In evaluating a map series it is necessary to consider the detail within a given map and the continuity of such detail on adjoining sheets. A series in which there is improper interrelation as well as discontinuity of detail cannot be rated as good. Usually all sheets of a series should be evaluated individually, but if all were based on

the same survey data, were compiled by the same methods, and were the results of a program of relatively short duration, a sampling of sheets may suffice. If the survey was by planetable methods, an additional condition for adequate sampling would be that all the terrain was equally accessible to field parties.

f. Map evaluations should be based primarily on an analysis of factual data, but when this is not possible, an evaluation based upon experience and deduction may be temporarily assigned until factual confirmation is possible.

5. Evaluating Large-Scale Maps

Topographic maps at large scale are those that are at 1:75,000 or larger scales, but the standard military scales for maps in this range are 1:25,000 and 1:50,000. Standard grids for large-scale maps as well as for medium- and small-scale maps are the Universal Transverse Mercator (UTM), Universal Polar Stereographic (UPS), and currently used British grids that have not been replaced by UTM or UPS grids. In evaluating these maps for military use, the following four factual components are analyzed: the geodetic base (including standard datum for horizontal and vertical control), physical features, cultural data, and marginal information. Depending upon intended use of the map, other aspects to be considered are legibility of lithographic or photographic detail, general appearance, number of colors, and presence or absence of romanized language.

a. Analysis of the Geodetic Base.

- (1) The basic determination in map evaluation is the accuracy of the geodetic survey and the horizontal- and vertical-control nets upon which the map has been constructed and the care with which these data have been utilized. These considerations require that the map analyst be provided with historic and scientific survey data. Essential elements of background information are assembled by the control analyst (cartometrist) before scaling the map for horizontal and vertical position accuracy. This information includes the type of survey, the survey methods used, and the type and precision of survey instruments; the order or accuracy and density of horizontal and vertical control; identification

of the datum, ellipsoid, and projection used; control diagrams; grid data; trig lists; and variations from standard-sheet size.

- (2) Large-scale maps that fulfill accuracy requirements for fire-control purposes are those on which 90 percent of all well-defined planimetric features (with the exception of those unavoidably displaced by exaggerated symbolization) are located within 0.02 inch (12½ meters at 1:25,000 scale) of their true geographic position as referred to the map projection, with no feature displaced more than 0.05 inch. Ninety percent of all contours and elevations of points interpolated from contours should be accurate to within one-half the basic contour interval.

b. Analysis of Physical Features.

(1) Relief.

- (a) In evaluating relief features, primary consideration should be given to the adequacy of the contour interval and correct symbolization as expressed in the marginal note. Occasionally, approximate contours may be erroneously understood to be the true contour values given in the marginal note (which also may be in error) or in symbolization on the map face. All or parts of the map may have been compiled from various questionable types of surveys, with no warning provided in the marginal notes to indicate the inadequacy of the sources.
- (b) Occasionally such symbols as cliffs or hachures are used to supplement contours to bring out topographic irregularities and unconformities that cannot clearly or easily be depicted by supplemental contours. Usually, such items enhance appreciation of relief. Sometimes cliff symbols, without a sufficient number of spot elevations, have been used in place of contours in the portrayal of mountainous areas. These instances may prove misleading.
- (c) Several contours on a map should be checked to determine that there is sufficient detail (spur slopes, terraces, depressions, gullies, etc.) to convey cor-

rect topographic information. They may be too generalized for artillery or infantry use. This determination can be made by comparison with contours on a larger-scale map of known reliability, intelligence reports, vertical-control survey data, vertical aerial photographs (stereo pairs) used with a pocket stereoscope or multiplex models if photogrammetric equipment is available.

- (d) All prominent peaks and isolated hills shown on the map should be checked for the number, location, and distribution of spot elevations, and the contour values should be shown on the index contours to facilitate reading. Contours should be especially checked at stream crossings, at which points they provide one of the best clues as to the care taken in plotting.
 - (e) Since relief is frequently related to underlying rock or soil conditions, a large-scale geological or soil map may provide clues as to the adequacy or inadequacy of the topographic map. This is true particularly of regions for which complete geodetic-survey information or larger-scale topographic maps than the one being evaluated are not available.
 - (f) The maps should finally be checked against the vertical accuracy requirement for large-scale maps used by the artillery (a(2)); that is, 90 percent of all contours should be accurate to within one-half the basic contour interval. The standard interval for 1:25,000-scale maps is normally accepted as 10 meters, with alternate contour intervals of 5 meters or 20 meters. The standard contour interval for 1:50,000-scale maps is normally accepted as 20 meters, with alternate contour intervals of 5, 10, or 40 meters. The interval selected must be based upon the terrain.
- (2) *Drainage and associated features.*
- (a) The major stream courses should be checked against aerial photographs or larger-scale cadastral, planimetric, or topographic maps for accurate alignment and width. The streams should be adjusted properly to the relief as depicted by the contours, and stream intersections should be examined for proper entrance of the tributaries.

- (b) The density of streams shown should be commensurate with the amount and type of rainfall received in the area and should be representative of the density shown on available aerial photographs.
 - (c) Symbolization of the types of streams (perennial, intermittent, disappearing, etc.) should be examined for accuracy of interpretation based upon aerial photographs, large-scale maps, and seasonal distribution of rainfall from available statistics.
 - (d) Lake-level values, when given, should be carefully checked with adjacent contour values for acceptability.
 - (e) Depiction of local or regional features or conditions requires extra investigation as an indication of the care with which detail has been handled. These features or conditions might include braided streams, interweaving channels of swamps and delta areas, areas subject to flood, islands and sand bars in streams, shorelines of intermittent lakes, drainage canals or ditches, wadies, reservoirs and dams, springs, wells, rapids, waterfalls, tidal marshes, fords, rice paddies, cranberry bogs, salt evaporators, areal extent of playa lakes, etc.
 - (f) The position accuracy of at least 90 percent of the drainage features should conform to the 0.02-inch accuracy required for fire-control purposes.
- (3) *Vegetation.*
- (a) Symbols in the legend should be compared with those on the map face in order to ascertain the degree of conformance. The method of symbolization used (areal tint or individual symbol by type or species) should not contribute to a crowded appearance or interfere with clarity of hill shading or expression of other features. The method of symbolization should be examined to determine whether or not

the system of representation used is the most effective. The best method of portrayal will change from area to area according to variations in vegetation, the density of other physical and cultural features, as well as how these features are symbolized. Depending upon the choice of symbols for other features, it may not always be practical to utilize the best method for portraying vegetation.

- (b) The areal distribution of vegetation should be checked for accuracy of delimitation and for position by comparing the map with current vertical aerial and terrestrial photographs, current vegetation maps of comparable scale, or larger scale topographic maps showing vegetation. Detailed intelligence reports and personal knowledge of the area are also of value in checking portrayal.
- (c) The breakdown of vegetation types or species, as the case may be, should also be analyzed to determine whether the choice of criteria was good or poor. Items of inconsequential value may be included on some maps, while important characteristic types may be entirely ignored.
- (d) If complete areal coverage of vegetation was not available at the time the map was compiled, a note to that effect should be carried in the margin to indicate incompleteness of data or coverage.
- (e) Plants are excellent indications of environment as there is a relationship between them and other natural features. It should not take the map user long to recognize the fact that certain types of vegetation are associated with certain relief features or soil conditions. This knowledge should assist him in detecting errors in the portrayal of vegetation distribution.
- (f) As the nature and density of vegetation vary from area to area, so will methods of symbolization. Symbols are frequently difficult to interpret. For these reasons, it is not possible to adhere to the standard of 0.02-inch accuracy in position required for planimetric fea-

tures. It is important, however, that proper correlation of vegetative features with other features be made. If rice paddies are shown in blue, for instance, such areas should not be overprinted to any extent by green representing woodlands. For the same reason roads, railroads, and power lines should be clear of any vegetative overprint.

c. Analysis of Cultural Features.

- (1) Cultural or manmade features should be checked against reliable source material for completeness of detail commensurate with scale of the map and currency of the information. Not only should the map be examined for the features commonly found throughout most of the habitable world, but it should be examined more particularly for such cultural items of local or regional distinctiveness and importance as religious temples or shrines, burial mounds, cave dwellings, etc. All cultural features should be examined for precise adherence to one or more of the following items: position, shape, size, alinement, pattern, density, distribution, and category.
- (2) Among the cultural features that should be checked are urban areas, political boundaries, roads, railroads, and waterways. Cities, towns, and settlements should be checked for correct position, true shape of built-up area outline or grouping of building symbols, and for classification category as shown in the legend. Buildings and industrial and public works should be checked for identity, position, shape, and alinement.
- (3) Place names and physical- and cultural-feature names should be carefully examined for accuracy of location, spelling, and existence of alternate names by which the place may be known.
- (4) Political boundaries should be scrutinized for their correct delineation, identification, symbolization, and category. In the International boundaries, whether determined by treaty, operating or de facto, field commander's decision, or similar peculiar local-boundary conditions, should be analyzed for correct portrayal.

Major and minor political-administrative divisions should be verified as to identity and choice of categories employed, consideration being given to the scale of the map being evaluated. The divisions should be identified as to type, such as civil, religious, judicial, military, etc.

- (5) Highways, roads, and tracks and trails should be reviewed for correct category classification. Route numbers, width, surfacing, condition, type of base, alignments, and measured distances should be verified.
- (6) Railroads should be checked for correct designation as to type (mineral, industrial, logging, etc.), name, gage (broad, normal, narrow), number of tracks, power used, status (destroyed or abandoned), transfer points, spurs, marshalling yards, stations, halts, and special installations. Cableways, cog railroads, etc., should be labeled as to their identity.
- (7) Waterway features should be scanned for true alinement; name; correct location of locks, weirs, dams, and passing places; status of use (abandoned); differentiation of canalized and noncanalized portions; existence of river-port facilities, etc.
- (8) Airports and seaplane bases or anchorage areas should be scutinized for type (military or civilian), correct positioning, orientation, and outlining. If facilities are shown, they should be checked against aerial photographs (vertical and/or oblique) and intelligence sources for confirmation.
- (9) Bridges should be checked for position, type, classification, length, construction material used, and status (destroyed).
- (10) The nature of telecommunications is such that topographic maps seldom give complete data. Some maps have special symbols for location of telephone exchanges and telegraph facilities. Others show location of submarine cables. One item more or less consistently shown is the radio tower, which should be checked for correct location.
- (11) The position accuracy of at least 90 percent of all cultural features should con-

form to the 0.02-inch accuracy required for fire-control purposes.

d. Analysis of Map Design.

- (1) Map design is the manner in which representation and explanations of ground features on a map are presented. It includes map symbols, lettering, and notes within the neatlines as well as the marginal information shown in the map's border. Ineffective design can impair legibility, defeating the purpose of the map.
- (2) Criteria used to evaluate map design within the body of the map include: recognizability of symbols for features represented; minimum possible exaggeration in size of symbols; proper gradation in emphasis, both in gage and color, of symbols to reflect relative importance of features represented; use of color; proper density of features mapped in relation to map scale; and legibility, particularly of the portrayal and identification of important and characteristic features in the area covered by the map.
- (3) A critical examination of the marginal information presented should be made to determine if the user has been given sufficient information to utilize the map as completely as possible.
- (4) In evaluating marginal information, the following items must be considered for completeness of presentation: series title; sheet name and number; map scale and bar scale; credit note; publisher's name; reliability notes and diagram; the survey, revision, and publication dates; the methods of compilation; grid notes and reference box; boundary diagram; disclaimer notes; index of adjoining sheets; declination diagram with notes as to annual magnetic change; glossary; legend; graticule and grid lines or ticks and values; edition; contour-interval note; projection; road objectives; and security classification. Without uniformity of treatment throughout a series, much of the value of marginal data is lost.

6. Evaluating Medium- and Small-Scale Maps

a. In general, the criteria and methods used to evaluate medium- and small-scale sources are the

same as those used for large-scale maps. The scope and emphasis of the criteria, however, should vary with the limits imposed by scale and intended use. Topographic maps at medium scale are those at a scale smaller than 1:75,000, but larger than 1:600,000. Small-scale maps are at 1:600,000 or smaller scales. Standard military scales for medium-scale maps are 1:100,000 and 1:250,000, and the standard military small scale is 1:1,000,000.

b. Accuracy requirements of the U. S. Army for medium-scale maps are the same as those for large-scale maps (par. 5*a*(2)). Representation, however, necessarily becomes more generalized from large- to medium- and from medium- to small-scale maps. Therefore, the evaluation should be influenced by proper emphasis of major patterns of physical and cultural features rather than by abundance of detail. Particular attention should be focused, for instance, on the drainage patterns in order to ascertain whether the basic patterns are correctly portrayed or have been destroyed by generalization during the compilation process. Obviously the amount of detail that can be shown on a large-scale map cannot be legibly shown on a medium- or small-scale map, but the density should be commensurate with the scale. It has become the practice in some quarters to purposely skeletonize areas of dense detail in the generalization process in order to effect a balanced map. Care should be exercised in determining that the detail shown is not only commensurate with the scale but is also truly representative of the detail of the area.

c. Because of the limits imposed by scale and by use (general, strategic or logistic planning), there are no rigid accuracy requirements in the evaluation criteria as used by the U. S. Army for small-scale maps. In areas where the small-scale map represents the only or the largest scale coverage available, it is not always possible to provide a reliable evaluation owing to the lack of available or adequate source material for comparison.

7. References Used in Preparing Evaluations

a. The completeness of a map evaluation will be affected by the use to which the map will be put and the facilities available to the evaluator. In mapping institutions and base topographic plants enough equipment should be available to do a complete analysis by photogrammetric methods. The lack of these facilities in the field will pre-

clude a complete evaluation; nevertheless, an evaluation of sufficient completeness to cover ordinary needs should be possible if trig lists, large-scale maps, and aerial photographs are available.

b. The sources desirable for map-evaluation work are listed as follows:

- (1) Histories of various surveys (geodetic, standard, triangulation, vertical control, topographic, etc.) of the area.
- (2) Trig lists and publications on compilation methods, procedures, projections, ellipsoid, etc.
- (3) Legal regulations pertaining to surveying and mapping.
- (4) Town plans and cadastral maps.
- (5) Engineer sketches, profiles, and port plans.
- (6) Largest scale topographic and planimetric maps.
- (7) Special-purpose maps (roads, railroad, pipeline, land use, postal, electric power, telecommunications, soils, geology, vegetation, population, etc.).
- (8) Special military-intelligence overprints.
- (9) Photomaps and mosaics.
- (10) Terrestrial and aerial (vertical and oblique) photographs.
- (11) Specifications used in compiling the map being evaluated.
- (12) Symbol books.
- (13) Gazatteers.
- (14) Glossaries of foreign geographic and cartographic terminology.
- (15) Foreign-language dictionaries.
- (16) "Table of equipment" charts of the organization making maps.
- (17) Transportation timetables (rail, highway, sea, and air).
- (18) Statistical handbooks and yearbooks.
- (19) Intelligence and mapping reports.
- (20) Travel manuals, guides, and route books.
- (21) Geographical and engineering publications.
- (22) Industrial and trade journals.
- (23) Census reports.
- (24) Postal guides.
- (25) Consultation with natives and others familiar with the area.
- (26) Field verification where possible.

(27) Evaluator's personal knowledge of the area.

c. The above-listed items are used in varying degrees for evaluating one or more features shown on the map. The basic items listed include geodetic information, map sources, aerial photographs, and intelligence sources. Any one of the basic items, if available, should be used for evalu-

ating the map. If basic sources are not available, a *temporary* evaluation may be assigned on the basis of such criteria as the publisher's established reputation; the clarity and care of presentation and reproduction; design; amount and choice of detail, etc. Such an evaluation should be qualified as temporary, and revised as soon as basic source material becomes available.

Section III. HOW FOREIGN MAPS ARE ADAPTED TO U. S. ARMY USE

8. General

a. The extent to which a foreign map may be modified for U. S. Army use depends upon the extent of requirements for the military maps of the area, the adequacy of available sources, the urgency of the request, the scale being utilized, the complexity of detail shown, and the facilities available for preparation and reproduction.

b. Except during emergencies, when reprints of foreign maps are made by photomechanical means without any change whatsoever, the following preliminary procedure is usually followed in adapting map series of a foreign area for U. S. Army use: definition of the army requirement for maps of the area; investigation of the availability of map coverage and other source materials such as control and aerial photographs; and evaluation of the source maps for geodetic accuracy and currentness and completeness of detail. If the source maps were originally produced by a country friendly to the United States, the Army may be able to obtain color-separation reproduction material from that country. In this case the U. S. Army requirement may be met from the material by making the necessary revisions and/or marginal and grid changes as indicated in paragraphs 9 and 10. If color-separation reproduction material is not obtainable, maps may be produced if Army requirement warrants the effort.

c. Foreign maps at odd scales are converted to one of the standard military scales of the U. S. Army, except when urgency permits only facsimile reproductions. These standard scales are 1:25,000, 1:50,000, 1:100,000, 1:250,000, and 1:1,000,000. In planning a new series for an area that has not been covered by maps adapted to U. S. Army use, one of the following scale groupings is utilized: 1:25,000, 1:100,000, 1:250,000, and 1:1,000,000 or 1:50,000, 1:250,000, and 1:1,000,000. That is, 1:50,000-scale maps will normally not be pro-

duced for areas in which 1:25,000 or 1:100,000 series are planned. Maps at 1:500,000 scale are produced if a theater requires maps at this scale.

9. Adapting Geodetically Accurate Foreign Maps to U. S. Army Use

If sufficient time is available, geodetically accurate foreign maps are adapted to U. S. Army use by one of the following procedures:

a. Maps on which detail is current will be reproduced with the following additions and changes, if necessary: a standard grid and grid reference information; names converted to roman type; translation of the legend after it has been checked for adequacy; and the addition of a glossary, reliability diagram or statement, credit notes, AMS series and edition identifications, and publisher notes. The standard United States numbering system may also be used.

b. For maps that are not up to date, a revision of major features or a complete revision of all features may be made utilizing intelligence and/or *aerial photographs*, together with marginal and grid changes specified in paragraph 9a.

10. Adapting Geodetically Inaccurate Foreign Maps to U. S. Army Use

a. In converting geodetically inaccurate foreign maps to U. S. Army use, an investigation is begun immediately to determine if both identifiable control of sufficient density and vertical aerial photographs of mapping quality are available for a stereophotogrammetric program. If there is incomplete control or aerial photographic coverage, a stereophotogrammetric compilation may be carried out for that part of the area for which control values and photographs are available. When only control is available, it may be plotted and the inadequate maps panelled to the control. If only

aerial photographs are available, cultural and vegetation features may be revised. In some cases where both aerial photographs (of a later date than the map sources) and control are nonexistent, it may be possible for the U. S. Army to assist in establishing control and in taking aerial photographs in cooperation with the country involved. The standard topographic symbols for U. S. mili-

tary maps are usually used for all maps that are completely recompiled stereophotogrammetrically. If only a few sheets of a series are recompiled stereophotogrammetrically, the foreign symbolization is retained.

b. After the map detail has been revised, grid information is added and marginal data is revised as specified in paragraph 9*a.*

CHAPTER 2

NORTHWEST AFRICA

Section I. SPANISH MOROCCO

11. Mapping Activities

a. Official. The Spanish Servicio Geográfico del Ejército (Army Geographic Service), formerly known as Depósito de la Guerra (War Depository), is the official mapping agency of the Spanish protectorate, Spanish Morocco. The Instituto Geográfico y Catastral (Geographic and Cadastral Institute) is responsible for the gathering of geodetic data and the publishing of maps. The maps covering Spanish Morocco west of 5° W. are based on a first-order triangulation net. East of 5° W. the basic control consists of reconnaissance and tachymetric or stadia surveys which are considered to be low in geodetic accuracy. Map series at 1:50,000, 1:100,000, and 1:200,000 scales have been published by the Servicio Geográfico del Ejército. Town-plan series are made by the Alta Comisaría de España en Marruecos (Spanish High Commissariat in Morocco).

b. Other. Topographic coverage by other agencies includes reprints of the Spanish 1:50,000 series by the British Directorate of Military Survey, War Office (Geographical Section, General Staff), the German Generalstab des Heeres (General Staff of the Army), and the U. S. Army Map Service. "Reconnaissance" series at scales of 1:100,000 and 1:200,000 were published by the French Institut Géographique National—Annexe du Maroc (National Geographic Institute—Annex of Morocco). The 1:200,000 series was reprinted by both German and British agencies during World War II.

12. Major Official Maps of Spanish Morocco

a. Topographic Series.

- (1) *Marruecos-Mapa Provisional en Escala 1:50,000* (Morocco—Provisional Map at 1:50,000 Scale); Servicio Geográfico del Ejército; 1929- ; Spanish military grid.

This large-scale series (fig. 2) provides complete coverage of Spanish Morocco except for a few scattered areas in the undefined parts of the southern international boundary. The original series was published in five colors in 1927-36. The Servicio Geográfico del Ejército, however, began to publish a revised edition of the series in 1941, and the new sheets are a monochrome (sepia) edition. Relief is shown on both editions by slightly generalized contours at 20-meter intervals. Index contours are shown for every 100 meters and are generally labeled. Symbolization of elevations as spot heights on the original series was changed to that of triangulation stations on the revised edition. Names of relief features are shown. Special attention is given to cultural features such as shrine symbols, and to areas of tribes and their confederations. Extensive planimetric revisions from photography of hydrographic, vegetation, and cultural data are incorporated in the revised edition. In general, it is necessary to use the multicolored series for clarification of the revised edition, since the latter is illegible in parts because of its monochrome characteristic and heavy printing. The grid based on a conic secant projection is in 1,000-meter divisions. The Hayford spheroid is used and the graticule is measured in degrees from Madrid. The sheet numbering system for the series is divided into 20 large blocks, each of which is made up of eight sheets. The sheet lines are not the same as those of any other Spanish series of Morocco.



Figure 2. Section of Marruecos—Mapa Provisional en Escala 1: 50,000 by the Servicio Geográfico del Ejército.

(2) *Mapa del Norte de Marruecos* (Map of North Morocco); 1: 100,000; Servicio Geográfico del Ejército; 1943–47; Spanish military grid.

This 14-sheet lithographic series (fig.

3) in six colors covers all of Spanish Morocco and the International Zone of Tanger. Relief is generalized and is shown by contours at 100-meter intervals and by numerous spot heights; it



Figure 3. Section of Mapa del Norte de Marruecos at 1:100,000 by the Servicio Geográfico del Ejército.

is emphasized by hill shading. The series was compiled from the Spanish 1:50,000 and 1:200,000 series with revisions. The graticule is in grads from Madrid. The grid division is in 1,000-meter squares. Roads are classified ac-

ording to national importance and are emphasized by bold symbolization.

- (3) *Mapa del Norte de Marruecos* (Map of North Morocco); 1:200,000; Servicio Geográfico del Ejército; 1950- ; Spanish military grid.

This multicolored six-sheet series covers all of Spanish Morocco and is similar in style to (2) above. The graticule is in degrees and is referred to the prime meridian of Madrid. Relief is shown by contours at 100-meter intervals. Some sheets carry hill shading in addition to the regular contours.

b. Town Plans. Official town plans are published at both 1:2,000 and 1:5,000 by the Alta Comisaría de España en Marruecos. Relief is shown by contours at one-meter intervals; on some sheets, however, the contours are not labeled. Relief and cultural features are shown in detail. The Spanish metric grid is shown. No graticule is given.

Section II. FRENCH MOROCCO

13. Mapping Activities

a. Official. The official mapping in French Morocco is under the authority of two French agencies; the Institut Géographique National (National Geographic Institute), formerly known as Service Géographique de l'Armée (Geographic Service of the Army), and the Institut Géographique National—Annexe du Maroc (National Geographic Institute-Moroccan Annex), previously called Service Géographique du Maroc (Geographic Service of Morocco). Two types of topographic maps are published by these agencies: the "Régulière" and the "Reconnaissance." The "Régulière" maps, published at 1:50,000 and 1:100,000 scales, are based on geodetic triangulation of first, second, and third orders. The "Régulière" series are published, revised, and are being extended in areal coverage by the Institut Géographique National. The "Reconnaissance" series at 1:100,000 and 1:200,000 are based on control consisting of triangulation hastily established to meet military needs during the early French pacification of Morocco. The Institut Géographique National—Annexe du Maroc maintains the "Reconnaissance" 1:100,000 and 1:200,000 series. Large-scale topographic plans of major cities were originally published by the Service Géographique du Maroc. They are being revised by the Institut Géographique National—Annexe du Maroc.

b. Other. The Directorate of Military Survey, War Office (Geographical Section, General Staff) is the only mapping agency that has reproduced the official French "Régulière" 1:50,000 series. An English-language legend, road-classification revisions, and the addition of the North West Africa Zone grid were incorporated in the British reproductions. The "Reconnaissance" 1:200,000 series, published by the Institut Géographique National—Annexe du Maroc was reprinted by British, U. S., and German mapping agencies during

World War II. These reprints differ little from the French originals, but because French sheets have been revised or recompiled, and published since World War II, the reprints have become obsolete. Several sheets of a multicolored 1:50,000 series have been published by the Army Map Service. These sheets were compiled by stereophotogrammetric methods.

14. Major Official Maps of French Morocco

a. Topographic Series.

- (1) *Maroc au 50,000* (Morocco 1:50,000); Institut Géographique National; 1924—; Lambert Nord Maroc grid.

This is the basic topographic "Régulière" series (fig. 4) which covers the important plains and plateau regions through the Tasa Pass region to Oujda near Algeria. The Lambert Conical orthomorphic projection based on the Clarke spheroid is used. The graticule is in degrees measured from Greenwich, and is shown by ticks along the neatline only. The sheets, which are 15' x 15', are numbered according to the *International Map of the World* indexing system. The grid system used is the Lambert Nord Maroc which is indicated by ticks along the neatline at every 1,000-meter interval with grid lines drawn on the face of the map at every 10,000 meters. Relief is shown by contours at 10-meter intervals and by 5-meter auxiliary contours on some sheets. The relief is further emphasized by hill shading. This series carries a great amount of cultural and relief detail. Since 1945, new-style sheets, "Type 1922," have been published. These sheets include a legend in the



Figure 4. Section of Maroc au 50,000°, the "Régulière" series, by the Institut Géographique National.

margin. Final editions are multi-colored; provisional editions published at 1:40,000 scale, however, are in two colors only, black and brown.

- (2) *Maroc au 100,000°* (Morocco 1:100,000); Institut Géographique National; 1924-; Lambert Nord Maroc grid. This multicolored "Régulière" topographic series (fig. 5) covers the north-

ern part of French Morocco, and the narrow corridor area between Spanish Morocco and Algeria. Some areas are covered by this series that are not covered by the "Régulière" 1:50,000 French series. Except for a few minor differences, this series is identical to (1) above in format, style, and symbolization. Corner coordinates are shown in



Figure 5. Section of Maroc au 100,000°, the "Régulière" series, by the Institut Géographique National.

degrees measured from Greenwich. The graticule is given in grads measured from Paris and is shown on the face of the map in 10-minute divisions. The grid is indicated by marginal ticks at 1,000-meter intervals. A standard legend is given in the margin.

- (3) *Carte de Reconnaissance au 100,000°* (Reconnaissance Map, 1:100,000); Institut Géographique National—Annexe du Maroc; 1921- ; Lambert Nord Maroc and Lambert Sud Maroc grids.

This multicolored series (fig. 6) covers most of French Morocco except for small areas in the east and south. It is based on the Clarke 1880 spheroid and the Boone projection. The graticule is in grads measured from Paris, and is indicated by marginal ticks. The grids are shown by 1,000-meter divisions in green and 5,000-meter divisions in black. Relief is shown on all sheets by contours at 25-meter intervals, and also by hill shading on some sheets. Roads are classified according to national importance. This is the largest scale map that covers most of the area. Special attention should be given to the survey reference diagram for areal reliability which appears on all sheets.

- (4) *Maroc au 200,000°* (Morocco 1:200,000); Institut Géographique National—Annexe du Maroc; 1913- ; Lambert Nord Maroc and Lambert Sud Maroc grids.

This series covers the entire country (fig. 7) and is similar to (3) above because the same spheroid, projection, grids, style, and symbolization are used. Grid divisions are shown at 1,000-meter intervals. Relief is shown by contours at 25- or 50-meter intervals. A diagram in the upper-left corner shows the date, scale, and type of surveys that were used in the compilation of the sheet.

- (5) *Carte Generale du Maroc au 500,000°* (General Map of Morocco, 1:500,000); Institut Géographique, National; 1936-47; Lambert Nord Maroc and Lambert Sud Maroc grids.

French Morocco is completely covered by this multicolored series. It is based on the Lambert projection and the *International Map of the World* sheet lines. A kilometric grid is indicated by marginal ticks at every 100,000 meters. The graticule is in degrees measured from Greenwich, and is indicated on the map face in 30-minute divisions. Relief is shown by con-

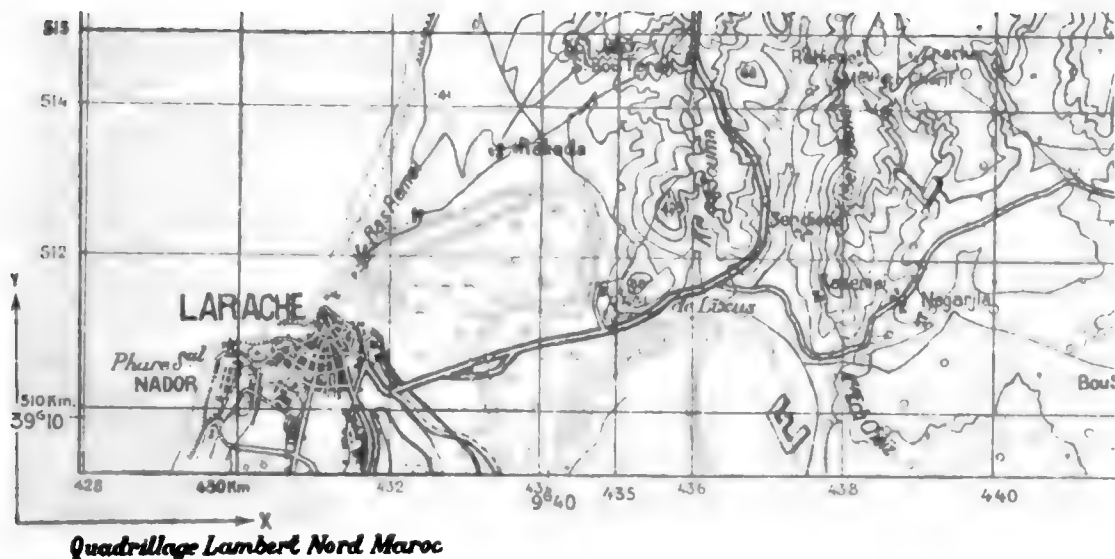

(Larache-6)

Dressé, dessiné et publié par le Service Géographique du Maroc

Figure 6. Section of *Carte de Reconnaissance au 100,000°* of French Morocco, by the Institut Géographique National—Annexe du Maroc.

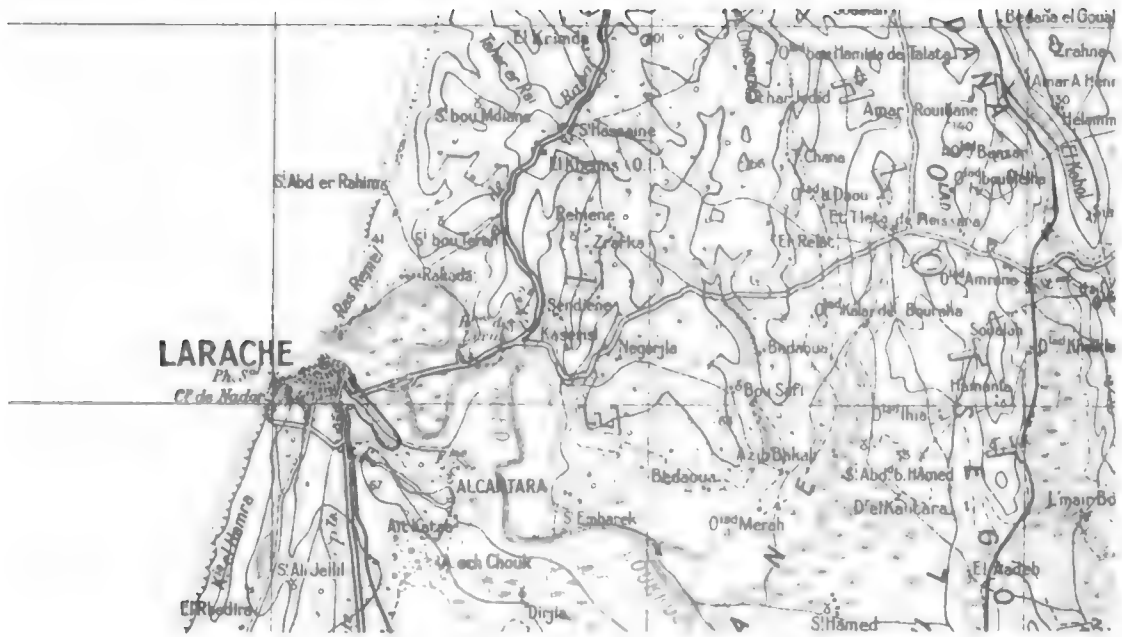

Figure 7. Section of Maroc au 200,000^e by the Institut Géographique National—Annexe du Maroc.

tours at 100-meter intervals, form lines, and cliff symbols and is further accented by layer tints at 500-meter intervals. Desert areas are shown by symbol and occasional terrain descriptive notes.

b. *Town Plans.* Large-scale topographic plans

of major cities, originally published by the Service Géographique du Maroc are being revised and re-edited by the Institut Géographique National—Annexe du Maroc. Relief is shown by $2\frac{1}{2}$ - or 5-meter intervals and by spot heights. Cultural information is extremely detailed on the town plans that are based on surveys (fig. 8).

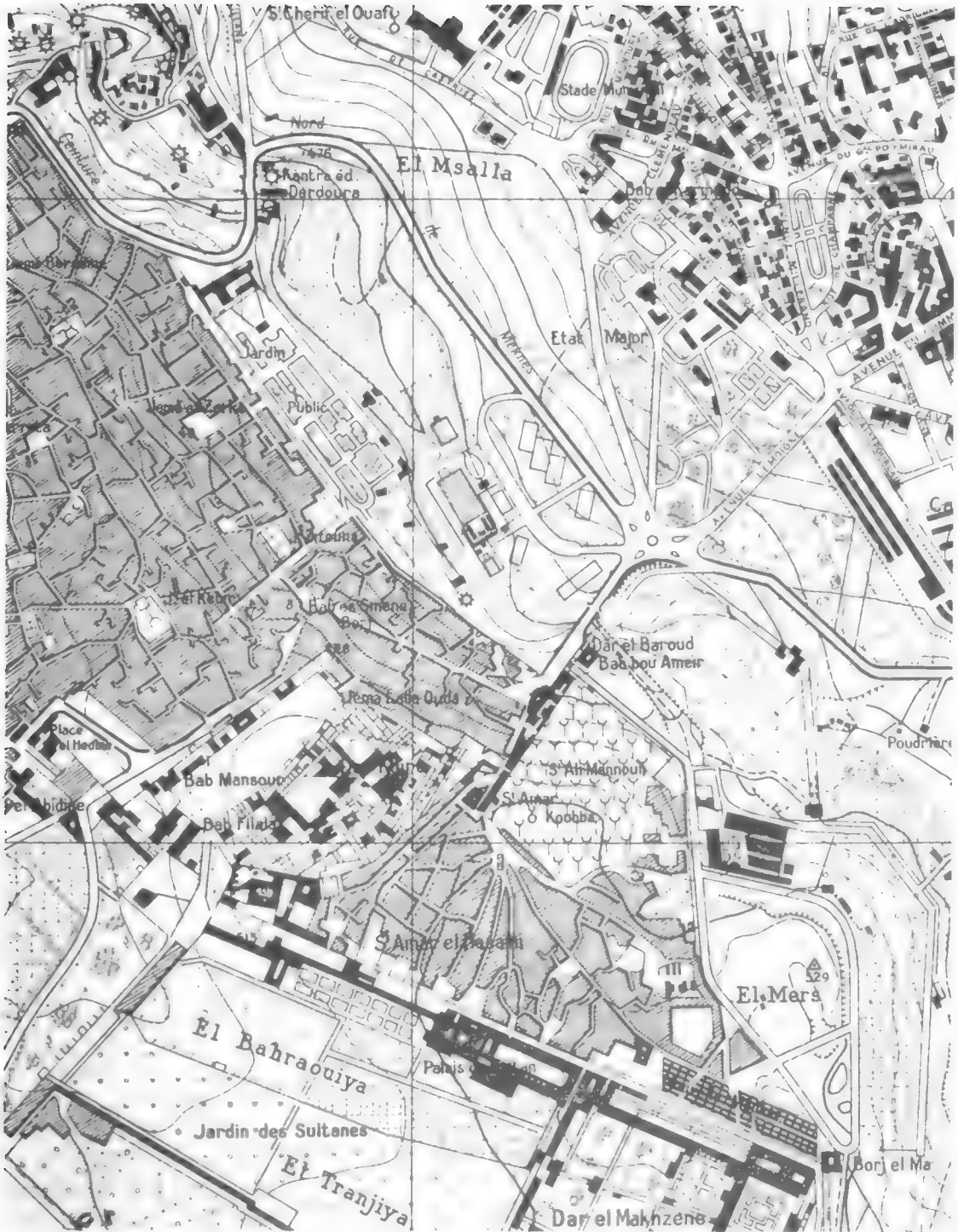

Figure 8. Section of Town Plan at 1:10,000 for Meknes, French Morocco, by the Institut Géographique National.

Section III. ALGERIA AND TUNISIA

15. Mapping Activities

a. Official. Official topographic mapping of Algeria and Tunisia is carried out by the French Institut Géographique National—IGM (National Geographic Institute), formerly known as the Service Géographique de l'Armée (Geographic Service of the Army). Their maps range in scale from 1:10,000 to 1:1,000,000. Some mapping is delegated by IGN to the Service Topographique (Topographic Service) of Tunisia and to the Service Cartographique (Cartographic Service) of Algeria. The Service Topographique performs local surveys for civil use, reconnaissance work, and produces cadastral maps. The Service Topographique is under the direction of The Directeur de Travaux Publics (Director of Public Works).

b. Other.

(1) *Topographic maps.* During World War II, all of the official topographic series of Algeria and Tunisia, i. e., maps at 1:50,000, 1:100,000, 1:200,000, and 1:500,000 scales, were copied by the British Directorate of Military Survey, War Office (Geographical Section, General Staff)—GSGS. The British sheets are characterized by the addition of the North West Africa Zone grid, an English legend, grad-degree conversion tables, and special road overprints. The Army Map Service reprinted the British series without any major changes. The British Survey Directorate General Headquarters, Middle East Forces compiled 1:25,000 and 1:50,000 series by enlarging the official French 1:100,000 series, copying the French 1:50,000's for the area south and west of Gabes, and by the reduction of the *Plans Directeurs* (Guide Plans) of towns in northern Algeria and Tunisia (par. 16a(3)). Some revisions were made from aerial photography. Other topographic coverage of Algeria and Tunisia consists of German copies of the French 1:50,000 and 1:200,000 series with additions and revisions from intelligence data.

(2) *Town plans.* The British and United States during World War II responded to military needs by compiling town plans

from all available sources. Because of the lack of available plans, reprints were the exception rather than the rule. Hydrographic charts, 1:50,000 maps, old tourist guides, and intelligence reports were the sources most used. GSGS, Survey Directorate General Headquarters, Middle East Forces (now known as the Middle East Land Forces), and the Army Map Service are the agencies that have published English-language plans. The Germans also produced several town plans during the second World War; most of these were direct copies of French maps with the addition of a German legend.

16. Major Official Maps of Algeria and Tunisia

a. Topographic Series.

(1) *Environs de Tunis au 5,000^e* (Environs of Tunis at 1:5,000); Directeur des Travaux Publics (Director of Public Works); 1947-48; Lambert Nord Algeria grid.

This polychrome series covers an area of approximately 190 square miles around Tunis, and comprises the largest scale topographic coverage of any part of Tunisia. It was based on surveys made by the Service Topographique and compiled from aerial photographs. Relief is shown by contours at 5-meter intervals. No graticule is shown on the sheets.

(2) *Oases Algeriennes au 10,000^e* (Algerian Oases, 1:10,000); Institut Géographique National; 1909- ; no grid.

These polychrome sheets (fig. 9) cover most of the oases of the desert. They are based on ground surveys, and the graticule when given is in grads measured from Paris. Relief is shown by contours at 1-meter intervals. Sheets covering three of the oases do not have a graticule.

(3) *Plans Directeurs de Alger, Oran, Phillipville, Bizerte* (Guide Plans of Algiers, Iran, Phillipville, Bizerte); 10,000 and 1:20,000; Institut Géographique National; 1906-42; no grid.

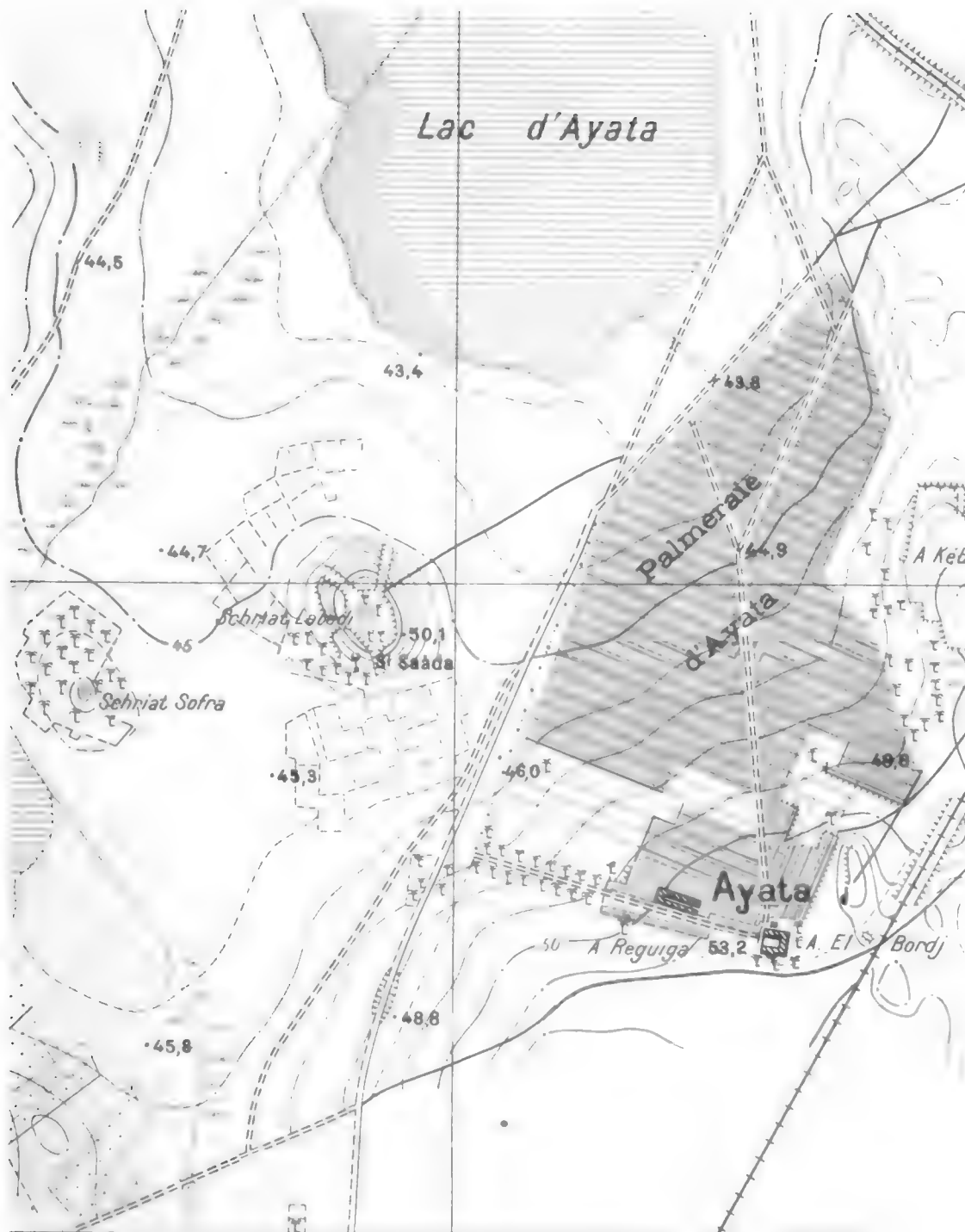

Figure 9. Section of Oases Algeriennes au 10,000^e by the Institut Géographique National.

Plans cover Algiers and Oran at 1:10,000 scale, and Phillipville and Bizerte at 1:20,000 scale. All plans have a graticule in grads measured from Paris. Relief is shown by con-

tours at 5- or 10-meter intervals. Roads are classified according to importance and use. Natural and cultural features are shown in great detail. The 1:10,000 series are monochrome,

whereas the 1:20,000 series are printed in three colors.

- (4) *Algerie et Tunisie au 50,000** (Algeria and Tunisia, 1:50,000); Institut Géographique National; 1906- ; Lambert Nord Algerie grid.

This basic topographic series provides partial coverage of Algeria and Tunisia on a continuous and uniform sheet layout. The series covers the coastal section of the countries inland to approximately one hundred miles. Coverage below 35° N in Tunisia consists of scattered sheets in the Gabes, Sfax, and Gafsa areas. The series is based on first- through third-order triangulation and 1:40,000 ground surveys and is first published in monochrome as a provisional edition at 1:40,000 (fig. 10). The final publication is a polychrome edition at 1:50,000 (fig. 11). A completely new format, "Type 1922," was derived for the series, and sheets published since 1945 have been drafted under the new specifications. The graticule, formerly based on grads measured from Paris was recalibrated to degrees measured from Greenwich, and the new sheets carry both systems. Although the sheets appear identical in style, distinction can be easily made between the Algerian and Tunisian sheets by the series title and numbering system. The *Tunisie au 50,000** series is numbered by Roman numerals, whereas Arabic numbers are carried on the sheets of the Algerian series. Relief is shown by contours at 10-meter intervals and is emphasized by hill shading. Roads are classified on the basis of importance and use. A survey diagram and standard legend are shown in the margin of the sheets.

- (5) *Carte de la Tunisie au 100,000** (Map of Tunisia, 1:100,000); Institut Géographique National; 1901-41; no grid.

This six-color series (fig. 12) covers all of Tunisia with the exception of the extreme north and northeast, and the extreme south and southwest. The sheets are cut on the same sheet lines as those

of the Tunisia 1:50,000 and 1:200,000 series. Relief is shown by contours at 25-meter intervals and by shading.

- (6) *Carte de l'Algerie et de la Tunisie au 200,000** (Map of Algeria and Tunisia, 1:200,000); Institut Géographique National; 1904-42; no grid.

This polychrome series (fig. 13) covers only the northern third of Algeria and all of Tunisia. The graticule is in grads measured from Paris. Relief is shown by contours at 50-meter intervals and by hill shading. The legend is on a separate sheet.

- (7) *Carte des Regions Sahariennes au 200,000** (Map of the Saharan Regions, 1:200,000); Institut Géographique National; 1922-49; no grid.

Sheets of this monochrome series (fig. 14) are based on rapid ground surveys at 1:200,000 and cover central and southeastern Algeria. The projection used is the same as that of the *International Map of the World*. Relief is shown by contours at 50-meter intervals and by auxiliary contours, form lines, and hachures. The symbolization of the desert features is detailed. Marginal information includes a standard legend.

- (8) *Maroc au 100,000** (Morocco 1:100,000); Institut Géographique National-Annexe du Maroc; 1924-; Lambert Nord Maroc grid.

For further details about this series, which includes coverage of a small section of the western portion of Algeria, see paragraph 14a (2).

- (9) *Carte de l'Afrique du Nord au 500,000** (Map of North Africa 1:500,000); Institut Géographique National; 1927-48; no grid.

This series in five colors covers French North Africa, with the exception of the southern part of Algeria. The basic information was taken from surveys of larger scale maps. Sheet lines are those of the *International Map of the World* and the graticule is in degrees measured from Greenwich. Relief is shown by contours at 100-meter intervals.

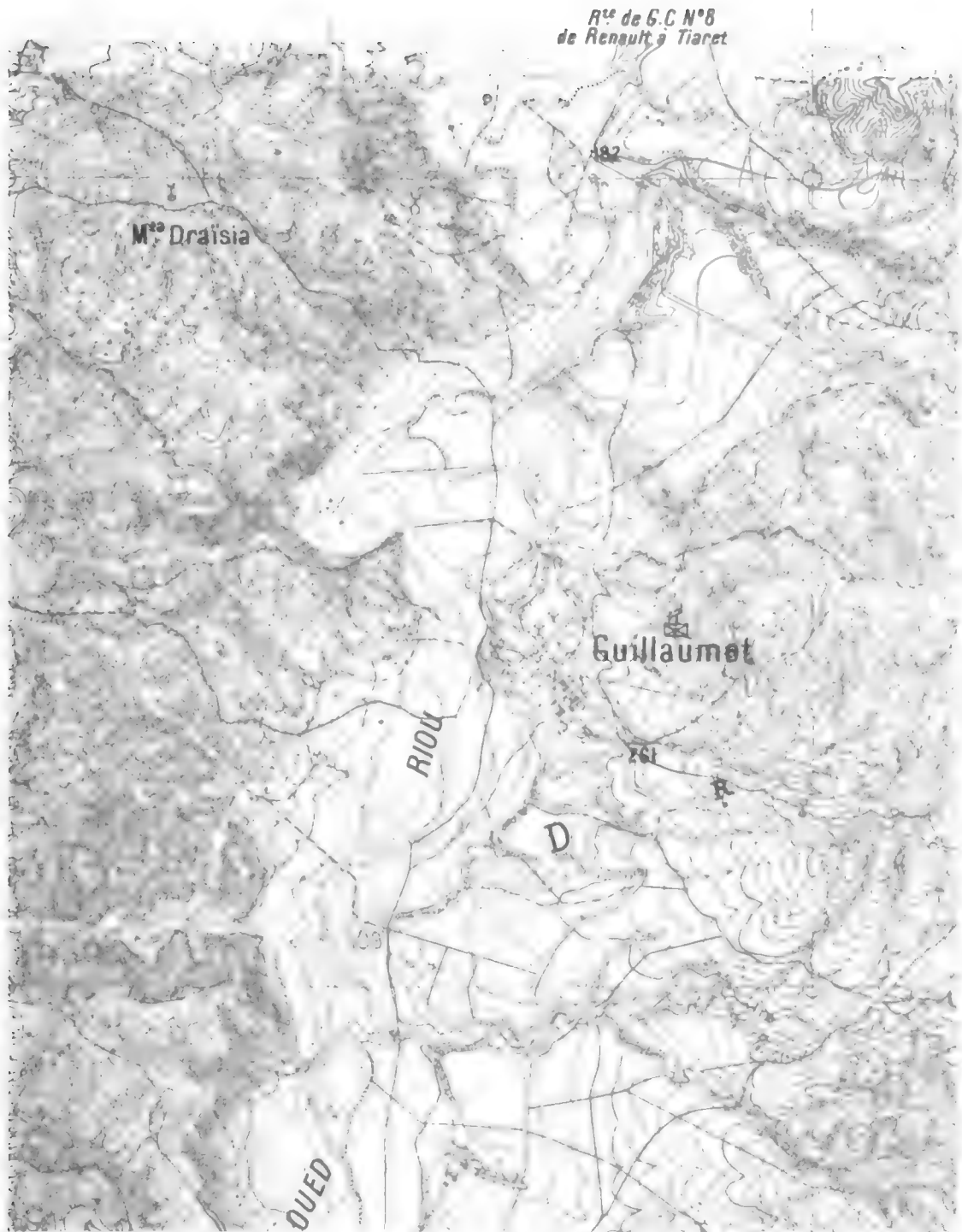

Figure 10. Section of monochrome provisional edition at 1:40,000 of *Algerie et Tunisie au 50,000'* by the Institut Géographique National.

b. Town Plans. The official French agencies have never made basic plans for mapping urban areas of Algeria and Tunisia. Instead there exist only a few small-scale plans made by private French concerns. Some of the important cities

of Algeria and Tunisia are covered by the *Environs de Tunis au 5,000'* (par. 16a(1)) and *Plans Directeurs de Alger, Oran, Phillipville, Bizerte* (par. 16a(3)).



Figure 13. Section of Carte de l'Algérie et de la Tunisie au 200,000^e by the Institut Géographique National.

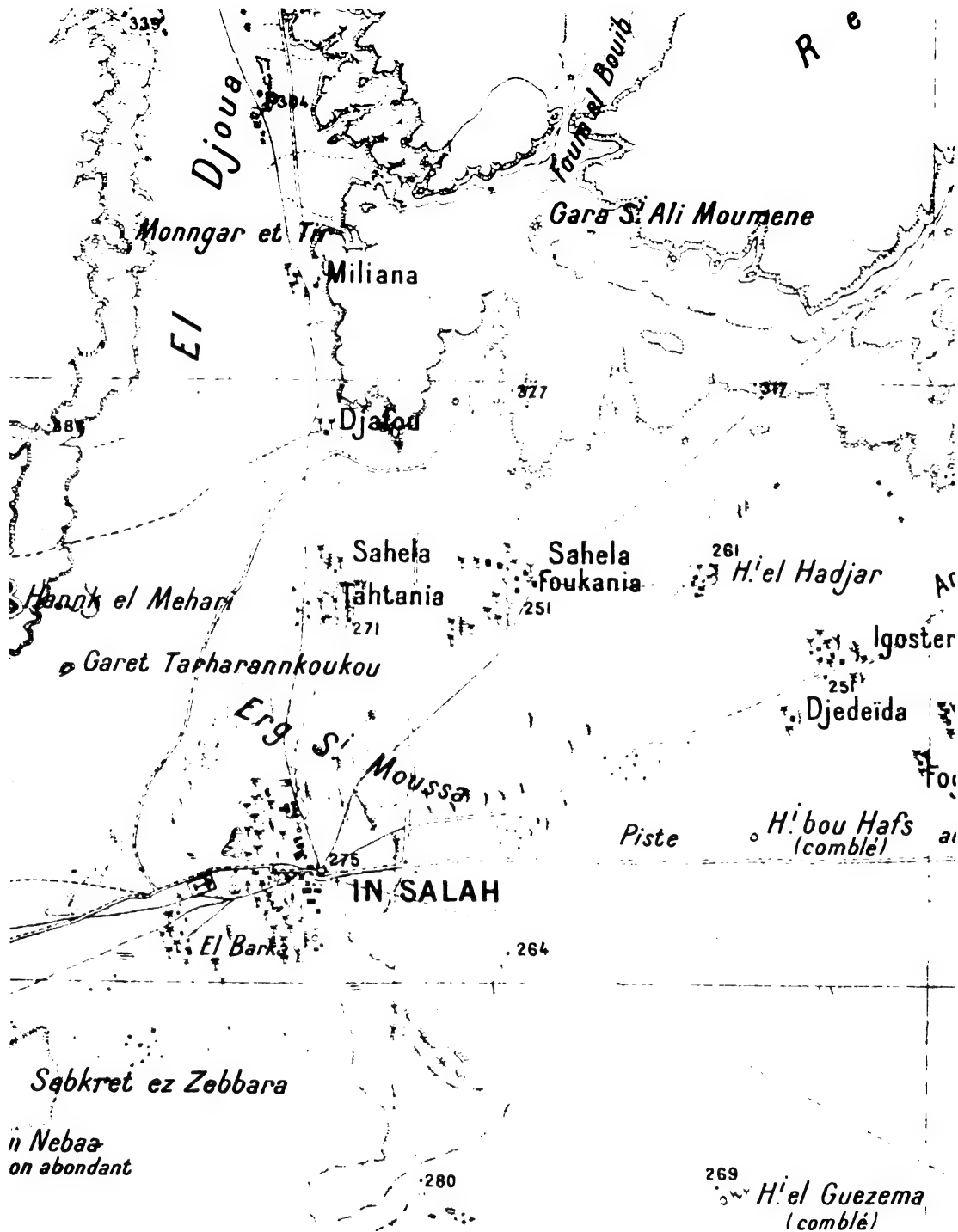

Figure 14. Section of Carte des Régions Sahariennes au 200,000^e by the Institut Géographique National.

CHAPTER 3

NORTHEAST AFRICA

Section I. LIBYA

17. Mapping Activities

a. Official.

- (1) Libya only recently became an independent nation, and because no government organization now exists that would be able to accomplish mapping on a national scale, native mapping is non-existent. The Italian Istituto Geografico Militare — IGM (Military Geographic Institute) performed the official topographic mapping prior to World War II. It established a second- and third-order net of geodetic control that covers all of the Libyan coastal area, except part of the Gulf of Sirte, where they used a fourth-order net. The IGM produced topographic maps at scales ranging from 1:25,000 to 1:100,000, but the areas covered are limited to the coast and a few important oases of the interior. The Italian Comando Superiore Forze Armate Africa Settentrionale Ufficio Topografico (High Command, Armed Forces, North Africa, Topographic Office) compiled a 1:1,000,000 map which is the largest scale map completely covering the country.
- (2) Official mapping of Tripolitania and Cyrenaica was the responsibility of the British Military Administration (BMA) between 1943 and 1951. During this time, special-purpose maps were published as needed, and maintenance of the regular map series consisted largely of reprinting British World War II series without revision.

b. Other.

- (1) A large number of maps were produced during World War II by other than official agencies. These were mainly the

British Directorate of Military Survey, War Office (Geographical Section, General Staff)—GSGS, the British Survey Directorate General Headquarters, Middle East Forces—MEF (now known as Middle East Land Forces—MELF), and the German Generalstab des Heeres (General Staff of the Army). The maps were made mainly by adapting the original Italian maps to the particular needs of the military forces of both the British and German armies. An extensive amount of revision was performed, however, and some original mapping was done to cover areas not mapped in the official series. Much of the British work was executed by the MEF in the field. In many cases, the unrevised rather than the revised MEF reprints of Italian sheets were reprinted by GSGS. The Army Map Service has reprinted both the MEF and GSGS sheets, but these reprints have not always been of the latest revised sheet.

- (2) The British revised and reproduced the Italian Istituto Geografico Militare 1:25,000, 1:50,000, 1:100,000, and 1:1,000,000 maps and compiled a 1:200,000 series covering northern Tripoli, a 1:250,000 series covering northern Cyrenaica, and a 1:500,000 series covering most of Libya. The Germans both reproduced and extended the native 1:100,000 sheets to cover the entire coastal area, and compiled a 1:200,000 series covering northern Libya. They also performed extensive reconnaissance work in the desert, the results of which appear on some of their 1:1,000,000 sheets. The Army Map Service has reprinted the majority of sheets published by the

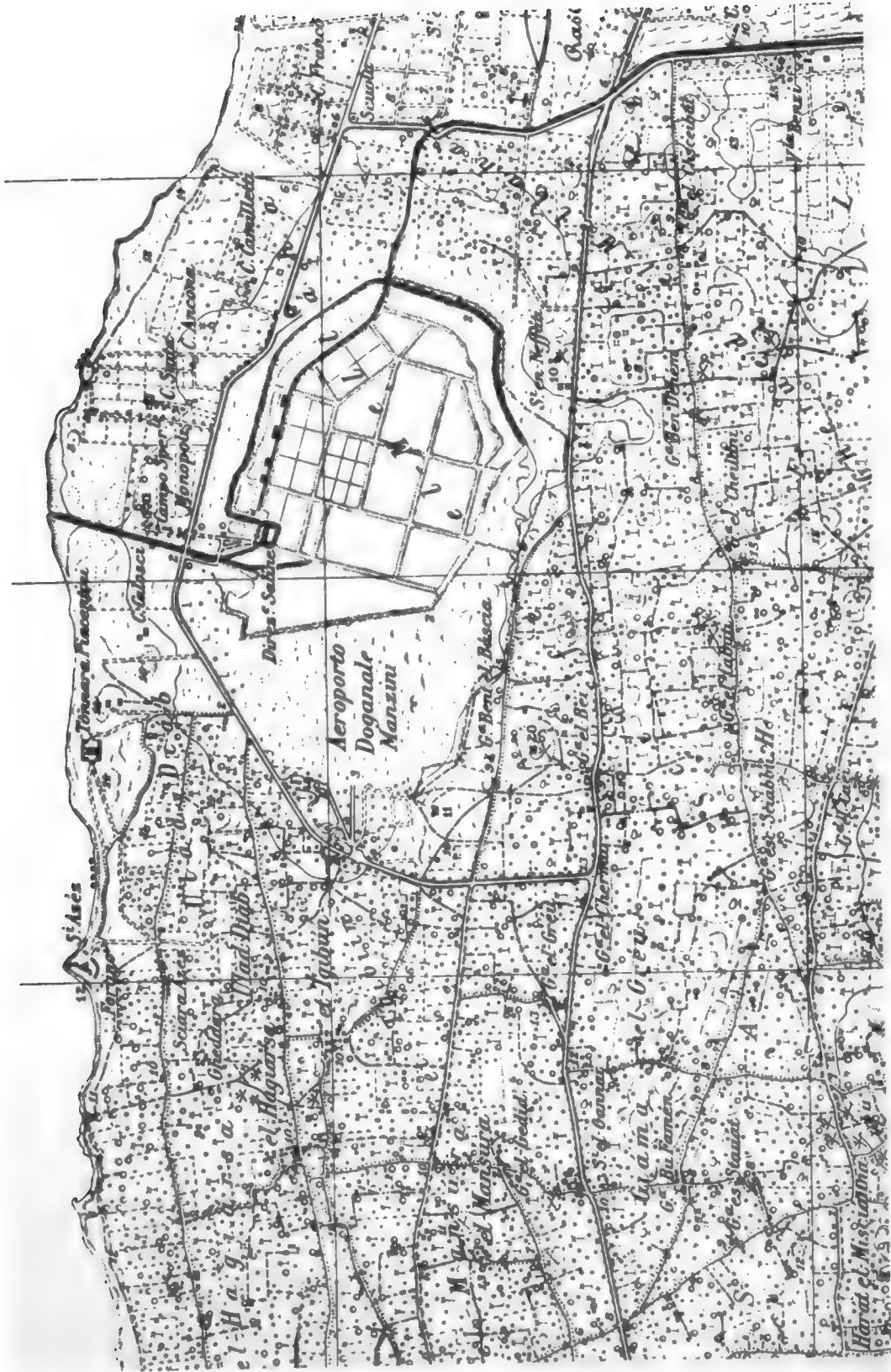

Figure 15. Section of Carta della Tripolitania at 1:25,000 by the Istituto Geografico Militare.

British and German authorities. City plans, which are of later date than the official plans, were compiled by the British during World War II.

18. Major Official Maps of Libya

a. Topographic Series.

- (1) *Carta della Cirenaica* (Map of Cyrenaica); 1:25,000; Istituto Geografico Militare; 1920; no grid.

These monochrome sheets cover a coastal area of Cyrenaica and are actually enlargements of the 1:50,000 sheets ((3) below). The 1:50,000 series, however, has a legend, and the 1:25,000 series does not.

- (2) *Carta della Tripolitania* (Map of Tripolitania); 1:25,000; Istituto Geografico Militare; 1931; no grid.

The immediate area of Tripoli is covered by these monochrome sheets (fig. 15) which are based on a topographic survey of 1931. Both physical and cultural features are shown in great detail. Contours are at 5-meter intervals, and roads are classified according to width.

- (3) *Carta Topografica della Cirenaica* (Topographic Map of Cyrenaica); 1:50,000; Istituto Geografico Militare; 1923-36; no grid.

These monochrome sheets cover the coastal area between Bengasi and Derna. They were based on 1920-23 triangulation and ground surveys. These maps are standard topographic maps and were intended for civil use. A marginal note on each sheet states the shift necessary to adjust this series to the survey of 1933-34. Relief is shown by contours at 10-meter intervals augmented by numerous spot elevations. The road pattern is fairly dense, and roads are classified according to trafficability and weatherability. This series also was published with an overprint indicating water supply and soil conditions.

- (4) [*Tripoli 1:50,000*]; Istituto Geografico Militare; 1935-40; no grid.

This monochrome series covers scattered areas of northwest Libya. Re-

lief is shown by contours at 25-meter intervals, and by approximate contours at 5-meter intervals. The road pattern is extensive and road classification indicates width and trafficability. Although the sheets vary in size and the sheet numbering system is not consistent, they are similar symbolization.

- (5) *Carta della Libia* (Map of Libya); 1:100,000; Istituto Geografico Militare; 1915-38; no grid.

This polychrome series (fig. 16) covers all of the Libyan coastline except along the Gulf of Sirte. It is based on several surveys, ranging in date from 1915 to 1938. The sheets based on surveys before 1920 show relief by 50-meter contour intervals; those based on 1920-25 surveys have contours at 10-meter intervals; and those based on post 1935 surveys have contours at 25-meter intervals. The sheets carry an adequate amount of detail presented in a legible manner and each sheet has a complete legend. Roads are classified according to width, type of construction, and condition. Some of the later date sheets are based on photography.

- (6) *Carta Dimostrativa della Libia* (General Map of Libya); 1:400,000; Istituto Geografico Militare; 1934-42; no grid.

This series covers all of Libya except the extreme southern portion. Sheets covering coastal areas were compiled from larger scale maps such as the Italian 1:100,000 series. Sheets for the desert areas were made from the results of rapid reconnaissance surveys; horizontal control was based on astronomic points and elevations were determined by barometric methods. Relief is shown by hachures. An important item is the breakdown of water features, such as wells, pools, and cisterns, into five classes according to type and potability. Roads are classified according to surface, construction, and suitability for auto traffic. Each sheet contains a legend.

- (7) *Carta Dimostrativa della Libia* (General Map of Libya); 1:1,000,000; Italian Co-

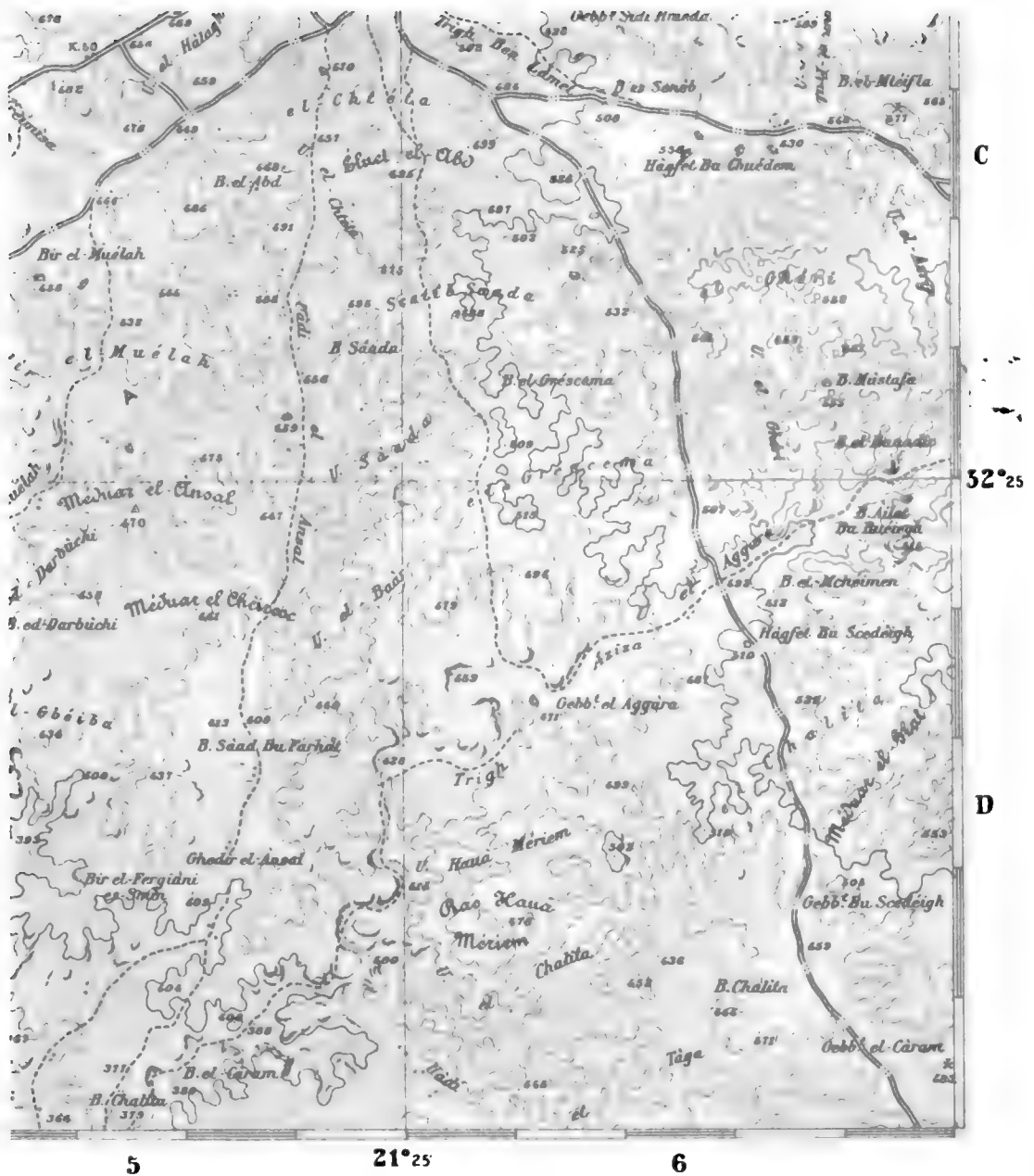

L'equidistanza è di metri 25
(Per le curve punteggiate è di m. 5)

Figure 16. Section of Carta della Libia at 1:100,000 by the Istituto Geografico Militare.

mando Superiore Forze Armate Africa Settentrionale Ufficio Topocartografico; 1935-42; reference grid only.

All of Libya is covered by this polychrome series, designed for general-reference use. It was compiled chiefly from the IGM 1:100,000 and 1:400,000 series and was also published later as a

part of the *International Map of the World*.

b. Town Plans. Polychrome series of plans at both 1:2,000 and 1:5,000 cover each of the towns of Tripoli and Bengasi. These plans were printed in 1913 and 1914 by the Istituto Geografico Militare. They contain no legend, and are without graticule or grid.

Section II. EGYPT

19. Mapping Activities

a. Native.

- (1) The Survey of Egypt at Giza, a department of the Ministry of Public Works, is the principal topographic mapping agency of Egypt. Other government departments distribute special-purpose maps, but their maps are printed and in some cases compiled by the Survey of Egypt. Some sheets still exist that were produced between 1936 and 1942 by the Egyptian Department of Survey and Mines. At the time of their production, the Survey of Egypt was amalgamated with the Department of Survey and Mines under the direction of the Egyptian Ministry of Finance.
- (2) The maps of the Survey of Egypt are based on a network of geodetic control, radiating from the observatory of Helwan, toward Libya, Israel (Palestine), and southward along what is known as the 30th meridional arc of triangulation. The actual work of surveying and mapping was executed by the Survey of Egypt which generally operated according to the high standards set forth by British administration. The basic maps can be used for both military and cadastral purposes. The Survey of Egypt also produces some special-purpose maps, such as road and railroad maps, but its chief function is the production of topographic maps at scales of 1:25,000 and 1:100,000 for the cultivated areas, and at 1:100,000 for the desert areas. A large portion of the desert area is covered by 1:100,000 maps that are similar in presentation and quality, but for the areas not covered by maps at this scale, the *Egypt 1:500,000* map is used.
- (3) The Survey of Egypt produced town plans for all of the important cities of Egypt from surveys made between 1930 and 1940. Some of the work is based on pre-1930 surveys. Town-plan revisions are made on a priority basis and plans for larger cities such as Cairo and Alexandria, are revised more frequently.

b. Other.

- (1) The British Survey Directorate General Headquarters, Middle East Forces—MEF (now known as Middle East Land Forces—MELF) published and partially revised Egyptian maps to such an extent during World War II, that a large number of the latest available editions are the British reproductions. World War II publishing codes such as MDR, WDR, PDR, etc. were used by this organization for series identification. These codes are being canceled and converted to GSGS numbers by the Directorate of Military Survey, War Office (Geographical Section, General Staff)—GSGS. Many sheets upon which these codes appear, however, are still available for distribution at MELF, and some sheets published as late as 1949 by MELF carry MDR series numbers. Some British maps were reprinted by the Army Map Service and assigned AMS series numbers. Most of the British reproductions can be recognized by the British military grids (Egyptian Red, Purple, and Palestine) which have been applied to the original Egyptian sheets. On these British wartime reproductions, however, the military grids often obliterate fine details. At times the green tint (indicating cultivated areas) was not included and in many cases hasty wartime printing processes resulted in illegibility.
- (2) From field operations and from aerial photography flown during World War II, the British also revised and extended the coverage of the 1:25,000 series in the northwest coast and Suez Canal areas, compiled a new 1:50,000 series in the Alexandria-Matruh area, extensively revised the Western Desert 1:100,000's, and compiled a 1:250,000 series covering northern Egypt. Since World War II, MELF, located at Fayid, Egypt, has continued to reproduce and revise Survey of Egypt maps, and has maintained stock and reproduction material for use by the British Army. The only Survey of Egypt series described in this technical

manual that has not been reproduced by MELF is the new 1:100,000 *Topographical Map of Egypt*. MELF also produced a 1:10,000 multiplex series covering the Fayid area in the Suez Canal Zone.

- (3) During World War II, the German Generalstab des Heeres (General Staff of the Army) reproduced and partially revised practically every series that the Egyptians and British had produced. In most cases, however, German sheets differ from the originals only in sheet size, sheet numbering, and in language of the marginal data. During World War II, the British and Germans reproduced Survey of Egypt plans for strategically important cities, but most of these have been superseded.

20. Major Native Maps of Egypt

a. Topographic Series.

- (1) 1:25,000 "Normal" Series; Survey of Egypt; 1929- ; Kilometric Rectangular grid.

This polychrome series (fig. 17) covers the cultivated areas of the Nile River valley and delta, Suez Canal, and the oases of Kharga, Dakhla, and Siwa. Desert features are shown only on a few sheets. The sheets published since World War II are bilingual editions of English and Arabic (fig. 17 ①) so that it is possible to obtain English-language sheets for the greater portion of the series. The areas covered only by Arabic editions (fig. 17 ②) are mainly in the upper Nile and oases regions. A few sheets are available only in English (fig. 17 ③). All of the sheets are cut and numbered on a rectangular kilometric grid, and all have grid coordinates, but only a few have geographic coordinates. This fact lowers their usefulness in some phases of map-reference work. Some sheets vary in content and manner of presentation but most of the relief is depicted by contours at .5-, 1-, 5-, and 10-meter intervals, and numerous hydrographic features are shown. Railroads are classified according to gage, and roads according to surface, width, use, and

motorability depending upon the area covered. Vegetation is symbolized. The sheets are based on excellent topographic and geodetic surveys and contain completely legible details commensurate with the scale. Many sheets are not up to date, however, because field-check revisions can be made only on a small part of such an extensive series each year.

- (2) *Daba 1:25,000 and Matruh 1:25,000*; Survey of Egypt; 1939; no grid.

These polychrome series, which cover the El Daba and Matruh areas on the north coast, were prepared for the defense of Egypt during World War II. All of the sheets are bilingual editions in English and Arabic. No geographic coordinates are given. Relief is indicated by contours at 5-meter intervals, spot heights, and descriptive notes on the map face. Desert features are shown. Marshes and *sebkh*as (in Egypt, flat saline mud areas with internal drainage and no vegetation), cisterns, and wells are portrayed. Gardens and cultivable areas are shown in green.

- (3) *Canal Zone 1:40,000*; Directorate of Military Survey, War Office (Geographical Section, General Staff), published by the Survey of Egypt as GSGS 4012 under authority of the War Office; 1916-17; Old British "Squared Grid."

This English-language polychrome series (fig. 18) covers the Suez Canal and the coastal areas of North Sinai eastward to the Palestine frontier. None of the sheets have geographic coordinates. Relief is indicated by contours at 15-, 20-, 35-, 50-, and 100-foot intervals, layer tints, and by notes on the map face. Numerous hydrographic features are shown. This series is based on a good topographic survey.

- (4) *Egypt 1:50,000*; Survey of Egypt; 1906-19; no grid.

This polychrome series covering the Nile valley and Nile delta was prepared for administrative use. Most of the work was the result of rough, ex-

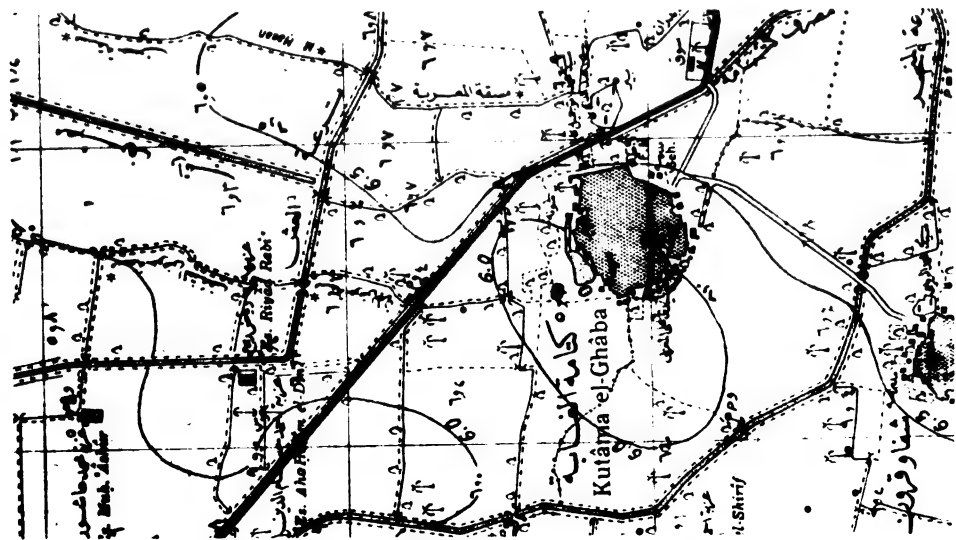

① Bilingual Edition

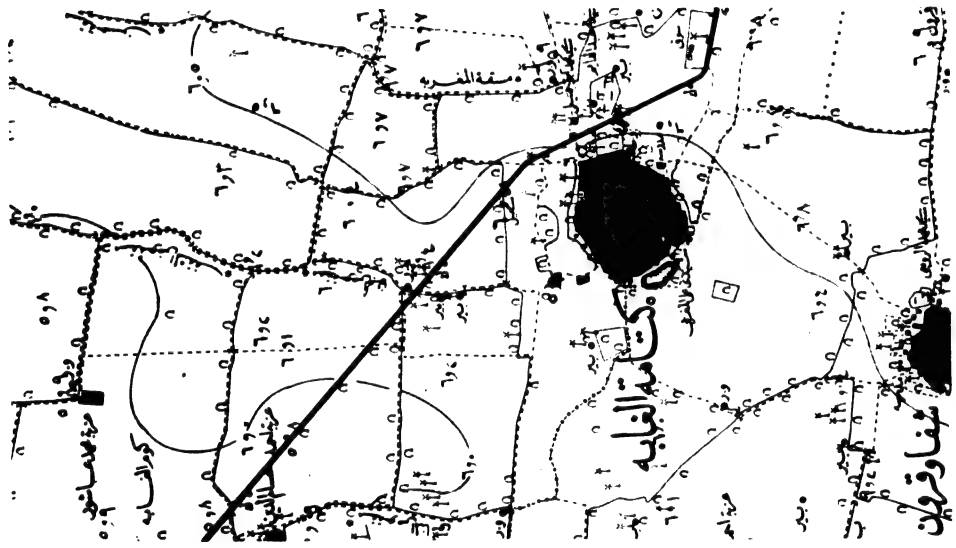

② Arabic Edition

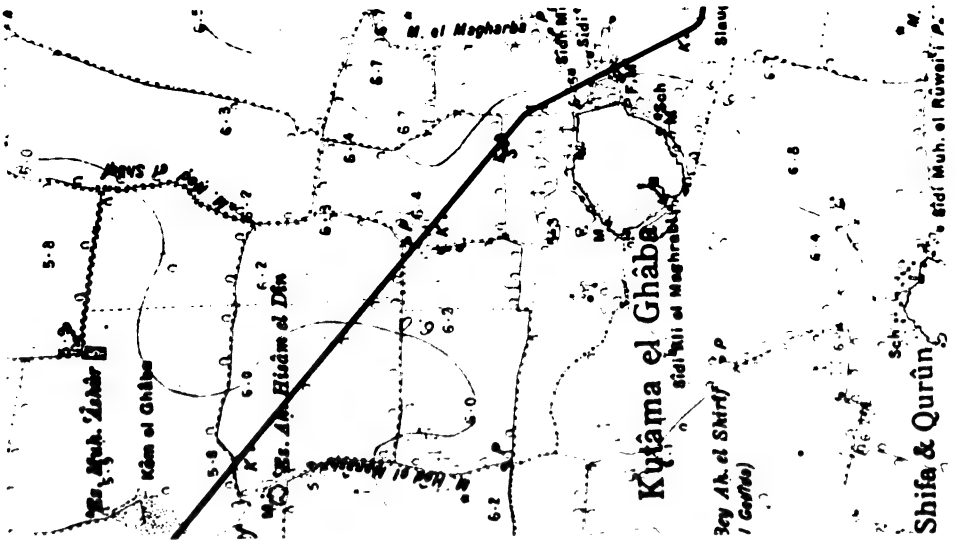

③ English Edition

Figure 17. Sections of 1:25,000 "Normal" Series by the Survey of Egypt.

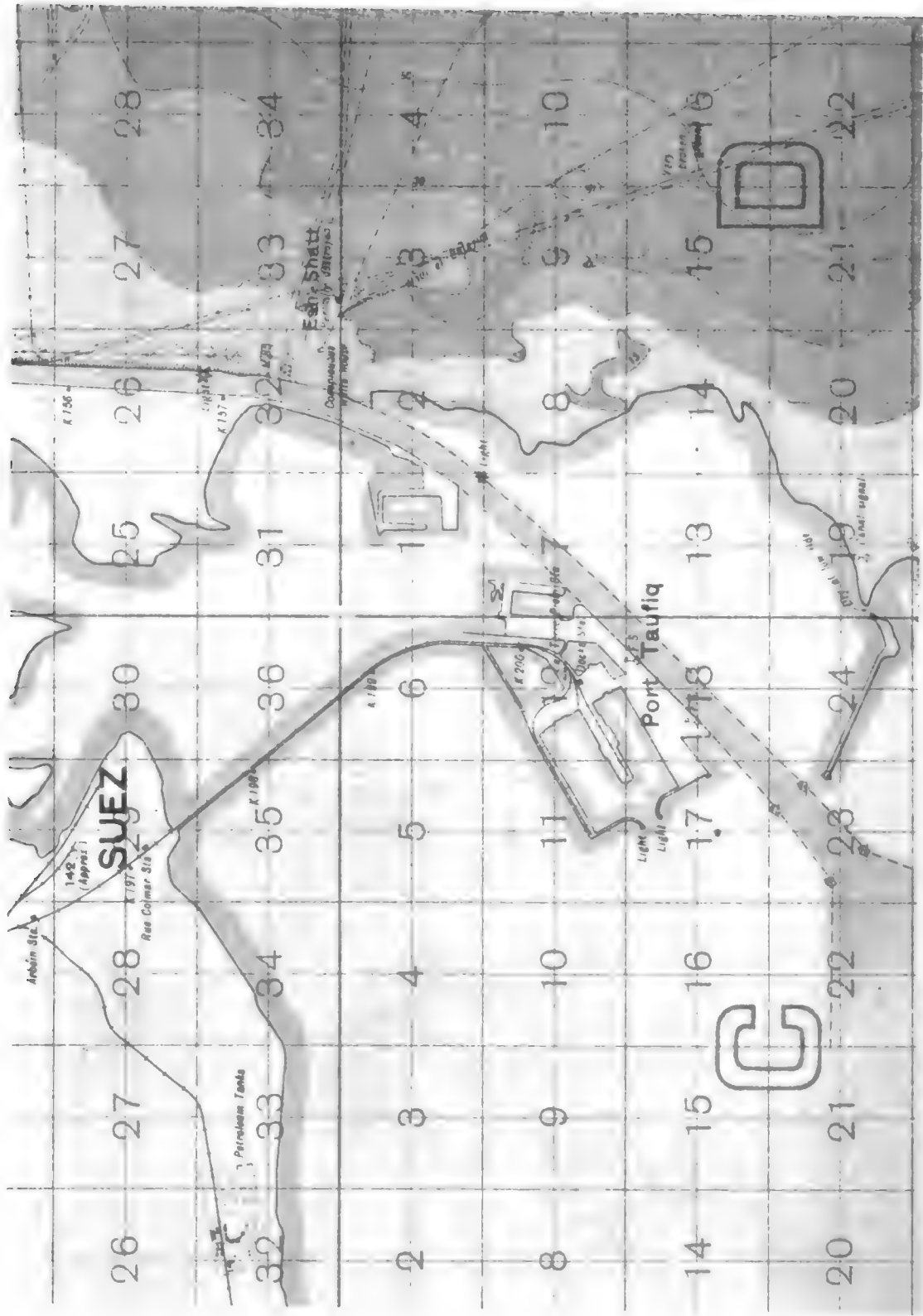

Figure 16. Section of Canal Zone 1: 40,000 series by the Directorate of Military Survey, War Office (Geographical Section, General Staff), GSGS 4012.

ploratory surveys, not based upon triangulation. All sheets are bilingual editions in English and Arabic. Relief is shown by form lines and hachures; some contours are given at 30-meter intervals. When the 1:25,000 "normal" series was adopted for the standard topographic map of the country, the 1:50,000 series became obsolete.

- (5) *1:100,000 "Normal" Series; Survey of Egypt; 1927-* ; Kilometric Rectangular grid.

The coverage of this polychrome series (fig. 19) is very much the same as that of the *1:25,000 "Normal" Series* ((1) above), except that desert features also are shown. Portions of sheets that cover cultivated areas were compiled from larger scale Survey of Egypt maps. Portions of sheets that cover desert areas, however, are based on special *1:100,000* surveys by the Desert Section, which has its own system of triangulation. The contour interval for the desert areas is usually larger than that for the cultivated areas. The map face of each sheet in this series is in English, and the marginal information is bilingual (English and Arabic). The sheets are cut and numbered on the basis of a kilometric rectangular grid. There is some variety in the style of sheets but most of the relief is represented by contours at 1-, 5-, 10-, and 30-meter intervals, canals are symbolized according to width, and the cultivated areas are indicated by a green tint. Roads are classified according to usability and railroads by gage. Topographic detail is commensurate with the scale. Though many sheets have recently been revised, this series is gradually being replaced by the new topographic series at the same scale ((6) below).

- (6) *Topographical Map of Egypt; 1:100,000; Survey of Egypt; 1949-* ; Kilometric Rectangular grid.

This polychrome series (fig. 20) is planned to replace all of the other *Egypt 1:100,000* series described. The completed series will provide uniform

coverage for all of Egypt except the uninhabited parts of the Western and Eastern Deserts, and will therefore cover areas not previously mapped at this scale. It differs from the *1:100,000 "Normal" Series* ((5) above) in that sheet lines are cut and numbered on graticule rather than grid lines, altitude tints have been added, macadamized roads are indicated, and symbolization of various features has been altered. Relief is shown by contours at intervals of 1-, 10-, 25-, and 100-meter intervals. This series represents a very fine cartographic effort by the Egyptians.

- (7) *Egypt 1:100,000, Western Desert and Egypt 1:100,000 (North Coast)* ; Survey of Egypt; 1937- ; no grid.

These two series provide coverage for that part of the Western Desert that is between El Alamein and Sidi Barrani and as far south as Siwa and Bahariya Oases. They are the only desert series that show relief by contours. The *Egypt 1:100,000 (North Coast)* series will eventually be incorporated in the *Egypt 1:100,000 Western Desert* series.

- (8) *Egypt 1:100,000, Northern Sinai* (fig. 21) and *Egypt 1:100,000, Southern Sinai*; Survey of Egypt; 1935- ; no grid.

Together these series provide complete coverage of the Sinai Peninsula. Relief is shown by hachures.

- (9) *Egypt 1:100,000 Eastern Desert*; Survey of Egypt; 1935-; no grid.

This series covers the entire Egyptian Red Sea coastal area. Relief is shown by hachures.

- (10) *Egypt 1:500,000*; Survey of Egypt; 1941-; no grid.

This multicolor series covers all of Egypt in twelve sheets. Relief is portrayed by contours at 100-meter intervals, layer tints, form lines, and hachures. The layer tinting of some parts of the desert give a false impression that all of Egypt has been mapped.

b. Town Plans. Most of the important towns in Egypt are covered by the *Egypt Town Series* published by the Survey of Egypt. These polychrome plans range in scale from 1:500 to 1:5,000. Publishing dates also vary, but features

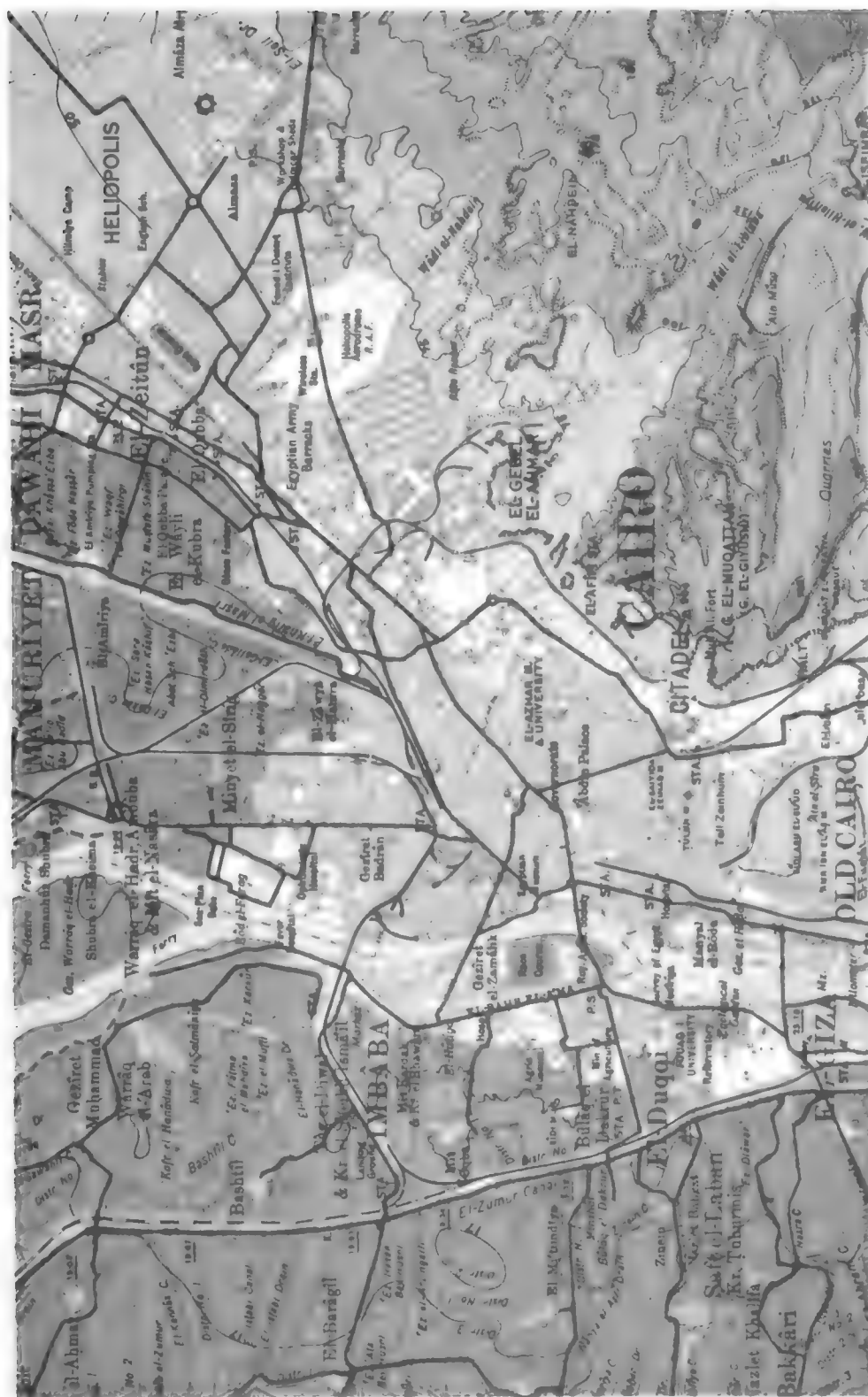

Figure 20. Section of the Topographical Map of Egypt at 1:100,000 by the Survey of Egypt.

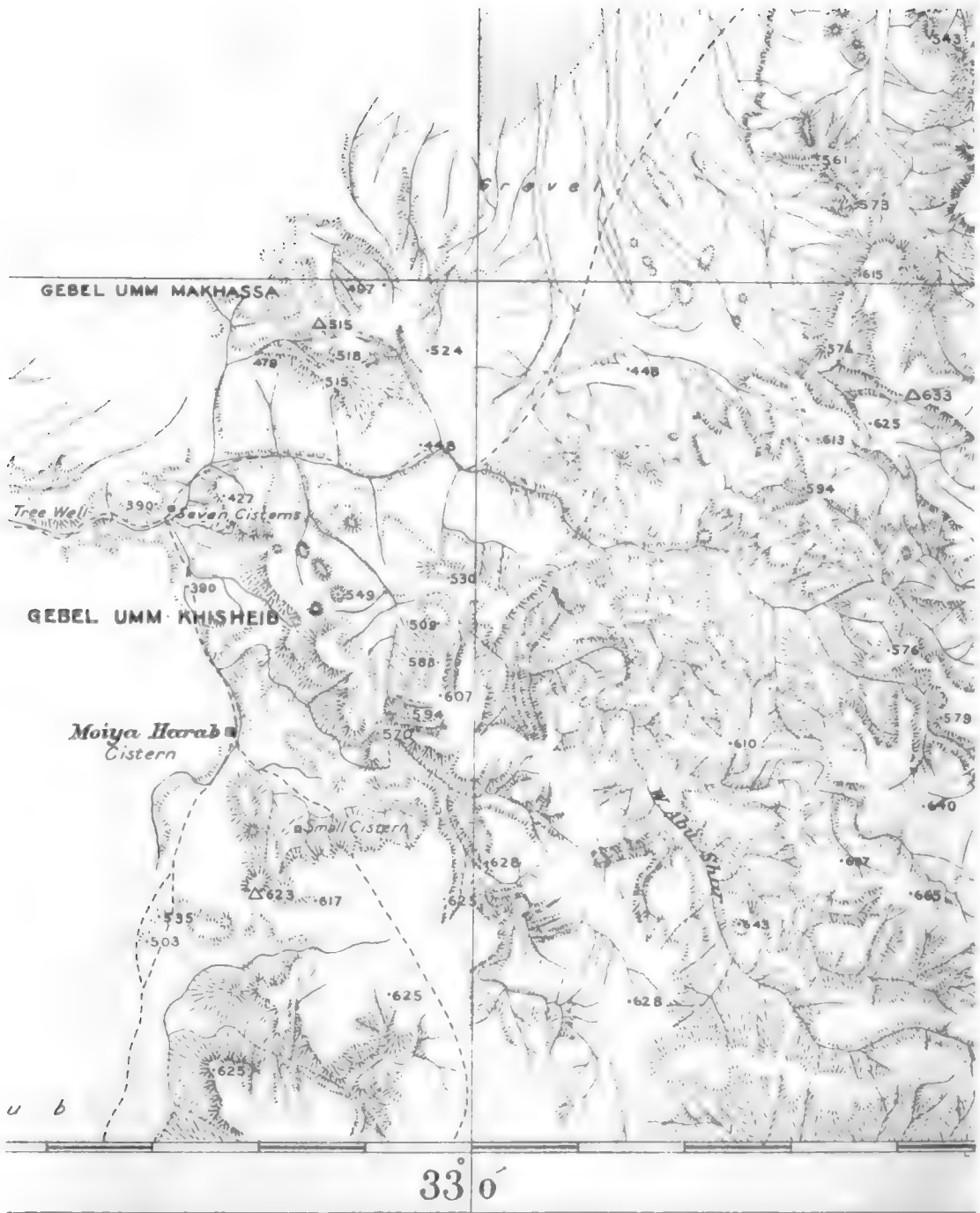

Figure 21. Section of Egypt 1:100,000 Northern Sinai by the Survey of Egypt.

are presented in a similar manner throughout the series. Plans for most of the larger towns are at the scale of 1:5,000 and were made from larger scale cadastral maps. On all plans important buildings are identified and most of the streets are named. Legends and a kilometric grid are

shown. Relief is not indicated. The plans are revised periodically by the Survey of Egypt.

21. Characteristics

The lack of continuity among the various topographic series covering Egypt lessens their use-



Figure 22. Section of Carta della colonia Eritrea at 1:100,000 by the Istituto Geografico Militare.

fulness. The most serious problem, however, is the lack of symbol sheets or complete legends on the sheets. These are needed for a fuller understanding of the unique and complex symboliza-

tion of features shown on the Survey of Egypt 1:25,000 and 1:100,000 series. This is especially true with respect to drainage and vegetation features.

Section III. ETHIOPIA (INCLUDING ERITREA)

22. Mapping Activities

a. Official. Prior to World War II, the Italian Istituto Geografico Militare — IGM (Military Geographic Institute) was the official mapping agency for Ethiopia and Eritrea. Only reconnaissance type maps resulting from expeditions, travellers' route sketches, etc., were produced by IGM for Ethiopia proper before the Italian invasion in 1935. In fact, so little mapping existed prior to this date, that the Italians were forced to produce maps of the invasion areas from aerial photography tied to existing sketches. These maps were later improved, but most of them, as well as the reproduction and manuscript material, were lost during World War II. Scattered areas of Eritrea are covered by maps at 1:25,000, 1:50,000, and 1:100,000. Ethiopia proper, however, is not covered to a great extent by any maps at a scale larger than 1:500,000.

b. Other. During World War II, the British East Africa Forces (EAF) reproduced the Italian maps mainly for the Eritrea areas, and compiled the *East Africa 1:500,000* map, the largest scale series covering all of Ethiopia. Since World War II, the British Survey Directorate, Middle East Land Forces has continued to reprint the Italian maps and to assign them GSGS numbers.

23. Major Official Maps of Ethiopia

a. Topographic Series.

- (1) *Carta dell'Eritrea* (Map of Eritrea); 1:25,000; Istituto Geografico Militare; 1933-38; no grid.

This monochrome series covers an area of Eritrea along the Eritrea-Ethiopia border and was based on 1929-34 surveys. Some sheets were revised in 1938. Relief is shown by contours at 5-meter intervals and roads are classified according to motorability. The British reprint of this series is unchanged except for the translation of marginal data to English.

- (2) *Carta della Colonia Eritrea* (Map of Colonial Eritrea); 1:50,000; Istituto Geografico Militare; 1909-38; no grid.

This monochrome series covers an area of central Eritrea. It was based on ground surveys made in 1888-91. Some sheets were revised in 1938. Relief is shown by contours at 50-meter intervals. Roads are classified according to motorability and surface. The British reprint of this series is unchanged except for the addition of a reference grid on the map face and an index of adjoining sheets on the back of the map.

- (3) *Carta della Colonia Eritrea* (Map of Colonial Eritrea); 1:100,000; Istituto Geografico Militare; 1909-38; no grid.

This polychrome series (fig. 22) covers central Eritrea and was based on surveys dated 1888-1902. Some sheets published in 1934 carry a revised communication system. Relief is shown by contours at 100-meter intervals. Roads shown on earlier editions are classified as to foundation. Maps of a later edition classify roads as to weatherability. In reproducing this series, the British added the East Africa Meter grid and translated marginal data to English.

- (4) *Carta Dimostrativa della Colonia Eritrea e della Regioni Adiacenti* (General Map of the Eritrea Colony and adjacent areas); 1:400,000, Istituto Geografico Militare; 1934; no grid.

These polychrome sheets cover Eritrea and the adjacent areas and were compiled from larger scale series, reconnaissance surveys, partial sketches, and itineraries. The sources used in compilation are indicated by source notes and diagrams. Relief is shown by hachures. Roads are classified as motorable, roads under construction, and roads with natural foundation.

(5) [*Italian East Africa 1:1,000,000*]; Istituto Geografico Militare; 1936-41; no grid.

These polychrome sheets cover Ethiopia and were compiled from various larger- and smaller-scale maps. Relief is shown by contours and by altitude tints. Roads are classified as

those with natural foundation and as tracks.

b. Town Plans. Most of the town plans made by the Italians for Ethiopian urban areas are of a diagrammatic nature. During World War II the British East Africa forces copied and revised most of the Italian plans. English-language plans have been made for most of the important towns of Ethiopia.

Section IV. BRITISH SOMALILAND

24. Official Mapping Activities

Topographic mapping in British Somaliland is performed by the British Directorate of Colonial Surveys (DCS) and the Directorate of Military Survey, War Office (Geographical Section, General Staff)—GSGS.

The British East African Forces compiled some maps during World War II. British town plans exist for the important urban areas of British Somaliland, but are of a diagrammatic nature.

25. Major Official Topographic Maps of British Somaliland

a. Somaliland 1:250,000; Directorate of Military Survey, War Office (Geographical Section, General Staff)—GSGS; GSGS 3927; 1935-52; East Africa grid on some sheets.

This polychrome series (fig. 23) covers all of

Somaliland. Relief is shown by contours at 100-meter intervals and by approximate contours. Roads are classified as motor road and motorable route. Each sheet carries a reliability diagram giving types of sources used in compilation. The sheets published in 1952 carry the East Africa grid. Sheets dated 1935 and 1938 carry a different grid which is probably a Lambert type grid.

b. East Africa 1:500,000; East African Forces, MDR 566, GSGS 4355; 1946; East Africa grid.

Sheets of this polychrome series (fig. 24) which cover British Somaliland were compiled during World War II. Relief is shown by approximate contours at intervals that vary from sheet to sheet. Roads are classified as principal and "other." Each sheet carries a diagram giving sources used in compilation.

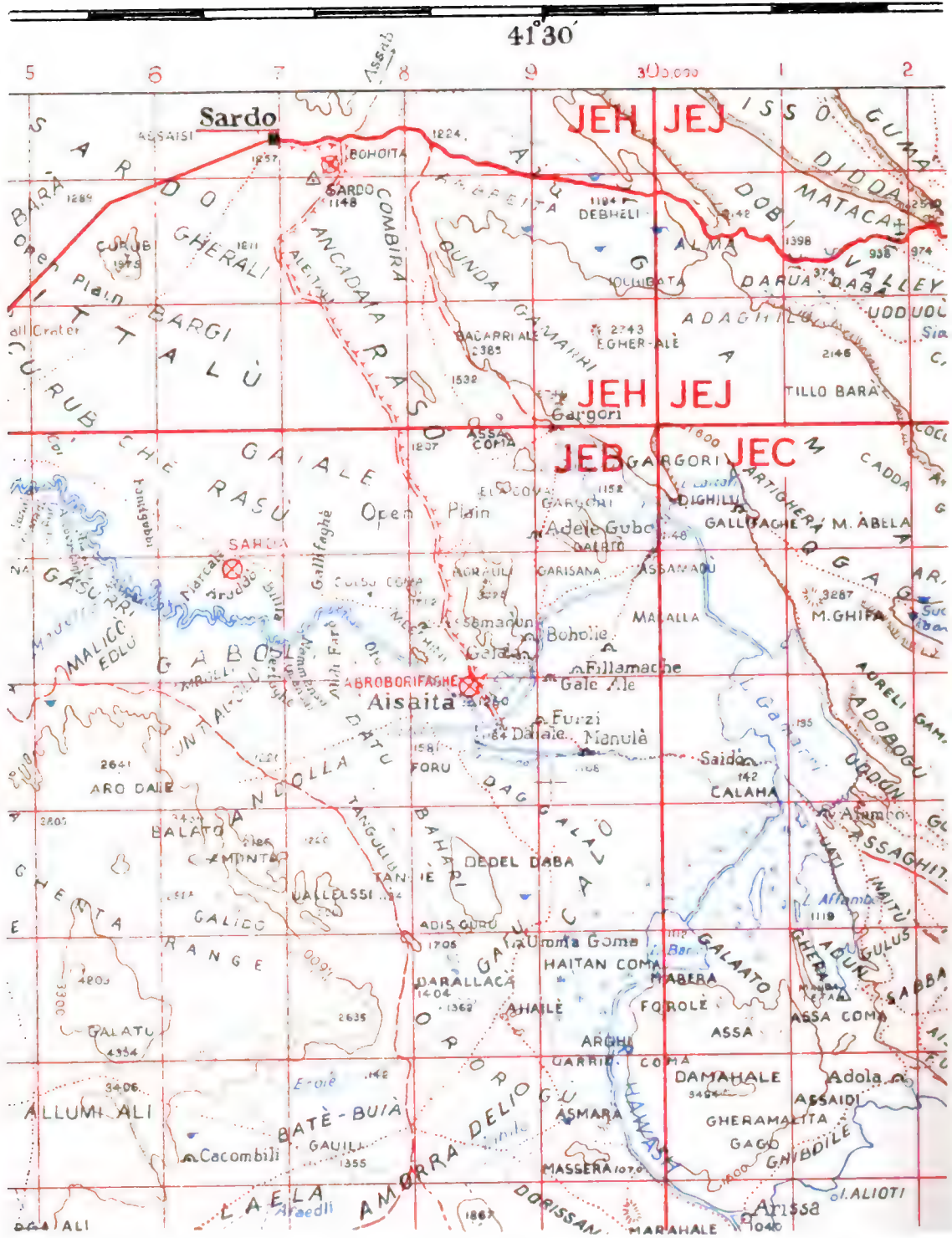

Figure 24. Section of East Africa 1:500,000 series (MDR 586, GSGS 4355) by the East African Forces.

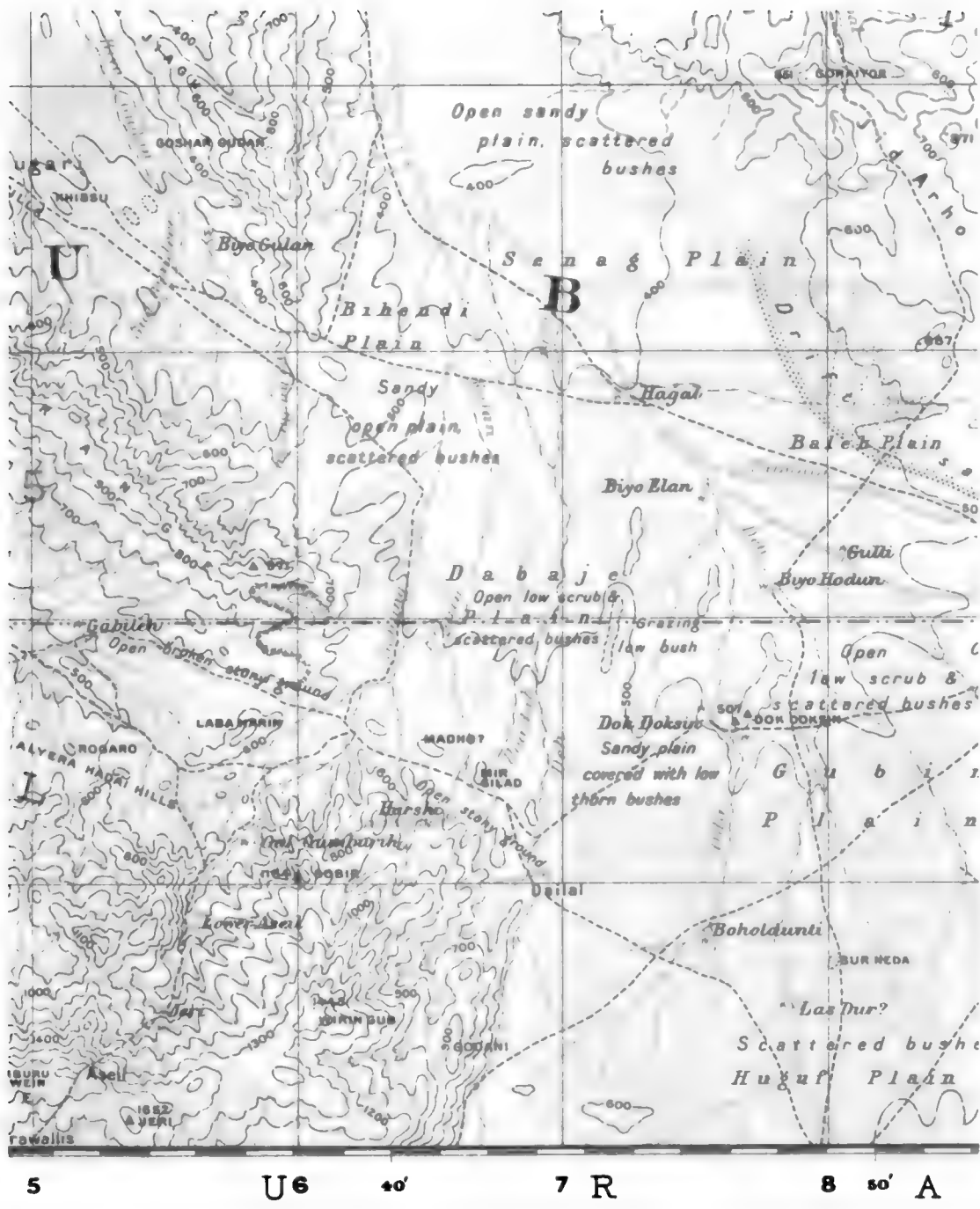

Figure 23. Section of Somaliland 1:250,000 map (GSGS 3927) by the Directorate of Military Survey, War Office (Geographical Section, General Staff).

Section V. FRENCH SOMALILAND

26. Mapping Activities

a. *Official.* Topographic mapping of French Somaliland is performed by the French Institut Géographique National—IGN (National Geo-

graphic Institute). An acting mapping program by the IGN is in progress whereby preliminary plots at 1:80,000 are being made from ground surveys.

b. *Other.* During World War II, the British Directorate of Military Survey, War Office (Geographical Section, General Staff) and the British East Africa Survey Group reprinted maps published by French authorities with the addition of British military grids. The East African Forces also compiled sheets of the *East Africa 1:500,000* series, but these have been superseded by postwar sheets of the IGN 1:200,000 series.

27. Major Official Maps of French Somaliland

a. Topographic Series.

- (1) *Edition Provisoire au 80,000*° (Provisional Edition 1:80,000); Institut Géographique National; 1951 kilometer grid.

This monochrome preliminary map at 1:80,000 (fig. 25) will cover all of French Somaliland and will eventually be published at the scale of 1:100,000. It is being compiled from ground surveys begun in 1947. Relief is shown by contours at 2- and 25-meter inter-

vals, but it has not been matched on those parts of sheets that cover areas where surveys join.

- (2) *Carte de la Côte Française des Somalis au 200,000*° (Map of French Somaliland, 1:200,000); Institut Géographique National; 1947; no grid.

This polychrome series (fig. 26) covers all of French Somaliland and was revised in 1947 by the IGN from an earlier edition. The geographic coordinates are given in degrees and are referred to both Greenwich and Paris. Relief is shown by contours at 50-meter intervals. Roads are shown as auto routes.

b. *Town Plans.* A 1:10,000 plan of Djibouti was published in 1950 by the Institut Géographique National. It is based on a 1942 survey, but has no legend. It shows a kilometer grid. Early French plans of the town have been reprinted by the British.



Figure 25. Section of *Edition Provisoire au 80,000*° by the Institut Géographique National.

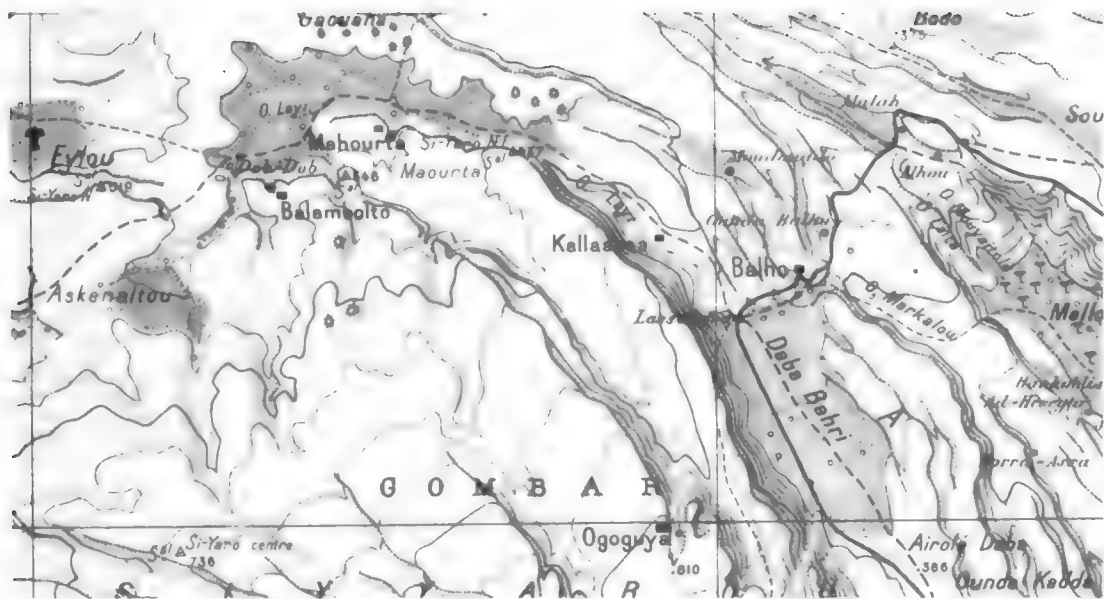

Figure 26. Section of Carte de la Côte Française des Somalis au 200,000^e by the Institut Géographique National.

CHAPTER 4

WESTERN HEMISPHERE

Section I. GREENLAND

28. Mapping Activities

a. Official. The Danish Geodaetisk Institut (Geodetic Institute) of Copenhagen publishes the official topographic maps for Greenland and supervises most of the cartographic work accomplished by explorers.

b. Other. The U. S. Army Map Service (AMS) has compiled and published topographic maps covering scattered areas throughout Greenland at scales of 1:4,800, 1:20,000, 1:25,000, 1:50,000, and 1:100,000. AMS also has compiled a 1:250,000 map series covering all of Greenland's ice-free areas.

29. Major Official Maps of Greenland

a. Topographic Series.

- (1) *Grönland* (Greenland); 1:250,000; Geodaetisk Institut; 1937-46; no grid.

This polychrome topographic series (fig. 27), providing coverage for the south-central areas of the east and west coasts of Greenland, was compiled from ground and aerial surveys dating from 1932 to 1937. Relief is shown by contours at 50-meter intervals, supplemented by hill shading to indicate sheer rock slopes, and by spot elevations in meters. The Army Map Service has reprinted this series in monochrome with the addition of a Universal Transverse Mercator grid.

- (2) *May of North Greenland*; 1:300,000; Geodaetisk Institut; 1932; no grid.

This polychrome topographic series provides coverage for the northern and northwestern coastal areas of Greenland from offshore islands inland to the icecap. This series is based on surveys of 1917-23 by Lauge Koch and additional data from earlier expeditions. Relief is shown by hill shading and spot heights in meters.

b. Town Plans. The principal towns of Greenland or covered by 1:2,000 polychrome plans published by the Geodaetisk Institut. The plans were compiled from ground and aerial surveys. Relief is shown by contours and spot heights in meters. Prominent buildings are identified by Danish names.

30. Coordinate Systems

Graticules are indicated on all map series of Greenland published by the Geodaetisk Institut. Geographic coordinates are expressed in the sexagesimal (degree) system and longitude values are referred to the Greenwich meridian. No grid is shown on Danish map series of Greenland.

31. Characteristics

Place names are in Danish and Eskimo. Marginal information includes a legend of conventional signs in which map features are described in Danish, Eskimo, and English (fig. 28). Bar scales in statute miles and kilometers are also shown. For key terms and English translation of marginal data, see table IX.

70 Ö. 1 SCORESBYSUND

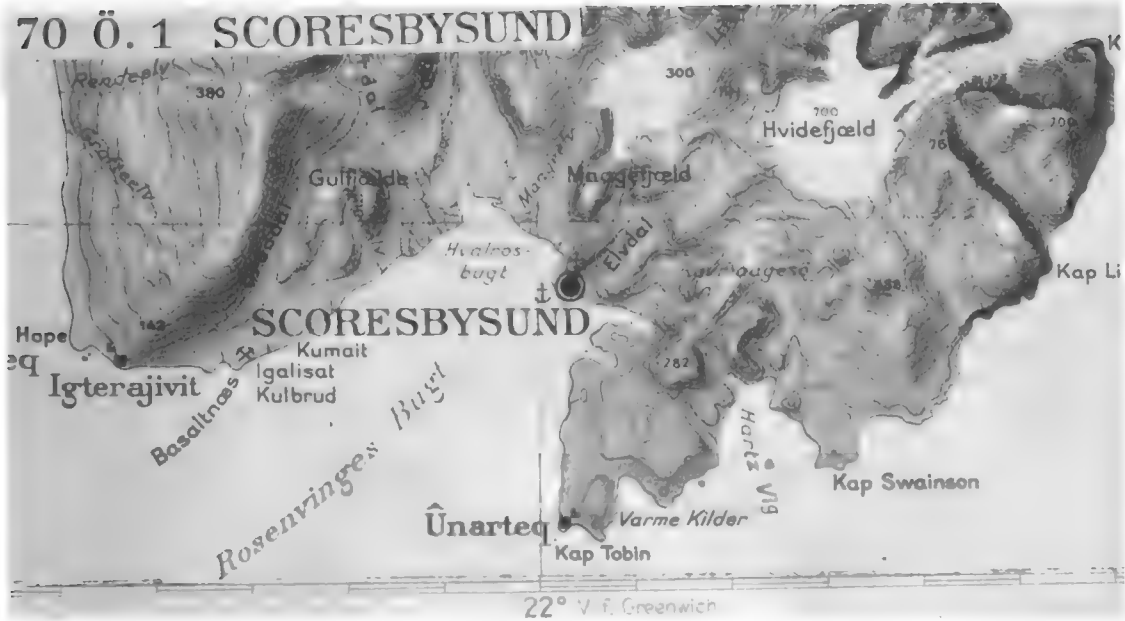

Surveyed 1933

1 : 250 000

Maalt 1933

Geodetic Institute. Copenhagen 1941

Geodætisk Institut. København 1941

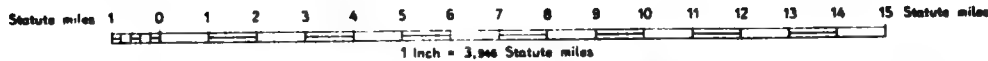
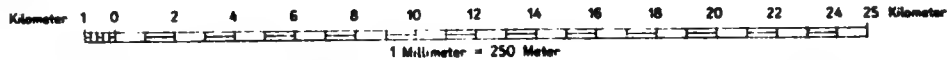

Højdekurver
(Højdeforskel 50 m)
Contours
(interval 50 m)

Krat
Scrub

Anden Bevoksning
Other vegetation

Sand og Ler
Sand and clay

Delta
Delta

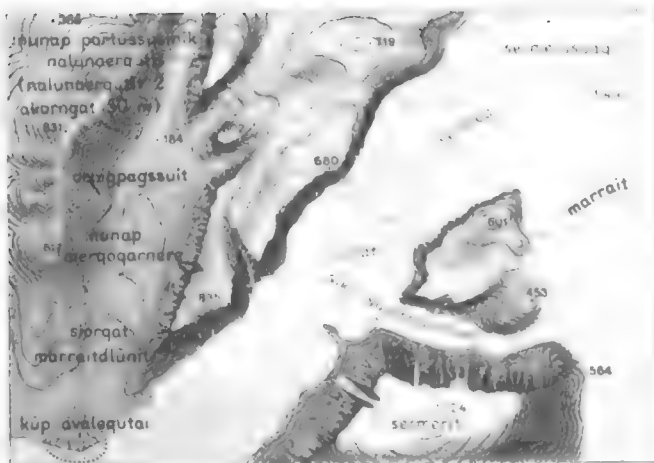

Indlandsis
Inland-ice

Gletscher (Bræ)
Glacier

Moræne
Moraine

Isbjerge (Isfjælde)
Icebergs

Aargammel Is
Palæocrystic ice

Højfjælds is
Ice - cap

0-25 200 m

Lavland

nunap pükinnera

Lowland

Figure 27. Section of Grønland 1:250,000 series by the Geodætisk Institut.

⚓ Havn (Ankerplads) umiarsuaivik (kiaeafik) Harbour (anchorage)	△ Trigonometrisk el. astronomisk Station nunamik ūgtuivfik imlt. uvdlorisanik misigssuifkat ūgtuivfik Triangulation or astronomical point
⚓ Baadehavn umiatsialivik Boat - harbour	⚡ Radio - og Telegrafstation radioqarfik Wireless station
† Sømarke imarsiovtunut nalunaerqutaq Sea - mark	⚡ Mine, Brud piaivfik Mine
•• Undervandsskær (usikker Beliggenhed) ikardluk tinuneq ajugd Submerged rock (position doubtful)	o Kilde puilassoq Spring
942 Højder i Meter qáqaaq ūgtorparput meters atordlugo Heights in meters	----- Slædevej qimugsertarfik Sledging route

Copyright reserved

● GODHAVN

Koloni
niuertorqarfik
Principal settlement

■ Eneliggende Hus
igdle
Isolated house

● SKANSEN

Udsted
niuertoruseqarfik
Outpost

→ Kirkeruin
aqalugfikaaq itsarnisoq
Church ruin

■ Sioraq

Boplads
asimioqarfik
Dwelling place

■ Tidligere Eskimobebbyggelse
igdlukut
Former Eskimo dwelling - place

--- Sysselgrænse
sysselaqarfiup kigdlinga
District boundary

× Nordbo Gaardtomt
qavdlundtsiait igdlukue
Site of Norse farm

..... Kommunegrænse
kommunaqarfiup kigdlinga
Settlement boundary

× Mindre Nordboruin
qavdlundtsiait igdlukunguet
Lesser Norse ruin

Figure 28. Legend in three languages (Danish, Eskimo, and English) appearing on Geodaetisk Institut maps of Greenland.

Section II. ICELAND

32. Mapping Activities

a. *Official.* The Danish Geodaetisk Institut (Geodetic Institute) of Copenhagen, under contract to the Icelandic government, serves as the official mapping agency for compiling and publishing the topographic map series of Iceland.

b. *Other.* In the post-World War II era the Army Map Service revised all the major series covering Iceland using photogrammetric (multiplex) methods.

33. Major Official Maps of Iceland

a. *Topographic Series.*

- (1) *Iceland*; 1:50,000; Geodaetisk Institut; 1910, 1935, 1941; no grid.

This polychrome topographic series covering the western and south-central areas of Iceland is based on surveys of 1904-14 with some revisions of the early 1930's. In glacial areas relief is shown by form lines. In the remaining areas contours at 20-meter intervals and spot heights in meters depict relief.

- (2) *Uppdráttur Islands (Map of Iceland)*; 1:100,000; Geodaetisk Institut; 1944-45; no grid.

This polychrome topographic series covering all of Iceland was compiled from early ground surveys and 1937-38



Figure 29. Section of Uppdráttur Islands by the Geodætisk Institut, reprinted by the Generalstab des Heeres.

aerial photography. Relief is shown by contours at intervals of 20 meters, spot heights in meters, and form lines in the glacial areas. During World War II, this series was reprinted (fig. 29) by the German Generalstab des Heeres (General Staff of the Army).

- (3) *Uppdráttur Íslands* (Map of Iceland); 1:250,000; Geodaetisk Institut; 1938-46; no grid.

This polychrome topographic series covering all of Iceland was compiled from surveys of various dates. Relief is shown by contours at 20-meter intervals and spot heights in meters, and by form lines in glacial areas.

b. Town plans. The Geodaetisk Institut has published monochrome plans for the principal towns in Iceland. A polychrome plan of Reykjavik was printed in 1947.

34. Coordinate Systems

On all major map series of Iceland published by the Geodaetisk Institut, geographic coordinates are expressed in the sexagesimal (degree) system. On the 1:50,000 series, graticule ticks are indicated and longitude values are referred to Copen-

hagen; on all remaining series full line graticules are shown and Greenwich is the prime meridian. No grid is shown on the Danish maps of Iceland.

35. Characteristics

Place names are in Icelandic and Danish. On the 1:50,000 series no legend is shown, but a symbol sheet provides this information. Marginal data on the other series include a legend of conventional signs; a legend in which map features are described in Icelandic, Danish, and English; an index to adjoining sheets; and surveying and publishing dates. A bar scale in kilometers is also shown. For key terms and translation of marginal data in Danish, see table IX.

Table I. Glossary of Icelandic Map Expressions

alnir-alin	-----	units of measurement (2.06 feet— 0.63 meters)
blad	-----	sheet
endurskodad	-----	revised
haedamismunur	-----	contour interval
hæ d atölur í metrum	-----	elevation in meters.
landmælingadeild herforingjarddsins	-----	General Staff, Topographical Section
mælt	-----	surveyed
uppráttur (íslands)	-----	map of Iceland

CHAPTER 5

EASTERN ASIA

Section I. EAST CHINA AND HONG KONG

36. Mapping Activities

a. Native Mapping of East China

- (1) Chinese mapping of China began between 1708 and 1718, when a group of Jesuit Fathers commissioned by the Emperor Hsu carried out a survey of China. The results of this survey were in use until recently.
- (2) In the early part of the twentieth century surveys were carried out by provincial offices under the supervision of the Central Land Survey Board in Pei-p'ing. Many maps at scales of 1:100,000 and 1:300,000 have been made from these surveys. Since its formation, the Chinese mapping agency has undergone many changes in name: the Bureau of Land Survey (1929), the Fourth Department of the Board of Military Operations of the Chinese National Military Council (1943), and the Bureau of Survey, Ministry of National Defense (1946). After the withdrawal of the Chinese Nationalist government from the mainland to Taiwan, the Bureau became the Survey Department, Combined Services Forces Headquarters, Ministry of National Defense.
- (3) In the 1930's the Survey Department compiled a few town plans. No information is available on any major mapping by the Chinese since the end of World War II. In 1950, however, the Survey Department reprinted sheets of the 1944-45 editions of the Army Map Service 1:250,000 series covering part of the southeast coast of China. In addition, Chinese tourist agencies, book stores, municipal governments, and various geo-

graphical societies have published town plans since World War II.

b. Official Topographic Mapping of Hong Kong. The British Directorate of Military Survey, War Office (Geographical Section, General Staff)—GSGS, prepared maps of Hong Kong at 1:20,000 and 1:80,000.

c. Other Mapping of East China.

(1) *Japanese.*

- (a) Japanese mapping in Manchuria began during the Sino-Japanese War of 1894-95. Most of the early mapping activities consisted of hastily performed surveys at 1:5,000, 1:20,000, 1:50,000, and 1:100,000. After the Russo-Japanese War and the Treaty of Portsmouth in 1905, and until the 1930's, the Japanese carried out more accurate surveys at 1:25,000 and 1:50,000 of strategic areas in the central plains and Jehol Province. As the Japanese completed surveys in these areas, they compiled sheets at 1:100,000 based mainly on these survey data. Most of these surveys prior to 1931 were performed in comparative secrecy, and therefore high-order triangulation and precise planetable surveys were virtually impossible.
- (b) When the Japanese took control of Manchuria and Jehol in 1931, they published several map series at 1:100,000, 1:200,000, and 1:500,000 that had been based on earlier Japanese, Chinese, and Russian surveys.
- (c) After 1933 the Japanese set up the Kwantung Army Survey Unit and other military units and the "Manchukuo" Survey Office under the "Manchukuo" puppet government.

Many maps were published also by the Japanese General Staff (JGS) or the Imperial Land Survey (JILS), a Japanese civilian agency.

- (d) Large-scale ground or photo surveys dating from 1933 to 1943 were the bases for several series at 1:50,000 and larger scales. Concurrently, the Japanese also prepared series at 1:100,000 and smaller scales from various ground surveys, maps, and aerial photography. From 1938 to 1940 the General Staff published a series at 1:200,000 covering a large part of Manchuria; in 1942-43 the Kwantung Army Headquarters compiled a series at 1:200,000 covering a large part of the area of the General Staff 1:200,000 series, but incorporating later date source material.
 - (e) During the Japanese occupation of East China (excluding Manchuria and Jehol) which began in 1937, many series were prepared at scales of 1:10,000; 1:25,000; 1:50,000, and 1:100,000. These series covered the major communication lines, points of strategic importance, and major urban areas. The Japanese also published military special-purpose maps at scales of 1:50,000, 1:100,000, 1:200,000, and 1:500,000 for practically all of East China. All Japanese maps produced during the Japanese occupation were based on either aerial-photo surveys or Japanese field reconnaissance, or compiled from Japanese or Chinese maps.
 - (f) In addition, the Japanese have compiled 1:500,000 and 1:1,000,000 topographic series that cover all of East China including Manchuria. Before and during World War II the Japanese General Staff or subordinate units also published monochrome topographic town plans for urban areas throughout East China at the scales of 1:5,000, 1:8,000, 1:9,000, 1:10,000, and 1:15,000.
- (2) *British.* The Directorate of Military Survey, War Office (Geographical Section, General Staff)—GSGS prepared maps at a scale of 1:126,720 for the Shanghai area.

(3) *United States.*

- (a) *Topographic series.* Since the early part of World War II, the Army Map Service has carried out an extensive mapping program for China. In 1944-45 AMS compiled a 1:250,000 series covering East China and another covering Inner Mongolia. A series at 1:250,000, covering about three-fifths of Manchuria, was prepared in 1945-46; it has since been recompiled and extended to cover the entire area of Manchuria. A 1:250,000 plastic relief series for most of the China-Korea border was made in 1950 from the recompiled series. A number of 1:1,000,000 sheets have also been compiled by AMS for East China.
- (b) *Town plans.* In 1944-46 AMS compiled multicolored topographic town plans of major cities from World War II USAF photography and map sources; most of these were published at a scale of 1:12,500. A number of monochrome or multicolored small-scale town plans of various cities were also published in 1944-45 by the Research and Analysis Branch of the Office of Strategic Services.

37. Major Topographic Maps

a. *Native Series of East China*

- (1) [*1:100,000 and 1:300,000 Maps of China*]; Survey Department, Combined Services Forces Headquarters, Ministry of National Defense; 1901-47; no grid. These monochrome sheets, providing coverage for most of East China, were based mainly on reconnaissance surveys made from 1900 to 1930. Revisions dated 1931-35 were incorporated on some sheets. Relief is portrayed by approximate contours at 50-meter intervals or by form lines with or without assigned values. Some sheets are partly or entirely planimetric. Approximate straight-line distances between major built-up areas are indicated by dashed lines. On some of the 1:300,000 sheets cartographic representation is similar to that of (2) below (fig. 30).

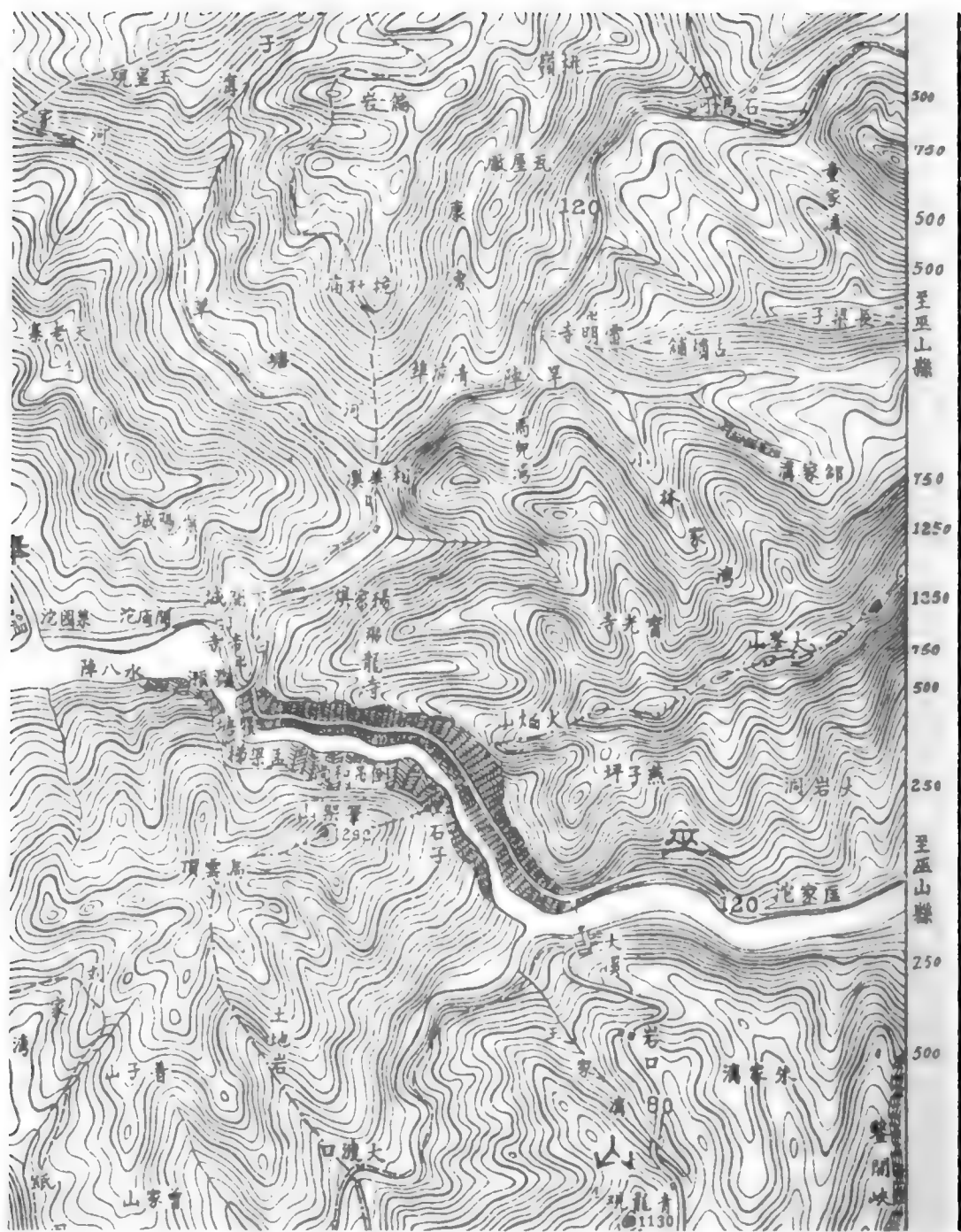

Figure 30. Section of Szechwan Province Map at 1:100,000 by the Chinese Survey Department, Combined Services Forces Headquarters, Ministry of National Defense. Figures in border are approximate contour-interval values in meters.

(2) [*Szechwan Province*]; 1:100,000; Survey Department, Combined Services Forces Headquarters, Ministry of National Defense; 1931-41, no print dates given for some sheets; no grid.

These monochrome and multicolored

sheets (fig. 30), made from traverse surveys of 1929 to 1939, provide coverage for about 95% of Szechwan Province. Relief is shown by approximate contours at 50-meter intervals. Small populated places are named, but

CH'ENG-HSIEN

中華民國三十九年五月翻印

Re-printed 1950

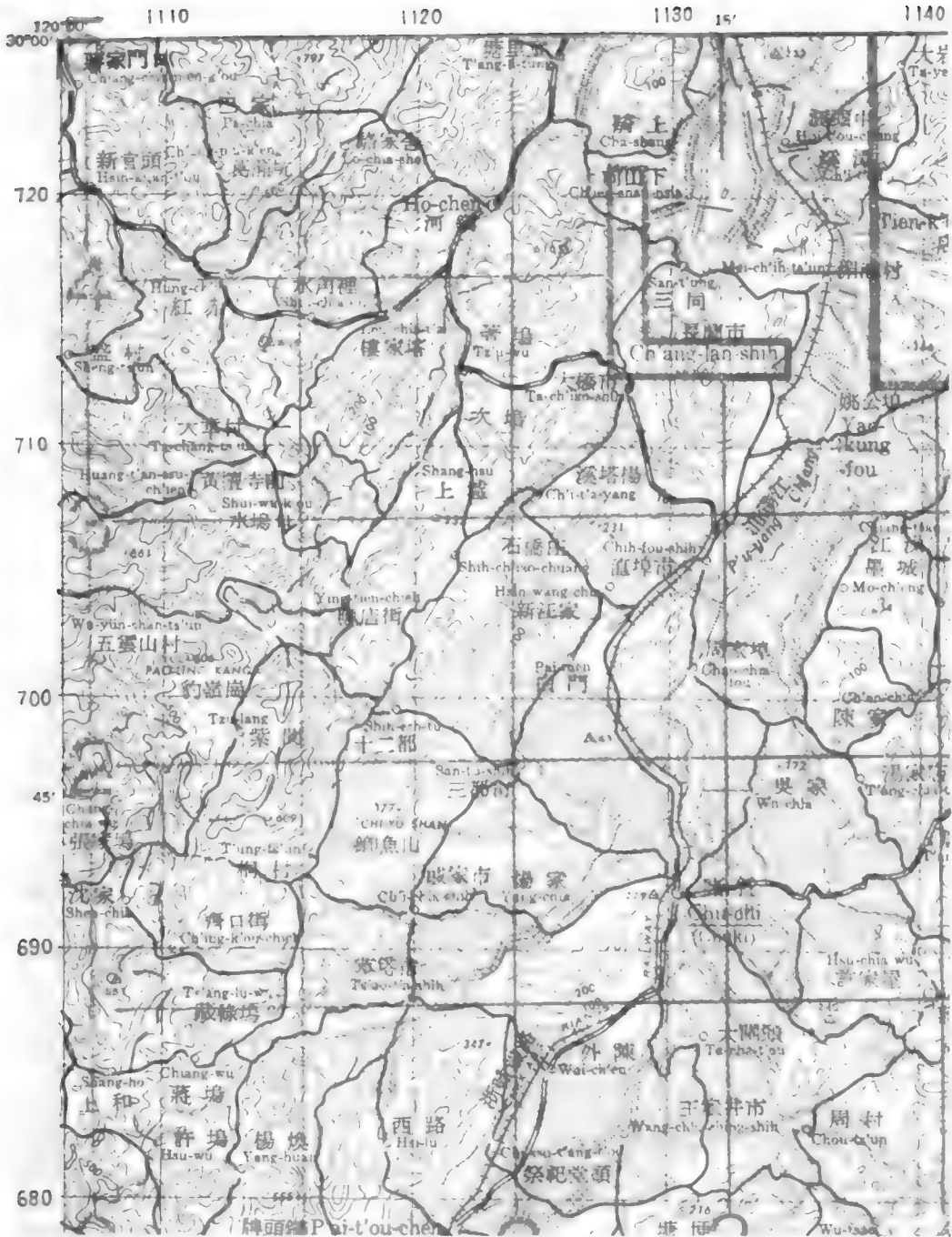

Figure 31. Section of Army Map Service 1944-45 edition of map at 1:250,000 of Southeast China, reprinted by the Chinese Survey Department, Combined Services Forces Headquarters, Ministry of National Defense.

there are no symbols to show their exact location. The Japanese General Staff has reprinted these Chinese sheets.

(3) [Southeast China]; 1:250,000; Survey

Department; Combined Services Forces Headquarters, Ministry of National Defense; 1950; World Polyconic and Air Defense grids.

These multicolored sheets (fig. 31) are

reprints of the 1944–45 editions of the AMS 1:250,000 series. An Air Defense grid has been added and marginal information has been revised; the sheets cover 1° of latitude and 1°30' of longitude instead of the original 1°×1°. Chinese ideographs have been added for all place names. The series provides coverage for Taiwan, P'eng-hu Islands (Pescadores Islands), and the China coast along the East China Sea and the Formosa Strait. Relief is portrayed by contours at 100-meter intervals or by form lines.

- (4) (*China Atlas 1:500,000*); Survey Department, Combined Services Forces Headquarters, Ministry of National Defense; 1913–36; no grid.

These 2° latitude by 3° longitude sheets providing coverage for all of East China vary considerably in presentation of detail. Both monochrome and multicolored sheets are included in the series. Relief is portrayed by contours with the contour interval increasing with elevation and by form lines, hill shading, or hachures. All populated places are named, but symbols indicating the exact location of some towns are lacking.

- (5) (*China Atlas 1:1,000,000*); Survey Department, Combined Services Forces Headquarters, Ministry of National Defense; 1948; no grid.

These monochrome sheets, compiled in 1943 from various map sources, provide coverage for all of East China, Taiwan, and the P'eng-hu Islands (Pescadores Islands). Relief is shown by contours with irregular intervals, presumably with the object of applying layer tints, as evidenced by the presence of a gradient tint diagram in the margin.

b. Official Series of Hong Kong.

Hong Kong and New Territory; 1:20,000; 1930–52; and [*Hong Kong, the New Territories, and the Lema Islands*]; 1:80,000; 1949; Directorate of Military Survey, War Office (Geographical Section, General Staff); GSGS 3868 and GSGS 3961; World Polyconic grid.

These multicolored sheets are based on areal surveys and controlled ground surveys of the early 1920's. Most of the sheets were field revised in the late 1930's. The latest revisions were in 1952. Relief is portrayed by contours at 10-meter intervals on the 1:20,000 series and at 50-meter intervals on the 1:80,000 sheets. Main roads are shown in red on the 1:80,000 sheets. The Army Map Service reprinted these 1:20,000 and 1:80,000 sheets with minor revisions in the late 1940's.

c. Other Series of East China.

- (1) [*1:25,000 and 1:50,000 Topographic Maps*]; Japanese General Staff and/or Japanese Imperial Land Survey; 1896–1945; local grids in gold on some sheets.

Many small series provide coverage for various parts of East China. Most of the sheets are monochrome; on a few, drainage is indicated in blue. These sheets are based on aerial-photo (fig. 32) or ground surveys; or compiled from other maps. Many of these sheets have been revised. Relief is shown by contours at 10- and 20-meter intervals or by form lines. Some areas on the sheets are planimetric. Sheets vary greatly in size. Two editions are available for some sheets covering areas of militarily strategic importance in Manchuria—one with partial and one with complete information.

- (2) [*Japanese Military Intelligence Series*]; 1:50,000 to 1:500,000; Japanese General Staff and/or Japanese Imperial Land Survey; 1937–44; reference grid on some sheets.

These sheets provide coverage for most of East China. Standard-size, monochrome sheets were panelled together, and military information based on field reconnaissance was overprinted in 1 to 3 colors on these oversize sheets.

- (3) (*Manchuria, Siberia, and Mongolia*), (*North China Reduced Map*), (*Military Map, Aerial Photo Survey*); 1:100,000; Japanese General Staff; 1904–44; local grid on some sheets.

These monochrome maps provide coverage for almost all of East China.

祖家江	湖都八	雁家殿
龍波東	湖漢波	
湖遠馬	湖陽華	

昭和十三年十一月撮影
昭和十四年六月編製

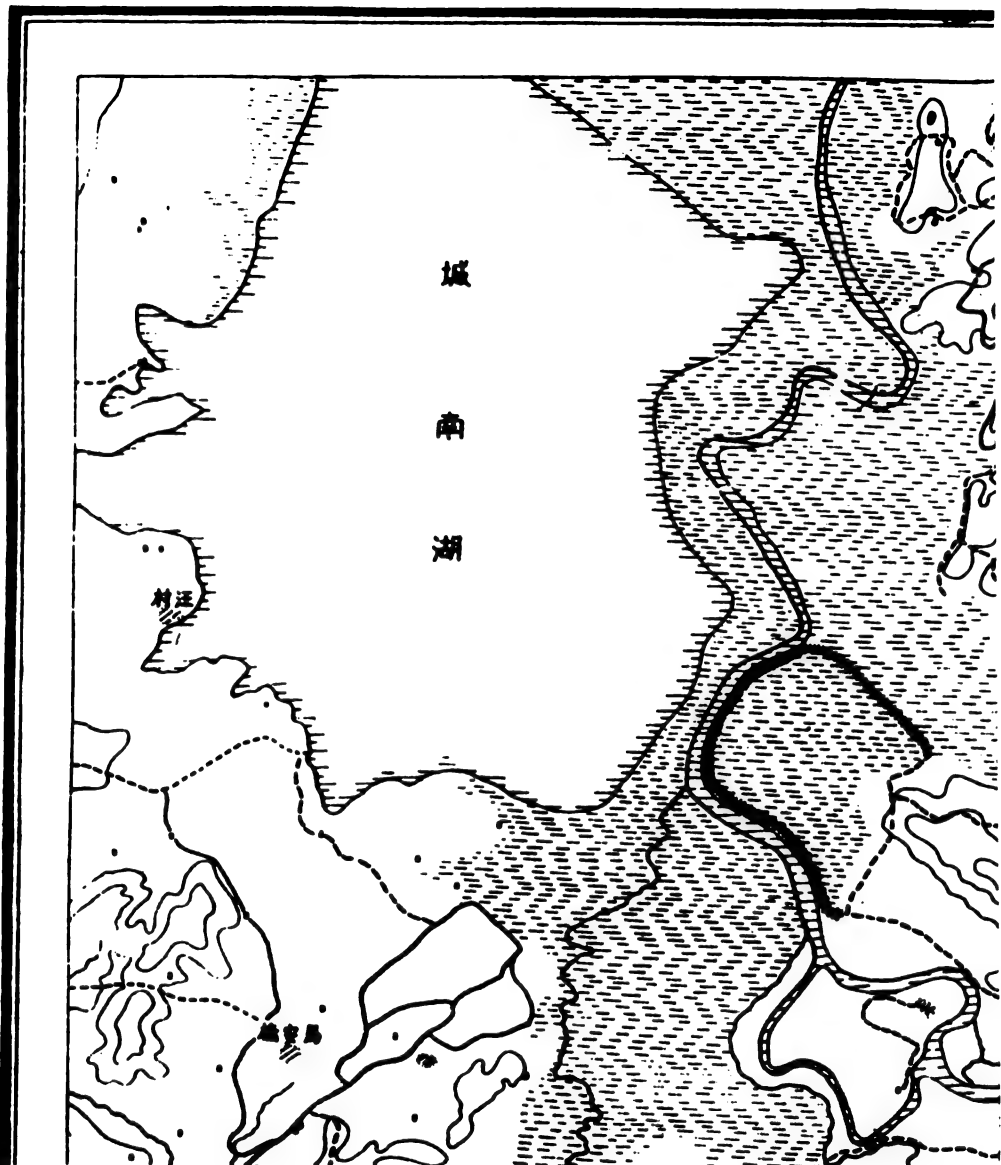
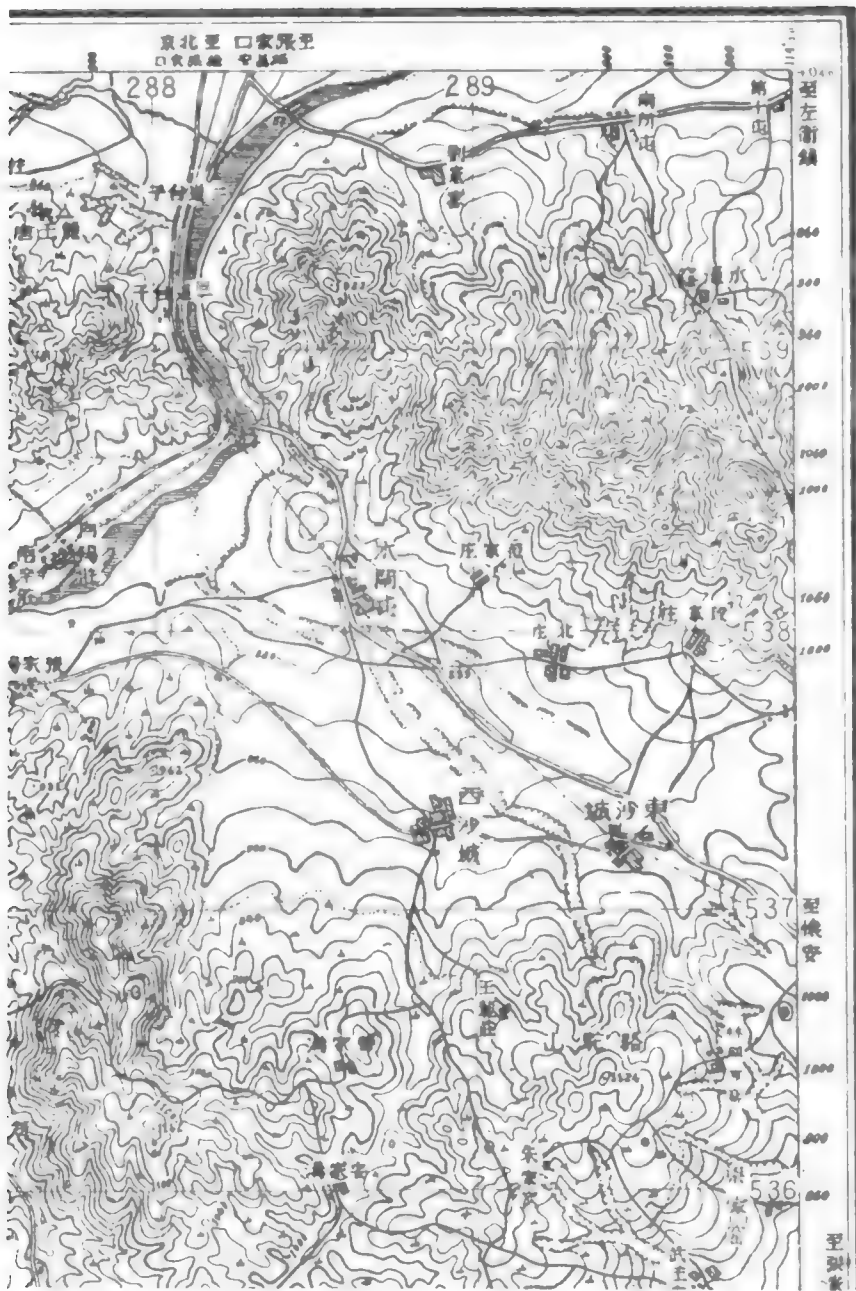

Figure 32. Section of Sheet An-Ching 19 (based on an aerial-photo) of Japanese 1:50,000 Topographic Map covering part of East China.

Their appearance varies depending upon the sources used in their preparation. They were compiled from Chinese and Russian maps, or based on Japanese ground or aerial-photo (fig. 33) surveys, or reprinted from Chinese maps. Some sheets have been revised

from aerial-photo surveys. A few sheets are oversized. Relief is shown by contours at various intervals, (50, 40, 20, and 21 meters) or by form lines. (4) [1:200,000 Topographic Maps]; Japanese General Staff or Japanese Imperial Land Survey; 1932-44; no grid.

(T' IEN - CHEN) 祕極事軍



天 要 圖 鎮 空 中 寫 真 測 量

察南自治政府 萬安縣
 吉北自治政府 天鎮縣
 巴彥塔拉盟 興和縣

北支那十分分一圖壹四〇一八九
 比例尺 約五厘五十分
 昭和十六年

和 卯	安 屬	口 家 張
高 陽		堂 井 原
堂 井 原	原 陽	堂 瓦 橋

Figure 33. Section of Sheet No. 14WA119 at 1:100,000 (based on an aerial-photo survey) by the Japanese General Staff.

This series (fig. 34) provides coverage for most of Manchuria and part of Jehol, and includes both monochrome and multicolor sheets. Some are compiled sheets; others are panelled and reduced Japanese 1:100,000 sheets. Relief is portrayed by contours at various

intervals (50, 40, 20, and 21 meters) or by form lines.
 (5) (*East Asia 1:500,000*); Japanese Imperial Land Survey and/or the Japanese General Staff; 1931-45; no grid.
 This series provides coverage for all of East China, Taiwan, and the P'eng-hu

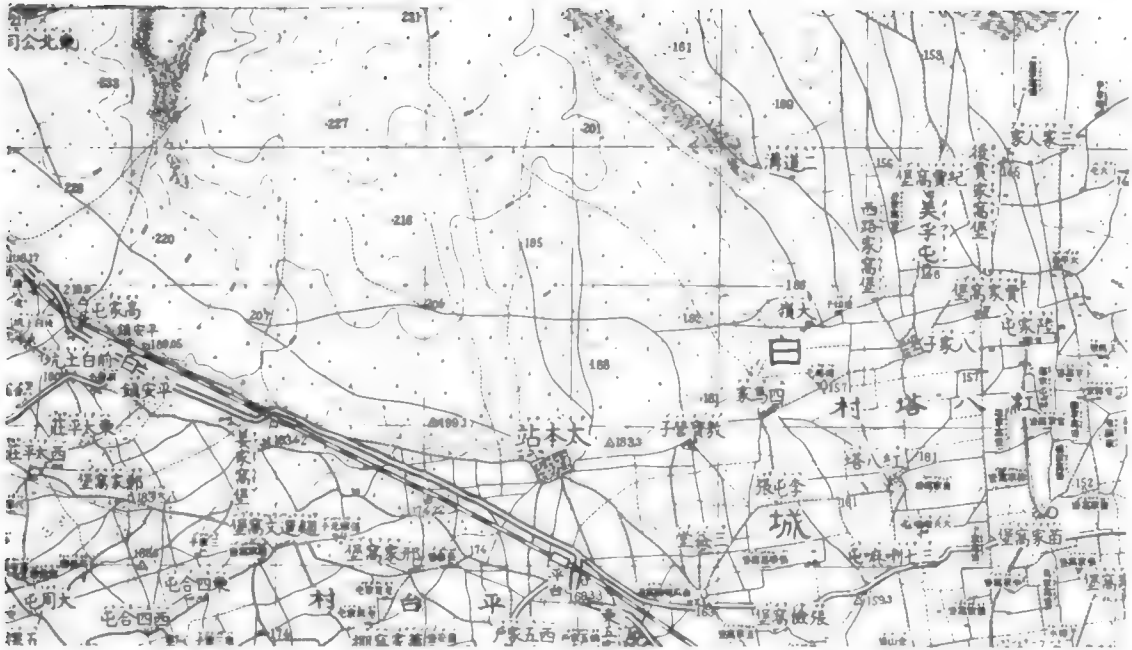

Figure 34. Section of Sheet No. 12KA212 of Japanese 1:200,000 Topographic Map of the China area.

Islands (Pescadores Islands). Most of the sheets are available in a two-color edition (drainage in blue); many are multicolored with some sheets layer tinted; and others are monochrome. For parts of Manchuria, two issues are available for some sheets that cover areas of military strategic importance—one with complete and one with partial information. Relief is portrayed by contours or approximate contours at 100-meter intervals or by form lines. Some areas of these maps are planimetric.

- (6) (1:1,000,000 Topographic Map); Japanese General Staff; 1944-45; no grid.

This series, which includes both monochrome and multicolored sheets, was compiled mainly from Japanese 1:500,000 maps. It provides partial coverage for the northeastern part of East China. Relief is shown by form lines.

38. Coordinate Systems

a. *Geographic.* Geographic coordinates are expressed in degrees with longitude values referred to the Greenwich meridian. Many sheets do not show coordinate information.

b. *Grid.*

- (1) Plane-rectangular coordinates on the In-

ternational spheroid on the Lambert conformal conic projection with two standard parallels were computed by the Chinese for the maps by the Survey Department, Combined Services Forces Headquarters, Ministry of National Defense. Eleven Lambert zones extend from 21°40'N to 55°10'N, with each zone extending 3°30' in latitude and having an overlap of 30'. The two standard parallels of each zone are 2°30' apart, so that the upper limit of each zone becomes the lower parallel of the zone just above. The central meridian is 105°E.

- (2) There is no information available concerning any overall regional grid system used by the Japanese for Manchuria, although there is evidence of a local grid system.

39. Characteristics

a. In general, maps of East China are characterized by poor legibility and absence of legends, coordinates, and/or grids. Many sheets are partly blank. There is generally a lack of uniformity as to symbolization throughout any given series and between various series. Arbitrary vertical datums have been used on these maps, and it is often difficult or impossible to determine the true vertical datum for the series.

b. Many maps, especially those at large scale, show an abundance of detail, including such special features in China as the canals, loess (wind-blown soil), and karst formations (limestone pinnacles).

c. Roads are classified by arbitrary administrative breakdown rather than by surface, width, trafficability, etc. Towns are classified, with few exceptions, according to administrative importance or relative size (for example, city, village, isolated settlement) rather than by population.

d. Most of the native maps are in Chinese, the major exception being the Chinese reprints of 1944-45 Army Map Service 1:250,000 sheets, which are in both English and Chinese. A glossary of Chinese nomenclature generally appearing on Chinese maps is shown as figure 35. British sheets are in English. All Japanese maps are in Japanese, some carrying kana as well as ideographs. For a description of Japanese mapping authorities, units of measurement, and mapping terms, see paragraph 50 and figures 53, 54, 56, 57, and 58.

e. All measurements are expressed in the metric system, with one exception: in some of the cases where Russian compilation sources were used for the Japanese 1:100,000 sheets, elevations are in sazhen (1 sazhen = 2.1336 meters).

40. Marginal Data

Although there are minor variations, there are certain basic arrangements for marginal information on Chinese (fig. 36) and Japanese (fig. 37) maps. A major exception is the Chinese 1:250,000 series reprinted from the 1944-45 AMS 1:250,000 sheets (fig. 38).

a. Legends.

- (1) *Chinese maps.* Frequently, there are no legends on the Chinese series. Major exceptions are the Chinese reprints of the 1944-45 Army Map Service 1:250,000 sheets, which carry a bilingual legend (Chinese and English), and the 1:1,000,000 series. Separate legend sheets or symbol books have been published for most sheets without legends. A major exception is the Chinese 1:500,000 map for which no legend is available. Positive identification of features on this map cannot be made because of the lack of uniformity in symbolization between series.
- (2) *Japanese maps.* Many of the Japanese

1:25,000 and 1:50,000 maps have partial, complete, or tailored legends; on some sheets, however, no legend is shown. On the military intelligence series at various scales many sheets have legends for base and/or overprint information. On some sheets no legend is shown. Many of the 1:100,000, 1:200,000, and 1:500,000 sheets and all of the 1:1,000,000 sheets have legends.

- (3) *British maps.* The GSGS 1:20,000 and 1:80,000 series carry legends.

b. *Dates.* Dates on maps published by native Chinese agencies are calculated from the first year of the Chinese Republic (Chung Hua Ming Kuo), 1912. To convert a Chinese year to our calendar, add 1911 to the number of the Chinese year. Thus, Chung Hua Ming Kuo 1 is 1912, and Chung Hua Ming Kuo 30 is 1941. For ideographs for the Chinese Republic and those for year, month, and day, see figure 35 ⊙. For description of Japanese dates see paragraph 50b and figure 55.

c. Numbering Systems.

- (1) In sheet numbering of the Chinese 1:100,000 and 1:300,000 series (fig. 39), the sheet covering Nanking is designated as the middle sheet. The column and horizontal row running through this sheet are designated as M. The next column to the east is E1; the next, E2; etc. The column to the west of Nanking is designated as W1; the next, W2; etc. The row to the north of Nanking is N1; the next, N2; etc. The row to the south is S1; the next, S2; etc. The E or W numbers are always listed first in the numbering system; e. g., E3-S2.
- (2) The Chinese 1:500,000 sheets are designated merely by sheet name.
- (3) The Japanese Kana block-numbering system for maps of the China area is used on Japanese maps at scales ranging from 1:25,000 to 1:1,000,000 (fig. 40). In this system, columns, which are 5° in width, are designated by arabic numerals, starting from 180° westward; e. g. No. 1 (175°-180°) No. 2 (170°-175°), etc. Rows, which are 3°20' in width, are designated by different Kana syllabaries (e. g. KA, WA, YO, RE, etc.). Within the 3°20'x5° blocks formed by the columns and rows, individual sheets are

中華民國	Republic of China (Chung Hua Min Kuo) 1912 -	八	Eight
年	Year	九	Nine
月	Month	十	Ten
日	Day	十一	Twelve
一	One	十二	
二	Two	二十	Twenty
三	Three	中華民國	First, February 36 th Year of the Republic of China. (1947)
四	Four	三十六年	
五	Five	二月	
六	Six	一日	
七	Seven	日	

①

Figure 35. Glossary of Chinese nomenclature generally appearing on Chinese maps.

公里	Kilometer	圖式	Mapping Specifications
公尺	Meter	標高	Elevation, or Elevations Note.
公分	Centimeter	省	Province
市里	$\frac{1}{2}$ Kilometer (Shih li)	縣	Hsien
千	Thousand	測量	Surveyed
萬	Ten Thousand	調查	Field Examination
縮尺 or 比例尺	Scale	編繪	Compiled
十萬分一	1: 100,000	修正 or 修繪	Revised
圖	Map	製板	Engraved

⑧

Figure 35—Continued.

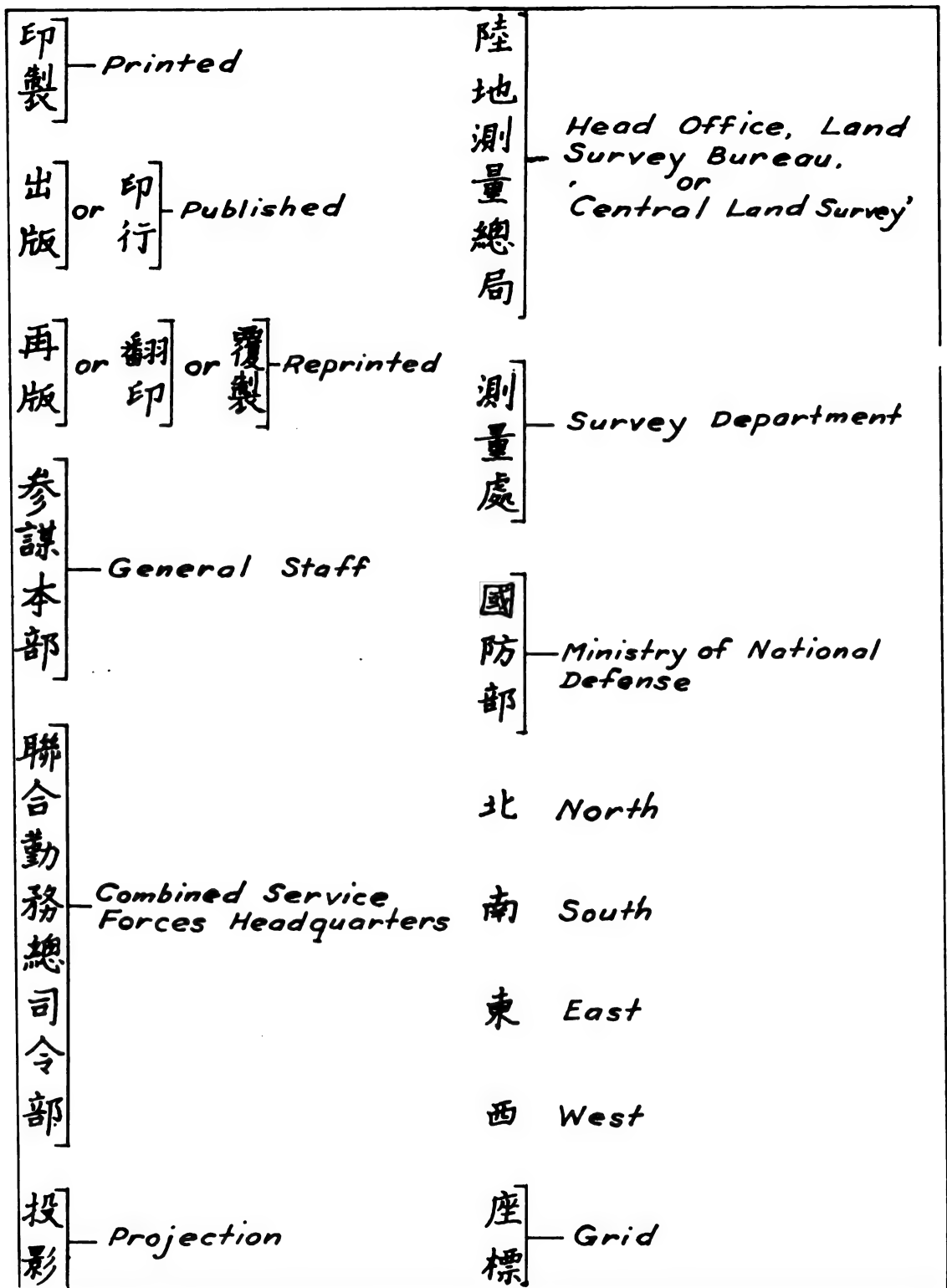

©

Figure 35—Continued.

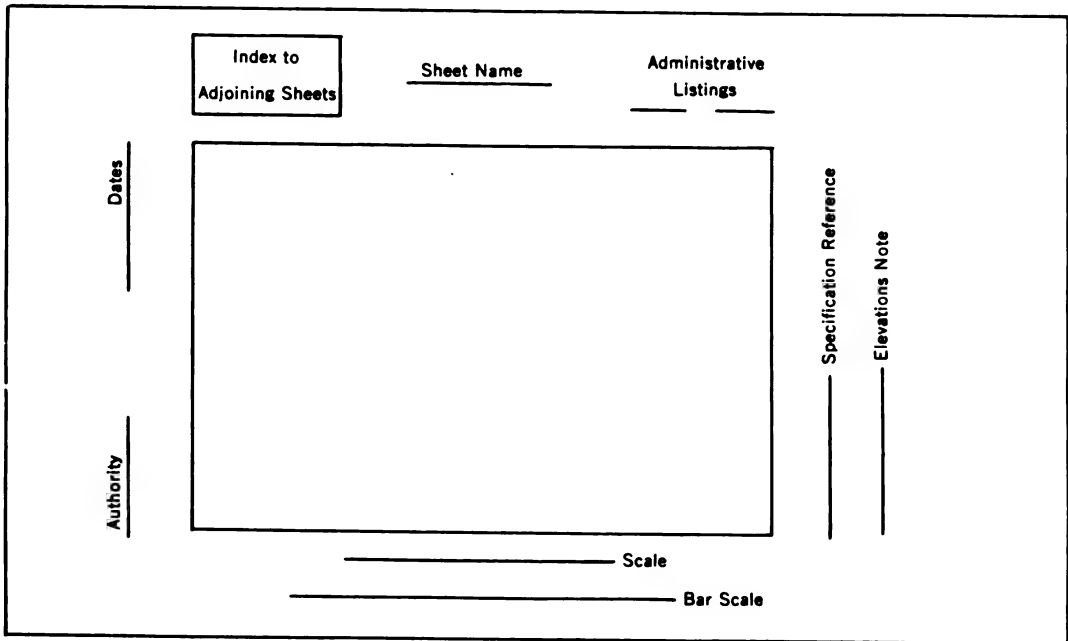

Figure 36. General positioning of marginal data on Chinese maps.

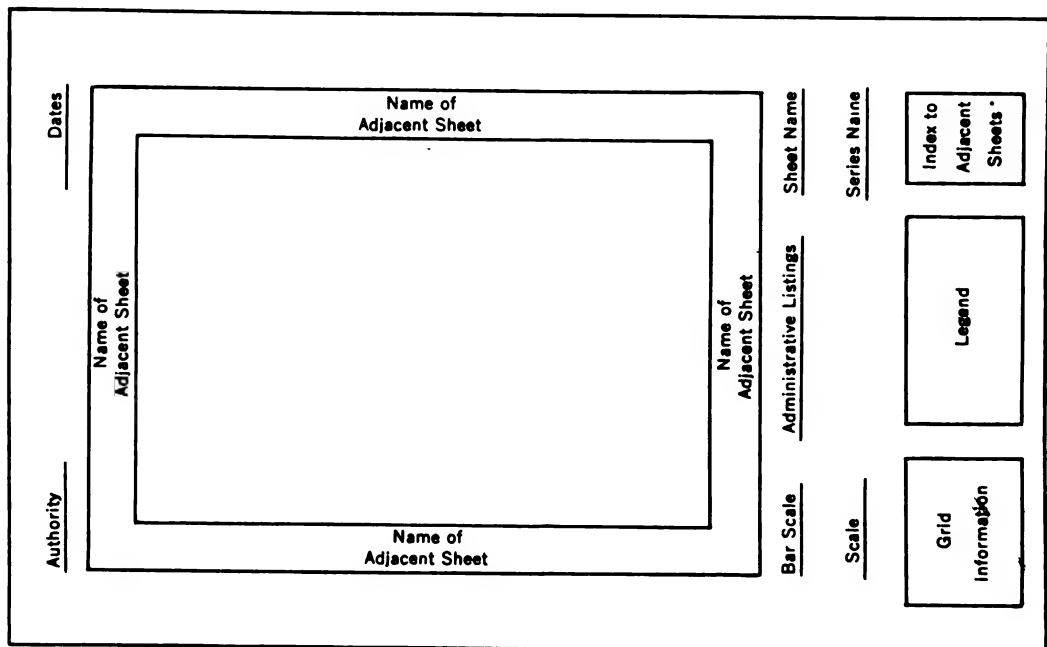

Figure 37. General positioning of marginal data on Japanese maps of China.

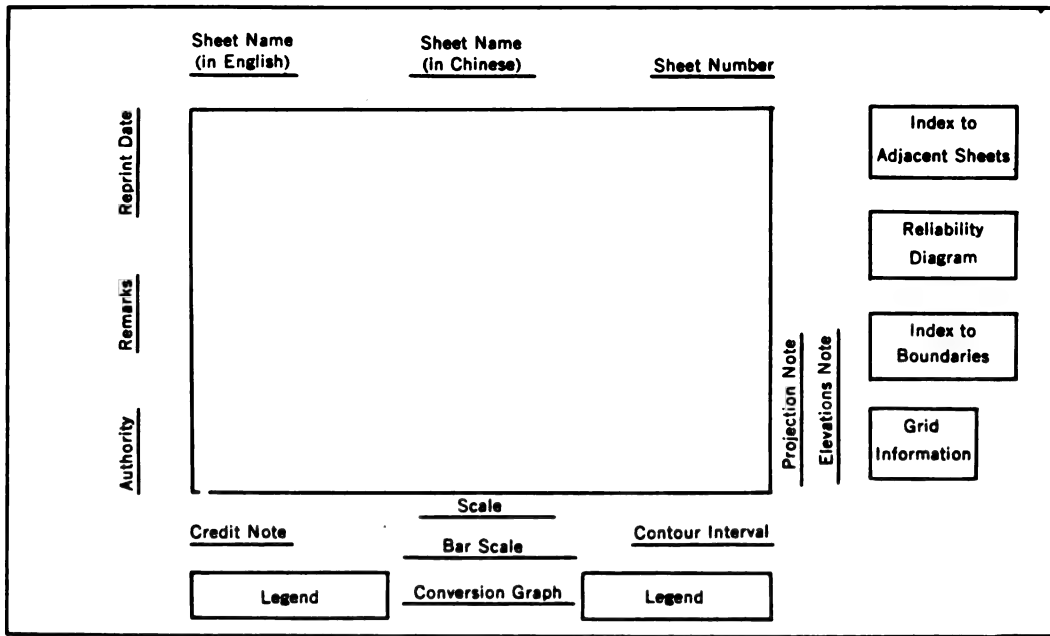

Figure 38. Positioning of marginal data on Chinese reprints of Army Map Service 1:250,000 maps, 1944-45 edition.

W2	W1	M	E1	
W2 N2	W1 N2	M N2	E1 N2	N2
W2 N1	W1 N1	M N1	E1 N1	N1
W2 M	W1 M	M M	E1 M	M
W2 S1	W1 S1	M S1	E1 S1	S1

119°

Figure 39. Chinese 1:100,000 and 1:300,000 numbering system.

numbered from top to bottom and from right to left. Sheet numbers for the 1:25,000 and 1:50,000 series are based on the sheet numbers for the 1:100,000 in which they fall, e. g., 12WA196-51 and 12WA196-16.

- (4) The Japanese also set up a numbering system whereby blocks are titled with the name of the most important populated place within the block and the sheets within the block are assigned consecutive numbers. There is overlapping between series, however, and the position of any particular sheet number varies from block to block. The Japanese apparently never completed or coordinated this system.

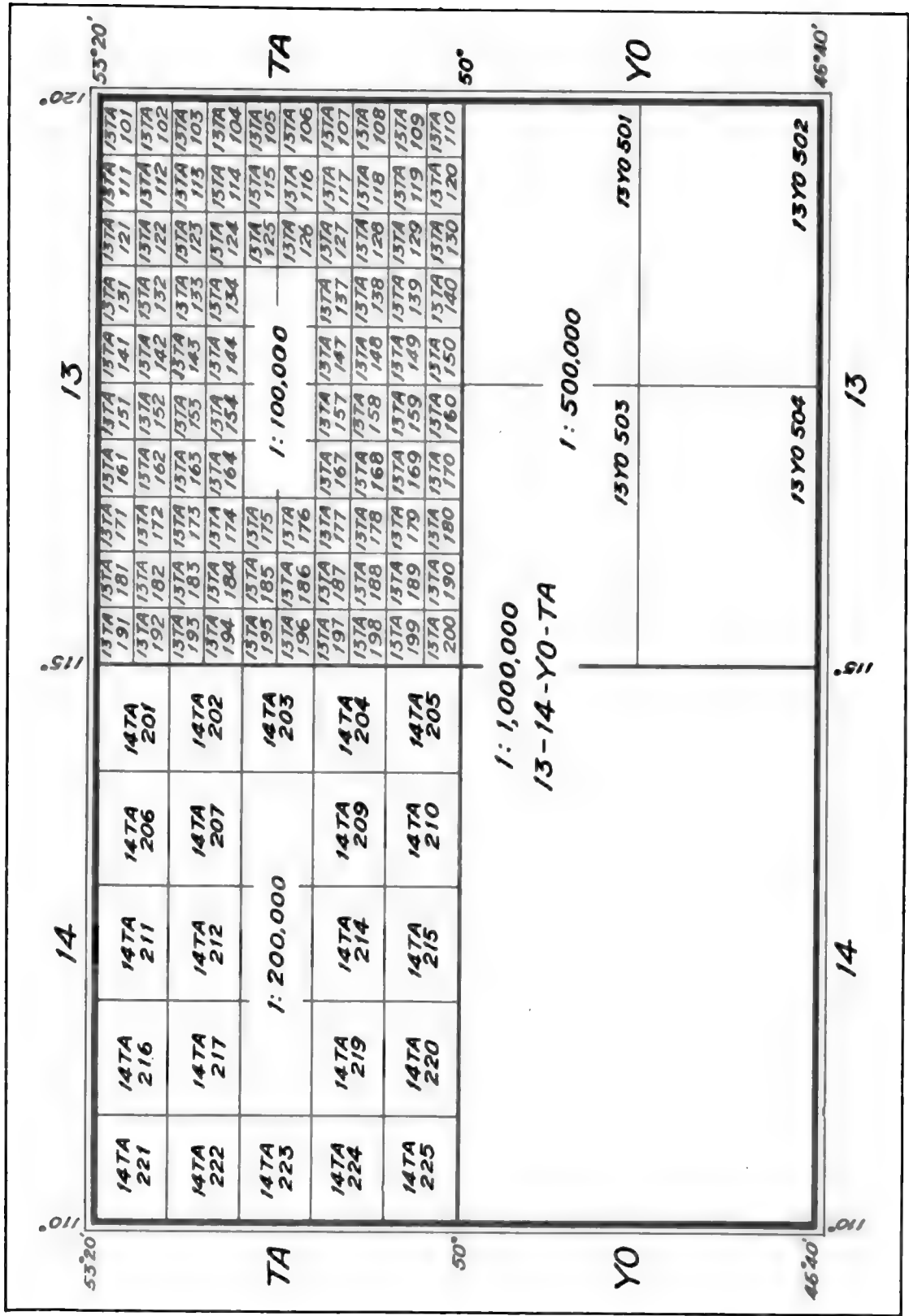

Figure 40. Japanese Kana block-numbering system for maps of the China area.

Section II. INDOCHINA

41. Mapping Activities

a. Native. A few civilian and military groups have issued maps, primarily town plans and special-purpose maps; but these are of little importance to the overall mapping of Indochina.

b. Official. Most mapping of Indochina has been done since the French acquired control of the area. The mapping agencies established by them are considered "official."

- (1) The first mapping of Indochina of any importance was performed by the Bureau Topographique (Topographic Bureau), which was set up as a section of the General Staff after the French assumed control of the area in 1886. This organization started triangulation work in Indochina and compiled topographic maps at scales of 1:100,000, 1:200,000, 1:500,000, and 1:1,000,000 as well as boundary and river maps. The 1:500,000 series, which was completed in 1899, was the most important of these maps.
- (2) The major mapping organizations are Service Géographique de l'Indochine in Dalat—SGI (Geographic Service of Indochina), Institut Géographique National in Paris—IGN (National Geographic Institute), and the Service Cartographique des Forces Armées d'Extrême Orient in Saigon—SC (Cartographic Service of the Far East Armed Forces). Service Géographique de l'Indochine was established in 1899 as the topographic mapping agency for the country. Service Cartographique, set up in 1949 as a bureau under the General Staff of the French Army in Indochina, is the military mapping agency of the country. These mapping organizations, principally SGI, have produced regular surveys, based on first-, second-, and third-order triangulation, for 55% of Indochina. The remainder of the area is covered by reconnaissance surveys. The major series for the area are at scales of 1:25,000, 1:100,000, 1:400,000, 1:500,000, and 1:1,000,000. A series at 1:50,000 was also published, but the area of coverage is limited.

c. Other.

- (1) *British.* The Directorate of Military Survey, India (HIND); Survey of India (SI); and the Directorate of Military Survey, War Office (Geographical Section, General Staff)—GSGS, compiled or reprinted many maps of Indochina during World War II. The French series at 1:25,000, 1:50,000, 1:100,000, and 1:400,000 were reprinted by the British with minor revisions. Series at 1:253,440 and 1:500,000 were compiled by HIND and the Survey of India compiled a 1:1,000,000 series. The British also compiled series at scales of 1:63,360 and 1:126,720 but the area of coverage of these series is limited. For further details, see paragraph 74.
- (2) *Japanese.* Contributions by the Japanese to the mapping of Indochina consist of reproduction of the French 1:100,000, 1:400,000, and 1:500,000 series.
- (3) *U. S.* The Army Map Service compiled a 1:50,000 series covering limited areas of Indochina and a 1:250,000 series that provides complete coverage. AMS also reprinted the British 1:253,440 series with a scale conversion to 1:250,000.

42. Major Official Topographic Maps of Indochina

a. [Indochina 1:25,000] Service Géographique de l'Indochine; 1906–54; Bonne, and Universal Transverse Mercator grids.

This topographic series (fig. 41) provides coverage for scattered areas along the coast. Most of the sheets were revised by the Service Cartographique des Forces Armées des Extrême Orient. This series was originally prepared as a multicolored edition but when the sheets were revised, most of them were reproduced as monochrome copies. Some features on the monochrome copies are difficult to distinguish. Most of the sheets are divided into halves, labelled East and West. Relief is delineated by contours with values in meters on most sheets and by ridgelines on the remainder (fig. 43). Kampongs (native settlements) are shown, but are not symbolized in

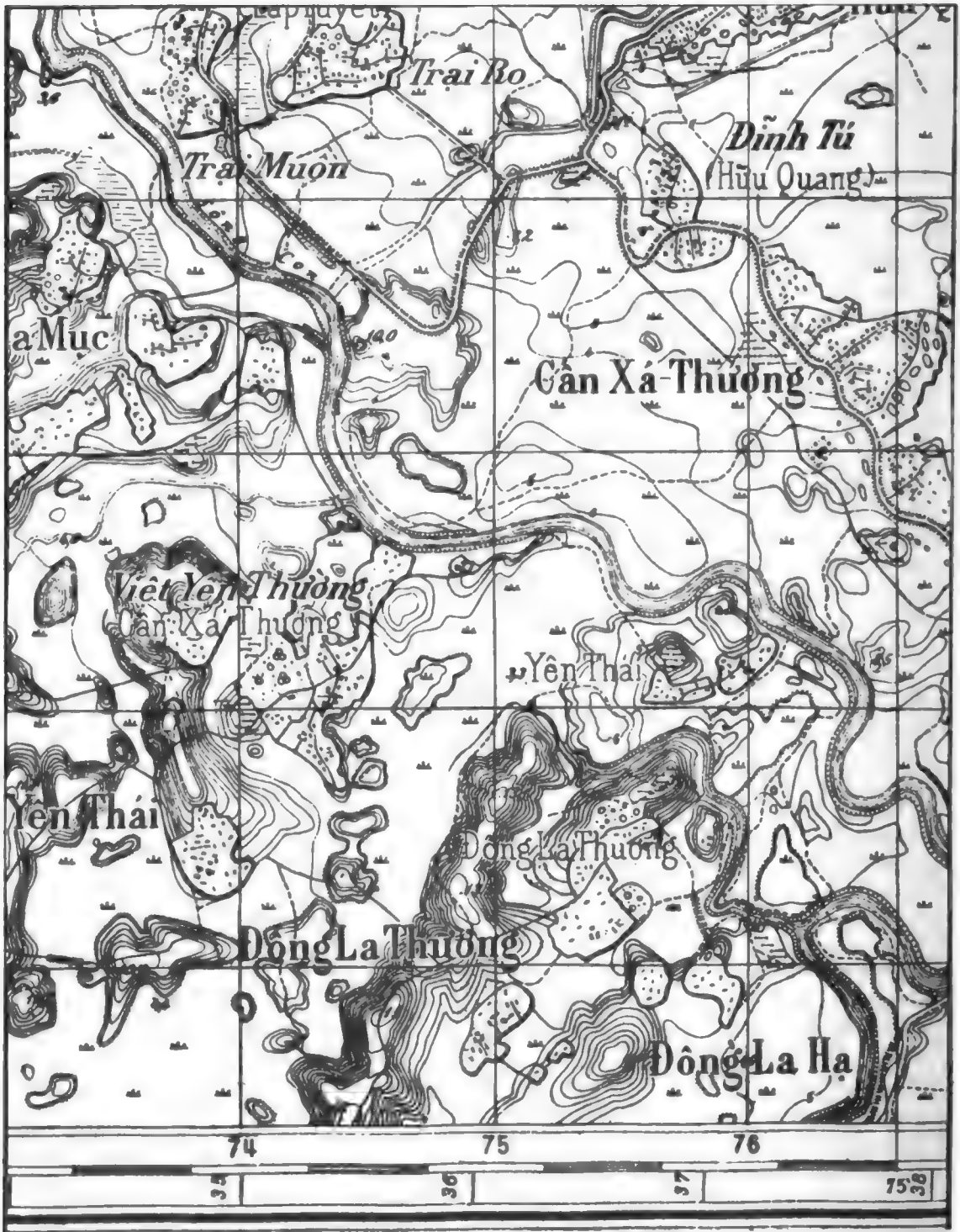
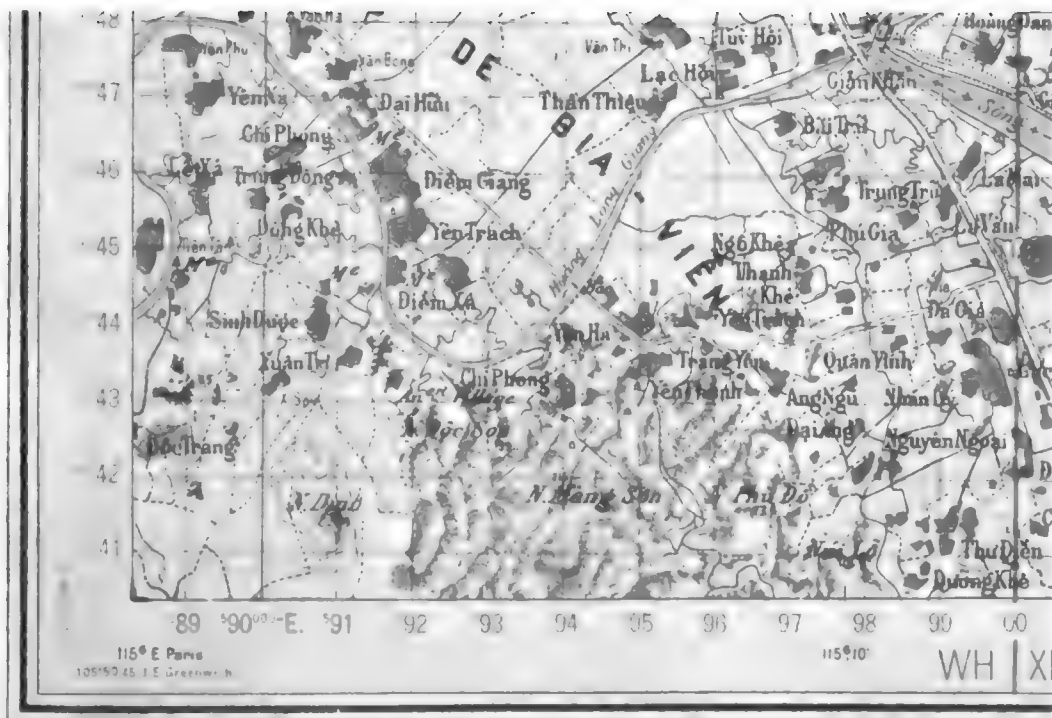

Figure 41. Section of Sheet No. 18E of the Indochina 1:25,000 series by the Service Géographique de l'Indochine.

the legend. The Army Map Service reprinted most of this series with minor revisions on a few sheets.

b. *Carte du Cambodge au 50,000* (Map of Cambodia at 1:50,000); Service Géographique de l'Indochine; 1908-33; Bonne grid.

This five-color topographic series provides coverage for two isolated areas in Cambodia. Relief is delineated by contours with values in meters. Kampongs are shown by a special symbol. AMS has reprinted all but one sheet



Dressé, dessiné et publié par le Service Géographique de l'Indochine en 1906 - Mise à jour partielle de 1952
 Drawn, designed and published by Service Géographique de l'Indochine in 1906 - Partially revised 1952

ROUTES	CHEMINS DE FER	PASSAGES DE RIVIÈRES
First class road	Gare	RIVER CROSSING
Route nationale	Tunnel	Bridge
Route empierrée	Station	Port en maçonnerie
Route non empierrée	Viaduc	for non wood
Chemin muletier	PASSAGES	Passerelle
Piste de piétons	en-dessus	Foot bridge
	en-dessous	Gué
	à niveau	Bac
	Tramway	Dam
	Remblai	Fall
	Déblai	Cascade
	Digue de protection	Rapide
		Canal navigable
		Canal d'irrigation
		Torrent saisonnier

Figure 42. Section of Sheet No. 61W of the Carte de l'Indochine 1:100,000 series by the Service Géographique de l'Indochine.

SRÉ KHTUM

Est

Edition Provisoire

Poste Deshayes Est

FEUILLE

830

11664C



Figure 43. Section of Sheet No. 191E of the Carte de l'Indochine 1:100,000 series by the Service Géographique de l'Indochine showing relief by ridge lines.

and added a Universal Transverse Mercator grid.

c. Carte de l'Indochine (Map of Indochina); 1:100,000; Service Géographique de l'Indochine; 1901-54; Bonne or Universal Transverse Mercator grid.

This multicolored topographic series (fig. 42), providing coverage for about 75% of the area, is based on ground surveys with a few sheets compiled from photo mosaics. Most of the sheets are divided into halves, labelled East and West. On sheets (or parts of sheets) that cover areas for which surveys were made, relief is delineated by contours and form lines; on those that were compiled from photo mosaics, relief is indicated by ridge lines (fig. 43). Kampongs are shown by a special symbol (fig. 42). This series was reprinted by the Army Map Service.

d. Carte Routière de l'Indochine (Road Map of Indochina); 1:400,000; Institut Géographique National; 1945-52; no grid.

This multicolored topographic series provides complete coverage for Indochina. Sheets are of two types—those compiled in 1945 with some revisions, and those compiled in 1950-52. The basic difference between these two types is that a layer tint has been added to the later date sheets. Relief is shown by contours with values in meters or by form lines. In areas of uncertain relief, a yellow tint is used. Roads are emphasized.

e. Carte Routière de l'Indochine (Road Map of Indochina); 1:400,000; Service Géographique de l'Indochine; 1937-44; no grid.

This topographic series provides coverage for all of Indochina and is basically the same as the IGN 1:400,000 series.

f. Carte de l'Indochine (Map of Indochina); 1:500,000; Service Géographique de l'Indochine; 1913-42; no grid.

This multicolored series provides coverage for all of Indochina. Relief is delineated by contours, with values in meters, or by hill shading with a layer tint. On some of the sheets, relief is shown only by spot elevations.

g. Carte de l'Indochine (Map of Indochina); 1:500,000; Institut Géographique National; 1947-48; no grid.

This three-color planimetric series provides coverage for all of Indochina. Spot elevations are given in meters.

h. Carte Internationale de Monde au 1:000,000 (International Map of the World at 1:1,000,000); Service Géographique de l'Indochine; 1939-50; no grid.

This four-color topographic series provides coverage for most of Indochina. Relief is delineated by contours and by layer tint. Values are in meters.

43. Coordinate Systems

a. Geographic. Geographic-coordinate values are expressed either in grads or degrees; Paris is the prime meridian on sheets using grads and longitudinal values are referred to Greenwich on sheets showing degrees. On the 1:25,000 and 1:100,000 series, coordinate values are shown in both degrees and grads.

b. Grid. The grids on the series covering this area include the Bonne, India Zone (Lambert), and the Universal Transverse Mercator.

44. Characteristics

a. On all series a detailed vegetation classification is shown. Series at all scales indicate areas of karst terrain (limestone pinnacles) by a rock symbol (fig. 42) but on some sheets the symbol for this feature is not shown in the legends.

b. Populated places are classified according to political or administrative importance. Roads are classified by trafficability and administrative jurisdiction. Also shown are hydrographic features, railroads, and airfields. No powerlines are shown on any series.

45. Marginal Data

a. Legends are shown on most sheets, and all but the 1:50,000 and 1:1,000,000 series carry a bilingual (French and English) legend (fig. 42). Glossaries are shown on some of the 1:100,000 sheets only.

b. The sheet numbers for the 1:25,000 series are based on the 1:100,000 numbering system; each 1:100,000 half-sheet contains approximately 16 sheets of the 1:25,000 series. The first three digits represent the 1:100,000 sheet number and the remaining digits represent an arbitrary sheet designation within the 1:100,000 sheet.

c. All the French series except the 1:25,000 and 1:50,000 sheets show reliability diagrams indicating the date and type of information used; e. g., surveys, map sources, photo revisions, and intelligence.

Section III. JAPAN

46. Mapping Activities

a. Native. The authority for major mapping programs in Japan, both past and present, has been concentrated in the national government. From 1888, when the Japanese Imperial Land Survey was established, to the present, the primary Japanese mapping agency has existed under three different titles: (1) 1888–1945, Japanese Imperial Land Survey (JILS); (2) 1945–48, Geographical Survey Bureau of the Home Ministry (GSB of HM); and (3) 1948–, Geographical Survey Institute (GSI). Prior to 1945, JILS was also engaged in meeting the mapping demands of the Japanese General Staff (JGS) under whose authority many map sheets were prepared, especially of fortified areas. By 1925, complete topographic coverage of the home islands at the basic scale of 1:50,000 was accomplished by JILS. They also prepared other topographic maps at scales ranging from 1:25,000 through 1:3,000,000. Since 1945 GSB and GSI have continued the topographic mapping program initiated by JILS. Town plans prepared by the Japanese Imperial Land Survey were limited to 1:10,000-scale series of major metropolitan areas. In 1946, however, an extensive city-plan mapping program was begun by the War Rehabilitation Commission of the Japanese government. The program was later decentralized, with various local governments (city and prefectural offices) assuming the authority for continuance of the program.

b. Other. Other than native Japanese mapping, map series prepared by the U. S. and the U. S. S. R. are of primary significance. The General'nyy Shtab, Krasnaya Armiya (General Staff of the Red Army) has prepared a multicolor 1:200,000 topographic series that provides almost complete coverage of Japan. The Army Map Service has compiled series that provide multicolor topographic coverage at scales ranging from 1:25,000 to 1:1,000,000, as well as extensive plastic relief and photomap coverage.

47. Major Native Maps of Japan

a. Topographic series.

- (1) (*Japan 1:25,000 Topographic Map*); Japanese Imperial Land Survey, Japanese General Staff, Geographical Survey Bureau of the Home Ministry, and Geo-

graphical Survey Institute; 1915–54; no grid.

Japanese 1:25,000 topographic map coverage of Japan is generally limited to areas considered by the Japanese to be of strategic value. Total coverage of the series (fig. 44 ①) represents approximately one-fourth of the total area of the country. Initial mapping was accomplished between 1915 and 1942, but many sheets of the series have been revised, some as late as 1954. The majority of the sheets are monochrome, but some two-color editions have been prepared in recent years. Relief is indicated by contours and elevations are in meters.

- (2) (*Japan 1:50,000 Topographic Map*); Japanese Imperial Land Survey, Japanese General Staff, Geographical Survey Bureau of the Home Ministry, and Geographical Survey Institute; 1888–1954; Gauss-Schreiber type grid on over sized sheets.

Complete coverage of Japan is provided by the 1:50,000 topographic series (fig. 44 ②). Original surveying and mapping was accomplished between 1888 and 1925. All sheets have been revised, some as late as 1954. All sheets of the series are monochrome editions with relief shown by contours and elevations in meters. Maps prepared for the use of the Japanese military forces before and during World War II were oversized sheets made from four regular 1:50,000 sheets. These oversized sheets carried a military grid (fig. 45).

- (3) (*Empire Map*); 1:200,000; Japanese Imperial Land Survey, Japanese General Staff, Geographical Survey Bureau of the Home Ministry, and Geographical Survey Institute; 1915–52; no grid.

The sheets of this series (fig. 46) covering all of Japan are polychrome (3 colors). Relief is indicated by contours and elevations in meters. Post-World War II revisions, incorporating boundary, railroad, and place-name

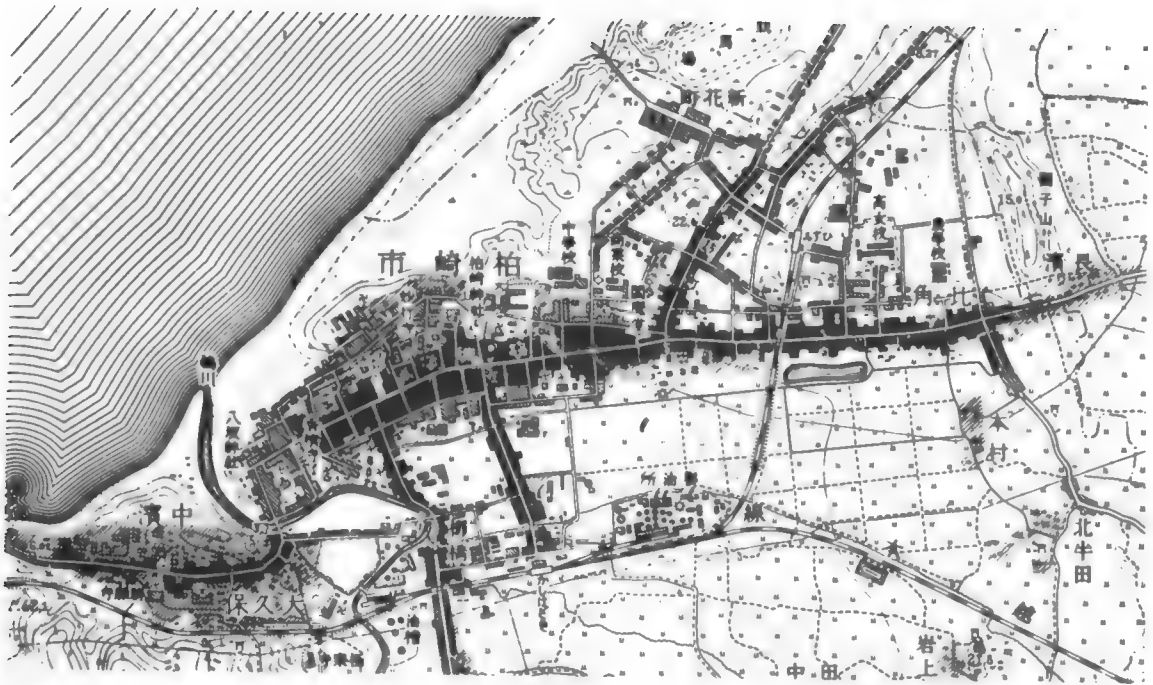

① 1:25,000

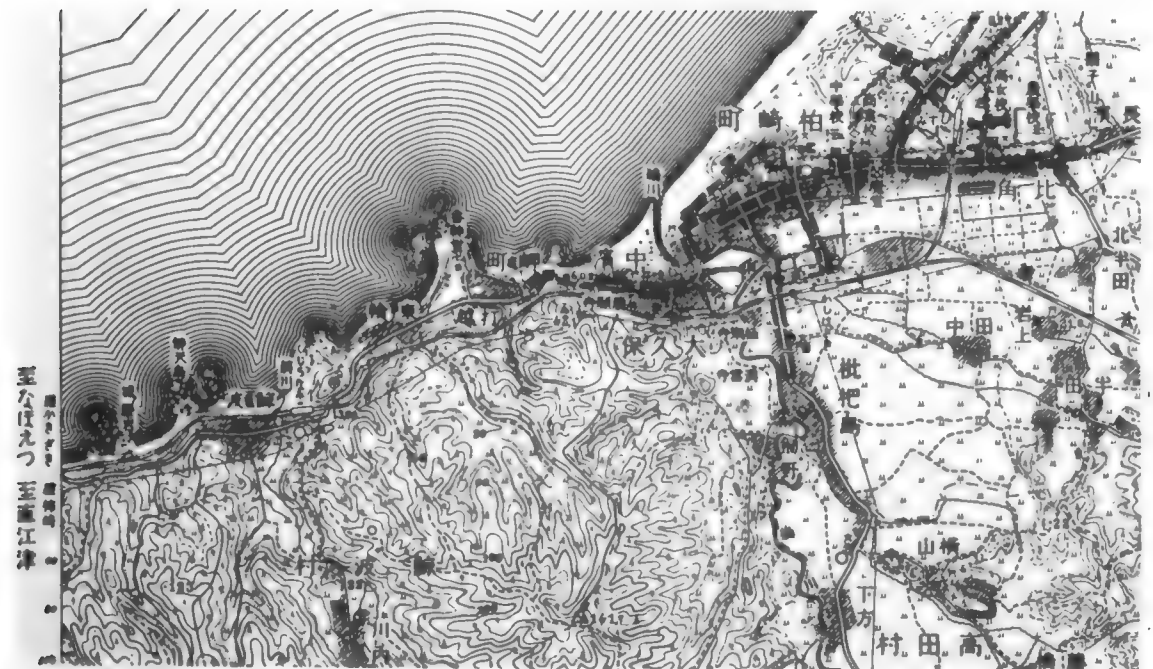

② 1:50,000

Figure 44. Sections of standard Japanese topographic maps showing parts of the city of Kashizaki.

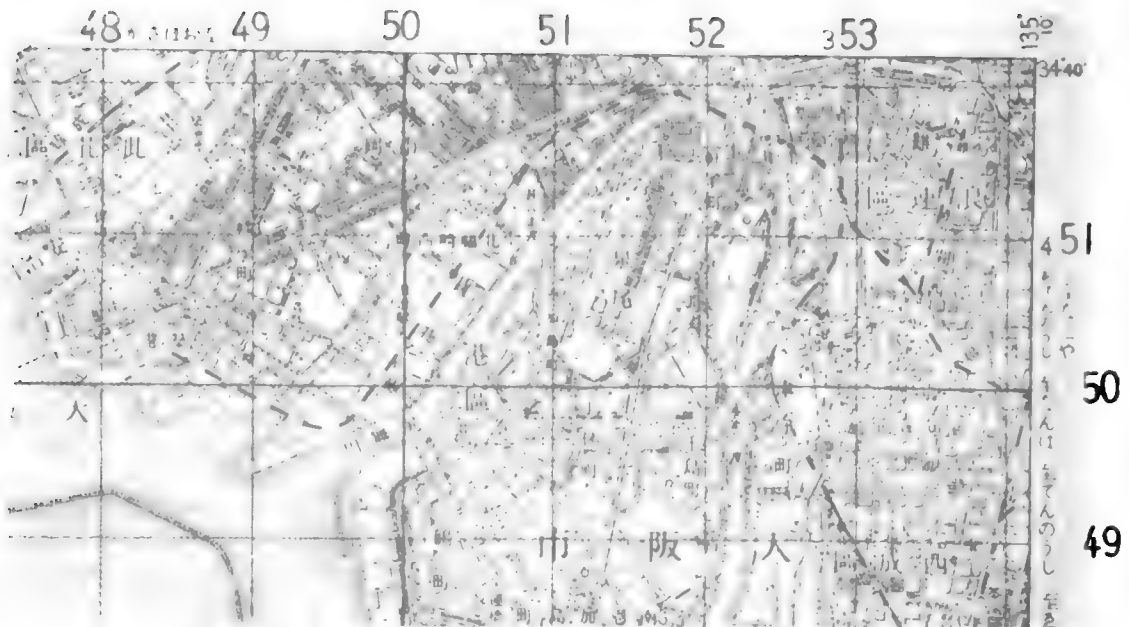

Figure 45. Section of sheet (Osaka) from oversized Japanese 1:50,000 series with Gauss-Schreiber type grid.

changes, have been made on most of the sheets.

- (4) (*Regions of Japan*); 1:500,000; Geographical Survey Bureau of the Home Ministry; 1948-49; no grid.

This multicolor topographic series (fig. 47) covering all of Japan was compiled between 1947 and 1948. Relief is indicated by contours and elevations in meters. These sheets have not been revised.

b. Town Plans. The Japanese Imperial Land Survey published a series of 1:10,000-scale town plans dated 1929-35 providing coverage for five major urban centers and their environs. These sheets, which have not been revised, are monochrome editions with relief shown by contours and elevations in meters. Since 1946, a voluminous number of monochrome town plans have been prepared by the War Rehabilitation Commission of the Japanese national government and by various local governments (city and prefectural). Although the plans range in scale from 1:3,000 through 1:35,000, the majority are at 1:5,000 or 1:10,000. Relief is shown by contours and elevations in meters. Planning data are shown by overprint on some plans. A plane-rectangular grid is used on many of these plans.

48. Coordinate Systems

a. Geographic. Geographic coordinates are shown on most Japanese maps. Longitude values,

expressed in Arabic numerals, are referred to the Greenwich meridian. Meridians and parallels are not indicated on the face of large-scale maps but are used to form the neatlines of individual sheets. Longitude values on maps are based on one of two longitudinal values for the Tokyo observatory, the two values being results of observations of different periods. East and west neatlines of Japanese maps showing areas west of the 142° meridian were originally based on the earlier longitude value of the observatory. The Japanese have revised the longitude values of those neatlines to conform with the later observatory value by the application of plus 10".4. Corner geographic coordinates are shown on pre-World War II 1:10,000-scale town plans. The majority of the post-World War II town plans, however, do not have graticule information.

b. Grid. Two types of grids are shown on Japanese military maps prepared before 1945. An arbitrary point-designator grid is shown for a few specially prepared oversized 1:50,000 topographic sheets covering major urban areas, and a Gauss-Schreiber military grid is indicated on an oversized 1:50,000 topographic series prepared for use of Japanese military forces. Post-World War II editions of Japanese topographic series do not carry a grid, although a majority of the town plans prepared for rehabilitation and land-use planning carry a plane-rectangular coordinate grid network.

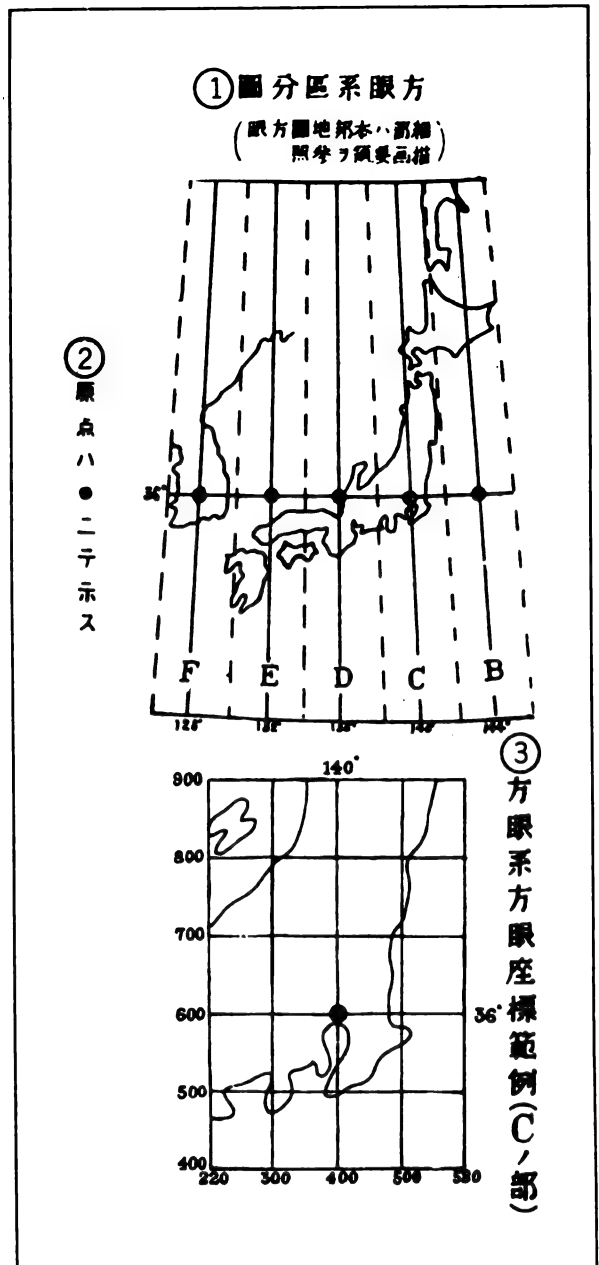

Figure 46. Section of sheet (covering Kashiwazaki and vicinity) from Japanese 1:200,000 Empire Map.



Figure 47. Section of sheet (covering Kashiwazaki and vicinity) from Japanese 1:500,000 Regions of Japan series.

- (1) *Point-designator grid.* The point-designator grid of the urban-area sheets (fig. 48) is designed to be complete within a single map sheet and does not tie to a continuous grid network. It consists of brown overprinted primary 05' grid squares, each of which is further subdivided into twenty-five 01' squares. Both the primary and secondary grid squares carry Arabic number designators and both are numbered from left to right beginning in the lower left corner.
- (2) *Military grid system.* Oversized 1:50,000 topographic maps compiled prior to 1945 for the use of the Japanese military forces carried a Gauss-Schreiber type grid (fig. 45). It was prepared by the Japanese Imperial Land Survey Bureau (JILS) and is based on the Bessel spheroid. It consists of longitudinal zones on which kilometric grids are placed (fig. 49). The basic grid interval is one kilometer. Grid coordinates are read right and up.
- (3) *Plane-rectangular coordinate grid.* The Japanese have prepared a system of plane-rectangular coordinates based on the Gauss double-conformal projection. It was adopted for large-scale public surveys and a large number of the Japanese post-World War II town plans carry these plane-rectangular grid coordinates (fig. 50). Boundaries of the grid zones do not coincide with lines of geographic coordinates but are delimited by political boundaries (prefecture, subprefecture, and gun). Each zone of the plane-rectangular coordinate system contains a base meridian of origin and a northing line of origin. The point of origin for each zone is located at the intersection of the two lines. In addition to the zonal points of origin, local surveys using the plane-rectangular grid system may originate the grid from any first- to fourth-order triangulation station.
- (4) *Polar coordinates.* Polar coordinates are used by the Japanese for point designation. Azimuths are measured clockwise in degrees or in mils. Elements of polar coordinates are given in the following



① Map of grid zones.
 ② Point of origin is designated by a dot.
 ③ An example of the application of the grid for zone "C."

Figure 49. Grid zones and points of origin for Japanese military (Gauss-Schreiber) grid.

order: reference or base point, azimuth, and distance.

49. Characteristics

Japanese topographic maps, especially those at large scales, are characterized by an abundance of detail.

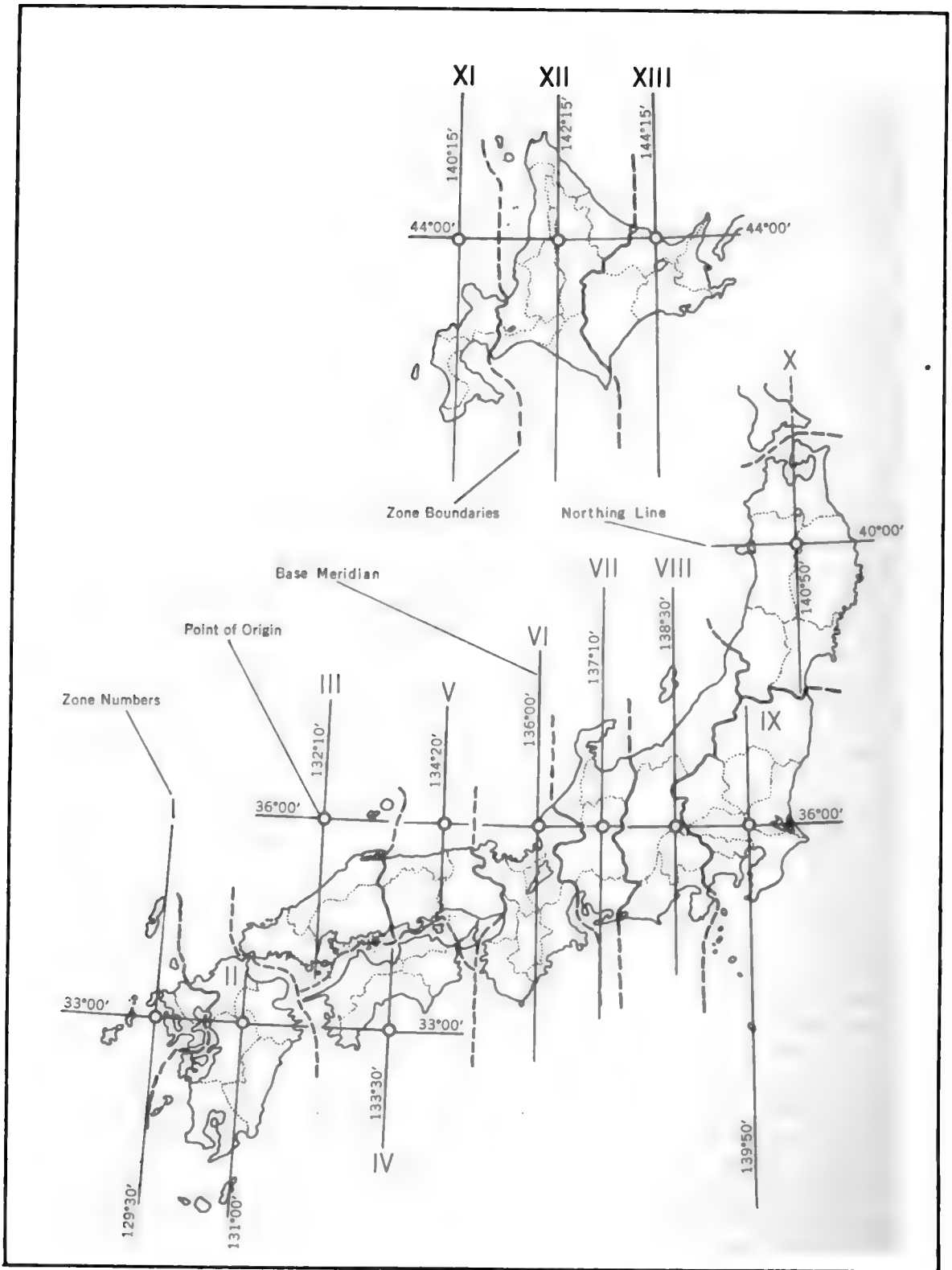

Figure 50. Japanese plane-rectangular grid coordinate system.

a. *Relief*. Contour intervals for various series are listed in table II.

Table II. Basic and Auxiliary Contour Intervals for Japanese Topographic Series of Japan.

Map scale	Basic contour interval	Auxiliary contour interval
1:25,000	10 meters	2.5 and 5 meters
1:50,000	20 meters	5 and 10 meters
1:200,000	100 meters	50 meters
1:500,000	200 meters	100 meters
1:10,000 (city plans)	5 meters	2.5 meters
1:3,000 through 1:35,000 (city plans).	0.5, 5, 10, 50 meters. Form lines.	0.25 and 5 meters

Although relief is represented basically by contours, some relief features are indicated by other methods. Rock outcrop, scattered rock, cliffs, and ravines are symbolized graphically. Earthen mounds, embankments, and levees are shown by hachures, and depressions are indicated by arrows.

b. *Cultural and Vegetation Features*. Cultural features are shown on Japanese topographic maps in great detail. At all scales, roads are divided into numerous categories based on jurisdiction and width; railroads are classified according to type (national or special) and number of tracks. On large-scale maps, a wide range of miscellaneous-type buildings (banks, police stations, warehouses, etc.) are symbolized and densities of built-up areas are shown by hatching. On small-scale maps, urban areas are classified according to size. Vegetation is generally shown by sym-

bols on most series, with delimiting lines shown on the large-scale series. Vegetation is not indicated on the 1:500,000 series.

c. *Names*. On Japanese topographic maps names are treated in a uniform manner. Ideographs, called *Kanji* by the Japanese, are used at all scales. Japanese syllabary called *Kana*, are printed alongside the *Kanji* place names on topographic sheets at 1:50,000 and larger scales. On the 1:200,000-scale maps, *Kana* is shown in addition to the *Kanji* only for railroad station names. *Kana* is used to simulate local pronunciations as determined by the Japanese from field surveys. Relative size, importance, or type of map features may be determined from the style and size of the *Kanji* and *Kana*. At large scale, individual settlement names are shown with an area name in close proximity. On the smaller-scale maps, the area names are used and the settlement names are usually dropped.

50. Marginal Information

On standard Japanese topographic maps at 1:50,000 and larger scales marginal information generally appears as illustrated in figure 51. Maps in the 1:200,000 scale series generally contain the same information, but with some variation in position. The oversized 1:50,000 topographic series contains marginal information as illustrated in figure 52. The marginal items on the post-World War II town plans and on the 1:500,000 series, vary in number and position from sheet to sheet.

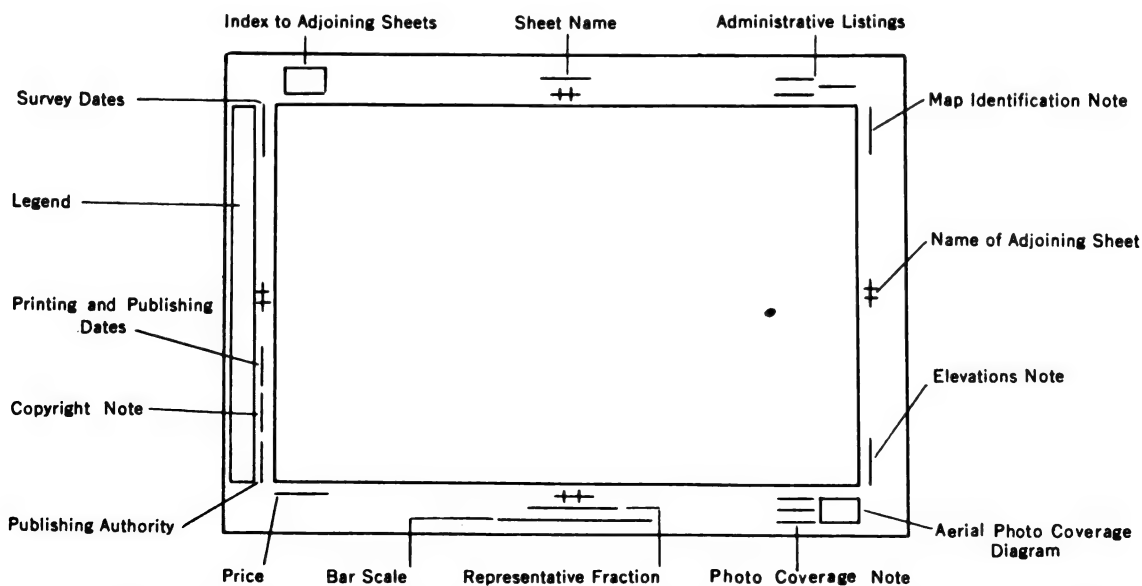

Figure 51. Diagram showing approximate position of Marginal information on standard Japanese 1:50,000 maps.

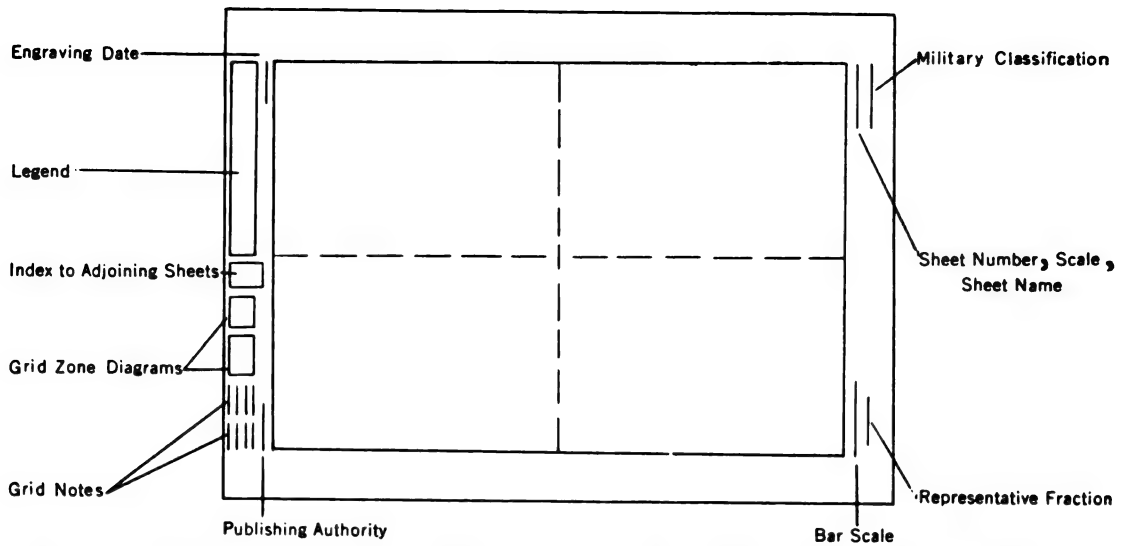

Figure 52. Diagram showing approximate position of marginal information on overcasted Japanese 1:50,000 maps.

a. Authorities. Authority names generally appear in the lower left margin of all Japanese maps except on post-World War II town plans, where they are found in the lower right margin. Major Japanese authorities, as they appear on Japanese topographic maps, are translated in figure 53.

b. Dates. Many Japanese map dates may be translated into English equivalents by a knowledge of certain basic Japanese characters associated with map dates and with an understanding of the system used in Japanese number writing.

- (1) The basic characters in the Japanese system of writing numbers are illustrated in figure 54 ①. From these basic numbers, two-digit numbers are formed. For numbers above 10 and below 20, the values of the two characters are added (fig. 54 ②). For two-digit numbers above 20, the first two characters are multiplied. If the two-digit number is made up of three Japanese numbers, the value of the last character is added to the result of multiplying the first two (fig. 54) ③.
- (2) Japanese dates found on maps dating from 1868 are calculated from the year that precedes the beginning of the reign of each of three emperors: Meiji (1867); Taisho (1911); or Showa (1925). The Japanese characters for each of these reigns are shown in figure 55. ①. The first two characters of a Japanese date will represent one of these reigns. The

year of the reign follows the name of the regime as shown in figure 55. ②. The Japanese year may be converted to our calendar year by taking the year in a given regime and adding it to the beginning year of that regime as illustrated in the right hand column of figure 55. ③. If month and day of the year are given, they are translated as shown in figure 55. ④.

- (3) In many instances when two or more dates appear in the date column and each of the dates begins with the same regime, the Japanese character for "ibid" (fig. 56 ①) replaces the characters for the regime in the second date.
- (4) The type of survey; i. e., survey, revision, etc., is usually indicated with each map date. Japanese characters for common map terms related to date types are translated in figure 56 ①. These terms follow the Japanese dates as illustrated and translated in figure 56 ②.

c. Legends. Most Japanese topographic maps carry a comprehensive legend (see *Symbols Appearing on Original Japanese Maps of all Scales*, Army Map Service, Key Number 201542). Post-World War II town plans and maps prepared by the Japanese General Staff, however, are the exception. On the former, legends appear only on a minority of the plans, while on the JGS maps legends are seldom, if ever, shown.

d. Bar scale and representative fractions. All

大日本帝國陸地測量部	Japanese Imperial Land Survey
參謀本部	[Japanese] General Staff
地理調查所	[Japanese] Geographical Survey Institute
內務省	Home Ministry
戰災復興院	War Rehabilitation Commission

Figure 53. English translation of major Japanese authorities.

Japanese maps contain bar scales. On town plans, and on 1:50,000- and 1:25,000-scale sheets, the bar scale is usually graduated in meters, *cho*, and *ri*. On the 1:200,000- and 1:500,000-scale sheets, the scales are graduated in kilometers and *ri*. Japanese characters representing these units of measurements are shown in figure 57; equivalents in the metric and English systems are given in appendix II. Representative fractions generally appear in

①			
1	一	6	六
2	二	7	七
3	三	8	八
4	四	9	九
5	五	10	十
②			
11	十一	(10+1)	
14	十四	(10+4)	
17	十七	(10+7)	
③			
20	二十	(2×10)	
31	三十一	(3×10 = 30+1 = 31)	
44	四十四	(4×10 = 40+4 = 44)	

- ① Basic Japanese numbers.
- ② Numbers from 11 through 19.
- ③ Numbers from 20 through 99.

Figure 54. English translation of Japanese numbers.

the bottom margin, centered above the bar scale. The translations for various representative fractions are given in figure 58.

①		
1867	Meiji	明治
1911	Taisho	大正
1925	Showa	昭和
②		
Meiji	明治	} — 1867
30th	三十	
Year	年	
		} — 30
		1897
U. S. Calendar Year		
③		
Meiji	明治	} — March 23, 1897
30th Year	三十年	
3rd Month	三月	
23rd Day	二十三日	

- ① Japanese characters for reigns from which dates are calculated.
- ② An example of conversion of Japanese year to U. S. calendar year.
- ③ An example of conversion of Japanese date in which month and day of the year are given.

Figure 55. English translation of Japanese dates.

①			
Surveyed	測圖	Administrative Revision	行政區區
Printed	印刷		區區
Published	發行	Emergency Edition	應急修正
Engraved	製版		修正
Revised	修正	Field Checked	現地調查
Aerial Photo	空中写真		同
Railroad Added	鐵道補入	Planimetric Revisions	平面圖化法
			同
②			
明治三十二年測圖	1867	} — Surveyed 1899	
	32nd		
	Year		
	Surveyed		

- ① Japanese terminology for types of dates.
 - ② Example of Japanese date and type of date.
- Figure 56. English translation of Japanese terminology associated with dates.

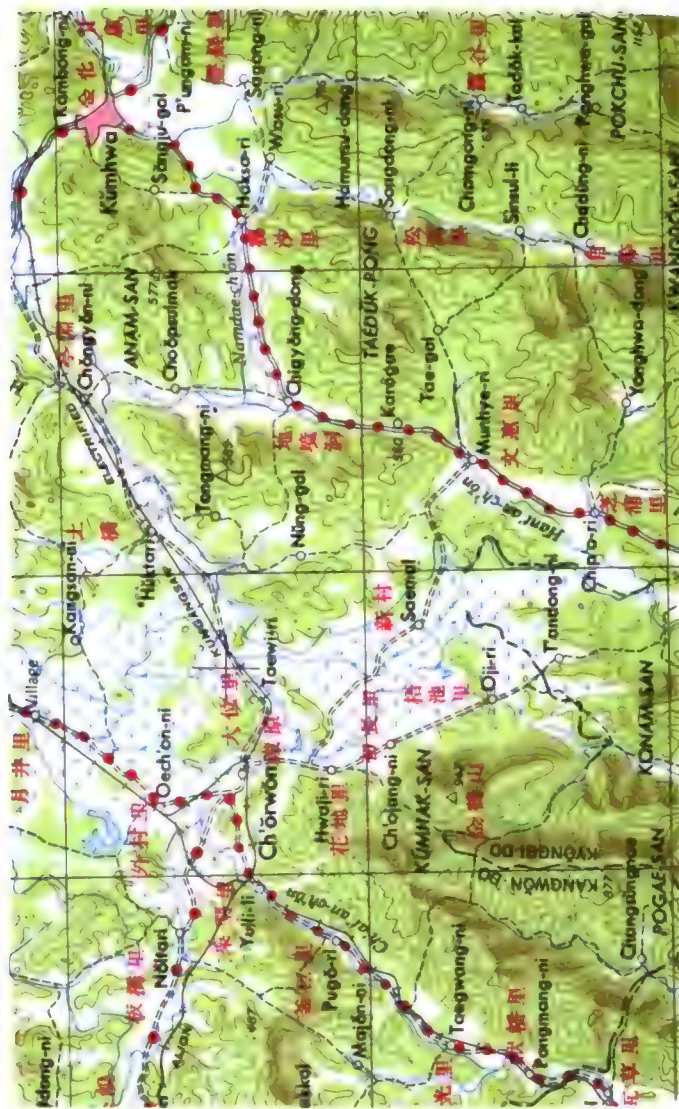
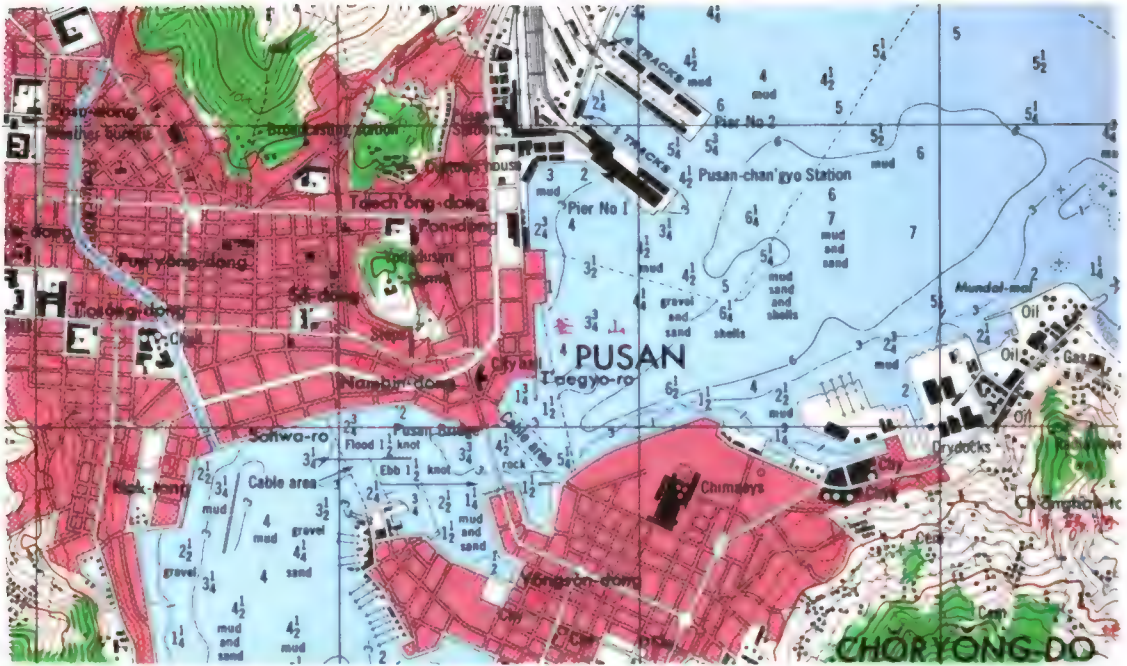

Figure 58. Section of sheet from Army Map Service 1:250,000 series L552.



© Army Map Service 1:25,000 series L851



© Korea 1:25,000 Topographic Map by a Japanese Authority

Figure 60. Sections of sheet from topographic series showing Pusan Area.

cho	町
ri	里
meter	米
kilometer	千米

Figure 57. English translation of Japanese characters representing units of map measurement.

ENGLISH REPRESENTATIVE FRACTION	JAPANESE EQUIVALENT
1:25,000	尺之一分千五万
1:50,000	尺之一分万五
1:200,000	尺之一分万十二
1:500,000	尺之一分万十五
1:3,000	尺之一分千三
1:5,000	尺之一分千五
1:10,000	尺之一分万一

Figure 58. English equivalents for Japanese representative fractions as found on Japanese maps.

Section IV. KOREA

51. Mapping Activities

a. Native. Korean mapping authorities include the General Staff, Peoples Army (North Korea)—GSPA; the Korean Department of Public Works (South Korea); and the Republic of Korea Army Map Service (South Korea). After World War II, the Korean Department of Public Works reproduced a few sheets from Japanese press plates that were captured by U. S. Armed Forces and turned over to the South Korean Government for retention. Their activity, however, was extremely limited and of little importance. At the present time, the GSPA and the ROK Army Map Service are the only active mapping authorities. The GSPA is producing sheets for the North Korean Army at scales of 1:25,000, 1:50,000, 1:200,000, and 1:500,000, while the ROK Army Map Service is preparing to reproduce several Korean-language map series.

b. Official. Most of the original mapping of Korea was done during the period of Japanese occupation from 1910 to 1945, when the Japanese carried out an extensive surveying and mapping program in the area. By 1926, all of Korea was covered by the basic 1:50,000 topographic series. Other series prepared by the Japanese include topographic maps at scales of 1:25,000, 1:200,000, 1:500,000, and 1:1,000,000 and 1:10,000 town plans. All Japanese mapping ceased with the

surrender of Japan at the end of World War II.

c. Other. Maps of Korea have been published by many non-Korean nations, including the United States, China, U. S. S. R., and Great Britain. Of primary significance are those published by the United States and the Chinese Communists.

(1) *United States.* Since 1945 most of the non-Korean maps of Korea have been published by the United States. The Army Map Service has published multi-color topographic series providing complete coverage for Korea at scales of 1:50,000, 1:250,000 (fig. 59), and 1:1,000,000 and limited coverage at 1:25,000 (fig. 60 ①). A 1:25,000 controlled photomap series prepared from the latest available aerial photography provides coverage for most of Korea south of 39°20'N. Plastic relief maps at 1:25,000 and 1:50,000 have been prepared for small areas of central Korea and medium-scale relief plastic maps provide coverage for all of the area except the island of Cheju-do. Town plans for 56 Korean cities have been compiled either by the Army Map Service or by G-2 Geographic Branch of General Headquarters, Military Intelligence Section, General Staff of Far East Command (FEC).

(2) *Chinese Communist*. Chinese Communists in Korea have made facsimile reproductions, with some modification, of captured sheets of the Japanese 1:50,000 topographic series of Korea. Apparently the topographic series were compiled independently of similar maps prepared by GSPA.

52. Major Topographic Maps of Korea

a. Native Topographic Series.

(1) [*Korea 1:25,000 Topographic Map*]; General Staff, Peoples Army, North Korea; dates unknown; kilometric military grid.

The General Staff, Peoples Army (North Korea) has published sheets of a 1:25,000 topographic series. The actual extent of published coverage is unknown, but it is believed to be limited in quantity. The sheets that are available for analysis are facsimile reproductions, with modifications, of the standard Japanese 1:25,000 topographic maps of Korea. Relief is indicated by contours and elevations.

(2) [*Korea 1:50,000 Topographic Map*];

General Staff, Peoples Army, North Korea; dates unknown; kilometric military grid.

This 1:50,000 series provides almost complete coverage of Korea including the islands of Cheju-do and Ullung-do. The sheets are monochrome facsimile reproductions of the Japanese standard 1:50,000 topographic maps (par. 52b(1)(b)) that have embodied various modifications to provide map content necessary for military use by the North Korean Army. Relief is indicated by contours and spot elevations.

(3) [*Korea 1:200,000 Topographic Map*]; General Staff, Peoples Army, North Korea; 1945; kilometric military grid.

This 1:200,000 series (fig. 61) provides almost complete coverage for Korea. The sheets are multicolor editions with relief indicated by contours at 50-meter intervals. A grid network identical to the USSR military grid system is shown. Initial publication of this series took place in 1945 during the period of Russian occupation of North Korea.

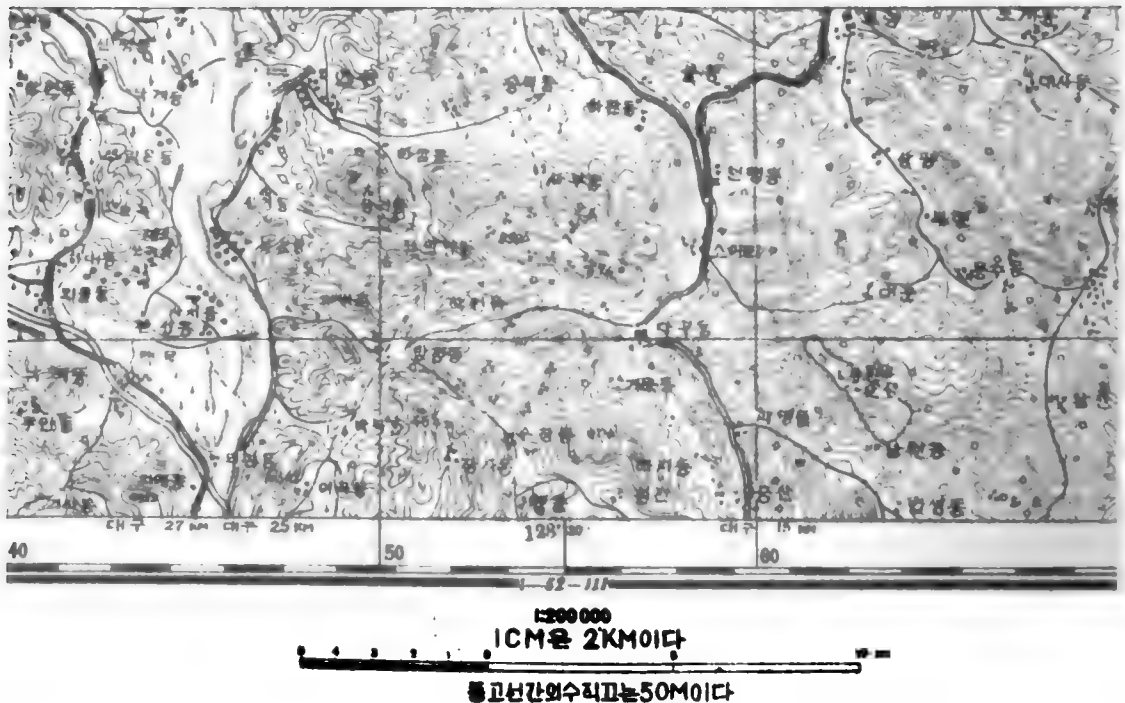

Figure 61. Section of Korea 1:200,000 Topographic Map by General Staff, Peoples Army, North Korea.

- (4) [*Korea 1:500,000 Topographic Map*]; General Staff, Peoples Army, North Korea; 1948; no grid.

This 1:500,000 multicolored series provides complete coverage of Korea. Relief is shown by contours. Available sheets of the series are dated 1948.

b. *Official Maps.*

(1) *Topographic series.*

- (a) (*Korea 1:25,000 Topographic Map*); Japanese Korean Provisional Land Survey Bureau, Japanese Imperial Land Survey, and Japanese General Staff; 1911-43; no grid.

Japanese 1:25,000 topographic maps of Korea (fig. 60 ②) are limited in coverage to strategic areas around the major urban centers. The original planetable surveying for this series was accomplished from 1911 to 1917. A majority of the sheets were revised, some as late as 1943. The sheets are polychrome. Relief is shown by contours and elevations.

- (b) (*Korea 1:50,000 Topographic Map*); Japanese Korean Provisional Land Survey Bureau, Japanese Imperial Land Survey, and Japanese General Staff; 1910-42; no grid.

The 1:50,000 Japanese topographic series (fig. 62) provides complete coverage for Korea. Initial sheets were prepared between 1910-26. Supplemental surveys for revision purposes were carried out, some as late as 1942. Relief is indicated by contours at 20-meter intervals with auxiliary contouring where necessary, and by elevations.

- (c) (*Korea 1:200,000 Topographic Map*); Japanese Korean Provisional Land Survey Bureau and Japanese Imperial Land Survey; 1916-45; no grid.

Complete coverage is provided by this Japanese 1:200,000 multicolored topographic series (fig. 63). Original mapping of the series was accomplished by the Japanese-established Korean Provisional Land Survey Bureau—KPLSB. The sheets were revised by JILS, the successor to

KPLSB. Relief is shown by various methods within the series; by contours at 50- to 100-meter intervals, or by form lines or shaded relief. Elevations are used also to indicate relief.

- (d) (*Korea 1:500,000 Topographic Map*); Japanese Imperial Land Survey and Japanese General Staff; 1934-41; no grid.

Korea is completely covered by this Japanese 1:500,000 multicolored topographic series. Relief is portrayed by gradient tints. Contour intervals vary from 100 meters at lower elevations to 500 meters for elevations above 1,000 meters.

- (2) *Town plans.* Plans for 75 urban areas in Korea were prepared by the Japanese Imperial Land Survey, Japanese General Staff, and the Japanese Korean Provisional Land Survey. Surveys for the plans date from 1915 to 1943 with revisions on some as late as 1941. A majority of these plans were prepared both in multicolored and monochrome editions. Relief is indicated by contours at 5-meter intervals on at least one edition of every plan.

c. *Other Topographic Series.*

[*Korea 1:50,000 Topographic Map*]; Chinese Communist, authority unknown; 1951; kilometeric military grid.

Although the actual extent of the coverage of this series (fig. 64) is unknown, captured maps provide coverage for a large part of Korea, particularly south of 39° N. The sheets were compiled in 1951 by copying Japanese topographic maps. Individual sheet sizes vary from a 10' x 15' copy of the standard Japanese topographic map to a 20' x 15' sheet, compiled by placing two standard 1:50,000-scale sheets together. A kilometeric grid system identical to the Russian and North Korean grid systems has been incorporated into the sheets. Relief is indicated by contours and elevations.

53. Coordinate Systems

a. *Geographic.* Geographic coordinates on all series are expressed in degrees with longitudinal

郡化金 } 道原江
 郡康平 }
 郡原康 }
 郡川海 } 道畿京

Administrative Listings

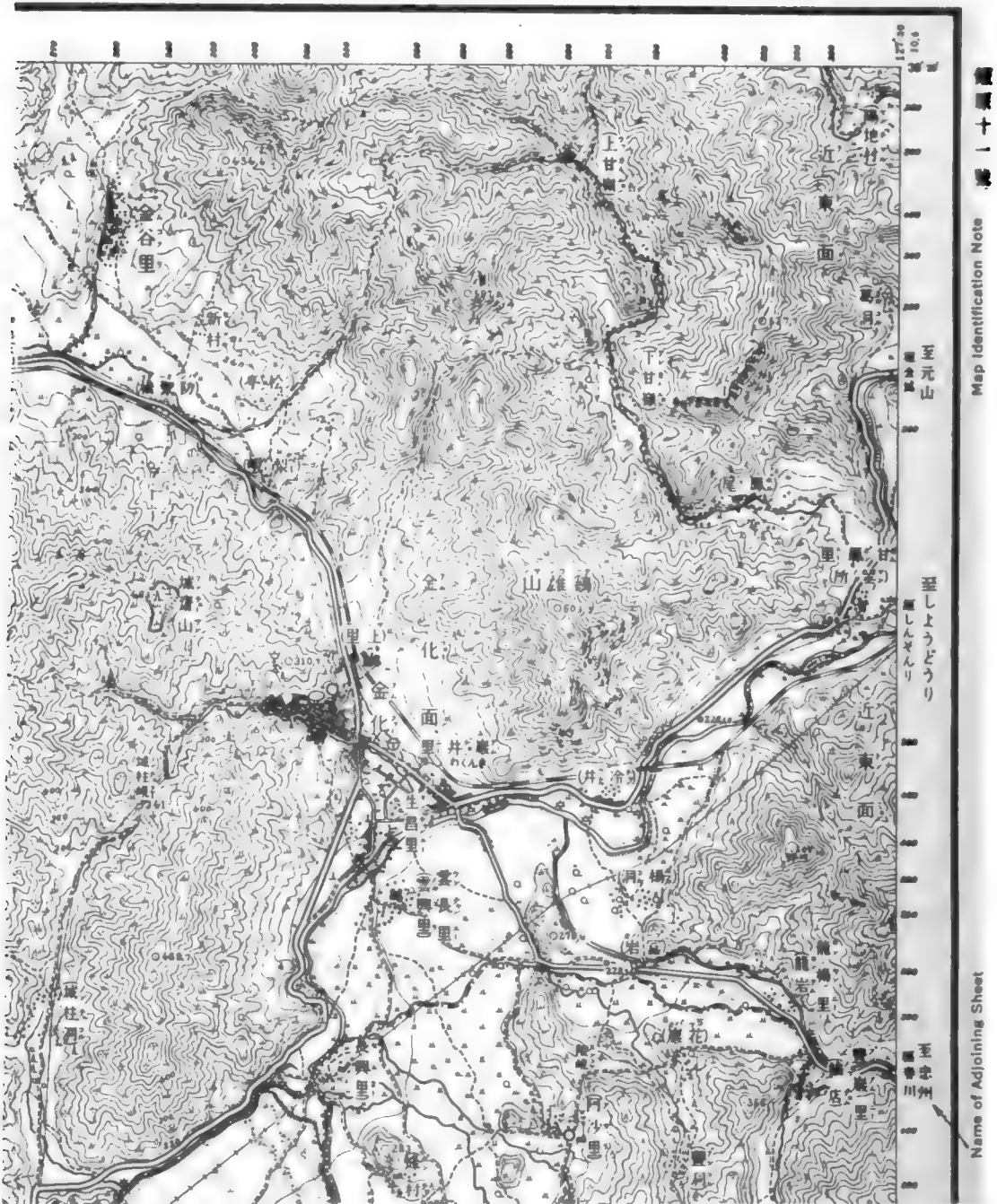

Figure 62. Section of sheet from Japanese Standard 1:50,000 Topographic Map of Korea.

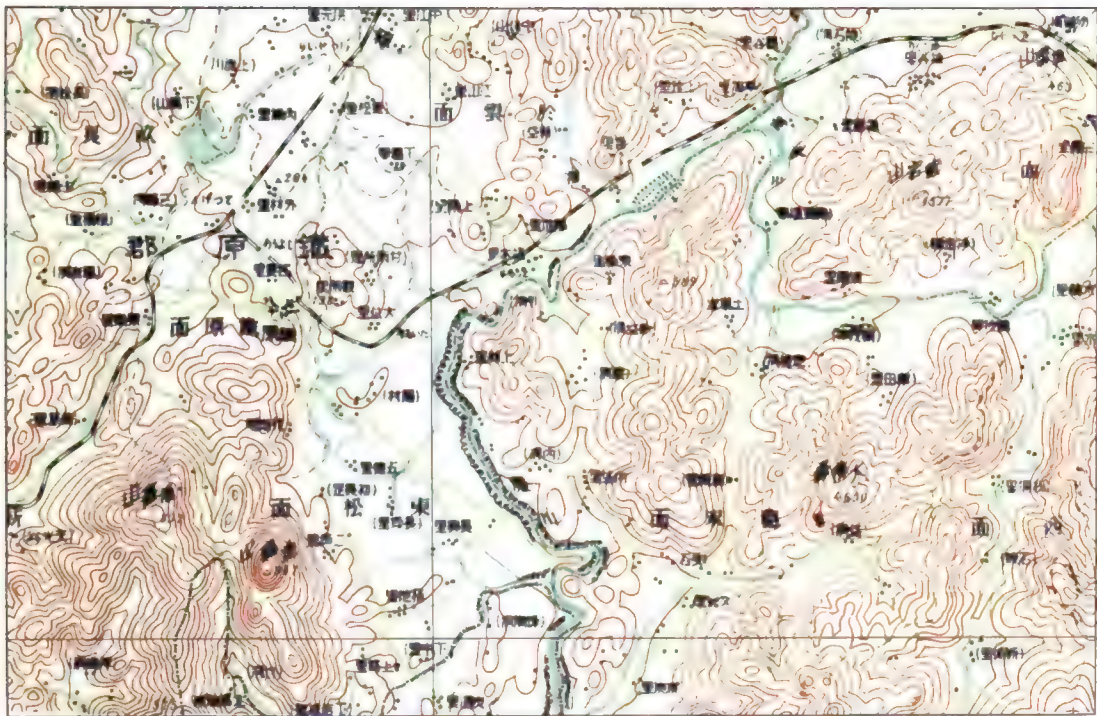
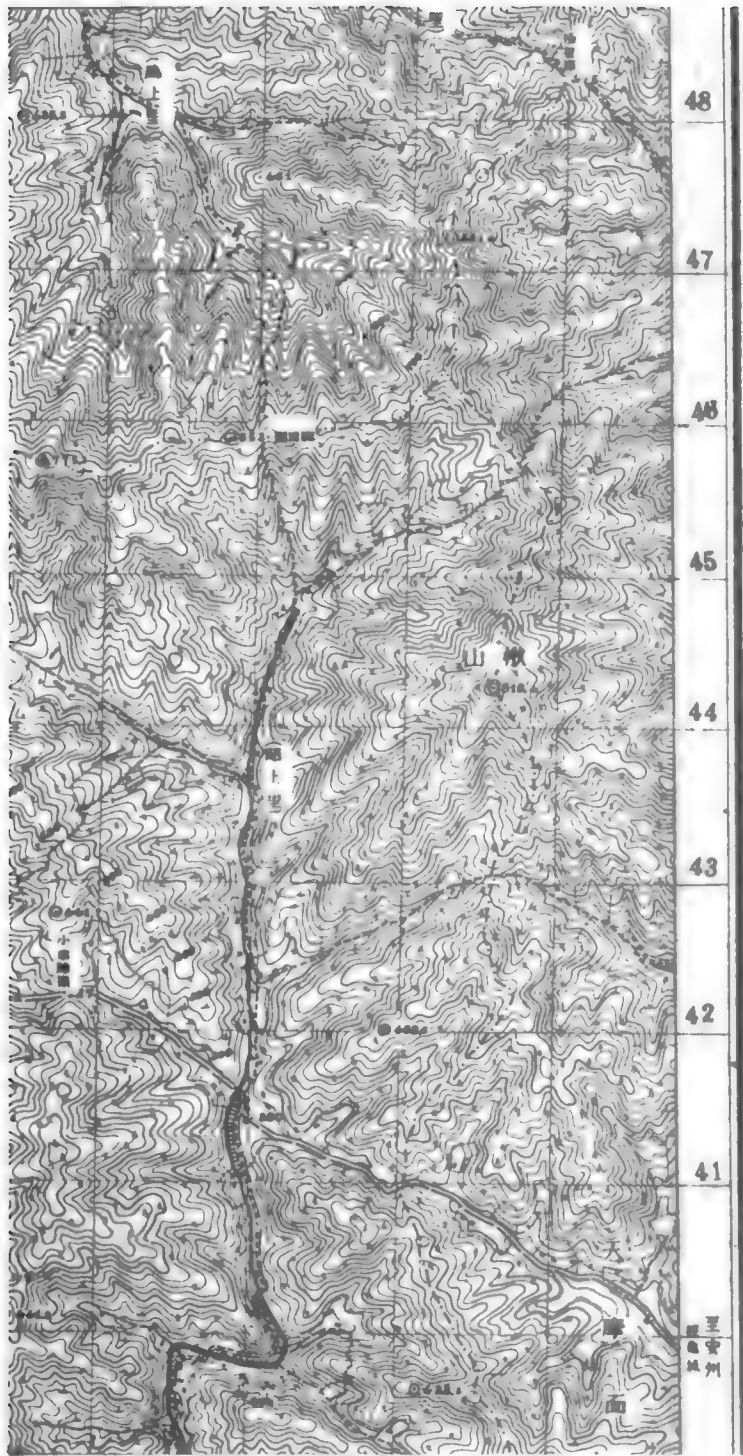

Figure 63. Section of sheet from Japanese Korea 1:200,000 Topographic Series, covering Ch'orwon and vicinity.



永山市

縣城區 } 延北安平
縣州義 }

州義	河德天	館大
州義		河德
館軍車	河市新	市南



子午線與直交坐標網線
之角度 (個角)

地圖之西側線: $\frac{1^{\circ}-11'}{0-20(0-21)}$

地圖之東側線: $\frac{1^{\circ}-21'}{0-22(0-24)}$

附記: 分子為度數, 分
母為密位數.

Figure 64. Section of sheet from Chinese Communist 1:50,000 Korea series. Marginal information (top to bottom); sheet name, political administrative units, adjoining-sheet index, declination diagram, and declination note.

values referred to the Greenwich meridian. On maps at 1:50,000 and larger scales, geographic coordinates are indicated by sheet corner values only. It is cautioned that coordinate values on some of these sheets may be based on the older longitude value for Tokyo observatory. An adjustment of plus 10''.4 in longitude should be made to sheets of this type in order that coordinates conform to the accepted value for the Tokyo observatory that is used for recent and current mapping. On sheets of the 1:200,000 series, corner values are indicated and graticule ticks are given at intervals of 15' east and west and 10' north and south. On the 1:500,000 series, full geographic coordinates at 15' intervals east and west and 10' intervals north and south are shown.

b. Grid.

- (1) The military grid on maps by GSPA and Chinese Communist authorities is a Gauss-Kruger (kilometric) type and is identical to the Russian military grid system. It is based on the Bessel spheroid and consists of longitudinal zones on which kilometric grids are placed. Grid coordinates are read up and to the right. The western boundary of the first zone is formed by the Greenwich meridian; successive zones, which are numbered consecutively, occur at 6° intervals. Korea is covered by zones 21 and 22. The origin of each grid zone is at the intersection of its central (axial) meridian and the equator. This point is given the arbitrary value of 500 kilometers east and 0 kilometers north. The grid interval for the 1:25,000- and 1:50,000-scale sheets is 1 kilometer. The 1:200,000-scale series utilizes 10-kilometer grid squares.
- (2) No military grid is shown on Japanese maps of Korea.

54. Characteristics

a. General Staff, Peoples Army (North Korea) Maps. For the most part, characteristics of GSPA maps are identical to those of the Japanese topographic series from which they were copied.

- (1) *Relief.* Relief on most GSPA maps agrees with the Japanese sheets from which they were compiled. On the 1:200,000 series, there is evidence that

some topographic sources other than Japanese were used. All series, however, use contours augmented by elevations to indicate relief. Basic and auxiliary contour intervals for various-scale maps are shown in table III.

Table III. Basic and Auxiliary Contour Intervals for GSPA Maps

<i>Map scale</i>	<i>Basic contour interval</i>	<i>Auxiliary contour interval</i>
1:25,000.....	10 meter.....	2.5 and 5 meter
1:50,000.....	20 meter.....	10 meter
1:200,000.....	50 meter.....	25 meter
1:500,000.....	100 meter.....	

Although relief is represented basically by contours, some features, such as rock outcrops, scattered rocks, cliffs, and ravines, are symbolized. Earthen mounds, embankments, and levees are shown by hachures whereas depressions are indicated by arrows.

- (2) *Cultural features and vegetation.* Cultural features including communications are portrayed on most GSPA series in the same manner as they appear on comparable Japanese series. For further details, see paragraphs 46 through 50 (JAPAN). Variation in cultural representation from the Japanese style exists on the multicolored 1:200,000 series on which detail is indicated by Russian-type symbols. Roads and railroads on this series are each classified into three categories, and vegetation is shown by a green overprint or by symbols.
- (3) *Names.* Place names on GSPA maps vary from scale to scale. On 1:25,000- and 1:500,000-scale maps, the majority of the sheets contain place names in Sino-Korean ideographs with Korean Onmun transcriptions added. A few sheets of the 1:50,000 series and all of the 1:200,000 series have Sino-Korean ideographs only.

b. Japanese Maps. Japanese series, especially those at large scales, are characterized by an abundance of map detail.

- (1) *Relief.* Contour intervals for various series are listed in table IV.

Table IV. *Basic and Auxiliary Contour Intervals for Japanese Maps of Korea*

Map scale	Basic contour interval	Auxiliary contour interval
1:25,000	10 meters	2.5 and 5 meters
1:50,000	20 meters	10 meters
1:200,000	50 meters	25 meters
1:500,000	graduated 100-200-300-500 meters.	
1:10,000 (city plans)	5 meters	2.5 meters

Although relief is represented basically by contours, some features, such as rock outcrops, scattered rocks, cliffs, and ravines are symbolized.

Earthen mounds, embankments, and levees are shown by hachures, and depressions are indicated by arrows.

(2) *Cultural features and vegetation.* The treatment of cultural features and vegetation on Japanese maps of Korea is similar to that for Japanese maps of Japan. For further details, see paragraph 49b.

(3) *Names.* Names are treated in the same manner as those on the native series of Japan, with one exception: on the large-scale Japanese series of Korea, individual settlement names are shown in parentheses, with the area name in close proximity.

c. Chinese Communist Maps. Characteristics of the 1:50,000 topographic series prepared by Chinese Communist forces in Korea are similar in most respects to the 1:50,000 series prepared by the GSPA.

(1) *Relief.* The depiction of relief is identical to the Japanese base map and to North Korean compilations. The basic contour interval is 20-meters supplemented by auxiliary contours and elevations. Contour values are not indicated in the margin of the sheets in the manner they appear on the Japanese base maps (fig. 62).

(2) *Cultural features and vegetation.* Cultural and vegetation features as portrayed on Chinese Communist maps are the same as on the Japanese topographic 1:50,000 series.

(3) *Names.* It is evident that in copying sheets of the Japanese 1:50,000 series the Chinese removed the place names, omitted the Kana, and reentered the names in ideograph form only. A few differ-

ences in names exist between the Chinese sheets and the Japanese sheets from which they were copied.

55. Marginal Information

a. GSPA Maps.

(1) Marginal information on GSPA maps at 1:50,000 scale generally appears as illustrated in figure 65. The extent of inclusion and position of individual items, as shown in the illustration, may vary within a series or amongst the different scale series. Legends do not appear on any series.

(2) Dates, presumed to be publishing dates, usually appear near the west neatline in the top margin in all series. Individual sheet names and sheet numbers are centered in the top margin. Sheets of the 1:500,000 series are not named but have a sheet number. A declination diagram and a declination note appear on the lower right margin. The declination note has been translated as follows:

“The grid declination with the west meridian [west neat line] of sheet is [deg. and mils], the grid declination with the east meridian [east neat line] of sheet is [deg. and mils].”

(3) On all series a bar scale graduated in metric units is centered in the bottom margin. A notation is made near the bar scale indicating the number of centimeters per kilometer. A slope diagram (fig. 66) is shown in the lower-left margin in large-scale series. To determine the steepness of slope in degrees, compare the distance between contour lines with the distance between the edges of the scale. The measurement of distance may be taken between adjacent contour lines or between every fifth contour. An index to adjoining sheets, located in the lower-left margin, contains identification of *International Map of the World* sheets and an individual sheet designation as shown in figure 67.

b. Japanese Maps.

(1) Marginal information on the Japanese maps at 1:50,000 scale generally appears as illustrated in figure 68. Positions of

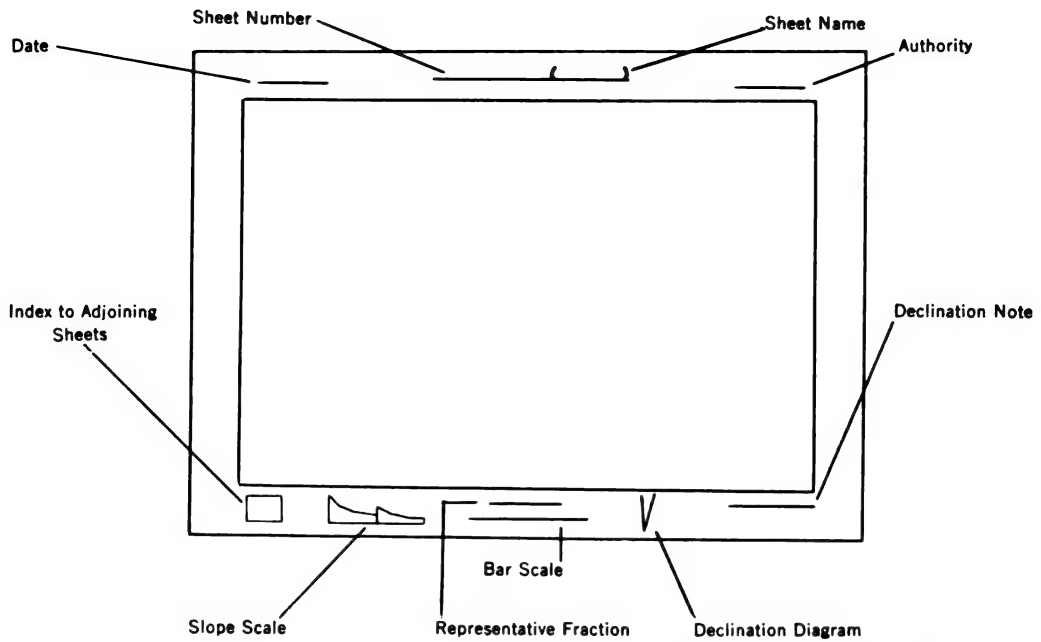

Figure 65. Diagram showing approximate position of marginal information on GSPA (NK) 1:50,000 map.

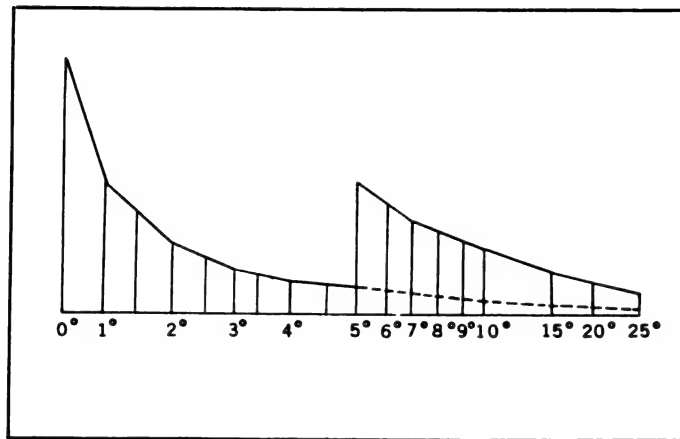

Figure 66. Slope scale as shown on large-scale maps by GSPA (NK) and Chinese Communist Forces in Korea.

marginal items may vary on different maps and map series.

- (2) An index to adjoining sheets, the sheet name, and a partial listing of political administrative units which fall within the area portrayed on the sheet are shown in the top margin. A note identifying the sheet with a smaller-scale map and one citing the use of meters as a unit of measurement for elevations appears in the right margin. The bottom margin includes the representative fraction, a bar scale graduated in metric units, and a public sale price. The translations for

the representative fraction are shown in figure 69. The left margin contains dates, authorities, and legend. Publishing authorities that may appear are translated in figure 70. Legends given on sheets issued for public sale are comprehensive. It should be noted, however, that legends generally do not appear on sheets carrying a Japanese military classification in the upper-right margin.

c. Chinese Communist Maps. Marginal information on Chinese Communist maps at 1:50,000 scale generally appears as illustrated in figure 71. Positions of various items may vary on some

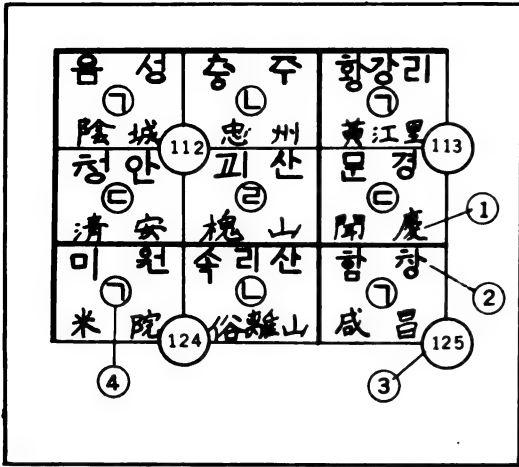

- ① Sheet name in Sino-Korean
- ② Sheet name in Korean "Onmun"
- ③ Quad number
- ④ Sheet letter

Figure 67. Enlarged copy of index to adjoining sheets found on large-scale maps of GSPA (NK).

sheets. Since the Chinese sheets were compiled by joining two standard Japanese 1:50,000 maps north to south, some marginal items are repeated both in the top and bottom portions of the right

margin. Repeated items are unlabeled in figure 71. The date of the sheets is located in the top-left margin. Other than the date, all marginal data are positioned in the right margin. Duplication of most of the individual items is shown in order to provide separate information for the two segments of the oversized sheet. Only one bar scale, graduated in metric units, and one slope scale are shown per sheet. The slope scale is similar to the one found on GSPA maps. Each of the two map segments has its own number, name, a partial listing of administrative units which fall within the area portrayed on the sheet, a declination diagram, and a declination note, which reads as follows:

Angular difference between meridian and vertical grid line. Declination of the map at the west neat line [deg. and mils]. Declination of the map at the east neat line [deg. and mils].

Note. Numerator is in degrees, denominator in mils. 1 mil = 3.6 (3.375).

Annual westerly magnetic deviation:

Annual rate of change:

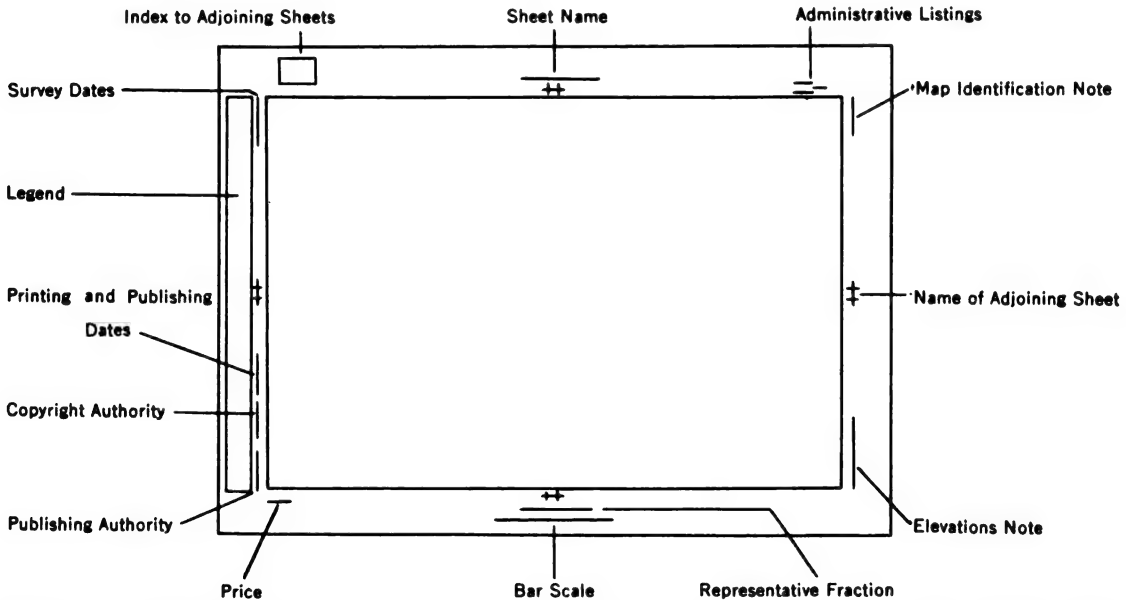

Figure 68. Diagram showing approximate position of marginal information on Japanese 1:50,000 maps.

ENGLISH REPRESENTATIVE FRACTION	JAPANESE EQUIVALENT
1:25,000	一分千五萬二尺縮
1:50,000	一分萬五尺縮
1:200,000	一分萬十二尺縮
1:500,000	一分萬十五尺縮
1:10,000	一分萬一尺縮

Figure 69. English equivalents for Japanese representative fractions as found on Japanese maps of Korea.

朝鮮總督府臨時土地調查局

Korea Government General,
Provisional Land Survey
Bureau

參

謀

[Japanese] General
Staff

本

部

大日本帝國陸地測量部

Japanese Imperial
Land Survey

陸

地

[Japanese Imperial]
Land Survey

測

量

部

Figure 70. English translation of major Japanese authorities as found on Japanese maps of Korea.

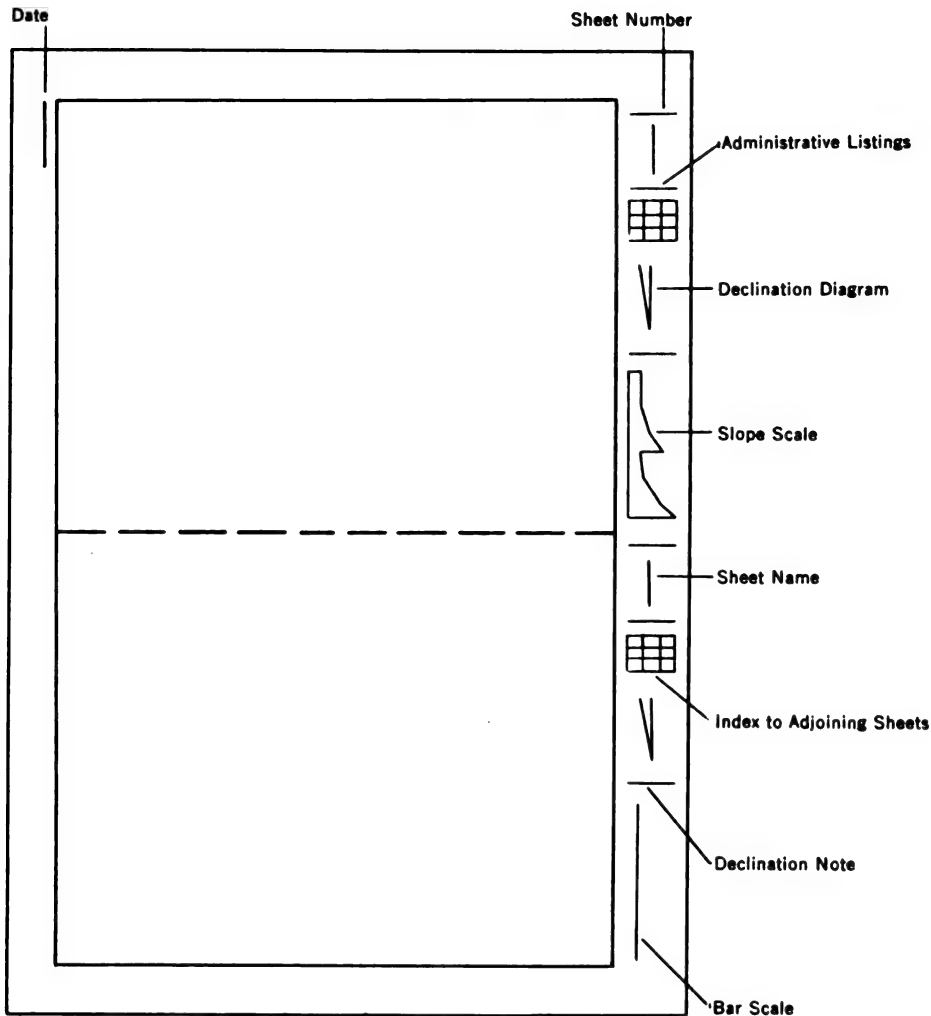

Figure 71. Diagram showing approximate position of marginal information on Chinese Communist 1:50,000 maps of Korea.

Section V. KARAFUTO (SAKHALIN ISLAND SOUTH OF 50° N.)

56. Mapping Activities

a. Native. The Japanese maintained possession of Karafuto from 1905 to 1945. During this time the Japanese Imperial Land Survey Bureau (JILS) and the Japanese General Staff (JCS) were the primary mapping agencies of the area. Most of the topographic map series prepared by the two agencies were based on planetable surveys, although the latest Japanese editions of 1:25,000- and 1:50,000-scale maps covering an east-west strip just south of the 50th parallel have utilized aerial-photo surveys of 1937 to 1943. Town plans for a number of cities were prepared by JGS. All mapping activities of the Japanese in Karafuto

ceased upon their surrender in 1945. Nothing is known of mapping in Karafuto since its occupation by the forces of the U. S. S. R.

b. Other. Multicolor and/or monochrome coverage has been prepared by the Army Map Service. Although there is complete coverage for Karafuto, the large- and medium-scale series (1:50,000 and 1:250,000) have many unsurveyed areas. Town plans have also been compiled for the more important urban centers by U. S. authorities.

57. Major Native Maps of Karafuto

a. Topographic Series.

- (1) (*Karafuto, 1:25,000 Topographic Map*); Japanese Imperial Land Survey and

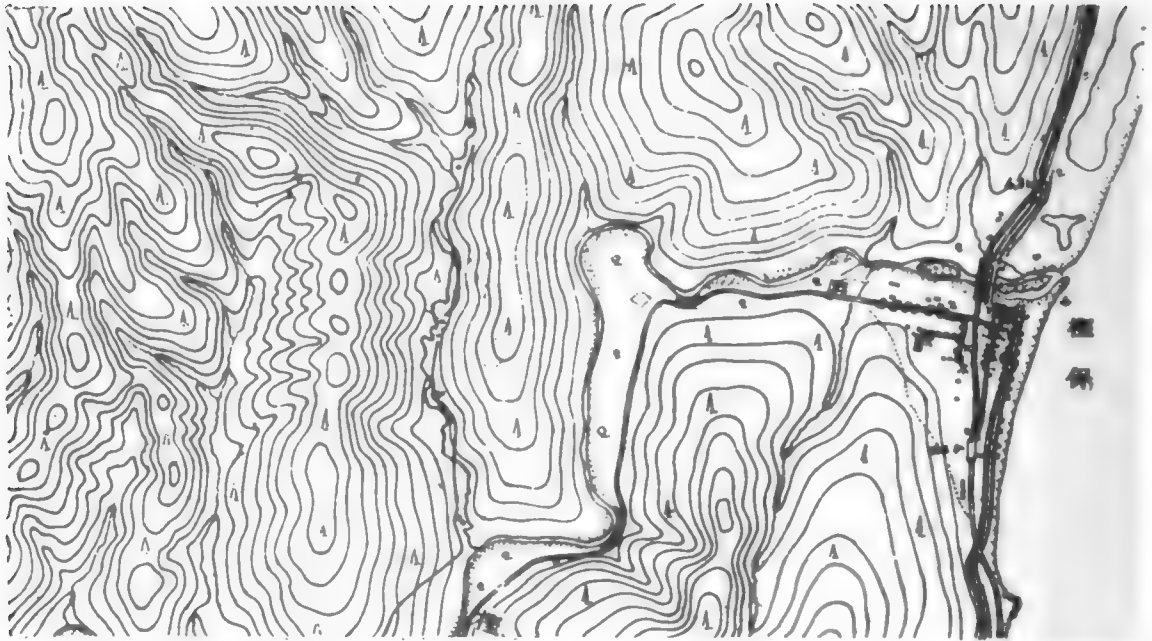

Figure 72. Section of sheet (covering Kashiho and vicinity) from Japanese 1:25,000 Topographic Map of Karafuto.

Japanese General Staff; 1932-42; no grid. Published coverage of the Japanese 1:25,000 topographic series of Karafuto is complete north of 47°20' N. latitude. This monochrome series (fig. 72) is based on planetable and aerial-photo surveys accomplished between 1930 and 1942. Relief is indicated by contours and elevations.

- (2) (*Karafuto, 1:50,000 Topographic Map*); Japanese Imperial Land Survey and Japanese General Staff; 1929-41; no grid.

Complete coverage has been published for Karafuto in this monochrome series (fig. 73) prepared from planetable and aerial-photo surveys. Some of the earlier sheets are only partially mapped. Aerial photography utilized by the Japanese ranges in date from 1931 through 1942. Relief is indicated by contours and elevations.

- (3) (*Karafuto, 1:100,000 Topographic Map*); Japanese Imperial Land Survey and Japanese General Staff; 1941-42; geographic-coordinate reference grid.

The JGS and JILS prepared these 1:100,000 topographic sheets (fig. 74) for the northern part of Karafuto. These maps were photo-reduced from

mosaicked 1:50,000 topographic maps and hydrographic charts. Relief is indicated by contours and elevations.

- (4) (*1:200,000 Empire Map*); Japanese Imperial Land Survey and Japanese General Staff; 1934-45; no grid.

Although this topographic series (fig. 75) provides almost complete coverage of Karafuto, approximately one-half of the coverage is in unpublished map manuscript form. These incomplete compilation boards were captured from the Japanese by U. S. authorities at the end of World War II. The series is multicolored except for the captured manuscripts. Relief is depicted in most instances by contours, elevations, and relief shading; but some sheets contain areas of shaded relief only.

- (5) (*1:500,000 Empire Map*); Japanese Imperial Land Survey and Japanese General Staff; 1936-37; no grid.

The multicolored 1:500,000 *Empire Map* series, also referred to as the *Atlas Map* series, provides coverage for approximately one-half of Karafuto. Relief is generally shown by contours and elevations on the 1936 editions and by hachures and elevations on the 1937 sheets. The relief of some areas that



Figure 73. Section of sheet (covering Kashiho and vicinity) from Japanese 1:50,000 Topographic Map of Karafuto.

are considered by the Japanese to be of strategic value, is not indicated in any manner.

b. Town Plans. Detailed information on Japanese plans or urban centers in Karafuto is extremely limited. It is known, however, that some plans, primarily of a planimetric nature, were prepared by the Japanese General Staff around 1930-40. The extent of their coverage is unknown. Relief, when indicated, is generally shown by form lines or hachures.

58. Coordinate Systems

a. Geographic. Geographic coordinates are used on all Japanese topographic maps of Karafuto. Longitude values are referred to the Greenwich meridian. Maps at scales smaller than 1:50,000 have graticule subdivisions of the neat-lines. Only one series, the 1:500,000 *Empire Map*, carries a full graticule. The town plans prepared by the Japanese General Staff generally do not indicate graticule information.

b. Grid.

(1) The Japanese 1:100,000 series of Karafuto carries a geographic-coordinate reference grid. This grid network is also found on other Japanese 1:100,000 series of the Far East including North Sak-

halin, China, and Manchuria. Grid lines are coincidental with geographic coordinates; therefore, grid zones, usually associated with grid systems, are non-existent. All grid lines are numbered consecutively, east to west, south to north, from one point of origin located at 39°20' N., 125°00' E. The meridian of longitude and the parallel of latitude passing through this point are given the false value of 5000. Horizontal grid lines are shown at 02' intervals; vertical grid lines, at 03' intervals. Grid coordinates are expressed in eight-digit numbers, and are read right and up in the conventional manner. The first three digits indicate the vertical grid line; the fourth digit, the subdivision of the grid square expressed in tenths. The fifth, sixth, and seventh digits represent the horizontal grid line and the eighth, the northward subdivision in tenths.

(2) It should be noted that the placement of the grid on sheets of the Karafuto series prepared in 1941 (fig. 74 ①) varies from the grid placement on sheets prepared in 1942 (fig. 74 ②). The two grids are identical, but a shift of the grid approxi-

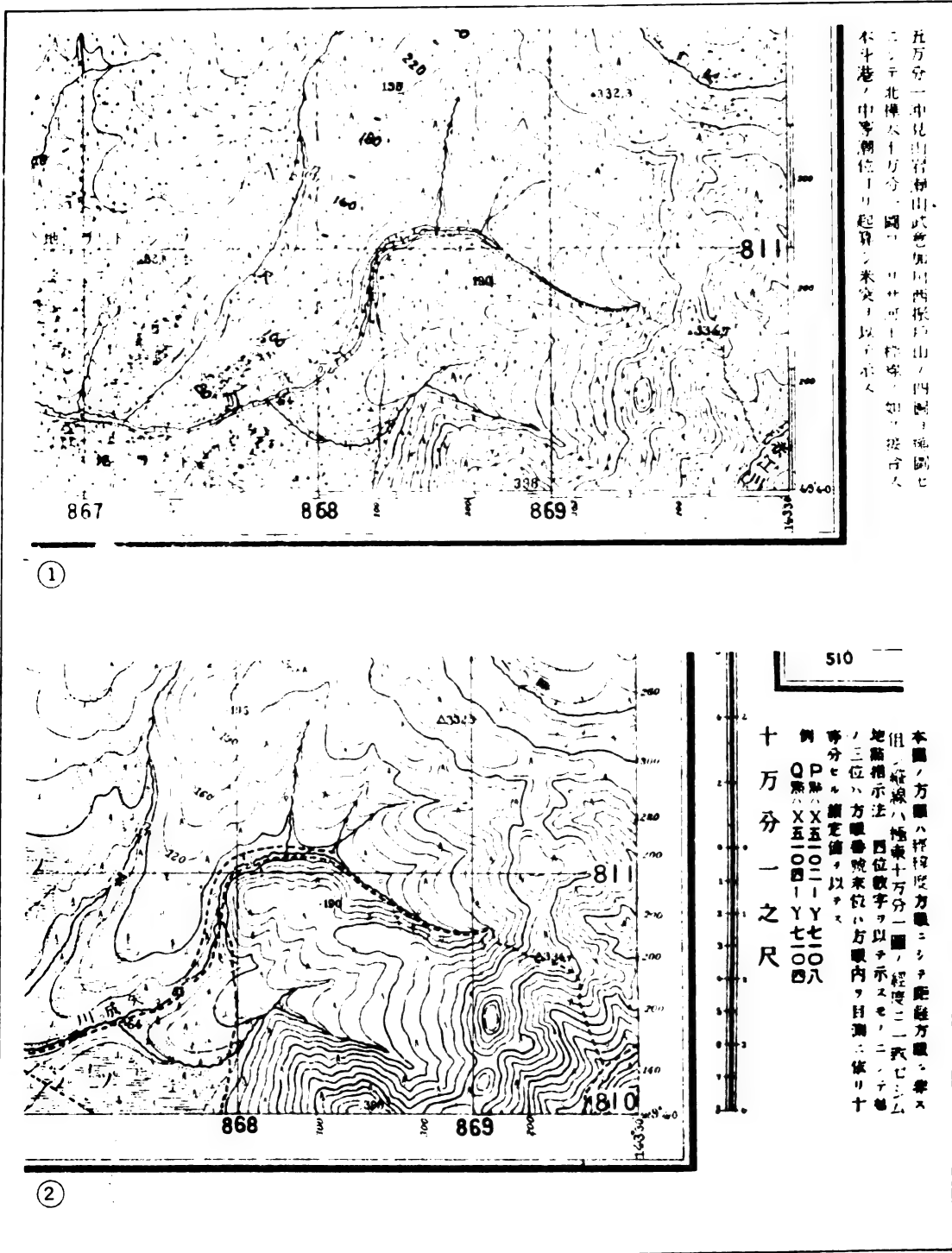

- ① Section of sheet that carries the geographic-coordinate reference grid
- ② Section of sheet that shows the grid shift found on sheets prepared in 1942

Figure 74. Sections of sheets from the 1:100,000 Topographic Map of Karafuto.



Figure 76. Section of Sheet No. 2 of 1:25,000 Aden series (EAF 1591, MDR 592) by the East African Forces, reprinted by the Army Map Service as AMS K861.

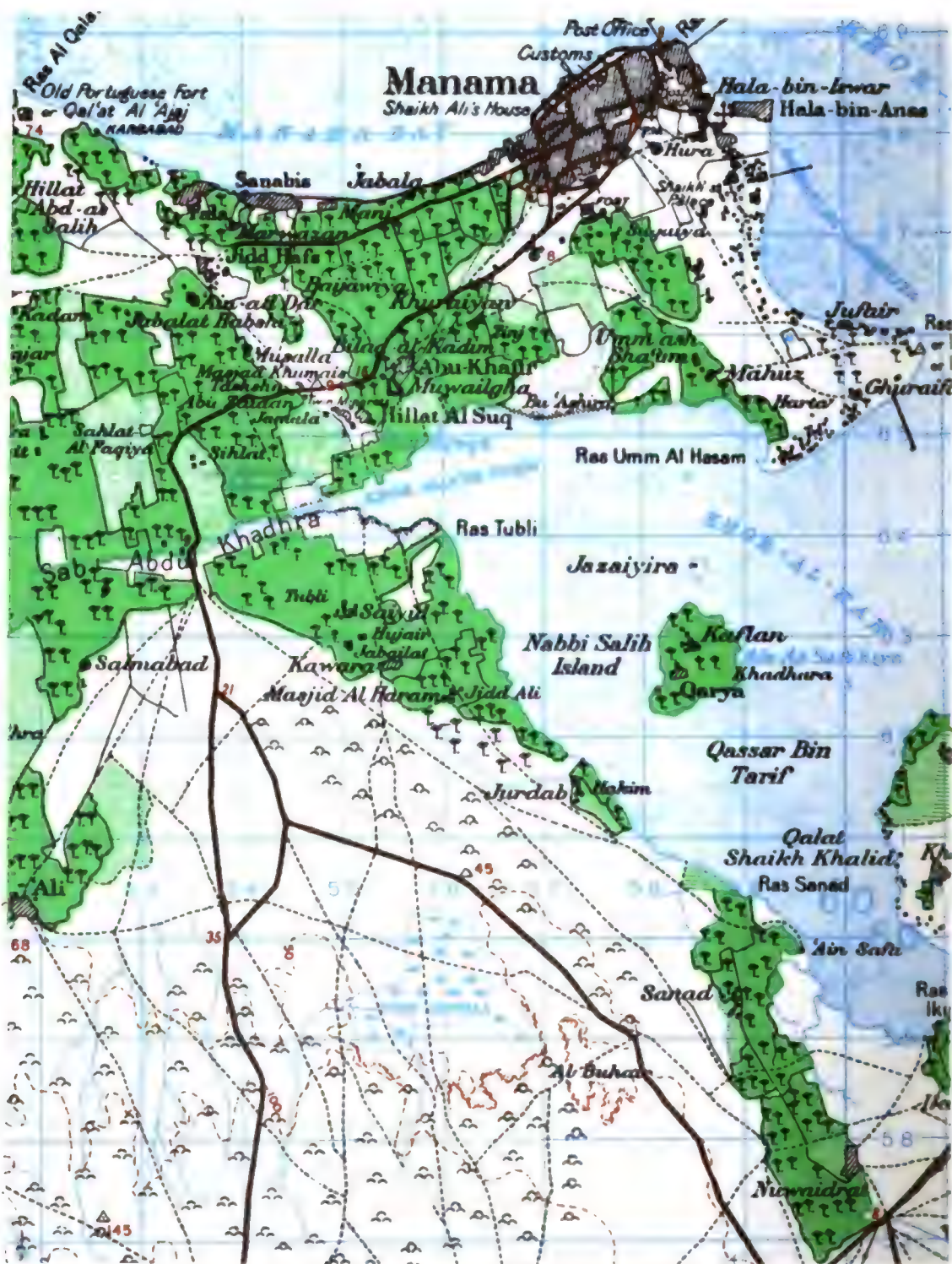

Figure 77. Section of Directorate of Military Survey, War Office (Geographical Section, General Staff) 1:63,360 map of Bahrain Island, reprinted by the Army Map Service as AMS K761.

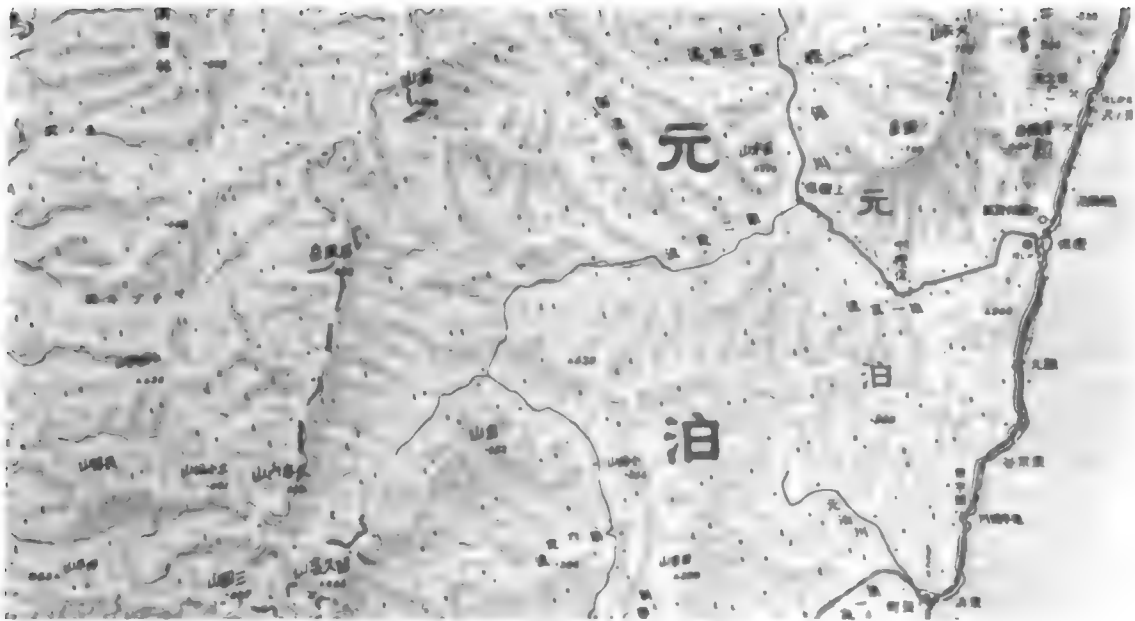

Figure 75. Section of sheet (covering Kashiho and vicinity) from Japanese 1:200,000 Empire Map.

mately 01' to the east was made in order that the vertical grid lines of the Karafuto series would agree with those of the 1:100,000 series of North Sakhalin.

59. Characteristics

Japanese topographic maps of Karafuto, especially those at large scales, are characterized by an abundance of map detail.

a. Relief. Relief is generally shown by contours and elevations although hachures and shadings are also used, particularly on the smaller-scale series. Elevations are based on mean sea level of Honto harbor. Contour intervals for the various series are listed in table V.

Table V. Basic and Auxiliary Contour Intervals for Japanese Topographic Series of Karafuto

Map scale	Basic contour interval	Auxiliary contour interval
1:25,000	10 and 20 meters	2.5, 5, and 10 meters
1:50,000	20 meters	5 and 10 meters
1:100,000	20 meters	5 and 10 meters
1:200,000	100 meters and/or shaded relief.	25 and 50 meters
1:500,000	200 meters or hachures.	50 and 100 meters.

Although relief is represented basically by contours on maps at 1:100,000 and larger scales, some relief features, such as rock outcrops, scattered rock, cliffs and ravines, are symbolized graphically. Earthen mounds, embankments, and levees

are shown by hachures, and depressions are indicated by arrows.

b. Cultural Features, Vegetation, and Names. The treatment of cultural features, vegetation, and names is similar to that used for Japanese maps of Japan (par. 49b).

60. Marginal Information

a. Most marginal information shown on Japanese maps of Karafuto—authorities, dates, legends, bar scales, and representative fractions—is shown in the same manner as on native maps of Japan (fig. 51).

b. The gridded Japanese 1:100,000 series (fig. 74) carries a grid note usually positioned in the lower-right margin, but it may also be found in the center of the left margin. The grid note as found on sheets prepared in 1941 is translated as follows:

“The grid of this map is not a distance grid. It is a division of the inner neat line at an interval of 3 minutes of longitude and 2 minutes of latitude. The point of origin of the grid is established at 125° E. longitude and 39°20' N. latitude with the value of 5000-5000.

“Use four-digit number to indicate a geographic position on the land. First three digits represent grid number and the last digit is visual calculation within the grid . . .”

Section VI. SAKHALIN ISLAND, NORTH OF 50° N.

61. Mapping Activities

a. Native. Prior to the 1917 Bolshevik Revolution, tsarist explorers made only simple sketches and hasty reconnaissance maps on Sakhalin. Interest in oil, coal, and timber resources promoted Russian reconnaissance in Northern Sakhalin from 1925 to 1933, and in 1935 semi-instrumental surveys were carried out in the area.

b. Other.

(1) *Japanese.* The Japanese Sakhalin Expeditionary Force made reconnaissance between 1919 and 1921 in the area north of 50° N. During 1941-43 the Japanese flew reconnaissance photography in the area north of 50° N. With this material, they revised their 1:100,000 sheets on North Sakhalin that were based on earlier Russian 1:200,000 maps. In 1942-43 the Japanese Imperial Land Survey published a series covering all of Northern Sakhalin at a scale of 1:500,000.

(2) *United States.* In the post-World War II period the Army Map Service published a 1:250,000 series based on Russian maps and covering all of North Sakhalin.

62. Major Native Topographic Maps of North Sakhalin

[U. S. S. R.]; 1:200,000; General'nyy Shtab, Krasnaya Armiya (General Staff, Red Army); 1933-35; Gauss-Krüger Grid.

Sheets of this multicolor series that cover Sakhalin Island north of 48°20' N. are based on reconnaissance of 1925-33 and semi-instrumental surveys of 1935. Relief is shown by contours at 40-meter intervals, with approximate contours indicated in poorly surveyed areas. Single sheets cover 1° EW by 40' NS; in narrow parts of the island, however, some sheets have been combined.

63. Coordinate Systems

Geographic coordinates, with longitudinal values referred to Greenwich, are shown on all Russian maps of North Sakhalin. The Gauss-Krüger grid is used on the 1:200,000 series of North Sakhalin. For further details concerning this grid, see paragraph 197b.

64. Characteristics and Marginal Information

On Russian series of Sakhalin, the presentation of map detail and marginal data is similar to that on Russian maps of the U. S. S. R. For further information see paragraphs 195 to 199.

Section VII. TAIWAN AND THE P'ENG-HU ISLANDS

65. Mapping Activities

a. Official. Between 1895 and 1945 the Japanese General Staff (JGS), in conjunction with the Japanese Imperial Land Survey (JILS), was responsible for the official surveying and mapping of Taiwan (Formosa) and the P'eng-hu Islands (Pescadores). Japanese mapping activities include: (1) a 1:50,000 topographic survey of P'eng-hu in 1895, (2) surveying of Taiwan and mapping at 1:25,000 and 1:50,000 in 1895-1939, with partial revisions in 1944-45 from aerial photography, (3) compilation of a 1:200,000 series in 1897, with revisions in the mid-thirties and in 1944, (4) compilation of a 1:20,000 series in 1903-04 covering the P'eng-hu Islands, (5) compilation of a 1:100,000 series of Taiwan and the P'eng-hu Islands in 1904, (6) a 1:25,000 survey of the

P'eng-hu Islands in 1921, and (7) compilation of a number of small-scale maps for the area. Town plans for a few built-up areas have also been published by city government agencies and private concerns such as bookstores and tourist bureaus.

b. Native. Mapping by Chinese authorities since 1945 is generally limited to special-purpose maps. The Survey Department, Combined Services Forces Headquarters, Ministry of National Defense reprinted the 1944 Army Map Service 1:250,000 series covering this area with minor revisions. In 1946 and 1947 the Chinese Taiwan Tourist Bureau published several monochrome and multicolored planimetric sketch maps covering important sections of major Taiwan cities. Several Chinese military groups, civilian agencies, and private concerns such as bookstores have also produced town plans for a few populated places.

c. *Other.*

- (1) *Topographic series.* The only other important topographic coverage has been published by the Army Map Service. A 1:25,000 series was compiled in 1944 for a large part of the coastal areas of Taiwan and for the P'eng-hu Islands. A series at 1:50,000 covering P'eng-hu Islands and the coastal areas of Taiwan was compiled by AMS in 1944 and in 1952 a 1:50,000 series covering the entire area was published. Series at 1:250,000 covering the entire area were compiled in 1944 and 1951. In 1952, AMS published a 1:250,000 plastic relief series based on the 1951 series.
- (2) *Town plans.* In 1944-45 AMS published 26 multicolored topographic town plans at scales ranging from 1:6,000 to 1:10,000. Aerial photography dated 1943-44 and map sources that were mainly Japanese were used in their compilation. A number of multicolored planimetric plans at various scales were compiled in 1944 by the Research and Analysis Branch, Office of Strategic Services from map sources and aerial photography. The British Directorate of Military Survey, War Office (Geographical Section, General Staff) in 1944 published several town plans and photomaps.

66. Major Topographic Maps of Taiwan and the P'eng-hu Islands

a. *Official Series.*

- (1) (*Taiwan 1:25,000 Topographic Map*); Japanese Imperial Land Survey (JILS) and Japanese General Staff; 1922-45; no grid.

These monochrome sheets cover the P'eng-hu Islands and the western, northern, and northeastern coasts of Taiwan. The P'eng-hu Islands sheets are based on surveys of 1921 and have not been revised. Sheets on Taiwan are based on surveys of 1921-35. A few of these sheets have not been revised; some were revised from 1936 to 1943; and others, overprinted in red, were revised from 1944-45 aerial photography and reproduced by the Japanese

Taiwan Army Headquarters in 1945. Relief is portrayed by contours at 10-meter intervals.

- (2) (*Taiwan 1:50,000 Topographic Map*) Japanese General Staff and Japanese Imperial Land Survey; 1904-45; no grid.

These monochrome sheets cover all of Taiwan and the P'eng-hu Islands. The P'eng-hu Islands sheets are based on surveys of 1895 and have not been revised. Sheets on Taiwan are based on surveys of 1924-38. Sheets overprinted in red were revised from 1944-45 aerial photography and were reproduced by the Japanese Taiwan Army Headquarters in 1945. Relief is portrayed by contours or "form lines" at 20-meter intervals.

- (3) (*East Asia 1:500,000*); Japanese Imperial Land Survey and Japanese General Staff.

For further details about this series, see paragraph 37c(5).

- (4) *Carte Internationale du Monde au 1,000,000** (International Map of the World, 1:1,000,000); Japanese Imperial Land Survey; 1937-39; no grid.

This multicolored series covering the entire area was compiled from several Japanese sources. Relief is portrayed by contours and by layer tints.

b. *Native Series.*

[Southeast China]; 1:250,000; Survey Department, Combined Services Forces Headquarters, Ministry of National Defense; 1950; World Polyconic and Air Defense grids.

For further details on this series see paragraph 37a(3) and figure 31.

67. Coordinate Systems

Geographic coordinates are expressed in degrees with longitude values referred to Greenwich.

68. Characteristics

Japanese and Chinese maps of Taiwan are generally characterized by an abundance of detail.

a. *Language.* Chinese reprints of 1944 AMS 1:250,000 sheets carry both ideographs and romanization of all place names. Japanese maps carry ideographs and/or *Kana*, except for the Japanese 1:1,000,000 series, which carries only English on the map face.

b. Unit of Measurement. All measurements are expressed in the metric system.

c. Built-Up Areas. Built-up areas are classified by importance except on the AMS 1:250,000 sheets, which classify built-up areas by population.

69. Marginal Information

Although there are minor variations, there are certain basic arrangements for marginal information on Chinese and Japanese maps (figs. 37 and 38).

a. Most maps of the area carry either source

diagrams or compilation or credit notes. There are no legends on Japanese 1:25,000 and 1:50,000 series and on some of the Japanese 1:500,000 sheets of the area. Chinese reprints of 1944 AMS 1:250,000 sheets carry a bilingual (Chinese and English) legend. The Japanese 1:1,000,000 series has a bilingual (Japanese and English) legend.

b. For description of Chinese dates, mapping terms, and mapping authorities see figure 35. For a description of Japanese dates, mapping terms, units of measurement and mapping authorities see figures 53 through 58.

CHAPTER 6

SOUTHERN ASIA

Section I. ARABIAN PENINSULA

70. Mapping Activities

a. Introduction. The Arabian Peninsula includes Aden Colony, Aden Protectorate, Bahrein, Kuwait, Muscat and Oman, two Neutral Zones, Qatar, Saudi Arabia, Trucial Oman, and Yemen. None of the various countries or independent sheikhdoms in the peninsula has its own local mapping agency. Before the development of interest in the oil resources of this strategic region, maps were essentially compilations from British Admiralty surveys and charts, old Turkish (Ottoman Empire) reconnaissance mapping in the area adjacent to the Red Sea, and fragmentary inland exploratory data. Although much of this basic work is at small scale, it is still included in many of the contemporary maps of the area because of the lack of more recent and reliable surveys.

b. Official. Most of the mapping of several of the political units closely connected with the United Kingdom (Aden Colony, Aden Protectorate, Bahrein, and Kuwait) has been carried out by various British civil and military organizations. Foremost among these are the Survey of India (SI), the Middle East Land Forces (MELF), the East African Forces (EAF), and the Directorate of Military Survey, War Office (Geographical Section, General Staff)—GSGS. All of these agencies have published sheets of the *Asia* and *Africa-Asia* series at 1:1,000,000. The latest editions of several of these sheets give evidence of partial utilization of oil-company surveys and of trimetrogon photography taken during World War II by the USAF. AMS has reprinted selected sheets of these series.

- (1) *EAF.* The East African Forces published a 1:15,840 map of Perim Island in 1942 and a two-sheet 1:25,000 series of Aden Colony in 1944. The latter publication was based on aerial photography.
- (2) *GSGS.* In 1939, GSGS published a

1:63,360 single-sheet map of Bahrein Island. GSGS has also revised the Survey of India 1:126,720 and 1:253,440 series of Aden Colony and Western Aden Protectorate and has published the *Southwest Arabia* 1:253,440 series, the 1:500,000 *Ottoman Empire* series covering parts of northwestern Saudi Arabia, and sheets in the *Quarter-Inch Series* (1:253,440) and the *Iraq Desert* 1:500,000 series, some of which include Kuwait, the Neutral Zones, and part of northern Saudi Arabia. For further details, see paragraphs 80–82.

- (3) *MELF.* The Middle East Land Forces published, in 1941, the 1:100,000 *Trans-Jordan-Nejd Boundary* series. For further details, see paragraphs 83–85. In addition, MELF reprinted the GSGS *Iraq Desert* series in 1941.
- (4) *SI.* Survey of India mapping in the Arabian Peninsula generally preceded that of the other British agencies. Most of the work by SI has been incorporated into—or superseded by—the publications of those agencies.
- (5) *RAF.* The Royal Air Force in 1946 compiled and published a 1:253,440 series of Aden Protectorate.

c. Other.

- (1) *Survey of Egypt.* A small amount of mapping in the Arabian Peninsula has been accomplished by the Survey of Egypt. As a result of that agency's topographical survey in Saudi Arabia, a road-strip series at 1:100,000 in the Jidda-Mecca-Medina area was published in 1945–47. The eight sheets are in Arabic script. The Survey of Egypt has contributed several bilingual sheets for

western Saudi Arabia to the *International Map of the World*. It has published also a few town plans in Arabic script.

- (2) *Explorers*. Explorers have supplied valuable geographic data on poorly mapped areas of the Arabian Peninsula. Outstanding among them are Alois Musil, Carl Rathjens, and Herman von Wissmann. Musil has prepared 1:500,000 and 1:1,000,000 maps of north-western Saudi Arabia; Rathjens and von Wissmann, a 1:100,000 reconnaissance map of portions of Yemen.
- (3) *Oil companies*. Since the 1930's, significant contributions to the mapping of the Arabian Peninsula have also been made by the various oil companies operating in the area.

71. Major Maps of the Arabian Peninsula

a. Topographic Series.

(1) Official.

- (a) *Perim Island*; 1:15,840; East African Forces; EAF 1075, GSGS 3894; 1942; Aden Zone grid.

This contoured polychrome one-sheet map provides complete coverage of Perim Island, strategically located in the Bab el Mandeb. The sheet was reproduced, with the addition of a British military grid, from the 1930 edition of GSGS 3894, which in turn was compiled from a Survey of India map dated 1917.

- (b) 1:25,000 *Aden*; East African Forces; 1946; Aden Zone grid. Originally published by the East African Forces as EAF 1951 and 1952, this map gives detailed coverage of cultural and physical features of Aden Colony and adjacent parts of the Protectorate. Relief is shown by contours. The two sheets of this polychrome map were compiled primarily from aerial photography dated 1942 and were revised in 1944 from material supplied by Headquarters Troops, Aden. Both sheets were reprinted without revision by the Middle East Land Forces in 1946; and one sheet by the Directorate of Military Sur-

vey in 1949. AMS has also reprinted both sheets (fig. 76).

- (c) *Aden*; 1:50,000; Middle East Land Forces; MDR 593, GSGS 8001; 1943; Aden Zone grid.

This one-sheet polychrome map covers a somewhat larger area than the EAF *Aden* 1:25,000 series for Aden and the nearby hinterland.

- (d) *Bahrein Island*; 1:63,360; Directorate of Military Survey, War Office (Geographical Section, General Staff); GSGS 4035; 1942; Mecca-Muscat Zone grid.

This single-sheet polychrome map supplies complete coverage for Bahrein and Muharraq Islands. Relief is indicated by approximate contours, supplemented by symbols for cliffs and mounds. The sheet was compiled in 1937 from aerial photographs and was originally published in 1939. A British military grid was added in 1942. Cultural developments since 1937 made much of the information obsolete. AMS has reprinted this sheet (fig. 77).

- (e) *Transjordan-Nejd Boundary*; 1:100,000; Middle East Land Forces; PDR 1501; 1941; Iraq Zone grid.

This is a two-color series covering the Saudi Arabia-Jordan frontier area from Aqaba east to 38° E. No definite compilation information is available, but the treatment of detail suggests that the series may have been compiled from aerial photography. For most areas covered, relief is indicated by contours, but for some areas in the eastern part of the series, hachures have been used. The few roads shown are not classified. The sheets are not complete to the neatline, and the Jordan-Saudi Arabia boundary is not delineated.

- (f) *Aden*; 1:126,720; Directorate of Military Survey, War Office (Geographical Section, General Staff); GSGS 3879; 1930; Aden Zone grid.

This polychrome series covers Aden Colony and parts of Western Aden Protectorate. Originally published

in 1917 by the Survey of India, it is based on ground surveys. The GSGS edition of 1930 includes revised cultural and topographic detail. Relief is shown by form lines.

- (g) *Aden Protectorate*; 1:253,440; Directorate of Military Survey, War Office (Geographical Section, General Staff); GSGS 3892; Aden Zone grid.

This one-sheet polychrome map was compiled by the Survey of India in 1914 from surveys conducted from 1891 to 1904. Minor revisions were made in the first GSGS edition of this sheet in 1930. It covers the Colony of Aden, southern Yemen, and parts of Western Aden Protectorate. Relief is indicated by hachures. Routes are classified only as metalled roads and footpaths.

- (h) *Quarter-Inch Series*; 1:253,440; Survey of India (SI); 1941-48; Iraq and Mecca-Muscat Zone grids.

Published basically as coverage for Iraq, Iran, and countries of southern Asia, this series covers most of Kuwait and a limited area south of the Strait of Hormuz. Three of the four sheets have been reprinted by GSGS. For further details see paragraphs 76-79.

- (i) *Southwest Arabia*; 1:253,440; Directorate of Military Survey, War Office (Geographical Section, General Staff); GSGS 3108; 1915-17; no grid.

This polychrome series (fig. 78) covers the Asir mountainous region and the Tihama plain along the Red Sea coast between Jidda, in Saudi Arabia, and Aden Protectorate. The series is based on old Admiralty Charts, exploratory maps, and documentary materials dated 1824 to 1916. Relief is shown by very generalized form lines.

- (j) *Sketch Map of Aden Protectorate*; 1:253,440; Royal Air Force (RAF); 1946; no grid.

This two-sheet map, of which only photocopies are available, covers the part of Aden Protectorate between Shuqrah and Mukalla. Compiled in

1946, it was based on compass traverse surveys by the RAF. Relief is shown along the traverse route by dense hachures, and elsewhere by sparse hachures.

- (k) *Iraq Desert*; 1:500,000; Directorate of Military Survey, War Office (Geographical Section, General Staff); GSGS 3954; 1937-42; Levant and Iraq Zone grids and Palestine Belt grid.

All of Kuwait, the two Neutral Zones, and a small part of northern Saudi Arabia are covered by an extension of this series into the Arabian Peninsula. MELF has reprinted the series as MDR 53, with revision of aeronautical data. AMS has reprinted selected sheets of both MELF and GSGS series. For further details see paragraphs 80-82.

- (l) *Ottoman Empire*; 1:500,000; Directorate of Military Survey, War Office (Geographical Section, General Staff); GSGS 4011; 1916-20; no grid.

Compiled during World War I from a variety of materials, three sheets of the series cover parts of northwestern Saudi Arabia. The numerous warning notes appearing on the sheets regarding internal inconsistencies and the lack of adequate control emphasize the unreliability of the series.

- (2) *Other.*

- (a) *Saudi Arabia, Regions of Hejaz*; 1:100,000; Survey of Egypt; 1945-47; no grid.

This polychrome series furnishes coverage for a narrow strip along the road between Mecca and Jidda and from Jidda north to Medina. Relief is shown on some sheets by contours, supplemented by hachures; on others, only by hachures. Drainage is shown in green. Roads are classified as main and secondary. The series, based on field work by the Survey of Egypt, is in Arabic script.

- (b) *Karte des Reisegebiets in Jemen* (Map of the Region Traversed in Yemen); 1:100,000; Rathjens and von Wissmann; 1934; no grid.

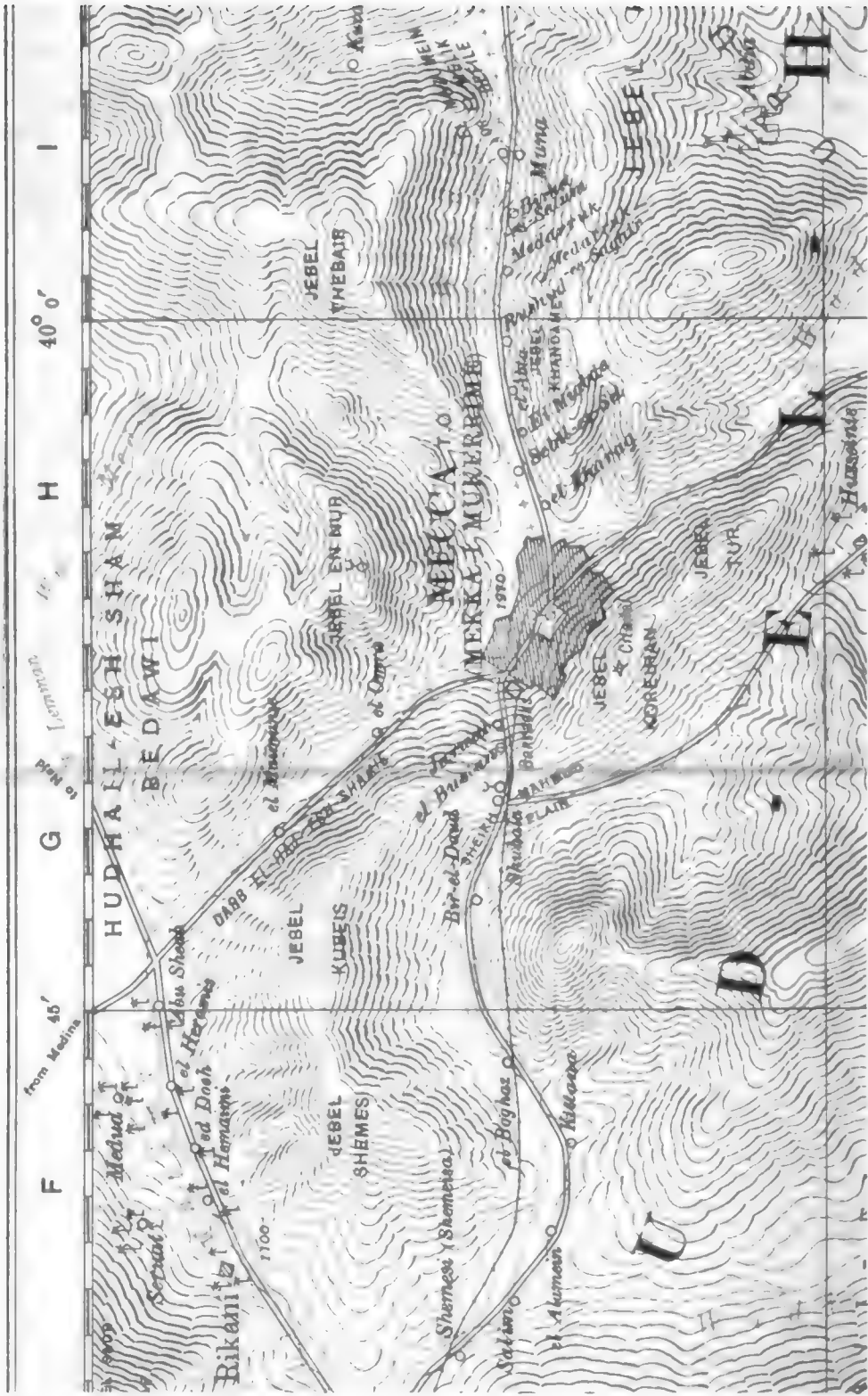

Figure 78. Section from Sheet No. 8 of 1:253,440 South-west Arabia series (OSG S 3108) by the Directorate of Military Survey, War Office (Geographical Section, General Staff).

Covering a limited area of Yemen between the capital San'ā, and the coast, this three-sheet German polychrome map is based on road surveys, supplemented by information from diaries, sketches, and maps of other travelers. Relief is represented by form lines or hachures. Slopes, areas of lava flow, and passes are indicated. Routes of the author's expedition, routes of other travelers, and approximate locations of roads (unclassified) are shown.

- (c) *The Northern Hejaz*; 1:500,000; Alois Musil; 1926; atlas grid.

This one-sheet polychrome map supplies coverage for northwestern Saudi Arabia south to Al Ula station on the Hejaz Railroad. It was compiled by Musil from results of his investigations and explorations and was printed in polychrome by the American Geographical Society. Relief is indicated by form lines, and lava areas are located. Roman roads, caravan routes, and the author's route are shown. The map carries a key to the author's somewhat unusual transliteration system.

- (d) *Northern Arabia*; 1:1,000,000; Alois Musil; 1927; no grid. This map covers northern Saudi Arabia as well as parts of adjoining countries, partially du-

plicating the coverage of Musil's 1:500,000 map. Like the latter, it was compiled in 1926 from the results of Musil's investigations, and format and symbolization the same. Road classification includes carriage roads, in addition to those categories shown on the 1:500,000 map.

b. *Town Plans*. Town plans for the Arabian Peninsula vary considerably in scale, date, style, and quality. Those prepared by British agencies (notably the Naval Staff Intelligence Division) are generally at small scales, and are out of date and lacking in detail. Although those plans published by the Survey of Egypt are more recent than the British plans, they are in Arabic script. Several compiled by a private engineer (native) are bilingual.

72. Coordinate Systems

a. *Geographic*. For all sheets described, Greenwich is the prime meridian, and geographic coordinates are expressed in degrees.

b. *Grid*. Most of the British maps of the Arabian Peninsula utilize the British grid system. These maps fall within the area covered by the Aden, Iraq, and Mecca-Muscat Zone grids and the East Africa and Palestine Belt grids. All are computed on the Clarke 1880 spheroid. The Lambert Conical Orthomorphic projection is used for the Zone grids; the Transverse Mercator, for the Belt grids. The standard unit of measurement is the meter.

Section II. BURMA

73. Mapping Activities

a. Official.

- (1) *Survey of India (SI)*. Until 1937, the Survey of India was responsible for the mapping of Burma. This agency conducted all of the principal triangulation and the ground surveys of Burma between 1885 and 1937, produced town plans of major cities, and published map series at the following scales: 1:63,360, 1:126,720, 1:253,440, and 1:1,000,000.
- (2) *Burma Survey Party*. From 1937 to the outbreak of World War II, the official mapping agency of Burma was the

Burma Survey Party. Although this agency did prepare several original compilations from ground and aerial surveys, most of the work accomplished consisted of revisions to communications on existing maps.

- (3) *Survey of Burma*. The Survey of Burma, currently responsible for the mapping of Burma, was organized in 1946. No work of this agency is known to have been published to date.

b. Other.

- (1) *Japanese*. The Japanese General Staff compiled a 1:500,000 series covering Burma and parts of India, China, Thai-

land, and Indochina. Various field units of the Japanese Army prepared original compilations at scales of 1:50,000 and 1:100,000 covering parts of northwestern Burma and most of the Mergui Archipelago.

- (2) *United States*. The Army Map Service reprinted wartime editions of the IMW 1:1,000,000 series covering all of Burma.

74. Major Maps of Burma

a. Topographic Series.

- (1) *Official*. From the 1890's through World War II, Survey of India sheets covering Burma were published in two to six colors. The two-color sheets are post-1940 reprints on which the significant distinction between perennial and intermittent drainage is lost. Areas of cultivation and forest growth are differentiated, and various vegetation types are symbolized. Vertical data are given in feet; contours, form lines, and hachures are used to indicate relief.

- (a) *One-Inch Series*; 1:63,360; Survey of India; 1905-43; India Zone II B, III B, and IV B grids.

This series (fig. 79), based on original one-inch-to-the-mile planetable surveys, covers most of Burma except the northern tip and an area in the northwest, bordering India. During World War II the Japanese reprinted sheets of this series enlarged to 1:50,000.

- (b) *Half-Inch Series*; 1:126,720; Survey of India; 1921-44; India Zone II B, III B, and IV B grids.

This series was based on one-inch surveys, where completed, and elsewhere on original half-inch surveys. All of Burma except the central part is covered by this series. During World War II the Japanese reprinted about 15% of these sheets, enlarged to 1:125,000.

- (c) *Quarter-Inch Series*; 1:253,440; Sur-

vey of India; 1923-43; India Zone II B, III B, and IV B grids.

This series covering all of Burma was compiled from completed one-inch and half-inch surveys, various reconnaissance and exploratory surveys, and other sources. The Army Map Service and GSGS have reprinted sheets of this series. During World War II the Japanese reprinted the series, enlarging it to 1:250,000.

- (2) *Other*.

- (a) (*Bates [Mergui] Islands*); 1:50,000; Japanese Army I 1160 Unit; 1944; no grid.

These monochrome sheets cover most of the Mergui Archipelago. They were compiled by unknown methods from aerial photography, with control taken from British Admiralty Charts. Relief is shown by contours at intervals of 20 meters. Very few spot elevations are shown.

- (b) *World (Asia)*; 1:1,000,000; Army Map Service; AMS 1301; 1944-45; no grid.

These multicolored sheets, covering all of Burma, are reprints of wartime 1:1,000,000 sheets. They are basically the same as Survey of India IMW sheets, with changes in style and cultural detail. With one exception, the sheets are bilingual (English and French). GSGS has reprinted the same sheets.

- b. *Town Plans: Official*. The Survey of India published *Guide Maps* for a few towns in Burma, ranging in scale from 1:10,000 to 1:63,360.

75. Coordinate Systems

a. *Geographic*. On all series of Burma, geographic coordinates are expressed in degrees, and longitude is referred to Greenwich.

b. *Grid*. The British grid system is used on SI series and is retained on AMS and GSGS reprints. India Zone II B, III B, and IV B grids cover Burma.

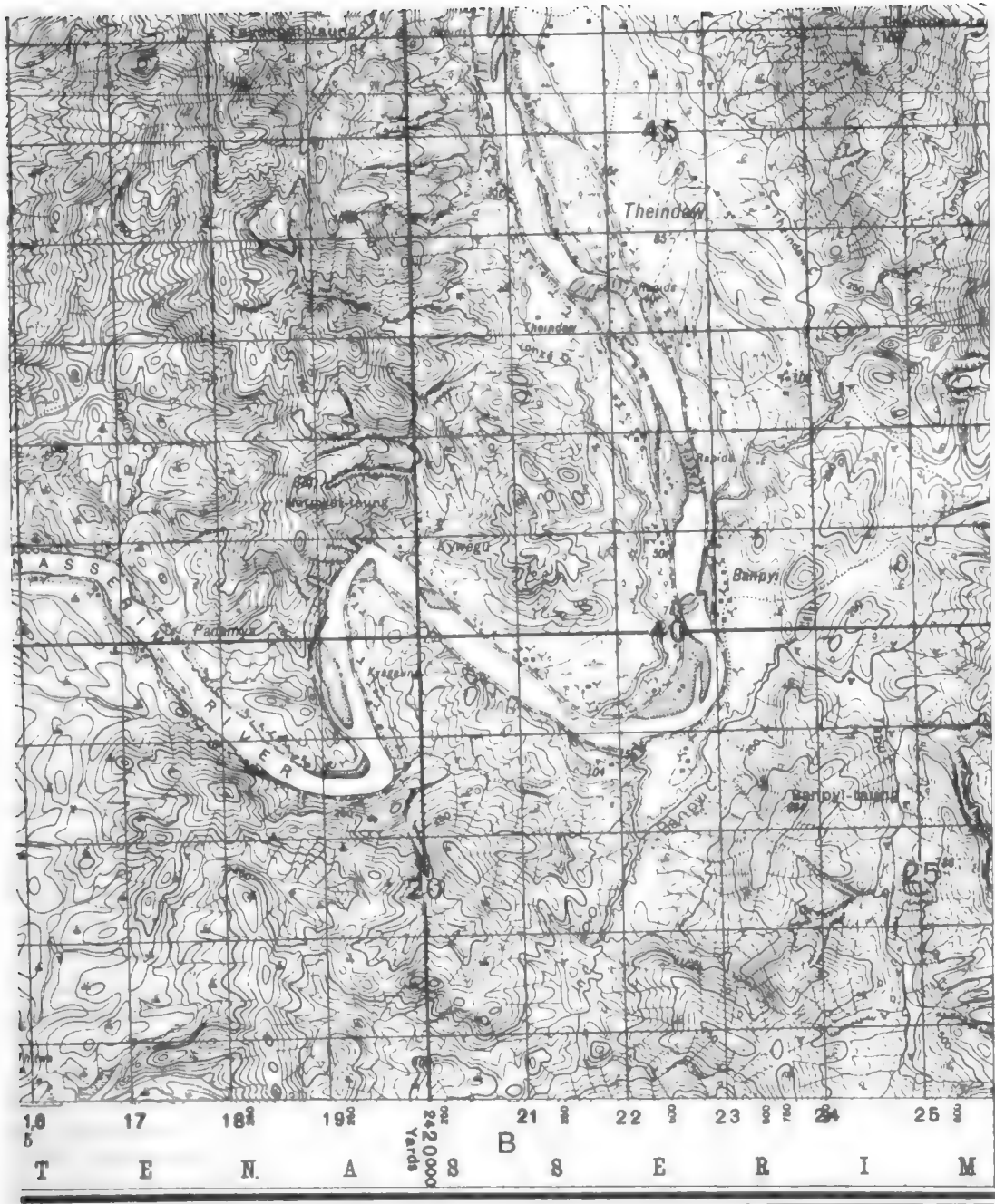

Published for the Government of Burma under the direction of the Surveyor General of India,

Edition: 1919

Scale 1 Inch to a Mile **ONE INCH** or 1 : 63,360.

Figure 79. Section of sheet from the Burma One-Inch Series (1:63,360) by the Survey of India.

Section III. IRAN

76. Mapping Activities

a. Historical Background. Until 1914, maps of Iran were only rough compilations from the results of work done hurriedly in the course of minor military expeditions or on exploratory journeys. Modern mapping of Iran was initiated by both British and Russian organizations during World War I and has continued to be carried out primarily by other than local mapping agencies. British agencies have been the principal contributors to the mapping of Iran, although notable contributions have been made also by the Russians.

b. Native Mapping by the Geographical Section of the Iranian General Staff. The Geographical Section of the Iranian General Staff is the local agency responsible for military mapping activities, but mapping under its direction is limited in scope. Iranian maps, published in Persian script in many cases, are basically reproductions or enlargements of British and Russian maps. Among the topographic series published by the Geographic Section are the following: limited 1:10,000 and 1:20,000 series of the Tehran areas; a 1:50,000 series covering scattered areas, primarily in the vicinity of cities and towns; 1:84,000 and 1:100,000 coverage of northwestern Iran; and complete coverage (except for unsurveyed areas) at 1:253,440 and 1:1,000,000 (essentially reprints, in Persian script, of the Survey of India $4^{\circ} \times 4^{\circ}$ 1:1,000,000 series, *India and Adjacent Countries*). The 1:10,000 and 1:20,000 series are based on original work; the others are Persian-script editions of British and Russian series. The Geographic Section has prepared a number of Persian-script plans of important towns in Iran.

c. Other.

(1) *The Survey of India (SI).* During World War I, SI units operating in both Iran and Iraq under the Mesopotamia Expeditionary Forces (MEF) carried out the first systematic mapping of Iran. SI published the *Quarter-Inch Series* (1:253,440), utilizing the results of various original surveys and of subsequent field work covering small areas, as well as reconnaissance and exploratory data of various dates. Sheets were numbered according to a system based on that of the 1:1,000,000 *India and Adjacent Countries* series of $4^{\circ} \times 4^{\circ}$ sheets, also

published by SI. Other basic mapping by SI has been published at 1:50,000 and 1:126,720. The 1:50,000 series is based on surveys conducted during World War II; the 1:126,720 series, on 1888–1921 surveys. In addition, SI published sheets of the *Asia* $4^{\circ} \times 6^{\circ}$ 1:1,000,000 series covering Iran.

(2) *British Directorate of Military Survey, War Office (Geographical Section, General Staff)—GSGS.* Between World Wars I and II, GSGS inherited from SI the responsibility for the 1:253,440 sheets of southwestern Asia as far east as 48° E. A new numbering system based on the $4^{\circ} \times 6^{\circ}$ sheets of the *International Map of the World* was introduced, although sheets continued to carry the old number based on the *India and Adjacent Countries* series as well. Shortly after the outbreak of World War II, the War Office reprinted the GSGS sheets and some of the SI sheets as GSGS 3919, incorporating hasty revisions, principally along motorable routes. GSGS has also published sheets covering Iran as part of the *Asia* 1:1,000,000 series (GSGS 2555). Many of these sheets are reprints of SI or MELF editions. A number of other small-scale publications are also available. In addition, GSGS series numbers have been assigned to all of the MELF publications, and it is assumed that these series will be reprinted with the GSGS designations when existing stocks are depleted. Several town plans for Iran have been published as GSGS 4738.

(3) *Middle East Land Forces (MELF).* During World War II, new field work was started by the Indian Field Survey Companies operating under the Middle East Command in western Iran, as well as in Iraq. The results have been incorporated into wartime and postwar re-compilations of the *Quarter-Inch Series* and, where sufficiently detailed, have been published at various larger scales ranging from 1:10,000 to 1:100,000. The *Quarter-Inch Series* (ID, IDR, MDR, PID, and XDR 9002) has also incor-

porated some of the results of the Russian reconnaissance surveys of northern Iran during World War II, which were published in 1942 at 1:200,000. MELF has also contributed sheets to the *Asia* 1:1,000,000 coverage (as MDR 1) and has produced plans of several of the major towns of Iran.

- (4) *The Russian Voyenno-Topograficheskoye Upravleniye (Military-Topographic Administration), Upravleniye Voyennykh Topografov (Administration of Military Topographers), and General'nyy Shtab, Krasnaya Armiya (General Staff, Red Army)*. During the first World War, the Russians published the first detailed topographic maps of Iran. The sheets, at 1:84,000, were limited in coverage to a small area in the extreme northwestern part of the country and were based on surveys of 1896 and 1909 and on the 1911-14 surveys of the Turko-Persian boundary. Later (1938-41) the Russians published a 1:100,000 series compiled from the 1:84,000 sheets and other sources. The results of the survey work carried out during the Russian occupation of northern Iran during World War II were published in 1942 at the scale of 1:200,000. This more recent Russian work is only of a reconnaissance nature. It was partially used in the compilations of recent editions of the *Quarter-Inch Series* by MELF.
- (5) *The German Generalstab des Heeres (General Staff of the Army)*. Map coverage of Iran at 1:200,000 scale prepared by the Generalstab des Heeres was extensive, but was based primarily on the British *Quarter-Inch Series*; German wartime series at 1:500,000 and 1:1,000,000 were both based on the *SI India and Adjacent Countries* series.

77. Major Maps of Iran

a. Topographic Series.

(1) Native.

- (a) (*Environs of Tehran*); 1:10,000; Geographical Section of the Iranian General Staff; 1944-50; unidentified grid.

This polychrome contoured series covers a small area in the vicinity of

Tehran. The sheets are based on original work by the Geographical Section. Several sheets carry a note to the effect that aerial photography (undated) by the Imperial Iranian Army was used in the compilation. Much of the detail, however, differs from that shown on the British *Lar Valley* 1:10,000 series, also based on aerial photography. Road classification includes the categories "main road" and "road," with no information on seasonal use or on surface.

- (b) [*Iran*]; 1:20,000; Geographical Section of the Iranian General Staff; 1949- ; Iraq Zone grid.

The one available sheet of this series covers a small area south of Tehran; the exact extent of the series is unknown. Available evidence indicates that this polychrome map was compiled from sheets of the 1:10,000 series, dated 1944. Relief is shown by contours.

- (c) [*Iran*]; 1:50,000; Geographical Section of the Iranian General Staff; 1936-49; Iraq Zone grid on sheets in Tehran area, but no grid on others.

This monochrome series (fig. 80) presumably intended to cover all of Iran, affords coverage for only discontinuous areas in the vicinity of some of the important cities and towns. The sheets were prepared by enlargement of the British *Quarter-Inch Series*, although the latest editions were not used in all cases. Revisions of planimetry were made from uncontrolled field observations. Relief is shown by form lines. Road classifications are copied from those used on British series.

- (d) [*Iran*]; 1:1,000,000; Geographical Section of the Iranian General Staff; 1941; no grid.

This is a postwar reprint (without the hill shading) of the 1942 edition, which in turn was compiled, with minor revisions, from the now-obsolete sheets of the *SI India and Adjacent Countries* 1:1,000,000 series. The chief value of the series is the

شیاتی ۱
۵۶,۰۰۰

Scale 1:50,000

نقشه طهران شماره ۲

"Tehran 2"

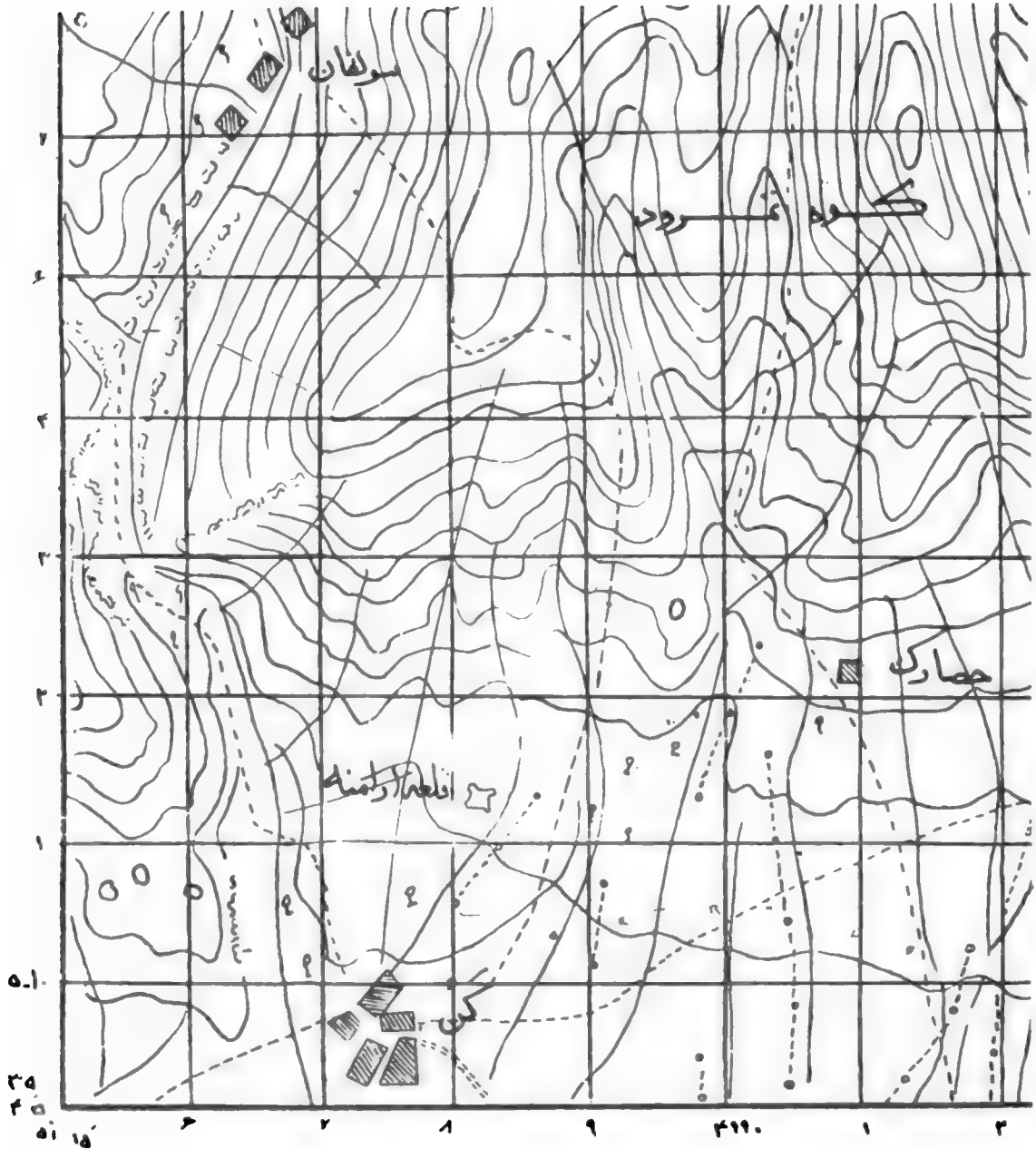

Figure 80. Section of sheet "Tehran 2" of the 1:50,000 Iran series by the Geographical Section of the Iranian General Staff.

delineation of Iranian claims to the disputed portion of the northern boundary east of the Caspian Sea; the delineation on the British maps, in contrast, was derived from Russian sources.

(2) Other.

(a) Lar Valley; 1:10,000; Middle East Land Forces; MDR 683, GSGS 4634; 1947-49; Iraq Zone grid.

This series provides coverage for Tehran and for a very limited area

to the east and southeast of the city. These polychrome sheets are based on aerial photography dated 1945, with control taken from existing trig lists and from field work in 1945 by MELF. Contours are used to show relief. Among the significant features shown in detail are railroad and telecommunications facilities, main streets, drainage features, and vegetation. This series, supplemented by the *Lar Valley* 1:25,000 series, provides complete coverage for this area.

- (b) *Lar Valley*; 1:25,000; Middle East Land Forces; MDR 681, GSGS 4630; 1946-47; Caucasus and Iraq Zone grids.

These polychrome sheets extend the coverage of the 1:10,000 series to provide complete information for the *Lar Valley*. The series are based on similar sources.

- (c) [*Iraq and Iran*]; 1:25,000; Middle East Land Forces; ID and IDR 9005, GSGS 8037; 1942-43; Caucasus and Iraq Zone grids.

This is a group of two-color topographic series—each consisting of a few sheets that cover scattered areas in west-central Iran and parts of Iraq. The sheets are based on aerial and ground surveys dated 1940-42. Relief is shown mainly by contours, although form lines are used for a few small areas. Sheet lines follow British grid lines.

- (d) [*Iraq and Iran*]; 1:50,000; Survey of India; 1941-46; Iraq Zone grid.

This series (fig. 81) covers parts of Iraq and of southwestern Iran. A variety of aerial and ground surveys and map sources were used in the compilation of these one- or two-color sheets; hence the treatment of physical and cultural detail varies. Relief is shown by contours in areas reliably surveyed. For other areas, approximate contours and form lines are used, and in the low tidal flats on the southern coast, only planimetry is shown. Small areas are unsur-

veyed. High- and low-water levels are marked, and arrows indicate tidal movement in streams. Sheet lines are based on the British Iraq Zone grid. The series has been reprinted, with revision of a few sheets, by MELF as MDR 685.

- (e) [*Iraq and Iran*]; 1:50,000; Middle East Land Forces; MDR 685, GSGS 8035; 1946-47; Iraq Zone grid.

This series is essentially a reprint of the SI 1:50,000 series. Some of the sheets, however, are available in the MELF edition only. Aerial photography dated 1945 has been used for planimetric revision of a few sheets.

- (f) [*Iraq and Iran*]; 1:50,000; Middle East Land Forces; IDR, PID, and XDR 9004, GSGS 8036; 1942-43; Iraq Zone grid.

The sheets of this series cover three of the five scattered areas included in the MELF 1:25,000 series and an additional small area northwest of Tehran, as well as two discontinuous areas of Iraq. These polychrome sheets are based on aerial and ground surveys of 1942 and provide detailed information on topography and communications. Relief is shown by contours.

- (g) [*Caucasus*]; 1:84,000; Voyenno-Topograficheskoye Upravleniye (Military - Topographic Administration), Upravleniye Voyennykh Topografov (Administration of Military Topographers), and General'nyy Shtab, Krasnaya Armiya (General Staff, Red Army); 1913-41; no grid.

This series covers an area that extends from the Black Sea across the Caucasus region of the U. S. S. R. and northeastern Turkey into northwestern Iran. The sheets for Iran afford coverage for the region north of 36° N. and west of 47° E. Compiled from ground surveys by the Imperial Russian Army in 1896, 1909, and 1911-14, these sheets in the Russian language have been reprinted at various dates. Cultural information is not up to date, but

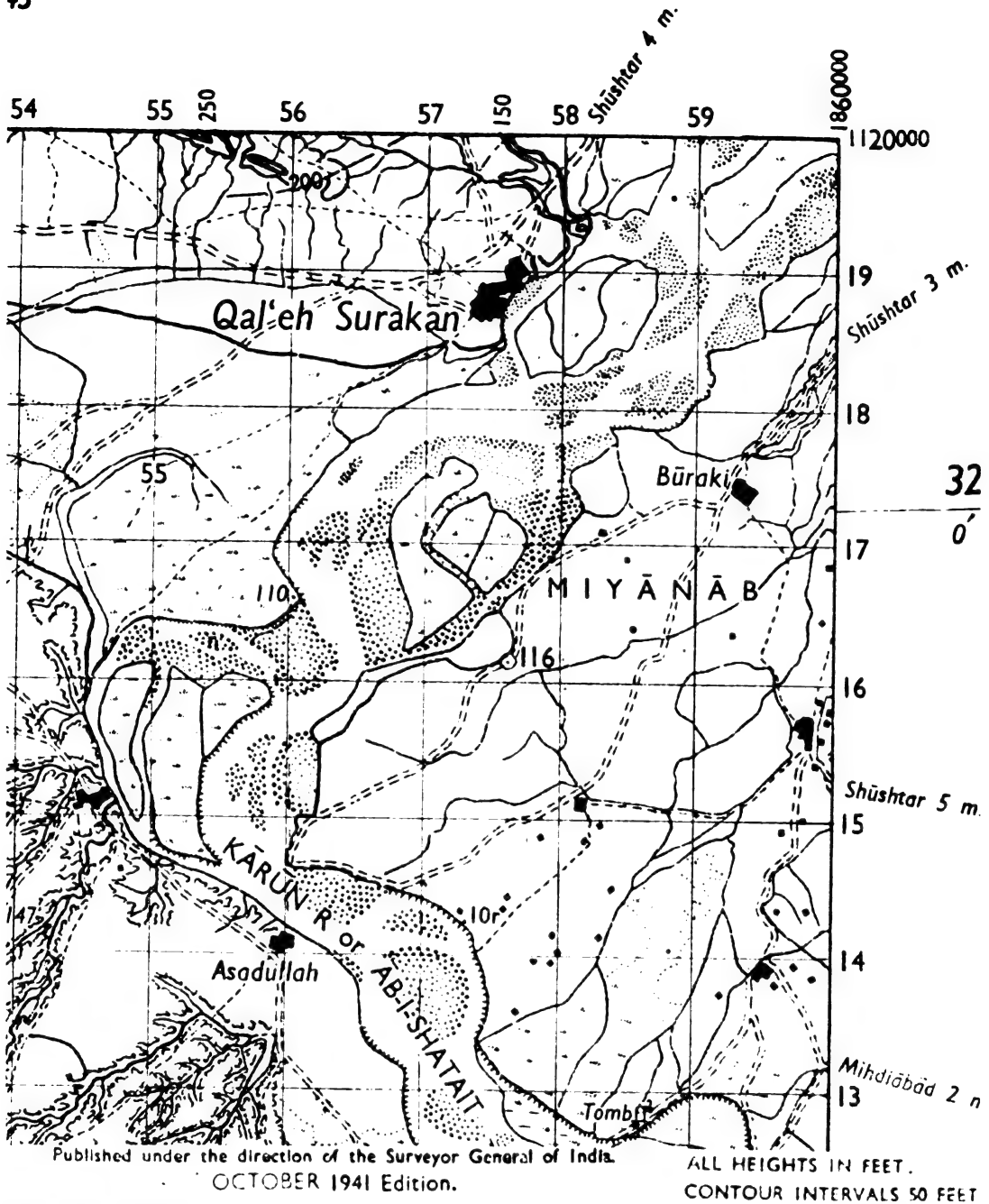

Figure 81. Section of Sheet No. 50 OT 40 from the Iraq and Iran 1: 50,000 series by the Survey of India.

the series constitutes the largest scale topographic coverage for much of the area. The series has been used in compiling sheets of the various British 1: 253,440 series. Relief is shown by contours with values expressed in sazhens, supplemented by

hachures representing steep slopes, cliffs, and ravines. Because of crowding, the detail for some areas is almost impossible to decipher. The series has been reprinted in Persian script by the Geographical Section of the Iranian General Staff.

- (h) *Iraq and Iran*; 1: 100,000; Middle East Land Forces; IDR, ID, PID and XDR 9003, GSGS 4644; 1942- ; Caucasus and Iraq Zone grids.

This polychrome series furnishes coverage for a broad belt of west-central Iran stretching from the Iraq-Iran boundary to the Caspian Sea; for northern and central Iraq, and for a limited area in southwestern Iran. The sheets were, for the most part, compiled from a variety of British and Russian sources dating to 1942. Those sheets for southwestern Iran, however, are based on aerial photography dated 1945. Relief is shown mainly by form lines. Road classification is detailed, but varies from one group of sheets to another. Copies of approximately 50% of the sheets have been published in Persian script by the Geographical Section of the Iranian General Staff.

- (i) [*U. S. S. R. and Northwestern Iran*]; 1: 100,000; General'nyy Shtab, Krasnaya Armiya (General Staff, Red Army); 1938-41; Russian Gauss-Kruger grid.

This series designed primarily for use by the U. S. S. R., includes a group of sheets that extends into northwestern Iran. The sheets, in Russian, were compiled from the Russian 1: 84,000 series and additional unidentified sources dating to 1940. Contours (with values converted to meters) are supplemented by distinctive terrain symbols. Cultural features are shown in detail commensurate with the scale. The number of families in each town is given under the town name, and nomadic camps are identified. Most of the sheets are polychrome editions; the others are monochrome.

- (j) *Half-Inch Series*; 1: 126,720; Survey of India; 1920-23, 1944; atlas grid (on most sheets) or India Zone I grid (on two sheets).

These sheets are based on early (1888-1921) survey work by the SI

and on enlargements of sheets of the *SI Quarter-Inch Series*. Intended primarily as coverage for British India and adjacent countries, a few sheets extend into Iran along the present Pakistan-Iran border. These polychrome sheets show relief by contours, form lines, and hachures. Much of the cultural data is superseded by that of the GSGS 1: 253,440 series.

- (k) [*U. S. S. R., Turkey, Iraq, and Iran*]; 1: 200,000; General'nyy Shtab, Krasnaya Armiya (General Staff, Red Army); 1941-42; Russian Gauss-Kruger grid.

This extensive topographic series (fig. 82), intended primarily as medium-scale coverage for use by the Soviet Union, includes sheets that show the part of Iran north of 34° N. The sheets most of them polychrome, were compiled from larger scale Russian sources dated to 1941 and from very early editions of sheets of the *SI Quarter-Inch Series*. The 1942 edition, covering much of the area north of 36° N., incorporated 1942 Russian reconnaissance survey work carried out during the early period of the Russian occupation of northern Iran during World War II. This series, representing in large part the latest survey data for northern Iran, has been partially incorporated in the relevant sheets of the *MELF Quarter-Inch Series*. Relief is shown by contours (in meters).

- (1) *Quarter-Inch Series*; 1: 253,440; Survey of India; 1912-46; India Zone I, II A, and O grids on most sheets.

This polychrome series provides coverage for several countries of southern Asia, including Iran (exclusive of unsurveyed areas). For most of western Iran and an area in the east-central part near the Afghanistan border, relief is shown by approximate contours. For the rest of the country, relief is shown by form lines and hachures, interspersed with numerous blank areas, notably in the

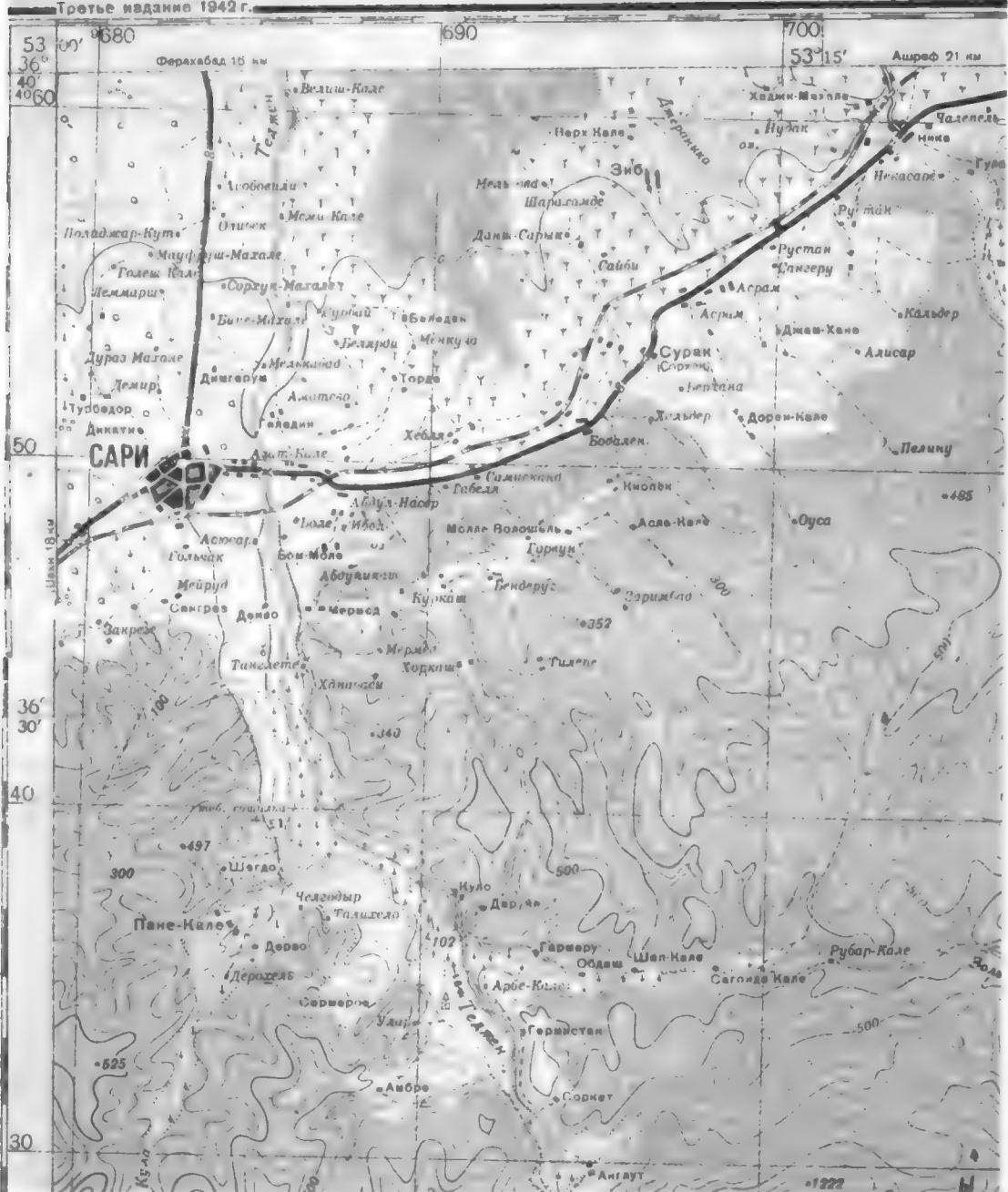

Figure 82. Section of sheet from Iran 1:200,000 series by the General'nyy Shtab, Krasnaya Armiya.

desert areas of the central plateau, which are unsurveyed or unexplored. Spelling of place names varies within the series, and is not in complete agreement with maps at other scales, mainly in the use of local terms. Many of the sheets in this series have been reprinted by GSGS. Revised

editions of some of the sheets have been published by MELF, with various series designations, and selected sheets of the various agencies have also been reprinted by AMS (fig. 83). In addition, copies have been published in Persian script by the Geographical Section of the Iranian

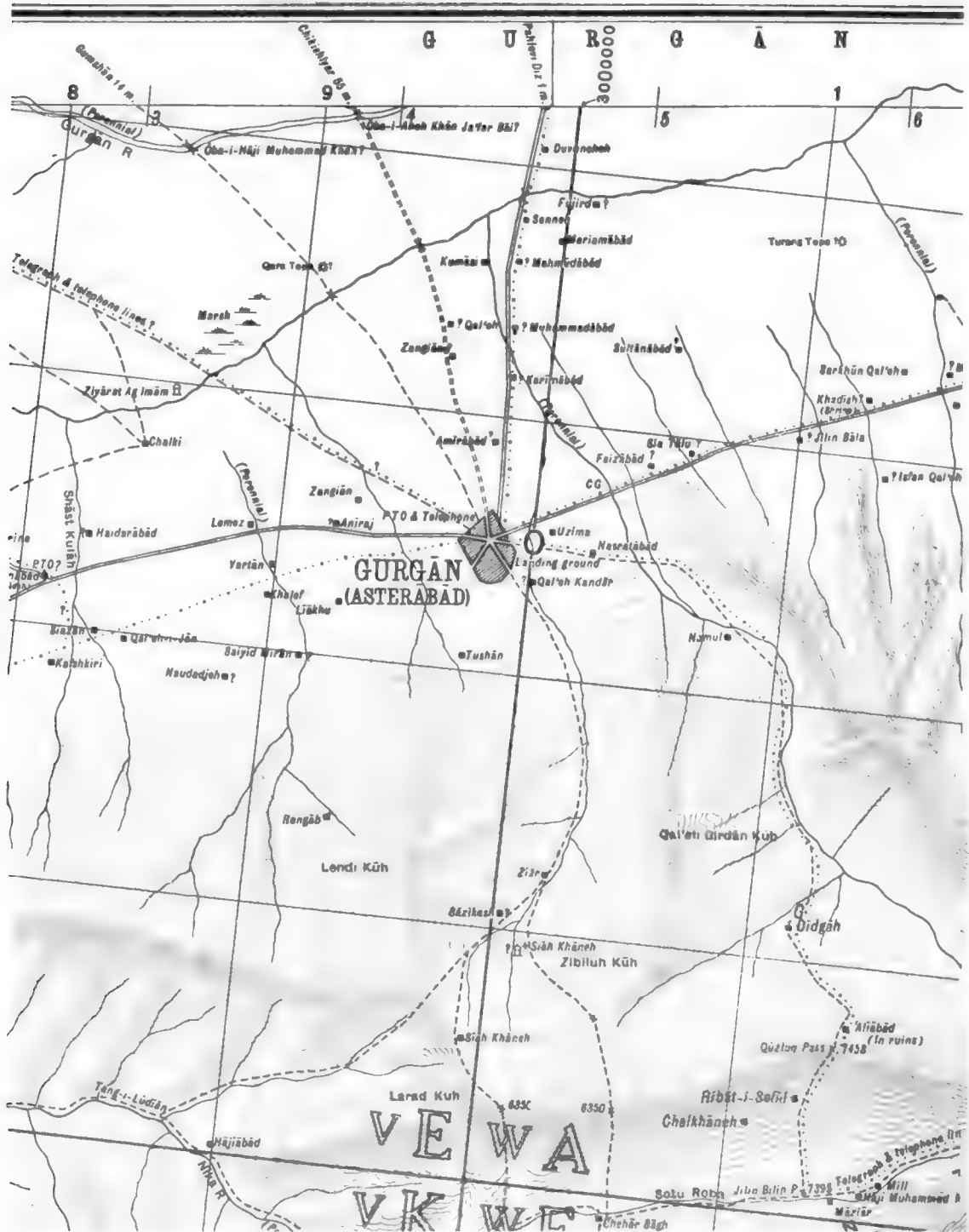

Figure 88. Section of the sheets from the Quarter-Inch Series (1:253,440) by the Survey of India, reprinted by the Army Map Service as AMS K501.

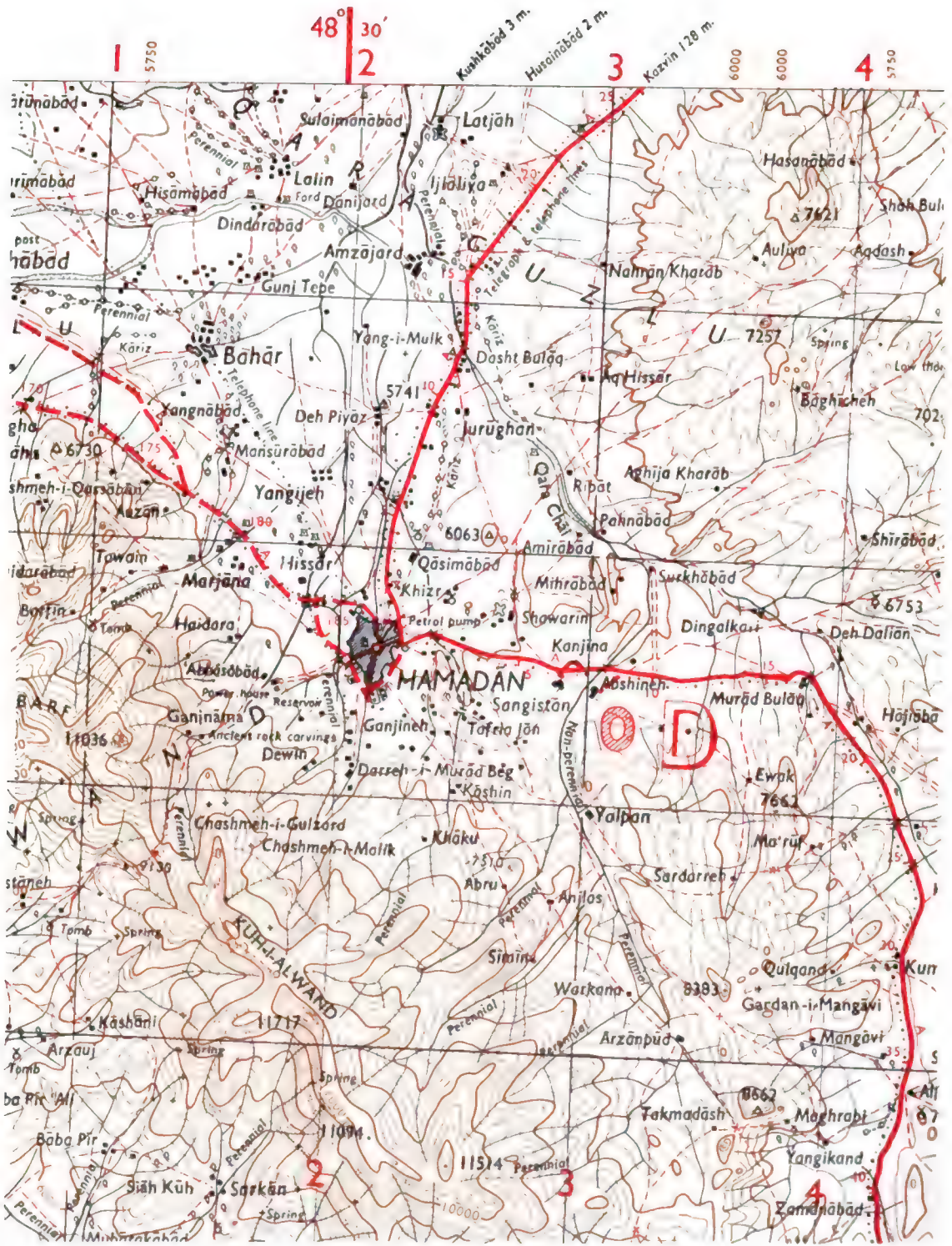

Figure 84. Section of sheet from Quarter-Inch Series (1:253,440) by the Middle East Land Forces, reprinted by GSGS.

General Staff, but the latest British editions have not been used in all cases.

- (m) *Quarter-Inch Series*; 1:253,440; Middle East Land Forces; ID, IDR, MDR, PID, XDR 9002, MDR 503, GSGS 3919; 1941-47; Iraq and Caucasus Zone grids and India Zone I, II A, and O grids.

The sheets of this series (fig. 84) cover parts of Iraq, northern and northwestern Iran (west of 54° E.), and limited border areas of adjoining countries. Relief is shown by approximate contours. These multi-colored sheets were compiled from various British and Russian surveys at large and medium scales and from scattered exploratory surveys dating from 1920 to 1942; they were revised from intelligence data, route surveys, and aerial photography. AMS has reprinted sheets of this series.

- (n) *Quarter-Inch Series*; 1:253,440; Directorate of Military Survey, War Office (Geographical Section, General Staff); GSGS 3919; 1941- ; Caucasus and Iraq Zone grids, India Zone I, IIA, and O grids.

This series is essentially a reprint of selected sheets from the SI and MELF editions. Some of the SI sheets, however, were hastily revised, principally along motorable routes.

b. Town Plans.

- (1) *Native*. The Geographical Section of the Iranian General Staff has published a number of plans of important towns in Iran ranging in scale from 1:4,000 to 1:10,000 and in date from 1945 to 1948. These one-sheet Persian-script plans, most of which are monochrome, identify the main streets and buildings, and show the built-up and cultivated areas. On some of the plans, major drainage is shown, and prominent hills are represented by form lines.

- (2) *Other*.

- (a) *GSGS*. GSGS recently inaugurated a program for the preparation of plans for the principal cities and towns in

Iran. These plans are being compiled from the best available sources and are being published as GSGS 4738. Principal buildings, main streets, oil and water pipelines, and power lines are identified on the plans available for inspection.

- (b) *MELF*. Town plans published by MELF have been assigned individual MDR miscellaneous numbers and vary widely in style, scale (1:6,000 to 1:25,000), and date. Generally, they are planimetric monochrome plans compiled during World War II. Built-up areas, railroad installations, and connecting through routes are shown; main streets and buildings are identified.

78. Coordinate Systems

a. *Iranian*. Geographic coordinates, expressed in degrees, are referred to Greenwich on all Iranian series except the 1:84,000 series, on which they are referred to Ferro. This series has no grid. Unidentified metric grids appear on the Iranian 1:10,000 series and on those sheets of the 1:50,000 series for the Tehran area. The British grid reference system is used on the 1:20,000, 1:100,000, and 1:253,440 series.

b. *British*. Greenwich is the prime meridian for all British maps of Iran, and the British grid system is used on most of them. Among the grids shown are the India Zone O, I, and II A grids; the Caucasus Zone grid; and the Iraq Zone grid.

c. *Russian*. On the Caucasus 1:84,000 series, geographic coordinates are referred to Ferro, and no grid is shown. On the 1:100,000 and 1:200,000 Russian series, Greenwich is the prime meridian, and the Russian Gauss-Kruger grid appears.

79. Characteristics

In general, all topographic maps of Iran published by both official and foreign mapping agencies are not up to date for information on transportation and communications or on other cultural data. Road classification systems are not readily adaptable to U. S. standards. For example, the British term "metalled" is subject to varying interpretations, including both hard- and loose-surface roads. Internal ("ostan") boundaries are not shown within the neatline, although for some series (for example, the British *Quarter-*

Inch Series) this information is shown in an administrative diagram. The British 1:100,000 series and the sheets of the *Quarter-Inch Series*

published by SI, GSGS, and MELF carry warning notes to the effect that contours shown are only approximate.

Section IV. IRAQ

80. Mapping Activities

a. Native.

- (1) *The Survey Directorate, Baghdad (SDB)*. The SDB was established soon after the British occupation of Baghdad in 1917 and developed under close British supervision. In the beginning, military considerations confined the work to mapping only the areas of the sedentary population, at scales of 1:63,360, 1:126,720, and 1:253,440. This early work (for example, the 1:126,720 *Mesopotamia* series covering northern and central Iraq) was published in English, but later publications were in Arabic script. The SDB has also published a number of plans of Iraqi towns, primarily in Arabic script. These plans range in scale from 1:500 to 1:20,000 and in date from 1925 to 1945. Upon the establishment of the Iraqi state under British mandate in 1920, the SDB, formerly a military organization, was transferred to the civilian Ministry of Economics and Communications. In 1926 the Irrigation Survey Division was added to the SDB. This division undertook the leveling and contouring of extensive areas. Since the recognition of the independence of Iraq in 1932, Iraqi mapping has continued gradually along the same lines followed under the mandate.
- (2) *The Directorate General of Land Settlement (DGLS)*. The DGLS was established in 1932. The base maps for the cadastral work by this agency come from the SDB and are usually planimetric.
- (3) *The Directorate General of Surveys (DGS)*, Ministry of Agriculture. After World War II the DGS became the responsible mapping agency of the government.
- (4) *The Directorate General of Municipalities (DGM)*. The DGM performs city surveys at scales of 1:500 to 1:2,500.

b. Official.

- (1) *Survey of India (SI) and Mesopotamia*

Expeditionary Force (MEF). Significant British mapping of Iraq began with the work undertaken during the war years, 1914–18, by the SI units that operated in Iraq and Iran under the MEF. Surveys carried out at the scale of 1:126,720 and larger resulted in the publication of the *Mesopotamia* 1:126,720 series, covering the southern portion of the Iraq-Iran border, and other series that are only of historical interest. In addition, sheets of the *Quarter-Inch Series* (1:253,440) covering all of Iraq except the western and southern deserts, a part of the mountain region, and the southern marsh area, were published. In 1924, the responsibility for the publication of this series was transferred to the Directorate of Military Survey, War Office (Geographical Section, General Staff)—GSGS. Subsequent work by SI consisted of the publication in 1941 of a 1:50,000 series covering the Tigris and Euphrates valleys and the Shatt al Arab area. MEF activities included the publication in 1918 of a series at 1:63,360 that covered a strip along the Euphrates River (downstream from approximately 42°30' E.) and an area extending eastward to Baghdad.

- (2) *British Directorate of Military Survey, War Office (Geographical Section, General Staff)—GSGS.*

(Note. Mapping by GSGS began during the period of British mandate and continued after the termination of the mandate. Hence, this mapping is both official and "other," but for continuity all GSGS work is treated as official).

After assuming responsibility for the *Quarter-Inch Series*, GSGS undertook a revision program, but the monochrome sheets lost the precision of the older polychrome printings of SI. Shortly after the outbreak of World War II, the GSGS series was reprinted with hasty revisions, chiefly along motorable routes. Recent editions of the sheets of this series—

basically reprints of sheets published by the Middle East Land Forces (MELF) during World War II—have been issued by GSGS as part of GSGS 3919, and in the future this series number will be assigned to all sheets. About 1934, GSGS compiled the *Iraq Desert* 1:500,000 series, which duplicates, in part, the coverage at 1:253,440 and larger scales, but also covers the southern and western desert areas of Iraq not mapped at the larger scales, as well as a limited part of the Arabian Peninsula. This series, based primarily on astro-controlled surveys for the desert areas, was revised by GSGS in 1941. GSGS has also published sheets covering Iraq as part of the *Asia* 1:100,000 series. Many of these sheets are reprints of SI or MELF editions. GSGS has recently completed several plans of Iraqi towns, but none as yet available.

c. *Other.*

- (1) *Middle East Land Forces (MELF)*. At the time that the 1:253,440 series was being revised by GSGS, new field work was started by Indian field survey companies operating under MELF. The results were published at various scales (1:25,000, 1:50,000, and 1:100,000) and were incorporated into the recom compilations of the *Quarter-Inch Series* by MELF. Recent editions of sheets of this series have been published as GSGS 3919. Editions of the GSGS *Iraq Desert* 1:500,000 series, with revised aeronautical data, were published by MELF in 1941–42. During World War II, MELF also contributed sheets to the *Asia* 1:1,000,000 coverage as MDR 1. Recent activities of the Middle East Land Forces includes publication of a number of sheets as part of the 1:100,000 series GSGS 4644 (MDR). These sheets, covering part of west-central Iraq, are based on aerial photography dated 1951 and supplementary map sources. The Middle East Land Forces have published several plans for major towns of Iraq.
- (2) *Service Géographique des Forces Françaises du Levant—SGFFL (Geographic Service of the French Forces of the Levant)*. The SGFFL published, as part of

the *Levant* 1:200,000 series (designed primarily as coverage for Syria and Lebanon), sheets covering parts of north-western Iraq along the Syria-Iraq border. Basically, these sheets are compilations from existing British and Iraqi sources. For further details, see paragraphs 86–88.

- (3) *Generalstab des Heeres (General Staff of the Army) and other German agencies*. Topographic map coverage of Iraq prepared during World War II by the Generalstab des Heeres was extensive, but was based on old editions of British sources. Topographic maps produced by the Germans included complete coverage by the 1:500,000 *Deutsche Weltkarte* series, by the 1:1,000,000 *Internationale Weltkarte* series, and by maps at smaller scales, as well as extensive coverage by the 1:200,000 *Iraq* series. Sheets of the latter series are basically enlargements of those of the British *Quarter-Inch Series*. Various German agencies published a number of town plans between 1917 and 1942.

81. Major Maps of Iraq

a. *Topographic Series.*

(1) *Native.*

- (a) [*Iraq*]; 1:20,000; Survey Directorate, Baghdad; 1930– ; an unidentified grid on some sheets.

This one- or two-color Arabic-script series provides coverage for scattered areas of Iraq, including most of the central part of the courses of the Tigris and Euphrates Rivers. Relief is shown by contours; isolated hills and embankments are indicated by hachures. Some sheets are planimetric. Only two categories of roads are shown.

- (b) [*Iraq*] 1:50,000; Survey Directorate, Baghdad; 1931– ; unidentified grid on one sheet.

These polychrome sheets (fig. 85) in Arabic script cover much of the area between the Tigris and Euphrates Rivers from Baghdad south to the Persian Gulf. Sources are unknown for most of this series, but a

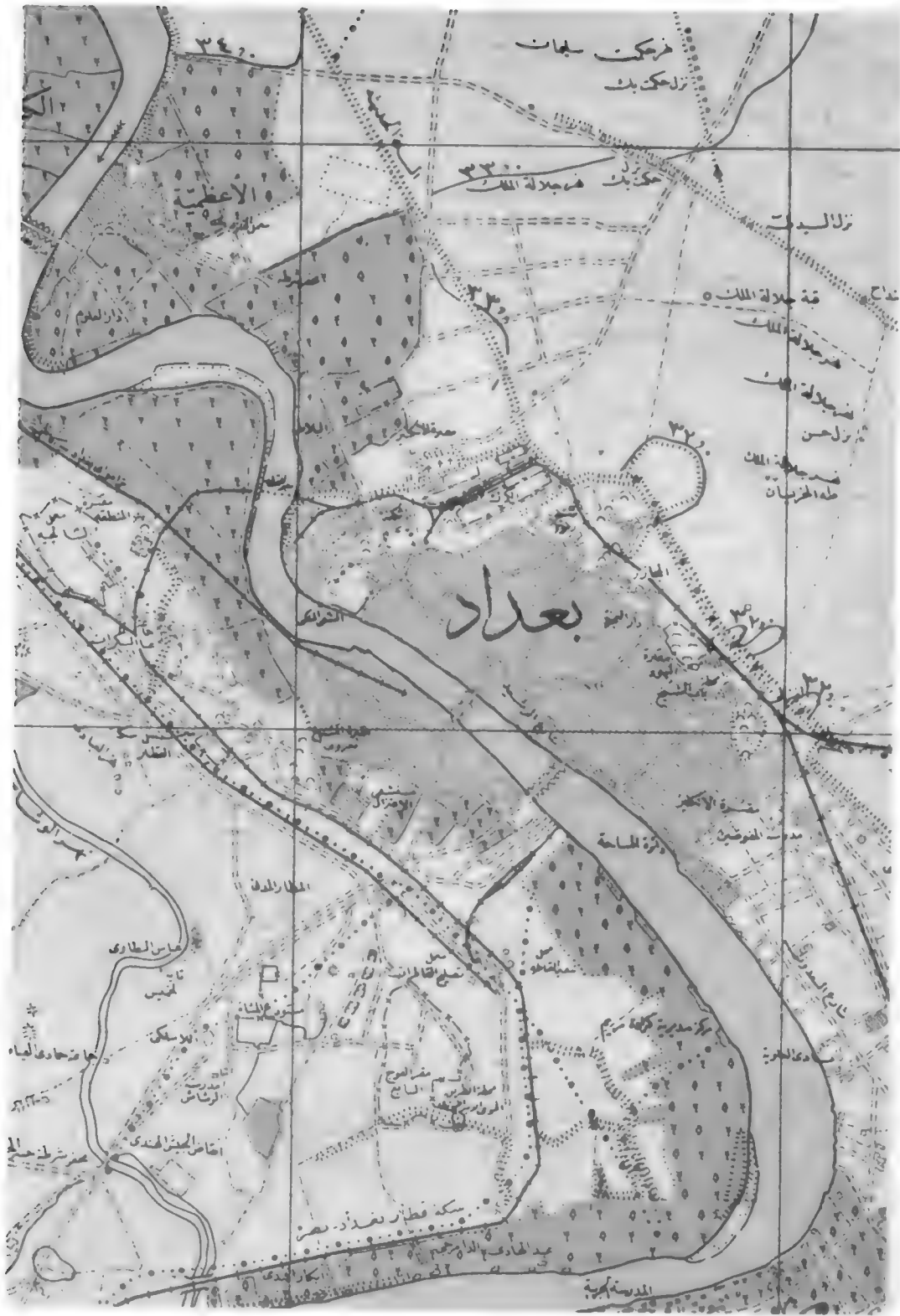

Figure 85. Section of sheet from Iraq 1: 50,000 series by the Survey Directorate, Baghdad.

few sheets were compiled from maps at scales of 1:10,000 to 1:40,000. Relief is shown by contours, with supplementary hachures indicating the numerous banks or levees. Routes are classified only as unmetalled roads and camel tracks.

- (c) [*Iraq*] 1:100,000, Survey Directorate, Baghdad; 1935- ; no grid.

This polychrome Arabic-script series covers a small area north of Baghdad and another in the vicinity of Ad Dīwāntyah, in central Iraq. Relief is indicated by contours and hachures. Routes are designated only as main and secondary roads. The sheets were compiled from maps of various scales, some undated and others published in 1935-36.

- (d) [*Mesopotamia*]; 1:126,720; Survey Directorate, Baghdad; 1919-27; no grid.

This series, primarily polychrome, covers northern and central Iraq. Relief is shown by approximate contours, form lines, and hachures. Road classifications include metalled and unmetalled roads, which are also designated according to their suitability for various types of military transport. This English-language series was compiled from 1919-27 surveys at 1:63,360 and 1:126,720 by the SDB and MEF.

- (e) [*Cadastral Map of Iraq*]; 1:500 to 1:250,000; Survey Directorate, Baghdad; and Directorate General of Land Settlement; 1933- ; no grid.

This monochrome Arabic-script series covers central Iraq and scattered areas in southeastern and northwestern Iraq. The scale of the individual sheets varies in accordance with the amount of detail in the area, the larger scales being used for cultivated areas. Isolated hills and embankments are indicated by hachures. Roads are shown, with widths given in meters, but without data as to classification.

- (f) [*Iraq*]; 1:500,000; Survey Directorate, Baghdad; 1934-35; no grid.

This polychrome series in Arabic

script covers northern and eastern Iraq. Relief is indicated by contours and altitude tints and by supplementary hachures. Motor roads and caravan routes are shown.

- (2) *Official.*

- (a) [*Iraq and Iran*]; 1:50,000; Survey of India and Mesopotamia Expeditionary Force; 1941; Iraq Zone grid.

This series (fig. 81) reproduced in one or two colors, covers the Tigris and Euphrates valleys and the Shatt al Arab area of Iraq, as well as parts of southwestern Iran. Place names for Iraq on many sheets are in both Arabic script and English; marginal information is in English. Two sheets for the Iraq area have been reprinted without change by MELF, as MDR 685 (GSGS 9035). For additional details, see paragraphs 76-79.

- (b) [*Central Iraq*]; 1:63,360; Mesopotamia Expeditionary Force; 1918; unidentified grid.

This series covers a strip along the Euphrates River extending eastward to Baghdad. Relief is indicated by contours, supplemented by auxiliary contours at various intervals, form lines, and hachures. Roads are classified as main roads, cart tracks, and other tracks. This series was compiled from field surveys at 1:21,120, 1:63,360, and 1:126,720 conducted in 1918 by a MEF survey party.

- (c) [*Mesopotamia*]; 1:126,720; Survey of India; 1917; atlas grid.

This polychrome series covers an area adjacent to the southern part of the Iraq-Iran boundary. The sheets were compiled from half-inch (1:126,720) ground surveys, aerial reconnaissance surveys, the Turko-Persian Boundary Commission surveys, and enlargements of early editions of the *Quarter-Inch Series*. Relief is indicated by form lines except for a small area that is contoured.

- (d) [*Quarter-Inch Series*]; 1:253,440; Sur-

vey of India; 1922-42; Caucasus and Iraq Zone grids.

This series covers most of Iraq except the southern and western deserts; it is generally superseded by the GSGS and MELF editions. For additional details, see paragraphs 76-79.

- (e) *Quarter-Inch Series*; 1:253,440; Directorate of Military Survey, War Office (Geographical Section, General Staff); GSGS 3919; 1941- ; Caucasus and Iraq Zone grids.

This series (fig. 84) covers northern and eastern Iraq as well as the other areas of southern Asia. Most of the sheets that cover Iraq are reprints of SI or MELF editions. AMS has reprinted selected sheets in this series. For additional details, see paragraphs 76-79.

- (f) *Iraq Desert*; 1:500,000; Directorate of Military Survey, War Office (Geographical Section, General Staff); GSGS 3954; 1940-43; Palestine Belt grid and Levant and Iraq Zone grids.

This is a polychrome series that partially duplicates the coverage of 1:253,440 and larger scales but also covers the southern and western desert areas of Iraq as well as Kuwait, the two Neutral Zones, and a limited area of northern Saudi Arabia. Relief is indicated by hachures and conventional symbols for depressions, ridges, and cliffs. Sand dunes and stony and sandy areas also are shown. Small areas are planimetric. This series was compiled from aerial photographs and from the results of trigonometric surveys by SDB and MEF, dated 1917-33, and astro-controlled 1929-39 surveys by officers of the Royal Engineers, covering most of Iraq. Roads are classified as main motor roads, secondary roads (suitable for motor transport), and camel-caravan routes. The entire series has been reprinted by AMS.

(3) *Other.*

- (a) [*Iraq and Iran*]; 1:25,000; Middle East Land Forces; ID and IDR 9005,

GSGS 8037; 1942; Caucasus and Iraq Zone grids.

This group of similar polychrome series, each consisting of a few sheets, covers strategic and urban areas of Iraq and Iran. Basic sources for Iraq, in addition to those common to both Iraq and Iran, include Iraqi large-scale and British large- and medium-scale maps dated 1917-41. For additional details see paragraphs 76-79.

- (b) [*Iraq and Iran*]; 1:50,000; Middle East Land Forces; IDR and PID 9004, GSGS 8036; 1942-43; Caucasus and Iraq Zone grids.

This group of several scattered series, each consisting of only a few sheets, includes coverage for the Ruwandiz and Az Zubair areas of Iraq. Relief is indicated by contours on the Ruwandiz sheets and by form lines on the Az Zubair sheet. The former sheets were compiled from 1:25,000 aerial surveys dated 1942; the latter, from the 1:25,000 series. For additional details see paragraphs 76-79.

- (c) [*Iraq and Iran*]; 1:100,000; Middle East Land Forces; ID, IDR, PID 9003, IDR 9106, GSGS 4644; 1942- ; Caucasus and Iraq Zone grids.

This series covers northern and central Iraq as well as parts of Iran. The sheets for Iraq were compiled from a variety of sources, including maps at 1:10,000 (dated 1927-42) and results of original Iraqi and British surveys at 1:10,000-1:126,720 dated 1919-42. Most of the sheets were revised in 1941-42, primarily along lines of communications. Several sheets that cover part of west-central Iraq and are based on aerial photography dated 1951, supplemented by map sources, have recently (1954) been published. For additional details, see paragraphs 76-79.

- (d) *Levant 1:200,000* e; Service Géographique des Forces Françaises du

Levant; 1945; Levant, Caucasus, and Iraq Zone grids.

This series covers Syria and Lebanon and extends into northwestern Iraq. Most of the sheets for Iraq show evidence of recent topographic revisions not indicated on the *Quarter-Inch Series*. For details, see paragraph 86-88.

- (e) *Quarter-Inch Series*; 1:253,440; Middle East Land Forces; ID, IDR, PID, and XDR 9002, GSGS 3919; 1914-47; Caucasus and Iraq Zone grids.

This polychrome series covers all of Iraq except the southern and western deserts, as well as part of Iran. Sources for Iraq—in addition to those common to both Iraq and Iran—include maps and surveys by the SDB and MEF. Sheets in this series have been reprinted by AMS. For additional details, see paragraphs 76-79.

- (f) *Iraq Desert*; 1:500,000; Middle East Land Forces; MDR 53, GSGS 3954; 1941-2; Palestine Belt grid and Levant and Iraq Zone grids.

This series is a reprint, with revision of the aeronautical data on some sheets, of the GSGS series. Some sheets in this series have been reprinted by AMS.

- (g) *Levant 1:500,000*; Middle East Land Forces; PDR 449, GSGS 4194; 1941-45; Levant, Iraq, and Caucasus Zone grids.

This series, which was published primarily as coverage for Syria, Lebanon, and the former British mandates of Palestine and Transjordan, also covers northwestern Iraq. Sheets for the Iraq area are largely based on the *Levant 1:200,000* and *Iraq Desert* series. For details, see paragraphs 86-88.

- (h) *Iraq*; 1:1,000,000; Generalstab des Heeres; 1943; no grid.

This convenient one-sheet polychrome map covers all of Iraq, in addition to parts of neighboring countries. Relief is indicated by

contours and altitude tints. The maps were compiled from German 1:1,000,000 *Internationale Weltkarte* sheets that were not in all cases based on the latest British sources. Roads are differentiated as through routes and non-through routes, and are also classified on the basis of vehicular use and seasonal limitations on traffic.

b. *Town Plans.*

- (1) *Native.* The Survey Directorate, Baghdad, has published a number of plans of Iraqi towns, primarily in Arabic script. These plans range in scale from 1:500 to 1:20,000 and in date from 1928 to 1945. Many of these plans are very large-scale cadastral maps. The main streets, buildings, property boundaries, and other cultural features are generally identified. Some of these plans are monochrome and others polychrome. Some are very generalized and others extremely detailed.

(2) *Other.*

- (a) *MELF.* The Middle East Land Forces have published several plans for the major towns of Iraq with various series designations. These plans range in scale from 1:5,000 to 1:12,500 and in date from 1918 to 1947. Most were compiled from aerial photography and/or by reduction or enlargement of other maps. Main streets, buildings, and important sections of the towns are usually identified. Railways, tramways, and main through routes are delineated for most of the towns. Some plans are monochrome and some polychrome. Some have been revised and reprinted by the Army Map Service.

- (b) *German.* Various German agencies published a number of town plans between 1917 and 1942. Those by the Generalstab des Heeres, Abteilung für Kriegskarten- und Vermessungswesen (IV-Mil-Geo) (General Staff of the Army, Military Cartographic and Survey Division, Section IV, Military Geography) were prepared as backups to the 1:500,000 series, *Mil-Geo-Karte Vd. Orient* (Military-Geographic Map of the Near East). They depict cultural features not shown on plans by other

agencies. Details shown include street patterns, building identifications for the built-up sections of towns, and other important cultural features.

82. Coordinate Systems

a. Geographic. For all sheets described, Greenwich is the prime meridian. Geographic coordinates are expressed in degrees; and on the 1:200,000 and 1:500,000 *Levant* series, both degrees and

grads are shown. Maps published by native Iraqi agencies carry either geographic coordinates or an unidentified grid.

b. Grid. Most of the British maps use the British grid system. Those sheets covering northern Iraq carry the Caucasus Zone grid; those covering central and southern Iraq, the Iraq Zone grid; and those in western Iraq, the Levant Zone grid or the Palestine Belt grid. The grid used on some native maps is not identified.

Section V. ISRAEL AND JORDAN

Note. The mapping of the areas that now constitute the independent countries of Israel and Jordan began during the period of the British Mandates of Palestine and Transjordan, established in 1923. This early work is discussed as a unit for two reasons. The first is the common origin and continuity of the mapping; the second is the fact that small disputed border areas that were formerly part of Palestine are now not recognized as part of Israel, Jordan, Syria, or Egypt. Maps produced during this period show only the mandate boundaries and do not include the present armistice lines between Israel and adjoining countries.

83. Mapping Activities

a. Official Mapping of Palestine and Transjordan under British mandate.

(1) *Historical background.* Modern mapping of Palestine Transjordan dates from the establishment of the Survey of Palestine in 1921. Official Turkish maps of the Ottoman Empire period (pre-World War I) were entirely superseded by British work carried out during the mandate. In 1937 the Transjordanian Department of Lands and Surveys took over from the Survey of Palestine the responsibility for mapping the area east of the Jordan, and carried on the work under British direction. Military mapping during and after World War II was the responsibility of the British Middle East Land Forces (MELF). Work in the northern part of the area was done in cooperation with the Free French Forces in Syria and Lebanon. Before World War I, southwestern Palestine was mapped by the British War Office cooperatively with the Survey of Egypt. Although the British Mandate of Transjordan ended in 1946 and that of Pales-

tine in 1948, the Jordanian Department of Lands and Surveys still operated under British direction. The functions of the Survey of Palestine now are under the native Survey of Israel.

(2) *Survey of Palestine.* The framework of triangulation in Palestine and Transjordan was executed by the Survey of Palestine after World War I. Subsequent detailed surveys of this agency provided the control for various topographic map series, as well as for cadastral maps and town plans. The Survey published the basic 1:20,000 *Series Topocadastral*, covering northern Palestine, and other series, including the *Hula Basin Contour Survey* at 1:5,000, *Central Judea* at 1:50,000, and the three-sheet 1:250,000 *Palestine* series. The Survey also published several town plans of Palestine based on detailed property surveys by the same agency.

(3) *Middle East Land Forces (MELF).* During and immediately following World War II, military mapping in Transjordan and Palestine was carried out under orders of MELF. Whether the actual surveying, drafting, and reproduction were performed by various field parties or by agencies other than MELF headquarters, all maps were assigned MDR or PDR serial numbers designating a MELF authority. Among the MELF publications covering parts of Palestine and Transjordan are three series at 1:25,000, three at 1:50,000, four at 1:100,000, two at 1:250,000, and one each at 1:500,000 and 1:750,000. MELF reprinted some of the Survey of Palestine town plans and pub-

lished others independently, including one for Transjordan. For a number of Palestine towns, MELF published photomaps that were based on aerial photographs of 1944-45.

- (4) *Directorate of Military Survey, War Office (Geographical Section, General Staff)*—GSGS. GSGS series numbers have been assigned to many of the MELF series, and as existing stocks are depleted, reprints are issued bearing the new GSGS series designations. GSGS also has contributed sheets covering Palestine and Transjordan to the *Asia and Africa-Asia* 1:1,000,000 series, and two sheets in the new *World* 1:1,000,000 series. Earlier original work by GSGS includes the *Transjordan Lava Belt* series at 1:50,000 and the *Africa 1:25,000 Sinai Peninsula* series. Among the obsolete GSGS maps of Palestine and Transjordan are the *Transjordan 1:50,000* series (GSGS 3939), now replaced by *1:50,000 South Levant*; two 1:100,000 series (GSGS 4078 and 4079), both superseded by *Palestine 1:100,000*; and the 1:250,000 *Palestine and Transjordan* series (GSGS 3930).

b. Other Mapping of Palestine and Transjordan under British mandate. During World War II the German Generalstab des Heeres (General Staff of the Army) published maps of the area at several scales. These were copied from original British maps of various dates, frequently old editions. The topographic series are at scales of 1:25,000 (*Palästina*), 1:100,000 (*Palästina* and *Ägypten*), 1:200,000 (*Palästina-Transjordanien, Syrien, and Ägypten*), 1:50,000 (*Deutsche Weltkarte*), and 1:100,000,000 (*Internationale Weltkarte*).

c. Native Mapping of Israel and Jordan.

(1) *Israel.*

(a) *Governmental.* Since the establishment of the State of Israel, May 1948, the Survey of Israel has become the successor to the Survey of Palestine and is responsible, theoretically, for all mapping done by the Government of Israel. Actually, various other agencies do a limited amount of mapping. Organizationally, the Survey of Israel

is a part of the Ministry of Labour and is officially designated as the Survey Department, Ministry of Labour. The latter title, however, and the title, "Survey of Israel," are used interchangeably, and on English-language publications the publisher is designated as the Survey of Israel. Responsibilities of the Survey of Israel include establishment of a triangulation net for the entire country, and execution of the basic cadastral and topographic surveys. The Survey also revises the major map series at regular intervals. Field parties are often loaned by the Survey to other government ministries for surveys in connection with development projects. Among the maps published by the Survey of Israel are *Israel*, a 1:250,000 series with an English edition dated 1951 and a Hebrew edition dated 1953; the one-sheet map, *Israel: Jubilee Map of the Jewish National Fund*, at 1:400,000, dated 1950 (in both English and Hebrew editions); and the 1:500,000 map, *Israel*, dated 1952 (Hebrew edition only). Generally, these maps present up-to-date cultural information, including the location of new villages and settlements. Other basic mapping by the Survey of Israel has been published at 1:10,000, 1:20,000, and 1:100,000. Some of the town plans published by the Survey have been reprints of plans by the Survey of Palestine. Two original plans of Tel Aviv have been prepared by the Survey of Israel.

(b) *Private.* The Photogrammetric Institute, Jerusalem (also referred to as the Jerusalem Institute of Photogrammetry), is a private organization that is closely affiliated with the government of Israel in its operations. Since the fall of 1949, it has been engaged in conducting aerial surveys of the country. This survey information, at scales of 1:1,000 to 1:5,000, is for use in the analysis of the development programs of Israel, including road building, the establishment of settlements, and city

planning. The Jewish Agency of Israel (in Jerusalem), Litour Limited (in Tel Aviv), and Zvi Friedlander (in Haifa) are some of the private organizations that have published maps of Israel. Notable contributions include a number of plans of principal towns, physical maps, and tourist guide maps (of towns).

- (2) *Jordan*. Since the establishment of the independent Hashemite Kingdom of the Jordan (commonly known as Jordan) in 1946, the Department of Lands and Surveys of the Jordan has carried on the work initiated during the period of the British mandate. This Department is under the Ministry of Finance. All maps for the Department (with the exception of several prepared by private firms) are printed by the Ordnance Survey of Great Britain. The Department has published several 1:10,000 series based on aerial photography flown by British commercial firms. Two series cover areas in the Yarmuk Valley and the Zarqa Basin, both located in northwestern Jordan. Another series covers the lower Jordan Valley. The Department has published a 1:100,000 series covering an area of northwestern Jordan, a 1:250,000 series covering much of western Jordan, a 1:500,000 series covering most of Jordan, and complete 1:1,000,000 coverage. Numerous cadastral plans are being made by the Department of Lands and Surveys of the Jordan. A few large-scale town plans have been published by the Bureau of Municipalities, Department of the Interior; and two plans, by the Municipal Council of Amman.

84. Major Maps of Israel and Jordan

a. Topographic Series.

- (1) *Official maps of Palestine and Transjordan under British mandate.*
- (a) *1:20,000 Series Topocadastral; Survey of Palestine; 1930-47; Palestine civil grid.*
- This polychrome topocadastral series covers most of Palestine north of approximately 31°15' N. as well as border areas of northwestern Trans-

Jordan. Details for some sheets were compiled from topocadastral surveys and from large-scale block plans and town plans, dated 1922 to 1940. For the western coastal area from Haifa southward and for an area adjacent to the northwestern boundary of Transjordan, contours were derived from surveys at 1:20,000; and for the area around Jerusalem, from surveys at 1:10,000 and larger scales. In other areas contours were compiled from surveys at 1:40,000-1:50,000 and are, therefore, somewhat generalized. Data for some areas adjacent to the Dead Sea were compiled from aerial photographs at 1:28,000 scale. Data for the Transjordan area were compiled from the *1:25,000 Transjordan Series*, dated 1942, and from 1929-33 sheets and undated sheets of an unspecified 1:50,000 series. On many of the sheets, a purple overprint is used for revisions of communications and other cultural detail as of 1941-44. Relief is shown for Palestine by contours and spot elevations. Relief data are incomplete beyond the limits of Palestine. Road classifications and symbolization vary from sheet to sheet.

- (b) *1:25,000 Transjordan Series; Middle East Land Forces; PDR 1505, GSGS 8053; 1942-47; Palestine Belt grid.*

This polychrome series covers a limited area of northwestern Transjordan and border areas of southwestern Syria and northeastern Palestine. Except for the coverage of a small area that is based on ground surveys, the entire series was compiled from aerial photography dated 1941-42. Relief is shown by contours.

- (c) *El Aqaba 1:25,000; Middle East Land Forces; MDR 616; 1943; Palestine Belt grid.*

This is a two-sheet polychrome map that provides coverage for the head of the Gulf of Aqaba, including very limited parts of northeastern Egypt, southern Israel, southwestern Trans-

Jordan, and northwestern Saudi Arabia. The series was compiled from aerial photography dated 1943. Relief is shown by contours. Roads are classified as metalled and unmetalled roads, and tracks. Boundaries are not shown.

- (d) *1:25,000 Palestine Series*; Middle East Land Forces; MDR and PDR 1503, GSGS 8052; 1941-47; Palestine Belt grid.

This series covers substantially the same area as the *1:20,000 Series Topocadastral*, by the Survey of Palestine. The majority of the sheets were reproduced from this series by means of photo reduction. Coverage for some areas, however, was compiled from 1:20,000-1:50,000 maps dated 1945-47 and from aerial photography dated 1941-42. Most of the sheets of this series are monochrome. Relief is shown by means of contours (in orange on the polychrome sheets). Many of the monochrome reproductions of the polychrome 1:20,000 sheets are difficult to read. The Army Map Service has reprinted sheets in this series (fig. 86).

- (e) *Levant 1:50,000* and *1:50,000 South Levant*; Middle East Land Forces; MDR and PDR 1510, GSGS 8061, and MDR and PDR 1521; 1942-51; Palestine Belt grid.

Since the MDR and PDR 1521 series supplements and is similar in style to some sheets of MDR 1510 (fig. 87), the two series are treated as one and are described together. Some sheets are reprints or revisions of originals by the Service Géographique des Forces Françaises Libres au Levant (Geographic Service of the Free French Forces in the Levant). The series are in English or in French and English. Reprints or revisions of French sheets carry French transliterations and bilingual marginal data. All sheets are polychrome, but the styles of the British and French compilations

differ. The series provide coverage for northwestern Transjordan north of 31° 40' N. except for small areas north of Jerusalem and others west of the Dead Sea. Some of the sheets are British compilations based on large-scale maps of 1942-45, air photos of 1941-45, and topographic surveys of 1944-48. Others are reprints or revisions of French maps compiled in part from 1941-42 aerial surveys, and in part from 1941-43 large-scale ground surveys, 1941-42 sheets of the *1:20,000 Series Topocadastral*, and 1942 sheets of the *1:20,000 Palestine Series*. The series were revised in part from air photos of 1941 and 1945. Relief is shown by contours and is treated in detail. Steep slopes, cliffs, isolated hills, and escarpments are also symbolized. Roads on sheets compiled by the British are classified according to importance, surface, width, and use; whereas on sheets compiled by the French, roads are classified only as to importance and use. These series have been reprinted by AMS.

- (f) *Trans-Jordan, Lava Belt, Azraq-Burqu-Qa'a Umm Sa'd*; 1:50,000; Directorate of Military Survey, War Office (Geographical Section, General Staff); GSGS 3937; 1943; Palestine Belt grid.

This polychrome series (fig. 88) covers a part of the lava belt of north-central Transjordan. The sheets were compiled in 1933 from 1931 air photos. In 1943 a grid was added to the series. Relief is depicted by means of contours. Lava areas are in gray, sand areas are in yellow, and areas of mud are uncolored. Numerous ancient walled enclosures (corrals) and stone walls are depicted by special symbols.

- (g) *1:100,000 Transjordan-Nejd Boundary*; Middle East Land Forces; PDR 1501; 1941; Iraq Zone grid.

This series covers limited areas along the Transjordan Saudi Arabia

REFER TO THIS MAP AS
1:25,000 PALESTINE SERIES
SHEET 17-13 (JERUSALEM)

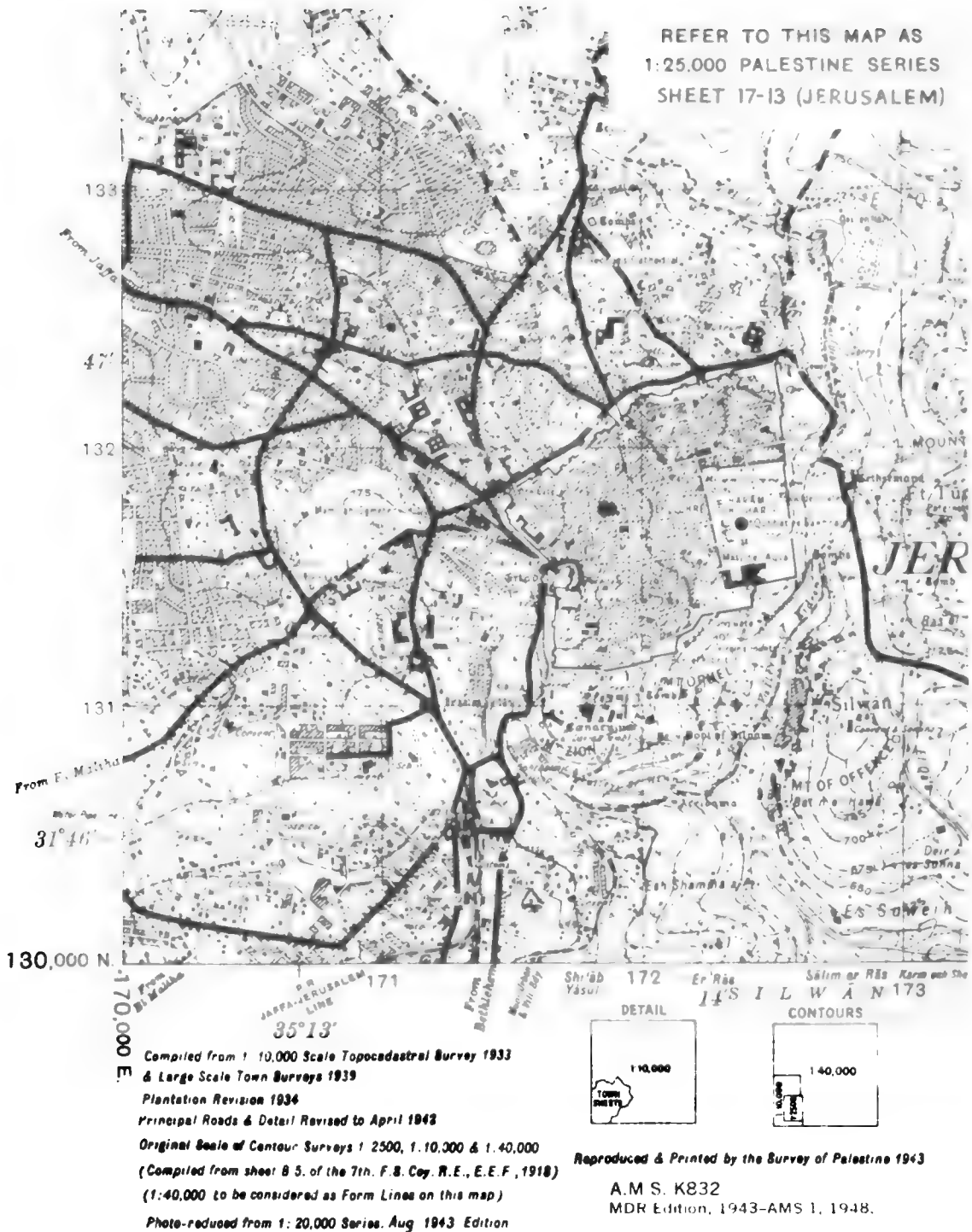
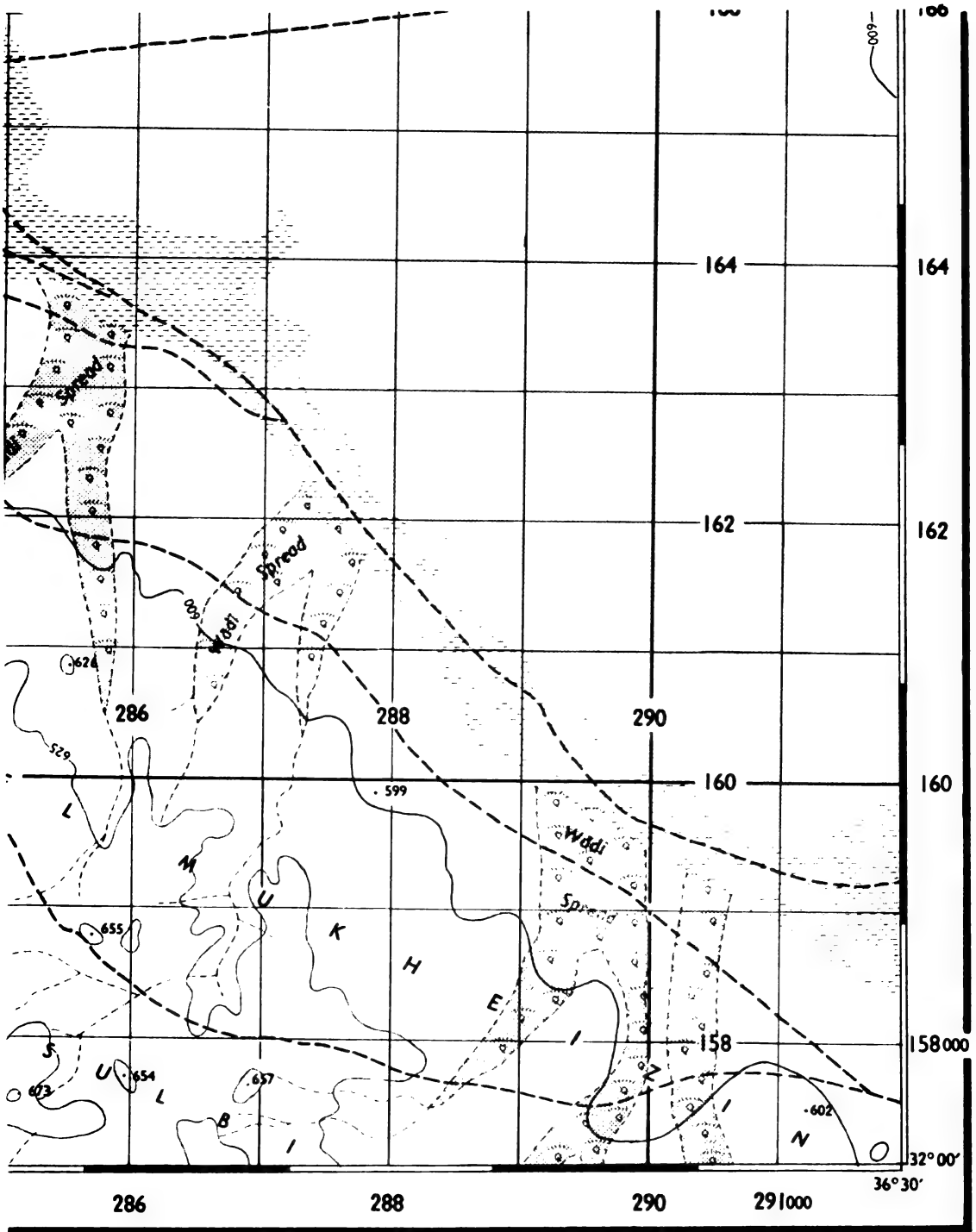

Figure 86. Section of Sheet 17-13 of the 1:25,000 Palestine Series by the Middle East Land Forces, reprinted by the Army Map Service as AMS K832.

boundary. It was compiled in 1941, apparently from aerial photography. Relief is shown by contours, some of which are isolated and disconnected.

The identification of rock ridges and mud flats provides an aid to interpretation of the terrain. The disputed boundary between Transjordan



Drawn and reproduced by No. 1 Base Survey Drawing and Photo Process Office. Oct. 1946

Figure 87. Section of Sheet 50-M-25 from Levant 1:50,000 series (MDR 1510) by the Middle East Land Forces.



Figure 88. Section of Sheet 10 from the 1:50,000 Trans-Jordan, Lava Belt—Azraq-Burqu-Qa'a Umm Sa'd series (GSGS 3937) by the Directorate of Military Survey, War Office (Geographical Section, General Staff).

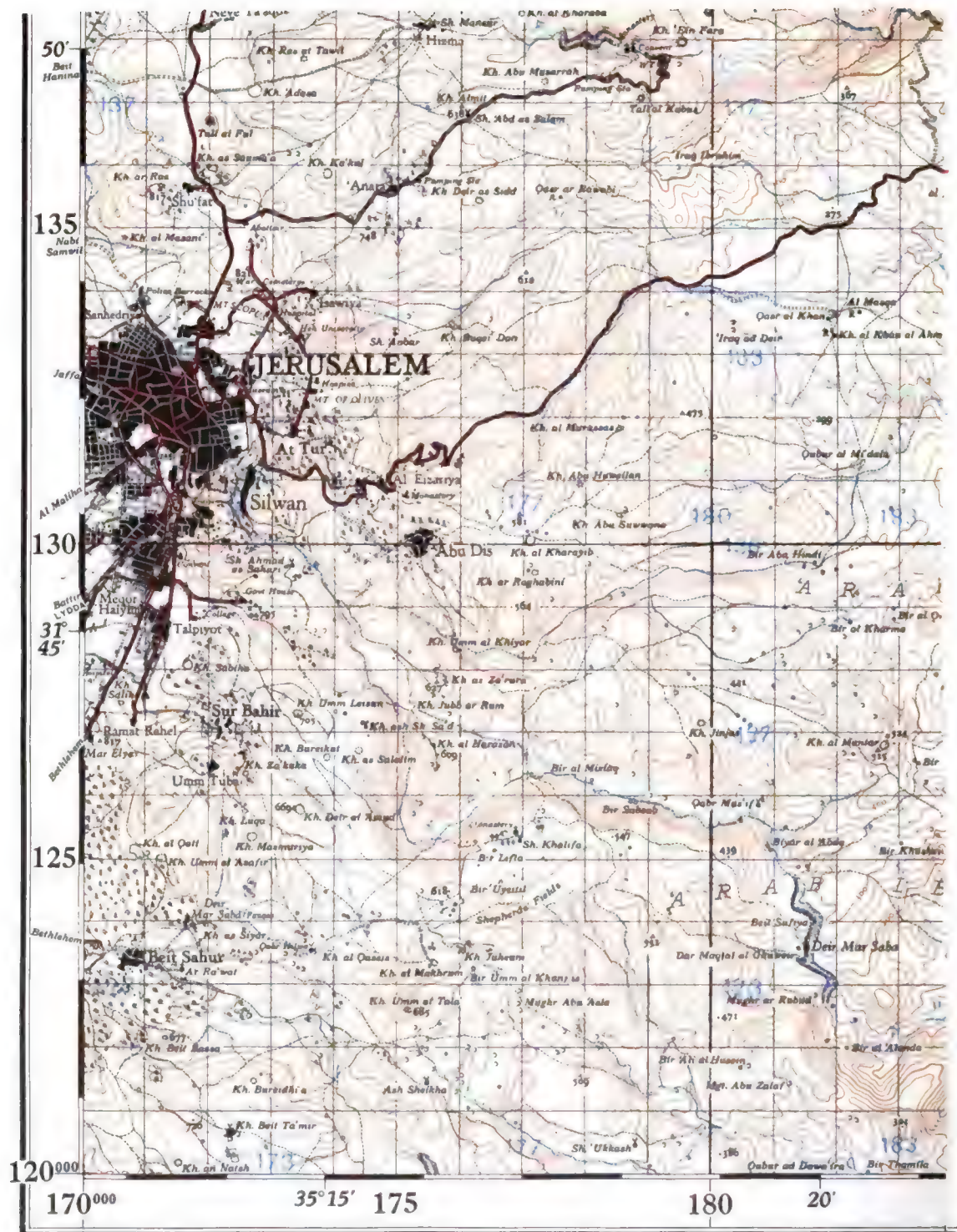

Figure 89. Section of sheet from 1:100,000 Palestine series by the Middle East Land Forces, reprinted by the Army Map Service as AMS K631.

and Saudi Arabia (Nejd) is not delineated on these sheets, some of which are polychrome and others monochrome.

- (h) *1:100,000 Palestine*; Middle East Land Forces; MDR and PDR 1512, GSGS 4645; 1942-51; Palestine Belt and Levant Zone grids.

This polychrome series covers Palestine north of 30°57' N. and extends into border areas of Transjordan, Lebanon, Syria, and Egypt. The sheets were originally compiled by the Survey of Palestine from surveys at scales ranging from 1:4,000 to 1:125,000, as well as from aerial photography dated 1936-37 and 1944. Most of the sheets were revised by the Survey from 1:20,000-scale maps dated 1941-42, with later revision for roads, settlements, and other cultural features. Relief is indicated by contours, and terrain features such as cliffs, gorges, and broken ground are symbolized. This series has been reprinted by AMS (fig. 89).

- (i) *Africa 1:125,000, Sinai Peninsula*; Directorate of Military Survey, War Office (Geographical Section, General Staff); GSGS 2230; 1914-15; no grid.

This polychrome series provides significant coverage of southern Palestine west of 35° E. and south of 31° N. The area was surveyed in 1911-14 by a British survey unit; geodetic positions and elevations do not always agree with maps based on surveys conducted during the period of the mandate. Relief is generally shown by contours, but generalized form lines are used for the southernmost part of Palestine.

- (j) *Palestine*; 1:250,000; Survey of Palestine; 1944-46; Palestine civil grid.

This three-sheet polychrome map covers all of Palestine and that part of Transjordan north of 29°30' N. and west of 35°44' E. Source materials from which this series was compiled include *Levant 1:50,000*, 1944; *1:100,000 Palestine*, 1943; and *Africa 1:125,000, Sinai Peninsula*,

1912-14. Detail for a strip extending approximately 40 airline kilometers northeast from the Gulf of Aqaba was supplied by a Palestine Government geologic survey. Coverage for the extreme southern part of Palestine was compiled from *El Aqaba 1:25,000* (MDR 616), 1943. Relief is shown by contours and altitude tints; other terrain features are symbolized.

- (k) *Levant 1:500,000*; Middle East Land Forces; MDR and PDR 449, GSGS 4194; 1942-45; Palestine Belt and Iraq and Levant Zone grids.

Although designed primarily as coverage for Lebanon and Syria, this polychrome series also covers the northern part of Palestine and Transjordan. For a detailed description, see paragraphs 86-88.

- (l) *Trans-Jordan*; 1:750,000; Middle East Land Forces; MDR 693, GSGS 8048; 1946- ; no grid.

This one-sheet polychrome map covers nearly all of Transjordan (except for a small part east of 38°15' E.) and small parts of Syria, Palestine, and Saudi Arabia. The map, originally compiled and drawn by the Transjordan Department of Lands and Surveys, was reproduced by the Survey of Palestine in 1940; it was partially revised and reprinted by the Survey of Palestine in 1943, and was reprinted by the Middle East Land Forces in 1946. Relief is indicated by contours and altitude tints. East of the Hejaz Railroad, the contours are highly generalized. Roads are classified by surface and seasonal trafficability.

- (2) *Native maps of Israel*.

- (a) *Israel*; 1:250,000; Survey of Israel; 1953; Palestine civil grid.

This three-sheet polychrome map covers Israel and parts of adjacent countries. Although the credit note states that compilation was from 1:100,000 series dated 1941-45, with the addition of new settlements and roads to 1952, it is evident that other

sources must have been utilized in order to secure coverage for the entire area included on these sheets. Other cultural information is shown in detail commensurate with the scale. Relief is shown by contours. Elevations (above or below sea level) of inland bodies of water are given. The Palestine (Mandate) boundary, the armistice lines, and the demilitarized zones are portrayed. The representation of the armistice lines and demilitarized zones agrees quite closely with the official United Nations maps except for minor discrepancies in the Jerusalem area.

- (b) *Israel: Jubilee Map of the Jewish National Fund*; 1:400,000; Survey of Israel; 1950; Palestine civil grid and atlas grid.

This polychrome map covers all of Israel and parts of neighboring countries. Compiled by the Survey of Israel (1950), it has been published in both English and Hebrew editions. Relief is shown by contours and altitude tints. The major drainage is depicted, and prominent escarpments are named. A marginal list of towns and Jewish villages is keyed to an atlas grid. Those settlements located on the Jewish National Fund lands are designated. The armistice lines for Israel are shown, but they are not wholly in agreement with those shown on the official United Nations maps (1949). For example, the El Auja Neutral Zone along the Israel-Egypt boundary and the demilitarized zones along the Syria-Israel boundary are not shown.

- (c) *(Israel)*; 1:500,000; Survey of Israel; 1952; Palestine civil grid and atlas grid.

This polychrome map covers all of Israel and parts of adjacent countries. The available sheet is printed in Hebrew only. Relief is shown by contours and altitude tints. Prominent landmarks are named, and major drainage systems are symbolized. Marginal insets at 1:50,000

are shown for the metropolitan areas of Jaffa-Tel Aviv, Haifa, and Jerusalem. This sheet has also been published to accompany the text of a book entitled "Road Distances," published by the Survey of Israel in 1953.

- (3) *Native maps of Jordan.*

- (a) *1:10,000 Yarmuk Valley*; Department of Lands and Surveys of the Jordan; 1951; Palestine Belt grid.

This completely bilingual (Arabic-English) polychrome series covers the Jordanian side of the Yarmuk Valley, along the Syria-Jordan boundary between 35°37' E. and 35°54' E. The sheets were compiled (from aerial photography of unspecified date) and printed by Hunting Aerosurveys, Ltd., in 1951, under the direction of the Department of Lands and Surveys. Boundaries (political and cadastral) were taken from surveys by the Department. Relief is indicated by contours and cliffs are symbolized. No detail is shown for the area of Syria covered by the sheets.

- (b) *1:10,000 Zarqa Basin*; Department of Lands and Surveys of the Jordan; 1950; Palestine Belt grid.

This entirely bilingual (Arabic and English) polychrome series, covering part of northwestern Jordan, was compiled and printed in 1950 by the British commercial firm, Air Survey Co., and was published under the direction of the Department. The sheets were compiled from aerial photography of unspecified date flown by Air Survey Co. Relief is shown by contours, although for parts of some sheets, only planimetry is indicated, and other areas are blank.

- (c) *1:10,000 Jordan Valley*; Department of Lands and Surveys of the Jordan; 1950; Palestine Belt grid.

This completely bilingual (Arabic-English) monochrome series covers the Jordan Valley from the northern end of the Dead Sea northward

to approximately 32°08' N. The series was compiled (from aerial photography flown during June 1950) and printed by the British commercial firm, Air Survey Co., London, under the direction of the Department of Lands and Surveys of the Jordan. Relief is shown by contours, although for parts of some sheets, only planimetry is indicated, and other areas are blank.

- (d) (*The Hashemite Kingdom of the Jordan 1:100,000*); Department of Lands and Surveys of the Jordan; 1951; Palestine Belt grid.

Published sheets of this series cover northwestern Jordan between the Dead Sea and Lake Tiberias (Sea of Galilee) and between approximately 35°00' and 36°25' E. They were apparently compiled from two MELF series. Marginal diagrams identical with those on the 1:100,000 sheets indicate that the original sources were 1:4,000–1:100,000 maps dated 1930–46 and aerial photography dated 1941–42. The compilation diagrams differentiate between those sources utilized for base information and those utilized for contours. A detailed symbol legend includes nearly all features shown in the map. Indigenous vegetation, mud pans, lava, large wadi spreads, and dry and perennial wadies are designated. Three classes of roads are shown, and railway gauges are distinguished. Boundaries shown are defined as international, provincial, or district. The Jordan-Israel armistice lines are not shown. The sheets in Arabic script, are polychrome publications.

- (e) *The Hashemite Kingdom of the Jordan*; 1:250,000 Department of Lands and Surveys of the Jordan; 1949–50; Palestine Belt grid.

The polychrome sheets of this series cover western Jordan and limited parts of Israel, Syria, and Saudi Arabia. This group of sheets was compiled by the Department of

Lands and Surveys from various medium-scale maps dated 1932–47 and from aerial photography dated 1947. A small area of Jordan, east of 36° E. and south of 30°30' N., and part of Saudi Arabia are shown as unsurveyed. For the rest of the area, relief is shown by contours at varying intervals and by altitude tints. Other terrain features shown include mud flats, lava, marsh lands, and large wadi beds. Wadies are distinguished as perennial or dry. A list of the ten ancient cities of the Decapolis is given in the margin. The Jordanian international boundaries, as well as the *Livra* (district) and *Qada* (sub-district) boundaries are shown for the area west of the Hejaz Railroad. The armistice lines between Israel and Jordan are not indicated.

b. *Town plans.*

- (1) *Official.* The Survey of Palestine published plans of several towns in Palestine over an extended period during the British mandate. Many of these have been used by other agencies—especially MELF—in the preparation of town plans. Scales range from 1:2,500 to 1:20,000, and dates from 1935 to 1947; cartographic representation is not entirely consistent. Most of the sheets, however, are contoured and depict vegetation and the usual cultural features, including names of principal streets and important buildings. A larger number of town plans of Palestine and Transjordan have been published by MELF. Some of these are based on older Survey of Palestine plans or on aerial photography. Those for Palestine generally are at 1:10,000 and are dated 1945–46, while the plan of Amman, the capital of Transjordan, is at 1:4,000 and is dated 1947. On the photomaps prepared by MELF from aerial photography dated 1944–45, significant buildings are identified in a marginal list. Other features shown include side roads and main roads. Contours are used to show relief.

(2) *Native plans of Israel.*

(a) *Governmental.* Two polychrome plans, both covering Tel Aviv and Jaffa, have been prepared by the Survey of Israel. One, at 1:10,000, was published in 1950; the other, at 1:5,000, in 1952. Both show built-up areas and indicate proposed, as well as existing, streets and park areas. Public buildings are identified in a marginal index. Streets are named, both of the face of the plans and in the marginal index. English and Hebrew editions of the 1:10,000 plans and a Hebrew edition of the 1:5,000 plan were published. Other town plans issued by the Survey of Israel are reprints of plans by the Survey of Palestine.

(b) *Private.* Nongovernmental organizations that prepare town plans include the Jewish Agency of Israel (in Jerusalem), Litour Limited (in Tel Aviv), and Zvi Friedlander (in Haifa). These plans vary widely in scale and in the amount of detail shown. Generally, they are planimetric plans of principal towns in Israel and depict public buildings, main streets, and other points of interest. Plans by the Jewish Agency are in Hebrew; those by Litour Limited, in English; and those by Friedlander, in Hebrew or English.

(3) *Native plans of Jordan.*

(a) *Department of Lands and Surveys of the Jordan.* As of March 1953, the cadastral survey of east-bank Jordan had been completed for 446 of the 450 villages to be covered, and maps prepared for 350 of these. In addition to the regular cadastral maps resulting from the survey, compilations at 1:10,000 are prepared from them re-

portedly to serve as substitutes for town plans. Cadastral work in west-bank Jordan began in October 1952. In addition, a 1:2,500-scale plan of Amman, based on aerial photography flown by Hunting Aerosurveys, Ltd., was in work as of March 1953.

(b) *The Bureau of Municipalities, Department of Interior.* The Bureau has published a number of 1:1,000 plans of Jordanian towns. It is reported that the usual information is shown except for street names. This lack is due to the fact that only recently have names been assigned to the streets.

(c) *Municipal Council, Amman.* The Municipal Council has published two plans of Amman, one at 1:4,000 (dated 1951) and one at 1:10,000 (undated).

85. Coordinate Systems

a. *Geographic.* On most of the maps of Israel and Jordan, geographic coordinates are expressed in degrees, with longitude referred to Greenwich.

b. *Grid.* All available Jordanian series and most British series carry the Palestine Belt grid. This grid is based on the Transverse Mercator projection and computed on the Clarke 1880 spheroid. In small areas adjacent to other countries, the Iraq and Levant Zone grids and the Egypt (Red) Belt grid appear. The zone grids are based on the Lambert conical orthomorphic projection and the Clarke 1880 spheroid. The Egypt (Red) Belt grid is based on the Transverse Mercator projection and the Helmert spheroid. The meter is the unit of measurement for all of these grids, which are part of the British grid system. On a few British series and on the Survey of Israel series the Palestine civil grid (Cassini) is utilized. It is based on the Cassini-Soldner projection and the Clarke 1880 spheroid.

Section VI. LEBANON AND SYRIA

Note. Mapping in Lebanon and Syria developed along parallel lines, not only while they were part of the Ottoman Empire (before World War I) but also later while they were under French mandate. To avoid repetition, the discussion of mapping activities common to both countries precedes those for the two separate countries; and the descriptions of the major maps common to both precedes those for the separate countries. Before World War I, the mapping of Lebanon and Syria was carried

out by the Turkish government. With the fall of the Ottoman Empire and the consequent ascendancy of the French in this area, Turkish maps gradually were superseded by more precise French work. Several different French agencies operated under the mandate, and, during World War II, they cooperated with British military units in the mapping of the area. Since World War II, both Lebanon and Syria have established their own military and civil mapping organizations.

86. Mapping Activities

a. *Official Mapping of Lebanon and Syria under French Mandate.*

- (1) *Bureau Topographique des Troupes Françaises du Levant—BTTFLL (Topographic Bureau of the French Troops of the Levant)*. When the French assumed the Mandate of Lebanon and Syria in 1920, a twofold mapping policy was instituted. Immediate needs were to be satisfied by a service staffed by engineers of the army of occupation (BTTFLL), and an accurate detailed survey was to be carried out by regular survey officers of the French Service Géographique de l'Armée—SGA (Geographic Service of the Army). The BTTFLL—responsible for rapid surveys and the publication of provisional maps—at first reproduced sheets of the Ottoman Empire 1:200,000 series, substituting romanized place names. To improve legibility, some of these sheets were enlarged to 1:100,000. The BTTFLL also published maps at 1:100,000 of the Jebel Druse (southwestern Syria) and the northern Jezireh (northeastern Syria), as well as plans of the important cities of Lebanon and Syria. Much of the work by the BTTFLL has been superseded by later mapping of other agencies.
- (2) *Service Géographique de l'Armée—SGA (Geographic Service of the Army)—and Institut Géographique National—IGN (National Geographic Institute)*. In 1920, a brigade of the French SGA arrived in Beirut to undertake the basic triangulation of Lebanon and Syria. Most of this primary triangulation was executed before 1937. Although the BTTFLL was still charged with providing general maps for military and administrative purposes, the more detailed surveys—particularly in the coastal areas—became the responsibility of the SGA. The work of the SGA resulted in plans of the principal towns, complete coverage of Lebanon and Syria at 1:200,000, the beginning of a 1:50,000 series, and other large-scale maps of limited areas, as well as useful 1:500,000, 1:1,000,000, and other smaller-scale maps. After the defeat of

France by Germany in World War II, the SGA (Paris) was abolished in July 1940 and was replaced by a civilian agency, IGN. At this time, the SGA in Lebanon and Syria consisted of several units, including the Bureau Topographique des Troupes du Levant—BTTL (Topographic Bureau of the Troops of the Levant). In the gradual transformation from a military to a civilian organization, the BTTL assimilated the functions of the other units. In April 1941, the agency became known as the Annexe de l'Institut Géographique National au Levant (Annex of the National Geographic Institute in the Levant). As of July 1941, the Annexe came under British control. The most significant contribution by IGN to the mapping of Lebanon and Syria was the compilation of the more recent sheets of the SGA *Levant 1:50,000*^e series. IGN also reprinted sheets in this series as late as 1950.

- (3) *Service Géographique des Forces Françaises du Levant—SGFFL (Geographic Service of the French Forces of the Levant)—and Service Géographique des Forces Françaises Libres au Levant—SGFFLL (Geographic Service of the Free French Forces in the Levant)*. French military mapping of Lebanon and Syria during the latter part of World War II was the responsibility of the SGFFL and the SGFFLL. Both contributed sheets to the French *Levant 1:50,000*^e series, covering scattered areas of Lebanon and Syria, and to the French *Levant 1:200,000*^e series, covering all of Lebanon and Syria. They cooperated also with units of the British Middle East Land Forces—MELF—in the preparation of sheets of the British *Levant 1:50,000*^e series, covering Lebanon and most of western Syria. In addition, the SGFFL, in conjunction with MELF, compiled sheets of the British *Levant 1:200,000*^e series. British DR, MDR, and PDR series numbers were assigned to these sheets, and bilingual marginal data were provided for sheets printed by French as well as British units. The SGFFL also printed a convenient one-

sheet 1:1,000,000 map covering all of Lebanon and Syria, and the SGFFLL issued a number of plans of important cities and towns.

(4) *British Middle East Land Forces (MELF)*. In addition to the work carried out in conjunction with the French, MELF also published during World War II a group of scattered 1:25,000-scale series based primarily on British surveys, but supplemented to some extent by French data. Sheets of several other MELF series (one at 1:50,000, three at 1:100,000, one at 1:250,000, and one at 1:253,440), primarily designed as coverage for adjoining countries, extend into Lebanon and Syria for limited areas. Other MELF publications include the *Levant 1:500,000* series and sheets of the *Asia 1:1,000,000* series (MDR 1), as well as plans of several of the major towns.

(5) *French publishers of town plans*. The following official French authorities also have published town plans of Lebanon and Syria: Bureau Topographique de l'Armée Française du Levant—BTAFL, Bureau Topographique des Troupes du Levant—BTTL, and Régie des Travaux du Cadastre et d'Amélioration Foncière (Administration of Cadastral Works and Land Improvement).

b. Other Mapping Common to Lebanon and Syria.

(1) *British Directorate of Military Survey, War Office (Geographical Section, General Staff)—GSGS*. GSGS series numbers have been assigned to those series originally published by MELF, and as existing stocks are depleted, reprints are issued bearing the new GSGS series designations. GSGS has published also a few additional sheets not included in the MELF series and has reprinted several of the MELF town plans with English, rather than French, marginal information. GSGS has contributed sheets covering Lebanon and Syria to the *Asia 1:1,000,000* series (GSGS 2555), and one sheet to the new 1:1,000,000 series (GSGS 4646). Earlier work by GSGS included the *Syria 1:200,000* series (GSGS 4195), published in 1941–42

(superseded by the joint French-British *Levant 1:200,000* series), and the *1:250,000 Palestine and Transjordan* series (GSGS 3930), which covers southern Lebanon and Syria, but which also is largely superseded.

(2) *German Generalstab des Heeres (General Staff of the Army)*. During World War II, the Generalstab des Heeres published two series entitled *Syrien*—one at 1:50,000, covering most of Lebanon and western Syria, and the other at 1:200,000, covering all of Lebanon and Syria. Other topographic publications by the Germans included complete coverage of the area at 1:500,000 (*Deutsche Weltkarte*) and 1:1,000,000 (*Internationale Weltkarte*). All of these series were copied from early French work and are superseded by later French and British publications. Town plans produced by the Germans also are superseded, with the exception of several prepared by the Generalstab des Heeres, Abteilung für Kriegskarten u. Vermessungswesen (IV. Mil.-Geo.) (General Staff of the Army, Military Cartographic and Survey Division, Section IV, Military Geography).

c. Native Mapping of Lebanon and Syria.

•(1) *Lebanon.*

(a) *Governmental*. The Geographic Service of the Lebanese Army, organized about 1949, is assigned the responsibility for the topographic mapping of Lebanon. Work has been started on a 1:50,000 series that will eventually cover the entire country. In addition, an isolated 1:20,000 sheet has been prepared by enlargement of a French 1:50,000 sheet. It is reported that the Geographic Service is engaged in the preparation of 1:10,000-scale plans for the major towns of Lebanon. Several other Lebanese government agencies have prepared town plans and large-scale topographic series covering limited areas. A number of very large-scale (1:1,000–1:2,000) topographic and cadastral maps have been published by the Service Hydraulique (Hydrologic Service) and the Bureau



Figure 90. Section of Sheet 50.L.16 from the Levant 1:50,000* series by the Middle East Land Forces, reprinted by the Army Map Service as AMS K722.

de Municipalite et Urbanisme (Bureau of Municipalities and Town Planning).

- (b) *Private*. The Société d'Encouragement au Tourism à Beyrouth—SET (Society for the Encouragement of Tourism, Beirut) has published a number of plans for historic Lebanese towns. The Compagnie du Port des Quais et Entrepôts de Beyrouth (Port Company of the Wharves and Warehouses of Beirut) has published several plans of the Beirut port area.
- (2) *Syria*. The Map Division of the Syrian Army, which has only recently begun to produce maps, has published a six-sheet 1:500,000 series, covering Syria and Lebanon. The Service du Cadastre (Cadastral Service), a part of the Ministry of Justice, prepares cadastral maps at scales ranging from 1:500 to 1:100,000. Several scales are generally utilized for each town to portray various types of information. These maps are planimetric and usually do not show street names or building identifications. Several government agencies, including the Ministry of Interior, Department of Planning and Development of Cities, and the Technical Bureau of the Damascus Municipality, have prepared plans of Syrian towns.

87. Major Maps of Lebanon and Syria

a. Topographic Series.

(1) *Official Maps of Lebanon and Syria under French Mandate*.

- (a) [*Lebanon and Syria*]; 1:25,000; Middle East Land Forces; various MDR and PDR series numbers; 1941–45; Levant Zone and Palestine Belt grids.

This is a group of polychrome series, each having a few sheets that cover scattered areas in Lebanon and southwestern Syria, including the vicinity of Damascus. Primary sources utilized in the compilation of these series are aerial and ground surveys dated 1941–44. For most of the area covered, relief is shown by contours. Some of the sheets have been reprinted by GSGS.

- (b) *Levant 1:50,000*; Service Géographi-

que des Forces Françaises du Levant and Service Géographique des Forces Françaises Libres au Levant; 1942–50; Levant Zone and Palestine Belt grids.

Coverage for scattered areas of Lebanon and Syria is provided by this series. Sources include ground surveys dated 1931–45, large-scale maps of various dates, and aerial photography dated 1941–43 covering limited areas. Routes and names on some sheets were revised in 1945. Relief is shown by contours; rocky ground, slopes, and lava areas are also indicated. These polychrome sheets are in French or in both French and English. A few have been reprinted by AMS.

- (c) *Levant 1:50,000*; Service Géographique de l'Armée and Institut Géographique National; 1935–50; Levant Zone grid.

This polychrome series covers most of Lebanon and scattered areas of western Syria. It is based on 1925–38 ground surveys by the SGA at scales of 1:40,000 and 1:50,000. Relief is shown by contours, supplemented by shading.

- (d) *Levant 1:50,000*; Middle East Land Forces: MDR/PDR 1510, GSGS 8061; 1942–51; Levant Zone and Palestine Belt grids.

This series covers Lebanon and most of western Syria. It was based on French 1:20,000 to 1:50,000 ground surveys dated 1926–45 and was revised in part from aerial photography dated 1941–45. With minor exceptions, relief is shown by contours. These polychrome sheets are published in French and/or English. Some of the sheets have been reprinted by GSGS, and a few additional sheets have been compiled by GSGS. AMS has also reprinted this series (fig. 90).

- (e) [*Northeastern Syria*]; 1:100,000; Bureau Topographique des Troupes Françaises du Levant; 1928–30; unidentified grid.

An area east of El Haseke, Syria,

extending northward to the Turkey-Syria boundary and thence east to the Syria-Iraq boundary, is covered by this series. Sources include surveys by the Turkey-Syria Demarcation Commission, aerial photographs documentary materials, and Ottoman Empire maps of unspecified date. Relief is portrayed by contours for approximately 50% of the area, while the remainder is generally planimetric, with occasional form lines. Roads are classified only as "good" and "bad" tracks. These polychrome sheets are in French.

- (f) *Levant 1:200,000**; Service Géographique des Forces Françaises du Levant and Service Géographique des Forces Françaises Libres au Levant; 1930-50; Levant Zone grid.

This polychrome series covers all of Lebanon and Syria. It was compiled mainly from French 1927-45 ground surveys at 1:40,000 and 1:50,000 and from British 1942 surveys at 1:50,000 and 1943 surveys at 1:100,000. Minor sources include undated aerial photography of limited extent the British *Quarter-Inch Series* (described with maps of Iran in par. 76-79) and international boundary maps of 1928-30. Sheets for the western and northern parts of the area are contoured, but those for the desert vary widely in the use of contours, approximate contours, form lines, and shading, with some areas blank or showing only a few planimetric details. The sheets are in French or in both French and English. Only one sheet has been reprinted by AMS.

- (g) *Levant 1:100,000*; Bureau Topographique des Troupes Françaises du Levant; 1931-32; Levant Zone grid.

Most of the sheets of this series, which covers parts of southwestern Syria and an area around Homs, were compiled from 1928-32 ground surveys and from undated aerial photography; parts of several other sheets were compiled by enlargement of un-

dated Ottoman Empire 1:200,000 sheets or by reduction of various undated sources at scales of 1:40,000 and 1:50,000. Relief is shown by contours, except for desert areas, for which either form lines or shading is used or no relief is shown. The series is published in French.

- (h) *Levant 1:200,000**; Middle East Land Forces; MDR/PDR 589, GSGS 4195; 1941-45; Palestine Belt grid and Caucasus, Iraq, and Levant Zone grids.

This polychrome series covers all of Lebanon and Syria, except for a relatively small area in eastern Syria. Sources include 1930-45 French ground surveys at scales ranging from 1:40,000 to 1:200,000, 1941-43 British ground surveys at scales ranging from 1:25,000 to 1:200,000, undated oil-company surveys at 1:50,000, Ottoman Empire 1:200,000 ground surveys revised to 1936, and undated, unidentified aerial photography. Sheets for the western and northern parts of the area are contoured, but those for the desert vary widely in the use of contours, approximate contours, form lines, and shading, with some areas blank or showing only a few planimetric details. The sheets are in English or in both English and French. The series is reprinted by both GSGS and AMS (fig. 91).

- (i) *Levant 1:500,000*; Middle East Land Forces; PDR 449, GSGS 4194; 1945; Palestine Belt grid and Caucasus, Iraq, and Levant Zone grids.

Covering all of Lebanon and Syria, this polychrome series was originally compiled and published by the SGFFL, presumably from French and British maps in the 1:200,000-to-1:250,000 scale range. Some sheets, however, show evidence of topographic revisions not included on the 1:200,000 sources. Relief is shown by altitude tints and contours, supplemented by hachures and form lines. The sheets are in both English and French and are reprinted

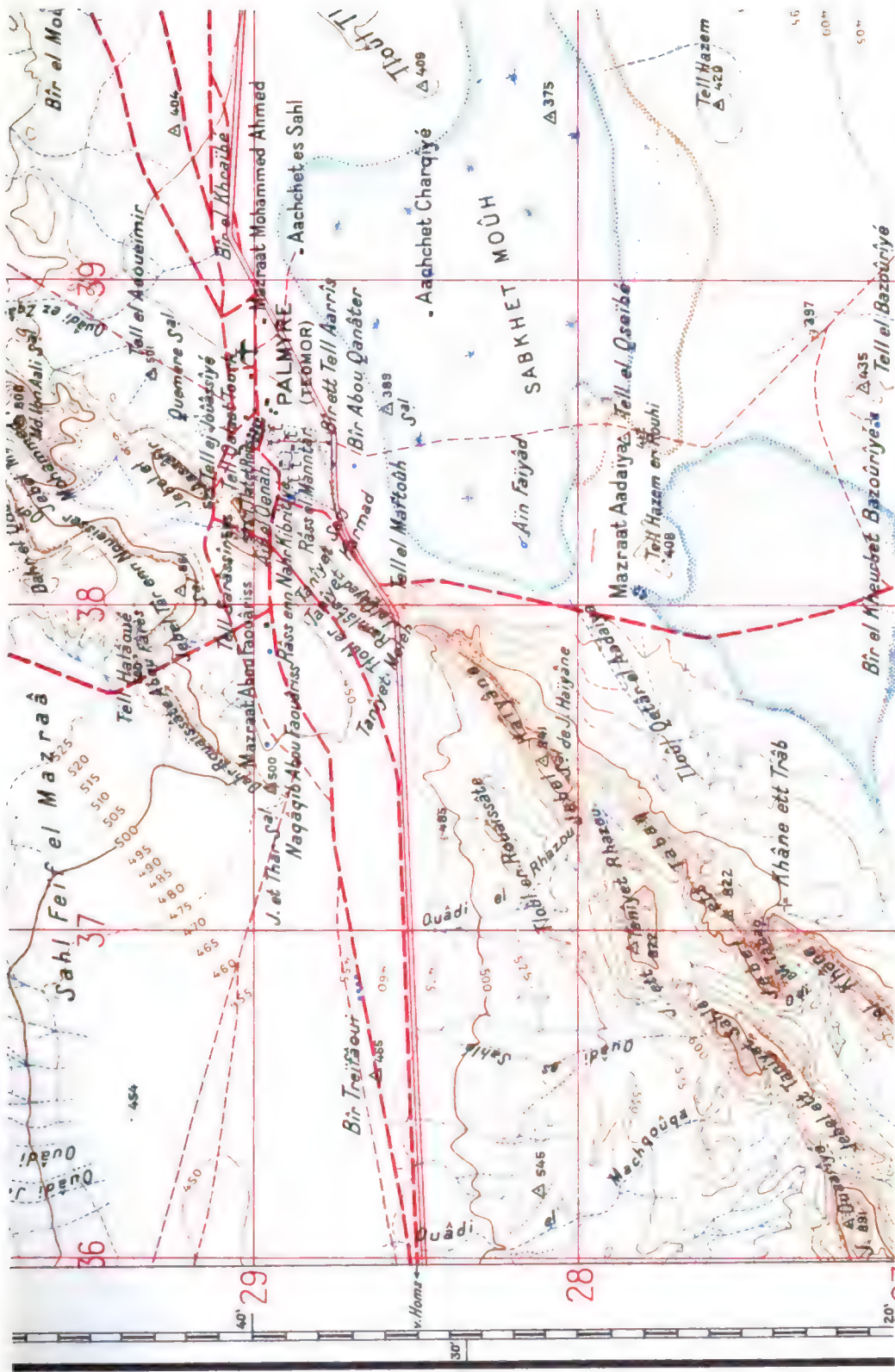

Figure 91. Section of Sheet NI 57-XV from the Levant 1:200,000 series by the Middle East Land Forces, reprinted by the Army Map Service as AMS K521.

by GSGS (with minor corrections) and by AMS.

- (j) *Syrie & Liban* (Syria and Lebanon); 1:1,000,000; Service Géographique des Forces Françaises du Levant; 1945; Levant Zone grid.

This one-sheet map covering all of Lebanon and Syria was presumably based on French and British medium-scale maps. Originally published in 1941, it was subsequently revised to 1945. Relief is represented by contours and gradient tints. The map, in French, was reproduced in polychrome.

- (2) *Native map of Lebanon*. (*Levant 1:50,000*); Geographic Service of the Lebanese Army; 1952- : Levant Zone grid.

Sheets of this polychrome series cover the central part of the Lebanese coast. They are basically copies—with cultural revisions—of the corresponding French SGA sheets. They are published in French and/or Arabic editions.

- (3) *Native map of Syria*. (*Syria and Lebanon*); 1:500,000; Map Division of the Syrian Army; no date; Palestine Belt grid and Caucasus, Iraq, and Levant Zone grids.

This map is based on the 1945 *Levant 1:500,000* sheets published by the French and reprinted by MELF and AMS. The principal revisions made by the Syrians are the substitution of Arabic script for Roman type, and, on the ozalid copies, the deletion of contours and altitude tints.

b. Town Plans.

- (1) *Official plans of Lebanon and Syria under French mandate*.

- (a) The SGFFLL published plans of the important cities and towns of Lebanon and Syria in 1941-42. Most of these have been used by other agencies—including MELF—in the preparation of plans. Scales range from 1:3,000 to 1:10,000, and the treatment of cultural features is not entirely consistent. Built-up areas are generally indicated, however, and important public and

military buildings and streets are identified.

- (b) MELF has published several town plans of Lebanon and Syria. Most of these have been reprinted, with minor revisions of marginal data, by GSGS. The MELF plans generally were based on older French plans or aerial photographs. Most of them are contoured, but those based on aerial photography usually are planimetric. Detailed street patterns are shown; town sections, public and military buildings, and through routes are identified.

- (c) The Bureau Topographique de l'Armée Française du Levant—BTAFL—during the early 1920's prepared a number of polychrome town plans. These French-language plans, at scales of 1:5,000 to 1:10,000, are generalized, and few features are identified.

- (2) *Other plans of Lebanon and Syria under French mandate*. German plans of several Syrian and Lebanese towns—at scales of 1:5,000 to 1:10,000—present information not shown on other plans. They were based on pre-World War II French plans, which were revised by the Germans to show cultural information. Some of these polychrome German-language plans are contoured and some planimetric. Public buildings are generally identified, but on some plans, streets are not named.

- (3) *Native plans of Lebanon*. Native town plans at various scales, featuring points of historical interest, have been published for some ancient cities of Lebanon by the Société d'Encouragement au Tourisme à Beyrouth—S E T. These polychrome planimetric maps generally show little more than the street patterns of modern cities, reserving details for the historical sites. They are in French and carry bilingual (French and English) marginal information.

88. Coordinate Systems

a. *Geographic*. On most maps of the area, geographic coordinates, expressed in degrees and/or grads, are referred to Greenwich.

b. *Grid*. Most of the maps of Lebanon and

Syria utilize the Levant, Iraq, and Caucasus Zone grids and the Palestine Belt grid, all computed on the Clarke 1880 spheroid. The zone grids are based on the Lambert Conical Orthomorphic pro-

jection, while the Transverse Mercator projection is the basis of the belt grid. The meter is the unit of measurement for all of these grids, which are part of the British grid system.

Section VII. MALAYA AND SINGAPORE

89. Mapping Activities

a. Native.

(1) *Federated Malay States and Straits Settlements Survey (FMS & SS)*. The FMS & SS accomplished most of the basic surveying and mapping of Malaya between 1923 and 1945. Topographic sheets were based on planetable surveys made at the scales of 1:31,680 and 1:63,360, except for areas on the east coast where sheets were based on sketch and reconnaissance surveys and poor planetable work. Numerous city plans, small-scale maps, and planimetric state maps were also produced. Much of the work done by FMS & SS was superseded or revised by World War II mapping.

(2) *Survey Department, Federation of Malaya*. Since 1948 the governmental mapping agency has been called the Survey Department, Federation of Malaya, a continuation of FMS & SS. Work has been concentrated on providing 1:63,360 air reconnaissance or "emergency" maps for areas not previously mapped at large scales. A few city plans and most of the state maps have also been revised.

b. Official.

(1) *Survey of India (SI)*. SI in 1941 compiled the first editions of the Malayan portion of the *International Map of the World (IMW)*, at 1:1,000,000.

(2) *Directorate of Military Survey, War Office (Geographical Section, General Staff)—GSGS*. GSGS has compiled and revised town plans, compiled some sheets of the air reconnaissance 1:63,360 series, and reprinted numerous topographic series, including some of the latest editions of the 1:253,440 sheets. A new 1:25,000 series covering Singapore has been published also.

(3) *Directorate of Colonial Survey (DCS)*. DCS since 1948 has aided the Survey Department, Federation of Malaya, in the

compilation of some of the air reconnaissance 1:63,360 sheets.

(4) *Far East Land Forces (FAREL F)*. FARELF has revised part of the 1:253,440 sheets from aerial photography for the series GSGS 4218 and has compiled some of the air reconnaissance 1:63,360 sheets for the Survey Department, Federation of Malaya.

c. *Other*. The Japanese General Staff (JGS) and Japanese Army field units compiled original sketch maps at 1:50,000 and 1:100,000 in northern Malaya from 1941-45 Japanese aerial photography, hydrographic charts, Thailand 1:200,000 maps, and other sources. This agency also reprinted or enlarged some of the FMS & SS series.

90. Major Maps of Malaya and Singapore

a. Topographic Series.

(1) Native.

(a) *Penang 1:15,480*; Federated Malay States and Straits Settlements Survey; 1934; no grid.

This polychrome contoured series provides complete coverage for the island of Penang.

(b) *Johore and Singapore 1:25,000*; Federated Malay States and Straits Settlements Survey; 1937; Johore grid.

This series covers southern Johore and Singapore. Sheets covering Singapore are superseded by GSGS 4797 series, and the remaining sheets are superseded by GSGS 4686 series. Both were published by the Directorate of Military Survey, War Office (Geographical Section, General Staff).

(c) [*Malaya*]; 1:42,440; Federated Malay States and Straits Settlements Survey; 1926-41; no grid.

These one- or two-color sheets are provisional issues of the more complete 1:63,360 series described in (d) below.

- (d) [*Malaya*]; 1: 63,360; Federated Malay States and Straits Settlements Survey; 1925-43; no grid.

This series provides coverage for two-thirds of Malaya. The sheets are based on 1910-41 planetable surveys and other miscellaneous surveys, including cadastral, revenue, and reconnaissance. Relief is shown by contours or form lines. The majority of the sheets are superseded by sheets of the GSGS 4203 series. A 1: 50,000 series published by the Japanese General Staff is a monochrome enlargement of this series.

- (e) [*Air Reconnaissance Series*]; 1: 63,360; Survey Department, Federation of Malaya; 1948-53; Malay grid.

This polychrome series was compiled from aerial photography. It provides coverage for parts of southern Thailand and the parts of Malaya not covered by the FMS & SS 1: 63,360 series. Supplementary information has been obtained from all possible sources to complete the cultural information.

(2) *Official.*

- (a) *Singapore 1: 25,000*; Directorate of Military Survey, War Office (Geographical Section, General Staff); GSGS 4797; 1953; Johore grid.

This provisional series was compiled from 1951 aerial photography. Relief is indicated by contours. Cultural and drainage features are shown in detail.

- (b) *Johore and Singapore 1: 25,000*; Directorate of Military Survey, War Office (Geographical Section, General Staff); GSGS 4686; 1949-51; Johore grid.

This polychrome series covers southern Johore and Singapore. Sheets covering Singapore are superseded by the GSGS 4797 series. Relief is shown by contours or form lines. These sheets are reprints of revised wartime editions.

- (c) [*Air Reconnaissance*]; 1: 63,360; Directorate of Military Survey, War Office (Geographical Section, General

Staff); GSGS 4690; 1948- ; Malay grid.

These sheets (fig. 92) are compiled jointly with the Directorate of Colonial Survey (DCS) or reproduced from the sheets compiled by the Survey Department, Federation of Malaya.

- (d) [*Malaya*]; and [*Siam*]; 1: 253,440; Directorate of Military Survey, War Office (Geographical Section, General Staff); GSGS 4218; Malaya and Johore grids.

These two polychrome series cover all of Malaya, including offshore islands. They are reprints of wartime sheets that were compiled from available sheets of the 1: 63,360 series or from traverse, sketch, and reconnaissance maps. Roads are classified according to weather and traffic limitations; railroads according to gauge. Other cultural information is symbolized in detail. Relief is shown by contours or form lines.

- (e) *World (Asia) and World (East Indies)*; 1: 1,000,000; Survey of India; 1941; no grid.

This polychrome series was compiled from larger scale maps. Relief is indicated by contours, emphasized by gradient tints. Cultural and drainage features are symbolized in detail, and a bilingual French-English legend is on all sheets. These sheets have been reprinted (as GSGS 2555 or 4205) by GSGS and by the Army Map Service. Minor revisions were made to planimetry, aeronautical data, and isogonic lines.

b. *Town Plans.*

- (1) *Native.* FMS & SS produced numerous polychrome town plans before World War II. Most have been recompiled or revised by GSGS. Since the war, SD-FM has revised cultural detail on a few town plans from aerial photography.
- (2) *Official (GSGS).* Between 1941 and 1945 GSGS published city plans at various scales, as GSGS 4476. These polychrome plans may be divided into three

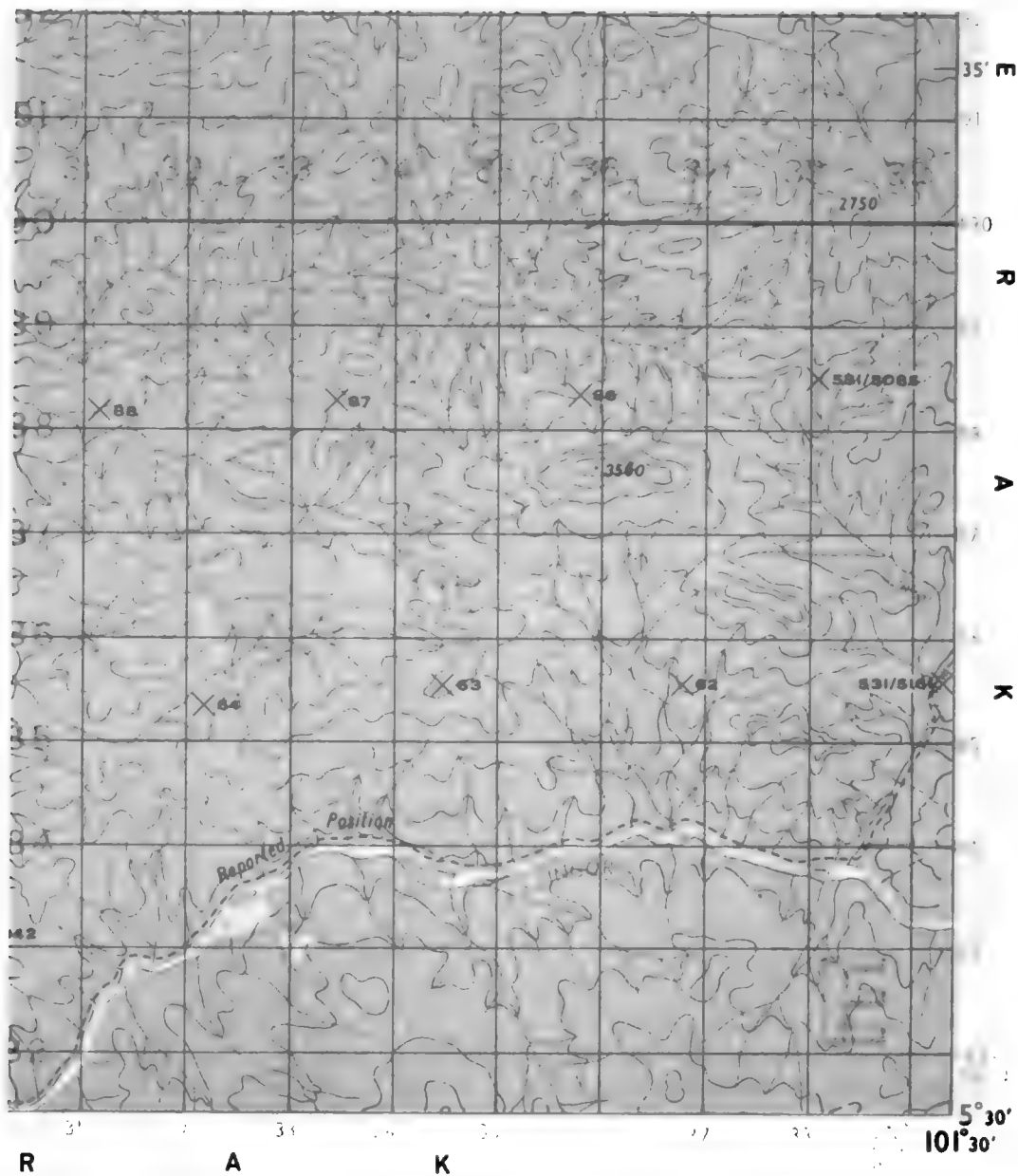

Compiled and drawn by Directorate of Colonial Surveys and War Office with the aid of ground control supplied by the Survey Department, Malaya.

Air photography by 81 Squadron, R.A.F.

Reproduced by War Office, 1950.

Figure 92. Section of sheet from Air Reconnaissance Series (GSGS 4690) at 1:63,360, covering parts of Thailand, by the Directorate of Colonial Surveys and GSGS.

groups. The first group was produced from aerial photographs in 1945 by the Allied Central Interpretation Unit (ACIU), working in conjunction with GSGS. Cultural features shown include

railways, roads, important buildings, and built-up areas. The important buildings are labeled, and the amount of space occupied by strategic structures is given in square feet. The second group



Figure 93. Section of sheet from the Luzon 1:50,000 series (AMS S711), by the 64th Engineer Base Topographic Battalion.

was based on original FMS & SS city plans compiled in the 1930's and revised to 1941 by the Inter Service Topographical Department (ISTD), working for GSGS. Some of this group of plans were also revised from aerial photography in 1945 by the Allied Central Interpretation Unit. All streets and important buildings are identified, and roads are classified according to surface and type. The plans of the third group, compiled by ISTD, have very generalized street patterns and limited cultural detail. Most plans of these three groups carry the Johore or Malay provisional grid.

91. Coordinate Systems

a. Geographic. On all maps of Malaya and Singapore, geographic coordinates are given in degrees, and longitudes are referred to Greenwich.

b. Grid. The British grid system is used on GSGS and HIND series and on two of the native series—the FMS & SS 1:25,000 series and the SDFM 1:63,360 series. Those sheets covering Singapore and the southern part of Malaya carry the Johore grid, and sheets covering the remaining part of Malaya carry the Malay grid. The remaining native series and the Japanese series have no grid.

Section VIII. THE PHILIPPINES

92. Mapping Activities

a. Native. The Philippine Coast and Geodetic Survey, although primarily concerned with hydrographic charting, has represented the Philippine Islands in cartographic matters since they became independent in 1946. To date, it has produced only small-scale general maps.

b. Official, by United States and Allied Mapping Agencies:

(1) *United States Coast and Geodetic Survey (USC & GS).* USC & GS began the earliest topographic work of significance in 1901 and continued to 1942. The results of the basic trigonometric surveys were reported on topographic and hydrographic field sheets that are still in unpublished form. This agency compiled city plans and a topographic series at 1:200,000 (except sheets for Mindanao, which are at 1:600,000) from its field sheets and from other available small-scale maps. These have been superseded by wartime mapping.

(2) *Army Map Service (AMS).* After the outbreak of World War II, AMS reproduced existing USC & GS and other miscellaneous series, some with minor revisions. This agency also compiled maps at 1:25,000, 1:50,000, and 1:100,000 covering parts of the area; maps at 1:500,000 and 1:1,000,000 for all of the islands; a one-sheet topographic map at 1:1,500,000 and numerous city plans.

(3) *Southwest Pacific Area (SWPA) and Army Forces, Pacific (AFPAC).* Wartime topographic field units of the U. S. Engineers and the Australian Survey Corps carried out the mapping responsibilities of the Southwest Pacific Area Command (SWPA) prior to 1945, and the Army Forces, Pacific (AFPAC) after 1945. Map series at 1:25,000–1:50,000 covering strategic areas and a 1:250,000 series covering most of the islands were produced. Field mapping was generally based on aerial photography and made use of stereocomparagraph or multiplex methods, and radial-line plotting, although numerous sheets were based on earlier AMS editions, with revisions from aerial photography.

(4) *64th Engineer Base Topographic Battalion, U. S. Army Forces, Far East (AFFE).* The 64th Engineer Base Topographic Battalion, under the direction of AFFE since 1948 has compiled sheets at 1:50,000 based on aerial photography.

c. Other. During World War II the Japanese General Staff and various aerial and topographic field units of the Japanese Army published significant series at scales of 1:50,000 and 1:100,000, based on Japanese 1944 aerial photography, available prewar maps and charts, and Japanese ground surveys. A number of medium-scale series also were produced. The sheets are printed in Japanese and have no legends; standard Jap-

anese symbols are used. Most of the series are monochrome. Although some of the maps provide the only coverage for the area, much of the information shown is generalized.

93. Major Maps of the Philippines

a. Topographic Series.

(1) *Native.*

Philippines; 1:1,000,000; Philippine Coast and Geodetic Survey; 1950; no grid.

This polychrome map covering all of the islands was compiled from various map sources. Relief is portrayed by hachures. Province and subprovince boundaries are indicated.

(2) *Official.*

(a) *Luzon 1:25,000, Palawan 1:25,000, Central Philippines 1:25,000, Sulu Archipelago 1:25,000 and Mindanao 1:25,000*; Army Map Service and Southwest Pacific Area; AMS S812, S821, S831, S841, and S851; 1944-45; Philippine Polyconic grid, and N. E. I. Equatorial Zone U. S. Yard grid.

These polychrome series cover the islands or parts of the islands named in the titles. Over half of these sheets are superseded by later date or more complete AMS 1:50,000 coverage (AMS S712, S722, S741, S731, and S751). Sheets covering parts of Luzon produced by AMS were compiled from the USC & GS field sheets and other maps. Limited revisions were made from pre-1940 photography. A small group was stereo-compiled or revised from wartime aerial photography. Sheets from the other four series produced by AMS were compiled from the USC & GS field sheets, with additions from miscellaneous existing maps, documentary data, and sparse pre-1940 photography. Of the sheets produced by SWPA, more than half are based on Army Map Service first editions, with revisions from aerial photography; the remaining sheets are original photo compilations. Relief is indicated by contours and form lines on the Luzon sheets and by form

lines on the other sheets. Cultural detail on AMS sheets is based on pre-war and a small amount of wartime information. On sheets produced in the field, cultural data is based on wartime information and in many cases reflects conditions that no longer exist. Vegetation is indicated only where the information was available. Railroads are classified by a number of tracks and by gage if known; otherwise they are unclassified. On the AMS sheets, roads are classified by weather limitations; on the field sheets, roads are classified as hard-surfaced highway, hard-surfaced road, lightly surfaced road, earth road suitable for minor military traffic, jeep track, and trail.

(b) *Luzon 1:50,000, Palawan 1:50,000, Leyte 1:50,000, Mindoro 1:50,000; Central Philippines 1:50,000; Sulu Archipelago 1:50,000, and Mindanao 1:50,000*; Army Map Service, Southwest Pacific Area, and Army Forces, Pacific; AMS S712, S722, S731 (for three series), S741, and S751; 1944—; Philippine Polyconic grid. Universal Transverse Mercator grid, or N. E. I. Equatorial Zone U. S. Yard grid.

The AMS polychrome sheets provide coverage for the west coast of Luzon, part of southern Luzon, all of Homonhon, Lubang, Ticao, Burias, Dinagat, Siargao, and adjacent islands, and all islands of the Sulu Archipelago except Jolo. The Luzon sheets were based on the Philippine Department 1:31,680 series, with very minor revisions from pre-1940 photography, and on USC&GS charts and topographic field sheets. A few sheets carry a red overprint incorporating changes from wartime aerial photography. Sheets covering the other islands were based on the USC&GS charts and field sheets, with the exception of some of the Sulu Archipelago sheets, which were stereo-compiled or revised from pre-war aerial photography. Polychrome sheets compiled by SWPA

and AFPAC cover most of northern Luzon, the Manila area, parts of the coastal areas of the central Philippines, most of Jolo Island, and the central, southeastern, and southwestern parts of Mindanao. Most of these sheets are based on wartime aerial photography, supplemented with information from map sources and intelligence data. A few sheets are based on map sources only. Relief on the AMS sheets is indicated by contours and form lines in the Luzon area, and by form lines in the remaining areas. On the SWPA and AFPAC sheets, relief, which is restricted to the immediate coast, is shown by contours, approximate contours, or form lines. Planimetry and relief, especially on the AMS sheets, are sketchy and incomplete, and large parts of many sheets are entirely blank. On the AMS sheets, roads are classified according to weather limitations; on the SWPA and AFPAC sheets they are classified as national highway, hard-surfaced highway, hard-surfaced road, lightly surfaced road, irregularly surfaced road, earth road, track, and jeep trail. Railroads are classified by gage and number of tracks or are unclassified.

- (c) *Central Philippines 1:50,000* and *Luzon 1:50,000*; 64th Engineer Base Topographic Battalion; AMS S733 and AMS S711; 1952; Universal Transverse Mercator grid.

These polychrome series cover Cebu, Marinduque, and the coastal area of Luzon north of Manila Bay (fig. 93). Sheets were compiled in 1952 by multiplex methods from aerial photography. Information is very detailed. Roads, of which only the major ones have been checked by reconnaissance, are classified by surface and width. Railroads are classified by gage and number of tracks. Vegetation is symbolized. Relief is indicated by contours at 20-meter intervals.

- (d) [*United States Coast and Geodetic Survey Topographic Field Sheets*];

1:50,000 to 1:80,000; USC&GS; unpublished; no grid.

These field sheets provide the only large-scale coverage available for some coastal areas. They are the preliminary results of 1902-40 topographic surveys. Relief is indicated by contours at various intervals. Cultural information is sparse and not up to date. Information from these sheets was incorporated into the USC&GS hydrographic charts and was frequently used in producing wartime maps.

- (e) *Mindanao 1:100,000*; Army Map Service; AMS S651; 1944; Philippine Polyconic grid.

This is a polychrome series covering most of Mindanao and Basilan Island. It was compiled from USC&GS charts and field sheets, a few pre-1940 vertical and oblique aerial photographs, and other miscellaneous maps and reports. Relief, where shown, is indicated by contours, form lines, or hachures. Most sheets contain only sketchy relief and planimetry, and numerous large areas are blank. Drainage is very generalized; vegetation is shown only in scattered areas; and location and delineation of cultural features are often approximate.

- (f) *Philippine Islands 1:250,000*, *Mindoro 1:250,000*, and *Mindanao 1:250,000*; Southwest Pacific Area and Army Map Service; AMS S512, S531, and S551; 1944-51; Philippine Polyconic and Universal Transverse Mercator grids.

These polychrome series cover all of the Philippines except the Sulu Archipelago, Palawan, and adjacent islands, several islands north of Panay, and others north of Luzon. These sheets were compiled from the available prewar series, the AMS large-scale series, and documentary information. Scattered areas were revised from 1944 aerial photography. Relief on sheets covering Samar and Leyte is indicated by

crude hachuring and on all other sheets by hill shading. Roads are classified by surface; railroads, by number of tracks and occasionally by gage. Vegetation is incomplete, and drainage is generalized.

- (g) *Philippine Islands 1:500,000*; Army Map Service; AMS S401; 1944; Philippine Polyconic grid and N. E. I. Equatorial Zone U. S. Yard grid.

This polychrome series covering all of the Philippines was compiled in 1944 from source material available at the time. Relief is indicated by sparse hachuring and a few scattered contours. Planimetric detail is sketchy and generalized.

- (h) *World (Eastern Asia) 1:1,000,000*; Army Map Service; AMS 1301; 1944-45; no grid.

These sheets covering the Philippines are printed in six colors, plus gradient tints. They were compiled in 1943 and revised in 1944-45. They were based on the AMS 1:500,000 series (AMS S401) and USC&GS charts. Relief is indicated by contours or approximate contours. Some of the sheets have been reprinted by the Survey of India, and by the Directorate of Military Survey, War Office (Geographical Section, General Staff) as GSGS 2555. Minor revisions to the isogonic lines were made.

- (i) *Eastern Asia 1:1,500,000*; Army Map Service; AMS 5305; 1944; no grid.

This one-sheet map covering the Philippine Islands was compiled in 1944 from sheets of the *World*

(*Eastern Asia*) 1:1,000,000 (AMS 1301) series and a USC&GS chart. It is printed in seven colors, plus altitude tints. Relief is indicated by contours or approximate contours at intervals ranging from 500 to 3,000 feet.

b. *Town Plans.*

- (1) *Native.* Since World War II the Philippine Bureau of Public Works and various City and District Engineers have made a number of ozalid city plans intended primarily for use in road rehabilitation. Streets, through routes, and a few buildings are identified on these schematic plans.

- (2) *Official.* Town plans produced by the Army Map Service (AMS S911) are based on pre-1942 photography and miscellaneous map sources. Plans show the city proper and the surrounding areas. Buildings are shown in great detail, but only a few are identified. Streets are named and classified as main or secondary roads; destinations of through routes are given.

94. Coordinate Systems

a. *Geographic.* On all maps of the Philippines, geographic coordinates are expressed in degrees, and longitude is referred to Greenwich.

b. *Grid.* On various wartime English-language maps, the following grids were used: Philippine Zone grid, N. E. I. Equatorial Zone U. S. Yard grid, and World Polyconic grid (Band III N, Zone 1). On reprints of these sheets and on new sheets, the Universal Transverse Mercator grid is used. No military grid is shown on Japanese wartime maps, although a local grid is occasionally found.

Section IX. THAILAND

95. Mapping Activities

a. *Native.*

- (1) *The Royal Survey Department (RSD).* RSD, the governmental mapping agency of the country since 1885, produced large-scale maps, 1:5,000 through 1:50,000, for 42 percent of Thailand between 1912 and 1954. The sheets were made from planetable surveys. Aerial photography

also was used on recently published 1:25,000 and 1:50,000 sheets. For the remaining 58 percent of Thailand, reconnaissance surveys and other miscellaneous information were used by the RSD to compile coverage at smaller scales, 1:100,000 through 1:1,000,000. In the past, Thai script and numerals have been used on RSD maps. On the

most recent sheets, however, geographic coordinates and spot heights are given in Arabic numerals. Elevations are in meters. Important features included on RSD maps are roads, classified according to importance or motorability; railroads, without classifications; telegraph lines; various types of boundaries, including those of the "monthon" (not in use since 1932). The RSD has also published numerous town plans.

- (2) *The Thailand Department of Public and Municipal Works*. Between 1906 and 1950 the Thailand Department of Public and Municipal Works published many town plans ranging in scale from 1:5,000 to 1:25,000.

b. Other.

- (1) *Survey of India (SI)*. Before 1943 SI published Thailand-Burma border sheets of the *One-Inch* and *Half-Inch Series*, 1:253,440 sheets for all of Thailand, and those sheets of the *World (Asia)* 1:100,000 series that cover Thailand. The *One-Inch Series* sheets were compiled from native Thai sources and the *SI Half-Inch Series* sheets. The *Half-Inch Series* sheets were based on Thai and British sources at various scales.
- (2) *The Directorate of Military Survey, War Office (Geographical Section, General Staff)—GSGS*. GSGS reprinted the original Survey of India sheets during the early years of World War II. This agency has also published sheets at 1:1,000,000 scale and has reprinted all of the latest editions of the *World (Asia)* series that cover Thailand (GSGS 2555). GSGS has reprinted one sheet of a wartime 1:25,000 series covering the Langkawi Islands (GSGS 4716); about half the sheets of a 1:63,360 series covering peninsular Thailand from 7° to 10° N. (GSGS 4670); two sheets of another 1:63,360 series covering west-central Thailand (GSGS 4671); and nine sheets of the 1:253,440 series covering all of Thailand (GSGS 4218). Part of a series of town plans based on original Thai maps, aerial photography, and intelligence data has been revised and reprinted as GSGS 4572.

- (3) *The Army Map Service*. AMS has reprinted several of the GSGS series with changes only to marginal information.
- (4) *The Survey Department, Federation of Malaya*. This agency, in cooperation with the Directorate of Colonial Survey and GSGS, has recently published a series at 1:63,360 covering the part of Thailand south of 7° N. The sheets were made from 1948–50 aerial photography, with supplementary information from limited ground surveys.
- (5) *Japanese agencies*. The Japanese General Staff and Japanese Army field units during World War II published several original series at 1:50,000–1:100,000, based primarily on aerial photography. Although the maps provide fairly detailed coverage of important communications routes not otherwise mapped, positioning of detail is often distorted, due to sparse geodetic control. The Japanese General Staff reprinted the border sheets of the *SI one-inch series* enlarged to 1:50,000 and also reprinted sheets of various native Thailand series. On all but the reprinted sheets, elevations are given in meters. All sheets are in Japanese except the reprinted sheets, which retain the original language on the face of the map, but have Japanese legends.
- (6) *The Far East Land Forces (FAREL F)*. This agency has revised two 1:253,440 sheets that cover areas in Thailand south of 10° N.
- (7) *French agencies*. The Service Géographique de l'Indochine (Geographic Service of Indochina), and the Institut Géographique National (National Geographic Institute) have published medium-scale series of Indochina. The parts of the sheets extending into Thailand are based on Thai sources.

96. Major Native Maps of Thailand

a. Topographic Series.

- (1) [*Thailand*]; 1:25,000; Royal Survey Department; 1936–38; unidentified grid. This monochrome series was compiled (1931–39) from aerial photography and controlled planetable surveys. The sheets cover a part of the Thai-

land-Indochina border, as well as scattered areas of northeastern Thailand. Relief is shown by contours or form lines, with numerous spot heights.

(2) [Thailand]; 1:50,000; Royal Survey Department; 1912-51; unidentified grid. This polychrome series (fig. 94) cov-

ers a large area of central Thailand and affords the most extensive large-scale coverage of the country. The sheets were compiled from the 1905-41 plane-table surveys at scales of 1:20,000 to 1:80,000. Relief is shown by contours.

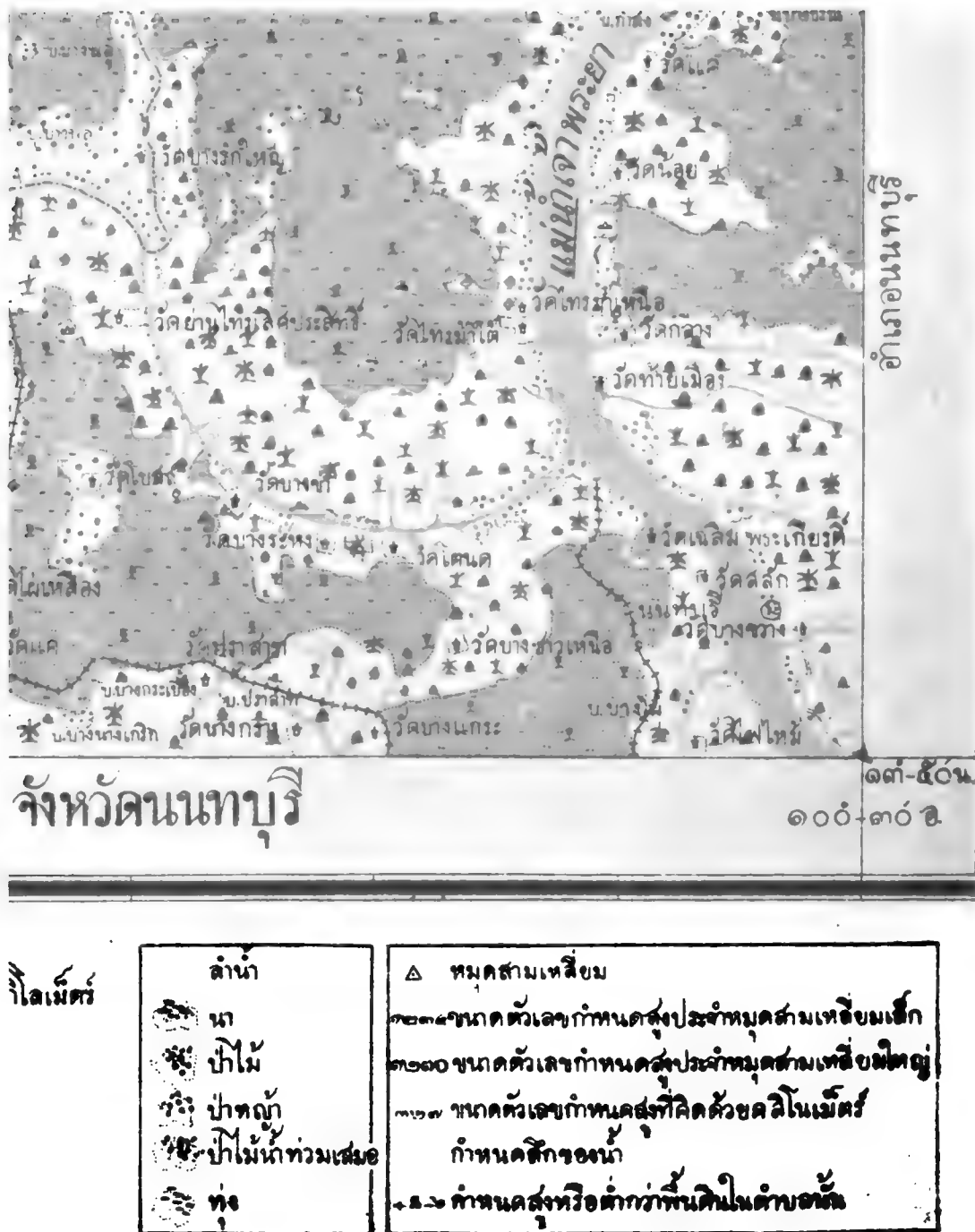

Figure 94. Section of sheet from the Thailand 1:50,000 series by the Royal Survey Department.

- (3) [*Thailand*]; 1:100,000; Royal Survey Department; 1916-42; no grid.

This polychrome series covers an extensive area of central Thailand. The sheets are based on those of larger scale series, where available, or on the results of original 1:50,000 and 1:80,000 planetable surveys dated 1912-28. Relief is shown by contours.

- (4) [*Thailand*]; 1:200,000; Royal Survey Department; 1931-51; no grid.

This series covers the entire country and is based on the 1:50,000 and 1:100,000 series, a 1:200,000 reconnaissance survey dated 1921-26, and other miscellaneous information. Relief is indicated by contours on sheets compiled from larger scale series and by approximate contours and form lines on the remaining sheets. Sheets of the series are printed in one to six colors.

- (5) (*Map of the Royal Kingdom of Siam*); 1:250,000; Royal Survey Department; 1932; no grid.

These four polychrome sheets cover part of central Thailand. They were compiled from the Thailand 1:200,000 series and/or larger scale native series.

- (6) [*Thailand*]; 1:500,000; Royal Survey Department; 1941-52; no grid.

All of this series is based on the 1:200,000-scale series except parts of three sheets for northeastern Thailand; these are based on manuscript compilations from photographic and planetable surveys designed for 1:25,000-scale compilation. The series is published in one to four colors. Relief is shown by form lines except on a few

sheets that have contours. The international boundary claims of Thailand and Indochina shown on the map are no longer recognized.

b. Town Plans.

- (1) *Royal Survey Department* (RSD). Between 1930 and 1950 the RSD published a 137-sheet polychrome series covering Bangkok. This 1:5,000 plan, entitled (*Map of Environs of Krung Thep*), is extremely detailed but has no grid. Many other RSD town plans exist; those for some of the important cities have been reprinted by GSGS.

- (2) *Thailand Department of Public and Municipal Works*. Numerous Thai-language plans at scales ranging from 1:5,000 to 1:25,000, are available. All are monochrome lithographs, but poor reproduction has obscured the identification of buildings and streets. The plans are generally undated.

97. Coordinate Systems

a. *Geographic*. Geographic coordinates on all sheets covering Thailand except those of series extended from Indochina are expressed in degrees. Longitude is measured from Greenwich. Coordinates on sheets extended from Indochina series are expressed in grads measured from Paris.

b. *Grid*. No military grids are shown on RSD and Japanese maps, although an unidentified grid is occasionally found. All British series use the British grid system. Thailand falls within the limits of the India Zone III B grid north of 15°30' N., the India Zone IV B grid north of 8° N., and the Malay grid south of 8° N. The Universal Transverse Mercator grid is the primary grid on sheets of the AMS *Indochina* 1:250,000 series, and British grid is a secondary grid.

Section X. TURKEY

Note. In the past, the mapping of Turkey was notably independent of that of adjacent countries. The trend in recent years, however, has been to effect a coordination among these various surveys.

98. Mapping Activities

a. Native.

- (1) In 1909, a cartographic office was established in Turkey under the General Staff. This topographic Commission of the Ottoman Empire was the forerunner of the

present-day cartographic organization. The name Harita Umm Müdürlüğü (General Map Directorate) was adopted in 1926. This was subsequently changed to Harita Genel Direktörlüğü (General Map Directorate) and later to the current

Harta Genel Müdürlüğü (General Map Directorate usually paraphrased in English-language publications and maps for public distribution as "Turkish Geodetic Survey"). This agency is charged with the responsibility of producing the maps required by all government organizations. In 1944, the Harta Genel Müdürlüğü published an excellent plan of Ankara, but there is no evidence of publication of other town plans by this organization.

- (2) A reconnaissance map at the scale of 1:200,000 based on a rapid preliminary triangulation, was completed in the years 1910–29. The Bonne projection (with longitudes referred to Istanbul) was utilized for this series and for others produced during this period.
- (3) In the course of the rapid triangulation, it was decided to proceed simultaneously with the preparation of a map of the country at the scale of 1:50,000. Later, the publication scale was changed to 1:100,000 except for maps of certain military garrisons at 1:25,000. After the publication of a number of sheets according to this plan, however, the scale of 1:25,000 was adopted for mapping the entire country. This program has continued in effect, although for many years progress was extremely slow.
- (4) About 1933, a new 1:25,000 series was begun. This series is based on new geodetic work, and compilation is by photogrammetric methods, utilizing the Zeiss stereoplanigraph. German techniques, instruments, and training of Turkish personnel have influenced this work to a great extent.
- (5) All maps published prior to 1930 were in Arabic script. Although the Turkish alphabet was officially romanized in 1928, the new script did not appear on maps until 1930. The replacement of Arabic-script sheets by romanized editions has been slow, and current editions are still in the old script.
- (6) In 1935 the Harta Genel Müdürlüğü produced, by reduction of the 1:200,000 sheets available at that time, a 1:800,000 topographic series covering the entire country. In 1936, a revised, simplified

edition of this map was published, with subsequently revised editions appearing as late as 1950.

- (7) In 1946, a 1:500,000 series, based on the 1:200,000 series and covering all of Turkey, was published. This is the only Turkish topographic series affording comprehensive coverage that is based on geographic sheet lines, with longitudes referred to Greenwich.
- (8) The publications of the Harta Genel Müdürlüğü and its predecessors have formed the basis for most of the work by British and German mapping agencies.
- (9) The İller Bankası (Bank of the Provinces), in connection with its assigned functions, has produced large-scale plans for over 140 Turkish towns.

b. Other.

- (1) *Directorate of Military Survey, War Office (Geographical Section, General Staff)—GSGS.* Maps of Turkey prepared by GSGS have, for the most part, consisted of English-language reprints of Turkish maps or compilations from Russian and/or Turkish sources of various dates. In those cases where the original Turkish maps were in Arabic script, names were romanized but frequently do not agree with modern Turkish spellings. In 1922–23, GSGS published a series for the Dardanelles area (GSGS 2993). Primary sources were Turkish large-scale (1:25,000) maps. In more recent years (1941–45) GSGS, together with the Middle East Land Forces (MELF), published the *Turkey* 1:200,000 series (GSGS 4193, MDR 3), covering most of Turkey. In addition, the standard British *Quarter-Inch Series* (1:253,440) extends into southeastern Turkey. The sheets in this area were published by MELF as MDR 503 and IDR 9002 and by GSGS as part of its series GSGS 3919. Small-scale maps published by GSGS—including the 1:800,000 *Turkey* series (GSGS 4235) and the sheets of the two 1:1,000,000 series, *Asia* (GSGS 2555) and *Europe* (GSGS 2758), covering Turkey—are essentially reprints of or compilations from Turkish sources.

- (2) *Middle East Land Forces (MELF)*. Map series of Turkey published by MELF—like those of GSGS—are essentially English-language reprints of (or compilations from) Turkish large-, medium-, and small-scale sources. Greek materials also have been utilized to a very limited extent. MELF has published (1943–45) two 1:100,000 series entitled *Turkey* (MDR 626 and MDR 677): the first series covers part of the Dardanelles area and the second covers a section along the Greece-Turkey boundary. sheets of the *Levant 1:200,000* series (MDR/PDR 589), designed primarily as coverage for Lebanon and Syria but also covering an area along the Turkey-Syria boundary, were published in 1941–45. MELF also published (as MDR 3) sheets of the *Turkey 1:200,000* series and the *quarter-inch series* (IDR 9002, MDR 503), which supplement those prepared by GSGS. Sheets of the *Asia 1:1,000,000* series (MDR 1) covering Turkey were also contributed by MELF. During World War II, MELF produced plans for a number of Turkish towns.
- (3) *The German Oberkommando des Heeres/Generalstab des Heeres (High Command of the Army, General Staff of the Army)*. German maps of Turkey published prior to World War II are of historical interest only. The 1:25,000 *Turkei* series, which appeared in 1941–43, and covered the Edirne, Bosphorus, and Dardanelles areas, was copied (with minor revisions) from Turkish 1:25,000 maps dated 1910–22. Greek materials dated 1919–22 were used in the preparation (in 1943) of the German 1:25,000 series of the Izmir area. A few sheets of the *Greichenland (Greece) 1:100,000* series that cover the region adjacent to the Greece-Turkey boundary are based on Greek 1:100,000 maps. The Germans also published, during World War II, the *Turkei 1:200,000* series. This series covering most of Turkey was compiled from a variety of sources, including Turkish 1:200,000- and 1:800,000-scale maps and Russian 1:200,000-scale maps for parts of eastern Turkey. Two series at 1:500,000—*Karte der Turkei* (Map of Turkey) and *Deutsche Weltkarte* (German World Map)—and sheets of the *Internationale Weltkarte* (International Map of the World), at 1:1,000,000 cover all of Turkey. All three were compiled from the Turkish 1:800,000 series.
- (4) *The Greek Khartografiki Ipiesia Stratoú, Khartografiki Ómas Mikrás Asías (Cartographic Service of the Army, Cartographic Team of Asia Minor) and Yeografiki Ipiesia Stratoú (Geographic Service of the Army)*. A limited amount of Greek mapping was carried in European Turkey and western Asiatic Turkey shortly after World War I. The German 1:25,000 series of the Izmir area, however, was based on Greek 1:20,000 maps and surveys dated 1920–21 and Greek 1:10,000 surveys dated 1919–22. Greek agencies also have published (1921–35) a 1:100,000 series of European and western Asiatic Turkey. Those sheets for Asiatic Turkey were compiled from Greek plane-table surveys at 1:100,000.
- (5) *The Russian Voyenno-Topograficheskoye Upravleniye (Military-Topographic Administration), Upravleniye Voyennykh Topografov Krasnoy Armii (Administration of Military Topographers of the Red Army), and General'nyy Shtab, Krasnaya Armiya (General Staff, Red Army)*. Russian surveys were carried out in eastern Turkey at various times between 1869 and 1917, with some reconnaissance work as late as 1932. The results of these surveys were published at scales of 1:42,000, 1:84,000, and 1:200,000. Some of the 1:84,000 sheets were used in the preparation of the British *Quarter-Inch Series* (1:253,440). The Germans used a number of the 1:200,000 Russian sheets in the Lake Van area as source material for the 1:200,000 *Türkei* series.

99. Major Maps of Turkey

a. Topographic Series.

(1) Native.

- (a) *Türkiye*; 1:500,000; Harta Genel Müdürlüğü; 1946; no grid.

This series covers all of Turkey. The sheets were compiled from a 1:200,000-scale series and are reproduced in several colors. Relief is represented by contours and gradient tints at intervals varying with the elevation. Cities, towns, and villages are classified according to population; the figures appear to be taken from the 1945 census. This series is one of the few original Turkish publications that has longitude computed from Greenwich.

- (b) *Turkiye*; 1:800,000; Harta Genel Müdürlüğü; 1950; atlas grid.

Covering all of Turkey, this polychrome series, originally compiled in 1934, was based on the Turkish 1:200,000 sheets available at that time. Subsequent revisions have been confined to cultural data and cartographic style. Relief is represented by contours. The retention of much detail from the 1:200,000 sources results in a crowded appearance. The 1936 edition of the series was reprinted by GSGS with minor revisions, and the latter publication was, in turn, reprinted by AMS.

(2) *Other.*

- (a) *Periokhi Smirnis* (Region of Izmir); 1:20,000; Khartografikí Ipiresía Stratoú, Khartografikí Omás Mikrás Asías; 1920–21; Greek military grid.

This series covers a limited area in the vicinity of Izmir. The sheets are based on original Greek survey work carried out after World War I, and were utilized in the compilation of the German 1:25,000 series. Relief on these polychrome sheets is shown by contours and shading.

- (b) *Türkei*; 1:25,000; Oberkommando des Heeres/Generalstab des Heeres; 1941–43; Bonne grid.

This series (fig. 95) provides coverage for the Istanbul, Edirne, and Dardanelles areas of northwestern Turkey. All sheets are basically copies of the Turkish 1:25,000 sheets dated 1910–22. On some of the sheets, roads and towns have been

revised to 1943, apparently from aerial photography. Six sheets are polychrome; the remainder, monochrome. Relief is represented by contours.

- (c) *Türkei-Umgebung von Izmir (Smyrna)* (Turkey—Environsof Izmir); 1:25,000; Oberkommando des Heeres; 1943; German Army grid.

Covering a limited area around Izmir, this series is based on 1:10,000 and 1:20,000 Greek maps and surveys, dated 1919–22, and miscellaneous German sources, dated 1930–41. Relief is shown by contours on these polychrome sheets.

- (d) [*Turkey, Georgian S. S. R., Armenian S. S. R., Azerbaijan S. S. R., and Russian Soviet Federated Socialist Republic*] 1:42,000; Voyenno-Topograficheskoye Upravleniye, Upravleniye Voyennykh Topografov Krasnoy Armii, and General'nyy Shtab, Krasnaya Armiya; 1931–41; Russian Army grid on a few sheets.

A limited area of northeastern Turkey is covered by this series, primarily intended as coverage for the U. S. S. R. For Turkey, basic surveys are dated 1869–1916, with a few sheets incorporating revisions as late as 1932. Relief is shown by contours in sazhen (one sazhen equals 7 feet). Some sheets are monochrome and some polychrome. For additional details see paragraphs 195–199.

- (e) [*Dardanelles*]; 1:50,000; Directorate of Military Survey, War Office (Geographical Section, General Staff); GSGS 2993; 1922–23; unidentified British grid.

This polychrome series covers part of the Dardanelles area. All sheets except one are copies of a French 1:50,000 series dated 1920. Relief is shown by contours.

- (f) [*Caucasus*]; 1:84,000; Voyenno-Topograficheskoye Upravleniye and General'nyy Shtab, Krasnaya Armiya; 1914–40; Russian Army grid on a few sheets.

Türkei 1:25 000

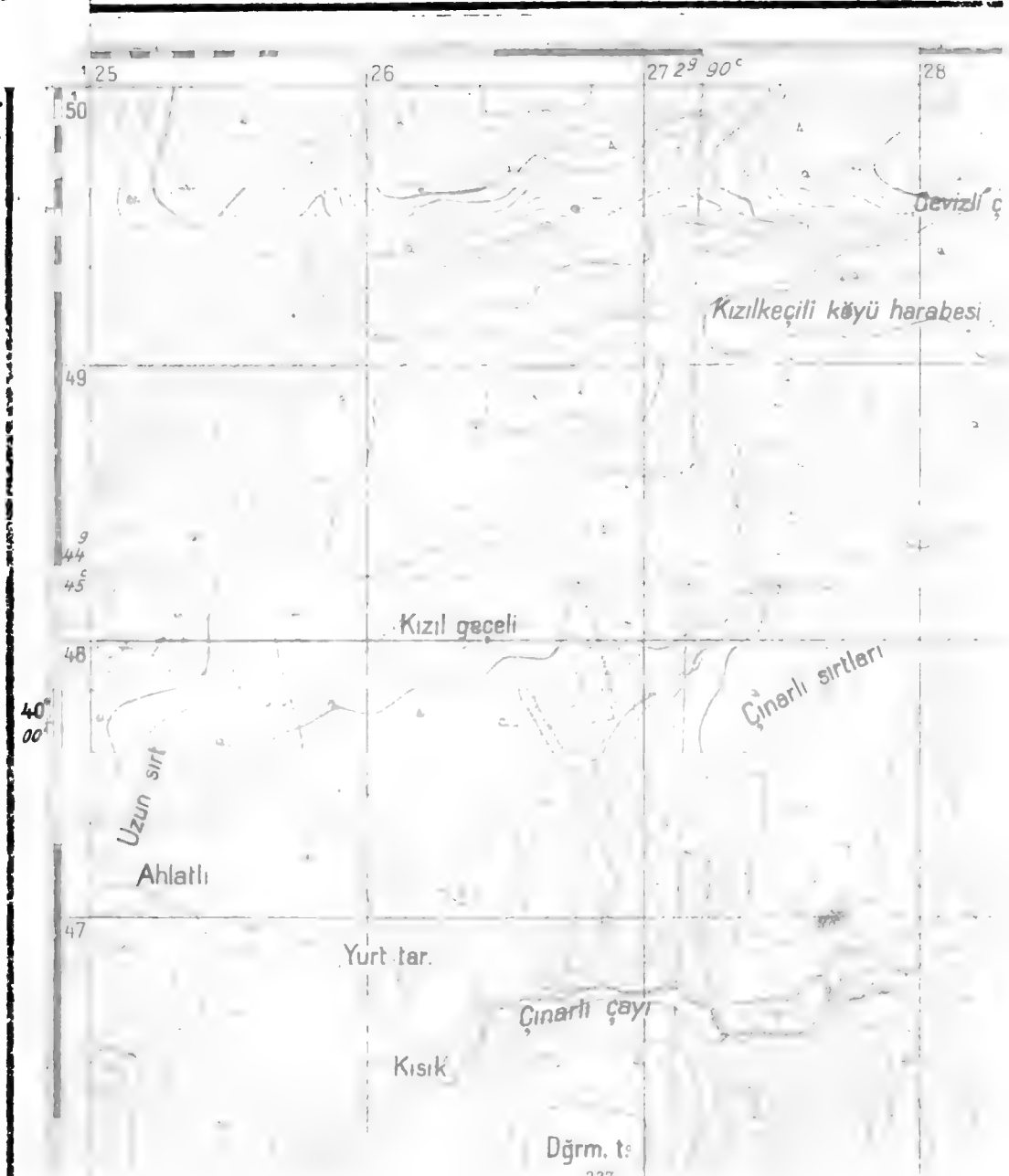

Figure 95. Section of Sheet No. VIII-25 from the *Türkei 1:25,000* series by the Oberkommando des Heeres/Generalstab des Heeres.

This series covers a somewhat more extensive area of northeastern Turkey than does the 1:42,000 series. The sheets for Turkey are based on ground surveys dated 1872-1916. For additional details, see paragraphs 76-79.

(g) *Turkey*; 1:100,000; Middle East Land Forces; MDR 626; 1943; Mediterranean grid.

One polychrome sheet of this series covers part of the Dardanelles area. The basic material used in the compilation was a Greek 1:100,000 sheet

- dated 1927. Relief is represented by contours.
- (h) *Tourkia* (Turkey); 1:100,000; Middle East Land Forces; MDR 677; 1945; Mediterranean grid.
The two available polychrome sheets of this series cover an area along the Greek-Turkish border. Only one sheet gives the sources used in compilation: Greek 1:100,000 maps (dated 1932) and Turkish 1:25,000 maps (dated 1914-15). Contours are used to show relief. Marginal information is in Greek, but names in Turkey are romanized.
- (i) *Greichenland* (Greece); 1:100,000; Oberkommando des Heeres/Generalstab des Heeres; 1944; Greek Conical, Bulgarian Gauss-Kruger, and German Army grids.
A few sheets of this series cover part of Turkey along the Greek border. Basic source materials used for the Turkish area were Greek 1:100,000 maps dated 1932-39. Names, roads, and some drainage features were revised from miscellaneous sources. Relief is shown by contours on these polychrome sheets. For additional details, see paragraphs 180-182.
- (j) [Greece]; 1:100,000 Yeografikí Ipire-sía Stratoú; 1921-35; no grid.
Sheets of this series, designed primarily as coverage for Greece, extend into European and western Asiatic Turkey. The sheets covering areas along the Greek-Turkish border are based on old Turkish (Ottoman Empire) large-scale maps and 1:200,000 Austrian maps dated 1890. Those covering areas entirely within Turkey were compiled from original Greek planetable surveys at 1:100,000. For additional details, see paragraphs 180-182.
- (k) [*U. S. S. R., Turkey, Iraq, and Iran*]; 1:200,000; General'nyy Shtab, Krasnaya Armiya; 1941-42; Russian Gauss-Kruger grid.
Sheets of this extensive topographic series, published primarily as coverage for the Soviet Union, cover part

of eastern Turkey. A number of the German 1:200,000 sheets in the Lake Van area are based on this series. For additional details, see paragraphs 76-79.

- (l) *Turkey*; 1:200,000; Middle East Land Forces and Directorate of Military Survey, War Office (Geographical Section, General Staff); MDR 3 and GSGS 4193, respectively; 1941-45; Caucasus and Levant Zone grids and Mediterranean grid.

These two polychrome series are considered together, since in many cases one agency has reprinted the sheets of the other. The series covers all of Turkey except for part of northern European Turkey, the Hatay Province in southern Turkey, an area along the Syria-Turkey boundary, and an area in the east at the junction of the Turkey-Iraq-Iran boundaries. The primary source materials used in compilation were sheets of a 1:200,000 series dated 1913-41. Other sources (Greek, Russian, British, and Turkish) were used for compilation in border areas or for revision. Relief is shown by contours. The legends vary, depending upon which agency published the original sheets; the MELF legend is the more comprehensive. Each sheet carries a brief glossary and a key to the pronunciation of certain Turkish letters. Selected sheets from these series have been reprinted by AMS (figs. 96 and 97).

- (m) *Levant 1:200,000**; Middle East Land Forces; MDR/PDR 589, GSGS 4195; 1941-45; Iraq, Levant, and Caucasus Zone grids.

Several sheets cover an area along the Turkey-Syria boundary. The parts of these sheets covering Turkey were compiled from the Turkish 1:200,000 and 1:800,000 series, from surveys by the French Service Géographique de l'Armée, and from surveys in 1928-30 by the commission for the demarcation of the Turkey-Syria boundary. For additional de-

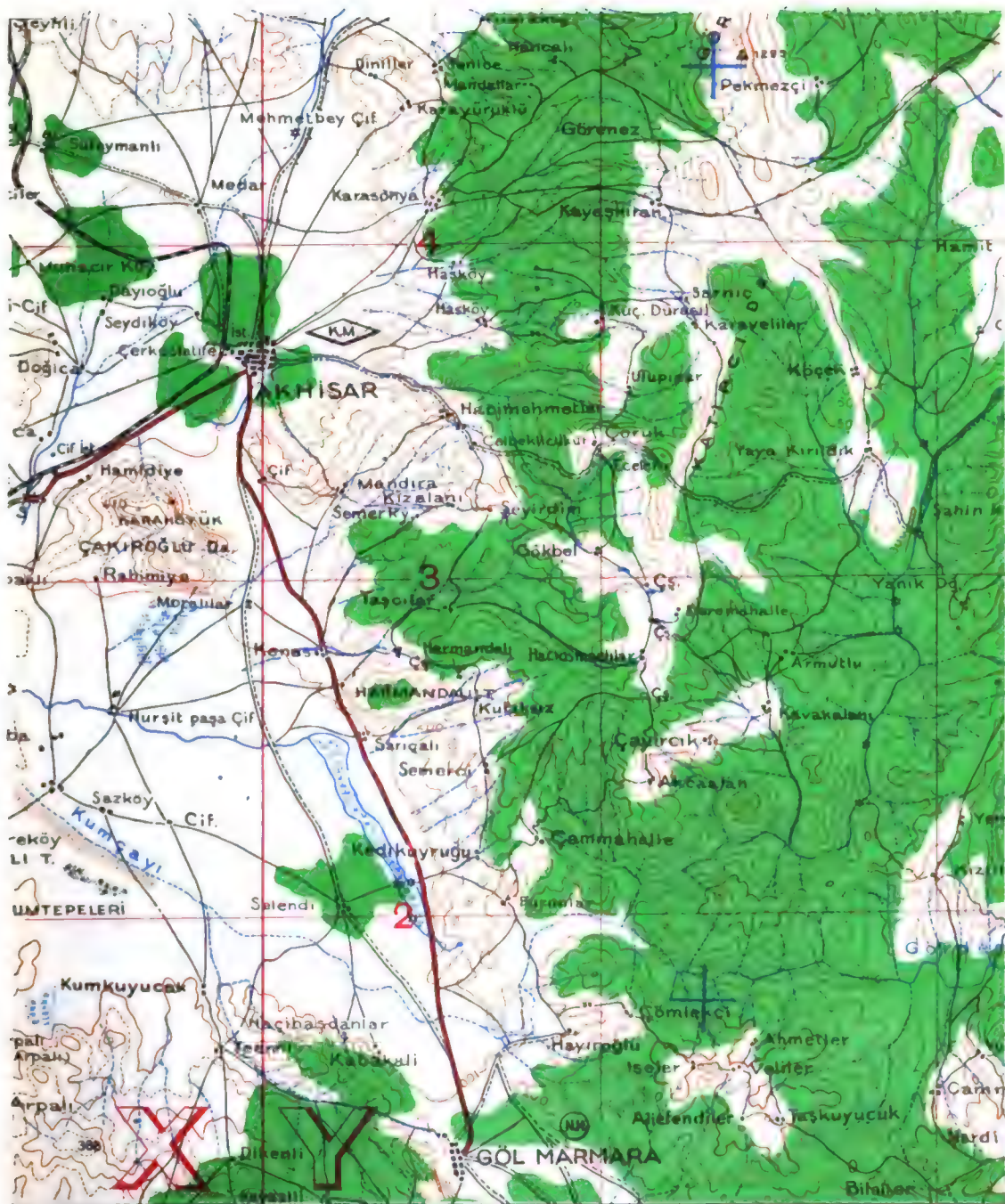

01° 00' WEST OF ISTANBUL

28 00' EAST OF GREENWICH

Figure 98. Section of Sheet "Akhisar," a basic Middle East Land Forces compilation, from the Turkey 1:200,000 series (MDR 3, GSGS 4193), reprinted by the Army Map Service as AMS K511.

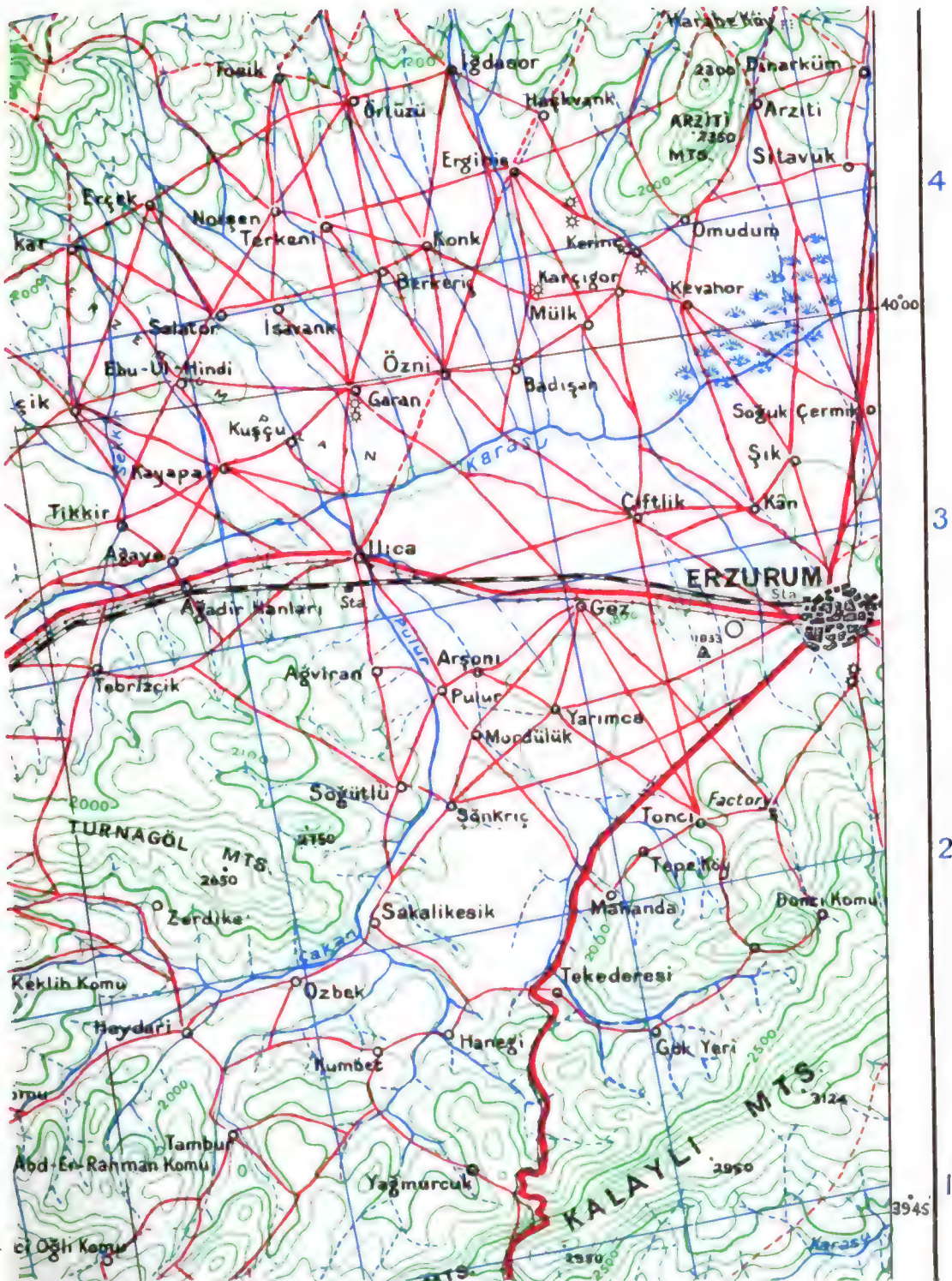

Figure 97. Section of Sheet "Erzurum," a basic Directorate of Military Survey, War Office compilation, from the Turkey 1:200,000 series (GSGS 4195), reprinted by the Army Map Service as AMS K511.

tails, see paragraphs 86-88 and figure 91.

- (n) *Turkai*; 1:200,000; Okerkommando des Heeres/Generalstab des Heeres; 1941-44; Bonne and German Army grids.

Coverage for all of Turkey except part of the Hatay Province in southern Turkey and an area along the Turkey-Iraq boundary is provided by this polychrome series. Most of the sheets are based on Turkish 1:200,000 sources dated 1910-37. A considerable number are merely enlargements of the Turkish 1:800,000 series dated 1936. An extensive block of sheets covering the Lake Van area of eastern Turkey incorporates data from Russian 1:200,000 sheets of 1941. Nearly all of the sheets were revised from the Turkish 1:800,000 series, and some sheets covering parts of western Turkey were revised from German wartime aerial photography. Relief is shown by contours. Each sheet carries a pronunciation key and a list of abbreviations of Turkish terms with Turkish and German equivalents.

- (o) *Quarter-inch series*; 1:253,440; Directorate of Military Survey, War Office (Geographical Section, General Staff) (GSGS 3919) and Middle East Land Forces (IDR 9002, MDR 503); 1942-47; Iraq, Levant, and Caucasus Zone grids.

Several sheets of these series cover part of Turkey, including the Lake Van area, the Turkey-Iran and Turkey-Iraq borders, and part of the Turkey-Syria border. The parts of these sheets that cover Turkish areas were compiled from original Turkish 1:200,000 sources dated 1929-40, British 1:200,000 sheets dated 1941-42, and Russian 1:84,000 sheets dated 1916. The sheets of the two series are similar in style and source materials utilized, but the presentation of relief varies from sheet to sheet (contours or approximate contours at varying intervals). Selected

sheets from the two series have been reprinted by AMS. For additional details, see paragraphs 76-79.

b. *Town Plans.*

(1) *Native.*

- (a) The Iller Bankasi has produced over 140 plans, generally at the scale of 1:2,000. These plans are ozalids showing streets, important buildings, railroad installations, cultivated areas, and other features—usually identified. Many of the plans were prepared by private contractors, usually individual engineers. They depict proposed, as well as actual construction. Because the plans are monochrome, however, the distinction between proposed and existing features is not readily discernible. All work is reportedly based on ground surveys, and no aerial photography is used.

- (b) The Harta Genel Müdürlüğü produced (in 1944) a 1:8,000 polychrome plan of Ankara. Town sections, important public buildings, and main streets are named. Relief is shown by contours.

- (2) *Other.* During World War II, the Middle East Land Forces produced several plans of Turkish cities. These polychrome plans show built-up areas, streets, important buildings, and other features.

100. Coordinate Systems

a. *Native.* On early Turkish maps, geographic coordinates were given in grads and were referred to Istanbul. No grid was shown. Later, the Bonne grid was adopted for use on the series at scales of 1:25,000-1:200,000. Geographic coordinates, in degrees and grads, were still referred to Istanbul. Subsequently, with the adoption of the Gauss-Krüger projection and grid and, later, the Universal Transverse Mercator projection and grid, geographic coordinates were referred to Greenwich. Turkish maps at 1:500,000 and smaller scales vary in the use of degrees or grads and of Istanbul or Greenwich as the prime meridian. These series generally do not carry a grid (except that an atlas grid is shown on the 1:800,000 series); in some cases, both geographic coordinates and grid are lacking.

b. *Other.*

- (1) *British.* Geographic coordinate infor-

mation varies considerably from one British series to another. Several of the large-scale series show both degrees from Greenwich and grads from Istanbul. On the 1:100,000 series based on Greek sources, coordinates are expressed in degrees from Greenwich and Athens. The original GSGS sheets in the 1:200,000 series carry values in degrees from Greenwich only, whereas the MELF sheets refer (in degrees) to both Istanbul and Greenwich. Coordinates on the 1:800,000 series are expressed in degrees from Istanbul. Many of the British maps of Turkey use the British grid system. The specific grids utilized are the Mediterranean grid and the Caucasus, Iraq, and Levant Zone grids. The 1:800,000 series carries an atlas grid; several large-scale publications use an unidentified grid.

(2) *German*. On German maps of Turkey, geographic coordinates are expressed in

degrees and are referred to Greenwich, Istanbul, or Athens. Those on the 1:25,400 *Türkei* series are given in both degrees and grads from Istanbul. These maps carry a variety of grids, including the Bonne, the Greek Conical, and the Bulgarian Gauss-Krüger. In most instances, the Deutsches Heeresgitter (German Army grid) is shown also.

(3) *Greek*. No graticule is shown on the Greek 1:20,000 series; on the 1:100,000 series, longitude is expressed in degrees from Greenwich or Athens. The 1:20,000 series carries the Greek military grid; the 1:100,000 lacks a grid.

(4) *Russian*. On the Russian 1:42,000 and 1:84,000 series longitude is expressed in degrees from Ferro; only a few sheets carry a grid. On the 1:200,000 series, longitude is expressed in degrees from Greenwich; the Gauss-Krüger grid is shown.

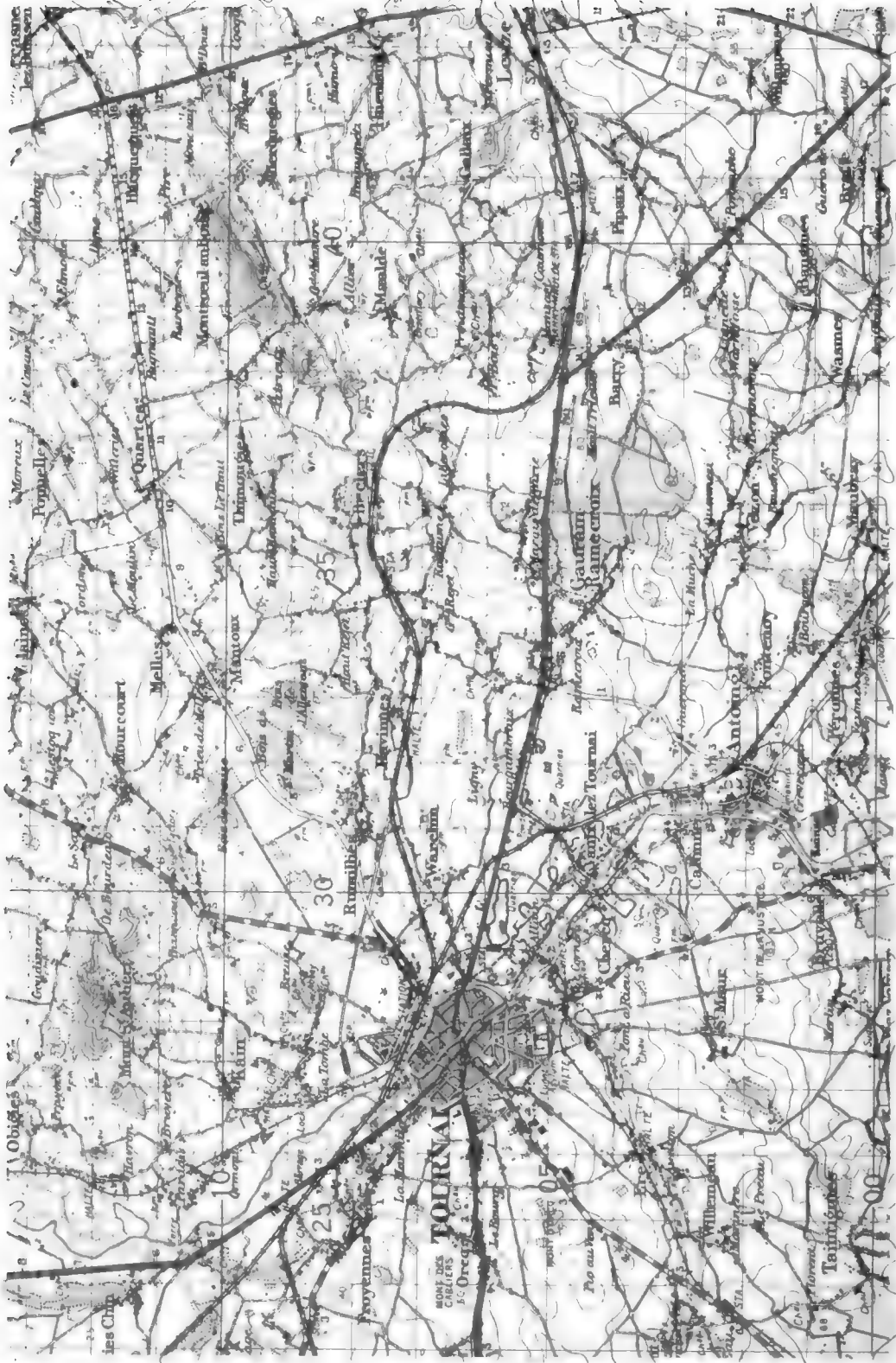

Figure 98. Section of sheet from the Belgium and N. E. France 1:100,000 series by the Directorate of Military Survey, War Office (Geographical Section, General Staff), reprinted by the Army Map Service as AMS M608.

CHAPTER 7

WESTERN EUROPE

Section I. BELGIUM

101. Mapping Activities

a. Native. The military mapping agency of Belgium is the Institut Géographique Militaire (IGM), formerly known as the Institut Cartographique Militaire (ICM). The agency has produced topographic series at scales of 1:10,000, 1:20,000, 1:40,000, 1:50,000, 1:100,000, 1:160,000, and 1:200,000 and part of a 1:25,000 series. The language used in map margins of most native series is French; place names are in French or Flemish. Private firms issue town plans.

b. Other.

(1) *British.*

(a) The Directorate of Military Survey, Survey, War Office (Geographical Section, General Staff)—GSGS—has produced topographic series with complete coverage of Belgium at scales of 1:25,000, 1:50,000, 1:100,000, 1:250,000, 1:380,000, 1:500,000, and 1:1,000,000.

(b) At 1:25,000, *France and Belgium* and *Germany* are polychrome series compiled by GSGS before World War II from native Belgian maps. They were revised in 1943–45 from aerial photographs and the UTM grid was added in 1951. About 90 percent of Belgium is covered by the *France and Belgium* series and about 5 percent of the area is covered by the *Germany* series. About 5 percent of Belgium, in the extreme northern portion, is not covered by either of the latest editions, although wartime editions cover this area.

(c) At 1:50,000, *France and Belgium* and *Germany* are polychrome series compiled by GSGS in 1937–38 from Belgian maps. They were revised in 1943–44 from aerial photography and

intelligence information, and the UTM grid was added in 1951. About 95 percent of Belgium is covered by the *France and Belgium* series, and the remainder of the area is covered by the *Germany* series.

(d) Several editions of the *Belgium and N. E. France* (fig. 98) and the *Germany* series, both at 1:100,000, have been produced by GSGS. They were compiled from GSGS maps that had been based on native Belgian sheets. They were revised in 1942–43 from aerial photography. In 1951 the UTM grid was added, and major communications data were revised on some sheets. About 95 percent of Belgium is covered by the *Belgium and N. E. France* series, and the remainder of the country is covered by the *Germany* series. Both are polychrome series, and the projection is the Lambert conical orthomorphic. Information shown is of the same type as that on the GSGS 1:50,000 series covering Belgium.

(e) Several polychrome editions of the *North West Europe* 1:250,000 series, which completely covers Belgium, have been published by GSGS. The series was compiled just before World War II from native Belgian 1:100,000 sheets, and was revised in 1943 from aerial photography. The grid is the Nord de Guerre.

(f) Several editions of the *Europe* 1:1,000,000 sheets of the *International Map of the World* series also have been published by GSGS. This polychrome series was compiled from larger-scale GSGS maps that had been compiled

from Belgian maps; it was revised in 1944.

- (g) GSGS has reprinted many Belgian town plans, and also has made a number of compilations. Both the reprints and the compilations were published during World War II, and range from greatly detailed polychrome sheets of important cities to monochrome sketches of lesser towns. Most plans carry the Nord de Guerre grid; a few carry a reference grid, and the remainder have no grid.
- (2) *German.* The Generalstab des Heeres (General Staff of the Army) has produced topographic series with complete coverage of Belgium at scales of 1:20,000, 1:25,000, 1:50,000, 1:100,000, 1:300,000, 1:500,000, and 1:1,000,000. During the early part of World War II, this agency reproduced Belgian topographic maps at all scales, using captured plates and adding marginal information and the Orange Report Net grid. The Bonne grid appearing on the native sheets was renumbered, and revisions were made. Early editions were monochrome, and some later editions polychrome. No post-World War II topographic maps have been produced by German agencies. The Generalstab des Heeres copied, in World War II, native Belgian town plans in monochrome and added overprint data in color. This consisted of through-way information and usually the identification of buildings of military use. The plans were not revised except for the addition of this overprint material.
- (3) *French.* The Institut Géographique National—IGN (National Geographic Institute)—has produced a 1:200,000 polychrome series with complete coverage of Belgium. In 1951, it was partially revised, the UTM grid was added, and the marginal data made bilingual (French and English). In addition, the Service Géographique des Forces Françaises en Allemagne—SGFFA (Geographic Service of the French Forces in Germany)—has compiled the monochrome *Allemagne*

1:25,000 series from 1:25,000 German maps dated 1937–38. Three sheets cover a small part of eastern Belgium. The sheets were printed in 1951 with the UTM grid. Marginal information appears in both French and English.

- (4) *United States.* Although the Army Map Service has not produced any original topographic series, it has reprinted most of the GSGS maps and, in addition, has issued schematic town plans of the major cities. The town plans, published in two colors in 1950–51, show military, industrial, and residential areas. The scales, which range from 1:30,000 to 1:50,000, are small for town plans. During World War II, several of the lesser town were mapped by U. S. Army topographic field units. These monochrome plans were usually compiled from Belgian maps.

102. Major Native Maps of Belgium

a. Topographic Series.

- (1) *Carte Topographique de Belgique* (Topographic Map of Belgium); 1:20,000; Institut Géographique Militaire; 1905–49; no grid.

This series (fig. 99) provides complete coverage of Belgium. The earliest sheets (published at the beginning of this century) are monochrome, and several post-World War II sheets have been issued in monochrome with corrections and additions overprinted in purple. The polychrome sheets are in four colors. The series is drawn on the Bonne projection, and the military edition carries the Lambert North Zone grid. The surveys and the subsequent revisions were made in the period between 1905 and 1949. Revisions made after World War II are of a minor nature and are limited to a few sheets. Relief is shown by contours and spot elevations. The contour interval for sheets covering areas west of the Meuse River is 1 meter, and for those east of the Meuse it is 5 meters. Roads are classified by surface, and railroads by gage and number of tracks. Vegetation is symbolized in great detail.

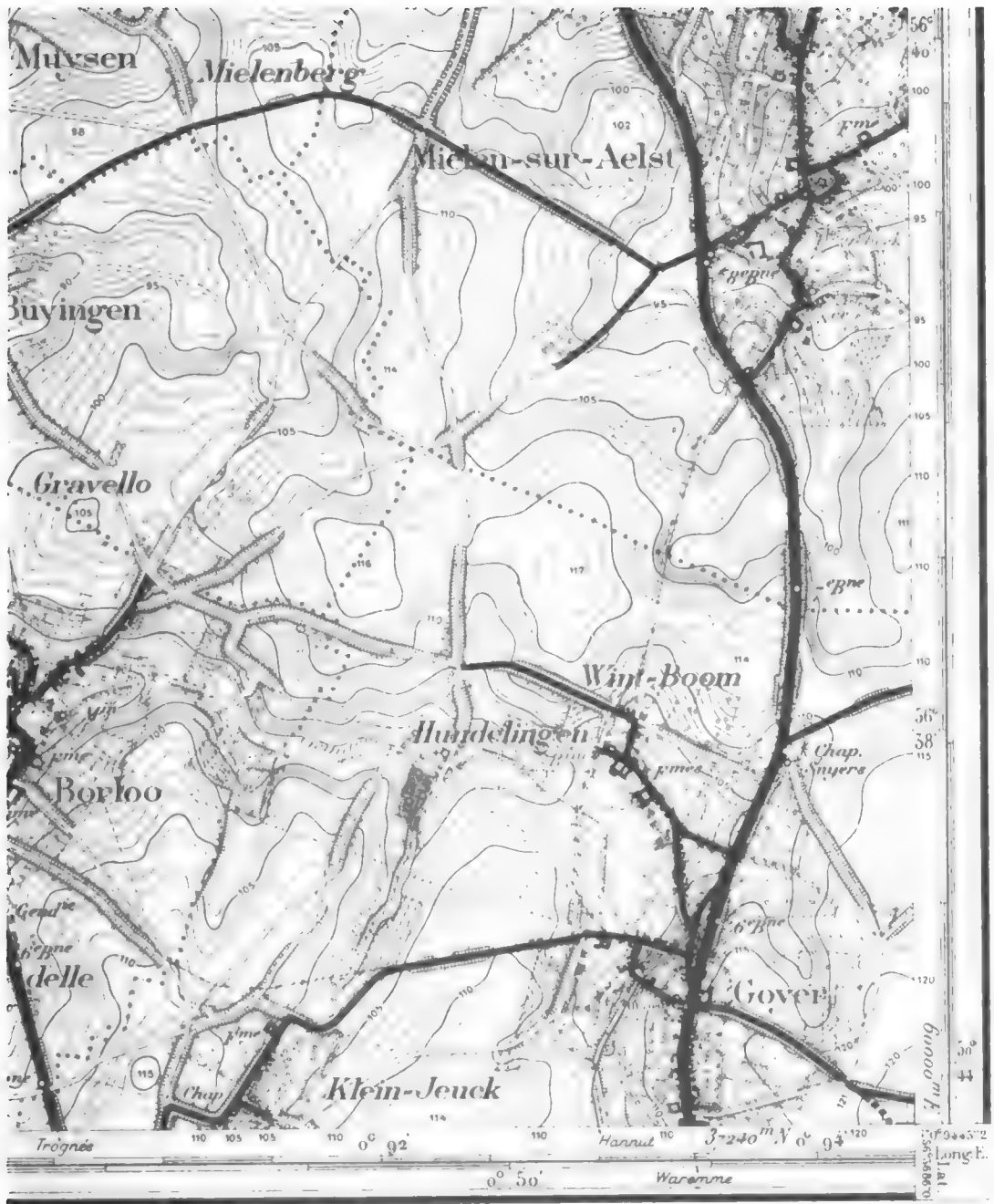

Imp. litho de l'Institut Cartographique Militaire 1938.

Figure 99. Section of sheet from the 1:20,000 *Carte Topographique de Belgique* by the Institut, Géographique Militaire.

Five administrative boundary symbols are shown. There is no legend, and the series title does not appear on any of the sheets.

(2) *Carte Topographique de Belgique* (Topographic Map of Belgium); 1:40,000;

Institut Géographique Militaire; 1861–1951; no grid.

This polychrome series, based on results of a survey of 1861–63, completely covers Belgium. It was drawn on the Bonne projection and has no grid. Re-

lief is shown by contours at intervals of 5 meters and by spot elevations. Eight types of vegetation are shown. Roads are classified by surface, and railroads by gage and number of tracks. Five administrative symbols are shown. There is no legend.

- (3) *Carte Topographique de Belgique* (Topographic Map of Belgium); 1:50,000; Institut Géographique Militaire; 1951; no grid.

This series was produced by photo reduction of the 1:40,000 sheets, without change of information shown.

- (4) *La Nouvelle Carte de Belgique au 50,000^e, Type Rapide* (The New Map of Belgium at 1:50,000, Type R [Rapid]); Institut Géographique Militaire; 1952-; no grid on civilian edition.

Available sheets in the civilian edition of this new series cover parts of northwestern and central Belgium. Marginal information appears in French, Flemish, and English. Sixteen sheets of this series were compiled from Belgian 1:40,000 series, with revisions from 1947-52 aerial photographs and a 1952-53 field check. Five sheets were compiled by photogrammetric methods from 1947-52 photographs, with revisions from a 1952-53 field check. The series is drawn on the Bonne projection. Relief is shown by contours, dune symbols, and spot heights. The contour interval is 10 meters. Hydrography is shown in considerable detail, with emphasis on canals, which are classified by width. Roads are classified by width and importance; railroads by motive power and number of tracks. Three administrative boundaries are shown. Other cultural features are shown in detail, and vegetation is classified.

- (5) *Carte de Belgique au 100,000^e* (Map of Belgium at 1:100,000); Institut Géographique Militaire; 1906-52; Universal Transverse Mercator grid on 1951 edition only.

Several 1:100,000 series have been published by the Belgians. Each of the early series contains 28 sheets, but these have been superseded by a series of 10

sheets that completely cover the country. Several editions of this series have been published. The sheet-line system of the 1:100,000 series does not coincide with that of the larger scale Belgian series. This polychrome series in eight colors is drawn on the Bonne projection. The only edition that shows a grid was printed in 1951; it carries the UTM grid, and marginal information appears in French, English, and Flemish. The series was based on a survey of 1906-12 and has been revised to 1952. Relief is shown by contours at 10-meter intervals and by spot elevations; hachures are used to show local relief. Roads are classified according to surface, and railroads according to gage and number of tracks. Three administrative symbols are shown. The legend is comprehensive.

b. Town Plans. The only native Belgian town plans are those prepared by commercial firms and by agencies of various towns for commercial or cadastral purposes. R. de Rouck of Brussels is the only commercial firm that has made important postwar contributions to town-plan coverage. All of the larger towns and several of the lesser towns have been mapped commercially. Cadastral plans are probably available for every town in Belgium. The locally compiled plans are usually monochrome, but plans compiled by national commercial firms are polychrome. The projections are either not known or were specifically designed for town plans. Grids are only of the reference type. Most of the plans were compiled after World War II, and the latest were issued in 1951-53. Usually no relief is shown. On about half of the plans, through routes are indicated, and on most plans both tramlines and buslines are shown. Vegetation is indicated. Usually the legend is either very brief or is nonexistent, but a detailed glossary appears on most sheets.

103. Coordinate Systems

a. Geographic. The geographic coordinates on native series are expressed in degrees and grads and are referred to Bruxelles (Brussels). GSGS and AMS maps show coordinates in degrees referred to Greenwich. In contrast, the French IGN 1:200,000 series shows coordinates in grads referred to Paris. German series that are re-

prints of native series show the same information as the source sheets. The coordinates are shown by ticks in the margins, and corner values are given. Small-scale sheets show coordinates by full lines. The only town plans that show coordinates are those by GSGS and AMS.

b. Grid.

- (1) *Native.* The only Belgian series that shows a grid is the 1:100,000 series, which has the UTM grid shown by full lines.
- (2) *Other.* British GSGS sheets have the Nord de Guerre grid shown by full lines.

The latest editions of series at 1:25,000, 1:50,000, 1:100,000, and 1:250,000 have the UTM grid shown by full lines, and the Nord de Guerre grid shown by ticks in the margin. British town plans have the Nord de Guerre or a reference grid shown by full lines. German series have the Belgian Bonne grid and/or the Orange Report Net grid shown by full lines. Town plans use a reference grid. French IGN 1:200,000 sheets show the UTM grid by full lines. AMS town plans have no grid.

Section II. THE BRITISH ISLES

104. Mapping Activities

a. Native.

- (1) Until 1922, Ordnance Survey was the civil mapping agency of the British Isles (England, Wales, Scotland, Ireland, and the littoral islands). In 1922, Northern Ireland and Ireland assumed responsibility for the mapping of their respective areas, and organized their own Ordnance Surveys. The three Ordnance Survey offices have produced maps as standard scales of 1:1,250, 1:2,500, 1:10,560, 1:63,360, 1:126,720, and 1:253,440. Since World War II a 1:25,000 map has been begun for Great Britain as a result of the recommendations of a special committee appointed to investigate British mapping. These series are often referred to by scale in terms of the number of inches on the map that represent a mile on the ground. For example, the *Six-Inch Map* is at the scale of six inches to the mile, or 1:10,560; the *Two-and-a-Half-Inch Map*, at 1:25,000; the *One-Inch-to-the-Mile Map*, at 1:63,360; the half-inch, at 1:126,720; and the quarter-inch, at 1:253,440. The Ordnance Survey has compiled a 1:1,000,000 physical map that has the new National grid.
- (2) The Directorate of Military Survey (Geographical Section, General Staff—GSGS), is the agency responsible for supplying military topographic maps for the War Office and for providing air charts for the Royal Air Force. Maps

produced by the Directorate are generally derived from map sources, and those for the British Isles are Ordnance Survey maps published by the GSGS.

- (3) Some maps—two-and-a-half-inch, one-inch, quarter-inch, and a few miscellaneous maps—produced by the Ordnance Survey of Great Britain are published as War Office maps also, and each series is then assigned a GSGS series number. One-inch and quarter-inch maps of Ireland, originally produced by the Ordnance Surveys of Ireland and Northern Ireland, are recompiled and published by the War Office also, with GSGS series numbers.
- (4) Production of maps for the British Commonwealth of Nations, exclusive of the British Isles, is the responsibility of the Directorate of Colonial Surveys.

b. Other. Maps of the British Isles published by the Germans in World War II are either reductions or enlargements of native sheets; they have no present value.

105. Major Native Maps of the British Isles

a. Topographic Series.

- (1) *Six-Inch Map*; 1:10,560; Ordnance Survey; 1900– ; National grid on sheets printed since 1938, no grid on earlier sheets.

There are four six-inch (1:10,560) series for Great Britain. The old series on county sheet lines completely covers the British Isles in 15,000 sheets; they were derived from ground sur-

veys. A Provisional series on county sheet lines was begun in 1938 and was continued through 1953, when the program was terminated. A total of 6,950 sheets were published to replace earlier sheets, and of these Provisional sheets, 830 were revised a second time. Two hundred sheets of a Provisional Edition on National grid sheet lines (fig. 100) have been published. These were based on the two earlier series, which they replaced; they cover London and parts of Northumberland, Yorkshire, Durham, and Cheshire. Only eighteen sheets of the Regular Edition, which is based on new survey data, have been published. They cover part of Devonshire. Ireland is completely covered by six-inch maps, some of which have been revised since World War II; these are for densely populated areas. The sheets of these series are in black and white with red contours, instrumentally determined at 50 and 100 feet, thence at 100-foot intervals up to 1,000 feet, and thereafter at 250-foot intervals; interpolated contours at 25-foot intervals are shown on some sheets. A few maps of northern Scotland are not contoured. Altitude values are related to the Liverpool datum on some sheets and to the Newlyn datum on others.

- (2) *Channel Islands (Sark, Herm, and Jethon)*; 1:10,560; War Office; GSGS 4377; 1943; French Lambert Zone grid.

This polychrome sheet was stereocompiled (from aerial photography), drawn, and reproduced by the Home Forces. Detail below high-water mark was taken from Admiralty Charts. Relief is shown by form lines, supplemented by spot heights with values in meters. A diagram in the margin shows the incidence of grid letters.

- (3) *Alderney*; 1:10,560; War Office; GSGS 2558; Third Edition; 1943; French Lambert Zone grid.

This polychrome sheet provides complete coverage for the island. It was drawn and reproduced by the Home Forces from a 1:10,560 Ordnance Sur-

vey map, dated 1911. Aerial photography was used in revising the map. Relief is shown by contours at 10-foot intervals, supplemented by spot heights with values in feet above mean sea level. Geographic coordinates, spaced at one-minute intervals, are indicated along the neatline.

- (4) *Ordnance Survey Map of Guernsey and Ordnance Survey Map of Jersey*; 1:31,680 and 1:21,120, respectively; War Office; GSGS 4205; First Edition; 1942; French Lambert Zone grid.

These two polychrome maps provide complete coverage for Jersey and Guernsey. They were developed from early six-inch surveys and were revised in 1933 by the Ordnance Survey. Relief is indicated by contours at 25-foot intervals, supplemented by cliff symbols and spot heights with values in feet above sea level at St. Peter Port. Extensive areas of sand and reefs are shown along the coast. Geographic coordinates are shown at one-minute intervals. Marginal data consist of a short legend and various explanatory notes pertaining to the datum, survey, map sources, grid, etc.

- (5) *Two-and-a-Half-Inch Map*; 1:25,000; Ordnance Survey Office or War Office; Provisional Edition; 1947-; National grid.

These maps, in four colors, are based on six-inch maps, and some have recent revision material incorporated. The present coverage (about 1960 sheets) extends over practically all of England and most of Wales and southern and eastern Scotland. Relief is shown by contours at 25-foot intervals, supported by spot heights with values in feet above mean sea level at Newlyn, Cornwall. Bench marks and trigonometric stations are shown without elevations; lists of these, properly referenced, may be obtained from the publisher. The maps are drawn according to National grid sheet lines, and National grid lines appear at one-kilometer intervals. Scales of miles, furlongs, yards, and feet are indicated



SIX INCHES TO ONE MILE. Provisional Edition, with National Grid.

Figure 100. Section of sheet from Six-Inch Map (1:10,560) by the Ordnance Survey.

along the border. Late sheets do not carry much marginal information; conventional symbol sheets for the series may be secured from the Ordnance Survey.

(6) War Office Edition, Ordnance Survey [Map] of Scotland; 1:63,360; War Of-

fice, GSGS 4639; 1947-50; National Grid, Military System.

Ninety-one overlapping sheets provide complete coverage for Scotland, including nearby islands. These poly-chrome sheets were derived from earlier editions of maps at the same

scale. They are based on a fairly accurate survey. The sheets carry the National Grid, Military System, but, unlike the one-inch maps for England and Wales, they are not drawn according to the sheet lines of the new grid. Geographic coordinates are indicated at 5-minute intervals. Instrumentally determined contours are shown at 50 and 100 feet, thence at 100-foot intervals up to 1,000 feet, and thereafter at 250-foot intervals. Numerous spot heights and trigonometric stations with altitudes in feet above mean sea level are shown. Besides a legend of approximately fifty items, various notes of warning and explanation are carried in the margin.

- (7) *Ordnance Survey [Map] of Great Britain: England and Wales*; 1: 63,360; War Office; GSGS 4620; New Popular Edition, New Popular (Provisional) Edition, and Seventh Series; 1947-; National grid.

Originally, the one-inch maps of Great Britain were developed from surveys at the same and larger scales. The Fifth Edition, which served as a base for the New Popular Edition (fig. 101), was produced from new survey material available for southern England. Sheets of the New Popular (Provisional) Edition were derived from the Fourth Edition, and they cover central and northern England. Thirty-seven sheets of a completely redrawn edition, the Seventh Series, have been completed. They were compiled from revised 1:25,000 Provisional maps for the British Isles, exclusive of Ireland and the Channel Islands. These polychrome maps carry the National grid, which was used in determining their sheet lines. Geographic coordinates are indicated at 5-minute intervals. The wide space between the neat and margin lines is utilized for magnetic declination diagrams, grid numbers, geographic grid coordinates, road destinations, and, on the definitive edition, county names. An abundance of marginal information, including a leg-

end of approximately fifty items, notes of warning and explanation, and diagrams showing the incidence and use of the grid, etc., is shown.

- (8) [*Northern Ireland*]; 1: 63,360; Ordnance Survey of Northern Ireland; One-Inch Popular Edition; 1939-; Irish (Red) grid.

These maps, which supply complete coverage for Northern Ireland, were based on six-inch maps, and were revised in 1936-51. They are printed in five colors and eight altitude tints. Contours are shown as dotted lines at 100-foot intervals, supported by spot heights and trigonometric stations with elevation values in feet, computed from low water of spring tide in Dublin Bay. Marginal data include a legend of approximately 30 items; indexes to sheets of the old and new series; representative fraction; bar scales in miles, yards, and kilometers; and notes of explanation and warning. Geographic coordinates are shown at 5-minute intervals.

- (9) [*Ireland*]; 1: 63,360; Ordnance Survey of Ireland; 1900-49; atlas grid.

These sheets, which are in six colors, provide complete coverage for the whole island. They were based on six-inch survey data and were drawn on the Cassini projection. Of the 170 sheets only 21, covering scattered areas, have been brought up to date. Relief is shown by a poor grade of hachuring. Representation of most of the data on the sheets is subordinated to that for roads. Marginal data consist of a legend of approximately 23 items; an index to sheets, magnetic declination and coverage diagrams, representative fraction and bar scales, and credit and explanatory notes.

- (10) *Ireland [One-Inch-to-the-Mile Large-Sheet Series]*; 1: 63,360; War Office; GSGS 4136; Second and Third Editions; 1941-42; Irish (Red) grid.

These sheets were compiled by the War Office, probably from Ordnance Survey sheets, which were developed from six-inch surveys. Relief on sheets of the



Figure 101. Section of sheet from *New Popular Edition of One-Inch (1:63,360) Maps of England and Wales by the War Office.*

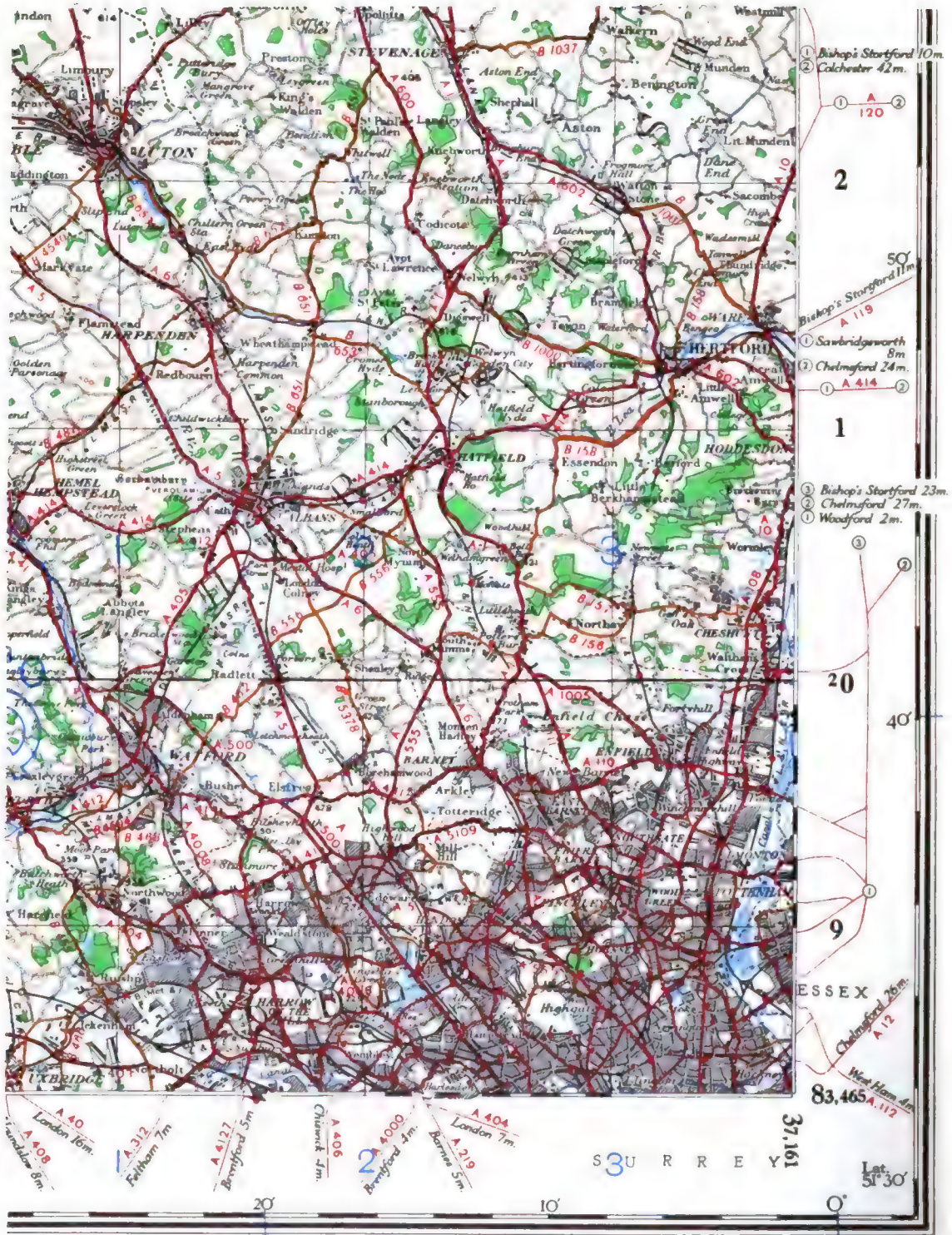

Figure 102. Section of sheet from England and Wales 1:253,440 series by the Directorate of Military Survey, War Office (Geographical Section, General Staff), reprinted by the Army Map Service as AMS M521 (GSGS 4628).

Third Edition is represented by contour lines drawn at 50 and 100 feet, then at 100-foot intervals up to 1,000 feet, and thereafter at 125-foot intervals; other contours are interpolated. On sheets of the Second Edition, contours appear as dotted lines at 100-foot intervals. Numerous spot heights and trigonometric stations with altitude values, computed in feet above low water of spring tide in Dublin Bay, are shown. The neat line shows one-minute intervals, and geographic coordinates are indicated at 5-minute intervals. Marginal data include a legend of approximately 18 items, a diagram and instructions for using the grid, representative fraction and bar scales, and various notes of explanation and warning.

- (11) [*Ireland*]; 1: 126,720; Ordnance Survey of Ireland [and predecessor]; 1914-45; atlas grid.

These 25 sheets provide complete coverage for the island. They are in five colors. Relief is represented by contours at intervals of 100 feet and by hill shading; numerous trigonometric stations are shown with elevations values in feet above low water of spring tide in Dublin Bay. Road information is predominant. The neat lines show one-minute intervals, and geographic coordinates are indicated at 5-minute intervals. Marginal data include a legend of approximately twenty items; indexes to the one-inch and half-inch sheets; scales; and credit, warning, and explanatory notes. In 1940 the British War Office substituted the military (Irish) grid for the atlas grid on the sheets and published them as GSGS series 4127.

- (12) *War Office Edition, Ordnance Survey [Map] of Great Britain: England and Wales* and *War Office Edition, Ordnance Survey [Map] of Scotland*; 1: 253,440; Directorate of Military Survey (Geographical Section, General Staff); GSGS 4628 and 4650; 1948-; National Grid, Military System.

Nineteen sheets (fig. 102), some over-

lapping, provide complete coverage for the British Isles with the exception of Ireland and the Channel Islands. The border sheet is common to both the *Scotland* and the *England and Wales* series; there is no sheet 5 in the latter series. They are all reprints of Ordnance Survey maps. Terrain is depicted by contour lines at intervals of 200 feet, by spot heights with values in feet above mean sea level, by altitude tints, and by the graphic representation of such features as rocks, cliffs, marshes, and sand. The maps are drawn on the Transverse Mercator projection, and the National grid is overprinted; the inner margin line is marked off in one-minute divisions, and geographic coordinates are given at 5-minute intervals. Marginal information includes a legend of 20-30 items; a scale of altitude tints; an index to adjoining sheets; credit, warning and explanatory notes; declination diagrams, etc.

- (13) *Ireland [Large-Sheet Series]*; 1: 253,440; War Office; GSGS 4338; 1942; Irish (Red) grid.

Seven polychrome sheets provide complete coverage for the whole island. They were compiled in 1942 by the War Office from maps of the GSGS 4136 series. Sheet sizes and format were changed, and the Irish (Red) grid, as well as contours at various intervals, were added. The drainage pattern is detailed for the scale. International and county boundaries are shown. The boundary between Northern and Southern Ireland as shown on the map is not authoritative. In the lower margin are notes of explanation and warning, diagrams to illustrate the use of the grid, a legend of ten items, an index to the quarter-inch and one-inch maps, credit notes, etc. The neat line shows one-minute intervals and geographic coordinates are given ten minutes apart. Cultural information is not up to date. In 1950 the Army Map Service reprinted the sheets without the gradient tints and isogonic data.

NORTHERN IRELAND GRID.

A grid similar to that now appearing on the maps of Great Britain will appear on the margins of the new editions of the small scale maps of Northern Ireland. Later the same grid will also appear on the larger scale maps. The Origin of the Grid will be a point 200 kilometres west and 250 kilometres south of the intersection of the meridian of 8° West Longitude with the parallel of 53° - 30' North Latitude.

The position of any point can be referred to this Origin by measurements from the nearest grid line to the west of the point and the nearest grid line to the south of the point. For example, on a gridded one-inch map, Binevenagh, a hill point to the S.S.E. of Magilligan Point in Co. Londonderry lies 0.2 km. to the east of Grid Line 269 km. E. and 0.1 km. to the north of Grid Line 430 km. N. Its position is therefore 2692/4301.

On larger Scale maps where more precise values are required for certain purposes, additional decimal places of a kilometre are used. For example, if we had a gridded map of the same area on a scale of 1:2500 with grid lines 100 metres apart, the position of Binevenagh would have a value to the nearest metre of 269181/430135.

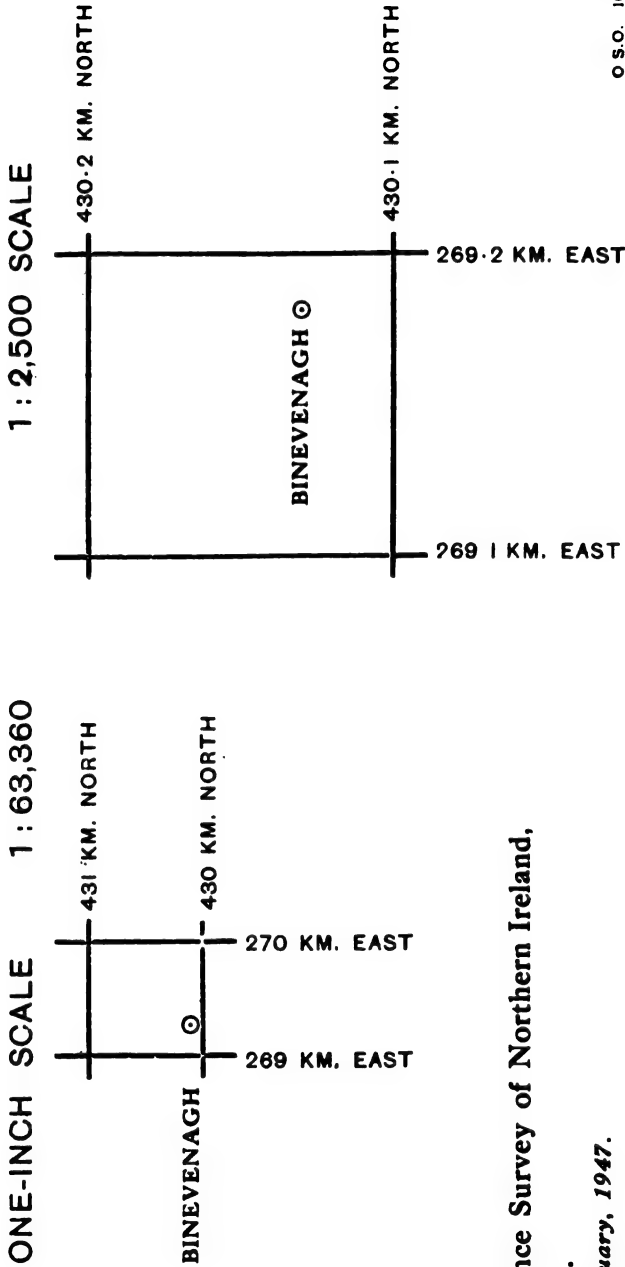

Ordnance Survey of Northern Ireland,
Belfast.

1st January, 1947.

Figure 105. Diagram of grid now appearing on maps of Northern Ireland.

- (14) [*Ireland*]; 1:253,440; Ordnance Survey of Ireland; 1903-50; atlas grid.

The 16 polychrome sheets in this series cover the whole island. The sheets were developed from one-inch maps. Eleven of the sheets were partially revised from 1944 through 1950. Relief is shown by hill shading and by numerous spot heights and elevations at trigonometric stations with values in feet above low water of spring tides in Dublin Bay. Road information is predominant. Marginal information consists of a legend of seven items, scales, credit notes, and indexes to the one-inch and quarter-inch maps. The neat lines show one-minute spaces, and geographic coordinate values are given 10 minutes apart.

- (15) *Europe RAF 1:500,000*; War Office; GSGS 4072; Third Edition for Ireland, 1943; First Edition for Great Britain, 1951 (isogonic information, 1953); Irish (Red), UTM, National, and Georef (geographic reference) grids.

These sheets cover Great Britain, Ireland, and part of the Continent. They are in four colors, exclusive of the altitude tints. The sheets were compiled, drawn, revised, and reproduced by Ordnance Survey. Air information was supplied by the Ministry of Defense. Contours are shown at various intervals. Main arteries of communication are emphasized, and extensive information of value to aviators is included; other information is current but sparse. Radio information and danger areas are not shown on the maps. The two sheets covering Ireland are out of date.

- (16) *Europe 1:1,000,000*; War Office; GSGS 2758; 1943-50; no military grid.

Seven sheets of this series are required to cover the British Isles; these vary in format, colors, and method used in presenting data. They were compiled from Ordnance Survey quarter-inch maps and British Admiralty charts. Relief is shown by contours at 100- and 200-meter heights and thence at 200-meter intervals. Some of the sheets have altitude tints. All elevations are given in meters. Main arteries of communication are emphasized. Marginal data include a legend of approximately twenty items, an index to adjoining sheets, an index to county boundaries on some sheets, a glossary of abbreviations on a few sheets, notes of explanation, etc. Projection lines are at one-degree intervals.

b. Town Plans. Except for cities of the Channel Islands, the six-inch (1:10,560) series provides complete town-plan coverage for the British Isles. Most of these are out of date. A number of private concerns publish current town plans, the best of them being those put out by John Bartholomew and Son, Ltd., "Geographia" Ltd. and Edward Stanford, Ltd.

106. Coordinate Systems

a. Geographic. Geographic coordinates are given in degrees referred to Greenwich.

b. Grid. Recent Ordnance Survey and War Office maps carry the National grid. Most old War Office sheets carry the English (Purple) and Irish (Red) (fig. 103) grids; the War Office maps of the Channel Islands carry the French Lambert Zone grid. No grid is shown on the War Office *Europe 1:1,000,000* series.

Section III. FRANCE

107. Mapping Activities

a. Native. French military maps are issued by the Institut Géographique National—IGN (National Geographic Institute)—a civilian agency attached to the Ministère des Travaux Publics et des Transports (Ministry of Public Works and Transportation). In 1940 the IGN took over

from the Service Géographique de l'Armée—SGA (Geographic Service of the Army)—the duty of supplying the French General Staff with maps for planning and operations. Incomplete topographic series at scales of 1:10,000, 1:20,000, and 1:50,000 have been compiled from planetable surveys or from aerial photography by stereophoto-

grammetric methods. The same data have been used to revise sheets of the 1:80,000, 1:200,000, and 1:1,000,000 series, which completely cover France. Many town plans, generally based on local surveys, and revised from photography, have been published under the direction of the Ministère de la Reconstruction et l'Urbanisme (Ministry of Reconstruction and City Planning).

b. Other.

(1) *German.* Before and during World War II, the Germans issued topographic series at 1:25,000 and 1:300,000 for parts of France, and at 1:50,000, 1:80,000, and 1:200,000 for all of France. The first German 1:25,000 series, an emergency edition, was made in 1939-42 by reducing or enlarging French sheets at scales of 1:20,000-1:80,000. This series, covering about a third of France, was replaced in 1943-44 by another German 1:25,000 series, on different sheet lines. Most sheets were based on the same French maps but revised to varying degrees from German photography. Sheets covering two narrow strips on the northern and southern parts of the French coast were based on German ground surveys, with contours added and with road revisions from Michelin road maps. This series was published by the Kriegskarten-und Vermessungsamt, Paris (Office of Military Mapping and Survey, Paris). All other German topographic series for France were issued by the Generalstab des Heeres (General Staff of the Army). The two French 1:50,000 series and the 1:80,000 and 1:200,000 series were reproduced in the 1930's and 1940's at their original scales, with German translations of marginal information. The northeastern and central parts of France were covered also by the German 1:300,000 strategic map of central Europe, on which communications and relief were emphasized. Numerous French town plans were reprinted, with the addition of German legends and information of military significance.

(2) *British and United States.* In 1935, the British War Office (GSGS) started the mapping of France. During World War II, this work was shared with various

U. S. agencies (U. S. Geological Survey, TVA, AMS). This collaboration produced series at 1:25,000, 1:50,000, 1:100,000, and 1:250,000. Several combined 1:25,000 series cover 50 to 55 percent of France. They were made either by reduction of the French 1:20,000 maps, or by compilation from air photography, mostly by stereophotogrammetric methods. Three combined 1:50,000 series cover nearly all of France. Some of the sheets were copied from the French 1:50,000 monochrome map and have no contours; a grid, an overlay showing a road classification, and a legend translation were added. The other sheets, which have contours, either were prepared from the compilation manuscripts used for the 1:25,000 series or were based on French maps and revised from aerial photography. Two combined polychrome 1:100,000 series together cover all of France (excluding Corsica). About 10 percent of the mapped area was revised from aerial photographs; the balance was compiled from large-scale French maps. On all three of these series, the roads were classified from 1:200,000 Michelin road maps. A 1:250,000 series, together with sheets of series for adjacent countries, covers all of France. The sheets were compiled from various map sources and reconnaissance and survey photographs.

108. Major Native Maps of France

a. Topographic Series.

(1) *Carte au 10.000.* (1:10,000 Map); Institut Géographique National; 1907-51; French Lambert Zone grid.

This series was produced originally by SGA from surveys begun in 1840. The later sheets were made by IGN. About half of the sheets are based on a recent survey. The series covers only about 8 percent of France: the northeastern part, the area around Paris, and other scattered localities. The sheets are monochrome except those for the area around Paris. Relief is shown by contours at 5-meter intervals and by numerous elevation points. Vegetation,

hedges, fences, walls, and cuts and fills are shown in great detail. Roads are classified by importance and by regularity of maintenance. Railroad information includes number of tracks, gage, sidings, and stations.

- (2) *Carte au 20.000^e*. (1:20,000 Map); Institut Géographique National; 1915- ; French Lambert Zone grid.

The published sheets of this series (fig. 104) cover about one-fourth of France; the northern and eastern parts, the Rhone Valley, and some scattered points near the Pyrenees. Some sheets are monochrome, but most are polychrome. Relief is shown by contours at 5- or 10-meter intervals and by spot elevations. Vegetation, communications, and boundaries are shown. About 60 percent of the sheets were based on the new French triangulation and compiled at a recent date; half of these were compiled by stereophotogrammetric methods or revised from aerial photography.

- (3) *Carte de France au 50.000^e*. (1:50,000 Map of France); *Service Géographique de l'Armée and Institut Géographique National*; 1900- ; French Lambert Zone grid.

This polychrome series (fig. 105) covers the same areas as the 1:20,000 map—about one-fourth of France. Relief is shown by contours at intervals of 5, 10, or 20 meters, and by shading and spot elevations. Drainage, boundaries, built-up areas, rocks, and various types of vegetation are shown. Railroads are classified by gage and number of tracks. Road classifications vary somewhat; the recent editions show classification by administrative authority, importance, trafficability, and regularity of maintenance. All of this series has been reprinted by the Army Map Service as AMS M761 (fig. 106), with the addition of English marginal data and the UTM grid.

- (4) *Carte de France au 50.000^e. en noir* (Monochrome 1:50,000 Map of France); Institut Géographique National 1840- ;

French Lambert Zone grid, if any; UTM grid on late reprints.

Sheets of this series were enlarged from the 1:80,000 hachured *Carte d'Etat-Major au 80.000^e*. (1:80,000 General Staff Map). Most of the sheets for areas not covered by the polychrome 1:50,000 series have been revised. Furthermore, all sheets of this series have been reissued in an emergency military edition since 1952 by IGN, AMS, and GSGS. This edition consists of two types of sheets. On sheets of the "M Bis Type," covering most of the southern half of France, the only additions are the UTM grid (in purple) and marginal translations in English. Sheets of the "M Type," covering northeastern France, include also a (red) road classification overprint, indicating importance and trafficability; 20-meter approximate contours (shown in brown); and a green overprint for wooded areas, as determined from aerial photography.

- (5) *Carte d'Etat-Major au 80.000^e*. (1:80,000 General Staff Map); Institut Géographique National; 1818- ; no grid.

This monochrome series (fig. 107) covers all of France. In the areas not covered by the new 1:50,000 polychrome series, some sheets of this series have been recently revised. They are based on the old French triangulation and survey, and sheet lines conform to the Bonne projection. Relief is shown by hachures and spot elevations. All cultural features are symbolized.

- (6) *Carte de France et des Frontières* (Map of France and Adjacent Areas); 1:200,000; Institut Géographique National; 1911- ; French Lambert Zone grid or Universal Transverse Mercator grid.

This polychrome series covers all of France and Belgium and parts of the Netherlands, Germany, Switzerland, Italy, and Spain. The earliest editions were based on the old 1:80,000 series, and the later ones on the French 1:20,000 series (where coverage existed) or on other large-scale maps.

NIMES N°4

Carte Géographique Nationale

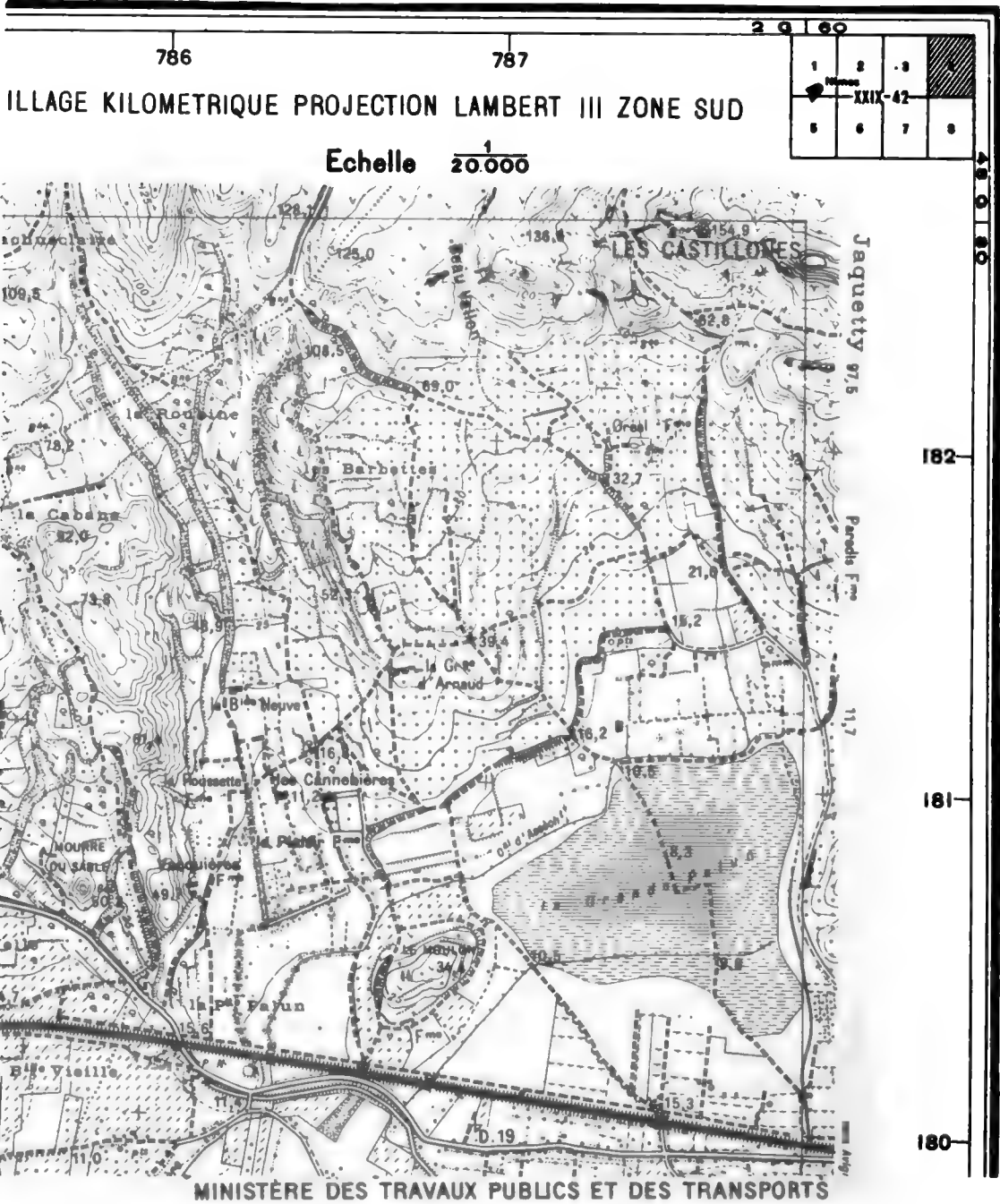

INSTITUT GÉOGRAPHIQUE NATIONAL — 126^{bis} Rue de Grenelle - Paris (VII^e)

Figure 104. Section of sheet from the Carte au 20.000^e by the Institut Géographique National.

CARTE DE FRANCE AU 50.000^e (Type 1922)

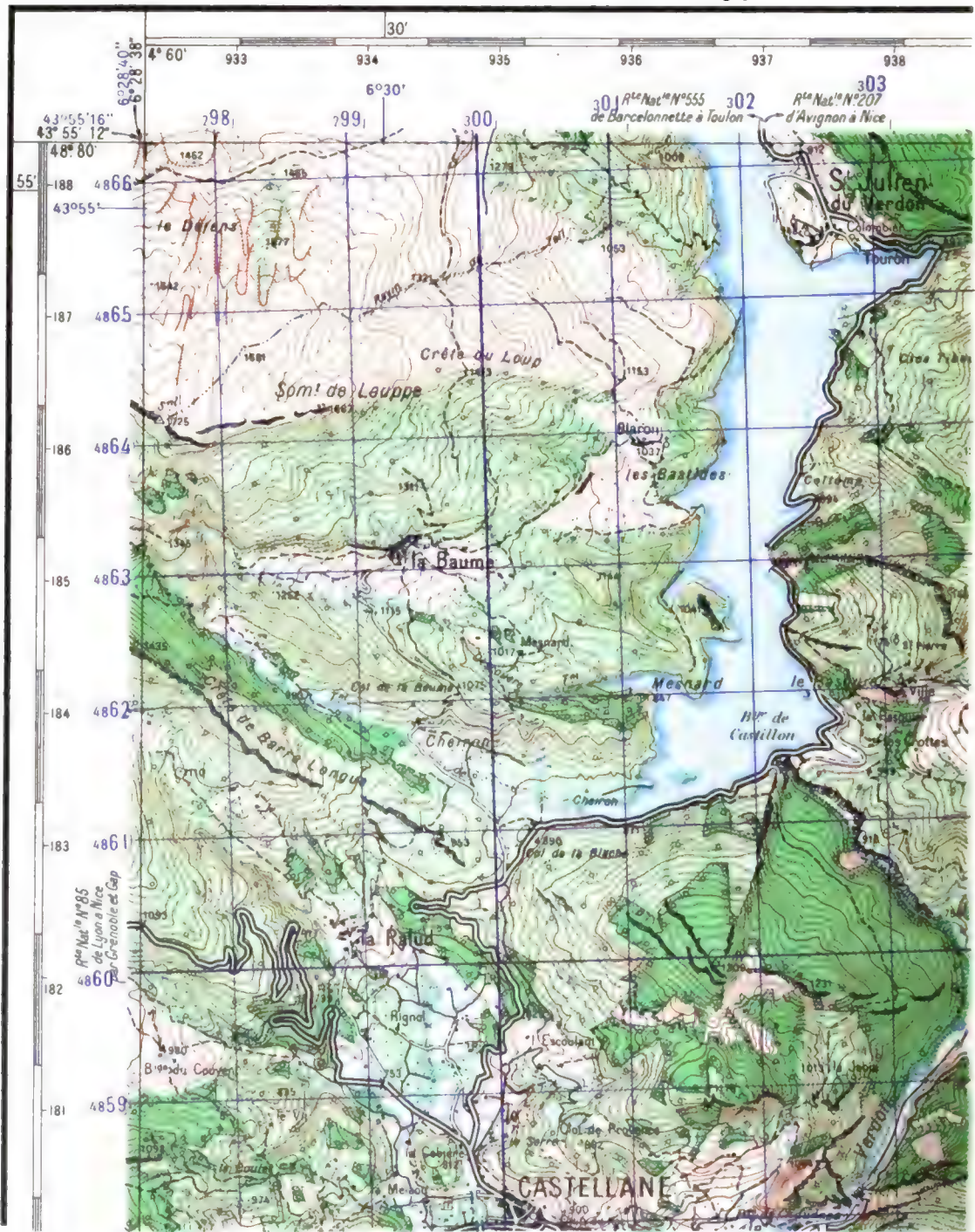

Figure 106. Section of sheet from Carte de France au 50.000^e by the Institut Géographique National, reprinted by the Army Map Service as AMS M761.

1:50,000

XXXIII 40	XXXIV 40	XXXV 40
XXXIII 41	XXXIV 41	XXXV 41
XXXIII 42	XXXIV 42	XXXV 42
XXXIII 43	XXXIV 43	XXXV 43
XXXIII 44	XXXIV 44	XXXV 44

INDEX FOR FRANCE

Figure 105. Sheet-numbering system of the French 1:50,000 series by the Service Géographique de l'Armée and Institut Géographique National.

Cultural revisions have been made on most sheets. Relief is shown by contours at 20- and 40-meter intervals, supplemented by hill shading and spot elevations. Roads are classified by importance and trafficability; railroads, by gage and number of tracks. All sheets have been reprinted by IGN or AMS with the UTM grid and English

translations of marginal data added—some with minor revisions.

(7) *Europe au 1.000.000*°. (1:1,000,000 Map of Europe); Institut Géographique National; 1940–; no grid.

This polychrome series covers all of Europe and some parts of northern Africa and western Asia. Relief is shown by altitude tints and contours at elevations of 200, 500, 1,000, 2,000, and 3,000 meters. The series shows international boundaries, main communications, and other cultural data with a density commensurate to the scale. Sheets covering France were compiled or revised (or both) in the 1940's.

b. *Town plans.* A great many town plans have been published under the direction of the Ministère de la Reconstruction et l'Urbanisme. They are based on local surveys, and are generally corrected from aerial photography. They show damaged areas and reconstruction projects. Scales of these plans range from 1:1,000 to 1:20,000. Numerous other plans have been issued by various publishers, such as the city Chambers of Commerce or private concerns.

109. Coordinate Systems

a. *Geographic.* Most current French maps at all scales show geographic coordinates both in grads referred to Paris and in degrees referred to



Figure 107. Section of sheet from the *Carte d'État-Major au 80.000*° by the Institut Géographique National.

Greenwich. On maps with French-English marginal data, the Greenwich meridian is called the International meridian. German reproductions of French maps retain the French system.

b. Grid.

- (1) *Native.* Some sheets of the French 1:50,000 monochrome series and all sheets of the 1:80,000 and 1:1,000,000 series have no grid. Other French series show the Lambert Zone I, II, or III grid. The UTM grid also has been added on all recent sheets of the French 1:50,000 polychrome series and on military editions of the other French 1:50,000 series. The UTM grid is shown also on all sheets of the French 1:200,000 series.
- (2) *German.* German reproductions of French sheets retain the grids originally shown; on some sheets of the 1:50,000 German reprints, the Orange Report Net grid was added. The sheets of the German 1:300,000 map of central Europe that cover northeastern and central France have the French Lambert grid.
- (3) *British and United States.* GSGS and AMS large-scale maps covering northeastern France have the British grid (Nord de Guerre Zone), taken from French maps published during World War I. GSGS and AMS series covering northwestern, central, and southern

France have the French Lambert Zone I, II, or III grids. On sheets published during the last few years the UTM grid appears—generally as the main grid, with the original grid shown as a secondary grid.

Table VI. Glossary of French Map Expressions

amorces numerotées en caractères penché	ticks numbered in italics
dessiné	drafted
dressée	compiled
échelle	scale
équidistance des courbes de niveau	contour interval
feuille adjacente	adjoining sheet
gravé, gravée	engraved
imprimé	printed
la lettre	names
le figuré du terrain	hachures
les eaux	hydrography
levé en 1940	surveyed in 1940
levés stéréotopographiques aériens complétés sur le terrain	aerial stereocompiled, with field check
mise à jour	brought up to date
publié	issued
nivellement général de la France	general leveling of France
nouvelle triangulation	new triangulation
publié en 1950	issued in 1950
reproduction interdite	copyright reserved
révisé en 1951	revised in 1951
quadrillage	grid
tirage de Juin 1938	printing of June 1938
tous droits réservés	all rights reserved

Section IV. GIBRALTAR

110. Mapping Activities

a. Official. Since the area of Gibraltar is only two square miles, the only significant coverage is that at large scale. A military map of the area was produced in 1943 by the British Directorate of Military Survey, War Office (Geographical Section, General Staff)—GSGS. Other map series by the British cover all or part of the Iberian Peninsula, with Gibraltar appearing as only a small part of one sheet. Spanish maps were used to compile these series, at scales of 1:25,000, 1:50,000, 1:200,000, 1:250,000, and 1:1,000,000.

b. Other. Maps covering Gibraltar have been made by agencies of several other countries. The Army Map Service in 1943 compiled a hachured town plan, based on a British Admiralty chart. The Spanish Institut Geográfico y Catastral

(Geographic and Cadastral Institute) has produced series at 1:25,000, 1:50,000, 1:100,000, and 1:500,000 that cover all or part of Spain. The German Generalstab des Heeres (General Staff of the Army) produced maps at 1:10,000, 1:25,000, 1:50,000, and 1:200,000—all based on Spanish mapping. The maps are parts of series covering all or part of the Iberian Peninsula. The Italian Istituto Geografico Militare (Military Geographic Institute) has produced one series at 1:100,000 based on Spanish sheets. On all of these Spanish, German, and Italian series, Gibraltar appears only as a small part of one sheet.

111. Major Map of Gibraltar

Plan of the Fortress and Peninsula of Gibraltar; 1:5,280; Directorate of Military Survey;

War Office (Geographical Section, General Staff); GSGS 4389; 1944; Iberian Peninsula Zone grid.

This polychrome plan covering all of Gibraltar has contours at 10- or 20-foot intervals, spot elevations, and hachures. Roads are classified by surface and width. Railroads are shown but not classified. No vegetation is shown, and the legend is not complete.

112. Coordinate Systems

a. *Geographic.* Geographic coordinates on the

British 1:5,280 map are expressed in degrees and referred to Greenwich. On other maps of Gibraltar they are expressed in degrees and referred to Greenwich and/or Madrid. In addition, some sheets show grads referred to Madrid.

b. *Grid.* Grid systems used vary on different maps. All British sheets and the AMS plan carry the Iberian Peninsula Zone grid. Spanish and German maps use the Spanish Lambert Military grid. The Italian map carries an unidentified grid based on grads.

Section V. LUXEMBOURG

113. Mapping Activities

a. *Native.* Military maps of Luxembourg at 1:20,000 and 1:50,000 are produced for the government by a commercial firm, J. Hansen, of Paris. Private firms and one or two municipal and government agencies issue a few town plans.

b. *Other.*

(1) *British.* The Directorate of Military Survey, War Office (Geographical Section, General Staff)—GSGS—has produced topographic series with complete coverage of Luxembourg at scales of 1:25,000, 1:50,000, 1:100,000, 1:250,000, 1:500,000, and 1:1,000,000, as well as a few town plans. Several editions have been made of the two 1:25,000 polychrome topographic series, which together provide complete coverage of Luxembourg—35 percent coverage by *France and Belgium 1:25,000*, and 65 percent by *Germany 1:25,000*. The grids shown are the Norde de Guerre Zone grid on earlier editions, with the addition of the UTM grid on the *France and Belgium 1:25,000* series in 1951. The series were compiled in 1939, with revisions made to 1944 from aerial photography. Several editions have been made of the two polychrome series at 1:50,000—*France and Belgium 1:50,000* and *Germany 1:50,000*, which together provide complete coverage of Luxembourg. The series were compiled in 1937–38 from native maps and were revised in 1943–44 from aerial photography and intelligence information. The UTM grid was added to both series in 1951. At 1:100,-

000, two polychrome series in several editions have been produced by GSGS—*Belgium and N. E. France and Germany 1:100,000*. Together they provide complete coverage for Luxembourg, 65 percent by the Germany series and 35 percent by the other. They were compiled from large-scale GSGS maps that were, in turn, compiled from native sheets. They were revised in 1942–43 from aerial photographs. In 1951 the UTM grid was added, and major communications were revised. At 1:250,000, complete coverage is provided by the GSGS polychrome series, *Northwest Europe 1:250,000*, of which several editions have been issued. The series was completed just before World War II from larger scale GSGS maps and was revised in 1943 from aerial photography. *Europe 1:100,000,000*, a series of the IMW (International Map of the World) type, covers all of the country. It was compiled before World War II. During the war, GSGS sheets that had been compiled from native maps. The series was revised in 1944. GSGS has reprinted only one native town plan—a polychrome plan of the city of Luxembourg, compiled at 1:4,800, before World War II. During the war, GSGS drafted three monochrome sketch maps.

(2) *United States.* The Army Map Service has reprinted all maps prepared by GSGS and has also published a 1:25,000 polychrome series of Germany that covers about one-third of Luxembourg. Relief is shown by form lines and spot elevations. The series was compiled in 1951

from GSGS sheets that were based on native maps. The latest revision was made in 1944 from aerial photography. The UTM grid is shown. AMS in 1950 compiled a 1:17,000 schematic monochrome plan of Luxembourg city. It shows military, industrial, and residential areas. During World War II, U. S. Army topographic field units mapped three towns (including Luxembourg city). Of these monochrome plans, two were made from native plans and one from an uncontrolled photomosaic.

(3) *German.* The Generalstab des Heeres (General Staff of the Army) compiled sheets of various series from native maps during the early part of World War II. The area was mapped (as part of several polychrome series covering Germany, Belgium, or Europe) at scales of 1:25,000, 1:50,000, 1:100,000, 1:300,000, 1:500,000, and 1:1,000,000. No postwar topographic series have been produced by German agencies. The Generalstab des Heeres in World War II copied four sketch plans from guide books and also one native plan of Luxembourg city. A colored overprint was added for through routes and important buildings.

(4) *French.*

(a) The Institut Géographique National—IGN (National Geographic Institute)—has produced topographic series with partial coverage of Luxembourg at 1:20,000 and one with complete coverage at 1:200,000. The 1:20,000 monochrome topographic series, compiled by stereophotogrammetric methods in 1939, covers part of France and about one-third of Luxembourg. The 1:200,000 series provides complete contoured polychrome coverage of France, Belgium, and Luxembourg. The sheets covering the latter country were compiled in 1913 from native sheets and have been revised periodically. The latest revision was in 1951, at which date the UTM grid was added. Marginal information on this latest edition is in English and French. IGN has compiled maps by stereophotogrammetric methods at scales of 1:25,000

and 1:50,000 for the Luxembourg Government. About 1939, the IGN produced one monochrome town plan of Luxembourg city at 1:10,000.

(b) The Service Géographique des Forces Françaises en Allemagne—SGFFA (Geographic Service of the French Forces in Germany)—compiled the *Allemagne 1:25,000* series from 1:25,000 German maps dated 1937–39, which, in turn, were based on Luxembourg 1:20,000 maps. This monochrome contoured series covers the French Zone of Germany and one-third of Luxembourg. It carries the UTM grid, and marginal information appears in both French and English.

(c) Private French firms have produced some town plans.

114. Major Native Maps of Luxembourg

a. Topographic Series.

(1) *Carte Topographique du Grand-Duché de Luxembourg* (Topographic Map of the Grand Duchy of Luxembourg); 1:20,000, J. Hansen; 1883–1936; no grid.

This monochrome series covers all of Luxembourg. The projection is not uniform on all sheets; no grid, geographic coordinates, or legend is shown. The dates of survey were 1883–1903, with revisions made to 1936. Relief is indicated by form lines and spot elevations. Roads are classified by administrative authority; railroads, by gage. Vegetation is not indicated.

(2) *Carte Topographique du Grand-Duché de Luxembourg* (Topographic Map of the Grand Duchy of Luxembourg); 1:50,000; J. Hansen; 1883–1934; no grid.

This polychrome series (fig. 108) covers all of Luxembourg. The projection is not uniform on all sheets, and there is no grid. The dates of the original survey were 1883–1907, with revisions made to 1934. Relief is shown by form lines and spot elevations. Roads are classified by administrative authority; railroads by gage. Vegetation shown includes woods and vineyards. The legend is comprehensive.

b. *Town Plans.* Only two cities, Luxembourg

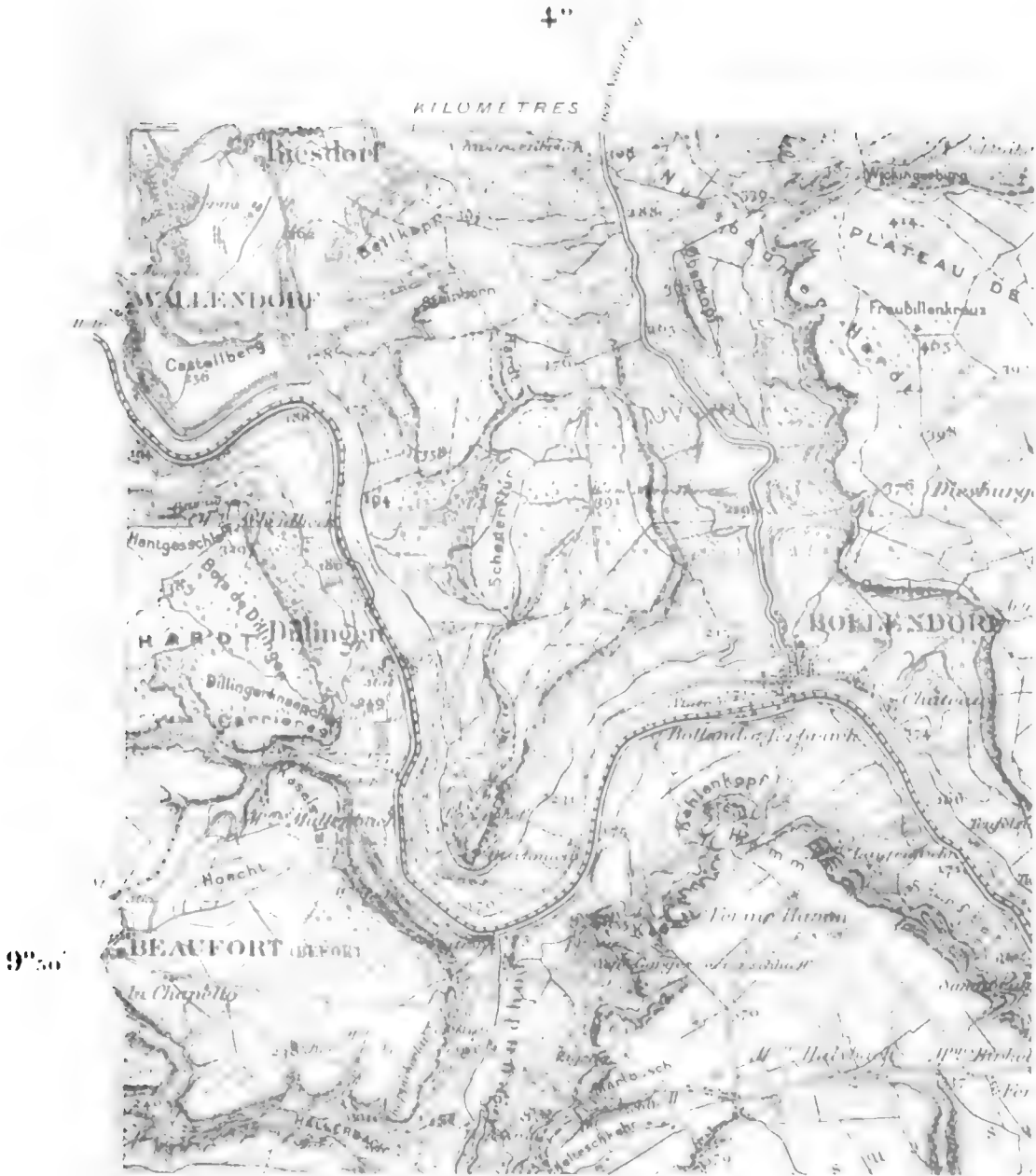

Figure 108. Section of sheet from the 1:50,000 *Carte Topographique du Grand-Duché de Luxembourg* by J. Hansen

and Esch-sur-Alzette, are covered by postwar plans—made by government or municipal agencies. Cadastral maps are available for every town in Luxembourg. The few other existing plans were drawn by commercial firms before World War II. These plans vary considerably: some are sketch plans; some are polychrome and some monochrome; relief may be shown by hachures or not at all. Woods, parks, and tramways are usually shown, but not throughways and bound-

aries. A legend and a glossary are usually present, and a reference grid shown.

115. Coordinate Systems

a. Geographic. The geographic coordinates on the native Luxembourgian series (produced by J. Hansen) are expressed in degrees, referred to Paris. No coordinates are shown on the native 1:20,000 series. GSGS, AMS, and German maps, the IGN 1:200,000 series, and the SGFFA 1:25,-

000 series have coordinates in degrees, referred to Greenwich. In addition, the IGN 1:200,000 series have coordinates in grads, referred to Paris. The IGN 1:20,000 series have coordinates only in grads, referred to Paris. Town plans except those made by GSGS do not have coordinates.

b. Grid.

- (1) *Native.* No grids appear on the native topographic series by J. Hansen. Native town plans show reference grids or none at all.
- (2) *Other.* British sheets have the Nord de Guerre Zone grid shown by full lines. On the latest editions of most series the UTM grid is shown by full lines and the

Nord de Guerre Zone grid by ticks in the margin. The British town plans show no grid. The AMS series has the UTM grid shown by full lines and the Nord de Guerre Zone grid shown by ticks in the margin. AMS town plans bear no grid. German series have the Gauss-Krüger grid or the Orange Report Net grid shown by full lines. The German town plan has a reference grid. French IGN map series have the Nord de Guerre Zone grid shown by full lines except for the latest editions of the 1:25,000 and the 1:200,000 series, on which the UTM grid is shown by full lines.

Section VI. NETHERLANDS

116. Mapping Activities

a. Native. Military maps are produced by the Dutch Topografische Dienst (Topographic Service) at scales of 1:25,000, 1:50,000, and 1:200,000. Part of the 1:25,000 series has been hastily revised, with the addition of bilingual marginal data and the UTM grid.

b. Other.

- (1) *Summary.* The British Directorate of Military Survey, War Office (Geographical Section, General Staff)—GSGS—has issued topographic series at scales of 1:25,000, 1:50,000, 1:100,000, 1:250,000, 1:500,000, and 1:1,000,000. This agency has also produced many town plans. The Army Map Service has compiled a topographic series at 1:25,000 covering the eastern third of the Netherlands, and also schematic town plans of the major cities. Some town plans have been prepared by U. S. topographic field units. The German Generalstab des Heeres (General Staff of the Army) has produced series covering the Netherlands at scales of 1:25,000, 1:50,000, 1:200,000, 1:250,000, 1:300,000, 1:500,000, and 1:1,000,000, as well as various town plans. The French Institut Géographique National—IGN (National Geographic Institute)—has issued at 1:200,000 series with partial coverage of the Netherlands.
- (2) *British (GSGS).* Several series at 1:25,000 have been produced, the latest

(1943–44) being a polychrome series. The 1:50,000 series, covering all of the Netherlands, was compiled in 1939–41 from native sheets. Three 1:100,000 polychrome series together provide complete coverage, as follows: *Holland 1:100,000* (50 percent of the area), *Germany 1:100,000* (35 percent), and *Belgium and N. E. France 1:100,000* (15 percent). The sheets were compiled in 1939–44, with revisions from aerial photography. They were drawn on the Lambert conical orthomorphic projection. The grid used on earlier editions is the Nord de Guerre Zone grid. In 1951 the UTM grid was added, and major communications data were revised. Two polychrome contoured series at 1:250,000 have been produced by GSGS, each in several editions. Complete coverage of the Netherlands is provided by a combination of the two series, *Northwest Europe 1:250,000* (65 percent) and *Central Europe 1:250,000* (35 percent). The latest editions have extended the central Europe series to cover 85 percent of the country and have canceled the other series. Both series were compiled in 1937–44 from native 1:200,000 sheets, with revisions from wartime aerial photography. In 1951 the UTM grid was added, and major communications were revised. *Europe 1:1,000,000* is a poly-

chrome contoured series of the *IMW* (*International Map of the World*) type. Several editions have been produced, covering the entire country. The latest was compiled in 1939-40 from larger scale GSGS maps that were in turn compiled from native maps and revised to 1944. GSGS has reprinted many native town plans, and during World War II also made a number of compilations. Greatly detailed polychrome plans were made for the important cities, and schematic monochrome plans for several of the less important cities and towns. Most plans carry the Nord de Guerre Zone grid and a comprehensive legend. Tramlines and vegetation are usually shown, but not relief, or through routes.

(3) *United States*. The Army Map Service has reprinted all series prepared by GSGS and has itself issued several editions of a polychrome contoured series at 1:25,000, covering the eastern third of the Netherlands. AMS compiled this series in 1943-45 from native 1:25,000 sheets, with revisions from aerial photographs. The UTM grid was added in 1951. In 1950-51 AMS compiled schematic two-color plans of the major cities. They show military, industrial, and residential areas. The scales range from 1:30,000 to 1:50,000. During World War II, several of the less-important towns were mapped by U. S. Army topographic field units. These monochrome plans were usually compiled from native plans.

(4) *German*. The Generalstab des Heeres during the early part of World War II reproduced native Dutch topographic maps at all scales, using captured plates, and adding marginal information, the Gauss-Krüger grid, and revisions up to the print date. In addition, the sheets for the Netherlands included in a series covering all of Europe were compiled from Dutch maps, with revisions up to the print date. Early editions are usually monochrome, and later editions polychrome. No post-World War II topographic maps for the Netherlands have been produced by German agencies. During World War II, the Generalstab des

Heeres copied native town plans in monochrome and added throughway information in color. Usually buildings of military use were also identified and emphasized by color. These town plans were not revised except for the addition of this overprint material.

(5) *French*. The IGN has produced one 1:200,000 polychrome topographic series that covers the southern part of the Netherlands (20 percent). This series was partially revised in 1951 and the UTM grid added.

117. Major Native Maps of the Netherlands

a. Topographic Series.

(1) *Fotogrammetrische Kaart des Rijks* (Photogrammetric Map of the Kingdom); 1:25,000; Topografische Dienst; 1904-; Universal Transverse Mercator grid and Nord de Guerre Zone grid on latest edition, and stereographic grid on the preceding edition of the latest series.

The latest (fig. 109) of the several polychrome series produced at 1:25,000 is composed of double-size sheets. The old series cover all of the Netherlands; the latest series, about 65 percent at present. The ground surveys for the old series were made in 1904-35. Sheets of the new series, begun in 1935, were compiled by photogrammetric methods, with field revisions. The Bonne projection and grid were used on the original series, the stereographic projection and grid on later series, and the stereographic projection and UTM grid on the latest edition. Relief is shown by 5-meter contours, 2.5-meter auxiliary contours, spot elevations, and hachures. Roads are classified by surface, and railroads by number of tracks. Four types of boundaries are shown. Vegetation information includes type of trees and land use of open ground. A comprehensive symbol legend appears on the recent sheets, but not on the older sheets. Marginal information is shown in both Dutch and English on the latest edition.

(2) *Topografische en Militaire Kaart des Rijks* (Topographic and Military Map

of the Kingdom); 1:50,000; Topografische Dienst; 1904-53; UTM grid and Nord de Guerre Zone grid on latest edition, and stereographic grid on preceding edition.

Several 1:50,000 series covering the whole country have been produced; the latest series has half-size sheets. Sixteen old-style 1:25,000 sheets make up one old-style 1:50,000; four new-style 1:25,000 sheets make up one new-style 1:50,000. For the latest series, surveys were made from 1935 to the present. Since 1935, photogrammetric methods of compilation have been used, and frequent field revisions have kept the sheets relatively up to date. The stereographic grid and projection were used on the later series, and the UTM grid appears on the latest edition. Relief is shown by 10-meter contours, 5-meter auxiliary contours, spot elevations, and hachures. Roads are classified by surface, and railroads by number of tracks. Four types of boundaries are shown. Vegetation shown includes types of trees and land use of open ground. The legend on the new sheets is comprehensive. On some of the older sheets no legend is shown. Marginal information is shown in both Dutch and English on the latest edition.

- (3) *Chromo-Topografische Kaart des Rijk*s (Polychrome Topographic Map of the Kingdom); 1:200,000; Topografische Dienst; 1923-52; no grid.

Several 1:200,000 polychrome series covering the country have been issued. Four old-style or eight new-style 1:50,000 sheets were used to compile one 1:200,000 sheet. Frequent field revisions have kept the sheets relatively up to date. The stereographic grid is used on post-World War II series. Relief is shown by 10-meter contours, spot elevations, and hachures (for such local relief as dunes). Roads are classified by surface, and railroads by number of tracks. Two types of

boundaries are shown. Vegetation shown includes woods, meadows, and heath. No legend is shown.

b. *Town Plans.* There has been no official program for making town plans. The only native plans are those prepared by private firms or by various town governments for commercial purposes and/or cadastral use. The commercial firms that have made important contributions are H. Van Diehlen ("Cito" type of plan), J. Smulders ("Kompas" type), and N. V. Cartografisch Instituut Bootsma ("Falk" type). All of the larger towns and several of the lesser towns have been mapped commercially. Cadastral plans are probably available for every town in the Netherlands. The commercial plans are polychrome, and locally compiled plans are usually monochrome. Most of the plans were compiled before World War II and have been revised periodically, the latest plans having been issued in 1951 and 1952. Relief is usually not shown. Through routes are shown on about half of the plans. Tramlines and buslines are shown on most plans. Bomb damage is usually shown on the plans of the larger cities. The polychrome plans show vegetation. The "Cito" type plans include coverage of the environs. The legend usually is either very limited or nonexistent, but a detailed glossary appears on most sheets.

118. Coordinate Systems

a. *Geographic.* Geographic coordinates on the major topographic series are expressed in degrees and referred to Greenwich. The French 1:200,000 series in addition shows coordinates in grads, referred to Paris. The only town plans with geographic coordinates are those made by AMS and GSGS.

b. *Grid.*

(1) *Native.* On the earlier native sheets, the Bonne grid or the stereographic grid are shown by full lines. On the latest editions of the 1:25,000 and 1:50,000 series, the UTM grid is shown by full lines and the Nord de Guerre Zone grid by ticks in the margin. Town plans show reference grids by full lines.

(2) *British.* British series have the Nord de Guerre Zone grid shown by full lines. On the latest editions of the 1:100,000 and 1:250,000 series, the UTM grid is the

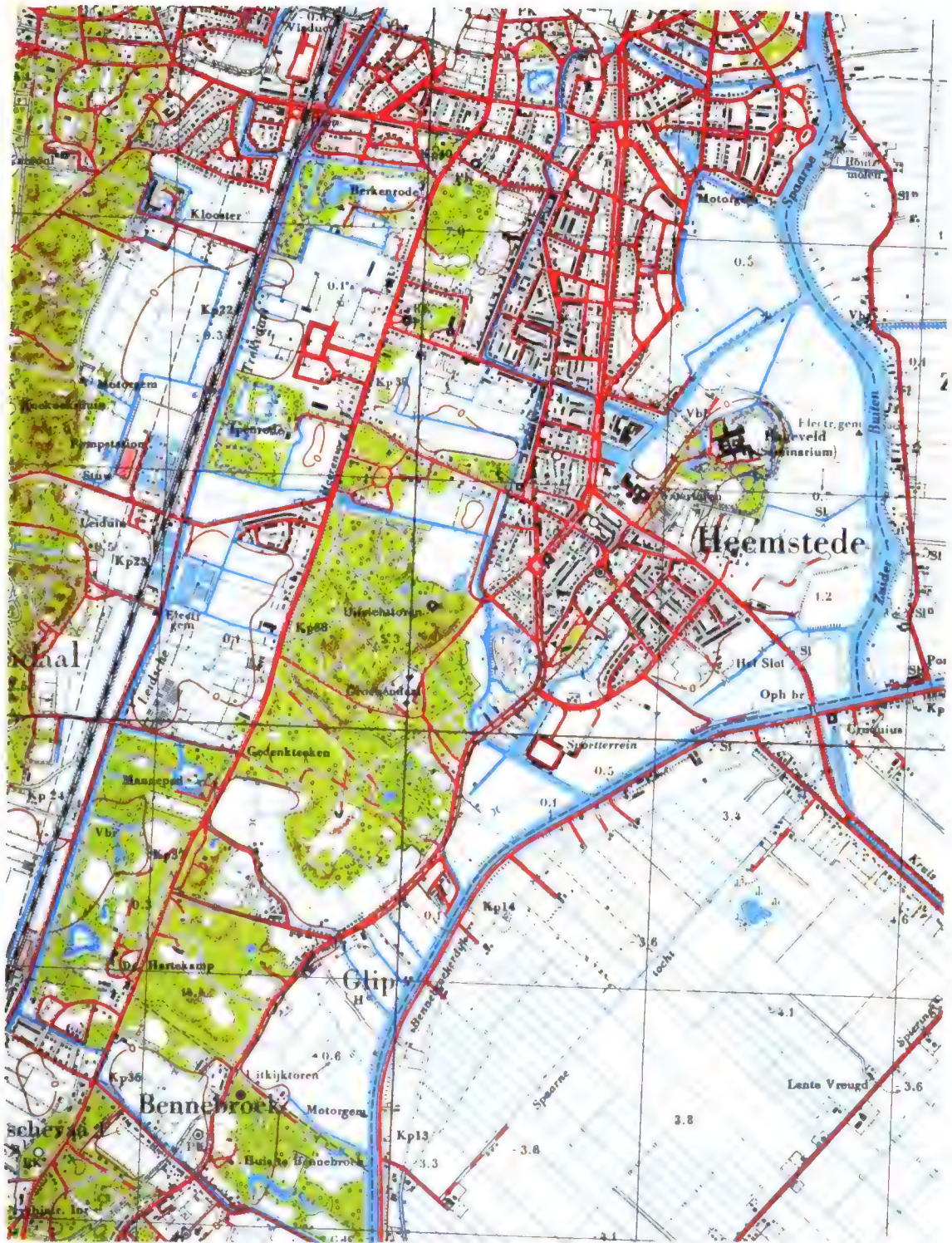

Figure 109. Section of sheet from the 1:25,000 Fotogrammetrische Kaart des Rijks by the Topografische Dienst.

primary grid and the Nord de Guerre Zone grid is the secondary grid. Town plans show the Nord de Guerre Zone grid or a reference grid by full lines.

- (3) *U. S.* Army Map Service sheets have the UTM grid shown by full lines, and the Nord de Guerre Zone grid by ticks. Town plans have no grid.
- (4) *German.* The German sheets retain the original Dutch grid—either the Bonne or the stereographic grid, shown by full lines—and also the German Gauss-Krüger grid or the Orange Report Net grid, also shown by full lines. Town plans have reference grids.
- (5) *French.* The French sheets show the UTM grid by full lines.

119. Characteristics

There are two characteristics peculiar to maps of the Netherlands. Large areas on many sheets show small rectangular patterns of land, called polders formed by drainage ditches. Except in the southeastern part of the Netherlands, relief is so slight that almost no contours are found on maps of this country.

120. Marginal Terms

Three important marginal terms not translated on the Dutch sheets are the following:

- Verkend—survey date (no indication of type of survey);
- Herzien—revision (complete field revision);
- Ged. Herzien—partial revision (no indication of extent).

Section VII. PORTUGAL

121. Mapping Activities

a. Native. The Instituto Geográfico e Cadastral—IGC (Geographic and Cadastral Institute)—is the oldest and most important civil mapping organization in Portugal. It published topographic series at 1:10,000, 1:50,000, 1:100,000, 1:200,000, 1:400,000, 1:500,000, and 1:1,000,000 of Portugal, Madeira, and the Azores. Since 1948 the IGC has begun a new topographic series at 1:10,000. In addition to its own publications, IGC is responsible for printing the work of other governmental agencies, including certain unrestricted maps of the Ministerio de Guerra (Ministry of War). The IGC produces plans for the larger cities, and a number of private concerns publish throughway plans for tourist use. In time of war the IGC is administratively under the jurisdiction of the Servicos Cartográficas do Exército—SCE (Army Cartographic Service)—a division of the Estado Maior do Exército (General Staff of the Army). The SCE has produced the standard topographic map series at 1:25,000 and is also responsible for producing maps of all military establishments.

b. Other. Major foreign mapping agencies are or have been the following: for the United States—the Army Map Service; for Great Britain—the Directorate of Military Survey, War Office (Geographical Section, General Staff)—GSGS; and for Germany,—the Generalstab des Heeres (General Staff of the Army). In 1940–42 the General-

stab des Heeres published a 1:50,000 series based on native 1:50,000 sheets or enlarged from native 1:100,000 sheets. The same agency published series covering the Iberian Peninsula at 1:200,000, 1:400,000, 1:500,000, and 1:1,000,000 and reprinted a number of native plans of the large cities. The British GSGS reprinted or redrafted native 1:50,000 sheets for the Lisbon area and published series covering the whole peninsula at scales of 1:250,000, 1:500,000, 1:2,000,000 and 1:4,000,000. The Army Map Service used the native 1:25,000 sheets and other sources to prepare 1:50,000 sheets for central Portugal. It also redrafted native 1:50,000 sheets for the south coast, with some revisions from 1941–43 photography. In 1944 AMS compiled a 1:250,000 series of the Iberian Peninsula from large- and medium-scale native maps and with partial revision from 1941–43 photography.

122. Major Maps of Portugal

a. Native Topographic Series.

- (1) *Carta Topográfica de Portugal na Escala 1:10,000* (Topographic Map of Portugal 1:10,000); Instituto Geográfico e Cadastral; 1948—; partial Bonne grid. Of this polychrome topographic series, begun in 1948 to cover the more populous areas of Portugal, very few sheets have been published. Compilation was based on the 1:500, 1:2,000,

and 1:10,000 cadastral surveys of Portugal. Relief is shown by 5-meter contours, supplemented by spot elevations. Roads are classified by administrative authority, and railroads by number of tracks, gage, and motive power. Cultural, vegetation, terrain, and hydrographic features are indicated. Geographic coordinates are referred to both Lisbon and Madrid. The "grid" consists of two lines, labeled "M" and "P" that intersect at the center of each sheet. The east-west grid values shown for the ends of line M are computed in meters positive to the west. The north-south values are positive to the south.

- (2) *Carta Militar de Portugal* (Military Map of Portugal); 1:25,000; Servicos Cartográficos do Exército; 1933-; Portuguese Military (Bonne) grid.

These sheets cover the entire area of Portugal except part of the southern tip. Geographic coordinates are referred to Lisbon and the Gauss conic projection is used.

- (a) *Old edition.* The earlier sheets of this topographic map series, begun in 1933, were prepared from field surveys as three-color editions, with hydrographic information in blue and vegetation in green. Relief is portrayed by 10-meter contours, supplemented by spot elevations. Railroads are classified according to number of tracks, gage, and motive power.

- (b) *New edition.* Most of the sheets made since 1940 were compiled by photogrammetric methods from aerial photography, and the remainder of the sheets from field-survey data. More colors are used and the road classification is more detailed than on the old edition.

- (3) *Carta Corográfica de Portugal na Escala 1:50,000* (Chorographic Map of Portugal 1:50,000); Instituto Geográfico e Cadastral; 1902-; partial Bonne grid.

These sheets provide complete coverage of Portugal. The early sheets were classified as provisional and are printed in black. Revised provisional

editions are in black with a red overprint; on a few sheets a green vegetation overprint is shown. On older series the longitude values are referred to Lisbon. Published sheets of a new polychrome edition are thorough revisions based on surveys begun in 1930. The Bonne projection is used. Geographic coordinates are in degrees, referred to both Greenwich and Lisbon. Each sheet has only two grid lines, intersecting at the center. The contour interval of both series is 25 meters. Spot elevations are shown in meters. Culture and terrain, vegetation, and shore features are also indicated. Roads are classified by administrative authority, and railroads by number of tracks, gage, and motive power. The Generalstab des Heeres copied all of these sheets in 1941-42, with minor revisions from intelligence data. The British GSGS in 1942 reprinted some of the sheets for the area around Lisbon. The Army Map Service in 1944 redrafted some of the sheets for the southern coast, with revisions from 1941-42 photography.

- (4) *Carta Corográfica de Portugal na Escala 1:100,000* (Chorographic Map of Portugal 1:100,000); Instituto Geográfico e Cadastral; 1856-1904; Bonne grid on old series; partial Bonne grid on new series.

- (a) *Old series.* This was the first topographic map completed for Portugal. The first few sheets of this monochrome series portrayed relief by hachures which were later replaced by contours at 25-meter intervals, supplemented by spot elevations. The Bonne projection was utilized; the prime meridian is that of Castelo San Jorge and the standard parallel is 39°40' N. A border with 1-minute-interval divisions is parallel to the neatline. A grid system of rectangles measuring 8 km. E-W and 5 km. N-S is used. This series is now culturally out of date. In 1938 the IGC reprinted many of these maps with road revisions overprinted in red. Roads are classified according to administra-

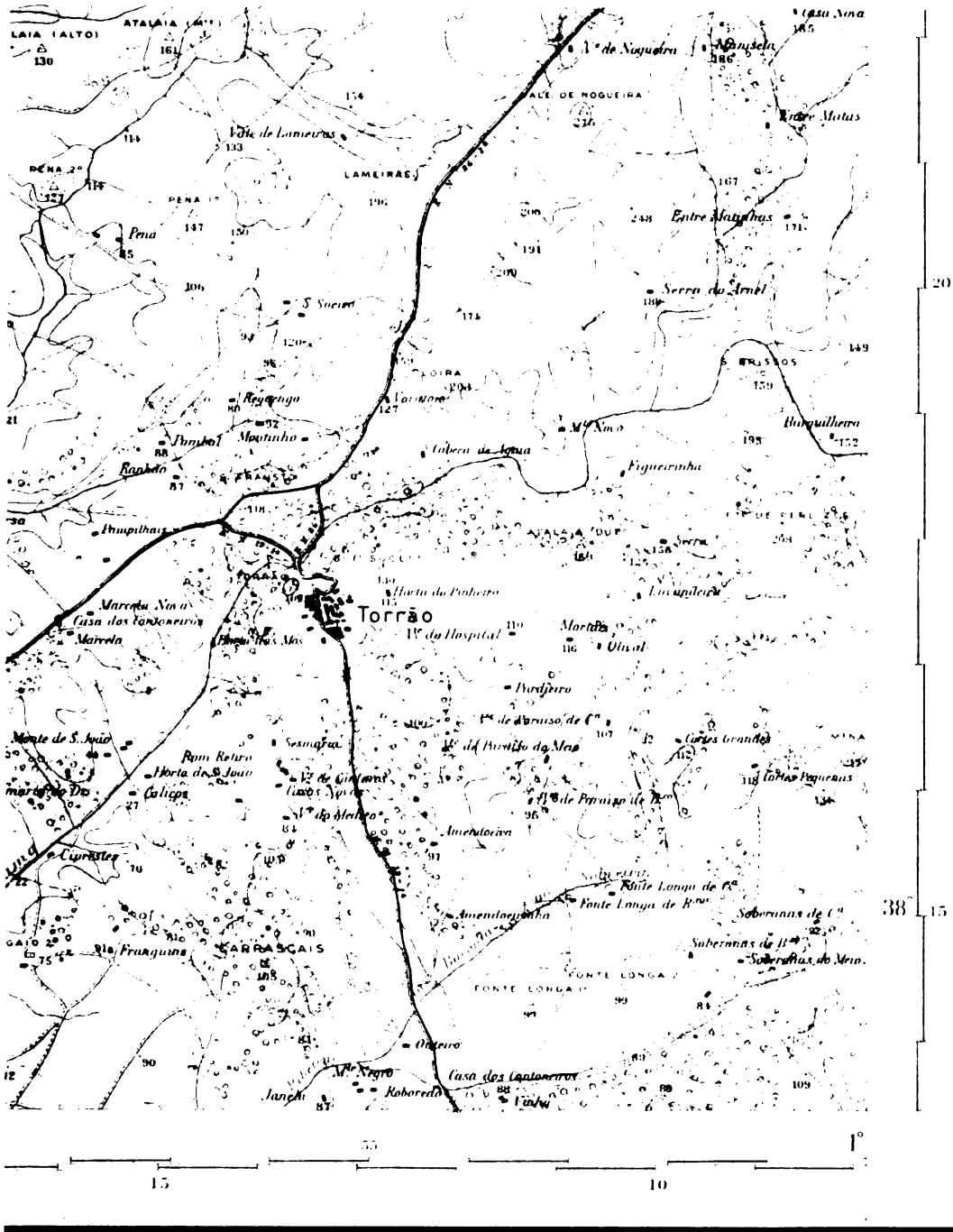

Figure 110. Section of sheet from Carta Corográfica de Portugal na Escala 1:100,000 by the Instituto Geográfico e Cadastral.

itive authority, while railroad information includes stations, tunnels, and number of tracks.

(b) *New series.* In 1936 the IGC published its first sheet of the new 1:100,000 series. This polychrome series (fig. 110) consists of 53 sheets. They

closely resemble the new 1:50,000 series in the projection, origin of grid, symbols, colors, and detail shown. One special feature of the new 1:100,000 series is the light tan color covering the land area. Scattered coverage exists for central and northeastern

Portugal. Roads are classified according to administrative authority. Railroads are classified by number of tracks, gage, and motive power. Cultural, vegetation, terrain, and hydrographic features are indicated.

- (5) *Carta Itineraria de Portugal* (Travel Map of Portugal); 1:250,000; Estado Maior do Exército; 1927-38; Bonne grid.

The latest editions of these sheets, which fall in two groups, have a format based on the Portuguese Bonne grid; grid lines are shown at 10-kilometer intervals. The central meridian is that of Lisbon. The sheets published from 1927 to 1932 have a red grid, black coordinates, and roads in red or green. The second group of sheets, published in 1934-38, has a blue grid, black coordinates, shaded contours, and thin-line roads. Most sheets of both groups have 100-meter contours; a few in each group have no contours. The language is Portuguese. Most sheets of the series were enlarged to 1:200,000 in the 1930's by the Italian Istituto Geografico Militare (Military Geographic Institute).

- (6) *Carta Corográfica de Portugal na Escala 1:400,000* (Chorographic Map of Portugal 1:400,000); Instituto Geográfico e Cadastral; 1941- ; no grid.

This polychrome topographic series consists of three sheets completely covering Portugal. Relief is shown at 200-meter intervals, supplemented by gradient tints for areas higher than 600 meters. Full-degree lines are shown on the face of the map, with longitude values referred to Lisbon. Roads are classified according to administrative authority. Railroads are classified by number of tracks and gauge; important stations are shown. Cultural, terrain, and hydrographic features are indicated.

- (7) *Carta Internacional do Mundo* (International Map of the World—IMW); 1:1,000,000; Instituto Geográfico e Cadastral, in collaboration with the Spanish Instituto Geográfico y Catastral, in Madrid; 1928-35; atlas grid.

Two sheets have been published in Lisbon: Lisboa, Sheet J 29, in 1934, and Arquipelago da Madeira, Sheet I 29, in 1935. One planimetric sheet covering part of Portugal—Porto, Sheet K 29—was published in Madrid in 1928. The Lisbon sheets were compiled from Portuguese 1:100,000 and Spanish 1:200,000 sheets and from hydrographic charts of both countries. The Portuguese sheets are made according to IMW specifications. The sheets are 6° E-W by 4° N-S; the prime meridian is Greenwich. The Portuguese and Spanish languages are used, with an English glossary.

b. *Town Plans.* The town plans of Portugal produced by the Instituto Geográfico e Cadastral (IGC) are relatively detailed plans that emphasize built-up areas, communication networks, vegetation, and hydrographic features. The plans produced by private agencies are mainly through-way plans for tourist use. The most notable are Serviços do Turismo-Portuguese (Portuguese Tour Services); the French Michelin et Cie Service du Tourisme (Michelin and Company Tourist Service); Sección Cartográfico, Firestone-Hispania, S. A. (Cartographic Section, Firestone [Tire Company in] Spain, Inc); and the Touring Club Italiano (Italian Touring Club).

123. Coordinate Systems

a. Geographic.

- (1) *Native.* On all Portuguese maps geographic coordinates are shown in degrees, both from Greenwich and from Lisboa (Lisbon), which is 9°07' W of Greenwich.
- (2) *German.* The German 1:50,000 series has geographic coordinates in degrees referred to both Greenwich and Lisbon. The 1:200,000 series refers to three prime meridians: Madrid, Lisbon, and Greenwich. The 1:400,000 and 1:1,000,000 series refer to Greenwich only.

b. Grid.

- (1) *Native.* The Portuguese military grid, with lines at 100-meter intervals, is shown on the native 1:25,000 military map. The grid shown on sheets of the 1:50,000, the 1:10,000, and the new 1:100,000 series is limited to a pair of lines intersecting

Table VII. Glossary of Portuguese Map Expressions

atualizada.....	revised or brought up to date
altura en metros.....	height in meters
carta aeronautica.....	air chart
carta topográfica.....	topographic map
curva de nivel.....	contour line
declinação magnetica.....	magnetic declination
desenhado.....	designed or drawn
edição.....	edition
escala.....	scale
estereofotogrametria aéreo e restituição.....	aerial stereophotogrammetry and restitution
equidistancia.....	contour interval
equipos terrestres.....	field team
folha adjacente.....	adjoining sheet
legenda.....	legend
levantado.....	surveyed
mapa indice.....	index map
ponto trigonométrico de 1ª ordem.....	first-order triangulation point
ponto trigonométrico auxiliar.....	auxiliary triangulation point
prancheta de levantamentos.....	plane table
publicado.....	published
reimpressao.....	reprint
revista.....	revised
senhais geodésicos de 1ª ordem.....	first-order triangulation marker
trabalhos de campo.....	field work

at the center of each sheet. They are labeled with grid values and refer to the Portuguese Bonne grid system. Sheets of the old 1:100,000 series have Bonne

grid lines at an E-W interval of 8 kilometers and a N-S interval of 5 kilometers. The 1:250,000 travel map uses the Bonne grid, with lines at 10-kilometer intervals. No grid appears on the 1:400,000 series. The IMW sheets have the usual atlas grid.

- (2) *German.* The German 1:50,000 series carries the Portuguese Bonne grid. The 1:200,000 and 1:400,000 series have the Spanish Lambert grid. No grid appears on the 1:1,000,000 series.
- (3) *British.* GSGS series at 1:50,000 and 1:500,000 carry the Iberian Peninsula Zone grid; the 1:250,000 series the Lambert Zone 3 (Red) grid.
- (4) *United States.* On the 1:50,000 AMS sheets that cover a south-coast area of Portugal and on the 1:250,000 series, the Iberian Peninsula Zone grid appears, some of the 1:50,000 AMS sheets for the Lisbon area have this grid and/or the Universal Transverse Mercator grid.

124. Characteristics

a. The scales on all Portuguese maps are based on the metric system of measurement and the geographic mile.

b. Most Portuguese maps carry a declination diagram or note giving approximate mean declination and annual magnetic change.

Section VIII. SPAIN AND THE BALEARIC ISLANDS

125. Mapping Activities

a. Native.

- (1) The first real results of organized scientific cartographic work began with the creation of the Instituto Geográfico Catastral y Estadístico (Geographic, Cadastral, and Statistics Institute) in 1873.
- (2) The Instituto Geográfico y Catastral (IGC) is responsible for civilian geodetic and topographic work in Spain; in addition, this agency has the responsibility for weights and measures, geodesy, physics, astronomy, photogrammetry, and cadastral surveys. The Institute has produced incomplete topographic map series at 1:25,000, 1:50,000, and 1:200,000 (province maps) and complete series

at 1:400,000, 1:500,000, and 1:1,000,000, as well as cadastral city plans.

- (3) The Servicio Geográfico del Ejército—SGE (Army Geographic Service)—is the military map-making agency. It coordinates and produces topographic mapping and geodetic work for the military; trains personnel; publishes, procures, stores and distributes maps; and cooperates with the IGC and the Servicio Cartográfico y Fotográfico del Ejército del Aire (Cartographic and Photographic Service of the Air Force). Other map series produced by the SGE include the three series (at 1:5,000, 1:10,000 and 1:25,000 scale) called *Plano Directores* (Planning Charts); the new *Mapa de Mundo* (Com-

mand Map) at 1:100,000 scale; the *Mapa Militar Itinerario de España* (Military Route Map of Spain) at 1:200,000 scale; the *Mapa Itinerario* [Tipo 1951] (Route Map) [Type 1951]; the *Mapa Militar Estrategico* (Military Strategic Map) at 1:500,000; and maps of the colonial territories and the Canary Islands at various scales.

- (4) Most of the available town plans of Spain, other than the IGC cadastral plans, are made for tourist use, some in atlas form.

b. Other. Many foreign agencies have published map series of Spain; most are either reprints of native large-scale maps or compilations at medium and small scales made from various native sources. The most outstanding foreign agencies in this respect have been the German Generalstab des Heeres (General Staff of the Army); the British Directorate of Military Survey, War Office (Geographical Section, General Staff); the Italian Istituto Geografico Militare (Military Geographic Institute); the French Institut Géographique National (National Geographic Institute); and the U. S. Army Map Service. The Germans reproduced the native 1:50,000 sheets and added intelligence data. They also compiled series at 1:200,000, 1:400,000, 1:500,000, and 1:1,000,000. The British reprinted native sheets or compiled series for parts of Spain at 1:25,000, 1:50,000, 1:100,000, and 1:200,000, and for all of the peninsula at 1:250,000, 1:500,000, 1:1,000,000, 1:2,000,000, and 1:4,000,000. The Italians reprinted the Spanish 1:100,000 sheets for the environs of Gibraltar and Madrid. The French made five sheets at 1:200,000 for the Pyrenees area. The Army Map Service reproduced British series at 1:50,000, 1:100,000, and 1:500,000, and smaller scales; made redrafts, reprints, or photo reproductions of the Spanish 1:50,000 series in northeastern and southern Spain; and compiled series at 1:250,000 and 1:2,000,000. Many private companies and organizations have published through-route city plans of Spain and the Balearic Islands, the most important being Michelin et Cie Service du Tourisme (Michelin and Company Tourist Service). The wartime German through-route "Mil-Geo" city plans were based on available Michelin maps. The Army Map Service also made a series of Spanish city plans.

126. Major Maps of Spain and the Balearic Islands

a. Native Topographic Series.

- (1) *Mapa Topográfico Nacional de España* (National Topographic Map of Spain); 1:50,000; Instituto Geográfico y Catastral and the Servicio Geográfico del Ejército; 1882- ; Spanish Lambert Military grid on Edición Militar (Military Edition) sheets only.

This incomplete map series (fig. 111) provides 96 percent coverage of Spain, including the Balearic Islands, and Andorra. The series, initiated in 1875, was based primarily on ground-controlled surveys and in some mountainous areas by terrestrial photogrammetry. A few sheets in recent years were compiled from aerial photographs by photogrammetric (stereoplanigraph) methods. Relief is shown by contours at 20-meter intervals, supplemented by spot elevations in meters. Vertical datum is based on the mean sea level at Alicante. On many Military Edition sheets for coastal areas, isobathic lines appear at depths of 10, 20, 40, 70 and 100 meters. The series is a standard polychrome edition, with some monochrome Civil War provisional sheets. The Spanish Lambert grid appears only on the Military Edition, which covers areas along the international boundaries, coasts, and certain other strategic areas. Longitude is referred to Madrid and is expressed in degrees. The maps use conventional symbols for culture, hydrography, terrain features, and vegetation—the latter including information on land use. Roads are classified according to administrative responsibility for maintenance. Marginal information is scant, but a symbol book, *Signos Convencionales* (Conventional Signs), legend sheets, and glossaries exist. The language used is Spanish.

- (2) *Mapa Militar Itinerario de España* (Military Route Map of Spain); and *Mapa Itinerario* [Tipo 1951] (Route Map) [Type 1951] 1:200,000; Servicio Geo-

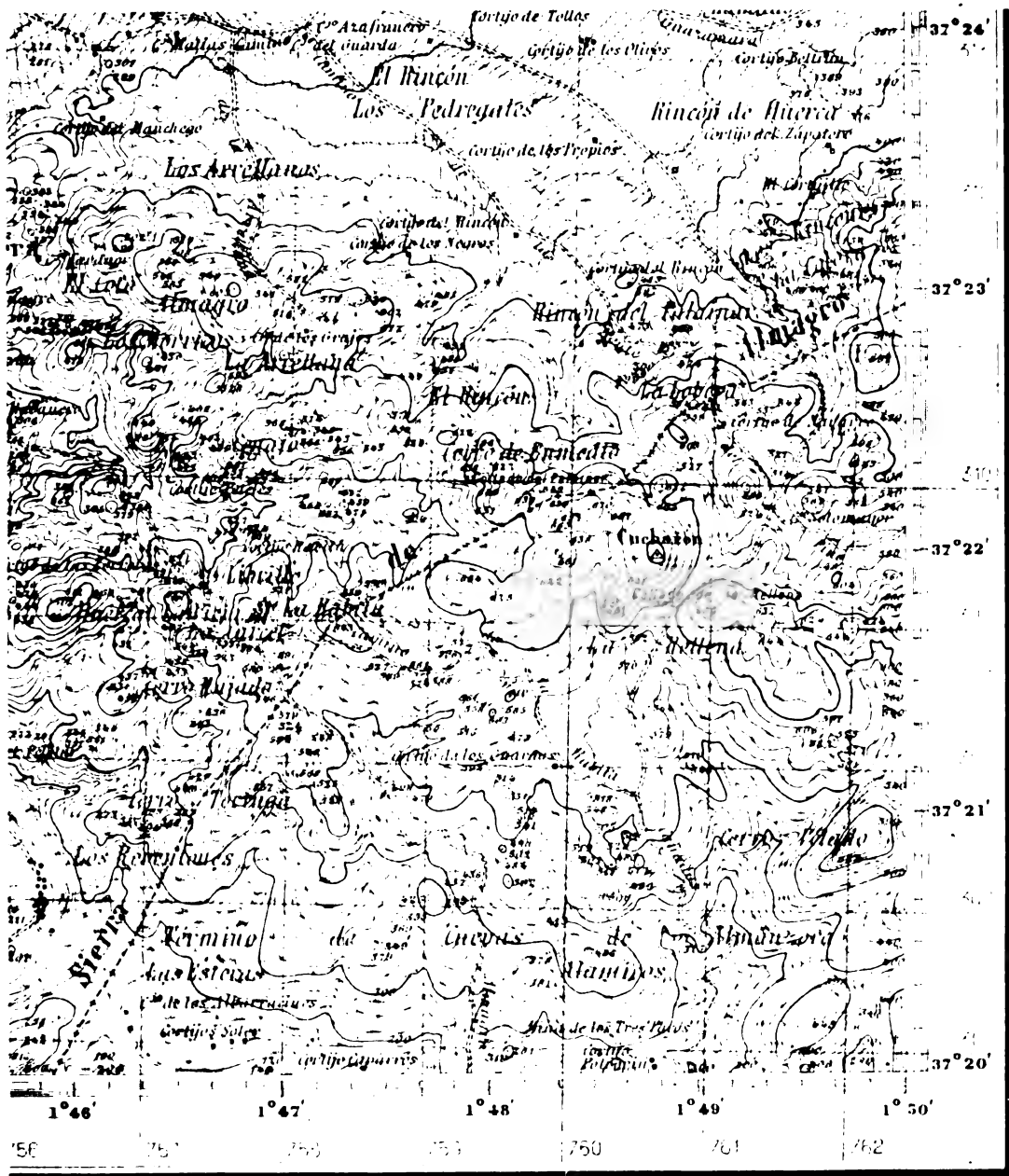

Efectuados los trabajos Geodésicos y Topográficos por la Dirección general del Instituto Geográfico y Catastral. 1ª edición 1950.

Figure 111. Section of sheet from *Mapa Topográfico Nacional de España* at 1:50,000 by the Instituto Geográfico y Catastral and the Servicio Geográfico del Ejército.

gráfico del Ejército; 1931 to present for first series and 1951 to present for second series; Spanish Lambert Military grid. (a) The Edición Moderna (Modern Edition) of the first-named series covers all of Spain and the Balearic Islands.

Most of these polychrome sheets were compiled from the 1:50,000 series; the remainder, from other sources. The sheets are contoured at 50-meter intervals, except for some early sheets of the provisional edition that had con-

tours at 100- and 200-meter intervals. Spot elevations are shown in meters. The Bonne projection and the Spanish Lambert Military grid were used. Longitude in degrees is referred to Madrid. Conventional symbolization includes cultural features, hydrography, vegetation, and administrative centers and boundaries. Shaded relief, altitude tints, and dense detail tend to lessen legibility. Roads are classified by administrative responsibility for maintenance. On some sheets, marginal information is incomplete, but additional symbol legends and glossaries exist. A key to the sheet numbering system is shown in the margin.

- (b) Eleven polychrome sheets of the *Mapa Itinerario* [Tipe 1951] incorporating the new specifications for the Route Map have recently been published for part of the northeastern Spain (the Pyrenees Mountains and Catalonia). Five of the sheets were compiled from 1:50,000 sheets that were prepared by terrestrial-photogrammetric methods. The new series eliminates much of the detail that impaired legibility on the older series. Sheet lines have been changed to conform to the system used for the 1:25,000 and 1:50,000 series and the new 1:100,000 series. The new Route Map is drawn on the Lambert projection. Marginal information includes a symbol legend, indexes to boundaries and adjoining sheets, and a source index that shows the relationship of the sheet lines of the different Spanish series.

- (3) *Mapa General de España* (General Map of Spain); and *Mapa Estratégico de España* (Strategic Map of Spain); 1:500,000; Instituto Geográfico y Catastral and the Servicio Geográfico del Ejército respectively; no date; no grid.

This nine-sheet polychrome series covers Spain and parts of Portugal and France. Compilation sources are unknown. Relief is shown by 200-meter contours, 100-meter auxiliary contours, and hill shading. Longitude is meas-

ured from Madrid in degrees. The sheets are drawn on the Tissot projection. Features shown include hydrography, administrative centers and boundaries, lighthouses, port detail, and other culture. Road classification is unspecified. Sheet 7 includes the legend for the series.

- (4) *Mapa Internacional del Mundo* (International Map of the World—IMW); 1:1,000,000; Instituto Geográfico y Catastral; 1928; no grid.

Six polychrome sheets of the IMW series cover Spain, Portugal, southern France, part of northern Africa, and the Balearic Islands. Of these, three sheets were produced by the Spanish, and the others by the French, Portuguese, or Germans. The three native sheets are Valencia (NI 30), Madrid (NK 30), and Porto (NI 29). The maps follow IMW specifications and were compiled from larger scale native sources in 1928. Longitude, measured from Greenwich, is expressed in degrees. Culture, relief, hydrography, and administrative centers and boundaries are shown by conventional IMW symbols. Roads are classified according to use and surface. The legend is in three languages, but the language within the neatline is Spanish.

b. *Town Plans.* The Patronato Nacional del Turismo (National Tourist Agency) and affiliated organizations, make and distribute tourist plans for many cities in Spain as part of a tourist publicity program. Other private organizations, such as banks and publishers, print good tourist plans as a form of advertisement. The city governments of Spain occasionally print town plans, the best of which is the partially contoured city plan of Barcelona, dated 1949; this is printed at both 1:10,000 and 1:20,000 and is frequently revised. A number of private companies publish through-route city plans of Spain in atlas form. Among the most notable are the French Michelin et Cie Service du Tourisme (Michelin and Company Tourist Service) and the Sección Cartográfico, Firestone-Hispania, S. A. (Cartographic Section, Firestone [Tire Company in Spain, Inc.]

127. Coordinate Systems

a. Geographic. Longitude is measured in degrees from Madrid on all native maps except the IMW sheets at 1:1,000,000, on which Greenwich is the prime meridian. On British, U. S., and German maps of Spain longitude values are given in degrees from both Madrid and Greenwich.

b. Grid.

- (1) *Native.* The Spanish Lambert Military grid is shown on the two series of 1:200,000 route maps and on the Military Edition sheets of the 1:50,000 national topographic map of Spain. No grid is shown on the 1:500,000 and 1:1,000,000 series.
- (2) *Other.* The British grid system, used on all available U. S. and British maps, the Iberian Peninsula Zone covers most of Spain, and the French Lambert Zone III covers the remainder, in the western Pyrenees.

Table VIII. Glossary of Spanish Map Expressions

altitud en metros.....	altitude in meters.
altitud obtenida por nivelación de precisión ó geométrica.....	altitude obtained by precise or trigonometric leveling.
coordenadas.....	coordinates.
cuadrícula.....	grid.

Table VIII. Glossary of Spanish Map Expressions—Con.

curvas de depresión.....	depression contours.
curvas interpoladas.....	intermediate contours.
curvas isobáticas.....	bathymetric contours.
curvas de nivel.....	contour lines.
detalles no rotulados.....	details not labeled.
dimensiones interiores del recuadro.....	interior dimensions of the square.
edición con altimetría.....	topographic edition.
efectuados.....	compiled or made.
equidistancia de las curvas de nivel.....	contour interval.
estadística.....	statistics.
formado.....	compiled.
hoja.....	sheet.
levantados.....	surveyed.
metros.....	meters.
nivel medio.....	mean level.
origen.....	origin.
proyección.....	projection.
punto de altitud.....	spot elevation.
punto determinado astronómicamente.....	astronomical position.
reglamentaria.....	standard (by law).
revisado.....	revised.
talleres.....	[produced by] workshops.
trabajos en campo.....	field survey or work.
trabajos geodésicos.....	geodetic work.
trabajos topográficos.....	topographic work.
vertice geodésico de primer orden.....	1st-order triangulation station.
vertice geodésico de segundo orden.....	2d-order triangulation station.
vertice geodésico de tercer orden.....	3d-order triangulation station.

CHAPTER 8

NORTHERN EUROPE AND THE BALTIC STATES

Section I. DENMARK AND THE FAEROE ISLANDS

128. Mapping Activities

a. Native. The military maps of Denmark and the Faeroe Islands are prepared and published by the Geodaetisk Institut (Geodetic Institute). Topographic series of Denmark and Bornholm Island are published at scales of 1:20,000, 1:40,000, 1:100,000, 1:160,000, 1:200,000, 1:500,000, and 1:1,000,000. Coverage for the Faeroes includes series at 1:20,000, 1:100,000, 1:200,000, and 1:1,000,000. The Geodaetisk Institut also provides the Generalstabens Topografiske Afdeling (Topographic Division of the General Staff) with domestic topographic maps for planning and operations.

b. Other. Military maps of Denmark and the Faeroe Islands also have been produced by Great Britain, Germany, and the United States.

(1) *British.* The Directorate of Military Survey, War Office (Geographical Section, General Staff)—GSGS, has published series covering Denmark at scales of 1:20,000, 1:25,000, 1:100,000, 1:250,000, and 1:1,000,000. GSGS series of the Faeroes have been published at scales of 1:20,000, 1:100,000, 1:200,000, 1:250,000, and 1:1,000,000. These series, which were published during 1944–47, are based on Danish or German maps, with some revisions from aerial photography. The Inter-Service Topographical Department GSGS, and the Joint Intelligence Bureau (JIB) have also produced numerous maps at various scales, mainly town plans of ports and strategic planning maps.

(2) *German.* The Generalstab des Heeres—GSH (General Staff of the Army) revised and reproduced many of the original Geodaetisk Institut maps of Denmark and the Faeroes. Maps of Denmark were published at scales of 1:25,000,

1:100,000, 1:300,000, 1:500,000, and 1:1,000,000. German series at 1:100,000 and 1:500,000 provide coverage for the Faeroe Islands. In addition, the Germans published a large number of special maps and studies. Two items of particular interest to mapping are a military geographic map series at a scale of 1:100,000 and a folio entitled *Militärgeographische Angaben über Danmark* (Military Geographic Data for Denmark).

(3) *United States.* The Army Map Service has published map series of Denmark at scales of 1:250,000 and 1:1,000,000, and of the Faeroes at scales of 1:200,000 and 1:250,000. These series are based on Danish sources.

129. Major Native Maps of Denmark and the Faeroe Islands

a. Topographic Series.

(1) *Danmark*; 1:20,000; Geodaetisk Institut; 1901–46; reference grid on some sheets.

Original surveys for this polychrome series covering Denmark, Bornholm, and the Faeroe Islands were made in 1760, 1860, and from 1884 to 1945. Minor revisions on these sheets are made regularly. Relief on most of the coverage is shown by contours at intervals of 5 Danish feet (one Danish foot=0.31 meters=1.03 English feet). On sheets covering the islands and some of the sheets of south Jutland, contours are shown at intervals of 2 and 2.5 meters. Vegetation is shown by symbol. Communications features include five types of roads and three types of railroads. Parish boundaries are

shown. In 1944 this series was reprinted by GSGS. The German Generalstab des Heeres reduced and reprinted sheets of this series at a scale of 1:25,000.

- (2) *Danmark 1:40,000 Generalstabskort* (Denmark 1:40,000 General Staff Map); Geodaetisk Institut; 1870-1947; reference grid on some sheets.

This polychrome series covers Denmark and the island of Bornholm. The sheets, which were originally based on surveys of 1866 and 1887, have been revised regularly from 1901 to 1946. Relief is shown by contours at intervals of 10 Danish feet or 2.5 meters. Spot heights are indicated in Danish feet, and cliffs and depressions are shown by shading. Woodlands are shown by brown or green overprint; other vegetation features are shown by symbol. Communications features shown include railways and stations, freight lines, and three types of roads. No international or amt (county) boundaries are shown. Parish boundaries are indicated in black.

- (3) *Danmark; 1:100,000; Geodaetisk Institut; 1921-38; no grid.* This polychrome series covering Denmark and the island of Bornholm is based on surveys of 1760-1860. Cultural features have been revised with each reprinting from 1937 to 1945. Relief is shown by contours at 5-meter intervals. Vegetation features are shown by color and symbol. Five categories of roads and standard and narrow gage railroads are indicated. International, amt (county), administrative, and parish boundaries are shown. Sheets of this series were reprinted in 1941-44 by the British Directorate of Military Survey, War Office (Geographical Section, General Staff). In 1942-44 the German Generalstab des Heeres reprinted this series, overprinting it with military geographic information.
- (4) *Danmark; 1:160,000; Generalstabens Topografiske Afdeling (Topographic Division of the General Staff); 1909-32; no grid.*

This polychrome series covering Denmark and the island of Bornholm is based on large- and medium-scale ground surveys. The most recent revisions to these sheets were made in 1920. Relief is shown by contours at 5-meter intervals and spot heights in meters. Vegetation is indicated by color. Communication features shown include main roads, other roads, and railroads. Four types of boundaries are shown: county, district, judicial district, and parish.

- (5) *Danmark; 1:200,000; Geodaetisk Institut; 1939-50; no grid.* This polychrome series covering all of Denmark is revised and reprinted regularly. It is also published in atlas form as an aid to motorists. Relief is shown by shading and spot heights in meters; steep slopes are indicated by hachures. Vegetation is shown by symbol. Communication features shown include four classes of roads and two classes of railroads.
- (6) *Kongeriget Danmark (Kingdom of Denmark); 1:500,000; Geodaetisk Institut; 1941; no grid.*

This polychrome sheet covering Denmark, Bornholm, and the Faeroes is based on larger scale Danish sources. Relief is shown by hachures and spot heights in meters. Woodlands are indicated by color; other vegetation features are shown by symbol. Railroads and three categories of roads are indicated. Administrative boundaries are symbolized. This sheet was reprinted in 1941 by the German Generalstab des Heeres.

- (7) *Danmark; 1:1,000,000; Geodaetisk Institut; 1937; no grid.*

This polychrome sheet covering Denmark, Bornholm, and the Faeroe Islands was compiled according to modified specifications for the *International Map of the World* and has been issued periodically since 1924. Woodlands are shown by color. Two categories of roads are shown. Railroads are indicated as single or multiple track and standard or narrow gage. International and county boundaries are

symbolized. Air data include airfields, landing grounds, and beacons.

b. Town Plans. Town plans produced by the Geodaetisk Institut are limited in number. Local surveying companies and city engineers have produced a number of plans, but they are intended primarily for tourists.

130. Coordinate Systems

a. Geographic. On Danish maps and British reprints of Danish sources, geographic coordinates are expressed in degrees with longitude measured from Copenhagen (12°34'40" East of Greenwich). On German or United States maps of Denmark, longitude values in degrees are referred to Greenwich.

b. Grid. No military grid is shown on most Danish sources; a reference grid, however, is shown for some sheets.

131. Characteristics and Marginal Information

All recent Danish maps are based on the metric system of measurement. Some of the older series, which are still used as base material, make use of both the metric system and the old land measurement in Danish feet. Most of the native Danish maps of older printing do not carry declination diagrams.

Table IX. Glossary of Danish Map Expressions

automobilkort.....	automobile map
bovl.....	shelter for sheep
bo.....	cultivated land, farm
bro.....	bridge
enkelte rettelser.....	some corrections
eftertryk forbydes.....	copyrighted

Table IX. Glossary of Danish Map Expressions—Con.

forkortelser.....	abbreviations
faerdsels turistkort.....	travel and tourist map
forste udgave, første udgave.....	first edition
Generalstabskort.....	General Staff map
Geodaetisk Institutskort.....	Geodetic Institute map
haerkort.....	army map (military map)
hammer.....	precipitous mountainside
hojdekort, højdekort.....	physical map
kilde.....	source, spring
kilometersten.....	kilometer stone (marker showing distance)
klippe i overfladen.....	rocks awash
kraegv.....	peat supply shelter
landkurver-hojdekurver, landkurver højdekurver.....	contours
magnetisk misvisning.....	magnetic declination
middelvandstand.....	mean sea level
maalebordsblad, maalebordsblad.....	planetable sheet
maalestok, målestok.....	scale
målt, maalt.....	surveyed
naes.....	point, headland
nøglekort, nøglekort.....	key, index-map
optryk.....	print or reprint
oversigtakort.....	general map
revideret.....	revised
rettet.....	corrected
rullesten.....	shingle
skraent.....	slopes, cliff
skrift og signaturforklaring.....	symbol explanation
sognegraense.....	parish boundary
søkort, søkort.....	hydrographic chart
spang.....	narrow footbridge
stengaerde.....	rock fence
tilstodende blad, tilstødende blad.....	adjoining sheet
til tjenestebrug.....	restricted, for official use
topografisk kort.....	topographic map
topografiske opmåling.....	topographic survey
torveskaer.....	peat cutting
zonebetegnelse.....	grid-zone designation

Section II. ESTONIA, LATVIA, AND LITHUANIA

132. Mapping Activities

a. Native. Before 1918, the General'ny Shtab Russkoy Armii (General Staff of the Russian Army) was the primary agency for surveying and mapping activities in the Russian area that was to become the republics of Estonia, Latvia, and Lithuania. In the early part of the post-1918 period, the cartographic agency in each of the three new sovereign states used the Russian survey and mapping data as the initial base for its own mapping activities. When these native cartographic agencies attempted to develop national series on a common datum, the elimination of

discrepancies resulting from the different triangulation systems of the early Russian period became a major problem. It was for this reason that each of the cartographic agencies of Estonia, Latvia, and Lithuania initiated state triangulation surveys designed to produce sound geodetic bases for modern large-scale maps.

(1) *Pre-1918 Russian mapping.* Several Russian planetable surveys were made independently and under several different triangulation systems. The old Russian land survey, which was made at scales of 1:21,000, 1:42,000, and 1:84,000, was

used for the basic topographic maps, the so-called half-verst, one-verst, and two-verst maps, respectively (one verst equals 1.067 km.).

- (2) *Estonian mapping.* During the period from 1918 to 1940, most of Estonia was mapped by the Sojavae Staabi Topo-Hüdrograafia Osakund (Topo-Hydrographic Section of the General Staff) at scales of 1:25,000, 1:50,000, and 1:200,000.
- (3) *Latvian mapping.* The Geodezijas Topografijas Dala Armijas Steba (Geodetic-Topographic Division of the Army Staff) was responsible for the mapping and surveying of Latvia from 1920 to 1940. The initial efforts of this agency were directed toward the necessary field reconnaissance for revision of the existing Russian maps of Latvia and for compilation of new Latvian maps. The long-range program included new topographic surveys at 1:25,000, some of which were completed in southeastern Latvia between 1928 and 1936.
- (4) *Lithuanian mapping.* In Lithuania, the Kar. Stabo Karo Topografijos Skyrius (Military Topographic Section of the General Staff) functioned as the primary mapping agency from 1918 to 1940. Some mapping and surveying was accomplished by city surveying offices and by the Vandens Valdybos Hidrologijos Skyrius (Hydrological Section of Waterways Department). By 1939, the Kar. Stabo Karo Topografijos Skyrius had produced partial coverage in two standard series, one at the scale of 1:100,000 covering about one-half of Lithuania and another at the scale of 1:25,000 covering about one-tenth of the country. The Karo Topografijos Skyrius provided complete coverage of Lithuania at scales of 1:400,000, 1:500,000, 1:630,000, and 1:750,000.

b. Other. Both Russian and German military cartographic agencies developed new series of the area during the period of 1931 to 1945. These series are of major importance in the Baltic area because of their uniformity, relative recency, and accuracy. The maps published by the Ger-

mans generally are more recent, ranging in date from 1940 to 1945.

- (1) *Russian.* During the period from 1931 to 1941, the General'nyy Shtab, Krasnaya Armiya (General Staff, Red Army) compiled new map series at 1:25,000, 1:50,000, 1:100,000, and smaller scales covering all or parts of Estonia, Latvia, and Lithuania. Many of the sheets were based on the old Russian verst maps; but all available recent German and native Estonian, Latvian, and Lithuanian materials and some aerial photos and field reconnaissance data were also used. These newly-compiled sheets were, for the most part, westward extensions of the new Soviet series based on the 1:1,000,000 *International Map of the World* numbering system.
- (2) *German.* During the years 1940 to 1945, the German Generalstab des Heeres (General Staff of the Army) worked in Estonia, Latvia, and Lithuania on several mapping projects. Using the map and survey data coordinated by the Heeresvermessung (Military Survey Division) and the available native and Russian maps, the Generalstab des Heeres compiled topographic maps at scales of 1:10,000, 1:25,000, 1:50,000, 1:100,000, 1:300,000, 1:500,000 and 1:1,000,000 covering all or parts of Estonia, Latvia, and Lithuania. The Reichsamt für Landesaufnahme (Federal Land Survey Office) and the Hauptvermessungsabteilung (Regional Survey Office) compiled a 1:25,000 series that covers the southern and western border areas of Lithuania.

133. Major Maps of Estonia, Latvia and Lithuania

a. Native Topographic Series.

(1) *Estonian.*

- (a) [*Estonia*]; 1:25,000; Sojavae Staabi Topo-Hüdrograafia Osakund; 1923-38; Estonian army grid.

This polychrome series covering about one-fourth of Estonia, mainly areas in the east and along the northern coast, is based on native surveys of 1923-38. On most sheets the contour interval is 2 or 4 meters; on a

few sheets the interval is 2 sulda (4.27 meters). Many spot heights are shown. The symbolization of vegetation features is unusually detailed. No legend is shown on these sheets; reference must be made to a separate symbol sheet published for the series. The size and format vary considerably from sheet to sheet. This variation is due to two factors: (1) the inclusion of outlying coastal regions by extending the sheet size and (2) an attempt to coordinate maps cut on even Greenwich longitudes with those cut on even Pulkovo longitudes. A notable example of this latter type of irregularity is the north-south band of sheets in northern Estonia eastward from 27°24' E. longitude (Greenwich) to 2°48' W. longitude, Pulkovo.

- (b) [*Estonia*]; 1:50,000; Sojovae Staabi Topo-Hüdrograafia Osakond; 1936-40; Estonian Army grid.

Sheets of this five-color series (fig. 112) provide coverage for about 75 percent of Estonia; only the western coast, the islands, and a few other scattered areas are not mapped. This detailed series is based on surveys of 1926 to 1939. Relief is shown on most sheets by contours at intervals of eight meters; on two sheets the contour interval is two meters. Spot heights are shown on all sheets. No legend appears on the sheets; a separate symbol sheet, however, has been published for this series. On most sheets, the principal roads are indicated by a red fill.

- (c) *Esti Topograafiline Ulevaate-Kaart*; (Estonian Topographic Survey Map); 1:200,000; Sojovae Staabi Topo-Hüdrograafia Osakond; 1931-40; no grid.

This five-color series providing coverage for Estonia and Latvia is the result of a joint agreement, as to format and mapping style, between the Estonian and Latvian General Staffs. Each agency worked essentially within its own borders and the

maps that were produced are quite detailed for the scale. Relief is shown by contours at intervals of 16 meters. Roads, which are shown in great detail, are classified into six categories. The major routes are indicated by a red fill.

- (2) *Latvian*.

- (a) [*Latvia*]; 1:25,000; Geodezijas-Topografijas Dala Armijas Staba; 1928-40; Soldner Army grid.

This series (fig. 113) provides coverage for southeastern Latvia. The sheets, printed in four colors, are based on new Latvian topographic surveys. Relief is shown by contours at intervals of 4 meters.

- (b) [*Latvia*]; 1:75,000; Geodezijas-Topografijas Dala Armijas Staba; 1922-40; Signal grid or Soldner army grid.

These polychrome sheets (5 colors) provide coverage for all of Latvia. They are based on Russian maps, with revisions from Latvian field reconnaissance and new topographic survey material around Riga and in areas in the southeast of the country. Relief is shown by contours at intervals of 2 or 4 asis (4.268 or 8.536 meters).

- (c) [*Latvia*]; 1:200,000; Geodezijas-Topografijas Dala Armijas Staba; 1931-40; no grid.

This series, which was produced in cooperation with the Estonian Sojovae Staabi Topo-Hüdrograafia Osakond provides complete coverage for Latvia. These detailed sheets, published in 5 colors, are based on Russian maps, and field reconnaissance and topographic survey work accomplished by the Geodezijas-Topografijas Dala Armijas Staba. Relief is shown by contours at intervals of 16 meters.

- (3) *Lithuanian*.

- (a) [*Lithuania*]; 1:25,000; Kar. Stabo Karo Topografijos; 1926-38; German Gauss-Krüger grid.

This polychrome series (fig. 114) provides coverage for the central-southeastern part of Lithuania. The

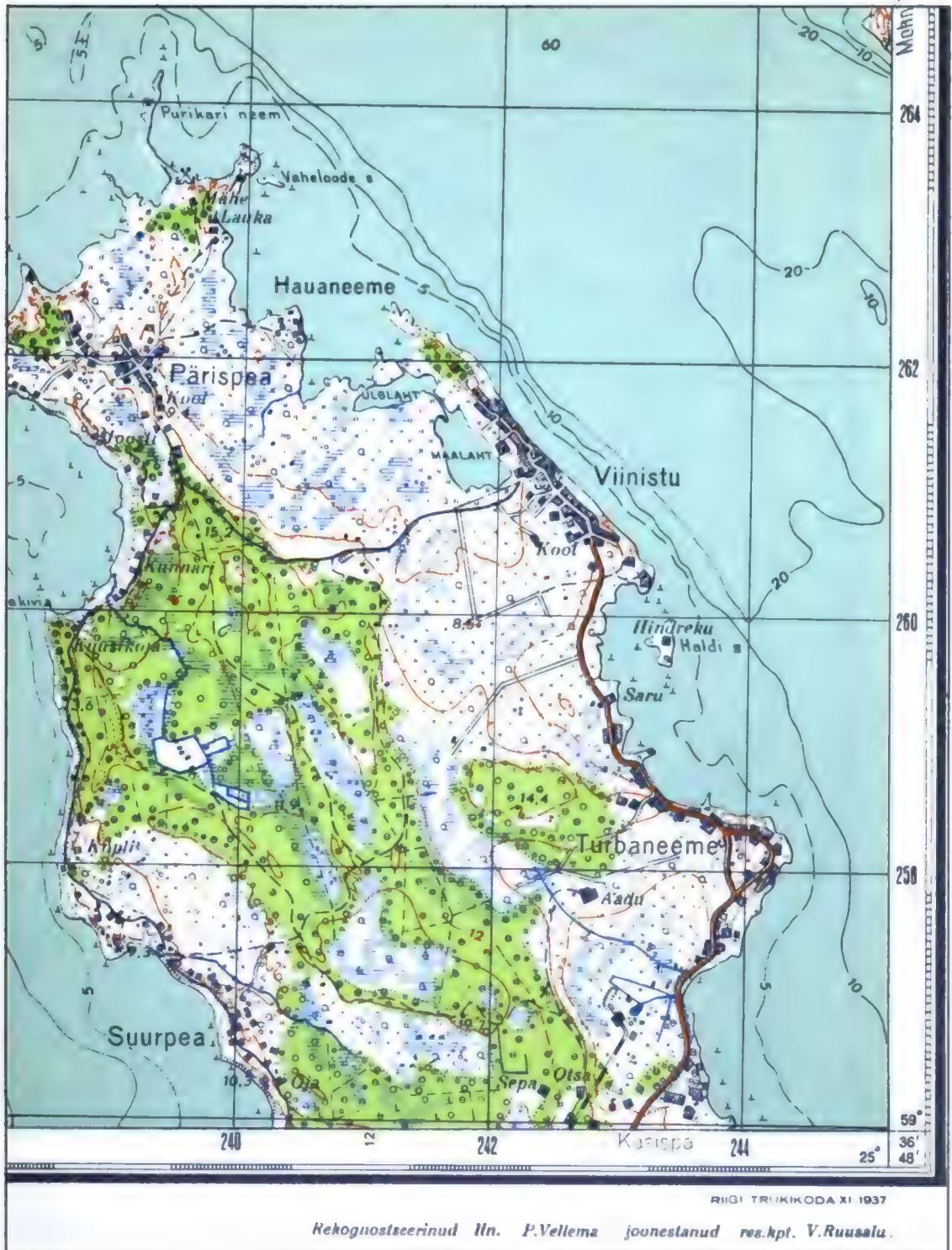

Figure 112. Section of sheet from 1:50,000 series of Estonia by the Sojovae Staabi Topo-Hüdrograafia Osakond.

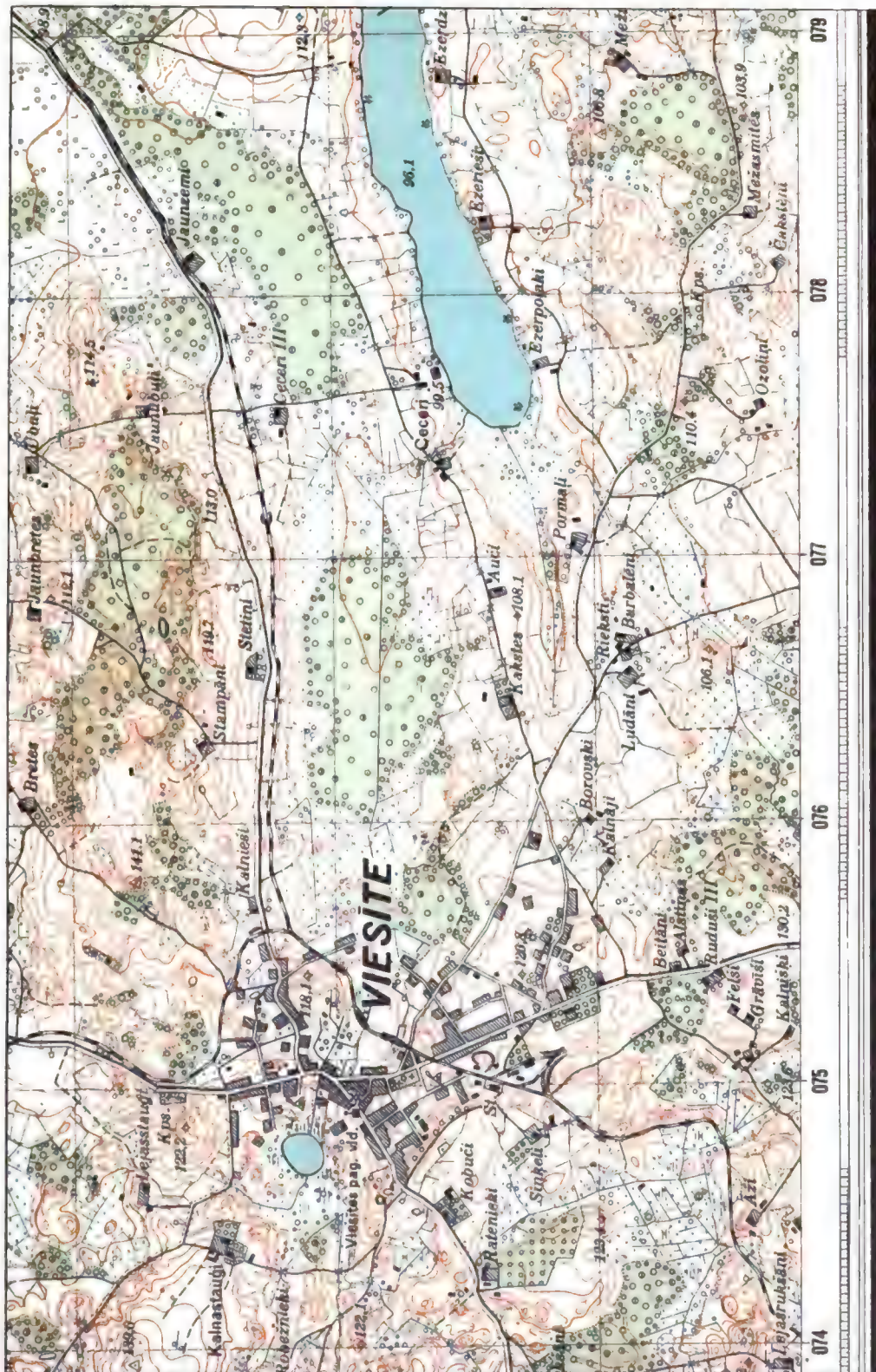
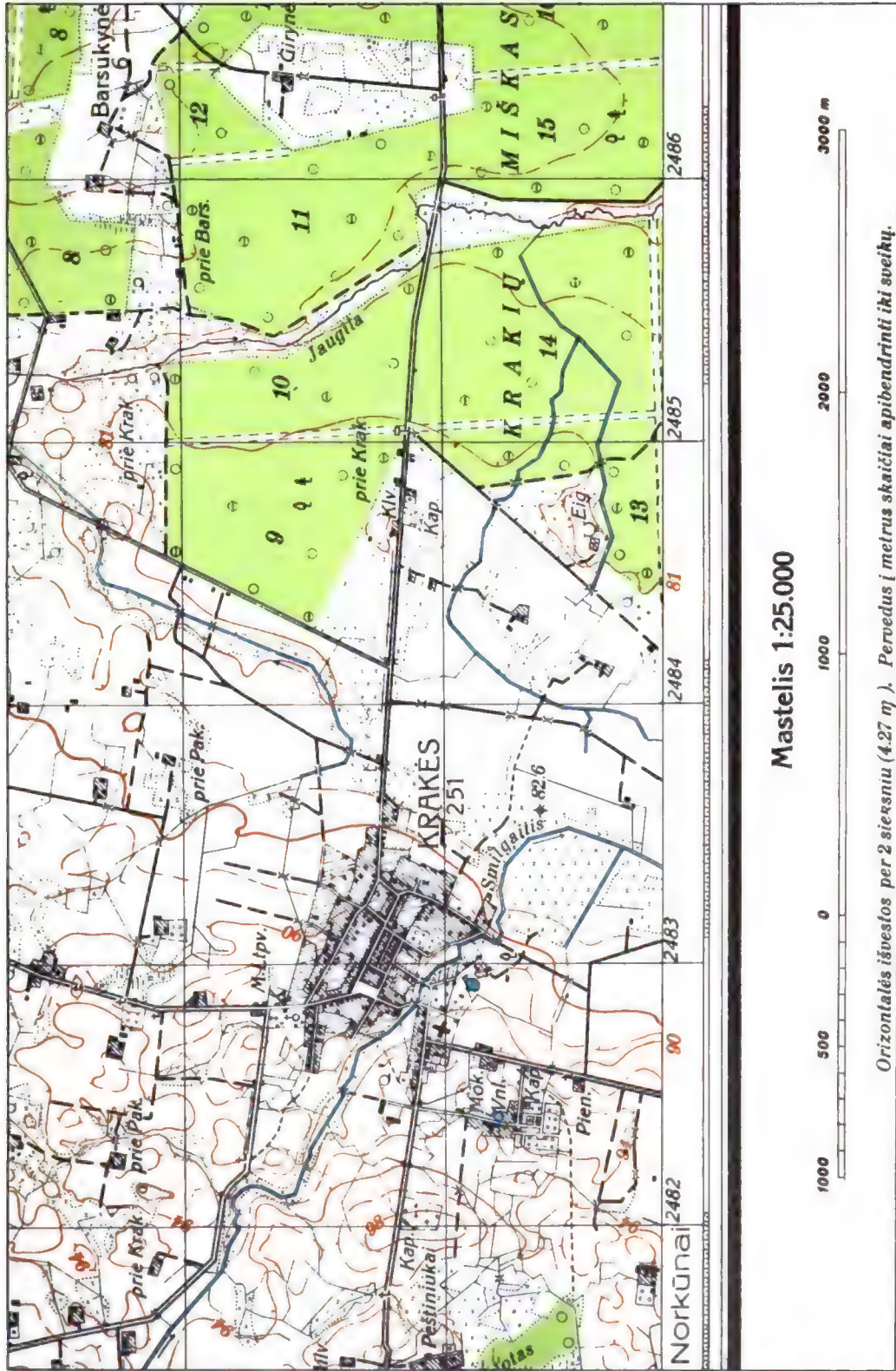

Figure 115. Section of sheet from 1:25,000 series of Latvia by the Geodezijas-Topografijas Data Armijas Staba.



Horizontalės išvestos per 2 sieksnius (4,27 m). Paveikslas į metrus skaitčiai apibendrinti iki sveikų.

Figure 114. Section of sheet from 1:25,000 series of Lithuania by the Kar. Štabo Karo Topografsjos.

contour values are in meters and were converted from the original Russian survey material with a contour interval of 2 sazhen (4.27 meters). The converted metric values occur at irregular intervals of 4 and 5 meters. Symbol legends are not indicated on the sheets; this information is published only in book form.

- (b) [*Lithuania*]; 1:100,000; Kar Stabo Karo Topografijos; 1931-38; German Gauss-Krüger grid.

This polychrome series provides coverage for the eastern, southern, and central parts of Lithuania. Relief is shown by contours at intervals of 10 meters. The legend in the sheet margin is limited to symbols for railroads, roads, boundaries, and vegetation.

b. *Other Topographic Series.*

(1) *Russian.*

- (a) [*Lithuania*]; 1:25,000; General'nyy Shtab, Krasnaya Armiya; 1940-43; Russian Gauss-Krüger grid.

This series provides coverage for northeastern Estonia and scattered areas of central and southwestern Lithuania. For a description of these sheets, see paragraph 196a(1).

- (b) [*U. S. S. R.*]; 1:50,000; General'nyy Shtab, Krasnaya Armiya; 1931-44; Russian Gauss-Krüger grid.

This series provides almost complete coverage for Estonia, Latvia, and Lithuania. For a description of the sheets, see paragraph 196a(2).

- (c) [*U. S. S. R.*]; 1:100,000; General'nyy Shtab, Krasnaya Armiya; 1936-44; Russian Gauss-Krüger grid.

The original basic surveys at 1:21,000, 1:42,000, and 1:84,000 for this series, which provides complete coverage for the Baltic States, were accomplished when the area was still a part of Russia. For a description of this series, see paragraph 196a(3).

(2) *German.*

- (a) *Topographische Karte* (Topographic Map) and *Deutsches Reich* (German Reich); 1:25,000; Reichsamt für Lan-

desaufnahme, Generalstab des Heeres, and Hauptvermessungsabteilung; 1937-44; Gauss-Krüger grid.

This series provides coverage along the southern and western border areas of Lithuania. For a description of this series, see paragraph 160a(2).

- (b) *Ostland* (Eastern Territories) and *Russland* (Russia); 1:50,000; Generalstab des Herres; 1942-45; Deutsches Heeresgitter (German Army grid).

This polychrome series provides coverage for the eastern half of Estonia, about four-fifths of Latvia, and a small part of northern Lithuania. The majority of the maps do not have a legend, but the map symbols used are the same as those on the native German and Russian maps from which they were compiled. Relief is shown on most sheets by contours at intervals of 5 and 10 meters. On some sheets based on Russian maps, however, the intervals are 4.27 and 8.53 meters (2 and 4 sazhen). A photo-coverage diagram in the sheet margin shows the extent of the photography used in the compilation. In contrast to the sheet-line system used for German 1:50,000 series elsewhere in Europe, the sheet lines of the *Ostland* and *Russland* series follow the Russian system of sheet lines and numbering.

- (c) *Ostland* (Eastern Territories) and *Russland* (Russia); 1:100,000; Generalstab des Herres; 1942-45; Deutsches Heeresgitter (German Army grid).

This polychrome series provides coverage for Estonia, Latvia, and the Latvian-Lithuanian border area. These sheets were based on various scale native and Russian maps. Relief is shown by contours at 20-meter intervals. Numerous spot elevations are given in meters. The majority of the sheets of this series do not have a symbol legend. A photo-coverage diagram in the margin shows the extent of the photography used in compilation. In contrast to the

sheet-line system used for German 1:100,000 series elsewhere in Europe the sheet lines of the *Ostland* and *Russland* series follow the Russian system of sheet lines and numbering.

- (d) *Karte des Deutschen Reichs (Grossblatt)* (Map of the German Reich-Large Sheet); 1:100,000; Generalstab des Heeres; 1940-44; Deutsches Heeresgitter (German Army grid) and Heeresmeldenetz (Army Reference grid) on some sheets.

This series (fig. 115) provides complete coverage for Lithuania, a small part of southern Latvia, and most of East Prussia. Each of the sheets was compiled by combining four standard-size 1:100,000 German maps, which were based on various scale German, Latvian, Lithuanian, Polish, and Russian sources. Some revisions to this series were made from aerial photography and other later-date materials. Legends, which are shown on all sheets, vary in symbolization according to the base material used. On sheets or parts of sheets that cover the area of Lithuania and Latvia as of 1914 (excluding the Memel Land of Lithuania) relief is shown by contours. The majority of the contours are shown at intervals of 10 meters, with auxiliaries at 5-meter intervals. Some sheets originally derived from Russian maps, however, retain contours in sazhen or use metric contour values converted from sazhen. Sheets or parts of sheets that include Memel Land and East Prussia indicate relief features by hachures. On some of the sheets for Memel Land and East Prussia, a secondary grid, the Heeresmeldenetz (Army reference grid) is overprinted in orange.

- (e) *Osteuropa* (Eastern Europe and *Mittleuropa* (Central Europe); 1:300,000; Generalstab des Heeres; 1942-44; Deutsches Heeresgitter (German Army grid).

This single series providing coverage for Estonia, Latvia, Lithuania, and East Prussia is printed under two titles. The sheets, which are polychrome, are based on various-scale native and foreign maps and are revised from information supplied by the Chef des Transportwesens (Chief of the Transport System). This series is very detailed and a complete symbol legend is shown on each sheet. In contrast to the sheets of the 1:300,000 series covering the central European areas, which depict relief by hill shading and hachures, relief is shown on these Baltic sheets by contours at intervals of 20 meters. For a description of this series, see paragraph 160a(9).

- (f) *Mil-geo karte* (Military Geographic Map); 1:300,000; Militargeographische Dienststelle; 1943-44; Deutsches Heeresgitter (German Army grid).

This series, covering nearly all of Latvia and Estonia and a small part of northern Lithuania, is based on the *Osteuropa* and *Mittleuropa* 1:300,000 series. Information of military importance has been overprinted in purple. Roads, except for the lower grade roads which are not overprinted, are classified under three categories: good all-weather roads; roads not passable in all weather; and good dry-weather roads not passable after rain. The number of lanes is shown for all overprinted roads. Railroad and road bridges are symbolized according to capacity and length. Terrain conditions are shown by symbol and explained by text. Vegetation types are identified by abbreviations or by symbol. Other important features shown by overprint include visibility from vantage points, width and depth of streams, power lines, and types of cliffs. Information in the margin and on the reverse side of the map is extensive. It includes climatic

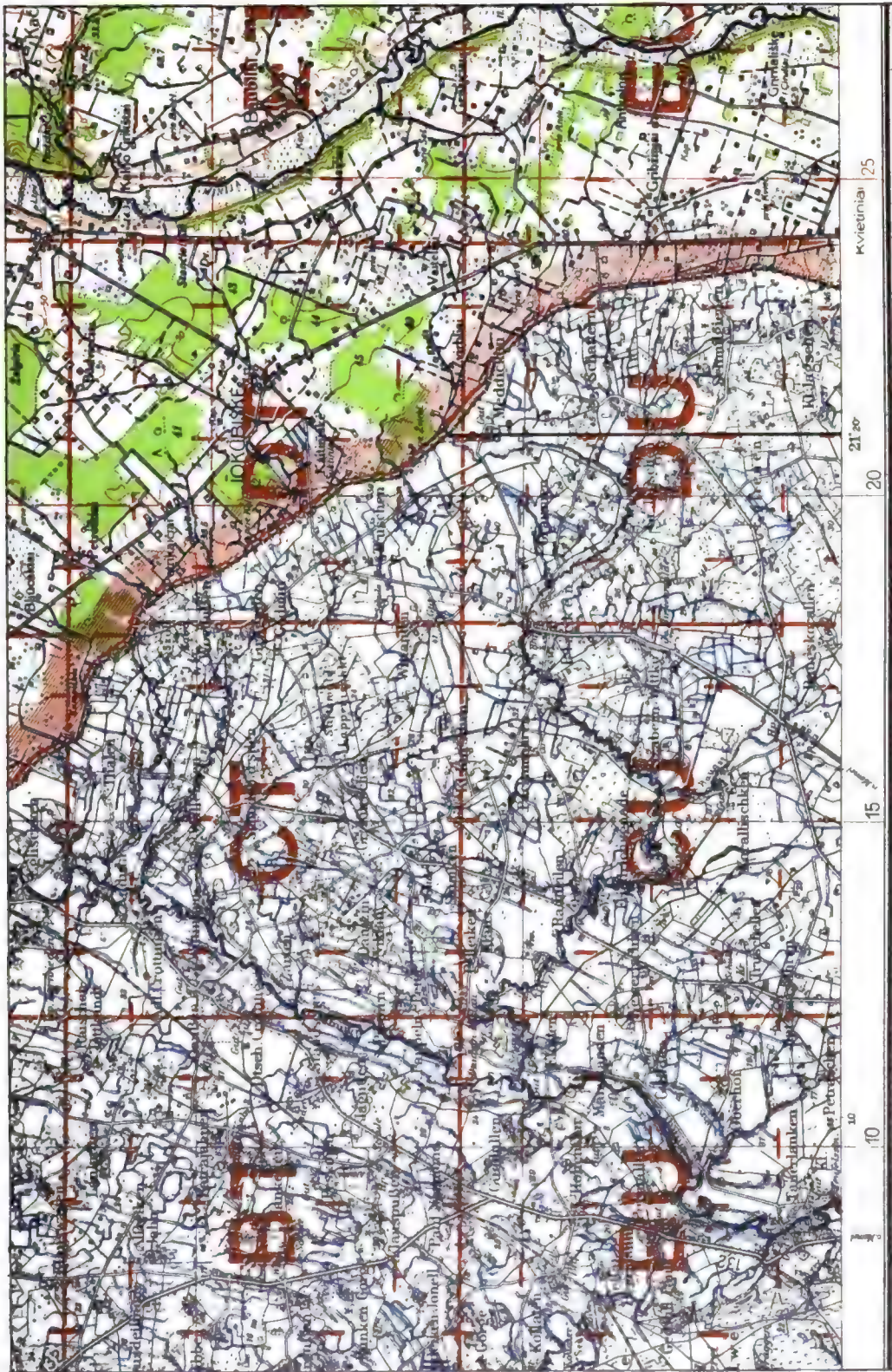

Figure 115. Section of sheet from Karte des Deutschen Reichs (Grossblatt) by the Generalstab des Heeres.

graphs and tables, textual information on general geographic conditions of the area; terrain and streams; and bridges, mines, and fords; and town plans, with throughways emphasized and information given on population, industries, and number and type of buildings.

c. Town Plans. Planimetric town plans for most of the major urban areas of Estonia, Latvia, and Lithuania were published by the Germans between 1941 and 1944.

134. Coordinate Systems

a. Geographic. On the native series by Estonian, Latvian, and Lithuanian mapping agencies geographic coordinates are expressed in degrees and the prime meridian is Greenwich. On some of the 1:25,000 Estonian maps, longitudinal values are referred to both Greenwich and Pulkovo.

b. Grid.

(1) *Estonia.* The native series at scales of 1:25,000 and 1:50,000 carry the Estonian Army grid. On the 1:25,000 sheets the grid interval is 1,000 meters and on the 1:50,000 series, 2,000 meters. The origin of this grid is at latitude 59°06' N and longitude 25°00' E, with a false northing and easting of 200,000 meters. No grid is shown on the 1:200,000 series.

(2) *Latvia.* The standard military grid for Latvia is the Soldner army grid. This grid is shown on the 1:25,000 series and the second edition sheets of the 1:75,000 series. On the first edition sheets of the 1:75,000 series, a 4 cm. Signal grid is indicated. No military grid is shown on the 1:200,000 series.

(3) *Lithuania.* The German Gauss-Krüger grid is shown on the native Lithuanian series at scales of 1:25,000 and 1:100,000. The grid interval on the 1:25,000 sheets is 1,000 meters and on the 1:100,000 series, 5,000 meters.

135. Characteristics

a. Estonia. The land area in square kilometers covered by a sheet is printed below the bar scale on most sheets at 1:25,000 and 1:50,000. In the lower right-hand margin of maps at 1:50,000 there

is a grid romer. On the 1:25,000 and 1:50,000 series, grid and geographic coordinate values for the control points used in the preparation of the map are indicated in the margin.

b. Latvia. Marginal information on the 1:25,000 series and the second edition sheets of the 1:75,000 series generally includes the following: index to boundaries, declination and magnetic variation diagrams, slope scale, and list of trigonometric points.

c. Lithuania. A conversion table, usually located in the right margin of the sheet, gives the exact values for the contours shown on the 1:25,000 series.

Table X. Glossary of Estonian Map Expressions

astane juurdekasu.....	annual variation
pindala suurus.....	land area (of sheet)
rekognostseerinud.....	surveyed
Riigi Trukidoda XI 1937.....	State Printing Office Nov. 1937
rkm.....	square kilometers
salajane.....	restricted
1 suld.....	2.1336 meters

Table XI. Glossary of Latvian Map Expressions

aerofotografjām.....	aerial photography
instrumentali.....	instrumentally
izdevums.....	edition
izlabojis.....	corrected
kartes.....	map
korigeja.....	editorial corrections
labojusi.....	corrected
pa daļai.....	partially
papildinājis.....	supplemented
pārtīlaisita.....	recompiled
pēc.....	from
pusinstrumentali.....	semi-instrumentally
rekognoscēts.....	reconnaissance
sastādījis.....	compiled
uzmerījis.....	surveyed
uzņēmuma.....	surveyed
uzņemuma.....	survey
zīmējis.....	drawn

Table XII. Glossary of Lithuanian Map Expressions

Vyr. Štabo, Karo Topogr.	General Staff, Military
Skyriaus 1930 Vytauto	Topographical Section,
Didžiojo m. leidiny	1930 Vytautas the Great, year issue
1929-30 m. nuotrauka ir in-	1929-30 survey and instru-
strument rekognosk	mental reconnaissance
perspausdinimo teises Skyri-	reproduction rights the
aus pasilike sau	Section reserves for it-
	self
1935 m. perspausdinta (s) ..	reprinted in 1935

Table XII. Glossary of Lithuanian Map Expressions—Con.

palleka -----	leaves behind	papildyta -----	supplemented
rekognoskavimas -----	reconnaissance	papildytos oro nuotraukomis--	supplemented by aerial photographs
Karo Topografinis Skyriaus 1939 m. leidinys iš Senos kartografinės medžiagos papildytos rekognoskuotomis oro nuotraukomis	Military Topographical Sections 1939 issue compiled from the old cartographical material, supplemented by aerial photographs	dalis-----	unit
nuotrauka -----	survey	Vyr. Štabo Oper. Skyriaus Topografinis Dalies leidinys 1927 m.	Published by Chief of Operations Topographical Section, issued 1927
		(Kar.) Karliuomenes Štabo---	Military Staff

Section III. EAST PRUSSIA

136. Mapping Activities

a. *Native.* The Zentraldirektorium der Vermessungen im Preussische Staate (Central directorate of the Prussian Survey) was founded in 1870 under the Chief of the General Staff. Five years later the two chief sections, the Topographische Abteilung (Topographic Division) and the Bureau der Landestriangulation (Bureau of Land Triangulation), were combined into the Preussische Landesaufnahme (Prussian Land Survey), known after the war of 1914–18 as the Reichsamt für Landesaufnahme (Federal Land Survey Office). In 1937 an official decree made the Reichsamt für Landesaufnahme responsible for all mapping carried on within the German Reich and for the fulfillment of the mapping requirements of the Generalstab des Heeres (General Staff of the Army).

b. *Other.* The standard Russian topographic series at 1:25,000, 1:50,000 and 1:100,000 by the General'nyy Shtab, Krasnaya Armiya (General Staff, Red Army) cover most of East Prussia.

137. Major Maps of East Prussia

a. Native Topographic Series.

- (1) *Topographische Karte* (Topographic Map) and *Deutsches Reich* (The German Reich); 1:25,000; Reichsamt für Landesaufnahme, Generalstab des Heeres and Hauptvermessungs-abteilung (Regional Survey Office); 1937–44; Gauss-Krüger grid.

These sheets, although printed under two titles and three authorities, serve as a single series and provide coverage for all of East Prussia. In this East Prussian area, sheets of this series were based on German and Russian materials. The sheets are monochrome with the exception of a few polychrome

lithographs. Relief is shown by contours; the interval is usually dependent upon the source material used. The majority of the sheets have a contour interval of 5 meters with auxiliary contours at 2.5 meters. The contour interval of the remaining sheets is 4.27 meters (2 sazhen). The sheets of the *Deutsches Reich* series show no symbol legend. Symbolization is complete and detailed for all sheets compiled by the Reichsamt für Landesaufnahme and the Hauptvermessungsabteilung. For a complete description of this series, see paragraph 160a(2).

- (2) *Karte des Deutschen Reiches (Grossblatt)* Map of the German Reich (Large Sheet); 1:100,000; Generalstab des Heeres; 1940–44; Deutsches Heeresgitter (German Army grid).

This series (fig. 157) provides almost complete coverage for East Prussia. For a description of this series, see paragraph 133b(2)(d).

- (3) *Osteuropa* (Eastern Europe) and *Mittel-europa* (Central Europe); 1:300,000; Generalstab des Heeres; 1942–44; Deutsches Heeresgitter (German Army grid).

This series provides complete coverage for East Prussia. For a complete description of the series, see paragraph 133b(2)(e).

b. Other Topographic Series.

- (1) [*U. S. S. R.*]; 1:25,000; General'nyy Shtab, Krasnaya Armiya; 1940–43; Russian Gauss-Krüger grid.

This series provides coverage for three-fourths of East Prussia. For a description of this series, see paragraph 196a(1).

- (2) [*U. S. S. R.*]; 1:50,000; General'nyy

Shtab, Krasnaya Armiya; 1931-39; Russian Gauss-Krüger grid.

This series provides coverage for most of East Prussia. For a description of the series, see paragraph 196a(2).

- (3) [*U. S. S. R.*]; 1:100,000; General'nyy Shtab, Krasnaya Armiya; 1936-40; Russian Gauss-Krüger grid.

This series provides complete coverage for East Prussia. For a description of this series, see paragraph 196a(3).

c. *Town Plans.* Various scale town plans of

urban areas in East Prussia were published by the Germans from 1927 to 1944. The majority of the plans show detail for both the city proper and its environs. Most of the plans are monochrome and planimetric, but a few are polychrome and contoured.

138. Coordinate Systems, Characteristics, and Marginal Information

For a description of the characteristics, coordinates, and marginal information, see paragraph 160.

Section IV. FINLAND

139. Mapping Activities

a. *Native.* The Maanmittaushallitus (General Survey Office) produces seventy-five percent of all maps published in Finland. This includes all large-scale topographic series and communications and general maps. Only very specialized maps, such as hydrographic charts by the Merikarttalaitos Suomi (Hydrographic Chart Division), are made by other agencies. When Maanmittaushallitus began the production of maps, there existed only a limited accumulation of survey and map data. This included the Finnish planimetric maps at large scales and the limited survey and map data of Russian and Swedish origin. The Maanmittaushallitus policy of developing as rapidly as possible from these materials the maps urgently needed for economic development and national security led to a confusion of several formats in each of the larger-scale series. This coverage was of a temporary nature until such time as standard maps could be completed. In 1941 a new format was adopted for all maps at standard scales (i. e., 1:20,000, 1:100,000, 1:200,000 and 1:400,000) made by Maanmittaushallitus (see figs. 117 and 118). Some of the pre-1941 maps, however, with sheet lines based on the graticule and longitudinal values referred to Helsinki are still currently revised and maintained.

b. *Other.* The only non-Finnish mapping authority that has contributed maps of any consequence to the overall map coverage of Finland is the U. S. Army Map Service. During the post-World War II period, AMS has published a 1:250,000 series covering all of Finland. During World War II medium-scale maps of Finland were also made by the British Directorate of Mili-

tary Survey, War Office (Geographical Section, General Staff) and the General Staffs of both the German and Russian armies, but all of these have been superseded by recent Finnish maps.

140. Major Native Maps of Finland

a. *Topographic and Planimetric Series.*

- (1) *Peruskartta* (Basic Map); 1:20,000; Maanmittaushallitus; 1948-53; Finnish Gauss-Krüger grid.

The *Peruskartta* was designed in 1948 to combine the cultural, hydrographic, and hypsometric data shown on the *Topografinen Kartta* and the property lines and land uses shown on the *Pitäjänkartta* of the same scale. One base map complete in planimetric detail is made from controlled photography, field checked, and drafted. The contour plate (printed in brown) is added to the base to make the *topografinen painos* (topographic print). Cadastral data (printed in red) are added to the base map to make the *taloudellinen painos* (economic print). A combination of all three may be made (fig. 116). Complete coverage for the country is planned, but at present only scattered areas of strategic or economic importance have been mapped. Survey data used for these maps include supplementary surveys initiated in 1948. The compilation of this series was begun in 1948 and the yearly production (1952) is approximately thirty sheets. Relief is shown by numerous spot

heights on the base drawing and by contours at 5-meter intervals on the *topografinen painos* (topographic print). Six categories of railroads and seven classes of roads are shown. Roads suitable for automobile traffic and their general condition are shown in addition to the classes identified on other large-scale maps. Winter roads and trails, both unique and important to this northern area, are shown. Telecommunications and power lines are shown in detail. The two official languages appear on these maps in the areas where Swedish-speaking people predominate and only Finnish in other areas.

- (2) *Topografinen Kartta 1:20,000* (Topographic Map 1:20,000); Maanmittaushallitus; 1933-48; Finnish Gauss-Krüger grid.

The *Topografinen Kartta* is a polychrome print (four colors) providing coverage for widely scattered strategic areas of Finland. These sheets are stereo-compiled and controlled by large-scale ground surveys. Relief is shown by contours at 5-meter intervals and by numerous spot heights in meters. Types of vegetation are shown by symbol and their limits are indicated. The extent of cultivated areas is shown in white, without symbol. Six categories of railroads and seven classes of roads are shown. Telecommunications and power lines are shown in detail.

- (3) *Merikarttalaitoksen Topografikartta* (Hydrographic Editions of the Topographic Map); 1:20,000; Merikarttalaitos Suomi; 1940-45; Finnish Gauss-Krüger grid.

Marine-topographic maps showing both topographic and detailed hydrographic data cover the coastal area and the islands of the Gulf of Finland. These maps were stereo-compiled from aerial photography flown prior to 1940 and include the data of the hydrographic survey of 1932-33. They have not been revised nor has the coverage been extended. Relief is shown by contours at 5- and 10-meter intervals and

by numerous spot heights. Depth lines are also shown for the off-shore area. No legend appears on the map, but standard Finnish symbols are used for both land and hydrographic detail.

- (4) *Pitäjänkartta* (Parish Map); 1:20,000; Maanmittaushallitus; 1920-52; Finnish Gauss-Krüger grid.

The *Pitäjänkartta* is the oldest large-scale series of Finland and covers by far the largest area. These sheets cover most of southern Finland, with scattered coverage in west central area. Two formats are being maintained currently, but only the later one is being revised. Further compilation was discontinued on the whole series in 1948, when the information on this map was combined with the *Topografinen Kartta* to make the *Peruskartta*. The *Pitäjänkartta* is a monochrome print and since 1924 has used the standard map symbols. A symbol legend is shown on sheets of the latest format. Relief is shown only by scattered spot heights in meters.

- (5) *Topografinen Kartta 1:50,000* (Topographic Map), Maanmittaushallitus; 1937-52; Finnish Gauss-Krüger grid.

Topografinen Kartta 1:50,000 was discontinued in 1924 as the standard large-scale map of Finland, but the sheets that had been completed are still maintained. They cover a small area in southeast Finland and the more important tourist areas. They are printed in four colors and are contoured with varying intervals depending on the type of terrain.

- (6) *Topografinen Kartta 1:100,000* (Topographic Map); Maanmittaushallitus; 1941-52; Finnish Gauss-Krüger grid.

This five-color series will eventually cover all of Finland but at present, only the southeast section and two small, widely separated areas are mapped. Notes on the map inform the user as to the sources used in compilation. This series is being currently compiled mainly from the *Peruskartta* 1:20,000. Contours are shown at 10-meter intervals. Types of vegetation

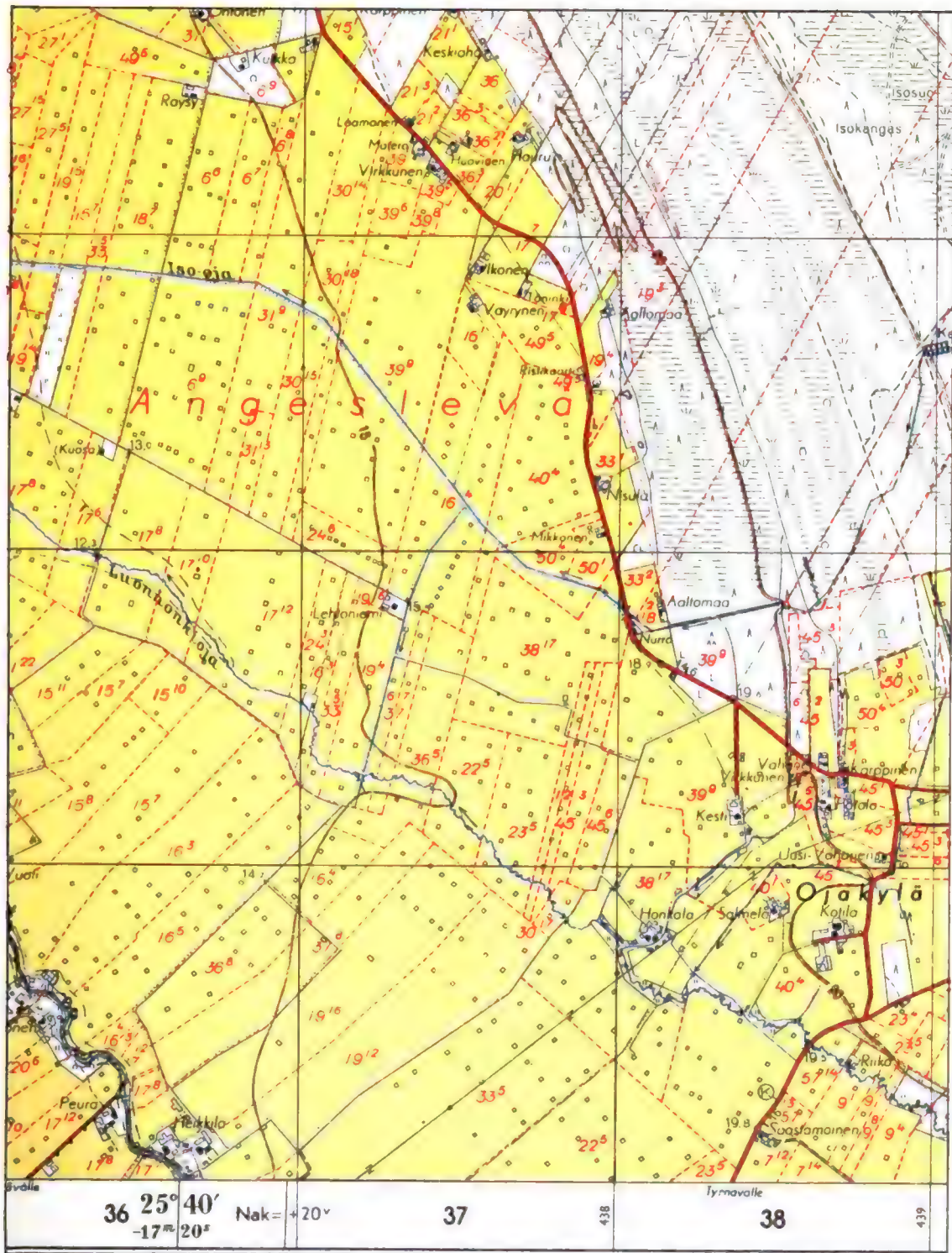

Figure 118. Section of sheet from the 1:20,000 Peruskartta by the Maanmittaushallitus.

are shown by symbol and the extent is indicated by color. Six categories of railroads and nine classes of roads are shown on this detailed map. Telecommunications systems are complete and clearly shown. The maps in southeastern Finland cover an area where there is a junction of two spheroid measurements. The Russians used the computations of Bessel and the Finnish used the International spheroid of Hayford, so that difficulty is encountered in reconciling the data computed from the two sources. Appropriate notes appear on the map sheets warning the user.

- (7) *Taloudellinen Kartta* (Economic Map); 1:100,000; Maanmittaushallitus; 1923-53; Gauss-Krüger grid shown on standard sheets.

The *Taloudellinen Kartta* furnishes the most complete coverage of Finland at this scale. Only the Gulf of Bothnia area is not mapped. This is an old series, antedating by many years the Finnish Republic, and it lacks uniformity in projection, format, prime meridian, and symbols. Uniform, complete coverage, however, is planned for the country. This series varies as to the number of colors (two to five) depending on the format of the sheets. It is primarily a land-use map and is planimetric. On the latest format (Gauss-Krüger projection) cultivated areas and natural meadow areas are shown in color. Forest is indicated by white areas; swamp, cultivated, or cleared areas are shown by symbol or color. Five categories of railroads and from three to five classes of roads are shown on the various formats.

- (8) *Suomen Yleiskartta* (General Map of Finland); 1:400,000; Maanmittaushallitus; 1940-52; no grid.

The *Suomen Yleiskartta* provides the largest-scale complete coverage of Finland. It has been revised and redrafted many times. The sheets now in print are on atlas grid sheet lines, but the series is presently being recast on standard sheet lines, Gauss-Krüger

projection, and longitude values are referenced to Greenwich, rather than Helsinki. The *Yleiskartta* shows a wealth of detail for the scale. Relief is shown by shading and spot heights in meters. It is printed in four colors and is also published in atlas form (1950). Two categories of railroads and four classes of roads are shown. Longitude values are referred to the Helsinki meridian.

b. Town Plans. The town plans for important and strategic towns of Finland vary greatly in type, authority, completeness, date and scale. Most of these plans are planimetric, but all major cities are also covered by the basic topographic series at 1:20,000. The plans are made locally, this is, by city engineers or planning commissions, except those for the most important and largest cities. They vary in scale from 1:2,000 to 1:38,500 and in date from 1937 to 1951.

141. Coordinate Systems

a. Geographic. Graticule information is shown on all native Finnish maps. On series at 1:100,000 or larger scales, geographic position is indicated by marginal ticks only. On most maps Greenwich is the prime meridian; but on the old-style economic 1:20,000 and 1:100,000 maps and on the current 1:400,000 series longitudinal values are referenced to Helsinki.

b. Grid. The Finnish Gauss-Krüger grid is shown on all maps compiled after 1941 by Maanmittaushallitus at 1:100,000 or larger scales. Some of the older formats of the economic 1:100,000 scale map have only grid ticks.

142. Characteristics

a. The maps show hydrography in great detail.

b. Sheet numbers for all standard-scale maps (1:20,000, 1:100,000, 1:200,000, and 1:400,000) published since 1941 by Maanmittaushallitus are based on the Gauss-Krüger grid as adapted to the northern latitudes by the Finns (fig. 117). In order to standardize sheet size of the 1:20,000 and 1:100,000 maps, sheets at these scales are combined at the junction of grid bands whenever the size becomes less than half the standard size for that scale, e. g., 2733-07, 3711-04 and 2744-3722. See figure 118 for areas in which the 1:20,000 and 1:100,000 sheets are combined.

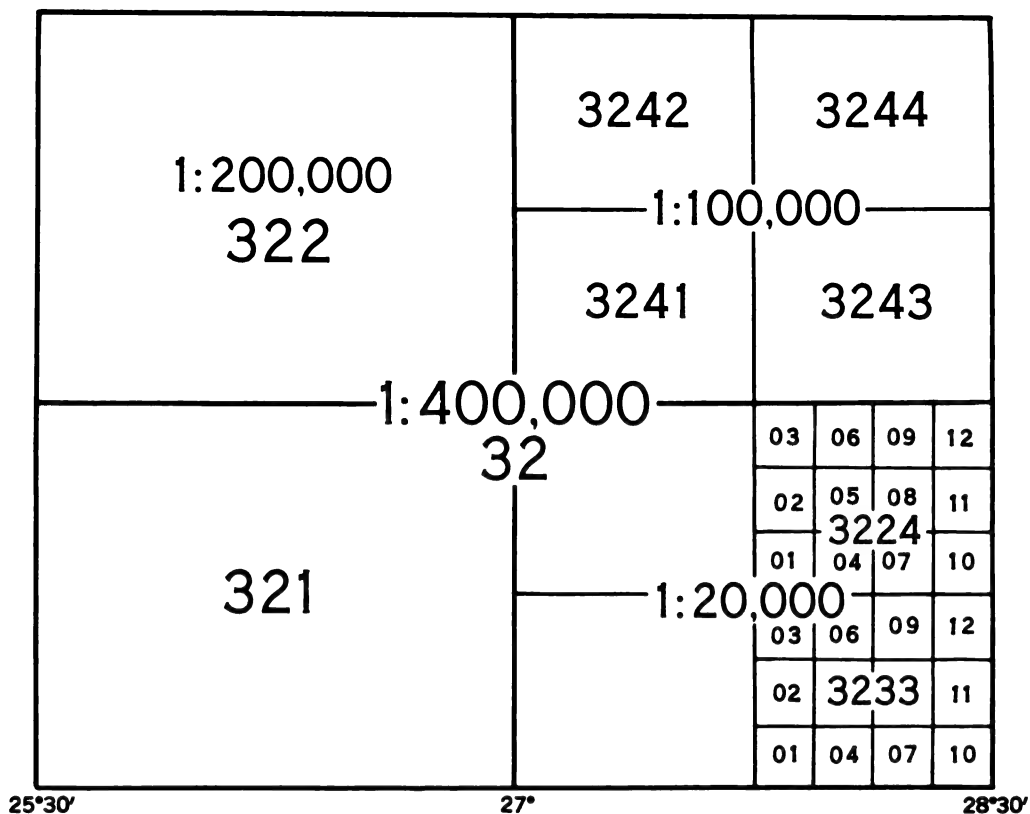

Figure 117. Finnish standard sheet numbers.

143. Marginal Information

a. Each sheet has appropriate notes conspicuously placed to explain or warn the user of any irregularity or geodetic discrepancy.

b. Unless there is information on the sheet to the contrary, the map is considered to be revised to the publication date printed to the lower right of the neat line.

c. Finnish and Swedish are official languages. The following are departments of the General Survey Office, which may be shown as the authority on individual sheets. (Swedish terms, where applicable, are given in parentheses):

Maanmittaushallituksen kartografinen toimisto Topographic Department of the General Survey Office

Maanmittaushallituksen kartografinen toimisto (Lantmäteristyrelsens Kartografiska Byrå)

Puolustusoolmain Paaeskunnan topografinen osasto

Maanmittaushallituksen kivipaino, Helsinki (Lantmäteristyrelsens Stentryckeri)

Cartographic Department of the General Survey Office

Topographic Section of the Defense Department of the General Staff

Government Printing Office, Helsinki

Table XIII. Glossary of Finnish Map Expressions

tehty	produced by
laadittu	compiled
piirretty	drawn
piirlänyt	drawn by
mittaus	survey
mitattu	surveyed by
korjattu	corrected

1:20,000 SHEETS
 COMBINED AS THE
 FUNCTION OF GRID BANDS
 1:20,000 AND
 1:100,000 SHEETS
 COMBINED.

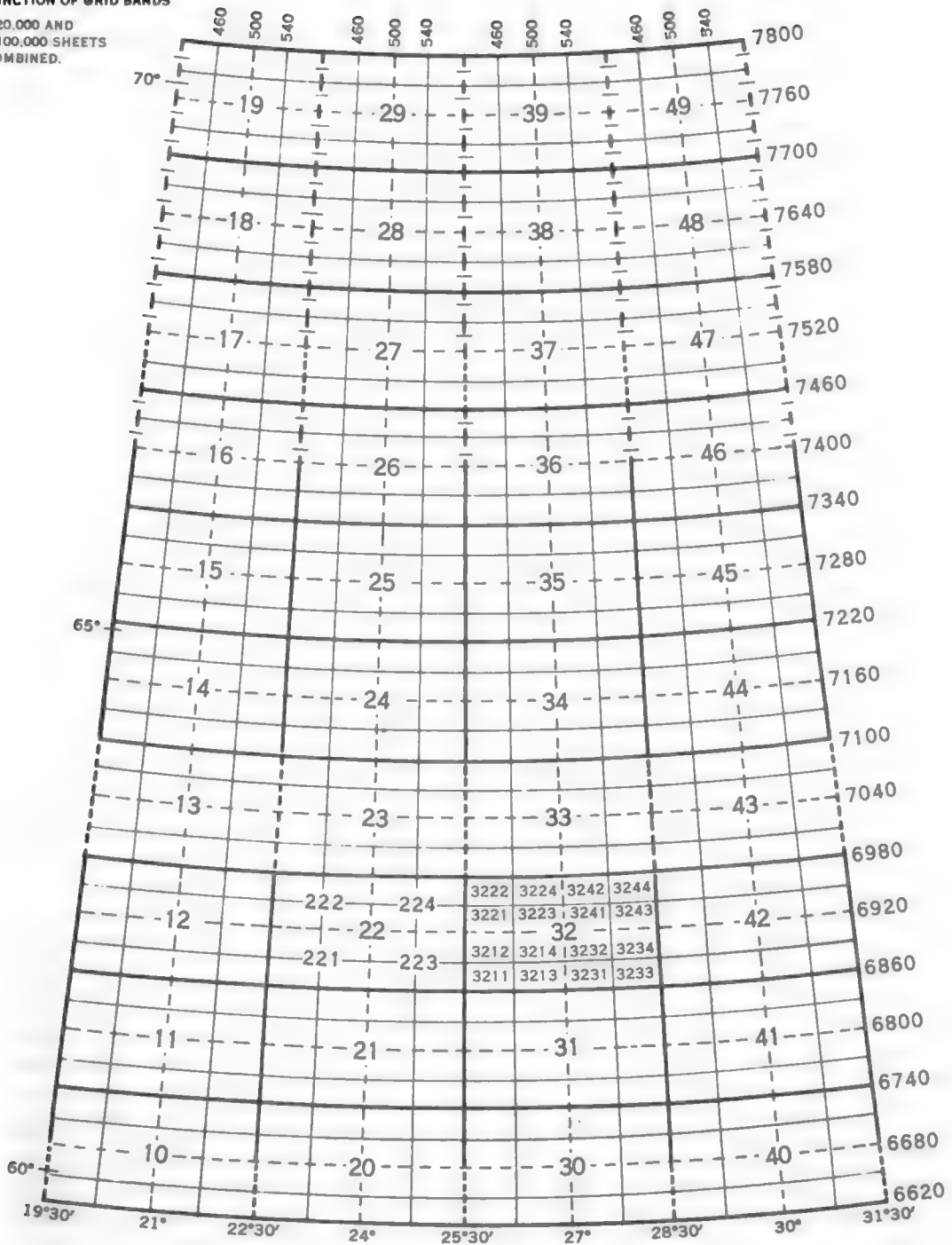

Figure 118. Diagram showing Finnish standard map sheets and numbers.

Section V. NORWAY

144. Mapping Activities

a. Native. The military maps of Norway are published by the Norges Geografiske Oppmåling—NGO (Norwegian Geographic Survey) at scales of 1:5,000, 1:10,000, 1:25,000, 1:50,000, 1:100,000, 1:200,000, 1:250,000, 1:400,000, and 1:1,000,000. This agency provides the Norwegian General Staff with domestic topographic maps. The Norsk Polarinstitut (Norwegian Polar Institute), an agency of the Norwegian Department of Interior, is responsible for the surveying and mapping of the Norwegian dependencies of Svalbard, Bear Island, and Jan Mayen. A private agency, H. Aschehoug and Co., has published topographic maps at scales of 1:300,000 and 1:500,000. Other private map-making firms have published medium- and small-scale maps and atlases, mainly of communications. Town plans for the larger urban areas are published by local bookstores, surveying companies, and city engineers.

b. Other. Military maps have also been produced by Great Britain, Germany, the United States, U. S. S. R., and Sweden.

(1) *British.* During World War II extensive mapping of Norway was accomplished by the Directorate of Military Survey, War Office (Geographical Section, General Staff)—GSGS. Series at scales of 1:25,000, 1:50,000, 1:100,000, 1:200,000, 1:300,000, 1:500,000, and 1:1,000,000 were produced. Most of these series were either direct copies or enlargements of the original Norwegian maps. Some, however, were revised from wartime photography. In addition, the Inter-Service Topographical Department, GSGS, and the Joint Intelligence Bureau (JIB) have produced numerous strategic planning maps and town plans of Norwegian coastal cities.

(2) *German.* During the years of the German occupation, the Generalstab des Heeres (General Staff of the Army) revised and reproduced most of the existing Norwegian maps. Enlargements were also made of medium- and small-scale maps to complete the coverage at large scale. German military topo-

graphic maps of Norway are at scales of 1:10,000, 1:25,000, 1:50,000, 1:100,000, 1:300,000, 1:500,000, and 1:1,000,000 on these series the Gauss-Krüger grid is shown. Numerous large-scale plans of strategic urban areas were also produced.

- (3) *United States.* The Army Map Service (AMS) has published map series of Norway at scales of 1:50,000, 1:100,000, 1:250,000 and 1:1,000,000 that are based on German and Norwegian maps. A few strategic town plans have also been produced.
- (4) *Russian.* The General'nyy Shtab, Krasnaya Armiya (General Staff, Russian Army) compiled and published two ungridded map series of Norway at scales of 1:500,000 and 1:100,000,000. These series are based on the Norwegian 1:100,000 and 1:400,000 series.
- (5) *Swedish.* The Generalstabens Topografiska Avdelning (General Staff Topographic Section) compiled a 1:300,000 series that provided partial coverage of northern Norway. A metric grid is shown on these maps.

145. Major Native Maps of Norway

a. Topographic Series.

- (1) *Omegn Karte* (Environs Map); 1:25,000; Norges Geografiske Oppmåling; 1914-52; no grid.

This polychrome topographic series providing scattered coverage for strategic and urban areas of Norway is based on 1912-39 surveys. Cultural revisions were made in 1914-51. Relief is shown by contours at 5-, 10-, or 30-meter intervals, supplemented by spot heights and elevations values at trigonometric stations. Deciduous and coniferous woods are differentiated by symbol. Roads are classified by maintenance responsibility, or by suitability for various types of traffic. Railroad information includes number of tracks and type of power. Administrative divisions are shown.

- (2) *Turistkart* (Tourist Map); 1:50,000;

Norges Geografiske Oppmåling; 1911-51; no grid.

This polychrome series providing coverage for scattered areas is primarily for tourist use. These sheets, which are based on 1911-48 surveys, have incorporated cultural revisions of 1920-50. Relief is shown by contours at 20- and 30-meter intervals. Deciduous and coniferous woods are shown by symbol. Roads are classified mainly by maintenance responsibility and to some extent by surfacing. Railroad information includes number of tracks and gage. Boundaries are indicated.

- (3) *Topografisk Kart over Kongeriket Norge* (Topographic Map of the Kingdom of Norway); 1:100,000; Norges Geografiske Oppmåling; 1872-1952; no grid.

This polychrome series (fig. 119) providing coverage for all of Norway except the extremely mountainous areas in the north and southwest is the basic topographic series for the country. It is based on 1870-1940 surveys and some sheets have been revised to the present time. Relief is shown by contours at 30-meter intervals and by hill shading, spot heights, and elevations at trigonometric stations. Deciduous and coniferous woods are differentiated by symbol. Roads are classified according to maintenance responsibility and weatherability. Railroad information includes number of tracks and gage.

- (4) *Landgeneralkart over Norge* (General Land Map of Norway); 1:250,000; Norges Geografiske Oppmåling; 1920-52; no grid.

This polychrome topographic series providing coverage for about 40 percent of Norway is based on surveys of 1917-43. Most of the sheets have been revised since 1930. This series is published in two mapping styles; on the older sheets, relief is shown by contours and hill shading; on the newer editions, contours are shown at 50-meter intervals, with spot heights and elevations at trigonometric stations. Vegetation is indicated by color on some sheets; on later editions vegeta-

tion features are not indicated. Roads are classified by weatherability. Railroad information includes only the number of tracks. Three types of administrative boundaries are shown.

- (5) *Internasjonalt Verdenskart i Malstokken* (International Map of the World); 1:1,000,000; Norges Geografiske Oppmåling; 1926-48; no grid.

These multicolor sheets published in atlas form were compiled during the period 1926-48 and provide complete coverage for Norway. Relief is shown by contours at 100-meter intervals, emphasized by altitude tints. Vegetation is not indicated. Three types of roads are shown. Railroads are classified according to number of tracks. Two administrative divisions are shown.

b. Town Plans. Town plans of native origin are limited. Local surveying companies, bookstores, and city engineers produce plans that are intended primarily for tourist use. Postwar plans of damaged cities compiled by city engineers usually show urban long-range redevelopment planning.

146. Coordinate Systems

a. Geographic. On all maps of Norway geographic coordinates are expressed in degrees. On Norwegian series and some German maps Oslo is the prime meridian. On British, U. S., Russian, Swedish, and some German maps, longitude values are referred to Greenwich.

b. Grid. Although most Norwegian maps have no grid, the Gauss-Krüger grid appears on a few military editions, and reference grids are used on some tourist maps and town plans. On most British maps of Norway the North European grid, Zones I, II, and III (10,000-meter grid interval) is used. On recent maps of Norway by the Army Map Service, the Universal Transverse Mercator grid is shown; on older AMS maps the World Polyconic grid is used.

147. Characteristics and Marginal Information

On all recent Norwegian maps scales are based on the metric system of measurement and the geographic mile. Older native maps are sometimes based on the Norwegian mile.

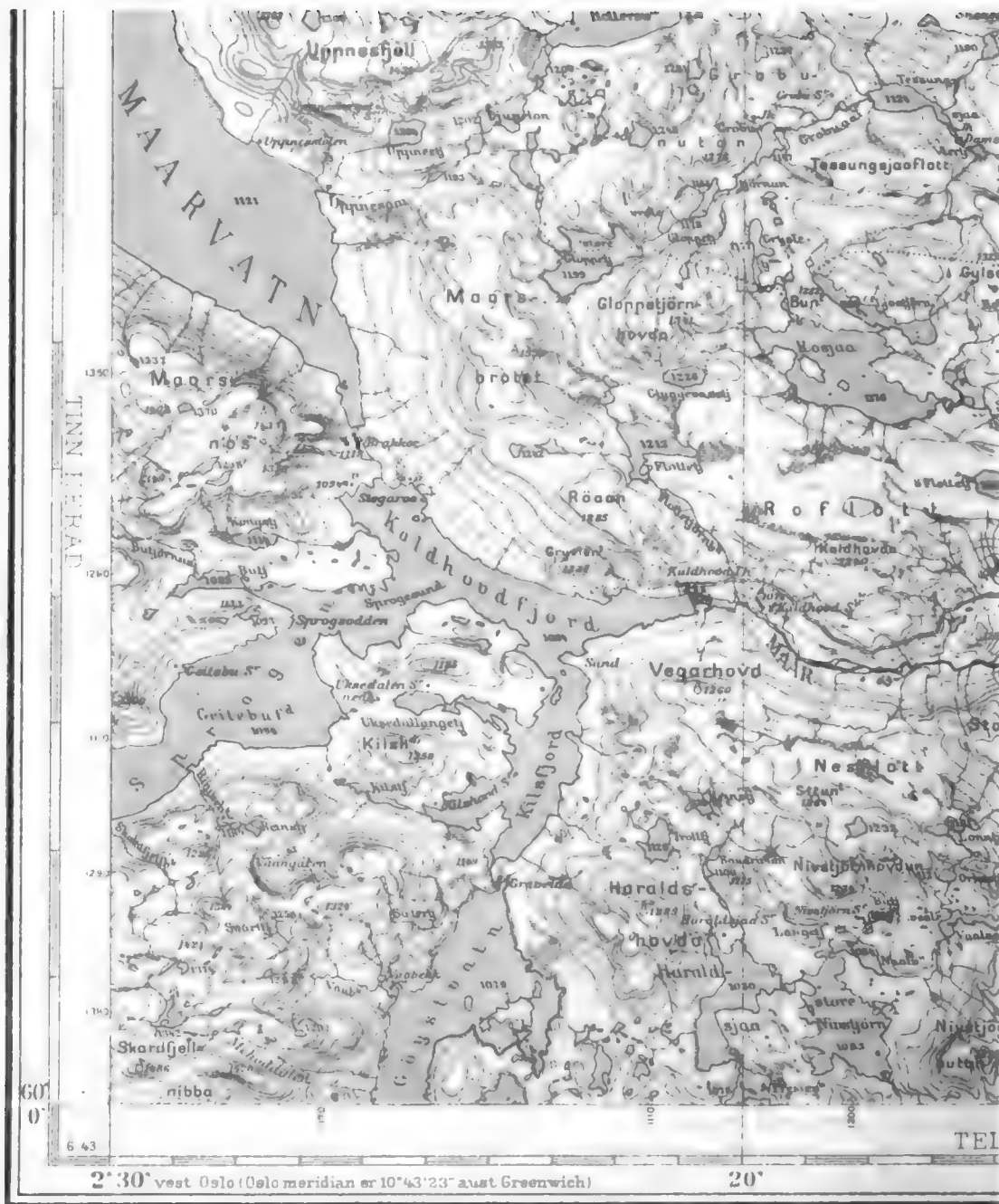

Uppmælt 1925-29. Utgjeve av Norges geografiske Oppmåling 1936

Figure 119. Section of sheet from the Topografisk Kart over Kongeriket Norge at 1:100,000 by the Norges Geografiske Oppmåling.

Table XIV. Glossary of Norwegian Map Expressions

delvis ført a jour.....	partly brought up to date	målestokk.....	scale
direkte reproduksjon.....	direct reproduction	omland, omegens kart.....	environs map
ekserseplasskart.....	drillfield map	omstridde grenser er ikkje avlagde på kartet.	disputed boundaries do not appear on the map
etterprent forbøde.....	copyright	oppmålt.....	surveyed
fargar for høgd og djupn.....	layer shading	oversynskart.....	index, index map
flykart.....	air map	Polarsirkel.....	Arctic Circle
førebels utgave.....	preliminary edition	rektangelkarta.....	rectangle map
forstørrelse.....	enlargement	revideret.....	revised
fylkeskart (amt kart).....	county map	revideret i marken.....	revised in the field
gradeteigskarta.....	graticule map	skjærgård.....	group of skerries
granneblad.....	adjoining sheet	sjøkart, sjøkart.....	hydrographic chart
grunnlag.....	basis	tegne, telkna.....	drawn, drawn
høider i meter.....	heights in meters	telkntydning, tegnforklaring..	legend
høidekurver.....	contours	topografisk kart.....	topographic map
kroki.....	rough sketch	utgave.....	edition
landgeneralkart.....	general land map	utgitt, utgjeve.....	published
magnetisk misvisning.....	magnetic declination	veler a jourført.....	roads brought up to date
militærkroking.....	military sketches		
målebordskart.....	planetable map		

Section VI. SWEDEN

148. Mapping Activities

a. Native. Topographic mapping in Sweden is the responsibility of Rikets Allmänna Kartverk (National Public Map Service)—RAK, a civilian organization under the Department of Agriculture. The military maps of Sweden are prepared by Militärbyrån (Military Bureau), one of the divisions of RAK that maintains liaison with the General Staff of the Army. The printing and distribution of the maps is handled by a private company, Generalstabens Litografiska Anstalt (Lithographic Institute of the General Staff)—GLA. The GLA is part of the Esselte, A. B. (Esselte Corporation), one of 67 corporations making up the gigantic A. B. Sveriges Litografiska Tryckerier (Swedish Lithographic Publishers, Incorporated). These organizations do contract printing for the Swedish government and provide the Swedish General Staff with domestic topographic maps for planning and operations. The principal map series are produced at scales of 1:10,000, 1:50,000, 1:100,000, 1:200,000, 1:300,000, 1:400,000, 1:500,000, 1:800,000, and 1:1,000,000. These map series, with the exception of some of the economic maps, are to be thoroughly revised during the 15 year period, 1945–60. These independent corporations also compile and publish various maps, charts, town plans, atlases, and cartographic and geographic books.

b. Other. Military maps have also been produced by Great Britain, Germany, France, U. S. S. R., and the United States.

- (1) *British.* The Directorate of Military Survey, War Office (Geographical Section, General Staff)—GSGS has published map series of Sweden at scales of 1:100,000, 1:200,000, 1:250,000, 1:300,000, 1:500,000, and 1:1,000,000. In addition, the Joint Intelligence Bureau (JIB), The Ministry of Defence, and the Naval Intelligence Division, have produced town and port plans at various scales.
- (2) *German.* The Generalstab des Heeres (General Staff of the Army) prepared a 1:100,000 hachured series, based on the Swedish 1:100,000 and 1:200,000 maps, that completely covers Sweden. It also compiled complete topographic series at 1:300,000 (*Schweden Sonderausgabe, Nordeuropa, and Europa* series), which are based on the Swedish series at scales 1:400,000, 1:500,000, and 1:1,000,000. A special series of military geographic studies in folio form containing town plans, general maps, and geographic information was also published.
- (3) *French.* The Institut Géographique National (National Geographic Institute) published a 1:1,000,000 series of Europe that provides complete coverage of Sweden.
- (4) *Russian.* The Russian General'nyy Shtab, Krasnaya Armiya (General Staff,

Red Army) published in 1943 a 1:200,000 series covering parts of central Sweden.

- (5) *United States*. The Army Map Service reprinted the British maps at 1:300,000, 1:500,000, and 1:1,000,000 scales and in 1950-53 compiled a 1:250,000 topographic contoured series covering Sweden.

149. Major Native Maps of Sweden

a. Topographic and Planimetric Series.

- (1) *Ekonomiska Kartor* (Economic Map); 1:10,000; Rikets Allmänna Kartverk; 1934-53; no grid.

This polychrome economic photomap series provides coverage for scattered strategic and densely populated areas of Sweden. To date, sheets have been published for Göteborgs-Bohuslän, Kalmar län, Öland, and Gotland, and parts of Norrbottens, Östergötland, Jönköpings, Blekinge, Stockholms, and Uppsala läns. Roads are classified according to importance, and railroads and canals are also shown. Forest cover and areas under cultivation are indicated by color overprint. Administrative boundaries and property lines are shown.

- (2) *Generalstabens Konceptkartor i skalen 1:50,000, Norra Sverige-Södra Sverige* (General Staff Preliminary Map, Northern Sweden-Southern Sweden); Rikets Allmänna Kartverk; 1910-53; no grid.

This two-color series, which at present provides partial coverage for Sweden between 61°30' N and 64° N, the coast of the Gulf of Bothnia, and central and southwestern Sweden, will eventually cover all of Sweden. Survey and revision dates range from 1910 to 1948. Relief is shown by hachures and spot elevations and as meter contours above the tree lines. Five types of roads and trails are shown. Railroads are classified according to gage. Deciduous and coniferous forest is indicated by symbol. Six types of administrative boundaries are shown.

- (3) *Topografisk Karta över Sverige (Linköping Forsöksblad)*; Topographic Map of Sweden (Linköping Experimental

Sheet); 1:50,000; Rikets Allmänna Kartverk; 1946; no grid.

This polychrome sheet of the Linköping area was compiled from aerial photography of 1945. It is the first published sheet of a series planned to cover all of Sweden. Relief is shown by contours at 5-meter intervals.

- (4) *Generalstabens karta över Södra Sverige i skalen 1:100,000* (General Staff Map of South Sweden) and *Generalstabens karta över Norra Sverige i skalen 1:100,000* (General Staff Map of North Sweden); Allmänna Kartverk; 1926-53; no grid.

This polychrome topographic series provides coverage for all of Sweden south of 63° N and along the northeast coast from 63° N to the Finnish border. These sheets are based on surveys of 1842 to 1946. Revisions have been made during the period from 1940 to 1948. Relief is shown by hachures and hill shading and contours at 15-meter intervals above the tree line. Four classes of roads are shown. Coniferous and deciduous forest is symbolized. Five types of administrative boundaries are shown. These sheets are also issued as a special road series with recent road data overprinted. This series was reprinted in 1940-48 by the Directorate of Military Survey, War Office (Geographical Section, General Staff).

- (5) *Svenska Fjällkartan (Swedish Mountain Maps)* 1:100,000 and 1:200,000; Generalstabens Litografiska Anstalt; 1944, 1947-53; no grid.

This polychrome topographic series covering the mountain area along the Sweden-Norway frontier from 61° N to 69° N was compiled from Swedish and Norwegian topographic maps and aerial photography. Relief is shown by hachures, hill shading, and spot elevations and by contours at 15-meter intervals above the tree line. Communication features shown include five classes of roads, winter roads, paths, trails, railroads, and boat routes. Vegetation features are shown by symbol.

Names are given in Swedish and Norwegian, with Lapp on some sheets.

- (6) *1:200,000; Generalstabens Karta över Sverige. Norra Delen* (General Staff Maps of Sweden. Northern Part); Rikets Allmänna Kartverk; 1886–1924; no grid.

This polychrome topographic series provides coverage for all of north Sweden except where 1:100,000 sheets exist. The sheets are based on surveys of 1887–1910, with some revisions to 1946. Relief is shown by hachures, hill shading, and spot elevations, and by contours at 15-meter intervals above the tree line. Four classes of roads are indicated. Railroads are shown but not classified. Deciduous and coniferous forest is shown by color. Six types of boundaries are shown. In 1940 this series was reprinted in monochrome by the Directorate of Military Survey, War Office (Geographical Section, General Staff).

- (7) *1:300,000 Svenska Orter* (Swedish Places); Generalstabens Litografiska Anstalt; 1934–51; no grid.

This polychrome series covering all of Sweden south of 61°30'N is published in atlas form with text descriptions. Complete coverage of Sweden is planned. Relief is shown by contours at 50-meter intervals. Vegetation and land under cultivation are shown by color and symbol. Four types of roads and six types of railroads are indicated.

- (8) *1:400,000 Generalstabens Översiktskarta över Sverige* (General Staff, General Map of Sweden); Rikets Allmänna Kartverk; 1927–48; no grid.

This polychrome series providing complete coverage of Sweden is regularly revised. Relief is indicated by hill shading and spot elevations and by contours at 50-meter intervals above the tree line. Communication features shown include roads, railroads, and canals. Forest cover is shown by color. This series is also issued as a road edition entitled *Vagbreddskartan*.

- (9) *1:500,000 Generalstabens Höjdkarta över Sverige* (General Staff Topographic

Map of Sweden); Rikets Allmänna Kartverk; 1896–1930; no grid.

This polychrome topographic series is the largest scale contoured source completely covering Sweden and is the main source of contour information for maps published by foreign nations. This series has not been revised since its original publication. Relief is indicated by altitude tints at various intervals. Roads and railroads are shown but not classified. Vegetation is not shown. International and Län (county) boundaries are indicated.

- (10) *1:800,000 Generalkarta över Sverige* (General Map of Sweden); Rikets Allmänna Kartverk; 1942; no grid.

On this polychrome series covering all of Sweden, relief is shown by hill shading and spot elevations. Vegetation features are shown by color. Railroads are classified according to gage and number of tracks. Roads, cart tracks, and footpaths are shown. Four types of national and administrative boundaries are shown, and restricted military areas are also indicated.

b. Town Plans. Town plans of native origin are limited in number. Local surveyors, bookstores, private publishing firms, and city engineers have produced plans, but these are intended primarily for the tourist trade.

150. Coordinate Systems

a. Geographic. On all maps of Sweden, geographic coordinates are expressed in degrees and on most Swedish and British series and some German maps longitudinal values are referred to Stockholm. On the Russian and United States maps Greenwich is the prime meridian.

b. Grid. At present, military grids are not shown on Swedish maps; but in the future, all military series will carry a Universal Transverse Mercator grid. Reference grids are used on tourist maps and town plans.

151. Characteristics and Marginal Information

The scales on the Swedish maps are based on the metric system of measurement. On some of the earlier maps the Swedish mile is used. Most of the native maps do not carry declination diagrams.

Relief is represented by hachures, spot elevations, hill shading, and layer tints; form lines and contours are used above the tree line.

Table XV. Glossary of Swedish Map Expressions

arméns förläggningsorter	army installation locations
bilkartor	automobile maps, highway maps
ekonomiska karta	economic maps
endast for tjänstebruk	for official use only
flygfotografi	aerial photography
förkortningar	abbreviations
förstoring	enlargement
försöksblad	experimental sheet
höjdkurvor, ekvidistans 5 meter.	contours, 5-meter intervals
höjdsiffrorna	numbers indicating elevations

Table XV. Glossary of Swedish Map Expressions—Con.

kompassens misvisning	magnetic declination
konceptkartor	sketch maps
lantmäteriet	land survey
lutningsskala	inclination scale
meter över havet	meters above sea level
omtrycka	reprint
revidera	revise
ritat	drawn
sjökort, sjökart	hydrographic charts
stomkartor	skeleton maps
särtryck	special edition
teckenförklaring	explanation of symbols; legend
topografiska karta	topographic maps
tryckt	printed
upplag	edition
uppmätt	surveyed
översiktskort, översiktskart	general maps

CHAPTER 9

CENTRAL EUROPE

Section I. AUSTRIA

152. Mapping Activities

a. Native. The Austrian Bundesamt für Eich- und Vermessungswesen (Federal Office of Standards and Surveying) publishes topographic series at scales of 1:25,000, 1:50,000, 1:200,000, 1:300,000, 1:500,000 and 1:750,000, as well as town plans for the principal cities at scales of 1:10,000 and 1:25,000. In addition to its own publications, the Bundesamt publishes the maps prepared by other departments of the government. Some large-, medium-, and small-scale maps and atlases are published by private map-making firms. Of particular importance are the tourist maps and special large-scale topographic series of scenic areas within the Austrian Alps being published currently by Freytag-Berndt und Artaria. A similar map series is being produced by the Deutscher und Osterreichischer Alpenverein (German and Austrian Alp Society).

b. Other. Major mapping agencies that have published maps of Austria are the following: the U. S. Army Map Service; the French Service Géographique des Troupes d'Occupation en Autriche (Geographical Service of the Occupation Forces in Austria), the Italian Istituto Geografico Militare (Military Geographic Institute); the British Directorate of Military Survey, War Office (Geographical Section, General Staff); the German Generalstab des Heeres (General Staff of the Army); the Survey Director of Allied Forces Headquarters; the Czechoslovakian General Staff; M. Kir. Allami Terkepezseti Intezet (Royal Hungarian Cartographic Institute); and the U. S. S. R. General'nyy Shtab, Krasnaya Armiya (General Staff, Red Army).

153. Major Maps of Austria

a. Native Topographic Series.

- (1) *Österreichische Karte 1:25,000* (Austrian Map 1:25,000); Bundesamt für

Eich- und Vermessungswesen; 1919-49; no grid.

The sheets of this polychrome series provide coverage of scattered areas throughout the country. They were based on a post-World War I topographic survey, and revisions have been made to the sheets since World War II. Relief is portrayed by contours at 20-meter intervals and an auxiliary contour at the 10-meter altitude on relatively level land; these are supplemented on some sheets by hachures and on others by hill shading. Spot heights, horizontal-control stations with altitude values, and benchmarks are shown. These sheets cover areas in west-central Austria near Salzburg, in western Karnten and East Tyrol, and a few scattered areas in the vicinities of Graz, Fulpmes, Baden, Murzzuschlag, Vienna, and the Boden See. Railroads are classified according to gage, number of tracks, use, and type. Cultural, hydrographic, vegetation, and terrain features are indicated. Geographic coordinate ticks are shown, and longitude values are referred to Greenwich and Ferro. The language is German.

- (2) *Schneeberg und östliche Rax 1:25,000* (Schneeberg and east of the Rax Alps 1:25,000), Kartographischen früher Militargeographischen, Institut in Wien (Cartographic, formerly the Military Geographic Institute in Vienna); 1934; no grid.

This polychrome sheet covers a small area west of Neunkirchen in eastern Austria and was based on new surveys available at that time. Relief is shown

by contours at 20-meter intervals, by auxiliary contours, and by spot heights and triangulation stations with elevations. Roads and railroads are shown with no description. Cultural, hydrographic, vegetation, and terrain features are also indicated. Geographic coordinates are computed from Ferro.

- (3) *Umgebungskarte von Linz 1:30,000* (Map of the Linz Area 1:30,000); Kartographischen, früher Militargeographischen, Institut in Wien; 1913-20; no grid.

This polychrome sheet provides coverage for the city of Linz and its vicinity. It was based on a 1920 survey. Relief is shown by contours at 20-meter intervals and supplemented by hachures, spot heights, and by triangulation stations with elevations. There are five classes of roads. Railroads are classified in two categories. Cultural, hydrographic, vegetation, and terrain features are also indicated. The place names are in German. Marginal geographic coordinates are shown, and longitude values are referred to Ferro and Greenwich.

- (4) *Österreichische Karte 1:50,000* (Map of Austria 1:50,000) and *Provisorische Ausgabe der Österreichischen Karte 1:50,000* (Provisional Edition of Austria Map 1:50,000); Bundesamt für Eich-und Vermessungswesen; 1946-47; no grid.

Sheets of the provisional edition of this multicolored series are enlargements of the 1:75,000 Spezialkarte (Special Map). Relief is depicted by hachures (fig. 120). A few sheets covering the vicinities of Vienna, Salzburg, Graz, and Murzzuschlag, and areas along the Austrian-Italian frontier show terrain represented by con-

tours and auxiliary contours (fig. 121). These contoured sheets were based on the new 1:25,000 contoured maps. This series provides complete coverage for Austria. Spot heights and triangulation stations with elevation values are shown. Roads are classified by importance and use. Railroads are classified by gage and number of tracks. Cultural, hydrographic, vegetation, and terrain features are indicated. Place names are in German. Marginal geographic coordinates and longitude are computed from Ferro.

b. *Town Plans.* Town plans for the larger cities are being produced by both native and foreign mapping agencies.

154. Characteristics

The scales on Austrian maps are based on the metric system of measurement and the geographic mile. The metric system has replaced the fathom measurements formerly used for soundings and bathymetric contours. The native Austrian maps do not carry a declination diagram.

Table XVI. *Glossary of Austrian Map Expressions*

Abkürzungen.....	abbreviations
Aufnahme.....	survey
Ausführung und Verlag.....	compiler and publisher
eingehende Kartenberichter- gung.	detailed map revision
einzelne Nachträge.....	minor additions
herausgegeben von.....	published by
jede Vervielfältigung vorbe- halten.	reproduction rights reserved
Kartenberichtigung.....	map revision
Kartograph. Anstalt.....	Cartographic Institute
Längenmassstab.....	scale (linear)
Nachdruck verboten.....	reprints not permitted
Nadelabweichung.....	magnetic declination
nicht evident gehalten.....	not kept up to date
Österreichische Karte.....	Map of Austria
Östlich von.....	east of
provisorische Ausgabe der.....	provisional edition of
Zeichenerklärung.....	legend

Section II. CZECHOSLOVAKIA

155. Mapping Activities

a. *Native.* The topographic maps covering the area of Czechoslovakia are of heterogenous nature, derived from both Czech and German maps, some of which, in turn, were based on old Austrian sur-

veys (1860-98) and others on new modern Czech and German survey work. The principal topographic mapping agency in Czechoslovakia is the Vojenský zeměpisný ústav v Praze (Military Geographic Institute at Prague). Military maps were

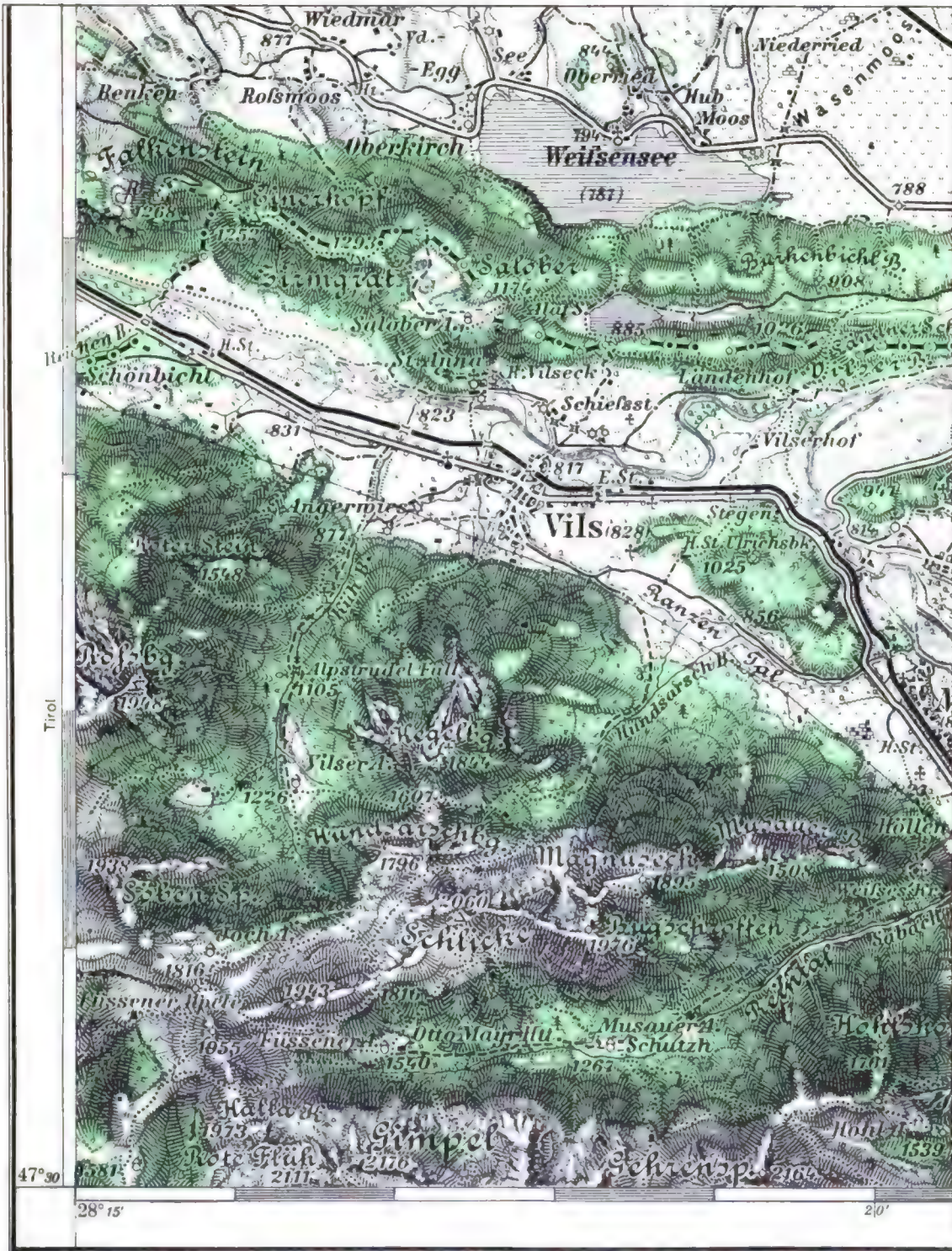

Figure 120. Section of sheet from the Provisorische Ausgabe der Österreichischen Karte 1:50,000 by the Bundesamt für Eich-und Vermessungswesen.

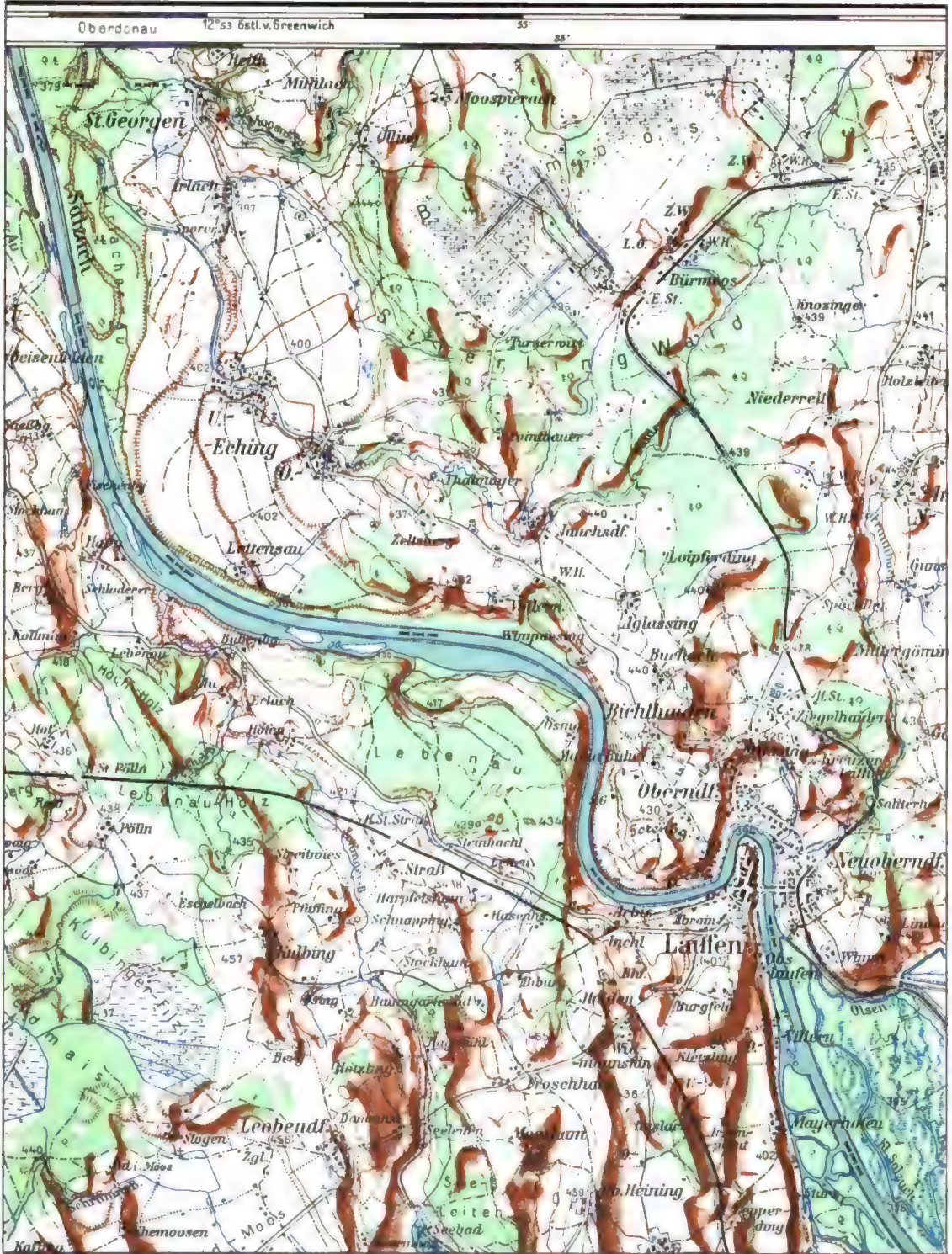

Figure 121. Section of sheet from the Österreichische Karte 1:50,000 by the Bundesamt für Eich-und Vermessungswesen.

published to provide complete coverage at scales of 1:25,000, 1:75,000, and 1:200,000. A few sheets at scales of 1:20,000 and 1:50,000, based on modern triangulation and leveling, recently have been published. The *Zeměpisný ústav ministerstva vnitra* (Geographical Institute of the Ministry of Interior) published some maps at the scale of 1:20,000 during the middle thirties.

b. Other. The German topographic series were produced during World War II by the *Reichsamt für Landesaufnahme* (Federal Land Survey Office), the *Landesvermessungsamt Böhmen und Mähren* (Land Survey Office of Bohemia-Moravia), and the *Generalstab des Heeres* (General Staff of the Army).

156. Major Maps of Czechoslovakia

a. Topographic Series.

(1) *Native.*

(a) *Mapa Československé Republiky 1:20,000, 5 centimetrová* (Map of the Czechoslovak Republic 1:20,000, 5 centimeters); *Vojenský zeměpisný ústav v Praze* and *zeměpisný ústav ministerstva vnitra*; 1933–36; Czechoslovak military grid.

This polychrome series (fig. 122) covers small and scattered areas throughout the country. The sheets are based on new geodetic survey and photogrammetric work and show corner and marginal geographic coordinates referred to both Ferro and Greenwich. Relief is shown by contours at intervals of 10 meters and supplementary contours at 2.5 and 5 meters.

(b) [*Czechoslovakia*]; 1:20,000; *Vojenský zeměpisný ústav v Praze*; 1927–31; Czechoslovak military grid.

This two-colored series provides scattered coverage of small areas of the country. They are based on new surveys started in 1926 and show corner and marginal geographic coordinates referred to Ferro and Greenwich. Relief is shown by contours at 10-meter intervals with supplementary contours at 0.5, 1, and 2 meter or 1.25-, 2.5-, and 5-meter intervals.

(c) [*Czechoslovakia*]; 1:25,000; *Vojenský zeměpisný ústav v Praze*; 1927–31;

Czechoslovak military grid on some sheets.

Complete coverage of the country is furnished by this extensive series (fig. 123), originally prepared by the Austro-Hungarian Empire. It was based on the old Austro-Hungarian third military survey of 1869–87. Because the series was obsolete, the Czechs revised about one-third of the sheets in the field (*reambulováno*). Relief is shown on these revised sheets by contours ranging from 2.5- to 100-meter intervals. Cultural information on the other two-thirds of the sheets was only superficially corrected.

(d) [*Czechoslovakia*]; 1:75,000; *Vojenský zeměpisný ústav v Praze*; 1938; Czechoslovak military grid on some sheets.

This two-colored series provides complete coverage of Czechoslovakia. It was originally based on the old Austro-Hungarian mapping but cultural data were revised. The sheets were kept up to date during the lifetime of the first Czechoslovak Republic, and still constitute the best reference for the international boundaries of Czechoslovakia, as of 1937. Geographic coordinates referred to Ferro and Greenwich are shown on later date sheets. The older sheets are referred to Ferro only. Relief is shown by contours at intervals of 100 meters and by hachures.

(e) [*Czechoslovakia*]; 1:200,000; *Vojenský zeměpisný ústav v Praze*; 1920–46; no grid.

This polychrome series provides complete coverage of the country. It is based on the old Austro-Hungarian series, but was revised between 1920 and 1946. Longitude values are referred to Ferro. Relief is shown by hachures.

(2) *Other.*

(a) *Topographische Karte 1:25,000 4 CM Karte* (Topographic Map 1:25,000, 4 CM Map); *Reichsamt für Landesaufnahme*; 1926–44; Gauss-Krüger grid.

Coverage of a narrow strip along the 1937 Czechoslovak-German border

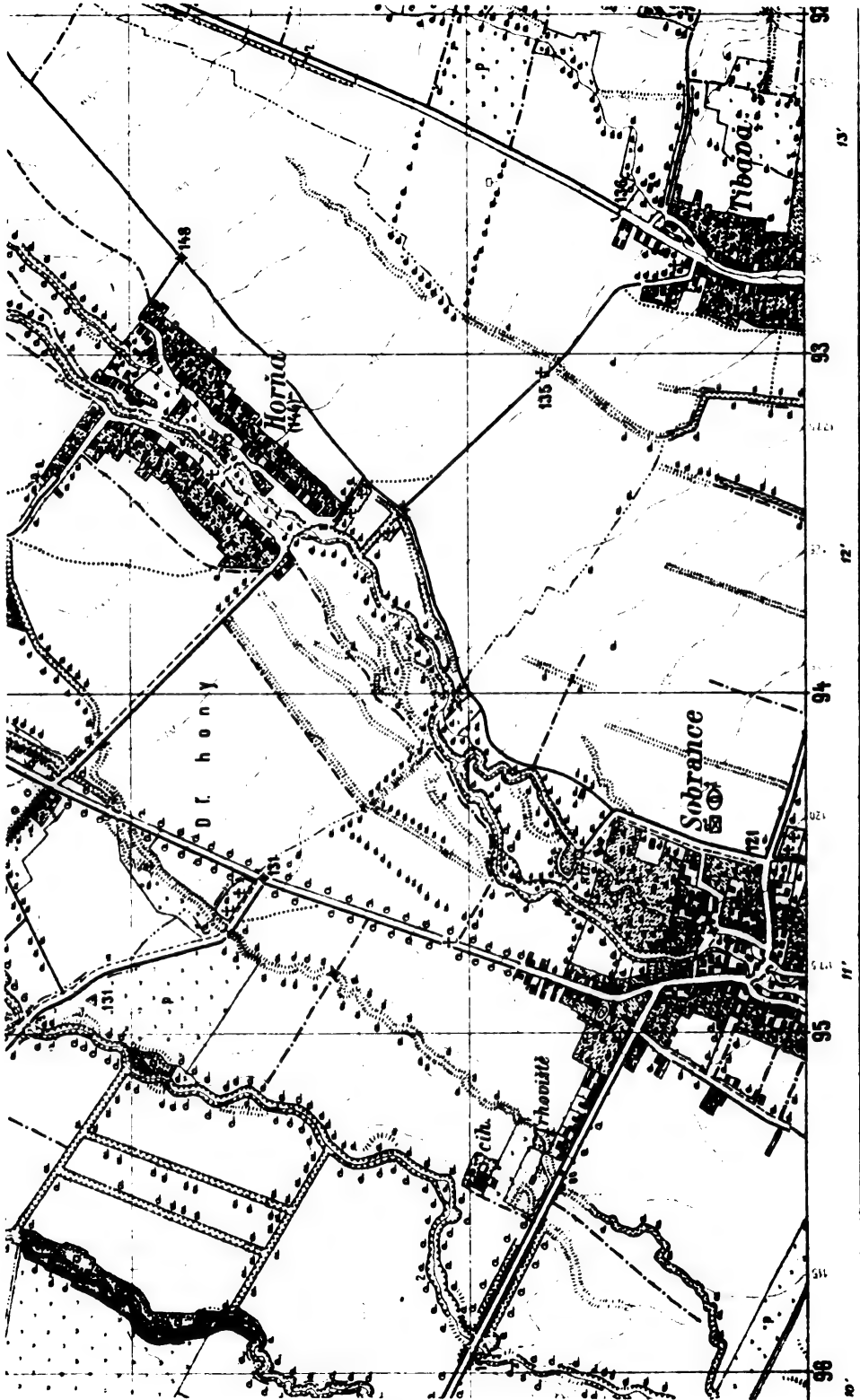
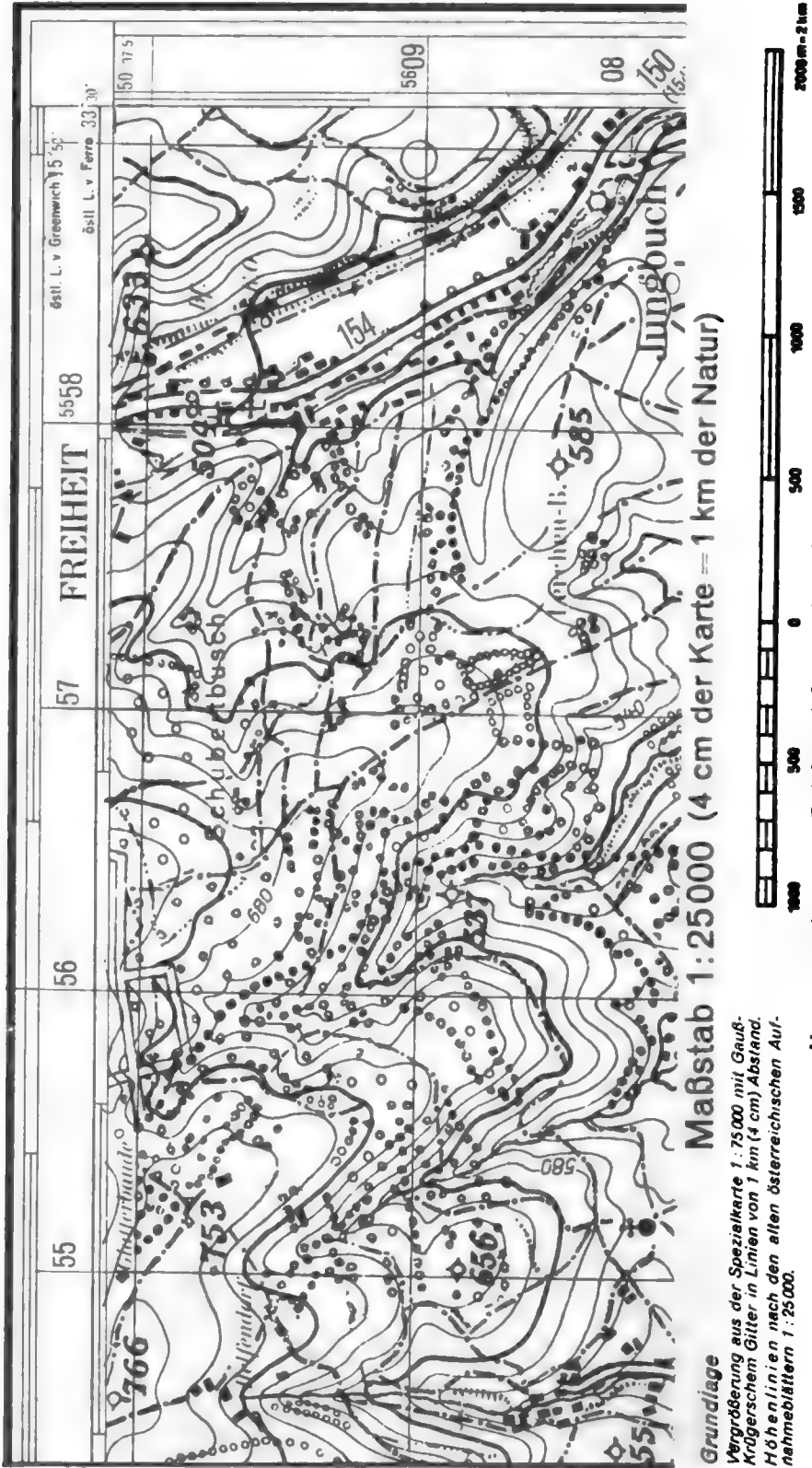

Figure 122. Section of sheet from the Mapa Československé Republiky 1:20,000 by the Vojenský zeměpisný ústav v Praze.

Karte des Sudetenlandes 1:25000 3755/4



Grundlage

Vergrößerung aus der Spezialkarte 1:75000 mit Gauß-Krügerschem Gitter in Linien von 1 km (4 cm) Abstand. Höhenlinien nach den alten österreichischen Aufnahmestritten 1:25000.

Herausgegeben vom Reichsamt für Landesaufnahme 1940

Letzte Berichtigung 1938

Figure 124. Section of sheet from the Karte des Sudetenlandes at 1:25,000 by the Generalstab des Heeres.

(southwest, northwest, and north-central boundaries of present-day Czechoslovakia) is furnished by sheets of this polychrome series. Relief is shown by contours at intervals of 5 meters, with auxiliary contours at intervals of 1.25 meters. Spot heights also are indicated.

- (b) *Topographische Karte 1:25,000 4 CM Karte*; (Topographic Map 1:25,000 4 CM Map); Landesvermessungsamt Böhmen und Mähren; 1939-44; Gauss-Krüger grid.

This monochrome series is based on new surveys and was produced while the Germans occupied Czechoslovakia. It provides coverage for about 15 percent of the area (Moravia).

- (c) *Karte des Sudetenlandes* (Map of the Sudetenland), *Karte der Slowakei* (Map of Slovakia), and *Ungarn* (Hungary); 1:25,000; Generalstab des Heeres; 1938-44; Gauss-Krüger grid.

The coverage of this monochrome series is almost complete. Relief is shown by contours at 20-meter intervals on most sheets and 100-meter intervals on others. Geographic coordinates and marginal ticks are referred to Ferro and/or Greenwich. A section of a sheet entitled *Karte des Sudetenlandes* is shown as figure 124.

- (d) *Protektorat 1:50,000* (Protectorate 1:50,000) and *Slowakei 1:50,000* (Slovakia 1:50,000); Generalstab des Heeres; 1944-45; Gauss-Krüger grid.

This two-colored series, which provides almost complete coverage of the country, is an enlargement of the Czech 1:75,000 series with improvements made by field survey and aerial photography. Corner and marginal geographic coordinates are shown. Only a few sheets portray relief by contours.

b. Town Plans. Pre-1946 plans for the important towns of the Czechoslovak Republic were produced

almost wholly under the direction of the *Militärgeographische Dienststelle* (Military Geographic Service) of the *Generalstab des Herres*, through the *Landesvermessungsamt Böhmen und Mähren*. These plans, drawn at the scale of 1:10,000, include full topographic information for both the city environs and the surrounding areas. The *Militärgeographische Dienststelle* added an overprint of detailed military information to these base maps. A German collection in book form includes throughway plans covering all towns for which there are no detailed plans. These German throughway plans together with planimetric tourist-type plans provide the only coverage for a number of the lesser towns.

157. Coordinate Systems

The Czech grid system differs from most others in that grid values are numbered from the northeastern corner of the map and are read to the left and down instead of to the right and up.

158. Characteristics

The sheet numbering scheme used for standard-scale Czech and German maps covering the Czechoslovak area is based on the original Austro-Hungarian system (fig. 125).

SHEET NUMBERING SCHEME FOR STANDARD-SCALE CZECH AND GERMAN MAPS COVERING CZECHOSLOVAKIA

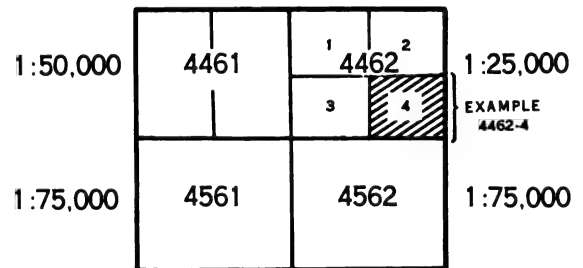

THE ORIGIN OF THIS SYSTEM WAS THE AUSTRO-HUNGARIAN MAPPING WITH ITS SHEET LINES BASED ON THE FERRO PRIME MERIDIAN. THE STANDARD UNIT IS THE SHEET AT THE SCALE OF 1:75,000. SPLITTING THIS SHEET INTO EASTERN AND WESTERN HALVES YIELDS TWO SHEETS AT 1:50,000, AND THE QUARTERING OF IT YIELDS FOUR SHEETS AT 1:25,000.

Figure 125. Sheet-numbering scheme for standard-scale Czech and German maps covering Czechoslovakia.

Table XVII. Glossary of Czech Map Expressions

Částečně doplněno podle re- vise a reambulace z r. 1925.	partial additions based on revision and field check in 1925
Částečně opraveno do.....	partially revised
Částečně podle reambulace a revise z r. 1927.	partially based on field check and revision in 1927
Část listu podle reambulace z r a nov. měř. z r.	part of the sheet according to the field check made in year.....and new survey of year.....
Krok, kroky (Kroků).....	pace, step,-(s) (genitive case, plural)
List	sheet
Mapováno r.....	map compiled in.....
Měřítka sklonu.....	gradient scales
Měřítka	scale
Měřítka délek.....	longitudinal scale
Nákladem	published by the...
Nové měření z r. 1926.....	new survey, 1926

Table XVII. Glossary of Czech Map Expressions—Con.

Oblasti ČSR místy opraveny do.	districts of the Czecho- slovak Republic locally revised
Politické hranice.....	political boundaries
Politický přehled.....	political synopsis
Pravděpodobná magnetická deklinace pro střed roku.	approximate magnetic decli- nation for the year...
Prozatímní vydání.....	provisional edition
Reambulováno v roce 1926...	field checked in 1926
Rok vydání.....	year of publication
Rozmnožovací právo je vyhrazeno VZU.	copyright by the Military Geographic Institute
Sekce	section
Situace a písmo.....	location of adjacent sheets
Systém vrstevnic.....	contour lines
Vrstevnice	contour line
Vych. od Ferra.....	east of Ferro
Vydání.....	edition
Výhradně pro služební potřebu.	for official use only
Výška vrstvy.....	contour interval
Zaměřeno roku 1922.....	survey taken in 1922

Section III. GERMANY

159. Mapping Activities

a. Native.

- (1) Prior to World War I, German topographic mapping was almost exclusively the responsibility of military mapping organizations. Following the Treaty of Versailles, control of German mapping was transferred to civilian administration. The most important of these was the Reichsamt für Landesaufnahme (Federal Land Survey Office), newly organized under the Ministry of the Interior as the successor to the Preussische Landesaufnahme (Prussian Land Survey Office). The South German States of Bavaria, Württemberg, Hessen, and Baden maintained their own mapping agencies, which functioned with varying degrees of independence and concentrated on large-scale mapping. When mapping activities were resumed after World War II, all mapping responsibility was vested in the respective state agency-Landesvermessungsamt.
- (2) During World War II the Generalstab des Heeres, Abteilung für Kriegskarten- und Vermessungswesen (General Staff of the Army, Division of Surveying and Mapping) and its many attached and subordinate organizations issued a multi-
tude of maps covering large areas of the world. The function of this office ceased in 1945.
- (3) At present, mapping activities in the Federal Republic of Germany are the responsibility of the Institut für Angewandte Geodäsie (Institute for Applied Geodesy) and of the Landesvermessungsämter of the West German States. Mapping activities in the German Democratic Republic (Soviet Zone of Occupation) are the responsibility of the Ministry of the Interior and its five subordinate regional survey offices, which are called Vermessungsdienst.
- (4) Additional mapping agencies are Deutsches Hydrographisches Institut (German Hydrographic Institute), AMT für Landeskunde (Institute for Regional Studies), Bundesanstalt für Bodenforschung (Federal Geological and Soil Survey), Deutsche Bundesbahn (German Federal Railroads) and its subordinate agencies, Bundesverkehrsministerium (Ministry of Communications) and its subordinate agencies, and numerous local and cadastral survey offices.
- (5) There are many private German mapping concerns. Some of these concerns are known the world over, for example, Jus-

tus Perthes, Stieler's Hand Atlas, Petermanns Geographical Reports, Vogel's map of Central Europe 1:500,000, Haack's wall maps, Carl Baedeker (travel guides and maps), Karl Wenschow G. M. B. H. (relief maps), Georg Westermann Verlag (school atlas, and wall maps), and Ravenstein's Geographische Anstalt (Political and Road Maps).

b. Other. Other mapping agencies that have published maps of Germany are the U. S. Army Map Service; the British Directorate of Military Survey, War Office (Geographical Section, General Staff)—GSGS; Northern Army Group—formerly known as the British Army of the Rhine (BAOR); the French Service Géographique des Forces Françaises en Allemagen-SGFFA (Geographical Service of French Forces in Germany); and the French Mission de Documentation de Géographie Militaire (Office of Military Geographic Documentation).

160. Major Native Maps of Germany

a. Topographic Series.

- (1) *Deutsche Grundkarte* (Basic Map of Germany); 1:5,000; Reichsamt für Landesaufnahme 1925–38, Hauptvermessungsabteilung 1938–45, and Landesvermessungsamt 1945– ; 1925– ; Gauss-Krüger grid.

Only a part of this two-colored series has been published. The area within Germany that is the most completely covered by this series is northwest Germany. The series is designed on the Gauss-Krüger projection. The grid interval is 200 meters. Relief is shown by contours at intervals 1, 5, and 10 meters, auxiliary contours, and spot heights. Triangulation stations and leveling points are shown. The presentation of cultural features is extremely detailed. Most structures are represented true to scale. Many cadastral features are included. The present style sheet was adopted in 1937 and was slightly changed in 1942. Sheets of the *Katasterkarte* (Cadastral Map) were (1) produced by stereophotogrammetric methods, (2) derived from planetable surveys, or (3) reduced from larger scale cadastral maps. The preliminary

edition of the series was published in monochrome, and is now being used as a planimetric base for the contoured *Deutsche Grundkarte*.

- (2) *Topographische Karte 1:25,000* (Topographic Map 1:25,000); Reichsamt für Landesaufnahme to 1945; Generalstab des Heeres 1936–45; Hauptvermessungsabteilung, 1938–47; Landesvermessungsamt, circa 1900– ; circa 1875– ; Gauss-Krüger grid.

Sheets of this series (fig. 126) were originally compiled and published by the various German state mapping authorities. Therefore, uniformity of sheet size and symbolization had not been achieved until the standardized style sheet was published by the Reichsamt für Landesaufnahme in 1939. These specifications were used in subsequent revisions and new compilations. This series provided almost complete coverage for Germany within the 1937 boundaries with the exception of the southern half of Bavaria. The Generalstab des Heeres extended this series during World War II to include partial coverage for German occupied areas in Central Europe. These sheets have been issued under a variety of titles. The compilation of this series has primarily been based on planetable surveys at 1:25,000. Some sheets have been compiled from sheets of the *Deutsche Grundkarte* (Basic Map of Germany) at 1:5,000, or are stereocompilations. The majority of the sheets are monochrome. Relief is shown by contours at intervals of 10 and 20 meters and by supplemental contours where necessary in order to portray relief accurately. In addition, triangulation stations, leveling points, and numerous spot elevations are shown. Presentation of cultural features is very detailed. Some of the marginal data included are illustrated in figures 127 and 128.

- (3) *Topographische Karte von Bayern 1:25,000 or Positionsblätter* (Topographic Map of Bavaria Position Map 1:25,000); Bayerisches Landesvermessungsamt; circa 1872; Gauss-Krüger grid.

Topographische Karte 1:25000 (4-cm-Karte)

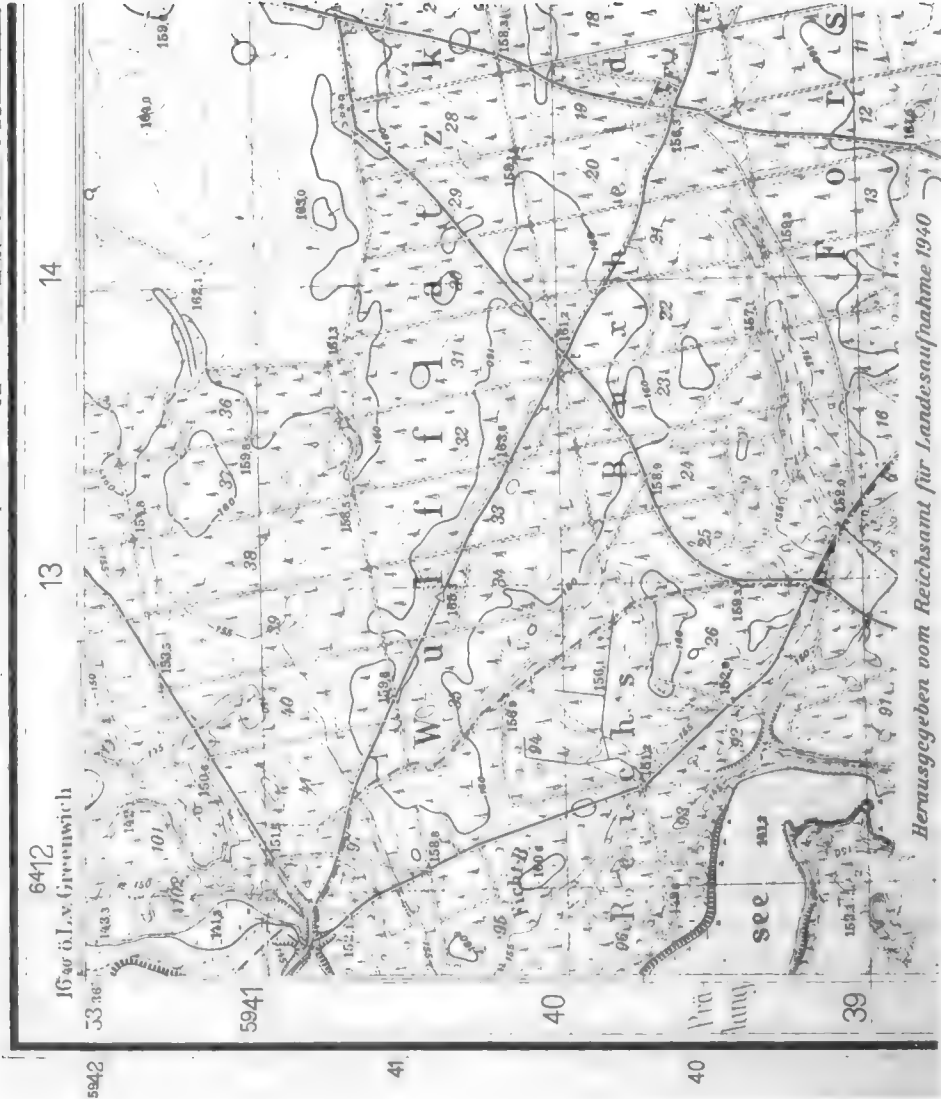

Figure 126. Section of sheet from Topographische Karte 1:25,000 by the Reichsamt für Landesaufnahme, with marginal insets showing Planzeiger (protractor scale or scale romer) and Lagekizze (index to sheets).

Planzeiger:

Zum Ablesen ist die meagerochte Teilung so an eine meagerochte Gitterlinie zu legen, daß die senkrechte Teilung den zu bestimmenden Koordinatenpunkt berührt. Dann ist an der meagerochten Teilung bei der nächsten linken senkrechten Gitterlinie der „Rechts“-Wert, und an der senkrechten Teilung der „Bach“-Wert abzulesen.

Der Rechenwert ist stets zuerst zu nennen. Die Punkteangabe erfolgt in Metern. Nicht abzulesbare Werte sind bei nur Angabe des vollen Meters durch Nullen zu ersetzen.

Beispiel: Punkt p liegt in Metern: .
 - „Rechts“ - 57 000 - 200 - 57 200 - (Meters) 57 200
 - „Bach“ - 57 0000 - 450 - 57 06450 - (Meters) 57 06450

• Kennziffer des Meridiananwinkels

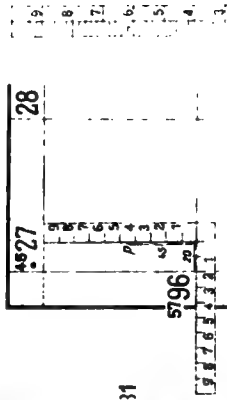

Planzeiger 1:25000

Lagekizze

2365	2366	2367
2465	2466	2467
2565	159160	2567
	191192	
	2566	2567

Blatt-Von-Maßstab

2466 Von V.r. = 1 : 25 000

159 - 1 : 100 000

zum Großblatt 40

① **Nadelabweichung für Mitte 1936**
 Jährliche Abnahme - 0,5' oder 2,1"

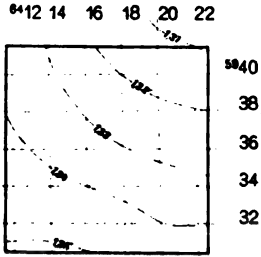

— Thacher wegen zu geringer Beobachtungszahlen.

② **Umrechnungstabelle für Grad in Strich**
 ($1^\circ = 17,77 \dots'$)

Grad = Strich	Grad = Strich
1° = 18"	1/10° = 2"
2° = 36"	2/10° = 4"
3° = 53"	3/10° = 5"
4° = 71"	4/10° = 7"
5° = 89"	5/10° = 9"
6° = 107"	6/10° = 11"
7° = 124"	7/10° = 12"
8° = 142"	8/10° = 14"
9° = 160"	9/10° = 16"
10° = 178"	10/10° = 18"

Beispiel: $4,4^\circ =$ wieviel Strich?
 $4^\circ = 71"$
 $+ 4/10^\circ = 7"$
 also $4,4^\circ = 78"$

③ **Als Nadelabweichung**
 wird der Winkel zwischen der fehlerfreien, durch Eisen, elektr. Strömungen (Gleichstrom) u.ä. nicht beeinflussten Richtung der Magnetnadel und den allgemein nach Norden weisenden Gitterlinien dieses Kartenblattes berechnet. Für einen bestimmten Standpunkt erhält man die Größe dieses Winkels aus den Werten in nebeneinanderstehenden Kästchen unter Umrechnung auf das Kalenderjahr.

Anwendung: 1) Die Karte ist eingerichtet, wenn eine Bussole mit ihrer Nord-Südrichtung an eine Gitterlinie nicht Blattverdrehts gelegt wird und die Nadel auf den Abweichungswert einstellt. Oder: 2) Die Richtung der Magnetnadel erhält man durch Verbindung des in die Gradteilung am unteren Blattende zu übertragenden Nadelabweichungswertes mit der Marke „M“ am oberen Blattende. Die angegebenen Winkelwerte bezeichnen eine mittlere Nadelabweichung.

④ **Politische Grenzen:**
 44,73 cm

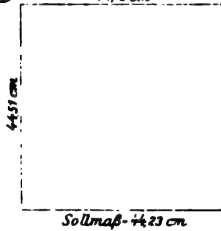

*Proo. Pommern
 Reg. Bez. Grenzmark
 Posen-Westpreußen
 Kreis Neustettin*

⑤ **Aufnahme:**

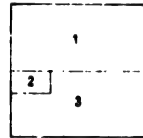

1 : 25000
 Reichsamt f. L. A. 1935
 1. Reibmann, 2. Thibon,
 3. Grunow

⑥ **Berichtigungsstand:**

Berichtigt:

Letzte Nachträge:
 Reichsamt f. L. A. 1931/39

⑦ **Nachdruck und Vervielfältigung jeder Art, auch einzelner Teile, sowie die Anfertigung von Vergrößerungen oder Verkleinerungen sind verboten und werden gerichtlich auf Grund des Urheberrechtsgesetzes verfolgt.**

⑧ **Neigungsmaßstab**

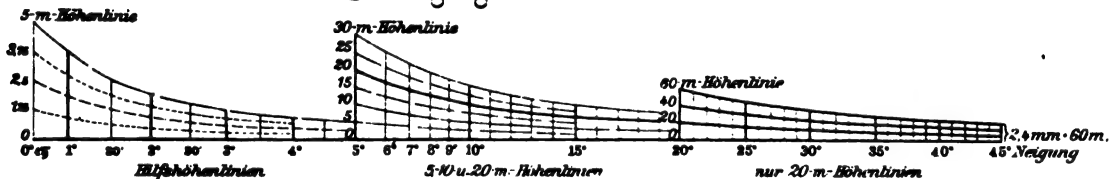

- ① Magnetic declination diagram
- ② Conversion table from degrees to mils
- ③ Explanation of magnetic declination and instructions for use
- ④ Boundary diagram
- ⑤ Compilation diagram
- ⑥ Revision statement
- ⑦ Copyright statement
- ⑧ Slope scales

Figure 127. Border information from a German 1:25,000 map.

This series provides coverage of the southern half of Bavaria and was compiled from ground surveys. The sheets are on the Söldner Polyhedric projection, with a one-kilometer grid interval. The sheetlines are not based on

the geographic graticule. The later sheets of this edition are polychrome, and symbolization is quite similar to that shown on the *Topographische Karte 1:25,000* (Topographic Map 1:25,000) series. The monochrome

2466 Barkenbrügge

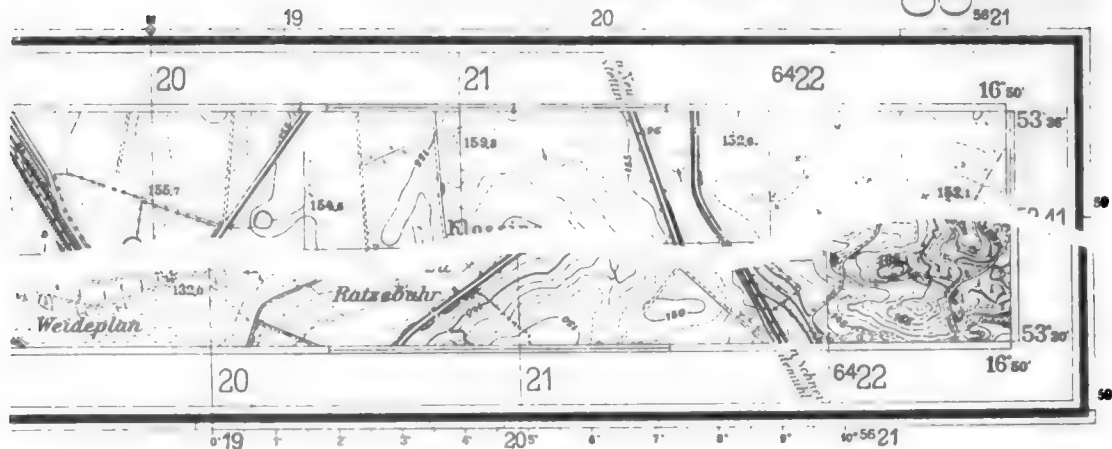

Figure 128. Sections from a German 1:25,000 map showing declination protractor "M" on top margin and calibrated scale in degrees on bottom margin.

sheets of the earlier edition have considerable variations in the symbols used. Relief is shown by hachures, combined hachures and contours, or contours. These are supplemented by triangulation stations, leveling stations, and numerous spot elevations.

- (4) *Topographische Karte 1:50,000* (Topographic Map 1:50,000); Reichsamt für Landesaufnahme to 1945; Landesvermessungsämter since 1950; 1921- ; Gauss-Krüger grid.

This large-scale series of 85 sheets provide partial coverage of the area of Polish Occupied Zone and scattered coverage of western Germany. Several formats and sheet sizes were used until 1944. In 1952, the present sheet size was adopted by the German states to cover an area of four sheets of the *Topographische Karte 1:25,000* series. About half of the sheets of the series are on the old sheet lines which cover seven and one half sheets of the *Topographische Karte 1:25,000*. The older sheets (*Deutsche Karte 1:50,000*) were designed on the Prussian Polyhedral projection. The new standardized specifications for the *Topographische Karte 1:50,000* provide for the Gauss-Krüger projection. The series is published in three colors, with considerable detail shown. Relief is shown by con-

tours at intervals of 10 meters. Auxiliary contours at intervals from 2.5 to 5 meters also are shown for some areas, leveling stations, numerous spot elevations, and heights at triangulation stations are shown. Within the area of Wurttemberg, partial coverage is available on 12 sheets under the title of *Wanderkarte der Schwabischen Alb*. (Tourist Map of the Schwabian Alps). These sheets are on the same format as the *Topographische Karte 1:50,000*.

- (5) *Topographic Atlas von Bayern 1:50,000* (Topographic Atlas of Bavaria 1:50,000); Bayerisches Landesvermessungsamt; 1867- ; geographic grid.

This series of 198 sheets provides complete coverage of Bavaria. The projection used is the Bonne Equal-Area Conic projection. The grid is a 5-minute geographical grid. The series was compiled from controlled ground surveys. Approximately one-eighth of the sheets are polychrome; the remainder are monochrome. Relief on the monochrome sheets is represented by hachures. On the polychrome sheets, relief is shown by contours at 20-meter intervals. Both are supplemented by spot elevations.

- (6) *Karte des Deutschen Reiches 1:100,000* (Map of Germany 1:100,000); Reichsamt für Landesaufnahme and others to 1861-

1945; Generalstab des Heeres 1936-45; Landesvermessungsamt since 1945; Gauss-Krüger grid.

This 674-sheet series (fig. 129) is the largest scale at which complete coverage of Germany exists. The sheets are designed on the Prussian Polyhedral projection, and the grid interval is 5 kilometers. The series is basically monochrome with relief shown by hachures. In addition, there is a partial three-color edition limited to the small sheet size, portraying relief by contours at 50-meter intervals and hachures. Relief on all editions is supplemented by spot elevations. Bathymetric curves are shown in areas of open water. Detail on this series is extremely dense for the map scale. The *Grossblatt* edition was extended by the Generalstab des Heeres to cover occupied areas outside of Germany. These multicolored sheets show relief by contours. The majority of these sheets are copies of native series of the occupied countries. The remainder are new compilations by the Generalstab des Heeres.

- (7) *Topographische Karte 1:100,000* (Topographic map 1:100,000); Landesvermessungsämter; 1950-; Gauss-Krüger grid.

Scattered coverage of Germany is furnished by this series. Sheet size, numbering system, and sheet names of the *Karte des Deutschen Reiches* (Map of Germany) 1:100,000 series have been maintained for the small number of published sheets of this new series. Relief representation has been changed to 10- and 20-meter contours. The symbolization on sheets is not uniform because of the variation in the style sheets used by the individual Landesvermessungsämter. A new style sheet was developed in 1952 by the Landesvermessungsämter of the various Länder of the Federal Republic of Germany. The sheets are on the Gauss-Krüger projection covering 24' latitude by 40' longitude and each sheet equals sixteen sheets of *Topographische Karte 1:25,000* from which

it was compiled. The grid interval is 5 kilometers. The standard edition is in three colors. Germany has been divided into three physiographic regions for purposes of varying specifications for relief representation. This physiographic division permits the use of contours which portray relief as accurately as possible. Symbolization is detailed but presents a justifiable generalization of the *Topographische Karte 1:25,000* base sheets.

- (8) *Topographische Übersichtskarte des Deutschen Reiches 1:200,000* (General Topographic Map of Germany 1:200,000); Reichsamt für Landesaufnahme 1899-1944; Gauss-Krüger grid.

This 185-sheet polychrome series (fig. 130) covers the area of Germany within 1914 boundaries. It is based on the 1:25,000 series. Relief is represented by 20- and 100-meter contours, supplemented by 10-meter auxiliary contours where necessary.

Symbolization is quite detailed. The sheets are designed on the Delisle Conic projection with two standard parallels at 50° and 53° N latitude. The grid interval is 10 kilometers. Publication of this series was terminated in 1927 and resumed in 1937. No sheets have been published since 1944.

- (9) *Übersichtskarte von Mitteleuropa 1:300,000* (General Map of Central Europe 1:300,000); Reichsamt für Landesaufnahme to 1945; Generalstab des Heeres 1938-1945; Landesvermessungsämter since 1945; 1930-Gauss-Krüger grid.

This polychrome series completely covers Germany and adjacent countries. Compilation of these sheets was based on a privately published map at the same scale and later completely redone from an official larger scale series. Two projections are used: the western and northern portion of the series is on the Prussian Polyhedral projection, the eastern part on Kaupert's Conic projection. Each sheet measures 1° in latitude by 2° in longitude. The grid interval is 10 kilo-

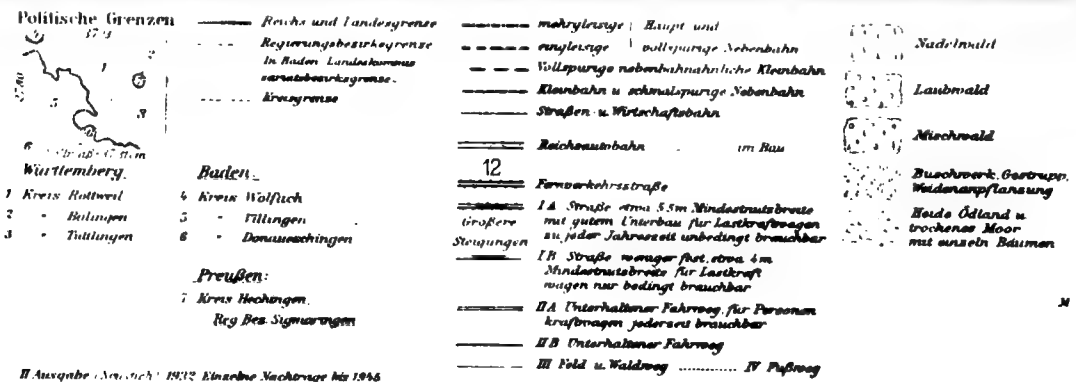
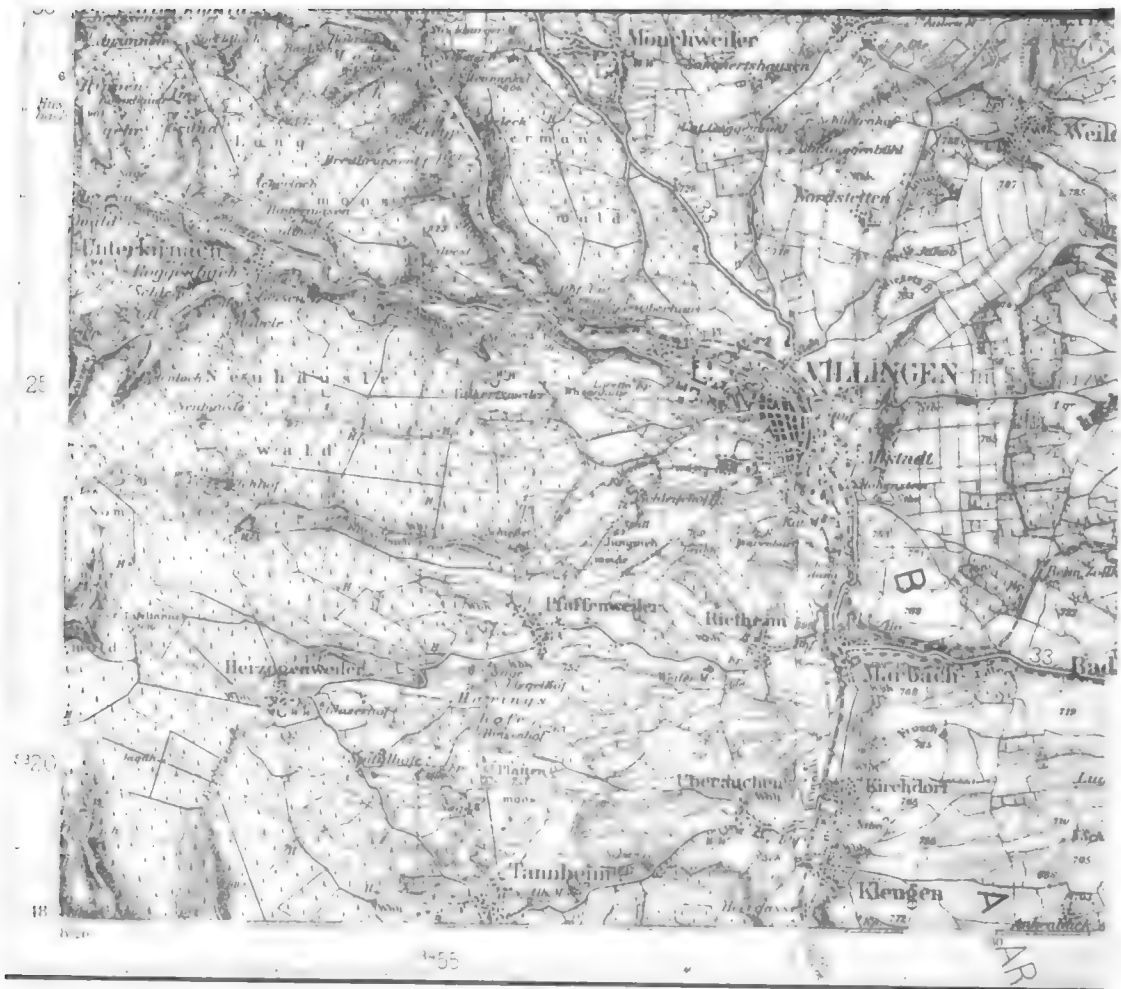

Figure 129. Section of Karte des Deutschen Reiches 1: 100,000.

meters. Relief is represented by hachures or shading, supplemented by spot elevations. The one available sheet showing extensive post-World War II revisions omits relief representation, except spot elevations. This series was extended during World War

II by the Generalstab des Heeres to cover all of Northern Europe and European Russia. Sheets in this series were issued as *Nordeuropa* (Northern Europe) 1: 300,000, *Osteuropa* (Eastern Europe) 1: 300,000, *Mitteleuropa* (Central Europe) 1: 300,000 and

Europa 1:300,000. They appeared in a variety of styles, and colors, and with varying methods of relief representation.

- (10) *Vogel's Karte von Mitteleuropa: Flieger Karte 1:500,000* (Vogel's Map of Central Europe: Air Map 1:500,000);

Justus Perthes and Generalstab der Luftwaffe; 1950; reference grid.

This polychrome series, covering Germany and its neighboring countries, was published in two basic editions: the regular edition and an air edition. Each sheet, designed on the Bonne

Topogr. Übersichtskarte des Deutschen Reiches 1:200000 ($\frac{1}{2}$ cm Karte)

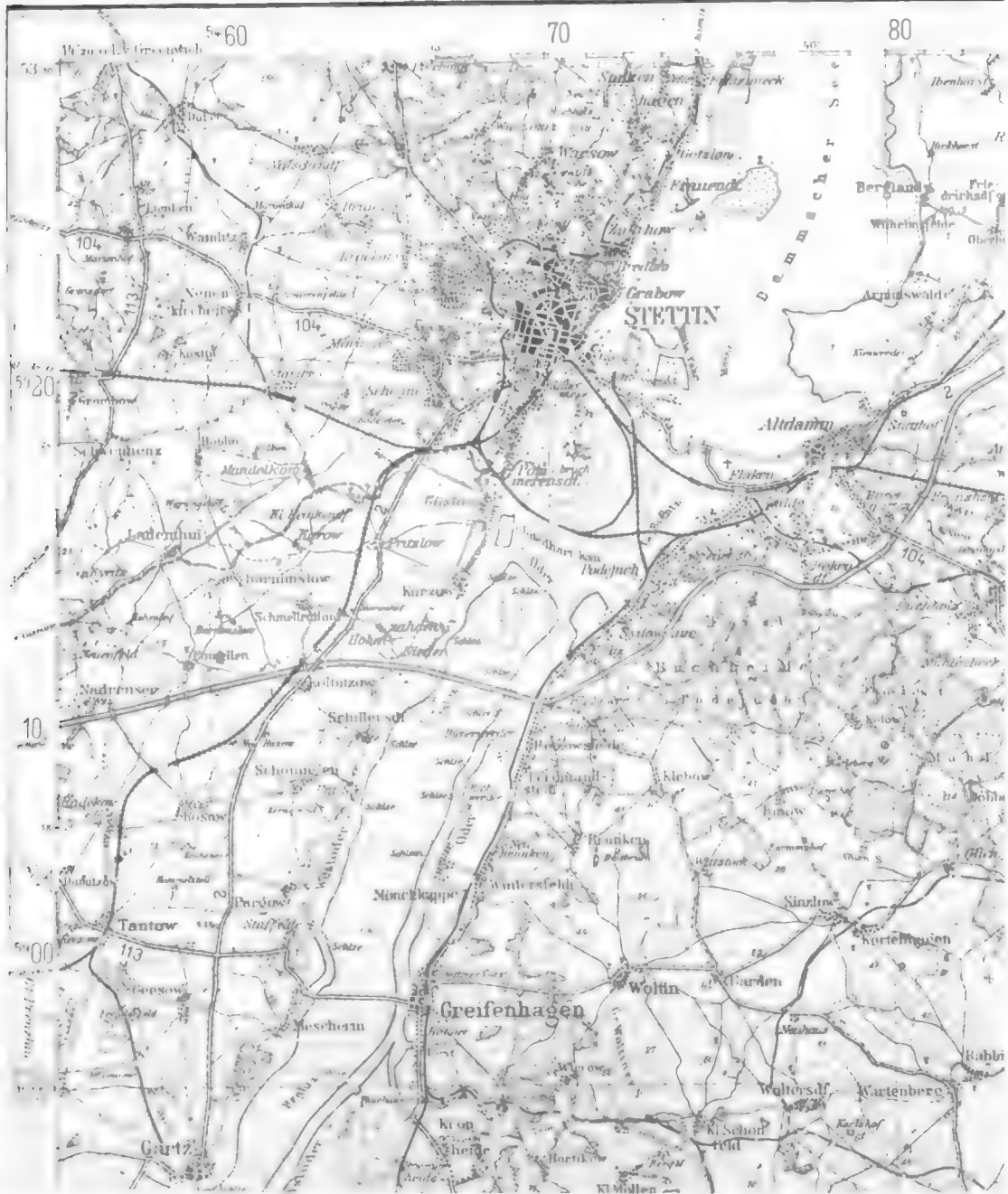

Figure 130. Section of *Topographische Übersichtskarte des Deutschen Reiches 1:200,000*.

Conic projection, measures 2° in latitude by 3° in longitude, and has a geographical reference grid, with an interval of 15' in latitude and 30' longitude. Relief is shown by hachures and spot elevations. The air edition includes aeronautical information and a special reference grid for the use of the German Air Force. A 13-sheet edition, designed on irregular sheet lines, showing the boundaries of the Länder of the Federal Republic of Germany and the German Democratic Republic, was issued in 1949–1950.

- (11) *Europa 1:500,000* (Europe 1:500,000); Generalstab des Heeres; 1938–45; reference grid.

This series was originated by the Generalstab des Heeres to close a gap in the German official mapping program. It provides only partial coverage for Germany. Each sheet covers one-quarter of the area of an *International Map of the World* sheet (2° in latitude by 3° in longitude). The sheets are polychrome lithographs with a varying number of colors. Relief is shown by contours, auxiliary contours, and spot heights. Some sheets are also layer tinted. The geographical grid is shown at an interval of 30 minutes. For the area of Germany not covered, this is supplemented by *Vogel's Karte von Mitteleuropa* (Map of Middle Europe)—Item 10—which is designed on the same sheet lines.

- (12) *Übersichtskarte* (General Map); 1:1,000,000; Reichsamt für Landesaufnahme; 1927–45; reference grid.

The original coverage of the German part of the *International Map of the World* consists of eight sheets. The sheets are designed on the Polyconic projection. This series, compiled from various sources, covers Germany within the 1937 borders. All sheets are polychrome. Relief is depicted by contours, altitude tints, and spot heights. The reference grid has intervals of 1°. This series has been extended by the Generalstab des Heeres to cover all of Europe and large parts of Asia and Africa under the title *Weltkarte* (World Map).

b. Town Plans. Numerous town plans by official city agencies and commercial concerns have been published for most of the cities in Germany.

Table XVIII. Glossary of German Map Expressions.

Abdruck.....	reproduction
Abteilung.....	department
Aequidistanz der Höhenkurven.	contour interval
Alle Rechte vorbehalten....	copyright reserved
Amt.....	administrative office
Anschlussblatt.....	adjoining sheet
aufgenommen.....	surveyed
Auflagedruck.....	impression, printing
Aufnahme.....	survey
Ausgabe.....	edition, issue
bearbeitet.....	compiled, prepared
berichtigt.....	revised
Berichtigungsstand.....	status of revision
bereinigt.....	expurgated
Bezirk.....	district
Druck.....	impression, printing
einzelne Nachträge.....	minor additions
ergänzt bis.....	complete as of
Freigegeben durch.....	released for publication by
gedruckt.....	printed
gezeichnet.....	drawn
herausgegeben.....	published
Höhenlinie.....	contour line
Höhenpunkt.....	spot elevation
Höhenschichten.....	contour intervals
Höhenzahl.....	elevation number
Kegelprojektion.....	conical projection
kleine Nachträge.....	minor additions
Lageskizze.....	location diagram, sheet index
Lieferung.....	press run, series
Masstab.....	scale (of map)
Messtisch.....	plane table
Nachdruck.....	reprint
Nachgeführt.....	brought up to date
Nachträge.....	additions
Nadelabweichung für Mitte.	magnetic declination for middle of the year (followed by date)
neubearbeitet.....	recompiled
nur für den Dienstgebrauch.	for official use only
neue Ausgabe.....	new edition
Planzeiger.....	grid reference box
redaktionelle Änderungen....	editorial changes
rekognosziert.....	reconnoitered
tellweise.....	partial
trigonometrischer Punkt....	trigonometric point
Umrechnungstabelle.....	conversion table
Vervielfältigungsrecht vorbehalten.	reproduction rights reserved
vorläufig.....	provisional
Zeichenerklärung.....	legend
zeitweilig.....	temporary
Zusammendruck.....	composite print
zweite Ausgabe.....	second edition

KISMARTON



Figure 131. Section of 1:25,000 map of Hungary by the M. Kir. Honvéd Térképészeti Intézet.

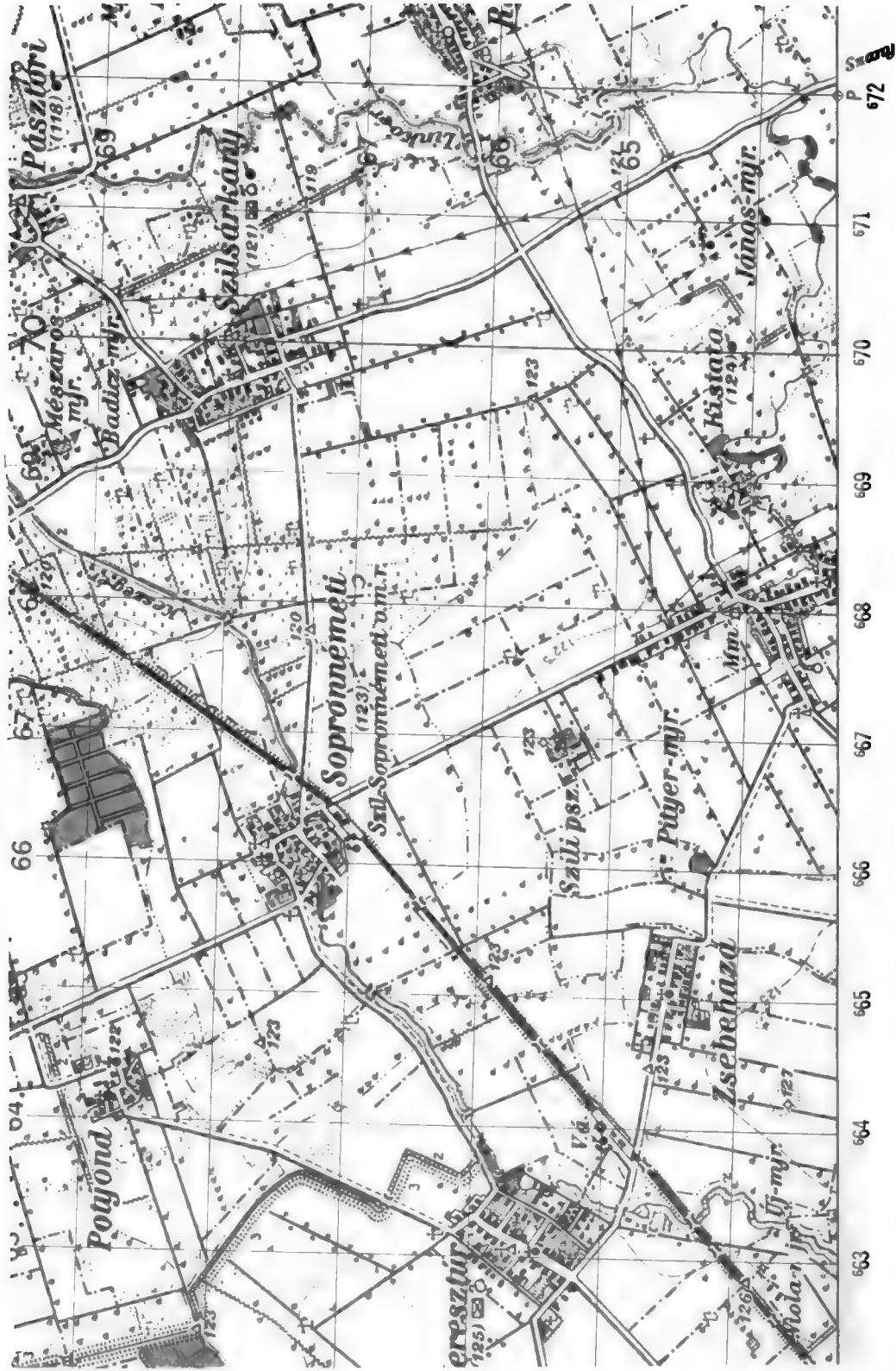

Figure 132. Section of 1:50,000 map of Hungary by the M. Kir. Honvéd Térképészeti Intézet reprinted by the Army Map Service as AMS M773.

Section IV. HUNGARY

161. Mapping Activities

a. Native. The native military maps of Hungary were produced by the M. Kir. Allami Térképészeti Intézet (Royal Hungarian State Cartographic Institute) or their successor agency, the M. Kir. Honvéd Térképészeti Intézet (Royal Hungarian Military Cartographic Institute). They were based on the Austro-Hungarian surveys (1860-98) and originally published at 1:25,000, 1:75,000, 1:200,000, and smaller scales. At large scales they vary in type from the Hungarian adaptation of the first Austro-Hungarian surveys (1860-98) to modern contoured military maps at scales of 1:25,000 and 1:50,000. As of 1947, over one-half of the total area, mainly the more rugged northern terrain and the frontiers, was covered by Hungarian maps at scales of 1:25,000 and 1:50,000. The 1:50,000 series, not published until 1943-44, was drawn on the stereographic projection, as were the 1:25,000 sheets covering areas of the new Hungarian surveys (1920-40).

b. Other. Map series at 1:100,000 (incomplete), 1:300,000, 1:500,000, and smaller scales, were produced by the German Generalstab des Heeres (General Staff of the Army) in 1944-45. These series are extensions into Hungarian territory of the standard German series. For their detailed description, see paragraph 160a.

162. Major Native Maps of Hungary

a. Topographic Series.

- (1) [*Hungary*]; 1:25,000; M. Kir. Honvéd Térképészeti Intézet; 1927-40; stereographic military grid.

This series, about half of which are based on the new topographic survey or revision, provides complete coverage of the country. Two types of sheets comprise this series. The monochrome sheets show relief by hachures and have corner and marginal geographic coordinates referred to Ferro. The polychrome sheets (fig. 131) portray relief by contours at 2.5-, 5-, and 10-meter intervals and have corner and marginal geographic coordinates referred to both Ferro and Greenwich. Different combinations of the following features are printed in the margin on some of both types of sheets:

graphic scales, location diagrams, slope scales, and magnetic declination diagrams. The stereographic grid is superimposed, but it serves only as a reference grid.

- (2) [*Hungary*]; 1:50,000; M. Kir. Honvéd Térképészeti Intézet; 1942-44; stereographic military grid.

This map series (fig. 132) was published during World War II to give the Hungarian armed forces a standardized large-scale map. It provides complete coverage of the country. The sheet lines are on the Austro-Hungarian System (fig. 125). Each sheet portrays one-half the area shown on the standard 1:75,000 sheet. Corner and marginal geographic coordinates are referred to Ferro and Greenwich. These polychrome sheets were based on the 1:25,000 series where available. Relief is shown by contours at intervals of 5, 10, 20, 50, and 100 meters. For some areas the revised 1:75,000 sheets were enlarged; for territories to which the Hungarians had no access, the unimproved hachured Viennese 1:75,000 sheets were used as a base. These sheets that were either enlarged from 1:75,000's or based on 1:75,000's are monochrome. In numerous cases the edges of the sheets of different origin do not meet, and small crosses show the correct meeting line inside or outside of the neatline of the map. The sheets carry the date of survey or revision, reference to the symbol key to be used, a slope diagram, and a grid protractor. The latest maps of the series have the new 1942 symbol key printed in the left margin.

- (3) [*Hungary*]; 1:75,000; M. Kir. Honvéd Térképészeti Intézet; 1920-42; stereographic military grid on the revised sheets, none on the old style.

This series, based on old Austro-Hungarian surveys, provides complete coverage for Hungary. Two types of sheets comprise this series. On the monochrome sheets, the planimetry was revised, but the geodetic base, the polyhedral projection, and hachured relief remained as on the original. The polychrome sheets were newly drafted on

the stereographic projection, using as base material the 1:25,000 series ((1) above). Relief is shown by contours at 2:5, 5-, 10-, and 50-meter intervals. Fractional and graphic scales are shown on all sheets. The old sheets have corner and marginal geographic coordinates referred to Ferro, but on the new sheets they are referred to both Ferro and Greenwich.

- (4) [*Hungary*]; 1:200,000; M. Kir. Honvéd Térképészeti Intézet; 1920-40; stereographic grid on the latest sheets only.

The origin of this medium-scale planning map was the Austro-Hungarian map, which the Hungarians revised and republished. Only cultural data were revised; the sheet lines and the polyhedral projection were retained. Polychrome sheets provide complete coverage of the country. Relief is portrayed by hachures. The chief meridian and the chief parallel run through the center of the sheet, and, combined with the name of the largest locality shown on the sheet, give the sheet identification, e. g., "38° 48' Miskolc." Corner and marginal coordinates are referred to Ferro and, on the later sheets, also to Greenwich.

b. Town Plans. Only about one-half of the more important towns are covered by plans, and of these only a few are topographic and postwar editions. The capital city, Budapest, is portrayed by contoured plans at scales of 1:10,000 and 1:25,000. Plans also cover Baja, Debrecen, Kecskemet, Komárom, Miskolc, Pecs, Sopron, Szeged and Szolnok. For the towns not covered by individual plans, a throughway collection, published by the Royal Automobile Club, is available in book form.

163. Coordinate Systems

After World War I the old Austro-Hungarian polyhedral projection was changed to the stereographic, but longitude was still referred to the Ferro meridian. The leveling is referred to the mean level of the Adriatic Sea, as determined by the tidal gage at Trieste.

164. Characteristics

As is also the case for Czech maps, the origin of the sheet-numbering system for Hungarian

mapping was the Austro-Hungarian system, by which the sheet lines are based on the Ferro meridian (fig. 125). The standard-size Hungarian maps at 1:25,000 indicate, besides the name of the largest locality shown on the sheet, the number of the respective 1:75,000 square, with the 1:25,000 divisions thereof indicated by fractional numbers from 1 to 4. The 1:50,000 sheets are identified at the center of the top margin by the name of the largest locality on the sheet, and by the number of the 1:75,000 square, combined with the letters NY (meaning West) or K (meaning East) in the upper-right margin.

Table XIX. *Glossary of Hungarian Map Expressions*

Budapesti rendszer.....	Budapest system [of coordinates]
Sztereografikus vetület.....	stereographic projection
Megújítási adatok.....	revision data
Új felvétel éve.....	year of new survey
Helyszíni megújítás éve.....	year of revision in the field
Kiadás.....	edition
Megjegyzés.....	note
1923 évi jelkulcs.....	1923 symbol key
a bécsi felvételi szelvény sarkpontjai.	sheet corners of the Viennese survey section
Csatlakozás a szomszéd térképpel csak ennek sarkpontjait összekötő vonal mentén lehetséges.	this sheet may be matched with the adjoining sheet only along the line connecting its corner points [marked with crosses]
Mérték.....	scale
Szintvonalak.....	contour lines
Lejtálmértékek.....	scales of gradients
Helyesbítési adatok.....	correction data
Helyszíni helyesbítés éve.....	year of correction in the field
Nyilvántartás alapján részben helyesbítve.	partially corrected from cadastral data
K. [Kelet].....	east
NY. [Nyugat].....	west
Ideiglenes kiadás.....	provisional edition
A javított új 75-ezres térkép nagytípusa.	enlarged from the corrected new 1:75,000 map
Példa a négyzetmutató használatára.	example how to use the grid square protractor
Km. (kilométer).....	kilometer
Lépés.....	pace
Trianoni határ.....	Trianon boundary
Mágneses elhajlás.....	magnetic declination
Mágneses tájékozozószög.....	magnetic orientation angle
Délkori összehajlás.....	meridian convergence
Évi változás.....	yearly change
Felmérte és rajzolta.....	surveyed and drafted [by]
Felmérés.....	survey
Készült a 25-ezres újfelmérés alapján.	produced on the basis of the new survey at the scale of 1:25,000

Section V. POLAND

165. Mapping Activities

a. Native. The initial surveying and map work was executed by German, Russian, and Austrian agencies for areas that later became parts of Poland. Figure 133 delimits the different triangulation nets resulting from the initial work of these agencies. It also provides a guide to the character of Polish mapping as related to the original surveys from which the present survey systems and maps are derived. In 1919 the Polish Wojskowy Instytut Geograficzny (Military Geographic Institute)—WIG was formed from the "Surveying School for Officers" and the "Topographic Section of the Ministry of War." From the beginning the organization covered all phases of mapping—topographic, cartographic, geodetic, and photogrammetric. In 1932 the Institut published "Catalog 8" which contained coordinates and elevations of 24,000 points on nine separate systems of coordinates and four reference ellipsoids. Because sound mapping could not result from these heterogeneous materials, and because half of the control points were destroyed, the Institut began work on a new system of triangulation in 1925. The datum point of the new triangulation was the first order station Borowa-Gora, located about 27 km. north of Warsaw. The conformal stereographic projection by Roussilhe was used and the Bessel ellipsoid was selected as the reference ellipsoid. This new Polish triangulation had not been completed as planned when World War II disrupted further work (1939).

b. Other. The German agencies primarily responsible for the surveying and mapping of Poland were the civilian agency, the Reichsamt für Landesaufnahme (Federal Land Survey Office) and the military agency, the Generalstab des Heeres (General Staff of the Army). The Reichsamt für Landesaufnahme was the direct result of a consolidation of many local survey bureaus, and during the German occupation of Poland, did much of the work for the Generalstab des Heeres. Russian surveying of eastern Poland started in 1816, when mapping of European Russia was initiated by Russian agencies. In the year 1897, a special commission, under the presidency of Scharnhorst, was charged with adjusting all existing triangulation carried out after 1816. In the late 1930's new surveying and mapping was initiated by the General'nyy Shtab Krasnaya Armiya

(General Staff, Red Army) to extend and complete the earlier work of the Scharnhorst Commission.

166. Major Maps of Poland

a. Topographic Series.

(1) *Native.*

- (a) *Polwysep Hel* (Hel Peninsula); 1:5,000; Wojskowy Instytut Geograficzny; 1930; local Polish grid.

This monochrome series provides coverage for the Hel Peninsula. The sheets were compiled from surveys dated 1928–29 and have a complete complete Polish legend and symbolization. Contours at intervals of .5, 1, 2, 3, 4, 5, and 10 meters indicate the relief. Numerous spot elevations are also shown.

- (b) *Wilno 1:10,000*; Wojskowy Instytut Geograficzny; 1928–32; Polish stereographic grid on most sheets.

These monochrome sheets provide coverage of the Wilno area. Relief is portrayed by contours at intervals of 1.25, 2.5, 5, 10 and 20 meters. They are based on the Polish survey dated 1926–31 and have a complete Polish legend.

- (c) *Mapa Szczegolowa* (Detailed Map); 1:25,000; Wojskowy Instytut Geograficzny; 1931–36; Polish stereographic grid on some sheets; no grid on others.

These sheets (fig. 134) provide almost complete coverage of Poland and vary from monochrome to five-color tourist editions. Relief is shown by contours at intervals of 4 to 20 meters. Where available, the new Polish (1927–38) ground-controlled surveys were used as compilation material. Elsewhere, old German, Russian, and/or Austro-Hungarian material was used. The sheets based on the new survey or revised sheets have the Polish stereographic grid. The uncorrected reproductions of the old surveys in the Russian and German language with Polish nomenclature are ungridded



Figure 133. Areas of old triangulation in Poland.

in most cases. Other sheets are comprised of uncorrected reproductions of Russian and Austrian maps based on old triangulation material and have various grids.

- (d) *Rejon Brzesc nad Bugiem* and *Rejon Deblin* (Region of Brest on the Bug River and Region of Deblin); 1:25,000; Wojskowy Instytut Geograficzny; 1925-26; Russian grid.

These sheets are based on old surveys that were checked in the field

in 1923-24. Relief is shown with contours at 2.13-, 4.17-, and 8.33-meter intervals. The sheets that provide coverage of the city of Deblin are monochromes and vegetation is shown by symbols. The sheets that provide coverage of the city of Brest are polychrome with green tints indicating vegetation.

- (e) [*Poland*]; 1:100,000; Wojskowy Instytut Geograficzny; 1932-39; Polish stereographic grid.

This series provides complete coverage of (1937) Poland. It is based on Polish, German, and Russian material, some of which had been revised to the date of compilation. These contoured sheets have a complete symbol legend.

- (f) *Mapa Operacyjna Polski* (Operational Map of Poland); 1:300,000; Wojskowy Instytut Geograficzny; 1932-39; Polish stereographic grid.

These polychrome sheets (fig. 135) provide complete coverage of (1937) Poland. Relief is shown by contours at 2.5- to 10-meter intervals. The German 1:300,000 format was used based on the revised Polish 1:100,000. In a few cases, special revisions were made in the field. Symbolization is complete.

- (g) *Mapa Polski* (Map of Poland); 1:500,000; Wojskowy Instytut Geograficzny; 1946-47; Polish stereographic grid.

This series (fig. 136) covers all of Poland west of 25° 30' E. of Greenwich. These polychrome sheets are contoured at either 20- or 50-meter intervals. The series was compiled from native medium-scale sources. The symbolization is complete.

- (h) *Mapa Polski* (Map of Poland); 1:1,000,000; Wojskowy Instytut Geograficzny; 1947; atlas grid.

Complete coverage of (1937) Poland is provided by this polychrome series. The sources used in compilation are unknown. Relief is shown by contours at 50- to 500-meter intervals. Symbolization is not detailed but does include four types of administrative boundaries.

(2) *Other.*

- (a) *General government 1:25,000, Topographische Karte 1:25,000, Deutsches Reich 1:25,000, USSR 1:25,000 (4 CM Karte), and the general government 1:25,000 (4 CM Karte)* (General Government Map 1:25,000, Topographic Map 1:25,000, German Reich 1:25,000, USSR 1:25,000 Four-centimeter Map, and General Government

1:25,000-Four-centimeter Map); Generalstab des Heeres, Reichsamt für Landesaufnahme, and Hauptvermessungsabteilung 1934-45; Gauss-Krüger grid.

This series provides coverage of (1937) Poland except for the southeastern portion. Most of the sheets are monochrome with the exception of a few covering western Poland. The bases for these sheets includes Polish, German, Austro-Hungarian, and Russian ground-controlled surveys and/or maps ranging in scale from 1:21,000 to 1:100,000. Many of these German sheets were enlargements of the maps at 1:42,000 and 1:100,000. Relief is shown by contours. With the interval dependent upon the source material used.

- (b) [*Russia*]; 1:50,000 and 1:100,000; Russian General'nyy Shtab, Krasnaya Armiya; 1932-34; Gauss-Krüger grid.

These two series provide coverage of of the western half of 1937 Poland. The base used was that of the Russian 1:21,000 and 1:42,000 series and/or surveys, and the Polish 1:25,000 and 1:100,000 sheets. Relief on these polychrome sheets is shown by contours with the interval in meters or sazhen.

- (c) *Deutsches Reich 1:50,000, Deutsche Karte 1:50,000, Polen 1:50,000, ehem. Polen 1:50,000, and Russland* (Germany 1:50,000, Map of Germany 1:50,000, Poland 1:50,000, former Poland 1:50,000, and Russia 1:50,000); Generalstab des Heeres 1934-45; Gauss-Krüger grid.

See paragraph 160a(4) for further details on this series.

- (d) *Europa 1:300,000, Mitteleuropa 1:300,000 and Osteuropa 1:300,000*; (Europe 1:300,000, Central Europe 1:300,000, and East Europe 1:300,000); Generalstab des Heeres; 1943-45; Gauss-Krüger grid.

See paragraph 160a(9) for details on this series.

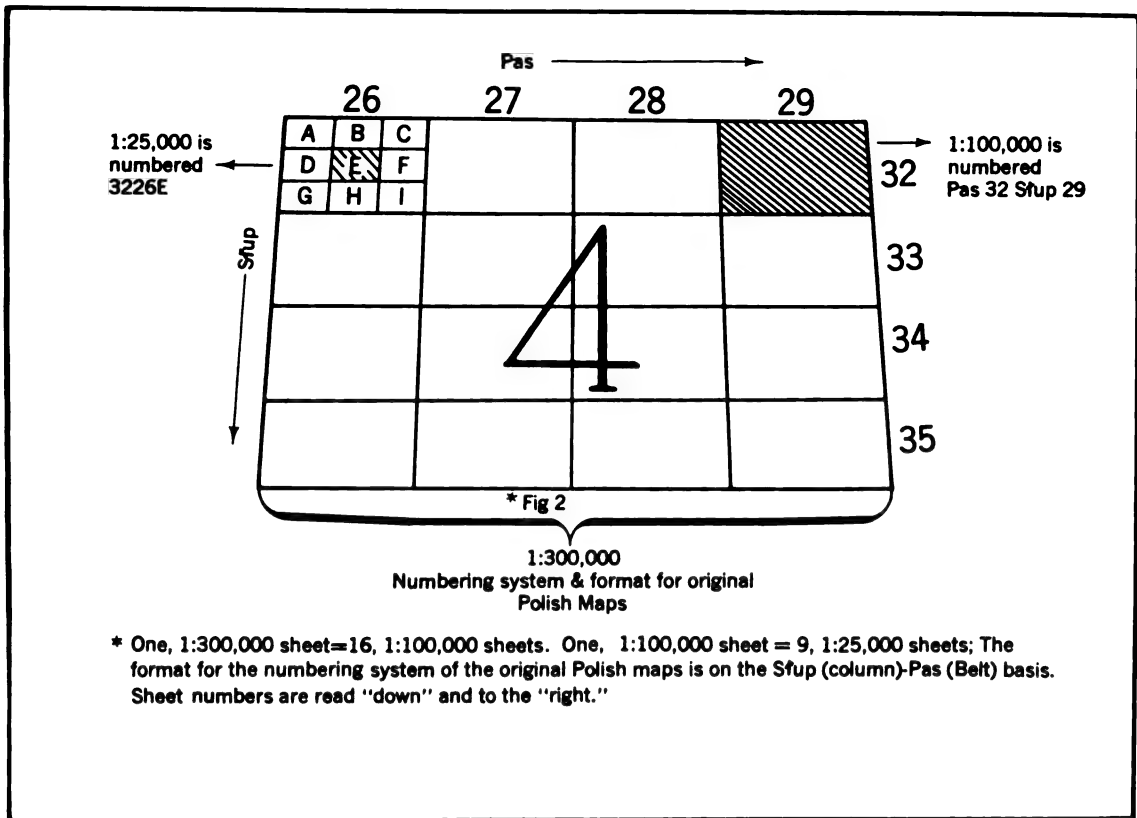

Figure 135. Numbering system and format for original Polish maps.

b. Town Plans. Plans of Polish urban areas published by authorities of various countries range in scale from 1:5,000 to 1:25,000. These plans provide coverage of all of the more strategic towns of Poland, but for the most part are culturally out of date. The sheets vary in format and sheet size. Most of the native city plans are contoured and contain insets that indicate through routes.

167. Coordinate Systems

a. Geographic. Geographic coordinates on the later-date Polish maps are read in degrees, and longitude is referred to Greenwich. On a few older sheets, however, longitude is referred to Ferro and Pulkovo.

b. Grid. Most of the native sheets have a military grid. The grid interval on 1:100,000 maps is 2 kilometers. Two-digit numbers on alternate

grid lines give grid distance in units and tens of kilometers. Grid lines nearest the sheet corners have an additional digit in smaller type giving grid distances in hundreds of kilometers. Maps at the scale of 1:25,000 contain grid lines at 1-kilometer intervals. All grid coordinates are read right and up.

168. Characteristics

The Russian maps of the area often have a double grid falling in the zones of overlapping surveys. This graphic indication of the discrepancies between identical points of different triangulation arcs, is often as much as 160–250 meters. Early German and Polish sheets (pre-1939) seldom show these discrepancies, because of the generalization in the compilation of these sheets.

Table XX. Glossary of Polish Map Expressions.

Cześć polska unaczęsniona w r.	Polish part revised in the year.
Druk V. 1931.....	print of 5th edition, 1931.
Druk na podstawie map 1:75,000 z r. 1935.	printing based on the 1:75,000 map of the year 1935.
Druk i wydanie W. I. G. 1926 r.	printed and published by the W. I. G. in the year 1926.
Na podstawie zdjęć stolikowych z lat 1926-27-28.	based on the plane table surveys during the years 1926-27-28.
Opracowano w r.....	compiled in the year.
Opracowano i wydano w r. 1924.	compiled and published in 1924.
Opracowano na podstawie map 1:84,000 wydania 1915 r. (zdjęcie oryginalne z 1909-10 i 11 r.)	compilation based on 1:84,000 map of 1915 (original survey of the years 1909-10 and 1911).
Częściawo uzupełniono.....	partly supplemented.
Sprawdził—dzili—dzono ----	verified by.

Table XX. Glossary of Polish Map Expressions—Con.

Sprawdzili część polska w r..	Polish part verified in the year.
Sprawdzono w terenie w r. 1924.	verified in the field in the year 1924.
Sprawdzono i uzupełniono w r. 1923.	verified and supplemented in 1923.
W. R.....	in the year.
Wznowiono w r. 1938.....	reissued in 1938.
Wznowienie wydania z r. 1926.	reissue of the 1926 edition.
Wszelkie prawa zastrzeżone	all rights reserved.
Wznowiono w r. 1938 bez zmian	reissued in the year 1938, without changes.
Wznowiono w r. 1942, w Szkocji przez Sekcję Wojsk. Inst. Geogr.	reissued in 1942, in Scotland, by the section of Military Geographic Institute.
Zdjęcie stolikowe wykonali...	plane table survey prepared by.
Zdjęcie W. I. G. z r. 1927 wykonali.	survey by W. I. G. in 1927 prepared by.

Section VI. SWITZERLAND

169. Mapping Activities

a. Native. Swiss topographic maps are produced by two agencies: Eidgenössische Landestopographie—ELT (Federal Topographic Office) and Eidgenössische Vermessungsdirektion (Federal Survey Administration). The ELT is a section of the Swiss Military Department. This office is responsible for all operations necessary to the production of military and topographic maps. The Eidgenössische Vermessungsdirektion supervises the work of fourth-order triangulation, and the production and maintenance of cadastral maps at 1:5,000 of the plain and hill lands and at 1:10,000 of the mountainous areas. These maps of local areas are not a series covering the entire country.

b. Other. Series covering the countries adjoining Switzerland have been published by the British Directorate of Military Survey, War Office (Geographical Section, General Staff)—GSGS and by the German Generalstab des Heeres (General Staff of the Army). Sheets of these series that cover parts of Switzerland have been revised, and provide complete cover of the country.

170. Major Native Maps of Switzerland

a. Topographic Series.

- (1) *Atlas Siegfried*; 1:25,000 and 1:50,000; *Carte au 25,000*^o and *Karte 1:25,000*; (Map at 1:25,000) Eidgenössische Landestopographie; 1884- ; Swiss grid. The 1:25,000 sheets of these poly-

chrome series (fig. 137) provide coverage of the plain and hill lands that constitute half of the area of Switzerland. The remaining areas have been mapped at the scale of 1:50,000. The 1:50,000 sheets have now been completely superseded by the *Landeskarte*; see (b) below. They were based on a triangulation survey begun in 1832. Relief is shown by contours at 10-meter intervals on the 1:25,000 sheets and 30-meter intervals on the 1:50,000 sheets. Various kinds of vegetation, rocks, quarries, drainage, etc. are shown by symbols. The built-up areas are well symbolized and are shown true to scale.

- (2) *Landeskarte* (National Map); 1:50,000; Eidgenössische Landestopographie; 1938- ; Swiss grid.

This polychrome series provides coverage of more than half of Switzerland. The sheets are based on a post-World War I ground survey. Relief is shown by contours at 20-meter intervals, shading, and elevation points. Built-up areas are shown true to scale and symbolization is varied.

- (3) *Dufourkarte* (Dufour Map); 1:100,000; Eidgenössische Landestopographie; 1842- ; Swiss grid.

This series (fig. 138) provides complete coverage of the country. Some edi-

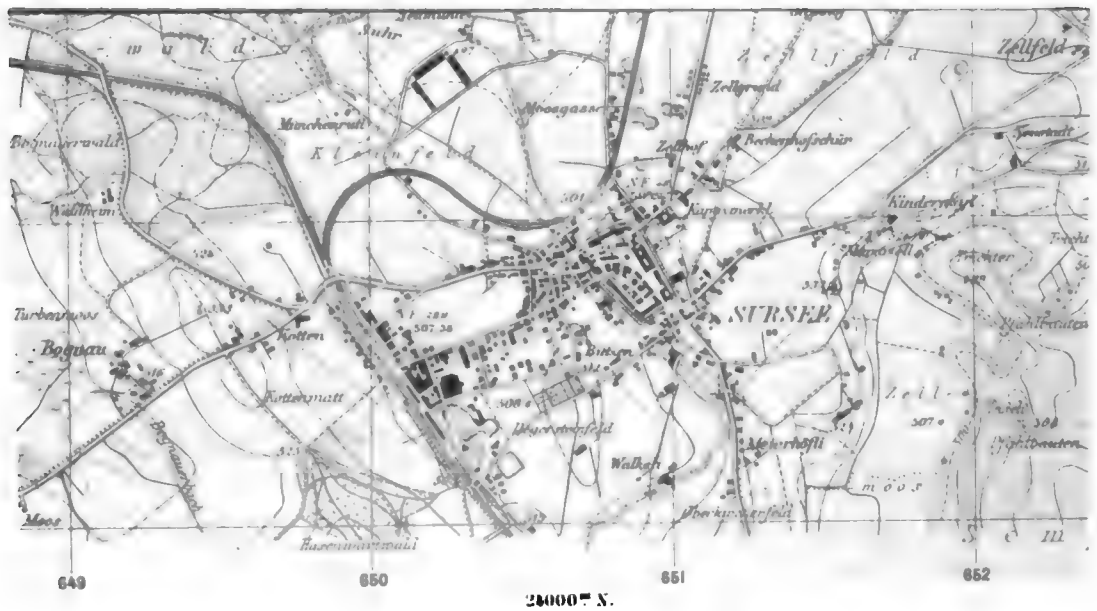

Figure 137. Section of sheet from Atlas Siegfried at 1:25,000 by the Eidgenössische Landestopographie.

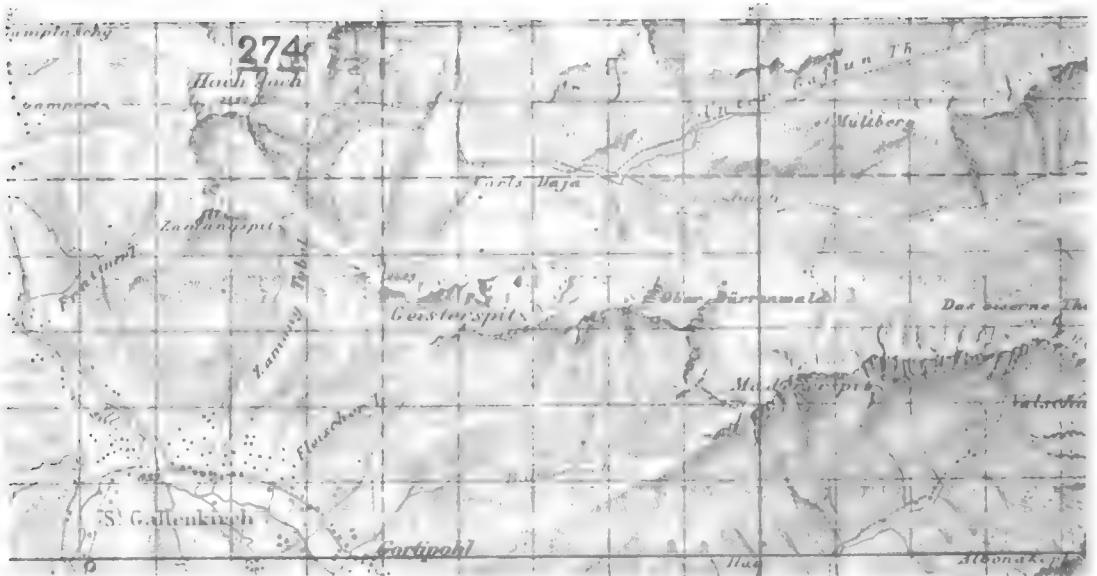

Figure 138. Section of sheet from Dufourkarte at 1:100,000 by the Eidgenössische Landestopographie.

tions are monochrome, and others are polychrome. Relief is shown by hachures and elevation points. Woods, marshes, glaciers, and rocks are indicated. Built-up areas are shown true to scale. This series was based on a triangulation survey begun in 1832.

b. Town Plans. Most of the cities in Switzerland are covered by native town plans. They range in scale from 1:5,000 to 1:15,000, and were published by local commercial authorities in 1948-49.

171. Coordinate Systems

a. Geographic. Swiss maps are drawn on a cylindrical conformal projection with oblique axis; the projection is computed on the Bessel spheroid and its origin corresponds to the meridian mark of the old observatory of Bern ($46^{\circ}57'08''$ N- $7^{\circ}26'20''$ E. of Greenwich).

b. Grid. The Swiss grid is referred to Bern, with false coordinates adding 200 kilometers to the northings and 600 kilometers to the eastings.

CHAPTER 10

SOUTHEASTERN EUROPE

Section I. ALBANIA

172. Mapping Activities

a. Official. Albania has not accomplished mapping. Major contributions to Albanian mapping have been made by agencies of other countries. The Italian Istituto Geografico Militare (Military Geographic Institute) was authorized by the Albanian government to perform surveys and produce maps of the country.

b. Other. During World War II, Italian maps were reproduced by the German Generalstab des Heeres (General Staff of the Army), the British Directorate of Military Survey, War Office (Geographical Section, General Staff—GSGS), and the Middle East Command. Recently Army Map Service reprinted Italian and British maps with the addition of the Universal Transverse Mercator grid.

173. Major Maps of Albania

a. Official Topographic Series.

- (1) *Bonafiche Dell'Albania 1:5,000* (Reclamation of Albania 1:5,000); Istituto Geografico Militare; 1939-43; arbitrary grid.

This detailed monochrome series is based on aerophotogrammetric surveys of 1937-42 by Istituto Geografico Militare and covers scattered areas and major communities in Albania. Vegetation and drainage features are shown on some sheets. Relief is shown on some sheets by contours at intervals of 0.50 meters.

- (2) [*Albania*]; 1:50,000; Istituto Geografico Militare; 1941-42; geographic grid.

This polychrome series provides complete coverage of Albania. Sheets covering northern and central areas were surveyed in 1928-38. Some of these sheets were compiled by stereophoto-

grammetric methods; the others are based on ground surveys. Sheets covering the southern part were compiled from various map sources based on 1914-25 surveys. The whole series was partially revised in 1941-42. It is printed in the Albanian and Italian languages. Relief is shown by contours at intervals of 20, 25, 30 or 50 meters. Vegetation is shown. Longitudes are referred to the Tirane prime meridian (19°46'45" East of Greenwich). This series was reproduced by the Germans in 1943-44 with some major cultural revisions and with the addition of a German Gauss-Krüger military grid. A Yugoslav Gauss-Krüger military grid was added to some sheets. Army Map Service also reproduced this series with major communications data revised from intelligence to 1952 and the addition of the Universal Transverse Mercator grid.

- (3) [*Albania*]; 1:100,000; Istituto Geografico Militare; 1941; geographic grid.

Complete coverage for Albania is provided by this polychrome series. It was based on the Italian 1:50,000 sheets (1928-38). Relief is indicated by contours at intervals of 50 and 100 meters. Woods are shown. Longitude references are the prime meridians of Tirane and Paris.

b. Town Plans.

- (1) *Official.* Town plans dated 1937-42 produced by the Istituto Geografico Militare are available for several of the most important urban areas of Albania.
- (2) *Other.* The British and the Germans compiled plans of the most important towns during World War II.

174. Coordinate Systems

See paragraph 185.

175. Characteristics

The maps of Albania utilize standard Italian

symbolization and are cut on the same sheet-line system as the maps of Italy. Sheet lines of the German and British coverage correspond to those of the Yugoslav system.

Section II. BULGARIA

176. Mapping Activities

a. Native. The native topographic mapping agency of Bulgaria is the Durzhaven Geografski Institut (State Geographic Institute). It has been reported that a new organization was formed in January 1952 named "Geokartproekt." It was to be responsible for all type of topographic surveying, photogrammetric, and cartographic work. No information is available concerning their publications.

b. Official. Two series of Rumanian maps are discussed in this section as official mapping because they cover the Dobruja area, which formerly was part of Rumania. The Dobruja area was mapped by the Rumanian Institutul Geografic Militar (Military Geographic Institute).

c. Other. During World War II the German Generalstab des Heeres (General Staff of the Army) and the British Directorate of Military Survey, War Office (Geographical Section, General Staff)—GSGS, have compiled new maps at medium scales and reprinted some Bulgarian maps. Until the end of World War I all maps of Bulgaria were based on Russian surveys at 1:42,000 dated 1877-79. All modern Bulgarian maps are based on the topographic survey at 1:25,000 undertaken in 1931. Frontier and strategic areas were given first attention in this survey, which was accomplished by a combination of aerial and terrestrial photogrammetric and planetable methods. Maps based on this survey are at the scales of 1:25,000, 1:50,000, 1:100,000, and 1:200,000.

177. Major Maps of Bulgaria

a. Topographic Series.

(1) *Native.*

- (a) [*Bulgaria*]; 1:25,000; Durzhaven Geografski Institut; 1935-41; Bulgarian Gauss-Krüger grid.

Available sheets of this polychrome series (fig. 139) provide scattered coverage for a strip across southern

Bulgaria and for parts of the northwestern and northeastern sections. The sheets are based on the 1:25,000 surveys dated 1932-36 and show relief by contours at intervals of 10 meters with auxiliary contour intervals of 2.5 and 5 meters. Some sheets were reproduced as monochrome editions by the Germans. These latter sheets provide coverage for portions of the southern frontier area for which no native maps are available in the United States.

- (b) [*Bulgaria*]; 1:40,000; Durzhaven Geografski Institut; 1903-40; Bulgarian Gauss-Krüger grid on some sheets.

This series covers all but the central and southwestern area of Bulgaria. These monochrome sheets are enlargements of Russian 1:105,000 sources that were based on a survey at 1:42,000 executed in 1877-79. Relief is shown by approximate contours at intervals of 10 meters. The sheets contain no legend but use standard Bulgarian symbolization. Cultural revisions were made on sheets of the northern and northeastern sections in 1939-40 by troops in the field. A few sheets for the Sofia area were reduced to 1:50,000 and published as polychrome editions.

- (c) [*Bulgaria*]; 1:50,000; Durzhaven Geografski Institut; 1935-41; Bulgarian Gauss-Krüger grid.

This series covers the southern third of Bulgaria and a small part of the northwestern area. Based on the 1:25,000 survey, the maps show relief by contours at intervals of 20 meters, with auxiliary contour intervals of 5 and 10 meters. A few sheets are monochrome. The British reprinted a few of these sheets in 1944. They

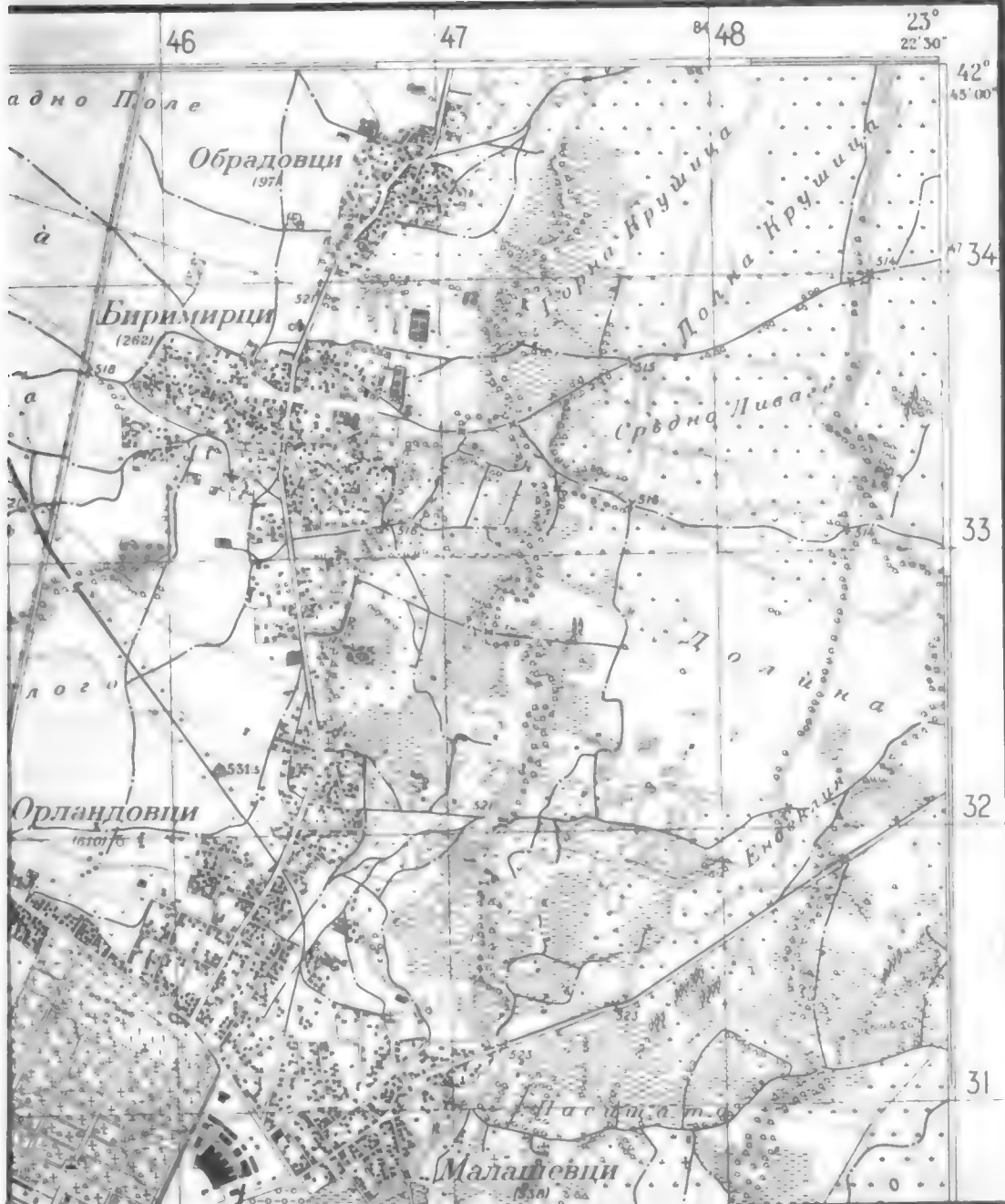

Figure 139. Section of sheet from 1:25,000 series of Bulgaria by the Durzhaven Geografski Institut.

added their military grid and a red overprint for principal roads; marginal information was translated and place names were transliterated.

- (d) [Bulgaria]; 1:100,000, Durzhaven Geografski Institut; 1943–; Bulgarian Gauss-Krüger grid.

Publication of this map series was probably begun in 1943. Coverage at that time was limited to the southeastern corner of Bulgaria. Based on the 1:25,000 survey, the maps show relief by contours at 50-meter intervals. Other symbolization is

identical to that used on the native 1:25,000 map series.

- (e) [*Bulgaria*]; 1:125,000; Durzhaven Geografski Institut; 1939-41; Bulgarian Gauss-Krüger grid.

This polychrome series provides coverage for all but the southwestern part of Bulgaria. It is an enlargement of Bulgarian reproductions of the Russian 1:126,000 map based on surveys at 1:42,000 dated 1877-79. The grid was added and revisions to the communications data, place names, and vegetation features were incorporated from maps and various sources in 1939-41. Relief is shown by contours at 10-sazhen intervals [10 sazhen=21.34 meters]. During World War II the Germans enlarged the Bulgarian 1:126,000 map and added corrections from the 1:125,000 series on sheets for which the new 1:25,000 survey data were not available, thus providing complete coverage of Bulgaria at the scale of 1:100,000.

- (f) [*Bulgaria*]; 1:200,000; Durzhaven Geografski Institut; 1943; no grid.

Scattered coverage of southwestern and northeastern Bulgaria is provided by this polychrome series. Based on the 1:25,000 survey, relief is indicated by contours at intervals of 100 meters, by auxiliary contours at 50-meter intervals, and by hill shading.

(2) *Official.*

- (a) *Planul Director de Tragere 1:20,000* (Direct Firing Map 1:20,000); Institutul Geografic Militar; 1934-40; Stereographic grid.

A few sheets of this series provide partial coverage for northeastern Bulgaria and southern Dobruja. These polychrome sheets are based on a Rumanian 1:20,000 ground survey made in 1932-38. Relief is shown by contours at 10-meter intervals and by auxiliary contours at intervals of 1.25, 2.50 and 5 meters.

- (b) *Planul Director de Tragere 1:20,000* (Direct Firing Map 1:20,000); Insti-

tutul Geografic Militar; 1923-39; Lambert grid.

Sheets of this series cover an area in southern Dobruja. They are based on 1:20,000 ground surveys dated 1898, 1910-15, and 1928. Many were revised from a field survey at 1:50,000 dated 1912-15. Relief is shown by contours at 10-meter intervals and auxiliary contours at 5-meter intervals.

b. *Town Plans.* It has been reported that numerous town plans have been published by Durzhaven Geografic Institut since World War II. These plans range in date from 1928 to 1952. Standard town plans are available for only a few of the more important urban areas. Tourist plans and sketches are available.

178. Coordinate Systems

a. *Geographic.* Modern Bulgarian maps show degrees with reference to Greenwich. The 1:125,000 series show degrees with reference to Pulkovo. The 1:40,000 series does not show any geographic coordinate information.

b. *Grid.* All Bulgarian maps based on the new 1:25,000 survey material, except the 1:200,000 series, show the Bulgarian Gauss-Krüger (Transverse Mercator) grid on the Gauss-Krüger projection, Hayford spheroid. The 1:40,000 and 1:125,000 series, which are based on the old Russian survey material, are based on Pulkovo. Some 1:40,000 sheets of northern Bulgaria carry a Bulgarian Gauss-Krüger grid. All sheets of the 1:125,000 series carry the Bulgarian Gauss-Krüger grid. Rumanian maps carry the Lambert and Stereographic grids.

179. Characteristics

All maps of Bulgaria indicate types of vegetation and include information on the number of dwellings in villages. Bulgarian maps use the Cyrillic alphabet (tables XXI and XXII). Road classification is based on importance. Contours on the 1:40,000 series are only of approximate value because of the conversion from the sazhen system of measures, employed on the original Russian survey material, to the metric system. The interpolation of additional contours to achieve an even contour interval resulted in a generalization of relief information.

Table XXI. Transliteration System for Bulgarian Geographic Names

<i>Bulgarian</i>	<i>Transliteration</i>	<i>Bulgarian</i>	<i>Transliteration</i>
А а	a	П п	p
Б б	b	Р р	r
В в	v	С с	s
Г г	g	Т т	t
Д д	d	У у	u
Е е	e	Ф ф	f
Ж ж	zh	Х х	kh
З з	z	Ц ц	ts
И и	i	Ч ч	ch
Й й	y	Ш ш	sh
К к	k	Щ щ	sht
Л л	l	Ъ ъ	ŭ
М м	m	Ь ь	'
Н н	n	Ю ю	yu
О о	o	Я я	ya

The following procedures apply to transliteration from sources written in the orthography which was official before February 1945:

1. Word-final ъ should be omitted in transliteration.
2. The obsolete letter ж, now replaced by ъ, should be transliterated by ŭ.
3. The obsolete letter Ъ, replaced in February 1945 by е or я according to local pronunciation, should be transliterated by ye, if sources written in the new orthography are not available. Names transliterated with ye resulting from Ъ should be corrected to agree with the new Bulgarian spellings as they become available.

Table XXII. Glossary of Bulgarian Map Expressions

Bulgarian	Transliteration	Translation
ВОЕННО	VOENNO	Military
ГЕОГРАФСКО	GEOGRAFSKO	Geographic
ДАННИ	DANNI	Data
ДЪРЖАВЕНЪ	DŪRZHAVEN	State
ЗА	ZA	For, to, by, at, etc.
ЗАБРАНЕНО	ZABRANENO	Prohibited
И	I	And
ИЗДАДЕНЪ	IZDADEN	Published
ИНСТИТУТЪ	INSTITUT	Institute
КАБИНЕТНО	KABINETNO	Council
КАРТА	KARTA	Map
КАРТОГРАФСКИ	KARTOGRAFCHESKI	Cartographic
ЛИСТЪ	LIST	Sheet
МЕТРА	METRA	Meter
МИЛИЦИЯ	MILITSIYA	Militia
МРЕЖА	MREZHA	Network
МЪРКА	MŪRKA	Scale
НА	NA	Of, to, on, etc.
НОВИ	NOVI	New
ОТЪ	OT	Of, from
ПО	PO	To, by, on, etc.
ПОПЪЛНЕНЪ	POPŪLNEN	Completed
ПОПРАВЕНЪ	POPRAVEN	Revised, corrected
ПРЕЗЪ	PREZ	Circa
ПРЕПЕЧАТВАНЕТО	PREPECHATVANETO	Reprint(ing)
РУСКАТА	RUSKATA	Russian
СНИМКА	SNIMKA	Survey
СПОРЕДЪ	SPORED	According to, in regard to, from
СЪСТАВИЛ И ИЗДАБА	SŪSTAVIL I IZDAVA	Compiled and published
ТОПОГРАФСКА	TOPOGRAFSKA	Topographic
ЦЪЛИ	TSYELI	Entire
ШОСЕЙНАТА	SHOSEYNATA	Macadam road
КИЛОМЕТЪРЪ	KILOMETŪR	Kilometer
ХОРИЗОНТАЛИ	KHORIZONTALI	Contour lines

Section III. GREECE

180. Mapping Activities

a. Native. The principal topographic mapping agency in Greece is the Yeografikí Ipiresía Stratoú (Geographic Service of the Army). Additional large-scale topographic maps as well as town plans are published by the Ipourýion Dhimosíon Érgon (Ministry of Public Works). All maps published by these agencies use the Greek alphabet. Lettering used on Greek maps is illustrated in table XXIV.

b. Official. Some series of Italian maps are discussed in this section as official mapping because they cover areas that formerly were Italian possessions. These island areas were mapped at large scales by the Italian Istituto Geografico Militare (Military Geographic Institute).

c. Other. During World War II the German Generalstab des Heeres (General Staff of the

Army) and the British Directorate of Military Survey, War Office (Geographic Section, General Staff)—GSGS reprinted and revised Greek maps at various scales. Some original sheets were compiled by these agencies. Since World War II, the Army Map Service has reprinted sheets with the addition of the Universal Transverse Mercator grid and has published large-scale photogrammetrically compiled sheets covering the Pelopónnisos.

181. Major Maps of Greece

a. Topographic Series.

(1) *Native.*

(a) [*Greece*]; 1:5,000, Ipourýion Dhimosíon Érgon; 1952; unidentified local grid.

This series provides coverage for

scattered areas, mostly near the towns of Porto Lago and Pírgos. Relief is shown by contours at intervals ranging from 0.5 meters to 10 meters. Types of vegetation are indicated. These monochrome sheets were compiled by stereophotogrammetric methods from aerial photography dated 1938 and 1951. These maps have no legend, but utilize standard Greek symbols.

- (b) [*Greece*]; 1:20,000; Ipourýion Dhimosón Érgon; 1952; unidentified local grid.

The monochrome sheets of this series provide scattered coverage, mostly in the Kavalla-Komotini and Agrínion areas. Relief is shown by contours at 20-meter intervals and by auxiliary contours at intervals ranging from 0.5 to 10 meters. The sheets were compiled by stereophotogrammetric methods from aerial photography dated 1945. Types of vegetation are shown. The maps have no legend but use standard Greek symbols.

- (c) [*Greece*]; 1:20,000; Yeografikí Ipiresía Stratoú; 1926-47; Greek military grid on some sheets.

This series covers the northern frontier and scattered strategic areas throughout Greece. The sheets are based on planetable surveys dated 1924-40, with relief shown by contours at 10-meter intervals and some auxiliary contours at 5-meter intervals. Vegetation is indicated. Although most of the sheets are multi-colored, the ones with the earliest published dates are monochrome. See figure 140 for illustration of sheet-line system of maps published by the Greek Yeografikí Ipiresía Stratoú.

- (d) [*Greece*]; 1:50,000; Yeografikí Ipiresía Stratoú; 1925-48; British military grid on some sheets.

Scattered coverage of the mainland of Greece is provided by this polychrome series. The sheets are based on 1:20,000 ground surveys dated 1902-36 and some were revised from

field checks in 1932-37. The postwar sheets have road classification revisions. Relief is shown by contours at 20-meter intervals and auxiliary contours at 10-meter intervals. Various types of vegetation are shown. The coverage is extended by photo-revised British and German editions of Crete, and a German edition of parts of the northern mainland.

- (e) *Épitelikós khártis tis Elládhos 1:100,000* (Staff Map of Greece 1:100,000); Yeografikí Ipiresía Stratoú; 1928-41; Greek military grid on one sheet.

This polychrome series provides partial coverage of the mainland area of Greece. Relief is indicated by contours varying from 20- to 50-meter intervals. The sheets are based on 1:20,000 and 1:50,000 ground surveys dated 1896-1932. Various types of vegetation are shown. The Germans and the British reproduced this series during World War II with revisions from wartime aerial photography and were field checked. They extended the coverage by compiling new sheets from Greek 1:50,000 maps, where available, and from aerial photography. The sheets based on aerial photography cover the western Pelopónnisos. They are not as detailed as the rest of the series. Relief is indicated on them by form lines at approximately 100-meter intervals.

- (f) *Stratigikós Khártis tis Elládhos 1:200,000* (Strategic Map of Greece 1:200,000); Yeografikí Ipiresía Stratoú; 1947-52; British military grid.

This polychrome series covers most of the mainland and Pelopónnisos as well as a large number of the islands. Relief is shown by contours at 100-meter intervals and auxiliary contours at 50-meter intervals. These polychrome sheets were compiled in 1947-52 from the 1:50,000 and 1:100,000 series with postwar cultural revisions. Vegetation is indicated.

- (g) *Yenikós Khártis tis Elládhos 1:400,000*



ΓΕΩΓΡΑΦΙΚΗ ΥΠΗΡΕΣΙΑ ΣΤΡΑΤΟΥ
 Geographic Service of the Army
 Diagram

ΔΙΑΓΡΑΜΜΑ

ΟΝΟΜΑΣΙΑΣ ΤΩΝ ΦΥΛΛΩΝ ΕΚΔΟΣΕΩΣ
 of Sheet Names

ΗΠΕΙΡΟΣ 2 x 2 κλ. 1:400.000

ΑΘΗΝΑΙ (1" x 1") κλ. 1:200.000

ΜΥΛΑΣΑ (1/4 Η) (30' x 30') κλ. 1:100.000

ΚΛΙΜ. ΔΙΑΓΡΑΜΜΑΤΟΣ 1:2.500.000

ΤΑΙΝΑΡΟΝ ΜΑΚΕΑΣ
 4221 ΚΥΘΗΡΑ 4222

ΤΑΙΝΑΡΟΝ-ΚΥΘΗΡΑ
 422

4223 4224

ΚΥΘΗΡΑ
 42

4241 4242

424

4243 4244

Figure 140. Section of Greek index illustrating sheet-line system of maps published by the Yeografiki Ipirestia Stratou.

000 (General Map of Greece 1:400,000); Yeografiki Ipirestia Stratou; 1946-52; British military grid.

This polychrome series provides coverage for most of the mainland and Crete and for some of the Dodecanese

Islands. It was compiled from 1:100,000 maps dated 1925-41, and contains postwar cultural revisions. Relief is shown by contours at 200-meter intervals and vegetation is indicated.

(2) *Official.*

(a) [*Dodecanese Islands*]; 1:25,000; Istituto Geografico Militare; 1928-40; geographic grid.

This monochrome series covers all of the Dodecanese Islands and a few of the Kikladhes Islands. Some sheets were based on surveys of 1922-34, and others were partially revised in 1939. Geographic coordinates are referred to Greenwich. Relief is shown by contours at 10-meter intervals and auxiliary contours at 5-meter intervals. Vegetation is indicated. The Germans reprinted this series in 1943 with the addition of a grid. The British reproduced the series in 1942-43 with revisions to communications data.

(b) *Isole Ionie 1:25,000* (Ionian Islands 1:25,000); Istituto Geografico Militare; 1943-44; Italian Gauss-Krüger grid on all but three sheets. Coverage for only one of the Ionian Islands, Kefallinía, is furnished by this series. The monochrome sheets were compiled from aerial photography dated 1942. Rome is the prime meridian for the

series. Relief is indicated by contours at 25-meter intervals and vegetation is shown.

(c) *Isola di Corfu 1:50,000* (Corfu Island 1:50,000); Istituto Geografico Militare; 1941; no grid.

This single-sheet monochrome map provides coverage for the island of Kérkira (formerly Corfu). It is based on a survey dated 1923 and was partially revised from aerial photographs in 1941. Relief is shown by contours at 20-meter intervals and vegetation is indicated.

b. *Town Plans.*

(1) *Native.* The Ipouryíon Dhimosíon Érgon and Ipouryíon Singkoínonías have published postwar monochrome plans of some of the important towns, but cultural features are not identified by names.

(2) *Other.*

The majority of the city plans of Greece were compiled by the British during World War II from aerial photography. The plans of the more important ports have been revised since the war.

Table XXIII. *Glossary of Greek Map Expressions*

Greek	Transliteration	English
Ἀεροφωτογραφία	Aerofotografíai	Aerial photographs
Ἀναθεωρήσεις	Anatheorísis	Revisions
Ἀνατύπωση	Anatíposis	Reprint
Ἔκδοσις	Ekdhosis	Edition
Ἔργασια Συνθέσεως (τοῦ φύλλου)	Ergasíai Sinthéseos (tóu fíllou)	Compilation data (of sheet)
Ἐσχεδιάσθη καὶ Ἐξεδόθη	Eskhedhiásthi kaí exedóthi	Drafted and printed
Κλίμαξ	Klímax	Scale
Κλίμαξ Κλίσεων	Klímax Klíseon	Inclination scale
Ἰσοδιάσταση	Isodhiástasis	Contour interval
Ὀδικόν Δικτύων	Odhikón Dhíktion	Road network
Οἰαδήποτε ἀνατύπωση ἀπαγορεύεται	Oiadhíποτε Anatíposis Apagorévetai	Reprint forbidden
Προσωρινή Ἔκδοσις	Prosorínē Ekdhosis	Provisional edition
Σύνθεσις	Sínthesis	Compilation
Σμίκρυνσις	Smikrýnsis	Reduction

AUTHORITIES

Γεωγραφικὴ Ἱπηρεσία Στρατοῦ
(Yeografikí Ipíresía Stratóu)
Ἱπουργεῖον Συμμοινωνίας
(Ipouryíon Singoinonías)
Ἱπουργεῖον Δημοσίων Ἔργων
(Ipouryíon Dhimosíon Érgon)

Geographic Service of the Army

Ministry of Communications

Ministry of Public Works

Table XXIV Greek Lettering
as Found on Greek Maps

						BROAD TRANSLITERATION*
A α	Α α	Α α	Α α	A α	Α	A
B β	Β β	Β β	Β β	B β β β	Β	V
Γ γ	Γ γ γ	Γ γ γ	Γ γ γ	Γ γ	Γ	G or Y
				(ΓΓ γγ)	(ΓΓ)	NG)
				(ΓΚ γκ)	(ΓΚ)	G or NG)
Δ δ	Δ δ	Δ δ	Δ δ	Δ δ δ	Δ	DH
E ε	Ε ε	Ε ε	Ε ε	E ε	E	E
				(ΕΙ ει)	(ΕΙ)	I)
Z ζ	Ζ ζ	Ζ ζ	Ζ ζ	Z ζ	Z	Z
H η	Η η	Η η	Η η	H η η	H	I
Θ θ	Θ θ	Θ θ	Θ θ	Θ θ	Θ	TH
I ι	Ι ι	Ι ι	Ι ι	I ι	I	I
K κ	Κ κ	Κ κ	Κ κ	K κ κ	K	K
Λ λ	Λ λ λ λ	Λ λ λ λ	Λ λ λ λ	Λ λ	Λ	L
M μ	Μ Μ μ	Μ Μ μ	Μ Μ μ	M μ μ	M	M
				(ΜΠ μπ)	(ΜΠ)	B or MB)
N ν	Ν ν	Ν ν	Ν ν	N ν	N	N
				(ΝΤ ντ)	(ΝΤ)	D or ND)
Ξ ξ	Ξ ξ	Ξ ξ	Ξ ξ	Ξ ξ	Ξ	X
O ο	Ο ο	Ο ο	Ο ο	O ο ο	O	O
Π π	Π π	Π π	Π π	Π π π	Π	P
P ρ	Ρ ρ	Ρ ρ	Ρ ρ	P ρ ρ	P	R
Σ σ ς	Σ σ ς	Σ σ ς	Σ σ ς	Σ σ ς σ	Σ	S
T τ	Τ τ	Τ τ	Τ τ	T τ τ	T	T
Υ υ	Υ υ	Υ υ	Υ υ	Υ υ	Υ	I
				(ΑΥ αυ)	(ΑΥ)	AV)
				(ΕΥ ευ)	(ΕΥ)	EV)
				(ΗΥ ηυ)	(ΗΥ)	IV)
				(ΟΥ ου)	(ΟΥ)	OU)
				(ΥΙ υι)	(ΥΙ)	I)
Φ φ	Φ φ	Φ φ	Φ φ	Φ φ φ	Φ	F
X χ	Χ χ	Χ χ	Χ χ	X χ χ	X	KH
Ψ ψ	Ψ ψ	Ψ ψ	Ψ ψ	Ψ ψ ψ	Ψ	PS
Ω ω	Ω ω	Ω ω	Ω ω	Ω Ω ω	Ω	O

* The right hand column gives a rough guide only to the transliteration of the Greek alphabet. For precise rules of transliteration, including exceptions to the equivalents given here, see P.C.G.N. Glossary of Modern Greek.

182. Coordinate Systems

a. *Geographic.* Geographic coordinate information is expressed in degrees from the prime meridian of Athens (23° 42' 59" East of Greenwich) except where otherwise noted.

b. *Grid.*

- (1) Maps published by the Yeografikí Ipire-sía Stratoú in 1925–28 have either no grid or have local grids. Large-scale maps

published in 1931–41 have the Greek military grid. Postwar sheets by this agency use the British military grid (Crete and Mediterranean Zones) based on the Lambert Conic Orthomorphic projection, Bessel spheroid.

- (2) The large-scale maps produced by the Ipourýion Dhimosión Érgon have an unidentified kilometer grid.

Section IV. ITALY AND THE FREE TERRITORY OF TRIESTE

183. Mapping Activities

a. *Native Mapping of Italy.*

- (1) The principal topographic mapping agency in Italy is the Istituto Geografico Militare—IGM (Military Geographic Institute), which has published maps at 1:25,000, 1:50,000, 1:100,000, and 1:200,000, as well as maps at smaller scales. Many of the topographic maps are published in both military and civilian editions. The military edition was formerly stamped "Riservata"; since World War II the term "Vietate Divulgazione" has been printed in the upper left-hand corner of the military editions. These sheets contain more detailed industrial and military information than the civilian editions. Many sheets of northern Italy published by the Italians since World War II are reprints of prewar editions with the addition of the Universal Transverse Mercator grid. Some sheets at 1:25,000 and 1:100,000 have been published as a part of a revision program. The "Ricognizioni Parziali" is designed to provide a provisional edition of fairly up-to-date maps. Only major planimetric features are revised from aerial photography. The "Ricognizioni Generali" of the 1:25,000 maps is a complete revision of all topographic detail as well as the resurveying of areas formerly poorly surveyed. General revisions of the 1:100,000 maps are made on the basis of either 1:25,000 surveys or field reconnaissance.

- (2) Postwar town plans published by IGM are available for only a few of the major cities of Italy. The Touring Club Italiano (Italian Touring Club) is a private

map-making concern that is internationally known for its special-purpose maps which include road maps and throughway town plans. The Istituto Geografico Visceglia (Visceglia Geographic Institute) is another private agency that publishes town plans.

b. *Native Mapping of the Free Territory of Trieste.* Because this area was part of the territory of Italy until 1947, it was included in the mapping program of the Italian Istituto Geografico Militare. Therefore, the description of the map series providing coverage of Trieste are included within paragraph 184a(2). Several town plans of the city of Trieste have been published by native mapping agencies since 1947. No topographic publications have been made. Postwar Italian plans of the city of Trieste are available.

c. *Other Mapping of Italy and the Free Territory of Trieste.* Maps compiled by the Istituto Geografico Militare were reproduced during World War II by the German Generalstab des Heeres (General Staff of the Army), with revisions from aerial photograph and from field reconnaissance. The British Directorate of Military Survey, War Office (Geographical Section, General Staff)—GSGS also utilized the maps to provide coverage of Italy and Trieste at all scales. The Army Map Service has also reprinted selected sheets of British, German, and Italian editions at various scales with the addition of the Universal Transverse Mercator grid. During World War II, the British produced plans of ports, towns, and major cities of Italy, including a town plan and port plan of the city of Trieste compiled from aerial photograph. The Germans reproduced only a few Italian town plans during World War II. Postwar plans of the city of Trieste were prepared by the Italians.

184. Major Native Maps of Italy and the Free Territory of Trieste

a. Topographic Series.

- (1) *Carta d'Italia* (Map of Italy); 1:25,000; Istituto Geografico Militare 1879- ; Universal Transverse Mercator grid or Gauss-Boaga grid on some sheets, and no grid on others.

This series provides coverage of all of Italy north of approximately 43°30', a strip along the western coast, the Taranto area, the southern toe, Sicily, parts of Sardinia, and adjacent islands. The Free Territory of Trieste and the Venezia Giulia area of Yugoslavia are also included in the coverage. The maps were compiled from planetable surveys at 1:25,000 and from aerial photogrammetric surveys. For a few areas for which 1:25,000 surveys were lacking, the corresponding 1:50,000 sheets were enlarged to 1:25,000 or the 1:50,000 planetable surveys were used. A few sheets covering areas of northern Italy were based on Austrian 1:25,000 or French 1:20,000 surveys. Since World War II some sheets have been published as "parziale" or "generale" revised editions. The 1:25,000 series was originally based on the Bessel spheroid. All newly surveyed or revised sheets in this area are being referred to the International ellipsoid. A slight break in continuity or a small overlap between sheets based on different spheroids is to be expected. Sheets covering the Free Territory of Trieste and the Venezia Giulia area on the Bessel spheroid. Most of the sheets are monochrome, but all sheets published since 1949 are multicolored. Relief is shown by contours at 5- and 10-meter intervals. Types of vegetation are indicated; detailed information on communications is included. This series was reprinted by both the Germans and the British during World War II with revisions from aerial photography, field reconnaissance, or captured large-scale maps. The Army Map Service has added bilingual marginal information to the sheets in north-

ern Italy that have the Universal Transverse Mercator grid.

- (2) *Carta Topografica d'Italia* (Topographic Map of Italy); 1:50,000; Istituto Geografico Militare; 1870-1947; Universal Transverse Mercator grid on some sheets.

This series provides coverage for all of Italy except the north-central part, scattered areas along the western coast, and parts of Sardinia and Sicily. The Free Territory of Trieste and the Venezia Giulia area are also covered. The sheets are based on planetable surveys at 1:50,000. The earlier sheets were published as monochrome editions and were partially revised in 1910-30. Later editions with revisions from new surveys were published in color and furnish coverage of scattered strategic areas. A few sheets covering parts of northern Italy have been printed with the Universal Transverse Mercator grid. Relief is shown by contours at varying intervals. Types of vegetation are indicated and cultural information is presented in detail. The Germans made only a direct reprint of this series, while the AMS and GSGS reproduced it with extensive revisions from topographic maps, aerial photography, and field checks by engineer units. Where there were no Italian 1:50,000 maps available, the 1:25,000 sheets were reduced and redrawn at 1:50,000 scale. Sheets of this series that cover northern Italy have been printed by the Army Map Service with the Universal Transverse Mercator grid.

- (3) *Carta Topografica d'Italia* (Topographic Map of Italy); 1:100,000; Istituto Geografico Militare; 1879- ; Universal Transverse Mercator grid on some sheets. Gauss-Boaga grid on some sheets.

This series (fig. 141) provides coverage of all of Italy, Sicily, Sardinia, and adjacent islands, as well as the Free Territory of Trieste and the Venezia Giulia area of Yugoslavia. These multicolored sheets are based on 1:25,000 and 1:50,000 maps. Since 1947, revisions of the 1:100,000 series

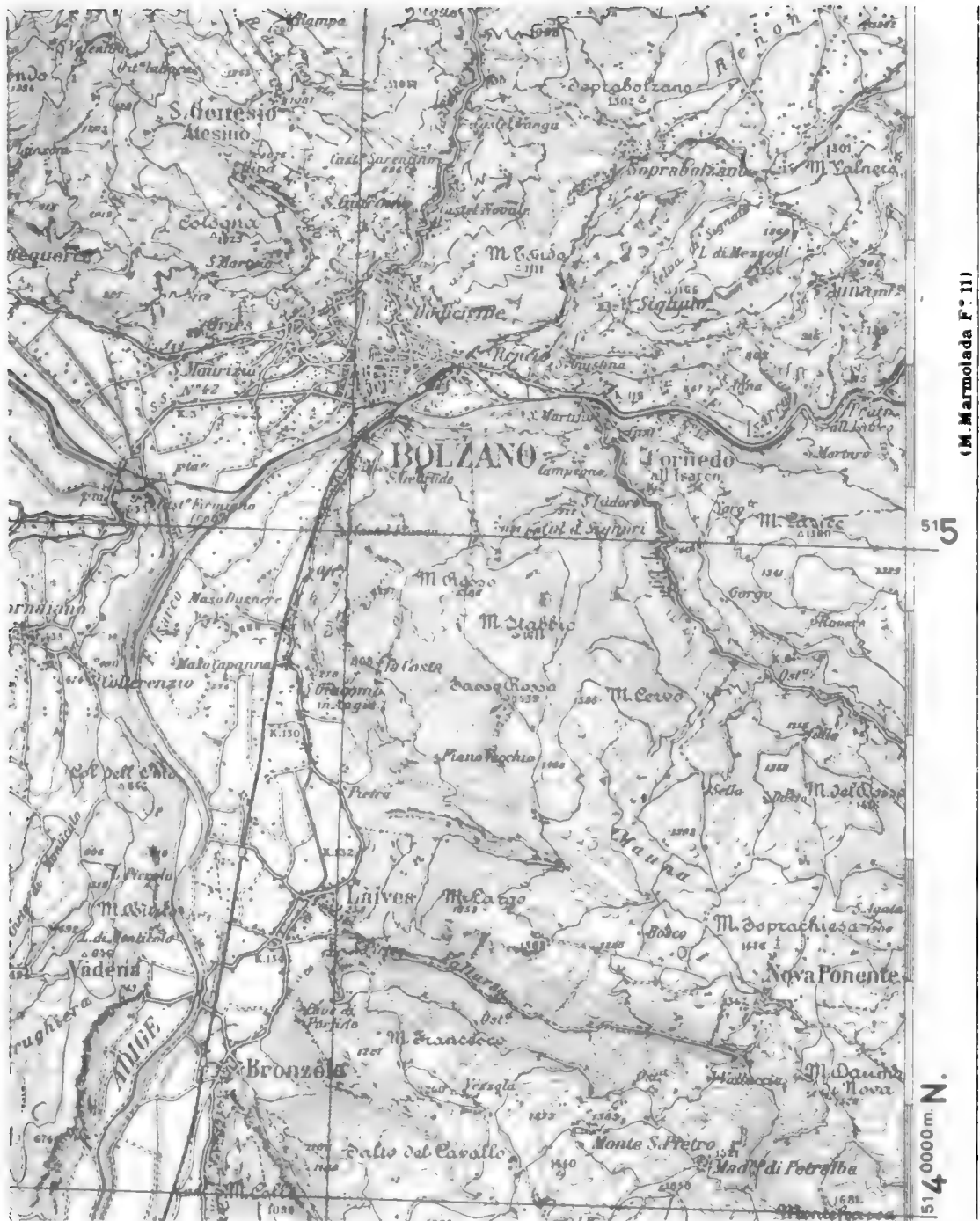

Figure 141. Section of sheet from Carta Topografica d'Italia at 1:100,000 by the Istituto Geografico Militare.

have been made from field reconnaissance and new 1:25,000 surveys. Sheets covering northern Italy carry the Universal Transverse Mercator grid referred to the International ellipsoid; the Gauss-Boaga grid is used on a few sheets covering southern Italy.

Relief is shown by contours at 50-meter intervals. Revisions from field reconnaissance and aerial photography were made on a few later-date sheets. The British reprint of this series was published in 1941-48, and incorporates revisions from aerial photography, large-

scale topographic maps, and field checks.

- (4) [Italy]; 1:200,000; Istituto Geografico Militare; 1952- ; Universal Transverse Mercator grid.

Currently published sheets of this series (fig. 142) provide coverage of northeast Italy. The Free Territory of Trieste and the Venezia Giulia area are also included. Complete coverage of Italy with this series is planned. These multicolored sheets were compiled in 1950 from the 1:100,000 series. Intended primarily for use as a road map, the sheets contain detailed information on road widths, gradients, and distances between towns, as well as the location of possible landslides and avalanches. Principal roads are classified according to surface. Relief is shown by contours at intervals of 100 meters and, in areas of low relief, by auxiliary contours at 50-meter intervals. Vegetation is classified according to type. Symbolization of other topographic features is very detailed but all information is legible.

- (5) *Carta d'Europa* (Map of Europe); 1:500,000; Istituto Geografico Militare; 1952; no grid.

Eighteen sheets of this polychrome series provide coverage of Italy, Sicily, Sardinia, and adjacent areas. The Free Territory of Trieste and the Venezia Giulia area are also covered. These maps were compiled from the 1:100,000 series ((3) above). Two sheets for northern Italy carry a note stating that information was brought up to date in 1950. Relief is shown by contours at varying intervals. On some sheets, relief is emphasized by layer tints. A new edition of this series on different sheet lines was started by Touring Club Italiano (Italian Touring Club). Of the three sheets necessary to provide coverage of Italy, two sheets of northern Italy have been published.

- (6) *Carta Ipsometrica del Regno d'Italia e Regioni Adiacenti* (Hypsometric Map of

the Kingdom of Italy and Adjacent Regions); 1:1,000,000; Istituto Geografico Militare; 1932-35 (edition date); no grid.

This six-sheet multicolored series provides coverage for all of Italy, Sicily, Sardinia, and adjacent areas. The Free Territory of Trieste and the Venezia Giulia area are included. The sheets were compiled from the 1:100,000 series and are cut on the *International Map of the World* sheet lines. Relief is shown by contours at varying intervals, by layer tints, and by spot heights.

b. Town Plans. The Istituto Geografico Militare—IGM has published postwar town plans of a few major cities of Italy. Most of these were brought up to date in 1950. Throughway plans, published by the Touring Club Italiano in 1938-49, are available for many of the principal towns of interest to tourists. A booklet of throughway plans of 130 towns was published in 1950 by the Automobile Club d'Italia (Automobile Club of Italy). Since 1948, the Istituto Geografico Visceglia has produced plans for most of the larger cities of Italy.

185. Coordinate Systems

a. Geographic. Geographic coordinates on Italian maps are in degrees. Longitude is referred to the prime meridian of Rome (Monte Mario), which is 12°27'08" E. of Greenwich. On Italian maps published prior to 1945, meridians and parallels are used as the basis for a lettered system of reference.

b. Grid. Until 1945, Italian maps were on the Bessel spheroid and had no military grid. In 1945 the Gauss-Boaga grid on the International ellipsoid was adopted. This grid divided Italy into two zones with the central meridians of 9° ("West Zone") and 15° ("East Zone") respectively. The area of overlap between the two zones is the Rome meridian. Only maps of northern Italy have been converted to the UTM grid. Maps of southern Italy have either the Gauss-Boaga grid or the graticule.

186. Characteristics

Relief, drainage, and cultural information are shown in detail on all Italian maps. The same conventional symbols are used on all series. The 1:100,000 series is multicolored, but only a few

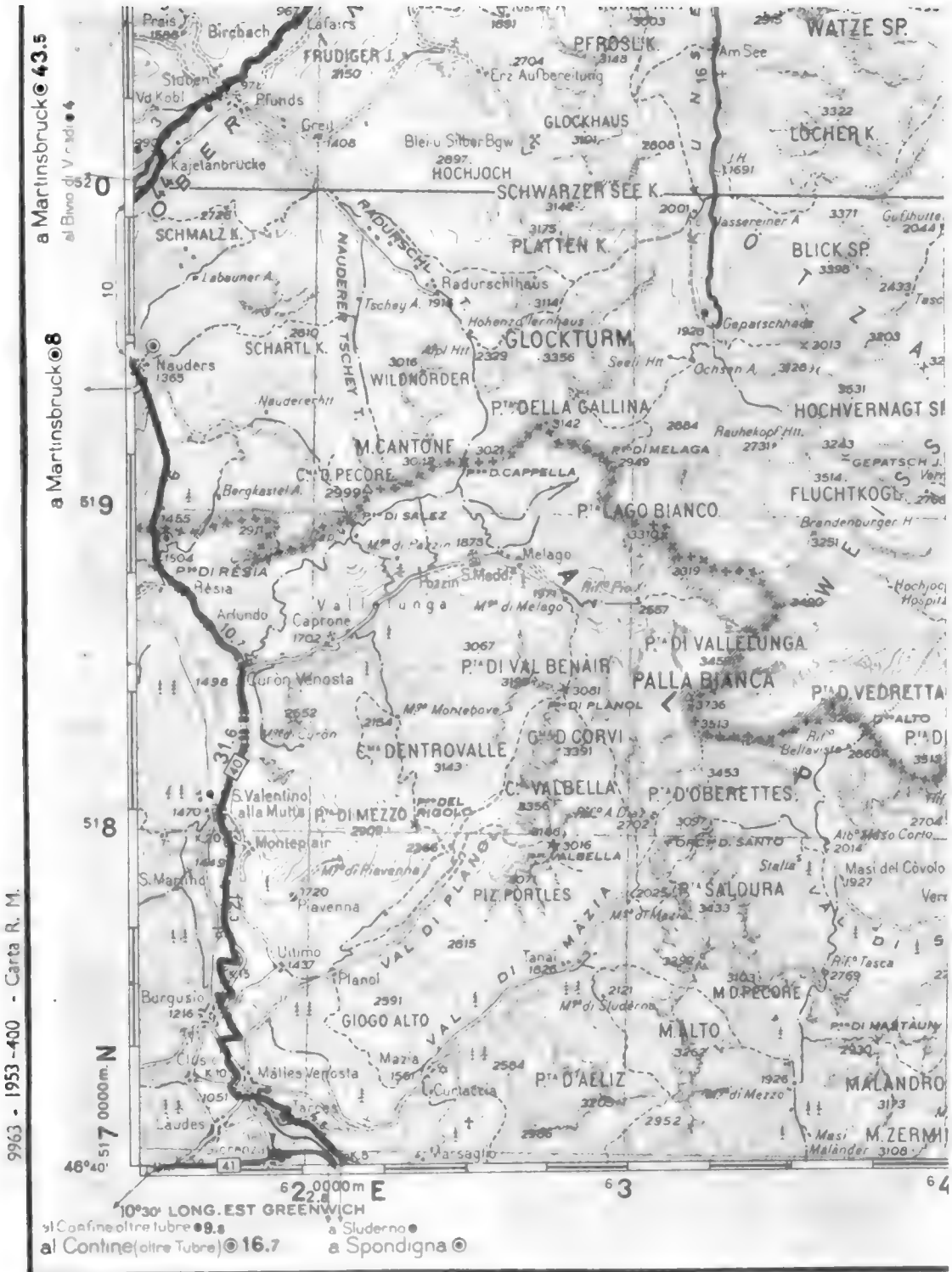

Figure 142. Section of sheet from 1:200,000 series of Italy published by the Istituto Geografico Militare.

CARTA D'ITALIA

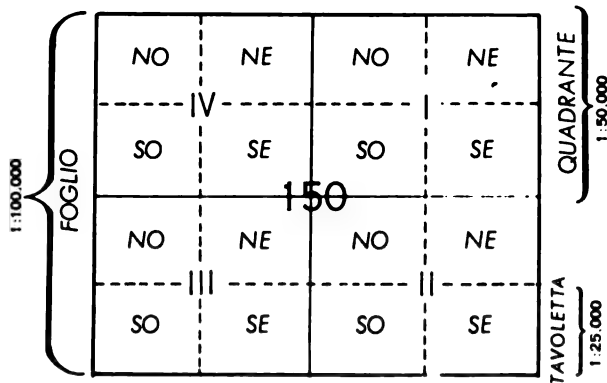

Figure 143. Diagram showing the sheet-numbering system of the 1:100,000 and larger scale maps published by the Istituto Geografico Militare.

sheets of the 1:25,000 and 1:50,000 series have been printed in color. For a diagram illustrating the sheet-numbering system of maps published by IGM, see figure 143.

Table XXV. Glossary of Italian Map Expressions

Aggiornam ento del.....	revision (date)
Aggiornato.....	revised to date
Aggiunte.....	partial revision

Table XXV. Glossary of Italian Map Expressions—Con. Con le aggiunte e varianti..... with the additions and variations

Compilate.....	compiled
Correzione.....	correction
Editi.....	published
Editore.....	publisher
Edizione.....	edition
Equidistanza delle curve di livello.....	contour interval
Eseguito.....	executed
Foglio contiguo.....	adjoining sheet
Impresso.....	printed
L'angolo di declinazione e valevole per l'anno.....	magnetic declination for the year
Levata.....	survey, elevation
Proprietà riservata.....	copyrighted
Redazione.....	compiled
Ricognizione per le strade rotabili e ferrovie nel.....	reconnaissance for highways and railroads in
Ricognizioni generali.....	general reconnaissance
Recognizioni parziali.....	partial reconnaissance
Ridisegno.....	redrawn
Rillevamento.....	survey, relief
Riproduzione.....	reproduction
Riproduzione vietate.....	all rights reserved
Riveduto.....	revised
Stampato.....	printed
Tutti i diritti di riproduzione riservati.....	all reproduction rights reserved

ITALIAN SECURITY CLASSIFICATION

Riservata.....	restricted
Segreto.....	secret
Vietata divulgazione.....	disclosure forbidden

Section V. RUMANIA

187. Mapping Activities

a. *Native.* The principal mapping agency in Rumania is the Institutul Geografic Militar (Military Geographic Institute)—IGM, formerly known as the Serviciul Geografic al Armatei (Geographic Service of the Army). The standard series published by IGM are 1:20,000, 1:100,000, 1:500,000 and 1:1,000,000.

b. *Official.* One series of Hungarian maps is discussed in this section as official mapping because the sheets cover an area that formerly was Hungarian territory. This area was mapped by the Hungarian Magyar Kifalyi Honvéd Térképészeti Intézet (Royal Hungarian Army Cartographic Institute).

c. *Other.* The German Generalstab des Heeres (General Staff of the Army), the British Directorate of Military Survey, War Office (Geographical Section, General Staff)—GSGS, and Army

Map Service have reproduced and revised Rumanian maps.

188. Major Maps of Rumania

a. Topographic Series.

(1) Native.

(a) *Planul Director de Tragere 1:20,000* (Direct Firing Map 1:20,000); Institutul Geografic Militar; 1888–1944; Lambert grid.

This series, based partly on Austrian-Hungarian 1:25,000 maps and partly on Rumanian surveys of 1883–1931, provides scattered coverage for approximately four-fifths of Rumania. The majority of the sheets are polychrome but the older ones are monochrome prints. Relief is indicated by contours at intervals varying from

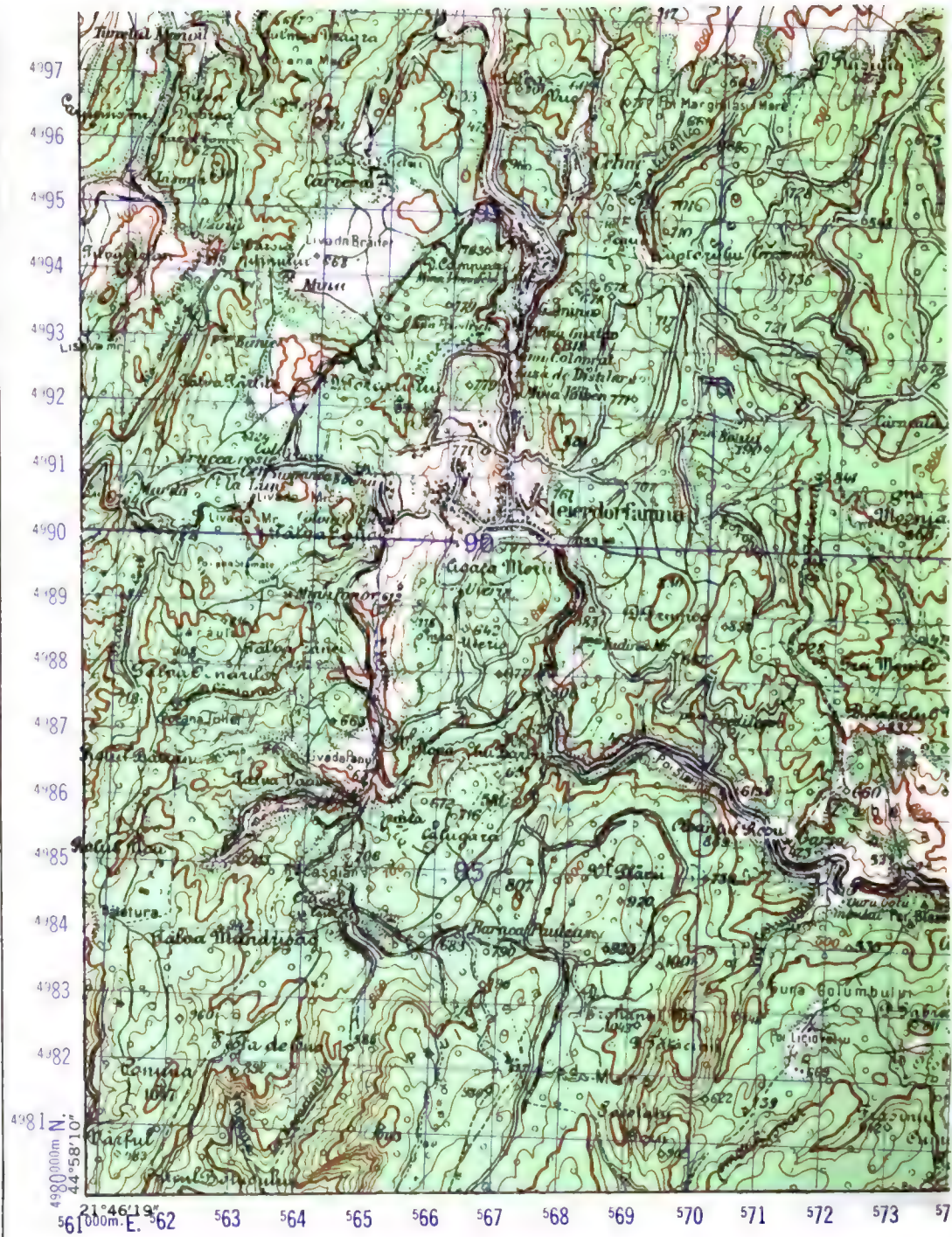

Figure 144. Section of sheet from the 1:100,000 series of Rumania by the Institutul Geografic Militar reprinted by the Army Map Service as AMS M806.

1 to 20 meters. Woods, brush, and orchards are some of the types of vegetation shown.

- (b) *Panul Director de Tragera* 1:20,000 (Direct Firing Map 1:20,000); Institutul Geografic Militar; 1934-40; Stereographic grid.

This polychrome series, based on a Rumanian survey of 1934-40, provides scattered coverage of southeastern Rumania. Relief is indicated by contours at 2.5- and 5-meter intervals. Vegetation features shown are woods and vineyards.

- (c) [*Rumania*]; 1:100,000; Institutul Geografic Militar; 1939; Lambert grid.

This series is based on Austrian 1:75,000 maps and Rumanian surveys of 1883-1932 and completely covers Rumania. Relief is portrayed by contours ranging in intervals from 10 to 100 meters. Caution is necessary when interpreting the relief, because on some sheets three different intervals are shown. Vegetation features are indicated. During World War II, the British and Germans reprinted this series and each substituted its own grid. The Army Map Service reprinted the series with revisions to railroad and boundary information from 1948-52 data and added the Universal Transverse Mercator grid (fig. 144).

- (2) *Official*.

[*Hungary*]; 1:50,000; Magyar Kifalyi Honvéd Térképészet Intézet; 1943-44; Stereographic grid.

This polychrome series, which covers a large part of Transylvania, was produced during World War II. About

half of the sheets are based on a wartime survey. The sheets show relief by contours at 10- and 20-meter intervals. The others are enlargements of 1:75,000 maps and indicate relief by contours at 100-meter intervals and hachures. Vegetation features shown are woods, vineyards, and pastures.

b. Town Plans.

- (1) *Native*. Rumanian city plans provide coverage for a few of the more important urban areas. The plans range in date from 1926 to 1947. The majority of them were published by private concerns; a few were compiled by local or national government agencies.

- (2) *Other*. The best available plans of Rumanian cities are those produced by the Germans during World War II.

189. Coordinate Systems

a. Geographic. The stereographic 1:20,000 is the only Rumanian series that contains geographic coordinates expressed in grads and referred to Greenwich. On the Hungarian 1:50,000 maps, geographic-coordinates are referred to Ferro and Greenwich and is expressed in degrees. German, British, and U. S. maps contain geographic-coordinates expressed in degrees and referred to Greenwich.

b. Grid. Most of the native maps have the Lambert grid. The British and the Germans used the Danube Zone grid and the Gauss-Krüger grid respectively.

190. Characteristics

On native Rumanian maps roads are classified according to administrative authority. German and Hungarian maps classify roads as to use and condition. On British and Army Map Service maps roads are classified according to surface and width.

Section VI. YUGOSLAVIA

191. Mapping Activities

a. Native. The principal mapping agency in Yugoslavia is the Geografski Institut Jugoslovske Armije—GIJA (Geographic Institute of the Yugoslavian Army). The pre-World War II equivalent to GIJA was Vojni Geografski Institut—VGI (Military Geographic Institute). Post-World War II . . . Post-World War II

Yugoslav coverage of various scales exists for the newly acquired territory, however, native Italian sheets represent the only large-scale coverage. For discussion of Italian coverage of this area, see paragraph 184.

b. Other. Various editions of all basic map series of Yugoslavia were produced by U. S., British, and German mapping agencies during World

War II. Most of the maps were direct copies of the Yugoslav originals, but as the war progressed, both content and methods of presentation were revised. Military grids were added to almost all of the large-scale series. Most of the revisions were based on field reconnaissance, aerial photography, and captured maps. The three principal agencies were the Army Map Service (AMS); the British Directorate of Military Survey, War Office (Geographical Section, General Staff)—GSGS; and the German Generalstab des Heeres (General Staff of the Army).

192. Major Native Maps of Yugoslavia

a. Topographic Series.

- (1) [*Yugoslavia*]; 1:5,000 Glavna Geodetska Uprava; 1948–; Yugoslav Gauss-Krüger military grid.

This detailed topographic series, prepared for cadastral use in the plains area, is in two to four colors. Compilation of the sheets covering northern Serbia was started in 1948 by G. G. U. from 1:5,000 ground surveys, aerial photography, and from old Austro-Hungarian cadastral maps at 1:2,880. Relief is shown by contours at 5-meter, and hachures or shading. The sheet-line system of this series differs from that of all other Yugoslav series in that it is on the Yugoslav Gauss-Krüger grid.

- (2) *Kotor*; 1:100,000; Vojni Geografski Institut; 1937; Yugoslav Gauss-Krüger military grid.

This two-sheet polychrome series provides coverage of the entrance to Kotor Bay. The sheets are based on a Yugoslav survey of 1931 and are drawn on the Polyhedric projection. Relief is indicated by contours at intervals of 1.5 and 5 meters; triangulation stations, numerous bench marks, and spot elevations are also shown.

- (3) [*Yugoslav*]; 1:25,000; Vojni Geografski Institut; 1938–41; Yugoslav Gauss-Krüger military grid.

This series provides coverage of portions of the area bordering Austria, Hungary, and the pre-1947 Italian boundary. These polychrome sheets

are based on the Yugoslav survey of 1934–37. Relief is shown by contours at intervals of 10 meters and 1.25 meters.

- (4) [*Yugoslavia*]; 1:25,000; Glavna Geodetska Uprava; 1950–; Yugoslav Gauss-Krüger military grid.

This two-colored series, intended for use as a cadastral map, is based on 1:5,000 surveys begun in 1948. It portrays relief by contours at intervals of 2.5 and 5 meters. Urban-area detail was taken from old Austro-Hungarian cadastral plans at 1:2,880. The legend contains information on all railroad gages used within Yugoslavia and includes a symbol for electrified lines. This type of information has not appeared on any previous Yugoslav map. The series is on sheet lines of the *International Map of the World*. Geographic coordinates are given with longitudes referred to Greenwich.

- (5) [*Yugoslavia*]; 1:50,000; Vojni Geografski Institut; 1938–41; Yugoslav Gauss-Krüger grid.

Complete coverage of the entire country except the western tip of Istria is provided by this series. The polychrome sheets are direct prints of quarter sections of the 1:100,000 series which were drafted at 1:50,000. Geographic coordinates are sheets covering the areas of Vojvodina south of 45°, Serbia, Macedonia, and Montenegro, and are based on 1:50,000 surveys begun after World War I and completed in 1928. Austrian 1:25,000 planetable sheets, for which surveys had been made in 1806–69, cover the Yugoslav area of the former Austro-Hungarian Empire. They were reduced to 1:50,000 and revised in the field by planetable and alidade in 1920–40. In 1943–44, the Germans reproduced the Yugoslav 1:50,000 maps. This was a straight reproduction with the addition of German marginal information on most of the sheets. Corrections from aerial photography were overprinted on a few sheets. Relief is shown by contours at intervals of 20 meters with auxiliary contours at 5-

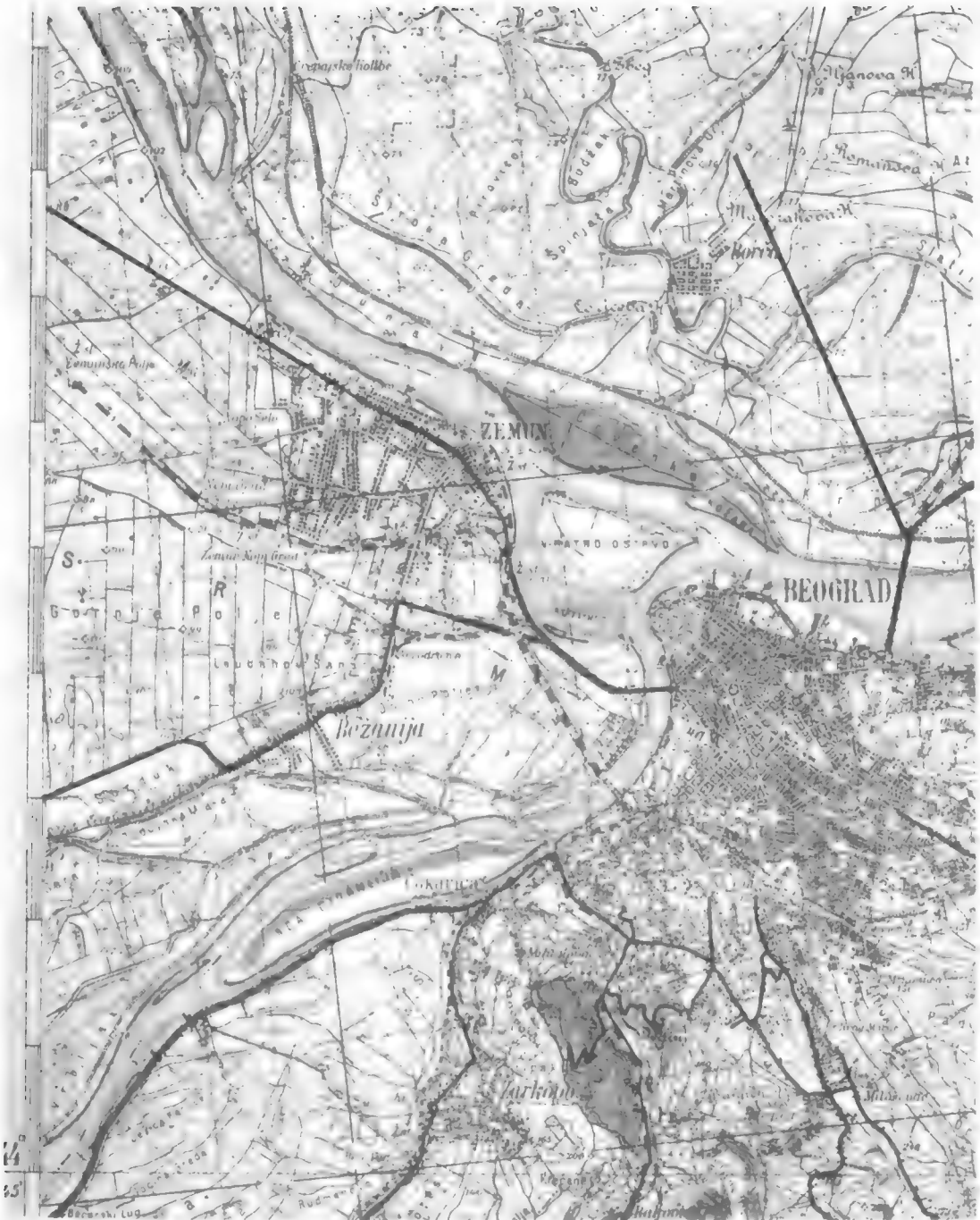

Figure 145. Section of sheet from the 1:100,000 map of Yugoslavia by the Vojni Geografski Institut.

and 10-meter intervals. Most of the sheets use the Roman alphabet but a few use the Cyrillic.

(6) [*Yugoslavia*]; 1:100,000; Vojni Geografski Institut; 1926-40; no grid.

This series (fig. 145) in Serbo Croat (some sheets with the Cyrillic alpha-

bet) provides coverage of the entire country except for a portion of Venezia Giulia. These polychrome sheets are based on the same surveys and compilation material as the 1:50,000 sheets described in (5) above. Relief is shown by contours at intervals of 20 meters

and by auxiliary contours at 5- and 10-meter intervals.

- (7) [*Yugoslavia*]; 1:200,000; Vojni Geografski Institut; 1916-40; no grid.

This polychrome series provides coverage for the entire country and is mostly in Cyrillic with only a few sheets using the Roman alphabet. The pre-1939 sheets are based on the old Austrian 1:75,000 and 1:200,000 sheets, and use the old road classification (par. 194). Sheets dated 1939 and later are based on the native Yugoslav 1:100,000 series. These have the new road classification system and use the Roman alphabet. Relief is shown by contours at intervals of 100 meters with auxiliary contours at 12.5-, 25-, and 50-meter intervals.

- (8) [*Yugoslavia*]; 1:500,000; Geografski Institut Jugoslovenske Armije 1950; no grid.

This 13-sheet polychrome series (fig. 146) provides coverage of the entire country. It is based on the compilations of the 1:100,000 and 1:200,000 series and the latest available information, and was designed for use by the Army General Staff. Relief is indicated by contours of 100-meter intervals below the 500-meter level and at 250-meter intervals above that level. Values for spot elevations are also given.

- (9) *Federativna Marodna Republika Jugoslavija* (Federative Peoples Republic of Yugoslavia); 1:750,000; Geografski Institut Jugoslovenske Armije 1950; no grid.

Two editions of the map of Yugoslavia at this scale, dated 1946 to 1950, have been published and are identical in style and type of content. Most of the corrections on the later edition concern transportation and place names. This multicolored map is printed in six sections and covers all of Yugoslavia and parts of neighboring countries. Through highways are shown in red; country roads and paths in black. Railroads are classified according to gage and number of tracks; urban areas, by population and administrative impor-

tance. The map provides the largest-scale authoritative information available on current first-order administrative units. Relief is portrayed by shading and by contours at intervals of 100 meters below the 500-meter level and at 250 meters above that level. Altitude tints are shown but are not definitive.

b. Town Plans. Town plans that have been produced by native agencies vary in date and cover only the larger or more important centers of population. United States and British agencies have reprinted and/or revised the native plans.

193. Coordinate Systems

a. Geographic. On maps at 1:200,000 scale and larger, geographic coordinates are given with longitude referred to Paris and/or Greenwich. On maps at 1:500,000 scale and smaller, geographic coordinates are referred only to Greenwich.

b. Grid. On maps at 1:100,000 scale and larger, the Gauss-Krüger military grid is used. On city plans, only an atlas grid appears.

194. Characteristics

Pre-World War II topographic maps at 1:100,000 scale and larger carry no legend. Reference should be made to the 1939 issue of the Yugoslav symbol book "Topografski Znaci, Beograd, 1939" (Topographic Symbols, Belgrade, 1939). On native topographic maps, depending upon the date of publication, roads are classified (1) according to administrative authority (old system), and (2) as first, second, and third class (new system)—based on surface, width, and foundation criteria. The prewar 1:100,000 series used the "old system" of road classification but the 1:200,000 series used both systems. Railroads are classified as to gage, track, and operating status. Vegetation is indicated by color and conventional symbols.

Table XXVI. Glossary of Yugoslav Map Expressions

Dopunjeno.....	completed with new data)
Iscrtao.....	drafted by
Izdanje.....	edition
Izradjeno na osnovu karata 1:100,000, 1:200,000 i najnovijih podataka.	based on 1:100,000 and 1:200,000 maps and the latest data
Premravano.....	topographic survey made
Reambulirano.....	revised (field check)
Reprodukovano.....	reprinted
Sadržaj prilagedjen vojnim potrebama.	map adapted for military use

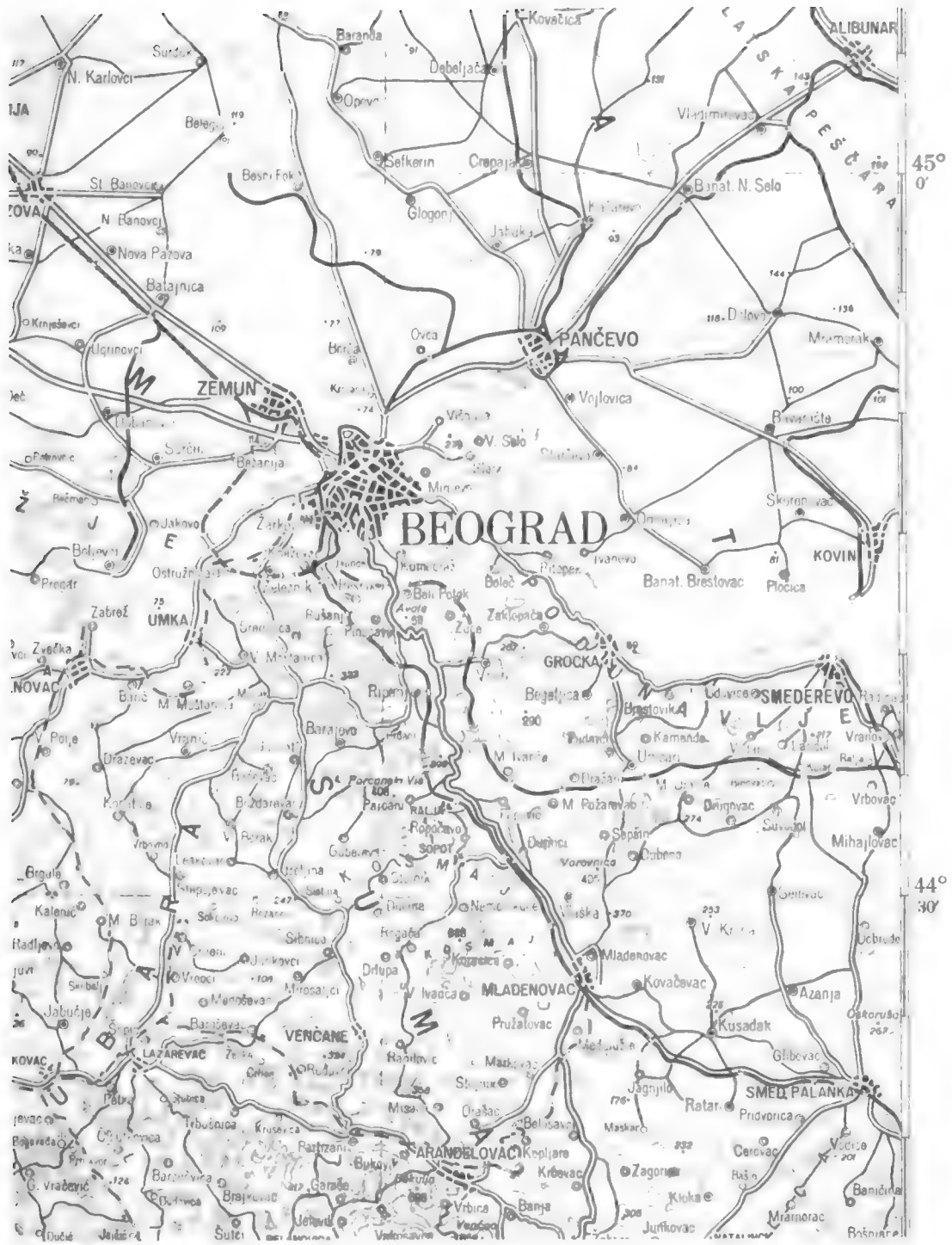

Figure 146. Section of sheet from the 1: 500,000 map of Yugoslavia by the Geografski Institut Jugoslovenske Armije.

CHAPTER 11

U. S. S. R.

195. Mapping Activities

a. Native. Russian military maps have been published by the General'nyy Shtab, Krasnaya Armiya (General Staff, Russian Army—GSRA), in conjunction with the Glavnoye Upravleniye Geodezii i Kartografii—GUGK (Chief Administration of Geodesy and Cartography), the Glavnoye Aero-Geodezicheskoye Upravleniye (Chief Aero-Geodetic Administration), the Voyenno-Topograficheskoye Upravleniye (Military-Topographic Administration), and local sub-authorities. These have been made for economic and administrative purposes, as well as for military uses. European Russia and southern Siberia are covered by maps based on accurate surveys, but northern Siberia and parts of Central Asia are poorly mapped. Recent maps are available in the Officer's Atlas (1947). In a few localities (Caucasus, Urals, and central Asia), old tsarist sheets at 1:42,000, 1:84,000, and 1:126,000 are still usable, despite origin at Pulkovo (30°19'36" E.) and contours in sazhen (one sazhen equals 2.134 meters). The successor to the General'nyy Shtab, Krasnaya Armiya is the General'nyy Shtab Vooruzhennikh Sil, Soyuza SSR (General Staff of the Armed Forces, U. S. S. R.), which now controls the Voyenno-Topograficheskoye Upravleniye.

b. Other. Other mapping agencies have published partial editions of earlier Russian maps. The German Generalstab des Heeres (General Staff of the Army) reproduced large-scale editions for European Russia and medium-scale series for Caucasia and central Asia with minor revisions and field reconnaissance and aerial photography dated 1941–44. The series at 1:25,000, 1:50,000, and 1:100,000 are made from editions of captured Russian originals and provide scattered coverage of western and southern European Russia. At medium scales, the German Generalstab des Heeres (General Staff of the Army) compiled the following series from Russian maps and tex-

tual data: 1:200,000 of Caucasia and central Asia; 1:300,000, and 1:500,000 of European Russia and parts of Siberia. The Japanese General Staff, with the Kwantung Army Survey Unit, compiled several series of sheets covering parts of southeastern Siberia. The scales of these series are 1:25,000, 1:50,000, 1:100,000, 1:200,000 and 1:500,000. A small percentage of the 1:100,000, sheets covering areas along the Manchurian border have been reprinted by Army Map Service. The Army Map Service and the British Directorate of Military Survey, War Office (GSGS) have compiled maps covering areas of European Russia and Siberia at the scales of 1:250,000 and 1:1,000,000. Russian, German, and Japanese maps were used in the compilation.

196. Major Maps of U. S. S. R.

a. Native Topographic Series.

- (1) [*U. S. S. R.*]; 1:25,000; General'nyy Shtab, Krasnaya Armiya; 1932–44; Gauss-Krüger grid.

This polychrome series (fig. 147) is based on instrument and reconnaissance surveys dated 1874–1940 with minor aerial photo revisions. It provides scattered coverage of European Russia and southeastern Siberia, Relief is shown by contours at 5-meter intervals.

- (2) [*U. S. S. R.*]; 1:50,000; General'nyy Shtab, Krasnaya Armiya; 1928–44; Gauss-Krüger grid.

This polychrome series furnishes complete coverage of southern European Russia and scattered coverage of Caucasia and Southern Siberia. It is based on instrument and reconnaissance surveys with aerial photo revisions dated to 1942. Relief is shown by contours at intervals of 10 meters.

- (3) [*U. S. S. R.*]; 1:100,000; General'nyy

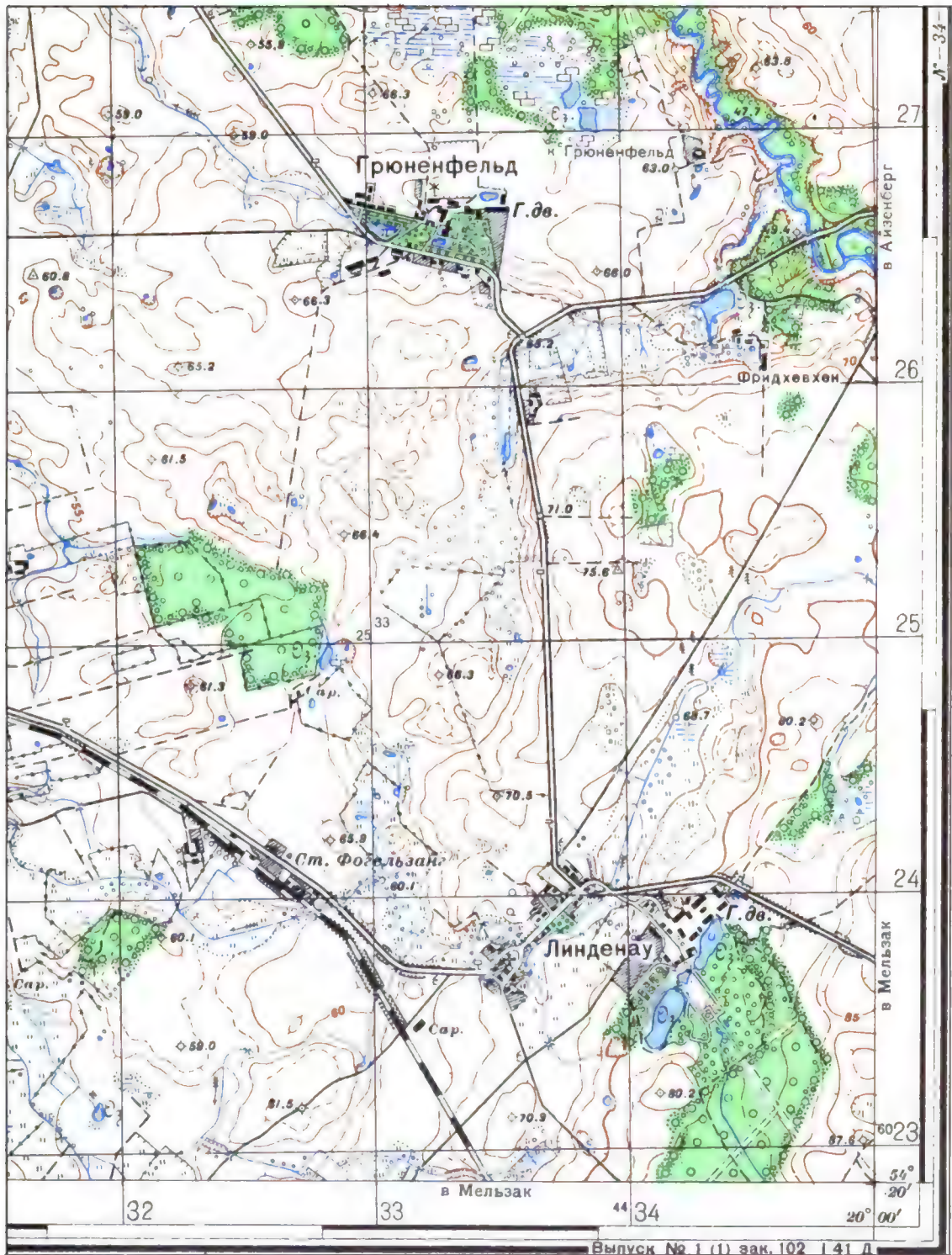

Figure 147. Section of sheet from 1:25,000 series of U. S. S. R. by the General'nyy Shtab, Krasnaya Armiya.

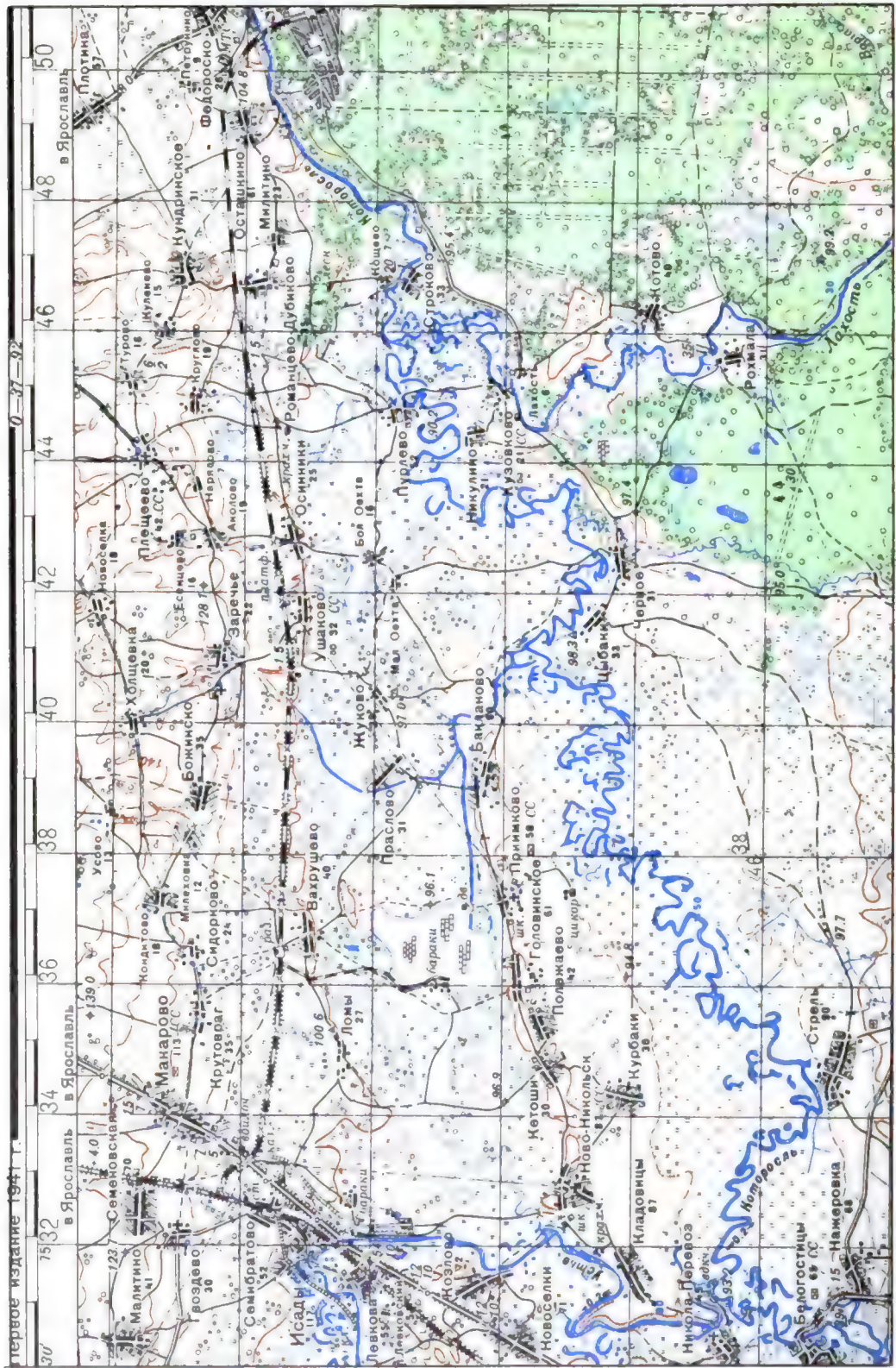

Figure 148. Section of sheet from 1:100,000 series of U. S. S. R. by the General'nyy Shtab, Krasnaya Armiya.

degree and relief is not indicated. Roads and railroads are shown but are not classified, and a few cultural features, such as churches and monuments, are indicated.

- (2) *Other.* The German town plans are reprints of Russian plans with revisions from aerial photography and ground surveys dated 1941–44. These plans cover most of the towns in the German wartime occupation area (Southwestern European Russia) besides major towns eastward to central Siberia. Relief, vegetation, and drainage features are more detailed than on Russian plans, and the entire metropolitan areas of the towns are usually shown. Street names are more numerous and such features as through-highways, narrow-gage railways, and overpasses are indicated. Some plans of larger towns indicate locations of factories, and civil and military installations.

197. Coordinate Systems

a. Geographic. Geographic coordinates are expressed in degree and longitude is referred to Greenwich.

b. Grid. The Gauss-Krüger grid system is based on the Bessel spheroid (superseded in 1946 by the improved Krasovskiy ellipsoid). The western boundary of the first zone is formed by the Greenwich meridian, successive zones occurring at 6° intervals to the east with zones overlapping by 30'. The origin of each grid zone is at the intersection of its central meridian and the equator. This point is given a false easting of 500 kilometers.

198. Characteristics

On maps of the U. S. S. R., stream navigability, and elevation above sea-level are indicated and such features as canals, rapids, dams, and soundings and isobaths in open water are shown. Vegetation is distinguished as to types of woods and crops. Roads are classified according to surface, importance, and use. Railroads are shown by num-

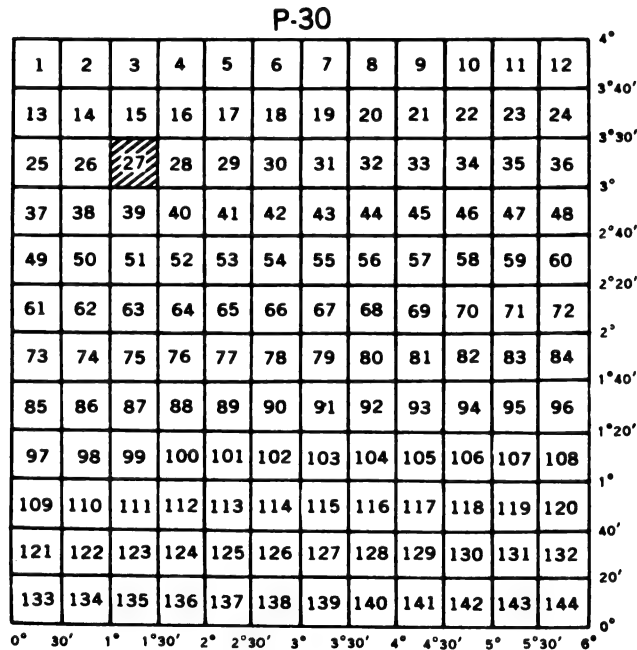

The entire block indicates a 1:1,000,000-scale sheet. At 1:500,000 scale it is divided into 4 squares. The 144 internal blocks indicate the 1:100,000-scale sheet lines. Each 1:100,000 block is divided into 4 quarters at 1:50,000 scale and each quarter into 4 smaller quarters at 1:25,000 scale.

Figure 149. Diagram showing standard Russian sheet-numbering system.

ber of tracks, gage, and electrification. Towns are classified according to population and administrative importance. Cultural features include telecommunications, power facilities, bridges, ferries, airports, radio and weather stations, and many others. Political and administrative boundaries are shown.

199. Marginal Information

The title, sheet number, administrative area, metric bar-scale, print date, authority, and adjoining sheet index are indicated on each sheet. Standard Russian map-numbering is based primarily on the 1:1,000,000 *International Map of the World* system (fig. 149). Relationship of 1:200,000 scale maps to the 1:1,000,000 scale numbering system is explained in figure 150. Other information concerning the legend may be found in Russian symbol handbooks or FM 30-22-2.

Table XXVIII. Glossary of Russian Map Expressions

Standard Russian Map Authorities	
<i>Russian original & transliteration</i>	<i>English equivalent</i>
Генеральный Штаб, Красная Армия (General'nyu Shtab, Krasnaya Armiya)	General Staff, Red Army
Генеральный Штаб Вооруженных Сил Союза ССР (General'nyu Shtab Vooruzhennykh Sil Soyuza SSR)	General Staff of the Armed Forces, USSR
Главное Управление Геодезии и Картографии (Glavnoye Upravleniye Geodezii i Kartografii)	Chief Administration of Geodesy & Cartography

Table XXVIII. Glossary of Russian Map Expressions—Continued

<i>Russian original & transliteration</i>	<i>English equivalent</i>
Главное Аэро-Геодезическое Управление (Glavnoye Aero-Geodesicheskoye Upravleniye)	Chief Aero-Geodetic Administration
Военно - Топографическое Управление (Voyenno - Topograficheskoye Upravleniye)	Military-Topographic Administration

Marginal Terms

съёмка.....	survey
инструментальная.....	instrumental
рекогносцировка.....	reconnaissance
составлена.....	compiled
дополнена.....	completed (revised)
исправлена.....	revised
фото.....	photo
печатано; отпечатано.....	printed
подписано к печати.....	authorized for printing
сдано в производство.....	published (given for publication)
издание.....	edition
первое.....	first
второе.....	second
временное издание.....	provisional (temporary) edition
масштаб.....	scale
горизонталь.....	contour
сечение.....	interval
схема расположения прилегающих листов	adjoining sheet diagram
схема административного деления листа	administrative-division diagram
изогоны.....	isogons
схематический.....	schematic

Note. Special sheets drawn for training purposes carry the label "Учебная карта" in the northeast corner, and must not be accepted as true maps.

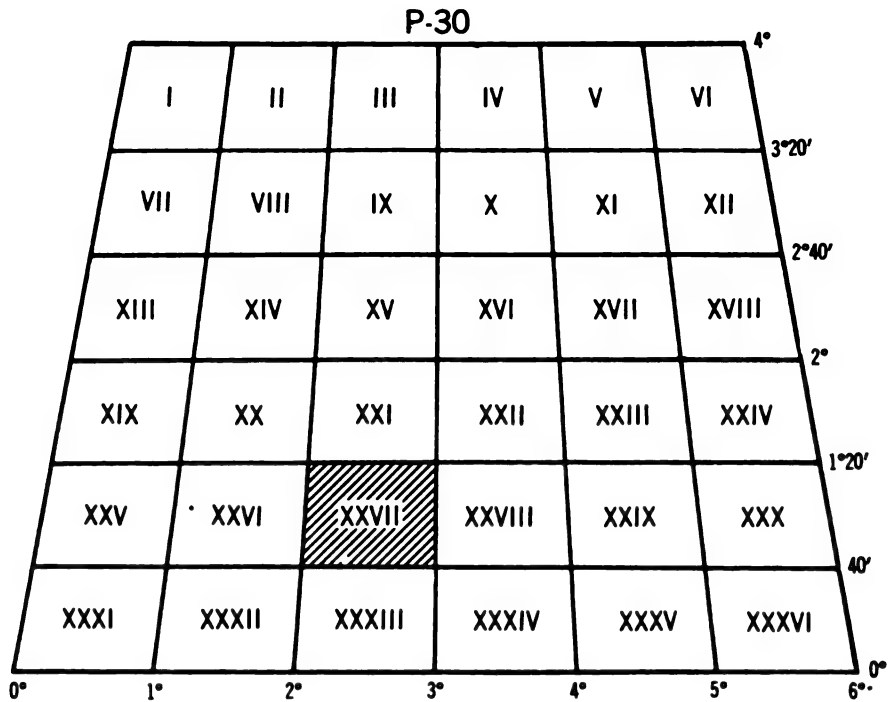

Russian maps at 1:200,000 scale are numbered I through XXXVI within the 1:1,000,000 block. Double-width sheets have also been published, numbered I through XVIII.

Figure 150. Diagram showing U. S. S. R. sheet-numbering system for 1:200,000-scale maps.

APPENDIX I

REFERENCES

1. Department of the Army Publications

a. Regulations.

- AR 300-15 Mapping and Charting
 DA Pam 108-1 Index of Army Motion Pictures, Television Recordings, and Film Strips
 SR 117-5-1 Mapping and Surveying
 DA Pam 310-3 Index of Training Publications
 DA Pam 310-4 Index of Technical Manuals, Technical Regulations, Technical Bulletins, Supply Bulletins, Lubrication Orders, Modification Work Orders
 DA Pam 310-1 Index of Administrative Publications
 SR 320-5-1 Dictionary of United States Army Terms
 SR 320-50-1 Authorized Abbreviations

b. Field Manuals.

- FM 21-5 Military Training
 FM 21-8 Military Training Aids
 FM 21-25 Elementary Map and Aerial Photograph Reading
 FM 21-26 Advanced Map Reading
 FM 21-30 Military Symbols
 FM 21-31 Topographic Symbols
 FM 21-35 Sketching, Field Service Pocket-books
 FM 30-21 Aerial Photography, Military Applications

c. Technical Manuals.

- TM 44-225 Orientation for Artillery
 TM 5-230 General Drafting
 TM 5-231 Mapping Functions, Corps of Engineers
 TM 5-235 Special Surveys
 TM 5-236 Surveying Tables and Graphs
 TM 5-240 A Guide to the Compilation and Revision of Maps
 TM 5-241 Universal Grid System
 TM 5-244 Multiplex Mapping

- TM 5-245 Map Reproduction in the Field
 TM 5-545 Geology and its Military Applications
 TM 5-9990 Map Reading Kit, (Instructions for use)
 TM 30-246 Tactical Interpretation of Air Photos
 TM 30-259 Italian Military Dictionary
 TM 30-500 Spanish Military Dictionary
 TM 30-501 Portuguese Military Dictionary
 TM 30-502 French Military Dictionary
 TM 30-506 German Military Dictionary
 TM 30-533 Chinese Military Dictionary
 TM 30-537 Mongolian Vocabulary
 TM 30-541 Japanese Military Dictionary, Japanese-English, English-Japanese
 TM 30-544 Glossary of Soviet Military Terminology, English-Russian, Russian-English

d. Films and Film Strips.

- TF 5-1270 Map Reading, British Conventional Signs and Symbols
 TF 5-1788 Basic Map Reading, Part I—Topographic Symbols
 TF 5-1789 Basic Map Reading, Part II—Elevation, Distance and Grid
 TF 5-1791 Basic Map Reading, Part III—Direction, Orientation and Location with Compass
 TF 5-1790 Basic Map Reading, Part IV—Direction, Orientation and Location without Compass
 TF 5-1792 Basic Map Reading Part V—Photos and Photo Maps
 FS 4-174 Orientation for Seacoast Artillery—Part IV Maps—Types and Features
 FS 19-4 Preparing and Reading a Circulation Map

e. Army Map Service Technical Manuals.
 (These manuals may be obtained by writing to the Commanding Officer, Army Map Service, 6500 Brooks Lane, Washington 25, D. C., ATTN: Chief, Map Distribution Division. Requests for publications should specify the AMS key number and the title of the item desired.)

	<i>AMS Key No.</i>
TM 5 Icelandic Map Symbols.....	204691
TM 12 Glossary of Russian Map Terms.....	204323
TM 13 Glossary of Polish Map Terms.....	204334
TM 16 Glossary of Terms appearing on German Maps of Russian Areas.....	204343
TM 17 Russian Map Symbols.....	204388
TM 18 Polish Map Symbols.....	204389
TM 19 Universal Transverse Mercator Grid.....	204457
TM 22 Map Identifications and other Marginal Information.....	200653
TM 23 Symbols for Large Scale Maps.....	202499
TM 24 Nautical Abbreviations.....	204707
TM 25 Greek Map Symbols.....	204712
TM 28 Glossary of Cartographic Terms.....	204717
TM 29 Portuguese Map Symbols.....	204739
TM 30 Japanese Intelligence Symbols.....	202336
TM 33 Symbols for Medium Scale Maps.....	204902
TM 34 Turkish Map Symbols.....	204885
TM 36 Grids and Grid References.....	204839
TM 42 Turkish Cartographic Glossary.....	204827
TM 43 Symbols for Small Scale Maps.....	209038
TM 51 Glossary of Indochinese Terms.....	203591
Arabic Words Commonly Used on Maps.....	200553
Italian Words Commonly Used on Maps.....	200368
Japanese Map Symbols.....	201542
Japanese Terms on Maps.....	201108
Spanish Words Commonly Used on Maps.....	200412

2. Directorate of Military Survey Publications

(These publications may be obtained either from the Directorate of Military Survey, War Office, Whitehall, S. W. 1, London, or from the Army Map Service. Requests to Army Map Service, which should specify the title and the AMS key number of the publications desired, should be directed to the Commanding Officer, Army Map Service, 6500 Brooks Lane, Washington 25, D. C., ATTN: Chief, Map Distribution Division.)

	<i>AMS Key No.</i>
Albanian Glossary.....	200630
Bulgarian Short Glossary.....	200619
Chinese Topographic Terms.....	200555
Czech and Slovak Short Glossary.....	200577
Danish Short Glossary.....	201219
Estonian Short Glossary.....	200620
Finnish Short Glossary.....	200621
French Short Glossary.....	200972
Greek Short Glossary.....	200642
Hungarian Short Glossary.....	200649
Italian Short Glossary.....	200523
Lithuanian Short Glossary.....	200655
Norwegian Short Glossary.....	200561
Polish Short Glossary.....	200624
Portuguese Short Glossary.....	200625
Rumanian Short Glossary.....	200626
Russian Short Glossary.....	200640
Serb and Croat Short Glossary.....	200641
Swedish Short Glossary.....	200562
Turkish Short Glossary.....	200629

3. Department of Commerce Publications

Definitions of Terms Used in Geodetic and
 other surveys—Special Publ. 242
 Cartography—Special Pub. 205

APPENDIX II

REFERENCE DATA

Table XXIX. Foreign Units of Measure.

a. Linear Measure.

(1) Equivalent units of length.

	<i>Mile</i>	<i>Yd</i>	<i>Ft</i>	<i>In.</i>	<i>Km</i>	<i>M</i>	<i>Cm</i>
Mile.....	1. 0000	1760. 0000	5280. 0000	63, 360. 0000	1. 6093	1609. 3490	-----
Yd.....	-----	1. 0000	3. 0000	36. 0000	-----	. 9144	91. 44
Ft.....	-----	. 3333	1. 0000	12. 0000	-----	. 3048	30. 48
In.....	-----	. 0277	. 0833	1. 0000	-----	. 0254	2. 54
Km.....	. 6214	1093. 6112	3280. 8336	39, 370. 0032	1. 0000	1000. 0000	100, 000. 00
M.....	-----	1. 0936	3. 2808	39. 3700	. 0010	1. 0000	100. 00
Cm.....	-----	. 0109	. 0328	. 3937	-----	. 0100	1. 00

(2) Metric system (with equivalents in English system).

1 millimeter.....	0.1 centimeter.....	0.0393 inch.
10 millimeters.....	1.0 centimeter.....	0.3937 inch.
10 centimeters.....	1.0 decimeter.....	3.937 inches.
10 decimeters.....	1.0 meter.....	39.37 inches.
10 meters.....	1.0 dekameter.....	32.81 feet.
10 dekameters.....	1.0 hectometer.....	328.1 feet.
10 hectometers.....	1.0 kilometer.....	0.62 mile.
10 kilometers.....	1.0 myriameter.....	6.21 miles.

(3) Japanese system (with equivalents in metric and English systems).

1 rin.....	1 rin.....	0.303 millimeter.....	0.012 inch.
10 rin.....	1 bu.....	3.03 millimeters.....	0.12 inch.
10 bu.....	1 sun.....	3.03 centimeters.....	1.2 inches.
10 sun.....	1 shaku.....	30.3 centimeters.....	0.994 foot.
6 shaku.....	1 ken.....	1.82 meters.....	1.99 yards.
10 shaku.....	1 jo.....	3.03 meters.....	3.31 yards.
60 ken.....	1 cho.....	109.0 meters.....	119.0 yards.
36 cho.....	1 ri.....	3.93 kilometers.....	2.44 miles.

(4) Chinese system (with equivalents in metric and English systems).

10 hou.....	1 hou.....	0.032 millimeter.....	0.0012 inch.
10 li.....	1 li.....	0.32 millimeter.....	0.0125 inch.
10 feng.....	1 feng.....	3.2 millimeters.....	0.1259 inch.
10 chun.....	1 chun.....	3.2 centimeters.....	1.259 inches.
10 chi.....	1 chi.....	32.0 centimeters.....	12.59 inches.
180 chang.....	1 chang.....	3.2 meters.....	10.49 feet.
	1 shi li.....	576.0 meters.....	1,889.28 feet.

Note. When length of shi li differs from that shown above, all other units change correspondingly.

(As used on Chinese general staff maps.)

150 chang.....	1 chang.....	3.333 meters.....	10.935 feet.
	1 shi li.....	500.0 meters.....	1,640.5 feet.

(5) *Russian system (with equivalents in metric and English systems).*

12 duims.....	1 duim.....	2.54 centimeters.....	1.0 inch.
7 foutes.....	1 foute.....	30.48 centimeters.....	12.0 inches.
500 sasshen.....	1 sasshen.....	2.1336 meters.....	7.0 feet.
7 versts.....	1 verst.....	1.066 kilometers.....	0.663 mile.
	1 milya.....	7.467 kilometers.....	4.64 miles.

b. Square Measure.

(1) *English units with metric equivalents.*

1 sq. inch.....		6.452 sq. cm.
1 sq. foot.....	144 sq. inches.....	929.01 sq. cm.
1 sq. yard.....	1,296 sq. inches.....	0.8361 sq. meters
	9 sq. feet	
1 sq. rod, perch, or pole.....	30.25 sq. yards.....	25.29 sq. meters
	272.25 sq. feet	
1 acre.....	43,560 sq. feet.....	4,047 sq. meters
	4,840 sq. yards.....	40.47 acres
	160 sq. rods.....	0.4047 hectares
1 sq. mile.....	640 acres.....	2.59 sq. km.
1 rood.....	40 sq. rods.....	0.25 acre

(2) *Metric units with English equivalents.*

1 centiare.....	1 sq. meter.....	1,550 sq. inches
		1.196 sq. yards
1 are.....	100 sq. meters.....	119.6 sq. yards
		0.0247 acres
1 hectare.....	10,000 sq. meters.....	2.471 acres
	100 ares	

c. Equivalent Units of Angular Measure.

1 mil.....	1/6400 circle.....	0.0166 degree.....	0.0185 grad
1 grad.....	1/400 circle.....	16.0 mils.....	9/10°
1 degree.....	1/360 circle.....	17.8 mils.....	10/9 grad

Table XXX. Conversion to Centesimal to Sexagesimal Values

a. The centesimal system for identification of geographic positions has been used by some mapping authorities. The basic unit of the system is the right angle. The angle divisions are commonly called grads, centesimal minutes, and centesimal seconds; the grad (°) being defined as the hundredth part of a right angle, the centesimal minute (′) as the hundredth of a grad, and the centesimal second (″) as the hundredth of a centesimal minute.

b. The notation (°), (′), and (″) is recommended in preference to the French system of (°), (′), and (″) to avoid confusion with the symbolization of the sexagesimal system. This notation is somewhat clumsy, however; in practice, instead of

$$18^{\circ} 04^{\prime} 13^{\prime\prime} 9$$

it is customary to write

$$18^{\circ} 04 13 9 \text{ (or } 18.04 13 9^{\circ}\text{)}$$

or

$$18^{\circ} 04139 \text{ (or } 18.04139^{\circ}\text{)}$$

c. The relation of divisions of the sexagesimal system to those of the centesimal system is as follows:

$$\begin{aligned} 1^{\circ} &= 1^{\circ} 11111 & 1^{\circ} &= 0^{\circ} 90 = 54' = 3240'' \\ 1' &= 1^{\circ} 85185 & 1' &= 0.54 = 32.4 \\ 1'' &= 3^{\circ} 08642 & 1'' &= 0.324 \end{aligned}$$

d. By use of the table, the conversion of 18° 04′ 13″ 9 to its sexagesimal equivalent is made as follows:

$$\begin{aligned} 18^{\circ} &= & 16^{\circ} & 12' & '' \\ 04^{\prime} &= .04^{\circ} & = & 2 & 09.6 \\ 10^{\prime\prime} &= .001^{\circ} & = & & 3.24 \\ 3^{\prime\prime\prime} &= .0003^{\circ} & = & & .97 \\ .9^{\prime\prime\prime\prime} &= .00009^{\circ} & = & & .29 \end{aligned}$$

$$16^{\circ} 14' 14.71''$$

Table XXX. Conversion of Centesimal to Sexagesimal Values—Continued

Grads ° ' "	Grads ° ' "	Grads ° ' "	Grads ° ' "	Grads ° ' "	Grads ° ' "	Grads ° ' "	Grads ° ' "	Grads ° ' "	Grads ° ' "	Grad ' "	Grad ' "	Grad ' "
1 0 54	51 45 54	101 90 54	151 135 54	201 180 54	251 225 54	301 270 54	351 315 54	0.01 0 32.4	0.51 27 32.4	0.001 3.24		
2 1 48	52 46 48	102 91 48	152 136 48	202 181 48	252 226 48	302 271 48	352 316 48	0.02 1 04.8	0.52 28 04.8	0.002 6.48		
3 2 42	53 47 42	103 92 42	153 137 42	203 182 42	253 227 42	303 272 42	353 317 42	0.03 1 37.2	0.53 28 37.2	0.003 9.72		
4 3 36	54 48 36	104 93 36	154 138 36	204 183 36	254 228 36	304 273 36	354 318 36	0.04 2 09.6	0.54 29 09.6	0.004 12.96		
5 4 30	55 49 30	105 94 30	155 139 30	205 184 30	255 229 30	305 274 30	355 319 30	0.05 2 42.0	0.55 29 42.0	0.005 16.20		
6 5 24	56 50 24	106 95 24	156 140 24	206 185 24	256 230 24	306 275 24	356 320 24	0.06 3 14.4	0.56 30 14.4	0.006 19.44		
7 6 18	57 51 18	107 96 18	157 141 18	207 186 18	257 231 18	307 276 18	357 321 18	0.07 3 46.8	0.57 30 46.8	0.007 22.68		
8 7 12	58 52 12	108 97 12	158 142 12	208 187 12	258 232 12	308 277 12	358 322 12	0.08 4 19.2	0.58 31 19.2	0.008 25.92		
9 8 06	59 53 06	109 98 06	159 143 06	209 188 06	259 233 06	309 278 06	359 323 06	0.09 4 51.6	0.59 31 51.6	0.009 29.16		
10 9 00	60 54 00	110 99 00	160 144 00	210 189 00	260 234 00	310 279 00	360 324 00	0.10 5 24.0	0.60 32 24.0	0.010 32.40		
11 9 54	61 54 54	111 99 54	161 144 54	211 189 54	261 234 54	311 279 54	361 324 54	0.11 5 56.4	0.61 32 56.4			
12 10 48	62 55 48	112 100 48	162 145 48	212 190 48	262 235 48	312 280 48	362 325 48	0.12 6 28.8	0.62 33 28.8			
13 11 42	63 56 42	113 101 42	163 146 42	213 191 42	263 236 42	313 281 42	363 326 42	0.13 7 01.2	0.63 34 01.2			
14 12 36	64 57 36	114 102 36	164 147 36	214 192 36	264 237 36	314 282 36	364 327 36	0.14 7 33.6	0.64 34 33.6			
15 13 30	65 58 30	115 103 30	165 148 30	215 193 30	265 238 30	315 283 30	365 328 30	0.15 8 06.0	0.65 35 06.0			
16 14 24	66 59 24	116 104 24	166 149 24	216 194 24	266 239 24	316 284 24	366 329 24	0.16 8 38.4	0.66 35 38.4			
17 15 18	67 60 18	117 105 18	167 150 18	217 195 18	267 240 18	317 285 18	367 330 18	0.17 9 10.8	0.67 36 10.8			
18 16 12	68 61 12	118 106 12	168 151 12	218 196 12	268 241 12	318 286 12	368 331 12	0.18 9 43.2	0.68 36 43.2			
19 17 06	69 62 06	119 107 06	169 152 06	219 197 06	269 242 06	319 287 06	369 332 06	0.19 10 15.6	0.69 37 15.6			
20 18 00	70 63 00	120 108 00	170 153 00	220 198 00	270 243 00	320 288 00	370 333 00	0.20 10 48.0	0.70 37 48.0			
21 18 54	71 63 54	121 108 54	171 153 54	221 198 54	271 243 54	321 288 54	371 333 54	0.21 11 20.4	0.71 38 20.4	0.0001 0.324		
22 19 48	72 64 48	122 109 48	172 154 48	222 199 48	272 244 48	322 289 48	372 334 48	0.22 11 52.8	0.72 38 52.8	0.0002 0.648		
23 20 42	73 65 42	123 110 42	173 155 42	223 200 42	273 245 42	323 290 42	373 335 42	0.23 12 25.2	0.73 39 25.2	0.0003 0.972		
24 21 36	74 66 36	124 111 36	174 156 36	224 201 36	274 246 36	324 291 36	374 336 36	0.24 12 57.6	0.74 39 57.6	0.0004 1.296		
25 22 30	75 67 30	125 112 30	175 157 30	225 202 30	275 247 30	325 292 30	375 337 30	0.25 13 30.0	0.75 40 30.0	0.0005 1.620		
26 23 24	76 68 24	126 113 24	176 158 24	226 203 24	276 248 24	326 293 24	376 338 24	0.26 14 02.4	0.76 41 02.4	0.0006 1.944		
27 24 18	77 69 18	127 114 18	177 159 18	227 204 18	277 249 18	327 294 18	377 339 18	0.27 14 34.8	0.77 41 34.8	0.0007 2.268		
28 25 12	78 70 12	128 115 12	178 160 12	228 205 12	278 250 12	328 295 12	378 340 12	0.28 15 07.2	0.78 42 07.2	0.0008 2.592		
29 26 06	79 71 06	129 116 06	179 161 06	229 206 06	279 251 06	329 296 06	379 341 06	0.29 15 39.6	0.79 42 39.6	0.0009 2.916		
30 27 00	80 72 00	130 117 00	180 162 00	230 207 00	280 252 00	330 297 00	380 342 00	0.30 16 12.0	0.80 43 12.0	0.0010 3.240		
31 27 54	81 72 54	131 117 54	181 162 54	231 207 54	281 252 54	331 297 54	381 342 54	0.31 16 44.4	0.81 43 44.4			
32 28 48	82 73 48	132 118 48	182 163 48	232 208 48	282 253 48	332 298 48	382 343 48	0.32 17 16.8	0.82 44 16.8			
33 29 42	83 74 42	133 119 42	183 164 42	233 209 42	283 254 42	333 299 42	383 344 42	0.33 17 49.2	0.83 44 49.2			
34 30 36	84 75 36	134 120 36	184 165 36	234 210 36	284 255 36	334 300 36	384 345 36	0.34 18 21.6	0.84 45 21.6			
35 31 30	85 76 30	135 121 30	185 166 30	235 211 30	285 256 30	335 301 30	385 346 30	0.35 18 54.0	0.85 45 54.0			
36 32 24	86 77 24	136 122 24	186 167 24	236 212 24	286 257 24	336 302 24	386 347 24	0.36 19 26.4	0.86 46 26.4			
37 33 18	87 78 18	137 123 18	187 168 18	237 213 18	287 258 18	337 303 18	387 348 18	0.37 19 58.8	0.87 46 58.8			
38 34 12	88 79 12	138 124 12	188 169 12	238 214 12	288 259 12	338 304 12	388 349 12	0.38 20 31.2	0.88 47 31.2			
39 35 06	89 80 06	139 125 06	189 170 06	239 215 06	289 260 06	339 305 06	389 350 06	0.39 21 03.6	0.89 48 03.6			
40 36 00	90 81 00	140 126 00	190 171 00	240 216 00	290 261 00	340 306 00	390 351 00	0.40 21 36.0	0.90 48 36.0			
41 36 54	91 81 54	141 126 54	191 171 54	241 216 54	291 261 54	341 306 54	391 351 54	0.41 22 08.4	0.91 49 08.4			
42 37 48	92 82 48	142 127 48	192 172 48	242 217 48	292 262 48	342 307 48	392 352 48	0.42 22 40.8	0.92 49 40.8			
43 38 42	93 83 42	143 128 42	193 173 42	243 218 42	293 263 42	343 308 42	393 353 42	0.43 23 13.2	0.93 50 13.2			
44 39 36	94 84 36	144 129 36	194 174 36	244 219 36	294 264 36	344 309 36	394 354 36	0.44 23 45.6	0.94 50 45.6			
45 40 30	95 85 30	145 130 30	195 175 30	245 220 30	295 265 30	345 310 30	395 355 30	0.45 24 18.0	0.95 51 18.0			
46 41 24	96 86 24	146 131 24	196 176 24	246 221 24	296 266 24	346 311 24	396 356 24	0.46 24 50.4	0.96 51 50.4			
47 42 18	97 87 18	147 132 18	197 177 18	247 222 18	297 267 18	347 312 18	397 357 18	0.47 25 22.8	0.97 52 22.8			
48 43 12	98 88 12	148 133 12	198 178 12	248 223 12	298 268 12	348 313 12	398 358 12	0.48 25 55.2	0.98 52 55.2			
49 44 06	99 89 06	149 134 06	199 179 06	249 224 06	299 269 06	349 314 06	399 359 06	0.49 26 27.6	0.99 53 27.6			
50 45 00	100 90 00	150 135 00	200 180 00	250 225 00	300 270 00	350 315 00	400 360 00	0.50 27 00.0	1.00 54 00.0			

Table XXXI. Conversion of Sexagesimal to Centesimal Values.

a. The sexagesimal system for identification of geographic positions is used in most countries. The basic unit of this system is the degree (°). Each degree is divided into 60 minutes (') and each minute into 60 seconds (''). Latitude is measured north and south of the Equator and longitude east and west of a prime meridian.

b. By use of the table, conversion of 16° 14' 14." 1 to its centesimal equivalent is made as follows:

$$\begin{aligned}
 16^\circ &= 17.777778'' = 17^\circ 77' 77'' 78 \\
 14' &= .259259'' = 25^\circ 92'' 59 \\
 14'' &= .004321'' = 43'' 21 \\
 0.1 &= .000031'' = 00'' 31 \\
 &= 18.04139'' = 18^\circ 04' 13'' 9
 \end{aligned}$$

c. The degree of accuracy to which the conversion should be written can be determined by noting that

$$1'' = 3'' 1 \text{ or } 1'' = 0.324$$

Table XXXI. Conversion of Sexagesimal to Centesimal Values—Continued

Degrees Grads	Degrees Grads	Degrees Grads	Degrees Grads	Degrees Grads	Degrees Grads	Minutes Grads	Seconds Grads
1	1.111111	61	67.777778	121	134.444444	181	201.111111
2	2.222222	62	68.888889	122	135.555556	182	202.222222
3	3.333333	63	70.000000	123	136.666667	183	203.333333
4	4.444444	64	71.111111	124	137.777778	184	204.444444
5	5.555556	65	72.222222	125	138.888889	185	205.555556
6	6.666667	66	73.333333	126	140.000000	186	206.666667
7	7.777778	67	74.444444	127	141.111111	187	207.777778
8	8.888889	68	75.555556	128	142.222222	188	208.888889
9	10.000000	69	76.666667	129	143.333333	189	210.000000
10	11.111111	70	77.777778	130	144.444444	190	211.111111
11	12.222222	71	78.888889	131	145.555556	191	212.222222
12	13.333333	72	80.000000	132	146.666667	192	213.333333
13	14.444444	73	81.111111	133	147.777778	193	214.444444
14	15.555556	74	82.222222	134	148.888889	194	215.555556
15	16.666667	75	83.333333	135	150.000000	195	216.666667
16	17.777778	76	84.444444	136	151.111111	196	217.777778
17	18.888889	77	85.555556	137	152.222222	197	218.888889
18	20.000000	78	86.666667	138	153.333333	198	220.000000
19	21.111111	79	87.777778	139	154.444444	199	221.111111
20	22.222222	80	88.888889	140	155.555556	200	222.222222
21	23.333333	81	90.000000	141	156.666667	201	223.333333
22	24.444444	82	91.111111	142	157.777778	202	224.444444
23	25.555556	83	92.222222	143	158.888889	203	225.555556
24	26.666667	84	93.333333	144	160.000000	204	226.666667
25	27.777778	85	94.444444	145	161.111111	205	227.777778
26	28.888889	86	95.555556	146	162.222222	206	228.888889
27	30.000000	87	96.666667	147	163.333333	207	230.000000
28	31.111111	88	97.777778	148	164.444444	208	231.111111
29	32.222222	89	98.888889	149	165.555556	209	232.222222
30	33.333333	90	100.000000	150	166.666667	210	233.333333
31	34.444444	91	101.111111	151	167.777778	211	234.444444
32	35.555556	92	102.222222	152	168.888889	212	235.555556
33	36.666667	93	103.333333	153	170.000000	213	236.666667
34	37.777778	94	104.444444	154	171.111111	214	237.777778
35	38.888889	95	105.555556	155	172.222222	215	238.888889
36	40.000000	96	106.666667	156	173.333333	216	240.000000
37	41.111111	97	107.777778	157	174.444444	217	241.111111
38	42.222222	98	108.888889	158	175.555556	218	242.222222
39	43.333333	99	110.000000	159	176.666667	219	243.333333
40	44.444444	100	111.111111	160	177.777778	220	244.444444
41	45.555556	101	112.222222	161	178.888889	221	245.555556
42	46.666667	102	113.333333	162	180.000000	222	246.666667
43	47.777778	103	114.444444	163	181.111111	223	247.777778
44	48.888889	104	115.555556	164	182.222222	224	248.888889
45	50.000000	105	116.666667	165	183.333333	225	250.000000
46	51.111111	106	117.777778	166	184.444444	226	251.111111
47	52.222222	107	118.888889	167	185.555556	227	252.222222
48	53.333333	108	120.000000	168	186.666667	228	253.333333
49	54.444444	109	121.111111	169	187.777778	229	254.444444
50	55.555556	110	122.222222	170	188.888889	230	255.555556
51	56.666667	111	123.333333	171	190.000000	231	256.666667
52	57.777778	112	124.444444	172	191.111111	232	257.777778
53	58.888889	113	125.555556	173	192.222222	233	258.888889
54	60.000000	114	126.666667	174	193.333333	234	260.000000
55	61.111111	115	127.777778	175	194.444444	235	261.111111
56	62.222222	116	128.888889	176	195.555556	236	262.222222
57	63.333333	117	130.000000	177	196.666667	237	263.333333
58	64.444444	118	131.111111	178	197.777778	238	264.444444
59	65.555556	119	132.222222	179	198.888889	239	265.555556
60	66.666667	120	133.333333	180	200.000000	240	266.666667
241	267.777778	301	334.444444	361	401.111111	421	471.111111
242	268.888889	302	335.555556	362	402.222222	422	472.222222
243	270.000000	303	336.666667	363	403.333333	423	473.333333
244	271.111111	304	337.777778	364	404.444444	424	474.444444
245	272.222222	305	338.888889	365	405.555556	425	475.555556
246	273.333333	306	340.000000	366	406.666667	426	476.666667
247	274.444444	307	341.111111	367	407.777778	427	477.777778
248	275.555556	308	342.222222	368	408.888889	428	478.888889
249	276.666667	309	343.333333	369	409.999999	429	479.999999
250	277.777778	310	344.444444	370	410.000000	430	480.000000
251	278.888889	311	345.555556	371	411.111111	431	481.111111
252	280.000000	312	346.666667	372	412.222222	432	482.222222
253	281.111111	313	347.777778	373	413.333333	433	483.333333
254	282.222222	314	348.888889	374	414.444444	434	484.444444
255	283.333333	315	350.000000	375	415.555556	435	485.555556
256	284.444444	316	351.111111	376	416.666667	436	486.666667
257	285.555556	317	352.222222	377	417.777778	437	487.777778
258	286.666667	318	353.333333	378	418.888889	438	488.888889
259	287.777778	319	354.444444	379	419.999999	439	489.999999
260	288.888889	320	355.555556	380	420.000000	440	490.000000
261	290.000000	321	356.666667	381	421.111111	441	491.111111
262	291.111111	322	357.777778	382	422.222222	442	492.222222
263	292.222222	323	358.888889	383	423.333333	443	493.333333
264	293.333333	324	360.000000	384	424.444444	444	494.444444
265	294.444444	325	361.111111	385	425.555556	445	495.555556
266	295.555556	326	362.222222	386	426.666667	446	496.666667
267	296.666667	327	363.333333	387	427.777778	447	497.777778
268	297.777778	328	364.444444	388	428.888889	448	498.888889
269	298.888889	329	365.555556	389	429.999999	449	499.999999
270	300.000000	330	366.666667	390	430.000000	450	500.000000
271	301.111111	331	367.777778	391	431.111111	451	501.111111
272	302.222222	332	368.888889	392	432.222222	452	502.222222
273	303.333333	333	370.000000	393	433.333333	453	503.333333
274	304.444444	334	371.111111	394	434.444444	454	504.444444
275	305.555556	335	372.222222	395	435.555556	455	505.555556
276	306.666667	336	373.333333	396	436.666667	456	506.666667
277	307.777778	337	374.444444	397	437.777778	457	507.777778
278	308.888889	338	375.555556	398	438.888889	458	508.888889
279	310.000000	339	376.666667	399	439.999999	459	509.999999
280	311.111111	340	377.777778	400	440.000000	460	510.000000
281	312.222222	341	378.888889	401	441.111111	461	511.111111
282	313.333333	342	380.000000	402	442.222222	462	512.222222
283	314.444444	343	381.111111	403	443.333333	463	513.333333
284	315.555556	344	382.222222	404	444.444444	464	514.444444
285	316.666667	345	383.333333	405	445.555556	465	515.555556
286	317.777778	346	384.444444	406	446.666667	466	516.666667
287	318.888889	347	385.555556	407	447.777778	467	517.777778
288	320.000000	348	386.666667	408	448.888889	468	518.888889
289	321.111111	349	387.777778	409	449.999999	469	519.999999
290	322.222222	350	388.888889	410	450.000000	470	520.000000
291	323.333333	351	390.000000	411	451.111111	471	521.111111
292	324.444444	352	391.111111	412	452.222222	472	522.222222
293	325.555556	353	392.222222	413	453.333333	473	523.333333
294	326.666667	354	393.333333	414	454.444444	474	524.444444
295	327.777778	355	394.444444	415	455.555556	475	525.555556
296	328.888889	356	395.555556	416	456.666667	476	526.666667
297	330.000000	357	396.666667	417	457.777778	477	527.777778
298	331.111111	358	397.777778	418	458.888889	478	528.888889
299	332.222222	359	398.888889	419	459.999999	479	529.999999
300	333.333333	360	400.000000	420	460.000000	480	530.000000
1	0.018519	1	0.000809	1	0.000306	1	0.000117
2	0.037037	2	0.001617	2	0.000612	2	0.000234
3	0.055556	3	0.002426	3	0.000918	3	0.000351
4	0.074074	4	0.003234	4	0.001224	4	0.000468
5	0.092593	5	0.004043	5	0.001530	5	0.000585
6	0.111111	6	0.004851	6	0.001836	6	0.000702
7	0.129630	7	0.005660	7	0.002142	7	0.000819
8	0.148148	8	0.006468	8	0.002448	8	0.000936
9	0.166667	9	0.007277	9	0.002754	9	0.001053
10	0.185185	10	0.008086				

Table XXXII. Conversion of Meters to Feet

[Reduction factor: 1 meter=3.28083333 feet]

Meters	Feet	Meters	Feet	Meters	Feet	Meters	Feet	Meters	Feet	Meters	Feet	Meters	Feet	Meters	Feet				
0	-----	100	328.08333	200	656.16667	300	984.25000	400	1,312.33333	500	1,640.41667	600	1,968.50000	700	2,296.58333	800	2,624.66667	900	2,952.75000
1	3.28083	1	331.36417	1	659.44750	1	987.53083	1	1,315.61417	1	1,643.69750	1	1,971.78083	1	2,299.86417	1	2,627.94750	1	2,956.03083
2	6.56167	2	334.64500	2	662.72833	2	990.81167	2	1,318.89500	2	1,646.97833	2	1,975.06167	2	2,303.14500	2	2,631.22833	2	2,959.31167
3	9.84250	3	337.92583	3	666.00917	3	994.09250	3	1,322.17583	3	1,650.25917	3	1,978.34250	3	2,306.42583	3	2,634.50917	3	2,962.59250
4	13.12333	4	341.20667	4	669.29000	4	997.37333	4	1,325.45667	4	1,653.54000	4	1,981.62333	4	2,309.70667	4	2,637.79000	4	2,965.87333
5	16.40417	5	344.48750	5	672.57083	5	1,000.65417	5	1,328.73750	5	1,656.82083	5	1,984.90417	5	2,312.98750	5	2,641.07083	5	2,969.15417
6	19.68500	6	347.76833	6	675.85167	6	1,003.93500	6	1,332.01833	6	1,660.10167	6	1,988.18500	6	2,316.26833	6	2,644.35167	6	2,972.43500
7	22.96583	7	351.04917	7	679.13250	7	1,007.21583	7	1,335.29917	7	1,663.38250	7	1,991.46583	7	2,319.54917	7	2,647.63250	7	2,975.71583
8	26.24667	8	354.33000	8	682.41333	8	1,010.49667	8	1,338.58000	8	1,666.66333	8	1,994.74667	8	2,322.83000	8	2,650.91333	8	2,978.99667
9	29.52750	9	357.61083	9	685.69417	9	1,013.77750	9	1,341.86083	9	1,669.94417	9	1,998.02750	9	2,326.11083	9	2,654.19417	9	2,982.27750
10	32.80833	110	360.89167	210	688.97500	310	1,017.05833	410	1,345.14167	510	1,673.22500	610	2,001.30833	710	2,329.39167	810	2,657.47500	910	2,985.55833
1	36.08917	1	364.17250	1	692.25583	1	1,020.23917	1	1,348.42250	1	1,676.50583	1	2,004.58917	1	2,332.67250	1	2,660.75583	1	2,988.83917
2	39.37000	2	367.45333	2	695.53667	2	1,023.62000	2	1,351.70333	2	1,679.78667	2	2,007.87000	2	2,335.95333	2	2,664.03667	2	2,992.12000
3	42.65083	3	370.73417	3	698.81750	3	1,026.90083	3	1,354.98417	3	1,683.06750	3	2,011.15083	3	2,339.23417	3	2,667.31750	3	2,995.40083
4	45.93167	4	374.01500	4	702.09833	4	1,030.18167	4	1,358.26500	4	1,686.34833	4	2,014.43167	4	2,342.51500	4	2,670.59833	4	2,998.68167
5	49.21250	5	377.29683	5	705.37917	5	1,033.46250	5	1,361.54583	5	1,689.62917	5	2,017.71250	5	2,345.79583	5	2,673.87917	5	3,001.96250
6	52.49333	6	380.57667	6	708.66000	6	1,036.74333	6	1,364.82667	6	1,692.91000	6	2,020.99333	6	2,349.07667	6	2,677.16000	6	3,005.24333
7	55.77417	7	383.85750	7	711.94083	7	1,040.02417	7	1,368.10750	7	1,696.19083	7	2,024.27417	7	2,352.35750	7	2,680.44083	7	3,008.52417
8	59.05500	8	387.13833	8	715.22167	8	1,043.30500	8	1,371.38833	8	1,699.47167	8	2,027.55500	8	2,355.63833	8	2,683.72167	8	3,011.80500
9	62.33583	9	390.41917	9	718.50250	9	1,046.58583	9	1,374.66917	9	1,702.75250	9	2,030.83583	9	2,358.91917	9	2,687.00250	9	3,015.08583
20	65.61667	120	393.70000	220	721.78333	320	1,049.86667	420	1,377.95000	520	1,706.03333	620	2,034.11667	720	2,362.20000	820	2,690.28333	920	3,018.36667
1	68.89750	1	396.98083	1	725.06417	1	1,053.14750	1	1,381.23083	1	1,709.31417	1	2,037.39750	1	2,365.48083	1	2,693.56417	1	3,021.64750
2	72.17833	2	400.26167	2	728.34500	2	1,056.42833	2	1,384.51167	2	1,712.59000	2	2,040.67833	2	2,368.76167	2	2,696.84500	2	3,024.92833
3	75.45917	3	403.54250	3	731.62583	3	1,059.70917	3	1,387.79250	3	1,715.87583	3	2,043.95917	3	2,372.04250	3	2,700.12583	3	3,028.20917
4	78.74000	4	406.82333	4	734.90667	4	1,062.99000	4	1,391.70333	4	1,719.15667	4	2,047.24000	4	2,375.32333	4	2,703.40667	4	3,031.49000
5	82.02083	5	410.10417	5	738.18750	5	1,066.27083	5	1,394.35417	5	1,722.43750	5	2,050.52083	5	2,378.60417	5	2,706.68750	5	3,034.77083
6	85.30167	6	413.38500	6	741.46833	6	1,069.55167	6	1,397.63500	6	1,725.71833	6	2,053.80167	6	2,381.88500	6	2,709.96833	6	3,038.05167
7	88.58250	7	416.66583	7	744.74917	7	1,072.83250	7	1,400.91583	7	1,728.99917	7	2,057.08250	7	2,385.16583	7	2,713.24917	7	3,041.33250
8	91.86333	8	419.94667	8	748.03000	8	1,076.11333	8	1,404.19667	8	1,732.28000	8	2,060.36333	8	2,388.44667	8	2,716.53000	8	3,044.61333
9	95.14417	9	423.22750	9	751.31083	9	1,079.39417	9	1,407.47750	9	1,735.56083	9	2,063.64417	9	2,391.72750	9	2,719.81083	9	3,047.89417
30	98.42500	130	426.50833	230	754.59167	330	1,082.67500	430	1,410.75833	530	1,738.84167	630	2,066.92500	730	2,395.00833	830	2,723.09167	930	3,051.17500
1	101.70583	1	429.78917	1	757.87250	1	1,085.95583	1	1,414.03917	1	1,742.12250	1	2,069.28917	1	2,398.28917	1	2,726.97250	1	3,054.45583
2	104.98667	2	433.07000	2	761.15333	2	1,089.23667	2	1,417.32000	2	1,745.40333	2	2,073.48667	2	2,401.57000	2	2,729.65333	2	3,057.73667
3	108.26750	3	436.35023	3	764.43417	3	1,092.51750	3	1,420.60083	3	1,748.68417	3	2,076.76750	3	2,404.85083	3	2,732.93417	3	3,061.01750
4	111.54833	4	439.63167	4	767.71500	4	1,095.79833	4	1,423.89167	4	1,751.96500	4	2,080.04833	4	2,408.13167	4	2,736.21500	4	3,064.29833
5	114.82917	5	442.91250	5	770.99583	5	1,099.07917	5	1,427.16250	5	1,755.24583	5	2,083.32917	5	2,411.41250	5	2,739.49583	5	3,067.57917
6	118.11000	6	446.19333	6	774.27667	6	1,102.36000	6	1,430.44333	6	1,758.52667	6	2,086.61000	6	2,414.69333	6	2,742.77667	6	3,070.86000
7	121.39083	7	449.47417	7	777.55750	7	1,105.64083	7	1,433.72417	7	1,761.80750	7	2,089.89083	7	2,417.97417	7	2,746.05750	7	3,074.14083
8	124.67167	8	452.75500	8	780.83833	8	1,108.92167	8	1,437.00500	8	1,765.08833	8	2,093.17167	8	2,421.25500	8	2,749.33833	8	3,077.42167
9	127.95250	9	456.03583	9	784.11917	9	1,112.20250	9	1,440.28583	9	1,768.36917	9	2,096.45250	9	2,424.53583	9	2,752.61917	9	3,080.70250
40	131.23333	140	459.31667	240	787.40000	340	1,115.48333	440	1,443.56667	540	1,771.65000	640	2,099.73333	740	2,427.81667	840	2,755.90000	940	3,083.98333
1	134.51417	1	462.59750	1	790.68083	1	1,118.76417	1	1,446.84750	1	1,774.93083	1	2,103.01417	1	2,431.09750	1	2,759.18083	1	3,087.26417
2	137.79500	2	465.87833	2	793.96167	2	1,122.04500	2	1,450.12833	2	1,778.21167	2	2,106.29500	2	2,434.37833	2	2,762.46167	2	3,090.54500
3	141.07583	3	469.15917	3	797.24250	3	1,125.32583	3	1,453.40917	3	1,781.49250	3	2,109.57583	3	2,437.65917	3	2,765.74250	3	3,093.82583
4	144.35667	4	472.44000	4	800.52333	4	1,128.60667	4	1,456.69000	4	1,784.77333	4	2,112.85667	4	2,440.94000	4	2,769.02333	4	3,097.10667
5	147.63750	5	475.72083	5	803.80417	5	1,131.88750	5	1,459.97083	5	1,788.05417	5	2,116.13750	5	2,444.22083	5	2,772.30417	5	3,100.38750
6	150.91833	6	479.00167	6	807.08500	6	1,135.16833	6	1,463.25167	6	1,791.33500	6	2,119.41833	6	2,447.50167	6	2,775.58500	6	3,103.66833
7	154.19917	7	482.28250	7	810.36583	7	1,138.44917	7	1,466.53250	7	1,794.61583	7	2,122.69917	7	2,450.78250	7	2,778.86583	7	3,106.94917
8	157.48000	8	485.56333	8	813.64667	8	1,141.73000	8	1,469.81333	8	1,797.89667	8	2,125.98000	8	2,454.06333	8	2,782.14657	8	3,110.23000
9	160.76083	9	488.84417	9	816.92750	9	1,145.01083	9	1,473.09417	9	1,801.17750	9	2,129.26083	9	2,457.34417	9	2,785.42750	9	3,113.51083
50	164.04																		

Table XXXII. Conversion of Meters to Feet—Continued

Meters Feet	Meters Feet	Meters Feet	Meters Feet	Meters Feet	Meters Feet	Meters Feet	Meters Feet	Meters Feet	Meters Feet
60 196.85000	160 524.98333	260 853.01667	360 1,181.10000	460 1,509.18333	560 1,837.26667	660 2,165.35000	760 2,493.43333	860 2,821.51667	960 3,149.60000
1 200.13083	1 528.21417	1 856.29750	1 1,184.38083	1 1,512.46417	1 1,840.54750	1 2,168.63083	1 2,496.71417	1 2,824.79750	1 3,152.88083
2 203.41167	2 531.49500	2 859.57833	2 1,187.66167	2 1,515.74500	2 1,843.82833	2 2,171.91167	2 2,499.99500	2 2,828.07833	2 3,156.16167
3 206.69250	3 534.77583	3 862.85917	3 1,190.94250	3 1,519.02583	3 1,847.10917	3 2,175.19250	3 2,503.27583	3 2,831.35917	3 3,159.44250
4 209.97333	4 538.05667	4 866.14000	4 1,194.22333	4 1,522.30667	4 1,850.39000	4 2,178.47333	4 2,506.55667	4 2,834.64000	4 3,162.72333
5 213.25417	5 541.33750	5 869.42083	5 1,197.50417	5 1,525.58750	5 1,853.67083	5 2,181.75417	5 2,509.83750	5 2,837.92083	5 3,166.00417
6 216.53500	6 544.61833	6 872.70167	6 1,200.78500	6 1,528.86833	6 1,856.95167	6 2,185.03500	6 2,513.11833	6 2,841.20167	6 3,169.28500
7 219.81583	7 547.89917	7 875.98250	7 1,204.06583	7 1,532.14917	7 1,860.23250	7 2,188.31583	7 2,516.39917	7 2,844.48250	7 3,172.56583
8 223.09667	8 551.18000	8 879.26333	8 1,207.34667	8 1,535.43000	8 1,863.51333	8 2,191.59667	8 2,519.68000	8 2,847.76333	8 3,175.84667
9 226.37750	9 554.46083	9 882.54417	9 1,210.62750	9 1,538.71083	9 1,866.79417	9 2,194.87750	9 2,522.96083	9 2,851.04417	9 3,179.12750
70 229.65833	170 557.74167	270 885.82500	370 1,213.90833	470 1,541.99167	570 1,870.07500	670 2,198.15833	770 2,526.24167	870 2,854.32500	970 3,182.40833
1 232.93917	1 561.02250	1 889.10583	1 1,217.18917	1 1,545.27250	1 1,873.35583	1 2,201.43917	1 2,529.52250	1 2,857.60583	1 3,185.68917
2 236.22000	2 564.30333	2 892.38667	2 1,220.47000	2 1,548.55333	2 1,876.63667	2 2,204.72000	2 2,532.80333	2 2,860.88667	2 3,188.97000
3 239.50083	3 567.58417	3 895.66750	3 1,223.75083	3 1,551.83417	3 1,879.91750	3 2,208.00083	3 2,536.08417	3 2,864.16750	3 3,192.25083
4 242.78167	4 570.86500	4 898.94833	4 1,227.03167	4 1,555.11500	4 1,883.19833	4 2,211.28167	4 2,539.36500	4 2,867.44833	4 3,195.53167
5 246.06250	5 574.14583	5 902.22917	5 1,230.31250	5 1,558.39583	5 1,886.47917	5 2,214.56250	5 2,542.64583	5 2,870.72917	5 3,198.81250
6 249.34333	6 577.42667	6 905.51000	6 1,233.59333	6 1,561.67667	6 1,889.76000	6 2,217.84333	6 2,545.92667	6 2,874.01000	6 3,202.09333
7 252.62417	7 580.70750	7 908.79083	7 1,236.87417	7 1,564.95750	7 1,893.04083	7 2,221.12417	7 2,549.20750	7 2,877.29083	7 3,205.37417
8 255.90500	8 583.98833	8 912.07167	8 1,240.15500	8 1,568.23833	8 1,896.32167	8 2,224.40500	8 2,552.48833	8 2,880.57167	8 3,208.65500
9 259.18583	9 587.26917	9 915.35250	9 1,243.43583	9 1,571.51917	9 1,899.60250	9 2,227.68583	9 2,555.76917	9 2,883.85250	9 3,211.93583
80 262.46667	180 590.56000	280 918.63333	380 1,246.71667	480 1,574.80000	580 1,902.88333	680 2,230.96667	780 2,559.05000	880 2,887.13333	980 3,215.21667
1 265.74750	1 593.84083	1 921.91417	1 1,249.99750	1 1,578.08083	1 1,906.16417	1 2,234.24750	1 2,562.33083	1 2,890.41417	1 3,218.49750
2 269.02833	2 597.12167	2 925.19500	2 1,253.27833	2 1,581.36167	2 1,909.44500	2 2,237.52833	2 2,565.61167	2 2,893.69500	2 3,221.77833
3 272.30917	3 600.40250	3 928.47583	3 1,256.55917	3 1,584.64250	3 1,912.72583	3 2,240.80917	3 2,568.89250	3 2,896.97583	3 3,225.05917
4 275.59000	4 603.68333	4 931.75667	4 1,259.84000	4 1,587.92333	4 1,916.00667	4 2,244.09000	4 2,572.17333	4 2,900.25667	4 3,228.34000
5 278.87083	5 606.96417	5 935.03750	5 1,263.12083	5 1,591.20417	5 1,919.28750	5 2,247.37083	5 2,575.45417	5 2,903.53750	5 3,231.62083
6 282.15167	6 610.24500	6 938.31833	6 1,266.40167	6 1,594.48500	6 1,922.56833	6 2,250.65167	6 2,578.73500	6 2,906.81833	6 3,234.90167
7 285.43250	7 613.52583	7 941.59917	7 1,269.68250	7 1,597.76583	7 1,925.84917	7 2,253.93250	7 2,582.01583	7 2,910.09917	7 3,238.18250
8 288.71333	8 616.80667	8 944.88000	8 1,272.96333	8 1,601.04667	8 1,929.13000	8 2,257.21333	8 2,585.29667	8 2,913.38000	8 3,241.46333
9 291.99417	9 620.08750	9 948.16083	9 1,276.24417	9 1,604.32750	9 1,932.41083	9 2,260.49417	9 2,588.57750	9 2,916.66083	9 3,244.74417
90 295.27500	190 623.35833	290 951.44167	390 1,279.52500	490 1,607.60833	590 1,935.69167	690 2,263.77500	790 2,591.85833	890 2,919.94167	990 3,248.02500
1 298.55583	1 626.63917	1 954.72250	1 1,282.80583	1 1,610.88917	1 1,938.97250	1 2,267.05583	1 2,595.13917	1 2,923.22250	1 3,251.30583
2 301.83667	2 629.92000	2 958.00333	2 1,286.08667	2 1,614.17000	2 1,942.25333	2 2,270.33667	2 2,598.42000	2 2,926.50333	2 3,254.58667
3 305.11750	3 633.20083	3 961.28417	3 1,289.36750	3 1,617.45083	3 1,945.53417	3 2,273.61750	3 2,601.70083	3 2,929.78417	3 3,257.86750
4 308.39833	4 636.48167	4 964.56500	4 1,292.64833	4 1,620.73167	4 1,948.81500	4 2,276.89833	4 2,604.98167	4 2,933.06500	4 3,261.14833
5 311.67917	5 639.76250	5 967.84583	5 1,295.92917	5 1,624.01250	5 1,952.09583	5 2,280.17917	5 2,608.26250	5 2,936.34583	5 3,264.42917
6 314.96000	6 643.04333	6 971.12667	6 1,299.21000	6 1,627.29333	6 1,955.37667	6 2,283.46000	6 2,611.54333	6 2,939.62667	6 3,267.71000
7 318.24083	7 646.32417	7 974.40750	7 1,302.49083	7 1,630.57417	7 1,958.65750	7 2,286.74083	7 2,614.82417	7 2,942.90750	7 3,270.99083
8 321.52167	8 649.60500	8 977.68833	8 1,305.77167	8 1,633.85500	8 1,961.93833	8 2,290.02167	8 2,618.10500	8 2,946.18833	8 3,274.27167
9 324.80250	9 652.88583	9 980.96917	9 1,309.05250	9 1,637.13583	9 1,965.21917	9 2,293.30250	9 2,621.38583	9 2,949.46917	9 3,277.55250

Table XXXIII. Conversion Factors

a. Linear Measure.

	To convert	Multiply by:	
		Exact	Approximate
Inches into centimeters	2.540	2.5
Feet into meters3048	.3
Yards into meters9144	.9
Miles into kilometers	1.609	1.6
Centimeters into inches3937	.4
Meters into feet	3.281	3.3
Meters into yards	1.094	1.1
Kilometers into miles6214	.62

b. Square Measure.

	To convert	Multiply	By factor
sq. inches to sq. centimeters	sq. inches	6.452
sq. meters to sq. feet	sq. meters	10.764
sq. feet to sq. meters	sq. feet	.0929
sq. meters to sq. yards	sq. meters	1.196
sq. yards to sq. meters	sq. yards	.8361
hectares to acres	hectares	2.471
acres to hectares	acres	.4047
sq. kilometers to sq. miles	sq. kilometers	.3861
sq. miles to sq. kilometers	sq. miles	2.59

c. Angular Measure.

	To convert	Multiply	By factor
Grads into mils	16.00	16.0
Degrees into grads	1.11	1.1
Degrees into mils	17.77	17.8

Table XXXIV. Map Equivalents of Ground Measurements

Scale: 1 to—	Inches per mile	Inches per 1,000 yards	Inches per 1,000 meters
5,000	12.672	7.199	7.874
10,000	6.336	3.60	3.937
12,500	5.068	2.88	3.150
20,000	3.168	1.80	1.969
25,000	2.534	1.44	1.575
31,680	2.000	1.136	1.243
40,000	1.584	.90	.984
50,000	1.267	.72	.787
62,500	1.014	.576	.630
63,360	1.000	.569	.621
80,000	.792	.45	.492
100,000	.634	.36	.394
125,000	.507	.288	.315
200,000	.317	.18	.197
250,000	.253	.144	.157
253,440	.25	.142	.155
500,000	.127	.072	.079
506,880	.125	.071	.078
1,000,000	.063	.036	.039

Table XXXV. Prime Meridians of Reference with Longitudinal Distances from Greenwich

	°	'	"	
Amsterdam, Netherlands.....	4	53	01	E
Antwerp, Belgium.....	4	22	50	E
Athens, Greece.....	23	42	59	E
Batavia, Netherlands Indies.....	106	48	28	E
Berlin, Germany.....	13	23	55	E
Brussels, Belgium.....	4	22	06	E
Copenhagen, Denmark.....	12	34	40	E
Ferro, Canary Islands.....	17	40	00	W (German value)
Helsinki, Finland.....	24	57	17	E
Istanbul, Turkey.....	28	58	50	E
Leningrad, U.S.S.R.....	30	18	59	E (1933)
	30	18	22	E (1892)
Lisbon, Portugal.....	9	07	55	W
London, England.....	0	05	43	W
Madrid, Spain.....	3	41	15	W
Moscow, U.S.S.R.....	37	34	15	E
Munich, Germany.....	11	36	31	E
Oslo, Norway.....	10	43	23	E
Padang, Netherlands Indies.....	100	22	01	E
Paris, France.....	2	20	14	E
Pulkovo, U.S.S.R.....	30	19	39	E
Rio de Janeiro, Argentina.....	43	10	21	W
Rome, Italy.....	12	27	08	E (1940)
	12	27	07	E (1904)
Rotterdam, Netherlands.....	4	29	46	E
Singkawang, Netherlands Indies.....	108	59	41	E
Stockholm, Sweden.....	18	03	30	E
Tirane, Albania.....	19	46	45	E

GLOSSARY OF MAPPING TERMS

Note. Many of the terms in this glossary have several different meanings in current military use. Only the definition pertaining to maps is included.

- Altitude tints.* System of showing relief by use of a graduated series of color tints to indicate various levels of altitude.
- Approximate contour.* Line on a map representing an imaginary line on the ground that passes through points of estimated equal elevation. It appears on maps usually as a brown dashed line.
- Arbitrary (or reference) grid.* Any rectangular network of lines superimposed on a map, chart, or photograph adapted to the special requirements of the map and net conforming to any of the established grid systems.
- Atlas grid.* A reference system that permits the designation of the location of a point or an area on a map in terms of numbers and letters.
- Auxiliary (supplementary) contours.* Additional contours, usually shown by dashed lines, used to indicate significant topographical formations that could not be shown by using only the basic contour interval.
- Bar Scale.* See *Graphic scale*.
- Base map.* 1. Map showing certain fundamental information used with specialized data to compile a special-purpose map. 2. Map showing all of the information from which maps showing specialized information can be prepared; a master map. 3. Map showing selected information over which other information can be reproduced, such as an index.
- Basic control.* The horizontal and vertical control of third- or higher-order accuracy, determined in the field and permanently marked or monumented, that is required to control further dependent surveys.
- Bench mark.* A permanently or semipermanently marked control point of known elevation along a line of survey. Accuracy of elevation is of third or higher order. Often used as a reference point in subsequent surveys.
- Cadastral map.* A map showing the boundaries of subdivisions of land for purposes of describing and recording ownership. Culture, drainage, and other features relating to the value and use of the land may also be shown.
- Centesimal system.* System for identification of geographic position. The basic unit of the system is the grad (one four-hundredth part of a circle). See tables XXX and XXXI in appendix II.
- Chart.* A map designed especially for use in aircraft or ship navigation.
- City Plan.* A large-scale comprehensive map of a city, including the street pattern, buildings, and other detail compatible with the scale of the map.
- Contour.* The graphic representation of an imaginary line on the earth's surface that passes through points of the same elevation. Such a line is the result of an accurate survey. See also *Auxiliary contours* and *Contour interval*.
- Contour interval.* Difference in elevation between two adjacent contour lines; vertical interval.
- Control.* A system or network of points on the ground, accurately fixed in position horizontally or vertically (or both) by ground survey methods. Horizontal positions are usually established by triangulation or traverse; elevations are usually established by leveling. Accuracy of control is described in terms of order, as first order, second order, etc.
- Controlled mosaic.* Mosaic laid on ground control to provide an accurate representation of distances and directions.
- Control point.* Any station in a horizontal or vertical control system; in photogrammetry, any such point identifiable on an aerial photograph and usable for orienting features of the photograph.
- Coordinate system.* A system of linear or angular quantities, or both, that designates the position of a point in reference to a given datum. Two types of coordinate systems are in general use on maps: geographic coordinates (graticule) and plane rectangular coordinates (grid).

Coverage diagram. A miniature diagram of a map sheet appearing in the margin of the sheet and showing sources and methods of compilation.

Credit note. Note printed in the margin of a map including all or some of the following information: authority, preparing agency, method of preparation, year of preparation, an abridged list of source materials, added references for revised sheets, date of aerial photography, and any explanatory notes. Proper use of the credit note is extremely important to the map user in evaluating the accuracy of the map.

Culture (cultural features). The representation on a map of features constructed by man—such as roads, trails, buildings, and railroads—as well as boundary lines and all names.

Dates.

Compilations. Indicates the time that the data were integrated into the map but does not necessarily reveal the date of the map information.

Copy. Indicates the time that a map was reproduced, essentially without change, from an existing map, but does not reflect the date of the map information.

Print or reprint. Indicates only the time that the press work was accomplished.

Publication or edition. Indicates the time that the map was made available for distribution. It is the most common date found on maps.

Revision. Normally denotes the time of additions and changes. Generally it refers to the revision of man-made features.

Survey. Indicates the time that essential data were obtained by ground or aerial survey.

Declination diagram. A representation (in the map margin) of the direction of true north and magnetic north from grid north. Representation of angles in the diagram is usually exaggerated, but correct numerical values are given in degrees-minutes and in mils.

Declination protractor. Map-orienting device, consisting of a horizontal degree scale and a pivot point, through which a magnetic north line can be drawn across the face of a map.

Edition. The particular publication of a finished map. Edition numbers are assigned consecutively; thus a map with a higher edition number can be assumed to contain more recent informa-

tion than another printing of the same map with a lower edition number.

Elevation. The vertical distance of ground forms above the datum; it is usually measured in feet or meters above mean sea level (a plus elevation) or below mean sea level (a minus elevation).

Embossed relief map (plastic relief map). A topographic map printed on vinyl plastic and molded to three-dimensional form by the application of heat and vacuum.

Form line. Dashed line on a map used to give a generalized impression of relief. Unlike contours, the lines represent no actual elevations, but are drawn by the compiler from his knowledge of topographic form.

Geographic coordinates. Values expressing the latitude and longitude of a point. The origin for latitude is the Equator, and values increase N. and S. to 90°. The usual origin for longitude is the meridian, or great circle, passing through Greenwich, England, called the prime meridian; values increase E. and W. to 180°.

Grad. Unit of angular measurement equal to 1/400 of the circumference of a circle.

Graphic scale (bar scale). A line or system of parallel lines divided at specified intervals, by means of which distances on the map may be measured in terms of actual ground distances.

Graticule. A system of lines representing latitude and longitude on a map or chart.

Grid. A system of two sets of parallel lines, mutually perpendicular, drawn on a plane surface and used as a rectangular coordinate system (a reference system) for plotting positions and scaling distances and directions. A map grid may or may not be based on a map projection. The interval selected for the grid lines is based on the map scale and purpose. The grid interval for maps at scales larger than 1:100,000 is generally 1,000 meters or 1,000 yards; for maps at scales of 1:100,000 and smaller, an interval of 10,000 meters or yards is often used.

Grid coordinates: Numbers and/or letters of a coordinate system by which the position of a point on a gridded map, photograph, or chart is indicated.

Grid North. North as indicated on a map by the north-south lines of a military grid. See *Declination diagram*.

Ground survey. Survey made by ground methods, as distinguished from an aerial survey. A

ground survey may or may not include the use of ground photographs, but does not include the use of aerial photographs.

Hachures. A method of portraying relief by short, wedge-shaped marks radiating from high elevations and following the direction of slope to the lowland.

Hill shading. A method of showing relief, generally by stippling a map to give the light-and-shadow effect that would be obtained by a light shone upon a relief map from the northwest corner. Ordinarily this is accomplished with crayon or air-brush.

Hypsometric. Pertaining to the measurement of heights with relation to sea level. Hypsometric tints. See *Altitude tints*.

Index to adjoining sheets. A diagram, located in the margin of a map sheet, in which the outlines of that sheet and all adjacent sheets are shown. Principal shorelines are usually delineated in the index.

Index to boundaries. A diagram of a map sheet, located in the margin of the sheet and containing the delineation and identification of all boundaries appearing on the face of the map. Usually principal shorelines are also delineated.

Isopleths. Lines on a map that connect places of equal density or value of distribution of any certain element. If such lines connect places of equal temperatures, they are called "Isotherms," places of equal rainfall are called "Isohyets," etc.

Layer tints. See *Altitude tints*.

Legend. An explanation of symbols and other information shown on the face of a map. It is usually a list or table appearing in the margin of the map.

Lithograph. A print made by lithography, which is the process of applying the design of a map on a plate with a greasy material, and of producing printed impressions therefrom.

Magnetic north. The direction at any point toward the magnetic pole, or the direction in which the compass needle points. See *Declination diagram*.

Manuscript map. The original drawing of a map as compiled or constructed from various data, as ground surveys, photographs, etc.

Map. A representation (usually two-dimensional) of the surface of the earth, or some part of it. It may consist of one or more sheets. A map is primarily concerned with land; a chart

is concerned with either land or water, primarily in its relation to aircraft or ship navigation. See *Chart*.

Map compilation. Preparation of a new map, excluding final drafting and reproduction, from aerial photographs, maps charts, and other source materials used either singly or in combination. Also the map drawing containing all information to be shown on the finished map ready for final drafting for reproduction. Also a manuscript map.

Marginal data. The technical information shown on a map outside the neatline to identify the map or insure its correct use. Such data may include any or all of the following: the series name, number, and scale; the edition number, sheet name and number, unit imprint with printing date and key number, the geographic location name, symbol legend, bar scales, grid reference box, glossary, declination protractor, altitude tint legend; the location, coverage, reliability, and declination diagrams; and notes pertaining to copyright, sources and credits, contour interval, projection, datum, grid, users, etc.

Monochrome. One-colored; a map produced all in one color (usually black), often for emergency or temporary use. It is usually printed by lithography.

Mosaic. An assemblage of aerial photographs to form a continuous photographic representation of a portion of the earth's surface.

Multiplex mapping. Precise method of mapping based upon stereoscopic principles; it is the most widely used method of preparing topographic maps from vertical aerial photographs.

Neatline. The line that bounds the body of a map. The margin of the map lies outside the neatline.

Oblique aerial photography. Photography taken from aircraft, with the camera axis intentionally directed between the horizontal and the vertical.

Oblique: high. Oblique aerial photograph that has a relatively large angle of deviation from the vertical and includes the apparent horizon.

Oblique: low. Oblique aerial photography that has a relatively small angle of deviation from the vertical and does not include the apparent horizon.

Overprint. New material printed or stamped upon a map or a chart to show data of impor-

tance or special use, in addition to that originally printed.

Photo copy. A photographic reproduction of material, such as maps, documents, etc.

Photogrammetry. The science or art of obtaining reliable measurements by means of photography. Either ground or aerial photography may be used, with or without stereoscopic equipment and methods.

Photo map. Reproduction of a photograph or mosaic, upon which additional data such as place names, grid lines, and marginal data have been placed.

Photo revision. The process of making changes on a map based upon information obtained from a study of aerial photographs.

Planetable map. A large-scale topographic map prepared in the field by locating points directly on the map by graphical methods. The map is fastened to a tabletop (supported by a tripod), from which both the instrument used and the method of compilation derive their names.

Planimetric map. Map representing only the horizontal positions of features; it is distinguished from a topographic map by the omission of relief in measurable form.

Planimetry. Parts of a map that represent everything except relief: that is, works of man and natural features, such as woods and water.

Polychrome. Many-colored; a lithograph map with many colors.

Prime meridian. An initial or zero meridian from which the positions of other meridians are reckoned.

Projection. Any one of a number of systems by which parallels and meridians are represented on a plane surface for the purpose of preparing a map; method by which the earth or a section of the earth is represented on a plane surface.

Provisional edition. Term applied to a preliminary issue of a map of which a later, more complete issue is expected.

Reconnaissance map. A map not based on rigid trigonometric surveys, but possessing detailed data—generally made from rapid surveys.

Reconnaissance survey. A quickly executed field inspection using compass and barometer but not the customary surveying instruments. Features are generally not accurately positioned on the resulting map.

Relief. Representation on a map of ground forms, such as ridges, valleys, mountains, etc., by means

of one or more of the following: contours, approximate contours, form lines, hachures, hill shading, spot heights, and altitude tints.

Reprint. The impression from plates that have not been materially changed since previous impressions were released as an accepted edition of the map.

Romanization. Transcription of transliteration or non-Roman systems of writing into the Roman alphabet.

Scale. The relationship between map distances and ground distances. The scale of a map may be expressed in one of three ways:

Numerical scale. The proportion between the length of a line on the map and the corresponding length on the earth's surface, shown in the form of a fraction ($1/25,000$) or a ratio (1:25,000).

Equivalent scale. The relationship between 1 inch on the map and the corresponding distance in miles on the ground, for example, 1 inch to 3 miles.

Graphic scale. Indication of ground distances on a graduated line. Representation of scale in this manner has the advantage of remaining true if the map is reproduced by photographic processes. Figure 152 may be used as an aid to determine the numerical scale of any map on which either parallels of latitude or a graphic scale are shown, or to lay out a graphic scale in kilometers, statute miles, or feet for any map of known scale.

Scale factor. Value by which an actual ground distance is multiplied in order to compensate for map distortion when determining the ground distance as represented on a map.

Series. A group of one or more map sheets produced at the same scale and designed in accordance with the same general specifications. Practically all map series consist of similarly designed sheets that when properly placed together constitute a single large map of a selected part of the earth's surface.

Shaded relief. A method of portraying relief artistically by shading, which permits a ready interpretation of the general forms of an area. See *Hill shading*.

Sheet. A single printed copy of map, usually one of a series.

Sheet lines. The limits of the body of a map, generally formed by parallels and meridians.

- Usually, the sheet lines of a series are uniformly spaced. Thus, the geographic dimensions of the sheets are the same, while the linear dimensions vary with latitude.
- Spot height (spot elevation).* Printed figure on a map that designates the elevation of a point above the datum (usually mean sea level).
- Stereocomparagraph.* A relatively simple, inexpensive, and mobile stereoscopic instrument used for the preparation of topographic maps from photography. Differences in elevation are determined by measuring differences in image displacement on a stereoscopic pair.
- Streophotogrammetry.* Photogrammetry with the aid of stereoscopic equipment and methods.
- Stereoplaniagraph.* A very precise stereoscopic plotting instrument, especially valuable for control extension, and capable of handling all types of stereoscopic photography, including terrestrial.
- Stereoscope.* Optical instrument for assisting the observer to view two properly prepared photographs or diagrams to obtain the mental impression of a three-dimensional model.
- Stereoscopic pair.* Two photographs of the same area taken from different camera stations in such a manner that when properly oriented they will afford stereoscopic vision.
- Strip map.* Sketch of a route of march, which may or may not be drawn to scale but should include such identifying landmarks as towns, bridges, outstanding buildings, crossroads, etc.
- Survey.* The act or operation of making measurements for determining the relative positions of points on or beneath the earth's surface; also the results of such operations; also an organization for making surveys.
- Terrain model.* A three-dimensional graphic representation of an area showing the conformation of the ground, modeled to scale and usually colored to emphasize the various physical features. The vertical scale is usually exaggerated to convey the aspect of relief.
- Tick.* A short line or small cross to show a location.
- Topographic map.* Map that presents relief, or the vertical positions of features in measurable form, as well as their horizontal positions.
- Trafficability.* A measure of the ability of the soil (or other terrain surface) to support foot troops, animals, vehicles, or aircraft during various seasons.
- Triangulation.* Method of surveying in which the locations of the different terrain features are found by establishing a system of triangles, each with a base line accurate as to location and length. As locations of new points are determined, new base lines are established, and the locations of other points are determined from them.
- Triangulation station.* A permanently marked point for which the geographic coordinates are accurately known from precise surveys.
- Trig list.* A list that includes descriptions and positions of accurately located survey points.
- Trigonometric point.* A point on the ground of which the position (horizontal or vertical) has been determined and marked by an instrumental survey.
- Trimetrogon photography.* A type of aerial photography often used for charting. A tri-camera installation allows three photographs to be taken simultaneously, one vertical and two high obliques, in a direction at right angles to the line of flight. The obliques are taken at an angle of 60° from the vertical, and sidelap the vertical photograph. The three photographs give a composite picture from horizon to horizon and overlap the next series of three pictures in the line of flight.
- True North.* Geographic north; the direction of the geographic North Pole from a given point on the earth's surface. See *Declination diagram*.
- Uncontrolled mosaic.* Mosaic made without the check of scale or position that would be given by a framework of control points.
- Vertical aerial photo.* Aerial photograph made with a camera the optical axis of which is approximately vertical to the earth's surface, or the film of which is as nearly horizontal as is practicable.

INDEX

	Paragraphs	Page
Adapting foreign maps to U. S. Army use	8-10	10
Aden Colony, maps. (<i>See Arabian Peninsula, maps.</i>)		
Aden Protectorate, maps. (<i>See Arabian Peninsula, maps.</i>)		
Albania, maps	172-175	225
Algeria, maps	15, 16	20
Arabian Peninsula, maps	70-72	95
Austria, maps	152-154	199
Bahrein, maps. (<i>See Arabian Peninsula, maps.</i>)		
Balearic Islands, maps	125-127	173
Belgium, maps	101-103	147
Bornholm Island, maps. (<i>See Denmark, maps.</i>)		
British Isles, maps	104-106	151
British Somaliland, maps	24, 25	40
Bulgaria, maps	176-179	226
Bulgarian map expressions	Table XXII	230
Bulgarian transliteration table	Table XXI	229
Burma, maps	73-75	99
Centesimal coordinate system	Table XXX	254
	Table XXXI	255
China, maps. (<i>See East China, maps.</i>)		
Chinese units of measurement	Table XXIX	253
Conversion factors for linear, square, and angular measure	Table XXXIII	259
Conversion tables:		
Meters to feet	Table XXXII	257
Sexagesimal to centesimal values (degrees to grads)	Table XXXI	255
Centesimal to sexagesimal values (grads to degrees)	Table XXX	254
Coordinate systems:		
Centesimal	Table XXX	254
Sexagesimal	Table XXXI	255
Cyrillic alphabet	Table XXI	229
	Table XXVII	247
Czech map expressions	Table XVII	206
Czechoslovakia, maps	155-158	200
Danish map expressions	Table IX	180
Degree, conversion to grads	Table XXXI	255
Denmark, maps	128-131	172
East China, maps	36-40	48
East Prussia, maps	136-138	186
Egypt, maps	19-21	31
England, maps. (<i>See British Isles, maps.</i>)		
Eritrea, maps	22, 23	39
Estonia, maps	132-135	180
Estonian map expressions	Table X	185
Ethiopia, maps	22, 23	39
Evaluation, methods:		
General	4	4
Large-scale maps	5	5
Medium- and small-scale maps	6	8
Evaluations, references used in preparing	7	9
Faeroe Islands, maps	128-131	172
Finland, maps	139-143	187

	Paragraphs	Page
Finnish map expressions	Table XIII	190
Formosa. (<i>See</i> Taiwan.)		
France, maps	107-109	157
French Morocco, maps	13, 14	15
French Somaliland, maps	26, 27	41, 42
German map expressions	Table XVIII	214
Germany, maps	159, 160	206
Gibraltar, maps	110-112	162
Glossaries:		
Austrian	Table XVI	200
Bulgarian	Table XXII	230
Czech	Table XVII	206
Danish	Table IX	180
Estonian	Table X	185
Finnish	Table XIII	190
French	Table VI	162
German	Table XVIII	249
Greek	Table XXIII	233
Hungarian	Table XIX	216
Icelandic	Table I	47
Italian	Table XXV	240
Latvian	Table XI	185
Lithuanian	Table XII	186
Mapping terms	Glossary	261
Norwegian	Table XIV	195
Polish	Table XX	223
Portuguese	Table VII	173
Russian	Table XXVIII	249
Spanish	Table VIII	177
Swedish	Table XV	198
Yugoelav	Table XXVI	244
Grads, conversion to degrees	Table XXX	254
Greece, maps	180-182	230
Greek alphabet, transliteration table	Table XXIV	234
Greek map expressions	Table XXIII	233
Greenland, maps	28-31	44
Hong Kong, maps	36b, 37b, 38-40	48, 52, 55
Hungarian map expressions	Table XIX	216
Hungary, maps	161-164	215
Icelandic map expressions	Table I	47
Iceland, maps	32-35	46
Indochina, maps	41-45	63
International Zone of Tanger, maps. (<i>See</i> Spanish Morocco, maps.)		
Iran, maps	76-79	102
Iraq, maps	80-82	110
Ireland, maps. (<i>See</i> British Isles, maps.)		
Israel, maps	83-85	116
Italian map expressions	Table XXV	240
Italy, maps	183-186	235
Japan, maps	46-50	68
Japanese units of measurement	Table XXIX	253
Jehol, maps. (<i>See</i> East China, maps.)		
Jordan, maps	83-85	116
Karafuto, maps	56-60	87
Korea, maps	51-55	77
Kuwait, maps. (<i>See</i> Arabian Peninsula, maps.)		
Latvia, maps	132-135	180
Latvian map expressions	Table XI	185
Lebanon, maps	86-88	125
Libya, maps	17, 18	27, 29

	Paragraphs	Page
Lithuania, maps	132-135	180
Lithuanian map expressions	Table XII	186
Luxembourg, maps	113-115	163
Malaya, maps	89-91	130
Manchuria, maps. (<i>See East China, maps.</i>)		
Mapping terms, definitions	Glossary	261
Map scale, ground equivalents	Table XXXIV	259
Measurements, units of angular, metric, and square	Table XXIX	253
Mongolia, maps. (<i>See East China, maps.</i>)		
Muscat, maps. (<i>See Arabian Peninsula, maps.</i>)		
Netherlands, maps	116-120	166
Norway, maps	144-147	192
Norwegian map expressions	Table XIV	195
Oman, maps. (<i>See Arabian Peninsula, maps.</i>)		
Palestine, maps. (<i>See Israel, maps.</i>)		
P'eng-hu Islands, maps	65-69	92
Pescadores. (<i>See P'eng-hu Islands.</i>)		
Philippines, maps	92-94	133
Poland, maps	165-168	217
Polish map expressions	Table XX	223
Portugal, maps	121-124	169
Prime meridians	Table XXXV	260
Qatar, maps. (<i>See Arabian Peninsula, maps.</i>)		
Reference data, mapping	App. II	253
References, mapping	App. I	251
Rumania, maps	187-190	240
Russian alphabet transliteration	Table XXVII	247
Russian map expressions	Table XXVIII	249
Russian units of measurement	Table XXIX	253
Sakhalin Island, maps	61-64	92
Saudi Arabia, maps. (<i>See Arabian Peninsula, maps.</i>)		
Scotland, maps. (<i>See British Isles, maps.</i>)		
Sexagesimal coordinate system	Table XXXI	255
Singapore, maps	89-91	130
Spain, maps	125-127	173
Spanish map expressions	Table VIII	177
Spanish Morocco, maps	11, 12	12
Sweden, maps	148-151	195
Swedish map expressions	Table XV	198
Switzerland, maps	169-171	223
Syria, maps	86-88	125
Tables:		
I. Glossary of icelandic map expressions		47
II. Basic and auxiliary contour intervals for Japanese topographic series of Japan		73
III. Basic and auxiliary contour intervals for GSPA maps		82
IV. Basic and auxiliary contour intervals for Japanese maps of Korea		83
V. Basic and auxiliary contour intervals for Japanese topographic series of Karafuto		91
VI. Glossary of French map expressions		162
VII. Glossary of Portuguese map expressions		173
VIII. Glossary of Spanish map expressions		177
IX. Glossary of Danish map expressions		180
X. Glossary of Estonian map expressions		185
XI. Glossary of Latvian map expressions		185
XII. Glossary of Lithuanian map expressions		186
XIII. Glossary of Finnish map expressions		190
XIV. Glossary of Norwegian map expressions		195
XV. Glossary of Swedish map expressions		198
XVI. Glossary of Austrian map expressions		200
XVII. Glossary of Czech map expressions		206
XVIII. Glossary of German map expressions		214

Tables—Continued

	Paragraphs	Page
XIX. Glossary of Hungarian map expressions.....		216
XX. Glossary of Polish map expressions.....		223
XXI. Transliteration system for Bulgarian geographic names.....		229
XXII. Glossary of Bulgarian map expressions.....		230
XXIII. Glossary of Greek map expressions.....		233
XXIV. Greek lettering as found on Greek maps.....		234
XXV. Glossary of Italian map expressions.....		240
XXVI. Glossary of Yugoslav map expressions.....		244
XXVII. Russian alphabet transliteration according to United States Board of Geographic Names.....		247
XXVIII. Glossary of Russian map expressions.....		249
XXIX. Foreign units of measure.....		253
XXX. Conversion of centesimal to sexagesimal values.....		254
XXXI. Conversion of sexagesimal to centesimal values.....		255
XXXII. Conversion of meters to feet.....		257
XXXIII. Conversion factors.....		259
XXXIV. Map equivalents of ground measurements.....		259
XXXV. Prime meridians of reference with longitudinal distances from Greenwich.....		260
Taiwan, maps.....	65-69	92
Tangier (Tanger), maps. (See Spanish Morocco, maps.)		
Thailand, maps.....	95-97	136
Transjordan, maps. (See Jordan, maps.)		
Transliteration tables:		
Bulgarian.....	Table XXI	229
Greek.....	Table XXIV	234
Russian.....	Table XXVII	247
Trieste, maps.....	183-186	235
Trucial Oman, maps. (See Arabian Peninsula, maps.)		
Tunisia, maps.....	15, 16	20
Turkey, maps.....	98-100	139
U. S. S. R., maps.....	195-199	246
Wales, maps. (See British Isles, maps.)		
Yemen, maps. (See Arabian Peninsula, maps.)		
Yugoslavia, maps.....	191-194	241
Yugoslavian map expressions.....	Table XXVI	244

[AG 061 (20 Feb 56)]

By Order of *Wilber M. Brucker*, Secretary of the Army:

MAXWELL D. TAYLOR,
General, United States Army,
Chief of Staff.

Official:

JOHN A. KLEIN,
Major General, United States Army,
The Adjutant General.

Distribution:

Active Army:

CNGB (1)
Tec Svc, DA (1) except
COFENGRS (2)
Engr Bd (1)
Hq CONARC (2)
Army AA Comd (1)
OS Maj Comd (10)
OS Base Comd (5)
Log Comd (1)
MDW (1)
Armies (3)
Corps (3)
Div (2)
Engr Brig (2)
Engr Gp (2)

Ft & Cp (1)
USMA (10)
Div Engr (1)
Engr Dist (1)
Mil Dist (1)
Units organized under following
TOE's:
5-15R, Engr Cmbt Bn, Div (1)
5-35R, Engr Cmbt Bn, Army (1)
5-55R, Engr Topo Bn, Army (1)
5-56R, Hq, H & S Co, Engr Topo
Bn, Army (1)
5-57R, Engr Maps Repro and
Distr Co, Army (1)

5-59R, Engr Photomapping Co,
Army (1)
5-167R, Engr Topo Co, Corps (1)
5-215, Armd Engr Bn (1)
5-346R, Hq & Hq Det, Engr
Base Topo Bn (1)
5-347R, Engr Base Repro Co (1)
5-348R, Engr Base Surv Co (1)
5-349R, Engr Base Photomap-
ping Co (1)
5-500R (AA-AC), Engr Svc
Org (1)
11-54C, Sig Air Photo Repro &
Dlur Co (1)

NG: State AG (6); units—same as Active Army except allowance is one copy to each unit.

USAR: None.

For explanation of abbreviations used, see SR 320-50-1.

[A]

Read on
1° latitude

Scale 1: 2

