

TM 5-272

WAR DEPARTMENT

TECHNICAL MANUAL

**STEEL TREADWAY BRIDGE
EQUIPAGE**

July 10, 1942

U113
.2
TM 5:272

STEEL TREADWAY BRIDGE EQUIPAGE

Table of Contents



CHAPTER 1. CHARACTERISTICS, COMPOSITION, AND ASSIGNMENT OF EQUIPAGE.

	Paragraph	Page
Characteristics	1	1
General features of design	2	1
Bridge unit	3	3
Issue	4	3

CHAPTER 2. DESCRIPTION OF EQUIPMENT.

Pneumatic ponton	5	5
Trestle	6	6
Treadways and accessories	7	7
Ponton and trestle spans	8	9
Reconnaissance boats	9	11
Transportation	10	11

CHAPTER 3. OUTBOARD MOTOR.

Issue	11	12
Description	12	13
Outboard motor bracket	13	13
Care and maintenance of motors	14	13
Employment of the motor	15	14
Element of surprise	16	15

CHAPTER 4. POWER BOAT.

Issue	17	15
Description	18	15
Employment	19	16
Care and maintenance	20	16

CHAPTER 5. CONSTRUCTION METHODS AND GENERAL CONSIDERATIONS.

General	21	17
Trestles	22	17
Anchors	23	17
Night construction	24	19
Preparation of equipage for use	25	20

CHAPTER 6. SELECTION OF BRIDGE SITE.

General	26	20
Reconnaissance	27	20

CHAPTER 7. CONSTRUCTION BY METHOD OF PARTS.

General	28	21
Preparation of site	29	22
Unloading and assembly areas	30	22

Table of Contents (Continued)

	Paragraph	Page
Unloading bridge trucks	31	23
Location of air compressors	32	23
Truck crane location	33	23
Location of other equipment	34	23
CHAPTER 8. SECTIONS AND DUTIES OF SECTIONS.		
General	35	24
Officers	36	24
Abutment section	37	24
Anchor section	38	25
Alignment	39	25
Raft section	40	26
Assembly section	41	28
Approach section	42	29
Security section	43	30
CHAPTER 9. CONSTRUCTION BY METHOD OF SUCCESSIVE PONTONS OR TRESTLES.		
General	44	31
Floating bridge procedure	45	31
Fixed bridge procedure	46	32
CHAPTER 10. REINFORCED BRIDGES.		
Floating bridge reinforcement	47	32
Trestle bridge reinforcement	48	33
CHAPTER 11. TRAFFIC CONTROL, MAINTENANCE AND DISMANTLING BRIDGE.		
Traffic control and bridge maintenance	49	33
Dismantling bridge	50	33
CHAPTER 12. FERRYING.		
Pneumatic float	51	34
Raft ferries	52	34
Propulsion	53	36
Loading	54	37
Crew and equipment	55	37
Conduct during crossing	56	37
CHAPTER 13. MAINTENANCE OF EQUIPAGE.		
General	57	37
Pneumatic floats	58	38
Trestles, treadways, and accessories	59	38
CHAPTER 14. LIST OF EQUIPAGE.		
Steel treadway bridge equipage	60	39

LIST OF ILLUSTRATIONS

	Page
Figure 1. Floating steel treadway bridge -----	2
Figure 2. Typical shore connection -----	3
Figure 3. Fixed steel treadway bridge -----	4
Figure 4. Pneumatic float -----	5
Figure 5. Saddle -----	6
Figure 6. Treadway adaptor -----	6
Figure 7. Steel treadway -----	7
Figure 8. Treadways used as car loading ramps -----	8
Figure 9. Treadway wedges -----	8
Figure 10. Steel treadway bridge accessories -----	9
Figure 11. Reconnaissance boat -----	10
Figure 12. Bridge truck -----	12
Figure 13. 22-HP outboard motor -----	13
Figure 14. Outboard motor bracket -----	14
Figure 15. Power boat mounted on trailer -----	15
Figure 16. Anchor spacing -----	18
Figure 17. Layout of site -----	21
Figure 18. Typical unloading and assembly area -----	22
Figure 19. Truck crane -----	23
Figure 20. Inflation of pneumatic floats -----	26
Figure 21. Launching ponton -----	27
Figure 22. Placing treadways in assembling a ponton section -----	27
Figure 23. Ponton section -----	28
Figure 24. Assembling a ponton section into the bridge -----	29
Figure 25. Installing connecting pins -----	30
Figure 26. Installing far shore approach treadways -----	31
Figure 27. Bridging a blown culvert -----	32
Figure 28. Typical raft ferry -----	34
Figure 29. Method of loading and unloading raft ferries -----	35

Chapter 1

CHARACTERISTICS, COMPOSITION, AND ASSIGNMENT OF EQUIPAGE

	Paragraph
Characteristics -----	1
General Features of Design -----	2
Bridge Unit -----	3
Basis of Issue -----	4

1. Characteristics.— The steel treadway bridge is the stream crossing means furnished the Armored Force. It is designed to carry all vehicles in the Armored Division up to and including the medium tank (approximately 34 tons). When reinforced with additional floats, the capacity of the bridge is approximately 45 tons. Because of its simplicity and relatively light weight, it can be constructed in comparatively short time. The use of collapsible pneumatic floats and high alloy steel beam treadways reduces the volume and weight of the equipage and makes it possible to transport a long length of bridge in few vehicles. The flotation of the floats and the continuous beam action of the treadway combine to give the bridge a great load-carrying capacity. The equipage can be used to construct either a fixed or floating bridge. The pneumatic floats support the floating bridge and trestles support the fixed bridge. The treadways are used in both.

2. General features of design.— *a. Floating Bridge.*— (Fig. 1) The bridge consists of two tracks of continuous beam action steel treadways, supported at regular intervals by pneumatic pontons and connected to the shore by one or more trestle spans or by shore treadways. The method of connecting the floating section to the shore (Fig. 2) will depend upon the depth of stream near the shore and the slope and condition of the banks. Because of the difficulty of constructing and finding adequate support for trestle footings, trestles will be used only when absolutely necessary.

b. Fixed Bridge.— (Fig. 3) The short-span fixed bridge employs one or two lengths of treadway as a simple beam for each track. It is supported on end abutments and does not require interior supports. The long-span fixed bridge employs

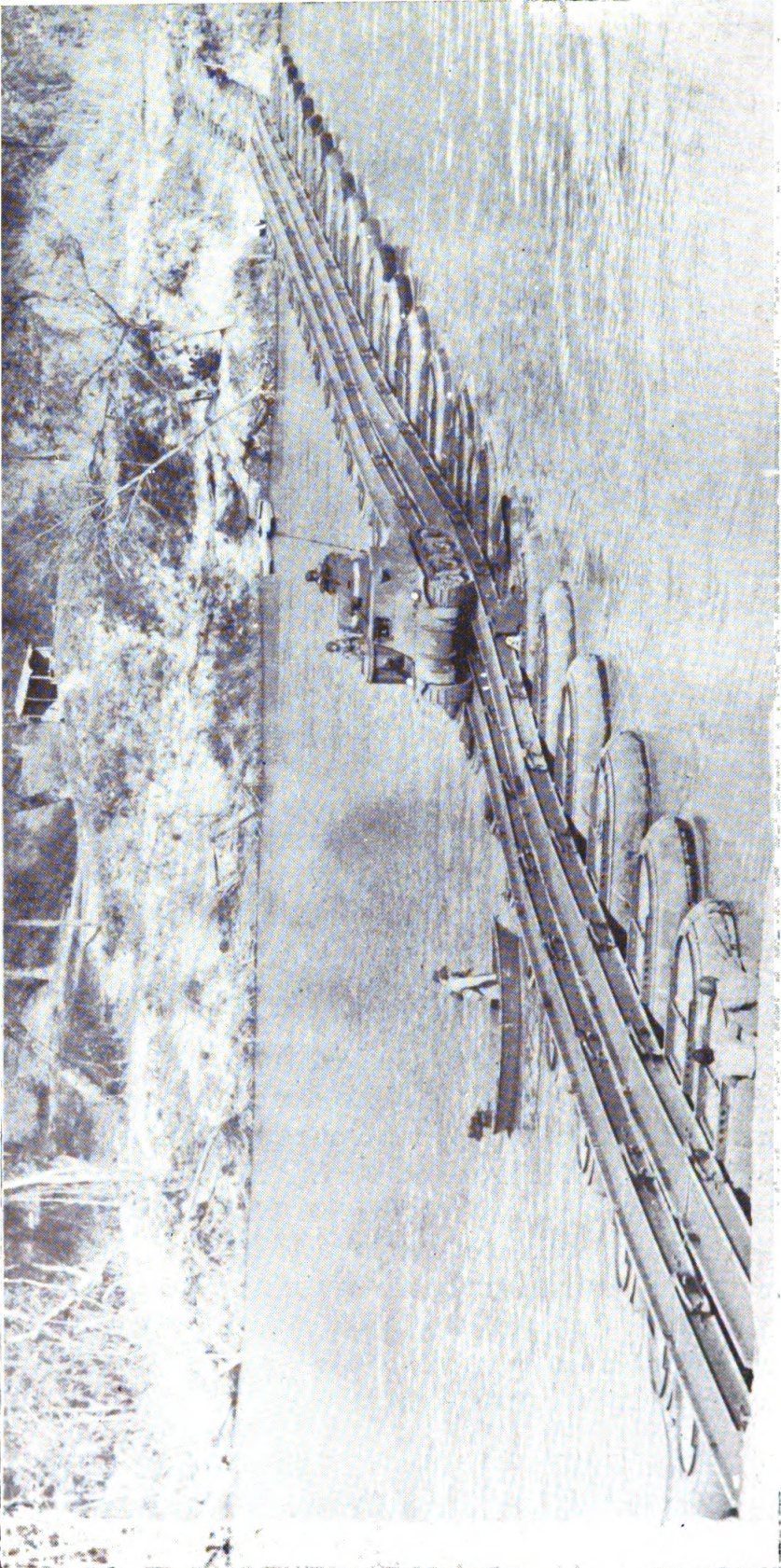

Figure 1. Floating Steel Treadway Bridge.

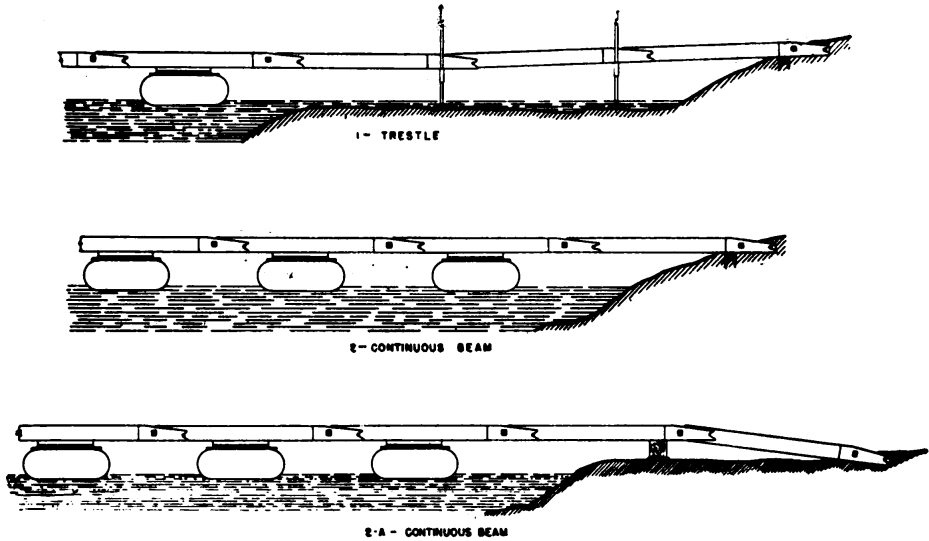

Figure 2. Typical Shore Connection.

three or more lengths of treadway for each track. It utilizes interior supports (trestles or adjustable shores) in addition to the end abutments.

3. Bridge Unit.— The principal components of the unit of steel treadway bridge equipment are twenty-four trestles, seventy-two pneumatic floats, twenty spare floats, and 2160 feet of treadway. These together with certain spare parts and accessories are transported on thirty-six 6-ton (6 x 6) bridge trucks and eighteen 2½-ton cargo trucks. One unit of equipment provides a maximum of 1080 feet of bridge which may be floating or fixed or a combination of the two. See par. 60 for a complete list of the components of one unit of equipment.

4. Issue.— The normal assignment is one bridge unit to each armored division. The bridge is transported and maintained by the bridge company of the armored engineer battalion.

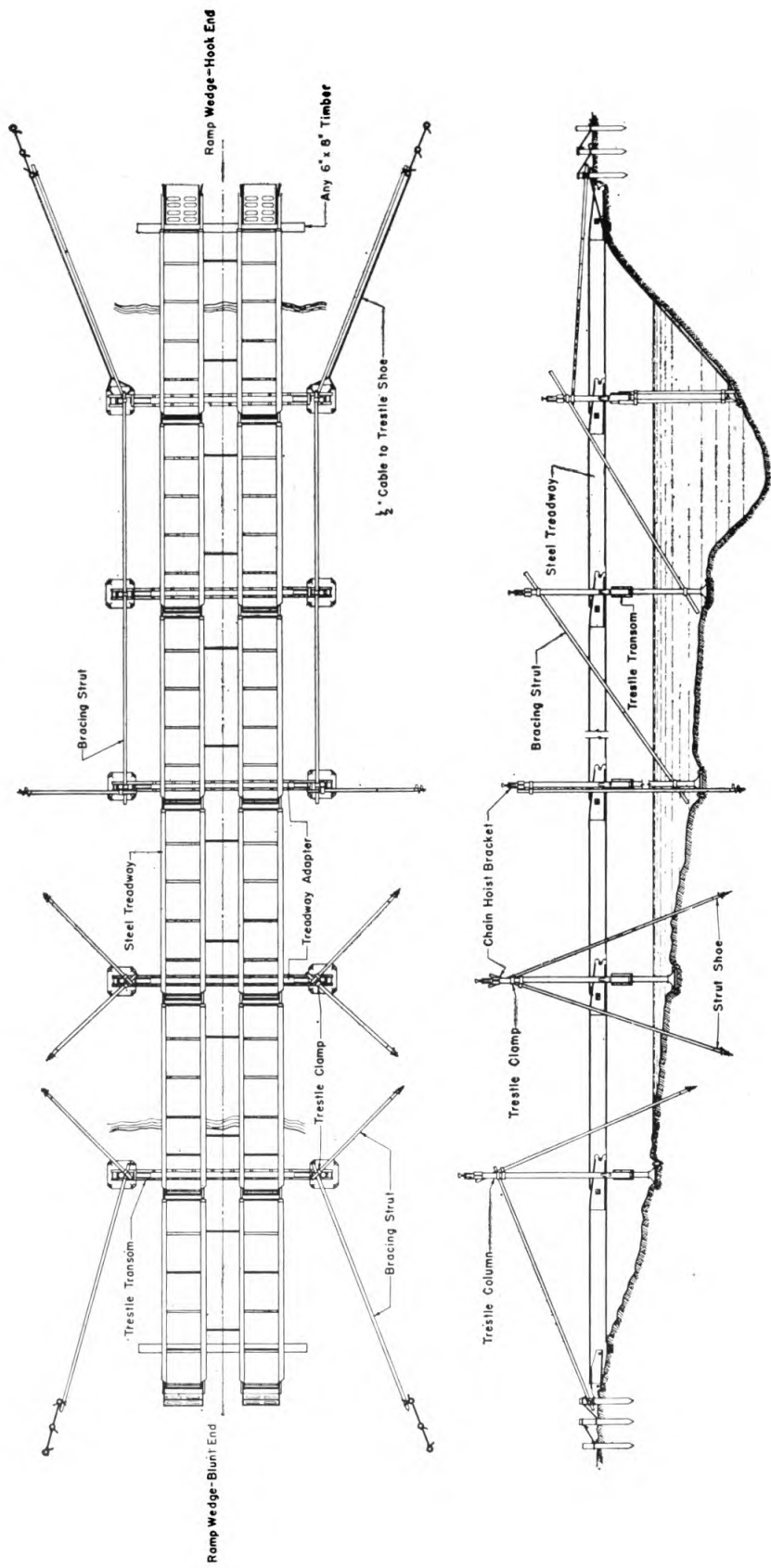

Figure 3. Fixed steel treadway bridge.

Chapter 2

DESCRIPTION OF EQUIPMENT

	Paragraph
Pneumatic Ponton -----	5
Trestle -----	6
Treadways and Accessories -----	7
Pontons and Trestle Spans -----	8
Reconnaissance Boats -----	9
Transportation -----	10

5. Pneumatic Ponton.— The pneumatic ponton is composed of the pneumatic float and saddle.

a. Pneumatic Float (Fig. 4).— The pneumatic float is seven and one-half feet in width, twenty-five feet in length, and thirty inches in depth. It is formed by a perimeter of rubberized canvas tubing, thirty inches in diameter, with a floor of the same material. A detachable tube of the same diameter is placed in the center of the float. This adds to the rigidity of the float and gives added bouyancy when the float is submerged. The float weighs about four hundred pounds and has a flotation of approximately twelve tons. The air pressure should be maintained at two pounds per square inch. The maximum allowable pressure under any condition is two and one-quarter pounds per square inch and the minimum is one and one-quarter pounds per square inch.

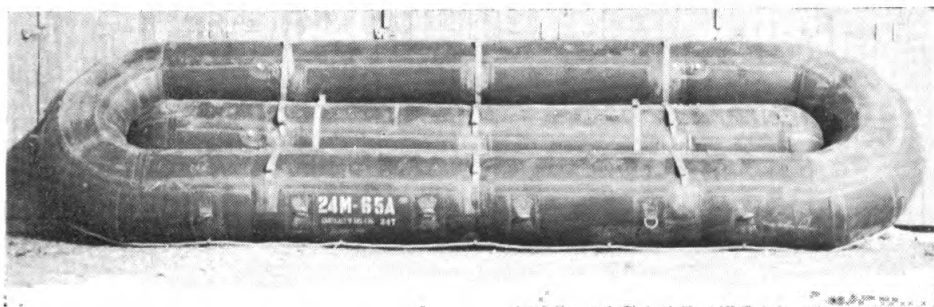

Figure 4. Pneumatic Float.

b. Saddle.— The load of the bridge and the weight of the treadways is transmitted to the floats by a saddle. As shown in Fig. 5, the saddle consists of a system of steel beams surmounting a bearing plate. The beams transmit the load to

the float through the bearing plate which is constructed of $\frac{5}{8}$ -inch, five-ply, resin bonded Douglas Fir plywood. For convenience in handling, the saddle is made in three sections: a center section and two end sections. Figure 5 shows one end section in position to be joined to the center section and the other end section already joined. The complete saddle weighs about nine-hundred pounds.

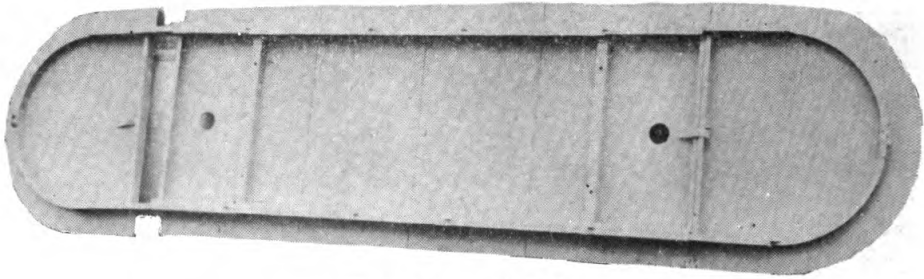

Figure 5. Saddle.

6. Trestle.— Twenty-four 25-ton aluminum trestles, the same as those of the 25-ton ponton bridge equipage (see TM 5-273), are included in the steel treadway bridge equipage for use as supports for the long-span fixed bridge. Each trestle is provided with a special treadway bearing plate called a "treadway adaptor." (See Fig. 6.) The adaptor consists essentially of a 5" channel on which the treadways bear. The under surface of the channel is fitted with 4 semicircular "bent bars" (see Fig. 6) which bear on the tube of the transom. The upper surface of the channel is fitted with spacing lugs and clamps which hold the treadways securely in position.

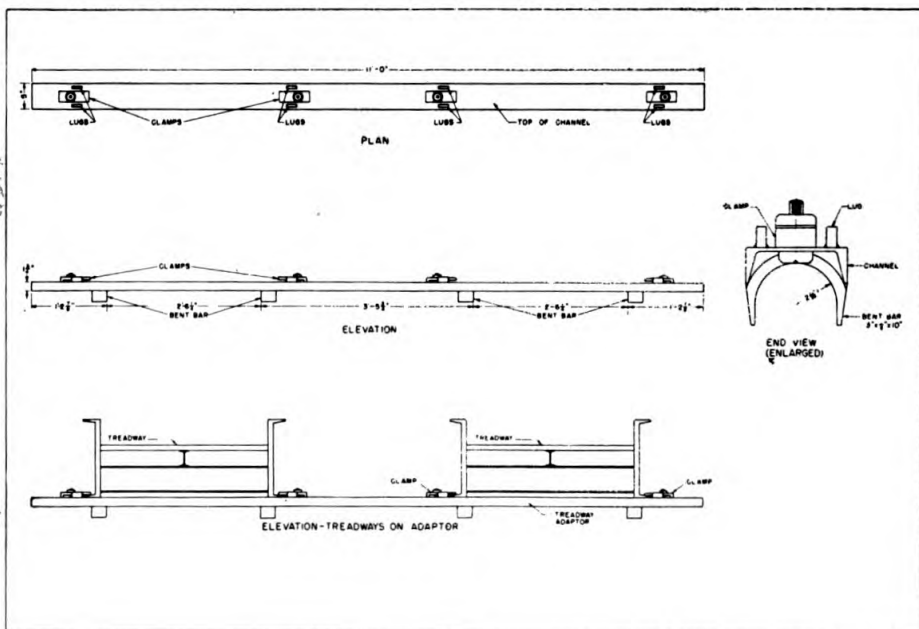

Figure 6. Treadway adaptor.

7. Treadways and Accessories (Figs. 7 and 9).— *a. General.*— The roadway of the bridge consists of two tracks of treadways designed to accommodate narrow gauge vehicles, such as cars and trucks, and vehicles of wide gauge and wide tracks, such as the medium tank.

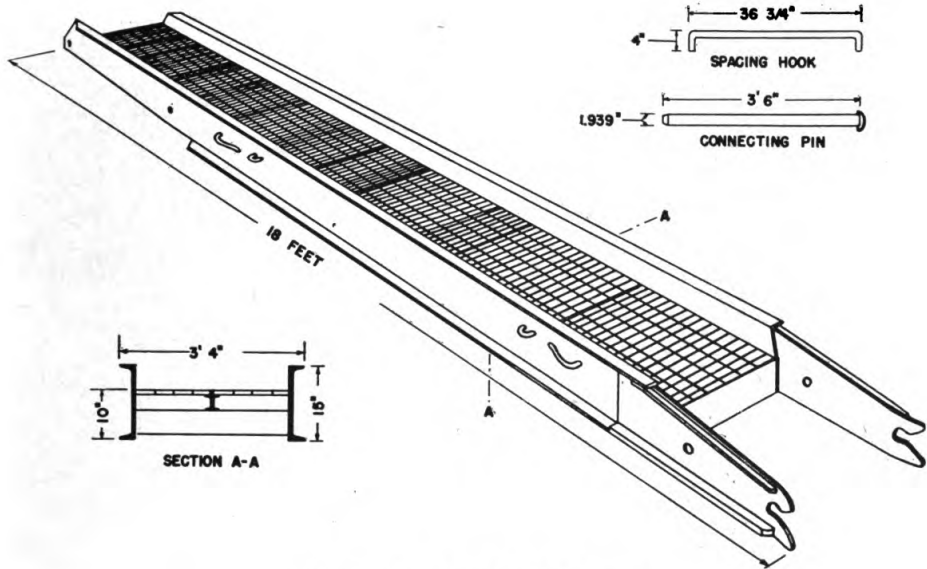

Figure 7. Steel treadway.

b. Description.— The effective length of a treadway is fifteen feet and the clear track width is two feet, nine inches. Its overall length is eighteen feet, two and one-eighth inches. It is built up with two 18-inch, 33.9 pound high strength steel channel beams tied together laterally by six 5-inch, 6.7 pound and one 9-inch, 13.4 pound channel beams. These lateral beams are stiffened with a 3-inch, 5.7 pound I-beam. A single treadway weighs about 1980 pounds.

c. Connections.— The treadways are connected longitudinally to form a continuous beam or to form hinge spans. A system of engaging plates and two connecting pins per joint connect the sections rigidly. When one pin is left out the connection acts as a hinge joint. Spacing hooks or bars are provided to prevent lateral movement of the treadways. They hook into spacer eyes welded to the web of the channel irons.

d. Uses.— Treadways are used primarily to provide a floor and stringer system for floating and fixed bridges. They may be used to reinforce the floor system of a weak bridge, to span short distances without intermediate support, and to span long distances with intermediate supports, such as tres-

tles or shores. In addition to their use in bridging they are useful for improvised car and barge loading ramps (see Fig. 8) and for roadways over marshy areas.

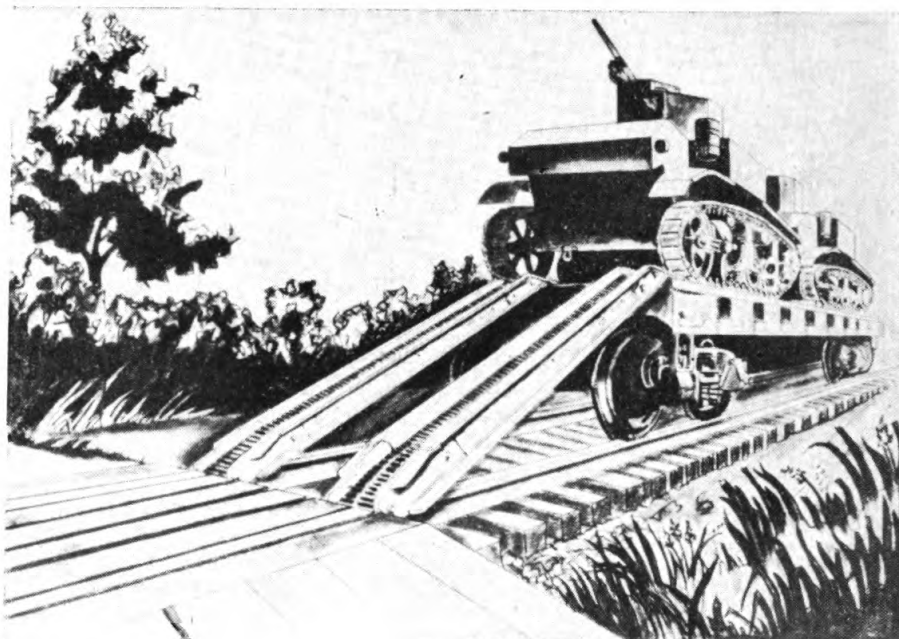

Figure 8. Treadways used as car loading ramps.

e. Treadway wedges.— Treadway wedges are used on the near shore and far shore ends of steel treadway bridges (both floating and trestle) to facilitate the movement of vehicles on and off the bridge. Their employment in a trestle bridge is shown in Figure 3. The wedges are of two types. The hook end type (see Fig. 9) is employed on the engaging plate end of the treadway and the blunt end type is employed on the butt end of the treadway. The wedges are of welded construction throughout.

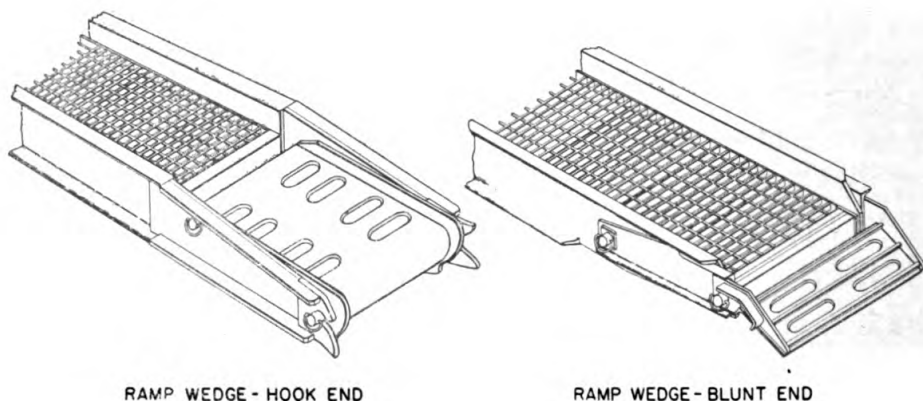

Figure 9. Treadway wedges.

f. *Treadway bridge accessories.*— Various accessories of the treadways bridge are shown in Figure 10.

8. **Ponton and Trestle spans.**— a. *General.*— The continuous beam action of the treadways makes it possible to space pontoons and trestles at irregular intervals without loss

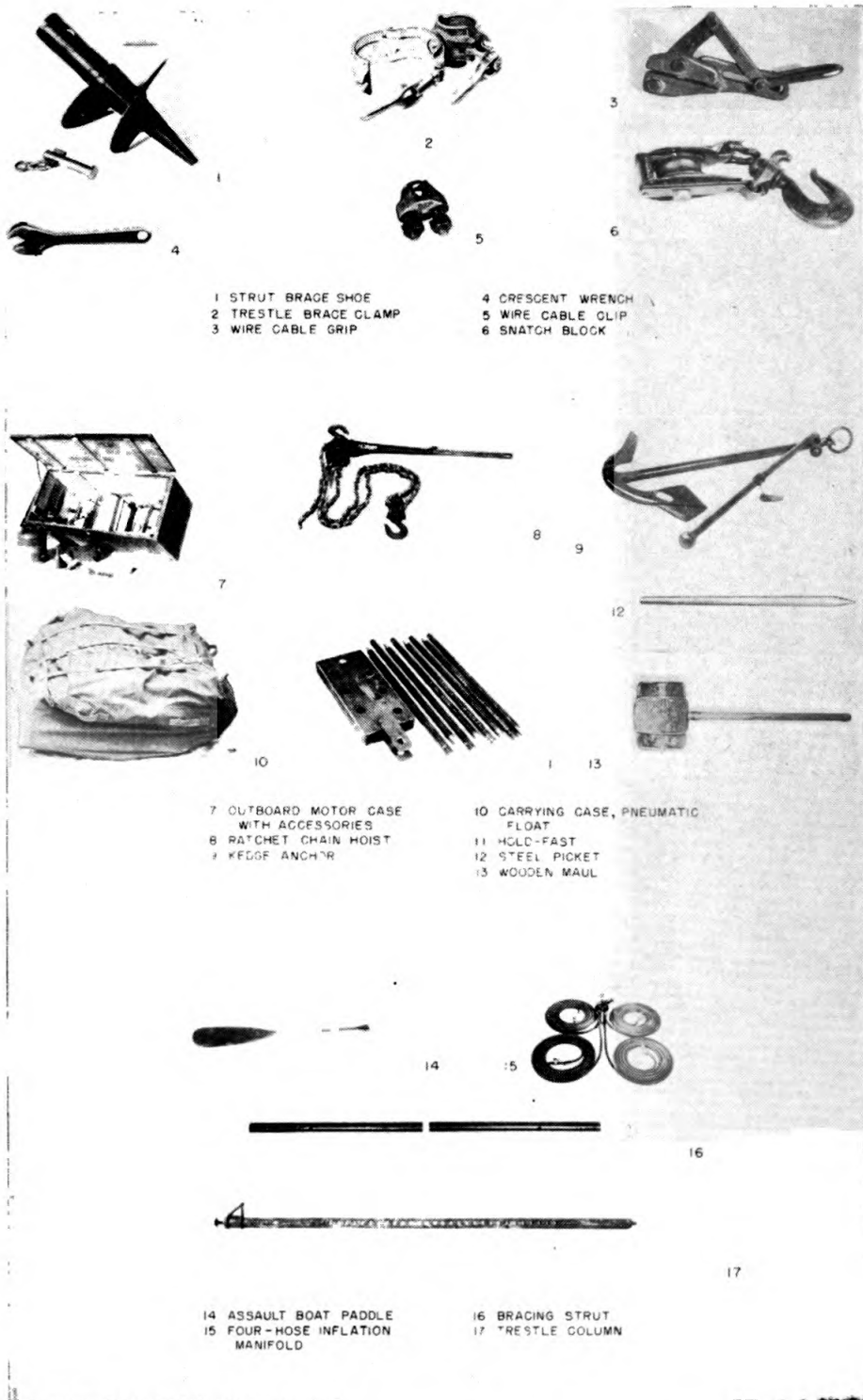

Figure 10. Steel treadway bridge accessories.

of bridge efficiency. Generally, spacings are approximately fifteen feet, measured center to center of supports. For ease in construction, trestles are usually placed under the pin connections and pontoons under the center of gravity of the treadways.

b. Ponton Spans.— One ponton with two treadways is called a ponton section. This is a basic part of the bridge and

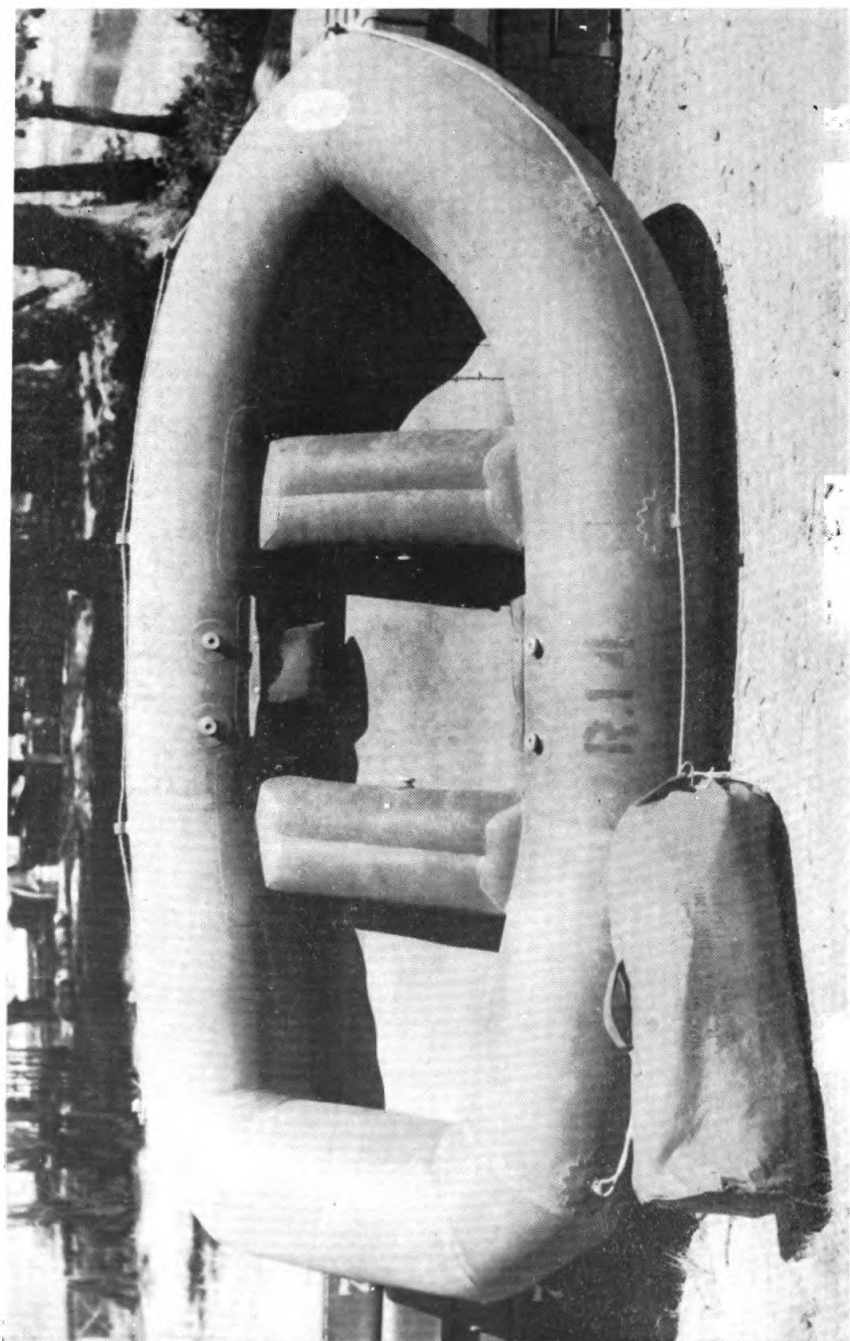

Figure 11. Reconnaissance boat.

the bridge will usually be assembled by adding these sections successively.

c. Trestle Spans.— Trestles will normally be spaced at a distance of fifteen feet and placed under pin connections. All trestles will be braced longitudinally by the use of bracing struts or by ropes and cables. Footings may be improved by using expanded metal mats with plank as a distribution plate. Where footings are unstable, additional trestles should be placed in each treadway length. These may be installed as the need appears after the bridge is in use.

9. Reconnaissance boats (Fig. 11).— *a. Description.*— The pneumatic reconnaissance boat is made of rubberized cotton fabric. It weighs about forty to fifty pounds packed in a carrying case. It has a capacity of six men. The boat is inflated by mouth or by a hand pump. Inflation is limited to the minimum pressure required barely to round out the air chambers. Standard assault boat paddles are provided.

b. Employment.— These boats will find their greatest use in reconnaissance of river crossing sites. However, their light weight and the ease of transportation adapt them for all-round employment in patrolling and servicing the floating treadway bridge and in transporting small items of equipment. In an emergency the boats may be used to transport men, ammunition, and small items of equipment in initial stages of a river crossing operation or retrograde movement.

10. Transportation.— *a. Issue.*— The steel treadway bridge equipment is transported by thirty-six, 6-ton bridge trucks and eighteen, 2½-ton cargo trucks.

b. Description.— The bridge truck (see figure 12) is a specially designed type (6 x 6) cargo truck with adequate power take-off and framework for unloading, placing, and loading steel treadways. The cargo body is slightly longer than the overall length of a single treadway and wider than the overall width of two treadways. These dimensions enable it to transport four treadways stacked two-high and loaded symmetrically. The 2½-ton (6 x 6) cargo truck is a standard issue, quartermaster vehicle. The loadings of these vehicles has not yet been determined definitely but they will be so loaded that a minimum amount of equipment will have to be unloaded to give access to the steel treadways. Such loading is desirable since treadways will be used on numerous occasions where no other equipment will be required.

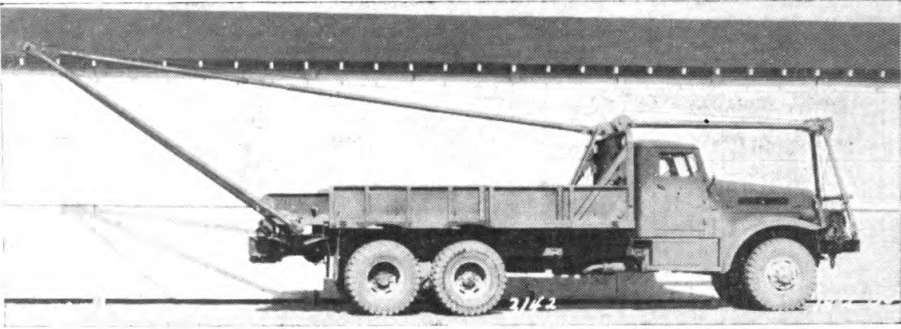

Figure 12. Bridge Truck.

c. *Employment.*— (1) *Fixed bridge procedure.*— For spans of fifteen feet or less the treadways are placed directly into final position in a single operation. For spans greater than fifteen feet and not over thirty feet, treadways will be unloaded, connected in pairs longitudinally on some flat surface, picked up by the use of the frame work, and lowered into position over the span to be bridged.

(2) *Floating bridge procedure.*— To employ the frame work for unloading and placing treadways on the pneumatic pontons the trucks are backed to the water's edge. The treadways are removed and placed directly in position on the pontons. As each truck is unloaded it pulls out and another is backed into its place, continuing the assembly of ponton parts which go to make up the floating bridge. Raft ferries are made up in a similar manner. Unless unusually favorable conditions exist, a means should always be provided for towing or winching the bridge trucks up from the water's edge.

Chapter 3

OUTBOARD MOTOR

	Paragraph
Issue	11
Description	12
Outboard Motor Bracket	13
Care and Maintenance of Motors	14
Employment of the Motor	15
Element of Surprise	16

11. Issue.— Included in the organizational equipment of each bridge unit are six 22-HP outboard motors and six attachment brackets.

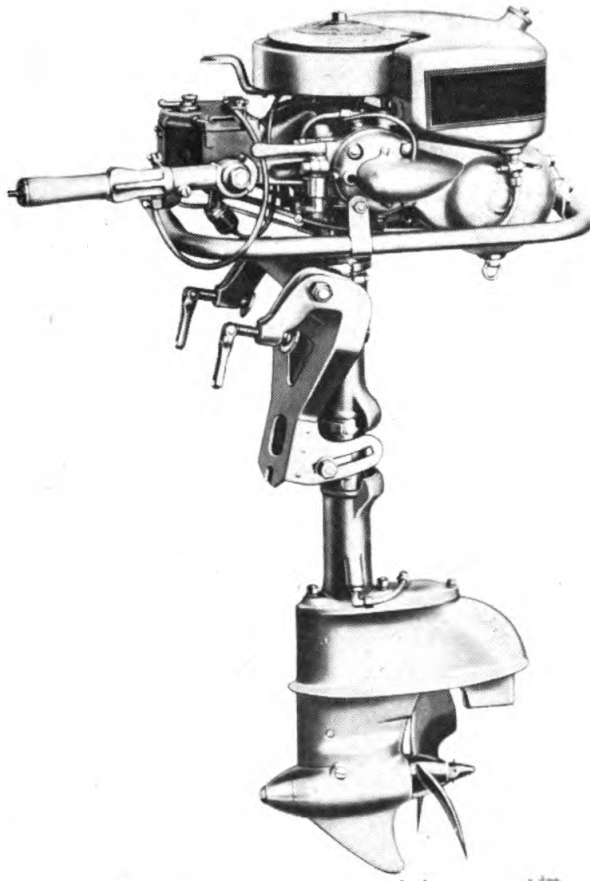

Figure 13. 22-HP Outboard Motor.

12. Description.— The 22-HP outboard motor (see Fig. 13) is the same as the one supplied for the 10-ton and for the 25-ton ponton bridges. An instruction book on the operation and care of the motor is furnished with each outboard unit. The latest models permit turning the motor through 360°. This makes it possible to use the motor to pull as well as push loads and greatly facilitates the assembly of ponton sections in the bridge and the ferrying of ponton rafts.

13. Outboard Motor Bracket.— An attachment bracket especially adapted for use on the pneumatic ponton is supplied for each motor. It is secured to the circular angle-iron of the end of the saddle by special fasteners. Metal arms carry a board to which the motor is attached. Figure 14 illustrates the pneumatic ponton adaptor bracket.

14. Care and Maintenance of Motors.— Outboard motors should be operated by trained men. If this is done, and the directions in the manufacturer's instruction book are faithfully and precisely followed, successful and dependable opera-

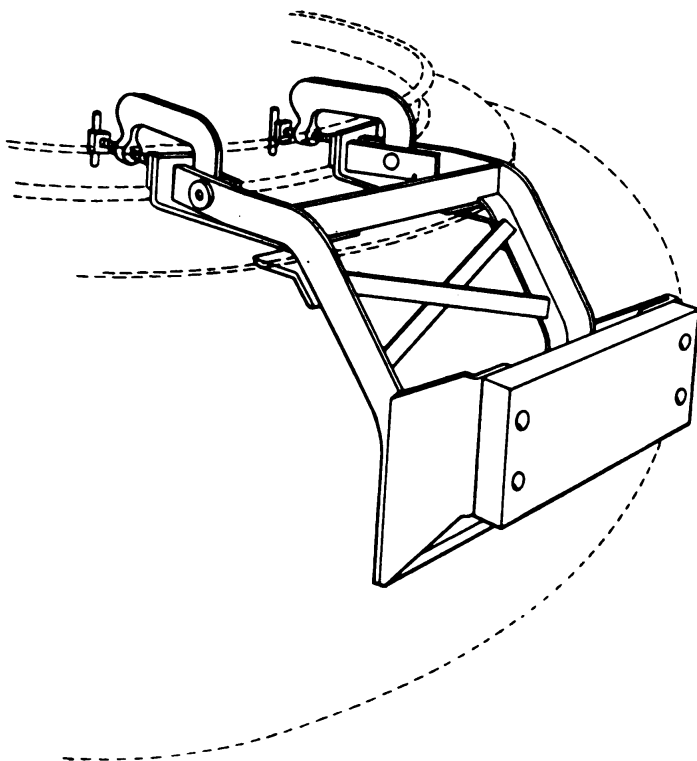

Figure 14. Outboard motor bracket.

tion of the motor is assured. The following points should be watched closely in the care and maintenance of motors:

- a.* Motors should be protected by the canvas cover when mounted and not in use.
- b.* They should be transported only in cases provided.
- c.* Spare sparkplugs should always be available.
- d.* Fuel should be mixed properly.
- e.* Only first echelon maintenance should be executed by operators, unless they are well-trained and parts are available for further repairs.
- f.* The tactical situation permitting, the motors always should be warmed up before using.

15. Employment of the Motor.— *a.* The motor greatly facilitates the movement of the pneumatic ponton. A single ponton with outboard motor has many uses, such as ferrying troops, placing anchors, towing ponton sections into bridge position, and reconnaissance and patrolling.

b. Outboard motors are also used to propel rubber ponton rafts in ferrying operations. Two motors should power each raft to reduce stoppages in mid-stream and to insure easy and positive handling of the raft.

c. Motors should be used only in streams of sufficient depth to provide adequate draft for the propeller.

16. Element of Surprise.— Speed, dispersion, and surprise are the three essential elements in a successful assault boat crossing. Outboard motors have a characteristic sound and should not be used in the initial waves of the assault but should be used on assault boats to speed up the crossing as soon as the enemy discovers the operation.

Chapter 4

POWER BOAT

	Paragraph
Issue	17
Description	18
Employment	19
Care and Maintenance	20

17. Issue.— Two power boats with trailers are supplied to the bridge company of the armored engineer battalion.

18. Description.— *a. Dimensions.*— The boat (see Fig. 15) is eighteen feet long and has a maximum breadth to the outside of the bumper rail of six feet, seven inches. The maximum depth of the hull is two feet. To the bottom of the skid and including the top of the towing bits, the depth is three feet, two inches. The boat with accessories has a weight of about 1800 pounds.

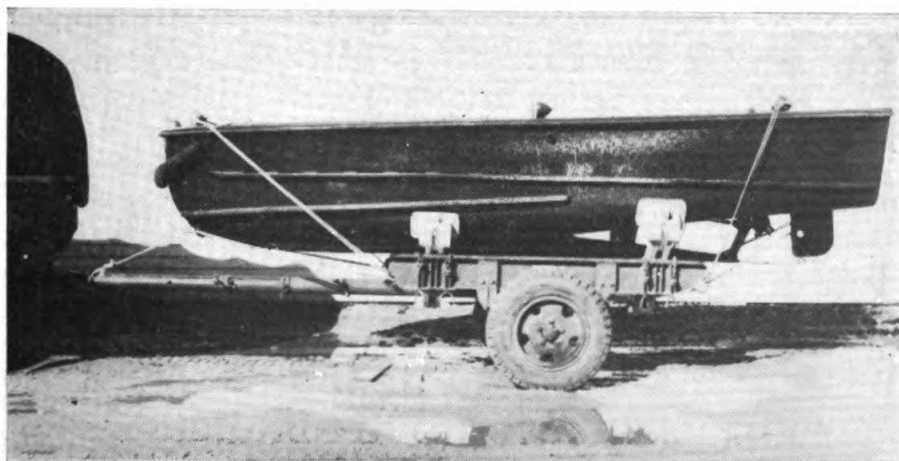

Figure 15. Power boat mounted on trailer.

b. Power.— The boat is powered with a Marine engine, including clutch and reverse gear. The connection of the propeller to the engine is through a three to one reduction gear. It is equipped with a governor which controls the engine at a safe and economical speed and allows it to develop its full fifty-seven horsepower for tow work.

c. Hull.— The hull, constructed of seven sixteenths-inch (7/16") molded plywood, is both strong and light and has no seams to calk. It is fitted with rope bumpers and a carrying rail.

d. Trailer.— The two-wheel dolly type trailer is so designed that the power boat can be launched easily or loaded by a system of rollers permanently mounted on the trailer chassis. The trailer is equipped with a towing bar adapting it to the pintle of most quartermaster or engineer vehicles.

19. Employment.— The power boat finds its greatest use in towing ponton sections and parts for assembly in the floating bridge. In addition, it is used to place and remove anchors, propel raft ferries, and remove debris endangering the bridge. The boat is designed for tow work and not for speed.

20. Care and Maintenance.— An instruction book covering operation, care, and maintenance of the mechanical parts is supplied with each boat. Other points which require special attention are as follows:

a. Care and judgment should be exercised in launching and loading. If the water at the launching or loading point is shallow, the trailer should be backed into the water until sufficient depth is reached for proper flotation. The boat should always be raised clear of obstructions when moved.

b. Shallow places and places where obstructions such as logs or sticks may be present should be approached at slow speed.

c. The operating temperature of the motor should be watched closely. Numerous causes contribute to stoppages of the cooling system intake that may result in high and destructive motor temperatures.

d. Propeller wheels become entangled easily. Avoid crossing anchor and shore lines and heavily weeded water areas. When it is necessary to pass over a line the rotation of the propeller should be stopped by throwing the clutch into neutral and the boat allowed to drift over the line.

Chapter 5

CONSTRUCTION METHODS AND GENERAL CONSIDERATIONS

	Paragraph
General	21
Trestles	22
Anchors	23
Night Construction	24
Preparation of Equipage for Use	25

21. General.— The steel treadway floating bridge may be constructed either by the method of successive pontoons or by parts. Ordinarily, the latter method will be employed.

(1) In construction by successive pontoons, trucks loaded with bridge equipment are backed out over the completed portion of the bridge and treadways are laid on pontoons floated into position.

(2) In construction by parts, parts consisting of one or more sections are assembled near the shore or in some protected tributary stream and floated into their place in the bridge. The number of ponton sections to be included in each part will depend upon necessity for concealment, speed of current, and other related factors. A part containing one section is easiest to assemble into the bridge. However, the single section is somewhat unstable longitudinally. In rough water, a two-section part is preferable.

22. Trestles.— Trestle sections of the bridge will be constructed by the method of successive bays. Trestles usually will be assembled on the near shore, and carried to and swung into position with the use of crane or bridge trucks.

23. Anchors. (Fig. 16).— *a.* The normal method of securing the treadway floating bridge against current and wind action is by anchors with three-quarter-inch rope anchor lines. The spacing of anchors on the line of upstream anchors will vary according to the velocity of the current. Anchors are cast at appropriate intervals across the stream. They are spaced at fifteen feet in a swift stream, thirty feet in a current of two or three feet per second, and forty-five feet in a slug-

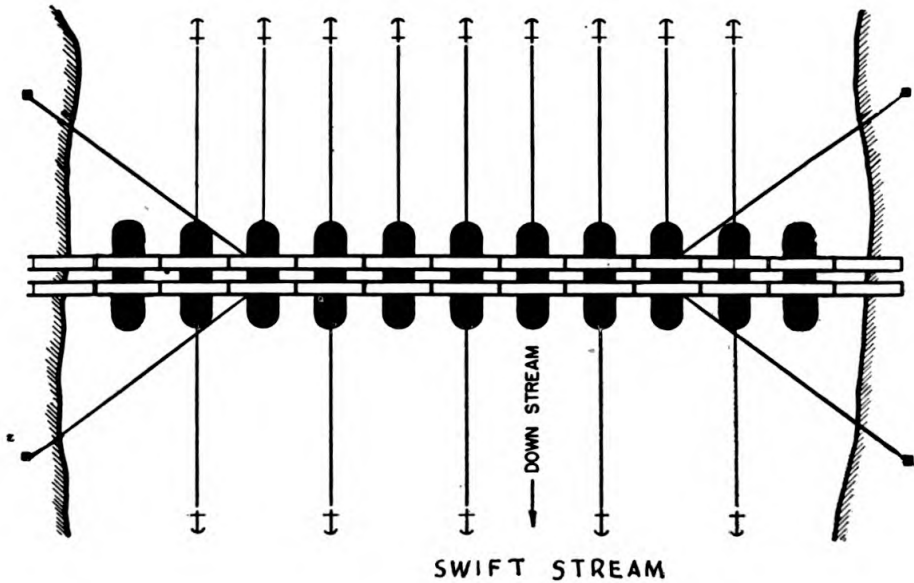
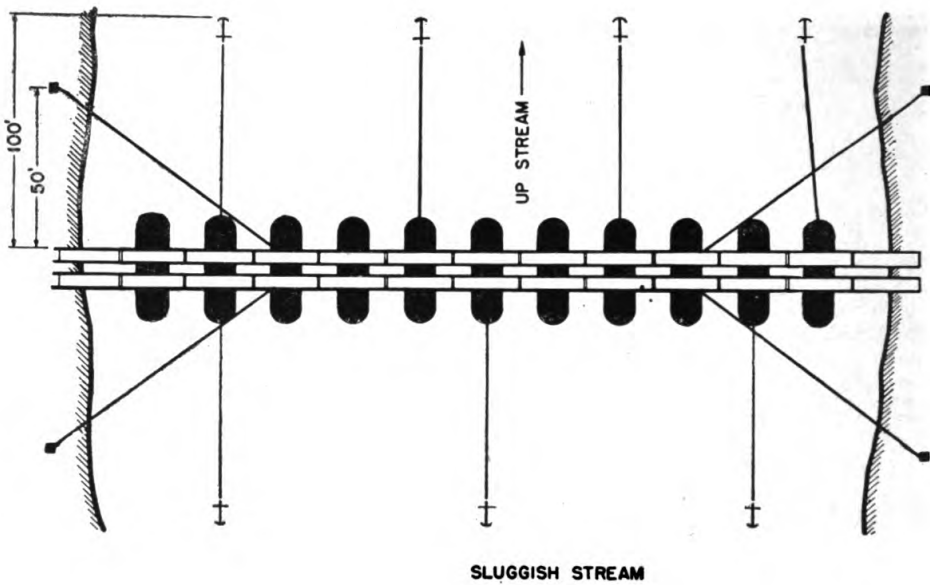

Figure 16. Anchor Spacing.

gish stream. Down stream anchors are spaced at intervals of thirty feet in swift water and sixty feet in moderate or sluggish streams.

b. The line of upstream and downstream anchors should be located by reconnaissance prior to the construction of the bridge. Signal cloth or flagging may be used to mark these lines.

c. Shore lines are used at each end of the bridge as shown in Fig. 16 to anchor the bridge against longitudinal movement. The lines are fastened to the near shore loops on

the fourth treadways. Anchors should be located directly upstream from the final position of the pontoons so that the anchor cables will not impose a longitudinal thrust on the structure.

24. Night construction.— *a. Limitations of Equipment.*— The equipment is not well adapted for use as an assault bridge, that is, one which must be thrown over a stream quickly, without the knowledge of the enemy, and before a bridgehead has been established. Because of the nature of the transportation and equipment, assembly at the bridge site creates noise which is audible for some distance.

b. Operations at Night.— During actual operations, construction of the bridge under cover of darkness is a normal procedure and is generally identical with construction in daylight. However, a successful and rapid construction at night is much more dependent upon careful planning, close control, and adequate training. Prior practice and rehearsal should always be given when practicable, preferably at night and on an actual stream.

c. Difficulties Imposed by Darkness.— No particular difficulty is involved in the assembly of individual ponton sections and incorporating them into the bridge during darkness, although the process is somewhat slower. The chief difficulty arises in getting the equipment to the unloading points, in placing and handling cables and lines, and in directing the bridge to the proper point on the enemy shore. These difficulties will vary widely with the width of stream, force of current, and the degree of darkness. They may be minimized by careful prior training, reconnaissance, planning, and organization. Suitable arrangements for signals and inter-communication during the process of construction must be made.

d. Special Measures Desirable in Night Construction.— A single flashlight providing a shielded weak white light can be used on the far bank to assist in securing proper direction and alignment of the bridge. Similar lights may be used to show the position of upstream and downstream line of anchors. Unshielded flashlights to aid in the assembly should never be used. If available, luminous markers or paints, white tracing tape, or pieces of cloth are useful in outlining essential points such as the routes of approach to the unloading points, vehicular parking areas, and the heads of pickets and connecting pins.

e. Maintenance of Secrecy.— Although actual construction will be started ordinarily only after the need for secrecy has passed, the use of lights or sound should be held to a minimum at the bridge site.

25. Preparation of Equipage.— *a. General.*— Bridging a stream consists of three phases: the preparation of the site; the unloading of the equipment and its preparation for use; and the actual construction of the bridge. The first and second phases will usually be more time consuming than the third and will require careful organization and planning.

b. Loading.— Each load must comprise all component parts of a definite length of bridge, whether it be trestle or floating. The loading should be such that those items used first will be unloaded first. Insofar as possible the bridge truck bed is built to facilitate this type of loading.

Chapter 6

SELECTION OF BRIDGE SITE

	Paragraph
General	26
Reconnaissance	27

26. General.— The selection of a bridge site generally will be governed by both tactical and technical requirements. The speed that characterizes armored force operations severely limits the time available for engineers to study the tactical plan, the map and aerial photographs and to conduct ground reconnaissance prior to the selection of a bridge site. Bridges will be repaired, improvised, or built when and where they are needed as determined by the tactical commander. The steel treadway bridge is highly adaptable to such use.

27. Reconnaissance.— *a.* Reconnaissance will be made as far in advance of construction as possible. If practicable, the tactical commander and the unit engineer, or respective reconnaissance sections, or both, should make joint reconnaissances. The engineer, or his reconnaissance section, must make a careful technical reconnaissance in any case. Where speed is urgent, the reconnaissance may be accomplished while the bridge equipment is being moved to the site.

b. Data secured by reconnaissance will include adequate information on stream width, velocity, banks, depth, variation in water elevation, approaches, tributary streams, and location of the main thread of the channel.

Chapter 7

CONSTRUCTION BY METHOD OF PARTS

	Paragraph
General -----	28
Preparation of Site -----	29
Unloading and Assembly Areas -----	30
Unloading Bridge Trucks -----	31
Location of Air Compressors -----	32
Crane Truck Location -----	33
Location of Other Equipment -----	34

28. **General.**— The bridge equipment usually will be brought up to the bridge site in one or more columns. Protection on the march will be gained by taking full advantage of all cover and concealment and by maintaining proper intervals (see FM 25-10). The column will be led to the unloading point or points by the reconnaissance personnel who assisted in reconnoitering the routes and bridge site and who are fa-

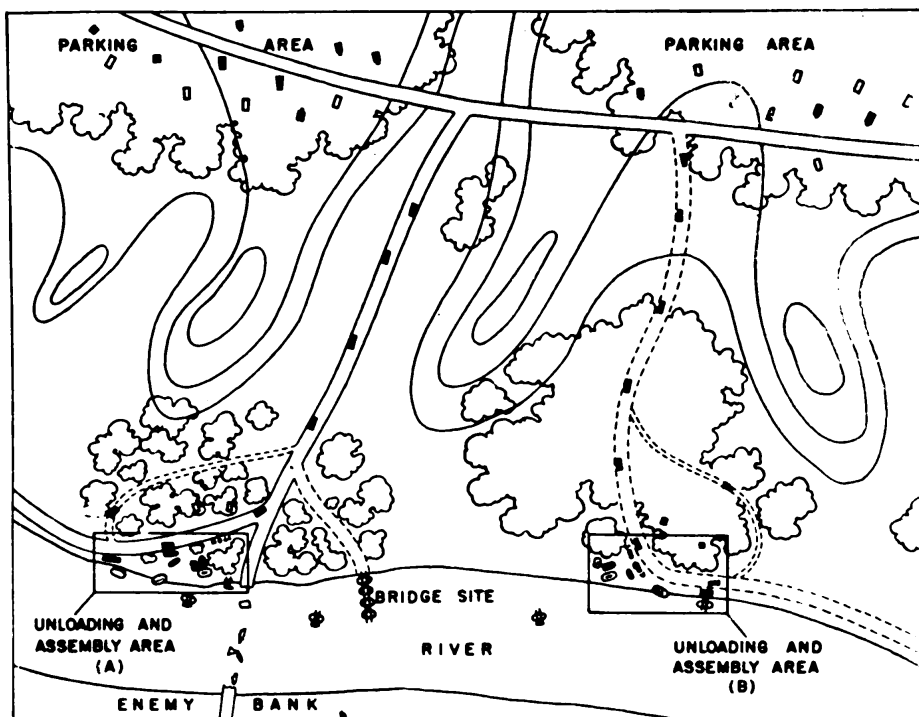

Figure 17. Layout of Site.

miliar with the engineer plan. Trucks will maintain an interval of 50 yards or more until they are unloaded. Unloaded vehicles will move back immediately to the vehicle parking area (Fig. 17). Columns should be organized with engineer personnel carriers in the lead, followed by truck crane, air compressors, and bridge trucks.

29. Preparation of Site.— The approach road should be improved in advance to the extent that time permits to expedite the movement of equipment to the bridge site. Turn-arounds (see Fig. 17) and passing points should be provided. The bull-dozer, power saw, and explosives are useful in this work. The use of explosives may be limited by the tactical situation. Hasty work to improve the unloading points generally will be worthwhile.

30. Unloading and Assembly Areas (Figs. 17 & 18).— In the method of parts, special attention should be given to the location of unloading and assembly areas. The essential element in locating these areas is their accessibility to bridge trucks. Where possible they should be located on firm, stable ground with a down grade approach, preferably on an existing roadway. There should be ample room for nearby truck movement and for inflating pontons, assembling saddles, launching pontons, and placing treadways. Generally, the accessibility of the unloading and assembly areas to bridge trucks is more important than the distance of the unloading areas from the bridge site.

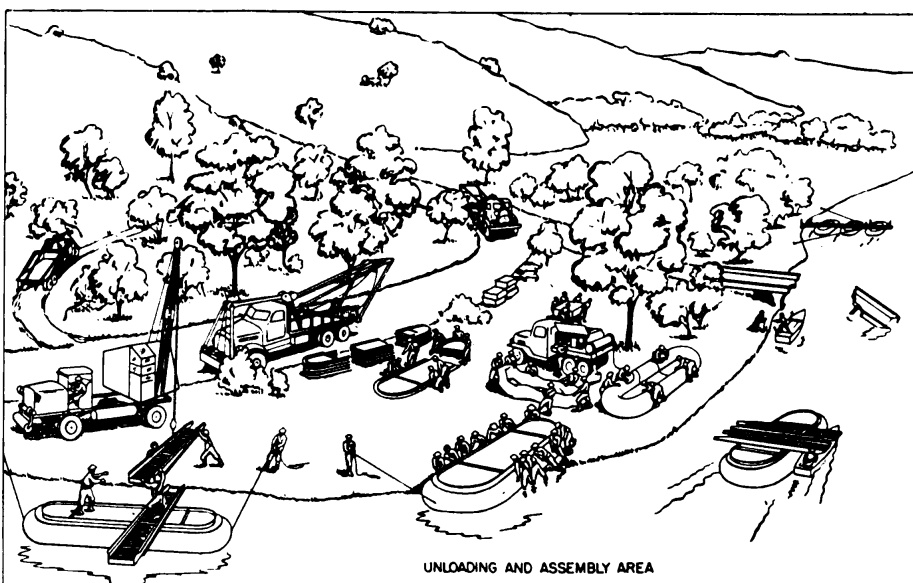

Figure 18. Typical Unloading and Assembly Area.

31. Unloading Bridge Trucks.— Bridge trucks pass through the unloading area in such a manner that anchors, rubber floats, saddles, hand tools, and other bridge accessories are unloaded at the respective assembly points. If the bank conditions permit the truck to be backed to the water's edge, the treadways are placed directly on pontoons floated just off shore. Under less favorable conditions, the truck cranes, of which there are two in the bridge company, may be used to transfer treadways from bridge trucks to pontoons. Unloaded trucks will move off immediately to the vehicle parking area or areas.

32. Location of Air Compressors.— The motorized air compressors, of which there are four in the bridge company, will be placed in the inflation section of the unloading and assembly area between the truck roadway and the stream bank. They will be placed so that the air lines can reach conveniently all pontoons to be inflated.

33. Crane Truck Location.— The crane truck (see Fig. 19) will be spotted on the stream bank in such a position that it can efficiently lift treadways from trucks and transfer the treadways to pontoons floating just off shore. When placing the near and far shore treadway spans and trestle spans the crane will be backed into placing position along the longitudinal axis of the bridge.

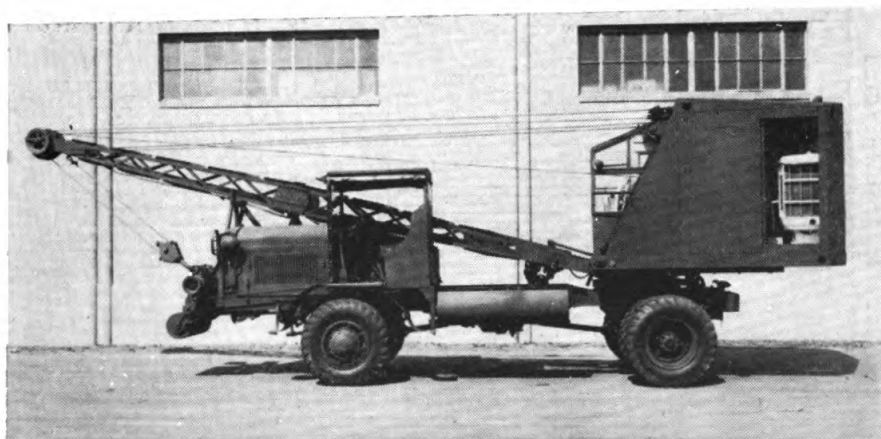

Figure 19. Truck Crane.

34. Location of Other Equipment.— Anchors will be unloaded in the unloading area. Shore lines will be spotted for the line crews. Peaveys, extra connection pins, chain hoists, loading hooks, other equipment, and hand tools will be unloaded by the crews using them.

Chapter 8

SECTIONS AND DUTIES OF SECTIONS IN CONSTRUCTION BY PARTS

	Paragraph
General	35
Officers	36
Abutment Section	37
Anchor Section	38
Alignment Section	39
Raft Section	40
Assembly Section	41
Approach Section	42
Security Section	43

35. General.— Suggested organization for construction of the treadway bridge, and the duties of sections, is given in the following paragraphs.

36. Officers.— *a.* Officers supervise the bridge construction program in the same general manner as for other ponton and fixed bridges.

b. The senior officer selects the crossing, unloading and assembly points, routes of approach, and parking areas of vehicles. He determines the method of construction and the general plan for local security.

c. One junior officer supervises the placing of treadways on pneumatic pontoons and another the construction of abutments, trestle spans, and approaches. The placing of treadways on pneumatic pontoons by bridge trucks or the truck crane is the critical or controlling operation in the construction of the bridge. Close supervision should be given this operation.

37. Abutment Section.— *a.* The abutment section consisting of one squad will commence work immediately upon arrival at the site. Its first task is to unload all necessary tools and supplies.

b. The near shore abutment normally utilizes a 3 x 12-inch or heavier timber as a sill. The sill is placed with upper surface one foot below grade of finished approach and two feet or less above water surface. It is anchored securely as illustrated by Figures 2 and 3.

c. Upon completion of near shore abutment, this squad moves across to far shore and similarly prepares the far abutment. It then lays out the upstream and downstream shore lines. Shore lines are tied to holdfasts, or, if available, to tree trunks about 50 feet above and below the axis of the bridge. Free ends of the lines are coiled on banks, pending attachment to fourth ponton section by alignment section.

d. The abutment section assists assembly section in the placing of any near or far shore trestle sections. The noncommissioned officer in general charge of the construction of the bridge supervises this operation.

38. Anchor Section.— *a.* The anchor section consists of an engineer squad and is divided into two details of one noncommissioned officer and five anchormen each. As soon as unloading starts, both details assemble anchors with cables attached on the first treadway raft constructed. To provide stability these rafts should have two pontoons each. They accommodate ten or more anchors per load. Rafts should be powered with outboard motors. Power boats will be used instead of rafts if they are available.

b. The first detail is known as the upstream anchor detail. It moves the anchor raft to the previously determined line for upstream anchors and casts anchors according to the stream current and wind as described in par. 23. Additional anchors are procured and cast as necessary until all upstream anchors are in place. Anchor lines are transferred to the alignment section as soon as it is able to handle them.

c. After assisting in *a* above, the downstream anchor detail, using another two-ponton outboard motor powered raft or power boat, places the downstream anchors as described in par. 23. Anchor lines are turned over to the alignment section.

39. Alignment Section.— This section, consisting of one noncommissioned officer and three cable or linemen, carries out the following sequence of work:

a. Lay out up and downstream shore lines if this has not already been accomplished by abutment detail.

b. Fasten free ends of shore lines to shoreward treadway loops of fourth ponton section as soon as the latter is assembled in bridge. Adjust up and down stream shore lines to

insure correct alignment of bridge. Install treadway spacer hooks between treadways to which shore lines are attached.

c. Receive upstream and downstream anchor lines from anchor sections and fasten them to mooring cleats on ponton saddles. Adjust lines as necessary for proper alignment of bridge.

d. Upon completion of bridge, fasten and adjust far abutment shore lines, and install spacer hooks between treadways to which shore lines are attached. Thereafter, the section patrols the bridge constantly, checking line fastenings, pin connections, inflation of boats, and alignment of bridge. It checks and reports to the engineer officer in charge each six-inch rise or fall of water level. It reports to the bridge maintenance detail any other items requiring attention.

40. Raft Section.— *a.* The raft section consists of two or more squads per unloading area. It constructs the treadway rafts or the ponton sections and assists in placing them in the bridge. The section is broken down into half-squad working details whose duties are as follows:

(1) Unload saddles, pneumatic floats, and other equipment from bridge trucks.

(2) Inflate float (see Fig. 20), attach saddle, launch (see Fig. 21) and move to the treadway placing position. Continue inflation and launching of pontoons if bridge trucks or truck cranes are not yet in position to place treadways.



Figure 20. Inflating Pneumatic Float.



Figure 21. Launching Ponton.

(3) Assisted by bridge truck personnel, place treadways on ponton (see Fig. 22). Care should be exercised in placing treadways to assure that ends are exactly even. This enables rapid placing of rafts or sections in the bridge assembly. Each treadway should have two pins; one installed in the inner hole of the butt end, the other on floor of treadway near the engaging plate end.



Figure 22. Placing treadways in assembling a ponton section.

(4) Move treadway raft or ponton section (see Fig. 23) to end of bridge. The power boat, or an outboard motor, is used, if available, in moving rafts or sections into position. Otherwise, they are moved by paddling.

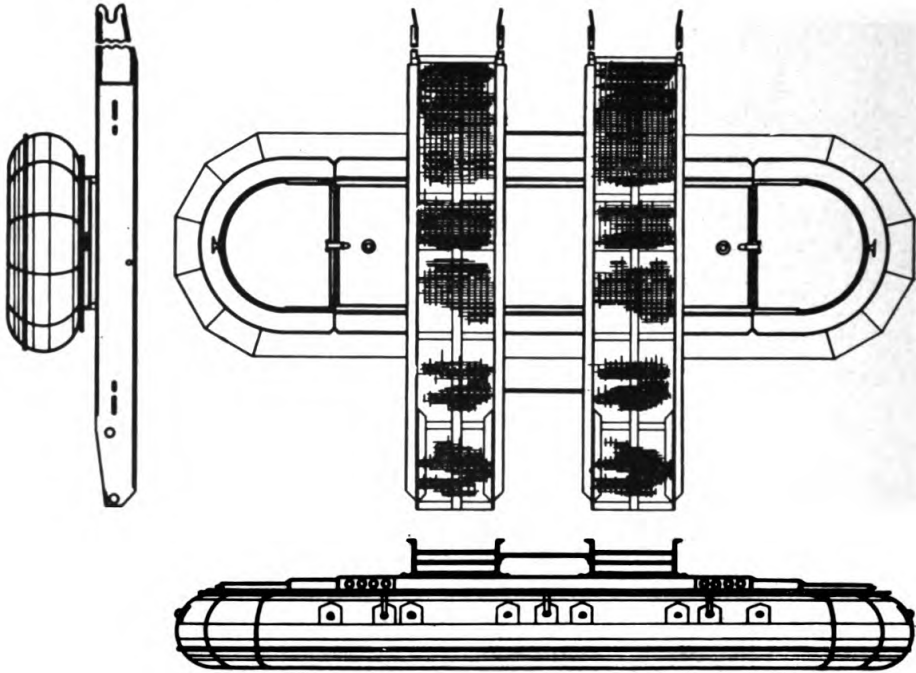

Figure 23. Ponton Section.

(5) Assist assembly section in placing raft or ponton section in bridge. The section then returns to the unloading point and repeats the operation.

b. When necessary to avoid congestion at unloading points or to secure additional protection of cover and concealment, pneumatic floats may be inflated under cover, have saddles attached, and then be carried by hand to the launching site. In this event, additional raft sections should be provided for carrying.

c. Because of the difficulty usually encountered in securing adequate and numerous unloading positions for bridge trucks or because of the limited number of truck cranes, the placing of treadways on pontoons is the critical or controlling operation. For this reason pontoons should be made available for placement of treadways as fast as the crane can handle them.

41. **Assembly Section.**— *a.* The assembly section consists of one noncommissioned officer and seven privates. It

places the trestles, treadways and rafts or sections in position in the bridge. The duties of the assembly section are as follows:

(1) Upon arrival at bridge site, assemble peaveys, spare pins, and other necessary hand tools and equipment. The section then helps to place the truck crane in position for handling trestles. This section is assisted by the abutment section in placing trestle spans.

(2) This detail assembles rafts or ponton sections into the bridge as they are brought up by the raft sections. The detail guides the sections (see Fig. 24) together and inserts connecting pins. In this operation men work in pairs on

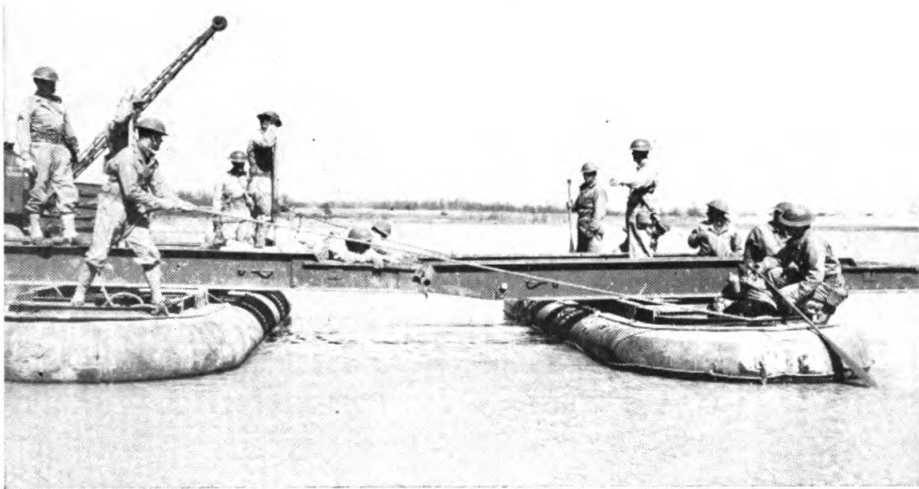

Figure 24. Assembling a ponton section into the bridge.

each treadway. Each of the pair assists in guiding the free raft or ponton section into position and then one, with a peavey, brings the free treadway into final position while the other inserts the connecting pin. (See Fig. 25.) The fifth man follows up, inserting a cotter-key or large horse-blanket pin. The sixth and seventh men handle guy ropes as shown to assist in placing the part in position.

42. Approach Section.— The size and composition of the approach section varies to meet the requirements of the situation. The work is accomplished, insofar as possible and practicable, by power equipment, and is generally carried on simultaneously with the construction of the bridge. This crew is often used during the early phases of construction in preparing the unloading and assembly areas. In the latter phases they are frequently assisted in completing the approaches by



Figure 25. Installing connecting pins.

sections that have completed their specific operation in the construction of the bridge.

43. Security Section.— Local security is a duty of the unit commander in all operations and situations. Although the bridging operation may be protected by troops other than engineers assigned this mission, local security and anti-aircraft protection is the responsibility of the engineer officer and he will insure that adequate protection is provided within the means available to him and properly coordinated with security furnished by other troops.

COMPOSITION OF CONSTRUCTION SECTIONS

Section	Equipment	Total Enlisted Men
Abutment	1 boat, reconnaissance	1 squad
Anchor	2 rafts, two-ponton (Powered with outboard motors) or 2 power boats (with operators)	1 squad
Raft	1 air compressor with operators 1 crane truck with operators 1 outboard motor or motor boat with operators	2 squads per unloading area. More if necessary
Alignment Assembly		4) 1 squad 8)

Approach (size and composition as required).
 Security (size and composition as required by the situation).

Chapter 9

CONSTRUCTION BY METHOD OF SUCCESSIVE PONTONS OR TRESTLES

	Paragraph
General -----	44
Floating Bridge Procedure -----	45
Fixed Bridge Procedure -----	46

44. General.— In construction by the method of successive pontoons or trestles, the bridge is built progressively by adding one pontoon or trestle after another and extending the treadways so as to connect each one as it is placed. Trestle bridges are constructed by this method almost without exception.

45. Floating Bridge Procedure.— Floats are usually inflated at one or more points, saddles are placed, and the complete pontoons are floated into position at the end of the bridge as needed. The bridge trucks back out near the end of the

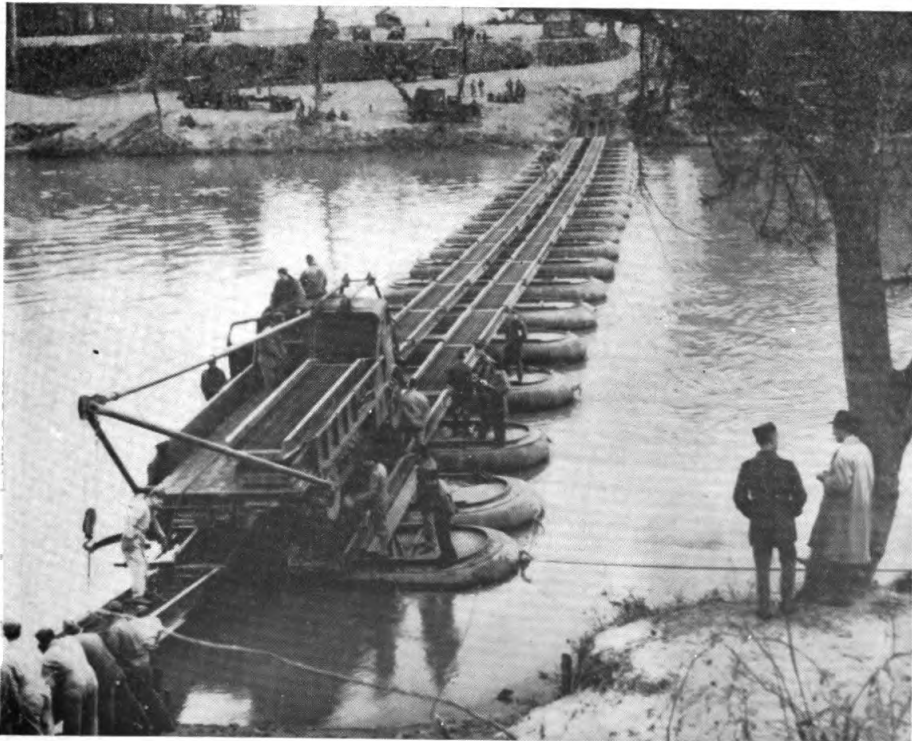

Figure 26. Installing far shore approach treadways.

partially completed bridge and lay the treadways on the pontons. The truck is then moved toward shore, after which the ponton section is connected to the completed bridge in the same manner as in the method of parts. The far shore approach treadways are installed as shown in Figure 26.

46. Fixed Bridge Procedure.— Trestles are usually assembled and swung into position off the near shore or off the end of the partially completed bridge, as the case may be, by the bridge truck or the truck crane. The transom is brought to the proper height and the trestle is temporarily guyed by rope lines. Treadways are swung into position resting on trestle transom and connected to treadways already in place. Spacing hooks are attached, and treadways are clamped down to the adaptor of the transom. If necessary, intermediate

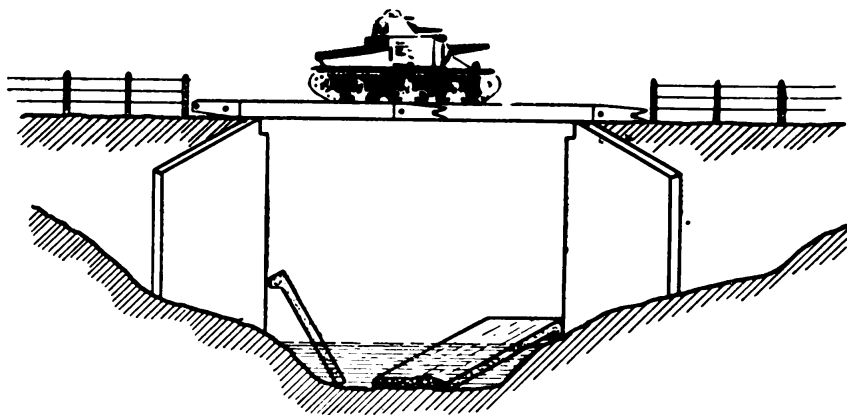

Figure 27. Bridging a blown culvert.

trestles are placed during the process of construction. Whenever possible the treadway is pinned to form a continuous beam. The use of treadways to bridge a blown culvert is shown in Figure 27.

Chapter 10

REINFORCED BRIDGES

	Paragraph
Floating Bridge Reinforcement	47
Trestle Bridge Reinforcement	48

47. Floating Bridge Reinforcement.— The capacity of the normal floating treadway is increased by adding an additional ponton for each treadway length or by shortening the spans in equal amounts between pontons. In adding additional

pontons, the ponton should be only partially inflated so that it can be easily floated under the assembled treadways. Trestle and hinge spans should be eliminated, if possible, and the bearing plate or sill of approaches should be reinforced by the use of a subsill. Additional anchors, shore lines, and hold-fasts should be provided to assist in preventing lateral and longitudinal movement of the bridge. Traffic control should be very strict when a bridge is under heavy loading.

48. Trestle Bridge Reinforcement.— The capacity of the bridge is increased by increasing the number of trestles used for each unit of bridge. Additional bearing power of footings may be secured by using larger footing shoes and by using a bearing plate or sub footing of logs, expanded metal, brush, or planks under each shoe. The bridge is secured against lateral and longitudinal movement by using additional shore lines and strut bracing. A subsill should be placed under each approach sill.

Chapter 11

TRAFFIC CONTROL, MAINTENANCE AND DISMANTLING BRIDGE

	Paragraph
Traffic Control and Bridge Maintenance	49
Dismantling Bridge	50

49. Traffic Control and Bridge Maintenance.— Rigid control of traffic and proper bridge maintenance is essential at all times. Medium tanks should maintain a constant speed in crossing and should maintain intervals of at least twenty yards. Halted vehicles should be chocked. Particular attention should be given to insure that a pressure of two pounds is maintained in the rubber floats. The maintenance detail should patrol the bridge constantly.

50. Dismantling Bridge.— In general, the bridge is dismantled by a reversal of the erection procedure. The trestle bridge is dismantled by successive trestles. The floating bridge may be dismantled either by the method of parts or by the method of successive pontons. In dismantling by the method of successive pontons, the far shore approach treadways are removed by crane. In dismantling by parts, the bridge is disassembled by parts of one or more ponton sections. The parts are floated to loading points along the shore, taken apart, and loaded on trucks.

Chapter 12

FERRYING

	Paragraph
Pneumatic Float -----	51
Raft Ferries -----	52
Propulsion -----	53
Loading -----	54
Crew and Equipment -----	55
Conduct During Crossing -----	56

51. Pneumatic Float.— A single pneumatic float less the center tube may be used advantageously for ferrying personnel with their combat equipment. It may be used also for the same purposes and in the same manner as the reconnaissance boat. The float is loaded by placing twelve paddlers astride the outside tubes and twelve passengers in the center compartment. Those in the center will sit facing the front. All combat equipment should be slung or carried and not laid on the canvas floor. Passengers should board and unload from the ponton in knee deep water to prevent rupture of the ponton by sharp stones and sticks. Five men usually can paddle the ponton on its return trip.

52. Raft Ferries. (Figs. 28 & 29).— *a. General.*— Rafts suitable for all loads up to the capacity of the normal treadway floating bridge may be constructed from the steel treadway bridge equipage. Rafts are usually of the same construction as two or more spans of the normal reinforced bridge. Additional treadway sections placed on each end make it possible to load and unload along any usual stream bank without the use of landing stages. The raft of two ponton sections is much used.

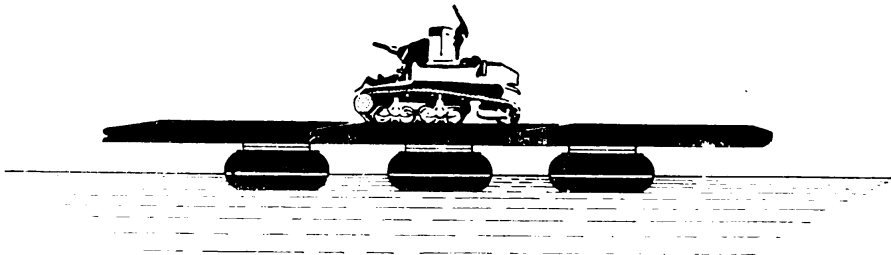

Figure 28. Typical raft ferry.

b. Various Types and Capacities.— The various types of commonly used rafts and their capacities are listed below.

(1) *Light rafts.*— This raft, consisting of two connected ponton sections powered by an outboard motor, is convenient for ferrying personnel, placing anchors, towing bridge parts, and for reconnaissance and patrolling.

(2) *Three ponton -three treadway.*— This raft consists of three lengths of treadway pairs supported by three pontoons. Its capacity is:

40 infantrymen

1 light tank or equivalent weight

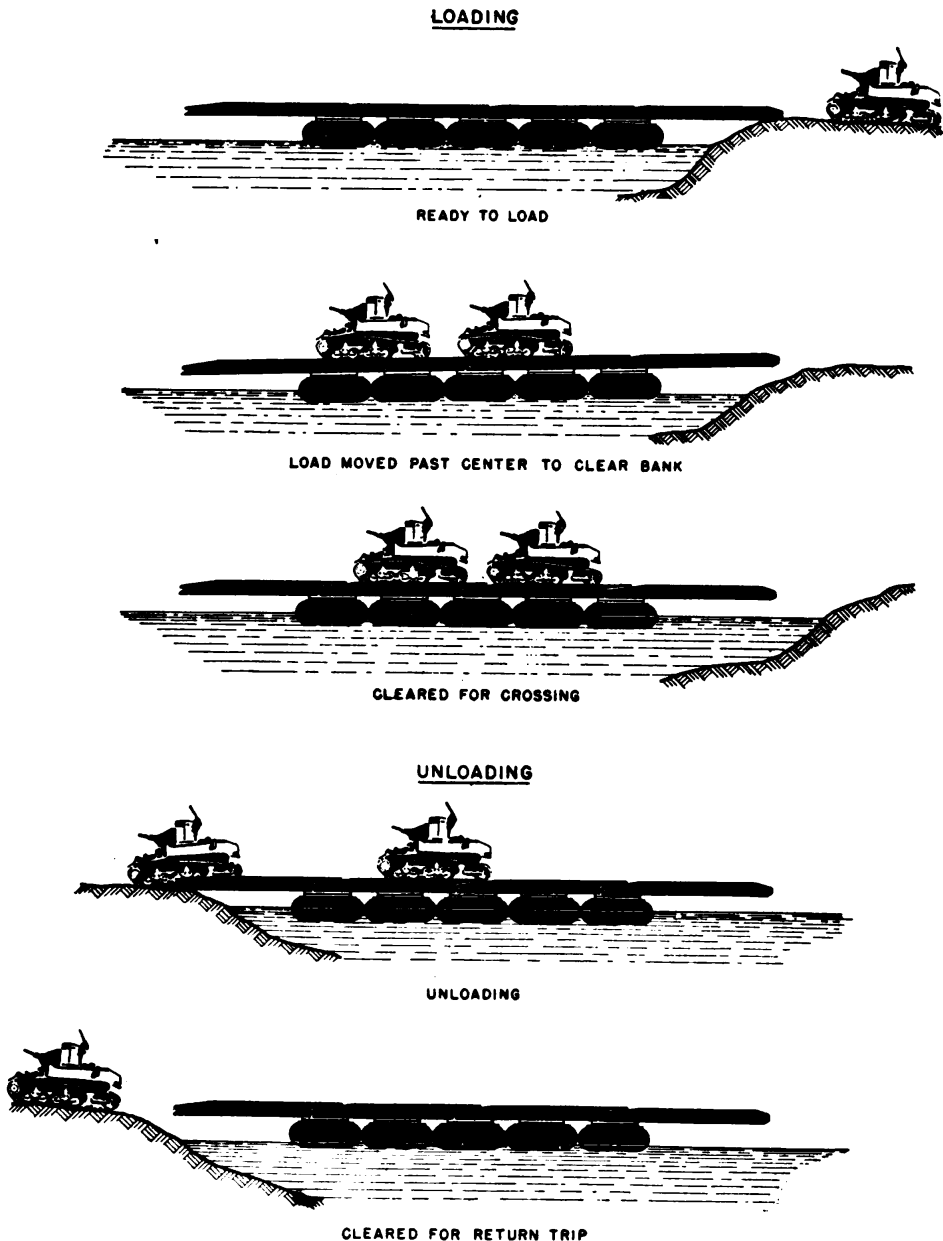

Figure 29. Method of loading and unloading raft ferries.

(3) *Five ponton - four treadway.*— This raft consists of four lengths of treadway pairs supported by five pontoons. It provides a usable roadway length of thirty feet. Its capacity is:

80 infantrymen

1 medium tank

2 light tanks or equivalent weight

53. Propulsion.— *a. Outboards.*— Pneumatic ponton rafts generally cannot be paddled effectively and paddling should not be attempted in a current which exceeds one mile per hour. The 22-HP outboard motors of the equipage provide an excellent means of maneuvering rafts of various sizes in all streams whose currents are within the power capabilities of the motors. Motors should be used in pairs to insure against stoppages in midstream. The attachment bracket described in paragraph 13 is used to attach the outboard motor to the ponton. For better control outboard motors should be attached to the center pontoons. For the two-ponton light raft a motor should be attached to each ponton.

b. Power boats.— Power boats are the best means of propelling pneumatic ponton rafts. They are used to push the rafts as a river boat pushes barges. The power boat may be tied to the ponton raft or the bow may be butted up against a treadway or ponton and guyed into place.

c. Truck Winch.— (1) Two vehicles with winch lines, one placed on each stream bank, provides a satisfactory method of towing a raft across a stream. The first vehicle is rafted across. A winch line from each vehicle is then attached to the raft and the raft is shuttled back and forth. Two winches on each bank give better control of the raft and a speedier crossing.

(2) The winch on the truck crane can be used to shuttle a raft across a narrow stream. A rope line run through a snatch block fastened on the far shore is tied to the raft. Another rope line is tied directly to the raft. Each rope line is looped loosely over the turning rope drums or capstans on the ends of the winch shaft; one on the right and one on the left. When drawn tight, one line will draw the raft across the stream. When this line is released and the other line is drawn tight, the raft will be pulled back to the near shore.

54. Loading.— Treadway rafts provide their own landings under usual conditions. The treadways are extended to such lengths that they bridge the shallow water between the shore and the first ponton. The tilting of the raft when the loads are shifted, as illustrated in Fig. 29, makes it possible to load and unload safely and quickly without landing stages. Vehicles must be chocked to keep them from rolling while on the raft. Personnel to be ferried will march on in double file, one file for each treadway. These files will close up to a uniform distance for favorable load distribution.

55. Crew and Equipment.— An engineer officer with a suitable detail of engineer enlisted men will be assigned to supervise each raft. This officer will be responsible for the safe and speedy loading, passage, and unloading of the raft. The raft should be provided with the necessary anchors and attached anchor lines with which to hold the raft in the stream if the means of propulsion fails or the towing line parts. Men should be stationed at these anchors with no other duties except to cast them when necessary.

56. Conduct During Crossing.— From the time the loads are turned over to the engineer officer in charge of the raft for loading until they are unloaded on the opposite bank, the loads are under his orders and those of the noncommissioned officers of his crew. All instructions issued by them will be promptly and strictly complied with. All officers and noncommissioned officers who are passengers on the raft will assist the engineer officer in any way that may be necessary.

Chapter 13

MAINTENANCE OF EQUIPAGE

	Paragraph
General	57
Pneumatic Floats	58
Trestles, Treadways and Accessories	59

57. General.— A regular program of inspection, cleaning, replacement, repair, and painting must be set up and adhered to. All parts of the equipment, particularly the pneumatic floats, must be carefully inspected and put in good condition before the equipment is stored after extended use. Complete instruction books covering repair and maintenance are provided for most items of equipage.

58. Pneumatic floats.— *a. Small Leaks.*— Small leaks can be found by blowing up the floats, painting the outside with thick soap suds and watching for soap bubbles. Repair of small leaks is accomplished in the same manner as in repairing an automobile inner tube. The surface around the leak is first roughened lightly with a buffer and sandpaper and then washed with benzine. At least two coats of air curing cement are applied around the leak. While this is drying, a patch of rubberized fabric is cut to the correct size and roughened up in the same manner. Then a coat of cement is applied to the patch. The patch is applied over the leak and rolled or pressed down firmly.

b. Large Leaks.— For large leaks such as snags and tears it is desirable first to place a patch on the inside of the tube. If necessary, the tear may be cut larger to facilitate the application of this patch. An uncured rubber friction patch is applied so good adhesion may be obtained. Some cement should be spread around the inside of the tube near the tear and the patch inserted. After this inside patch is pressed and rolled firmly, a patch is applied to the outside of the tube in the same manner as described for the small leak.

c. Storage.— All rubber articles are directly affected by heat and sunlight. For this reason, pneumatic floats should be stored in cool, dark places. When it is necessary to store them on the beach for short periods of time the floats should be dried out as much as possible. Since mildew will readily attack cotton duck in the presence of moisture, the floats should be supported by treadways or trestle parts. Pneumatic floats should be carried in the carrying cases.

59. Trestles, Treadways, and Accessories.— The steel elements of the bridge are rugged and of strong construction, but nevertheless must be handled with care. Struts, shoes, hoists, hold-fasts, peaveys, and tools should be used only for the purpose intended. The protective paint covering must be maintained to prevent rust. Paint should be renewed whenever inspection indicates the need; and any chipping, scaling, or disintegration of the paint which exposes the steel should be corrected at once by the application of a rust prevention priming coat and a second coat of paint. Slight bends in trestles, treadway, engaging plates, and grating and wedge ends may be straightened in the field. Repairs other than these generally require shop facilities.

Chapter 14

LIST OF EQUIPAGE

Paragraph
60

Steel Treadway Bridge Equipage -----

60. Steel treadway bridge equipage.— The following is a list of the equipage of one 1080-foot unit of steel treadway bridge:

<i>Article</i>	<i>Basic Quan. with unit</i>	<i>Spares with unit</i>	<i>Total with unit</i>
Anchor (kedge 100#)	72	6	78
Block, snatch	32	0	32
Boat, Rcn., (Pneumatic)	20	0	20
Bracket, auxiliary, trestle column	24	0	24
Bracket, outboard motor, 22HP	6	0	6
Bracing, trestle, parts consisting of the following:			
Clamp, column (complete)	16	2	18
Shoe, strut, with pin and latch	8	0	8
Strut, bracing	8	0	8
Chain, with hook, ring, and load binder, 16' long, complete, $\frac{3}{8}$ " diam.	100	50	150
Clip, wire rope, $\frac{1}{2}$ "	160	0	160
Clip, wire rope, $\frac{5}{8}$ "	160	0	160
Float, pneumatic, 12-ton, complete with carrying case and emergency kit	72	20	92
Grip, cable, $\frac{5}{8}$ " wire rope capacity	16	0	16
Grip, cable, $\frac{1}{2}$ " wire rope capacity	16	0	16
Hoist, chain, ratchet, $1\frac{1}{2}$ " 3-ton capacity	12	0	12
Holdfast, complete w/steel pickets	12	0	12
Kit, repair, pneumatic float	12	0	12
Manifold, inflation, 4 hose	12	4	16
<i>Manifold, spare parts:</i>			
Nozzle, assembly, complete	12	0	12
Clamp, hose	48	0	48
Hose	12	0	12
Nipple, hose	24	0	24
Seal, valve stem	24	0	24
Maul, wooden, round 8" x 10", 36" handle, reinforced	36	0	36
Motor, outboard, 22HP w/chest	6	0	6
Paddle	72	72	144
Picket, steel, $1\frac{1}{4}$ " diam., 36" long	144	0	144
Pin, treadway	288	36	324
Rope, manila, $\frac{1}{2}$ " diam., ft.	1400	1400	2800
Rope, manila, $\frac{3}{4}$ " diam., ft.	7200	3600	10800
Rope, wire, $\frac{1}{2}$ " diam., 6 x 19 galv., plow steel on 8 spools, 250' each, ft.	2000	0	2000
Rope, wire, $\frac{5}{8}$ " diam., 6 x 19 galv., plow steel on 3 spools, 600' each, ft.	1800	0	1800
Saddle, complete	72	0	72
Treadway, complete	144	0	144
Trestle, 25-ton, complete with treadway adaptor less ch. hoist	24	0	24

<i>Article</i>	<i>Basic Quan. with unit</i>	<i>Spares with unit</i>	<i>Total with unit</i>
<i>Trestle Spare Parts:</i>			
Bracket, chain hoist	2	0	2
Column, complete	1	0	1
Column, foot, casting	4	0	4
Shoe, complete	1	0	1
Chain, shoe, column	4	0	4
Chain, foot, column	4	0	4
Pin, transom, complete with chain	8	0	8
Wedge, treadway, blunt end	20	0	20
Wedge, treadway, hook end	20	0	20
Wrench, end, adjustable, 10" (crescent)	32	0	32

