

406 *4113*
.2
7M
1942
U.S. Dept. of Army

TM5-5060

WAR DEPARTMENT
MAINTENANCE MANUAL
AND PARTS CATALOG

MOTORIZED AIR COMPRESSOR
MODEL 105 GA

LE ROI COMPANY
MILWAUKEE, WISCONSIN
NOVEMBER 30, 1942

TM5-5060

WAR DEPARTMENT

TM5-5060, Maintenance Manual and Parts Catalog, Motorized Air Compressor, Model 105GA, published by the Le Roi Company is furnished for the information and guidance of all concerned.

(AG 062.11 (4/26/41) PC (C), June 10, 1941.)

G. C. MARSHALL.
Chief of Staff.

Official:

J. A. ULIO,
Major General,
The Adjutant General.

*Done by
guy
W. H. H. H.*

TECHNICAL MANUAL

MAINTENANCE MANUAL AND PARTS CATALOG, MOTORIZED AIR COMPRESSOR MODEL 105 GA, LE ROI COMPANY

CHANGES }
No. 1 }

WAR DEPARTMENT,
WASHINGTON 25, D. C., 4 December 1944.



TM 5-5060, 30 November 1942, is changed as follows:

On page 47, below paragraph "Pressure Adjustments" add:

MAXIMUM AIR PRESSURE.

Many of the air compressors as furnished were adjusted for a maximum air pressure of from 100 to 105 pounds per square inch. As this pressure sometimes causes breakage of the smaller tools, the maximum pressure is to be adjusted to 90 pounds per square inch. (Complete instructions for the reduction of air pressure may be found on page 47 of TM 5-5060.)

[AG 300.7 (8 Nov 44).]

BY ORDER OF THE SECRETARY OF WAR:

OFFICIAL:

J. A. ULIO

Major General

The Adjutant General

G. C. MARSHALL

Chief of Staff

DISTRIBUTION:

AAF (10); AGF (10); ASF (10); T of Opns (C of Engrs) (2); Dept (10); Base C (C of Engrs) (2); Arm & Sv Bd (2) except The Engr Bd (10); Def C (1); Tech Sv (2); except C of Engrs (20); Sv C (10); PE (Port Engr) (2); ASF Dep (Engr Sec) (2); Dep 5 (2) except Albany (Pub Off) (7) & Granite City Engr Dep (25); Dist O 5 (2) except Seattle Dist Engr (4); Div Engr (2); Gen & Sp Sv Sch (2); USMA (2); Library of Congress (2); ASF Tng Ctr (Engr Sec) (2); A (10); CHQ (10); D (2); T/O & F 5-247 (6); Two copies to following: T/O & E 5-157, 5-267, 5-357, 5-377, 5-567, 5-16, 5-17, 5-22, 5-26, 5-27, 5-36, 5-37, 5-66, 5-67, 5-87, 5-96, 5-97, 5-116, 5-136, 5-137, 5-138, 5-192, 5-216, 5-217, 5-236, 5-237, 5-238,

TM 5-5060

C 1 MAINTENANCE MANUAL AND PARTS CATALOG

5-252, 5-256, 5-257, 5-276, 5-277, 5-297, 5-327, 5-367, 5-412, 5-416, 5-417, 5-466, 5-467, 5-500, Composite Co, Map Det (Ca), Utilities Det (EA), Gas Generating Unit (GA), Model Making Team (MA), Dredge Crew, Floating Power Plant Det (NE), Port Rep Ship Crew (NF), Survey Liaison Det (OA) Foundry Team (PA), 5-510-1S, 5-512S, 5-516S, 5-517S, 5-526S, 5-527S, 5-536S, 5-537S, 5-538S, 5-539S, 5-547S, 5-627, Hq & Hq & Serv Co, Shore Regt, Hq & Hq Serv Co, Shore Bn, Shore Co.

For explanation of symbols see FM 21-6.

LE ROI
AIR COMPRESSOR MODEL 105GA
TECHNICAL MANUAL

Includes
 Independent Pneumatic "Thor" Air Tools

WAR DEPARTMENT		SERIAL NO. SPAN	
PURCHASE ORDER	CONTRACT NUMBER	ENGINE	COMPRESSOR
55861 } 55668 }	W978-Eng-3969	{ 157000 to 158998 160200 to 160274	157001 to 158999 160201 to 160275
57727	W978-Eng-5371	171500 to 172508	171501 to 172509
C23-1489	W1122-Eng-969	172510 to 177260	172511 to 177261
23-1432DA	W1122-Eng-972	177262 to 177488	177263 to 177489
23-1286	W1088-Eng-2067	177490 to 178888	177491 to 178889
C5260	W1088-Eng-2332	183900 to 184010	183901 to 184011
23-1296	W1088-Eng (MSP)-2751	189000 to 190212	189001 to 190213
23-1297	W1088-Eng (MSP)-2929	190214 to 192030	190215 to 192031
23-1439	W11-032-Eng (MSP)-38	194000 to 195556	194001 to 195557
23-3497	W47-013-Eng (MSP)-460	201004 to 204620	201005 to 204621
23-3467	W11-114-Eng-134	200560 to 201002	200561 to 201003

NOTE: Even numbers are all engines, odd numbers are all compressors. Compressor number is always next number higher than its respective engine.

Manufactured by
LE ROI COMPANY
 1706 So. 68th St.
 MILWAUKEE, WISCONSIN

*All prices shown in this manual are
 subject to correction without notice.*

Copyright, 1944
 by
 LE ROI COMPANY
 Milwaukee, Wisconsin, U. S. A.



*Le Roi Air Compressor Model 105GA as Mounted on GMC,
2½ Ton, 6X6 Ordnance Truck*

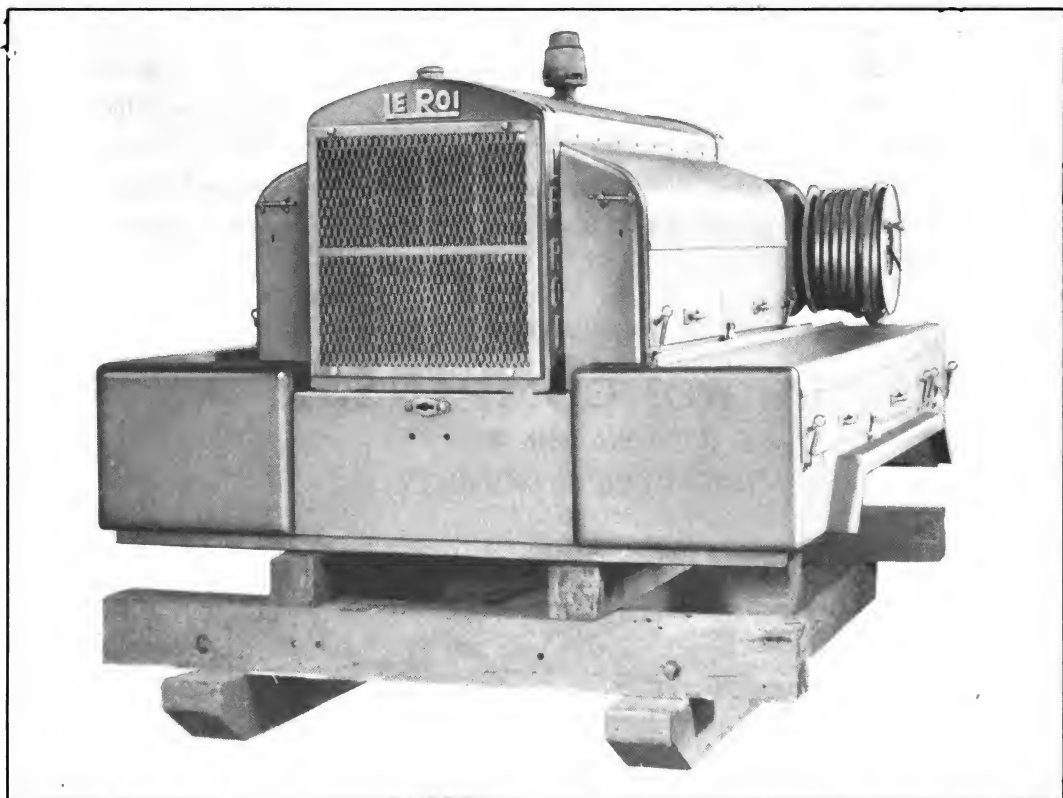

*Le Roi Air Compressor Model 105GA as mounted on Wood
Skids to be Mounted on any Convenient Vehicle*

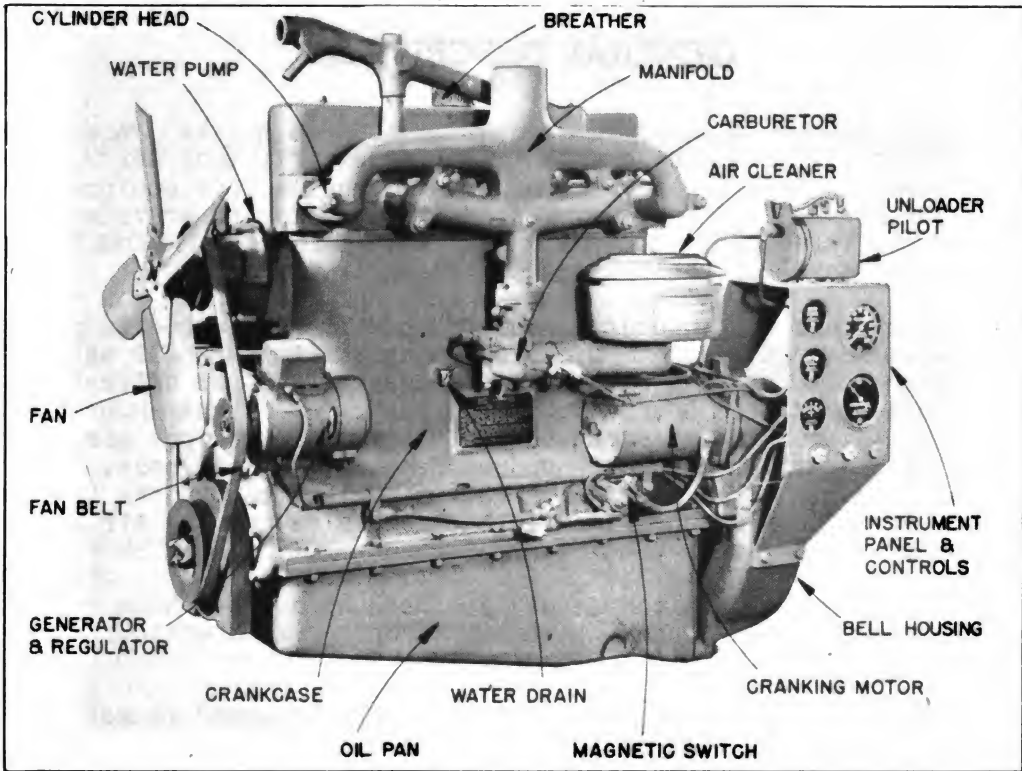

Model D318, Gasoline Engine

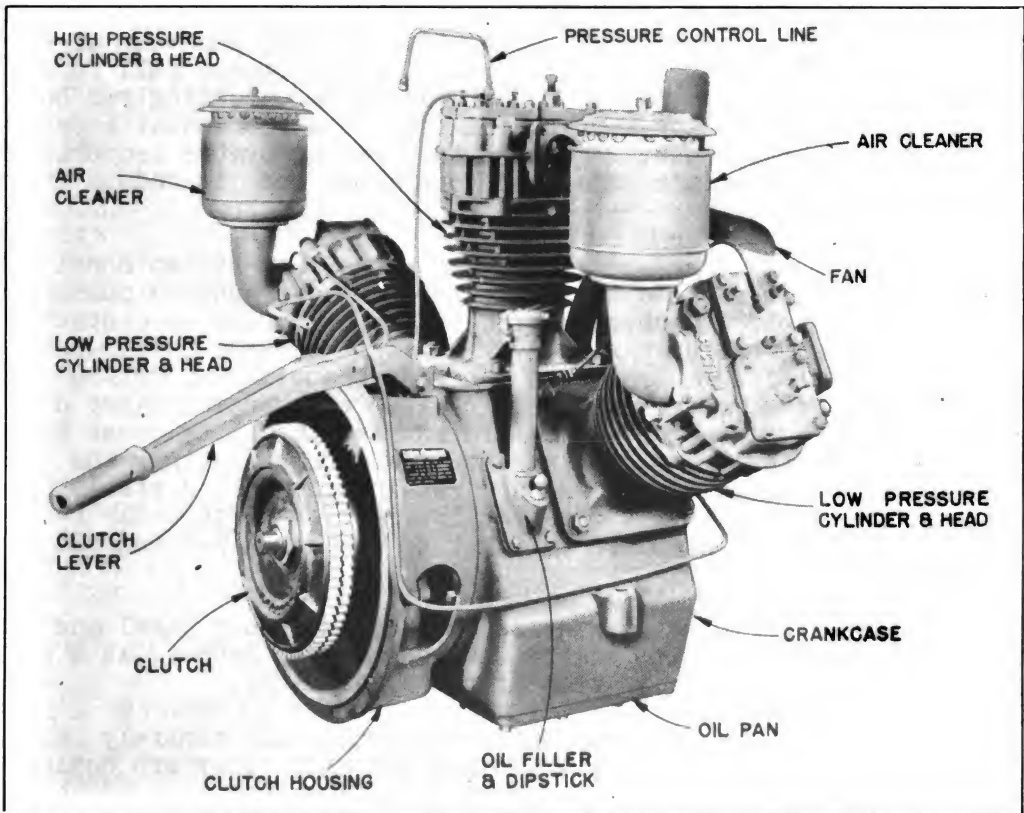

Model 105, 2 Stage, Air Cooled, Air Compressor

GENERAL DESCRIPTION

The Le Roi Motorized Air Compressor is mounted on a six wheel General Motor's Truck. It is equipped with easily accessible tool boxes for convenient storage of air tools, spare parts, miscellaneous equipment, etc. The tool box mounted transversely behind the truck cab provides seating facilities for three men, and is arranged with safety straps and hand-rail to reduce the danger of their being accidentally thrown off.

A fifty gallon fuel tank, located beneath the air receiver, is partially shielded by a heavy steel guard, protecting about one-half of its contents. When full, this tank provides adequate fuel to drive the truck about 150 miles and also operate the compressor for eight hours. Two live hose reels, mounted at each end of the eight cubic foot air receiver tank, are each equipped with one-hundred feet of 3/4" air hose. A fifty foot reserve length of air hose is stored in toolbox behind the truck cab. Two fixed air outlets are provided in the rear side of the air receiver, for emergency connections.

The air compressor unit is completely enclosed by a steel hood top, hinged side panels, and a splash pan, thereby affording protection from the weather.

The compressor is driven by a four cylinder valve-in-head Le Roi gasoline engine coupled to the compressor through a manually operated Twin Disc Clutch. The clutch is the "spring loaded" type which affords a maximum of plate wear before adjustment is required. The engine has a displacement of 318 cubic inches and can develop a maximum of thirty-four horse power running at 865 R.P.M. The cylinders are removable wet sleeve type. Special steel inserts practically eliminate pitting and wear of exhaust valve seats. A large capacity gear type oil pump insures full force feed lubrication to all moving parts. Both main and connecting rod bearings are babbit lined, steel back, precision type. A thermostat located in the engine water outlet hose, regulates the cooling system temperature to at least 160° F. to maintain efficient operation and to reduce the tendency to form sludge.

The air compressor is a three cylinder two stage, air-cooled model and delivers 105 cubic feet of free air per minute, at one-hundred pounds gauge pressure at sea level. Connecting rod bearings are the precision type, same as in engine, but crankshaft mains are tapered roller bearings. Lubrication is positive by means of a plunger type oil pump driven through a connecting rod from the crankshaft. Valves are special alloy circular plate type assembled in cages which are mounted in the cylinder heads so that they may be quickly and easily removed without removing the heads. They rest on forged steel seats and are retained by forged steel bumpers. The tubular, sectional type, air cooled intercooler efficiently cools the air entering the high pressure cylinder to within a few degrees of the intake temperature.

All controls are conveniently grouped on the instrument panel and sufficient gauges are provided to enable the operator to detect, at a glance, any irregularities in the operation of the compressor.

The air tools furnished with each unit are quickly and securely attached to the hose ends by means of universal couplings; they are designed to give a maximum of service with a minimum of maintenance. A combination vise is attached to a rigid, portable work bench which is conveniently stored in the transverse tool box when not in use.

SPECIFICATIONS—ENGINE AND AIR COMPRESSOR

APPROX. CAPACITIES (U. S. MEASURE)

Fuel Tank.....	50 gals.
Cooling System.....	8 gals.
Crankcase (Oil Pan) Engine.....	14 qts.
Crankcase (Oil Pan) Compressor.....	8 qts.
Air Cleaner - Engine.....	1/2 pt.
Air Cleaner - Compressor, each.....	1 pt.

ENGINE

Model (Gasoline).....	D318
Cylinders.....	4
Bore.....	4-1/2"
Stroke.....	5"
Engine Speed (Governed).....	865 R.P.M.
Magneto (Fixed Spark) Clockwise Rotation American Bosch.....	MJC4C
Magneto Breaker Gap.....	.012" to .014"
Spark Plug Gap.....	.025" to .030"
Valve Clearance (Engine Hot).....	.015"
Carburetor (Zenith) Updraft.....	62A10
Firing Order.....	1-2-4-3

CLUTCH

Double Plate (Spring Loaded) Twin Disc Model SL-211.....	11-1/2"
--	---------

COMPRESSOR

Model.....	105G
Cylinders (2 low pressure - 1 high pressure).....	3
Bore (low pressure).....	5-3/4"
Bore (high pressure).....	5"
Stroke.....	5"
Stages.....	2
Capacity (cubic feet of air per minute delivered at 100 lbs. gauge pressure at sea level).....	105

GENERAL - TRUCK MOUNTED

Length Overall (Bumper to Bumper).....	254"
Width Overall (From outsides of fenders).....	90"
Height Overall (To top of muffler).....	93" *
Weight Total (Complete with all tools, fuel & oil).....	14,300#

*87" with muffler removed.

GENERAL - SKID MOUNTED

Length Overall.....	120"
Width Overall.....	90"
Height Overall.....	80"†
Weight Total (Complete with tools, fuel & oil).....	6700 lbs.

†74" with muffler removed.

**IDENTIFICATION AND INDEX TO MANUFACTURERS
OF ACCESSORIES AND EQUIPMENT USED ON LEROI
MODEL 105GA AIR COMPRESSOR**

ENGINE AND COMPRESSOR

<u>PART NAME</u>	<u>LE ROI NUMBER</u>	<u>MANUFACTURER NAME AND ADDRESS</u>	<u>MODEL, TYPE OR PART NO.</u>
AIR CLEANER (ENGINE).	A77-145-1	AIR MAZE CORP. CLEVELAND, OHIO	37L-0BF
AIR CLEANER (COMPRESSOR)	A77-166	AIR MAZE CORP. CLEVELAND, OHIO	V31-0B
BATTERY	A117-49	GLOBE-UNION, INC. MILWAUKEE, WISCONSIN	#134 6 Volt.
CARBURETOR.	A84-546-2	ZENITH CARBURETOR DIVISION BENDIX AVIATION CORP. DETROIT, MICHIGAN	62A10
CLUTCH.	A75-279	TWIN DISC CLUTCH CO. RACINE, WISCONSIN	SL-2-11½"
CRANKING MOTOR.	A107-93	DELCO-REMY DIVISION GENERAL MOTORS CORP. ANDERSON, INDIANA	700
CYLINDER HEAD BREATHER	A77-137	AIR MAZE CORP. CLEVELAND, OHIO	Z0H
FUEL PUMP	A81-99-5	A.C. SPARK PLUG DIVISION GENERAL MOTORS CORP. FLINT, MICHIGAN	1537453
GENERATOR AND REGULATOR	A108-85	DELCO-REMY DIVISION GENERAL MOTORS CORP. ANDERSON, INDIANA	1101374
MAGNETIC SWITCH	A76-49	DELCO-REMY DIVISION GENERAL MOTORS CORP. ANDERSON, INDIANA	#1459
MAGNETO	A85-126-1	AMERICAN BOSCH CORP. SPRINGFIELD, MASS.	MJC4C-334 CW
OIL FILTER.	A43-114	PUROLATOR PRODUCTS INC. NEWARK, NEW JERSEY	N1744 Assy. N-17 Element
UNLOADER PILOT.	A76-81	PENN ELECTRIC SWITCH CO. GOSHEN, INDIANA	G-1

AIR TOOLS

CLAY DIGGER	A88-169-2	INDEPENDENT PNEUMATIC TOOL CO. CHICAGO, ILLINOIS	412
PAVING BREAKER.	A88-168-1	INDEPENDENT PNEUMATIC TOOL CO. CHICAGO, ILLINOIS	25
SINKER ROCK DRILL	A88-167	INDEPENDENT PNEUMATIC TOOL CO. CHICAGO, ILLINOIS	75
WOOD BORING MACHINE	A88-170	INDEPENDENT PNEUMATIC TOOL CO. CHICAGO, ILLINOIS	62-WB

LE ROI COMPANY
MILWAUKEE, WISCONSIN

OPERATING INSTRUCTIONS

STARTING
MACHINE SHOULD BE SET APPROXIMATELY LEVEL TO INSURE EQUAL LUBRICATION TO ALL PARTS. SEE THAT THERE IS FUEL IN TANK. OPERATE FUEL PUMP LEVER BY HAND TO FILL CARBURETOR. SEE THAT ENGINE COOLING SYSTEM IS FULL OF WATER. CHECK OIL LEVEL IN ENGINE & COMPRESSOR CRANKCASES. SEE THAT COMPRESSOR CLUTCH IS DISENGAGED. PULL CHOKE OUT & CRANK ENGINE ONE REVOLUTION. PUSH CHOKE IN HALF WAY. PULL IGNITION SWITCH OUT, & CRANK ENGINE. IF ENGINE DOES NOT START IMMEDIATELY, PUSH IN CHOKE & CRANK UNTIL ENGINE FIRES.

IN EXTREME COLD WEATHER WHEN STARTING IS DIFFICULT, CRANK THE ENGINE WITH THE CHOKE ALL THE WAY OUT FOR A FEW REVOLUTIONS, OR IT MAY BE NECESSARY TO REMOVE SPARK PLUGS & POUR A SMALL AMOUNT OF GASOLINE INTO EACH CYLINDER. WAIT A FEW MINUTES FOR THE GASOLINE TO EVAPORATE. PULL OUT IGNITION SWITCH & START

ALLOW ENGINE TO WARM UP A FEW MINUTES BEFORE STARTING COMPRESSOR.

STOPPING
DISENGAGE CLUTCH TO STOP COMPRESSOR. ALLOW ENGINE TO IDLE A FEW MINUTES BEFORE CLOSING IGNITION SWITCH. OPEN RECEIVER DRAIN COCK.

For the operator's convenience, the simplified instruction plate is reproduced above. For detailed instructions covering care, operation and maintenance of Le Roi Motorized Air Compressor, please refer to section entitled Data.

LE ROI COMPANY
MILWAUKEE, WISCONSIN

ENGINE OIL CAP 3½ GALS.
USE: S.A.E. 30 ABOVE 32 DEG. F.
S.A.E. 10 BELOW 32 DEG. F.
CHANGE OIL EVERY 128 HRS.
KEEP OIL TO FULL MARK ON
BAYONET GAUGE.

This is a reproduction of the oiling instruction plate fixed to side of engine. For detailed lubrication instructions see section "Lubrication".

LE ROI COMPANY
MILWAUKEE, WISCONSIN

COMPRESSOR OIL CAP 2 GALS.
USE: S.A.E. 30 ABOVE 32 DEG. F.
S.A.E. 10 BELOW 32 DEG. F.
CHANGE OIL EVERY 256 HRS.
KEEP OIL TO FULL MARK ON
BAYONET GAUGE.

This is a reproduction of the oiling instruction plate fixed to side of compressor. For detailed lubrication instructions see section "Lubrication".



When ordering spare or replacement parts for this Motorized Air Compressor Unit or when corresponding with the factory regarding it, it is necessary this serial number be indicated.

THIS IS THE SERIAL NUMBER WE REQUIRE.

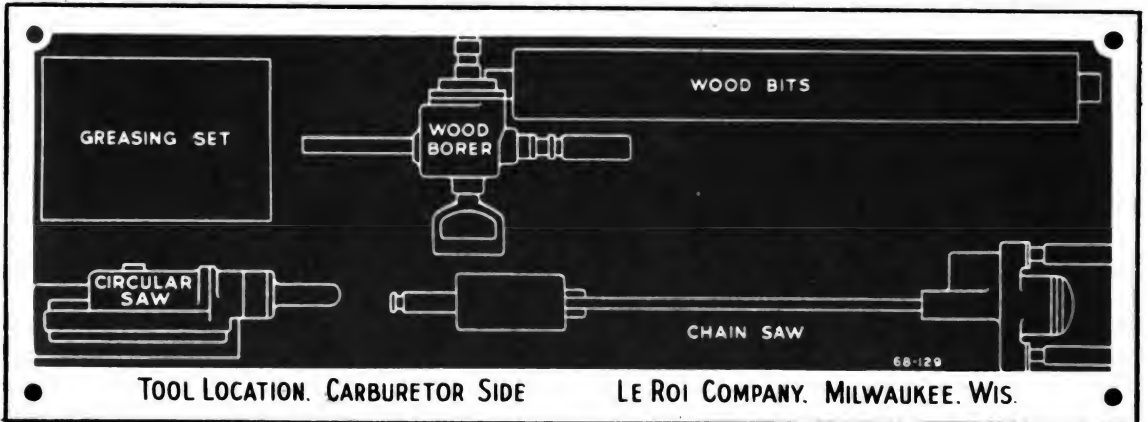

Above plate shows storage facilities provided for tools and equipment in Tool Box (Carburetor side).

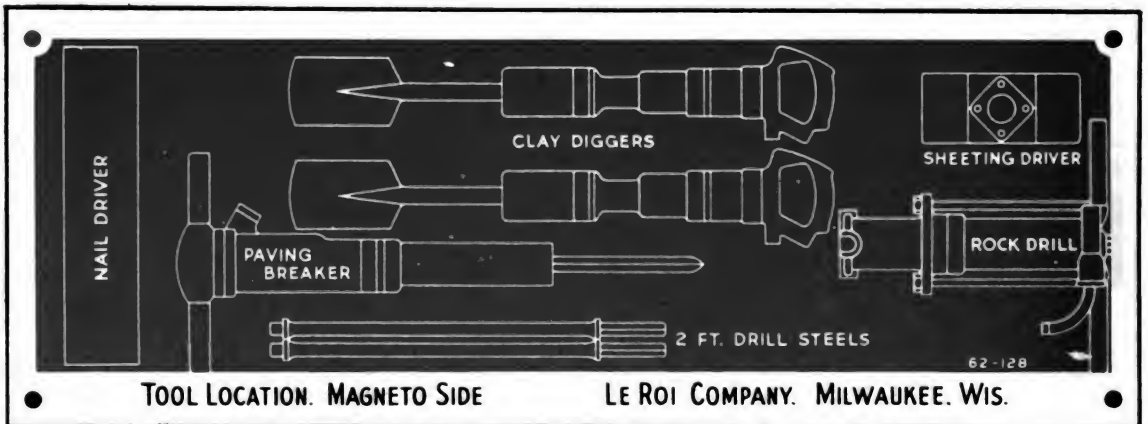

Above plate shows storage facilities provided for tools and equipment in Tool Box (Magneto side).

TABLE OF CONTENTS

SECTION	PAGE
Introduction	I to X
General Description	IV
Specifications	V
Index to Manufacturers	VI
Name Plates	VII & VIII
Operator's Instructions1 to 34
Data1 to 6
Instruments and Controls1
Before Starting a New Air Compressor2
Starting the Engine3
Stopping the Engine4
Preparing Air Compressor for Storage4
Starting Air Compressor that has been in Storage5
Extreme Weather Conditions6
Clutch7
Compressor8 to 12
Minor Service Operations8
Cooling System	13
Electrical	15 to 21
Storage Battery	15
Battery Testing Chart	16
Magneto	15
Spark Plugs	18
Generator	18
Cranking Motor	20
Magnetic Switch	21
Engine	22 to 24
Minor Service Operations	22
Fuel System	25 to 28
Carburetor	25
Fuel Pump	26
Lubrication	29 to 33
Maintenance Schedule	31
Engine Lubrication	32
Compressor Lubrication	32
Maintenance Instructions35 to 90A
Clutch	35
Compressor	37 to 50
Pressure Control System	46
Compressor Service Chart	49B
Cooling System	51 to 52
Water Pump	51
Electrical	53 to 66
Wiring Diagram	53
Magneto	54
Generator	57
Step Voltage Control Unit	59
Cranking Motor	62
Magnetic Switch	65
Engine	67 to 76
Engine Service Chart	76
Fuel System	77 to 85
Zenith Updraft Carburetor	77
AC Fuel Pump	83
Governor86 & 87

TABLE OF CONTENTS (Continued)

SECTION	PAGE
Parts List	Complete Engine and Compressor Unit91 to 146 Spare Parts List.147
Air Tools	Operator's Instructions 149 to 153 No. 62 Wood Boring Machine.149 No. 412 Clay Digger150 No. 75 Sinker Rock Drill.151 No. 25 Paving Breaker152 Maintenance Instructions. 154 to 166 No. 62 Pneumatic Piston Type Wood Boring Machines . .155 No. 412 Clay Digger159 No. 75 Sinker Rock Drill.161 No. 25 Paving Breaker163 Parts List. 166 to 178 Air Tool Accessories.176-178

**INDEX
TO
OPERATOR'S
INSTRUCTIONS**

**DATA
OPERATING INSTRUCTIONS**

CLUTCH

COMPRESSOR

COOLING SYSTEM

ELECTRICAL SYSTEM

ENGINE

FUEL SYSTEM

LUBRICATION

INSTRUMENTS AND CONTROLS

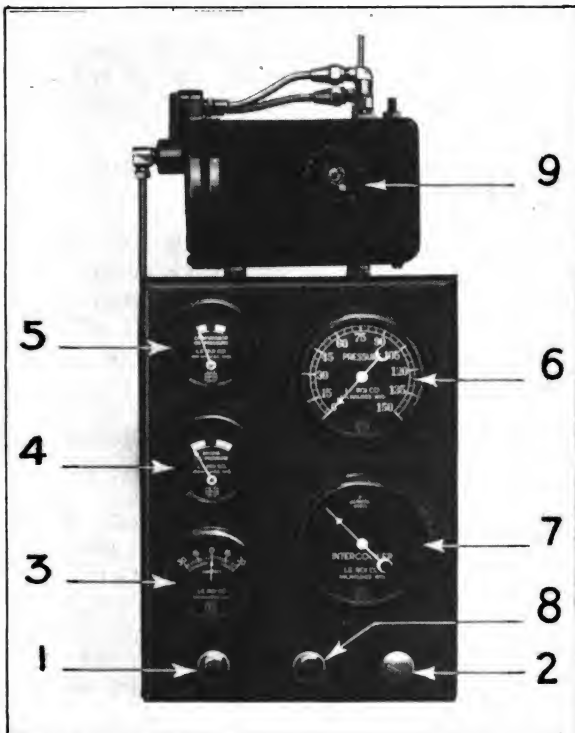

Instrument and Control Panel

1. **ELECTRIC STARTER BUTTON:** Pulling this button completes the electrical circuit between the battery and the cranking motor and causes the cranking motor pinion to engage the flywheel ringgear, thereby cranking the engine.
2. **CHOKE BUTTON:** Helps start the engine when the engine is cold. Pulling out the button shuts off air to the carburetor, giving a rich mixture. After the first revolution, push choke button in half way or to a point where engine runs without misfiring. Push choke button all the way in after engine has started and has warmed up sufficiently. NEVER run engine with choke all the way out. In hot weather it may not be necessary to choke the engine to start.

3. **AMMETER:** This is a check on the electrical system. It indicates whether the battery is being charged or discharged. When en-

gine is running at normal speed, ammeter needle should be in the "charge" range. If the ammeter shows discharge continuously, the cause should be investigated in order to avoid completely discharging the battery.

4. **OIL PRESSURE GAUGE-ENGINE:** This gauge indicates the pressure of the oil circulating through the engine. The indicator hand should hold in or slightly above the green section of dial when engine is running at operating speed. If indicator does not show pressure, stop engine immediately and investigate cause.

5. **OIL PRESSURE GAUGE-COMPRESSOR:** This gauge performs similar function as the engine gauge.

Caution: Neither the engine nor compressor oil pressure gauge indicate the condition of the oil; they indicate only the pressure.

6. **AIR PRESSURE GAUGE:** This gauge indicates the pressure of the air in the air receiver tank. In normal operation it should read 100 pounds maximum after engine and compressor have been thoroughly warmed up to operating temperatures.

7. **INTERCOOLER GAUGE:** This gauge indicates the functions of the compressed air system. When every part of the system is operating normally the indicator hand will ride in the center position. When the machine is not in operation and when the unit, in operation, unloads, the hand will drop to the left hand side. If the hand continuously rides in the left hand section of the dial it indicates a leak in the low pressure system somewhere, either in the valves or lines or connections. If the hand rides continuously in the right hand portion it indicates similar condition in the high pressure system.

8. **MAGNETO GROUND SWITCH:** When this button is pulled out magneto is in "on" position. Pushing this button in short circuits the magneto, thereby making it inoperative and stops engine.

9. UNLOADER PILOT SWITCH: This unit automatically regulates the air pressure in the air receiver tank. When pressure in receiver reaches 100 pounds it causes compressor to unload and engine to slow down. When pressure in receiver drops approximately 12 pounds it causes engine to accelerate and compressor to load.

BEFORE STARTING A NEW AIR COMPRESSOR

This air compressor was given a rigid operating test and final inspection before it was shipped from the factory, but we recommend that you read and follow the procedure outlined below before starting or operating a new air compressor.

LUBRICATION:

1. Lubricate the entire air compressor, using the "Maintenance Schedule" section as a guide.
2. Check the oil levels of the engine and air compressor crankcases, air cleaner to see that they are filled to the proper levels with the correct grades of oil for the prevailing temperature (refer to "Lubrication Chart" Section Data.
3. Before starting a new engine, remove the spark plugs and pour about two tablespoonfuls of mixture of half oil and half gasoline into each cylinder to insure lubrication of the pistons and cylinders when the engine first starts. This practice is recommended for engines that have been idle for the 30 days or more.
4. Add one pint of light engine oil to every 5 gallons of fuel in the tank, for the first two fillings only.

ENGINE COOLING SYSTEM

The capacity is approximately 8 gallons U.S.

1. Close drain cock in radiator bottom tank and close drain cock on right side of cylinder block near carburetor. Fill system with clean water (use soft or rain water if possible). Never pour cold water into an empty system if the engine is hot as it may cause the cylinder head of engine to crack.
2. If air compressor is to be operated in freezing temperatures (32°F. or lower) refer to "Cold Weather Operations".

FUEL SYSTEM

1. The air compressor engine is designed to operate on gasoline that has a maximum of 68 octane rating. To get the maximum efficiency we recommend you use the fuel for which the engine is designed and be sure the fuel used is clean and of good quality.
2. Fill the fuel tank with clean gasoline--The capacity of the fuel tank is approximately 50 gallons (U.S.)

Safety First. Never fill the fuel tank with an open flame near or when the engine is running. Keep funnel in contact with metal of fuel tank when filling to avoid the possibility of an electric spark igniting the vapors. See that vent hole in the fuel tank filler cap is kept open at all times to assure proper flow of the fuel.

STARTING THE ENGINE**PREPARATION FOR USE**

1. It is advisable to locate truck so it will be as near level as possible to insure equal lubrication to all parts.
2. Check entire unit according to "Maintenance Schedule". Before starting a new engine or one that has been idle for any length of time, remove spark plugs and pour about two tablespoonfuls of mixture of half engine oil and half gasoline into each cylinder to insure lubrication of pistons and cylinder walls when engine first starts.
3. Check and make sure there is fuel in fuel tank. (Add one pint of light engine oil to every five gallons of fuel in tank for first two fillings only.)
4. Open valve in gasoline line located beneath fuel tank--operate hand priming lever of fuel pump to fill carburetor float chamber.
5. See that clutch is disengaged, (lever pulled away from engine).
6. Open drain cock in air receiver and allow any moisture to drain out--then close cock. NOTE: Repeat this every four to eight hours during operation, depending upon weather conditions.
7. With magneto ground switch in the "OFF" position (pushed in) and choke lever pulled all the way out, crank engine over one revolution. Push choke in half way and pull magneto ground switch to "ON" position and crank engine. It may not be necessary to choke a warm engine. If engine does not fire immediately, push in choke and continue to crank until engine fires. In extremely cold weather when starting is difficult, crank the engine with the choke all the way out for a few revolutions, or it may be necessary to remove spark plugs and pour a small amount of gasoline into each cylinder. Wait a few minutes for the gasoline to evaporate, pull ignition switch to "ON" position and crank.

Caution: Never operate cranking motor more than 30 seconds at a time without pausing to allow cranking motor to cool. Excessive cranking periods will cause cranking motor to overheat and fail.

8. After engine starts, allow to warm up a few minutes before starting the compressor.
9. When starting with pressure in receiver Tank, lift hand unloader lever on unloader pilot before starting compressor. See Ill. page 9.
10. To start compressor, engage the clutch by moving lever toward engine.
11. Trip hand unloader lever on unloader pilot after compressor reaches operating speed.
12. Trip intercooler and air receiver tank safety valves by hand to make certain of their operation.
13. If either engine or compressor oil gauge fails to show pressure, stop immediately and determine cause.

STOPPING THE ENGINE

1. Disengage clutch to stop compressor.
2. Allow engine to idle a few minutes, then push in magneto ground switch.
3. Open drain cock in air receiver tank.
4. It is advisable to close gasoline shut-off valve if the engine is to be stopped for any length of time.

PREPARING AIR COMPRESSOR FOR STORAGE

When the air compressor is not to be used for a period of time, it should be stored in a dry and protected place. To leave equipment outdoors -- exposed to the elements, will result in materially shortening its life.

The following procedure should be followed when the unit is placed in storage for thirty days or more. Lubrication precautions should be repeated every six months thereafter.

1. Before shutting down air compressor, remove air cleaners and pour one-half cup of engine oil in each air intake, allow to run for approximately one minute and stop.
2. Wash, clean, and completely lubricate the engine and air-compressor. (Refer to "Maintenance Schedule".)
3. Drain both engine and compressor crankcases and refill to full mark with light engine oil. Run unit about five minutes to insure oil reaching all lines.
4. Drain water from cooling system, and leave drain cock open.
5. Disengage clutch by moving lever from engine.
6. Drain all fuel from tank, lines, pump and carburetor.

CAUTION: A gummy substance will form in the gasoline if it is allowed to stand in the tank, lines or carburetor. This gum accumulates in the carburetor jets and passages, causing serious damage.

7. When engine is cold, pour one-half cup of engine oil in each cylinder through spark plug holes. Then replace spark plugs but leave wires disconnected from plugs. Turn engine over several times to work oil in between pistons and cylinder walls. **REPEAT THIS OPERATION EVERY THIRTY DAYS.**
8. Open drain cock in air receiver allowing any water to drain and leave cock open.
9. Remove battery and store in a warm dry place. Make certain battery is filled to proper level and fully charged before storing.

CAUTION: Battery should be recharged every thirty days while it is in storage.

10. Inspect entire unit for worn or damaged parts which may later cause expensive repairs. While unit is in storage it is an excellent time to touch up any spots where paint has been removed.
11. Coat safety pop-valves with light grease to prevent corrosion.

STARTING AIR COMPRESSOR THAT HAS BEEN IN STORAGE

1. Remove spark plugs and pour about 2 tablespoonfuls of a mixture of half engine oil and half gasoline into each cylinder to insure lubrication of pistons and cylinder walls when engine first starts.
2. Install battery making certain connections are made to proper terminals. **NOTE:** This battery is grounded to positive terminal.
3. With magneto ground switch in "OFF" position (pushed in), crank engine over until the excess oil has been blown out of the spark plug holes. This operation will loosen any tight piston rings and wash the old gummy oil from the valves and pistons.
4. Drain engine and compressor oil pans and refill to full mark with proper grade of oil. (Refer to Lubrication Chart.)
5. Install spark plugs and connect cables to proper terminals.
6. Fill cooling system with clean soft water.
7. Fill fuel tank, open valve in gasoline line, operate hand priming lever of fuel pump to fill carburetor float chamber.
8. Close drain cock in air receiver tank.
9. Start engine and allow to run slowly until sufficiently warmed up before engaging compressor.

EXTREME WEATHER CONDITIONS

HOT WEATHER OPERATION

The Air Compressor will operate successfully in extreme temperatures without additional adjustments.

LUBRICATION

Particular care should be given that the engine and compressor are filled with proper grade of oil.

COOLING SYSTEM

Keep radiator filled with clean water. Radiator and Intercooler fins must be kept free of accumulated dirt, leaves, insects etc. Clean as described in Cooling System Page 13. Be sure fan belts are properly adjusted at all times.

EXTREME DUST CONDITIONS

Follow hot weather operation suggestions.

AIR CLEANERS

Check as often as necessary to insure against accumulation of dirt. **KEEP THEM CLEAN.**

COLD WEATHER OPERATION

If the Air Compressor is to be operated in temperatures of 32° F. or lower, observe the following precautions:

FUEL SYSTEM

Use only a high-test winter-grade gasoline for starting, and keep supply in a closed container so the more volatile portion does not evaporate.

Fill the fuel tank at the end of the day's operation to prevent moisture from collecting in the tank.

LUBRICATION

Be sure to use the correct grade of lubricating oil in the engine and compressor crankcases, and air cleaners as specified in the "Lubrication Chart"

COOLING SYSTEM

When operating temperatures are 32° F. or lower, there is danger of the water freezing in the cooling system. To overcome this condition, use one of the recommended anti-freeze solutions shown below.

FREEZING POINT		® ANTI-FREEZE SOLUTIONS (32 U.S. QUART COOLING SYSTEM)								
		METHYL ALCOHOL			ETHYL ALCOHOL			ETHYLENE GLYCOL		
		APPROX. QUANTITY IN QUARTS (U.S.)	SPECIFIC GRAVITY	PER CENT BY VOLUME	APPROX. QUANTITY IN QUARTS (U.S.)	SPECIFIC GRAVITY	PER CENT BY VOLUME	APPROX. QUANTITY IN QUARTS (U.S.)	SPECIFIC GRAVITY	PER CENT BY VOLUME
CENT.	FAHR.									
-7°	20°	4	.9822	12.5%	5¼	.9796	16.5%	5¼	1.022	16.5%
-12°	10°	6½	.9726	20.5%	8¼	.9704	25.5%	8¼	1.034	25.5%
-18°	0°	9	.9638	28%	10¾	.9611	33.5%	10¾	1.044	33.5%
-23°	-10°	11	.9560	34.5%	13	.9511	40.5%	12½	1.051	39%
-29°	-20°	12½	.9493	39%	15¼	.9392	47.5%	14	1.058	44%
-34°	-30°	14	.9421	44%	17½	.9244	54.5%	15¼	1.062	47.5%
-40°	-40°	15¼	.9358	47.5%	20½	.9068	63%	16½	1.064	51.5%

® ABOVE FIGURES, COURTESY OF U S INDUSTRIAL CHEMICALS INC

CAUTION: Do not use a solution of kerosene or other oils, calcium chloride, magnesium chloride, sodium silicate, or other inorganic salts, honey, glucose or sugar, or any alkaline solution, as they are injurious to metal or rubber parts.

COOLING SYSTEM CAPACITY IS 8 GALLONS, 32 QUARTS. (U. S.)

DRAINING THE SYSTEM

1. Open the drain cock located in cylinder block beneath carburetor.
2. Open the drain cock located in the radiator bottom tank.
3. Be certain that drain cocks are not plugged and system drains completely before closing cocks.

CLUTCH

The Air Compressor is equipped with an 11½" diameter, spring loaded, double plate, Twin Disc Clutch.

CARE OF THE CLUTCH

This type of clutch is designed to give long and continued service with very little adjustment. Due to the intermittent or shock loads common to this type of installation, the friction surfaces may wear and cause the clutch to slip sufficiently to overheat and damage the clutch plates and discs. This wear, which occurs while the clutch is in operation and carrying a maximum load, is automatically taken up by the heavy coil springs which bear against the pressure plate. When the clutch is new and is in "engaged" position, with the throwout collar assembly pulled away from the main clutch body, the pressure springs will measure approximately 1-5/16". As the friction discs wear these dimensions increase until the springs are extended as far as possible and can not automatically take up any additional wear. At this point the clutch will have to be adjusted in order to make use of the remaining life of the friction discs.

Lubrication is provided for by means of a grease cup which should be turned down snug at the start of each day and/or every eight working hours. When empty, refill the grease cup with WB-2 (Grease, general purpose No. 2) ball bearing grease, for operating temperatures of 200° F.

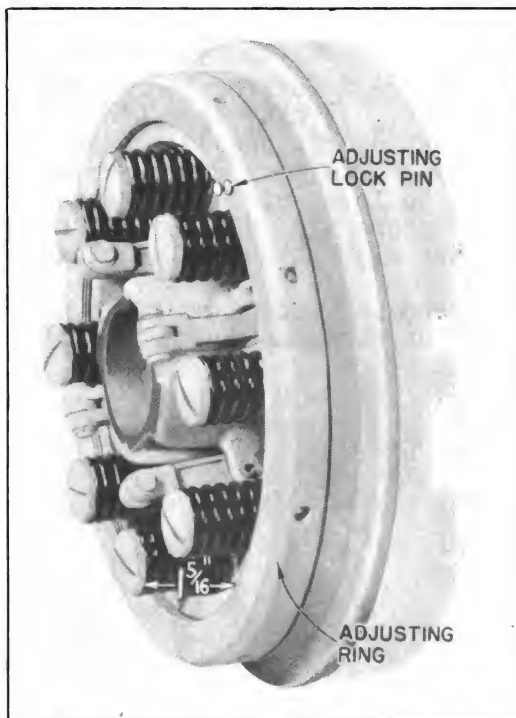

Twin Disc Clutch Adjustment

ADJUSTMENT

When adjustment becomes necessary pull out the adjusting lock pin and turn the adjusting ring to the right or clockwise about two and a half revolutions or until the springs are compressed to their original height in the "engaged" position of the clutch. **CAUTION** - Extreme care should be taken that when the clutch is disengaged the driving plates are "disengaged" and do not drag when the engine is idling. When the collar assembly is pushed out to engage the clutch, the pressure plate against which the springs bear should compress the springs to approximately 1-5/16".

MINOR COMPRESSOR SERVICE OPERATIONS

CYLINDER HEAD-COMPRESSOR

After a new compressor has been run a short time and is thoroughly warmed up it is advisable to check cylinder head stud nuts for tightness. Stop compressor and tighten all nuts a little at a time until all are tight. Go over all the nuts several times to make certain that all are uniformly tight.

AIR CLEANER

Clean air is assured in the compressor by the use of oil bath air cleaners. The air after entering the intake passes to the oil bowl where it goes through a bath of oil. As the air rises to the cleaner outlet it passes through a series of oil bathed screens where the fine dust is removed. As the oil from the screen works back down to the bowl, it carries with it the dust removed from the air. A relief valve is provided to by-pass the air returning from the cylinder heads when the compressor unloads eliminating the danger of the oil being forced out of the bowl. The air cleaner can work efficiently only so long as the bowl is free from accumulated dust. When dust accumulates in the bowl, the bowl must be removed and cleaned and refilled with new clean oil of the recommended viscosity.

OIL BOWL

Starting each day and/or every 8 working hours stop compressor and check bowl for accumulated dust. (This operation is advised at closer intervals under extreme dust conditions.) Loosen thumb screw and remove filter element and oil bowl. Bowl may now be cleaned by wiping with a rag and refilled with oil to level of bead. Relief valve felt should be brushed or wiped clean before air cleaner is reassembled. Every 100 working hours entire filter element should be cleaned thoroughly.

CAUTION: When cleaning becomes necessary it must be cleaned in light engine oil, not gasoline nor kerosene due to possibility of explosion in air receiver.

GENERAL PRECAUTIONS

As an added precaution against dirt entering compressor, inspect all connections and gaskets, making certain they are tight and in good conditions.

SAFETY VALVES

Safety valves are provided to prevent serious trouble if air pressure should rise above recommended limits.

AIR RECEIVER SAFETY POP VALVE

This valve is located in the air receiver tank and is set to trip at 125# pressure. Valve should be tripped by hand daily to prevent sticking. To trip, pull down lever on side of valve.

INTERCOOLER SAFETY POP VALVE

This valve located in the top tank of the intercooler performs the same function as the receiver safety valve except it is set to trip at 50#

OPERATOR'S INSTRUCTIONS

pressure. Valve should be tripped by hand daily or every 8 hours to prevent sticking. To trip, pull down lever on side of valve.

CAUTION: If either the air receiver or intercooler safety pop valves trip when the compressor is set for normal operating pressure, it is an indication of trouble. The machine should be stopped immediately and the trouble corrected.

PRESSURE CONTROL SYSTEM (See Diagram next page)

OPERATION

The purpose of the control system is to regulate automatically the operating pressure of the compressor within set limits.

Regulation of pressure is accomplished in the following manner: When the pressure in receiver "A" reaches a predetermined maximum (approximately 100 lbs.) it causes the pilot unloading valve "B" to trip and admit air from the receiver to unloader valve "C", intercooler relief valve "D" and slowdown assembly "E", there unloading the compressor by holding the intake valves open, relieving the intercooler pressure to atmosphere and idling the engine by closing the carburetor butterfly valve.

When pressure in receiver "A" drops to a predetermined minimum, (approximately 88 pounds) the pilot unloading valve again trips and allows the air to escape from unloader "C" intercooler relief valve "D" and slowdown assembly "E" and pass through check and bleed valve "F". Check and bleed valve "F" is constructed so that air from the slowdown assembly can escape freely while air from the unloaders and intercooler relief valve is restricted, thereby causing a time delay and allowing the engine to attain normal operating speed before the compressor load comes on.

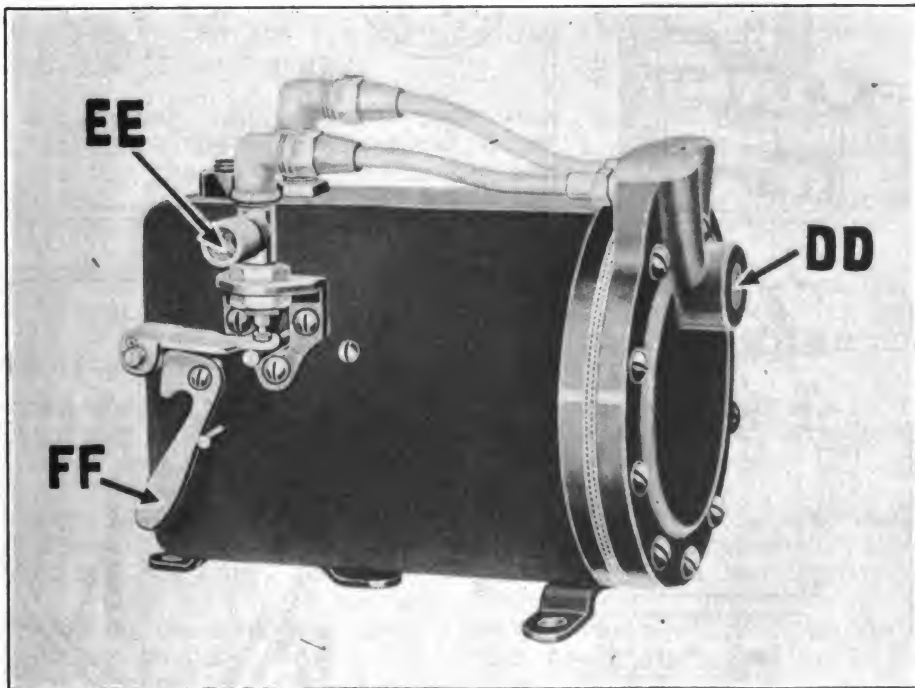

BACK VIEW TYPE GI UNLOADER PILOT

DD--Connection to air receiver

EE--Connection to cylinder heads

FF--Hand unloader lever

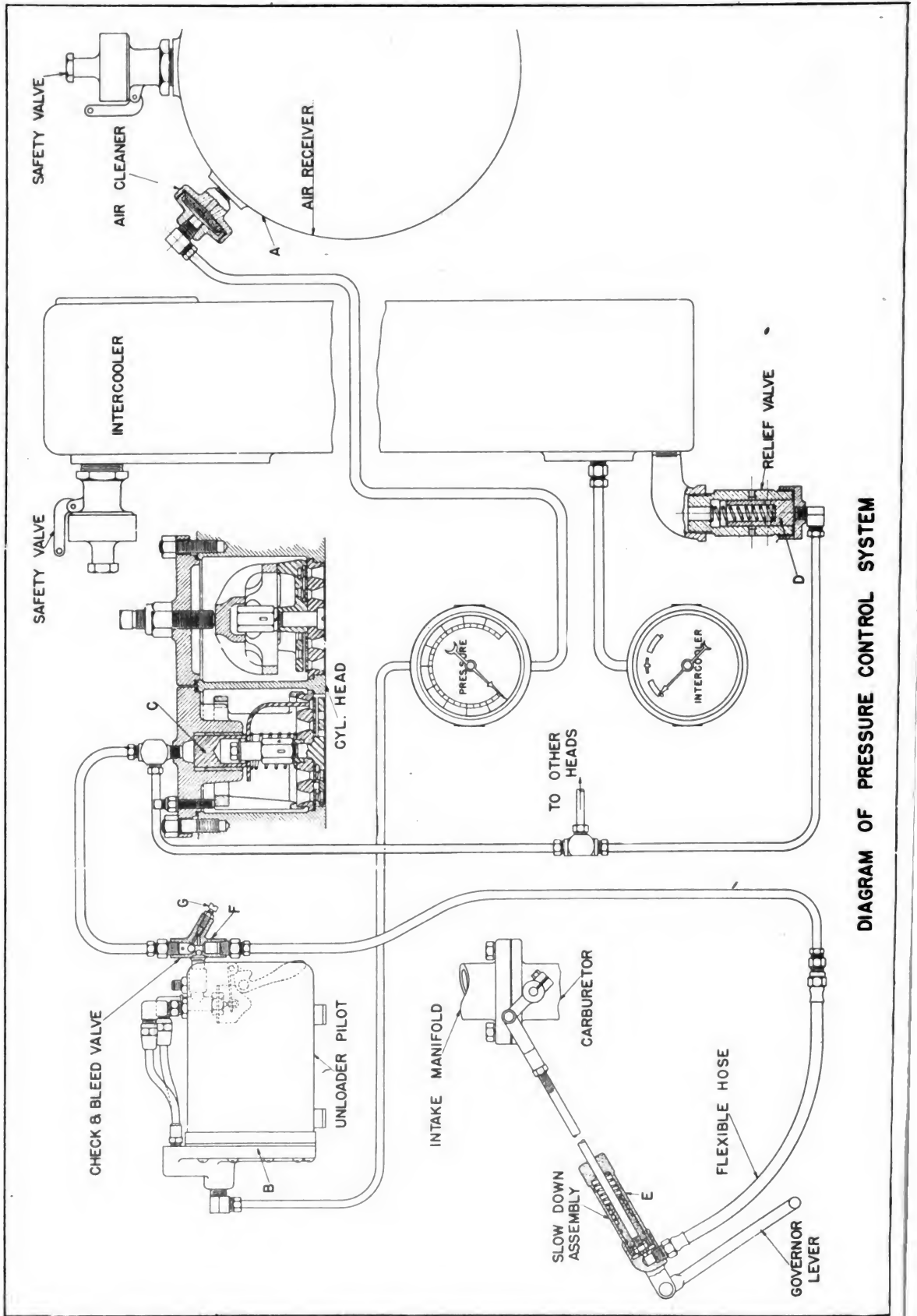

DIAGRAM OF PRESSURE CONTROL SYSTEM

UNLOADER PILOT SWITCH (PENN ELECTRIC SWITCH CO. TYPE GI)

The Penn Unloader Pilot automatically unloads and loads the compressor on the rise or drop in receiver pressure. The unloader pilot has been correctly set for pressure and sealed at factory. If adjustment becomes necessary consult a competent mechanic.

When starting compressor lift hand unloader lever "FF" (See figure) which places equipment in unloaded position relieving compressor of heavy starting load. When compressor reaches normal speed, move hand unloader lever "FF" to running position as shown.

SUCTION UNLOADERS

The suction unloaders are located in the cylinder heads directly over the suction valves. The purpose of these unloaders is to hold the suction valve open and unload the compressor when desired receiver pressure is reached. This is accomplished by admitting air from the receiver to the unloader, which forces the plunger down. When the plunger moves down it contacts a set of fingers which hold the valve open. While the suction valves are open, compression cannot take place in the cylinders.

When the pressure in the receiver drops, air is released from the unloader and a spring under the fingers returns the plunger to its original position, allowing the compressor to start pumping again.

The unloader bodies are fitted to very close tolerances. This eliminates the use of piston rings or other packing. Because of the close tolerances held between the body and plunger it is necessary to service the suction unloaders as a complete assembly.

INTERCOOLER RELIEF VALVE

This valve is located in the intercooler bottom tank. It consists of a cylinder, plunger and spring.

When the compressor unloads, air from the receiver is admitted to the cylinder, forcing the plunger forward until holes in the plunger and cylinder are in line, allowing the air in the intercooler to escape to the atmosphere. When the relief valve by-passes air, it automatically drains moisture from receiver.

When pressure in the receiver drops, air is released from the relief valve and a spring returns the plunger to its normal operating position.

CARBURETOR SLOWDOWN

The slowdown assembly is designed in such a way that it becomes a part of the engine governor rod. One end of this assembly is attached to the governor lever and the other end to the carburetor lever.

When the compressor unloads, air from the receiver is admitted to the slowdown assembly, forcing the plunger outward and increasing the length of the governor rod until the carburetor lever is in the idle position.

When pressure in the receiver drops, the air is released from the slowdown and the plunger is returned to its normal operating position by a spring, allowing the engine to return to full load speed.

CHECK AND BLEED VALVE

This valve is inserted in the control air line between the pilot unloading valve and the unloaders, intercooler relief valve and slowdown.

The purpose of this valve is to allow the air to flow freely into the unloaders, intercooler relief valve and slowdown when the compressor unloads and to restrict the escape of air from the unloaders and relief valve and at the same time allow air to escape rapidly from the slowdown when the compressor load is applied to the engine.

To change time delay, adjust screw "G" (Plate No. 2S-14-1) on side of valve. Turn screw inward to increase time delay and outward to decrease time delay.

This valve is adjusted for best performance. Do not change it unless it is absolutely necessary.

COOLING SYSTEM

GENERAL

The engine is equipped with an efficient bypass-type thermostatically controlled cooling system.

The water is circulated through the engine block, cylinder head and radiator by a positive centrifugal type pump. The water temperature is controlled by the thermostat located in the engine outlet to radiator hose which does not allow water to flow through the radiator until the engine has reached the operating temperature. With the thermostat closed the water circulates only through the engine.

The air compressor is air cooled and requires no special attention.

TO CLEAN OUT DIRT AND SLUDGE

1. Drain the cooling system by opening drain cock in lower radiator connection and in cylinder block (located beneath carburetor). Allow system to drain and close cocks.
2. Fill the cooling system with a solution of $2\frac{1}{2}$ pounds of ordinary washing soda mixed with 8 U.S. gallons of water (cooling system capacity.)
3. Leave the radiator filler cap off and run engine until water is hot, then drain and flush the system with clean water.
4. Refill with clean soft water.

RADIATOR CORE

Overheating is often caused by bent or clogged radiator fins. If the spaces between the fins become clogged, clean them with an air hose. When straightening bent fins be careful not to injure the tubes, or break the bond between the fins and tubes.

INTERCOOLER CORE

The intercooler core is similar to the radiator except air travels through the core instead of water. It requires no internal cleanings but fins should be cleaned as described in "Radiator Core".

FAN BELT TENSION

The adjustment of fan belts should be checked frequently to assure maintenance of the correct tension. The tension is correct when the belts can be depressed without effort, approximately $1/2$ to $3/4$ inch midway between the pulleys. (As shown in illustration).

ADJUSTING THE BELTS

Adjust the tension of a fan belt by changing the width of the groove in the fan pulley. To change the width of the pulley grooves loosen the lock screws and move pulley flanges together to tighten it and apart to loosen it. Retighten the lock screws after correct tension is obtained. After a new belt has been run approximately 64 hours check the tension and adjust it again if necessary. The belt should at no time contact the bottom of the pulley groove because this will cause the belt to wear rapidly. Adjust the pulley for a narrower groove, if this is possible, without increasing the tension more than allowable. Having a "V" belt tighter than the tension specified, will also result in excessive wear.

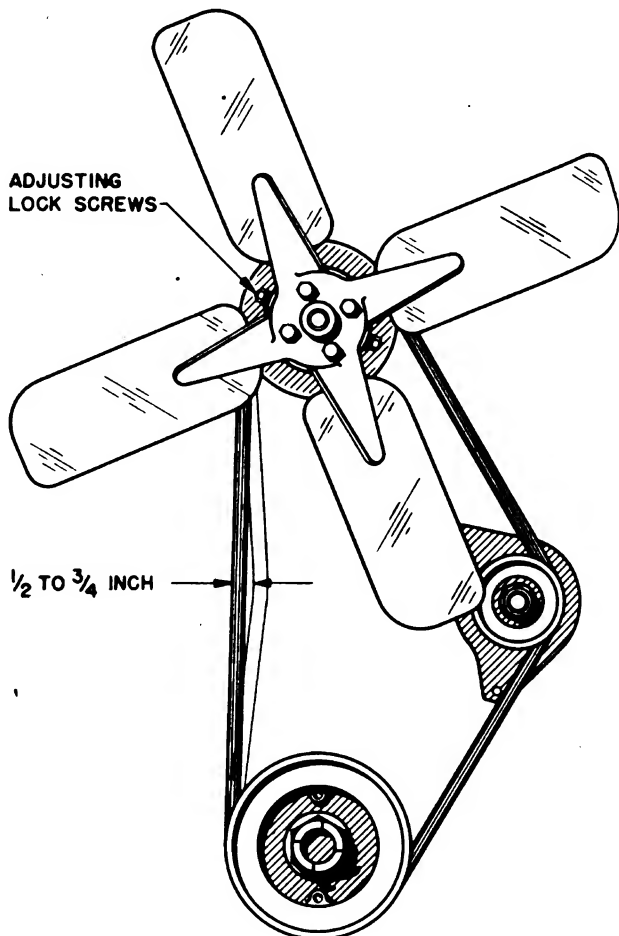

Correct "V" Belt Tension

the pulleys. The belt can now be worked over the top of the fan blades.

REMOVING THE FAN BELTS

To remove a fan belt, loosen the set screw in the fan pulley flange and move flanges out as far as possible. Start the belt over the outer flange of the lower pulley and pry it out with a light bar or rod. Slowly crank the engine at the same time and the belt will work off

REPLACING FAN BELTS

The fan belt should be replaced with a new one when it becomes soaked with grease, or when it becomes so badly worn that it does not drive the fan at the proper speed. When replacing the belt, reverse the procedure outlined under "Removing the Fan Belts" except the belt can be started on the lower pulley by hand, and, by slowly cranking the engine, the belt will find the correct position.

WATER PUMP

The water pump may leak, due to wear after considerable use. If this occurs see "Repair of Water Pump", Maintenance Section "Cooling".

OPERATOR'S INSTRUCTIONS**ELECTRICAL EQUIPMENT****PRECAUTIONS**

before working on any part of the Electrical System, disconnect the Battery ground cable. Do not reconnect this cable until all the connections have been made. This will avoid short circuiting and possible damage to any of the electrical units.

Be sure that all of the terminals are clean and securely fastened. Make certain there are no broken wires anywhere in the electrical circuit.

STORAGE BATTERY**GENERAL DESCRIPTION**

The battery is a 6 volt Globe-Union #134.

CARE OF BATTERY

To insure proper life of battery it is important that the electrolyte be kept at the proper level at all times. The water level in all cells should be at least $\frac{3}{8}$ " but not over $\frac{5}{8}$ " above the top of the separators. When the level is too high the electrolyte leaks through the vent plugs. When too low the separators and plates may be damaged due to drying and warping.

Only distilled water or water of known purity should be added to electrolyte. Impurities present in most natural waters can cause severe injury to the plates, decrease efficiency and materially shorten the life of the battery. In cold weather when the temperature falls to 32° F., water should be added immediately before the start of a run. This will permit the charging process to thoroughly mix the water and electrolyte and will prevent the added water from freezing.

Inspect the battery at the start of each day to maintain the water level and check the specific gravity every 64 hours. The specific gravity of the electrolyte should be tested with a reliable hydrometer. All cells will have an approximate gravity reading of 1.285 when fully charged and 1.150 when completely discharged. See Chart for the variations of specific gravity with temperature.

The battery cable terminals must be kept clean and tight. Corroded terminals may be cleaned by washing in pure ammonia or a saturated solution of soda bicarbonate. Cleaning solution must be rinsed away with clear water.

CAUTION: Scraping of terminals is not advisable due to danger of damaging the lead coating. After terminals have been cleaned a light coating of CG-(Grease, general purpose) will restrict the formation of this corrosion. Make certain battery is fastened securely to carrier frame.

MAGNETO**GENERAL DESCRIPTION**

The engine is equipped with a high-tension American Bosch Magneto Model MJC4C which is designed and built in accordance with the latest ignition practices. It is superior from the standpoint of performance, long life, and trouble-free operation.

BATTERY TESTING CHART

CONDITION	CAUSE	PROCEDURE	REMEDY
1. Hydrometer test shows all cells over 1.250 Sp. Gr. and readings practically equal (within 10 or 15 points).	Battery is probably in good condition.	Battery does not require a recharge in summer months, but may require a boosting charge in cold weather.	Examine battery terminals to see that they are tight and clean; ascertain charging rate of generator.
2. Hydrometer test shows all cells reading 1.250 or less and readings practically equal (within 10 or 15 points).	Demand from battery greater than input from generator.	Recharge battery.	Make a thorough check on electrical system for short circuits, loose connections, and charging rate of generator. Recommend an increase in charging rate to suit.
3. Cells unequal (20 or more points variation) and highest reading over 1.225 Specific Gravity.	<ul style="list-style-type: none"> a. Short circuit in low cell or cells. b. Evaporation caused by overcharging. c. Unnecessary addition of acid. d. Loss of electrolyte by leakage. 	Make momentary high rate test on each cell.	If high rate test shows all cells are within 1-10 volt of each other, recharge battery until gravity of electrolyte remains constant for 4 hours. Adjust gravity of all cells by adding water or small amount of acid (1.400 Sp. Gr. or less).
4. Cells unequal (20 or more points variation) and highest cell reading 1.225 or less.	<ul style="list-style-type: none"> a. Short circuit in low cell or cells. b. Evaporation caused by overcharging. c. Unnecessary addition of acid. d. Loss of electrolyte by leakage. 	Recharge battery, if possible, and then make momentary high rate discharge test on each cell.	If battery takes a recharge and high rate test shows all cells within 1-10 volt, adjust gravity of all cells by adding water or small amount of acid (1.400 Sp. Gr. or less).
5. Hydrometer tests show cells with gravity readings over 1.300 at 80 deg. Fahr.	<ul style="list-style-type: none"> a. Unnecessary addition of acid to cells. b. Addition of battery compounds commonly known as battery "dope" solutions. 	<ul style="list-style-type: none"> a. If battery has not been operated for a long period or at an excessively high gravity, this condition may be remedied by careful treatment. b. No positive assurance can be given that conditions arising from the use of battery compounds can be remedied. A number of battery manufacturers construe the use of battery "dope" solutions as grounds for cancelling their warranty. 	<ul style="list-style-type: none"> a. Drain out all solution from cells. Refill with dilute (1.100 Sp. Gr.) electrolyte and charge at a low rate of current until gravity of electrolyte remains constant for 4 hours. Then drain cells again and refill with 1.285 Sp. Gr. electrolyte and after 3 hours charging adjust gravity to 1.285. Continue charge until the gravity of all cells is constant for a period of 2 hours. b. Treat as in preceding paragraph (a). UN- DER NO CIRCUMSTANCES SHOULD BATTERY COMPOUND BE INTRO- DUCED INTO A BATTERY.
6. Battery is fully charged but hydrometer tests show gravity to be 1.265 or less at 80 deg. Fahr.	Excessive evaporation usually caused by overcharging.	Adjust gravity of electrolyte to proper limits by adding small amount of acid (1.400 Sp. Gr. or less).	Ascertain charging rate of generator and reduce the rate if necessary.

7. Frequent additions of water to all cells of battery.	Excessive overcharging.		Reduce charging rate of generator.
8. Container cracked causing frequent additions of water to one cell of battery.	a. Loose installation. b. Stone bruise. c. Frozen battery.		Replace with new container.
9. Bulge in battery container.	Excessive temperature probably caused by overcharging.	Same as for condition No. 3 or No. 4.	If high rate test indicates any weak cells, the battery probably is beyond repair. In all cases, ascertain charging rate and reduce the rate if necessary.
10. Corrosion on battery terminals.	a. Excessive charging rate causing spray of acid on terminals. b. Lead coating destroyed on terminals.	Remove terminals from posts. Clean posts and terminals thoroughly. Replace terminal cable if corroded excessively.	Grease terminals and posts thoroughly to prevent access of acid to terminals, bolts and nuts. Ascertain charging rate and reduce rate if necessary.
11. Broken terminal posts.	a. Loose battery installation. b. Terminal cable too short.	Remove battery and build up new terminal post.	Replace terminal cable with one of proper length; tighten battery in carrier and also battery terminals on posts.

To diagnose the conditions stated in the foregoing paragraphs the battery station must have the following tools:

1. A good, accurate hydrometer graduated to read from 1.100 to 1.325 with divisions to indicate differences in gravities within ten points.
 2. A good, accurate thermometer graduated to read as high as 115 deg. F. Many batteries are damaged because of high temperatures; this condition can only be determined by means of a thermometer.
 3. A good, single-cell type voltmeter having a 3-volt scale with division showing 1/10 of a volt (possibly an additional scale reading 15 volts to read total battery voltage).
 4. A good, high-rate discharge tester; this instrument may be either a single-cell tester or a more elaborate type adapted to test the complete battery.
- CHARGING INSTRUCTIONS.** Regular starting and lighting batteries should be charged at a current rate not exceeding one ampere per positive plate. A rate of four or five amperes is usually suitable for the majority of batteries. During the charge, a thermometer should be used to check the temperature of the electrolyte in the cells. If the temperature exceeds 110 deg. F., reduce the charging rate immediately, or else discontinue the charge until the battery temperature is less than 90 deg. F. Charge the battery until all cells gas freely and the specific gravity of the electrolyte remains constant for 4 hours. Adjust

Corrections for Hydrometer Readings When Battery Temperature Is Above or Below 80 Deg. F.

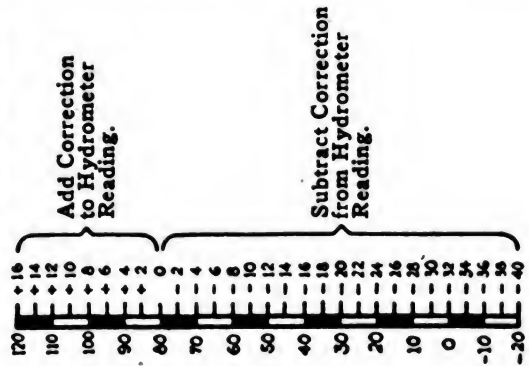

gravity of cells at end of charge to proper limits if necessary. The specific gravity of a fully charged battery should be between 1.275 and 1.295 at a temperature of 80 deg. F.

CONDITIONS WITHIN THE BATTERY. No battery should be returned to the manufacturer nor should it be opened for inspection before its condition is diagnosed in accordance with the procedure given in this chart. When readings are obtained with the high-rate tester that differ considerably more than 1/10 of a volt, as described in paragraph No. 3 or No. 4, it is proper to open the battery. The separators may be found to be worn thin in places, or broken, or split. If the plates in such a battery are in good condition, the separators may be replaced with new separators and the battery recharged. If the positive plates are badly buckled or the positive grids are broken, the battery is not in condition for further service. Such a battery either was badly overcharged or else may have been in service for a long period of time.

EXAMPLE: A battery cell has a hydrometer reading of 1.245 at 10 deg. F. What is specific gravity at 80 deg. F.?
From correction scale, illustrated at the left, we find that the correction is minus 28 points in gravity. Subtracting 28 points from hydrometer reading gives the correct specific gravity of the battery, 1.217 at 80 deg. F.

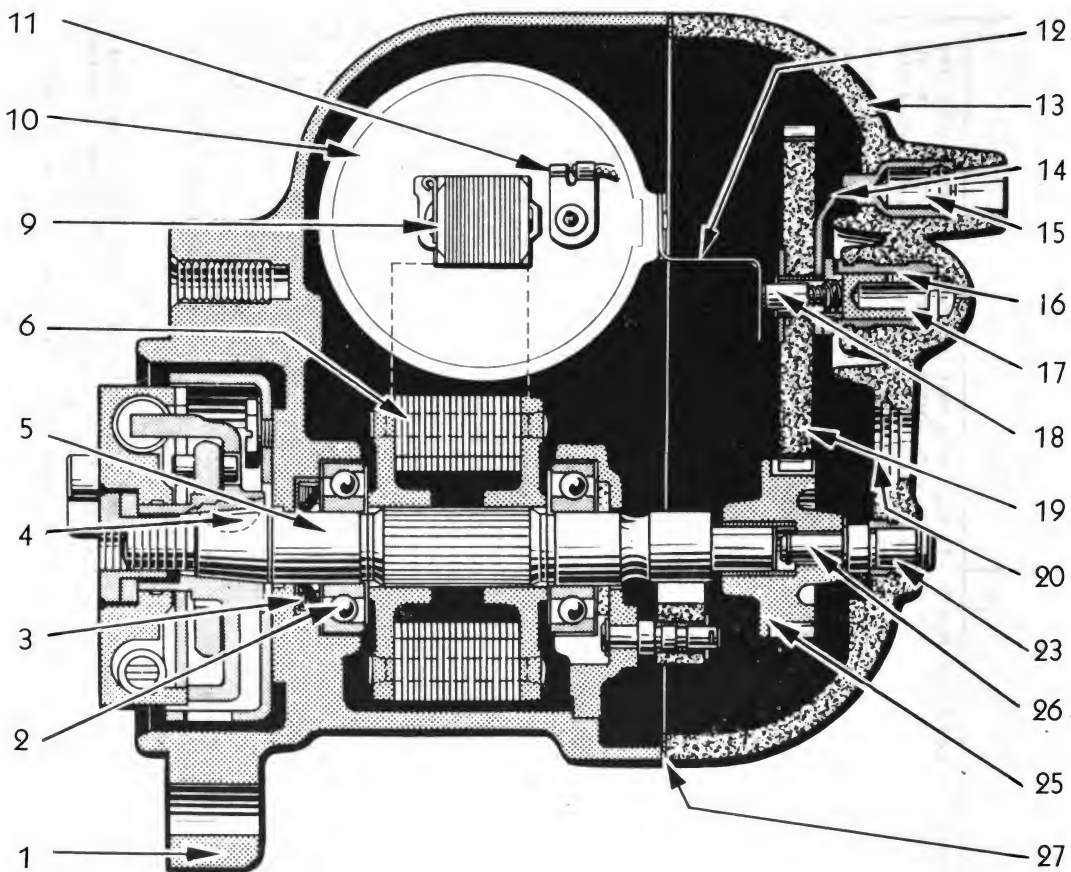

Longitudinal Section Thru Magneto

NOMENCLATURE

- | | |
|----------------------------|-------------------------------|
| 1. Magneto housing | 14. Electrode |
| 2. Ball bearings | 15. Cable clip |
| 3. Oil seal | 16. Distributor gear bearing |
| 4. Woodruff key | 17. Distributor gear shaft |
| 5. Magnet rotor shaft | 18. Dist. gear brush & spring |
| 6. Alnico magnet | 19. Distributor gear |
| 9. Coil core | 20. Observation window |
| 10. High tension coil | 23. Rotor gear shaft bearing |
| 11. Terminal clip | 25. Magnet rotor gear |
| 12. High tension conductor | 26. Magnet rotor gear shaft |
| 13. Distributor plate | 27. Distributor plate gasket |

The numerals contained in the following paragraphs are illustrated in the Magneto cross section drawings.

The MJC edition C series magnetos employ the induction principle of current generation, the coil windings (10) being stationary and magnet

OPERATOR'S INSTRUCTIONS

(6) rotated between laminated pole shoes (37). The condenser (48) and interrupter are also stationary. Labrynth type ventilators (31) are mounted on either side of the magneto housing (1). Magnet rotor ball bearings (2), packed in high-temperature American Bosch U.S. 508 grease, require no additional lubricant for at least one year. Use WB-2 (Grease, general purpose No. 2). The distributor gear bearing (16) is of bronze, requiring lubrication only at yearly intervals. A single casting (1), the open end of which is covered by the distributor plate (13), encloses the magneto. An observation window (20) in the distributor plate (13)

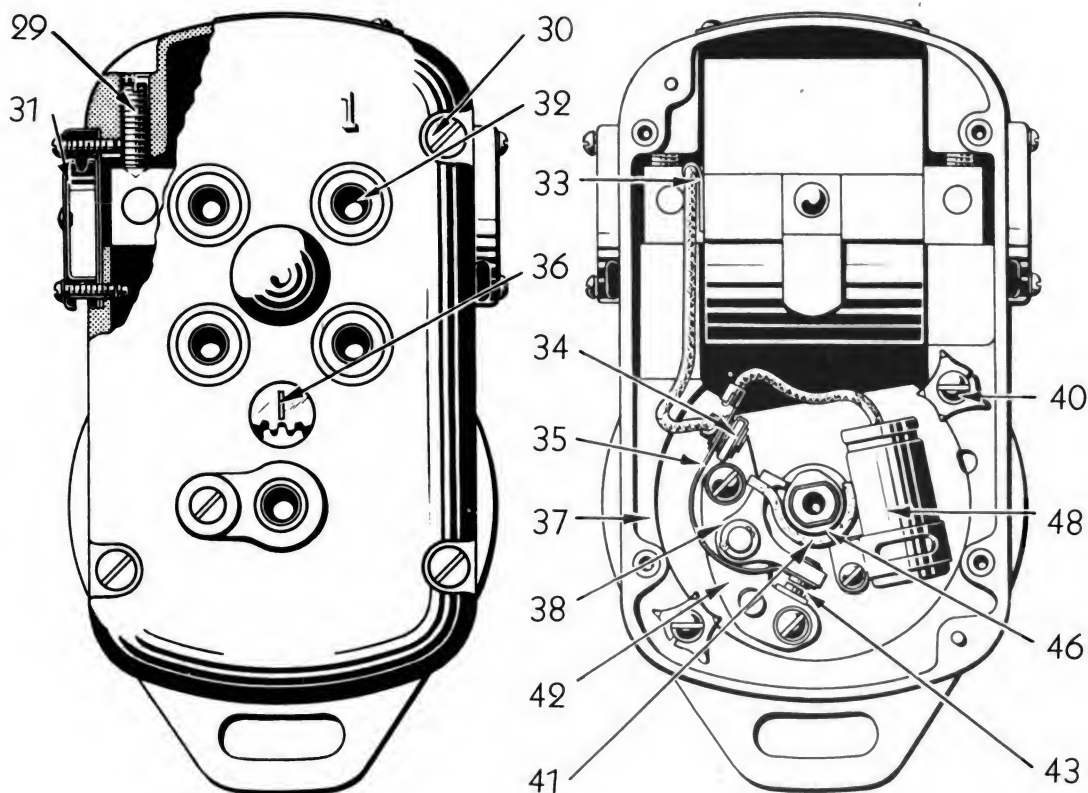

Cross Section Thru Magneto

NOMENCLATURE

- | | |
|------------------------------|--------------------------------|
| 29. Coil mounting screw | 37. Pole shoes |
| 30. Dist. plate fast. screw | 38. Interrupter lever |
| 31. Ventilator | 40. Inter. holding brkt. screw |
| 32. Cable tower | 41. Cam felt wick |
| 33. Coil cable | 42. Adj. contact bracket |
| 34. Insulated bracket | 43. Contact points |
| 35. Inter. operating spring | 46. Cam |
| 36. Line on distributor gear | 48. Condenser |

with a line (36) on the distributor gear (19) facilitate timing the magneto to the engine.

The new type ICA coupling used with this magneto represents an improved coupling design. The cushioned action of the coupling minimizes wear and eliminates the metallic click produced with previous designs.

LUBRICATION

Cam lubricating felt wick (41) is saturated with Mobile grease No. 2 at the factory and should be re-lubricated every 512 hours with OE-30 (oil, engine SAE30). The ball bearings are packed with American Bosch U.S. 508 grease and should be repacked with WB-2 (Grease, general purpose No. 2) every 2048 hours. Extreme care must be exercised so that contact points remain free from oil and grease. When a periodic repair of the engine is undertaken the magneto should be completely checked and overhauled if necessary by a competent mechanic. See page 54.

SPARK PLUGS

The spark plugs selected after careful tests as best suited for this engine are the Champion No. 6 Comm. or AC No. 83 Spec. and should be used ordinarily. Use only a full set of either type.

Remove spark plugs every 256 working hours, or oftener if necessary, for cleaning and checking the gaps between electrodes. A gap of .025" to .030" should be maintained at all times. When making this adjustment, always bend the outer electrode. Never bend the center electrode as it may damage the insulator. If the gap between electrodes is too great, due to improper setting or burning off the ends, the engine will misfire and be hard to start.

CLEANING SPARK PLUGS

The recommended method of cleaning spark plugs is sand-blasting. Never scrape or clean the insulator with anything which will scratch the porcelain, because scratched porcelain allows carbon and dirt to accumulate much faster.

SPARK PLUG CABLES

If the spark plug cables are removed for any reason, note the position of each cable on the magneto. (Wiring diagram (page 53) shows correct wiring.)

There should be 1/4" minimum clearance between the spark plug cables and the cylinder head; by maintaining this clearance, shorting-out the spark plug will be prevented, and the cable will be away from the extreme heat of the cylinder head. If a cable is allowed to touch the cylinder head, the heat of the engine will soon cause the rubber to become soft and the cable will be ruined.

DELCO-REMY MODEL 1101374 GENERATOR

GENERAL

Delco-Remy Model 1101374 Generator is a 2 pole, third brush, sealed type unit, with a ball bearing in the drive end and a bronze bushing in the commutator end to support the armature and is used in connection with a step-voltage control unit, Model 5889.

OPERATOR'S INSTRUCTIONS

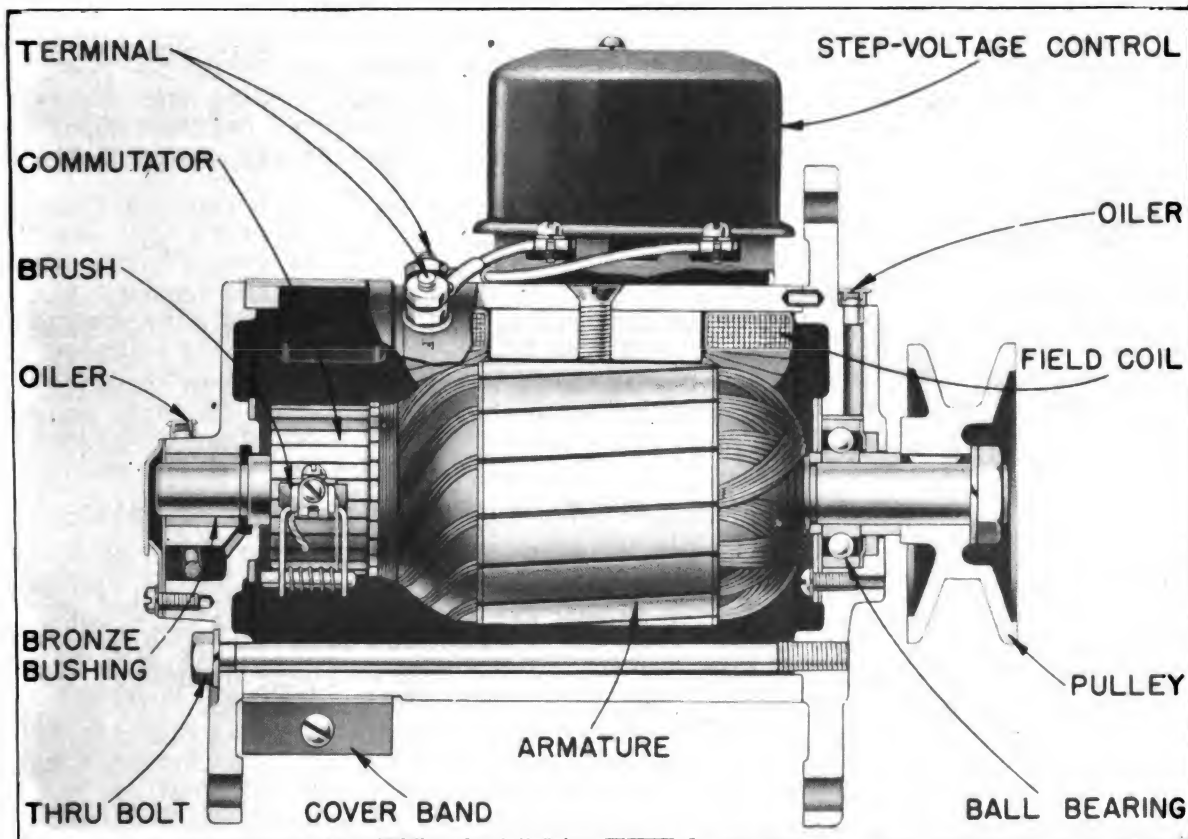

Longitudinal Section Thru Generator

LUBRICATION

The two hinge cap oilers should be supplied with 8 to 10 drops of OE (oil, engine) crankcase grade every 64 hours. Do not oil excessively. Never oil commutator.

CARE AND OPERATION

Inspection--The cover band should be removed and the commutator and brushes inspected at regular intervals. If the commutator is dirty, it may be cleaned with No. 00 sandpaper. Blow out dust.

CAUTION: NEVER USE EMERY CLOTH TO CLEAN COMMUTATOR.

If the commutator is rough, out of round, or has high mica, the generator must be removed from engine and referred to a competent mechanic.

Worn brushes should be replaced. They can be seated with a brush seating stone. The brush seating stone is an abrasive material which, held against the revolving commutator, carries under and seats the brushes in a few seconds. Blow out dust.

CAUTION: NEVER USE EMERY CLOTH.

ADJUSTMENT

The output of the generator may be adjusted by moving the third brush in the direction of armature rotation to increase the output and in the opposite direction to lower the output. Third brush generator output should be checked and adjusted at the voltage specified since the generator output increases with voltage. Normally, if the generator is checked with an accurate ammeter and a fully charged battery is not

available, connect a 1/4 ohm variable resistance into the circuit and cut in resistance until the proper voltage is obtained. NEVER SET OUTPUT ABOVE SPECIFIED SETTING AS THIS WILL RESULT IN GENERATOR FAILURE. NOTE: Make sure the generator field is directly grounded during the above check and adjustment--that is, either the voltage control points should be closed, or a jumper lead should be used to temporarily ground the generator "F" terminal.

CUT-OUT RELAY

The cut-out relay prevents the battery from discharging back through the generator whenever the engine has stopped or is not running fast enough for the generator to charge. It is entirely automatic in its action, but should have an occasional inspection to see that the contact points are clean.

DELCO-REMY MODEL 700 CRANKING MOTOR

GENERAL

The Delco-Remy Model 700 Cranking Motor is a 6-volt, 6 pole unit with oilless bearings at the center, commutator and drive ends, and is provided with a sealed type cover band to guard against the entrance of dust. The motor uses a Bendix type drive. Specifications are as follows:

Clockwise rotation viewing drive end.

Brush spring tension 36-40 ounces.

No load--3000 r.p.m. at 70 Amperes at 5.0 volts

Lock Torque test--19 lb. ft. at 500 amperes at 3.0 volts

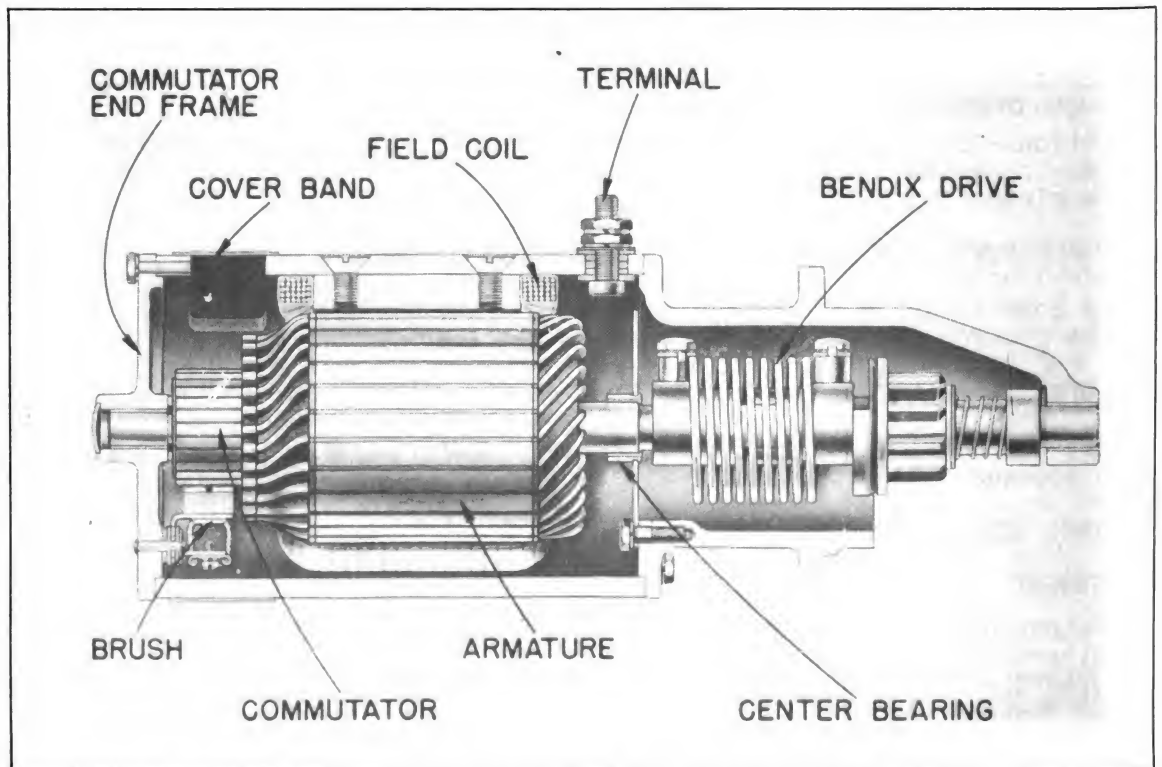

OPERATOR'S INSTRUCTIONS

CRANKING MOTOR MAINTENANCE

Cranking motor maintenance may be divided into two sections, normal maintenance required to assure continued normal operation of the cranking motor, and the checks and repairs of an inoperative cranking motor.

NORMAL MAINTENANCE

Lubrication: Since the bearings are all of the oilless type, no lubrication will normally be required. A few drops of OE-10 (oil, engine SAE10) can be added to each bearing during the disassembly-assembly procedure.

Inspection: The cover band should be removed and the commutator and brushes inspected at regular intervals. If the commutator is dirty, it may be cleaned with #00 sandpaper. Blow out dust. Never use emery cloth to clean commutator. If the commutator is rough, out of round, or has high mica, it should be referred to a competent mechanic. Worn brushes should be replaced. If brushes wear rapidly, check for excessive brush spring tension and roughness or high mica on the commutator.

CHECKING OF IMPROPERLY OPERATING CRANKING MOTOR

If the cranking motor does not develop rated torque and cranks the engine slowly or not at all, check the battery, battery terminals and connections, and battery cables. Corroded, frayed, or broken cables should be replaced and loose or dirty connections corrected. The cranking motor switch should be checked for burned contacts and the switch contacts cleaned or replaced if necessary.

If all these are in order, remove the cover band of the cranking motor and inspect the brushes and commutator. The brushes should form good contact with the correct brush spring tension. A dirty commutator can be cleaned with a strip of No. 00 sandpaper held against the commutator with a stick while the cranking motor operates.

CAUTION: NEVER USE EMERY CLOTH TO CLEAN COMMUTATOR.

If the commutator is very dirty, or burned, or has high mica, the cranking motor should be removed and referred to a competent mechanic to take a cut off the commutator in a lathe.

DELCO-REMY MODEL 1459 MAGNETIC SWITCH

The Delco-Remy Model 1459 Magnetic Switch does not require servicing other than to check periodically to make sure the mounting and connections are tight and in good condition.

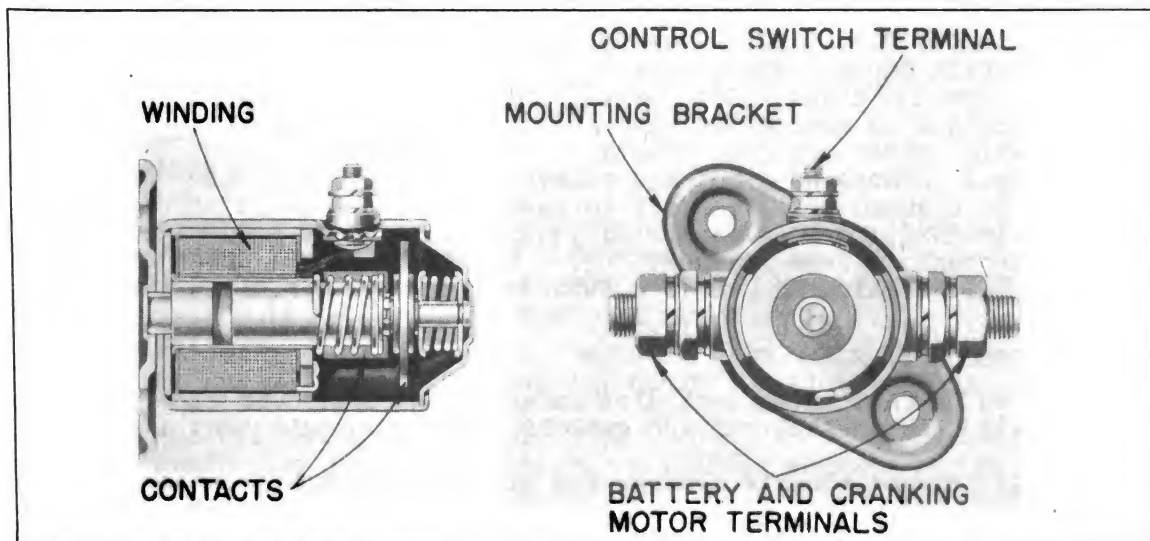

MINOR ENGINE SERVICE OPERATIONS

CYLINDER HEAD ENGINE

After a new engine has been run a short time and is thoroughly warmed up, it is advisable to check the cylinder stud nuts for tightness. Stop the engine and first tighten the center cylinder head stud nut, and then proceed as outlined in chart, putting an equal tension on all the nuts. Go over the nuts several times to make certain that all are uniformly tight before starting engine.

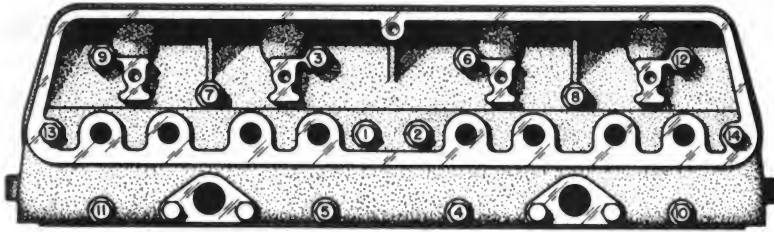

Sequence for Tightening Cylinder Head Nuts

CAUTION

Be sure to adjust the valve tappet clearance after retightening cylinder stud nuts. (See valve clearance adjustment).

AIR CLEANER

Clean air is assured in the engine by an oil bath air cleaner. The air after entering the intake passes to the oil bowl where it goes through a bath of oil. As the air rises to the cleaner outlet it passes through a series of oil bathed screens where the fine dust is removed. As the oil from the screen works back down to the bowl, it carries with it the dirt removed from the air. The air cleaner can work efficiently only so long as the bowl is free from accumulated dust. When this dust accumulates in the bowl, the bowl must be removed and cleaned and re-filled with new clean oil of the recommended viscosity.

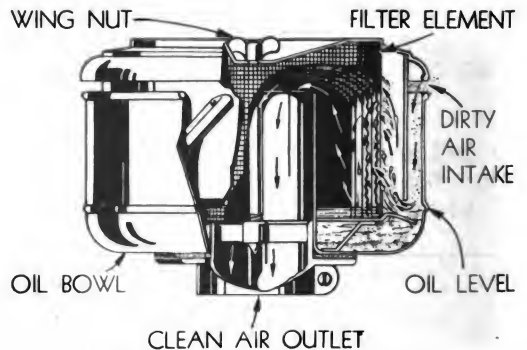

Air-Maze Air Cleaner

OIL BOWL

Starting each day and/or every eight working hours, stop engine and check bowl for accumulated dust. (This operation is advised at closer intervals under extreme dusty conditions.) Remove wing nut and remove filter element and oil bowl. Bowl may be cleaned refilling oil to level of bead. Should filter element require cleaning, dip in clean OE (oil, engine) crankcase grade and allow to drain thoroughly before reassembling. **CAUTION. DO NOT CLEAN COMPRESSOR AIR CLEANERS IN GASOLINE DUE TO A POSSIBILITY OF AN EXPLOSION IN AIR RECEIVER.**

GENERAL PRECAUTIONS

As an added precaution against dirt entering the engine or air compressor inspect all hose connections and gaskets, making certain they are tight.

All joints between the air cleaner and the connections between the manifold and the cylinders of the engine should be tight. All gaskets must be in good condition and the bolts should be drawn up tight.

OIL FILTER

The life of the engine depends mainly upon clean oil being circulated to all bearings. Minute particles of foreign matter eventually accumulate in the engine crankcase and in the normal course of operation the lubricating oil undergoes changes which produce sludge, acids, gums, varnish and other harmful by-products.

The purpose of the oil filter is to separate and remove the dirt and other foreign substances from the oil thereby preventing these injurious materials from being circulated through the engine. This filter is efficient only so long as the element is not saturated with these foreign particles or substances. When the element becomes saturated to the point it can no longer remove foreign substances from the oil, it loses its efficiency and the element must be replaced. The interval between element replacements depends entirely upon operating conditions. After every hundred working hours when the crankcase oil is changed, if the oil removed was black and dirty, it is an indication that cartridge must be replaced.

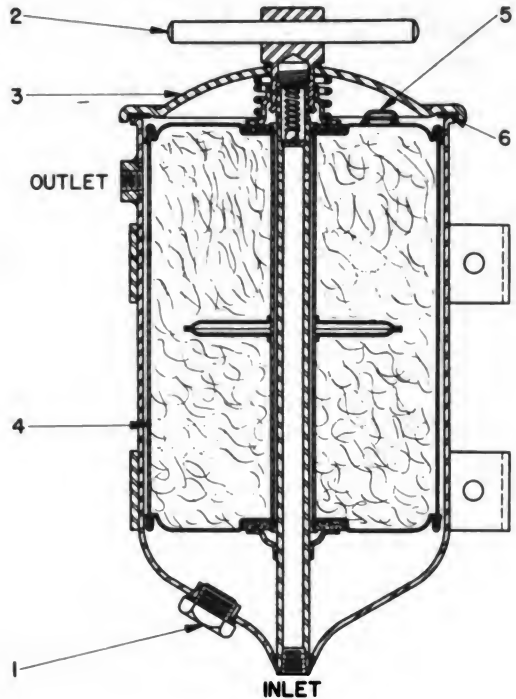

N1744 Purolator Oil Filter

SERVICING INSTRUCTIONS

1. Stop engine.
2. Drain filter by removing drain plug. (1)
3. Turn handle (2) in counter-clockwise direction to remove cover. (3)
4. Lift out old element (4) by using handle (5) on top of element. (Element is the non-cleanable type and must be replaced.)
5. Insert new element and new cover gasket (6) making certain handle end is on top.
6. Replace cover making certain gasket is in good condition and turn handle in clockwise direction, until secure, **HAND TIGHT**.
7. After starting engine check for leaks.

VALVE CLEARANCE ADJUSTMENT

Check valve clearance every four hundred working hours of operation and adjust clearance if necessary. A clearance of .015 of an inch is necessary between valve stem ends and rocker arm tappets when valves are closed and engine is warm - .018" when engine is cold.

1. Before checking valve clearance, make certain magneto ground switch button is pushed in eliminating any danger of accidentally starting the engine.
2. Remove the cylinder head cover.
3. Remove spark plug from #1 cylinder. (Cylinder nearest radiator.)
4. Place thumb over spark plug opening and crank engine slowly until an outward pressure can be felt. Pressure indicates #1 piston is moving toward upper dead center of compression stroke.

5. Continue to crank slowly until top dead center position is indicated by timing pointer on fly-wheel. Both valves are now closed on compression stroke of #1 cylinder.
6. Loosen the lock nut and adjust screw in rocker arm so that feeler gauge slips snugly between tap-pet and valve stem. (See illustration.)
7. Tighten lock nut and re-check clearance.
8. Crank engine one half revolution at a time checking clearance of each cylinder's valves, adjusting if necessary. Do this on each set of cylinder valves in suc-cession according to fir-ing order of the engine which is 1-2-4-3.

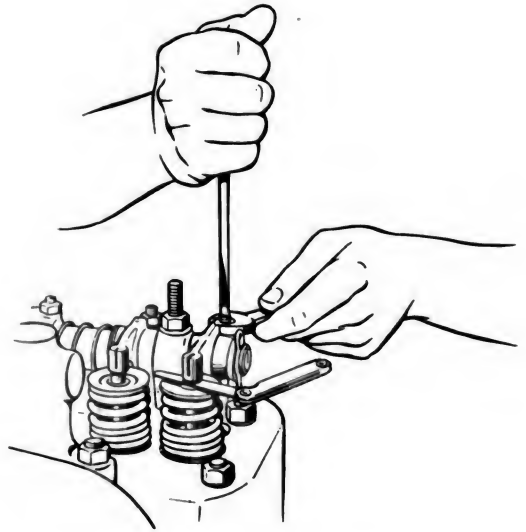

Adjusting Engine Valves

9. Replace the cylinder head cover. Check to see that cylinder head cover gasket is in good condition and makes an oil-tight seal with cylinder head. Replace the gasket if necessary.

IMPORTANT Be accurate - use an accurate feeler gauge for checking valve clearance.

OPERATOR'S INSTRUCTIONS

CARBURETOR

GENERAL DESCRIPTION

The general purpose of the carburetor (Zenith Model 62A10) is (1) to discharge the desired amount of fuel into the air stream entering the engine; (2) to atomize the fuel, and (3) to make a homogenous air-fuel mixture. The air to fuel ratio is not constant for all speeds and loads. The carburetor varies that ratio to give the best operating performance for all conditions. The carburetor has been calibrated to meter the correct amount of fuel for smooth operation throughout operating range; the function of the carburetor can not extend beyond the proportionate mixing of fuel and air.

MAIN JET SYSTEM

The Main Jet (2), often referred to as the "high speed jet", exerts its principal influence at the higher engine speeds. Fuel from the bowl is metered through the Main Jet (2) and discharged into the air stream at the point of greatest suction, in the secondary Venturi (3) through the Main Discharge Jet (4).

The Main Jet (2) determines the maximum amount of fuel which may be obtained for high speed operations. The Main Jet Adjustment (8) reduces this amount if it is turned toward its seat. Ordinarily the main jet adjustment has no effect after it is two turns open.

To set this adjustment, open the throttle to approximately 1/4 open. Turn the adjustment clockwise, shutting off the fuel until the engine speed decreases due to too lean mixture. Now open the adjustment until the engine speed decreases due to too much fuel. The adjustment should be set at a position half way between these two extremes.

COMPENSATING SYSTEM

The compensating system consists of the Main Discharge Jet (4) and the Well Vent (5). The flow of fuel from the Main Jet (2) is controlled by the size of the Well Vent (5) and the size of the Main Discharge Jet (4). The mixture delivered through the Main Discharge Jet may be made richer by either increasing the size of the Main Discharge Jet or by decreasing the Well Vent. Conversely the mixture may be made leaner by either decreasing the size of the Main Discharge Jet or by increasing the size of the Well Vent.

IDLING SYSTEM

The Idling System consists of the Idling Jet (6) and the Idle Adjusting Needle (7). The Idling Jet (6) receives its fuel from the main Jet (2) through channel (A). The fuel is metered through the Idling Jet (6) and is mixed with air which is admitted, from behind the Venturi (1), through channel (B). The Idle Adjusting Needle (7) controls the amount of air which is admitted to the Idling System. The Idling System functions only at Idling and Low Speeds. At these speeds, the Throttle Plate is almost closed and there is a very strong suction past the edge of the Throttle Plate. This suction draws the mixture of fuel and air from the Idling Jet (6) which discharges into the air stream through the Priming Plug.

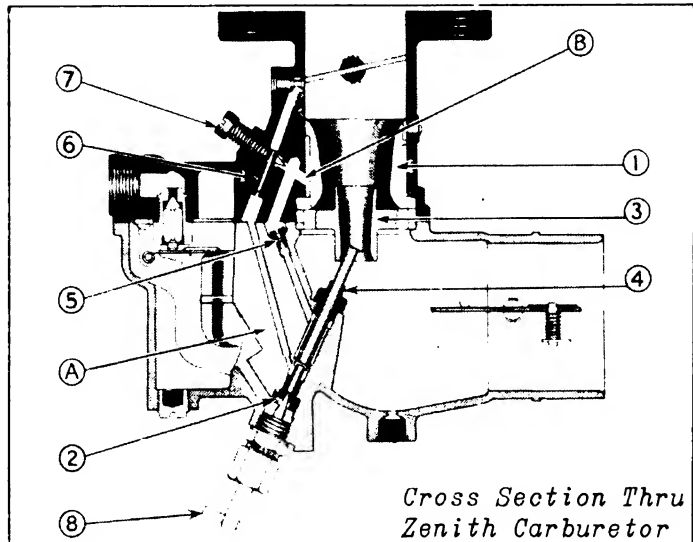

Cross Section Thru
Zenith Carburetor

FUEL PUMP

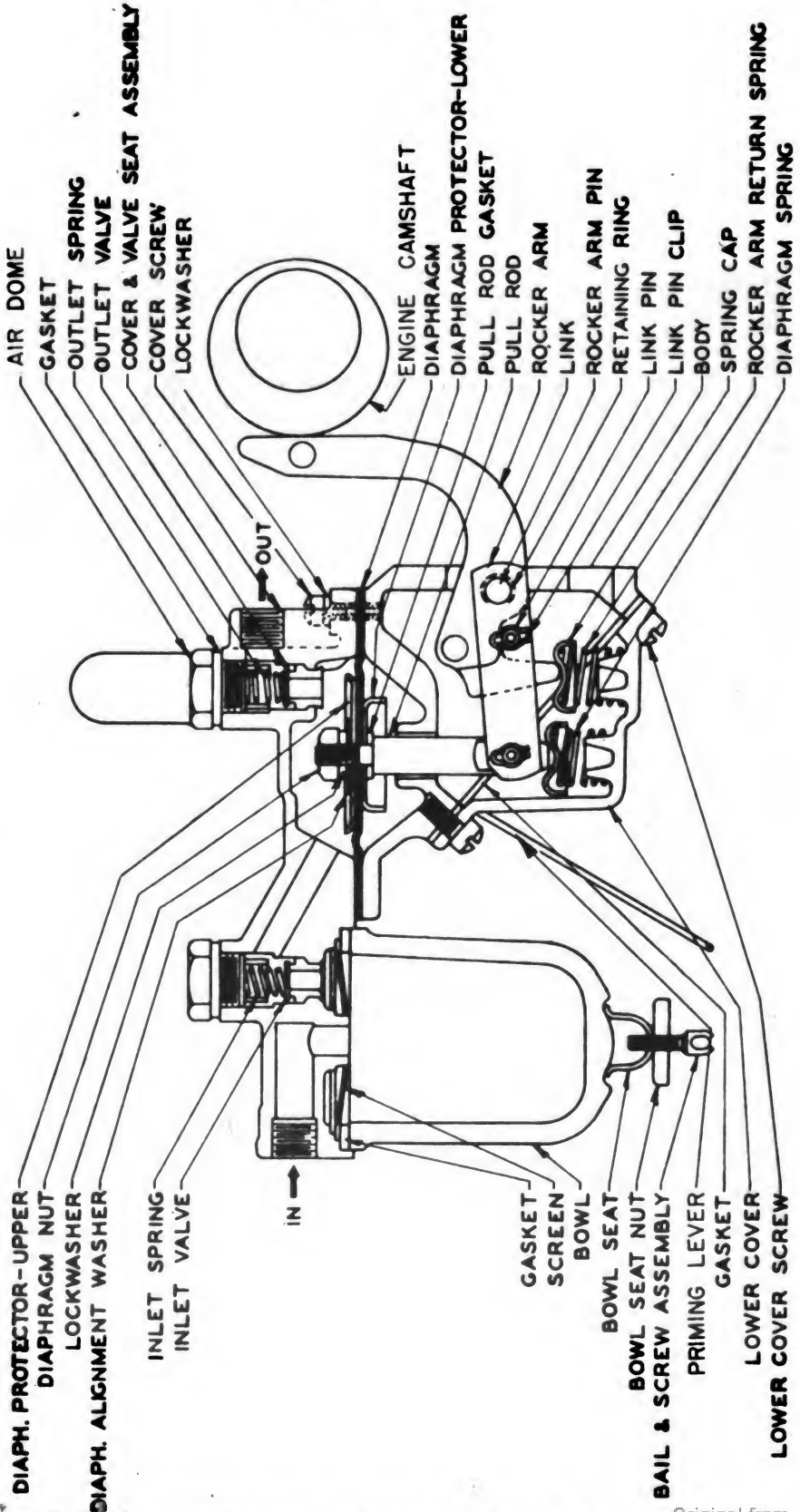

OPERATOR'S INSTRUCTIONS

SYNOPSIS OF OPERATIONS

The rotation of the camshaft eccentric actuates the rocker arm, which pulls the link and the diaphragm and pull rod assembly downward against diaphragm spring pressure which creates a vacuum in the pump chamber.

On the suction stroke of the pump, fuel from the tank enters through the inlet into the sediment bowl, passes through the screen and on through the inlet valve into the pump chamber.

On the return stroke, the diaphragm spring pressure pushes the diaphragm upward forcing fuel from the pump chamber through the outlet valve and out through the outlet to the carburetor.

When the carburetor bowl is filled, the float in the carburetor will shut off the needle valve, thus creating a pressure in the pump chamber. This pressure will hold the diaphragm downward against the spring pressure where it will remain inoperative in the downward position until the carburetor requires further fuel and the needle valve opens. The rocker arm spring is merely for the purpose of keeping the rocker arm in constant contact with the cam shaft.

SERVICE ADJUSTMENTS & MINOR REPAIRS

If there is evidence of a lack of fuel in the carburetor or the carburetor is flooding, check the float and needle valve for proper functioning. Examine the gas line for leaks, kinks or obstructions.

LACK OF FUEL AT THE CARBURETOR

Check as follows:

CAUSE	REMEDY
Gasoline tank empty	Refill
Leaky tubing or connections.	Replace tubing and tighten all pipe connections at the fuel pump and gasoline tank.
Loose Valve Plug	Tighten valve plug securely, replacing valve plug gasket if necessary.
Bent or kinked tubing	Replace tubing.
Dirty Screen	Clean the screen. Make certain that cork gasket is properly seated when reassembling.
Dirty or warped valves.	Remove valve plugs and valves. If valves are damaged or warped, replace them. Examine valve seats to make certain there are no irregularities which prevent proper seating of valves. Place valves in valve chambers. Reassemble valve plugs and springs making certain that springs are around the lower stems of the valve plugs properly. Use new gaskets under valve plugs if necessary.

FUEL LEAKAGE AT EDGE OF DIAPHRAGM

Check as follows:

CAUSE	REMEDY
Loose Cover Screws	Tighten cover screws alternately and securely. Also check inlet and outlet pipe connections.

NOTE: Check if leak occurs at pipe fittings thus allowing fuel to run down pump to flange and appear to originate there. Do not use shellac or any other adhesive on diaphragm.

OPERATOR'S INSTRUCTIONS

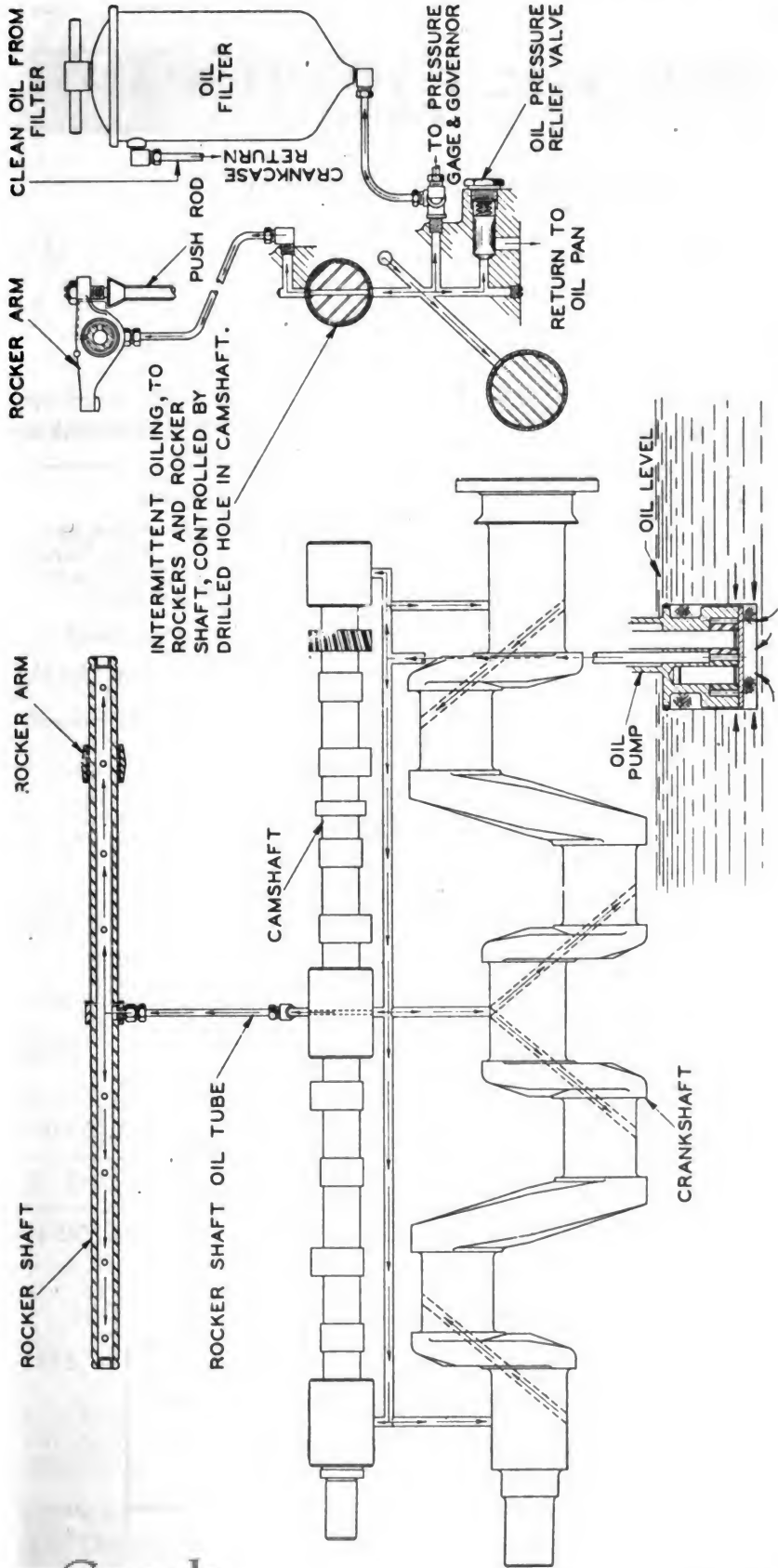

OIL DIAGRAM

PLATE D318-1

EFSB L-1014

No. 1014

WAR DEPARTMENT LUBRICATION GUIDE
CORPS OF ENGINEERS

**COMPRESSOR, AIR, 105 C. F. M.,
GASOLINE
(LE ROI MODEL 105 GA)**

MFR'S. SERIAL No. located on plates on engine and compressor crankcases.

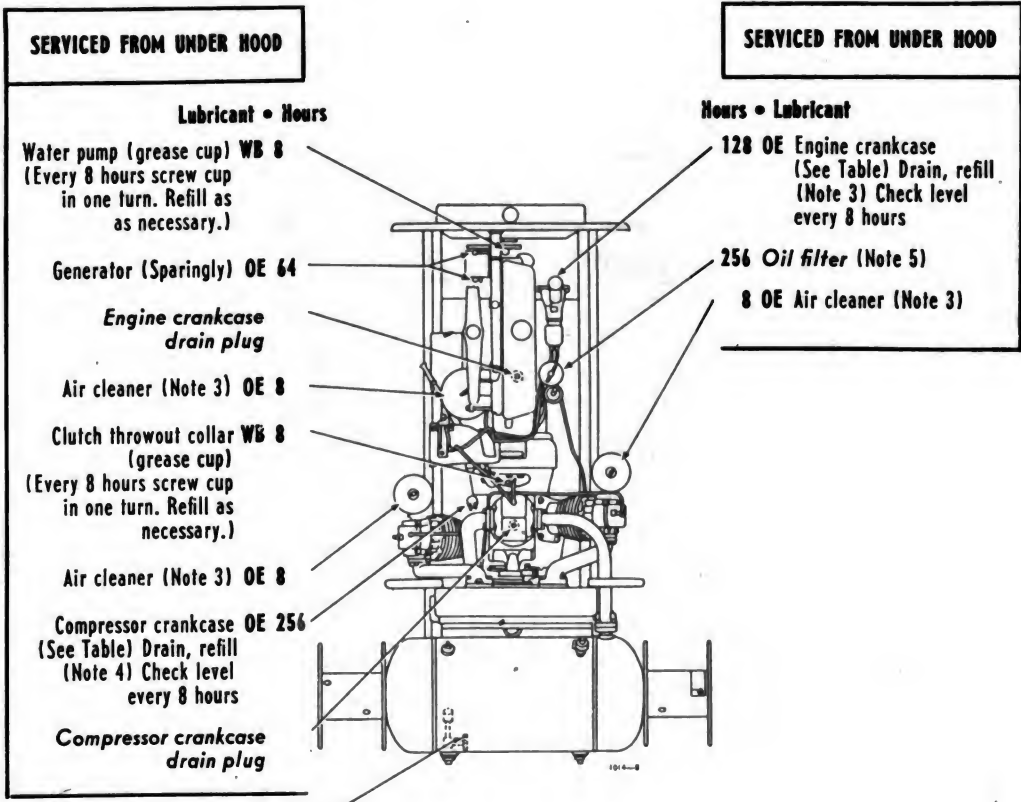

Air receiver drain valve
(Drain moisture every 8 hours,
or more often if necessary)

KEY

LUBRICANTS	
OE—OIL, engine Crankcase grade (unless otherwise specified)	WB—GREASE, general purpose No. 2
CG—GREASE, general purpose No. 1 (above +32° F.) No. 0 (+32° F. to 0° F.)	

MEK-CHART NO. 1014

OPERATOR'S INSTRUCTIONS

EFSB L-1014*

ENGINEERS FIELD SERVICE
BULLETIN NO. L-1014

WAR DEPARTMENT
Office, Chief of Engineers
Washington, D. C.

LUBRICATION INSTRUCTIONS FOR COMPRESSOR, AIR, 105 C.F.M., GASOLINE (LE ROI MODEL 105 GA)

1. GENERAL - The following lubrication instructions for the Compressor, air, 105 C.F.M., gasoline (Le Roi model 105 GA), are published for the information and guidance of all concerned, and supersede all previous instructions.

a. **References** - Lubricate equipment in accordance with the latest instructions contained in Engineer Field Service Bulletins. Reference is made to the General Instruction section (EFSB L-1000-A) for additional lubrication information, and to the Product Guide section (EFSB L-1000-F) for latest approved lubricants.

2. LUBRICATION GUIDE - Lubrication instructions for all points to be serviced are shown in Lubrication Guide published herein, which specifies the types of lubricants required and the intervals at which they are to be applied. Guides from which this information is reproduced are 10x15 in. and are an accessory of each piece of equipment.

3. REPORTS AND RECORDS - a. **Reports** - If lubrication instructions are closely followed, proper lubricants used, and satisfactory results are not obtained, a report will be made to the engineer officer responsible for the maintenance of the equipment.

b. **Records** - A complete record of lubrication servicing for this equipment will be kept on a Lubrication Check Card.

* Supersedes that part of EFSB L-1013 and EFSB L-1014 covering lubrication of Air Compressor.

TABLE OF CAPACITIES AND LUBRICANTS TO BE USED

UNIT	CAPACITY (Approx.)	LOWEST EXPECTED AIR TEMPERATURE		
		Above +32°F.	+32°F. to 0°F.	Below 0°F.
Engine Crankcase	14 qt.	OE SAE 30	OE SAE 10	Refer to EFSB L-1000-D
Compressor Crankcase	8 qt.			

HIGH TEMPERATURE: For Lubrication and Service above +90°F., refer to EFSB L-1000-E.

NOTES

1. FITTINGS - Clean before applying the lubricant gun.

2. HOURS - The hours indicated are for normal service. For extreme conditions of heat, water, snow, and dust, change crankcase oil and lubricate more frequently.

3. AIR CLEANERS - (Power Unit and Compressor) - Every 8 hours, remove, clean and refill oil cup to lower bead mark with OE. Every 8 to 256 hours.

depending on dust conditions, remove entire assembly and clean. CAUTION: Do not wash compressor air cleaners in gasoline or kerosene as vapors may collect in the air receiver causing an explosion. Pour 1 pt. OE through filter and drain. Clean entire air cleaner and air pipes. Keep all connections tight.

4. **CRANKCASE** - Every 8 hours, check and fill to level. Drain only when engine is thoroughly warm. Refill to FULL mark on gage. See Table. CAUTION: When running engine or compressor, be sure pressure gage indicates oil is circulating. For prolonged operation above 100°F., OE SAE 50 may be used in compressor. (Power Unit Crankcase Breather). Every 8 hours, remove breather caps and wash. Oil valve chamber breather with OE.
5. **OIL FILTER** - Every 128 hours, drain dirt and water. Every 256 hours, or as necessary, renew filter element. Use new cover gasket. Refill crankcase to FULL mark on gage. CAUTION: When running engine, be sure pressure gage indicates oil is circulating.
6. **MAGNETO** - Every 512 hours, remove distributor cover and lubricate cam felt with OE, SAE 30, sparingly. Every 2048 hours, remove, clean and repack rotor bearings, clean and coat distributor gear teeth with WB.
7. **OIL CAN POINTS** - Every 64 hours, lubricate throttle cross shaft, throttle and governor linkage with OE.
8. **POINTS REQUIRING NO LUBRICATION** - Fan, Governor, Power Unit Starter, Compressor Hose Reel Bearings.
9. **BATTERY** - Weekly, check level of water in battery. Add distilled, rain, or other clean fresh water to level of 3/8 in. above top of separators. Clean terminals, tighten snugly and coat lightly with CG.

AIR TOOLS

1. **PAVING BREAKER** (Thor model 25) - Every 2 hours of continuous operation, remove oil reservoir plug from end of back head handle and fill with OE. Every 64 hours, remove oil control felt on side of handle, wash, dry and replace; flush mechanism by pouring a small amount of cleansing solution into air inlet. Operate machine a few minutes and pour a small amount of OE, SAE 10, into air inlet.
2. **SINKER ROCK DRILL** (Thor model 75) - Every 2 hours of continuous operation, remove oil reservoir plug from side of cylinder and fill with OE. Every 64 hours, remove oil control plugs and felts from rear of cylinder, wash and dry. Clean oil holes and cylinder with compressed air before replacing felts. Pour a small amount of cleaning solution into air inlet, operate machine a few minutes and add a small amount of OE, SAE 10. If equipped with Thor line oilers, fill before operation with OE, SAE 10, and refill when necessary.
3. **CLAY DIGGER** (Thor model 412) - Every 4 hours, inject OE, SAE 10, through the exhaust holes. Every 64 hours, wash tool and thoroughly oil with OE, SAE 10.
4. **WOOD BORING MACHINE** (Thor model 62) - Every 4 hours, lubricate valve mechanism through live air handle reducer, with OE, SAE 10. Every 8 hours, fill 1/3 full through fitting with CG. Every 256 hours, remove crank chamber plates, wash tool, and fill crankcase and gear case 1/3 full with CG.
5. **CIRCULAR SAW** (Skilsaw model 2127) - Every 8 hours, lubricate rotor

shaft bearings and governor with CG or through oilers with OE. Every 4 to 8 hours, check air motor reservoir, located at top front of handle, through fill plug and fill with OE, SAE 10. Every 64 hours, flush motor by removing hose and pouring a small quantity of OE into air inlet. Replace hose and operate motor until oil is driven out exhaust port. Check level of lubricant in blade reduction gear case through plug in top front of saw housing. Fill to level of top of worm gear with GO. Every 1024 hours, drain, flush and refill.

6. PNEUMATIC NAIL DRIVER (Ingersol-Rand model 6CND) - Before operation and every hour of continuous operation, apply a small quantity of OE, SAE 10, through ball oiler located at base of handle. CAUTION: Do not lubricate with air turned on. Every 64 hours, disassemble hose connection strainer, clean and reassemble.

7. CHAIN SAW (Reed Prentice "Timberhog") - (Driven end) Keep oil tank filled with OE, SAE 10, and filler cap tight unless using gravity feed. Chain and cutter bar may be lubricated from tank by air pressure or gravity. Pump up pressure through gun connection in rear of tailstock with pump supplied. CAUTION: Close oil tank breather knob on filler cap before pumping. Turn 3-way valve to "ON" position and adjust petcock for rate of flow. (Driving end) Every 8 hours, fill rotor with OE, SAE 10. Every 512 hours, add 1 tablespoon CG through governor fill plug on side of motor cap. CAUTION: Do not fill completely. Every 256 hours, fill gear box through fill plug with CG above +32°F., and GO below +32°F. Keep air strainer in throttle handle clean.

8. SHEETING DRIVER - After using tool, clean and coat machined surfaces with OE to avoid rust.

**INDEX
TO
MAINTENANCE
INSTRUCTIONS**

CLUTCH

COMPRESSOR

COOLING SYSTEM

ELECTRICAL SYSTEM

ENGINE

FUEL SYSTEM

GOVERNOR

CLUTCH

SPECIFICATIONS

Manufacturer.....Twin Disc Clutch Co.
 Type.....Spring Loaded, Dry Disc
 Double Plate
 Size.....11-1/2"
 Torque Capacity.....5840 Inch-pounds

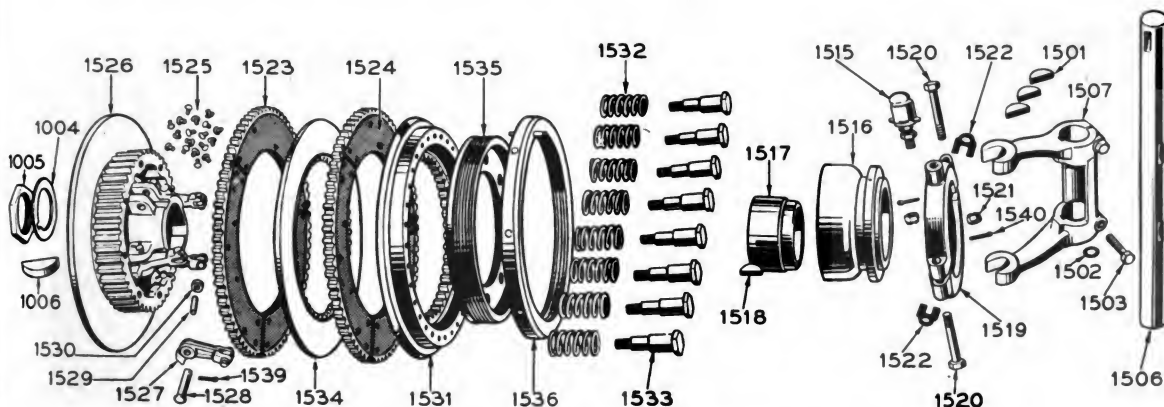

Twin Disc Clutch Model SL-2-11 1/2"

ADJUSTMENT - MADE WITH CLUTCH DISENGAGED

After considerable wear the clutch may require adjustment to bring it into proper position. As the clutch wears, the springs 1532 taking up the wear, reach a limit of their expansion. When this occurs the clutch must be adjusted. Pull out lock-pin 1538 and rotate adjusting ring 1536 clockwise approximately 2-1/2 turns or until the pressure springs are compressed to their original height of 1-5/16". (This measurement is taken when clutch is in "engaged" position - lever towards engine).

DISASSEMBLY (See drwg. above also No. 2S-23C, Page 37)

Before clutch may be dismantled it is necessary to loosen engine at its mountings and move it forward to effect clearance. NOTE: Rear of engine must be blocked up before loosening it to prevent "jack-knifing" when engine is parted from compressor.

FRICITION DISCS: If friction discs only, are to be replaced, disengage clutch lever 1512 which will remove pressure. Old discs can be lifted out and replacements inserted. CAUTION: Friction discs are numbered and must be installed with numbers corresponding also gear teeth of both rows must line up to engage flywheel.

CLUTCH UNIT: If entire unit is to be disassembled proceed as follows:

- (1) Make certain clutch lever is in "disengaged" position.
- (2) Remove lockwasher 1004 and nut 1005 from compressor crankshaft, and remove clutch assembly.
- (3) If throw-out cone 1516 is to be serviced it is necessary to remove lever 1512, rotate shaft 1506, and remove cone.
- (4) To dismantle clutch assembly loosen and remove lock ring 1536. With wrench, remove spring bolts 1533 and springs 1532. Entire unit can now be separated.

REASSEMBLY

- (1) Install clutch components in order removed.
- (2) Install springs and spring bolts making certain bolts are seated against their shoulders.
- (3) Install adjusting ring but do not make final adjustment.
- (4) Install throwout cone and clutch lever, keying in place.
- (5) Install clutch assembly on crankshaft, keying in place, tighten nut and lock securely.
- (6) Move engine into position and fasten to compressor.
- (7) Engage clutch and adjust as described in "Adjustment"

IMPORTANT: Whenever compressor is to be idle for any length of time, clutch must be left in "Engaged" position.

MAINTENANCE INSTRUCTIONS

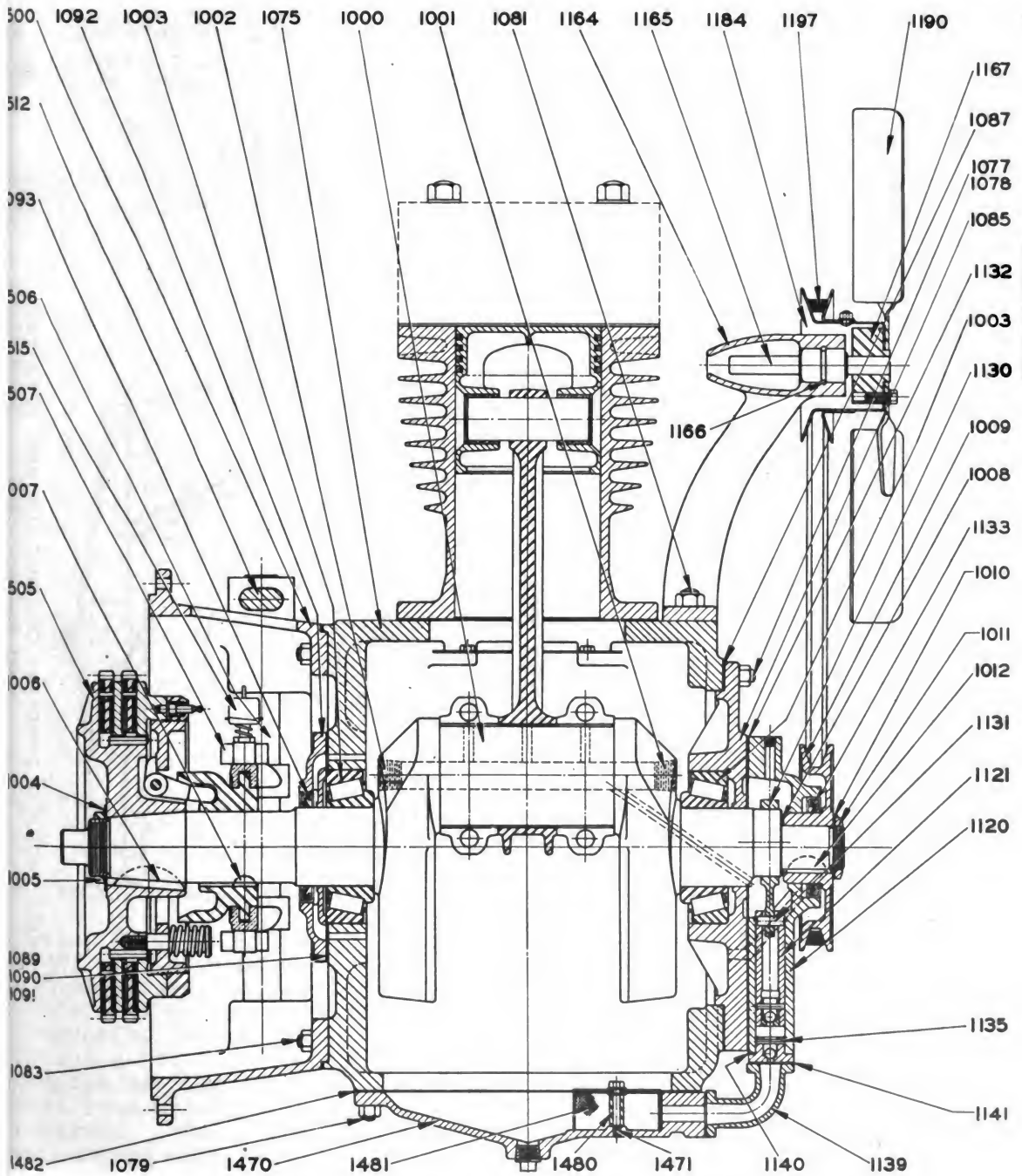

LONGITUDINAL SECTION THROUGH COMPRESSOR

PLATE 2S-23C

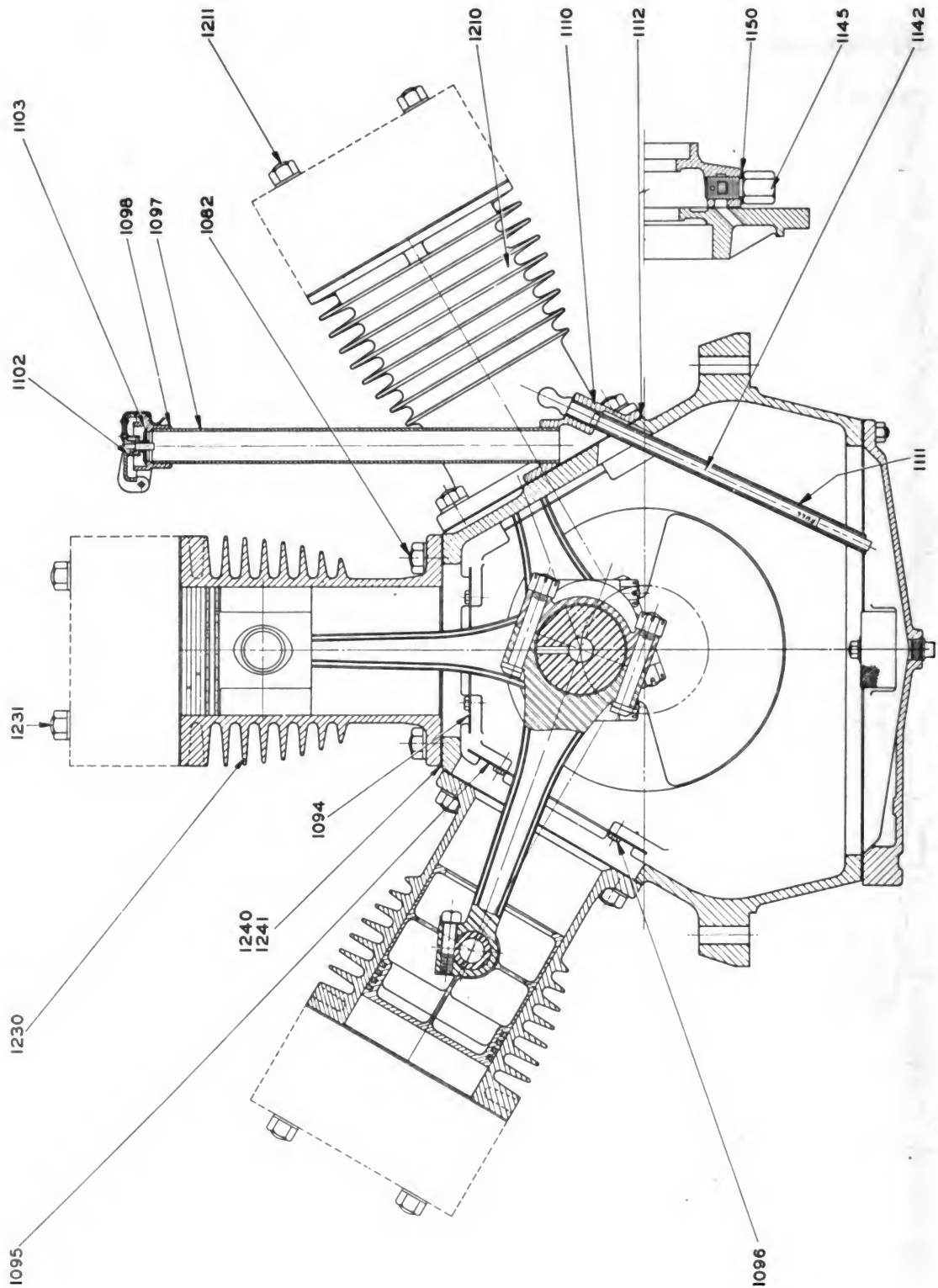

CROSS SECTION THROUGH COMPRESSOR AND BREATHER
PLATE 25-24C

MAINTENANCE INSTRUCTIONS

AIR COMPRESSOR

SPECIFICATIONS

Cylinders.....	3
High Pressure.....	1
Low Pressure.....	2
Stages.....	2
Bore (High Pressure).....	5"
Bore (Low Pressure).....	5-3/4"
Stroke.....	5"

AIR CLEANERS

Two Air-Maze "oil bath" air cleaners are attached to low pressure cylinder heads by means of cast iron connections. Air passes through the opening under the top, down through the bath of oil and upward through the filter element. Here the oil is removed and drains back into the bowl cleansing the element. The clean air passes on down through the cleaner unit and out at the bottom center to enter the cylinder head. A valve has been provided to allow the air, which returns to the cleaner when the compressor unloads, to by-pass to the atmosphere without passing through the oil bath.

Oil bowl must be kept filled to level of bead with clean engine oil of viscosity specified in "lubrication". Periodically, depending upon operating conditions, entire unit should be disassembled and cleaned thoroughly. **CAUTION:** (1) Do not allow felt valve washer to become saturated with oil. (2) Never clean compressor air cleaners in gasoline or fuel oil because of the possibility of an explosion in air receiver tank.

LUBRICATION

Pressure lubricated.....	Yes*
Oil pump type.....	Plunger
Capacity.....	8 Quarts.

* Piston pins and bushings are splash lubricated.

Lubrication is positive to tapered roller main bearings 1003 and connecting rod bearings by means of a plunger type oil pump 1121 driven directly off the crankshaft 1000. Piston pins and bushings are splash lubricated.

OIL PUMP (Also see Illustrations "2S-23C, 2S-24C")

Plunger type driven through a special connecting rod 1130 off the crankshaft. Oil travels through a screen 1481 which strains out the larger foreign particles, up through the pump plunger 1121 to the oil pressure chamber. From here part of the oil enters the drilled passages in the crankshaft, part of it passes past the close fitting circular baffle which separates oil pressure chamber from rear tapered roller bearing, lubricating the bearing, and part of it passes through the circular baffle 1008 which fits closely over the fan drive pulley hub, to be returned to the crankcase. The oil surplus is regulated by a pressure relief valve 1145 and is then returned to the crankcase. A special pipe plug 1002 with a 1/16" orifice, located in the front crankcheek sprays oil into the front bearing 1003. The oil pump screen should be cleaned of sludge and foreign particles whenever the oil pan 1470 is removed.

DISASSEMBLY:

Remove intercooler fan belt 1197, fan drive pulley nut 1011, and lockwasher 1010. Remove fan drive pulley 1009, being careful not to damage oil seal. Remove capscrews holding connection 1139 to oil pan 1470. Disconnect oil line from top of oil pump body at elbow. Remove capscrews and stud nut

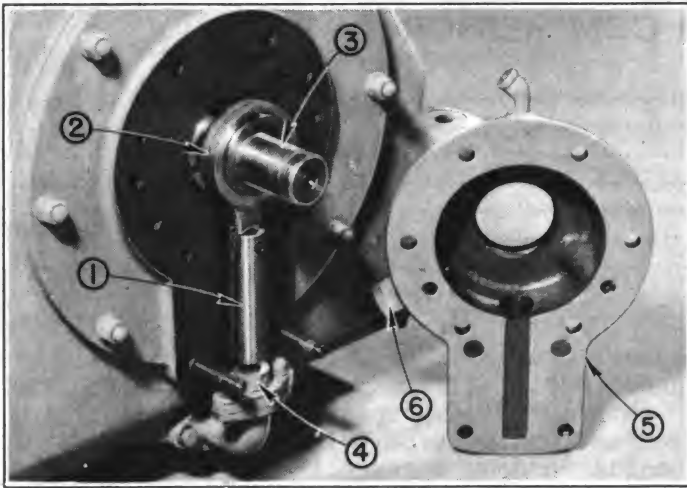

Oil Pump Assembly

- | | | |
|--------------------|--------------------|-----------------------------------|
| 1.Oil Pump Plunger | 3.Crankshaft | 5.Oil Pump |
| 2.Connecting Rod | 4.Check Valve Body | 6.Oil Pressure Relief Screw Assy. |

holding pump body to bearing retainer 1085. Oil pump body with check valve assembly 1135 may now be removed from compressor. Connecting rod 1130 and plunger assembly 1121 can be withdrawn from pump body by turning and twisting. Connecting rod is easily separated from plunger assembly by driving out pin 1131. **NOTE:** Because of close tolerances maintained in the plunger assembly it must be serviced as a unit. Check valve assembly is removed from pump body by removing two nuts from studs. **NOTE:** Check valve assembly is serviced only as a unit.

If connecting rod was dismantled from plunger assembly it should be connected and installed now. Make certain pin 1131 is in place and does not extend out beyond the diameter of the plunger assembly. **CAUTION:** Dip plunger in oil before assembling into pump body. Assemble check valve assembly to body and place body on compressor making certain connecting rod is in place on crankshaft. Install oil seal in body. **NOTE:** It is recommended that oil seal be replaced if it shows slightest irregularities. **CAUTION:** When installing oil seal be sure not to drive it beyond outside face of pump body. Clearance behind oil seal must be maintained for oil passage. Install capscrews holding pump body to compressor hand-tight, set dowels in place and tighten capscrews. Install fan drive pulley, nut and lock in place. Reconnect oil line and install intercooler fan belt.

CYLINDER HEADS

REMOVAL:

Removal is accomplished by removing intercooler and pressure control connection, cylinder head nuts and lifting cylinder head 1249 assembly off.

Before replacing cylinder head, make certain that the surfaces of the head and the cylinder, where the gasket 1310 rests, are absolutely clean. It

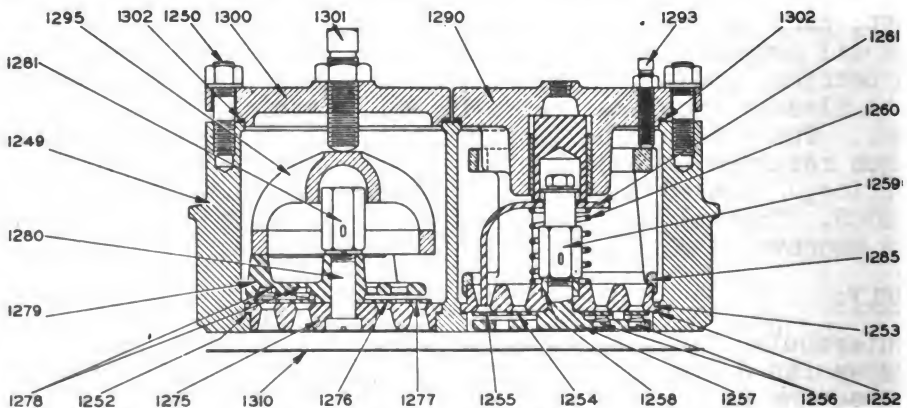

CYLINDER HEAD ASSEMBLY

is important to securely tighten the cylinder head whenever it is replaced. This must be done carefully to prevent damage to the gasket between the cylinder head and the cylinder. Nuts should be drawn down snug with a wrench. Cylinder head stud nuts tightened when compressor is cold, be retightened when compressor is hot.

Cylinder head does not have to be removed to service the valves.

VALVES

The compressor valves are the circular plate type and are mounted in assemblies with their seats and guides (bumpers) for quick replacement in cylinder heads. There is no physical difference between suction and discharge valves, valve springs, or seats.

REMOVAL OF SUCTION VALVE ASSEMBLY FROM CYLINDER HEAD:

1. Disconnect air control line by loosening 1/4" tube nut;
2. Loosen three 5/16" setscrew locknuts several turns;
3. Loosen three 5/16" setscrews 1293 several turns;
4. Remove four nuts and washers that hold suction valve cover to cylinder head;
5. Remove suction cover 1290 being careful that unloader plunger does not drop out to be marred, as its operation depends on very close fit;
6. Remove suction valve assembly clamp 1285;
7. Remove suction valve assembly.

REMOVAL OF DISCHARGE VALVE ASSEMBLY FROM CYLINDER HEAD:

1. Loosen 5/8" setscrew locknut several turns;
2. Loosen 5/8" setscrew 1301 several turns;
3. Remove four nuts and washers which hold discharge valve cover to cylinder head;
4. Remove discharge valve cover 1300;
5. Remove discharge valve clamp 1295;
6. Remove discharge valve assembly;

The suction valve assembly has the bumper 1257 mounted on bottom and is provided with unloader push rod 1261 and spring 1260 which will hold the outer valve 1255 off its seat when compressor is unloaded.

The discharge valve assembly has the bumper 1279 mounted on top.

The valve lift in both suction and discharge valve assemblies is approximately 3/32".

When assemblies have been taken apart for close inspection and cleaning, care must be taken that the seats and the valves are not marred. When reassembling it is important that the valve plates 1254, 1255, 1276, 1277 be replaced in same position as before because the valve becomes tighter as it wears to a seat. See that springs 1256, 1278 are in an upright position with their large end in the pockets in the bumper. See that the valves are free; this can be checked by depressing them with a screw driver and letting them snap back into their seat. Damaged parts must be replaced, as the valves are the heart of the compressor and very serious damage will result if broken parts of the valve assembly falls on top of the piston.

ASSEMBLY OF SUCTION VALVE ASSEMBLY IN CYLINDER HEAD:

1. Make certain that copper gasket 1252 rests properly on shoulder in head 1249;
2. Insert suction valve assembly and rotate back and forth to insure that it seats properly on gasket;
3. Place suction valve assembly clamp 1285 and rotate back and forth to insure that it seats properly on suction valve;
4. Make certain that copper-asbestos gasket 1302 rests properly on cylinder head shoulder.
5. Carefully place suction valve cover, 1290 making sure that three nodes (nibs) on underside properly engage notches in clamp 1285, provided so that setscrews 1293 will clamp over staves;
6. Assemble four nuts 1250 and washers which hold suction valve cover 1290 to cylinder head, but tighten them alternately to prevent cover from tilting on one corner;
7. Tighten setscrews 1293 alternately to insure equalized clamping of valve assembly;
8. Tighten locknuts on setscrews;
9. Connect air control line;

Note: Make certain gaskets are in good condition--if damaged, replace.

ASSEMBLY OF DISCHARGE VALVE ASSEMBLY IN CYLINDER HEAD

1. Make certain that copper gasket 1252 rests properly on shoulder in head 1249;
2. Insert discharge valve assembly and rotate back and forth to insure that it seats properly on gasket;
3. Place discharge valve clamp 1295 in position;
4. Make certain that copper-asbestos gasket 1302 rests properly on cylinder head shoulder;
5. Carefully place discharge valve cover 1300 in position;
6. Assemble four nuts 1250 and washers which hold discharge valve cover to cylinder head, but tighten them alternately to prevent cover from tilting on one corner;
7. Tighten setscrew 1301;
8. Tighten locknut on setscrew;

Note: Make certain gaskets are in good condition--if damaged, replace. After installation of valve covers has been completed, and compressor has reached operating temperature, set screws 1293, 1301 should be rechecked for tightness.

PISTON (See special note after paragraph "Cylinder")

Material.....	Cast Iron
Clearance:	
High pressure lands.....	.010" to .021"
High pressure skirt.....	.0045" to .0065"
Low pressure lands.....	.013" to .024"
Low pressure skirt.....	.0055" to .0075"

PISTON RINGS:

Total Required.....	4
Compression.....	2
Oil Control.....	2
Width.....	3/16"
Gap:	
High pressure compression.....	.010" to .020"
High pressure oil.....	.015" to .025"
Low pressure compression.....	.010" to .020"
Low pressure oil.....	.010" to .018"

PISTON PIN:

Type.....Clamped in Rod
 Length, (High pressure cylinder).....4-5/16"
 Length, (Low pressure cylinders).....5-1/4"
 Diameter.....1.500"
 Clearance in bushing......0015" to .002"

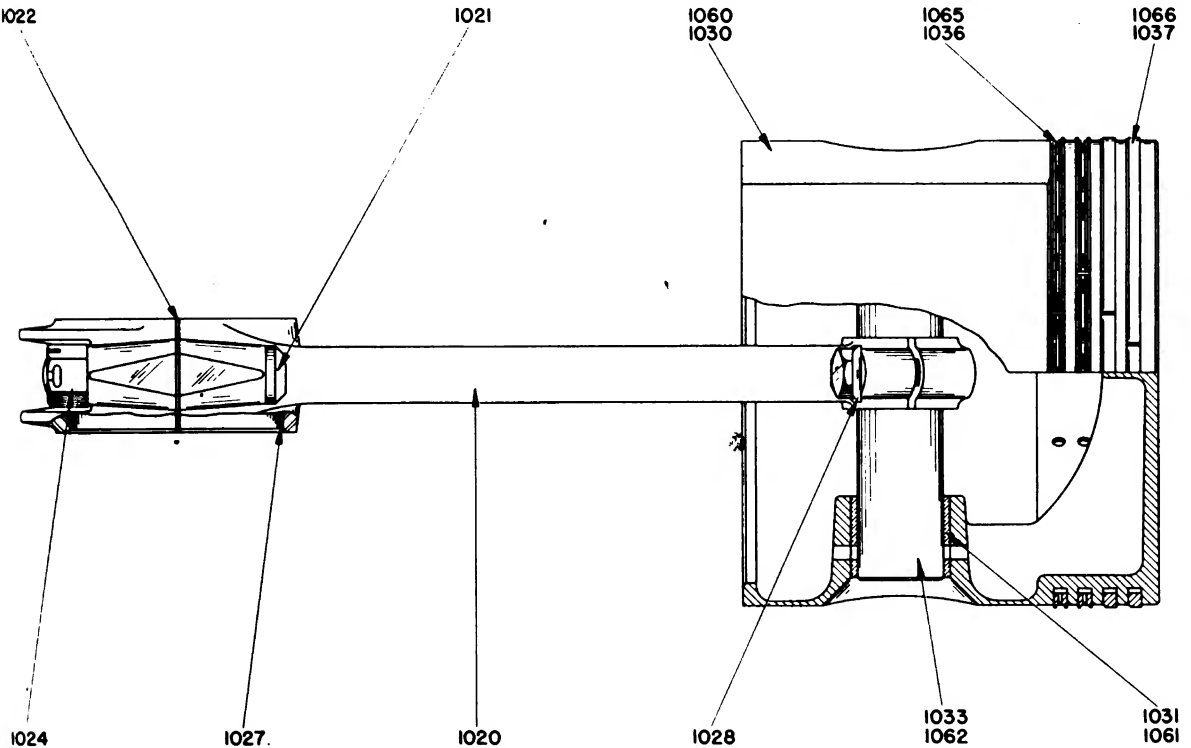

CONNECTING ROD & PISTON ASSEMBLY

PLATE 2S-27

When assembling piston 1030, 1060 to connecting rod, 1020 place oil baffle plate ●1094, ●1095 on rod, place rod in piston and slide piston pin 1033, 1062 through bushings 1031, 1061. Tighten clamp bolt in connecting rod securely and lock in place. Never attempt to remove piston pin 1033, 1062 from connectingrod before removing the clamp screw. Fit piston rings 1036, 1037, 1065, 1066 in bore and assemble to piston making certain rings are free in grooves and gaps are staggered. Note: The two top rings 1037, 1066 are compression rings and must be assembled to piston with the grooves down. Oil piston 1030, 1060 before replacing cylinder.

● Parts illustrated in Drawings Nos. 2S-23C and 2S-24C, Pages 37 and 38.

CONNECTING ROD (See special note after paragraph "Cylinder")

Connecting rod length, center to center.....12-1/2"
 Crank pin, diameter.....3.500"
 Bearing material.....Babbitt-steel back
 Bearing length, total.....1-27/32"
 Bearing running clearance......0025" to .004"
 Bolts, number.....2
 Bolts, material.....Nickel-Steel, heat treated
 Bolts, size (special).....5/8" - 18 x 3-3/4"

Connecting rod bearings 1027 are not adjustable and when clearance becomes excessive, replacement is necessary. Connecting rods 1020 should be free from twist and parallel with pistons 1030, 1060. Connecting rods and caps are numbered and should be assembled with numbers corresponding. In the low pressure cylinders, numbered sides of connecting rods should be placed so they face upwards. It makes no difference which way they face in the high pressure cylinder. When installing bearings 1027 be sure bearing backs and rod surfaces are absolutely clean, smooth, and free from oil. Bearings have a nib or projection which prevents turning and should be assembled with nib engaging milled notch in rod and cap. **CAUTION:** Do not scrape shell bearings and do not file connecting rod or connecting rod cap parting faces. Adjustment is correct when nuts 1024 are tight and the crankshaft may be rotated by hand.

CYLINDERS (See Illustration 2S-24C, Page 38)

Cylinders 1210, 1230 must be removed in order to service rings, piston, connecting rod etc. **SPECIAL NOTE:** Upon replacing, bolt cylinder down tight and check to see that piston in T.D.C. position is from .005" below to flush with top of cylinder. "Spacing gaskets" as required, must be installed, under cylinder base flange, to maintain this clearance.

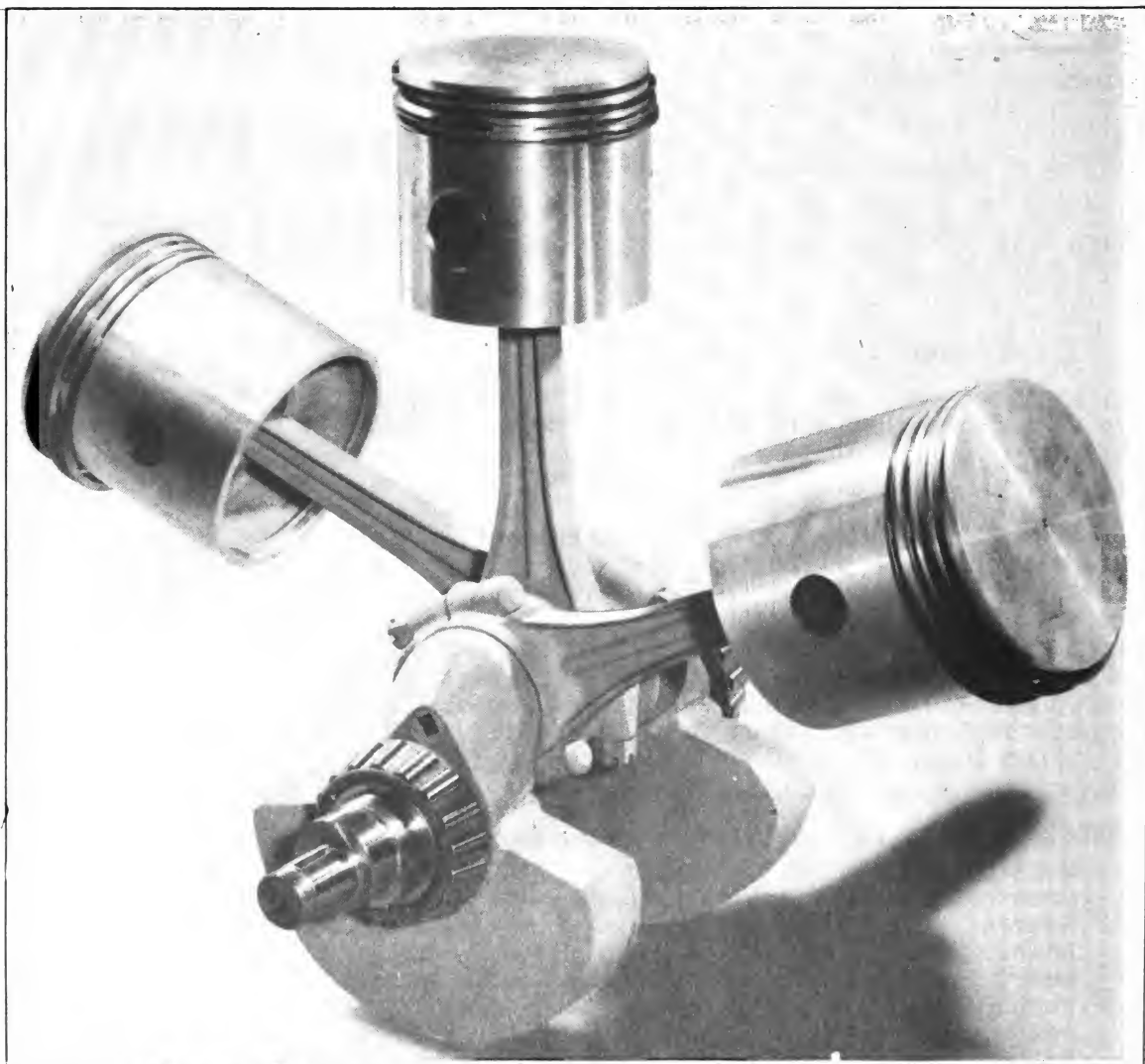

MAINTENANCE INSTRUCTIONS

CRANKSHAFT (See special note after paragraph "Cylinders")

Drilled for pressure lubrication.....Yes
Bearing journal diameter.....3.500"

REMOVAL: (See Illustration 2S-23C, Page 37)

To remove crankshaft 1000 it is necessary to remove compressor from the frame, remove oil pan 1470 and disconnect connecting rods. Remove clutch assembly 1505 and attaching parts, front bearing cover 1092 with shims. Remove inter-cooler fan belt 1197 and fan drive pulley 1009, being careful not to damage oil seal 1133. Remove oil pump body 1120 with connection, noting position of tapered dowells. Block crankshaft up to support weight until ready to remove. Remove rear bearing retainer 1085 using extreme care not to damage rear main bearing 1003. Crankshaft may now be removed through rear opening of crankcase.

REPLACEMENT:

Enter crankshaft through opening in rear of crankcase, block up to hold weight and install rear main bearing retainer 1085. Remove blocks. Assemble front bearing cover 1092 with shims (see paragraph "Oil Seals") and check end clearance, as outlined in paragraph "Bearings". Install oil pump body 1120 making certain oil pump connecting rod 1130 is in proper position on crankshaft, replacing dowells. Replace fan drive pulley 1009, making certain gasket is in place, and oil seal 1133 is not damaged. Tighten crankshaft nut 1011 and lock in place.

BEARINGS:

Number.....2
Type.....Tapered Roller
Manufacturer.....Timken #643-632

Main bearing cones are shrunk onto crankshaft; by heating in oil to not more than 500° F., rear main bearing cup is pressed into bearing retainer 1092. Front bearing cup is a push fit in crankcase 1075. Adjustment is obtained by adding or removing shims under bearing cover 1092. Correct end play of crankshaft is .003" to .006" as checked by indicator and must be maintained at all times.

OIL SEALS:

Oil seals 1093, 1133 are pressed into housings and must be installed with lip pointing inward as shown. CAUTION: Do not press oil seals in beyond face of housings as oil return passages behind oil seals must remain open.

After front oil seal 1093 is installed in retainer, installation to compressor should be made by aid of a metal sleeve. Insert sleeve into oil seal and slip retainer, seal and sleeve over crankshaft. After retainer is in place remove sleeve into oil seal and slip retainer, seal and sleeve over crankshaft. After retainer is in place remove sleeve. Sleeve can be made of shim stock that can be bent into position. Rear oil seal 1133 requires no special installation instructions. CAUTION: Make certain seals are not scratched or marred.

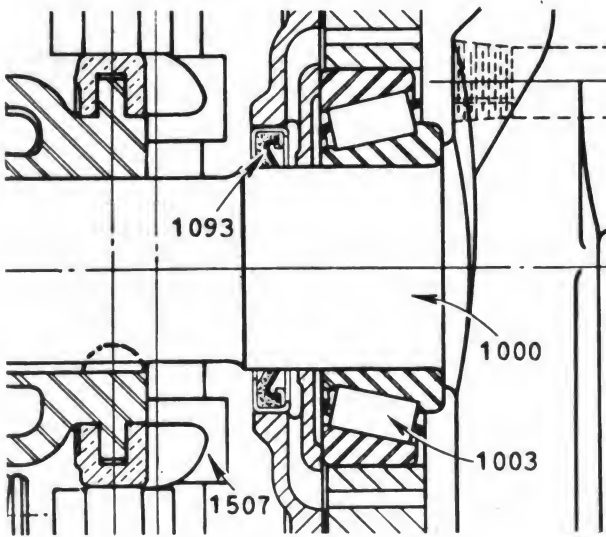

Front Oil Seal

- 1093. Oil seal
- 1003. Main bearing
- 1507. Clutch yoke
- 1000. Crankshaft

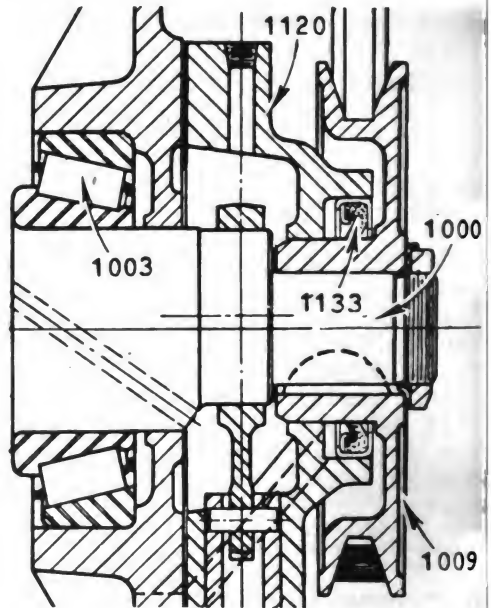

Rear Oil Seal

- 1133. Oil seal
- 1009. Fan drive pulley
- 1120. Oil pump body
- 1000. Crankshaft
- 1003. Main bearing

PRESSURE CONTROL SYSTEM (See "Diagram of Pressure Control System" Page 10)

AIR CLEANER:

Periodically the cleaner unit should be removed from the system for cleaning. Unscrew top from bottom and remove screens and felt, clean with air hose and replace. CAUTION: Make certain screens are not damaged in any way and felt is not saturated with oil.

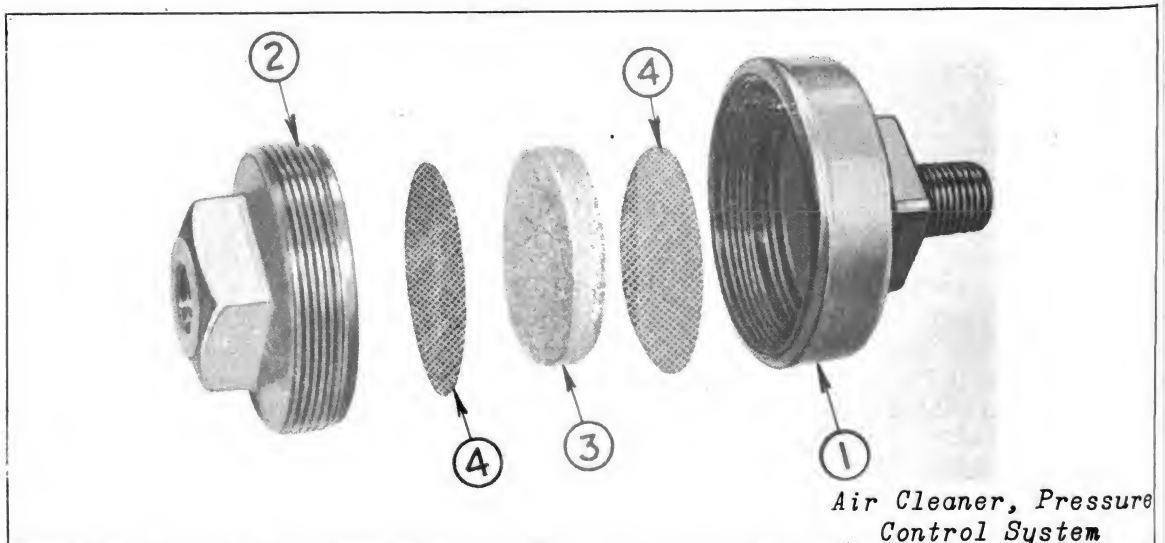

Air Cleaner, Pressure Control System

- 1. Cleaner bottom
- 2. Cleaner top
- 3. Felt
- 4. Screen

UNLOADER PILOT SWITCH:

SPECIFICATIONS:

Manufacturer.....Penn Electric Switch Co.
Goshen, Indiana

Model.....GI

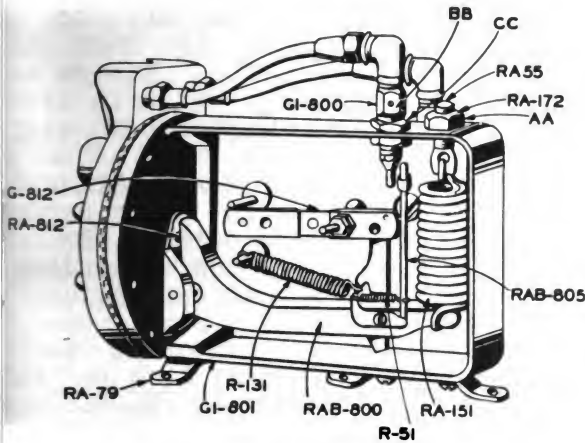

Front View Unloader Pilot

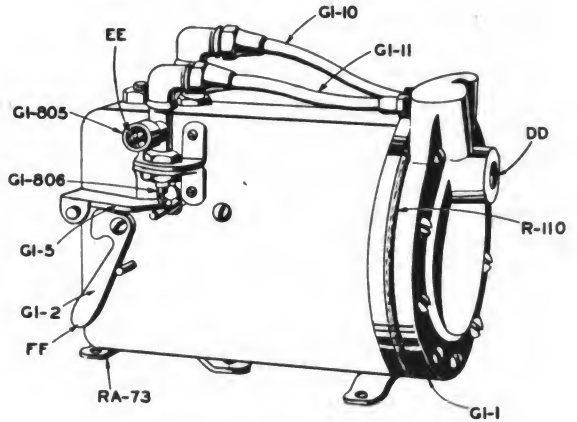

Rear view Unloader Pilot

GENERAL:

The Penn type GI unloader Pilot is designed for use in air compressors, equipped with unloading devices, to maintain close regulation of receiver pressure. It automatically unloads or loads the compressor on rise or drop in receiver pressure.

DIAPHRAGM CHAMBER:

Diaphragm casting is provided with 1/4" Female I.P.T. tapping (see "DD" in rear view) for pipe connection to air receiver.

UNLOADER VALVE:

Unloader valve "EE" (see rear view) is connected to check and bleed valve by means of 1/4" tube fittings. CAUTION: Clean all tubing and fittings thoroughly before connecting to prevent pipe scale, filings, metal chips, or other foreign matter from reaching valves.

PRESSURE ADJUSTMENTS:

Unloading pressure--approximately 100 lbs. Loading pressure--approximately 88 lbs. If for any reason these pressures must be changed they may be reset as follows: Turn adjusting nut "AA" (see front open view) to right (clockwise) to raise unloading pressure; turn to left (counter-clockwise) to lower unloading pressure. The pressure at which the compressor loads will be raised or lowered a corresponding amount.

DIFFERENTIAL ADJUSTMENT:

The differential pressure at which the control unloads or loads the compressor is set at factory and should not be changed. If for any reason

it becomes necessary to vary the differential pressure, it may be reset by changing position of valve "BB". Loosen lock nuts "CC" and raise valve "BB" to widen differential (lower loading pressure); lower valve "BB" to narrow differential (raise loading pressure). Note: Differential adjustment affects only loading pressure, unloading pressure remains constant. This is a delicate adjustment and differential should never be closer than 10 lbs. or "chattering" may result.

DISASSEMBLY

Loosen conveyor tubes (G1-10, 11) at elbows. Unless they are to be serviced do not break connections at diaphragm casting as they are soldered in place. Remove nut (RA-172) and spring RA-151. Remove extension spring R-51, kick off valve plunger rod RAB-805, and trip lever spring R-131. Remove top and bottom center screws from diaphragm housing. Diaphragm housing assembly with conveyor tubes and main arm assembly RAB-800 can be removed as a unit. If diaphragm only is to be replaced, further disassembly of unit is not required. Remove eight other screws from diaphragm housing and separate the two parts, being careful plunger disc does not drop out to become lost. Diaphragm is now accessible. NOTE: See "Reassembly" instructions before proceeding with assembly.

Main arm assembly RA8-800 may be removed by driving out pivot pin. Kick-off valve assembly, 91-800, may be removed by removing lower lock nut and withdrawing from main frame G1-801. Unloader valve assembly G1-805 may be removed from case by withdrawing 3 screws holding the bracket. Removing the lower lock nut will allow valve assembly to be serviced. Make certain valve plunger pin is not lost. NOTE: Service on other parts of unloader is infrequent and disassembly is obvious upon inspection. Because of close adjustments necessary in assembling valve assembly G1-805 and G1-800 they are serviced only as assemblies. If service becomes necessary entire units must be replaced.

REASSEMBLY:

Place rubber diaphragm R110 on lower casting, then place plunger disc into position so projection will fit through center hole of upper diaphragm casting. Install the eight screws (omitting the top and bottom center) and tighten firmly and evenly. Place main arm in channel on back of upper diaphragm casting and insert pivot pin in place. Assemble kick-off valve plunger rod to main arm and connect extension spring. Fasten valve bracket to back of main frame with 3 screws. Screw unloader plate pivot stud into main frame and place hand unloader plate on this stud and secure with cotter key. Place bushing through hand unloader handle and attach to frame. Insert trip lever and cover mounting screw from back of case, place trip lever bushing over screw, and place felt washer between the yoke of trip lever and mount over bushing. Install lock nut, then washer and other locknut in place. Attach diaphragm housing and main arm assembly in place installing 2 screws in holes left empty before. (1-1/2" screw in top and 1-1/8" screw in bottom.) Install main spring and tighten lock nut only enough to hold assembly in place. Install trip lever spring. Insert valve plunger pin, pointed end, into unloader valve assembly and mount in bracket as illustrated in Rear View B and lock in place. Adjust height of valve so there is a little clearance between plate G1-5 and end of plunger pin when switch is in loaded position, (trip lever down).

Attach conveyor tubes to elbows making certain connections are air tight. Make pressure adjustments and differential adjustments as described. CAUTION: Proper operation of the compressor depends upon the correct adjustments of this unloader pilot. Follow directions carefully.

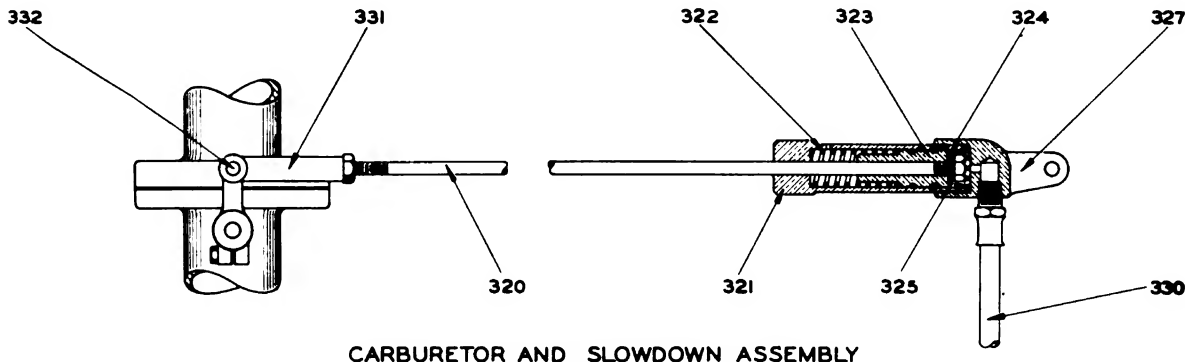

CARBURETOR AND SLOWDOWN ASSEMBLY

SLOW DOWN ASSEMBLY:

The slow down assembly 321 is designed in such a way that it becomes a part of the engine governor rod 320. One end of this assembly is attached to the governor lever and the other end to the carburetor lever. When the compressor unloads, air from the receiver is admitted to the slow down assembly, forcing the plunger 323 outward and increasing the length of the governor rod until the carburetor lever 332 is in the idle position. When pressure in the receiver drops the air is released from the slow down and the plunger is returned to its normal position by a spring 322, allowing the engine to return to full operating speed.

Regularly the plunger shaft should be oiled and periodically the entire unit should be dismantled and cleaned thoroughly. Remove flexible hose 330 and unscrew slowdown body 321 from nut 327. Plunger 323, leather washer 324 and spring 322 are now exposed for service. Reassemble plunger, spring, and nut as shown and screw body into nut. Reconnect flexible air hose.

SAFETY POP VALVES: (See Ill. "Intercooler and Relief Valve Assembly")

The intercooler Safety Pop Valve 1580 is set to trip at 50 lbs. and must not be changed. If service becomes necessary the entire valve must be replaced. Keep exterior of valve clean and free of corrosion, trip lever must be tripped daily by hand to insure its operation.

Air Receiver Safety Pop Valve is similar to intercooler pop valve except it is set to trip at 120# pressure. No maintenance is required on either valve.

CHECK AND BLEED VALVE

This valve, inserted in the pressure control line between the unloader pilot and compressor and the slow down assembly allows the air to flow freely into unloaders and intercooler relief valve but restricts the flow of air from unloaders and intercooler relief valve. At the same time it allows air to escape rapidly from the slow down assembly when the compressor loads again, providing a time delay which allows engine to gather speed before full load is applied.

To change time delay, adjust screw on side of valve, turning inward to increase and outward to decrease. This is set correctly at factory and should not be changed unless absolutely necessary.

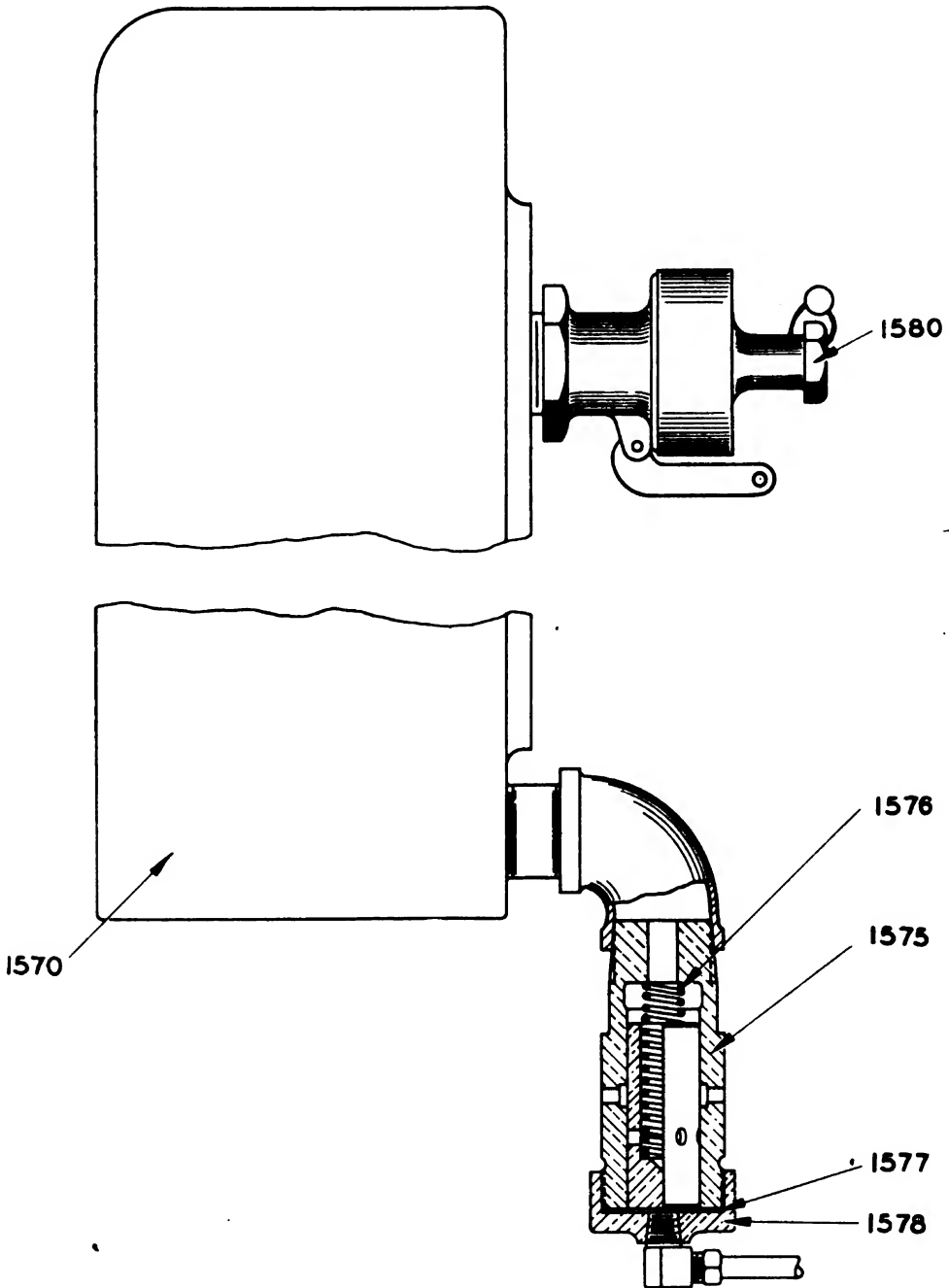

INTERCOOLER AND RELIEF VALVE ASSEMBLY

INTERCOOLER RELIEF VALVE:

This valve, consisting of a cylinder, plunger 1575, and spring 1576, is located in the bottom of the intercooler 1570. When the compressor unloads, air from the receiver forces the plunger back until ports are uncovered and the air in the intercooler is released to atmosphere, at the same time blows condensate out of intercooler. The valve is easily dismantled for cleaning and service. DISASSEMBLY: Disconnect air line and unscrew cap 1578 from body 1575 being careful not to lose gasket 1577. Reassemble by installing spring 1576 and plunger, screw body into cap and connect air line.

COMPRESSOR SERVICE CHART

TROUBLE	CAUSE	REMEDY
Noise in Air Receiver or hot air breathing from intercooler relief valve when compressor is idling.	High pressure discharge valve not seating properly or valve is broken.	Remove valve assembly and examine. Check valve seats for low spots. Replace any parts necessary.
Air leaking from intercooler relief valve when compressor is pumping or intercooler relief valve failing to open and relieve intercooler pressure when compressor is idling.	Intercooler relief not functioning properly.	Remove intercooler relief valve assembly. Replace any parts necessary. Grease and replace.
Intercooler pressure shown on gauge is below normal.	Leaking low pressure valves.	Remove and examine valves. Clean and inspect. Replace any parts necessary.
Intercooler pressure shown on gauge is above normal.	Leaking high pressure valves.	Remove and examine valves. Clean and inspect. Replace any parts necessary. Remove intercooler relief valve assembly. Replace any parts necessary. Grease and replace.
Compressor failing to pump up to pressure and intercooler safety valve popping off.	Worn or broken high pressure valves.	Remove valves, clean and inspect. Replace any parts necessary.
Failure of compressor oil gauge to indicate pressure.	Restricted fitting to gauge plugged up or defective gauge.	Disconnect pipe leading to gauge, clean thoroughly, and replace. Make sure that all joints are tight. If gauge is defective, replace with a new one.
	Dirt under ball seat in oil pump or sticking pressure relief valve.	Dismantle oil pump and clean thoroughly. Examine balls, seats and relief valve. Replace any parts necessary.
	No oil in crankcase or oil pump screen plugged up.	Fill crankcase to "F" mark on bayonet gauge with oil. See lubrication. Clean oil pump screen if necessary.
Pilot unloading valve chattering.	Differential pressure set too close.	See instructions on Pilot Unloading Valve.
Knock in compressor.	Loose or worn connecting rod or piston wrist pin bearing.	Be sure that compressor crankcase is full of oil by checking on bayonet gauge. Remove cylinder and examine for damaged parts, such as piston, piston rings, scored cylinder bore or connecting rod bearings.

MAINTENANCE INSTRUCTIONS

COOLING SYSTEM

Capacity--U. S. Gal.....	8
Type.....	Flat Tube
Thermostat Opens.....	160° F
Water Pump Drive.....	V Belt
Water Pump Fan Belt. Tension Adjustment.....	Turn one flange of pump pulley
Water Pump Capacity. Gallons per minute.....	27
Fan Diameter.....	22"
Fan Blades.....	4"

OPERATION

Positive centrifugal pump circulates water in closed system between engine block, cylinder head and radiator. Temperature is controlled by thermostat, by-pass type, located in engine outlet hose connection. Path of water circulation when engine is cold is from radiator bottom up through pump, through engine block, up to cylinder head and out into thermostat, through thermostat and by-passed back into pump. Any water escaping into radiator is made up from supply at bottom of radiator. This circulation during warm up period prevents formation of steam pockets. The thermostat opens at 160° and when open, the by-pass is closed and water is circulated thru the radiator. Temperature controls the opening of thermostat which controls amount of water recirculated through pump and also amount of cooler water added from radiator.

WATER PUMP

Fan blade and pulley assembly are secured to fan hub by four cap screws. Fan hub is secured to water pump shaft by means of a pin. Impellor is pressed onto water pump shaft. Water pump shaft is mounted in bronze bushings. Sealing is accomplished by means of a carbon sealing washer held in contact with a shoulder and a rubber bellows and spring which automatically takes up normal wear preventing leakage. Due to wear after considerable service the pump may leak and when this occurs the pump must be removed and dismantled and carbon sealing washer and bellows replaced.

REMOVAL

To remove water pump the following steps should be followed:

1. Drain radiator and cooling system.
2. Release tension on fan belt and remove.
3. Remove hose connections at water pump.
4. Remove capscrews holding water pump to water pump bracket and remove pump.

INSTALLATION

Reverse of removal.

DISMANTLEING

Following notes refer to illustration "Water Pump Assembly".

1. Remove fan.
2. Drive pin #481 out of hub.
3. With gear puller pull fan hub (480) off of shaft.
4. Draw impellor with shaft out of pump.
5. Press pump shaft (475) out of impellor (478).
6. Upon reassembling make certain that driving lugs of carbon seal are engaged in slots in impellor before pressing impellor on shaft.
7. Upon reassembling shaft with impellor into pump body it will be necessary to align thrust ring (472) with bushing and flat surface of shaft.
8. Service bushings are reamed to size. However, the bores should be checked after bushings are installed. Front bushing should be .753". Rear bushing should be .878". Running clearance for both is .0015 to .0035".
9. Gasket between pump and bracket should be replaced whenever pump is dismantled.

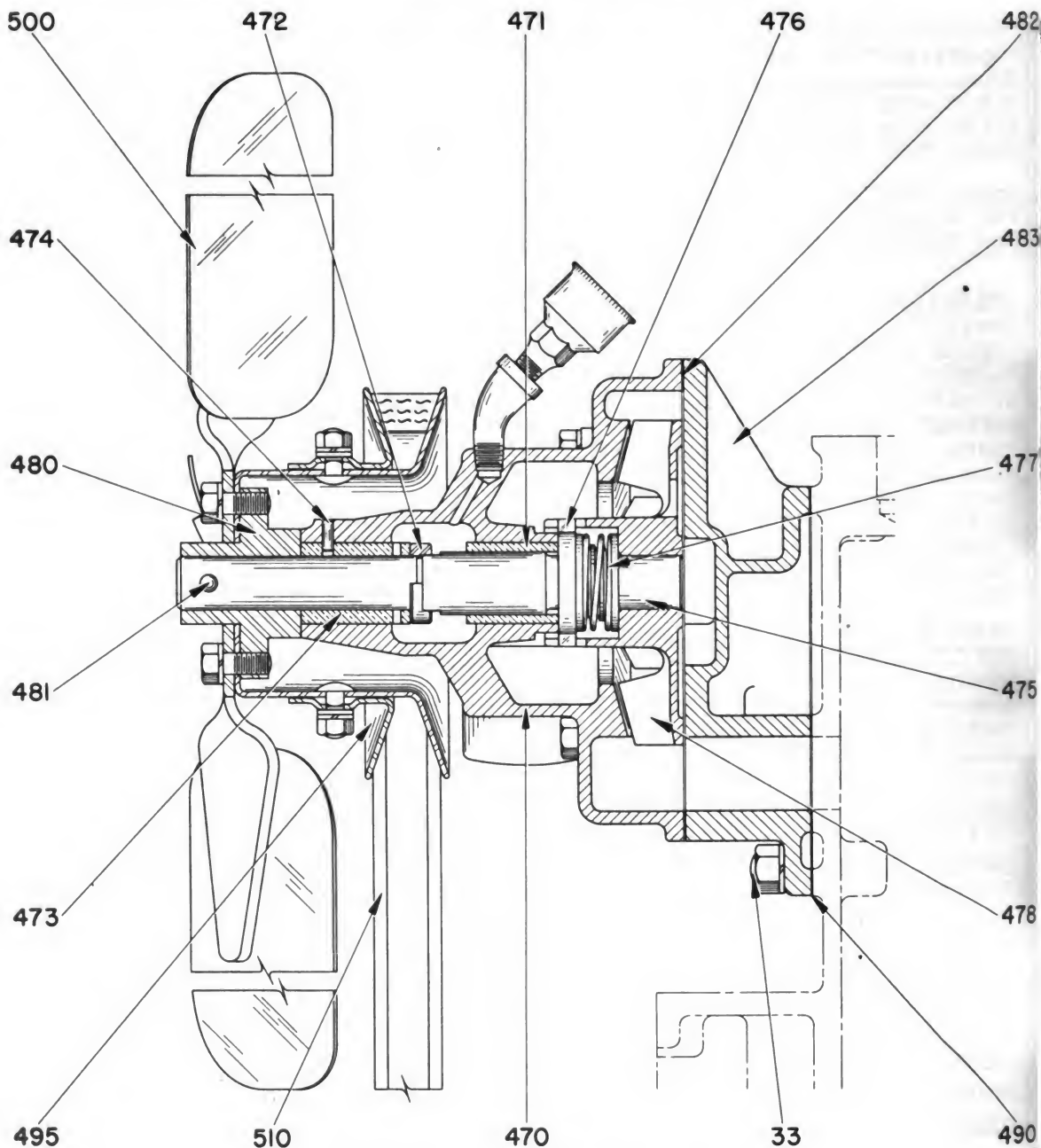

WATER PUMP ASSEMBLY

PLATE D318-7A

NOMENCLATURE

33 Support Stud
470 W.P. Body
471 Bushing
472 Thrust Washer
473 Bushing
474 Bushing Pin

475 Shaft
476 Carbon Seal Washer
477 Bellows Seal
478 Impellor
480 Fan Hub
481 Taper Pin

482 Gasket
483 Bracket
490 Gasket
495 Fan Pulley Assy.
500 Fan Blade
510 Fan Belt

WIRING DIAGRAM

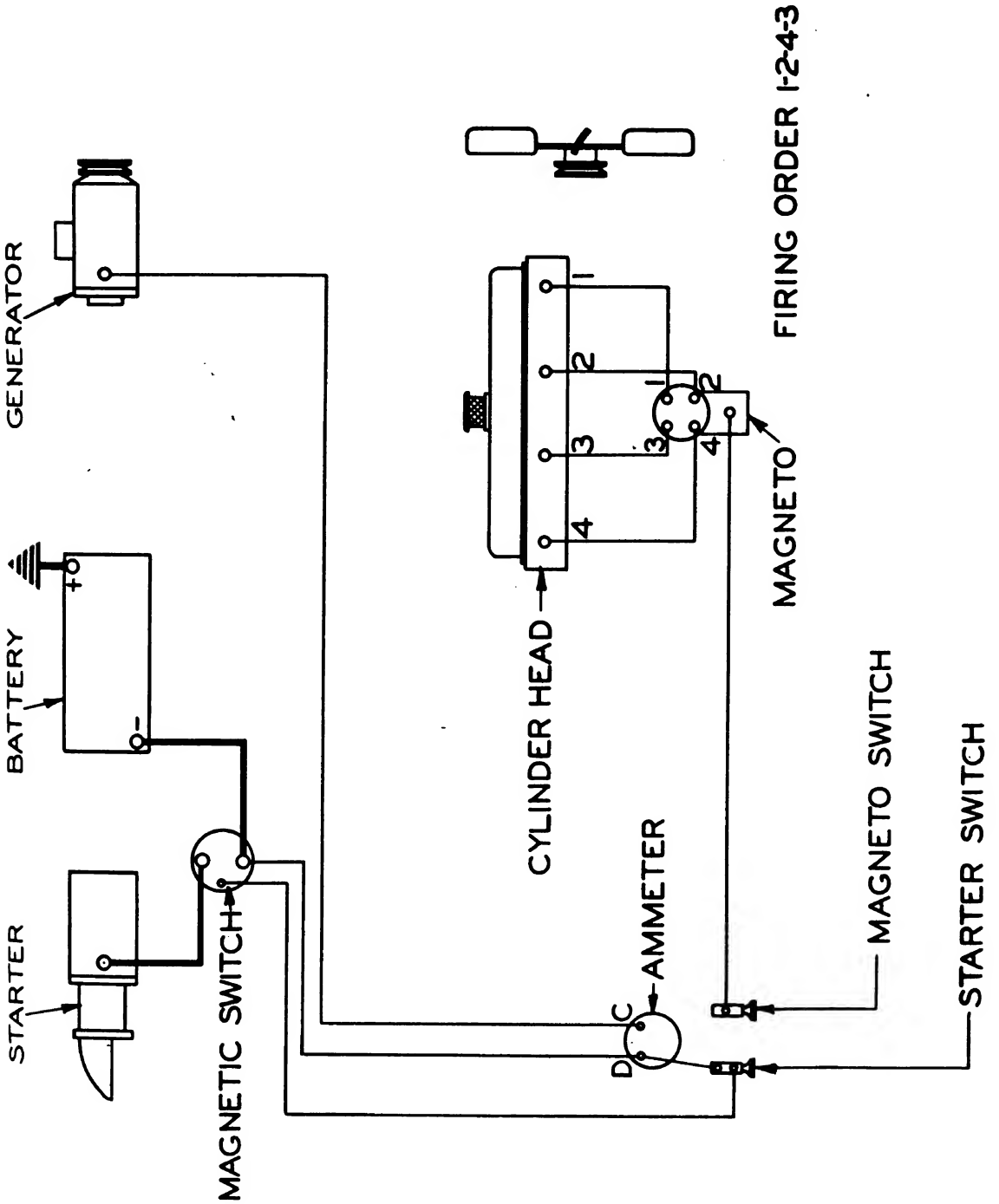

MAGNETO

SPECIFICATIONS

American Bosch Corp., Springfield, Mass.....	Model MJC4C-334
Rotation.....	C.W.
Impulse Coupling.....	1CA2A
Spark.....	Fixed
Contact Points.....	{ 1 Tungsten 1 Platinum

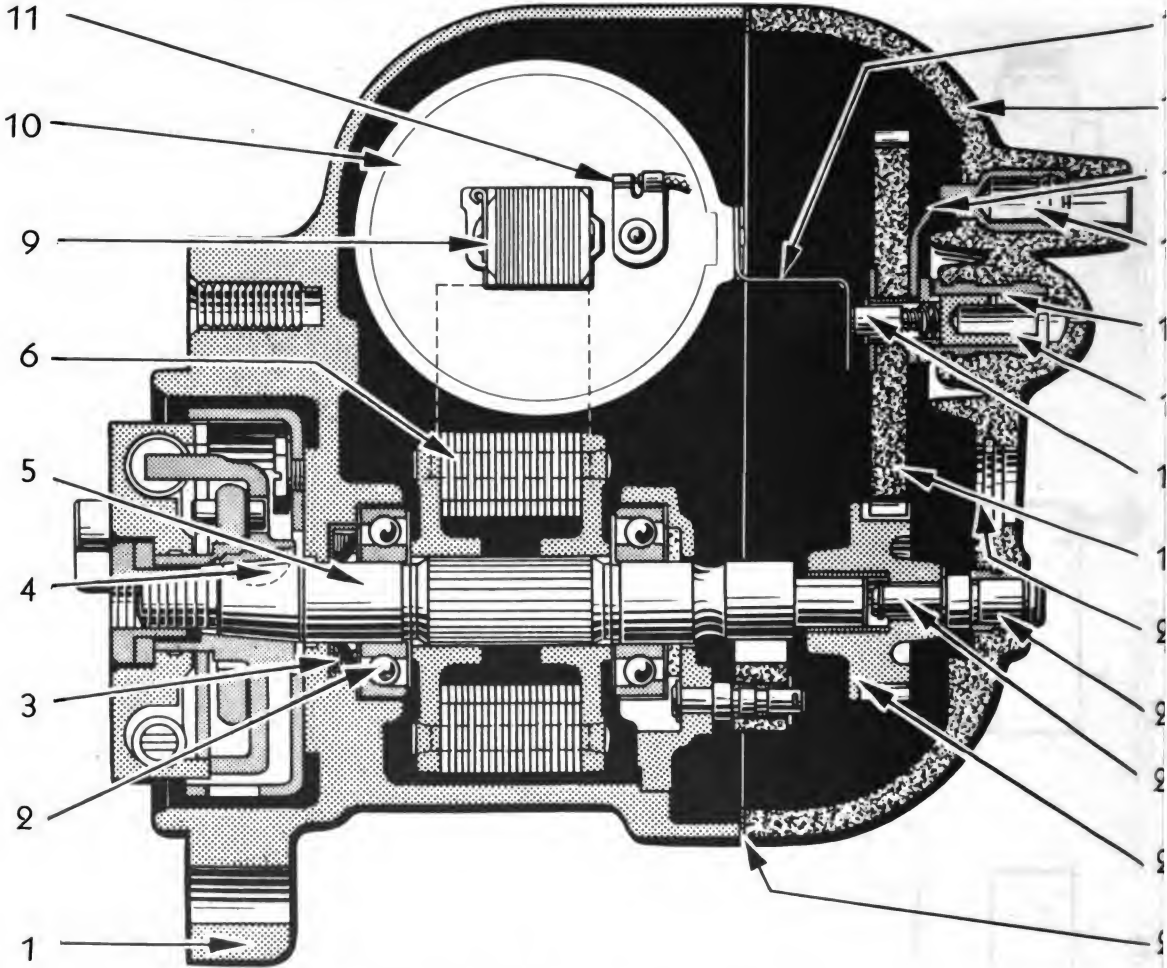

Longitudinal Section Thru Magneto

TIMING THE MAGNETO

The magneto, producing an ignition spark only at certain definite points in the rotation of the magnet rotor (6), must be connected and timed to the engine in such a manner that the spark is always available at the instant when required in the cylinder.

Turn engine with hand crank until the piston in cylinder No. 1 moves upward on the compression stroke to the location where ignition is to occur. See Flywheel markings.

- A. Rotate the impulse coupling until the line (36) on the distributor gear (19) is visible in the observation window (20). This operation is best performed by turning the impulse coupling in the opposite

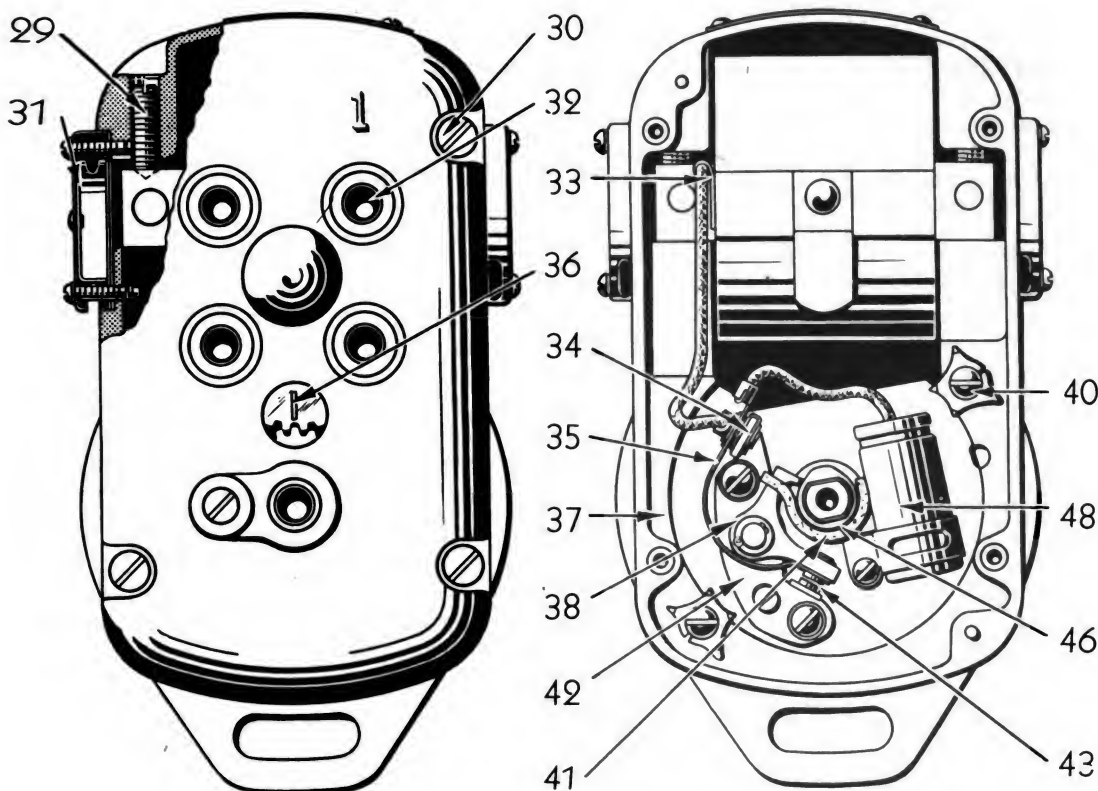

Cross Section Thru Magneto

direction of rotation to that in which it will be driven by the engine, thus eliminating the engagement of the impulse weights.

- B. With the engine and the magneto in the positions outlined above, the impulse coupling drive tongues will engage the slot in the engine drive member when the magneto is flanged into position. Approximate timing to the engine is now obtained.
- C. Tighten the flange fastening screws by hand but not to the extent that the magneto cannot be moved toward or away from the cylinder block.
- D. Remove the distributor plate by loosening the four screws. This will expose the interrupter assembly.
- E. To obtain the exact timing, the interrupter points must just begin to open. It may be necessary, in order to get that position, to turn the magneto slightly toward or away from the cylinder block.
- F. Reinstall the distributor plate and insert the cable between outlet No. 1 and cylinder No. 1 which is then timed to fire correctly.

Complete the installation by connecting the remaining cables of the magneto to the spark plugs in their proper firing order (1-2-4-3). The firing sequence on the distributor or high-tension end of the magneto follows the opposite direction of rotation from that indicated by the

arrow on the magneto name plate and must be taken into consideration when the cables are connected to the spark plugs.

TROUBLE SHOOTING

In case of defective ignition, it must first be determined whether the fault is in the magneto or elsewhere. In general, when only one cylinder misfires, the fault is in the spark plug. The most common plug difficulties are as follows:

PLUG GAP TOO WIDE: The proper distance between the electrodes of the spark plugs varies in some engines but, normally, this distance should not be less than .025". On the other hand, however, too wide a gap increases the electrical resistance and interferes with the operation of the engine at low speed. Difficulty in starting an engine and missing at low speeds are very often due to the spark plug gaps being too wide, and as the spark will have a tendency to burn the electrodes and thereby gradually increase the gap, it is especially important that the plugs be examined occasionally to see that the gap is not too great; any difficulty due to this cause may be readily overcome by readjusting the electrodes.

PLUG SHORT-CIRCUITED: This is usually caused by a cracked or porous insulator, or by fouling of the electrodes or insulator. Any of these conditions will cause misfiring by permitting the current to stray from its intended path.

CABLES: Misfiring of one cylinder, either continuous or intermittent, may be due also to a chafed or broken cable or a loose cable connection. The metal terminals of the cables must not come into contact with any metal parts of the engine or the magneto, except those designated as being correct according to the instructions given.

IRREGULAR FIRING: If the cables and plugs are in good condition and yet the ignition is irregular, the trouble is probably with the magneto, and the interrupter assembly (40) should be carefully examined. It should be seen that the interrupter lever (38) moves freely and contacts (44) are clean and in correct alignment (see paragraph headed "Interrupter").

DAMAGED INSULATING PARTS: As it sometimes happens that distributor plate parts of the magneto are damaged, it should be carefully examined for possible arcing or leakage of high-tension current.

SERVICE ADJUSTMENTS

INTERRUPTER: The contacts (43) should be adjusted to an opening of .014"-.018" when the interrupter lever (38) fibre bumper rests on the top of the cam lobe (46). This is done by shifting the adjustable contact bracket (42) until the correct opening has been reached. After adjustment, the bracket (42) must be secured by means of its fastening screw. Contact points (43) must be free from oil or grease and be in proper alignment, so that the full surfaces of both contacts meet squarely. Pitted contacts (43) can be cleaned on a suitable stone. The use of a file is not recommended.

When point renewal becomes necessary, always replace both interrupter lever (38) and contact bracket (42) at the same time.

IMPORTANT: Proper method of removing and replacing the distributor plate assembly to permit contact point inspection or adjustment:

Rotate the engine until line (36) on distributor gear (19) is visible in

MAINTENANCE INSTRUCTIONS

observation window (20). Remove the four fastening screws (30) and withdraw the entire distributor plate assembly. Adjustments can now be made as outlined above.

When replacing the distributor plate assembly, line (36) on distributor gear (19) must be visible in observation window (20). Engage magnet rotor shaft (5) with rotor gear (25) and tighten distributor plate fastening screws (30).

NOTE: If the distributor plate assembly was removed before the instructions given above were noted, it will be necessary to rotate the engine until piston of No. 1 cylinder, this is the cylinder nearest the radiator, is in approximate firing position of compression stroke. Rotate the distributor gear (19) until line (36) is visible in observation window (20). Engage magnet rotor shaft (5) with rotor gear (25), slightly moving rotor gear (25) in either direction, as required, to permit engagement. Tighten distributor plate fastening screws (30).

DISASSEMBLY OF MAGNETO

NOTE: To facilitate the reassembly of a magneto, it is suggested that the parts be laid on a clean bench or placed in a clean pan in the order in which they are disassembled. (Remove impulse coupling before proceeding with the disassembly of the magneto.)

Remove distributor plate assembly by loosening fastening screws. The spring ring holding the rotor gear to the rotor gear shaft can easily be removed by taking the distributor plate assembly up in one hand and bringing it down rapidly on a bench so that the four corners of the open end of the distributor plate strike simultaneously. Rotor gear and distributor gear can then be removed.

Remove the interrupter assembly by withdrawing two screws and locking plates.

TO DISASSEMBLE THE INTERRUPTER ASSEMBLY, PROCEED AS FOLLOWS:

1. Remove coil primary lead screw and lockwasher.
2. To remove condenser and wick retaining bracket, withdraw fastening screw and lockwasher.
3. Remove interrupter lever cotter pin and washer, and pull out interrupter lever.
4. To remove contact bracket, withdraw fastening screws and lockwashers. Loosen coil set screws on the outside top of the magneto housing and pull out high tension coil.

Remove Woodruff key from drive end of magnet rotor and pull out magnet rotor.

Remove ball cages from either end of magnet rotor. Remove ball bearing inner race rings. Remove ball bearing outer race rings from drive end of magneto frame and reverse side of interrupter bracket.

INSPECTION AFTER DISASSEMBLY

Visually inspect the rotor gear, distributor gear and carbon brush for possible wear. Check the distributor plate for current leakage or damage. If the distributor plate has no carbonized track, it is only necessary to wipe out the inside of the plate with a cloth dampened with a suitable cleaner such as acetone, alcohol, etc. However, if the plate has a car-

bonized track, the track should be scraped clean and the entire plate wiped out with a cloth dampened with alcohol.

The interrupter contacts should be checked. Pitted points can be dressed on a suitable stone; the use of a file is NOT recommended. If point renewal is necessary, always replace both the interrupter lever and contact bracket at the same time.

Check the condenser for short circuit, leakage or damage.

Examine the high tension coil for cracked housing, loose core, loose primary cable connection. Inspect all soldered connections. Check continuity of secondary winding on a condensoscope, neon light or other similar testing device.

Inspect ball bearing inner and outer race rings for scores and excessive wear. Inner and outer race tracks and balls should not be discolored and should have a mirror finish.

REASSEMBLY OF MAGNETO

BALL BEARINGS

Before installing ball bearings, make sure all surfaces of bearing seats are clean.

Previous to installing the bearing outer race rings, place paper washer IS 222 at the bottom, and packing strip IS 504 around the side of the bearing recess in the magneto housing and interrupter plate. Both ends of the packing strip are to meet at the milled out slot in the recess of the magneto housing and interrupter bracket. Center bearing outer race ring over recess and press into place.

After bearing outer race rings have been installed, trim off excess portion of packing strip IS 504 with a sharp pen knife or razor blade. Place ball cage on bearing inner race rings and install magnet rotor into magneto housing.

HIGH TENSION COIL

Slide coil into the upper portion of the magneto housing. Each end of the coil core is to rest on top of the magneto pole shoes in the magneto housing. The counter-sunk holes at either end of the coil core should be up right so as to allow the tapered end of the coil securing screws to engage the counter-sunk holes. Drive screws into holes provided on the outside top of the magneto housing. Securely tighten screws so as to assure a good electrical connection between the coil core and pole shoes. Apply a coat of shellac to the protruding end of each screw to prevent the entrance of moisture.

INTERRUPTER ASSEMBLY

Set contact bracket on boss of interrupter plate provided for this purpose. Replace fastening screws and lockwashers and tighten securely.

Place interrupter lever with felt wick on pivot pin of interrupter plate. Place interrupter lever washer on pivot pin after interrupter lever has been installed. Replace cotter pin in hole provided on pivot pin.

Set condenser on interrupter plate. Put felt wick retaining bracket and lockwasher on fastening screw and engage hole of condenser bracket. Drive screw into place.

MAINTENANCE INSTRUCTIONS

Loosely replace primary lead fastening screw and lockwasher (engaging interrupter lever springs and condenser lead) into insulated post of contact bracket. Place interrupter assembly on magnet rotor shaft and slide it into the recess of the magneto housing provided for this purpose. The slot in the outer edge of the interrupter plate is to line up with the stake mark in the recess of the magneto housing. Drive interrupter plate fastening screws with washers and locking plates into place. Make certain that the two points on the narrow end of the locking plates grip the interrupter plate firmly.

Connect coil primary lead clip to insulated post of contact bracket and tighten screw.

DISTRIBUTOR PLATE ASSEMBLY

Insert shaft of distributor gear into bronze bearing of distributor plate. Make sure that the spacing washer is on the shaft. Rotate distributor gear until the white line points directly to the rotor gear shaft. Place the spacing washer and the rotor gear on the rotor gear shaft engaging the tooth painted red on the rotor gear with the distributor gear slot marked with a white line. Put spring ring on rotor gear shaft. Place distributor plate assembly into place. The oblong shaped hole of the rotor gear is to engage the magnet rotor shaft. Drive distributor plate fastening screws into place.

EDGE DISTANCE

It is important, from the standpoint of efficiency, to interrupt the primary circuit in the high tension coil at the time when the magnet rotor is in its most favorable position for maximum magnetic disturbances or change of flux. This position of the magnet rotor in relation to the pole shoe is expressed in terms of a mechanical measurement called the "edge distance".

The edge distance is ALWAYS determined as the magnet rotor leaves the pole shoe; never when the magnet rotor approaches it. The proper edge distance for this magneto is 2 mm minimum and 3 mm maximum, an average of 2.5 mm.

To measure the edge distance, remove the distributor plate assembly. Turn the magnet rotor in the direction the magneto is to be driven until the rotor has gone slightly beyond the edge of the pole shoe. Insert a 2.5 mm. edge distance gauge between the magnet rotor and pole shoe. Turn the magnet rotor back against the edge distance gauge. While holding the rotor in this position, adjust the interrupter contacts so that they just begin to open. This is done by loosening the contact bracket fastening screws and by turning the eccentric screw until proper adjustment has been obtained. Do not forget to tighten the contact bracket fastening screws after the proper contact adjustment has been obtained.

Since the contact points and fibre block on the interrupter lever wear, it is recommended that the edge distance be checked periodically in order to assure maximum efficiency at all times.

MAINTENANCE INSTRUCTIONS

GENERATOR

SPECIFICATIONS

The specifications of the 1101374 Generator are as follows:

MANUFACTURER	DELCO-REMY, ANDERSON, IND.
Rotation.	clockwise, viewing drive end
Brush spring tension.	22-26 ounces for main brushes and 16-20 ounces for the third brush
Cold output	11-13 amperes at 7.5-7.8 volts at 1800 r.p.m.
Hot output.9-11 amperes at 7.3-7.6 volts at 2100 r.p.m.
Field current35-4.5 amperes at 6 volts

General maintenance may be divided into two sections, normal maintenance required to assure continued operation of the generator and the checking and repair of inoperative generator.

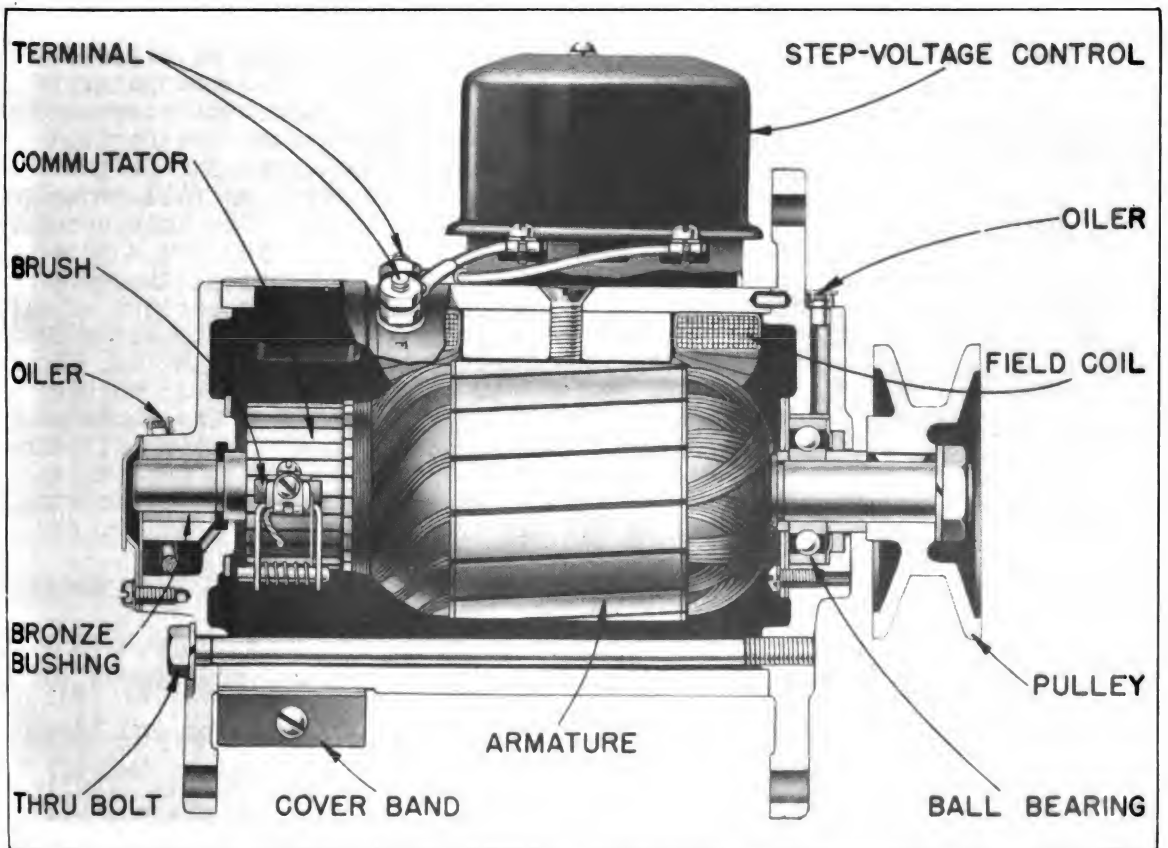

Longitudinal Section Thru Generator

QUICK CHECKS TO DETERMINE IF UNITS ARE OPERATING NORMALLY

- (1) A FULLY CHARGE BATTERY AND A LOW CHARGING RATE INDICATES NORMAL OPERATION. A check may be made to determine the maximum generator output as explained below.

- (2) WITH A FULLY CHARGE BATTERY AND A HIGH CHARGING RATE, it is necessary to determine whether or not the step-voltage control has operated to insert its resistance into the generator field circuit. This can be ascertained by removing the voltage control cover and checking to see if the voltage control points are open. If they are not, open them by depressing the voltage control armature by hand. If the output now falls off, the voltage control must be readjusted, as below. If the output does not drop off with the points held open, disconnect the lead from the voltage control "F" terminal. The output should drop off to zero. If it does not, it indicates a grounded field in the generator. If it does, it indicates a grounded field circuit in the voltage control unit.

It must be remembered that even after the step-voltage control has operated and inserted its resistance into the generator field circuit, it may still be possible for the generator to overcharge the battery. Under these conditions, it is desirable to reduce the generator output as explained below.

- (3) WITH A LOW BATTERY AND A LOW OR NO CHARGING RATE, momentarily ground the voltage control "F" terminal. This should normally cause the output to increase. If it does not, check the generator further, since it is apparently incapable of producing specified output. If the output does come up, check the voltage control, since it is apparently not grounding the generator field circuit in a normal manner to permit increased output as the battery drops to a low state of charge. This may be caused by the voltage control points not making contact, due to oxidation or improper adjustment. Loose connections, defective wiring, or other causes of excessive resistance in the charging circuit will cause the voltage control to operate and reduce the generator output even though the battery is still in a low state of charge.

At regular intervals, time depending on the type of operation, the generator should be disassembled for a thorough cleaning and inspection of all parts. Never clean the armature or fields in any degreasing tank, or with grease dissolving materials, since these may damage the insulation. Clean with blow gun or with clean, dry brush. The ball bearing should be cleaned and repacked with a good grade of ball bearing grease. The commutator should be trued in a lathe and the mica undercut if necessary. All wiring and connections should be checked. Rosin flux should be used in making all soldered connections. Acid flux must never be used on electrical connections.

DISASSEMBLY

1. Loosen cover band screw and remove cover from frame assembly.
2. Unscrew brush lead screws from top of brush holders and remove lock washers and lead clips.
3. Unscrew 2 thru bolts and remove lockwashers. Commutator end frame can be removed from frame assembly.
4. Grasp pulley and remove armature from field frame assembly (pulley and drive end frame are still connected to the armature shaft.) Place laminated section of the armature between the copper jaws of a vise. Loosen and remove pulley shaft nut and lockwasher. Pulley can now be pulled from shaft and the woodruff key removed using a pair of pliers.
5. Drive end frame can now be removed by pressing from armature shaft. Outside collar and space washer on drive end frame can be removed at this time.
6. Loosen control unit's 2 terminal screws and remove leads from "A" and "F" terminals. Loosen and remove control units 2 mounting screws,

MAINTENANCE INSTRUCTIONS

lockwashers, and plain washers. Control unit may now be removed from the frame of the generator.

DISASSEMBLY OF FIELD FRAME ASSEMBLY:

7. Unscrew and remove 2 terminal nuts, 2 lockwashers, 1 plain washer, and 1 insulating washer from both "A" and "F" terminals. Also the 2 lead wires going to control unit can be removed at this time. Terminal stud "F" must be unsoldered from field lead. Care must be taken not to burn insulation from leads and field coils. Both terminal studs can be removed from the holes in the field frame assembly.
8. Using a screw bit and brace, unscrew 2 pole shoe screws. Pole shoes and field coils may be lifted out of field frame.

DISASSEMBLY OF COMMUTATOR END FRAME:

9. While tension is relieved from brush holder springs, lift brush holders and springs from hinge pins. Brush ground lead and third brush plate spring washer may now be removed.
10. Remove 3 brush attaching screws with their lockwashers, and plain washers.
11. Commutator end cover plate and gasket may be removed by unscrewing 3 cover plate screws and removing 3 lockwashers.
12. Oiler may be removed using pliers. Oil plug must be drilled out of its hole. Oil wick may be removed at this time.
13. Remove third brush plate spring washer pin so that spring washer and brush ground lead can be removed.
14. Unscrew third brush plate clamp screw and remove lockwasher and third brush plate clamp. This enables the third brush plate to be removed.
15. Using a punch and hammer 2 brush hinge pins and 2 brush stop pins may be removed from commutator end frame.
16. Commutator end frame bushing may be pressed from commutator end frame.
17. Using a pair of pliers, dowel pin may be removed from commutator end frame.

DISASSEMBLY OF DRIVE END FRAME:

18. Unscrew ball bearing retainer plate screw and remove lockwasher. Retainer plate and retainer plate gasket may now be removed.
19. Ball bearing in drive end frame can be pressed from the frame. Retainer plate and felt washer may be removed.
20. Drive end frame oiler may be removed using pliers.
21. Using a pair of pliers dowel pin can be removed from drive end frame.

REASSEMBLY

Reassembly is made by reversing procedure outlined in Disassembly.

CHECKING INOPERATIVE GENERATOR

Several conditions may require removal of the generator from the engine and further checking of the generator, as follows:

- | | |
|---------------------------|---------------------|
| 1. No output | 3. Excessive output |
| 2. Unsteady or low output | 4. Noisy generator |

1. No output.

Remove cover band and check for sticking or worn brushes and burned commutator bars. Burned bars, with other bars fairly clean, indicate open circuited coils. If brushes are making good contact with commutator and commutator looks okay, use test leads and light and check as follows:

- a. Raise grounded brush, check with test points from "F" terminal to frame. Light should not light. If it does, the generator is grounded; raise other brushes from commutator and check field, commutator and brush holder to locate ground.
- b. If generator is not grounded, check field for open circuit.
- c. If the field is not open, check for shorted field. Field draw at 6 volts should be 3.5-4.5 amperes. Excessive current draw indicates shorted field.
- d. If trouble has not yet been located, remove armature and check on growler for short circuit.

2. Unsteady or Low Output

Check as follows:

- a. Check drive.
- b. Check brush spring tension and brushes for sticking.
- c. Inspect commutator for roughness, grease and dirt, dirt in slots, high mica, out of round, burned bars. With any of these conditions, the commutator must be turned down in a lathe and the mica undercut. In addition, with burned bars which indicate open circuit, the open circuit condition must be eliminated or the armature replaced.

3. Excessive Output

Excessive output usually results either from wrong adjustment of the third brush or from a grounded generator field--grounded either internally or externally. Opening the field circuit (disconnecting lead from "F" terminal of generator) with generator operating at a medium speed will determine if the generator is at fault. If the output drops off, the field is grounded externally. If the output remains high, the field is grounded in the generator, either at the pole shoes, leads, or at the "F" terminals.

4. Noisy Generator

Noisy generator may be caused by loose mounting, drive unit, worn, dry or dirty bearings, or improperly seated brushes. Brushes may be seated by using brush seating stone.

INSTALLATION CAUTION

After the generator or control unit is reinstalled on the engine, or at any time after leads have been disconnected and then reconnected, a jumper lead should be connected **MOMENTARILY** between the BATTERY AND GENERATOR terminals of the voltage control before starting the engine. This allows a momentary surge of current from the battery to the generator which correctly polarizes the generator with respect to the battery it is to charge.

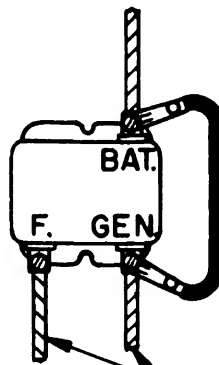

Momentarily Connect "Gen." and "Bat." Terminals with Jumper Lead to Polarize Generator.

To Generator

MAINTENANCE INSTRUCTIONS

STEP VOLTAGE CONTROL

SPECIFICATIONS

Manufacturer Delco-Remy, Anderson, Ind.
Model. 5889

CUT-OUT RELAY UNIT:

Air gap (inch with points closed)015"
Point opening (inch).020"
Points close (volts). 6.3-6.9

STEP-VOLTAGE CONTROL UNIT:

Air gap (inch).035"
Point opening (inch).010"
Contact spring tension (ounce). 5-1.1
Armature travel (inch).035"
Points open (volts at 150°F). 6.45-7.35
Points close (volts at 150° F). 6.0 max.

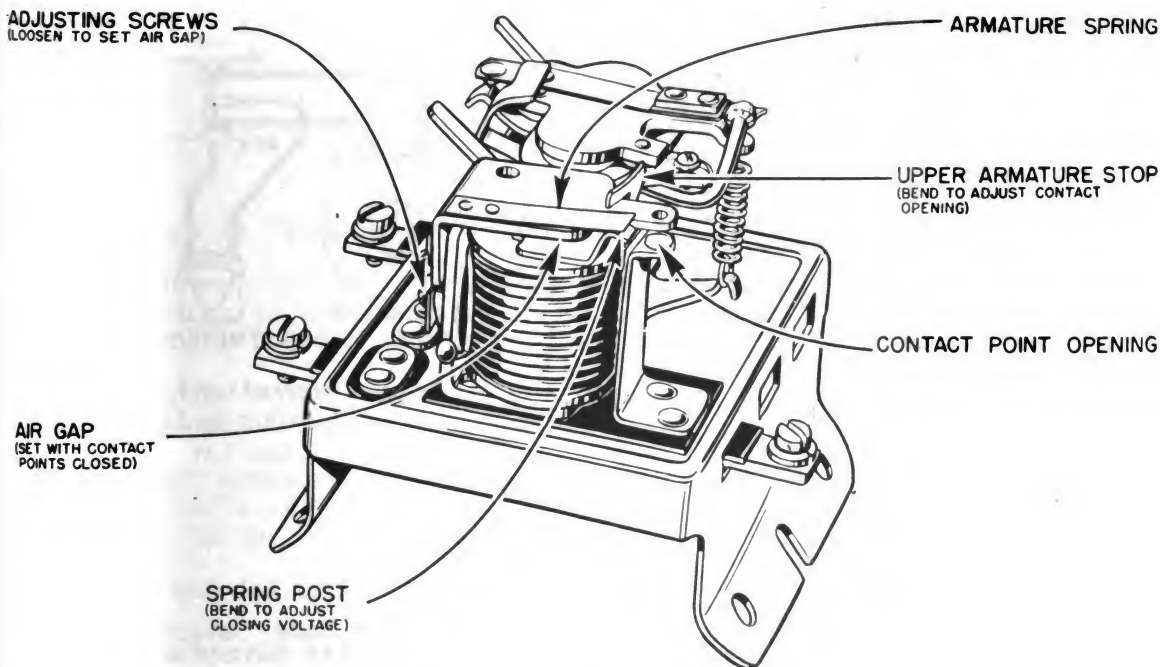

Cut Out Relay Adjustments

CUT-OUT RELAY

The cut-out relay prevents the battery from discharging back through the generator whenever the engine has stopped or is not running fast enough for the generator to charge. It is entirely automatic in its action, but should have an occasional inspection to see that the contact points are clean. No other maintenance required. If service becomes necessary entire unit must be replaced.

ADJUSTMENT: (Mechanical checks to be made with unit disconnected)

- A. AIR GAP--With the contact points held closed, check the air gap between the armature and the center of the core. To adjust, loosen the two screws at the back of the relay and raise or lower the armature as required. Tighten screws securely after adjustment.
- B. POINT OPENING--The point opening is adjusted by bending the upper armature stop.
- C. CLOSING VOLTAGE--Connect a voltmeter between the control unit "GEN" terminal and ground. Gradually increase generator speed and note cut-out relay closing voltage. Bend the spring post down to decrease the spring tension and the closing voltage. Bend up to raise the closing voltage.

The reverse current necessary to open the contact points can be checked by inserting an ammeter in the charging circuit at the "BAT" terminal of control unit.

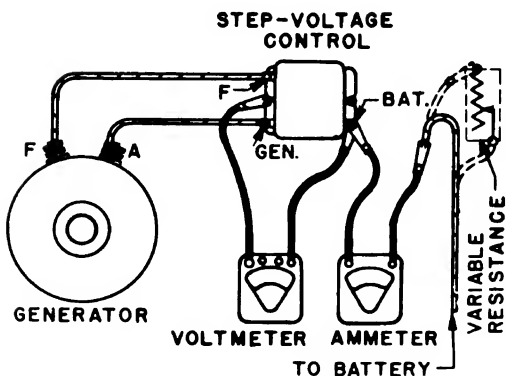

NOTE: AMMETER NOT NECESSARY EXCEPT TO CHECK GENERATOR OUTPUT

Meter Connections to Check Step-Voltage Control and Generator Output

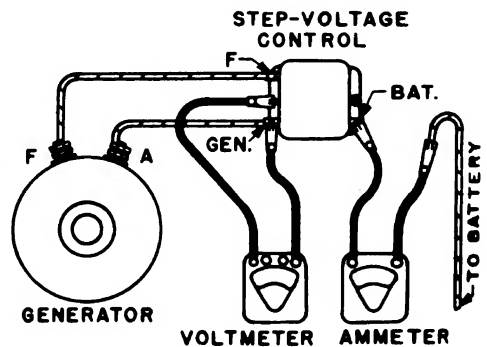

Meter Connections to Check Cut-Out Relay

STEP-VOLTAGE CONTROL UNIT:

The step-voltage control unit, mounted on the same base and enclosed by the same cover with the cut-out relay, is a magnetic switch which automatically permits full generator output (as determined by the third brush position and generator speed) when the battery is low and requires a high charging rate. When the battery comes up to charge the step-voltage control cuts down the generator output to a low value so battery overcharge can be avoided.

CHECKS AND ADJUSTMENTS (Electrical):

Opening and closing checks. With the voltage control at operating temperature (180° F.), connect a test voltmeter between the "BAT" terminal and the voltage control points do not open, cut in resistance. Check voltage at which points open. Cut out resistance or reduce generator speed.

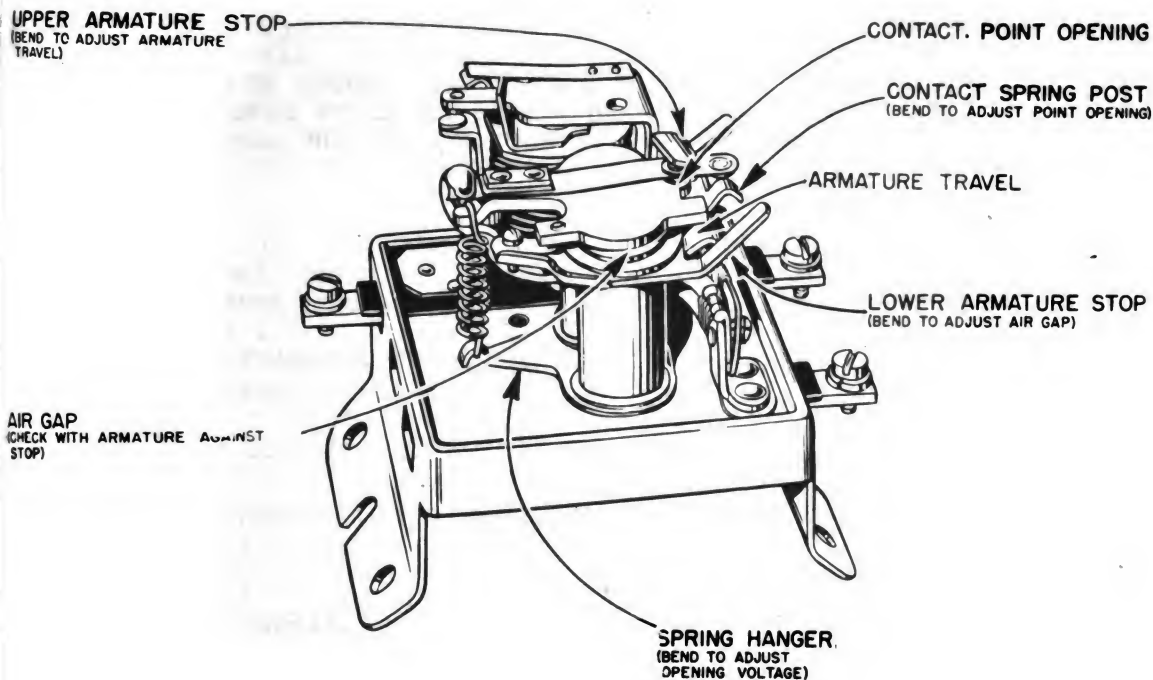

Step-Voltage Control Adjustments

Check voltage at which points close.

- A. The opening voltage may be adjusted by bending the spiral spring hanger down to increase the opening voltage setting or up to decrease the opening voltage setting.
- B. The closing voltage setting may be adjusted by adjusting the AIR GAP. To raise the closing voltage, increase the air gap. To lower the closing voltage, decrease the air gap. It is only necessary to bend the lower armature stop slightly when adjusting the closing voltage. NOTE: After this adjustment, it may be necessary to readjust the contact spring post to maintain the correct contact point opening.

Checks and Adjustments (Mechanical—unit disconnected)

The contact point pressure should be measured with a spring gauge hooked to the flat spring which carries the upper contact, at the contact point. Check pull required to separate points. Adjust by bending flat spring.

The air gap is checked by pushing the armature down against the lower armature stop and measuring between the armature and core. Adjust by bending the lower armature stop.

- C. The armature travel is checked between the armature and the lower armature stop and is adjusted by bending the upper armature stop.
- D. The point opening check is made with the armature held down against the lower armature stop and is adjusted by bending the contact spring post.

CRANKING MOTOR

GENERAL

The Delco-Remy Model 700 Cranking Motor is a 6-volt, 6 pole unit with oilless bearings at the center, commutator and drive ends, and is provided with a sealed type cover band to guard against the entrance of dust. The motor uses a Bendix type drive.

SPECIFICATIONS

Rotation	Clockwise rotation viewing drive end
Manufacturer	Delco-Remy, Anderson, Indiana
Brush spring tension	36-40 ounces
No load	3000 r.p.m. at 70 amperes at 5.0 volts
Lock Torque test	19 lb. ft. at 500 amperes at 3.0 volts

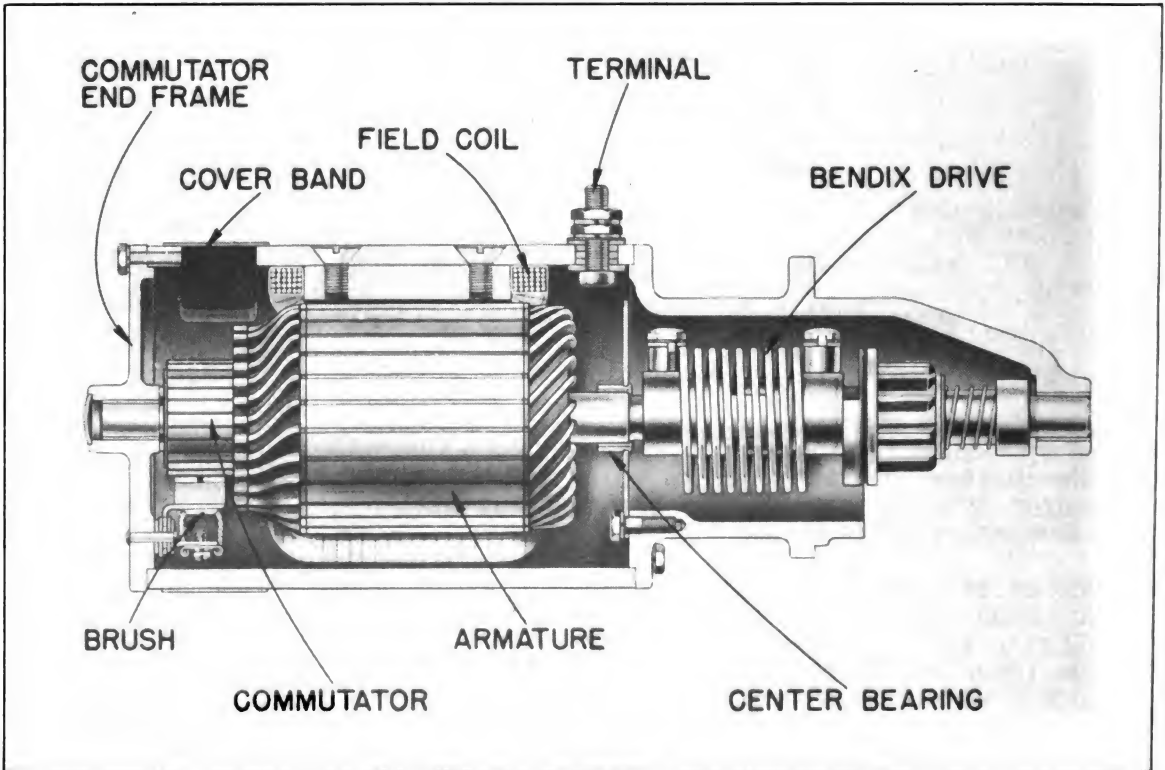

Longitudinal Section Through Cranking Motor

At regular intervals, the actual time depending on the type of operation, the cranking motor should be disassembled for a thorough cleaning and inspection of all parts. The Bendix drive should be cleaned and oiled with a penetrating oil, as any accumulation of dirt on the drive might restrict the free movement of the pinion. Put a few drops of light engine oil in each bearing. Never clean the armature or fields in any degreasing tank, or with grease dissolving materials, since these may damage the insulation. Clean with blow gun or with clean, dry brush. The commutator should be trued in a lathe if necessary and the mica undercut. Replace all parts showing excessive wear. All wiring and connections should be checked. Rosin flux should be used in making soldered connections. Acid flux must never be used on electrical connections. Submit reassembled unit to NO-LOAD and LOCK tests.

HECKING OF IMPROPERLY OPERATING CRANKING MOTOR

If the cranking motor does not develop rated torque and cranks the engine slowly or not at all, check the battery, battery terminals and connections, and battery cables. Corroded, frayed, or broken cables should be replaced and loose or dirty connections corrected. The cranking motor switch should be checked for burned contacts and the switch contacts cleaned or replaced if necessary.

If all these are in order, remove the cover band of the cranking motor and inspect the brushes and commutator. The brushes should form good contact with the correct brush spring tension. A dirty commutator can be cleaned with a strip of No. 00 sandpaper held against the commutator with a stick while the cranking motor operates. NEVER USE EMERY CLOTH TO CLEAN COMMUTATOR. If the commutator is very dirty, or burned, or has high mica, remove the armature from the cranking motor and take a cut off the commutator in a lathe. Under-cut the mica.

If there are burned bars on the commutator, it may indicate open circuited armature coils which will prevent proper cranking. Inspect the soldered connections at the commutator riser bars. An open armature will show excessive arcing at the commutator bar which is open, on the no-load test. Repair may sometimes be made if the commutator is not too badly burned by resoldering leads in riser bars (rosin flux), turning down commutator and undercutting mica. Tight or dirty bearings will reduce armature speed or prevent the armature from turning. A worn bearing, bent shaft, or loose field pole screws will allow the armature to drag on the pole shoes, causing slow speed or failure of the armature to revolve. Check for these conditions.

If the brushes, brush spring tension and commutator appear in good condition, the battery and external circuit found satisfactory, and the cranking motor still does not operate correctly, it will be necessary to remove the cranking motor for no-load and torque checks.

NO LOAD TEST:

Connect the cranking motor in series with a battery of the specified voltage and an ammeter capable of reading several hundred amperes. If an r.p.m. indicator is available, read the armature r.p.m. in addition to the current draw.

TORQUE TEST:

It is advisable to use in the circuit a high current carrying variable resistance, so that the specified voltage at the motor can be obtained. A small variation of the voltage will produce a marked difference in the torque developed.

Interpreting results of NO-LOAD AND TORQUE TESTS

1. Rated torque, current draw and no load speed indicates normal condition of cranking motor.

2. Low free speed and high current draw with low developed torque may result in from:
 - a. Tight, dirty, or worn bearings, bent armature shaft or loose field pole screws which would allow the armature to drag.
 - b. Shorted armature. Check armature further on growler.
 - c. A grounded armature or field. Check by raising the grounded brushes and insulating them from the commutator with cardboard and then checking with a test lamp between the insulated terminal and the frame. If test lamp lights, raise other brushes from commutator and check fields and commutator separately to determine whether it is the fields or armature that is ground.
3. Failure to operate with high current draw:
 - a. A direct ground in the switch, terminal or fields.
 - b. Frozen shaft bearings which prevent the armature from turning.
4. Failure to operate with no current draw:
 - a. Open field circuit. Inspect internal connections and trace circuit with a test lamp.
 - b. Open armature coils. Inspect the commutator for badly burned bars. Running free speed, an open armature will show excessive arcing at the commutator bar which is open.
 - c. Broken or weakened brush springs, worn brushes, high mica on the commutator, or other causes which would prevent good contact between the brushes and commutator. Any of these conditions will cause burned commutator bars.
5. Low no-load speed, with low torque and low current draw indicates:
 - a. An open field winding. Raise and insulate ungrounded brushes from commutator and check fields with test lamp.
 - b. High internal resistance due to poor connections, defective leads, dirty commutator and causes listed under 4.c. above.

DISASSEMBLY

1. Mark drive housing and frame assembly to establish relationship. Remove six motor drive housing attaching screws and lock washers from drive end housing. Tap housing away from field frame housing with a soft hammer.
2. Remove drive housing, Bendix drive assembly, center bearing plate and armature as one assembly on the armature shaft from the field frame housing. Remove two center bearing attaching screws and lock washers; also remove center bearing plate and center bearing bushing. Drive housing may now be taken off of Bendix assembly. Remove space washer from armature shaft on drive end. Bend down tangs on drive head spring screw lockwasher. Remove head spring screw and head spring screw lockwasher; also remove Bendix assembly from armature shaft, Drive head may be removed from Bendix assembly. Bend down tangs on shaft spring screw lockwashers. Remove shaft spring screw and shaft spring screw lockwasher. This allows drive spring to be removed. The remainder of the Bendix assembly is serviced as a complete unit and is known as the Gear and Shaft Assembly. The service sleeve is a

MAINTENANCE INSTRUCTIONS

part of the gear and shaft assembly and will be shipped with such as a service part; however, the service sleeve is also a serviceable part by itself. Remove space washer from armature shaft on the commutator end.

3. Mark commutator end frame and field frame to establish relationship. Remove cover band by removing cover band screw and nut. Note relationship of leads and brushes. Disconnect field coil leads from field frame. Remove six commutator end frame attaching screws and lockwashers. Tap commutator end frame away from field frame with a soft hammer. Remove commutator end plug and C.E. bushing.
4. Remove six brush lead attaching screws, lockwashers, brush springs and brushes.
5. Remove terminal stud nut from the terminal stud in the frame housing. Also remove terminal stud lockwasher, other terminal stud nut, other lockwasher, plain washer, and insulating washer. Unsolder field coil lead from terminal stud; terminal stud may now be removed from the frame housing. Then remove from the terminal stud the three insulating washers and other insulating washer.
6. Unscrew twelve pole shoe screws and remove the six pole shoes from the frame housing. The field coils may be removed from the pole shoes. The field coil insulating strip may be removed from the inside of the field frame housing.

REASSEMBLY

Reassembly is made by reversing procedure outlined in Disassembly.

MAGNETIC SWITCH

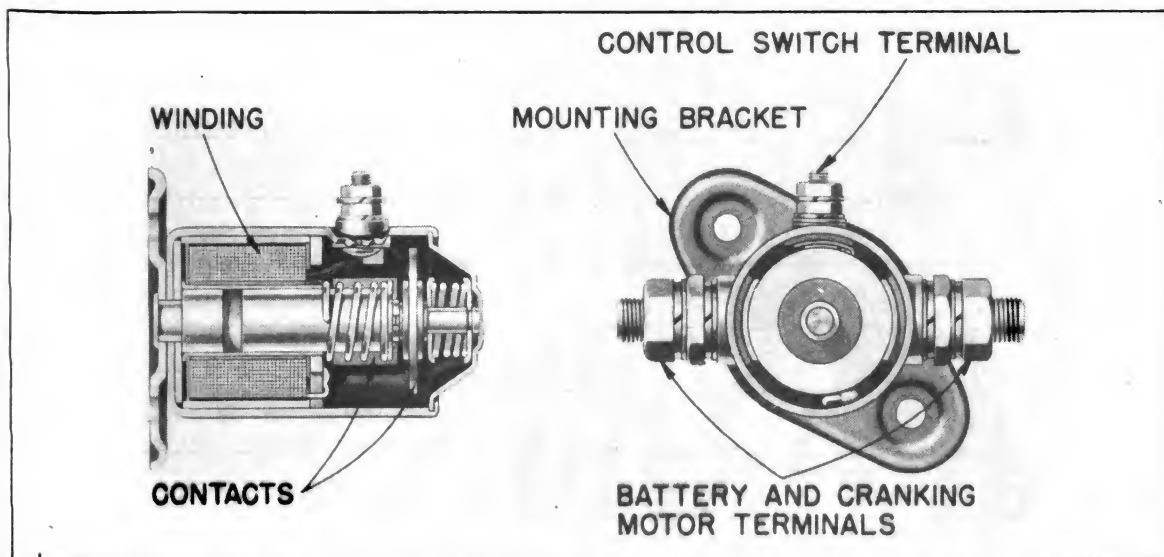

Longitudinal & Cross Section Thru Magnetic Switch

SPECIFICATIONS

Manufacturer Delco-Remy, Anderson, Ind.
 Model 1459

GENERAL

The model 1459 magnetic switch does not require servicing other than to check periodically, to make sure the mounting and connections are tight and in good condition. If service becomes necessary, entire unit must be replaced.

OIL FILTER

The life of the engine depends mainly upon clean oil being circulated to all bearings. Minute particles of foreign matter eventually accumulate in the engine crankcase and in the normal course of operation the lubricating oil undergoes changes which produce sludge, acids, gums, varnish and other harmful by-products.

The purpose of the oil filter is to separate and remove the dirt and other foreign substances from the oil thereby preventing these injurious materials from being circulated through the engine. This filter is efficient only so long as the element is not saturated with these foreign particles or substances. When the element becomes saturated to the point it can no longer remove foreign substances from the oil, it loses its efficiency and the element must be replaced. The interval between element replacements depends entirely upon operating conditions. After every hundred working hours when the crankcase oil is changed, if the oil removed was black and dirty, it is an indication the cartridge must be replaced.

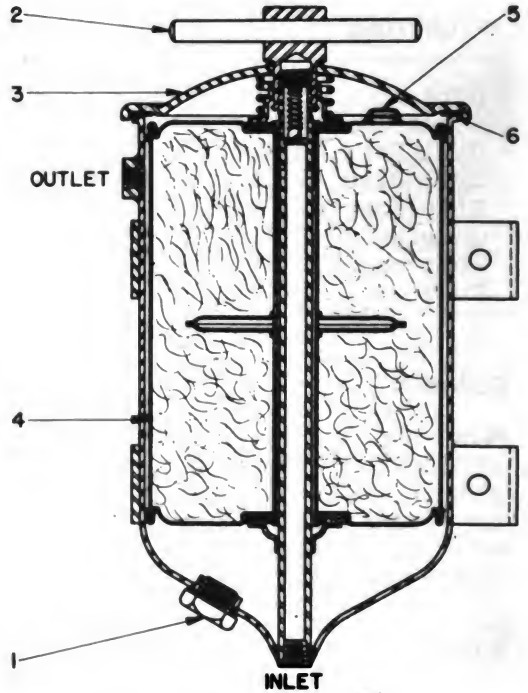

N1744 Purolator Oil Filter

SERVICING INSTRUCTIONS

1. Stop engine.
2. Drain filter by removing drain plug. (1)
3. Turn handle (2) in counter-clockwise direction to remove cover. (3)
4. Lift out old element (4) by using handle (5) on top of element. (Element is the non-cleanable type and must be replaced.)
5. Insert new element and new cover gasket (6) making certain handle end is on top.
6. Replace cover making certain gasket is in good condition and turn handle in clockwise direction until secure, HAND TIGHT.
7. After starting engine check for leaks.

OIL PUMP

Located between fuel pump and bellhousing on Magneto side of engine. Single stage gear driven type operating off camshaft. Pump is attached to crankcase by capscrews. Oil travels through the screen 144, which strains out the large particles, up through pump body 130 to opening between pump body and crankcase where it enters drilled passages in the crankcase. Both drive pinion 134 and idler gear 141 are keyed to their shafts 132, 139. Upper drive gear 137 (which meshes with camshaft is also keyed to shaft.) Oil Pump screen should be cleaned of sludge and foreign particles whenever oil pan is removed.

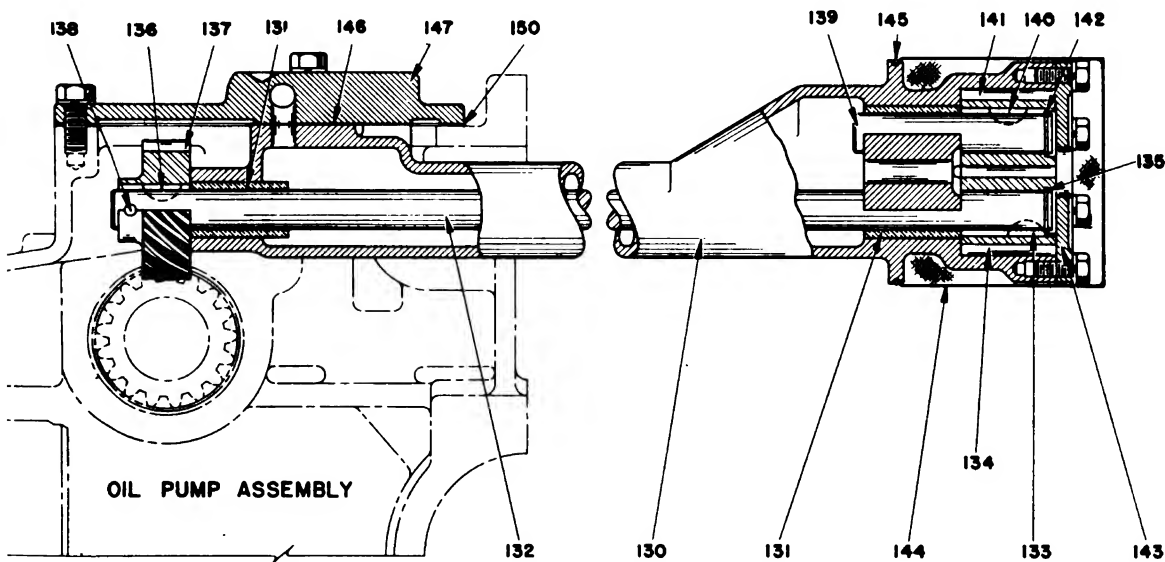

DISASSEMBLY:

Remove five capscrews holding cover 147 to crankcase and withdraw oil pump assembly out thru hole in crankcase. Drive gear 137 is pressed onto shaft 132 and may be removed by driving out pin 138. Remove wire 145 and screen 144 to service lower portion of pump. Remove capscrews holding cover 143 to pump body 130. Drive shaft with gear 134 may now be removed from pump body. To remove gear from shaft, remove lock ring 135 with screwdriver and push shaft out of gear. NOTE: Driven shaft 139 and gear 141 are removed and dismantled in a like manner. CAUTION: All gears are keyed to shafts--be sure not to damage keyways in dismantling; also make certain they are in place when reassembling.

REASSEMBLY:

SPECIAL NOTE: If either gears 134 or 141 are to be serviced they must be replaced in pairs. Install gear 141 onto shaft 139 and lock in place--install shaft assembly into pump body. Install gear 134 onto shaft 132, lock in place and install in pump body. Replace cover 143 and invert pump body to install drive gear 137 making certain pin 138 is in place. Replace screen over lower end of pump and wire in place. NOTE: If screen is damaged, it should be replaced.

Insert pump assembly thru crankcase opening and install capscrews holding oil pump in place.

TIMING GEARS

With the engine front cover removed timing gear train is accessible. The camshaft gear operates directly off the crankshaft gear and drives the magneto and governor drive gear. These three gears must be in their proper places to have engine timed properly. When installing camshaft gear, make certain timing marks are aligned as illustrated.

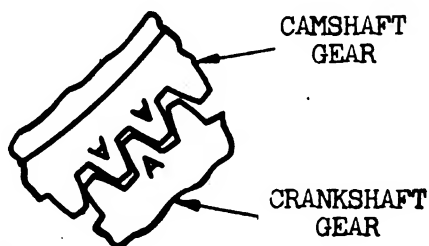

Timing Gear Marks
Original from

Before meshing governor drive gear it is necessary to move crankshaft until impulse mark on flywheel is aligned with timing pin in bell housing when #1 cylinder is in firing position. To get #1 cylinder in firing position turn engine over until #4 exhaust valve just closes, which will bring flywheel markings into position as shown. After crankshaft is in position as described move governor drive gear until number 1 impulse fires then move back approximately 1/4 turn and mesh gears without further movement. After installation is made it is best to check position by removing #1 spark plug and reconnect wire. Ground plug but do not install in cylinder head. Move flywheel up towards impulse position. It should fire as flywheel is moved in direction of rotation as impulse mark is reached. Engine front gear cover can be removed after taking off cranking jaw and fan drive pulley. Care should be taken so as not to damage oil seal when cover is removed. In replacing engine front cover make certain oil seal and gaskets are in good condition--if damaged in any way, replace. (See paragraph "Oil Seals" before assembly.)

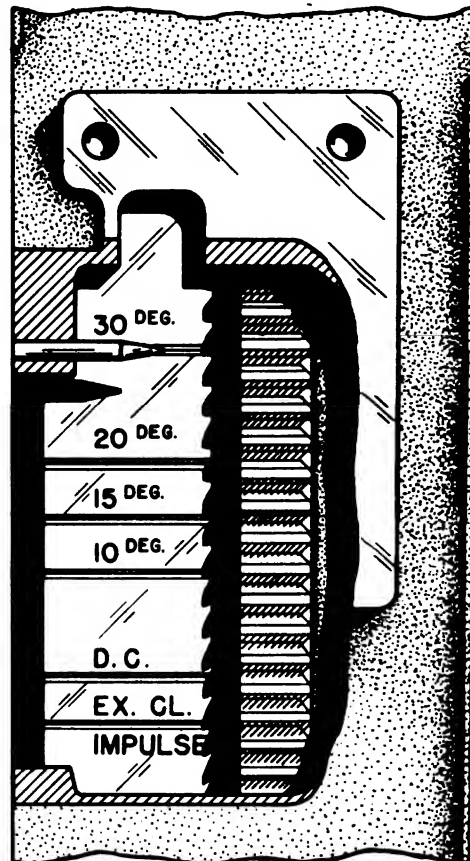

Section Thru Bellhousing Showing Flywheel Timing Marks

CYLINDER SLEEVES

Wet type cylinder sleeves do not fit as tight as dry type sleeves, and can be driven out by using a block of hard wood and a hammer. End of the sleeves carry rubber sealing rings and the cylinder block should be cleaned thoroughly at both this and the upper contact point before the sleeves are inserted. Clean sleeves thoroughly at the contact points and place the rubber rings in position in the bore covering them with a thin coat of soft soap. Set the sleeve in the bore of the cylinder block with seal rings down and drive (with hard wood block) the sleeve into position. Care should be taken that the sleeve be driven down straight in the block to avoid damage to the rubber sealing rings, which could result in a water leak in the crankcase; when the cylinder sleeve is in place the top will project approximately .005" above the top surface of the cylinder block. This permits the cylinder head to clamp the cylinder head gasket tightly against the top of the sleeve holding it in place and sealing it at the upper end.

Because of the removable sleeve construction of this engine, over size pistons and rings are not necessary. When appreciable wear occurs, new standard size parts should be installed.

CYLINDER HEAD

REMOVAL:

Remove--water connections and manifold, cylinder head cover 224, oil lines, rocker arm mechanism 217, disconnect spark plug wires, and carburetor and accessories. Withdraw push rods and remove cylinder head stud nuts 222

and lift off cylinder head 190. Valve seat inserts 191 are standard for exhaust valve ports and minimize valve regrinding.

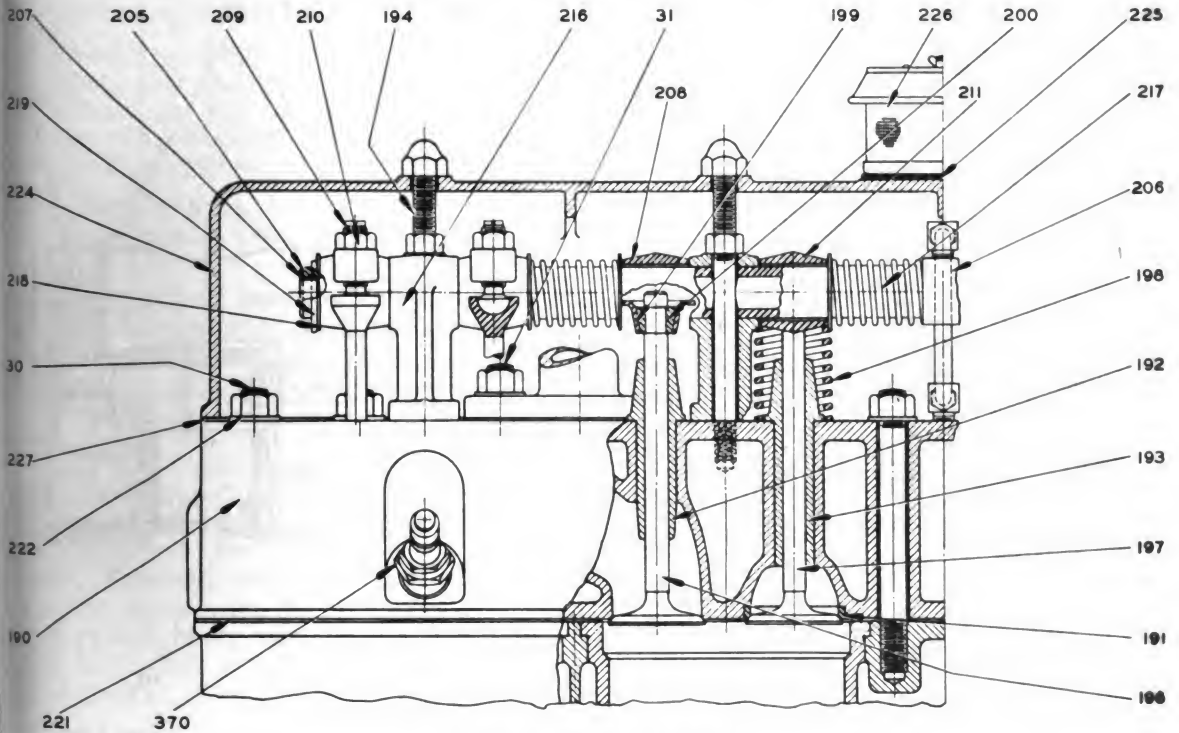

CYLINDER HEAD ASSEMBLY

PLATE D318-5C

Before replacing cylinder head make certain that the surfaces of the cylinder block and head where the gasket 221 rests are absolutely clean. It is important to securely tighten the cylinder head whenever it is replaced.

This must be carefully done to prevent damage to the copper-asbestos gasket between the cylinder head and the cylinder block. When installing cylinder head gasket place it on the cylinder block with the beaded side up. For correct sequence in tightening cylinder head stud nuts, refer to chart.

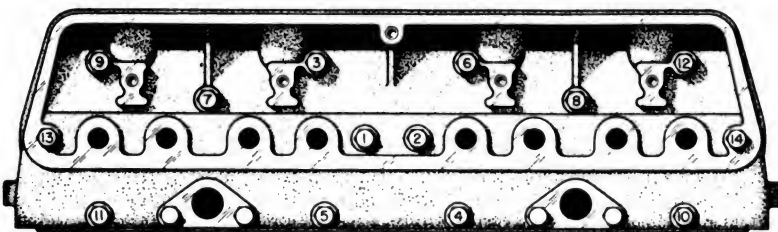

SEQUENCE FOR TIGHTENING CYLINDER HEAD NUTS

Nuts should be drawn down to one hundred foot pounds with a torque tension wrench. Cylinder head stud nuts properly tightened to specified tension when engine is cold, need not be retightened when engine is hot.

PISTON ASSEMBLY

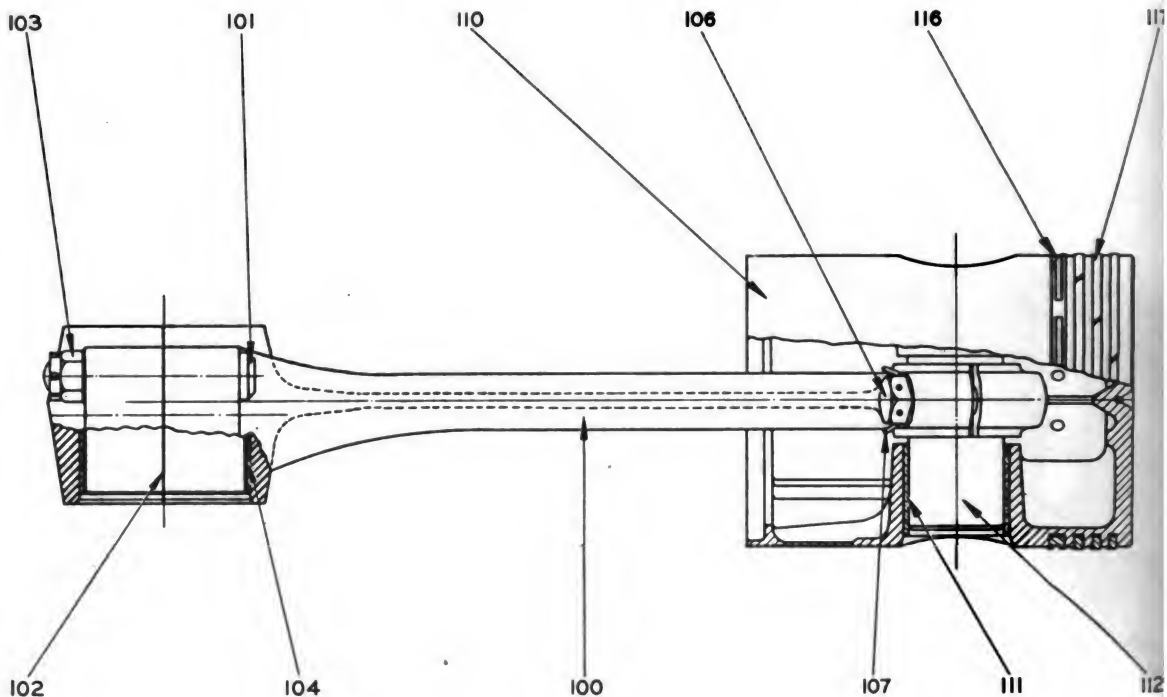

CONNECTING ROD & PISTON ASSEMBLY

PLATE D318-6

Material.....Cast Iron
Clearance at bottom of skirt......005" to .007"

PISTON RINGS:

Total required.....16
Compression.....12
Oil control.....4
Width, compression.....1/8"
Width, oil control.....3/16"
Gap......015" to .025"

PISTON PIN:

Type.....Clamped in rod
Length.....3-15/16"
Diameter.....1.500"
Clearance in bushing......002" to .003"

When assembling piston 110 to connecting rod 100 place rod in piston and slide piston pin 112 through bushings 111. Tighten clamp bolt 106 in connecting rod securely and lock 107 in place. Fit piston rings 116, 117 in bore. Oil piston before replacing in engine. Pistons are numbered and should be reassembled into correct cylinders (No. 1 starts at front of engine).

CONNECTING ROD

Connecting Rod Length, center to center.....	12-1/2"
Cranking pin diameter.....	2.4995"
Bearing materials.....	Babbitt-steel back
Bearing length, total.....	2.455"
Bearing running clearance.....	.0015" to .004"
Bearing end clearance.....	.010" to .020"
Bolts, Number.....	4
Bolts, Material.....	Nickel Steel-Heat treated
Bolts, Size (Special).....	7/16" x 3-1/16"
Removable from top of block.....	Yes

Connecting Rod bearing 104 material is Babbitt with a steel back. Bearings are not adjustable and when clearance becomes excessive, replacement is necessary. Connecting rods 100 should be free from twist and parallel with pistons. Connecting rods and caps are numbered with number of cylinder bore--make certain proper cap is assembled to rod and also numbers correspond (#1 starts at front of engine). Assemble numbered side towards camshaft. When installing bearings be sure bearing backs and rod surfaces are absolutely clean, smooth and free from oil. Bearings have a nib engaging milled notch in rod and cap. CAUTION--Do not scrape shell bearings and do not file connecting rod or connecting rod cap parting faces. Install cap and turn nuts 103 down tightly. By turning engine over by hand make sure that cap does not bind on the cranking pin. Adjustment is correct when the nuts are tight and the crankshaft may be rotated by hand with the starting crank. CAUTION--Replace all cotter pins and locking wires.

CRANKSHAFT

Drilled for pressure lubrication.....	Yes
Bearing Journal Diameter.....	2.6245"

Crankshaft is drilled for pressure lubrication of connecting rod bearings. Each bearing cap bears a number which corresponds to a number stamped on the side of the crankcase,

To remove crankshaft from engine it is recommended, the entire crankcase assembly be removed from frame. After removing oil pan, shaft is then easily removed. Remove bolts from flywheel and remove flywheel and bell housing. Remove engine front gear cover. Remove rear oil retainer assembly and disconnect connecting rods. Remove main bearing caps.

Crankshaft can now be lifted out of crankcase. When replacing crankshaft be sure bearing caps, bearings, crankshaft journals and crankcase are all clean and absolutely dry.

OIL SEALS:

Front oil seal is of Neoprene, located in engine front gear cover and is assembled with lip pointing inward toward engine. Installation should be made by aid of a thin metal sleeve inserted inside of seal -- slip seal and sleeve over crankshaft and remove sleeve - CAUTION: Make certain seal is not scratched or marred. Sleeve can be made of shim stock that can be bent into position. Rear oil seal is split type and rear main bearing cap and rear oil retainer must be removed to replace oil seal. If oil leaks behind flywheel, check fit of welch plug at rear of camshaft, replace felt oil seal and check rear main bearing for excessive wear.

BEARINGS: (Precision, steel back)

Number.....	3
Material.....	Babbitt-Steel back
Running clearance.....	.0015" to .0035"

Bearings are not adjustable so when clearance becomes excessive replacement is necessary. End thrust of the crankshaft is taken up by thrust washers on either side of the rear main bearing. Correct end clearance is .001 to .012 and this clearance must be maintained. Bearings may be replaced without removing crankshaft. To remove upper half of bearing shell, insert in crankshaft journal oil hole a cotter pin or its equivalent which has had rounded head flattened to form a "T" and then rotate crankshaft to push out bearing liner. Cap and bore are milled to receive a projection on back of bearing liner. Projection end is removed first. When replacing, rotate shaft, see that projection end enters last. Bearing backs, crankcase bore and cap bore should be absolutely clean and dry when replacing shells.

CAMSHAFT

Bearings, Number.....	3
Bearing Material.....	Bronze
Bearing Journal Diameter, Front and Center.....	2.250"
Bearing Journal Diameter, Rear.....	2.250"
Running Clearance.....	.002" to .004"
Bearing length, front and center.....	3"
Bearing length, rear.....	2"
Thrust plate material.....	Bronze
End clearance.....	.006" to .009"
Service bushings.....	Reamed to size
Camshaft drive.....	Helical gear
Number of teeth in gear.....	72
Pressure lubricated.....	Yes

The camshaft rests in three bearings. For replacement, bearings are furnished reamed to size. It is only necessary to press them into place. For sizes and running clearance refer to table.

In order to complete assembly of the camshaft, put the thrust plate on the shaft, put the key in the shaft and press the gear, (72 teeth) on the shaft. Now put on the lockwasher and the nut. Camshaft assembly is attached to the motor block with two capscrews 5/16" x 3/4" with lockwashers accessible through holes in the flange of the gear. After assembly, camshaft is put in place into the engine. It is necessary to rotate the gear slightly either forward or backwards in order to install the capscrews.

The drilled holes in the camshaft center bearing journal gives metered oil supply to the valve rocker mechanism. Valve tappets may be removed when camshaft is removed.

When installing camshaft make certain that marked teeth on gear meshes with marked teeth on crankshaft gear as illustrated. (See "Crankshaft").

VALVES

Valve Seat, width.....	1/16" to 3/32"
Valve Seat, angle.....	.450
Valve Seat, insert.....	Exhaust only
Valve Stem Guides (replaceable).....	Grey iron
Valve Stem, diameter.....	.434"
Valve Stem clearance in guide (intake).....	.0025" to .004"
Valve Stem clearance in guide (exhaust).....	.0045" to .006"
Valve clearance, hot.....	.015"
Valve clearance, cold.....	.018"
Rocker Arm Shaft, diameter.....	.998" to .999"
Rocker Arm bushing, diameter.....	1.001" to 1.0015"
Rocker Arm Bushing reamed to size.....	Yes

INTAKE VALVES:

Material.....	SAE 3140
Head diameter.....	1-7/8"
Port diameter.....	1-11/16"
Valve opens.....	5° After T.D.C.
Valve closes.....	41° After B.D.C.

EXHAUST VALVES:

Material.....	Thompson XCR
Head diameter.....	1-3/4"
Port diameter.....	1-11/16"
Valve opens.....	42 1/2° Before B.D.C.
Valve closes.....	8 1/2° After T.D.C.

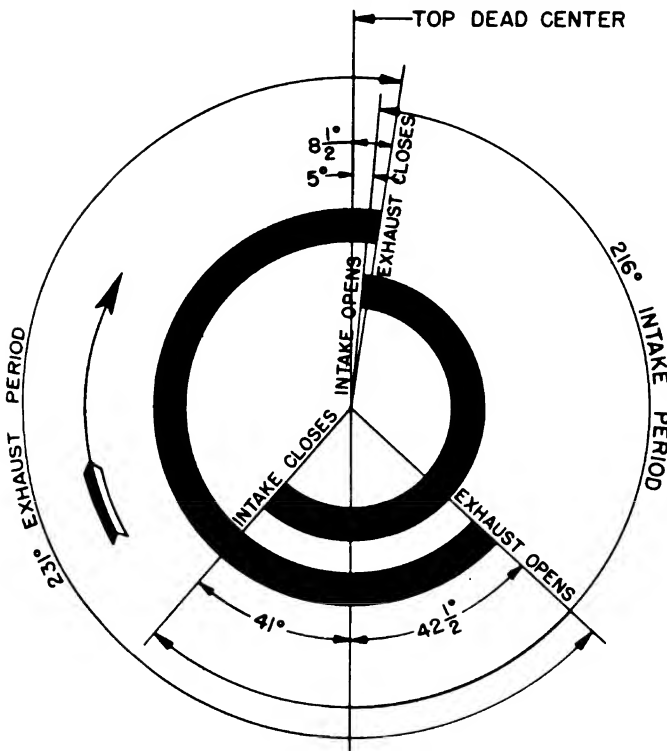

Valve Timing Diagram

Valve stem guides are furnished as service parts but not finished reamed to size. It is necessary to press them into place and ream. After new valve guides are installed it is necessary to recut valve seats.

When service inserts are to be installed, in most cases it is necessary to use over-size inserts and also necessary to remachine insert seat for true fit. Allow approximately .004" to .005" for press fit of insert. Do not drive insert into place as this will invariably cause trouble--if furling tool is available it should be used but it is not necessary, nor is it necessary to pean head, since this does not insure a tight fit. Extreme care should be given in making this replacement. Bushing in Rocker Arms can be replaced. Be sure bushing lines up with hole in rocker

arm. Rocker arms can be removed as outlined for the cylinder head.

Recheck valve tappet settings after removing rocker mechanism or head. Push rods are tubular steel. Tappets are fit in crankcase, removable from bottom after removing camshaft. Lubrication to tappets is by splash and by returning oil from rocker mechanism.

ENGINE SERVICE CHART

TROUBLES--POSSIBLE CAUSES:

Engine Hard to Start:

1. Weak battery.
2. Defective magneto.
 - (a) Worn brushes.
 - (b) Oil or water soaked.
 - (c) Coils broken.
 - (d) Brushes sticking.
 - (e) Magnets weak.
 - (f) Points worn or pitted.
3. No gasoline in tank.
4. Gasoline flow obstructed.
5. Water in fuel supply.
6. Loose or defective wiring.
7. Spark plugs cracked.
8. Spark plugs fouled.
9. Wires connected to wrong plugs.
10. Improper gas mixture.
11. Throttle or governor valve loose on shafts.
12. Intake manifolds leaking.
13. Valve seats leaking.
14. Improper timing of ignition or valves.

Engine Missing:

1. Spark plugs fouled.
2. Spark plugs cracked.
3. Spark plug gap wrong.
4. Defective wiring.
5. Ign. breaker points sticking.
6. Breaker point gap wrong.
7. Cylinder head gasket leaking.
8. Manifold gaskets leaking.
9. Valves warped or broken.
10. Valves or tappets sticking.
11. Valve tappets improperly adjusted.

Engine Overheating:

1. Lack of water.
2. Fan belt slipping.
3. Spark retarded too far.
4. Water hose obstructed.
5. Water hose collapsing.
6. Carburetor choke valve partly closed.
7. Improper gas mixture.
8. Radiator clogged.
9. Limed up cylinders.
10. Improper timing.
11. Valves leaking.
12. Oil badly diluted.
13. Lack of oil.

Engine Lacks Power:

1. Valve seats worn.
2. Piston rings weak or worn.
3. Piston rings sticking.
4. Improper gas mixture.
5. Improper timing of ignition or valves.
6. Muffler stopped up.
7. Governor or throttle loose.
8. Oil badly diluted.
9. Air cleaner needs cleaning.

Engine Knocks:

1. Carbon in cylinders.
2. Loose main bearing.
3. Loose rod-bearing.

Engine Knocks--(Continued):

4. Worn pistons and cylinders.
5. Loose valve tappets.
6. Motor overheated.
7. Tight pistons.
8. Loose flywheel.
9. Lack of oil or water.
10. Stuck valve.
11. Worn timing gears.

Faulty Carburetion:

1. Carburetor improperly adjusted.
2. Valves leaking.
3. Intake manifold leaking.
4. Gaskets leaking.
5. Shut off valve closed.
6. Using too much fuel, float not working freely.
7. Water in fuel.
8. Sediment in fuel tank.

Excessive Smoke from Exhaust:

1. Too much oil in crankcase.
2. Carburetor needle valve open too far.
3. Carburetor float sticking or leaking.
4. Lubricating oil too thin to seal pistons.
5. Worn bearings, rings, cylinders and valve guides.

Explosion in Muffler:

1. Ignition too late.
2. Weak spark.
3. Valves holding open or out of time.
4. Exhaust valves warped.
5. Missing on two or more cylinders.

Explosion in Carburetor or Intake Manifold:

1. Gas mixture too lean.
2. Intake valves or tappets sticking.
3. Ignition wires crossed or engine out of time.
4. Intake valve springs weak.
5. Intake manifold leaking.
6. Intake valves warped or broken.
7. Intake tappets set too close.
8. Incorrect timing of ignition.
9. Cylinder head gasket leaking.

Poor Compression:

1. Valves not seating.
2. Valves sticking.
3. Valve tappets sticking.
4. Valve tappets set too close.
5. Piston rings weak or worn.
6. Piston rings broken.
7. Piston rings sticking.
8. Loose or cracked spark plugs.
9. Cylinder head loose.
10. Cylinder head gasket leaking.
11. Oil too thin to seal pistons.
12. Scored cylinders.
13. Worn pistons and cylinders.
14. Weak valve springs.
15. Camshaft incorrectly timed.

MAINTENANCE INSTRUCTIONS**ZENITH UPDRAFT CARBURETOR****SPECIFICATION**

Carburetor used is a Zenith updraft unit of double venturi design with main jet and well vent discharging into venturi and is illustrated in figure on next page. It is manufactured by the Zenith Carburetor Division, Bendix Aviation Corporation, Detroit, Michigan.

GENERAL OPERATION

MAIN JET SYSTEM: The Main Jet (2), often referred to as the "high speed jet," exerts its principal influence at the higher engine speeds. Fuel from the bowl is metered through the Main Jet (2) and discharged into the air stream at the point of greatest suction, in the secondary Venturi (3) through the Main Discharge Jet (4).

The main jet (2) determines the maximum amount of fuel which may be obtained for high speed operations. The Main Jet Adjustment (8) reduces this amount if it is turned toward its seat. Ordinarily the main jet adjustment has no effect after it is two turns open.

To set this adjustment, retard the spark and open the throttle to approximately 1/4 open. Turn the adjustment clockwise, shutting off the fuel until the engine speed decreases due to too lean mixture. Now open the adjustment until the engine speed decreases due to too much fuel. The adjustment should be set at a position half way between these two extremes.

COMPENSATING SYSTEM: The compensating system consists of the Main Discharge Jet (4) and the Well Vent (5). The flow of fuel from the Main Jet (2) is controlled by the size of the Well Vent (5) and the size of the Main Discharge Jet (4). The mixture delivered through the Main Discharge Jet may be made richer by either increasing the size of the Main Discharge Jet or by decreasing the Well Vent. Conversely the mixture may be made leaner by either decreasing the size of the Main Discharge Jet or by increasing the size of the Well Vent.

IDLING SYSTEM: The Idling system consists of the Idling Jet (6) and the Idle Adjusting Needle (7). The Idling Jet (6) receives its fuel from the Main Jet (2) through Channel (A). The fuel is metered through the Idling Jet (6) and is mixed with air which is admitted, from behind the Venturi (1), through channel (B). The Idle Adjusting Needle (7) controls the amount of air which is admitted to the Idling System. The Idling System functions only at Idling and Low Speeds. At these speeds, the Throttle Plate (10) is almost closed and there is a very strong suction past the edge of the Throttle Plate. This suction draws the mixture of fuel and air from the Idling Jet (6) which discharges into the air stream through the Priming Plug.

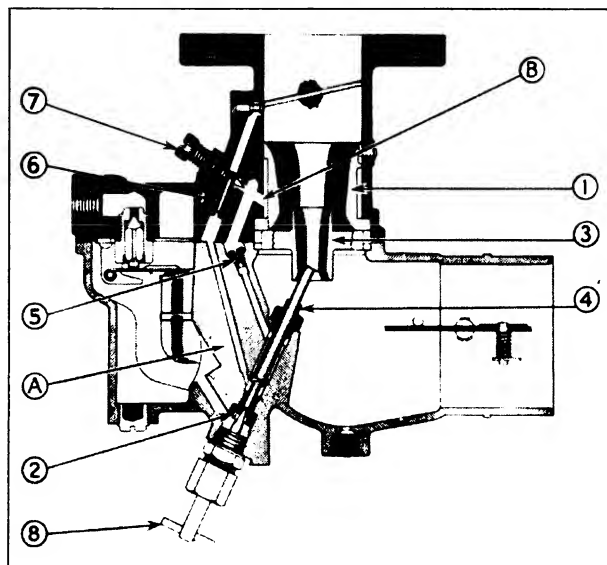

*Cross Section Through
Zenith Carburetor*

REMOVAL

Removal of the carburetor may be accomplished in the following manner.

1. Disconnect Air cleaner and connection from carburetor.
2. Disconnect choke wire and remove lever from end of governor operating cross shaft.
3. Disconnect fuel inlet line.
4. Remove carburetor to manifold cap screws and remove carburetor by pulling away from engine, using caution not to damage cross shaft or bushings.

REPLACEMENT

Carburetor can be replaced in reverse order of removal. Make certain gasket is in good condition and all connections are tight.

DISASSEMBLY

To properly repair the Zenith 62-Series Carburetor, we suggest the following routine:

1. Loosen clamp screw and remove the throttle lever.
2. Remove idling adjusting screw (7) and spring.
3. Remove assembly screws, using a screwdriver, or a 5/16" wrench.
4. Raise the throttle body slightly and loosen the gasket from the bowl assembly, so you may
5. Lift the throttle body and gasket clear of the bowl without damaging the float.
6. Turn the throttle body upside down on the bench and
7. Remove body to bowl gasket.
8. Remove float axle, using a small screwdriver to push the axle from the slotted end of the float hinge bracket and the fingers to remove it the rest of the way to
9. Remove the float and the fuel valve needle.
10. Remove the fuel valve seat and gasket, using C161-85 service tool.
11. Remove secondary venturi (3) and main venturi (1) as a unit.
12. Remove idling jet (6), using a small screwdriver with 3/16" blade.
13. Remove economizer jet and gasket, using a screwdriver. (This jet is located in the lower face of the throttle body, directly under one of the throttle shaft bearings.)
14. Remove throttle plate screws, plate and shaft.
15. Remove throttle stop lever taper pin, using a small punch and a light hammer.
16. Drive the throttle shaft out of the stop lever hub, using a small drift and a light hammer.
17. Remove throttle shaft packing retainers and packings, using a screwdriver to pry out the retainers.

NOTE: Do not remove the identification disc which is riveted to the bowl cover; the throttle stop; the venturi locating pin; the priming plug; the float hinge bracket; or the channel plugs.

8. Remove the well vent (5 in Fig. 1), using a small screwdriver.
9. Remove the main discharge jet (4) and gasket, using C161-9 service tool.
10. Remove lower plug (or main jet adjustment (8)), using a $\frac{1}{2}$ " open end wrench for 9 and 10 sizes and $\frac{5}{8}$ " wrench for the 12 size carburetors.
11. Remove the main jet (2) and gasket, using C161-1 service tool (or suitable screwdriver).
12. Remove air shutter lever retainer nut, using a $\frac{5}{16}$ " wrench.
13. Remove air shutter lever.
14. Remove air shutter bracket retainer screw and bracket, using a $\frac{1}{2}$ " wrench.
15. Remove air shutter screws and lockwashers to
16. Remove air shutter and shaft.
17. Remove air shutter shaft hole plug, using a $\frac{1}{2}$ " wrench.

NOTE: Do not remove air shutter stop in, bowl vent channel plug, or drip plug.

18. Clean the bowl and throttle body castings in gasoline or other solvent and blow through each channel with compressed air to make sure all channels are clean.

REASSEMBLY

1. Install air shutter shaft and air shutter (see Note C). Be sure the air shutter valve is correctly located (See Illus.) and that the air shutter is properly centered before tightening the screws and lockwashers securely.
2. Install air shutter shaft hole plug and gasket, using a $\frac{1}{2}$ " wrench.
3. Hold air shutter bracket in position and install retainer screw, using a $\frac{1}{2}$ " wrench, then
4. Install air shutter lever with retainer nut and lockwasher, using a $\frac{5}{16}$ " wrench.
5. Check for complete closing and full opening of air shutter and change position of the lever on the shaft, if necessary, to obtain correct operation.
6. Replace main jet (2 in Illus.) and new gasket, using C161-1 service tool.
7. Install lower plug (or main jet adjustment) and new gasket, using a $\frac{1}{2}$ " open end wrench.
8. Replace main discharge jet (4) and new gasket, using C161-9 service tool.
9. Replace well vent (5), using a small screwdriver (no gasket required).
10. Place new throttle shaft packings in retainers and
11. Install throttle shaft packing retainers (with packings), using a light hammer.
12. Install new throttle shaft and throttle plate. Use new throttle plate screws.
13. Adjust throttle stop screw to hold throttle just slightly open as a preliminary adjustment.
14. Install stop lever assembly on the shaft so that the stop lever is resting against the stop pin when the throttle plate is wide open (straight up and down in the barrel).
15. Drill and pin stop lever hub to shaft, using a No. 45 drill and CT63-2 taper pin.
16. Replace economizer jet and new gasket, using a small screwdriver ($\frac{1}{4}$ " blade).
17. Replace idling jet (6), using small screwdriver ($\frac{3}{16}$ " blade). No gasket is required.

18. Place main venturi (1) in position with locating groove on the locating pin.
19. Place secondary venturi (3) in slots provided in main venturi.
20. Replace fuel valve seat and new gasket, using C161-85 service tool.
21. Replace fuel valve needle.
22. Replace float assembly and float axle, using the handle end of a screwdriver to drive the float axle into the slotted end of the float hinge bracket.
23. Check position of float assembly for correct fuel level. As shown in Illus., the "A" dimension should be 1-39/64" plus or minus 3/64".
NOTE: Float should move freely on its axle.
24. Place a new bowl to body gasket in position on the throttle body. Be sure that the economizer channel in throttle body coincides with hole in gasket.
25. Place bowl assembly in position on the throttle body, being careful to avoid damaging the float.
26. Install assembly screws and lockwashers. Be sure to tighten screws evenly and securely, using a screwdriver, or a 5/16" wrench.
27. Install idling adjusting screw (7) and spring. Adjust to one full turn open as a preliminary adjustment.
28. Install throttle lever and tighten clamp screw.

NOTE A: The location of the priming hole plug in relation to the throttle plate is extremely important for uniform idling and part throttle operation. To maintain a uniform relation between the priming hole plug and the throttle plate, our factory assembles the throttle shaft and plate in the throttle body before drilling the body for the priming hole plug, locating the hole in a definite relation to the throttle plate in each case. It is readily apparent from the above that throttle plates and throttle bodies cannot be interchanged indiscriminately. When it becomes necessary to replace the throttle shaft or throttle plate, we suggest the following routine:

1. Unscrew the throttle stop screw to permit closing of the throttle plate.
2. Hold throttle in tightly closed position and mark the inside of the throttle body close to the throttle plate with a steel scriber.
3. Using this scribed line as a guide, replace the throttle shaft or plate. If new plate used shows a noticeable variation from old one, select another new plate to get one that fits very close to the scribed line when installed.

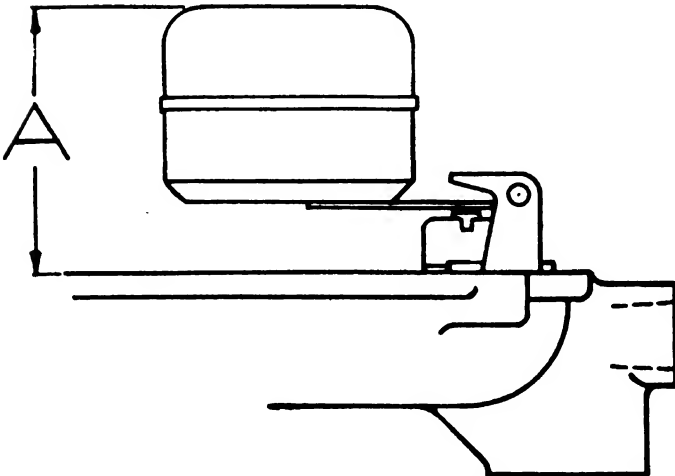

Correct Float Level Adjustment

4. If throttle body has to be replaced, we recommend obtaining a complete throttle body assembly, including shaft, plate, priming hole plug, etc., built to the outline number which appears on the identification tag on the bowl cover.

NOTE B: A round identification tag riveted to the carburetor bowl cover specifies the assembly outline number to which the carburetor was originally built. When ordering special parts such as the throttle bodies,

MAINTENANCE INSTRUCTIONS

throttle lever and stop lever assemblies, throttle plates or throttle shafts be sure to specify outline number of the carburetor to prevent errors in selecting parts required.

NOTE C: The air shutter bracket and lever assemblies can be installed on either side of the air inlet. Be sure to assemble on same side and in same position as when received for overhaul.

TOOL LIST

To properly service the Zenith 62 Series carburetor we recommend the following tools:

		Net
C161-1	Main Jet Wrench.....	\$0.50
C161-9	Main Discharge Jet Wrench.....	.95
C161-85	Fuel Valve Seat Wrench.....	.70

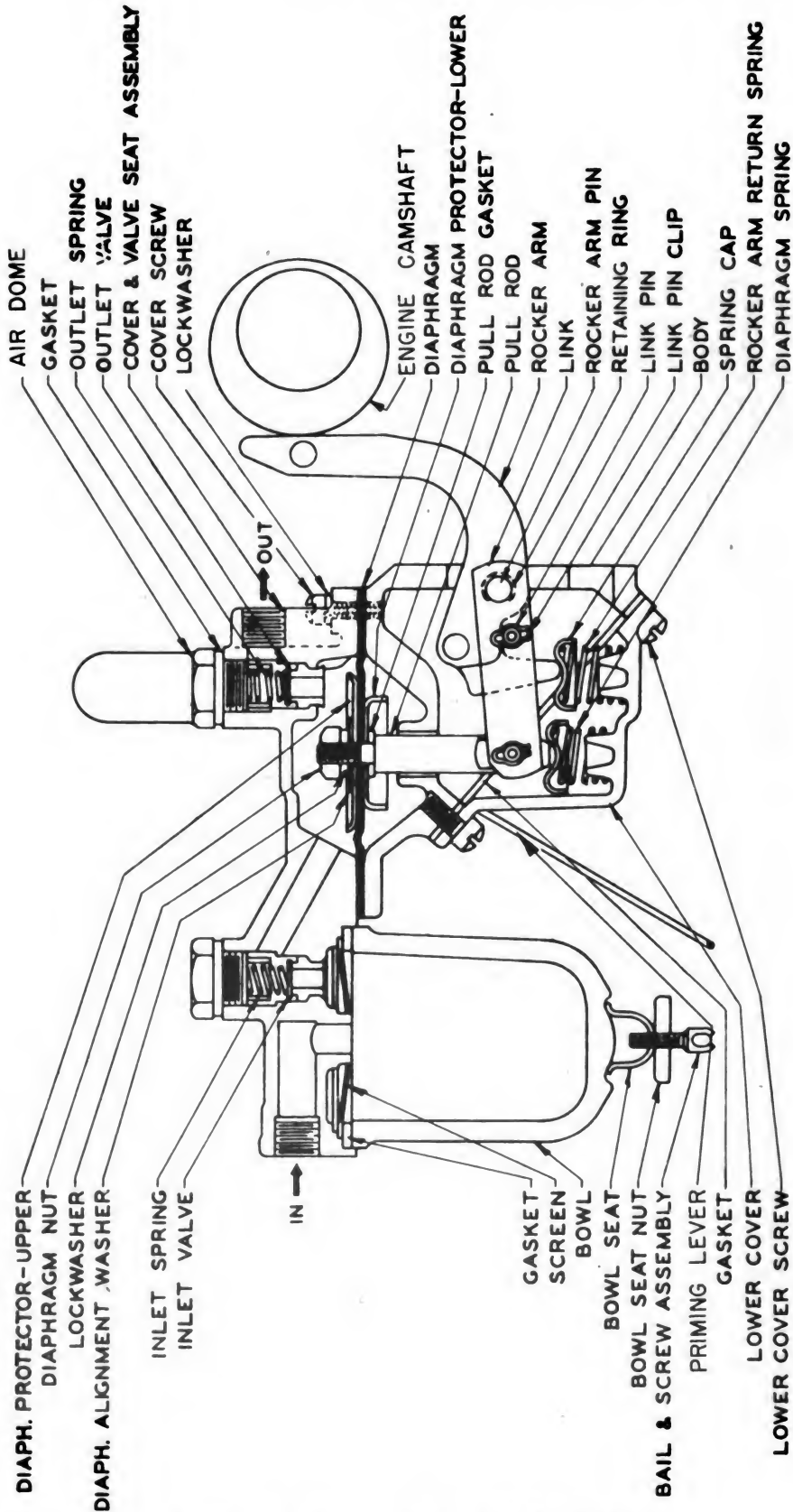

Cross Section Thru AC Fuel Pump

MAINTENANCE INSTRUCTIONS

AC FUEL PUMP

SPECIFICATIONS

Manufacturer AC Spark Plug Division
General Motors, Corp.
Flint, Michigan.
Model 1537453

Repairs Which Necessitate Removal and Disassembly of the Pump

FUEL PUMP TROUBLE CHART

Trouble	Evidenced by	Remedy
Broken rocker arm	Visible	Replace rocker arm
Broken rocker arm spring	Visible	Replace rocker arm spring
Defective or worn links	Pump does not supply sufficient fuel	Replace links. Also check for air leaks
Broken Diaphragm Return Spring	Does not supply fuel to carburetor	Replace spring.
Punctured or worn-out Diaphragm	Fuel leaking through vent hole.	Replace complete diaphragm. Do not attempt to replace just one or two layers.
Leakage around pull rod.	Fuel leaking through vent hole in body.	Replace pull rod gasket, tightening pull rod nut securely.

IMPORTANT: Mark the top cover and body before disassembling so that in reassembling they are placed back in the same relative position.

PROCEDURE IN ASSEMBLING

BODY, ROCKER ARM AND LINK ASSEMBLY:

The links used with the rocker arm are assembled together by a link pin (assembled in the hole nearest the larger rocker arm pin hole). The movement of the linkage and pull rod is procured by the rocker arm striking this link pin.

1. Assemble the two side pieces making up the linkage using the link pin and clips.
2. Attach the linkage to the pull rod using link pin and clips. Make certain that the sheared corners of the two side pieces are assembled upward.
3. Insert the rocker arm pin through the holes of the pump body, linkage and rocker arm. Place washer over counterbored end of pin and then swedge pin over against washer.
4. Check assembly to see that rocker arm and linkage move freely on rocker arm pin.

DIAPHRAGM ASSEMBLY:

1. With fuel pump body held in bench vise, place the pull rod gasket over threaded end of pull rod, seating the gasket against the shoulder of the pull rod.

2. Place lower diaphragm washer over threaded end of pull rod, cup-side down.
3. Place diaphragm over threaded end of pull rod.
4. Line up holes in diaphragm with screw holes in body diaphragm flange.
5. Place upper diaphragm protector washer over threaded end of pull rod, cup-side up.
6. Place hexagon-shaped diaphragm alignment washer over end of pull rod. Assemble lockwasher and pull rod nut, using special wrench to hold diaphragm alignment washer stationary and prevent diaphragm from twisting or turning. Tighten pull rod nut securely.

NOTE: It is extremely important that the diaphragm be held exactly in alignment while the pull rod nut is being tightened. If it is allowed to twist or become distorted unsatisfactory operation of the pump will result.

VALVE ASSEMBLY:

1. Blow out each valve chamber and make certain that no foreign particles are present which might prevent valves from seating properly. Also observe that no burrs or irregularities exist in the valve seats and that the valve seats are securely held in place in the upper cover.
2. Place valves in proper position in valve chambers. Make certain that valves lie flat against the valve seats and are not standing on edge or tipped.
3. Insert valve springs on top of valves.
4. Place fibre gasket on valve plugs and then place stems of valve plugs into the valve springs and tighten plugs securely. Be certain that the stems of the valve plugs do not distort the valve springs but fit properly inside of them.

COVER ASSEMBLY:

THE POSITION OF THE DIAPHRAGM WHEN THE FUEL PUMP COVER IS ASSEMBLED IS THE MOST IMPORTANT SINGLE ITEM TO BE OBSERVED IN REPAIRING AND ASSEMBLING AC FUEL PUMPS. IF THE DIAPHRAGM IS NOT IN THE PROPER POSITION WHEN THE TOP COVER SCREWS ARE TIGHTENED, THE PUMP WILL NOT FUNCTION CORRECTLY WHEN REPLACED ON THE ENGINE. FOLLOW INSTRUCTIONS CAREFULLY.

1. Lay cover on pump in proper position determined by marks made before pump was disassembled.
2. Insert screws from top through lockwashers, upper cover and diaphragm.
3. Tighten screws until they barely engage lockwashers.
4. Insert the handle of the diaphragm alignment washer wrench (or small screw driver) through the fuel pump body and exert pressure upward on the linkage. This forces the diaphragm to its extreme high position and while it is held in this position, the cover screws should be tightened alternately and securely.

BOTTOM COVER ASSEMBLY:

1. Holding pump bottom side up, place rocker arm spring cap and diaphragm spring cap over end of the pull rod and the projection on the rocker arm in their proper positions.

MAINTENANCE INSTRUCTIONS

2. Place gasket between pump body and lower cover.
3. Locate springs for diaphragm and rocker arm in their proper position on bosses in lower cover, then carefully assemble lower cover to the pump body, making certain the spring caps and springs remain in their proper positions.
4. Assemble and tighten cover screws securely.

FINAL ASSEMBLY:

1. Assemble screen in pump cover. Make certain that it fits snugly around the gasoline inlet and edges of the casting.
2. Place bowl gasket next to screen, then complete the assembly of the bowl and bail and screw assembly.

SERVICE HINTS

Never stretch or in any way change the tension of the valve springs as this will change the pressure of this spring against the valve and reduce the capacity of the pump, particularly under extreme conditions. Always use new valve springs if the old springs are at all questionable.

GUM IN GASOLINE AND STICKING VALVES

There have been some reports in the field of fuel pump operation being impaired due to a gum-like substance forming on the valves and making it impossible to operate properly. When this trouble is encountered in connection with the fuel pump, it is necessary to thoroughly clean and polish the pump valves, valve seats and gas strainer parts to insure correct operation of the pump.

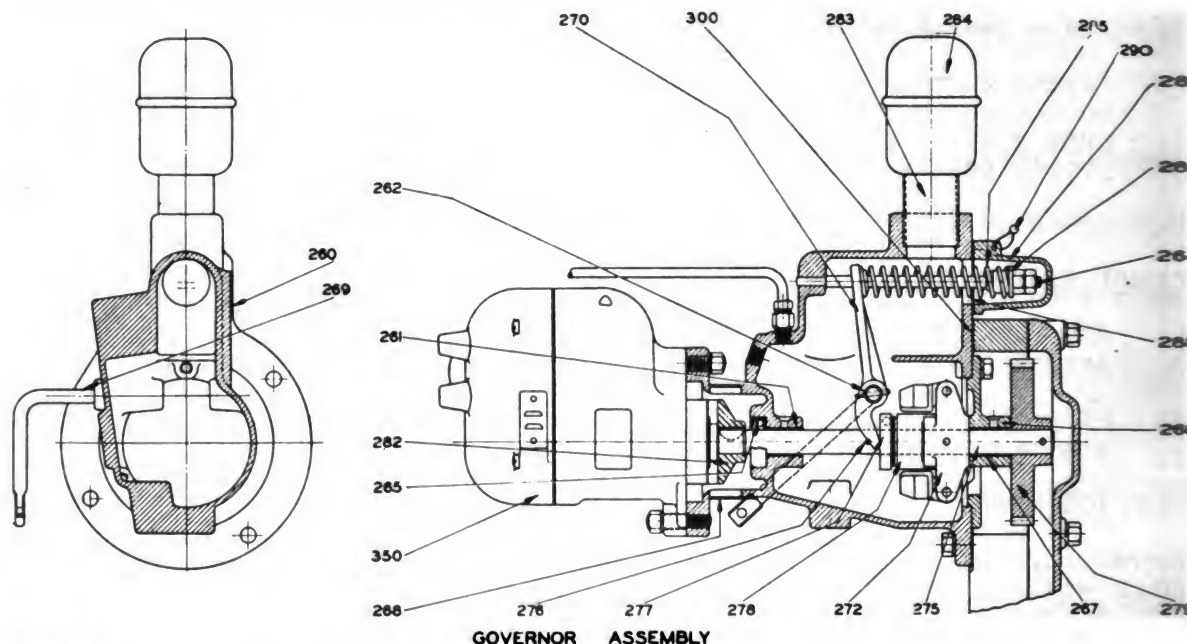

GOVERNOR ASSEMBLY

GENERAL

The governor used on this engine is the flyball, direct acting, mechanical type which acts also as an accessory drive shaft. It is driven by the camshaft gear and drives the magneto.

The speed is set at 865 R.P.M. maximum at the factory and the adjustment sealed. Under normal conditions this setting should not be changed, however if it becomes necessary to change the setting proceed as follows:

ADJUSTING THE SPEED

Remove seal (290) and cover (287). Loosen lock nut and turn second nut clockwise to increase speed, counter-clockwise to decrease speed. Speed of engine should be set at 865 R.P.M. as tested with an indicator. NOTE: 1/4 turn on the adjusting nut, varies the engine speed approximately 15 R.P.M. After correct speed adjustment is reached, tighten lock nut securely and replace cover and seal.

LUBRICATION

The governor is lubricated automatically from the engine oil supply and requires no additional lubrication.

REMOVAL

To effect removal of governor assembly from engine proceed as follows:

- (1) Disconnect all ignition cables at magneto, noting position of cables to aid in replacement.
- (2) Disconnect Slowdown Assembly air connection and throttle connection at cross shaft.
- (3) Disconnect governor oil supply line.
- (4) Remove four capscrews holding governor assembly to gear cover and remove governor assembly as a unit.

DISSASSEMBLY

- (1) Disconnect Slowdown Assembly at governor operating cross shaft (269).
- (2) Loosen capscrews and remove magneto (350).
- (3) Remove magneto coupling (282) from governor shaft (275).
- (4) Remove three capscrews holding governor body plate (266) to governor body (260).

- (5) Remove cover (287) as outlined in "Adjusting the Speed" and remove lock nuts, spring sleeve (286) and spring (285). Move cross shaft (269) end up which will rotate operating lever (270) and allow shaft (275) and all attaching parts to be withdrawn thru front opening in body (260).
- (6) Drive gear (279) has a press fit onto the shaft and must be removed, before plate (266) can be removed from shaft (275).
- (7) Thrust bearing (277) can be removed from shaft (275) after stop pin (276) is driven out.
- (8) If operating lever (270) is to be removed, withdraw taper pin and slide cross shaft (269) out of housing.

ASSEMBLY

- (1) If shaft bushings (267) and (261) are to be replaced, it is necessary to press bushing (261) into body (260) and bushing (267) into plate (266). Install plate (266) to body (260) and line ream bushings to .668" I.D. CAUTION: When installing bushings make certain oil holes line up.
- (2) If operating lever (270) was removed, install now by sliding cross shaft (269) thru opening in housing and thru bore in lever (270). Install taper pin.
- (3) Slip body plate (266) over shaft, insert capscrews in cover, press gear (279) on shaft so it does not bind against cover, install taper pin.
- (4) Insert entire shaft (275) with attached parts into housing making certain operating lever is in proper position as shown; tighten capscrews, holding body plate (266) in place.
- (5) If oil seal (265) is damaged or marred in any way, it must be replaced.
- (6) Install spring (285), sleeve (286) and lock nuts, turning down to position shown for temporary adjustment.
- (7) Replace coupling key and magneto coupling (282).
- (8) Assemble Slowdown Assembly to governor operating cross shaft (269).
- (9) Install magneto centrally with adjustment slots.

INSTALLATION

- (1) Rotate engine until "D C" on flywheel is under timing pin with #1 piston in firing position. Rotate governor driver gear backwards till line on distributor gear centers in observation window. Install governor assembly carefully so as not to move magneto setting. Tighten governor assembly capscrews securely. Make final timing adjustment as outlined in paragraph "Timing the Magneto" in section "Magneto".
- (2) Connect Slowdown Assembly air connections and connect to throttle cross shaft.
- (3) Connect governor oil supply line.
- (4) Install ignition cables, making certain they are in their proper position. No. 1 is marked on magneto cover, proceed clockwise from there installing No. 2, 4, and 3. (Firing order of engine).
- (5) Adjust governor speed to 865 R.P.M. as outlined in paragraph "Adjusting the Speed"

FAN BELT: Maintain belt so there is $\frac{1}{2}$ to $\frac{3}{4}$ " movement at a point midway between pulleys. Adjust by moving pulley flanges.

VALVES: Clearance in guides is .0025" to .004" intake, .0045" to .006" exhaust. Correct valve clearance, engine hot, is .015". Insert seat exhaust only. Valve seat width $\frac{1}{16}$ " to $\frac{3}{32}$ ", angle 45°. Rocker arm bushings reamed to size. Valve lift is $1\frac{1}{2}$ " intake, $\frac{7}{16}$ " exhaust.

PISTON, RINGS, PIN, ETC.: cast iron. Clearance .005". Pistons are numbered with bores and should be replaced same cylinders. 3 compress 1 oil ring required. Width of oil ring $\frac{1}{8}$ "—oil $\frac{3}{16}$ ". Gap .025". Piston pin is clamped. Clearance in bushing .002". Length $3\frac{1}{16}$ ", diameter 1.50". Connecting rods and caps are numbered and should be assembled correct cylinders and numbers correspond. Length center to $12\frac{1}{2}$ ".

THERMOSTAT: Dole #HTS-11 controls water temperature at 160° F. Should be assembled $\frac{1}{4}$ " from water outlet connection.

CARBURETOR: Updraft, Model 62A10, Size $1\frac{1}{4}$ ".

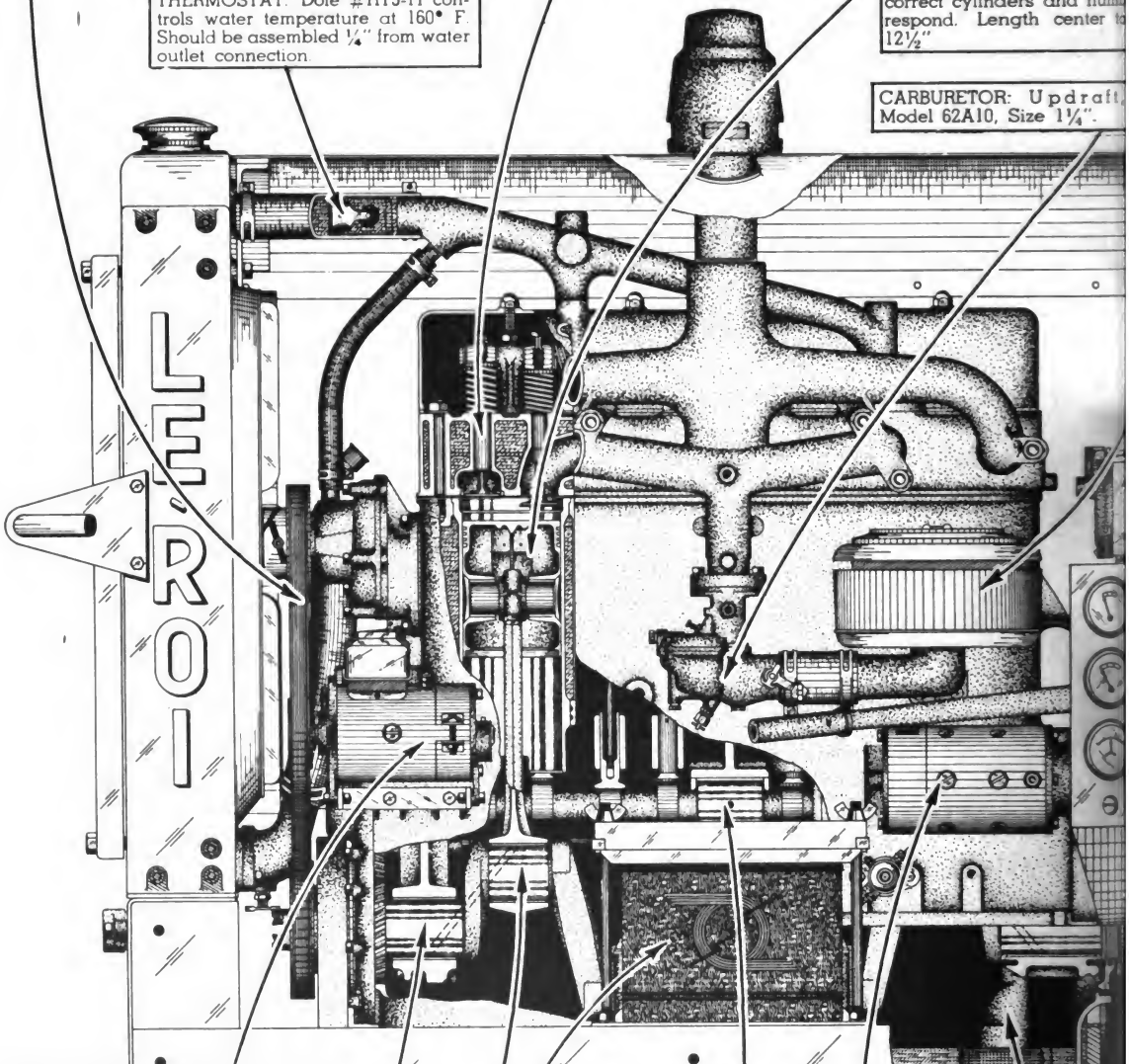

GENERATOR: Delco-Remy Model 1101374, 2 Pole, 3rd Brush, sealed type unit with ball bearing in drive end, bronze bushing in commutator end. Used in conjunction with #5889 Control Unit

CRANKSHAFT BEARINGS: Three precision, replaceable, non-adjustable type bearings are used, rear bearing takes end thrust. Journal diameter is 2.6245". End clearance is .001" to .012". Running clearance .0015" to .0035".

CAMSHAFT: Shaft runs in 3 bronze bushings having .002" to .004" running clearance. End clearance is .005" to .009". End thrust is taken on bronze plate between helical gear and front bearing. Journal diameter is 2.480". Service bushings reamed to size. Valve tappet clearance in guides is .002" to .0025".

OIL PUMP: Positive gear type oil from oil pan and supplies pressure to crankshaft, connecting rod bearings, camshaft and mechanism. Pressure is regulated by a non-adjustable relief valve. Pressure should hold indicator in green portion of gauge, under normal running conditions.

CONNECTING ROD BEARINGS: Precision replaceable type bearings have .0015"-.00" running clearance and .010" to .020" end clearance. Crank pin diameter is 2.4995".

BATTERY: Globe-Union #134, 6 volt unit. Electrolyte must be maintained to $\frac{1}{2}$ " above plates at all times. Specific Gravity, fully charged, 1.285 and 1.150 completely discharged.

CRANKING MOTOR: Delco-Remy Model 700, 6 Volt, 6 Pole unit with oilless bearings. Brush spring tension, 36-40 ounces. Clockwise rotation viewing drive end. No load 3000 r.p.m. at 70 amp. at 5.0 volts. Lock Torque Test—19 lb. ft. at 3.0 amps. at 3.0 volts. Used in conjunction with Delco-Remy Magneto Switch Model 1564.

LEANER: Air-Maze Model Oil Bath Cleaner. Keep oil level to level of bead. Use oil in crankcase.

CYLINDER HEAD: Valves are circular plate type mounted in such a way they may be serviced without removing cylinder heads.—Valve lift is $\frac{3}{32}$ ". Check tightness of valve cover studs frequently. Suction valve cover plunger is lapped into bore. When clearance becomes excessive, entire unit must be replaced.

PISTON, RINGS, PINS, ETC.: Material, cast iron. Clearance .005" to .007". 2 compression and 2 oil rings required each piston. Width $\frac{3}{16}$ ". Gap .015" to .025". Piston pin is clamped in rod. Clearance in bushing .002" to .003". Length (H.P.) $4\frac{1}{4}$ ". (L.P.) $5\frac{1}{4}$ ". Diameter 1.500". Connecting rods and caps are numbered and should be assembled with numbers corresponding. Length, center to center, $12\frac{1}{2}$ ".

UNLOADER PILOT SWITCH: Penn Electric Switch Co., Type GI. Unloads at 100 lbs. and loads at 88 lbs.

AIR RECEIVER: Manufactured according to A.S.M.E. standards with a volume of 8 cubic feet of air. Two hose reels attached, each equipped with 50 foot lengths of $\frac{3}{4}$ " I.D. air hose.

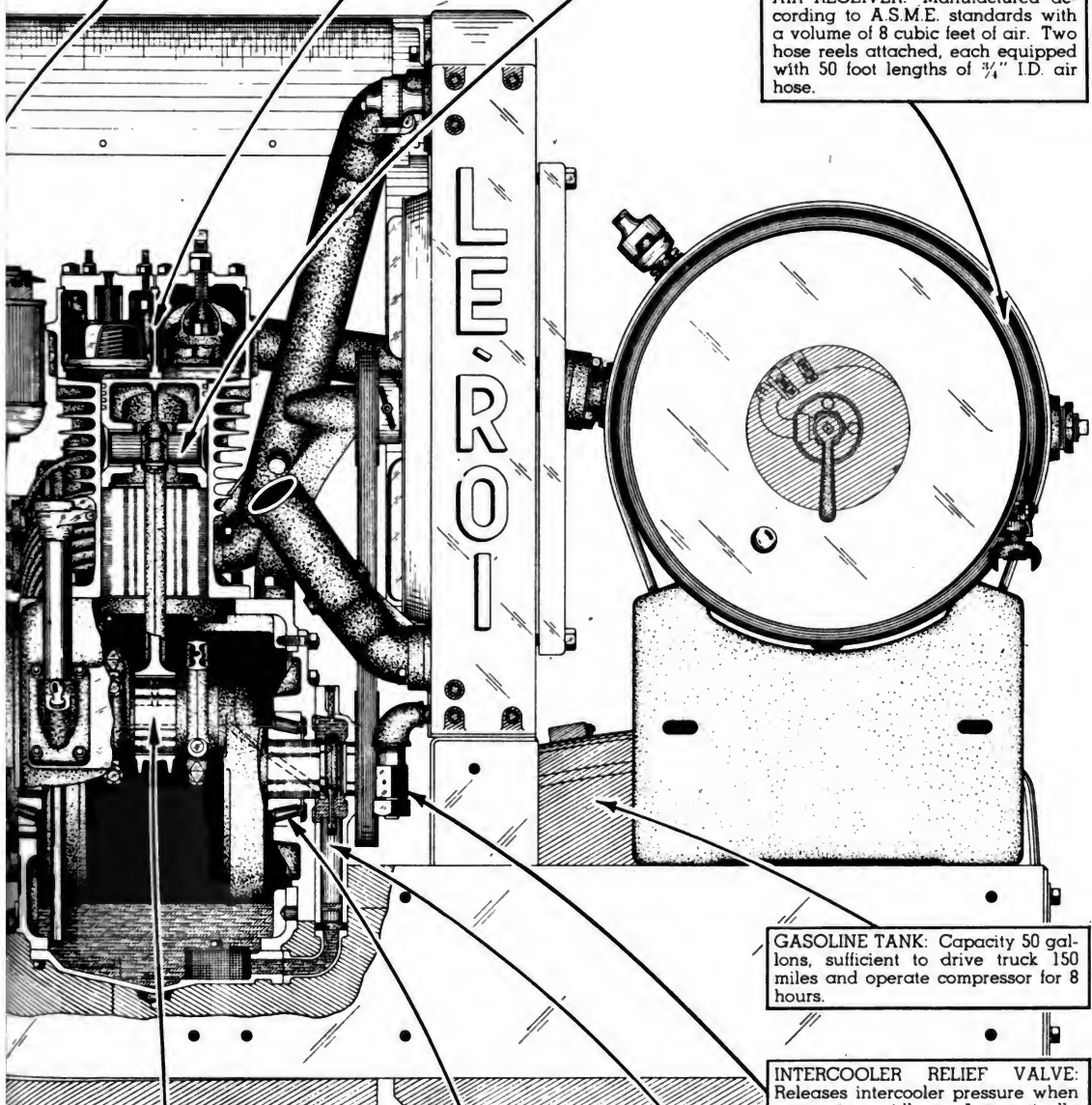

CONNECTING ROD BEARINGS: Precision, replaceable type bearings have .002" to .004" running clearance. Combined end clearance, three rods, .010" to .050". Crank pin diameter is 3.500"

CRANKSHAFT BEARINGS: Timken Tapered Roller #643-632. Correct end clearance of crankshaft is .003" to .006" as checked by indicator. Adjustment is gained by shims under front bearing cover. Cones are shrunk onto crankshaft after heating in oil to not above 500° F.

GASOLINE TANK: Capacity 50 gallons, sufficient to drive truck 150 miles and operate compressor for 8 hours.

INTERCOOLER RELIEF VALVE: Releases intercooler pressure when compressor idles. Automatically drains condensate.

OIL PUMP: Plunger type driven off eccentric on crankshaft through special connecting rod supplies positive lubrication to main and connecting rod bearings. Pressure is controlled by a non-adjustable relief valve and should hold indicator in green section of gauge, under normal working conditions.

DRIVE SHAFT: Double plate, dry disc, loaded, $11\frac{1}{2}$ ". Twin Disc Model SL-211 adjustable and replaceable through openings in housing.

**INDEX
TO
PARTS
LIST**

**AIR PRESSURE
REGULATING**

AIR RECEIVER

CLUTCH

COMPRESSOR

**ELECTRICAL &
MAGNETO**

ENGINE

FRAME

FUEL SYSTEM

GOVERNOR

HOUSING

INTERCOOLER

RADIATOR

SPARE PARTS

PREPARATION OF REQUISITIONS

SAMPLE COPY FOR USE IN THE PREPARATION OF REQUISITIONS

State PERIOD designation by use of one of the following terms:

- (1) "INITIAL" — first requisition of authorized allowances.
- (2) "REPLENISHMENT" — subsequent requisitions to maintain authorized allowances.
- (3) "SPECIAL" — requisitions for necessary repairs not covered by allowances.

Emergency requisitions sent by telephone, telegraph, or radio must always be confirmed immediately with requisition marked: "Confirming (state identifying data)"

Prepare a separate requisition for each different machine.

Type "SPARE PARTS" in upper right hand corner of requisition form.

Give complete shipping instructions. Special instructions for packing, marking, routing, etc., should be given at the end of the requisition.

State proper nomenclature of machine, and make, model, serial number and registration number.

State basis or authority, and date delivery is required, immediately below description of machine.

Double space between items.

State manufacturers' parts numbers and nomenclature accurately and completely. Do not use abbreviations.

Group parts required under group headings as shown in manufacturers' parts catalogs.

Nonexpendable items must be accounted for.

(SAMPLE) REQUISITION

SPARE PARTS

WAR DEPARTMENT
U. S. FORM NO. 488
REVISED APR. 6, 1931

To: Engineer Supply Officer
Columbus Quartermaster Depot, Columbus, Ohio
Requisition No. E-531-3-43 Date August 14, 1942 Period Special

SHIP TO: Engineer Property Officer, Pine Camp, New York
MARKED FOR: Engineer Supply Officer, 802nd Engr. Battalion, Pine Camp, N.Y.

REQUISITIONED BY (show Signature, Rank, Organization, Destination. If different from "SHIP TO" include address):
Robert E. Roe
Robert E. Roe
Major, C.E.
Engineer Property Officer.

APPROVED FOR the Commanding Officer
John E. Doe
John E. Doe
Col., C.E.
Executive Officer

ARTICLES	UNIT	ON HAND AND DUE	CONSUMED	REQUIRED	APPROVED
<u>SPARE PARTS</u>					
PARTS FOR POWER UNIT, ENGINE, GASOLINE, LE ROI MODEL D140					
SERIAL NO. 189853, U.S.A., REG. NO. W-84997					
Basis: Repair of Disabled Equipment.					
Delivery is requested by August 20, 1942.					
<u>ENGINE GROUP</u>					
18-288	PISTON RING, Compression	ea.	0	8	8
18-289	PISTON RING, Oil Control	ea.	0	4	4
A6-154	CAMSHAFT ASSEMBLY	ea.	0	1	1
26-546	GEAR, Camshaft	ea.	0	1	1
<u>TOOLS</u>					
88-224	SOCKET WRENCH	ea.	0	1	1
NONEXPENDABLE ARTICLES SHOWN HAVE BEEN PLACED ON I & I REPORT (REPORT OF SURVEY, ETC.)					

U. S. GOVERNMENT PRINTING OFFICE C. S. 1933

PREPARATION OF REQUISITIONS

A Sample requisition in the correct form for submission by the Engineer Property Officer is shown on the opposite page.

THIS SHALL BE FOLLOWED IN MAKING OUT REQUISITIONS.

In order to eliminate duplication of work, Property Officers may authorize organizations to prepare requisitions in final form, leaving requisition number space blank for completion by Property Officer.

THE FOLLOWING RULES WILL BE OBSERVED CAREFULLY IN PREPARING REQUISITIONS FOR SPARE PARTS:

- a. Prepare a separate requisition for each different machine.
- b. Type "SPARE PARTS" in upper right hand corner of requisition form.
- c. State PERIOD designation by use of one of the following terms:
 - (1) "INITIAL"—first requisition of authorized allowances.
 - (2) "REPLENISHMENT"—subsequent requisitions to maintain authorized allowances.
 - (3) "SPECIAL"—requisitions for necessary repairs not covered by allowances.
- d. Give complete shipping instructions.
- e. State proper nomenclature of machine, and make, model, serial number and registration number.
- f. State basis or authority, and date delivery is required, immediately below description of machine.
- g. Group parts required under group headings as shown in manufacturers' parts catalogs.
- h. State manufacturers' parts numbers and nomenclature descriptions accurately and completely. Do not use abbreviations.
- i. Double space between items.
- j. Emergency requisitions sent by telephone, telegraph, or radio must always be confirmed immediately with requisition marked: "Confirming (state identifying data)."
- k. Nonexpendable items must be accounted for.

PARTS LIST

INSTRUMENT PANEL GROUP 1

PART No.	NAME AND DESCRIPTION	QUAN.	PRICE EACH
A151-194	Instrument panel assembly (A to B).....	1	\$ 62.00
151-194	Panel, instrument.....A	1	7.00
A76-81	Penn unloader pilot assembly, 90-100 P.S.I.....	1	25.00
02-2	Capscrew, hex. 1/4" - 20 x 1/2".....	4	.02
05-49	Lockwasher, 1/4".....	4	.01
A15-286	Check and bleed valve assembly.....	1	.60
A182-13	Connector, straight, on bleed valve, 1/4" tube x 1/8" M.P.T. (top).....	1	.20
A182-33	Connector, elbow, on bleed valve, 1/4" tube x 1/8" M.P.T. x 90° (bottom).....	1	.25
A182-34	Connector, elbow, for Penn unloader pilot 1/4" tube x 1/4" M.P.T. x 90°.....	1	.16
60-83	Gauge, air receiver pressure.....	1	3.50
013-601	Pipe tee, 1/8 x 1/8 x 1/8".....	1	.16
A182-33	Connector, elbow, for air pressure gauge, 1/4" tube x 1/8" M.P.T. x 90° (top of tee).....	1	.25
55-29-78	Tube, Penn pilot to pressure gauge, 1/4" tube, 11-3/4" lg.....	1	.24
A182-13	Connector, straight, for air pressure gauge, 1/4" tube x 1/8" M.P.T. (bottom of tee).....	1	.20
60-117	Gauge, intercooler pressure.....	1	2.50
013-401	Pipe elbow, 1/8" PT x 90°.....	1	.12
A182-13	Connector, straight, for intercooler pressure gauge, 1/4" tube x 1/8" M.P.T.....	1	.20
60-82-1	Gauge, compressor oil pressure.....	1	2.00
A182-13	Connector, straight, for compressor oil gauge, 1/4" tube x 1/8" M.P.T.....	1	.20
60-80-1	Gauge, engine oil pressure.....	1	2.30
A182-33	Connector, elbow, for engine oil gauge, 1/4" tube x 1/8" M.P.T. x 90°.....	1	.25
A113-28	Ammeter assembly.....	1	2.30
A120-2-8	Choke control assembly.....B	1	.80
02-52	Capscrew, hex. 7/16 - 14 x 3/4".....	4	.04
05-52	Lockwasher, 7/16".....	4	.01
55-2-84	Air line from check valve to slow down, 5/16" tube x 43" lg.....	1	.80
A182-14	Connector, straight, for air line to slow down 5/16" tube x 1/8" M.P.T.....	1	.16
79-41	Clamp, tube, for 1/4" tube.....	2	.08
02-2	Capscrew for clamp, hex. 1/4 - 20 x 1/2".....	1	.02
05-49	Lockwasher, 1/4".....	1	.01
04-101	Nut, hex. for clamp screw, 1/4" - 20.....	1	.01
79-121	Tube clamp for 2 - 1/4" & 1 - 5/16" tubes on bell housing.....	1	.20
02-2	Capscrew, hex., for clamp, 1/4 - 20 x 1/2".....	1	.02
05-49	Lockwasher, 1/4".....	1	.01
A182-33	Connector, elbow, for L.P. suction valve cover, 1/4" tube x 1/8" M.P.T. x 90°.....	2	.25
55-29-73	Air line from L.P. suction valve cover to tee connector, magneto side, 1/4 x 27" long.....	1	.24

INSTRUMENT PANEL GROUP 1--Cont'd

PART No.	NAME AND DESCRIPTION	QUAN.	PRICE EACH
55-29-33	Air line from L.P. suction valve cover to tee connector, carburetor side, 1/4 x 19" long.....	1	\$.1
A182-92	Connector, tee, for H.P. suction valve cover 1/4" tube x 1/8" M.P.T. x 1/4" tube	1	.3
55-29-33	Air line from H.P. suction valve cover to tee 1/4" x 19" lg.....	1	.1
A182-123	Connector, tee, air line from suction valves, 1/4" tube x 1/4" tube x 1/4" tube.....	2	.3
55-29-9	Air line from tee to tee on crankcase, 1/4" tube x 10-3/4" lg.....	1	.1
79-41	Clamp, tube, on crankcase for 1/4" tube...	2	.0
02-2	Capscrew, hex., for clamp, 1/4 - 20 x 1/2"	2	.0
05-49	Lockwasher, 1/4".....	2	.0
55-29-49	Air line from H.P. suction valve to check valve, 1/4 x 20" lg.....	1	.2

PENN PART No.	NAME AND DESCRIPTION	QUAN.	PRICE EACH
F-65	Trip lever bushing.....	1	.05
G-806	Valve plunger pin.....	1	.50
G-812	Trip lever assembly.....	1	.65
GI-2	Hand unloader lever.....	1	.05
GI-3	Hand unloader lever bushing.....	1	.12
GI-5	Hand unloader plate.....	1	.10
GI-6	Elbow (1/8" pipe to 1/4" S.A.E. Flare conn.).....	2	.25
GI-12	Compression coupling.....	2	.25
GI-14	Unloader lever stop pin.....	1	.03
GI-21	Unloader valve bracket.....	1	.05
GI-23	Unloader plate pivot stud.....	1	.35
GI-32	Trip lever and cover mounting screw.....	1	.09
GI-800	Hex. valve assembly (kickoff valve).....	1	2.50
GI-801	Frame casting and spring studs.....	1	2.05
GI-803	Conveyor tube (to unloader valve).....	1	.30
GI-804	Conveyor tube (to kickoff valve).....	1	.30
GI-805	Unloader valve assembly.....	1	4.00
GI-810	Lower diaphragm casting.....	1	1.95
HP-50	Valve lock nut.....	4	.03
HP-60	Lock washer (mounting feet).....	4	.01
HP-805	Diaphragm plunger disc.....	1	.19
L-88	Cotter key.....	1	.01
R-51	Extension spring.....	1	.04
R-82	Cover wing nut.....	1	.02
R-89	Lock nut (No. 8-32) 5/16" hex.....	1	.01
R-110	Diaphragm rubber.....	1	.50
R-131	Trip lever spring.....	1	.05
R-157	Lock nut (No. 8-32) 3/8" hex.....	1	.01
RA-25	Side cover.....	1	.18

PARTS LIST

INSTRUMENT PANEL GROUP 1--Cont'd

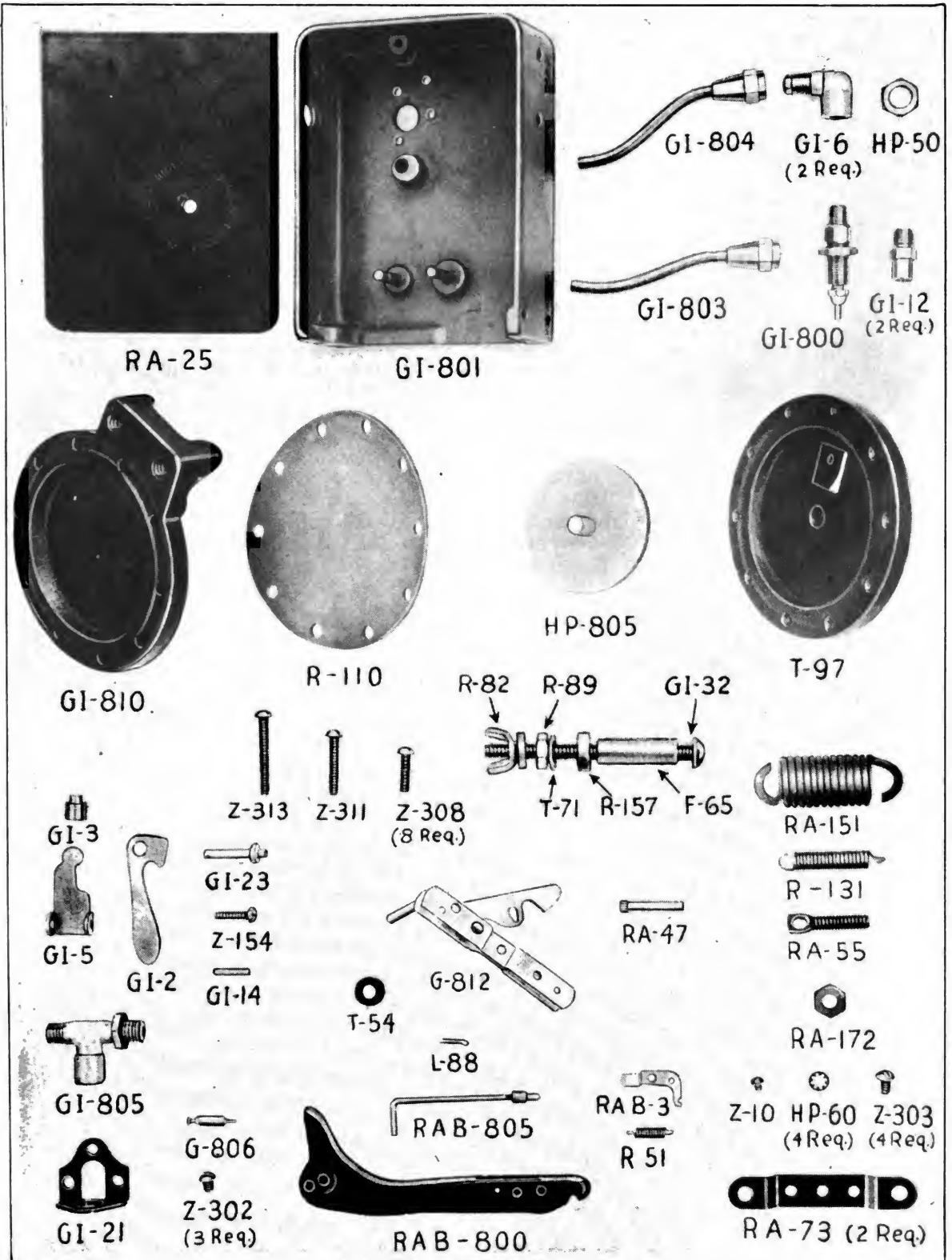

Penn Unloader Pilot Parts View

INSTRUMENT PANEL GROUP 1--Cont'd

PENN PART No.	NAME AND DESCRIPTION	QUAN.	PRICE EACH
RA-47	Main arm pivot pin.....	1	\$.02
RA-55	Main spring tension screw.....	1	.05
RA-73	Mounting foot.....	2	.06
RA-151	Main Spring.....	1	.45
RA-172	Main spring adjusting nut.....	1	.03
RAB-3	Spring stud keeper.....	1	.03
RAB-800	Main arm assembly.....	1	1.00
RAB-805	Kickoff valve plunger rod.....	1	.25
T-54	Felt washer.....	1	.01
T-71	Lock washer.....	1	.01
T-97	Upper diaphragm casting.....	1	.80
Z-10	Spring stud keeper screw No. 6-32 round head iron 3/16" long.....	1	.01
Z-154	Hand unloader bearing screw No. 8-32 round head iron, 5/8" long.....	1	.01
Z-302	Unloader valve mounting bracket screw No. 10-32 round head iron, 1/4" long.....	3	.01
Z-303	Mounting feet screw No. 10-32 round head iron, 5/16" long.....	4	.01
Z-308	Diaphragm mounting screw No. 10-32 round head iron, 3/4" long.....	8	.01
Z-311	Diaphragm to frame mounting screw No. 10-32 round head iron, 1-1/8" long.....	1	.01
Z-313	Diaphragm to frame mounting screw No. 10-32 round head iron, 1-1/2" long.....	1	.01

PARTS LIST

AIR RECEIVER GROUP 1

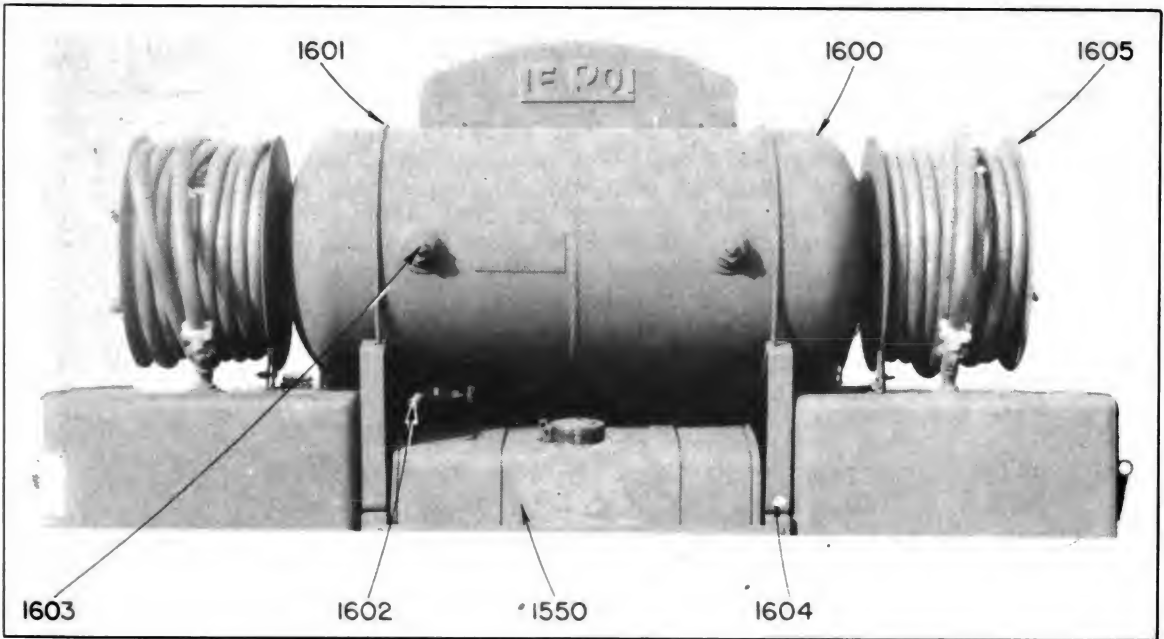

REF. No.	PART No.	NAME AND DESCRIPTION	QUAN.	PRICE EACH
1604	39-1378	Support, air receiver.....	2	\$ 8.75
....	02-71	Capscrew, for receiver support, hex. 1/2 - 13 x 1-1/2".....	4	.06
....	06-71	Washer, plain, 1/2".....	4	.02
....	05-53	Lockwasher, 1/2".....	4	.01
....	04-105	Nut, hex. 1/2" - 13.....	4	.02
1600	69-282	Air receiver (includes 33-555).....	1	60.00
....	33-555	Pipe for hose reel (welded in 69-282).....	1	3.70
1601	83-24	Strap, air receiver.....	2	.80
....	05-52	Lockwasher, 7/16".....	4	.01
....	04-604	Nut, hex. 7/16" - 20.....	4	.02
....	013-9	Nipple, pipe, for receiver inlet, 2" PT x 2".....	1	.20
....	54-151	Fitting, pipe, 2" F.P.T. special.....	1	1.40
....	33-538	Pipe, bent, H.P. cyl. head discharge.....	1	2.30
....	54-151	Fitting, pipe, 2" F.P.T. special.....	2	1.40
....	16-640	Gasket, air connection flange.....	2	.10
....	02-71	Capscrew, hex. for air connection to H.P. head 1/2 - 13 x 1-1/2".....	4	.06
....	02-74	Capscrew, hex. for air connection to air receiver, 1/2 - 13 x 2-1/4".....	4	.08
....	05-53	Lockwasher, 1/2".....	8	.01
....	04-105	Nut, 1/2" - 13.....	4	.02
....	A15-21	Valve, safety pop, 1" M.P.T. set for 125# max.....	1	9.00
....	013-502	Street ell, for air receiver drain, 1/4" PT.....	1	.08
....	013-77	Nipple, pipe, for drain, 1/4 x 6".....	1	.10
1602	15-350	Cock, drain, 1/4" F.P.T. Globe.....	1	4.30
....	013-532	Street ell, for drain cock, 1/4" PT x 45°.....	1	

AIR RECEIVER GROUP 1--Cont'd

REF No.	PART No.	NAME AND DESCRIPTION	QUAN.	PRICE EACH
....	013-790	Bushing, reducer, for receiver rear outlet 2" M.P.T. x 1" P.T.....	2	\$.24
1603	011-6	Pipe plug, 1" sq. hd.....	2	.08
....	A77-207	Filter, air, for air control line, 1/4" M.P.T.....	1	2.40
....	A182-34	Connector, elbow, for air filter, 1/4" tube x 1/4" M.P.T. x 90°.....	1	.16
....	55-29-50	Air line from filter to air pressure gauge, 1/4" tube x 81" lg.....	1	1.10
....	73-263	Hose, rubber, for air line, 1/4" I.D. x 6".....	1	.10
....	79-41	Clamp, tube, for air line from receiver	1	.08
....	02-2	Capscrew, hex. for tube clamp, 1/4 - 20 x 1/2".....	1	.02
....	05-49	Lockwasher, 1/4".....	1	.01

HOSE REEL GROUP 2

1605	A180-7	Hose reel assembly, Includes parts mark- ed ●.....	2	28.50
1606	39-1381	● Support for hose reel.....	2	7.25
1605	180-7	● Hose reel.....	2	9.25
1607	31-427	● Ring, locking, for hose reel.....	2	.05
1608	15-323-1	● Valve, hose reel, Cleco air valve, 1" x 3/4" R.A., angle handle.....	2	4.50
1609	54-297	● Fitting for air hose.....	2	2.00
1610	54-287	● Fitting, gland.....	2	1.50
1611	125-69	● Packing, slip joint.....	8	.08
1612	54-296	● Fitting, slip.....	2	2.50
1613	106-156	● Capscrew, hex. for gland fitting, 5/16 18 x 7/8" special.....	8	.08
1614	61-44	● Locking wire.....	4	.04
1615	50-99	Handle for air hose reel.....	2	.45
1616	83-102	Clamp for air hose.....	2	.08
....	05-176	Lockwasher, ctrsk., 5/16".....	2	.01
....	03-559	Screw, flat, hd. 5/16 - 18 x 1".....	2	.06

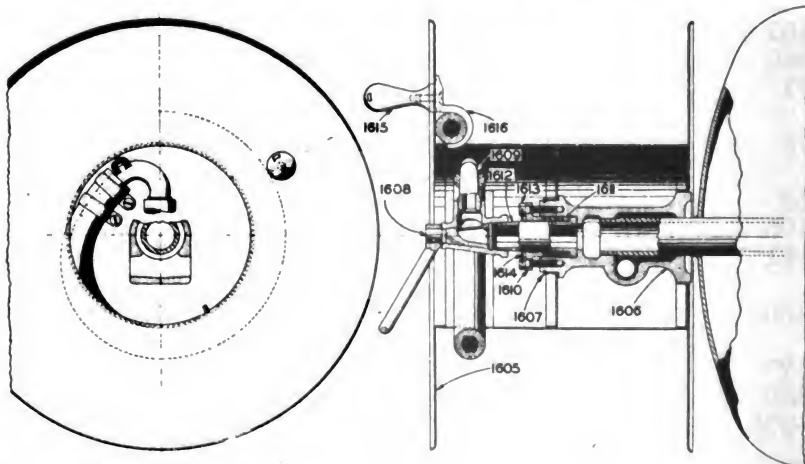

PARTS LIST

CLUTCH GROUP i (See illustration 2S-23C)

REF. No.	PART No.	NAME AND DESCRIPTION	QUAN.	PRICE EACH
1500	75-324	Clutch housing.....	1	\$ 17.00
....	05-52	Lockwasher, 7/16".....	8	.01
....	04-604	Nut, hex. 7/16" - 20.....	8	.02
1505	A75-279	Clutch assembly, Twin Disc SL-2-11-1/2"....	1	90.00
1506	27-1314	Shaft, clutch yoke.....	1	1.50
1501	09-32	Key, clutch yoke shaft, Woodruff #D.....	3	.04
1507	45-44	Yoke, clutch operating.....	1	4.50
1502	05-51	Lockwasher, 3/8" dia.....	2	.01
1503	02-38	Capscrew, hex. 3/8" - 16 x 1-1/2".....	2	.04
1512	48-498	Lever, clutch operating.....	1	6.00
....	05-53	Lockwasher, 1/2".....	1	.01
....	02-72	Capscrew, hex. 1/2 - 13 x 1-3/4".....	1	.08
1515	166-7	Cup, grease. #00 x 1/8" M.P.T.....	1	.80
....	02-37	Capscrew, hex. 3/8 - 16 x 1-1/4".....	12	.04
....	05-51	Lockwasher, 3/8".....	12	.01

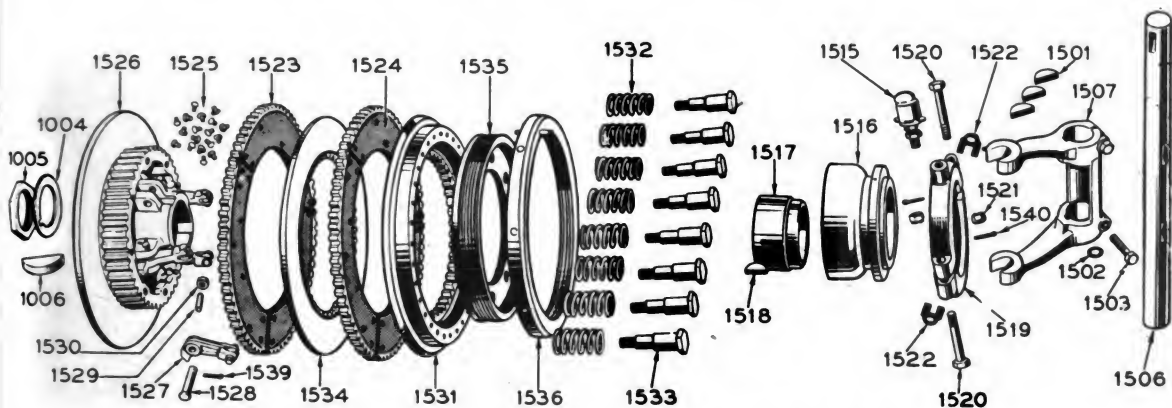

Twin Disc Clutch Model SL-2-11 1/2"

REF. No.	TWIN DISC PART No.	NAME AND DESCRIPTION	QUAN.	PRICE EACH
....	C-192	1 Cone Assembly, includes parts marked †....	1	\$ 27.75
1516	A5156	†Cone, bore 3.380-3.379, Ky. 1/4 x 9/64.....	1	15.00
1517	A1981A	†Cone sleeve, bore 2.504-2.506, Ky. 1/4 x 9/64.....	1	6.50
1518	M291	†Woodruff Key.....	1	.10
1519	6599	†Cone collar assembly, includes next 4 items.	1	4.40
1520	118	Bolt.....	2	.11
1521	118C	Nut.....	2	.06
1522	A1413	Shim.....	2	.11
1540	105	Cotter pin.....	2	.01
....	06662A	Driving plate assembly, includes parts marked \$.....	2	11.10
1523	6662A	\$Driving plate.....	1	6.35
1524	6663A	\$Friction Disc.....	2	1.80
1525	M116	\$Tubular rivet.....	25	.01
....	H438	Hub & back plate assembly, includes parts marked †.....	1	30.00

LE ROI COMPANY, MILWAUKEE, WISCONSIN

CLUTCH GROUP 1--Cont'd

REF. No.	TWIN DISC PART No.	NAME AND DESCRIPTION	QUAN.	PRICE EACH
1526	Z8177B	†Hub & back plate.....	1	26.50
1527	A3271	†Finger lever.....	4	1.60
1528	1904	†Finger lever pin.....	4	.17
1539	M596	†Cotter pin, 3/32 x 3/4.....	4	.01
1529	1735	†Roller pin.....	4	.22
1530	A1937	†Rollers.....	4	.40
....	105	†Cotter pins.....	4	.01
1531	A5180	Floating plate.....	1	9.50
1532	A1215	Pressure springs.....	8	.18
1533	A1217	Spring bolts.....	8	.66
1534	6615	Driven plate.....	1	9.90
1535	A5179	Pressure plate.....	1	9.60
1536	A5178	Adjusting ring.....	1	10.20
1537	114 B-2-9	Adjusting lock pin.....	1	.24
1538	115	Adjusting lock pin spring.....	1	.06

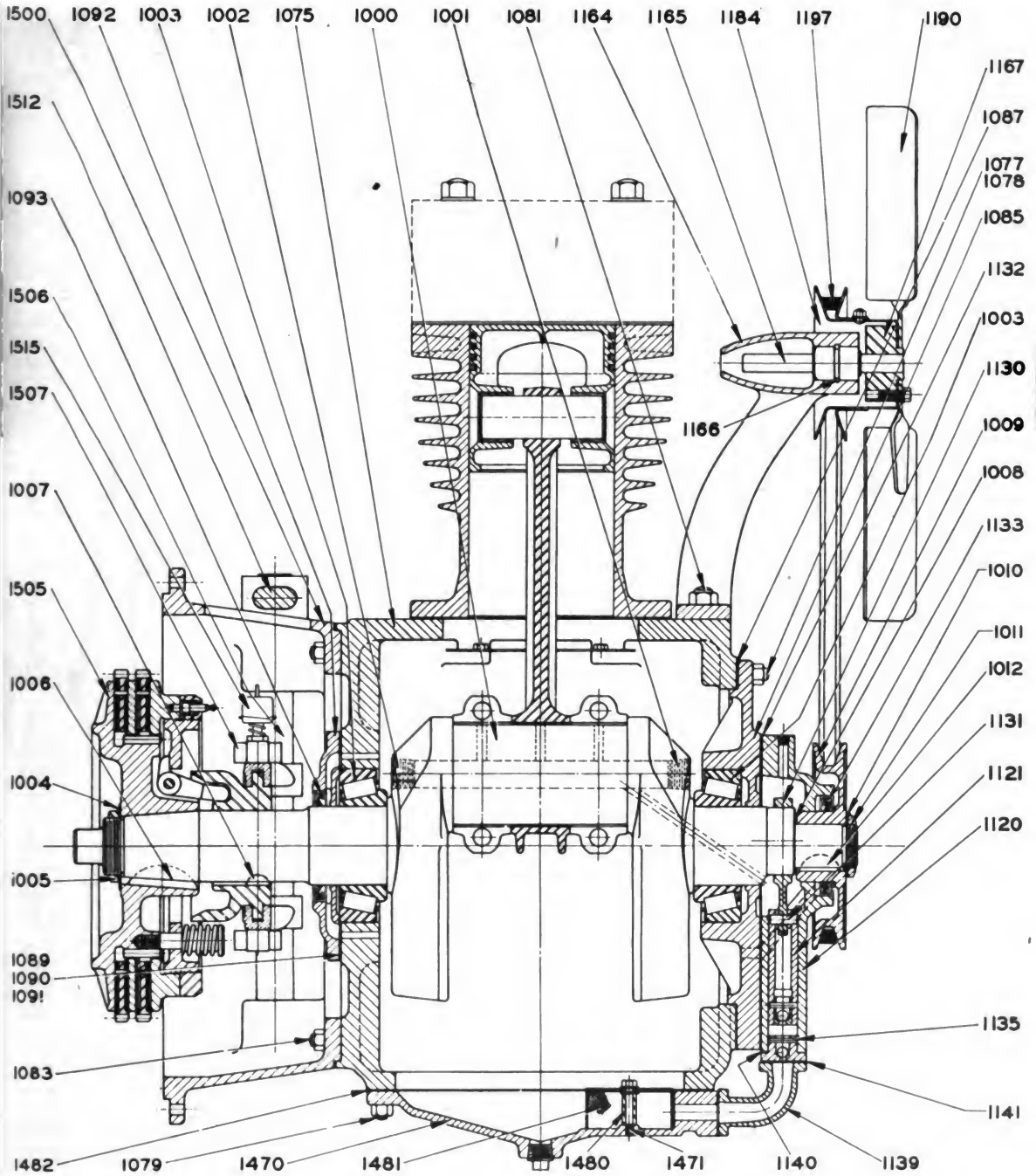

LONGITUDINAL SECTION THROUGH COMPRESSOR

PLATE 2S-23C

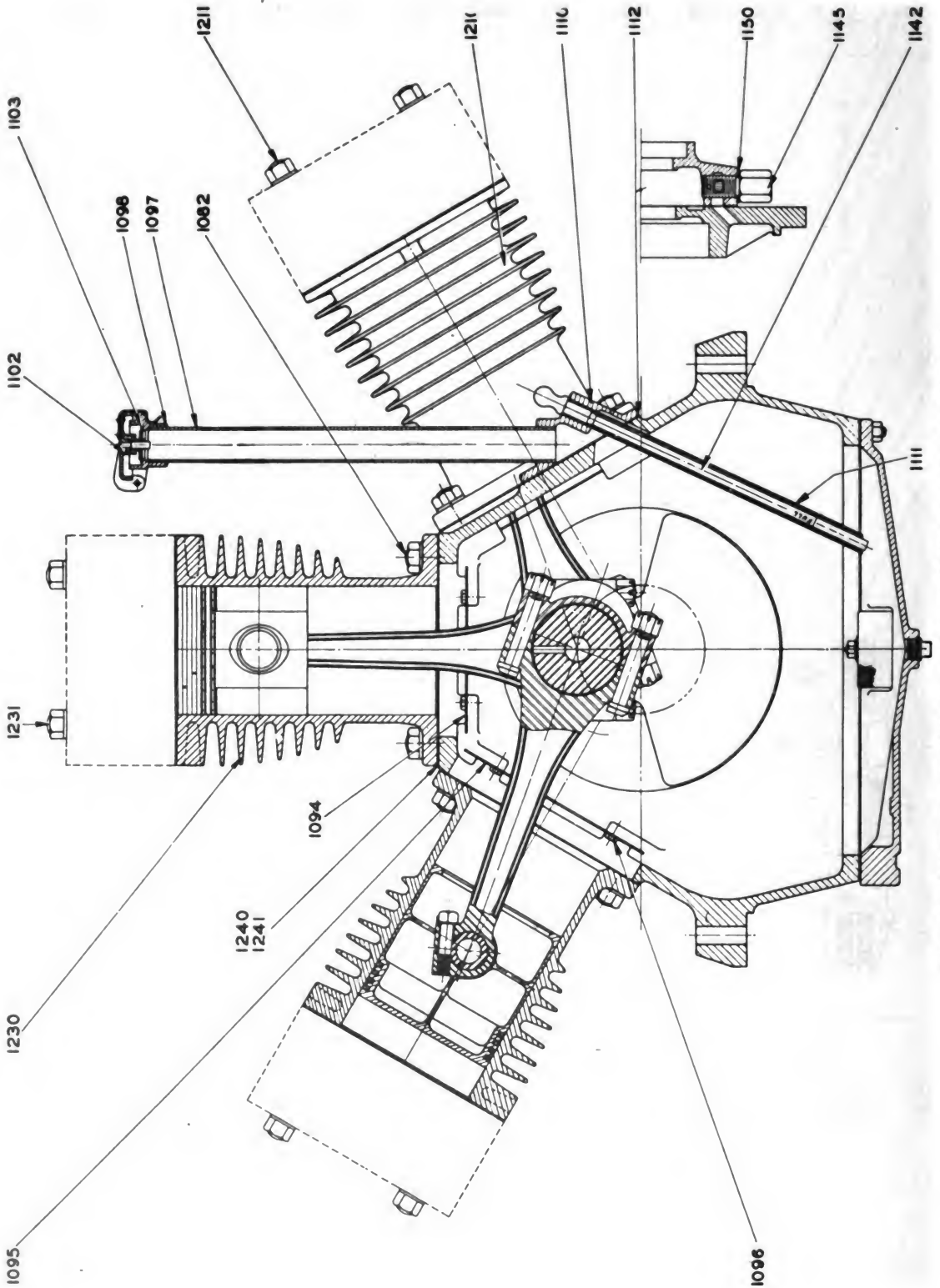

CROSS SECTION THROUGH COMPRESSOR AND BREATHER
PLATE 25-24C

PARTS LIST

CRANKSHAFT GROUP 1
See illustration 2S-23C, 2S-24C

REF. No.	PART No.	NAME AND DESCRIPTION	QUAN.	PRICE EACH
1000	A5-265-8	Crankshaft, includes pipe plugs.....	1	\$ 105.50
1001	011-105	Plug, pipe, 3/4" P.T. Ctrsk. head.....	1	.12
1002	19-41	Plug, pipe, 3/4" P.T. Special with ori- fice.....	1	.20
1003	181-117	Bearing, #643-632, tapered roller.....	2	13.50
1004	20-177	Lockwasher, 2" special.....	1	.14
1005	53-112	Nut, 2" - 12 hex. special.....	1	1.90
1006	09-57	Key, 1/2" x 2-5/16" lg. #V Woodruff.....	1	.02
1007	09-15	Key, 1/4" x 7/8" lg. #A Woodruff.....	1	.02
1008	16-422	Gasket, for fan drive pulley.....	1	.08
1009	36-246-2	Pulley, fan drive.....	1	3.70
1010	2019	Lockwasher, 1-1/2" special.....	1	.08
1011	53-100	Nut, 1-1/2" - 12 hex. special.....	1	.48
1012	91-84	Key, 1/4" - 1-1/2" lg. #24 Woodruff spec..	1	.20
	63-109	Sleeve, fan drive pulley.....	1	2.00

CRANKCASE GROUP 2
See illustration 2S-23C, 2S-24C

1075	4A100-145-2	Crankcase assembly, (optional) includes parts marked †.....	1	127.00
1075	2A100-145-2	†Crankcase assembly, (optional) includes studs.....	1	90.00
....	105-84	Stud, bearing cover, 7/16 x 1-13/16" lg...	6	.08
1077	105-84	Stud, bearing retainer, 7/16 x 1-13/16"	7	.08
1078	105-347	Stud, bearing retainer, 7/16 x 3-1/4" lg..	2	.18
1079	105-61	Stud, oil pan flange, 3/8 x 1-1/2" lg.....	13	.08
....	105-68	Stud, breather body, 5/16 x 1-1/8" lg.....	4	.08
1081	105-206	Stud, fan bracket, 5/8 x 2-1/8" lg.....	2	.10
1082	105-206	Stud, cylinder flange, 5/8 x 2-1/8" lg.....	12	.10
1083	105-84	Stud, clutch housing, 7/16 x 1-13/16" lg..	8	.08
1085	31-233-1	†Bearing retainer.....	1	14.50
1087	16-344	†Gasket, bearing retainer.....	1	.22
....	05-52	†Lockwasher, 7/16".....	7	.01
....	04-604	†Nut, 7/16" - 20 hex.....	7	.02
1089	22-109	†Shim, bearing cover, .005" thick.....	3	.12
1090	22-144	†Shim, bearing cover, .007" thick.....	3	.16
1091	22-111	†Shim, bearing cover, .020" thick.....	3	.30
1092	14-739	†Bearing cover.....	1	8.00
1093	125-59-1	†Oil seal, 2-3/4" I.D.....	1	1.20
....	05-52	†Lockwasher, 7/16".....	6	.01
....	04-604	†Nut, 7/16" - 20 hex.....	6	.02
....	010-306	†Dowel pin, #5 taper x 1", threaded.....	2	.06
....	04-101	†Nut, 1/4" - 20 hex.....	2	.01
1094	38-274	†Plate, oil baffle, H.P. cylinder.....	1	1.00
1095	38-275	†Plate, oil baffle, L.P. cylinder....	2	1.00
1096	106-226	†Capscrew, special, 1/4 - 20 x 1/2" hex.....	12	.16
....	61-44	†Wire, locking, #18 ga., 14" lg. B.S. annealed iron wire.....	6	.04
1097	49-10	Tube, breather, 1-3/8" x 8.....	1	.50
1098	2A49-8	Breather tube body assembly, includes next two items.....	1	1.50
1102	24-53	Spring, breather valve.....	1	.06
1103	A15-10	Breather valve assembly.....	1	.15
1110	13-267	Body, breather.....	1	2.80
1111	49-46	Tube, dipstick.....	1	1.30
1112	16-616	Gasket, oreather body.....	1	.06

CRANKCASE GROUP (CONT'D)

REF. No.	PART No.	NAME AND DESCRIPTION	QUAN.	PRICE EACH
....	05-50	Lockwasher, 5/16".....	4	\$.01
....	04-102	Nut, 5/16" - 18 hex.....	4	.02
....	62-88	Name plate, serial number.....	1	.30
....	62-87	Plate, compr. instruction.....	1	.60
....	03-2001	Screw, Parker Kalon, #2 x 3/16" type U.....	8	.02

CONNECTING ROD GROUP 3

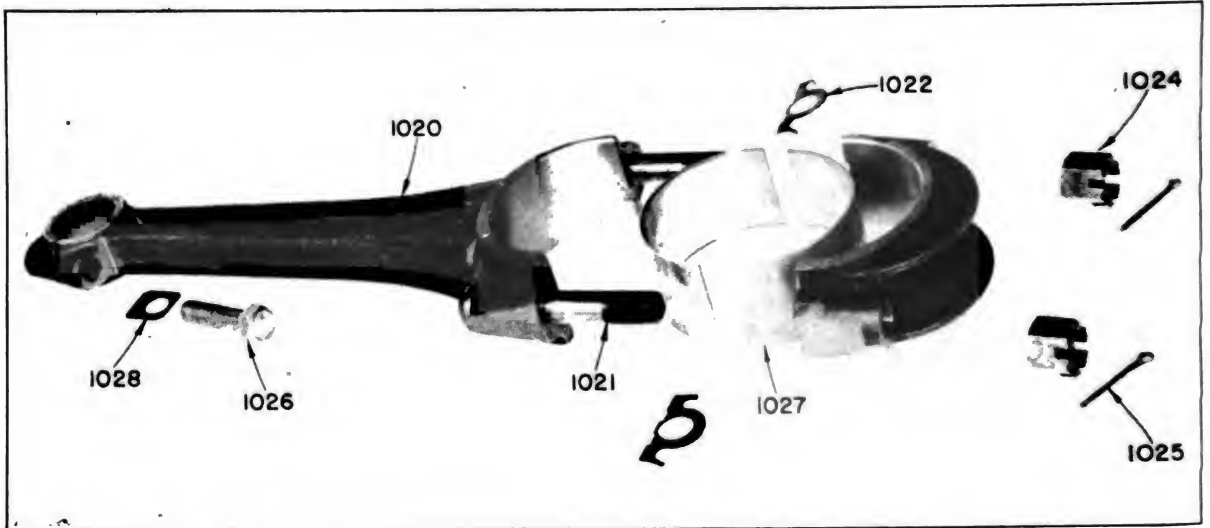

Unnumbered parts are identical to corresponding numbered parts

REF. No.	PART No.	NAME AND DESCRIPTION	QUAN.	PRICE EACH
1020	A7-48	Connecting rod assy., (optional) includes parts marked *.....	3	20.00
1020	1A7-48	*Connecting rod assy., (optional) includes bolts, shims, and nuts.....	3	17.00
1021	B35-3	Bolt, 5/8" - 18 x 3-3/4" (special).....	6	.40
1022	22-123	Shim, laminated, .012" thick.....	6	.10
1024	B53-26	Nut, 5/8" - 18, special hex.....	6	.08
1027	21-212	*Bearing shell, one half.....	6	.80
1025	07-43	*Cotter pin, 1/8" x 1-1/2".....	6	.01
1026	02-573	*Capscrew, 1/2" - 20 x 2", hex.....	3	.10
1028	20-223-1	*Lockwasher, 1/2" special.....	3	.06

PARTS LIST

PISTON GROUP 4

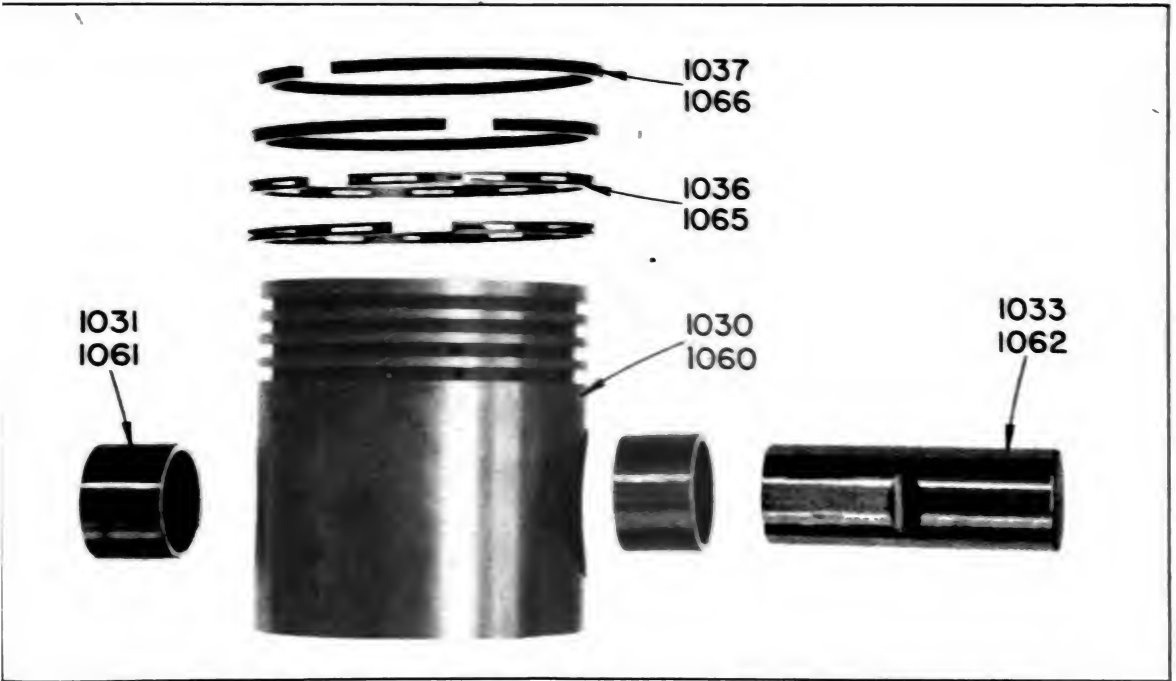

Unnumbered parts are identical to corresponding numbered parts

REF. No.	PART No.	NAME AND DESCRIPTION	QUAN.	PRICE EACH
1030	1A8-169	Piston assembly, includes bushings and pin, 5-3/4" dia. - low pressure cylinder	2	10.40
1031	21-329	Bushing, piston pin.....	4	.40
1033	17-270	Pin, piston, 1-1/2 x 5-1/4".....	2	1.80
1036	18-148	Ring, oil, PC #85, 5-3/4 x 3/16".....	4	1.40
1037	18-147	Ring, compression, PC #70, 5-3/4 x 3/16"	4	.75
1060	1A8-142	Piston assembly, includes bushings and pin, 5" dia. - high pressure cylinder.....	1	10.40
1061	21-330	Bushing, piston pin.....	2	.40
1062	17-280	Pin, piston, 1-1/2 x 4-5/16".....	1	2.40
1065	18-236	Ring, oil, PC #85, 5 x 3/16".....	2	1.00
1066	18-180	Ring, compression, PC #70, 5 x 3/16".....	2	.60

CYLINDER GROUP 5

See illustration 2S-23C, 2S-24C

1210	A1-273	Cylinder assembly, includes studs, 5-3/4" bore, low pressure.....	2	28.00
1211	105-253	Stud, cylinder head, 5/8 x 5-1/2".....	8	.32
1230	A1-224	Cylinder assembly, includes studs, 5" bore, high pressure.....	1	26.00
1231	105-253	Stud, cylinder head, 5/8 x 5-1/2".....	4	.32
1240	16-518	Gasket, cylinder flange, .015" thick.....	6	.08
1241	16-519	Gasket, cylinder flange, .010" thick.....	6	.08
....	B20-2	Washer, plain, 5/8".....	12	.02
....	04-607	Nut, 5/8" - 18 hex.....	12	

CYLINDER HEAD GROUP 6

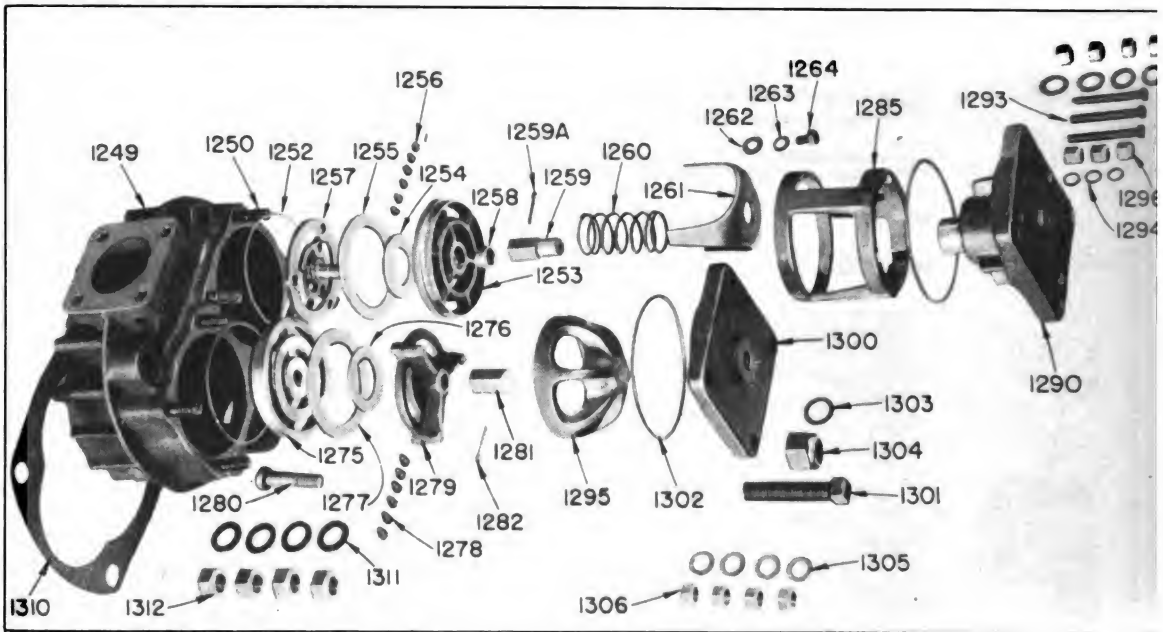

Unnumbered parts are identical to corresponding numbered parts

REF. No.	PART No.	NAME AND DESCRIPTION	QUAN.	PRICE EACH
1249	A2-198-1	Cylinder head assembly, (optional), for high and low pressure cylinder, includes Studs #105-84.....	3	\$ 15.00
1249	1A2-198-1	Cylinder head assembly, (optional), for high and low pressure cylinder, includes parts marked ⊕.....	3	56.00
1250	105-84	⊕Stud, valve cover, 7/16 x 1-13/16".....	24	.08
1252	16-744	⊕Gasket, suction and discharge valve.....	6	.14
	A15-325	⊕Suction valve seat assembly, includes next 13 items.....	3	14.00
1253	15-325	Seat, suction valve.....	3	4.60
1254	R15-7	Valve, small suction.....	3	.75
1255	R15-8	Valve, large suction.....	3	1.50
1256	R24-1	Spring, valve.....	18	.08
1257	R15-18-1	Bumper, suction valve.....	3	4.60
1258	66-509	Spacer, for special nut.....	3	.30
1259	53-215	Nut, special.....	3	.30
1259A	07-25	Cotter pin, for nut, 3/32 x 1-1/4".....	3	.01
1260	R24-2	Spring, unloader push rod.....	3	.08
1261	R99-2	Rod, unloader push.....	3	.40
1262	06-2	Washer, plain, 1/4".....	3	.01
1263	05-50	Lockwasher, 5/16".....	3	.01
1264	02-16	Capscrew, hex. 5/16 - 18 x 1/2" lg.....	3	.04
....	2A15-325	⊕Discharge valve seat assembly, includes next 8 items.....	3	12.00
1275	15-325	Discharge valve seat.....	3	4.60
1276	R15-7	Valve, small discharge.....	3	.75
1277	R15-8	Valve, large discharge.....	3	1.50
1278	R24-1	Spring, valve.....	18	.08
1279	15-336	Bumper, discharge valve.....	3	3.60

PARTS LIST

REF. No.	PART No.	NAME AND DESCRIPTION	QUAN.	PRICE EACH
1280	34-168	Bolt, discharge valve seat.....	3	\$.20
1281	R53-3	Nut, special, for bolt.....	3	.20
1282	07-25	Cotter pin, 3/32 x 1-1/4".....	3	.01
1285	83-21	⊕Clamp, suction valve assembly.....	3	3.00
1290	A14-794	⊕Suction valve cover assembly.....	3	3.00
1293	014-222	⊕Setscrew, oval point, 5/16 - 18 x 2".....	9	.05
1294	20-368	⊕Washer, copper, 5/16".....	9	.04
1296	04-1302	⊕Nut, elastic stop, 5/16" - 18.....	9	.08
1295	83-58	⊕Clamp, discharge valve.....	3	1.00
1300	14-649	⊕Cover, discharge valve.....	3	3.80
1301	014-296	⊕Setscrew, oval point, 5/8 - 11 x 2-3/4"lg.	3	.18
1303	20-367	⊕Washer, copper, 5/8".....	3	.04
1304	04-1307	⊕Nut, elastic stop, 5/8" - 11.....	3	.30
1302	16-745	⊕Gasket, suction and discharge valve cover	6	.30
1305	20-139	Washer, plain, 7/16".....	24	.04
1306	04-604	Nut, hex. 7/16" - 20.....	24	.02
1310	16-801	Gasket, cylinder head, service packing.....	3	.40
1311	B20-2	Washer, plain, 5/8".....	12	.02
1312	04-607	Nut, hex. 5/8" - 18.....	12	.04

AIR CLEANER GROUP 7

1324	65-503	Connection, air cleaner (carburetor side)	1	3.20
1324	65-504	Connection, air cleaner (magneto side).....	1	3.20
....	16-640	Gasket, for cleaner connection flange.....	2	.10
....	05-53	Lockwasher, 1/2" dia.....	6	.01
....	02-70	Capscrew, hex. 1/2 - 13 x 1-1/4".....	6	.04
1336	16-627	Gasket, air cleaner base.....	2	.08
1326	A77-166	Air cleaner, oil bath. Air Maze V31-OB.....	2	10.50

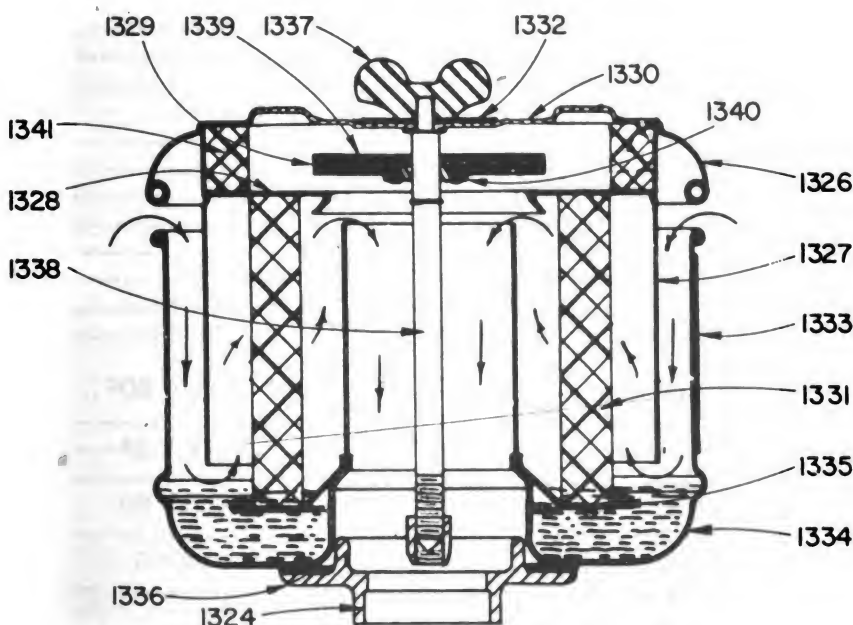

AIR-MAZE MODEL V31-OB AIR CLEANER

AIR CLEANER GROUP 7

REF. No.	AIR-MAZE PART No.	NAME AND DESCRIPTION	QUAN.	PRICE EACH
1326	AN-V1138	Complete upper assembly, includes parts marked ↓	2	\$ 7.50
1327	AN-V63	↓ Perforated skirt	2	1.40
1328	AN-V61	↓ Metal valve seat	2	.50
1329	AN-V62	↓ Relief valve..leather	2	1.25
1330	AN-V51	↓ Top	2	1.00
1331	AN-18	↓ Filter element	2	2.25
1332	AN-3	↓ Name plate only	2	.10
1333	AN-4	Decalcomania	2	.10
1334	AN-V13	Bowl	2	1.25
1335	AN-17	Baffle plate	2	.25
1337	AN-15	↓ Wing nut	2	.50
1338	AN-V16	↓ Stem	2	.25
1339	AN-V10	↓ Felt relief valve cushion	2	.25
1340	AN-V11	↓ Felt valve washer only	2	.25
1341	AN-V12	↓ Auxillary screen	2	.75

LUBRICATION GROUP 8

See Illustration No. 2S-23C

1120	A13-350-1	Body, oil pump, includes #A34-212 and B16-117	1	12.00
1121	A25-81	Oil pump plunger assembly	1	4.00
1130	7-42	Rod, oil pump connection	1	3.00
1131	17-235	Wrist pin, oil pump	1	.20
1132	16-418	Gasket, body to bearing retainer	1	.12
....	05-52	Lockwasher, 7/16"	8	.01
....	04-604	Nut, hex. 7/16" - 20	2	.02
....	02-55	Capscrew, 7/16 - 14 x 1-1/4"	5	.04
....	02-58	Capscrew, 7/16 - 14 x 2", hex.	1	.06
....	010-306	Dowel pin, #5 taper x 1" threaded	2	.06
....	04-101	Nut, hex. 1/4" - 20	2	.01
1133	125-58-1	Oil seal, 2-1/2" I.D.	1	1.00
1135	A13-349	Check valve assembly	1	2.40
1139	65-395	Connection, body to oil pan	1	3.00
1140	16-419	Gasket, check valve body	1	.04
1141	16-419-1	Gasket, connection	2	.04
....	05-50	Lockwasher, 5/16"	4	.01
....	02-21	Capscrew, 5/16 - 18 x 1-1/4", hex.	2	.04
....	02-20	Capscrew, hex. 5/16 - 18 x 1"	2	.04
1142	A60-43-27	Dipstick, oil level	1	.50
1145	A34-212	Oil pressure relief screw assembly	1	1.90
1150	B16-117	Gasket, for oil pressure relief screw	1	.04
....	55-29-34	Tubing, copper, 1/4" x 57", to gauge	1	.36
....	A182-33	Connector, elbow, 1/4" x 1/8" MPT x 90°, pump	1	.25
....	A182-13	Connector, str. 1/4" x 1/8" MPT, gauge	1	.20
....	60-82-1	Gauge, oil pressure	1	2.00
....	83-34	Clamp, tube, 3-1/4" tubes, fastened on compr. hold down stud	1	.12
....	83-97	Clamp, tube, 3/16" fastened to clutch hsg. bolt	1	.04

PARTS LIST

OIL PAN GROUP 9

REF. No.	PART No.	NAME AND DESCRIPTION	QUAN.	PRICE EACH
1470	A3-188-1	Oil bottom assembly, includes #105-29.....	1	8.60
1471	105-29	Stud, screen, 5/16 x 2-1/4" lg.....	1	.08
1480	66-224	Spacer, screen, 1-5/16" lg.....	1	.25
....	06-3	Washer, plain, 5/16".....	2	.01
....	04-102	Nut, hex. 5/16" - 18.....	1	.02
1481	43-48	Oil screen.....	1	.90
1482	16-605	Gasket, oil bottom.....	1	.20
....	04-603	Nut, hex. 3/8" - 24.....	13	.01
....	05-51	Lockwasher, 3/8".....	13	.01
....	013-115	Nipple, pipe, 1/2 x 4".....	1	.10
....	013-704	Coupling, 1/2", pipe.....	1	.16
....	011-4	Plug, pipe, 1/2".....	1	.02

FAN GROUP 10

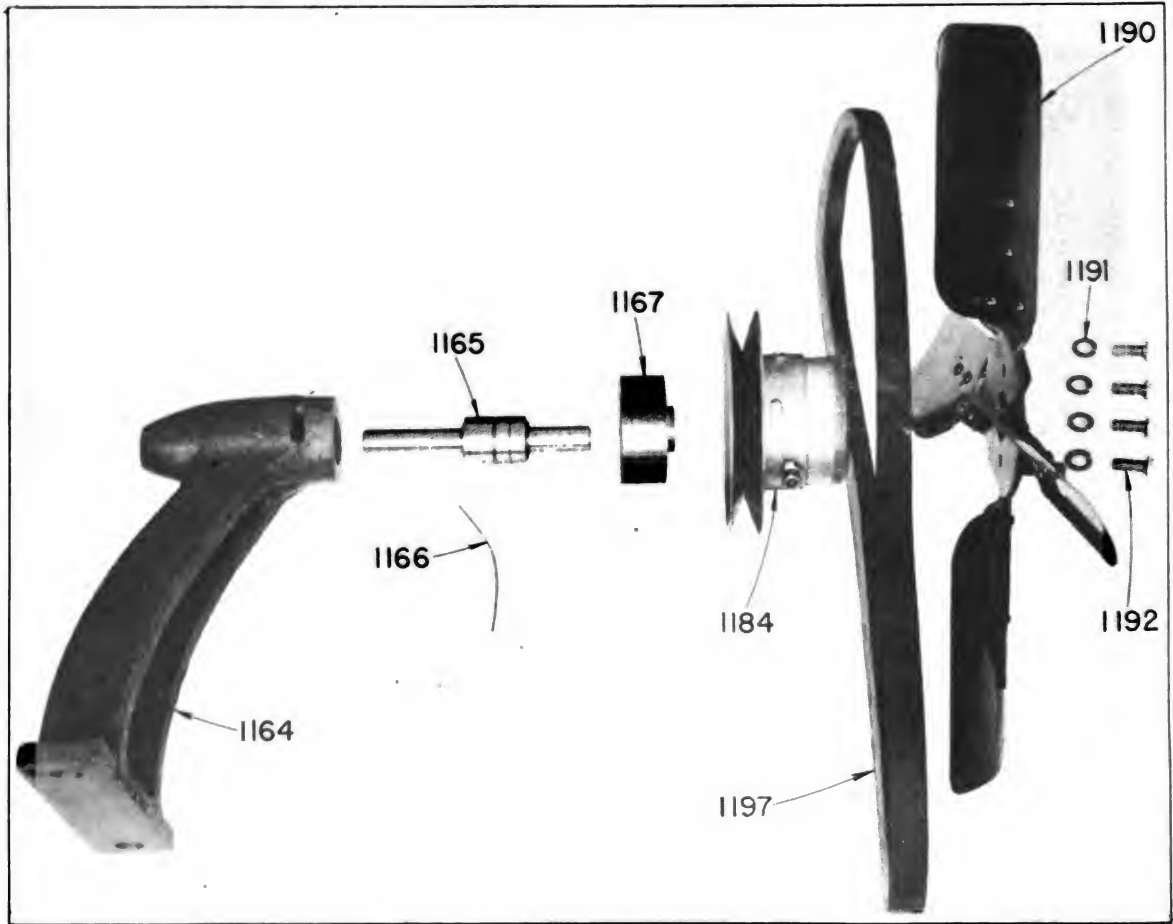

Unnumbered parts are identical to corresponding numbered parts

REF. No.	PART No.	NAME AND DESCRIPTION	QUAN.	PRICE EACH
....	1A39-1214	Fan bracket assembly, includes parts A to B.....	1	10.40
1164	39-1214	Fan bracket.....A	1	5.00
1165	1A181-161	Fan shaft and bearing, includes fan hub.	1	5.25
1167	132-99	Fan hub.....	1	2.00
1166	61-418	Wire, locking, #15 US gauge, .055" x 4".... lg. spring steel wire.....B	1	.02
1184	1A36-249	Pulley assembly.....	1	1.60
1190	42-109	Fan.....	1	3.50
1191	05-50	Lockwasher, 5/16".....	4	.01
1192	02-18	Capscrew, 5/16 - 18 x 3/4".....	4	.04
1197	41-143	Fan belt.....	1	2.90
....	B20-42	Washer, 5/8" plain.....	2	.04
....	04-607	Nut, for fan bracket stud, 5/8" - 18 hex..	2	.04

PARTS LIST

MAGNETO GROUP 1

REF. No.	PART No.	NAME AND DESCRIPTION	QUAN.	PRICE EACH
350	A85-126-1	Magneto, fixed spark, American Bosch MJC4	1	\$ 40.75
...	06-4	Washer, 3/8" plain.....	2	.01
...	05-51	Lockwasher, 3/8".....	2	.01
...	02-37	Capscrew, 3/8" - 16 x 1-1/4" hex.....	2	.04
351	39-1255-2	Bracket, ignition wire.....	1	.20
352	150-1	Grommet for bracket.....	1	.04
...	04-103	Nut, 3/8" - 16 hex.....	1	.02
...	05-51	Lockwasher, 3/8".....	1	.01
...	3A61-1-3	Spark plug wire assembly to #1 cylinder....	1	.36
...	5A61-1-15	Spark plug wire assembly to #2 cylinder....	1	.36
...	3A61-1-5	Spark plug wire assembly to #3 cylinder....	1	.36
...	3A61-1-12	Spark plug wire assembly to #4 cylinder....	1	.36
369	124-2	Insulator, spark plug.....	4	.16
370	86-9-5	Spark plug, 18 mm.....	4	.60
371	16-796	Gasket, spark plug, 18 mm.....	4	.01

ILL. No.	BOSCH No.	NAME AND DESCRIPTION	PRICE EACH
1	DP 52231	Distributor plate with observation window.....	\$ 3.50
2	WN 521	Observation window.....	.05
3	RG 5210	Ring for window.....	.05
4	GA 524	Gasket under distributor plate.....	.15
5	SC 1037 CA	Screw for fastening distributor plate.....	.05
6	WA 98922	Plain washer under fastening screw.....	.05
7	WA 5280	Sealing washer under fastening screw.....	.05
8	WA 288	Lock washer under fastening screw.....	.05
9	SC 1163	Magneto grounding screw and lock washer.....	.05
11	SD 5249	Rotor gear shaft.....	.10
12	SP 1021	Shaft spring ring - outside distributor plate..	.05
12	SP 5254	Shaft spring ring - gear end.....	.05
13	WA 1070	Rotor gear spacing washer.....	.05
14	GE 5282	Distributor gear.....	2.10
15	BR 529	Carbon brush and spring in distributor gear....	.25
16	WA 528	Distributor gear spacing washer.....	.05
17	HG 5221	Magneto housing.....	9.50
18	PN 1001	Distributor plate locating pin.....	.05
19	PK 521	Leather oil seal - drive end.....	.40
20	WA 1071	Washer under oil seal.....	.05
21	CV 52126	Ventilator cover.....	.15
22	NP 5222	Name Plate.....	.10
23	SC 1152	Ventilator cover fastening screw and lock washer.....	.05
25	GA 5215	Gasket under ventilator cover.....	.05
26	WA 5281	Washer under ventilator cover.....	.05
27	NP 521	Name plate for type designation.....	.10
28	SC 121-4 CA	Screw for fastening name plate.....	.05
29	GE 5238	Rotor gear.....	.85
30	WA 81751	Rotor felt washer.....	.05
31	RT 5294	Magnet rotor.....	11.75
32	BB 60226	Ball bearing - either end.....	1.55
33	IS 504	Packing strip for ball bearing.....	.05
34	IS 222	Paper washer for ball bearing.....	.05
35	WA 61	Bearing shim (.0126" thick).....	.05
35	WA 106	Bearing shim (.0071" thick).....	.05

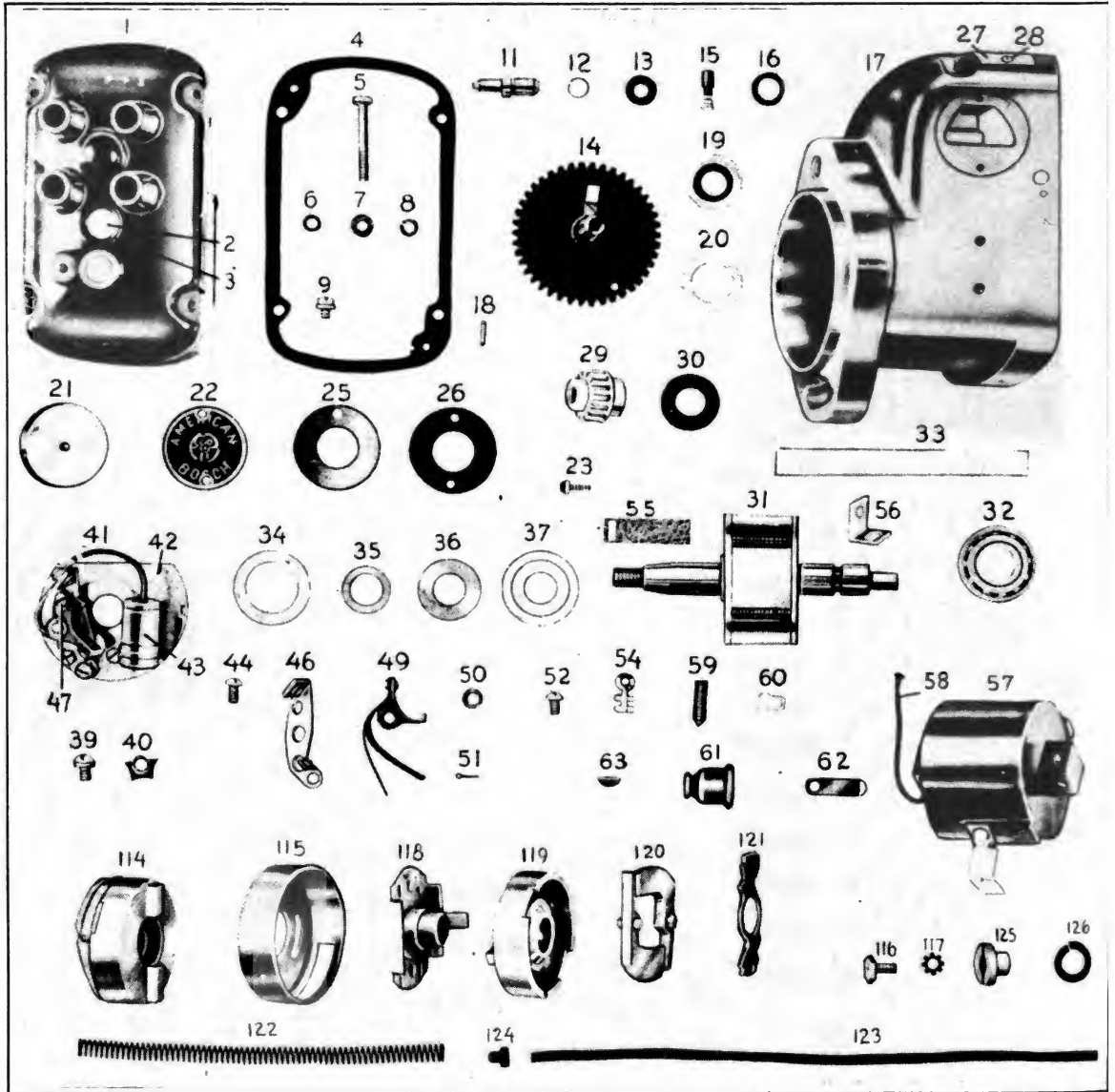

MAGNETO GROUP (CONT'D)

ILL. No.	BOSCH No.	NAME AND DESCRIPTION	PRICE EACH
35	WA 107	Bearing shim (.0040" thick).....	\$.05
35	WA 1009	Bearing shim (.0197" thick).....	.05
36	WA 1034	Bearing spacing washer.....	.05
37	WA 5245	Rotor felt retaining washer.....	.05
38	SC 1155	Interrupter bracket fastening screw and lock washer.....	.05
40	PL 52125	Locking plate.....	.05
41	BK 5263	Interrupter assembly with one tungsten and one platinum point - for MJC 4C 334.....	9.25
42	BK 5259	Interrupter bracket with riveted parts only....	1.30
43	CW 5232	Condenser.....	.70
44	SC 1161	Fastening screw and lock washer for condenser and cam oiler wick retaining bracket.....	.05

PARTS LIST

MAGNETO GROUP (CONT'D)

ILL No.	BOSCH No.	NAME AND DESCRIPTION	PRICE EACH
46	127-8	Contact bracket with platinum point - for MJC 4C 334..... 1	4.75
47	SC 1150	Fastening screw and lock washer for contact bracket..... 1	.05
49	127-9	Interrupter lever with tungsten point - for MJC 4C 334..... 1	.60
50	WA 1012	Plain washer for lever stud..... 1	.05
51	PN 1007	Interrupter lever cotter pin..... 1	.05
52	SC 1151	Conducting lead fastening screw and lock washer..... 1	.05
54	EC 1012	Terminal clip for cable..... 1	.05
55	WK 5231	Cam oiler wick..... 1	.05
56	BK 5283	Cam oiler wick retaining bracket..... 1	.05
57	CL 5238	High-tension coil..... 1	5.15
58	KL 100657	Coil cable..... 1	.05
59	SC 1060	Lock screw for mounting coil..... 2	.05
60	FP 81953	Clip for distributor plate cable..... 1	.05
61	IS 82927	Rubber insulation nipple..... 4	.05
62	GG 522	Gauge for contact point setting..... 1	.05
63	KY 1004	Woodruff key..... 1	.05
114	HG 73118	Impulse member assembly - for clockwise rotation..... 1	6.25
115	PL 9365	Arrester plate..... 1	1.25
116	SC 732	Arrester plate fastening screw..... 4	.10
117	WA 1116	Lockwasher for fastening screw..... 4	.05
118	HB 7328	Coupling plate and hub assembly..... 1	1.50
119	HG 73120	Housing - for clockwise rotation..... 1	2.60
120	SA 65972	Weights..... 2	.50
121	CA 739	Cam..... 1	.50
122	SP 736	Spiral spring..... 1	.75
123	PK 734	Felt wick for spring..... 1	.05
124	PN 731	Pin for spring..... 2	.05
125	NT 731	Round nut for rotor shaft..... 1	.25
126	WA 5-16	Lock washer under nut..... 1	.05

STARTING MOTOR GROUP 2

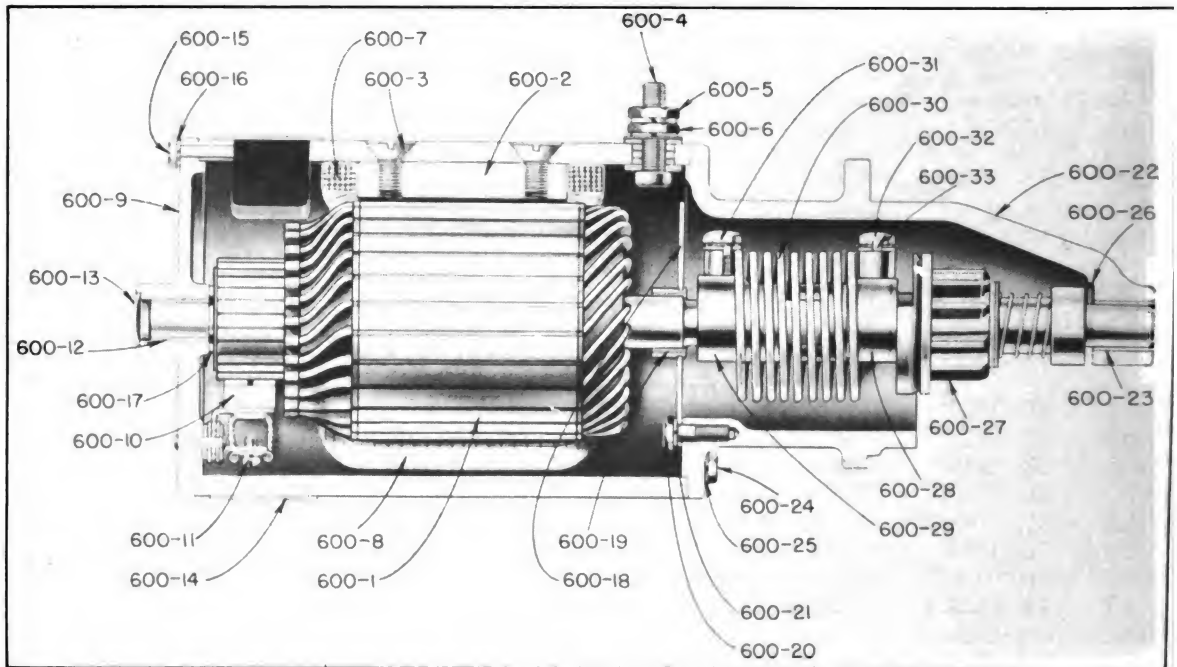

Unnumbered parts are identical to corresponding numbered parts

REF. No.	PART No.	NAME AND DESCRIPTION	QUAN.	PRICE EACH
600	A107-93	Starting motor assembly (6 volt).....	1	\$ 36.00
....	05-51	Lockwasher, 3/8".....	3	.01
....	02-36	Capscrew, hex. 3/8" - 16 x 1".....	3	.04
601	A76-49	Magnetic switch assembly (6 volt).....	1	2.50
....	05-49	Lockwasher, 1/4".....	2	.01
....	02-2	Capscrew, hex. 1/4" - 20 x 1/2".....	2	.02

REF. No.	DELCO-REMY PART No.	NAME AND DESCRIPTION	QUAN.	PRICE EACH
600-1	37895	Armature.....	1	16.50
600-2	36497	Pole shoe.....	6	.75
600-3	828675	Pole shoe screw.....	12	.05
600-4	826938	Terminal stud.....	1	.10
....	1861076	Terminal stud Ins. washer (3/4 O.D.).....	2	.01
....	809051	Terminal stud Ins. washer (9/16 O.D.).....	3	.05
....	805790	Terminal stud plain washer.....	1	.01
....	110730	Terminal stud lockwasher.....	2	.01
600-5	805258	Terminal stud nut (5/32 thk).....	1	.05
600-6	134569	Terminal stud nut (1/4 thk).....	1	.05
600-7	16819	Field coil (R.H.).....	1	1.80
....	16820	Field coil (L.H.).....	1	1.80
600-8	16818	Field coil (Lower).....	1	1.80
....	33345	Field coil Ins. strip.....	1	.05
600-9	38290	Commutator end frame.....	1	6.00
600-10	16083	Brush.....	6	.30
....	34846	Brush spring.....	6	.10
600-11	115607	Brush lead attaching screw.....	6	.01
....	106496	Brush lead attaching screw lockwasher.....	6	.01

PARTS LIST

STARTING MOTOR GROUP (CONT'D)

REF. No.	DELCO-REMY PART No.	NAME AND DESCRIPTION	QUAN.	PRICE EACH
600-12	38296	Bushing (C.E.).....	1	.10
600-13	810819	End plug (C.E.).....	1	.05
600-14	1880355	Cover band.....	1	.65
....	132929	Cover band screw.....	1	.02
....	103088	Cover band screw nut.....	1	.02
600-15	37872	C. E. Frame attaching screw.....	6	.05
600-16	106497	C. E. Frame attaching screw lockwasher.....	6	.01
600-17	1838568	Space washer (C.E.).....	1	.05
600-18	16199	Center bearing plate.....	1	.75
600-19	820148	Center bearing bushing.....	1	.25
600-20	828483	Center bearing attaching screw.....	2	.10
600-21	103319	Center bearing attaching screw lockwasher	2	.01
600-22	16999	Motor drive housing.....	1	7.50
600-23	810620	Motor drive housing bushing.....	1	.10
600-24	37872	Motor drive housing attaching screw.....	6	.05
600-25	106497	Motor drive housing attaching screw lock- washer.....	6	.01
600-26	833602	Space washer (D.E.).....	1	.05
....	124546	Woodruff Key.....	1	.05
....	1861363	Motor drive assembly.....	1	5.50
600-27	1859720	Gear & shaft assembly.....	1	3.90
600-28	1849782	Service sleeve.....	1	.30
600-29	1848530	Drive head.....	1	.40
600-30	1850812	Drive spring.....	1	.55
600-31	1850811	Head spring screw.....	1	.08
600-32	1850810	Shaft spring screw.....	1	.07
600-33	805057	Lockwasher.....	2	.01
....	1861234	Take-up ring.....	1	.02

GENERATOR GROUP 3

REF. No.	LE ROI PART No.	NAME AND DESCRIPTION	QUAN.	PRICE EACH
602	A108-85	Generator and Regulator Assy., 6 Volt.....	1	\$ 22.50
603	40-1314	Bracket for generator.....	1	.60
....	05-51	Lockwasher, 3/8".....	2	.01
....	02-34	Capscrew, 3/8" - 16 x 3/4", hex.....	2	.04
....	02-20	Capscrew, 5/16" - 18 x 1", hex.....	2	.04
....	02-50	Lockwasher, 5/16".....	2	.01
....	04-102	Nut, For #02-20, 5/16" - 18, hex.....	2	.02

REF. No.	DELCO-REMY PART No.	NAME AND DESCRIPTION	QUAN.	PRICE EACH
602-1	1841027	Armature.....	1	6.50
602-2	816331	Pole shoe.....	2	.50
602-3	828675	Pole shoe screw.....	2	.05
602-4	1858754	Terminal stud & lead assembly.....	1	.10
....	1858749	Terminal stud.....	1	.10
....	1858753	Terminal stud Ins. washer.....	2	.02
....	1858752	Terminal stud plain washer.....	2	

GENERATOR GROUP (CONT'D)

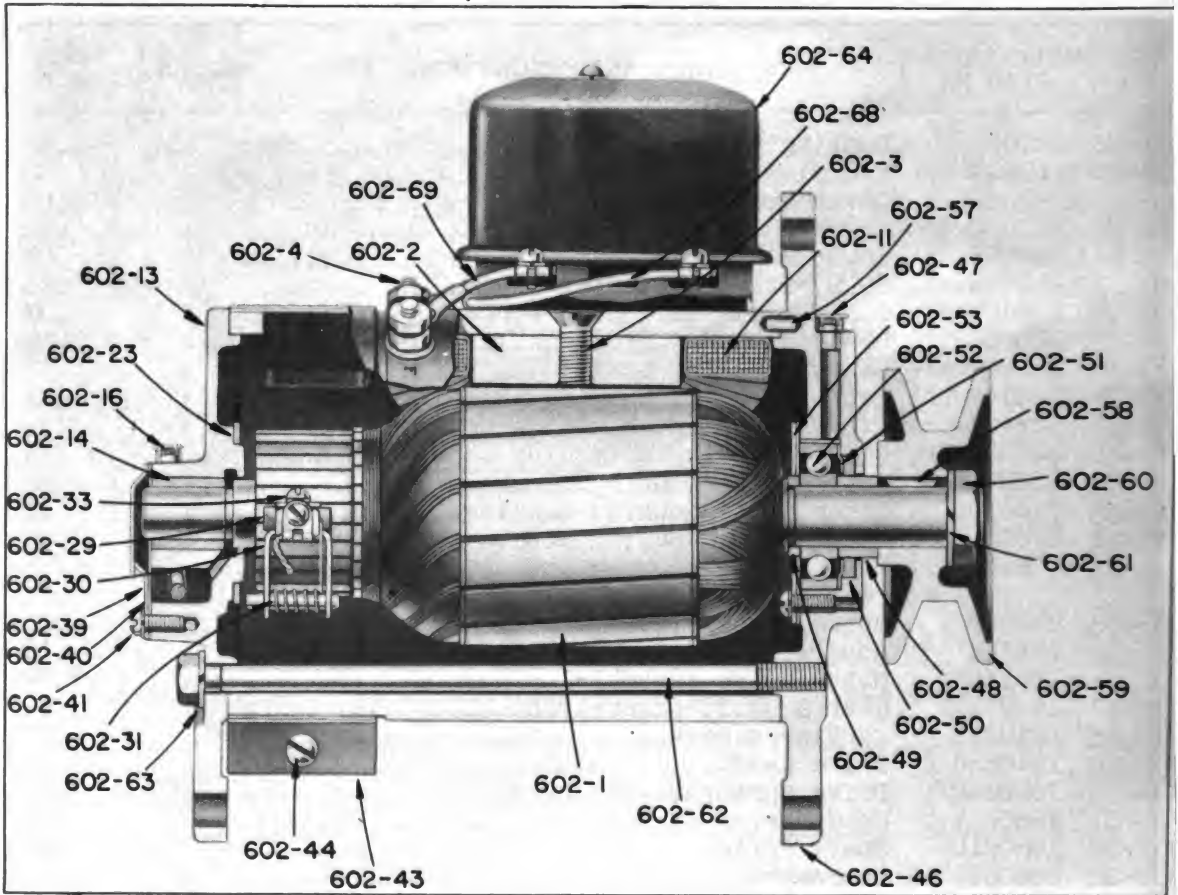

Unnumbered parts are identical to corresponding numbered parts

REF. No.	DELCO-REMY PART No.	NAME AND DESCRIPTION	QUAN.	PRICE EACH
....	802757	Terminal stud lock washer.....	4	.01
....	121743	Terminal stud nut.....	4	.05
....	1857107	Terminal clip (To brush).....	2	.01
602-11	1838576	Field coil (R.H.).....	1	1.00
602-11	1879441	Field coil (L.H.).....	1	1.00
602-13	817216	Commutator end frame.....	1	1.25
602-14	812823	Bushing (C.E.).....	1	.20
....	809062	Dowel pin (C.E.).....	1	.05
602-16	1880635	Oiler (C.E.).....	1	.05
....	804076	Oil wick (C.E.).....	1	.05
....	816315	Oil hole plug (C.E.).....	1	.05
....	817313	Brush holder hinge pin.....	1	.05
....	817314	Brush holder stop pin.....	1	.10
....	812016	Brush holder hinge pin & Ins.....	1	.10
....	812015	Brush holder stop pin & Ins.....	1	.10
....	809698	Third brush plate.....	1	.30
....	817532	Third brush plate clamp.....	1	.05
....	141543	Third brush plate clamp screw.....	1	.01
....	106497	Third brush plate clamp screw lockwasher..	1	.01
....	809824	Third brush plate spring washer.....	1	.05
....	809614	Third brush plate spring washer pin.....	1	.05

PARTS LIST

GENERATOR GROUP (Cont'd)

REF. No.	DELCO-REMY PART No.	NAME AND DESCRIPTION	QUAN.	PRICE EACH
602-29	820517	Brush.....	3	\$.10
602-30	809642	Brush holder.....	3	.10
602-31	809644	Brush spring (3rd & ground).....	2	.05
....	809658	Brush spring (Ins. main).....	1	.05
602-33	1862803	Brush attaching screw.....	3	.01
....	106495	Brush attaching screw lockwasher.....	3	.01
....	809551	Brush attaching screw plain washer.....	3	.05
....	809688	Brush ground lead.....	1	.10
....	141540	Brush lead attaching screw.....	2	.01
....	802730	Brush lead attaching screw lockwasher.....	2	.01
602-39	820524	End cover plate (C.E.).....	1	.05
602-40	817220	End cover plate gasket (C.E.).....	1	.05
602-41	1888975	End cover plate screw (C.E.).....	3	.01
....	106496	End cover plate screw lockwasher (C.E.)....	3	.01
602-43	1872638	Cover band.....	1	.50
602-44	107728	Cover band screw.....	1	.05
....	103088	Cover band screw nut.....		.02
602-46	817223	Drive end frame.....	1	1.00
602-47	1880635	Oiler (D.E.).....	1	.05
602-48	817224	Space collar (Outside - D.E.).....	1	.10
602-49	809945	Space washer (Inside - D.E.).....	1	.05
602-50	809961	Felt washer (D.E.).....	1	.05
602-51	819104	Felt washer retainer plate (D.E.).....	1	.05
602-52	903203	Ball bearing (D.E.).....	1	1.15
602-53	1855702	Ball bearing retainer plate (D.E.).....	1	.10
....	1855701	Ball bearing retainer plate gasket (D.E.)	1	.05
....	1866970	Ball bearing retainer plate screw (D.E.)..	3	.01
....	802731	Ball bearing retainer plate screw lock- washer (D.E.).....	3	.01
602-57	809593	Dowel pin (D.E.).....	1	.05
602-58	124545	Woodruff key (D.E.).....	1	.05
602-59	1883223	Pulley.....	1	1.75
602-60	806915	Shaft nut (D.E.).....	1	.10
602-61	804000	Shaft nut lockwasher (D.E.).....	1	.05
602-62	815018	Thru bolt.....	2	.10
602-63	108579	Thru bolt lockwasher.....	2	.01
....	132900	Control unit mounting screw.....	2	.01
....	138479	Control unit mounting screw lockwasher.....	1	.01
....	1856056	Control unit mounting screw plain washer..	2	.01
602-68	1872924	Lead ("A" term. to control unit).....	1	.10
602-69	1877569	Lead ("F" to control unit).....	1	.10
602-64	5889	Control unit includes parts from A to B...	1	4.75
....	1865603	Cover..... A	1	.20
....	1871636	Cover gasket.....	1	.05
....	1865614	Cover screw.....	1	.05
....	1865616	Cover screw Ins. washer.....	1	.01
....	1869662	Relay armature.....	1	.25
....	141542	Relay armature attaching screw.....	2	.02
....	106495	Relay armature attaching screw L.W.....	2	.01
....	813157	Relay armature attaching screw washer (Inside).....	1	.01
....	1856614	Relay armature attaching screw washer (Outside).....	1	.02
....	1860809	Voltage reg. armature.....	1	.45

GENERATOR GROUP (Cont'd)

REF. No.	DELCO-REMY PART No.	NAME AND DESCRIPTION	QUAN.	PRICE EACH
....	1855733	Voltage reg. armature spring.....	1	\$.05
....	1853901	Voltage reg. armature attaching screw.....	2	.01
....	20793	Voltage reg. armature attaching screw L.W.....	2	.01
....	814627	Voltage reg. armature attaching screw plain washer.....	2	.01
....	1859967	Regulator armature lead (To Resistance)....	1	.10
....	1860286	Resistance.....	1	.10
....	141542	Resistance attaching screw.....	2	.02
....	106495	Resistance attaching screw lockwasher.....	2	.01
....	1881998	Terminal screw.....	3	.01
....	802729	Terminal screw lockwasher.....	3	.01

CABLES AND WIRES GROUP 4

PART No.	NAME AND DESCRIPTION	QUAN.	PRICE EACH
A61-416-4	Wire assembly, #10 x 54 lg., generator to charge post on ammeter.....	1	\$.40
A61-416-8	Wire assembly, #10 x 21 lg., D on ammeter to magnetic switch.....	1	.18
A76-40	Starting switch.....	1	.90
A61-416-7	Wire assembly, #10, x 4" lg., D on ammeter to starting switch.....	1	.04
A61-416-6	Wire assembly, #10 x 21" lg., starting switch to magnetic switch.....	1	.16
A76-42	Magneto switch.....	1	.90
A61-416-5	Wire assembly, #10 x 41" lg., magneto switch to magneto.....	1	.30
A61-107-4	Cable, starter, 10" centers, magnetic switch to starter.....	1	.40
A61-107-3	Cable, starter, 8-1/2" centers, magnetic switch to minus post on battery.....	1	.30
A61-419	Cable, battery ground, 13" centers.....	1	.50
55-653	Conduit for wires.....	1	.80
83-38	Clamp, tube, for conduit.....	2	.10
02-33	Capscrew, hex. 3/8 - 16 x 5/8".....	1	.04
02-32	Capscrew, hex. 3/8 - 16 x 1/2".....	1	.04
05-51	Lockwasher, 3/8".....	2	.01

BATTERY GROUP 5

A117-49	Battery, 6 volt Globe #134 (Wet Charge)....	1	14.95
A117-49-1	Battery, 6 volt Globe #134 (Dry Charge)....	1	16.95
105-323	Stud for battery cover, 1/2" x 11-1/8".....	2	1.50
05-53	Lockwasher, 1/2".....	4	.01
04-105	Nut, hex. 1/2" - 13.....	4	.02
14-797	Battery cover.....	1	1.70
04-1004	Nut, wing, 1/2" - 13.....	2	.12

PARTS LIST

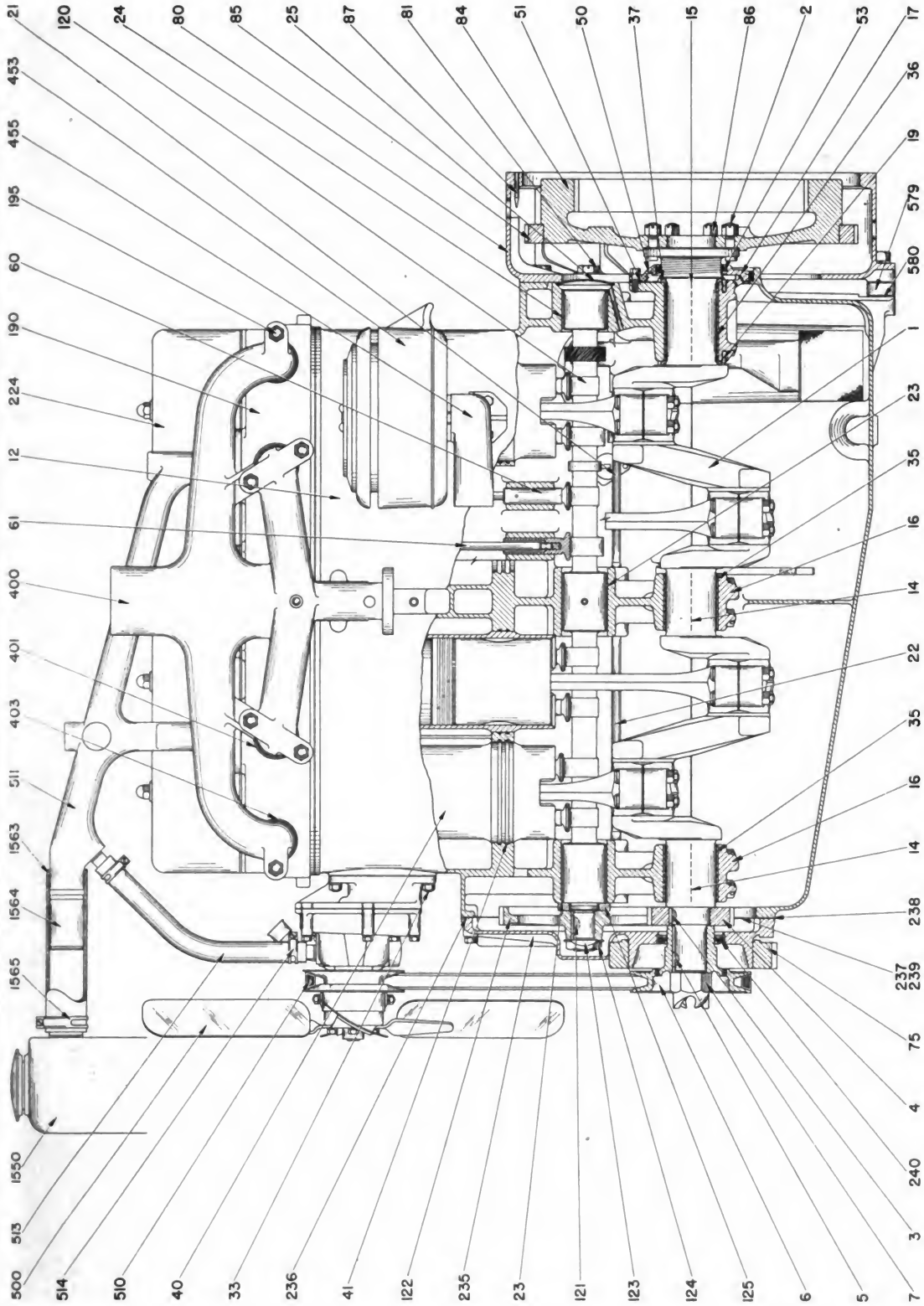

LONGITUDINAL SECTION THRU ENGINE

PLATE D318-11

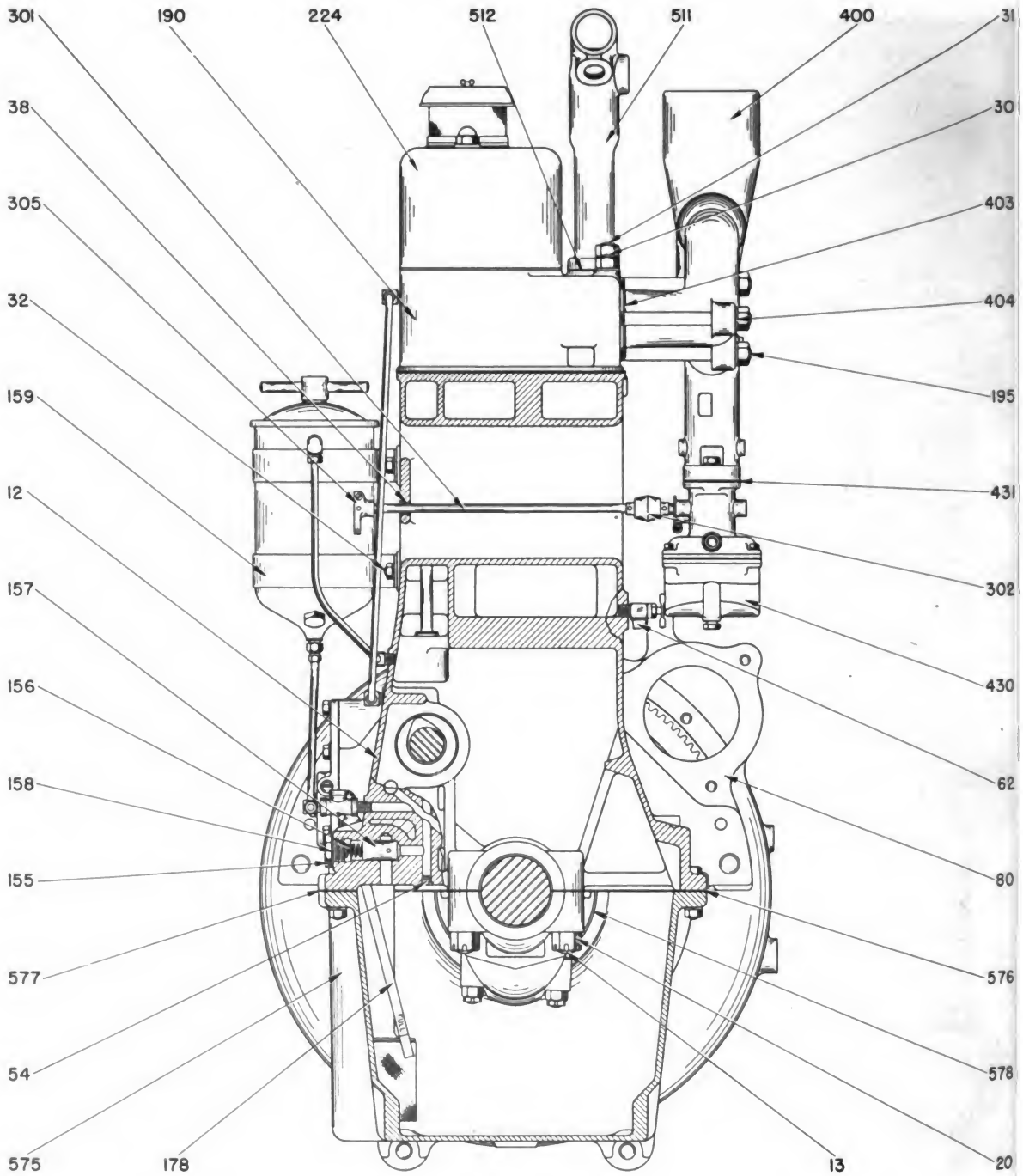

GROSS SECTION THRU ENGINE

PLATE D318-12

PARTS LIST

CRANKSHAFT GROUP 1

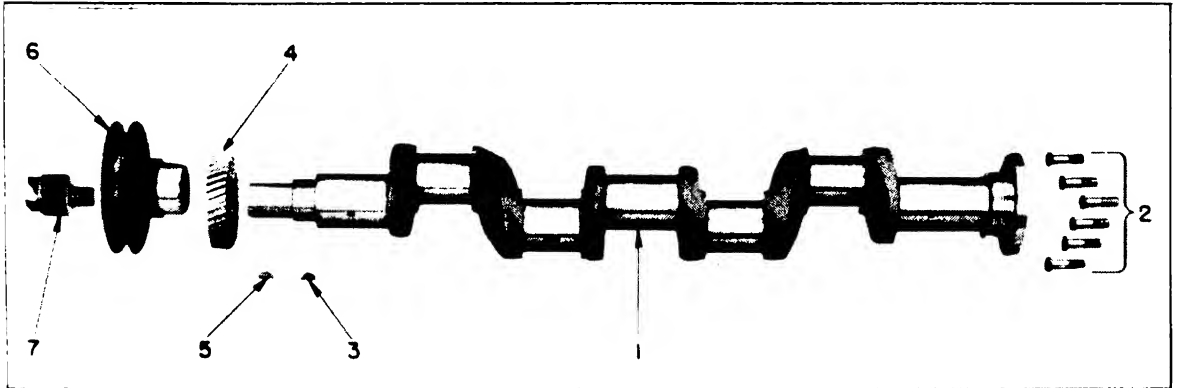

REF. No.	PART No.	NAME AND DESCRIPTION	QUAN.	PRICE EACH
1	1A5-282	Crankshaft, includes parts marked ●.....	1	\$ 123.00
2	34-122	●Bolt, crankshaft flange, 1/2 x 1-3/4".....	6	.50
3	09-15	●Key, crankshaft gear, Woodruff #A.....	1	.02
4	26-325	●Crankshaft gear.....	1	8.00
5	09-15	Key, water pump drive pulley, Woodruff #A	1	.02
6	36-256	Pulley, water pump drive, 6-5/16" O.D. x 7/8".....	1	7.50
7	96-27	Cranking jaw.....	1	2.00
	B53-25	●Nut, for #34-122.....	6	.04

CRANKCASE GROUP 2

See illustrations D318-11 and D318-12

REF. No.	PART No.	NAME AND DESCRIPTION	QUAN.	PRICE EACH
12	6A100-149-2	Crankcase assy. (optional), includes parts from A to B inclusive.....	1	\$ 185.00
12	7A100-149-2	Crankcase assy. (optional), includes parts from A to C inclusive.....	1	258.00
12	8A100-149-2	Crankcase assy. (optional), special service assy., includes parts A to D plus parts E to F.....	1	430.00
13	B105-43	Stud, main bearing (below Serial 158578)A	12	.24
13	34-217	Capscrew, main bearing (Serial 158578 and up)	12	.20
14	22-132	Shim, front and center main bearing.....	4	.12
15	22-133	Shim, rear main bearing.....	2	.20
16	4-117	Bearing cap, front and center main.....	2	2.50
17	A4-118	Bearing cap, rear main.....	1	3.60
20	B53-26	Nut, for #B105-43, 5/8-18 hex., castel.....	12	.08
21	55-397	Tube, rear oil line.....	1	.40
22	55-398	Tube, front oil line.....	1	.40
23	11-134	Bushing, front and center camshaft bearing	2	1.10
24	11-133	Bushing, rear camshaft bearing.....	1	.90
25	019-40	Welch plug, 3".....	1	.16
30	105-232	Stud, cylinder head, 1/2" x 5-1/4".....	14	.20
31	B105-31	Stud, cylinder head, 1/2" x 5-3/4".....	4	.20
32	B105-39	Stud, oil filter, 5/16" x 1".....	4	.04
33	105-245	Stud, water pump bracket, 3/8" x 1-5/16".....	4	.17

CRANKCASE GROUP 2 (CONT'D)

REF. No.	PART No.	NAME AND DESCRIPTION	QUAN.	PRICE EACH
38	21-324	Bushing, governor cross shaft.....	1	\$.16
	011-1	Pipe plug, 1/8" sq. head.....	5	.02
	011-103	Pipe plug, 3/8" ctrsk. special.....	1	.06
	62-88	Name plate, serial number.....	1	.30
	62-86	Name plate, engine instruction.....	1	.30
	62-85	Name plate, compressor instruction.....	1	.30
	03-2001	Screw, for name plates, P.K. #2 x 3/16" ..B	12	.02
35	21-233	Bearing shell, one half, front and center main.....	4	1.50
36	21-234	Bearing shell, one half, rear main.....	2	1.80
40	175-6-1	Cylinder sleeve, 4-1/2" bore.....	4	10.50
41	74-41	Packing ring, for cylinder sleeve.....	8	.14
50	31-325	Oil retainer.....	1	2.50
51	16-777	Gasket, oil retainer.....	1	.05
	02-19	Capscrew, for oil retainer, 5/16" - 18 x 7/8" hex.....	3	.04
	05-50	Lockwasher, 5/16".....C	3	.01
37	20-242-1	Thrust washer, rear main bearing.....	1	.80
	014-3215	Setscrew, Allen, 5/16" - 18 x 5/16" oval point.....	3	.10
	61-44	Lockwire, main bearing.....	6	.04
52	16-626	Gasket, oil retainer parting.....	2	.04
53	20-243-2	Oil seal, felt, one half.....	2	.16
60	23-12	Valve tappet.....D	8	1.00
61	99-72	Push rod.....	8	.60
62	52-59	Drain cock, 3/8" MPT x 90°.....	1	.40
54	19-13	Pipe plug, 1/8" slotted.....	3	.02

Following parts are also listed elsewhere in this manual.

1	1A5-282	Crankshaft assy.....E	1	123.00
100	A7-59	Connecting rod assy.....	4	22.00
110	1A8-203-1	Piston assy.....	4	8.00
116	18-114	Piston ring, oil, PC 85, 4-1/2 x 3/16".....	4	.75
117	18-233	Piston ring, compression, 4-1/2 x 1/8".....	12	.35
120	6-132	Camshaft.....	1	36.00
121	09-17	Key, camshaft gear, Woodruff #13.....	1	.04
122	26-326	Camshaft gear.....	1	8.00
123	20-276	Lockwasher, for #53-171, special.....	1	.10
124	53-171	Nut, camshaft gear, 1-1/8 - 12, special....	1	.40
125	31-327	Retainer, for camshaft.....	1	1.40
	02-18	Capscrew, camshaft retainer, 5/16" - 18 x 3/4".....	2	.04
	20-274	Lockwasher, 5/16".....F	2	.10

PARTS LIST

ENGINE
Page 121

FRONT SUPPORT, BELL HOUSING, FLYWHEEL GROUP 3 See illustration D318-11

75	39-1223	Support, front, engine.....	1	4.50
80	A37-154-1	Bell housing, includes timing mark pin.....	1	35.50
87	17-141	Pin, timing mark.....	1	.12
81	34-37	Capscrew, 3/4 - 16 x 1-1/2", hex. Special	5	.16
	61-44	Wire, locking.....	3	.04
	010-115	Pin, taper, #8 x 1-1/4" lg.....	2	.06
84	A9-484	Flywheel, includes ring gear.....	1	36.50
85	26-273	Ring gear, flywheel, 8/10" pitch.....	1	6.00
86	B53-25	Nut, flywheel bolt, 1/2 - 20, hex. castel	6	.04
	07-23	Pin, cotter, 3/32 x 1".....	6	.01

CONNECTING ROD GROUP 4

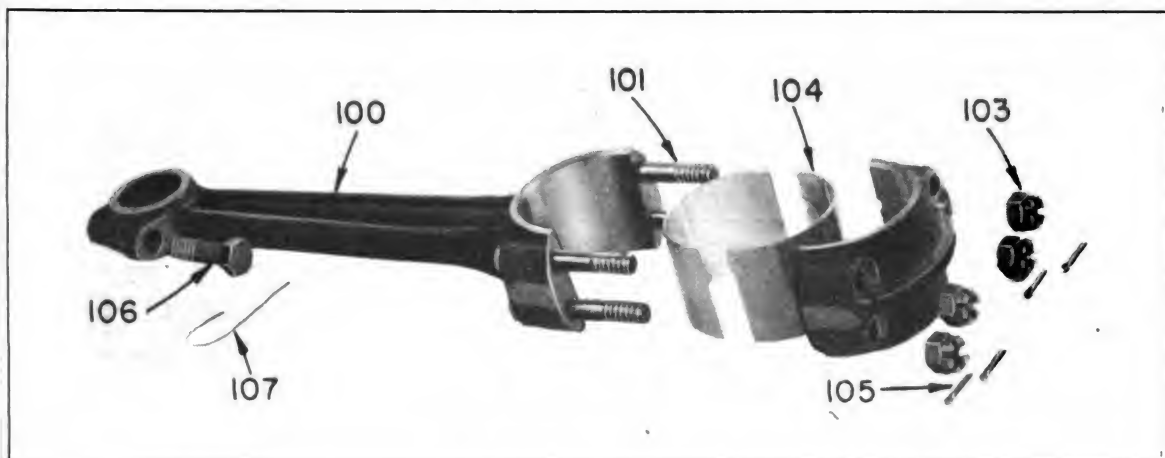

Unnumbered parts are identical to corresponding numbered parts

REF. No.	PART No.	NAME AND DESCRIPTION	QUAN.	PRICE EACH
100	1A7-59	Connecting rod assembly (optional, includes parts A to B).....	4	\$ 20.40
100	A7-59	Connecting rod assembly (optional, includes parts A to C).....	4	22.00
101	35-23	Bolt, connecting rod, 7/16" x 3-1/16" special..... A	16	.24
	22-134	Shim, connecting rod, .012" laminated.....	8	.12
103	53-31	Nut, connecting rod bolt, 7/16" - 20 special..... B	16	.08
104	21-195	Bearing shell, connecting rod, one-half....	8	0.80
105	07-23	Cotter pin, 3/32" x 1".....	16	.01
106	B35-8	Capscrew, hex. hd. 1/2" - 13 x 2" special	4	.30
107	61-5-3	Wire, locking 1/16 x 5" soft iron..... C	4	.04

PISTON GROUP 5

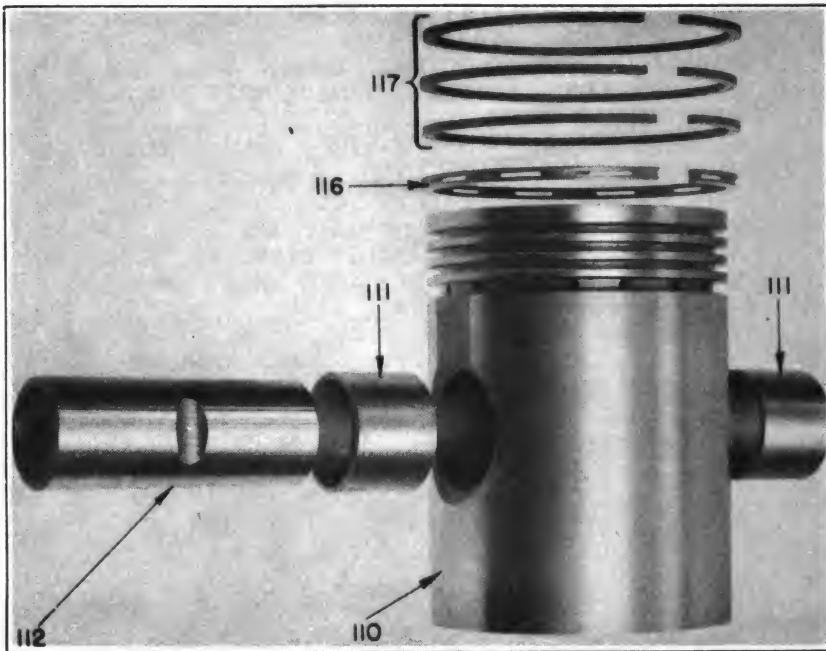

REF. No.	PART No.	NAME AND DESCRIPTION	QUAN.	PRICE EACH
110	1A8-203-1	Piston assembly, includes bushings and pin.....	4	\$ 8.00
111	21-334	Bushing, piston pin.....	8	.40
112	B17-17	Piston pin, 1-1/2 x 3-15/16".....	4	1.20
116	18-114	Ring, oil control P.C. 85, 4-1/2 x 3/16".....	4	.75
117	18-233	Ring, compression P.C. 4-1/2 x 1/8".....	12	.35

CAMSHAFT GROUP 6

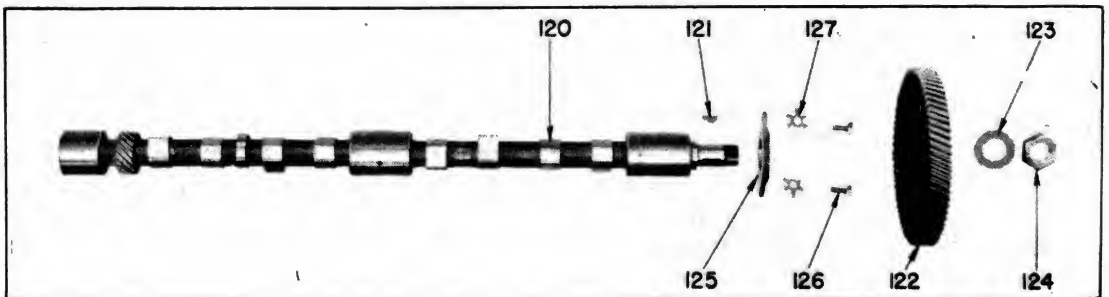

REF. No.	PART No.	NAME AND DESCRIPTION	QUAN.	PRICE EACH
120	6-132	Camshaft.....	1	\$ 36.00
121	09-17	Key, camshaft gear, Woodruff #13.....	1	.04
122	26-326	Gear, camshaft.....	1	8.00
123	20-276	Lockwasher, camshaft gear.....	1	.10
124	53-171	Nut, camshaft gear, 1-1/8" - 12 special....	1	.40
125	31-327	Retainer, camshaft.....	1	1.40
126	02-18	Capscrew, hex. 5/16 - 18 x 3/4".....	2	.04
127	20-274	Lockwasher, 5/16" special.....	2	.10

OIL PUMP GROUP 7 (CONT'D)

REF. No.	PART No.	NAME AND DESCRIPTION	QUAN.	PRICE EACH
153	05-50	Lockwasher, 5/16".....	3	.01
	19-13	Pipe plug, 1/8" slotted.....	1	.02
150	16-635	Gasket, oil pump cover flange.....	1	.04
154	02-18	Capscrew, hex., 5/16 - 18 x 3/4".....	5	.04
154A	05-50	Lockwasher, 5/16".....	5	.01
....	53-150	Plug, oil pressure relief.....	1	.32
....	24-236	Spring, oil pressure relief plunger.....	1	.08
....	25-54	Plunger, oil pressure relief.....	1	.25
....	B16-117	Gasket, oil pressure relief plug.....	1	.04
....	55-29-33	Tube, oil pressure, crankcase to cylinder head, 1/4 x 19" lg.....	1	.16
....	A182-33	Connector, elbow, crankcase and cylinder head, 1/4" tube, 1/8" MPT x 90°.....	2	.25
....	013-1	Nipple, close, for crankcase, 1/8 x 3/4".....	1	.04
....	013-601	Pipe tee, 1/8 x 1/8 x 1/8" PT.....	1	.16
....	55-29-44	Tube, oil pressure, crankcase to gauge 1/4" tube, 40" lg.....	1	.50
....	A182-13	Connector, straight, for oil pressure tube 1/4" tube x 1/8" MPT.....	1	.20
....	55-51-8	Tube, oil pressure, crankcase to governor, 3/16 x 24" lg.....	1	.20
....	A182-12	Connector, straight, for oil pressure line at governor, 3/16" tube x 1/8" MPT..	1	.08
....	A182-81	Tee connector, for oil line from crankcase 3/16" tube x 3/16" tube x 1/8" MPT..	1	.24
161	55-51-1	Tube, oil pressure, from crankcase to Purolator 3/16" x 10-3/4" lg.....	1	.16
163 } 162 }	A182-12	Connector, straight, for Purolator oil pressure line, 3/16" tube x 1/8" MPT.....	1	.08
164	55-29-78	Tube, oil overflow, from Purolator to crankcase 1/4 x 11-3/4" lg.....	1	.24
166 } 165 }	A182-33	Elbow connector, for oil overflow line, 1/4" tube x 1/8" MPT x 90°.....	2	.25
178	A60-43-9	Dipstick, oil level.....	1	.50
	A60-162	Hourmeter, Durant (Serial No. 174050 and up)	1	13.75
	B16-110	Gasket, Hourmeter to cover.....	1	.04
	02-18	Capscrew, 5/16 - 18 x 3/4".....	2	.04
	05-50	Lockwasher, 5/16".....	2	.01

PARTS LIST

OIL FILTER GROUP 8

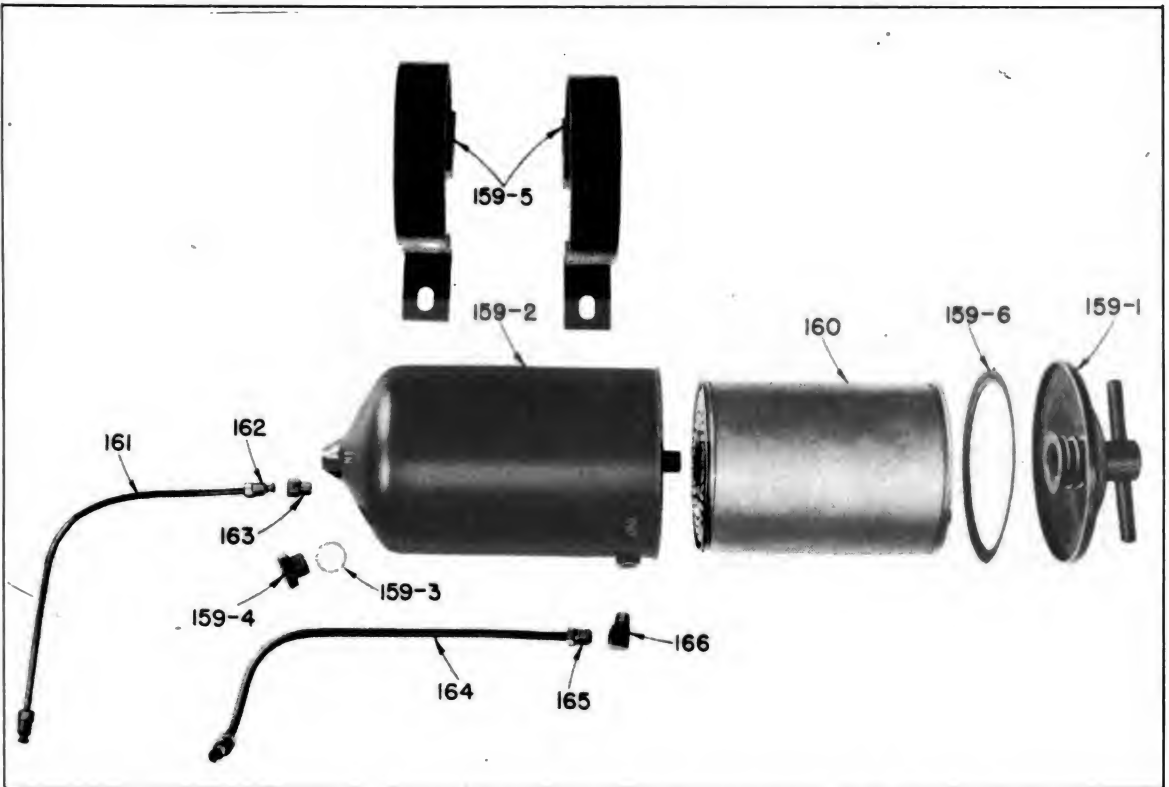

Unnumbered parts are identical to corresponding numbered parts

REF. No.	PART No.	NAME AND DESCRIPTION	QUAN.	PRICE EACH
159	A43-114	Oil filter assembly, Purolator #N1744.....	1	\$ 8.00
160	A77-184	Filter element, replaceable, Purolator #N17.....	1	1.40
	05-50	Lockwasher, 5/16".....	4	.01
	04-102	Nut, hex., 5/16" - 18.....	4	.02
	06-3	Plain Washer, 5/16".....	4	.01

REF. No.	PUROLATOR PART No.	NAME AND DESCRIPTION	QUAN.	PRICE EACH
159-1	19894	Handle assembly.....	1	\$.75
159-1	19888	Gasket.....	1	.02
159-1	19926-1	Cover.....	1	1.50
159-6	20509	Case gasket.....	1	.15
159-1	19561-1	Element Spring.....	1	.15
159-1	19911	Sealing cup.....	1	.15
159-2	19976	Case assembly.....	1	4.20
159-3	19666	Gasket.....	1	.02
159-4	7335.	Drain plug.....	1	.
159-5	19982	Bracket assembly.....	2	

CYLINDER HEAD ASSEMBLY

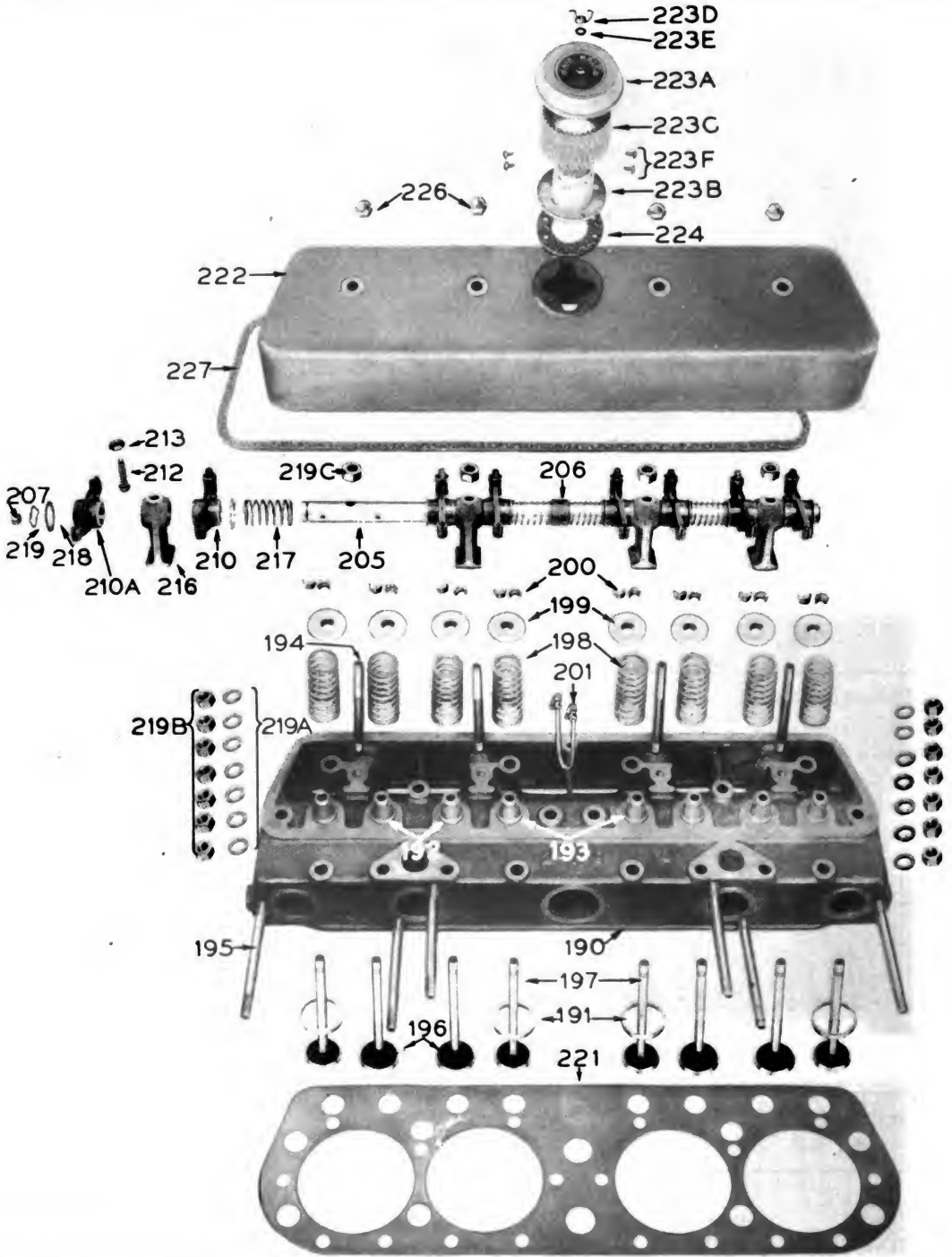

Unnumbered parts are identical to corresponding numbered parts

PARTS LIST

CYLINDER HEAD GROUP 9
(See Illustration "Cylinder Head Assy.")

REF. No.	PART No.	NAME AND DESCRIPTION	QUAN.	PRICE EACH
190	3A2-149	Cylinder head assembly (optional), Includes parts A to B.....	1	\$ 58.00
190	5A2-149	Cylinder head assembly (optional), Includes parts A to C, also part #4A27-839.....	1	118.00
191	64-33	Seat insert, exhaust valve.....A	4	1.10
192	58-26	Guide, intake valve.....	4	.30
193	58-27	Guide, exhaust valve.....	4	.40
194	105-216	Stud, rocker arm bracket.....	4	.18
195	105-191	Stud, manifold.....B	6	.22
196	15-200	Intake valve.....	4	1.40
197	15-201-1	Exhaust valve.....	4	1.90
198	B24-26	Valve spring.....	8	.28
199	20-278	Washer, valve spring.....	8	.16
200	20-279	Lockwasher, valve stem, special.....	16	.05
201	A55-51-24	Oil line, rocker arm to cylinder head 3/16" x 8".....C	1	.20
205	4A27-839	Rocker arm shaft assembly, Includes 1A27-839 Plus parts marked t.....	1	22.00
205	1A27-839	Rocker arm shaft assembly, Includes sleeve and plugs.....	1	5.60
206	63-41	Sleeve, rocker arm shaft.....	1	.90
207	19-87	Plug, rocker arm shaft.....	2	.02
210	A98-19-2	tRocker arm assembly, intake, includes bushing, bolt and locknut.....	4	.80
212	B34-25	Bolt, valve adjusting.....	4	.28
213	B53-8	Lock nut, valve adjusting bolt.....	4	.04
...	11-135	Bushing, rocker arm.....	4	.15
210A	A98-19-3	tRocker arm assembly, exhaust, includes bushing, bolt and locknut.....	4	.80
212	B34-25	Bolt, valve adjusting.....	4	.28
213	B53-8	Lock nut, valve adjusting bolt.....	4	.04
216	40-795-2	tBracket, rocker arm shaft.....	4	.70
217	24-86	tSpring, rocker arm shaft.....	4	.06
218	20-74	tWasher, rocker arm shaft.....	8	.02
219	61-59	tLock wire.....	2	.12
...	11-135	Bushing, rocker arm.....	4	.15
219A	B20-1	Washer, cylinder head stud, 1/2".....	14	.02
219B	04-605	Nut, cylinder head stud, 1/2", 20 hex.....	14	.02
219C	04-604	Nut, rocker arm bracket.....	4	.02
...	06-70	tWasher, rocker arm bracket stud, 7/16" plain.....	4	.01
221	16-629	Cylinder head gasket.....	1	1.50
222	A14-535	Cylinder head cover assembly, includes parts from F to G incl.....	1	10.

CYLINDER HEAD GROUP 9 (CONT'D)

REF. No.	PART No.	NAME AND DESCRIPTION	QUAN.	PRICE EACH
222	14-535	Cover, cylinder head.....F	1	\$ 8.50
...	A77-137	Breather, air maze ZOH, includes parts marked ♣.....	1	1.70
223A	Z0-001	♣Breather top, includes name plate #Z0-3..	1	.25
223B	Z0-003	♣Breather base.....	1	.50
223C	Z0-18	♣Breather element.....	1	.75
223D	04-1002	♣Wing nut, 3/8" standard.....	1	.06
223E	05-51	♣Lockwasher, 3/8".....	1	.01
223F	03-1538	Screw, breather, Parker Kalon, type Z stove head, #10 x 3/8".....	4	.02
224	16-643-1	Breather gasket.....	1	.10
226	04-1129	Nut, cylinder head cover, 7/16", 20 Acorn	4	.12
227	16-634-3	Gasket, cylinder head cover.....	1	.50

GEAR COVER GROUP 10

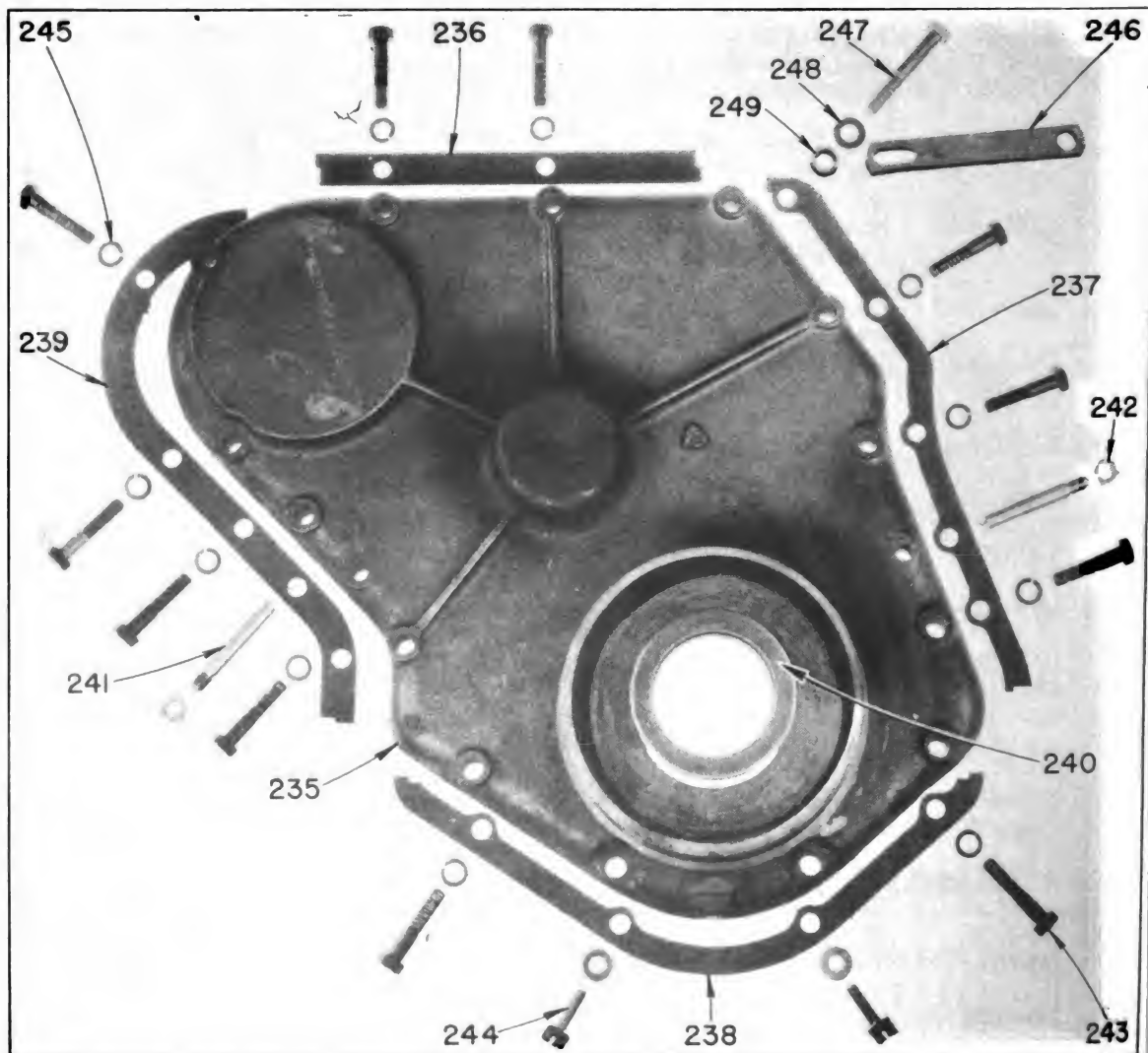

Unnumbered parts are identical to corresponding numbered parts.

PARTS LIST

GEAR COVER GROUP 10 (CONT'D)

REF. No.	PART No.	NAME AND DESCRIPTION	QUAN.	PRICE EACH
235	14-540	Gear cover.....	1	\$ 14.00
236	16-650	Gasket, gear cover (upper).....	1	.06
237	16-651	Gasket, gear cover (manifold side).....	1	.08
238	16-652	Gasket, gear cover, (lower).....	1	.08
239	16-653	Gasket, gear cover, (magneto side).....	1	.08
240	125-58-1	Oil retainer, 2-1/2" I.D.....	1	1.00
243	02-39	Capscrew, 3/8" - 16 x 1-3/4" hex.....	12	.04
244	03-427	Capscrew, 3/8" - 16 x 1-1/4" fill. head....	2	.06
245	05-51	Lockwasher, 3/8".....	14	.01
241	010-315	Taper pins, #7 x 2" lg.....	2	.12
242	04-603	Nut, for #010-315, 3/8" - 24, hex.....	2	.01
246	40-1315	Bracket, generator adjusting.....	1	.50
247	02-42	Capscrew, hex. 3/8 - 16 x 2-1/2" (gear cover).....	1	.06
248	06-69	Washer, plain, 3/8".....	1	.01
249	22-188	Spacer for bracket.....	1	.20

MANIFOLD GROUP 11

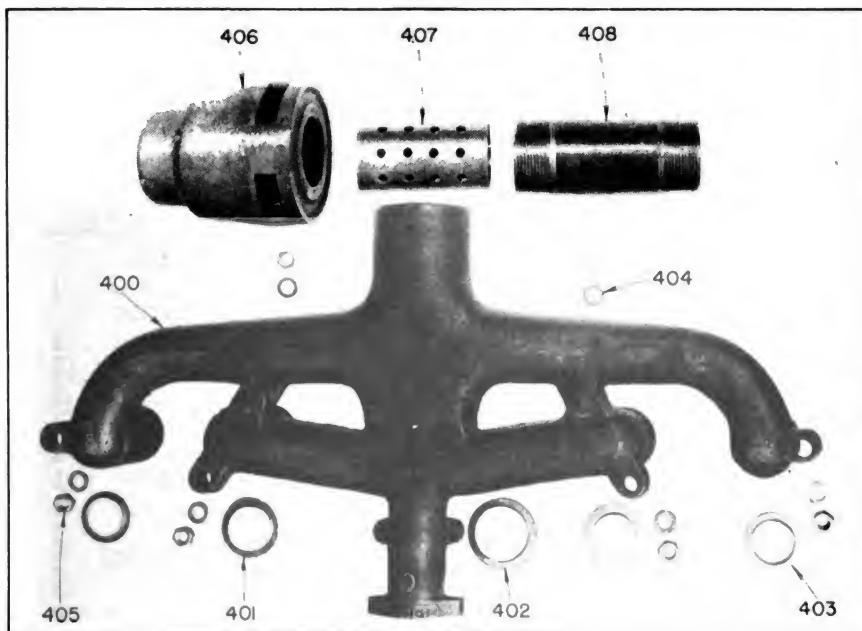

Unnumbered parts are identical to corresponding numbered parts

REF. No.	PART No.	NAME AND DESCRIPTION	QUAN.	PRICE EACH
400	10-284-10	Manifold, intake and exhaust.....	1	\$ 21.50
401	16-630	Gasket, intake.....	2	.08
402	16-631	Gasket, exhaust center.....	1	.12
403	16-632	Gasket, exhaust end.....	2	.12
404	B20-1	Washer, plain, 1/2".....	6	.02
405	04-605	Nut, 1/2" - 20 hex.....	6	.02
406	78-69	Muffler body.....	1	4.00
407	78-70	Muffler silencer.....	1	.80
408	013-236	Pipe nipple, 2-1/2" x 7".....	1	.70

WATER PUMP GROUP 12

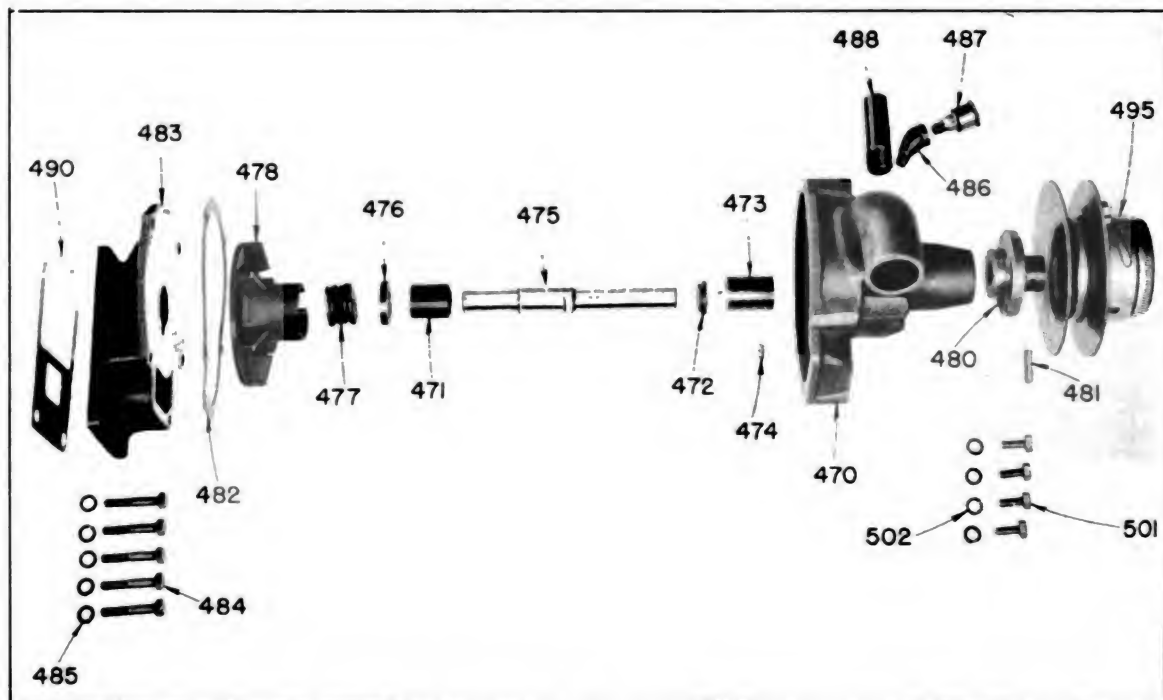

Unnumbered parts are identical to corresponding numbered parts

REF. No.	PART No.	NAME AND DESCRIPTION	QUAN.	PRICE EACH
...	2A13-360-1	Water pump assembly, (optional) includes parts marked ▲.....	1	\$ 21.00
...	A13-360-1	▲Water pump assembly, (optional) includes parts marked †.....	1	10.00
471	21-368	†Bushing.....	1	1.12
472	20-378	†Thrust washer.....	1	1.12
473	21-367	†Bushing.....	1	1.40
474	17-418	†Bushing pin.....	1	.12
475	A27-1381	▲Shaft, water pump (includes next 3 items)	1	7.00
476	20-379	▲Seal washer.....	1	.24
477	125-68	▲Bellows seal assembly.....	1	1.50
478	101-28	(†)▲Impeller, water pump (serviced only as A27-1381)	1	
480	132-73	▲Fan hub.....	1	2.40
481	010-53	▲Pin, fan hub taper, #4 x 1".....	1	.04
482	16-754	Gasket, pump body.....	1	.08
483	40-1075	Bracket, pump body.....	1	5.00
484	02-23	Capscrew, 5/16 - 18 x 1-3/4".....	5	.04
485	05-50	Lockwasher, 5/16".....	5	.01
486	013-531	▲Street ell, 1/8" PT x 45°.....	1	.18
487	017-11	▲Grease cup, 1/8" MPT.....	1	.12
488	33-114-21	Nipple, 1/2 MPT x 2-1/2", thread one end..	1	.09
490	16-638	Gasket, water pump bracket to cylinder...	1	.08
...	04-603	Nut, hex. 3/8" - 24.....	4	.01
...	05-51	Lockwasher, 3/8".....	4	.01
495	1A36-249	Fan pulley assembly.....	1	1.60
500	42-110	Fan blade assembly.....	1	5.00
501	02-18	Capscrew, hex, 5/16 - 18 x 3/4".....	4	.04
502	05-50	Lockwasher, 5/16".....	4	.01
510	41-225	Fan belt.....	1	3.00
511	65-585-2	Connection, water outlet.....	1	6.00

PARTS LIST

WATER PUMP GROUP 12 (CONT'D)

REF. No.	PART No.	NAME AND DESCRIPTION	QUAN.	PRICE EACH
...	33-114-21	Nipple, 1/2 MPT x 2-1/2" threaded one end	1	\$.09
512	16-646	Gasket.....	2	.06
...	B20-1	Plain washer, 1/2".....	4	.02
...	04-605	Nut, 1/2" - 20 hex.....	4	.02
513	73-29-8	Hose, by-pass, 3/4 x 11-1/2".....	1	.32
514	83-92	Hose clamp assembly, for 3/4" hose.....	2	.06

OIL PAN GROUP 13

See Illustration Plate Nos. D318-11, D318-12

575	3-166-1	Oil pan.....	1	33.00
576	16-647	Gasket, oil pan flange, manifold side.....	1	.12
577	16-648	Gasket, oil pan flange, magneto side.....	1	.12
578	16-649-1	Gasket, oil pan flange, bell housing end..	1	.38
...	02-40	Capscrew hex. for oil pan flange 3/8" - 16 x 2".....	16	.04
...	05-51	Lockwasher 3/8".....	16	.01
...	04-103	Nut, hex. 3/8" - 16.....	16	.02
579	22-182	Spacer, bell housing to oil pan.....	2	.50
580	22-187	Shim for spacer.....	6	.08
...	02-107	Capscrew, hex. bell housing to oil pan 5/8" - 11 x 3".....	2	.10
...	05-55	Lockwasher 5/8".....	2	.02
...	013-535	Street ell 3/4" x 45° oil drain.....	1	.20
...	013-136	Nipple, pipe, 3/4" x 6" oil drain.....	1	.12
...	013-705	Coupling, pipe, 3/4" oil drain.....	1	.20
581	011-5	Plug, pipe, 3/4" sq. head oil drain.....	1	.04

COMPRESSOR FRAME GROUP 1

PART No.	NAME AND DESCRIPTION	QUAN.	PRICE EACH
All8-433-1	Frame for engine & compressor unit.....	1	\$115.00
3-223	Pan, splash.....	2	3.35
02-69	Capscrew, for splash pan, hex. 1/2 - 13 x 1".....	8	.04
05-53	Lockwasher, 1/2".....	8	.01
06-71	Washer, plain, 1/2".....	8	.02
105-49	Stud, for bolting compressor to frame, 5/8" x 3-1/4".....	2	.24
04-607	Nut, hex. 5/8" - 18.....	2	.04
02-101	Capscrew for engine front support, hex. 5/8 - 11 x 1-1/2".....	2	.08
B20-2	Washer, plain, 5/8".....	2	.02
05-55	Lockwasher, 5/8".....	2	.02
39-1225	Support, starting crank.....	1	.40
02-7	Capscrew for crank support, hex.....	2	.04
05-53	Lockwasher, 1/2".....	2	.01
04-105	Nut, hex. 1/2" - 13.....	2	.02

FRAME FITTINGS, SIDE TOOL BOX GROUP 2

39-1397	Tail light bracket, truck.....	1	.55
39-1398	Bracket, tail light and receptacle, truck	1	.65
55-2-67	Gasoline line from truck, 5/16 x 90", truck..	1	.80
182-187	Connector, SAE str., 5/16" tube, truck.....	1	.14
182-181	Tube nut, SAE, for 5/16" tube, truck.....	1	.10
39-1380	Rear bracket - truck.....	2	2.00
02-604	Capscrew for rear brkt. to frame, hex. 5/8 - 18 x 2-1/4".....	4	.09
39-1384	Support, tool box, front & rear.....	2	7.50
02-70	Capscrew, hex. for tool box support, 1/2 - 13 x 1-1/4".....	8	.04
05-53	Lockwasher, 1/2".....	8	.01
06-71	Washer, plain, 1/2".....	8	.02
22-211	Spacer, wood, between unit and frame.....	2	6.60
All9-124	Tool box, carburetor side.....	1	153.00
All9-125	Tool box, magneto side.....	1	152.00
02-70	Capscrew for tool box to comp. frame, hex. 1/2 - 13 x 1-1/4".....	24	.04
05-53	Lockwasher, 1/2".....	24	.01
02-70	Capscrew for support to box, hex. 1/2 - 13 x 1-1/4".....	6	.04
05-53	Lockwasher, 1/2".....	6	.01
04-105	Nut, hex. 1/2" - 13.....	6	.02
39-1235	Bracket for U bolt.....	4	.32
02-72	Capscrew for U bolt support to box, hex. 1/2 1-1/2".....	8	.06
05-53	Lockwashers, 1/2".....	8	.01
22-215	Block for truck frame, wood filler.....	4	.70
34-183	U bolt for front end of frame.....	2	.74
24-307	Spring for U bolt.....	12	.06
06-71	Washer, plain, 1/2".....	8	.02
04-605	Nut, hex. 1/2" - 20.....	16	.02
04-854	Nut, castel, 1/2" - 20.....	4	.04
07-23	Pin, cotter, 3/32 x 1".....	4	.01
34-184	U bolt for rear end of frame.....	2	.68
05-53	Lockwasher, 1/2".....	8	.01
04-605	Nut, hex. 1/2" - 20.....	4	.02
Original from	SKIT Assembly, Complete.....	1	255.00

PARTS LIST

FRAME FITTINGS, SIDE TOOL BOX GROUP (CONT'D)

PART No.	NAME AND DESCRIPTION	QUAN.	PRICE EACH
A83-99	Hose reel clamp assembly.....	2	\$ 1.40
83-103	Clamp, hose end.....	2	.35
02-4	Capscrew for reel clamp, hex. 1/4 - 20 x 3/4".....	8	.04
05-49	Lockwasher, 1/4".....	8	.01
04-101	Nut, hex. 1/4" - 20.....	8	.01
62-129	Plate, tool location, (carb. side).....	1	.50
62-128	Plate, tool location (magneto side).....	1	.50
03-2001	Screws, Parker Kalon.....	8	.02

HOOD SIDES GROUP 3

68-722-1	Hood sides.....	2	30.00
02-3	Capscrew for hood sides, 1/4 - 20 x 5/8".....	20	.04
06-67	Washer, plain, 1/4".....	20	.04
05-49	Lockwasher, 1/4".....	20	.01
04-101	Nut, hex. 1/4" - 20.....	20	.01
02-2	Capscrew, hex., hood ends to side tool boxes, 1/4 - 20 x 1/2".....	4	.02
05-49	Lockwasher, 1/4".....	4	.01
04-101	Nut, hex. 1/4" - 20.....	4	.01
83-101	Fastener catch.....	4	.30
03-1541	Screw for staple, Rd. hd., Parker Kalon, type Z #10 x 1/2".....	8	.02
83-32	Staple for hood side hasp.....	2	.44
03-1541	Screw for staple, Rd. hd., Parker Kalon, type Z #10 x 1/2".....	4	.02

NEXT 9 ITEMS APPLY TO TRUCK MOUNTED UNITS ONLY

142-27	Hand rail.....	1	1.50
39-1389	Support, hand rail.....	2	.25
39-1388	Support, hand rail end.....	2	.90
02-34	Capscrew for rail support, hex. 3/8 - 16 x 3/4".....	6	.04
06-4	Washer, plain, 3/8".....	6	.01
05-51	Lockwasher, 3/8".....	6	.01
83-104	Safety strap.....	2	1.20
83-105	Clamp for safety strap.....	2	.30
03-1541	Screw for strap clamp, Parker Kalon, #10 x 1/2".....	12	.02

RUNNING BOARD, FENDER GROUP 4 (TRUCK MOUNTED UNITS ONLY)

68-758	Running board.....	2	13.75
39-1236	Bracket, running board, R.H.....	2	2.70
39-1239	Bracket, running board, L.H.....	2	2.70
39-1383	Support, truck exhaust pipe.....	1	.95
02-70	Capscrew for running board brkt., 1/2 - 13 x 1-1/4".....	16	.04
05-53	Lockwasher, 1/2".....	16	.01
04-105	Nut, hex. 1/2" - 13.....	16	.02
38-367	Truck platform.....	1	13.27
83-28-1	Clamp for truck platform.....	2	.75
02-69	Capscrew for platform clamp, hex. 1/2 - 13 x 1".....	4	.04
05-53	Lockwasher, 1/2".....	4	.01
68-759	Fender.....	4	5.

RUNNING BOARD, FENDER GROUP 4 (TRUCK MOUNTED UNITS ONLY) (CONT'D)

PART No.	NAME AND DESCRIPTION	QUAN.	PRICE EACH
02-69	Capscrew for fender 1/2 - 13 x 1"	24	\$.04
06-6	Washer, plain, 1/2"	24	.01
05-53	Lockwasher, 1/2"	24	.01
04-105	Nut, hex. 1/2" - 13	24	.02
03-619	Capscrews, Rd. hd., 1/4 - 20 x 1/2"	4	.01
05-49	Lockwasher, 1/4"	4	.01
04-101	Nut, hex. 1/4" - 20	4	.01
83-39	Clamp for truck engine exhaust pipe	1	1.00
02-38	Capscrew, hex. 3/8 - 16 x 1-1/2"	1	.04
05-51	Lockwasher, 3/8"	1	.01
04-103	Nut, hex. 3/8" - 16	1	.02

SPECIAL TOOL BOX GROUP 5 (TRUCK MOUNTED UNITS ONLY)

A119-126	Tool box assembly	1	51.00
83-108	Clamp for stud	4	1.00
105-231	Stud for tool box, 1/2 x 14"	4	.70
05-53	Lockwasher, 1/2"	4	.01
04-105	Nut, for tool box stud, hex. 1/2" - 13	8	.02
A61-107-5	Starter cable, for truck battery	1	.80
188-22	Connector for starter cable	1	1.50
02-37	Capscrew, hex. 3/8 - 16 x 1-1/4"	1	.04
05-51	Lockwasher, 3/8"	1	.01
04-103	Nut, hex. 3/8" - 16	1	.02
A61-419-1	Ground cable, for truck battery	1	.65
02-37	Capscrew, hex. 3/8 - 16 x 1-1/4"	1	.04
05-51	Lockwasher, 3/8" (inside of frame)	1	.01
04-103	Nut, hex. 3/8" - 16	2	.02
A178-15	Padlocks with chain & 1 key per lock, "Master #3", set of 8	1	12.50
07-35	Cotter pins for padlock chain, 1/8 x 1/2"	9	.01
53-227	Tire carrier nut, 3/4" - 10	2	.55
A178-14	Lock for spare wheel, U.S. Gov. 900 #H700	1	1.70
A61-141	Sealing wire	8	.02

SKID MOUNTED UNITS ONLY

07-35	Cotter pin, padlock chain, 1/8 x 1/2"	7	.01
A61-141	Wire Seal	7	.02
A178-17	Padlock, individual, with chain, all keyed alike	1	1.65

PARTS LIST

CARBURETOR GROUP 1

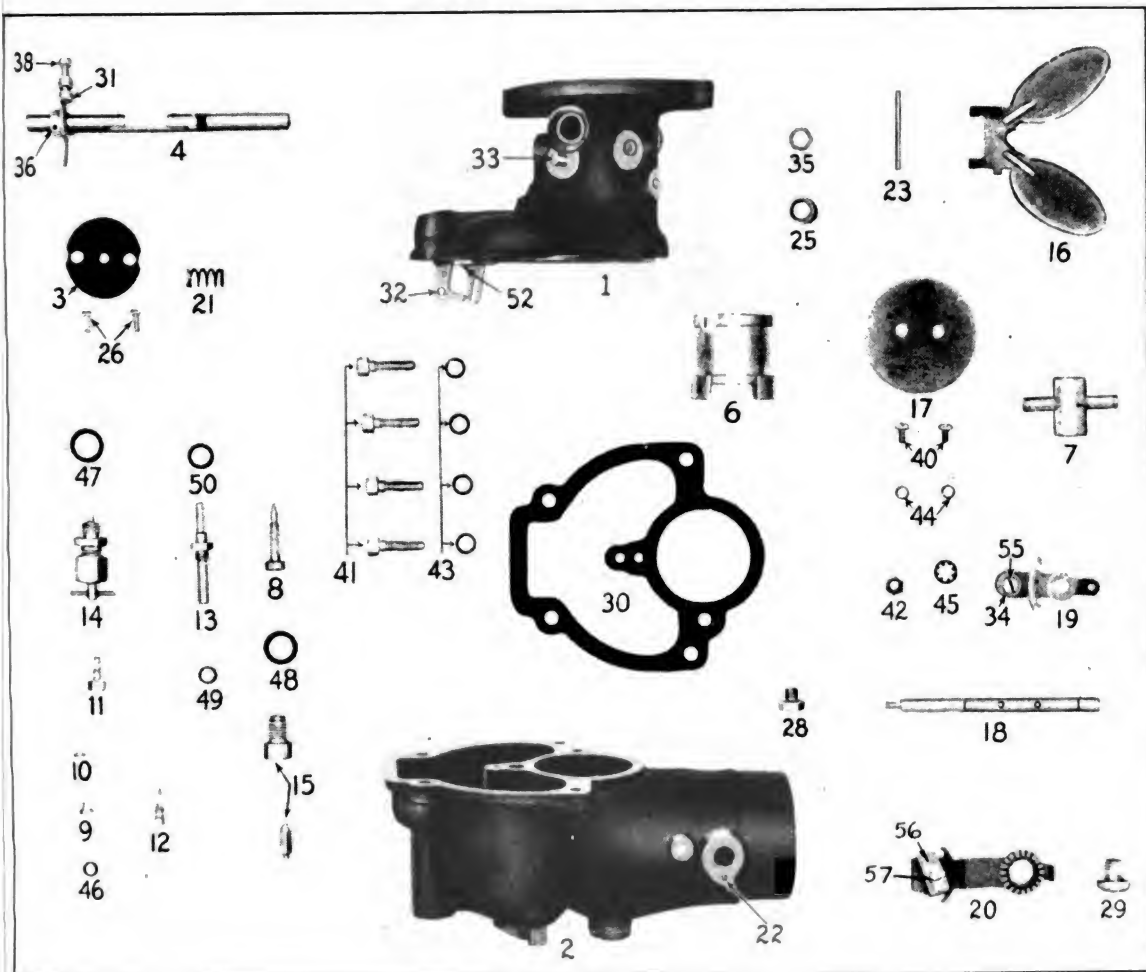

REF. No.	PART No.	NAME AND DESCRIPTION	QUAN.	PRICE EACH
430	A84-546-2	Carburetor assembly, Zenith #62A10.....	1	\$ 17.00
431	16-27	Gasket, carburetor flange.....	1	.08
...	05-51	Lockwasher, 3/8".....	2	.01
...	02-36	Capscrew, hex. 3/8 - 16 x 1".....	2	.04
...	A182-35	Elbow connector for pump line, 5/16" tube x 1/8" M.P.T. x 90°.....	1	.12

REF. No.	ZENITH PART No.	NAME AND DESCRIPTION	QUAN.	PRICE EACH
1	B2-104	Throttle body.....	1	5.00
2	B3-37C	Fuel bowl assembly.....	1	4.00
3	C21-79	Throttle plate.....	1	.75
4	C29-326	Throttle shaft.....	1	1.05
6	C38-24	Main venturi, size 25.....	1	1.60
7	C39-7	Secondary venturi.....	1	.75
8	C46-38	Idle adjusting needle.....	1	.30
9	C52-1	Economizer jet (blank).....	1	.35
10	C52-2	Well vent, size 19.....	1	.35
11	C52-6	Main jet, size 25.....	1	.75

CARBURETOR GROUP (CONT'D)

REF. No.	ZENITH PART No.	NAME AND DESCRIPTION	QUAN.	PRICE EACH
12	C55-7	Idling jet, size 13.....	1	\$.50
13	C66-25-1	Main discharge jet, size 70-1.....	1	.75
14	C71-21	Main jet adjustment.....	1	.90
15	C81-1	Fuel valve assembly, size 40.....	1	.75
16	C85-26	Float assembly.....	1	1.00
17	C101-2	Air shutter plate.....	1	.75
18	C105-18	Air shutter shaft.....	1	.50
19	C106-2	Air shutter lever.....	1	.35
20	C109-2	Air shutter bracket.....	1	.35
21	C111-17	Idle adjusting needle spring.....	1	.10
22	C120-9	Bracket locating pin.....	1	.10
23	C120-15	Float axle.....	1	.10
25	C131-3x3	Packing retainer.....	1	.05
26	C136-3	Throttle plate screws.....	2	.05
28	C138-24	Air shutter shaft hole plug.....	1	.35
29	C140-7	Air shutter bracket screw.....	1	.60
30	C142-15	Bowl to body gasket.....	1	.15
31	CR28-28	Throttle stop lever (R.H. side).....	1	.60
32	CR88-7	Float Bracket.....	1	.05
34	CR134-1	Air shutter lever swivel.....	1	.20
35	CT57-8	Throttle shaft packing washer.....	1	.05
36	CT63-2	Taper pin.....	1	.05
..	CT91-3	Pipe plug (not illustrated).....	1	.10
38	T188-10	Throttle stop screw.....	1	.05
40	T15B6-4	Air shutter plate screw.....	2	.05
41	T18812-12	Bowl to body screw.....	4	.05
42	T22S8	Air shutter shaft nut.....	1	.05
43	T41-12	Bowl to body screw lockwasher.....	4	.05
44	T43-6	Air shutter screw lockwasher.....	2	.05
45	T45-8	Air shutter shaft nut lockwasher.....	2	.05
46	T56-4	Economizer jet washer.....	1	.05
47	T56-23	Main jet adjusting.....	1	.05
48	T56-23	Fuel valve washer.....	1	.05
49	T56-24	Main jet washer.....	1	.05
50	T56-48	Main discharge jet washer.....	1	.05
..	T73-8	Secondary venturi locating pin (not illustrated).....	1	.05
52	T73-9	Float bracket pin.....	1	.05
..	CT52-1	Swivel washer (not illustrated).....	1	.05
55	T188-6	Swivel screw.....	1	.05
..	C150-12	Filter screen (not illustrated).....	1	.50
..	T56-10	Filter screen washer (not illustrated)....	1	.05
..	C182-252	Carburetor repair kit.....	1	3.75
..	C181-134	Gasket kit.....	1	.55

PARTS LIST

FUEL PUMP GROUP 2

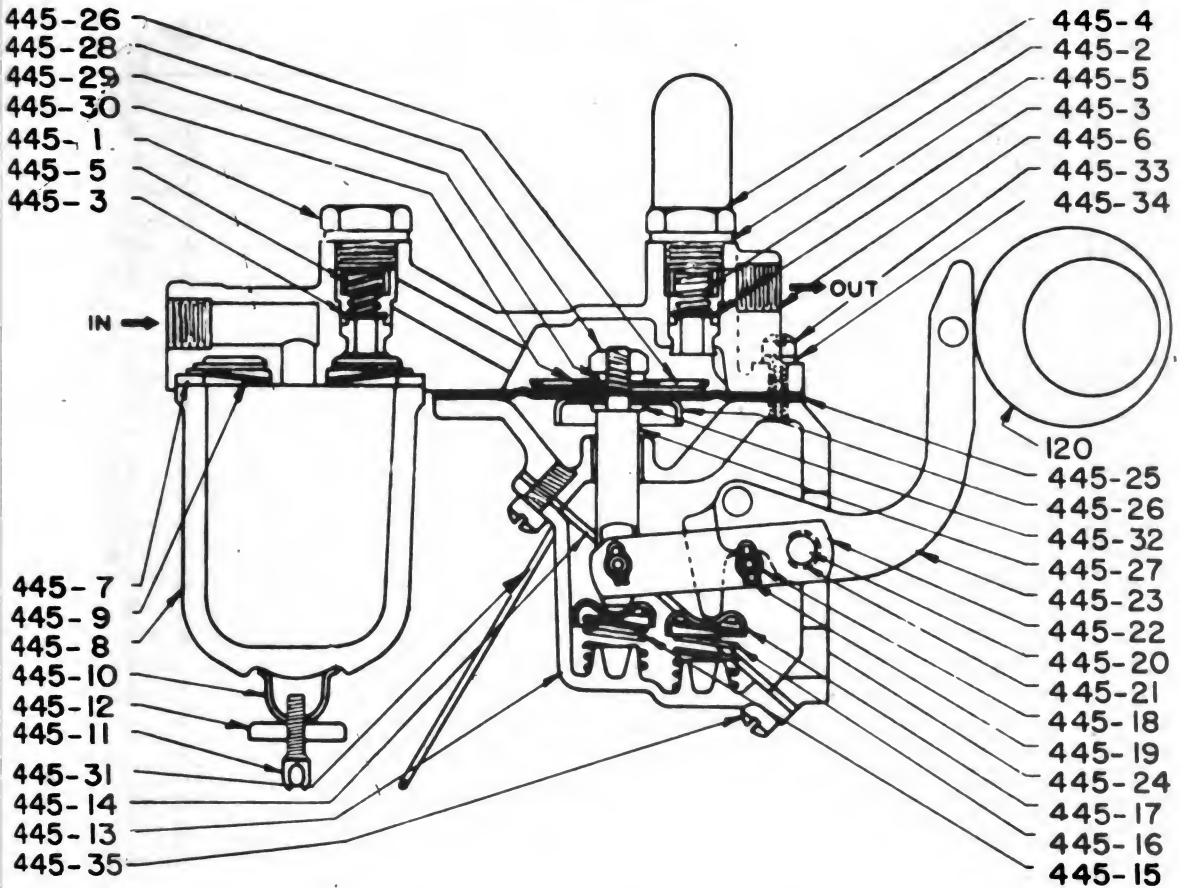

REF. No.	PART No.	NAME AND DESCRIPTION	QUAN.	PRICE EACH
445	A81-99-5	Fuel pump assembly.....	1	\$ 9.00
446	16-229	Gasket, fuel pump flange.....	1	.04
...	02-18	Capscrew, hex. 5/16 - 18 x 3/4".....	2	.04
...	05-50	Lockwasher, 5/16".....	2	.01
...	A182-35	Connector for pump, elbow, inlet & outlet 5/16" tube x 1/8" MPT x 90°.....	2	.12
...	55-2-84	Tube, pump to carburetor, 5/16 x 43".....	1	.80

REF. No.	AC PART No.	NAME AND DESCRIPTION	QUAN.	PRICE EACH
445-1	855281	Valve plug.....	1	.25
445-2	855282	Valve plug gasket.....	2	.01
445-3	855279	Valve.....	2	.01
445-4	855918	Air dome.....	1	.60
445-5	856270	Valve spring.....	2	.01
445-6	855761	Top cover & valve seat assy.....	1	1.60
445-7	16-921-1	Bowl gasket.....	1	.07
445-8	184-2	Glass bowl.....	1	.15

FUEL PUMP GROUP (CONT'D)

REF. No.	A-C PART No.	NAME AND DESCRIPTION	QUAN.	PRICE EACH
445-9	854009	Screen.....	1	\$.05
445-10	854005	Bowl seat.....	1	.01
445-11	864016	Bail & screw.....	1	.10
445-12	855763	Bail thumb nut.....	1	.05
445-13	855573	Bottom cover.....	1	.15
445-14	855585	Bottom cover gasket.....	1	.03
445-15	1537038	Diaphragm spring.....	1	.05
445-16	1522195	Rocker arm spring.....	1	.05
445-17	1522196	Spring cap.....	2	.01
445-18	855016	Link pin.....	2	.02
445-19	855017	Link pin clip.....	4	.01
445-20	1521289	Rocker arm pin.....	1	.15
445-21	1521288	Rocker arm pin washer.....	1	.02
445-22	855574	Link.....	2	.02
445-23	1537454	Rocker arm.....	1	2.05
445-24	855874	Body.....	1	1.60
445-25	186-9	Diaphragm (5 pieces).....	1	.37
445-26	855274	Upper and lower diaphragm protector	2	.10
445-27	1523172	Pull rod.....	1	.20
445-28	855213	Pull rod nut.....	1	.05
445-29	855390	Pull rod nut lockwasher.....	1	.01
445-30	855029	Diaphragm alignment washer.....	1	.01
445-31	1522280	Priming lever.....	1	.25
445-32	856307	Pull rod gasket.....	1	.01
445-33	855493	Top cover screw.....	10	.01
445-34	855064	Top cover screw lockwasher.....	10	.01
445-35	132108	Bottom cover screw.....	3	.01

AIR CLEANER GROUP 3

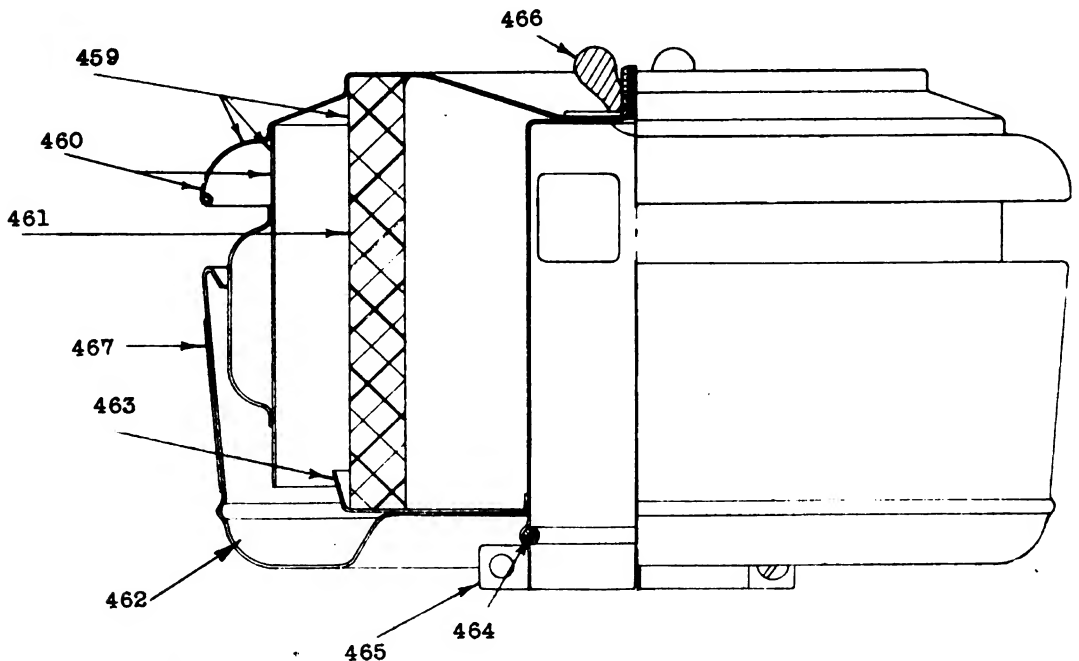

PARTS LIST

AIR CLEANER GROUP (CONT'D)

REF. No.	PART No.	NAME AND DESCRIPTION	QUAN.	PRICE EACH
453	A77-145-1	Air Maze oil bath air cleaner, #37L-0BF...	1	\$ 7.00
455	65-620	Connection, air cleaner.....	1	2.00
456	16-908-1	Gasket, air cleaner connection.....	1	.16
...	02-34	Capscrew, hex. 3/8 - 16 x 3/4".....	2	.04
...	05-51	Lockwasher, 3/8".....	2	.01
457	73-1-16	Hose, air conn. 2" I D. x 3" lg.....	1	.16
458	83-94	Hose clamp assembly, 2-3/8" I.D. for 2" hose.....	2	.04

REF. No.	AIR MAZE PART No.	NAME AND DESCRIPTION	QUAN.	PRICE EACH
459	AP-1128U	Upper assembly only.....	1	4.75
460	AP-112U	Top and skirt assembly only.....	1	1.25
461	AP-18	Filter element only.....	1	3.50
462	AP-137F	Lower bowl only.....	1	1.75
463	AP-17F	Baffle plate only.....	1	.25
464	AP-137Z	Felt liner & retaining spring.....	1	.25
465	AP-22F	Clamp assembly only.....	1	.15
466	AP-15	Wing nut only.....	1	.10
467	AP-4	Instruction decalcomania only.....	1	.10

GASOLINE TANK GROUP 4

1550	A69-261	Gasoline tank assembly, includes 60-142 & 16-881.....	1	38.00
....	60-142	Gauge, gasoline tank.....	1	3.00
....	16-881-1	Gasket, gasoline gauge.....	1	.20
....	4-186	Cap, gasoline tank, easy-on #GD-297.....	1	1.00
....	A83-25	Gasoline tank strap assembly.....	2	1.90
....	06-69	Washer, plain, 3/8".....	4	.01
....	05-51	Lockwasher, 3/8".....	4	.01
....	04-103	Nut, hex. 3/8" - 16.....	4	.02
....	013-2	Nipple, close, tank drain, 1/4" pipe, 7/8" long.....	1	.04
....	013-632	Pipe cross, 1/4" PT.....	1	.40
....	013-761	Bushing, reducer, 1/4 x 1/8" PT.....	2	.08
....	52-56	Cock, elbow shut off, 5/16" tube, 1/8" PT x 90°.....	2	.40
....	A15-330	Cock, drain, 1/4" PT.....	1	.40
....	55-2-89	Gasoline line from tank to fuel pump on compressor engine, 5/16 x 84" lg.....	1	.75
....	B79-10	Clamp, tube, for 5/16" tube.....	3	.04
....	02-4	Capscrews, hex. for tube clamp, 1/4 - 20 x 1/2".....	3	.04
....	05-49	Lockwasher, 1/4".....	3	.01
....	156-138	Guard, gasoline tank.....	1	2.60
....	02-69	Capscrew for tank guard, hex. 1/2 - 13 x 1".....	4	.04
....	05-53	Lockwasher, 1/2".....	4	.01
....	A61-416-20	Gasoline gauge wire assembly, #10 ga. x 70" lg., from tank to truck line.....	1	.25

GOVERNOR GROUP 1

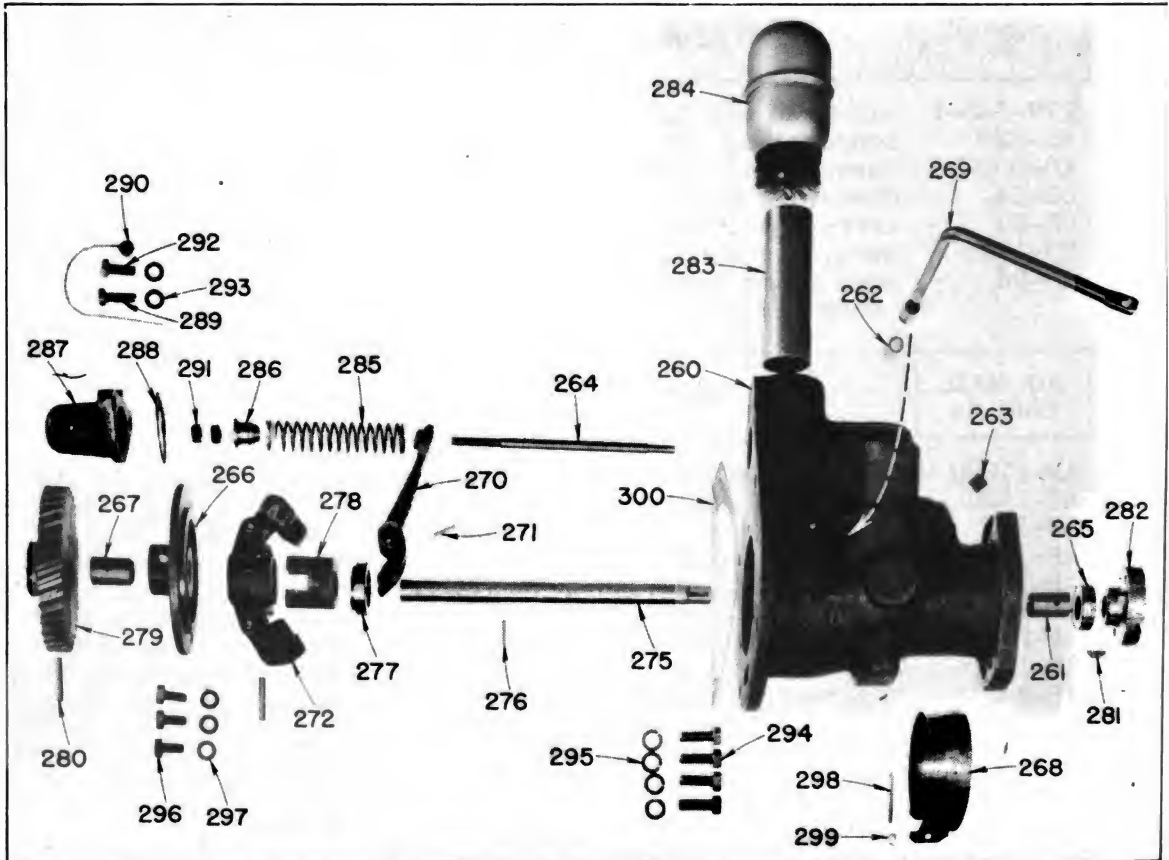

Unnumbered parts are identical to corresponding numbered parts

REF. No.	PART No.	NAME AND DESCRIPTION	QUAN.	PRICE EACH
	3A13-266-3	Governor assembly complete, includes #4A13-266-3, A27-870, also parts marked ⊕	1	\$48.00
	4A13-266-3	Governor body assy., incl. items marked ø..	1	20.00
260	13-266-3	øGovernor body.....	1	14.00
261	11-145	øBushing, governor shaft.....	1	.15
262	11-144	øBushing, governor cross shaft.....	2	.16
263	011-102	øPipe plug, 1/4" MPT, countersunk.....	1	.08
264	47-533	øRod, fixed speed and spring guide.....	1	.35
298	03-99	øScrew, 1-1/2" lg., fillister head, #10.....	1	.01
299	04-13	øNut, #10-hex.....	1	.01
268	14-782	øCover, magneto coupling hole.....	1	.30
269	27-1317	øCross shaft, governor operating.....	1	.45
270	48-325	øLever, governor operating.....	1	1.30
271	010-2	øTaper pin, for #48-325, #00 x 3/4" lg.....	1	.02
283	49-43	øBreather tube.....	1	.24
286	63-61	øSleeve, tube.....	1	.60
291	53-29	øNut, speed adjusting, 5/16"-hex.....	2	.02
287	14-796	øCover, governor spring.....	1	.40
288	16-879	øGasket, governor spring cover.....	1	.01
292	02-18	øCapscrew, 5/16-18 x 3/4".....	1	.04
289	106-156	øCapscrew, 5/16" special.....	1	.08
293	05-50	øLockwasher, 5/16".....	2	.01
265	125-28	øOil seal.....	1	.70
	A27-870	Governor shaft assy., incl. items marked ø..	1	25.50

PARTS LIST

GOVERNOR GROUP (CONT'D)

REF. No.	PART No.	NAME AND DESCRIPTION	QUAN.	PRICE EACH
275	27-870	*Governor shaft.....	1	\$ (1)
276	17-160	*Pin, governor weight stop.....	1	(1)
277	181-18	*Thrust bearing.....	1	(1)
278	63-51	*Thrust sleeve.....	1	(1)
279	26-334	*Gear, governor drive.....	1	(1)
266	A38-222	*Plate assy., governor body, incl. bushing	1	(1)
267	11-145	Bushing, governor shaft (included in A38-222)	1	(1)
280	010-42	*Taper pin, governor gear and yoke #3 x 1-1/4" lg.....	2	(1)
272	1A45-50	*Weight and Yoke assy.....	1	(1)
296	02-17	⊕Capscrew, governor body plate to governor 5/16" -18 x 5/8", hex.....	3	.04
297	05-50	⊕Lockwasher, for 02-17.....	3	.01
282	28-159	⊕Magneto coupling.....	1	1.50
281	09-6	⊕Key, magneto coupling, Woodruff.....	1	.02
284	A49-44-1	⊕Breather cap.....	1	1.50
285	24-286-1	⊕Governor spring.....	1	.08
290	A61-141	⊕Wire seal.....	1	.02
300	16-669	Gasket, governor body.....	1	.08
294	02-36	Capscrew, 3/8"-16 x 1" hex.....	4	.04
295	05-51	Lockwasher, 3/8".....	4	.01
301	A27-1152	Cross shaft, governor operating, includes next two items.....	1	4.00
302	28-198	Coupling, cross shaft.....	1	2.20
	010-201	Taper pin, cross shaft coupling, #000 x 1/2" lg.....	1	.02
305	48-441-1	Lever, governor operating cross shaft.....	1	.52
	03-92	Screw, fillister head, #10-24 x 1/2".....	1	.01
	010-201	Taper pin, governor shaft lever, #000 x 1/2" lg.....	1	.02

(1) Parts supplied only in assembly #A27-870.

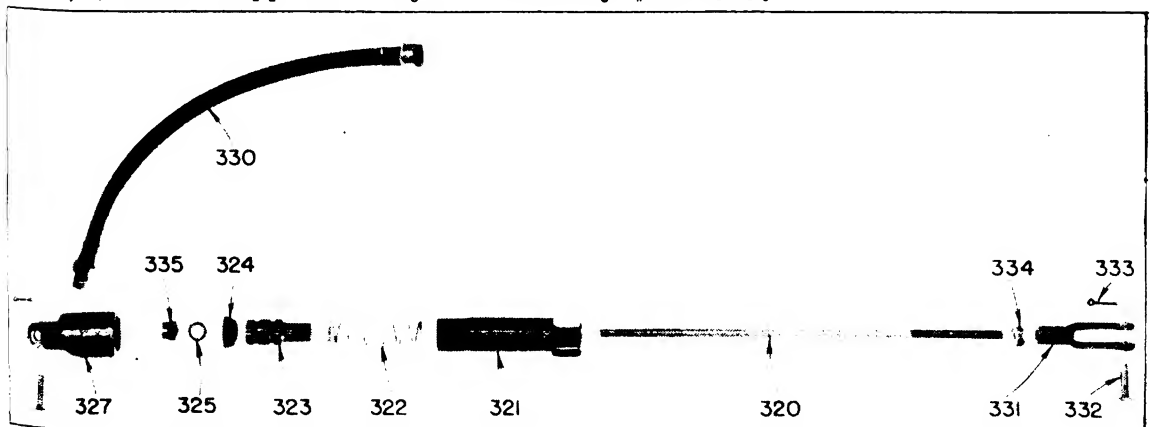

Unnumbered parts are identical to corresponding numbered parts

All6-47	Governor slow down assembly, includes items marked ▲.....	1	8.00
320	47-534 ▲Rod, governor slow down.....	1	.60
321	116-47 ▲Slow down body.....	1	2.00
322	24-282 ▲Spring.....	1	.45
323	25-96 ▲Plunger.....	1	1.20

GOVERNOR GROUP (CONT'D)

REF. No.	PART No.	NAME AND DESCRIPTION	QUAN.	PRICE EACH
324	20-310	▲Washer, leather cup.....	1	\$.40
325	20-316	▲Washer, steel.....	1	.06
335	04-801	▲Nut, 1/4"-28 castel., hex.....	1	.01
333	07-2	▲Cotter pin, 1/16" x 7/16".....	1	.01
327	53-221	▲Nut, slow down body.....	1	1.50
330	A73-253-12	▲Flexible hose connection, 1/4" MPT x 1/4" FPT.....	1	1.06
334	04-601	▲Nut, for clevis, 1/4"-28, hex.....	1	.01
331	031-2	▲Clevis rod end.....	1	.20
332	031-62	▲Clevis end pin.....	2	.04
333	07-2	▲Cotter pin, 1/16" x 7/16".....	2	.01

PARTS LIST

HOOD GROUP 1

PART No.	NAME AND DESCRIPTION	QUAN.	PRICE EACH
68-721-1	Hood top includes bail hole cover.....	1	\$ 29.50
74-69	Packing, hood top ends, 1/2 x 5/16" x 32 sponge, rubber cemented to hood top.....	2	.20
02-69	Capscrews, hex. for hood top ends, 1/2 - 1 3/4".....	6	.04
05-53	Lockwasher, 1/2".....	6	.01
06-71	Washer, plain, 1/2".....	2	.02
A68-723-2	Hood end, carb. side, front.....	1	5.20
A68-723-3	Hood end, magneto side, rear.....	1	5.40
A68-724-2	Hood end, magneto side, front.....	1	5.40
A68-724-3	Hood end, carb. side, rear.....	1	5.40
02-34	Capscrew, hex. for hood ends, 3/8 -16 x 3/4".....	12	.04
06-69	Washer, plain, 3/8".....	12	.01
05-51	Lockwasher, 3/8".....	12	.01

LIFTING BAIL GROUP 2

39-1454	Support, lifting bail.....	4	1.65
06-8	Washer, plain 5/8".....	8	.01
02-600	Capscrew, 5/8-18 x 1-1/4" hex.....	8	.12
05-55	Lockwasher, 5/8".....	8	.02
04-607	Nut, 5/8"-18, hex.....	8	.04
47-565	Rod, lifting bail, compressor end.....	1	3.00
47-564	Rod, lifting bail, engine end.....	1	3.00
04-109	Nut, 3/4"-10, hex.....	8	.06
05-57	Lockwasher, 3/4".....	8	.01

COMPRESSOR COOLING GROUP 1

REF. No.	PART No.	NAME AND DESCRIPTION	QUAN.	PRICE EACH
1570	A71-419-3	Intercooler assy. with guard, Optional, Perfex No. R6101; Young No. 27899, Includes part A to B, incl.....	1	\$150.00

NOTE: Intercoolers as assys. also service parts are interchangeable.

Perfex Part No.	Young Part No.	NAME AND DESCRIPTION	QUAN.	PRICE EACH
G-1343	27090B	Top tank.....	A 1	\$ 30.00
G-345	27091C	Bottom tank.....	1	28.00
G-5759	38690A	Side member, R.H.....	1	8.50
G-5758	38689A	Side member, L.H.....	1	8.50
71-467	71-467	Core sections.....	4	24.00
16-880-1	16-880-1	Gaskets.....	8	.06
FR-6101	39100	Fan Shroud.....	1	10.00
A12-43	38693	Front guard.....	1	12.00
G-21237	16282	Studs--1/2 - 13 x 3-1/2".....	4	.30
G-21410	28982	Spacers--1/2 - 13 x 1-1/4".....	4	.35
G-2284	39095	Hollow Hd. Bolt--1/2 - 13 x 1-1/4".....	4	.35
G-2285	39096	Hollow Hd. Bolt--1/2 - 13 x 2-1/4".....	8	.45
G-2002	39097	Lockwashers--1/2".....	20	.06
G-2086		Hex. nuts--1/2 - 13.....	12	.10
G-2288		Plain washers--1-1/8 O.D.....	20	.06
G-2070	39098	Rd. Hd. bolt--1/4 - 20 x 1/2".....	6	.06
G-2025	39099	Lockwashers - 1/4".....	6	.04
G-2052	39101	Hex. Hd. bolt--1/2 - 13 x 3/4".....	4	.12
G-2205	39102	Pipe plugs--1" hollow head.....	2	.45
G-2057	32832	Hex. Hd. bolt--1/2 - 13 x 2-3/4".....	B 12	.20

REF. No.	PART No.	NAME AND DESCRIPTION	QUAN.	PRICE EACH
....	B74-4	Packing, intercooler base.....	2	\$.30
....	02-101	Capscrew for intercooler, hex. 5/8 - 11 x 1-1/2".....	2	.08
....	B20-2	Washer, plain, 5/8".....	2	.02
....	05-55	Lockwasher, 5/8".....	2	.01
....	013-4	Nipple, close, 1/2" M.P.T. x 1-1/8".....	1	.06
....	013-457	Elbow, pipe reducing, 1 x 1/2" - 90°.....	1	.28
1575	A13-387	Intercooler relief valve assembly, includes plunger and next three items.....	1	10.50
1576	24-275	Spring, intercooler relief valve.....	1	.08
1577	16-791	Gasket, intercooler relief valve cap.....	1	.02
1578	4-128	Cap, intercooler relief valve.....	1	1.50
....	A182-33	Connector, elbow, air line from relief valve, 1/4" tube x 1/8" M.P.T. x 90°.....	1	.25
....	55-29-10	Air line from intercooler relief valve to rear tee on crankcase, 1/4" tube x 21"lg.....	1	.24
1580	A15-21-2	Valve, safety pop, 1" M.P.T., set for 50#.....	1	8.50

PARTS LIST

COMPRESSOR COOLING GROUP (CONT'D)

REF. No.	PART No.	NAME AND DESCRIPTION	QUAN.	PRICE EACH
....	65-637	Air connection, L.P., head to inter-cooler carb. side.....	1	8.10
....	65-638	Air connection, L.P., head to inter-cooler magneto side.....	1	8.10
....	65-639	Air connection, H.P., head to inter-cooler.....	1	8.10
....	16-664	Gasket, intercooler connection flange.....	3	.16
....	16-640	Gasket, cylinder head flange.....	3	.10
....	05-53	Lockwasher, 1/2".....	18	.01
....	02-71	Capscrew, hex. 1/2 - 13 x 1-1/2".....	18	.06
....	A182-33	Connector, elbow for air line from intercooler to intercooler gauge, 1/4" tube x 1/8" M.P.T. x 90°.....	1	.25
....	55-29-44	Air line from intercooler to intercooler gauge, 1/4 x 40" lg.....	1	.50

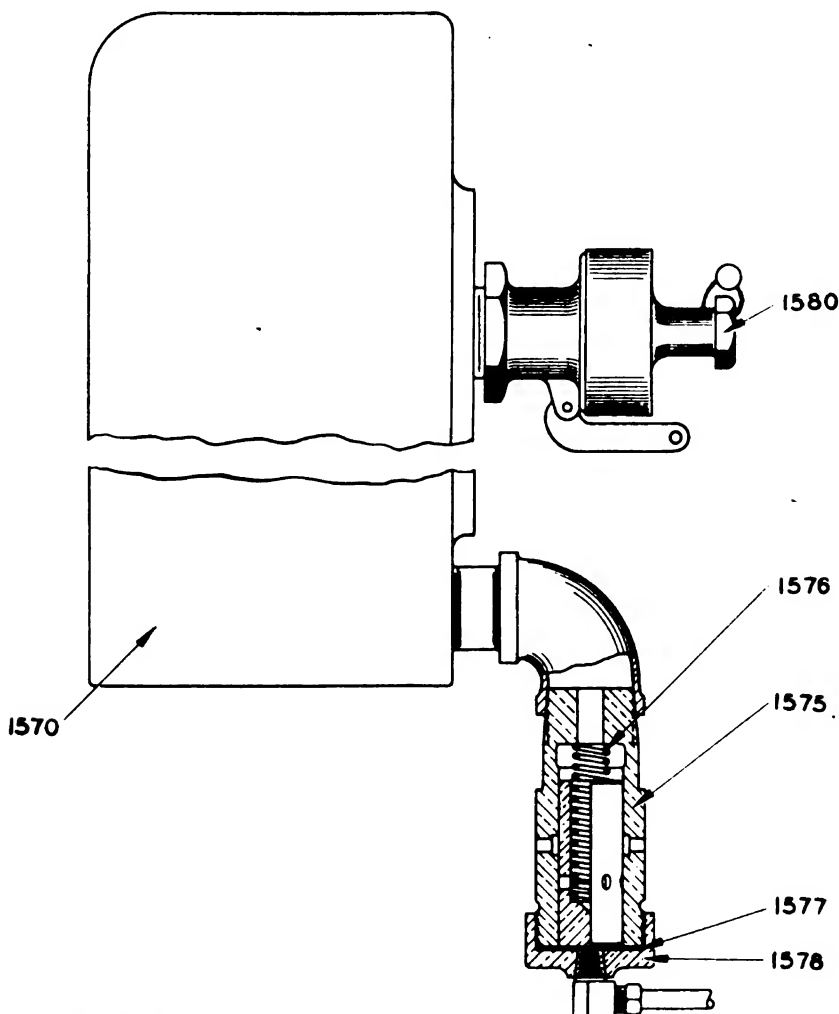

Intercooler and Relief Valve Assembly

ENGINE COOLING GROUP 1

PART No.	NAME AND DESCRIPTION	QUAN.	PRICE EACH
A71-422-3	Radiator assy. with guard, Optional, Perfex No. R-6100, Young No. 38688. Includes parts from A to B, Incl.....	1	\$ 125.00

NOTE: Radiators as assys. also service parts are interchangeable.

Perfex Part No.	Young Part No.	NAME AND DESCRIPTION	QUAN.	PRICE EACH
G-1342	27325B	Top tank.....A	1	\$ 28.00
G-344	16887A	Bottom tank.....	1	26.00
G-5789	38690	Side member, R.H.....	1	8.50
G-5790	38689	Side member, L.H.....	1	8.50
71-483	71-483	Core section.....	4	17.00
16-880-1	16-880-1	Gasket, for core section top and bot- tom.....	8	.06
FR-6100	39092	Fan shroud.....	1	10.00
AL2-42	38694	Front Guard.....	1	12.75
G-13500	12090	Cap, radiator filler.....	1	1.30
G-12521	11080	Filler neck.....	1	1.20
G-21671	39093	Overflow tube, 3/8" x 40".....	1	1.30
G-2278	39094	Connector.....	1	1.10
G-21237	16282	Stud, guard and core section, 1/2 - 13 x 3-1/2".....	4	.30
G-21410	28982	Spacer, 1/2 - 13 x 1-1/4", special.....	4	.35
G-2284	39095	Capscrew, 1/2 - 13 x 1-1/4", hollow head.....	4	.35
G-2285	39096	Capscrew, 1/2 - 13 x 2-1/4", hollow head.....	8	.45
G-2002	39097	Lockwashers, 1/2".....	20	.06
G-2086		Nut, 1/2" - 13, Hex.....	12	.10
G-2288		Plain washer, 1/8" O.D.....	20	.06
G-2070	39098	Screw, 1/4 - 20 x 1/2" Rd. head.....	6	.06
G-2025	39099	Lockwasher.....	6	.04
G-2057	32832	Capscrew, 1/2 - 13 x 2-3/4".....B	12	.20
G-2052	39101	Hex. hd. bolt, 1/2 - 13 x 3/4".....	4	.12

PART No.	NAME AND DESCRIPTION	QUAN.	PRICE EACH
33-22-5	Nipple, special pipe, for rad, inlet, 1-1/4" M.P.T., thrd. one end only.....	1	.16
B74-4	Packing, radiator base.....	2	.30
02-101	Capscrew for radiator.....	2	.08
B20-2	Washer, plain, 5/8".....	2	.02
05-55	Lockwasher, 5/8".....	2	.01
16-664	Gasket for radiator outlet.....	1	.16
12-380	Connection, radiator outlet.....	1	3.00
02-70	Capscrew for radiator connection, hex. 1/2--13 x 1-1/4".....	2	.04
05-53	Lockwasher, 1/2".....	2	.01
52-48	Drain, cock 3/8" M.P.T.....	1	.50
73-41-6	Hose for radiator outlet to water pump, 1-5/8" I.D. x 11" lg.....	1	.56
83-95	Hose clamp assembly for 2" O.D. hose.....	2	.06
73-41-19	Hose for engine outlet to radiator, 1-5/8" I.D. x 8-1/2" lg.....	1	.40
71-71	Thermostat assembly.....	1	1.80
95	Hose clamp assembly for 2" O.D. hose.....	2	.06

PARTS LIST

COMPRESSOR GASKETS GROUP 1

PART No.	NAME AND DESCRIPTION	QUAN.	PRICE EACH
16-344	Gasket, bearing retainer to crankcase.....	2	\$.22
16-418	Gasket, oil pump body to retainer.....	2	.12
16-419	Gasket, oil pump body to check valve.....	2	.04
16-419-1	Gasket, oil pump body conn.....	4	.04
B16-117	Gasket, oil relief body.....	2	.04
16-616	Gasket, breather body to crankcase.....	2	.06
16-422	Gasket, fan drive pulley.....	2	.08
16-519	Gasket, cylinder flange (.010" thick).....	12	.08
16-518	Gasket, cylinder flange (.015" thick).....	12	.08
16-801	Gasket, cylinder head.....	6	.40
16-744	Gasket, suction and discharge valve seat..	12	.14
16-745	Gasket, suction and discharge valve cover	12	.30
16-605	Gasket, oil pan flange.....	2	.20
16-627	Gasket, air cleaner base.....	4	.08
16-640	Gasket, air connection flange.....	14	.10
16-791	Gasket, intercooler relief valve cover.....	2	.02
16-664	Gasket, intercooler connection flange.....	6	.16
16-880-1	Gasket, intercooler and radiator core.....	16	.06

ENGINE GASKETS GROUP 2

16-777	Gasket, retainer to crankcase.....	1	.05
16-626	Gasket, oil retainer to crankcase flange..	2	.04
16-636	Gasket, oil pump body to cover.....	1	.06
16-635	Gasket, oil pump cover flange.....	1	.04
B16-117	Gasket, oil relief plug.....	1	.04
16-650	Gasket, gear cover, upper.....	1	.06
16-651	Gasket, gear cover, manifold side.....	1	.08
16-652	Gasket, gear cover, lower.....	1	.08
16-653	Gasket, gear cover, magneto side.....	1	.08
16-647	Gasket, oil pan flange manifold side.....	1	.12
16-648	Gasket, oil pan flange, magneto side.....	1	.12
16-649-1	Gasket, oil pan flange, Bell Housing End..	1	.38
16-879	Gasket, governor spring cover.....	1	.01
16-669	Gasket, governor body.....	1	.08
16-630	Gasket, intake manifold.....	2	.08
16-631	Gasket, exhaust manifold, center.....	1	.12
16-632	Gasket, exhaust manifold, end.....	2	.12
16-629	Gasket, cylinder head.....	1	1.50
16-643-1	Gasket, cylinder head breather.....	1	.10
16-634-3	Gasket, cylinder head cover.....	1	.50
16-27	Gasket, carburetor flange.....	1	.08
16-229	Gasket, fuel pump.....	1	.04
16-754	Gasket, water pump body.....	1	.08
16-638	Gasket, water pump bracket.....	1	.08
16-646	Gasket, water outlet connection.....	2	.06
16-796	Gasket, spark plug.....	4	.01
16-921-1	Gasket, fuel pump glass bowl, AC #854003..	1	.07
186-9	Diaphragm, fuel pump, AC #855389.....	1	.37
16-664	Gasket, radiator flange, see "Intercooler Flange Gasket".....	1	.16
16-908-1	Gasket, air cleaner support.....	1	.16
16-881-1	Gasket, gasoline gage.....	1	.20

SPARE PARTS BOX GROUP 3

PART No.	NAME AND DESCRIPTION	QUAN.	PRICE EACH
119-128	Spare parts box.....	1	\$ 7.00
2A15-325	Discharge valve assembly.....	2	12.00
A15-325	Suction valve assembly.....	2	14.00
R24-1	Springs, suction and discharge valve.....	12	.08
15-200	Valve, intake.....	4	1.40
15-201-1	Valve, exhaust.....	4	1.90
B24-26	Spring, valve.....	8	.28
86-9-5	Spark plug.....	4	.60
20-379	Washer, water pump carbon seal.....	1	.24
127-8	Bracket, magneto contact, Am. Bosch: BK 5264.....	1	4.75
127-9	Lever, magneto breaker, Am. Bosch: LE 5236.....	1	.60
184-2	Bowl, fuel pump glass.....	1	.15
15-323-1	Valves, air, Cleco, 1" x 3/4" R.A. angle handle.....	2	4.50
013-6	Nipple, close, 1" Pt.....	2	.10
41-143	Belt, for intercooler fan.....	1	2.90
41-225	Belt, for radiator fan.....	1	3.00

**INDEX
TO
AIR TOOLS
AND
ACCESSORIES**

**OPERATING
INSTRUCTIONS**

**MAINTENANCE
INSTRUCTIONS**

PARTS LIST

ACCESSORIES

**NUMERICAL
PARTS LIST**

MEMORANDUM

TOOLS, AIR**GENERAL**

Although pneumatic tools are in general use, the care and maintenance of the pipe lines and hose is generally neglected. This is, more or less, water in the pipe line and it is one of the worst enemies to pneumatic tools as it not only washes out the lubrication in the tool but rapidly forms scale in the pipe line which finally loosens up and is carried into the tools. A large percentage of repairs to pneumatic tools is due to water, dirt and scale from the pipe lines. Keep them clean.

HOSE

Be sure hose is free from grit, scale or loose rubber from inside of hose and will pass air freely to maintain 80# to 90# air pressure while tool is in operation. Before making any connections to pneumatic tools, blow out hose line.

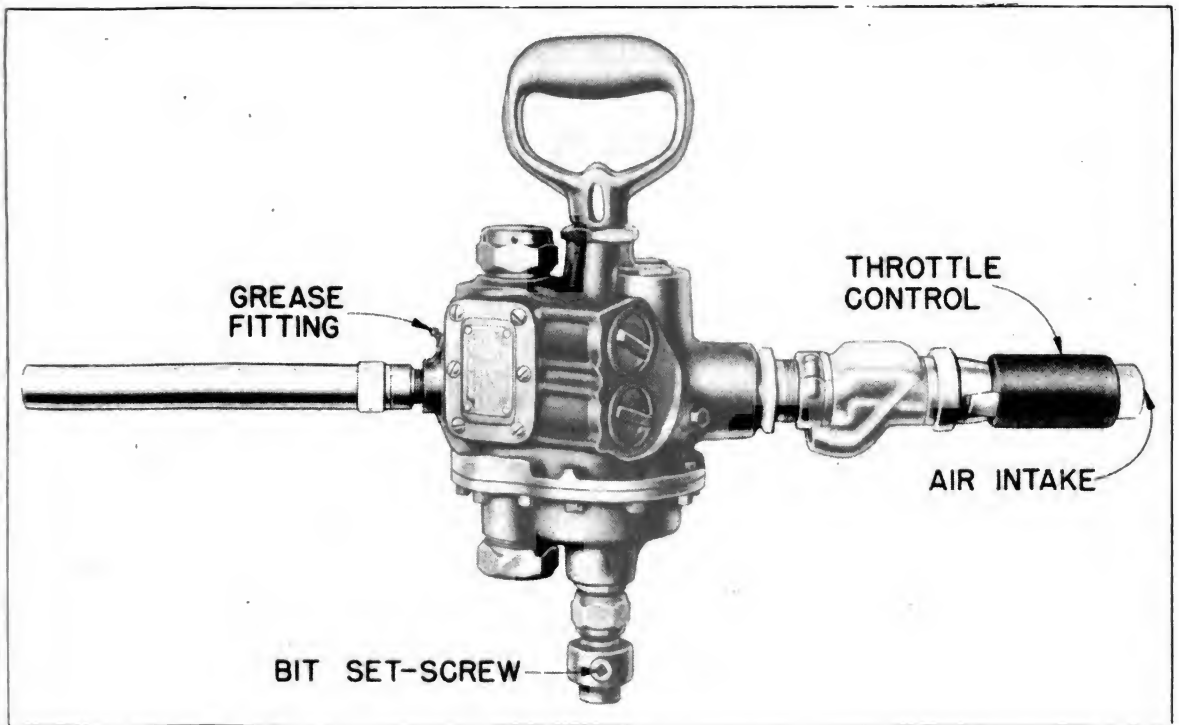
No. 62 WOOD BORING MACHINE

No. 62 Wood Boring Machine

#62 Wood Boring Machine is used for drilling holes up to 2" in diameter in dry, green or water soaked lumber or timber.

CARE AND OPERATION

Before connecting the machine to the hose line inject OE-10 (oil, engine S.A.E. 10) through the reducer of live air handle. When the air is turned on this will give the throttle and valve parts the proper lubrication. Oiling in this manner should be done at least every 4 hours, to prevent corrosion and sticking of the valve parts.

The gear parts, connecting rod, eccentrics, pistons, crank, bearing parts etc. depend upon the lubricant in the crankcase which will be thrown or splashed over all the parts provided the correct grade of grease is used. Use CG-1 (Grease, general purpose No. 1) above +32° F; CG-0 (Grease, general purpose No. 0) +32° F. to 0° F. every 8 hours.

Under no condition should a machine be packed more than 1/3 full with CG.

When the machine has been in service a long time and is returned for repairs, disassemble machine and carefully inspect all parts.

CAUTION

Do not allow the machine to run without load for any length of time.
Do not use a mutilated wood bit.
Do not fail to make certain that the cutting angle of the bit is correct. Use gauge in resharpening bits.
Do not allow the machine to lie idle on shop floors or yards for any length of time.
Do not leave the air hose connected to the machine over night.
Do not neglect to blow out the air hose before connecting to the machine.
Do not neglect lubricating; oil throttle every four hours and put grease in crankcase every 8 hours before starting.

No. 412 CLAY DIGGER

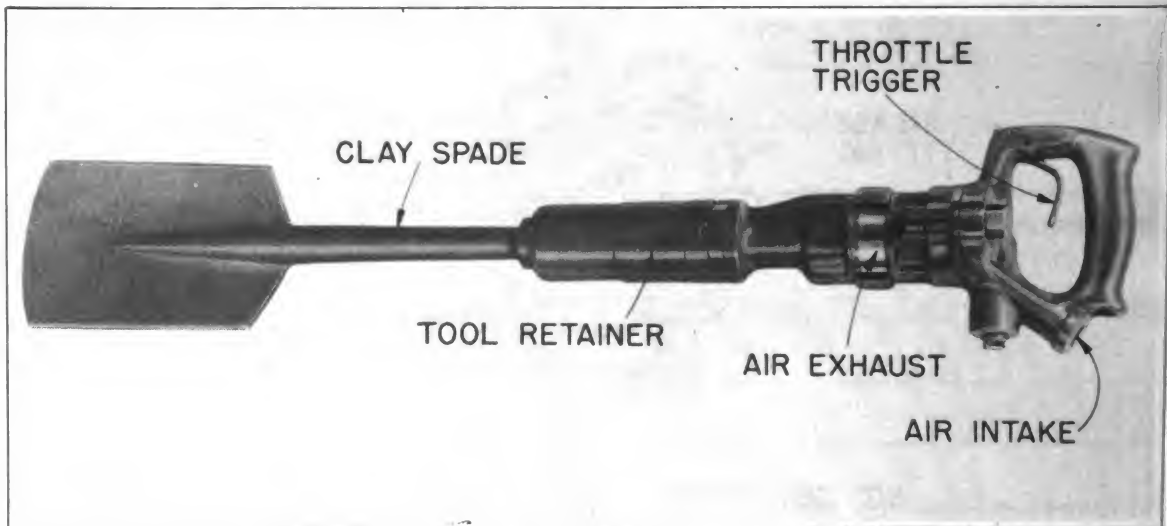

No. 412 Clay Digger

The #412 Clay Digger is a light weight tool used for light duty trimming and overhead cutting and on side walls, in panels and caissons and other excavations.

CARE AND OPERATION

Inject OE-10 (oil, engine S.A.E. 10) through the exhaust holes. Oiling in this manner should be done every four hours. To prevent corrosion and sticking of valve parts, wash tool every 64 hours with kerosene after which they should be thoroughly oiled. If the tool is to be stored for a long time a very liberal amount of oil should be poured in the air intake with the throttle held open.

No. 75 SINKER ROCK DRILL

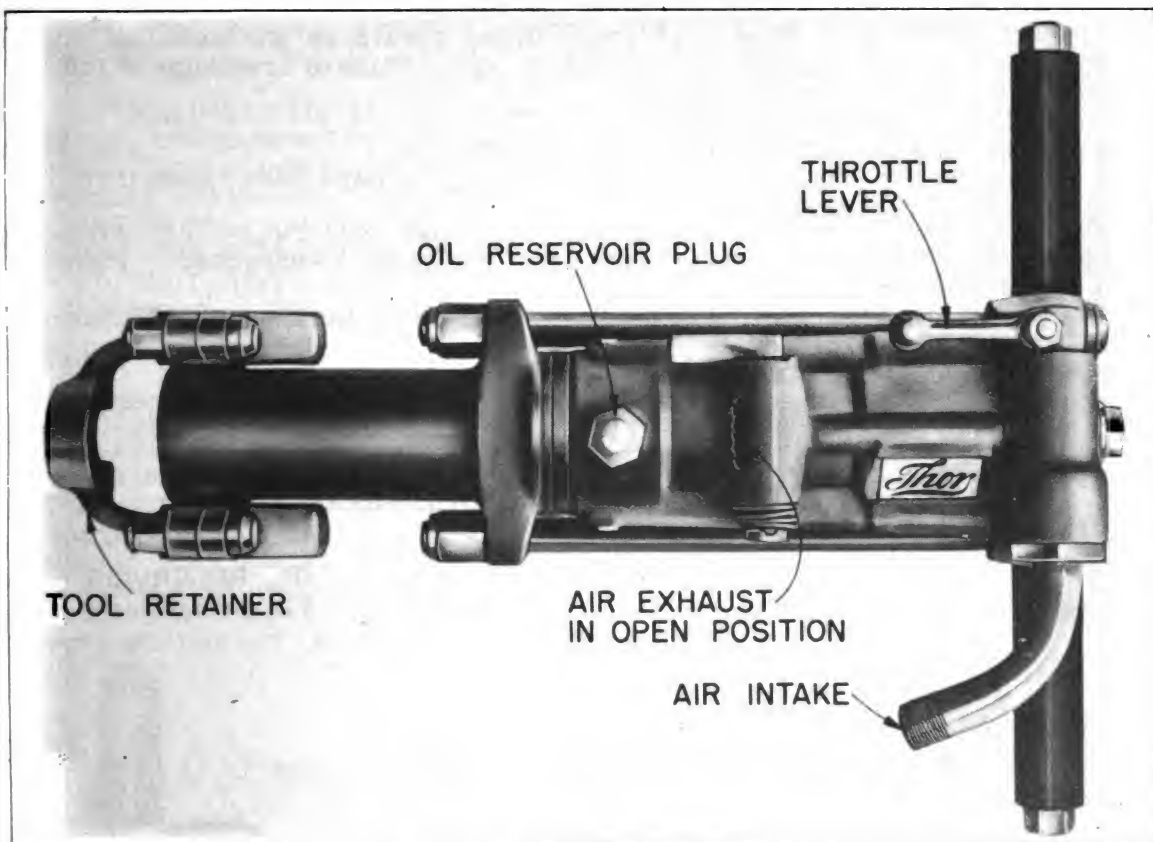

No. 75 Sinker Rock Drill

The #75 Singer Rock Drill is a medium weight machine used for hard deep hole drilling, shaft sinking and quarrying.

CARE AND OPERATION

When the machine is in operation the oil in the reservoir is under air line pressure and becomes aerated thereby carrying through numerous air holes to all parts of the drill. Every 2 hours of continuous work fill the oil reservoir, unscrew the oil plug on top of the cylinder and fill with OE (oil, engine) crankcase grade. The nature of the oil to be used will depend primarily upon the temperature and humidity in the locality where the machine is being operated.

Every 64 hours flush the working parts of the Rock Drill by pouring a small amount of kerosene thru the air inlet, running the machine for a short time, and then pouring into the same inlet a small amount of OE-10 (oil, engine S.A.E.-10).

The two oil control Felts in back of the cylinder should be removed and washed in kerosene then dried by a blast of air. Before replacing the Felts, the cylinder should be cleaned and a strong blast of air blown through all holes to make certain that the oil holes are free from any obstacles that might retard lubrication.

Care should be taken that all lubricating oil is clean and free from impurities. Under no condition should used crankcase oil be employed.

CAUTION

Do not attempt to drive a drill steel after it has become so dull as to cut with difficulty. This will cause undue strain on the working parts, crystallization and fatigue of the metal and ultimate breakage which may extend back into the drill itself.

Do not fail to keep all nuts tight.

Do not fail to keep machine well lubricated.

Do not attempt to repair drills on the job; always take them into the shop or some enclosed place.

Do not leave drills on the job as long as they will run. At frequent intervals they should be taken down into the shop, inspected, cleaned, worn parts replaced and lubricated.

Do not install new parts in conjunction with badly worn ones; neither can function at top efficiency.

Do not use badly worn chucks.

Do not use bad drill steel shanks. Make sure they are of proper length (4½" collar to end), up to size (1" hexagon), and have perfect square ends.

MODEL 25 PAVING BREAKER

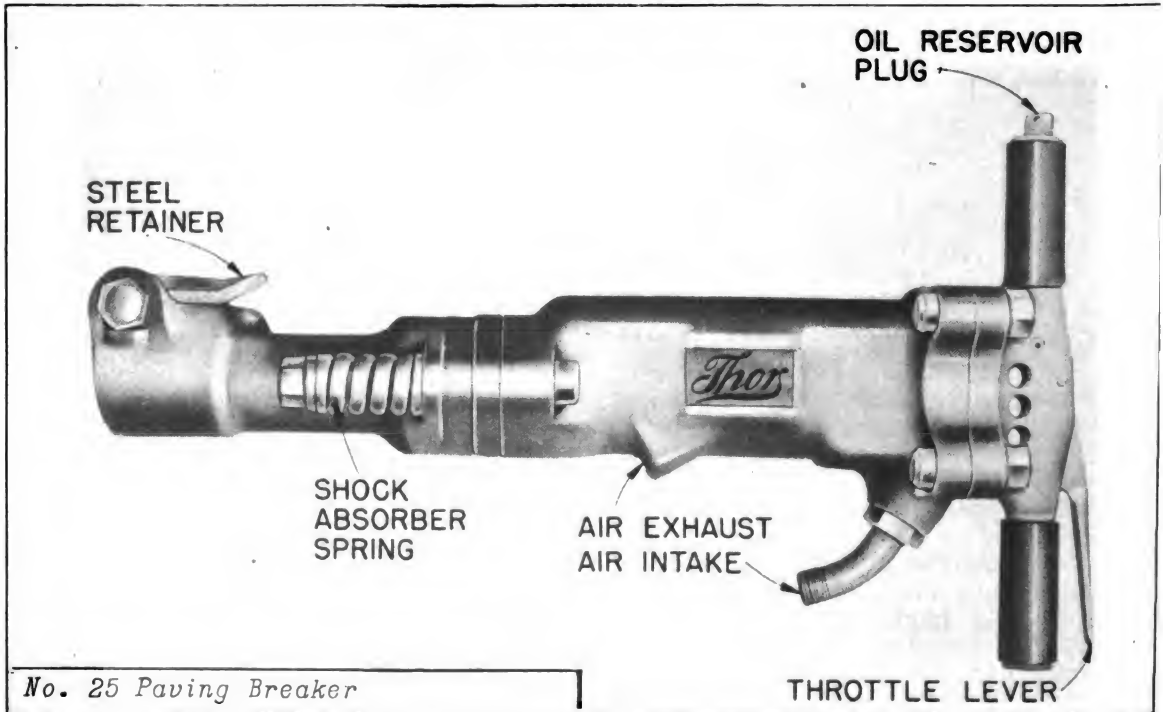

The #25 Paving Breaker is designed for the hardest kind of demolition work - breaking up concrete, brick, and asphalt pavement; walls, columns, piers and the like. A sheeting driver attachment is furnished and can be quickly attached to paving breaker by 2 bolts converting unit to a sheeting driving tool. Sheeting driver head will handle up to 2" planks.

CARE AND OPERATION

The oil reservoir in the handle of the back head should be filled every two hours during continuous operation. The oil may have to be replenished more frequently depending upon the viscosity of the oil, and the operating conditions. To fill the oil reservoir, unscrew the oil plug in the end of the handle and fill the reservoir with OE-10 (oil, engine S.A.E.-10).

OPERATOR'S INSTRUCTIONS

TOOLS—AIR
Page 153

Every 64 hours flush the working parts of the machine by pouring a small amount of kerosene into the air inlet, run the machine for a short time, and then pour a small amount of light lubricant into the same inlet.

The oil control Felt in the side of the handle should be removed and washed in kerosene at frequent intervals, dried by a blast of air and replaced. It is important that this Felt be kept free of dirt or other substances which would render it less porous. If it is allowed to become clogged it will impair the lubrication and shorten the life of the machine. The Felt may be removed by unscrewing the small oil plug on the side of the handle. Care should be taken that only clean oil be used in the reservoir. Under no conditions should used crankcase oil be employed.

CAUTION

Do not fail to keep all nuts tight.

Do not fail to keep machine well lubricated.

Do not attempt to repair the machine on the job; always take it into the shop or some enclosed place.

Do not leave machines on the job as long as they will run. At frequent intervals they should be taken down in the shop, inspected, cleaned, worn parts replaced and lubricated.

Do not install new parts in conjunction with badly worn ones; neither can perform at top efficiency.

THOR AIR TOOLS

SPECIFICATIONS

MANUFACTURER.....INDEPENDENT PNEUMATIC TOOL CO
CHICAGO, ILLINOIS

TOOL NAME	NUMBER/MODEL
Wood Boring Machine (Reversible).....	62WB, 958
Clay Digger.....	412, 4913
Sinker Rock Drill.....	75
Paving Breaker.....	25
(Includes Sheeting Driver).....	25S, C-2590

GENERAL

All service problems and repair parts orders are to be referred to Independent Pneumatic Tool Co., Chicago, Ill., or any of their branch offices listed below.

I N D E P E N D E N T P N E U M A T I C T O O L C O .
600 WEST JACKSON BOULEVARD CHICAGO, ILLINOIS

- | | | |
|---|--|---|
| BIRMINGHAM, ALA.
229 So. 21st St. | BOSTON, MASS.
1119 Little Bldg. | BUFFALO, N. Y.
521 Genesee Bldg. |
| CLEVELAND, OHIO
1740 E. 12th St. | DETROIT, MICH.
15605 Woodrow Wilson Ave. | LOS ANGELES, CALIF.
6200 E. Slauson Ave. |
| MILWAUKEE, WIS.
2637 W. Clybourn St. | NEW YORK, N. Y.
330 W. 42nd St. | PHILADELPHIA, PA.
1701 Fairmount Ave. |
| PITTSBURGH, PA.
803 Wabash Bldg. | ST. LOUIS, MO.
4044 Forest Park Blvd. | SALT LAKE CITY, UTAH
216 S. W. Temple St. |
| SAN FRANCISCO, CALIF.
315 S. Van Ness St. | SEATTLE, WASH.
1741 1st Ave. S. | TORONTO, ONT.
32 Front St., W. |

LONDON, ENGLAND - 40 Broadway, S.W.1

FACTORIES: AURORA, ILLINOIS AND LOS ANGELES, CALIF.

Be sure to accompany your request with detailed information covering tool in question, such as; Model, Number, Name, Serial Number, etc.

HOSE & PIPE LINES

Although pneumatic tools are in general use, the care and maintenance of the pipe lines and hose is generally neglected. This is, more or less, water in the pipe line and it is one of the worst enemies to pneumatic tools, as it not only washes out the lubrication in the tool, but rapidly forms scale in the pipe line which finally loosens up and is carried into the tools. A large percentage of repairs to pneumatic tools is due to the water, dirt, and scale from the pipe lines. Keep them clean.

Be sure hose is free from grit, scale or loose rubber from inside of hose, and will pass air freely and maintain 80 to 90 lbs. air pressure while tool is in operation. These tools should never be operated on less than 3/4" inside diameter air hose.

MAINTENANCE INSTRUCTIONS

**THOR No. 62 WB PNEUMATIC PISTON TYPE
WOOD BORING MACHINES**

INSPECTION:

Remove 80 clamp nut for throttle and inspect 150 copper gasket for throttle. If gasket is broken, replace with a new one. 80 clamp nut for throttle should be tightened securely when replacing.

Remove 84 crank chamber plates by first removing 85 screws and inspect all four connecting rods, 914 and 915 connecting rod screws. Test them to be sure they are tight.

Turn over crank to see if it is free after several revolutions. Check lubrication. Remove all four 42 cylinder head and look for scale, dirt, rust, and if piston is galled in cylinder.

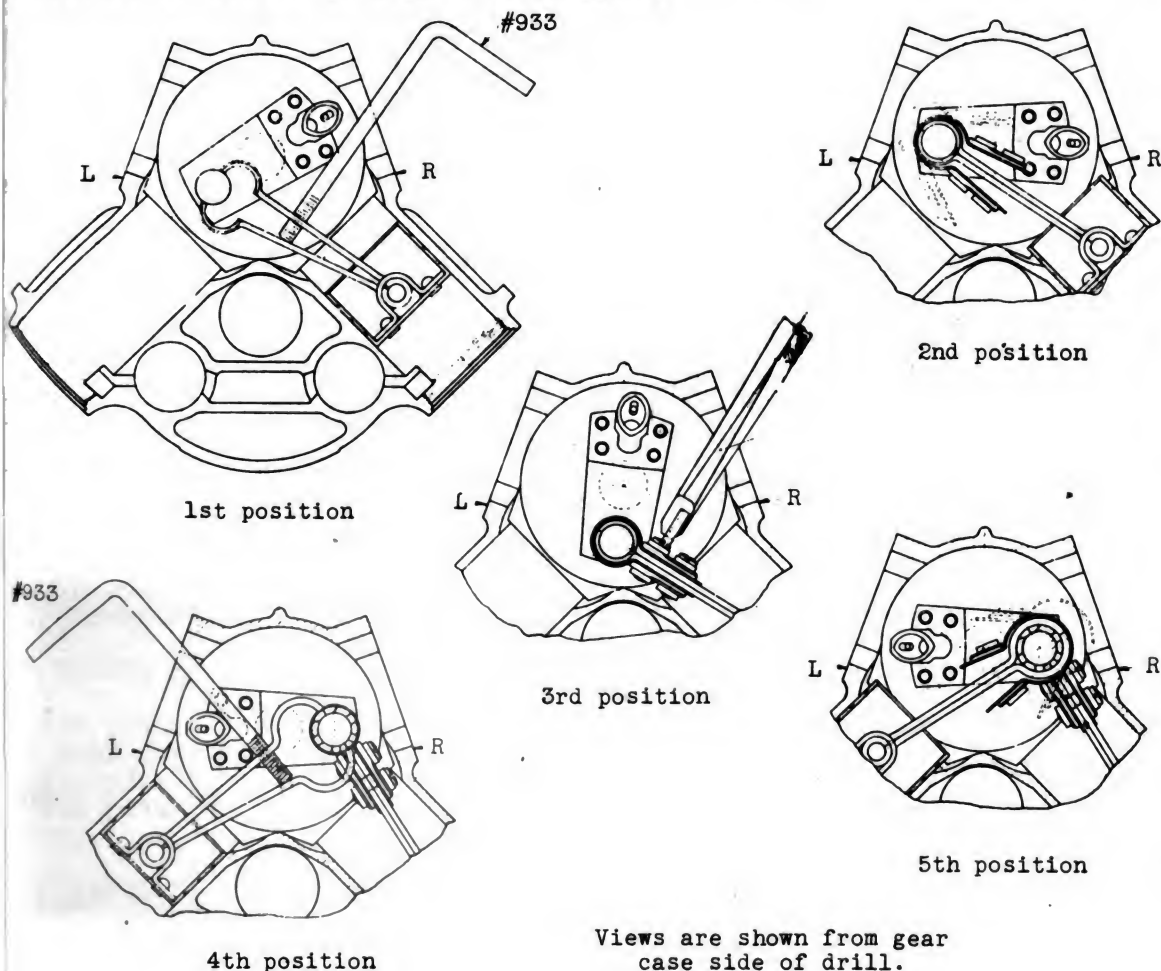

TO REMOVE PISTON AND RODS, FOLLOW DIAGRAM:

First remove 915 screws in 11 clamp for out side connecting rods. Remove 11 clamp for outside connecting rod. Open connecting rods with #933 wrench, or use 1/4" x 20 thread set screw or stove bolt, to open connecting rods until they can be released from crank pin. Remove #933 wrench or 1/4" x 20 thread screw and slide 913 outside connecting rod and piston out of top of cylinder. See 5th and 4th positions on drawing.

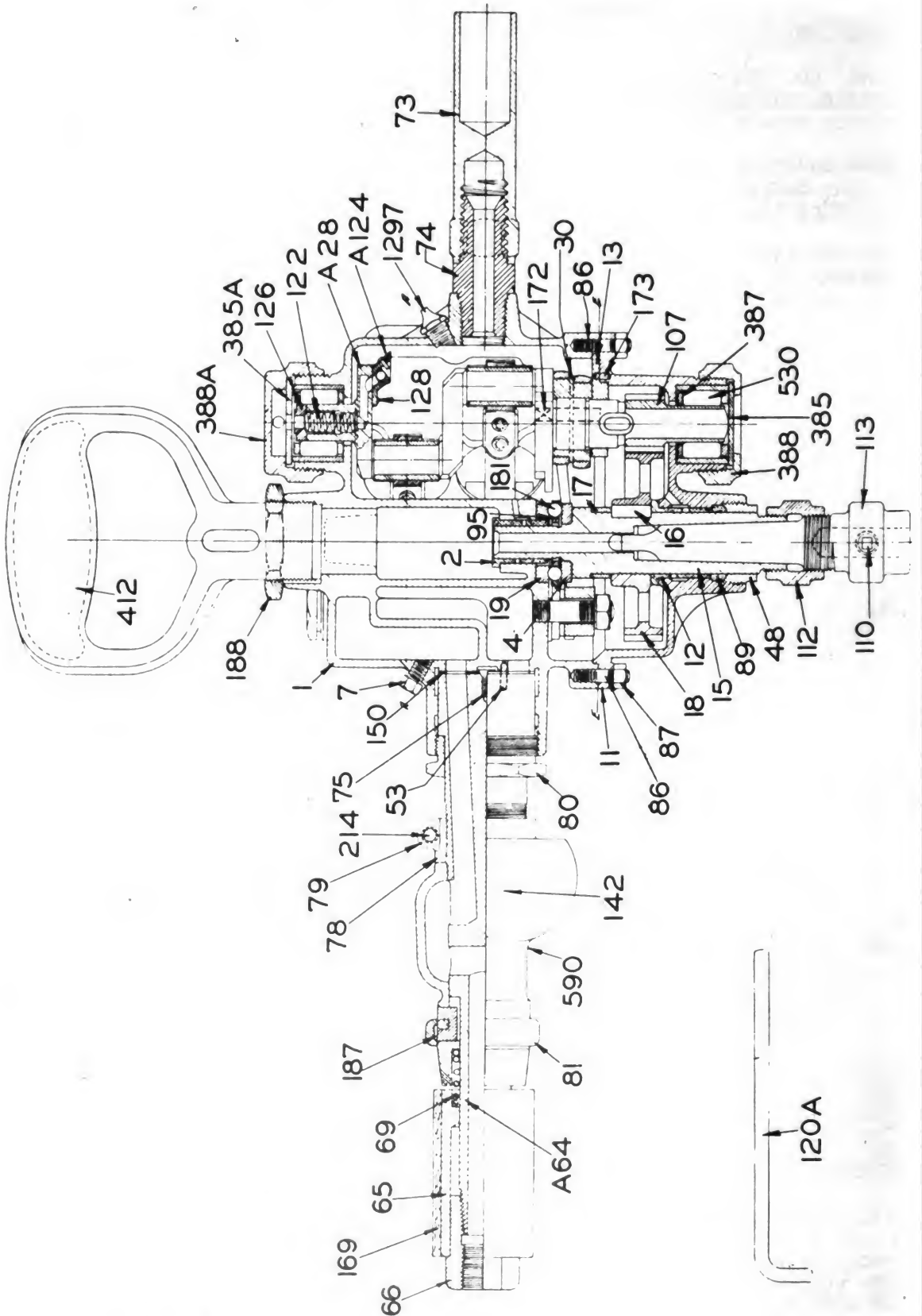

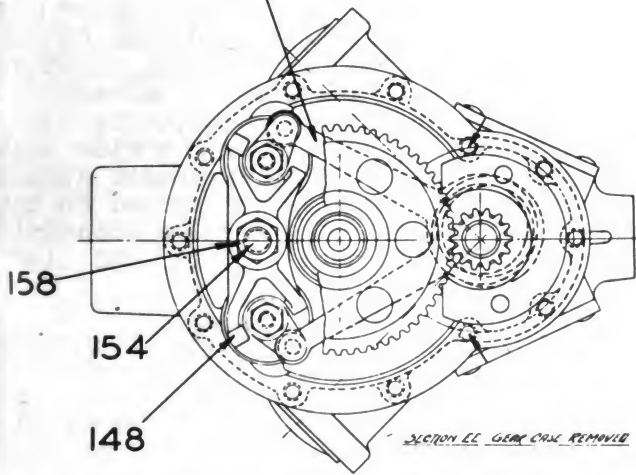
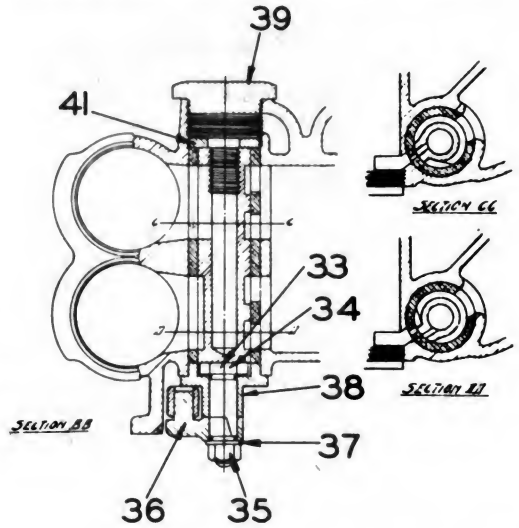
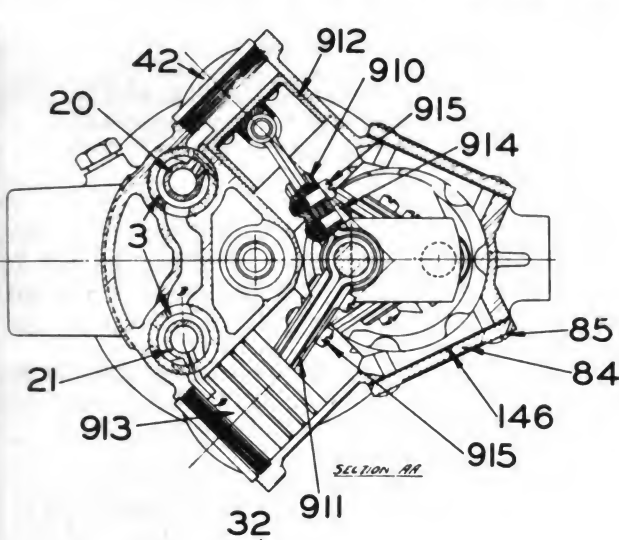

TO REMOVE INSIDE CONNECTING ROD:

Remove 914 and 915 connecting rod screws. Remove 910 clamp for inside connecting rod. Open connecting rod with #933 wrench or use 1/4" x 20 thread screw or stove bolt to open connecting rod until it can be released from crank pin. Remove #933 wrench or 1/4" x 20 thread screw and slide 12 inside connecting rod and piston out of top of cylinder. See 3rd, 2nd and 1st positions on drawing.

To assemble the connecting rods use reverse rotation in operation.

TO REMOVE A28 CRANK:

First remove all connecting rods and pistons as outlined above. Remove 11 gear case by first removing all 87 gear case stud nuts. Remove right and left 35 valve stud nuts and 37 washer. Remove right and left 36 valve lever which are pressed on 33 right valve stud and 34 left valve stud.

TO REMOVE 36 VALVE LEVERS:

Tap blade of screw driver lightly under valve lever. Thread 35 nut back on 33 and 34 valve studs to protect threads. Tap end of valve stud with hand hammer to release press fit. Remove nuts from valve stud and continue to remove valve levers by prying off with screw driver blade. A small bearing puller can also be used in removing valve levers if convenient. When striking valve stud with hand hammer caution should be exercised not to strike hard enough to break threaded stem of valve stud.

Remove 13 centerplate.

Remove 30 eccentric and the two eccentric straps.

A28 crank is now free to lift out.

TO REMOVE 20 RIGHT VALVE AND 21 LEFT VALVE:

Remove 39 exhaust caps right hand thread. Remove 41 valve end plates right hand thread and valves are then free to slide out of open end.

TIMING OF THE MACHINE:

The timing of the machine is in setting of the 3 valve bushings that are pressed into the 1 cylinder and these valve bushings should never be tampered with under any circumstances, for it takes special equipment and timing device to accurately set these valve bushings.

The 20 and 21 are Corliss Valves and are self-seating. When the valve bushings become worn the air behind the valve holds it on its seat and the valves are free to follow up their own wear in the bushing.

When replacing eccentrics, eccentric straps, valves and valve studs, caution must be taken to replace them carefully in their right or left positions. The flange on the 1 cylinder is stamped "R" for right and "L" for left directly opposite to the 3 valve bushings. The 20 right valve is stamped with the letter "R" and the 21 left valve is stamped with letter "L" on end. The 33 right valve stud is stamped "R" on the flat of valve stud. The 34 left valve stud is stamped "L" on the flat of valve stud. The 30 eccentric is stamped "R" on one side and "L" on the opposite side, and cannot be assembled wrong because there is a keyway on the side that slides in a key slot in the end of the crank flange. 32 eccentric straps although not stamped right or left, the eccentric strap assembled to the right side of the eccentric should go to the right valve and the eccentric strap assembled to the left side of the eccentric should go to the left valve.

In case the 590 valve should become locked, making it impossible to rotate throttle handle, strike open exhaust end of 590 exhaust valve and this will release its seat. Hold the valve off of seat and pour oil through exhaust opening to reach the valve seat. If the valve sticks frequently it is advisable to disassemble the 590 valve from A64 stem and lubricate the valve seat with a very thin film of beeswax, which will last much longer than lubricating oil.

THOR No. 412 CLAY DIGGER

INSTRUCTIONS FOR DISASSEMBLY:

Remove 57674 throttle cap, 2502 valve spring and 61961 throttle valve. Clean thoroughly. Inspect intake hole in 57675 valve bushing for scale, dirt or loose rubber from inside of air hose. Blow out bushing with compressed air through 37674 throttle cap opening. Be careful not to lose 61965 valve stem. Assemble in reverse order and be sure to pull up 57674 throttle cap as tight as possible.

If tool does not start remove 61942 nut from 64135 bolt. Lift off 69085 handle assembly. Remove 69098 cylinder valve block assembly. Press off 69082 valve sleeve from 69098 cylinder valve block assembly. Remove 69083 thrust plug and 68419 cylinder valve. Clean thoroughly. Inspect intake holes in top of 69081 valve block.

Remove 65891 piston. Clean piston and 65889 barrel thoroughly. Inspect lower end of barrel to be sure mud has not worked up into barrel past spade shank in 69084 nozzle and accumulated in bottom of barrel.

Assemble in reverse order. Be sure to tighten 61942 nuts evenly in order to prevent breakage.

MAINTENANCE INSTRUCTIONS

SPECIFY SERIAL NO. AND MODEL NO. OF TOOL WHEN ORDERING PARTS

69085 HANDLE ASSEMBLED COMPLETE WITH
2502 SPRING, 57874 CAP, 69381 VALVE,
61963 TRIGGER, 61964 TRIGGER PIN, 71683
VALVE STEM, 68990 HANDLE ASSEMBLY

68990 HANDLE ASSEMBLED WITH 57875 VALVE
BUSHING, 6952 STEM BUSHING

61963 TRIGGER

61964 TRIGGER PIN

6952 VALVE STEM BUSHING
71683 VALVE STEM

61942 NUT

69082 VALVE SLEEVE

68419 CYLINDER VALVE

69083 THRUST PLUG

61943 WASHER

64135 BOLT

69081 VALVE BLOCK

61890 DEFLECTOR

69381 THROTTLE VALVE

2502 VALVE SPRING

57875 VALVE BUSHING

57874 THROTTLE CAP

69098 CYLINDER VALVE BLOCK ASSEMBLED
COMPLETE INCLUDES 68419 VALVE,
69081 BLOCK, 69082 SLEEVE, 69083 PLUG

68991 BARREL & NOZZLE ASSEMBLY INCLUDES
65889 BARREL, 69084 NOZZLE

65889 BARREL

65891 PISTON

61948 RETAINER SPRING

69095 RETAINER BODY

69084 NOZZLE $\frac{1}{8}$ HEXAGON

61945 SPLIT SLEEVE

69024 RUBBER BUMPER

69096 BUMPER PLATE (TWO HALVES)

No. 412 Clay Digger

HOW TO REMOVE SPADE FROM BARREL:

Lift up 61948 lock spring with screw driver blade until it releases 69095 retainer body, which will then unscrew (right hand thread).

HOW TO REMOVE SPADE FROM RETAINER:

After retainer is removed from barrel, slide 69095 retainer body down on shank of spade and if necessary drive out 69096 split bumper plate,

69124 rubber bumper and 61945 split sleeve with punch and hammer out o top of retainer body. Remove 69124 rubber bumper from shank of spade an retainer body will slide over shoulder of spade.

HOW TO INSTALL SPADE IN RETAINER:

Slide 69095 retainer body over shoulder of spade shank with large openin on top. Install 69124 rubber bumper on spade shank. Install 61945 spli sleeve on shank of spade under collar, and 69096 split bumper plate o shank of spade under rubber bumper. Hold assembly together with one han and turn up-side-down and let retainer body drop down over assembly which will hold the bumper parts in place.

HOW TO INSTALL SPADE & RETAINER TO BARREL:

When inserting spade assembled in retainer in 69084 hex nozzle, be sur the spade blade faces forward parallel with handle, with the hose inlet to the right before threading retainer body on barrel.

To lock 69095 retainer body, thread on barrel until top of retainer body reaches 61948 retainer spring. Lift retainer spring with screw driver blade and continue to thread retainer body on barrel until the lug or 61948 retainer spring engages in slot in 69095 retainer body and release retainer spring.

MAINTENANCE:

The piston should be replaced when worn from .003" to .004". The pistor diameters are 1.0600" and 1.6850".

Throttle valve stem and throttle stem guide should be replaced when badly worn to assure keeping the tool at greatest operating efficiency.

To remove the nozzle of the Clay Digger use #2213 Rod.

No. 75 SINKER ROCK DRILL

INSTRUCTIONS FOR DISASSEMBLING:

Before dismounting, the machine should be flushed throughout inside with liberal applications of kerosene. As kerosene leaves the machine dry, it is essential that it be thoroughly oiled before being put into operation.

WATER TUBE PLUG: (Part 708)
Unscrew Water Tube from Back Head.

AIR TUBE: (Part 719)
Withdraw air tube and Water Tube Packing (Part 632).

SIDE RODS: (Part 774)
Remove Side Rods and Side Rod Nuts (Part 772).

BACK HEAD: (Part 704)
Remove Back Head.

BACK HEAD PLATE: (Part 705)
Drive out with brass rod inserted in Water Tube Plug hole.

AIR INLET SWIVEL: (Part 725)
Unscrew Air Inlet Swivel Nut (Part 726). Swivel and Nut may now be removed together.

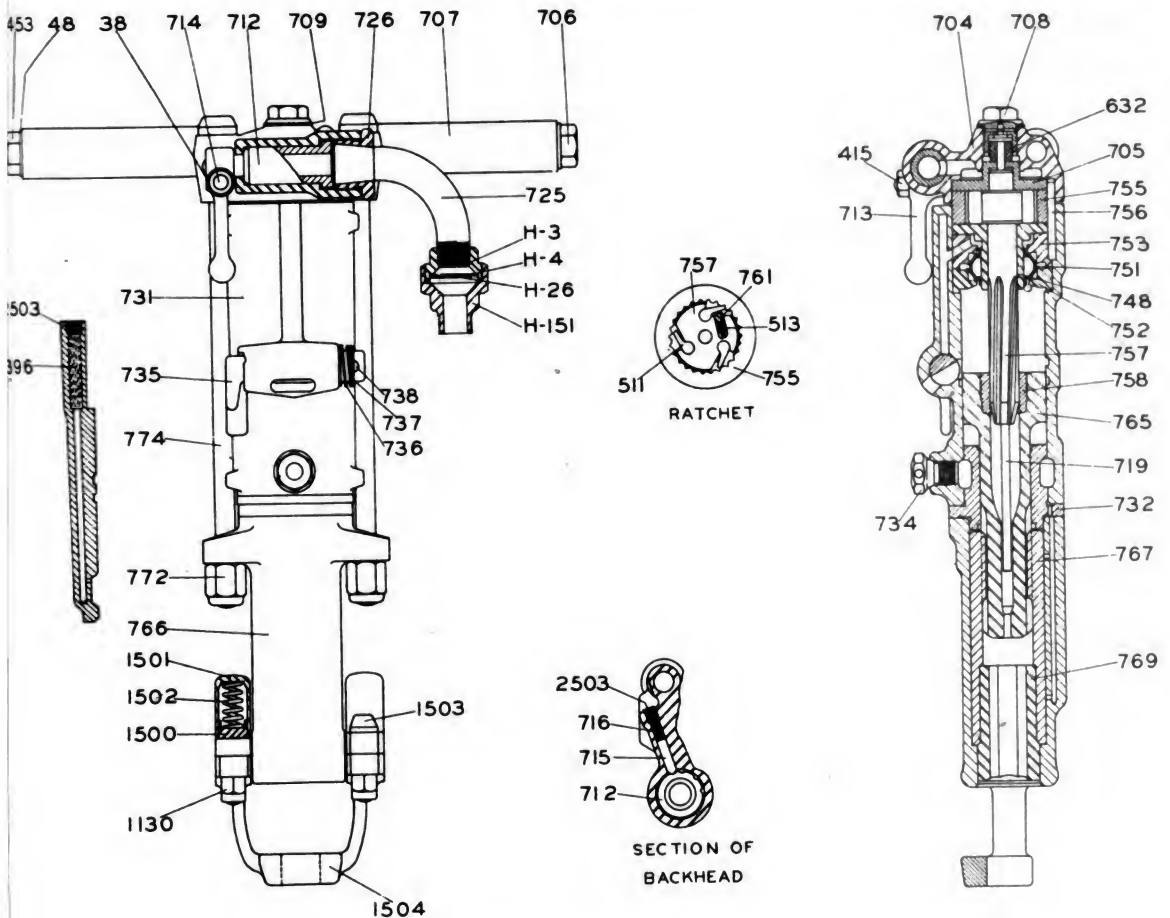

No. 75 Sinker Rock Drill

AIR SCREEN: (Part H-4)

Unscrew Air Screen Housing (Female) (Part H-151). Remove air Screen Lock Ring (Part H-26) from the Air Screen Housing (Male) (Part H-3) and remove Air Screen from male part.

THROTTLE VALVE DETENT PLUNGER: (Part 715)

Unscrew Throttle Valve Detent Plug (Part 2503) from Back Head and remove Throttle Valve Detent Plunger Spring (Part 716). Throttle Valve Detent Plunger can now be removed.

THROTTLE VALVE HANDLE: (Part 713)

Remove Throttle Valve Handle Nut (Part 415) and Throttle Valve Handle Bolt (Part 714). Slide Handle off Throttle Valve.

THROTTLE VALVE: (Part 712)

Slide Throttle Valve out through Air Inlet Opening.

RUBBER GRIPS: (Part 707)

Remove Handle Bolt Nut (Part 453), Handle Bolt Washers (Part 48), and withdraw the Handle Bolt (Part 706). Rubber Grips can now be removed.

RIFLE BAR: (Part 757)

Withdraw Rifle Bar from Ratchet Ring.

PAWLS: (Part 511)

Slide Pawls out of Pawl slots in Rifle Bar. Be careful not to lose

the Pawl Plunger (Part 761) and the Pawl Spring (Part 513), which will fly out when the Pawl is removed.

FRONT HEAD: (Part 766)
Remove Front Head from Cylinder (Part 731).

CHUCK DRIVER: (Part 767)
Remove Chuck Driver from rear of Front Head.

STEEL RETAINER: (Part 1504)
Remove four Steel Retainer Nuts (Part 1130) and Bolts (Part 1503).
Remove Steel Retainer.

STEEL RETAINER CAP: (Part 1501)
Remove Steel Retainer Caps.

STEEL RETAINER LOCK PLUNGER: (Part 1500)
Remove Steel Retainer Lock Plungers from Steel Retainer Caps.

STEEL RETAINER SPRING: (Part 1502)
Withdraw Steel Retainer Springs from Steel Retainer Caps.

VALVE AND VALVE CHEST: (Parts 748, 751, 752, 753, 755, and 756)
Push the Piston Hammer (Part 765) as far back in the Cylinder (Part 731) as it will go. Then place a hard wood block against the end and tap gently until the complete valve chest assembly can be removed.

PISTON HAMMER: (Part 765)
Withdraw Piston Hammer from Cylinder.

RIFLE NUT: (Part 758)
To remove the Rifle Nut, place the Piston Hammer in a vise having lead or copper jaws. Be careful not to mar or damage the flutes or the large diameter. Place the Rifle Bar (Part 757) in the Rifle Nut and turn clockwise with a Stillson pipe wrench having lead or copper jaws.

CYLINDER FRONT BEARING: (Part 732)
Use a hard wood or brass rod and drive cylinder front bearing out front end of Cylinder.

OIL CONTROL FELT: (Part 396)
Unscrew two Oil Control Plugs (Part 2503) from rear of Cylinder and remove Oil Control Felts.

OIL PLUG: (Part 734)
Unscrew Oil Plug from top of Cylinder.

EXHAUST VALVE: (Part 735)
Depress Exhaust Valve Spring (Part 736) and remove Exhaust Valve Retainer Pin (Part 738) and Exhaust Valve Washer (Part 737). Withdraw Exhaust Valve from Exhaust Valve Lug on top of Cylinder.

INSTRUCTIONS FOR ASSEMBLING:

All parts should be cleaned and lubricated before assembling.

All parts, except valve chest parts, may be assembled in reverse order.

When reassembling, follow this sequence of operations:

1. Place front half of Valve Chest (Part 752) in Cylinder, as shown in diagrammatical view.
2. Place Automatic Valve (Part 751) as shown.

MAINTENANCE INSTRUCTIONS

3. Place rear half of Valve Chest (Part 753) in position.
4. Place Valve Guide Plate (Part 748) in position.
5. Place Ratchet Ring (Part 755) in position.
6. Make sure all holes for Valve Chest Dowel Pin (Part 756) are in perfect alignment. Tap Valve Chest Dowel Pin in position.

Care must be taken to have all holes properly aligned to show a clear passage through before putting in bolts or pins.

The Side Rod Nuts should be tightened equally in order to insure correct alignment of all parts. This is most important, as binding of any reciprocating or turning parts causes excessive wear and loss of the foot pound blow of the Piston Hammer.

MODEL 25 PAVING BREAKER

INSTRUCTIONS FOR DISASSEMBLING:

Before dismantling, the Paving Breaker should be flushed throughout inside with liberal applications of kerosene. As kerosene leaves the machine dry, it is essential that it be thoroughly oiled before being put into operation.

BACK HEAD: (Part 2550)

Remove four bolts and nuts holding Back Head to cylinder, permitting removal of entire assembly.

PLUNGER: (Part 2505)

Remove plunger from bottom of Back Head.

PLUNGER SPRING: (Part 2506)

Withdraw plunger spring from inside plunger.

THROTTLE VALVE: (Part 2005)

Withdraw from bottom of Back Head. When installing new throttle valve, part must be lapped into valve seat with a fine lapping compound. Care should be taken to remove all traces of compound before assembly.

THROTTLE VALVE STEM BUSHING: (Part 2004)

Drive Throttle Valve Stem bushing out with a 3/8" round punch. (This part should be replaced if worn, at the factory or repair station.)

If the repair is not done at the factory, ream the bushing .00025 of an inch over the diameter of the throttle valve stem, after Bushing has been assembled in place.

THROTTLE VALVE SPRING: (Part 2006)

Remove Throttle Valve Spring from recess in cylinder.

THROTTLE LEVER: (Part 2302)

Drive out two throttle valve lever pins (Part 2002), with 1/4" round punch. Throttle Lever can now be removed. When reassembling,peen over ends of pins.

OIL CONTROL FELT: (Part 2504)

Unscrew small oil control plug, (Part 2503), from side of handle and withdraw Felt.

FRONT HEAD: (Part 2573)

Remove two Front Head bolts, nuts, lock washers and springs. (Parts 2025, 2024, 2023 and 2022). Front Head can now be removed.

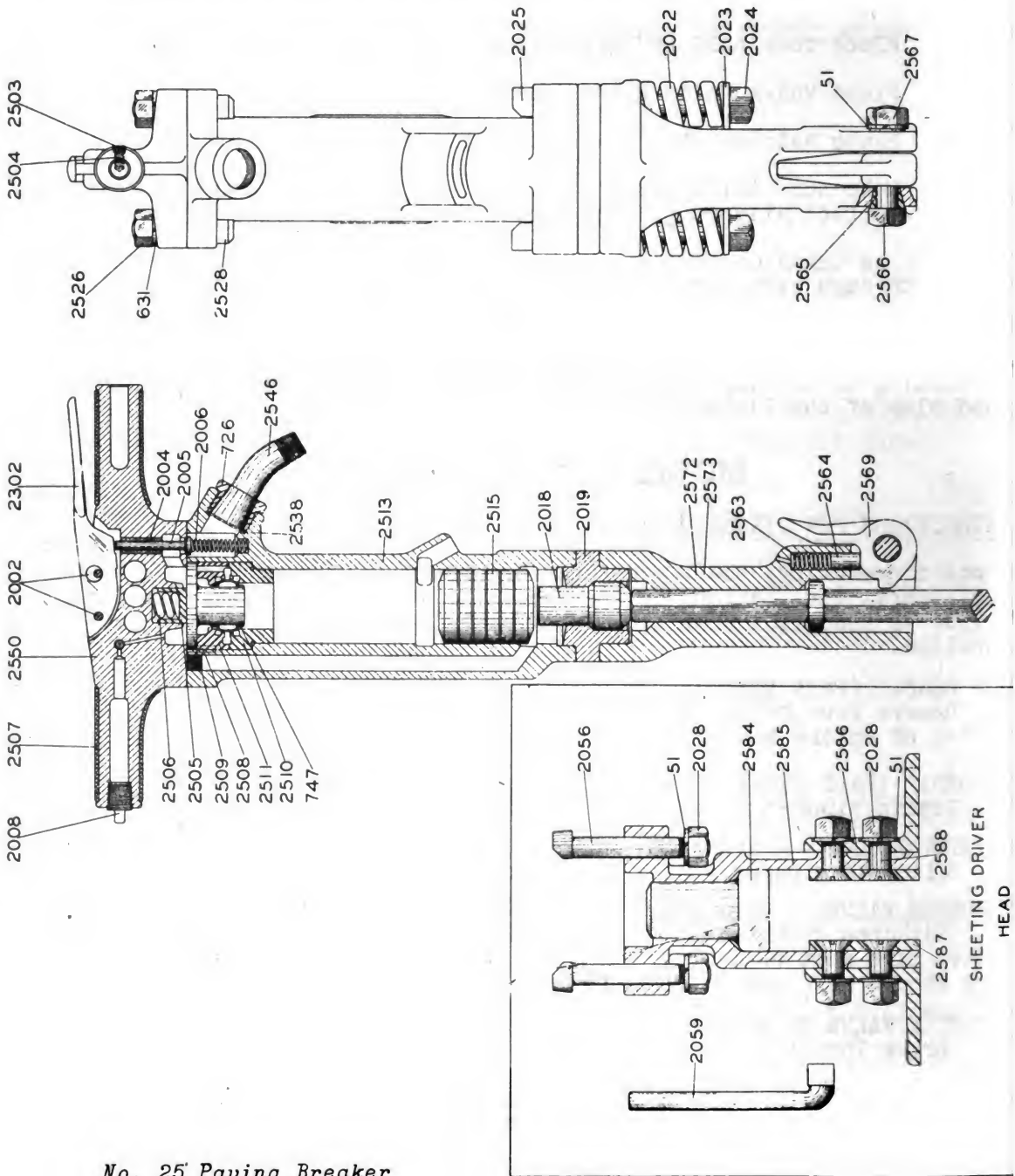

No. 25 Paving Breaker

TAPPET: (Part 2018)

Withdraw tappet from tappet seat.

STEEL RETAINER: (Part 2569)

Remove Steel Retainer Bolt, Cotter Pin, Nut, and Lock Washer. (Parts 2568, 2567, 2566 and 51). Withdraw Steel Retainer.

STEEL RETAINER PLUNGER: (Part 2564)

Withdraw Plunger from Front Head.

STEEL RETAINER PLUNGER SPRING: (Part 2563)

Withdraw Plunger Spring from Front Head.

STEEL RETAINER BOLT BUSHING: (Part 2565)

Remove steel retainer bolt bushings from both sides of Steel Retainer Lug on Front Head.

TAPPET SEAT: (Part 2019)

Remove Tappet Seat from front of Cylinder.

VALVE AND VALVE CHEST: (Parts 747, 2510, 2511, 2508 and 2509)

Use great care so as not to scratch or mar the inside of the Cylinder or damage the Valve Chest Parts. Gently tap the complete Valve Chest assembly out, working from the front end of the Cylinder.

AIR INLET SWIVEL: (Part 2546)

To remove Air Inlet Swivel, unscrew Air Inlet Swivel Nut (Part 726). Swivel and Nut may now be removed together.

AIR INLET SCREEN: (Part 2348)

The air inlet screen may now be withdrawn for cleaning.

INSTRUCTIONS FOR ASSEMBLING:

All parts should be cleaned and lubricated before assembly.

All parts, except Valve Chest Parts, may be assembled in reverse order.

When reassembling follow this sequence of operations:

1. Place front half of Valve Chest (Part 2510) in Cylinder, as shown in diagrammatical view.
2. Place Automatic Valve (Part 747) as shown.
3. Place rear half of Valve Chest (Part 2511) in position, making sure to have hole for Valve Chest Dowel Pin (Part 2508) in alignment.
4. Insert Valve Guide (Part 2509) as shown.
5. Tap Valve Chest Dowel Pin (Part 2508) in position, flush with top of cylinder.

Care must be taken to have all holes properly aligned to show a clear passage through before putting in bolts or pins.

SINKER ROCK DRILL GROUP 1

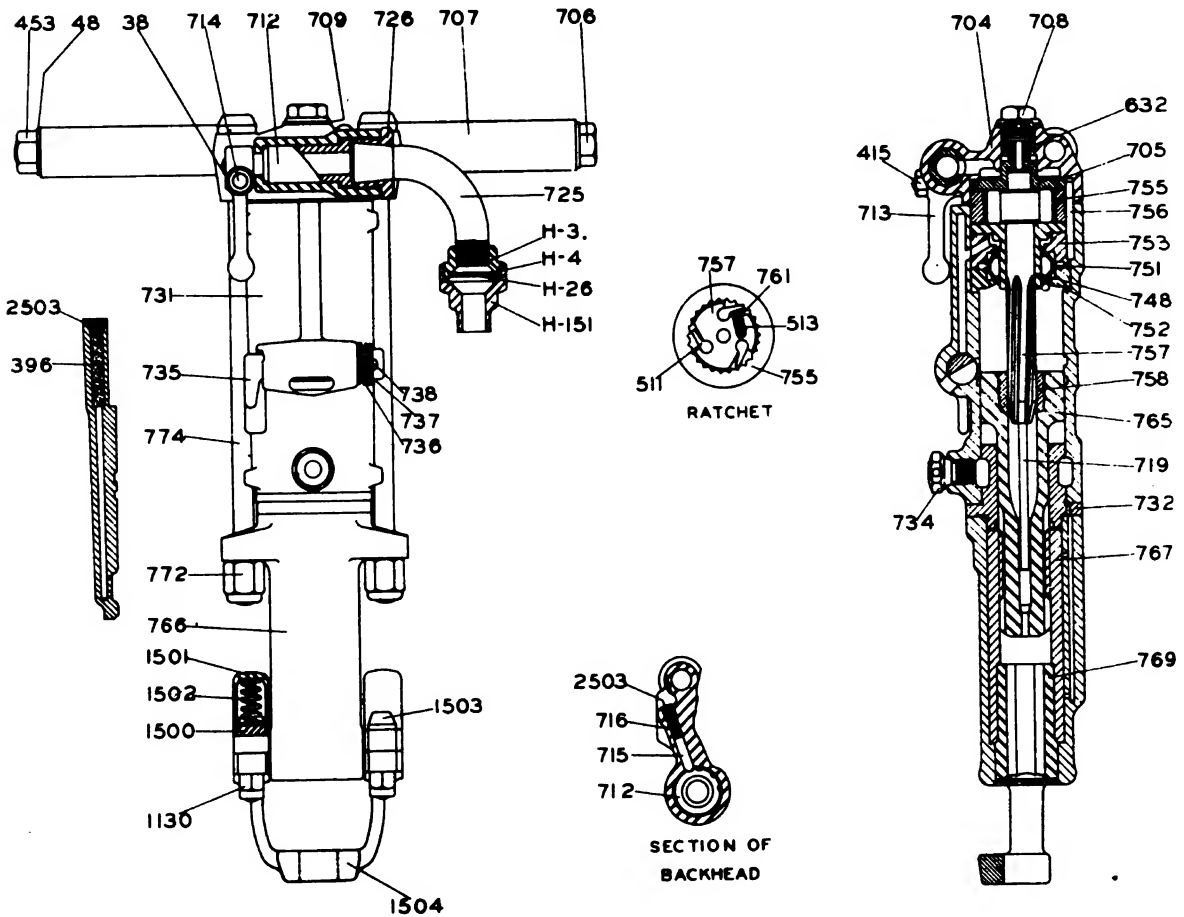

No. 75 Sinker Rock Drill

CODE WORD	PART No.	NAME AND DESCRIPTION	QUAN.	PRICE EACH
USGRD	A88-167	Sinker rock drill, #75 Thor, complete, dry, fitted for 1" hex. x 4-1/4" shank collared steels.....	1	(1)
		Wrench, Allen set screw, 3/16" hex.....	1	
		Wrench, double open end, 1-1/16" x 1-1/4".....	1	

REF. No.	THOR PART No.	NAME AND DESCRIPTION	QUAN.	PRICE EACH
38	C-38	Throttle Valve Handle Bolt Lockwasher.....	1	\$.10
48	C-48	Handle Bolt Washer.....	1	.10
396	C-396	Oil Control Felt.....	2	.15
415	C-415	Throttle Valve Handle Bolt Nut.....	1	.15
453	C-453	Handle Bolt Nut.....	1	.10
511	C-511	Rotation Pawl.....	3	1.10
513	C-513	Pawl Spring.....	3	.10
632	C-632	Water Tube Packing.....	1	.10
704	C-704	Back Head.....	1	20.50

(1) All service problems and repair parts orders for air tools are to be referred to Independent Pneumatic Tool Co., Chicago, Ill. or any of their branch offices.

PARTS LIST

SINKER ROCK DRILL GROUP 1 (CONT'D)

REF. No.	THOR PART No.	NAME AND DESCRIPTION	QUAN.	PRICE EACH
705	C-705	Back Head Plate.....	1	\$ 5.00
706	C-706	Handle Bolt, Nut and Washer (Inc. C-48 and C-453).....	1	.95
707	C-707	Rubber Grip.....	2	.75
708	C-708	Water Tube Plug.....	1	1.50
709	C-709	Water Tube Plug Gasket.....	1	.10
712	C-712	Throttle Valve.....	1	4.00
713	C-713	Throttle Valve Handle.....	1	2.50
714	C-714	Throttle Valve Handle Bolt Nut and Lock- washer (Inc. C-38 and C-415).....	1	.90
715	C-715	Throttle Valve Detent Plunger.....	1	.50
716	C-716	Throttle Valve Detent Plunger Spring.....	1	.10
719	C-719	Air Tube.....	1	.95
725	C-725	Air Inlet Swivel.....	1	3.25
726	C-726	Air Inlet Swivel Nut.....	1	1.95
731	C-731	Cylinder.....	1	47.50
732	C-732	Cylinder Front Bearing.....	1	9.25
734	C-734	Oil Plug.....	1	.50
735	C-735	Exhaust Valve.....	1	5.50
736	C-736	Exhaust Valve Spring.....	1	.50
737	C-737	Exhaust Valve Washer.....	1	.10
738	C-738	Exhaust Valve Retainer Pin.....	1	.50
748	C-748	Valve Guide Plate.....	1	8.00
751	C-751	Automatic Valve.....	1	6.50
752	C-752	Valve Chest (Front).....	1	5.50
753	C-753	Valve Chest (Rear).....	1	7.75
755	C-755	Ratchet Ring.....	1	7.00
756	C-756	Valve Chest Dowel Pin.....	1	.25
757	C-757	Rifle Bar.....	1	11.55
758	C-758	Rifle Nut.....	1	3.40
761	C-761	Pawl Plunger.....	3	.15
765	C-765	Piston Hammer.....	1	21.95
766	C-766	Front Head.....	1	22.50
767	C-767	Chuck Driver.....	1	15.50
769	C-769	Chuck, 1" Hex. x 4-1/4" Shank.....	1	5.80
772	C-772	Side Rod Nut.....	1	.45
774	C-774	Side Rod and Nut (Inc. C-772).....	2	1.55
789	C-789	Machine Wrench.....	1	1.05
1130	C-1130	Steel Retainer Nut.....	4	.35
1500	C-1500	Steel Retainer Lock Plunger.....	2	1.60
1501	C-1501	Steel Retainer Cap.....	2	4.00
1502	C-1502	Steel Retainer Spring.....	2	.60
1503	C-1503	Steel Retainer Bolt and Nut (Inc. C-1130).....	4	.90
1504	C-1504	Steel Retainer, 1" Hex. x 4-1/4" Shank.....	1	7.70
2503	C-2503	Oil Control and Throttle Valve Detent Plunger Plug.....	3	.15
H-3	C-H-3	Air Screen Housing (Male).....	1	.80
H-4	C-H-4	Air Screen.....	1	.25
H-26	C-H-26	Air Screen Lock Ring.....	1	.10
H-151	C-H-151	Air Screen Housing (Female).....	1	1.25
H-152	C-H-152	Air Strainer Complete (Inc. C-H-3, C-H-4, C-H-26 and C-H-151).....	1	2.40

All service problems and repair parts orders for air tools are to be referred to Independent Pneumatic Tool Co., Chicago, Ill. or any of their branch offices.

PAVING BREAKER GROUP 2

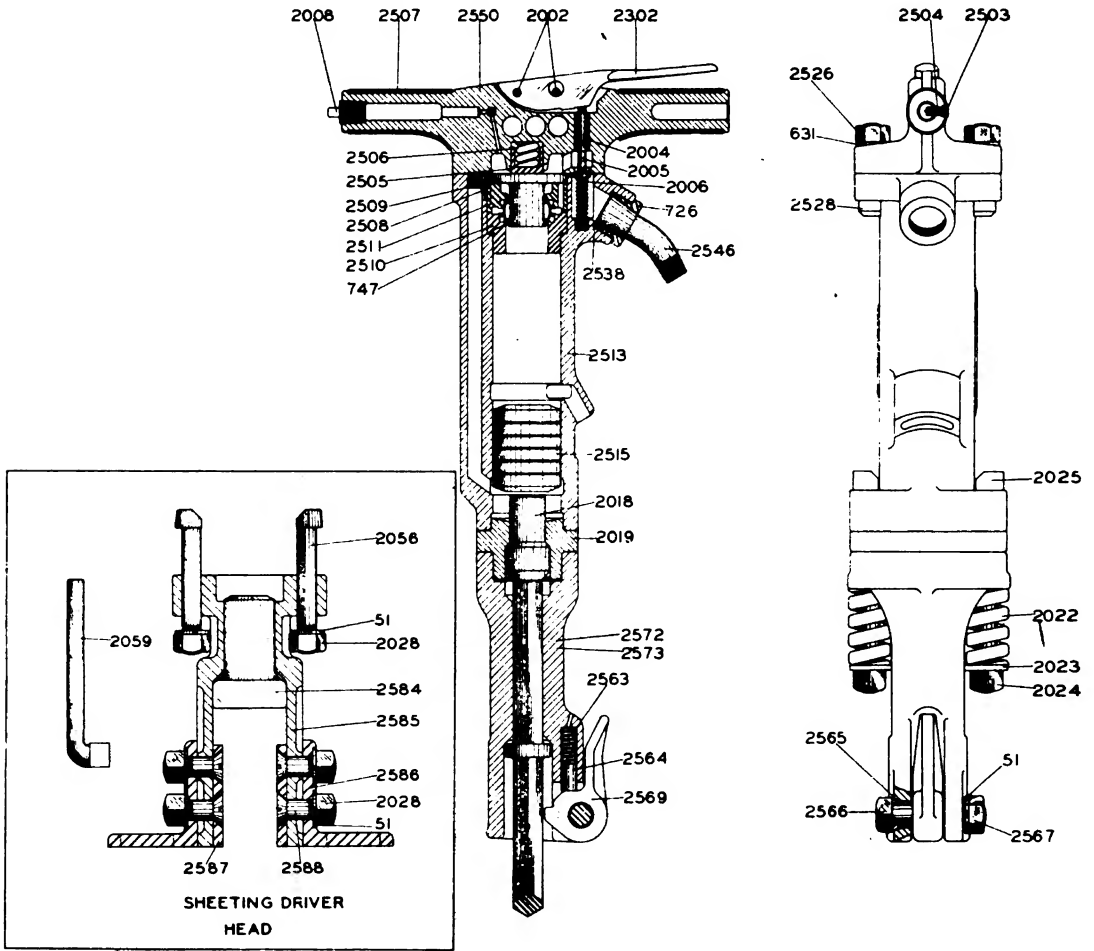

No. 25 Paving Breaker

CODE WORD	PART No.	NAME AND DESCRIPTION	QUAN.	PRICE EACH
PVPIN A88-168-1		Paving breaker, #25 Thor, complete, fitted for 1-1/4" hex. x 6" shank collared steel..	1	(1)
PLANK		Sheeting driver head, complete, Thor, fitted for 2" planks.....	1	(1)
		Screw driver, Thor.....	1	(1)
		Bolt spring, front head, Thor.....	2	(1)
		Retainer bolt, Steel, Thor, nut and lock-washer.....	2	(1)

REF. No.	THOR PART No.	NAME AND DESCRIPTION	QUAN.	PRICE EACH
726	C-726	Air Inlet Swivel Nut.....		\$ 1.95
747	C-747	Automatic Valve.....		6.50
2002	C-2002	Throttle Valve Lever Pin.....	2	.20

(1) All service problems and repair parts orders for air tools are to be referred to Independent Pneumatic Tool Co., Chicago, Ill. or any of their branch offices.

PARTS LIST

PAVING BREAKER GROUP 2 (CONT'D)

REF. No.	THOR PART No.	NAME AND DESCRIPTION	QUAN.	PRICE EACH
2004	C-2004	Throttle Valve Stem Guide.....		\$ 2.20
2005	C-2005	Throttle Valve.....		3.65
2006	C-2006	Throttle Valve Spring.....		.15
2008	C-2008	Oil Plug.....		.45
2018	C-2018	Tappet.....		7.00
2019	C-2019	Tappet Seat.....		12.00
2022	C-2022	Front Head Bolt Spring	2	.95
2023	C-2023	Front Head Bolt Lockwasher	2	.45
2024	C-2024	Front Head Bolt Nut	2	.20
2025	C-2025	Front Head Bolt and Nut (Inc. C-2024).....	2	1.50
2302	C-2302	Throttle Lever.....		4.40
2503	C-2503	Oil Control Plug.....		.15
2504	C-2504	Oil Control Felt.....		.10
2505	C-2505	Plunger.....		.65
2506	C-2506	Plunger Spring.....		.60
2507	C-2507	Rubber Grip.....	2	.75
2508	C-2508	Valve Chest Dowel Pin.....		.20
2509	C-2509	Valve Guide.....		7.80
2510	C-2510	Valve Chest (Front).....		6.25
2511	C-2511	Valve Chest (Rear).....		8.20
2513	C-2513	Cylinder.....		78.75
2515	C-2515	Piston Hammer.....		12.00
2524	C-2524	Oil Control Plug Wrench.....		.10
2526	C-2526	Back Head Bolt Nut	4	.20
2528	C-2528	Back Head Bolt, Nut and Lockwasher. (Inc. C-51 and C-2526).....	4	1.40
2538	C-2538	Air Inlet Screen.....		.25
2546	C-2546	Air Inlet Swivel.....		2.90
2550	C-2550	Back Head. (Inc. C-2004, C-2503, C-2504, and C-2507).....	2	45.50
2563	C-2563	Steel Retainer Plunger Spring.....		.25
2564	C-2564	Steel Retainer Plunger.....		.30
2565	C-2565	Steel Retainer Bolt Bushing	2	.55
2566	C-2566	Steel Retainer Bolt, Cotter Pin Nut and Lockwasher. (Inc. C-51 and C-2567-2568).....		1.60
2567	C-2567	Steel Retainer Bolt Nut.....		.45
2569	C-2569	Steel Retainer.....		2.05
2573	C-2573	Front Head, 1-1/4" Hex. x 6".....		
		Shank Collared Steel.....		31.50

SHEETING DRIVER CONSTRUCTION

2056	C-2056	Sheeting Driver Head Bolt, Nut and Lockwasher. (Inc. C-51 and C-2028).....	2	1.40
2059	C-2059	Screw Driver.....		1.25
2584	C-2584	Ram.....		30.00
2585	C-2585	Sheeting Driver Head for 2" Planks.....		55.00
2586	C-2586	Foot Bracket	2	6.50
2587	C-2587	Filler Plate	2	3.50
2588	C-2588	Filler Plate Bolt, Nut and Lockwasher. (Inc. C-51 and C-2028).....	6	.95
2590	C-2590	Sheeting Driver Head Complete.....		111.50

All service problems and repair parts orders for air tools are to be referred to Independent Pneumatic Tool Co., Chicago, Ill. or any of their branch offices.

CLAY DIGGER GROUP 3

SPECIFY SERIAL NO. AND MODEL NO. OF TOOL WHEN ORDERING PARTS

69085 HANDLE ASSEMBLED COMPLETE WITH
2502 SPRING, 57674 CAP, 69381 VALVE,
61963 TRIGGER, 61964 TRIGGER PIN, 71663
VALVE STEM, 68990 HANDLE ASSEMBLY

68990 HANDLE ASSEMBLED WITH 57675 VALVE
BUSHING, 61952 STEM BUSHING

61963 TRIGGER

61964 TRIGGER PIN

61952 VALVE STEM BUSHING
71663 VALVE STEM

61942 NUT

69082 VALVE SLEEVE
68410 CYLINDER VALVE
69083 THRUST PLUG

61943 WASHER
64135 BOLT

69081 VALVE BLOCK

68990 DEFLECTOR

65691 PISTON

69095 RETAINER BODY

69096 BUMPER PLATE (TWO HALVES)

69381 THROTTLE VALVE

2502 VALVE SPRING
57675 VALVE BUSHING

57674 THROTTLE CAP

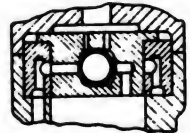

69098 CYLINDER VALVE BLOCK ASSEMBLED
COMPLETE INCLUDES 68410 VALVE,
69081 BLOCK, 69082 SLEEVE, 69083 PLUG

65689 BARREL

69091 BARREL & NOZZLE ASSEMBLY INCLUDES
65689 BARREL, 69084 NOZZLE

61946 RETAINER SPRING

69084 NOZZLE 7/8" HEXAGON

61945 SPLIT SLEEVE

69124 RUBBER BUMPER

PART No.	NAME AND DESCRIPTION	QUAN.	PRICE EACH
----------	----------------------	-------	------------

A88-169-2	Clay digger, #412 Thor, complete, fitted for 7/8" hex. x 2-3/4" shank steels.....	2	(1)
	Rubber bumper, Thor.....	4	(1)

PARTS LIST

CLAY DIGGER GROUP 3 (CONT'D)

THOR PART No.	NAME AND DESCRIPTION	QUAN.	PRICE EACH
2502	Valve Spring.....	1	\$.10
57674	Throttle Cap.....	1	1.25
57675	Valve Bushing.....	1	2.55
61890	Deflector.....	1	1.25
61942	Nut.....	2	.15
61943	Washer.....	2	.05
61945	Split Sleeve (2 Halves).....	1	.95
61948	Retainer Spring.....	1	1.25
61952	Valve Stem Bushing.....	1	.40
69381	Throttle Valve.....	1	2.25
61963	Trigger.....	1	1.15
61964	Trigger Pin.....	1	.05
71683	Valve Stem.....	1	.65
64135	Bolt.....	2	.50
65889	Barrel.....	1	41.00
65891	Piston.....	1	6.35
68419	Cylinder Valve.....	1	.85
68990	Handle Assembled with 57675 & 61952.....	1	25.00
68991	Barrel & Nozzle Assembly, Includes 65889 & 69084.....	1	44.50
69081	Valve Block.....	1	7.50
69082	Valve Sleeve.....	1	9.00
69083	Thrust plug.....	2	.85
69084	Nozzle, 7/8" Hex.....	1	4.00
69085	Handle assembled complete with 2502, 57674, 71683, 61963, 61964, 69381, 68990..	1	28.00
69095	Retainer body.....	1	12.00
69096	Bumper plate (two halves).....	1	1.00
69098	Cylinder valve block assembled, includes: 68419, 69081, 69082, 69083.....	1	25.00
69124	Rubber bumper.....	1	.85

PNEUMATIC REVERSIBLE WOOD BORING GROUP 4

LE ROI PART No.	NAME AND DESCRIPTION	QUAN.	PRICE EACH
A88-170	Pneumatic reversible wood boring machine, #62-WB, complete fitted for 1/2" dia.		
	Shank Auger bits.....	1	(1)
	Chuck set screw wrench, 1/4" square.....	1	(1)

REF. No.	THOR PART No.	NAME AND DESCRIPTION	QUAN.	PRICE EACH
1	PD-12-1	Cylinder Complete (Consisting of 2, 3, 19, 86, 154, 407).....	1	\$54.25
2	PD-2-2	Spindle Bushing.....	1	1.25

(1) All service problems and repair parts orders for air tools are to be referred to Independent Pneumatic Tool Co., Chicago, Ill. or any of their branch offices.

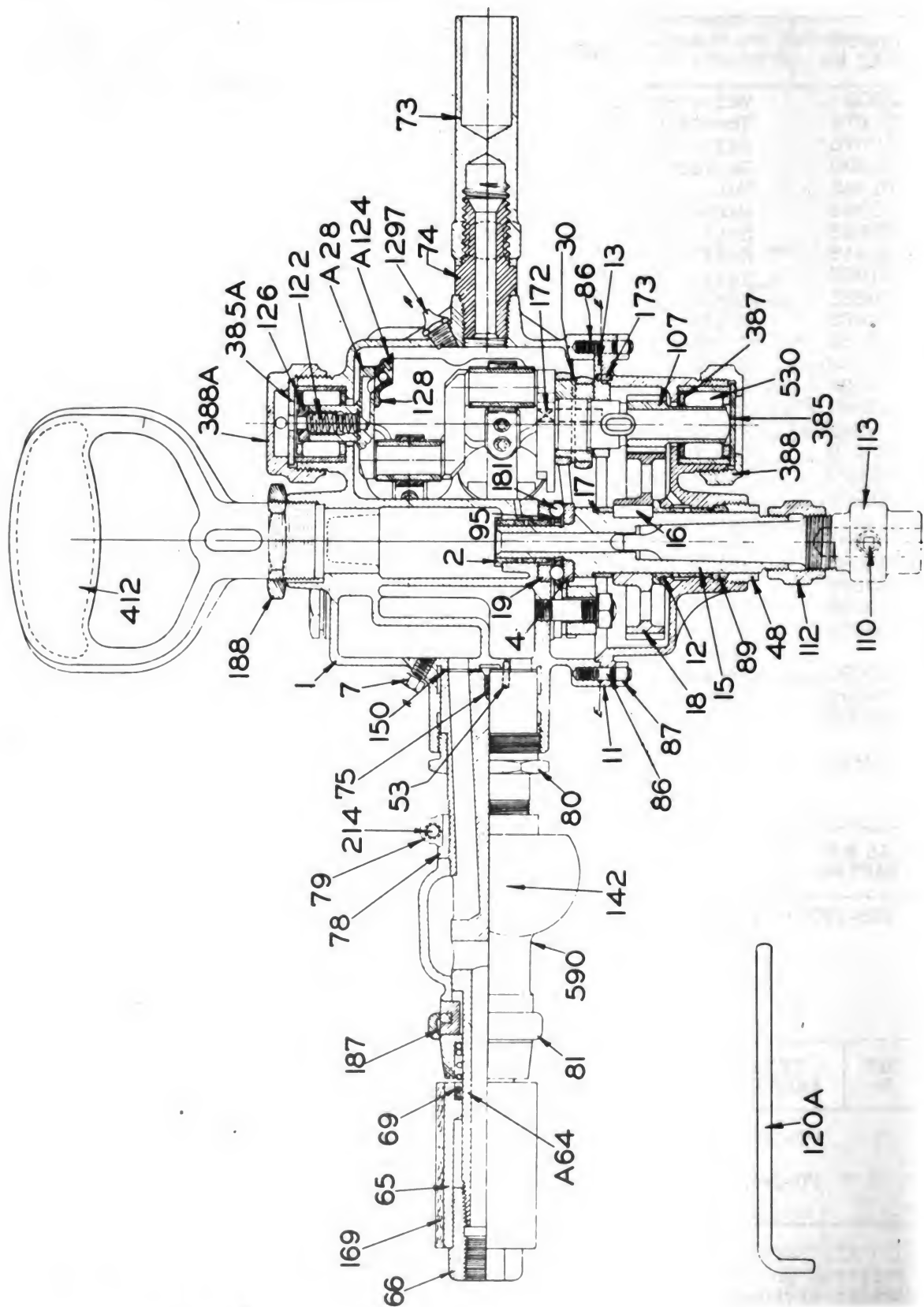

PARTS LIST

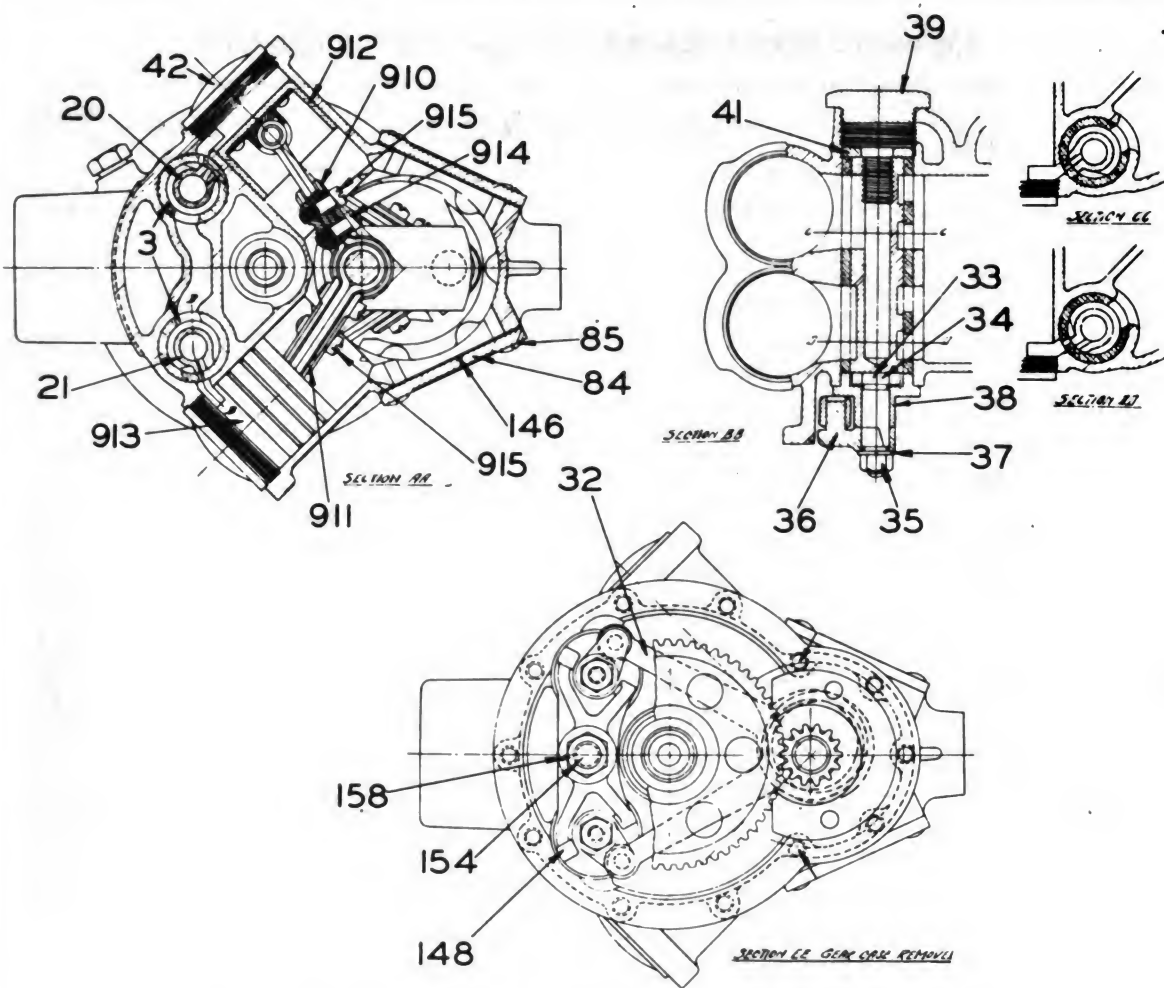

PNEUMATIC REVERSIBLE WOOD BORING GROUP 4 (CONT'D)

REF. No.	THOR PART No.	NAME AND DESCRIPTION	QUAN.	PRICE EACH
3	PD-2-3	Valve Bushing with four live air holes (Right or Left).....	2	\$ 2.90
4	PD-2-4	Lower Ball Race.....	1	1.10
7	PD-12-7	Oil Plug.....	1	.15
11	PD-2-11	Gear Case Complete (Consisting of 12, 173, 408).....	1	12.75
12	PD-2-12	Gear Case Bushing.....	1	2.25
13	PD-2-13	Center Plate.....	1	2.90
15	PD-2-15	Spindle Complete (Consisting of 4, 16, 17, 409).....	1	10.75
16	PD-2-16	Spindle Key.....	1	.20
17	PD-2-17	Spindle Collar.....	1	.35
18	PD-62-18	Gear Wheel.....	1	5.40
19	PD-2-19	Upper Ball Race.....	1	1.60
20	PD-12-20	Right Valve.....	1	3.15

(1) All service problems and repair parts orders for air tools are to be referred to Independent Pneumatic Tool Co., Chicago, Ill. or any of their branch offices.

PNEUMATIC REVERSIBLE WOOD BORING GROUP 4 (CONT'D)

REF. No.	THOR PART No.	NAME AND DESCRIPTION	QUAN.	PRICE EACH
21	PD-12-21	Left Valve.....	1	\$ 3.15
A28	PD-62-A28	Vented Crank Complete (Consisting of 107, 122, 124, 126, 128, 442).....	1	14.50
30	PD-2-30	Eccentric.....	1	2.90
32	PD-2-32	Eccentric Strap.....	2	2.25
33	PD-2-33	Right Valve Stud.....	1	1.80
34	PD-2-34	Left Valve Stud.....	1	1.80
35	PD-2-35	Valve Stud Nut.....	2	.10
36	PD-2-36	Valve Lever.....	2	1.40
37	PD-2-37	Valve Stud Washer.....	2	.05
38	PD-2-38	Valve Stud Guide.....	2	1.25
39	PD-12-39	Exhaust Cap.....	2	.95
41	PD-2-41	Valve End Plate.....	2	.40
42	PD-2-42	Cylinder Head.....	4	.95
48	PD-2-48	Stuffing Box.....	1	2.55
53	PCH-A-53	Dowel Pin for Throttle.....	1	.10
53	PD-2-53	Hose Nipple.....	1	.45
A64	PD-12-A64	Throttle Stem.....	1	8.85
65	PD-12-65	Throttle Sleeve.....	1	2.55
66	PD-12-66	Throttle Cap Nut.....	1	1.15
69	PD-12-69	Tension Spring.....	1	.35
73	PD-2-73	Dead Handle.....	1	2.25
74	PD-2-74	Dead Handle Plug.....	1	1.25
75	PD-00-75	Screw for Gasket.....	1	.05
78	PD-12-78	Stop Nut for Valve.....	1	.60
79	PD-12-79	Clamp for Stop Nut for Valve.....	1	1.20
80	PD-12-80	Clamp Nut for Throttle.....	1	1.25
81	PD-12-81	Lock Sleeve Complete.....	1	1.25
84	PD-2-84	Crank Chamber Plate.....	2	.95
85	PD-2-85	Crank Chamber Plate Screw.....	12	.05
86	PD-2-86	Gear Case Stud.....	12	.15
87	PD-2-87	Gear Case Stud Nut.....	12	.10
89	PD-2-89	Packing for Spindle.....	1	.45
95	PD-1-95	Balls and Retainer Complete.....	1	1.90
107	PD-62-107	Crank Pinion.....	1	2.90
110	PD-00-110	Set Screw for Wood Bit Chuck.....	1	.15
112	PD-62-112	Retainer Nut for Wood Bit Chuck.....	1	1.60
113	PD-62-113	Wood Bit Chuck with taper shank and Set Screw.....	1	3.15
120A	PD-6-120A	Chuck screw wrench.....	1	.85
122	PD-2-122	Tension Spring for Metal Packing.....	1	.10
A124	PD-2-A124	Mouthpiece for Vent Complete.....	1	1.45
126	PD-2-126	Metal Packing.....	1	.70
128	PD-2-128	Rivet for Mouthpiece and Crank.....	2	.05
142	PD-12-142	Throttle Complete.....	1	21.75
146	PD-2-146	Gasket for Crank Chamber Plate.....	2	.10
148	PD-2-148	Valve Guide Clamp.....	1	.45
150	PD-12-150	Gasket for Throttle.....	1	.35
154	PD-2-154	Stud for Valve Guide Clamp.....	1	.15
158	PD-2-158	Nut for Valve Guide Clamp.....	1	.10
169	PD-BW-169	Rubber sleeve for throttle sleeve.....	1	.35

All service problems and repair parts orders for air tools are to be referred to Independent Pneumatic Tool Co., Chicago, Ill., or any of their branch offices.

PARTS LIST

PNEUMATIC REVERSIBLE WOOD BORING GROUP 4 (CONT'D)

REF. No.	THOR PART No.	NAME AND DESCRIPTION	QUAN.	PRICE EACH
172	PD-2-172	Eccentric Driver Pin.....	1	\$.20
173	PD-2-173	Center Plate Key.....	2	.10
181	PD-1-181	1/4" Ball for Ball Retainer.....	13	.02
187	PD-12-187	Spring for Lock Sleeve.....	1	.20
188	PD-12-188	Check Nut for Grip Handle.....	1	.50
214	DC-2-214	Screw for Stop Nut Clamp.....	1	.05
384	PD-2-384	Roller for part No. PD-2-530 (Not shown on parts plate).....	16	.10
385	PD-2-385	Lower Crank Bearing Thrust Plate.....	1	.20
385A	PD-2-385A	Upper Crank Bearing Thrust Plate.....	1	.35
387	PD-2-387	Upper and Lower Crank Bushing.....	2	1.25
388	PD-2-388	Crank Cap, Lower.....	1	.95
388A	PD-2-388A	Crank Cap, Upper.....	1	.95
412	PD-62-412	Grip Handle.....	1	2.55
442	PD-62-442	Crank Shaft without Pinion (Not shown on parts plate).....	1	12.00
530	PD-2-530	Rollers and Retainer.....	2	5.00
590	PD-12-590	Valve Complete.....	1	6.90
900	PD-2-900	Inside Connecting Rod Complete (Consisting of 910, 912, 914, 915).....	2	10.15
901	PD-2-901	Outside Connecting Rod Complete (Consisting of 911, 913, 915).....	2	8.85
910	PD-2-910	Clamp for Inside Connecting Rod.....	2	2.70
911	PD-2-911	Clamp for Outside Connecting Rod.....	2	2.30
912	PD-2-912	Inside Connecting Rod and Piston.....	2	7.15
913	PD-2-913	Outside Connecting Rod and Piston.....	2	6.45
914	PD-2-914	Clamp Screw for Inside Connecting Rod.....	4	.10
915	PD-2-915	Clamp Screw for Inside and Outside Connecting Rod.....	4	.10
1297	ACK-1297	Zerk Grease nipple for cylinder.....	1	.10

All service problems and repair parts orders for air tools are to be referred to Independent Pneumatic Tool Co., Chicago, Ill., or any of their branch offices.

ACCESSORIES GROUP 5

PART No.	NAME AND DESCRIPTION	QUAN.	PRICE EACH
A88-242	Combination vise, 4½" x 4" Le Roi, 90° swivel.....	1	\$26.00
39-1415	Support, vise end, for work bench,	1	.35
02-60	Capscrew, hex. 7/16" - 14 x 2-1/2",	2	.06
02-61	Capscrew, hex. 7/16" - 14 x 2-3/4",	2	.08
04-404	Nut, half, hex. 7/16" - 14 steel,.....	4	.02
A88-238	Work bench assembly,	1	31.00
88-172	Drill, steel, 2 ft. x 1 in. hex., 4-1/4 in. shank (up to Serial 200560).....	2	(2)
88-280	Drill, steel, 2 ft. x 1 in. hex., 4-1/4 in. shank (Serial 200560 up).....	2	(8)
88-173	Drill, steel, 4 ft. x 1 in. hex., 4-1/4 in. shank (up to Serial 200560).....	2	(2)
88-281	Drill, steel, 4 ft. x 1 in. hex., 4-1/4 in. shank (Serial 200560 up).....	2	(8)
88-174	Drill, steel, 6 ft. x 1 in. hex., 4-1/4 in. shank (up to Serial 200560).....	2	(2)
88-282	Drill, steel, 6 ft. x 1 in. hex., 4-1/4 in. shank (Serial 200560 up).....	2	(8)
88-175	Drill, steel, 8 ft. x 1 in. hex., 4-1/4 in. shank (up to Serial 200560).....	2	(2)
88-283	Drill, steel, 8 ft. x 1 in. hex., 4-1/4 in. shank (Serial 200560 up).....	2	(8)
88-176	Bit, rock, detachable, Timken H, 1-5/8 in. (up to Serial 200560).....	20	(3)
88-310	Bit, rock, detachable, Ingersoll-Rand, 1-5/8 in. (Serial 200560 up).....	20	(9)
88-177	Bit, rock, detachable, Timken H, 1-3/4 in. (up to Serial 200560).....	20	(3)
88-311	Bit, rock, detachable, Ingersoll-Rand, 1-3/4 in. (Serial 200560 up).....	20	(9)
88-178	Bit, rock, detachable, Timken H, 1-7/8 in. (up to Serial 200560).....	20	(3)
88-312	Bit, rock, detachable, Ingersoll-Rand, 1-7/8 in. (Serial 200560 up).....	20	(9)
88-179	Bit, rock, detachable, Timken H, 2 in. (up to Serial 200560).....	20	(3)
88-313	Bit, rock, detachable, Ingersoll-Rand, 2 in. (Serial 200560 up).....	20	(9)
88-203	Bit, rock, detachable, Timken H, 2-1/8 in. (up to Serial 200560).....	20	(3)
A88-180-1	Pad, dirt tamper, 7" round, together with Dirt tamper rod, 1-1/4" hex. x 6" shank....	2	(2)
88-181	Chisel, Bit, 3" x 14", 1-1/4" hex. x 6" shank.....	2	(2)
88-182	Moil point, 1-1/4" hex. x 14", 1-1/4 hex. x 6" shank.....	3	(2)
88-183	Clay, spade, 4-1/2" x 8-1/4" x 15", 7/8" hex. x 2-3/4" shank.....	2	(2)

(2):Procure from Manufacturer; Brunner & Lay, Chicago, Illinois.
 (3):Procure from Manufacturer; Timken Roller Brg. Co., Canton, Ohio.
 (8):Procure from Manufacturer; Rock Bit Sales & Service Co., Phila., Penn.
 (9):Procure from Manufacturer; Ingersoll-Rand Co., Chicago, Illinois.

PARTS LIST

ACCESSORIES GROUP 5 (CONT'D)

PART No.	NAME AND DESCRIPTION	QUAN.	PRICE EACH
88-184	Flat, pick, 3" x 7-3/16" x 15", 7/8" hex. x 2-3/4" shank.....	2	(2)
88-185	Moil Point, 1" dia. x 15", 7/8" hex. x 2-3/4" shank.....	2	(2)
119-127	Tool box for auger bits.....	1	\$11.50
A88-244	Bits, set of ship auger, with screws and 1/2" dia. shank with one flat, consisting of the following parts.....	1	(4)
	Heavy canvas case with 2 tie cords.....	1	
	Bit, ship auger, 7/16" x 36".....	3	
	Bit, ship auger, 3/4" x 36".....	3	
	Bit, ship auger, 1" x 36".....	1	
	Bit, ship auger, 2" x 36".....	1	
A88-245	Bits, set of ship auger, with screws and 1/2" dia. shank with one flat, consisting of the following parts:.....	1	(4)
	Heavy canvas case with one tie core.....	1	
	Bit, ship auger, 7/16" x 12".....	3	
	Bit, ship auger, 3/4" x 12".....	3	
	Bit, ship auger, 1" x 12".....	1	
	Bit, ship auger, 2" x 12".....	1	
91-86	Key for air tool clips, 3-1/2" lg.....	13	.20
91-87	Key for air tool clips, 5-3/4" lg.....	4	.20
73-261	Air hose, 3/4" - 3 braid x 50 ft.....	4	(6-7)
73-261-1	Air hose, 3/4" - 3 braid x 18".....	2	(6-7)
73-262	Air hose, 1/2" - 3 braid x 10 ft.....	3	(6-7)
A28-237	Coupling, Universal hose, 3/4" male end, Dixon AB-7.....	2	(5)
A28-238	Coupling, Universal hose, 3/4" hose end, Dixon AB-6.....	20	(5)
A28-239	Coupling, Universal hose, 1/2" hose end, Dixon AB-1.....	7	(5)
20-381	Washer for Universal hose coupling, Dixon AWS-6.....	6	(5)
A28-240-1	Air hammer coupling assembly, 3/4" female Dixon "Boss" BF-8, but less clamp.....	2	(5)
54-280	Stem, air hose, 1/2" male, Dixon "Boss" MS-1.....	3	(5)
A83-33	Hose clamp assembly, 3/4", Dixon "Air King".....	20	(5)
A83-119	Hose clamp assembly, 3/4", Dixon "Boss".....	2	(5)
A83-35	1/2" hose clamp assembly, Dixon "Boss".....	10	(5)
A83-98	Clamp, single bolt hose, Dixon "King" #6.....	4	(5)
83-102	Clamp for air hose.....	2	.08
50-99	Handle for air hose reel.....	2	.45
03-559	Capscrew, flat hd., for hose reel clamp, 5/16 - 18 x 1".....	2	.06
05-176	Lockwasher, ctrsk. 5/16".....	2	.01

(2):Procure from Manufacturer; Brunner & Lay, Chicago, Illinois.

(4):Procure from Manufacturer; Forest City Bit & Tool Co., Rockford, Ill.

(5):Procure from Manufacturer; Dixon Valve & Coupling Co., Phila., Penn.

(6):Procure from Manufacturer; Goodyear Tire & Rubber Co., Akron, Ohio.

(7):Procure from Manufacturer; Gates Rubber Co., Chicago, Illinois.

ACCESSORIES GROUP 5 (CONT'D)

PART No.	NAME AND DESCRIPTION	QUAN.	PRICE EACH
50-91	Starting crank, compressor engine.....	1	\$2.90
88-88	Wrench, spark plug, 18mm compr. engine.....	1	.35
88-157	Funnel, 10" dia.....	1	4.20
A88-158	Tire inflating attachment.....	1	(7)
A88-241	Blow gun attachment, less blow gun.....	1	3.30
88-246	Blow gun, 3/8" PB Cleco.....	1	3.60
88-104	Wrench, box socket, 3/4 x 25/32.....	1	.60
88-105	Wrench, box socket, 15/16" x 1".....	1	1.00
88-166	Oil can, 1 gallon.....	1	.42
A83-31	Oil can strap assembly.....	1	1.20
88-200	Wrench, Allen set screw.....	1	.60
88-161	Wrench, double open end.....	1	2.50
88-198	Screw driver, special.....	1	1.25
88-199	Wrench, chuck.....	1	2.00
88-100	Tool bag.....	1	.40
88-72	Wrench, adjustable.....	1	1.30
88-73	Pliers, 6" combination.....	1	.30
88-74	Screw driver, 6".....	1	.30
88-101	Wrench, open end, 3/8" x 7/16".....	1	.30
88-102	Wrench, open end, 1/2" x 9/16".....	1	1.10
88-103	Wrench, open end, 5/8" x 3/4".....	1	.45
88-227	Oil can, 8 oz., 4" dia.....	1	.60
39-1404	Holder, for oil can.....	1	.28

(7):Procure from Manufacturer; Gates Rubber Co., Chicago, Illinois.

NUMERICAL PARTS INDEX

PART NUMBER	TOTAL QUANTITY	MFGR'S. CODE	PAGE NUMBER	PART NUMBER	TOTAL QUANTITY	MFGR'S. CODE	PAGE NUMBER
PD-00-75	1	L	174	PD-2-387	2	L	175
PD-00-110	1	L	174	PD-2-388	1	L	175
ZO-001	1	D	128	PD-2-388A	1	L	175
ZO-003	1	D	128	PD-2-530	2	L	175
PD-1-95	1	L	174	PD-2-900	1	L	175
PD-1-181	13	L	175	PD-2-901	2	L	175
A1-224	1	A	103	PD-2-910	2	L	175
A1-273	2	A	103	PD-2-911	2	L	175
GI-2	1	B	92	PD-2-912	2	L	175
PD-2-2	1	L	171	PD-2-913	2	L	175
PD-2-3	2	L	173	PD-2-914	4	L	175
PD-2-4	1	L	173	PD-2-915	4	L	175
114B-2-9	1	C	98	AN-3	2	D	106
PD-2-11	1	L	173	C-H-3	1	L	167
PD-2-12	1	L	173	GI-3	1	B	92
PD-2-13	1	L	173	RAB-3	1	B	94
PD-2-15	1	L	173	B3-37C	1	H	135
PD-2-16	1	L	173	3-166-1	1	A	131
PD-2-17	1	L	173	A3-188-1	1	A	107
PD-2-19	1	L	173	3-223	2	A	132
PD-2-30	1	L	174	AN-4	2	D	106
PD-2-32	2	L	174	AP-4	1	D	139
PD-2-33	1	L	174	C-H-4	1	L	167
PD-2-34	1	L	174	4-117	2	A	119
PD-2-35	2	L	174	A4-118	1	A	119
PD-2-36	2	L	174	4-128	1	A	144
PD-2-37	2	L	174	4-186	1	A	139
PD-2-38	2	L	174	GI-5	1	B	92
PD-2-41	2	L	174	WA-5-16	1	E	111
PD-2-42	4	L	174	A5-265-8	1	A	101
PD-2-48	1	L	174	1A5-282	1	A	119,120
PD-2-53	1	L	174	GI-6	2	B	92
PD-2-73	1	L	174	T15B6-4	2	H	136
PD-2-74	1	L	174	PD-6-120A	1	L	174
PD-2-84	2	L	174	6-132	1	A	120,122
PD-2-85	12	L	174	7-42	1	A	106
PD-2-86	12	L	174	A7-48	3	A	102
PD-2-87	12	L	174	1A7-48	3	A	102
PD-2-89	1	L	174	A7-59	4	A	120,121
B2-104	1	H	135	1A7-59	4	A	121
PD-2-122	1	L	174	T22S8	1	H	136
PD-2-A124	1	L	174	T1S8-6	1	H	136
PD-2-126	1	L	174	T1S8-10	1	H	136
PD-2-128	2	L	174	1A8-142	1	A	103
PD-2-146	2	L	174	1A8-169	2	A	103
PD-2-148	1	L	174	1A8-203-1	4	A	120,122
3A-2-149	1	A	127	A9-484	1	A	120
5A-2-149	1	A	127	AN-V10	2	D	106
PD-2-154	1	L	174	Z-10	1	B	94
PD-2-158	1	L	174	10-284-10	1	A	129
PD-2-172	1	L	175	AN-V11	2	D	106
PD-2-173	2	L	175	11-133	1	A	119
A2-198-1	3	A	104	11-134	2	A	119
1A2-198-1	3	A	104	11-135	4	A	127
DC-2-214	1	L	175	11-144	2	A	140
PD-2-384	16	L	175	11-145	2	A	140,141
PD-2-385	1	L	175	AN-V12	2	D	106
PD-2-385A	1	L	175	GI-12	2	B	92

NUMERICAL PARTS INDEX—Cont'd

PART NUMBER	TOTAL QUANTITY	MFGR'S. CODE	PAGE NUMBER	PART NUMBER	TOTAL QUANTITY	MFGR'S. CODE	PAGE NUMBER
PD-12-1	1	L	171	15-325	6	A	104
PD-12-7	1	L	173	A15-325	5	A	104,148
T18S12-12	4	H	136	2A15-325	5	A	104,148
PD-12-20	1	L	173	A15-330	1	A	139
PD-12-21	1	L	174	15-336	3	A	104
PD-12-39	2	L	174	15-350	1	A	95
A12-42	1	K	146	AN-V16	2	D	106
A12-43	1	K	144	16-27	2	A	135
PD-12-A64	1	L	174	B16-117	5	A	{106,124, 147
PD-12-65	1	L	174	16-229	2	A	137,147
PD-12-66	1	L	174	16-344	3	A	101,147
PD-12-69	1	L	174	16-418	3	A	106,147
PD-12-78	1	L	174	16-419	3	A	106,147
PD-12-79	1	L	174	16-419-1	6	A	106,147
PD-12-80	1	L	174	16-422	3	A	101,147
PD-12-81	1	L	174	16-518	18	A	103,147
PD-12-142	1	L	174	16-519	18	A	103,147
PD-12-150	1	L	174	16-605	3	A	107,147
PD-12-187	1	L	175	16-605	3	A	101,147
PD-12-188	1	L	175	16-616	3	A	101,147
12-380	1	A	146	16-626	4	A	120,147
PD-12-590	1	L	175	16-627	6	A	105,147
AN-V13	2	D	106	16-629	2	A	127,147
1A13-260-2	1	A	123	16-630	4	A	129,147
3A13-260-2	1	A	123	16-631	2	A	129,147
13-266-3	1	A	140	16-632	4	A	129
3A13-266-3	1	A	140	16-634-3	2	A	128,147
4A13-266-3	1	A	140	16-635	2	A	124,147
13-267	1	A	101	16-636	2	A	123,147
A13-349	1	A	106	16-638	2	A	130,147
A13-350-1	1	A	106	16-640	21	A	{95,105, 145,147
A13-360-1	1	A	130	16-643-1	2	A	128,147
2A13-360-1	1	A	130	16-646	4	A	131,147
A13-387	1	A	144	16-647	2	A	131,147
GI-14	1	B	92	16-648	2	A	131,147
14-535	1	A	128	16-649-1	2	A	131,147
A14-535	1	A	127	16-650	2	A	129,147
A14-536-3	1	A	123	16-651	2	A	129,147
14-538	1	A	123	16-652	2	A	129,147
14-540	1	A	129	16-653	2	A	129
14-649	3	A	105	16-664	14	A	{145,146, 147
14-739	1	A	101	16-669	2	A	141,147
14-782	1	A	140	16-744	18	A	104,147
A14-794	3	A	105	16-745	18	A	105,147
14-796	1	A	140	16-754	2	A	130,147
14-797	1	A	116	16-777	2	A	120,147
AN-15	2	D	106	16-791	3	A	144,147
AP-15	1	D	139	16-796	8	A	109,147
R15-7	3	A	104	16-801	9	A	105,147
R15-8	6	A	104	16-877	1	A	147
A15-10	1	A	101	16-879	2	A	140,147
R15-18-1	3	A	104	16-880-1	16	A	{144,146, 147
A15-21	1	A	95	16-881-1	1	A	139
A15-21-2	1	A	144	16-908-1	1	A	139
15-200	8	A	127,148	16-921-1	1	A	147
15-201-1	8	A	127,148				
A15-286	1	A	91				
15-323-1	4	A	96,148				

NUMERICAL PARTS INDEX—Cont'd

PART NUMBER	TOTAL QUANTITY	MFGR'S. CODE	PAGE NUMBER	PART NUMBER	TOTAL QUANTITY	MFGR'S. CODE	PAGE NUMBER
AN-17	2	D	106	22-109	3	A	101
AP-17F	1	D	139	22-111	3	A	101
B17-17	4	A	122	22-123	6	A	102
17-141	1	A	120	22-132	4	A	119
17-160	1	A	141	22-133	2	A	119
17-235	1	A	106	22-134	8	A	121
17-270	2	A	103	22-144	3	A	101
17-280	1	A	103	22-182	2	A	131
17-418	1	A	130	22-187	6	A	131
AN-18	2	D	106	22-188	1	A	129
AP-18	1	D	139	22-211	2	A	132
ZO-18	1	D	128	22-215	4	A	132
18-114	8	A	120,122	GI-23	1	B	92
18-147	4	A	103	23-12	8	A	120
18-148	4	A	103	C23-329	1	H	135
18-180	2	A	103	R24-1	48	A	104,148
18-233	24	A	120,122	R24-2	3	A	104
18-236	2	A	103	B24-26	16	A	127,148
19-13	4	A	120,124	24-53	1	A	101
19-41	1	A	101	24-86	4	A	127
19-87	2	A	127	24-236	1	A	124
B20-1	24	A	{127,129, 131	24-275	1	A	144
B20-2	30	A	{103,105, 132,144, 146	24-282	1	A	141
				24-286-1	1	A	141
				24-307	4	A	132
				RA-25	1	B	92
20-19	1	A	101	25-54	1	A	124
B20-42	2	A	108	A25-81	1	A	106
20-74	8	A	127	25-96	1	A	141
20-139	24	A	105	C-H-26	1	L	167
20-177	1	A	101	26-273	1	A	120
20-223-1	3	A	102	26-325	1	A	119
20-242-1	1	A	120	26-326	2	A	120,122
20-243-2	2	A	120	26-327	1	A	123
20-274	4	A	120,122	26-334	1	A	141
20-276	2	A	120,122	26-519	2	A	123
20-278	24	A	127	1A27-839	1	A	127
20-279	16	A	127	4A27-839	1	A	127
20-310	1	A	142	27-850	1	A	123
20-316	1	A	142	27-870	1	A	141
20-367	3	A	105	A27-870	1	A	140
20-368	9	A	105	A27-1152	1	A	141
20-378	1	A	130	27-1314	1	A	97
20-379	2	A	130,148	27-1317	1	A	140
20-381	6	A	177	27-1337	1	A	123
GI-21	1	B	92	A27-1381	1	A	130
C21-79	1	H	135	CR28-28	1	H	136
21-195	8	A	121	28-159	1	A	141
21-212	6	A	102	28-198	1	A	141
21-233	4	A	120	A28-237	2	A	177
21-234	2	A	120	A28-238	22	A	177
21-324	1	A	120	A28-239	7	A	177
21-334	8	A	122	A28-240-1	2	A	177
21-329	4	A	103	C29-326	1	H	135
21-330	2	A	103	31-233-1	1	A	101
21-367	1	A	130	31-325	1	A	120
21-368	1	A	130	31-327	2	A	120,122
21-370	3	A	123	31-427	2	A	96
AP-22F	1	D	139	GI-32	1	B	92
				33-22-5	1	A	146

NUMERICAL PARTS INDEX—Cont'd

PART NUMBER	TOTAL QUANTITY	MFGR'S. CODE	PAGE NUMBER	PART NUMBER	TOTAL QUANTITY	MFGR'S. CODE	PAGE NUMBER
33-114-21	2	A	130,131	C46-38	1	H	135
33-538	1	A	95	RA-47	1	B	94
33-555	1	A	95	47-533	1	A	140
B34-25	8	A	127	47-534	1	A	141
34-37	5	A	120	C-48	1	L	166
34-122	6	A	119	48-325	1	A	140
34-168	3	A	105	48-441-1	1	A	141
34-183	2	A	132	48-498	1	A	97
34-184	2	A	132	2A49-8	1	A	101
A34-212	1	A	106	49-10	1	A	101
34-217	12	A	119	49-43	1	A	140
B35-3	6	A	101	A49-44-1	1	A	141
B35-8	4	A	121	49-46	1	A	101
35-23	16	A	121	HP-50	4	B	92
36-246	1	A	101	50-91	1	A	177
1A36-249	2	A	108,130	50-99	4	A	96,177
36-256	1	A	119	AN-V51	2	D	106
A37-154-1	1	A	120	R-51	1	B	92
C-38	1	L	166	C52-1	1	H	135
C38-24	1	H	135	CT52-1	1	H	136
A38-222	1	A	141	C52-2	1	H	135
38-274	1	A	101	C52-6	1	H	135
38-275	2	A	101	52-48	1	A	146
38-367	1	A	133	52-56	2	A	139
C39-7	1	H	135	52-59	1	A	120
39-1214	1	A	108	PCH-A-53	1	L	174
1A39-1214	1	A	108	R53-3	3	A	105
39-1223	1	A	120	B53-8	8	A	127
39-1225	1	A	132	B53-25	12	A	119,120
39-1235	4	A	132	B53-26	18	A	102,119
39-1236	2	A	133	53-29	2	A	140
39-1239	2	A	133	53-31	16	A	121
39-1255-2	1	A	109	53-100	1	A	101
39-1378	2	A	95	53-112	1	A	101
39-1380	2	A	132	53-150	1	A	124
39-1381	2	A	96	53-171	2	A	120,122
39-1383	1	A	133	53-215	3	A	104
39-1384	2	A	132	53-221	1	A	142
39-1388	2	A	133	53-227	2	A	134
39-1389	2	A	133	T-54	1	B	94
39-1397	1	A	132	54-151	3	A	95
39-1398	1	A	132	54-280	3	A	177
39-1415	1	A	176	54-287	2	A	96
40-795-2	4	A	127	54-296	2	A	96
40-1075	1	A	130	54-297	2	A	96
40-1314	1	A	113	RA-55	1	B	94
40-1315	1	A	129	55-2-67	1	A	132
T41-12	4	H	136	55-2-84	2	A	91,137
41-143	2	A	108,148	55-2-89	1	A	139
41-225	2	A	130,148	C55-7	1	H	136
42-109	1	A	108	55-29-9	1	A	92
42-110	1	A	130	55-29-10	1	A	144
T43-6	2	H	136	55-29-33	3	A	92,124
43-48	1	A	107	55-29-34	1	A	106
43-70	1	A	123	55-29-44	2	A	124,145
A43-114	1	A	125	55-29-49	1	A	92
T45-8	2	H	136	55-29-50	1	A	96
45-44	1	A	97	55-29-73	1	A	91
1A45-50	1	A	141	55-29-78	2	A	91,124

NUMERICAL PARTS INDEX—Cont'd

PART NUMBER	TOTAL QUANTITY	MFGR'S. CODE	PAGE NUMBER	PART NUMBER	TOTAL QUANTITY	MFGR'S. CODE	PAGE NUMBER
55-51-1	1	A	124	62-128	1	A	133
55-51-8	1	A	124	62-129	1	A	133
A55-51-24	1	A	127	PD-62-442	1	L	175
55-397	1	A	119	AN-V63	2	D	106
55-398	1	A	119	CT63-2	1	H	136
55-653	1	A	116	63-41	1	A	127
T56-4	1	H	136	63-51	1	A	141
T56-10	1	H	136	63-61	1	A	140
T56-23	1	H	136	64-29	2	A	123
T56-24	1	H	136	64-33	4	A	127
T56-48	1	H	136	F65	1	B	92
T73-8	1	H	136	65-395	1	A	106
CT57-8	1	H	136	65-503	1	A	105
58-26	4	A	127	65-504	1	A	105
58-27	4	A	127	65-585-2	1	A	130
HP-60	4	B	92	65-620	1	A	139
A60-43-9	1	A	124	65-637	1	A	145
A60-43-27	1	A	106	65-638	1	A	145
60-80-1	1	A	91	65-639	1	A	145
60-82-1	2	A	91, 106	C66-25-1	1	H	136
60-83	1	A	91	66-224	1	A	106
60-117	1	A	91	66-509	3	A	104
60-142	1	A	139	68-721	1	A	143
AN-V61	2	D	106	68-722-1	2	A	133
WA-61	†	E	109	A68-723-2	1	A	143
3A61-1-3	1	A	109	A68-723-3	1	A	143
3A61-1-5	1	A	109	A68-724-2	1	A	143
3A61-1-12	1	A	109	A68-724-3	1	A	143
5A61-1-15	1	A	109	68-758	2	A	133
61-5-2	1	A	123	68-759	4	A	133
61-5-3	4	A	121	A69-261	1	A	139
61-44	19	A	96, 101	69-282	1	A	95
61-59	2	A	120	T-71	1	B	94
A61-107-3	1	A	127	C71-21	1	H	136
A61-107-4	1	A	116	A71-419-3	1	A	144
A61-107-5	1	A	116	A71-422-3	1	A	146
A61-141	9	A	134	71-467	4	A	144
A61-416-4	1	A	134, 141	71-483	4	A	146
A61-416-5	1	A	116	RA-73	2	B	94
A61-416-6	1	A	116	73-1-16	1	A	139
A61-416-7	1	A	116	T73-8	1	H	136
A61-416-8	1	A	116	T73-9	1	H	136
A61-416-20	1	A	116	73-29-8	1	A	131
61-418	1	A	139	73-41-6	1	A	146
A61-419	1	A	108	A73-41-19	1	A	146
AN-V62	2	D	116	A73-253-12	1	A	142
PD-62-18	1	L	106	73-261	5	A	177
PD-62-A28	1	L	173	73-261-1	2	A	177
62-85	1	A	174	73-262	3	A	177
62-86	1	A	120	73-263	1	A	96
62-87	1	A	120	B74-4	4	A	144, 146
62-88	2	A	102	74-41	8	A	120
PD-62-107	1	L	102, 120	74-69	2	A	143
PD-62-112	1	L	174	A75-279	1	A	97
PD-62-113	1	L	174	75-324	1	A	97
PD-62-412	1	L	174	A76-40	1	A	116
			175	A76-42	1	A	116
				A76-49	1	A	112

† As required.

NUMERICAL PARTS INDEX—Cont'd

PART NUMBER	TOTAL QUANTITY	MFGR'S. CODE	PAGE NUMBER	PART NUMBER	TOTAL QUANTITY	MFGR'S. CODE	PAGE NUMBER
A76-81	1	A	91	88-177	20	A	176
A77-137	1	A	128	88-178	20	A	176
A77-145-1	1	A	139	88-179	20	A	176
A77-166	2	A	105	A88-180-1	2	A	176
A77-184	1	A	125	88-181	2	A	176
A77-207	1	A	96	88-182	3	A	176
78-69	1	A	129	88-183	2	A	176
78-70	1	A	129	88-184	2	A	177
B79-10	3	A	130	88-185	2	A	177
79-41	5	A	{ 91, 92, 96	88-198	1	A	178
79-121	1	A	91	88-199	1	A	178
C81-1	1	H	136	88-200	1	A	178
A81-99-5	1	A	137	88-203	20	A	176
R82	1	B	92	A88-238	1	A	176
83-21	3	A	105	A88-241	1	A	178
83-24	2	A	95	A88-242	1	A	176
A83-25	2	A	139	A88-244	1	A	177
83-28-1	2	A	133	A88-245	1	A	177
A83-31	1	A	178	88-246	1	A	178
83-32	2	A	133	88-280	2	A	176
A83-33	22	A	177	88-281	2	A	176
83-34	1	A	106	88-282	2	A	176
A83-35	10	A	177	88-283	2	A	176
83-38	2	A	116	88-310	20	A	176
83-39	1	A	134	88-311	20	A	176
83-58	3	A	105	88-312	20	A	176
83-92	2	A	131	88-313	20	A	176
83-94	2	A	139	R-89	1	B	92
83-95	4	A	146	CT91-3	1	H	136
83-97	1	A	106	91-84	1	A	101
A83-98	4	A	177	91-86	13	A	177
A83-99	2	A	133	91-87	4	A	177
83-101	4	A	133	96-27	1	A	119
83-102	4	A	96, 177	T-97	1	B	94
83-103	2	A	133	A98-19-2	4	A	127
83-104	2	A	133	A98-19-3	4	A	127
83-105	2	A	133	R99-2	3	A	104
83-108	4	A	134	99-72	8	A	120
A83-119	2	A	177	2A100-145-2	1	A	101
A84-546-2	1	A	135	4A100-145-2	1	A	101
C85-26	1	H	136	6A100-149-2	1	A	119
A85-126-1	1	A	109	7A100-149-2	1	A	119
86-9-5	8	A	109, 148	8A100-149-2	1	A	119
L-88	1	B	92	C101-2	1	H	136
CR88-7	1	H	136	101-28	1	A	130
88-88	1	A	178	105	6	C	97, 98
88-104	1	A	178	C105-18	1	H	136
88-105	1	A	178	105-29	1	A	107
88-157	1	A	178	B105-31	4	A	119
A88-158	1	A	178	B105-39	4	A	119
88-161	1	A	178	B105-43	12	A	119
88-166	1	A	178	105-49	2	A	132
A88-167	1	A	166	105-61	13	A	101
A88-168-1	1	A	168	105-68	4	A	101
A88-169-2	2	A	170	105-84	45	A	101, 104
A88-170	1	A	171	105-191	6	A	127
88-172	2	A	176	105-206	14	A	101
88-173	2	A	176	105-216	4	A	127
88-174	2	A	176	105-231	4	A	134
88-175	2	A	176	105-232	14	A	119
88-176	20	A	176	105-245	4	A	119
				105-253	12	A	103

NUMERICAL PARTS INDEX—Cont'd

PART NUMBER	TOTAL QUANTITY	MFGR'S. CODE	PAGE NUMBER	PART NUMBER	TOTAL QUANTITY	MFGR'S. CODE	PAGE NUMBER
105-323	2	A	116	151-194	1	A	91
105-347	2	A	101	Z154	1	B	94
WA 106	†	E	109	156-138	1	A	139
C106-2	1	H	136	R-157	1	B	92
106-156	9	A	96,140	166-7	1	A	97
106-226	12	A	101	PD-BW-169	1	L	174
WA 107	†	E	110	RA-172	1	B	94
A107-93	1	A	112	175-6-1	4	A	120
A108-85	1	A	113	A178-14	1	A	134
C109-2	1	H	136	A178-15	1	A	134
R-110	1	B	92	A178-17	1	A	134
C111-17	1	H	136	180-7	2	A	96
AP-112U	1	D	139	A180-7	4	A	96
A113-28	1	A	91	181-18	1	A	141
115	1	C	98	181-117	2	A	101
M116	25	C	97	C181-134	1	H	136
116-47	1	A	141	1A181-161	1	A	108
A116-47	1	A	141	C181-252	1	H	136
116-71	1	A	146	C181-134	1	H	136
A117-49	1	A	116	C182-252	1	H	136
A117-49-1	1	A	116	184-2	1	A	148
118	2	C	97	186-9	1	A	147
118C	2	C	97	188-22	1	A	134
A118-433-1	1	A	132	C-192	1	C	97
A119-124	1	A	132	IS 222	1	E	109
A119-125	1	A	132	WA 288	4	E	109
A119-126	1	A	134	M 291	1	C	97
119-127	1	A	177	Z-302	3	B	94
119-128	1	A	148	Z-303	4	B	94
A120-2-8	1	A	91	Z-308	8	B	94
C120-9	1	H	136	Z-311	1	B	94
C120-15	1	H	136	Z-313	1	B	94
SC121-4 CA	2	E	109	G-344	1	K	146
124-2	4	A	109	G-345	1	K	144
125-28	1	A	140	C-396	2	L	166
125-58-1	2	A	106,129	C-415	1	L	166
125-59-1	1	A	101	H 438	1	C	97
125-68	1	A	130	C-453	1	L	166
125-69	8	A	96	IS 504	1	E	109
127-8	1	A	111,148	C-511	3	L	166
127-9	1	A	111,148	C-513	3	L	166
R-131	1	B	92	NP 521	1	E	109
C131-3x3	1	H	136	PK 521	1	E	109
132-73	1	A	130	WN 521	1	E	109
132-99	1	A	108	GG 522	1	E	111
CR134-1	1	H	136	GA 524	1	E	109
C136-3	2	H	136	WA 528	†	E	109
AP-137F	1	D	139	BR 529	1	E	109
AP-137Z	1	D	139	M 596	4	C	98
C138-24	1	H	136	C-632	1	L	166
C140-7	1	H	136	C-704	1	L	166
C142-15	1	H	136	C-705	1	L	167
142-27	1	A	133	C-706	1	L	167
150-1	1	A	109	C-707	2	L	167
C150-12	1	H	136	C-708	1	L	167
C-H-151	1	L	167	C-709	1	L	167
RA-151	1	B	94	C-712	1	L	167
C-H-152	1	L	167	C-713	1	L	167
				C-714	1	L	167
				C-715	1	L	167

† As required.

NUMERICAL PARTS INDEX—Cont'd

PART NUMBER	TOTAL QUANTITY	MFGR'S. CODE	PAGE NUMBER	PART NUMBER	TOTAL QUANTITY	MFGR'S. CODE	PAGE NUMBER
C-716	1	L	167	WA 1070	1	E	109
C-719	1	L	167	WA 1071	1	E	109
C-725	1	L	167	WA 1116	4	E	111
C-726	1	L	167,168	AP 1128U	1	D	139
C-731	1	L	167	C-1130	4	L	167
NT-731	1	E	111	AN-V1138	2	D	106
PN 731	2	E	111	SC 1150	1	E	111
C-732	1	L	167	SC 1151	1	E	111
SC 732	4	E	111	SC 1152	4	E	109
C-734	1	L	167	SC 1155	2	E	110
PK 734	1	E	111	SC 1161	1	E	110
C-735	1	L	167	SC 1163	1	E	109
C-736	1	L	167	A 1215	8	C	98
SP 736	1	E	111	A 1217	8	C	98
C-737	1	L	167	ACK 1297	1	L	175
C-738	1	L	167	G-1342	1	K	146
CA 739	1	E	111	G-1343	1	K	144
C-747	1	L	168	A1413	2	C	97
C-748	1	L	167	C-1500	2	L	167
C-751	1	L	167	C-1501	2	L	167
C-752	1	L	167	C-1502	2	L	167
C-753	1	L	167	C-1503	4	L	167
C-755	1	L	167	C-1504	1	L	167
C-756	1	L	167	1735	4	C	98
C-757	1	L	167	1904	4	C	98
C-758	1	L	167	A1937	4	C	98
C-761	3	L	167	A1981A	1	C	97
C-765	1	L	167	C-2002	2	L	168
M-765	8	J	144,146	G-2002	20	K	144,14
C-766	1	L	167	C-2004	1	L	169
C-767	1	L	167	C-2005	1	L	169
C-769	1	L	167	C-2006	1	L	169
C-772	1	L	167	C-2008	1	L	169
C-774	2	L	167	C-2018	1	L	169
C-789	1	L	167	C-2019	1	L	169
GI-800	1	B	92	C-2022	2	L	169
RAB-800	1	B	94	C-2023	2	L	169
GI-801	1	B	92	C-2024	2	L	169
GI-803	1	B	92	C-2025	2	L	146,16
GI-804	1	B	92	G-2025	6	K	144
GI-805	1	B	92	G-2052	4	K	144,14
HP-805	1	B	92	C-2056	2	L	169
RAB-805	1	B	94	G-2057	12	K	144,14
G-806	1	B	92	C-2059	1	L	169
GI-810	1	B	92	G-2070	6	K	144,14
G-812	1	B	92	G-2086	12	K	144,14
PN-1001	2	E	109	G-2205	2	K	144
KY 1004	1	E	111	G-2278	1	K	146
PN 1007	1	E	111	G-2284	4	K	144,14
WA 1009	†	E	110	G-2285	8	K	144,14
EC 1012	1	E	111	G-2288	20	K	144,14
WA 1012	1	E	111	C-2302	1	L	169
SP 1021	1	E	109	2502	1	L	172
WA 1034	1	E	110	C-2502	1	L	171
SC 1037 CA	4	E	109	C-2503	3	L	167,16
SC 1060	2	E	111	C-2504	1	L	169

† As required.

NUMERICAL PARTS INDEX—Cont'd

PART NUMBER	TOTAL QUANTITY	MFGR'S. CODE	PAGE NUMBER	PART NUMBER	TOTAL QUANTITY	MFGR'S. CODE	PAGE NUMBER
C-2505	1	L	169	G-5789	1	K	146
C-2506	1	L	169	G-5790	1	K	146
C-2507	2	L	169	5889	1	F	115
C-2508	1	L	169	FR-6100	1	K	146
C-2509	1	L	169	FR-6101	1	K	144
C-2510	1	L	169	6599	1	C	97
C2511	1	L	169	6615	1	C	98
C-2513	1	L	169	6662A	1	C	97
C-2515	1	L	169	6663A	2	C	97
C-2524	1	L	169	HB 7328	1	E	111
C-2526	4	L	169	7335	1	G	125
C-2528	4	L	169	Z8177B	1	C	98
C-2538	1	L	169	PL 9365	1	E	111
C-2546	1	L	169	06662A	2	C	97
C-2550	2	L	169	11080	1	J	146
C-2563	1	L	169	12090	1	J	146
C-2564	1	L	169	G-12521	1	K	146
C-2565	2	L	169	G-13500	1	K	146
C-2566	1	L	169	16083	6	F	112
C-2567	1	L	169	16199	1	F	113
C-2569	1	L	169	16282	4	J	144,146
C-2573	1	L	169	16818	1	F	112
C-2584	1	L	169	16819	1	F	112
C-2585	1	L	169	16820	1	F	112
C-2586	2	L	169	16887-A	1	J	146
C-2587	2	L	169	16999	1	F	113
C-2588	6	L	169	19561-1	1	G	125
C-2590	1	L	169	19666	1	G	125
A3271	4	C	98	19888	1	G	125
A5156	1	C	97	19894	1	G	125
A5178	1	C	98	19911	1	G	125
A5179	1	C	98	19926-1	1	G	125
A5180	1	C	98	19976	1	G	125
RG 5210	1	E	109	19982	2	G	125
GA 5215	2	E	109	20509	1	G	125
HG 5221	1	E	109	20793	2	F	116
NP 5222	2	E	109	G-21237	4	K	144,146
WK 5231	1	E	111	G-21410	4	K	144,146
CW 5232	1	E	110	G-21671	1	K	146
LE 5236	1	E	110	G-24020	8	K	144
CL 5238	1	E	111	27090-B	1	J	144
GE 5238	1	E	109	27091-C	1	J	144
WA5245	1	E	110	27325-B	1	J	146
SD 5249	1	E	109	28982	4	J	144,146
SP 5254	1	E	109	32832	12	J	146
BK 5259	1	E	110	33345	1	F	112
BK 5263	1	E	110	34846	6	F	112
BK 5264	1	E	111	36497	6	F	112
WA 5280	4	E	109	37872	12	F	113
WA 5281	2	E	109	37895	1	F	112
GE 5282	1	E	109	38290	1	F	112
BK 5283	1	E	111	38296	1	F	113
RT 5294	1	E	109	38689	1	J	146
G-5758	1	K	144	38689-A	1	J	144
G-5759	1	K	144	38690	1	J	146
				38690-A	1	J	144

NUMERICAL PARTS INDEX—Cont'd

PART NUMBER	TOTAL QUANTITY	MFGR'S. CODE	PAGE NUMBER	PART NUMBER	TOTAL QUANTITY	MFGR'S. CODE	PAGE NUMBER
38693	1	J	144	106497	7	F	113,114
38694	1	J	146	107728	1	F	115
39092	1	J	146	108579	2	F	115
39093	1	J	146	110730	2	F	112
39094	1	J	146	115607	6	F	112
39095	4	J	144,146	121743	4	F	114
39096	8	J	144,146	124545	1	F	115
39097	16	J	144,146	124546	1	F	113
39098	6	J	146	124567	1	F	
39099	6	J	146	132108	3	I	138
39100	1	J	144	132900	2	F	115
39101	4	J	146	132929	1	F	113
39102	2	J	144	134569	1	F	112
PL 52125	2	E	110	138479	1	F	115
CV 52126	2	E	109	141540	2	F	115
DP 52231	1	E	109	141542	4	F	115,116
57674	1	L	171	141543	1	F	114
57675	1	L	171	802729	3	F	116
BB 60226	2	E	109	802730	2	F	115
61890	1	L	171	802757	4	F	114
61942	2	L	171	804000	1	F	115
61943	2	L	171	804076	1	F	114
61945	1	L	171	805057	2	F	113
61948	1	L	171	805258	1	F	112
61952	1	L	171	805790	1	F	112
61963	1	L	171	806915	1	F	115
61964	1	L	171	809051	3	F	112
64135	2	L	171	809062	1	F	114
65889	2	L	171	809551	3	F	115
65891	1	L	171	809593	1	F	115
SA 65972	2	E	111	809614	1	F	114
68419	1	L	171	809642	3	F	115
68990	1	L	171	809644	2	F	115
68991	1	L	171	809658	1	F	115
69081	1	L	171	809688	1	F	115
69082	1	L	171	809698	1	F	114
69083	2	L	171	809824	1	F	114
69084	1	L	171	809945	1	F	115
69085	1	L	171	809961	1	F	115
69095	1	L	171	810620	1	F	113
69096	1	L	171	810819	1	F	113
69098	1	L	171	812015	1	F	114
69124	1	L	171	812016	1	F	114
69381	1	L	171	813157	1	F	115
71683	1	L	171	814627	2	F	116
HG 73118	1	E	111	815018	2	F	115
HG 73120	1	E	111	816315	1	F	114
WA 81751	1	E	109	816331	2	F	113
FP 81953	1	E	111	817216	1	F	114
IS 82927	4	E	111	817220	1	F	115
WA 98922	4	E	109	817223	1	F	115
KL 100657	1	E	111	817224	1	F	115
103088	1	F	113,115	817313	1	F	114
103319	2	F	113	817314	1	F	114
106495	7	F	115,116	817532	1	F	114
106496	9	F	112,115	819104	1	F	115
				820148	1	F	113

NUMERICAL PARTS INDEX—Cont'd

PART NUMBER	TOTAL QUANTITY	MFGR'S. CODE	PAGE NUMBER	PART NUMBER	TOTAL QUANTITY	MFGR'S. CODE	PAGE NUMBER
820517	3	F	115	1841027	1	F	113
820524	1	F	115	1848530	1	F	113
826938	1	F	112	1849782	1	F	113
828483	2	F	112,113	1850810	1	F	113
828675	14	F	112	1850811	1	F	113
833602	1	F	113	1850812	1	F	113
354005	1	I	138	1853901	2	F	116
854009	1	I	138	1855701	1	F	115
855012	1	I	138	1855702	1	F	115
855016	2	I	138	1855733	1	F	116
855017	4	I	138	1856056	2	F	115
855029	1	I	138	1856614	1	F	115
855064	10	I	138	1857107	2	F	114
855213	1	I	138	1858749	1	F	113
855274	1	I	138	1858752	2	F	113
855279	2	I	137	1858753	2	F	113
855281	1	I	137	1858754	1	F	113
855282	2	I	137	1859720	1	F	113
855390	1	I	138	1859967	1	F	116
855493	10	I	138	1860286	1	F	116
855573	1	I	138	1860809	1	F	115
855574	2	I	138	1861076	2	F	112
855585	1	I	138	1861234	1	F	113
855761	1	I	137	1861363	1	F	113
855763	1	I	138	1862803	3	F	115
855874	1	I	138	1865603	1	F	115
855918	1	I	137	1865614	1	F	115
856270	2	I	137	1865616	1	F	115
864016	1	I	138	1866970	3	F	115
903203	1	F	115	1869662	1	F	115
1521288	1	I	138	1871636	1	F	115
1521289	1	I	138	1872638	1	F	115
1522195	1	I	138	1872924	1	F	115
1522196	2	I	138	1877569	1	F	115
1522280	1	I	138	1879441	1	F	114
1523172	1	I	138	1880355	1	F	113
1537038	1	I	138	1880635	1	F	114,115
1537454	1	I	138	1881998	3	F	116
1838568	1	F	113	1883223	1	F	115
1838576	1	F	114	1888975	3	F	115

STANDARD PARTS LIST

PART NO.	SIZE	PART NO.	SIZE
	<u>CAPSCREWS (Hex. Head)</u>		<u>NUTS--Continued</u>
02-2	1/4 - .20 x 1/2	04-607	5/8 - 18 Hex.
02-3	1/4 - 20 x 5/8	04-801	1/4 - 28 Castle.
02-4	1/4 - 20 x 3/4	04-354	1/2 - 20 Castle, Hardened.
02-7	1/4 - 20 x 1-1/4	04-1002	3/8 - 16 Wing.
02-16	5/16 - 18 x 1/2	04-1004	1/2 - 13 Wing.
02-17	5/16 - 18 x 5/8	04-1129	7/16 - 20 Acorn.
02-18	5/16 - 18 x 3/4	04-1302	5/16 - 18 Elastic.
02-19	5/16 - 18 x 7/8	04-1307	5/8 - 11 Elastic.
02-20	5/16 - 18 x 1		
02-21	5/16 - 18 x 1-1/4		<u>LOCKWASHERS</u>
02-23	5/16 - 18 x 1-3/4		
02-32	3/8 - 16 x 1/2	05-49	1/4
02-33	3/8 - 16 x 5/8	05-50	5/16
02-34	3/8 - 16 x 3/4	05-51	3/8
02-36	3/8 - 16 x 1	05-52	7/16
02-37	3/8 - 16 x 1-1/4	05-53	1/2
02-38	3/8 - 16 x 1-1/2	05-55	5/8
02-39	3/8 - 16 x 1-3/4	05-176	#18 x 5/16 Shakeproof.
02-42	3/8 - 16 x 2-1/2		
02-50	7/16 - 14 x 1/2		<u>WASHERS</u>
02-52	7/16 - 14 x 3/4		
02-55	7/16 - 14 x 1-1/4	06-2	1/4 - 5/16 W.I.
02-58	7/16 - 14 x 2	06-3	5/16 - 3/8 W.I.
02-60	7/16 - 14 x 2-1/2	06-4	3/8 - 7/16 W.I.
02-61	7/16 - 14 x 2-3/4	06-6	1/2 - 8/16 W.I.
02-69	1/2 - 13 x 1	06-69	3/8 - 13/32 Steel.
02-70	1/2 - 13 x 1-1/4	06-70	7/16 - 15/32 Steel.
02-71	1/2 - 13 x 1-1/2	06-71	1/2 - 17/32 Steel.
02-72	1/2 - 13 x 1-3/4		
02-74	1/2 - 13 x 2-1/4		<u>COTTER PINS</u>
02-76	1/2 - 13 x 2-3/4		
02-101	5/8 - 11 x 1-1/2	07-2	1/16 x 7/16
02-107	5/8 - 11 x 3-1/2	07-23	3/32 - 1
02-573	1/2 - 20 x 2-1/2 N.F.	07-25	3/32 - 1-1/4
	<u>MACHINE SCREW</u>	07-35	1/8 - 1/2
03-427	5/16" - 16 x 1-1/4" F11. Head.	07-43	1/8 - 1-1/2
03-559	5/16" - 18 x 1" Flat Head.		<u>WOODRUFF KEYS</u>
03-619	1/4" - 20 x 1/2 Rd. Head.	09-6	#6
03-1538	#10 x 3/8" P-K "Z"	09-15	#A
03-1541	#10 x 1/2" P-K "Z"	09-17	#13
03-2001	#2 x 3/16" P-K "U"	09-32	#D
	<u>NUTS</u>	09-57	#V
04-13	#10 - 24 Hex.		<u>TAPER PINS</u>
04-101	1/4 - 20 Hex.	010-2	#00 - 3/4"
04-102	5/16 - 18 Hex.	010-29	#2 - 1"
04-103	3/8 - 16 Hex.	010-42	#3 - 1-1/4"
04-105	1/2 - 13 Hex.	010-53	#4 - 1"
04-404	7/16 - 14 Hex. Jam.	010-115	#8 - 1-1/4"
04-601	1/4 - 28 Hex.	010-201	#000 - 1/2"
04-603	3/8 - 24 Hex.	010-306	#5 - 1" Threaded.
04-604	7/16 - 20 Hex.	010-315	#7 - 2" Threaded.
04-605	1/2 - 20		

STANDARD PARTS LIST—Cont'd

PART NO.	SIZE	PART NO.	SIZE
	<u>PIPE PLUGS</u>		<u>PIPE FITTINGS--Continued</u>
011-1	1/8" Sq. Head.	013-535	3/4 St. Elbow 45°.
011-4	1/2"	013-601	1/8 Tee.
011-5	3/4"	013-632	1/4 Cross.
011-6	1"	013-701	1/8 Coupling.
011-10	2-1/2"	013-704	1/2 Coupling.
011-103	3/8" Ctrsk.	013-705	3/4 Coupling.
011-105	3/4" Ctrsk.	013-761	013-1061
	<u>PIPE FITTINGS</u>	013-790	013-1090
013-1	1/8 - 3/4" Nipple.	013-1061	1/4 x 1/8 Bushing.
013-2	1/4 - 7/8" Nipple.	013-1090	2 x 1 Bushing.
013-4	1/2 - 1-1/8" Nipple.		<u>GREASE CUPS</u>
013-6	1 - 1-1/2"	017-11	#000 x 1/8"
013-9	2 - 2" Nipple.		<u>WELCH PLUGS</u>
013-77	1/4 - 6" Nipple.		
013-115	1/2 - 4" Nipple.	019-40	3"
013-136	3/4 - 6" Nipple.		<u>YOKES</u>
013-236	2-1/2 - 7" Nipple.	031-2	1/4 - 28
013-401	1/8 Elbow.	031-62	1/4" Clevis Pin.
013-457	1 x 1/2 Elbow Red.		
013-502	1/4 St. Elbow.		
013-532	1/4 St. Elbow 45°.		

PART NO.

SIZE

COMPRESSION TUBE FITTINGS

†A182-12	Str. Conn. Assy.	3/16" tube,	1/8" MPT
1A182-13	Str. Conn. Assy.	1/4" tube,	1/8" MPT
†A182-14	Str. Conn. Assy.	5/16" tube,	1/8" MPT
†A182-33	90° Elbow Conn. Assembly	1/4" tube,	1/8" MPT
†A182-34	90° Elbow Conn. Assembly	1/4" tube,	1/4" MPT
†A182-35	90° Elbow Conn. Assembly	5/16" tube,	1/8" MPT
†A182-81	Tee Conn. Assy.	3/16" tube,	1/8" MPT
†A182-92	Tee Conn. Assy.	1/4" tube,	1/8" MPT
†A182-123	Tee Conn. Assy.	1/4" tube,	1/8" MPT
†182-181	Nut	5/16" tube,	1/2" SAE
†182-187	Union	5/16" tube,	1/2" SAE

† NOTE: Necessary tube nuts are included in assemblies.

MANUFACTURER'S CODE INDEX

- A - Le Roi Company
Milwaukee, Wisconsin
- B - Penn Electric Switch Co.
Goshen, Indiana
- C - Twin Disc Clutch Co.
Racine, Wisconsin
- D - Air-Maze Corporation
Cleveland, Ohio
- E - American Bosch Corporation
Springfield, Massachusetts
- F - Delco-Remy Division
General Motors Corporation
Anderson, Indiana
- G - Purolator Products Inc.
Newark, New Jersey
- H - Zenith Carburetor Division
Detroit, Michigan
- I - A-C Spark Plug Division
General Motors Corporation
Flint, Michigan
- J - Young Radiator Co.
Racine, Wisconsin
- K - Perfex Corporation
Milwaukee, Wisconsin
- L - Independent Pneumatic Tool Co.
Chicago, Illinois

