

1/4 rd  
1113  
12  
TM  
1945

# TM 5-9196

WAR DEPARTMENT TECHNICAL MANUAL

4.5 West. of Army

SPRAYER, INSECT,  
PORTABLE, PISTON-PUMP TYPE,  
GASOLINE ENGINE-DRIVEN,  
SKID-MOUNTED, 3-GPM, WITH  
4 50-FT. LENGTHS of  $\frac{3}{8}$ -IN.  
OIL-RESISTANT HOSE, AND SPRAY  
NOZZLE, BEAN MODEL C-64-S.I.



MAINTENANCE INSTRUCTIONS



*WAR DEPARTMENT TECHNICAL MANUAL*

*TM 5-9196*

---

SPRAYER, INSECT,  
PORTABLE, PISTON-PUMP TYPE,  
GASOLINE ENGINE-DRIVEN,  
SKID-MOUNTED, 3-GPM, WITH  
4 50-FT. LENGTHS of  $\frac{3}{8}$ -IN.  
OIL RESISTANT HOSE, AND SPRAY  
NOZZLE, BEAN MODEL C-64-S. I.

MAINTENANCE INSTRUCTIONS

---



*WAR DEPARTMENT • 13 FEBRUARY 1945*

---

WAR DEPARTMENT

Washington 25, D.C. 13 Feb 1945

TM 5-9196, Sprayer, Insect, Portable, Piston-Pump Type, Gasoline Engine-Driven, Skid-Mounted, 3-GPM, with 4 50-ft. Lengths of  $\frac{3}{8}$ -in. Oil-Resistant Hose and Spray Nozzle, Bean, Model C-64-S.I. is published for the information and guidance of all concerned.  
A.G. 300.7 (5 September 1944).

By order of the Secretary of War:

G. C. MARSHALL,  
Chief of Staff.

OFFICIAL:

J. A. ULIO,  
Major General,  
The Adjutant General.

DISTRIBUTION:

(for Explanation of Symbol see FM 21-6)

AAF (10); AGF (10); ASF (2); T of Opns (Eng) (2); Dept (10); Base Comds (Eng) (2); AAF Comds (2); Arm & Sv Bd (2) except Eng Bd (10); S Div ASF (1); Def Comds (1); Tech Sv (2) except OCE (20); SvC (10); PE (Port Eng) (2); ASF Dep (Eng Sec) (2); Dep 5 (2) except Granite City (25); Albany (Publ O) (7); Dist O 5 (2) except Seattle (4); Div Eng (2); Gen & Sp Sv Sch (2); USMA (2); ROTC (1); ASFTC (Eng Sec) (2); Library of Congress (2); A (10); CHQ (10); D (2); AF (2); T/O & E 5-157 (2); 5-247 (6); 5-267 (2); 5-357 (2); 5-377 (2); 5-567 (2). 8-137S (2); 8-500 SV ORGN, Malaria Control Unit (FA), Sanitary Team (JA) (2).

U 113  
12

TM 558196  
1945



## TABLE OF CONTENTS

### PART ONE. INTRODUCTION

	<i>Paragraphs</i>	<i>Page</i>
Section I. General .....	1- 2	5
Section II. Description and Data .....	3- 4	7
Section III. Tools and Spare Parts .....	5- 6	11

### PART TWO. OPERATION

Section IV. General .....	7- 8	13
Section V. Controls and Instruments .....	9-10	14
Section VI. Operating Instructions .....	11-14	17

### PART THREE. MAINTENANCE AND

#### REPAIR INSTRUCTIONS

Section VII. Fuel System .....	15-16	25
Section VIII. Ignition System .....	17-18	28
Section IX. Engine .....	19-22	33
Section X. Pump .....	23-28	45
Section XI. Spray Gun .....	29-30	54
Section XII. Trouble Shooting .....	31-32	55
Section XIII. Shipping and Storage .....	33-34	57

M558196

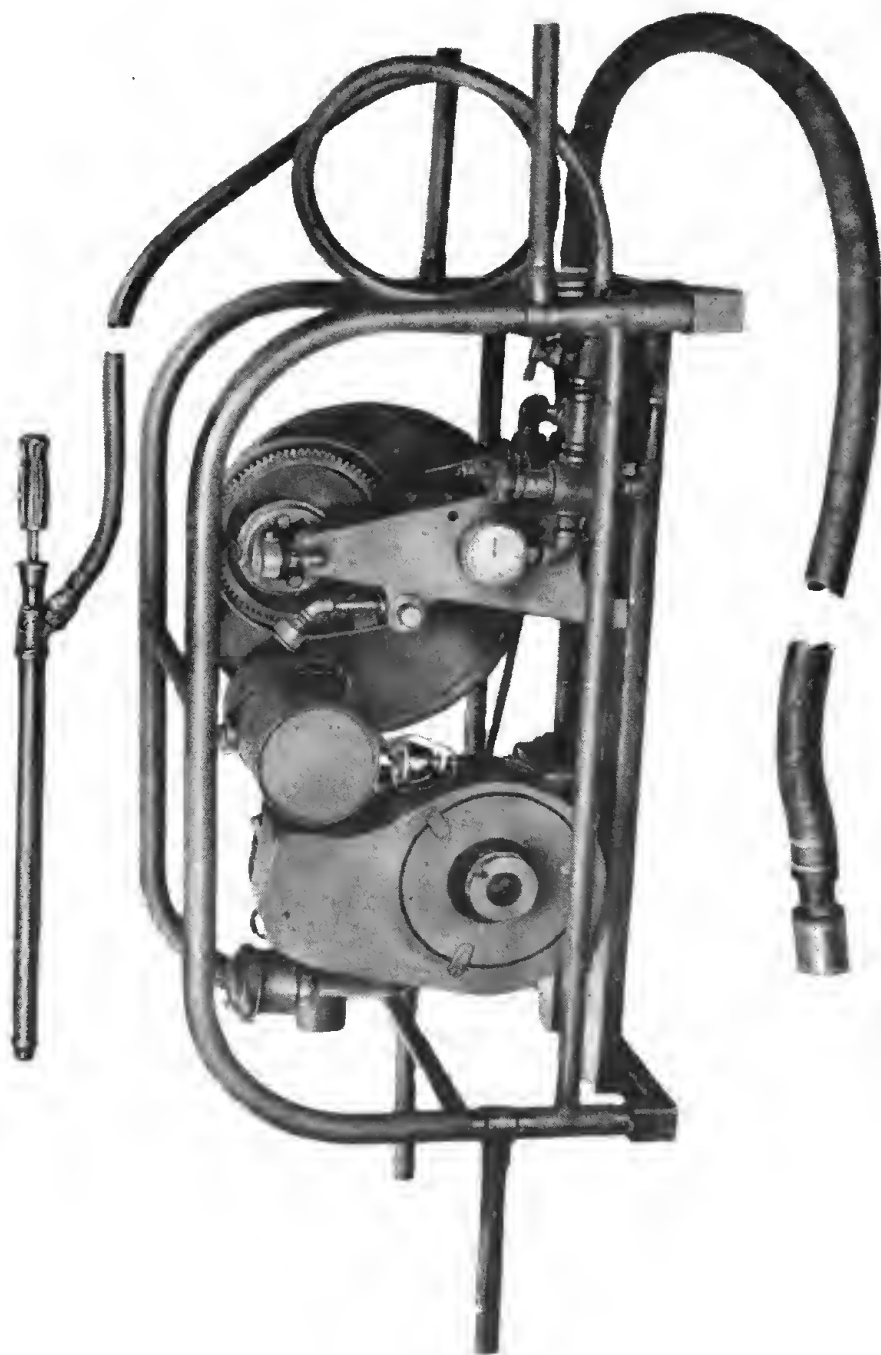


Figure 1—Portable Insect Sprayer, Hose and Spray Gun

# SPRAYER, INSECT, PORTABLE

## PART ONE

### INTRODUCTION

#### SECTION I

#### GENERAL

##### 1. SCOPE.

a. The instructions contained in this manual are published for the information and guidance of the personnel to whom this equipment is assigned. The manual contains information on the operation and maintenance of the equipment as well as descriptions of the major units and their functions in relation to the other components of the equipment.

b. The manual applies only to the Portable Insect Sprayer, and is arranged in three parts: Part One—Introduction; Part Two—Operation; Part Three—Maintenance and Repair Instructions.

##### 2. RECORDS.

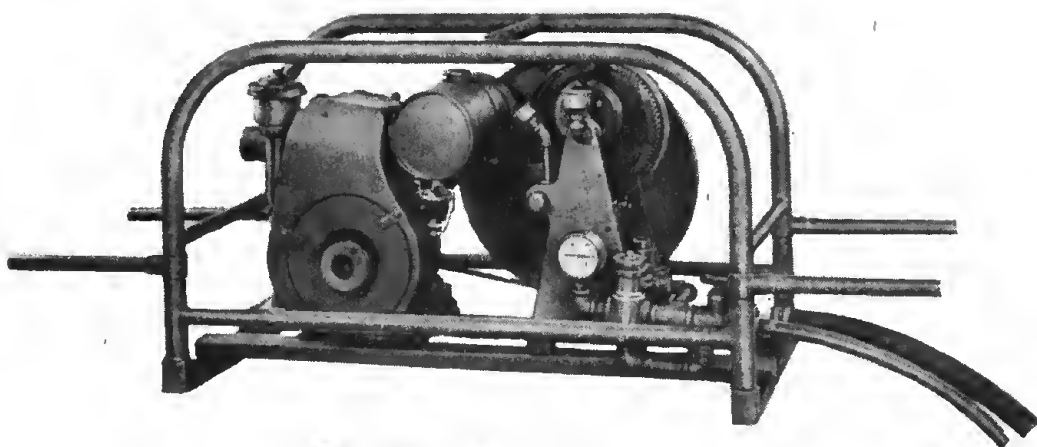
a. WD AGO Form No. 6—Duty Roster. This form slightly modified will be used for recording operation and scheduling lubrication and preventive maintenance services at the proper intervals on individual items of equipment.

b. WD AGO Form No. 48—Driver's Trip Ticket and P. M. Service Record. This form will be used by equipment operators for reporting the accomplishment of daily preventive maintenance services and for reporting any deficiencies observed on the equipment during operation.

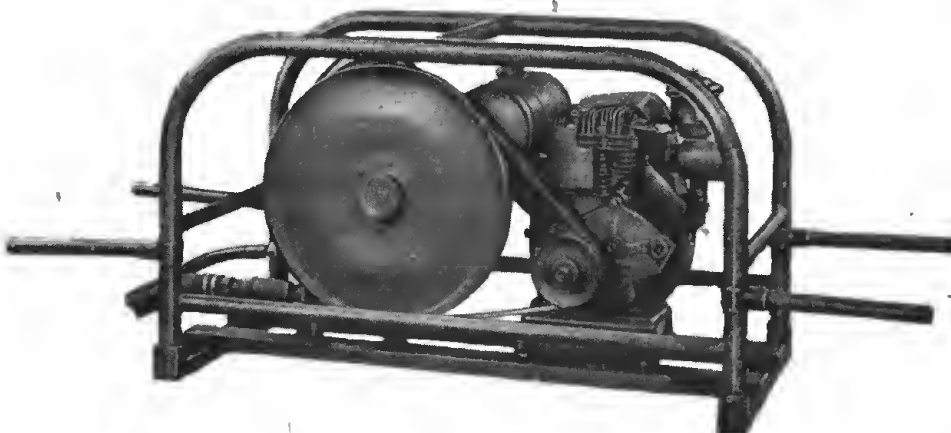
c. War Department Lubrication Order. This is a maintenance instruction form and is intended to instruct operators and personnel of the using organization as to the proper lubricants to be used and intervals to follow in lubricating individual items of equipment.

d. War Department Preventive Maintenance Services Engineer Equipment. This is a maintenance instruction form and prescribes daily maintenance services to be performed by the operator as well as the weekly and monthly services to be performed by mechanics of the using organization in providing proper maintenance on individual items of equipment.

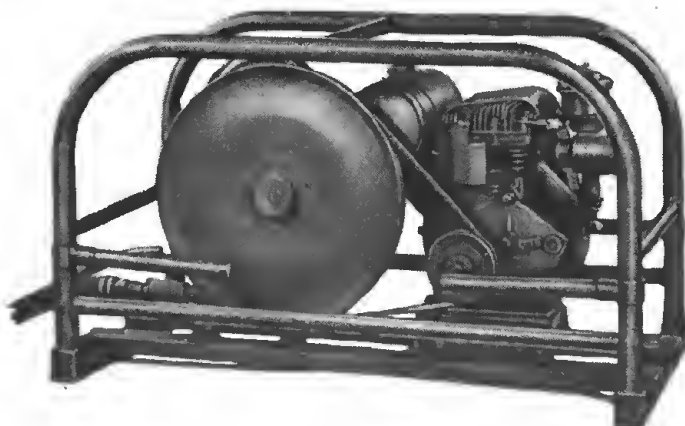
e. WD AGO Form No. 464.—Preventive Maintenance Services and Technical Inspection Work Sheet for Engineer Equipment. This form is used by personnel of the using organization and higher echelons for



**PRESSURE GAGE SIDE**



**DRIVE PULLEY SIDE**



**CARRYING HANDLES FOLDED**

**Figure 2—Sprayer, Insect, Portable**

reporting the results of preventive maintenance services, command, and technical inspections.

f. WD AGO Form No. 7353—Spot Check Inspection Report for All Motor Vehicles. This form may be used as a check list for items to be inspected during spot check inspections in lieu of WD AGO Form No. 464.

g. WD AGO Form No. 478—MWO AND Major Unit Assembly Replacement Record. Major repairs or rebuilding, the replacement of major unit assemblies and the accomplishment of equipment modifications will be recorded on this form.

## SECTION II

### DESCRIPTION AND DATA

#### 3. DESCRIPTION.

a. **General.**—The Portable Insect Sprayer (figure 2) covered by this manual combines a one cylinder, air cooled gasoline engine and a two cylinder plunger type pump. The pump and engine are mounted on a welded tubular steel frame equipped with carrying handles. The power of the engine is transmitted to the pump by means of a V-type, oil proof belt.



MAGNETO SIDE

DRIVE PULLEY SIDE

*Figure 3—Sprayer Engine*

b. **Engine.**—The sprayer engine (figure 3) is a one cylinder, four stroke cycle, air cooled, gasoline operated unit. It is equipped with a magneto, carburetor, governor, and oil pump and is started by means of a starter rope.

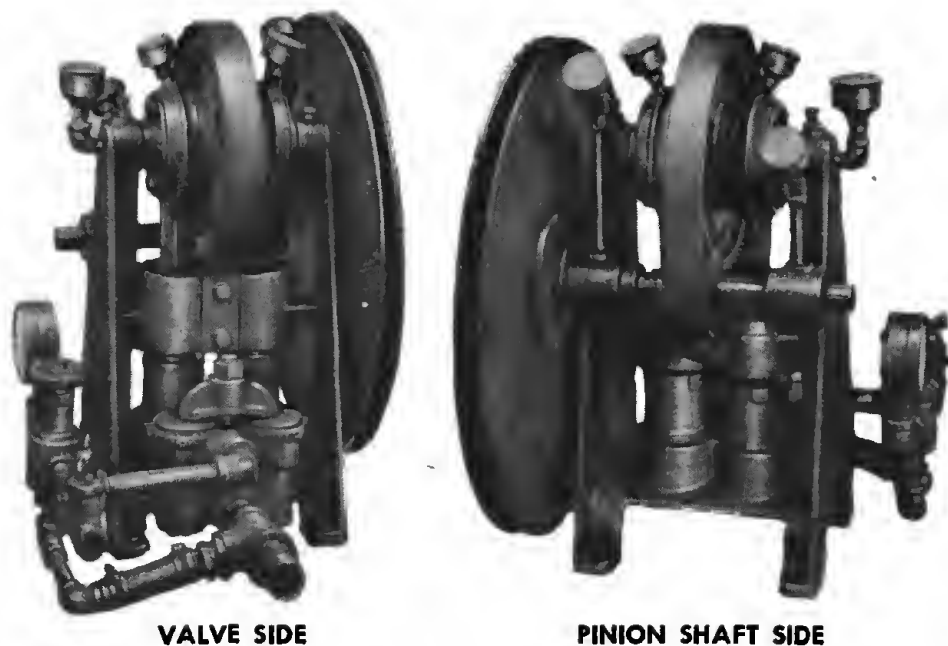


Figure 4—Sprayer Pump

c. **Pump.**—The sprayer pump (figure 4) is a two cylinder, plunger type pump, capable of delivering 3½ to 4 gallons per minute at three to four hundred pounds pressure. The foregoing performance is obtainable at normal operating speed; 100 to 120 revolutions per minute. The pump is 1¾ inch bore and 1¾ inch stroke and equipped with porcelain lined cylinders. The plunger packings are fabric and “Buna N” (synthetic rubber) material, especially designed to withstand operation on fuel oil or distillates, and are self expanding. The pump is equipped with bronze valve balls which seat in threadless cages.

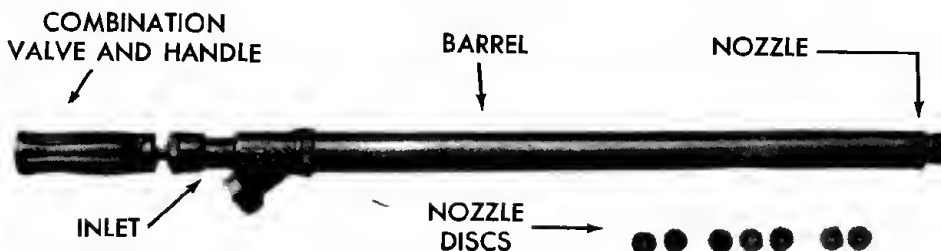


Figure 5—Spray Gun

d. **Spray Gun.**—The spray gun (figure 5) is designed to permit any variation in adjustment. The softest and finest mist or fog, or a pencil

stream which will reach extreme distances before breaking into a spray, may be obtained by turning the combination handle and valve one way or the other.

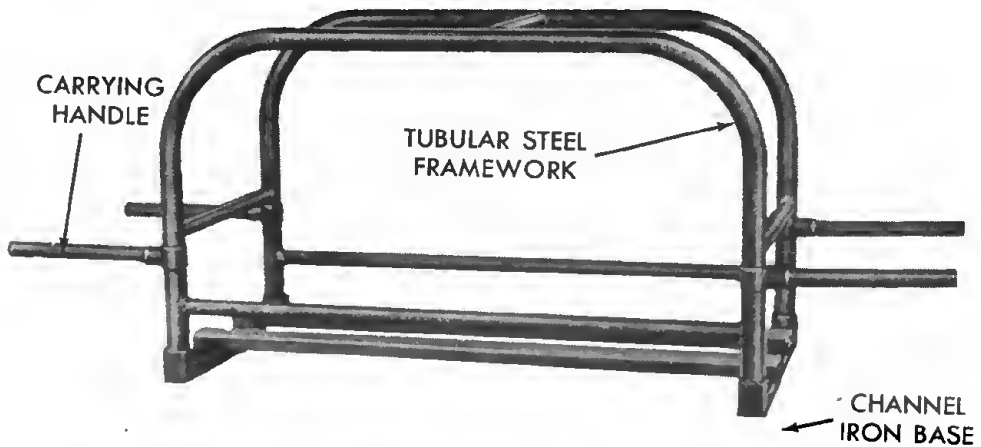


Figure 6—Carrying Frame

e. **Carrying Frame.**—The carrying frame (figure 6) consists of channel iron and tubular steel, welded together to form a sturdy, compact base and framework, on which the engine and pump are mounted. It is equipped with movable carrying handles which may be turned out of the way, when storing.

**4. DATA.**

- a. **Engine** ..... Cushman Motor Works, Lincoln, Nebraska  
 Model ..... 3M156 "Husky"  
 Horsepower ..... 2  
 Bore ..... 2<sup>5</sup>/<sub>8</sub> inch  
 Rotation ..... Clockwise  
 Spark Plug ..... 6M—Champion
- b. **Magneto** ..... Wico Electric Co., Springfield, Massachusetts  
 Model ..... F.W. 1642  
 Type ..... Flywheel
- c. **Carburetor** ..... Tillotson Mfg. Co., Toledo, Ohio  
 Model ..... ML2A
- d. **Pump** ..... John Bean Mfg. Co., Lansing, Michigan  
 Model ..... No. 64 "Duplex"  
 Bore ..... 1<sup>3</sup>/<sub>4</sub> inch  
 Stroke ..... 1<sup>3</sup>/<sub>4</sub> inch  
 R.P.M. ..... 100 to 120

**TM 5-9196**

**4**

Pressure at 100 to  
120 R.P.M. . . . . 300 to 400 pounds

Capacity at 300  
to 400 pounds  
pressure . . . . . 3½ to 4 gallons

- e. **Spray Gun** . . . . . John Bean Mfg. Co., Lansing, Michigan
  - Model . . . . . No. 780 Spraymaster
  - Nozzle Discs . . . . . No. 5—gallons per minute at 400 lbs.—2.4  
No. 6—gallons per minute at 400 lbs.—3.4  
No. 7—gallons per minute at 400 lbs.—4.6

(Above capacities are for straight stream position)

f. **Hose.**

Discharge Hose . . . ¾ inch—50 feet "Buna-N"  
Suction Hose . . . . . 1 inch I.D. x 10 feet "Buna-N"

- g. **Drive Belt** . . . . . Gates—55A.  
Allis-Chalmers—A55.

h. **Fits and Clearances.**

Connecting Rod Bearings  
(cap screws tight) . . . . . Slight amount of drag and side  
play to be felt

Piston . . . . . .003 to .005 inch, measured 90° to  
piston pin

Piston Pin . . . . . . Replace if diameter shows over  
.003 inch variation in diameter at  
any point

Connecting Rod Bushing . . . . . Ream to tight push fit in piston and  
a light push fit in connecting rod

Piston Rings . . . . . .015 to .020 inch between ring ends

Exhaust Valve Clearance . . . . .010 to .012 inch

Inlet Valve Clearance . . . . .008 to .010 inch

Valve Spring (Free Length) . . 1⅜ to 1⅝ inches

Main Crankshaft Bearings . . . . .003 to .005 end play (cold engine)

Spark Plug Gap . . . . . .030 to .033 inch

Breaker Point Gap . . . . . .020 inch

Pump Pedestal Bushings . . . . . Ream to .877 inch, +.000, −.001

**SECTION III  
TOOLS AND SPARE PARTS**



*Figure 7—Tool Box*

**5. TOOLS.**

A tool box, tools, and spare parts (figure 7) are furnished with each piece of equipment. The tools furnished are a combination of common and special tools required in servicing the equipment. (See figure 8.)



*Figure 8—Tools*

**6. SPARE PARTS.**

A supply of spare parts (figure 9) is furnished with each piece of equipment. The spare parts furnished for the pump will allow a complete rebuild of the plungers, valve assemblies, and spray gun. The parts furnished for the engine allow only some of the simpler repairs.



- |                                   |                                  |
|-----------------------------------|----------------------------------|
| 1. Rope, Starter—SK-6862          | 15. Cap, Nozzle—24977            |
| 2. V-Belt, Oil Proof—A55          | 16. Washer, Packing—U-26         |
| 3. Gasket, Cylinder Head          | 17. Gasket, Cap—15528            |
| 4. Gasket, Valve Cover—10064      | 18. Seat, Valve—25943            |
| 5. Clamp, Bulldog Hose—FIG-319X   | 19. Plunger Assembly—26043       |
| 6. Condenser—X2186                | 20. Packing, Relief Valve—25928  |
| 7. Plug, Spark—3M-156             | 21. Gasket, Valve Seat—10065     |
| 8. Gasket, Cylinder—10074         | 22. Gasket, Hose—20982           |
| 9. Key, Valve—23-27               | 23. Gasket, Drain Screw—A-14-B   |
| 10. Spring, Valve—63-21           | 24. Gasket, Suction Hose—SK-6866 |
| 11. Fitting, Female Hose—FIG-357X | 25. Packing, Rod—P-129           |
| 12. Fitting, Male Hose—FIG-357MX  | 26. Disc, Gun, No. 5—14191       |
| 13. Cut-off—FIG-343               | 27. Disc, Gun, No. 6—15066       |
| 14. Packing, Plunger—8083         | 28. Disc, Gun, No. 7—14192       |

Figure 9—Spare Parts

## PART TWO OPERATION

### SECTION IV GENERAL

#### 7. SCOPE.

Part Two contains information for the guidance of the personnel responsible for the operation of this equipment. It contains information on the operation of the equipment together with the description and location of the controls and instruments.

#### 8. SERVICE UPON RECEIPT OF EQUIPMENT.

a. **New Equipment.**—Remove equipment from shipping boxes.

b. **Remove Processing Material.**

(1) Remove wrapper from air cleaner, exhaust opening, and breather cap.

(2) Remove protective paper between drive belt and pulleys.

(3) Steam clean unit thoroughly. If steam cleaning equipment is not available, kerosene or any other petroleum solvent may be used to remove sealer and rust preventive compounds.

(4) Lubricate unit according to specifications set forth in paragraph 14.

c. **Assembly.**—Hose ends, gun end, and attaching points of equipment have been match marked with tags to show proper installation location.

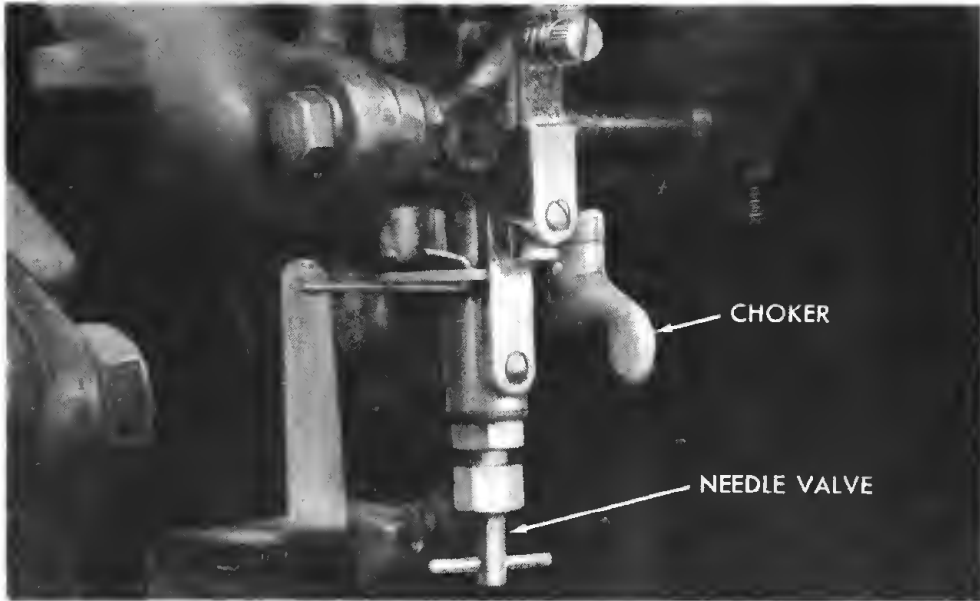
(1) Install suction hose (match marked "C") to suction hose connection (match marked "C").

(2) Install discharge hose (match marked "B") to discharge hose connection (match marked "B").

(3) Install spray gun (match marked "A") to end of discharge hose (match marked "A").

## SECTION V CONTROLS AND INSTRUMENTS

### 9. CONTROLS.

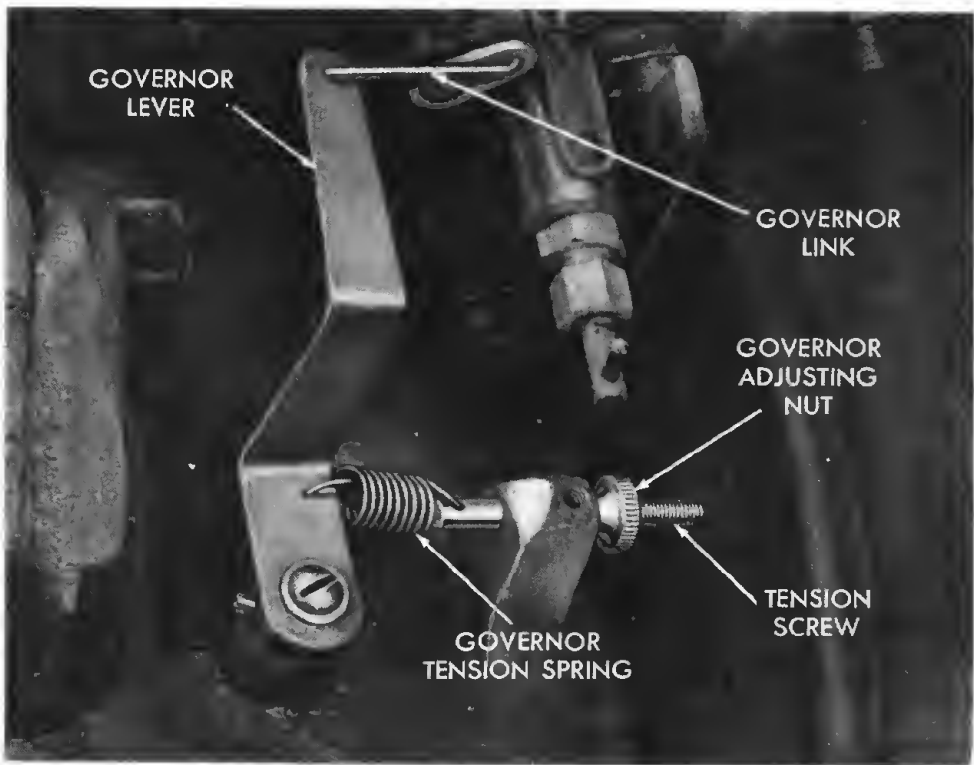


*Figure 10—Choker and Needle Valve*

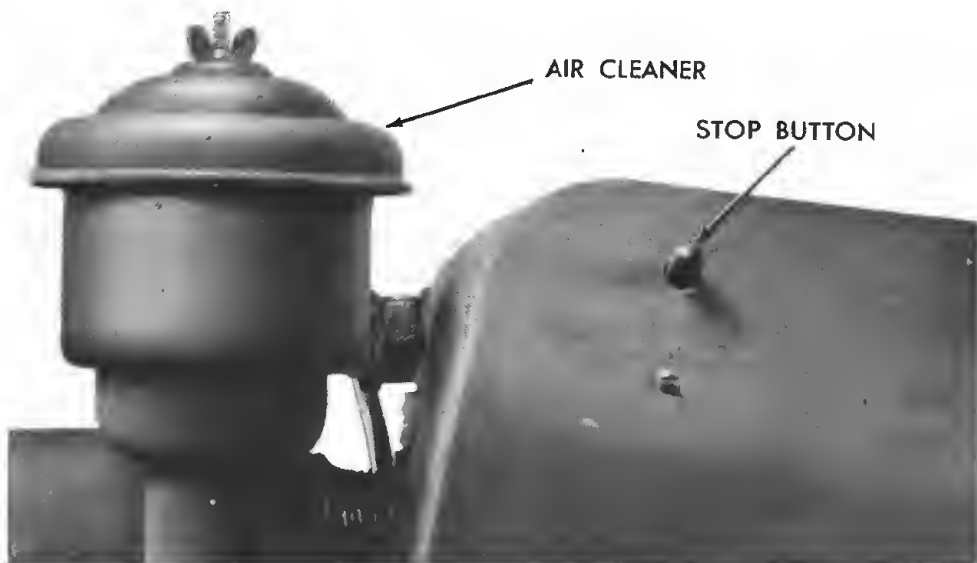
a. **Choker.**—A butterfly valve, located in the carburetor air intake and equipped with a handle to permit manual adjustment of choker (figure 10). Choker is used when starting engine. When choker (butterfly valve) is closed, air is shut off from carburetor permitting a greater amount of gasoline to be drawn into combustion chamber.

b. **Needle Valve.**—An adjustable valve, located on the carburetor (figure 10), which controls the fuel and air mixture passing into the combustion chamber. When starting engine, needle valve must be opened one and one-half turns to the left (counterclockwise); then adjusted to the best running position as the engine warms up.

c. **Governor.**—The governor is enclosed within the engine crankcase and is controlled by linkage attached to an adjusting nut and tension screw (figure 11) located adjacent to the carburetor and behind the needle valve. The adjusting nut controls the action of the governor, which in turn controls the speed of the engine. To increase engine speed, turn adjusting nut to the right (clockwise). The speed of the engine should be such that the pump will operate at 100 to 120 revolutions per minute.

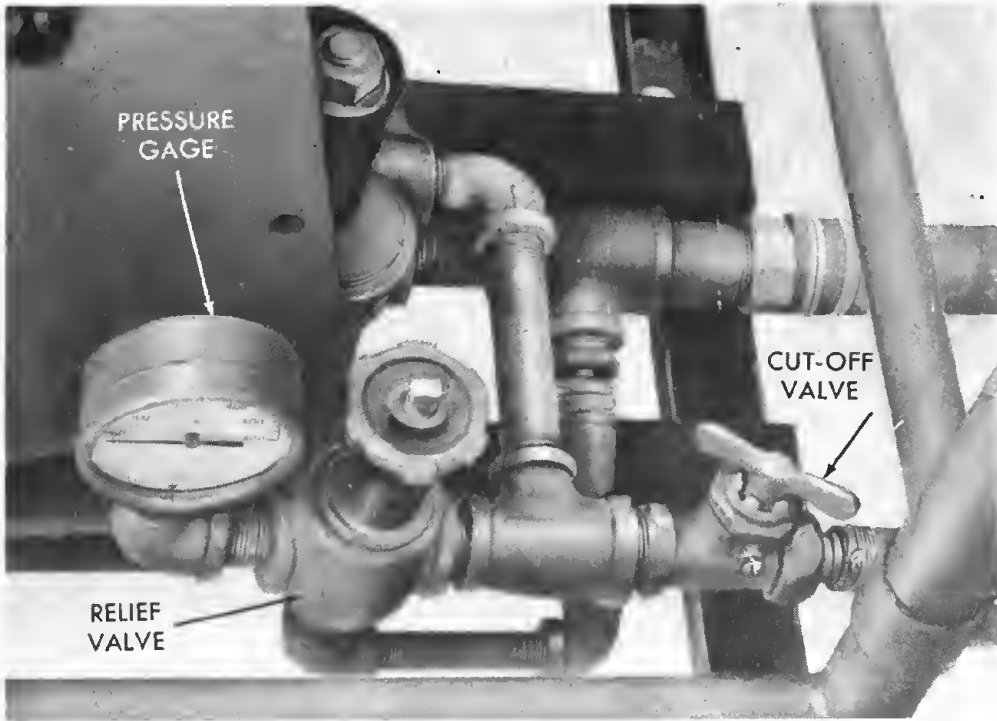


**Figure 11—Governor Adjusting Nut and Tension Screw**



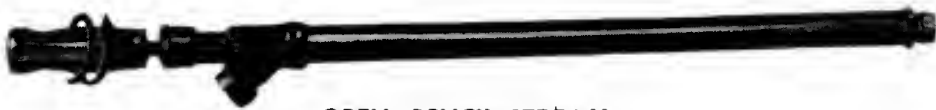
**Figure 12—Stop Button**

d. **Stop Button.**—The stop button (figure 12) is located on the fly-wheel housing and is used for stopping the engine. Pressure on the stop button causes the magneto to become grounded, thus eliminating the spark.



*Figure 13—Relief Valve, Cut-Off Valve and Pressure Gauge*

e. **Relief Valve.**—The relief valve (figure 13) is located adjacent to the pump, in the discharge or pressure line of the pump, and used for the purpose of automatically controlling the pressure of the equipment. For adjustment of the relief valve see paragraph 12 b. and d.



OPEN—PENCIL STREAM



CLOSE—FINE MIST

*Figure 14—Spray Gun Valve*

f. **Cut-Off Valve.**—The cut-off valve (figure 13) is located in the discharge line and is a means of stopping the flow of liquid to the spray gun.

g. **Spray Gun Valve.**—The spray gun valve is integral with the spray gun handle (figure 14). A straight pencil stream is obtainable by opening valve (turn handle counterclockwise). A fine fog like mist is obtained by partially closing valve (turn handle clockwise).

## 10. PRESSURE GAGE.

The pressure gage (figure 13) is located in the pressure line between the discharge side of the pump and the relief valve. It is a dial indicator calibrated to 600 pounds and is used for the purpose of gaging the pressure out-put of the pump.

# SECTION VI OPERATING INSTRUCTIONS

## 11. PLACING EQUIPMENT IN OPERATION.

### a. Pre-Starting Inspection.

- (1) Check all hose connections for tightness.
- (2) Make an inspection of engine and pump mounting bolts to insure tightness.
- (3) Inspect strainer on end of suction hose to make certain strainer is not clogged.
- (4) Check oil level in engine crankcase, follow instructions given on L.O.
- (5) Check fuel tank to insure adequate fuel supply.
- (6) Check grease cups on pump, follow instructions given on Lubrication Order.

### b. Starting Engine.

- (1) Close choker (figure 15).
- (2) Open needle valve to left, one and one-half turns (figure 15).
- (3) Slip knotted end of starter rope in notch of starter pulley and wind rope clockwise around pulley (figure 16).
- (4) On the first explosion, open choker and adjust needle valve to best running position as the engine warms up.

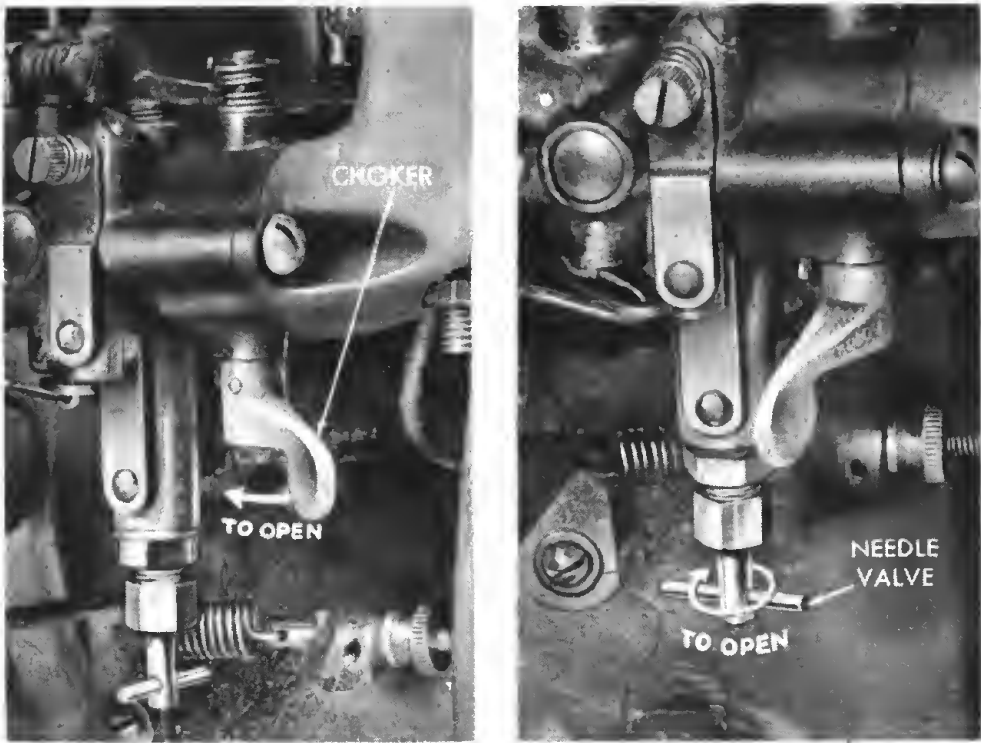


Figure 15—Choker and Needle Valve Positions

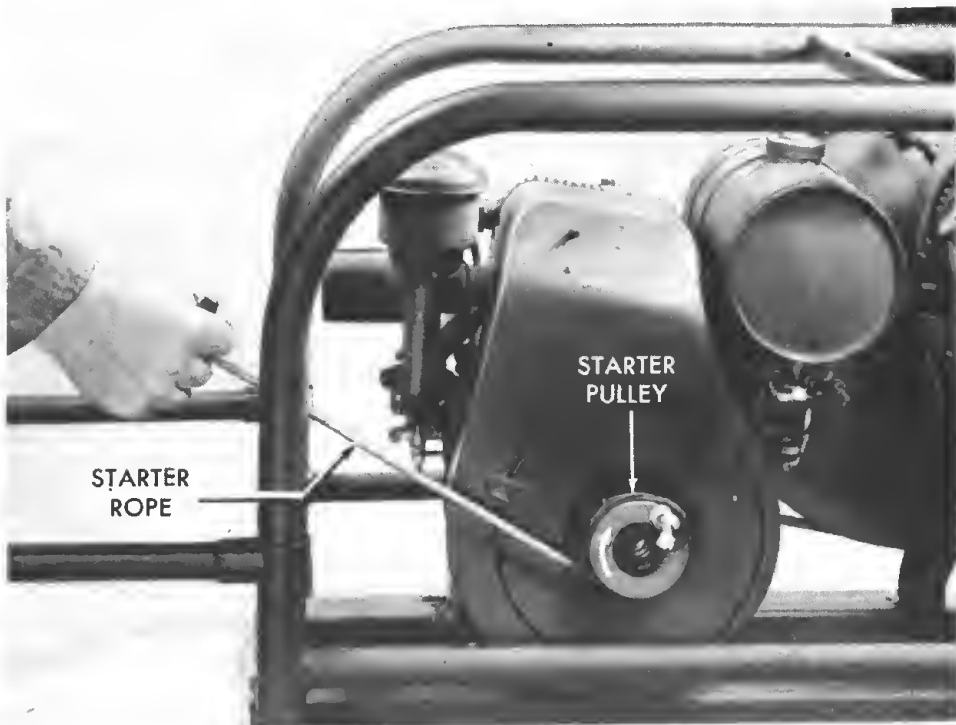
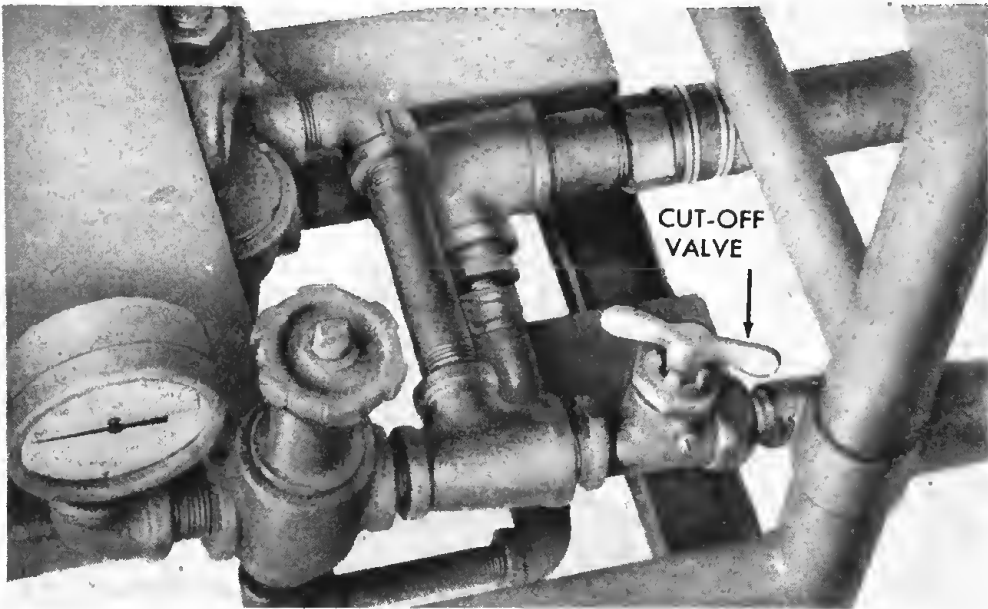


Figure 16—Starter Rope Installed

**Note**

One spin of the engine, with choker closed, is usually enough to choke or prime engine. If engine does not start on first pull, open choker before repeating cranking operation. Continued choking will flood the engine and cause hard starting.



**Figure 17—Cut-Off Valve**

**c. Spraying.**

- (1) Submerge strainer end of suction hose in spray material.
- (2) Open cut-off valve (figure 17) permitting spray material to travel through hose to spray gun.
- (3) Turn handle of spray gun to right (clockwise) or left (counterclockwise) to select type spray desired.

**Note**

With engine operating and equipment in condition to spray, make working adjustments as outlined in Paragraph 12.

**12. MAKING WORKING ADJUSTMENTS.**

**a. Carburetor Needle Valve.**—After starting engine, set needle valve so that engine will operate at peak, when warm.

**b. Operating Pressure.**—All other working adjustments are based on an operating pressure of 300 to 400 pounds, which is obtainable by turning the pump at the rate of 100 to 120 revolutions per minute.

c. **Setting Engine Governor.**—Count the strokes per minute of one pump plunger. If less than 100 strokes are recorded, governor should be advanced, permitting greater engine speed. To advance governor, turn governor adjusting nut (figure 11) to the right (clockwise). If more than 120 strokes per minute are recorded, governor should be retarded to reduce engine speed. To retard governor, turn governor adjusting nut to the left (counterclockwise).

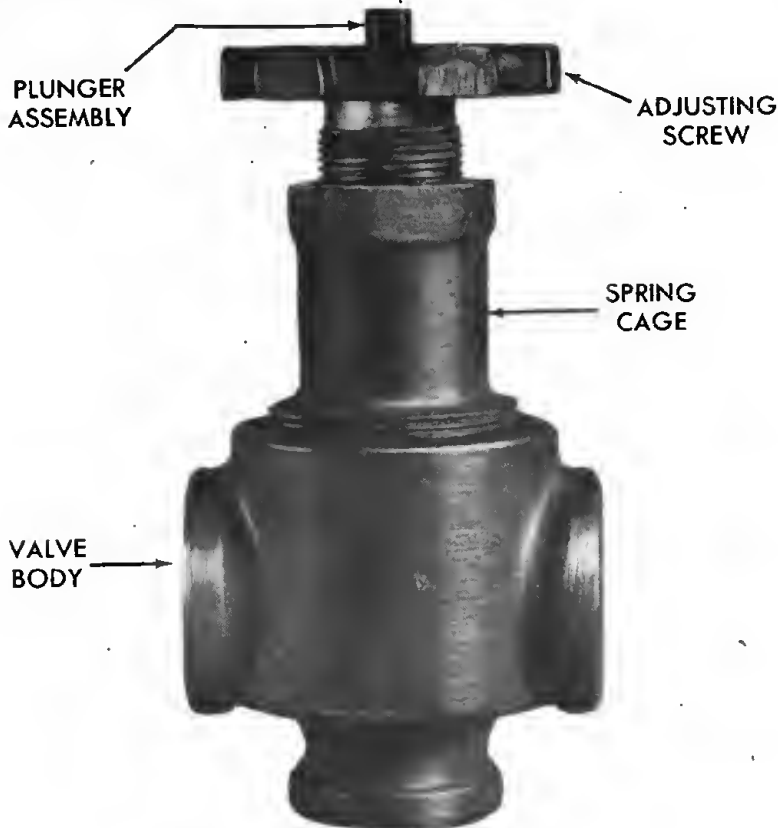


Figure 18—Relief Valve

d. **Setting Relief Valve.**—Relief valve (figure 18) setting is obtained by turning adjusting screw to right (clockwise) to increase pressure or to left (counterclockwise) to reduce pressure, while pump is operating at 100 to 120 R.P.M.

**Note**

Set relief valve to show 400 pounds pressure on pressure gage (with spray gun valve closed). With spray gun valve open, pressure gage will show approximately 370 pounds pressure.

e. **Spray Gun.**—Adjustment of the spray gun can be obtained by turning the handle to right or left. Gun will deliver a fine mist or fog, or a pencil stream; however, the capacity of the output can be varied by installation of different size nozzle discs. The following chart sets forth the performance obtainable with each size disc:

<i>Disc No.</i>	<i>Hole Size</i>	<i>Pressure</i>	<i>Gal. Per Minute</i>
5	$\frac{5}{64}$ -inch	400 pounds	2.4
6	$\frac{3}{32}$ -inch	400 pounds	3.4
7	$\frac{7}{64}$ -inch	400 pounds	4.6

**Note**

All capacities given in above chart are for the straight stream position—with spray gun valve full open.

**13. STOPPING ENGINE.**

To stop the engine a button is located on engine flywheel housing. Pressure on stop button will cause the engine to stop.

**14. LUBRICATON.**

a. **General.**—Lubrication instructions for this equipment are consolidated in a lubrication order (figures 20 and 21) at the end of this paragraph. The instructions specify the point to be lubricated, periods of lubrication, and lubricant to be used.

b. **Engine.**—The engine is completely lubricated by splash from a trough in the sub-base. The trough is fed by a plunger type pump which is driven by a cam on the governor shaft.

c. **Carburetor Air Cleaner.** (See figure 19.)—Fill to level indicated on inside of cleaner, using engine oil (O.E.).

(1) *Removal.*

- (a) Remove wing nut on top of air cleaner.
- (b) Lift off air cleaner cover and element.
- (c) Remove air cleaner body and drain oil from reservoir.

(2) *Cleaning.*

- (a) Slush cleaner element in cleaning solvent and allow element to dry.
- (b) Wipe out interior of oil reservoir.

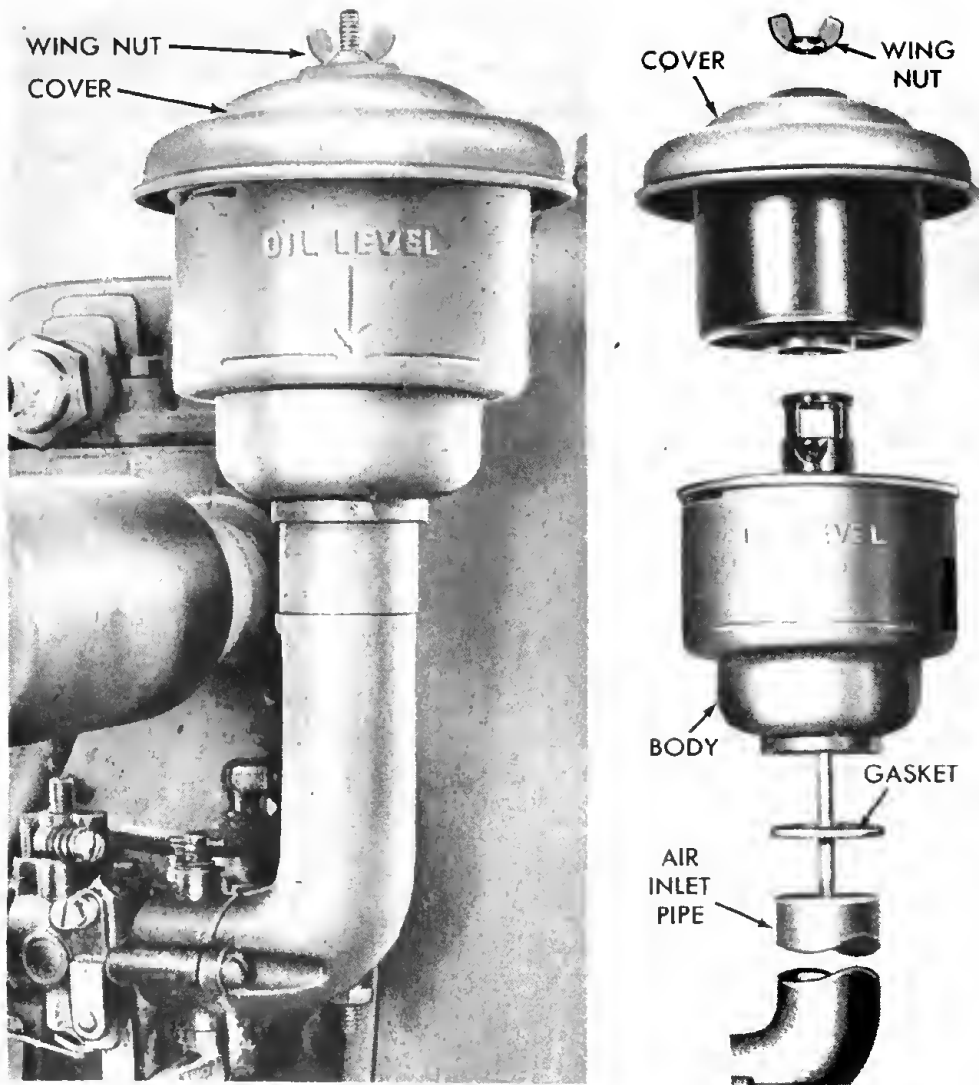


Figure 19—Carburetor Air Cleaner

(3) *Assembly and Installation.*

- (a) Install new gasket in base of air cleaner and place cleaner on air inlet pipe.
- (b) Fill oil reservoir to level indicated on base of cleaner (approximately  $\frac{1}{8}$  pint), using engine oil.
- (c) Install element and cover on cleaner base and secure with wing nut.

d. **Pump.**—The pump has eight lubrication points. The grease cups, one on the eccentric strap, one of the eccentric shaft, and one at each end of the pinion shaft. The wrist pins and crosshead guides at the lower end of eccentric straps are lubricated by using an oil can. The gears are lubricated by coating the teeth with lubricant.

e. **Carrying Handles.**—The carrying handles at their swivel point are lubricated by using an oil can.

WAR DEPARTMENT LUBRICATION ORDER **L05-9196**  
1 MAR 1945

**SPRAYER, INSECT, PORTABLE, PISTON-PUMP TYPE, GASOLINE  
ENGINE-DRIVEN, SKID-MOUNTED, WITH ATTACHMENTS**

Manufacturer's name plate located on pump pedestal, above pressure gage.

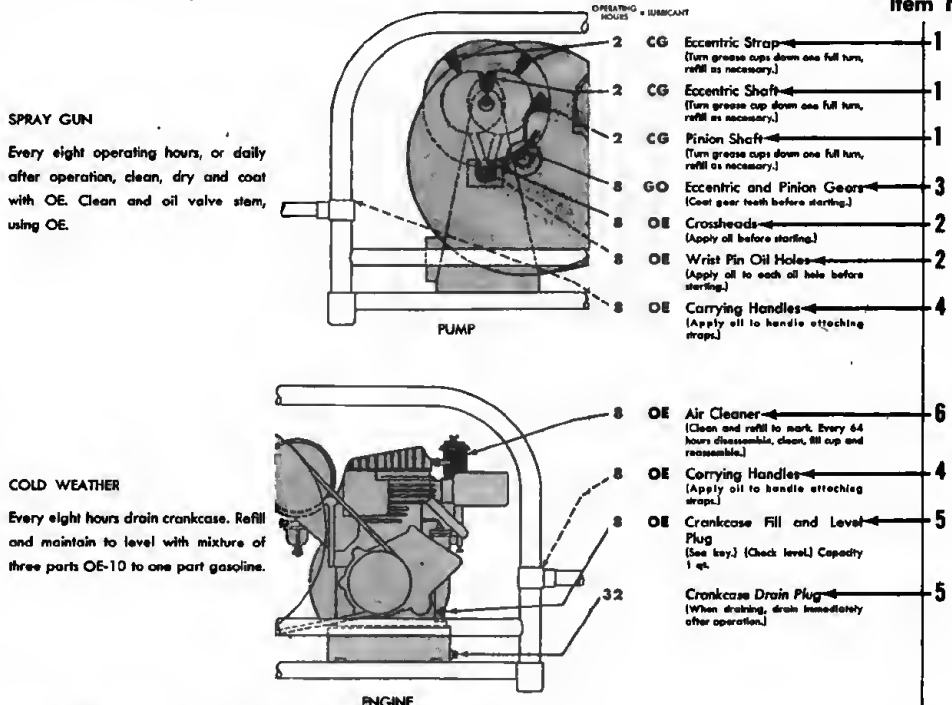
(BEAN, MODEL C-64-S.I.)

Reference TMS-9196

Clean fittings before lubricating. Lubricate after washing.  
Clean parts with SOLVENT, dry-cleaning or OIL, fuel, diesel.  
Dry before lubricating. Use of gasoline is prohibited.

Hours indicated are actual operating hours for normal service conditions. For extreme conditions of heat, water, mud and dust, change crankcase oil and lubricate more frequently.  
Lubricate dotted arrow points on BOTH sides.

Fig. 21  
Item No.



— KEY —

LUBRICANTS	LOWEST EXPECTED AIR TEMPERATURE		
	Above +32° F.	+32° to 0° F.	Below 0° F.
OE—Oil, Engine			
Crankcase	OE SAE 30	OE SAE 10	See Cold Weather note
Air Cleaner	OE SAE 30	OE SAE 10	OH or SA
Other Points	OE SAE 30	OE SAE 10	OE SAE 10
GO—LUBRICANT, Gear, Universal			
	GO SAE 90	GO SAE 90	GO Grade 75
CG—GREASE, General Purpose			
	CG No. 1	CG No. 0	CG No. 0
OH—OIL, Hydraulic			
SA—FLUID, Shock Absorber, Light			

Requisition necessary additional Lubrication Orders in conformance with instructions and lists in FM 21-6

Figure 20—Lubrication Order

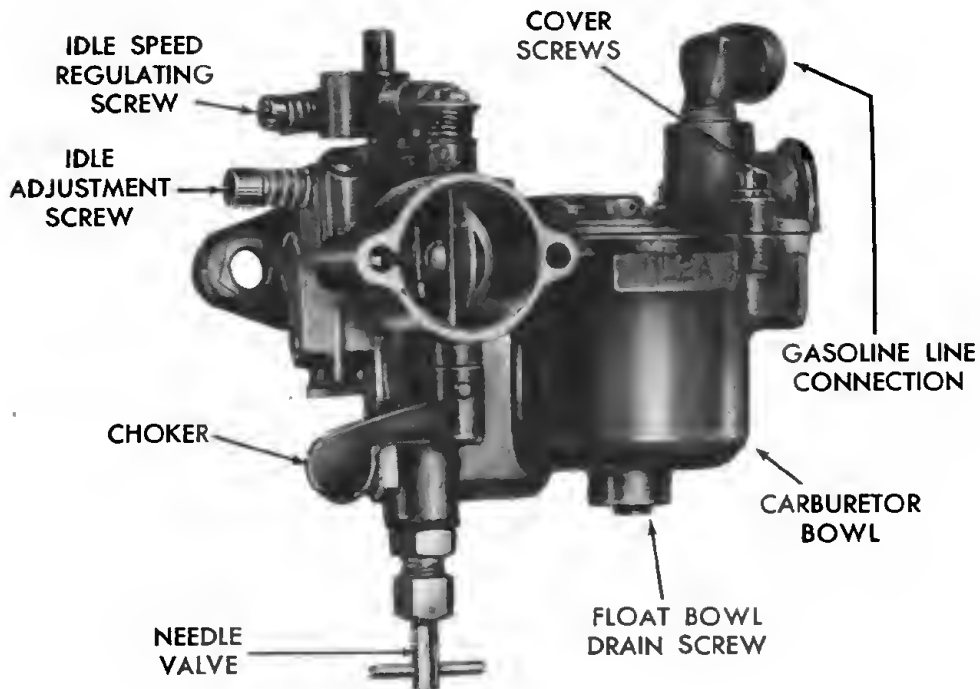
## PART THREE MAINTENANCE AND REPAIR INSTRUCTIONS

### SECTION VII FUEL SYSTEM

#### 15. CARBURETOR.

##### a. Removal.

- (1) Close shut-off valve in gasoline line.
- (2) Disconnect gasoline line at carburetor.
- (3) Remove air cleaner pipe at elbow.
- (4) Disconnect throttle control linkage.
- (5) Remove screws holding carburetor to intake manifold.

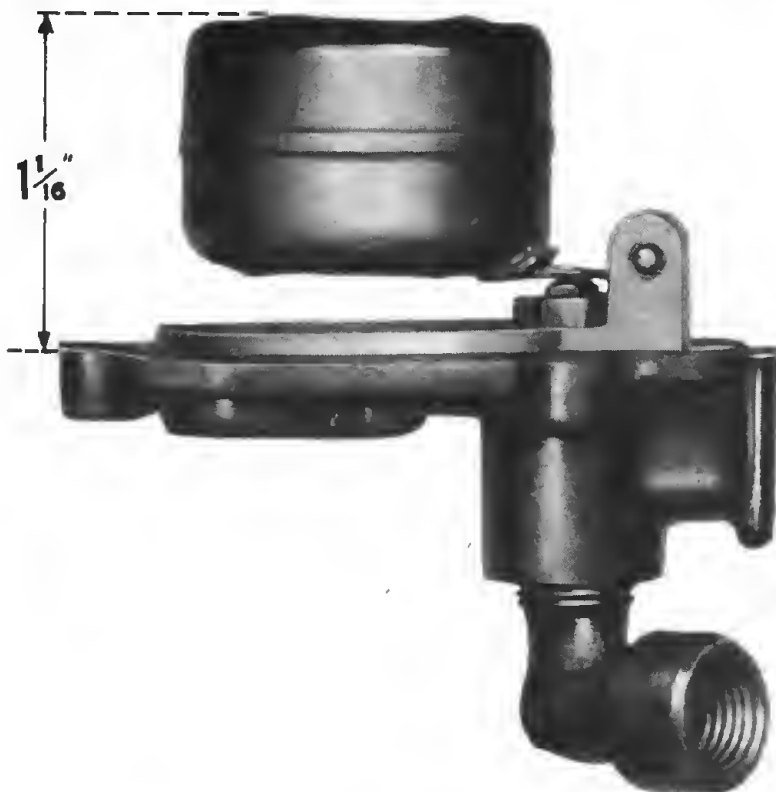


*Figure 22—Carburetor Adjustment Points*

##### b. Cleaning. (See figure 22)

- (1) Remove three bowl cover retaining screws.
- (2) Remove float and inlet needle and seat.

- (3) Remove needle valve.
- (4) Remove float bowl drain screw.
- (5) Remove jets, using a small screwdriver.
- (6) Remove idling adjustment screw.
- (7) Clean jets by blowing out all dirt with air.
- (8) Clean all passages in carburetor body by blowing out with air.



**Figure 23—Float Level Adjustment**

c. **Float Level Adjustment.** (See figure 23.)—Turn carburetor bowl cover upside down; then with float lever resting on inlet needle, the distance from the smooth faced edge of the float to the bowl cover, without gasket, should be  $1\frac{1}{16}$  inches. Bend float lever up or down to obtain this measurement.

d. **Carburetor Assembly and Installation.** (See figure 22.)

- (1) Install idling adjustment screw.
- (2) Install jets.

- (3) Install float bowl drain screw.
- (4) Install needle valve.
- (5) Position new float bowl cover gasket on carburetor body.
- (6) Carefully place bowl cover assembly on bowl and install three bowl cover retaining screws.
- (7) Attach carburetor to intake manifold.
- (8) Connect throttle control linkage.
- (9) Install carburetor air cleaner and pipe assembly.
- (10) Connect gasoline line to carburetor.
- (11) Open shut-off valve in gasoline line.

e. **Idling Adjustment.** (See figure 22.)—Close throttle and adjust idle speed regulating screw, so that engine operates slightly faster than normal idling speed. Close the idle adjustment screw until marked missing or fluttering is noticed, then slowly turn it back until engine runs smoothly. Reset the idling speed regulating screw to desired idling speed.

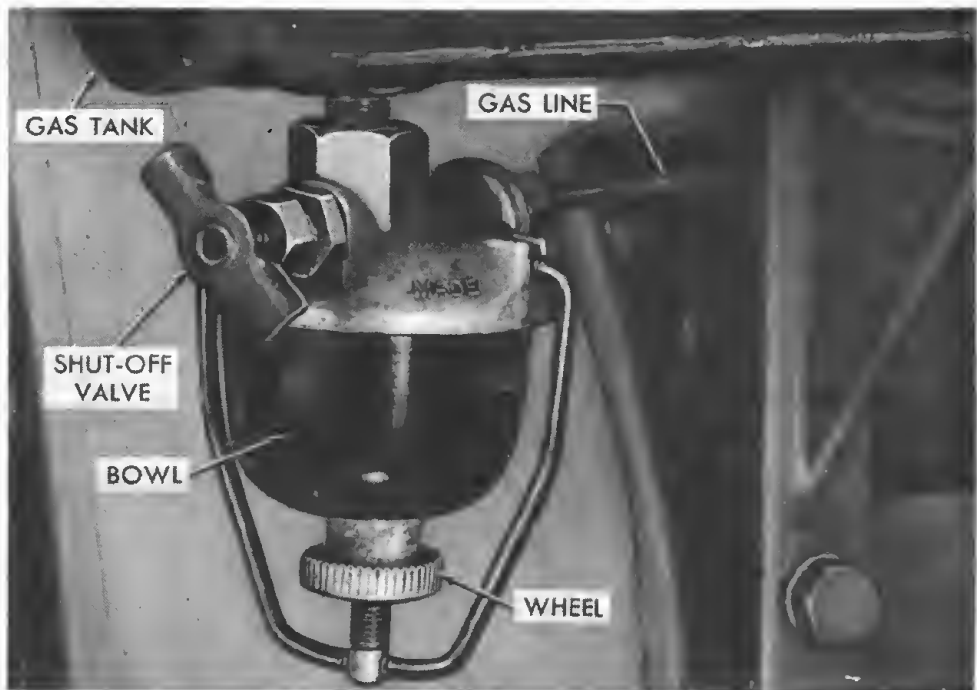


Figure 24—Sediment Bulb

**16. SEDIMENT BOWL.** (See figure 24.)

a. **Removal.**

- (1) Close shut-off valve.
- (2) Loosen handwheel below sediment bowl.
- (3) Lift off glass bowl.

(4) Remove strainer screen. Strainer screen will usually remain in housing above bowl.

**b. Cleaning.**

- (1) Wipe out sediment bowl, using a clean cloth.
- (2) Clean strainer screen.

**c. Installation.**

- (1) Install strainer screen in housing.
- (2) Position new gasket on housing and install bowl.
- (3) Tighten handwheel.
- (4) Open shut-off valve.
- (5) Check for leaks.

## **SECTION VIII**

### **IGNITION SYSTEM**

#### **17. MAGNETO.**

a. **General.**—If there is an indication that the magneto is causing trouble, make the following tests before attempting to repair it.

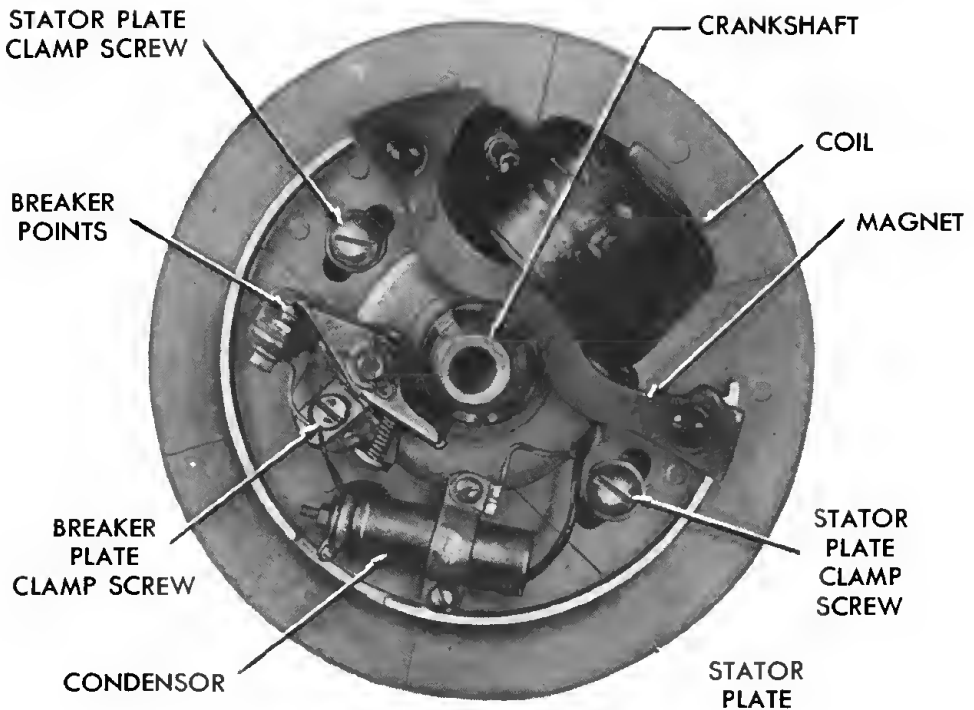
- (1) Make certain high tension cable insulation is not worn through and grounding.
- (2) Be sure stop button is functioning properly.
- (3) Disconnect spark plug cable and hold  $\frac{1}{8}$  inch away from a point on the engine, while engine is cranked in the usual manner. If magneto is performing properly, it will produce a spark which will jump this gap.

#### **CAUTION**

Do not allow spark to jump a long distance, as this will damage the magneto windings.

- (4) Check spark plug for correct gap or cracked porcelain. If plug is in good condition and magneto is functioning properly, engine should run without missing, while the spark plug cable is held not more than  $\frac{1}{16}$  inch away from spark plug terminal.

b. **Adjustments.**—The only adjustable parts on the magneto are the breaker plate, which provides adjustment of the breaker points, and the stator plate, which is a means of adjusting timing.



**Figure 25—Magneto**

**c. Breaker Point Adjustment.** (See figure 25.)

- (1) Unscrew and remove flywheel retaining nut, lock washer and starter pulley.
- (2) Tap end of shaft with lead mallet or block of hardwood to loosen flywheel; then remove flywheel.

**CAUTION**

Exercise care in removing flywheel, so as not to damage threads on shaft.

- (3) Turn engine over in direction of rotation until breaker points are fully open; then measure the gap between points with a feeler gage. Gap must be .020 inch.
- (4) Loosen the breaker plate clamp screw and move the plate to obtain proper point setting.
- (5) Tighten breaker plate clamp screw securely.

**CAUTION**

Do not loosen the fixed contact nor bend the breaker arm to obtain correct gap.

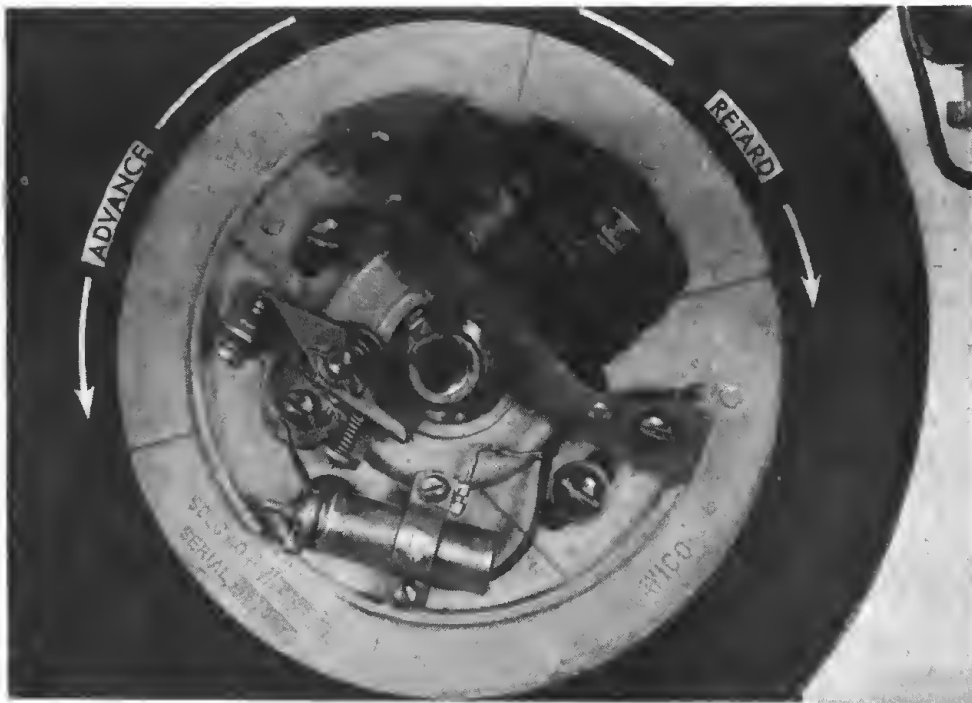


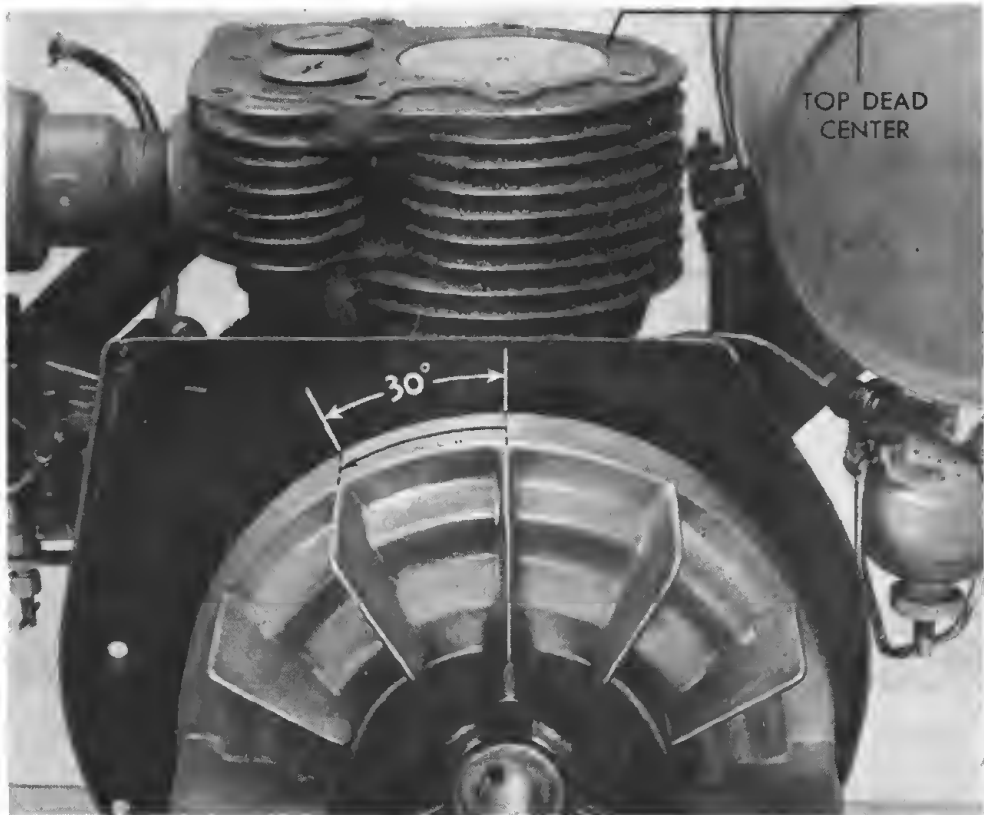
Figure 26—Timing Adjustment

d. **Timing Adjustment.** (See figure 26.)

- (1) Remove flywheel retaining nut, lock washer, and starter pulley; then remove flywheel.
- (2) Loosen two  $\frac{1}{4}$  inch screws which hold the stator plate to the engine.
- (3) To retard timing, turn stator plate clockwise.
- (4) To advance timing, turn stator plate counterclockwise.
- (5) Tighten two  $\frac{1}{4}$  inch screws securely, to lock plate in position.
- (6) Install starter pulley, lock washer, and flywheel retaining nut securely.

e. **Set Timing.**—Timing is correct when spark occurs 30 degrees before top dead center of piston travel. To obtain this setting, the following procedure must be performed.

- (1) Remove flywheel housing and cylinder head.
- (2) Remove flywheel retaining nut, lock washer, and starter pulley.
- (3) Loosen flywheel. Do not remove at this time.
- (4) Using flywheel, turn crankshaft until piston is **EXACTLY** at top of stroke.



**Figure 27—Flywheel Measurements for Setting Timing**

(5) Mark location of any flywheel air fin on shroud (see figure 27); then back the flywheel up, one fin (30 degrees) counterclockwise.

(6) Remove flywheel.

(7) Loosen two screws, which hold stator plate to engine, and turn stator plate until the points just start to open. (See figure 26.)

(8) Tighten two stator plate holding screws securely.

**f. Condenser Removal.** (See figure 28.)

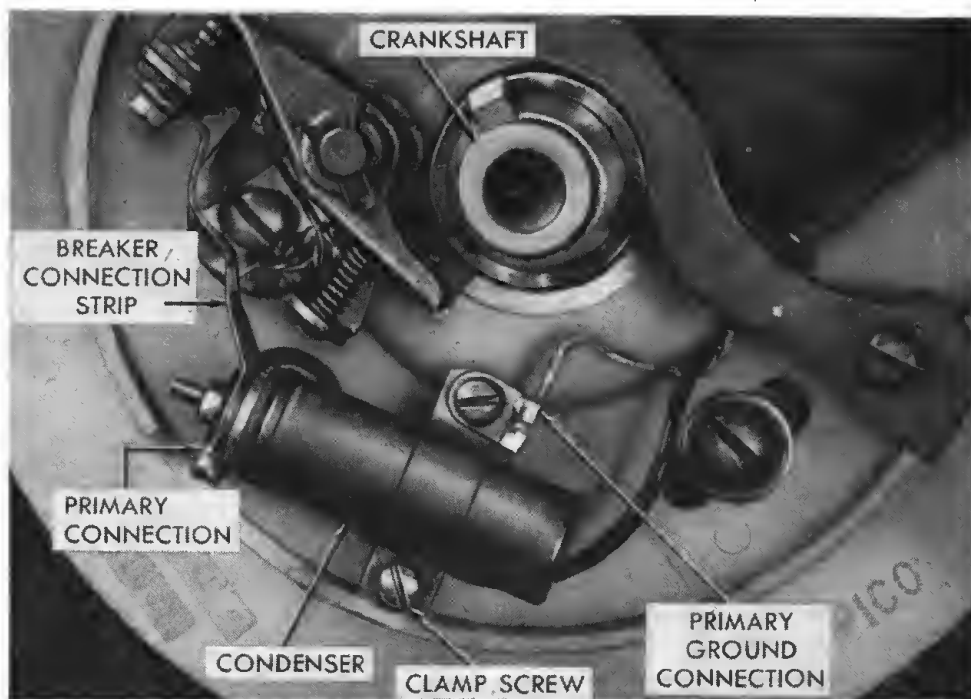
(1) Remove flywheel retaining nut, lock washer, starter pulley, and flywheel.

(2) Disconnect breaker connection strip and primary connections from live end of condenser.

(3) Remove two clamp screws; then lift off condenser and clamp assembly.

**Note**

Primary ground connection is fastened under inner clamp screw.



**Figure 28—Condenser and Attaching Parts**

**g. Condenser Installation.** (See figure 28.)

- (1) Position condenser assembly on stator plate and install outer clamp screw.
- (2) Insert remaining clamp screw through ground connection and inner side of clamp and secure to stator plate.
- (3) Install primary connection and breaker connection strip on live end of condenser.
- (4) Install flywheel, starter pulley, lock washer, and flywheel retaining nut on crankshaft.

**18. SPARK PLUG.**

a. **General.**—Spark plugs improperly adjusted, or dirty and worn, will cause hard starting and faulty operation. Clean and adjust spark plugs frequently.

b. **Gap Adjustment.**—Adjust gap clearance to between .030 and .033 inch.

## SECTION IX ENGINE

### 19. CONNECTING ROD AND PISTON ASSEMBLY.

#### a. To Tighten Connecting Rod.

- (1) Disconnect drive belt.
- (2) Remove four screws holding engine to the sub-base.
- (3) Lift engine straight up and place on bench.

#### Note

Connecting rod can be tightened without removing the rod and piston assembly from the engine.

- (4) Turn crankshaft until connecting rod is accessible.
- (5) Remove two cap screws.
- (6) Remove bearing cap, being careful to notice which way it is turned. The oil hole should be towards the valve side of engine.
- (7) Remove a layer of laminated shim by peeling it off with a knife. Remove the same amount from each side. Each layer is .003 inch thick and must be removed one at a time, and the bearing tried out.
- (8) Replace bearing cap with oil hole turned towards valve side of engine.

#### Note

The connecting rod and bearing cap each have a punch mark on the side, to identify the position of the cap to the rod. Always assemble the marks together.

- (9) Replace bearing cap with oil hole turned away from valve side of engine.

b. **Adjustment.**—With cap screws tightened securely, there should be a slight amount of drag on the bearing, and a slight amount of side play should be felt.

#### c. New Bearing Installation.

- (1) Remove bearing cap and push connecting rod away from crank pin.
- (2) Remove old bearings and slip new ones in place. Make certain bearings are in center of rod and oil holes are open.

- (3) Seat bearing onto shaft by pulling connecting rod down onto shaft.
- (4) Install lower half of bearing and adjust so as to have a slight amount of drag on the bearing and a slight amount of side play can be felt.

**d. Removal of Connecting Rod and Piston Assembly.**

- (1) Disconnect drive belt.
- (2) Remove three nuts on inside of shroud.
- (3) Remove cylinder head bolt holding the shroud brace.
- (4) Remove shroud, being careful to disconnect magneto grounding wire from the stop button connection inside shroud.
- (5) Remove remaining cylinder head bolts and lift off cylinder head.
- (6) Unscrew and remove four cap screws which hold engine to sub-base.
- (7) Lift engine straight up and place on bench.
- (8) Remove bearing cap retaining screws and bearing cap; then push connecting rod and piston assembly out of the upper end of cylinder.

**e. Piston and Piston Pin.**—When new piston and pin is installed, a clearance of .003 to .005 inch, measured 90° to the piston pin must be allowed between piston and cylinder. The piston pin should be replaced if it shows over .003 inch variation in diameter at any point. Replace the bronze connecting rod bushing when it is worn .003 inch oversize. An expanding ½-inch reamer must be used in fitting the piston pin to the piston and rod bearing. The piston must be reamed so the pin is a tight push fit and the bronze connecting rod bearing reamed to a light push fit.

**CAUTION**

When assembling piston on connecting rod, the split in the piston skirt must be on the opposite side from the oil hole in the connecting rod bearing cap. When installing the assembly in engine, the split on the piston must be opposite valve side of engine and oil hole in bearing cap towards valve side of engine. Assemble marked side of rod and bearing cap together.

**f. Piston Rings.**—The ring having a chamfered edge is an oil control ring and must be installed in the bottom groove of the piston, chamfered edge down. Clearance between ends of rings should be .015 to .020 inch.

**g. Installation of Connecting Rod and Piston Assembly.**

- (1) Install piston and rod assembly in cylinder with split side of piston positioned away from valve side of engine.
- (2) Compress rings and slide assembly into engine until connecting rod end seats firmly on crankshaft.
- (3) Install bearing cap and retaining screws securely; then check for proper adjustment as outlined in paragraph 19.-b.
- (4) Replace gasket and engine on sub-base and secure with four cap screws.
- (5) Position a new gasket on cylinder bloc. Install cylinder head and cylinder head bolts.

**Note**

Tighten all cylinder head bolts gradually, evenly, and firmly. It is best to go around the bolts about three times, pulling them up a little each time.

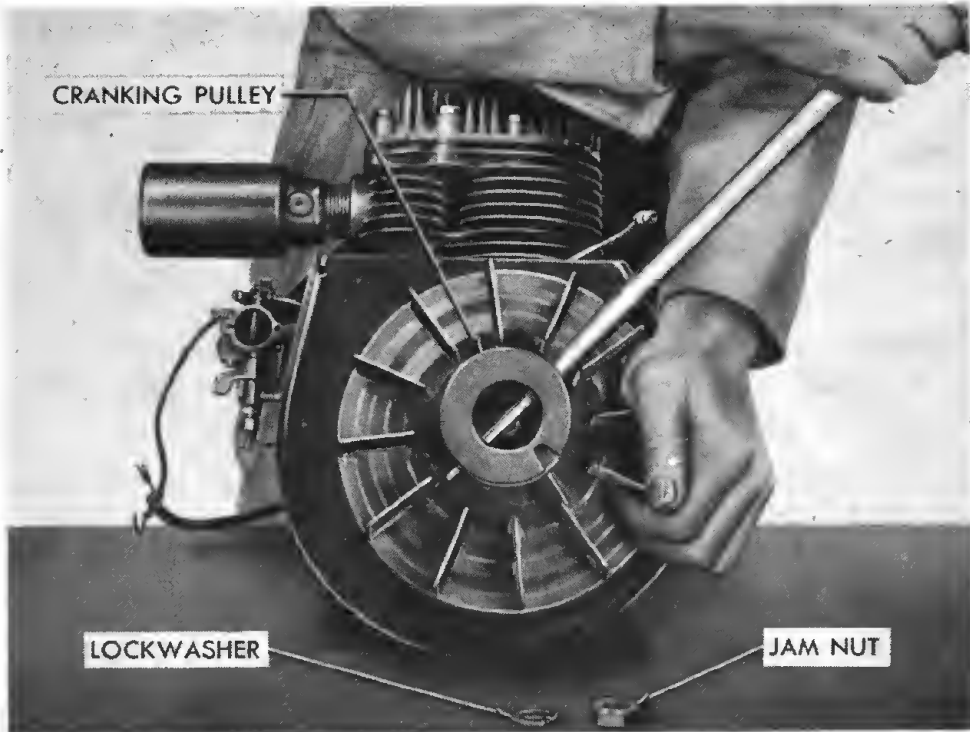
- (6) Remove bolt that secures shroud brace and install shroud after connecting magneto grounding wire to stop button connection on inside of shroud.
- (7) Install cylinder head bolt through shroud brace and spacer; then tighten bolt securely.
- (8) Install three shroud retaining nuts on inside of shroud.
- (9) Connect drive belt.

**20. MAIN BEARING INSTALLATION.**

**a. Disassembly.**

- (1) Remove oil filler plug and four screws and lock washers attaching engine to sub-base.
- (2) Lift engine straight up to prevent damaging oil pump, and place on bench.
- (3) Close gasoline shut-off at filter and disconnect gas line.
- (4) Remove two cap screws attaching gasoline tank bracket to engine and lift off gasoline tank and bracket assembly.
- (5) Remove cylinder head bolt attaching shroud brace, being careful not to loose the spacer under brace.
- (6) Remove three nuts and lock washers attaching shroud to shroud back plate. Move shroud away from engine and disconnect magneto ground wire.

- (7) Remove remaining cylinder head bolts, cylinder head, and gasket.
- (8) Remove connecting rod cap screws and lock washers. Lift off the bearing cap and shims. Push the piston and rod assembly out top of cylinder. Assemble shims, bearing cap, lock washers, and screws to connecting rod, being sure the marks on cap and rod coincide.



**Figure 29—Removing Cranking Pulley**

- (9) Remove the cranking pulley jam nut and lock washer.
- (10) Unscrew and remove the cranking pulley as shown in figure 29.
- (11) Loosen the flywheel by tapping the end of crankshaft with a soft hammer; then remove the flywheel.
- (12) Remove two screws, lock washers, and flat washers attaching magneto stator plate to engine. Remove magneto being careful not to damage stator plate.
- (13) Lift off flywheel drive key spring washer, and remove magneto breaker.

**Note**

The driving lug of the cam is positioned toward end of crankshaft.

- (14) Remove three screws and lock washers attaching back plate and lift off back plate.
- (15) Loosen two Allen set screws securing belt drive pulley. Remove drive pulley and drive key.
- (16) Remove three screws and lock washers attaching oil seal. Lift off oil seal assembly and gasket.
- (17) Remove one large and five small cap screws attaching side plate to engine. Lift off side plate and spacing shims.
- (18) Turn crankshaft so crank throws will clear cam gear and withdraw crankshaft through side plate opening.

#### **Note**

It may be necessary to tap end of crankshaft to force it from oil seal.

- (19) Force exhaust valve lifter down for clearance and remove cam shaft.
- (20) Scribe mark the oil seal retainer (magneto side) so it can be re-installed to the same depth.
- (21) Remove felt washer, and using a suitable driver remove the oil seal retainer.

#### **b. Inspection.**

- (1) Inspect the bearings for scoring, chipping, brinelling, rough spots, overheating, etc. Replace any parts found defective.
- (2) To replace bearing cones, mount crankshaft in a vise equipped with soft jaws, then use a suitable puller and remove bearing cones.
- (3) To remove bearing cup, magneto side, remove two headless screws, and install two  $\frac{1}{4}$ -20 x 2 $\frac{1}{2}$  inch cap screws as shown in figure 30. Turn these screws in alternately and evenly forcing bearing cup and oil seal plate from bearing recess in bloc.
- (4) To remove bearing cup from side plate, support the side plate near bearing cup as shown in figure 30 to prevent breaking or distorting side plate. Use a suitable driver to remove bearing cup.
- (5) Support side plate as near bearing bore as possible and press a new bearing cup into place, being sure it is against shoulder of bearing bore.
- (6) Install a new oil seal deflector in bearing bore, magneto side. Support the bloc as near bearing bore as possible and press a new bearing cup into place being sure deflector and cup are seated against shoulder of bearing bore.

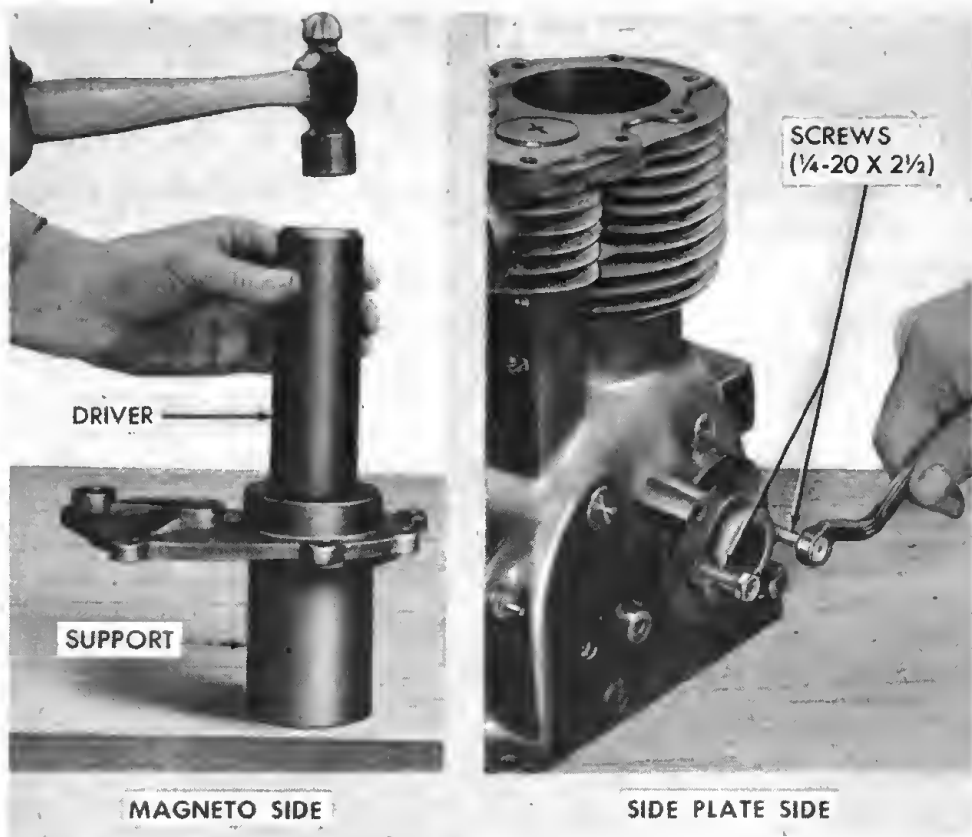


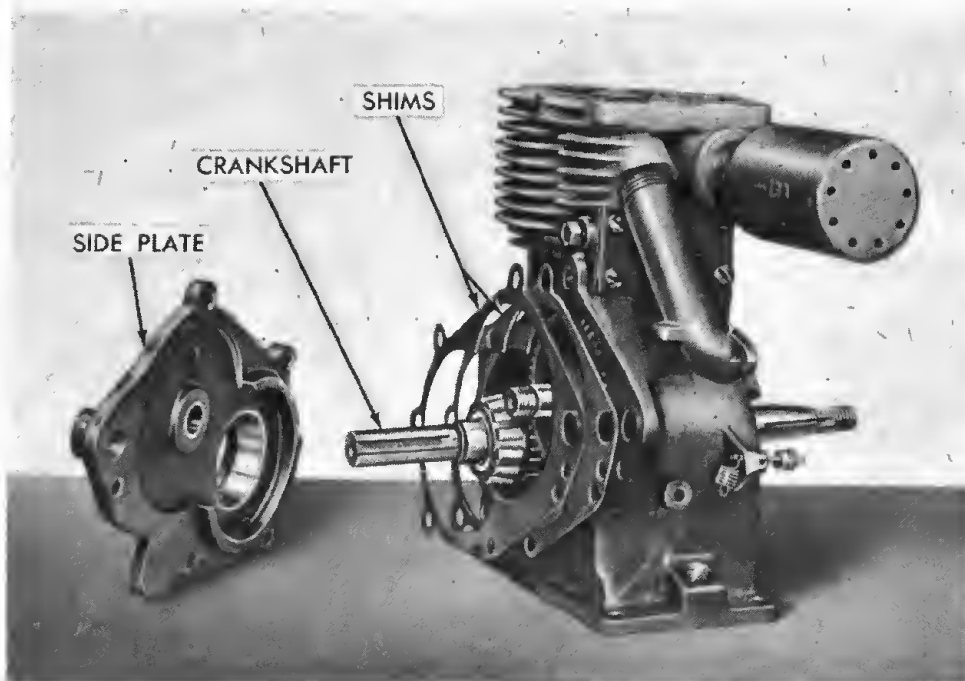
Figure 30—Main Bearing Cup Removal

(7) Support crankshaft under crank throw nearest bearing as shown in figure 31. Using a suitable driver, drive or press a new bearing cone on crankshaft, being sure bearing is against shoulder of shaft or gear.

c. **Assembly.**—Main bearings must be adjusted before oil seals are installed to prevent excessive drag on shaft during adjustment.

(1) Position the crankshaft in the bloc. Place shims between bloc and side plate as shown in figure 32. Install side plate and attaching screws. Tighten screws alternately a little at a time, and at the same time turn crankshaft to check for binding in bearings. Add or remove shims to give crankshaft .003 and .005 inch end play. After adjustment has been completed remove side plate, shims, and crankshaft, being sure the same shims are used in final assembly.

(2) Saturate a new felt washer with engine oil; then place felt in oil seal retainer. Using a suitable driver install the oil seal retainer, magneto side, to depth of scribe mark previously made on retainer.



**Figure 32—Shim Installation on Side Plate for Main Bearing Clearance**

(7) Position new oil seal gasket on side plate. Saturate new felt washer with engine oil, place on side plate in sequence, oil seal retainer, felt oil seal, seal shield, and shield plate. Install and tighten securely, three attaching screws and lock washers.

(8) Remove the connecting rod cap. Liberally oil piston and connecting rod bearing using engine oil. With the crank pin at bottom of engine, install piston and rod assembly. Install shims, bearing cap, lock washers and attaching screws; then tighten screws securely.

#### **CAUTION**

The slot in piston must be opposite cam shaft and oil hole in bearing cap must face cam shaft.

(9) Place shroud back plate in position. Install and tighten three attaching screws and lock washers.

(10) Place magneto cam on crankshaft with cam driving lug towards end of shaft and engaging key-way of shaft. Install spring washer and flywheel drive key.

(11) Place magneto in position, at the same time guiding spark and ground wires through slots provided in back plate. Install attaching screws, lock washers and flat washers. To time magneto refer to paragraph 17-e. Tighten attaching screws securely.

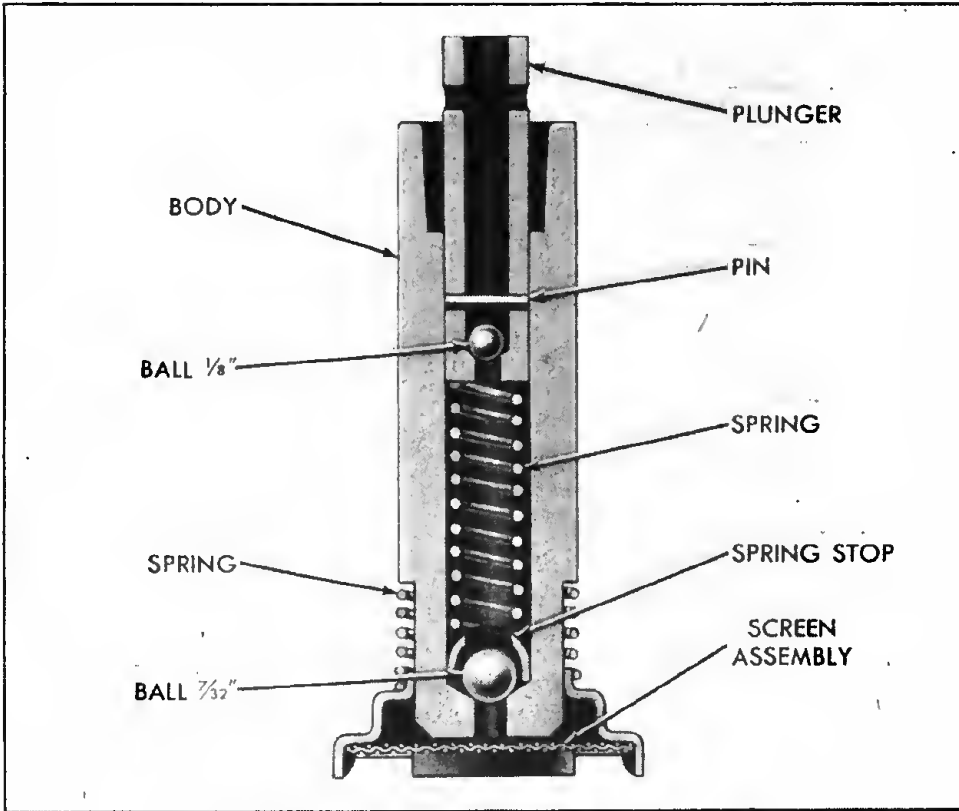


Figure 33—Oil Pump—Cross Sectional View

**b. Disassembly, Inspection and Repair.** (See figure 33.)

- (1) Remove in sequence, screen assembly, screen spring, plunger assembly, plunger spring, spring stop, and check ball.
- (2) Thoroughly clean all parts.
- (3) Inspection.

**Part to inspect**

- Ball seat
- Ball
- Spring stop
- Plunger Spring
- Screen spring
- Screen assembly
- Plunger

**Inspect for**

- Pits or scores
- Pits or scores
- Distortion
- Distortion or broken coils
- Broken coils
- Holes or plugged condition, distortion and fit on pump body.
- Freedom of movement

- (4) Test freedom of ball movement by shaking plunger. Test action of ball by blowing air through bottom of plunger. Air must pass freely through plunger in one direction but must not in opposite direction. Replace any parts found defective.

**c. Assembly.**

(1) Install in sequence, check ball, spring stop, plunger spring, plunger assembly, screen spring, and screen assembly, as shown in figure 33.

**d. Replace.**

(1) Drain oil from sub-base, and clean base thoroughly.

(2) Position pump assembly in base, being sure that the screen is properly fitted on pump body. Insert and tighten two attaching screws and lock washers.

(3) Fill the base with enough engine oil to cover pump screen. Try pump by moving plunger up and down. A full flow of oil should occur after a few strokes.

(4) Place a new gasket on sub-base and lower engine into place, install and tighten four attaching screws and lock washers.

(5) Fill with engine oil to proper level.

(6) Install and adjust drive belt. Refer to paragraph 27 for belt adjustment.

## **22. GRINDING OR REPLACEMENT OF VALVES.**

**a. Valve Removal.**

(1) Remove cylinder head, carburetor, and inlet manifold.

(2) Remove valve door retaining screws and valve door.

(3) Remove commercial sea moss which is packed in valve chamber, below the valve stems. This is to prevent too free passage of oil into the valve chamber.

(4) Lift spring retaining washer off horse-shoe shaped washer, using a valve lifter or two screwdrivers; then withdraw horse-shoe shaped washer and remove valve and valve spring.

**b. Valve Grinding.**—Grind valves using a fine grade of grinding compound. If valves are badly burned, they must be replaced. Adjust valve clearance by grinding stems off squarely.

**c. Valve Clearances.**—Valve clearances must be obtained when engine is cold.

(1) Exhaust valve clearance .010 to .012 inch.

(2) Inlet valve clearance .008 to .010 inch.

(3) Free length of valve spring is  $1\frac{5}{16}$  inches. If springs measure less than  $1\frac{3}{16}$  inches, replacement will be made.

**d. Valve Installation.**

- (1) With spring retaining washer and valve spring positioned in the valve chamber, install valve through spring and washer.
- (2) Lift spring and washer, using a suitable lifter and install horse-shoe shaped washer; then release spring and valve assembly will be locked into position.
- (3) Replace sea moss in valve chamber.

**e. Crankcase Breather.**—The crankcase breather is a small check valve screwed into the valve chamber on the side away from the magneto. This check valve maintains a vacuum in the engine, so that some fresh air will leak into the engine, and no oil will leak out. If inoperative, oil will leak around crankshaft and camshaft. The valve can be checked by blowing through it. Air should pass in an outwardly direction only. If valve becomes dirty, wash in any mineral oil solvent.

## SECTION X PUMP

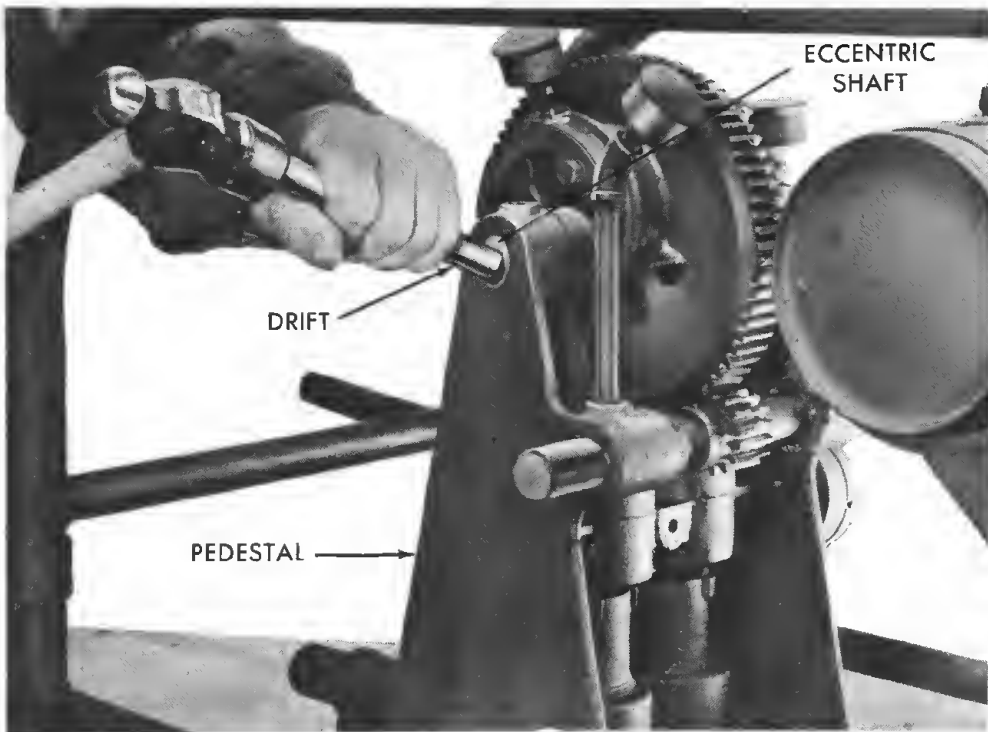
### 23. PLUNGER CUPS.

a. **General.**—Plunger cups are the parts which receive the greatest amount of wear; therefore, these parts will have to be replaced most often.

#### b. To Remove Plunger Assembly.

(1) Remove three gear guard retaining cap screws and lock washers; then lift off gear guard.

(2) Unscrew and remove lock nuts and set screws; then using a brass drift and hammer, drive out and remove eccentric shaft. (See figure 34.)



**Figure 34—Removing Eccentric Shaft**

(3) Remove eccentric, eccentric straps, cross heads, and plungers as an assembly. This will require a strong upward pull. (See figure 34.)

(4) Lay assembly on a bench; then using a monkey wrench, unscrew and remove the plunger nuts. (See figure 34.)

(5) Remove worn plunger cups and replace with new. Position new cups in a manner that will bring the convex surface of the cups in contact with the concave ends of the cross heads.

(6) Install plunger nuts.

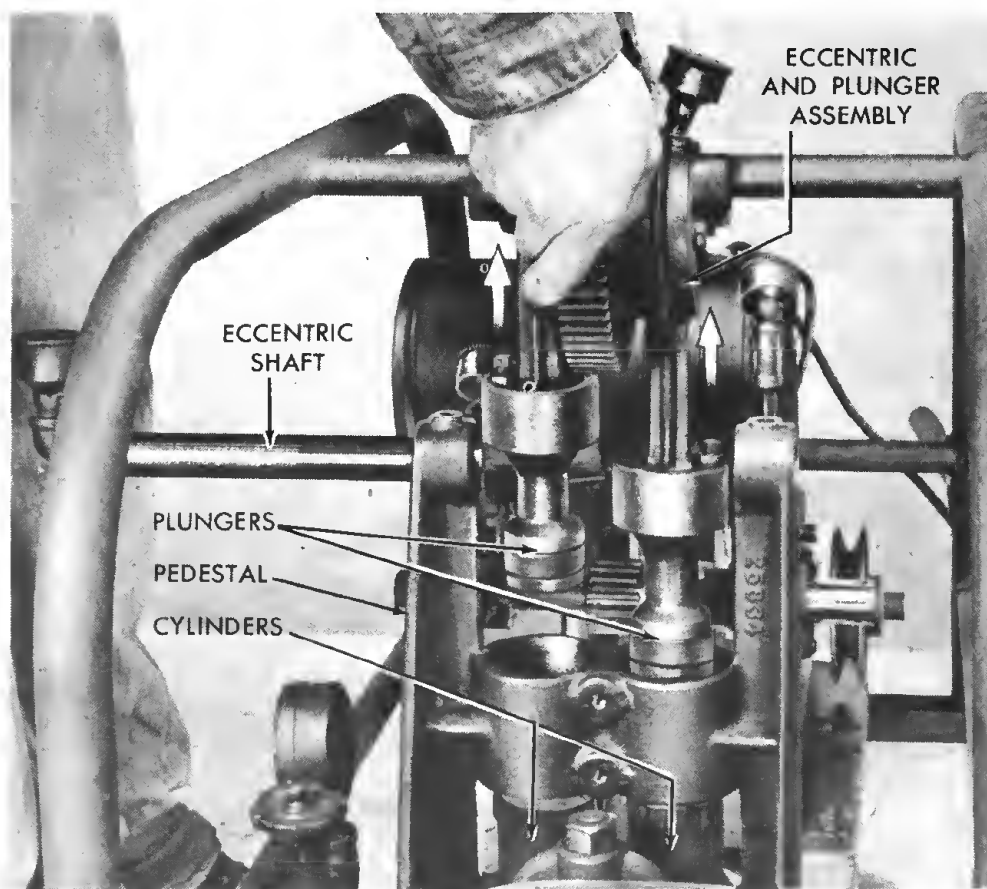
**c. To Install Plunger Assembly.**

(1) Apply coating of engine oil to plunger cups; then enter plunger assemblies in their respective cylinders and force down to a position which will permit installation of eccentric shaft.

(2) Install eccentric shaft.

**Note**

Position eccentric shaft (flat surfaces up) in a manner that will permit set screw ends to engage the flat surfaces on the shaft.



**Figure 35—Removing Eccentric and Plunger Assembly**

(3) Turn set screws down until shaft is securely locked in position; then tighten set screw lock nuts.

(4) Place gear guard in position over gears and secure with three retaining cap screws and lock washers.

#### 24. PUMP CYLINDERS.

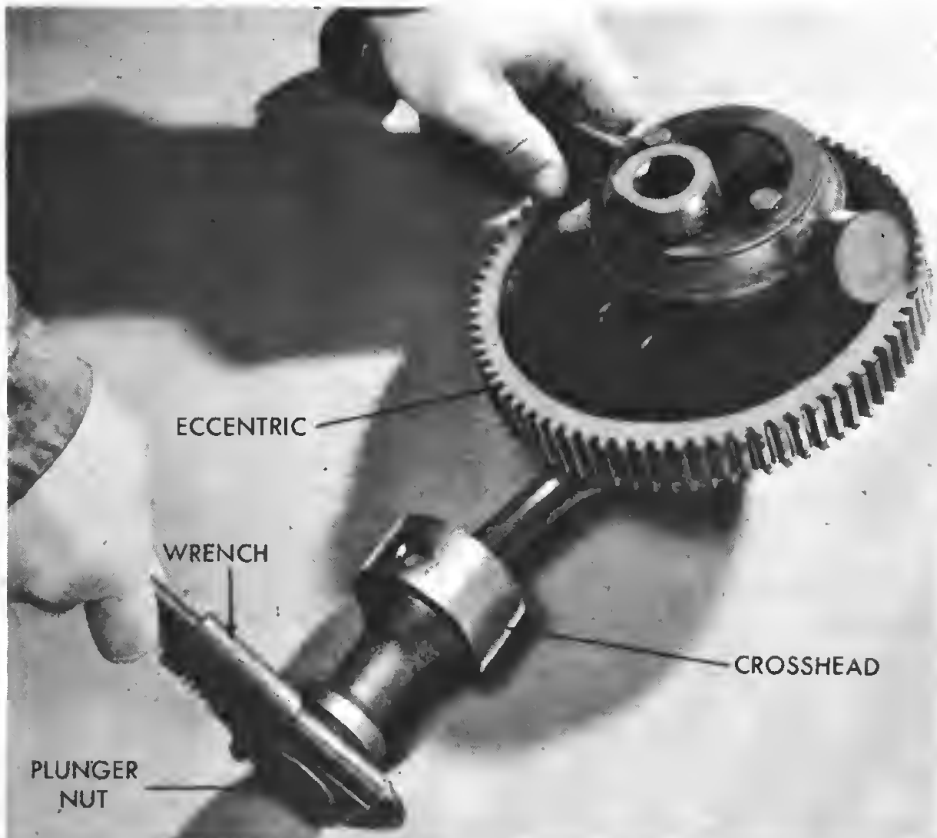
a. **General.**—Pump cylinders are threaded on the bottom end and are replaceable.

##### b. To Remove Pump Cylinders.

(1) Remove three gear guard retaining cap screws and lock washers; then lift off gear guard.

(2) Unscrew and remove lock nuts and set screws, then using a brass drift and hammer, drive out and remove eccentric shaft. (See figure 34.)

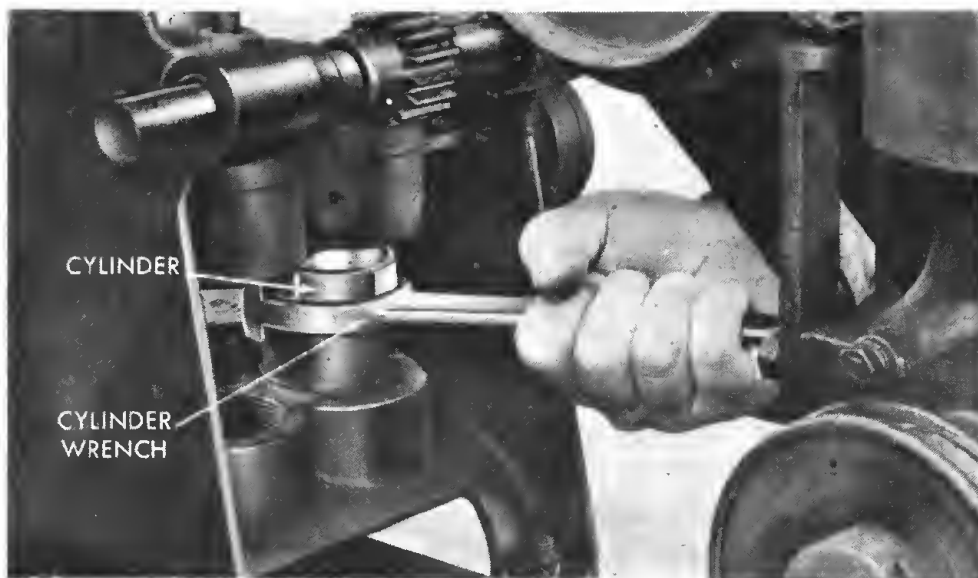
(3) Remove eccentric, eccentric straps, cross heads, and plungers as an assembly. This will require a strong upward pull. (See figure 35.)



**Figure 36—Plunger Nut Removal**

(4) Using cylinder wrench supplied with equipment, unscrew and remove cylinders. Cylinders are right-hand threaded; therefore, turn them to the left (counterclockwise) to remove. (See figure 37.)

(5) Remove gaskets from cylinder housings.



**Figure 37—Cylinder Removal**

**c. To Install Pump Cylinders.**

- (1) Install new cylinder gaskets in cylinder housings.
- (2) Install cylinders, using cylinder wrench to tighten.
- (3) Apply coating of engine oil to plunger cups; then enter plunger assemblies in their respective cylinders and force down to a position which will permit installation of eccentric shaft.
- (4) Install eccentric shaft.

**Note**

Position eccentric shaft (flat surfaces up) in a manner that will permit set screw ends to engage the flat surfaces of the shaft.

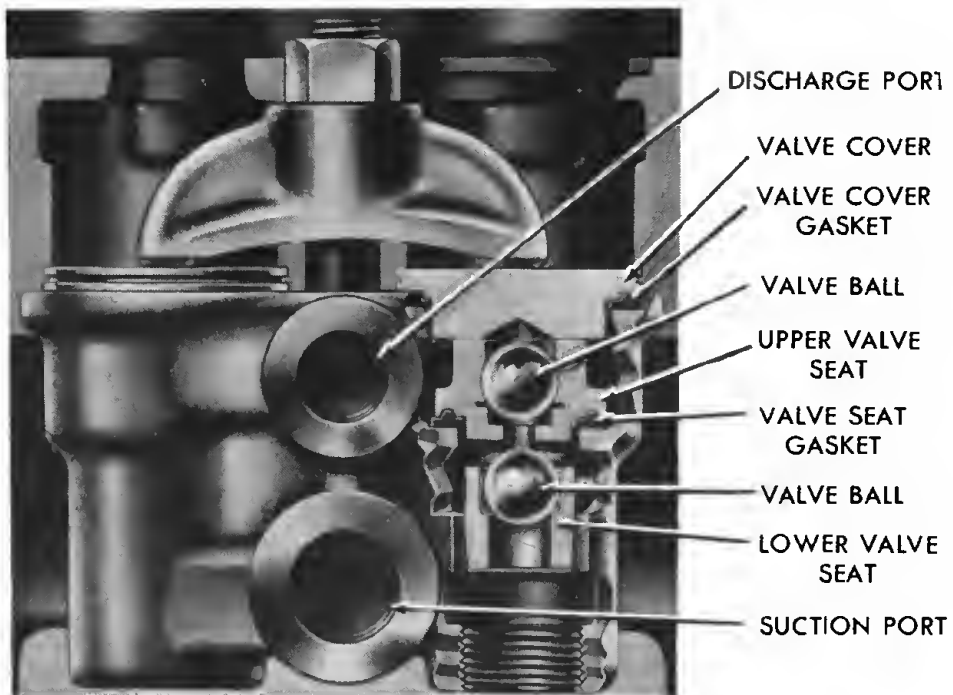
- (5) Turn set screws down until shaft is securely locked in position; then tighten set screw lock nuts.
- (6) Place gear guard in position over gears and secure with three retaining cap screws and lock washers.

**25. PUMP VALVES.**

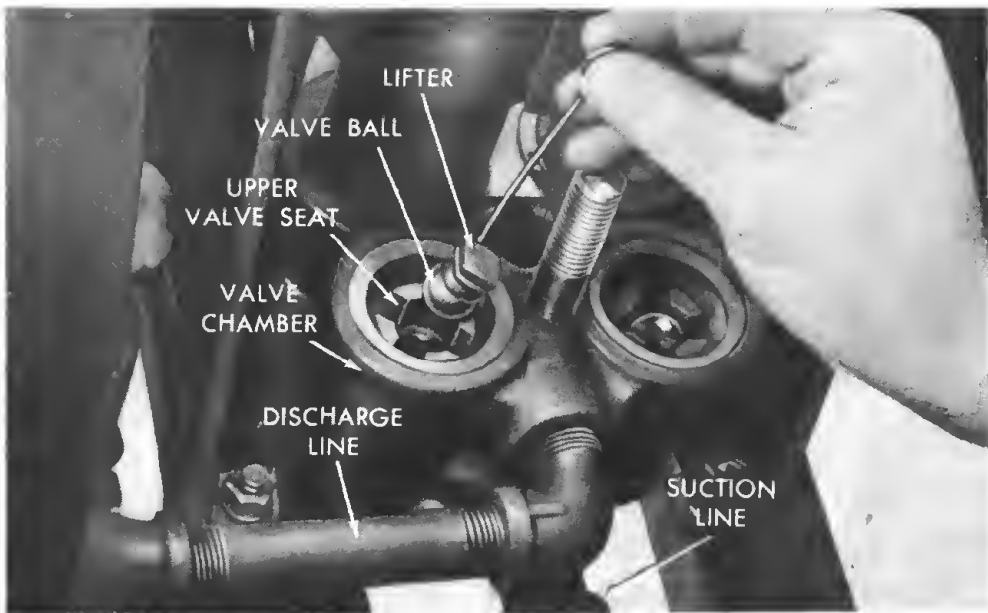
a. **General.**—Pump valves occasionally require cleaning and replacement of gaskets. The necessity of cleaning valves and replacement of gaskets is recognized by a loss of pressure or the inability to hold pressure.

**b. To Clean Valves and Replace Gaskets.** (See figure 38.)

- (1) Remove clamp screw, clamp, valve covers, and gaskets.



**Figure 38—Cross Sectional View of Valve Chamber**



**Figure 39—Removing Upper Valve Ball**

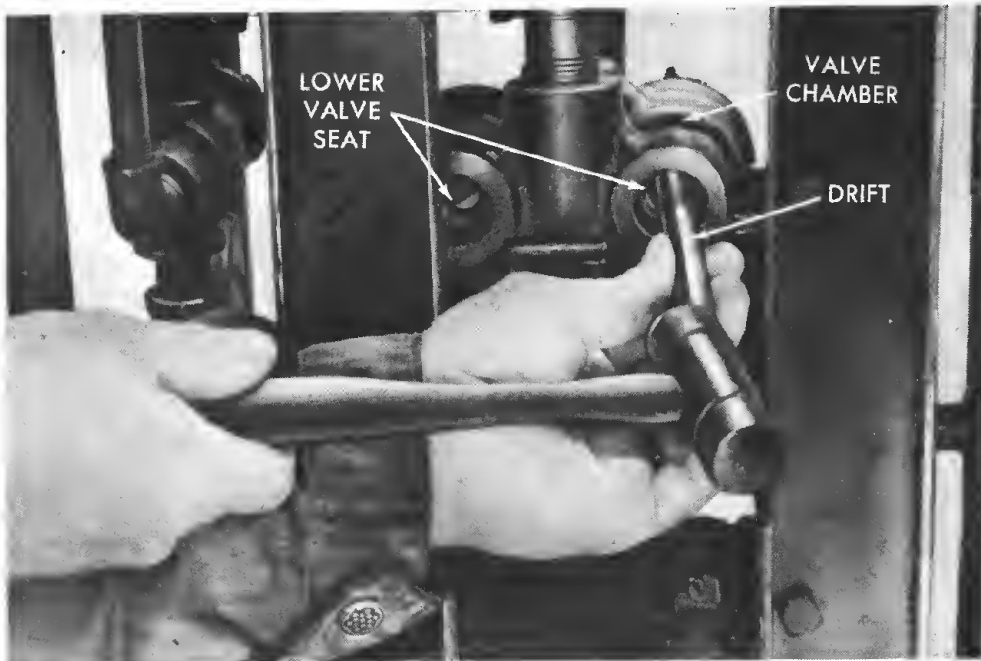
- (2) Using vacuum cup valve ball lifter, remove upper (discharge) valve balls (figure 39).
- (3) Lift out upper (discharge) valve seats and gaskets.
- (4) Using vacuum cup valve ball lifter, remove lower (intake) valve balls.

**Note**

Lower (intake) valve seats are tapered and do not require a gasket; however, should it be necessary to remove lower valve seat, the plug at base of valve chamber must be removed and the valve seat driven out from the bottom (figure 40).

**c. To Install Valves and Gaskets.**

(1) With lower (intake) valve seats in their approximate position, drop valve balls into place on the seats; then to insure that valve seats are tight, place a piece of wood or brass drift against valve ball and tap with hammer (figure 41).



**Figure 40—Removing Lower Valve Seat**

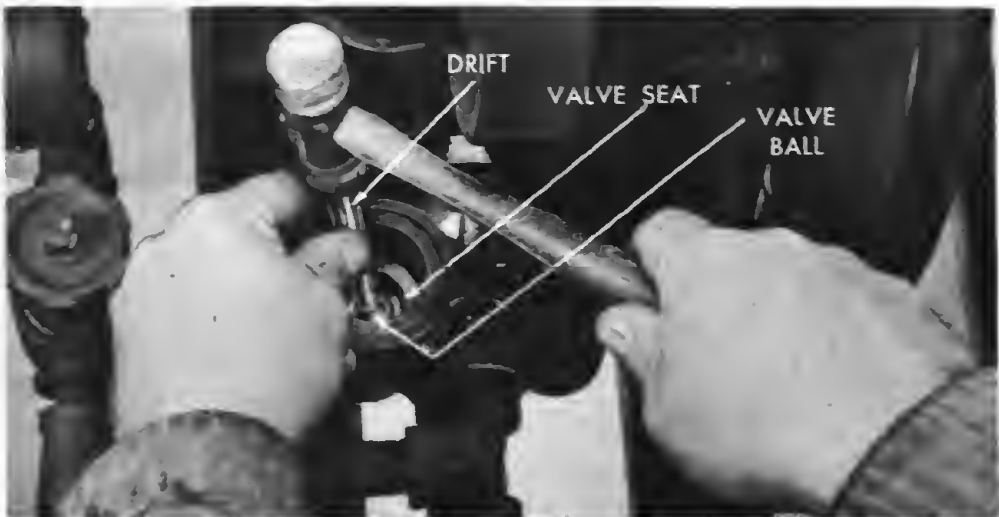
(2) Install gaskets on upper valve seats with molded side to seat; then place valve seats, cage side up, in valve chamber.

(3) Install upper valve ball.

(4) Place gaskets on valve covers, molded side to cover; then install covers, clamp, and clamp nut. Tighten clamp nut securely.

**26. RELIEF VALVE.**

a. **General.**—The relief valve is a means of keeping the pump and lines at the proper working pressure, and acts as a safety, taking care



**Figure 41—Seating Lower Valve Seat**

of excess pump capacity. Liquid under pressure, comes from the pump into the relief valve through an opening on one side of relief valve. Liquid passes directly under an hydraulic plunger assembly and out through the other side of valve to discharge hose and spray gun. Spring tension controls the operating pressure (usually 400 pounds). When pressure rises above this setting, it overcomes the spring tension and forces the plunger up, raising the valve. Raising of this valve permits excess liquid to escape through the opening in the bottom of the relief valve, through the overflow line and into the suction line.

**b. To Remove Plunger Packing. (See figure 42.)**

- (1) Remove adjusting screw.
- (2) Remove spring cage and spring.
- (3) Pull plunger assembly out of plunger packing; then remove packing and packing washer.

**Note**

If it is necessary to remove valve seat; disconnect overflow pipe from bottom outlet of relief valve. Insert pin punch or brass drift through bottom opening and drive valve seat out of housing.

**c. To Install Plunger Packing.**

- (1) Install plunger packing, friction lip down.
- (2) Install packing washer, flat side up.
- (3) Insert plunger assembly, plunger end first, through packing and down onto seat.

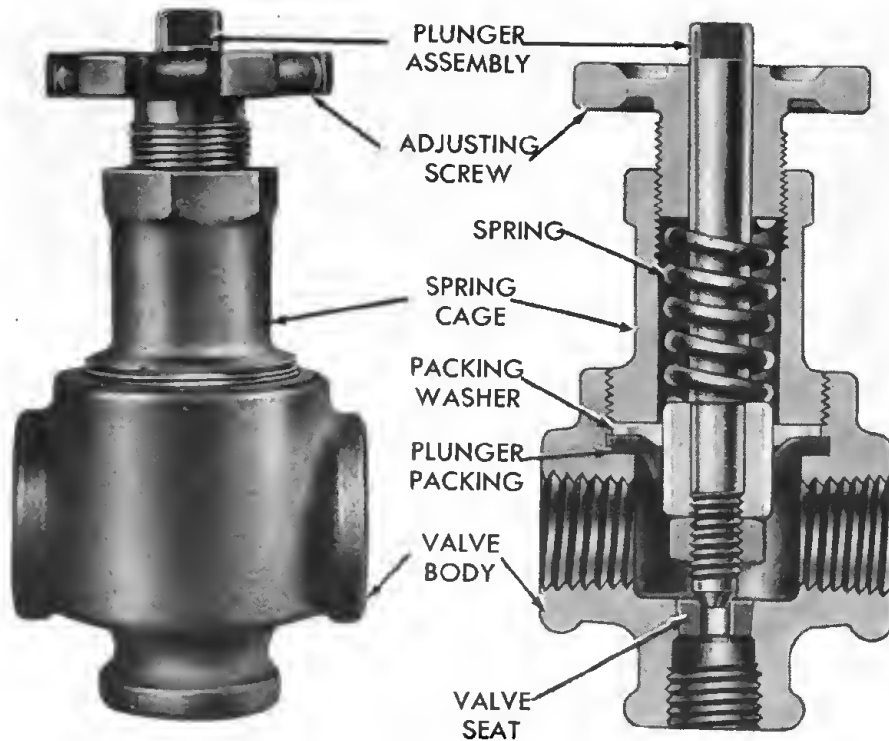


Figure 42—Cross Sectional View of Relief Valve

- (4) Place spring over stem of plunger; then install spring cage and tighten securely.
- (5) Install adjusting screw. Refer to paragraph 12-d. for proper setting of relief valve.

## 27. DRIVE BELT.

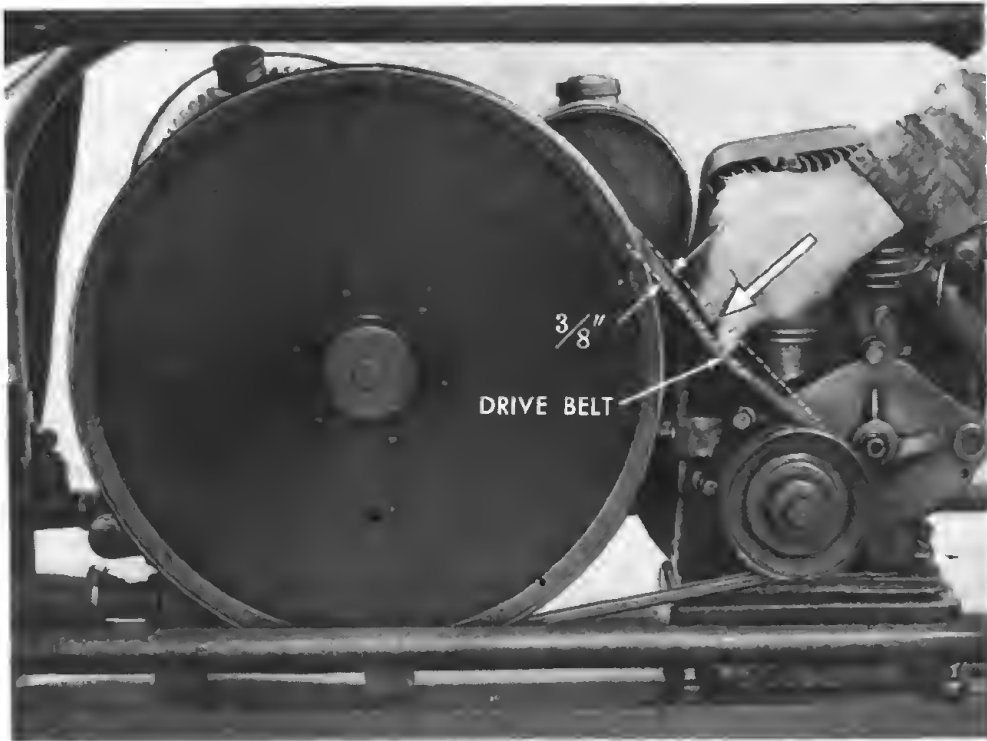
a. **General.**—All V-type belts require a certain amount of “Run-in” before they will seat properly in their sheaves; therefore, after ten hours operation, drive belt must be checked for tightness. If found to be loose or slipping, tighten as outlined in following paragraph.

### b. Tightening Drive Belt.

- (1) Loosen four engine mounting bolts.
- (2) Pull or pry engine away from pump until center of drive belt can be depressed a distance of  $\frac{3}{8}$  inch, under moderate thumb pressure (figure 43).
- (3) Tighten four engine mounting bolts securely.

## 28. DRAINING.

a. **General.**—Prior to stopping the apparatus, all liquid must be pumped out of the pump and lines.



**Figure 43—Drive Belt Adjustment**

**b. To Drain the Pump.**

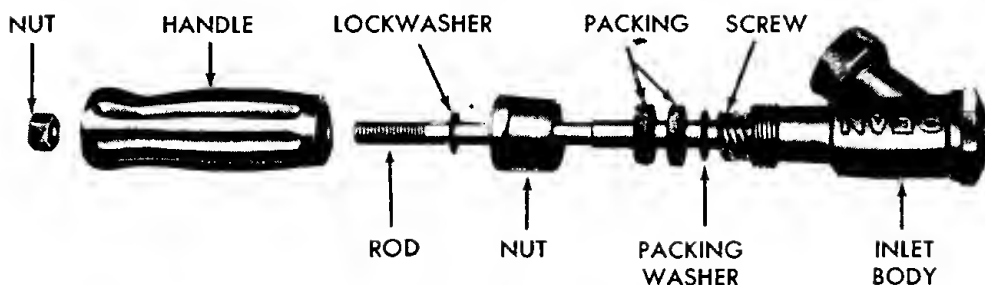
- (1) Remove suction hose from spray material.
- (2) Open spray gun valve and allow all liquid in lines to be pumped out.
- (3) Stop engine.
- (4) Remove spray gun from end of discharge hose.
- (5) Remove and drain discharge and suction hoses.
- (6) Remove thumb screw drain plugs from base of cylinders and allow to drain.
- (7) Remove drain plugs at base of valve chambers and allow chamber to drain.
- (8) Before replacing valve chamber drain plugs, remove clamp nut, clamp and valve covers; then using valve ball lifter, remove valve balls and allow liquid to drain.
- (9) Insert index finger or stick through drain hole at base of valve chamber, and raise lower valve balls off their seat to permit complete drainage.
- (10) Deposit upper valve balls in valve chamber and install cover gaskets, covers, clamp, and clamp nut.
- (11) Install cylinder drain screws and valve chamber plugs.

## SECTION XI SPRAY GUN

### 29. NOZZLE DISCS.

#### a. To Remove and Replace Nozzle Disc.

(1) Unscrew and remove nozzle nut and gasket from discharge end of spray gun.



*Figure 44—Spray Gun Packing*

- (2) Remove disc and replace with disc of desired size.
- (3) Install nozzle gasket and nut.

### 30. REPACKING SPRAY GUN VALVE.

#### b. To Repack Spray Gun Valve. (See figure 44.)

- (1) Remove handle retaining nut.
- (2) Unscrew and remove handle.
- (3) Unscrew and remove packing retainer.
- (4) Remove old packing rings and replace with two new packing rings.
- (5) Install packing retainer.
- (6) Install handle and lock with retaining nut.

## SECTION XII TROUBLE SHOOTING

### 31. GENERAL.

a. **Symptoms.**—Trouble symptoms must be recognized quickly. The longer the symptom exists before it is recognized, the more serious the trouble becomes, and if neglected entirely, will often result in failure during operation. In military operations, serious consequences may be the result of such neglect.

b. **Diagnosis.**—As soon as the symptom is detected, a diagnosis or orderly check should be made to determine the cause of the trouble. Accurate diagnosis is important because of the time element involved in military operation, as well as pointing out the application of the necessary remedy. In many cases a simple adjustment will remedy the trouble; in others, extensive repairs or replacements may be necessary.

### 32. TROUBLE, CAUSE, AND REMEDY.

a. **General.**—The following trouble, cause, and remedy chart is divided into two parts. The first section deals with troubles encountered in the operation of the gasoline engine; the second section covers troubles encountered in the operation of the pump.

#### b. Engine.

Trouble	Cause	Remedy
Overheating	Lack of oil.	Fill with oil, to correct level.
	Oil needs changing.	Drain and refill.
	Carbon.	Clean carbon.
	Overloaded.	Lighten load.
	Poor spark.	Check spark plug and magneto.
	Poor fuel.	Use at least 68 octane gasoline.
	Incorrect timing. Incorrect gas mixture.	Re-time. Adjust carburetor.
Knocks	Excessive carbon.	Clean carbon.
	Poor fuel.	Obtain better fuel.
	Lack of oil.	Drain and refill.
	Loose bearings.	Tighten.
	Loose flywheel.	Tighten.
	Carburetor adjusted too lean.	Enrich mixture.

Trouble	Cause	Remedy
Lack of power	Poor compression.	Clean carbon and grind valves.
	Poor spark.	Check magneto and spark plug.
	Spark timing incorrect.	Re-time.
	Incorrect gas mixture.	Adjust carburetor.
	Exhaust clogged.	Clean.
	Poor fuel.	Use at least 68 octane gasoline.
Stops	Leaking intake.	Check and repair.
	Valves sticking.	Lubricate with valve lubricant.
Stops	Out of fuel.	Refill tank.
	Spark failure.	Check magneto and plug.
	Overheated.	Allow to cool (check for overheating).
	Spark plug dirty or broken.	Clean or replace.
	Ignition cable grounded.	Replace or tape worn section.
	Magneto coil wet.	Dry out.
	Magneto points dirty.	Clean or replace.
<b>c. Pump.</b>		
Pressure low	Worn relief valve packing.	Replace valve packing.
	Worn relief valve seat.	Replace valve seat.
	Dirt between relief valve and seat.	Clean valve and seat.
	Worn plunger cups.	Replace.
	Worn pump valves.	Replace.
	Engine running too slow.	Advance governor.
	Drive belt slipping.	Tighten.
Overheating	Operating pressure too high.	Adjust relief valve.
Uneven flow of spray material	Clogged strainer.	Clean strainer.

## APPENDIX SHIPPING AND STORAGE

### 33. SHIPPING, DOMESTIC.

a. **Draining Pump.**—The pump must be thoroughly drained before shipment. Refer to paragraph 28, a. and b. for draining instructions.

b. Lubricate pump in accordance with lubrication order for equipment.

#### c. **Preparing Engine.**

- (1) Run engine until it reaches operating temperature.
- (2) Close shut-off cock at gas tank and allow engine to run until all gasoline in carburetor has been used.
- (3) Drain crankcase while engine is hot.
- (4) Refill engine with (OE) oil, seasonal grade.
- (5) Remove, clean, and refill carburetor air cleaner.
- (6) Remove and clean sediment bulb.
- (7) Drain gasoline tank and fuel lines.
- (8) Install sediment bulb, using a new bowl gasket if available.
- (9) Seal all openings (carburetor air cleaner, crankcase breather, muffler, etc.) using suitable tape and moisture proof paper.

#### d. **Cleaning and Painting.**

- (1) Thoroughly clean the equipment, and remove all rust spots.
- (2) Paint wherever necessary using (olive drab lusterless ES474B).

e. **Packing.**—Equipment with all hose, spray guns, tools, spare parts and accessories should be packed as a complete unit in a box of sufficient strength to withstand severe handling, and support other similar boxes or crates should it become necessary to stack them.

f. **Shipping, Export.**—Refer to technical order TB-5-9711-1 for preparing apparatus for export or overseas shipment.

### 34. STORAGE.

#### a. **Storage (Limited—30 Days or Less).**

- (1) Refer to paragraph 33, a., b., c., and d., for preparation of equipment.
- (2) If equipment is to be stowed where it will be subjected to the weather it must be blocked off the ground, and completely covered for protection.

b. **Storage (Dead).**—For preparation of apparatus for dead storage refer to tentative technical manual TM-5-9715.







