

WAR DEPARTMENT MANUAL
TM 5 - 9722

MAINTENANCE MANUAL AND
PARTS CATALOG FOR
SHOWER UNIT, FIELD, TRAILER-MOUNTED,
WITH HEATER, AND SHOWER HEADS,
CLEAVER-BROOKS MODEL EC-3

MAINTENANCE INSTRUCTIONS AND PARTS CATALOG



WAR DEPARTMENT • 18 SEPT 1944

WAR DEPARTMENT

Washington 25, D. C., 18 Sept. 1944

TM 5-9722, Shower Unit, Field, Trailer-Mounted, With Heater, 8 Shower Heads, Cleaver-Brooks Model EC-3, is published for the information and guidance of all concerned.

A. G. 300.7 27 April 1944.

By order of the Secretary of War:

G. C. MARSHALL,
Chief of Staff.

OFFICIAL:

J. A. Ulio,
Major General
The Adjutant General.

DISTRIBUTION:

(For Explanation of Symbol see FM 21-6)

TABLE OF CONTENTS U113

INTRODUCTION

TM 5.9722
1944
★ ★

	PAGE
Description	11
Specifications	11
Table of Approximate Capacities	12
Table of Approximate Consumptions for an Eight Hour Day	12
Shower Unit Instruction Plate	13
Engine Instruction Plate	14

OPERATION SECTION

Preparing Unit for Service	17
Location of Unit	17
Removing Shower Stand	19
Assembly of Shower Stand	19
Suction Hose	19
Suction Hose Hints	19
Discharge Hose	21
Water Pump	23
Prime Pump	23
Water Drain Valves	23
Shower Water Valve	23
Gasoline Tank	23
Fill Fuel Tanks	24
Burner Fuel Valve	25
Fuel Strainer	25
Fuel Pump	25
Fuel Pressure Regulator	25
Solenoid Valve	25
Generator	26
Ignition	26
Electrical Controls	26
Temperature Regulator	26
Manual Switch	27
Water Pressure Relief Valve	27
Gasoline Engine	30
Lubrication	30
Front Caster Wheel	30
Spring Hangers and Spring Shackles	30
Wheel Bearings	30
Blower Shaft Bearing at Damper	31
Blower Shaft Bearing—Drive End	31
Water Pump—Bearing Shaft Housing	31
Water Pump—"Lubri" Seal	31

TABLE OF CONTENTS

	PAGE
Engine Crankcase	31
Engine Air Cleaner	32
Magneto Oiling	32
Starting the Unit	32
To Start Engine	32
Check Fuel Oil Pressure	35
Filling Heater	36
Lighting Burner	36
Condensation	36
Temperature Rise	36
Controlling Water Temperature	37
To Shut Down	37
To Move to New Location	37
Precaution Against Freezing When Idle	37
To Prepare for Storage	40
Limited Storage	40
Dead Storage	40
Shipment	40
Export Shipment	42
Operating Irregularities and Their Correction	42
Burner Failure	42
1. Fuel Tanks	42
2. Oil Pressure	42
3. Fuel Strainer	42
4. Fuel Pressure Regulator	43
a. Disassembly	44
b. Reassembly	44
5. Fuel Pump	44
6. Fuel Oil Nozzle	45
7. Solenoid Valve	48
a. Loose Wire	49
b. Manual Switch Defective	49
c. Temperature Control Mercury Switch Broken	50
d. No Current from Generator	51
e. Coil Defective	54
(1) Disassembly	54
(2) Reassembly	54
8. Ignition Failure	54
a. Disassembly	55
b. Reassembly	55
Water Suction Failure	56
Engine Failure	57
1. Sparkplug Wire	57
2. Sparkplug	57

TABLE OF CONTENTS

	PAGE
3. Magneto Points	57
4. Gasoline Tank Fuel Line	57
5. Gasoline Tank Cap	57
Engine Adjustments	58
1. Carburetor	58
a. Idling or Low Speed	58
b. Intermediate and High Speed	58
2. Choke	59
3. Governor	60
a. Correct Motor Speed	60
4. Ignition	60
a. To Check for Spark	60
b. Sparkplug Adjustment	61
c. Ignition Wire	61
d. Magneto Timing	61
5. Oil Pump	63
6. Air Cleaner	65
7. Fuel Strainer	66
Removal of Lead Deposits in Combustion Chamber and on Valves	66
Reason for Lead Deposit Removal	66
Injecting Water	67

MAINTENANCE SECTION

Cleaning Heater Tubes	71
Removal of Rear Head	71
Cleaning Tubes	71
Replacing Head Gasket	72
Scaling Brickwork	72
Replacing Heater Tubes	73
Removal of Rear Head (Towing Head)	73
Preparing for Front Head Removal	73
Removal of Front Head	75
Removal of Defective Tube	75
Inserting New Tube	80
Hydrostatic Test with Water Pressure service	80
Hydrostatic Test with Water Pump Pressure	80
Reassembly after Tube Replacement	81
Replacing Rear Head (Towing End)	82
Refractory Brick Replacement	82
Rear Head Brick—Towing End	82
Front Head Cement Refractory—Firing End	83
Replacing Fire Tube Cement	85
Cleaning Water Side of Heater	85

TABLE OF CONTENTS

Hand-Hole Plates	86
Water Pump	86
Suction Line Check Valve	86
Priming Valve	87
Impeller	87
Impeller Clearance	88
"Lubri" Seal	88
Water Slinger	89
Support Head	89
Bearings and Shaft	89
Fuel Strainer	89
Disassembly	90
Reassembly	90
Fuel Pressure Regulator	90
Disassembly	90
Reassembly	91
Fuel Pump	92
Pumping Principle	92
Emergency Repair	92
Solenoid Valve	94
Checking Voltage to Coil	95
Replacing Coil	95
1. Disassembly	96
2. Reassembly	96
Cleaning Valve	96
1. Disassembly	96
2. Reassembly	96
Fuel Burner Assembly	97
Disassembly for Replacement and Cleaning	97
Reassembly	99
1. Burner Nozzle and Electrode Adjustments	100
Ignition Transformer	100
Replacement	100
1. Disassembly	100
2. Reassembly	100
Blower	101
Disassembly	101
Reassembly	102
Manual Switch	103
Generator	103
Cleaning Commutator	104
Replacing D C Brushes	104
Replacing A C Brushes	104
Disassembly	105
Reassembly	105

TABLE OF CONTENTS

	PAGE
Temperature Regulator	106
Replacing Broken Mercury Switch	106
Checking Adjustment With New Switch	107
Adjusting Temperature	109
Adjusting Differential	109
Light Wiring	110
Reflectors	111
Shower and Hose Rack	111
Fender Tanks	111
Sliding Door	112
Lunette Draw Bar	113
Caster Wheel	113
Removal of Wheels	114
Wheel Hub and Bearing	114
Engine	114
Removal of Muffler	115
Removal of Rope Starter Sheave	115
Removal of Air Shroud	115
Removal of Flywheel	115
Removal of Cylinder Head	119
Removal of Carburetor and Air Cleaner	119
Removal of Magneto	119
Removal of Valves	119
Removal of Engine Base	119
Removal of Connecting Rod and Piston Assembly	119
Removal of Crankshaft	119
Removal of Governor Control Lever and Governor Spring	123
Removal of Camshaft	123
Disassembly of Governor Weights	123
Removal of Oil Pump Plunger Push Rod	123
Disassembly of Oil Pump	123
Reassembly of Oil Pump	123
Reassembly of Oil Pump Push Rod	125
Reassembly of Governor Weights	125
Reassembly of Camshaft	125
Reassembly of Governor Control Lever and Governor Shaft	125
Reassembly of Crankshaft	125
Reassembly of Piston and Connecting Rod	127
Reassembly and Grinding of Valves	128
Reassembly of Magneto	129
Reassembly of Engine Base	130
Reassembly of Carburetor and Air Filter	130
Reassembly of Cylinder Head	130
Replacement of Flywheel and Starter Rope Sheave	131

TABLE OF CONTENTS

	PAGE
Replacement of Shroud and Fuel Tank	131
Replacement of Spark Plug and Wiring	131
Remounting of Engine	132
Running Engine In Before Using	132
Carburetor	132
Disassembly	137
Reassembly	137
Magneto	140
Breaker Cover	140
Breaker Points	140
Condenser	142
Cover	143
Ignition Coil Testing	143
Removal of Coil and Coil Core	143
Stop Button	143
Impulse Coupling Lock-Nut	146
Drive Gear	146
Drive Cup and Drive Spring	147
Driven Flange Group and Trip Arms	149
Trip Arm	149
Impulse Stop Group	151
Lag Angle Adjustment	151
Main Housing	151
Oiling System Parts	151
Rotor	152
Replacement of Rotor Bushing	152

PARTS SECTION

Preparation of Requisitions	154
Accessory List	156
Heater	157
Heater Shell	157
Front Head	158
Rear Head	159
Water Piping	160
Pump To Heater Piping	160
Heater Discharge Piping	162
Water Pump	164
Shower Stand	166
Fuel Piping	168
Fuel Assembly	168
Fuel Strainer	170

TABLE OF CONTENTS

	PAGE
Suction and Return Lines	171
Burner Assembly	172
Blower	174
Blower	174
Electrical	176
Generator and Ignition	176
Generator	178
Solenoid Valve	179
Light Wiring Assembly	180
Trailer	182
Chassis and Running Gear	182
Fender Tank Assemblies	184
Sliding Door, Hood and Rack Assemblies	186
Lunette and Caster Wheel	188
Engine	190
Engine and Tank	190
Block Assembly	192
Crankshaft and Piston Assemblies	194
Governor and Valves Assemblies	196
Speed Control Assembly	198
Oil Pump	200
Air Shrouding	201
Carburetor	202
Magneto Coil and Core	204
Magneto Gear and Impulse Coupling	205
Magneto Main Housing	206
Magneto Stop Button and Rotor	207
Magneto Breaker Points	208
Tools	210
Tools and Equipment	210
Numerical Parts List	211

INTRODUCTION

DESCRIPTION

The Cleaver-Brooks Portable Field Shower Unit is a self-contained oil-fired water heater designed to produce 16 gallons of warm bathing water per minute, distributed through eight shower heads. For mobility, the disassembled shower stand and shower heads are mounted on top of the unit, together with discharge and suction hoses. The entire machine is mounted as an integral unit on a two-wheel trailer. A caster wheel, mounted as a component part of the lunette towing ring, remains in its raised position while the unit is being towed but is lowered into position when the unit is released from the tractor, and aids in maneuvering the unit into position.

Of fire tube construction, the heater is equipped with four complete passes of flue gas travel, the first pass being the large center tube or combustion chamber, the second pass consisting of two groups of tubes at either side of the fire tube, and the third and fourth passes below. The vent pipe, or stack, is a part of the outer head at the firing end of the heater.

The oil burner is of the pressure-atomizing, single-nozzle type. For normal operation the nozzle, as installed at the factory, should be used, capacity, four gallons per hour. In cases where the raw water is very cold, the five-gallon nozzle supplied with the unit should be installed. Where warm supply water is encountered and little heating is required, the three-gallon per hour nozzle should be installed.

An automatic temperature control actuates a solenoid valve in the oil supply line to the burner, opening or closing it as required to maintain practically constant bath water temperature.

The burner fuel is ignited by constant electric spark while the machine is in operation. The spark is provided by a generator and a high-tension transformer that are component parts of the power plant.

Fuel is stored in identical tanks, one at each side of the unit. Piping from the tanks to the fuel pump is so arranged that the burner supply may be drawn from either or both tanks as desired by the operator. Half of each of the two side-mounted fender tanks is devoted to tool storage compartments.

Air for fuel combustion is supplied by a blower having a shutter-type damper at the blower inlet for proportioning the volume of air to the fuel.

By means of a suction pump water for the unit is drawn from a stream, lake, or reservoir, through a suction hose and discharged into the heater shell where it absorbs heat from the combustion gases within the tubes. Water thus raised to the desired bathing temperature is forced by the incoming water pressure through the discharge hose to the shower stand and out the 8 shower heads.

Power for operating the unit is provided by a single cylinder, air-cooled Wisconsin gasoline engine, Model AK, direct-coupled to the water pump. Power transmission to the blower, fuel pump, and generator is by means of V-belts.

SPECIFICATIONS

Gasoline Engine	Wisconsin Motors, Model AK.
Carburetor	Stromberg, OH-5 $\frac{1}{8}$ " , A-18020.
Magneto	Wico, CL Spec. C-1295.
Sparkplug	Champion, No. 8, 18mm.

INTRODUCTION

SPECIFICATIONS—Continued

Generator	Marathon, SS-50056-1, 3600 RPM. 550 Watts—110 Volts A. C.
Bearings, Generator	New Departure-ND87504.
Water Pump	Jaeger, Model 1½ P. O.
Bearings, Blower	Stephens-Adamson Sealmaster, NP-16.
Fuel Strainer	Detroit Lubricator, CRC 480.
Fuel Pressure Regulator	Monarch, G-49-B.
Fuel Pump	Tuthill Pump Co., Model OLK-C.
Solenoid Valve	Detroit Lubricator, No. 683-3, 110 Volt.
Temperature Regulator	Minneapolis-Honeywell, T-415 AX 323A 65°-140° F.
Ignition Transformer	Webster, 511-AJ, 110-10,000 Volt.
Tires	Goodrich Super Traction, 7.50 x 20, 8-ply.
Tires—Inflation Pressure	55 Pounds.
Wheels	Budd Wheel Co., No. 44530D1
Hub, Left Hand, Includes	
Bearing Cups	Budd Wheel Co., No. 46138.
Hub, Right Hand, Includes	
Bearing Cups	Budd Wheel Co., No. 46137.
Bearing Cup, Inner	Timken, No. 3920
Bearing Cup, Outer	Timken, No. 382.
Bearings, Inner Wheel	Timken, No. 3979.
Bearings, Outer Wheel	Timken, No. 385-A.
Weight—Empty	3525 Pounds.
Length	12 Ft.-0 in.
Width	6 Ft.-0 in.
Height	7 Ft.-6 in.
Cubage	540 cu. ft.

TABLE OF APPROXIMATE CAPACITIES

Engine Fuel Tank	3 Gallons.
Fuel Tanks Supply	25 Gallons Each—Total 50 Gallons.
Engine Crankcase	1¾ Pints.
Heater Shell—Water	140 Gallons.
Tool Box (each box)	17 inches (W) x 16 inches (H) x 27 inches (L) —7344 cu. inches.

TABLE OF APPROXIMATE CONSUMPTIONS FOR AN EIGHT-HOUR DAY

Water, Shower Supply	8640 Gallons.
Engine Gasoline	4 Gallons.
Grease	¼ Pound.
Oil—Engine	½ Pint (not including draining and refilling every 64 working hours).
Burner Fuel (Fuel oil, gasoline, kerosene)	30 Gallons.

DIRECTIONS

CAUTION

READ THESE INSTRUCTIONS BEFORE OPERATING. NEVER LIGHT BURNER WITHOUT WATER CIRCULATING THROUGH HEATER AND FLOWING FROM SHOWER HEADS. IF HEATER FIRED WHEN NOT COMPLETELY FILLED WITH WATER IT WILL BE DAMAGED BY OVERHEATING.

TO OPERATE

- 1. OPEN VALVES UNDER HEATER IN FUEL OIL LINES FROM BOTH FUEL - OIL TANKS.**
- 2. CLOSE RED FUEL OIL VALVE TO BURNER.**
- 3. START ENGINE, FILL HEATER WITH WATER, MAKING SURE ALL SUC-TION HOSE CONNECTIONS ARE TIGHT.**
- 4. WHEN WATER FLOWS FROM SHOWERS, START BURNER BY OPENING RED FUEL OIL VALVE.**
- 5. OPEN DAMPER IN BLOWER OUTLET ONLY ENOUGH TO CLEAR SMOKE.**
- 6. WATER TEMPERATURE MAY BE RAISED OR LOWERED BY ADJUSTING KNURLED BRASS COLLAR OF THERMOSTATIC FUEL OIL VALVE AS INDICATED ON VALVE.**
- 7. VALVE IN WATER OUTLET PIPE FROM HEATER SHOULD BE PARTLY OPEN. IF BURNER DOES NOT PROVIDE SUFFICIENT HOT WATER, GRADUALLY CLOSE VALVE UNTIL PROPER TEMPERATURE IS REACHED.**
- 8. IF KEROSENE USED AS FUEL, ADD 1 CUP NO. 20 LUBRICATING OIL PER 5 GALLONS. IF GASOLINE USED, ADD 1 QT. PER 5 GALLONS.**

WISCONSIN

air cooled

TYPE

AK

SIZE

2⁷/₈" x 2³/₄"

NO.

SERIAL NUMBER

R. P. M.

2050

OPERATING INSTRUCTIONS

Fill crankcase to level of oil filler plug with good, clean gas engine oil. For temperatures of 40° F. or over use S. A. E. No. 20 oil. For temperatures of 10° F. to 40° F. use S. A. E. No. 20 oil. For colder weather use S. A. E. No. 10W oil. Fill fuel tank with good clean gasoline of an octane rating of 67 or over.

TO START ENGINE —

- 1—Open gasoline cock on bottom of tank.
- 2—Close choke; it will release when engine starts.
- 3—Crank engine. Repeat if necessary.

Normal carburetor needle valve opening is approximately $\frac{3}{4}$ to $1\frac{1}{4}$ turns. In cold weather opening $\frac{1}{2}$ turn more facilitates starting.

Adjust for best running as engine warms up.

TO STOP ENGINE —

Push switch button in on magneto — hold until engine stops.

CARE IMPROVES SERVICE, REDUCES REPAIRS —

Drain old oil and refill after every 50 hours of operation. Spark plug gap must be .025". In dusty conditions a good air cleaner is necessary.

KEEP ENGINE CLEAN AT ALL TIMES.

WISCONSIN MOTOR CORPORATION

MILWAUKEE, WISC., U. S. A. SD - 53 - B

OPERATION
SECTION

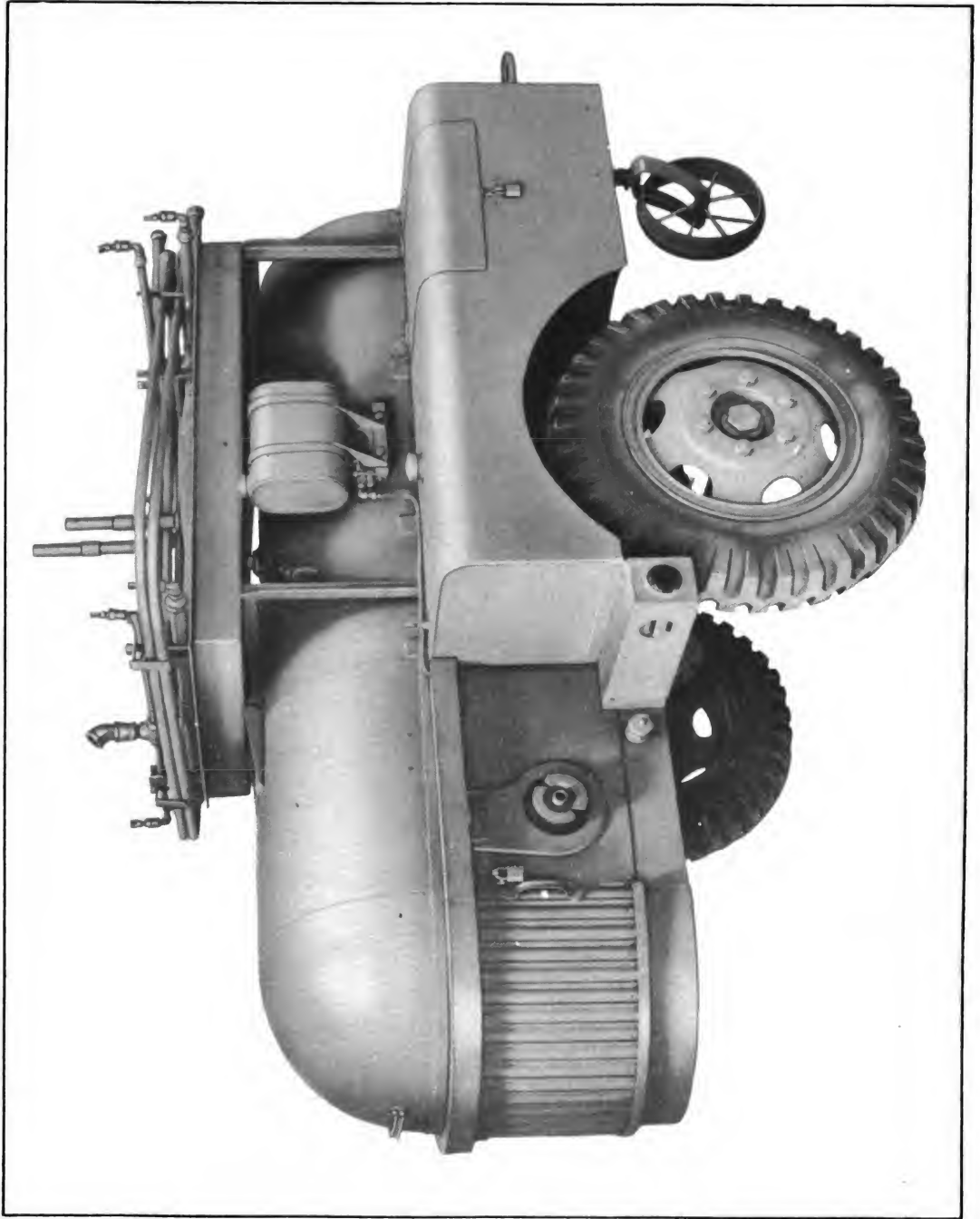

FIG. 1 Field Shower Unit Model EC-3

OPERATION SECTION

LOCATION

PREPARING UNIT

PREPARING UNIT FOR SERVICE

LOCATION OF UNIT (See Fig. 2)

Select an operating location at the bank of a stream, reservoir, river, or other water source, so that the suction lift will not be greater than 15 feet. (Note: Only under the best of pumping conditions will a suction lift of 20 to 25 feet be possible). Housing the unit under shelter is entirely a matter of local conditions. However, if wind exposure is reduced by a windbreak or other housing arrangement, fuel consumption will be reduced and more satisfactory operation assured.

When the site has been chosen, the shower rack should be so located, for sanitary reasons, as to prevent waste water from draining back into the stream above the suction hose inlet.

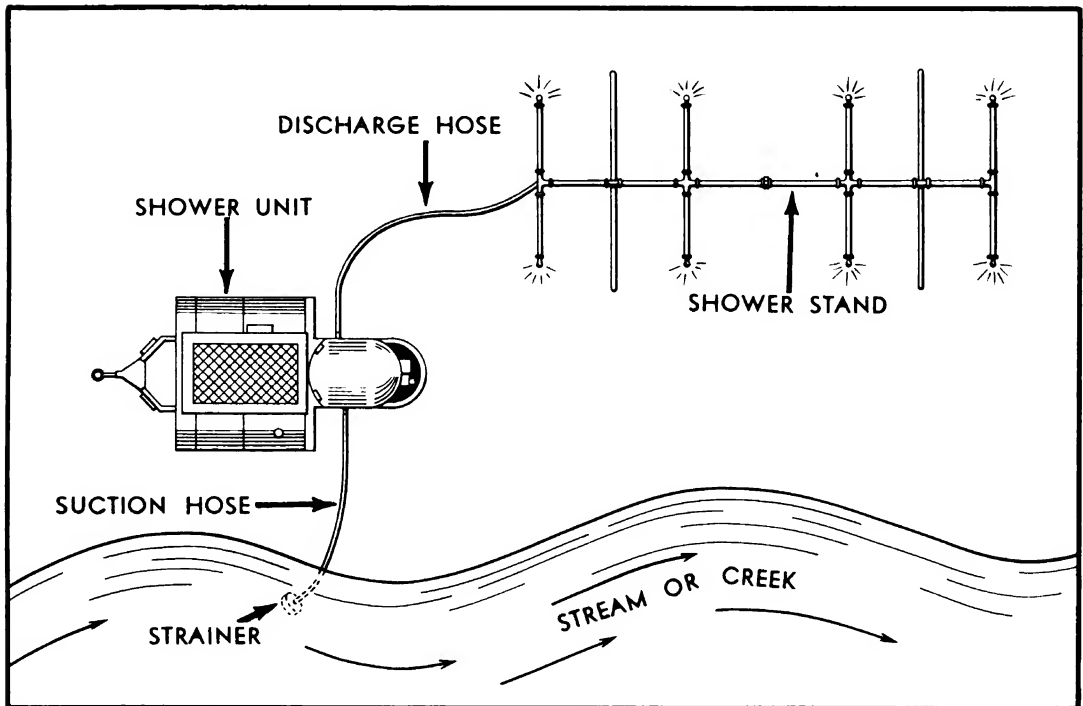

FIG. 2 Typical Set-Up at Stream—Plan View

Should operating conditions make it necessary to locate the shower stand assembly at a level higher than the heating unit, the total suction and discharge head of water should not exceed 50 feet.

First, level the unit. This can be done by removing earth from under the wheel on the high side or by blocking up the wheel on the low side. This will level the unit from side to side. Digging out earth under, or by blocking up the caster wheel at front of trailer will level the unit from front to rear.

OPERATION SECTION

SHOWER STAND

PREPARING UNIT

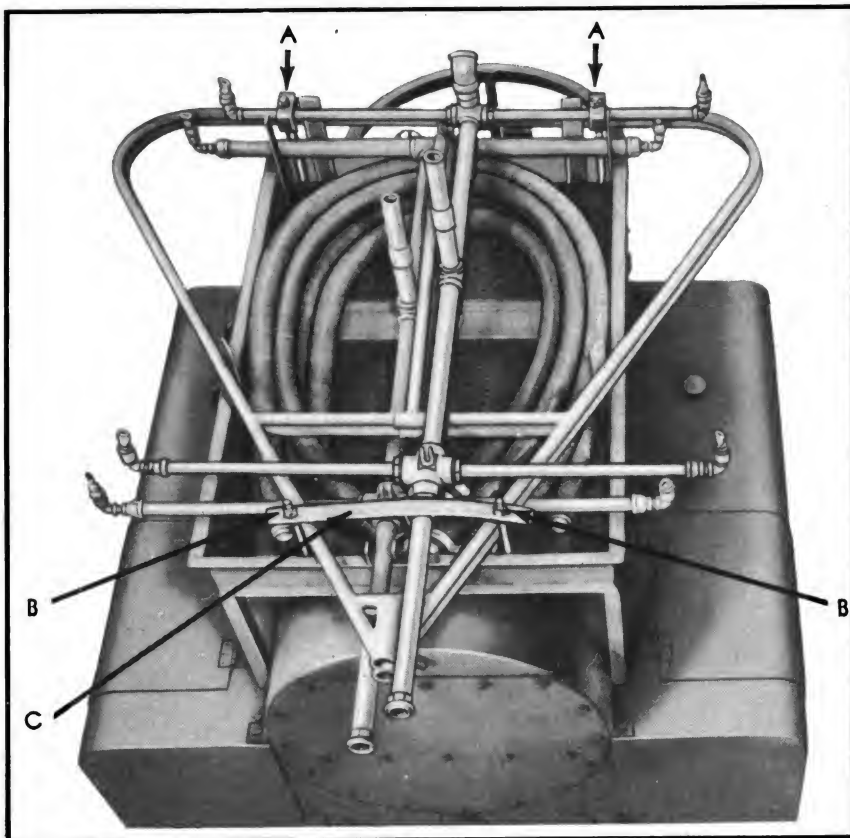

FIG. 3 Shower Stand Loading Arrangement

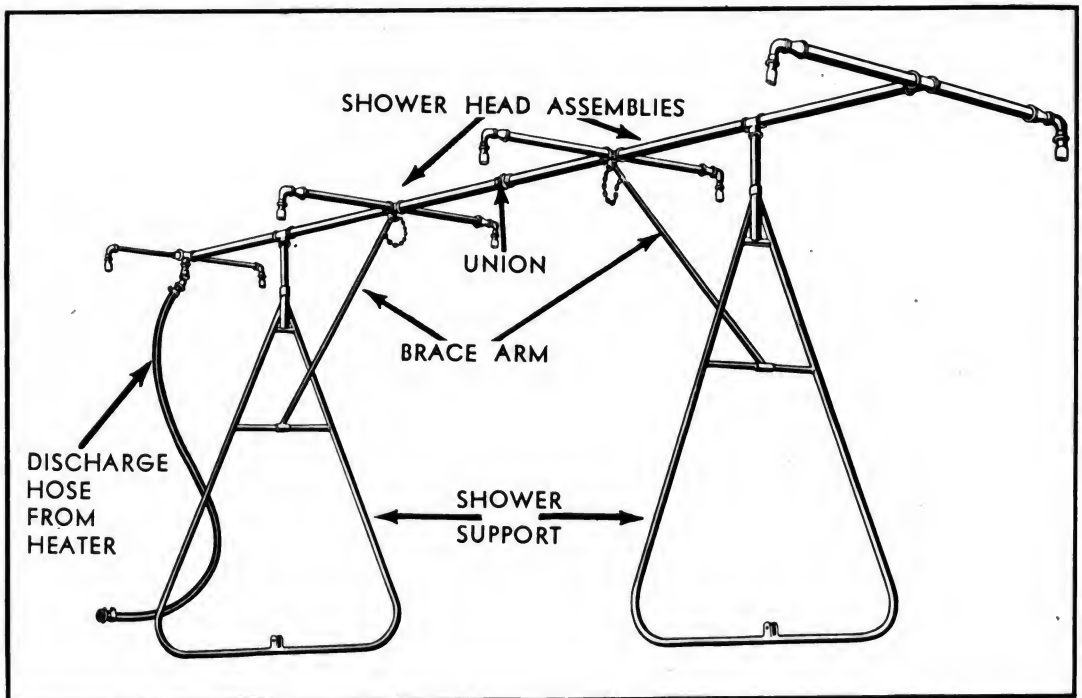

FIG. 4 Shower Stand Set Up

OPERATION SECTION

REMOVING SHOWER STAND (See Fig. 3)

Before removing any of the operating equipment packed on top of the unit, such as shower stand and hose, carefully inspect the stowage arrangement so that equipment may be repacked for travel in the same manner. Unlock the padlocks on the two side tool boxes, and also the lock on the sliding door around the circular end of the machine. Slide back the door as far as it will go, exposing the water pump suction inlet. Reach under the lower rear curved section of the hood over the power plant and remove the bit-snap which holds the hinge and hasp in the locked position. Raise hood until the automatic bracket latches catch and hold hood open. Stand on either fuel tank to remove the wing-nuts and hold-down clamps (A) that secure the shower stand to the bath unit at the power plant end. Also remove the wing-nuts (B) and hold-down bar (C) at the towing end of the unit.

ASSEMBLY OF SHOWER STAND (See Fig. 4)

Remove the four shower stand assemblies from the top of the unit. Lay the two shower head assemblies on the ground with shower nozzles pointing upward and union connections end to end. With the pipe wrench from the tool box, draw the union together tightly.

The end with the 45-degree elbow is the water supply end and should face the heating unit to permit as short a run of hose as possible between the unit and the stand.

Lift and turn over the completed assembly so that shower nozzles face the ground. Care should be taken to prevent dirt from plugging shower nozzles. Next, the triangular shower support should be lifted into place while the shower rack is raised and the pipe extension inserted into the pipe sleeve at top of shower support. The brace arm is then brought up and fastened into yoke on shower rack by means of the pin. A cotter pin inserted into the hole in the pin will prevent it from slipping out of the yoke. The remaining shower support is next positioned in a similar manner. When the shower stand is assembled, it should stand as nearly level as practicable. Remove earth under its supports as required in leveling.

SUCTION HOSE

Lay out enough hose to extend from water source to the suction inlet on the water pump, bearing in mind that the suction lift must not exceed 15 feet. Remove hose cap from pump suction inlet and couple female hose end to male coupling on pump, checking to see that a rubber gasket is in place in each coupling. (See Fig. 5).

Tighten all connections with hose spanner wrench. Remove 1½ inch brass suction strainer from tool box and attach to male end of suction hose, at water source. Submerge the strainer end of the hose in water. (See Fig. 6).

SUCTION HOSE HINTS

At this point, the operator can save himself trouble by taking precautions, as follows:

OPERATION SECTION

SUCTION HOSE

PREPARING UNIT

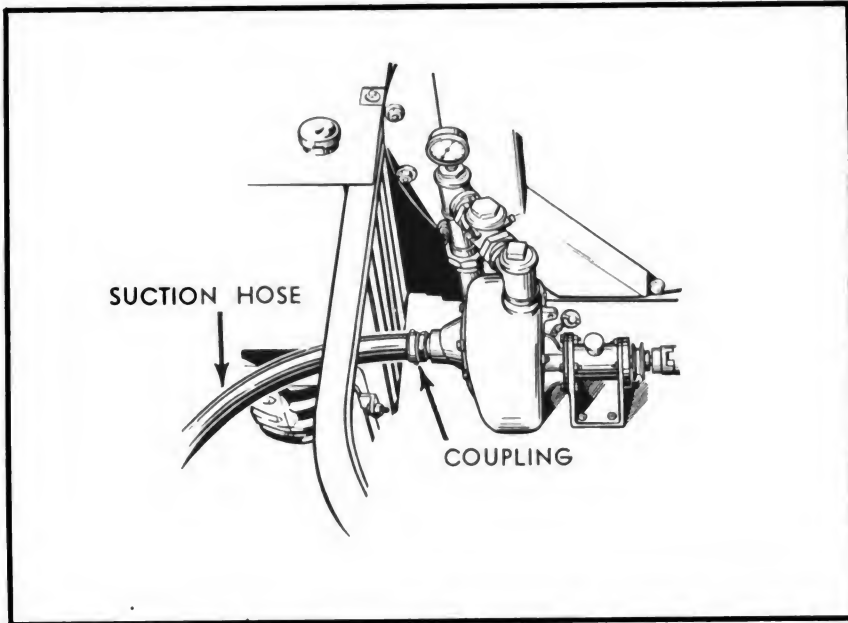

FIG. 5 Suction Hose Connected to Water Pump

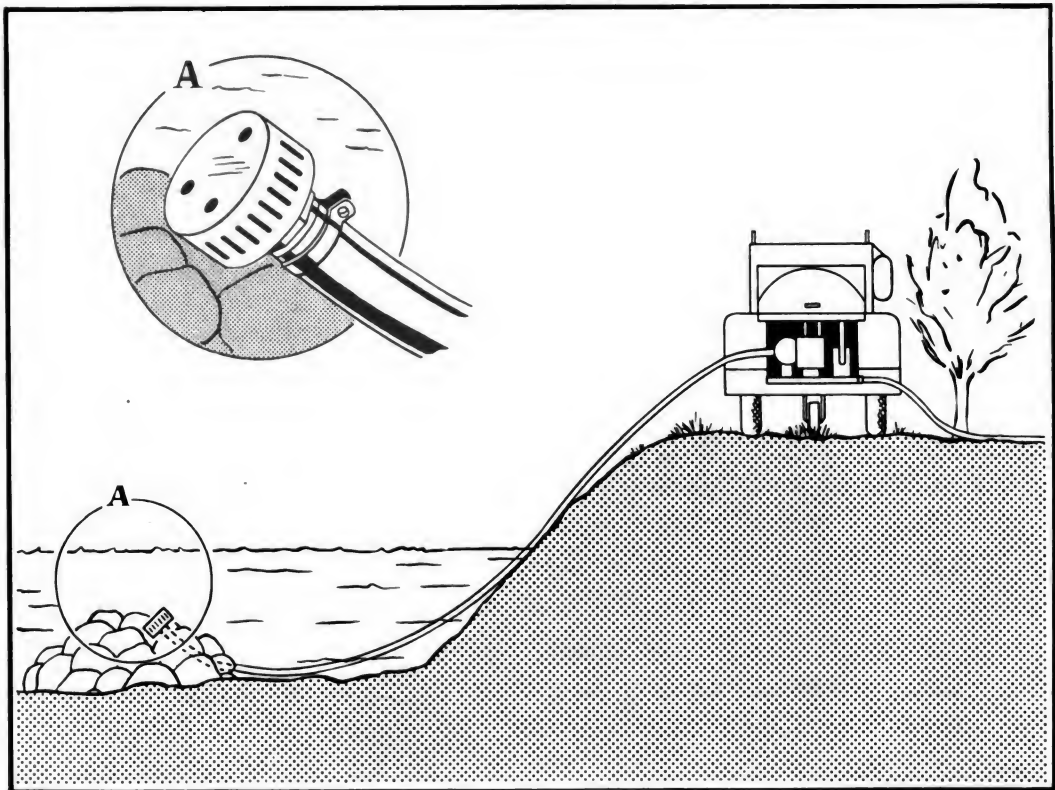

FIG. 6 Typical Suction Hose Arrangement

OPERATION SECTION

See that suction hose is laid out in as straight a line as the terrain permits.

See that all joints are made up tight.

See that suction strainer, when placed in water, will be covered at all times under sustained pumping conditions, and submerged deep enough to prevent "pulling air".

Rest the suction strainer on rocks or other support to prevent entry of sand and silt.

Protect suction strainer so that leaves, weeds, sand, or other stream refuse will not clog the inlet.

In the case of pumping from a small, shallow stream, locate suction strainer at a point where the water is deepest.

If these instructions are followed and reasonable care exercised in preparation of the suction line, the unit should be assured a good supply of water under sustained pumping conditions.

DISCHARGE HOSE (See Fig. 7)

With shower stand as close to the heating unit as local conditions will permit, the male end of the discharge hose should be connected to the 45-degree elbow on the shower stand. The female end should then be connected to the discharge outlet on the unit, after the hose cap has been removed. All couplings should be drawn up tight by means of the hose spanner wrench.

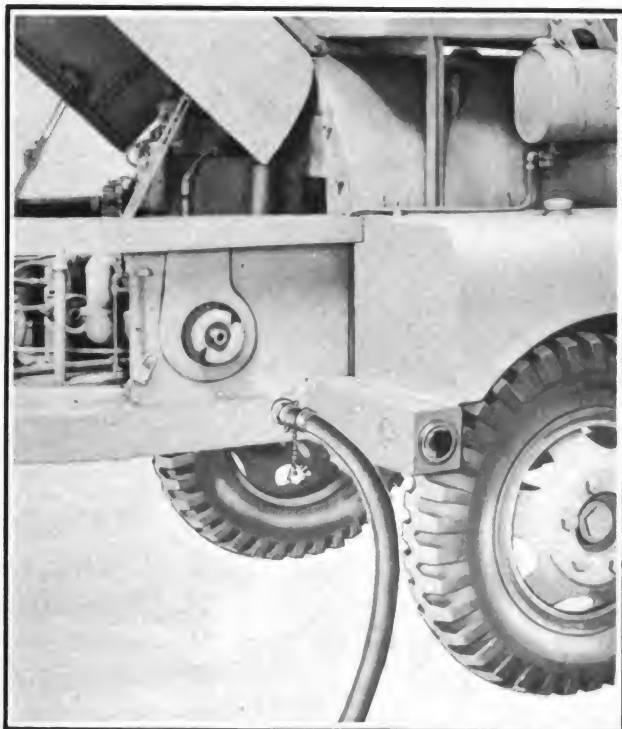

FIG. 7 Discharge Hose Connected to Unit

OPERATION SECTION

POWER PLANT

PREPARING UNIT

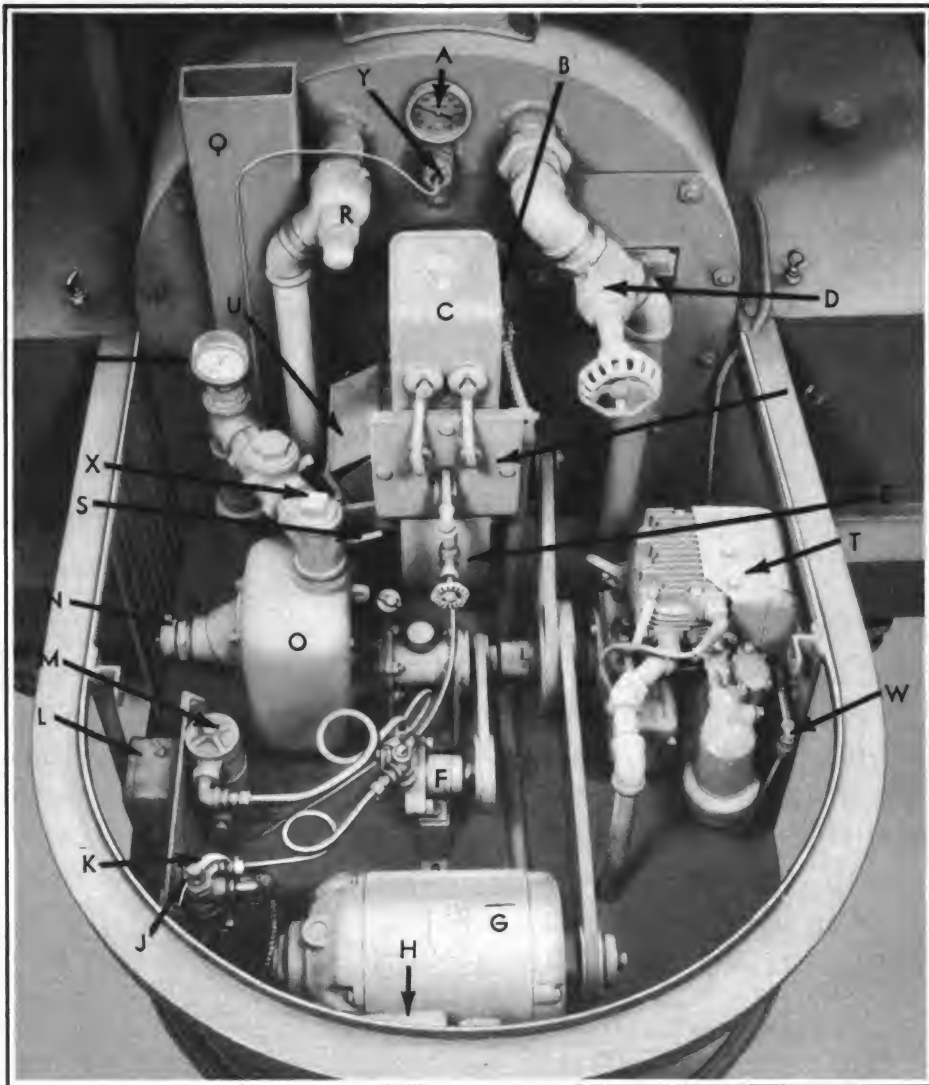

FIG. 8 Power Plant

- | | |
|---|---|
| A. Heater Water Thermometer | N. Water Suction Inlet |
| B. Burner Observation Port Hole | O. Water Pump |
| C. Burner Ignition Transformer | P. Water Pressure Gauge |
| D. Shower Water Valve | Q. Stack |
| E. Burner Fuel Valve | R. Water Pressure Relief Valve |
| F. Fuel Pump | S. Burner Air Shutter
Control Handle |
| G. Generator | T. Gasoline Engine |
| H. Manual Control Switch | U. Blower Damper |
| J. Fuel Oil Relief Valve (Fuel Pres-
sure Regulator, Adjusting
Screw under Cap) | V. Burner Assembly |
| K. Solenoid Valve | W. Engine Fuel Line |
| L. Temperature Regulator | X. Water Pump Prime Plug |
| M. Fuel Strainer | Y. Temperature Regulator Bulb |

OPERATION SECTION

WATER PUMP (See O, Fig. 8)

This shower unit is equipped with a Jaeger Model 1½ inch PO centrifugal pump of the open impeller type, so designed that clogging is reduced to a minimum. A special seal called a "Lubri Seal" replaces the conventional packing gland. The sealing surfaces are pressed together by a spring which provides uniform pressure and thus ensures long life. Lubrication is the only attention required.

The suction inlet is located in the upper portion of the priming chamber, to prevent priming water from leaking back past the suction check valve when the pump stands idle.

A cleanout port is provided below the priming valve so that it may be readily inspected and cleaned if necessary.

The impeller shaft is mounted in antifriction bearings. Fast priming is accomplished by aid of a recirculating jet which shuts off automatically as soon as the pump has primed.

PRIME PUMP

To prime pump, remove prime plug in tee on top of pump discharge piping, and pour water into tee until it overflows. (See X, Fig. 8). This operation will probably not be necessary if the unit has been operated recently, because enough water will be retained in the pump shell to insure satisfactory priming. Another method of priming the pump is to remove the strainer from the suction end of the hose, and raise the hose to the level of the pump inlet, then pour water into the hose until it overflows. Place a hand over the open end of the hose and submerge it in the water supply, then screw on the strainer, under water. The check valve in the pump discharge line and the priming valve on the inside of the pump will hold prime.

CAUTION: TO PREVENT OVERHEATING, THE WATER PUMP MUST NEVER BE RUN WITHOUT WATER IN THE PRIMING CHAMBER.

WATER DRAIN VALVES

All water drain valves on the unit should be closed. These valves are:

Heater drain valve, located at the bottom of the heater.

Pump discharge drain valve, located in heater feed water line, directly below water pump, on under side of power plant.

SHOWER WATER VALVE

The shower water valve should remain open; it is located directly above the gasoline engine. (See D, Fig. 8)

GASOLINE TANK (See Fig. 9)

Fill gasoline tank, located on the right side of the unit, with a non-leaded gasoline, if available, having an octane rating of at least 67. Tank capacity is three

OPERATION SECTION

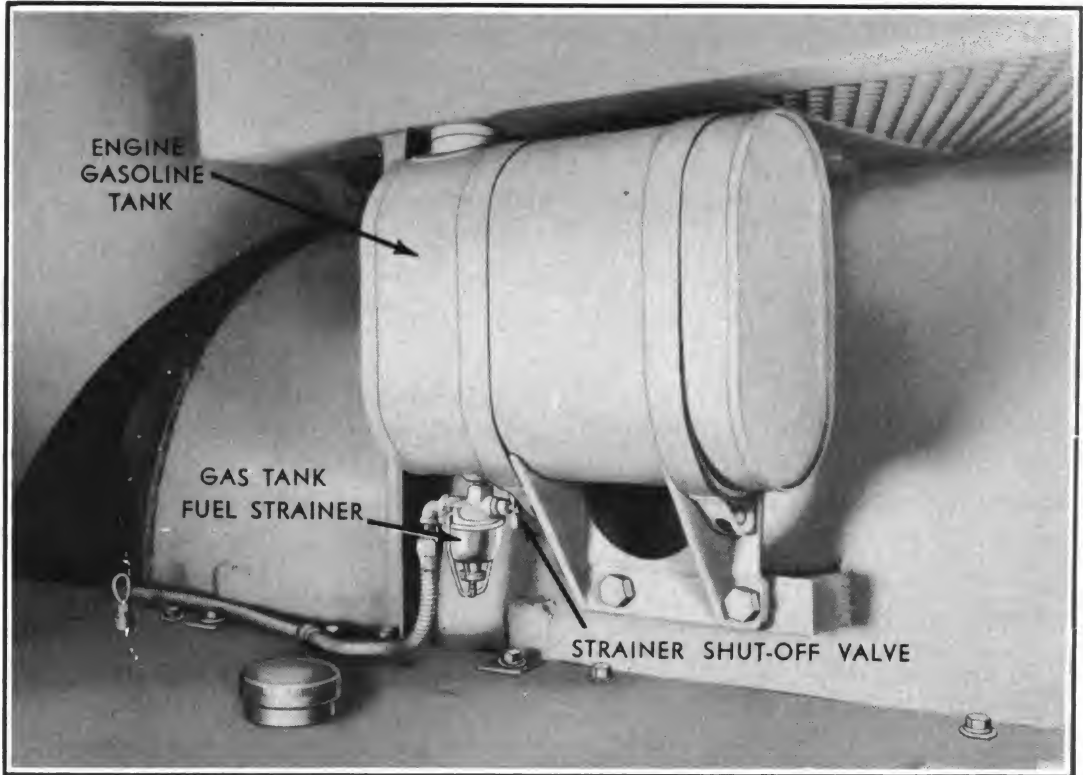

FIG. 9 Engine Gasoline Tank and Fuel Strainer

gallons. At the bottom of the tank is a fuel strainer fitted with a wing-handle shut-off valve controlling the gas flow to the tank. This valve should be opened fully at this time, allowing the strainer bowl to fill and fuel to flow by gravity to the carburetor on the engine.

FILL FUEL TANKS

Fill the fuel tank at the sides of the unit, with fuel oil. Capacity is 25 gallons each tank; total capacity, 50 gallons.

The fuel burner is designed for use with either No. 1, 2, or 3 U. S. Standard Fuel oil. Diesel fuels, lubricated gasoline, or lubricated kerosene may also be used. The lighter fuels, No. 1, or No. 2, may be used in extremely cold temperatures. Black, heavy, viscous oils should be avoided, as the pressure atomizing nozzle cannot atomize them as necessary for proper combustion unless the fuel is preheated.

If kerosene or gasoline is used, one quart of No. 30 lubricating oil must be added to each five U. S. gallons of kerosene or gasoline, to provide lubrication for the fuel pump.

WARNING: When firing the burner with gasoline, extra precautions must be taken for safety. Should it fail to ignite on the first operation, the combustion chamber must be purged of the carbureted or vaporized and highly explosive gases before again inserting the torch for a new start. *With the fuel supply shut off, run the unit, with the blower air damper open, for at least 15 minutes before again*

OPERATION SECTION

attempting to fire. Do not fail to add one quart of lubricating oil to each five gallons of gasoline.

On the under side of the unit and directly beneath the power plant are four one-fourth inch globe valves that control the suction and return of the fuel oil to the side tanks. The two valves beneath the water pump are the return valves; the two beneath the engine are the suction valves. **ALL FOUR VALVES SHOULD BE LEFT OPEN AT ALL TIMES, EXCEPT WHEN THE UNIT IS TO BE MOVED TO A NEW LOCATION.** In the event that one of the tanks should become punctured, the suction and return valves in the fuel lines to that tank should be closed, and the tank drained by removing the plug in the tee in the suction line at the bottom of the tank.

In each tank, near the operating end of the unit, is a bayonet-type gauge stick which is used to determine the oil level in the tank.

BURNER FUEL VALVE (See E, Fig. 8)

The valve in the fuel oil line to the burner should be checked to see that it is closed.

FUEL STRAINER (See M, Fig. 8)

Copper tubing carries fuel from the fuel tanks to a fuel strainer mounted on the back of the control panel, near the water pump. The strainer, having two screen baskets, filters out all grit which may have entered the system.

FUEL PUMP (See F, Fig. 8)

From the strainer the oil flows through copper tubing to the suction port of the fuel pump, located in the center of the power plant, between the generator and the water pump.

The fuel pump is of the internal gear type and is driven by means of a V-Belt from the water pump shaft. The discharge fuel line from the fuel pump leads to the pressure regulator.

FUEL PRESSURE REGULATOR (See J, Fig. 8)

The pressure regulator is mounted on the back of the control panel, on the end nearest to the generator. It has been adjusted at the factory to deliver fuel oil to the burner at a pressure of 100 pounds per square inch. Excess fuel oil is by-passed through the return tubing to the tank. A pressure gauge mounted on the regulator indicates the pressure of the oil fed to the burner.

SOLENOID VALVE (See K, Fig. 8)

In the fuel line from the pressure regulator to the burner is a solenoid valve that controls the oil flow to the burner. This valve is normally closed, and can be opened only by an electric current passing through the coil of its electromagnet. Fuel

OPERATION SECTION

ELECTRICAL CONTROLS

PREPARING UNIT

then passes to the burner. The solenoid valve is thermostatically controlled by the effect the temperature of the water leaving the heater has on the temperature regulator.

GENERATOR (See G, Fig. 8)

The current for the solenoid valve and the burner ignition is supplied by a 60 cycle A. C. generator driven by V-Belt from the gasoline engine. When driven at normal speed (3600 rpm) the generator output is 550 watts at 110 volts.

IGNITION

Current from the generator is supplied constantly to the primary winding of the ignition transformer (See C, Fig. 8) mounted on top of the burner assembly. The transformer increases the voltage to 10,000 volts. From the secondary terminals of the transformer, two ignition wires pass through insulators in the burner flange and are connected to two porcelain-covered electrodes. The high voltage between the tips of these electrodes, spaced $\frac{1}{8}$ inch apart, produces an arc that ignites the atomized oil delivered from the nozzle. This arcing is constant during engine operation and ignites the oil each time the solenoid valve opens and fuel is delivered through the nozzle.

ELECTRICAL CONTROLS

A manually operated toggle switch mounted on the outlet box of the generator (See H, Fig 8) and an automatic temperature control switch mounted on the front of the control panel, are wired in series with the solenoid valve and control its opening and closing. Current to the primary winding of the ignition transformer, which is wired in parallel with the solenoid valve, is also controlled by the manual and automatic switches. With the manual switch closed, the automatic control governs fuel delivery.

TEMPERATURE REGULATOR (See L, Fig. 8)

The temperature regulator is an automatic control and consists of two parts. One part, the bulb, is exposed to the water within the heater at a point just below the round dial thermometer at the operating end of the unit. (See Y, Fig. 8) The other part is the control box mounted on the control panel, and contains the switch mechanism.

The control box and the bulb are connected by a small copper tube. The operator should check to see that this tubing is not cut, bent, or flattened in any way, since this would seriously impair the proper operation of the control.

The control box is internally provided with a mercury tube switch which, when actuated by means of a series of levers, makes and breaks the electrical circuit to the solenoid oil valve.

The unit has been adjusted at the factory to maintain water temperature within a temperature range of approximately five degrees. When the temperature within the heater reaches 110 degrees F, the high limit of the control, the electrical circuit is

OPERATION SECTION

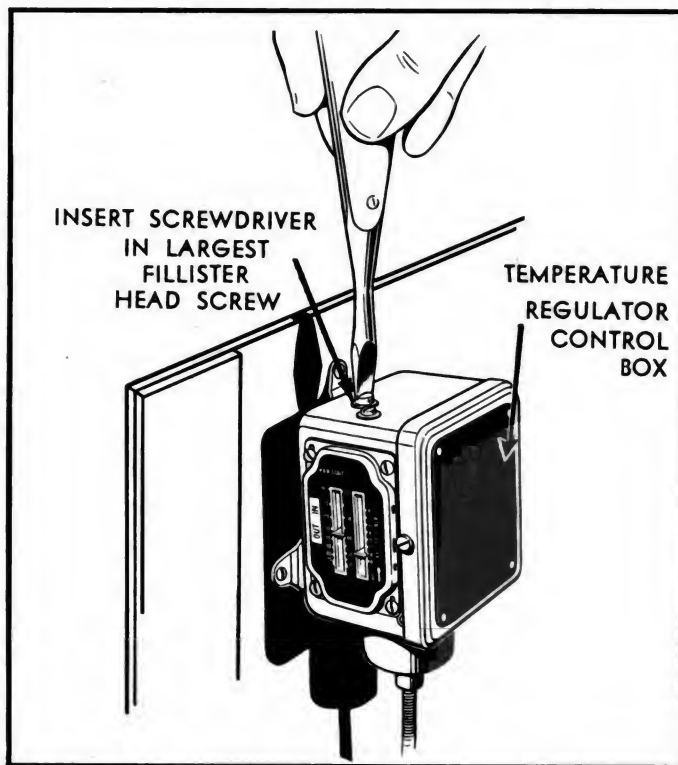

FIG. 10 Adjusting Temperature Setting

broken, allowing the solenoid valve to return to its normal or closed position and preventing fuel from flowing to the burner. When the temperature drops to the low limit, 105 degrees F., the electrical circuit is again closed, thereby opening the solenoid oil valve and supplying oil to the burner.

To change the low or cut-in setting of the control to a higher or lower temperature, insert a screwdriver in the slot in the larger of the two fillister head screws on the top of the control box and turn it to the right (clockwise). Turn it to the left (counterclockwise) to lower the setting, (See Fig. 10).

MANUAL SWITCH (See H, Fig. 8)

The manual switch should normally be left in the "ON" position, since in that position it completes the electrical circuit and will permit current to flow to the solenoid when the temperature regulator switch closes.

The switch should be set in the "OFF" position only when the operator desires to shut the bath unit down, since in the "OFF" position the electrical circuit to the solenoid valve is broken and the valve closes, thereby preventing fuel from passing to the burner.

WATER PRESSURE RELIEF VALVE (See R, Fig. 8)

To the left of the thermometer is a water pressure relief valve with its side out-let piped downward through the power plant base plate, to waste. This valve has

OPERATION SECTION

LUBRICATION CHART

LUBRICATION

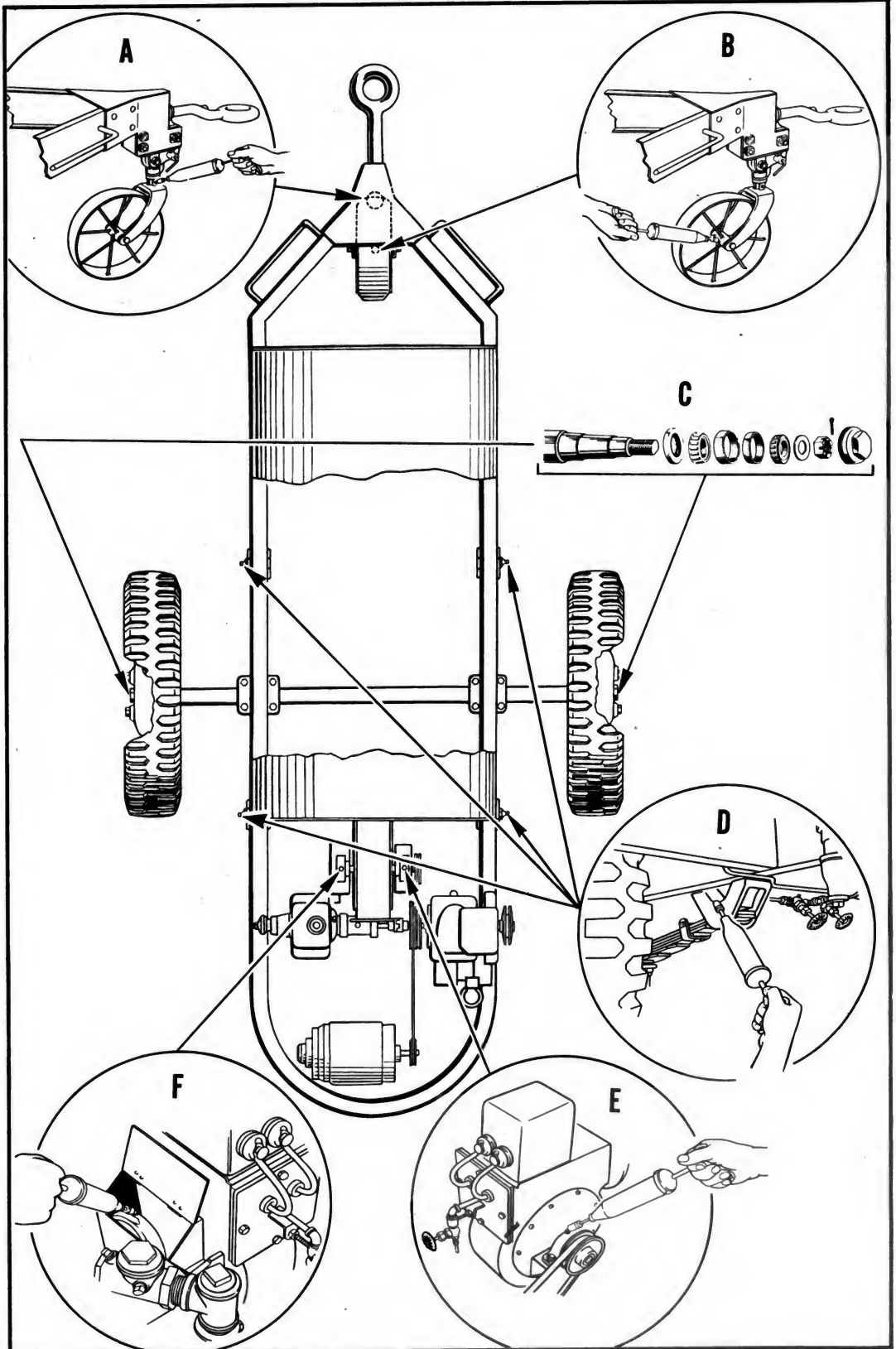

FIG. 11 Lubrication Chart

OPERATION SECTION

LUBRICATION CHART

LUBRICATION

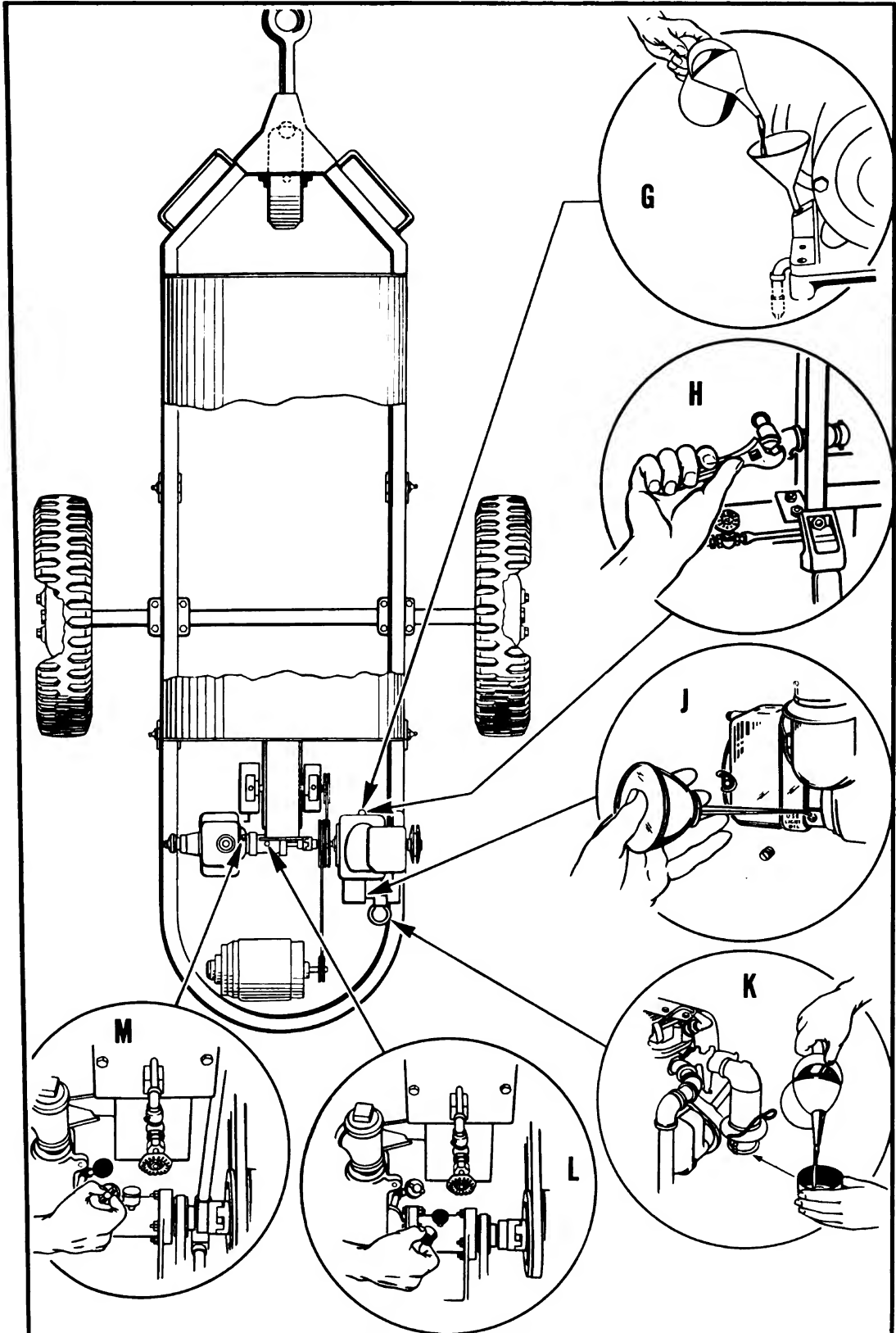

FIG. 12 Lubrication Chart

OPERATION SECTION

LUBRICATION

LUBRICATION

been adjusted at the factory to open and relieve at a pressure of 30 pounds per square inch, should the main water discharge become obstructed.

GASOLINE ENGINE

Remove the filler plug and fill crankcase with oil to the bottom edge of the filler plug opening. Capacity is $1\frac{3}{4}$ pints. If possible oil should correspond to the tabulation as outlined under "Lubrication—Gasoline Engine". (See G, Fig. 11)

The magneto should be oiled as described under "Lubrication—Magneto Oiling". (See J, Fig. 12)

The air cleaner should be filled with oil as described under "Lubrication — Engine Air Cleaner". (See K, Fig. 12)

LUBRICATION

(See Lubrication Charts Figures 11 and 12)

FRONT CASTER WHEEL (See A & B, Fig. 11)

Zerk Fittings. Use Zerk pressure gun.

Grease with WB-2 General Purpose Grease, U. S. Army Specification No. 2-108.

Grease after each 256 hours of operation. Grease before placing unit in storage.

SPRING HANGERS AND SPRING SHACKLES (See D, Fig. 11)

Zerk fittings. Use Zerk pressure gun.

Grease with WB-2 General Purpose Grease, U. S. Army Specification No. 2-108.

Grease after each 256 hours of service. Grease before placing unit in storage.

WHEEL BEARINGS (See C, Fig. 11)

Roller bearings are hand packed. After 1096 hours of service, remove wheel bearings, clean, inspect, install new parts in place of worn or damaged parts, repack bearings with WB-2 General Purpose Grease, U. S. Specification No. 2-108, and reassemble.

To grease—Set the jack under axle as close to wheel as possible, so that the wheel can be raised. Jack up unit until the wheel can be rotated. Remove six nuts holding wheel to hub. The wheel can then be removed.

Remove hub cap by unscrewing it counterclockwise (left). Remove cotter pin through castellated nut, unscrew nut, and remove washer.

Pull off hub. The outer bearing, outer bearing cup, and inner bearing cup will remain in the hub; the inner bearing will remain on the axle. Remove outer bearing with fingers, and slide inner bearing off axle. The grease seal should also be removed for cleaning. Thoroughly wash bearings in fuel oil or kerosene and carefully clean interior of hub.

To reassemble—Slide grease seal on axle shoulder, with leather face out. After thoroughly greasing inner bearing, slide it on axle, with taper toward axle end. With

OPERATION SECTION

LUBRICATION

LUBRICATION

both bearing cups in place, slide on wheel hub. After greasing outer bearing, insert it with taper away from axle end. Install washer and castellated nut, and while wheel is spinning, tighten nut until tension stops the wheel, then loosen nut to next cotter pin position (approximately $1/6$ turn) and install cotter pin. The wheel should now turn freely, if not, some obstruction may be lodged in the bearings. Cover outer bearing and nut with grease, and screw on hub cap.

BLOWER SHAFT BEARING AT DAMPER (See F, Fig. 11)

Zerk fitting. Use Zerk pressure gun.

Grease with WB-2 General Purpose Grease, U. S. Specification No. 2-108.

To grease—Slide damper control arm off of top shutter leaf pin and raise top shutter leaf, exposing grease fitting on bearing. After greasing, slide control arm back on pin.

Grease every eight hours. Grease before placing unit in storage.

BLOWER SHAFT BEARING—DRIVE END (See E, Fig. 11)

Zerk fitting. Use Zerk pressure gun.

Grease with WB-2 General Purpose Grease, U. S. Army Specification No. 2-108.

Grease every eight hours, and before placing unit in storage.

WATER PUMP—BEARING SHAFT HOUSING (See L, Fig. 12)

Grease cup. Hand packed.

Grease with CG-0 General Purpose Grease, U. S. Specification No. 2-106.

To grease—Remove cap from grease cup located on shaft housing, and fill cup with grease. Screw cap down until pressure point is reached.

Turn cap one turn every four hours of operation, and refill when empty. Fill cup, and screw down tightly before placing unit in storage.

WATER PUMP—"LUBRI" SEAL (See M, Fig 12)

Grease cup. Hand Packed.

Grease with CG-0 General Purpose Grease, U. S. Specification No. 2-106.

To Grease—Remove cap and fill grease cup with grease. Screw down wing-nut on cap until plunger is in its retracted position. Replace cap on grease cup, then back off wing-nut completely. This releases the plunger and forces the grease into the grease seal. Remove cap again and screw down wing-nut. Refill grease cup with grease, replace cap, and back off wing-nut about two turns.

Back off wing-nut two turns every 4 operating hours. Refill cup when wing-nut is completely backed off. Refill cup and back off wing-nut two turns before placing unit in storage.

ENGINE CRANKCASE (See G & H, Fig. 12)

If possible, oils of body and viscosity corresponding to those listed on the following page should be used.

OPERATION SECTION

ENGINE

STARTING UNIT

Temperature	Oil Used	Army Spec. No.	S.A.E. No.
+ 120 degrees F. to + 15 degrees F.	OE-30	2-104A	30
+ 15 degrees F. to - 15 degrees F.	OE-10	2-104A	10
- 15 degrees F. and below. Add diesel fuel or gasoline to OE-10 but do not add in excess of 20%, or about 1/4 pint.			

To drain—Remove plug at bottom of engine drain pipe under power plant. When crankcase is empty, replace plug. Drain while engine is warm.

To fill—Remove filler plug at side of crankcase and, with funnel in place, fill crankcase to level of filler hole. Capacity 1 3/4 pints.

Oil should be checked each four hours and if necessary, oil should be added to bring level up to filler hole. The crankcase should be drained completely after every 64 hours of operation. Drain crankcase when placing in storage, attaching tag marked "Crankcase Drained."

ENGINE AIR CLEANER (See K, Fig. 12)

Remove oil cup at bottom of air cleaner by pushing the wire clip to one side. Fill the cup with engine oil to the level of the mark on the cup. The frequency which this cup should be drained and refilled depends entirely upon local conditions; however, oil must be changed when accumulation of sediment is evident. Under normal conditions, drain and refill each eight hours of operation, using same type and grade of oil as is used in engine crankcase.

MAGNETO OILING (See J, Fig. 12)

The magneto should be oiled every 256 hours by removing the screw covering the oil hole and filling to overflowing. Use a grade and type of oil identical with that used in engine crankcase.

STARTING THE UNIT

Having made the following preliminary arrangements, the unit is ready for service:

Unit setting level.

Shower stand set up.

Suction and discharge hoses connected.

Water pump primed.

All water drain valves and the burner fuel oil valve are closed.

Gasoline and fuel oil tanks filled.

All four fuel oil tank valves opened.

Manual switch in "On" position.

Automatic temperature control switch set at low setting, 105 degrees F.

Gasoline engine crankcase filled with oil, and unit lubricated.

TO START ENGINE (See Fig. 13 and 14)

Close the choke on the carburetor air inlet horn. The choke opens automatically after the engine starts.

OPERATION SECTION

ENGINE

STARTING UNIT

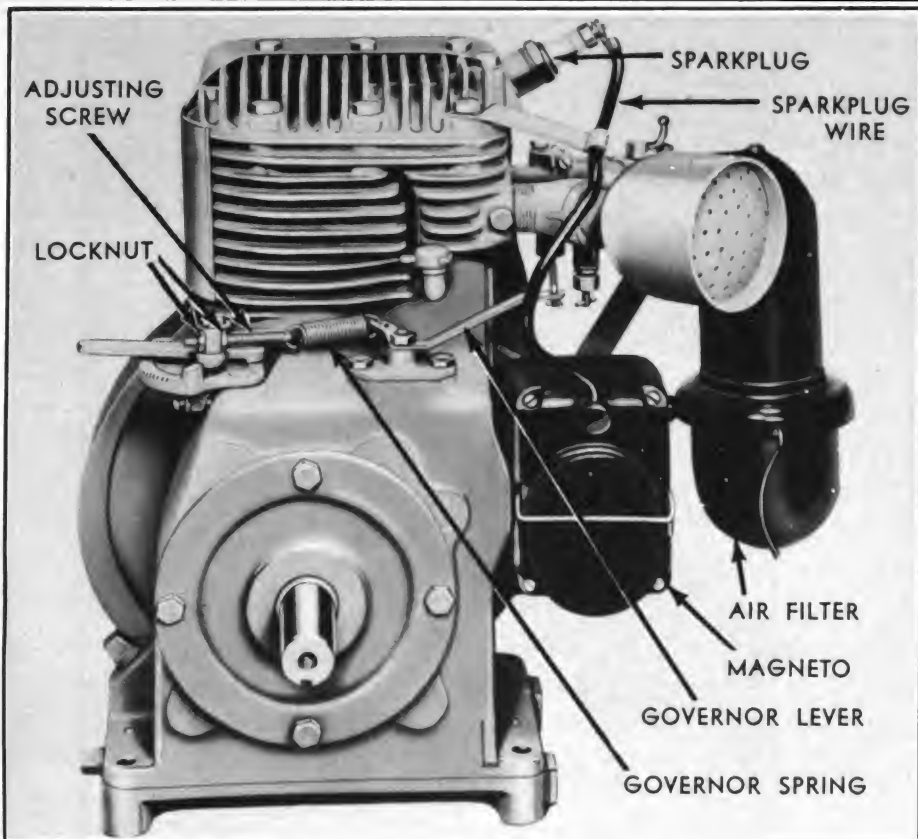

FIG. 13 Engine—Power Take-off End

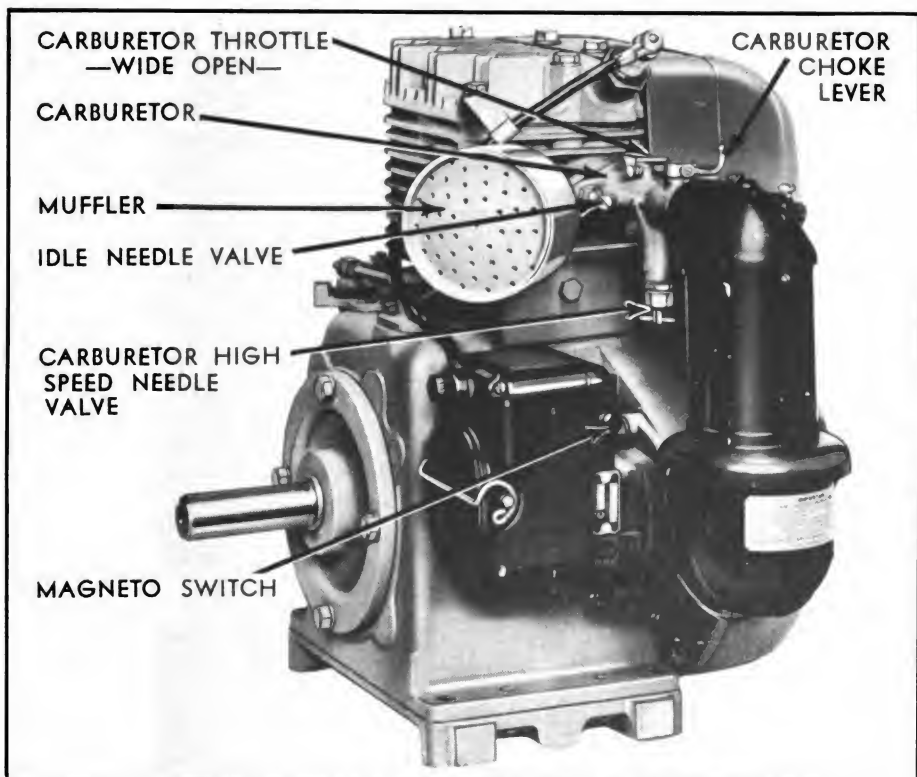

FIG. 14. Engine—Side View

OPERATION SECTION

ENGINE

STARTING UNIT



FIG. 15 Checking Magneto Breaker Points

The carburetor needle valve, which will be found directly under the carburetor body, should be turned to a closed position, then opened approximately $\frac{3}{4}$ to $1\frac{1}{4}$ turns. In cold weather, starting is sometimes facilitated by opening the needle valve slightly more, to where the engine runs the smoothest.

The gasoline engine is of the manual rope-pull starter type. Remove the starter rope from the tool box, insert the knotted end into the notch in the starter sheave, and wind the rope on the sheave in a clockwise direction. Turn starter sheave over by hand in a clockwise direction until stopped by compression. With only a small end of rope remaining, grasp the wooden handle, and exert a quick pull toward the operator, turning the crankshaft over clockwise.

If the engine does not start on the first attempt, the operation should be repeated.

If the choke on the carburetor accidentally snaps open during cranking it should be closed again for two or three turns of the engine. If fuel begins to drip from the carburetor, the choke should be opened. It is necessary to choke the carburetor more in cold than in warm weather.

If the engine will not start after repeated applications of the rope starter, the following points should be checked—The spark plug, to see that no carbon or other foreign matter is lodged between the points. The spark plug wire, to see that it is

OPERATION SECTION

connected to the magneto and to the spark plug, and that these connections are clean. The spark plug wire should also be checked to see that it is not punctured at some point and possibly "shorted." The magneto breaker cover should be removed and the breaker points checked to see that the opening is .015 inch and also to see that these points are clean and free from foreign matter (See Fig. 15).

Next, check to see if the fuel line from the fuel strainer is obstructed, by loosening the connections at the carburetor, with the shut-off valve in the fuel strainer closed. After the fuel line is loosened at carburetor, open the shut-off valve in the fuel strainer and see that fuel flows freely through the line. If it is found that some obstruction is present, this may be removed by blowing out the line with compressed air, after the line has been removed from the engine. Next, check to see that the air vent hole in the gasoline cap is open. This may be determined by blowing through the hole. If this hole is plugged, the obstruction may be removed by use of a sharp pointed instrument.

When warm, the engine speed should be 2050 rpm. **CAUTION:** The speed of the engine should never exceed 2050 rpm, since this would cause the generator to overload the solenoid coil and the ignition transformer and might burn them out. The speed should never drop below 2000 rpm, as not enough current would be generated to operate the electrical controls properly.

CHECK FUEL OIL PRESSURE

While the engine is warming up, the fuel pump should withdraw fuel from the tanks, building up a pressure of 100 pounds on the pressure gauge. If the pressure is above or below 100 pounds, adjust the fuel oil pressure relief valve to 100 pounds, the recommended pressure, by first removing the hexagon cap at the top of the pressure regulator. While the engine is running, insert a screwdriver in the slot of the pressure adjusting screw, and turn screw either *in* or *out*, watching fuel oil pressure gauge while making adjustment. (See Fig. 16).

To decrease oil pressure, turn screw *out*; to increase oil pressure, turn screw *in*.

When pressure has been adjusted to 100 pounds, replace cap and with a wrench, set it up oil-tight.

Check all fuel oil connections; if any are leaking, tighten with a wrench.

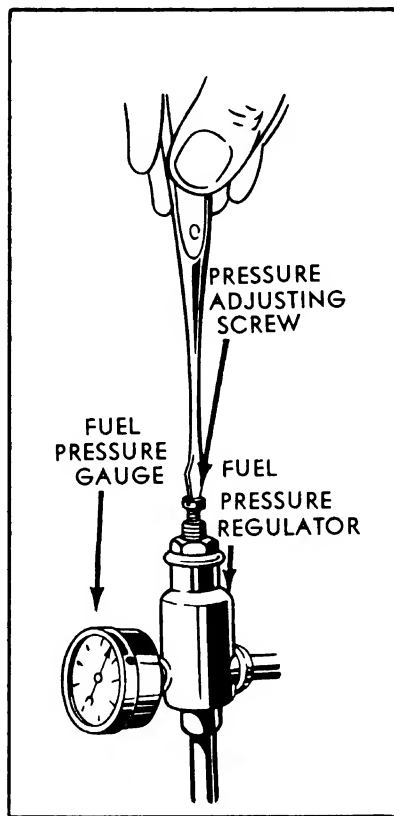

FIG. 16 Adjusting Fuel Pressure

OPERATION SECTION

LIGHTING BURNER

STARTING UNIT

FILLING HEATER

With the start of the engine, the water pump should begin to pump water from the water source. In order to determine if the pump has primed and is pumping water to the heater, the operator should open the auxiliary cold water take-off valve in the pump discharge line just below the pump. If a steady stream of water flows out, the pump is operating properly and the valve should be closed.

If only a trickle or no water appears when the valve is opened it should be closed, the engine stopped, and the pump again primed as described in the paragraph marked "Prime Pump". Also, check to see if all hose suction connections are tight, to prevent air leaks. Then start engine again, as previously described.

When water flows from shower heads, partially close the hot water discharge control valve until only a trickle of water flows from the shower heads.

LIGHTING BURNER

Close the air shutter (See S, Fig. 8) on the blower inlet.

Open burner fuel oil valve (See E, Fig. 8).

The electric spark should ignite the fuel at once. By operating handle (S, Fig. 8) open the air shutter in the blower inlet sufficiently to clear smoke emitted from stack. The air adjustment must be such as will provide sufficient air in proportion to the fuel burned. The unit is equipped at the factory with a four-gallon nozzle; however, should local conditions require more or less heat, the nozzle can be replaced with a five or three gallon nozzle, from the spare parts. In all cases, to properly adjust air supply to the burner, close the shutter until smoke appears at the stack, then open it just enough to eliminate smoke. Never allow burner to emit smoke. When making this adjustment, the operator should bear it in mind that the combustion gases must go through four passes of tubes before the results of the damper adjustment will be seen at the stack outlet.

CONDENSATION

During the first few minutes of firing, the products of combustion strike cold, water-backed steel surfaces and the moisture condenses into water, which may drip from the bottom of the heater. Do not assume from this condition that the heater has sprung a leak; the condition will disappear after a few hours of operation.

TEMPERATURE RISE

The absorption of heat from the fuel combustion will raise the temperature of the water in the heater, as will be indicated by the three inch round dial Fahrenheit thermometer located in the top center of the heater front.

The period of time required to heat cold incoming water sufficiently for bathing purposes varies with the temperature of the water supply, but is usually about ten minutes, after which the hot water discharge control valve should be adjusted as described in the following paragraph.

OPERATION SECTION

MOVING UNIT

TO SHUT DOWN

CONTROLLING WATER TEMPERATURE

The shower unit is designed to raise the temperature of sixteen gallons of water approximately 50 degrees Fahrenheit per minute, thus providing about two gallons of warm water per shower head per minute.

If the hot water discharge valve is fully opened, the water pump will be permitted to pump its full capacity, and a great deal more water than is required for the service will be circulated through the heater, resulting in too low a shower water temperature. Therefore, in order to cut down this volume, the operator should watch the water pressure gauge in the water pump discharge line while he adjusts the hot water discharge valve until a steady pressure of about 10 pounds is reached.

When the temperature rises to approximately 110 degrees F. the burner will automatically shut off and will remain off until the water temperature drops to about 105 degrees F. when it will again be automatically ignited. The unit will continue to operate in this manner without requiring the attention of the operator so long as the gasoline and fuel oil tanks contain fuel for engine and burner.

Slight puffs of blue vapor emitting from the stack at frequent intervals are due to the combustion that occurs each time the burner ignites or is extinguished, and are an indication to the operator that the unit is performing properly.

TO SHUT DOWN

First, close the burner fuel valve. When the flame is extinguished and the combustion chamber purged of gases—generally in about ten seconds—hold down the ignition cut-out button until the engine stops.

TO MOVE TO NEW LOCATION

Shut down the unit as previously described. Remove strainer from end of suction hose. Disconnect suction and discharge hoses, drain them thoroughly and place them in hose and shower stand rack on top of the unit (See Fig. 17). Screw hose caps on discharge and suction inlets. Disassemble shower stand by first removing the two shower supports. Next, turn over the shower head assembly so that heads point upward, and lay assembly on the ground. With a wrench, disconnect the union.

When loading disassembled shower stand on top of the unit, first lay one section of the shower head assembly on the rack as shown in Fig. 18, then lay the two shower stand supports on top as shown in Fig. 19. Lay the remaining shower head assembly on top of the other three units, and fasten by means of the holddown clamps and bar and wing-nuts as shown in Fig. 20.

PRECAUTION AGAINST FREEZING WHEN IDLE

Should the bath unit be shut down between operating periods, and likely to be subjected to temperatures below freezing, completely drain the water system as follows:

OPERATION SECTION

LOADING. SHOWER STAND

TO SHUT DOWN

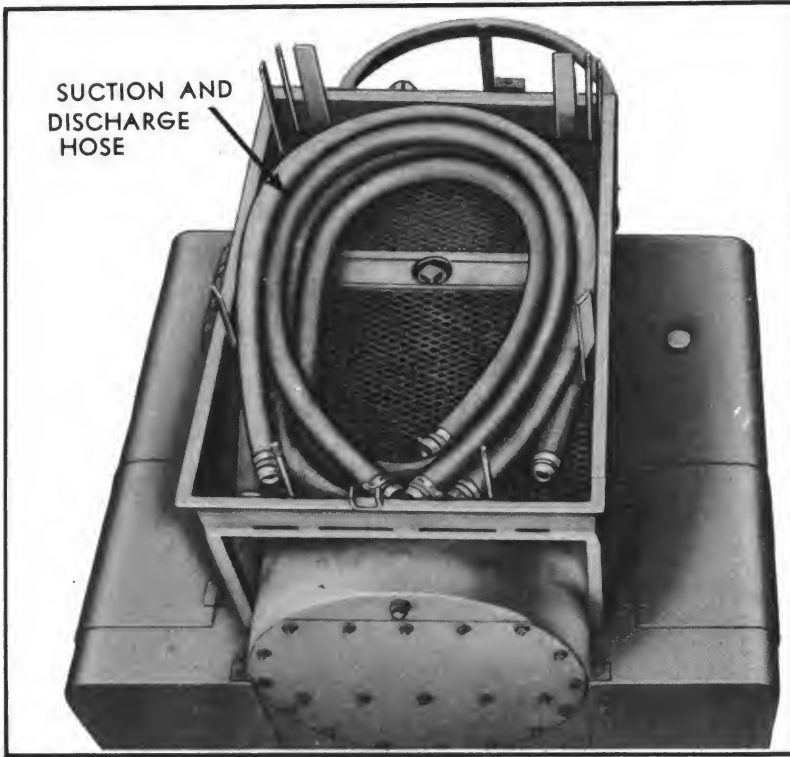

FIG. 17 Shower Hose Loading Arrangement

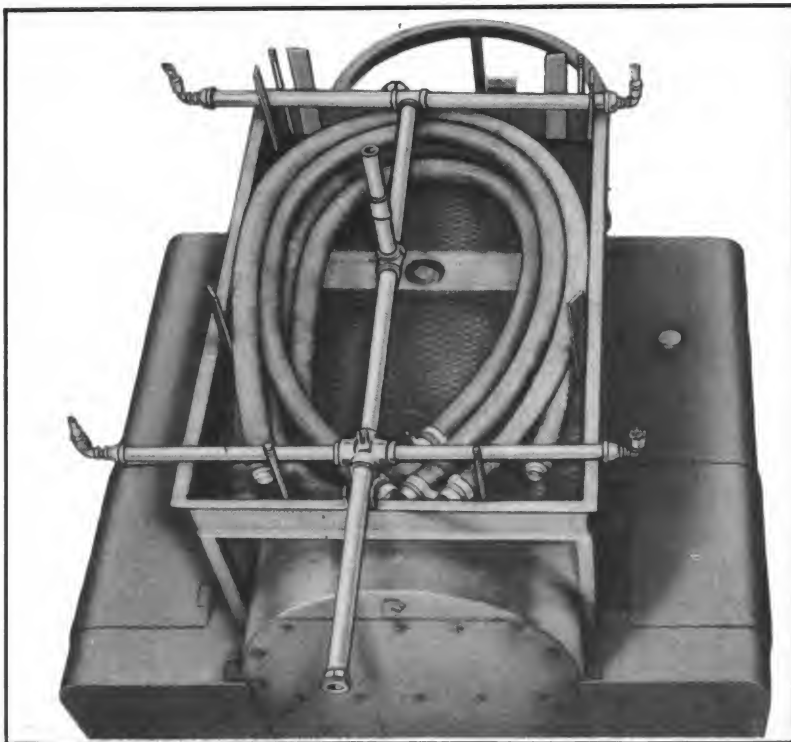

FIG. 18 First Shower Head Assembly Loaded on Unit

OPERATION SECTION

LOADING SHOWER STAND

TO SHUT DOWN

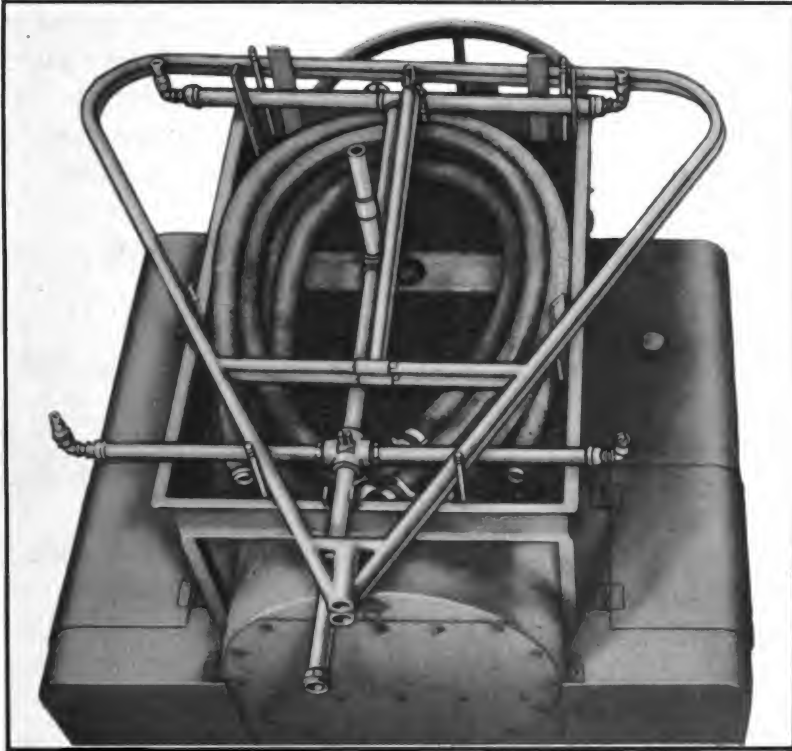

FIG. 19 Two Shower Supports Loaded on Unit

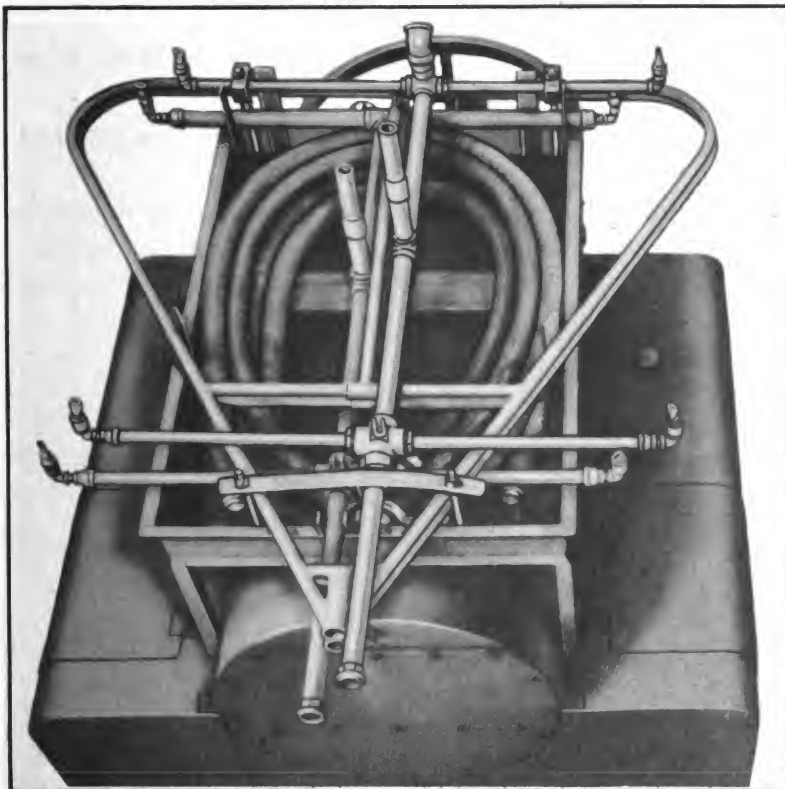

FIG. 20 Second Shower Head Assembly Loaded on Unit

OPERATION SECTION

SHIPMENT

STORAGE

Drain the heater by opening the drain valve at the bottom of heater near the towing end of the unit. Open water pump discharge drain valve located in the heater feed water line, directly below the water pump. Remove the drain plug at the base of the water pump, below the suction inlet. When the pump has completely drained, replace plug. Also open the hot water discharge valve.

TO PREPARE FOR STORAGE

LIMITED STORAGE

When the unit is to be stored for a limited length of time, such as 30 days or less, the following procedures should be followed.

Drain the water system as described in the previous chapter, "Precaution Against Freezing When Idle". Drain gasoline tank by removing gas filter sediment bowl and opening wing-nut shut-off valve.

Completely drain fuel from fuel tanks by opening drain cocks in the tees in fuel lines at bottom of tanks, then close drain cocks.

Completely drain oil from engine crankcase by removing plug in the one-fourth inch pipe passing through base plate directly below engine, then replace plug, attaching a caution tag to engine stating "Crankcase Drained".

The air cleaner bowl should also be removed, the oil drained and the bowl replaced.

Remove sparkplug and inject about a tablespoonful of cylinder oil into sparkplug hole. Replace sparkplug.

Clean all tools, dip them in oil, drain, then wrap them in waterproof paper and store in the tool boxes.

Close all valves and cocks, preventing entry of moisture and rendering the heater air-tight.

The wheels, blower, water pump and caster wheel should be lubricated as described under "Lubrication", using the types and grades of greases as outlined.

Disassemble the shower stand and pack discharge and suction hoses on unit along with shower stand as shown in Figs. 17, 18, 19, and 20.

DEAD STORAGE

To prepare the shower unit for dead storage refer to Paragraph 37, Heaters, Tank Car, in TM5-9715, Preparation of Engineers Equipment for Storage, issued by Engineer Field Maintenance Office, P. O. Box 1679, Columbus, Ohio.

SHIPMENT

With unit prepared as described under "Limited Storage" and "Dead Storage" the unit is ready for shipment by towing or rail shipment.

To tow—raise caster wheel to its retracted position and hook towing ring to tractor or towing vehicle. No disassembly of any kind is required, since unit is designed for road travel.

OPERATION SECTION

BLOCKING

STORAGE

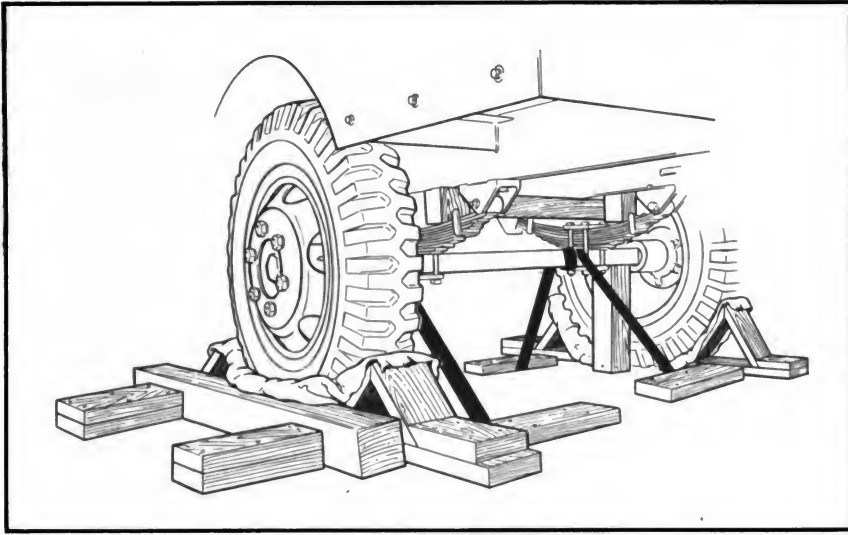

FIG. 21 Blocking—Wheels

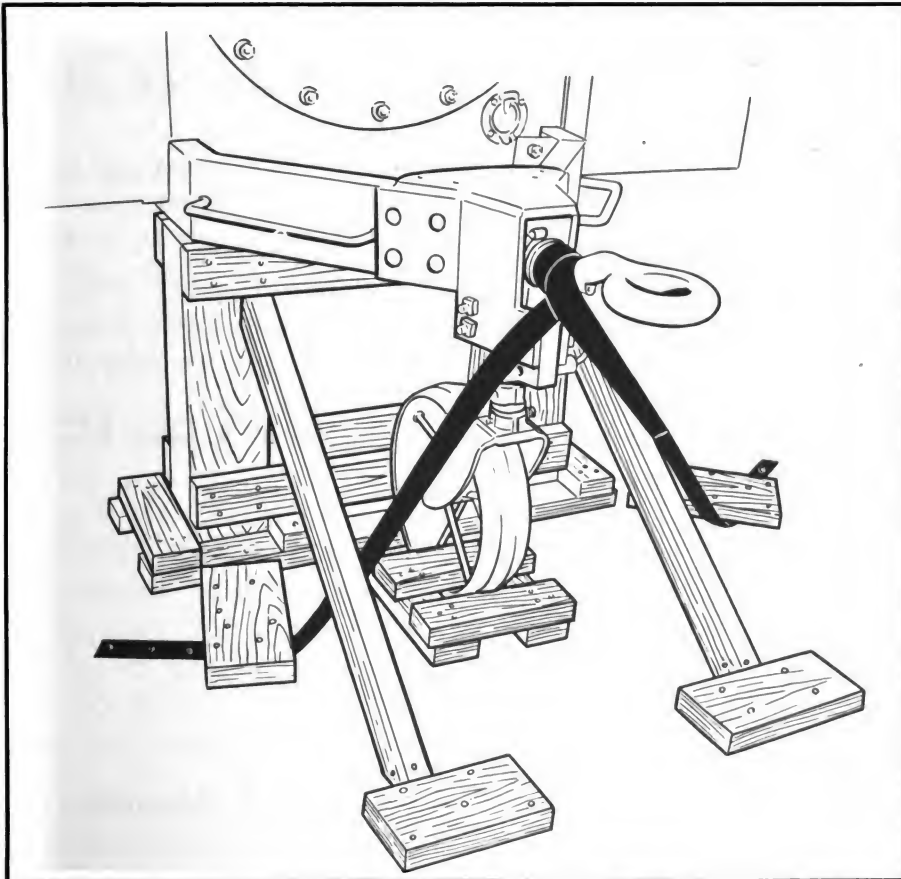

FIG. 22 Blocking—Caster Wheel

OPERATION SECTION

BURNER FAILURE

IRREGULARITIES

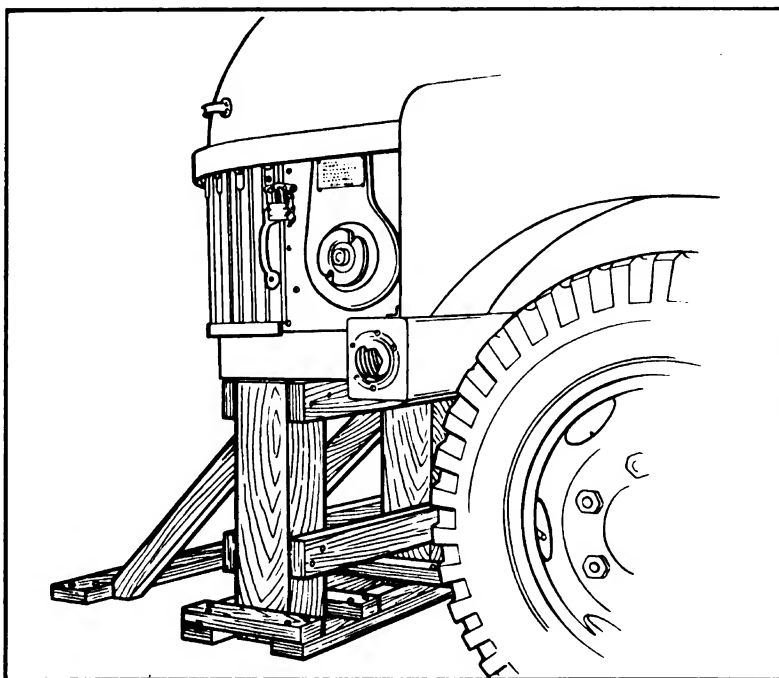

FIG. 23 Blocking—Power Plant End

CAUTION: MAXIMUM ROAD SPEED SHOULD NOT EXCEED 50 MPH.

To ship by rail—Load unit on flatcar or in boxcar and secure to floor by blocking and strapping as shown in Figs. 21, 22, and 23.

EXPORT SHIPMENT

Refer to TM5-9711, Preparation of Corps of Engineers Equipment for Export, issued by Engineer Field Maintenance Office, P. O. Box 1679, Columbus, Ohio.

OPERATING IRREGULARITIES AND THEIR CORRECTION

BURNER FAILURE

If fire goes out while running, or if burner fails to light, the fault may be with any of the following:

- 1. Fuel Tanks**

Check to see that there is sufficient fuel in tanks.

- 2. Oil Pressure**

Check oil pressure gauge to see that pressure is not less than 100 pounds.

- 3. Fuel Strainer**

All fuel passes through the strainer. Its purpose is to remove abrasive foreign

OPERATION SECTION

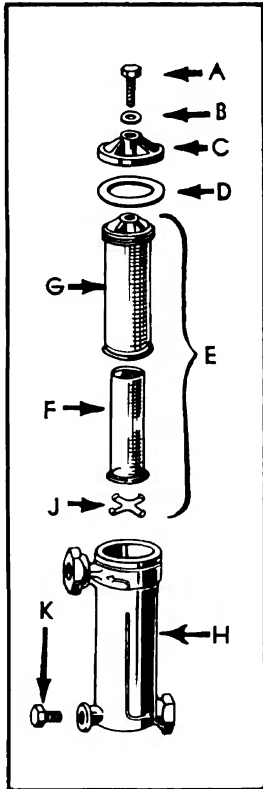

FIG. 24 Disassembly of Fuel Strainer

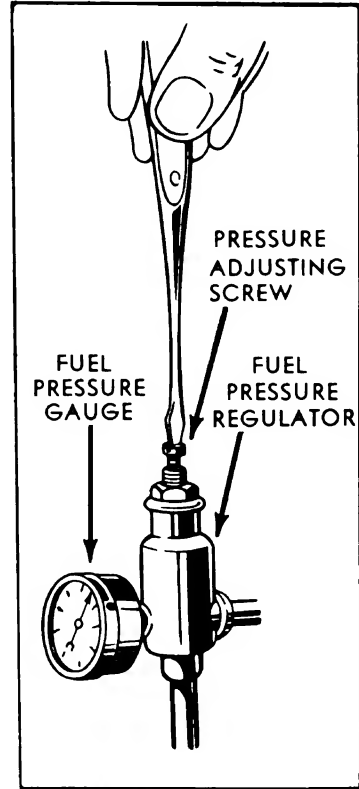

FIG. 25 Adjusting Fuel Pressure

matter from the fuel oil, thereby preventing excessive wear in the fuel pump. It also removes small particles which might otherwise lodge in the small passages of the fuel atomizing nozzle.

When the strainer becomes clogged with dirt, the full fuel requirement cannot pass through it and fuel pressure will fluctuate, possibly dropping so low as to extinguish the fire.

In such a case, first stop the engine, then with a wrench remove the hexagon capscrew (A) (See Fig. 24) and washer (B) at the top of the fuel strainer body. Lift off cover (C) and gasket (D). Remove screen assembly (E) by unscrewing it from the inside of the strainer body. This assembly consists of inner and outer screens (F and G) which may be separated after sliding off the bottom clip (J). Clean both screens. The brass plug (K) near the bottom of the strainer should be removed to permit flushing the strainer body (H). Replace plug (K), screw screen assembly (E) in place, replace gasket (D) and cover (C), and tighten down with capscrew (A) and washer (B). Make sure that the cap is tight to prevent air leaks in the fuel suction line.

4. Fuel Pressure Regulator

If the pressure does not rise to 100 pounds, the normal pressure after cleaning the strainer, and no oil is delivered to the burner, the trouble is probably caused by failure of the fuel pressure regulator to operate properly. Tap the device with a

OPERATION SECTION

BURNER FAILURE

IRREGULARITIES

hammer handle (not the hammer head), to dislodge foreign matter that may be causing it to stick. Should this treatment fail, remove the hexagon cap at the top of the valve and, while engine is running, use a screwdriver to turn pressure adjusting screw. Back it out to relieve spring pressure on the plunger while again tapping with hammer handle. Then re-adjust as required to obtain the proper pressure (See Fig. 25).

To decrease oil pressure, turn screw *out*; to increase oil pressure, turn screw *in*.

Should either of the above remedies prove unsuccessful, stop engine, disassemble and clean the device as follows: (See Fig. 26).

a. DISASSEMBLY

Detach copper tubing connector in fuel line to fuel pump. Detach copper tubing connector in return line to fuel tank.

Remove pressure gauge. Remove support bracket. Disconnect brass pipe at bottom of relief valve.

Remove cap (C) and cap gasket (H). Remove adjusting screw (D).

Hold device securely in a vise but do not compress vise jaws around it. Remove bonnet (B) and bonnet gasket (J). Withdraw spring guide (G), spring (K), and piston (F).

Disassemble bottom assembly by first unscrewing seat (P) and removing seat gasket (O). Unscrew locknut (L) from seat (P), remove locknut gasket (M), withdraw valve stem (E), and valve lifting spring (N).

b. REASSEMBLY

Clean all parts carefully, and reassemble as follows:

Insert valve lifting spring (N) into seat (P), followed by valve stem (E), seat locknut gasket (M), and locknut (L). Slip seat gasket (O) over seat (P), and screw the assembly into body (A).

Insert piston (F) into top of body (A), followed by spring (K) and spring guide (G). Slip bonnet gasket (J) into place and screw bonnet (B) down tightly, with a wrench. Screw in adjusting screw (D).

Replace the reassembled device on the unit, and connect copper tubing and pipe.

Start engine again, and regulate adjusting screw as previously described, to obtain 100 pounds pressure. When proper pressure is reached, replace cap gasket (H) and screw cap (C) in place.

5. Fuel Pump

Should none of these suggested remedies produce the proper fuel quantity and pressure, the fuel pump is worn or defective and a new pump must be installed.

Loosen capscrews at base block to release tension on the V-belt, and remove

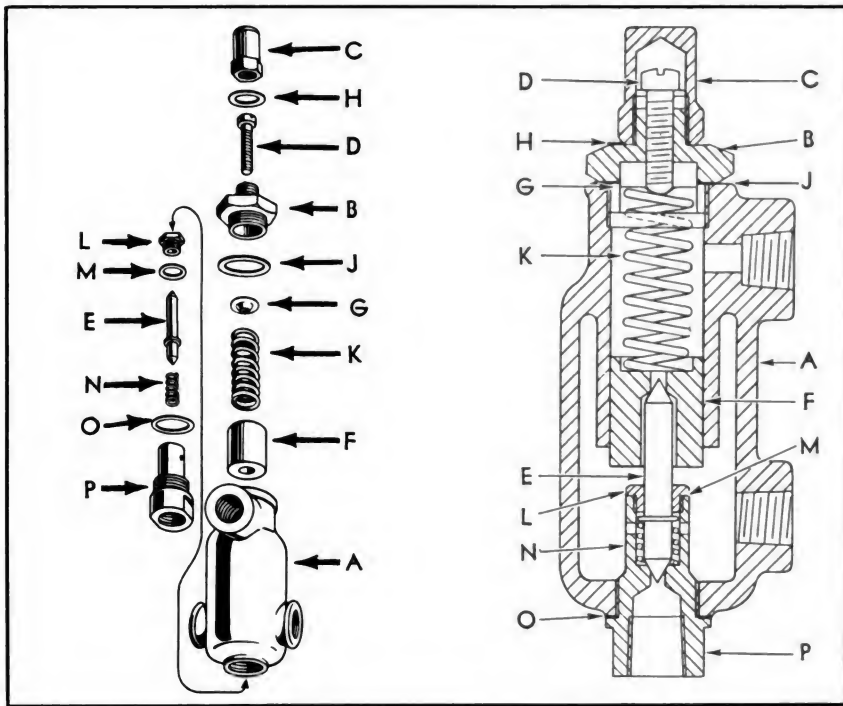

EXPLODED VIEW

CROSS-SECTIONAL VIEW

FIG. 26 Disassembly of Fuel Pressure Regulator

belt from sheaves. Remove sheave from defective pump shaft. Disconnect copper tubing connectors at suction and discharge ports, and remove bushings and elbow. Remove the two, seven-sixteenths inch capscrews that hold the pump to the foot and slide pump out of foot without removing foot from base block.

Slide the new pump in place, fastening it to the foot with the two capscrews. Connect suction and discharge lines. Replace sheave and V-belt. After pump sheave has been lined up, tighten base block capscrews.

The fuel pump is self-lubricating and requires no service attention. However, if the pump should require servicing for any reason, it should be replaced as described above, and if practicable, returned to the factory for repairs. In extreme cases when it is absolutely necessary to repair the pump in the field, proceed as explained in the Maintenance Section.

6. Fuel Oil Nozzle

If fuel is delivered to the burner but does not atomize through the nozzle, the burner must be removed in order to clean the nozzle and its strainer, by the following method. (See Fig. 27).

Disconnect the high tension ignition wires at the transformer. Remove four, three-eighths inch capscrews, one at each side of the square burner mounting flange through which the oil pipe passes. Disconnect copper tubing connector in burner oil line located just below the burner shut-off valve, and withdraw burner assembly by pulling it away from heater.

OPERATION SECTION

BURNER FAILURE

IRREGULARITIES

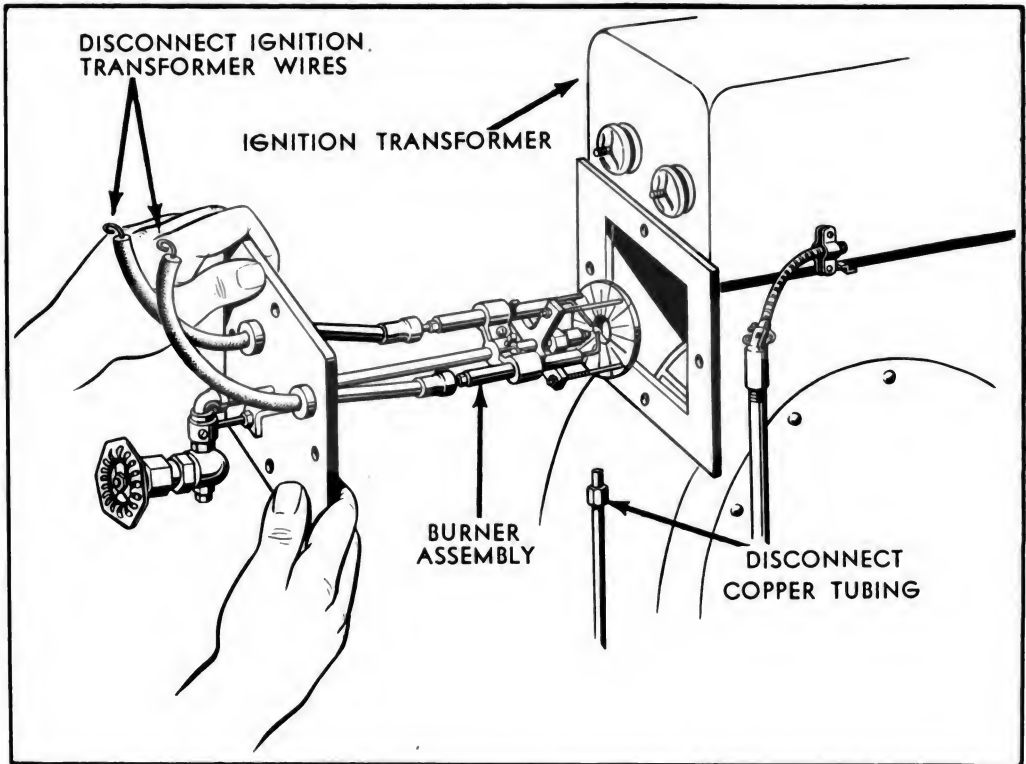

FIG. 27 Removing Burner Assembly

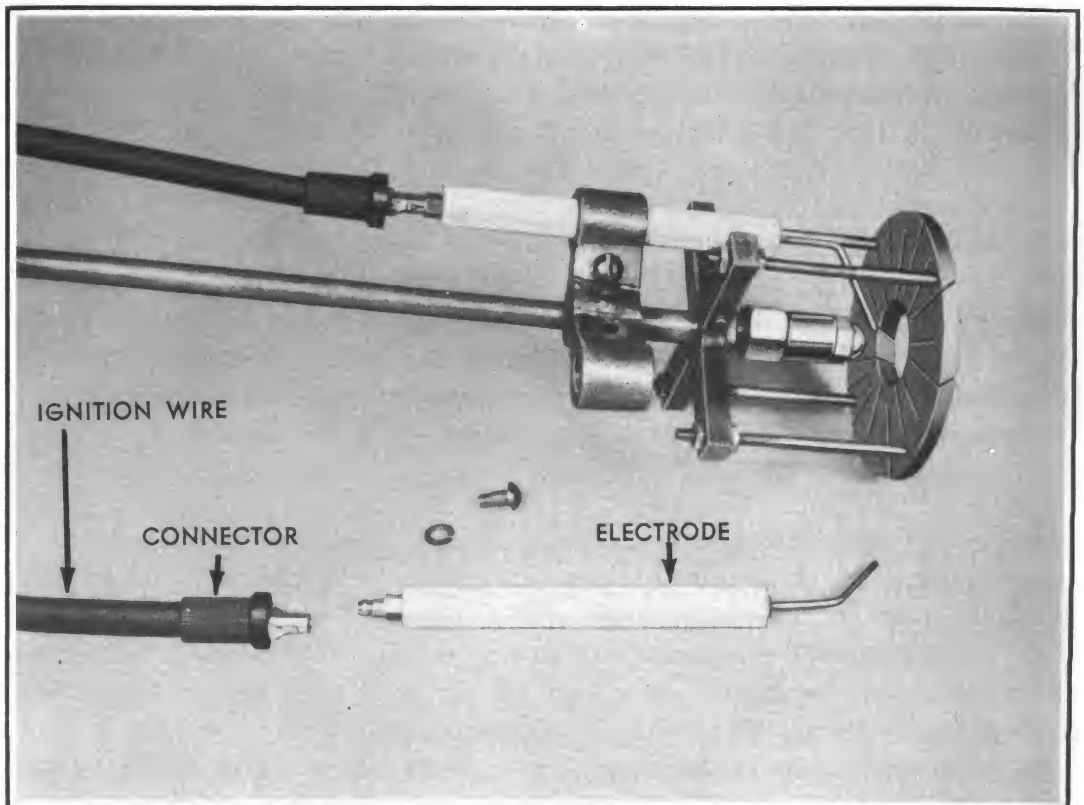

FIG. 28 Removing Porcelain Electrode

OPERATION SECTION

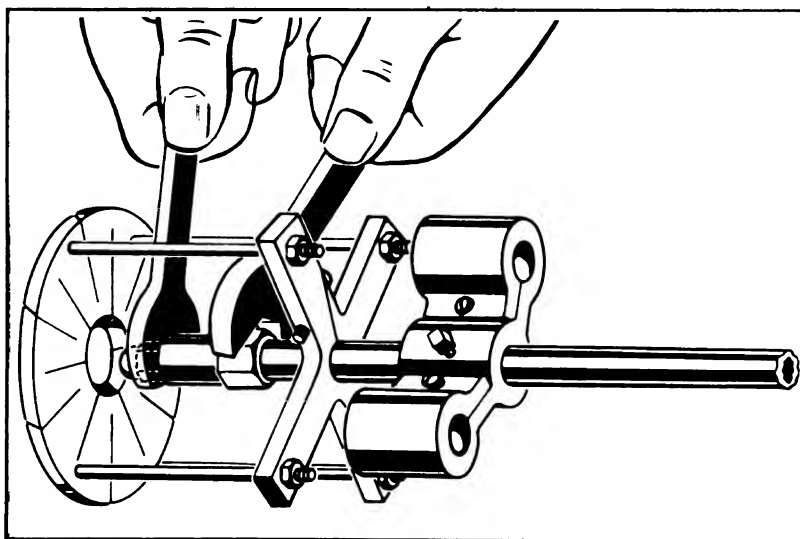

FIG. 29 Removing Nozzle Tip

Disconnect the two ignition wires from the electrodes at the connector by pulling apart. Loosen two, one-fourth inch round head machine screws that hold the porcelain insulators in the clamp, then slide out the porcelain electrode assemblies. (See Fig. 28).

Selecting two open end wrenches (See Fig. 29), one to fit the steel nozzle tip and the other to fit the hexagon fitting on the brass nozzle body, remove the nozzle tip from the body. With the fingers, remove nozzle strainer screen from nozzle tip, and with a screwdriver remove the internal core from the nozzle tip proper. (See Fig. 30).

Clean all internal surfaces of the nozzle tip and the slotted parts of the internal tip, using a wood splinter so that the small oil grooves will not be damaged, particularly the small hole in the nozzle tip proper. Clean the nozzle screen carefully, removing all foreign matter to allow free passage of fuel through the nozzle. Replace nozzle internal core, using a screwdriver to set it in tightly, but do not use excessive force.

FOR PROPER ATOMIZATION OF THE FUEL, IT IS ESSENTIAL THAT THE INTERNAL CORE BE TIGHTLY SEATED IN THE NOZZLE TIP.

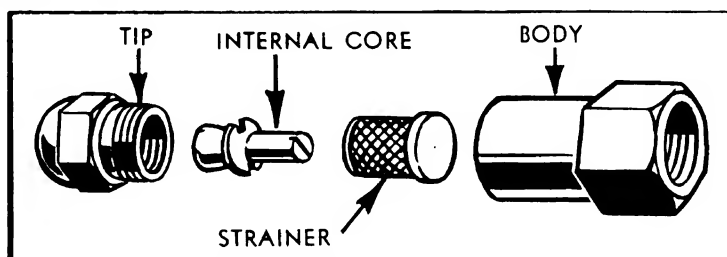

FIG. 30 Burner Nozzle Parts

OPERATION SECTION

BURNER FAILURE

IRREGULARITIES

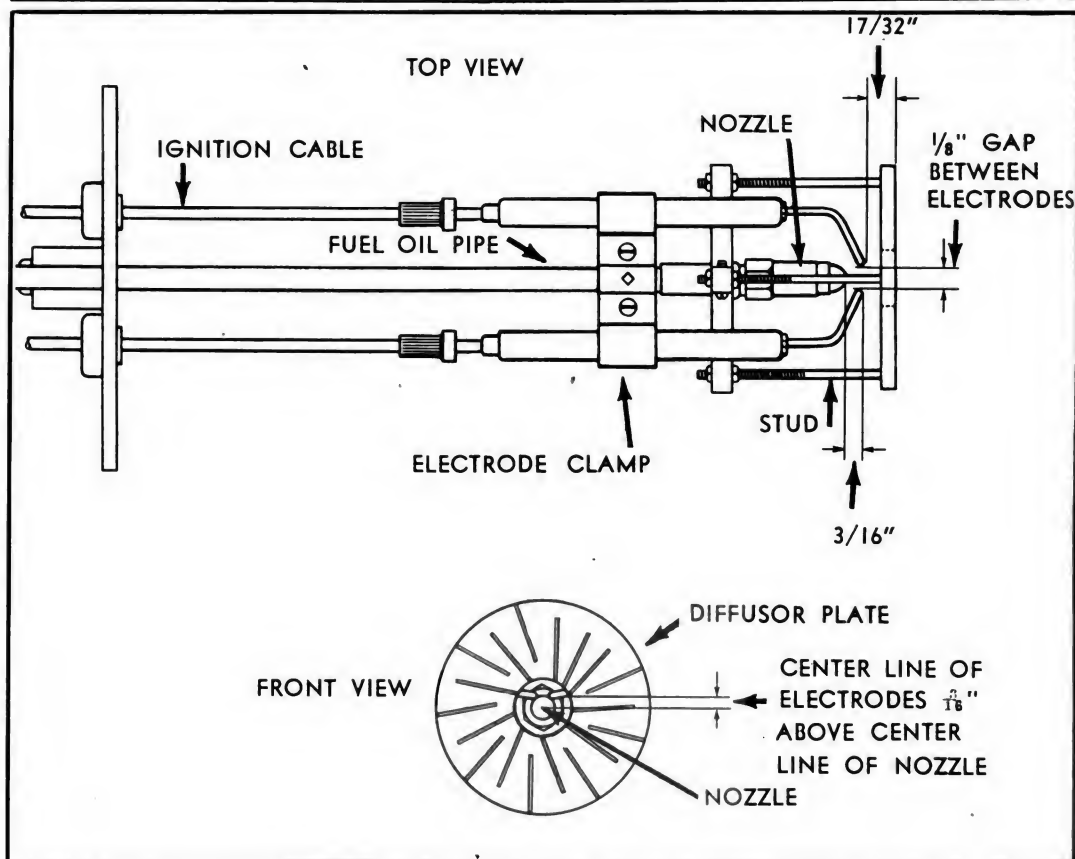

FIG. 31 Nozzle and Electrode Adjustments

Replace the strainer screen, screwing it into the nozzle tip only finger-tight. Replace nozzle in brass nozzle body, using wrenches as when removed. Seat tip tightly to prevent fuel leakage.

Insert the two electrodes into the electrode clamp, spacing them as follows: (See Fig. 31).

Spark gap should be $1/8$ inch.

Electrode tip should be $3/16$ inch forward of the nozzle tip.

Electrode tip should be $3/16$ inch above center of nozzle tip.

Nozzle tip should be $1 1/2$ inch from *front* surface of the diffuser plate.

Tighten machine screws in the electrode clamp, thereby securing the electrodes.

Attach ignition wires to electrodes by means of connectors, and pass wires through the two insulators in the burner mounting flange.

Insert reassembled burner into blower housing opening, and secure it with four, $3/8$ -inch capscrews. Connect ignition wires to the terminals on ignition transformer.

7. Solenoid Valve

The plunger of the solenoid valve is normally closed, and will open only if electric current is passing through its coil. If the strainer, pressure regulator, and

OPERATION SECTION

BURNER FAILURE

IRREGULARITIES

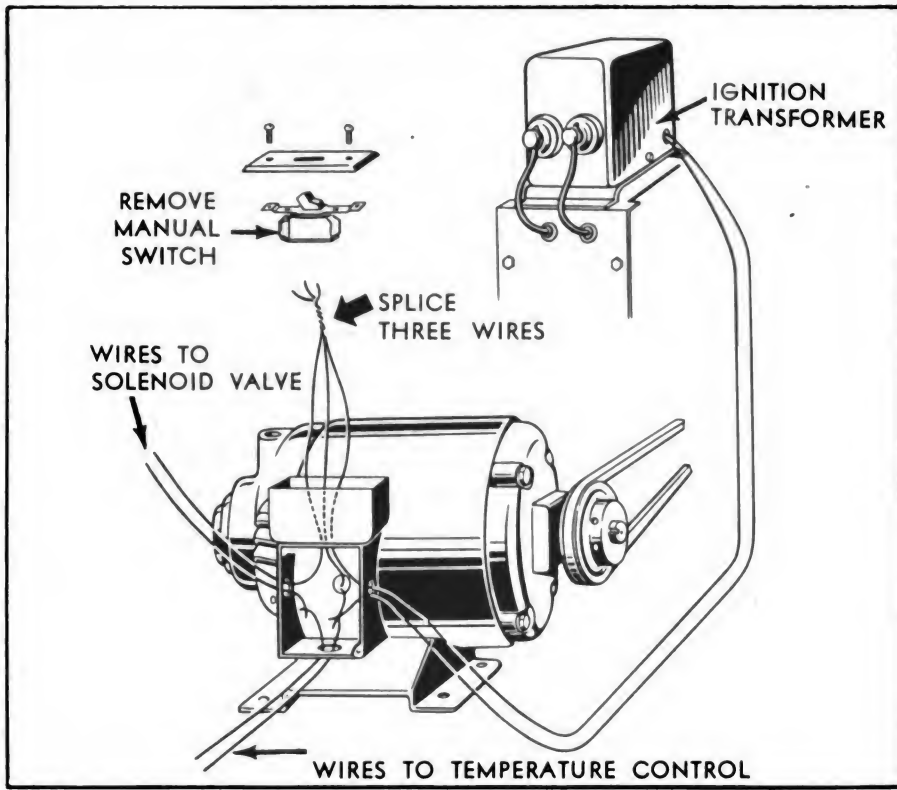

FIG. 32 Manual Switch Temporary Splice

fuel pump are all functioning properly, but no oil is being supplied to the burner, the solenoid valve coil is not being energized and the plunger is in a closed position, preventing the passage of fuel to the burner.

The absence of current to energize the coil may be due to any of the following:

a. LOOSE WIRE

Check all wiring to see that all wires are properly connected and all terminal screws tight.

b. MANUAL SWITCH DEFECTIVE

Remove switch cover and check to see if switch blade is making contact when in the "On" position. If found defective install a new switch, but if it should be impossible to secure a new switch immediately, the defective switch can be removed and a temporary connection made by splicing together the three wires (See Fig. 32) and taping the splice with electricians tape or—in emergency—with adhesive tape.

CAUTION: THIS SHOULD BE DONE ONLY AS A TEMPORARY MEASURE, AND A NEW SWITCH INSTALLED AS SOON AS POSSIBLE, BECAUSE THIS SPLICE IS EQUIVALENT TO A CLOSED MANUAL SWITCH; AND AS CURRENT WILL FLOW CONSTANTLY THROUGH THIS TEMPORARY CON-

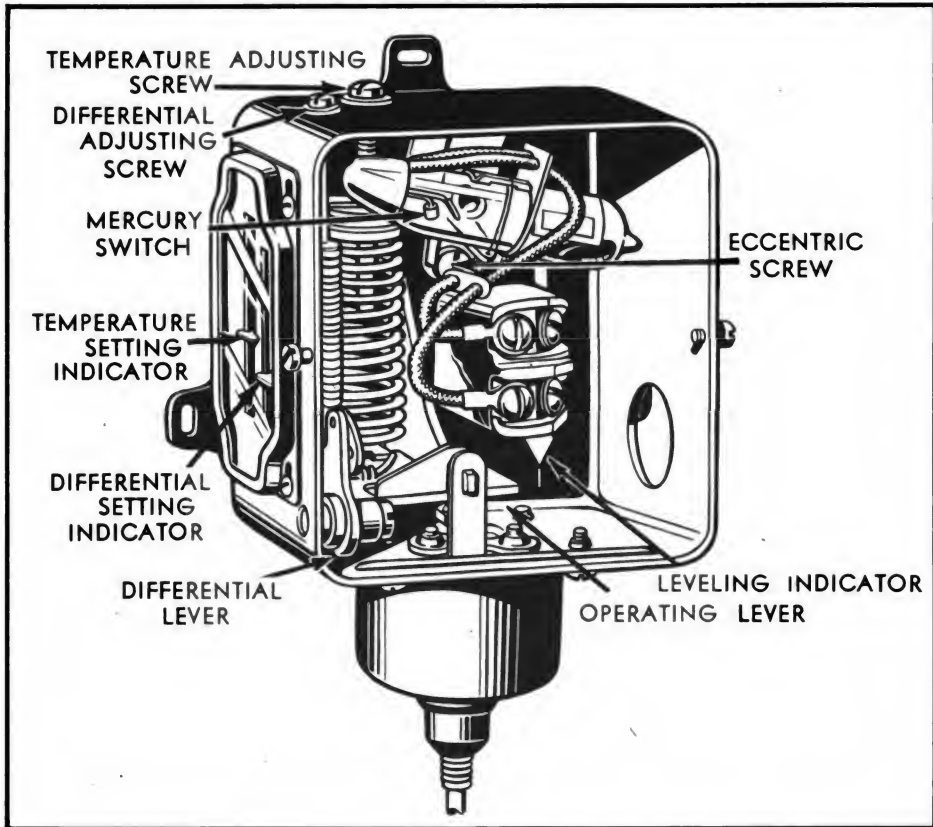

FIG. 33 Temperature Regulator Control Box

NECTION, THE SOLENOID VALVE AND IGNITION CANNOT BE MANUALLY CONTROLLED UNLESS THE WIRES ARE AGAIN SEPARATED.

c. TEMPERATURE CONTROL MERCURY SWITCH BROKEN (See Fig. 33)

Remove cover and note position of mercury in the switch. Mercury is normally in the terminal end of the switch when the shower unit is cold, or below 105 degrees F. (Fig. 33 shows mercury in its off position, such as when temperature of shower unit is above 110 degrees F.). If the glass tube has been broken, a new mercury switch should be installed as follows:

Disconnect the two switch leads and, with the point of a knife, pry the switch clip loose from the mercury switch—never attempt to break it loose with the fingers. Two layers of friction tape, which will take the place of the ambroid cement that was used on the original switch, should be wrapped around the new switch before placing it in the clip. When installing the new switch, care should be taken to place it in exactly the same position as the old one so as not to change the balance, since an unbalanced switch may throw the entire control out of adjustment.

When connecting the new leads the operator should bear in mind that sufficient slack is needed to allow free movement between the "On" to "Off" positions.

OPERATION SECTION

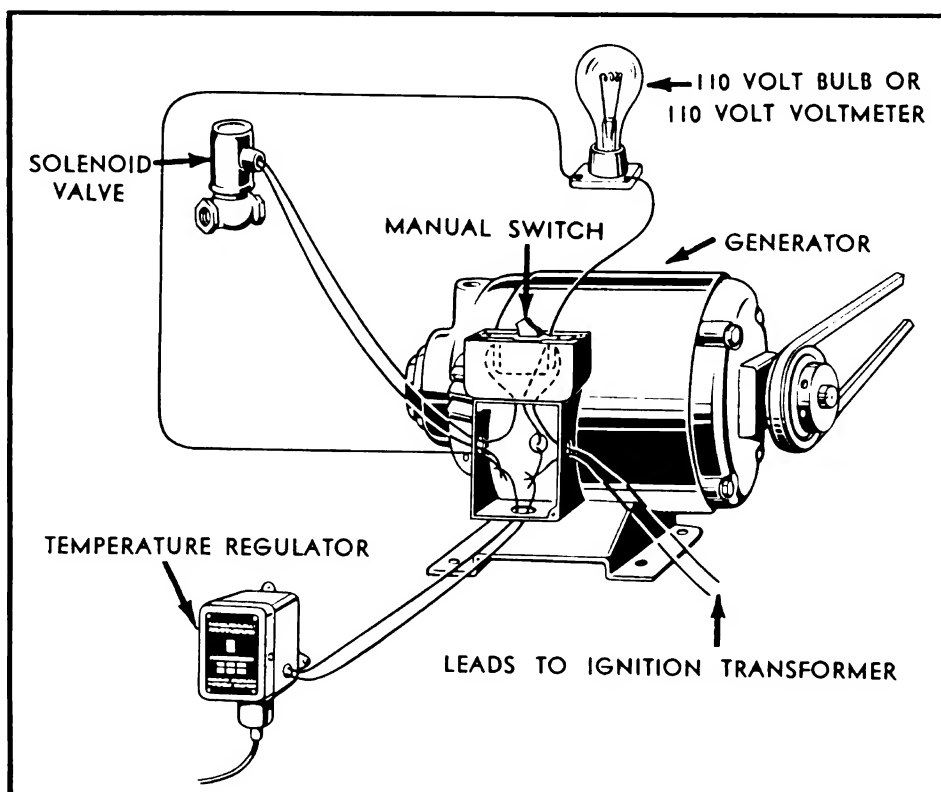

FIG. 34 Checking Voltage to Solenoid Valve

d. NO CURRENT FROM GENERATOR

If slippage of the generator belt occurs, the current furnished to the solenoid valve coil may not be enough to lift the plunger. To correct the slippage, the generator capscrew nuts should be loosened and the generator pulled away from the engine until the belt is tight. The sheaves should then be aligned and the nuts tightened.

To check the voltage to the solenoid, remove the generator terminal box cover and bare the tape-covered connection of the *black* wire from the temperature regulator and the *black* wire from the solenoid valve. (See Fig. 34). If a voltmeter is available, check the voltage between the spliced connection and the two-wire connection on the manual switch. The meter should indicate 110 volts. If no voltmeter is available, a 110-volt bulb, when connected between these two points, should burn with full brilliancy. If the voltage is low or the lamp burns dimly, or there is no voltage at all, the trouble lies in the generator. Replace terminal box cover, but first be sure to retape wires.

Generator failure is usually caused by poor brush contacts with commutator, or a dirty commutator.

To inspect the brushes, remove the terminal covers at the end of the generator opposite the drive end. There are two sets of brushes; two for A.C. and two for D.C.

OPERATION SECTION

BURNER FAILURE

IRREGULARITIES

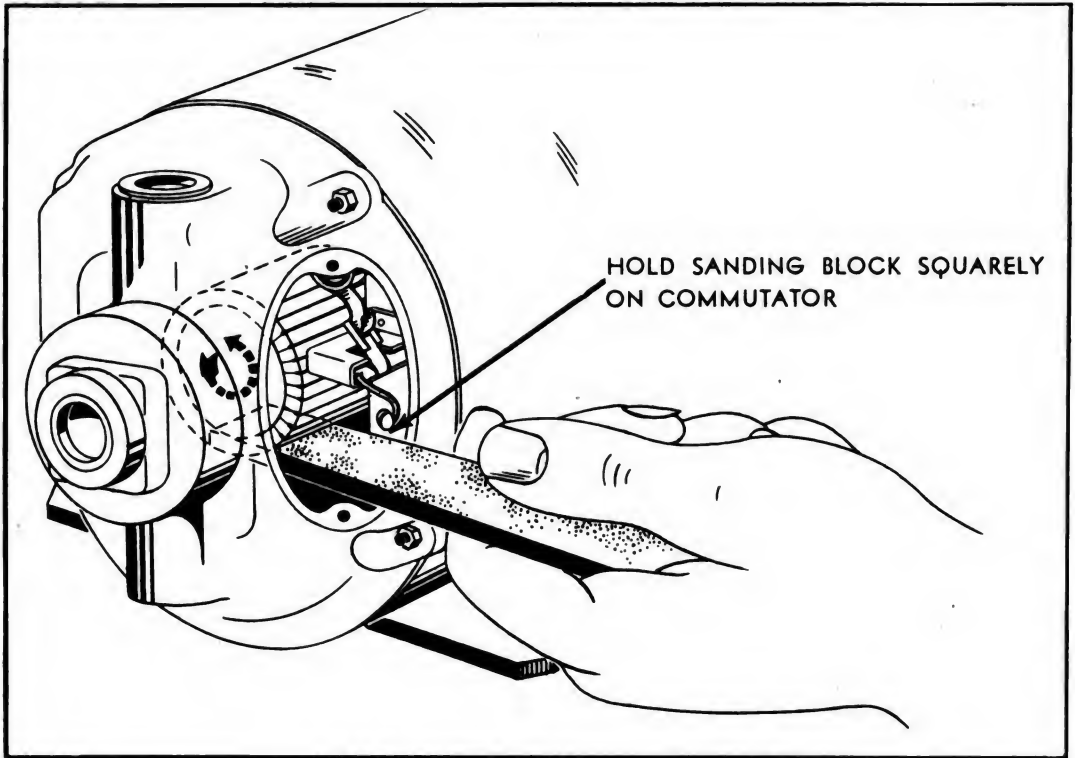

FIG. 35 Cleaning Generator Commutator

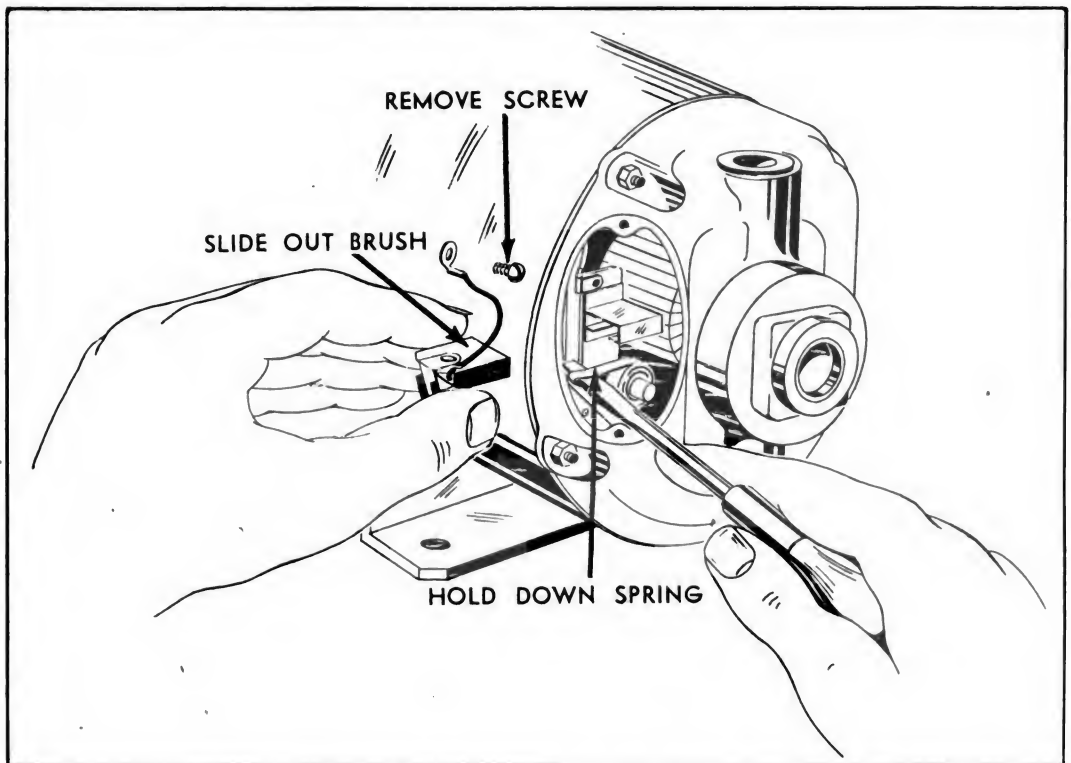

FIG. 36 Removing D.C. Brushes

OPERATION SECTION

BURNER FAILURE

IRREGULARITIES

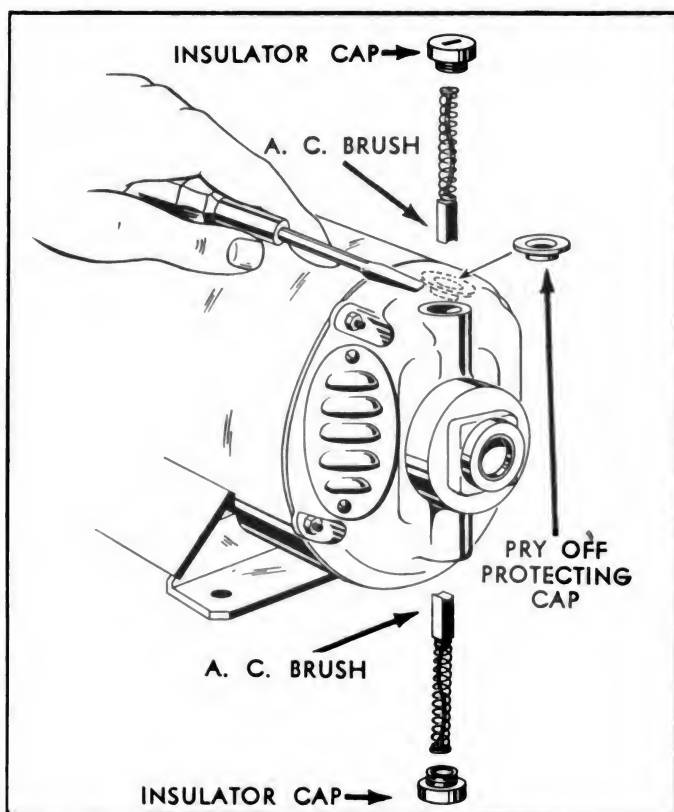

FIG. 37 Removing A.C. Brushes

The A.C. brushes rest on the solid slip rings. The D.C. brushes rest on the split commutator. With the engine running observe if there is an arc or sparking where the direct current brushes (the rectangular brushes) contact the commutator. If no arcing is apparent and the commutator is black, the commutator is dirty. A small strip of fine sandpaper (No. 3/0 or 4/0) folded over the end of a small, thin strip of wood can be used to clean the commutator. (See Fig. 35). Hold the sandpaper squarely on the commutator while the unit is in operation and move it slowly from left to right. After a short time, the black coating will be sanded off and a shiny copper color will appear. Do not sand more than is needed to secure this clean copper surface.

Should the brushes become worn, new brushes should be installed as follows: (See Fig. 36)

For the D.C. brushes, lift the spring that bears on the brush and the brush can then be removed from its holder. Remove the screw that holds the brush lead to the brush rigging assembly and the brush will then come free. To install a new brush, lift the spring and slide in the brush. Attach brush lead to brush rigging assembly.

To replace the A.C. brushes, (See Fig. 37) remove the metal protecting cap at the top of the vertical tubular shaped projection on the front bracket and, with the screwdriver, remove the insulator cap. This will release the brush and its attached spring. When installing a new (or replacing an old) brush, be sure that the

OPERATION SECTION

BURNER FAILURE

IRREGULARITIES

curved surface of the brush fits that of the slip ring. Replace insulator cap and metal protecting cap.

e. COIL DEFECTIVE

If all the above irregularities have been corrected and the solenoid valve still remains closed, it is then obvious that the solenoid coil is defective and should be replaced, as follows:

(1) Disassembly

Stop engine and disconnect wiring to solenoid valve at generator terminal box and manual switch. Unfasten flexible tubing and remove squeeze connector from coil housing. Remove screw (A) and nameplate (B) from coil housing (C). (See Fig. 38). Housing can then be lifted off of valve body (D). With a screwdriver, pry off steel washer (E) and bushing (F) that secures coil (G) to plunger guide tube. The coil can now be removed and a new coil inserted.

(2) Reassembly

Replace the bushing, housing, nameplate, and screw. Pass the new coil wires through flexible tubing to the generator terminal box, the *yellow* wire going to the manual switch. The *black* wire must be spliced to the *black* wire from the temperature control switch.

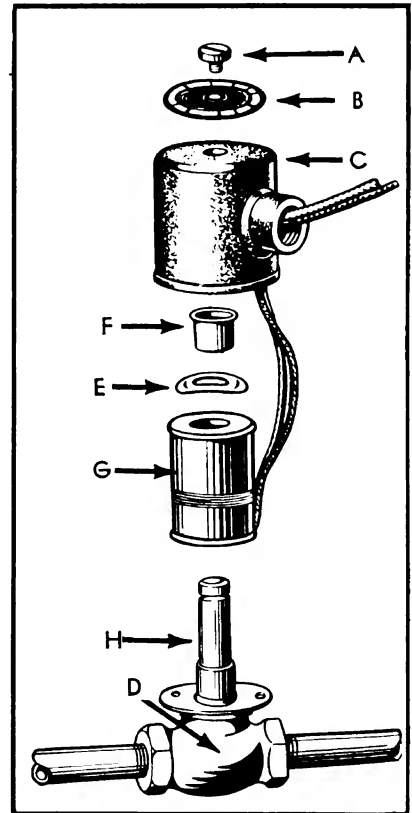

FIG. 38 Replacing Solenoid Valve Coil

8. Ignition Failure

If the solenoid valve is operating properly but the burner fails to light and, upon looking into the observation port hole, the operator fails to see an arc between the electrodes within the burner, it is an indication that either the ignition transformer is defective or no voltage is being supplied to it, since the arcing across the electrodes should be constant while the unit is running.

To locate the trouble, remove the terminal-box cover and bare the three-wire splice. Also remove the cover from the manual switch. If a voltmeter is available, check the voltage between these two connections. (See Fig. 39). The voltage should be 110 volts. If no voltmeter is available, a 110 volt bulb, when connected between these two points, should burn with full brilliancy.

If the voltage is low or there is no voltage present, the generator should be checked as outlined in previous paragraphs, "No current from generator".

If the voltage is correct, the trouble lies in the ignition transformer. Break-down of this unit is very rare and, upon failure it should be removed and a new one installed as follows:

OPERATION SECTION

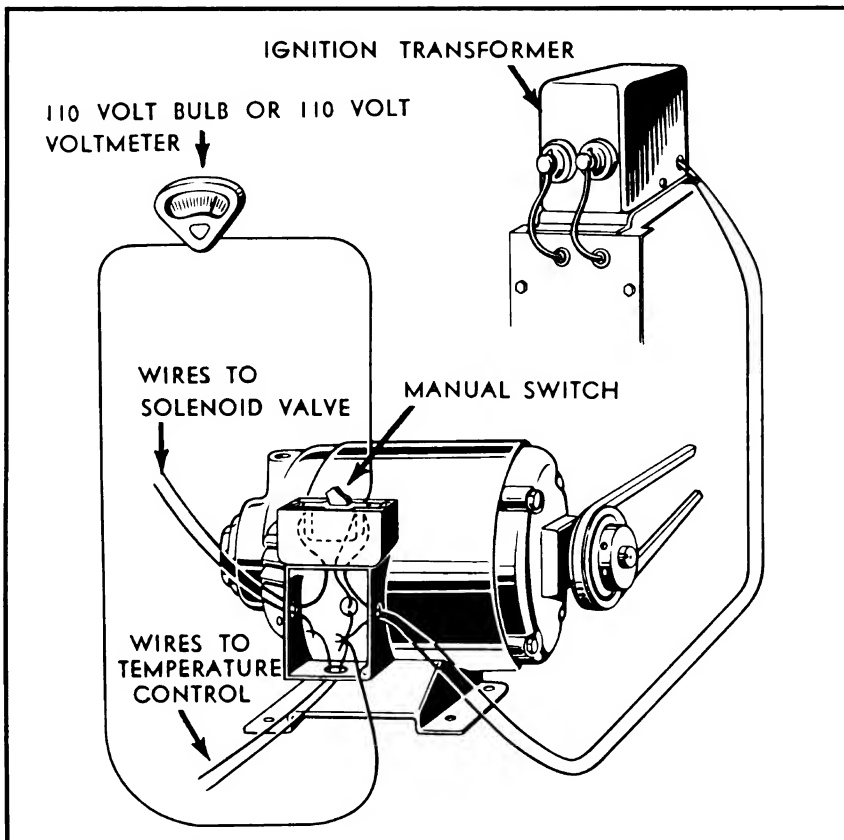

FIG. 39 Checking Voltage to Ignition Transformer

a. DISASSEMBLY

Shut down engine.

Disconnect the high-tension ignition wires from binding posts at front of transformer.

Remove cover plate at back of transformer and disconnect two leads found therein. Also disconnect the flexible tubing at the side of the transformer, pulling generator leads through the side. Remove 45 degree squeeze connector.

The three machine screws securing the transformer should be removed, the defective unit removed and the new one seated in its place.

b. REASSEMBLY

After new unit has been mounted, replace squeeze connector, pass wires through side of transformer, and tighten up flexible tubing. The new transformer leads can be spliced to the generator leads and the back cover replaced.

Connect ignition wires to secondary winding terminals at the front of the transformer.

Start up unit.

OPERATION SECTION

WATER SUCTION FAILURE

If no water is delivered from the shower heads or the pump is not pumping full capacity, the trouble lies either in the suction line or in the water pump itself, and the operator should make the following observations:

Make sure that the suction lift does not exceed 15 feet.

Check all suction hose connections and the gaskets on the pump for air leaks, for such leaks will prevent the pump from delivering water.

Inspect the suction strainer to see that it is not buried in mud or covered with grass, leaves, etc. Never lift the strainer out of water while the unit is running, for this will break suction and require repriming the pump.

Check water level in priming chamber, and fill if necessary.

Remove suction hose at pump suction inlet, and inspect suction line check valve. This valve should prevent the loss of prime, when the pump is idle, eliminating the necessity for a foot valve. It consists of a weighted composition fabric flap that acts both as the hinge and flap valve. The valve hangs vertical, thereby preventing dirt from lodging on the seat.

To test the valve, fill the priming chamber with water unless it remains filled from a previous filling. If the check valve is not seating properly, water will run out of the pump inlet opening, syphoning out the priming water with it.

Remove the check valve, and force the flanges apart—all valve parts will then be exposed. If the flap fabric is damaged, either around the seat or at the hinge, a new flap should be installed, as described under "Water Pump" in Maintenance Section.

To test the priming action, remove suction hose, fill pump with water, and start the engine. Then place a hand tightly over the suction opening. If the pump is working properly, a very strong suction will be felt in about thirty seconds. If no suction is felt, check the gaskets on the intake flanges and the seal on the impeller shaft. Air may be leaking into the pump at these joints.

In the lower half of the pump shell is a priming valve mechanism consisting of a spring blade, so located that the force of the pump discharge will lift it and close off the recirculating jet as soon as the pump has primed and starts pumping. A cleanout hole is provided so that sediment can be readily removed.

Trash may stop up the jet hole or cause the valve spring to become inoperative.

To inspect or repair this valve or clean out trash and sediment, remove the cleanout cover plate, taking care not to tear the gasket.

Turn the pump over several turns by hand to see that it rotates smoothly. If it sticks, it may be due to scale or mud that has settled on the impeller blades and

OPERATION SECTION

ENGINE FAILURE

IRREGULARITIES

coated the closely fitted working parts during a prolonged shut down. To disassemble the pump for cleaning, see "Water Pump" in Maintenance Section.

Inspect the grease cup on the impeller shaft support to see if it is filled with grease. If dry, lubricate as instructed under Lubrication, "Water Pump-Bearing Shaft Housing".

The "Lubri-Seal" grease cup in the support head should also be inspected to see that it is filled with grease. Lubricate as instructed under Lubrication, "Water Pump Seal".

ENGINE FAILURE

Should the engine stop, or if after having remained idle for some length of time it will not start by repeated application of the starter rope, the following should be checked:

1. Sparkplug Wire

Check to see that the sparkplug wire is connected to the magneto at one end and to the sparkplug at the other end. Also see that these connections are clean. Inspect the wire to see that it has not been punctured at some point, and possibly "shorted".

2. Sparkplug

Remove the sparkplug and check to see that no carbon or other foreign matter has lodged between the points.

3. Magneto Points

The magneto breaker cover should be removed and the breaker points checked with a feeler gauge to see that the opening is .015 inch (See Fig. 40). Also see that these points are clean and free from foreign matter, and that they are not pitted or pyramided.

4. Gasoline Tank Fuel Line

Next, check to see if the fuel line from the fuel strainer is obstructed, by first closing the shut-off valve on the fuel strainer, and then loosening the fuel line connection at the carburetor. Open the shut-off valve on the fuel strainer slightly, and see that the fuel flows freely through the line. If it is found that some obstruction is present, it may be removed by blowing out the line, after it has been removed from the engine.

5. Gasoline Tank Cap

Check to see that the air vent hole in the gasoline tank cap is open. This may be determined by blowing through the hole. If this hole is plugged, the obstruction may be removed with a sharp pointed instrument.

OPERATION SECTION



FIG. 40 Checking Magneto Breaker Points

ENGINE ADJUSTMENTS

I. Carburetor (See Fig. 41)

a. IDLING OR LOW SPEED

Have the engine well warmed up. Close the throttle until the minimum steady idling speed is established. The idler needle valve controls the quantity of fuel delivered to the idler discharge hole. Turning OUT the needle valve gives a richer mixture, and turning it IN gives a leaner mixture. Turn the needle valve in slowly until the engine speed decreases, then turn it out slowly until the engine runs steadily, and as fast as this throttle position will permit. If the engine idles too fast or too slow after adjusting the needle valve, the desired speed can be obtained by adjusting the throttle stop screw. If a satisfactory adjustment cannot be obtained, see that idler discharge hole is fully open and is permitting a full flow of fuel.

b. INTERMEDIATE AND HIGH SPEED

The mixture for intermediate or high speed is controlled by an adjustable needle valve. For adjusting, use the following procedure:

OPERATION SECTION

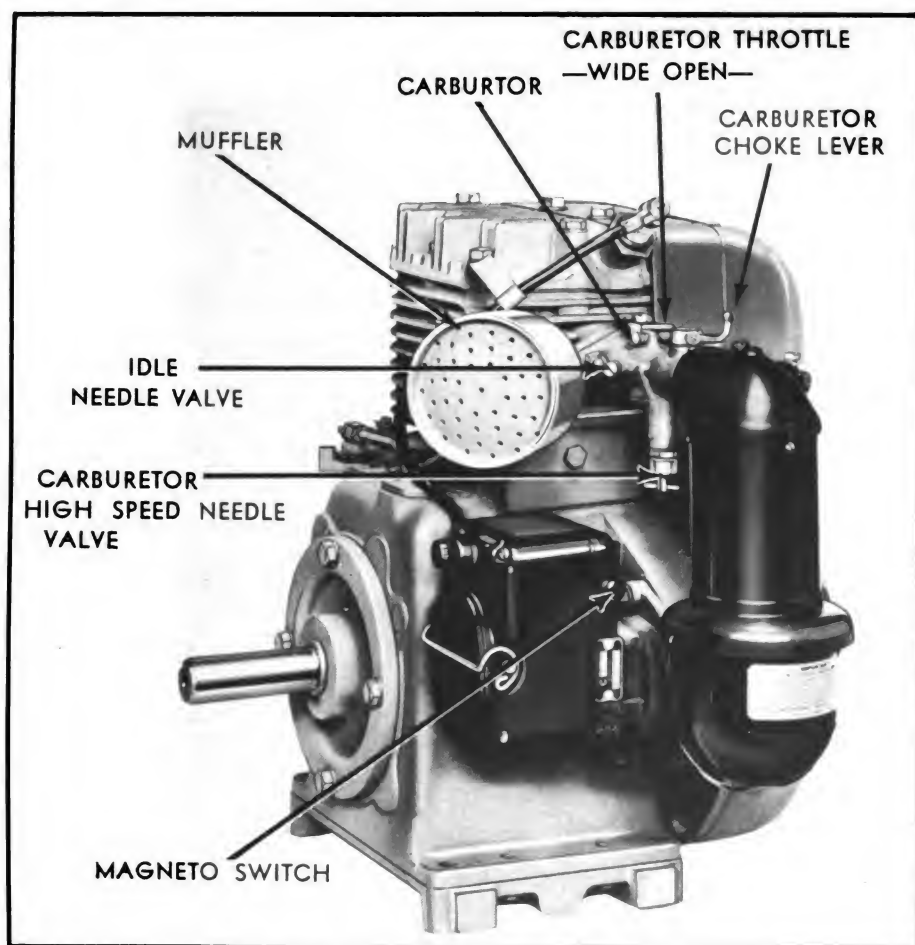

FIG. 41 Gasoline Engine—Side View

Set the hand throttle about one-third open, turn the adjustment IN until the speed of the engine is noticeably cut down, then turn the adjustment OUT slowly until the fastest and steadiest speed for that throttle position is obtained. This setting should be accurately made to assure obtaining the best possible economy and performance.

2. Choke (See Fig. 41)

When starting, the choke should be fully closed for three or four applications of the starting rope. If the choke accidentally snaps open during cranking and before the engine starts, it should be reset to the closed position. The amount of choking necessary will vary with the air temperature, the temperature of the engine, and the quality of the gasoline. When both air and engine are hot, less choking will be necessary. In fact, too much choking with a hot engine or with gasoline of a high volatility may make starting very difficult, due to the mixture of gasoline and air becoming too rich to ignite. Under such conditions the choke should be left open when starting the engine.

OPERATION SECTION

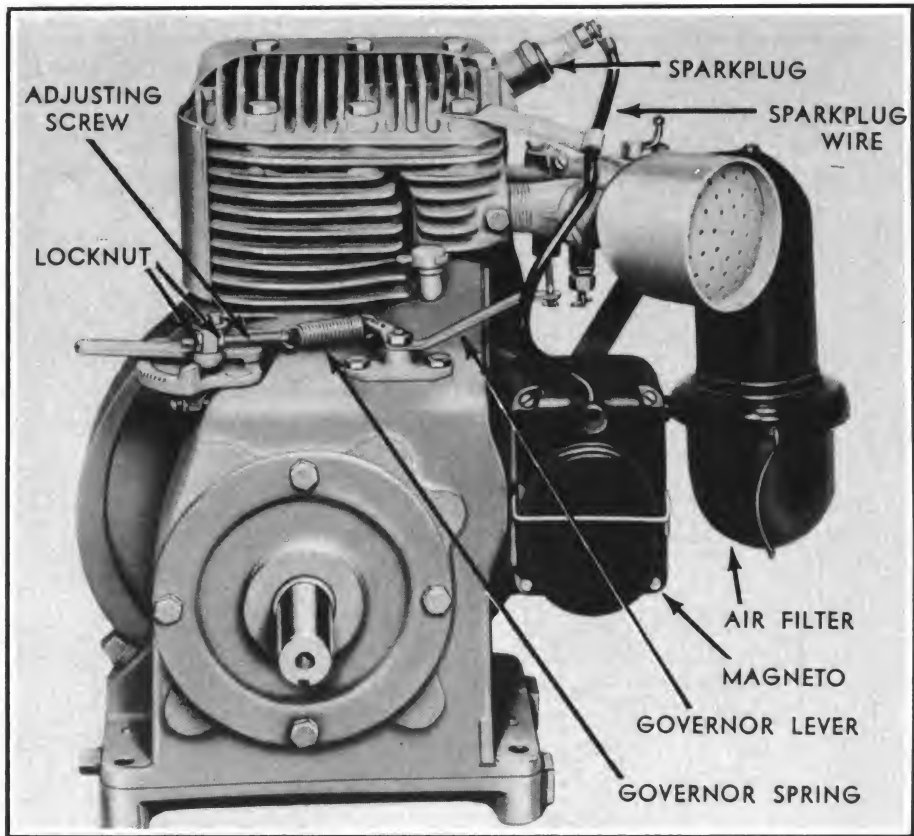

FIG. 42 Gasoline Engine—Power Take-off End

3. Governor (See Fig. 42)

a. CORRECT MOTOR SPEED

The recommended speed of the engine is 2050 rpm. under load. It will be noted, upon inspection, that the governor lever is drilled with three holes, numbered from the end of the lever toward the fulcrum as 1, 2, and 3. The governor spring should be hooked into hole No. 3, and the tension on the spring should be adjusted by means of the two nuts which lock the adjusting screw to the adjusting screw support bracket.

4. Ignition

The ignition spark is furnished by a Wico high tension magneto, fitted with an impulse coupling which makes normal starting very easy.

a. TO CHECK FOR SPARK (See Fig. 43)

To prove that a satisfactory spark is being obtained from the magneto, remove the ignition cable from the sparkplug and then hold the ignition cable terminal about $\frac{1}{8}$ inch from any metal part of the engine. Keep the hand on the insulated part of cable in order to avoid an electrical shock. Turn the engine sheave to the right (clockwise) with the starting rope or by hand and, if a spark jumps the gap, it

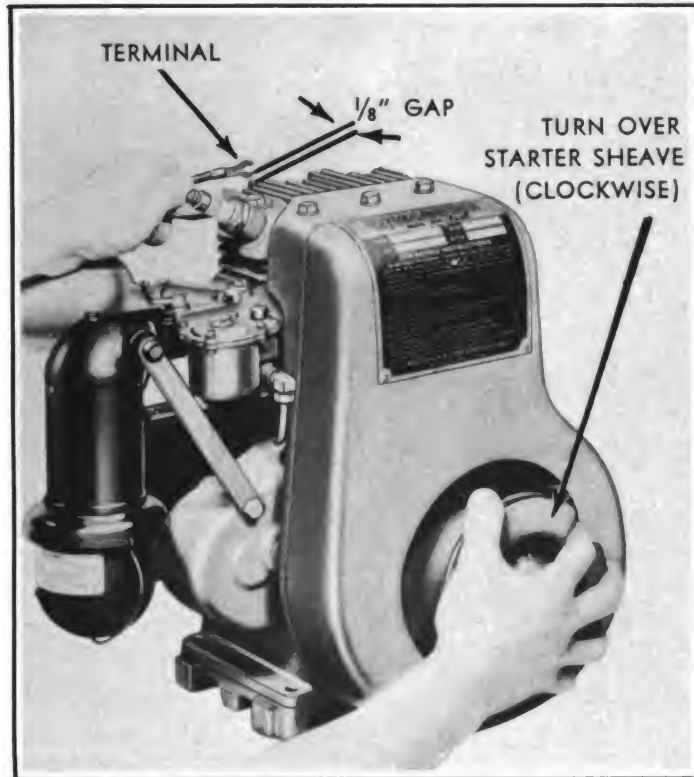

FIG. 43 Testing Engine for Spark

proves that the entire ignition system is in proper condition, with the possible exception of the sparkplug.

b. SPARKPLUG ADJUSTMENT

The sparkplug gap should be maintained at .025 inches. After approximately every 300 hours of operation the plug should be removed and inspected. The points should be scraped clean and the plug thoroughly washed in alcohol, gasoline, or carbon tetrachloride. The points should then be reset to .025 inches. To close the points tap lightly on the side contact with a sparkplug wrench or other suitable tool. (See Fig. 44).

c. IGNITION WIRE

When an inspection of the sparkplug is made the ignition wire should also be inspected. If the wire insulation shows signs of cracking a new wire should be installed.

d. MAGNETO TIMING

To facilitate reassembly of the magneto to the engine and also to time the engine properly, the gears are marked as follows: The magneto gear has a chisel mark on one of the teeth, which must be lined up with a similar mark on the camshaft gear. An inspection hole is provided on the crankcase of the engine. The camshaft gear should be turned to a position where the chisel mark is visible through

OPERATION SECTION

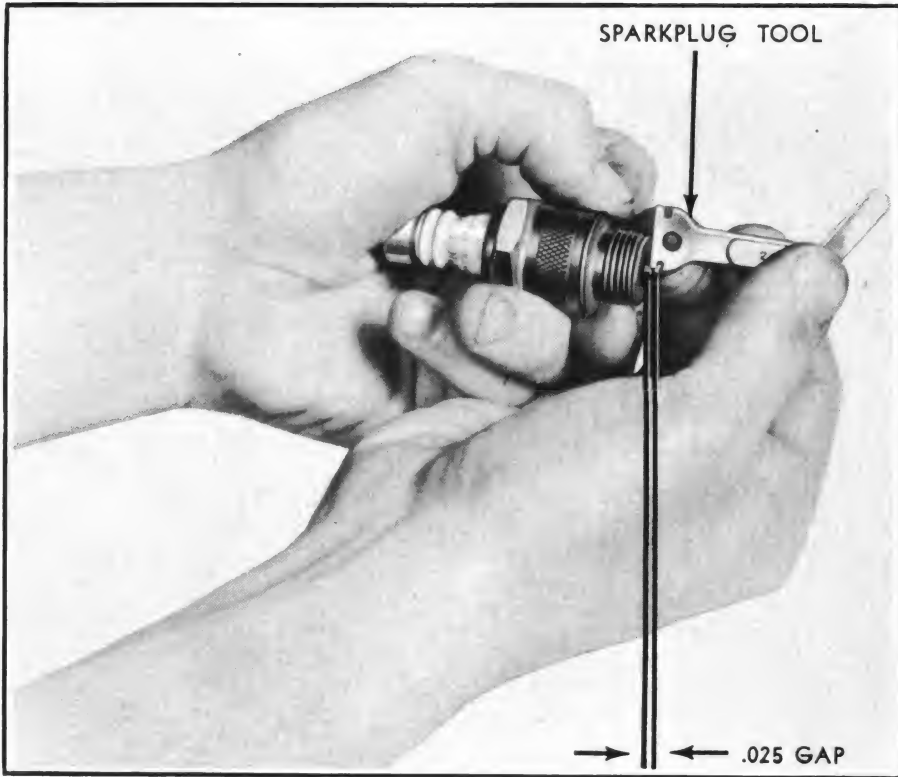

FIG. 44 Adjusting Sparkplug Points

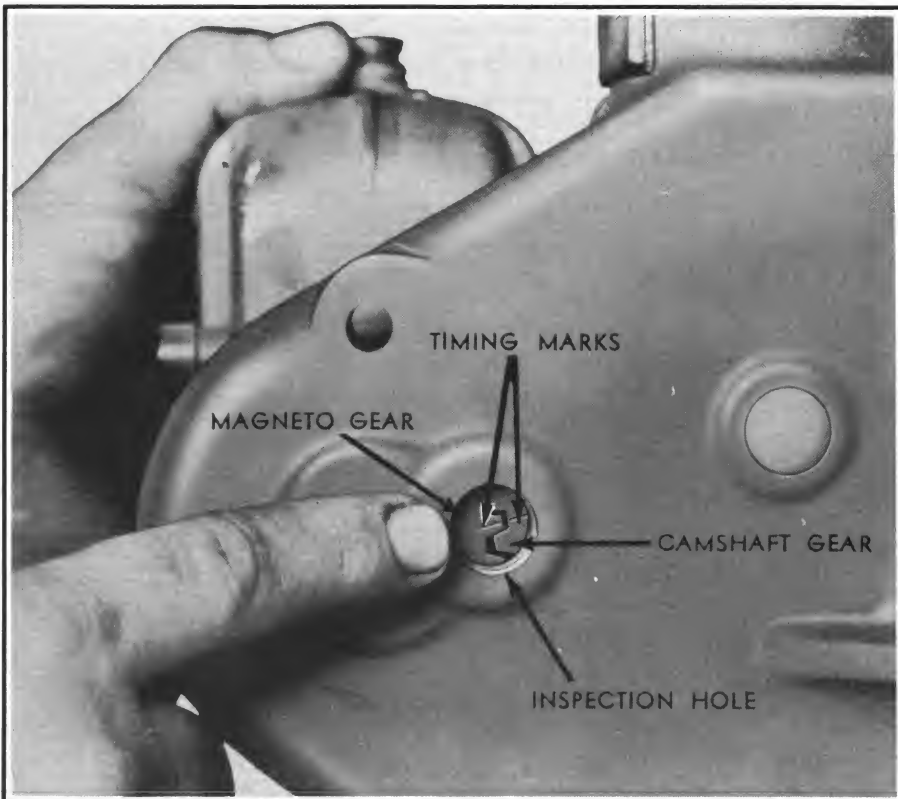

FIG. 45 Timing Diagram

OPERATION SECTION

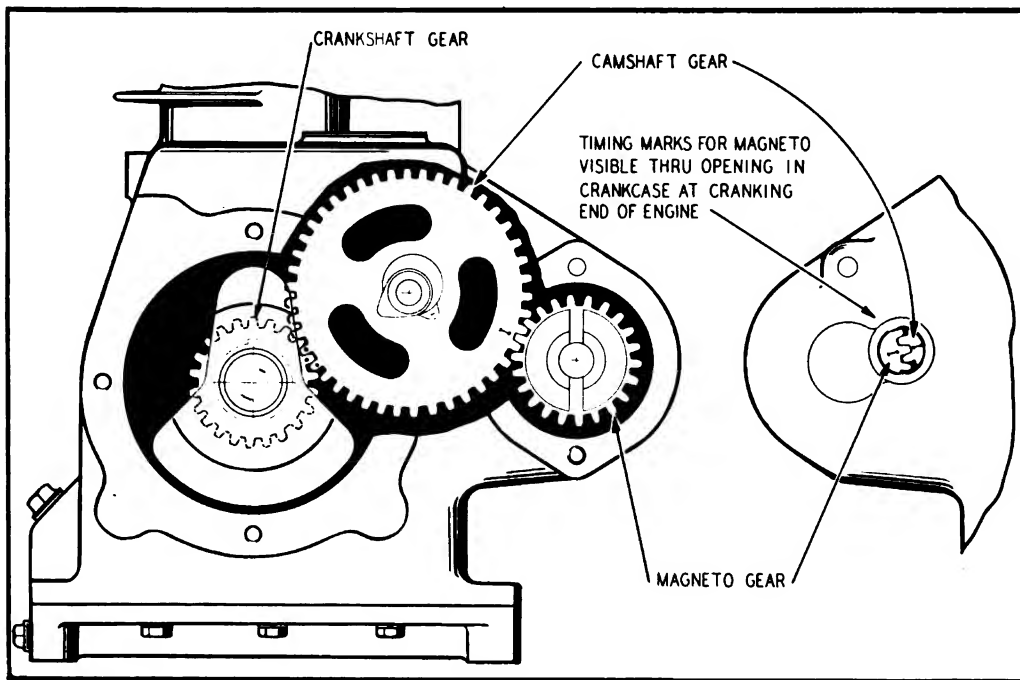

FIG. 46 Timing Diagram

the inspection hole. The magneto should then be assembled to the engine in such manner that the chisel mark on the magneto gear coincides with the mark on the camshaft gear. (See Timing Diagrams, Figs. 45 and 46). The camshaft gear is also marked with two dots or punch marks, and these two dots must line up with the one dot on the crankshaft gear.

For repairing the magneto, see "Magneto" in Maintenance Section.

5. Oil Pump

The oil pump in this engine is of the plunger type and is built into the engine base. An oil trough is provided, and the plunger base is a part of the trough. A push rod, actuated from the camshaft, operates the plunger of the oil pump, against the tension of a spring seated in the plunger bore. Two ball check valves are provided, one in the seat at the bottom of the plunger bore, held in place by a retainer, and one in the plunger itself. The stroke upward is the suction stroke, and the downward stroke is the discharge stroke. The plunger, through the action of the ball checks, draws oil from the bottom of the engine base, through a screen, and discharges into the oil trough. The connecting rod of the engine is provided with a dipper that dips into the oil in the trough once in each revolution, and thereby provides ample splash lubrication for all internal parts of the engines. (See Fig. 47).

The action of this type of oil pump is positive at all times unless dirty or gritty oil has been allowed to wear the plunger and plunger bore. Small particles of grit can be drawn through the oil filter screen and may lodge under one of the check-

OPERATION SECTION

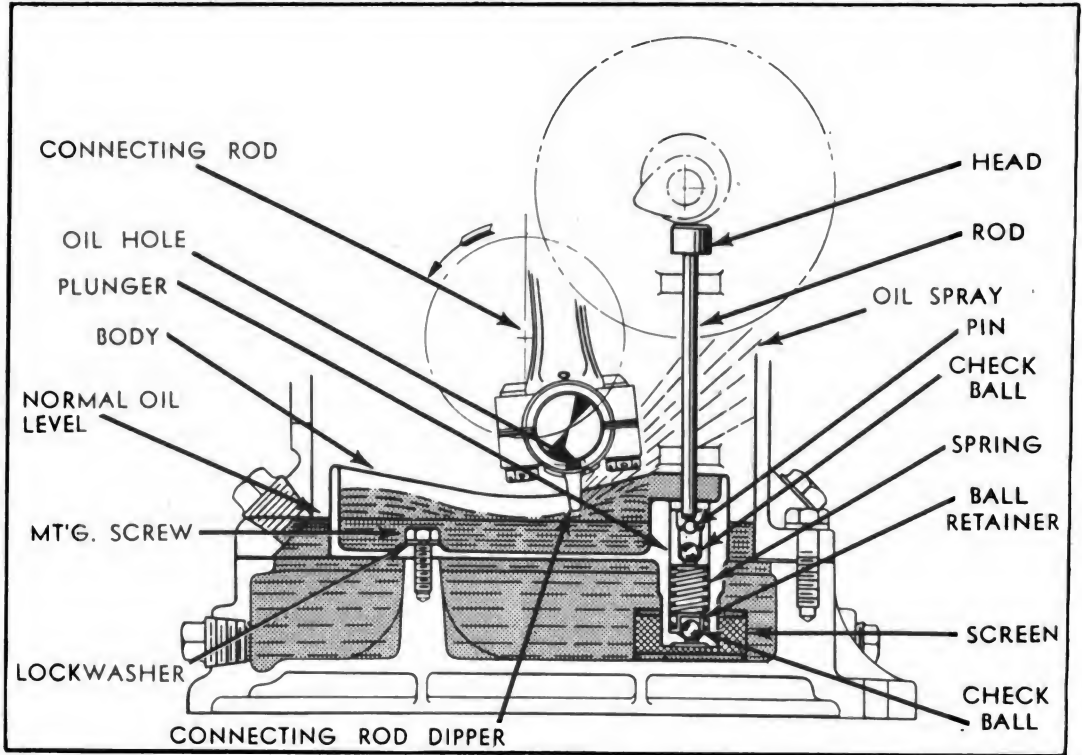

FIG. 47 Oil Pump Assembly

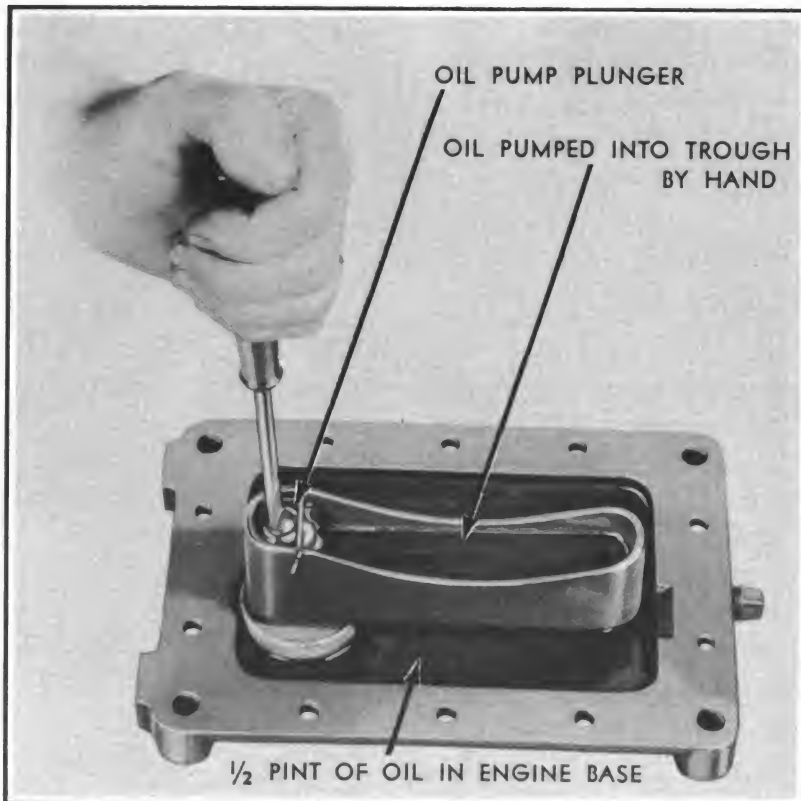

FIG. 48 Testing Oil Pump Plunger

OPERATION SECTION

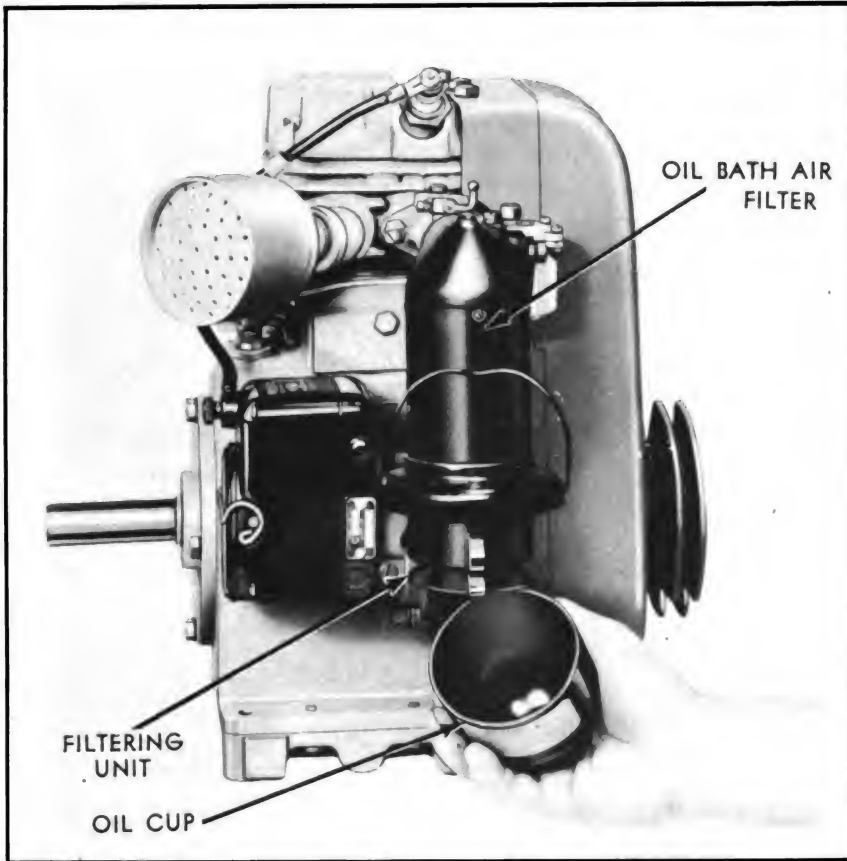

FIG. 49 Removing Air Cleaner Cup

balls. If the oil pump has failed to operate, it should be disassembled and the check valve seats thoroughly cleaned. If the pump will not operate satisfactorily when tested by manual operation of the plunger with a screwdriver, (See Fig. 48) a complete new unit should be installed as directed in the Maintenance Section.

6. Air Cleaner

The engine is equipped with an oil-bath type of air cleaner which cleans the air before it enters the carburetor. The air cleaner should be cleaned at regular intervals, depending upon the dust conditions. In extremely dusty conditions it may be necessary to service the air cleaner two or more times each day. The cup at the bottom of the cleaner should be removed, and the oil and accumulated dirt in the bottom of the cup should be emptied and the cup cleaned. The cup should then be refilled to the level shown on the cup, with the same grade of oil as used in the engine crankcase. (See Fig. 49). It is also necessary to clean the filtering unit of the air cleaner. This unit consists of a fine-mesh wire screen that prevents large bits of dust or dirt from entering the carburetor. To clean, the three screws that hold the air cleaner to the bracket must be removed and the body of the filter pulled free of the bracket. Clean the element thoroughly in gasoline, and reassemble. *Do not remove filtering unit from the air cleaner.*

OPERATION SECTION

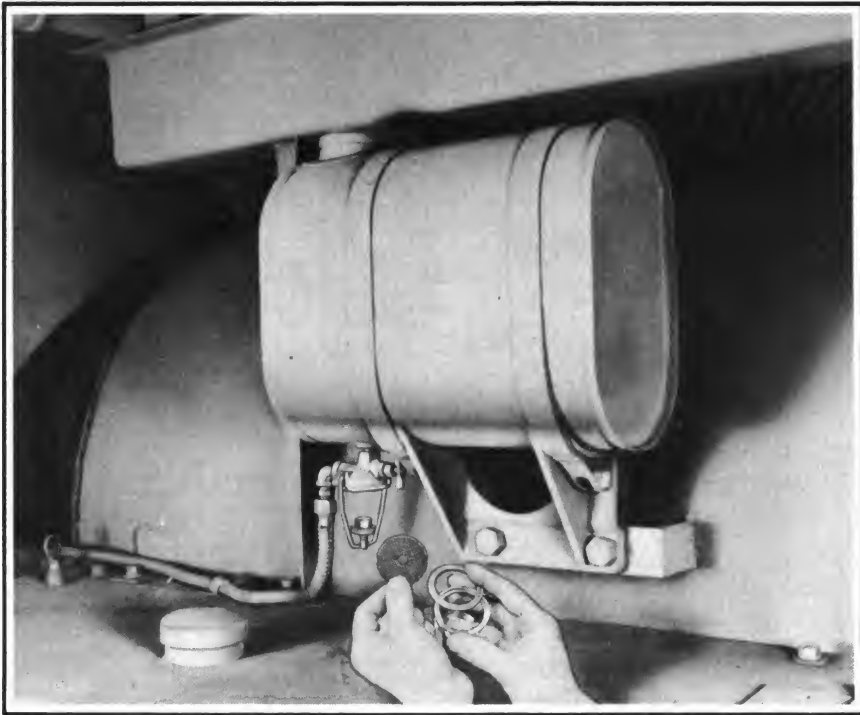

FIG. 50 Removing Engine Fuel Strainer

7. Fuel Strainer (See Fig. 50)

The fuel strainer filters the gasoline before it enters the carburetor. A daily visual inspection should be made, and if dirt is present in the bowl it should be emptied and the bowl and screen thoroughly cleaned.

REMOVAL OF LEAD DEPOSITS IN COMBUSTION CHAMBER AND ON VALVES

REASON FOR LEAD DEPOSIT REMOVAL

Many gasolines are now treated with lead compounds in order to raise the octane rating (or lower the "knocking" tendency) of these fuels so that they can be used in high compression engines without causing detonation and damage to the engine.

It will often be necessary to use leaded gasoline to operate this unit because non-leaded fuels will not be available. If non-leaded fuels are available, they should always be used to avoid the evils described in the following paragraphs.

While the lead treatment of gasoline raises the octane rating of the fuel, it is also a fact that lead compounds will deposit in the combustion chamber of the engine, on the valve heads and stems, and some will also work down into the crankcase lubricating oil, which may eventually take on the appearance of a light grey paint.

OPERATION SECTION

All of these deposits have a bad effect on the engines, but the one which will first produce serious results is the deposit on the valves. These deposits will build up to a thickness of about $\frac{1}{32}$ of an inch in about 64 hours of operation. This building up process is more pronounced with engines running constantly at the same speed and load than when operating intermittently and at varying loads and speeds.

When these deposits reach a thickness of about $\frac{1}{32}$ of an inch they will crack and flake away, after which they will again build up and repeat this process indefinitely.

When this flaking away occurs on the beveled seats of the valves, leakage will occur at these points and the flame of combustion will blow through, burning and pitting the valves. This condition occurs in all types of engines, whether air-cooled or water-cooled, and no method has been found for preventing the deposits from forming. The lead will not burn, but is left behind in the engine.

A method has been found for removing these deposits without taking the engine down and scraping. This consists of injecting water into the engine through the intake manifold while the engine is hot and running at normal speed. The water is instantly turned to steam when it strikes the hot walls of the combustion chamber and the valves and, during this process, the lead deposits will crack away. Much of the material so loosened will be discharged with the exhaust gases, but some will find its way to the crankcase lubricating oil. **IT IS THEREFORE ABSOLUTELY NECESSARY THAT THE CRANKCASE BE DRAINED AFTER THIS OPERATION AND FRESH OIL SUPPLIED. OTHERWISE, DAMAGE WILL RESULT FROM LUBRICATING THE ENGINE WITH CONTAMINATED OIL.**

The best time for the water injection operation is just before it is necessary to change the lubricating oil in the crankcase, which should be done after each 64 hours of operation.

This engine has no inlet manifold, the carburetor being bolted directly to the cylinder, and it will therefore, be necessary to inject the water directly into the carburetor air intake opening, *after* the air cleaner has been removed from the carburetor. **THE WATER MUST BE FRESH (NOT SALT WATER) AND CLEAN, FREE FROM SAND AND GRIT; OTHERWISE, THE ENGINE MAY BE SCORED.**

INJECTING WATER (See Fig. 51)

With an ordinary type of squirt oil can, inject water into the carburetor air intake, but only while the engine is hot, and running at normal speed.

With the squirt can in one hand and the other hand on the carburetor choke lever, squirt water into the carburetor until the engine slows down. Before the engine stops, interrupt the water injection and partially close the carburetor choke, until the engine recovers its speed. Then open the choke and continue water injection by the same process until about a pint of water has been used.

The squirt can should have a spout orifice of about $\frac{3}{32}$ inch in diameter, which is about standard for such oil cans.

OPERATION SECTION

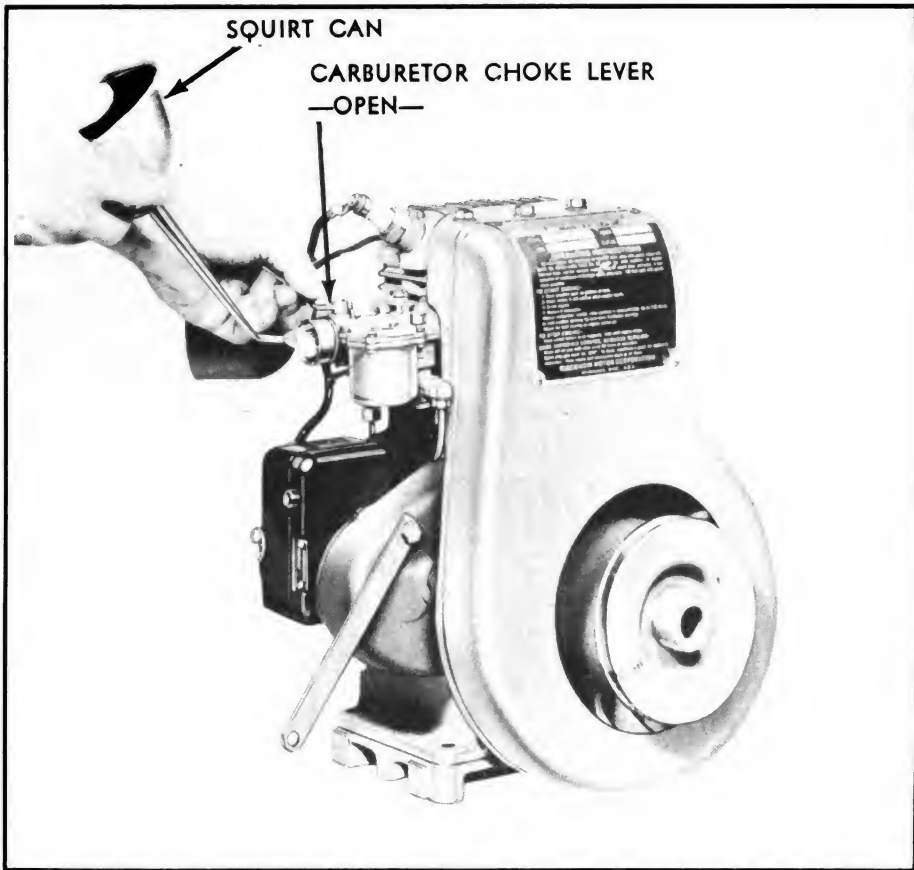

FIG. 51 Water Injection For Removal of Lead Deposits

BE SURE THAT THE AIR CLEANER IS REPLACED AFTER THE ABOVE OPERATION.

During very cold weather it is *especially* important that the engine be hot, for otherwise the injection operation will not be as effective. The injection had best be done immediately after the engine has been running under full load for several hours.

AFTER THE WATER TREATMENT HAS BEEN COMPLETED AND WHILE THE ENGINE IS STILL HOT, ALL OF THE CRANKCASE OIL SHOULD BE DRAINED, AND FRESH OIL SUPPLIED.

This water injection will also remove deposits back of the piston rings. After the injection operation and changing of the crankcase oil has been properly carried out, the engine should run appreciably smoother and with increased power.

MAINTENANCE SECTION

CLEANING HEATER TUBES

Tubes, or flues as they are sometimes called in some types of boilers or hot water heaters, require daily or, in some cases, weekly cleaning. Because of the principle of firing this Fired Shower Unit, the tubes do not require periodic cleaning. However, an inspection of the flues after every 1096 hours is good practice. This is done by removing the rear head (towing end) and inspecting the flues for carbon formation. Should inspection reveal a thick deposit of soot and carbon, the flues should be cleaned as outlined in the following paragraphs.

REMOVAL OF REAR HEAD

Remove heagon nuts from the studs attaching the rear outer head (towing end) to the heater shell.

With a screwdriver, chisel, or other prying instrument, free the head from the heater shell, leaving gasket attached to heater shell if possible.

Bearing in mind that the head weighs about 100 pounds and there is a brick attached to its fire side, remove it and lay it on the floor, brick up.

CLEANING TUBES

Stowed in the tool box is a three-section flue brush. Two sections of the $\frac{1}{4}$ inch pipe form the handle, and the third section is the brush. Assemble the handle and screw it on to the brush.

Tubes should be cleaned from the end opposite the firing end of the unit. (See Fig. 52)

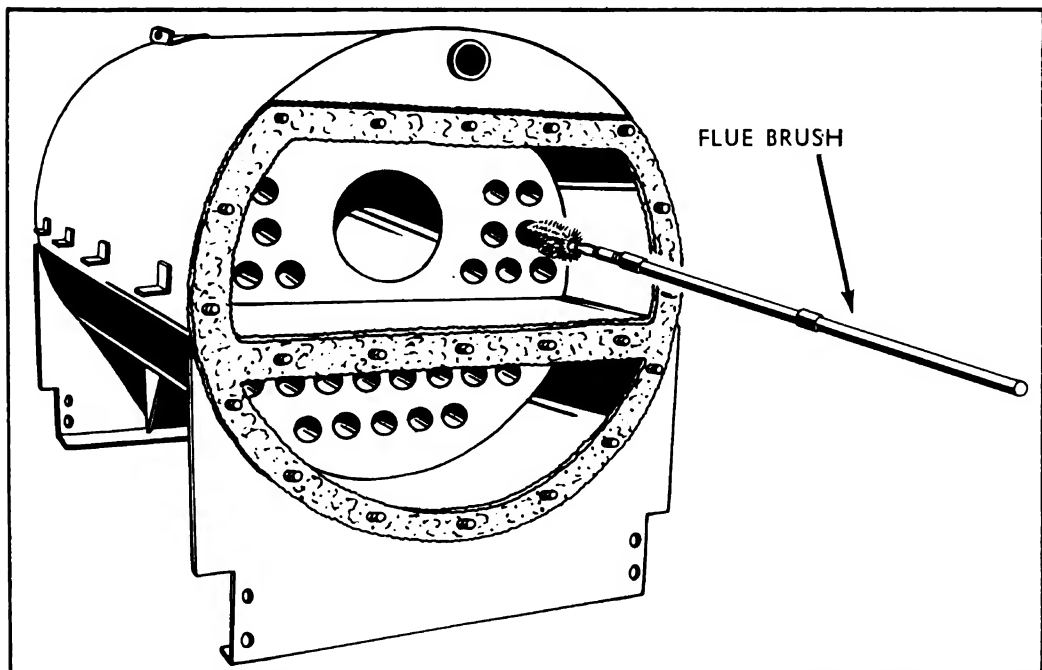

FIG. 52 Cleaning Heater Tubes

MAINTENANCE SECTION

CLEANING TUBES

HEATER TUBES

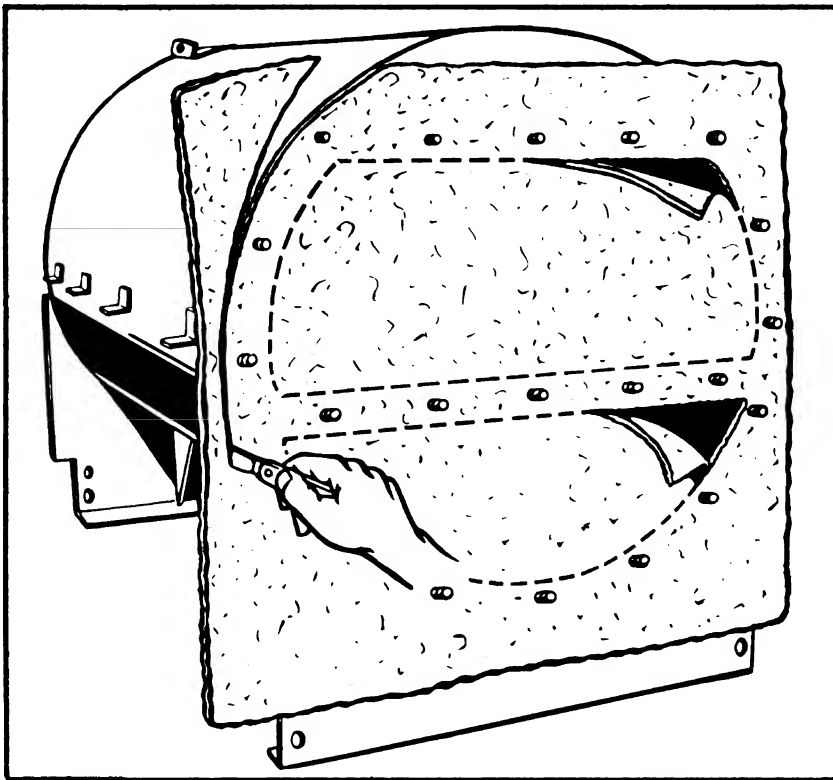

FIG. 53 Replacing Asbestos Head Gasket

Start cleaning the upper tubes, forcing the brush through the entire length of each tube until it is free at the opposite end, then pull the brush backward toward the open end of the heater in a continuous movement.

DO NOT ATTEMPT TO REVERSE BRUSH DIRECTION WHILE BRUSH IS IN A TUBE, AS IT WILL STICK.

Continue brushing each tube with full-length sweeps until brush comes out clean. Soot or carbon dislodged and pushed into the baffle chamber will be blown out when the machine is again in operation.

REPLACING HEAD GASKET

The asbestos head gasket should be inspected to see that it has not been torn or damaged in any way. If damaged, or if it should be replaced for any other reason, remove old gasket and, if available, brush a coat of lubricating oil mixed with graphite on heater shell flange. Cut a new gasket from $\frac{1}{16}$ inch asbestos paper 36 by 44 inches wide, as shown in Fig. 53. Brush a coat of lubricating oil and graphite on head side of new gasket.

SEALING BRICKWORK

The seal between the brick in the outer head and the heater inner shell is formed by a trowel coat of fine high temperature cement. If cement is available, remove the old cement coating from brick and heater surfaces, and apply a new coating of cement.

MAINTENANCE SECTION

REPLACING TUBES

HEATER TUBES

If brickwork is found to be defective, repair as instructed in later paragraphs headed "Replacing Brickwork".

Replace head, and pull up tight all outer attaching nuts, being sure a washer is under each nut.

REPLACING HEATER TUBES

The work of installing heater tubes should be performed by a skilled boiler-maker if at all possible. However, these instructions cover the operation fully, and any skilled mechanic possessing proper tools can perform the operation.

REMOVAL OF REAR HEAD (TOWING END)

The rear head should be removed as described in previous paragraphs headed "Cleaning Heater Tubes".

PREPARING FOR FRONT HEAD REMOVAL (See Fig. 54)

Raise the hood to its operating position and disengage the hood supporting brackets at the sliding door track. Next, remove the pin in the top hinge and set aside the hood.

Slip V-belts off generator (G), blower (U), and fuel pump (F) sheaves.

Loosen flared connection nuts in fuel oil suction line and discharge tubing at the strainer (M) and pressure regulator (J). Remove two capscrews holding fuel pump base block to base plate, and remove fuel pump (F) and base block.

Remove the power plant housing panel that covers the gasoline engine, then disconnect the flared fitting (W) in the gas line to the carburetor.

Unscrew muffler from engine exhaust piping under power plant base plate. Remove four capscrews holding engine to base plate and remove engine (T) taking care not to lose the filler block from flexible coupling. The two $\frac{1}{8}$ inch steel shims from under the engine should be tied to the engine for safe keeping.

Disconnect union in water pump discharge line just below water pressure gauge (P); also the $1\frac{1}{2}$ by 14 inch pipe passing down through the base plate. Remove the four capscrews in water pump base plate and remove pump (O).

Loosen the flared connector nut in the burner fuel oil line at the solenoid valve (K) end.

Remove the three hex. nuts and washers that hold the blower (U) to the heater headplate. The blower (U) with burner (V) and ignition transformer (C) attached can then be removed and set aside.

The temperature regulator bulb located in the center of the heater front directly below the thermometer (A) should be removed. CAUTION: When removing this bulb, the operator must be careful not to bend the tubing, since that would impair the operation of the fluid within the tube.

As a precautionary measure, it is advisable to remove the thermometer (A) to prevent its leakage.

The safety valve overflow pipe passing through the baseplate should next be un

MAINTENANCE SECTION

REPLACING TUBES

HEATER TUBES

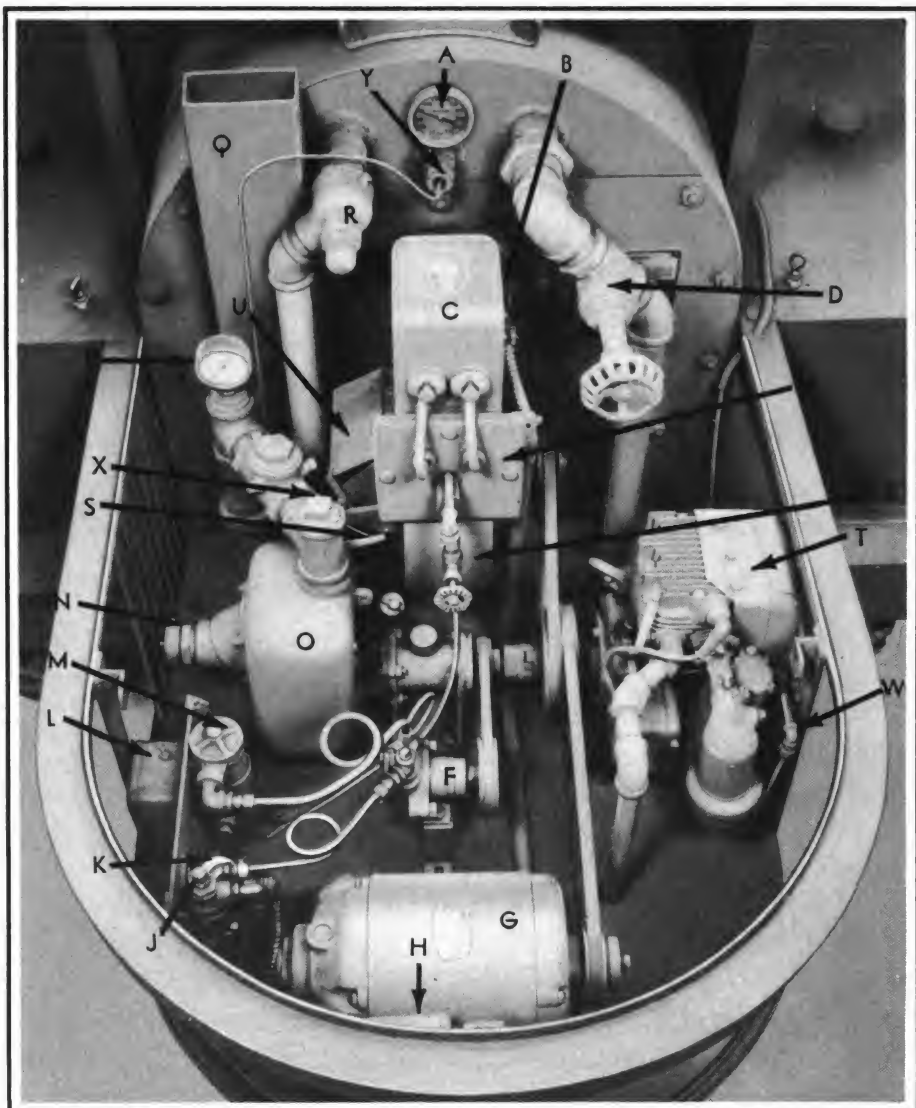

FIG. 54 Power Plant

- | | |
|---|--------------------------------|
| A. Heater Water Thermometer | N. Water Suction Inlet |
| B. Burner Observation Port Hole | O. Water Pump |
| C. Burner Ignition Transformer | P. Water Pressure Gauge |
| D. Shower Water Valve | Q. Stack |
| E. Burner Fuel Valve | R. Water Pressure Relief Valve |
| F. Fuel Pump | S. Burner Air Shutter |
| G. Generator | Control Handle |
| H. Manual Control Switch | T. Gasoline Engine |
| J. Fuel Oil Relief Valve (Fuel Pressure Regulator, Adjusting Screw under Cap) | U. Blower Damper |
| K. Solenoid Valve | V. Burner Assembly |
| L. Temperature Regulator | W. Engine Fuel Line |
| M. Fuel Strainer | X. Water Pump Prime Plug |
| | Y. Temperature Regulator Bulb |

MAINTENANCE SECTION

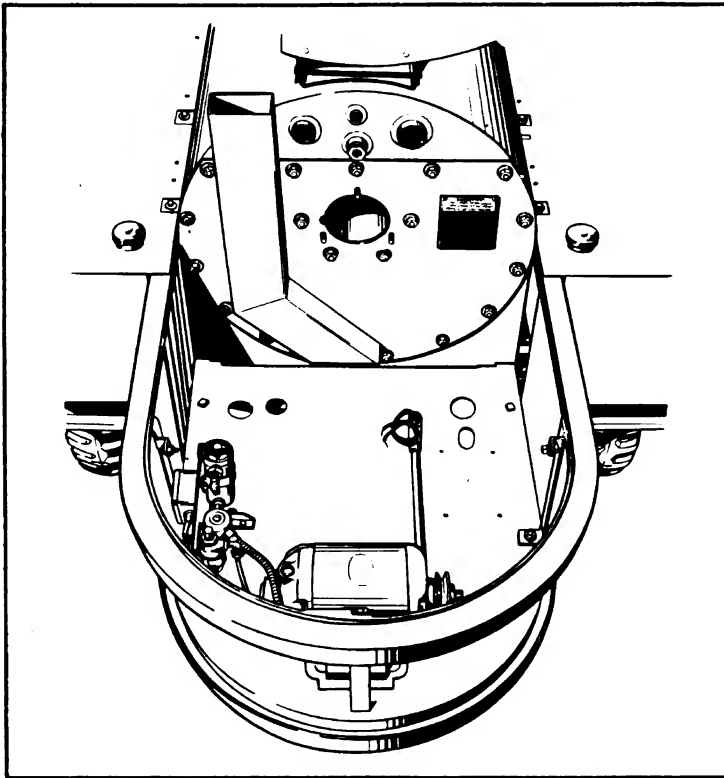

FIG. 55 Power Plant Cleared For Front Head Removal

screwed from the 45 degree elbow, and the safety valve (R) and its coupling also removed.

Loosen the union in the warm water discharge line at the heater outlet, just above the warm water discharge valve (D). Unscrew discharge pipe passing through baseplate and remove valve and pipe.

After all the above items have been removed as shown in Fig. 55, the front head plate may be taken off.

REMOVAL OF FRONT HEAD

With a wrench, remove all the hexagon nuts from the studs attaching the front outer head to the heater shell.

With a screwdriver, chisel, or other prying instrument, free head from the heater shell, leaving the gasket attached to heater shell if possible.

Bearing in mind that the head weighs about 100 pounds and that there is a brick attached to its fire side, remove it, and lay it on the floor, brick up.

If the defective tube is in the third or fourth pass, the bottom steel baffle plate must also be removed. This plate is tack-welded at the two ends and must be broken loose before removing.

REMOVAL OF DEFECTIVE TUBE

With ball-peen hammer and cold chisel, remove bead and weld from both tube ends, as shown in Fig. 56, but be very careful not to injure the tube sheet. Then

MAINTENANCE SECTION

REPLACING TUBES

HEATER TUBES



FIG. 56 Removing Bead and Weld From Tube End

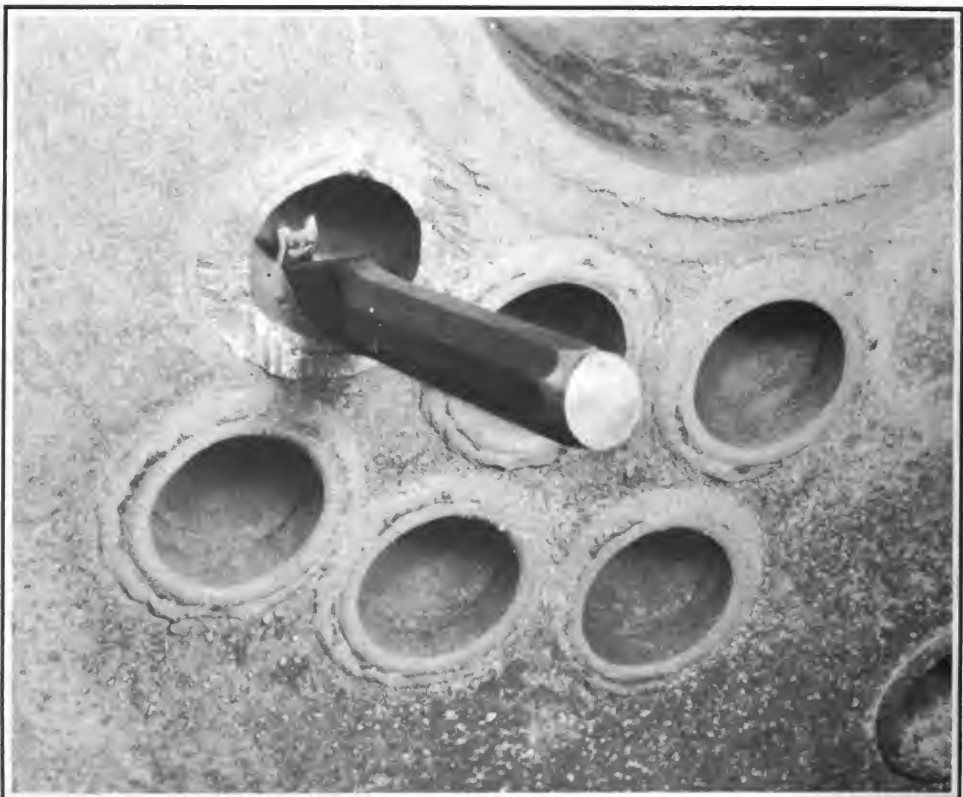

FIG. 57 Cutting Slit in Tube End With Cape Chisel

MAINTENANCE SECTION

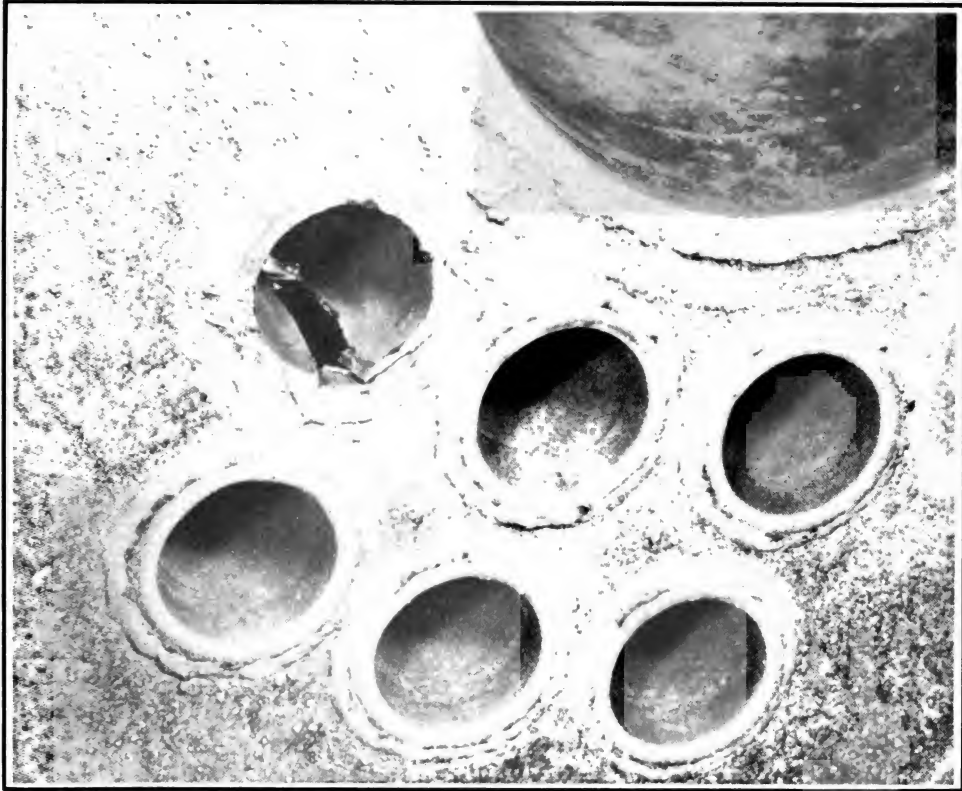

FIG. 58 Slit In Tube End

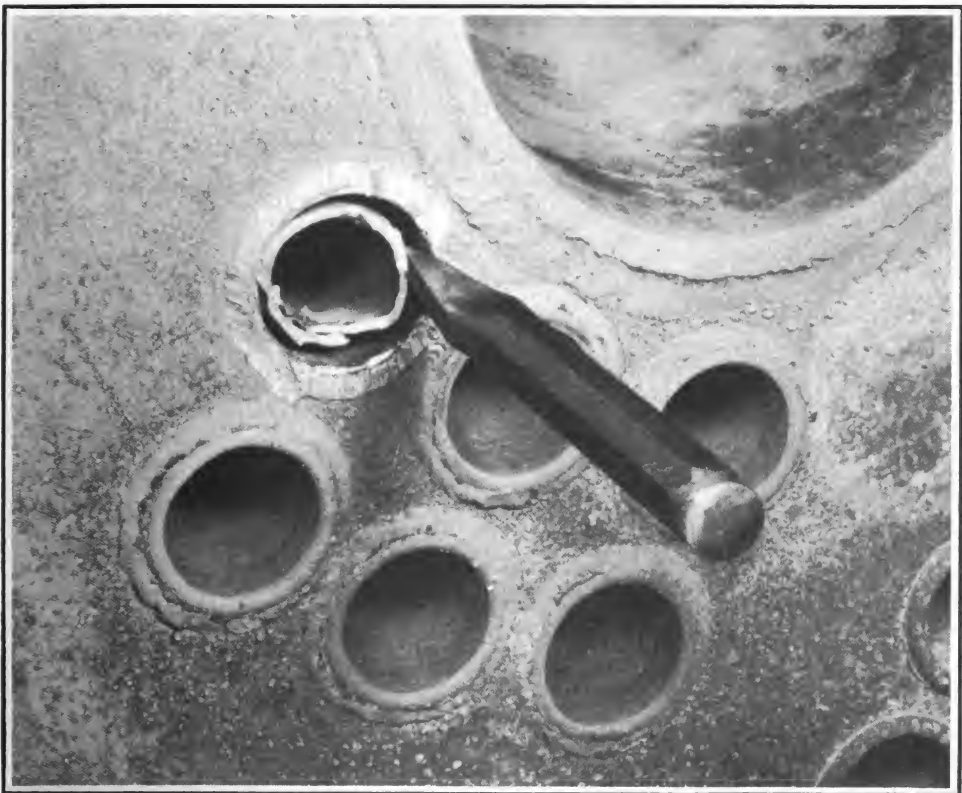

FIG. 59 Turning In End Of Tube

MAINTENANCE SECTION

REPLACING TUBES

HEATER TUBES

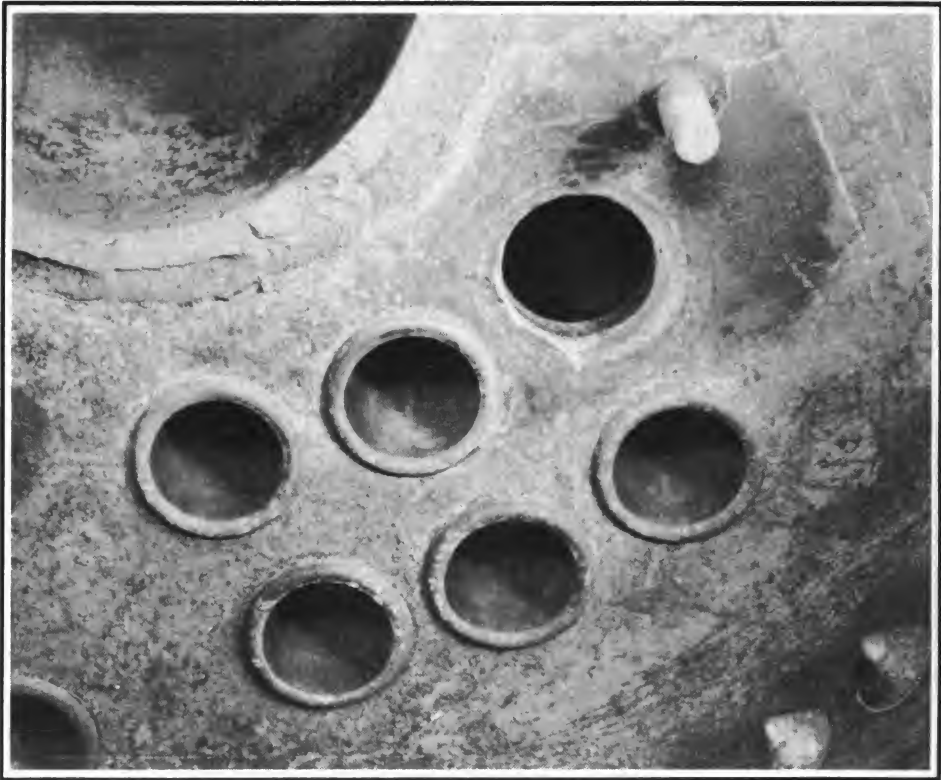

FIG. 60 Tube Hole In Tube Sheet



FIG. 61 Flaring The New Tube End

MAINTENANCE SECTION

REPLACING TUBES

HEATER TUBES



FIG. 62 Beading New Tube End

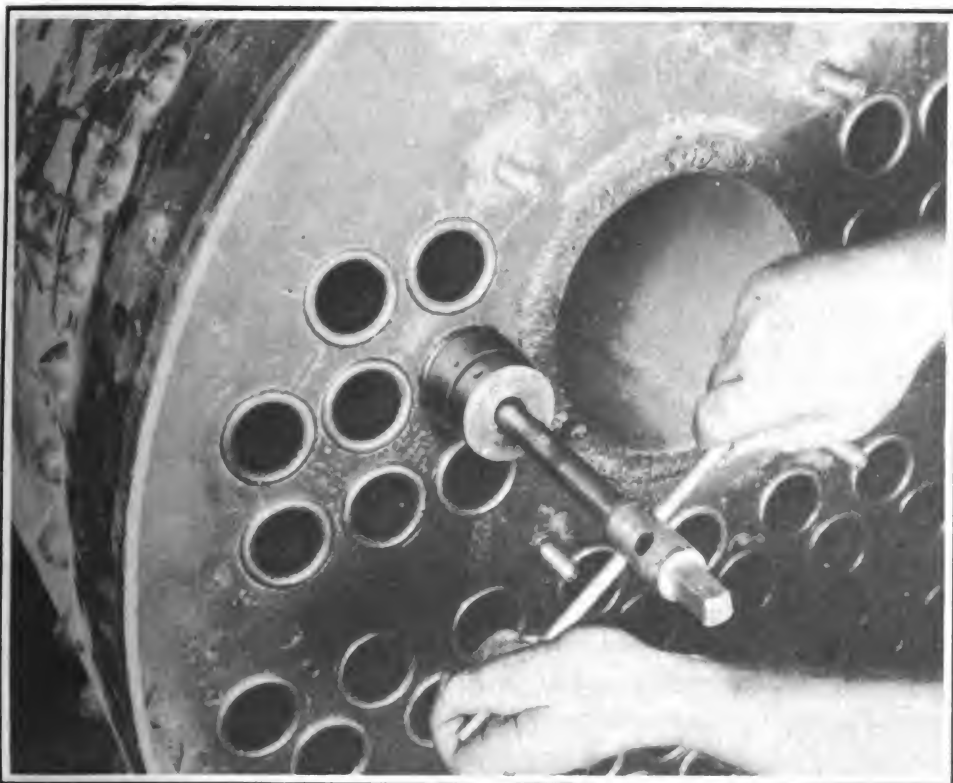

FIG. 63 Tube Expanding Operation

MAINTENANCE SECTION

REPLACING TUBES

HEATER TUBES

using a cape chisel, cut a slit in both tube ends as shown in Fig. 57 and 58.

With the cape chisel, turn in the free ends of the tube as shown in Fig. 59.

Because of the scale on the water side of the tube, it will be necessary to drive out the tube, shearing off the scale as the tube is driven through the tube sheet. After tube is out, file burrs from tube sheet hole, leaving clean, round hole as shown in Fig. 60.

INSERTING NEW TUBE

Inset the new tube, which should extend $\frac{1}{4}$ to $\frac{3}{8}$ inch beyond the outer sides of the tube sheets.

With a ball-peen hammer, flare the projecting section of the tube all the way around, as shown in Fig. 61.

NOTE: Fig. 61 shows all tubes being replaced. A single flaring hammer blow has been applied to each one, to hold the tubes in place.

After both ends have been flared with a hammer, use the beading tool to roll over the edge of the tube tightly against the flue sheet as shown in Fig. 62.

The final operation in tube replacement is to expand the tube to form a shoulder on the tube just inside the tube sheet. A tube expander will be found in the tool box and is used for this purpose as shown in Fig. 63.

The two above operations should be performed with the utmost care, for upon them will depend whether the tube will seal tightly.

HYDROSTATIC TEST WITH WATER PRESSURE SERVICE

After heater tube repairs or replacement operations have been completed, the heater should be pressure-tested for leakage. The most satisfactory method is the hydrostatic or water pressure test as follows:

Install pipe plugs in the water discharge hole, the safety valve hole, the thermometer hole, and the temperature regulator bulb hole.

If water pressure service is available, install the water pump discharge piping, including the water pressure gauge and check valve. Connect the outside pressure line to the check valve and build up the pressure within the heater shell to 30 pounds. After shutting off the outside pressure, the check valve will maintain the pressure, and the entire circles where the tube is rolled at the flue sheets should be closely inspected for leakage.

HYDROSTATIC TEST WITH WATER PUMP PRESSURE (See Fig. 64)

If no water pressure service is available, the hydrostatic test must be performed by building up water pressure within the heater shell by means of the water pump on the unit.

Mount the water pump on the baseplate and assemble the pump discharge piping. Mount the engine in its place, and connect the flexible coupling to the water pump, making certain that the filler block is in place and that the engine and pump shafts are in perfect alignment. Connect the gasoline line to the engine.

Connect water suction hose to water pump and, if possible, a barrel of water

MAINTENANCE SECTION

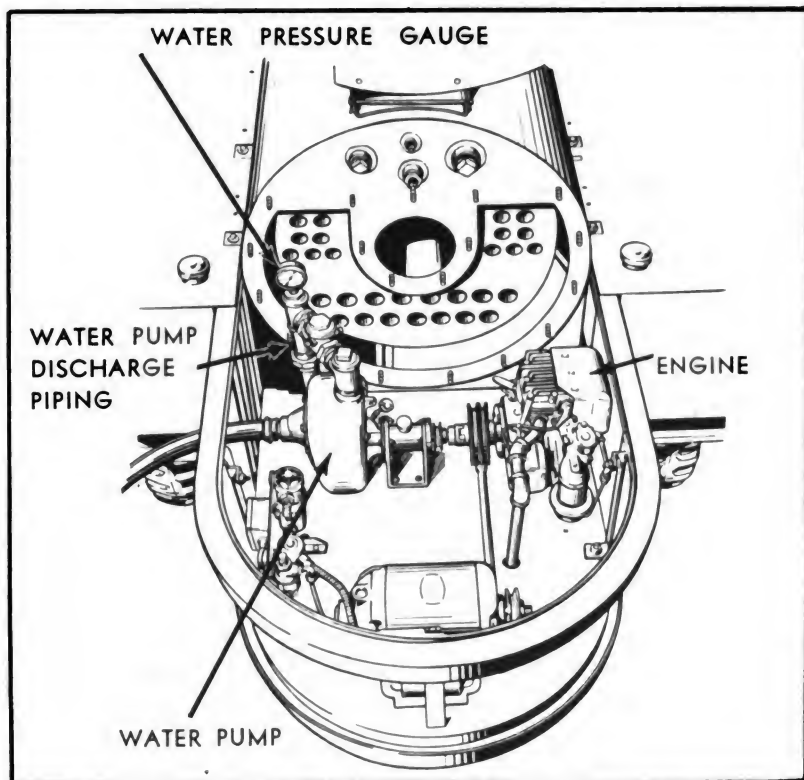

FIG. 64 Hydrostatic Test With Engine And Pump

should be provided to furnish the water source, since a short suction lift is essential in obtaining the required pressure

Start the engine and fill the heater, building up pressure to the maximum pressure obtainable by the pump, approximately 30 pounds. When the pressure no longer rises with continued operation, stop the engine. The check valve will hold pressure within the heater. Carefully inspect the entire circles where the tube is roiled at the flue sheets. If a leak is found, repeat the operation with the beading tool and tube expander at the point of leakage, then again test for pressure.

If no leak is found and the pressure does not drop after a few minutes wait, open the heater drain valve at the bottom of the heater and drain it of all water.

Remove the four plugs at the firing end of the heater. Also remove engine, water pump, and water pump discharge piping.

REASSEMBLY AFTER TUBE REPLACEMENT (See Fig. 54)

Replace bottom baffle plate on firing end of heater and tack-weld it in place. Also seal with furnace cement around its edges.

Remove the old gasket and, before applying a new $\frac{1}{16}$ inch asbestos paper gasket, brush a coat of oil and graphite on heater flange. Install the new gasket as shown in Fig. 53. Brush a coat of oil and graphite on side of gasket facing outer head.

Replace outer head, install washers and nuts on all studs, and tighten nuts securely.

Replace the warm water discharge piping and valve (D).

MAINTENANCE SECTION

Replace the safety valve (R) and the overflow pipe, passing it through the baseplate.

The thermometer (A) can be now screwed back in place.

Cut a new $\frac{1}{16}$ inch asbestos gasket for the blower mounting flange, and apply oil and graphite to both surfaces. The blower (U) can then be set in place, and the three washers and nuts replaced and tightened down. Before replacing the generator-to-ignition-transformer conduit, pass the generator wires through it and screw the conduit into the conduit fitting. Pass the two wires through the side outlet of the ignition transformer and connect them to the transformer leads. Tighten the flexible tubing connector to the side of the transformer (C) and replace transformer plate on back. The flared connector on the burner fuel line should be connected to the solenoid valve (K).

The temperature regulator bulb (Y) can then be screwed into its opening just below the thermometer, taking care not to bend or crack the tubing.

With the two $\frac{1}{8}$ inch shims in place, set the gas engine (T) in position, passing the exhaust pipe through the baseplate. With a washer and lockwasher and each cap-screw, secure the engine to the baseplate. Connect the flared fitting (W) in the gasoline line to the engine. Screw the muffler onto the end of the exhaust pipe that passes through the baseplate.

Replace water pump (O) connecting flexible coupling and filler block first making certain that pump and engine shafts are in perfect alignment.

Replace fuel pump (F) and base block. Tighten capscrews that hold base block to baseplate. Connect flared fittings on suction and discharge lines at strainer (M) and relief valve (J).

Replace the power plant housing panel that covers the engine.

REPLACING REAR HEAD (TOWING END)

The asbestos head gasket should be inspected to see that it has not been torn or damaged in any way. If a new gasket is needed, remove old gasket and brush a coat of lubricating oil and graphite on heater shell flange. Cut a new gasket from $\frac{1}{16}$ inch asbestos paper 36 by 44 inches, as shown in Fig. 53. Brush a coat of lubricating oil and graphite on the head side of new gasket.

The seal between the brick in the outer head and the heater inner shell is formed by a trowel coat of high temperature furnace cement. If cement is available, remove old coating from brick and heater shell surfaces, and apply new coating.

If brickwork is found to be defective, repair as instructed in later paragraphs "Refractory Brick Replacement".

Replace head, and pull up all attaching nuts tightly.

REFRACTORY BRICK REPLACEMENT

REAR HEAD BRICK—TOWING END

Remove all hexagon brass nuts from the studs attaching the rear outer head to the heater shell.

MAINTENANCE SECTION

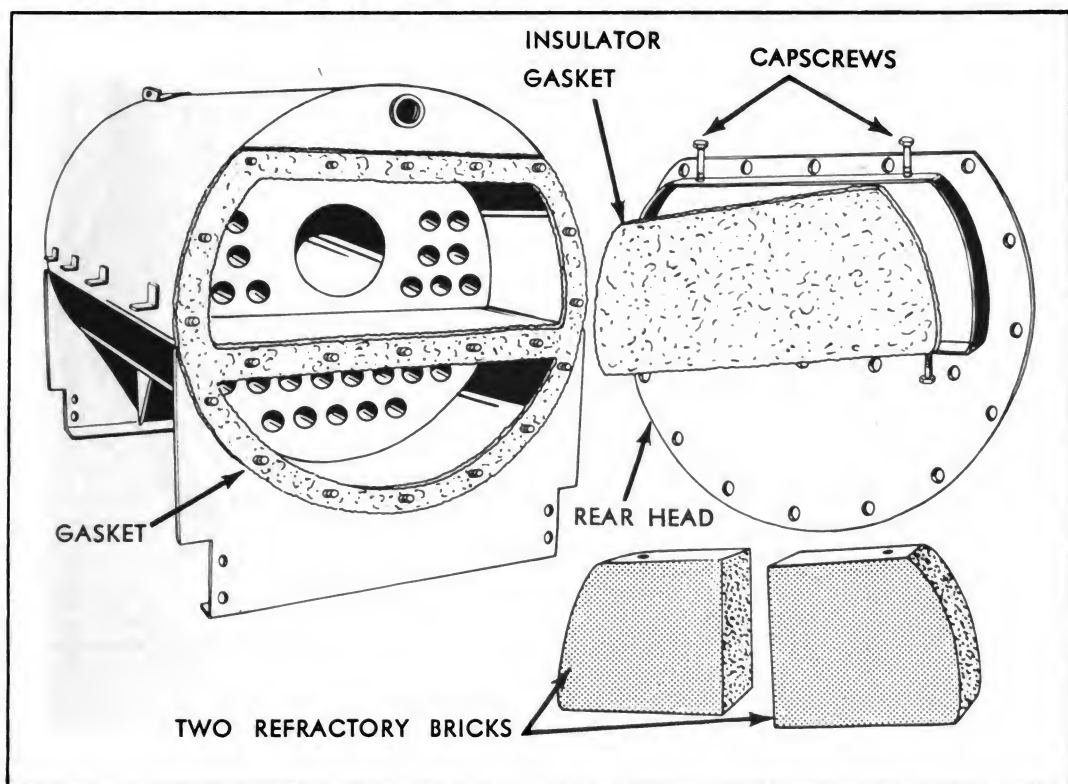

FIG. 65 Rear Head Removed

With a screwdriver, chisel, or other prying instrument, free head from the heater shell, leaving gasket attached to heater shell if possible.

With a hammer and chisel, break out the remaining pieces of brick in the head, exposing the bolts which pass through the supporting frame and secure the brick. With a small pipe wrench, turn out the bolts and discard them.

Install four new machine bolts with the ends flush with the inner surface of the steel supporting frame that is welded to the outer head. (See Fig. 65). Insert the old asbestos board insulator, or cut a new one if the old one is damaged, while the head rests flat on the floor. After applying a coat of high temperature furnace cement to all edges of the two bricks, set the bricks in place, engaging the machine bolts in the holes drilled into the brick and screw them in as far as they will go. With a hacksaw or cutting torch, cut off the protruding ends of the bolts flush with the frame.

Apply a trowel coat of high temperature cement to the protruding edges of the brick and, after inspecting the head gasket to see that there are no breaks, the head can be replaced and the nuts tightened with washers underneath.

FRONT HEAD CEMENT REFRACTORY—FIRING END (See Fig. 66)

Break out the remaining pieces of cement with a hammer and chisel.

Mix to a plastic-consistency, sufficient common Portland cement and water with about twenty pounds of crushed firebrick.

MAINTENANCE SECTION

FRONT HEAD BRICK

REFRACTORY BRICKWORK

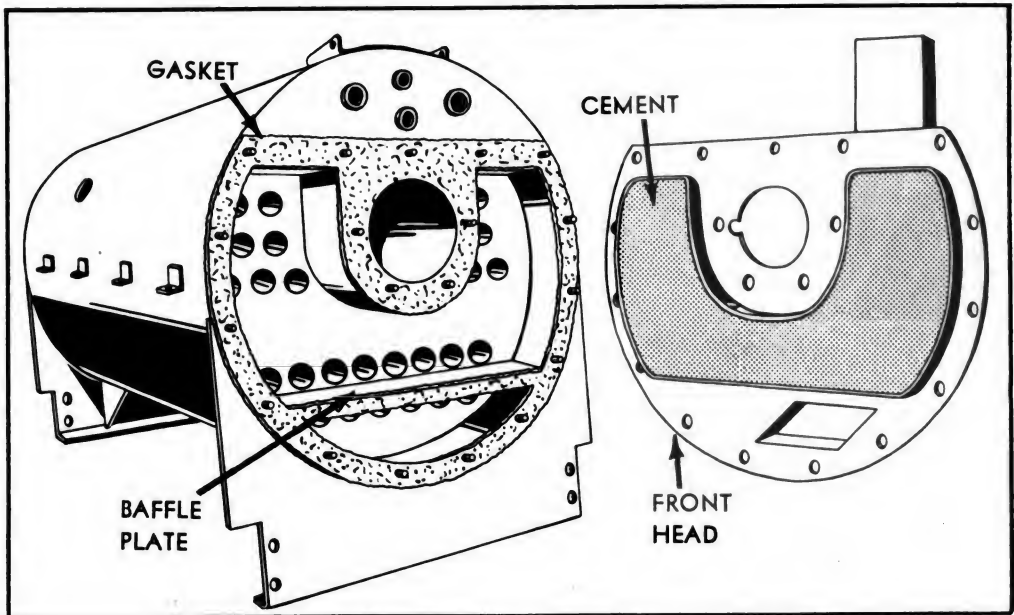

FIG. 66 Front Head Removed

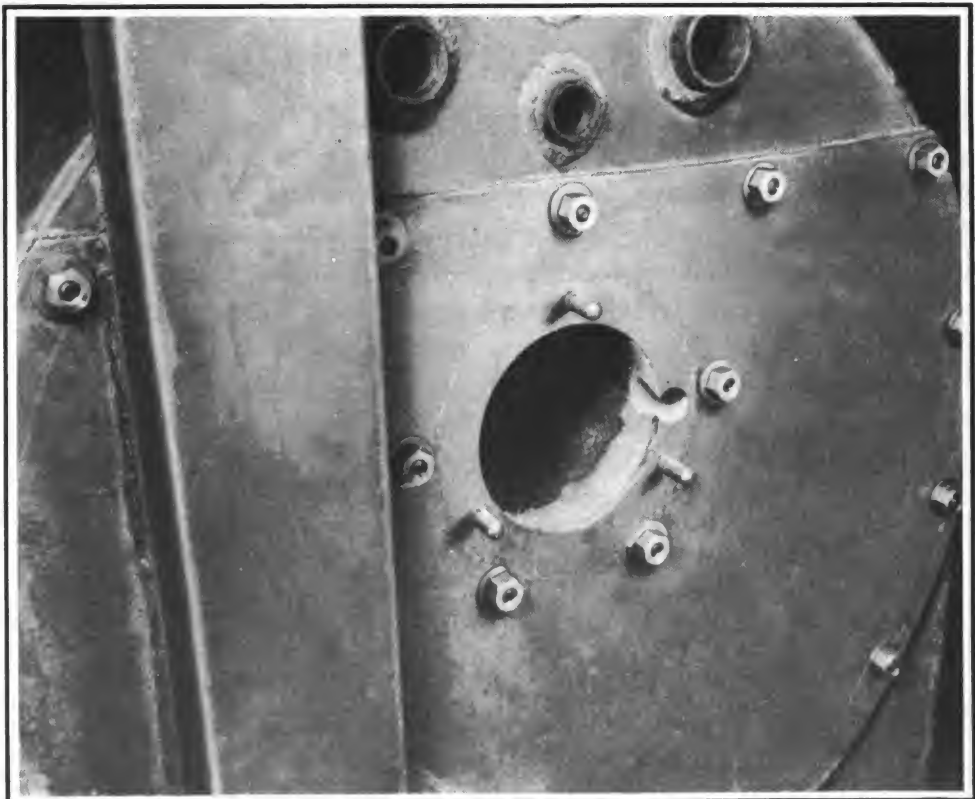

FIG. 67 Fire Tube Cement

MAINTENANCE SECTION

CLEANING HEATER WATER SIDE

HEATER

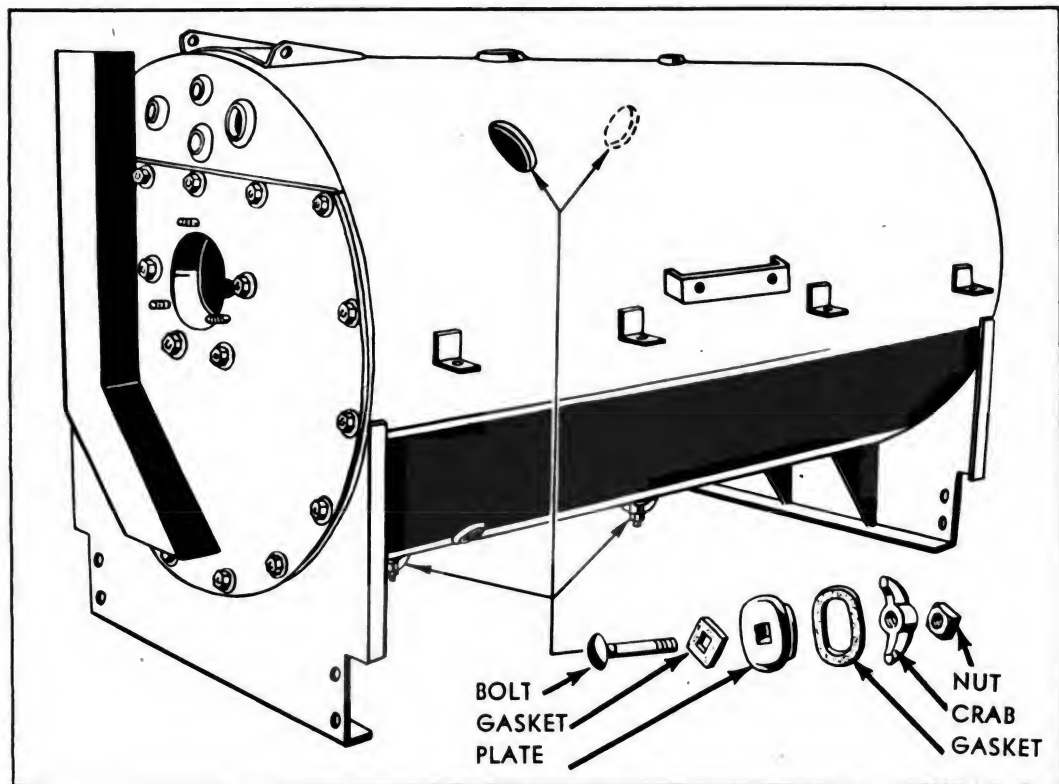

FIG. 68 Hand-Hole Plates

Completely fill the U-shaped supporting frame on the back of the head with the cement, leveling it off with a straight-edge or a flat board. Allow it to dry for 24 hours. Then, and after head gasket has been inspected for breaks, replace head, and tighten hexagon nuts, with washers underneath.

REPLACING FIRE TUBE CEMENT (See Fig. 67)

Should the cement rim around the mouth of the fire tube be damaged in any way, the remaining cement should be knocked out before the head is replaced.

After replacing the head, a layer of high temperature cement about one inch thick should be applied to the inside of the fire tube to taper off the difference in diameter between the head opening and the inside of the fire tube. A hole should be notched out of this rim on the right-hand side for the observation port.

CLEANING WATER SIDE OF HEATER

In field service, these units must handle feed water containing a wide variety of chemical combinations, and consequently, no fixed rule may be applied to the treatment of feed water to prevent formation of scale on the tubes or, as may also occur, pitting of the tubes. The important maintenance requirements is to remove the scale and flush out the heater as often as required, as determined by inspection after removal of one or more of the four hand-hole plates. See Fig. 68.

MAINTENANCE SECTION

SUCTION END

WATER PUMP

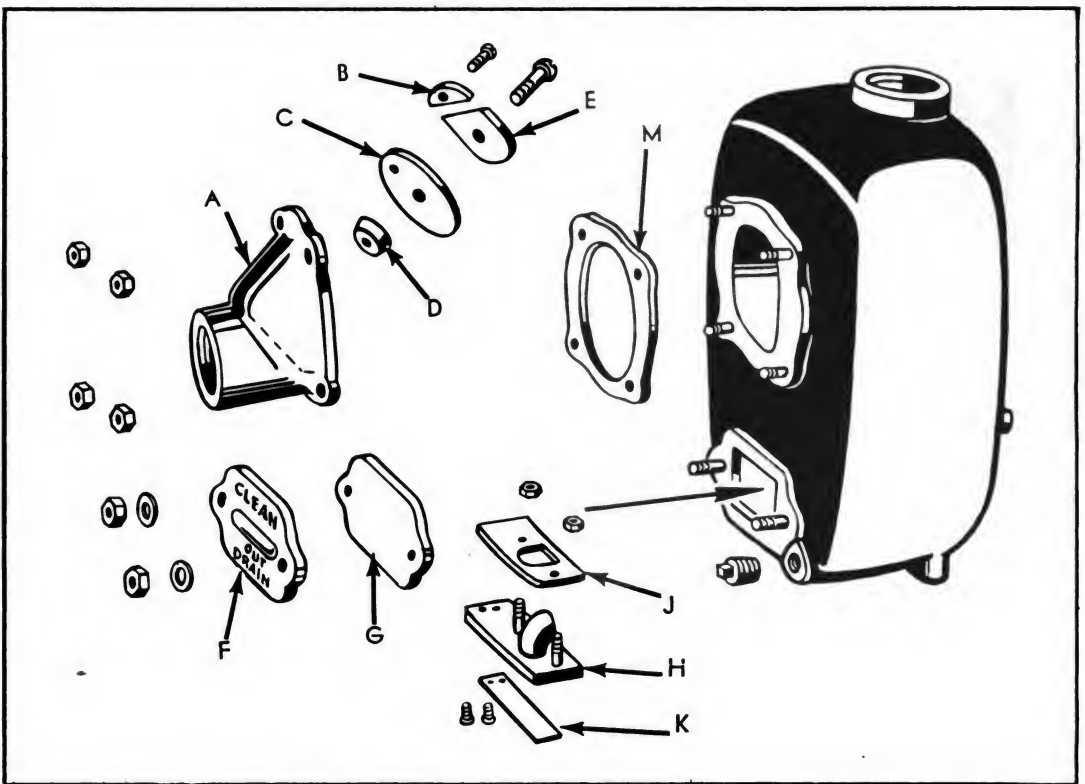

FIG. 69 Water Pump Suction End

Consult the nearest available authority on boiler water scale removal, and proceed according to his recommendation after he has studied the conditions.

HAND HOLE PLATES

Two hand-holes (See Fig. 68) are located in the sides of the top half of the heater shell, one toward the towing end, and the other toward the firing end. The remaining two hand-holes are located on the bottom side of the heater, front and rear.

When removing a hand-hole plate, be careful not to drop it inside the heater. With a pair of pliers, hold the hand-hole bolt and remove the outer nut. Remove the yoke, then if plate is stuck to the heater shell, release the plate and gasket with a hammer blow. Grasp the bolt and remove the plate.

When installing gaskets, apply a coat of graphite and oil to both surfaces.

WATER PUMP

SUCTION LINE CHECK VALVE (See Fig. 69)

The suction check valve consists of a weighted composition fabric flap which acts both as the hinge and the seating surface. The valve hangs vertical, which prevents dirt from lodging on the seat.

To test the valve, remove the suction line and fill the priming chamber with

MAINTENANCE SECTION

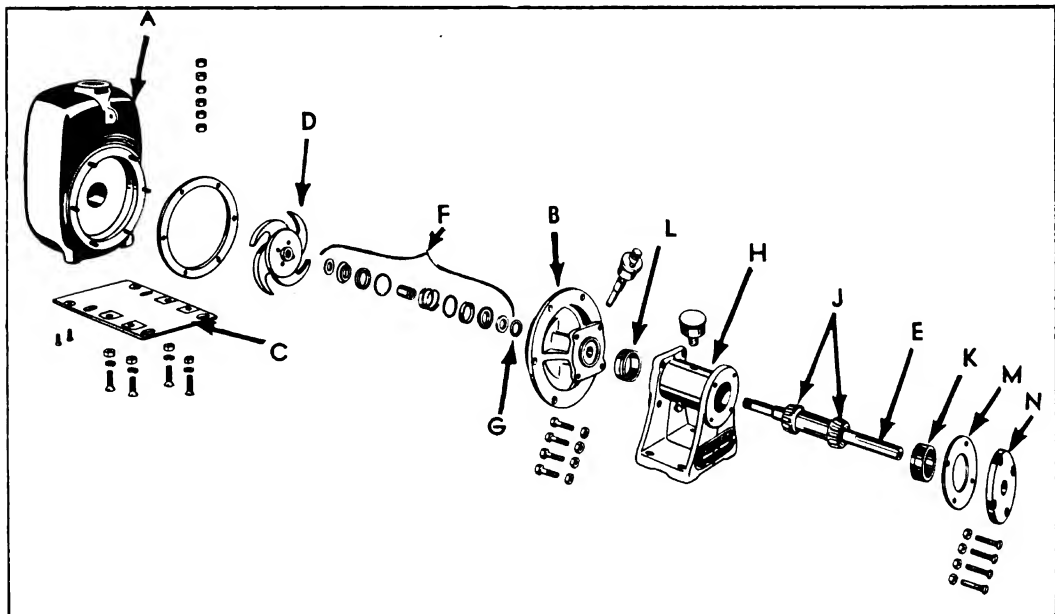

FIG. 70 Water Pump—Drive End

water. If the check valve is not seating properly, water will run out of the pump inlet opening.

To remove the check valve, take off the nuts and remove the check valve body (A) with check valve attached. If the flap fabric is damaged, either around the seat or at its hinge it should be replaced. Remove the hinge plate (B) and the hinge (C). Remove the two weights (D and E) from the hinge (C) and attach to new hinge. Attach new hinge to check valve body (A) by means of hinge plate (B). Replace check valve body (A) on pump, after gasket (M) has been put in place, and then tighten nuts.

PRIMING VALVE (See Fig. 69)

In the lower half of the pump is a built-in priming valve mechanism consisting of a spring blade so located that the force of water will lift it and close off the recirculating jet as soon as the pump has primed. A cleanout hole is provided so that sediment can be easily removed.

Trash may stop the jet hole or cause the valve spring to become inoperative.

To inspect or repair this valve or to clean out trash and sediment, remove the cleanout cover plate (F), taking care not to tear the gasket (G).

To remove the priming valve for replacement, remove through the check valve opening the two nuts that hold the elbow (H) and gasket (J) in place. The two round head screws that hold the valve spring (K) in place can then be removed and the new valve spring installed, and the screws replaced. Replace the elbow (H) and gasket (J), tightening the nuts through the check valve opening. Replace the cleanout plate gasket (G) and plate (F). Replace check valve.

IMPELLER (See Fig. 70)

The impeller is internally threaded to the projecting end of the impeller shaft.

MAINTENANCE SECTION

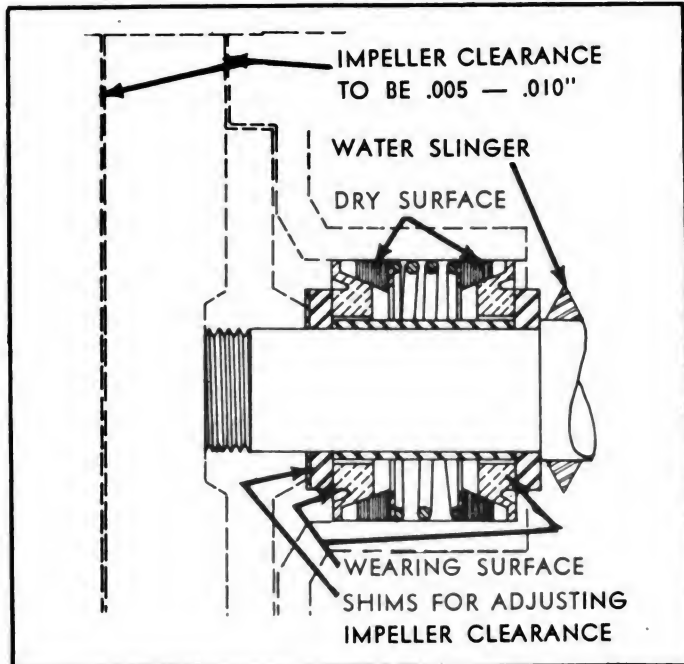

FIG. 71 Lubri Seal Cross Section

To remove the impeller, first unscrew the nuts holding the pump body (A) to the support head (B); second, remove the two cap screws which hold the pump body (A) to the base (C). If the body tends to stick to the support head, DO NOT strike the body a heavy blow with a hammer; instead, screw a short length (about 2 feet) of pipe into the suction opening and strike a sharp, light blow downward on the pipe near its outer end. This will free the body.

To remove the impeller (D) from the shaft (E), hold the crank shaft so that it cannot turn by applying a pipe wrench to the impeller shaft. The wrench handle should rest on the frame for solid support. Then place a piece of wood against the tip of an impeller blade and strike a sharp hammer blow. This should loosen the impeller so that it can be unscrewed.

CAUTION: DO NOT STRIKE HARD ENOUGH TO BREAK THE IMPELLER CASTING.

IMPELLER CLEARANCE (See Fig. 71)

The clearance between the impeller and the support head should be between .005 and .010 inch, and is regulated by placing shims between the impeller and the shaft seal.

"LUBRI" SEAL (See Figs. 70 and 71)

The "Lubri" seal (F) is made up of a spring-loaded seal washers, V-shaped packing rings, and a sleeve which fits into a recess in the support head (B). WHEN REPLACING, ORDER A COMPLETE SEAL UNIT.

To remove or replace the "Lubri" seal, first remove the impeller as previously described. The seal parts can then be pulled out of the recess.

MAINTENANCE SECTION

The seal parts slide on to the shaft head of the impeller, and the wearing surfaces of the sealing collars must be oiled as they are assembled.

CAUTION: THE "V" PACKING MUST NOT BE OILED.

The sealing collars are ground in pairs to an air-tight fit and should not be interchanged.

The "Lubri" seal grease cup in the support head should be inspected to see that it is filled with grease. Lubricate as instructed under Lubrication, "Water Pump Seal", in Operation Section.

WATER SLINGER (See Figs. 70 and 71)

The water slinger (G) is located at the back of the seal recess in the support head (B). Be sure it is placed on the impeller shaft and located over the drip hole in the support head before installing the "Lubri" Seal parts.

SUPPORT HEAD (See Fig. 70)

To remove the support head (B), first take off the pump body (A), the impeller (D), and seal (F) as previously described, then remove the bolts that hold the head to the bearing stand (H), and pull off the support head.

BEARINGS AND SHAFT (See Fig. 70)

To replace bearings or shaft, remove the support head as previously described, and also remove the closure plate (N) and gasket (M) by removing the four flat head stove bolts and nuts that hold them to the bearing stand. After placing a board over the threaded end of the shaft to protect the threads, strike the board a light blow with a hammer. This will loosen and possibly dislodge bearing cup (K). Shaft and bearings can then be removed. The other cup (L) can be removed by use of a screwdriver. The bearings (J) can then be slipped off the shaft and new ones slipped on.

After applying grease to the two bearings, the bearing cup (L) is replaced in the bearing stand (H) and the shaft (E) with bearings (J) are set in place. The bearing cup (K) is slid over the end of the shaft and bearing (J), being held in place by bolting on the closure plate (N) and gasket (M). The support head (B) is then bolted to the bearing support (H) by means of four capscrews and nuts.

The water slinger, "Lubri Seal", impeller, and body are replaced as described in previous paragraphs.

FUEL STRAINER

The purpose of the fuel strainer is to remove abrasive foreign matter from the fuel, thereby preventing excessive wear. The strainer also removes small particles which might lodge in the small passages of the fuel atomizing nozzles.

All fuel handled by the fuel pump must pass through the strainer. If the strainer becomes partially clogged with dirt enough fuel can not pass through it, and the fuel pressure will fluctuate, and possibly drop so low as to extinguish the fire

MAINTENANCE SECTION

CLEANING STRAINER

FUEL STRAINER

DISASSEMBLY (See Fig. 22)

With a wrench, remove hexagon capscrew (A) and washer (B) at the top of the fuel strainer. Lift off cover (C) and cover gasket (D).

Remove screen assembly (E) by unscrewing it from the inside of the strainer body (H). This assembly consists of an inner (F) and an outer screen (G) which may be separated after sliding off the bottom clip (J). Clean both screens and reassemble. The brass plug (K) near the bottom of the strainer should be removed to permit flushing out the strainer body (H).

REASSEMBLY

Replace plug (K). Screw screen assembly (E) into body (H). Replace gasket (D), cover (C), washer (B) and screw in capscrew (A). Make sure that cover (C) and plug (K) are tightly installed to prevent leaks on the suction line.

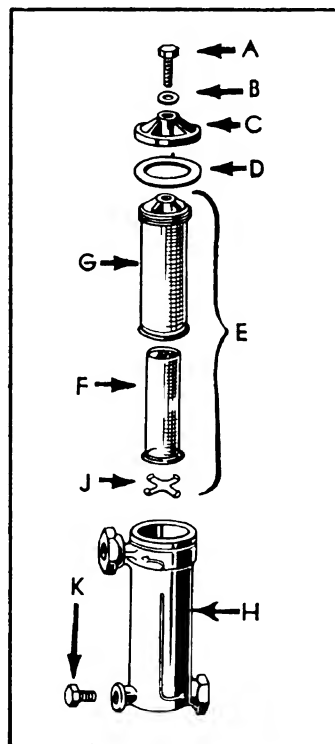

FIG. 72 Fuel Strainer Parts

FUEL PRESSURE REGULATOR

If, pressure does not come up to 100 pounds, the normal pressure after cleaning the strainer, and no oil is delivered to the burner, the trouble is probably due to the internal parts of the fuel pressure regulator having become stuck.

Tap the device with a hammer handle (not the hammer head) to dislodge foreign matter that may be causing it to stick.

Should this treatment fail, remove the hexagon cap at the top of the regulator and, while engine is running, insert screwdriver in slot of pressure adjusting screw and back out screw to relieve the spring pressure on the plunger while again tapping with the hammer handle. Readjust as required to obtain the proper pressure on the gauge.

To decrease oil pressure, turn screw *out*; to increase oil pressure, turn screw *in*.

DISASSEMBLY (See Fig. 73)

Should either of the above remedies prove unsuccessful, dismantle and clean the device as follows:

Stop engine. Detach copper tubing connector in fuel line to fuel pump. Detach copper tubing condenser in return line to fuel tank.

Remove pressure gauge. Remove support bracket. Disconnect brass pipe at bottom of regulator.

MAINTENANCE SECTION

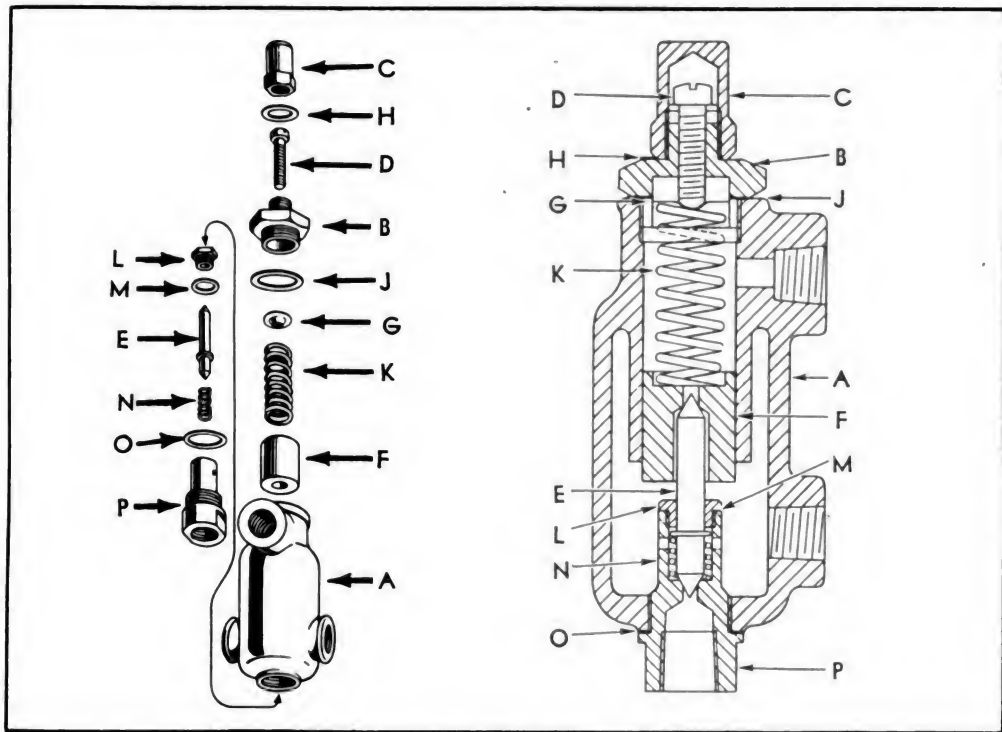

FIG. 73 Disassembly Of Fuel Pressure Regulator

Remove cap (C) and cap gasket (H). Remove adjusting screw (D).

Hold device securely in a vise, but do not compress vise jaws around it. Remove bonnet (B) and bonnet gasket (J). Withdraw spring guide (G), spring (K), and piston (F).

Dismantle bottom assembly by first unscrewing seat (P) and removing seat gasket (O). Unscrew locknut (L) from seat (P) remove locknut gasket (M) and withdraw valve stem (E), and valve lifting spring (N).

REASSEMBLY (See Fig. 73)

Clean all parts carefully, and reassemble as follows:

Valve lifting spring (N) is inserted into seat (P) followed by valve stem (E), locknut gasket (M) and locknut (L). Slip seat gasket (O) over seat (P), and screw assembly into body (A).

Insert piston (F) into top of body (A), followed by spring (K) and spring guide (G). Slip bonnet gasket (J) into place, and screw bonnet (B) down tightly, with wrench. Screw *in* the adjusting screw (D).

Reinstall the assembly, and connect copper tubing and pipe.

Start engine again, and regulate adjusting screw as previously described to obtain 100 pounds pressure. When proper pressure is reached, replace cap gasket (H) and screw cap (C) tightly in place.

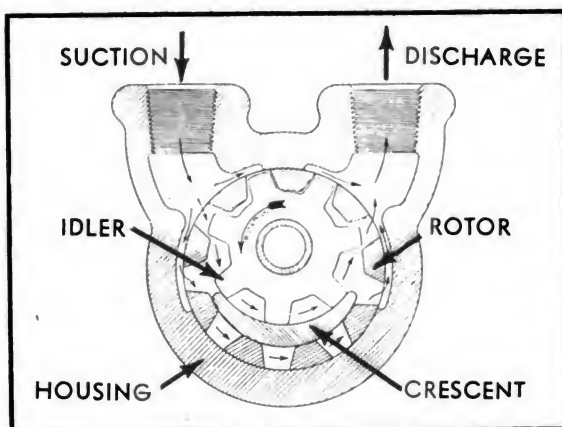

FIG. 74 Fuel Pump Pumping Principle

FUEL PUMP

PUMPING PRINCIPLE

The pumping principle for Tuthill Model L pumps is known as the "internal gear" principle. (See Fig. 74). Power is applied to the rotor and transmitted to the idler gear with which it meshes. The space between the outside diameter of the idler and the inside diameter of the rotor is sealed by a crescent-shaped projection. As the teeth come out of mesh, there is an increase in free space within the pump, thereby creating a partial vacuum. Liquid rushes into the pump to fill this vacuum, and stays in the spaces between the teeth, both of the idler and the rotor, until these teeth mesh. The liquid is then forced from these spaces and out of the pump.

EMERGENCY REPAIR (See Fig. 75)

If this pump should require service of any nature, it should be returned to the factory for correction, if that is at all possible. However, in extreme cases, when it is absolutely necessary to take the pump apart in the field, the following procedure must be strictly adhered to.

To remove the seal assembly, 30L13, first place the pump in a vise so that one jaw grips across the two ports. Do not squeeze too tightly, for that will deform the casting.

Remove cap 0L68, using a spanner wrench, if available.

Then, holding shaft from rotating by gripping the flat on the shaft with a wrench, loosen nut 0L41 in the vise—being careful not to deform the nut by applying too much pressure—pull assembly 0F9 off the shaft.

With a pair of small tweezers, remove pin key 0L69.

At this point care should be exercised to see if there is a small burr raised on the shaft where the pin key enters the shaft. If so, a small file should be used to remove the burr.

Then again place the pump in a vise as before, and remove housing plug assembly 30L11.

MAINTENANCE SECTION

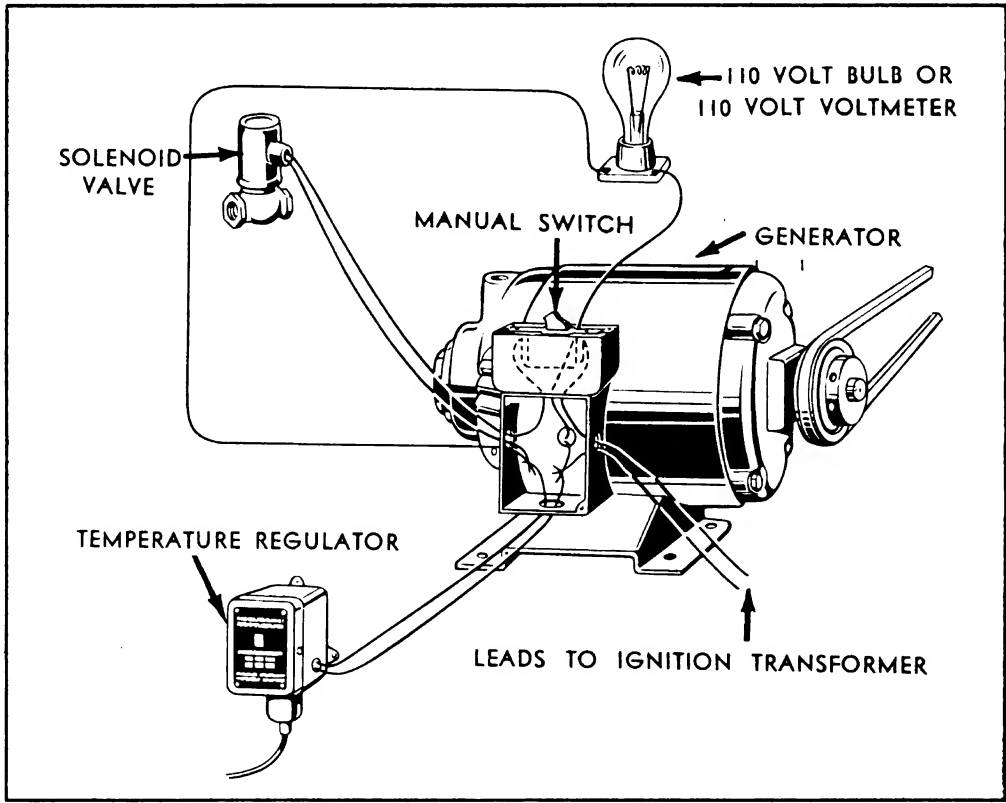

FIG. 76 Checking Voltage To Solenoid Valve Coil

Before the seal is again installed the shaft of the pump should be turned by hand to see that it does not bind. In case that tight spots are noted, tap the outer edge of the cover lightly with the hammer handle until the gears turn smoothly.

The seal may be reinstalled or replaced by reversing the procedure as outlined above. Put a few drops of clean lubricating oil on the seal seat before replacing assembly 0F9. When tightening nut 0L41, it is necessary to create about 7 pounds pressure on this nut, toward the seal. This is equivalent to compressing the seal .040 inch.

Before the pump is reinstalled, it should be tested for free operation by revolving the shaft by hand.

SOLENOID VALVE

The plunger of the solenoid valve is normally closed and will open only if electric current is passing through its coil. Obviously then, if the strainer, pressure regulator and oil pump are all functioning properly but no oil is being supplied to the burner, the solenoid valve coil is not being energized, and the plunger is in a closed position, preventing the passage of fuel to the burner.

The absence of current to energize the coil may be due to any of the following and an inspection should be made before attempting to dismantle the solenoid valve.

MAINTENANCE SECTION

REPLACING COIL

SOLENOID VALVE

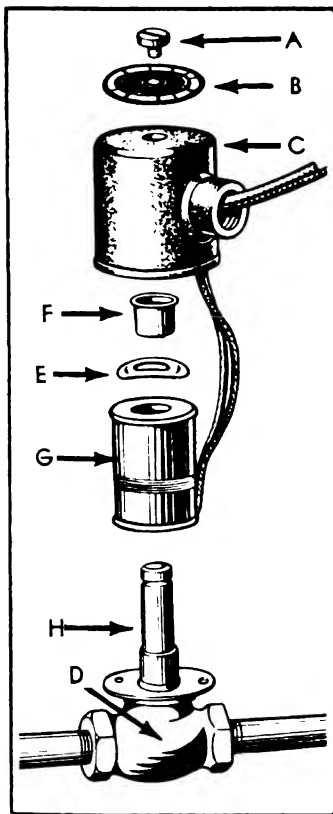

FIG. 77 Replacing Solenoid Valve Coil

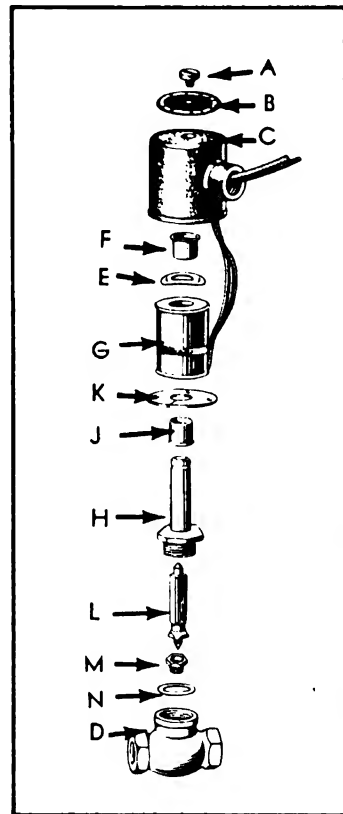

FIG. 78 Solenoid Valve Disassembled For Cleaning

- Loose wire.
- Manual switch is defective.
- Temperature control mercury switch is broken.
- No current from generator.

CHECKING VOLTAGE TO COIL (See Fig. 76)

To determine if the valve is closed due to any of the above reasons, or if the valve itself is inoperative, the voltage to the solenoid valve coil should be checked as follows:

Stop the engine, remove the terminal box cover on the generator, and bare the tape-covered connection between the black lead from solenoid valve and the black lead to the temperature regulator. Remove the cover on the manual switch.

Start engine.

If a voltmeter is available, check the voltage between the spliced connection and the two wire connection between the manual switch. The voltage should be 110 volts. If no voltmeter is available, a 110 volt bulb, when connected between these two points should burn with full brilliancy.

REPLACING COIL (See Fig. 77)

If the voltage is correct but the valve remains closed, it is then obvious that the

MAINTENANCE SECTION

CLEANING

SOLENOID VALVE

solenoid is defective and should be replaced as follows:

1. Disassembly

With engine stopped, disconnect wiring to solenoid valve, at generator terminal box and manual switch.

Unfasten flexible tubing and remove squeeze connector from coil housing.

Remove the screw (A) and nameplate (B) from coil housing (C). Housing can then be lifted off of valve body (D).

With screwdriver, pry off steel washer (E) and bushing (F) that hold coil (G) secure to plunger guide tube (H). Coil (G) can then be removed.

2. Reassembly

Insert new coil (G), replace washers (E), bushing (F), housing (C), nameplate (B), and screw (A).

Pass the wires from the new coil through the squeeze connector and flexible tubing to the generator terminal box, the yellow lead going to the manual switch, and the black lead being spliced to the black lead from the temperature control switch.

CLEANING VALVE (See Fig. 78)

With a dirty fuel strainer, it is possible that small particles of dirt may become lodged between the plunger and the seat, thereby preventing the solenoid valve from operating properly. Should such a condition be found, proceed as follows:

1. Disassembly

The electrical connections should be broken, and the screw (A), nameplate (B), coil housing (C), washer (E), bushing (F), and coil (G) removed as described in the previous paragraphs "Replacing Coil".

Disconnect solenoid valve piping and remove valve.

The coil base plate (K) and bushing (J) should be pryed loose and removed.

Holding the body (D) gently in a vise, loosen the plunger guide nut (H) with a wrench. Remove gasket (N).

The plunger assembly (L) should then be removed, after which seat (M) can be reached for inspection and cleaning.

Remove all deposits from plunger (L), seat (M) and plunger guide tube (H), using whatever solvent may be available. Do not use abrasives or hard, sharp instruments in this cleaning process.

2. Reassembly

The solenoid valve is reassembled as follows:

Replace seat (M) and plunger assembly (L). Replace gasket (N) and plunger guide tube nut (H).

NOTE: Be sure that gasket (N) is free from foreign particles. Carefully tighten plunger guide tube nut (H) to prevent oil leakage.

Replace coil base plate (K) and bushing (J).

Reinstall valve on unit, and connect piping to it.

Replace coil, coil housing, and wiring as described in previous paragraphs "Replacing Coil".

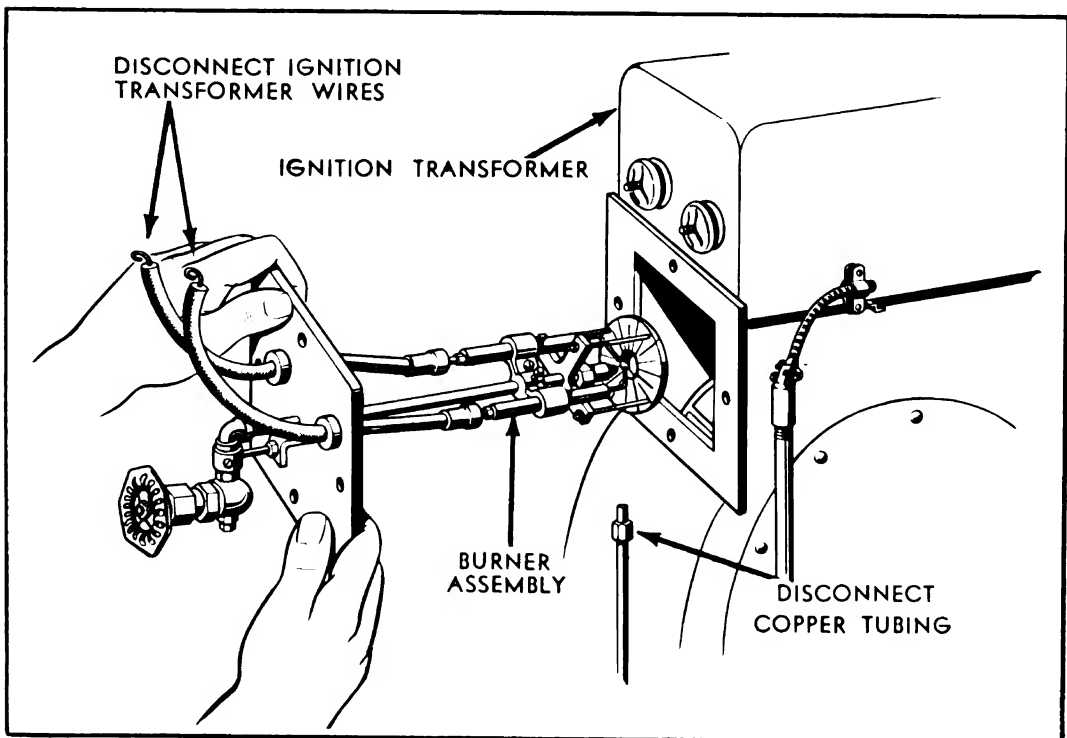

FIG. 79 Removing Burner Assembly

FUEL BURNER ASSEMBLY

DISASSEMBLY FOR REPLACEMENT AND CLEANING

If oil is delivered to burner but does not atomize through the nozzle, the burner assembly should be removed, and the nozzle and its strainer inspected for imperfections or clogging.

Disconnect high tension ignition wires at transformer.

Remove four $\frac{3}{8}$ inch capscrews, one at each side of square burner mounting flange through which oil pipe passes.

Disconnect copper tubing connector in burner oil line just below burner shut off valve, and withdraw burner assembly, pulling it out of blower housing (See Fig. 79.)

Disconnect the two ignition wires from the electrodes at the connector, by pulling apart.

Loosen the two $\frac{1}{4}$ inch round head machine screws that secure the porcelain insulators in the clamp, and then slide out the porcelain-electrode assemblies. (See Fig. 80).

Select two open-end wrenches, one to fit the steel nozzle tip and the other to fit the hexagon end of the nozzle body, and remove the nozzle tip from the body. (See Fig. 81).

With the fingers, remove nozzle strainer screen from nozzle tip and, with a screwdriver, remove the internal core from the nozzle tip proper. (See Fig. 81).

MAINTENANCE SECTION

DISASSEMBLY

FUEL BURNER

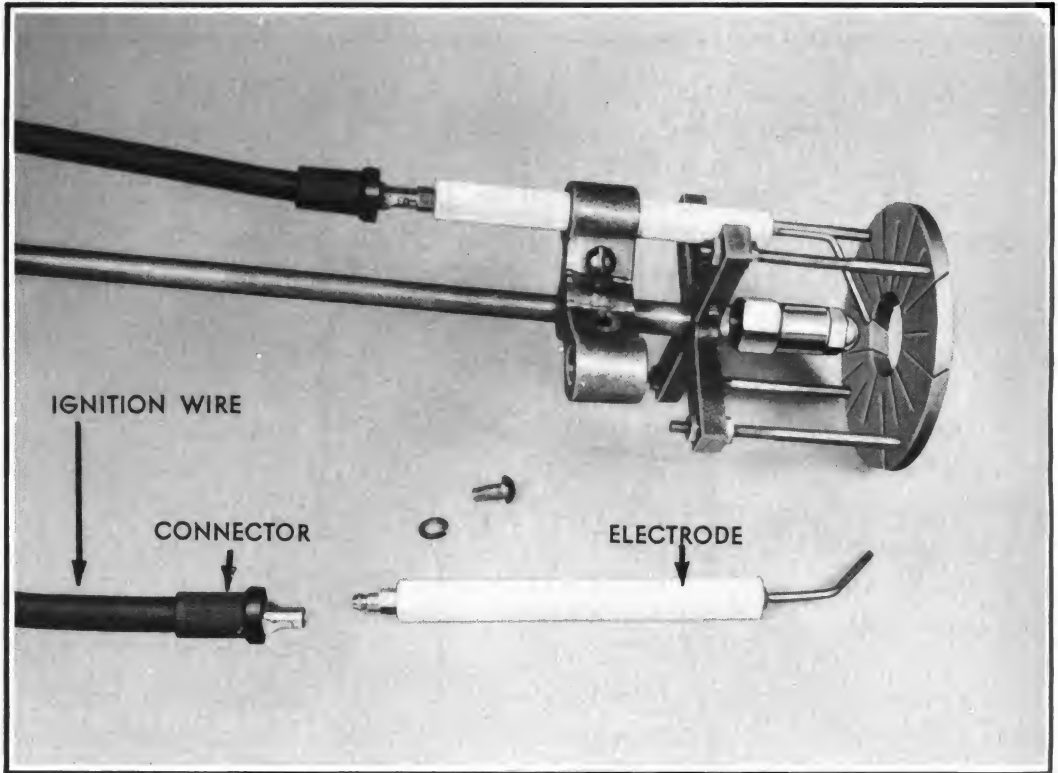

FIG. 80 Removing Porcelain Electrode

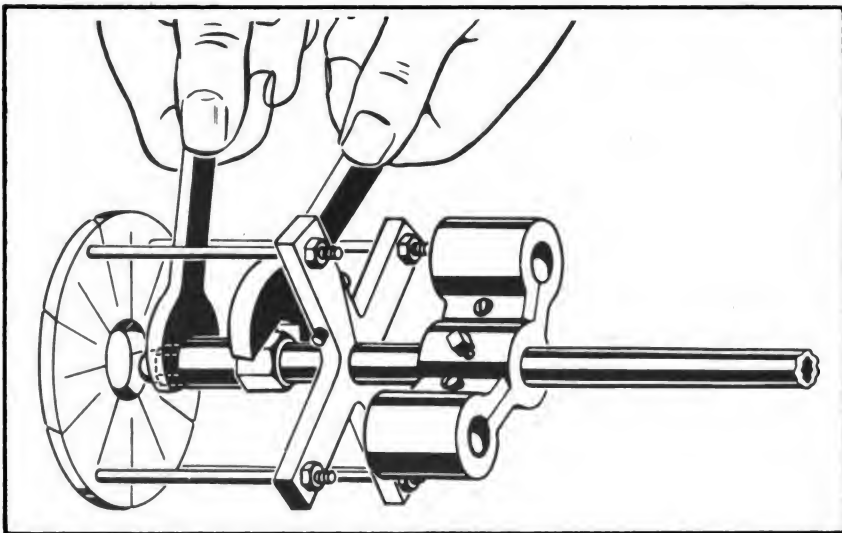

FIG. 81 Removing Nozzle Tip

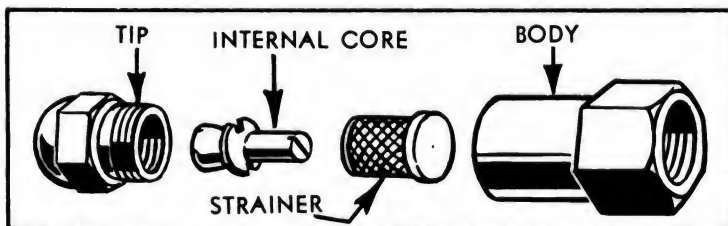

FIG. 82 Burner Nozzle Parts

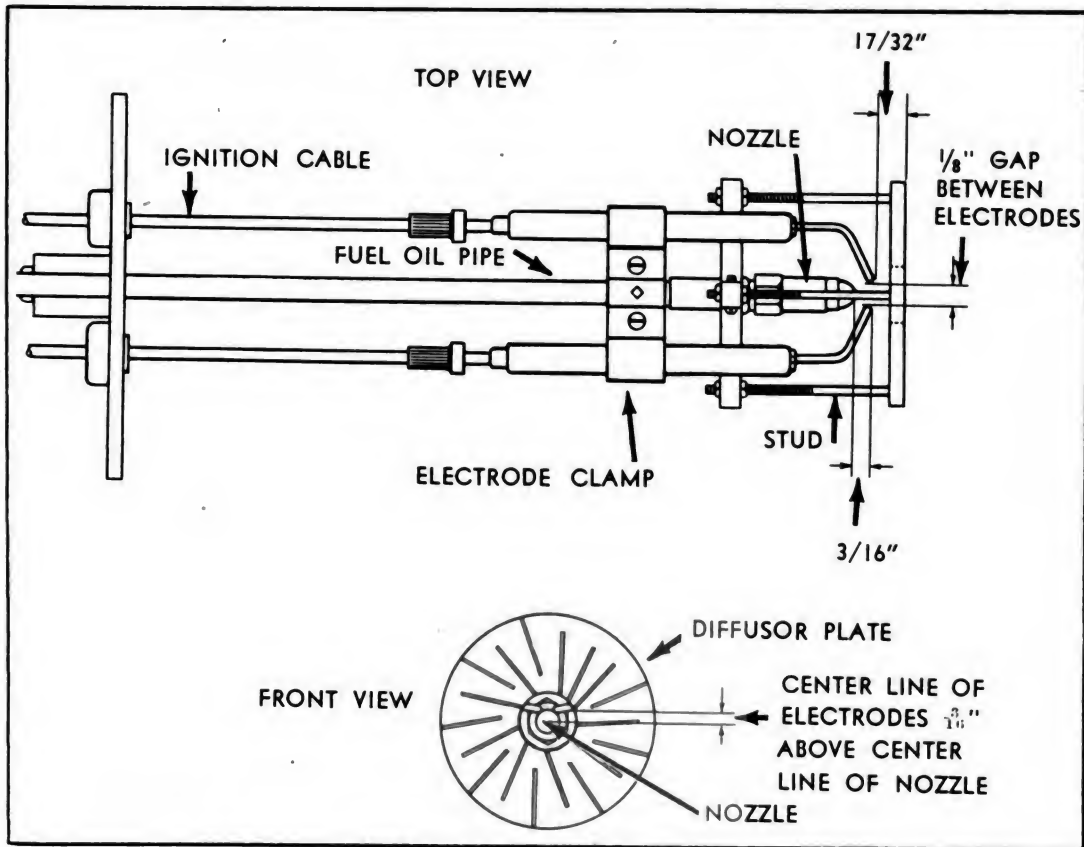

FIG. 83 Nozzle and Electrode Adjustments

Clean all internal surfaces of the nozzle tip and the slotted parts of the internal core, using a wood splinter so that the small oil grooves will not be damaged, particularly the small hole in the nozzle tip proper. Clean nozzle screen carefully, removing all foreign matter to allow free passage of fuel through nozzle.

REASSEMBLY

After thoroughly cleaning all its parts, the burner should be reassembled as follows:

Replace nozzle internal core, using a screwdriver to set it tightly, but without excessive force. **FOR PROPER ATOMIZATION OF THE FUEL, IT IS ESSENTIAL THAT THE INTERNAL CORE BE TIGHTLY SEATED IN THE NOZZLE TIP.**

Replace the strainer screen, screwing it into nozzle tip only finger-tight.

NOTE: Should the nozzle tip or any of its component parts show excessive wear, the entire nozzle tip assembly should be replaced with a new one from the spare parts.

Replace nozzle in brass nozzle body, using the open-end wrenches, seating tip tightly to prevent fuel oil leakage.

Insert the two electrodes into the electrode clamp, spacing them as follows: (See Fig. 83).

MAINTENANCE SECTION

NOZZLE & ELECTRODE ADJUSTMENTS

FUEL BURNER

1. Burner Nozzle and Electrode Adjustments

Spark gap between electrodes should be $\frac{1}{8}$ inch.

Electrode tips should be $\frac{3}{16}$ inch forward of nozzle tip.

Electrode tips should be $\frac{3}{16}$ inch above center of nozzle tip.

Nozzle tip should be $\frac{3}{4}$ inch from front of diffuser plate.

Tighten machine screws in electrode clamp, thereby securing the electrodes.

Attach ignition wires to electrodes by means of connectors, and pass the wires through the two insulators in front mounting plate.

Insert reassembled burner assembly into blower housing opening and secure it with the four $\frac{3}{8}$ inch capscrews.

Connect ignition wires to terminals on ignition transformer.

IGNITION TRANSFORMER

If the operator fails to see an arc across the electrodes within the burner when looking into the observation porthole, it is an indication that either the ignition transformer is defective or that no current is being supplied to it, since the arcing across the electrodes should be constant while the unit is running.

To locate the trouble, remove the generator terminal box cover and bare the three-wire splice. Also remove the cover from the manual switch. If a voltmeter is available, check the voltage between these two connections. The voltage should be 110 volts. If no voltmeter is available, a 110-volt bulb should burn with full brilliancy, when connected between these two points. (See Fig. 84).

If the voltage is low, or no voltage at all, the generator should be checked as described in a later paragraph under "Generator". If the voltage is correct, the trouble lies in the ignition transformer.

REPLACEMENT

Breakdown of this unit is very rare, and upon failure it should be removed and a new one installed as follows:

1. Disassembly

Shut down unit and disconnect high tension ignition wires from terminals at front of transformer.

Remove cover plate at back of transformer and disconnect the two leads. Also disconnect the flexible tubing at the side of the transformer, pulling generator leads through the side. Remove the 45 degree squeeze connector.

The three machine screws securing the transformer should be removed, and the defective unit removed.

2. Reassembly

After new unit has been securely mounted in place, replace the squeeze connectors at the side. Pass wires through side of transformer, and tighten flexible tubing. New transformer leads can now be spliced to the generator leads, and the back cover then replaced.

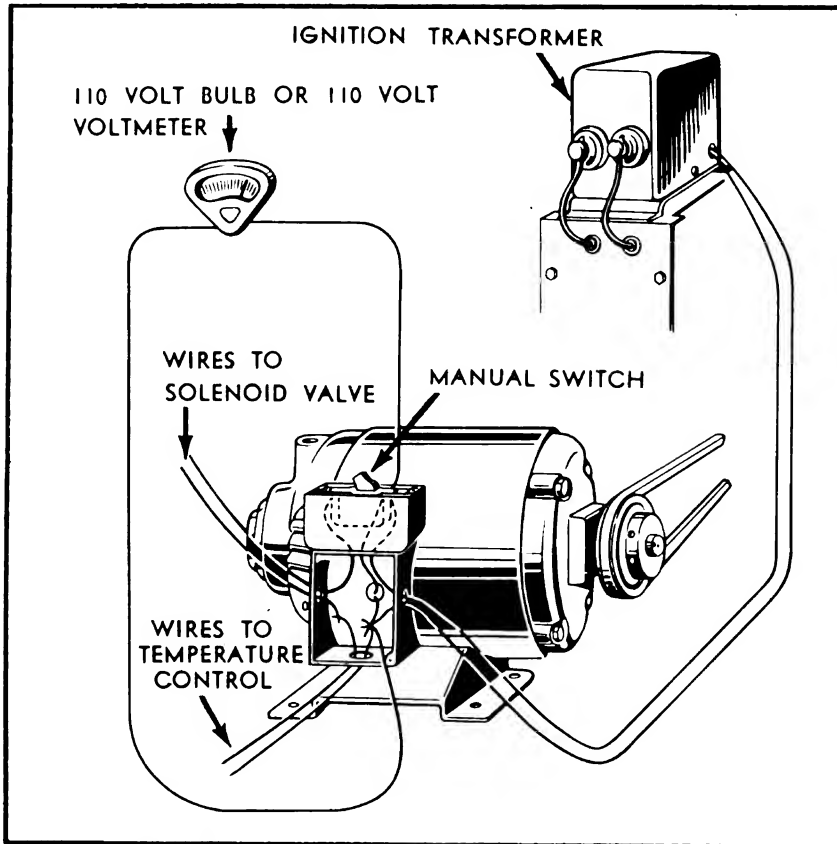

FIG. 84 Checking Voltage To Ignition Transformer

Connect ignition cables to secondary winding terminals at front of transformer.

BLOWER

The blower on this unit should require little attention other than regular greasing of the bearings. However, should it become necessary to replace any of the parts, such as bearings, shafts, or wheel, the blower should be disassembled as follows:

DISASSEMBLY (See Fig. 85)

Slip off blower V-belt and remove sheave and key.

Remove oil burner assembly and ignition transformer as described in previous paragraphs under "Fuel Burner Assembly" and "Ignition Transformer".

Remove the three brass nuts that hold the blower assembly to the front outer head, and remove the blower.

Remove the plate (A) that covers the bearing (B) in the air shutter (C) and slip the arm off the pin of the top shutter leaf and raise leaf, exposing bearing (B).

Remove ring (D) and setscrews (E) that hold the bearing (B) to the shaft (F).

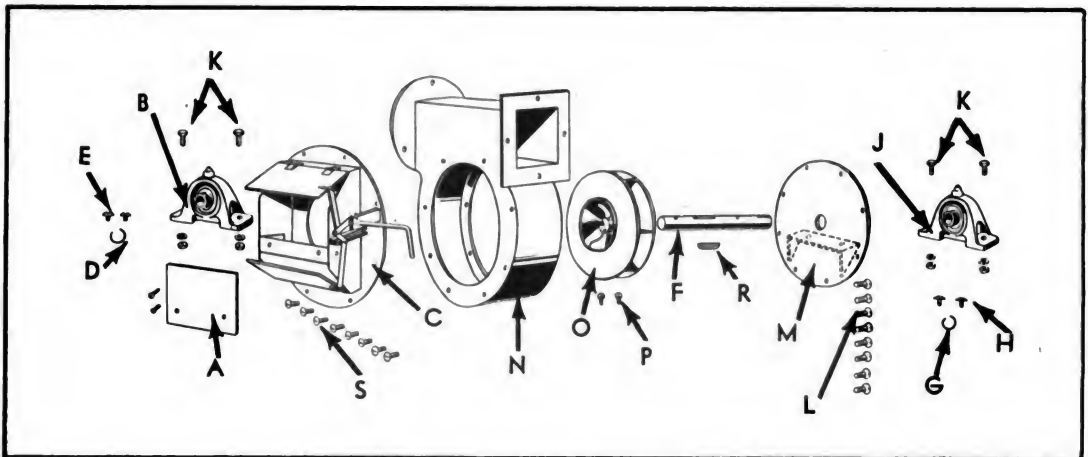

FIG. 85 Disassembly Of Blower

Remove ring (G) and setscrews (H) that hold bearing (J) to the shaft (F) on the opposite side of blower.

Remove capscrews and nuts (K) that hold bearings (B) and (J) to brackets. Bearing (J) can then be slid off the shaft (F).

After removing the eight round head machine screws (L) holding the blower side plate (M) to the blower body (N), the side plate (M) can be slid off the shaft (F), and the shaft (F) and wheel (D) withdrawn from the blower body. Bearing (B) in the air shutter can then be removed.

After removing the two setscrews (P) that hold the blower wheel (D) to the shaft (F), the wheel can be slid off the shaft. Be careful not to lose the Woodruff key (R) that holds the wheel in place.

After removing the eight round head machine screws (S) the air shutter assembly (C) can be removed.

REASSEMBLY (See Fig. 85)

Replace the air shutter assembly (C). Secure with eight machine screws (S).

Slide the wheel (O) over the shaft (F), with key (R) in place, then tighten the two wheel setscrews (P):

After air shutter bearing (B) has been set in place, insert wheel (O) and shaft (F) into blower housing (N). Replace side plate (M) and secure it with eight machine screws (L).

Slide bearing (J) over the shaft, and secure both bearings (B and J) with capscrews, nuts, and lockwashers (K). Replace bearing setscrews (E) and (H) and rings (D) and (G).

Replace air shutter plate (A).

If blower gasket is in good condition, the assembled blower can be fastened to the front head by means of three washers and nuts.

The sheave and key should be replaced and aligned.

Replace burner assembly and ignition transformer, and connect ignition wires and generator wires. Be sure that burner gasket is in place.

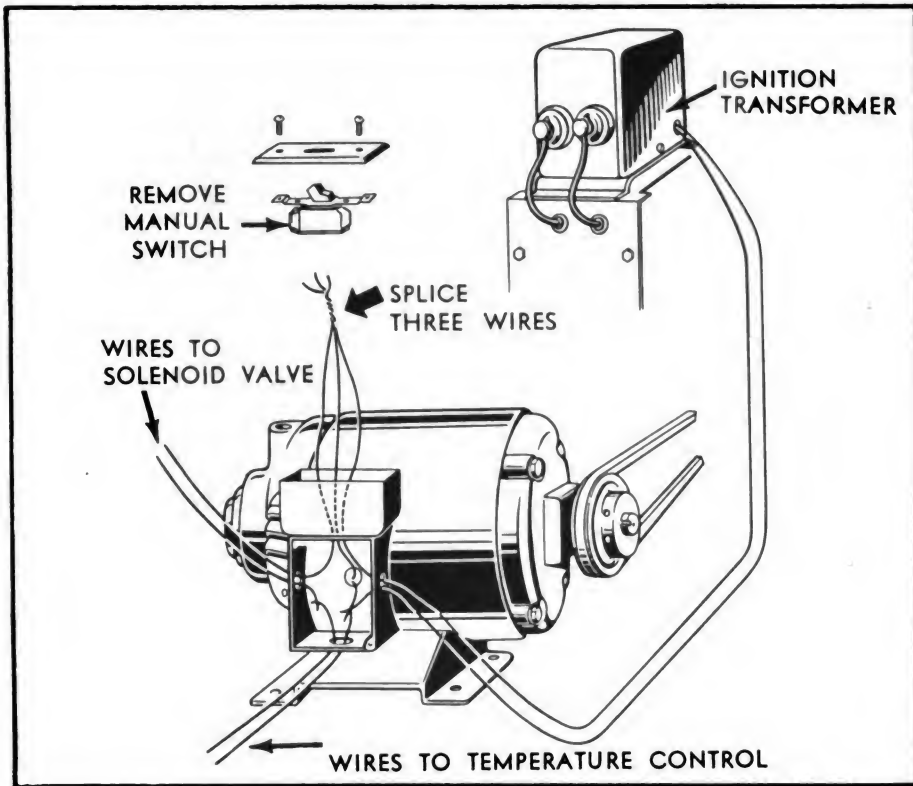

FIG. 86 Manual Switch Three Wire Splice

MANUAL SWITCH

If the manual switch is suspected of being defective, remove its cover and see if switch blade is making contact when in the "ON" position. If found defective, install a new switch.

Should it be impossible to secure a new switch immediately, the defective switch can be removed and a temporary connection made by splicing together the three wires and taping them with electricians tape, or (in emergency, adhesive tape) (See Fig. 86).

CAUTION: This should be done only as a temporary measure and a new switch must be installed as soon as possible, since current will flow constantly through this temporary connection and the solenoid valve and ignition cannot be controlled manually unless the wires are separated.

GENERATOR

If the operator should find the generator voltage is low or there is no voltage at all, the generator is probably inoperative. Generator failure is usually due to poor brush contact on commutator or a dirty commutator.

To inspect the brushes, remove the terminal covers at the end opposite the sheave end. There are two sets of brushes, two for A. C. and two for D. C. The A. C.

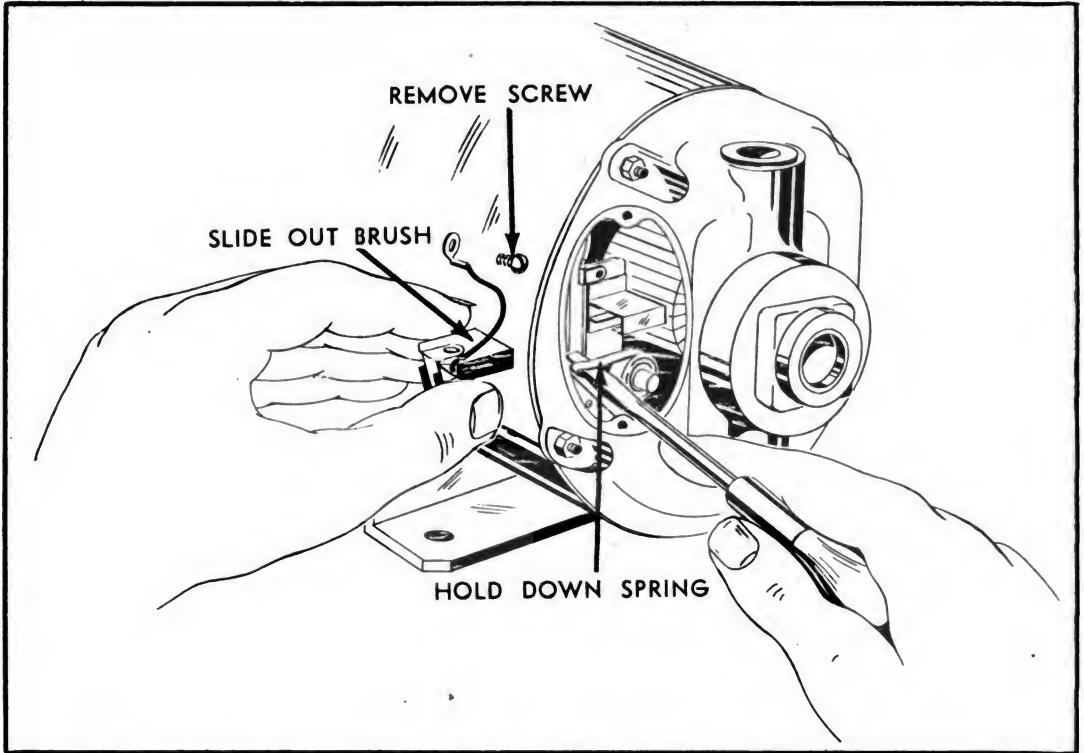

FIG. 87 Removing D. C. Brushes

brushes bear on the two collector or "slip rings". The D. C. bear on the commutator composed of many parallel copper bars.

CLEANING COMMUTATOR

If commutator needs cleaning, it should be cleaned as outlined under "Operating Irregularities and Their Correction" in the Operation Section. Also see Fig. 35 in the same section.

REPLACING D. C. BRUSHES (See Fig. 87)

Should the brushes become worn, they should be replaced as follows:

Lift the spring; the brush can then be slipped from its holder. Remove the screw that secures the brush lead to the brush rigging assembly and the brush will then come free. To install a new brush, lift spring and slide brush into the holder. Secure the lead to the brush rigging assembly.

REPLACING A. C. BRUSHES (See Fig. 88)

To replace the A. C. brushes, remove the metal protecting cap at the top of the vertical, tubular-shaped projection of the front bracket, and remove the insulator cap with screwdriver. This will release the brush and its spring. When installing new brushes, be sure that the curved surface of each brush fits that of the commutator. Replace insulator cap and metal projecting cap.

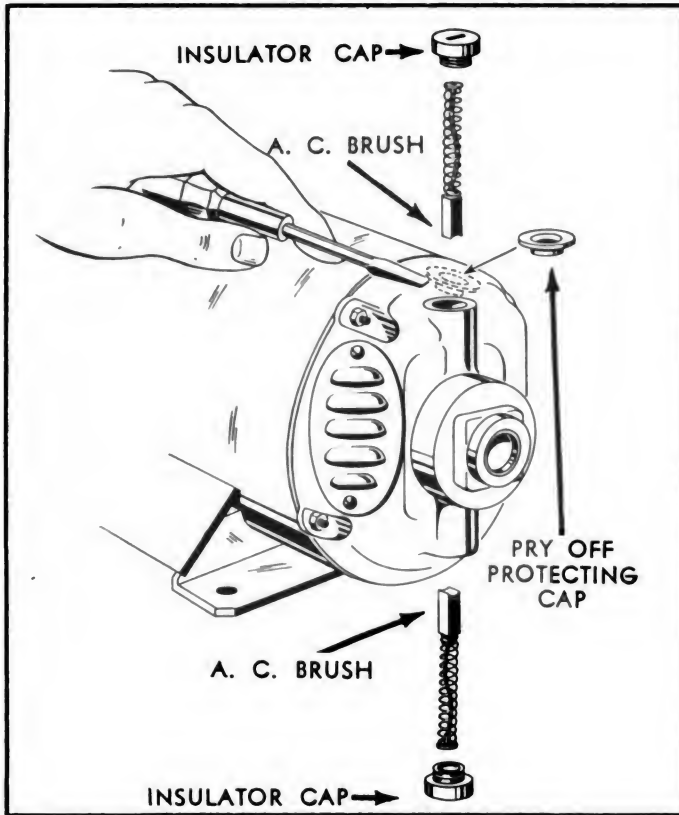

FIG. 88 Removing A. C. Brushes

DISASSEMBLY (See Fig. 89)

After removing all brushes, and the wiring to the generator has been disconnected, the generator can be removed from the unit by removing the four capscrews that hold it to the baseplate and dismantled, as follows:

Remove four nuts (A) and studs (B) that attach front and rear brackets (C) and (D) to the frame (E).

Remove rear bracket (D). Bearing (F) with its felt and steel washers and spring can then be removed.

Remove two round head machine screws attaching field coil leads (G) to brush rigging (H).

Front bracket (C) can then be removed and the armature assembly (J) withdrawn. Bearing (K) with its felt and steel washers, should be removed.

The brush rigging (H) can be removed for replacement after removing the two brush rigging clamps (L) that hold the rigging to the front bracket (C).

REASSEMBLY (See Fig. 89)

After replacing the worn or broken parts, the generator can be reassembled as follows:

Replace brush rigging (H) and secure it by means of brush rigging clamps (L).

Slide bearing (K) on armature shaft (J) and, with felt and steel washers in place, insert it into front bracket (C).

MAINTENANCE SECTION

MERCURY SWITCH

TEMPERATURE REGULATOR

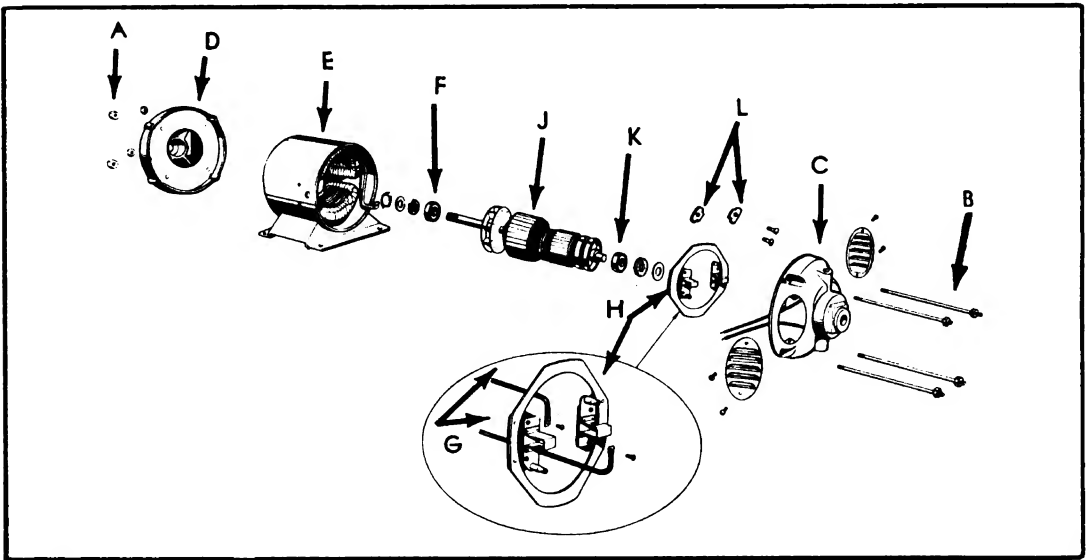

FIG. 89 Generator Parts

The armature should then be passed through the frame and, after sliding on bearing (F), felt and steel washers, and loading spring, the rear bracket (D) can be fastened in place by the four studs (B) and nuts (A).

The brushes should then be replaced as described under previous paragraphs.

The generator should then be remounted on the unit, the sheave mounted and aligned, and the wires connected as shown in the parts list under "Generator and Ignition Wiring Diagram".

TEMPERATURE REGULATOR

The automatic temperature control consists of two major parts. One part, the bulb, is exposed to the water within the heater at a point just below the 3" round dial indicating thermometer, at the operating end of the unit. The other part, is the metal box mounted on the control panel, containing the switch mechanism.

The control box and the bulb are connected by a thin copper tube. This tubing should be inspected frequently to see that it has not been cut, bent or flattened, since this would seriously impair the proper operation of the control.

REPLACING BROKEN MERCURY SWITCH (See Fig. 90)

The temperature control mercury switch may be broken by a severe jolt or mishandling. If the glass tube has been broken, a new mercury switch must be installed as follows:

Disconnect the two leads. Then with the point of a knife, pry the switch clip loose from the mercury switch—never attempt to break it loose with the fingers.

Two layers of friction tape, to replace the ambroid cement that was used on

MAINTENANCE SECTION

MERCURY SWITCH

TEMPERATURE REGULATOR

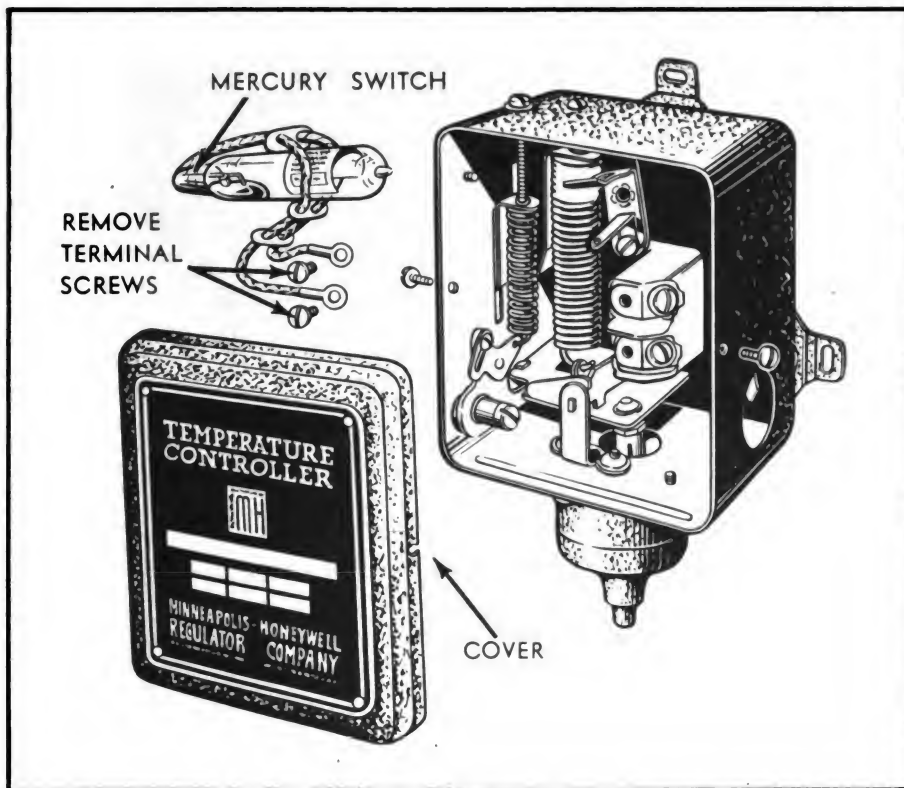

FIG. 90 Replacing Mercury Switch

the old switch, should be wrapped around the new switch before placing it in the clip.

When installing the new switch, care must be taken to place it in exactly the same position as the old one in order not to change the balance, since an unbalanced switch may throw the entire switch mechanism out of adjustment.

When connecting the new leads, the operator should bear in mind that sufficient slack is needed to allow free movement between "On" and "Off" positions.

CHECKING ADJUSTMENT WITH NEW SWITCH

After a new switch has been installed, it may sometimes be found that, the operating differential of the controller is considerably smaller than that for which the indicator is set, and this may be an indication that the mercury switch is out of adjustment. Before making any adjustments, however, be sure that the difficulty is not due to the controller being "off level." Note the level indicator (F) in Fig. 91.

The adjustments may be checked as follows: Set the differential indicator (E) approximately at mid-scale, and the temperature indicator (D) so that the operating level (G) rests lightly against its upper stop. Press down on the left-hand end of the operating lever (G) until it is about midway between its upper and lower stops and just touches the differential lever (H). This movement should not cause the mercury in the switch to change ends. Further downward pressure on the operating lever will force it to the lower stop, carrying the differential lever with it, and will cause the switch to tilt and shift the mercury. Next, allow the operating lever r

MAINTENANCE SECTION

MERCURY SWITCH

TEMPERATURE REGULATOR

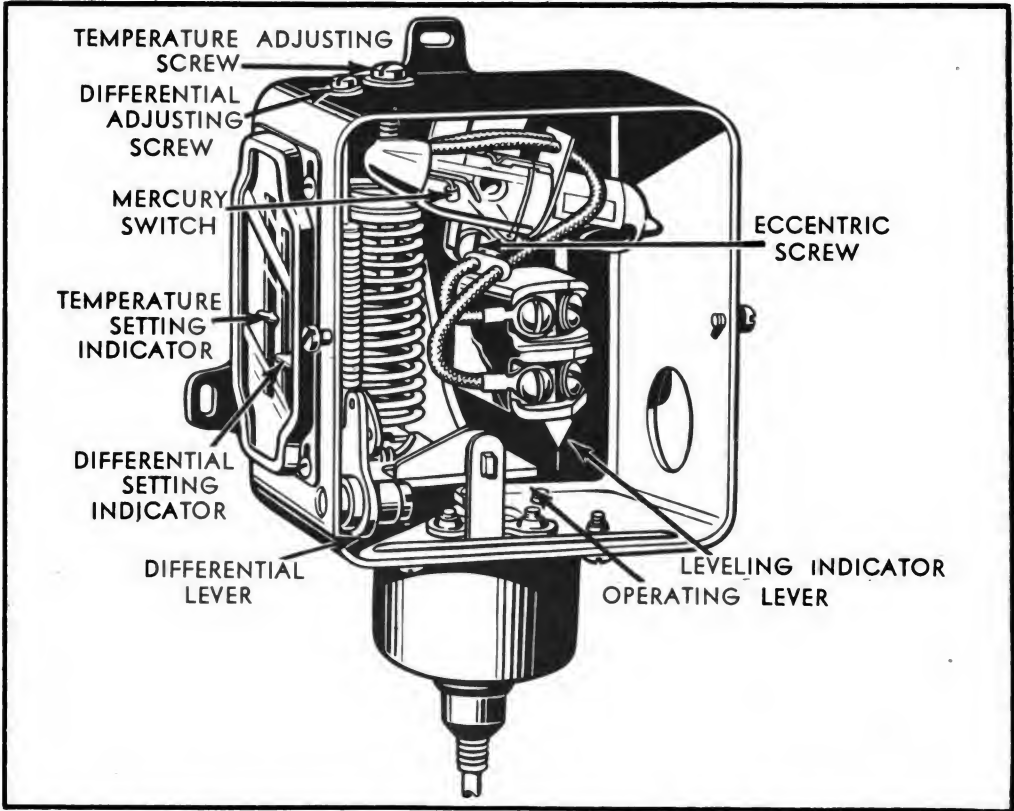

FIG. 91 Temperature Regulator Control Box

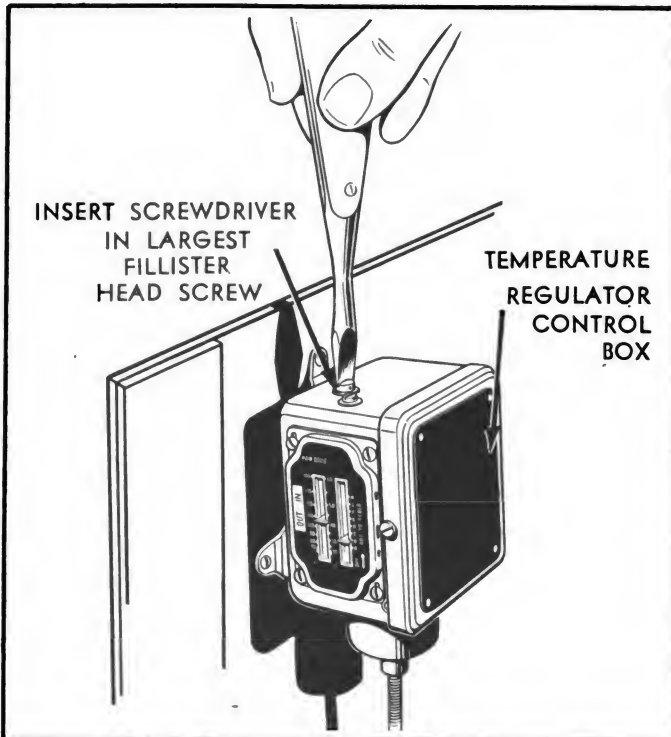

FIG. 92 Adjusting Temperature Scale

MAINTENANCE SECTION

MERCURY SWITCH

TEMPERATURE REGULATOR

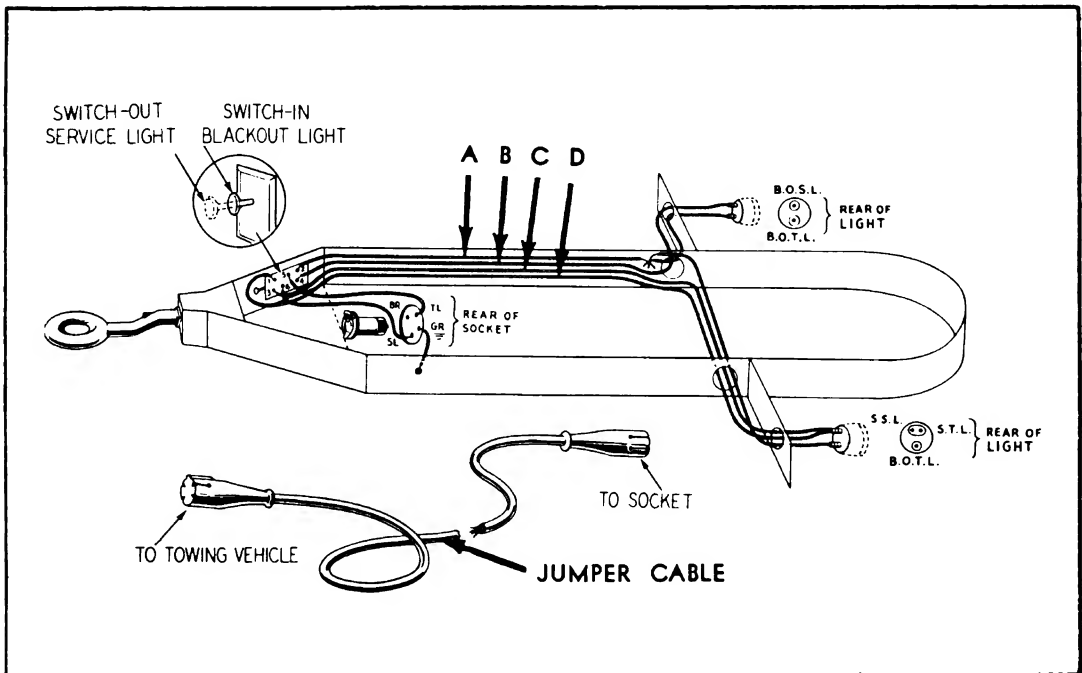

FIG. 93 Light Wiring Diagram

return slowly to midpoint between stops, and note that the mercury should not shift its position. Then allow the operating lever to return to its upper stop and the switch should tilt back to its original starting position.

ADJUSTING TEMPERATURE (See Fig. 92)

On top of the control box will be found two fillister type screwheads. The larger head controls the main scale temperature cut-in point. For example: If the pointer on the main scale points to 105 degrees F, the switch in the control box will close and fuel will be supplied to the burner. Should the operator desire a higher or lower cut-in temperature, he has only to insert a screwdriver into the slot in the large fillister head and turn the screw either to the right or left. Turn to the right to increase the setting; turn to the left to lower it.

ADJUSTING DIFFERENTIAL

The smaller fillister head screw controls the range (the difference in degrees) between the cut-in point and the cut-out point. This scale has been set at the factory to give a difference of five degrees when set at "B", and should not be changed unless a greater or smaller difference in water temperature is desired, since at this setting the cut-in temperature will always be 105 degrees F and the cut-out 110 degrees F. With the main scale set at 105 degrees F the number of degrees to each division from "A" to "H" will be about two and one-half.

MAINTENANCE SECTION

LIGHT WIRING

LIGHT WIRING

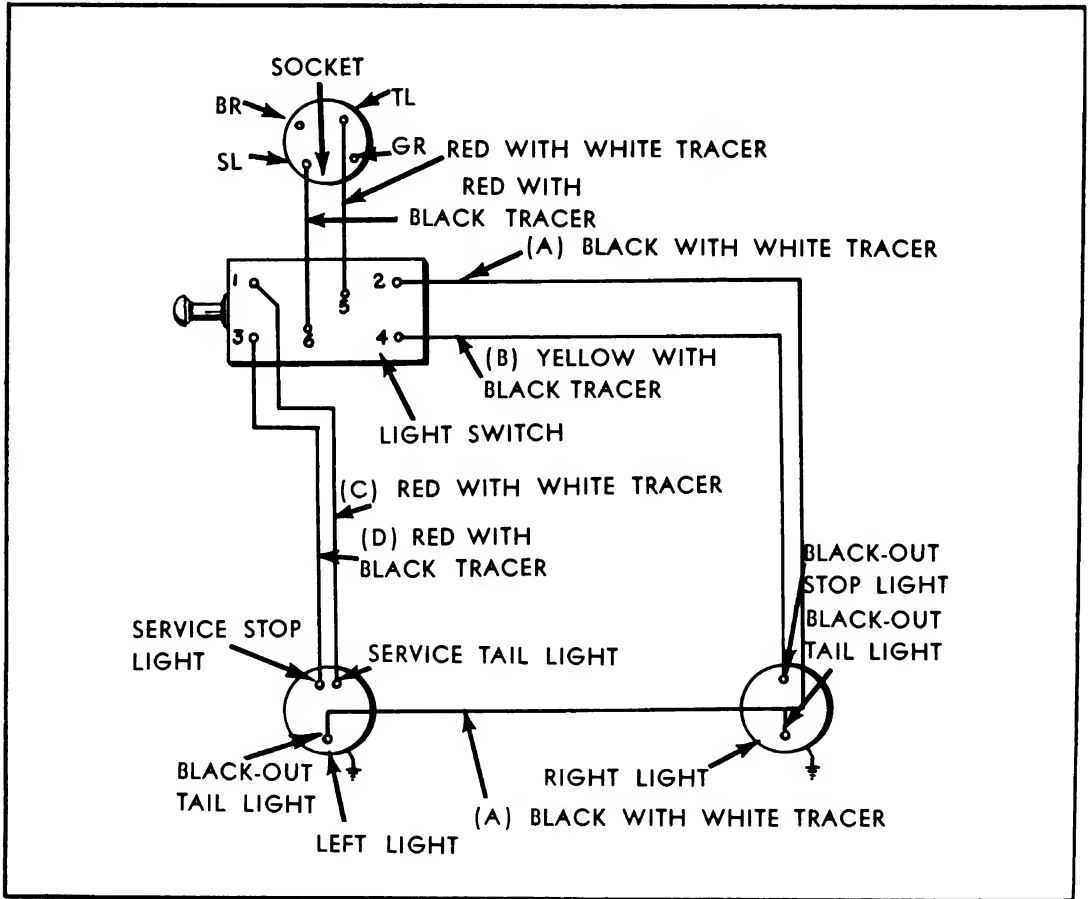

FIG. 94 Light Wiring Diagram

LIGHT WIRING

Six electrical cables lead from the light switch box located on the front end of the unit, inside the frame member, four of which connect to the blackout tail and stop lights, and the service tail and stop lights. The two remaining cables connect the switch to the jumper cable socket. The operator should refer to Figs. 93 and 94 when installing new cables on the unit. The four electrical cables are identified by the following color code.

The black wire with the white tracer (A) is the connection to the blackout tail light.

The yellow wire with the black tracer (B) is the connection leading to the blackout stop light.

The red wire with the white tracer (C) is the connection leading to the service tail light.

The red with the black tracer (D) is the connection leading to the service stop light.

Should any of the stop lights, tail lights, or blackout lights fail to light when the circuit is connected, the bulb should be removed and inspected for corrosion on the terminal points and if necessary a new bulb installed. If the new bulb does not light.

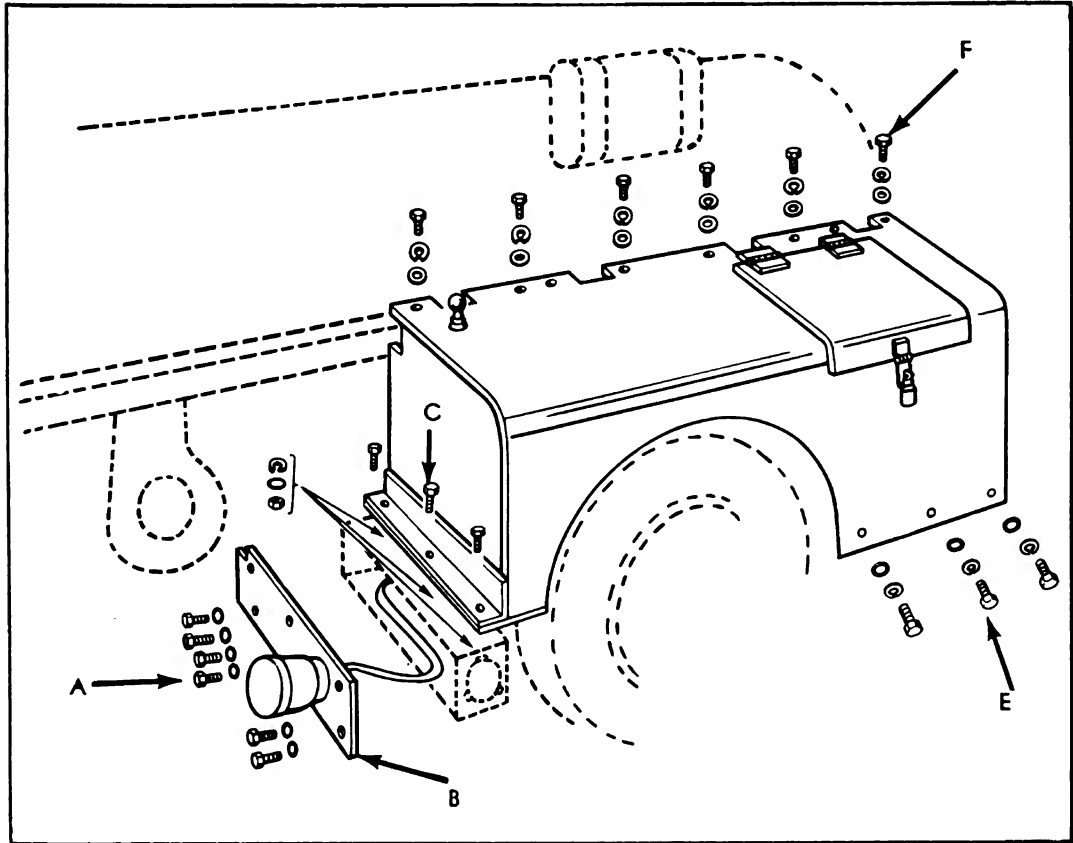

FIG. 95 Removing Fender Tank

check the cable connections between terminal board and tail light unit. If connections appear to be correct, check the towing connection between the towing vehicle and the unit for proper connections. If all connections have been determined to be correct, check unit towing vehicle for disconnections. Since the unit lights receive their source of current from the towing vehicle, it is possible that the source of current supply may be cut off through insufficient battery supply, or defective wiring or switches.

REFLECTORS

There is one reflector lens on each side of the unit, but they do not contain bulbs or electrical connections. The only replacement that may be necessary would be to install a new colored lens, which can be done by removing the two screws holding the reflector in place.

SHOWER AND HOSE RACK

To remove shower and hose rack, the four capscrews that secure the four legs to the unit should be removed and the rack lifted out.

FENDER TANKS

In order to remove either or both of the two fuel tanks from the unit, the following procedure should be followed: (See Fig. 95).

MAINTENANCE SECTION

REPAIR

SLIDING DOOR

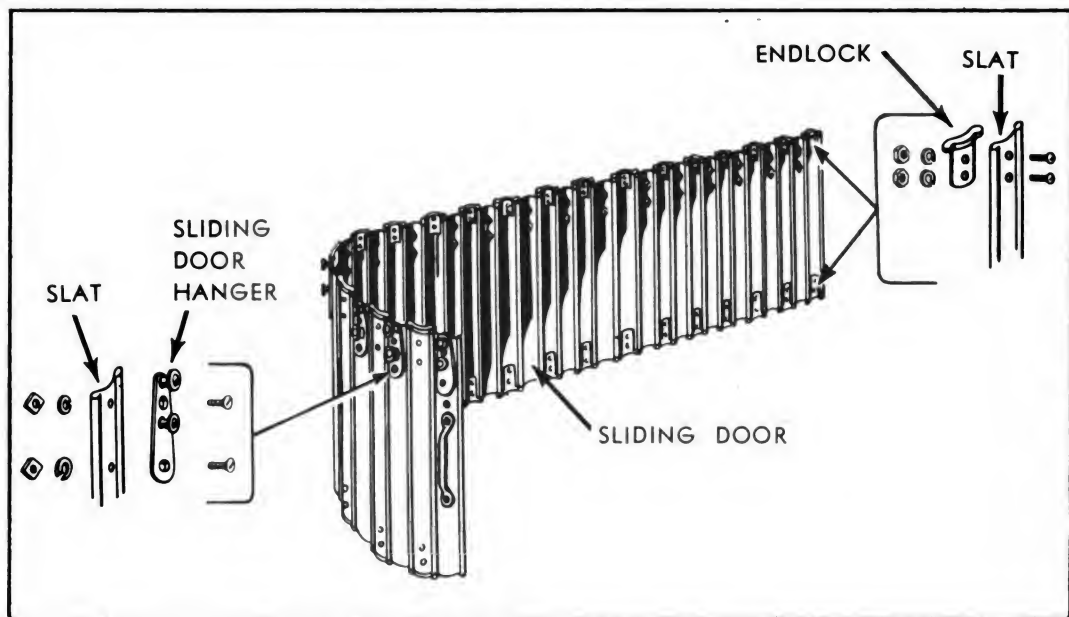

FIG. 96 Replacing Sliding Door Slats

After draining the tank by opening the petcock at the bottom of the tank, the suction and return tubing should be disconnected from the tank.

Remove the shower and hose rack assembly from the top of the unit, as previously described.

Remove the six capscrews (A) that hold the tail light panel (B) to the frame member. The three bolts (C) holding the end of the tank to the frame can then be removed. Remove the three capscrews (E) at the side of the tank. After removing the six capscrews (F) at the top of the tank, it can be removed.

Small leaks can be temporarily plugged with small wooden plugs. Large openings should be welded after proper cleaning of the tank to remove all fuel vapors. If tank cannot be repaired by welding, a new tank should be installed.

WARNING: IT is extremely dangerous to attempt welding any tank that has contained any type of petroleum product until it has been thoroughly cleaned, preferably with live steam.

To install tank, replace six capscrews (F) at top of tank, three capscrews at side, three bolts at end, and connect suction and return tubing at bottom of tank.

Replace shower rack and bolt down with four capscrews.

SLIDING DOOR

To remove sliding door, first remove the shower and hose rack, then remove the fender tanks as described in preceding paragraphs. Remove the power plant hood and brackets. Remove the four capscrews that hold the sliding door track to the heater. Also remove the three capscrews that hold the track to the base plate and the three capscrews that fasten the engine panel to the track leg.

When replacing sliding door slats, slat hangers, or slat endlocks, refer to Fig. 96.

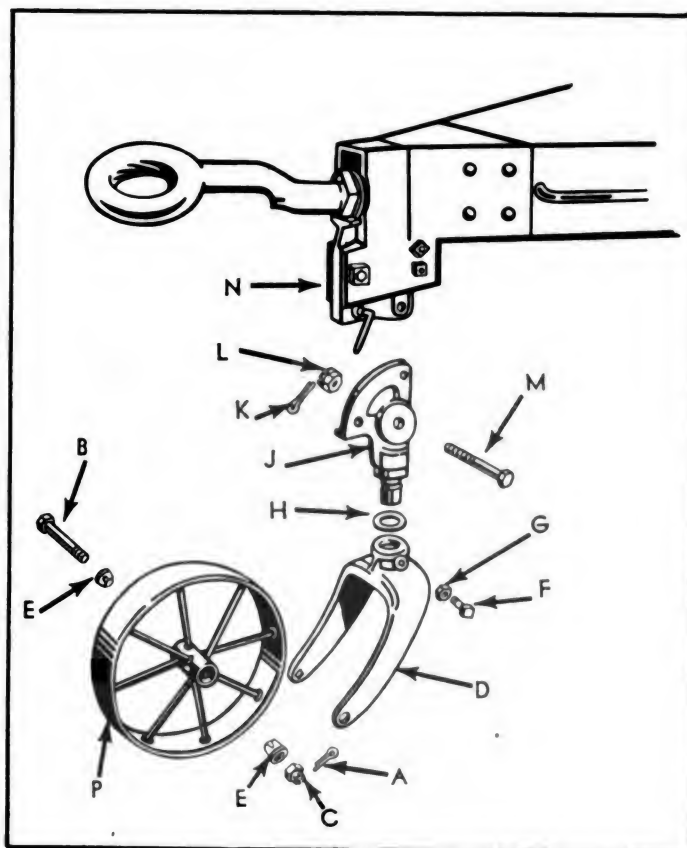

FIG. 97 Removing Caster Wheel

LUNETTE DRAWBAR

The lunette drawbar can be removed by removing the cotter pin and unscrewing the slotted nut that holds the lunette in drawbar bracket, which is bolted to the frame and cannot be removed. Lunette can then be withdrawn.

CASTER WHEEL

To remove the quadrant and swivel pin (J) (See Fig. 97) remove the cotter pin (K), castellated nut (L), and capscrew (M), that holds the quadrant (J), to the drawbar bracket (N).

To remove caster wheel (P), remove cotter pin (A) from axle wheel carriage bolt (B), then unscrew nut (C) from the axle bolt. Bolt (B) can then be withdrawn from the wheel fork assembly (D). There are two bushings (E), one on each end of the caster wheel hub. These bushings should be inspected after removal for excessive wear and, if necessary, new bushings installed. The caster wheel fork (D) can be removed from unit by removing the setscrew (F) and locknut (G), that holds the caster wheel fork to the quadrant and swivel pin. Be careful not to lose washer (H).

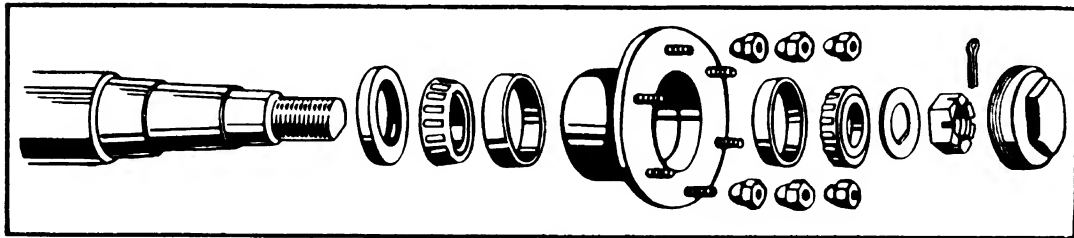

FIG. 98 Wheel Bearings And Cups

REMOVAL OF WHEELS

Place the jack under the axle as close to the wheel as possible, so that the wheel can be raised. Jack up unit until the wheel can be rotated. Remove six nuts holding wheel to hub. The wheel can then be removed.

WHEEL HUB AND BEARINGS

Remove wheel as previously described under "Removal of Wheels". Remove hub cap, screwed to the wheel hub with a right-hand thread. Remove cotter pin set through the castellated nut and remove nut and washer that hold outer bearing in place. (Fig. 98).

Pull off hub. The outer bearing, outer bearing cup and inner bearing cup will remain in the hub. The inner bearing will remain on the axle. With fingers, remove the outer bearing, and then slide the inner bearing off of the axle. Grease seal can also be slipped off the axle for cleaning. Wash bearings in fuel oil or kerosene and carefully clean interior of hub.

If the roller bearings or cups show evidence of wear, they should be replaced with new ones.

To reassemble—Slide grease seal on axle shoulder, with leather face out. After thoroughly greasing the inner bearing slide it on the axle, with taper toward axle end. With both bearing cups greased and in place, slide on the wheel hub. After greasing the outer bearing, insert it with taper away from axle end. Install washer and castellated nut, and while wheel is spinning tighten nut until tension stops the wheel. Then loosen the nut to the next cotter pin position (approximately $\frac{1}{6}$ turn) and install cotter pin. Cover the outer bearing and the nut with grease, then screw on hub cap.

ENGINE

To remove engine for disassembly, remove the four capscrews securing the engine to the baseplate, being careful not to lose the two $\frac{1}{8}$ inch shims under the engine or the filler block from the flexible coupling. Disconnect fuel line at carburetor.

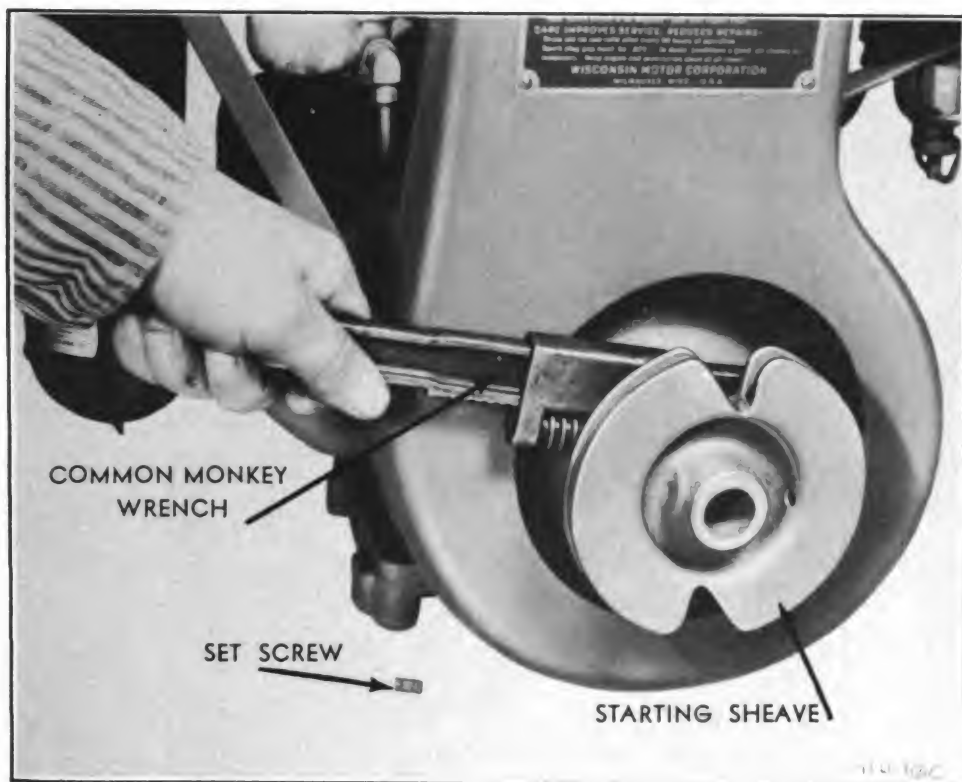

FIG. 99 Removal Of Rope Starter Sheave

REMOVAL OF MUFFLER

Unscrew the muffler from the exhaust pipe extending through the base plate. Next, unscrew the exhaust piping.

REMOVAL OF ROPE STARTER SHEAVE (See Fig. 99)

With a screwdriver, remove the setscrew in the hub of the starter rope sheave and unscrew the sheave from the crankshaft. This is facilitated by the use of a common monkey wrench.

REMOVAL OF AIR SHROUD (See Fig. 100)

Remove the three capscrews and plain washers which hold the shroud and cylinder head to the cylinder. Next, loosen and remove the two round head screws and lockwashers which hold the shroud to engine base. The shroud may then be removed as a unit.

REMOVAL OF FLYWHEEL (See Fig. 101)

The flywheel fits on a taper on the crankshaft. After the shroud has been removed, the flywheel should be grasped with the left hand and the end of the crankshaft then struck sharp blows with a babbitt hammer. The flywheel will then slide off the taper.

MAINTENANCE SECTION

DISASSEMBLY

ENGINE

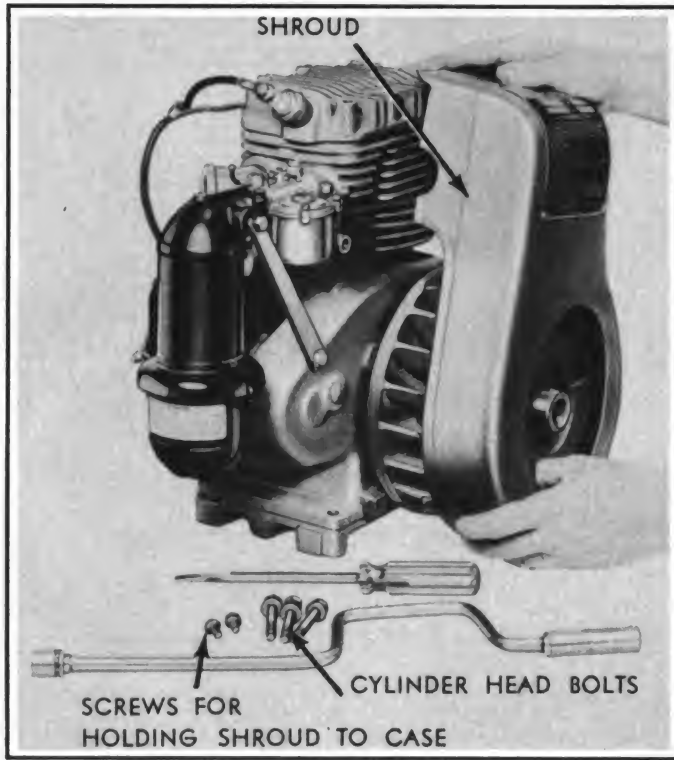

FIG. 100 Removal of Air Shroud

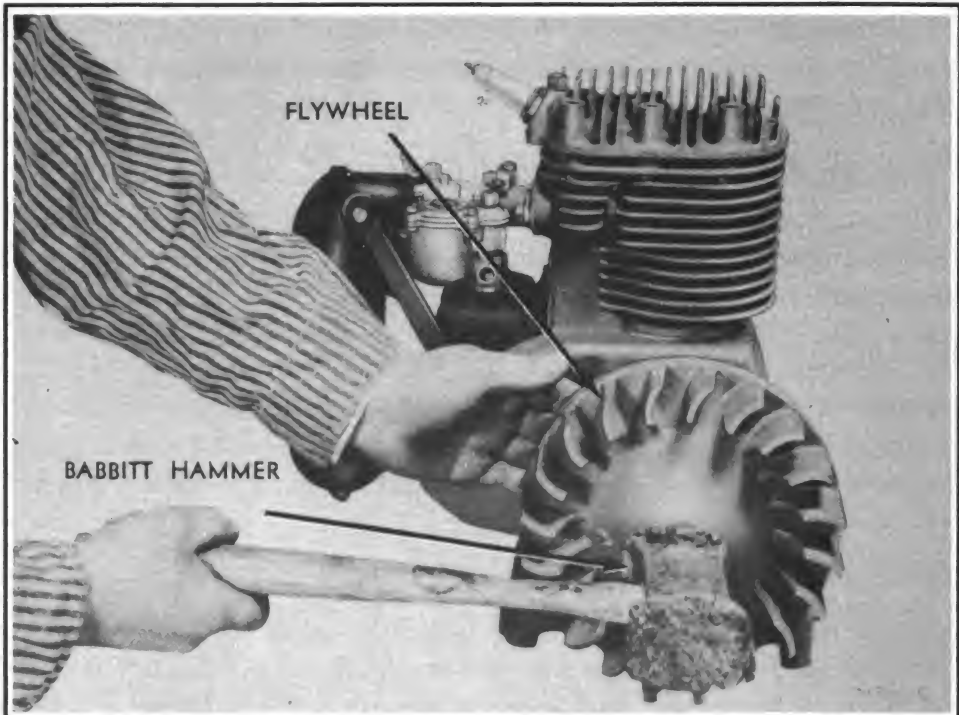

FIG. 101 Removal of Flywheel

MAINTENANCE SECTION

DISASSEMBLY

ENGINE

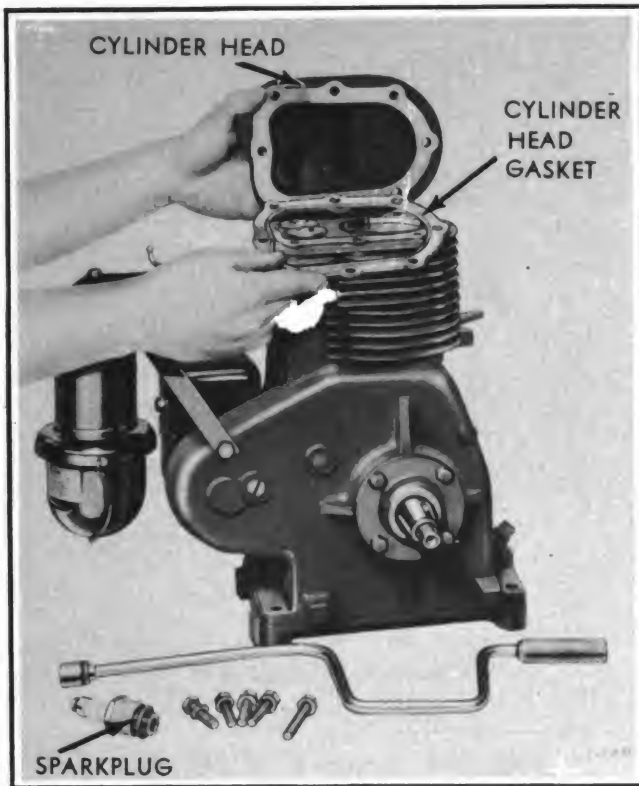

FIG. 102 Removal of Cylinder Head

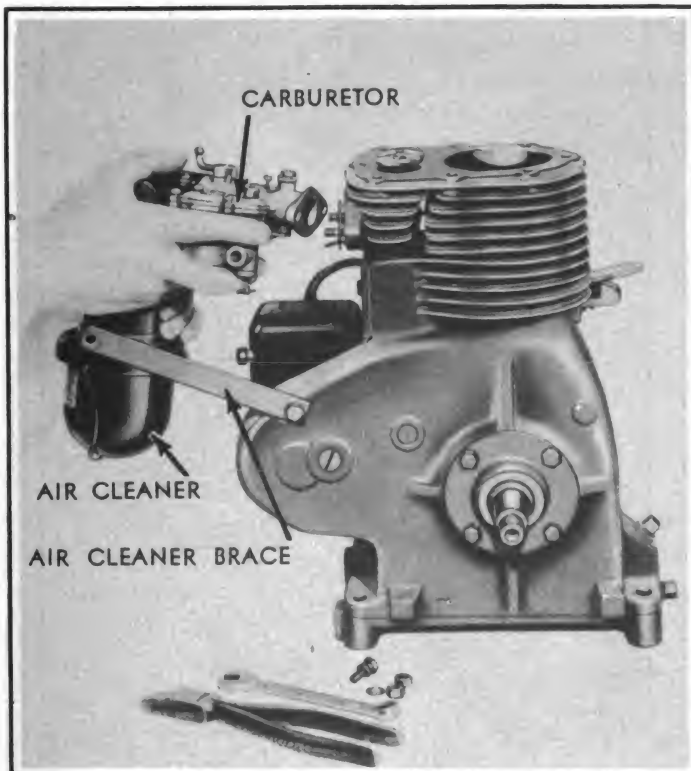

FIG. 103 Removal Of Carburetor

MAINTENANCE SECTION

DISASSEMBLY

ENGINE

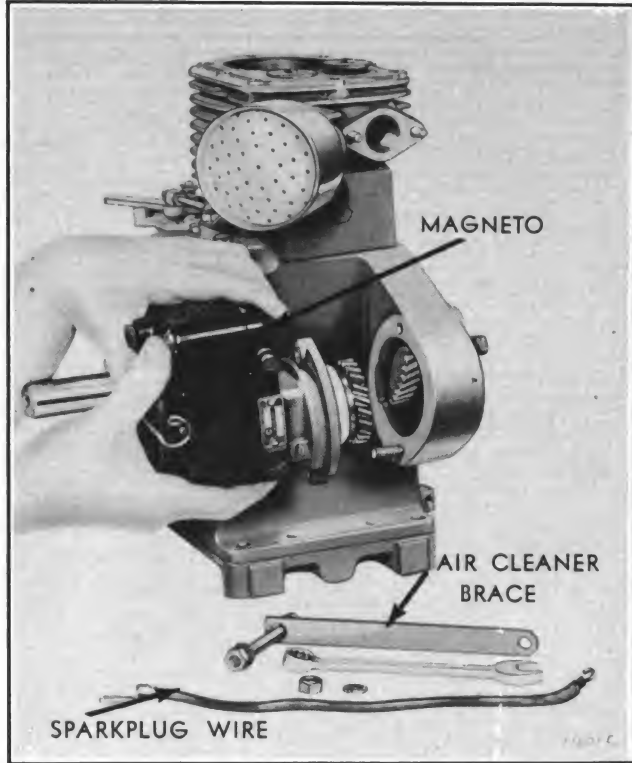

FIG. 104 Removal of Magneto

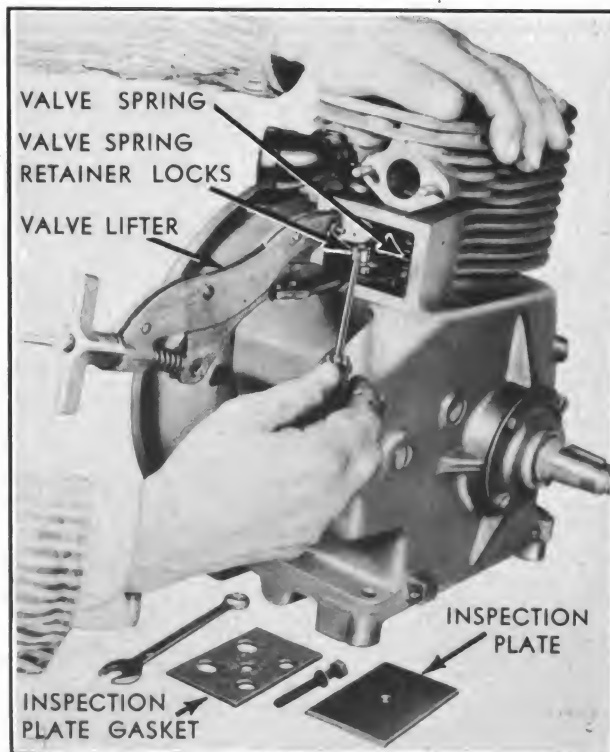

FIG. 105 Removal of Valves

MAINTENANCE SECTION

DISASSEMBLY

ENGINE

REMOVAL OF CYLINDER HEAD (See Fig. 102)

Disconnect the sparkplug wire and remove the sparkplug. Loosen and remove the five capscrews and washers that hold the head in place. The head and gasket can then be lifted off.

REMOVAL OF CARBURETOR AND AIR CLEANER (See Fig. 103)

Loosen the control rod that extends from the carburetor to the governor control level by removing the cotter pin which secures the control rod to the control lever. The control rod may be left threaded into the carburetor. Next, loosen and remove the capscrews and lockwashers which hold the carburetor to the cylinder. The assembly of the carburetor and air cleaner can then be removed. If it is desired to remove the air cleaner from the carburetor, loosen the clamp screw on the air cleaner bracket and pull the air cleaner and bracket off of the carburetor.

REMOVAL OF MAGNETO (See Fig. 104)

Loosen the knurled nut which fastens the wire to the magneto, and pull the wire off of the magneto. Next, loosen and remove the upper capscrew, nut, and lockwasher, and also the lower nut and lockwasher. The magneto assembly can then be pulled off of the engine. This will also remove the air filter brace, which is fastened by the upper magneto mounting screw.

REMOVAL OF VALVES (See Fig. 105)

Remove the capscrew and copper washer which holds the inspection plate to the engine. The plate can then be pried away from the cylinder, which will expose the valve spring keepers and locks. A standard adjustable-type valve lifter should be used to compress the valve springs. This will expose the retainer locks, which can be pried away from the valve stems by use of a screwdriver. The springs should then be removed with the valve spring seats, and the valve pulled upward out of its guide.

REMOVAL OF ENGINE BASE (See Fig. 106)

The engine base can be removed by loosening and removing the ten capscrews and washers and lifting the base off of the crankcase.

NOTE: Be sure to drain the oil out of the engine base before attempting this removal.

REMOVAL OF CONNECTING ROD AND PISTON ASSEMBLY (See Fig. 107)

Loosen and remove the two capscrews and lockwashers on the connecting rod cap, and remove the cap. The rod should then be tapped gently with a hammer handle to drive the piston out of the bore. As soon as the piston protrudes over the edge of the cylinder it should be grasped firmly in the hand and withdrawn.

REMOVAL OF CRANKSHAFT (See Fig. 108 and 109)

Loosen and remove the four capscrews and lockwashers that hold the main bearing plate to the crankshaft. The plate can then be pulled off of the crankcase

MAINTENANCE SECTION

DISASSEMBLY

ENGINE

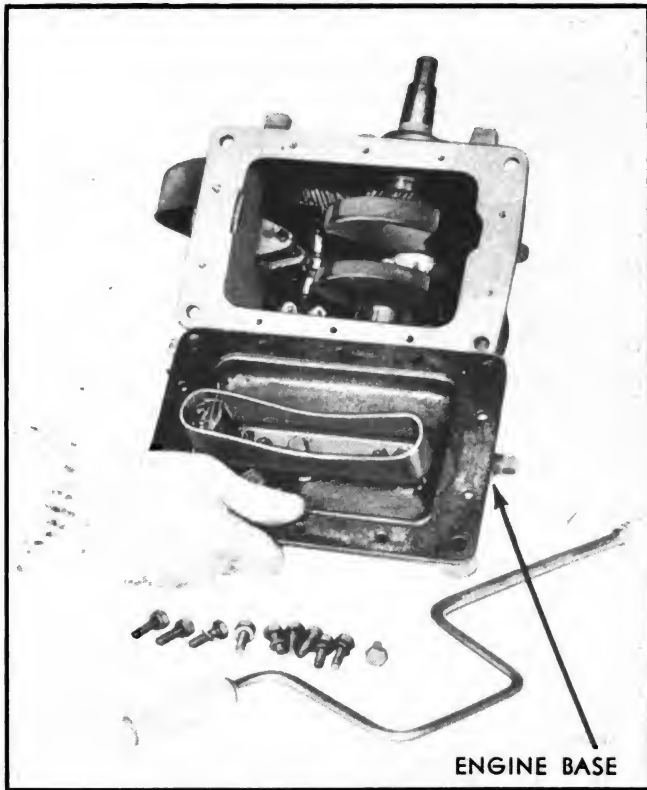

FIG. 106 Removal of Engine Base

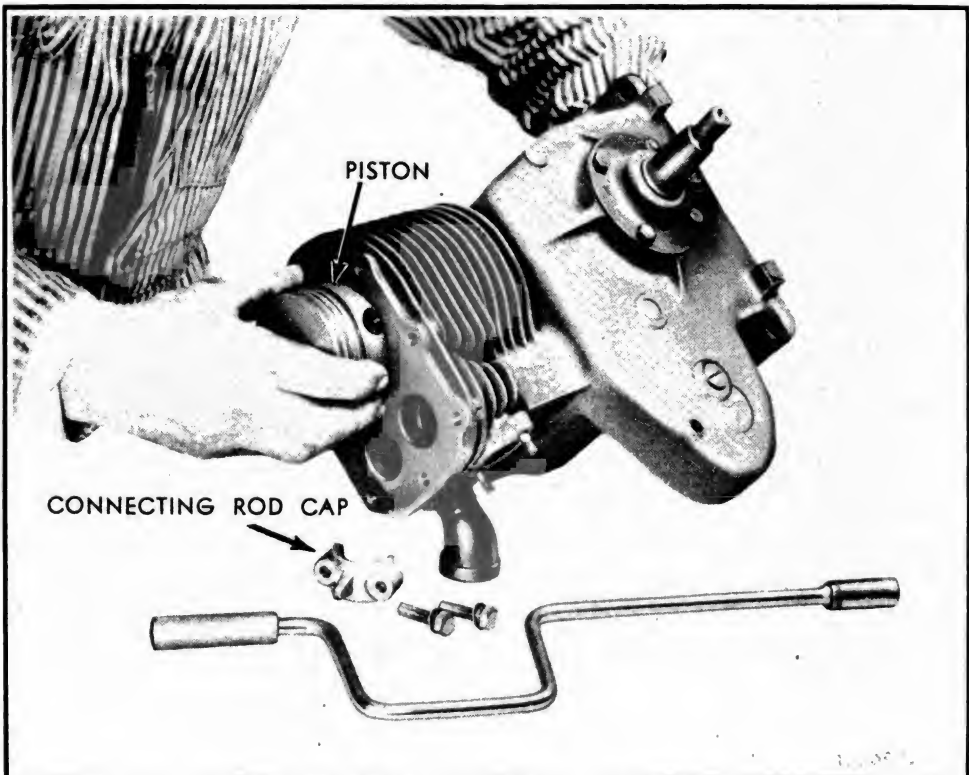

FIG. 107 Removal of Connecting Rod and Piston Assembly

MAINTENANCE SECTION

DISASSEMBLY

ENGINE

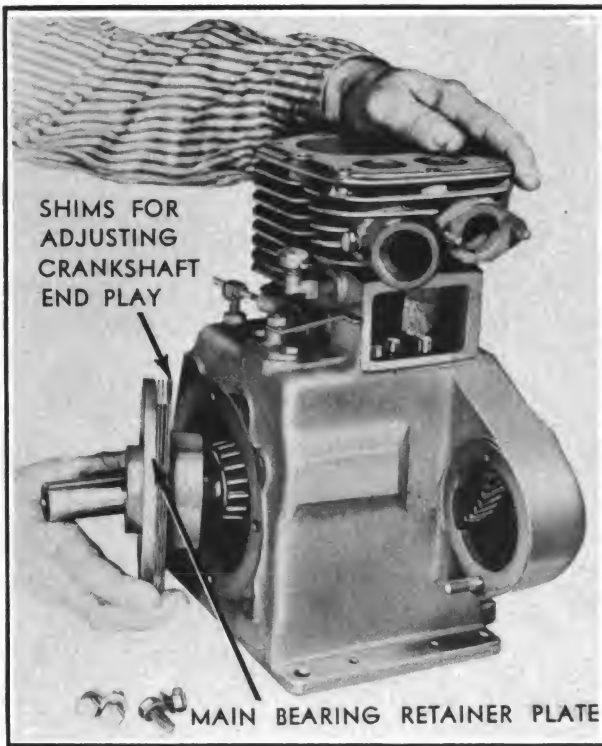

FIG. 108 Removal of Main Bearing Retainer Plate

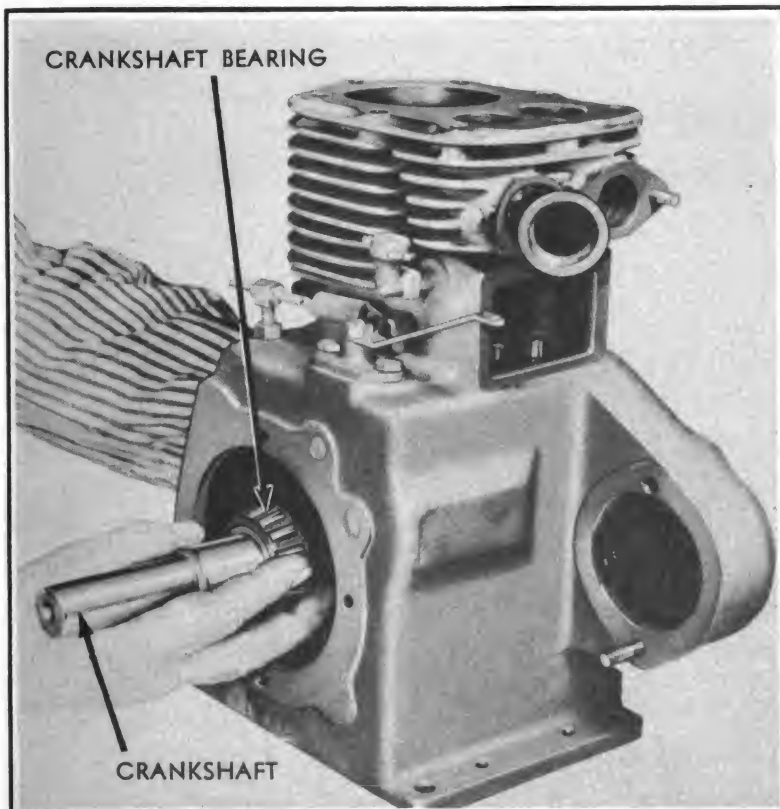

FIG. 109 Removal of Crankshaft

MAINTENANCE SECTION

DISASSEMBLY

ENGINE



FIG. 110 Removal of Camshaft Support Pin

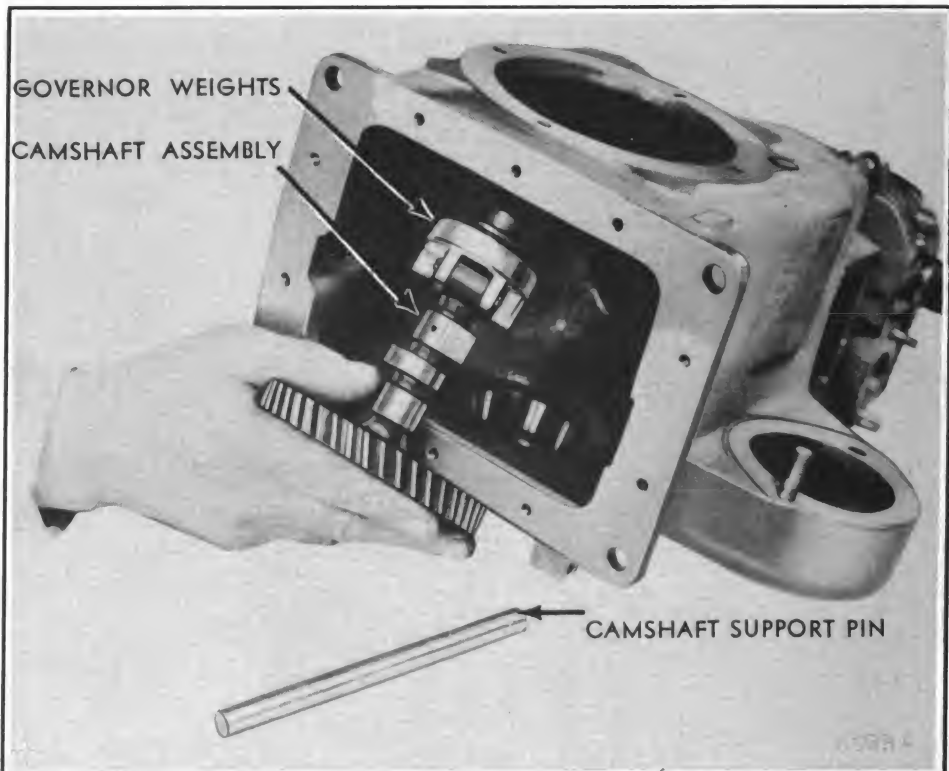

FIG. 111 Removal of Camshaft

MAINTENANCE SECTION

REASSEMBLY

ENGINE

The crankshaft assembly can then be pulled out of the case. When removing the crankshaft, the bearings should be protected with the hand so that they will not be scratched.

REMOVAL OF GOVERNOR CONTROL LEVER AND GOVERNOR SPRING

First, remove the governor spring, by detaching it from the governor lever and adjusting screw, then remove the nut that holds the governor lever to the shaft. The lever can then be pried off of the shaft. Loosen and remove the two capscrews that hold the governor shaft support bracket to the case. The bracket and shaft can then be withdrawn from the case.

REMOVAL OF CAMSHAFT (See Fig. 110 and 111)

Remove the welch plug on the take-off end of the engine by driving a sharp pointed tool into it and wedging it out of the boss. Use a drift punch to drive out camshaft support pin.

The entire camshaft assembly with weights assembled can then be removed from the bottom of the crankcase. (See Fig. 111).

DISASSEMBLY OF GOVERNOR WEIGHTS

The weights should be spread outward, away from the shaft, and the thrust sleeve and spacer pulled off of the shaft. The cotter pins which lock the fulcrum pin in place should then be removed, and the fulcrum pin driven out.

REMOVAL OF OIL PUMP PLUNGER PUSH ROD

The plunger push rod should be grasped firmly with a pair of pliers. The head of the push rod should then be driven off after which the push rod can be withdrawn from the guide. The valve tappets can also be pulled out of the guides.

DISSASSEMBLY OF OIL PUMP (See Fig. 112)

The cotter pin that holds the plunger in the core should first be removed; a screwdriver should be held against the plunger to prevent its popping out as the cotter pin is withdrawn. The plunger and spring can next be lifted out of the cylinder bore; if the oil pump body is then turned over, the retainer and check ball will fall out of the cylinder bore. The oil pump body can be removed from the base by removing the two capscrews and washers that hold it in place.

REASSEMBLY OF OIL PUMP

All parts of the pump should be thoroughly washed in gasoline, kerosene or fuel oil to remove all traces of thickened oil and sludge. The oil pump plunger should be fitted to the bore with a clearance of .0035" to .006". If the clearance is greater than .010", the plunger and oil pump body should be replaced. Inspect the check ball seat in the bottom of the pump cylinder. This seat must be perfectly cleaned, and must not be scored or pitted. The check ball should then be dropped into the cylinder and lightly tapped into the seat with a brass or hardwood rod and hammer. (See Fig. 113).

MAINTENANCE SECTION

REASSEMBLY

ENGINE



FIG. 112 Disassembly of Oil Pump

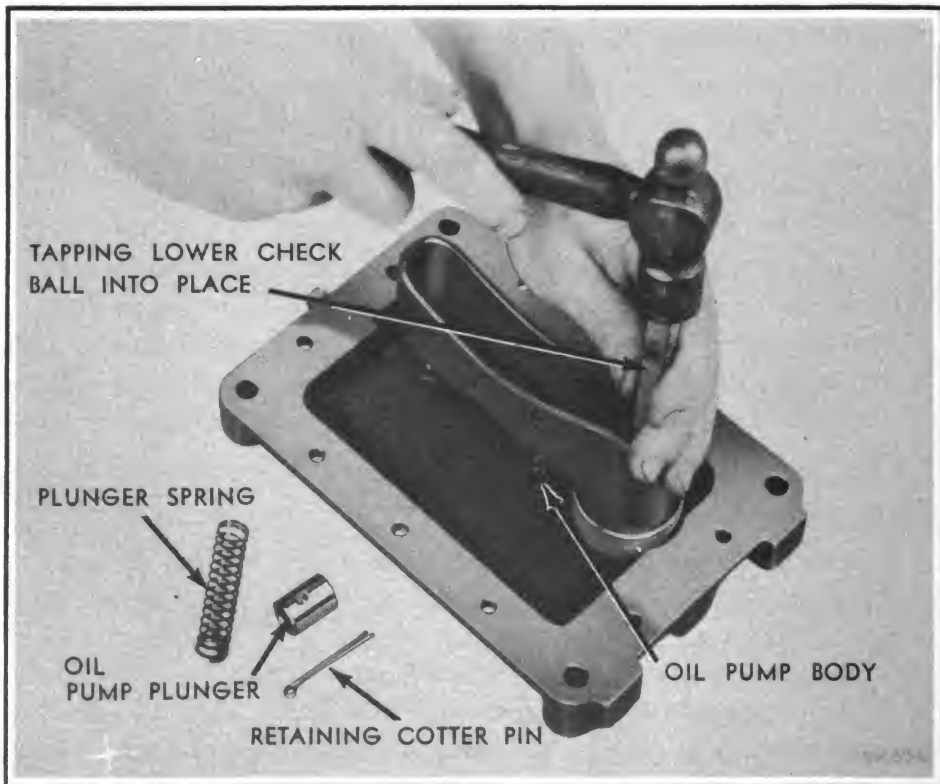

FIG. 113 Reassembly of Oil Pump

MAINTENANCE SECTION

REASSEMBLY

ENGINE

The retainer should then be put in place and the spring lowered into the cylinder bore. The other check ball should then be placed in the plunger and tapped lightly into its seat. Drive the retaining pin into place. Be sure to remove with a fine file any burrs on the plunger which might be caused by driving the retaining pin in place. The plunger should then be inserted into the cylinder and held in place with a screwdriver until the retaining cotter pin is replaced. (See Fig. 113) Next, fill the base with about one-half pint of oil. With a screwdriver, work the piston up and down until oil is drawn into the trough. If no oil is discharged into the trough, the body and plunger are badly worn and should be replaced.

REASSEMBLY OF OIL PUMP PUSH ROD

The push rod should be inserted into the guide and the cap held in place. Use a hammer to drive the rod into the cap. The valve tappers should also be replaced in their guides. The proper clearance for the tappers is .002 to .004 inch.

REASSEMBLY OF GOVERNOR WEIGHTS

The weights should be held in position, the fulcrum pin driven in place, and secured with cotter pins. The thrust sleeve should be placed over the spacer and so assembled to the camshaft that the thrust pins on the weights will bear on the flanges of the thrust sleeve. If excessive play or looseness is noted in the fit of the weights and fulcrum pins, new parts should be installed.

REASSEMBLY OF CAMSHAFT

The camshaft, together with governor weights and thrust sleeve, should be held in position in the crankcase with the camshaft support pin driven in place. The camshaft is fitted to the support pin with a clearance of .002 to .003 inch and the camshaft should have an end clearance of .002 to .013 inch. New welch plugs should be used to seal the camshaft pin holes in the crankcase.

REASSEMBLY OF GOVERNOR CONTROL LEVER AND GOVERNOR SHAFT

The governor shaft and support bracket should be installed with the yoke placed behind the governor sleeve. This is accomplished by pushing the thrust sleeve as far as possible toward the flywheel end of the engine before inserting the yoke and shaft assembly. The bracket should then be bolted to the case, using the two capscrews provided, and the control lever mounted and tightened in place. The spring may then be replaced by hooking it into the governor lever and the adjusting screw.

REASSEMBLY OF CRANKSHAFT

The crankshaft should be inserted into the crankcase and the main bearing plate replaced. The main bearing plate is fitted with shims to allow clearance in the main bearing. With the engine cold, this clearance should be .002 to .004 inch.

When meshing the crankshaft gear with the camshaft gear, care must be taken to insure that the timing marks line up. The crankshaft gear is marked with a punch

MAINTENANCE SECTION

REASSEMBLY

ENGINE

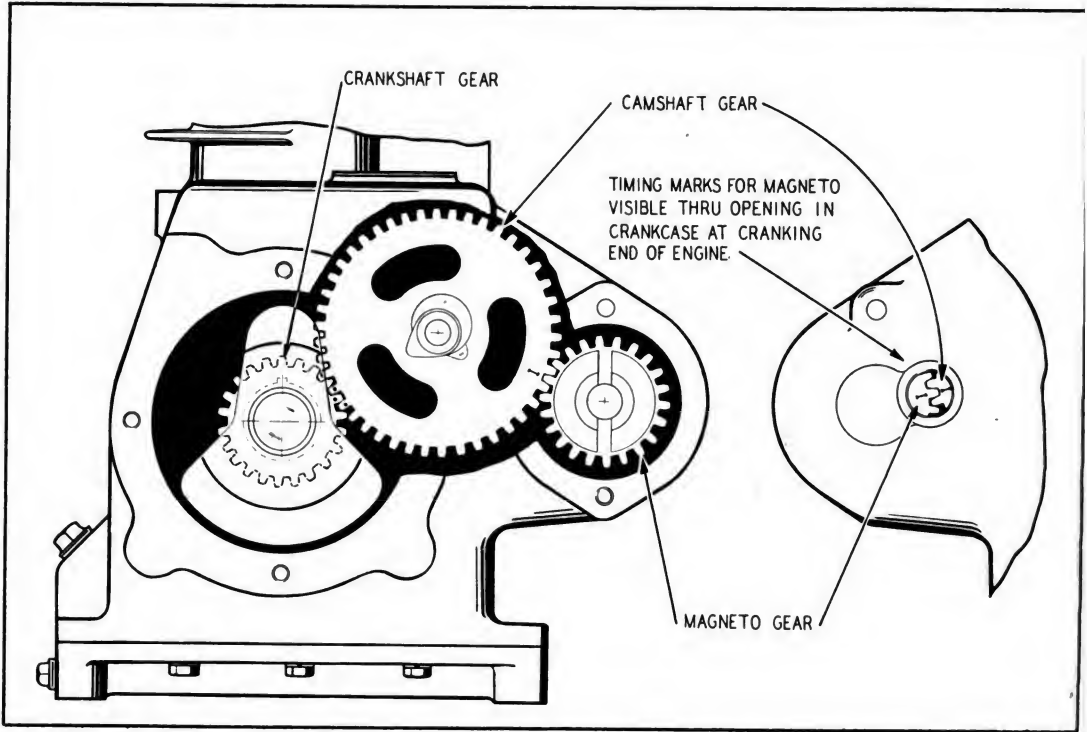

FIG. 114 Timing Diagram



FIG. 115 Assembly of Piston Rings

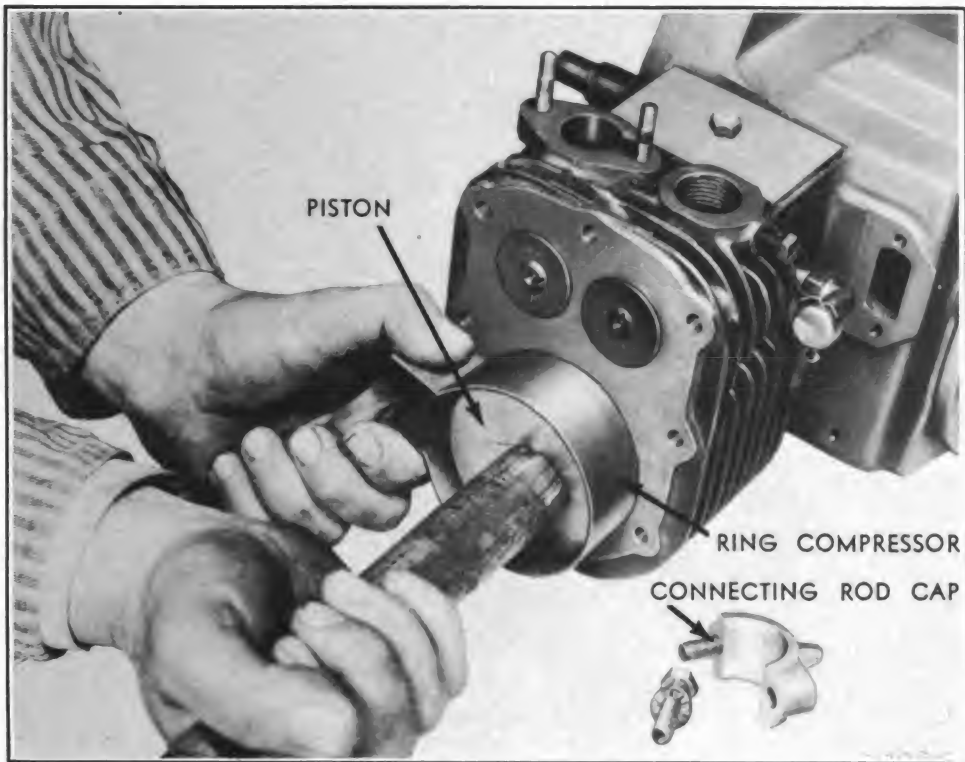

FIG. 116 Reassembly Of Piston And Connecting Rod

mark on one of its teeth and this mark must be placed between the two marks on the camshaft gear. (See Timing Diagram Fig. 114)

REASSEMBLY OF PISTON AND CONECTING ROD

The piston should be assembled to the connecting rod with a clearance of .0002 to .0008 inch between the piston pin and connecting rod. The piston pin is a light press fit into the piston bosses and an oversize pin should be installed if the old pin is loose. The rings should be installed on the piston with the oil ring in the lower groove, scraper in the third groove and compression rings in the top two grooves. (See Fig. 115).

The rings are fitted with a gap clearance, when installed in the ring grooves, of .002 to .003 inch. The piston is fitted to the cylinder with a clearance of .0055 to .006 inch measured on the skirt of the piston. To reinstall the piston and connecting rod assembly they should be lowered into the cylinder until the expanded rings contact the top of the cylinder. A ring compressor can be made from a piece of band iron, and should be used to compress the rings into the grooves of the piston until flush with the circumferences of the piston. Using the handle of a hammer, the piston should be tapped gently into the cylinder. (See Fig. 116). The cap and the top part of the connecting rod are marked and these marks must be on the same side.

The oil hole in the lower part of the connecting rod should face the carburetor side of the engine. The rod should be fitted to the crankshaft with a bearing clearance of .001 to .002 inch and a side clearance of .006 to .010 inch.

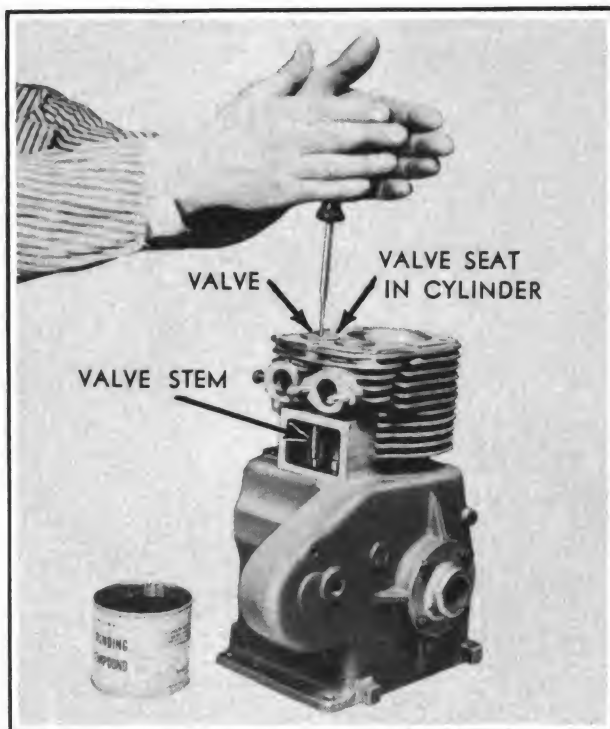

FIG. 117 Grinding Of Valves

REASSEMBLY AND GRINDING OF VALVES

The seat in the cylinder block should first be inspected and, if signs of pitting or burning are present, should either be replaced or reground. If it is determined that the seats should be reground, a standard automotive-type valve seat insert grinder should be used. The seat angle is 45 degrees.

The valves should be thoroughly cleaned, and scraped free of carbon deposits. If the seating surface of the valve shows signs of burning or pitting, it should be replaced. Valve grinding is accomplished by spreading a small amount of medium grade grinding compound on the seat of the valve. A small spring should then be placed on the stem of the valve, and the valve placed in the guide. Using a screwdriver, the valve should be twirled back and forth, while applying pressure toward the valve seat in the cylinder, occasionally allowing the pressure of the spring to lift the valve away from the seat in the cylinder. This allows the grinding compound to stay on the surface of the valve seat. The grinding should proceed with a combination of oscillatory, rotary, and tapping motions. (See Fig. 117)

During the grinding operation the valve seat should be inspected frequently. When the valve is properly ground, it will be indicated by a dull gray ring completely around the seating face of the valve. The actual width of this seat should be about $\frac{3}{32}$ inch. After grinding, the seats and valves should be thoroughly washed in gasoline to remove all traces of grinding compound. Any particle of compound left on the valve stems would result in rapid wear of the valve stem guide. The clearance in the guide should be .003 to .005 inch.

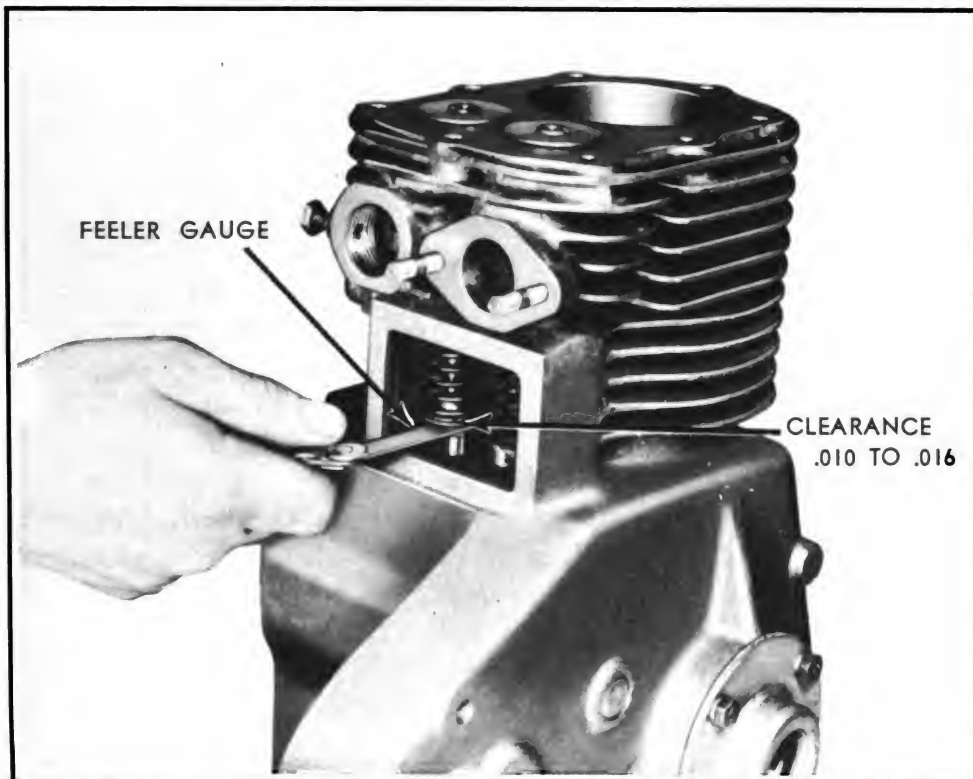

FIG. 118 Checking Tapper Clearance

The valves should now be placed in the guides and checked for clearance. Turn the crankshaft over until the valve tapper is at the bottom of its stroke, and then continue turning about one-fourth turn to make sure that the tapper is not riding the cam, which would result in a false reading. While pressing the valve to its seat, insert a feeler gauge between the tapper and valve. (See Fig. 118) The proper clearance is .010 to .016 inch, if the clearance is less than .010 inch, the valve should be removed and the bottom of the valve stem ground off as required to obtain proper clearance.

When reinstalling the valves the spring should be held in place so that the stem of the valve is in the center of the spring. The valve spring seat should then be slipped over the end of the valve, under the spring, and a valve lifter used to compress the spring and seat while holding valve against its seat. A sticky grease should be used to coat the retainer locks, and they can then be easily inserted with the help of a screwdriver. (See Fig. 119) The small end of the retainer lock should be upward. The spring and seat may now be lowered over the retainers.

Next, the tapper cover plate should be reinstalled against a new gasket.

REASSEMBLY OF MAGNETO

The magneto must be assembled to the engine in such a manner that the magneto gear will be properly timed with the camshaft gear. These gears are marked with a chisel, and these marks must coincide. In order to line up these timing marks, a peep hole is provided in the crankcase. (See Fig. 114) The crankshaft should be turned over until the chisel mark on the camshaft gear is visible through

MAINTENANCE SECTION

REASSEMBLY

ENGINE

the peep hole. The magneto should then be so assembled that the mark on the magneto gear is in line with the mark on the camshaft gear.

The bolts, lockwashers, and nuts should then be installed and securely tightened.

REASSEMBLY OF ENGINE BASE

In the reassembly of the engine base and oil pump, a new gasket should be used, and the engine base so assembled to the crankcase that the oil pump rod seats in the oil pump plunger. The bolts should then be installed and tightened alternately and securely.

REASSEMBLY OF CARBURETOR AND AIR FILTER

A new gasket should be used and the carburetor should be placed over the two studs on the cylinder and secured in place with the nuts provided. The governor control rod, which threads into a pivot on the carburetor, must be adjusted as required to give full travel of the carburetor throttle and proper governor regulation.

For this adjustment, the throttle on the carburetor should be held in the wide open position. The control lever should be held as far as possible toward the carburetor, and the control rod threaded into the swivel on the carburetor to a point where the bent end of the rod lines up perfectly with the hole in the governor control lever.

The air cleaner should then be attached to the carburetor by sliding it over the air horn and tightening the clamp screws. The brace can be fastened to the air cleaner bracket with the capscrew and lockwasher provided.

REASSEMBLY OF CYLINDER HEAD

By use of a stiff wire brush and scrapers, the cylinder head should first be cleaned of all carbon deposits, then thoroughly washed in gasoline. The cooling fins and the spaces between fins should be brushed free of all dust and dirt to allow proper engine cooling. All carbon deposits should also be scraped from the top of the cylinder and special care should be taken to see that the portion of the cylinder and cylinder head which contact the cylinder head gasket are absolutely clean and flat. Do not scratch the surface when scraping carbon deposits. A new cylinder head gasket should be used, and placed on the cylinder with the flange side of the gasket upward. The cylinder head should be placed over the gasket, and the five capscrews and washers nearest the take-off end of the engine installed and drawn down loosely. Do not replace the three capscrews and washers which hold the shroud.

CAUTION: SPECIAL CARE MUST BE TAKEN TO INSURE THAT ONLY CAPSCREWS OF THE PROPER LENGTH ARE USED. SOME OF THE CAPSCREWS ARE LONGER, SUCH AS THOSE WHICH ALSO HOLD THE SHROUD IN PLACE. IF A LONGER CAPSCREW IS USED, IT WILL THREAD TOO DEEPLY INTO THE HOLE AND WILL CRACK OFF THE FINS ON THE CYLINDER. MEASURE THE LENGTH OF THE BOLTS BY HOLDING THEM CLOSE TO THE HOLES IN WHICH THEY ARE TO BE USED.

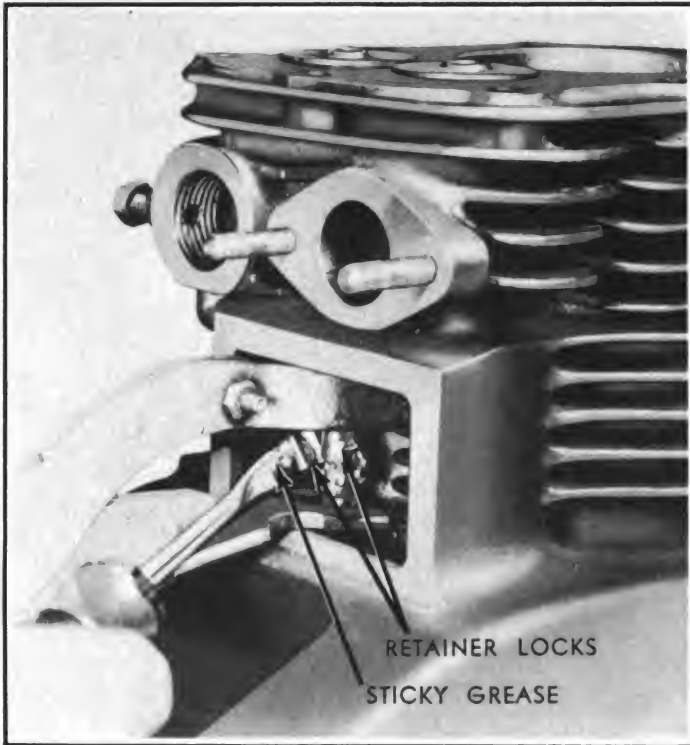

FIG. 119 Inserting Valve Spring Retainer Locks

REPLACEMENT OF FLYWHEEL AND STARTER ROPE SHEAVE

The Woodruff key which prevents the flywheel from turning on the shaft should be reinstalled. The flywheel can then be assembled to the shaft, but the keyway in the flywheel must line up with the key in the crankshaft. A new lockwasher should be used and the starter rope sheave threaded by hand on the crankshaft. A monkey wrench should be used to tighten the starting nut, and the wrench handle may be struck sharply with a hammer until the sheave is drawn tightly against the flywheel. Then install and tighten the setscrew that helps lock the sheave in place.

REPLACEMENT OF SHROUD AND FUEL TANK

The shroud should be assembled to the engine and secured by capscrews and washers. **AS PREVIOUSLY MENTIONED, BE SURE THAT ONLY CAPSCREWS OF THE RIGHT LENGTH ARE USED.** Then tighten all cylinder head capscrews, alternately and securely.

REPLACEMENT OF SPARKPLUG AND WIRING

The sparkplug should be inspected and thoroughly cleaned. Alcohol is a good solvent for this purpose and in most cases will loosen or remove carbon and gum deposits. The porcelain insulator in the plug should be inspected and, if chipped or cracked, a new plug should be installed. If the points of the sparkplug are badly burned, this will also necessitate replacement of the plug. If the points and porcelain insulator are found to be in good condition, the gap between the points should be

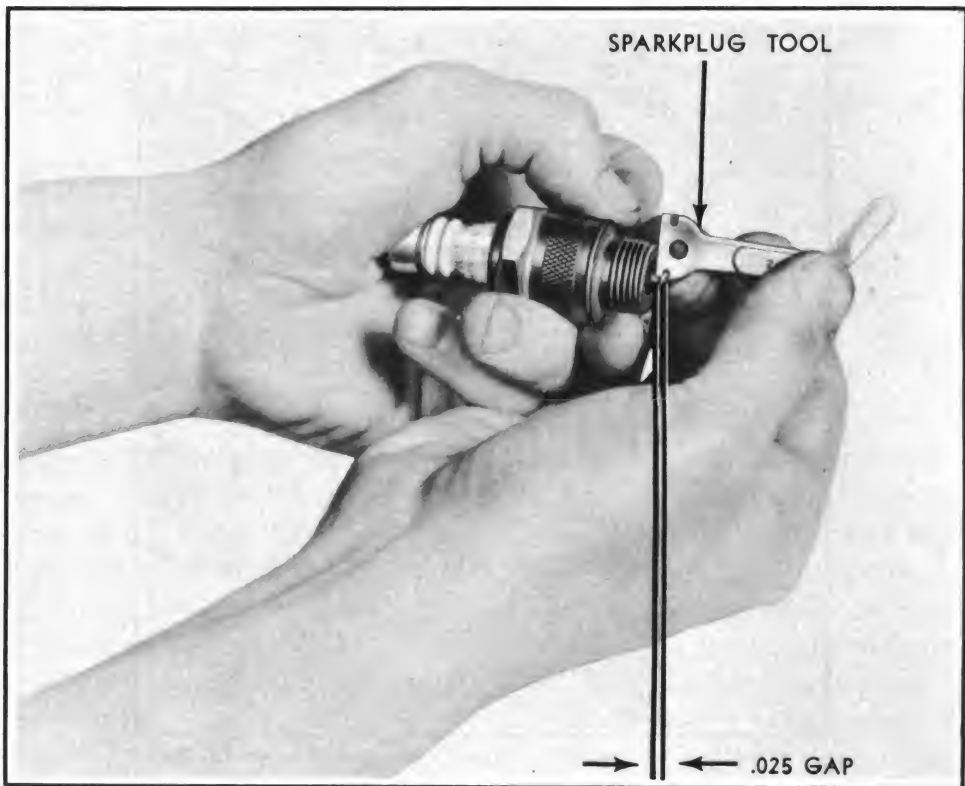

FIG. 120 Checking Sparkplug Gap

re-set to .025 inch. (See Fig. 120) Then replace the sparkplug and connect sparkplug wire.

REMOUNTING OF ENGINE

The engine exhaust piping should be screwed in place and the engine set in place on the base plate, being sure to have the $\frac{1}{8}$ inch shims and the flexible coupling filler block in place before tightening the capscrews to the base plate. Connect fuel line at carburetor.

RUNNING ENGINE IN BEFORE USING

After the engine has been completely assembled, it should be run-in before using. Run with throttle about one-fourth open for about one-half hour, then at governor speed but without load for two hours. Drain the oil used during this run-in and refill crankcase with fresh oil.

CARBURETOR

Fig. 121 shows Stromberg Model OH- $\frac{5}{8}$ completely assembled, showing high-speed needle valve adjustment, idling needle valve adjustment, and throttle stop adjustment.

MAINTENANCE SECTION

CARBURETOR

ENGINE

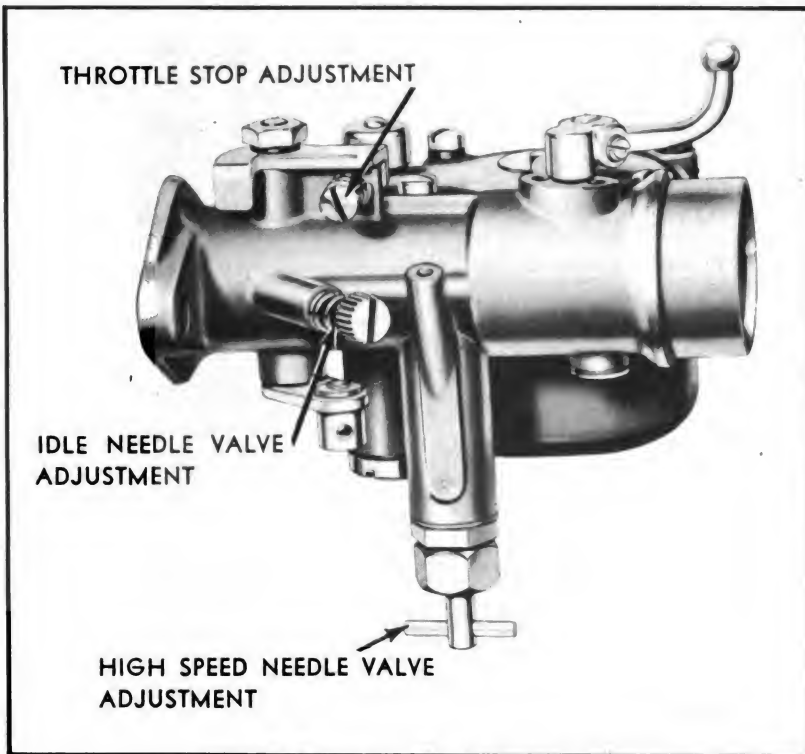

FIG. 121 Carburetor

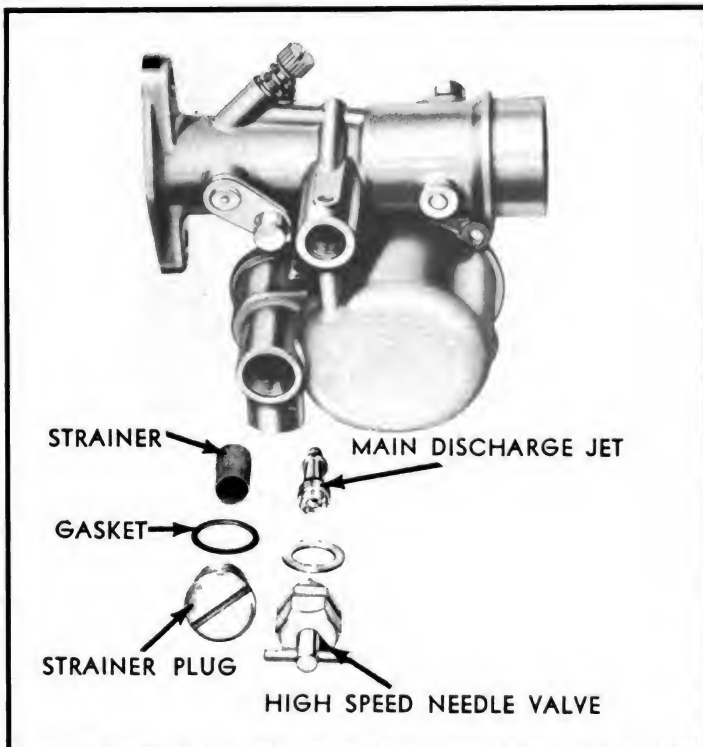

FIG. 122 Removal of High-Speed Needle Valve

MAINTENANCE SECTION

CARBURETOR

ENGINE

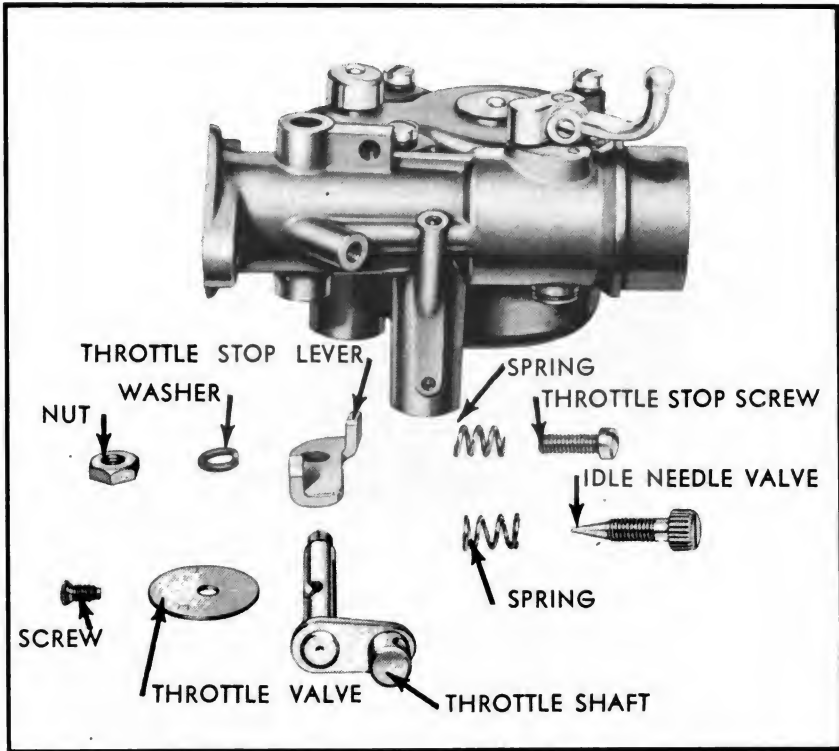

FIG. 123 Removal Of Idling Needle Valve And Throttle

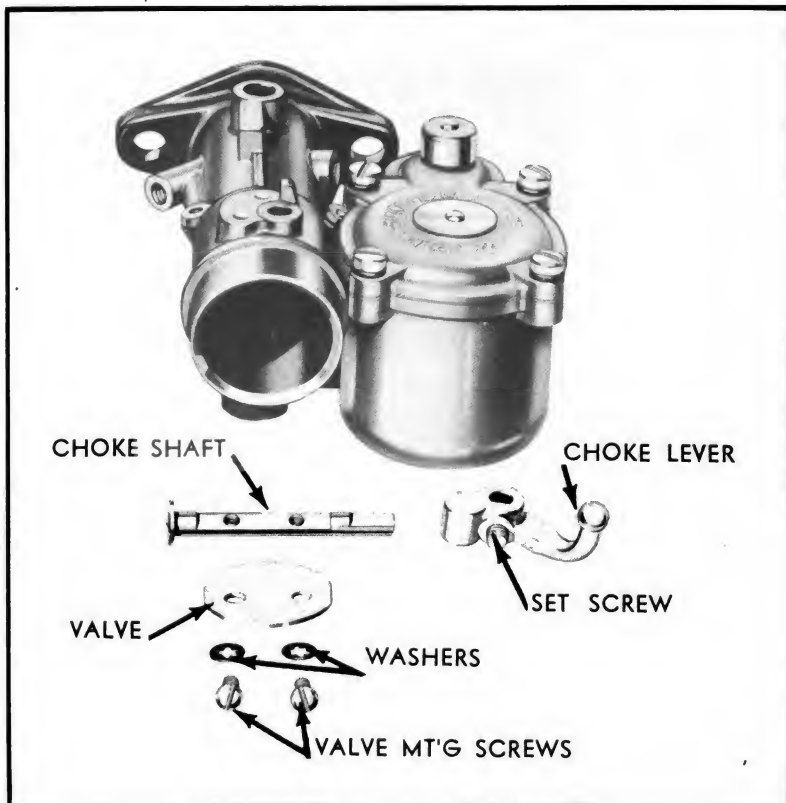

FIG. 124 Removal of Choke

MAINTENANCE SECTION

CARBURETOR

ENGINE

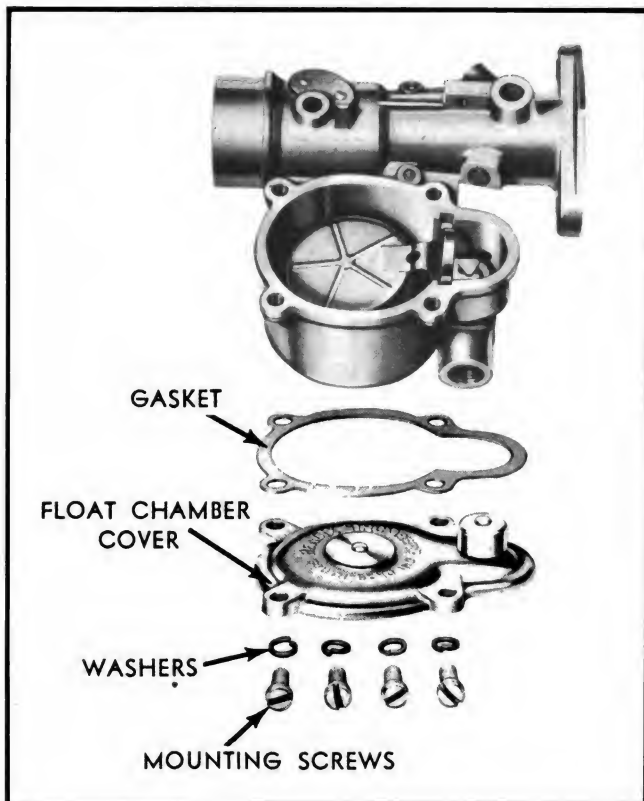

FIG. 125 Removal of Float Chamber Cover

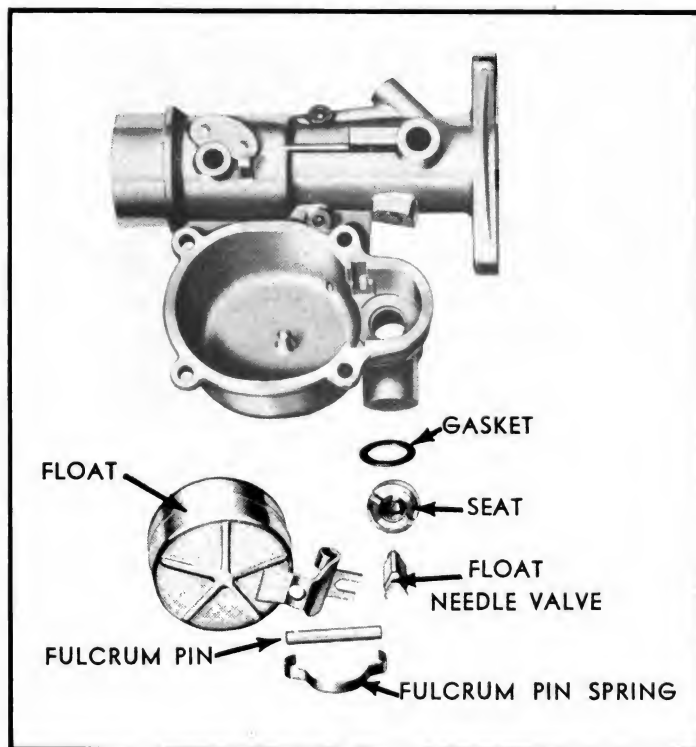

FIG. 126 Removal of Float

MAINTENANCE SECTION

CARBURETOR

ENGINE

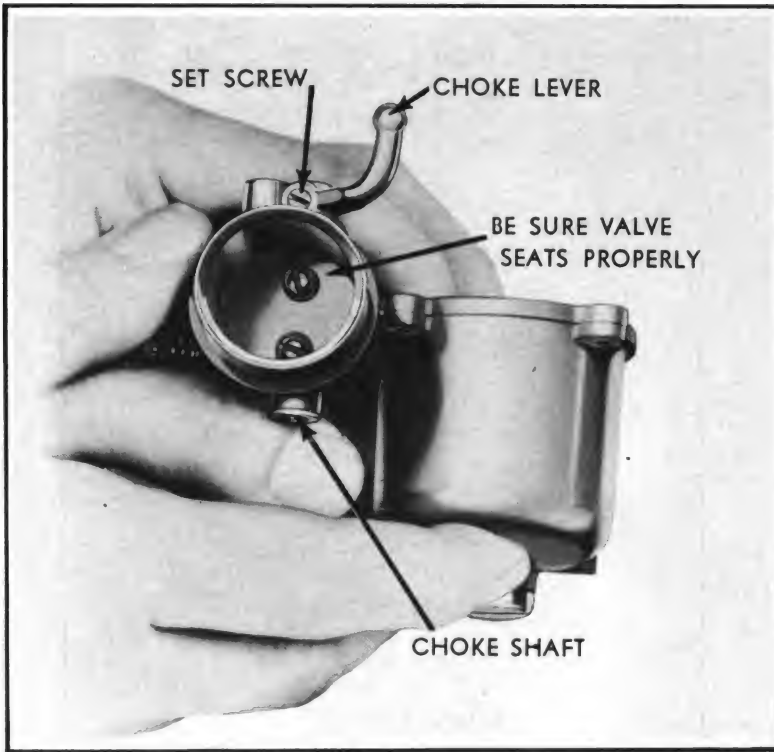

FIG. 127 Reassembly of Choke

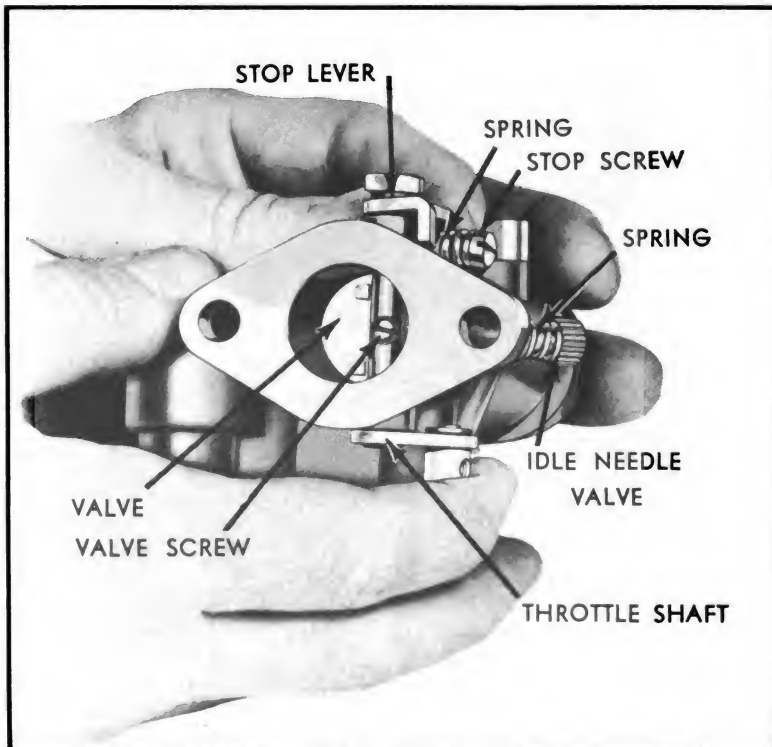

FIG. 128 Reassembly of Throttle And Idling Needle Valve

MAINTENANCE SECTION

CARBURETOR

ENGINE

DISASSEMBLY

Remove high-speed needle valve adjustment and gasket (See Fig. 122), using a $\frac{1}{2}$ inch open-end wrench. Remove main discharge jet, using a screw driver of suitable size to avoid damaging part. Remove strainer plug gasket and strainer.

Remove idling needle valve and spring. (See Fig. 123) Remove throttle stop screw and spring. Remove throttle stop lever, nut, lockwasher, and lever. Remove throttle valve screw, valve and throttle shaft.

Loosen choke lever set screw, and remove lever. (See Fig. 124) Remove choke lever screws, lockwashers, valve, and choke shaft.

Remove float chamber cover screws, lockwashers, cover, and cover gasket. (See Fig. 125)

Remove float fulcrum spring, float, fulcrum pin, and float needle valve. (See Fig. 126) With a large, suitable screwdriver, remove float needle valve seat and gasket.

REASSEMBLY

Insert choke shaft into body from lower side of main body and assemble choke valve, making certain that the valve seats around the entire edge when it is in closed position. (See Fig. 127) Assemble choke lever on choke shaft, with ball plunger in one of the indent holes on top of the body. Apply light pressure on the lever to slightly compress the plunger spring and when held in this position, fasten set screw securely. Make certain that choke valve operates freely.

Insert throttle shaft into body from lower side. (See Fig. 128) Hold shaft with the countersunk end of hole to the right side of center line. Place throttle valve in the shaft with the projections on the valve on the right hand side. Assemble throttle valve screw loosely, and with a small screwdriver, tap lightly on the high side of the valve to aid in centering it. Hold in closed position, then tighten screw securely. Place throttle stop lever on shaft, with long end toward choke shaft and with ear extending downward toward the body. Assemble lockwasher and nut. Assemble throttle stop screw and spring. Hold throttle valve in closed position while turning in the stop screw until it just contacts the lever, then turn in additional half-turn. With the fingers, assemble idling needle valve (See Fig. 128) and spring, seating needle valve lightly and turning out one-half turn.

Assemble float needle valve seat and gasket securely. Assemble gasoline strainer, plug, and gasket, making certain that the strainer fits over the lower end of the float needle valve seat. Assemble main discharge jet securely. Unscrew high speed needle adjustment at least two turns to avoid damaging needle valve point when it is assembled into the body. Assemble high-speed needle and gasket securely. (See Fig. 129) Turn the adjustment *in* until it seats, then turn it *out* approximately one and one-half turns. This is only a preliminary setting, the final adjustment will have to be made on the engine.

Insert float fulcrum pin in float lever. (See Fig. 130) Attach float needle valve into fork of float lever. Assemble float and these parts into the body. Assemble float fulcrum spring in slots in the body and with the flanged ends resting on top of float fulcrum pin; curved section of spring is toward the top.

MAINTENANCE SECTION

CARBURETOR

ENGINE

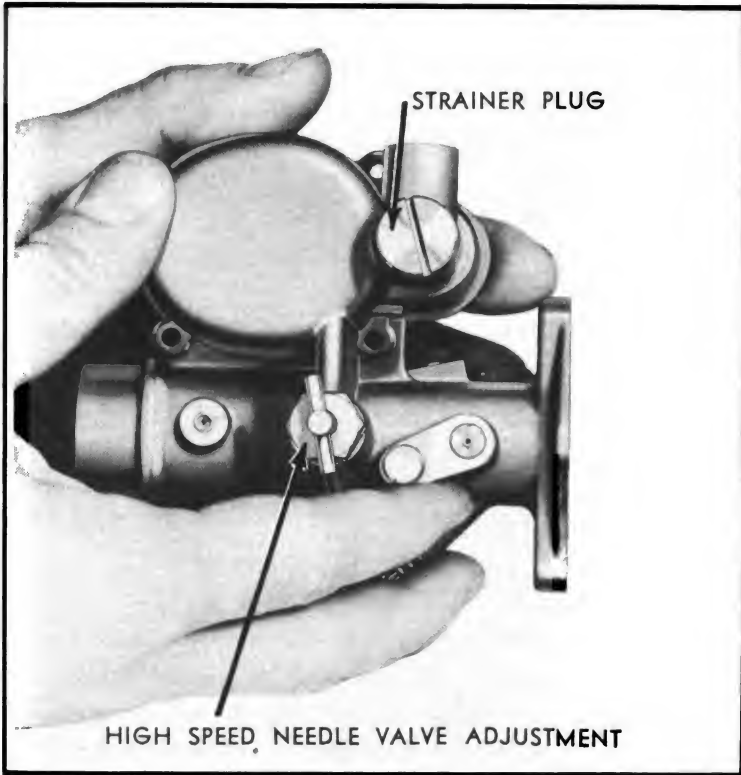

FIG. 129 Reassembly of High Speed Needle Valve Assembly

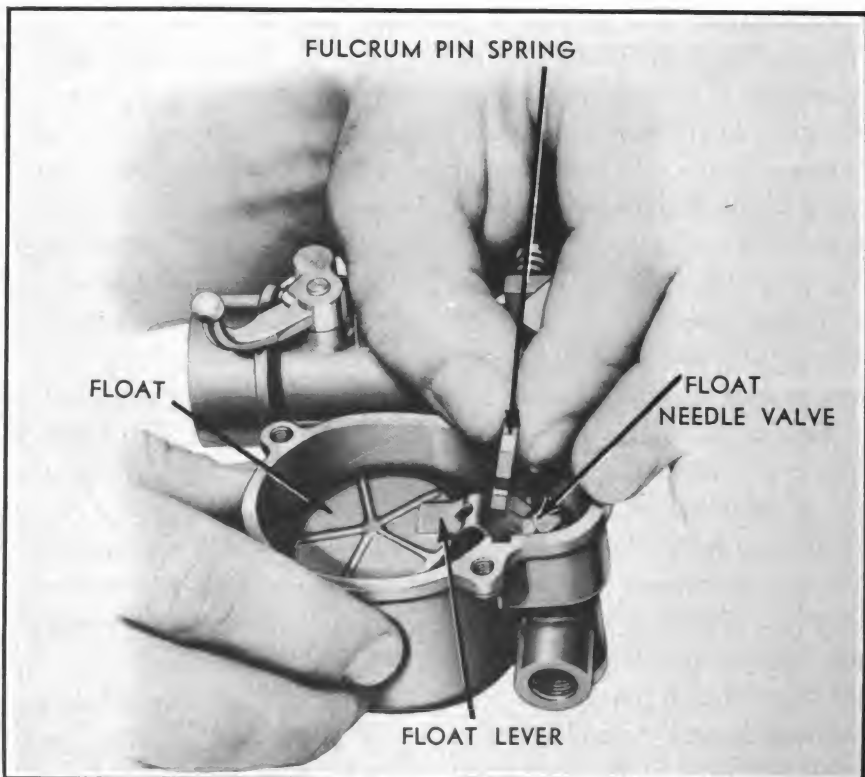

FIG. 130 Reassembly of Float

MAINTENANCE SECTION

CARBURETOR

ENGINE

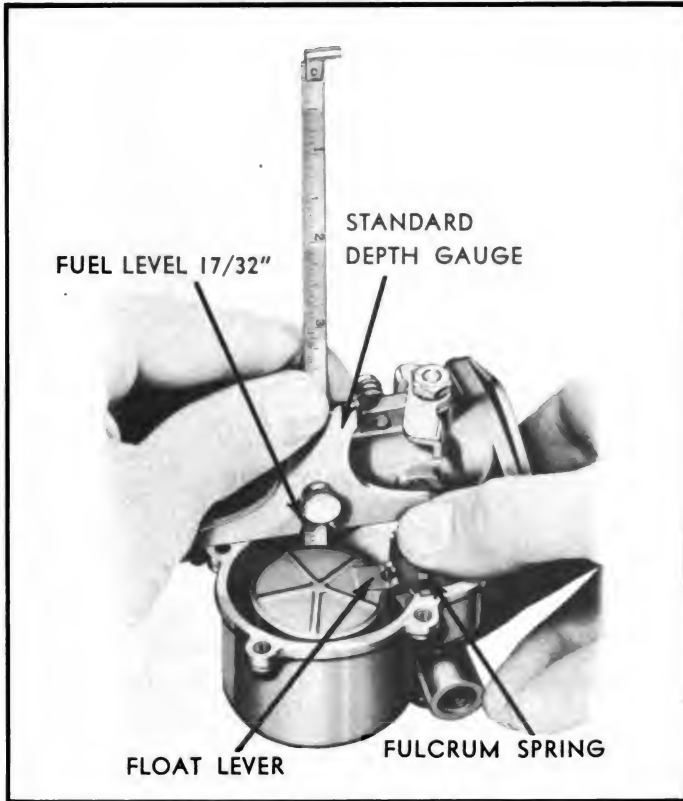

FIG. 131 Checking Fuel Level

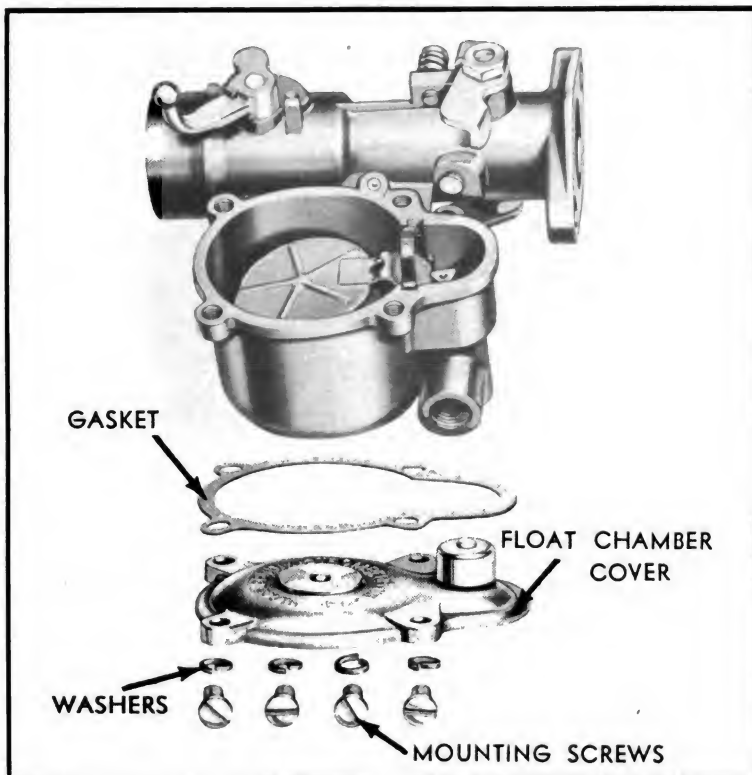

FIG. 132 Reassembly of Float Chamber Cover

MAINTENANCE SECTION

MAGNETO

ENGINE

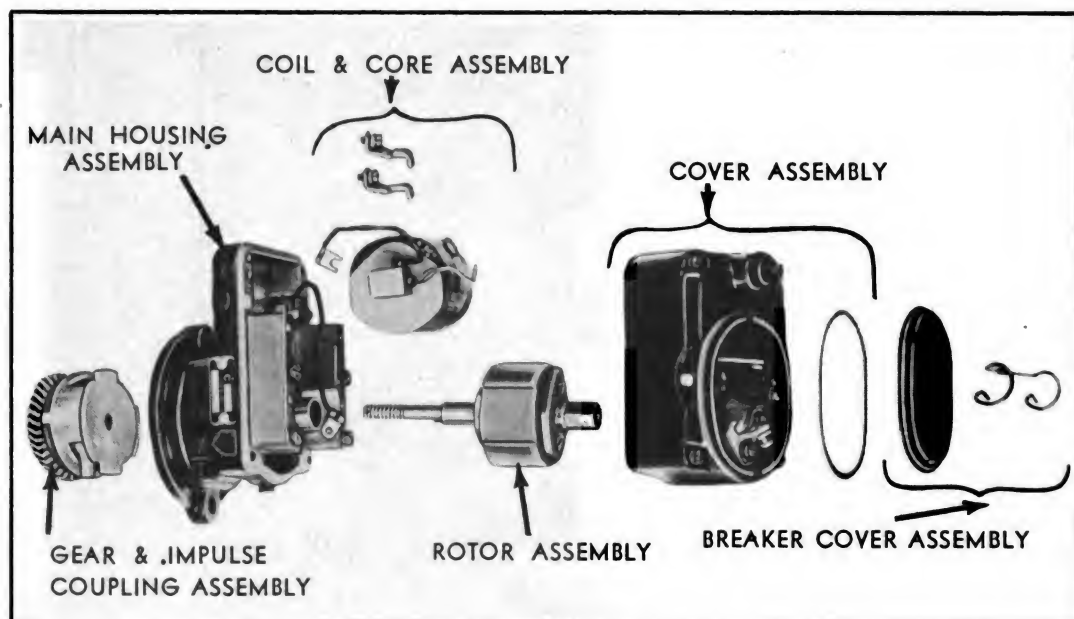

FIG. 133 Magneto Sub-Assemblies

In order to obtain the most efficient operation from a carburetor, it is necessary that the fuel level be maintained at the correct height in the float chamber. The correct fuel level for the carburetor is $17/32$ inch from the gasket surface of the float chamber, with one-half to one pound inlet pressure. This can be checked either on the engine or on a test stand. When checking the level, it is necessary to hold down the fulcrum spring so that the float parts are in their normal position. The height of the level can be measured by placing a standard depth gauge between the side of the float chamber and the float (See Fig. 131), making certain that the scale does not contact either part or it will result in an incorrect rating. If the level needs to be changed, bend the float level at the hole on top to obtain the desired height. When doing this operation, use a pair of long-nose pliers.

Assemble float chamber cover and gasket. (See Fig. 132)

MAGNETO

BREAKER COVER

The breaker compartment is covered by breaker cover held in place by a hold-down spring which can be easily removed by wedging the spring away from the pins in the cover that hold it in place. (See Fig. 133)

BREAKER POINTS

The breaker points should be adjusted to a gap of .015 inch when fully opened. (See Fig. 134) Adjustment is made by shifting the fixed contact by means of the small eccentric screw. After adjustment, tighten the fixed contact screw. (See Fig. 135)

The points should be flat, parallel, and free from foreign matter. Lacquer thinner is an ideal cleaner for this purpose. Use Wico tool S-5449 to adjust the alignment so

MAINTENANCE SECTION

MAGNETO

ENGINE



FIG. 134 Breaker Point Adjustment

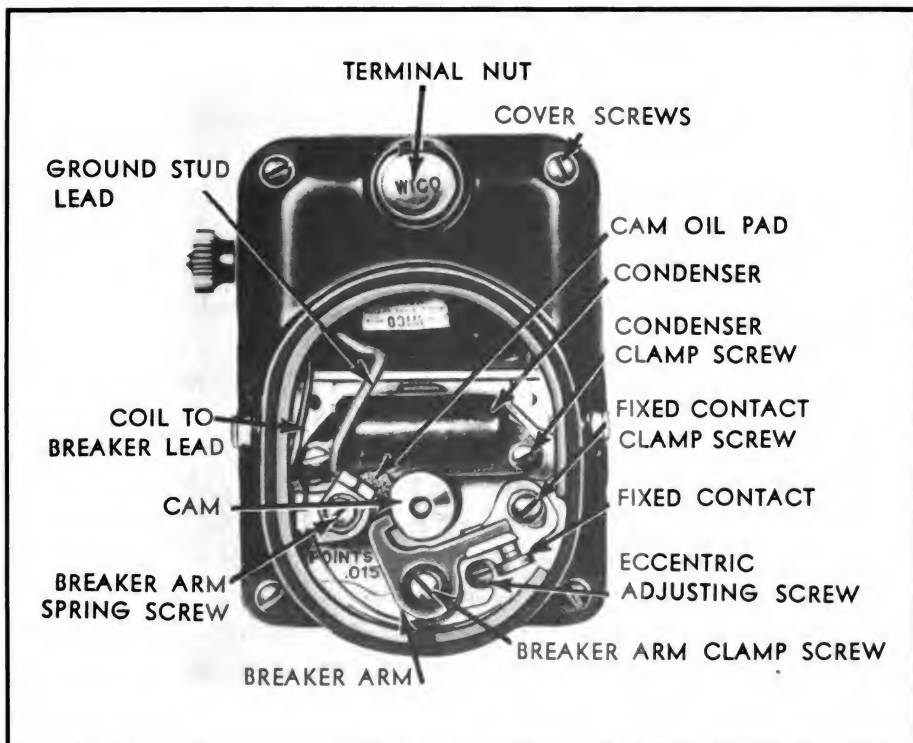

FIG. 135 Breaker Points

MAINTENANCE SECTION

MAGNETO

ENGINE

COVER

The cover, with the breaker assembly intact, may be removed after the breaker cover has been removed. However, it is first necessary to loosen the breaker arm spring screw and pull out the coil and ground lead terminals. Next, loosen the four screws, one in each corner of the cover, until they are free. It is not necessary to remove the screws from the cover completely. If the cover seems to stick, it may be loosened by slightly tapping it with the palm of the hand.

When replacing the cover, make certain that the gasket has been cemented to the main housing.

IGNITION COIL TESTING

It is not necessary to remove the ignition coil from the magneto for test. When using an Eiseman coil tester, connect the ground lead of the tester to the housing of the magneto, and the spark lead of the tester to the high tension terminal on the coil. Turn the cam until the breaker points are open. A new coil must be installed if more than 1.5 amperes is required to produce a steady spark across a five millimeter ($\frac{1}{8}$ inch) gap between points.

REMOVAL OF COIL AND COIL CORE

With the magneto cover off, remove the two fillister head screws, that hold the coil core clamps in place. Under one of these clamps will be found the ground end of the primary and secondary winding of the coil.

Turn the rotor until magnetism no longer grips the coil core to the main housing. Pull the coil and coil core free. When replacing the coil and coil core on the magneto, be sure that the ground surface of the core is against the laminated core of the housing.

When the coil is in place, the coil terminal should point upward and toward the breaker points. The surface of this contact must be clean. Be sure to place the ground lead of the coil under the core screw lockwasher, not under the core coil clamp.

The coil is held to the coil core by two wedges. It is therefore necessary to press against the coil core with considerable force to remove it from the coil. When removing the core from the coil, see that the coil is so supported that there will be no danger of the primary winding of the coil being pushed out of the secondary. (See Fig. 137)

When replacing a coil on the core, slide it on, being sure that the finished side of the core is *down*, and the high-tension button on the coil is *up*. Then, on the finished side of the core, press in the two wedges, (See Fig. 138) one on each side, until they are flush with the primary coil winding. Slide on the coil shields, one on each side. (See Fig. 139) Thread the primary lead through the slot provided in the coil shield.

STOP BUTTON

The stop button when pressed renders the magneto inoperative by short-circuiting the primary circuit and thus stopping the engine by preventing sparking at the plug. The magneto remains inoperative until the stop button is released, thus opening the grounding circuit.

MAINTENANCE SECTION

MAGNETO

ENGINE

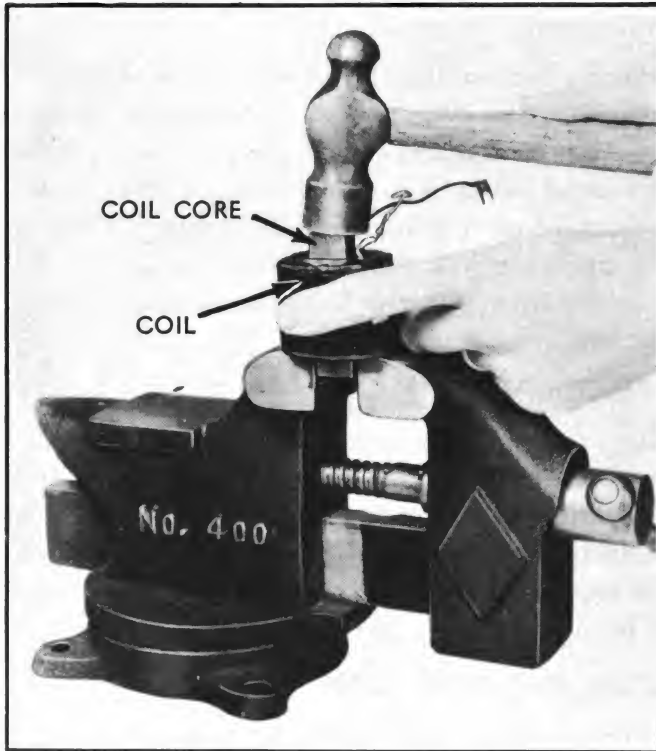

FIG. 137 Removing Core

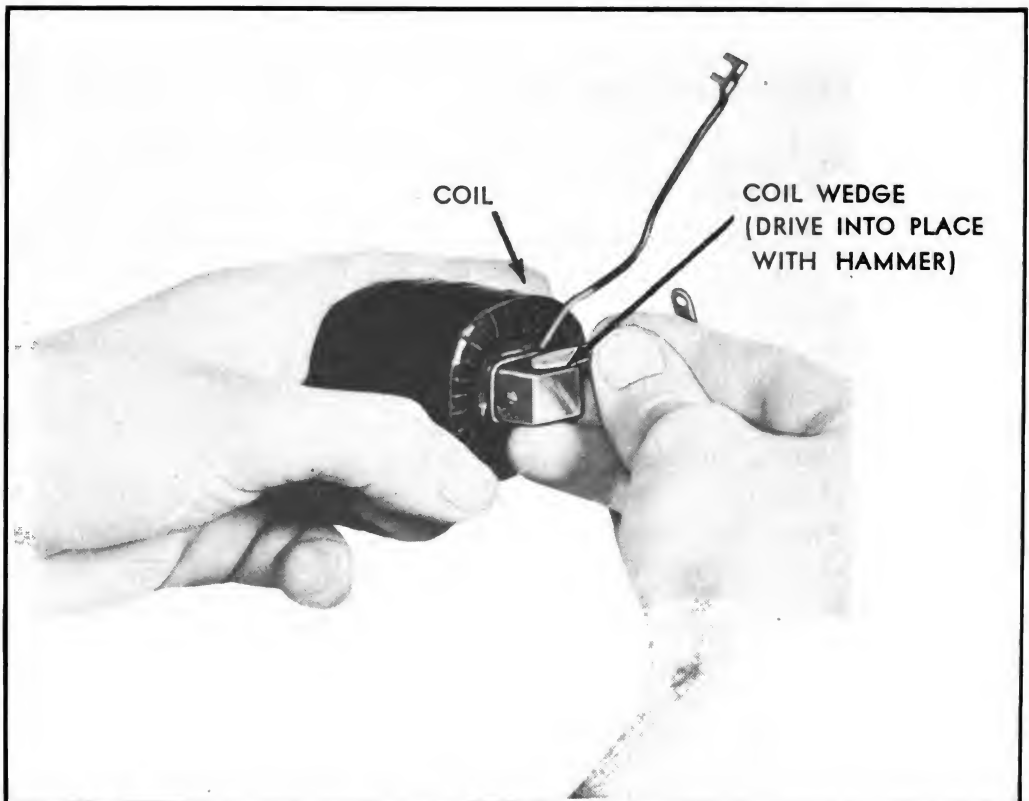

FIG. 138 Assembly of Coil On Core

MAINTENANCE SECTION

MAGNETO

ENGINE

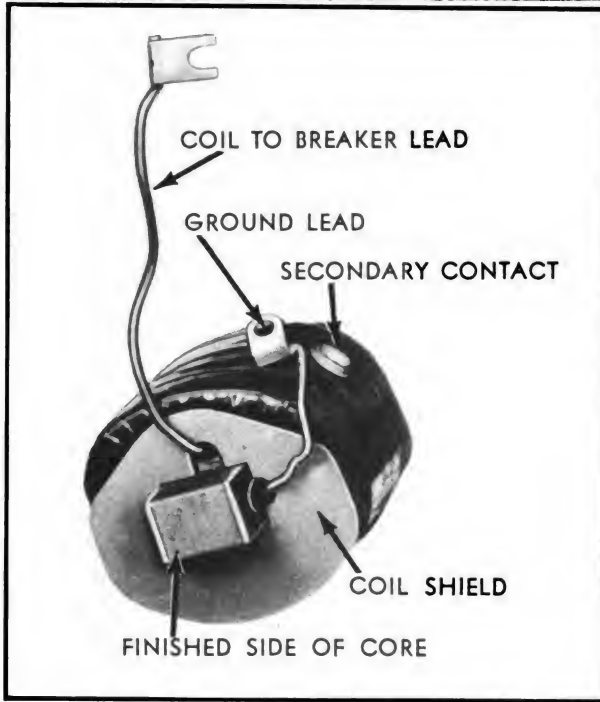

FIG. 139 Assembly Of Coil Shields

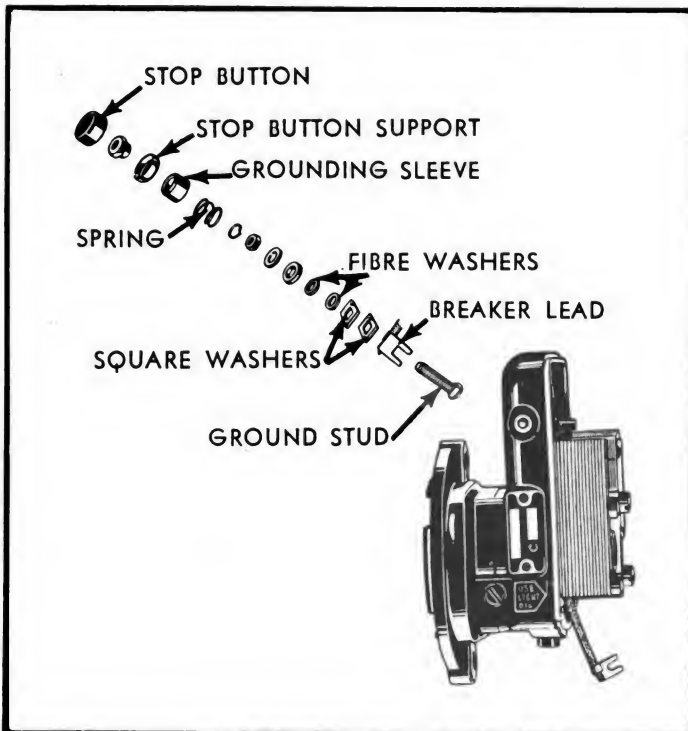

FIG. 140 Stop Button Assembly

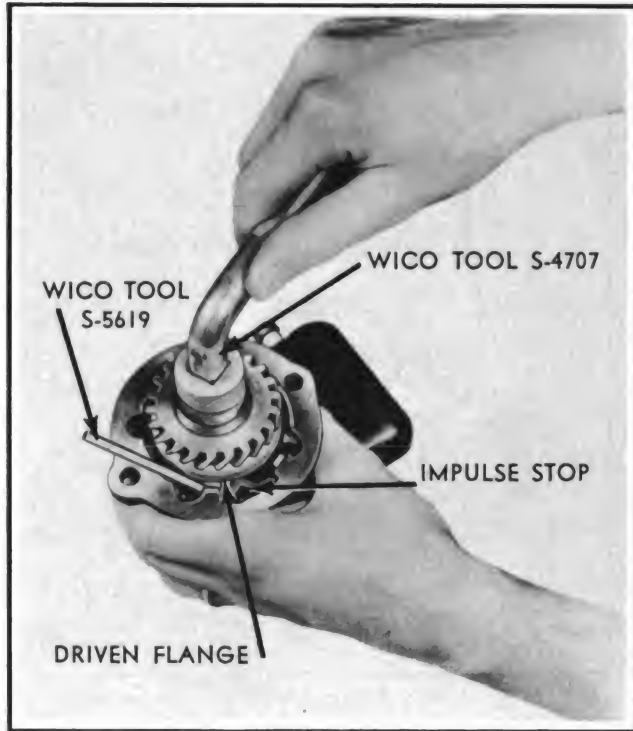

FIG. 141 Removing Impulse Coupling Lock-Nut

The exploded view of the stop button assembly (See Fig. 140) plainly shows the order of assembly. The two small fibre washers are first inserted into the hole in the housing, then the stop button to breaker lead, and the two square fibre washers are assembled to the ground stud and mounted to the housing from the inside. The other parts are then assembled from outside of the housing in the order shown.

All model C replacement housings are supplied with ground studs. When replacing the stop device, it will be necessary to remove the cover and the coil to gain access to the inside of the housing. Although it is recommended that complete replacement kits be ordered, all of the parts are available individually.

IMPULSE COUPLING LOCK-NUT

The impulse coupling locknut is best removed by using Wico tool number S-4704. The impulse nut has a right-hand thread and in order to unscrew it, it will be necessary to use Wico tool S-5619 (See Fig. 141) to prevent the rotor from turning.

When re-assembling the impulse locknut it is only necessary to turn the magneto over until the trip arm is against the impulse stop to prevent the rotor from turning when the nut is tightened.

DRIVE GEAR

After removal of the impulse locknut, the drive gear will fall off the magneto. When re-assembling, the drive gear should be so positioned that when the impulse

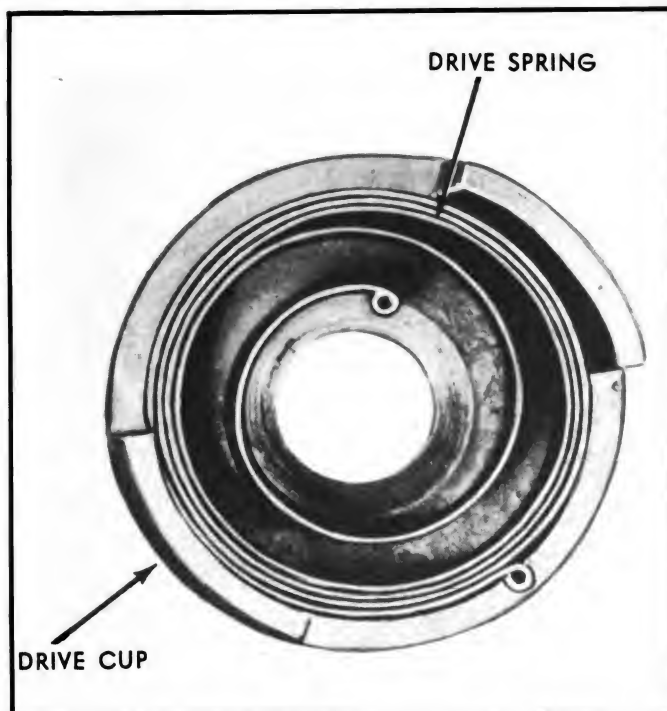

FIG. 142 Replacing Drive Spring

coupling is ready to trip, the "I" stamped on the gear will be in the upper left-hand quadrant. (See Fig. 146)

DRIVE CUP AND DRIVE SPRING

To remove the drive cup and drive spring, turn the drive cup in a clockwise direction until the trip arm latches against the impulse stop. Continue to turn the cup until the projection of the cup has cleared the projection of the driven flange. Without the friction of these parts against each other the cup can be pulled out far enough to allow it to unwind. A firm grip should be taken on the cup to prevent possible injury to the hand. Then, pull the cup (with the spring still in it) off the shaft.

To remove the impulse drive spring from the drive cup it is merely necessary to work the spring out of the cup with a screwdriver.

To replace the drive spring in the drive cup, insert the outer eye of the spring as far as possible into the slot (See Fig. 142) which shows the direction in which the spring should spiral. Next, take the drive cup spacer, which contains the slot for the inner eye, insert a large screwdriver in the center hole so it will bind, and the drive cup spacer can be turned with the screwdriver acting as a handle. (See Fig. 143) Insert the inner eye of the spring slot in the drive cup spacer until the spiral closes sufficiently to allow the spring to slide inside the drive cup. This method of winding the spring eliminates all possibility of distorting or scratching the spring surface. The spring may be more easily inserted if the lugs of the drive cup are securely held in a vise.

To re-assemble the drive cup and spring to the magneto, proceed as follows:

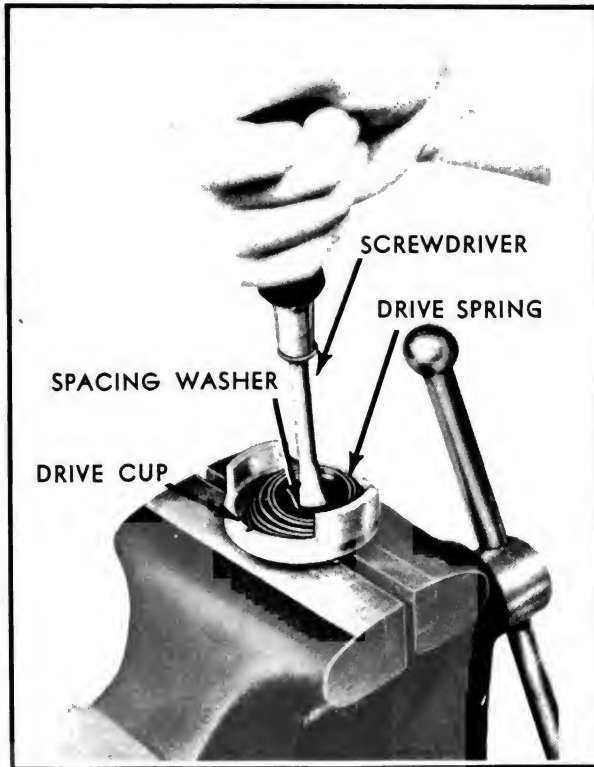

FIG. 143 Winding Drive Spring

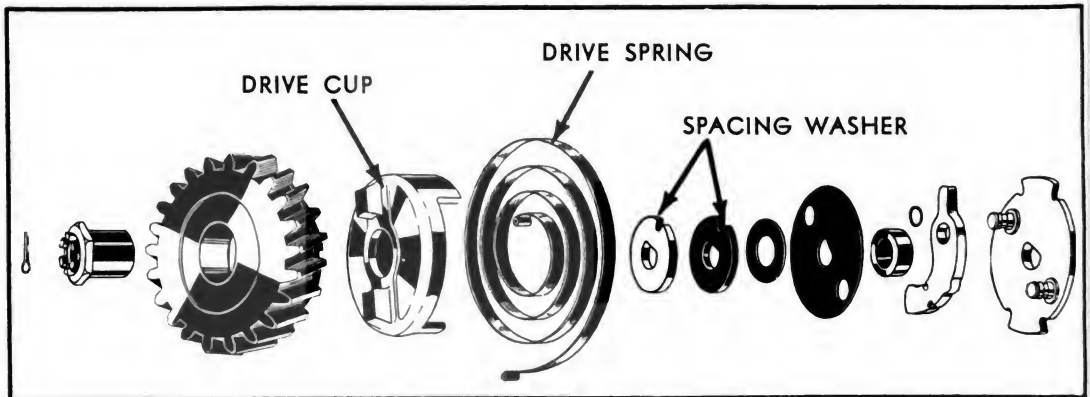

FIG. 144 Reassembly Of Drive Cup

(See Fig. 144) Make certain that all parts are clean and that there is grease between the turns of the impulse drive spring. Then put the two steel spacing washers into the drive cup with the inner eye, the springs, and the notch provided in the washer. Next, place on the shaft the drive cup with spring and spacing washers. Press the parts together while holding the impulse cup far enough out to allow the projection on the drive cup to clear the flange. Then give the cup a full turn, as follows: Make a half-turn, allow the cup projections to lock against the driven flange, then, with a fresh hold on the drive cup, make the other half-turn. When the cup is fully wound, press it firmly into place and apply a small amount of grease to the bearing surface of the impulse locknut.

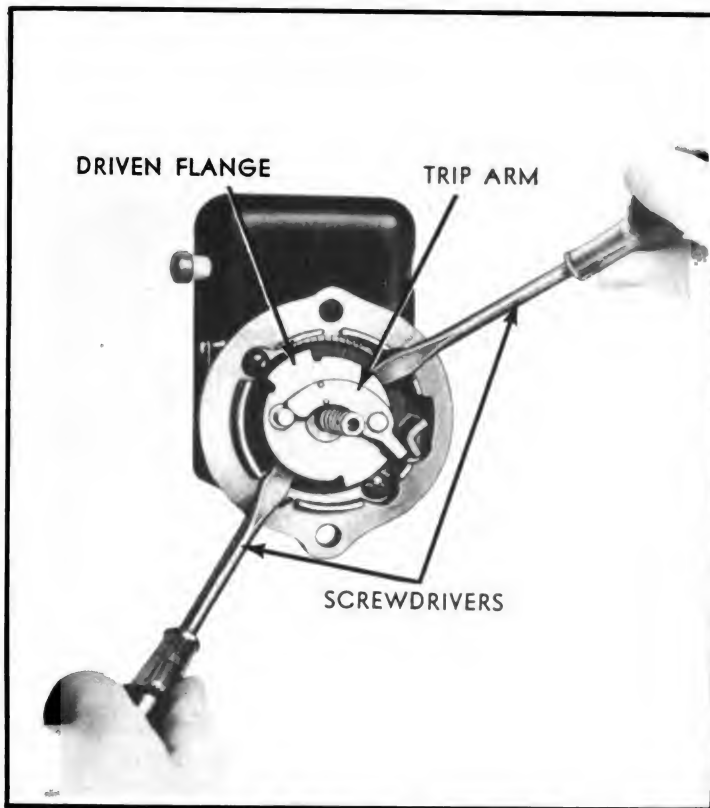

FIG. 145 Replacing Driven Flange Group

DRIVEN FLANGE GROUP AND TRIP ARMS

After having removed the impulse locknut, drive cup, drive spring, and various spacing washers, the driven flange group may be removed. If the flange sticks, insert two screwdrivers under the flange 180 degrees ($\frac{1}{2}$ circle) apart, and gently pry it off. (See Fig. 145). When replacing the driven flange group, make certain that it is pressed on the shaft as far as it will go. Since the flat on the rotor shaft is slightly tapered, being larger at the rotor end of the shaft, it is often necessary to press on the driven flange with considerable force, or to tap it gently into place with a soft-headed hammer.

TRIP ARM

To remove a trip arm, clamp the driven flange in a vise, then push the point of a knife between the snap ring and the trip arm pivot, near the opening of the snap ring. This will spring the snap ring a little and then, by inserting a knife between the snap ring and pivot as far from the opening as possible, the ring may be pulled off, after which the trip arm may be removed. It is recommended that a new snap ring be used if the old one becomes damaged in the process of removal.

The most simple method of installing a new snap ring is to use a socket wrench or similar device, of a size slightly larger than the pivot. Put the ring on the pivot, then press down on the ring with the open end of the socket wrench.

MAINTENANCE SECTION

MAGNETO

ENGINE

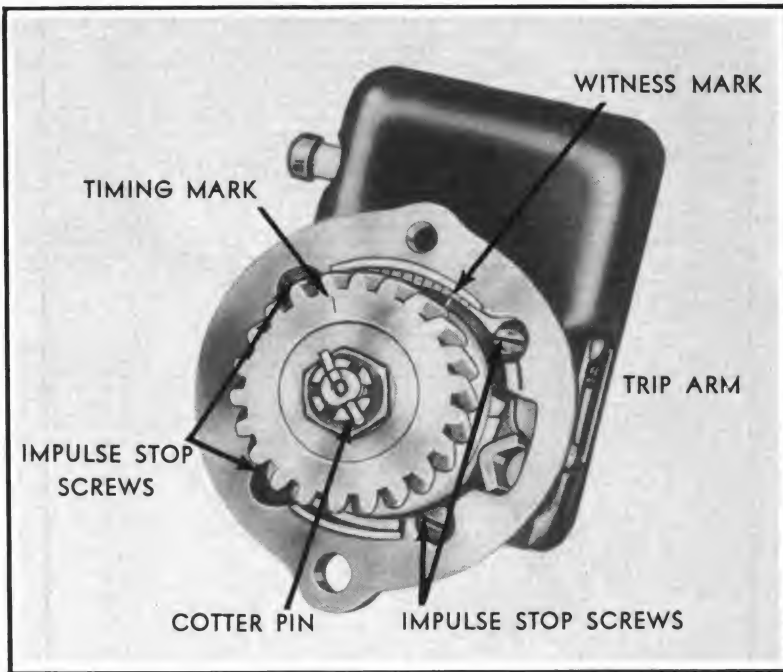

FIG. 146 Correct Impulse Stop

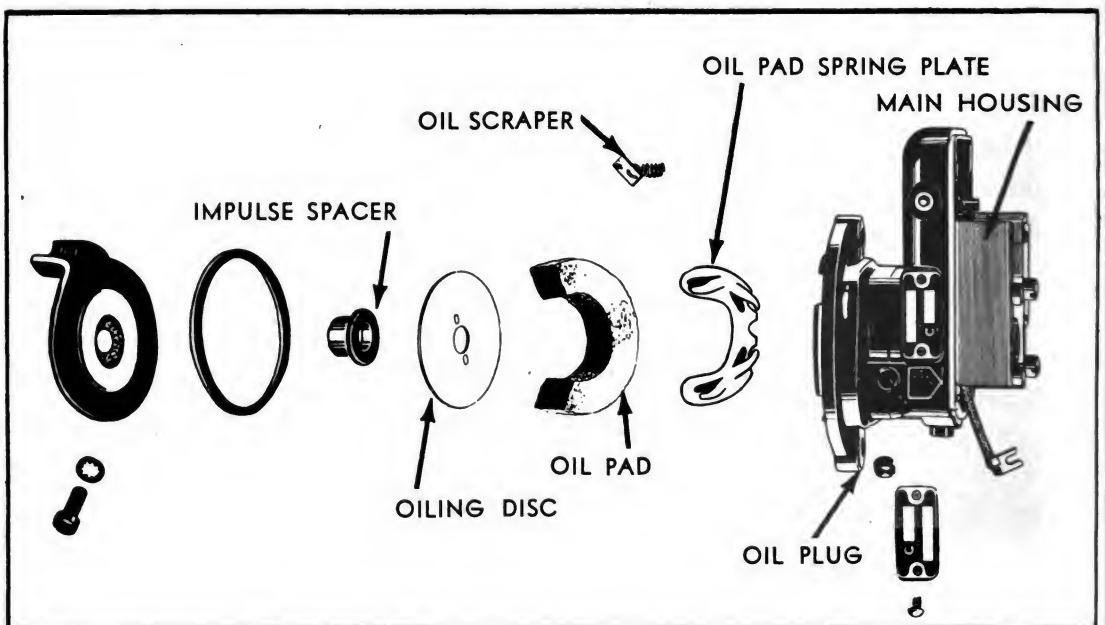

FIG. 147 Reassembly of Oiling System Parts

MAINTENANCE SECTION

IMPULSE STOP GROUP

The impulse stop group used on the model C magneto serves not only to hold the driven flange group and rotor stationary while the impulse is winding up, but also contains an oil seal which prevents the lubricating oil used in the magneto from leaking out, and foreign matter from entering the magneto. The impulse stop lug should be on the left-hand side of the magneto, as viewed from the drive end. When it is necessary to replace the oil seal, the impulse stop group must be replaced as a unit.

In replacing the impulse stop group, it is recommended that a new impulse stop gasket be used, rather than replacing the old gasket.

LAG ANGLE ADJUSTMENT

After the impulse coupling has been re-assembled, it is necessary to adjust the impulse lag angle, which provides a retarded spark during engine starting. The position of the impulse stop determines the lag angle of the magneto.

To set the lag angle, loosen the four impulse stop group clamp screws at the outer edge of the stop group, and turn as follows: The impulse stop plate has stamped on its face two witness marks 180 degrees apart, one of which is used for clockwise and the other for counter-clockwise magneto rotation. These marks register against corresponding marks five degrees apart on the main housing, acting as a guide to the amount of rotation of the stop plate during the adjustment of the lag angle. When the witness mark on the impulse stop group is even with the center mark on the main housing, an impulse range of 13 degrees is obtained. Rotation of the stop plate in *clockwise* direction increases the impulse range by the amount of its rotation. Thus, since the markings on the main housing are five degrees apart, turning the stop-plate three marks in a clockwise direction will produce the desired range of 28 degrees. The correct position of the impulse stop is shown in Fig. 146. These variances of range are only approximate, and the magneto should be tested on a rotary gap test stand and re-adjusted as required to give the exact range desired. After adjustment has been made, be sure to tighten the impulse stop group clamp screw. It is important that the lag angle be correctly adjusted to 28 degrees to insure the most efficient performance of the engine.

MAIN HOUSING

CAUTION: Under no condition should the four screws holding the laminated cores on the main housing be removed. These cores are installed at the factory and finished to very close tolerances in order to maintain the proper air gap between the cores and the rotor.

OILING SYSTEM PARTS

After the impulse stop group and all other impulse coupling parts have been removed, the impulse spaces and oiling disc may be removed from the rotor shaft. Then remove the main pad and the oil pad spring plate. After this, the oil scraper may be removed from the main housing.

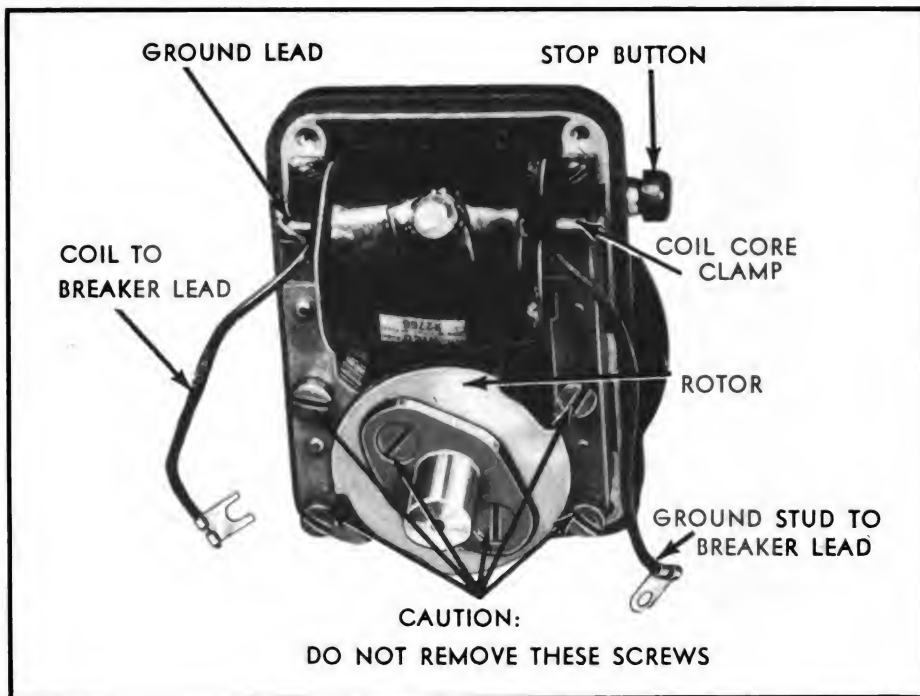

FIG. 148 Rotor

When re-assembling, refer to Fig. 147. First, insert the oil scraper unit in the hole provided making certain that the scraper itself is in the groove and does not get caught and lay over the oil hole, stopping the oil circulation. The oil pad spring plate should have sufficient tension in the spring to hold the main oil pad securely against the oiling disc. The oil pad should be thoroughly saturated with OE10 or OE30 oil before being installed in the magneto. Next, replace the oiling disc and the impulse spacer.

ROTOR

CAUTION: Do not remove the rotor screws. (See Fig. 148)

The ability of magnet steel to retain its magnetism is known as its coercive property. The magneto steel used in the model C rotors has such extremely high coercive value that it is practically impossible for these rotors to lose any appreciable amount of magnetism under any condition.

Great care should be taken when handling the rotor outside of the magneto to see that no metallic chips adhere to it, and before reinstalling the rotor it should be thoroughly examined to make certain that it is absolutely clean.

REPLACEMENT OF ROTOR BUSHING

In order to replace the bushings in a model C housing, the complete housing must be replaced.

PARTS SECTION

WARNING

SPARE PARTS can be supplied promptly and accurately only if positively identified by correct part number and correct part name.

FURNISH THIS INFORMATION ON ALL REQUISITIONS.

WITHOUT FAIL, on all requisitions, give name of machine, name of manufacturer, model or size, manufacturer's serial number of each machine and subassemblies attached to machine, and components and accessories for which spare parts are required.

List spare parts for only one make or kind of machine on each requisition.

Requisitions must be double spaced to provide room for office notations when necessary.

C&D SPA 304

PREPARATION OF REQUISITIONS

Sample Copy for Use in the Preparation of Requisitions

On this page is shown a sample spare parts requisition on QMC Form No. 400 which conforms to the latest revisions. The marginal notes give instructions for preparing a requisition for spare parts for Engineer equipment.

The revised QMC Form 400 has new column headings. Until new forms are available use the present form and type or write in corrections in column headings as shown below.

Under revised heading "Nomenclature" and "Unit" list the article and the unit (ea for each; lb for pound; etc.). Under heading "Maximum or Authorized Level" list the authorized organizational allowances or depot stock levels given in ENG 7 and ENG 8 of the ASF

Engineer Supply Catalog (superseding Part III, Corps of Engineers Supply Catalog). The total number on hand for each item is listed under "On Hand". In column headed "Due In" enter the total quantity previously requisitioned but not delivered. Column headed "Required" is to be changed to read "Quantity Desired" and column headed "Approved" is to read "Remarks." For "Initial" and "Replenishment" requisitions, the sum of "Quantity Desired", "Due In", and "On Hand" should equal "Maximum or Authorized Level."

(Additional details on this subject are covered in ENG 1 of the ASF Engineer Supply Catalog which incorporates information formerly contained in Section AA-1, Part III, Engineer Supply Catalog.)

State PERIOD designation by use of one of the following terms:

- (1) "INITIAL"—first requisition of authorized allowances.
- (2) "REPLENISHMENT"—subsequent requisitions to maintain authorized allowances.
- (3) "SPECIAL"—requisitions for necessary repairs not covered by allowances.

Type "SPARE PARTS" in upper right hand corner of requisition.

Address requisitions to Engineer Field Maintenance Office, P. O. Box 1679, Columbus, Ohio (except for spare parts for searchlights and barrage balloons which are addressed to Schenectady, N. Y. or Ogden, Utah ASF depots).

Give complete shipping instructions. Special instructions for packing, marking, routing, etc., should be given at bottom of requisition.

State proper nomenclature of machine, also make, model, machine serial number and U. S. A. registration number.

Prepare a separate requisition for each different machine.

State basis or authority and date delivery is required, immediately below description of machine.

Double space between items.

Group parts required under group headings as shown in manufacturers' parts catalogs (Technical Manuals).

State OCE stock numbers, manufacturers' parts numbers and nomenclature accurately and completely. Do not use abbreviations.

WAR DEPARTMENT
Q. M. C. Form No. 400
Revised 12 Aug 1943

REQUISITION

To: Engineer Field Maintenance Office No. of Sheets 1 Sheet No. 1
P. O. Box 1679, Columbus, Ohio
 Requisition No. E-908-4-44 Date 10 April 1944 Period Replenishment

SENT TO: Engineer Property Officer, PORT LEWIS, WASHINGTON

MARKED FOR: Supply Officer, 150th Engr. Regiment, PORT LEWIS, WASHINGTON
 Requisition By (show Signature, Rank, Organization, Destination. If different from "sent to" include address) Robert E. Roe For the Commanding Officer: John E. Doe
Robert E. Roe John E. Doe
 Major, C. E., Executive Officer
 Engineer Property Officer

QMC NO.	NOMENCLATURE AND UNIT	AUTH. OF MAX. LEVEL	ON HAND	DUE IN	QUANTITY DESIRED	REMARKS
	PARTS FOR SHOWER UNIT, FIELD, TRAILER-MOUNTED, CLEAVER-BROOKS MODEL EC-3					WITH HEATER, 8 SHOWER HEAD
	BASIS: to replenish second echelon set					
	DELIVERY: by 10 May 1944					
	Cleaver-Brooks					
	Parts Nos. HEATER PARTS					
901005	GASKET, Handhole ea.	2	1	0	1	
903002	NOZZLE, Burner ea.	4	3	0	1	
	ENGINE PARTS					
608058	GASKET, Cylinder Head ea.	2	1	0	1	
609008	VALVE, Exhaust ea.	2	1	0	1	
	MISCELLANEOUS PARTS					
616055	HEAD, Shower ea.	4	3	0	1	

*Nonexpendable items such as tools must be accounted for, when requisitioned, by a statement that they have been placed on REPORT OF SURVEY or STATEMENT OF CHARGES.

Emergency requisitions sent by telephone, teletype, cablegram, telegraph or radio must be confirmed immediately with requisition marked: "Confirming (state identifying data)."

PREPARATION OF REQUISITIONS

A sample requisition in the correct form for submission by the Engineer Property Officer is shown on the opposite page.

THIS SHALL BE FOLLOWED IN MAKING OUT REQUISITIONS

In order to eliminate duplication of work, Property Officers may authorize organizations to prepare requisitions in final form, leaving requisition number space blank for completion by Property Officer.

THE FOLLOWING RULES WILL BE OBSERVED CAREFULLY IN PREPARING REQUISITIONS FOR SPARE PARTS:

- a. Prepare a separate requisition for each different machine.
- b. Type "SPARE PARTS" in upper right hand corner of requisition form.
- c. State PERIOD designation by use of one of the following terms:
 - (1) "INITIAL"—first requisition of authorized allowances.
 - (2) "REPLENISHMENT"—subsequent requisitions to maintain authorized allowances.
 - (3) "SPECIAL"—requisitions for necessary repairs not covered by allowances.
- d. Give complete shipping instructions.
- e. State proper nomenclature of machine, and make, model, serial number and registration number.
- f. State basis of authority, and date delivery is required, immediately below description of machine.
- g. Group parts required under group headings as shown in manufacturer's parts catalogs.
- h. State manufacturers' parts numbers and nomenclature descriptions accurately and completely. Do not use abbreviations.
- i. Double space between items.
- j. Emergency requisitions sent by telephone, telegraph, or radio must always be confirmed immediately with requisition marked: "Confirming (state identifying data)."
- k. Nonexpendable items must be accounted for.

PARTS SECTION

ACCESSORY LIST

C-B CO. PART NO.	NOMENCLATURE	MANUFACTURER	MANUFACTURER'S ADDRESS	MANUFACTURER'S PART NO.
609300	ENGINE	Wisconsin Motors Corp.	Milwaukee, Wis.	Model AK
609034	CARBURETOR	Stromberg Div. of Bendix Aviation Corp.	South Bend, Ind.	OH-½
609085	MAGNETO	Wico Electric Co.	West Springfield, Mass.	C-1295
609586	SPARKPLUG	AC Sparkplug Div., General Motors Corp.	Flint, Mich.	Champion 8, 18MM
609588	FILTER, Gasoline	Tillotson Mfg. Co.	Toledo, Ohio	OW-418
911000	GENERATOR	Marathon Electric	Wausau, Wis.	SS-50056-1, 3600 RPM
911041	BEARINGS, Generator	New Departure Bearing Co.	Bristol, Conn.	ND87504
614176	PUMP, Water	Jaeger Machine Co.	Columbus, Ohio	1½ P.O.
614158	CONE, Bearing	Timken Roller Bearing Co.	Canton, Ohio	09078
614156	CUP, Bearing	Timken Roller Bearing Co.	Canton, Ohio	90196
903107	BEARING, Blower	Stephens-Adamson Mfg. Co.	Aurora, Ill.	Sealmaster, NP-16, 1"
913019	STRAINER, Fuel	Detroit Lubricator Co.	Detroit, Mich.	CRC-480
904007	VALVE, Fuel Regulating	Monarch Mfg. Co.	Philadelphia, Pa.	G-49-B
913006	PUMP, Fuel	Tuthill Pump Co.	Chicago, Ill.	OLK-C
903002	NOZZLE, Fuel	Monarch Mfg. Co.	Philadelphia, Pa.	F80PLP, 30°, 4.0 GPH
903034	STRAINER, Nozzle	Monarch Mfg. Co.	Philadelphia, Pa.	F80
906020	VALVE, Solenoid	Detroit Lubricator Co.	Detroit, Mich.	683-3, 110 Volt
907006	REGULATOR, Temperature	Minneapolis-Honeywell	Minneapolis, Minn.	T-415 AX323A, 65-140° F
906011	TRANSFORMER	Webster Electric Co.	Racine, Wis.	511-AJ, 110 V, 60 cy.
602175	WHEEL	Budd Wheel Co.	Detroit, Mich.	44530D1
602177	HUB, Left Hand	Budd Wheel Co.	Detroit, Mich.	46138
602187	HUB, Right Hand	Budd Wheel Co.	Detroit, Mich.	46137
602179	CUP, Bearing, Inner	Timken Roller Bearing Co.	Canton, Ohio	3920
602178	CUP, Bearing, Outer	Timken Roller Bearing Co.	Canton, Ohio	382
602184	BEARING, Inner	Timken Roller Bearing Co.	Canton, Ohio	3979
602183	BEARING, Outer	Timken Roller Bearing Co.	Canton, Ohio	385-A

PARTS SECTION

HEATER SHELL

HEATER

HEATER SHELL

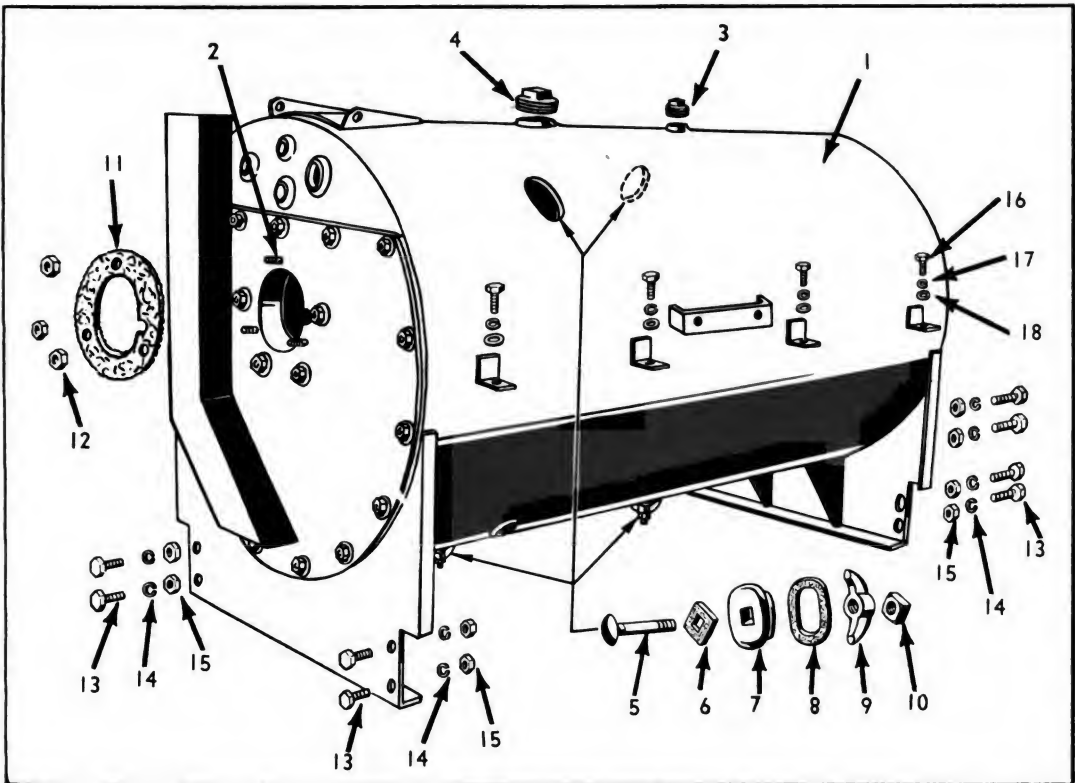

REF. NO.	C-B CO. PART NO.	NOMENCLATURE	NO. REQ'D
1	601011	SHELL, Boiler, Includes Head, Refractory, Tubes, Burner Mounting, Studs, Saddles, Handhole Plates	1
2	921115	STUD, NC, 1/2" x 1 1/2"	3
3	917548	PLUG, Galv., 1"	1
4	917942	PLUG, Galv., 2 1/2"	1
5	921072	BOLT, Carriage, NC, 5/8" x 4"	4
6	901006	GASKET, Handhole Bolt, 1 1/2" Sq. x 1/8"	4
7	101012	PLATE, Handhole, No. 33D	4
8	901005	GASKET, Handhole, 2 3/4" x 3 1/2"	4
9	101011	YOKE, Handhole, for No. 33D Plate	4
10	921331	NUT, Sq., NC, 5/8"	4
11	601010	GASKET, Blower Mounting Flange	1
12	921055	NUT, Hex, Brass, NC, 1/2"	3
13	921071	CAPSCREW, Hex Hd., NC, 1/2" x 1 1/2"	8
14	921053	LOCKWASHER, 1/2"	8
15	921346	NUT, Hex, NC, 1/2"	8
16	921008	CAPSCREW, Hex Hd., NC, 3/8" x 3/4"	8
17	921009	LOCKWASHER, 3/8"	8
18	921010	WASHER, 3/8"	8

When Ordering, Specify Model, Serial Number, Part Number and Name of Part Required.

PARTS SECTION

FRONT HEAD

HEATER

FRONT HEAD (FIRING END)

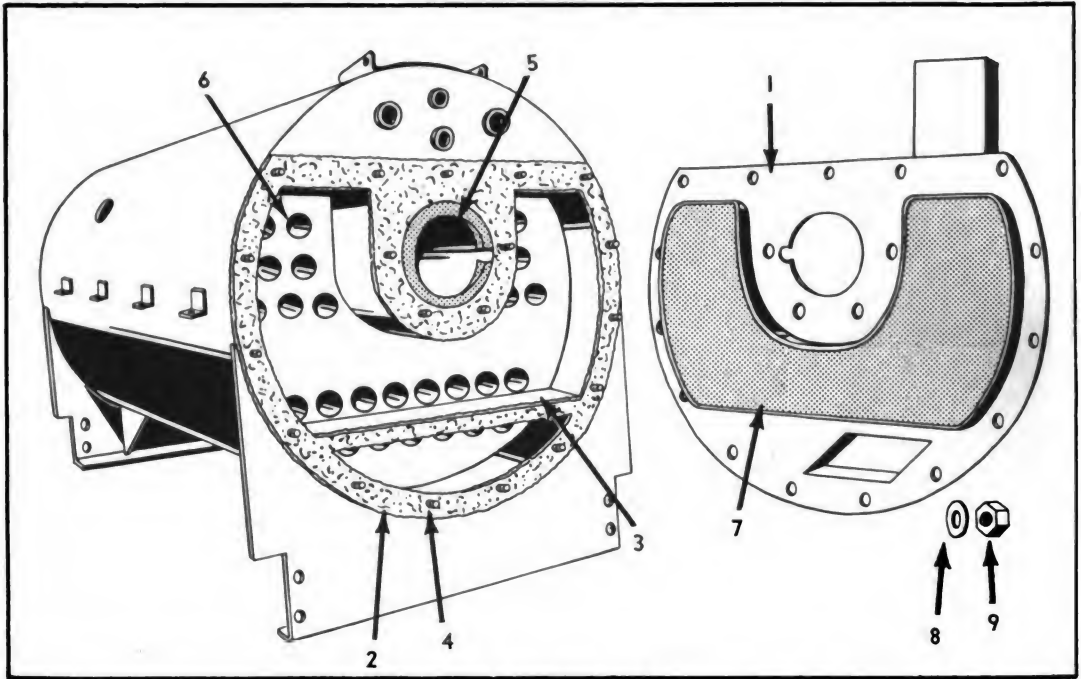

REF. NO.	C-B CO. PART NO.	NOMENCLATURE	NO. REQ'D
1	601004	HEAD, Front, Includes Stack, Blower Mounting Studs	1
2	901002	GASKET, Asbestos Paper, $\frac{1}{8}$ " x 36" x 44"	1
3	601005	BAFFLE, Front, Steel, $\frac{1}{2}$ " x $7\frac{3}{4}$ " x 26"	1
4	921115	STUD, NC, $\frac{1}{2}$ " x $1\frac{1}{2}$ "	19
5	605017	CEMENT, Silocel	5 lbs.
6	601006	TUBE, Boiler, 2" OD x $42\frac{5}{8}$ "	27
7	905038	CEMENT, Portland	10 lbs.
8	921078	WASHER, $\frac{1}{2}$ "	19
9	921055	NUT, Hex, Brass, NC, $\frac{1}{2}$ "	19

When Ordering, Specify Model, Serial Number, Part Number and Name of Part Required.

PARTS SECTION

REAR HEAD

HEATER

REAR HEAD (TOWING END)

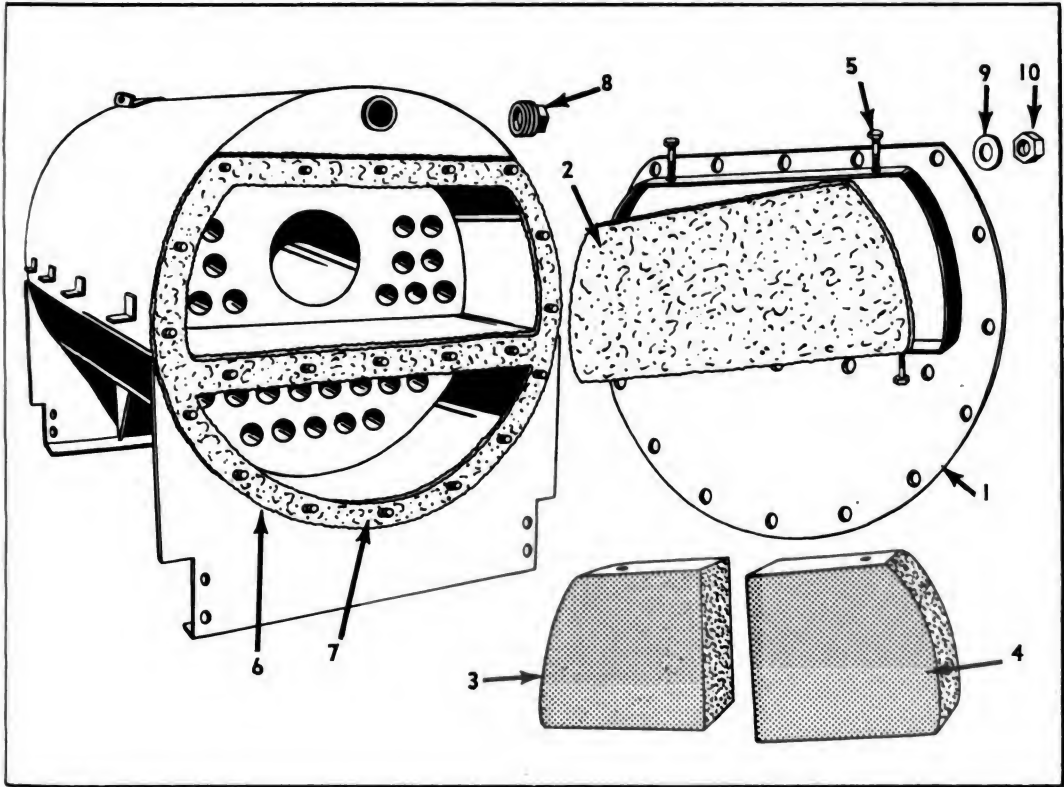

REF. NO.	C-B CO. PART NO.	NOMENCLATURE	NO. REQ'D
1	601152	HEAD, Rear, Includes Asbestos Insulator, Refractory Tile, Four Retainer Bolts	1
2	601148	INSULATOR, Asbestos, 1/4"	1
3	601149	TILE, Fire, Rear Outer Head, Cut to Fit, 4" x 12" x 12" Raw	1
4	601150	TILE, Fire, Rear Outer Head, Cut to Fit, 4" x 12" x 18" Raw	1
5	921097	BOLT, Machine, Sq Hd, NC, 5/8" x 1 3/4"	4
6	901002	GASKET, Asbestos Paper, 1/8" x 36" x 44"	1
7	921115	STUD, NC, 1/2" x 1 1/2"	21
8	917702	PLUG, Galv, 1 1/2"	1
9	921078	WASHER, 1/2"	21
10	921055	NUT, Hex, Brass, NC, 1/2"	21

PARTS SECTION

PUMP TO HEATER PIPING

WATER PIPING

PUMP TO HEATER PIPING

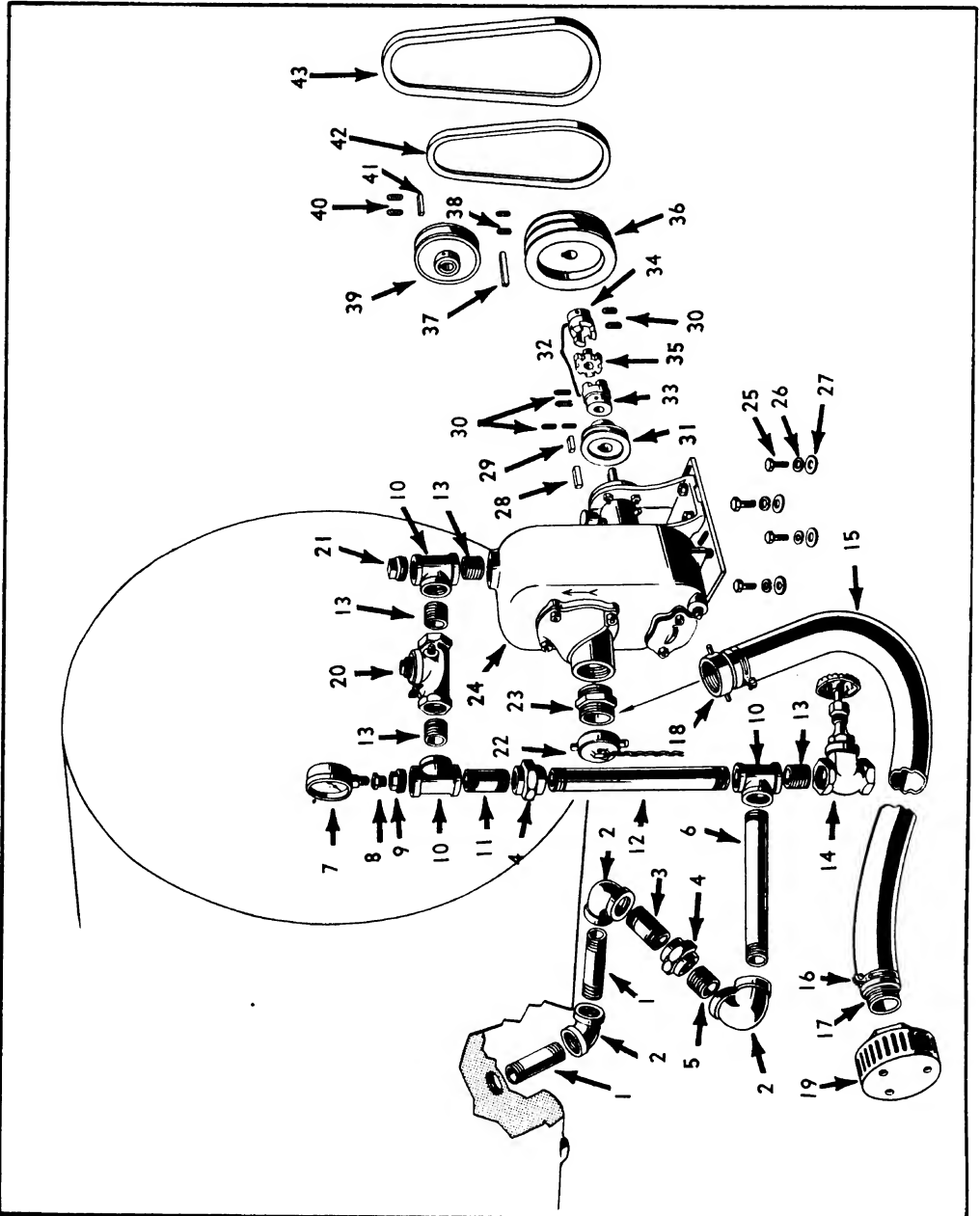

REF. NO.	C-B CO. PART NO.	NOMENCLATURE	NO. REQ'D
1	920795	NIPPLE, WI Galv, 1½" x 6"	2
2	917709	ELBOW, Galv, 90°, 1½"	3
3	920779	PIPE, WI Galv, 1½" x 13½"	1
4	917712	UNION, Galv, 1½"	2
5	920794	NIPPLE, WI Galv, 1½" x 4½"	1
6	923709	PIPE, WI Galv, 1½" x 12"	1
7	907004	GAUGE, Water Pressure, 2", 0-80 lbs.	1
8	917340	BUSHING, Galv, ½" x ¼"	1

PARTS SECTION

PUMP TO HEATER PIPING

WATER PIPING

PUMP TO HEATER PIPING

REF. NO.	C-B CO. PART NO.	NOMENCLATURE	NO. REQ'D
9	917714	BUSHING, Galv, 1½" x ½"	1
10	917703	TEE, Galv, 1½"	3
11	917752	NIPPLE, WI Ex Hvy. Galv, 1½" x 2½"	1
12	923708	PIPE, WI Galv, 1½" x 14"	1
13	920774	NIPPLE, WI Ex Hvy Galv, 1½" Close	4
14	904085	VALVE, Gate, 1½"	1
15	616007	HOSE, Smooth Bore, 1½" x 10', Male and Female Pin Lug Couplings	3
16	616027	CLAMP, Hose, Zinc Plated, 1½"	6
17	616063	COUPLING, Hose, Brass, Male, 1½" SPT	3
18	616064	COUPLING, Hose, Brass, Female, Pin Lug Type, 1½" SPT	3
19	616026	STRAINER, Suction, Brass Slotted Tube Type, Female Top Connection, 1½"	1
20	904090	VALVE, Swing Check, 1½"	1
21	917702	PLUG, Galv, 1½"	1
22	617703	CAP, Hose, Brass, Pin Lug Type with Chain	1
23	617702	NIPPLE, Hose, Brass, Double Male, 1½" SPT	1
24	614176	PUMP, Water, Jaeger, 1½ PO, Right Hand	1
25	921146	CAPSCREW, Hex Hd, NC, ⅜" x 1"	4
26	921009	LOCKWASHER, ⅜"	4
27	921010	WASHER, ⅜"	4
28	903030	KEY, ⅜" x ⅜" x 1¼", Oil Pump Drive Sheave	1
29	903042	KEY, ⅜" x ⅜" x 1"	1
30	921069	SETSCREW, Allen, ⅝" x ⅝"	6
31	912006	SHEAVE, C. I. 1A Groove, 2.6 PD, ¾" Bore, ⅜" x ⅜" KS, Includes two setscrews, Item 30	1
32	903015	COUPLING, Flexible, ¾" Bore, ⅜" x ⅜" KS x 1" Bore, ¼" x ⅛" KS, Lovejoy No. IA-095	1
33	903020	COUPLING, Half, ¾" Bore	1
34	903017	COUPLING, Half, 1" Bore	1
35	903019	CUSHION, Flexible Coupling for Lovejoy No. IA-095	1
36	912016	SHEAVE, C. I., 2 B Groove, 6.0 PD, 1" Bore, ¼" x ⅛" KS, Includes Item 38	1
37	912048	KEY, ¼" x ¼" x 2½"	1
38	921070	SETSCREW, Allen, ⅜" x ¾"	2
39	912212	SHEAVE, C. I., 1B Groove, Adjustable, 3.4 to 4.0 PD, 1" Bore, ¼" x ⅛" KS, Includes Item 40	1
40	921026	SETSCREW, Allen, ⅝" x ⅜"	2
41	912030	KEY, ¼" x ¼" x 2"	1
42	912045	V-BELT, Gilmer, No. 4380, Blower Drive	1
43	912046	V-BELT, Texrope, No. 2500, Generator Drive	1

PARTS SECTION

HEATER DISCHARGE PIPING

WATER PIPING

HEATER DISCHARGE PIPING

REF. NO.	C-B CO. PART NO.	NOMENCLATURE	NO. REQ'D
1	907007	THERMOMETER, 3", 0-200° F., 1/2" SPT	1
2	920695	NIPPLE, W. I., Ex Hvy Galv, 1 1/4" Close	2
3	917601	COUPLING, Galv, 1 1/4"	1
4	904010	VALVE, Pop, 1 1/4", 30 lbs.	1
5	917637	ELBOW, Galv, 45°, 1 1/4"	1
6	923608	PIPE, W. I. Galv, Threaded One End, 1 1/4" x 32"	1
7	920774	NIPPLE, W. I., Ex Hvy Galv, 1 1/2" Close	9
8	917712	UNION, Galv, 1 1/2"	3
9	917709	ELBOW, Galv, 90°, 1 1/2"	5
10	904085	VALVE, Gate, 1 1/2"	2
11	917747	ELBOW, Galv, 45°, 1 1/2"	2
12	923707	PIPE, W. I. Galv, 1 1/2" x 24 1/2"	1
13	917752	NIPPLE, W. I. Ex Hvy Galv, 1 1/2" x 2 1/2"	2
14	917708	COUPLING, Galv, 1 1/2"	1
15	617702	NIPPLE, Hose, Brass, Double Male, SPT, 1 1/2"	2
16	617703	CAP, Hose, Brass, Pin Lug Type with Chain, 1 1/2" SPT	2
17	923601	NIPPLE, W. I. Galv, 1 1/4" x 6"	1
18	904076	VALVE, Gate, 1 1/4"	1

PARTS SECTION

WATER PUMP

WATER PIPING

WATER PUMP

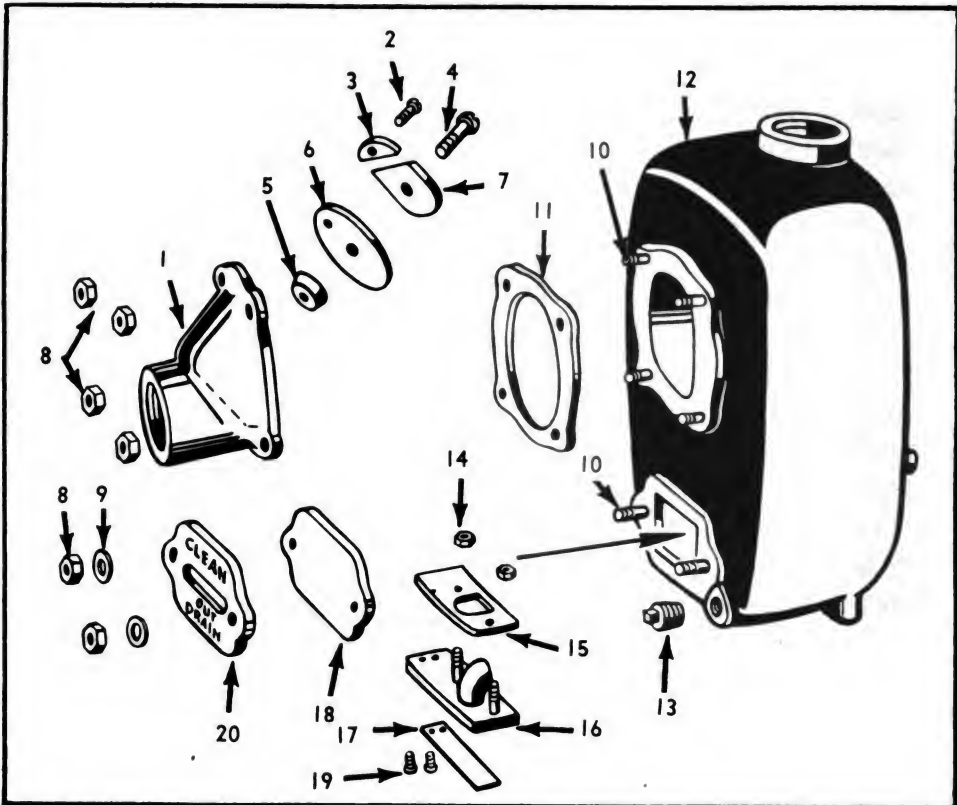

REF. NO.	C-B CO. PART NO.	NOMENCLATURE	NO. REQ'D
1	614132	BODY, Check Valve, Jaeger No. 26545-1	1
2	921120	SCREW, Mach, Brass, Rd Hd, NC, 1/4" x 1/2"	1
3	614133	PLATE, Hinge, Check Valve, Jaeger No. 26440-6	1
4	921599	SCREW, Mach, Brass, Rd Hd, NC, 1/4" x 3/4"	1
5	614134	WEIGHT, Check Valve, Lower, Jaeger No. 26440-3	1
6	614135	HINGE, Rubber, Check Valve, Jaeger No. 26545-5	1
7	614136	WEIGHT, Check Valve, Upper, Jaeger No. 26440-2	1
8	921012	NUT, Hex, NC, 5/16"	6
9	921274	WASHER, 5/16"	2
10	614026	STUD, NC, 5/16" x 1 1/4"	6
11	614139	GASKET, Check Valve Body, Jaeger No. 26545-6	1
12	614140	VOLUTE, Water Pump, Jaeger No. 26521-1	1
13	917108	PLUG, Brass, 1/4"	1
14	921017	NUT, Brass, Hex, NC, 1/4"	2
15	614145	GASKET, Priming Valve, Jaeger No. 26441-5	1
16	614146	ELBOW, Complete with Studs, Jaeger No. 28311-1	1
17	614147	SPRING, Water Pump Valve, Jaeger No. 28311-4	1
18	614148	GASKET, Cleanout Plate, Jaeger No. 26438-8	1
19	921600	SCREW, Mach, Rd Hd, #10-24 x 5/16"	2
20	614150	PLATE, Pump Cleanout, Jaeger No. 26438-6	1

When Ordering, Specify Model, Serial Number, Part Number and Name of Part Required.

PARTS SECTION

WATER PUMP

WATER PIPING

WATER PUMP

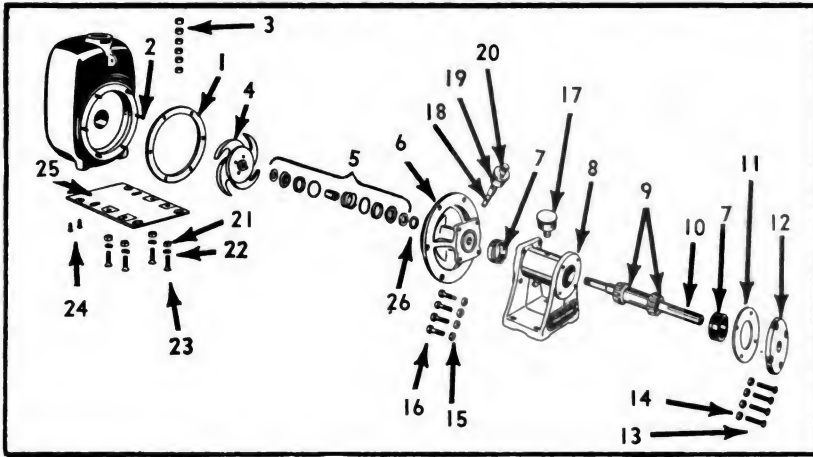

REF. NO.	C-B CO. PART NO.	NOMENCLATURE	NO. REQ'D
1	614151	GASKET, Volute, .021, Jaeger No. 26521-3	4
2	614152	STUD, NC, $\frac{5}{16}$ " x $1\frac{1}{8}$ "	6
3	921012	NUT, Hex, NC, $\frac{5}{16}$ "	6
4	614153	IMPELLER, Water Pump, C. I., Jaeger No. 26525-2	1
5	614154	SEAL, Set, Jaeger No. 26495-8	1
6	614155	HEAD, Support, Water Pump, Jaeger No. 26540-1	1
7	614156	CUP, Bearing, Timken No. 90196	2
8	614157	STAND, Bearing, Jaeger No. 26539-1	1
9	614158	CONE, Bearing, Timken No. 09078	2
10	614159	SHAFT, Impeller, Jaeger No. 26539-7	1
11	614161	GASKET, Bearing Stand, Jaeger No. 26539-4	1
11	614162	GASKET, Bearing Stand, Jaeger No. 26539-5	4
12	614163	PLATE, Bearing Stand Closure, Jaeger No. 26539-2	1
13	921601	BOLT, Stove, Flat Head, NC, $\frac{1}{4}$ " x 1"	4
14	921077	NUT, Hex, NC, $\frac{1}{4}$ "	4
15	921012	NUT, Hex, NC, $\frac{5}{16}$ "	4
16	921110	CAPSCREW, NC, $\frac{5}{16}$ " x $1\frac{1}{4}$ "	4
17	614167	CUP, Grease, No. 0, $\frac{1}{4}$ "	1
18	917002	NIPPLE, Brass, $\frac{1}{8}$ " x 2"	1
19	917054	COUPLING, Brass, $\frac{1}{8}$ "	1
20	616032	CUP, Grease, Compression, No. 00, $\frac{1}{8}$ "	1
21	921024	NUT, Hex, NC, $\frac{3}{8}$ "	4
22	921009	LOCKWASHER, $\frac{3}{8}$ "	4
23	921602	CAPSCREW, Flat Head, NC, $\frac{3}{8}$ " x $1\frac{1}{4}$ "	4
24	921603	BOLT, Stove, Flat Head, NC, $\frac{5}{16}$ " x $\frac{3}{4}$ "	2
25	614174	PLATE, Base, Jaeger No. 30419-4	1
26	614175	SLINGER, Water, Jaeger, No. 26465-3	1
	614218	SET, Gasket Complete. Consisting of 1 each No. 614139, 614145, 614148 and 614161. 4 each of No. 614151 and 614162.	

PARTS SECTION

SHOWER STAND

WATER PIPING

SHOWER STAND

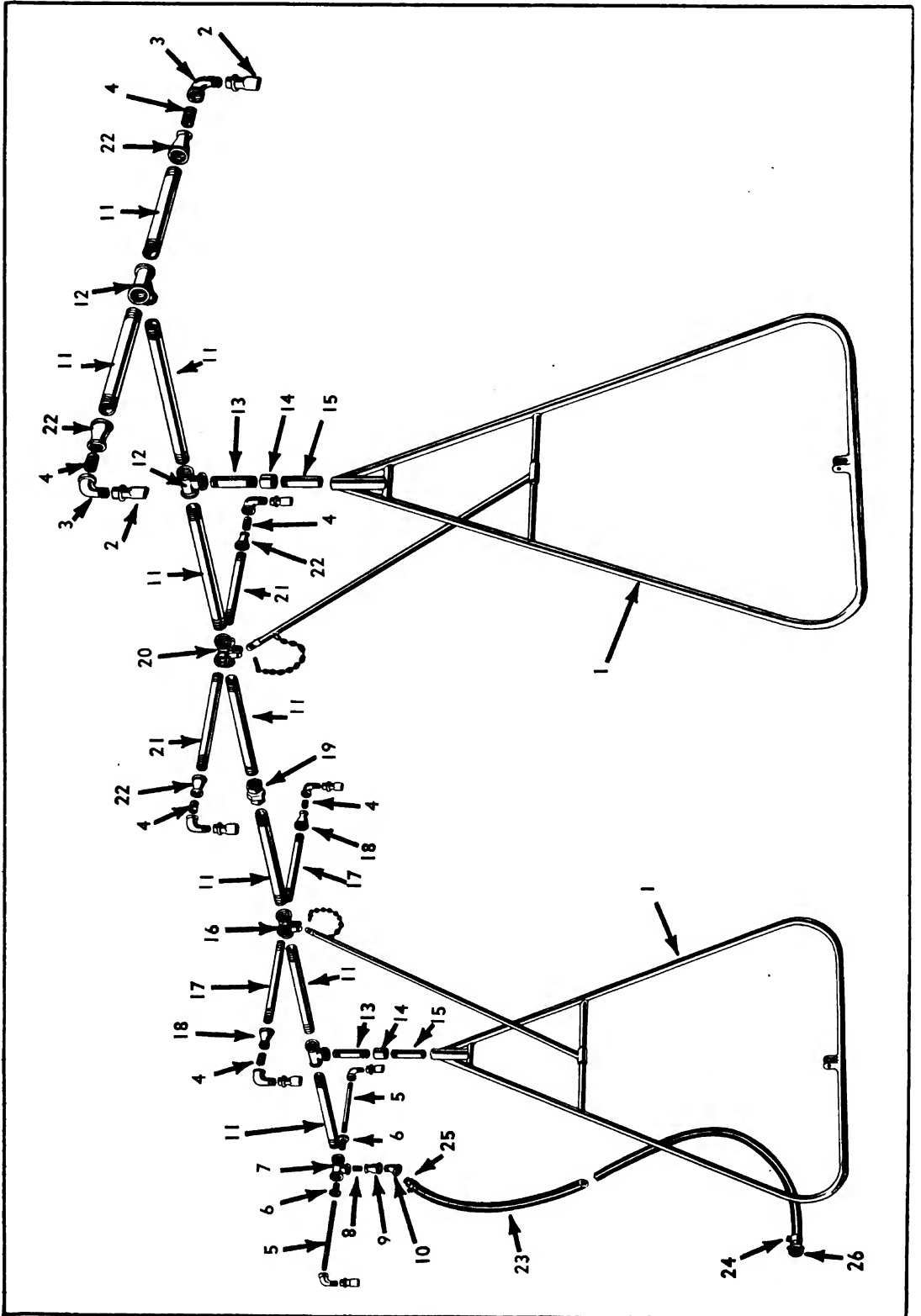

When Ordering, Specify Model, Serial Number, Part Number and Name of Part Required.

PARTS SECTION

SHOWER STAND

WATER PIPING

SHOWER STAND

REF. NO.	C-B CO. PART NO.	NOMENCLATURE	NO. REQ'D
1	616054	SUPPORT, Shower Stand, Complete	2
2	616055	HEAD, Shower Ball, Joint, 1/2", Crane No. 4871	8
3	917342	ELBOW, Street, Galv, 90°, 1/2"	8
4	920330	NIPPLE, WI Ex Hvy Galv, 1/2" Close	6
5	920334	PIPE, WI Galv, 1/2" x 22"	2
6	917608	BUSHING, Galv, 1 1/4" x 1/2"	2
7	917609	TEE, Galv, Side Outlet, 1 1/4"	1
8	920695	NIPPLE, WI Ex Hvy Galv, 1 1/4" Close	1
9	917740	COUPLING, Reducing, Galv, 1 1/2" x 1 1/4"	1
10	917705	ELBOW, Street, Galv, 45°, 1 1/2"	1
11	923615	PIPE, WI Galv, 1 1/4" x 22"	8
12	920640	TEE, Galv, 1 1/4"	3
13	923601	NIPPLE, WI Galv, 1 1/4" x 6"	2
14	917601	COUPLING, Galv, 1 1/4"	2
15	617602	NIPPLE, Special, Shower Stand, One End Threaded, Plug Welded in Other, 1 1/4" x 6"	2
16	617603	CROSS, Special, Shower Stand, Lugs Welded in Place, 1 1/4" x 1 1/4" x 3/4" x 3/4"	1
17	923455	PIPE, WI Galv, 3/4" x 22"	2
18	917427	COUPLING, Reducing, Galv, 3/4" x 1/2"	2
19	917607	UNION, Galv, 1 1/4"	1
20	617604	CROSS, Special, Shower Stand, Lugs Welded On, 1 1/4" x 1 1/4" x 1" x 1"	1
21	923501	PIPE, WI Galv, 1" x 22"	2
22	917547	COUPLING, Reducing, Galv, 1" x 1/2"	4
23	616007	HOSE, Smooth Bore, 1 1/2" x 10', Male and Female Pin Lug Couplings	2
24	616027	CLAMP, Hose, Zinc Plated, 1 1/2"	4
25	616063	COUPLING, Hose, Brass, Male 1 1/2" SPT	2
26	616064	COUPLING, Hose, Brass, Female Pin Lug Type, 1/2" SPT	2

PARTS SECTION

FUEL ASSEMBLY

FUEL PIPING

FUEL ASSEMBLY

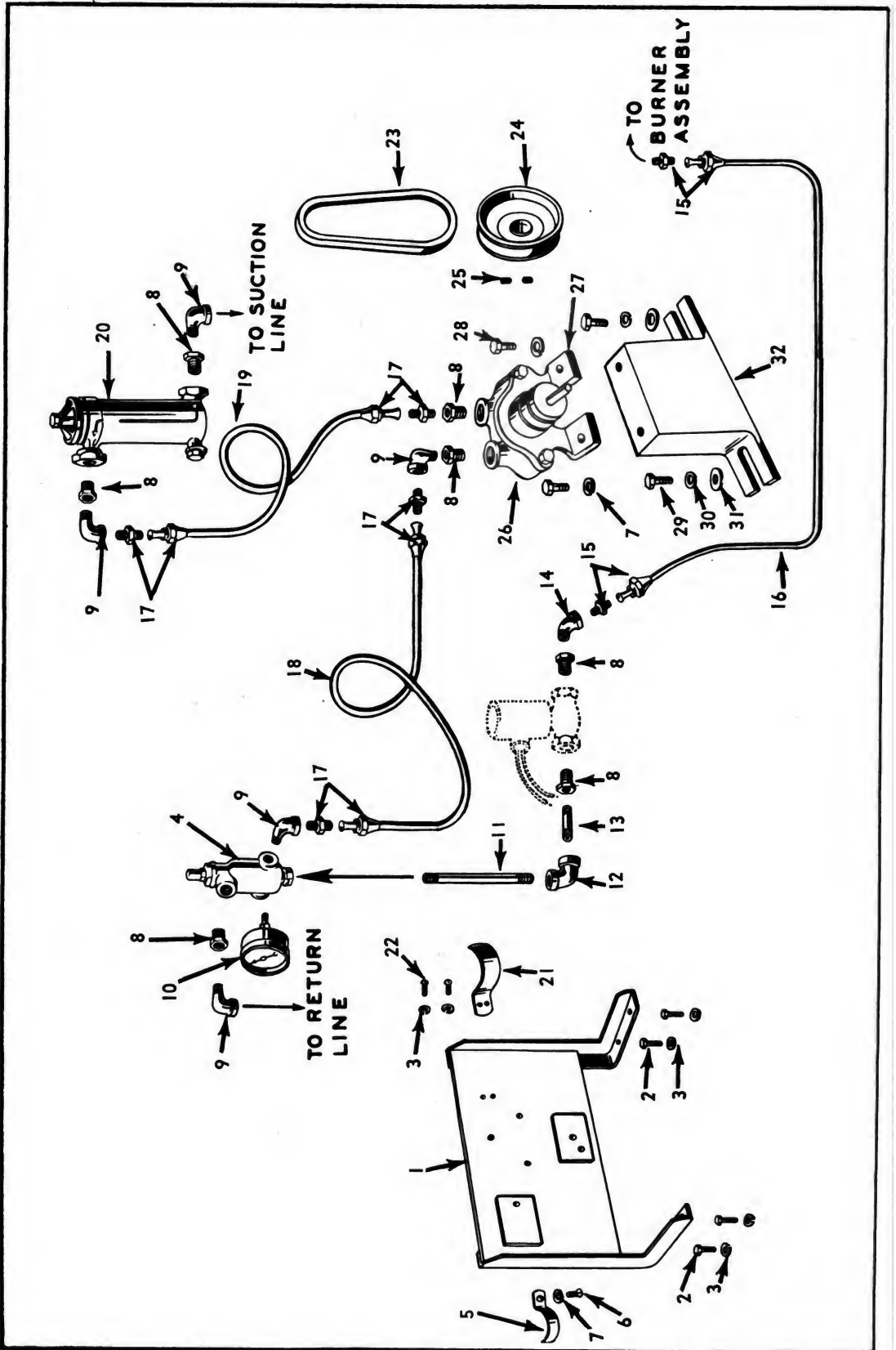

When Ordering, Specify Model, Serial Number, Part Number and Name of Part Required.

PARTS SECTION

FUEL ASSEMBLY

FUEL PIPING

FUEL ASSEMBLY

REF. NO.	C-B CO. PART NO.	NOMENCLATURE	NO. REQ'D
1	613009	PANEL, Includes 1" Angle Legs Welded On, 11" x 7 $\frac{3}{4}$ " x $\frac{3}{16}$ "	1
2	921027	CAPSCREW, Hex Hd, NC, $\frac{1}{4}$ " x $\frac{3}{4}$ "	4
3	921001	LOCKWASHER, $\frac{1}{4}$ "	6
4	904007	VALVE, Fuel Relief, Monarch G-49-BR	1
5	613010	BRACKET, Fuel Relief Valve	1
6	921002	SCREW, Mach, Rd Hd, NC, $\frac{5}{16}$ " x $\frac{3}{4}$ "	1
7	921003	LOCKWASHER, $\frac{5}{16}$ "	3
8	917254	BUSHING, Galv, $\frac{3}{8}$ " x $\frac{1}{4}$ "	7
9	917144	ELBOW, Street, Brass, 90°, $\frac{1}{4}$ "	5
10	907001	GAUGE, Fuel Pressure, 2", 0-200 lbs., $\frac{1}{4}$ " Male Back Connection	1
11	917106	NIPPLE, Brass, $\frac{1}{4}$ " x 3 $\frac{1}{2}$ "	1
12	917101	ELBOW, Brass, 90°, $\frac{1}{4}$ "	1
13	917105	NIPPLE, Brass, $\frac{1}{4}$ " x 3"	1
14	917115	ELBOW, Street, Brass, 45°, $\frac{1}{4}$ "	1
15	913013	CONNECTOR, Flared, $\frac{1}{4}$ " ODC x $\frac{1}{8}$ " SPT	2
16	613051	LINE, Fuel, $\frac{1}{4}$ " OD x 30" with Nuts	1
17	913127	CONNECTOR, Flared, $\frac{3}{8}$ " ODC x $\frac{1}{4}$ " SPT	4
18	913198	LINE, Fuel, $\frac{3}{8}$ " OD x 18" with Nuts	1
19	613050	LINE, Fuel, $\frac{3}{8}$ " OD x 20" with Nuts	1
20	913019	STRAINER, Fuel, Detroit CRC-480	1
21	913027	BRACKET, Fuel Strainer, for No. 913019	1
22	921197	SCREW, Mach, Rd Hd, NC, $\frac{1}{4}$ " x $\frac{1}{2}$ "	2
23	912033	V-BELT, Gilmer No. 3260	1
24	912015	SHEAVE, P. S., 1A Groove, 3.8 PD, $\frac{7}{16}$ " Bore, Includes Item 25	1
25	921365	SETSCREW, Allen, $\frac{5}{16}$ " x $\frac{1}{2}$ "	2
26	913006	PUMP, Fuel, Tuthill Model OLK-C	1
27	913007	FOOT, Fuel Pump, For 913006	1
28	921336	CAPSCREW, Hex Hd, NC, $\frac{5}{16}$ " x $\frac{3}{4}$ "	2
29	921008	CAPSCREW, Hex Hd, NC, $\frac{3}{8}$ " x $\frac{3}{4}$ "	2
30	921009	LOCKWASHER, $\frac{3}{8}$ "	2
31	921010	WASHER, $\frac{3}{8}$ "	2
32	613006	BLOCK, Fuel Pump Base	1

PARTS SECTION

FUEL STRAINER

FUEL PIPING

NO. 913019 FUEL STRAINER

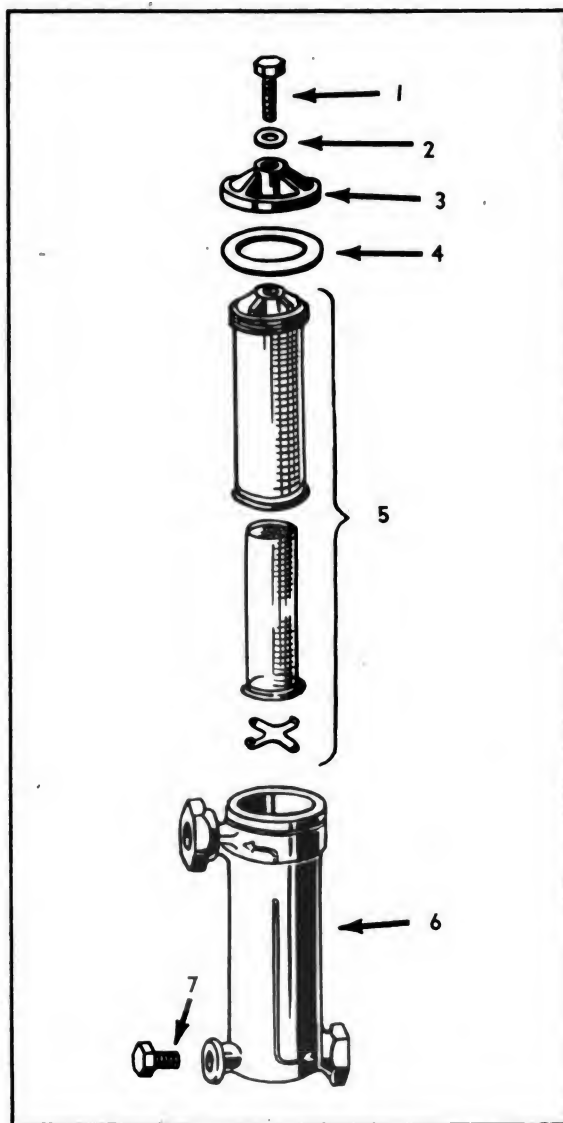

REF. NO.	C-B CO. PART NO.	NOMENCLATURE	NO. REQ'D
1	921079	CAPSCREW, Hex Hd, NC, $\frac{7}{16}$ " x $1\frac{1}{2}$ "	1
2	913020	GASKET, Copper	1
3	913021	COVER	1
4	913022	GASKET	1
5	913196	BASKET	1
6	913026	BODY	1
7	917108	PLUG, Brass, $\frac{1}{4}$ "	1

When Ordering, Specify Model, Serial Number, Part Number and Name of Part Required.

PARTS SECTION

SUCTION AND RETURN LINES

FUEL PIPING

SUCTION AND RETURN LINES

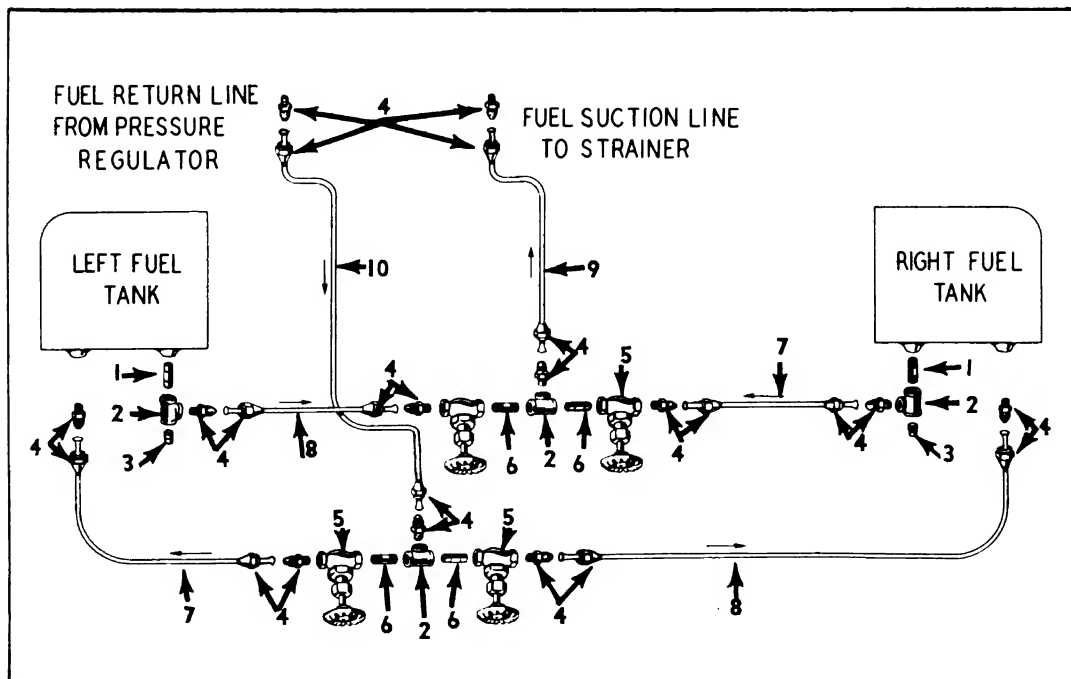

REF. NO.	C-B CO. PART NO.	NOMENCLATURE	NO. REQ'D
1	917126	NIPPLE, Brass, 1/4" Close	2
2	917109	TEE, Brass, 1/4"	4
3	917108	PLUG, Brass, 1/4"	2
4	913008	CONNECTOR, Flared, 3/8" ODC to 1/4" SPT	12
5	904008	VALVE, Globe, 1/4"	4
6	917102	NIPPLE, Brass, 1/4" x 1 1/2"	4
7	913231	LINE, Fuel, 3/8" OD x 30" with Nuts	2
8	913232	LINE, Fuel, 3/8" OD x 16" with Nuts	2
9	913233	LINE, Fuel, 3/8" OD x 26" with Nuts	1
10	913234	LINE, Fuel, 3/8" OD x 58" with Nuts	1

When Ordering, Specify Model, Serial Number, Part Number and Name of Part Required.

PARTS SECTION

BURNER

FUEL PIPING

BURNER ASSEMBLY

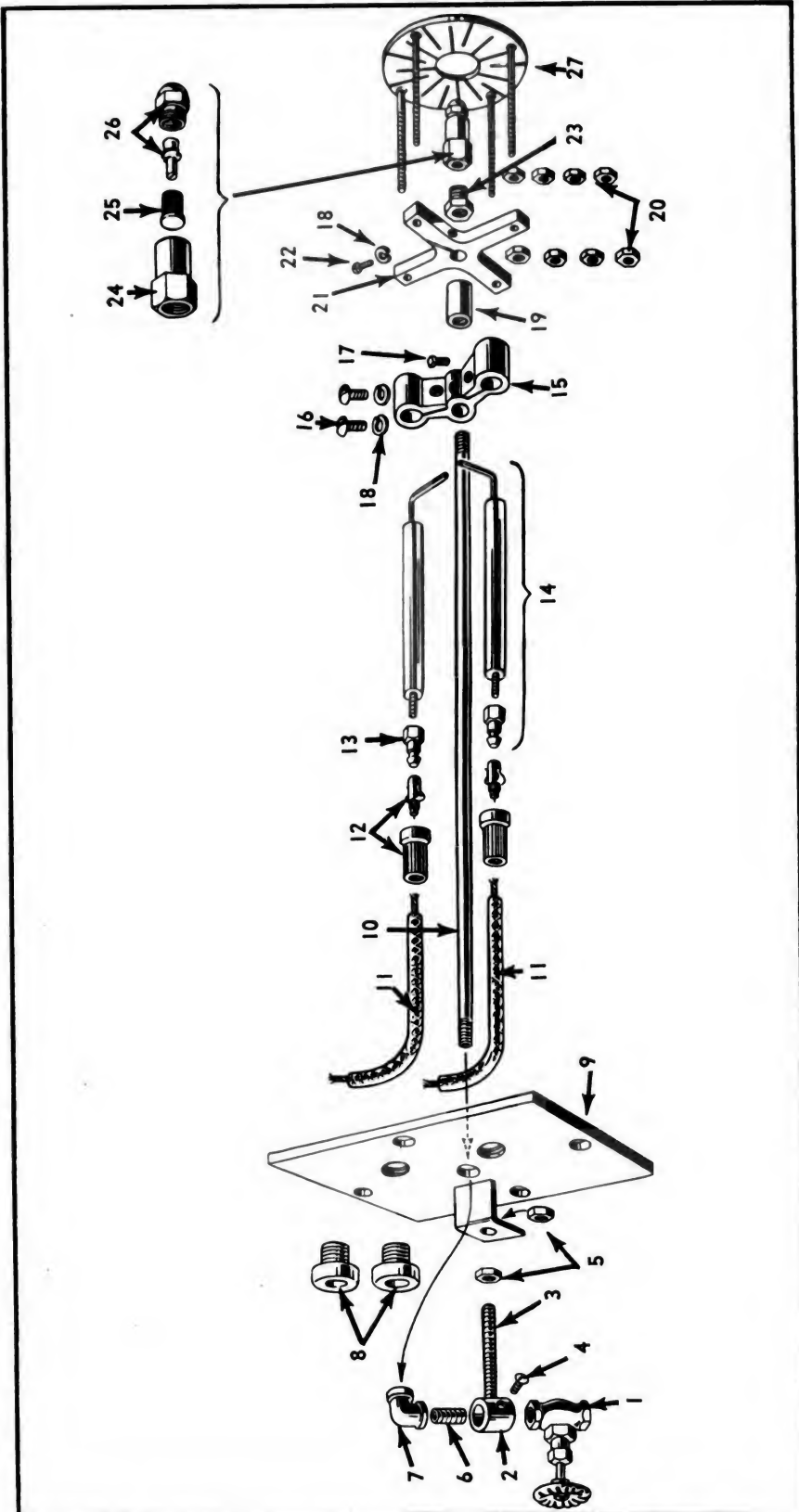

When Ordering, Specify Model, Serial Number, Part Number and Name of Part Required.

PARTS SECTION

BURNER

FUEL PIPING

BURNER ASSEMBLY

REF. NO.	C-B CO. PART NO.	NOMENCLATURE	NO. REQ'D
1	904041	VALVE, Globe, 1/8"	1
2	603020	SLEEVE, Burner Adjusting	1
3	603019	STUD, NC, 5/16" x 2"	1
4	921011	SCREW, Mach, Rd Hd, #10-32 x 3/8"	1
5	921012	NUT, Hex, NC, 5/16"	2
6	917003	NIPPLE, Brass, 1/8" x 2 1/2"	1
7	917000	ELBOW, Brass, 90°, 1/8"	1
8	903013	BUSHING, Porcelain, Multi, 1/2"	2
9	603024	FLANGE, Burner, Includes Adjusting Bracket	1
10	617001	PIPE, Brass, 1/8" x 14 1/2"	1
11	906001	CABLE, Ignition, GTO-15, 14" Long	2
12	906002	CONNECTOR, Ignition, Rajah .0395	2
13	906363	STUDS, Base Electrode Rajah 5-40	2
14	906216	ELECTRODE, 6", with Base Stud, Isolantite No. 872-AL-6	2
15	903063	CLAMP, Electrode, Brass, Includes Items 16 to 18 Incl.	1
16	921197	SCREW, Mach, Rd Hd, NC, 1/4" x 1/2"	2
17	921225	SETSCREW, Sq Hd, NC, 1/4" x 1/2"	1
18	921001	LOCKWASHER, 1/4"	3
19	903064	SLEEVE, Burner, 3/8" x 7/8"	1
20	921014	NUT, Hex, #10-32	8
21	603038	SPIDER, 4 Prong, 4" Dia., Includes Items 18 and 22	1
22	921339	SCREW, Mach, Rd Hd, NC, 1/4" x 5/8"	1
23	917100	BUSHING, Brass, 1/4" x 1/8"	1
24	903033	BODY, Nozzle, Monarch, Male	1
25	903034	STRAINER, Nozzle, Monarch F-80	1
26	903002	NOZZLE, Burner, 30°, 4.0 GPH, Monarch F-80 PLP	1
27	603037	PLATE, Diffuser, 1/4" x 3 7/8" Dia., Includes 4 Studs	1

PARTS SECTION

BLOWER

BLOWER

NO. 903160 BLOWER

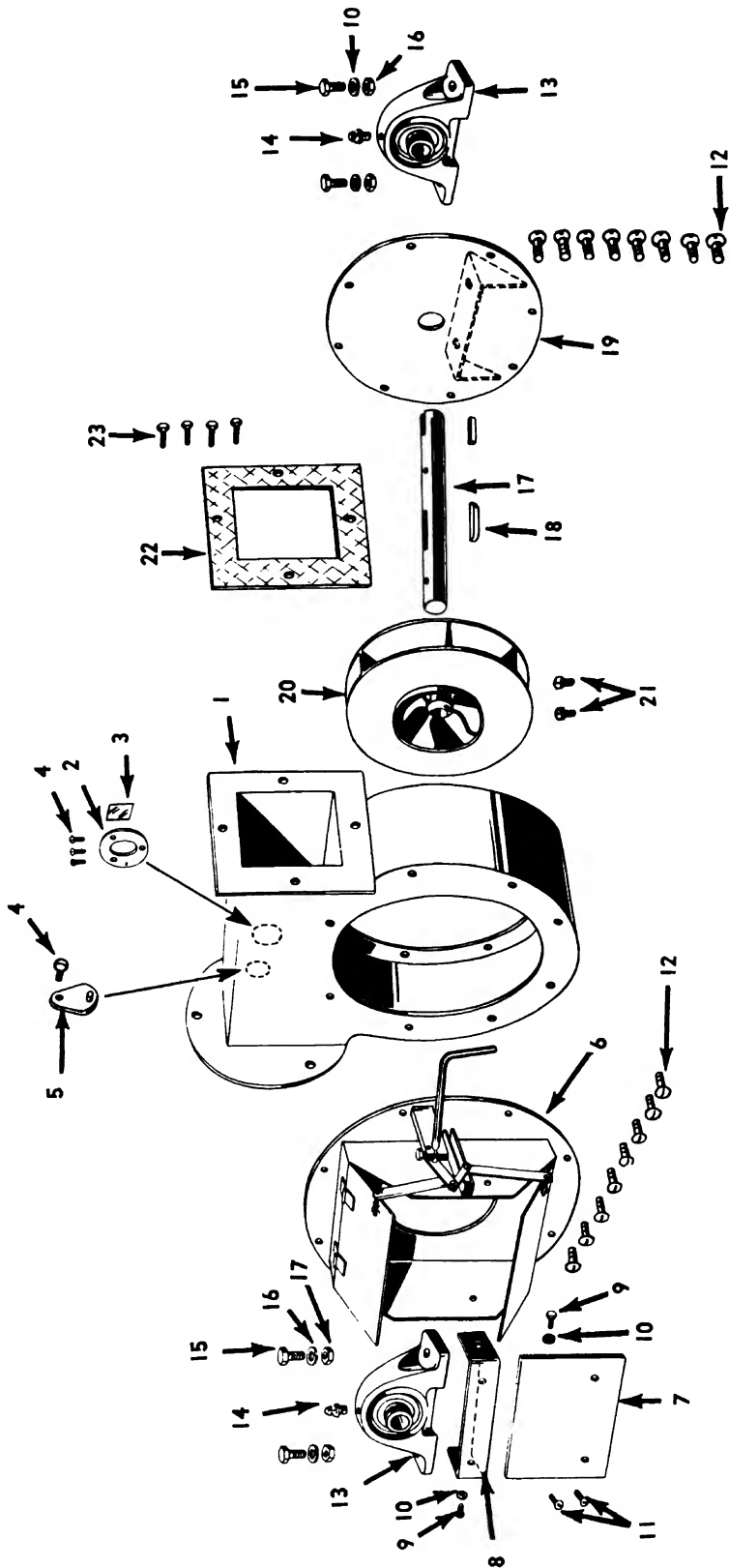

When Ordering, Specify Model, Serial Number, Part Number and Name of Part Required.

PARTS SECTION

BLOWER

BLOWER

NO. 903160 BLOWER

REF. NO.	C-B CO. PART NO.	NOMENCLATURE	NO. REQ'D
	903160	BLOWER, Bayley No. 15, Arr. 3, Complete, Includes Items 1 to 22 Incl.	1
1	903101	HOUSING, Blower, Includes Items 1 to 5 Incl.	1
2	903102	RING, Blower Observation Port Hole, 1" I. D.	1
3	903103	MICA, Blower Observation Port Hole, 1" Sq	1
4	921004	SCREW, Mach, Rd Hd, No. 10-32 x 1/2"	4
5	903001	COVER, Lighter Hole	1
6	603105	DAMPER, Air, Complete Assembly, Includes Items 7 to 11 Incl.	1
7	903105	PLATE, Blower Air Shutter Cover	1
8	903106	BRACKET, Blower Bearing Support	1
9	921341	SCREW, Mach, Rd Hd, NC, 1/4" x 3/8"	2
10	921009	LOCKWASHER, 3/8"	6
11	921197	SCREW, Mach, Rd Hd, NC, 1/4" x 1/2"	2
12	921341	SCREW, Mach, Rd Hd, NC, 1/4" x 3/8"	16
13	903107	BEARING, Ball, Pillow Block, 1", Includes Item 14	2
14	913067	FITTING, Zerk, 1/8", No. 1610	2
15	921023	CAPSCREW, Hex Hd, NC, 3/8" x 1 1/4"	4
16	921024	NUT, Hex, NC, 3/8"	4
17	903110	SHAFT, Blower, 1" Dia. x 11 1/4", 1/4" x 1/8" KS, Drilled for Setscrews	1
18	903111	KEY, 1/4" x 1/4" x 1 3/4"	1
19	903112	COVER, Blower Side, Includes Bearing Bracket	1
20	903113	WHEEL, Blower, 1" Bore, 1/4" x 1/8" KS, Includes Item 22	1
21	921363	SETSCREW, Sq Hd, NC, 5/16" x 1"	2
22	903114	GASKET, Burner Flange	1
23	921008	CAPSCREW, Hex Hd, NC, 3/8" x 3/4"	4

PARTS SECTION

GENERATOR AND IGNITION

ELECTRICAL

GENERATOR AND IGNITION

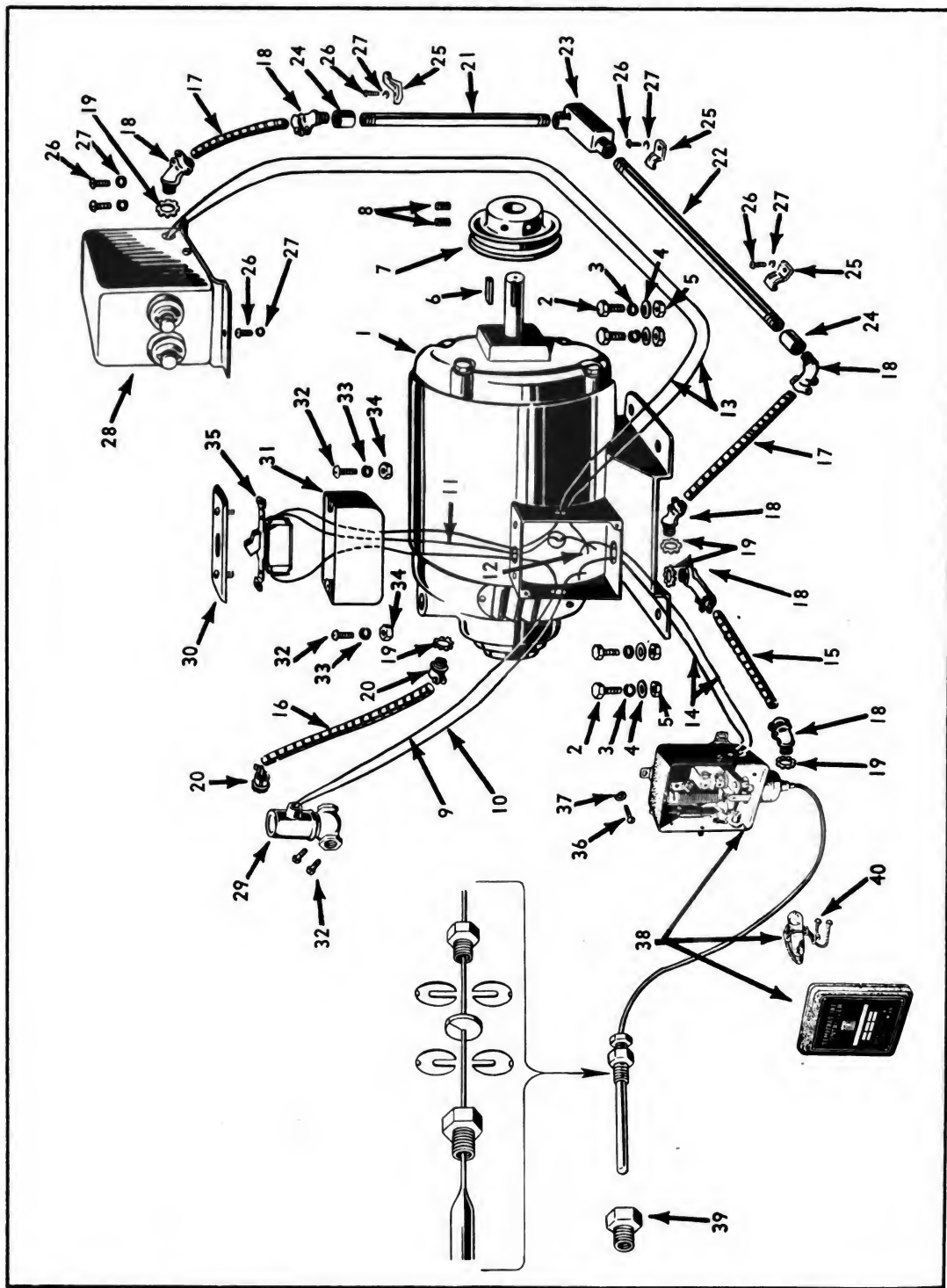

REF. NO.	C-B CO. PART NO.	NOMENCLATURE	NO. REQ'D
1	911000	GENERATOR, 110 V, 3600 rpm, 60 Cycle, Single Phase, Marathon BK549	1
2	921021	CAPSCREW, Hex Hd, NC, 3/8" x 1/2"	4

When Ordering, Specify Model, Serial Number, Part Number and Name of Part Required.

PARTS SECTION

GENERATOR AND IGNITION

ELECTRICAL

GENERATOR AND IGNITION

REF. NO.	C-B CO. PART NO.	NOMENCLATURE	NO. REQ'D
3	921009	LOCKWASHER, 3/8"	4
4	921010	WASHER, 3/8"	4
5	921024	NUT, Hex, NC, 3/8"	4
6	912029	KEY, 3/16" x 3/16" x 2"	1
7	912210	SHEAVE, CI, 1B Groove, 3.4 PD, 3/4" Bore, 3/16" x 3 1/2" KS, Includes Item 8	1
8	921365	SETSCREW, Allen, 5/16" x 1/2"	2
9	*	WIRE, Yellow, From Solenoid Valve	*
10	*	WIRE, Black, From Solenoid Valve	*
11	*	WIRE, From Generator	*
12	*	WIRE, From Generator	*
13	606005	WIRE, No. 14, Flamenol Red, 6 ft.	2
14	606006	WIRE, No. 14, Flamenol Black, 2 1/2 ft.	2
15	906368	GREENFIELD, Standard, 3/8" x 20"	1
16	606008	GREENFIELD, Standard, 3/8" x 12"	1
17	606009	GREENFIELD, Standard, 3/8" x 8"	2
18	906005	CONNECTOR, Squeeze, 2 Piece, 1 Screw, 45°, 3/8"	6
19	906195	LOCKNUT, Conduit, 3/8"	5
20	906007	CONNECTOR, Squeeze, Straight, 3/8"	2
21	606011	CONDUIT, Galv, 1/2" x 15"	1
22	606012	CONDUIT, Galv, 1/2" x 23"	1
23	906008	UNILET, 1/2", Conduit Type LL Rigid	1
24	906513	COUPLING, Conduit, Galv, 1/2"	2
25	906010	STRAP, Pipe, 1 Hole, 1/2"	3
26	921383	SCREW, Mach, Rd Hd, NC, 1/4" x 3/4"	6
27	921001	LOCKWASHER, 1/4"	6
28	906011	TRANSFORMER, 110 V, 60 Cycle, Webster No. 511-AJ	1
29	906020	VALVE, Solenoid, 115 V, 60 Cycle, 3/16" Orifice, 200 lb. W. P., Detroit No. 683-3	1
30	906013	COVER, Handy Box, Raised for Toggle Switch No. 2594	1
31	906012	BOX, Handy, 4" x 2 1/2", 1/2" KO, 2 1/2", No. 4-SSL	1
32	921004	SCREW, Mach, Rd Hd, No. 10-32 x 1/2"	4
33	921083	LOCKWASHER, No. 10	2
34	921014	NUT, Hex, No. 10-32	2
35	906004	SWITCH, Arrow No. 6444	1
36	921084	SCREW, Mach, Rd Hd, NC, 5/16" x 1/2"	3
37	921003	LOCKWASHER, 5/16"	3
38	907006	REGULATOR, Temperature, 65-140°, M-H No. T415AX323A	1
39	917500	BUSHING, Galv, 1" x 3/4"	1
40	906018	TUBE, Mercury, Two-wire	1

* Solenoid Valve and Generator Leads are part of units and cannot be purchased separately.

When Ordering, Specify Model, Serial Number, Part Number and Name of Part Required.

PARTS SECTION

GENERATOR

ELECTRICAL

NO. 911000 GENERATOR

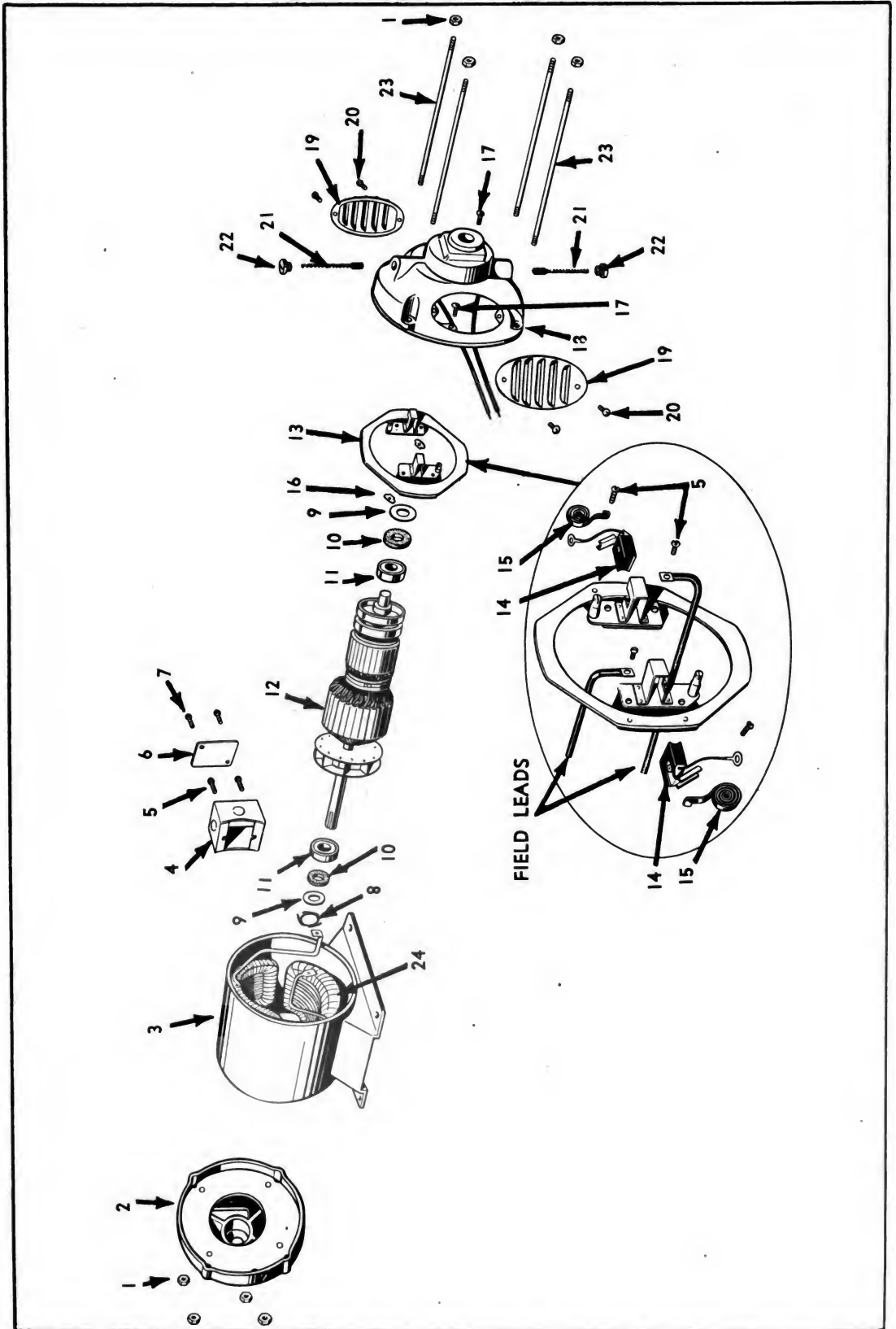

When Ordering, Specify Model, Serial Number, Part Number and Name of Part Required.

PARTS SECTION

GENERATOR AND SOLENOID VALVE

ELECTRICAL

NO. 911000 GENERATOR

REF. NO.	C-B CO. PART NO.	NOMENCLATURE	NO. REQ'D
1	911046	NUT, Stud, No. 6046	8
2	911029	BRACKET, Rear, No. 5860	1
3	911030	FRAME, No. 204-A, No. S-5376	1
4	911031	BOX, Junction, No. 8061	1
5	921178	SCREW, Mach, Rd Hd, No. 10-32 x 1/4"	6
6	911032	COVER, Junction, No. 2306	1
7	921204	SCREW, Mach, Rd Hd, No. 8-32 x 1/4"	2
8	911044	SPRING, Loading, No. 5039	1
9	911060	WASHER, Steel, No. 5040	2
10	911042	WASHER, Felt, No. 5035	2
11	911058	BEARING, Ball, ND-87504	2
12	911040	ARMATURE, Complete, No. S-50104	1
13	911035	RIGGING, Brush, No. S-5308	1
14	911047	BRUSH, DC, No. S-6160	2
15	911038	SPRING, Brush Tension, No. 5033	2
16	911036	CLAMP, Brush Rigging, No. 5313	2
17	911064	SCREW, Brush Rigging Clamp, No. 5892	2
18	911026	BRACKET, Front, No. 50051	1
19	911027	COVER, Open Terminal, No. 5324	2
20	921011	SCREW, Mach, Rd Hd, No. 10-32 x 3/8"	4
21	911024	BRUSH, AC, No. S-1563	2
22	911039	CAP, Brush, No. S-2183	2
23	911045	BOLT, Stud, No. 6047-2	4
24	911034	COIL, Field, No. 16011-1	1

NO. 906020 SOLENOID VALVE

REF. NO.	C-B CO. PART NO.	NOMENCLATURE	NO. REQ'D
1	906021	SCREW, Nameplate	1
2	916210	NAMEPLATE	1
3	906022	HOUSING, Coil	1
4	906024	BUSHING, Coil	2
5	906023	WASHER, Coil Spring	1
6	906025	COIL, 115 Volt, 60 Cycle	1
7	906026	PLATE, Coil Base	1
8	These items cannot be purchased separately.		

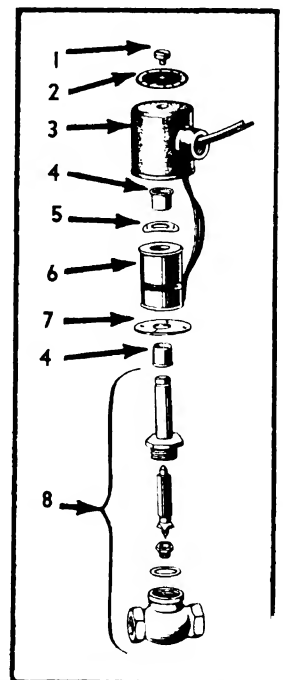

PARTS SECTION

LIGHT WIRING

ELECTRICAL

LIGHT WIRING ASSEMBLY

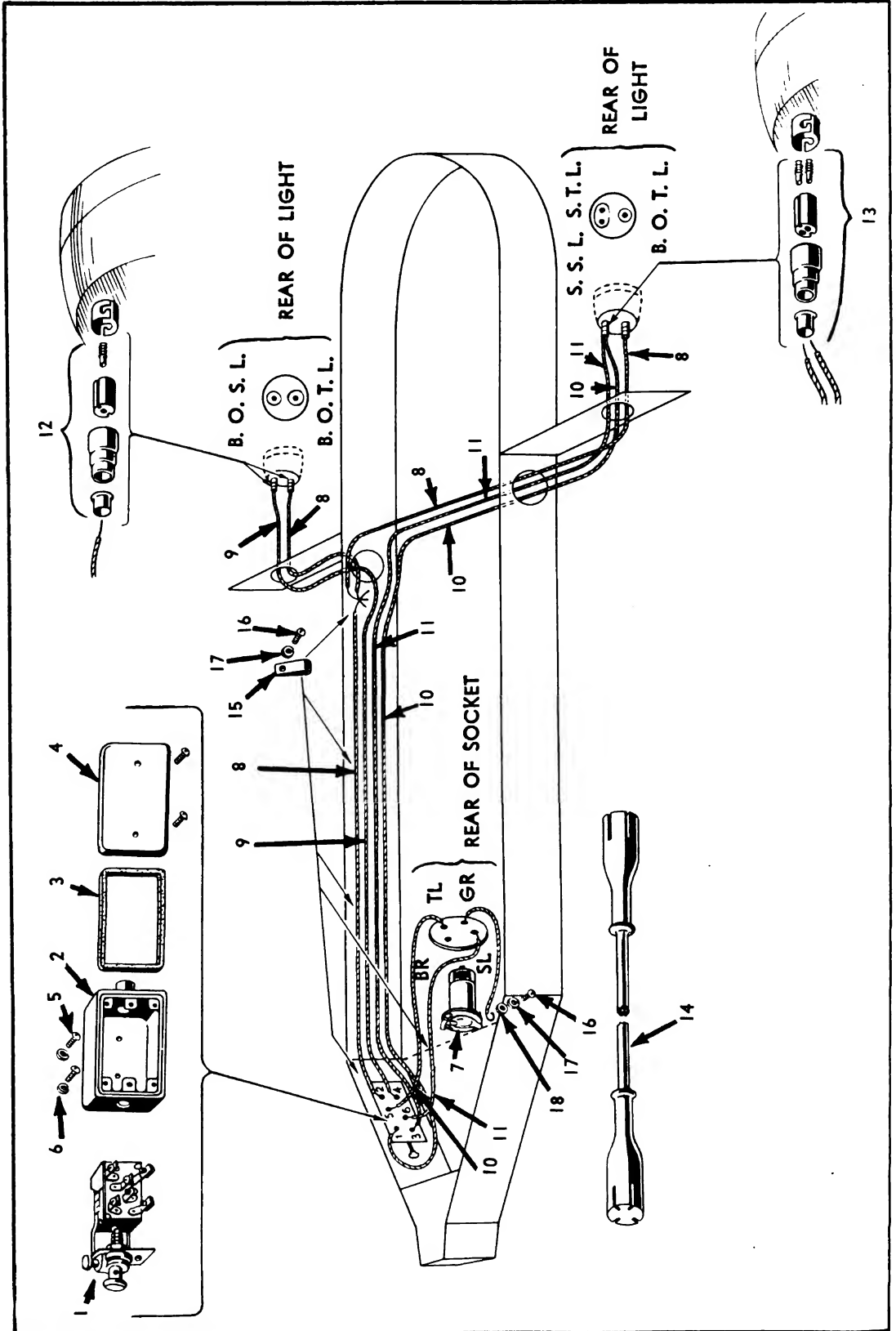

When Ordering, Specify Model, Serial Number, Part Number and Name of Part Required.

PARTS SECTION

LIGHT WIRING

ELECTRICAL

LIGHT WIRING ASSEMBLY

REF. NO.	C-B CO. PART NO.	NOMENCLATURE	NO. REQ'D
1	606013	SWITCH, Light, Cole Hersee No. 7133	1
2	906014	BOX, Condulet Switch, No. FS-1	1
3	906015	GASKET, Condulet Switch Box Cover, for No. 906014	1
4	906016	COVER, Condulet Switch Box, Includes 2 Screws, for No. 906014	1
5	921197	SCREW, Mach, Rd Hd, NC, 1/4" x 1/2"	2
6	921001	LOCKWASHER, 1/4"	2
7	606030	SOCKET, Brake, Warner No. 3604	1
8	606019	WIRE, No. 14, Armored, Black with White Tracer—Blackout Tail Light	18 ft.
9	606020	WIRE, No. 14 Armored, Yellow with Black Tracer—Blackout Stoplight	13 ft.
10	606021	WIRE, No. 14, Armored, Red with White Tracer—Service Tail Light	15 ft.
11	606022	WIRE, No. 14, Armored, Red with Black Tracer—Service Stop Light	14 ft.
12	606023	CONNECTOR, Single Lead, KD Lamp Co.	3
13	606024	CONNECTOR, Double Lead, KD Lamp Co.	1
14	606025	CABLE, Brake Jumper, 8 Ft., Ends Moulded on, Warner No. 3697	1
15	906291	CLAMP, Wire, Beldon No. 11937	5
16	921085	SCREW, Mach, Rd Hd, #10-32 x 3/4"	6
17	921083	LOCKWASHER, No. 10	6
18	921086	WASHER, Cut, No. 10	1

PARTS SECTION

CHASSIS AND RUNNING GEAR

TRAILER

CHASSIS AND RUNNING GEAR

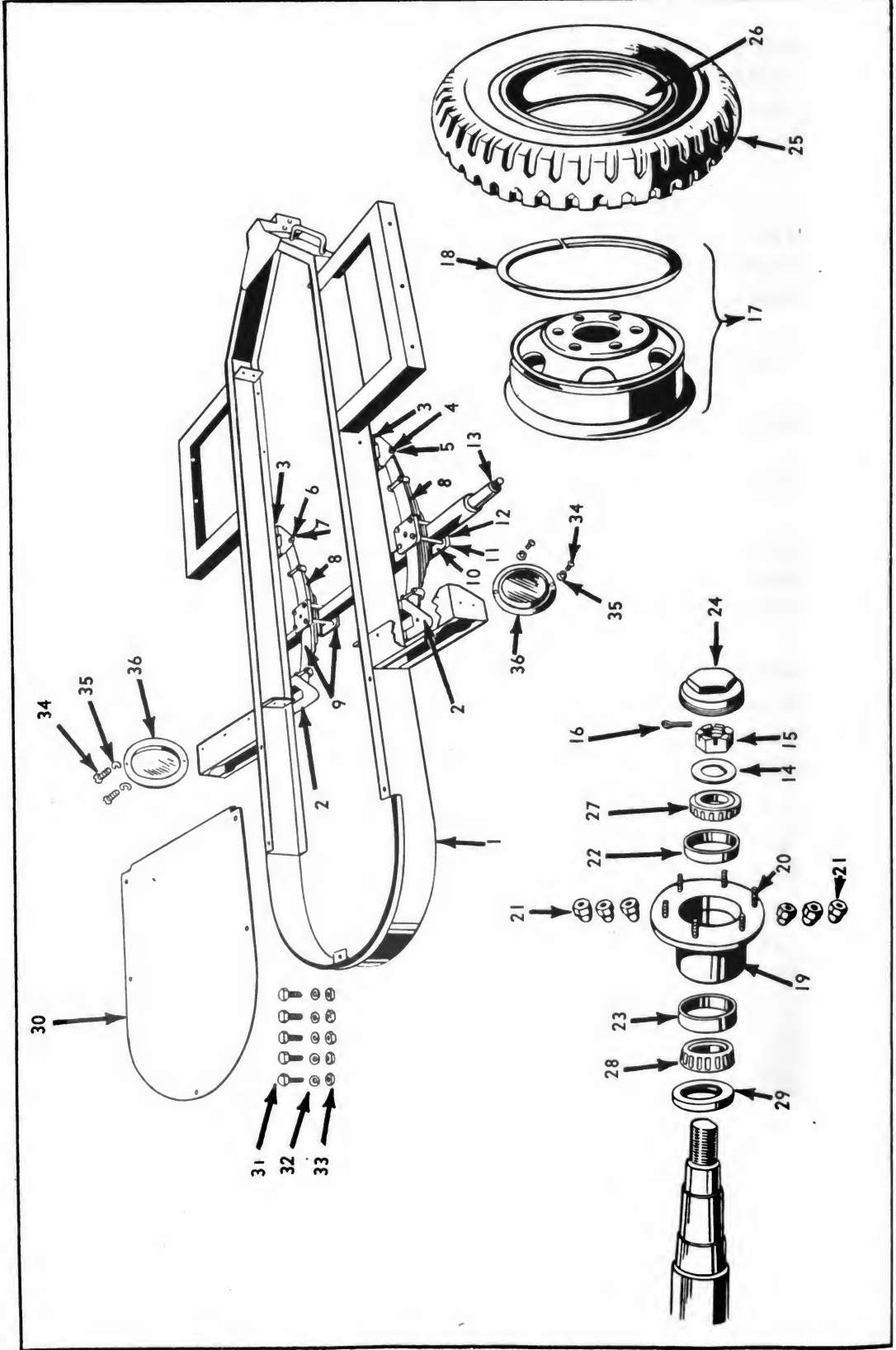

When Ordering, Specify Model, Serial Number, Part Number and Name of Part Required.

Original from

PARTS SECTION

CHASSIS AND RUNNING GEAR

TRAILER

CHASSIS AND RUNNING GEAR

REF. NO.	C-B CO. PART NO.	NOMENCLATURE	NO. REQ'D
1	602168	FRAME, Chassis, Includes Tank Supports, Lunette Brackets Plates Riveted On, Steering Handles Welded On	1
2	602169	HANGER, Spring, Rear	2
3	602170	HANGER, Spring, Front	2
4	621003	BOLT, Shackle, Special, NF, 5/8" x 4 1/2"	2
5	916102	FITTING, Zerk, 67 1/2°, 1/8"	4
6	921088	NUT, Castellated, NF, 5/8"	2
7	921080	PIN, Cotter, 3/32" x 1"	2
8	602171	SPRING, 7 Leaf, 2 1/2" Wide	2
9	602172	PLATE, Axle Spring Mounting, 5 1/4" Sq	4
10	921081	BOLT, Mach, Sq Hd, NC, 5/8" x 6 1/2"	8
11	921052	LOCKWASHER, 5/8"	8
12	921040	NUT, Hex, NC, 5/8"	8
13	602173	AXLE, Tire Center 58", 2 1/2" Sq, Includes Items 14, 15 and 16	1
14	921082	WASHER, Key, 1 1/4" for 1/4" Key	2
15	621005	NUT, Castellated, NF, 1 1/4"	2
16	921087	PIN, Cotter, 3/16" x 2 1/2"	2
17	602175	WHEEL, Disc, 20" x 7", Budd No. 44530D1, Includes Item 18	2
18	602176	RING, Tire Locking Type L	2
19	602177	HUB, Left Hand, Budd No. 46138	1
19	602187	HUB, Right Hand, Budd No. 46137	1
20	621006	STUD, Wheel Hub, Left Thread, 3/4"	6
20	621007	STUD, Wheel Hub, Right Hand Thread, 3/4"	6
21	621009	NUT, Tapered, Left Thread, 3/4"	6
21	621008	NUT, Tapered, Right Thread, 3/4"	6
22	602178	CUP, Small Outer Bearing, Timken No. 382	2
23	602179	CUP, Large Inner Bearing, Timken No. 3920	2
24	602180	CAP, Hub, Budd No. 44167	2
25	602181	TIRE, 7.50 x 20, Super Traction	2
26	602182	TUBE, Inner, 7.50 x 20	2
27	602183	BEARING, Roller, Small Outer, Timken No. 385-A	2
28	602184	BEARING, Roller, Large Inner, Timken No. 3979	2
29	602186	SEAL, Grease, No. 3783	2
30	602185	PLATE, Base, Power and Burner	1
31	921071	CAPSCREW, Hex Hd, NC, 1/2" x 1 1/2"	5
32	921053	LOCKWASHER, 1/2"	5
33	921346	NUT, Hex, NC, 1/2"	5
34	921197	SCREW, Mach, Rd Hd, NC, 1/4" x 1/2"	4
35	921001	LOCKWASHER, 1/4"	4
36	616059	REFLECTOR, Side, Tiger Eye	2

PARTS SECTION

FENDER TANKS

TRAILER

FENDER TANK ASSEMBLIES

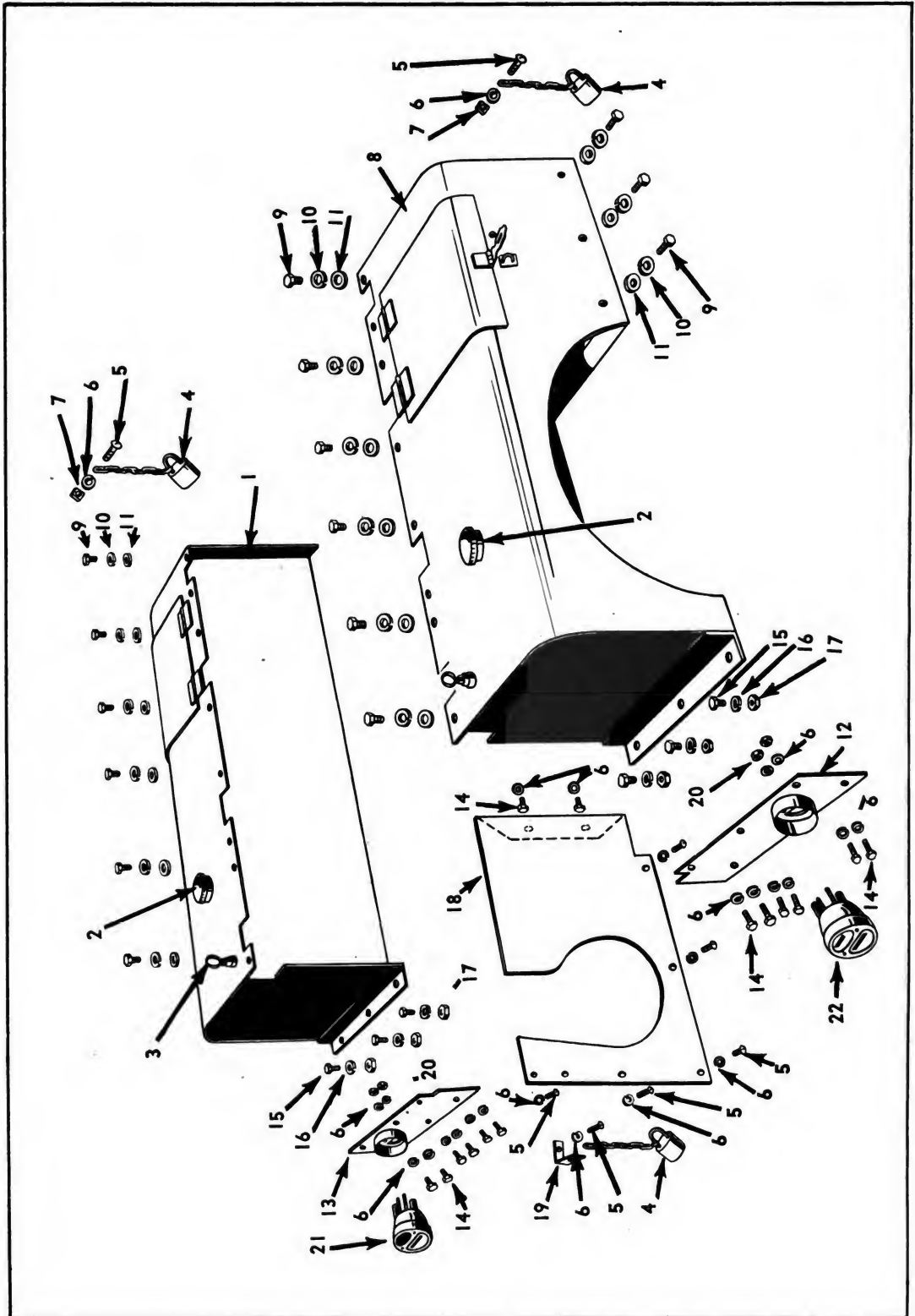

When Ordering, Specify Model, Serial Number, Part Number and Name of Part Required.

PARTS SECTION

FENDER TANKS

TRAILER

FENDER TANK ASSEMBLIES

REF. NO.	C-B CO. PART NO.	NOMENCLATURE	NO. REQ'D
1	603009	TANK, Fender, Left (Also Includes Items 2 and 3)	1
2	904026	CAP, Tank	2
3	607001	GAUGE, Bayonet, 1/4" x 16"	2
4	616060	LOCK, Yale, No. 830-1/2	3
5	921197	SCREW, Mach, Rd Hd, NC, 1/4" x 1/2" Std.	8
6	921001	LOCKWASHER, 1/4"	26
7	921195	NUT, Sq, 1/4" Std.	2
8	603104	TANK, Right, (Includes Items 2 and 3)	1
9	921021	CAPSCREW, Hex Hd, NC, 3/8" x 1/2"	18
10	921009	LOCKWASHER, 3/8"	18
11	921010	WASHER, 3/8"	18
12	616057	PANEL, With Tail Light Receptacle, Right Hand	1
13	616058	PANEL, With Tail Light Receptacle, Left Hand	1
14	921074	CAPSCREW, Hex Hd, NC, 1/4" x 1/2"	14
15	921075	CAPSCREW, Hex Hd, NC, 5/8" x 1/2"	6
16	921003	LOCKWASHER, 5/8"	6
17	921012	NUT, Hex, NC, 5/8"	6
18	605018	PANEL, Power Plant Housing	1
19	616116	HASP, Padlock	1
20	921077	NUT, Hex, NC, 1/4"	4
21	602277	LIGHT, Combination Tail & Stop & Blackout Tail, QMC Dwg No. 08242X	1
22	602276	LIGHT, Combination Blackout Tail & Stop, QMC Dwg. No. 08243X	1

PARTS SECTION

SLIDING DOOR, HOOD AND RACK

TRAILER

SLIDING DOOR, HOOD AND RACK ASSEMBLIES

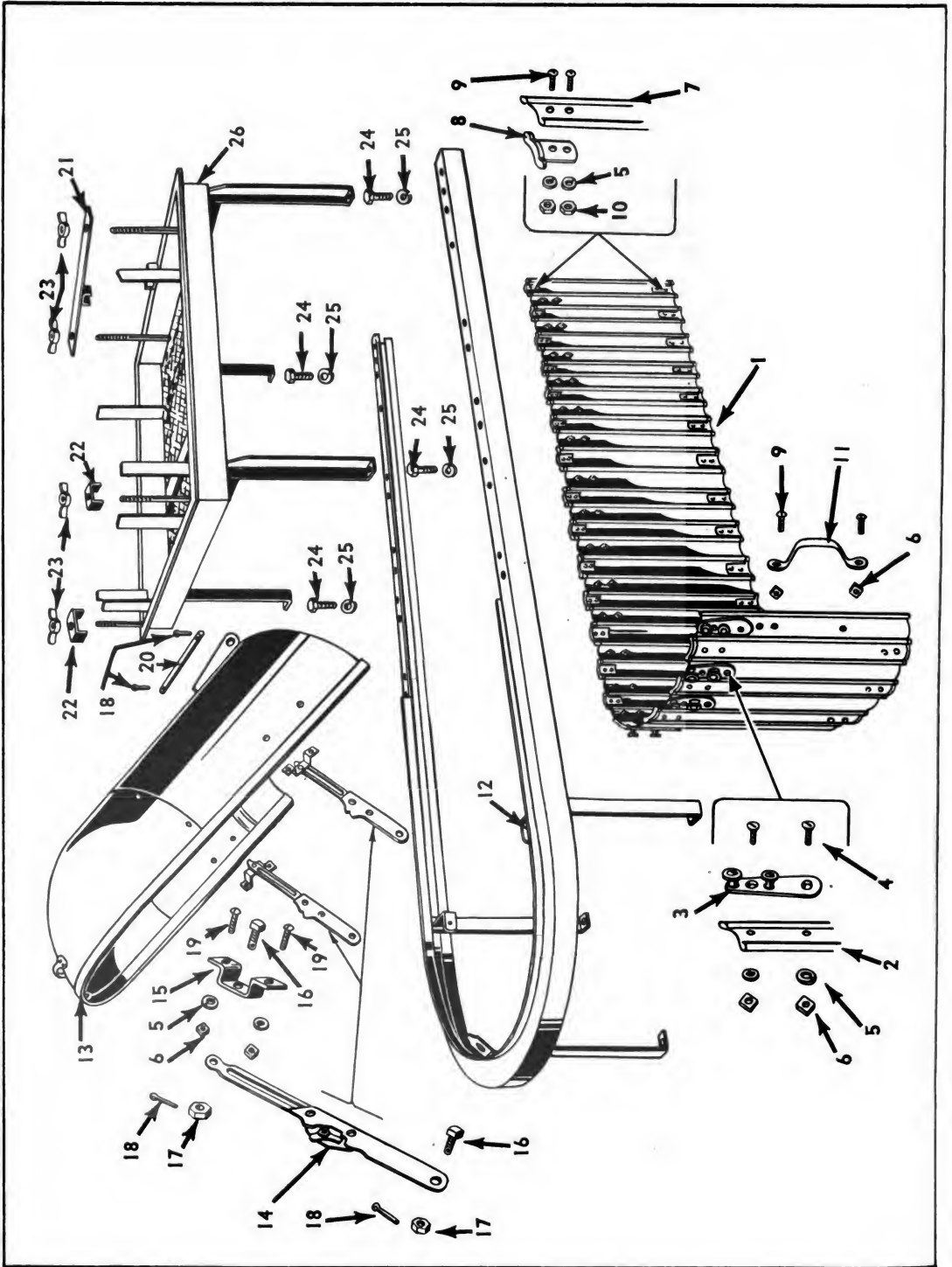

PARTS SECTION

SLIDING DOOR, HOOD AND RACK

TRAILER

SLIDING DOOR, HOOD AND RACK ASSEMBLIES

REF. NO.	C-B CO. PART NO.	NOMENCLATURE	NO. REQ'D
1	605002	DOOR, Sliding, 39 Slats, 17" High	1
2	605019	SLAT, Door, Drilled for Hanger	20
3	605003	HANGER, Sliding Door Slat, Eberhard G-112	20
4	921016	SCREW, Mach, Flat Hd, NC, 1/4" x 1/2"	40
5	921001	LOCKWASHER, 1/4"	198
6	921195	NUT, Sq, NC, 1/4"	46
7	605005	SLAT, Sliding Door, Drilled for End Lock	19
8	605021	END LOCK, Sliding Door Slat	38
9	921197	SCREW, Mach, Rd Hd, NC, 1/4" x 1/2"	154
10	921077	NUT, Hex, NC, 1/4"	154
11	605006	HANDLE, Sliding Door	1
12	605007	TRACK, Sliding Door	1
13	605008	HOOD	1
14	905011	BRACKET, Hood Holding, Complete	2
15	605101	SUPPORT, Hood Holding Bracket	2
16	621010	BOLT, Mach, NC, 3/8" Drilled, 3/8" x 1"	2
17	621011	NUT, Hex, NC, 1/8" Drilled, 3/8"	2
18	921018	PIN, Cotter, 1/8" x 1"	4
19	921383	SCREW, Mach, Rd Hd, NC, 1/4" x 3/4"	4
20	605023	ROD, Hood Hinge, 3/8" x 5 1/2"	1
21	605011	CLAMP, Shower Rack Front	1
22	605012	CLAMP, Shower Rack Rear	2
23	921020	NUT, Wing, NC, 1/2"	4
24	921021	CAPSCREW, Hex Hd, NC, 3/8" x 1/2"	4
25	921009	LOCKWASHER, 3/8"	4
26	605010	RACK, Shower Stand and Hose, Includes Items 21, 22 and 23	1

PARTS SECTION

LUNETTE AND CASTER WHEEL

TRAILER

LUNETTE AND CASTER WHEEL

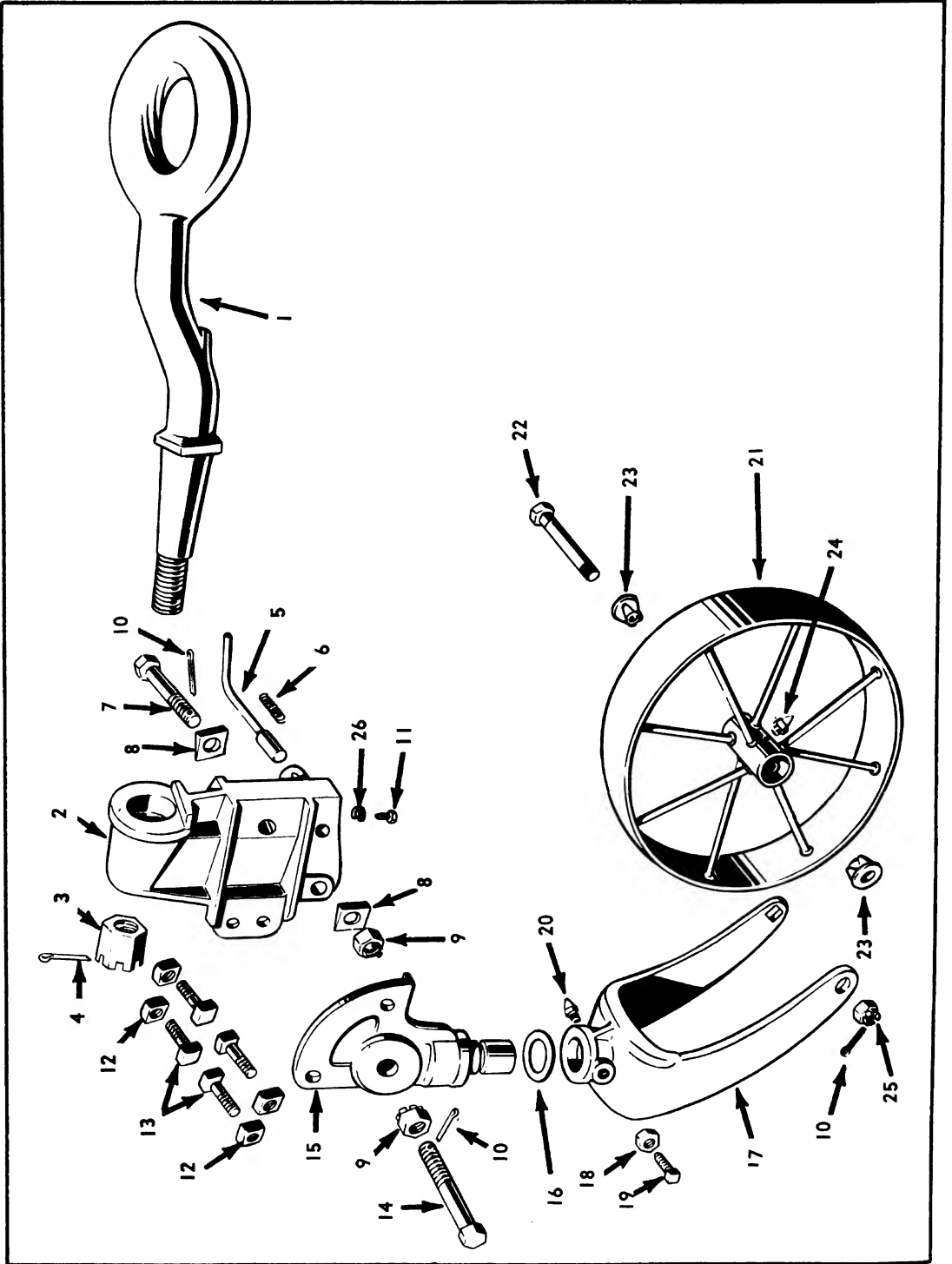

When Ordering, Specify Model, Serial Number, Part Number and Name of Part Required.

PARTS SECTION

LUNETTE AND CASTER WHEEL

TRAILER

LUNETTE AND CASTER WHEEL

REF. NO.	C-B CO. PART NO.	NOMENCLATURE	NO. REQ'D
1	602150	DRAWBAR, Lunette, Ben Hur No. 20B644	1
2	602151	BRACKET, Drawbar, Ben Hur No. 20B645	1
3	921343	NUT, Hex, Castellated, NF, 1 $\frac{1}{8}$ "	1
4	921029	PIN, Cotter, $\frac{5}{32}$ " x 2"	1
5	602153	PLUNGER, Ben Hur No. 20A411	1
6	602154	SPRING, Plunger, Ben Hur No. 20A388	1
7	602243	CAPSCREW, Hex Hd, NF, $\frac{1}{8}$ ", Drilled, $\frac{3}{4}$ " x 4 $\frac{1}{2}$ "	1
8	921030	WASHER, Bevel, $\frac{3}{4}$ "	2
9	921090	NUT, Hex, Castellated, NF, $\frac{3}{4}$ "	2
10	921031	PIN, Cotter, $\frac{1}{8}$ " x 1 $\frac{1}{4}$ "	3
11	921032	CAPSCREW, Hex Hd, NF, $\frac{1}{4}$ " x $\frac{3}{4}$ "	1
12	921331	NUT, Sq, NC, $\frac{5}{8}$ "	4
13	921380	BOLT, Mach, Sq Hd, NC, $\frac{5}{8}$ " x 1 $\frac{1}{2}$ "	4
14	602158	CAPSCREW, Hex Hd, NF, $\frac{1}{8}$ " Drilled, $\frac{3}{4}$ " x 4"	1
	602188	QUADRANT AND SWIVEL PIN UNIT, Includes Items 15 to 25, Incl., No. 6347-S	1
15	602157	QUADRANT AND SWIVEL PIN, No. 6347-16	1
16	602159	WASHER, Thrust, Brass, Caster Wheel, No. 63475-5	1
17	602160	FORK, Caster Wheel Swivel, No. 6347-5	1
18	921346	NUT, Jam, Hex, NC, $\frac{1}{2}$ "	1
19	921036	SETSCREW, Sq Hd, NC, $\frac{1}{2}$ " x 1"	1
20	602161	FITTING, Grease, Lincoln No. 5010N	1
21	602162	WHEEL, Caster, Includes Hub, No. 7548	1
22	602163	AXLE, Wheel, NF, $\frac{1}{8}$ " Drilled, $\frac{5}{8}$ " x 6 $\frac{1}{2}$ ", No. 6347-8	1
23	602164	BUSHING, Hub, NF, $\frac{5}{8}$ " x 1 $\frac{1}{2}$ ", No. 7548-2	2
24	913067	FITTING, Zerk, $\frac{1}{8}$ "	1
25	921088	NUT, Hex, Castellated, NF, $\frac{5}{8}$ "	1
26	921001	LOCKWASHER, $\frac{1}{4}$ "	1

PARTS SECTION

ENGINE AND TANK

ENGINE

ENGINE AND TANK

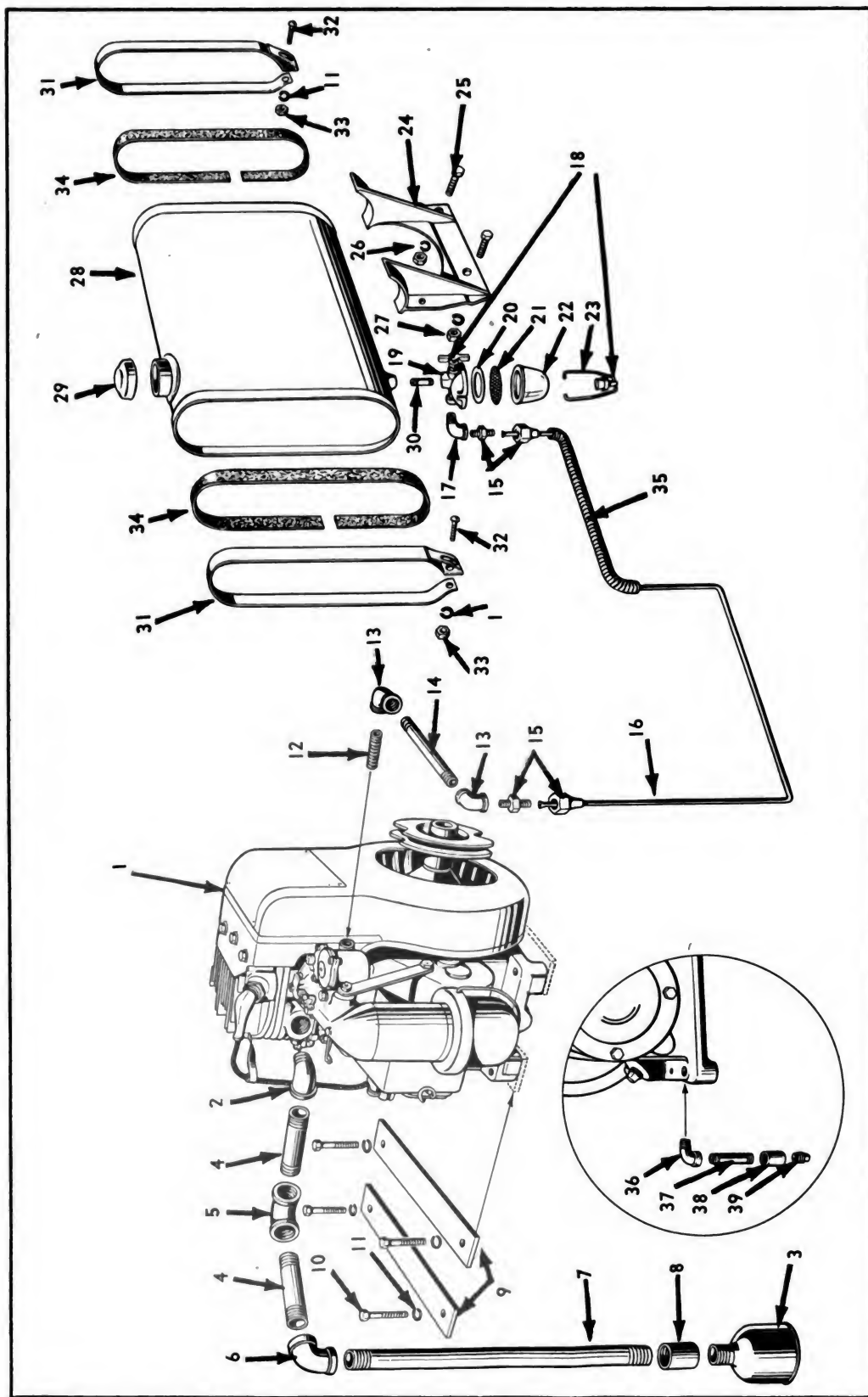

When Ordering, Specify Model, Serial Number, Part Number and Name of Part Required.

PARTS SECTION

ENGINE AND TANK

ENGINE

ENGINE AND TANK

REF. NO.	C-B CO. PART NO.	NOMENCLATURE	NO. REQ'D
1	609300	ENGINE, Wisconsin Motors Model AK, Includes Items 2 and 3	1
2	625018	ELBOW, Street, For Exhaust Muffler, 3/4" Wis. No. XK-66-2	1
3	609216	MUFFLER, Engine, Wis No. WD-17-B	1
4	917431	NIPPLE, Black, 3/4" x 2 1/2"	2
5	917452	ELBOW, Black, 45°, 3/4"	1
6	917451	ELBOW, 90°, 3/4"	1
7	920448	PIPE, Black, 3/4" x 15"	1
8	917453	COUPLING, Black, 3/4"	1
9	625067	SPACER, Engine Mount Steel, 1/8" x 1 1/4" x 8 1/2"	2
10	921068	CAPSCREW, Hex Hd, NC, 5/16" x 2 1/2"	4
11	921003	LOCKWASHER, 5/16"	6
12	917060	NIPPLE, Black, 1/8" Close	1
13	917017	ELBOW, Black, 90°, 1/8"	2
14	917023	NIPPLE, Black, 1/9" x 4"	1
15	913034	CONNECTOR, Flared, 1/8" ODC x 1/8" SPT	2
16	913246	LINE, Fuel, 1/8" OD x 7' with Greenfield and Nuts	1
17	917086	ELBOW, Street, Black, 45°, 1/8"	1
18	609588	STRAINER, Fuel, Complete, Includes Items 19-23 Incl.	1
19	609890	COVER, Fuel Filter, Tillotson No. OW-462	1
20	609590	GASKET, Fuel Filter, Tillotson No. OW-222	1
21	609891	SCREEN, Fuel Filter, Tillotson No. OW-352	1
22	609592	BOWL, Glass, Fuel Filter, Tillotson No. OW-363	1
23	609892	YOKE, Fuel Filter, Tillotson No. OW-447	1
24	609186	BRACKET, Fuel Tank Wis No. B1-170-C	1
25	921071	CAPSCREW, Hex Hd, NC, 1/2" x 1 1/2"	2
26	921053	LOCKWASHER, 1/2"	2
27	921346	NUT, Hex, NC, 1/2"	2
28	625062	TANK, Fuel, Includes Cap, Wis No. WE-37-C	1
29	109186	CAP, Gas Tank, Wis, No. RC-77	1
30	917011	NIPPLE, Brass, 1/8" Close	1
31	625063	STRAP, Fuel Tank, Includes Screw, Lockwasher & Nut, Wis. No. PG-99	2
32	921196	SCREW, Mach, Rd Hd, NC, 5/16" x 2"	2
33	921012	NUT, Hex, NC, 5/16"	2
34	625064	FELT, Fuel Strap, Wis. No. PH-244	2
35	906040	GREENFIELD, Extra Flexible, 3/8" x 3'	1
36	917169	ELBOW, Street, Black, 1/4"	1
37	917130	NIPPLE, Black, 1/4" x 2 1/2"	1
38	917166	COUPLING, Black, 1/4"	1
39	917122	PLUG, Black, 1/4"	1

When Ordering, Specify Model, Serial Number, Part Number and Name of Part Required.

PARTS SECTION

BLOCK ASSEMBLY

ENGINE

BLOCK ASSEMBLY

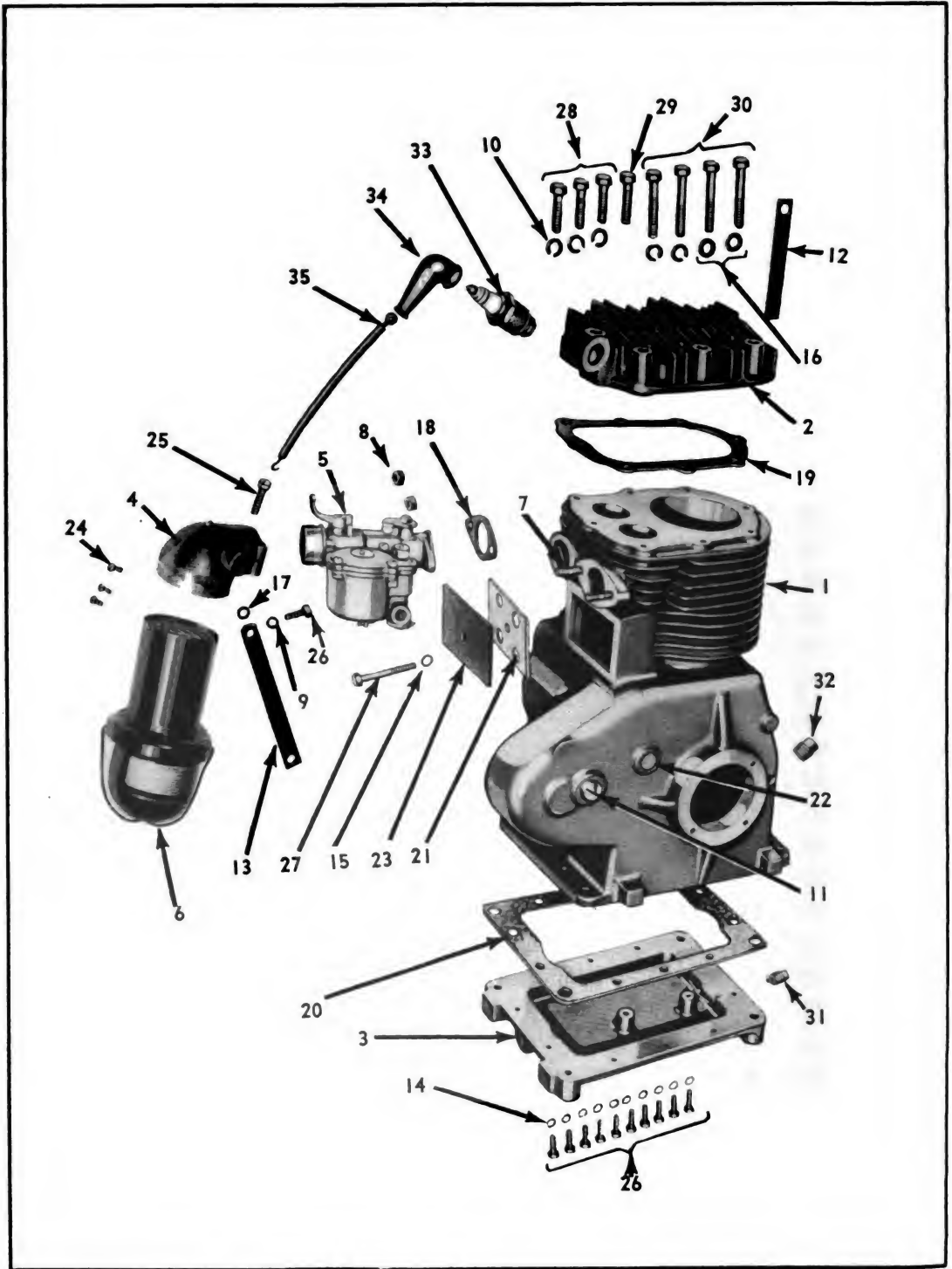

When Ordering, Specify Model, Serial Number, Part Number and Name of Part Required.

PARTS SECTION

BLOCK ASSEMBLY
ENGINE

BLOCK ASSEMBLY

REF. NO.	C-B CO. PART NO.	NOMENCLATURE	ENG. MFR. PART NO.	NO. REQ'D
1	609005	CYLINDER and CRANKCASE With Plugs	AA-83-S2	1
1	609006	CYLINDER and CRANKCASE with Valves, Springs, Seats and Inspection Cover	AA-83-S1	1
2	609007	HEAD, Cylinder	AB-78-B	1
3	609013	BASE, Engine	BB-116-B	1
4	609117	BRACKET, Air Filter	BI-225-B-1	1
5	609034	CARBURETOR, Zenith OH $\frac{5}{8}$	L-26-A	1
6	609921	FILTER, Air, United Oil Bath	LO-28-A	1
7	609044	STUD, Special Mtg. Carburetor	PC-368	2
8	921272	NUT, Hex, NF, $\frac{1}{4}$ "		2
9	921001	LOCKWASHER, $\frac{1}{4}$ "		1
10	921003	LOCKWASHER, $\frac{5}{16}$ "		5
11	609094	PLUG, Slotted Pipe, For Timing Hole	PF-25	1
12	609047	STRAP, Ignition Cable Support	PG-206	1
13	609923	STRAP, Air Filter Bracket Support	PG-287	1
14	921177	WASHER, $\frac{1}{4}$ "		10
15	609096	WASHER, Copper, Valve Tapper Inspection Plate, $\frac{1}{4}$ "	PH-30	1
16	921274	WASHER, $\frac{5}{16}$ "		2
17	609122	SPACER, Mtg. Support Air Filter Bracket	PH-84	1
18	609057	GASKET, Carburetor Flange	QC-53	1
19	609058	GASKET, Cylinder Head	QD-604-A	1
20	609059	GASKET, Engine Base	QD-569-A	1
21	609062	GASKET, Valve Tapper Plate	QD-572	1
22	609067	PLUG, Welch, Camshaft Hole	SA-26	2
23	609068	PLATE, Valve Tapper Inspection	SA-61	1
24	921276	SCREW, Mach, Rd Hd, #6-32 x $\frac{3}{8}$ "		3
25	921352	SCREW, Mach, Fill Hd, NC, $\frac{1}{4}$ " x 1"		1
26	921027	CAPSCREW, Hex Hd, NC, $\frac{1}{4}$ " x $\frac{3}{4}$ "		11
27	921277	CAPSCREW, Hex Hd, NC, $\frac{1}{4}$ " x 2"		1
28	921278	CAPSCREW, Hex Hd, NC, $\frac{5}{16}$ " x $1\frac{1}{4}$ "		3
29	921224	CAPSCREW, Hex Hd, NC, $\frac{5}{16}$ " x $1\frac{1}{2}$ "		1
30	921279	CAPSCREW, Hex Hd, NC, $\frac{5}{16}$ " x 2"		4
31	917122	PLUG, Sq Hd, $\frac{1}{4}$ "		1
32	917218	PLUG, Sq Hd, $\frac{3}{8}$ "		1
33	609586	SPARKPLUG, Champion No. 8	YD-6	1
34	609086	INSULATOR, Sparkplug Safety	YD-12	1
35	609185	WIRE, Sparkplug	YL-97	1

PARTS SECTION

CRANKSHAFT AND PISTON

ENGINE

CRANKSHAFT AND PISTON ASSEMBLIES

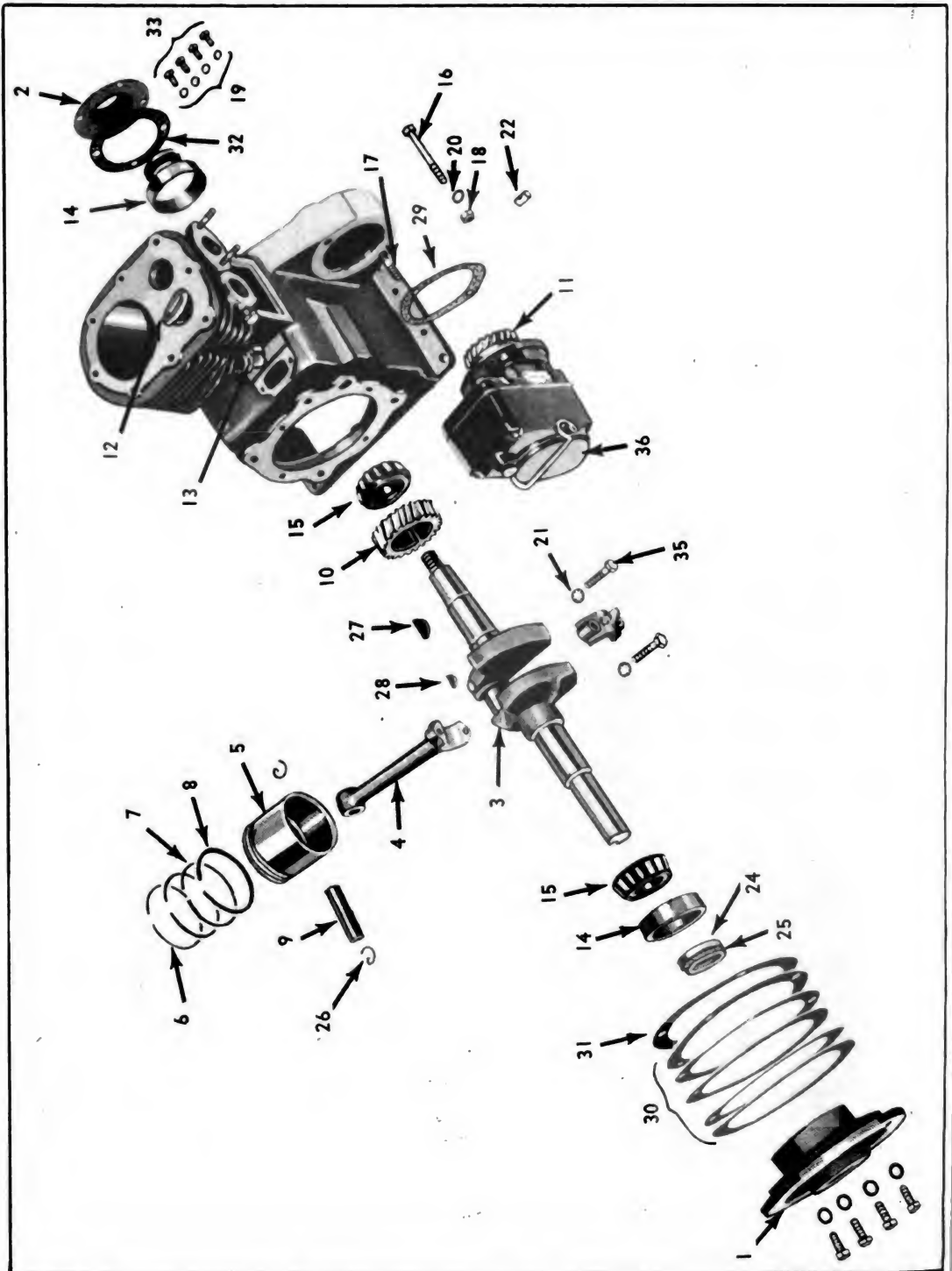

REF. NO.	C-B CO. PART NO.	NOMENCLATURE	ENG. MFR. PART NO.	NO. REQ'D
1	609014	PLATE, Main Bearing, T.O. End	BG-170	1
2	609015	PLATE, Main Bearing, Flywheel End	BG-171	1
3	609230	CRANKSHAFT, With Main Bearings and Crankshaft Gear and Key	CA-51-2	1

PARTS SECTION

CRANKSHAFT AND PISTON

ENGINE

CRANKSHAFT AND PISTON ASSEMBLIES

REF. NO.	C-B CO. PART NO.	NOMENCLATURE	ENG. MFR. PART NO.	NO. REQ'D
4	609167	ROD, Connecting, Complete	DA-55-B	1
5	609174	PISTON, Standard	DB-186-A	1
	609178	PISTON, Semi-Finished	DB-186-A	1
Note: Pistons are available in .005", .010", .020", and .030" oversize				
6	609021	RING, Piston, Compression	DC-161	2
7	609022	RING, Piston, Scraper	DC-161-1	1
8	609023	RING, Piston, Oil Regulating	DC-162	1
Note: Piston rings are also available in .005", .010", .020", and .030" oversize				
9	609024	PIN, Piston	DE-68	1
Note: Piston Pins are also available in .005", .010", .020", and .030" oversize				
10	609027	GEAR, Crankshaft	GA-34-A	1
11	609028	GEAR, Magneto	GD-87-B	1
12	609029	INSERT, Valve Seat—Exhaust	HG-149-1	1
13	609035	BREATHER, Assembly	LO-31	1
14	609179	CUP, Main Bearing—Timken No. 15250	ME-88-1	2
15	609180	CONE, Main Bearing—Timken No. 15118	ME-88-2	2
16	609042	SCREW, Special for Mtg. Magneto Upper Hole	PB-164	1
17	609043	STUD, Special for Mtg. Magneto	PC-362	1
18	921273	NUT, Hex, NF, $\frac{5}{16}$ "		2
19	921001	LOCKWASHER, $\frac{1}{4}$ "		4
20	921003	LOCKWASHER, $\frac{5}{16}$ "		2
21	609093	WASHER, Everlock, For Conn. Rod Bolt	PE-52	2
22	609927	BREATHER, Tapper Spring Compartment	PF-102	1
23	609184	WASHER, Main Bearing Plate—Flywheel End	PH-14-D	4
24	609048	CUP, Oil Seal, Main Bearing	PH-254	2
25	609049	SEAL, Oil, Main Bearing, Cork	PH-256	2
26	609052	RING, Piston, Pin, Retaining	PK-69	2
27	609053	KEY, Woodruff, Flywheel	PL-17	1
28	609054	KEY, Woodruff, Crankshaft Gear	PL-21	1
29	609060	GASKET, Mtg. Magneto	QD-570-A	1
30	609063	GASKET, Main Bearing Plate—T. O. End, .006" Thick	QD-573	5
31	609064	GASKET, Main Bearing Plate—T. O. End, .003" Thick	QD-573-A	1
32	609065	GASKET, Main Bearing Plate—Flywheel End	QD-574	1
33	921074	CAPSCREW, Hex Hd, NC, $\frac{1}{4}$ " x $\frac{1}{2}$ "		4
34	921336	CAPSCREW, Hex Hd, NC, $\frac{5}{16}$ " x $\frac{3}{4}$ "		4
35	921110	CAPSCREW, Hex Hd, NC, $\frac{5}{8}$ " x $1\frac{1}{4}$ "		2
36	609085	MAGNETO	Y-24-E	1

PARTS SECTION

GOVERNOR AND VALVE

ENGINE

GOVERNOR AND VALVE ASSEMBLIES

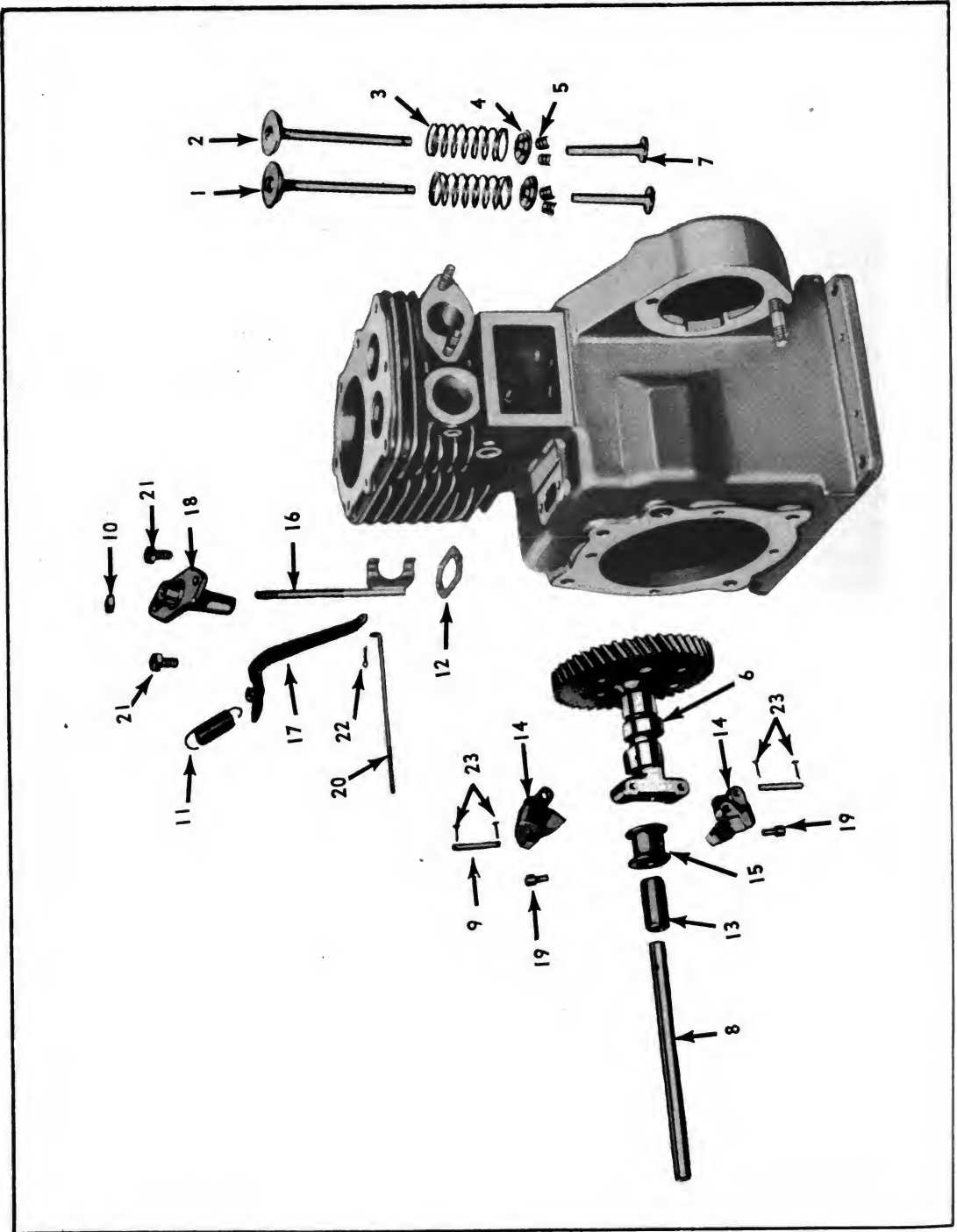

When Ordering, Specify Model, Serial Number, Part Number and Name of Part Required.

PARTS SECTION

GOVERNOR AND VALVE

ENGINE

GOVERNOR AND VALVE ASSEMBLIES

REF. NO.	C-B CO. PART NO.	NOMENCLATURE	ENG. MFR. PART NO.	NO. REQ'D
1	609008	VALVE, Exhaust	AE-74-C	1
2	609009	VALVE, Inlet	AE-74-N	1
3	609010	SPRING, Valve	AF-48	2
4	609305	SEAT, Valve Spring	AG-26	2
5	609012	LOCK, Seat, Valve Spring	AH-9	2 Pr.
6	609025	CAMSHAFT And GEAR With Support Pin	EA-101-A	1
7	609026	TAPPER, Valve	FA-42	2
8	609040	PIN, Camshaft Support	PA-264	1
9	609041	PIN, Toggle, Governor Flyweight	PA-265	2
10	921272	NUT, Hex, NF, 1/4"		1
11	609056	SPRING, Governor	PM-74	1
12	609061	GASKET, Gov. Shaft Bracket	QD-571	1
13	609071	SPACER, Governor	TC-321	1
14	609072	FLYWEIGHT, Governor	TC-322	2
15	609073	SLEEVE, Thrust, Governor	TC-323	1
16	609074	ASSEMBLY, Yoke and Shaft, Governor	TC-324-C	1
17	609076	LEVER, Control, Governor	TC-332	1
18	609075	BRACKET, Governor Shaft Support	TC-325	1
19	609077	PIN, Governor Flyweight	TC-328	2
20	609080	ROD, Governor Control	VE-304	1
21	921074	CAPSCREW, Hex Hd, NC, 1/4" x 1/2"		2
22	921281	PIN, Cotter, 1/2" x 3/8"		1
23	609109	PIN, Cotter, Special Governor Toggle Pin	XI-33	4

PARTS SECTION

SPEED CONTROL

ENGINE

SPEED CONTROL ASSEMBLY

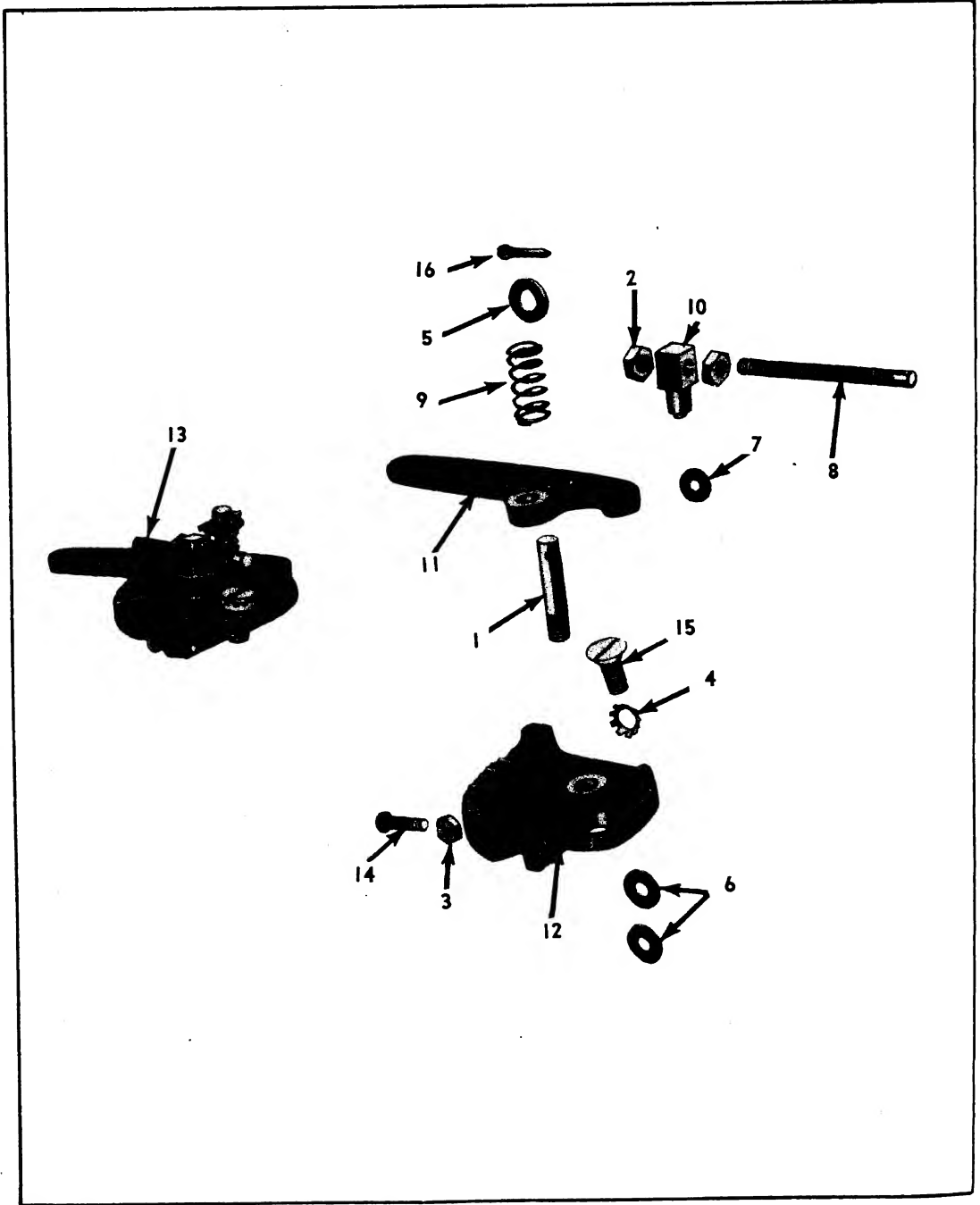

PARTS SECTION

SPEED CONTROL

ENGINE

SPEED CONTROL ASSEMBLY

REF. NO.	C-B CO. PART NO.	NOMENCLATURE	ENG. MFR. PART NO.	NO. REQ'D
1	609140	STUD, Speed Control Lever	PC-393-2	1
2	921014	NUT, Hex, #10-32		2
3	921231	NUT, Hex, #8-32		1
4	609132	LOCKWASHER, Mounting Bracket to Case	PE-55	1
5	609129	WASHER, Plain, Control Lever Spring, 17/64" ID	PH-84	1
6	609136	WASHER, Lead, For Bracket to Case, $\frac{7}{32}$ " ID	PH-221	2
7	609141	WASHER, Governor Spring Adj. Screw Pin	PH-253	1
8	609050	SCREW, Governor Spring Adj.	PI-121	1
9	609126	SPRING, Control Lever Stud	PM-117	1
10	609142	PIN, Governor, Spring Adj. Screw	TC-301-3	1
11	609125	LEVER, Speed Control	VB-112	1
12	609143	BRACKET, Speed Control	VC-22-C	1
13	609144	ASSEMBLY, Speed Control, Complete	VE-363-A	1
14	921592	SCREW, Mach, Rd Hd, #8-32 x $\frac{5}{8}$ "		1
15	921590	SCREW, Mach, Flat Hd, NC, $\frac{1}{4}$ " x $\frac{5}{8}$ "		1
16	921254	PIN, Cotter, $\frac{1}{8}$ " x $\frac{1}{2}$ "		1

PARTS SECTION

OIL PUMP

ENGINE

OIL PUMP

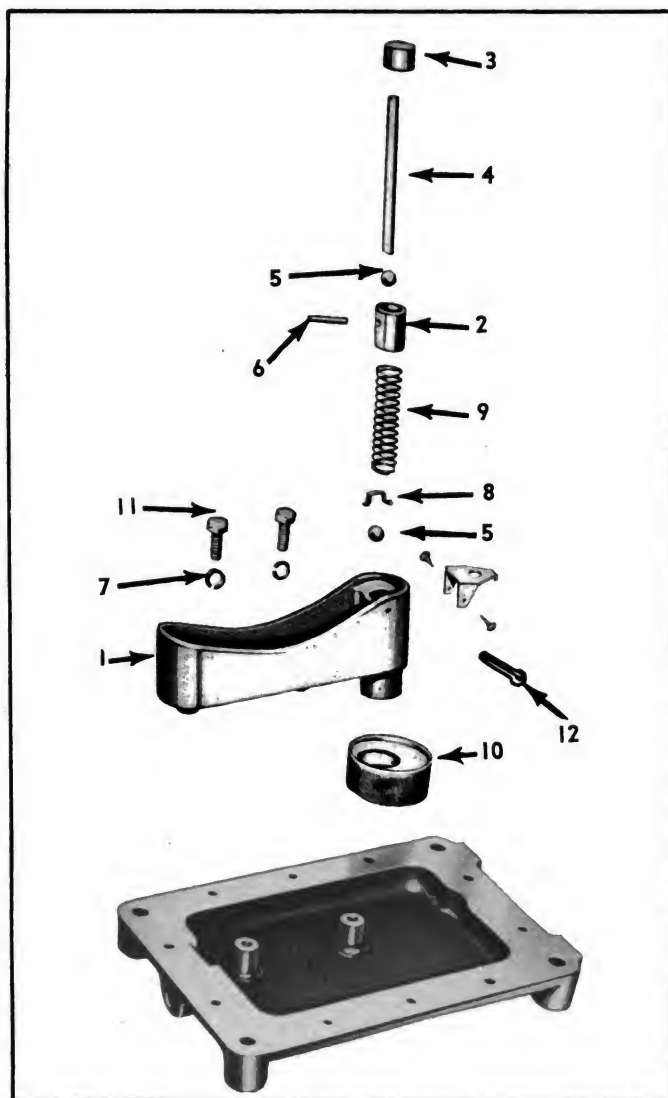

REF. NO.	C-B CO. PART NO.	NOMENCLATURE	ENG. MFR. PART NO.	NO. REQ'D
1	609030	PUMP, Oil, Body and Splash Trough	KA-59	1
2	609031	PLUNGER, Oil Pump	KF-14	1
3	609032	CAP, Oil Pump Plunger Push Rod	KF-19-A	1
4	609033	ROD, Oil, Push Pump Plunger.	KF-22	1
5	609036	BALL, Steel, in Oil Pump	ME-38	2
6	609039	PIN, Oil Pump Plunger	PA2-17	1
7	921001	LOCKWASHER, 1/4"		2
8	609051	RETAINER, Oil Pump Ball	PK-50	1
9	609055	SPRING, Oil Pump Plunger	PM-58	1
10	609066	STRAINER, Oil Pump Plunger	RD-107	1
11	921188	CAPSCREW, Hex Hd, NC, 1/4" x 1"		2
12	921606	PIN, Cotter, Oil Pump Body, 1/16" x 1 1/2"		1

When Ordering, Specify Model, Serial Number, Part Number and Name of Part Required.

PARTS SECTION

AIR SHROUDING

ENGINE

AIR SHROUDING

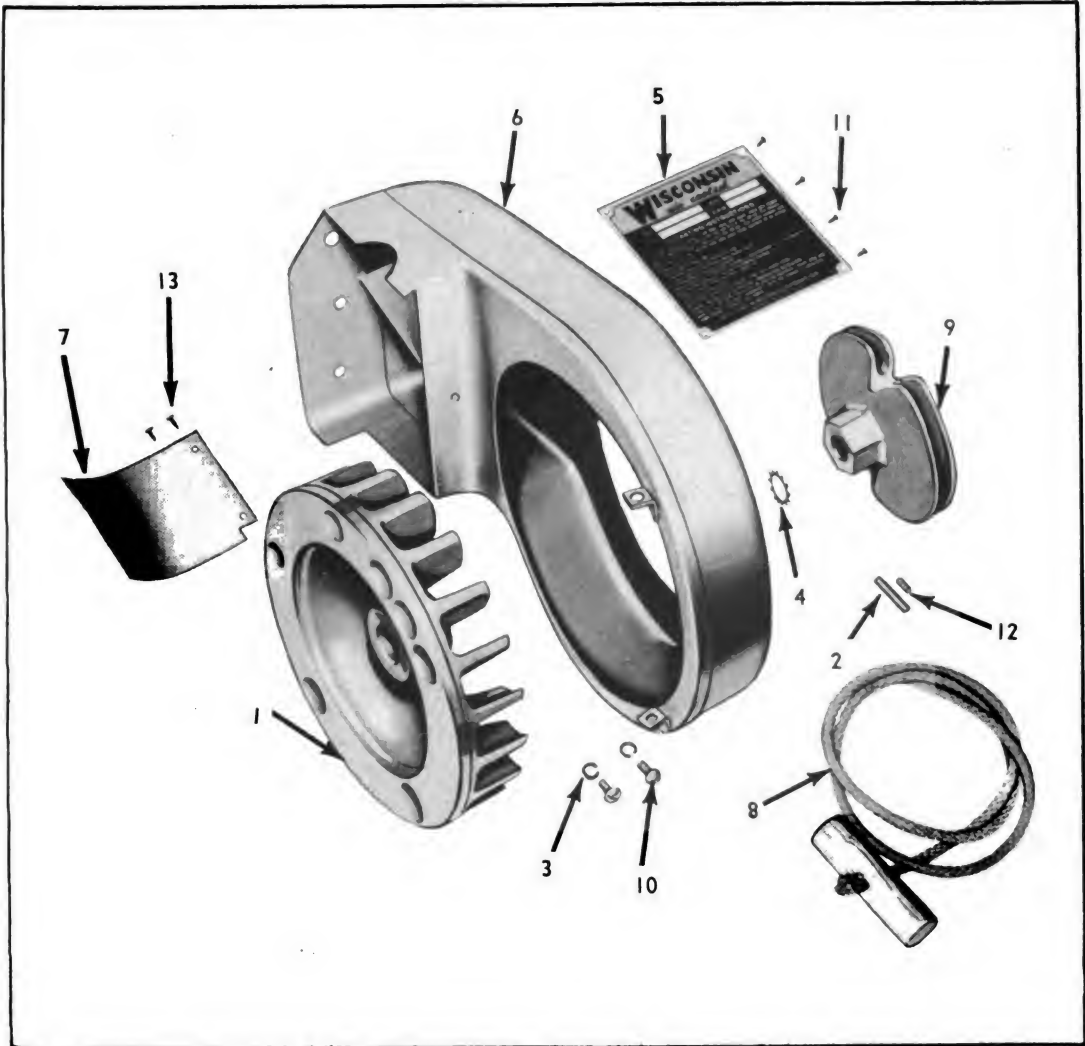

REF. NO.	C-B CO. PART NO.	NOMENCLATURE	ENG. MFR. PART NO.	NO. REQ'D
1	609038	FLYWHEEL	NC-137	1
2	609087	PIN, Groove Starter Sheave	PA-269	1
3	921001	LOCKWASHER, 1/4"		2
4	609046	WASHER, Everlock, Starter Rope Sheave, 5/8"	PE-57	1
5	609926	PLATE, Name and Instruction	SD-53-B	1
6	609929	SHROUD, Air	SE-53-A	1
7	609070	SHROUD, Cylinder Side	SE-54	1
8	625006	ROPE, Starting Assembly	U-218-A	1
9	609147	SHEAVE, Starting Rope	UC-76-C	1
10	921197	SCREW, Mach, Rd Hd, NC, 1/4" x 1/2"		2
11	921608	SCREW, Parker Kalon, No. 4 x 1/4"		4
12	921607	SETSCREW, Slot Hd, 1/4-20 x 3/8"		1
13	609162	RIVET, Cylinder Side Shroud	XJ-46	

PARTS SECTION

CARBURETOR

ENGINE

NO. 609034 CARBURETOR

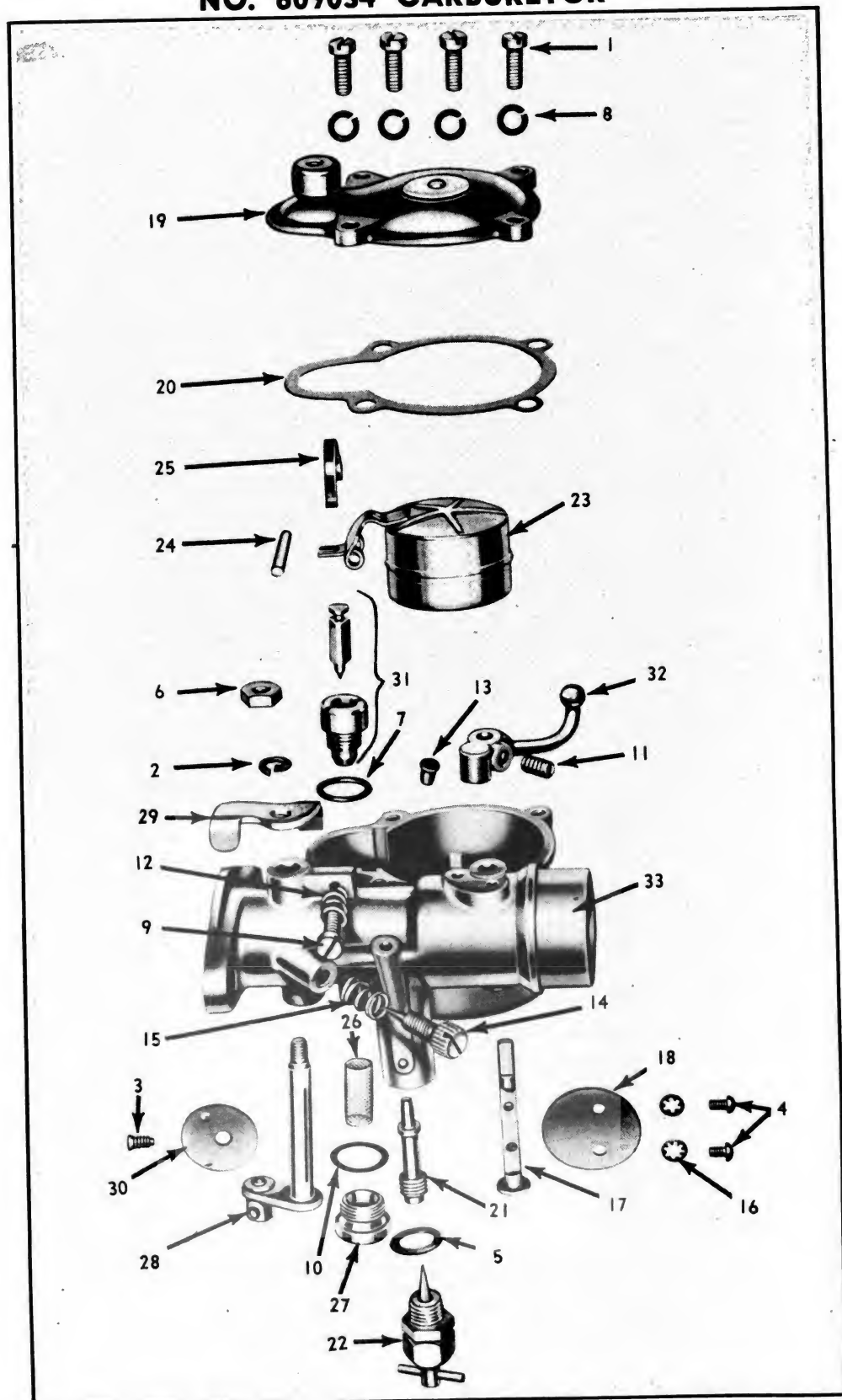

When Ordering, Specify Model, Serial Number, Part Number and Name of Part Required.

PARTS SECTION

CARBURETOR

ENGINE

NO. 609034 CARBURETOR

REF. NO.	C-B CO. PART NO.	NOMENCLATURE	ENG. MFR. PART NO.	NO. REQ'D
1	609271	SCREW, Float Chamber Cover Mtg.	P-47	4
2	609282	LOCKWASHER, Throttle Stop Mtg.	P-1791	1
3	609264	SCREW, Throttle Valve Mtg.	P-4522	1
4	609265	SCREW, Choke Valve Mtg.	P-6578	2
5	609645	GASKET, Main Discharge Jet	P-9600	1
6	609281	NUT, Throttle Stop Mtg.	P-10750	1
7	609612	GASKET, Float Needle Valve Seat	P-11572	1
8	609272	LOCKWASHER, Float Chamber Cover Mtg.	P-12167	4
9	609620	SCREW, Idle Adjustment	P-12375	1
10	609276	GASKET, Gas Strainer Plug	P-14364	1
11	609278	SETSCREW, Choke Lever	P-15287	1
12	609617	SPRING, Idle Adjustment Screw	P-15301	1
13	609283	PLUG, Idle Discharge Drilling Hole	P-15458	1
14	609251	VALVE, Idle Needle	P-15478	1
15	609252	SPRING, Idle Needle Valve	P-18710	1
16	609279	LOCKWASHER, Choke Valve Mtg.	P-20883	2
17	609267	STEM AND LEVER, Choke	P-22323	1
18	609266	VALVE, Choke	P-22969	1
19	609269	COVER, Float Chamber	P-23572	1
20	609270	GASKET, Float Chamber Cover	P-23574	1
21	609354	JET, Main Discharge, No. 54	P-23575	1
22	609253	JET, Metering, Adjustable	P-23576	1
23	609255	FLOAT	P-23579	1
24	609259	PIN, Fulcrum Float	P-23583	1
25	609273	SPRING, Float Fulcrum Pin	P-23584	1
26	609274	STRAINER, Gasoline	P-23586	1
27	609275	PLUG, Gasoline Strainer	P-23587	1
28	609262	STEM, Throttle and Lever	P-23588	1
29	609280	STOP, Throttle	P-23593	1
30	609263	VALVE, Throttle	P-23594	1
31	609250	SEAT, Float Needle Valve	P-23639	1
32	609277	LEVER, Choke	P-23841	1
33	609268	BODY, Main, Includes No. 60-69-69 Idle Holes, Throttle Stem Valve & No. 70 H. S. Bleeder	P-24817	1

PARTS SECTION

MAGNETO COIL AND CORE

ENGINE

MAGNETO COIL AND CORE

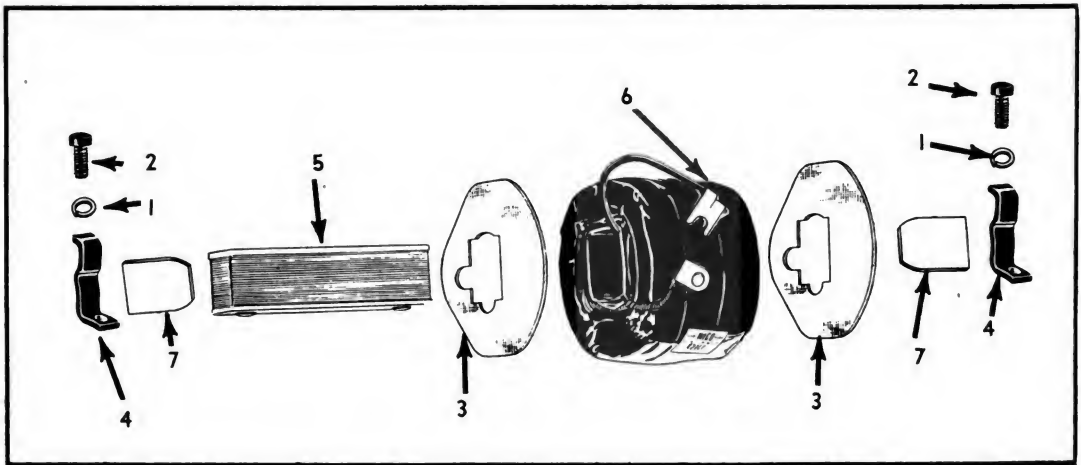

REF. NO.	C-B CO. PART NO.	NOMENCLATURE	ENG. MFR. PART NO.	NO. REQ'D
1	609157	LOCKWASHER, Coil Core Clamp Screw	M-55XA	2
2	609161	SCREW, Coil Core Clamp	M-126XB	2
3	609205	SHIELD, Coil	1760	2
4	609218	CLAMP, Coil Core	2503	2
5	609225	CORE, Coil	X2706	1
6	609233	COIL	X2766	1
7	609906	WEDGE, Coil	3497-B	2

PARTS SECTION

MAGNETO GEAR AND IMPULSE COUPLING

ENGINE

MAGNETO GEAR AND IMPULSE COUPLING

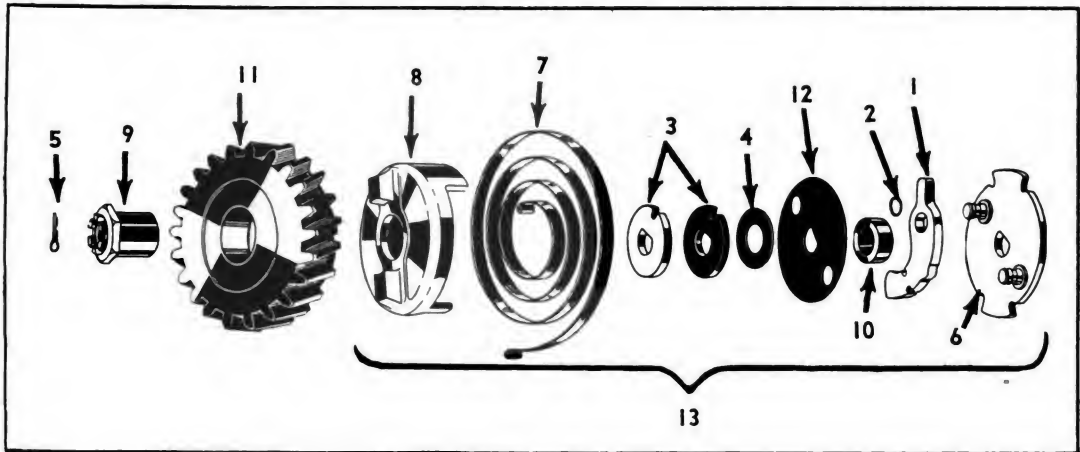

REF. NO.	C-B CO. PART NO.	NOMENCLATURE	ENG. MFR. PART NO.	NO. REQ'D
1	609928	ARM, Trip	A-179X	1
2	609171	RING, Snap	A-243X	1
3	609181	WASHER, Drive Cup Spacing	IVA-583	2
4	609155	WASHER, Driven Flange Spacing	M-42XA	1
5	609160	PIN, Impulse Locknut, Cotter	M-96X	1
6	609295	FLANGE, Driven	X2286	1
7	609170	SPRING, Impulse Coupling Drive	15-186	1
8	609207	CUP, Drive	2040	1
9	609208	LOCKNUT, Impulse	2076	1
10	609930	SPACER, Driven Flange	2122	1
11	609028	GEAR, Impulse (Wisconsin No. GD-87B)	2273	1
12	609214	RETAINER, Drive Spring	2288	1
13	609905	COUPLING, Impulse	X3107	1

When Ordering, Specify Model, Serial Number, Part Number and Name of Part Required.

PARTS SECTION

MAGNETO MAIN HOUSING

ENGINE

MAGNETO MAIN HOUSING

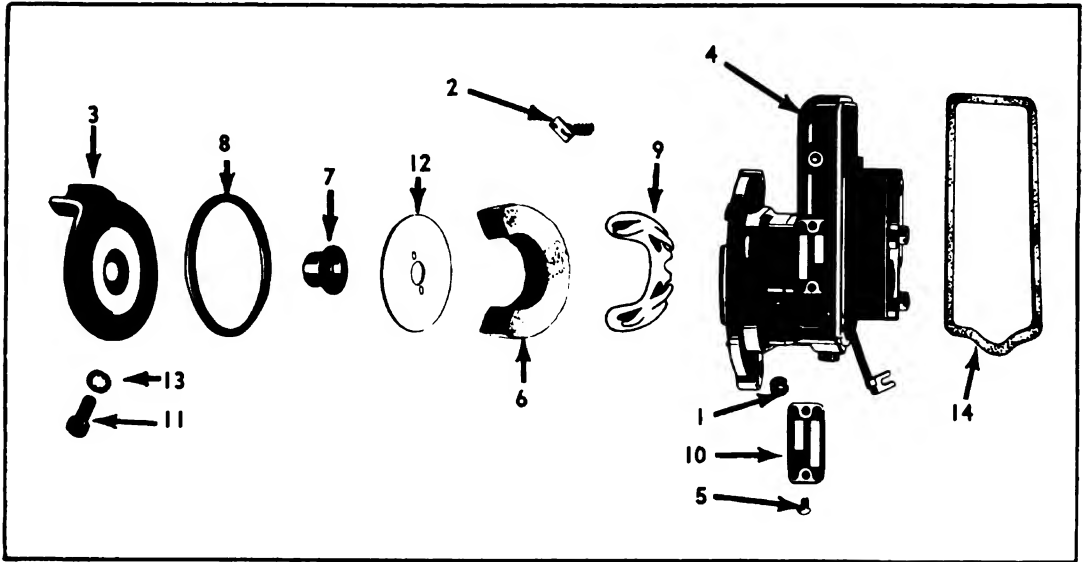

REF. NO.	C-B CO. PART NO.	NOMENCLATURE	ENG. MFR. PART NO.	NO. REQ'D
1	609175	PLUG, Oil	IXA-345	2
2	609201	SCRAPER, Oil	XI487	1
3	609226	STOP, Impulse	X2719	1
4	609289	HOUSING, Main	X3605	1
5	609194	SCREW, Identification Plate Mounting	1248	4
6	609195	PAD, Main Oil	1379	1
7	609209	SPACER, Impulse	2121	1
8	609903	GASKET, Impulse Stop	2496	1
9	609220	PLATE, Oil Pad Spring	2505	1
10	609221	PLATE, Identification	2506	2
11	609224	SCREW, Impulse Stop	2641	4
12	609229	DISC, Oiling	2745	1
13	609231	LOCKWASHER, Impulse Stop Screws	2749	4
14	609889	GASKET, Main Housing Cover	2504	1

When Ordering, Specify Model, Serial Number, Part Number and Name of Part Required.

PARTS SECTION

MAGNETO STOP BUTTON AND ROTOR

ENGINE

MAGNETO STOP BUTTON AND ROTOR

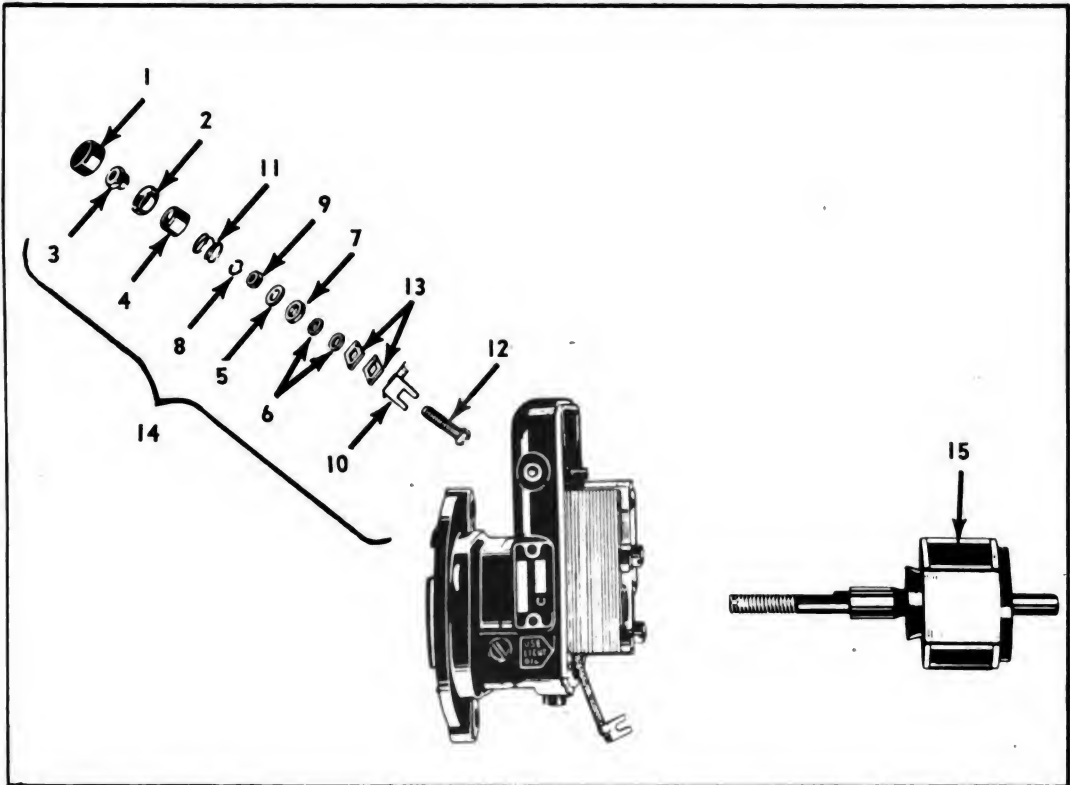

REF. NO.	C-B CO. PART NO.	NOMENCLATURE	ENG. MFR. PART NO.	NO. REQ'D
1	609163	BUTTON, Stop	A-138XA	1
2	609164	SUPPORT, Stop Button	A-139X	1
3	609166	NUT	A-142X	1
4	609168	SLEEVE, Grounding	A-170X	1
5	609151	WASHER, Ground Stud	M-33X	1
6	609152	BUSHING, Ground Stud Insulating	M-34X	2
7	609153	WASHER, Ground Stud Insulating	M-35X	1
8	609156	LOCKWASHER, Stop Button Nut	M-54X	1
9	609158	NUT, Ground Stud	M-72X	1
10	609227	WIRE, Ground Stud Lead	X2721A	1
11	609177	SPRING, Primary Grounding	16-369	1
12	609242	STUD, Ground	3538	1
13	609243	LOCK, Ground Stud Insulating	3539	2
14	609907	STOP BUTTON, Assembly	X4756	1
15	609288	ROTOR	X-4717	1

When Ordering, Specify Model, Serial Number, Part Number and Name of Part Required.

PARTS SECTION

MAGNETO BREAKER POINTS

ENGINE

MAGNETO BREAKER POINTS

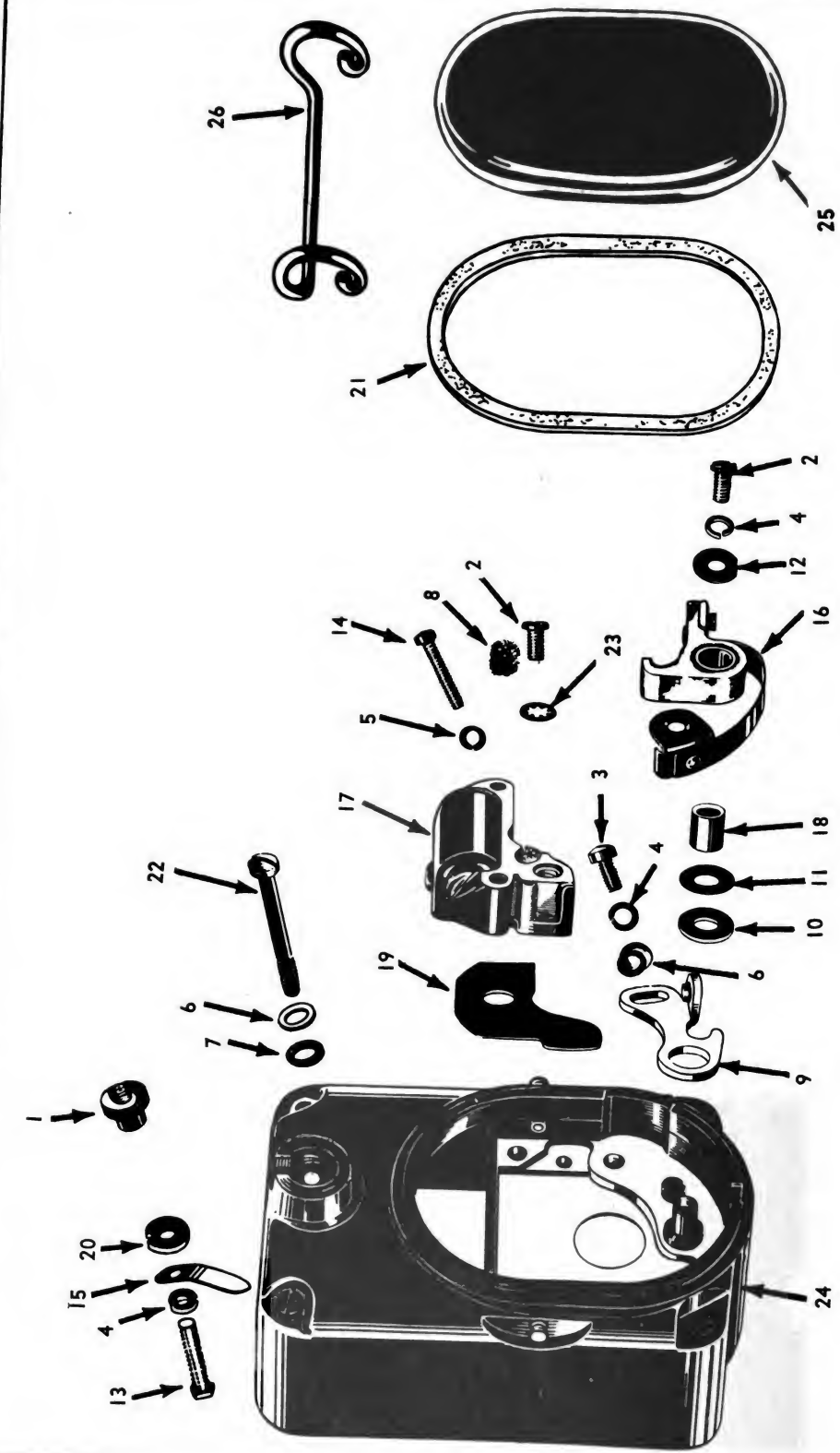

When Ordering, Specify Model, Serial Number, Part Number and Name of Part Required.

PARTS SECTION

MAGNETO BREAKER POINTS

ENGINE

MAGNETO BREAKER POINTS

REF. NO.	C-B CO. PART NO.	NOMENCLATURE	ENG. MFR. PART NO.	NO. REQ'D
1	609682	NUT, Lead Wire Clamp	16-463	1
2	609183	SCREW 1 for Breaker Arm Clamp 1 for Breaker Arm Spring	16-783	2
3	609150	SCREW, Fixed Contact	M-31X	4
4	609157	LOCKWASHER 1 for Fixed Contact Screw 1 for Breaker Arm Clamp 1 for Terminal Screw	M55XA	3
5	609159	LOCKWASHER, Condenser Screw	M-90X	2
6	609173	WASHER 1 for Fixed Contact Screw 4 for Mounting Cover	IXA-256	5
7	609898	WASHER, Cover Screw Leather	1118	4
8	609189	PAD, Cam Oil	1194	1
9	609190	CONTACT, Fixed	1196	1
10	609191	WASHER, Breaker Arm Spacing	1197	1
11	609192	WASHER, Breaker Arm Spacing	1197T	1
12	609193	WASHER, Breaker Arm Clamp	1207	1
13	609899	SCREW, Terminal	1328	1
14	609196	SCREW, Condenser	1383	2
15	609900	CONTACT, Coil	1397	1
16	609198	ARM, Breaker	X1408	1
17	609199	CONDENSER	X1413	1
18	609200	SPACER, Breaker Arm	1418	1
19	609203	GASKET, Condenser Case	1533	1
20	609901	NUT, Terminal Screw	1544	1
21	609699	GASKET, Breaker Box Cover	2497	1
22	609902	SCREW, Cover	2538	4
23	609286	LOCKWASHER, Breaker Arm Spring Screw	2573	1
24	609236	COVER	X2799	1
25	609238	COVER, Breaker	3101	1
26	609239	SPRING, Breaker Cover Hold Down	3103	1

PARTS SECTION

TOOLS AND EQUIPMENT

TOOLS

TOOLS AND EQUIPMENT

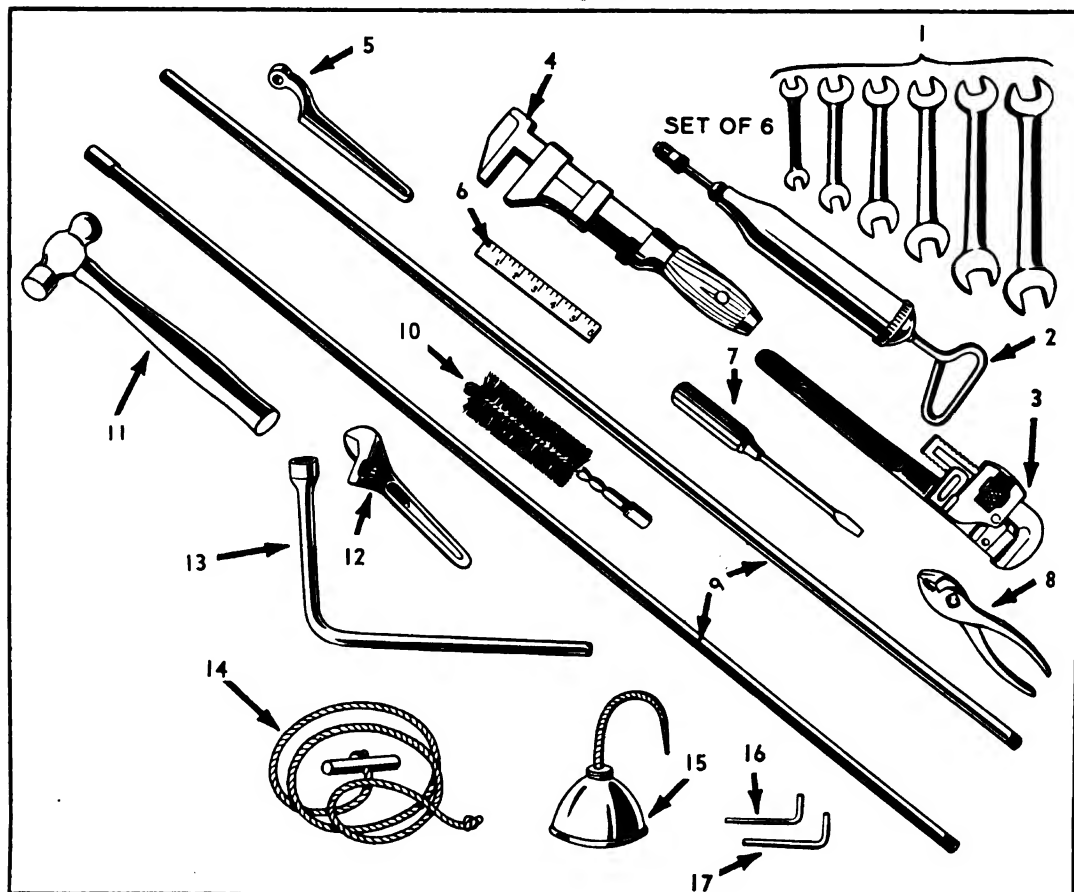

REF. NO.	C-B CO. PART NO.	NOMENCLATURE	NO. REQ'D
1	916024	WRENCH, Open End, Set of Six, 1/4" to 1"	1
2	916009	GREASE GUN, Alemite No. 6556, 8 oz.	1
3	916065	WRENCH, Pipe, 18", Type 11	2
4	916037	WRENCH, Monkey, Heavy Duty, 12"	1
5	616017	SPANNER WRENCH, Hose, Pin Lug Type, 1 1/2"	2
6	916029	RULE, Steel, 6"	1
7	916031	SCREWDRIVER, 4"	1
8	916007	PLIERS, Combination, Slip Joint, 6"	1
9	916021	HANDLE, Flue Brush	1
10	916008	FLUE BRUSH, 1 7/8"	1
11	916028	HAMMER, Ball Pien, 1 lb.	1
12	916033	WRENCH, Crescent Adjustable, 8"	1
13	916018	WRENCH, Wheel Stud, 3/4"	1
14	625006	STARTER ROPE, Gasoline Engine	1
15	616004	OIL CAN, 1 Pint, with 8" Flexible Spout	1
16	916014	WRENCH, Allen, For 5/16" Setscrew	1
17	916013	WRENCH, Allen, For 1/4" Setscrew	1

NUMERICAL PARTS LIST INCLUDES:

PART NUMBER

REFERENCE NUMBER

PAGE NUMBER

NUMBER REQUIRED

WEIGHT IN POUNDS

LIST PRICE EACH

PARTS SECTION

NUMERICAL PARTS LIST

C-B CO. PART NO.	REF. NO.	PAGE	NO. REQ'D	WEIGHT, LBS.	*LIST PRICE EA.
101011	9	157	4	2	\$.50
101012	7	157	4	2	.88
109186	29	191	1	1	1.06
601004	1	158	1	95	55.00
601005	3	158	1	20	10.00
601006	6	158	27	10	3.00
601010	11	157	1	1/2	2.40
601011	1	157	1	2400	2839.00
601148	2	159	1	5	1.50
601149	3	159	1	16	2.70
601150	4	159	1	24	4.50
601152	1	159	1	150	76.80
602150	1	189	1	75	42.42
602151	2	189	1	75	40.08
602153	5	189	1	1	.24
602154	6	189	1	1	.24
602157	15	189	1	8	6.00
602158	14	189	1	1/2	.84
602159	16	189	1	1/2	.84
602160	17	189	1	8	6.52
602161	20	189	1	1/4	1.16
602162	21	189	1	20	10.52
602163	22	189	1	1	1.16
602164	23	189	2	1/2	.84
602168	1	183	1	400	250.00
602169	2	183	2	10	18.70
602170	3	183	2	10	13.00
602171	8	183	2	45	12.50
602172	9	183	4	2	3.00
602173	13	183	1	50	83.00
602175	17	183	2	6	18.32
602176	18	183	2	2	2.50
602177	19	183	1	10	48.36
602178	22	183	2	1	1.60
602179	23	183	2	1	2.20
602180	24	183	2	1/2	1.50
602181	25	183	2	50	87.74
602182	26	183	2	10	8.48
602183	27	183	2	1	2.00
602184	28	183	2	1	2.80
602185	30	183	1	50	42.80
602186	29	183	2	1/2	2.30

* ALL PRICES SUBJECT TO CHANGE WITHOUT NOTICE.

PARTS SECTION

NUMERICAL PARTS LIST

C-B CO. PART NO.	REF. NO.	PAGE	NO. REQ'D	WEIGHT, LBS.	*LIST PRICE EA.
602187	19	183	1	10	\$ 48.36
602188	26	189	1	50	31.56
602243	7	189	1	1/2	.50
602276	22	185	1	2	3.50
602277	21	185	1	2	3.60
603009	1	185	1	300	167.00
603019	3	173	1	1/4	1.00
603020	2	173	1	1/4	1.00
603024	9	173	1	2	3.00
603037	27	173	1	2	15.00
603038	21	173	1	2	8.00
603104	8	185	1	300	167.00
603105	6	175	1	5	12.00
605002	1	187	1	20	56.00
605003	3	187	20	1	.90
605005	7	187	19	1	1.00
605006	11	187	1	1	.40
605007	12	187	1	50	50.00
605008	13	187	1	25	90.00
605010	26	187	1	75	100.00
605011	21	187	1	1	.60
605012	22	187	2	1/2	.40
605017	5	158	5	5	.14
605018	18	185	1	5	15.00
605019	2	187	20	1	1.00
605021	8	187	38	1	.50
605023	20	187	1	1	.40
605101	15	187	2	1/4	3.00
606005	13	177	2	1 1/2	.36
606006	14	177	2	1	.60
606008	16	177	1	1/2	.10
606009	17	177	2	1/2	.10
606011	21	177	1	1	3.30
606012	22	177	1	1 1/4	5.60
606013	1	181	1	1/2	2.50
606019	8	181	18 ft.	2	per ft. .10
606020	9	181	13 ft.	1	per ft. .10
606021	10	181	15 ft.	1	per ft. .10
606022	11	181	14 ft.	1	per ft. .10
606023	12	181	3	1	.40
606024	13	181	1	1	.40
606025	14	181	1	5	14.50

* ALL PRICES SUBJECT TO CHANGE WITHOUT NOTICE.

When Ordering, Specify Model, Serial Number, Part Number and Name of Part Required.

PARTS SECTION

NUMERICAL PARTS LIST

C-B CO. PART NO.	REF. NO.	PAGE	NO. REQ'D	WEIGHT, LBS.	*LIST PRICE EA.
606030	7	181	1	2	\$ 4.60
607001	3	185	2	1/4	1.00
609005	1	193	1	20	32.56
609006	1	193	1	23	37.58
609007	2	193	1	5	4.18
609008	1	197	1	1	1.68
609009	2	197	1	1	1.34
609010	3	197	2	1/4	.18
609012	5	197	2 Pr.	1/4	.04
609013	3	193	1	10	3.68
609014	1	194	1	2	3.50
609015	2	194	1	1	.26
609021	6	195	2	1	.40
609022	7	195	1	1	.52
609023	8	195	1	1	.58
609024	9	195	1	1/2	.74
609025	6	197	1	5	9.02
609026	7	197	2	1/2	.36
609027	10	195	1	2	2.94
609028	{11 11	{195 205}	1	3/4	3.30
609029	12	195	1	1	.56
609030	1	200	1	2	1.50
609031	2	200	1	1/2	.80
609032	3	200	1	1/4	.46
609033	4	200	1	1/2	.30
609034	5	193	1	3	19.88
609035	13	195	1	2	1.10
609036	5	200	2	1/4	.06
609038	1	201	1	5	9.18
609039	6	200	1	1/4	.16
609040	8	197	1	1	1.10
609041	9	197	2	1/2	.50
609042	16	195	1	1/4	.14
609043	17	195	1	1/4	.52
609044	7	193	2	1/4	.30
609046	4	201	1	1/4	.06
609047	12	193	1	1/4	.10
609048	24	195	2	1/4	.06
609049	25	195	2	1/4	.06
609050	8	199	1	1/4	.50
609051	8	200	1	1/4	.16

* ALL PRICES SUBJECT TO CHANGE WITHOUT NOTICE.

When Ordering, Specify Model, Serial Number, Part Number and Name of Part Required.

PARTS SECTION

NUMERICAL PARTS LIST

C-B CO. PART NO.	REF. NO.	PAGE	NO. REQ'D	WEIGHT, LBS.	*LIST PRICE EA.
609052	26	195	2	1/4	\$.06
609053	27	195	1	1/4	.06
609054	28	195	1	1/4	.06
609055	9	200	1	1/4	.26
609056	11	197	1	1/4	.50
609057	18	193	1	1/4	.06
609058	19	193	1	1/4	.34
609059	20	193	1	1/4	.16
609060	29	195	1	1/4	.06
609061	12	197	1	1/4	.06
609062	21	193	1	1/4	.06
609063	30	195	5	1/4	.06
609064	31	195	1	1/4	.06
609065	32	195	1	1/4	.06
609066	10	200	1	1/2	.50
609067	22	193	2	1/4	.06
609068	23	193	1	1/4	.12
609070	7	201	1	1	.26
609071	13	197	1	1/2	1.16
609072	14	197	2	1/2	.36
609073	15	197	1	1	1.26
609074	16	197	1	1	1.84
609075	18	197	1	1	.36
609076	17	197	1	1/2	.30
609077	19	197	2	1/4	.36
609080	20	197	1	1/2	.94
609085	36	195	1	5	39.52
609086	34	193	1	1/4	.34
609087	2	201	1	1/4	.06
609093	21	195	2	1/4	.06
609094	11	193	1	1/2	.24
609096	15	193	1	1/4	.06
609109	23	197	4	1/4	.06
609117	4	193	1	1 1/2	2.50
609122	17	193	1	1/4	.06
609125	11	199	1	1/2	.94
609126	9	199	1	1/4	.20
609129	5	199	1	1/4	.06
609132	4	199	1	1/4	.06
609136	6	199	2	1/4	.06
609140	1	199	1	1/4	.26
609141	7	199	1	1/4	.06

* ALL PRICES SUBJECT TO CHANGE WITHOUT NOTICE.

When Ordering, Specify Model, Serial Number, Part Number and Name of Part Required.

PARTS SECTION

NUMERICAL PARTS LIST

C-B CO. PART NO.	REF. NO.	PAGE	NO. REQ'D	WEIGHT, LBS.	*LIST PRICE EA.
609142	10	199	1	1/2	\$.94
609143	12	199	1	1	1.34
609144	13	199	1	2	4.18
609147	9	201	1	3	3.84
609150	3	209	4	1/4	.14
609151	5	207	1	1/4	.14
609152	6	207	2	1/4	.14
609153	7	207	1	1/4	.14
609155	4	205	1	1/4	.14
609156	8	207	1	1/4	.14
609157	{ 1	204	5	1/4	.14
	{ 4	209			
609158	9	207	1	1/4	.14
609159	5	209	2	1/4	.14
609160	5	205	1	1/4	.14
609161	2	204	2	1/4	.14
609162	13	201	2	1/4	.06
609163	1	207	1	1/4	.26
609164	2	207	1	1/4	.14
609166	3	207	1	1/4	.14
609167	4	194	1	5	8.86
609168	4	207	1	1/4	.26
609170	7	205	1	1/4	1.60
609171	2	205	1	1/4	.14
609173	6	209	5	1/4	.14
609174	5	194	1	2	4.18
609175	1	206	2	1/4	.14
609177	11	207	1	1/4	.14
609178	5	195	1	2	3.74
609179	14	195	2	1	.84
609180	15	195	2	2	1.94
609181	3	205	2	1/4	.26
609183	2	209	2	1/4	.14
609184	23	195	4	1/4	.06
609185	35	193	1	1	1.16
609186	24	191	1	1	1.88
609189	8	207	1	1/4	.14
609190	9	209	1	1/4	1.34
609191	10	209	1	1/4	.14
609192	11	209	1	1/4	.14
609193	12	209	1	1/4	.14
609194	5	206	4	1/4	.14

* ALL PRICES SUBJECT TO CHANGE WITHOUT NOTICE.

When Ordering, Specify Model, Serial Number, Part Number and Name of Part Required.

PARTS SECTION

NUMERICAL PARTS LIST

C-B CO. PART NO.	REF. NO.	PAGE	NO. REQ'D	WEIGHT, LBS.	*LIST PRICE EA.
609195	6	206	1	1/4	\$.26
609196	14	209	2	1/4	.14
609198	16	209	1	1/4	3.34
609199	17	209	1	1/4	4.00
609200	18	209	1	1/4	.14
609201	2	206	1	1/4	.26
609203	19	209	1	1/4	.14
609205	3	204	2	1/4	.14
609207	8	205	1	1/4	6.40
609208	9	205	1	1/4	.94
609209	7	206	1	1/4	.14
609214	12	205	1	1/4	.14
609216	3	191	1	1 1/2	1.10
609218	4	204	2	1/4	.14
609220	9	206	1	1/4	.14
609221	10	206	2	1/4	.51
609224	11	206	4	1/4	.14
609225	5	204	1	1/2	1.47
609226	3	206	1	1/4	2.40
609227	10	207	1	1/4	.80
609229	12	206	1	1/4	.14
609230	3	194	1	10	28.50
609231	13	206	4	1/4	.14
609233	6	204	1	2	8.68
609236	24	209	1	3/4	6.40
609238	25	209	1	1/4	1.47
609239	25	209	1	1/4	.44
609242	12	207	1	1/4	.26
609243	13	207	2	1/4	.14
609250	31	203	1	1/4	3.84
609251	14	203	1	1/4	1.34
609252	15	203	1	1/4	.20
609253	22	203	1	1/4	3.50
609255	23	203	1	1/4	1.68
609259	24	203	1	1/4	.16
609260	9	203	1	1/4	.16
609262	28	203	1	1/4	3.84
609263	30	203	1	1/4	.34
609264	3	203	1	1/4	.04
609265	4	203	2	1/4	.10
609266	18	203	1	1/4	.50
609267	17	203	1	1/4	.66

* ALL PRICES SUBJECT TO CHANGE WITHOUT NOTICE.

When Ordering, Specify Model, Serial Number, Part Number and Name of Part Required.

PARTS SECTION

NUMERICAL PARTS LIST

C-B CO. PART NO.	REF. NO.	PAGE	NO. REQ'D	WEIGHT, LBS.	*LIST PRICE EA.
609268	33	203	1	2½	\$ 12.52
609269	19	203	1	¼	1.68
609270	20	203	1	¼	.06
609271	1	203	4	¼	.16
609272	8	203	4	¼	.04
609273	25	203	1	¼	.34
609274	26	203	1	¼	.16
609275	27	203	1	¼	.66
609276	10	203	1	¼	.06
609277	32	203	1	¼	1.50
609278	11	203	1	¼	.16
609279	16	203	2	¼	.04
609280	29	203	1	¼	.50
609281	6	203	1	¼	.10
609282	2	203	1	¼	.06
609283	13	203	1	¼	.06
609286	23	209	1	¼	.14
609288	15	207	1	1½	17.64
609289	4	206	1	2½	19.36
609295	6	205	1	¼	1.34
609300	1	191	1	50	158.66
609305	4	197	2	¼	.26
609354	21	203	1	¼	1.68
609586	33	193	1	1	1.34
609588	18	191	1	2	2.22
609590	20	191	1	¼	.14
609592	22	191	1	¼	.36
609612	7	203	1	¼	.04
609617	12	203	1	¼	.16
609620	9	203	1	¼	.04
609645	5	203	1	¼	.06
609682	1	209	1	¼	.26
609699	21	209	1	¼	.14
609889	14	206	1	¼	.14
609890	19	191	1	¼	.36
609891	21	191	1	¼	.36
609892	23	191	1	¼	.36
609898	7	209	4	¼	.14
609899	13	209	1	¼	.14
609900	15	209	1	¼	.14
609901	20	209	1	¼	.14
609902	22	209	4	¼	.14

* ALL PRICES SUBJECT TO CHANGE WITHOUT NOTICE.

When Ordering, Specify Model, Serial Number, Part Number and Name of Part Required.

PARTS SECTION

NUMERICAL PARTS LIST

C-B CO. PART NO.	REF. NO.	PAGE	NO. REQ'D	WEIGHT, LBS.	*LIST PRICE EA.
609903	8	206	1	1/4	\$.14
609905	13	205	1	1	8.80
609906	7	204	2	1/4	.14
609907	14	207	1	3/4	1.60
609921	6	193	1	2	5.00
609923	13	193	1	1/2	.24
609926	5	201	1	1/4	.48
609927	22	195	1	1/2	.34
609928	1	205	1	1/4	.80
609929	6	201	1	5	5.88
609930	11	205	1	1/4	.26
613006	32	169	1	5	12.50
613009	1	161	1	5	4.50
613010	5	169	1	1	1.00
613050	19	169	1	1	.94
613051	16	169	1	1	.90
614026	10	164	6	1/4	.50
614132	1	164	1	2	7.64
614133	3	164	1	1/4	.16
614134	5	164	1	1/4	.66
614135	6	164	1	1/4	.59
614136	7	164	1	1/4	.66
614139	11	164	1	1/2	.84
614140	12	164	1	6	26.90
614145	15	164	1	1/4	.50
614146	16	164	1	1	2.05
614147	17	164	1	1	.86
614148	18	164	1	1	.66
614150	20	164	1	1	.84
614151	1	165	4	1/2	.84
614152	2	165	6	1/4	.50
614153	4	165	1	5	20.20
614154	5	165	1	4	16.54
614155	6	165	1	6	23.20
614156	7	165	2	1/2	1.20
614157	8	165	1	2	17.70
614158	9	165	2	1/2	2.08
614159	10	165	1	2	12.70
614161	11	165	1	1/2	1.50
614162	11	165	4	1/4	.50
614163	12	165	1	1	4.50
614167	17	165	1	1/2	.34

* ALL PRICES SUBJECT TO CHANGE WITHOUT NOTICE.

When Ordering, Specify Model, Serial Number, Part Number and Name of Part Required.

PARTS SECTION

NUMERICAL PARTS LIST

C-B CO. PART NO.	REF. NO.	PAGE	NO. REQ'D	WEIGHT, LBS.	*LIST PRICE EA.
614174	25	165	1	2	\$ 6.24
614175	26	165	1	1/4	.84
614176	24	161	1	35	114.60
614218		165	1	1	7.86
616004	15	210	1	1/2	1.88
616007	{15 23}	{161 167}	5	20	27.52
616017	5	210	2	2	1.54
616026	19	161	1	2	2.60
616027	{16 24}	{161 167}	10	1	.80
616032	20	165	1	1/4	4.20
616054	1	167	2	10	13.40
616055	2	167	8	2 1/2	5.10
616057	12	185	1	1/4	2.00
616058	13	185	1	1/4	2.00
616059	36	183	2	1/2	.80
616060	4	185	3	1/2	5.20
616063	{17 25}	{161 167}	5	1 1/4	1.50
616064	{18 26}	{161 167}	5	1 1/2	1.50
616116	19	185	1	1/4	.50
617001	10	173	1	1/2	.60
617602	15	167	2	2	1.00
617603	16	167	1	2	1.50
617604	20	167	1	2	1.50
617702	23	161	1	1	3.00
617703	22	161	1	1	4.38
621003	4	183	2	1	1.90
621005	15	183	2	1/4	.20
621006	20	183	6	1	.50
621007	20	183	6	1	.50
621008	21	183	6	1/2	.50
621009	21	183	6	1/2	.50
621010	16	187	2	1/4	1.50
621011	17	187	2	1/4	.16
625006	{14 8}	{210 201}	2	1	.84
625018	2	191	1	1/2	.68
625062	28	191	1	5	9.18

* ALL PRICES SUBJECT TO CHANGE WITHOUT NOTICE.

When Ordering, Specify Model, Serial Number, Part Number and Name of Part Required.

PARTS SECTION

NUMERICAL PARTS LIST

C-B CO. PART NO.	REF. NO.	PAGE	NO. REQ'D	WEIGHT, LBS.	*LIST PRICE EA.
625063	31	191	2	1	\$ 1.24
625064	34	191	2	1	.16
625067	9	191	2	1	1.00
901002	{ 2	158 }	2	3	1.70
	{ 6	159 }			
901005	8	157	4	1/4	.20
901006	6	157	4	1/4	.14
903001	5	175	1	1	.40
903002	26	173	1	1/4	1.60
903013	8	173	2	1/4	.10
903015	32	161	1	4	8.20
903017	34	161	1	1	5.40
903019	35	161	1	1/2	2.00
903020	33	161	1	1	5.40
903030	28	161	1	1/4	.30
903033	24	173	1	1/2	.30
903034	25	173	1	1/4	.20
903042	29	161	1	1/4	.30
903063	15	173	1	1/2	10.00
903064	19	173	1	1/4	.50
903101	1	175	1	20	48.40
903102	2	175	1	1/4	2.00
903103	3	175	1	1/4	.20
903105	7	175	1	2	1.50
903106	8	175	1	1/4	.20
903107	13	175	2	2	10.30
903110	17	175	1	3	9.20
903111	18	175	1	1/4	.20
903112	19	175	1	1/4	.20
903113	20	175	1	10	33.26
903114	22	175	1	1/4	.66
903160		175	1	40	135.00
904007	4	169	1	2	13.00
904008	5	171	4	1	3.90
904010	4	163	1	8	28.66
904026	2	185	2	1/4	1.80
904041	1	173	1	1/2	3.70
904076	18	163	1	3	9.78
904085	{ 14	161 }	3	6	13.02
	{ 10	163 }			
904090	20	161	1	3	16.74
905011	14	187	2	3	2.90

* ALL PRICES SUBJECT TO CHANGE WITHOUT NOTICE.

PARTS SECTION

NUMERICAL PARTS LIST

C-B CO. PART NO.	REF. NO.	PAGE	NO. REQ'D	WEIGHT, LBS.	*LIST PRICE EA.
905038	7	158	10 lbs	10 per lb.	\$.20
906001	11	173	2	1/2	.24
906002	12	173	2	1/2	.12
906004	35	177	1	1	6.32
906005	18	177	6	1/4	.30
906007	{ 1	{ 163	3	1/4	.20
	{ 20	{ 177			
906008	23	177	1	1/2	1.00
906010	25	177	3	1/4	.06
906011	28	177	1	17	26.70
906012	31	177	1	1/2	.40
906013	30	177	1	1	.20
906014	2	181	1	1	2.00
906015	3	181	1	1/2	.50
906016	4	181	1	1/2	.50
906018	40	177	1	1/4	2.50
906020	29	177	1	3	18.90
906021	1	179	1	1/4	.04
906022	3	179	1	2	5.00
906023	5	179	1	1/4	.20
906024	4	179	2	1/4	.30
906025	6	179	1	1	3.34
906026	7	179	1	1/4	.40
906040	35	191	1	1	.10
906195	19	177	5	1/4	.22
906216	14	173	2	1/2	1.58
906291	15	181	5	1/2	.10
906363	13	173	2	1/4	.10
906368	15	177	1	1/2	.20
906513	24	177	2	1/4	.24
907001	10	169	1	2	2.80
907004	7	160	1	3	2.80
907006	38	177	1	5	17.68
911000	1	176	1	35	165.40
911024	21	179	2	1/2	.70
911026	18	179	1	12	12.50
911027	19	179	2	1	1.30
911029	2	179	1	2	7.50
911030	3	179	1	5	10.00
911031	4	179	1	1	1.30
911032	6	179	1	1/4	.26
911034	24	179	1	4	20.00

* ALL PRICES SUBJECT TO CHANGE WITHOUT NOTICE.

PARTS SECTION

NUMERICAL PARTS LIST

C-B CO. PART NO.	REF. NO.	PAGE	NO. REQ'D	WEIGHT, LBS.	*LIST PRICE EA.
911035	13	179	1	1	\$ 7.40
911036	16	179	2	1/4	.16
911038	15	179	2	1/4	.70
911039	22	179	2	1/2	.26
911040	12	179	1	25	75.00
911042	10	179	2	1/4	.16
911044	8	179	1	1/4	.26
911045	23	179	4	1/4	.26
911046	1	179	8	1/4	.20
911047	14	179	2	1	3.20
911058	11	179	2	1	6.30
911060	9	179	2	1/4	.16
911064	17	179	2	1/4	.10
912006	31	161	1	1	5.82
912015	24	169	1	1/2	6.26
912016	36	161	1	3	12.70
912029	6	177	1	1/4	.30
912030	41	161	1	1/4	.20
912033	23	169	1	1	1.30
912045	42	161	1	1	2.20
912046	43	161	1	1	2.96
912048	37	161	1	1/4	.30
912210	7	177	1	2	5.82
912212	39	161	1	2	7.30
913006	26	169	1	10	30.06
913007	27	169	1	2	.80
913008	4	171	12	1/4	.60
913013	15	169	2	1/4	.40
913019	20	169	1	2	7.34
913020	2	170	1	1/4	.04
913021	3	170	1	1/2	1.10
913022	4	170	1	1/4	.08
913026	6	170	1	2	3.00
913027	21	169	1	1	1.00
913034	15	191	2	1/4	.64
913067	{14 24}	{175 189}	3	1/4	.10
913127	17	169	4	1/4	.60
913196	5	170	1	3	5.00
913198	18	169	1	1	.90
913231	7	171	2	1	1.08
913232	8	171	2	1	.84

* ALL PRICES SUBJECT TO CHANGE WITHOUT NOTICE.

PARTS SECTION

NUMERICAL PARTS LIST

C-B CO. PART NO.	REF. NO.	PAGE	NO. REQ'D	WEIGHT, LBS.	*LIST PRICE EA.
913233	9	171	1	1	\$ 1.00
913234	10	171	1	2	1.44
913246	16	191	1	2	1.18
916007	8	210	1	1	.80
916008	10	210	1	1	.80
916009	2	210	1	5	4.80
916013	17	210	1	¼	.20
916014	16	210	1	¼	.20
916018	13	210	1	3	2.60
916021	9	210	1	10	1.50
916024	1	210	1	3	2.70
916028	11	210	1	2	2.90
916029	6	210	1	½	3.00
916031	7	210	1	½	.96
916033	12	210	1	3	2.30
916037	4	210	1	5	5.40
916065	3	210	2	9	7.90
916102	5	183	4	¼	.20
916210	2	179	1	¼	.84
917000	7	173	1	½	.24
917002	18	165	1	¼	.16
917003	6	173	1	½	.18
917011	30	191	1	¼	.12
917017	13	191	2	½	.16
917023	14	191	1	½	.08
917054	19	165	1	¼	.24
917060	12	191	1	¼	.06
917086	17	191	1	¼	.16
917100	23	173	1	¼	.18
917101	12	169	1	½	.24
917102	6	171	4	1	.16
917105	13	169	1	½	.24
917106	11	169	1	2	.28
917108	13	164	4	½	.24
	7	170			
	3	171			
917109	2	171	4	½	.38
917115	14	169	1	¼	.38
917122	39	191	2	¼	.06
	31	193			
917126	1	171	2	¼	.14

* ALL PRICES SUBJECT TO CHANGE WITHOUT NOTICE.

When Ordering, Specify Model, Serial Number, Part Number and Name of Part Required.

PARTS SECTION

NUMERICAL PARTS LIST

C-B CO. PART NO.	REF. NO.	PAGE	NO. REQ'D	WEIGHT, LBS.	*LIST PRICE EA.
917130	37	191	1	1/4	\$.08
917144	9	169	5	1/2	.38
917166	38	191	1	1/4	.10
917169	36	191	1	1/4	.18
917218	33	193	1	1/4	.20
917254	8	169	7	1/2	.14
917340	8	160	1	1/2	.14
917342	3	167	8	1	.26
917427	18	167	2	1/2	.30
917431	4	191	2	1	.10
917451	6	191	1	1/2	.18
917452	5	191	1	1/2	.34
917453	8	191	1	1/2	.24
917500	39	177	1	1/2	.22
917547	22	167	4	1/4	.36
917548	3	157	1	1/4	.16
917601	{ 3 14 }	{ 163 167 }	3	1	.58
917607	19	167	1	1/2	1.42
917608	6	167	2	1	.26
917609	7	167	1	1	1.20
917637	5	163	1	1/4	.78
917702	{ 8 21 15 }	{ 159 161 163 }	4	1	.26
	10	161			
	16	163			
917703	{ 10 16 }	{ 161 163 }	5	1 1/2	1.10
	10	167			
917705	10	167	1	1	.96
917708	14	163	1	1/2	.72
917709	{ 2 9 }	{ 160 163 }	8	1/2	.84
	4	160			
917712	{ 4 8 }	{ 160 163 }	5	1/2	1.82
	9	161			
917714	9	161	1	1/2	.34
917740	9	167	1	1	.70
917747	11	163	2	1/2	1.00
917752	{ 11 13 }	{ 161 163 }	3	1	.42
	4	157			
917942	4	157	1	1/2	.68
920330	4	167	6	1/2	.20
920334	5	167	2	2	.86
920448	7	191	1	3	.24

* ALL PRICES SUBJECT TO CHANGE WITHOUT NOTICE.

When Ordering, Specify Model, Serial Number, Part Number and Name of Part Required.

PARTS SECTION

NUMERICAL PARTS LIST

C-B CO. PART NO.	REF. NO.	PAGE	NO. REQ'D	WEIGHT, LBS.	*LIST PRICE EA.
920640	12	167	3	1	\$.90
920695	{ 2 8	{ 163 167	3	1	.44
920774	{ 13 7	{ 161 163	13	1/2	.56
920779	3	160	1	3	1.34
920794	5	160	1	1	.70
920795	1	160	2	2	.74
	{ 3 18 27 6 35	{ 169 173 177 181 183			
921001	{ 6 5 26 9 19 7 3	{ 185 187 189 193 195 200 201	255	1/4	.02
921002	6	169	1	1/4	.02
	{ 7 37	{ 169 177			
921003	{ 16 11 10 20	{ 185 191 193 195	25	1/4	.02
921004	{ 4 32	{ 175 177	8	1/4	.02
	{ 16 29 23	{ 157 169 175			
921008	{ 17 26 22	{ 157 161 165	14	1/4	.04
921009	{ 30 10 3 10 25	{ 169 175 177 185 187	50	1/4	.02

* ALL PRICES SUBJECT TO CHANGE WITHOUT NOTICE.

When Ordering, Specify Model, Serial Number, Part Number and Name of Part Required.

PARTS SECTION

NUMERICAL PARTS LIST

C-B CO. PART NO.	REF. NO.	PAGE	NO. REQ'D	WEIGHT, LBS.	*LIST PRICE EA.
921010	{ 18	157	36	1/4	\$.02
	{ 27	161			
	{ 31	169			
	{ 4	177			
	{ 11	185			
921011	{ 4	173	5	1/4	.02
	{ 20	179			
	{ 8	164			
921012	{ 15	165	26	1/4	.02
	{ 3	165			
	{ 5	173			
	{ 17	185			
	{ 33	191			
	{ 20	173			
921014	{ 34	177	12	1/4	.02
	{ 2	199			
	{ 4	187			
921016	14	164	2	1/4	.06
921017	18	187	4	1/4	.02
921018	23	187	4	1/4	.10
921021	{ 2	176	26	1/4	.02
	{ 9	185			
	{ 24	187			
921023	15	175	4	1/4	.04
921024	{ 21	165	12	1/4	.02
	{ 16	175			
	{ 5	177			
921026	40	161	2	1/4	.10
921027	{ 2	169	15	1/4	.06
	{ 26	193			
921029	4	189	1	1/2	.02
921030	8	189	2	1/4	.20
921031	10	189	3	1/4	.02
921032	11	189	1	1/4	.02
921036	19	189	1	1/4	.04
921040	12	183	8		
921052	11	183	8	1/4	.06
921053	{ 14	157	15	1/4	.06
	{ 11	183			
	{ 26	191			

* ALL PRICES SUBJECT TO CHANGE WITHOUT NOTICE.

PARTS SECTION

NUMERICAL PARTS LIST

C-B CO. PART NO.	REF. NO.	PAGE	NO. REQ'D	WEIGHT, LBS.	*LIST PRICE EA.
921055	{ 12	157	43	1/4	\$.24
	{ 9	158			
	{ 10	159			
921068	10	191	4	1/4	.06
921069	30	161	6	1/4	.10
921070	38	161	2	1/4	.10
921071	{ 13	157	15	1/4	.08
	{ 31	183			
	{ 25	191			
921072	5	157	4	1/4	.24
921074	{ 14	185	20	1/4	.06
	{ 33	195			
	{ 21	197			
921075	15	185	6	1/4	.06
921077	{ 14	165	162	1/4	.02
	{ 20	185			
	{ 10	187			
921078	{ 8	158	40	1/4	.04
	{ 9	159			
921079	1	170	1	1/4	.20
921080	7	183	2	1/4	.02
921081	10	183	8	1	.44
921082	14	183	2	1/4	.10
921083	{ 33	177	8	1/4	.02
	{ 17	181			
921084	36	177	3	1/4	.02
921085	16	181	6	1/4	.02
921086	18	181	1	1/4	.02
921087	16	181	2	1/4	.02
921088	{ 6	183	3	1/4	.10
	{ 25	189			
921090	9	189	2	1/4	.10
921097	5	159	4	1/4	.16
921110	{ 16	165	6	1/4	.06
	{ 35	195			
	{ 2	157			
921115	{ 4	158	43	1/4	.34
	{ 7	159			
	{ 2	157			
921120	2	164	1	1/4	.06
921146	25	161	4	1/4	.04
921177	14	193	10	1/4	.02
921178	5	179	6	1/4	.02

* ALL PRICES SUBJECT TO CHANGE WITHOUT NOTICE.

PARTS SECTION

NUMERICAL PARTS LIST

C-B CO. PART NO.	REF. NO.	PAGE	NO. REQ'D	WEIGHT, LBS.	*LIST PRICE EA. \$
921188	11	200	2	1/4	.06
921195	{ 7 6 }	{ 185 187 }	48	1/4	.02
921196	32	191	2	1/4	.06
	{ 22 16 11 }	{ 169 173 175 }			
921197	{ 5 34 5 9 10 }	{ 181 183 185 187 201 }	176	1/4	.02
921204	7	179	2	1/4	.02
921224	29	193	1	1/4	.02
921225	17	173	1	1/4	.02
921231	3	199	1	1/4	.02
921254	16	199	1	1/4	.02
921272	{ 8 10 }	{ 193 197 }	3	1/4	.02
921273	18	195	2	1/4	.02
921274	{ 9 16 }	{ 164 193 }	4	1/4	.02
921276	24	193	3	1/4	.02
921277	27	193	1	1/4	.14
921278	28	193	3	1/4	.14
921279	30	193	4	1/4	.14
921281	22	197	1	1/4	.02
921331	{ 10 12 }	{ 157 189 }	8	1/4	.08
921336	{ 28 34 }	{ 169 195 }	6	1/4	.04
921339	22	173	1	1/4	.02
921341	{ 12 9 }	{ 175 175 }	18	1/4	.02
921343	3	189	1	1/4	.50
	{ 15 33 18 27 }	{ 157 183 189 191 }	16	1/4	.04
921352	25	193	1	1/4	.12
921363	21	175	2	1/4	.10

* ALL PRICES SUBJECT TO CHANGE WITHOUT NOTICE.

PARTS SECTION

NUMERICAL PARTS LIST

C-B CO. PART NO.	REF. NO.	PAGE	NO. REQ'D	WEIGHT, LBS.	*LIST PRICE EA.
921365	{ 25	169 }	2	1/4	\$.10
	{ 8	177 }			
921380	13	189	4	1/4	.16
921383	{ 26	177 }	10	1/4	.02
	{ 19	187 }			
921590	15	199	1	1/4	.02
921592	14	199	1	1/4	.02
921599	4	164	1	1/4	.06
921600	19	164	2	1/4	.04
921601	13	165	4	1/4	.04
921602	23	165	4	1/4	.14
921603	24	165	2	1/4	.02
921606	12	200	1	1/4	.02
921607	12	201	1	1/4	.10
921608	11	201	4	1/4	.02
923455	17	167	2	2	1.38
923501	21	167	2	3	1.66
923601	{ 17	163 }	3	2	.72
	{ 13	167 }			
923608	6	163	1	5	4.58
923615	11	167	8	4	1.82
923707	12	163	1	8	3.12
923708	12	161	1	6	1.90
923709	6	161	1	5	1.54

* ALL PRICES SUBJECT TO CHANGE WITHOUT NOTICE.
(P.O. 57524 — 18 Sept. 1944 — 6500 — Litho in U.S.A.)

When Ordering, Specify Model, Serial Number, Part Number and Name of Part Required.

MEMO

MEMO
