

U113  
.2  
JM  
1944

# TM 55-1100

WAR DEPARTMENT TECHNICAL MANUAL

*U.S. Dept. of Army*



## ENGINE, MARINE GASOLINE, CHRIS-CRAFT MODELS K, KR, AND KB

*note pos*  
NOTE. This is a reprint of undated TM 55-1100, Instruction Book and Parts List for Chris-Craft Marine Motors. No distribution will be made to personnel possessing the original publication.

WAR DEPARTMENT • 12 APRIL 1944



WAR DEPARTMENT TECHNICAL MANUAL  
TM 55-1100

---

ENGINE, MARINE  
GASOLINE, CHRIS-CRAFT  
MODELS K, KR, AND KB

---



WAR DEPARTMENT

• 12 APRIL 1944

---

*United States Government Printing Office*

*Washington : 1945*

*[Faint, illegible handwritten text]*

W113  
12

TM 55-1100  
1944



WAR DEPARTMENT,  
WASHINGTON 25, D. C., 12 April 1944.

TM 55-1100, Engine, Marine, Gasoline, Chris-Craft, Models K, KR, and KB, is published for the information and guidance of all concerned.

[A. G. 300.7 (12 Apr 44).]

BY ORDER OF THE SECRETARY OF WAR:

G. C. MARSHALL,  
*Chief of Staff.*

OFFICIAL:

J. A. ULIO,  
*Major General,  
The Adjutant General.*

M558650

## BREAKING IN A NEW ENGINE

The first few hours of operation has a great deal to do with the successful performance of an engine. An engine that is properly broken in will give much longer satisfactory service. Before leaving the Chris-Craft factory your motor has been properly run-in and block tested for continuous speeds up to three-quarter throttle. No further running-in on the part of the owner is necessary, except that no new engine should be run at wide open throttle during the first ten hours. It is recommended that a pint of good engine oil be added to each five gallons of gasoline for the first few hours of running. Be sure to mix it thoroughly before putting it into the gasoline tank.

During the entire life of the engine always run the engine at medium speed for a few minutes to allow the oil to warm up before running at sustained high speed.

## LUBRICATION

The capacity of the engine lubricating system should be governed entirely by the marking on the bayonet dip gauge because the angle of the engine in the boat determines the amount of oil to use. The quantity will vary from 6 quarts in the dual cockpit forward to 10 quarts in the other runabouts and cruisers. The oil should be changed after the first ten or fifteen hours of running of the motor and thereafter every forty to fifty hours.

## TO CHANGE OIL

To drain the oil use the piece of copper tubing with fitting that will be found in the tool kit. Unscrew the oil pressure gauge line from the fitting where it goes into the engine on the side of the cylinder block behind the ignition coil. Put the end of this tube in a pail and idle the engine slowly which will pump all of the oil out of the crankcase. Do not speed up the engine and watch it closely and stop the engine as soon as the oil stops running out of the tube.

## RECOMMENDED LUBRICANT

We are, of course, primarily interested in seeing that every Chris-Craft is serviced with good oil of character and quality, because of the use of such an oil means not only dollars in the owner's pocket, but smooth engine operation, freedom from trouble, and maximum engine performance. A marine engine works at maximum capacity virtually 90 per cent of its lifetime, whereas in an automobile, the engine rarely, if ever, works at the maximum more than 10 per cent or 15 per cent of its life time. Hence the demands on the oil are far greater in a marine engine.

For the engine in all Chris-Craft boats we recommend a high quality marine engine oil, the proper grade of which will be found stamped on the hull number plate attached to the engine room hatch covers and on the Chris-Craft engine it is a part of the engine number plate attached to the exhaust manifold.

Unless the oil you obtain is clean, pure, low in free carbon and free from emulsion-forming proclivities, it cannot be said to be equal to Chris-Craft standards. Very few people, unless they have expert an knowledge of oil can correctly interpret specifications, and there is no way of checking up the

K

specification of an oil offered you without laboratory analysis. We, therefore, urge you to take particular pains to see that the oil supplied you is equal to the high standards of quality of the engine in your boat. There is nothing as important to engine operation and life as the correct oil, and to a large extent the satisfactory performance of your boat and the happiness you will receive from it are dependent on the character of the oil used.

See that the grease cups on the water pump are full of Kasson Grease. Turn them one turn every eight to ten hours of running.

Put three drops of light engine oil in the oil cup on each end of the generator, the one on the end of the starting motor, and the one on the distributor every time you change the oil in the engine. Once a season remove the distributor cap and put a piece of vasoline the size of a match head on the head of the cam. (The cam is the six sided part on the end of the shaft.)

There are no other lubrication operations required on the engine.

### General Care of the Electrical Equipment

Most important in the care of the electrical equipment is the keeping of all connections not only clean and tight mechanically, but free from all corrosion. Brass or copper connections in a boat operated around salt water are especially subject to corrosion and they should be taken apart two or three times a year, cleaned with fine sandpaper, given a light coating of vaseline and reconnected, being sure they are tight.

Battery terminals should be given special attention and much trouble and annoyance can be avoided if they are periodically taken apart and washed in a strong ammonia or soda solution, given a light coating of vaseline and reassembled, being sure they are tight.

### Generator

The generator output should never be set above the maximum output as noted on the nameplate. All wiring and connections should be tight and the proper size as high resistance in the charging circuit will cause an over voltage that materially shortens the life of lamps or other electrical equipment. The owner should not attempt to repair or adjust the circuit breaker or regulator as these operations should only be handled by an Official Service Station who

is equipped with the proper tools and information to correctly repair these units.

### **Starting Motor**

The starting motor requires no special attention except to see that it is mounted securely and that the Bendix is free from dirt. There should be no voltage loss in the starting circuit and switch as a reduced voltage reduces the cranking power of the motor.

### **Distributor**

The distributor should be kept free from dirt and properly lubricated. The drain hole in the bottom of the housing should be kept open. Breaker point rubbing blocks are run in at the factory and can be set to the proper maximum gap of .020 inch without any run in period. If the points in use show a grayish color, are only slightly pitted and are within .002 inch of the proper maximum gap they need not be replaced or adjusted. However, before adjusting the points they should first be refaced so as to have a smooth flat contact with each other.

The ignition coil is sealed against moisture and needs no attention except to see that the connections are tight.

### **Lubrication**

Every 40 hours of engine use the following points should be lubricated with a medium engine oil:

1. The oilers in each end of the generator should be given 3 to 5 drops.
2. The commutator end oiler and the intermediate oiler in the starting motor should be given 3 drops.
3. The oiler on the outside of the distributor housing should be given 3 to 5 drops.

Every season the distributor cap and rotor should be removed and one drop of light oil put on the breaker arm hinge pin, a light wipe of grease on the cam and a few drops of light oil added to the hole in the top of the distributor drive shaft.

## REVERSE GEAR

### Adjustments

It is necessary that your reverse gear be properly adjusted before you operate it. The forward drive is obtained by means of a multiple disc clutch. The locking or clamping of these discs is brought about by the pressure produced by the outward movement of the fingers when the operating lever is thrown into the forward position. On the forward drive the whole reverse gear is locked together as a solid coupling. Unless the pressure on these discs is great enough to lock the whole gear together under full load, the clutch will slip and heat.

The reverse drive is obtained by clamping the brake band around the outside drum or case which carries the pinion gears. The reverse motion is obtained by driving through the gears. Unless the band is clamped tight enough to keep this gear cage from revolving, it will slip in the reverse position.

In neutral position, both discs and the brake band are free and the gears run idle.

### Adjustments for the Forward Drive—(See Page 16)

If the gear slips in the forward drive back out of the lock screw No. 76 until the end of it is clear of the hole in the pressure disc No. 11. Then turn the adjusting finger collar No. 28 to the right until the lock screw No. 76 is opposite one of the holes in the pressure disc No. 11.

Then tighten up the lock screw No. 76 and be sure that the end of screw enters the hole in the pressure disc No. 11. Repeat this procedure until the reverse gear holds on the forward drive. An adjustment of one or two holes is usually sufficient.

### Adjustment for the Reverse Drive—with Cam Clamping Mechanism

Throw the lever into the reverse position with the engine turning over slowly. Then tighten up the adjusting bolt No. 330 until the brake band clamps or grips the case or gear Cage No. 1 and holds it from revolving. It is well to screw up this adjusting bolt No. 330 a little tighter than is necessary. This will compensate for any wear on the brake band. The lock wire holds the adjusting bolt and keeps it from loosening.

### Adjustment for the Reverse Drive—with Toggle Clamping Mechanism

In the reverse position the brake band is supposed to grip and hold the gear cage or drum from turning. If this drum slips, it is necessary to tighten the adjustment of the brake band, which adjustment is made as follows:

Loosen the locknut No. 429 on the inside of the upright lug at the top of the brakeband to the amount you think the brake band needs adjusting. Then tighten the adjusting nut No. 431 on the outside of this lug until it is again tight against this lug. Repeat until the brake band grips the gear cage and keeps it from revolving.

The adjustment should be tight enough so that a decided snap is felt when the lever is thrown into the reverse position.

K

## Valves

It is not possible to put a final adjustment on the valves at the factory that will last for the entire season. After a few hours running the boat should be taken back to the dealer and the valves readjusted. Loss of engine speed and increase in gasoline consumption is the first indication of the need for grinding valves. An engine that is driven at sustained high speeds will need valve grinding much oftener than one used at normal speeds.

## Water Pump

Water leaks at the pump can be stopped by taking up on the packing glands. Tighten just enough to stop the leak and after they have been tightened a few times add more packing. If tightened too tight a scored water pump shaft will result.

## Breaker Points

Breaker point gap should be from .018" to .020". The surfaces of the contact points should be cleaned, free from rough pittings and grease. After 500 hours running of the boat it may be necessary to reface these contacts, or to install a new set. The same applies to spark plugs, in which the gap should be .035" and when the points become worn and corroded new plugs should be installed. It is important that only the correct type of plug be used in this motor. Replace only with the same type of plug which is in the motor when you get it.

To adjust the spark—Run the boat with the engine at about 2500 R.P.M. (2000 on Cruisers) and advance the spark until it starts to rattle. At this point speed will drop off, indicating detonation. Then retard it just enough to make the engine run smoothly without any rattle or spark knock. Then try it at full throttle and if there is any sign of spark knock, retard it just enough to make the engine run quietly. Make this adjustment with the gear in forward position. Do not attempt it with the gear in neutral.

## Carburetor

To adjust the carburetor for high speed—Screw the needle valve on the carburetor all the way in; then back it out about one and one-quarter turns. This should make it just a trifle too rich. Run the boat at full throttle and screw the needle valve in until the speed starts to drop off. (Watch the tachometer closely). Then unscrew it until the engine runs at highest speed. The approximate setting is about one full turn open. A too lean mixture will cause pre-ignition and it is better to run a little on the rich side.

## AVOID REVERSE GEAR ADJUSTMENT

It is not recommended that the boat be run at the dock with the reverse gear in the neutral position. Space here will not permit a detailed diagram on the construction and operation of a reverse gear but let it suffice to say that when the reverse gear is in the neutral position it compares to an automobile when the clutch pedal is pushed to the floor.

If you wish to warm up the engine at the dock put the nose of the boat

K

against the dock and put the lever in the go-ahead position and run the engine slowly.

If you are familiar with the operation of the reverse operation of the gear you will know that in reversing, the reverse band is clamped firmly to the clutch drum. Therefore, it is important that the reverse lever be pulled back firmly so that the band will not slip on the drum. Pull the lever back and hold it there as long as you want to reverse and control the speed by the throttle and not by allowing the band to slip.

### ENGINE ALIGNMENT

Many cases of excessive vibration, reverse or reduction gear noise, and loss of revolutions, are caused by engine misalignment. This alignment is checked by disconnecting the two halves of the shaft coupling just aft of the reverse or reduction gear. The faces of these flanges must be within .003 parallel in all directions. The engine is mounted on taper shims to facilitate this adjustment.

### ENGINE KNOCKS AND LOSS OF REVOLUTIONS

A sudden and otherwise inexplicable drop in revolutions, a new and disturbing period of vibration, and a sudden loss of speed without other apparent cause, are usually definite symptoms of propeller wheel disorders even though the propeller wheel itself looks to be undamaged.

Never attempt to judge the condition of a propeller from its appearance. Though undamaged to the naked eye it may show startling pitch discrepancies when subjected to careful measurements with proper instruments. It is not necessary to run aground or to become entangled with drift in order to throw a propeller out of pitch. Especially in the case of high-speed, high-power runabouts, loss of pitch will occur in the course of normal operation. A sudden turn at high speed, or bucking a heavy sea is often sufficient to submit one or more of the blades to a sudden shock or load beyond their normal ability to withstand, resulting in a propeller which, though not perceptibly damaged, is sufficiently "out of pitch" to account for several hundred lost R.P.M. on the tachometer or set up a serious vibration period.

Engine knocks are usually caused by faulty lubrication, and if you take proper care of the oiling of your motor you will probably never hear a knock.

Knocks which start suddenly and rapidly get louder are dangerous. Stop motor and investigate oil supply and water circulation, including water intake. Do not run a motor with a loose bearing.

Knocks which begin faintly and increase slowly if at all are not immediately dangerous, but should be investigated by a mechanic or your Chris-Craft dealer as soon as possible.

If you are caught offshore with a burned out rod bearing due to lack of oil in the crankcase and must run the motor in order to get to land, removing the spark plug in the bad cylinder is your best chance. Run slowly.

K

## MISFIRING

The most frequent causes of misfiring are as follows: (It is entirely unlikely that you will be troubled with any of these things, but it is well to know what to do in case of emergency): 1—Dirty or cracked plugs; remedy—install new ones or clean them. 2—Intermittent electric leak somewhere in the wiring; remedy—trace and insulate. 3—Stuck valve, or broken valve spring. Remove valve cover plate and inspect valve mechanism; remedy—new springs or grinding valves, or both. 4—Valve tappets too close. At high speed close-set tappets will ride the cams, prevent the valves from closing, and thus cause misfiring; remedy—adjust tappets to .008" to .012". 5—Breaker points out of adjustment; when a motor misses at low speeds only, inspect breaker points first. 6—Water in one or more cylinders due to blown gaskets or crack in water jacket. 7—Blown or leaky gaskets, either in manifold or cylinder head. 8—Loose spark plugs. 9—Too high oil level, causing sooty plugs.

## IMPORTANT NOTICE

Form the habit of watching the oil pressure gauge. This gauge is sometimes called the "watch dog" of the engine. Advance notice of serious trouble is nearly always given by the oil gauge. If the pressure suddenly drops off, stop the engine immediately and do not run it until the trouble is located and remedied. See if there is plenty of oil in the crankcase. An oil line may be broken or the gauge broken—Try a new gauge first. If the oil pressure suddenly goes too high look for a plugged oil line or the relief valve may be stuck. If the oil pressure falls off gradually, the oil may be worn out or diluted with gasoline. Do not change the oil pressure regulating valve to compensate for sudden changes in oil pressure or to compensate for the incorrect grade of oil.

## USEFUL INFORMATION

### Engine

Type—L-Head, vertical

Cylinders—6

Bore—3 7/16"

Stroke—4 1/8"

Brake Horsepower—

Model K, KR—95

Model KB—121

Piston Displacement—229.7 cu. in.

Compression Ratio—Model K, KR—7.3

Weight—

Direct Drive—626 lbs.

Reduction Drive—710 lbs.

### Electrical System—6-volt

Generator—Auto-Lite, Model GEO-4807—Standard Rotation

Generator—Auto-Lite, Model GEO-4809—Opp. Rotation

K

Starter—Auto-Lite, Model MAJ-4046—Standard Rotation  
 Starter—Auto-Lite, Model MAJ-4048—Opp. Rotation  
 Distributor—Auto-Lite, Model IGW-4149-A  
 Coils—Auto-Lite, Model IG-4065  
 Battery—Willard—15-Plate - - 6-volt  
 Generator charging rate—18 to 20 amperes max.  
 Generator cuts in at—800 R.P.M.

#### Oiling System

5 pounds (minimum)—idling speed  
 20 to 30 pounds—maximum speed, hot

#### Carburetor—Zenith, 655½-M2

Venturi	- - -	No. 27	Idle Jet	- . -	No. 16
Main Jet	- - -	No. 28	Needle Valve Seat	-	No. 54
Comp. Jet	- - -	No. 26			

### SPECIFICATIONS AND ADJUSTMENTS

#### Valve Clearance—Engine Hot

Exhaust Valve—.010 to .012

Intake Valve—.008 to .010

#### Valve Seat—Exhaust 1¼"—Face of seat ⅛" wide

Intake—1⅜"—Face of seat 3/32" Wide

#### Valve Guide Clearance—

Exhaust—.0025 to .003

Intake—.001 to .0015

#### Push Rod—.001 to .0015

#### Idler Gear Clearance—.0005 to .0015 backlash

#### Camshaft bearing clearance—.001 to .002

#### Crankshaft main bearing clearance—.0015 to .003

#### Crankshaft thrust clearance—.002 to .004

#### Crank pin bearing clearance - end .005 to .010

Rod to Shaft—.001 to .003

#### Piston Clearance—at skirt .0035 to .004

#### Piston pin clearance—Hand push fit

#### Piston Ring Gap—.015 to .020

#### Piston Ring Side Clearance—.00075 to .0015

#### Distributor point gap—.022

#### Spark Plug—J-8

#### Spark Plug Gap—.035

### TO DRAIN THE WATER SYSTEM

Open drain cock on side of cylinder block behind the water pump. Remove plug at bottom of water pump and plug in water line tee in bottom of exhaust manifold.

# PARTS LIST

## CHRIS-CRAFT MARINE MOTOR

MODEL K, KR  
(FOR MODEL KB, SEE PAGE 19)

See Your Chris-Craft Dealer or write direct to Factory for Prices

Part No.	No. Reqd.	Name
<b>CYLINDER BLOCK and CRANKCASE</b>		
46520	1	Cylinder & Crankcase, with valve guides, camshaft bushings, idler gear bushings (3 7/16" bore)
42993	2	Front Main Bearing—Upper & Lower
46694	2	Center Main Bearing—Upper & Lower
46695	2	Rear Main Bearing—Upper & Lower
42295	8	Intermediate Main Bearing—Upper & Lower
40070	10	Main bearing cap screw - Front & Intermediate - 1/2" x 2"
40071	8	Main bearing cap screw - Center & Rear—7-16" x 2"
4731	10	Main bearing cap screw lockwasher - 1/2"
4732	8	Main bearing cap screw lockwasher - 7-16"
46105	As Req.	Main bearing shim - Center & Rear - .002
46101	12	Main bearing shim - Center & Rear - .003
40550	As Req.	Main bearing shim - Front & Intermediate - .002
40552	30	Main bearing shim - Front & Intermediate - .003
14398	1	Cylinder drain cock
2534	8	Cylinder block expansion plug - 1 1/4"—Brass
4139	4	Cylinder block expansion plug - 1" —Brass
7239	8	Expansion plug—1 1/2"—Brass
60	1	Oil passage pipe plug - 1/4"—Slotted
59	8	Oil passage pipe plug - 1/8"—Slotted
3201	1	Oil passage pipe plug - 1/4"—Special slotted
1702	1	Cylinder block water jacket plate—large
1713	1	Cylinder block water jacket plate gasket—large
1687	1	Cylinder block water jacket plate—small
1688	1	Cylinder block water jacket plate gasket—small
46028	4	Cylinder block valve compartment plug
3256	1	Set of Gaskets—Complete

### CONNECTING ROD

46390	6	Connecting rod - with bearing and bolts
46156	12	Connecting rod bolt
46157	12	Connecting rod bolt nut
H 301	12	Connecting rod bolt nut cotter pin (3/32" x 3/4")
46111	6	Connecting rod clamp screw (holds pin)
14842	6	Connecting rod clamp screw lockwasher
46154	36	Connecting rod shim .003
46167	As Req.	Connecting rod shim .002
46697	12	Connecting rod bearing—upper & lower

### PISTONS

Used After Block No. 723999 and Before Block No. 731167

46345	6	Piston—Aluminum—3 7/16" Dia.—Standard Rotation
46344	6	Piston—Aluminum—3 7/16" Dia.—Opp. Rotation
46022	6	Piston Pin
46346	6	Piston Ring—Compression—(Top Groove)
46347	12	Piston Ring—Compression—(Inter. Grooves)
46348	6	Piston Ring—Oil Regulating—(Bottom Groove)
3 Ring Piston Used After Block No. 731166		
46258	6	Piston—Aluminum—3 7/16" Dia.—Standard Rotation

K

Part No.	No. Reqd.	Name
46259	6	Piston—Aluminum—3 7/16" Dia.—Opposite Rotation
46349A	12	Piston Ring—Compression—Top and Intermediate
46348	6	Piston Ring—Oil Regulating—Bottom

NOTE: Pistons and rings are supplied in the following oversizes—.005, .010 and .020. Piston pin supplied in .003 and .005 oversizes on orders for sizes other than specified above an additional 25 pct. will be added.

### CRANKSHAFT

46828	1	Crankshaft
40076	1	Crankshaft Oil Thrower
46039	1	Crankshaft Gear—Standard
46040	1	Crankshaft Gear—Opp. Rotation
4265	4	Crankshaft Gear Key

### VALVES

46121	6	Intake Valve
46123	6	Exhaust Valve
46043	12	Valve Spring
27011	12	Valve Guide
46013	12	Valve Spring Seat
46011	24	Valve Spring Seat Lock
46007	1	Valve Cover—Aft
1694	1	Valve Cover—Forward—With Fume Tube—Standard Rotation
4337	4	Valve Cover Screw— $\frac{3}{8}$ -16 x 2
46008	2	Valve Cover Gasket
46028	4	Valve Compartment Plug

### VALVE TAPPET

27317 S	12	Valve Tappet Assembly
46019	12	Valve Tappet Adjusting Screw
14974	12	Valve Tappet Screw Nut—Hardened
46089	12	Valve Tappet Guide

### CYLINDER HEAD

1962	1	Cylinder Head—Cast Iron—( 95 H.P.)
2033	1	Cylinder Head—Cast Iron—(121 H.P.)
46363	1	Cylinder Head Gasket
1832	22	Cylinder Head Stud
1841	2	Cylinder Head Stud—Tapped for Conduit
	24	Cylinder Head Stud Nut— $\frac{1}{2}$ "—20
	24	Cylinder Head Stud Plain Washer (Hardened)
4139	3	Cylinder Head Expansion Plug—( $1\frac{1}{8}$ ")
	1	Cylinder Head Temperature Gauge Plug— $\frac{1}{4}$ "

### SUPPORT BRACKETS

1613	1	Engine Front Support Bracket (Does not include rubber mounting)
1625	1	Engine Front Support Bracket to Cylinder Gasket
1624	1	Engine Rear Support Bracket
1627	1	Engine Rear Support Bracket Gasket
1777	2	Engine Rear Support Bracket Dowel Bushing
1674	4	Engine Support Bracket (On Keelson)
1430	4	Engine Rubber Mounting

Part No.	No. Reqd.	Name
<b>CAMSHAFT</b>		
46814	1	Camshaft—With Plunger—Standard
46816	1	Camshaft—With Plunger—Opp. Rotation
46041	2	Camshaft Bearing—Front & Rear
46044	2	Camshaft Bearing—Center
46049	1	Camshaft Gear—Standard
46050	1	Camshaft Gear—Opp. Rotation
4265	1	Camshaft Gear Key
46045	1	Camshaft Thrust Washer
40068	1	Camshaft Thrust Plunger
14956 S	1	Camshaft Thrust Adj. Screw Assembly
<b>IDLER GEAR</b>		
46138	1	Idler Gear—Standard Rotation
46141	1	Idler Gear—Opp. Rotation
46139	1	Idler Gear Shaft—With Plunger
22107	1	Idler Gear Thrust Washer
46140	1	Idler Gear Shaft Bearing
40068	1	Idler Gear Shaft Plunger
14956 S	1	Idler Gear Thrust Adj. Screw Assembly
<b>ACCESSORY DRIVE</b>		
46072 S	1	Accessory Drive Assembly—Standard Rotation
46078 S	1	Accessory Drive Assembly—Opp. Rotation
46195	1	Accessory Drive Gear—Standard
46077	1	Accessory Drive Gear—Opp. Rotation
4413	1	Accessory Drive Gear Key
27072	1	Accessory Drive Shaft
27257	1	Accessory Drive Bushing
46170	1	Accessory Drive Attaching Gasket
1864	1	Accessory Drive Attaching Screw— $\frac{3}{8}$ " x 1"
H 682	2	Accessory Drive Attaching Screw— $\frac{3}{8}$ " x $2\frac{1}{4}$ "
H 342	3	Accessory Drive Attaching Screw Lockwasher— $\frac{3}{8}$ "
40068	1	Accessory Drive Thrust Plunger
4024	1	Accessory Drive Thrust Washer
1809	1	Accessory Drive Housing
22336	1	Accessory Drive Distributor Driving Gear—Standard
27073	1	Accessory Drive Distributor Driving Gear—Opp. Rotation
H 1179	1	Accessory Drive Distributor Driving Gear Key
H 300	1	Accessory Drive Distributor Clamp Nut
8051	1	Accessory Drive Distributor Clamp Screw
<b>FLYWHEEL</b>		
1900	1	Flywheel—With Ring Gear—Standard Rotation
1901	1	Flywheel—With Ring Gear—Opp. Rotation
1707	2	Flywheel Dowel
22104	4	Flywheel Bolt
1609	4	Flywheel Bolt Nut
1562	1	Flywheel Ring Gear—Standard Rotation
1563	1	Flywheel Ring Gear—Opp. Rotation
1434	1	Starting Crank—Cruiser (Long)
1488	1	Starting Crank—Runabout (Short)
<b>OIL PAN</b>		
1612	1	Oil Pan
1626	2	Oil Pan Gaskets
2011	1	Oil Strainer Body and Screen
1639	1	Oil Strainer to Pump Flexible Tube Assembly
	1	Tube Elbow Fitting— $\frac{3}{4}$ -16; $\frac{3}{8}$ " Female Pipe Thread
	1	Oil Drain Plug— $\frac{1}{2}$ " Square Head

Part No.	No. Reqd.	Name
<b>OIL FILLER</b>		
1611	1	Oil Filler Plate and Filler Spout
1660	1	Oil Filler Cap & Test Rod Assembly (Mark as Required)
1610	1	Oil Filler Gasket
<b>OIL PUMP</b>		
45268	1	Oil Pump Assembly—Standard Rotation
23156	1	Oil Pump Assembly—Opp. Rotation
		NOTE: For engine with oil cooler pump cover 1642 is used and oil passage in pump is to be plugged. Without oil cooler use cover 1616.
22153	1	Oil Pump Body
1616	1	Oil Pump Cover—Without Oil Cooler (See note)
1642	1	Oil Pump Cover—With Oil Cooler Standard (See Note)
4387	2	Oil Pump Snap Ring
	4	Oil Pump Cover Screw— $\frac{1}{4}$ "-20x $\frac{7}{8}$ "
	2	Oil Pump Cover Screw— $\frac{1}{4}$ "-20x $\frac{5}{8}$ "
22154	2	Oil Pump Gear
H 1179	2	Oil Pump Gear Key
22124	1	Oil Pump Drive Shaft
45266	1	Oil Pump Drive Gear—Standard Rotation
45275	1	Oil Pump Drive Gear—Opp. Rotation
2047	1	Oil Pump Drive Gear Thrust Washer
4809	1	Oil Pump Drive Gear Pin—5/32 x 1 1/16
22155	1	Oil Pump Idler Shaft
22119	1	Oil Pump Attaching Gasket
H 1864	3	Oil Pump Attaching Screw— $\frac{3}{8}$ " x 1"
H 342	3	Oil Pump Attaching Screw Lockwasher— $\frac{3}{8}$ "
1551	1	Oil Line—Pump to Crankcase (Cooler only)
<b>OIL PRESSURE REGULATING PARTS</b>		
22129	1	Oil Pressure Regulating Piston
H 1347	1	Oil Pressure Regulating Spring
H 1385	1	Oil Pressure Regulating Spring Cap
H 2058	1	Oil Pressure Regulating Adj. Screw
H 1660	1	Oil Pressure Regulating Adj. Screw Nut
H 28	1	Oil Pressure Regulating Adj. Screw Lock Nut
<b>MANIFOLD</b>		
1718	1	Exhaust & Intake Manifold
1722	1	Exhaust & Intake Manifold Gasket
1406	6	Manifold Stud—Short
1661	2	Manifold Stud—Long—Used after engine 5100
	8	Manifold Stud Nut—7/16"—20 Hex.
	8	Manifold Stud Lockwasher—7/16"
1602	1	Manifold End Cover
1603	1	Manifold End Cover Gasket
	4	Manifold End Cover Screw— $\frac{3}{8}$ "-16 x 1"
	4	Manifold End Cover Lockwasher— $\frac{3}{8}$ "
3198	1	Manifold Drain Plug— $\frac{1}{2}$ " Pipe Hex Hd. Brass
<b>EXHAUST ELBOWS</b>		
1643	1	Exhaust Elbow—Vertical (18', 21' Utility—23 $\frac{1}{2}$ ', 25' Cruiser)
1644	1	Exhaust Elbow—Horizontal (28', 31' Cruisers Single Screw)
1683	1	Exhaust Elbow—Cruiser—twin screw—Standard
1644	1	Exhaust Elbow—Cruiser—twin screw—Opp. Rotation
1645	1	Exhaust Elbow—45 Degrees (Runabouts - 16' Utility)
1603	1	Exhaust Elbow Gasket
1748	1	Exhaust Pipe Flange—for 2 $\frac{1}{2}$ " Standard Iron Pipe

Part No.	No. Reqd.	Name
<b>LIFTING EYE</b>		
1662	1	Engine Lifting Eye
	1	Engine Lifting Eye-Lockwasher—9/16"
<b>CARBURETOR</b>		
(Order detail parts direct from manufacturer)		
3206	1	Carburetor Assembly—Zenith 63M2AWE-11—O-8983
1458	1	Carburetor Gasket
1821	2	Carburetor Stud
1539	1	Carburetor Flame Arrester—Zenith B-1807
C-182-313	1	Carburetor Repair Kit
<b>ELECTRICAL EQUIPMENT</b>		
1540	1	Generator—Auto-Lite—GEO-4807—Standard Rotation
1552	1	Generator—Auto-Lite—GEO-4809—Opposite Rotation
(Order detail parts direct from manufacturer)		
1711	1	Generator Retaining Screw
2003	1	Generator Pulley
1570	1	Generator Belt—2MO-37
1542	1	Starting Motor—Auto-Lite MAJ-4046—Standard Rotation
1553	1	Starting Motor—Auto-Lite MAJ-4048—Opposite Rotation
(Order detail parts direct from manufacturer)		
3234	1	Distributor Assy—Autolite—IGW-4149-A—Standard Rotation
3236	1	Distributor Assy—Autolite—IGW-4149-A—Opposite Rotation
(Order detail parts direct from manufacturer)		
22335	1	Distributor Driven Gear—Standard Rotation
27335	1	Distributor Driven Gear—Opposite Rotation
1530	1	Tachometer Fitting
	1	Tachometer Fitting Set Screw— $\frac{1}{4}$ "—20x $\frac{5}{8}$ " Cup Point
1410	1	Distributor Shaft Packing Gland
	As Req'd.	Distributor Shaft Packing Gland Washer
1469	1	Ignition Coil—Auto-Lite IG-4065
1861	1	Ignition Cable—Dist. to Coil—High Tension
1665	1	Ignition Cable—Dist. to Coil—Low Tension
1650	3	Ignition Cable—Dist. to Spark Plugs—Short
1651	3	Ignition Cable—Dist. to Spark Plugs—Long
	6	Spark Plugs—Champion—J-8—K, KR
1833	1	Ignition Wire Conduit
1838	2	Ignition Wire Conduit Spacer
1869	14	Ignition Wire Conduit Grommet
<b>WATER PUMP</b>		
1640	1	Water Pump Assy.—Standard Rotation
1667	1	Water Pump Assy.—Opp. Rotation
1544	2	Water Pump Gear—Herringbone (Sold in Pairs Only)
1545	1	Water Pump Drive Shaft—Standard Rotation
1569	1	Water Pump Drive Shaft—Opposite Rotation
1546	1	Water Pump Idler Shaft

Part No.	No. Reqd.	Name
7242	1	Water Pump to Manifold Hose $\frac{3}{4}$ " x 16 $\frac{1}{2}$ "
	2	Water Pump to Manifold Hose Clamp— $\frac{3}{4}$ "
1671	2	Water Pump to Manifold Hose Nipple— $\frac{1}{2}$ " x 2"
	1	Manifold Tee— $\frac{1}{2}$ "
	1	Manifold Tee Nipple— $\frac{1}{2}$ " x 1"
	3	Water Pump Inlet & Outlet Street Ell— $\frac{1}{2}$ "
1671	1	Water Pump Inlet Hose Nipple— $\frac{1}{2}$ " x 2"
1646	1	Cylinder Head Outlet Water Tube—Single Screw
1684	1	Cylinder Head Outlet Water Tube—Twin Screw Opposite Rotation
	1	Cylinder Head Outlet Water Tube Ell— $\frac{3}{4}$ " Tube; $\frac{1}{2}$ " Thread
1652	1	Cylinder Head Outlet Water Tube Elbow Gland
	1	Gland Asbestos Packing
3466	1	Water Pump Coupling and Pin

**FUEL PUMP**

(Order detail parts direct from manufacturer)

1461	1	Fuel Pump Assy—Complete with Filter—AC-1523050
1462	1	Fuel Pump Gasket
1663	1	Fuel Pump to Carburetor Line—With Fittings
	1	Fuel Line Fitting— $\frac{1}{4}$ " Line $\frac{1}{8}$ " thread; straight
3250	1	Fuel Pump Repair Kit—AC-1538121

**OIL COOLER**

1548	1	Oil Cooler
1755	1	Oil Cooler Bracket
3254	2	Oil Cooler Gasket
	2	Oil Cooler Bracket Screw— $\frac{3}{8}$ "—16 x 2 $\frac{3}{4}$ "
1551	1	Oil Pump to Connection Tube with Fittings
	1	Oil Pump to Connection Tube Ell— $\frac{7}{16}$ " Tube; $\frac{1}{4}$ " Pipe Thread
	1	Oil Pump to Connection Tube Double Union— $\frac{7}{16}$ " Tube
1818	1	Oil Cooler to Crankcase Tube
	1	Oil Cooler to Crankcase Tube Straight Connector— $\frac{1}{4}$ " Thread; $\frac{7}{16}$ " Tube
1819	1	Crankcase to Oil Cooler Tube
1664	1	Oil Cooler to Crankcase Tee—Special
	4	Hose Clamps— $\frac{3}{4}$ "
7242	1	Water Hose—Pump to Cooler— $\frac{3}{4}$ " x 7"
	1	Water Hose—Cooler to Manifold— $\frac{3}{4}$ " x 10"

**REVERSE GEAR—DIRECT DRIVE (1XE-90)**

1XE-4Q	1	Engine Gear
1635	1	Engine Gear Retaining Screw 1— $\frac{1}{2}$ " Lockwasher 1—No. 127 Woodruff Key
1XE-402	1	Pilot Roller Bearing
1XE-1A	1	Gear Cage or Drum
1XE-372	1	Gear Cage Front Bushing
1XE-401	1	Gear Cage Rear Ball Bearing
1XE-8	4	Pinion Stud
1XE-5	2	Pinion Gear—Short—With Bushing
1XE-5A	2	Pinion Gear—Long—With Bushing
1XE-7A	6	Pinion Gear Bushing
1XE-3B	1	Propeller Gear
1XE-47B	1	Disc Driver
1XE-10	3	Friction Disc—Inside

Part No.	No. Reqd.	Name
1XE-37	4	Friction Disc—Outside—Bronze
1XE-11	1	Finger Pressure Disc
1XE-28	1	Adjusting Finger Collar
2XE-76	1	Clutch Adjusting Lock Screw
1XE-21	3	Clutch Throwout Finger Assembly

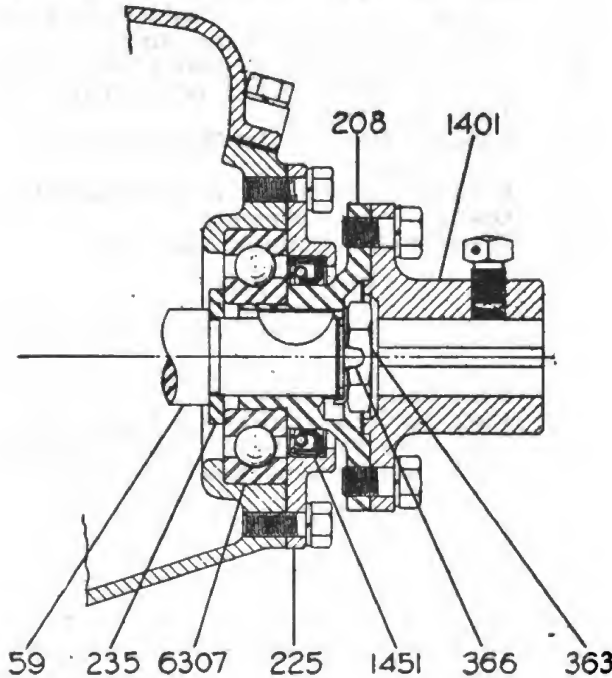

**REVERSE GEAR REAR END  
Direct Drive**

Numbers shown are key numbers only.  
Refer to parts list for complete part number

2XE-60B	1	Operating Sleeve—With Ball Bearing Collar
X-111D	1	Clutch Throwout Yoke
1XE-65	1	Clutch Throwout Yoke Shaft
1XE-24	1	Clutch Throwout Hand Lever
1XE-19	1	Reverse Brake Band
1XE-288	1	Reverse Brake Band Support
1XE-26A	1	Reverse Brake Band Locking Bar
X-330	1	Reverse Brake Band Adjusting Bolt—With Spring
1XE-59M	1	Reverse Gear Stub Shaft (For Shaft Flange)
1XE-235	1	Propeller Shaft Coupling Thrust Washer
1450	1	Thrust Bearing—S.K.F. No. 6307
1451	1	Housing Rear Oil Seal—Rawhide
RDA-225	1	Housing Rear Oil Seal Retainer
1416	1	Housing Rear Oil Seal Retainer Gasket
1452	1	Housing Operating Shaft Oil Seal—Rawhide
1615	1	Reverse Gear Housing
1621	1	Reverse Gear Housing Gasket
1386	1	Reverse Gear Housing Top Cover
1413	1	Reverse Gear Housing Top Cover Gasket
1XE-208	1	Propeller Shaft Flange—Engine Half
2XE-363	1	Propeller Shaft Nut
XS-366	1	Propeller Shaft Nut Washer
1401	1	Propeller Shaft Flange—Shaft Half

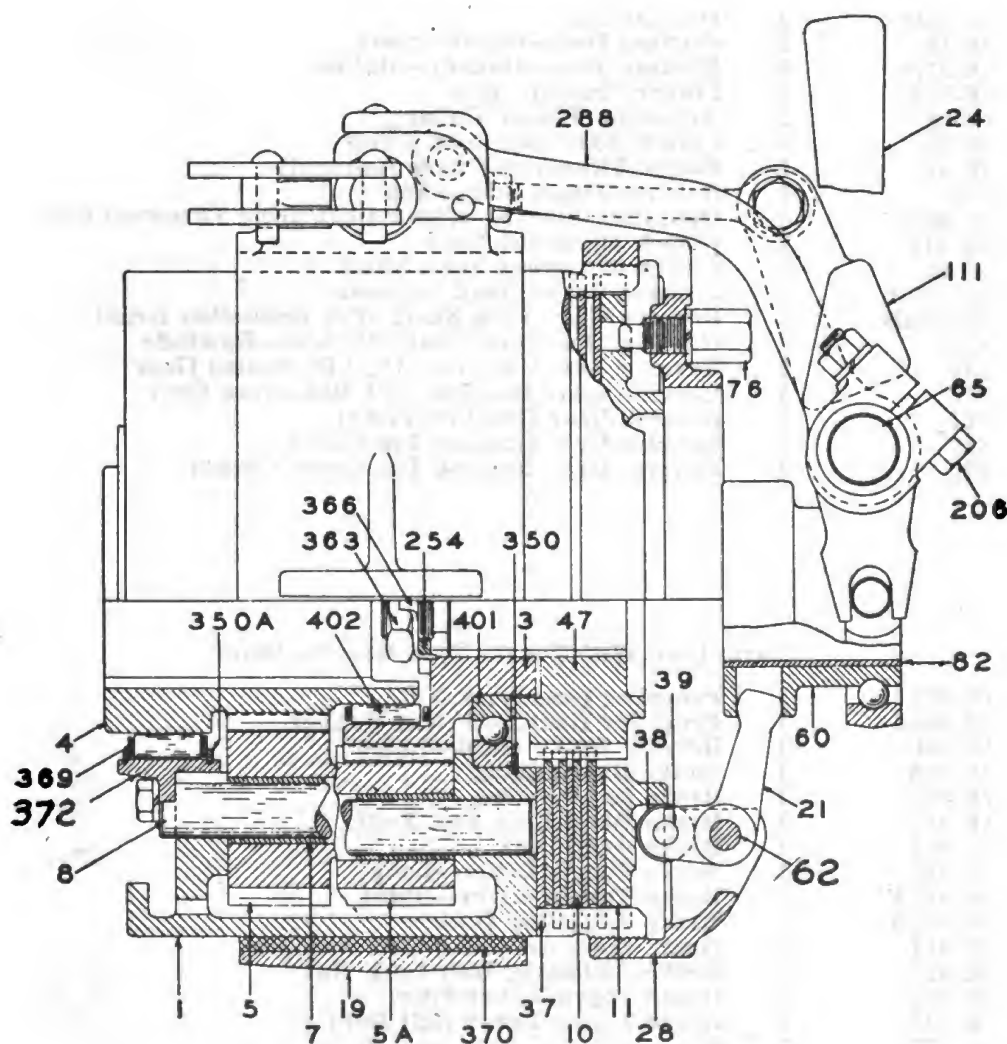
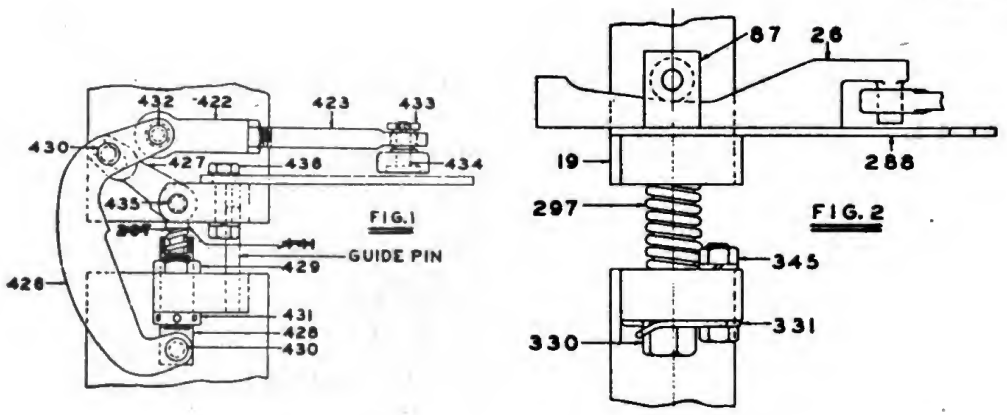

**REVERSE GEAR**

Numbers shown are key numbers only  
 Refer to parts list for complete part number

K

Part No.	No. Reqd.	Name
<b>REVERSE GEAR—REDUCTION DRIVE (2XE-90)</b>		
2XE-4 L	1	Engine Gear
1636	1	Engine Gear Retaining Screw
	1	½" Lockwasher
	1	No. 127 Woodruff Key
2XE-402	1	Pilot Roller Bearing
2XE-1A	1	Gear Cage or Drum—With Bushing
2XE-372	1	Gear Cage Front Bushing
RDB-350A	2	Gear Cage Front Bearing Ring
2XE-401	1	Gear Cage Rear Ball Bearing
2XE-8B	4	Pinion Stud
2XE-5D	2	Pinion Gear—Short—With Bushing
2XE-5C	2	Pinion Gear—Long—With Bushing
2XE-7H	6	Pinion Gear Bushing
2XE-3B	1	Propeller Gear
2XE-47B	1	Disc Driver
2XE-10	3	Friction Disc—Inside—Steel
2XE-37A	4	Friction Disc—Outside—Bronze
2XE-11A	1	Finger Pressure Disc
2XE-28	1	Adjusting Finger Collar
2XE-76	1	Clutch Adjusting Lock Screw
2XE-21	3	Clutch Throwout Finger Assembly
4X-62	3	Reverse Finger Hinge Pin
2XE-60B	1	Operating Sleeve—With Ball Bearing Throwout Collar
3XA-111	1	Clutch Throwout Yoke
3XA-65	2	Clutch Throwout Yoke Shaft
2XE-288A	1	Reverse Brake Band Support
2XE-59AB	1	Reverse Gear Stub Shaft (For Reduction Gear)
1452	1	Housing Operating Shaft Oil Seal—Rawhide
2449	1	Reverse Gear Housing—1½:1 Reduction Gear
2279	1	Reverse Gear Housing—2:1 Reduction Gear
1621	1	Reverse Gear Housing Gasket
1619	1	Reverse Gear Housing Top Cover
1620	1	Reverse Gear Housing Top Cover Gasket

#### Parts Used With Toggle Type Reverse Band

2XE-363	1	Propeller Gear Lock Nut
2XE-366A	1	Propeller Gear Lock Nut Washer
2XE-19C	1	Reverse Brake Band—Lined
2XE-370	1	Brake Band Lining
3XE-297	1	Brake Band Spring
3XE-422	1	Brake Band Link End Yoke
3XE-423	1	Brake Band Link
3XE-426	1	Brake Toggle Lever—Long
3XE-427A	1	Brake Toggle Lever—Short
3XE-428A	1	Brake Adjusting Bolt
3XE-431	1	Brake Long Adjusting Bolt Adj. Nut
3XE-429	1	Brake Adjusting Bolt Lock Nut
3XE-430	2	Brake Toggle Lever Pins
3XE-432	1	Brake Toggle Lever Ball Joint
3XE-433	1	Brake Reverse Yoke Ball Joint
3XE-434	1	Brake Reverse Yoke Ball Joint Screw
3XE-435	1	Brake Short Toggle Lever Pin
3XE-436	1	Brake Band Brace Screw
3XE-441	1	Brake Band Spring Plunger

Part No.	No. Reqd.	Name
----------	-----------	------

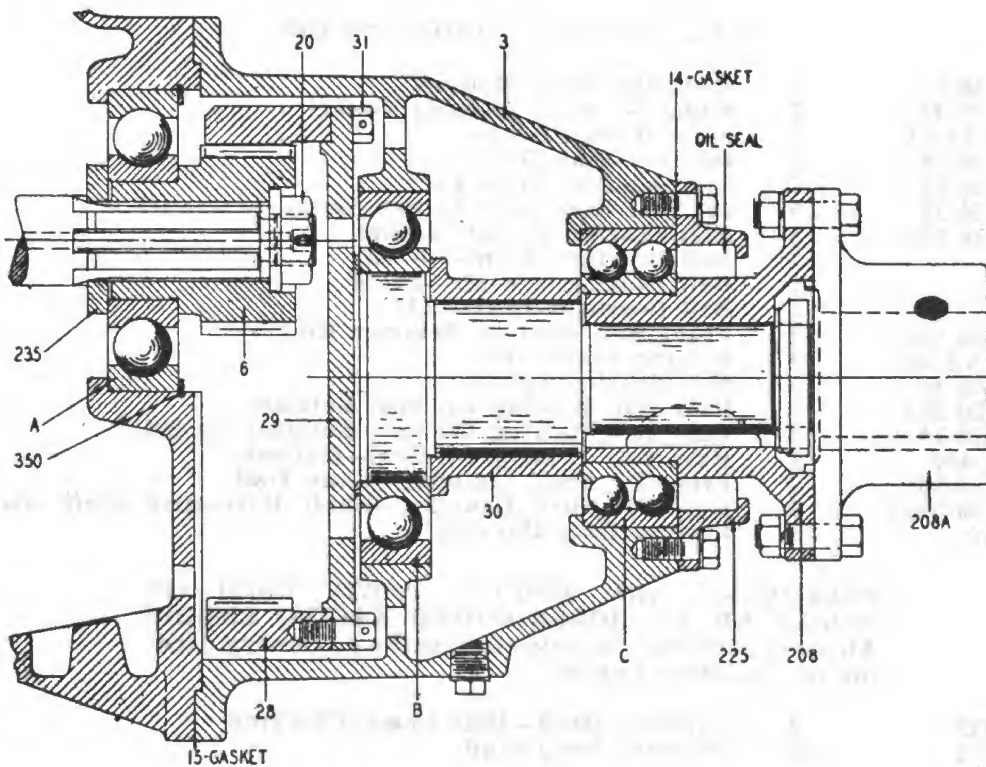

### REDUCTION GEAR—KR and KS

Numbers shown are key numbers only  
Refer to parts list for complete part number

#### REDUCTION GEAR—KR

##### RA20—2 to 1—SINGLE STAGE

RA20-3	1	Reduction Gear Housing
RA20-15	1	Reduction Gear Housing Gasket
RA20-6	1	Main Drive Pinion
RA20-28	1	Internal Ring Gear
RA20-29	1	Internal Ring Gear Flange
RA20-31	8	Internal Ring Gear Flange Screw
RA20-235	1	Ball Bearing Thrust Washer
A	1	Ball Bearing—Front—407-W
B	1	Ball Bearing—Center—310-W
C	1	Ball Bearing—Rear—5211
RA20-350	1	Front Ball Bearing Retainer Ring
RDAA-20	1	Driving Pinion Nut
RA20-30	1	Ball Bearing Spacer
RA20-225	1	Rear Ball Bearing Oil Seal Retainer
RA20-14	1	Rear Ball Bearing Oil Seal Retainer Gasket
RA-446	1	Rear Ball Bearing Oil Seal—Garlock
RA20-208	1	Propeller Shaft Coupling—Gear Half
RA20-208A	1	Propeller Shaft Coupling—Shaft Half—give shaft size
2279	1	Reverse Gear Housing

K

Part No.	No. Reqd.	Name
<b>REDUCTION GEAR—KS</b>		
<b>RA-15—1½ to 1—SINGLE STAGE</b>		
RA20-3	1	Reduction Gear Housing
RA20-15	1	Reduction Gear Housing Gasket
RA-15-6A	1	Main Drive Pinion
RA20-28	1	Internal Ring Gear
RA20-29	1	Internal Ring Gear Flange
RA20-31	8	Internal Ring Gear Flange Screw
RA20-235	1	Ball Bearing Thrust Washer
A	1	Ball Bearing—Front—407-W
B	1	Ball Bearing—Center—310-W
C	1	Ball Bearing—Rear—5211
RA20-350	1	Front Ball Bearing Retainer Ring
RDAA-20	1	Driving Pinion Nut
RA20-30	1	Ball Bearing Spacer
RA20-225	1	Rear Ball Bearing Oil Seal Retainer
RA20-14	1	Rear Ball Bearing Oil Seal Retainer Gasket
RA-446	1	Rear Ball Bearing Oil Seal—Garlock
RA20-208	1	Propeller Shaft Coupling—Gear Half
RA20-208A	1	Propeller Shaft Coupling—Shaft Half—give shaft size
2279	1	Reverse Gear Housing

**FOLLOWING ARE SPECIAL PARTS USED ON MODEL KB, 121 HORSE POWER RACING ENGINE**  
All other parts may be ordered from the preceding pages for the Standard Engine.

2033	1	Cylinder Head—High Comp. Cast Iron
1832	20	Cylinder Head Stud
1841	2	Cylinder Head Stud—Special
1738	2	Cylinder Head Stud—Special
1826	1	Cylinder Head Water Outlet Fitting
1827	1	Cylinder Head Water Outlet Fitting Gasket
1902	1	Flywheel—With Ring Gear
1823	1	Camshaft
1891	1	Fume Tube
1822	1	Exhaust Manifold
1825	1	Exhaust Manifold Gasket
1829	6	Exhaust Manifold Stud—Short
1830	2	Exhaust Manifold Stud—Long
1734	1	Exhaust Manifold End Cover
1741	1	Exhaust Manifold End Cover Gasket
1824	3	Carb. to Exhaust Manifold Elbow—(Specify Position & Elbow Required)
1774	1	Exhaust Elbow—Vertical—Utility Boat
1775	1	Exhaust Elbow—45 Degree—Runabout Boat
1899	1	Exhaust Pipe Packing Gland
1571	3	Carburetors (Zenith 20-BV-12-8351)
1789	3	Carburetors Gaskets
1572	3	Flame Arrester (Zenith B-1856)
1831	3	Throttle Control Bracket
	1	Throttle Control Shaft—¾ x 18 Brass Rod
	4	Throttle Control Shaft Lever (Zenith D-2880)
	4	Throttle Control Shaft Lever Screw (Zenith D-603)
	3	Throttle Control Link—¼ x 6½" Brass Rod—Threaded
7573	6	Throttle Rod Ball Joint
	6	Spark Plugs—Champion J-8 (Iron Head Only) (with .035 gap)





