

DOC.
W 1.35:
8-632

Ref

BOOKSTACKS-
DOCUMENTS

TM 8-632

WAR DEPARTMENT TECHNICAL MANUAL

THE LIBRARY OF THE

MAR 1 1945

UNIVERSITY OF ILLINOIS

X-RAY FIELD UNIT,
MACHINE,
CHASSIS AND TABLE
ITEMS 9608508,
9608510, 9609005,
9609010, 9614500

LIBRARY U. OF I. URBANA-CHAMPAIGN

UNIVERSITY OF ILLINOIS-URBANA



3 0112 104503419

WAR DEPARTMENT • FEBRUARY 1945

Original from

UNIVERSITY OF ILLINOIS AT
URBANA-CHAMPAIGN

**Government Document
Book Stacks**

X-RAY FIELD UNIT,
MACHINE,
CHASSIS AND TABLE
ITEMS 9608508,
9608510, 9609005,
9609010, 9614500



WAR DEPARTMENT • FEBRUARY 1945

UNITED STATES GOVERNMENT PRINTING OFFICE

WASHINGTON: 1945

For Sale by the Superintendent of Documents, Washington 25, D. C.

LIBRARY U. OF I. URBANA-CHAMPAIGN

WAR DEPARTMENT

WASHINGTON 25, D. C., 1 February 1945

TM 8-632, X-ray Field Unit, Machine, Chassis and Table, Items 9608508, 9608510, 9609005, 9609010, 9614500, is published for the information and guidance of all concerned.

[AG 300.7 (22 Nov 44)]

BY ORDER OF THE SECRETARY OF WAR:

OFFICIAL:

J. A. ULIO
Major General
The Adjutant General

G. C. MARSHALL
Chief of Staff

DISTRIBUTION:

AAF (5); AGF (5); ASF (2); T of Opns (10); Dept (10); Base C (5); S Div ASF (1); SvC (5); PE (2); ASF Dep (Med Sec) (10); Dep 8 (Cont) (25) except St. Louis Med Dep (75); GH (4); SH (2); Evac H (3); Conv H (2); Fld H Unit (2); Port Surg H (2); USMA (2); Lab 8 (Army) (1); Gen Lab 8 (1); A (2); CHQ (2); AF (5); T/O & E 8-187 (2); 8-510 (2); 8-550 (4); 8-560 (2); 8-527S (2); 8-580 (3); 8-581 (3); 8-590 (2); 8-610 (1); 8-611 (1); 8-667 (2)

For explanation of symbols, see FM 21-6.

CONTENTS

PART ONE. INTRODUCTION.

| <i>Section I.</i> | | <i>Paragraph</i> | <i>Page</i> |
|------------------------------------|------------------------|------------------|-------------|
| General. | | | |
| Scope | 1 | 1 | |
| Records | 2 | 1 | |
| <i>II.</i> | Description and data. | | |
| Description | 3 | 1 | |
| Tabulated data | 4 | 22 | |
| <i>III.</i> | Tools and accessories. | | |
| X-ray field unit tools | 5 | 26 | |
| X-ray field unit accessories | 6 | 26 | |
| Table unit tools..... | 7 | 26 | |

PART TWO. OPERATING INSTRUCTIONS.

| | | | |
|--|------------------------------------|----|--|
| <i>Section IV.</i> | General. | | |
| Scope | 8 | 27 | |
| <i>V.</i> | Service upon receipt of equipment. | | |
| Unpacking | 9 | 27 | |
| Assembling | 10 | 37 | |
| Adjustments | 11 | 66 | |
| <i>VI.</i> | Controls and instruments. | | |
| Controls on X-ray field unit, machine, X-ray..... | 12 | 72 | |
| Instruments on X-ray field unit, machine, X-ray..... | 13 | 77 | |
| Controls on X-ray field unit table unit..... | 14 | 77 | |
| Instruments on X-ray field unit table unit..... | 15 | 80 | |
| <i>VII.</i> | Operation. | | |
| X-ray field unit, machine, X-ray..... | 16 | 80 | |
| X-ray field unit table unit..... | 17 | 83 | |
| <i>VIII.</i> | Operation of auxiliary equipment. | | |
| X-ray field unit generator | 18 | 83 | |

PART THREE. MAINTENANCE INSTRUCTIONS.

| | | | |
|--|---|----|--|
| <i>Section IX.</i> | General. | | |
| Scope | 19 | 84 | |
| <i>X.</i> | Special organizational tools and equipment. | | |
| Organizational tools and equipment..... | 20 | 84 | |
| <i>XI.</i> | Lubrication. | | |
| Weekly | 21 | 84 | |
| <i>XII.</i> | Preventive maintenance services. | | |
| Operator maintenance (first echelon)..... | 22 | 84 | |
| Organizational maintenance (second echelon)..... | 23 | 85 | |
| <i>XIII.</i> | Trouble shooting. | | |
| Electrical | 24 | 85 | |
| Mechanical | 25 | 86 | |

| | <i>Paragraph</i> | <i>Page</i> |
|--|------------------|-------------|
| XIV. Maintenance operations. | | |
| To check source of current..... | 26 | 88 |
| To check and replace fuses..... | 27 | 88 |
| To replace line plug..... | 28 | 88 |
| To check X-ray filament..... | 29 | 88 |
| To service timer | 30 | 88 |
| To replace toggle mechanism in foot switch..... | 31 | 88 |
| To dress and adjust circuit breaker contacts..... | 32 | 89 |
| To check for punctured high-tension cables..... | 33 | 89 |
| To check for a defective X-ray tube..... | 34 | 89 |
| To replace meters | 35 | 89 |
| To adjust chassis brake | 36 | 90 |
| To adjust vertical carriage of tubestand if it tends to slip. | 37 | 90 |
| To adjust if vertical carriage develops excessive play.... | 38 | 90 |
| To correct if X-ray tube tends to rotate too feely on its axis | 39 | 90 |
| If excessive play develops in angulating housing..... | 40 | 90 |
| If carriage does not move freely along full length of table | 41 | 90 |
| If fluoroscopic shutters do not open to give full coverage of screen or will not close to give a small enough aperture | 42 | 91 |
| If fluoroscopic screen assembly will not hold depth marker in place | 43 | 91 |
| PART FOUR. AUXILIARY EQUIPMENT. | | |
| <i>Section XV.</i> X-ray field unit generator, item No. 9606000. | | |
| General | 44 | 93 |
| APPENDIX. | | |
| <i>Section I.</i> Procedure for converting old type chassis 9609005 to new chassis 9609010 pneumatic tires. | | |
| Preparation of old chassis base for conversion..... | 1 | 95 |
| Assembly of new parts to chassis base..... | 2 | 95 |
| <i>II.</i> Shipment and storage. | | |
| X-ray field unit, machine, X-ray..... | 3 | 96 |
| Chest MD X-1, old type | 4 | 98 |
| Chest MD X-1, new type | 5 | 99 |
| X-ray field unit table unit..... | 6 | 99 |
| Packaging and packing of fluoroscopic screen..... | 7 | 105 |
| <i>III.</i> List of references. | | |
| References | 8 | 105 |
| <i>IV.</i> Identification of assemblies. | | |
| General | 9 | 106 |

PART ONE
INTRODUCTION

Section I. GENERAL

1. Scope

a. These instructions are published for the information and guidance of all personnel to whom this equipment is assigned. They contain information on the operation and first- and second-echelon maintenance of the equipment as well as descriptions of the major units and their function in relation to the other components of the equipment. They apply to the following Medical Department items:

| <i>Med. Dept. No.</i> | <i>Nomenclature</i> | <i>Fig. No.</i> |
|-----------------------|---|-----------------|
| 9608508 | X-ray field unit, machine, X-ray, complete, 110-volt 60-cycle: | 1 & 2 |
| 9608510 | X-ray field unit, machine, X-ray, complete, 110-220-volt, 60-cycle: | 1 & 2 |
| 9609005 | Chest MD X-1, old type: | 3 |
| 9609010 | Chest MD X-1, new type: | 4 |
| 9614500 | X-ray field unit table unit: | 5 |

b. These instructions are arranged in four parts: Part One—Introduction; Part Two—Operating Instructions; Part Three—Maintenance Instructions; Part Four—Auxiliary Equipment.

c. All requisitions for spare parts should be submitted in accordance with latest revision of ASF Supply Catalog Med 7.

2. Records

No special maintenance forms or records are required to be kept by the using personnel except as may be prescribed by the officer in charge.

Section II. DESCRIPTION AND DATA

3. Description

a. GENERAL INFORMATION. (1) The X-ray field unit, machine, X-ray, is a 30 ma machine shipped in three chests and complete

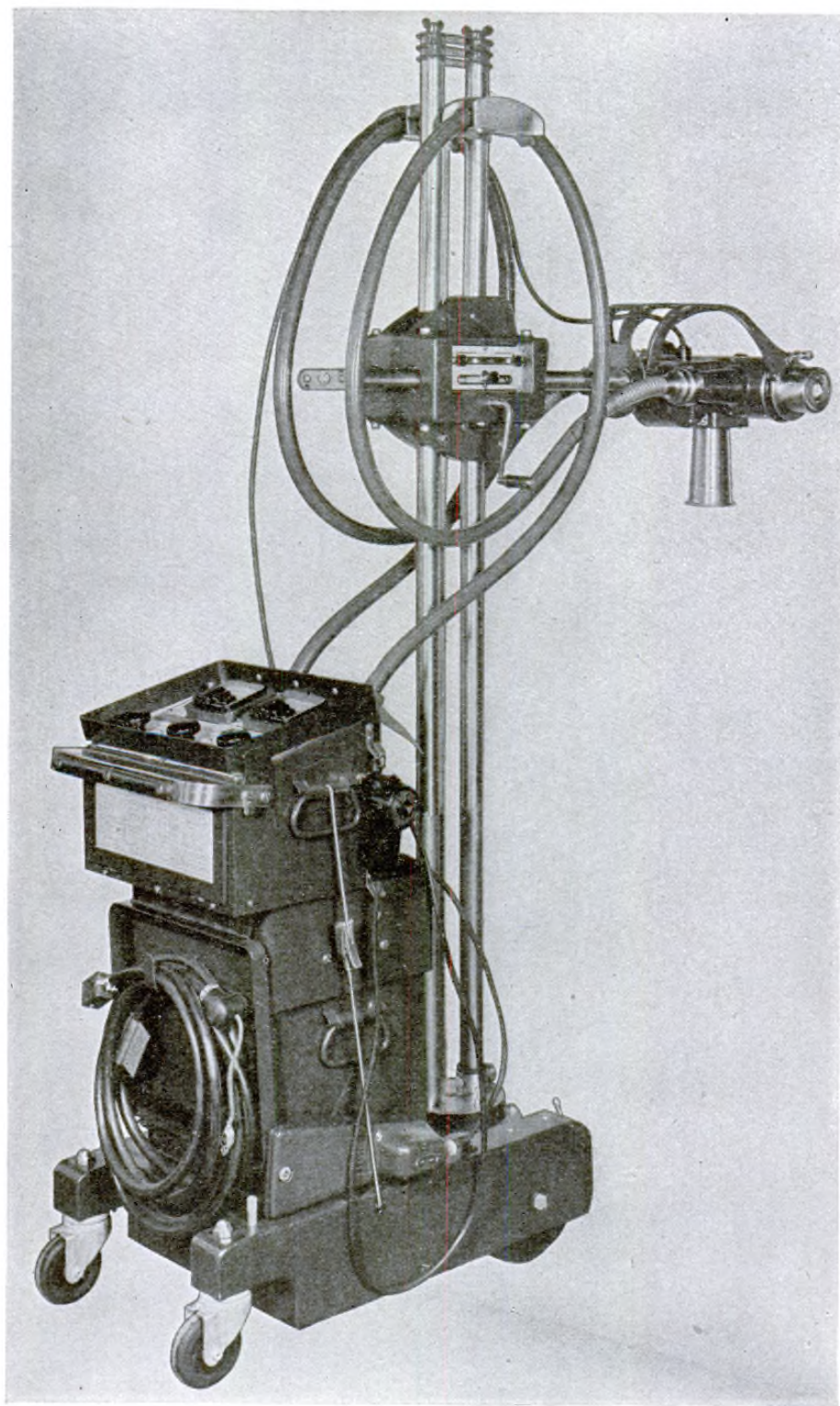

Figure 1. X-ray field unit, machine, X-ray, complete, 110-volt, 60-cycle, item No. 9608508, and parts contained in Chest MD X-1, old type, item No. 9609005.

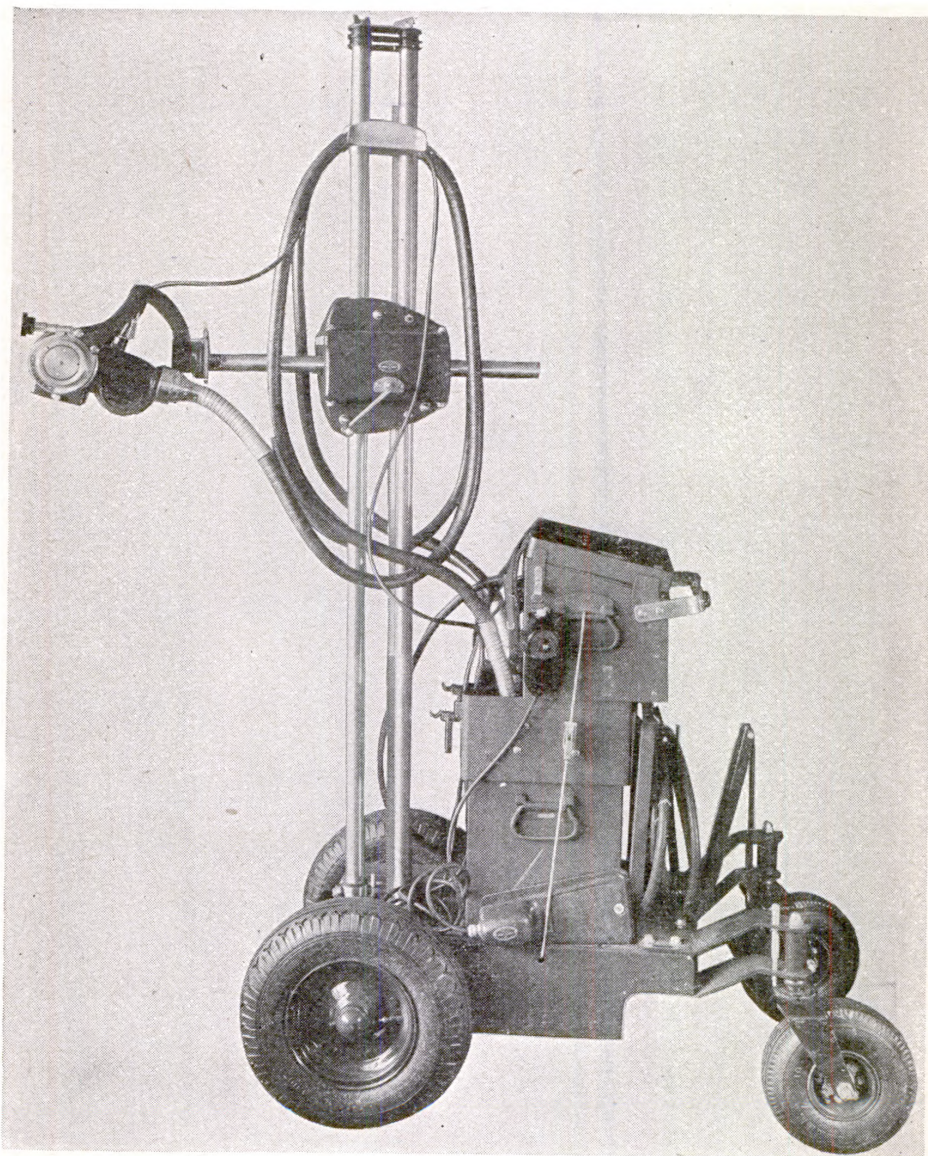

Figure 2. X-ray field unit, machine, X-ray, complete, 110-220-volt, 60-cycle, item No. 9608510, and parts contained in Chest MD X-1, new type, item No. 9609010.

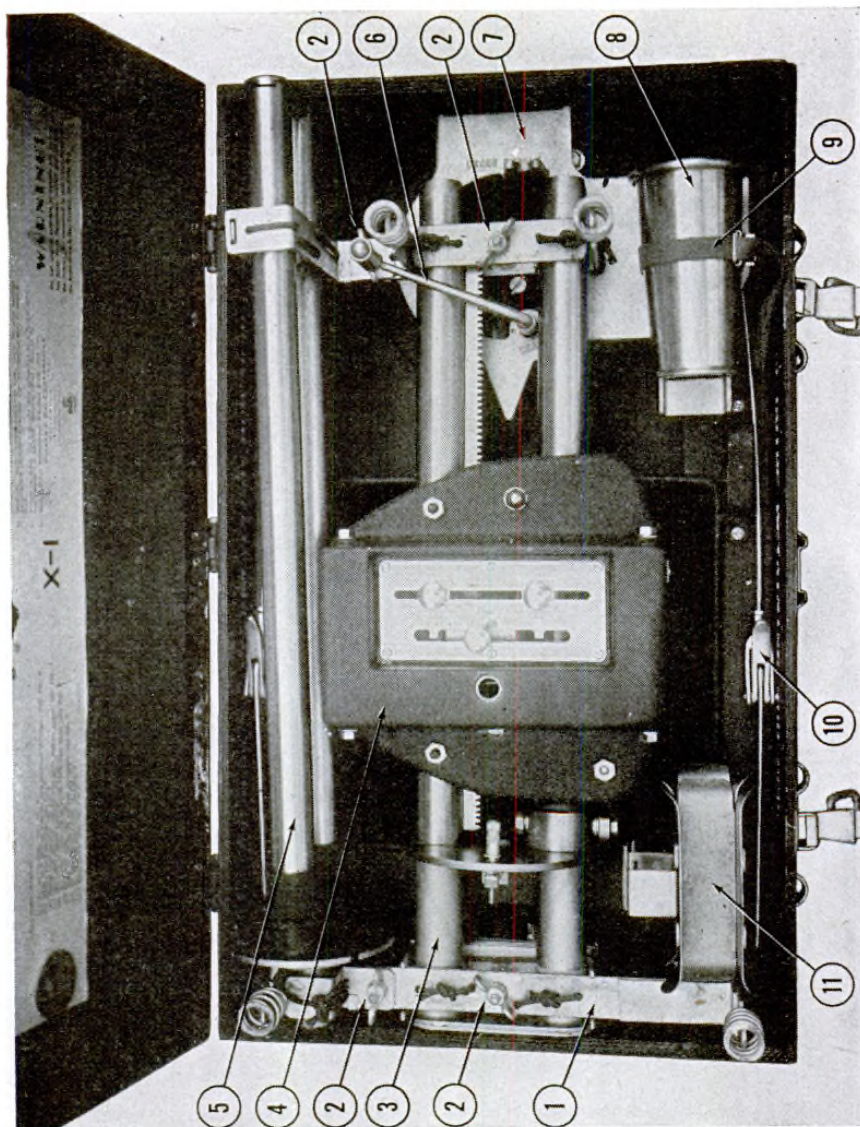

Figure 3. Chest MD X-1, old type, item No. 9609005.

- | <i>Med. Dept.
No.</i> | <i>Nomenclature</i> |
|---------------------------|---|
| 1. 9R15436 | Bracket, Long, Retaining, Cross Arm, Complete. |
| 2. SR00685 | Nut, 5/16 x 18, Wing, 100 to Pkg. |
| 3. 9R15470 | Mast, Bottom Section. |
| 4. 9R15477 | Carriage, Cross Arm, Complete. |
| 5. 9R15476 | Cross Arm, Twin, Horizontal. |
| 6. 9R15524 | Crank, Hand, Complete. |
| 7. 9R15438 | Bracket, Retaining, Cone and Crank, Aluminum, Complete. |
| 8. 9R15350 | Cone, Radiographic. |
| 9. 9R15440 | Strap, Retaining, Cone. |
| 10. 9R15554 | Rod, Guy, Retaining, Complete. |
| 11. 9R15566 | Support, Shockproof Cable. |

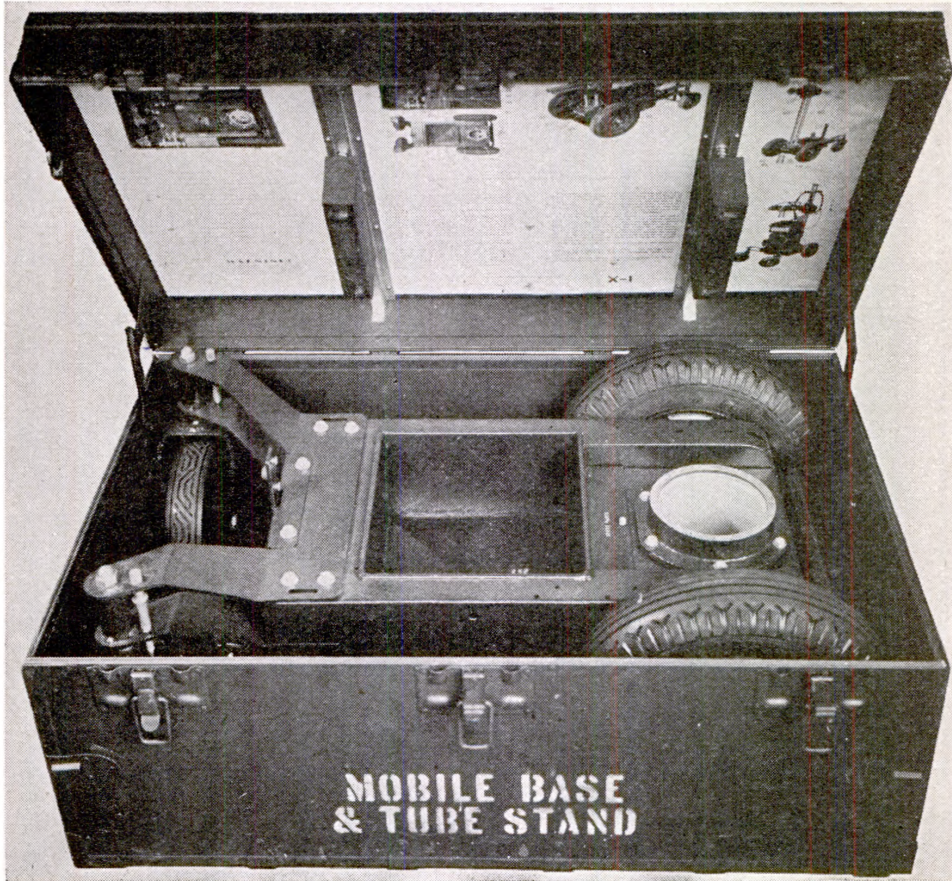

Figure 4. Chest MD X-1, new type, item No. 9609010.

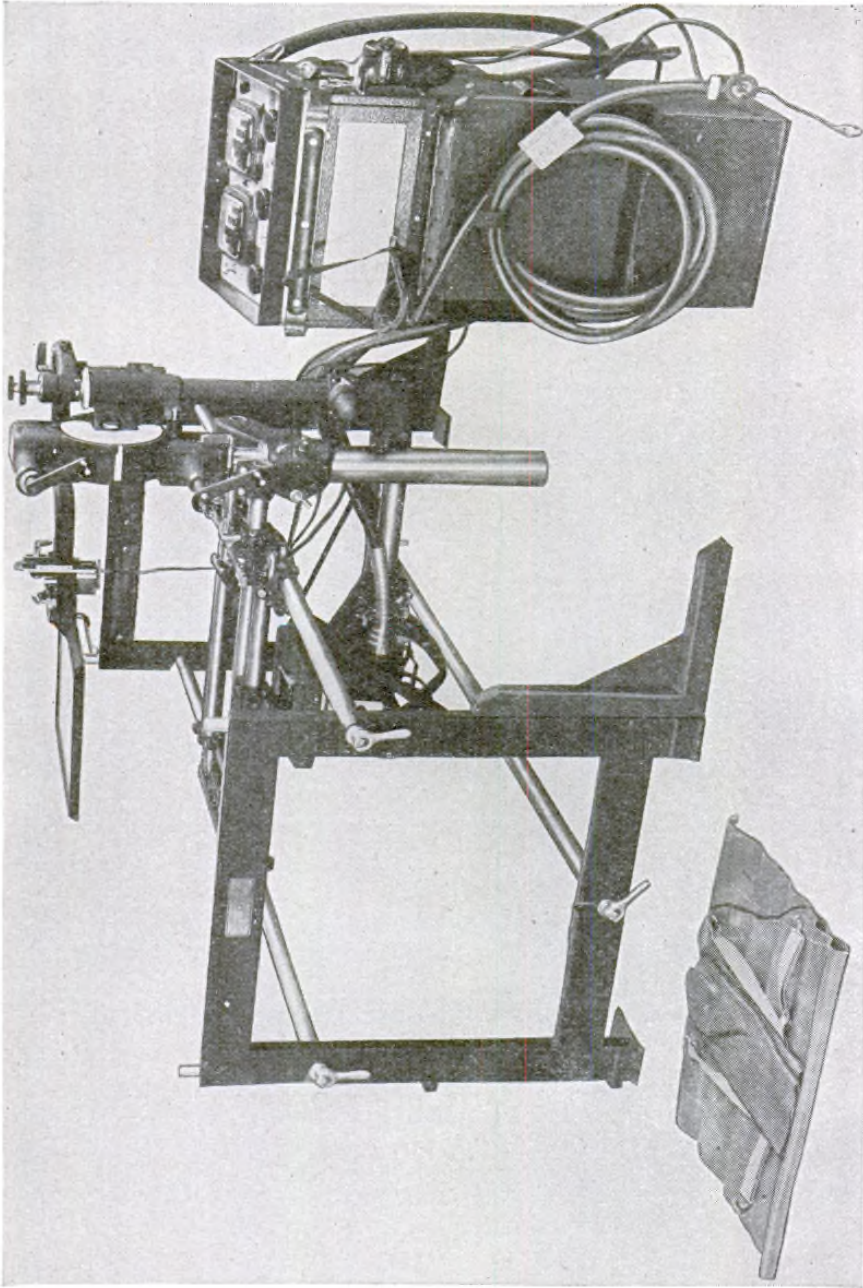

Figure 5. Item No. 9614500, X-ray field unit, table unit, in horizontal fluoroscopic position as set up for use with Item No. 9608508, X-ray field unit, machine, X-ray.

with accessories. The apparatus is designed for roentgenography, fluoroscopy, and therapy work in the field. It is not usable for this work unless supplied with one of the following: Chest MD X-1, old type, 9609005 (fig. 3); Chest MD X-1, new type, 9609010 (fig. 4); or the X-ray field unit table unit, 9614500 (fig. 5).

(2) Chest MD X-1 contains all the parts necessary to convert the X-ray field unit into a mobile unit for bedside work. Chest MD X-1, old type, or Chest MD X-1, new type, must be ordered separately if this conversion is desired.

(3) The X-ray field unit table unit may be used with both models of the X-ray field unit. It provides facilities for horizontal fluoroscopy; vertical fluoroscopy, sitting position; vertical fluoroscopy, standing position; chest roentgenography, vertical; chest roentgenography, horizontal; and horizontal roentgenography.

b. DIFFERENCES IN MODELS. (1) X-ray field unit, machine, X-ray. (See table I.)

Table I. Differences in models

| Med. Dept. No. | Voltage Range | Cycles | ac or dc | Component parts | Fig. No. |
|----------------|--------------------------|----------------|----------|--|----------|
| 9608508 | 100-130 | 60 | a-c | 9608600—X-ray field unit transformer unit, chest MD X-2. | |
| | | | | 9608700—X-ray field unit tube unit, chest MD X-3. | 6 |
| | | | | 9608808—X-ray field unit control unit, chest MD X-4, 110-volt, 60-cycle. | 7 |
| 9608510 | 100-130 or 205-250 | 50 or 60 | a-c | 9608600—X-ray field unit transformer unit, chest MD X-2. | |
| | | | | 9608700—X-ray field unit tube unit, chest MD X-3. | |
| | | | | 9608810—X-ray field unit control unit, chest MD X-4, 110-220-volt, 60-cycle. | |

(2) *Chest MD X-1. (a) Old type.* This chest is the same size as the tube and control chests of the field unit. Four hard rubber wheels are used to provide mobility to the chassis found in the chest.

(b) *New type.* This chest is considerably larger than the tube and control chests of the field unit. The wheels of the new type chassis are larger and are provided with pneumatic tires. Brake drums are used in place of the brake arms found in the old type. A base handle is provided to move the chassis over long distances.

(3) *X-ray field unit table unit* (See fig. 5.) This unit is shipped in two trunks, a large trunk, 9R05767 (fig. 8) and a small trunk, 9R05867 (fig. 9). There are a number of variations that distinguish the earlier models from the later models.

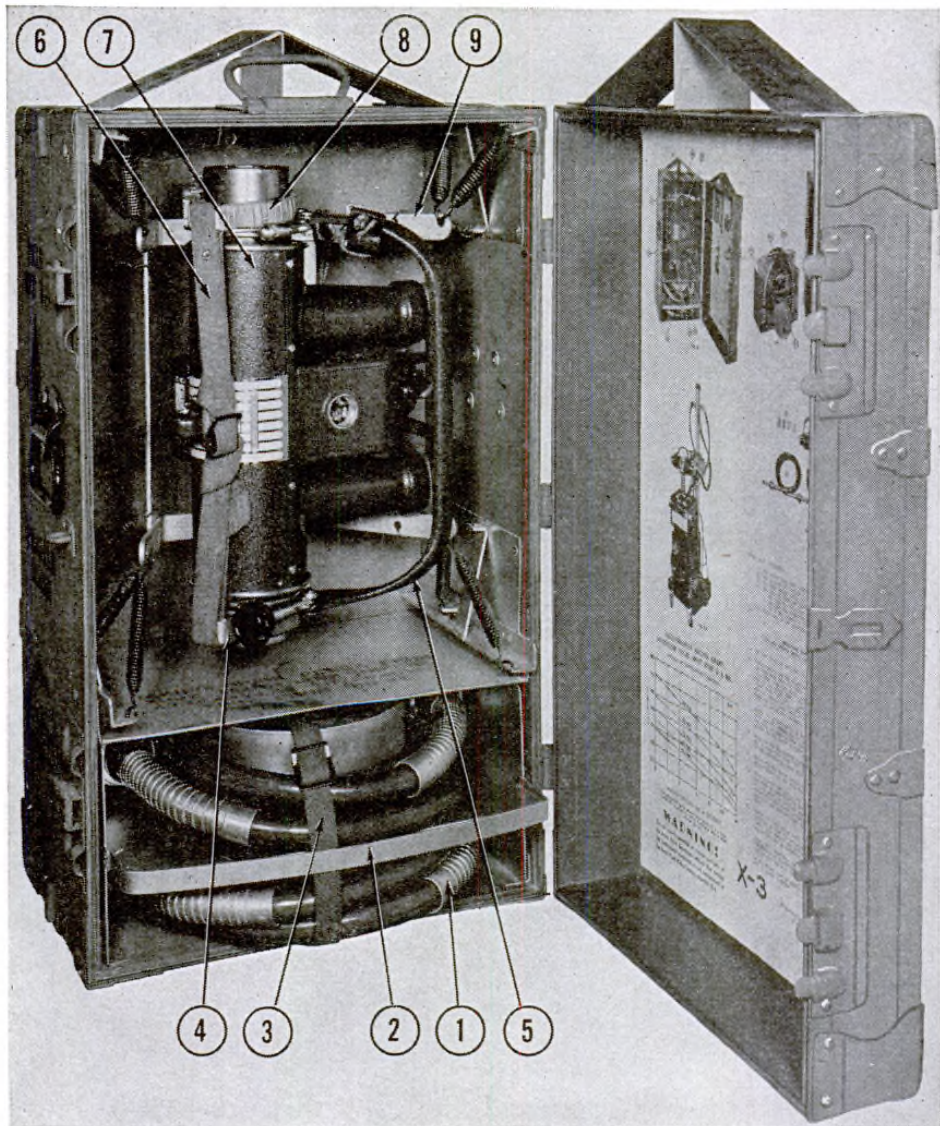

| <i>Med. Dept.</i> | <i>No.</i> | <i>Nomenclature</i> | <i>Med. Dept.</i> | <i>No.</i> | <i>Nomenclature</i> |
|-------------------|------------|---|-------------------|------------|--|
| | 1. | 9620500 X-ray Field Unit Shockproof Cable. | | 6. | 9R15458 Strap, Retaining, Tube Head, Complete. |
| | 2. | 9R15450 Drawer, Cables, Complete. | | 7. | 9620900 X-ray Field Unit Tube, X-ray. |
| | 3. | 9R15456 Strap, Retaining, Cables, Complete. | | 8. | 9R15458 Ring, Upper, Retaining, Tube Head. |
| | 4. | 9R15456 Ring, Lower, Retaining, Tube Head. | | 9. | 9620900 Cradle, Retaining, Tube Hanger. |
| | 5. | 9R15078 Hanger, Tube Head. | | | |

Figure 6. X-ray field unit tube unit, chest MD X-3, item No. 9608700.

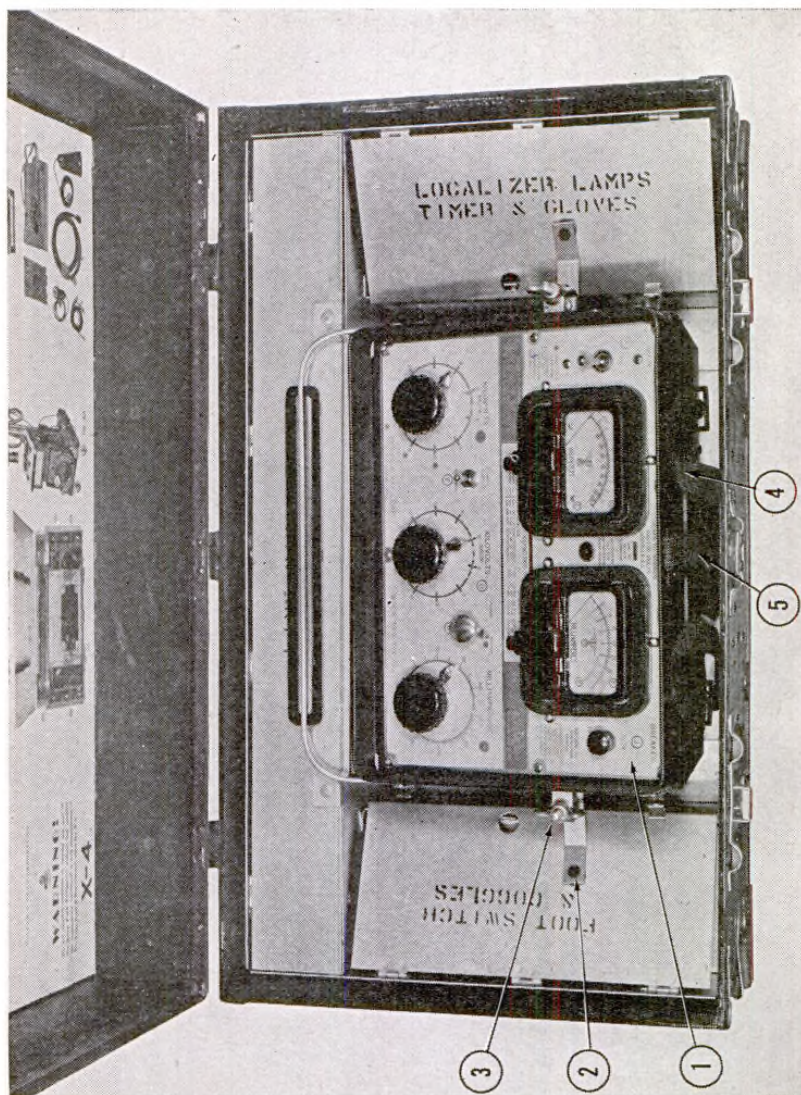

- | <i>Med. Dept.</i> | <i>Nomenclature</i> |
|-------------------|--|
| <i>No.</i> | |
| | Control Unit. |
| 1. | 9R15460 Clamp, Retaining, Control, Complete. |
| 2. | SR00685 Nut, 5/16 x 18, Wing, 100 to Pkg. |
| 3. | 9R15224 Strap, High-Tension Cable. |
| 4. | 9R15226 Strap, Retaining Cross Arm. |

Figure 7. X-ray field unit, control unit, chest MD X-4, 110-volt, 60-cycle, item No. 9608808.

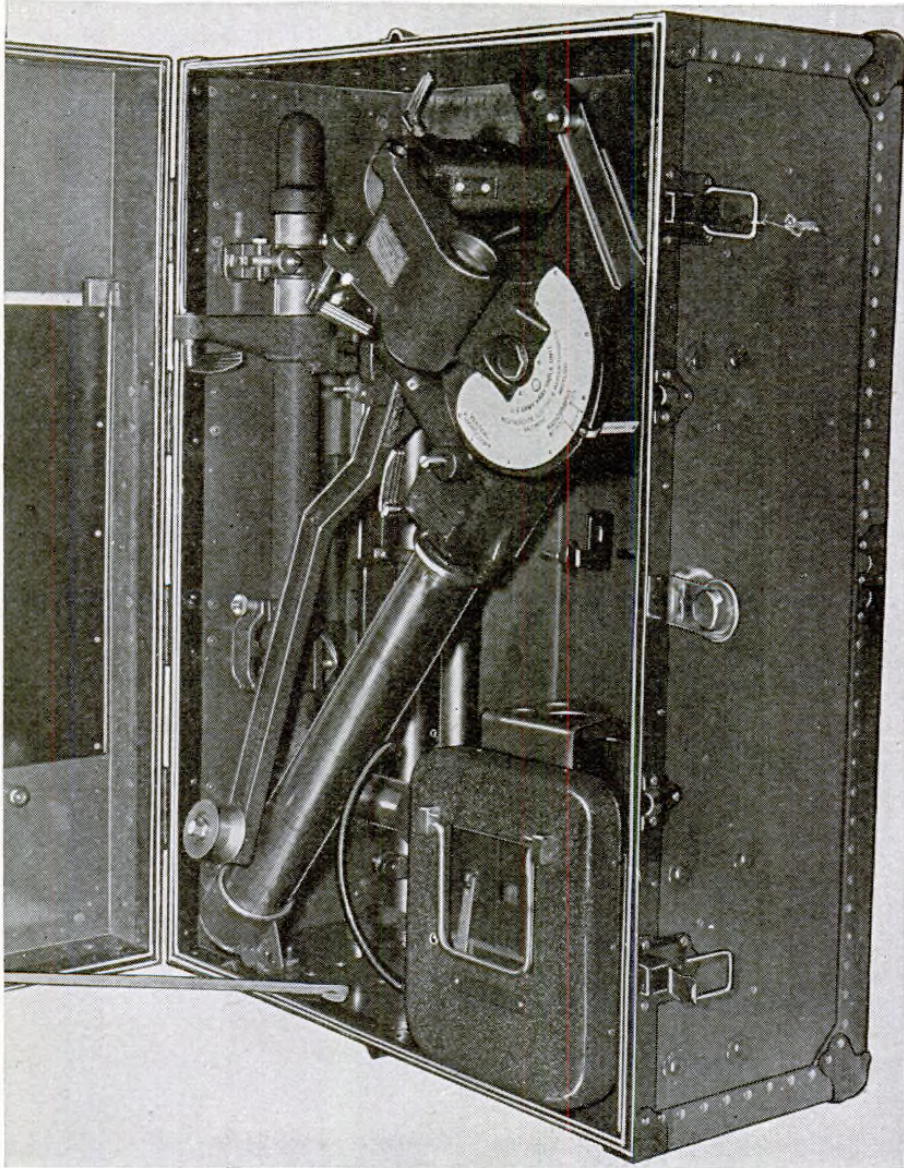

Figure 8. Large trunk, 9R05767, complete.

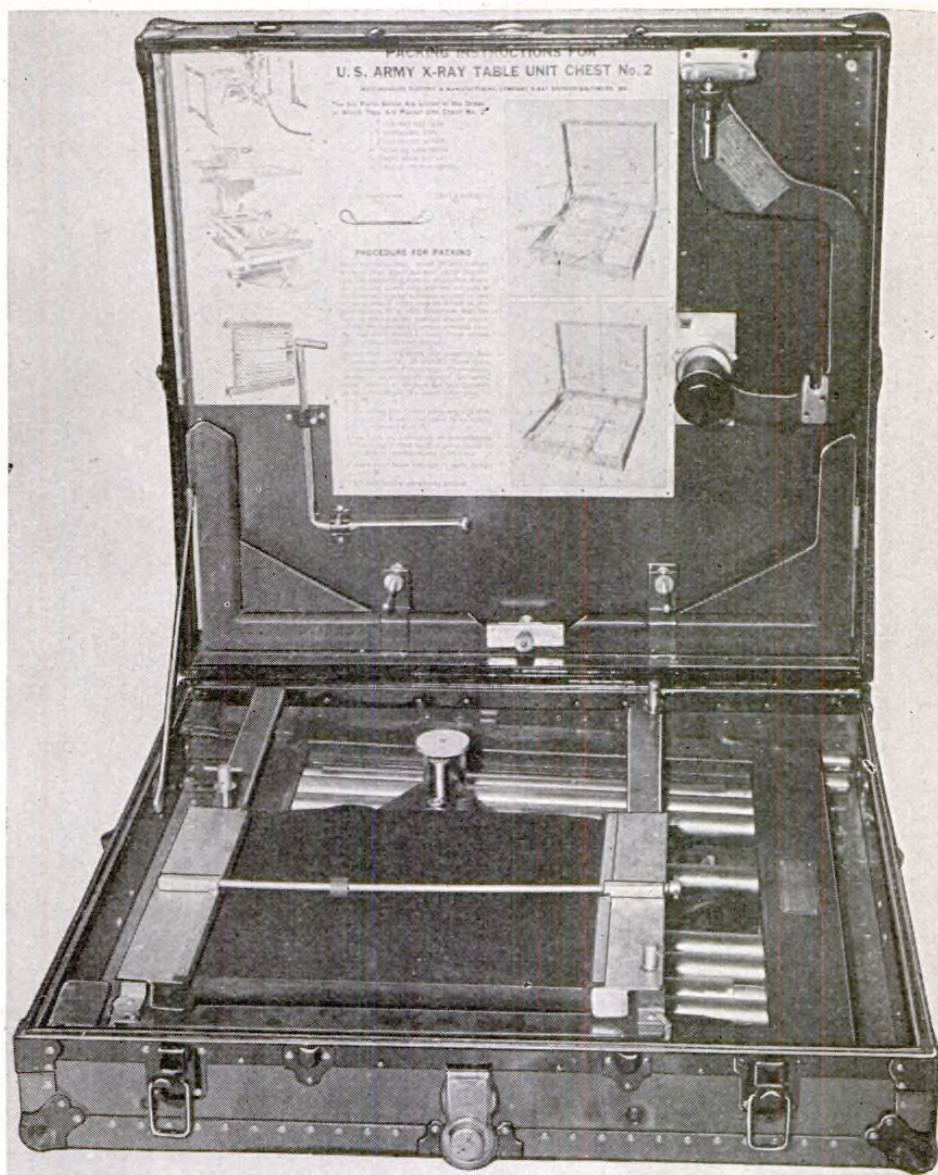

Figure 9. Small trunk, 9R05867, complete.

(a) *Screen arm and fluoroscopic screen.* In the earlier models there is no provision for raising or lowering the fluoroscopic screen with respect to the screen arm. With the old type the screen arm and fluoroscopic screen are rigidly connected after the screen has been attached with the lock handle. When replacing the old type screen arm, 9R05244 (fig. 10) without changing the old type fluoroscopic screen assembly (figs. 11 and 12) be sure to specify the correct number. When replacing the old type fluoroscopic screen assembly, it will be necessary to use the new type screen arm, 9R05246 and the fluoroscopic screen assembly complete, 9R05286. (See figs. 13 and 14.) The later models of the X-ray field unit table unit provide an adjustment for the screen-target distance on the fluoroscopic screen.

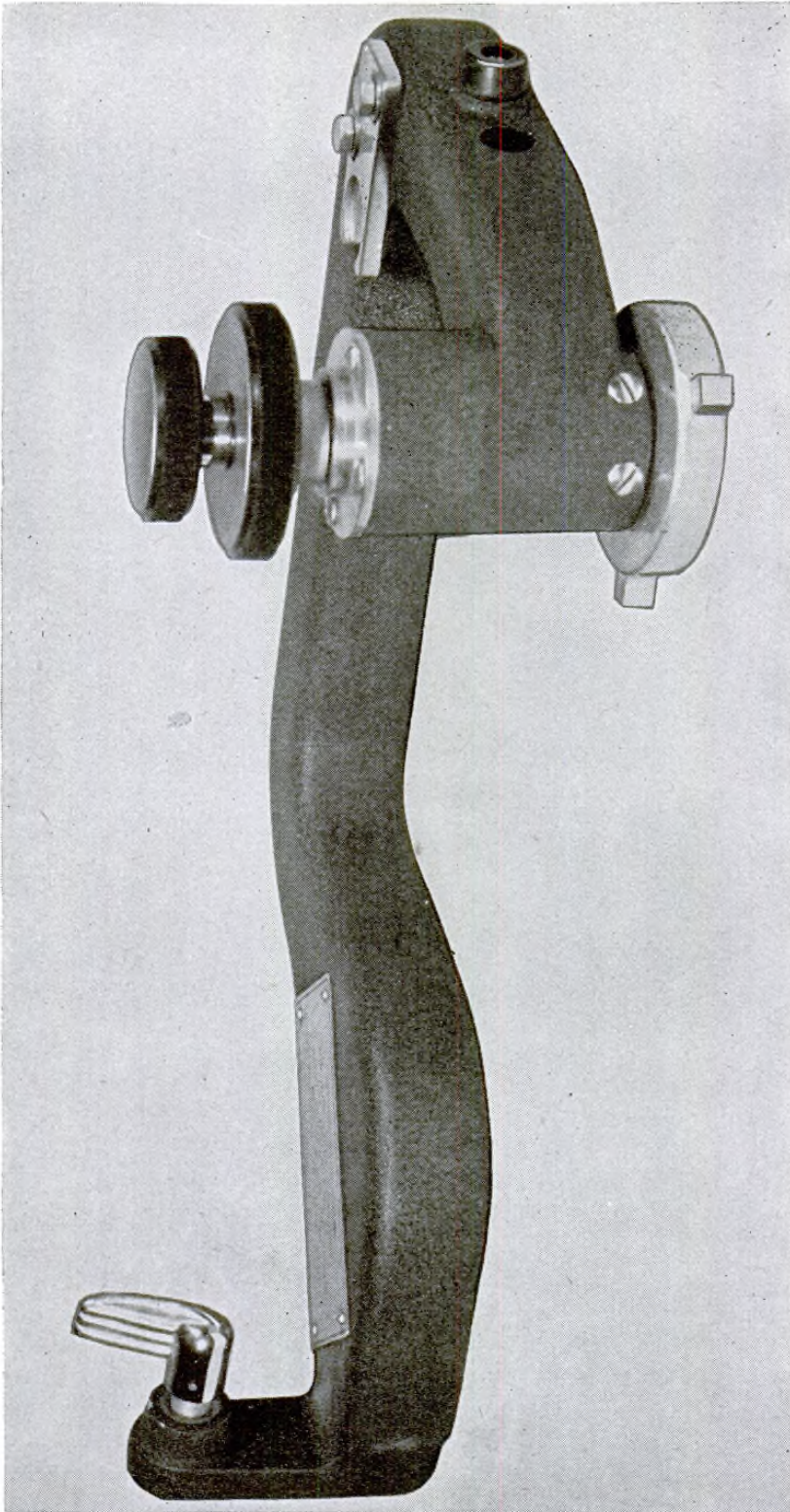
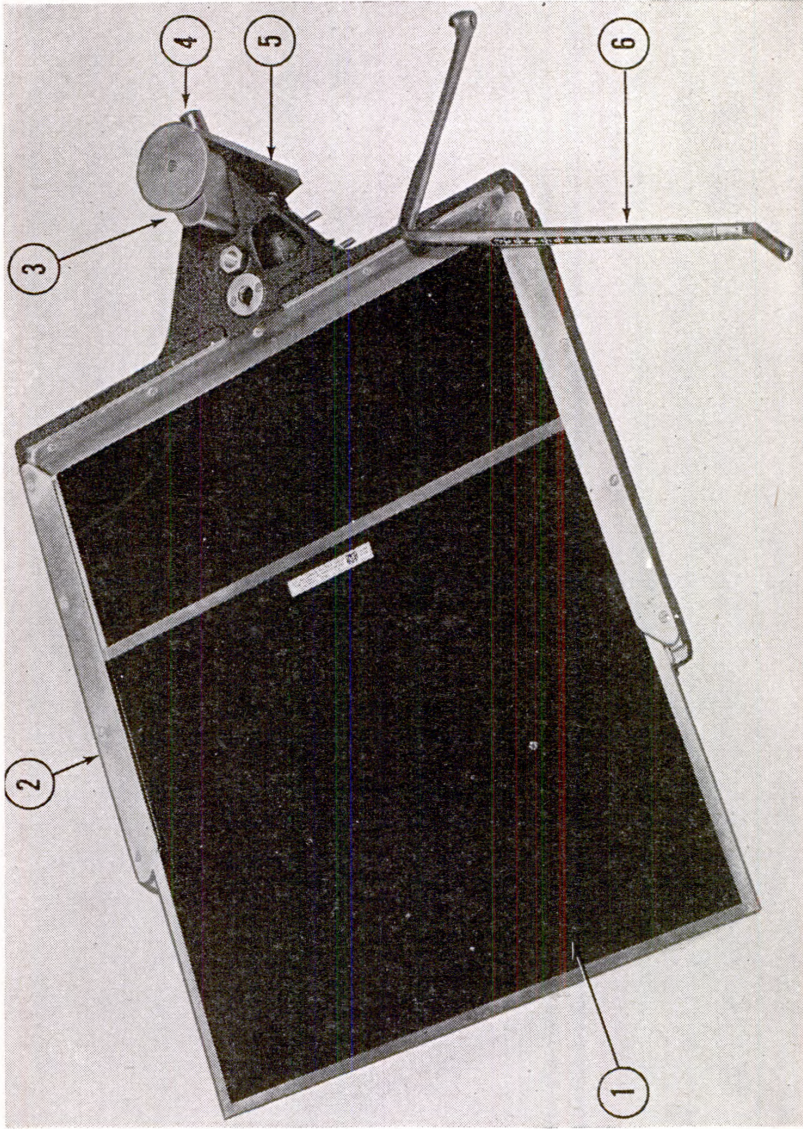
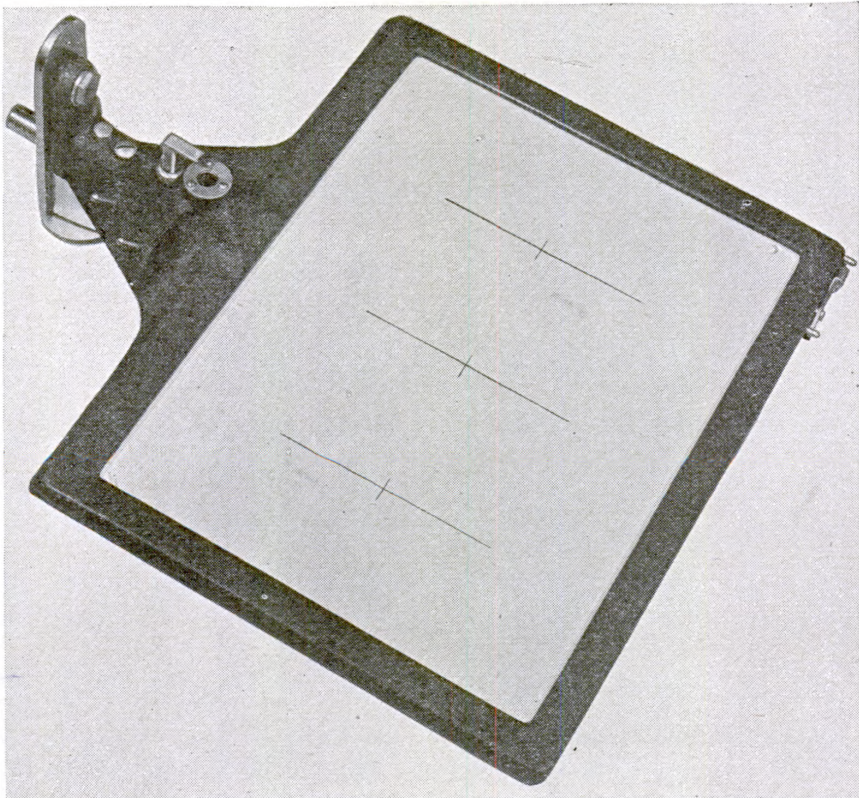

Figure 10. Screen arm and shutter knobs, part No. 9R05244.



- | <i>Med. Dept.
No.</i> | <i>Nomenclature</i> |
|---------------------------|--|
| 1. 9R05240 | Grid, Stationary. |
| 2. 9R05288 | Screen, Fluoroscopic, Bottom Adjusting Knob, Complete. |
| 3. 9R05384 | Retainer, Screen Adjusting Screw. |
| 4. 9R05400 | Knob, Metal, Screen Adjustment. |
| 5. 9R05388 | Plate, Guide, Adjustable Screen Mounting. |
| 6. 9R50242 | Rod, Measuring, Depth Marker. |

Figure 11. Fluoroscopic screen with bottom adjusting knob, part No. 9R05288, bottom view (including accessories).



*Figure 12. Fluoroscopic screen with bottom adjusting knob,
part No. 9R05288, top view.*

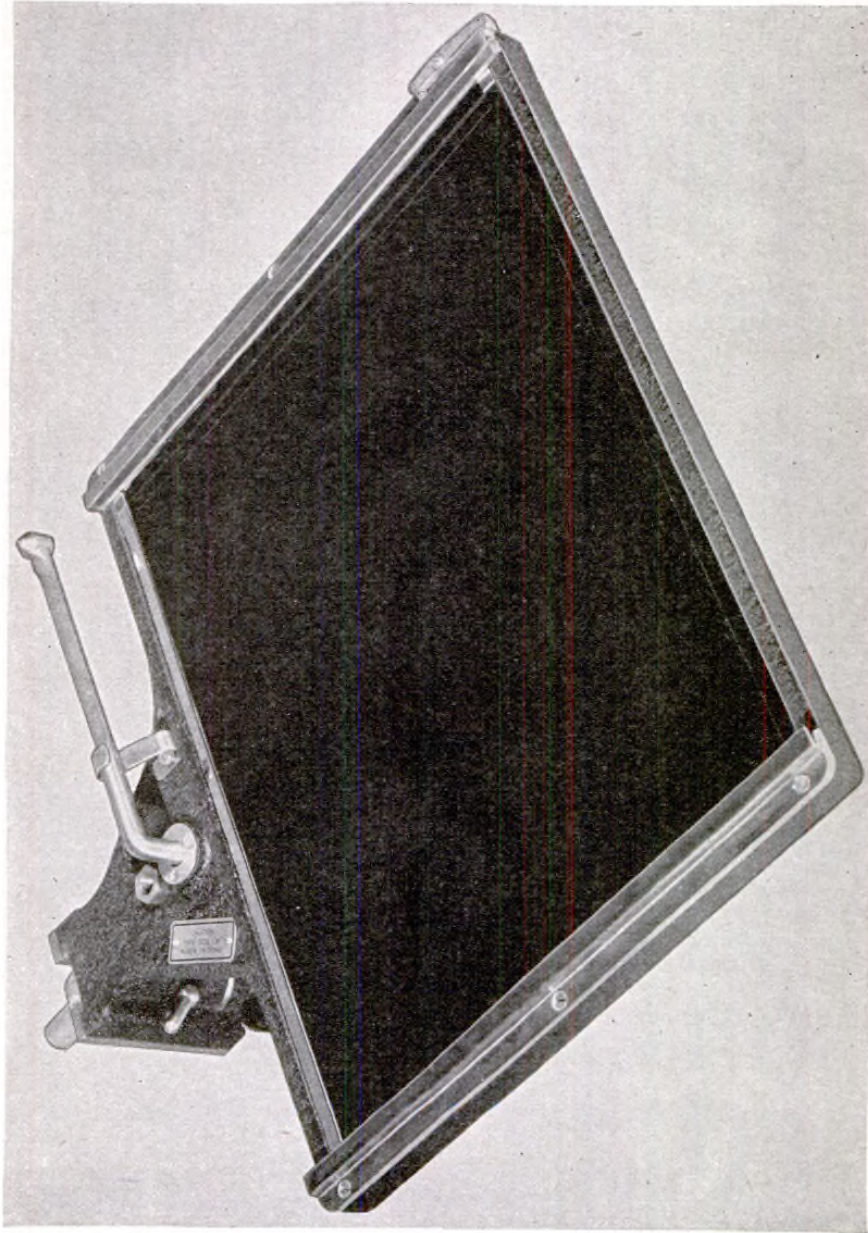

Figure 13. Fluoroscopic screen with top adjusting knob, part No. 9R05286, bottom view.

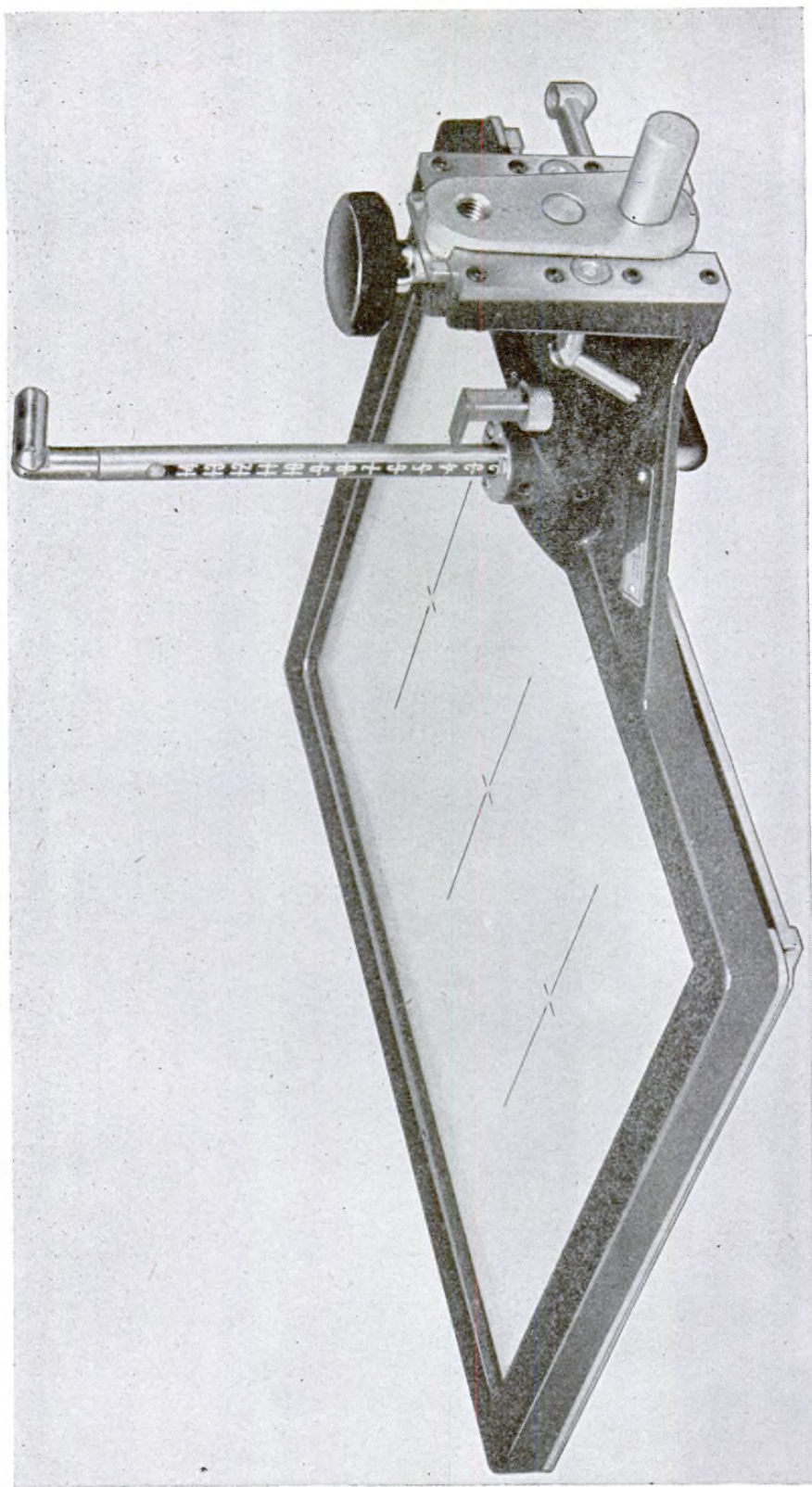

Figure 14. Fluoroscopic screen with top adjusting knob, part No. 9R05286, top view, with depth marker rod, part No. 9R05242.

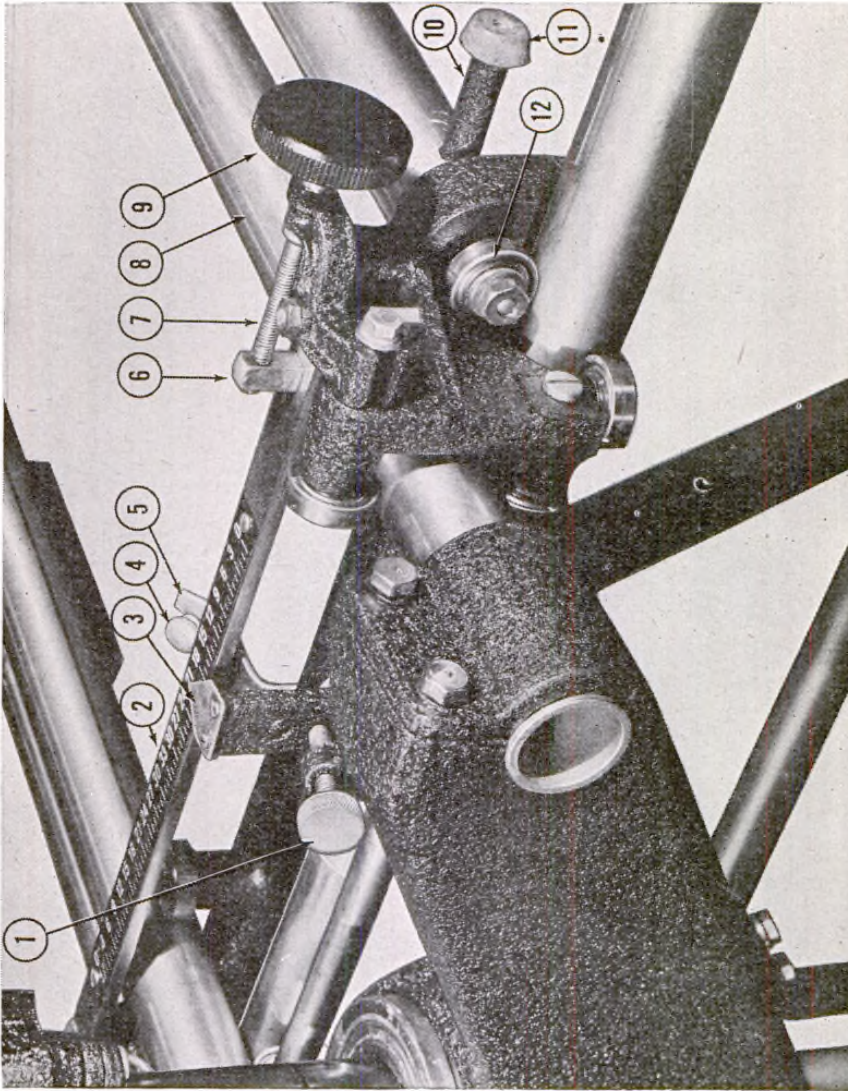

Figure 15. Localizer scale, viewed from right operating side.

- | <i>Med. Dept.</i> | <i>Nomenclature</i> |
|-------------------|--|
| <i>No.</i> | |
| 1. | 9R05508 Screw, Lock, Pointer Carriage, Localizer Scale. |
| 2. | 9R05502 Scale, Localizer, Small Knob Movement, Complete. |
| 3. | 9R05526 Pointer, Localizer Scale. |
| 4. | 9R05540 Screw, Thumb, Localizer Light, Localizer Scale. |
| 5. | 9R05506 Bracket, Localizer Light, Localizer Scale. |
| 6. | 9R05520 Nut, Adjusting Screw, Localizer Scale. |
| 7. | 9R05544 Screw, Adjusting, Localizer Scale. |
| 8. | 9R05428 Rail, Crosswise Carriage. |
| 9. | 9R05485 Knob, Small, Localizer Scale Adjustment. |
| 10. | 9R05444 Post, Bumper, Long, Lengthwise Carriage. |
| 11. | 9R05523 Bumper, Rubber. |
| 12. | 9R05536 Bearing, Ball, 1.1815-Inch Diameter. |

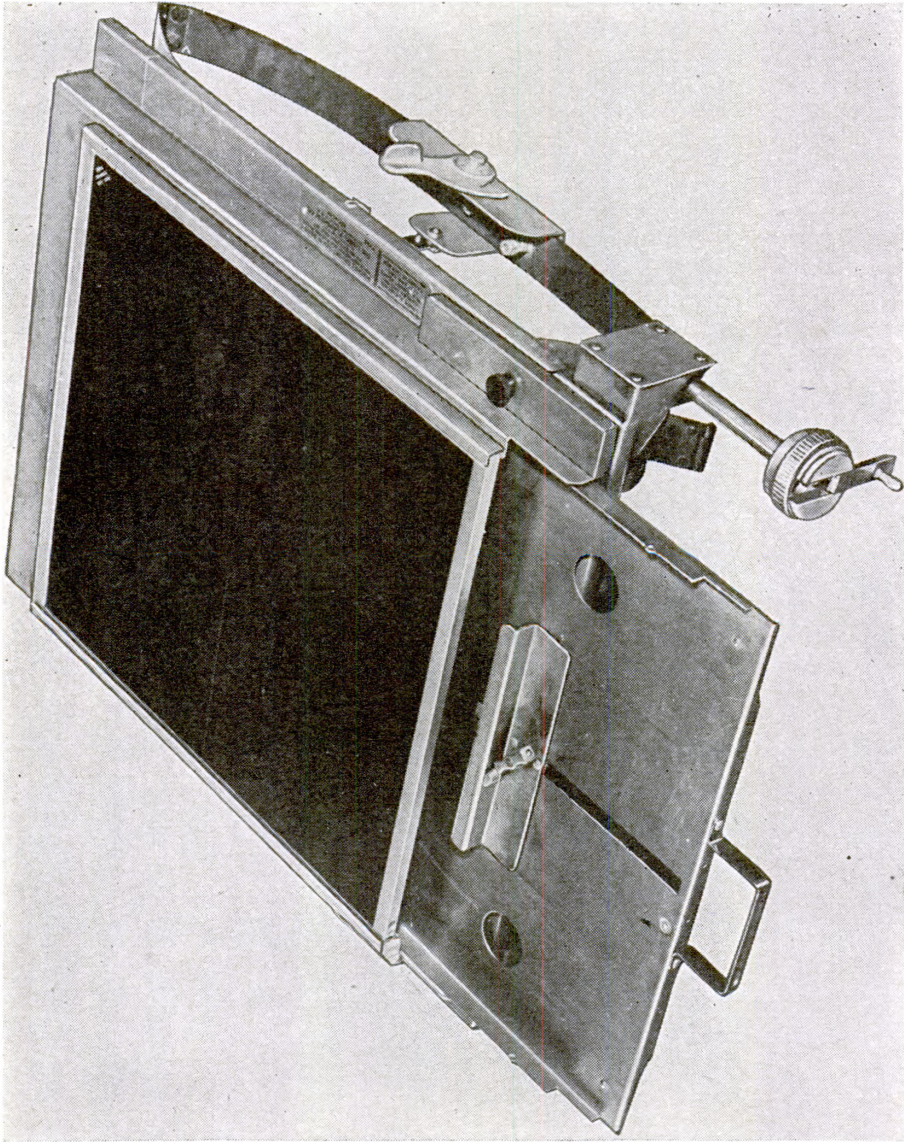
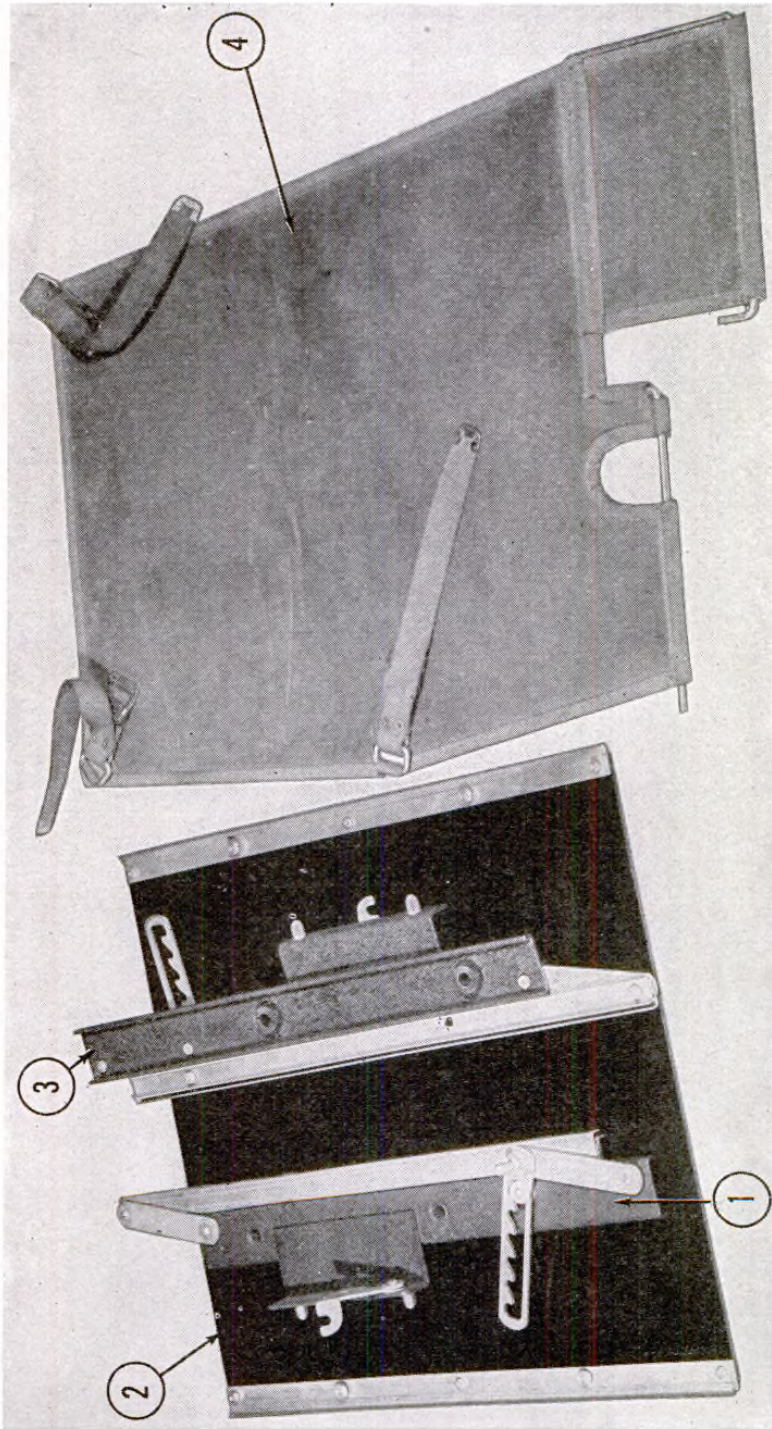
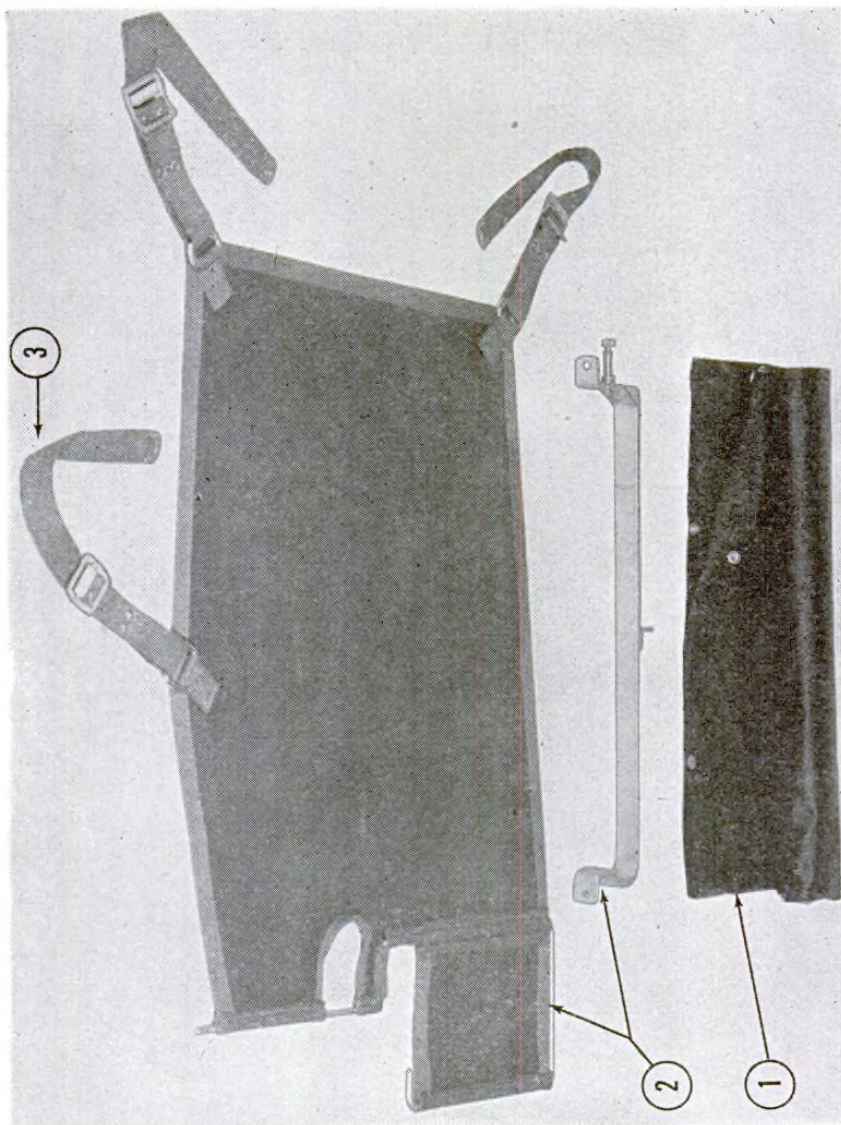

Figure 16. X-ray field unit portable grid, item No. 9607000.



- | <i>Med. Dept.
No.</i> | <i>Nomenclature</i> | <i>Med. Dept.
No.</i> | <i>Nomenclature</i> | <i>Med. Dept.
No.</i> | <i>Nomenclature</i> |
|---------------------------|---|---------------------------|--|---------------------------|---|
| 1. | 9R05962 Mounting, Panel, Right, Complete. | 3. | 9R05960 Mounting, Panel, Left, Complete. | 4. | 9R05238 Shield, Protective, Auxiliary, Leaded, Rubber: Less mounting bracket. |
| 2. | 9R05958 Panel, Cassette Lifting Device. | | | | |

Figure 17. Cassette lifting device, complete, part No. 9R05957 and protective shield, part No. 9R05238, without mounting bracket.



- | <i>Med. Dept.
No.</i> | <i>Nomenclature</i> |
|---------------------------|---|
| 1. 9R05956 | Casing, Protective Shield. |
| 2. 9R05238 | Shield, Protective, Auxiliary, Leaded, Rubber. |
| 3. 9R05955 | Strap, Web, Protective Shield, Com- plete. |

Figure 18. Protective shield, part No. 9R05238 and Protective shield casing, part No. 9R05956.

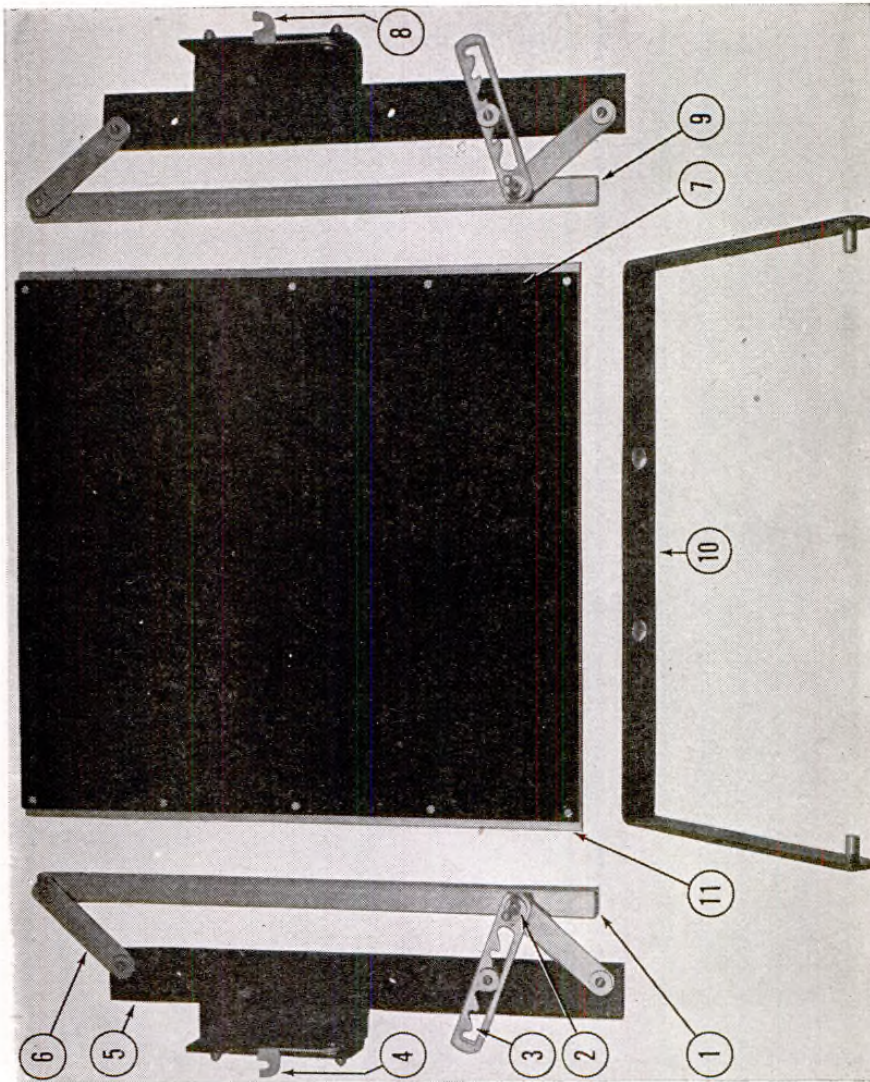

- | <i>Med. Dept.</i> | <i>Nomenclature</i> |
|-------------------|---|
| 1. | Channel, Panel Slide, Right. |
| 2. | Knob, Lifting Device. |
| 3. | Ratchet. |
| 4. | Latch, Right. |
| 5. | Mounting, Channel, Right. |
| 6. | Link, Connecting. |
| 7. | Panel, Cassette Lifting Device. |
| 8. | Latch, Left. |
| 9. | Channel, Panel Slide, Left. |
| 10. | Gage, Checking, Focal Distance, Complete. |
| 11. | Slide, Angle, Panel. |

Figure 19. Cassette lifting device, part No. 9R05957, and focal distance checking gauge, part No. 9R05994.

(b) *Localizer scale.* In the earlier models the localizer scale was shifted manually, with two knobs. The later models provide a small adjusting knob (fig. 15, part 9) for the localizer scale.

(c) *Cassette support for horizontal roentgenography.* In the early models the X-ray field unit portable grid, 9607000 (fig. 16), had to be ordered separately from the table unit, before horizontal roentgenography with a grid could be done. The wafer grid supplied with this unit was of a specially adapted design. In the case of the new models it is not necessary to order a grid or cassette holder separately. The new tables are equipped with a cassette lifting device assembly (fig. 17) for horizontal roentgenography and stationary grid, which is mounted beneath the fluoroscopic screen during shipment. This new grid is smaller than that supplied with item 9607000 assembly and may be used during fluoroscopy as well as horizontal roentgenography.

(d) *Protective shield.* The newer models of the field unit table unit are equipped with a protective shield, 9R05238 (fig. 18) which can be mounted on the table for protection of legs and feet of the operator.

(e) *Focal distance checking gauge, 9R05994* (fig. 19, part 10). This gauge is supplied with the newer models and will be discussed in paragraph 17.

4. Tabulated Data

a. PERFORMANCE. (See table 2.)

Table II. Performance.

| Med. Dept. No. | Voltage used | Max. current used |
|----------------|------------------------------------|------------------------------|
| 9608508..... | 100-130..... | 30 amperes |
| 9608510..... | 100-130..... or 200-250..... | 30 amperes 15 amperes |

b. CAPACITIES. The capacities of both X-ray field units, 9608508 and 9608510 are the same. (See table 3.)

Table III. Capacities (9608508 and 9608510).

| Type of work | Power source | Maximum values | | |
|-------------------|---------------------------------|----------------|-----|------------|
| | | ma | KVP | Seconds |
| Fluoroscopy | { X-ray field unit generator... | 5 | 85 | Continuous |
| | { Community line | 5 | 85 | Continuous |
| Radiography | { X-ray field unit generator... | 15 | 85 | 50 |
| | { Community line | 30 | 85 | 15 |

c. MANUFACTURERS. (1) *X-ray field unit, machine, X-ray.* This unit is manufactured by the Picker X-Ray Corporation, Waite Manufacturing Division, Inc., Cleveland, Ohio.

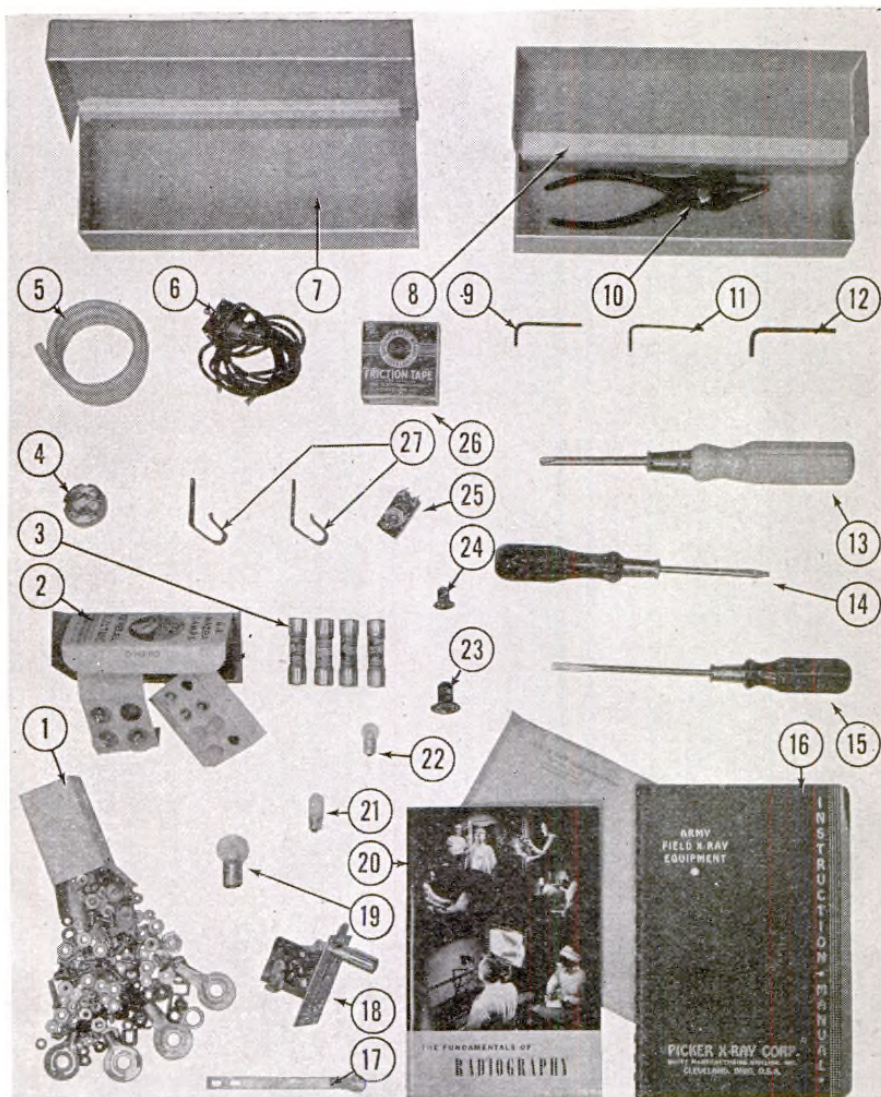

| <i>Med. Dept.</i> | <i>No.</i> | <i>Nomenclature</i> | <i>Med. Dept.</i> | <i>No.</i> | <i>Nomenclature</i> |
|-------------------|------------|--|-------------------|------------|--|
| | 1. | 9R15428 Screw and Nut Assortment. | | 15. | TR01710 Screw Driver, Normal Duty 1/4-Inch Shank, 6-Inch Blade Length. |
| | 2. | Carton, Light Bulbs. | | 16. | 9R15422 Manual, Army Field Unit, Instruction. |
| | 3. | SR00101 Fuse, Inclosed, 30 Amp. | | 17. | 9R15054 Contact, Arm, Curved. |
| | 4. | 9R15016 Insert, Plug, Line. | | 18. | 9R15374 Switch, Mechanism, Footswitch. |
| | 5. | SR00374 Wire, No. 14, Copper, Solid, Insulated. | | 19. | SR00689 Bulb, Localizer, 18-24 V., Double-Contact Bayonet. |
| | 6. | 9R15014 Switch, Check Filament. | | 20. | 9R15424 Manual, "The Fundamentals of Radiography." |
| | 7. | 9R15418 Carton, Cathode Connector. | | 21. | SR00071 Bulb, Pilot, 6-8 V., Miniature Screw Base. |
| | 8. | 9R15420 Carton, Tool. | | 22. | SR00365 Bulb, 6-8 V., 1 C.P., Single-Contact Bayonet. |
| | 9. | TR01915 Wrench, Setscrew, Allen, No. 10. | | 23. | 9R15371 Cap, Large, Rubber. |
| | 10. | TR01613 Plier, Slip Joint, Shear Cutting, 8-Inch. | | 24. | 9R15370 Cap, Small, Rubber. |
| | 11. | TR01912 Wrench, Setscrew, Allen No. 8. | | 25. | 9R15012 Switch, Toggle. |
| | 12. | TR01918 Wrench, Setscrew, Allen No. 1/4. | | 26. | Tape, Friction, 8-oz. |
| | 13. | TR01775 Screw Driver, Phillips, No. 2. | | 27. | 9R15194 Hook, Timer, Bent. |
| | 14. | TR01750 Screw Driver, Normal Duty 3/8-Inch Shank, 4 1/2-Inch Blade Length. | | | |

Figure 20. Spare parts furnished with X-ray field unit, control unit.

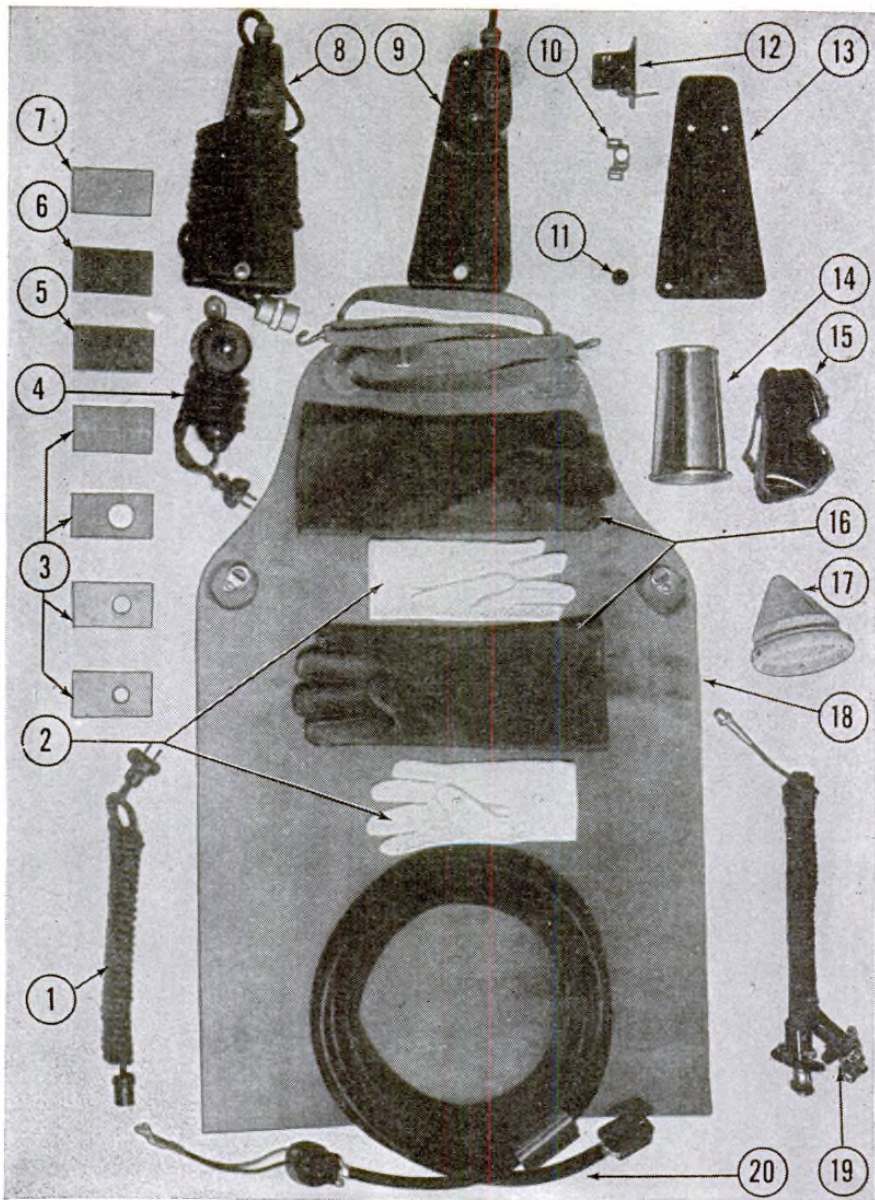

| <i>Med. Dept.</i> <i>No.</i> | <i>Nomenclature</i> | <i>Med. Dept.</i> <i>No.</i> | <i>Nomenclature</i> |
|---------------------------------|--|---------------------------------|---|
| 1. | 9R15399 Cable, Blower, Complete. | 11. | 9R15384 Bumper, Rubber, Footswitch. |
| 2. | Gloves, White: Furnished with radiopaque gloves. | 12. | 9R15374 Switch Mechanism, Footswitch. |
| 3. | 9R15416 Plate, Aperture, Lead Alloy. | 13. | 9R15380 Plate, Floor, Footswitch. |
| 4. | 9R15368 Timer, Hand, Complete. | 14. | 9R15350 Cone, Radiographic. |
| 5. | 6020000 Filter, Aluminum, 1 MM. | 15. | 6031000 Goggles, X-ray Operators. |
| 6. | 9R15414 Filter, Aluminum, 1/2 MM. | 16. | 6030000 Gloves, Radiopaque. |
| 7. | 9R15412 Filter, Aluminum, 1/4 MM. | 17. | 9R15002 Cone, Dental. |
| 8. | 9R15372 Switch, Foot, Complete. | 18. | 6002000 Apron, Radiopaque. |
| 9. | 9R15376 Housing, Footswitch. | 19. | 9R15402 Localizer Lights and Mountings, Complete. |
| 10. | 9R15378 Bracket, Guide, Footswitch. | 20. | 9R15388 Cable, Line, Complete. |

Figure 21. Accessories, X-ray field unit.

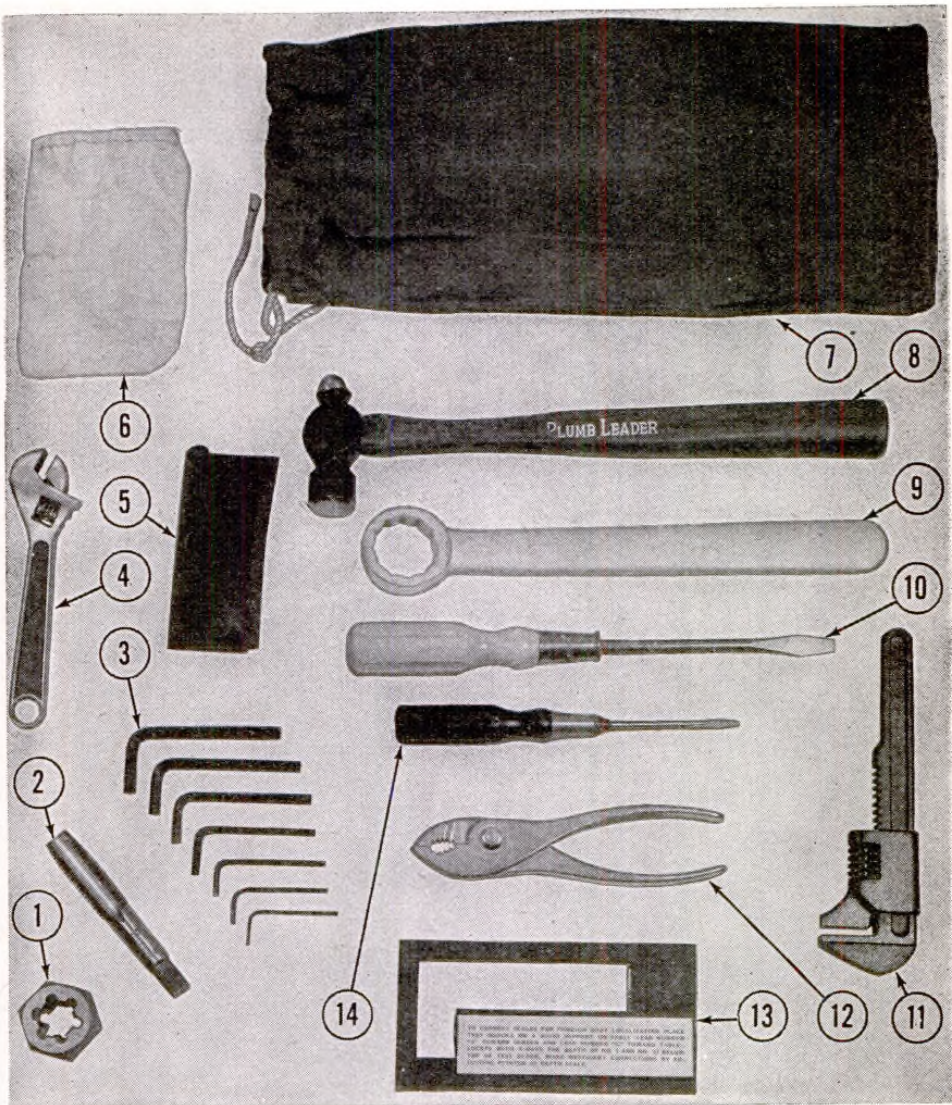

| <i>Med. Dept.</i> <i>No.</i> | <i>Nomenclature</i> | <i>Med. Dept.</i> <i>No.</i> | <i>Nomenclature</i> |
|---------------------------------|---|---------------------------------|---|
| 1. TRO1142 | Die, Rethreading, Hex, Carbon Steel, $\frac{3}{4}$ x 10. | 9. TRO1930 | Wrench, Box, Single End, $1\frac{1}{4}$ -Inch 12 Pt. Opening. |
| 2. TRO1824 | Tap, Hand, Carbon Steel, Plug, $\frac{3}{4}$ x 10. | 10. TRO1720 | Screw Driver, Normal Duty, $\frac{5}{16}$ -Inch Shank, 5-Inch Blade Length. |
| 3. TRO1909-TRO1927 | Wrenches, Allen: Set of seven. | 11. TRO1865 | Wrench, Adjustable, Auto Type, $8\frac{1}{2}$ -Inch Length, $2\frac{5}{8}$ -Inch Opening. |
| 4. TRO1875 | Wrench, Adjustable, Crescent Type, Single-End, 6-Inch, $\frac{3}{4}$ -Inch Jaw Opening. | 12. TRO1613 | Plier, Slip Joint, Shear Cutting, 8-Inch. |
| 5. | Case, Leather, Allen Wrenches. | 13. | Test Block Depth Phantom: For foreign body localization. |
| 6. | Tool Bag, Small. | 14. TRO1685 | Screw Driver, Normal Duty, $\frac{3}{16}$ -Inch Shank, 3-Inch Blade Length. |
| 7. | Tool Bag, Large, Canvas. | | |
| 8. TRO1440 | Hammer, Ball Pein, 8-oz. | | |

Figure 22. X-ray field unit table unit, tools.

(2) *Chest MD X-1*. This chest is manufactured by the Picker X-Ray Corporation, Waite Manufacturing Division, Inc., Cleveland, Ohio.

(3) *X-ray field unit table unit*. This unit is manufactured by the Westinghouse Electric and Manufacturing Company, X-Ray Division, 2519 Wilkens Avenue, Baltimore 3, Maryland, and H. G. Fischer and Co., 2323-2345 Wabansia Ave., Chicago 47, Illinois.

Section III. TOOLS AND ACCESSORIES

5. X-ray Field Unit Tools

For X-ray field unit, machine, X-ray, tools see figure 20.

6. X-ray Field Unit Accessories

For X-ray field unit, machine, X-ray, accessories see figure 21.

7. Table Unit Tools

For X-ray field unit, table unit, tools see figure 22.

Note. The tap and die (fig. 22, parts 1 and 2) are used for rethreading the table rods and table ends if they become damaged.

PART TWO

OPERATING INSTRUCTIONS

Section IV. GENERAL

8. Scope

Part Two contains information for the guidance of the personnel responsible for the operation of this equipment. It contains information on the operation of the equipment with the description and location of the controls and instruments.

Section V. SERVICE UPON RECEIPT OF EQUIPMENT

9. Unpacking

a. CHASSIS AND MAST. Chest MD X-1 (if furnished).

(1) *Old type, 9609005.* (*a*) Open the chest and remove the cross arm assembly (See fig. 23, part 1.) Loosen the two wing nuts and turn the two right-angle brackets under them counter-clockwise. Take out the cross arm assembly and place it aside temporarily.

(*b*) Remove the cross arm carriage (fig. 23, part 9) and the bottom mast section (fig. 23, part 8) in the following manner: loosen wing nut and revolve the plate under it through 90°. Remove wing nut, lift off the retaining bracket (fig. 23, part 4) and place this bracket just outside of the left-hand side of the chest as shown in figure 23. Remove the cross-arm carriage and the lower mast section and place it aside temporarily.

(*c*) Lift the aluminum bracket (fig. 23, part 6) which holds the crank, cone, and packing brackets just referred to out of the well of the base and place it alongside of the chest temporarily.

(*d*) Lift the chassis out of the chest by means of the two handles, place it on the floor (fig. 24), and engage the two brake levers by moving them until they point outward, longitudinally from the base. Release the screw caster locks by unscrewing the knurled heads as far as they will go.

(*e*) Take the lower mast section and cross-arm carriage assembly and carefully insert the bearing end into the mast section base (fig. 25, part 5) of the chassis. Do this by lifting the assembly at the top by means of the two projecting ends of the column. Never

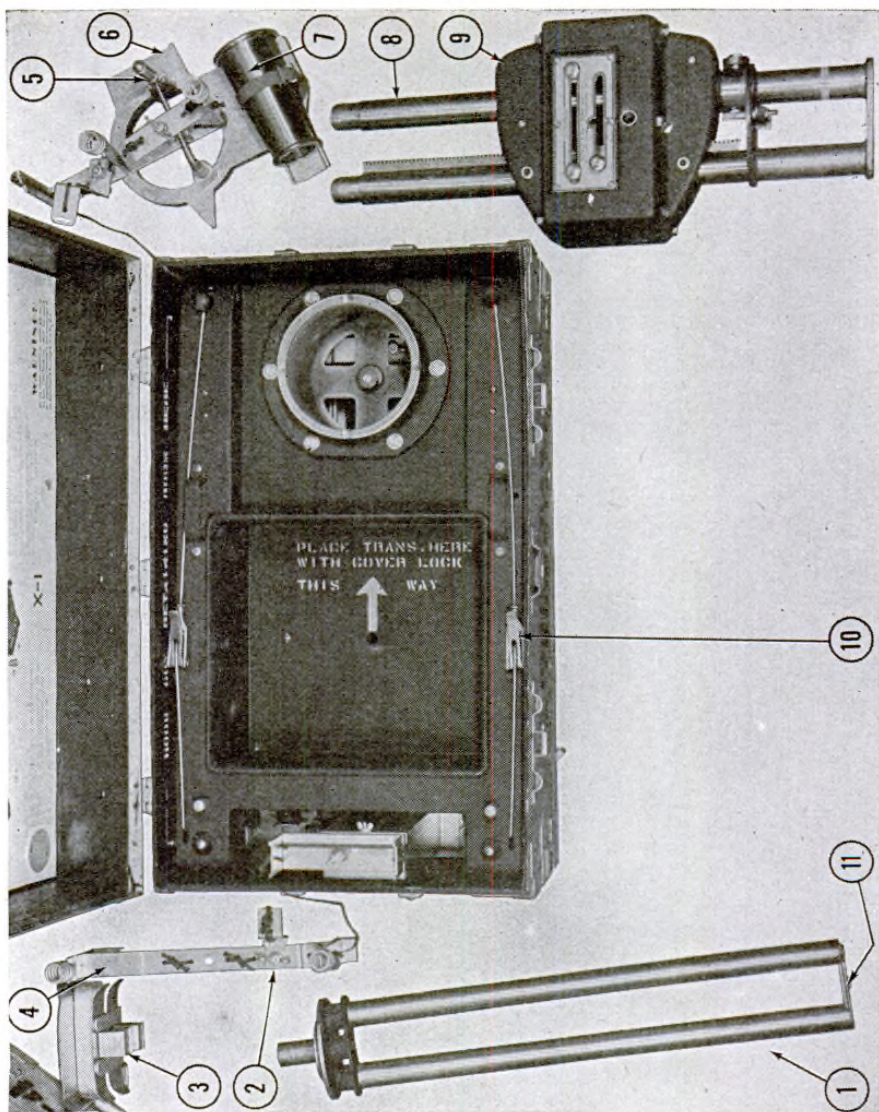
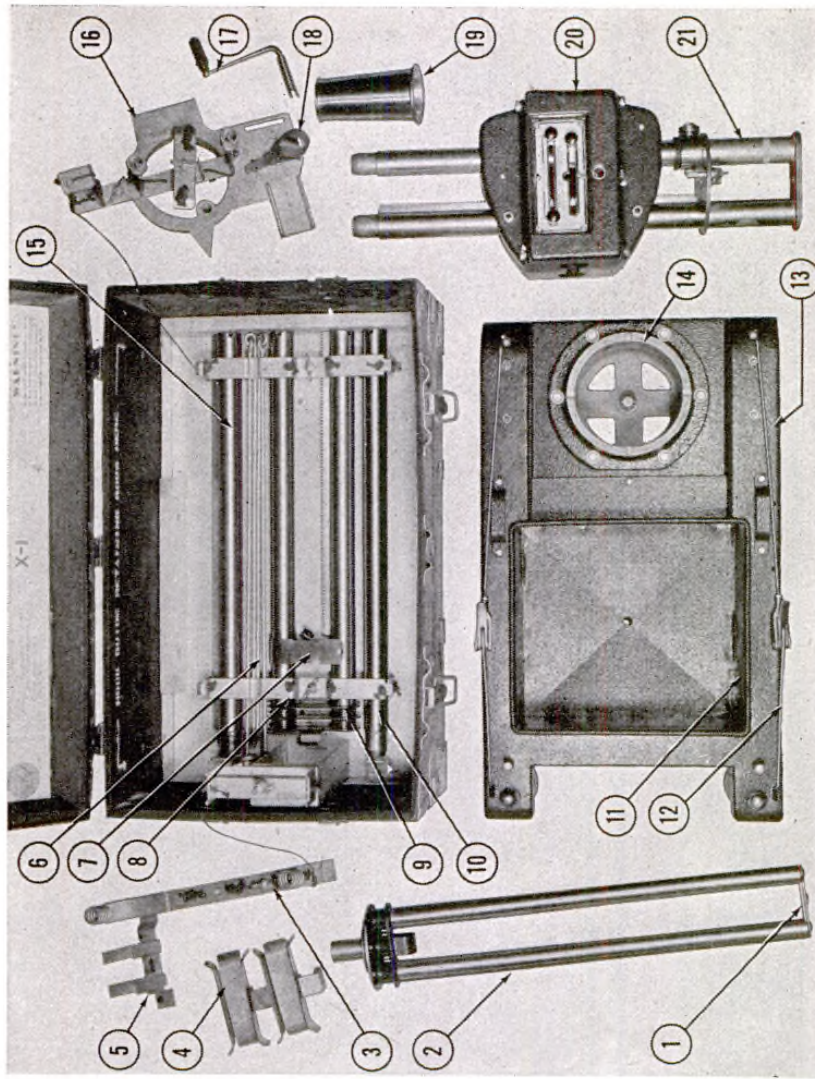

Figure 23. Chest MD X-1, old type, top section removed.

- | <i>Med. Dept.</i> | <i>No.</i> | <i>Nomenclature</i> |
|-------------------|------------|--|
| 1. | 9R15476 | Cross Arm, Twin, Horizontal. |
| 2. | SR00685 | Nut, 5/16 x 18, Wing, 100 to Pkg. |
| 3. | 9R15566 | Support, Shockproof Cable. |
| 4. | 9R15436 | Bracket, Long, Retaining, Cross Arm, Complete. |
| 5. | 9R15524 | Crank, Hand, Complete. |
| 6. | 9R15438 | Bracket, Retaining Cone and Crank, Aluminum, Complete. |
| 7. | 9R15350 | Cone, Radiographic. |
| 8. | 9R15470 | Mast, Bottom Section. |
| 9. | 9R15477 | Carriage, Cross Arm, Complete. |
| 10. | 9R15554 | Rod, Guy, Retaining, Complete. |
| 11. | 9R15484 | Plate, Removable End, Complete. |



- | <i>Med. Dept.</i> | <i>Nomenclature</i> |
|-------------------|---|
| <i>No.</i> | |
| 1. | 9R15484 Plate, Removable End, Complete. |
| 2. | 9R15476 Cross Arm, Twin, Horizontal. |
| 3. | S800685 Nut, 5/16 X 18, Wing, 100 to Pkg. |
| 4. | 9R15566 Support, Shockproof Cable. |
| 5. | 9R15436 Bracket, Long, Retaining, Cross Arm, Complete. |
| 6. | 9R15488 Bolt, Draw, Folding, Complete. |
| 7. | 9R15568 Slide, Cable Support, Complete. |
| 8. | Strap, Hinged, Steel. |
| 9. | 9R15464 Mast, Top Section. |
| 10. | 9R15468 Mast, Center Section, Plain. |
| 11. | Well, Transformer. |
| 12. | 9R15554 Rod, Guy, Retaining, Complete. |
| 13. | 9R15598 Base, Chassis. |
| 14. | 9R15462 Base, Mast Section. |
| 15. | 9R15466 Mast, Center Section, Rack. |
| 16. | 9R15438 Bracket, Retaining, Cone and Crank, Aluminum, Complete. |
| 17. | 9R15524 Crank, Hand, Complete. |
| 18. | 9R15440 Strap, Retaining, Cone. |
| 19. | 9R15350 Cone, Radiographic. |
| 20. | 9R15477 Carriage, Cross Arm, Complete. |
| 21. | 9R15470 Mast, Bottom Section. |

Figure 24. Chest MD X-1, old type, chassis and top sections removed.

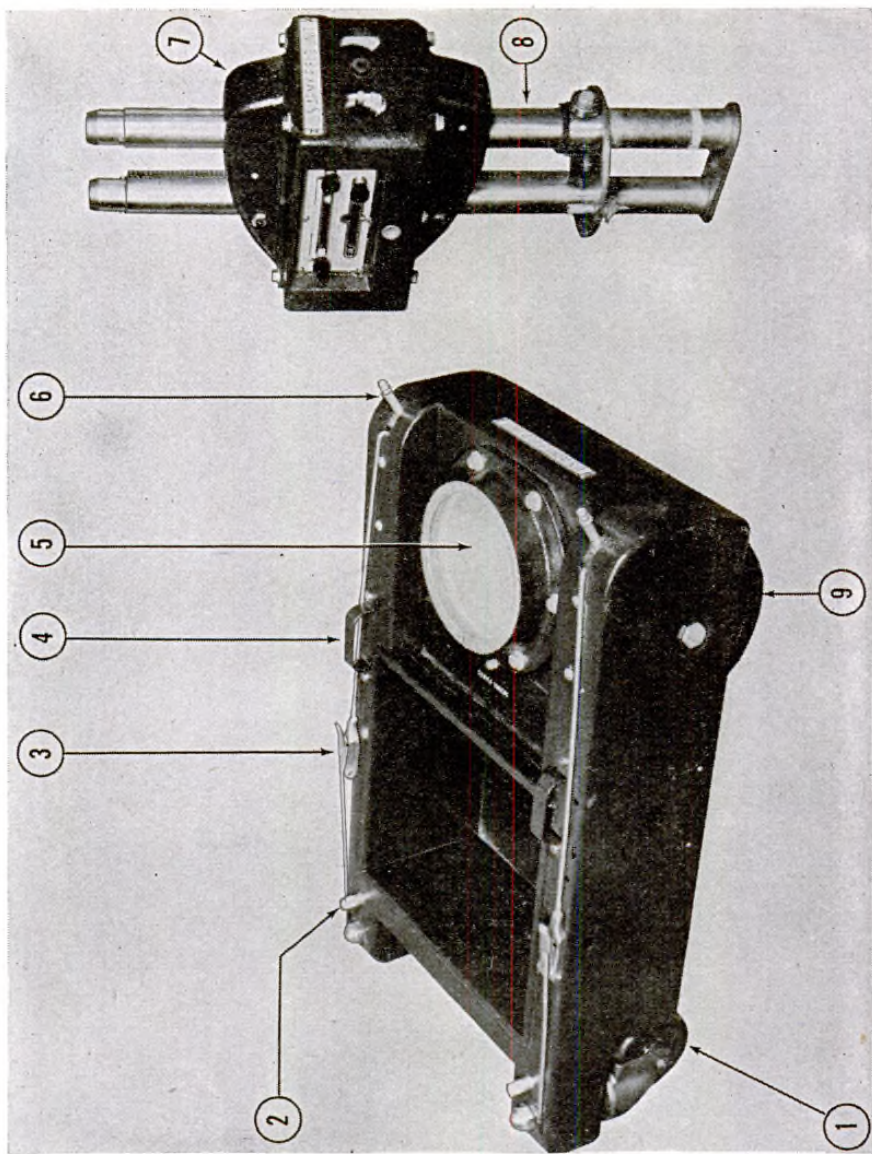

- | <i>Med. Dept.</i> | <i>No.</i> | <i>Nomenclature</i> |
|-------------------|------------|---|
| | 1. | Caster, Mobile, Base, Complete. |
| | 2. | Bolt, $\frac{3}{8}$ -16 x $5\frac{1}{2}$ -Inch, Knurled Head. |
| | 3. | Rod, Guy, Retaining, Complete. |
| | 4. | Handle, Chassis Base. |
| | 5. | Base, Mast Section. |
| | 6. | Lever, Brake. |
| | 7. | Carriage, Cross-Arm, Complete. |
| | 8. | Mast, Bottom Section. |
| | 9. | Wheel, 8-Inch, Mobile Base, Hard Rubber. |

Figure 25. Chassis, lower mast section, and cross-arm carriage, part of Chest MD X-1, old type.

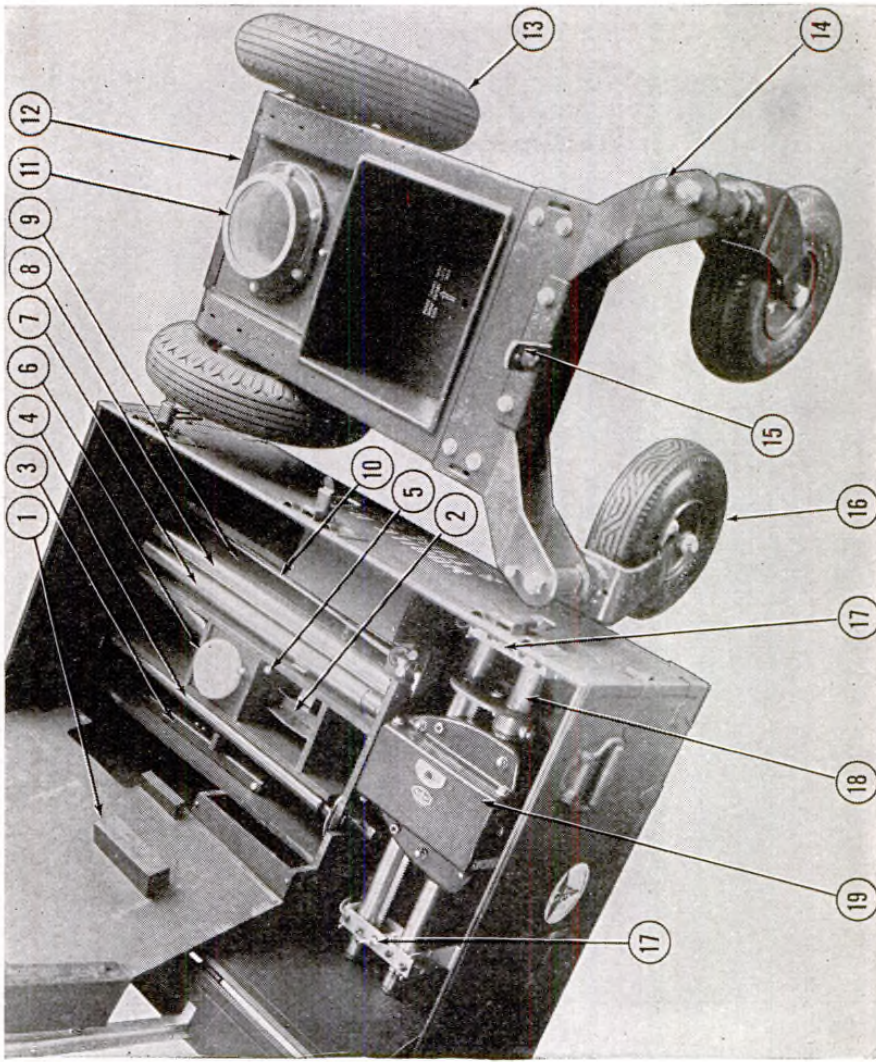

Figure 26. Chest MD X-1, new type, item No. 9609010, with chassis removed.

- | <i>Med. Dept.</i> | <i>Nomenclature</i> |
|-------------------|--|
| No. | |
| 1. | 9R15445 Cover, Compartment, Wood. |
| 2. | 9R15566 Support, Shockproof Cable. |
| 3. | 9R15632 Handle, Base, Complete. |
| 4. | 9R15476 Cross Arm, Twin, Horizontal. |
| 5. | 9R15524 Crank, Hand, Complete. |
| 6. | 9R15002 Cone, Dental. |
| 7. | 9R15468 Mast, Center Section, Plain. |
| 8. | 9R15466 Mast, Center Section, Rack. |
| 9. | 9R15464 Mast, Top Section. |
| 10. | 9R15488 Bolt, Draw, Folding, Complete. |
| 11. | 9R15462 Base, Mast Section. |
| 12. | 9R15638 Lever, Brake, Large Wheels. |
| 13. | 9R15624 Tire, 10 x 3.50-4, 2-Ply. |
| 14. | 9R15580 Bolt, 3/8-16 x 5 1/2-Inch, Knurled Head. |
| 15. | 9R15631 Plate, Mounting, Base Handle. |
| 16. | 9R15622 Tire, 4.00 x 8, 2-Ply. |
| 17. | SR00685 Nut, 5/16 x 18, Wing, 100 to Pkg. |
| 18. | 9R15470 Mast, Bottom Section. |
| 19. | 9R15477 Carriage, Cross-Arm, Complete. |

lift the assembly by the carriage since the lower mast section may drop out and be damaged.

(f) To release the sections on the bottom of the chest, remove the two wing nuts and lift the hinged steel straps. The center mast sections (fig. 24, parts 10 and 15), the top mast section (fig. 24, part 9), and the draw bolts (fig. 24, part 6), may now be taken from the chest.

(2) *New type, 9609010.* (a) Remove the chassis from the chest. This requires two men, one grasping the brake lever and the other lifting the caster support bracket. After the chassis has been removed, lock the foot brakes by pressing down on the brake lever. (See fig. 26, part 12.) Release the casters by turning the two knurled head bolts (fig. 26, part 14), until they are all the way up.

(b) Remove the compartment cover. The chest will now appear as in figure 26.

(c) Unscrew the wing nuts and remove the lower mast section and cross-arm assembly. Carefully place the bearing end of this assembly into the mast base of the chassis. (See fig. 26, part 11.)

(d) Remove the center mast sections and the two folding draw bolts.

(e) Rotate the retaining bracket 90° and remove the top mast section.

(f) The horizontal cross arm, the shockproof cable supports, the hand crank, the radiographic cone, and the dental cone may be removed as needed.

b. THE TABLE UNIT, 9614500 (if furnished).

(1) Open the small trunk (fig. 9) and remove the fluoroscopic screen assembly by unscrewing the screen tie-rod assembly from the left screen holder, and moving the screen holder to the left until the fluoroscopic screen assembly can be taken out. Store the fluoroscopic screen assembly in a place where it will not fall or be broken. Do not remove the fluoroscopic screen cover, 9R05234 (fig. 27), until ready for use.

(2) Remove the two cotter pins which help to retain the hinged frame. Unscrew the short, leg holding screw and lift the hinged frame until it rests against the top of the trunk.

(3) Remove the table end resting on top of the table rails.

(4) Remove the table rail sections being careful not to drop the tie rods which remain inside the end of the rails during shipment. If the trunk is equipped with a protective shield (fig. 18), be sure to disengage it from the two rails which secure it in place. Do not expose the rails to extensive moisture.

(5) Remove the remaining table end from the bottom of the trunk.

(6) The protective shield bracket, the protective shield, the detachable legs, the screen arm and shutter knobs, either 9R05244

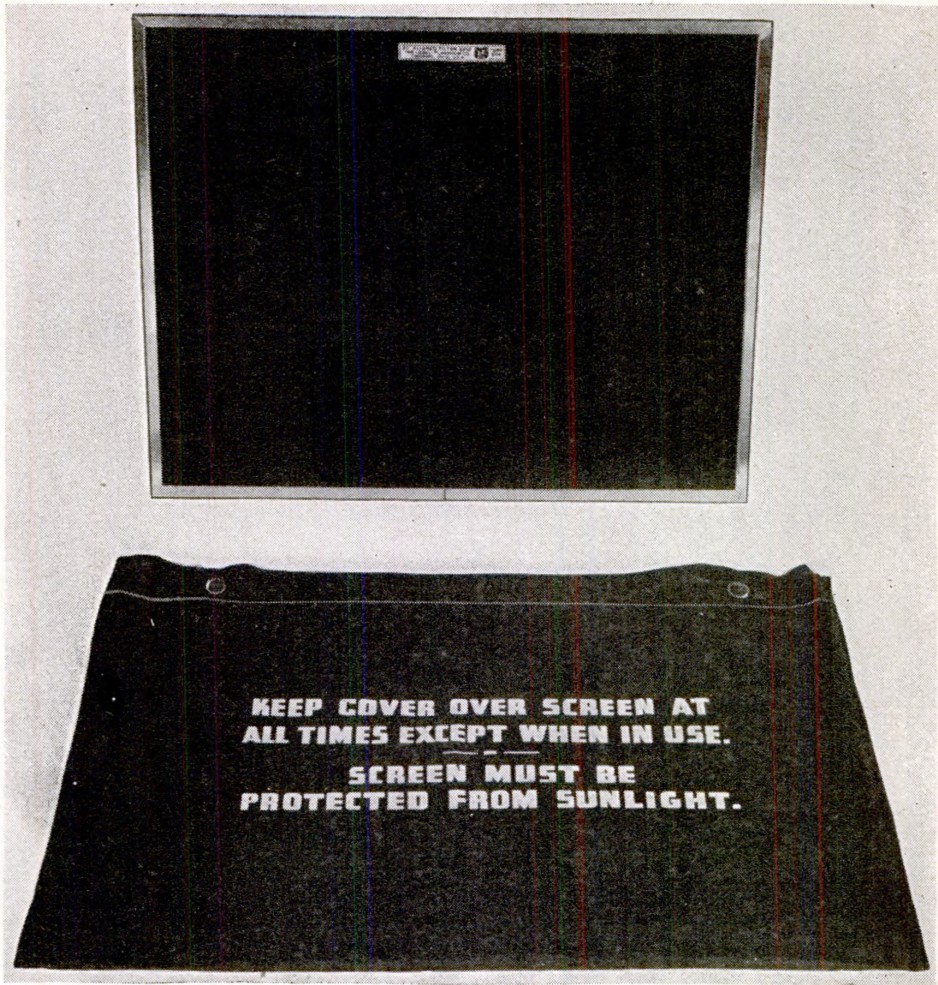

Figure 27. Fluoroscopic screen cover, part No. 9R05234, and stationary grid part No. 9R05240.

(fig. 10), or 9R05246, and the depth marker (fig. 11, part 6), may be removed as desired.

(7) Open the large trunk, 9R05767 (fig. 8), and remove the angulating housing assembly, 9R05545 (fig. 8). To free the assembly, lift the corner clamp, raise the carriage support arm, and pull the main vertical column out of the tube-stand support assembly. Remove the shutter assembly.

(8) To remove the L member assembly, release the L member clamp, the saddle web strap, and the shutter arm clamp. (See fig. 28.)

(9) To remove the carriage, release the two carriage clamps, the locking handle of the mast support, and the hinged handle assembly of the mast support. The carriage can now be pulled straight up and off the carriage post.

(10) To remove the two panel mountings for the cassette lifting device, release the two bracket clamps and lift out the mountings.

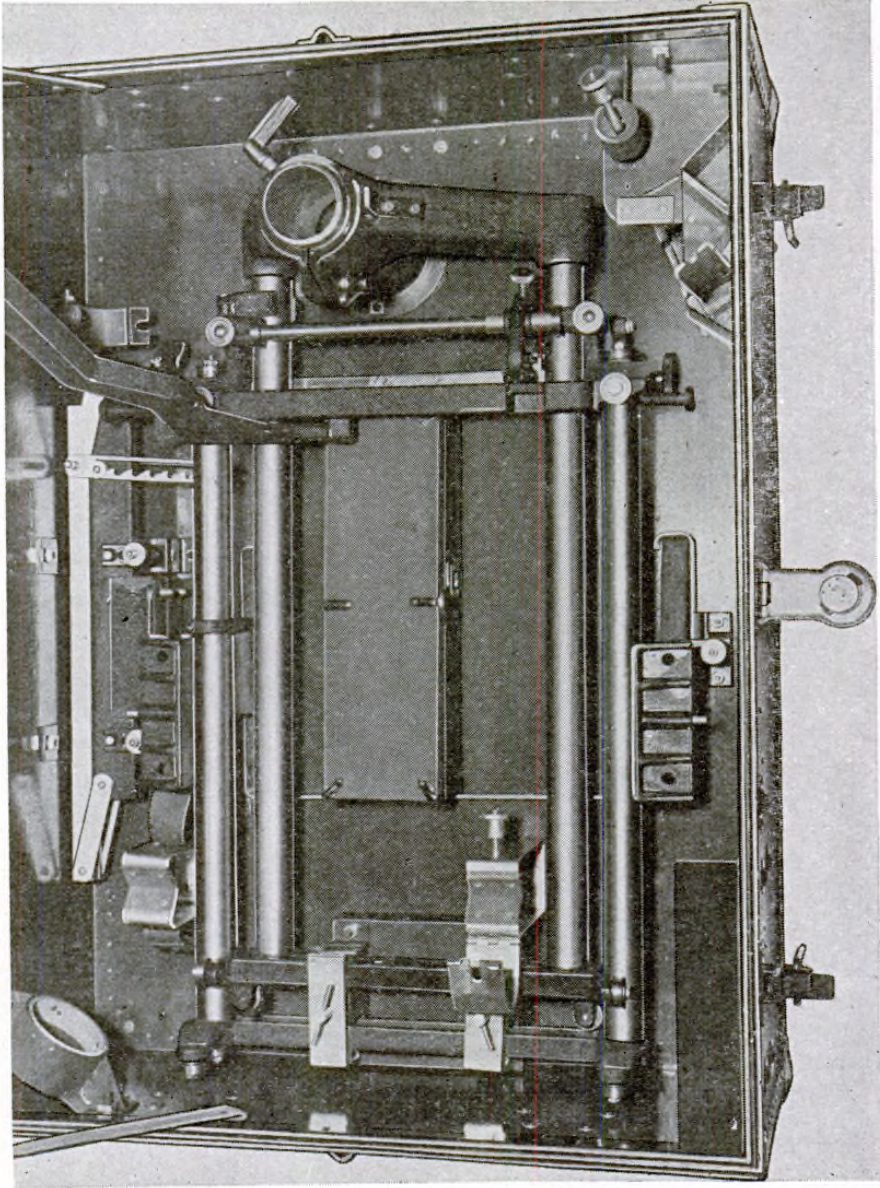
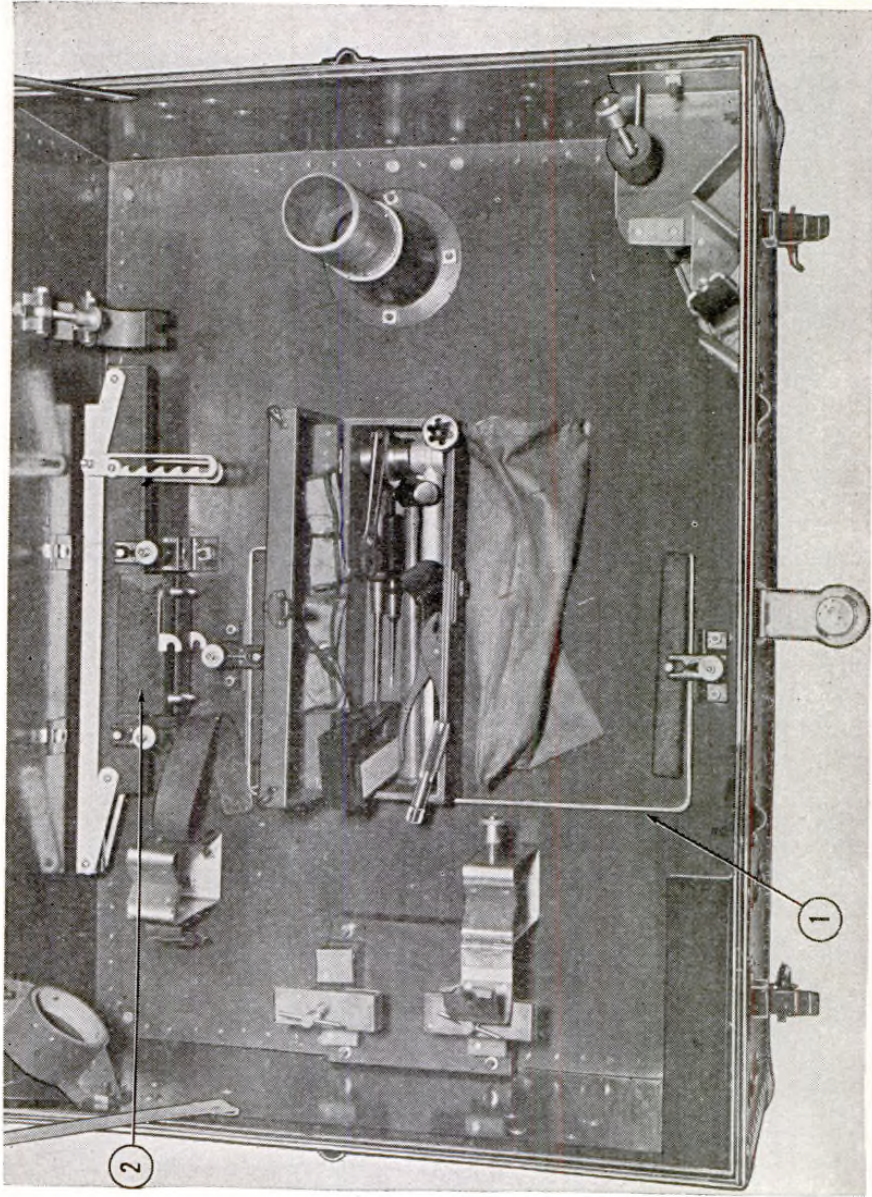

Figure 28. Large trunk 9R05767, less angulating housing, L member and screen shutters.



- | <i>Med. Dept.</i> | <i>Nomenclature</i> |
|-------------------|--|
| <i>No.</i> | |
| 1. 9R05994 | Gauge, Checking, Focal Distance, Complete. |
| 2. 9R05962 | Mounting, Panel, Right, Complete. |

Figure 29. Large trunk, 9R05767, with focal distance checking gauge and cassette lifting device.

- | <i>Med. Dept.
No.</i> | <i>Nomenclature</i> |
|---------------------------|---|
| 1. | Mounting, Protective Cover. |
| 2. | Cover, Protective, Cable Terminal, Complete. |
| 3. | Drawer, Cables, Complete. |
| 4. | X-ray Field Unit Shockproof Cable. |
| 5. | Cloth, Cleaning, Cable Terminals. |
| 6. | Petrolatum Tube. |
| 7. | Cable, Blower, Complete. |
| 8. | Strap, Retaining, Cables, Complete. |
| 9. | Ring, Lower, Retaining, Tube Head: Part of chest MD X-3. |
| 10. | Strap, Retaining, Tube Head, Complete. |
| 11. | Ring, Upper, Retaining, Tube Head: Part of chest MD X-3. |
| 12. | Cradle, Retaining, Tube Hanger: Part of chest MD X-3. |
| 13. | Plug, Tube Receptacle, Complete. |
| 14. | Screw, Thumb, Retaining. |
| 15. | X-Ray Field Unit Tube, X-Ray. |
| 16. | Hanger, Tube Head. |
| 17. | Cover, Cylindrical Compartment: Part of chest MD X-3. |
| 18. | Filters and Lead Aperture Plates: Furnished in cylindrical compartment. |

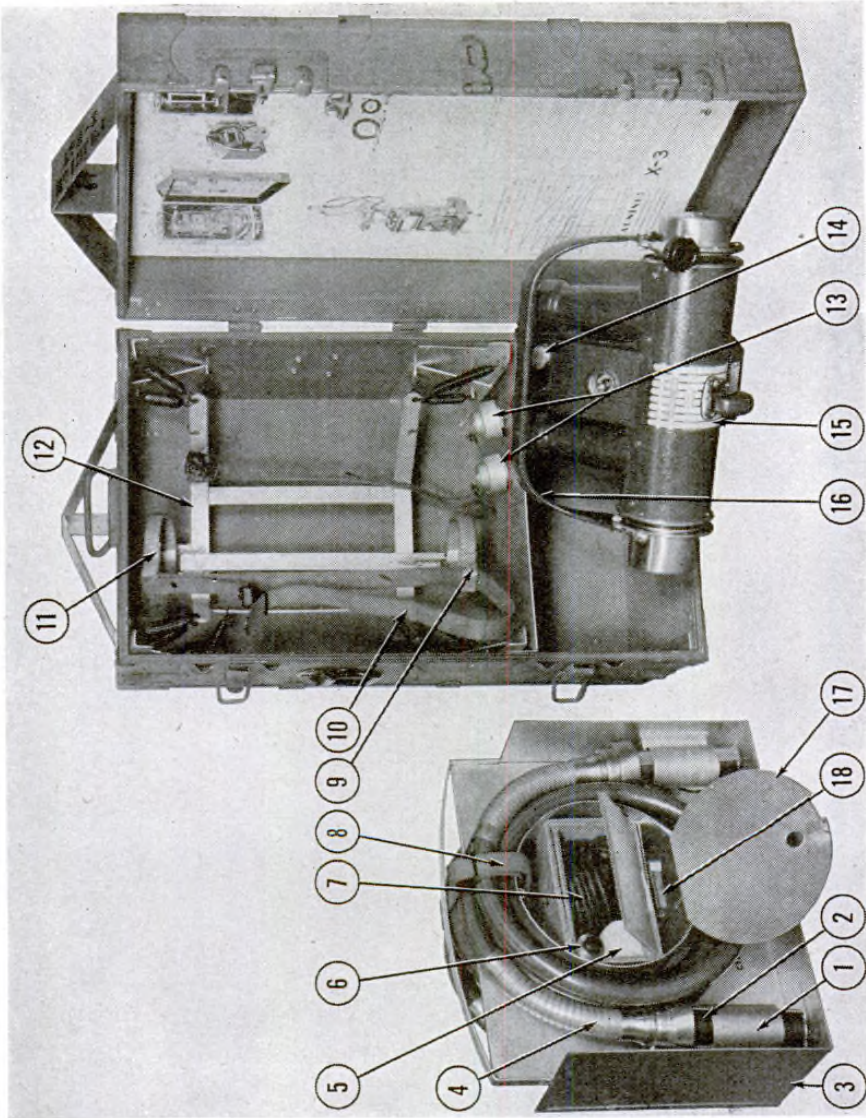

Figure 30. X-ray field unit tube unit, Chest MD X-3, item No. 9608700, cable drawer and tube head removed.

(11) The focal distance checking gauge (fig. 29, part 1) and the cassette lifting device panel (fig. 29, part 2) may be removed when needed.

c. CHEST MD X-3 (9608700). (1) Place the chest in a vertical position (fig. 30), open chest and remove the tube head. This is done by first taking out the two cable receptacle plugs and releasing the braided strap from the buckle. A slight pressure on the upper retaining ring (fig. 30, part 11) will release the upper end of the tube. Grasp this upper end and lift upward until the tube is released from its mounting. Take particular care of the two moulded cable receptacles when removing the tube head since they are easily broken when struck by any hard object.

(2) The shockproof cables (fig. 30, part 4), can be removed next by pulling the cable shipping drawer (fig. 30, part 3), out of the chest and placing the drawer as in figure 30. Release the braided strap from the buckle. Pull the cable terminal protectors out of their sockets to the limit of the cord length and unscrew the protectors from the cable terminals.

(3) The blower motor cable (fig. 30, part 7), as well as the aluminum filters and lead aperture plates (fig. 30, part 18), may be removed by opening the cylindrical compartment door in the center of the cable shipping drawer.

d. CHEST MD X-4 (9608808 or 9608810). (1) Turn the two large wing nuts (fig. 7, part 3), until the two remaining clamps (fig. 7, part 2), can be lifted out of the holes in the handle.

(2) The control unit may now be removed and the outer and rear compartments opened.

(3) The left compartment contains the X-ray operator's goggles and the footswitch assembly. The rear compartment contains the line cable and protective shield. The right compartment contains the lead gloves, localizer lamps, and the hand timer.

10. Assembling

a. WHEN CHEST MD X-1, (NEW TYPE OR OLD TYPE), IS SUPPLIED. (1) After the chassis, the lower mast section, and cross-arm carriage have been assembled, join the two separate center sections of the vertical mast to the corresponding lower mast columns.

(2) Remove the end plate assembly of the horizontal cross arm and carefully insert the twin tubes of this arm into the end of the vertical cross-arm carriage identified by the nameplate "U. S. ARMY FIELD UNIT." Be sure to guide the twin tubes through the double set of ball bearings and through the shift lock sleeve carefully. Insert the horizontal tube arm into the carriage the full distance and replace the end plate assembly to its original position. (See fig. 31.)

(3) Complete the mast assembly by joining the upper section of the mast to the center mast sections.

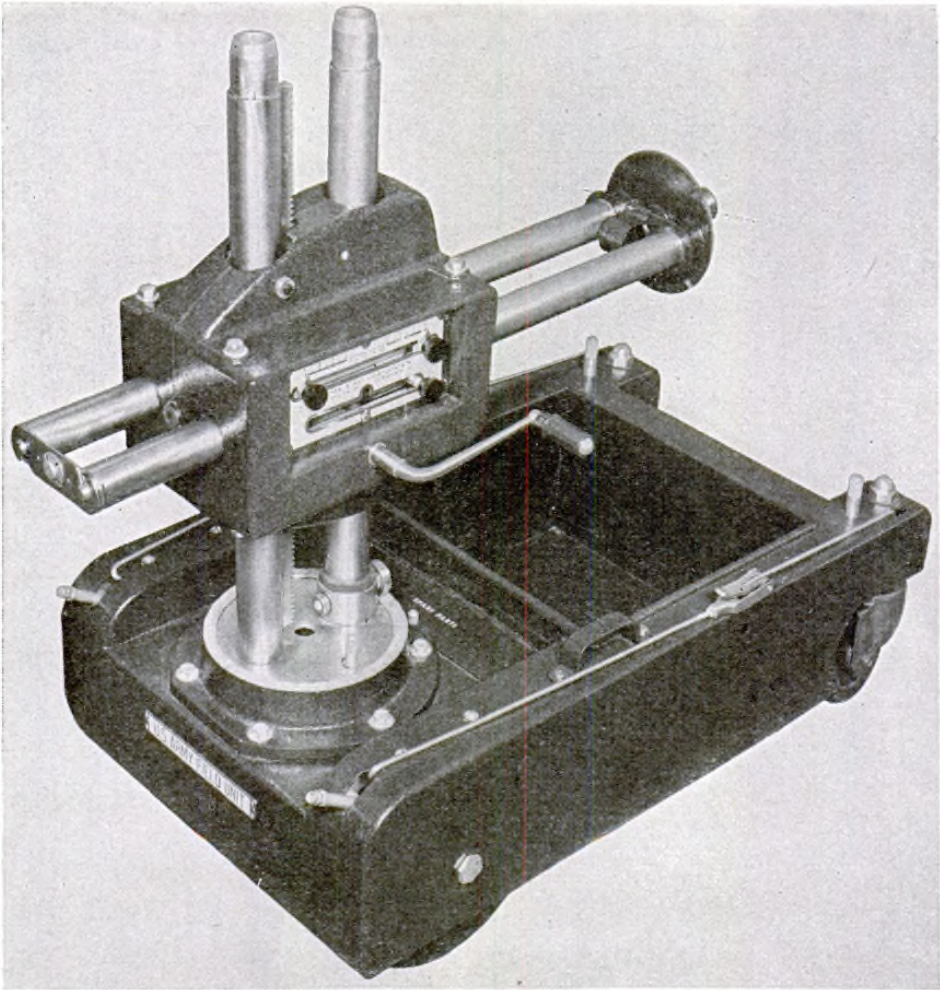

Figure 31. Chassis, lower mast section, cross-arm carriage, part of Chest MD X-1, old type, item No. 9609005.

(4) Unfold the draw bolts and insert them into the top of the mast. Turn the wing screws so that the threaded ends of the draw bolts will engage. Tighten the draw bolts to make the entire mast assembly rigid.

(5) Insert the high-tension transformer into the well of the carriage. The lock side of the transformer must be facing the mast.

(6) Release and fold back the cover of the transformer chest.

(7) Insert the hand crank into the socket provided on the cross-arm carriage.

(8) Raise the carriage up two-thirds of its travel.

(9) Remove the two cable supports from the chest and place them in position on the slide provided on the top section of the mast. The slide should be approximately at eye level when attaching the supports. (See fig. 32.)

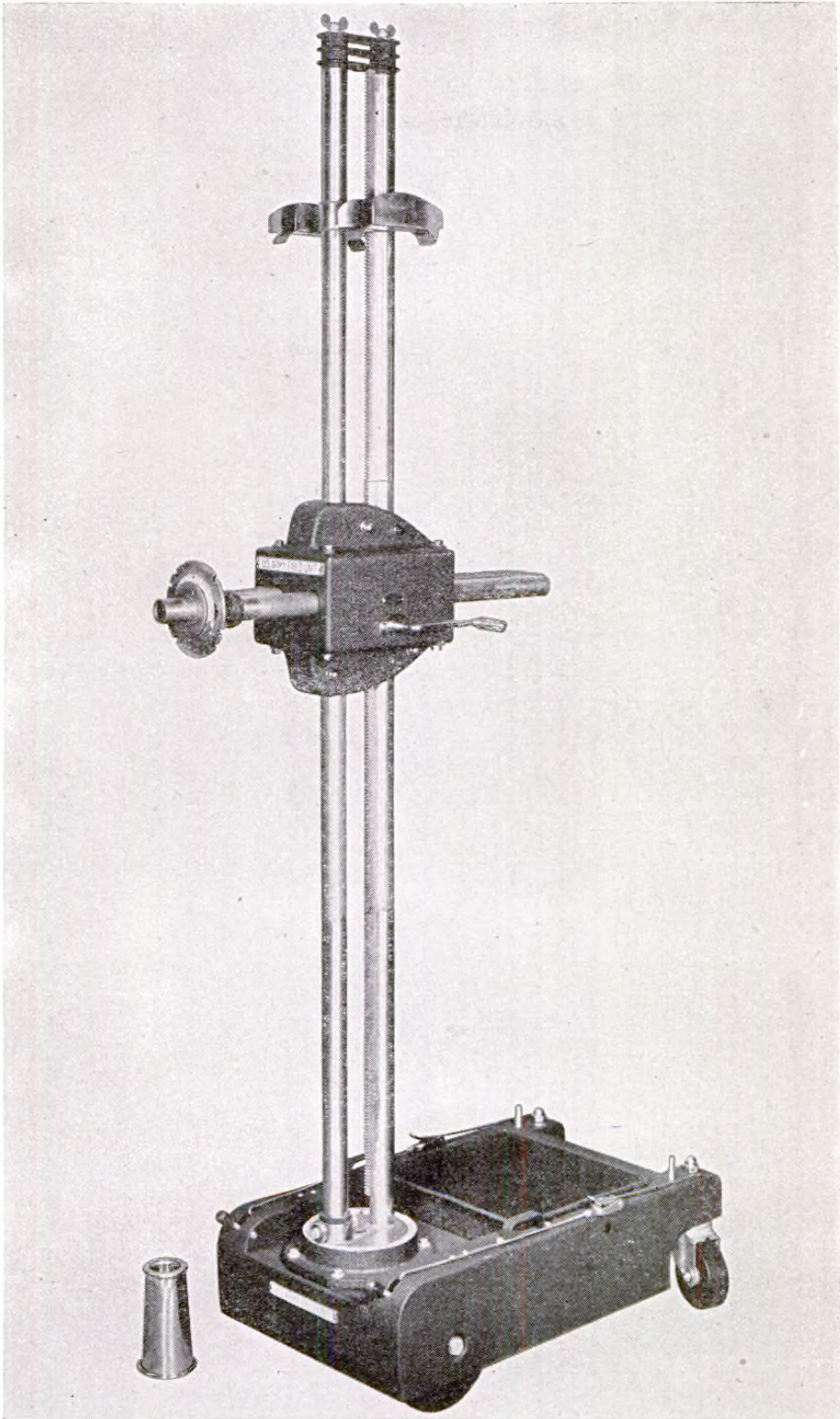

Figure 32. Chassis, mast and cross-arm carriage, part of Chest MD X-1, old type, item No. 9609005.

(10) When assembling it is advisable to mount the base handle so that the unit may be moved more easily. (New type).

(11) Inflate the tires to 35 pounds pressure. (New type).

(12) Carefully remove the cables, one at a time, from the shipping drawer. Be sure that the four cable inserts as well as the four cable receptacles are clean and dry, and approximately at the temperature of the location in which the unit is to be used. Do not touch the cable inserts or receptacles after they have been cleaned. Apply a liberal coating of vaseline to the cable inserts by means of a clean stick or cloth.

(13) Remove the two corks from the transformer cable receptacles. Insert one end of each cable into a transformer receptacle, screw down the threaded cap tightly, and uncoil the cables. Place the cables over the support as shown in figures 1 and 2, and let the remaining cable inserts hang free.

Caution: Be certain the transformer is in the well of the carriage before mounting tube head.

(14) To attach the tube head to the horizontal cross arm, loosen the thumbscrew on the tube hanger in order to allow the clamp to pass over the tapered retaining ring of the horizontal cross arm. Lift the tube head and hanger so that the mounting bearing of the hanger lines up with the projecting part of the horizontal cross arm. Push and rotate the mounting bearing on the projecting part until the tube hanger is completely engaged. Screw down the thumbscrew until the clamp is pulled down over the tapered retaining ring and tube head is secure.

(15) The tube ends of the cables may now be pushed into the tube cable receptacles and threaded down tightly. Be sure that one cable connects the "anode" receptacle of the transformer and the "anode" receptacle of the tube head. Note that the two shock-proof cables are alike, and that the two terminals of each cable are of the same construction.

(16) Remove the control unit from the chest and place it in position on top of the transformer. (See figs. 1 and 2.) The rear terminal panel of the control should be facing the mast.

(17) Secure the control unit to the transformer and chassis by means of the two guy retaining rods still attached to the chassis. Pass the short end of each rod under the control handle and engage the hook in the hole provided in the handle escutcheon. Engage the hooks of the long sections in the holes provided in the chassis. Pull down the catches of the retaining rods to clamp the control unit and transformer tightly to the base.

(18) Use the two short web straps to fasten the cables to the rear of the control.

(19) The long center strap is to be used for fixation of the horizontal cross arm or the mast while moving the unit between rooms.

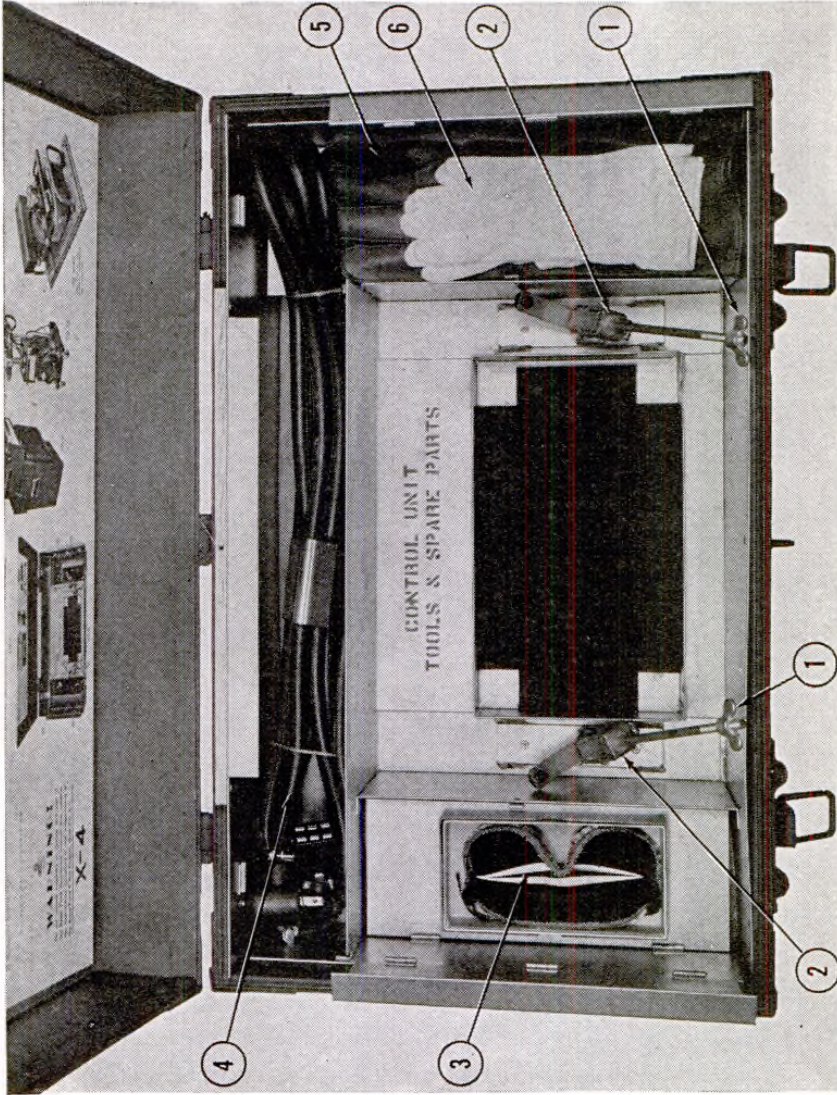

- | <i>Med. Dept.</i> | <i>Nomenclature</i> |
|-------------------|---|
| No. | |
| 1. SR00685 | Nut, 5/16 x 18, Wing, 100 to PKG. |
| 2. 9R15460 | Clamp, Retaining, Control, Complete. |
| 3. 6031000 | Goggles, X-Ray Operators. |
| 4. 9R15388 | Cable, Line, Complete. |
| 5. 6030000 | Gloves, Radiopaque. |
| 6. | Gloves, White, Part of Radiopaque Gloves. |

Figure 33. X-ray field unit control unit, Chest MD X-4, 110-volt, 60-cycle, item No. 9608808 or X-ray field unit control unit, Chest MD X-4, 110-220-volt, 60-cycle, item No. 9608810 control unit removed.

(20) Plug the female (tube) end of the blower cable into the receptacle provided on the tube head and the male (control) end of this cable into the receptacle on the rear of the control unit.

(21) Remove the transformer cable plug which is held in position in the transformer case by means of the clip provided, and insert the plug into the proper male receptacle on the rear of the control.

(22) Remove the main line cable (fig. 33, part 4) from the control chest and plug it into the receptacle provided on the rear of the control.

(23) If the rubber gloves and goggles (fig. 33, parts 6 and 3) will be used, remove them from the control chest; otherwise place them temporarily in the long compartment at the rear of the chest.

(24) With these accessories removed, release the catches holding the two covers of the lower compartments and remove the hand timer and footswitch.

(25) Connect the timer and footswitch to the rear control panel and support their cables on hooks provided on either side of the control unit.

(26) The line cable should be coiled up in a roll about 12 to 15 inches in diameter and placed over the hook provided in the cover of the transformer chest, when not connected to the supply line.

(27) The cone which may be attached to the tube head will be found mounted on the aluminum casting in the chassis and mast chest.

(28) Aluminum filters and lead aperture plates for the tube head are found in the center compartment of the cable drawer.

b. WHEN X-RAY FIELD UNIT TABLE UNIT IS SUPPLIED. When assembling the X-ray field unit with table unit, set up the table with the L member in position for vertical chest roentgenography.

(1) Assemble the rail sections to make three complete rails and place these rails into the cut-outs of the table ends. Be sure that the rails extend into the recesses bored in the cut-outs and that the hinged plates are in the correct position; that is, the table end pillows (fig. 34, part 2) and the floor plates facing toward the center of the table. Tighten tie rods.

(2) Raise the table ends and slide the detachable legs into position on the operating side of the table.

(3) Place the carriage (figs. 35, 36, and 37) on the top rails opposite the operating side, then lower the front of the carriage into position. Be sure that the pointer carriage lock screw (fig. 15, part 1) is loose so that the pointer lock casting clears the rail, that the lock for lengthwise carriage travel is in position, and that the bearing of the carriage support arm rests on the lower rail.

(4) Tighten locks for lengthwise and crosswise carriage travel.

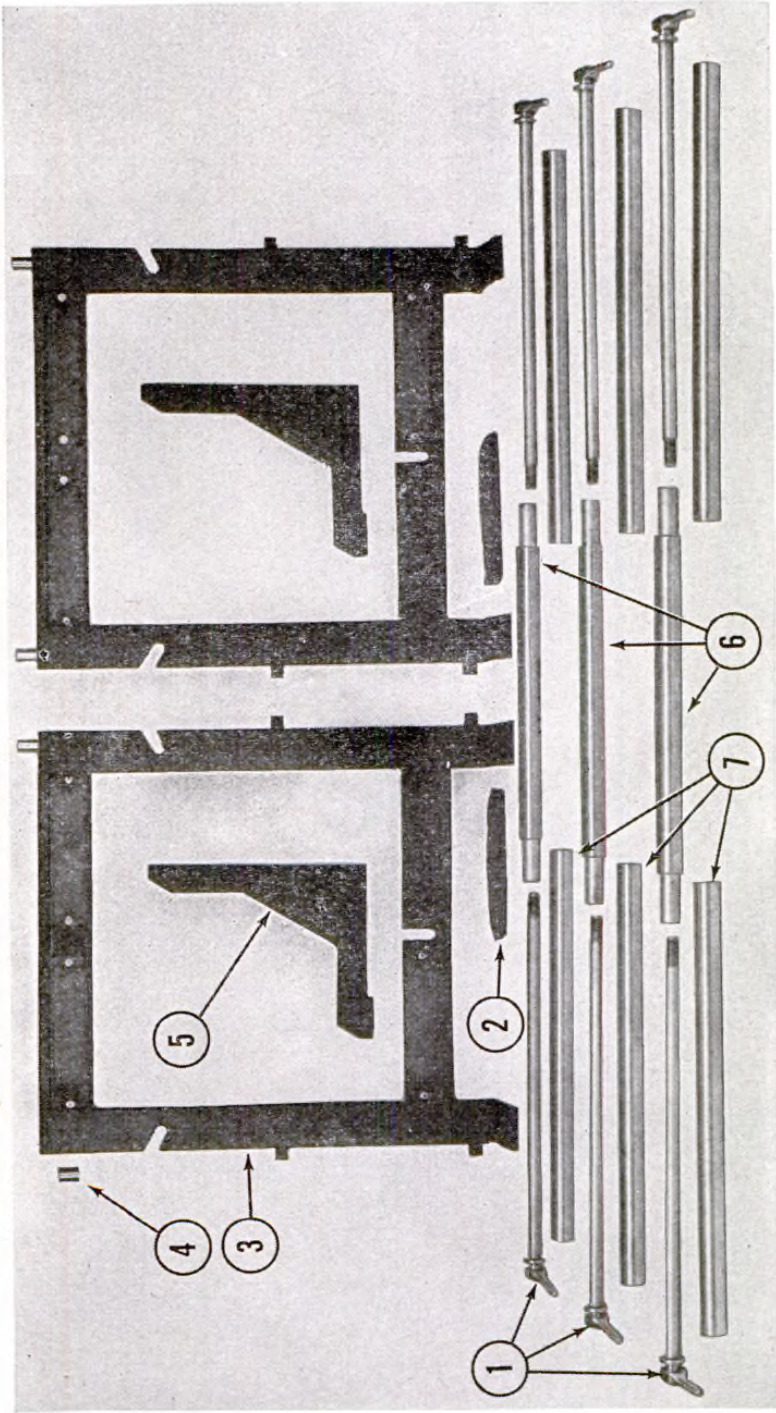

Med. Dept. Nomenclature
 No. 9R05208 Rail, Center.
 6. 9R05408 Rail, End, Table.
 7.

Med. Dept. Nomenclature
 No. 9R05404 Table End.
 3. 9R05206 Stop, Litter.
 4. 9R05414 Leg, Detachable, Table.
 5.

Med. Dept. Nomenclature
 No. 9R05210 Rod, Tie and Handle.
 1. 9R05406 Pillow, Table End.
 2.

Figure 34. Table unit, disassembled.

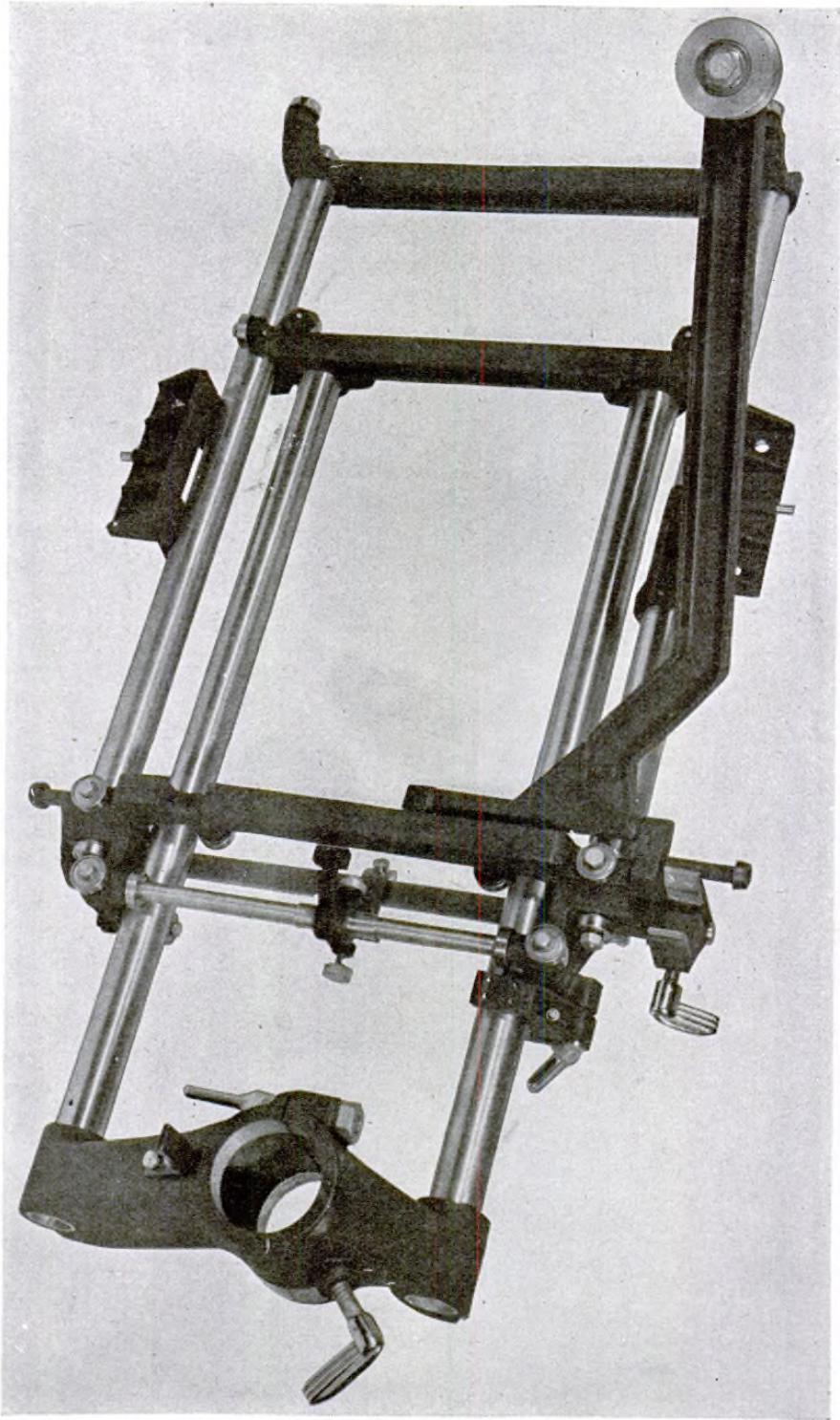

Figure 35. Carriage, part No. 9R05423, bottom view.

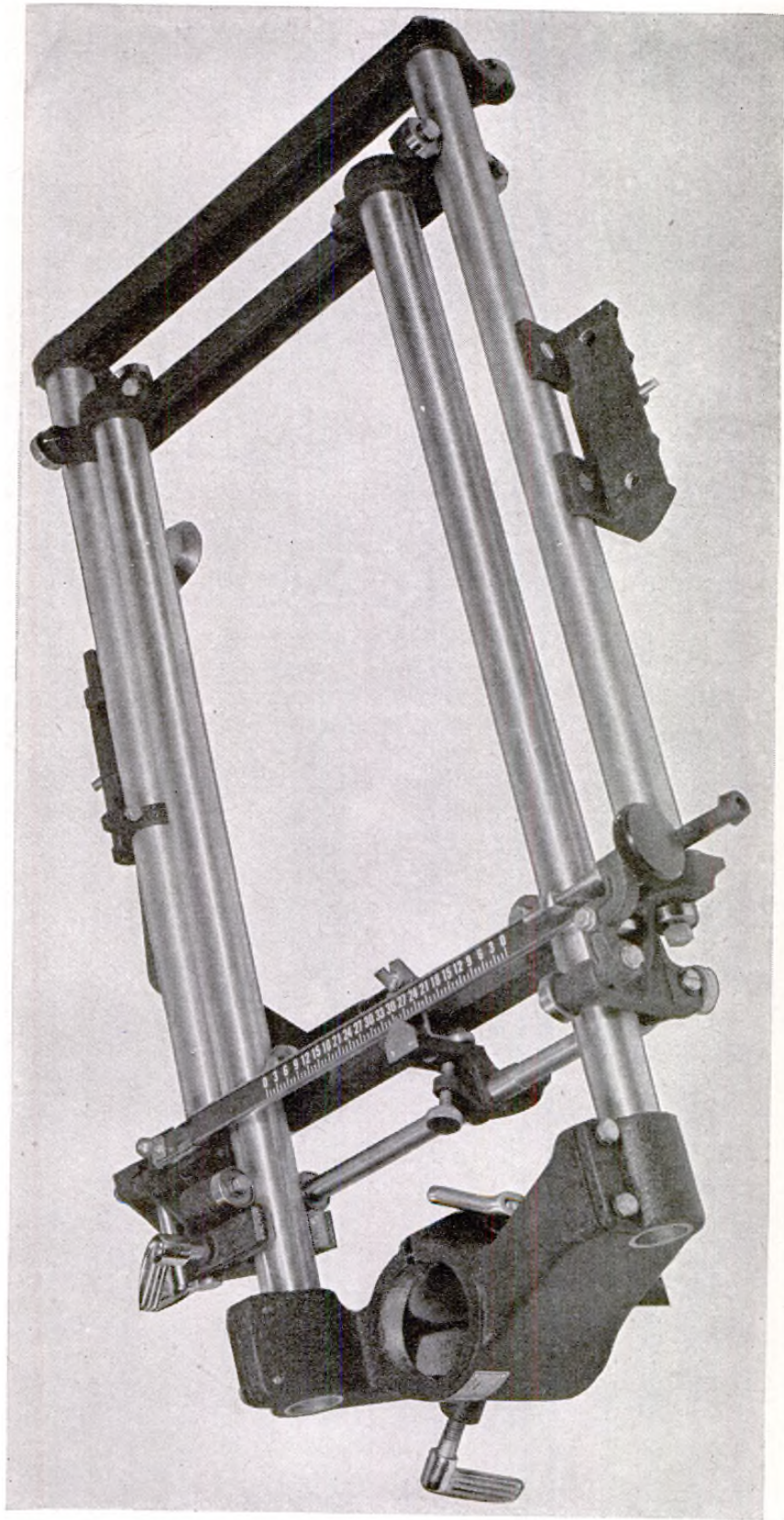

Figure 36. Carriage, part No. 9R05423, top view.

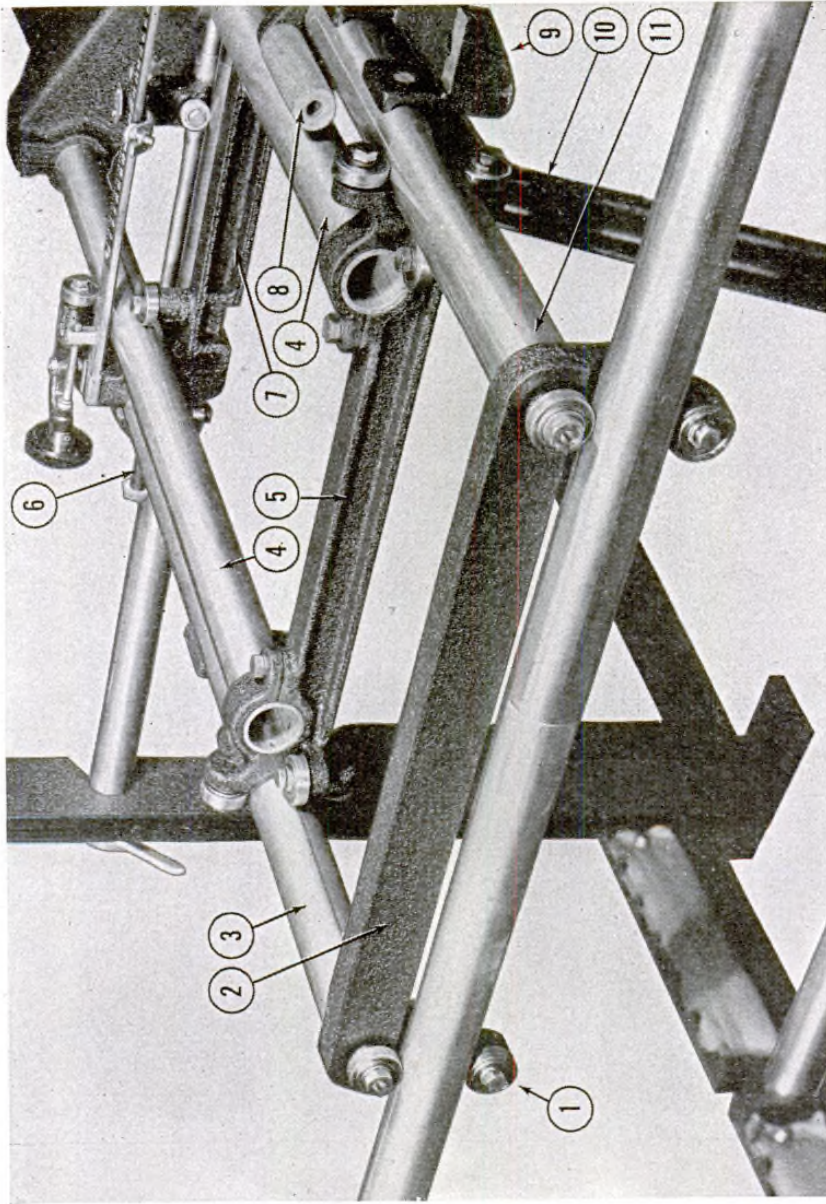
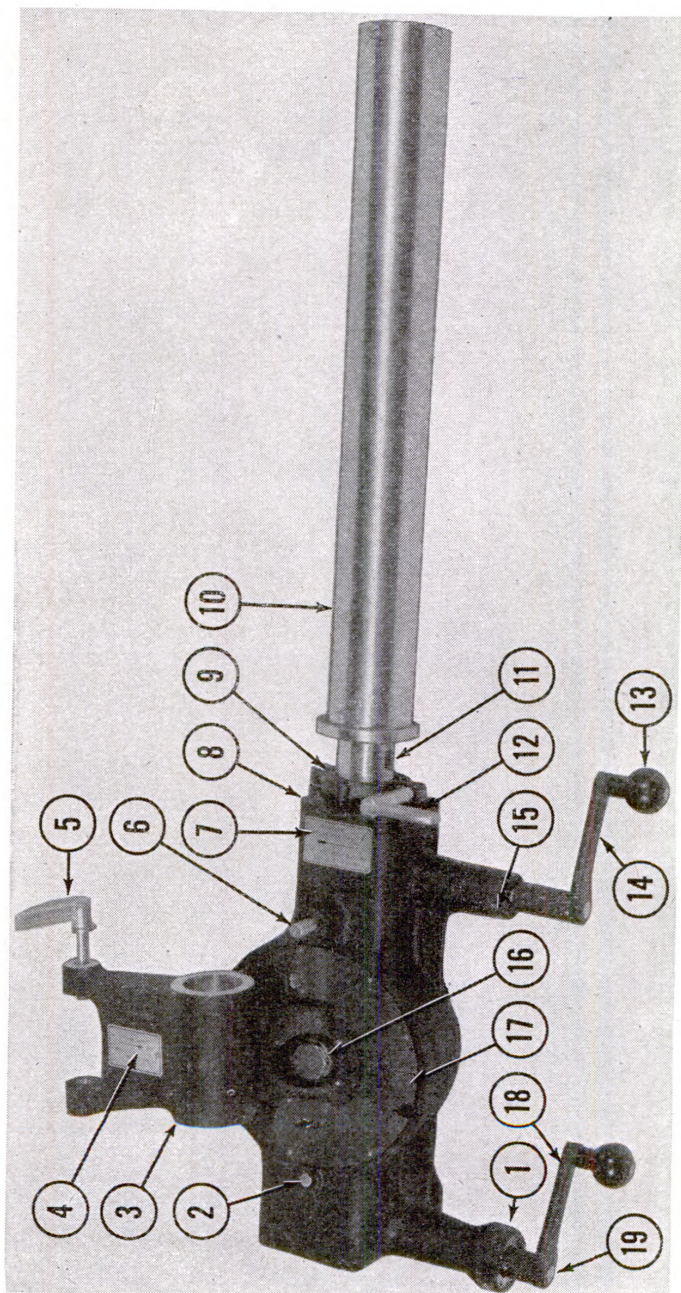

Figure 37. Carriage, part No. 9R05423, rear view.

| Med. Dept. No. | Nomenclature |
|-------------------|--|
| 1. 9R05536 | Bearing, Ball, 1.1815-Inch Diameter. |
| 2. 9R05472 | Tie Casting, Rear, Lengthwise Carriage. |
| 3. 9R05426 | Rail, Right Tie, Lengthwise Carriage. |
| 4. 9R05428 | Rail, Crosswise Carriage. |
| 5. 9R05470 | Tie Casting, Rear, Crosswise Carriage. |
| 6. 9R05444 | Post, Bumper, Long, Lengthwise Carriage. |
| 7. 9R05474 | Tie Casting, Front, Lengthwise Carriage. |
| 8. 9R05530 | Bushing, Bumper, Crosswise Carriage. |
| 9. 9R05468 | Bracket, Grid Base, Lengthwise Carriage rails. |
| 10. 9R05458 | Arm, Support, Carriage. |
| 11. 9R05424 | Rail, Left Tie, Lengthwise Carriage. |



| Med. Dept. No. | Nomenclature | Med. Dept. No. | Nomenclature | Med. Dept. No. | Nomenclature |
|----------------|--|----------------|--|----------------|---|
| 1. | 9R05620 Collar, Retaining, Worm Shaft. | 7. | 9R05562 Nameplate, Lock Housing. | 14. | 9R05652 Crankshaft and Long Crank, Complete |
| 2. | 9R05618 Shaft, Eccentric, Angulating Housing. | 8. | 9R05654 Support, Angulating Housing. | 15. | 9R05564 Nameplate, "Up-Down," Angulating Housing. |
| 3. | 9R05658 Cover, Angulating Housing. | 9. | 9R05202 Clamp and Lock, Rotation. | 16. | 9R05636 Screw, Center, Angulating Housing |
| 4. | 9R05570 Nameplate, Instruction, Disassembling "L" Member Handle. | 10. | 9R05582 Column, Vertical, Main. | 17. | 9R05680 Scale, Angulation. |
| 5. | 9R05630 Handle, Lock, Screen Arm, Complete. | 11. | 9R05588 Tube, Telescoping. | 18. | 9R05648 Crank, Short Shaft. |
| 6. | 9R05600 Screw, Vertical Stop, "L" Member. | 12. | 9R05212 Handle, Locking, Angulating Housing. | 19. | 9R05546 Cap, Crank Handle, Angulating Housing |
| | | 13. | 9R05624 Knob, Ball, Crank. | | |

Figure 38. Angulating housing, part No. 9R05545.

(5) Turn the long shaft crank (fig. 38, part 14), until the flange of the main vertical column coincides with black line on the telescoping tube.

(6) Insert the main vertical column (fig. 38, part 10), of the angulating housing assembly into the mast support. Be sure that the key on the flange of the main vertical column fits into the slot at the rear of the mast support.

(7) Secure the main vertical column by means of the hinged tube lock handle of the mast support.

(8) Turn the short shaft crank, 9R05648 (fig. 38, part 18), so that the angulating housing cover is turned to the position shown in figure 38 and screw it on the flange of the L member. Unscrew the shutter rods cap from the L-shaped member.

(9) Insert the L-shaped member assembly into the hole provided in the angulating housing and tighten the lock handle. (See fig. 39, part 3 and fig. 40, part 5.)

(10) After the X-ray field unit is unpacked as discussed in paragraph 9a, c, and d, section V, position transformer chest in a convenient place on the operating side of the table.

(11) Release and fold back the cover of the transformer chest.

(12) To attach the tube head to the end of the L member, loosen the thumbscrew on the tube hanger and allow the clamp to pass easily over the flange of the L member. Lift the tube head and hanger so that the mounting bearing of the hanger lines up with the flange of the L member. Push and rotate the mounting bearing on the flange until the tube hanger is completely engaged. Screw down the thumbscrew until the clamp is pulled down over the tapered retaining ring and the tube head is secure.

(13) Carefully remove the cables, one at a time, from the shipping drawer. Be sure that the four inserts as well as the four cable receptacles are clean, dry, and approximately at the temperature of the location in which the unit is to be used. Do not touch the cable inserts and receptacles after they are cleaned. Apply a liberal coating of vaseline to the cable inserts by means of a clean stick or cloth.

(14) Remove the two corks from the transformer cable receptacles, insert one end of each cable into transformer receptacle, screw down the threaded caps tightly, and uncoil the cables. Place the cables over the L member and insert the cable inserts into the tube cable receptacles and screw down the threaded caps tightly. Be sure that one cable connects to the "anode" receptacle of the transformer and the "anode" receptacle of the tube head, and the other to the "cathode" receptacle of the transformer and the "cathode" receptacle of the tube head. Note that the two shock-proof cables are alike, and that the two cable inserts of each cable are of the same construction.

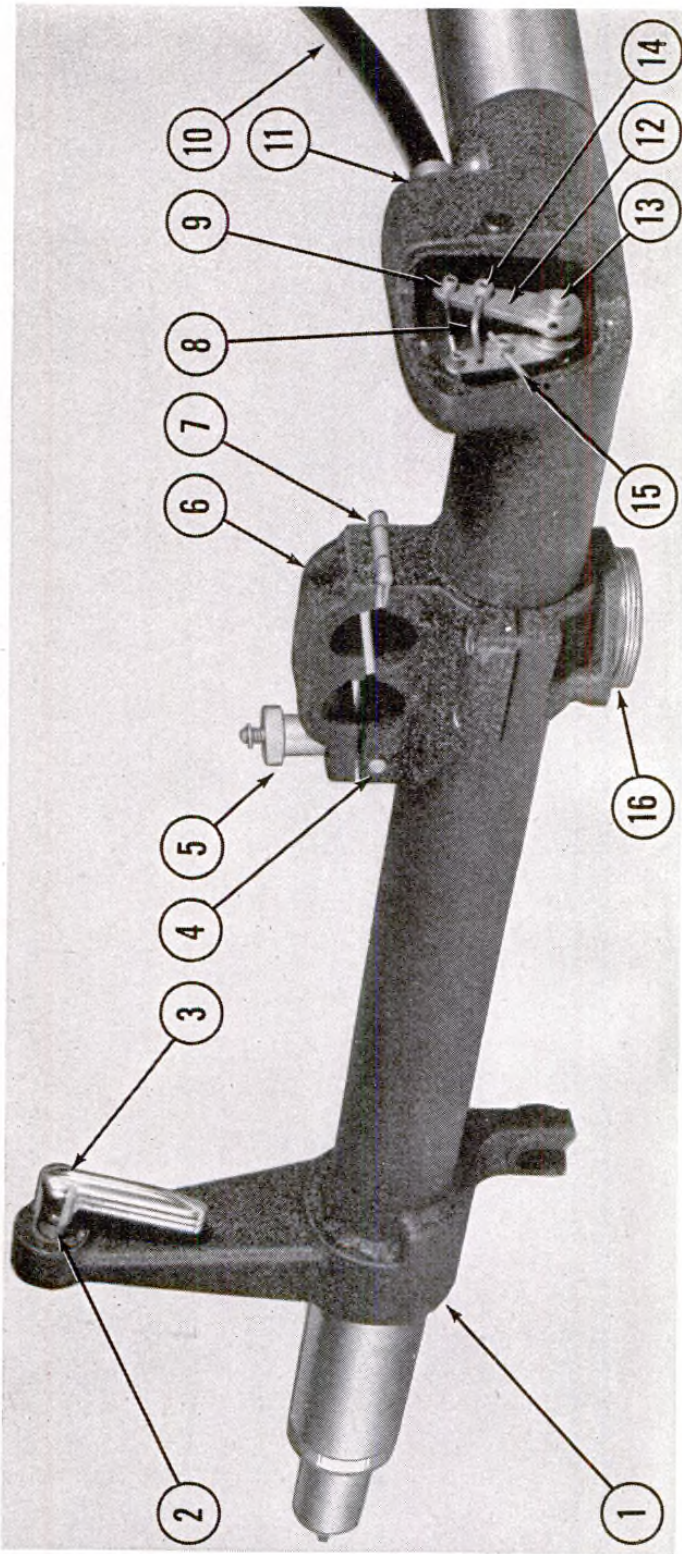

Med. Dept.

- | No. | Nomenclature |
|-----|------------------------------------|
| 1. | Elbow, Bracket and Tube, Complete. |
| 2. | Shaft, Lock, "L" Member. |
| 3. | Handle, Lock, "L" Member. |
| 4. | Pin, Lock Stud, Cable Clamp. |
| 5. | Nut, Cable Clamp. |

Med. Dept.

- | No. | Nomenclature |
|-----|---------------------------------------|
| 6. | Clamp, Cable. |
| 7. | Hinge, Cable Clamp. |
| 8. | Stop, Angle, Lower Shutter Lever. |
| 9. | Connector Wire. |
| 10. | Casing, Shutter Wire, Complete. |
| 11. | Bushing, Casing Clamp, Shutter Wires. |

Med. Dept.

- | No. | Nomenclature |
|-----|--|
| 12. | Lever, Shutter, Lower. |
| 13. | Rod, Shutter Operating. |
| 14. | Support, Stop, Shutter Levers. |
| 15. | Stop, Straight, Upper Shutter Lever. |
| 16. | Flange, Cap, Shutter Rods, "L" Member. |

Figure 39. L member, part No. 9R05720, partial view.

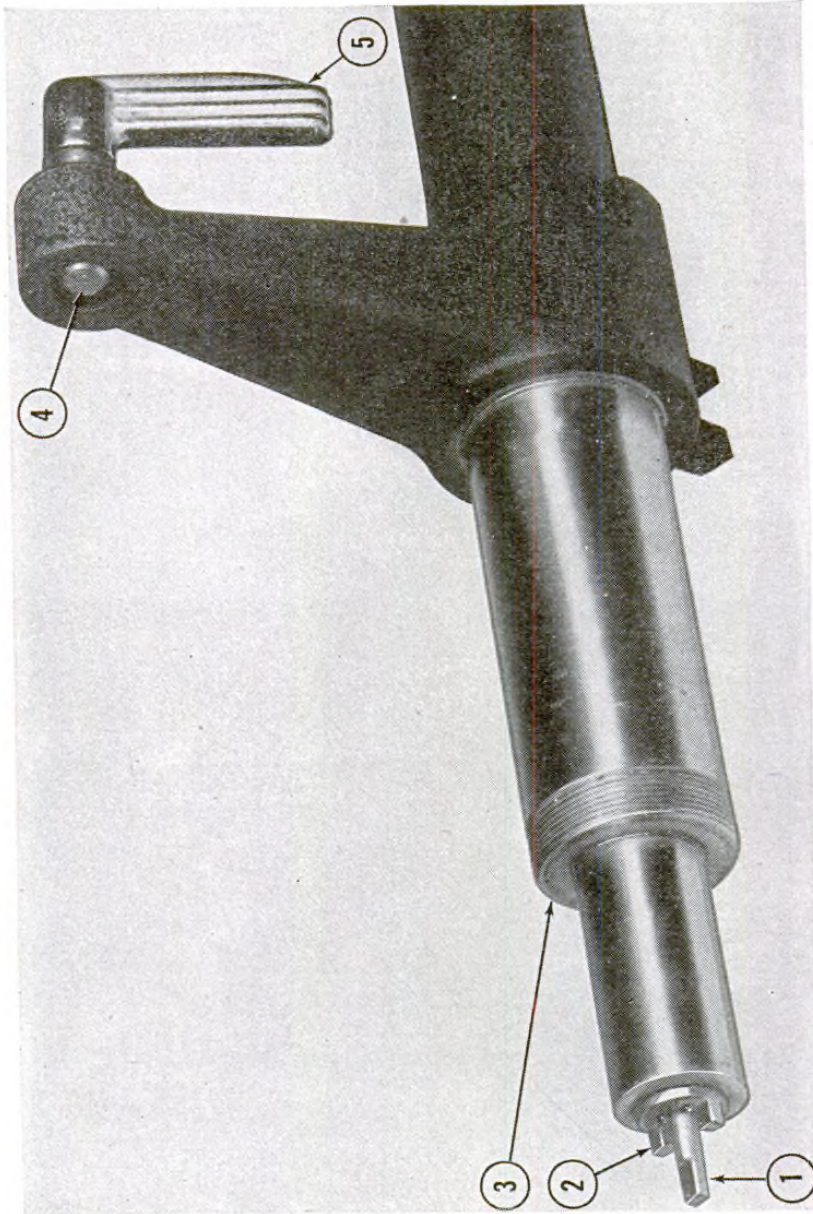

- | | | |
|---|--|--|
| <p>Med. Dept. No. 9R05754 Nomenclature Rod, Shutter Operating.</p> <p>1.</p> | <p>Med. Dept. No. 9R05726 Nomenclature Elbow, Bracket, and Tube, Complete.</p> <p>3.</p> | <p>Med. Dept. No. 9R05758 Nomenclature Handle, Lock, "L" Member.</p> <p>5.</p> |
| <p>Med. Dept. No. 9R05756 Nomenclature Tube, Shutter Operating.</p> <p>2.</p> | <p>Med. Dept. No. 9R05218 Nomenclature Shaft, Lock, "L" Member.</p> <p>4.</p> | |

Figure 40. L member, part No. 9R05720, view of control end.

(15) Secure the two cables of the **L** member by means of the cable clamp, 9R05746. (See fig. 39, part 6.)

(16) Remove the control unit from the chest and place it in position on top of the transformer. Use the two short web straps to fasten the shockproof cables to the rear of the control. The long center strap is not needed when the table unit is used.

(17) Plug the female (tube) end of the blower cable into the receptacle provided in the tube head, and the male (control) end of this cable into the receptacle on the rear of the control.

(18) Remove the high-tension transformer plug, which has been held in position in the transformer case by means of the clip provided, and insert the plug into the proper male receptacle, identified on the rear of the control.

(19) Remove the main line cable (fig. 33, part 4) from the control chest and insert it into the receptacle provided on the rear of the control.

(20) If use of the rubber gloves (fig. 33, parts 5 and 6) is desired, remove them from the control chest; otherwise place them temporarily in the long compartment at the rear of the chest.

(21) With these accessories removed, release the catches holding the two covers of the lower compartments and remove the hand timer and footswitch.

(22) Connect the timer and footswitch to the rear control panel and hang the timer on the hook provided for it. Support their cables on the cable hooks provided on either side of the control unit.

(23) The line cable should be coiled up in a roll about 12 to 15 inches in diameter and placed over the hook provided in the cover of the transformer chest, when not connected to supply line.

(24) Aluminum filters and lead aperture plates for the tube head are found in the center compartment of the cable drawer.

(25) Complete assembly for the desired position as described in *c.* below.

c. COMPLETION OF ASSEMBLY FOR VARIOUS POSITIONS WHEN X-RAY FIELD UNIT TABLE UNIT IS SUPPLIED. (1) For vertical roentgenography, proceed as follows (fig. 41):

(a) Screw the shutter rods cap on the knob end of the **L** member.

(b) Raise or lower the **L**-shaped member and tube assembly by loosening the vertical table locking handle (fig. 42, part 11), and turning the long shaft crank until the assembly is at the desired height. Secure the tube lock handle.

(c) To rotate the assembly horizontally, loosen the locking handle and turn the assembly to the desired position. Secure the locking handle.

(d) If it is necessary to rotate the **L** member vertically in order to obtain the proper tube height, turn the short shaft crank until

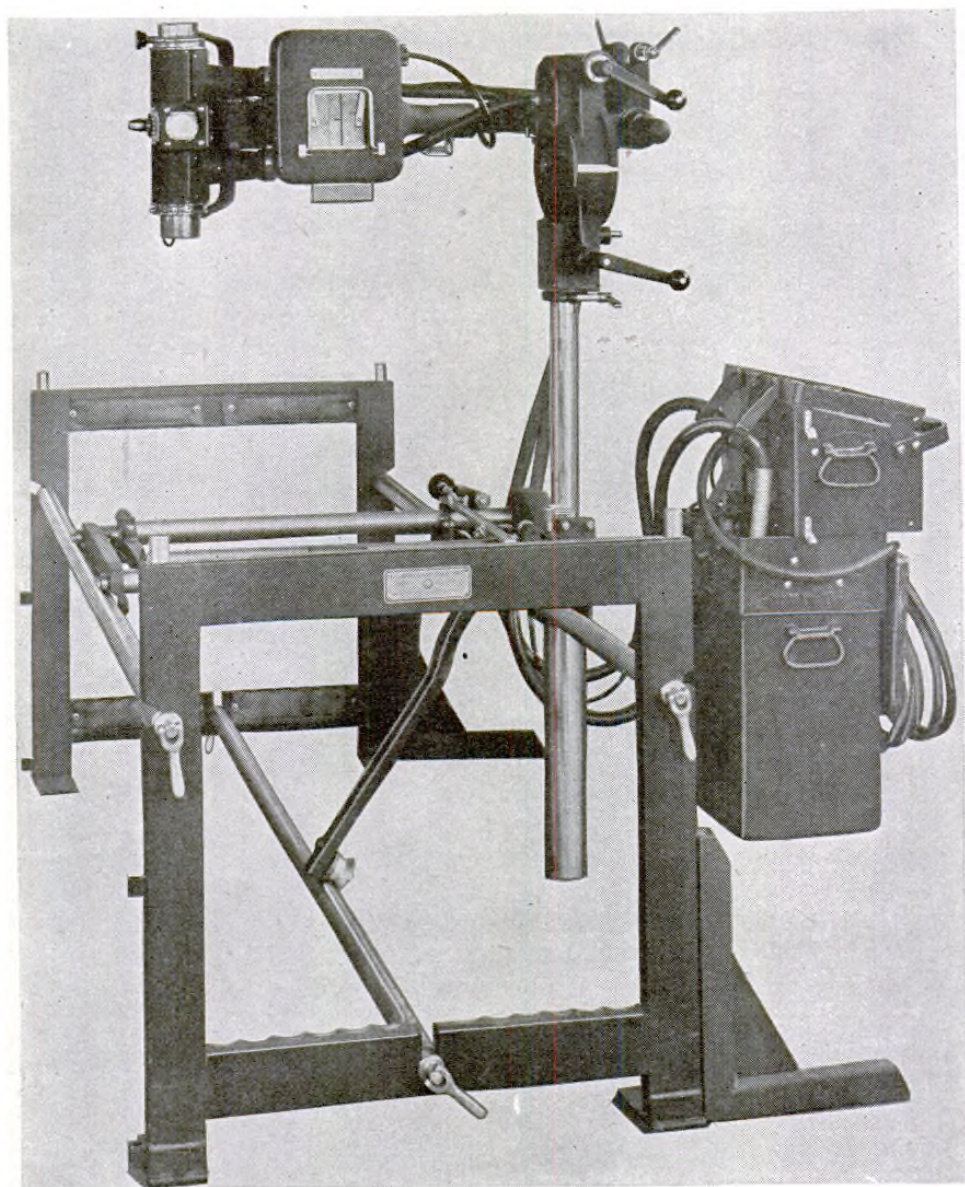

Figure 41.—X-ray field unit table unit, vertical radiographic position.

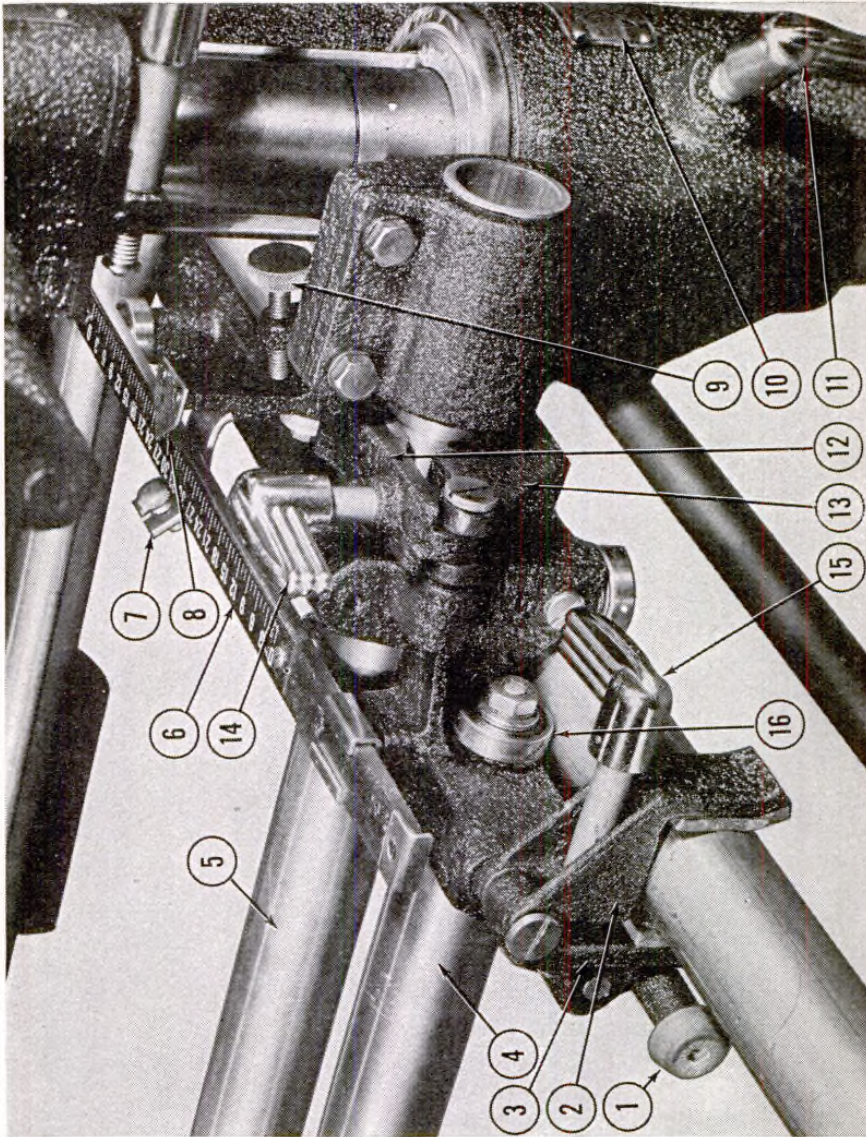

Figure 42. Localizer scale, viewed from left operating side.

| <i>Med. Dept.</i> | <i>No.</i> | <i>Nomenclature</i> |
|-------------------|------------|--|
| | 1. | 9R05523 Bumper, Rubber. |
| | 2. | 9R05434 Lock, Plain Section, Lengthwise Carriage. |
| | 3. | 9R05432 Lock, Tapped Section, Lengthwise Carriage. |
| | 4. | 9R05424 Rail, Left Tie, Lengthwise Carriage. |
| | 5. | 9R05428 Rail, Crosswise Carriage. |
| | 6. | 9R05502 Scale, Localizer, Small Knob Movement, Complete. |
| | 7. | 9R05506 Bracket, Localizer Light, Localizer Scale. |
| | 8. | 9R05526 Pointer, Localizer Scale. |
| | 9. | 9R05508 Screw, Lock, Pointer Carriage, Localizer Scale. |
| | 10. | 9R05460 Nameplate, Vertical Adjusting Clamp. |
| | 11. | 9R05216 Handle, Locking, Vertical. |
| | 12. | 9R05442 Lock, Plain Section, Crosswise Carriage. |
| | 13. | 9R05440 Lock, Tapped Section, Crosswise Carriage. |
| | 14. | 9R05430 Handle, Locking, Crosswise Carriage, Complete. |
| | 15. | 9R05214 Handle, Locking, Horizontal. |
| | 16. | 9R05536 Bearing, Ball, 1.1815-inch Diameter. |

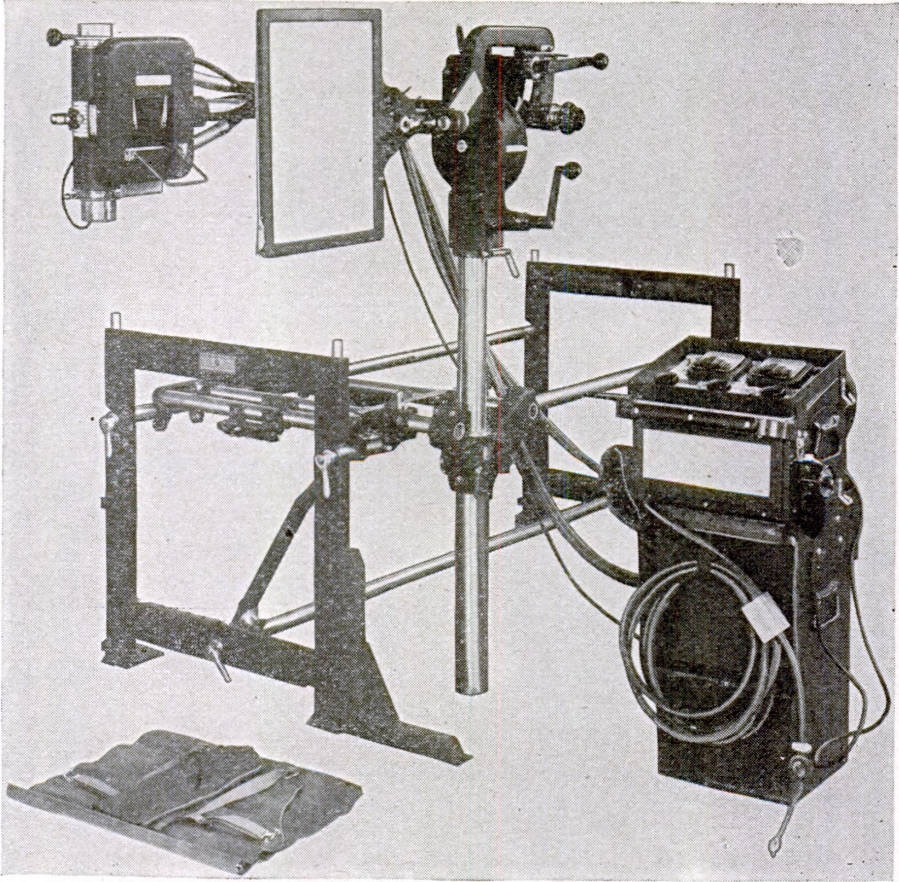

Figure 43. X-ray field unit table unit, standing fluoroscopic position.

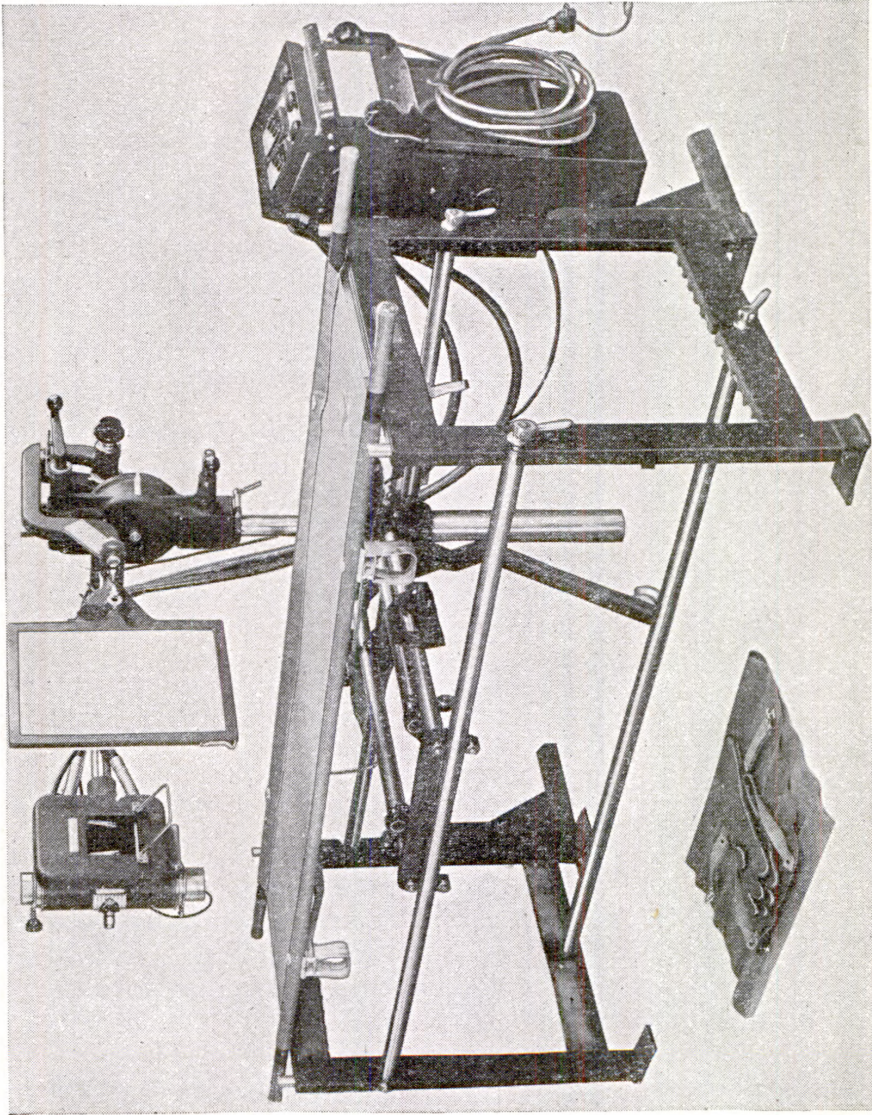

Figure 44. X-ray field unit table unit, sitting fluoroscopic position.

the tube head is in the proper position. Tilt the tube head until it is completely vertical.

(2) For vertical fluoroscopy in the standing or sitting position, proceed as follows (figs. 43 and 44):

(a) Mount the screen arm and shutter knob assembly on the end of the **L** member and tighten the large lock nut.

(b) Swing the screen arm into position and secure it with the lock handle.

(c) Mount the fluoroscopic screen assembly on the screen arm. Note that the fluoroscopic screen assemblies (figs. 11 and 12) are designed for mounting on screen arm (fig. 10) only. The fluoroscopic screen assembly (fig. 45) is designed for mounting on screen arm (fig. 45, part 4) only. Secure fluoroscopic screen assembly with the locking handle provided.

(d) Raise or lower the **L** member, tube, and fluoroscopic screen assembly by loosening the vertical table locking handle and turning the long shaft crank until the assembly is at the desired height. Secure the locking handle.

(e) To rotate the assembly horizontally, loosen the locking handle (fig. 38, part 12) and turn the assembly to the desired position.

(3) For horizontal fluoroscopy (fig. 5), proceed as follows:

(a) Mount the screen arm, put it into position, and mount the fluoroscopic screen assembly as described in paragraph 10c(2)(c) of this section.

(b) Rotate the shutter assembly (figs. 46 and 47), into position in front of the X-ray tube head. Be sure that both brackets of the shutter housing engage the tube head securely. Tighten the lock handle to secure the shutter.

(c) Loosen crosswise carriage lock handle and pull the crosswise carriage away from the table as far as it will go. Secure crosswise carriage locking handle.

(d) Loosen locking handle, and rotate the **L** member out away from the table while turning the short shaft crank so as to lower the tube head. Turn the crank until the **L** member touches the main vertical column. While lowering the tube head, be careful not to have the tube head touch the table rail.

(e) Rotate the fluoroscopic screen, **L**-shaped member, and tube head assembly into position and attempt to have the fluoroscopic screen assembly as nearly parallel to the table as possible. Secure the locking handle.

(f) Insert the handle end of the depth marker into the opening provided for it in the screen frame as shown. Secure the depth marker by means of the retainer clip provided.

(g) Obtain the localizer lights and mountings from the control chest. Mount the localizer light for the depth marker scale on the

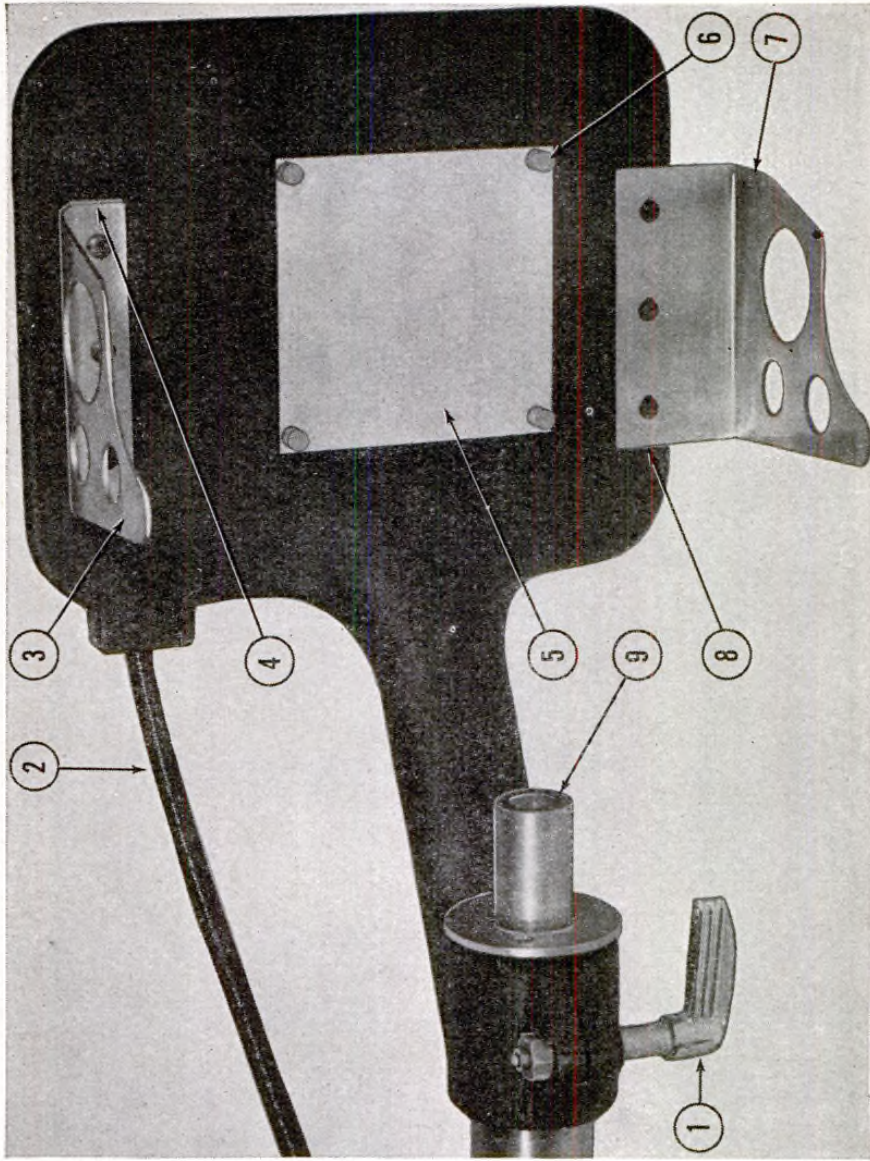
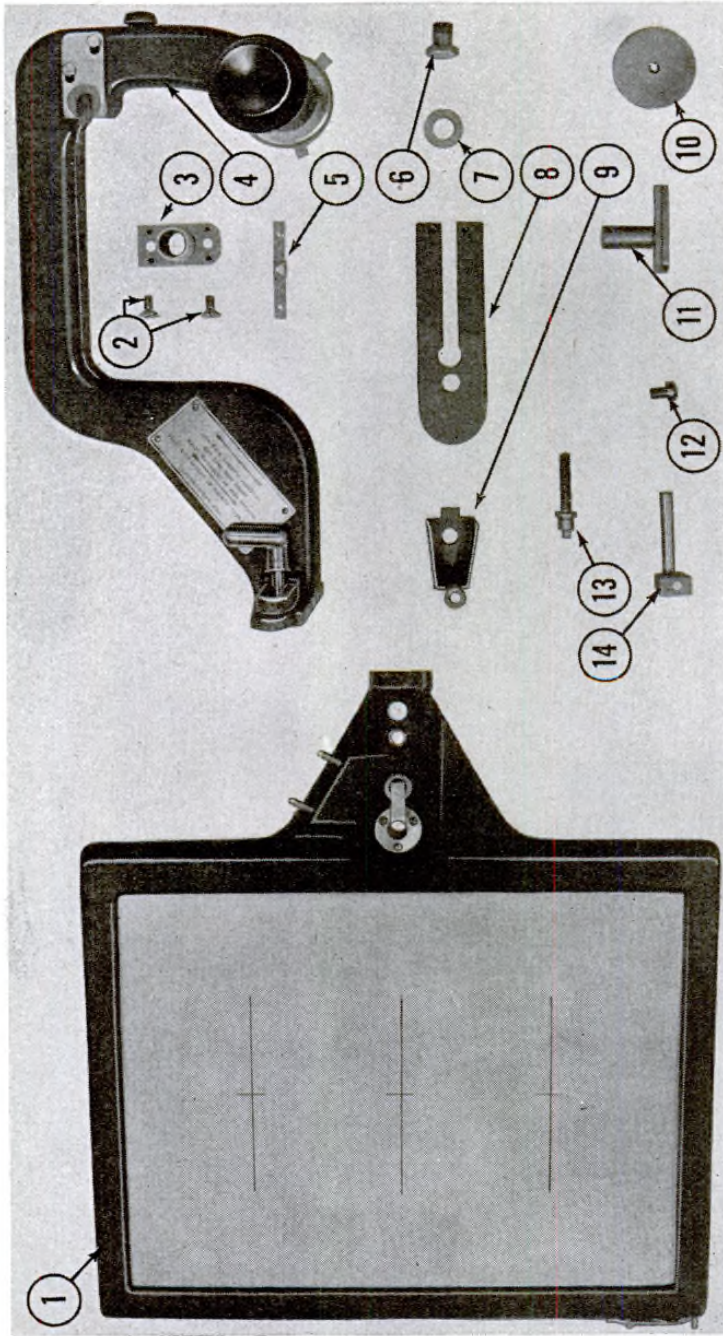

Figure 46. Shutter assembly, bottom view.

- | <i>Med. Dept.</i> | <i>No.</i> | <i>Nomenclature</i> |
|-------------------|------------|--|
| 1. | 9R05708 | Handle, Lock, Shutter Positioning, Complete. |
| 2. | 9R05221 | Casing, Shutter Wire, Complete. |
| 3. | 9R05694 | Bracket, Short Base, X-ray Tube. |
| 4. | 9R05684 | Shim, Thin, Base, X-ray Tube Bracket. |
| 5. | 9R05676 | Filter, Aluminum. |
| 6. | 9R05674 | Screw, Thumb, Filter. |
| 7. | 9R05696 | Bracket, Long Base, X-ray Tube. |
| 8. | 9R05682 | Shim, Thick, Base, X-ray Tube Bracket. |
| 9. | 9R05764 | Flange, "L" Member, X-ray Tube Mounting. |



- | <i>Med. Dept.</i> | <i>Nomenclature</i> | <i>Med. Dept.</i> | <i>Nomenclature</i> |
|-------------------|---|-------------------|---|
| <i>No.</i> | <i>No.</i> | <i>No.</i> | <i>No.</i> |
| 1. 9R05398 | Frame, Screen, Bottom Adjusting Knob. | 6. 9R05392 | Screw, Retaining, Guide Plate. |
| 2. 9R05282 | Adapter, Retaining, Adapter, Tube Arm. | 7. 9R05394 | Washer, Screw, Retaining, Guide Plate. |
| 3. 9R05278 | Adapter, Screen Mounting, Tube Arm. | 8. 9R05388 | Plate, Guide, Adjustable Screen Mounting. |
| 4. 9R05284 | Arm, Screen, New Type, Screen Mounting. | 9. 9R05384 | Retainer, Screen Adjusting Screw. |
| 5. 9R05280 | Pointer and Plate, Indicating, Screen Adjustment, Complete. | 10. 9R05400 | Knob, Metal, Screen Adjustment. |
| | | 11. 9R05390 | Mounting, Adjustable Screen. |
| | | 12. 9R05386 | Screw, Holding, Retainer. |
| | | 13. 9R05382 | Screw, Screen Adjustment. |
| | | 14. 9R05396 | Carriage, Screen Mounting. |

Figure 45. New type fluoroscopic screen with bottom adjusting knob and screen arm.

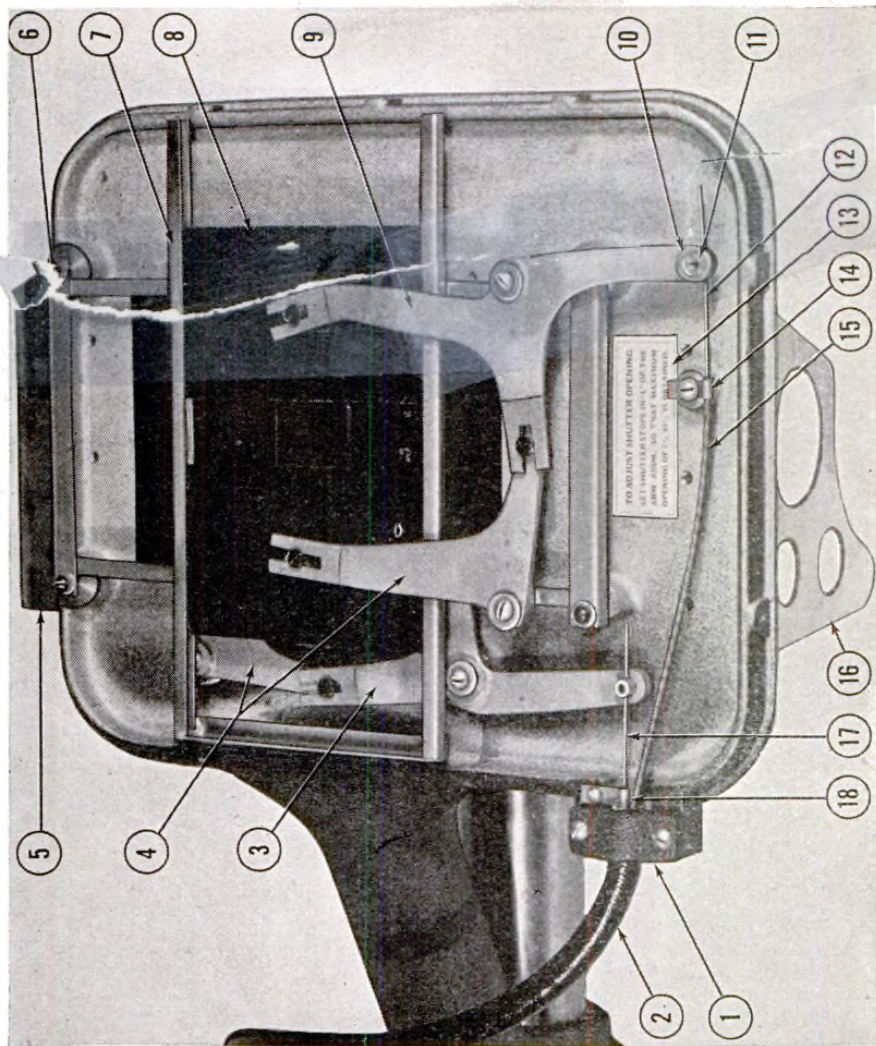
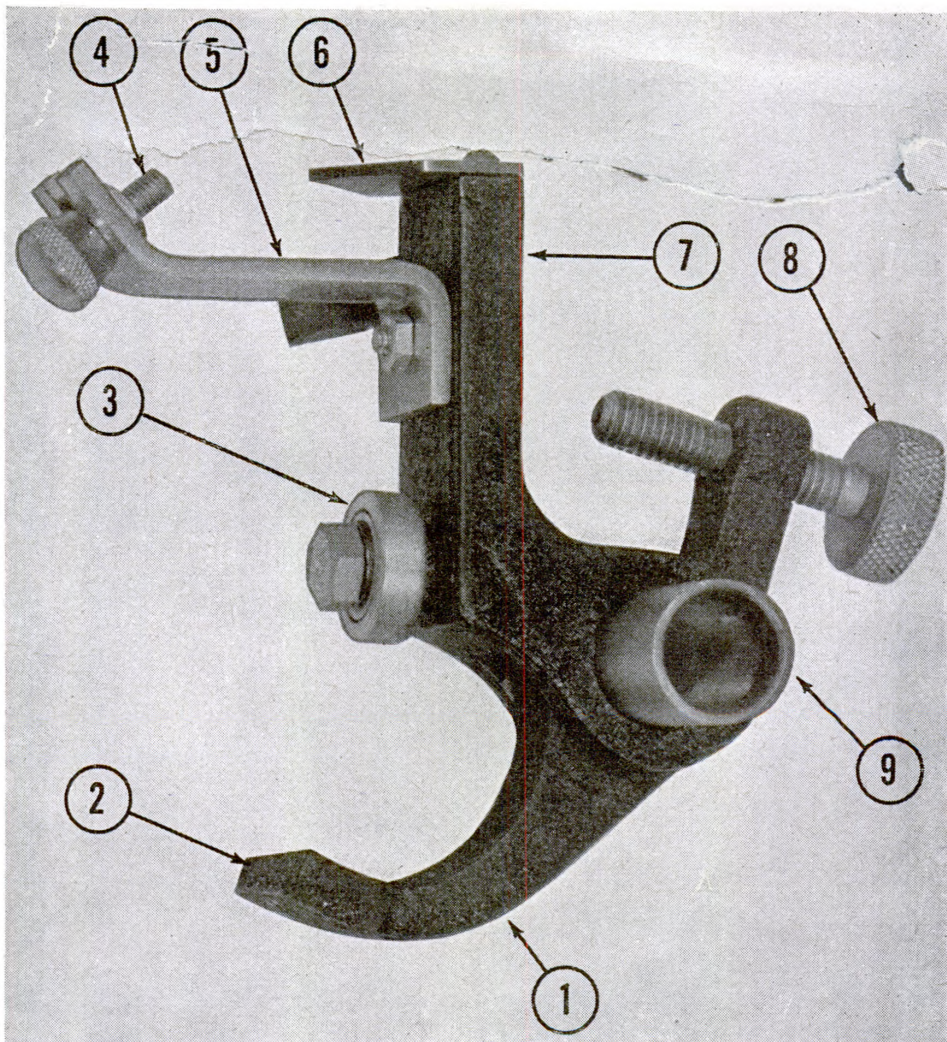

Figure 47. Shutter assembly.

- | <i>Med. Dept.</i> | <i>Nomenclature</i> |
|-------------------|---|
| <i>No.</i> | |
| 1. | 9R05710 Clamp, Shutter Cable. |
| 2. | 9R05221 Casing, Shutter Wire, Complete. |
| 3. | 9R05716 Link, Lower, Shutter Operating. |
| 4. | 9R05718 Link, Lower or Upper, Shutter Operating. |
| 5. | 9R05696 Bracket, Long Base, X-ray Tube. |
| 6. | 9R05688 Spacer, Guide Channel, Shutter Plate. |
| 7. | 9R05700 Guide, Shutter Plates. |
| 8. | 9R05690 Plate, Shutter. |
| 9. | 9R05714 Link, Upper, Shutter Operating. |
| 10. | Connector, Shutter Wire. |
| 11. | SR00862 Setscrew, 8-32 x 3/16-Inch, Allen H. Cup Pt., 100 to Pkg. |
| 12. | Shutter Wire, Long. |
| 13. | 9R05692 Label, Instruction, Shutter Operating. |
| 14. | 9R05678 Clip, Large Hole, Spring Casing, Shutter Wire. |
| 15. | 9R05694 Springs, Long, Shutter Wires. |
| 16. | Bracket, Short Base, X-ray Tube. |
| 17. | Shutter Wire, Short. |
| 18. | 9R05680 Clip, Small Hole, Spring Casing, Shutter Wire. |



| <i>Med. Dept.</i> <i>No.</i> | <i>Nomenclature</i> | <i>Med. Dept.</i> <i>No.</i> | <i>Nomenclature</i> |
|---------------------------------|---|---------------------------------|---|
| 1. 9R05488 | Lock, Casting, Pointer, Localizer Scale. | 5. 9R05506 | Bracket, Localizer, Light, Localizer Scale. |
| 2. 9R05514 | Lining, Lock Casting, Pointer, Localizer Scale. | 6. 9R05526 | Pointer, Localizer Scale. |
| 3. 9R05486 | Bearing, Ball, $\frac{13}{16}$ -Inch, Scale Slide, Localizer Scale. | 7. 9R05490 | Holder, Pointer, Localizer Scale. |
| 4. 9R05540 | Screw, Thumb, Localizer Light, Localizer Scale. | 8. 9R05508 | Screw, Lock, Pointer Carriage, Localizer Scale. |
| | | 9. 9R05494 | Bushing, Pointer Carriage, Localizer Scale. |

Figure 48. Localizer scale pointer carriage, part No. 9R05464.

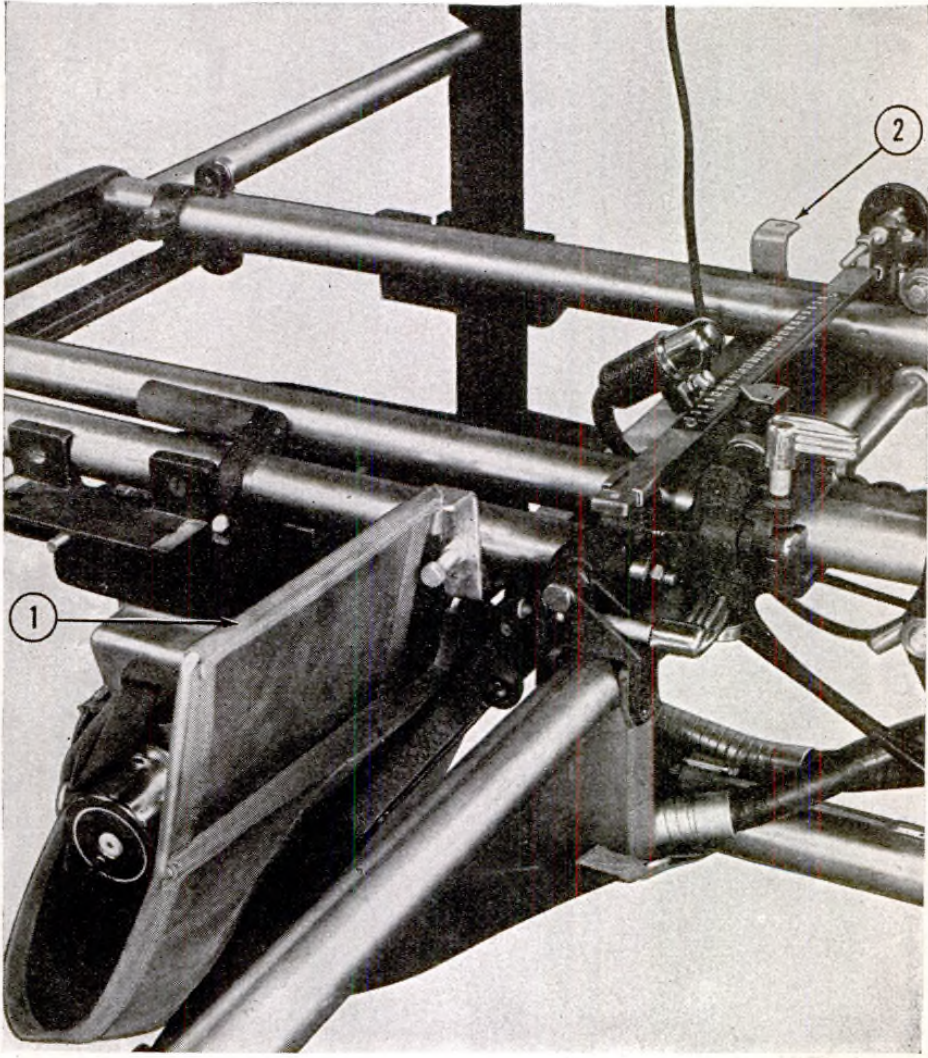

- | | |
|--|--|
| <p><i>Med. Dept.</i> No. <i>Nomenclature</i></p> <p>1. 9R05238 Shield, Protective, Auxiliary, Leaded, Rubber.</p> | <p><i>Med. Dept.</i> No. <i>Nomenclature</i></p> <p>2. 9R05403 Bracket, Auxiliary Shield, Complete.</p> |
|--|--|

Figure 49. Carriage, part No. 9R05423 with protective auxiliary shield, part No. 9R05238, front view.

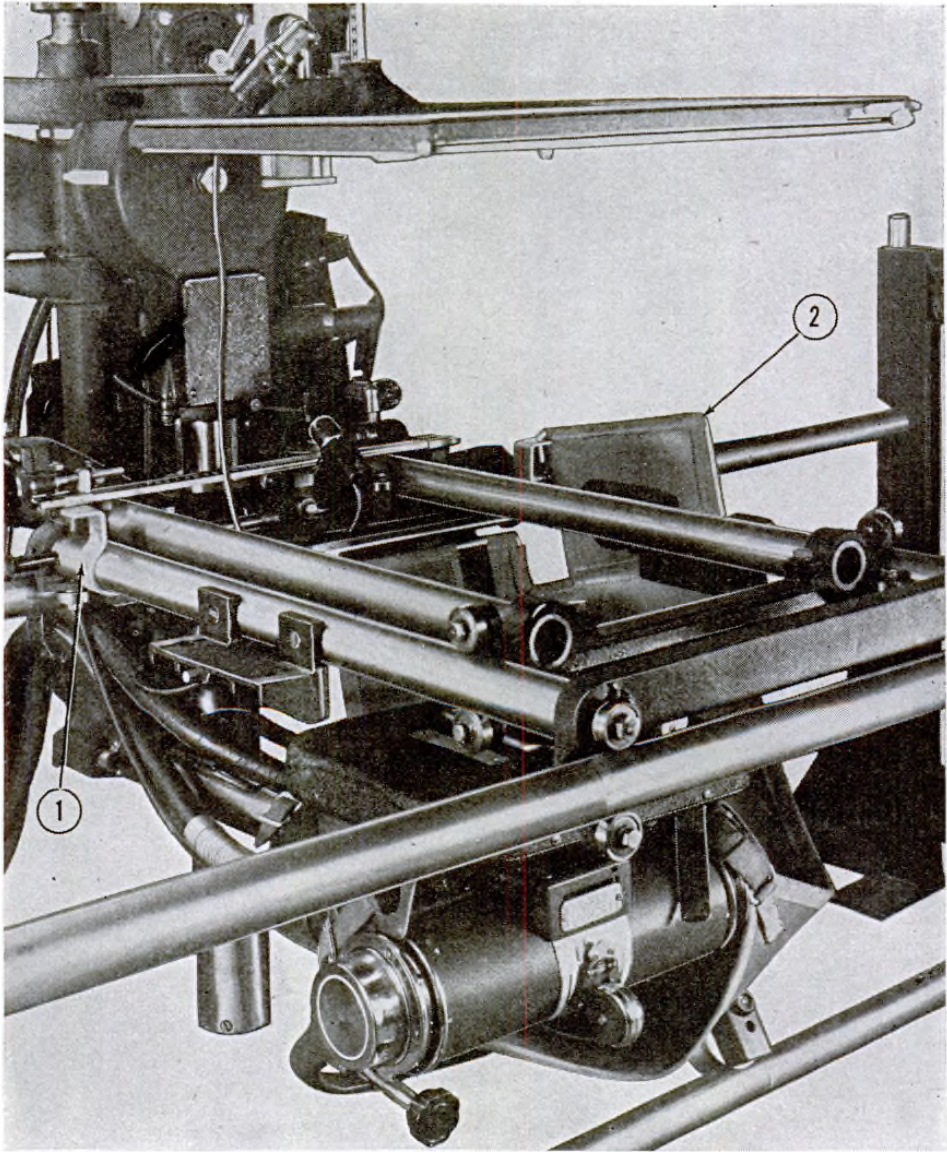

- | <i>Med. Dept.</i> | <i>No.</i> | <i>Nomenclature</i> | <i>Med. Dept.</i> | <i>No.</i> | <i>Nomenclature</i> |
|-------------------|------------|---------------------------------------|-------------------|------------|---|
| 1. | 9R05403 | Bracket, Auxilliary Shield, Complete. | 2. | 9R05238 | Shield, Protective, Auxilliary, Leaded, Rubber. |

Figure 50. Carriage, part No. 9R05423 with protective auxiliary shield, part No. 9R05238, rear view.

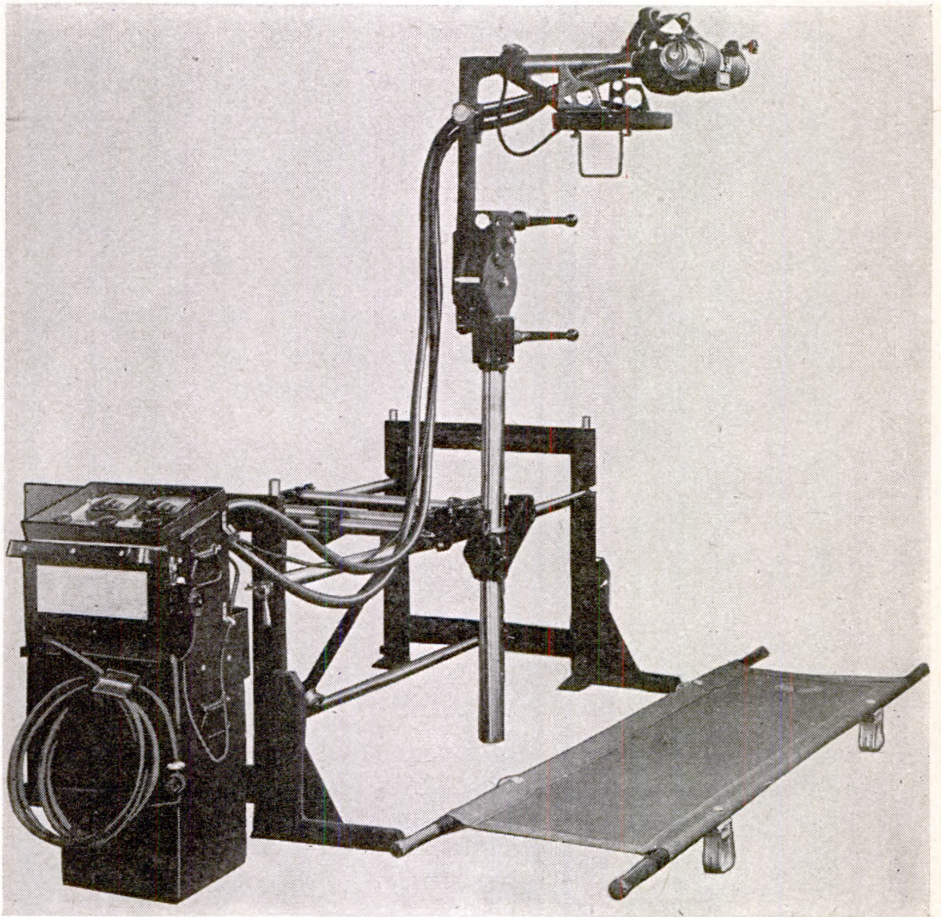

Figure 51. X-ray field unit table unit, horizontal chest radiographic position.

localizer light pins. Mount the localizer light for the localizer scale on the bracket provided on the pointer carriage (fig. 48). Insert the male plug of the localizer light cable in the receptacle provided on the rear of the X-ray field unit control unit.

(h) Mount the protective shield (fig. 18, part 2) on the table as shown in figure 49, part 1. Note that the protective shield bracket (fig. 49, part 2 and fig. 50, part 1) held in place by the right tie rail and left tie rail of the lengthwise carriage. It is secured to the left tie rail by a thumbscrew. Hang the protective shield on this bracket by inserting one end of the shield supporting rod through the center hole of the bracket, the other end of the supporting rod through the hole on the left end of the bracket. The lower opposite ends of the shield are held in place by the straps inserted through the holes of the X-ray tube brackets of the shutter. (See fig. 50.) The side of the shield is supported by placing the remaining strap around the X-ray tube supporting arm of the L member.

(4) For horizontal chest roentgenography (fig. 51), proceed as follows:

(a) Move the shutter back away from the tube head, sliding it on the guide rail provided until it can be drawn back no farther. Lock it into this position.

(b) Rotate the L member vertically by turning the short shaft crank until the tube head is in its highest position.

(c) Loosen the vertical locking handle and turn the long shaft crank until the L member reaches its highest position.

(d) Loosen the locking handle (fig. 38, part 12) and turn the L member until the tube head is as far away from the table as possible. Secure the locking handle.

(5) For horizontal roentgenography (fig. 52), proceed as follows:

(a) Move the shutter back away from the tube head, sliding it on the rail guide provided until it can be drawn back no farther. Lock it in this position.

(b) Rotate the L member vertically by turning the short shaft crank until the tube head is in its highest position or turn the crank until the pointer on the angulating scale is set for the type of work desired.

(c) Remove the complete cassette lifting device from the large trunk and mount it on the lengthwise carriage tie rails. If this assembly is not provided, uncrate the X-ray field unit portable grid, 9607000 (fig. 16), and mount it on the tie rails, if one is supplied with the table unit. Be sure that the tube is centered on the panel of the cassette lifting device or the center of the portable grid when either of these accessories is used.

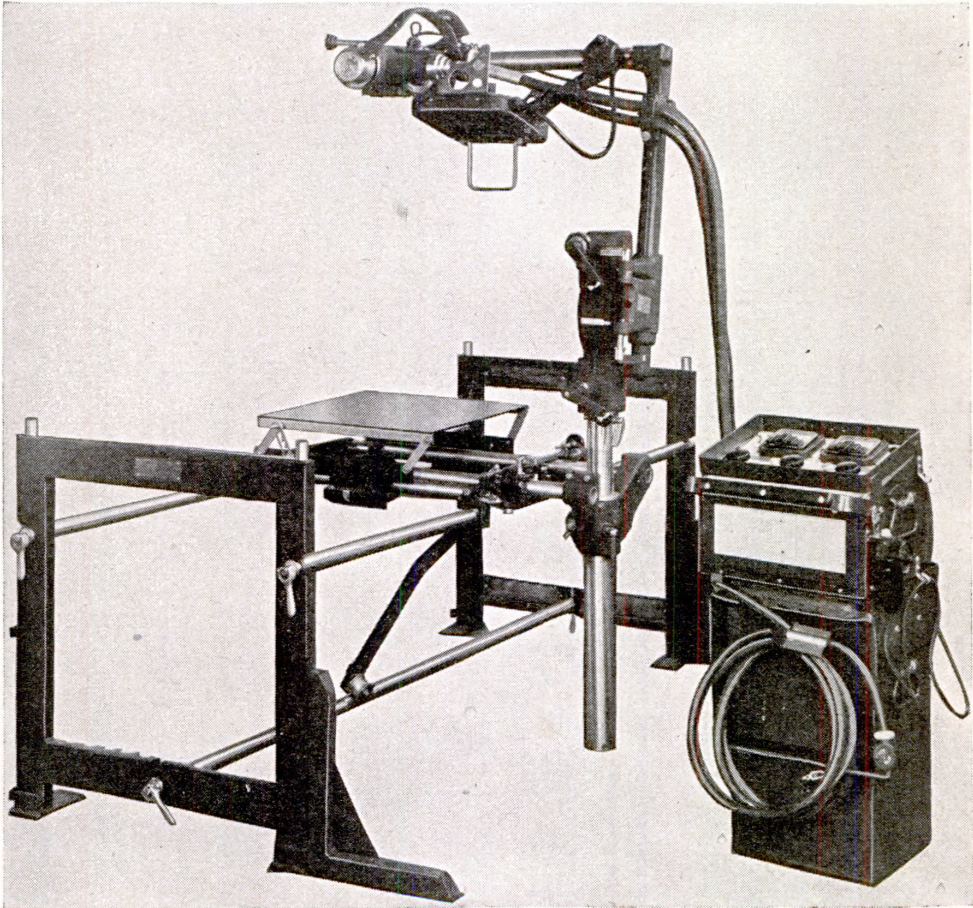

Figure 52. X-ray field unit table unit, horizontal radiographic position.

11. Adjustments

a. X-RAY FIELD UNIT, MACHINE, X-RAY. (1) *Safety precaution.* When operating the X-ray field unit, 9608510 on a 205–250-volt line, be sure to use 15 ampere fuses. Check fuses by removing the front terminal panel cover. When operating X-ray field unit 9608510 or 9608508 on 100–130-volt line, use 30-ampere fuses if the unit is operated up to 30 ma.

(2) *Zero adjustment for meters.* In order to obtain a true reading, the indicators of both meters must come to rest on the line to the extreme left of the scale. If they do not, remove the knurled nuts retaining the meter light cover. Using a small screw driver, turn the small adjusting screw visible in the center until the pointer comes to rest in the proper position. Replace the meter light cover.

(3) *Line adjustment.* (a) Turn the main switch of the control unit to the "off" position.

(b) Turn all controls to the lowest possible settings.

(c) Connect the male plug of the line cable to a community source, after noting the following line specifications: X-ray field unit, 9608508 requires 100–130-volt, 60-cycle, a-c. The X-ray field unit, 9608510 may be used within a line range of 100–130-volt, 205–250-volt, 50- or 60-cycle, a-c.

(d) If a voltmeter is available determine the line voltage.

(e) Remove the front terminal panel cover.

(f) Set the line adjuster strap of the front terminal panel of the control unit (figs. 53 and 54) on the tap most nearly corresponding to the line voltage. For example, if the line voltage measures between 100–108 volts, the line adjuster should be set on 104, between 108 and 116, set strap on 112, etc. In case a voltmeter is not available, determine the line voltage by using the kilovolt meter of the control unit.

(g) Set the major selector (C) to 6, and the minor selector (D) to 4. If the line adjuster strap is properly set, the kilovoltmeter will indicate 70. If the meter reads more than 70, set the line adjuster strap to a higher numbered tap until the meter indicates between 69 and 71. If the meter reads lower than 70, position the line adjuster strap to a lower numbered tap until the meter reads between 69 and 71.

Caution: When using an X-ray field unit generator as a source, always set the line adjuster strap on the 128 tap. Replace the front terminal panel cover.

(4) *Circuit breaker adjustment.* (a) Turn the main switch to the "on" position, adjust the major and minor kilovolt selectors until the kilovolt meter reads 70.

(b) Turn the radiographic and fluoroscopic switch to radiography.

(c) Set the hand timer to 3 seconds.

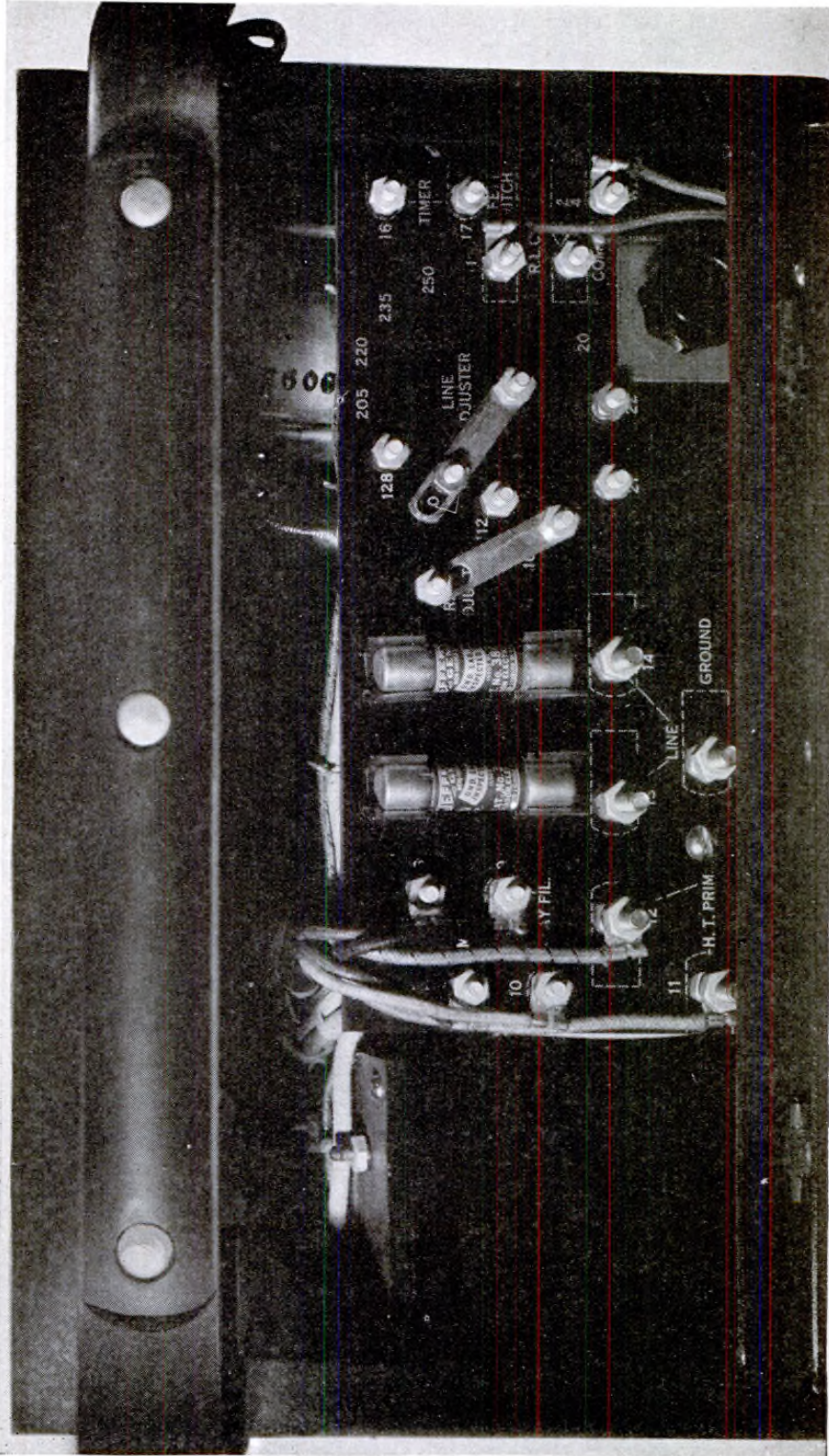

Figure 53. Terminal board, part No. 9R15090 for X-ray field unit control unit, part of Chest MD X-A, item No. 9608808.

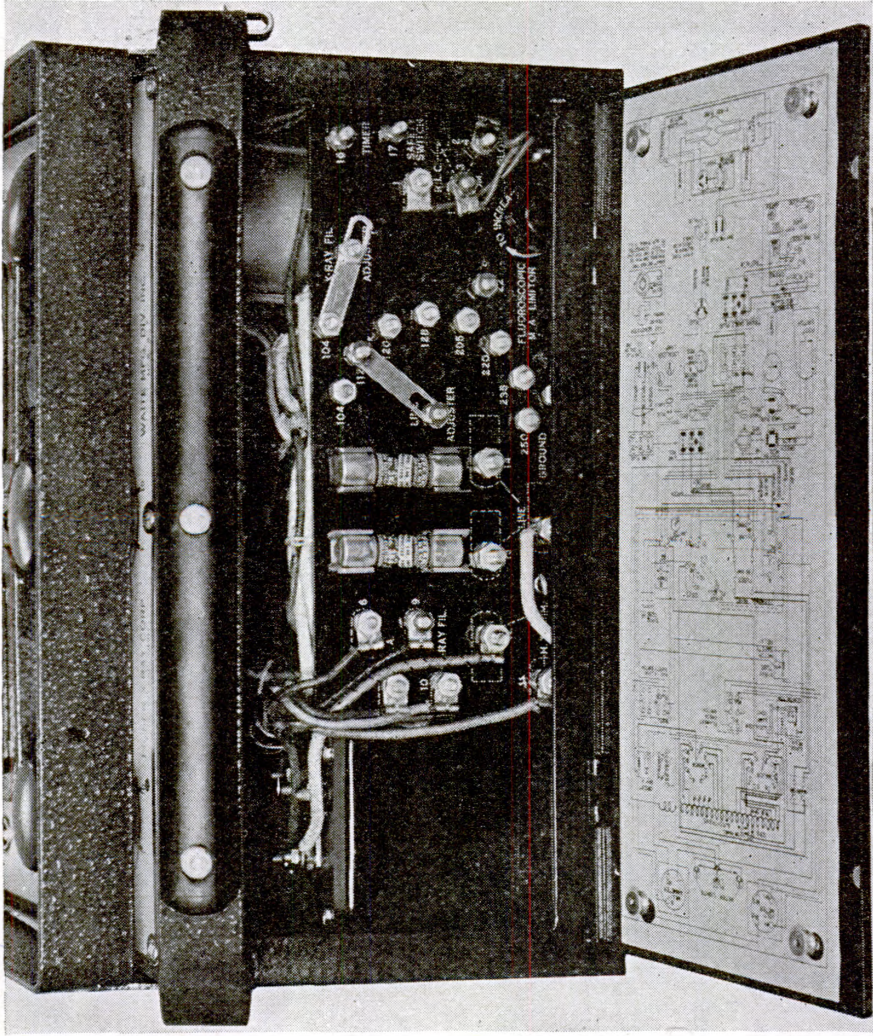

Figure 54. Terminal board, part No. 9R15092 for X-ray field unit control unit, part of Chest MD X-4, item No. 9608510.

(d) Taking as short an exposure as possible, press the timer button and, at the same time, turn the filament control knob clockwise until the milliammeter reads 37 ma on the upper scale. The circuit breaker should now trip.

(e) If it does not trip, remove the large snap-on cover plate covering a 3-inch diameter port at the rear of the control unit. The adjusting screw and locknut will now be visible at the base of the circuit breaker assembly. Loosen the locknut and raise the adjusting screw until the circuit breaker trips at 37 ma.

(f) If the circuit breaker tripped before the milliammeter read 37 ma, lower the adjusting screw until the circuit breaker trips at this value.

(g) After the adjustment is completed, set the locknut to keep the adjusting screw in place. Replace the snap-on cover plate.

(5) *Fluoroscopic limiter adjustment.* (a) Turn the main switch to the "on" position.

(b) Adjust the major and minor kilovolt selectors until the kilovolt meter reads 70.

(c) Turn the radiographic and fluoroscopic switch to the fluoroscopy position.

(d) Turn the filament control knob clockwise as far as it will go.

(e) Remove the front terminal panel cover and turn the knob of the fluoroscopic limiter (lower right hand corner) (fig. 55, part 1) counterclockwise as far as it will go.

(f) Press the footswitch and turn the knob of the fluoroscopic limiter clockwise until the milliammeter reads between 6 and 6½ ma on the lower scale.

(g) Replace the front terminal panel cover.

b. X-RAY FIELD UNIT TABLE UNIT. When the table unit is used for horizontal fluoroscopy, the following adjustments should be made:

(1) *Screen adjustment, horizontal.* (a) Place a litter on the field unit table unit as shown in figure 44. Place a board across the litter.

(b) Place a somewhat radio-opaque object, such as a key, on the board and energize the unit following the operating instructions for horizontal fluoroscopy. (See par. 16b.)

(c) Loosen the horizontal locking handle, and crosswise locking handle so that the carriage will be free to move in any horizontal direction.

(d) Remove the fluoroscopic screen cover.

(e) Press the footswitch and position the fluoroscopic screen so that the point of intersection of the center intersecting lines on the screen coincides with a prominent point of the shadow of the radio-opaque object. Be sure to move the screen only by grasping the top of the angulating housing. Release and lock the locking handle (fig. 38, part 12) if necessary.

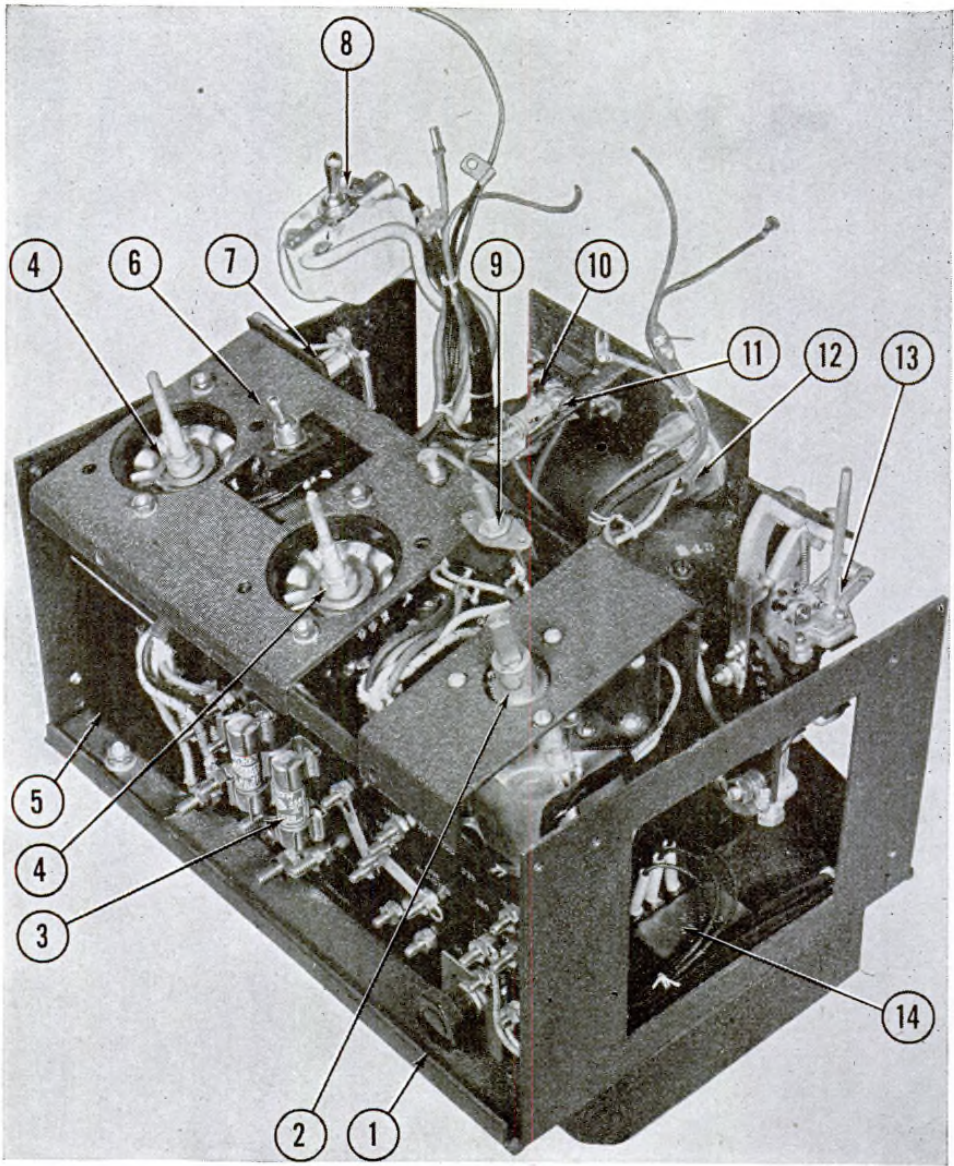

| <i>Med. Dept.</i> | <i>No.</i> | <i>Nomenclature</i> | <i>Med. Dept.</i> | <i>No.</i> | <i>Nomenclature</i> |
|-------------------|------------|--|-------------------|------------|---|
| 1. | 9R15164 | Knob, Fluoroscopic Limiter. | 9. | 9R15173 | Switch, Radiographic-Fluoroscopic, Complete. |
| 2. | 9R15166 | Control, Filament, Complete. | 10. | 9R15026 | Plug, Jones, Male. |
| 3. | SR00101 | Fuse, Inclosed, 30 Amp. | 11. | SR00365 | Bulb, 6-8 V., 1 C.P., Single Contact Bayonet. |
| 4. | 9R15102 | Switch, Selector, Ten Point, Complete. | 12. | 9R15182 | Receptacle, Female, Large, Four Wire. |
| 5. | 9R15116 | Tank, Contactor. | 13. | 9R15175 | Circuit Breaker, Complete. |
| 6. | 9R15014 | Switch, Check, Filament. | 14. | 9R15174 | Condenser Block, Complete |
| 7. | 9R15018 | Relay, Safety, Motor. | | | |
| 8. | 9R15020 | Switch, Main. | | | |

Figure 55. Front view of X-ray field unit control unit, control housing and front panel removed.

(f) Secure the crosswise locking handle. Adjust the fluoroscopic screen until the same prominent point of the shadow just mentioned coincides with each of the three points of intersection on the screen when the carriage is moved lengthwise.

(g) Be sure to release the footswitch as frequently as possible and follow operating instructions.

(2) *Screen adjustment vertical.* (a) Secure the U-shaped focal distance checking gauge from the large trunk and support it on the fluoroscopic screen assembly.

(b) Press the footswitch and align the gauge until it is about at the center of the fluoroscopic screen.

(c) Raise or lower the fluoroscopic screen by means of the adjusting knob provided, until the shadow of the two aligning pins on the gauge line up with the two long outer lines on the screen.

(d) Be sure to release the footswitch as frequently as possible and follow operating instructions.

(e) Remove the focal distance checking gauge.

(3) *Depth marker pointer adjustment.* (a) Place a flat radio-opaque object, such as a key, on the board previously mentioned. Be sure the object is no further than about 10 cm from the screen.

(b) Loosen the horizontal locking handle, and the crosswise locking handle so that the carriage will be free to move in any horizontal direction.

(c) Adjust the localizer scale until it is approximately centered between the two tie rails of the crosswise carriage.

(d) Press the footswitch and move the fluoroscopic screen until a prominent point of the shadow of the radio-opaque object coincides with the point of intersection on the right side of the fluoroscopic screen.

(e) Secure both horizontal and crosswise locking handles. Release the footswitch. Move the pointer carriage (fig. 48) until the pointer for the localizer scale indicates "O" on the right hand side of the scale. Lock the pointer carriage in this position.

(f) Release the horizontal locking handle only, press the footswitch, and move the fluoroscopic screen to the right until the same prominent point of the shadow of the radio-opaque object coincides with the point of intersection on the left side of the fluoroscopic screen.

(g) Secure the horizontal locking handle, release the footswitch, and read what the pointer indicates on the localizer scale. The figure indicated is the perpendicular distance in centimeters from the bottom of the fluoroscopic screen to the radio-opaque object.

(h) Release the horizontal locking handle, press the footswitch, and move the fluoroscopic screen to the left until the same prominent point of the shadow of the radio-opaque object coincides with the point of intersection in the center of the fluoroscopic screen.

- (i) Secure the horizontal locking handle.
- (j) Bring the marker end of the depth marker down to the radio-opaque object, making certain that the marker end is aligned with the center point of intersection and the radio-opaque object. Touch the radio-opaque object lightly with the marker end. Release the footswitch.
- (k) Adjust the depth marker scale pointer until the depth marker scale indicates the same figure as the localizer scale read in (g) above. Secure the pointer with the lower clamp nut.
- (l) Replace the fluoroscopic screen cover.

Section VI. CONTROLS AND INSTRUMENTS

12. Controls on X-ray Field Unit, Machine, X-ray (fig. 56)

a. **MAIN SWITCH.** The main switch (fig. 57, part 9) is located at the top left of the control panel. This switch serves to open and close both sides of the incoming line to the autotransformer. When the main switch is turned "on" the kilovolt meter should indicate, the pilot and meter lights should light, the X-ray filament should light, the X-ray tube blower should operate, and localizer lamps should light.

b. **RADIOGRAPHIC AND FLUOROSCOPIC SWITCH.** The radiographic and fluoroscopic switch (fig. 57, part 4) is located between the minor kilovolt selector and the milliamperage regulator (par. 12f) on the control panel. The radiographic and fluoroscopic switch is a deck switch. When the switch is set to the fluoroscopic side, one deck of the switch selects the footswitch and disconnects the hand timer, the second deck selects below scale of the milliammeter and disconnects the high scale, and the third deck selects the limiting resistor for the filament circuit of the X-ray tube. When the switch is set to the radiographic side, the first deck selects the hand timer and disconnects the footswitch, the second deck selects the high scale of the milliammeter and disconnects the low scale, and the third deck shunts out the limiting resistor of the filament circuit. It should be noted that a red dot marks the radiographic position of the switch indicating caution in operation for this position.

c. **KILOVOLT SELECTOR MINOR.** The knob at the bottom center of the control panel is the control for the minor kilovolt selector (fig. 57, part 5). This control allows the kilovoltage to be varied in less than 1 kilovolt per step. The change in kilovolts will be noticed on the kilovolt meter above the control.

Caution: Do not move this control during an exposure since it may cause serious damage to the selector switch.

d. **KILOVOLT SELECTOR MAJOR.** The knob at the bottom left of the control panel is the control for the major kilovolt selector. (See fig. 56.) This control allows the kilovoltage to be varied approximately 8 kilovolts per step. The change in kilovolts will be noticed on the kilovolt meter above the control.

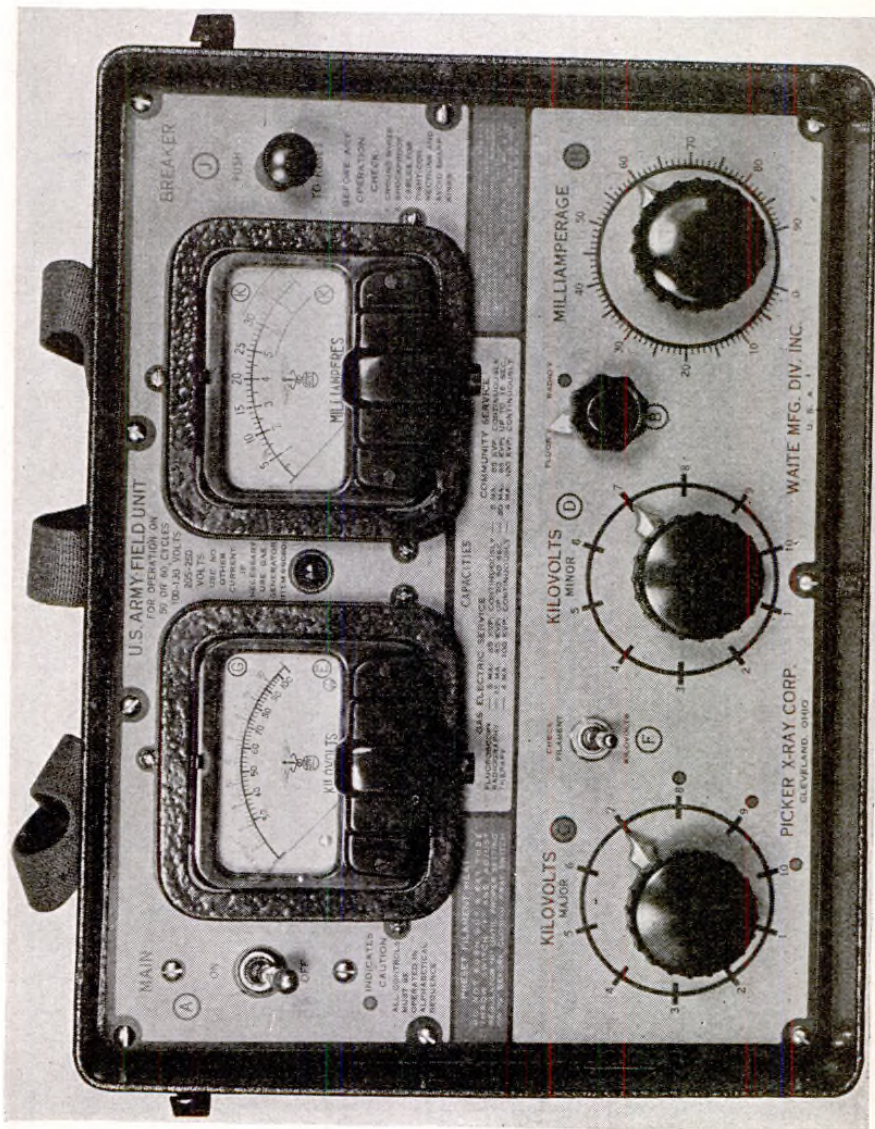
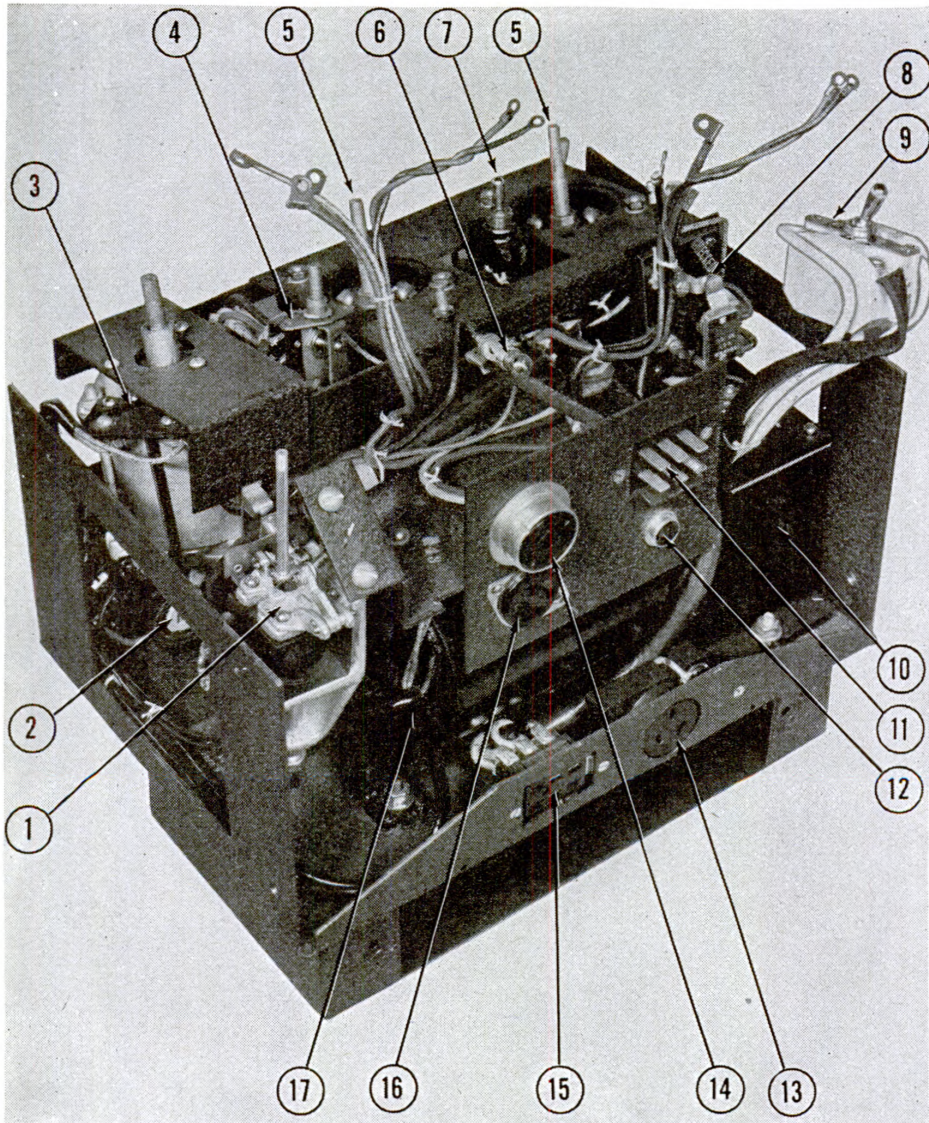

Figure 56. Control panel, X-ray field unit control unit, part of Chest MD X-4, item No. 9608810.



| <i>Med. Dept.</i> <i>No.</i> | <i>Nomenclature</i> | <i>Med. Dept.</i> <i>No.</i> | <i>Nomenclature</i> |
|---------------------------------|---|---------------------------------|---|
| 1. | 9R15175 Circuit Breaker, Complete. | 9. | 9R15020 Switch, Main. |
| 2. | 9R15162 Rheostat, Round. | 10. | 9R15116 Tank, Contactor |
| 3. | 9R15166 Control, Filament, Complete. | 11. | 9R15026 Plug, Jones, Male. |
| 4. | 9R15173 Switch, Radiographic-Fluoroscopic, Complete. | 12. | 9R15184 Receptacle, Female, Small, Two Wire. |
| 5. | 9R15102 Switch, Selector, Ten Point, Complete. | 13. | 9R15030 Receptacle, Tube, Motor. |
| 6. | SR00365 Bulb, 6-8 V., 1 C.P., Single Contact Bayonet. | 14. | 9R15182 Receptacle, Female, Large, Four Wire. |
| 7. | 9R15014 Switch, Check, Filament. | 15. | 9R15028 Receptacle, Jones. |
| 8. | 9R15018 Relay, Safety, Motor. | 16. | 9R15046 Receptacle, Timer. |
| | | 17. | 9R15094 Autotransformer, 9608808, Complete. |

Figure 57. Rear view of X-ray field unit control unit, control panel and control housing removed.

Caution: Do not move this control during exposure since it may cause serious damage to the selector switch. It will be noted that buttons 8, 9, and 10 are identified with a red dot indicating caution must be exercised and reference must be made to the kilovolt meter when using these steps or injury to the equipment will result.

e. **FILAMENT CHECK SWITCH.** The filament check switch (fig. 57, part 7) is located between the major and minor kilovolt selectors. The switch is of the toggle type and is normally held in the kilovolt position by spring tension. In this position the kilovoltage is indicated on the lower scale of the kilovolt meter. To check a filament setting it is necessary to throw the switch upward to the "check filament" position. In this position the upper scale of the kilovolt meter indicates the presetting of filament current for a given milliamperage. The switch will always return to the kilovolt position when released.

f. **FILAMENT CONTROL.** The filament control (fig. 57, part 3) is referred to as the "milliamperage regulator", and is located at the bottom right of the control panel. This control serves to regulate the filament current of the X-ray tube as indicated on the upper scale of the kilovolt meter when the toggle switch is thrown to the "check filament" position. The control may be moved during exposure as it is of the magnetic type and is stepless. It is designed that 30 milliamperes will be secured at about 90 percent of total rotation of the control knob when operating on the radiographic setting. Care must be exercised in setting this control so as not to overload the X-ray tube.

g. **CIRCUIT BREAKER.** The circuit breaker, 9R15175 (fig. 57, part 1 and fig. 58, part 7) is located at the top right of the control panel. It serves to open the operating circuit in case the high-tension transformer is overloaded. It is a safety device and if a shockproof cable becomes defective, or if an X-ray tube is considerably overloaded, this overload would be reflected to the primary causing the magnetic circuit breaker to trip its toggle mechanism which would immediately open the primary circuit by breaking the operating circuit. The contacts of the circuit breaker are reset by the knob marked "BREAKER" after they have been thrown open. The contacts are closed when the knob is pushed down, and open when the knob is up.

h. **TIMER.** The timer (fig. 21, part 4) is plugged into the rear of the control unit and hangs on a hook on the side of the control unit. The timer is used to determine the exposure time for radiography. If the timer is plugged into the control unit, it is automatically switched into the circuit when the radiographic and fluoroscopic switch is set for radiography. The timer has a range of from $\frac{1}{4}$ second to 12 seconds and is driven by a mechanical clock mechanism. The time values are set by the indicator on the calibrated dial, and the exposure starts when the button on top of the timer housing is pressed.

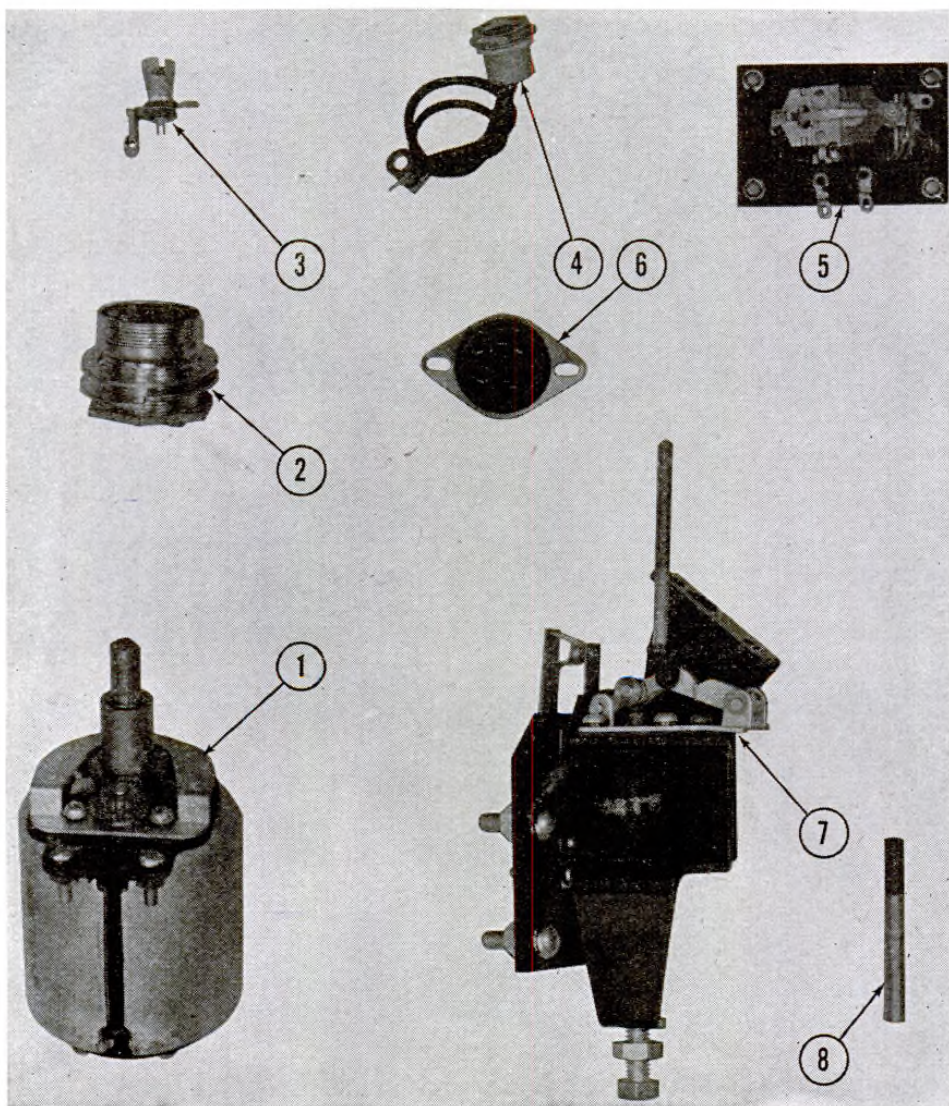

- | <i>Med. Dept.</i> | <i>No.</i> | <i>Nomenclature</i> |
|-------------------|------------|---------------------------------------|
| 1. | 9R15166 | Control, Filament, Complete. |
| 2. | 9R15182 | Receptacle, Female, Large, Four Wire. |
| 3. | 9R15180 | Socket, Pilot Light. |
| 4. | 9R15184 | Receptacle, Female, Small, Two Wire. |

- | <i>Med. Dept.</i> | <i>No.</i> | <i>Nomenclature</i> |
|-------------------|------------|----------------------------|
| 5. | 9R15018 | Relay, Safety, Motor. |
| 6. | 9R15046 | Receptacle, Timer |
| 7. | 9R15175 | Circuit Breaker, Complete. |
| 8. | 9R15176 | Plunger, Circuit Breaker. |

Figure 58. Replacement parts for X-ray field unit control unit.

i. **FOOTSWITCH.** The footswitch (fig. 21, part 8) is plugged into the rear of the control unit by a four-prong plug. While in use it is placed near the operator, and while not in use it may be neatly arranged on the chassis base of the machine. The footswitch is used to control intermittent exposures for fluoroscopy. If plugged into the control unit it is automatically switched into the circuit when the radiographic and fluoroscopic switch is set for fluoroscopy.

13. Instruments on X-ray Field Unit, Machine, X-ray

a. **KILOVOLT METER.** The kilovolt meter (fig. 56) is located on the left side of the control panel. It is a voltmeter placed in the primary circuit and is calibrated to read kilovolts. The meter used is of the "load on" type which indicates the kilovoltage when under exposure. If a presetting of this meter is desired, it will be necessary to determine what drop in meter reading is developed for each setting of milliamperage used. When the filament check switch is thrown upward, the filament current is indicated on the upper scale of this meter. This scale is printed in red figures and may be used as a basis for a filament chart to predetermine milliamperage values.

b. **MILLIAMMETER.** The milliammeter (fig. 56) is located on the right side of the control panel. The milliammeter indicates the amount of current passing through the X-ray tube. The meter has two scales. When the radiographic and fluoroscopic switch is in the radiographic position the 0-40 scale of the meter is used, but when the switch is moved to its fluoroscopic position the 0-8 scale is used. It should be especially noted that part of the scales of this meter are printed in red, indicating that operation is in the danger zone and the milliamperage should be lowered by adjusting the filament control counterclockwise. The milliammeter is provided with a meter light which is lighted by pressing and rotating the button at the bottom of the meter.

14. Controls on X-ray Field Unit Table Unit

a. **SHUTTER KNOBS.** The shutter knobs are located at the end of the screen arm where it joins the L member and angulating housing. There are two knobs, identified by their size. The small knob (9R05254) controls the shutters which adjusts the size of image crosswise on the screen, while the large knob (9R05256) controls the shutters which adjusts the size of image lengthwise on the screen.

b. **VERTICAL LOCK.** The vertical lock (9R05216) is located at the rear of the carriage. This lock secures the vertical column when the table is in use. The crank controlling vertical movement should never be moved before first loosening the vertical lock.

c. **ROTATION CLAMP AND LOCK.** The rotation clamp and lock (9R05202) is located on the angulating housing just below the large circular nameplate. (See fig. 59, part 2 and fig. 60.)

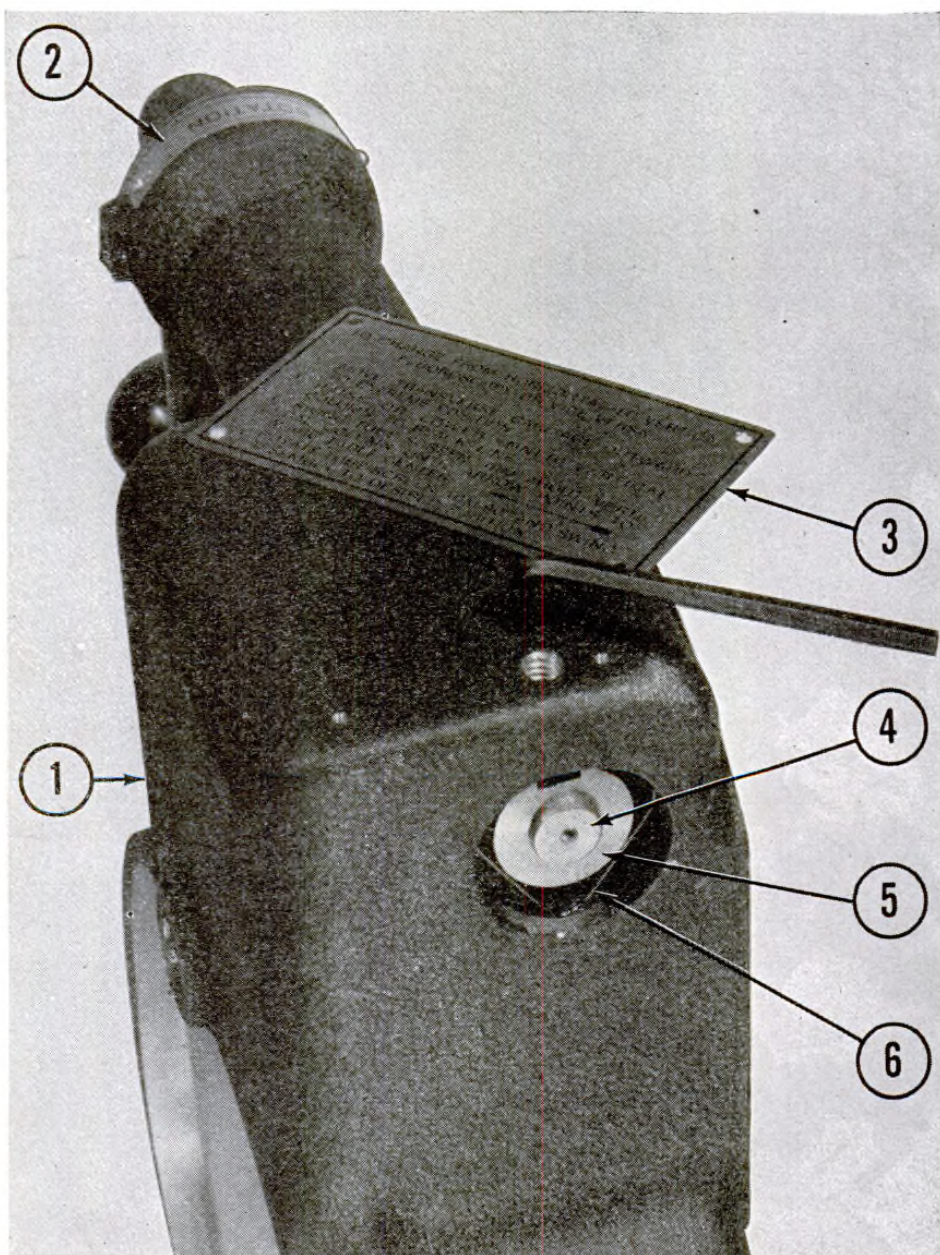

| <i>Med. Dept.</i> | <i>No.</i> | <i>Nomenclature</i> | <i>Med. Dept.</i> | <i>No.</i> | <i>Nomenclature</i> |
|-------------------|------------|---|-------------------|------------|--|
| 1. | 9R05660 | Housing, Angulating. | 4. | 9R05614 | Worm and Shaft, Angulating Housing. |
| 2. | 9R05566 | Nameplate, "Rotation," Short Crank, Angulating Housing. | 5. | 9R05632 | Bushing, Worm Shaft. |
| 3. | 9R05568 | Nameplate, Instruction, Horizontal, Vertical Fluoroscopy, Angulating Housing. | 6. | 9R05554 | Spring, Bushing, Worm Shaft, Angulating Housing. |

Figure 59. Angulating housing, part No. 9R05545, partial view.

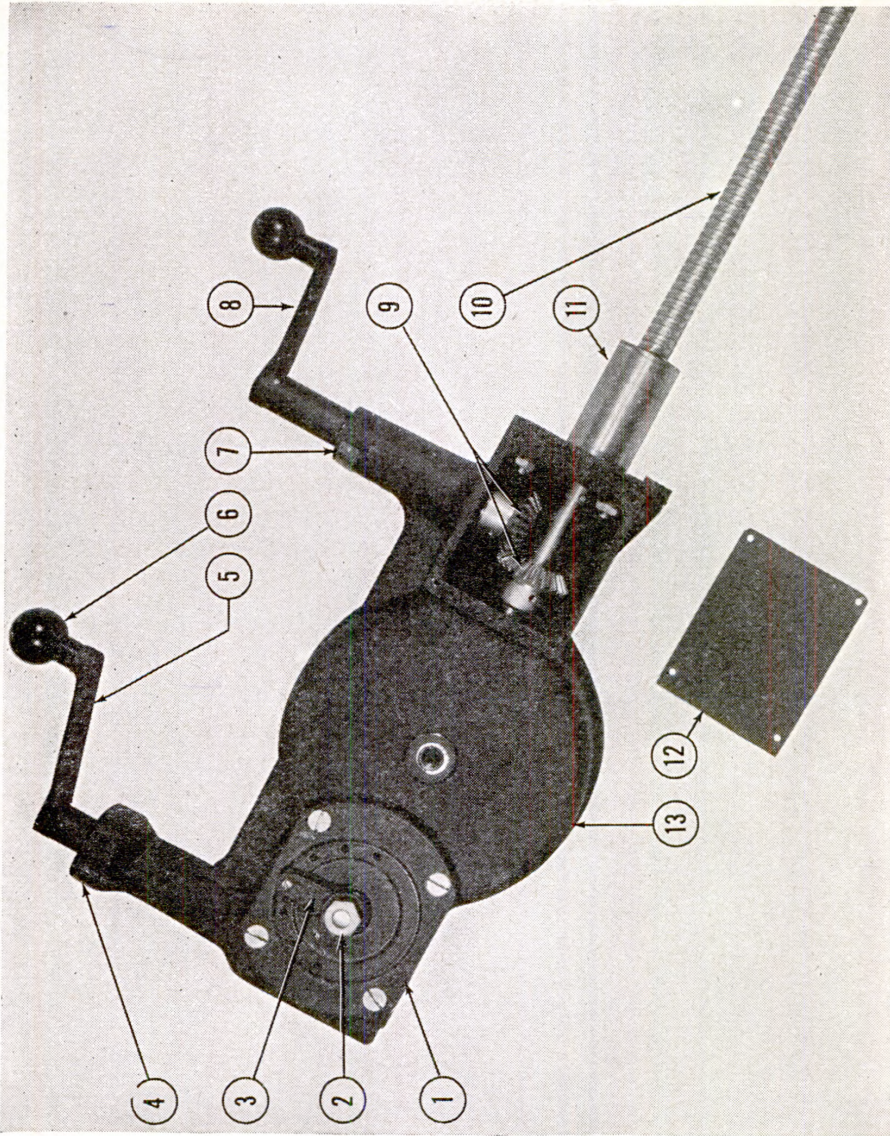

Figure 60. Angulating housing, part No. 9R05545, rear view.

Med. Dept.
No.

Nomenclature

1. 9R05656 Cover, Upper Gear Assembly.
2. 9R05618 Shaft, Eccentric, Angulating Housing.
3. 9R05662 Arm, Adjusting, Eccentric Shaft.
4. 9R05566 Nameplate, "Rotation," Short Crank, Angulating Housing.
5. 9R05648 Crank, Short Shaft.
6. 9R05624 Knob, Ball, Crank.
7. 9R05564 Nameplate, "Up-Down," Angulating Housing.
8. 9R05650 Crank, Long Shaft.
9. 9R05642 Gear, Raising.
10. 9R05596 Screw, Raising, Angulating Housing.
11. 9R05654 Support, Angulating Housing.
12. 9R05628 Cover, Rectangular, Gears.
13. 9R05660 Housing, Angulating.

This lock secures the screen and tube in position while in use. The crank controlling rotation of the angulating housing should never be moved before this lock is released or injury to the equipment may result. The lock is secured after each adjustment of the tube and screen to hold them firmly in place.

d. **SHORT SHAFT CRANK.** The crank with the short shaft (fig. 60, part 5) is used for controlling the rotation of the tube and screen. This crank is located on the upper section of the angulating housing and is identified by a nameplate marked "ROTATION". The crank should never be moved unless the rotation lock is released.

e. **LONG SHAFT CRANK.** The crank with the long shaft (fig. 60, part 8) is used for controlling the vertical movement of the vertical column. It is located below the rotation crank and is identified by a nameplate marked "UP-DOWN." Whenever it is desired to move the tube and screen vertically, this crank is used. It should never be moved unless the vertical lock is released.

f. **CARRIAGE LOCKS.** The carriage is secured in place by two locks.

(1) *Carriage lock for lengthwise travel.* The lock for lengthwise travel is located at the left front of the carriage. When the tube and screen are properly aligned lengthwise as compared to the table, this lock is fastened to retain proper alignment. The lock handle clamps the jaws of the lock to the table rail.

(2) *Carriage lock for crosswise travel.* The lock for crosswise travel is located at the left top of the carriage. When tube and screen are properly aligned crosswise as compared to the table, this lock is secured to retain alignment. When lock handle is tightened the jaws of the lock clamp to the tie rod and hold the carriage secure against crosswise movement.

g. **SHUTTER LOCK.** The shutter lock (fig. 46, part 1) is located on the shutter support and clamps to the L member. This lock secures the shutter assembly in place during fluoroscopic procedure and allows it to be moved out of the way for radiography. When the lock is loosened, the shutter assembly may be rotated and moved to a position from in front of the X-ray tube.

h. **LOCALIZER SCALE ADJUSTMENT.** The knob for localizer scale adjustment is located at the right of the localizer scale. This knob allows movement of the scale to proper value in centimeters while localizing foreign bodies.

15. Instruments on X-ray Field Unit Table Unit

The X-ray field unit table unit, does not employ any instruments.

Section VII. OPERATION

16. X-ray Field Unit, Machine, X-ray

a. **RADIOGRAPHY.** The tube should be properly positioned with

respect to the patient. The operation will be in alphabetical sequence as shown by the lettering on the control panel. (See fig. 56.) For radiography proceed as follows:

(1) Move main switch (A) to "ON" position. When the main switch is moved to the "ON" position the kilovolt meter should indicate, the pilot and meter lights should light, the blower motor should operate, the filament of the X-ray tube will light, and the localizer lamps become lighted.

(2) Place the radiographic and fluoroscopic switch (B) in the radiographic position. This position connects the hand timer for radiography, selects the 0-40 scale of the milliammeter, and shunts out the limiting resistor in the filament circuit.

(3) Adjust kilovoltage with major selector (C) as close as possible to the desired kilovoltage. The minor selector (D) can now be used to adjust to the desired kilovoltage. Kilovoltage will be indicated on the lower scale (E) of the kilovolt meter.

Caution: Never exceed 85 kilovolts.

(4) The filament check switch (F) should now be set to the "check filament" position. The filament current is registered on the upper scale (G) of the kilovolt meter.

(5) The filament control (H) must be adjusted to the proper setting as indicated on the upper scale (G) of the meter for desired milliamperage.

Caution: Do not exceed 30 milliamperes.

(6) The timer (I) should be set for the desired time by adjusting the indicator to time values marked on dial. Care should be taken not to press button on top of timer.

(7) The circuit breaker knob (J) must be pressed down which will reset the operating contacts of the circuit breaker.

(8) Press the button on top of the timer. This will cause the milliammeter to indicate. The 0-40 scale (K) should be read and if values are higher than desired or within the danger zone of the meter, turn filament control counterclockwise. If the values are lower than desired, turn filament control clockwise.

b. FLUOROSCOPY. The tube should be properly positioned with respect to the patient. The operation will be in alphabetical sequence as shown by the lettering on the control panel. For fluoroscopy proceed as follows:

(1) Move main switch (A) to "ON" position. When the main switch is moved to the "ON" position the kilovolt meter should indicate, the pilot and meter lights should light, the blower motor will operate, the filament of the X-ray tube should light, and the localizer lamps become lighted.

(2) Place the radiographic and fluoroscopic switch (B) in the fluoroscopic position. This position connects the footswitch for fluoroscopy, selects the 0-8 scale of the milliammeter, and places the limiting resistor in the filament circuit.

(3) Adjust kilovoltage by major and minor selectors (C and D) to desired kilovoltage as indicated on lower scale (E) of kilovolt meter.

Caution: Do not exceed 85 kilovolts.

(4) Filament check switch (F) should now be set to the "check filament" position. The filament current is indicated on the upper scale (G) of the kilovolt meter.

(5) The filament control (H) must be adjusted to the proper setting as indicated by the upper scale (G) of the kilovolt meter for desired milliamperage for fluoroscopy.

Caution: Do not exceed 5 milliamperes.

(6) Make certain the footswitch (I) is not depressed.

(7) The circuit breaker knob (J) should be pressed down which will reset the operating contacts of the circuit breaker.

(8) Depress the footswitch (I). This will cause the milliammeter (K) to register on the 0-8 scale. If value is higher than desired or within the danger zone of the meter, turn filament control counterclockwise. If value is lower than desired, turn filament control clockwise.

c. THERAPY. The tube should be properly positioned with respect to the patient. The order of operation for therapy will be in alphabetical sequence as shown by the lettering on the control panel. For therapy proceed as follows:

(1) Move main switch (A) to the "ON" position. When the main switch is moved to the "ON" position the kilovolt meter will indicate, the pilot and meter lights will light, the blower meter will operate, and the filament of the X-ray tube will light, and the localizer lamps become lighted.

(2) Place radiographic and fluoroscopic switch (F) in the fluoroscopic position, then the footswitch is connected, the small scale of the milliammeter is selected, and the limiting resistor is placed in the filament circuit.

(3) Adjust kilovoltage by major and minor selectors (C and D) to the desired kilovoltage as indicated on the lower scale (E) of the kilovolt meter.

Caution: Never exceed 100 kilovolts.

(4) The filament check switch (F) should now be set to the "check filament" position. The filament current is indicated on the upper scale (G) of the kilovolt meter.

(5) The filament control (H) should be adjusted to the proper setting for desired milliamperage.

Caution: Do not exceed 4 milliamperes at 100 kilovolts.

(6) Make certain footswitch (I) is not depressed.

(7) The circuit breaker knob (J) should be pressed down which will reset the operating contacts of the circuit breaker.

(8) Depress the footswitch (I). This will cause the milliammeter (K) to register on the 0-8 scale. If value is higher than

desired or in excess of 4 milliamperes, release the footswitch and turn filament control counterclockwise. If value is lower than desired, turn filament control clockwise. The footswitch must be depressed all the time during the treatment.

17. X-ray Field Unit Table Unit (foreign body localization)

The focal distance checking gauge (fig. 19, part 10) is placed on the fluoroscopic screen mounting. If the marks of the checking gauge do not coincide with the outside lines scribed on the fluoroscopic screen when exposed to X-ray, the focal screen distance is either too long or too short. The vertical lock should be released and crank controlling vertical movement adjusted so the lines coincide. The focal distance checking gauge should always be used to check the focal screen distance whenever the table unit is broken down and reassembled. To locate foreign body proceed as follows:

a. Check fixation locks and align the focal spot with the center of the fluoroscopic screen.

b. Align the foreign body with the central intersecting lines.

c. Dampen skin marker pad, on the end of the depth marker with tincture of iodine or ink. Lower the depth marker until the pad rests on the skin, thereby marking it.

d. Read the depth marker scale. The reading is the distance in centimeters between the screen and skin.

e. Shift tube and screen so as to align the foreign body to either of the outer intersecting lines.

f. Slide localizer scale and adjust pointer to the centimeter value read on the scale in step *d.* Clamp fixation of pointer to the side rail of table.

g. Move X-ray tube and screen in the opposite direction until the same alignment on the foreign body is secured with the opposite outer intersecting lines.

h. Read the localizer scale. The reading on the localizer scale is the depth in centimeters of the foreign body beneath the skin.

i. To check the accuracy of the localization a test block, depth phantom (fig. 22, part 13) is supplied with the table unit and packed with the tools. It is made of wood and has lead numbers imbedded at 3 and 12 centimeters depth. Check to see if the depth measurements located with X-ray correspond with the actual location of the lead numbers. If the depths of the test numbers as read on the localizer scale do not conform to the actual depth of each number, the reading level on the depth marker scale must be adjusted so that it indicates correctly.

Section VIII. OPERATION OF AUXILIARY EQUIPMENT

18. X-ray Field Unit Generator

For operation of the X-ray field unit generator item No. 9606000, see TM 8-630.

PART THREE

MAINTENANCE INSTRUCTIONS

Section IX. GENERAL

19. Scope

Part Three contains information for first- and second-echelon maintenance. It contains information needed for service as well as a description of the major units and their function in relation to other components of the equipment. There will accompany the machine, when shipped, the necessary parts, tools, and supplies to accomplish the service outlined in this part.

Section X. SPECIAL ORGANIZATIONAL TOOLS AND EQUIPMENT

20. Organizational Tools and Equipment

There are no special tools or equipment for the maintenance of this equipment.

Section XI. LUBRICATION

21. Weekly

a. The table bearings should be checked to be certain they are properly lubricated and move freely. Use GREASE, general purpose No. 2 (WB-2) for table bearings.

b. The mast and base bearings should be checked for free movement if the machine is mobile. Use GREASE, general purpose, No. 2 (WB-2).

Section XII. PREVENTIVE MAINTENANCE SERVICES

22. Operator Maintenance (First Echelon)

a. AFTER OPERATION. After operation the equipment should be cleaned of any dirt that has collected.

b. WEEKLY. Check the lubrication. (See par. 21.)

23. Organizational Maintenance (Second Echelon)

- a. Check for excessive play in angulating housing.
- b. Check the carriage so that it moves freely along the full length of the table.
- c. Check the fluoroscopic shutters so that they do not open to give full coverage of the screen or that they will not close to give a small enough aperture.
- d. Check to see that depth marker is held in place in fluoroscopic screen assembly.
- e. Check to see that chassis brake holds machine.
- f. Check to see that vertical carriage of tubestand does not slip or develop excessive play.

Section XIII. TROUBLE SHOOTING

24. Electrical

a. IF FUSES BLOW OUT IMMEDIATELY ON TURNING "ON" THE MAIN SWITCH.

Possible causes

Incorrect current supply.

Possible remedies

Check source of current. Be certain it is not d-c. (See par. 26.)

b. IF KILOVOLTMETER DOES NOT INDICATE.

Possible causes

- (1) Line cable improperly plugged in supply line.
- (2) Weight of line cable may pull plug out of receptacle.
- (3) Prongs of plug bent together.
- (4) No voltage at source of supply.
- (5) Line fuses blown.
- (6) Main switch not "on".
- (7) Major and minor selectors on "dead" buttons.
- (8) Loose connections on terminal panel.
- (9) Damaged or broken wires.
- (10) Defective line plug.

Possible remedies

- (1) Plug line cable in properly.
- (2) Check plug and receptacle.
- (3) Spread prongs of plug.
- (4) Check voltage at source of supply.
- (5) Replace line fuses. (See par. 27.)
- (6) Turn main switch "on".
- (7) Turn selectors to one of indexed positions.
- (8) Tighten all connections.
- (9) Repair all wires and solder connections to lugs.
- (10) Replace line plug.

c. IF MILLIAMMETER DOES NOT INDICATE.

Possible causes

- (1) X-ray filament not lighted.
- (2) Filament adjuster strap loose.
- (3) Poor contact of shock-proof cables.
- (4) Loose terminal connections.
- (5) Timer or footswitch improperly connected.
- (6) Circuit breaker knob out.
- (7) Radiographic and fluoroscopic switch improperly set.
- (8) Motor cable pulled from tube or control receptacles.
- (9) Improper connections to the control, transformer and tube head.
- (10) Defective meter.

Possible remedies

- (1) Check filament for open circuit. (See par. 29.)
- (2) Tighten filament adjuster strap.
- (3) Readjust cables in their receptacles to assure proper contact.
- (4) Tighten terminal connections under terminal cover of the high-tension transformer.
- (5) Connect properly so that good contact is established.
- (6) Reset circuit breaker.
- (7) Be certain radiographic and fluoroscopic switch is set for proper operation.
- (8) Plug in motor cable.
- (9) Examine all connections being sure they are properly made.
- (10) Replace meter. (See par. 35.)

d. IF CIRCUIT BREAKER KICKS OUT CONSTANTLY.

Possible causes

- (1) Filament control adjusted too high.
- (2) Punctured high-tension cable. (See par. 33.)
- (3) Defective X-ray tube. (See par. 34.)
- (4) Short circuit within the control.
- (5) Breakdown of insulation or coils within the high-tension transformer.

Possible remedies

- (1) Turn filament control counterclockwise.
- (2) Replace cable.
- (3) Replace X-ray tube.
- (4) Repair all wiring and poor connections.
- (5) Replace transformer.

25. Mechanical

a. IF CHASSIS BRAKE DOES NOT HOLD MACHINE.

Possible causes

Chassis brake out of adjustment.

Possible remedies

Adjust brake. (See par. 36.)

b. IF VERTICAL CARRIAGE OF TUBE STAND TENDS TO SLIP.

Possible causes

Possible remedies

Improper adjustment of carriage. Adjust screw beneath hand-crank. (See par. 37.)

c. IF VERTICAL CARRIAGE DEVELOPS EXCESSIVE PLAY.

Possible causes

Possible remedies

Improper adjustment of carriage. Adjust fiber adjusting screws. (See par. 38.)

d. IF X-RAY TUBE TENDS TO ROTATE TOO FREELY ON ITS AXIS.

Possible causes

Possible remedies

- | | |
|--|---|
| (1) Improper adjustment of adjusting screws. | (1) Tighten adjusting screws. (See par. 39.) |
| (2) Ring supports not riding properly. | (2) Check axis of tube to be certain that ring supports are not riding on the end covers of the X-ray tube. |

e. IF EXCESSIVE PLAY DEVELOPS IN THE ANGULATING HOUSING.

Possible causes

Possible remedies

Gears not meshing. Adjust meshing of gears. (See par. 40.)

f. IF CARRIAGE DOES NOT MOVE FREELY ALONG FULL LENGTH OF TABLE.

Possible causes

Possible remedies

- | | |
|--|--|
| (1) Improper assembly of table rails and tie rods. | (1) Check assembly and be sure table rails and tie rods are in grooves provided in table ends. |
| (2) Carriage bearings not in adjustment. | (2) Adjust. (See par. 41.) |
| (3) Dirty rails or bearings. | (3) Clean. |

g. IF FLUOROSCOPIC SHUTTERS DO NOT OPEN TO GIVE FULL COVERAGE OF SCREEN OR THAT THEY WILL NOT CLOSE TO GIVE A SMALL ENOUGH APERTURE.

Possible causes

Possible remedies

- | | |
|--|---|
| (1) Shutter wires too long or too short. | (1) Adjust length of wires. (See par. 42a.) |
| (2) Operating levers loose. | (2) Tighten. (See par. 42b.) |

h. IF FLUOROSCOPIC SCREEN ASSEMBLY WILL NOT HOLD DEPTH MARKER IN PLACE.

Possible causes

Possible remedies

Not enough friction on depth marker. Tighten adjusting screws. (See par. 43.)

Section XIV. MAINTENANCE OPERATIONS

26. To Check Source of Current

a. If voltmeter is available it may be used to measure the voltage. This voltage must be within the range specified on the terminal panel of the control.

b. If a voltmeter is not available, the source can be checked with a 110-volt lamp. If lamp illuminates naturally, the source is near 110-volt, but if lamp burns out, the source is 220-volt or higher. Do not connect machine to 220-volt source unless so specified on the control terminal panel.

c. Be certain the supply is not d-c. This information should be available from the engineer servicing the area. Observe the line and if a pole transformer is located it is an a-c line.

27. To Check and Replace Fuses

a. To check the fuses located on the terminal board, connect a 110-volt lamp across the tops of the fuses. If the lamp does not illuminate, replace the fuses by removing them from their clamps, and either changing the fuse link or replacing the whole cartridge.

b. If a voltmeter is available it may be placed across the tops of the fuses in the same manner to indicate presence of voltage. Proceed in the same manner as with the lamp.

28. To Replace Line Plug

To replace the line plug, remove the old plug from the line. Next, prepare the tips of the conductors and place new insert in cover. The conductors should then be secured to the prongs and soldered. (The new insert will be found in the spare parts cabinet under the control).

29. To Check X-ray Filament

The X-ray filament can be checked by throwing the filament check switch to the "check filament" position, and if meter (G) swings off scale, it indicates the filament circuit is open.

30. To Service Timer

Remove the back of the timer housing by taking out the three retaining screws, this will give access to the timer contacts. If contacts are burned and pitted, use crocus cloth to smooth them. Adjust by bending contacts so they will make good firm contact when the button is pressed.

31. To Replace Toggle Mechanism in Foot Switch

Remove the floor plate and take out the old mechanism. Replace with new toggle mechanism being sure to have the conductors prop-

erly connected to the switch. Be sure to replace the gasket, then reassemble floor plate.

32. To Dress and Adjust Circuit Breaker Contacts

a. Remove milliammeter for access to the contacts through meter port.

b. If contacts are burned and pitted use crocus cloth to dress smooth.

c. Contacts should be closed when knob is down, adjust by bending contact arm until good contact is established.

d. Replace milliammeter as it was originally.

33. To Check for Punctured High-tension Cables

This may be checked by first disconnecting one cable, and then the other to determine which cable caused the circuit breaker to kick out. If cable shows high-tension break-down by arcing or burning of rubber, it must be replaced with another cable.

34. To Check for a Defective X-ray Tube

Disconnect the high-tension cables from the tube and operate the X-ray unit. If the circuit breaker does not kick out with the cables disconnected and kicks out when connected the trouble lies within the tube. If trouble is evidenced within the tube head it will be necessary to replace it with another as the tube must not be opened in the field.

35. To Replace Meters

If meters are defective as indicated by operation or physical damage, they may be replaced.

a. Remove the old meter, observing the connections as it is removed.

b. Take new meter and make necessary connections. Note that each stud of the meter is marked to correspond with the lug marking for connection. Be certain that none of the lugs are touching, and that they have been properly made before reassembly.

c. Replace one meter at a time so it will not be possible to interchange meters.

d. If both meters are defective, in extreme emergency it may be necessary to operate the unit even though the meters are out. A shunt must be placed across the milliammeter before this can be accomplished. It would be well to record in some accessible place the setting of the major and minor kilovoltage selectors and the setting of the pointer of filament control for 5 milliamperes operation. The setting as recorded will only apply for one condition as sources of supply will vary. This operation should be limited to fluoroscopy only.

36. To Adjust Chassis Brake

Remove rubber tip of the brake lever, loosen locknut and turn the adjusting screw clockwise. Do not adjust so tight that brake lever will not snap past the center.

37. To Adjust Vertical Carriage of Tubestand if it Tends to Slip

Loosen the locknut of the adjusting screw beneath the handcrank and turn it clockwise. Be sure to retighten the locknut.

38. To Adjust if Vertical Carriage Develops Excessive Play

Loosen the locknut of the fiber adjusting screws and adjust for correction. These fiber screws should not be tightened to a point of drag on the motion of the carriage.

39. To Correct if X-ray Tube Tends to Rotate too Freely on its Axis

a. The acorn cap nut located at the ring support should be loosened and the adjusting screws behind the cap nut should be tightened. Be certain to relock the cap nut.

b. Check axis of tube to be certain that the ring supports are not riding on end covers of the X-ray tube.

40. If Excessive Play Develops in Angulating Housing

a. Loosen large hex nut located at the inside center of the angulating housing using the adjustable automobile wrench supplied with the table unit.

b. With the 1¼-inch socket wrench, also furnished, tighten head of bolt found above circular nameplate of the angulating housing just opposite the hex nut. Relock hex nut loosened in step *a* above.

c. Loosen adjusting lever above the hex nut at the inside center of angulating housing and adjust proper meshing of gears. This can be determined by turning the rotation crank and feeling the tension for turning. Relock adjusting lever.

d. Remove nameplate from the top of the angulating housing and a setscrew will become visible. Remove the setscrew and with Allen wrench tighten the adjusting screw to lower the worm gear so it will mesh properly. Be sure to replace the setscrew after adjustment.

e. Recheck all adjustments being sure they are tight.

41. If Carriage Does Not Move Freely Along Full Length of Table

a. Be certain the table rails and tie rods are properly assembled and are in the grooves provided in the table ends.

b. Loosen the bolts holding the eccentric ball bearings and adjust the carriage bearings until the carriage bears equal weight on all bearings. Be sure to retighten the bolts holding the bearings.

c. If the surfaces of the table rails or bearings have become dirty or irregular, clean off all foreign material to ease operation.

42. If Fluoroscopic Shutters Do Not Open to Give Full Coverage of Screen or Will Not Close to Give a Small Enough Aperture

a. Remove the covering at the angle of the L member. This will give access to the joining of the shutter wires with the shutter rods. Adjust length of wires where connection is made to the rods so the shutters will completely close and may be opened to allow coverage of the entire fluoroscopic screen. Make certain all adjustments are tight before replacing the cover.

b. The levers operating the shutters in the shutter housing should be cleaned and tightened for uniform movement. The aluminum filter on the bottom of the shutter housing must be removed to reach the bottom shutter levers. The aluminum filter should be replaced as soon as the cleaning and tightening is finished. (See figs. 46, 47, and 61.)

43. If Fluoroscopic Screen Assembly Will Not Hold Depth Marker in Place

Two adjusting screws for adjustment of the friction on the depth marker is provided. These screws are located in the screen mounting beside the hole provided for the depth marker. By tightening these screws the depth marker will remain in place.

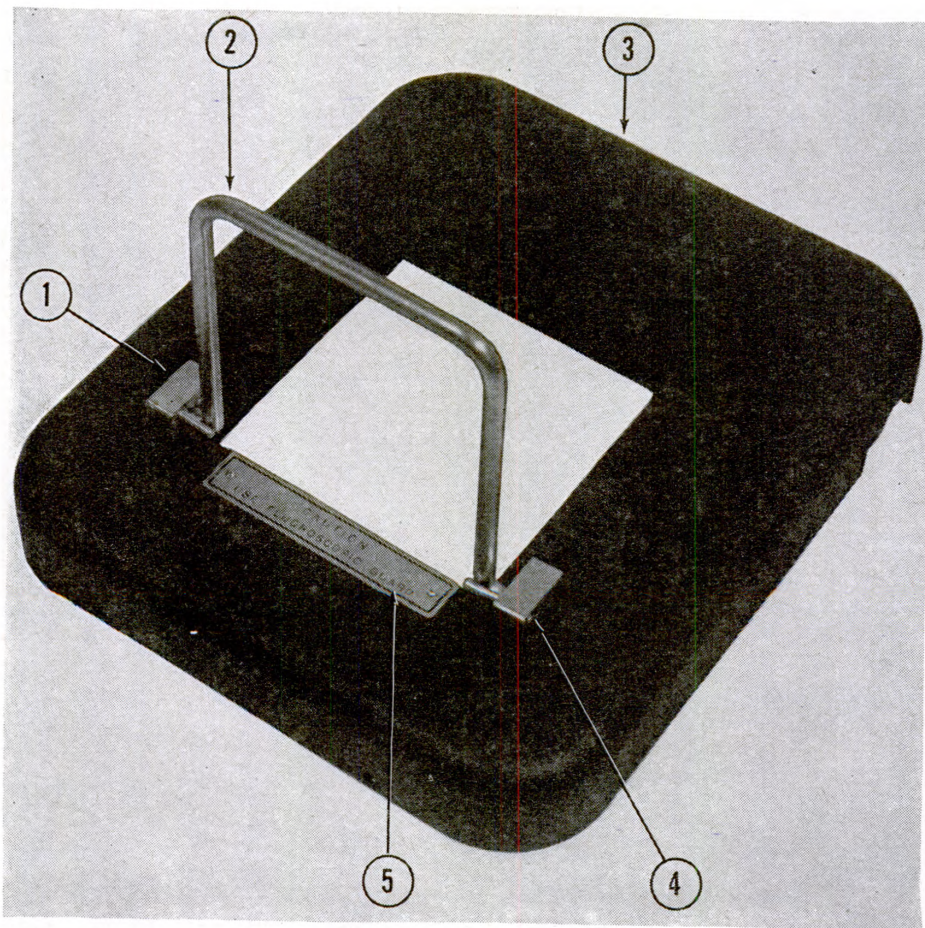

- | <i>Med. Dept.</i> | <i>No.</i> | <i>Nomenclature</i> |
|-------------------|------------|----------------------------|
| 1. | 9R05672 | Block, Fluoroscopic Guard. |
| 2. | 9R05698 | Guard, Fluoroscopic. |
| 3. | 9R05702 | Cover, Shutter Housing. |

- | <i>Med. Dept.</i> | <i>No.</i> | <i>Nomenclature</i> |
|-------------------|------------|---|
| 4. | 9R05704 | Pin, Fluoroscopic Guard. |
| 5. | 9R05668 | Nameplate, Instruction, Fluoroscopic Guard. |

Figure 61. Shutter housing cover, part No. 9R05702.

PART FOUR
AUXILIARY EQUIPMENT

Section XV. X-RAY FIELD UNIT GENERATOR, ITEM NO. 9606000,
(figure 62)

44. General

a. This item is designed for use as auxiliary power source for both models of the X-ray field unit, machine, X-ray. No generator having another item number should be used in conjunction with this field X-ray equipment. Two receptacles are provided, either of which may be used to connect the line cable plug of the X-ray field unit to the generator. Attach the ground clip of the X-ray field unit to the rod furnished with the generator, after the rod has been grounded as per instructions. The generator is shipped and stored in a shipping case provided for it.

b. Detailed instructions pertaining to this auxiliary equipment are contained in TM 8-630.

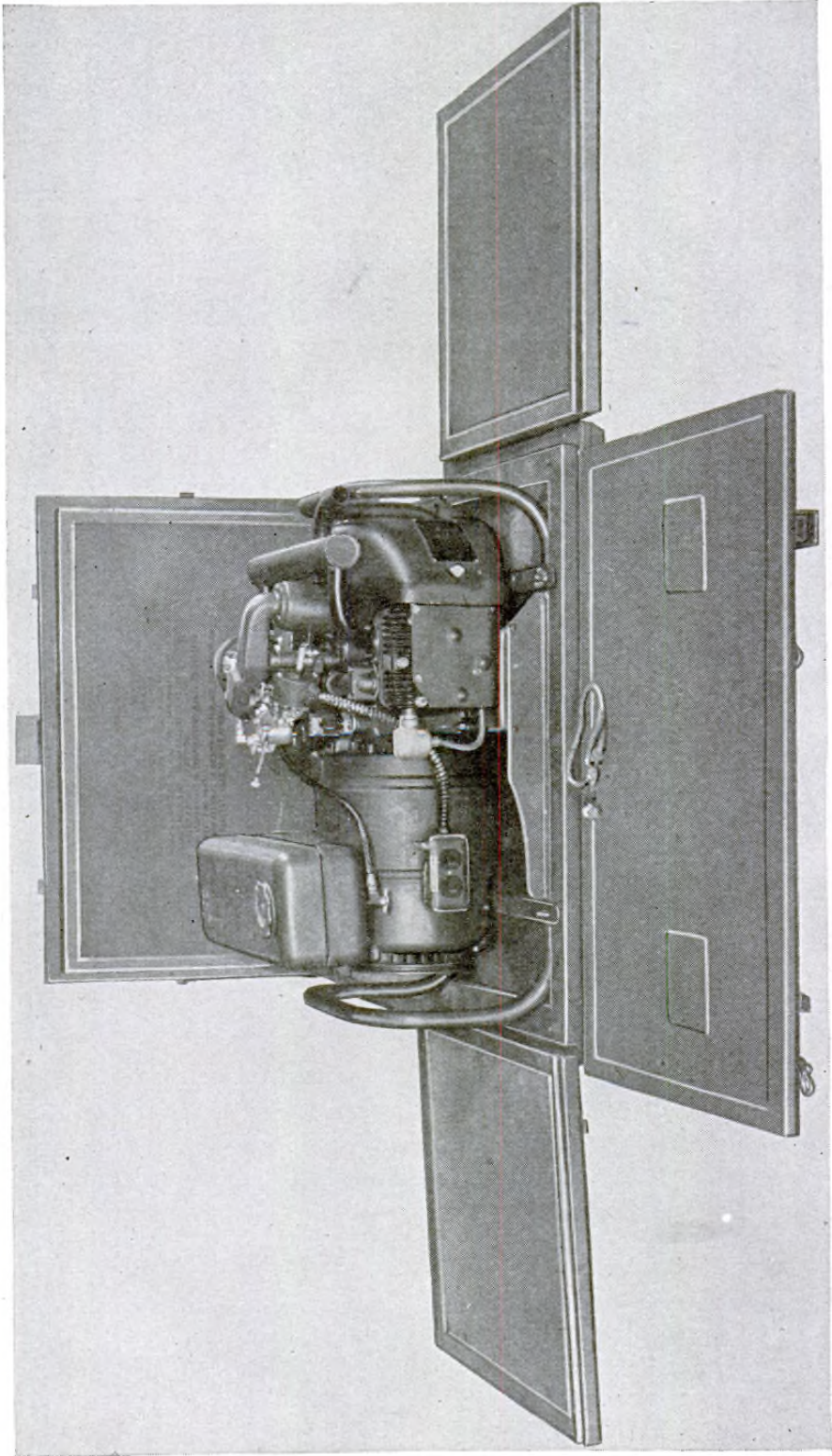

Figure 62. X-ray field unit generator, item No. 9606000.

APPENDIX

Section I. PROCEDURE FOR CONVERTING OLD TYPE CHASSIS 9609005 TO NEW CHASSIS 9609010 PNEUMATIC TIRES

1. Preparation of Old Chassis Base for Conversion

- a.* Remove the X-ray unit and the mast section from the chassis base.
- b.* The hex cap nuts are taken off the casters and casters removed.
- c.* Take out the caster locks which are secured with a pin that must be driven out.
- d.* Turn the chassis base over and loosen the large hex nuts which hold the axle bolts in place, remove the solid rubber wheels.
- e.* Remove the brake mechanism. Take out the two screws that secure the brake support and arm in place, and the whole mechanism may be lifted from the chassis base. The other mechanism is removed in the same manner.
- f.* The base is now ready for the new parts.

2. Assembly of New Parts to Chassis Base

a. PARTS NECESSARY TO CONVERT OLD CHASSIS TO NEW ARE AS FOLLOWS:

- 1....9R15614 Adapter, Base, Pneumatic Tires.
- 2....9R15616 Axle, Large Pneumatic Tires.
- 2....9R15618 Wheel, Large Pneumatic Tires.
- 2....9R15620 Wheel, Small Pneumatic Tires.
- 2....9R15622 Tire, 4.00 x 8, 2-ply.
- 2....9R15624 Tire, 10 x 3.50-4, 2-ply.
- 2....9R15626 Tube, Inner, 4.00 x 8.
- 2....9R15628 Tube, Inner, 10 x 3.50-4.
- 2....9R15630 Fork, Small Wheel.
- 1....9R15631 Plate, Mounting, Base Handle.
- 1....9R15632 Handle, Base, Complete: Assembly.
- 1....9R15640 Brake, Complete: Assembly.
- 2....9R15646 Bolt, $\frac{5}{8}$ -18 x 4 $\frac{3}{4}$ -inch, Hex H.M.
- 2....9R15648 Nut, $\frac{5}{8}$ x 18, Slotted, Hex.
- 12....SR00336 Washer, Screw Size $\frac{3}{8}$, 5-lb. Pkg., 340 Washers.

- 6. . . . SR00359 Washer, Lock, Screw Size $\frac{3}{8}$, 1,000 to Pkg.
- 2. . . . SR00659 Pin, Cotter, $\frac{3}{32}$ dia. x $1\frac{1}{2}$ -inch Length, 1,000 to Pkg.
- 6. . . . SR00661 Bolt, $\frac{3}{8}$ -16 x 4-inch, Hex H.M., 50 to Pkg.
- 6. . . . SR00526 Nut, $\frac{3}{8}$ x 16 Hex, 100 to Pkg.

b. PROCEDURE. (1) The adapter which holds the fork for the small wheels is assembled to the chassis base. This is secured in place by four SR00661 bolts using the holes from which the old caster and caster locks were taken. A SR00336 washer should be placed on the bolts and a SR00359 lock washer is used to hold the SR00526 hex nut secure. The small wheels, tires, and tubes, are assembled in the fork and this is placed in the holes provided in the adapter. The hex cap nuts that were taken from the old casters are used to secure the forks in place. The caster locks are placed in the holes provided in the adapter for locking the small wheels.

(2) The base handle is now assembled to the adapter. This is held in place by two of the SR00661 bolts. The handle is located between the two small wheels. Use washers and nuts as in the case of the adapter bolts. The handle should be assembled before it is secured in place.

(3) Brakes, large wheels, and axles are assembled to the base in the following manner: The brake assembly and the large wheels, with tires and tubes inflated, are placed together. With the flat plate surfaces of the brake assembly facing the chassis base, insert the axles through the wheel and brake assemblies which are mounted outside of the new type chassis base. The axles are secured in place by large hex nuts. Be certain all nuts are tight, and bolts are properly aligned.

(4) Adjust the brakes by turning the brake adjusting screws that are found on the brake assembly between the large wheel and the chassis base. Adjust so the brakes just hold the unit in place when the brake is on.

Section II. SHIPMENT AND STORAGE

3. X-ray Field Unit, Machine, X-ray

a. Remove the timer and footswitch from the control and replace them in the lower section of the right and left compartments in the control chest.

b. Secure the covers with the catches in each compartment and replace the goggles and lead gloves. Close each compartment by turning down the top lids.

c. Disconnect the male jones plug at the end of the transformer cable from the control.

- d.* Return the line cable to the rear compartment of the control chest and close the compartment.
- e.* Remove the blower cable and replace it in the center compartment of the cable shipping drawer.
- f.* If aluminum filters and lead aperture plates were used, they will be returned to this compartment also.
- g.* Turn the shipping drawer so that the compartment lid is down and pull out the two terminal protectors.
- h.* Remove a shockproof cable from the unit and form it in a coil of $3\frac{1}{2}$ turns, place it over the drum, thread on the protectors individually, and push the protectors into the sockets of the drawer. Pull the web strap around the cable, thread the strap under the handle, and turn over the drawer.
- i.* Replace the second cable in the same way. Pull the web strap through the buckle and tighten.
- j.* Return the cable drawer to the tube chest with the compartment door end nearest the X-ray tube compartment. It is recommended that the chest be in a horizontal position when replacing the cable drawer.
- k.* To remove the tube head, loosen the wing screw holding the mounting bearing of the hanger in place. While moving the tube head from side to side, gradually withdraw the tube head from its mounting.
- l.* Before returning the tube head to the chest, lock the hanger to the tube housing in the extreme angulated position where the blower housing of the tube nearly touches the back section of the yoke.
- m.* With the chest again in a vertical position, place the "anode" side of the tube head into the lower retaining ring. At the same time engage the tube hanger in the small cradle in the upper right of the chest. Place the upper retaining ring around the cathode end of the tube being careful that the safety switch cord is placed into the offset of the ring. This precaution is necessary to avoid pinching the cord between the ring and the cathode and section of the tube.
- n.* Engage the web strap with the teeth of the buckle tightly and pull the tip of the strap through a rectangular eye of the buckle firmly before knotting the surplus around the permanently secured section of the strap. This is most important to prevent possible breakage of the tube during transportation.
- o.* Replace the two cable receptacle plugs before closing the chest.
- p.* To pack the control, loosen the two guy retaining rods and attach them to the sides of the channel members of the mobile base as shown in figure 25, part 3.
- q.* Position the two retaining rods and clamps for the control as shown in figure 33.

r. Lift the control off the transformer top and replace it in the well of the control chest as shown in figure 7. It can be observed that the front handle of the control secures the top of the rear compartment.

s. Pull up the two retaining clamps and engage the top projection in the holes of the handle escutcheon. By tightening the two wing nuts, the control and the lids of the outer compartments will be secured. The chest may now be closed.

t. After the two cable receptacle corks are replaced and the connecting plug of the transformer cable has been secured with the small clip provided for that purpose, the transformer chest may now be closed and removed from the well of the mobile chassis.

4. Chest MD X-1, Old Type

a. To reassemble the chassis and mast chest, remove the end-plate of the cross arm and slowly pull the cross arm out of the cross-arm carriage.

b. Replace the end-plate and put this section aside temporarily.

c. Remove the cable supports and replace them on the long retaining bracket.

d. Crank the vertical carriage to its lowest position.

e. Remove the crank and replace it to its original position on the aluminum bracket.

f. Remove the two draw bolts by unscrewing the two wing screws on the top of the mast.

g. Place the draw bolts on the bottom of the chest as shown in figure 24, part 6.

h. Remove the top section and the two center sections of the mast and place them as shown in figure 24, parts 9, 10, and 15.

i. Secure the mast section and draw bolts with the two long steel straps and the two wing screws.

j. Remove the lower mast section and horizontal cross-arm carriage from the chassis and place it aside temporarily. Be sure to release the mast section by pressing the knurled knob at the mast base inward.

k. Before replacing the chassis, rotate the casters until they face the transformer well and secure the caster locks by screwing the knurled heads of the locks counterclockwise. Then release the floor locks by rotating them until they point inward towards the base. Lift the base by the two handles and place it into the chest.

l. Replace the aluminum casting in the mast well of the base after mounting the radiographic cone and crank as shown.

m. Replace the lower mast section, cross-arm carriage, and horizontal cross arm as shown in figure 3.

n. Be sure all retaining plates are in place and all wing nuts are tight before closing the chest.

5. Chest MD X-1, New Type

- a.* Remove the end plate of the cross arm and slowly pull the cross arm out of the cross-arm carriage.
- b.* Replace the end plate and position the cross arm.
- c.* Remove the cable supports and replace them in the chest.
- d.* Crank the vertical carriage to its lowest position.
- e.* Remove the crank and place it into the cable support compartment.
- f.* Unscrew the two draw bolts by means of the wing screws on top of the mast and remove them.
- g.* Lift off the upper mast section and place it into the chest.
- h.* Now place the draw bolts and the two center mast sections on top of the upper mast section as shown.
- i.* Position the lower mast and cross-arm carriage into the left of the chest as shown. Secure the assembly with the two retaining plates and wing screws.
- j.* If radiographic and dental cones were used replace them in the two compartments shown.
- k.* Remove the base handle from the base and mount it behind the cross arm.
- l.* Replace the wooden compartment cover.
- m.* Before returning the chassis to the chest, turn the casters inward (fig. 26) and secure them with the two thumb screws. Release the foot brakes by lifting the brake levers. With one man grasping the brake lever and another lifting the caster support brackets, place the chassis into the chest.
- n.* Close the chest.

6. X-ray Field Unit Table Unit

- a.* If the cassette lifting device was used, remove the panel and secure it to the cover of the large chest. Remove the two panel mountings and mount them in the rear of the large chest by means of the two bracket clamps.
- b.* If the fluoroscopic screen was used, be sure to replace the cover, remove the screen from the screen arm, and place it aside temporarily.
- c.* If the depth marker was used, mount it on the cover of the small chest. (See fig. 63, part 2.)
- d.* If the focal distance checking gauge was used, secure it on the bottom of the large chest.
- e.* If the fluoroscopic screen was used, remove the screen arm and mount it on the cover of the small chest as shown in figure 9.
- f.* If the protective shield was used for the table, remove it and place it aside temporarily.
- g.* Crank the L member into position.

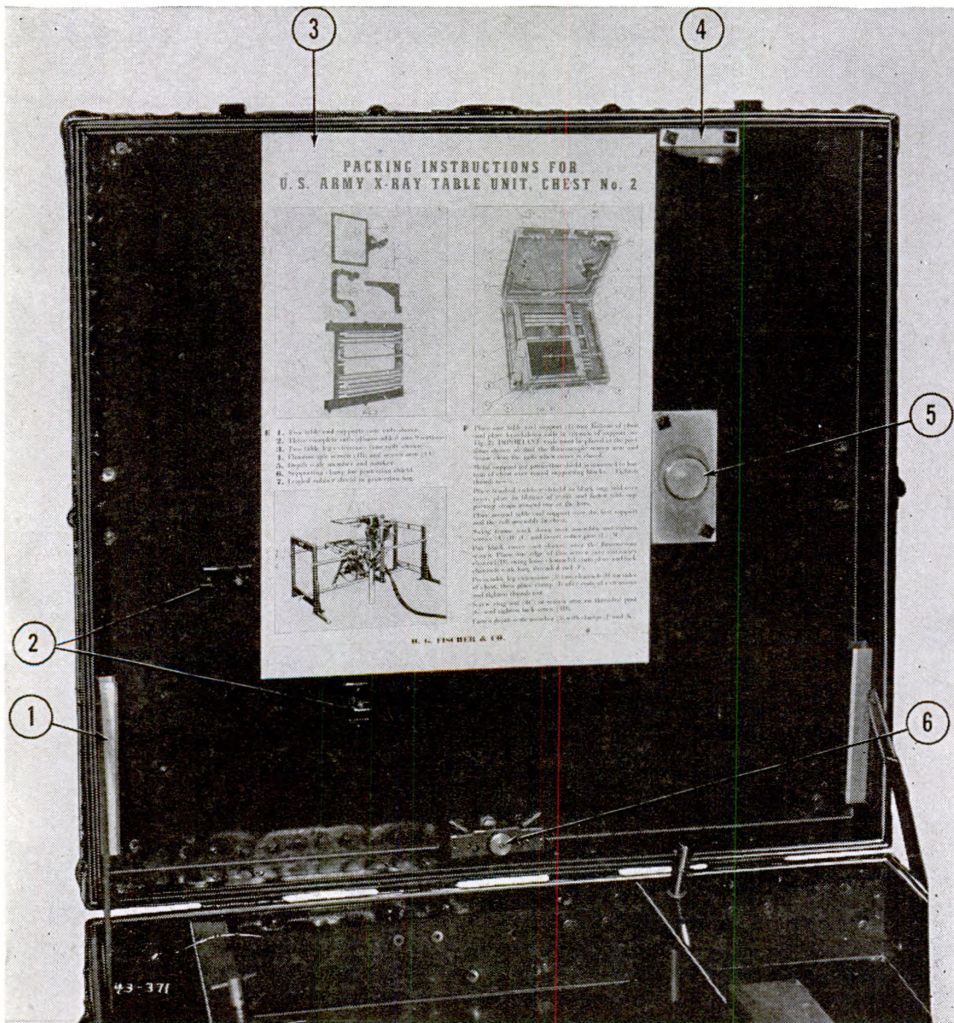

- | <i>Med. Dept.</i> | <i>No.</i> | <i>Nomenclature</i> |
|-------------------|------------|---------------------------------|
| | 1. 9R05914 | Clip, Detachable Leg. |
| | 2. 9R05932 | Holder, Depth Marker, Complete. |
| | 3. 9R05870 | Instruction Card, Small Trunk. |

- | <i>Med. Dept.</i> | <i>No.</i> | <i>Nomenclature</i> |
|-------------------|------------|---|
| | 4. 9R05934 | Support, Screen Arm. |
| | 5. 9R05924 | Flange, Screen Arm. |
| | 6. 9R05944 | Angle, Clamp, Detachable Leg, Complete. |

Figure 63. Small trunk cover mountings.

h. Loosen the locking handle securing the shutter housing and move the shutters to the center of the tube head supporting column of the **L** member. Rotate the shutters so that the housing faces directly upward and secure the locking handle.

i. Remove the **L** member from the angulating housing and place it aside temporarily. Replace the shutter rods cap to protect the shutter rod ends.

j. Secure the crosswise carriage with the angulating housing as close to the table rails as possible.

k. Turn the short shaft crank until the angulating housing cover faces in the same direction as the shafts of the two cranks.

l. Release the vertical locking handle and the hinged tube lock handle of the carriage mast support, remove the angulating housing assembly, and place it aside.

m. Remove the carriage assembly, invert it, and place into the large trunk as shown in figure 28. Secure the assembly by sliding the mast support over the carriage post and tightening the two locking handles. The remainder of the carriage is held in place by means of the two carriage clamps. Position the carriage support arm as shown in figure 28.

n. Replace the **L** member assembly and shutter. (See fig. 64.) Secure the assembly by means of the **L** member clamp, the saddle strap, and the shutter arm clamp.

o. Replace the angulating housing assembly. (See fig. 8.) Be sure the main vertical column is securely held by the tubestand support assembly and that the corner clamp is securely held in place.

p. The carriage support arm may now be folded down and chest closed for shipment.

q. Mount the protective shield bracket on the bottom of the small trunk.

r. Mount the two detachable legs on the cover of the small trunk.

s. Disassemble the table rails after removing them from the table ends.

t. Place one table end in the bottom of the small trunk.

u. Cover and secure the protective shield by means of two table rails. (See fig. 65.)

v. Replace the remaining table rails exactly in the order shown in figure 65. This is most important to assure proper clearance for the screen arm.

w. Position the remaining table end as shown in figure 9.

x. Lower the hinged frame and secure it by means of the three holding screws and the two cotter pins provided.

y. Mount the fluoroscopic screen with cover as shown in figure

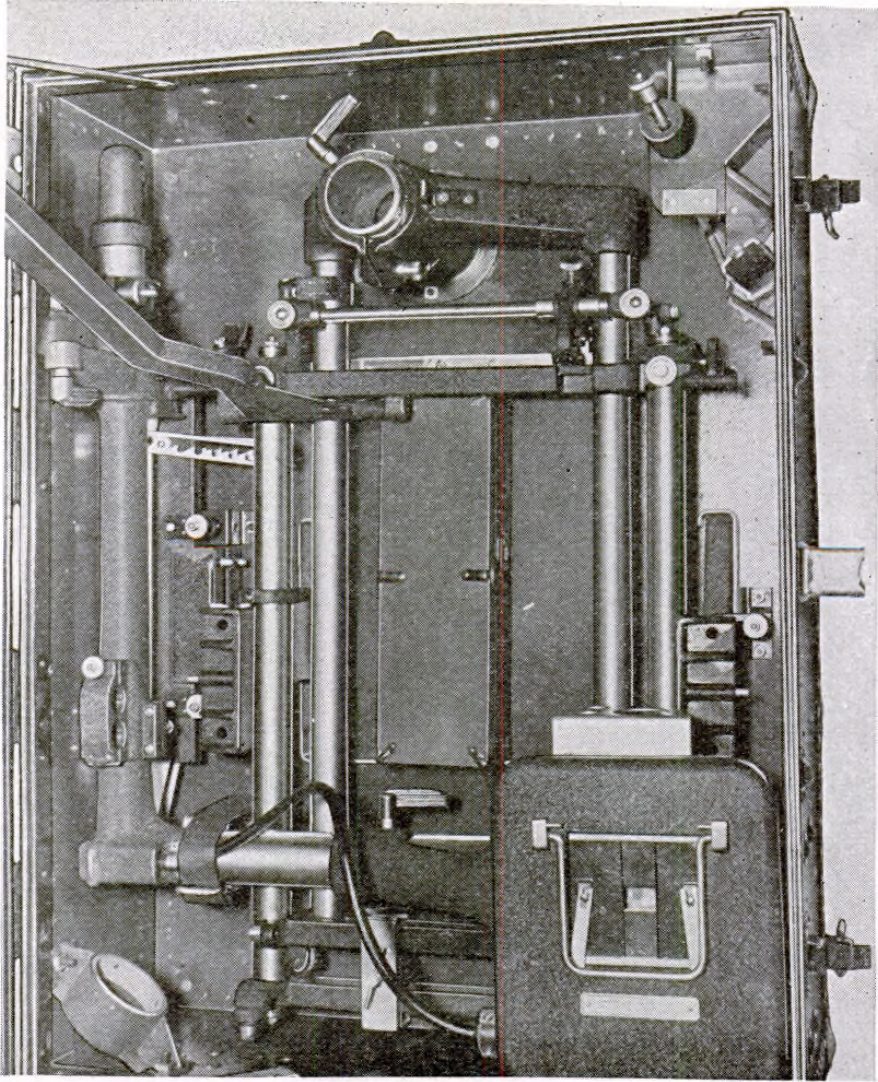

Figure 64. Large trunk, part No. 9R05767 without angulating housing.

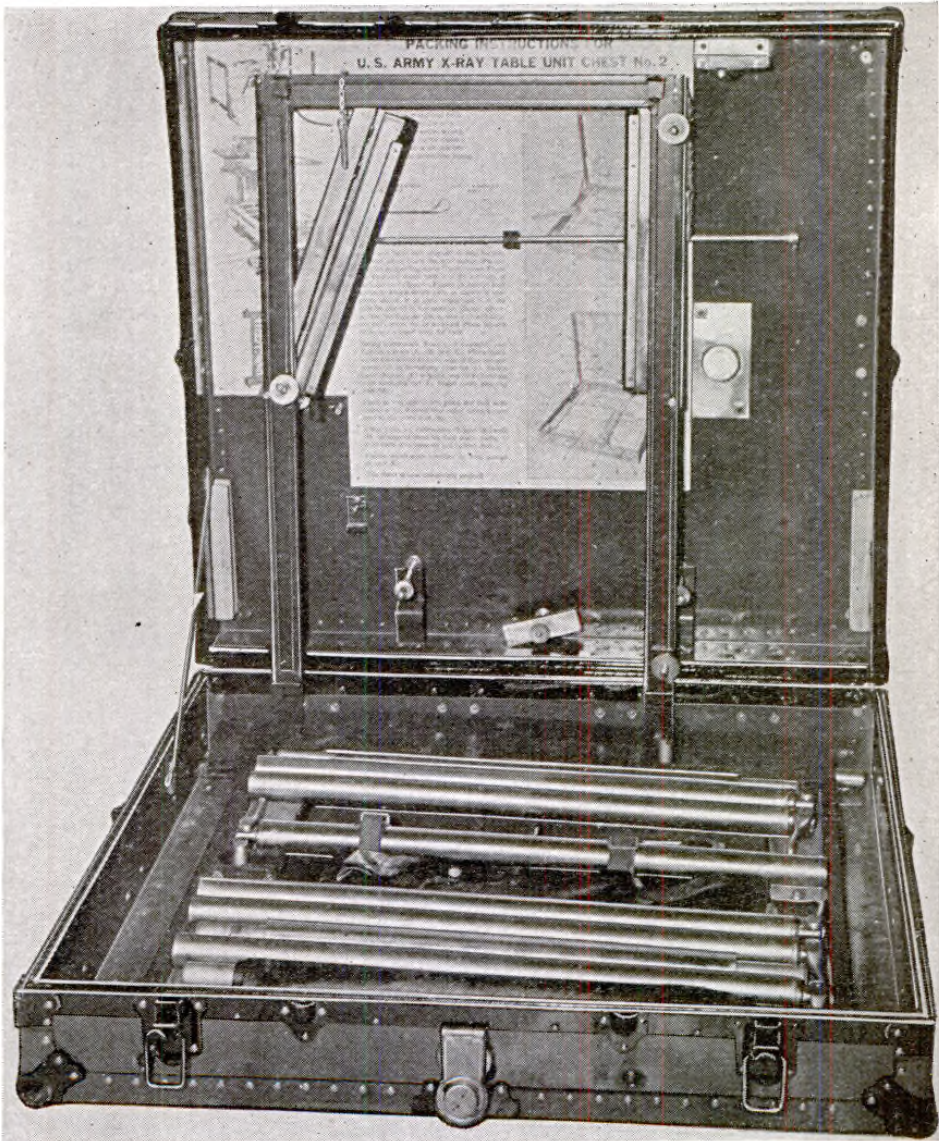

Figure 65. Small trunk part No. 9R05867, without table end and fluoroscopic screen.

- | <i>Med. Dept.
No.</i> | <i>Nomenclature</i> |
|---------------------------|---|
| 1. | 9R05900 Stud, Short, Leg Holding. |
| 2. | 9R05875 Pin, Cotter, Hinged Frame. |
| 3. | 9R05888 Bracket, Left, Clamp, Hinged Frame, Complete. |
| 4. | 9R05882 Chain, Hinged Frame. |
| 5. | 9R05912 Screw, Long, Leg Holding. |
| 6. | 9R05916 Insulator, Vibration, Screen Holder, 1/8-Inch Hole. |
| 7. | 9R05890 Frame, Hinged. |
| 8. | 9R05886 Bracket, Right, Clamp, Hinged Frame, Complete. |
| 9. | 9R05938 Holder, Right, Screen, Complete. |
| 10. | 9R05874 Bushing, Screen Tie Rod. |
| 11. | 9R05872 Tie Rod, Screen, Complete. |
| 12. | 9R05906 Spring, Long, Leg Holding Screw. |
| 13. | 9R05898 Stud, Long, Leg Holding. |
| 14. | 9R05884 Plate, Leg Holding Stud. |
| 15. | 9R05948 Holder, Plain, Attachment, Protective Shield. |
| 16. | 9R05954 Bolt, Clamp, Detachable Leg. |
| 17. | 9R05944 Angle, Clamp, Detachable Leg, Complete. |
| 18. | 9R05869 Nut, Clamp, Detachable Leg. |
| 19. | 9R05882 Handle, Lock, Leg Holding Screw. |
| 20. | 9R05904 Spring, Short, Leg Holding Screw. |
| 21. | 9R05946 Holder, Drilled, Attachment, Protective Shield. |
| 22. | 9R05868 Trunk, Small, Complete. |
| 23. | 9R05918 Insulator, Vibration, Screen Holder. |

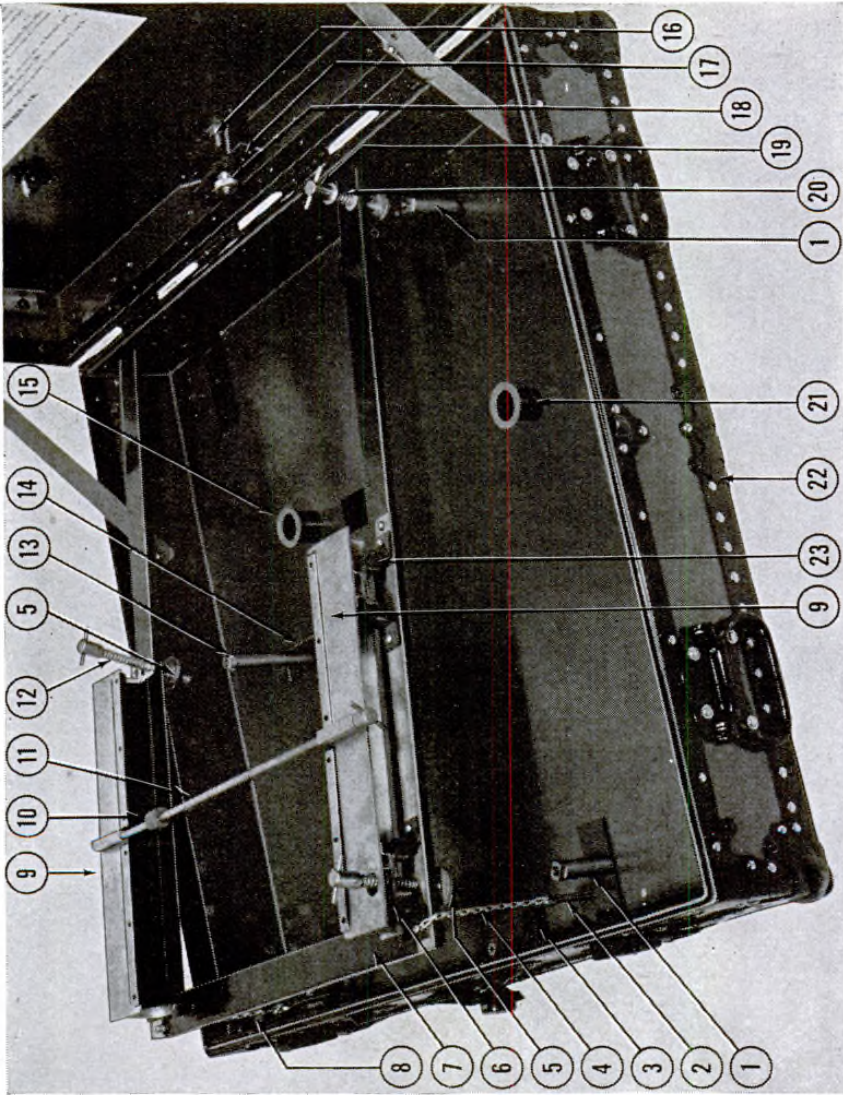

Figure 66. Small trunk, part No. 9R05868.

9. Be sure to secure the screen tie rod assembly figure 66, part 11 to the two screen holders in order to safeguard the screen.

z. The cover may now be closed and the small trunk is ready for shipment.

7. Packaging and Packing of Fluoroscopic Screen

To eliminate breakage of fluoroscopic screen packed as component of item No. 9614500 X-ray field unit table unit, it is desired that the following packaging practices be observed:

a. Remove screen unit comprising screen, leaded glass, and bakelite back, from metal frame and untape to permit separation of the three components.

b. Place fluoroscopic screen element in special parchment paper wrap and cardboard folder; place folder in laminated foil envelope and heat seal; wrap envelope in kraft paper and tape end flaps and longitudinal joint into position. Tape between two layers of double-faced corrugated board of same size as envelope.

c. Wrap leaded glass in kraft paper and tape end flaps and longitudinal joint into position. Place between two layers of double-faced corrugated board of same size as pieces used to back screen. Place plywood strips of thickness of glass and approximately $\frac{9}{16}$ inch in width around four edges of glass and the two layers of corrugated board (with glass and plywood blocks between) tightly taped together.

d. Wrap bakelite back in kraft paper and tape between two layers of double-faced corrugated board of the same size as envelope referred to in *b* above.

e. Place screen, glass, and bakelite back subunits together, with screen element in middle and an additional layer of double-faced corrugated board on each side. Place black fabric hood for screen unit between one of these layers and adjacent subunit. Tape tightly together into one compact unit, wrap in Grade C greaseproof wrapping, double dip in wax, and overwrap in kraft paper.

f. Place wrapped package inside a Style 1 wooden box approximately $30\frac{1}{4} \times 19\frac{1}{4} \times 4\frac{3}{4}$ inches outside dimensions with tightly packed layer of excelsior between box and all parts of package.

g. Place wooden box on edge at end of larger chest of table unit. Inclose box and chest in Style 2 nailed wooden box, approximately $47 \times 30\frac{1}{2} \times 19\frac{1}{4}$ inches, inside dimensions.

Section III. LIST OF REFERENCES

8. References

TM 8-275, Military Roentgenology.

TM 8-630, X-ray Field Unit Generators.

- FS 8-86 U. S. Army Field X-ray Equipment, Part I, Table Unit (Item 96145), Unpacking and Assembly.
- FS 8-87 U. S. Army Field X-ray Equipment, Part II Assembly and Adaptations of Field Table (Item 96145) with X-ray Machine, (Item 96085).
- FS 8-88 U. S. Army Field X-ray Equipment, Part III, Mobile Base And Tube Stand Assembly (Items 96090, 96090-10).
- FS 8-89 U. S. Army Field X-ray Equipment, Part IV, Transformer Tube and Control Assembly (Item 96085 with Item 96090).

Section IV. IDENTIFICATION OF ASSEMBLIES

9. General

This section is devoted to the identification of the various assemblies which make up the items covered in this manual. The components are shown as a break-down of each complete assembly. (See figs. 67 to 94.)

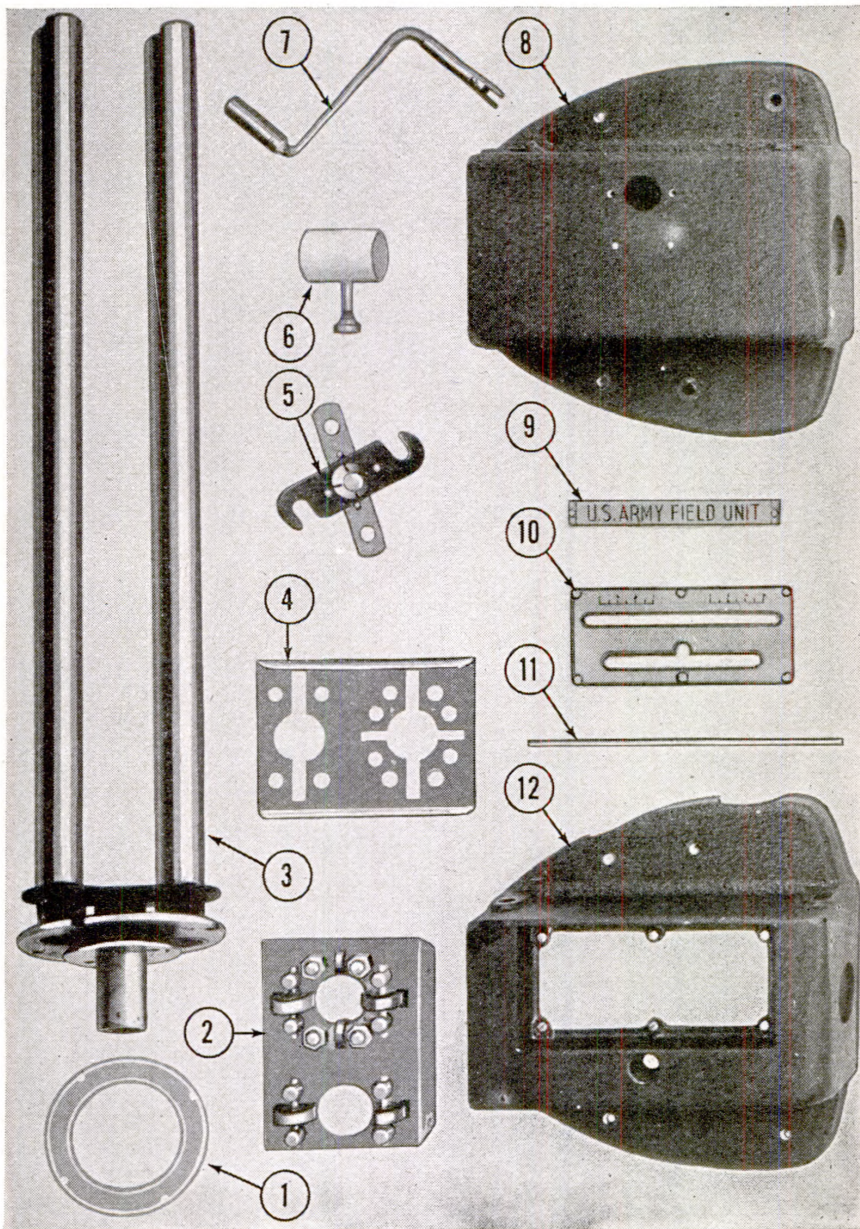

| <i>Med. Dept.</i> | <i>No.</i> | <i>Nomenclature</i> | <i>Med. Dept.</i> | <i>No.</i> | <i>Nomenclature</i> |
|-------------------|------------|------------------------------------|-------------------|------------|------------------------------------|
| 1. | 9R15486 | Dial, Tube Angulating. | 7. | 9R15524 | Crank, Hand, Complete. |
| 2. | 9R15494 | Plate, Bearing Complete. | 8. | 9R15492 | Housing, Plain Half. |
| 3. | 9R15476 | Cross Arm, Twin, Horizontal. | 9. | 9R15570 | Nameplate, "Army Field Unit". |
| 4. | 9R15496 | Plate, Ball Bearing. | 10. | 9R15552 | Nameplate, Indicating Stereoshift. |
| 5. | 9R15484 | Plate, Removable End, Complete. | 11. | 9R15538 | Rod, Guide. |
| 6. | 9R15544 | Lock, Shift, Horizontal, Complete. | 12. | 9R15490 | Housing, Stereo Half. |

Figure 67. Cross arm, part No. 9R15476, and carriage, part No. 9R15477 disassembled.

- | <i>Med. Dept.</i> | <i>No.</i> | <i>Nomenclature</i> |
|-------------------|------------|--|
| | 1. | 9R15602 Caster, Mobile Base, Complete. |
| | 2. | 9R15522 Bearing, Ball, 1 3/16-Inch OD, 1 3/32-Inch ID. |
| | 3. | SR00655 Bolt, 3/8-16 x 3-Inch, Hex H.M., 50 to Pkg. |
| | 4. | 9R15600 Wheel, 8-Inch, Mobile Base, Hard Rubber. |
| | 5. | SR00658 Bolt, 5/8-11 x 3-Inch, Hex H.M., 50 to Pkg. |
| | 6. | 9R15606 Arm, Brake. |
| | 7. | SR00379 Bolt, 5/16-18 x 1-Inch, Hex H.M., 100 to Pkg. |
| | 8. | 9R15579 Spring, Caster Lock. |
| | 9. | 9R15580 Bolt, 3/8-16 x 5 1/2-Inch, Knurled Head. |
| | 10. | 9R15554 Rod, Guy, Retaining, Complete. |
| | 11. | 9R15488 Bolt, Draw, Folding, Complete. |
| | 12. | 9R15470 Mast, Bottom Section. |
| | 13. | 9R15568 Slide, Cable Support, Complete. |
| | 14. | 9R15566 Support, Shockproof Cable. |
| | 15. | 9R15462 Base, Mast Section. |
| | 16. | 9R15586 Washer, Screw Size 5/8, Fiber. |
| | 17. | 9R15558 Bolt, 9/16-18 x 1 3/4-Inch, Pivot. |
| | 18. | 9R15562 Wedge and Guide. |
| | 19. | 9R15564 Bolt, 10-32 x 2 1/2-Inch, Knurled Head. |
| | 20. | 9R15560 Spring, 1 3/8-Inch Length, 1/4-Inch Diameter. |
| | 21. | 9R15598 Base, Chassis. |

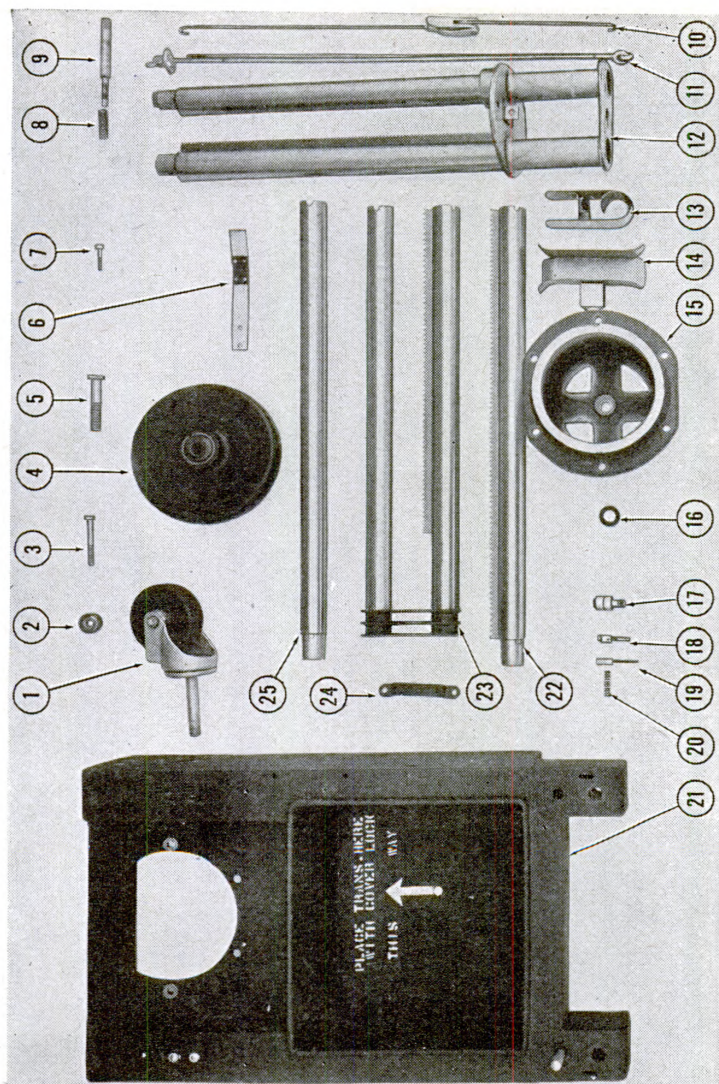

- | <i>Med. Dept.</i> | <i>No.</i> | <i>Nomenclature</i> |
|-------------------|------------|--------------------------------------|
| | 22. | 9R15466 Mast, Center Section, Rack. |
| | 23. | 9R15464 Mast, Top Section. |
| | | <i>Med. Dept.</i> |
| | | <i>No.</i> |
| | | <i>Nomenclature</i> |
| | 24. | 9R15556 Handle, Chassis Base. |
| | 25. | 9R15468 Mast, Center Section, Plain. |

Figure 68. Chassis, base and mast parts.

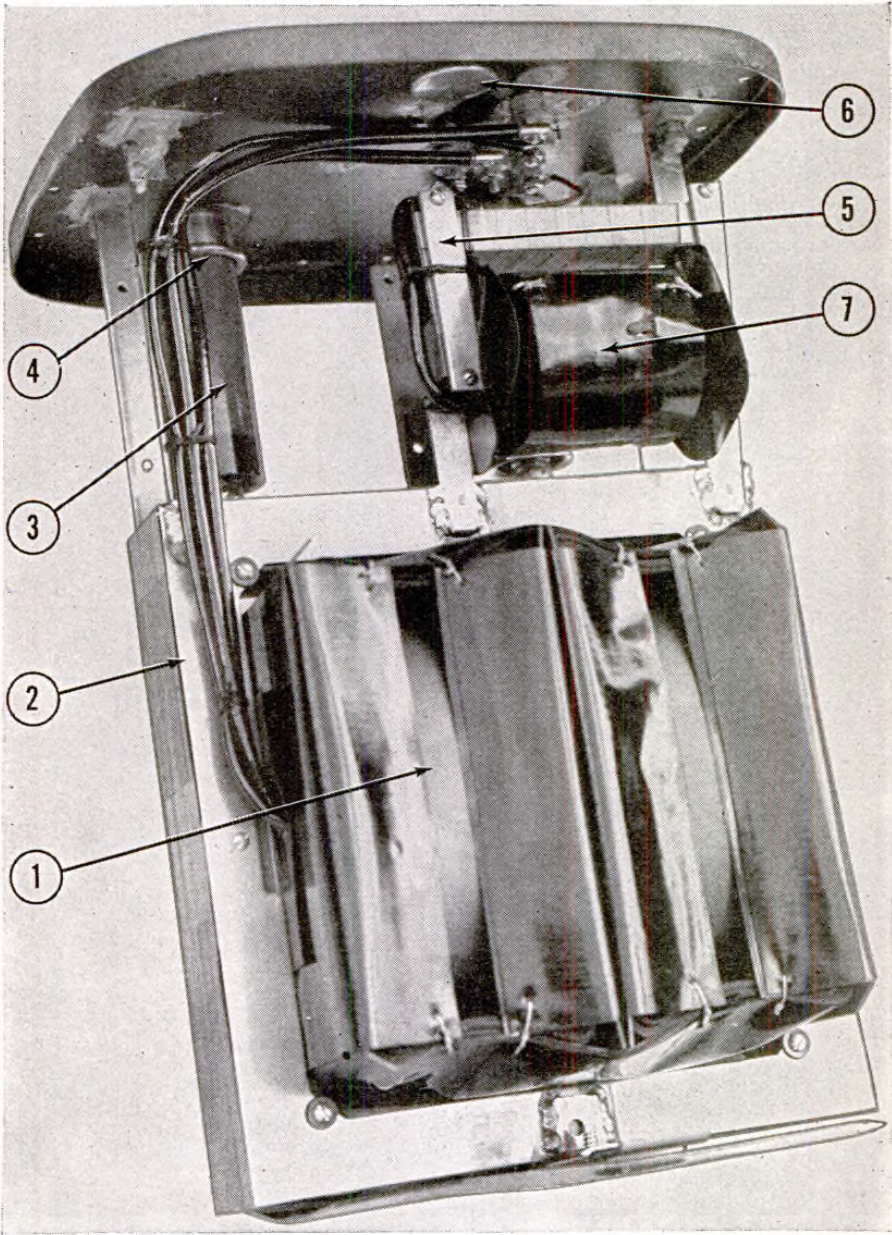

| <i>Med. Dept.</i> | <i>No.</i> | <i>Nomenclature</i> | <i>Med. Dept.</i> | <i>No.</i> | <i>Nomenclature</i> |
|-------------------|------------|--|-------------------|------------|------------------------------------|
| 1. | 9R15258 | Coil, Secondary, High-tension Transformer. | 4. | 9R15250 | Spinning, Cable Receptacle. |
| 2. | 9R15262 | Clamp, High-tension Transformer. | 5. | 9R15254 | Clamp, Core, Filament Transformer. |
| 3. | 9R15242 | Receptacle, Cable, Anode. | 6. | 9R15293 | Cap, Oil-Filling Port. |
| | | | 7. | 9R15252 | Transformer, Filament, Complete. |

Figure 69. X-ray field unit, transformer unit, chest MD X-2, item No. 9608600 without tank.

Med. Dept.
No.

Nomenclature

1. 9R15288 Cork, Cable Receptacle.
2. 9R15278 Cable, Power Supply, Transformer, Complete.
3. 9R15268 Cover, Terminal.
4. 9R15258 Coil, Secondary, High-tension Transformer.
5. 9R15262 Clamp, High-tension Transformer.
6. 9R15242 Receptacle, Cable, Anode.
7. 9R15252 Transformer, Filament, Complete.
8. 9R15064 Receptacle, Cable, Cathode.
9. 9R15290 Handle, Lifting, Transformer.
10. 9R15293 Cap, Oil-filling Port.
11. 9R15266 Gasket, Transformer Top.
12. 9R15270 Tank, Transformer.
13. 9R15272 Case, Shipping, Transformer.
14. 9R15280 Clip, Transformer Cable.
15. SR00045 Screw, 10-32 x $\frac{3}{8}$ -Inch, R.H.M., 144 to Pkg.
16. SR00637 Screw, $\frac{1}{4}$ -20 x $\frac{1}{2}$ -Inch, B.H.M., 144 to Pkg.
17. SR00643 Screw, 12 x $\frac{1}{2}$ -Inch, Sheet Metal, B.H., Type "Z," 144 to Pkg.
18. SR00641 Screw, 6 x $\frac{3}{8}$ -Inch, Sheet Metal, B.H., Type "Z," 144 to Pkg.
19. SR00330 Nut, 10 x 32, Hex, 144 to Pkg.
20. SR00017 Nut, 8 x 32, Hex, 144 to Pkg.
21. SR00273 Nut, 10 x 32, Hex, Brass, 144 to Pkg.
22. SR00217 Washer, Shakeproof, Screw Size 10, Int., 1,000 to Pkg.
23. SR00151 Washer, Lock, Screw Size 10, 1,000 to Pkg.
24. SR00297 Washer, Screw Size 10, 1-Lb. Pkg., 1,000 Washers.
25. 9R15294 Panel, Side, Transformer.
26. 9R15286 Panel, Bottom, Transformer.
27. 9R15276 Cleat, Right, Retaining Transformer.
28. 9R15274 Cleat, Left, Retaining Transformer.

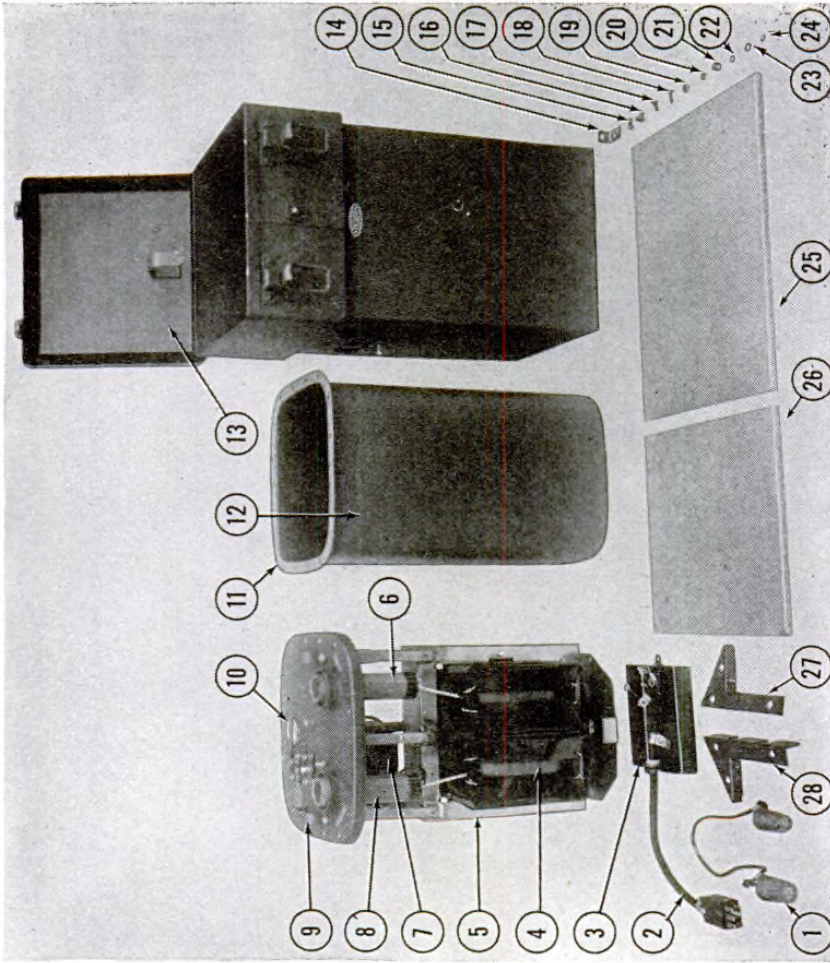
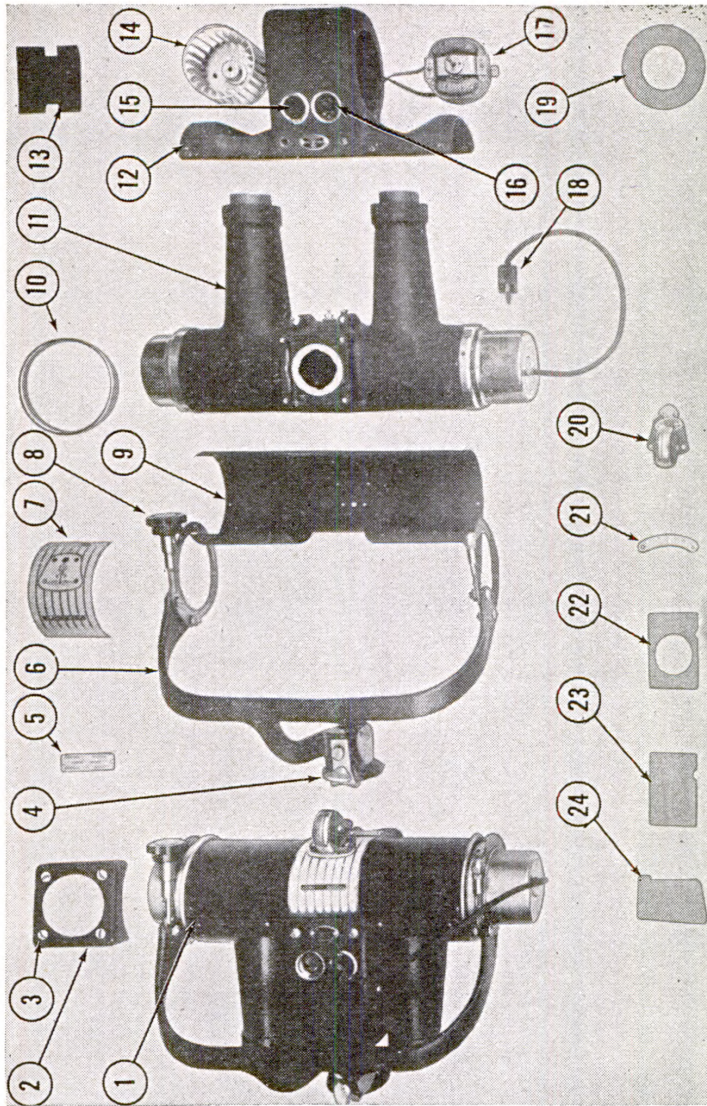
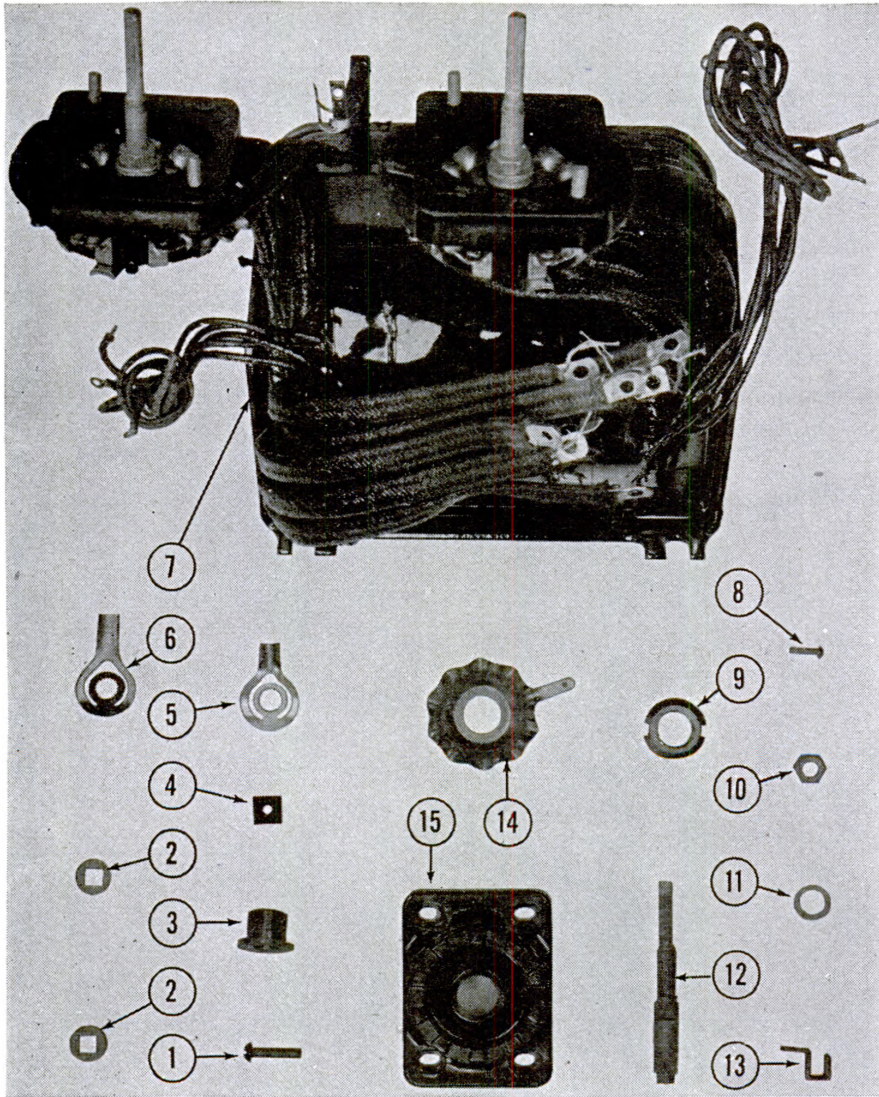

Figure 70. X-ray field unit, transformer unit, chest MD X-2, item No. 9608600 disassembled.



- | <i>Med. Dept.,
No.</i> | <i>Nomenclature</i> |
|----------------------------|---|
| 1. 9620900 | X-ray Field Unit Tube, X-ray. |
| 2. 9R15352 | Retainer, Cone, Tube Head. |
| 3. SR00632 | Screw, 1/4-20 x 3/4-Inch, B.H.M., 144 to Pkg. |
| 4. 9R15358 | Screw, Thumb, Retaining. |
| 5. 9R15335 | Nameplate, Tube Rating. |
| 6. 9R15078 | Hanger, Tube Head. |
| 7. 9R15338 | Nameplate, Tube Housing. |
| 8. 9R15346 | Knob, Lock, Tube Head. |
| 9. 9R15330 | Shell, Outer. |
| 10. 9R15328 | Trim, End Cover. |
| 11. 9R15322 | Tube Head Casting. |
| 12. 9R15323 | Housing, Blower. |
| 13. 9R15323 | Insulation, Blower Housing. |
| 14. 9R15320 | Wheel, Blower. |
| 15. 9R15040 | Receptacle, Thermal Switch Plug. |
| 16. 9R15032 | Receptacle, Tube Motor. |
| 17. 9R15318 | Motor, Blower, Tube Housing, Complete. |
| 18. 9R15038 | Plug, Switch, Thermal. |
| 19. 9R15334 | Band, Decorative, Tube Housing. |
| 20. 9R15366 | Scale, Flexible, Complete. |
| 21. 9R15340 | Dial, Angulation. |
| 22. 9R15416 | Plate, Aperture, Lead Alloy. |
| 23. 9R15342 | Filter, Fixed, 1/4 MM, Aluminum. |
| 24. 9R15344 | Spring, Retainer, Filter. |

Figure 71. Parts for X-ray field unit tube, X-ray.



| <i>Med. Dept.</i> | <i>No.</i> | <i>Nomenclature</i> | <i>Med. Dept.</i> | <i>No.</i> | <i>Nomenclature</i> |
|-------------------|------------|--|-------------------|------------|---|
| 1. | SR00143 | Screw, 10-32 x 1-inch, R.H.M., 144 to Pkg. | 8. | SR00047 | Screw, 4-36 x 3/8-inch, R.H.M., 144 to Pkg. |
| 2. | 9R15239 | Washer, 5/8-inch OD, Square Hole. | 9. | 9R15193 | Nut, Lock, 11/16 x 16. |
| 3. | 9R15108 | Bushing, Shaft, Selector Switch. | 10. | SR00670 | Nut, 5/16 x 24, Hex, 144 to Pkg. |
| 4. | 9R15105 | Stop, Selector Switch. | 11. | 9R15235 | Washer, 1/2-inch ID. |
| 5. | 9R15056 | Contact, Lever, Aligning. | 12. | 9R15110 | Shaft, Selector Switch. |
| 6. | 9R15058 | Contact, Lever. | 13. | 9R15060 | Contact, Switch, Selector. |
| 7. | 9R15094 | Autotransformer, 9608808, Complete. | 14. | 9R15106 | Plate, Aligning, Selector Switch. |
| | | | 15. | 9R15104 | Base, Selector Switch. |

Figure 72. Autotransformer with selector switches part No. 9R15094, including replacement parts.

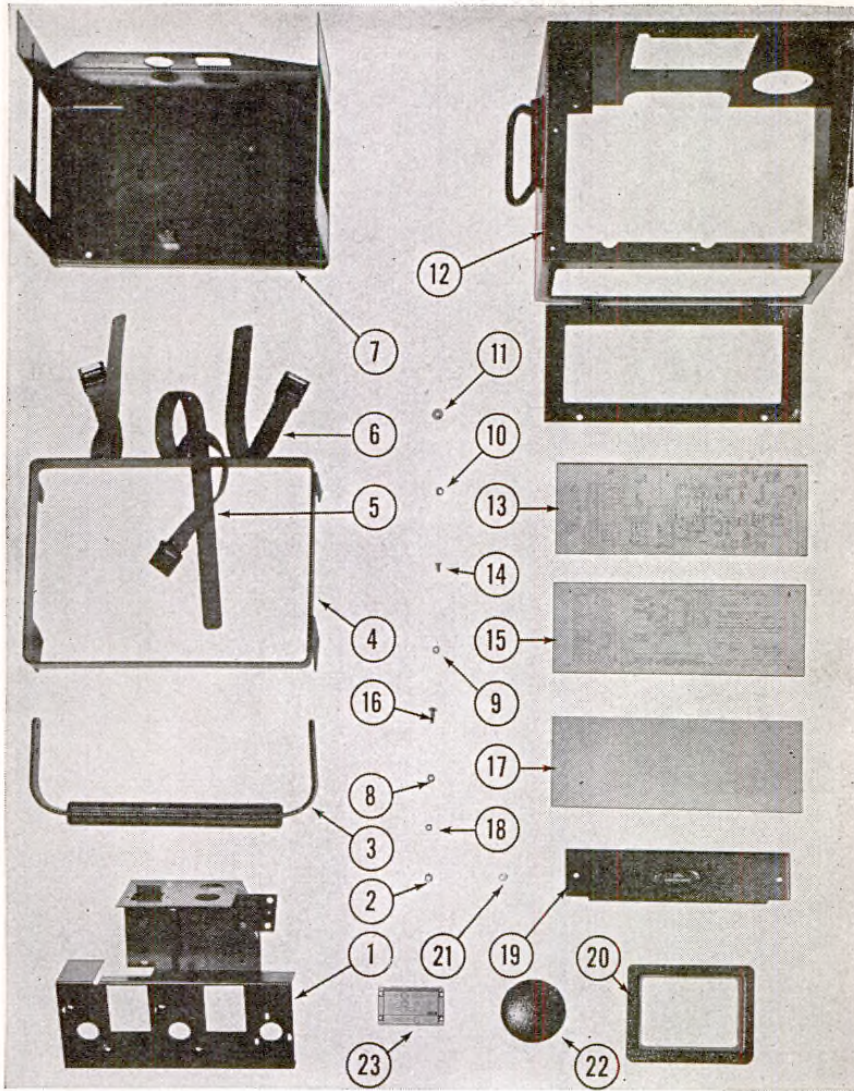

| <i>Med. Dept.</i> <i>No.</i> | <i>Nomenclature</i> | <i>Med. Dept.</i> <i>No.</i> | <i>Nomenclature</i> |
|---------------------------------|--|---------------------------------|--|
| 1. | 9R15098 Bracket, Autotransformer and Switches. | 12. | 9R15080 Housing, Control, Complete. |
| 2. | SR00330 Nut, 10 x 32, Hex, 144 to Pkg. | 13. | 9R15206 Chart, Diagram. |
| 3. | 9R15082 Handle, Front, Control Housing, Complete. | 14. | SR00003 Screw, 8-32 x 1/2-inch, R.H.M., 144 to Pkg. |
| 4. | 9R15086 Rail, Guard, Complete. | 15. | 9R15204 Chart, Technic. |
| 5. | 9R15226 Strap, Retaining Cross Arm. | 16. | SR00314 Screw, 10-32 x 5/8-inch, R.H.M., 144 to Pkg. |
| 6. | 9R15224 Strap, High-tension Cable. | 17. | 9R15202 Window, Technic Chart, Plastic. |
| 7. | 9R15084 Base, Control. | 18. | SR00151 Washer, Lock, Screw Size 10, 1,000 to Pkg. |
| 8. | SR00277 Washer, Shakeproof, Screw Size 10, Int., 1,000 to Pkg. | 19. | 9R15198 Cover, Cabinet, Spare Parts. |
| 9. | SR00017 Nut, 8 x 32, Hex, 144 to Pkg. | 20. | 9R15200 Frame, Rear Plugs. |
| 10. | SR00229 Washer, Lock, Screw Size 1/4, 1,000 to Pkg. | 21. | 9R15236 Nut, 8 x 32, Thumb. |
| 11. | SR00293 Washer, Screw Size 1/4, 1-lb. Pkg., 144 Washers. | 22. | 9R15178 Cover, Circuit Breaker Adjustment Part. |
| | | 23. | 9R15210 Nameplate, Plugs, Control. |

Figure 73. Replacement parts for X-ray field unit control unit.

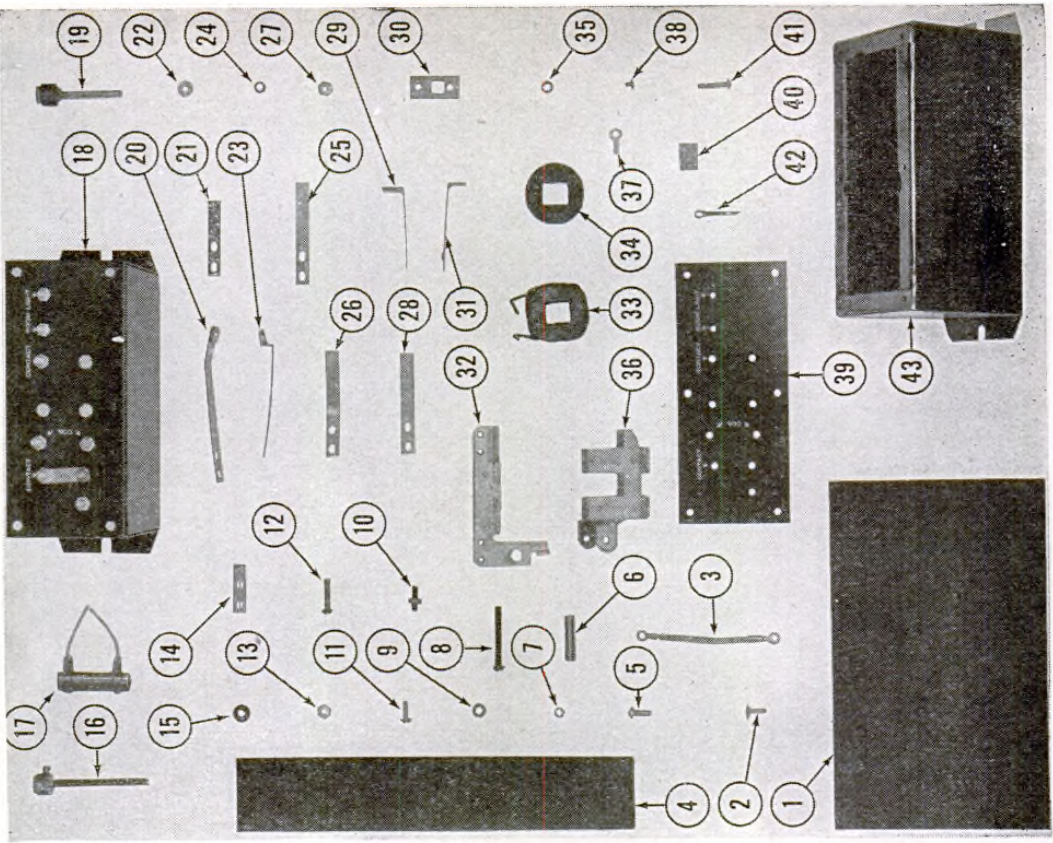

| Med. Dept. No. | Nomenclature | Med. Dept. No. | Nomenclature |
|----------------|--|----------------|---|
| 1. 9R15142 | Insulator, Tank Lining, Contactor. | 22. 9R15241 | Washer, 1/2-inch OD, Square Hole. |
| 2. SR00560 | Screw, 10-32 x 1/2-inch, B.H.M., 144 to Pkg. | 23. 9R15052 | Contact, Arm, Straight. |
| 3. 9R15146 | Connector, Woven, Contactor, Complete. | 24. SR00152 | Washer, Lock, Screw Size 8, 1,000 to Pkg. |
| 4. 9R15144 | Insulator, Tank Lining, Contactor. | 25. 9R15124 | Blade, Tension, Contactor. |
| 5. SR00314 | Screw, 10-32 x 5/8-inch, R.H.M., 144 to Pkg. | 26. 9R15126 | Support, Spring, Contactor, Contactor. |
| 6. 9R15123 | Bushing, Frame, Lamination, Armature. | 27. SR00017 | Nut, 8 x 32, Hex, 144 to Pkg. |
| 7. SR00151 | Washer, Lock, Screw Size 10, 1,000 to Pkg. | 28. 9R15124 | Blade, Tension, Contactor. |
| 8. SR00667 | Screw, 10-32 x 1 3/4-inch, R.H.M., 144 to Pkg. | 29. 9R15140 | Arm, Contact, Room Light, Contactor. |
| 9. SR00277 | Washer, Shakeproof, Screw Size 10, Int., 1,000 to Pkg. | 30. 9R15130 | Retainer, Contact Arm, Contactor. |
| 10. 9R15230 | Stud, 10-32 x 1/2-inch. | 31. 9R15136 | Arm, Contact, Room Light, Complete. |
| 11. SR00300 | Screw, 10-32 x 1/2-inch, R.H.M., 144 to Pkg. | 32. 9R15134 | Frame, Lamination, Armature, Contactor, Complete. |
| 12. SR00143 | Screw, 10-32 x 1-inch, R.H.M., 144 to Pkg. | 33. 9R15118 | Coil, Contactor. |
| 13. SR00330 | Nut, 10 x 32, Hex, 144 to Pkg. | 34. 9R15240 | Washer, 1 3/4-inch, OD, Square Hole. |
| 14. 9R15131 | Retainer, Main, Contact Arm, Contactor. | 35. SR00294 | Washer, Shakeproof, Screw Size 8, Int., 1,000 to Pkg. |
| 15. SR00297 | Washer, Screw Size 10, 1-lb. Pkg., 1,000 Washers. | 36. 9R15132 | Frame, Lamination, Contactor, Complete. |
| 16. 9R15120 | Stud, Contact, Long, Contactor, Complete. | 37. 9R15148 | Eyelet, Contactor. |
| 17. 9R15036 | Resistor, Surge. | 38. SR00669 | Screw, 4-36 x 3/16-inch, Phillips B.H.M., 144 to Pkg. |
| 18. 9R15112 | Contact, Complete. | 39. 9R15114 | Top, Tank, Contactor. |
| 19. 9R15122 | Stud, Contact, Short, Contactor, Complete. | 40. 9R15128 | Wedge, Contactor. |
| 20. 9R15054 | Contact, Arm, Curved. | 41. SR00115 | Screw, 8-32 x 7/8-inch, R.H.M., 144 to Pkg. |
| 21. 9R15138 | Arm, Engaging, Room Light, Contactor. | 42. SR00668 | Pin, Cotter, 3/32 Dia. x 1-inch Length, 1,000 to Pkg. |
| | | 43. 9R15116 | Tank, Contactor. |

Figure 74. Contactor, part No. 9R15112 and parts.

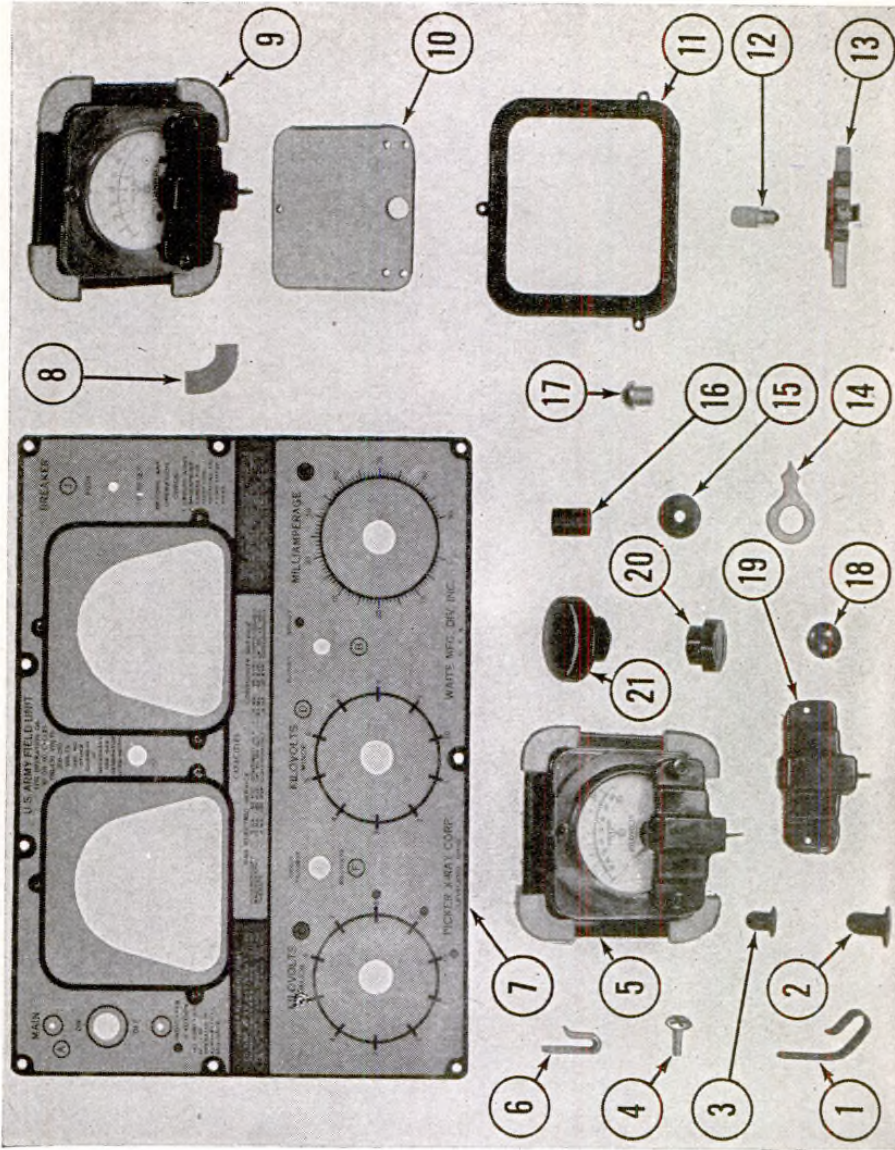

Med. Dept.

Nomenclature

- | <i>No.</i> | <i>Nomenclature</i> |
|------------|--|
| 1. | 9R15194 Hook, Timer, Bent. |
| 2. | 9R15371 Cap, Large, Rubber. |
| 3. | 9R15370 Cap, Small, Rubber. |
| 4. | SR00676 Screw, 1/4-20 x 5/8-inch, B.H.M., 144 to Pkg. |
| 5. | 9R15010 Voltmeter. |
| 6. | 9R15196 Hook, Timer, Straight. |
| 7. | 9R15208 Nameplate, Control Panel. |
| 8. | 9R15008 Cushion, Rubber, Sponge. |
| 9. | 9R15006 Milliammeter. |
| 10. | 9R15158 Window, Meter, Plastic. |
| 11. | 9R15154 Retainer, Meter, Complete. |
| 12. | SR00071 Bulb, Pilot, 6-8 V., Miniature Screw Base. |
| 13. | 9R15151 Mounting, Meter Light, Complete. |
| 14. | 9R15168 Pointer, Filament and Auto Controls. |
| 15. | 9R15237 Washer, 15/16 inch OD, x 1/4-inch ID, 1/32-inch Thick, Round Hole. |
| 16. | 9R15108 Bushing, Shaft, Selector Switch. |
| 17. | 9R15186 Jewel, Ruby, Pilot Light. |
| 18. | 9R15048 Knob, Breaker. |
| 19. | 9R15152 Housing, Meter Light. |
| 20. | 9R15172 Knob, Radiographic-Fluoroscopic Switch, Complete. |
| 21. | 9R15170 Knob, Filament and Auto Controls. |

Figure 75. Control panel parts.

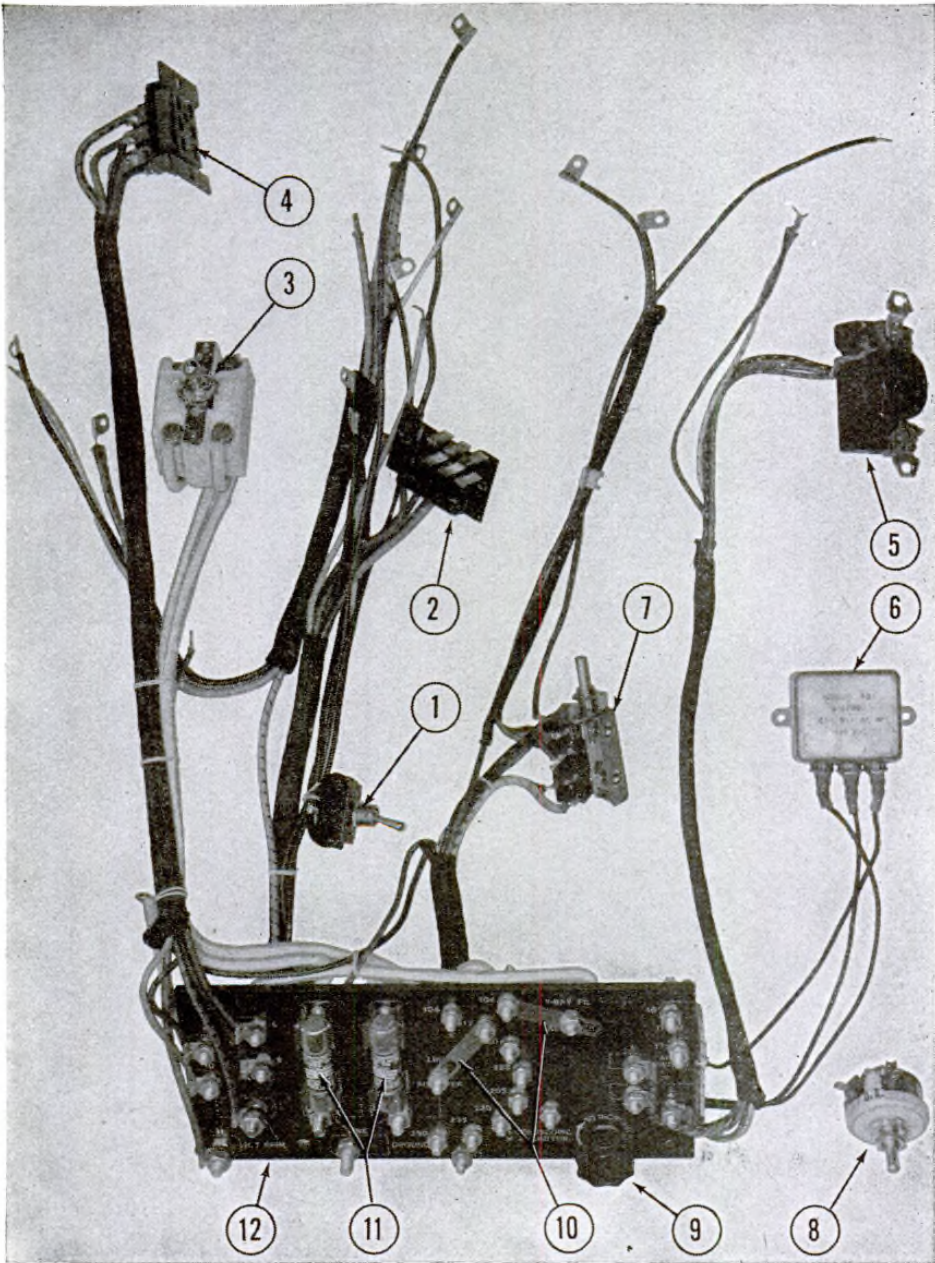

- | <i>Med. Dept.</i> | <i>No.</i> | <i>Nomenclature</i> |
|-------------------|------------|------------------------------------|
| | 1. | 9R15014 Switch, Check, Filament. |
| | 2. | 9R15026 Plug, Jones, Male. |
| | 3. | 9R15020 Switch, Main. |
| | 4. | 9R15028 Receptacle, Jones. |
| | 5. | 9R15030 Receptacle, Tube, Motor. |
| | 6. | 9R15174 Condenser Block, Complete. |

- | <i>Med. Dept.</i> | <i>No.</i> | <i>Nomenclature</i> |
|-------------------|------------|--|
| | 7. | 9R15173 Switch, Radiograph - Fluoroscopic, Complete. |
| | 8. | 9R15162 Rheostat, Round. |
| | 9. | 9R15164 Knob, Fluoroscopic Limiter. |
| | 10. | 9R15216 Strap, Adjuster, Terminal Board. |
| | 11. | SR00101 Fuse, Inclosed, 30-amp. |
| | 12. | 9R15092 Board, Terminal, 9608810, Complete. |

Figure 76. Terminal board, part No. 9R15092 and connected devices for X-ray field unit control unit.

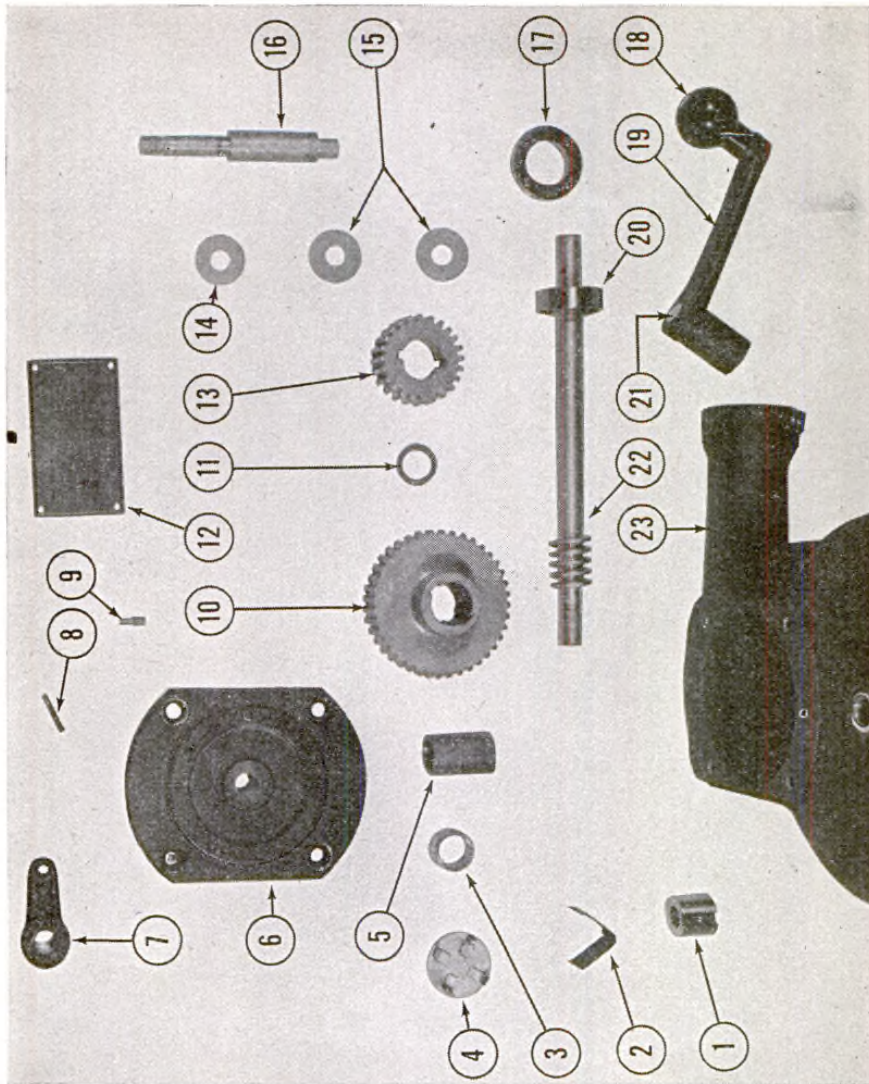

- | <i>Med. Dept.</i> | <i>Nomenclature</i> |
|-------------------|--|
| <i>No.</i> | |
| 1. | 9R05594 Bushing, Worm Wheel, Angulating Housing. |
| 2. | 9R05554 Spring, Bushing, Worm Shaft, Angulating Housing. |
| 3. | 9R05632 Bushing, Worm Shaft. |
| 4. | 9R05640 Cover, Worm Shaft. |
| 5. | 9R05634 Bushing, Compound, Pinion and Worm Wheel. |
| 6. | 9R05656 Cover, Upper Gear Assembly. |
| 7. | 9R05662 Arm, Adjusting, Eccentric Shaft. |
| 8. | 9R05664 Pin, Taper, 0 x 1 inch. |
| 9. | 9R05556 Screw, Adjusting, Worm, Angulating Housing. |
| 10. | 9R05612 Wheel, Worm. |
| 11. | 9R05592 Bushing, Pinion, Angulating Housing. |
| 12. | 9R05588 Nameplate, Instruction, Horizontal and Vertical Fluoroscopy, Angulating Housing. |
| 13. | 9R05638 Pinion, Angulating Housing. |
| 14. | 9R05606 Washer, Thick, Eccentric Shaft, Angulating Housing. |
| 15. | 9R05610 Washer, Crank Shaft, Angulating Housing. |
| 16. | 9R05618 Shaft, Eccentric, Angulating Housing. |
| 17. | 9R05620 Collar, Retaining, Worm Shaft. |
| 18. | 9R05624 Knob, Ball, Crank. |
| 19. | 9R05648 Crank, Short Shaft. |
| 20. | 9R05550 Bearing, Ball, 1.654-inch Diameter, Angulating Housing. |
| 21. | 9R05546 Cap, Crank Handle, Angulating Housing. |
| 22. | 9R05614 Worm and Shaft, Angulating Housing. |
| 23. | 9R05660 Housing, Angulating. |

Figure 77. Upper gear assembly and parts for angulating housing.

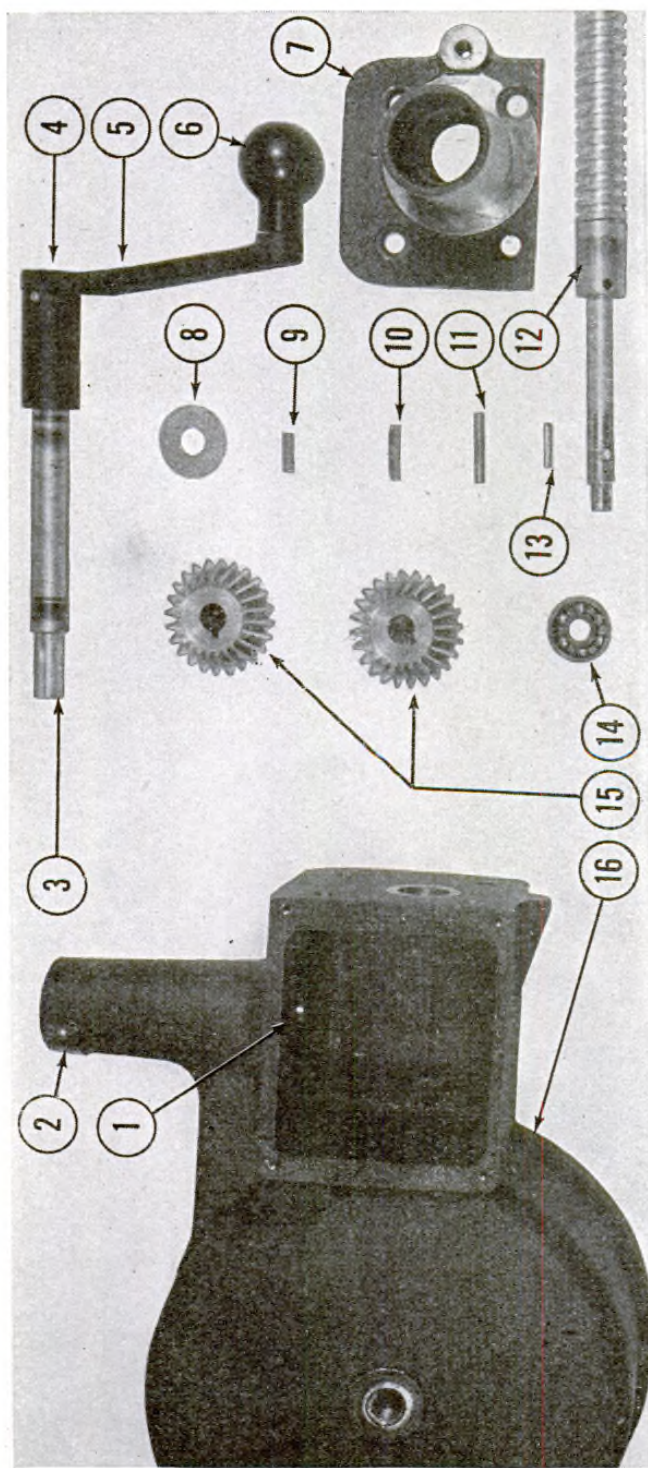

| Med. Dept. No. | Nomenclature | Med. Dept. No. | Nomenclature |
|----------------|---|----------------|--|
| 1. 9R05596 | Bushing, Crank Shaft, Angulating Housing. | 6. 9R05624 | Knob, Ball, Crank. |
| 2. 9R05564 | Nameplate, "Up-Down," Angulating Housing. | 7. 9R05654 | Support, Angulating Housing. |
| 3. 9R05626 | Crank Shaft, Angulating. | 8. 9R05610 | Washer, Crank Shaft, Angulating. |
| 4. 9R05546 | Cap, Crank Handle, Angulating Housing. | 9. 9R05558 | Gear Key, Short, Mitre, Angulating Housing. |
| 5. 9R05650 | Crank, Long Shaft. | 10. 9R05560 | Gear Key, Long, Mitre, Angulating Housing. |
| | | 11. 9R05552 | Pin, Grooved, 3/16 x 13/8-inch, Angulating Housing. |
| | | 12. 9R05586 | Screw, Raising, Angulating Housing. |
| | | 13. SR00640 | Setscrew, 10-32 x 3/4-inch, Headless, Cup Pt., 100 to Pkg. |
| | | 14. 9R05536 | Bearing, Ball, 1.1815-inch Diameter. |
| | | 15. 9R05642 | Gear, Raising. |
| | | 16. 9R05660 | Housing, Angulating. |

Figure 78. Angulating housing, disassembled.

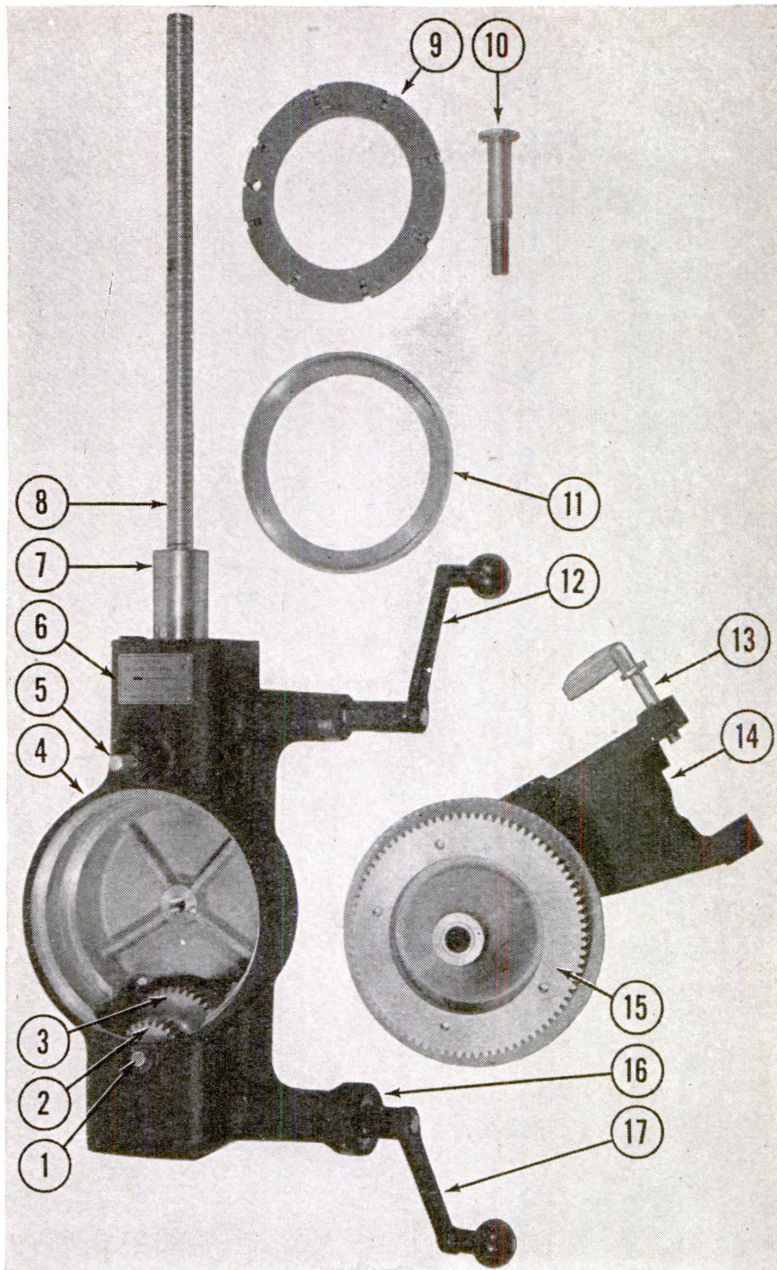

| <i>Med. Dept.</i> | <i>No.</i> | <i>Nomenclature</i> | <i>Med. Dept.</i> | <i>No.</i> | <i>Nomenclature</i> |
|-------------------|------------|---|-------------------|------------|--|
| 1. | 9R05618 | Shaft, Eccentric, Angulating Housing. | 10. | 9R05636 | Screw, Center, Angulating Housing. |
| 2. | 9R05638 | Pinion, Angulating Housing. | 11. | 9R05574 | Ring, Retaining, Thrust Bearing, Angulating Housing. |
| 3. | 9R05612 | Wheel, Worm. | 12. | 9R05650 | Crank, Long Shaft. |
| 4. | 9R05660 | Housing, Angulating. | 13. | 9R05212 | Handle, Locking, Angulating Housing. |
| 5. | 9R05600 | Screw, Vertical Stop, "L" Member. | 14. | 9R05658 | Cover, Angulating Housing. |
| 6. | 9R05562 | Nameplate, Lock Handle, Angulating Housing. | 15. | 9R05644 | Gear, Ring. |
| 7. | 9R05654 | Support, Angulating Housing. | 16. | 9R05620 | Collar, Retaining, Worm Shaft. |
| 8. | 9R05586 | Screw, Raising, Angulating Housing. | 17. | 9R05648 | Crank, Short Shaft. |
| 9. | 9R05572 | Ring, Thrust Bearing, Angulating Housing, Complete. | | | |

Figure 79. Angulating housing with angulating mechanism removed.

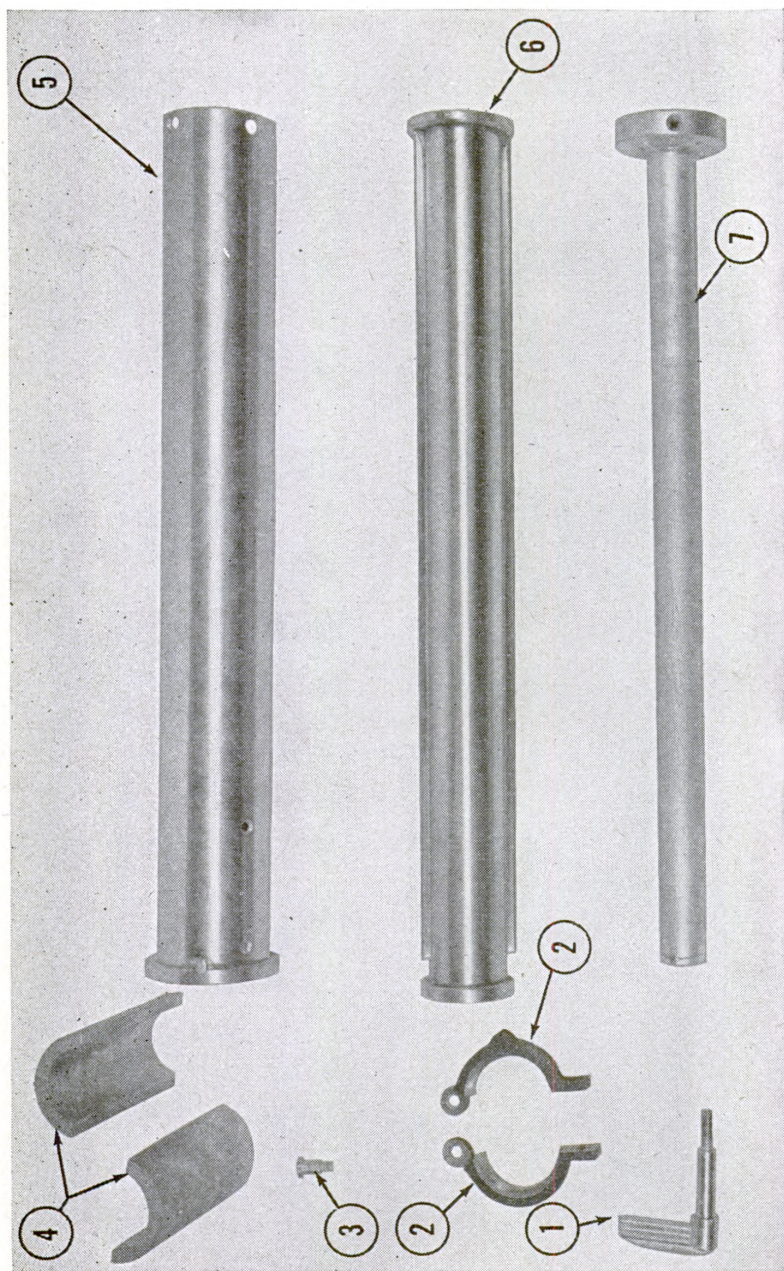

| <i>Med. Dept.</i> <i>No.</i> | <i>Nomenclature</i> | <i>Med. Dept.</i> <i>No.</i> | <i>Nomenclature</i> |
|---------------------------------|---|---------------------------------|--------------------------|
| 1. | Clamp and Lock, Rotation. | 5. | Column, Vertical, Main. |
| 2. | Handle, Locking, Angulating Housing. | 6. | Tube, Telescoping. |
| 3. | Screw, Split, Securing Rotation Clamp, Angulating, Housing. | 7. | Tube, Raising, Complete. |
| 4. | Brake, Shoe, Telescoping Tube. | | |

Figure 80. Main vertical column assembly.

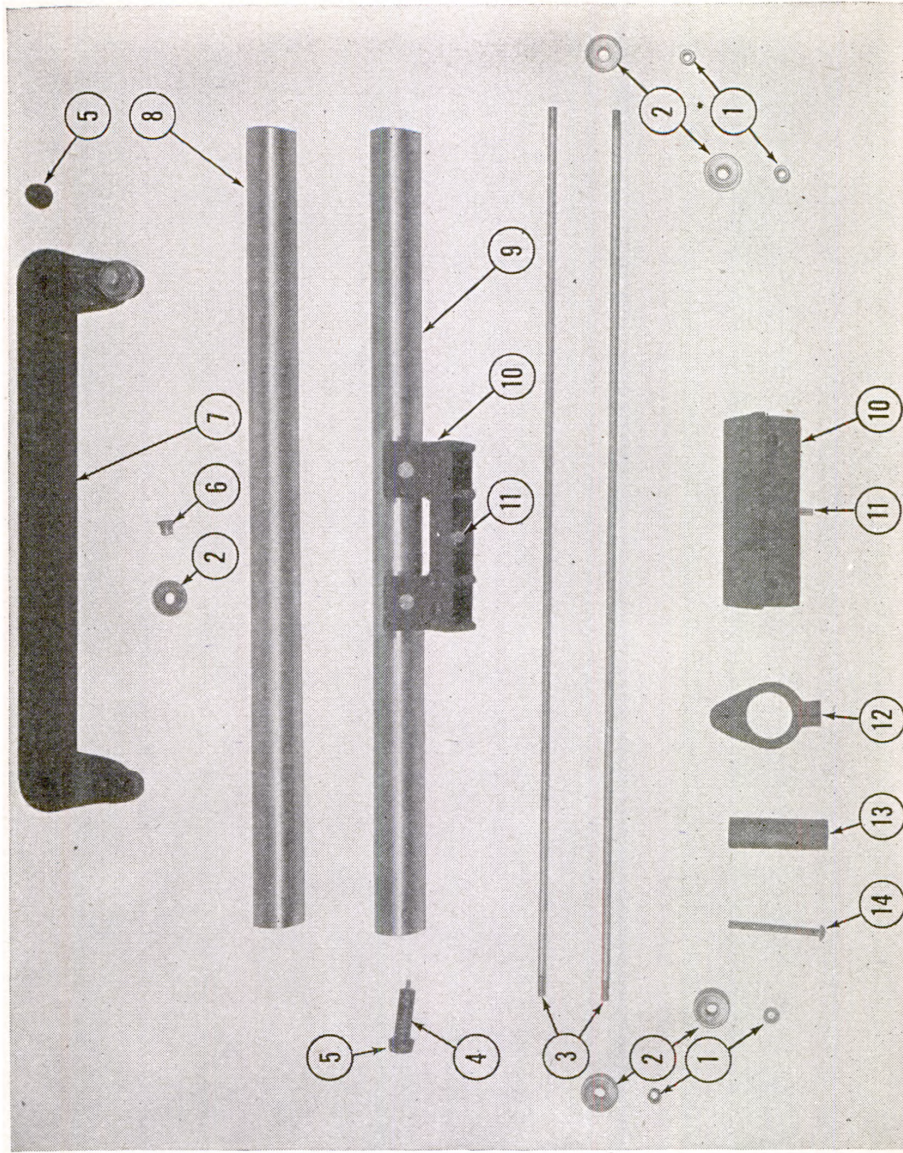
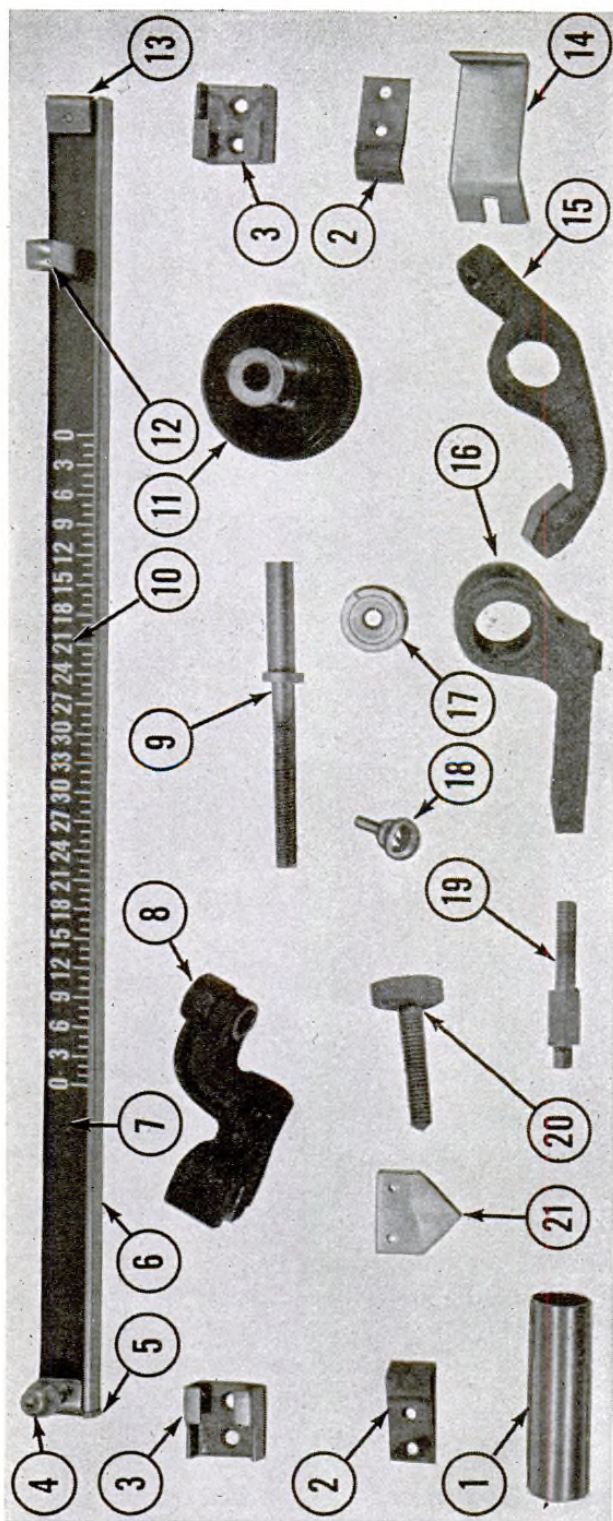

Figure 81. Parts for lengthwise carriage.

- | <i>Med. Dept.</i> | <i>No.</i> | <i>Nomenclature</i> |
|-------------------|------------|--|
| 1. | 9R05454 | Bushing, Ball Bearing. |
| 2. | 9R05536 | Bearing, Ball, 1.1815-Inch Diameter. |
| 3. | 9R05422 | Rod, Tie, Lengthwise Carriage. |
| 4. | 9R05446 | Post, Bumper, Short, Lengthwise Carriage. |
| 5. | 9R05523 | Bumper, Rubber. |
| 6. | 9R05542 | Bushing, Eccentric, Ball Bearing. |
| 7. | 9R05472 | Tie Casting, Rear, Lengthwise Carriage. |
| 8. | 9R05424 | Rail, Left Tie, Lengthwise Carriage. |
| 9. | 9R05426 | Rail, Right Tie, Lengthwise Carriage. |
| 10. | 9R05468 | Bracket, Grid Base, Lengthwise Carriage Rails. |
| 11. | 9R05480 | Pin, Lock, Grid Base Bracket. |
| 12. | 9R05466 | Holder, Bumper, Crosswise Carriage. |
| 13. | 9R05528 | Tube, Rubber, Bumper, Crosswise Carriage. |
| 14. | SR00434 | Screw, 1/4-20 x 3-inch, R.H.M., 144 to Pkg. |



| Med. Dept. No. | Nomenclature | Med. Dept. No. | Nomenclature | Med. Dept. No. | Nomenclature |
|----------------|---|----------------|--|----------------|--|
| 1. 9R05494 | Bushing, Pointer Carriage, Localizer Scale. | 9. 9R05544 | Screw, Adjusting, Localizer Scale. | 17. 9R05486 | Bearing, Ball, 13/16-inch, Scale Slide, Localizer Scale. |
| 2. 9R05516 | Spring, Friction, Localizer Scale. | 10. 9R05500 | Scale, Localizer. | 18. 9R05540 | Screw, Thumb, Localizer Light, Localizer Scale. |
| 3. 9R05496 | Slide, Localizer Scale. | 11. 9R05485 | Knob, Small, Localizer Scale Adjustment. | 19. 9R05522 | Bracket Stud, Adjusting Screw, Localizer Scale. |
| 4. 9R05512 | Handle, Localizer Scale. | 12. 9R05520 | Nut, Adjusting Screw, Localizer Scale. | 20. 9R05508 | Screw, Lock, Pointer Carriage, Localizer Scale. |
| 5. 9R05518 | Stop, Left, Localizer Scale. | 13. 9R05524 | Stop, Right, Localizer Scale. | 21. 9R05526 | Pointer, Localizer Scale. |
| 6. 9R05498 | Holder, Localizer Scale. | 14. 9R05506 | Bracket, Localizer Light, Localizer Scale. | | |
| 7. 9R05510 | Shield, Transparent, Localizer Scale. | 15. 9R05488 | Lock, Casting, Pointer, Localizer Scale. | | |
| 8. 9R05462 | Bracket, Adjusting Screw, Localizer Scale. | 16. 9R05490 | Holder, Pointer, Localizer Scale. | | |

Figure 82. Localizer scale, assembly, disassembled.

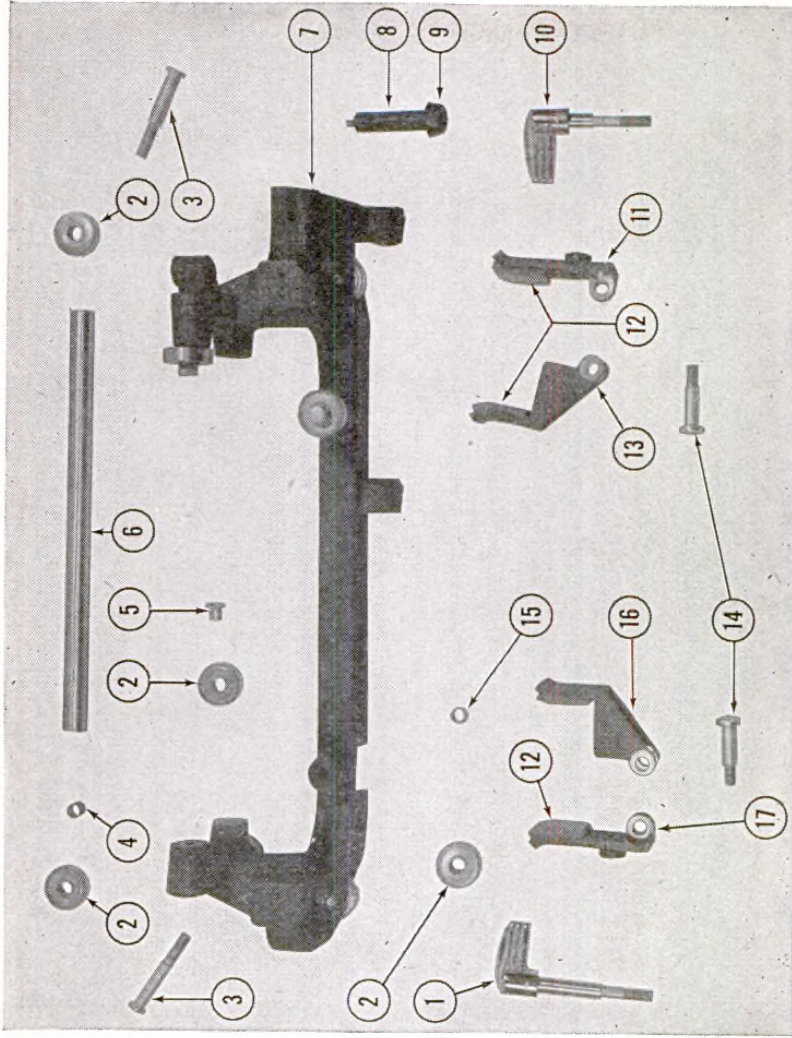

Med. Dept.
No.

Nomenclature

1. 9R05214 Handle, Locking, Horizontal.
2. 9R05536 Bearing, Ball, 1.1815-inch Diameter.
3. 9R05544 Screw, Adjusting, Localizer Scale.
4. 9R05454 Bushing, Ball Bearing.
5. 9R05542 Bushing, Eccentric, Ball Bearing.
6. 9R05504 Rod, Slide, Pointer, Localizer Scale.
7. 9R05428 Rail, Crosswise Carriage.
8. 9R05444 Post, Bumper, Long, Lengthwise Carriage.
9. 9R05523 Bumper, Rubber.
10. 9R05216 Handle, Locking, Vertical.
11. 9R05442 Lock, Plain Section, Crosswise Carriage.
12. 9R05436 Lining, Leather, Carriage Locks.
13. 9R05440 Lock, Tapped Section, Crosswise Carriage.
14. 9R05456 Screw, Carriage Locks.
15. 9R05454 Bushing, Ball Bearing.
16. 9R05432 Lock, Tapped Section, Lengthwise Carriage.
17. 9R05434 Lock, Plain Section, Lengthwise Carriage.

Figure 83. Table carriage, disassembled.

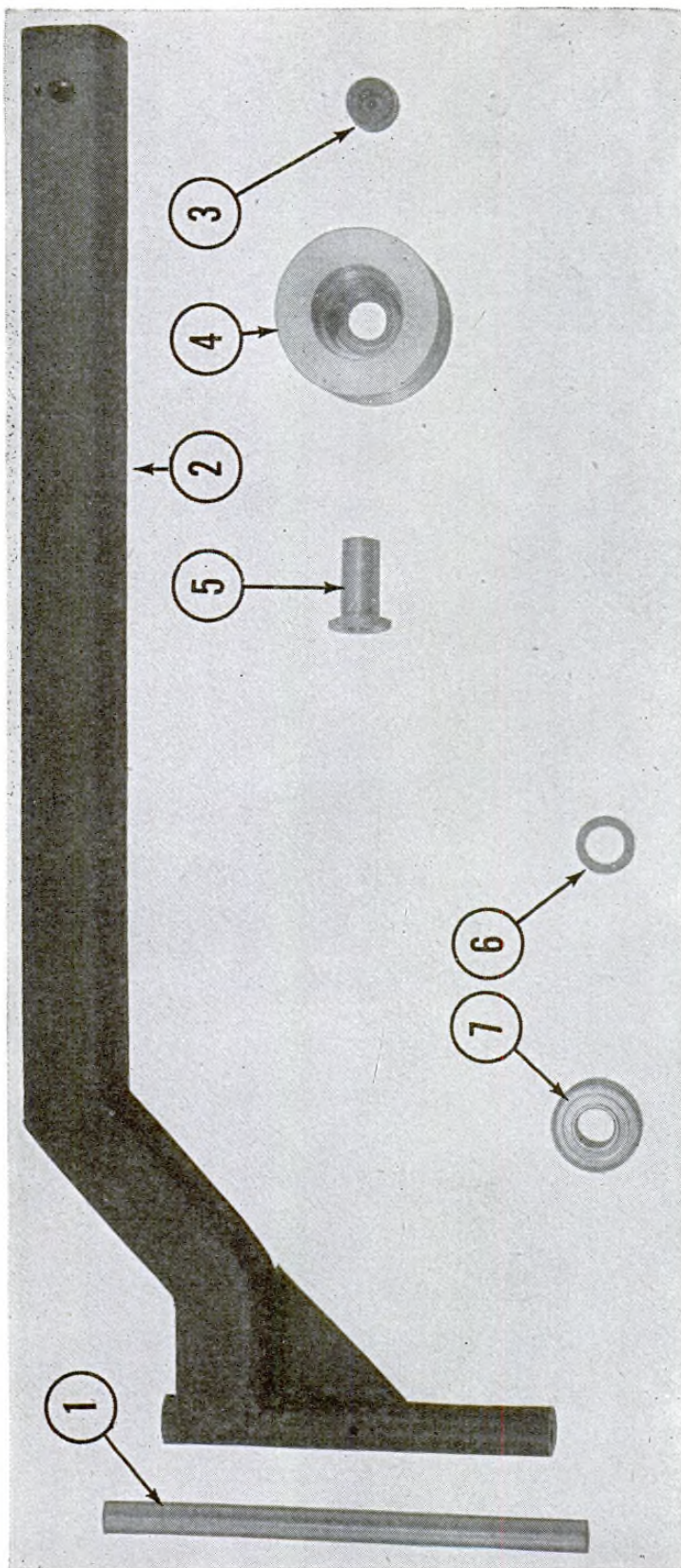

Med. Dept.
No.

Nomenclature

1. 9R05534 Pin, Swivel, Carriage Support.
2. 9R05458 Arm, Support, Carriage.
3. 9R05523 Bumper, Rubber.

Med. Dept.
No.

Nomenclature

4. 9R05438 Roller, Carriage Support.
5. 9R05448 Bushing, Eccentric, Carriage Support Roller.

Med. Dept.
No.

Nomenclature

6. 9R05452 Bushing, Center Roller.
7. 9R05532 Bearing, Ball, 1.378-inch Diameter.

Figure 84. Carriage support and parts.

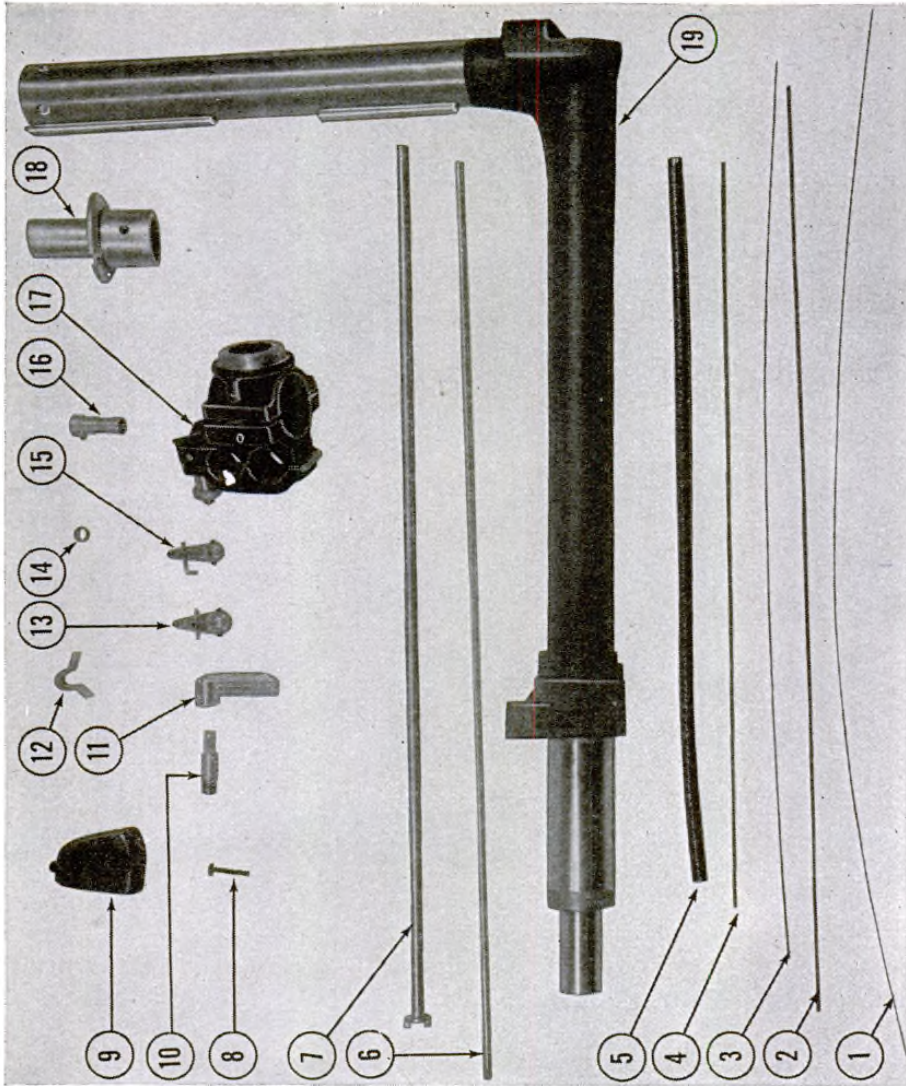
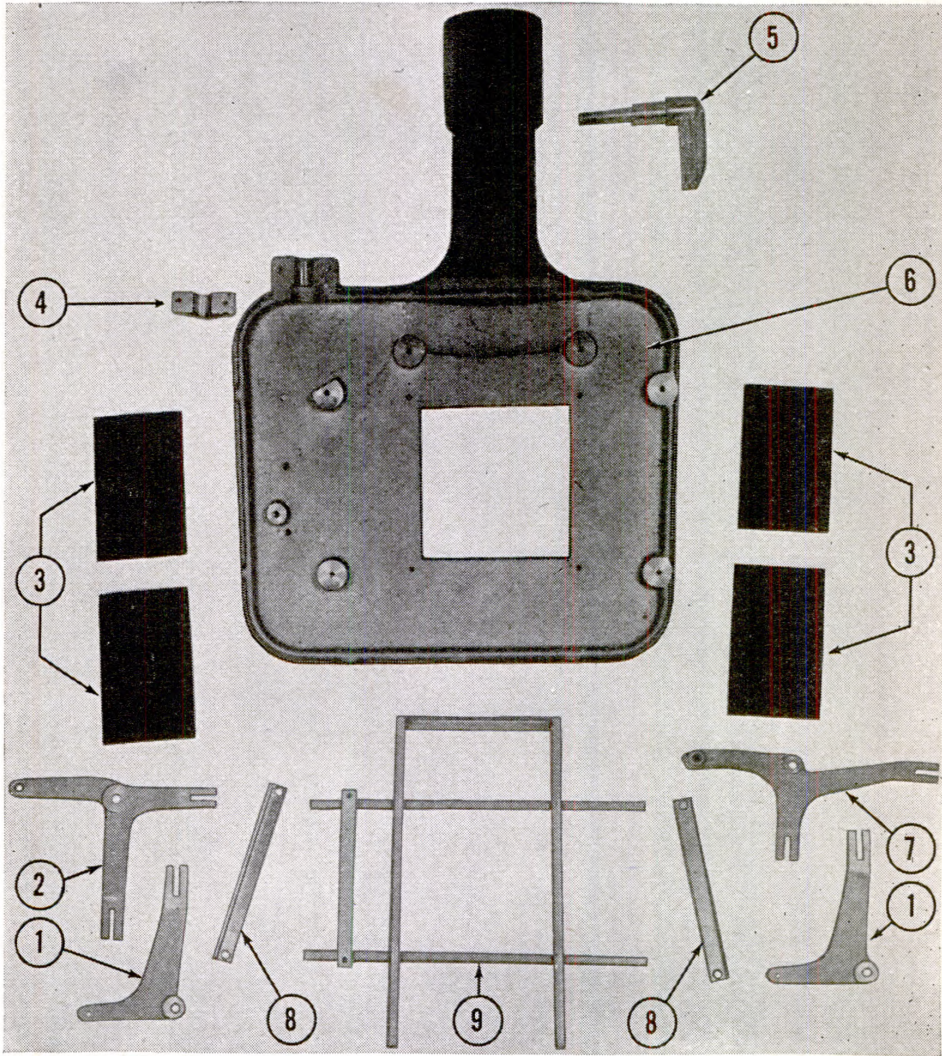

Figure 86. "L" member, disassembled.

| Med. Dept. No. | Nomenclature |
|----------------|--|
| 1. | Shutter Wire, Long: Part of 9R05221. |
| 2. | Shutter Wire Spring, Long: Part of 9R05221. |
| 3. | Shutter Wire, Short: Part of 9R05221. |
| 4. | Shutter Wire Spring, Short: Part of 9R05221. |
| 5. | Casing, Shutter Wires: Part of 9R05221. |
| 6. | Rod, Shutter Operating. |
| 7. | Tube, Shutter Operating. |
| 8. | Screw, 10-32 x 1 1/8-inch, R.H.M., 144 to Pkg. |
| 9. | Cap, Elbow, "L" Member. |
| 10. | Shaft Lock, "L" Member. |
| 11. | Handle, Lock, "L" Member. |
| 12. | Clamp, Shutter Cable. |
| 13. | Link, Upper, Shutter Operating. |
| 14. | Bushing, Shutter Levers. |
| 15. | Link, Lower, Shutter Operating. |
| 16. | Bushing, Shutter. |
| 17. | Clamp, Cable, Complete. |
| 18. | Flange, "L" Member, X-ray Tube Mounting. |
| 19. | "L" Member, Complete. |



| <i>Med. Dept.</i> <i>No.</i> | <i>Nomenclature</i> | <i>Med. Dept.</i> <i>No.</i> | <i>Nomenclature</i> |
|---------------------------------|--|---------------------------------|--|
| 1. | 9R05718 Link, Lower or Upper, Shutter Operating. | 5. | 9R05708 Handle, Lock, Shutter Positioning, Complete. |
| 2. | 9R05716 Link, Lower, Shutter Operating. | 6. | 9R05712 Housing, Shutter. |
| 3. | 9R05690 Plate, Shutter. | 7. | 9R05714 Link, Upper, Shutter Operating. |
| 4. | 9R05710 Clamp, Shutter Cable. | 8. | 9R05688 Spacer, Guide Channel, Shutter Plate. |
| | | 9. | 9R05700 Guide, Shutter Plates. |

Figure 87. Shutter housing, disassembled.

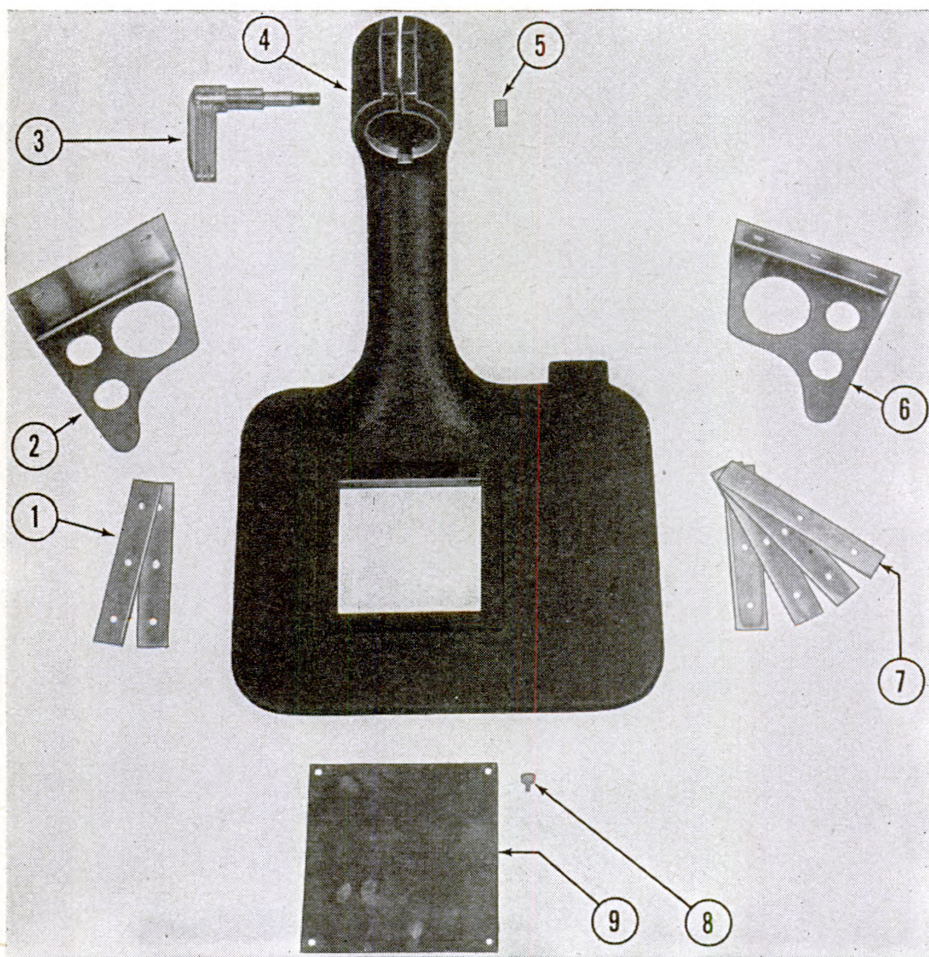

| <i>Med. Dept.</i> No. | <i>Nomenclature</i> | <i>Med. Dept.</i> No. | <i>Nomenclature</i> |
|--------------------------|--|--------------------------|---|
| 1. | 9R05682 Shim, Thick, Base, X-ray Tube, Bracket. | 5. | SR00526 Nut, $\frac{3}{8}$ x 16, Hex, 100 to Pkg. |
| 2. | 9R05696 Bracket, Long Base, X-ray Tube. | 6. | 9R05694 Bracket, Short Base, X-ray Tube. |
| 3. | 9R05708 Handle, Lock, Shutter Positioning, Complete. | 7. | 9R05684 Shim, Thin, Base, X-ray Tube, Bracket. |
| 4. | 9R05712 Housing, Shutter. | 8. | 9R05674 Screw, Thumb, Filter. |
| | | 9. | 9R05676 Filter, Aluminum. |

Figure 88. Shutter assembly, disassembled.

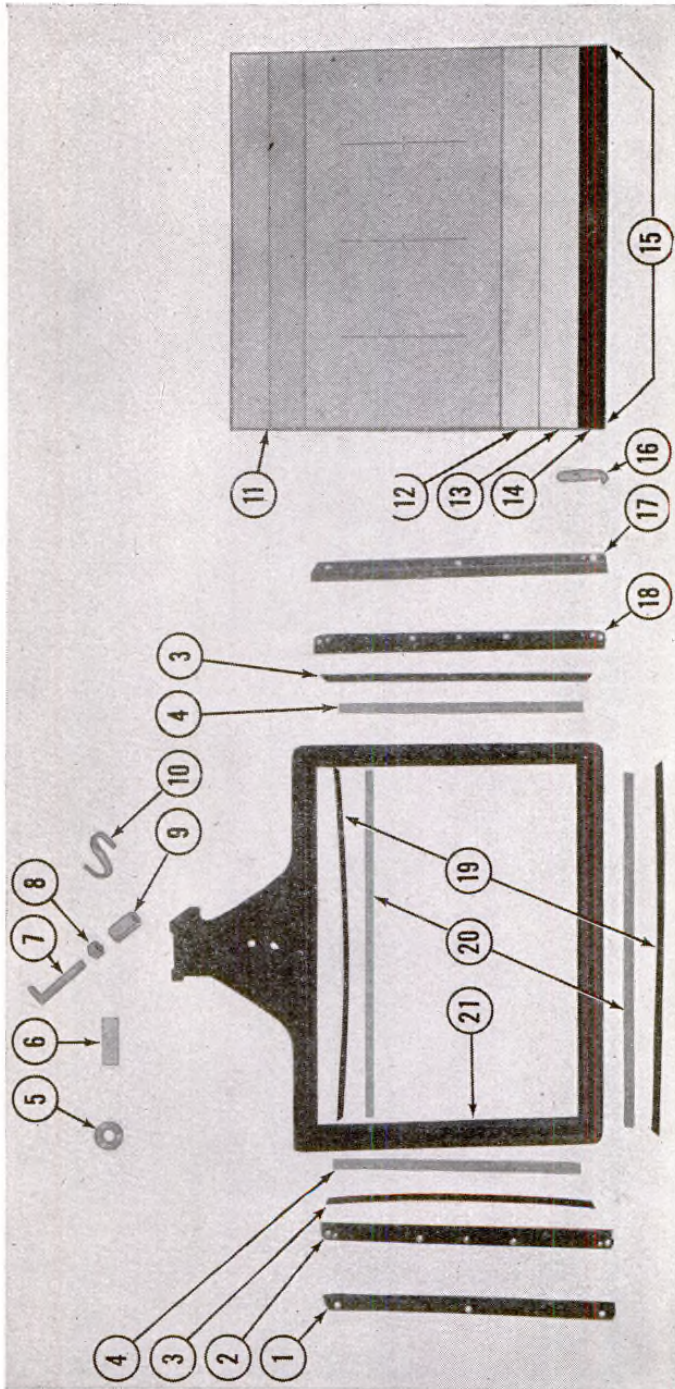

| Med. Dept. No. | Nomenclature | Med. Dept. No. | Nomenclature | Med. Dept. No. | Nomenclature |
|----------------|------------------------------------|----------------|---------------------------------------|----------------|-------------------------------------|
| 1. 9R05306 | Slide, Angular, Screen Grid, Left. | 8. 9R05348 | Nut, Adjuster, Pointer, Depth Marker. | 15. 9R05236 | Screen and Lead Glass. |
| 2. 9R05300 | Strip, Slide, Screen Grid, Left. | 9. 9R05350 | Nut, Clamp, Pointer, Depth Marker. | 16. 9R05362 | Catch, Grid. |
| 3. 9R05336 | Strip, Short, Screen Retaining. | 10. 9R05328 | Clip, Retaining, Depth Marker. | 17. 9R05304 | Slide, Angular, Screen Grid, Right. |
| 4. 9R05344 | Shim, Short, Lead Glass. | 11. 9R05342 | Glass, Lead, Screen. | 18. 9R05302 | Strip, Slide, Screen Retaining. |
| 5. 9R05370 | Plate, Countersunk, Depth Marker. | 12. 9R05366 | Plate, Vinylite, Screen. | 19. 9R05334 | Strip, Long, Screen Retaining. |
| 6. 9R05326 | Nameplate, Caution, "UP," Screen. | 13. 9R05330 | Screen, Fluoroscopic. | 20. 9R05340 | Shim, Long, Lead Glass. |
| 7. 9R05346 | Pointer, Depth Marker Scale. | 14. 9R05332 | Backing, Fluoroscopic Screen. | 21. 9R05376 | Frame, Screen, Top Adjusting Knob. |

Figure 89. Parts for fluoroscopic screen, with top adjusting knob part No. 9R05286.

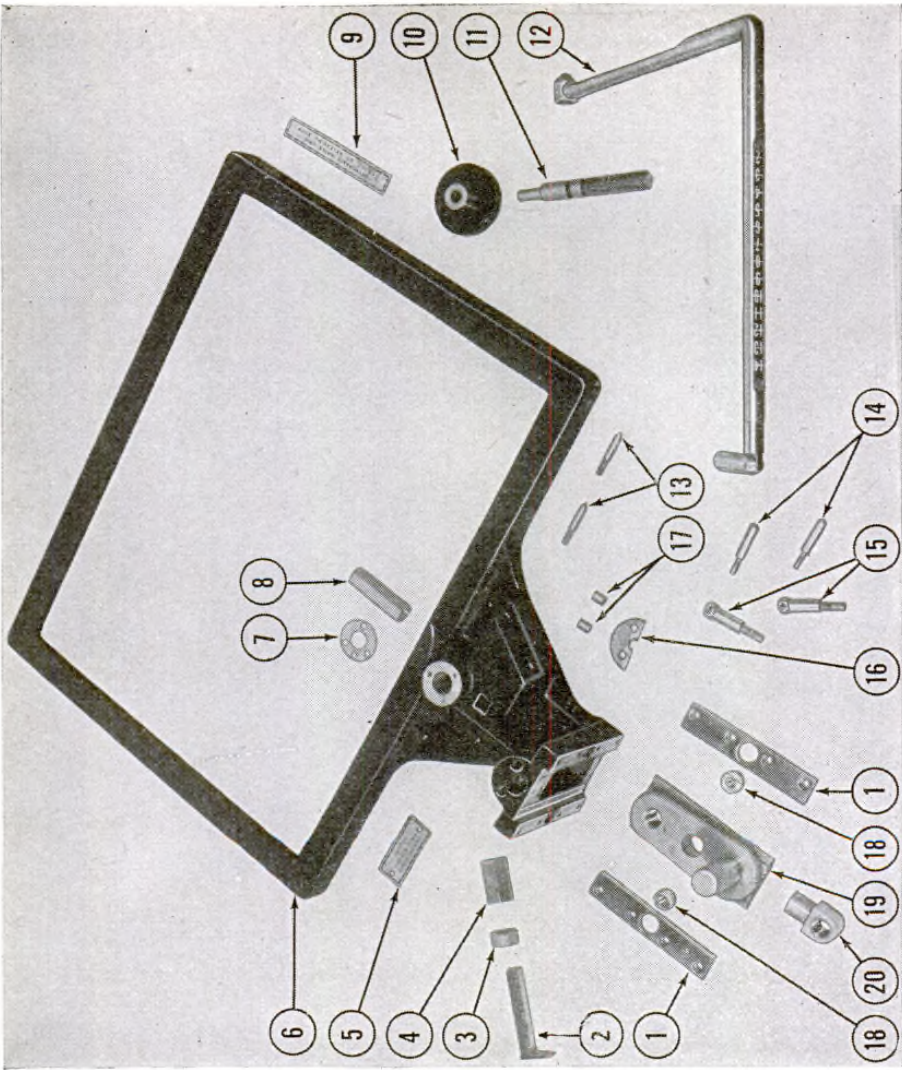

Med. Dept.

Nomenclature

No.

1. 9R05308 Strap, Clamp, Screen Adjustment.
2. 9R05346 Pointer, Depth Marker Scale.
3. 9R05348 Nut, Adjuster, Pointer, Depth Marker.
4. 9R05350 Nut, Clamp, Pointer, Depth Marker.
5. 9R05324 Nameplate, Caution, "Down," Screen.
6. 9R05376 Frame, Screen, Top Adjusting Knob.
7. 9R05368 Plate, Plain, Depth Marker.
8. 9R05364 Bushing, Split, Depth Marker.
9. 9R05290 Plate, Instruction, Grid Removing.
10. 9R05375 Knob, Small, Screen Adjustment.
11. 9R05318 Screw, Screen Adjustment.
12. 9R05242 Rod, Measuring, Depth Marker.
13. 9R05354 Pin, Localizer Light, Depth Marker Scale.
14. 9R05320 Handle, Clamp Screw, Screen Adjustment.
15. 9R05322 Screw, Clamp, Screen Adjustment.
16. 9R05316 Holder, Screw, Screen Adjustment.
17. 9R05314 Spacer, Screw Holder, Screen Adjustment.
18. 9R05312 Nut, Clamp, Screen Adjustment.
19. 9R05298 Bearing, Slide, Screen Adjustment.
20. 9R05310 Nut, Screen Adjustment.

Figure 90. Parts for fluoroscopic screen with top adjusting knob.

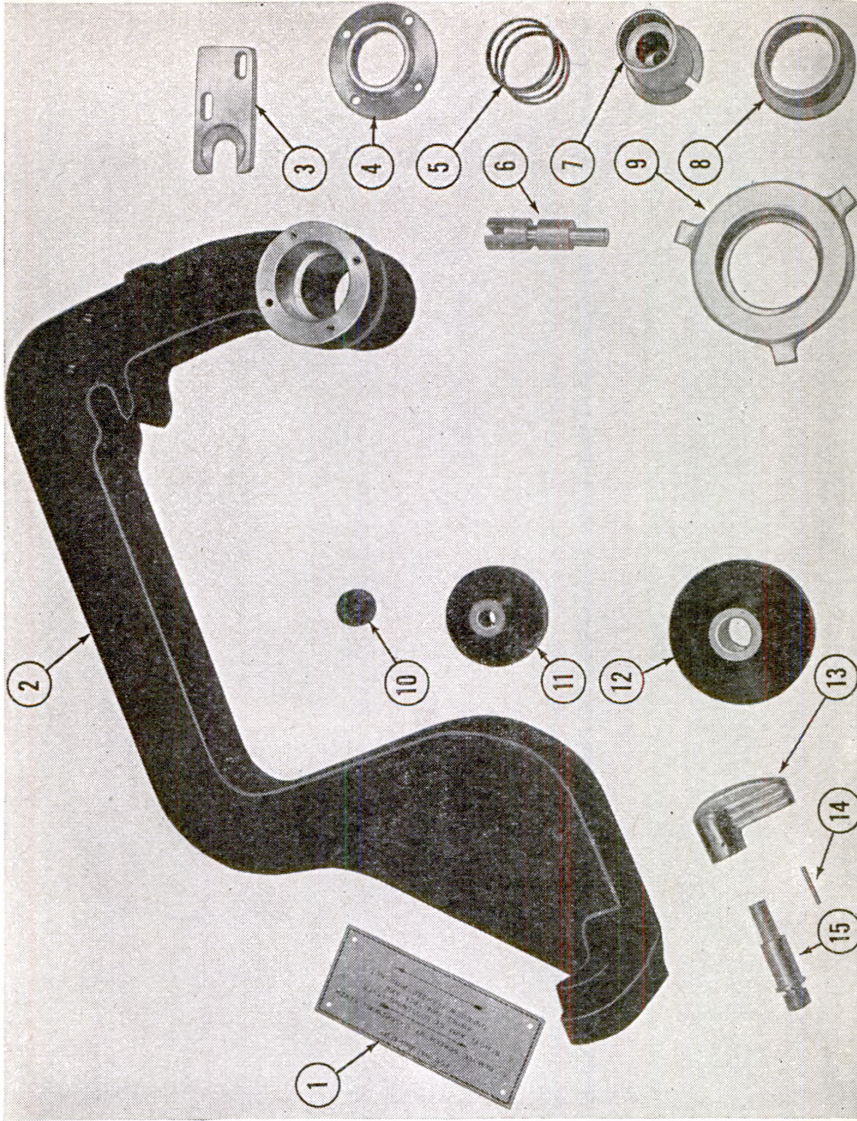

- | <i>Med. Dept.
No.</i> | <i>Nomenclature</i> |
|---------------------------|--|
| 1. | 9R05252 Nameplate, Instruction, "For Radiography," Screen Arm. |
| 2. | 9R05272 Arm, Screen. |
| 3. | 9R05250 Plate, Centering, Screen Arm. |
| 4. | 9R05262 Flange, Shutter Knob. |
| 5. | 9R05232 Spring, Shutter Knob. |
| 6. | 9R05260 Shaft, Small, Shutter Knob. |
| 7. | 9R05264 Bearing, Shutter Knob. |
| 8. | 9R05266 Collar, Retaining, Locknut, Screen Arm. |
| 9. | 9R05268 Nut, Lock, Large, Screen Arm. |
| 10. | 9R05270 Bumper, Rubber. |
| 11. | 9R05254 Knob, Small, Shutter Operating. |
| 12. | 9R05256 Knob, Large, Shutter Operating. |
| 13. | 9R05274 Handle, Lock, Screen Arm. |
| 14. | Pin, Lock, Screen Arm: Part of 9R05248. |
| 15. | Shaft, Lock, Screen Arm: Part of 9R05248. |

Figure 91. Screen arm and shutter knob assembly, disassembled.

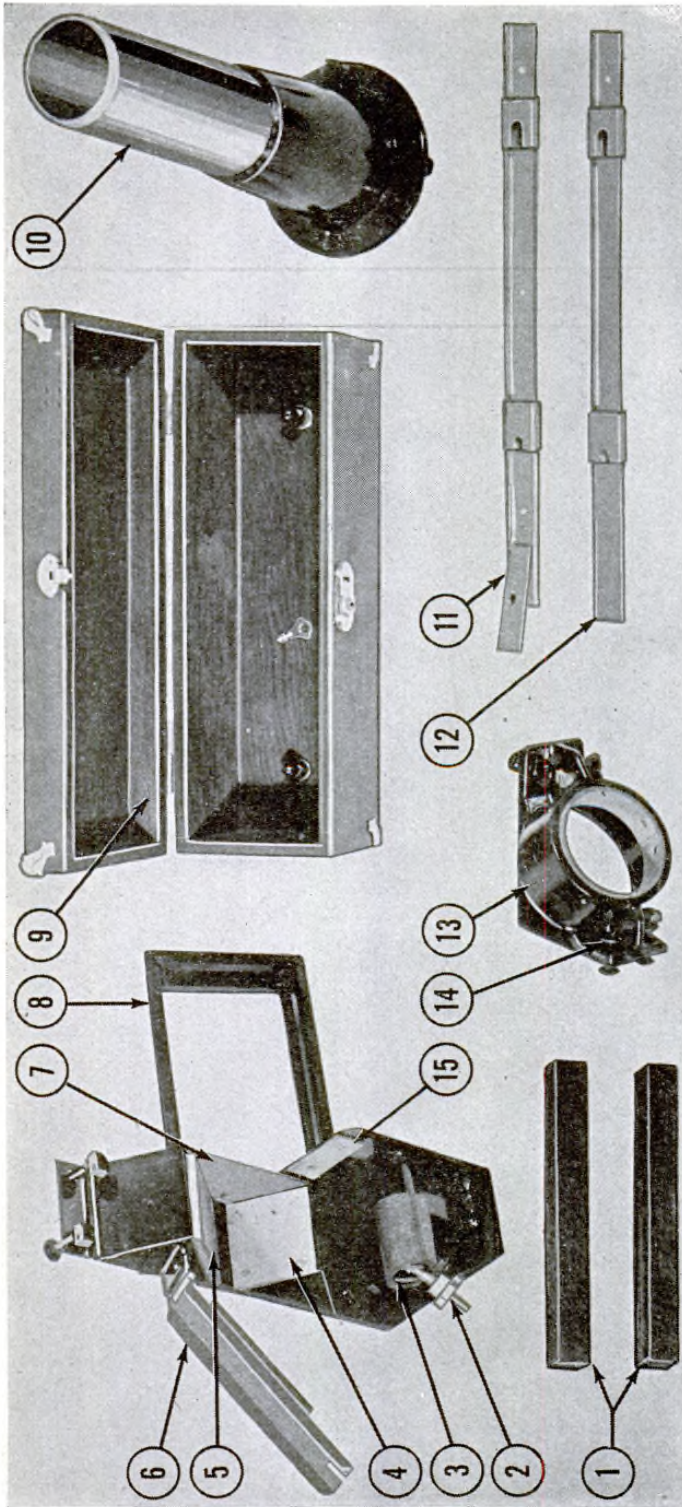

| Med. Dept. No. | Nomenclature | Med. Dept. No. | Nomenclature |
|----------------|---|----------------|---|
| 1. | Block, Clamp, Checking Gauge, Focal Distance. | 11. | Channel and Spring, Trunk Mounting, Panel. |
| 2. | Nut, Clamp, Corner Bracket. | 12. | Channel, Left, Trunk Mounting, Panel. |
| 3. | Bumper, Rubber, Corner Bracket. | 13. | Support, Corner, Tubestand. |
| 4. | Pad, Leather, 2 3/4 Inches Square, Corner Bracket. | 14. | Support, Tubestand, Complete. |
| | | 15. | Pad, Leather, 1 x 2 Inches, Corner Bracket. |
| 5. | 9R05820 Pad, Leather, 2 1/4 x 2 3/4 Inches, Corner Bracket. | | |
| 6. | 9R05854 Clamp, Corner, Complete. | | |
| 7. | 9R05818 Pad, Leather, Triangular, Corner Bracket. | | |
| 8. | 9R05864 Bracket, Corner. | | |
| 9. | 9R05866 Box, Tool. | | |
| 10. | 9R05802 Post, Carriage. | | |

Figure 92. Packing assemblies, large table unit trunk.

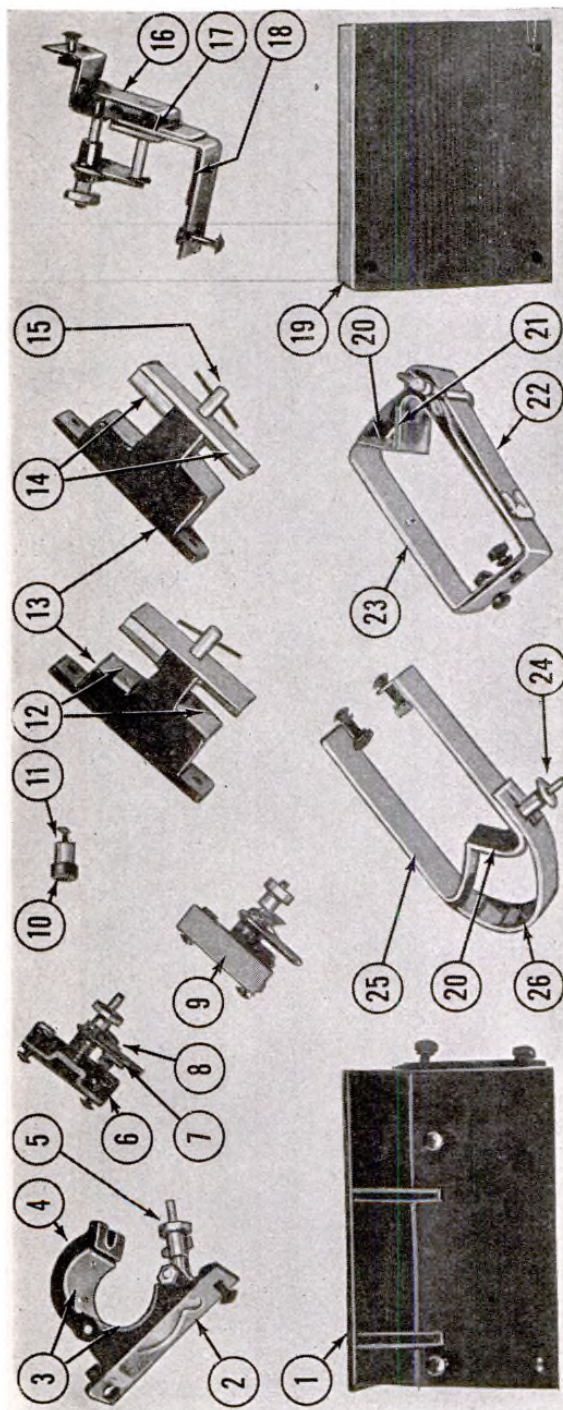

| Med. Dept. No. | Nomenclature | Med. Dept. No. | Nomenclature |
|----------------|---|----------------|---|
| 1. | Brace, Corner, Complete. | 10. | Bumper, Rubber. |
| 2. | Base, Clamp, Shutter Arm. | 11. | Spacer, Bumper. |
| 3. | Pad, Leather, Clamp, Shutter Arm. | 12. | Pad, Carriage Cleat. |
| 4. | Clamp, Shutter Arm. | 13. | Clamp, Carriage, Complete. |
| 5. | Nut, Clamp, Corner Bracket. | 14. | Pad, Carriage Clamp. |
| 6. | Clamp and Stud, Checking Gauge, Focal Distance. | 15. | Screw, Carriage Clamp, Complete. |
| 7. | Pad, Clamp, Bracket, Cassette Lifting Device. | 16. | Bracket and Stud, Trunk, Cassette Lifting Device; Complete. |
| 8. | Clamp, Bracket, Cassette Lifting Device. | 17. | Pad, Bottom, Bracket, Cassette Lifting Device. |
| 9. | Pad, Clamp Angle, Checking Gauge, Focal Distance. | 18. | Pad, Felt, Bracket, Cassette Lifting Device. |
| | | 19. | Block, Wood, Carriage Cleat. |
| | | 20. | Pad, Leather, 1 1/8 x 2 Inches, Saddle. |
| | | 21. | Pad, Leather, 1 1/4 x 2 Inches, Saddle. |
| | | 22. | Strap, Web, Saddle. |
| | | 23. | Saddle, Large Trunk. |
| | | 24. | Nut, Clamp, "L" Member. |
| | | 25. | Clamp, "L" Member. |
| | | 26. | Pad, Leather, 2 x 2 Inches, Clamp, "L" Member. |

Figure 93. Packing assemblies, large table unit trunk.

Med. Dept.

No. Nomenclature

1. 9R05884 Plate, Leg Holding Stud.
2. 9R05902 Washer, Bolt, Leg Holding.
3. 9R05878 Spacer, Rear, Hinged Frame, Wood.
4. 9R05872 Tie Rod, Screen, Complete.
5. 9R05880 Pad, Felt, Screen Holder.
6. 9R05904 Spring, Short, Leg Holding Screw.
7. 9R05910 Screw, Short, Leg Holding.
8. 9R05894 Pin, Lock Handle, Leg Holding Screw.
9. 9R05892 Handle, Lock, Leg Holding Screw.
10. 9R05936 Holder, Left, Screen, Complete.
11. 9R05906 Spring, Long, Leg Holding Screw.
12. 9R05952 Washer, Leg Holding Screw.
13. 9R05912 Screw, Long, Leg Holding.
14. 9R05938 Holder, Right, Screen, Complete.
15. 9R05916 Insulator, Vibration, Screen Holder, 1/8-inch Hole.
16. 9R05908 Strip, Short, Felt Holding.
17. 9R05920 Strip, Right, Screen Support.
18. 9R05909 Strip, Long, Felt Holding.
19. 9R05922 Strip, Left, Screen Support.
20. 9R05918 Insulator, Vibration, Screen Holder.
21. 9R05876 Spacer, Front, Hinged Frame, Wood.
22. 9R05886 Bracket, Right, Clamp, Hinged Frame, Complete.

23. 9R05882 Chain, Hinged Frame.
24. 9R05875 Pin, Cotter, Hinged Frame.
25. 9R05924 Flange, Screen Arm.
26. 9R05888 Bracket, Left, Clamp, Hinged Frame, Complete.
27. 9R05876 Spacer, Front, Hinged Frame, Wood.
28. 9R05869 Nut, Clamp, Detachable Leg.
29. 9R05942 Pad, Front, Clamp, Detachable Leg.
30. 9R05943 Pad, Top, Clamp, Detachable Leg.
31. 9R05934 Support, Screen Arm.
32. 9R05946 Holder, Drilled, Attachment, Protective Shield.
33. 9R05948 Holder, Plain, Attachment, Protective Shield.

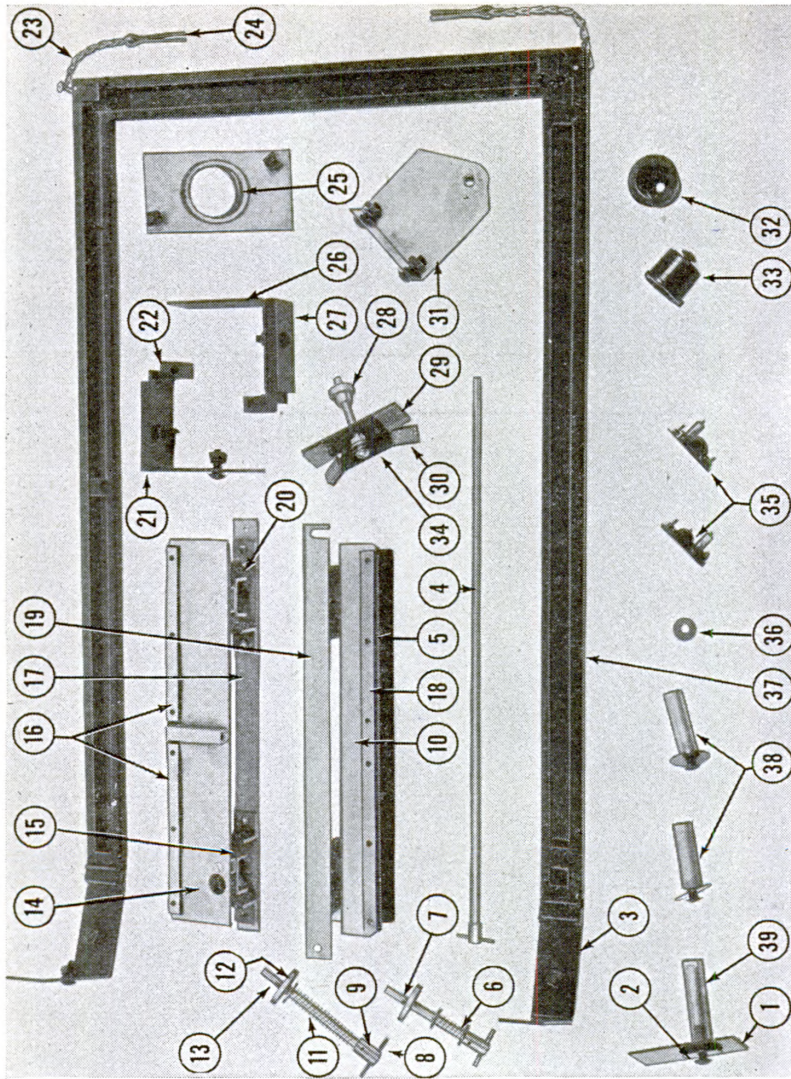

Med. Dept.
No.

Nomenclature

34. 9R05944 Angle, Clamp, Detachable Leg, Complete.
35. 9R05932 Holder, Depth Marker, Complete.
36. 9R05874 Bushing, Screen Tie Rod.

Med. Dept.
No.

Nomenclature

37. 9R05890 Frame, Hinged.
38. 9R05900 Stud, Short, Leg Holding.
39. 9R05898 Stud, Long, Leg Holding.

Figure 94. Packing assemblies for small trunk.

