

11 Oct 43
U113
TM
1943

TM 9-1618

WAR DEPARTMENT TECHNICAL MANUAL

U.S. Dept of Army

ORDNANCE MAINTENANCE

GENERATING UNIT

M7



WAR DEPARTMENT

11 OCTOBER 1943

FOR ORDNANCE PERSONNEL ONLY

STANDARD

WAR DEPARTMENT TECHNICAL MANUAL

ORDNANCE

STANDARD

WAR DEPARTMENT TECHNICAL MANUAL
TM 9-1618

ORDNANCE MAINTENANCE

GENERATING UNIT M7



WAR DEPARTMENT



11 OCTOBER 1943

WAR DEPARTMENT
Washington 25, D. C., 13 December 1943

TM 9-1618, Ordnance Maintenance, Generating Unit M7, is published for the information and guidance of all concerned.

[A.G. 300.7 (9 Oct 43)
O.O. 461/46668 Raritan (13 Oct 43)]

BY ORDER OF THE SECRETARY OF WAR:

G. C. MARSHALL,
Chief of Staff.

OFFICIAL:

J. A. ULIO,
*Major General,
The Adjutant General.*

DISTRIBUTION: R 9(4); Bn 9(2); C 9(5); IC 44(2)

(For explanation of symbols, see FM 21-6.)

CONTENTS

U113 TM 9-1618
 TM 9:1618
 1943
 ☆ ☆

	Paragraphs	Pages
CHAPTER 1. INTRODUCTION	1-7	6-14
CHAPTER 2. FRAME AND HOUSING.....	8-15	15-22
SECTION I. Frame	8-9	15-16
II. Housing	10-15	17-22
CHAPTER 3. ENGINE AND ACCESSORIES.....	16-85	23-196
SECTION I. Engine	16-27	23-78
II. Cooling system	28-33	79-90
III. Fuel system	34-53	91-134
IV. Exhaust system	54-56	134-135
V. Lubrication system	57-60	136-145
VI. Electrical system—battery-charging generator, regulator, and battery	61-70	145-173
VII. Electrical system—ignition	71-80	173-186
VIII. Electrical system—starting motor	81-85	187-196
CHAPTER 4. ELECTRICAL GENERATING SYSTEM	86-103	197-241
SECTION I. General	86-89	197-204
II. Alternator	90-96	204-230
III. Exciter	97-103	230-241
CHAPTER 5. INSTRUMENT PANEL AND INSTRUMENTS	104-134	242-271
SECTION I. Instrument panel	104-109	242-249
II. Instruments and switches.....	110-134	250-271
CHAPTER 6. MISCELLANEOUS	135-142	272-279
SECTION I. Lubrication instructions	135-138	272-276
II. Consolidated service data.....	139-140	276-277
III. References	141-142	278-279
INDEX		280-287

ORDNANCE MAINTENANCE - GENERATING UNIT M7

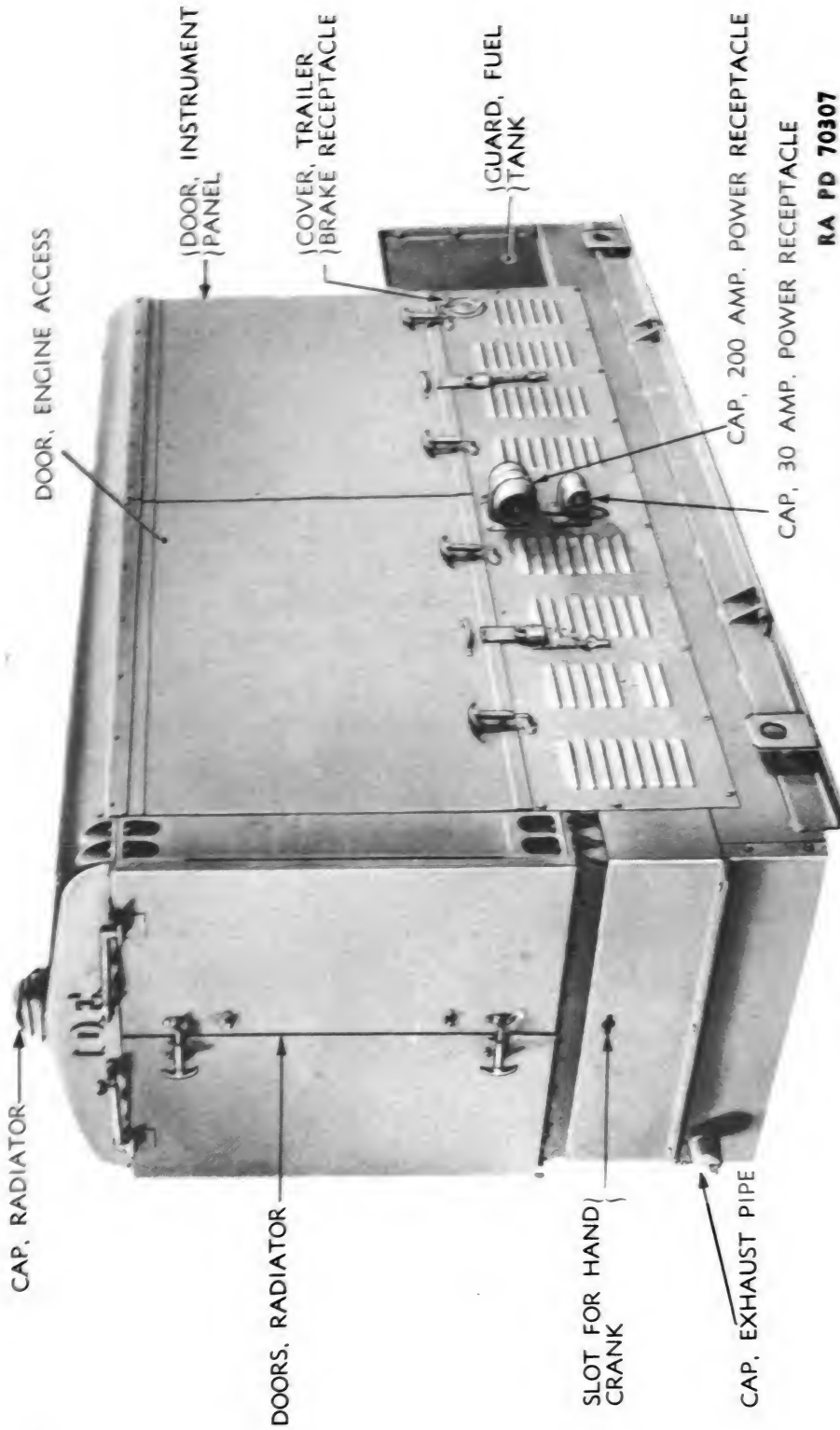

Figure 1 - Generating Unit M7 - Left Front View

ORDNANCE MAINTENANCE – GENERATING UNIT M7

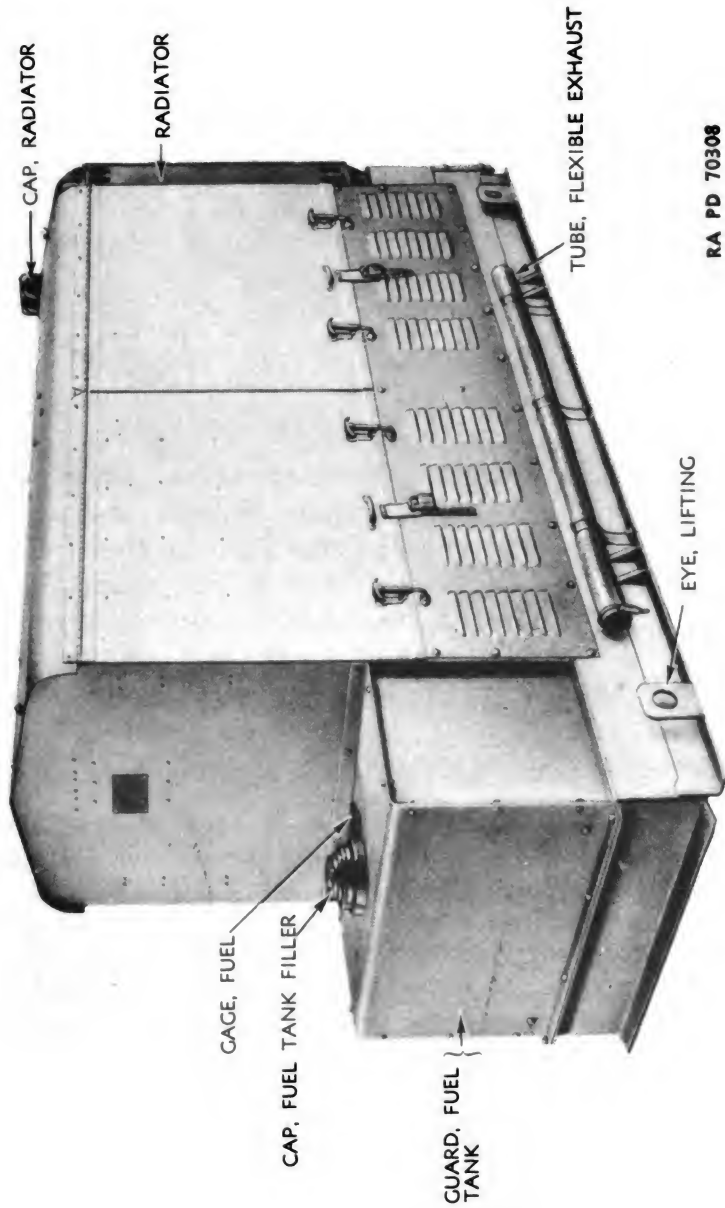

Figure 2 – Generating Unit M7 – Right Rear View

ORDNANCE MAINTENANCE – GENERATING UNIT M7

CHAPTER 1

INTRODUCTION

	Paragraph
Scope	1
Arrangement of manual	2
References	3
Description	4
Differences among models	5
Allocation of maintenance duties by echelons.....	6
Inspection	7

1. SCOPE.

a. This manual is published for the information and guidance of ordnance maintenance personnel. It contains detailed instructions for inspection, disassembly, assembly, and repair of the Generating Unit M7, supplementary to those in the Field Manuals and Technical Manuals prepared for the using arms. Additional descriptive matter and illustrations are included to aid in providing a complete working knowledge of the materiel.

2. ARRANGEMENT OF MANUAL.

a. This manual is divided into chapters, each chapter, with the exception of the first (Introduction) and the last (Miscellaneous), dealing with a major element of the generating unit.

b. Chapters are divided into sections and paragraphs which describe the materiel, explain its construction, and give detailed instructions for inspection, trouble shooting, removal, disassembly, maintenance, repairs, assembly, and installation. Certain accessories may be removed by the using arms. Removal of these accessories is described in TM 9-618 and not in this manual.

c. Chapter 6, Miscellaneous, gives general data applicable to the unit as a whole, and furnishes reference tables and guides.

3. REFERENCES.

a. Chapter 6, section III, lists all Technical Manuals, Standard Nomenclature Lists, and other publications relative to the materiel described herein.

INTRODUCTION

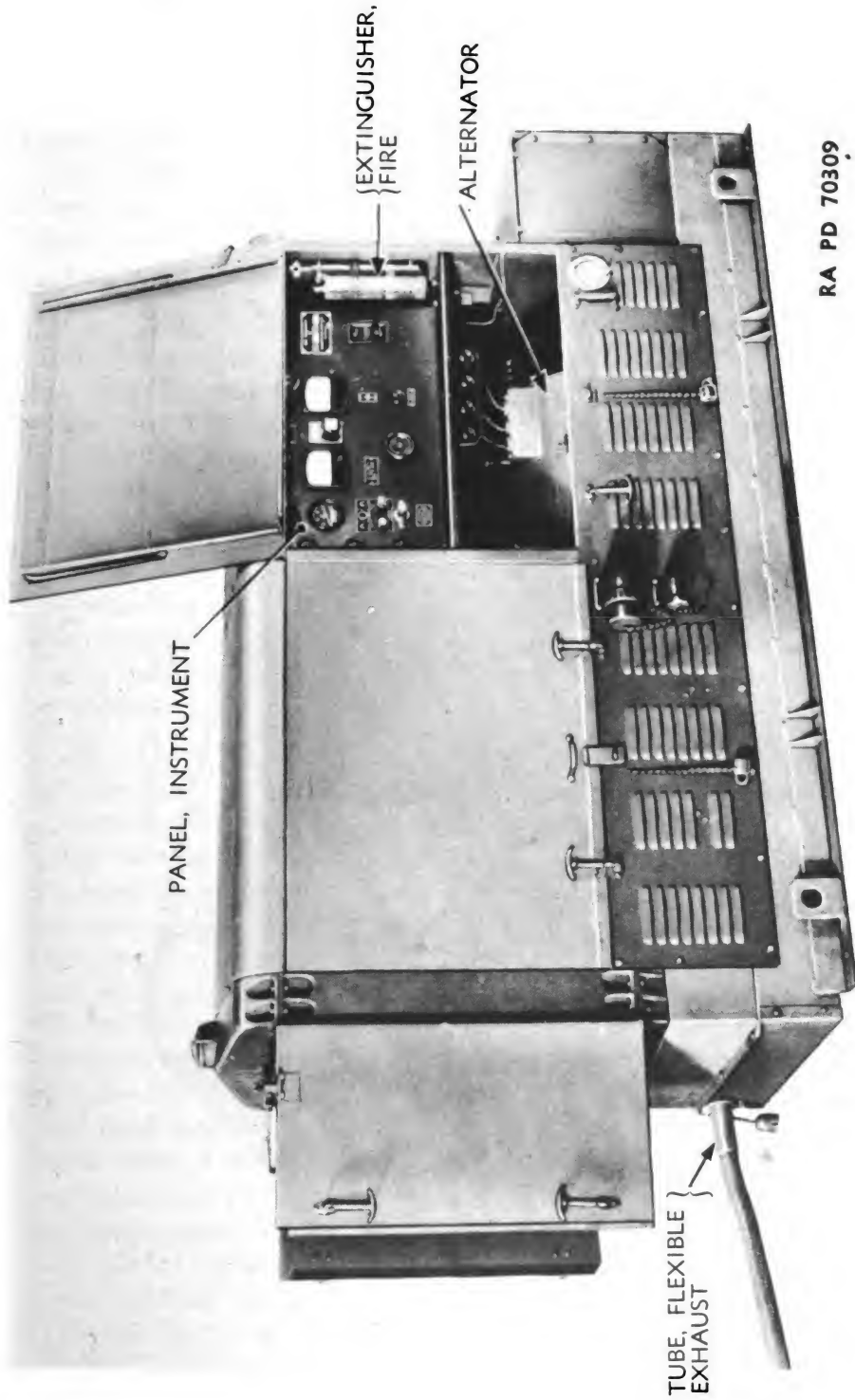

Figure 3 — Generating Unit M7 — Operating View

ORDNANCE MAINTENANCE – GENERATING UNIT M7

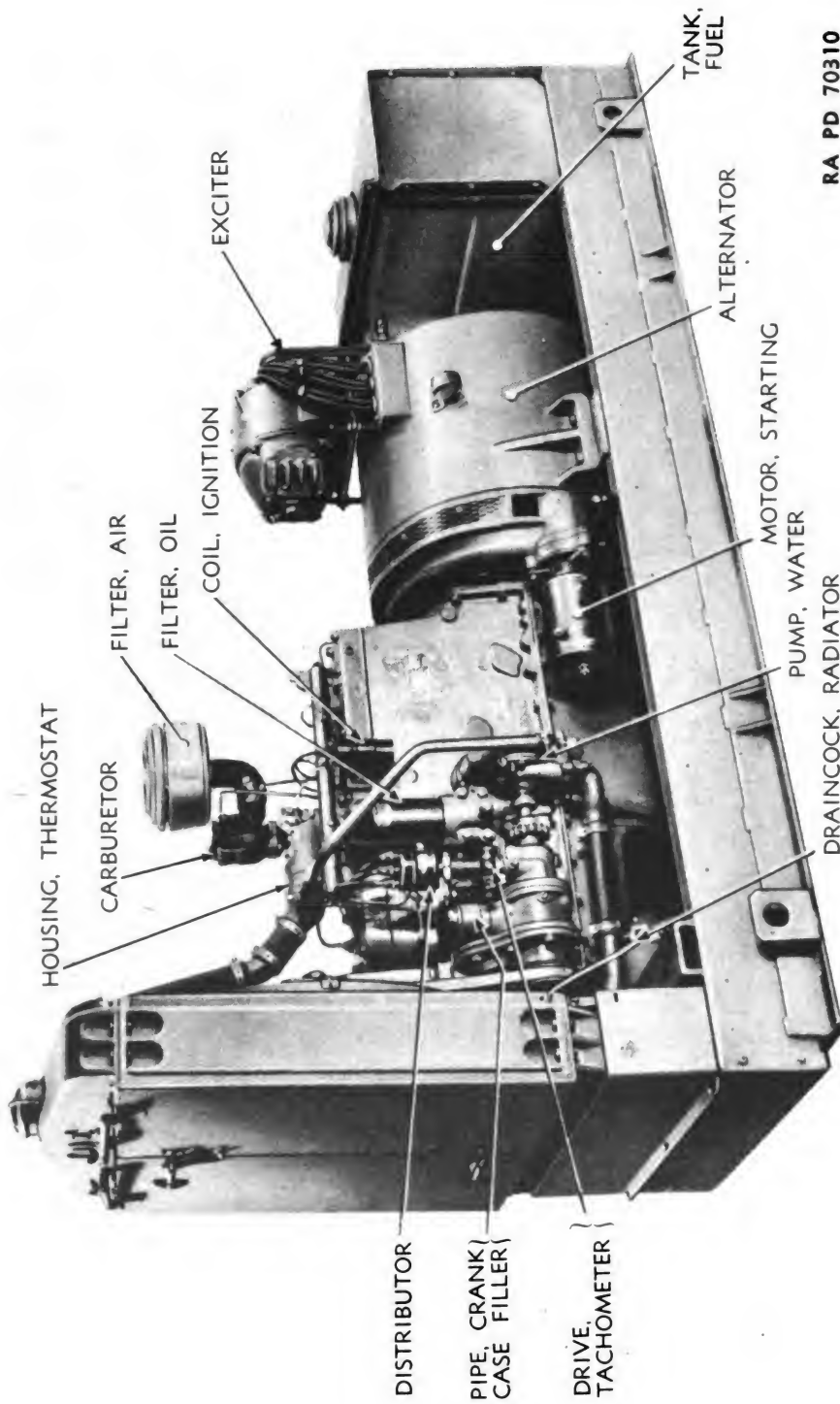

Figure 4 – Generating Unit M7 – Left Side: Housing Removed

INTRODUCTION

4. DESCRIPTION.

a. **General.** This unit (figs. 1 to 5) is a self-contained power plant mounted on a welded steel frame for use either on a specially designed trailer or set upon wood skids. The unit is completely enclosed by a sheet metal housing bolted to the base frame. Side doors give access to instrument panel, engine, generator, and other parts within the housing. The instrument and control panel is located over the alternator, on the left side of the unit. The radiator end of the unit is considered the front, and right and left sides are determined from the rear, facing toward the radiator.

b. **Engine.** The engine is a 6 cylinder, 4-stroke cycle, water-cooled gasoline engine developing approximately 67 hp at 1,200 rpm, and is directly connected to the alternator by a flexible coupling. It is equipped with an electric starting motor, battery-charging generator, oil bath air cleaner, oil filter, and gasoline strainer. Engine speeds are controlled by a mechanical governor.

c. **Alternator and Exciter.** The alternator is an a-c generator of the revolving field, stationary armature type, with separate excitation provided from a d-c generator, either mounted on the top of the alternator housing or placed inside the same housing and mounted on the same shaft. At 1,200 rpm, it delivers 35 kva-162 amperes at 125 volts, 3 phase.

d. **Controls.** Controls are mounted on an instrument panel immediately behind the left rear door of the unit. Engine controls are grouped on the left side of the panel. These consist of an oil pressure gage, temperature gage, starter switch, ignition switch, throttle, choke, tachometer or frequency meter, and the battery-charging generator ammeter with -30 to +30 ampere range. On some units an electric fuel gage is also mounted on the instrument panel. Most units make use of a mechanical float-type gage mounted directly on the fuel tank. To the right are the generator and line controls. These consist of the main, or load switch, power ammeter with 0 to 250 range, power voltmeter with 0 to 150 range, meter switch for obtaining phase readings, and field rheostat with tapered resistance of 100 ohms, maximum ampere rating 3.16, minimum 1.23. Illumination is provided by two 125-volt lamps at the top of the panel. As these will function only when the unit is in operation, auxiliary lighting is provided by a 6-volt light from the battery circuit, also at the top of the panel. Toggle switches control both lighting systems. A lamp-dimming rheostat is set between the 125-volt lights. In the engine control group at the left is a receptacle for the 6-volt trouble light. A T-slot receptacle for the 125-volt trouble light is at the right, and four more T-slot receptacles, for power tools, etc., are provided in the instrument panel apron. For convenience, the fire extinguisher is mounted at the right of the panel.

ORDNANCE MAINTENANCE – GENERATING UNIT M7

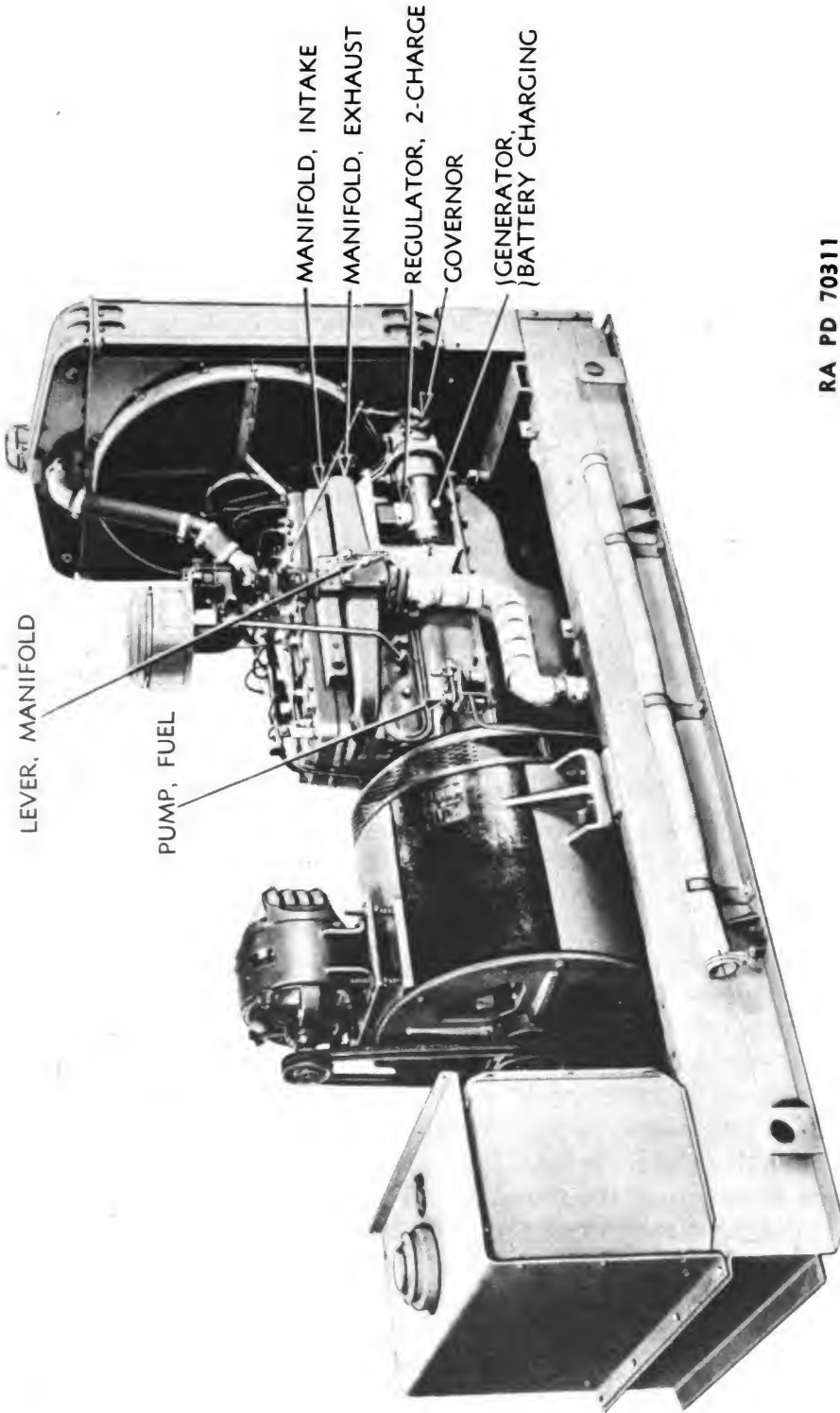

RA PD 70311

Figure 5 — Generating Unit M7 — Right Side: Housing Removed

INTRODUCTION

5. DIFFERENCES AMONG MODELS.

a. **Generating Units M7** have been produced by several manufacturers. Information and instructions given in this manual cover all **M7 Units**. Whenever, with units of certain manufacture, major differences in equipment occur, or changes in procedure are necessary, supplementary information or instructions are given, identified by the initials of the manufacturer. There are no primary differences in manufacture which would affect troop use or care, with the exception of the **Hobart Bros. Co.** unit, which has the exciter mounted on the same shaft and within the same housing as the alternator rotor.

b. **Generating Unit M7A1**. The designation **Generating Unit M7A1** has been assigned to all **Generating Units M7** which have been modified by the addition of a voltage regulator to the unit. The voltage regulator is designed to hold the voltage variation to within ± 2 per cent from full load to no load operation.

6. ALLOCATION OF MAINTENANCE DUTIES BY ECHELONS.

a. The outline below assigns specifically to each echelon its duties and functions in the proper care and maintenance of the generating unit. All echelons of maintenance should be capable of performing all lower echelons of maintenance. Maintenance in the field is necessarily a flexible matter. In a combat zone, where there is immediate danger of enemy attack, the organizational specialist, if qualified, would be perfectly correct in performing emergency third echelon repairs if no maintenance company is available. When, under field conditions, both the using arms and the ordnance maintenance troops must use their discretion as to how best to accomplish their maintenance mission. However, extreme care must be exercised if a lower echelon attempts the work of a higher one. Attempts at repair work that belong in higher echelons of maintenance may result in damage to the materiel.

b. **Echelons are Defined as Follows.**

(1) **FIRST ECHELON**. This consists of the personnel actually using the materiel (e.g., the gun crew). Proper care of the materiel, cleaning, lubrication, and a limited number of minor repairs are performed by this echelon. Preventive maintenance is the keynote here.

(2) **SECOND ECHELON**. This consists of the maintenance personnel in the company, battalion, regiment, or corresponding units in the using arms or services, and it performs limited unit replacement, lubrication, and minor repairs.

(3) **THIRD ECHELON**. Maintenance is normally performed by ordnance medium maintenance or antiaircraft maintenance companies using standard issued mobile equipment. Some activities of this

ORDNANCE MAINTENANCE – GENERATING UNIT M7

echelon are replacement of unit assemblies, overhaul of accessory unit assemblies and subassemblies, recovery of materiel, and evacuation. This maintenance is performed by ordnance personnel or ordnance medium maintenance units for the organizations they serve. The supply of spare parts to lower echelons is also a function of these medium maintenance companies.

(4) **FOURTH ECHELON.** This normally consists of ordnance heavy maintenance companies or post ordnance shops (other than base shops) having facilities for performing major disassemblies and heavy maintenance.

(5) **FIFTH ECHELON.** This normally consists of personnel of arsenals and authorized base shops with facilities for performing complete overhaul.

c. Maintenance Allocations.**(1) FIRST ECHELON.**

Maintain oil level in crankcase.

Maintain gas in tank.

Maintain air pressure in tires, and make tire repairs.

Maintain battery water level.

Maintain radiator water level.

Adjust louvers for proper operating temperature.

Renew fuze links.

Clean gasoline pump sediment bowl.

Replace lamps.

(2) SECOND ECHELON.

Grease, oil, and lubricate.

Clean or replace air and oil filters.

Adjust "rate of charge" of battery-charging generator.

Adjust engine governor.

Clean and adjust distributor points.

Clean and flush radiator and cooling system.

Repack water pump.

Adjust or replace fan or generator belts.

Clean spark plugs, and adjust gaps.

Adjust or replace exciter belts.

Replace battery.

Check and tighten all electrical terminals.

Adjust oil pump pressure.

Adjust spring tension, or replace brushes on starter motor, battery-charging generator, exciter, and/or alternator.

INTRODUCTION

Replace the following engine and generator accessories:

- Spark plugs and ignition wiring.
- Spark coil.
- Intake and exhaust manifolds.
- Fan assembly.
- Starter.
- Starter Bendix spring.
- Battery-charging generator.
- Battery-charging voltage regulator generator.
- Water-cooling system hose.
- Water-cooling system thermostat.
- Water pump packing.
- Oil gage.
- Oil lines and fittings.
- Oil strainer.
- Battery cables.
- Lighting switch.
- Starting switch.
- Tachometer.
- Muffler.
- Exhaust pipe.
- Throttle control.
- Choke control.
- Carburetor.
- Throttle box.
- Distributor rotor.
- Condenser.
- Distributor points.
- Ammeter.
- Battery-charging ammeter.
- Fuel pump.
- Fuel gage.
- Light receptacles.
- Field rheostat.
- Switches.

(3) THIRD AND FOURTH ECHELONS.

General repair, including valve grinding, carburetor repair, distributor repairs and adjustments, etc., but not including rebores, piston, bearing, or rod work.

ORDNANCE MAINTENANCE – GENERATING UNIT M7

Replace electrical or mechanical parts or assemblies.

Replace wheels, repair brakes, etc., on Generator Trailer M7.

(4) FIFTH ECHELON.

Perform all necessary repairs or replacements which cannot properly be done by lower echelons.

7. INSPECTION.

a. Description. Inspections by ordnance personnel are a follow-up and check on organization maintenance inspections and other maintenance functions. They determine whether the unit should be continued in service or withdrawn from operation for overhaul. These general inspections are similar to the monthly inspections described in TM 9-618.

b. Inspection Record. A permanent record, listing any maintenance performed, should be kept of each inspection. A suitable inspection form, listing the points of inspection itemized, can be prepared as a guide for maintenance personnel. Utility of the form will be increased if space is provided to record the date and remarks for each periodic inspection.

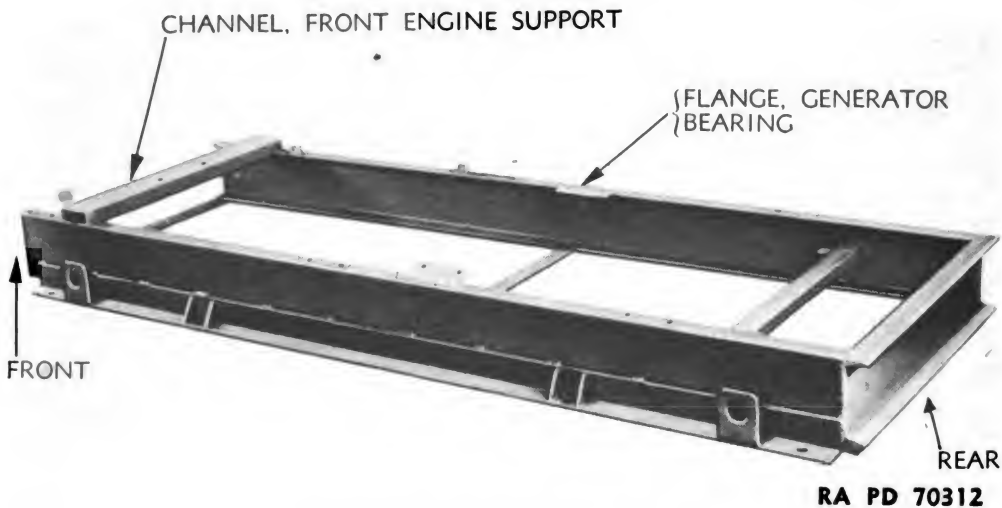

Figure 6 – Frame – Stripped

CHAPTER 2

FRAME AND HOUSING

Section 1

FRAME

	Paragraph
Description	8
Inspection and repair	9

8. DESCRIPTION.

a. The frame (figs. 6 and 7) is of welded steel construction, and is made up of four side members and six cross members. Centrally located pads braced by gusset plates provide bearing for the alternator. Lifting eyes are welded to the outer angles. Some units depart from the general design in that the generator bearing pads are replaced by a removable squared C-shape strap with pads at each end. This allows a variation in the method of assembling the unit.

b. Frame Dimensions (fig. 7).

Over-all length	97 1/8 in.
Width	36 3/8 in.
Distance between centers of engine mounting holes	11 in.
Distance between centers of each pair of alternator mounting holes	26 in.
Distance between centers in each pair of alternator mounting holes	4 in.

9. INSPECTION AND REPAIR.

a. Procedure.

(1) With all parts removed from frame, visually inspect welded joints. Repair any broken welded joints.

(2) Check corners with square. Check dimensions. If not according to specifications, replace or repair.

ORDNANCE MAINTENANCE — GENERATING UNIT M7

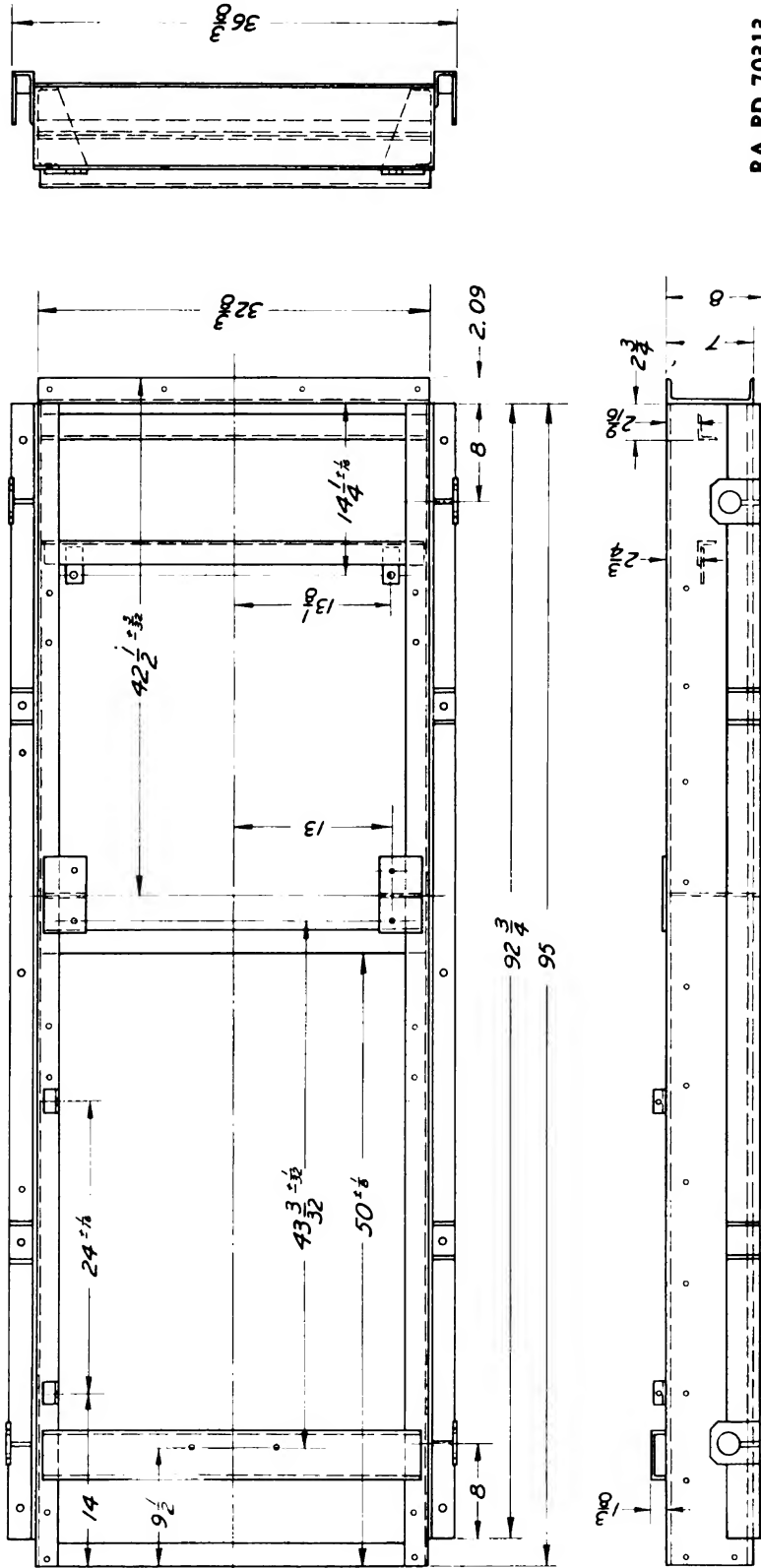

RA PD 70313

Figure 7 — Scale Drawing of Frame

FRAME AND HOUSING

Section II

HOUSING

	Paragraph
Description	10
Removal	11
Disassembly	12
Maintenance and repair	13
Assembly	14
Installation	15

10. DESCRIPTION.

a. From the radiator back, the entire unit is enclosed by a 16-gage sheet metal housing made up of four access doors, two side panels, an end panel, the roof, a fuel tank guard, and two fuel tank end panels. All housing components can be removed for replacement or repair.

b. Sheet metal radiator doors provide radiator protection, and form part of the cooling system.

11. REMOVAL.

a. There are several methods of supporting the power and brake receptacle leads and the alternator leads, etc., to each other and to either the housing or alternator. Examination before disassembly will reveal the proper method of uncoupling these leads, and also simplify reassembly.

b. Procedure.

(1) Disconnect the instrument panel. For procedure, refer to paragraph 105, *omitting* step (12).

(2) Loosen hold-down clamp nuts, and remove clamps. Loosen battery lead clamps, and remove leads from battery posts. Remove battery and inside tray. Remove nuts from cap screws through battery box flanges (fig. 8), and lift box off. Remove nuts from bolts through bottom of tool box, and remove box.

(3) Remove nuts and cap screws holding guard to rear housing panel. Remove cap screws holding guard to frame base. Remove nuts from strap-end bolts attaching fuel tank traps to frame cross member behind housing rear panel (fig. 86). Lift guard up and off.

(4) Remove nut holding back of brake receptacle housing. Remove nut attaching lead, and remove lead.

(5) Take out cap screws and nuts holding housing roof to radiator. Remove bottom cap screw and nut at each side of radiator holding side panels to radiator.

ORDNANCE MAINTENANCE — GENERATING UNIT M7

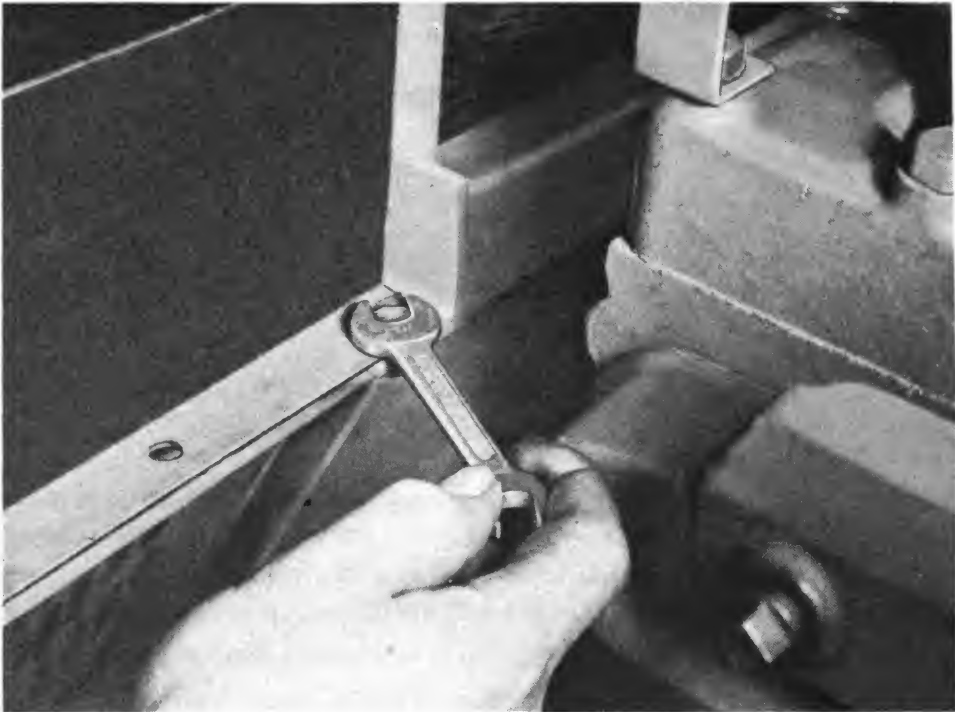

RA PD 56887

Figure 8 — Battery Box Removal

(6) Remove nuts which secure each radiator support rod to center bow, by holding rod with pliers while unscrewing nuts at bow. Unscrew rod from radiator, and remove (fig. 11).

(7) Remove cap screws and nuts attaching side panel to frame, radiator support panel, and exhaust guard tray.

(8) Remove cap screws and nuts holding center bow and end panel to frame. Attach hoist chains to corners of housing roof and lift housing as unit, including instrument panel (fig. 9).

12. DISASSEMBLY.

a. Procedure.

(1) Unscrew the elastic stop nuts from the cap screws holding the panel U-type mounting clips (fig. 10) to the support brackets. Remove cap screws and instrument panel. **NOTE:** These instructions apply to one method of instrument panel attachment. The procedure of actual panel removal will vary with the make of the unit.

(2) Remove the cap screws and nuts attaching the side doors to the housing roof. Remove doors.

(3) Remove nuts and screws holding power receptacles and side panels to center bow, and side panels to end panels. Remove side panels and power receptacles with leads.

FRAME AND HOUSING

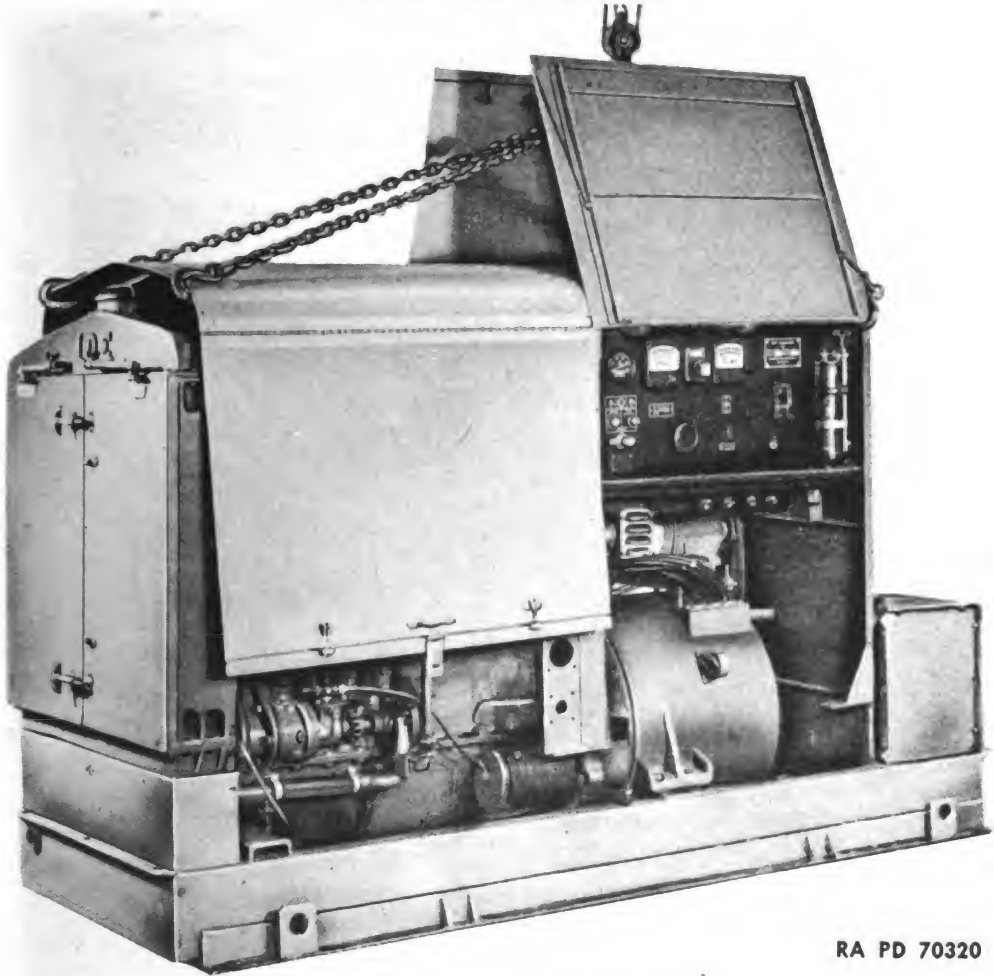

RA PD 70320

Figure 9 – Housing Removal

(4) Remove the cap screws and nuts holding the roof to the center bow and the end panel, and remove roof.

(5) Remove the cap screws and nuts attaching the gasket tray to the inside of the housing roof. Remove tray.

13. MAINTENANCE AND REPAIR.

a. Procedure.

(1) Hammer out all dents, and straighten any bent sections of housing.

(2) Repair or replace all broken hinges, catches, handles, hasps, etc. Bolt or weld them securely in place.

(3) Weld or repair all broken sections if possible.

(4) Clean up all rusted sections, and remove any loose paint. Clean bare surfaces with SOLVENT, dry-cleaning, and repaint.

ORDNANCE MAINTENANCE – GENERATING UNIT M7

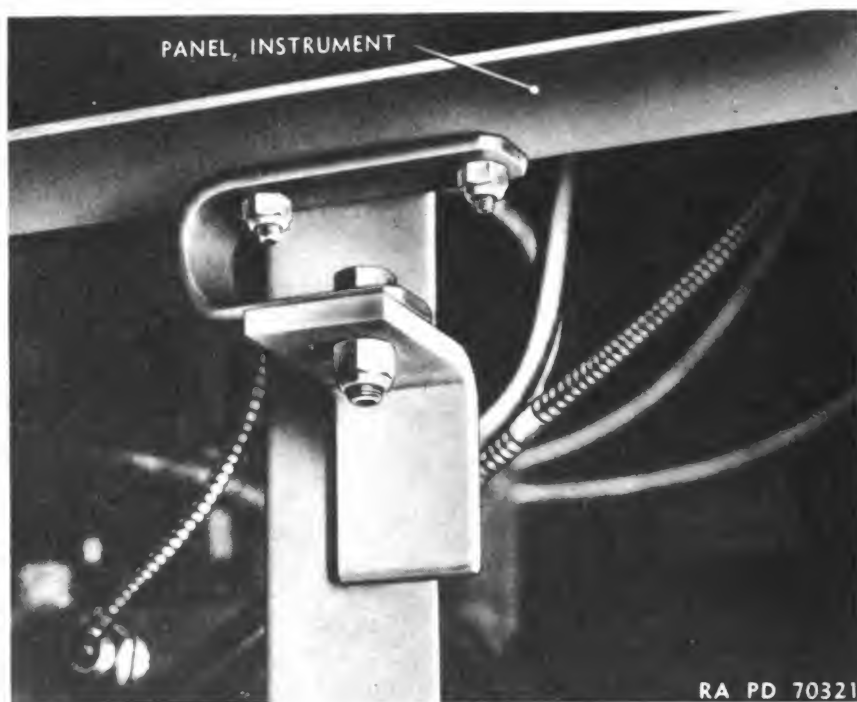
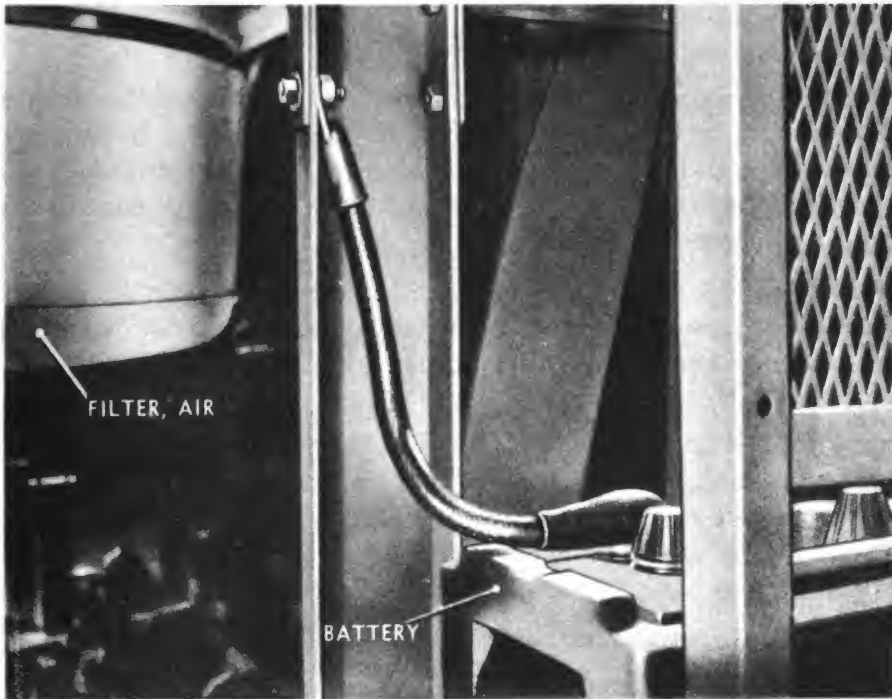

Figure 10 – Instrument Panel Mounting Bracket



Figure 11 – Radiator Support Rod Installation

FRAME AND HOUSING



RA PD 70324

Figure 12 – Battery Lead Grounded to Housing Support

14. ASSEMBLY.

a. Procedure.

- (1) Install gasket tray on the inside of the housing roof plate with cap screws and nuts.
- (2) Place center bow and end panel in position to receive roof, and bring roof down in place on bow and end panel. Secure with cap screws and nuts.
- (3) Hold each door in place, and secure to roof with cap screws and nuts.

15. INSTALLATION.

a. Procedure.

- (1) Attach hoist chains to corners of housing roof, lift housing up, and set down in place on frame (fig. 9). Remove chains and secure center bow and end panel to frame with cap screws and nuts. Secure housing to radiator with cap screws and nuts.
- (2) Place side panels in position and attach to frame, center bow, end panel, radiator support panel, and exhaust guard tray with cap screws and nuts. Attach upper lip of panel to angles bolted to cen-

ORDNANCE MAINTENANCE — GENERATING UNIT M7

ter bow, with round-head machine screws and nuts. Attach power receptacles with leads to left side panel.

(3) Screw nut on $2\frac{3}{8}$ -inch threaded end of each radiator support rod. Insert this end of each rod through holes provided in center bow uprights. Bring rods forward to meet tapped holes in radiator. Tighten rods in radiator holes (fig. 11). Put nut on other end of each rod, and tighten nuts against uprights.

(4) Remove nut holding back of brake receptacle housing. Remove nut on post marked "TL," attach lead from post "61" on terminal block, and secure with nut.

(5) Bring fuel tank guard down over fuel tank, at the same time carrying tank hold-down straps down under frame rear panel to holes provided for tank strap end bolts in frame rear cross member. Insert bolts and adjust nuts to hold straps firmly in place. With cap screws and nuts, fasten guard to base. Attach guard to rear panel with cap screws and nuts.

(6) Install instrument panel (par. 109).

(7) Attach tool box to support angles with cap screws and nuts. Attach outer battery tray to angles with cap screws and nuts, and bolt down (fig. 8). Set inside battery tray into outer tray. Set battery in place with negative pole adjacent to center bow (fig. 12). Connect the ground to the center bow with the negative pole of the battery. Remaining lead connects to positive pole. Install battery clamps. **NOTE:** Some units have negative pole of battery grounded to alternator frame.

CHAPTER 3
ENGINE AND ACCESSORIES

Section I

ENGINE

	Paragraph
Description	16
Construction	17
Specifications	18
Trouble shooting	19
Removal	20
Removal of accessories	21
Disassembly	22
Maintenance and repairs	23
Assembly	24
Installation of accessories	25
Installation	26
Tune-up	27

16. DESCRIPTION.

a. The gasoline engine (figs. 13, 14, and 15) is 6-cylinder, L-head, automotive-type, developing approximately 67 hp at 1,200 rpm. The cylinder block and crankcase are cast in one piece, and the water jacket extends the full length of the cylinder bore. The cylinder head is made of cast iron, and is easily removable to permit service operations.

17. CONSTRUCTION.

a. **Main Bearings.** The main bearings are of the shell-type, babbitt lined, brass back. The use of seven main bearings permits a main bearing being placed on each side of each connecting rod bearing. The center and rear main bearing caps are each held in position by four cap screws, 1/2 inch in diameter. A removable shell is in each lower cap, as well as in the crankcase. The upper and lower shells are interchangeable. These shells are of the precision-type and are completely finished before being put in place, thus eliminating the need for reaming or scraping. This feature allows easy renewal of bearings.

b. **Pistons.** The pistons (fig. 16) are aluminum, with three compression rings and one oil ring, all located above the piston pin. The piston pins are made of special alloy steel, heat-treated, and accurately ground to size. The pins are clamped in the upper end of the rod, and have a working fit in the piston.

ORDNANCE MAINTENANCE — GENERATING UNIT M7

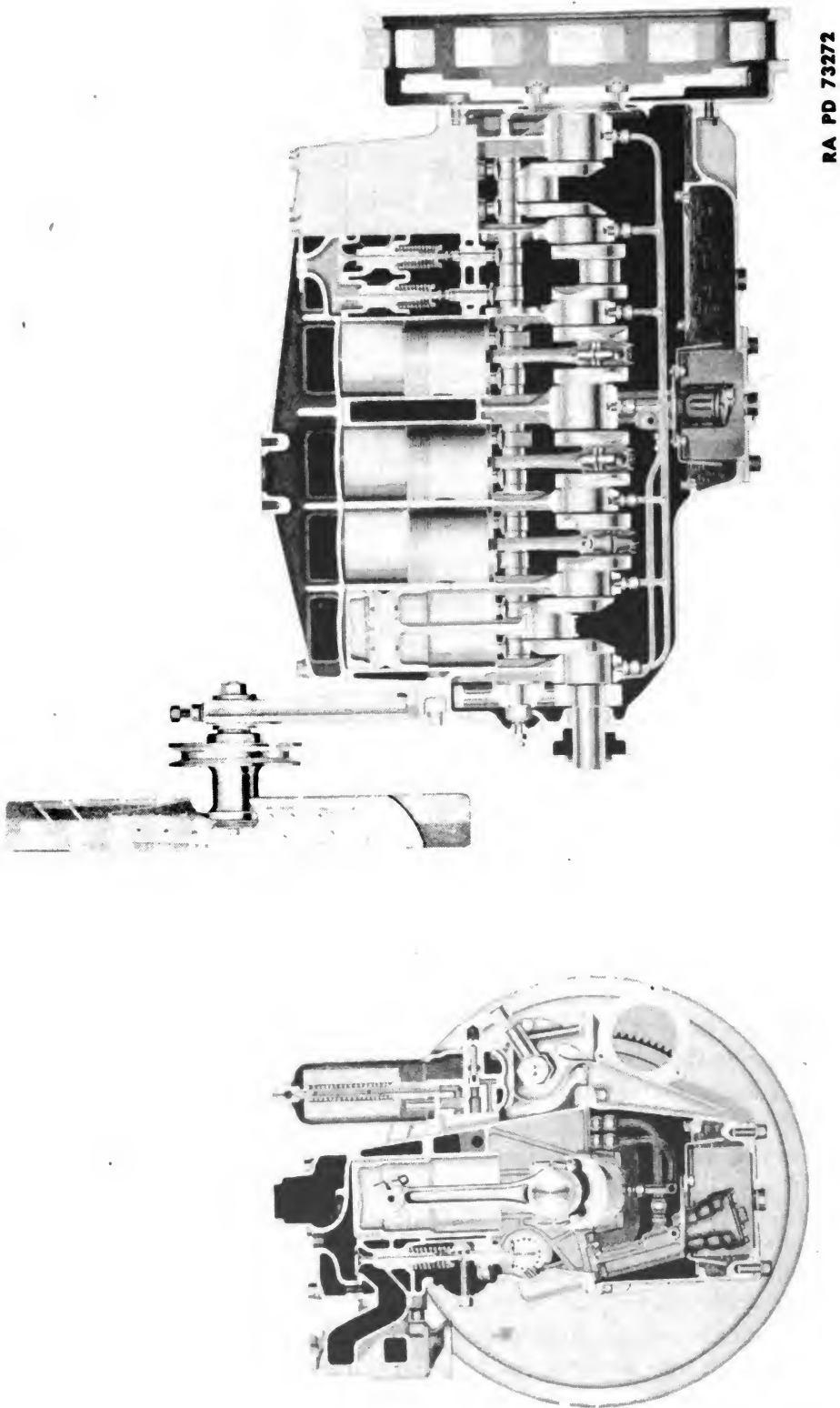
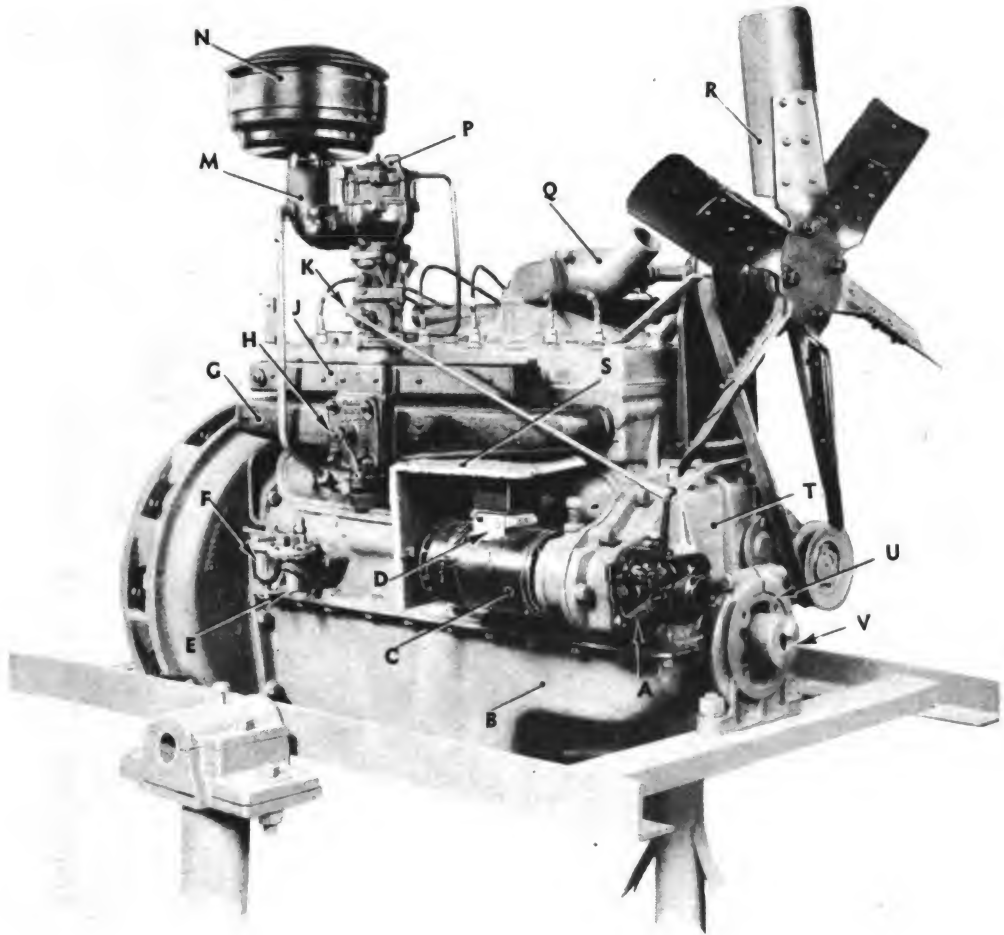

Figure 13 — Engine — Sectional View

ENGINE AND ACCESSORIES



- | | |
|---|------------------------------|
| A — GOVERNOR | L — PIPE, BREATHER |
| B — PAN, OIL | M — ELBOW, CARBURETOR |
| C — { GENERATOR,
BATTERY
CHARGING | N — FILTER, AIR |
| D — REGULATOR,
2-CHARGE | P — CARBURETOR |
| E — PUMP, FUEL | Q — HOUSING,
THERMOSTAT |
| F — BOWL, SEDIMENT | R — FAN |
| G — MANIFOLD, EXHAUST | S — BAFFLE, HEAT |
| H — LEVER, MANIFOLD | T — COVER, GEAR |
| J — MANIFOLD, INTAKE | U — SUPPORT, FRONT
ENGINE |
| K — BOX, THROTTLE | V — DOG, CRANKING |
- RA PD 70325

Figure 14 — Engine with Accessories — Right Side

ORDNANCE MAINTENANCE - GENERATING UNIT M7

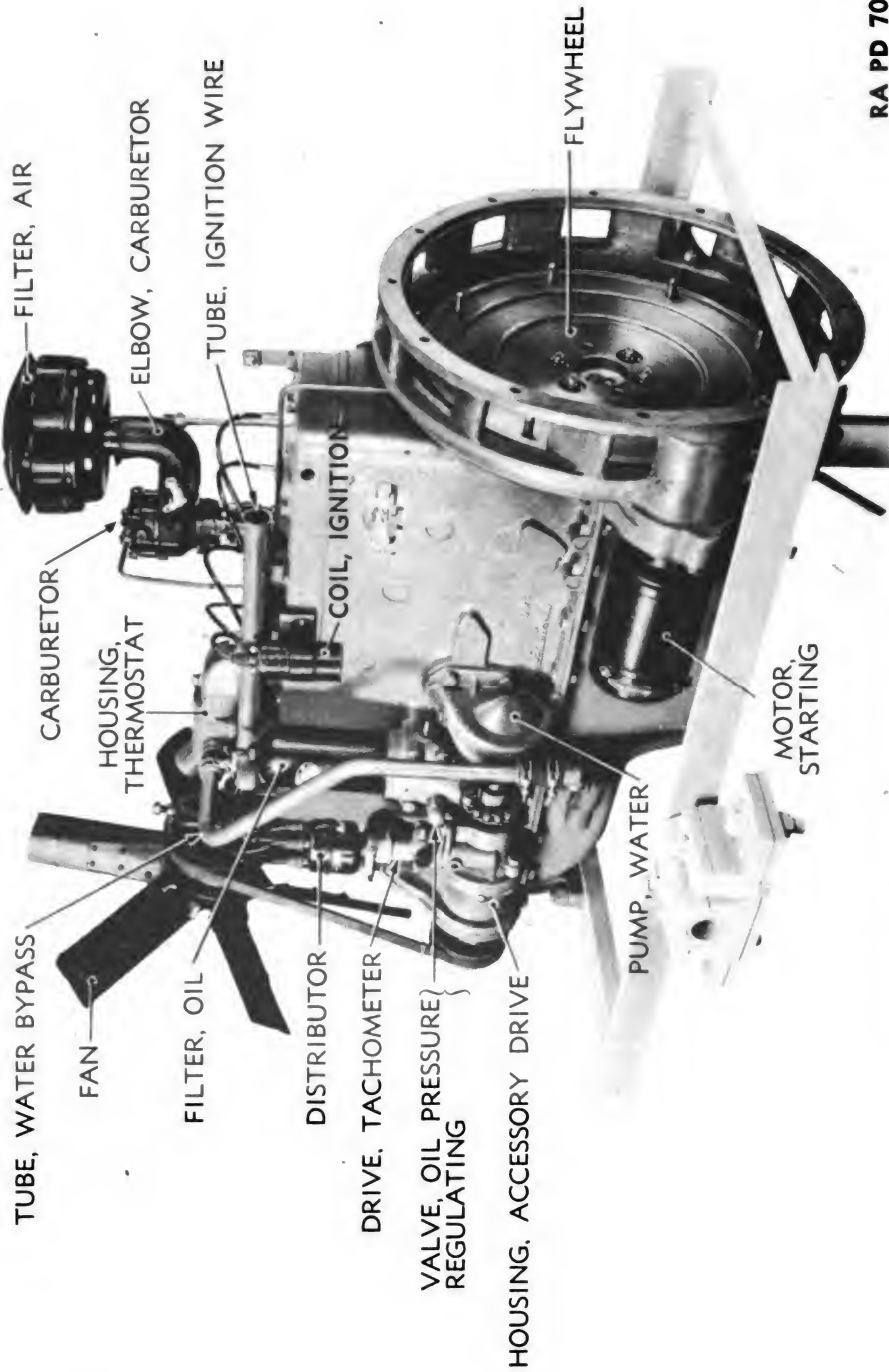

RA PD 70326

Figure 15 - Engine with Accessories - Left Side

ENGINE AND ACCESSORIES

c. **Camshaft and Idler Shaft.** The camshaft is supported on large diameter bearings in the crankcase. These bearings are removable and can be renewed. The idler gear is supported on a shaft which in turn is supported on a bushing pressed into the crankcase. This bushing is also removable and can be renewed.

d. **Valves.** The valve guides are removable bushings pressed into the cylinder block. The valves are forged from special steel. The exhaust valve steel is a special alloy designed to withstand high temperature. Valve tappets are of the mushroom-type, and are guided in removable clusters bolted to the crankcase (fig. 34). Some models of this generating unit have replaceable exhaust valve inserts.

e. **Manifold.** The intake and exhaust manifold (fig. 17) is made of cast iron, and is cast in one piece. The exhaust gases pass through a space which surrounds the intake manifold.

f. **Water Pump Drive.** A water pump drive on the left front corner of the engine is the means of driving the water pump, tachometer, distributor, and fan.

18. SPECIFICATIONS.

Make	Hercules
Model	WXLC-3
Rating	
Bore	4 $\frac{1}{4}$ in.
Stroke	4 $\frac{3}{4}$ in.
Maximum horsepower at rated speed	67 hp at 1,200 rpm
Piston displacement	404 cu in.
Firing order	1-5-3-6-2-4
Lubrication	Forced feed to all connecting rods and main bearings
Cylinder head	
Type	Detachable
Valve arrangement	L-head
Exhaust port diameter	1 $\frac{1}{2}$ in.
Intake port diameter	1 $\frac{5}{8}$ in.
Pistons	
Material	Aluminum
Rings above pin	4
Rings below pin	0
Number oil rings	1
Number compression rings	3
Oil ring width	$\frac{3}{16}$ in.
Compression ring width	$\frac{1}{8}$ in.

ORDNANCE MAINTENANCE – GENERATING UNIT M7



RA PD 70327

Figure 16 – Piston, Connecting Rod, and Bearing



RA PD 70329

Figure 17 – Manifold, Companion Flange, and Gaskets

ENGINE AND ACCESSORIES

Piston pin	
Diameter	1 1/8 in.
Number bearings per piston	2
Bearing location	In piston
Bearing length	1 1/2 in. each
Crankshaft	
Number bearings	7
Bearing diameter	2 5/8 in.
Bearing length (front)	1 3/4 in.
Bearing length (center)	2 3/4 in.
Bearing length (others)	1 1/2 in.
Camshaft	
Drive	Helical gear
Location	Right side of cylinder block
Number bearings	4
Bearing diameter	2 1/8 in.
Bearing length (front)	1 5/16 in.
Bearing length (center, 2)	7/8 in.
Bearing length (rear)	1 3/8 in.
Connecting rods	
Bearing diameter	2 1/4 in.
Bearing length	1 1/8 in.
Connecting rod length (center to center)	9 in.
Carburetor	
Size	1 5/8 in. SAE
Adjustment	Idling speed only
Cooling	Water pump
Generator	
Mounting	Right side of engine, behind governor
Drive	From timing gear
Starting motor mounting	Standard SAE mount on bellhousing
Spark plug size	7/8 in. thread, 1 5/16 in. nut
Exhaust manifold bore	2 1/2 in.

19. TROUBLE SHOOTING.

a. Engine Skips or Misses.

Possible Cause	Possible Remedy
Spark plugs cracked or dirty.	Clean or replace plugs.
High tension wires broken or shorted.	Replace wires. Find short, and remedy.
Distributor cap or rotor broken, damp, or dirty.	Service or replace cap or rotor.

ORDNANCE MAINTENANCE — GENERATING UNIT M7

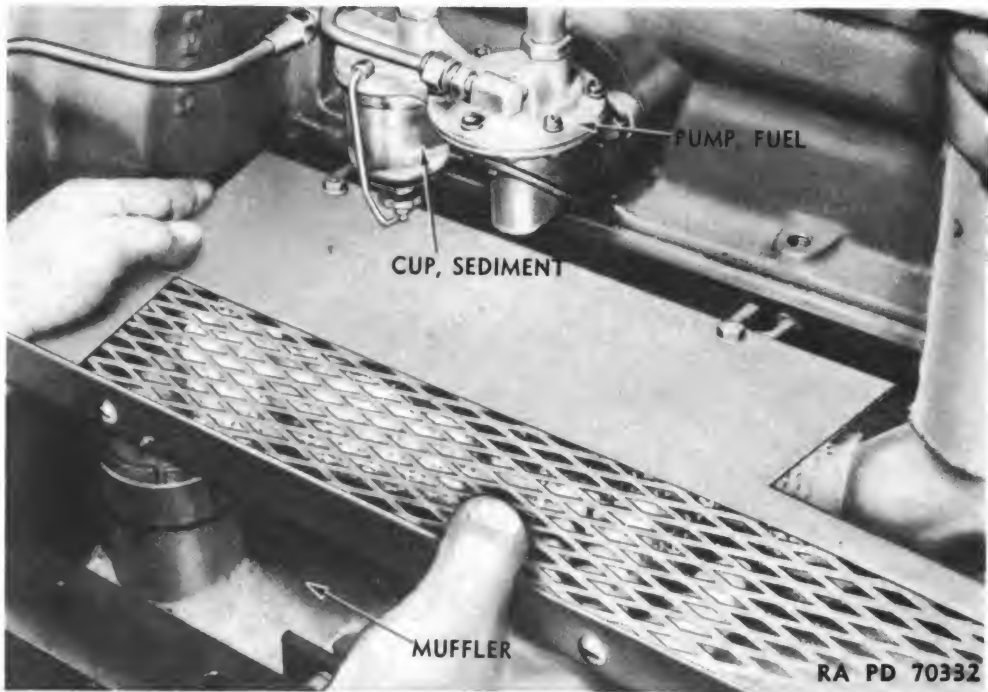

Figure 18 — Exhaust Guard Tray Removal

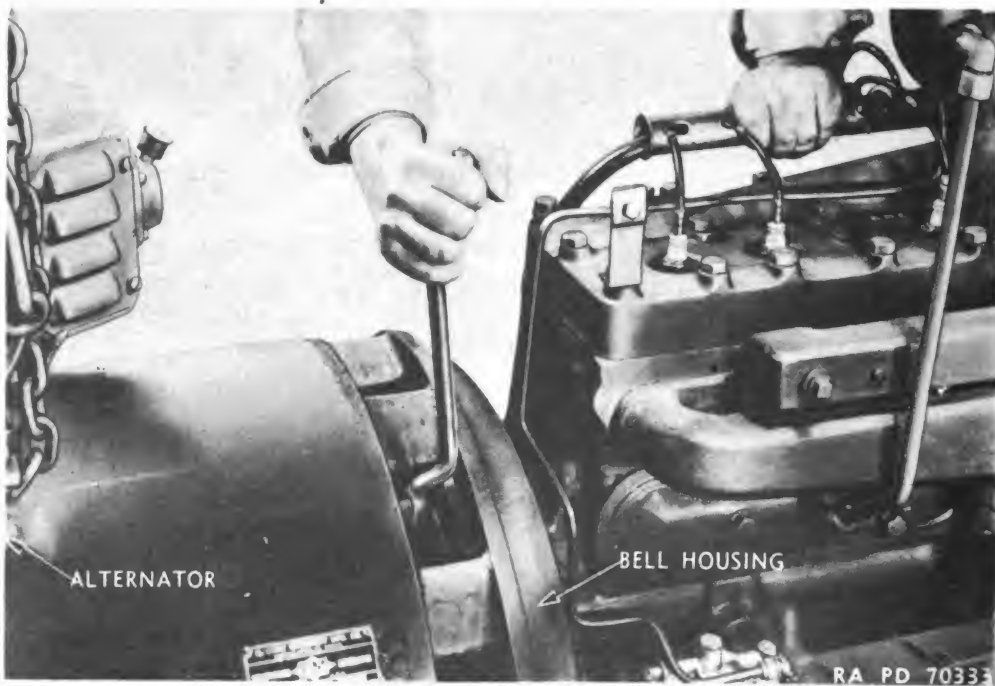

Figure 19 — Removing Alternator — Bell Housing Screws

ENGINE AND ACCESSORIES

Possible Cause	Possible Remedy
Faulty distributor points, condenser, or coil.	Replace points, condenser, or coil.
Valves adjusted to close, or badly worn guides.	Adjust valves, or replace guides.
Leaking head gasket.	Replace gasket.
Cracked water jacket.	Weld crack, or replace jacket.
Improperly adjusted carburetor.	Adjust carburetor correctly.
Air leak in intake manifold or head.	Discover leak, and correct.
Partially plugged gas line.	Blow out line.

b. Lack of Power in Engine.

Skipping engine.	Check ignition system (chapter 3, section VII).
Engine out of time.	Retime (par. 27a (9)).
Needs carbon removed and valves ground.	Remove carbon and grind valves (par. 23 d).
Low or uneven compression.	See paragraph 27 a (2).
Engine overheats.	See paragraph 29 a.
Mixture too rich.	Adjust carburetor idling screw for leaner mixture.

c. Engine Vibrates.

Mountings loose.	Tighten mountings.
Bad skip in engine.	Check ignition system (section VII).
Ignition and timing too far advanced.	Retard distributor.
Mixture too rich.	Adjust carburetor idling screw for leaner mixture.

d. Engine Overheats.

Circulation plugged in radiator forming cold spot in core.	Clean out radiator.
Radiator block dirty.	Clean out radiator.
Ignition late.	Advance distributor.
Fan belt slipping.	Tighten belt by belt adjusting screw.
Thermostat stuck closed.	Service or replace thermostat.

ORDNANCE MAINTENANCE – GENERATING UNIT M7

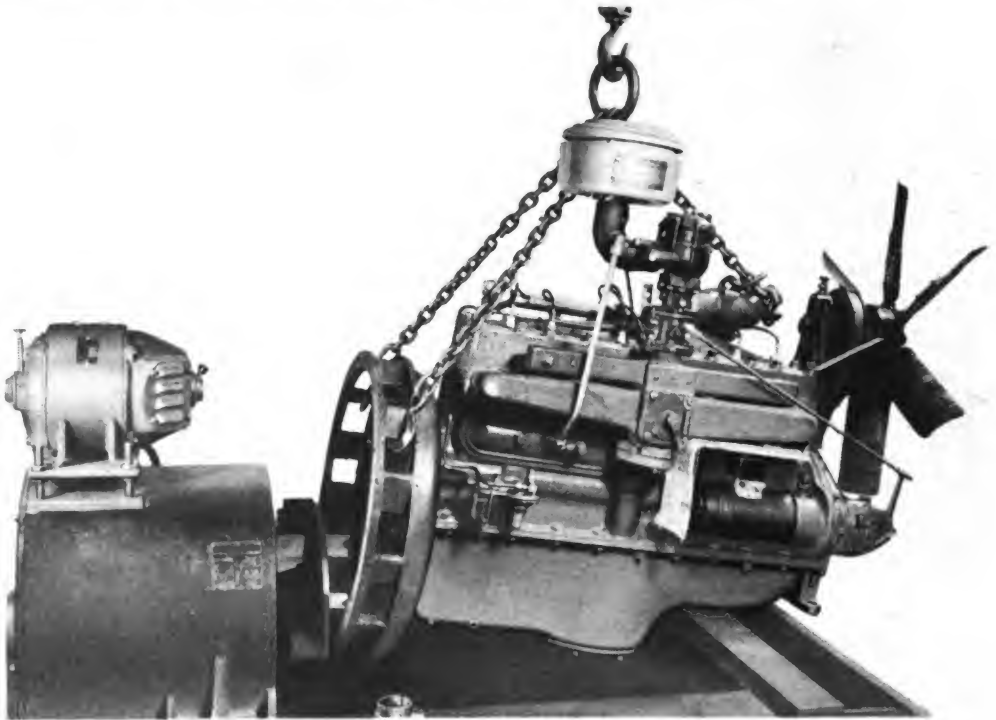

RA PD 56915

Figure 20 – Removing Engine from Frame



RA PD 56946

Figure 21 – Disconnecting Governor Lubrication Fitting

ENGINE AND ACCESSORIES

e. Engine Knocks.

Possible Cause	Possible Remedy
Carbon deposit in head.	Remove carbon.
Spark advanced too far.	Correct timing (par. 27 a (9)).
Governor weights stuck or springs weak.	Service or adjust governor (par. 50).
Loose wristpins.	Renew wristpins.
Connecting rod out of alignment.	Aline or replace.
Loose rod bearings.	Replace bearings.
Loose main bearings.	Replace bearings.
End play in camshaft.	Tighten end play adjusting screw so as to barely feel shaft, then back off not more than one-quarter turn.
Loose tappets.	Adjust tappets.
Sticky valve stems.	Clean stems with kerosene or dry-cleaning solvent.
Loose spark plugs.	Tighten plugs.
Flywheel loose.	Tighten flywheel attaching bolts.

f. Grinding or Scraping Noise in Engine.

Generator bearings worn.	Replace bearings.
Water pump bearings bad.	Replace bearings.
Broken ring or piston.	Replace ring or piston.

g. Engine Uses Too Much Oil.

Piston ring gaps lined up.	Turn rings.
Piston rings worn or carbon in ring grooves.	Replace rings or remove carbon.
Vacuum pump diaphragm cracked or porous.	Replace diaphragm.
Rod or main bearings have too much clearance.	Shim up for proper clearance (par. 24 a (4) and 24 a (13)).

h. Excessive Gas Consumption.

Worn out spark plugs.	Replace spark plugs.
Timing late.	Retime engine.

ORDNANCE MAINTENANCE — GENERATING UNIT M7

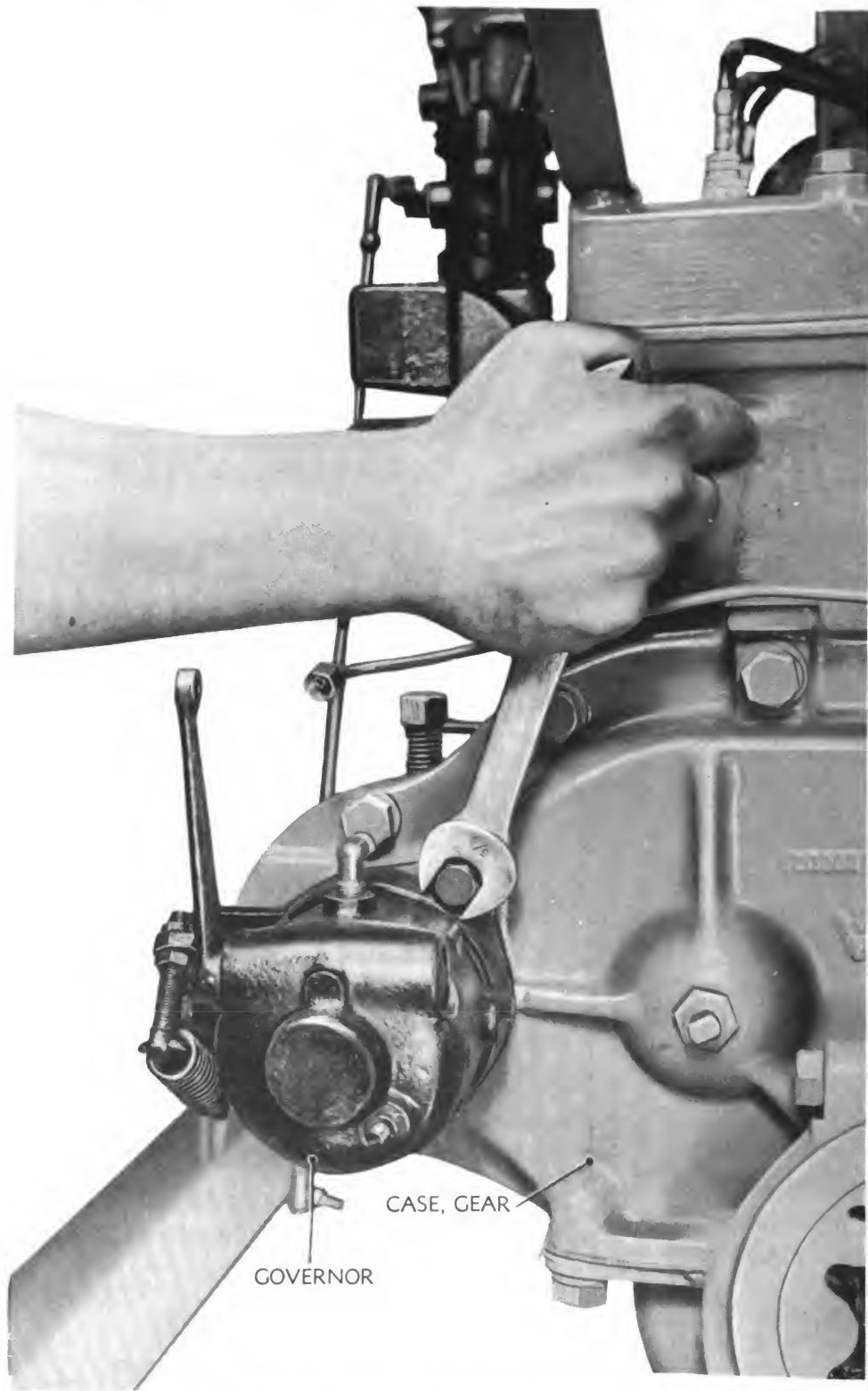

Figure 22 — Governor Removal

RA PD 70337

ENGINE AND ACCESSORIES

Possible Cause	Possible Remedy
Carburetor dirty, and out of adjustment.	Clean and adjust carburetor.
Engine idles too fast.	Adjust governor (par. 50).
Choke out of adjustment.	Adjust choke.
Air cleaner dirty or too full of oil.	Service cleaner.
 i. Engine Fails To Start.	
Fuel system clogged or fuel supply exhausted.	Blow out fuel lines or renew fuel supply.
Defective fuel pump.	Repair or replace pump.
No spark at spark plugs.	See chapter 3, section VII.
 j. Generator Fails To Charge.	
Voltage regulator out of order.	Repair or replace.
Generator not operating properly.	Repair or replace.
Poor connections in circuit.	Tighten connections.

20. REMOVAL.

a. Procedure.

- (1) Remove housing (par. 11).
- (2) Drain water from cooling system by opening drain cock in radiator outlet pipe.
- (3) Loosen metal straps binding two hose sections in upper radiator water line and one hose section in lower radiator line by loosening bolts. Work off hose sections.
- (4) Disconnect the fan guard sections by removing the attaching bolts and nuts. Take off square nuts holding the two guard sections to the housing, and remove guard.
- (5) Free radiator from frame by taking out four cap screws holding radiator to frame. Remove radiator.
- (6) Close shut-off cock on fuel line (fig. 83). Uncouple nut on engine side of cock and disconnect line. Remove fuel tank (par. 36 b).
- (7) Loosen the four cap screws attaching expanded metal exhaust guard tray to tabs, and remove tray (fig. 18).
- (8) Disconnect flare tube fitting in fuel pump inlet line. Remove line.
- (9) Loosen manifold flange retaining bolt. Remove exhaust pipe from manifold flanges.

ORDNANCE MAINTENANCE – GENERATING UNIT M7

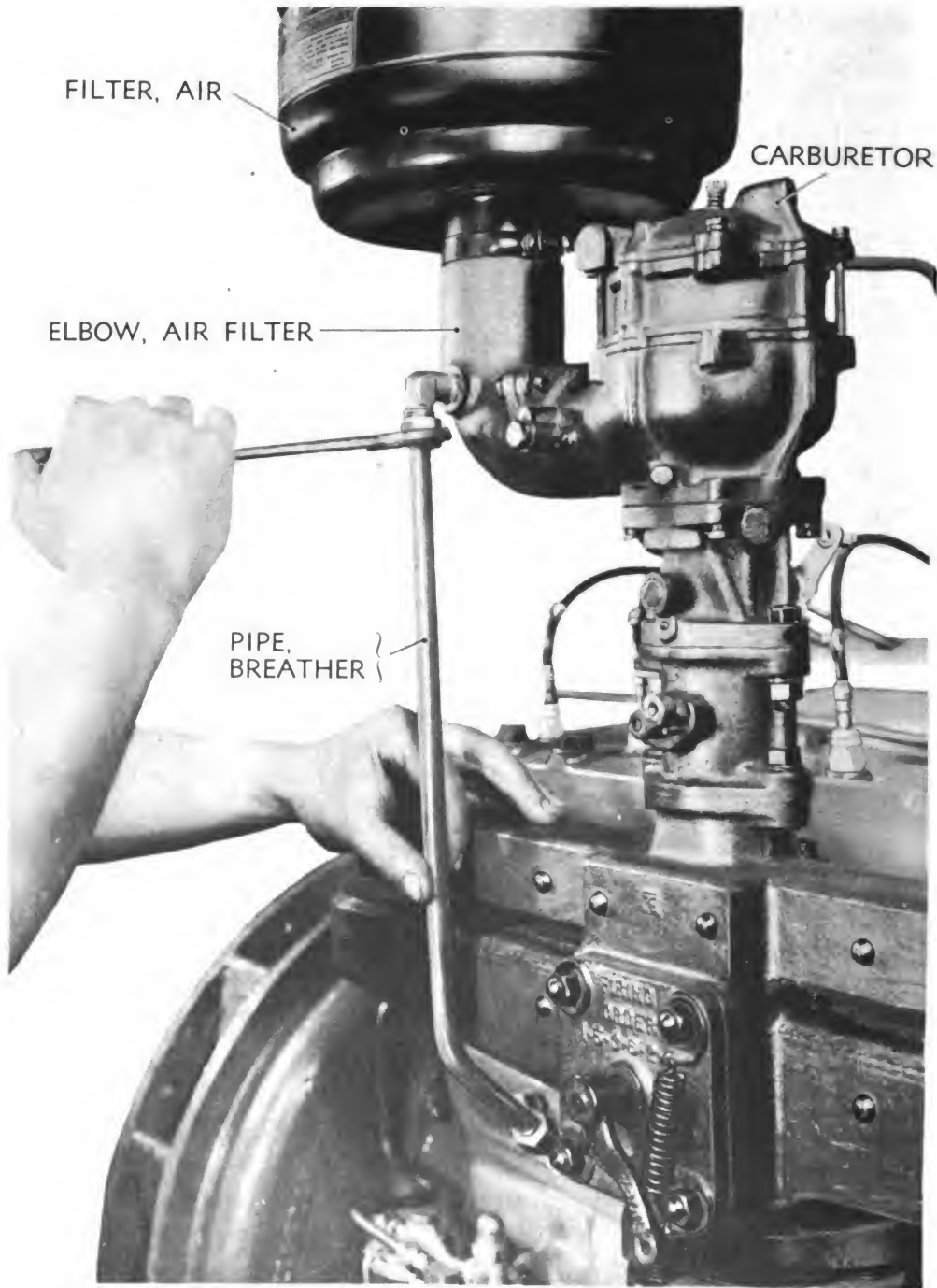

RA PD 70340

Figure 23 – Breather Tube Removal

ENGINE AND ACCESSORIES

(10) Take out screws attaching expanded metal guard to bell housing.

(11) Take out the eight cap screws attaching bell housing to alternator housing (fig. 19). Remove wires tying flywheel coupling bolts together. Remove castellated nuts from these bolts.

(12) Remove engine support cap screws. Adjust hoist chains about engine (fig. 20). Bring engine forward and then up from frame. Be sure engine is clear of alternator before lifting.

21. REMOVAL OF ACCESSORIES.

a. **Procedure.** For additional information on removal of accessories, see TM 9-618.

(1) Remove fan belt.

(2) Remove fan and bracket.

(3) Loosen nut holding lubricating oil line to the compression ell at the top of the governor (fig. 21). Hold hexagonal section of ball pin linkage joint at governor. Remove nut, and disconnect linkage from governor. Take out cap screws holding governor to engine (fig. 22), and remove governor.

(4) Remove battery-charging generator.

(5) Remove breather tube (fig. 23), after disengaging nuts at each end of tube.

(6) Disconnect fuel line by disengaging flare tube fitting at back of carburetor. Remove air cleaner, carburetor, and throttle box from engine as a unit, by taking out cap screws holding throttle box to upper manifold flange.

(7) Disconnect fuel line connection at fuel pump, by loosening flare tube fitting nut. Take out the two cap screws that hold fuel pump to engine and remove pump.

(8) Remove manifold.

(9) Remove starting motor.

(10) Unscrew machine bolts from clamps holding hose sections at top and bottom of bypass, and work bypass pipe out of the hose sections.

(11) Take out the two cap screws connecting the thermostat housing to the engine head, and remove housing (fig. 24).

(12) Remove oil filter (fig. 25).

(13) Remove ignition leads and ignition coil.

(14) Loosen vertical cap screw in arm below distributor, and loosen horizontal bolt at right (fig. 26). Loosen iron collar below clamp, and remove distributor (fig. 27).

(15) Take out cap screw and nut connecting tachometer drive flange to accessory drive housing flange. Raise and remove tachom-

ORDNANCE MAINTENANCE — GENERATING UNIT M7

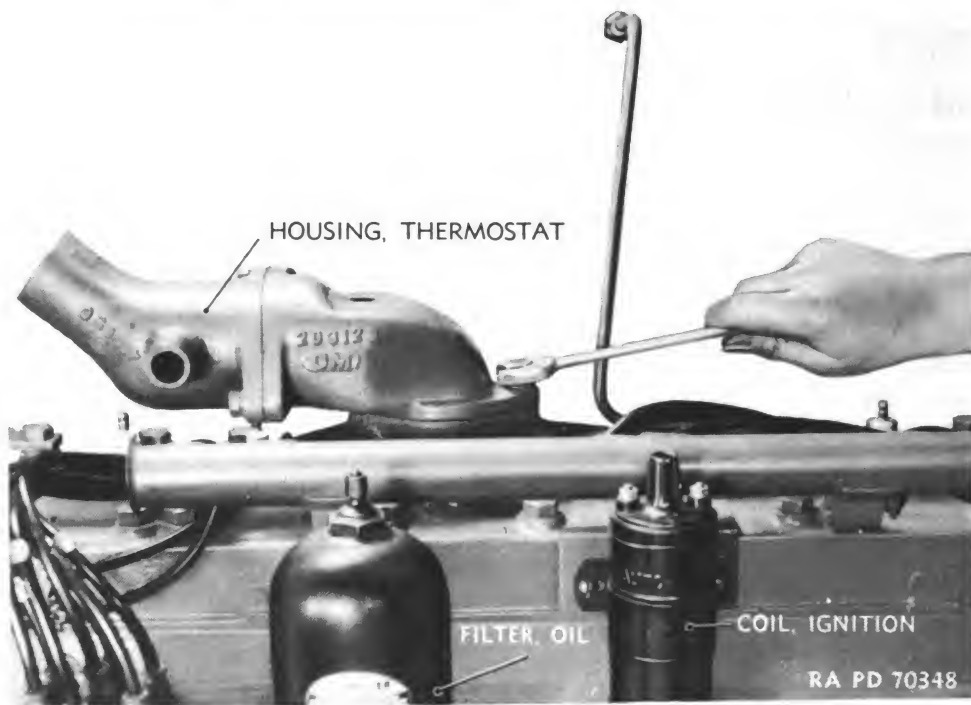

Figure 24 — Thermostat Housing Removal

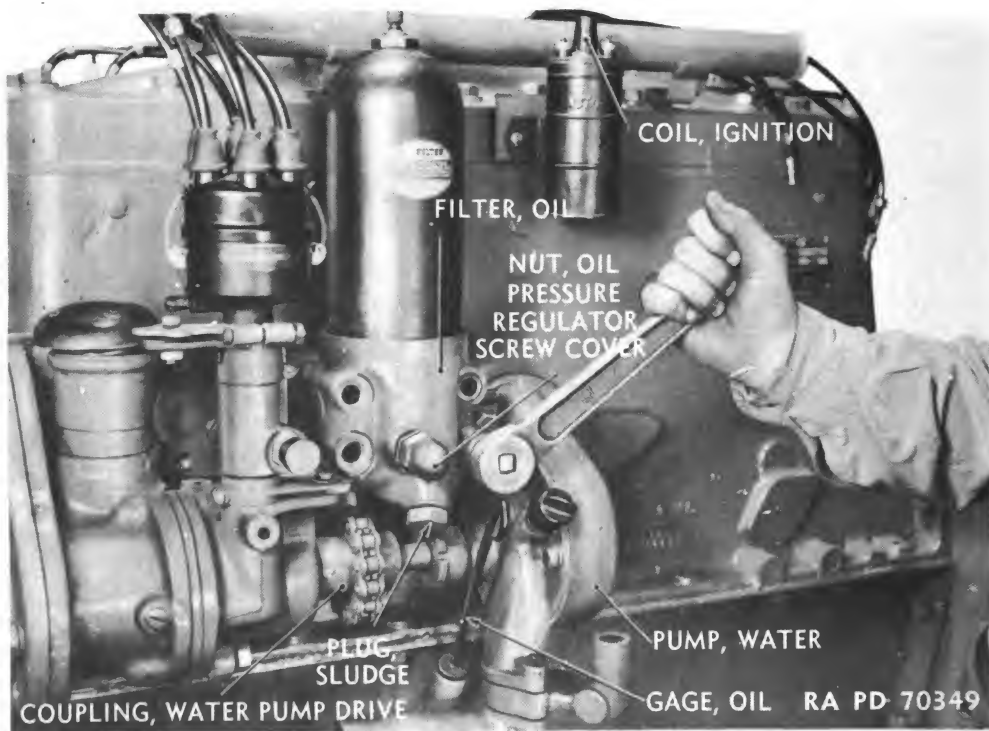

Figure 25 — Oil Filter Base Removal

ENGINE AND ACCESSORIES

eter drive. **NOTE:** On units which substitute a frequency meter for a tachometer, a gear on the distributor shaft directly engages the accessory drive.

- (16) Remove water pump.

22. DISASSEMBLY.

a. Procedure.

- (1) Pull out cotter pins holding fan belt pulley drift pin in place. Knock out drift pin through pulley and drive shaft (fig. 28). Remove pulley.

- (2) Knock out key from accessory drive shaft (fig. 29). Remove cap screws attaching drive housing (fig. 30), and remove housing and drive.

- (3) Loosen the lubricating oil filler pipe by holding a wood block against the lower lip and tapping block with hammer (fig. 31). Remove pipe.

- (4) Remove spark plugs.

- (5) Take out the cap screws attaching the cylinder head to the block (fig. 32), and remove head (fig. 33).

- (6) Insert valve spring lifter between valve spring seat and valve tappet cluster casting, compress spring, and lock lifter. Remove valve spring seat pin (fig. 35). Push valve through engine block and remove. Repeat for each valve. Keep valves in proper order after removal to insure the return of each valve to its former position.

- (7) Compress valve spring as much as possible with lifter. Insert screwdriver to hold valve spring under tension. Slide out lifter. Force valve spring and valve seat out of chamber with screwdriver (fig. 36). Repeat for each valve spring.

- (8) Take out cap screws attaching tappet clusters to engine block (fig. 37), and remove clusters (fig. 38).

- (9) Drain crankcase by opening draincock in bottom of oil pan. Take out cap screws holding pan to block and bell housing, and remove pan and gasket (fig. 39).

- (10) Disconnect oil line to oil pump by unscrewing flare tube fitting nut. Take out four cap screws holding pump bracket in place, and remove oil pump (fig. 40).

- (11) Take out oil lines connecting oil pump to lubrication points by loosening the flare tube fitting and disconnecting the lines (fig. 41).

- (12) Take cotter pins from castellated nuts on cap screws holding connecting rod bearing caps in place. Remove nuts (fig. 42), and push cap screws out. Force connecting rod and piston up through engine block (fig. 43). **NOTE:** Rejoin the connecting rod bearing cap

ORDNANCE MAINTENANCE – GENERATING UNIT M7

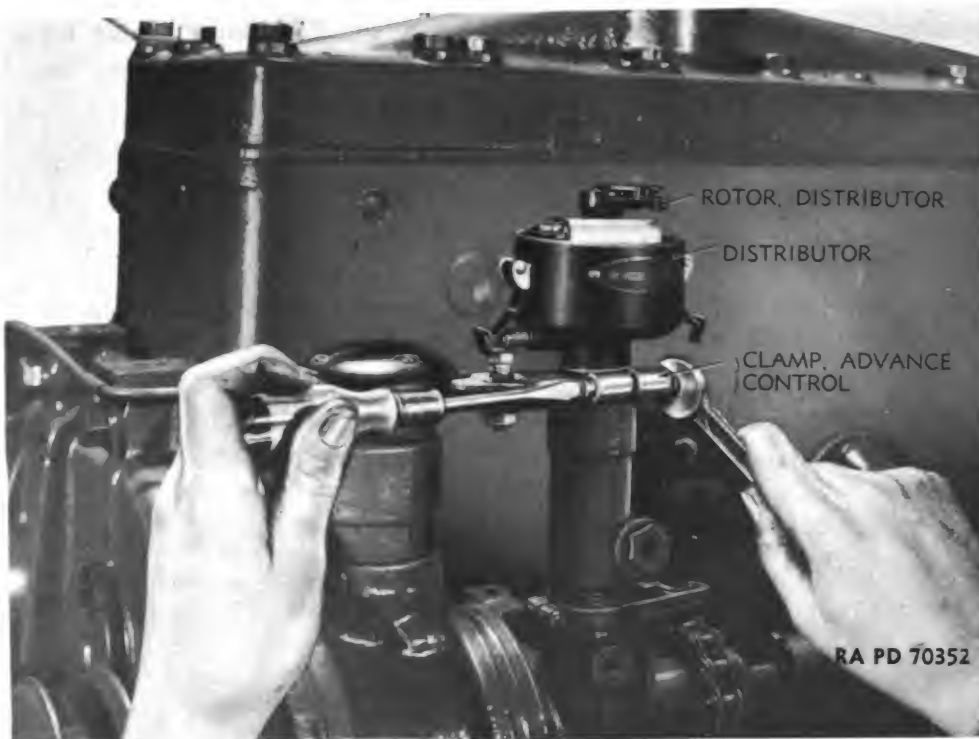

Figure 26 – Removing Distributor Screws



Figure 27 – Distributor Removal

ENGINE AND ACCESSORIES

to the proper connecting rod and piston before laying aside. The correct pistons and caps are labeled identically.

(13) Loosen horizontal cap screw at top of front engine support (fig. 44). If hold-down bolts have been used, remove them, and then slide support out (fig. 45).

(14) Loosen set screw holding drift pin through cranking dog and shaft. Remove drift pin and cranking dog.

(15) Take out cap screws attaching gear cover to engine block (fig. 46), and remove cover (figs. 47 and 48).

(16) Pull off oil retainer ring and gasket from the crankshaft.

(17) Pull out idler gear and shaft (fig. 49).

(18) Slide out camshaft with gear still attached. While one man pulls the shaft, another should guide the shaft carefully through the bearings, so that the cams will not injure babbitt linings (fig. 50).

(19) Take out cotter pins securing castellated nuts to crankshaft flywheel studs (fig. 51). Remove castellated nuts (fig. 52), and work off flywheel (fig. 53).

(20) Take out wires through pairs of crankshaft bearing cap screw heads. Take out cap screws (fig. 54) and remove bearings, lower shells, and shims. Mark back of each shell with number corresponding to that on its cap, so that at assembly correct shell will be used with each cap, if no new shell is required.

(21) Carefully pry out brass thrust bearing sections from between end flange of flywheel and engine block (fig. 55).

(22) Take out cap screws holding bell housing to engine block (figs. 56 and 57). Remove bell housing. (fig. 58).

(23) Lift crankshaft out of position and away from engine block.

(24) Remove upper bearing shells by pushing down with the hands on one end of each shell until it rotates in bearing web enough to get fingers under shell. Then lift out shell (fig. 59). Mark for correct replacement.

23. MAINTENANCE AND REPAIRS.

a. Cleaning Engine Parts.

(1) Before inspection, all parts should be thoroughly cleaned of oil, grease, or carbon. Methods of cleaning are given below.

(a) Soak all aluminum parts overnight in SOLVENT, dry-cleaning, and dry.

(b) Clean the aluminum pistons as above. Clean the ring grooves with a broken piston ring ground flat on the end.

(c) Place all steel parts in SOLVENT, dry-cleaning. Leave them only long enough to dissolve all grease and dirt. Remove the parts,

ORDNANCE MAINTENANCE – GENERATING UNIT M7

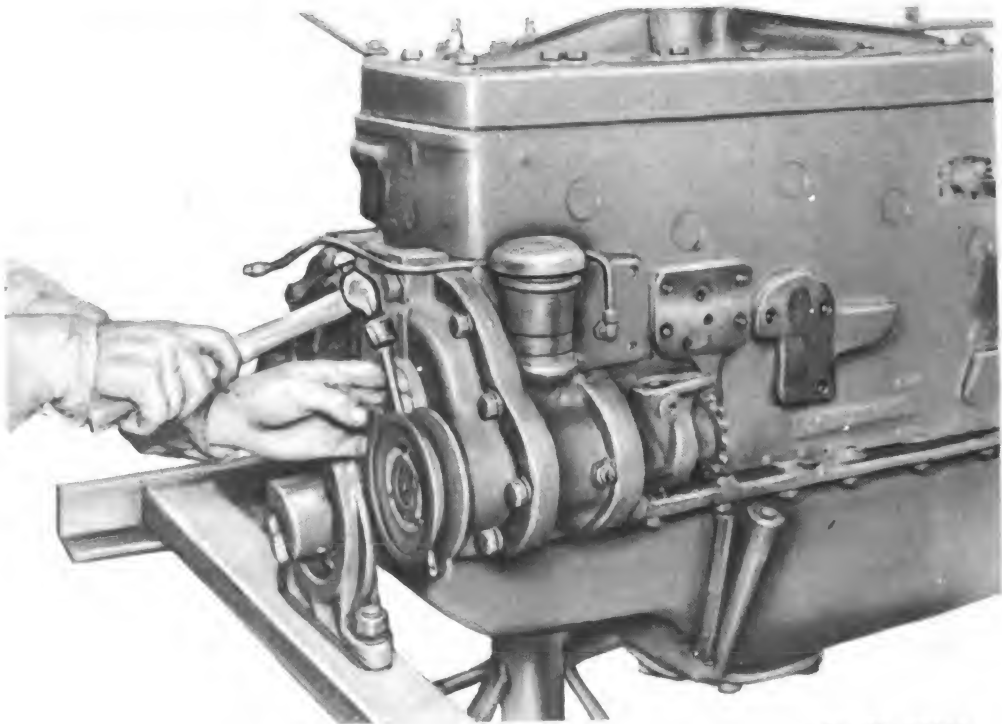

RA PD 70357

Figure 28 – Driving Out Pulley Pin

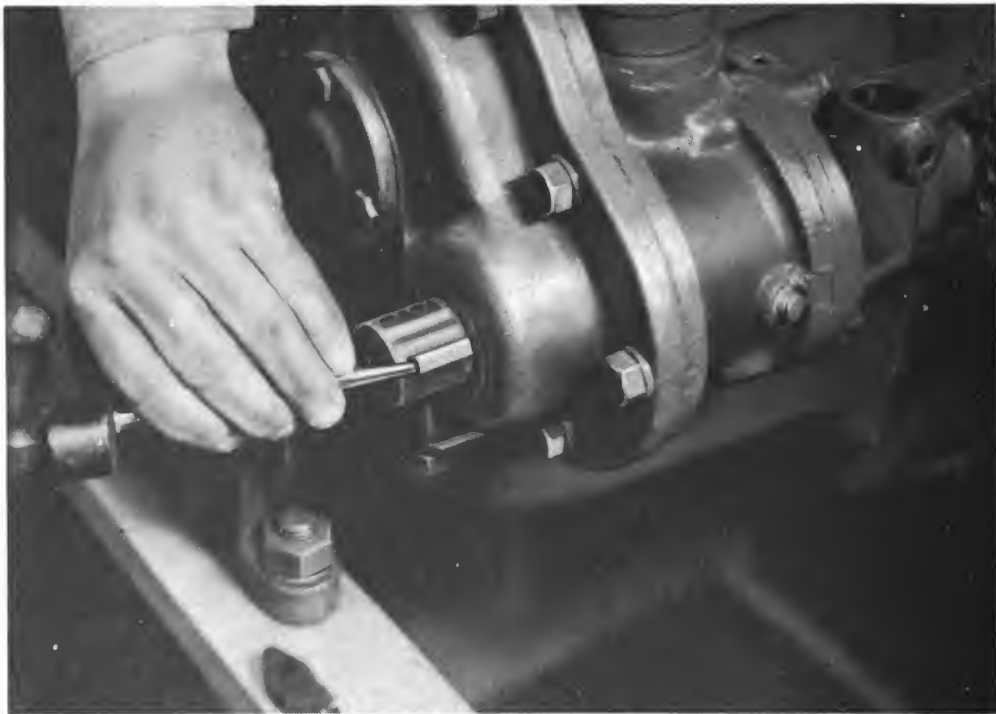

RA PD 70358

Figure 29 – Driving Out Accessory Drive Shaft Key

ENGINE AND ACCESSORIES



RA PD 70359

Figure 30 – Accessory Drive Housing Removal

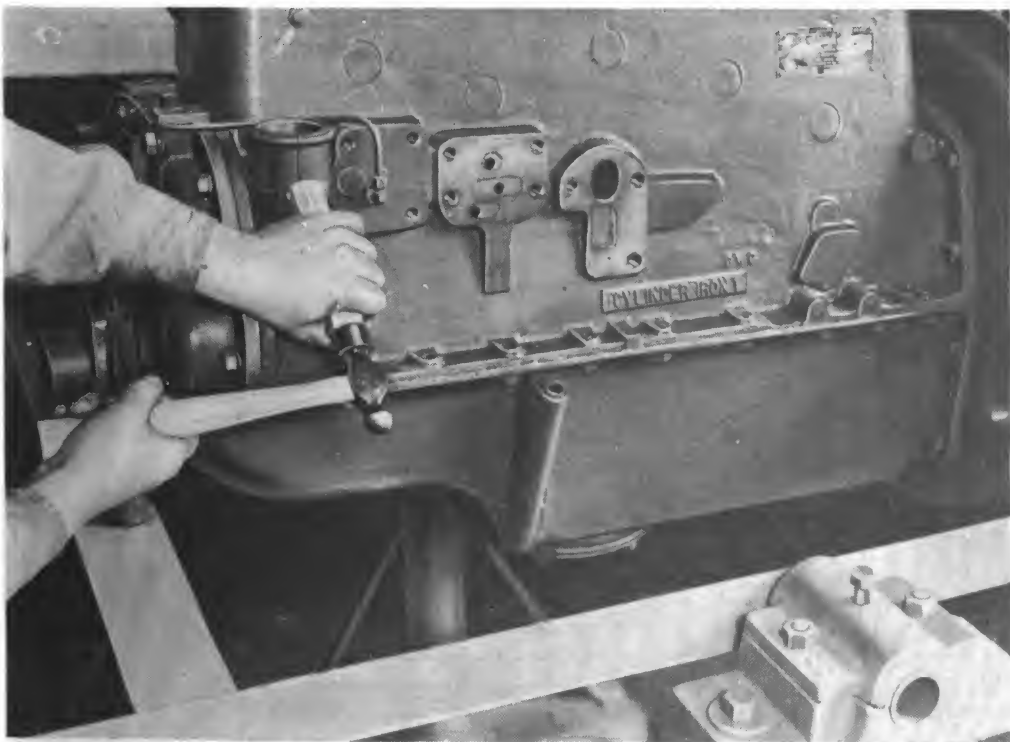

RA PD 70360

Figure 31 – Driving Out Lubricating Oil Filler Pipe

ORDNANCE MAINTENANCE – GENERATING UNIT M7

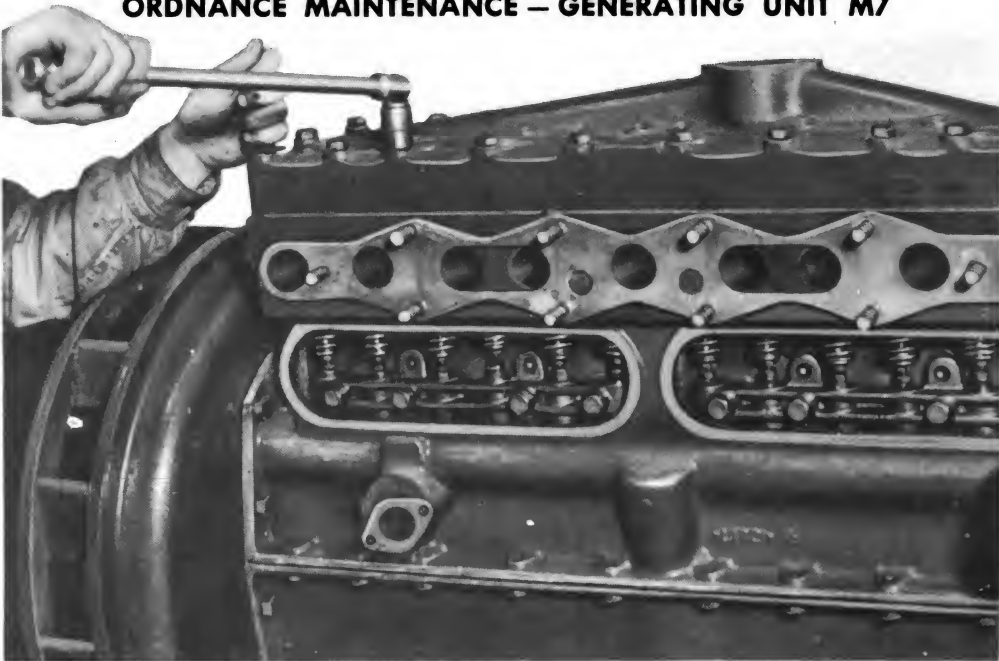

RA PD 70362

Figure 32 – Removing Cylinder Head Cap Screws

rinse in hot water, blow out with compressed air from an air hose, and wipe dry.

(d) Cylinder block and crankshaft oil passages should be cleaned thoroughly by forcing steam through each opening until it flows without restriction.

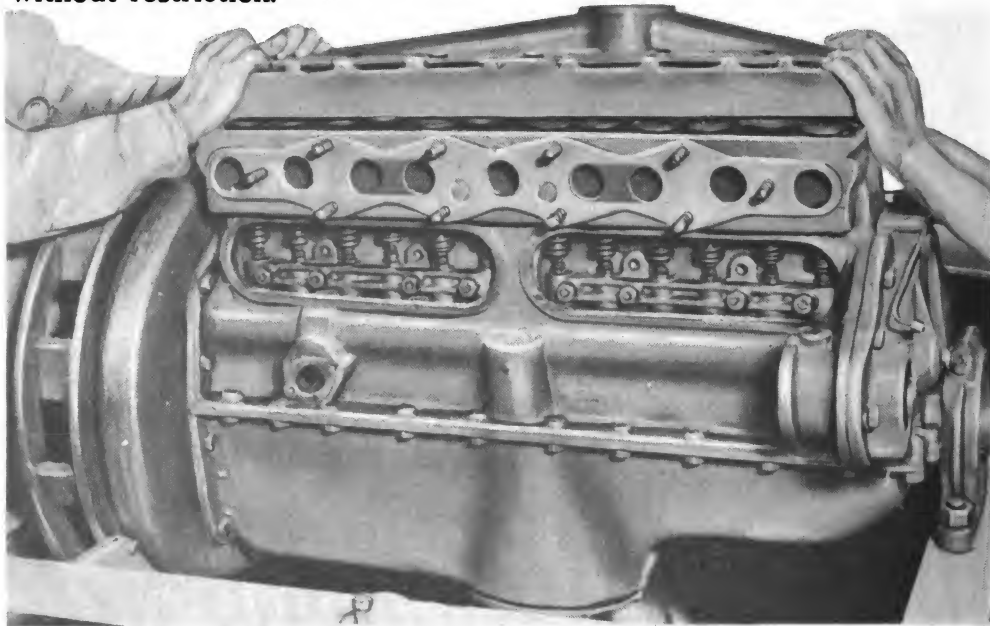

RA PD 70363

Figure 33 – Cylinder Head Removal

ENGINE AND ACCESSORIES

RA PD 70364

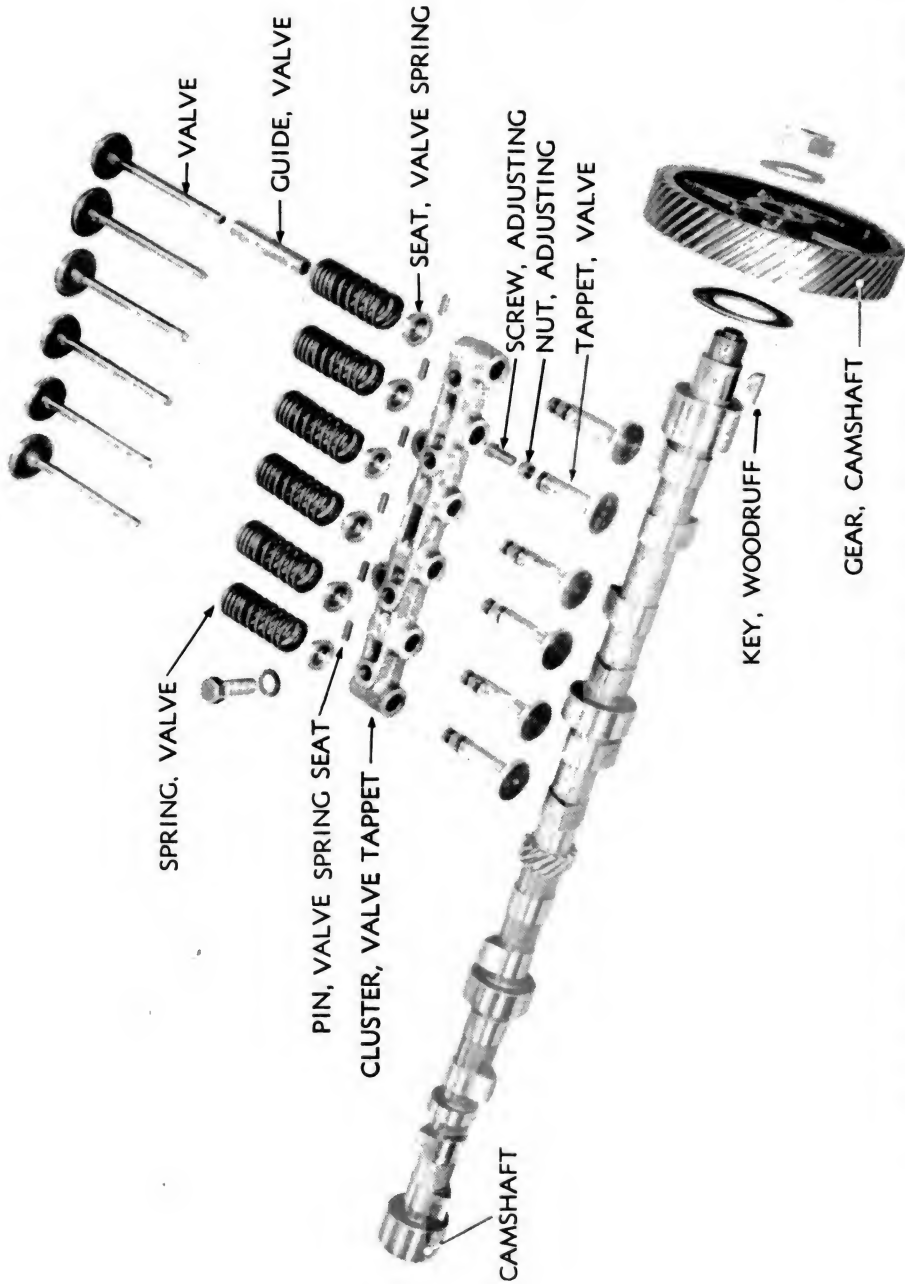
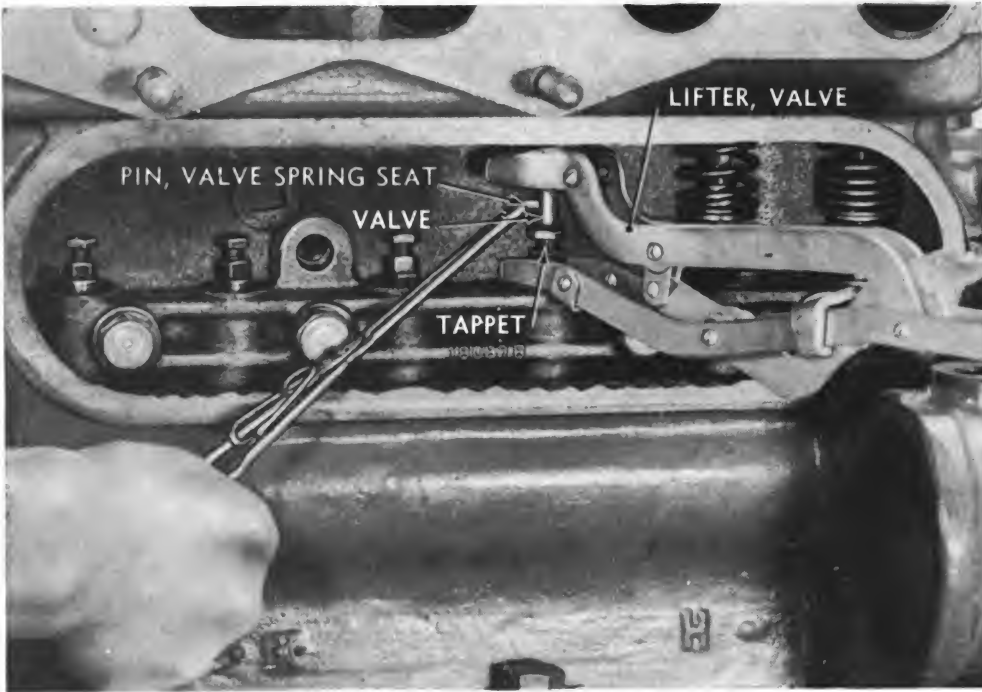

Figure 34 — Relation of Camshaft to Valve Tappets, Springs, Guides, and Valves

ORDNANCE MAINTENANCE — GENERATING UNIT M7



RA PD 70365

Figure 35 — Valve Spring Seat Pin Removal

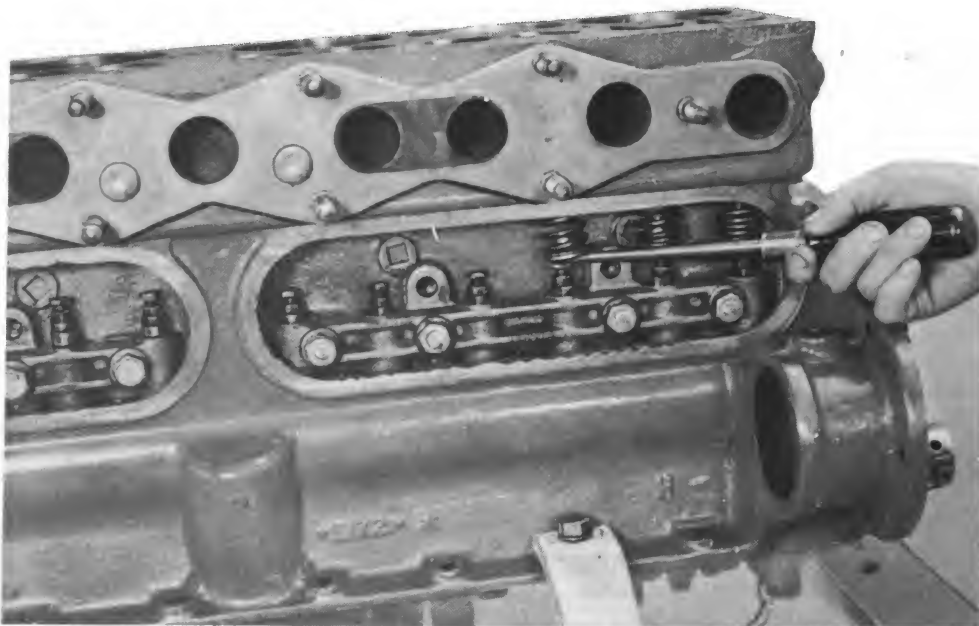

RA PD 70366

Figure 36 — Valve Spring Removal

(e) Strip off all gaskets and clean all surfaces where sealing compound has been used, by scraping and washing with a suitable solvent.

ENGINE AND ACCESSORIES



RA PD 73266

Figure 37 – Removing Valve Tappet Cluster Holding Cap Screw

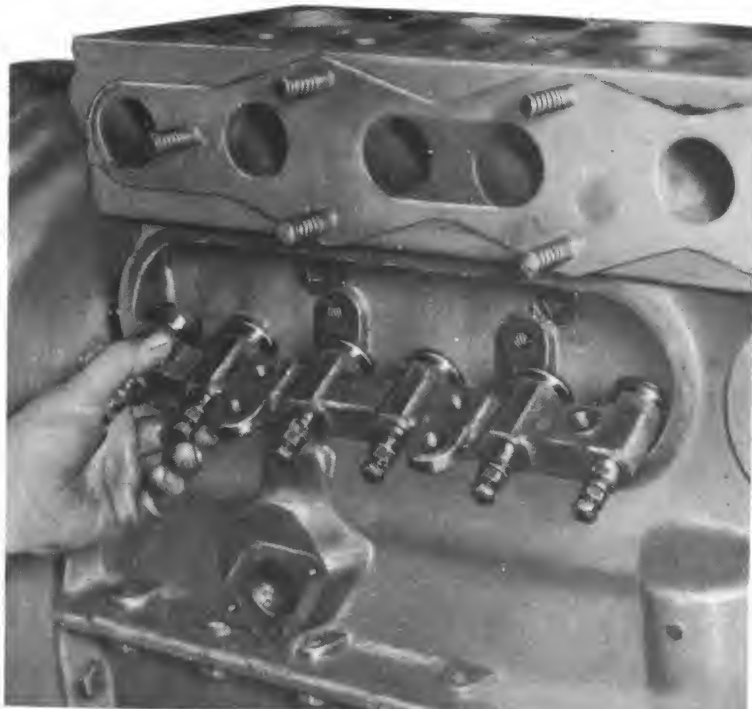

RA PD 73267

Figure 38 – Valve Tappet Cluster Removal

ORDNANCE MAINTENANCE — GENERATING UNIT M7

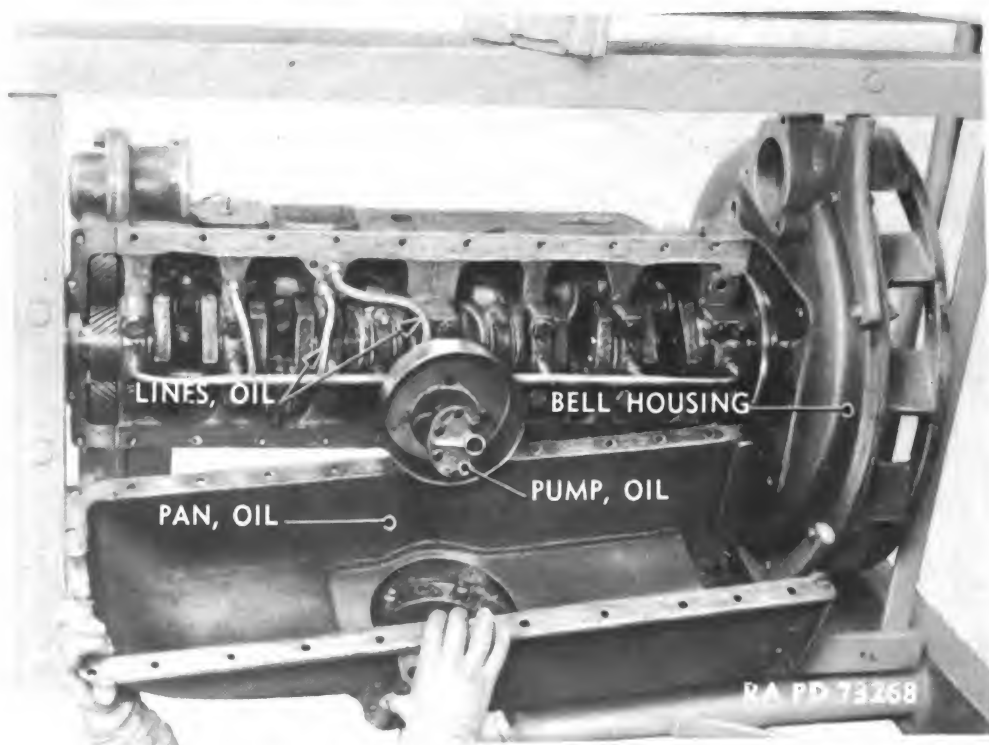
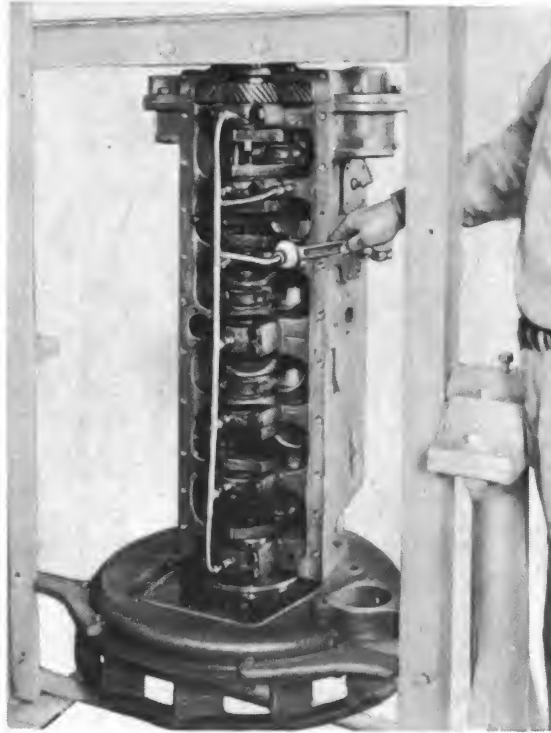

Figure 39 — Oil Pan Removal



Figure 40 — Oil Pump Removal

ENGINE AND ACCESSORIES



RA PD 73270

Figure 41 — Oil Line Removal

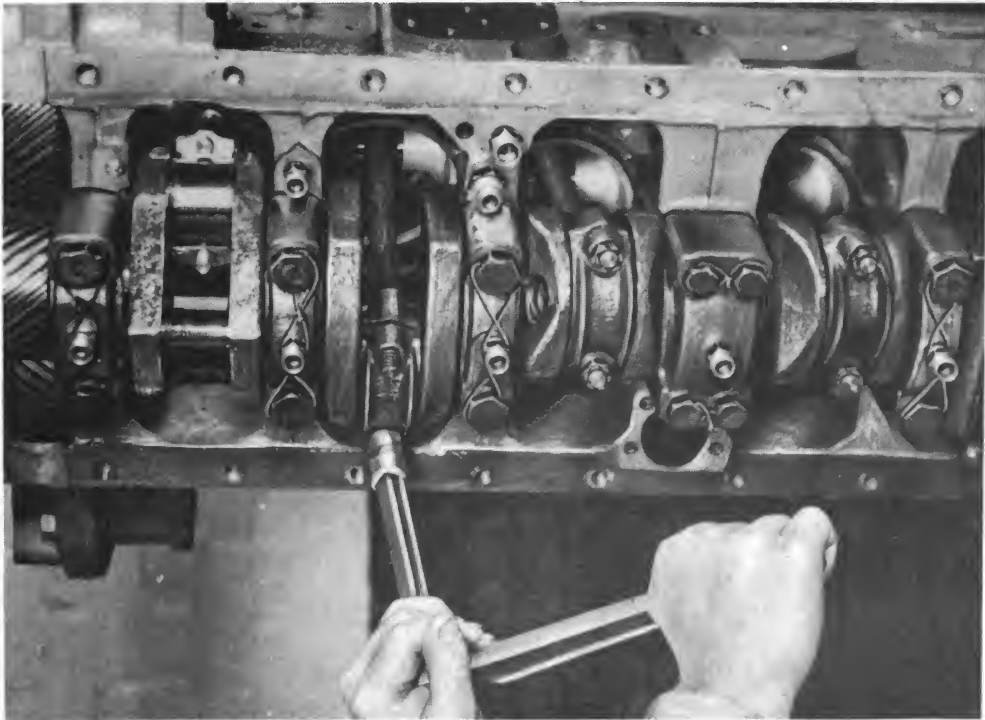

RA PD 73273

Figure 42 — Connecting Rod Bearing Cap Removal

ORDNANCE MAINTENANCE – GENERATING UNIT M7

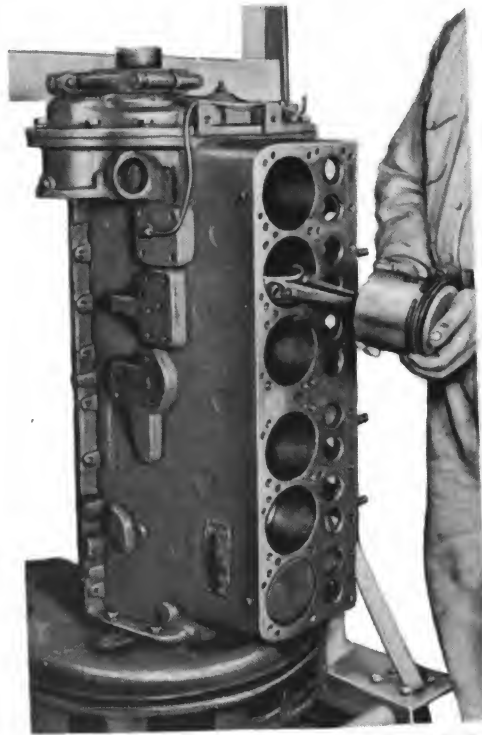

RA PD 73274

Figure 43 – Piston Removal

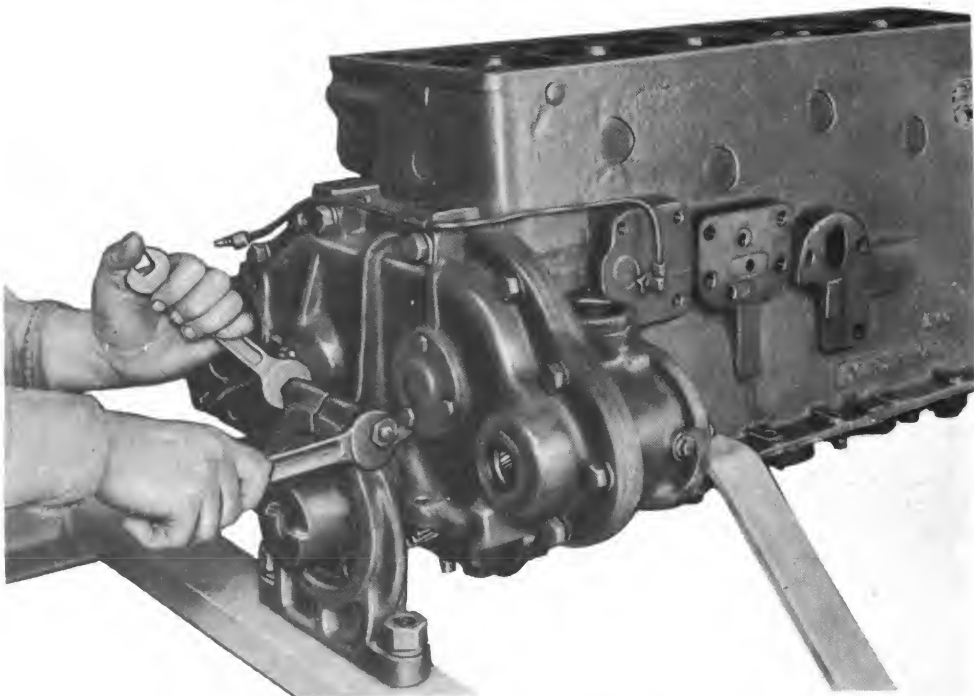

RA PD 73275

Figure 44 – Front Engine Support Removal

ENGINE AND ACCESSORIES

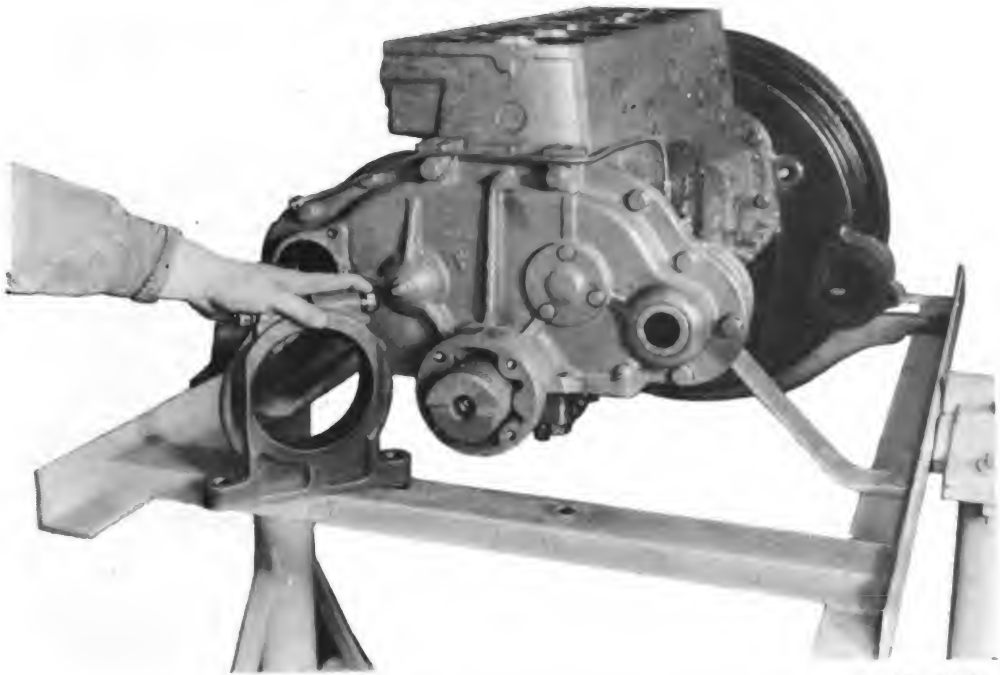

RA PD 73276

Figure 45 — Front Engine Support Removed

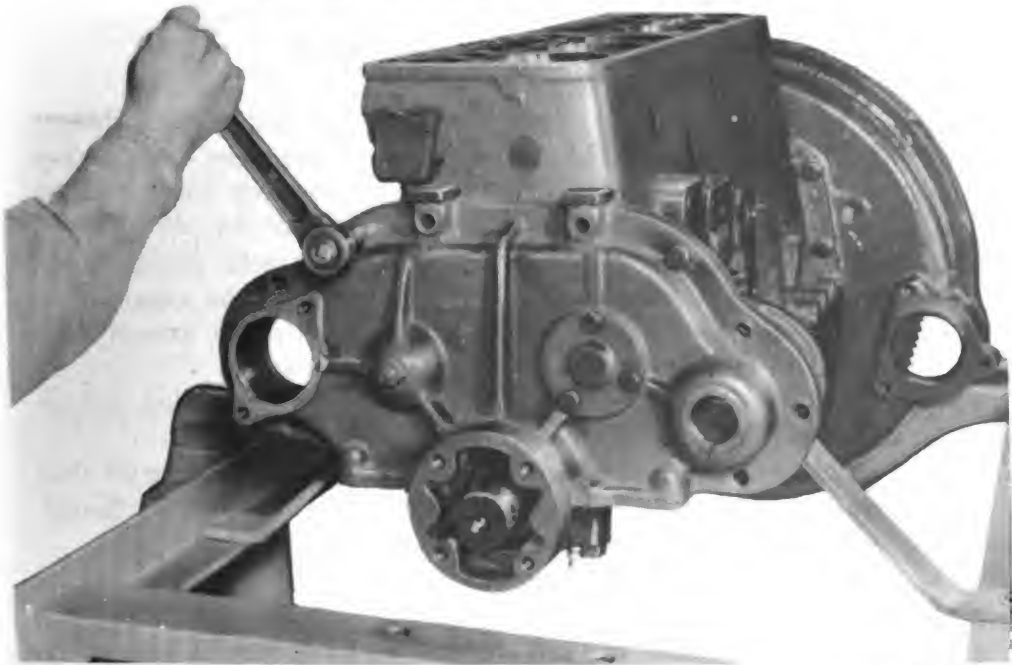

RA PD 73277

Figure 46 — Gear Cover Removal

b. Inspecting Engine Parts. After parts are cleaned, each part should be inspected and then covered to protect it from dust and dirt, etc., if it is to be used for reassembly. Set all discarded parts to

ORDNANCE MAINTENANCE — GENERATING UNIT M7

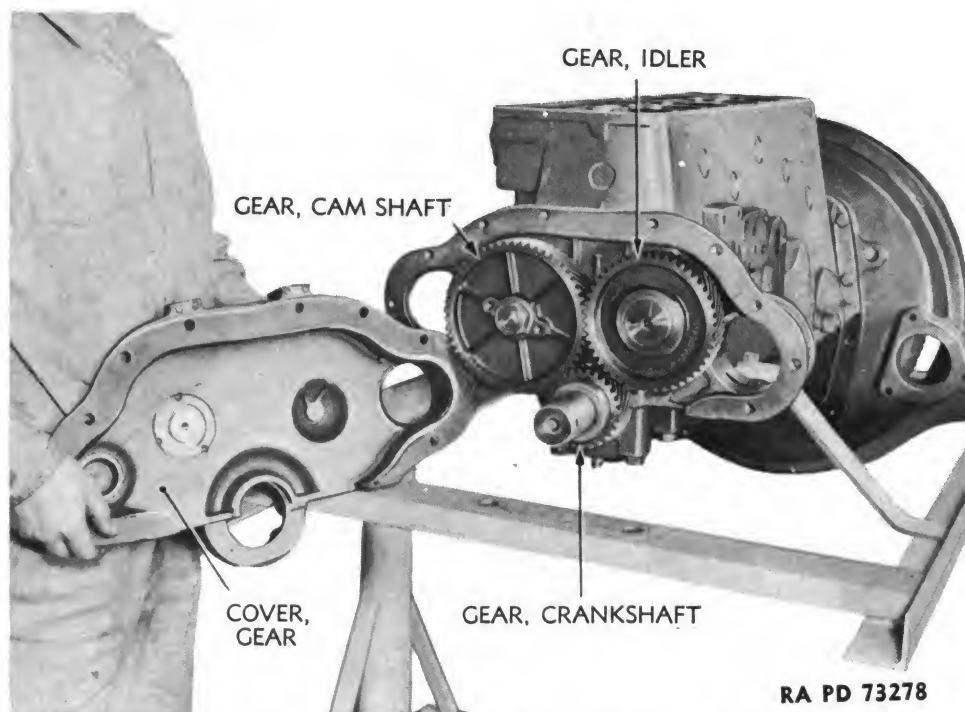

Figure 47 — Gear Cover Removed

one side, and mark in such a manner, that they will not become mixed with the new parts intended for replacement when the unit is assembled. When out-of-round, taper, or wear exceeds limit values specified, a new part or a permissible reworking of an old part to the standard of oversize or undersize is the only remedy, except complete replacement of the part or parts. If available, the magna-flux inspection process should be applied to all steel parts except ball and roller bearings, studs, standard nuts, and washers.

(1) **BUSHINGS.** Loose, damaged, or worn bushings must be removed, and new ones installed.

(2) **STUDS.** Any loose, broken, or damaged stud, or any stud that has been turned until it does not have proper height above its flange, must be removed, and a 0.003 inch oversize stud installed.

(3) **CYLINDER BLOCK AND CRANKCASE.**

(a) Check block for cracks.

(b) Check top surface for squareness, and replace, if necessary.

(c) Inspect all expansion plugs and remove loose or damaged plugs. Replace with new plugs.

(d) Examine case for cracks. If it is cracked, it must be repaired or replaced.

(e) Examine all studs for looseness and thread condition. Damaged studs and those impossible to tighten should be replaced.

ENGINE AND ACCESSORIES

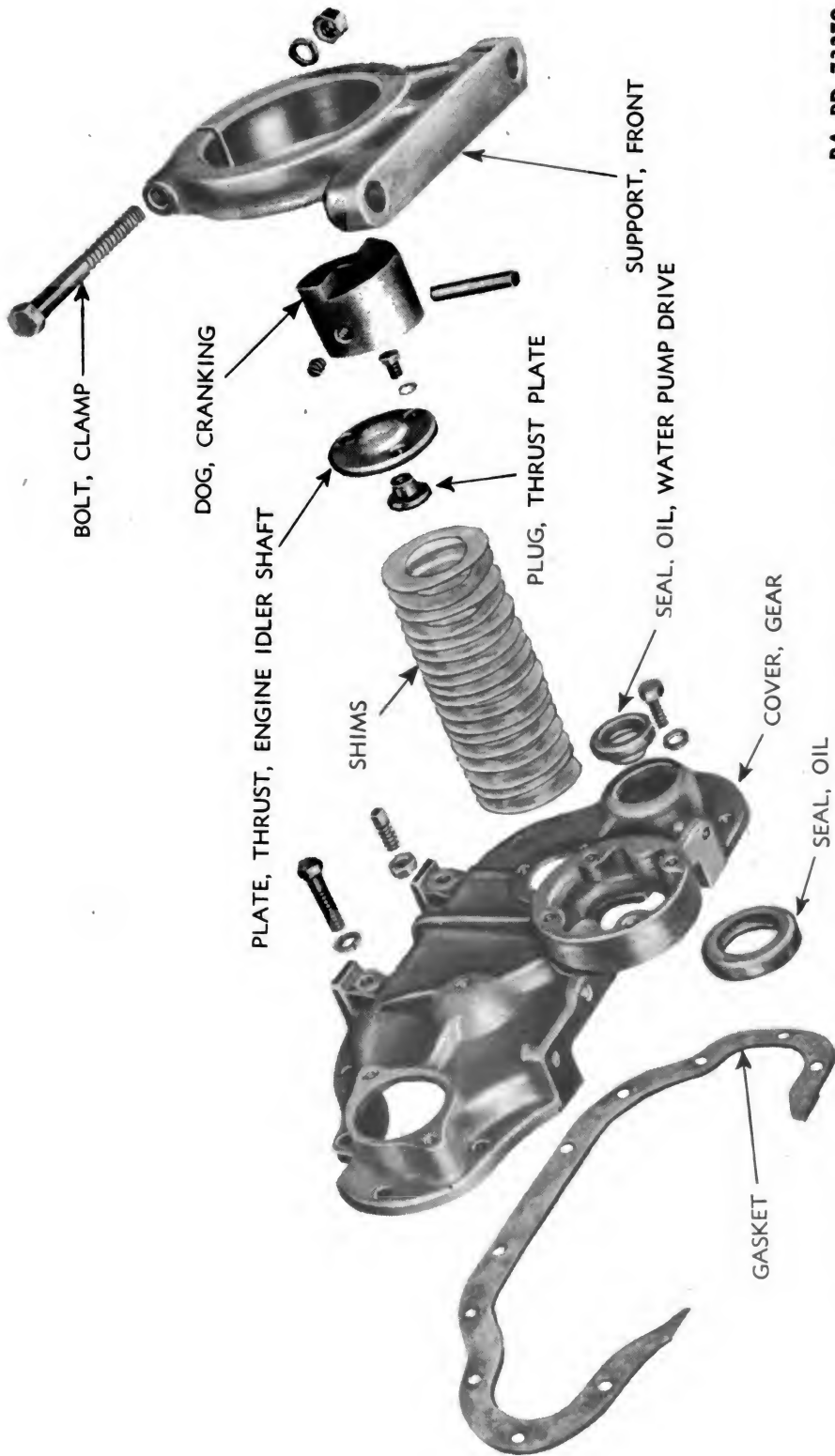

RA PD 73279

Figure 48 — Gear Cover, Front Engine Support, and Cranking Dog — Exploded View

ORDNANCE MAINTENANCE – GENERATING UNIT M7

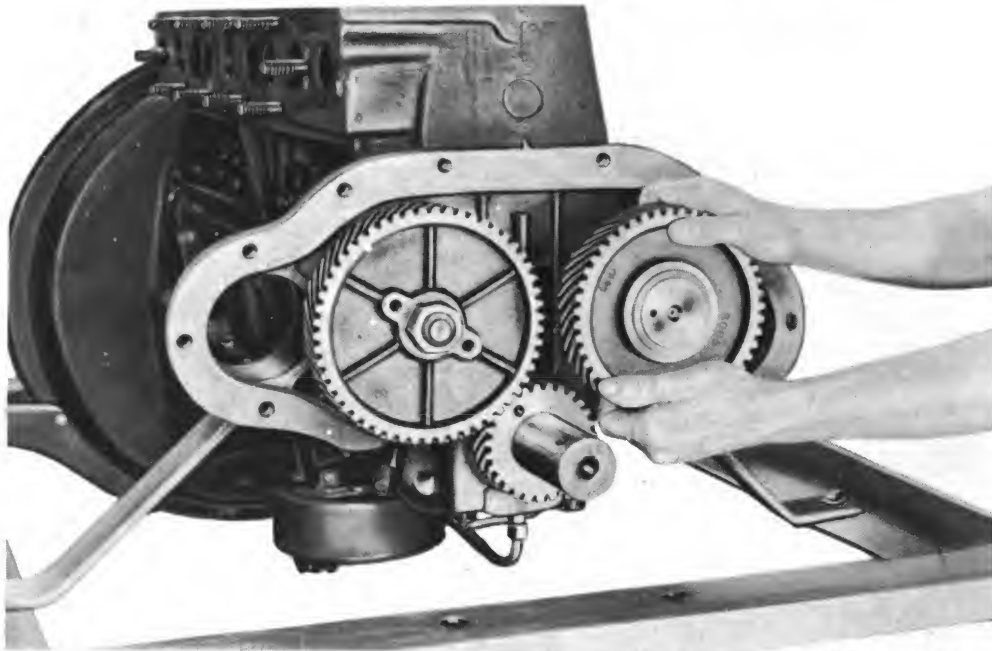

RA PD 73280

Figure 49 – Idler Gear and Shaft Removal

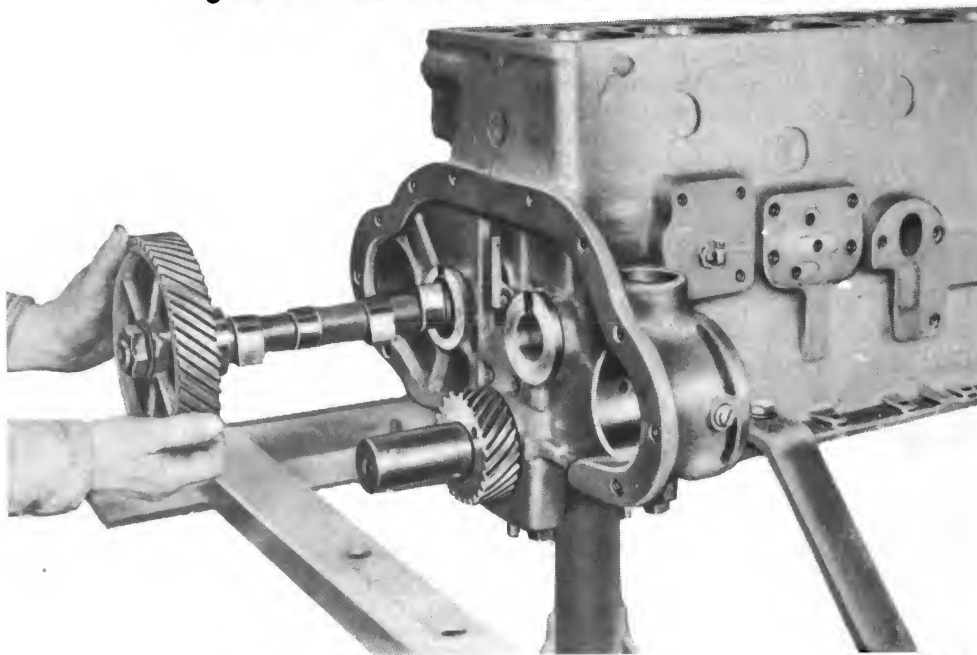

RA PD 73281

Figure 50 – Camshaft and Gear Removal

(f) Examine the four removable, babbitt-lined camshaft bearings, and replace, if necessary.

(g) Measure the cylinder bores with an inside micrometer to determine taper and out-of-round caused by wear. The measurements should be made at the top of the cylinder bore, preferably in the first

ENGINE AND ACCESSORIES

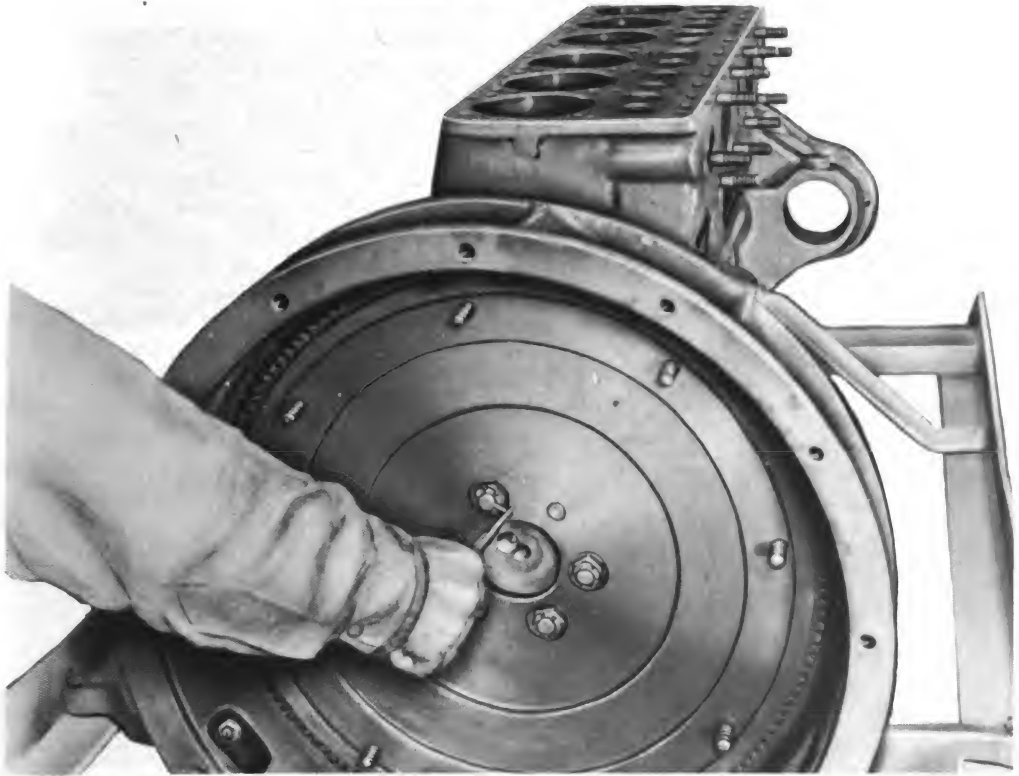

RA PD 73282

Figure 51 — Removing Cotter Pins Securing Flywheel Stud Nuts

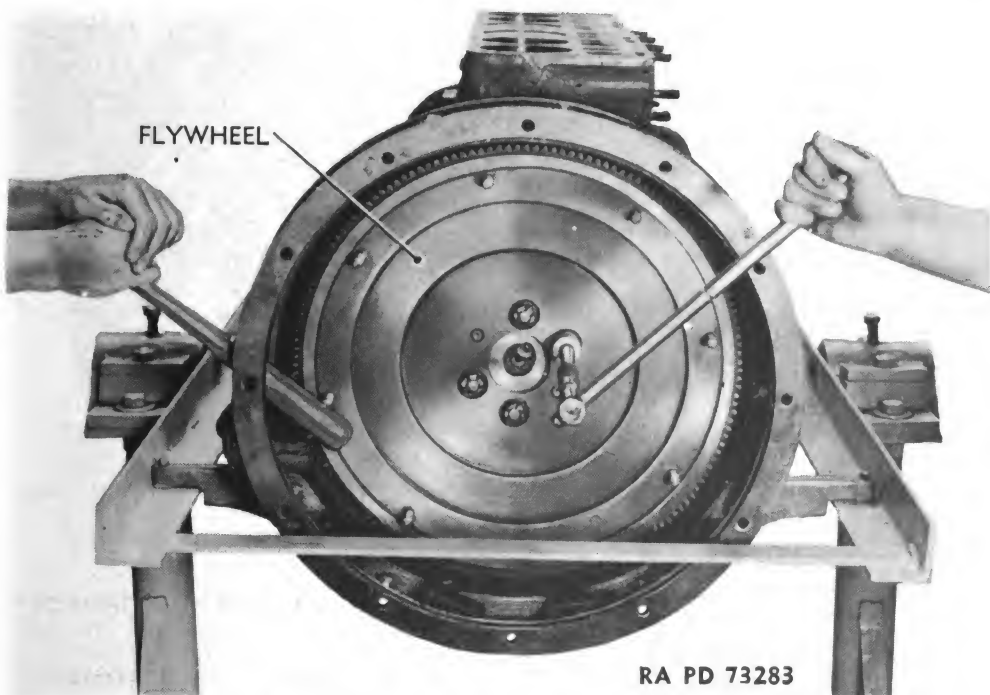

RA PD 73283

Figure 52 — Removing Nuts from Crankshaft Flywheel Studs

ORDNANCE MAINTENANCE – GENERATING UNIT M7

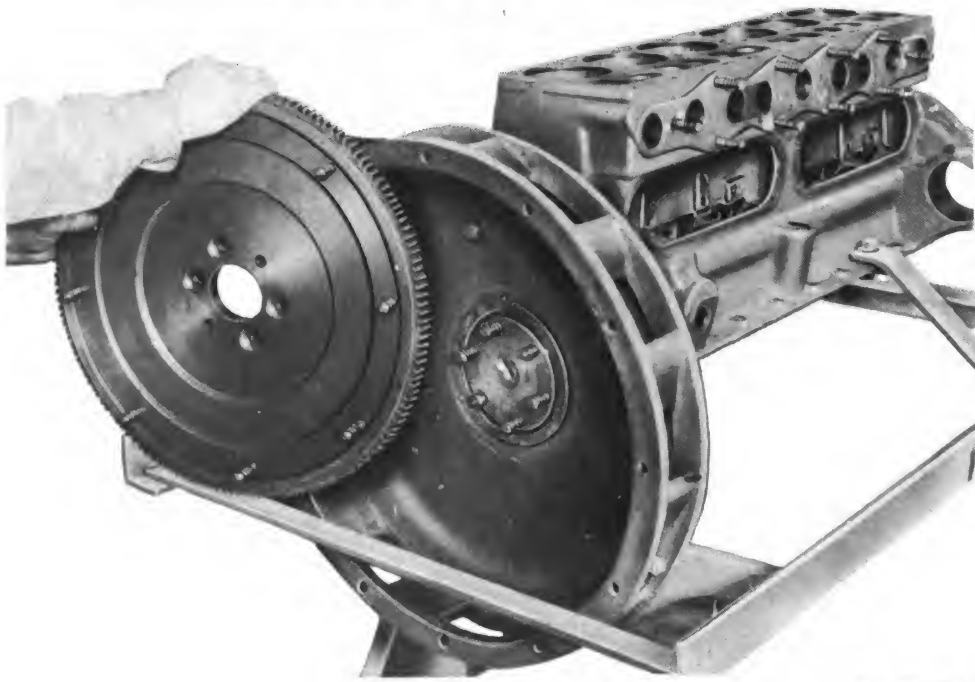

RA PD 73284

Figure 53 – Flywheel Removed

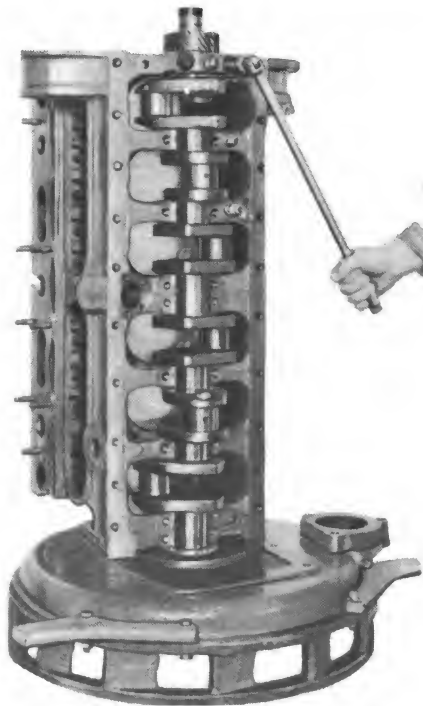

RA PD 73285

Figure 54 – Crankshaft Bearing Removal

ENGINE AND ACCESSORIES



RA PD 73286

Figure 55 – Thrust Washer Removal

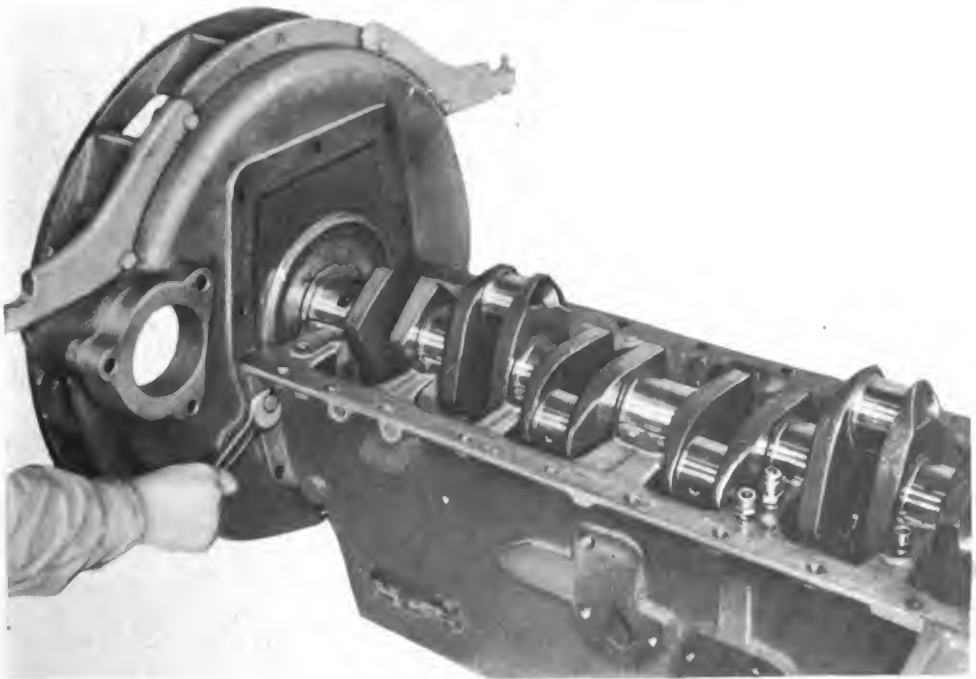

RA PD 73287

Figure 56 – Removing Bell Housing Cap Screws (1)

ORDNANCE MAINTENANCE – GENERATING UNIT M7

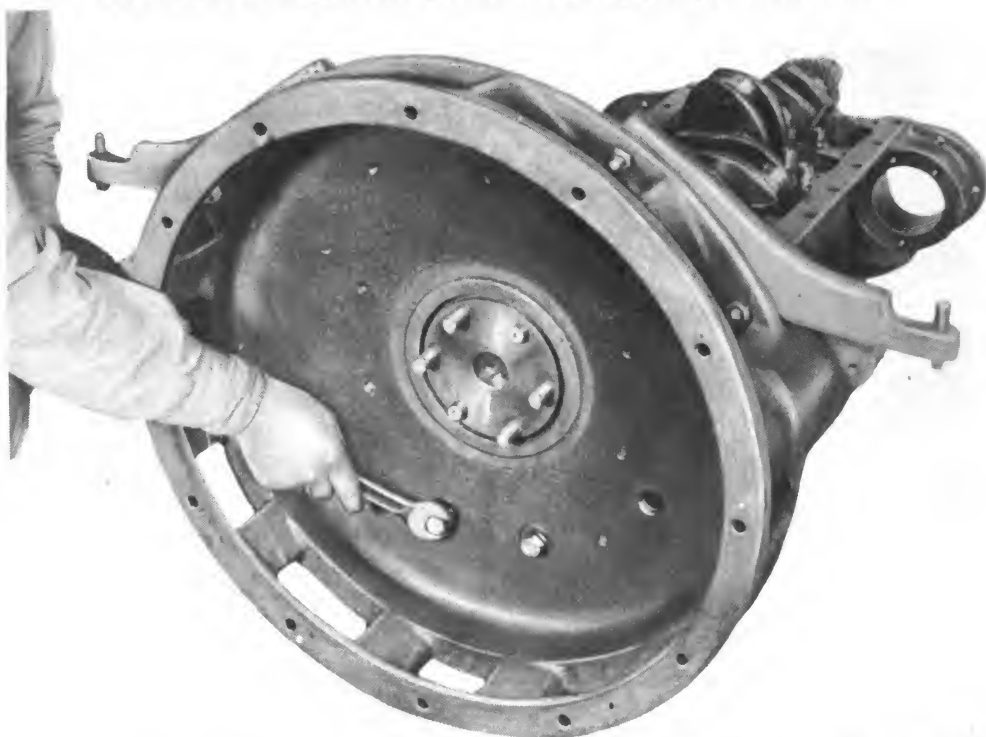

RA PD 73288

Figure 57 – Removing Bell Housing Cap Screws (2)



RA PD 73289

Figure 58 – Bell Housing Removed

ENGINE AND ACCESSORIES

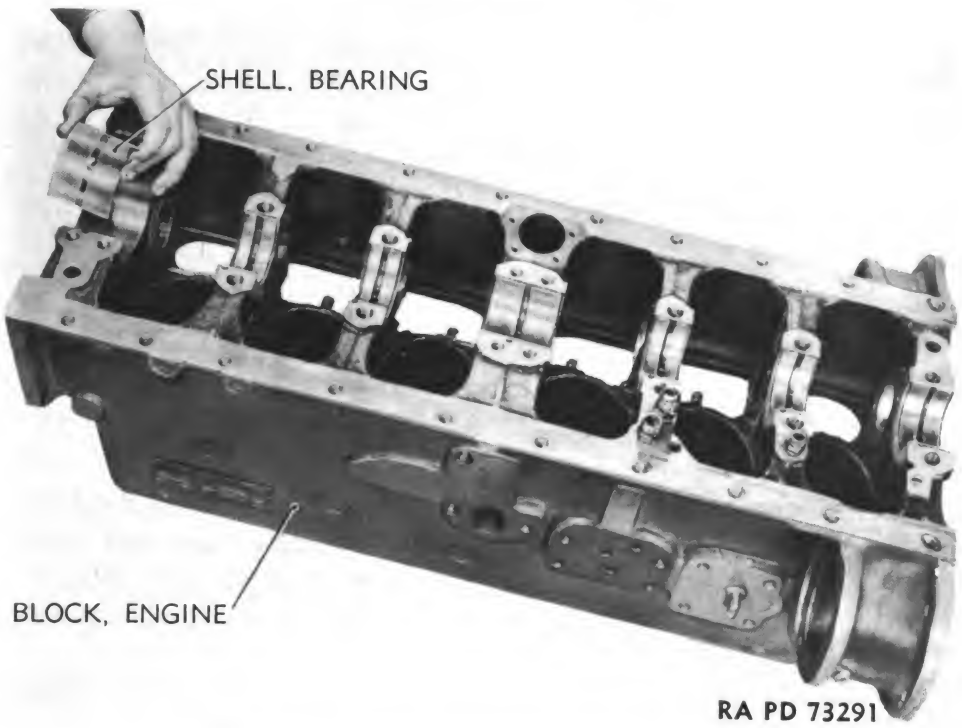

Figure 59 — Upper Bearing Shell Removal

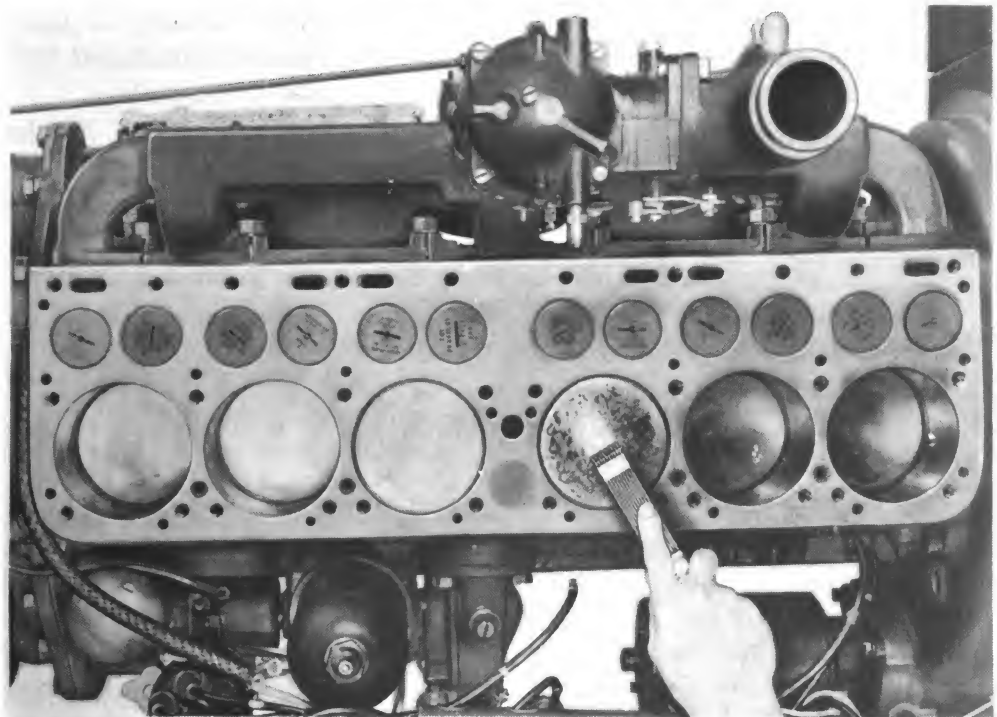
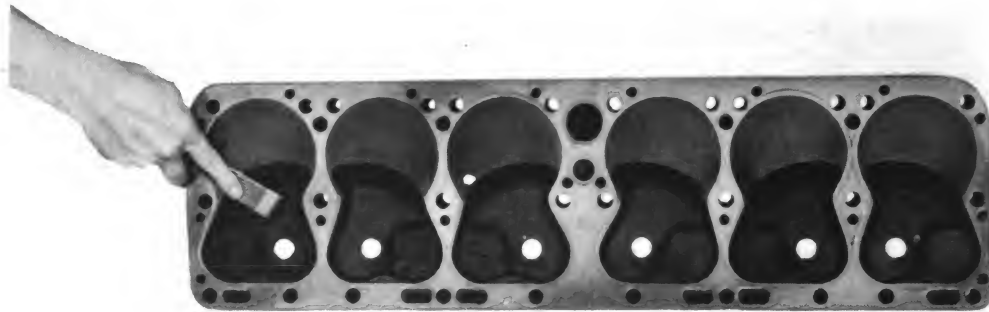

Figure 60 — Scraping Carbon from Piston

ORDNANCE MAINTENANCE — GENERATING UNIT M7



RA PD 56909

Figure 61 — Scraping Carbon from Cylinder Head

$\frac{1}{2}$ inch of top piston ring travel, in several places around the inside circumference of the bore, and again in several places near the bottom of the cylinder bore. If the difference between the top and the bottom measurements exceeds 0.008 inch, the cylinder should be rebored by fifth echelon personnel.

(h) Inspect valve stem and push rod guides for wear. Replace all worn guides.

(4) CRANKSHAFT.

(a) The crankshaft main bearing and connecting rod journals should be measured for wear with a micrometer. If any of these journals show excessive wear, they should be reground and fitted with the next standard undersize shells by fifth echelon personnel.

(b) Check crankshaft for alinement by placing it on "V" blocks, and using a dial indicator on two center journals.

(c) Inspect the four rear flange studs for stripped threads and looseness. Replace, if necessary.

(d) Examine the flywheel locating dowels for damage and fit.

(e) Examine the crankshaft timing gear for excessive wear or damaged teeth. Replace, if necessary.

(5) PISTONS.

(a) Check pistons for cracks or excessive wear. Replace with new pistons.

(b) Check piston pins for wear. Replace worn pins.

(6) CONNECTING RODS.

(a) Inspect connecting rods, caps, and shells. All connecting rod bearing shells are replaced with new ones at every major overhaul.

(b) Check for damaged or twisted rods. A slightly twisted rod can be realigned. A badly twisted or damaged rod should be replaced.

(c) Inspect cap screws, nuts, and piston pin locking screws for wear or damage. Replace if needed.

ENGINE AND ACCESSORIES

(7) VALVES.

(a) Inspect for warping or elongation of stem. Replace if any is evident.

(b) Inspect for burning, pitting, or excessive wear of face. Replace if any is evident.

(c) Inspect for wear of stem as determined by micrometer. Replace if necessary.

(d) Inspect for weak or broken valve spring. Replace if necessary.

(8) VALVE STEM GUIDES. Inspect all valve stem guides in the upper crankcase. If they do not check with the recommended fits (par. 139), replace with new ones.

(9) VALVE TAPPETS AND SCREWS. Inspect valve tappets and screws for wear. Replace if necessary.

(10) CAMSHAFT.

(a) Examine timing gear on front for excessive wear and damaged teeth. Replace damaged or badly worn gear.

(b) Inspect cam journals and oil pump driving gear in the center of the shaft. If this gear is badly damaged, the entire shaft must be replaced.

(11) FLYWHEEL.

(a) Inspect flywheel ring gear for broken or worn teeth. Replace with new gear, if necessary.

(b) Inspect flywheel for elongation of stud and dowel holes. If any elongation is evident, replace flywheel.

c. 750-hour Maintenance Procedure.

(1) After an engine has been run for 750 hours, it should be treated as follows:

(a) Remove cylinder head, and thoroughly clean out all deposits (figs. 60 and 61).

(b) Remove manifold, and clean out all deposits.

(c) Remove all valves, and clean out valve guides with SOLVENT, dry-cleaning.

(d) Clean and regrind intake valves, making sure all deposits and gums are cleaned off the valve stems and under surfaces of the valves.

(e) Reface exhaust valve seats in block. (If refaced valve seats are wider than $\frac{1}{8}$ inch, they should be narrowed by a 60-degree stone or tool, taking material off the inside port until $\frac{1}{8}$ inch width of seat is secured.)

(f) Replace exhaust valves with new valves. (If new material is not available, valves can generally be reused if refaced in grinder and valve stems thoroughly cleaned of corrosion and deposits. Stems should then be polished with CLOTH, crocus, or similar material.)

ORDNANCE MAINTENANCE — GENERATING UNIT M7

(g) Adjust tappets to 0.010 intake and 0.016 exhaust. This is the first setting for a cold engine. After the engine has been run sufficiently to warm up, the clearances should be rechecked, and set to 0.006, intake and 0.010, exhaust.

(h) Clean top of pistons and cylinder block of all deposits. Flood piston tops with oil, turning engine over by hand, and wiping oil off top of cylinder bores when piston is at bottom of stroke. This is to remove fine particles of deposits which may work down between piston and cylinder wall during cleaning operation.

(i) Reinstall cylinder head, using new cylinder head gasket.

(j) Install new spark plugs.

(k) Install manifold, using new gasket.

(l) Clean radiator core with compressed air and brush, and install new fan driving belt, if required.

(m) Install new distributor points and set gap for 0.020 inch. Lubricate the cam and pivot point of the new breaker arm, and check spring tension on the arm. Set ignition timing on top dead center.

(n) Dismantle and clean carburetor jets and check float mechanism and needle valves.

(o) Reassemble all accessories and connections, start engine, and warm up at idling speed.

(p) Recheck valve tappets for proper clearance as indicated in step (9) above.

(q) Install valve cover plates with new cork gaskets. (Use gasket cement on valve cover side only.) **NOTE:** It is assumed that such parts as oil filter and air cleaner will be thoroughly washed and serviced, and that the lubricating oil will have been drained and replenished. It is not necessary to open up the crankcase at this time unless there is evidence of loose bearings; or, due to dusty conditions or neglect of air cleaner servicing, the cylinder and pistons show abnormal wear.

d. Engine Repairs.

(1) **CARBON REMOVAL.** Whenever the cylinder head is taken off, the carbon deposits should be removed from the inside of the head, the top of the block pistons and valves. This can be done by scraping with a scraping tool (figs. 60 and 61).

(2) **REMOVING BROKEN STUDS.**

(a) Remove studs broken beyond the surface of the cylinder block with a stud remover.

(b) Remove studs broken flush with cylinder block or below the surface, by drilling a hole, about one-half the diameter of the stud, and the length of the stud, through its center. With a hammer, tap a stud removing tool into the drilled hole. Screw the stud from the cylinder block.

ENGINE AND ACCESSORIES

(3) REPAIRING DAMAGED THREADS.

(a) Burred threads are corrected by running a thread tap through them.

(b) Stripped threads can be corrected by cutting threads oversize, and replacing stud or screw with an oversize part, or by filling hole with weld, drilling out, and tapping.

(4) REPLACING WORN VALVE GUIDES.

(a) With a scale and straightedge, measure the exact distance the top of the worn valve guide is from the top machined surface of the cylinder block.

(b) Place a valve guide pilot in the top of the worn valve guide and, with a hammer, drive out guide.

(c) Place new valve guide in position. With pilot bar and hammer, drive new valve guide into cylinder block until the top of the new valve guide is the distance from the top of the cylinder block ascertained in step (a), above.

(d) Ream the new valve guide with a straight fluted reamer to obtain the proper clearance for the valve stem (0.001 to 0.0015).

(5) INSTALLING CAMSHAFT BEARINGS. If inspection indicates that camshaft bearings require replacing, proceed as follows:

(a) Press out worn bearings with an arbor press.

(b) Press in new bearings, making sure that each bearing oil-hole lines up with the oil passage in the cylinder block. Also make sure that the inner surface of the bearing retaining hole and the outer surface of the bearing are clean before the new bearing is installed.

(c) Line-ream the bearings to secure a clearance of 0.0015 to 0.0025 inch between each journal and its respective bearing surface.

(6) RESURFACING VALVE TAPPET SCREWS. If no new valve tappet screws are available, the old screws can be reused by resurfacing the top face with a file.

(7) REAMING VALVE SEATS. Inspect valve seats, and if they are pitted or if new guides have been installed, the seats should be re-finished. Valve seat tools with $\frac{3}{8}$ -inch diameter pilots are required. Valve seats are finished on a 45-degree angle, and should have an even width of $\frac{1}{8}$ inch to $\frac{5}{32}$ inch all the way around.

(8) REFACING VALVES. Inspect valves carefully, and if the stems are badly worn or are not straight, the valves should be replaced with new ones. However, valves that are only slightly pitted can be used by refacing them on a valve face grinder. Valves must have an accurately finished face of the correct angle. Care should be taken, while grinding, not to remove too much material from valve face.

(9) GRINDING VALVES. When grinding or lapping each valve to its seat, be sure the tappet is in such position that it does not hold the

ORDNANCE MAINTENANCE – GENERATING UNIT M7



Figure 62 – Installing Piston Rings



Figure 63 – Proper Meshing of Crankshaft and Camshaft Gears

ENGINE AND ACCESSORIES

valve off its seat. Use a light coil spring under each valve as it is being lapped in, to raise the valve off its seat during the process. Proceed as follows:

(a) Place each valve in its proper valve opening in the cylinder block.

(b) Place a small amount of COMPOUND, grinding, valve, fine, around the face.

(c) With only light pressure, rotate the valve only part of a turn with a screwdriver or other suitable tool before raising it off its seat and rotating while off to a new position before again lightly bringing it against the seat for another part of a turn. Avoid a continuous round and round motion that would cut grooves in the valve or seat. After the process of lapping has been repeated until a bright silver-like band of uniform width is produced on valve and seat, then clean off all traces of the compound, and test each valve for a tight seat, by making pencil marks across the face of the valve at short intervals, and then rotate the valve against its seat for part of a turn and with a firm pressure. Again lift out, and observe if the pencil marks are all rubbed out on the contact surface; if not, regrind until this test shows a gas tight mating of valve to seat. After valves have been resealed, adjust tappets as outlined in paragraph on valve tappet adjustment.

(10) PISTON RING REPLACEMENT (fig. 62).

(a) *Gap.* When installing new piston rings, each ring should be tried in the cylinder bore to see if it has the correct gap of 0.015 inch to 0.020 inch. If necessary to increase the gap by filing the ends, be sure to file so the ends are parallel.

(b) *Clearance.* Each new ring should be tried for clearance in the piston groove by rolling the ring all the way around the groove. If the grooves in the piston have been carefully cleaned, it will be found that the rings will fit correctly in this respect, but if they are not free, they can be lapped slightly on a sheet of CLOTH, abrasive, aluminum-oxide, 2/0, laid on a flat surface. Use a light uniform pressure when lapping.

(11) FLYWHEEL RING GEAR REPLACEMENT. If inspection indicates that a new ring gear is required, it should be replaced as follows:

(a) Saw through and knock off old ring gear.

(b) Heat new ring gear so that it will fit into position on flywheel. Place on flywheel, and allow it to cool.

(12) VALVE TIMING.

(a) The proper timing of the valves depends on the proper meshing of the camshaft gear with the crankshaft gear, and the proper valve tappet clearance. These gears are marked for this purpose with a prick punch mark near the end of a tooth on one, and at the base of a

ORDNANCE MAINTENANCE — GENERATING UNIT M7

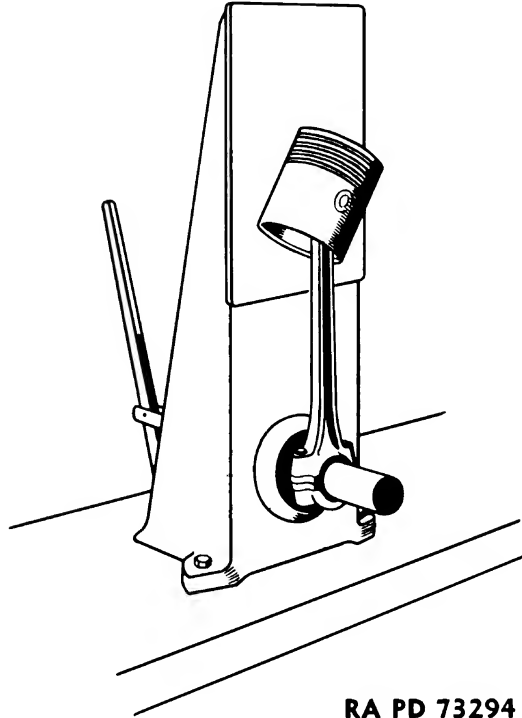

RA PD 73294

Figure 64 — Checking Connecting Rod for Bend

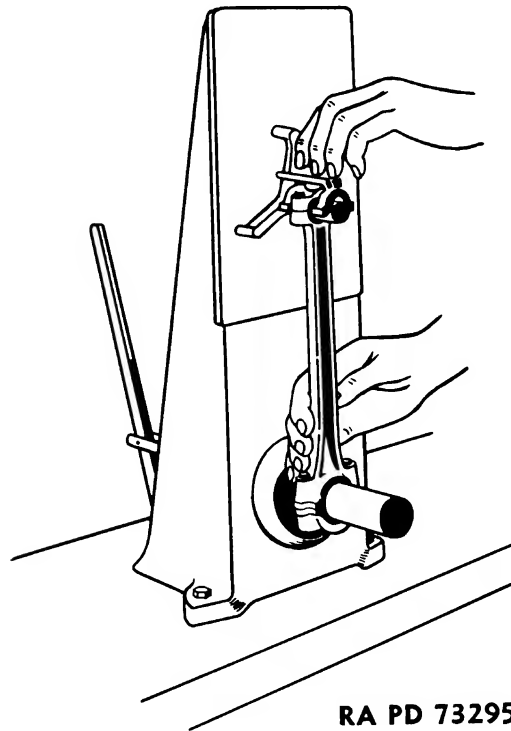

RA PD 73295

Figure 65 — Checking Connecting Rod for Twist

ENGINE AND ACCESSORIES

tooth space on the other. The mark in each instance is on the front face of the gear. When these marks line up (fig. 63), the valve timing is correct. The punch mark for timing on a new gear has the same position relative to the keyway as on the old gear. Therefore, one or more new gears can be installed, and the valves put in correct timing by simply meshing the gears so the marks line up.

(b) The valve timing with respect to crankshaft or flywheel travel in degrees and minutes is as follows: Intake opens 1° – $52\frac{1}{2}$ inch past top center; intake closes 46° – $52\frac{1}{2}$ inch past bottom center. Exhaust opens 43° – $7\frac{1}{2}$ inch before bottom center; exhaust closes 1° – $52\frac{1}{2}$ inch past top center. In checking valve opening or closing in degrees of crank travel, the valve clearance is set to 0.010 inch clearance for intake, and 0.016-inch clearance for exhaust valve on cylinder being used as a check. For proper running clearance, see subparagraph c (1) (g), above.

(13) CONNECTING ROD AND PISTON.

(a) *Bent Connecting Rod.* Clamp assembled connecting rod and piston, without piston rings, onto a connecting rod alining fixture (fig. 64). Draw piston up to the surface plate. If the piston lies flat against the plate, the connecting rod is straight. If the piston will not lie flat, the rod is bent and must be replaced or straightened.

(b) *Twisted Connecting Rod.* Clamp connecting rod without piston onto rod alining fixture. Check for twist as shown in figure 65. If all of the legs of the tripod do not set squarely on the face plate, the rod is twisted, and must be replaced or realined.

(14) FITTING PISTON RINGS.

(a) Measure cylinder wall wear with a dial indicator, to determine whether to use standard or oversize piston rings. Slip a piston ring into the cylinder. Push it down about an inch from the top of cylinder block with a piston. Using a feeler gage, measure end gap. If end gap exceeds 0.020 inch, use an oversize ring. If end gap is less than 0.015 inch, file ends of ring on a fine mill file secured in a file holding fixture or in a vice. Repeat these steps with all the rings. Test each ring in the cylinder in which it is to be used.

(b) *Piston Ring Grooves.* Carefully examine the ring grooves in each piston. Remove any carbon with a broken piston ring or standard piston ring groove cleaner. Carefully remove any burs with a fine file. Clean carbon from oil return holes in oil ring groove.

(c) *Cylinder Bores.* If cylinder wall wear exceeds 0.005 inch, walls will have to be rebored or honed, and oversize pistons fitted. If cylinder wall wear is 0.003 inch to 0.005 inch, install oversize piston rings. If cylinder wall wear is less than 0.003 inch, install standard piston rings. Inspect top of cylinder walls. If walls are worn, the top $\frac{3}{16}$ inch will be unworn, and will appear as a ridge. Remove ridge with a ridge reamer.

ORDNANCE MAINTENANCE — GENERATING UNIT M7

RA PD 73296

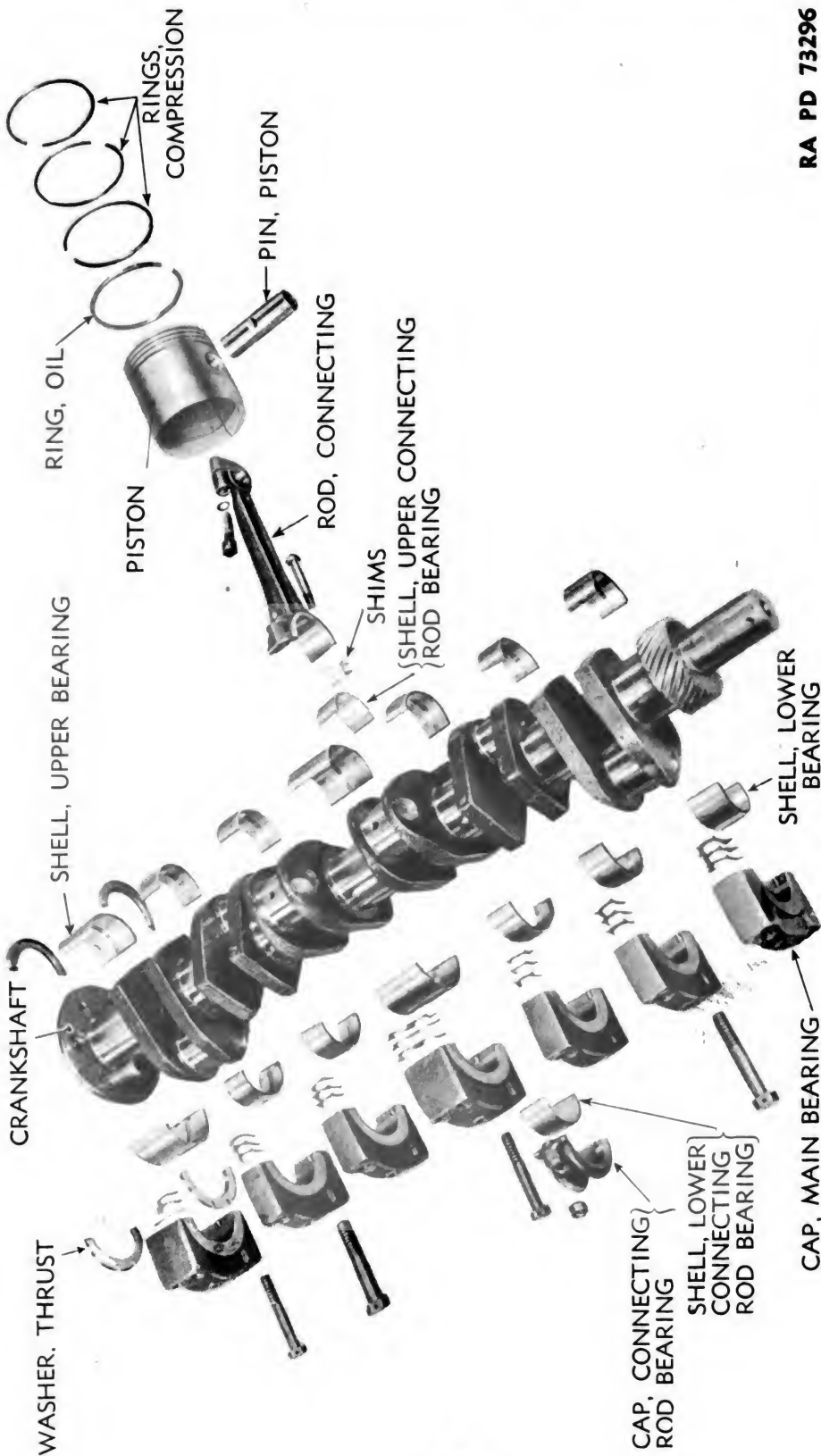

Figure 66 — Crankshaft, Piston and Bearings — Exploded View

ENGINE AND ACCESSORIES

RA PD 73297

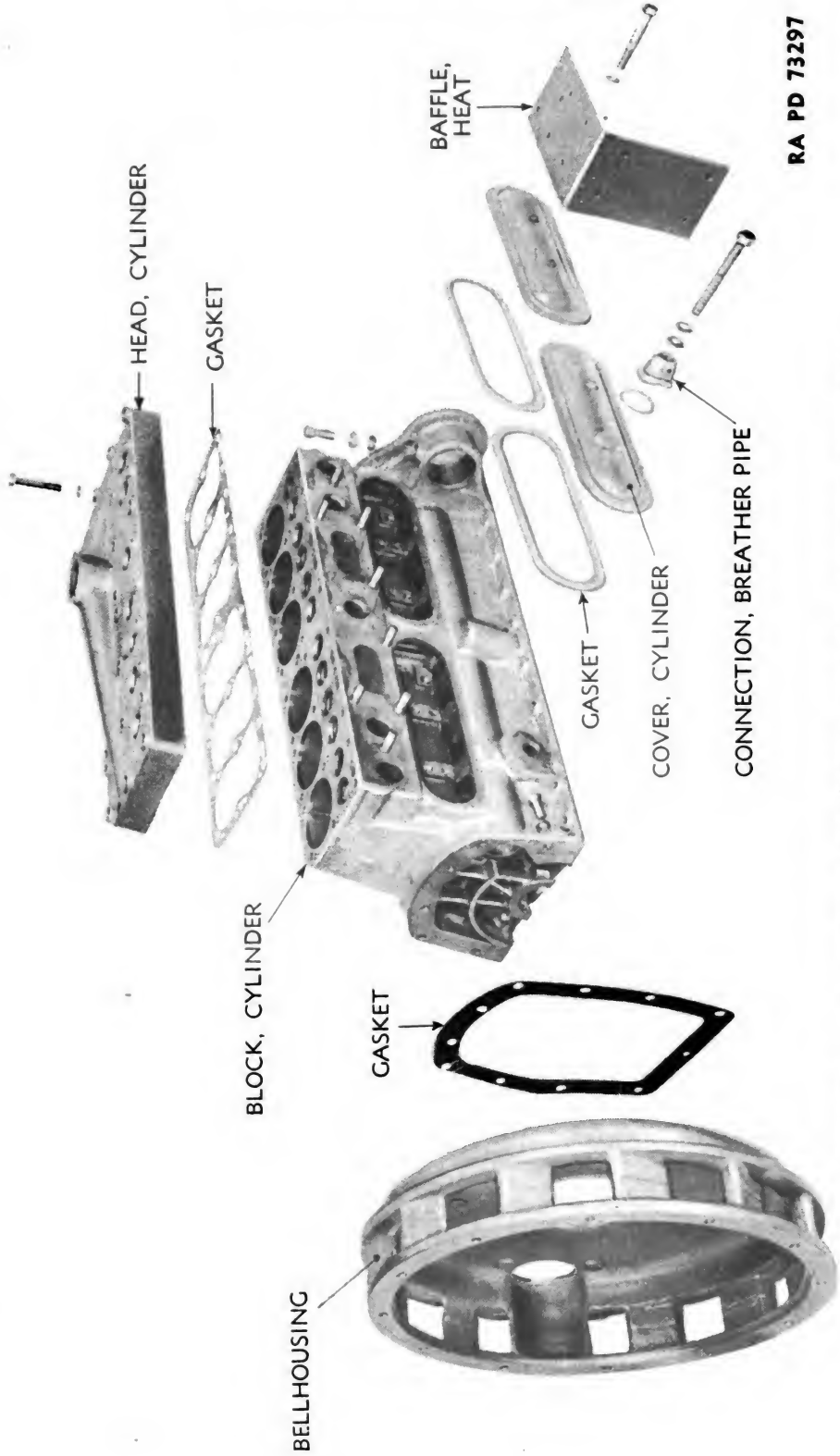
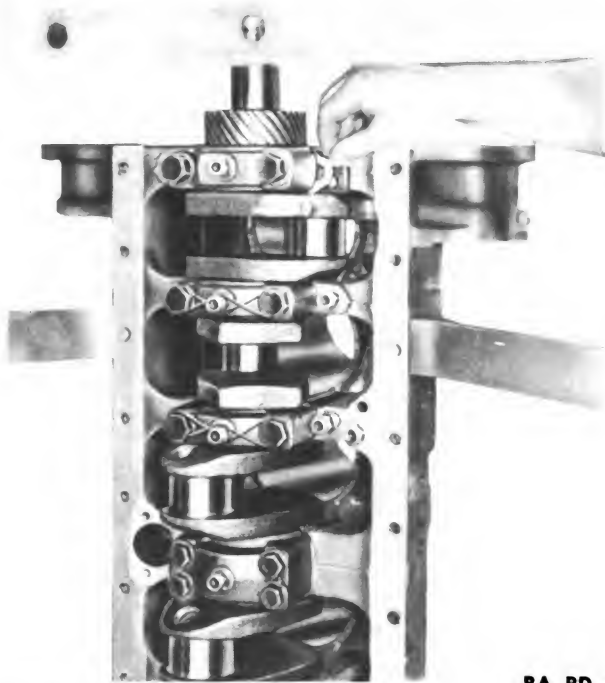

Figure 67 — Cylinder Block, Head, and Bell Housing Assembly

ORDNANCE MAINTENANCE – GENERATING UNIT M7



RA PD 73298

Figure 68 – Shimming Crankshaft Main Bearing

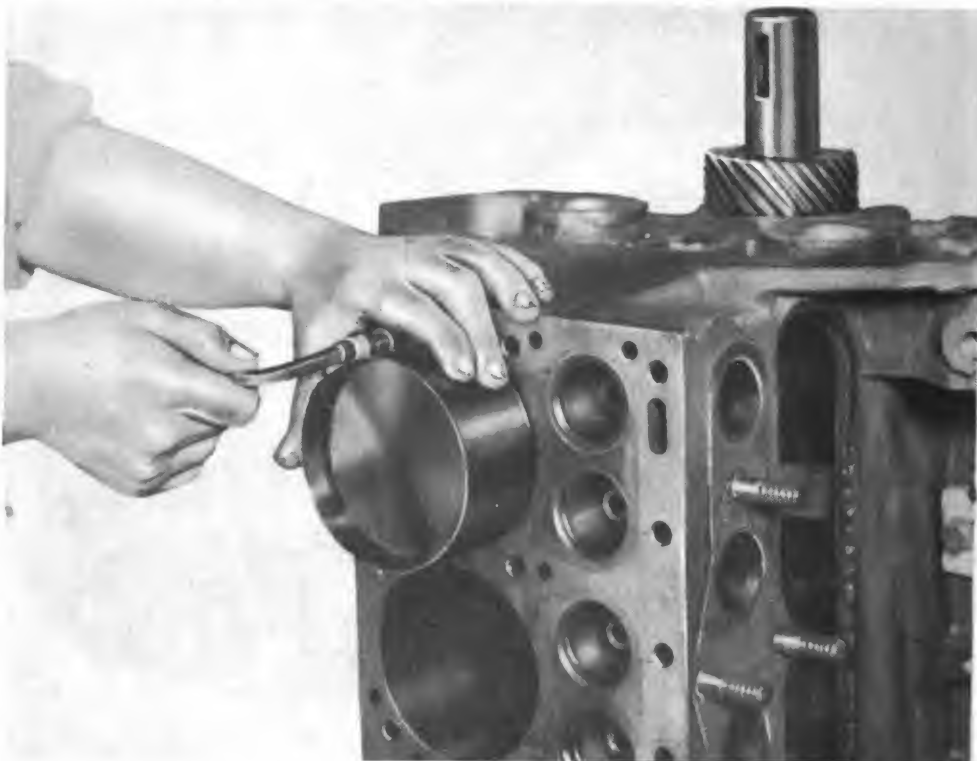

RA PD 73300

Figure 69 – Tightening Piston Ring Compressor

ENGINE AND ACCESSORIES

24. ASSEMBLY (figs. 66 and 67).

a. Procedure.

(1) Set upper bearing shells in place in upper bearings, carefully installing each shell in the bearing from which it was removed (fig. 59).

(2) Set crankshaft in position in upper bearings after coating bearing surface with OIL, engine (crankcase grade). Fit thrust washer halves into place between rear main bearing and crankshaft flange.

(3) Install bell housing (figs. 58 and 57).

(4) Install crankshaft main bearings (fig. 54).

(a) Place crankshaft rear main bearing cap and shell in position, shim up on side opposite the locking lug with the shims which were previously used. Secure bearings with cap screws, and rotate crankshaft to test for binding. If replacing the original cap and shells, crankshaft should turn freely without binding. If new bearing cap or shells have been installed, place shims until the crankshaft can be turned, but only with considerable effort. Then add shims to the one side to gain the required clearance of 0.002 to 0.003 inch (fig. 68). Tighten cap screws (tension wrench) to 70 foot-pounds tension. Wire each pair of cap screws together with No. 12 wire, running wire through holes in cap screw heads.

(b) Install center main bearing cap and shell. Repeat procedure outlined in step (a), above, given for installation of rear main bearing.

(c) Install front and intermediate bearing caps. Repeat procedure outlined in step (a), above except that proper tension wrench tension is 105 foot-pounds.

(5) Place flywheel against end of crankshaft, inside bell housing. Line up screw and dowel holes in flywheel and crankshaft. Install the four castellated nuts finger tight. Hold wood block against a flywheel stud to keep flywheel from moving while tightening castellated nuts (fig. 52).

(6) Holding camshaft clear, carefully pass camshaft into camshaft bearings in engine block. One man should carefully guide the shaft through the bearing so that cams do not injure the babbitt bearing linings (fig. 50).

(7) Mesh camshaft gear (par. 23 d (12) (a)).

(8) The third gear from the left is the idler gear, which acts only in transmitting power to the accessory or water pump drive. Press idler gear stub shaft into place, and mesh with the camshaft gear at any point (fig. 49).

(9) Press oil retainer ring, with outside rubber gasket in place, onto crankshaft. Set timing gear cover in place, and attach to block with cap screws (fig. 46).

ORDNANCE MAINTENANCE — GENERATING UNIT M7

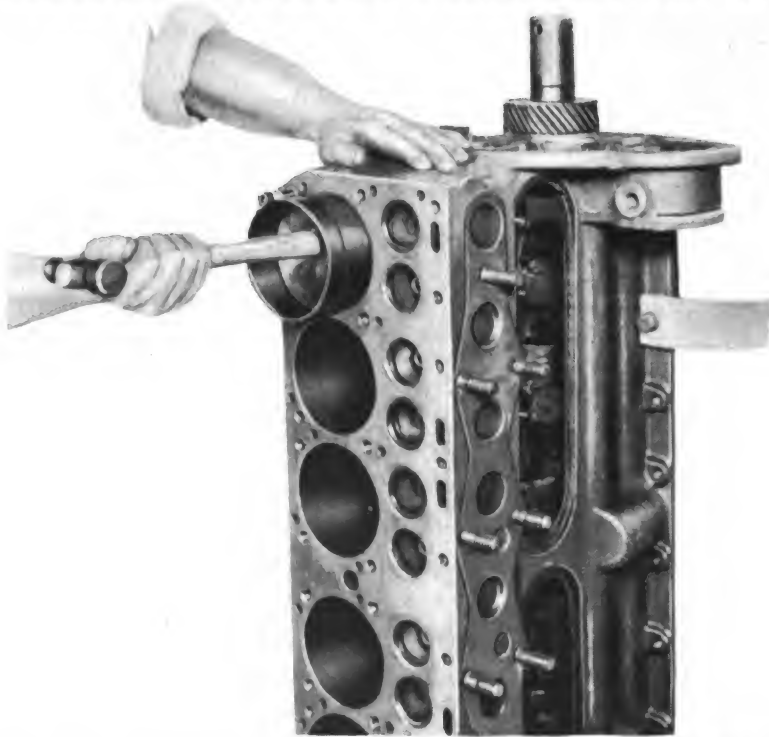

RA PD 73301

Figure 70 — Installing Piston Using Piston Ring Compressor

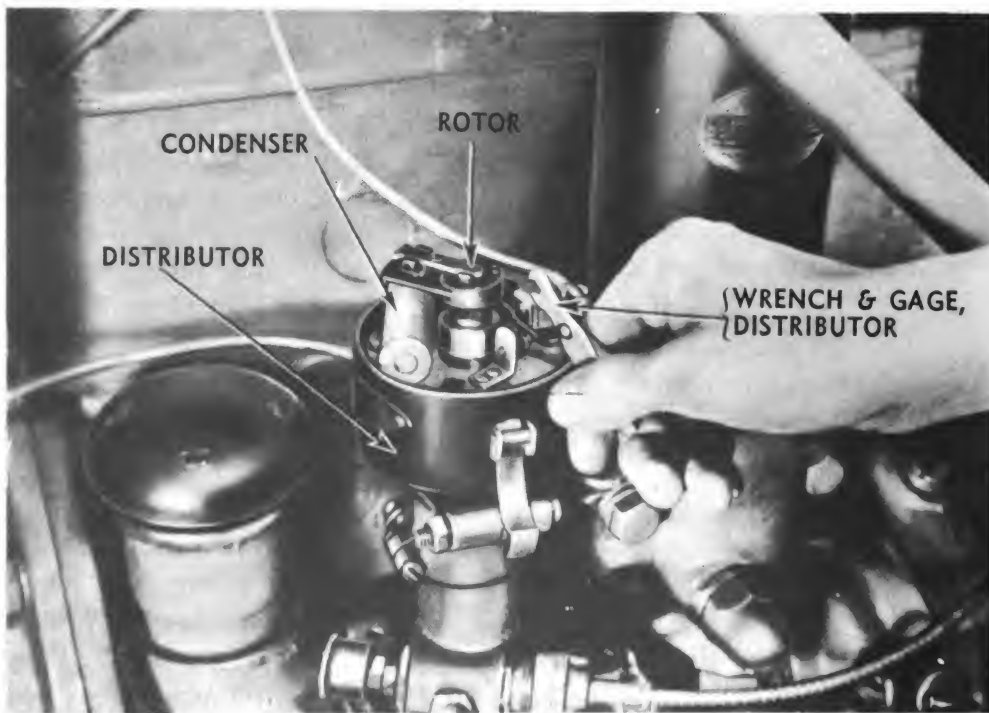

RA PD 73509

Figure 71 — Gaging Distributor Breaker Points

ENGINE AND ACCESSORIES

(10) Slide cranking dog over crankshaft, and adjust on shaft until drift holes in dog align with hole in shaft. Drive in drift pin. Tighten set screw holding drift pin in place.

(11) Slide outboard support ring over cranking dog, with horizontal cap screw at top. Tighten screw to hold firmly in place (fig. 44).

(12) Assemble pistons and connecting rods.

(a) Line up oilholes in piston and piston pin bushing, and press bushing into piston. Repeat operation to install other bushing. Ream out bushings to obtain a 0.0002 to 0.0003 piston pin clearance.

(b) Hold connecting rod in position in piston. Push piston pin in piston and connecting rod, and tighten connecting rod piston pin lock screw.

(c) Slide one oil and three compression piston rings on piston with piston ring expander.

(d) Repeat the above steps on all five remaining pistons.

(13) Install pistons and connecting rods.

(a) Coat piston and bearing surface of connecting rod with a thin coat of OIL, engine (crankcase grade). Compress piston rings on No. 1 piston ring compressor (fig. 69).

(b) Insert connecting rod and piston assembly connecting rod first, into top of No. 1 cylinder. Be sure side of piston marked "FRONT" is toward the front of engine. Tap top of piston into cylinder with wood block or hammer handle (fig. 70). Remove piston ring compressor from piston as piston rings enter cylinder.

(c) With upper connecting rod bearing shell in place, fit connecting rod over crankshaft. Insert connecting rod cap screws through holes in base of rod. Place connecting rod cap, with bearing shell in place, on screws. Insert the same shims originally removed around cap screw on side opposite the camshaft. Connecting rod bearing clearance should be 0.0015 to 0.002. Install connecting rod castellated nuts, tightening them to 63 foot-pounds pressure. Gage clearance and add or remove shims if proper clearance is not already gained. Insert cotter pins through holes provided in cap screw shank.

(d) Repeat procedure outlined in steps (a) through (c) above, for all pistons.

(14) Insert oil pump in position, and attach bracket with cap screws (fig. 40).

(15) Set bearing lubricating oil line in position, and connect end fittings to oil pump and oil line fittings on main bearing caps (fig. 41).

(16) Bring oil pan up to crankcase with gaskets in position, and attach with cap screws (fig. 39).

(17) Spin each tappet screw nut onto the tappet screw. Screw tappet screw into tappet (fig. 34).

ORDNANCE MAINTENANCE – GENERATING UNIT M7

(18) Return assembled tappets to their original position in the clusters. Install complete clusters in valve chambers with cap screws (fig. 37).

(19) Lower valves through engine block and valve guide, stem first, being careful to return each valve to its former position. Bring each valve spring and valve spring seat together, the seat inserted at the end that is most loosely coiled. Slide each valve up in sequence, and insert spring and seat in position between top of valve chamber and tappet. Insert the valve spring lifter between top of tappet cluster and spring seat. Compress spring, and lock lifter in place. Install key in slot of valve stem (fig. 35), release lifter tension on spring, and remove lifter.

(20) **ADJUST TAPPETS.** From front to rear of engine, exhaust valves are Nos. 1, 4, 5, 8, 9, and 12. Valves 2, 3, 6, 7, 10, and 11 are intake. Cylinders are also numbered from front to rear. To adjust valves for No. 1 cylinder, turn engine over with hand crank until intake valve of No. 6 cylinder begins to open. Hold valve adjustment bolt head with one wrench, and loosen lock nut with the other. Adjust so that clearance between bolt head and valve stem will just take 0.010-inch gage in case of intake valves, and 0.016-inch gage for exhaust valves. Crank engine until No. 2 cylinder intake valve opens; adjust valves in No. 5 cylinder. As No. 4 cylinder intake valve opens, adjust valves in No. 3 cylinder. When No. 1 cylinder intake valve opens, adjust valves in No. 6 cylinder. When No. 5 cylinder intake valve opens, adjust valves in No. 2 cylinder. When No. 3 cylinder intake valve opens, adjust valves in No. 4 cylinder. This is the first setting for cold engine. After engine has been run sufficiently to warm up, clearances should be rechecked and set to 0.006 intake and 0.010 exhaust.

(21) Set cylinder head on engine block with a new gasket in place. Secure head to block with cap screws, while locating and attaching by the same means, the ignition wire tube flange, choke and ignition line bracket flange, fuel line bracket flange, and ignition coil bracket flange. The cylinder head cap screws should be tightened in rotation, a few turns at a time, beginning at the center of the head and working to the outside. They should be tightened with a tension wrench to a tension of 60 foot-pounds when using copper asbestos cylinder head gaskets, or 75 foot-pounds when using steel asbestos cylinder head gaskets. The final tightening should be done after the engine has been run, and is thoroughly warmed up. Tension readings should be checked after the first 10 hours of operation.

(22) Screw spark plugs with gaskets in place into cylinder head finger tight. With spark plug wrench, give each plug three-quarters of a turn.

ENGINE AND ACCESSORIES

25. INSTALLATION OF ACCESSORIES.

a. **Procedure.** This procedure is the reverse of that outlined in paragraph 21 a.

26. INSTALLATION.

a. **Procedure.** This procedure is the reverse of that outlined in paragraph 20 a. (See paragraph 15 for housing installation.)

27. TUNE-UP.

a. **Procedure.**

(1) One of the most important operations in the maintenance of the engine is proper engine tune-up. This operation, more than any other, determines whether or not the engine delivers the maximum in performance and economy. Only by accurately making the following checks and adjustments can the maximum performance of the engine be obtained.

(2) **COMPRESSION.**

(a) Before making any checks on an engine, it should be run for several minutes to warm it up and lubricate the valve mechanism. The compression of the engine should be checked first when tuning, because an engine with uneven compression cannot be tuned successfully.

(b) Remove all spark plugs. The ignition should be turned off, with the throttle valve in the open position.

(c) Insert the compression gage in a spark plug hole, and hold it tightly. Crank the engine with the starting motor until the gage reaches its highest reading, which requires only a few turns. Repeat the same test on all cylinders, and make a note of the compression on each.

(d) The compression on all cylinders should be 110 pounds or better, and all cylinders should read alike, within 5 to 10 pounds, for satisfactory engine performance.

(e) Should there be a low compression reading on two adjacent cylinders, it indicates a possible intercylinder leak, usually caused by a leak at a cylinder head gasket.

(f) If the compression readings are low or vary widely, the cause of the trouble may be determined by injecting a liberal supply of oil on top of the pistons of the low reading cylinders.

(g) Crank the engine over several times, and then take a second compression test. If there is practically no difference in the readings when compared with the first test, it indicates sticky or poorly seating valves. However, if the compression reading on the low reading cylinders is about uniform with the other cylinders, it indicates compression loss past the pistons and rings.

ORDNANCE MAINTENANCE – GENERATING UNIT M7

(h) The cause of low or uneven compression must be corrected before proceeding with an engine tune-up job.

(3) SPARK PLUGS (par. 80).

(a) Clean the spark plugs thoroughly in a spark plug sand blast cleaner. If the porcelains are badly glazed or blistered, the spark plugs should be replaced. All spark plugs must be of the same make and heat range.

(b) Adjust the spark plug gaps at 0.025 inch, using a feeler gage. *Do not bend the center electrode.*

(c) Care must be used when installing the spark plugs, or the setting of the gap may be upset. When installing the plugs, put a new gasket on the plug, screw the plug in finger tight, then tighten with the spark plug wrench one-half to three-quarters of a turn.

(4) BATTERY TEST.

(a) Connect the negative terminal of a voltmeter to the starting switch terminal, and the positive terminal of the voltmeter to a good ground.

(b) Crank the engine for 15 seconds. If the starting motor cranks the engine over at a good rate of speed with the voltmeter reading 5 volts or better, it indicates a satisfactory starting circuit, which includes the condition of the battery, terminals, and cables. However, if the cranking speed is slow, or the voltmeter reading is under 5 volts, the starting motor, battery, and battery cable terminals should be checked individually to locate the source of the trouble.

(5) DISTRIBUTOR (fig. 71).

(a) Remove the spark plug wires from the distributor cap and examine the terminals for corrosion. The wires should also be checked for damaged insulation and for being oil-soaked.

(b) Remove the distributor cap, and check the cap and distributor rotor for cracks or burned contacts.

(c) Check the automatic advance mechanism by turning the distributor cam in a clockwise direction as far as possible, then release the cam and see if the springs return it to its retarded position. If the cam does not return readily, the distributor needs to be disassembled, and the cause of the trouble ascertained.

(d) Examine the distributor breaker points. Dirty points should be cleaned, and pitted or worn points should be replaced. Check the points for alinement, and aline them if necessary.

(e) Hand crank the engine until the cam follower rests on a peak of the cam. Adjust the point gap to 0.020 inch (fig. 71), using feeler gage. This operation must be performed very accurately. Hand crank the engine until the cam follower is located between the cam peaks. Hook the end of a point scale over the movable point, and pull steadily

ENGINE AND ACCESSORIES

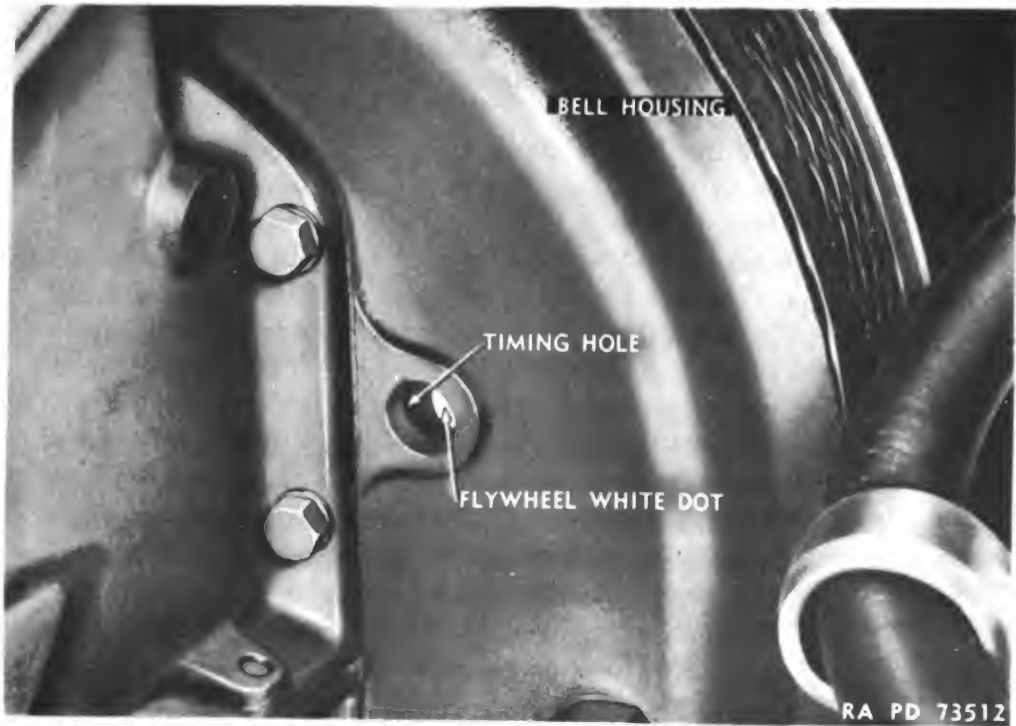

Figure 72 – Timing Hole in Bell Housing



Figure 73 – Valve Tappet Adjustment

ORDNANCE MAINTENANCE – GENERATING UNIT M7

on the spring scale until the points just start to open. Scale should read between 17 and 20 ounces. Adjust the point pressure by loosening the screw holding the end of the contact arm spring, and slide the end of spring in or out as necessary.

(f) Reassemble distributor cap and spark plug wires. Make sure that the terminals of the primary wire from the ignition coil to the distributor are clean and tight.

(6) **FUEL PUMP.** Remove the sediment cup and screen and wash them thoroughly in SOLVENT, dry-cleaning. When reassembling, make sure that the cork gasket is in good condition and properly seated. Tighten all fuel pump connections.

(7) **AIR FILTER** (fig. 105).

(a) Remove the air filter from the carburetor. Remove the wing nut from the top, and take off the cover.

(b) Empty the oil out of the filter and clean out all oil and accumulated dirt. Wash body with SOLVENT, dry-cleaning, and wipe dry. Wash filter element by slushing up and down in SOLVENT, dry-cleaning. Dry thoroughly, either with an air hose or by letting it stand until dry. Fill the body of the filter to bead level with used crankcase oil or OIL, engine, (crankcase grade).

(c) Install the filter on the carburetor elbow. Tighten clamp.

(8) **CARBURETOR.**

(a) Adjust mixing screw at top until engine runs smoothly at idling speed. This screw controls the amount of air mixed with the fuel.

(9) **IGNITION TIMING.**

(a) Attach one wire of the neon-timing light to No. 1 spark plug, and the other wire to the No. 1 spark plug wire. Start the engine and run it at idling speed. Loosen distributor clamp and slowly rotate distributor body clockwise or counterclockwise until the white dot on the flywheel (fig. 72) is visible through the timing hole in the bell housing each time the light goes on.

(10) **VALVE TAPPET ADJUSTMENT** (fig. 73).

(a) Start the engine and while it is warming up, tighten cylinder head cap screws and manifold nuts. Where torque wrenches are available, the cylinder head cap screws should be tightened to 60 foot-pounds, if copper asbestos cylinder head gasket is used, and 75 foot-pounds if steel asbestos cylinder head gasket is used.

(b) Adjust the valve tappets according to the procedure given in paragraph 24 a (20).

(11) **COOLING SYSTEM.**

(a) Tighten all hose connections and examine for any indications of water leaks. Check the fan and exciter belts for cracks, oil-soaking and for proper tension.

ENGINE AND ACCESSORIES

Section II

COOLING SYSTEM

	Paragraph
Description	28
Trouble shooting	29
Maintenance	30
Water pump	31
Radiator	32
Fan	33

28. DESCRIPTION (fig. 74).

a. **General.** The cooling system consists of a radiator, radiator cooling fan, water pump, water passages in the cylinder block and head, thermostat, and the various connections between these units. It has a capacity of 36 quarts. The function of the cooling system is to maintain the engine at an efficient operating temperature. To perform this function properly, the system must be kept free of foreign matter that might tend to clog the water passages. The water pump must be leakproof, and must keep the water circulating in the system. The water passages in the cylinder block and head must be kept free from rust and corrosion so that heat may be properly dissipated. The hose sections must be in good condition, and all connections must be kept tight so that they will not leak. Cylinder head bolts must be kept tight to eliminate the possibility of exhaust gases entering the cooling system. Water is drawn from the bottom of the radiator by the water pump, and is forced under pressure through the water passages in the cylinder block and head and back into the top of the radiator. The thermostat, mounted in the cylinder head, assists in maintaining proper water temperature under operating conditions.

29. TROUBLE SHOOTING.

a. **Overheating.**

Possible Cause	Possible Remedy
Lack of water or antifreeze.	Fill cooling system.
Leaks at connections, hoses, radiator core, or cylinder head gasket.	Tighten all connections, repair radiator core, and tighten or replace all hoses.
Radiator dirty, inside or out.	Clean radiator thoroughly.
Dirty water.	Drain, and refill with clean water.
Clogged system.	Flush system (par. 30 d).
Loose fan belt.	Adjust or replace.
Broken fan belt.	Replace.
Water pump not operating.	Rebuild (par. 31).
Ignition timing incorrect.	Time engine (par. 27 a (9)).

ORDNANCE MAINTENANCE – GENERATING UNIT M7

Possible Cause	Possible Remedy
Thermostat stuck closed.	Service or replace (par. 30 c (1)).
Radiator core passages clogged.	Clean radiator core (par. 30 d).
b. Overcooling.	
Thermostat stuck open.	Service or replace (par. 30 c (1)).

30. MAINTENANCE.

a. General. Externally inspect cooling system components daily. After each 250 hours of operation, a detailed inspection of the components must be made.

b. Daily Inspection.

- (1) See that radiator is full of water. Add water if necessary.
- (2) When antifreeze is used, test strength with a hydrometer.
- (3) Inspect all hose connections for water leaks. Tighten clamps, if necessary.
- (4) Give a slight turn to grease cup on water pump. Fill, if necessary.
- (5) Remove grease plug from fan, and fill fan hub with **GREASE**, general purpose, No. 2.
- (6) Check fan belt tension, and adjust if necessary.
- (7) Visually inspect radiator for leaks. Repair if leaking.

c. Periodic Inspection.

(1) Remove thermostat. Test its operation by placing it along with a thermometer in a pan of water. Heat the water. Measure temperature at which it opens. It should begin to open at 150 F., and should be fully opened at 180 F.

(2) Remove all radiator hose connections. Visually inspect exterior and interior. Replace if cracked, rotted, or if inside has become spongy or jelly-like.

(3) Clean cooling system. (For description of method, see TM 9-618.)

(4) If water drained from cooling system shows an unusual amount of scale and rust, the system must be reverse flushed as follows:

d. Reverse Flush Cooling System.

(1) **RADIATOR.** Remove upper and lower radiator hose from radiator. Attach a hose (long enough to conduct water to a drain) to the upper radiator inlet. Secure a length of hose to the lower radiator outlet pipe with a radiator hose clamp. Hold a reverse flushing gun (connected to water and air hose) to the other end of this hose. Turn on the water. When the radiator is full, turn on a short blast of air. Repeat the operation until water discharged from the hose attached to the upper radiator inlet pipe is clean.

ENGINE AND ACCESSORIES

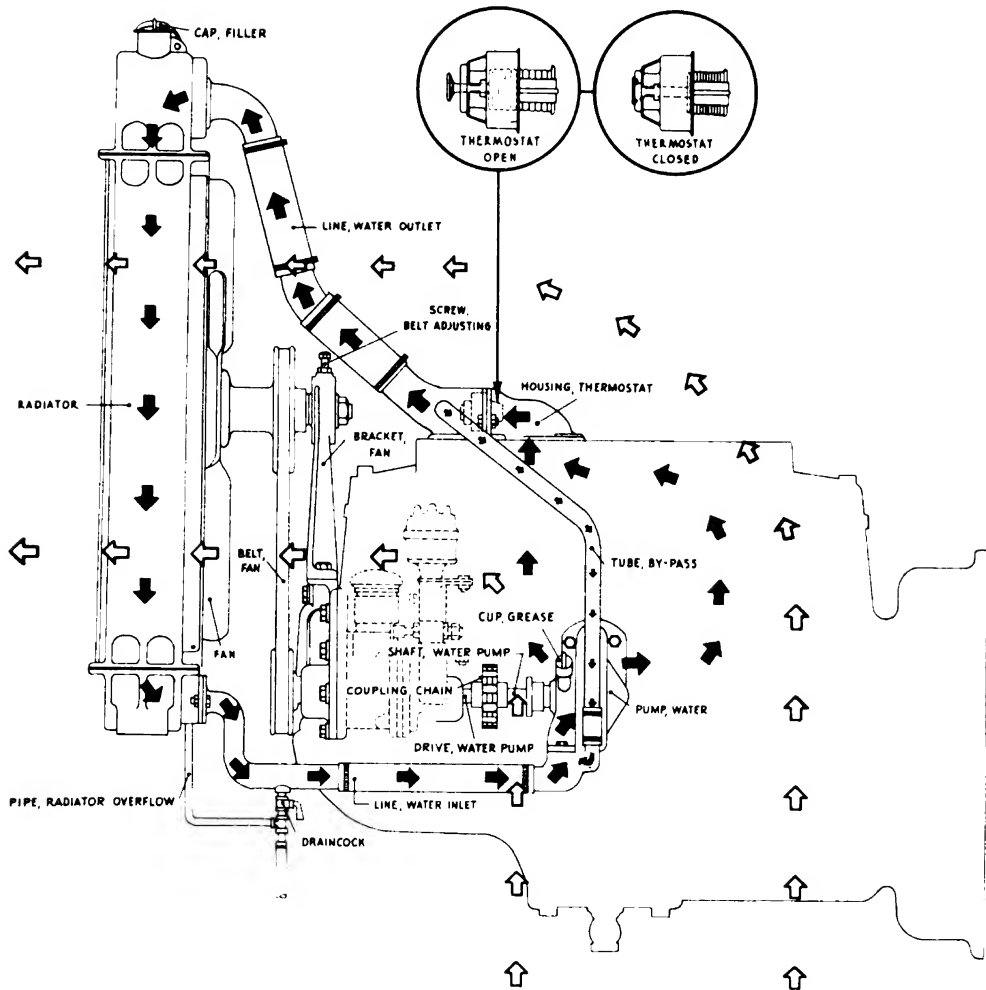

Figure 74 - Cooling System Diagram

RA PD 73513

(2) **ENGINE WATER JACKET.** Remove the thermostat from the cylinder head. Cold water would cause it to close and result in building up a pressure in the system and cause damage. Remove the radiator outlet hose. Attach drain hose to water pump inlet with a radiator hose clamp. Hold reverse flushing gun to the cylinder head water outlet. Allow the water jacket to fill with water. Turn on air in short blast. Repeat process until water hose attached to water pump discharges clean water.

e. Antifreeze Cooling System.

(1) Inspect all cooling system components for leaks. If leaks are found, repair. Tighten all radiator hose connections. Tighten cylinder head cap screws to tension specified in paragraph 140. Clean and reverse flush cooling system, and add antifreeze as prescribed in TM 9-618.

ORDNANCE MAINTENANCE — GENERATING UNIT M7

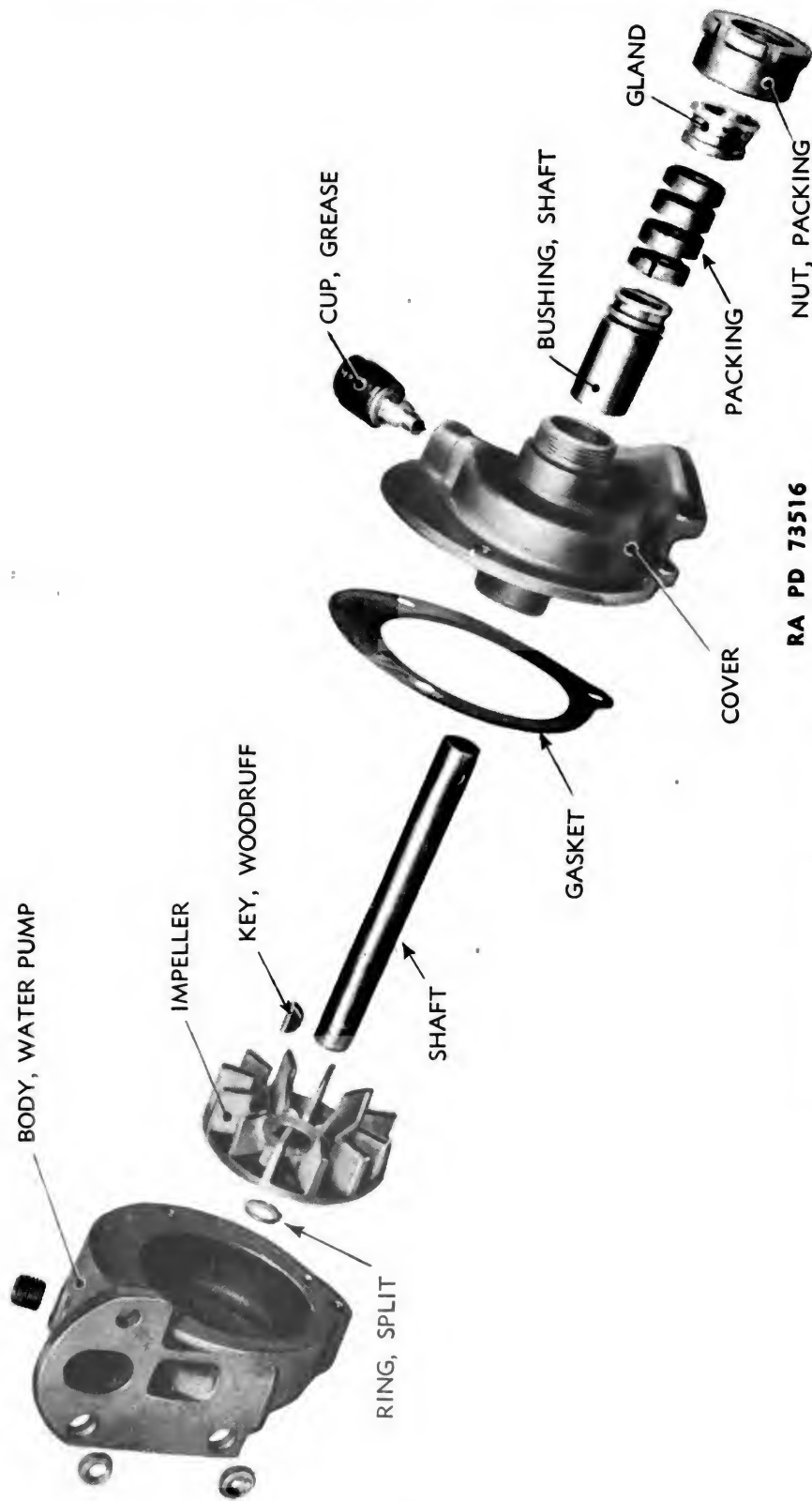

RA PD 73516

Figure 75 — Water Pump Assembly — Exploded View

ENGINE AND ACCESSORIES

RA PD 73517

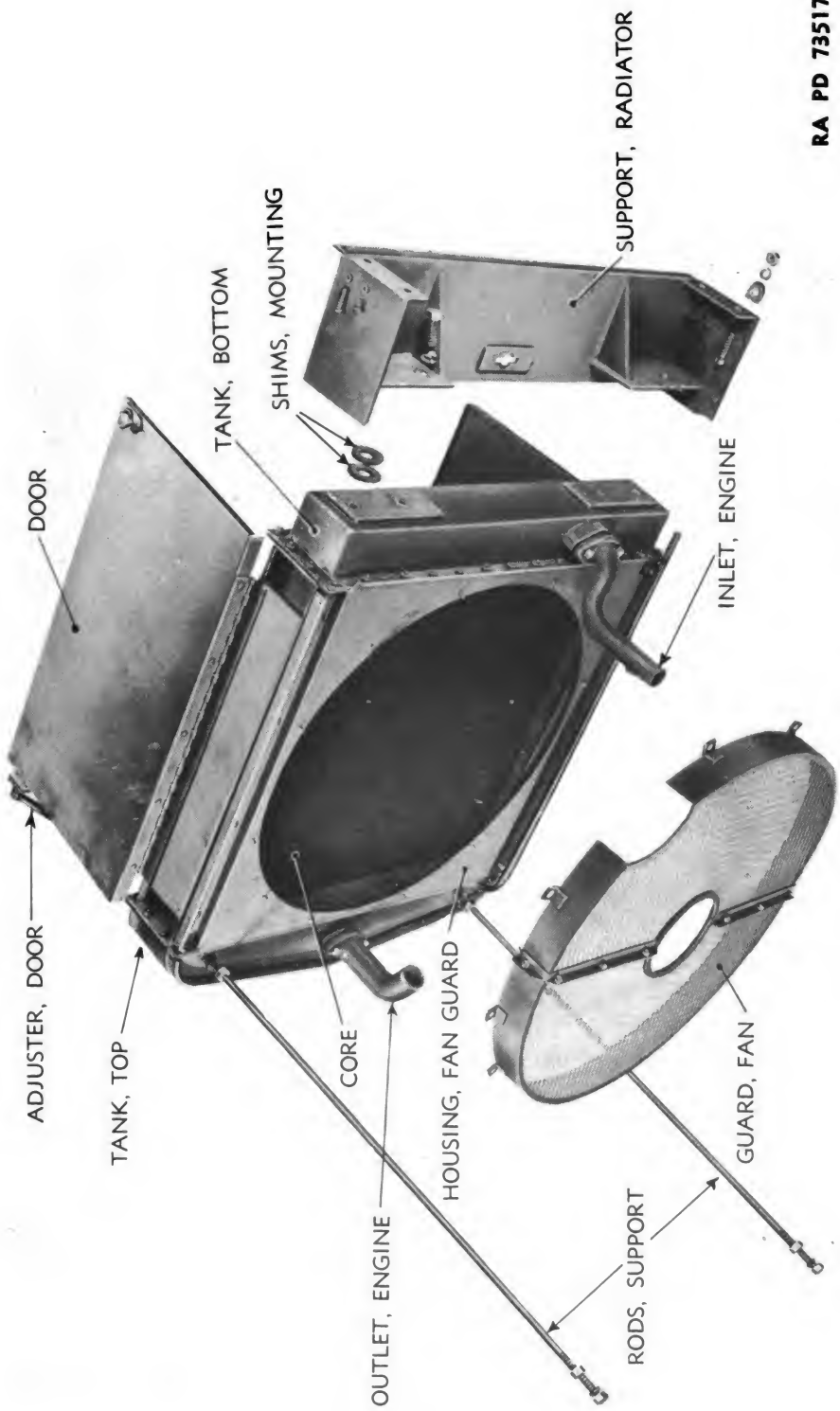

Figure 76 — Radiator and Supports Assembly

ORDNANCE MAINTENANCE – GENERATING UNIT M7

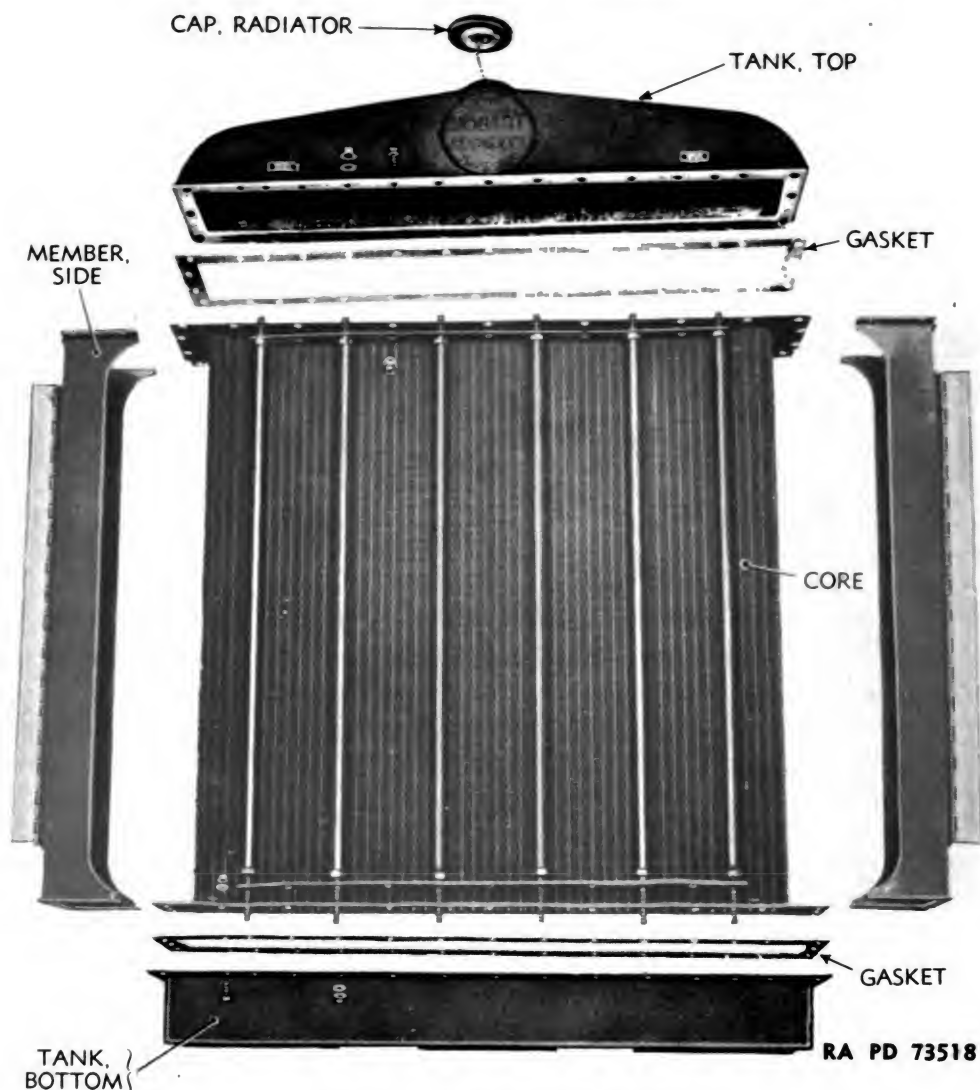

Figure 77 – Radiator Assembly

31. WATER PUMP.

a. **Description.** The water pump of the centrifugal-type, is on the left side of the engine, and is run by the accessory drive to which it is attached by a chain coupling. The shaft is supported on a bronze; babbitt lined bushing mounted in cover. This is lubricated through a pressure grease cup. The impeller is keyed to the pump shaft. Split ring type packing is used so that the pump can be repacked without disassembling.

b. **Disassembly** (fig. 75).

(1) Take out cap screws holding water pump inlet elbow to water pump and remove elbow. Remove cap screws connecting water pump cover and body. Remove cover.

ENGINE AND ACCESSORIES

(2) Loosen packing nut, remove nut, gland, and packing. Pull impeller off shaft, and remove Woodruff key. Pull shaft out of cover.

(3) Press bronze shaft bushing out of water pump cover.

c. Inspection.

(1) Clean all parts in dry-cleaning solvent, and dry with compressed air.

(2) Inspect water pump body and cover for cracks. If broken, replace or weld.

(3) Inspect water pump shaft thrust button in cover, and replace if worn.

(4) Inspect fit of water pump shaft in water pump shaft bushing, and replace bushing if worn enough to permit noticeable side play.

(5) Inspect water pump shaft for wear or damage. Replace if necessary.

d. Maintenance and Repair.

(1) Because of its construction, the water pump requires very little care, except that the grease cup must be kept filled with **GREASE**, water pump, and given a turn down every 8 hours to insure proper lubrication of water pump shaft bushing.

(2) In case of overhaul or repair, always use new gaskets. Replace other parts if worn or broken.

e. **Assembly.** This is the reverse of the procedure outlined in subparagraph **b**, above.

32. RADIATOR (fig. 76).

a. **Description.** The radiator is of the heavy-duty tractor type, and is mounted on the frame in front of the engine. Core tubes and fins are copper, and the upper tanks are cast iron. Water heated in the water jacket of the engine goes to the upper radiator tank, flows down the radiator tubes for cooling, and from there is drawn into the pump. Air drawn through louvers and up through the frame by the action of the fan, passes across the engine, and is forced out of the unit through the radiator fins, thereby cooling the water. On the top of the engine, at the point where the water returns to the radiator, is the thermostat whose function is to keep cool water from entering the radiator, and forces it to return directly to the pump through the bypass pipe until the engine is warmed up.

b. Removal.

(1) Open draincock in radiator outlet pipe. This will drain the cooling system. At point where copper radiator overflow pipe enters compression fitting below draincock, hold fitting, unscrew nut, and pull out pipe.

ORDNANCE MAINTENANCE – GENERATING UNIT M7

(2) Disconnect the fan guard sections by removing the attaching bolts and nuts. Take off square nuts attaching the two guard sections to the housing, and remove guard.

(3) Loosen metal straps binding two hose sections in upper radiator water line and one hose section in lower radiator line by loosening bolts. Work off hose sections.

(4) Take out cap screws and nuts holding housing roof to radiator. Remove bottom cap screw and nut at each side of radiator holding side panels to radiator.

(5) Remove nut which secures each radiator support rod to center bow by holding rod with pliers while unscrewing nuts at bow. Unscrew rod from radiator, and remove.

(6) Free radiator from frame by removing four cap screws holding radiator to frame. Remove radiator.

c. Inspection and Repair.

(1) Take out round-head machine screws and lock washers at back of radiator attaching guard to radiator. Remove guard.

(2) See that radiator filler cap fits down tightly over filler cap hole. If cap is not tight, bend top holding clamp wire to make a better fit.

(3) Visually inspect tanks and core for dents, breaks, or cracks. Weld cracks or breaks. Remove tank dents after disassembly.

(4) Inspect radiator core for leaks. Plug overflow tube, lower tank pipe, and radiator filler opening. Insert an air inlet plug in upper tank opening, and apply 3 pound air pressure in radiator core. Immerse core in tank of water. Mark places where air bubbles out of core. Solder leaks. Repeat inspection, again mark, and solder leaks, if any. **CAUTION:** Not more than 3 pounds air pressure should be used.

d. Disassembly (fig. 77).

(1) Take out cap screws holding radiator outlet and inlet pipe flanges to back of radiator, and remove pipes.

(2) Take out cap screws and nuts holding top tank flange to core flange. Remove nuts holding front radiator rods to radiator top tank flanges. Separate top tank from core, and remove gasket. Make sure copper overflow line from tank is free and clear.

(3) Take out cap screws and nuts holding core flange to bottom tank flange. Remove nuts holding front radiator rods to radiator bottom tank flanges. Remove core and gasket from bottom tank.

e. Assembly (fig. 77).

(1) Install front radiator rods in place between top and bottom core flanges. Set core upon lower radiator tank over a new gasket. Install nuts on ends of radiator rods projecting through lower tank flange. Install cap screws and nuts to clamp tank and core flanges together.

ENGINE AND ACCESSORIES

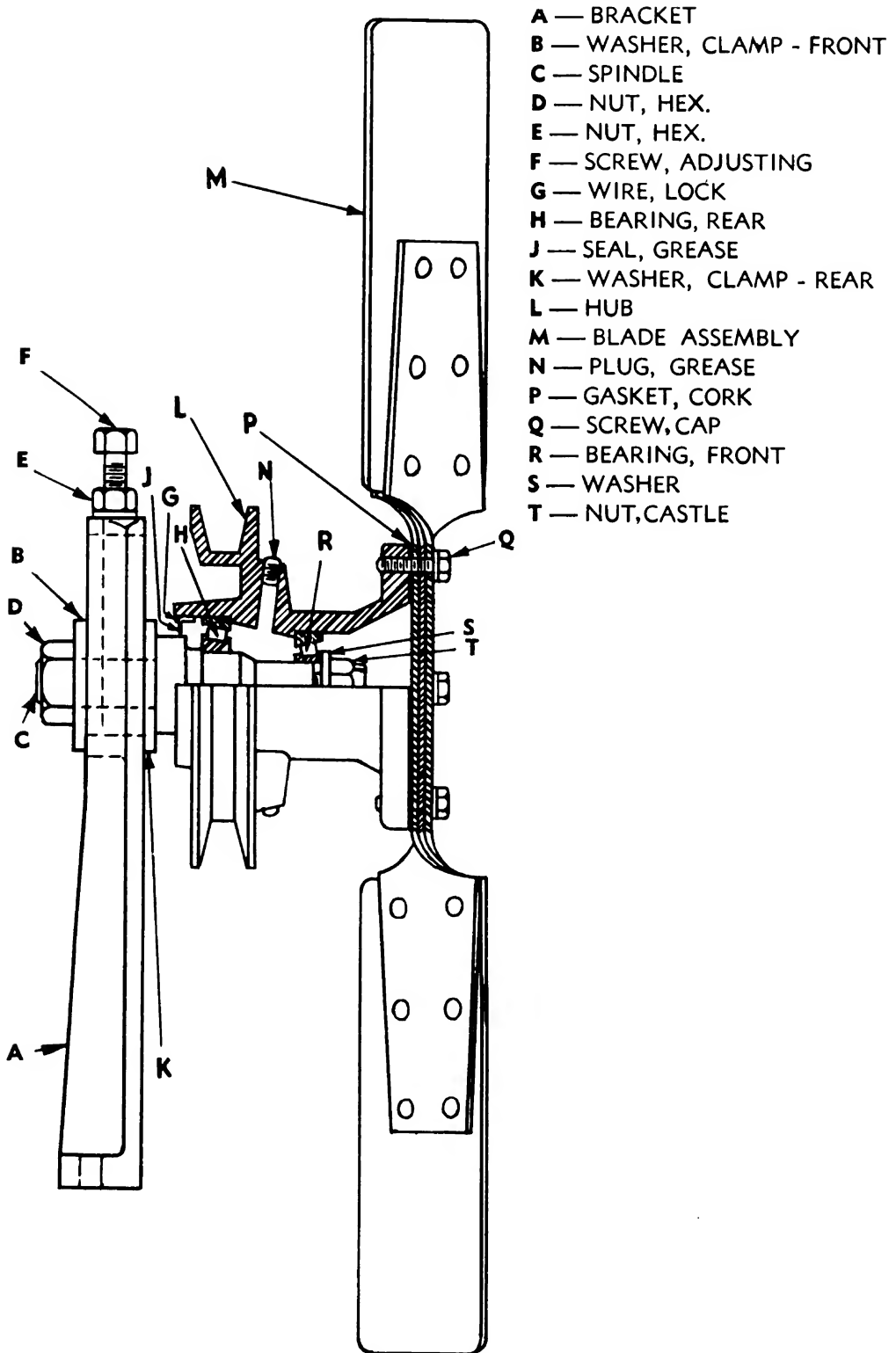

RA PD 73519

Figure 78 — Fan and Bracket Assembly

ORDNANCE MAINTENANCE — GENERATING UNIT M7

(2) Set a new gasket in place on top of the radiator core, and bring upper water tank down upon gasket and core. Secure tank to core with nuts and lock washers on front radiator rods and with cap screws and nuts through the flanges.

(3) Attach inlet and outlet pipes to radiator tanks with cap screws. If gaskets are at all mutilated or worn, replace.

(4) Attach radiator guard to rear of radiator with round-head machine screws.

f. Installation.

(1) Put shims in place on frame bracket (four over each mounting hole), set radiator in position, insert hold-down cap screws and nuts, and tighten nuts securely.

(2) Screw nut on 2³/₈-inch threaded end of each radiator support rod. Insert this end of each rod through holes provided in center bow uprights. Bring rods forward to meet tapped holes in radiator, and tighten rods in radiator holes. Put nut on other end of each rod and tighten nuts against center bow uprights (fig. 11).

(3) Attach radiator to housing with cap screws through roof and radiator flange, and install nuts.

(4) Place fan guard sections in position, and secure to fan guard housing with lock washers and nuts on the projecting bolts. Install machine screws and nuts to connect the sections.

(5) Install rubber hose sections connecting engine to radiator inlet and outlet pipes, and tighten clamp bolts.

(6) Attach end of flexible drainpipe to fitting below draincock.

g. Radiator Hose. The radiator hose is of reinforced rubber. The following sizes are used:

Upper radiator hose:

Inside diameter 2 in.

Length 4 in., 11½ in.

Lower radiator hose:

Inside diameter 1½ in.

Length 9 in.

Drain hose:

Inside diameter ½ in.

Length 18 in.

33. FAN (fig. 78).

a. Description. The fan, mounted on an adjustable bracket behind the radiator, is belt-driven from a pulley on the front of the accessory drive. The fan is of the pusher type, drawing the air through the unit and out through the radiator. The fan belt is V-type, 7/8 inch wide and 54 inches long. The fan roller bearings are lubricated through a grease plug in the hub.

ENGINE AND ACCESSORIES

RA PD 73520

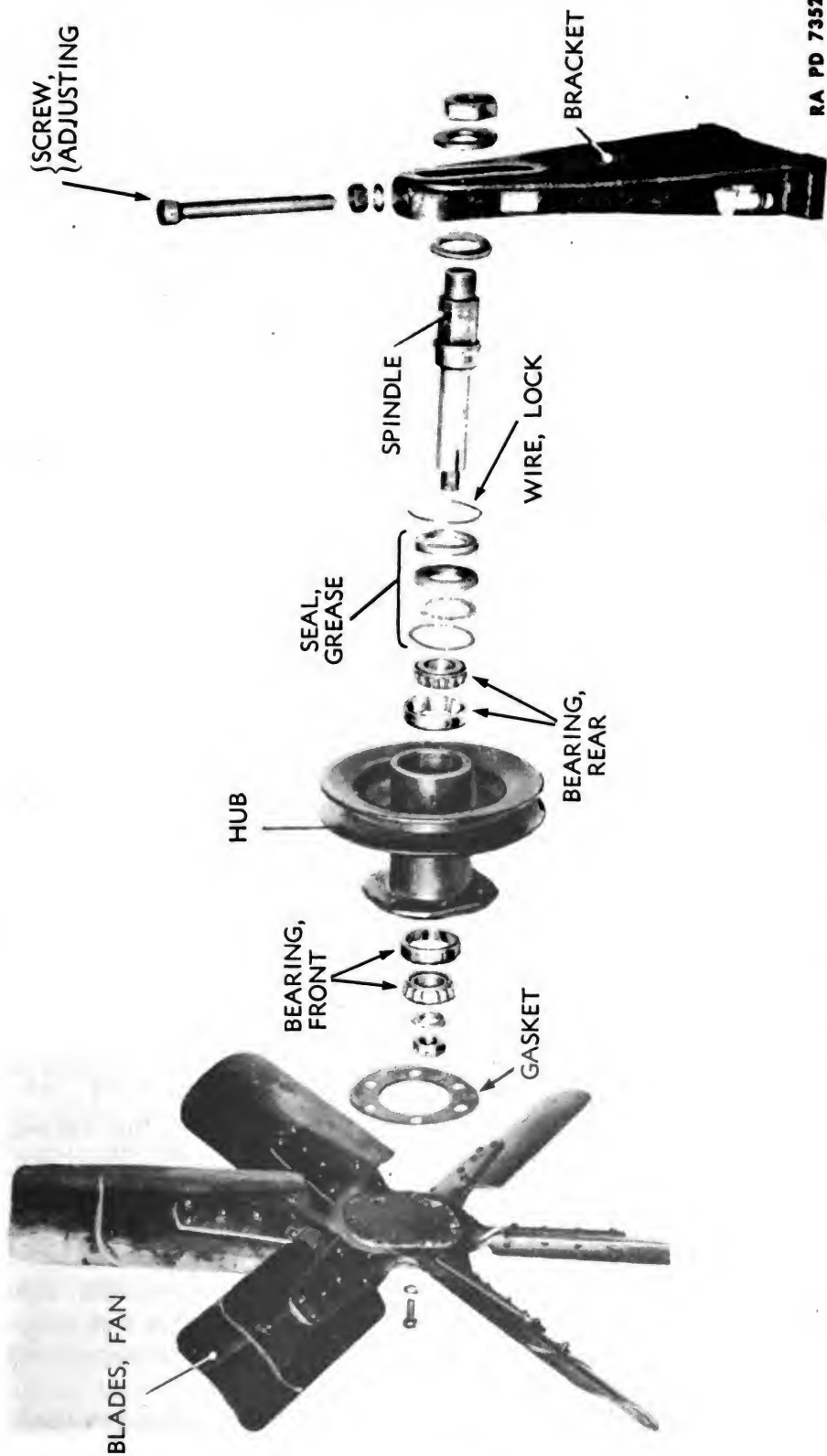

Figure 79 — Fan and Bracket Assembly — Exploded View

ORDNANCE MAINTENANCE – GENERATING UNIT M7**h. Disassembly (fig. 79).**

(1) Loosen lock nut on fan belt adjusting screw. Unscrew and remove adjusting screw and nut. Take nut and washer from spindle. Remove spindle from bracket.

(2) Remove cap screws holding fan assembly to hub.

(3) Pry out bearing retainer lock wire from groove in fan hub.

(4) Pull cotter pin and remove front bearing retaining nut and washer from fan spindle.

(5) Drive spindle from front roller bearing, and remove bearing core assembly from fan hub.

(6) Slide retainer, cork washer, and washer from spindle, and then drive rear bearing core assembly from spindle.

(7) Drive out front bearing cup and rear bearing cup from fan hub.

c. Inspection.

(1) Inspect spindle threads for damage or evidence of stripping, and check fit of spindle in bearings.

(2) Check fan for loose rivets or bent blades.

(3) Inspect roller bearings and retainers for scoring wear and evidence of loose fitting.

d. Maintenance and Repair.

(1) Keep fan hub filled with lubricant at all times. If grease-lubricated, remove plug and insert fitting to lubricate fan bearings. Replace plug. If oil-lubricated, use hand oiler.

(2) Replace all worn parts.

(3) Tighten loose fan rivets. Carefully straighten bent fan blades. If blades are badly bent, replace fan.

e. Assembly (fig. 79).

(1) Insert front and rear bearing cups and drive them in until they bottom against shoulder. Pack bearing cups and bearings with GREASE, general purpose, No. 2, and place bearings in cups if fan is grease-lubricated.

(2) In order named, install gasket, plain washer, and retainer in fan hub, back of rear bearing.

(3) Secure oil seal washer retainer lock wire in fan hub recess.

(4) Insert spindle in fan hub and replace washer, castellated nut, and cotter pin.

(5) Place fan blade assembly with gasket on fan hub, and install fan cap screws.

(6) Insert fan and hub assembly through slotted washer into slot in mounting bracket, and replace washer and spindle nut.

(7) Install fan adjusting screw with lock nut in top bracket, and thread screw into spindle.

(8) Remove oil plug in fan hub and fill with OIL, engine (seasonal grade), if fan is oil-lubricated.

ENGINE AND ACCESSORIES

Section III

FUEL SYSTEM

	Paragraph
Fuel system description	34
Fuel system trouble shooting	35
Fuel tank	36
Fuel pump	37
Carburetor description	38
Carburetor disassembly	39
Carburetor inspection	40
Carburetor maintenance and repair	41
Carburetor assembly	42
Air filter	43
Governor and throttle box description	44
Governor removal	45
Governor disassembly	46
Governor inspection and repair	47
Governor assembly	48
Governor installation	49
Governor adjustment	50
Throttle box disassembly	51
Throttle box inspection and repair	52
Throttle box assembly	53

34. FUEL SYSTEM DESCRIPTION (fig. 80).

a. The fuel system consists of the fuel tank, fuel pump, carburetor, air filter, intake manifold, governor, throttle and choke controls, and fuel and drain lines.

b. Suction action of the fuel pump takes the fuel from the tank to the pump, which then forces it to the top of the carburetor where it is mixed with the intake air to form a vapor. Suction of the engine pistons pulls air through the air filter into the carburetor where it picks up fuel vapor. The same action carries the vapor along to the intake section of the manifold.

c. The governor, operated from the timing gear, is set to hold the engine at a predetermined speed. The choke, operated manually from the instrument panel, regulates the air supply which makes the mixture rich or lean. The throttle, also operated from the instrument panel, reduces the amount of vapor supplied to the engine.

ORDNANCE MAINTENANCE – GENERATING UNIT M7

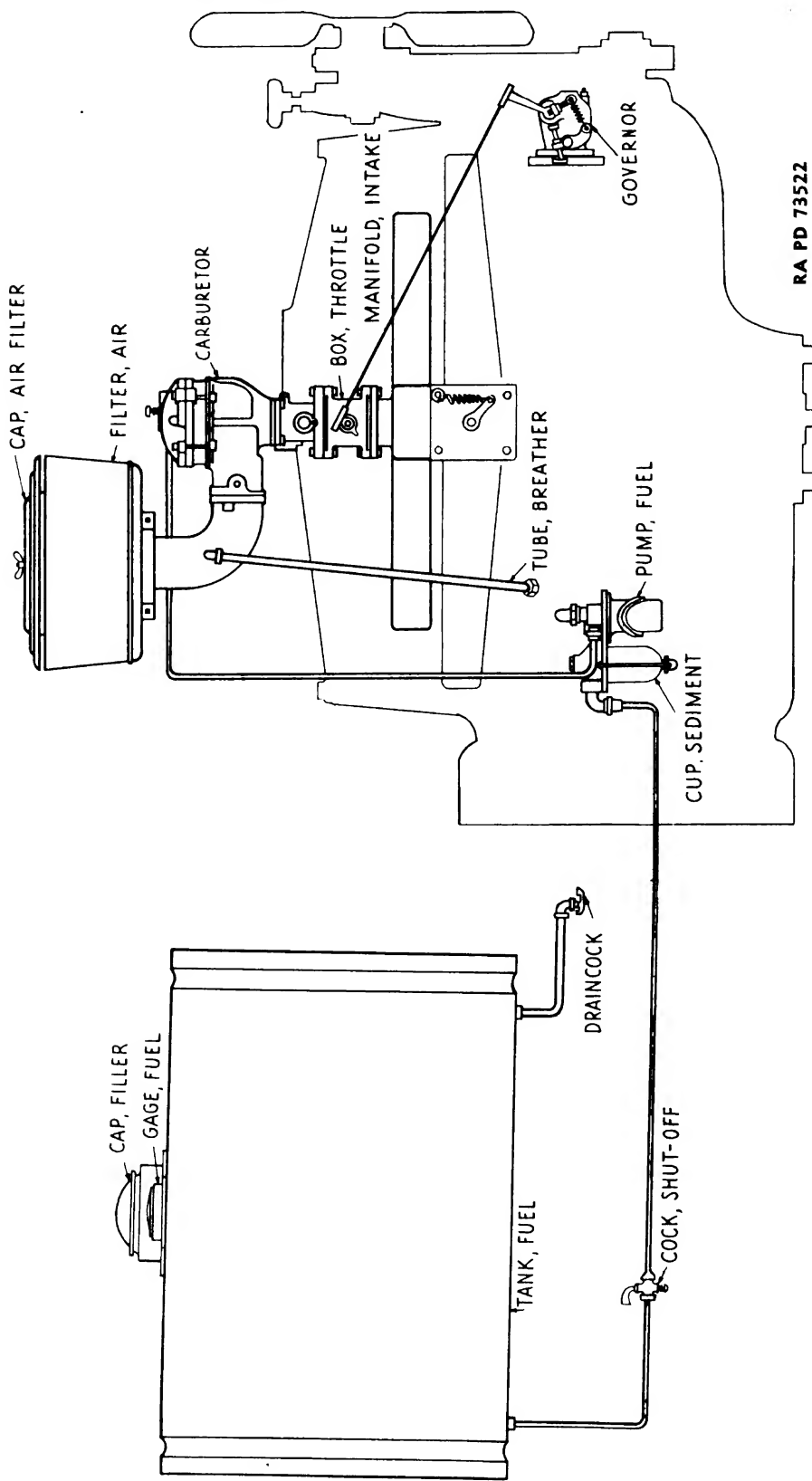

Figure 80 — Fuel System

ENGINE AND ACCESSORIES

35. FUEL SYSTEM TROUBLE SHOOTING.

a. Fuel Pump.

Possible Cause	Possible Remedy
(1) FUEL LEAKS.	
Loose sediment cup.	Tighten cup bracket nut.
Faulty sediment cup gasket.	Replace gasket.
Loose fuel line fittings.	Tighten fuel pump inlet and outlet fittings. Replace, if threads are stripped.
Broken fuel pump diaphragm.	Replace diaphragm.
Stuck valve.	Free up or replace valve or valve spring.

(2) LOW FUEL PRESSURE.

Air leaks in system.	Tighten connections.
Diaphragm out of order.	Replace diaphragm.
Stuck valve.	Free up, or replace valve or valve spring.
Broken lever or diaphragm spring.	Replace spring.

b. Carburetor.

(1) RICH MIXTURE.

Carburetor choke not fully opened.	Free up valve shaft and lubricate. Adjust choke control.
Dirt in carburetor.	Disassemble and clean.

(2) ENGINE DIES.

Engine will not idle.	Adjust idling screw.
-----------------------	----------------------

(3) FAST IDLING.

Improper control adjustment.	Adjust throttle control button and throttle stop screw.
Carburetor throttle.	Free up shaft and linkage and lubricate.
Carburetor controls sticking.	Free up and lubricate.
Air leaks.	Check intake manifold and carburetor gasket.

(4) LACK OF FUEL.

Empty fuel tank.	Fill tank with fuel.
Bent or kinked tubing.	Straighten or replace tubing.

ORDNANCE MAINTENANCE — GENERATING UNIT M7

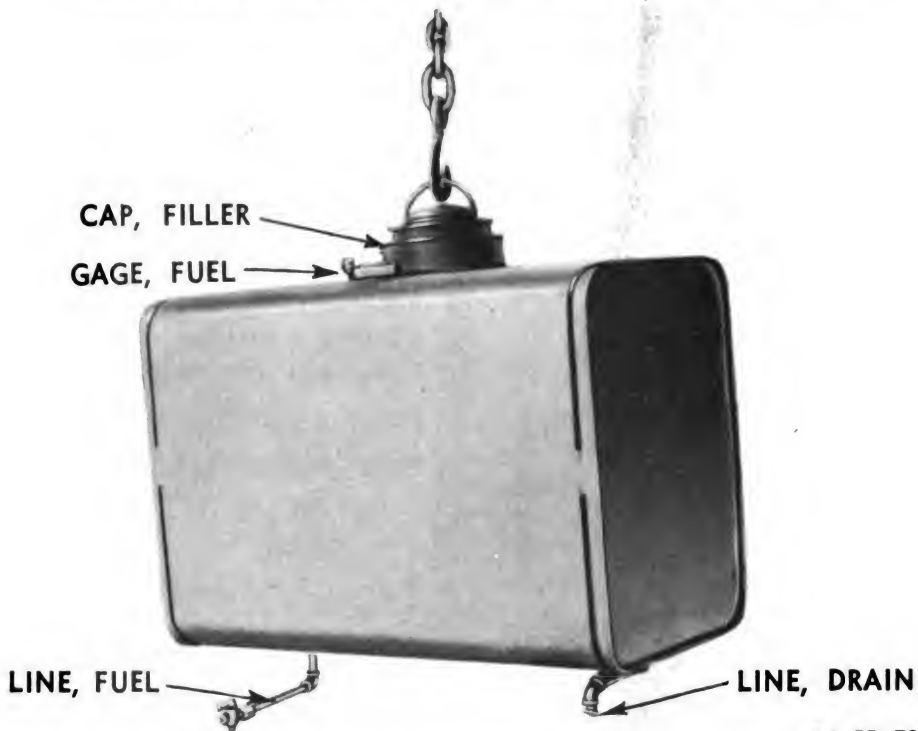

RA PD 73523

Figure 81 — Fuel Tank

Possible Cause	Possible Remedy
Sticking fuel valve in carburetor.	Replace fuel valve and seat.
Faulty fuel pump.	Repair or replace fuel pump.
(5) EXCESSIVE FUEL CONSUMPTION.	
Improper carburetor adjustment.	Adjust float level, idling screw, and throttle control stop screw.
Dirty air cleaner.	Clean air cleaner filter in SOLVENT, dry-cleaning. Change cleaner oil bath.
(6) FUEL LEAKS AT CARBURETOR.	
Loose body bolts or worn gaskets.	Tighten bolts, and replace gaskets.
Worn float needle valve.	Replace float needle valve and float needle valve seat.
Cracked float.	Replace float.
Choke valve stuck closed.	Free choke valve.
Choke lever loose on shaft and valve closed.	Open valve and tighten choke lever clamp screw.

ENGINE AND ACCESSORIES

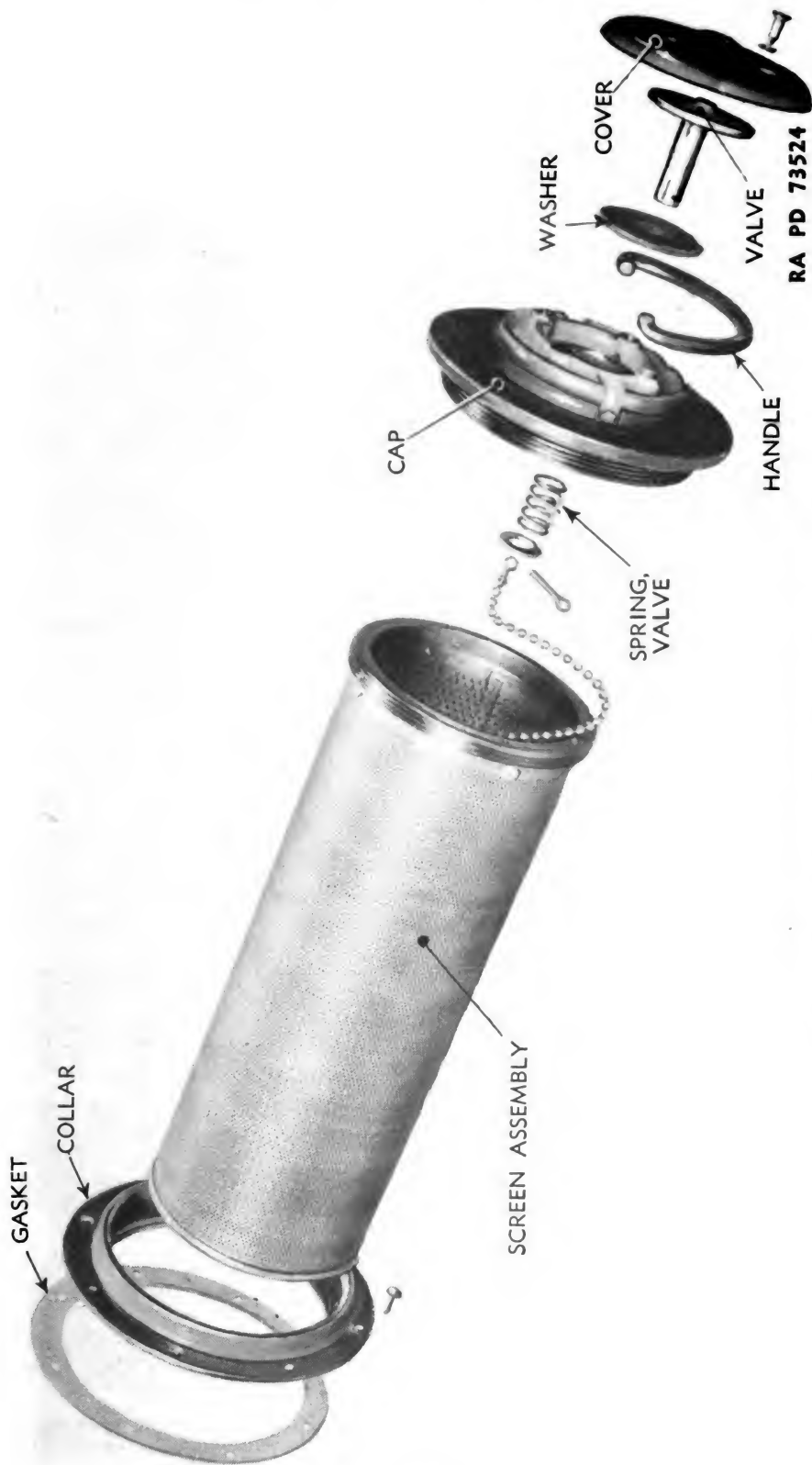
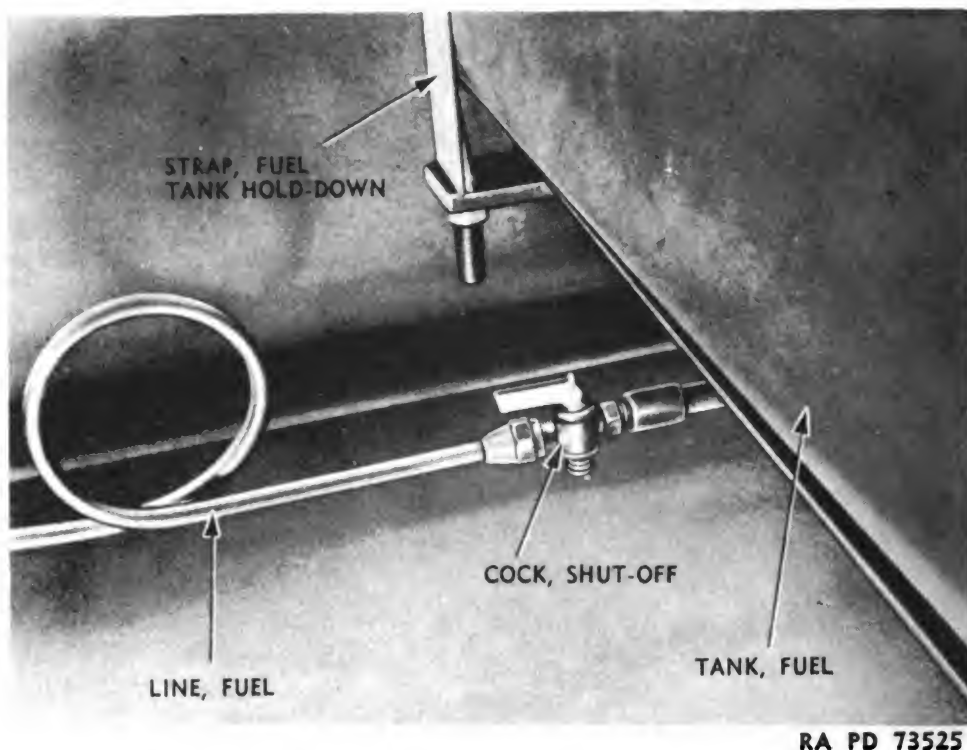

Figure 82 — Fuel Tank Filler Cap Assembly

ORDNANCE MAINTENANCE — GENERATING UNIT M7



RA PD 73525

Figure 83 — Fuel Line at Tank, Showing Shut-off Cock

36. FUEL TANK (fig. 81).

a. **Description.** The fuel tank is located at the rear of the unit, enclosed by a sheet metal guard. The fuel line feeds from a bottom pipe tap on the right-hand side. A short drain line ending with a drain-cock is placed opposite. A filler cap is provided with a special flame arrester screen (fig. 82).

b. Removal.

(1) Close shut-off cock on fuel line under fuel tank (fig. 83). Uncouple nut on engine side of cock, and disconnect line.

(2) Remove cap screws and nuts holding guard to rear housing panel. Remove cap screws and nuts holding guard to frame. Remove nuts from strap-end bolts attaching tank straps to frame cross member behind rear panel (fig. 86). Lift guard up and off. Remove tank.

c. Disassembly.

(1) Unscrew and remove filler cap. Unscrew and remove filler cap screen.

(2) Take out screws holding gage unit to tank and remove gage unit (fig. 85).

(3) Unscrew and remove drain line and fuel line connecting into base of fuel tank.

ENGINE AND ACCESSORIES

RA PD 73526

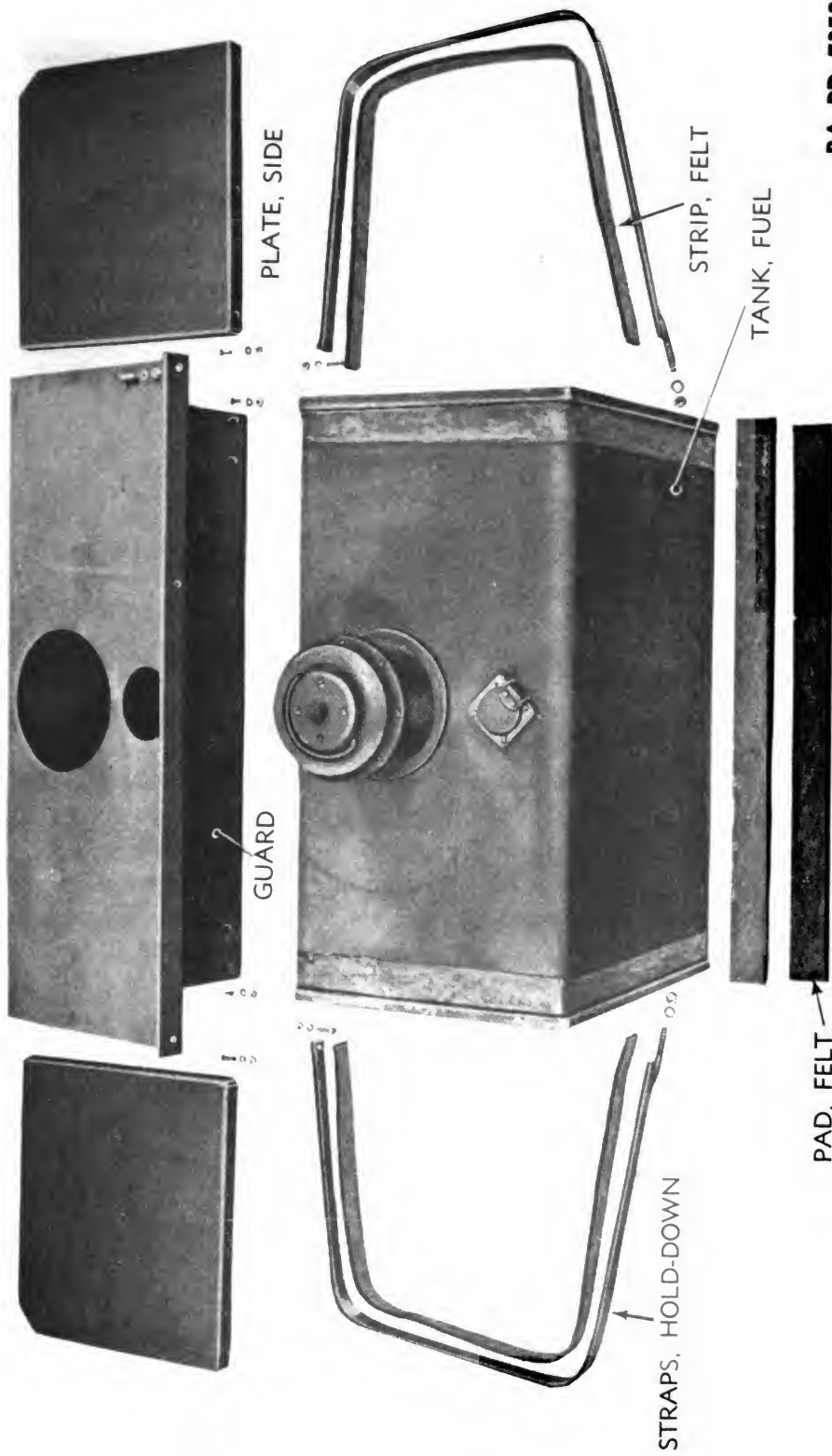
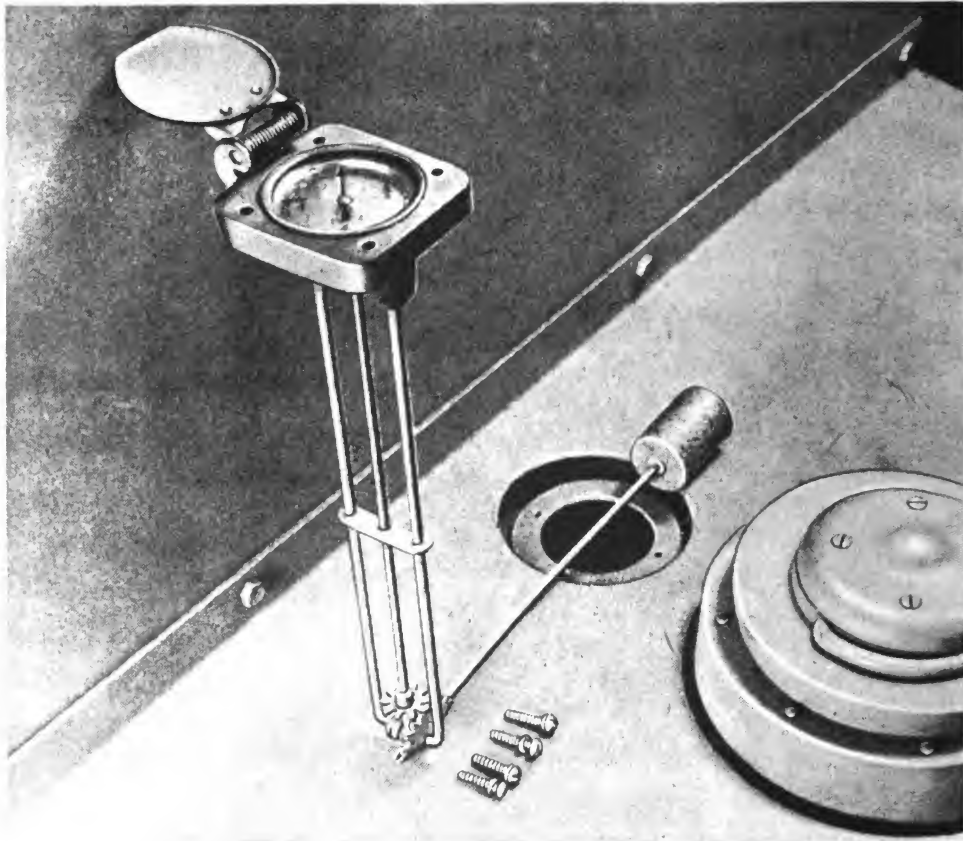

Figure 84 — Fuel Tank and Mounting Details

ORDNANCE MAINTENANCE — GENERATING UNIT M7



RA PD 56934

Figure 85 — Fuel Gage — Mechanical Type

d. **Cleaning.** Before attempting to repair any fuel tank, clean the tank thoroughly. This is absolutely necessary as a safety precaution against the explosion of gasoline or fumes remaining in the tank. The usual procedure is to fill the tank with a solution containing an alkaline cleaner (Q.M.C. Tentative Specifications ES-No. 542), and then flush it out with steam. While flushing, keep all the fittings open to drain the sediment and to avoid building up a steam pressure high enough to weaken or wreck the tank.

e. **Testing.** Fuel tanks are tested for leaks by either the wet or the air pressure method.

(1) The wet method is as follows:

(a) Tightly plug all openings except the filler neck.

(b) Dry the entire outer surface of the tank thoroughly with compressed air and a clean rag.

(c) Place the tank on a bench on top of blocks so that the under side can easily be seen with the aid of an electric light.

(d) Fill the tank with water.

ENGINE AND ACCESSORIES

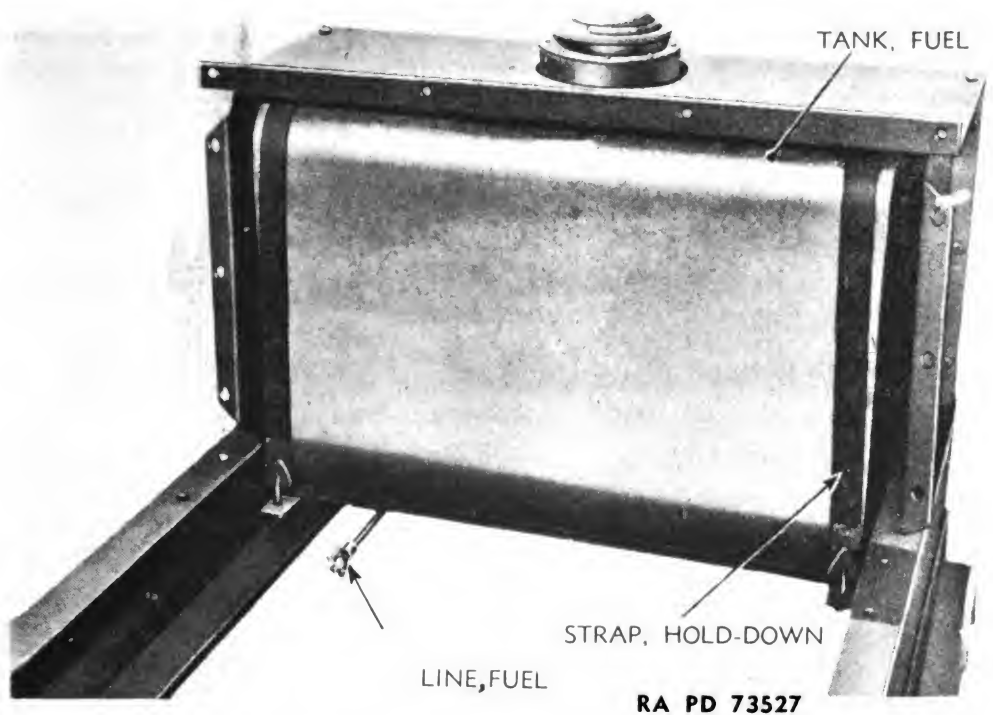

Figure 86 – Fuel Tank on Unit, Showing Hold-down Straps

(e) Insert the end of the air hose in the filler neck and cover the rest of the opening with the palm of the hand.

(f) Apply air pressure against the water by opening the air valve with the other hand for a few minutes.

(g) Examine the entire tank for moist spots where the water was forced through.

(2) The air pressure method is as follows:

(a) Plug all openings except the fuel outlet connection.

(b) Attach the loose end of the air supply hose to the fuel outlet connection by a short-threaded tube.

(c) Submerge the fuel tank in a tank of clean water, or cover it with a tank of soapy water.

(d) Turn on the air pressure, *not more than 5 pounds*.

(e) Draw a ring around each spot on the fuel tank where bubbles appear. The bubbles indicate leaks.

f. Repairing. The repair of fuel tanks is a soldering copper job, *not* a torch job, because of the danger of an explosion when an open flame is used. The soldering copper is safe and fast enough, if skillfully used. *Never use a torch.* If there are leaks about a fitting, remove the fitting, and clean and re-tin the joint before re-soldering the fitting to the tank. Use half-and-half solder. Holes in gas tanks can be repaired

ORDNANCE MAINTENANCE – GENERATING UNIT M7

by soldering a patch over the hole. Thoroughly clean and tin the section of the tank to be patched, tin one surface of the patch, and solder patch to fuel tank with tinned surface of patch against tank.

g. Assembly.

- (1) Screw fuel and drain pipes into collars at bottom of tank.
- (2) Set gage in position, and attach with screws.
- (3) Screw filler cap screen into collar, and then screw cap into place.

h. Installation.

- (1) Place tank on frame, and connect fuel line.
- (2) Bring fuel tank guard down over fuel tank, at the same time carrying tank hold down straps down under frame rear panel to holes provided for tank strap end bolts in frame rear cross member (fig. 86). Insert bolts and adjust nuts to hold straps firmly in place. Install cap screws and nuts to attach guard to frame. Install cap screws and nuts to attach guard end panel.

37. FUEL PUMP.

NOTE: Figures in parentheses correspond to those on figure 87.

a. Description.

(1) The fuel pump is a mechanical, diaphragm-type which is attached to the crankcase and operated by an eccentric on the engine camshaft.

(2) Diagram 1, figure 87 shows the action of drawing fuel from the fuel tank to the pump. The action of the eccentric cam (A) on the rocker arm (B) carries the end of bar (E) down, and with it the diaphragm (D). Suction action of the diaphragm opens the intake valve (H) over the sediment bowl (K), and draws fuel up through the valve and into the space created by the distended diaphragm. A half revolution of the camshaft, as shown in diagram 2, allows the lever (B) to fall back, releasing pressure on bar (E). The diaphragm spring (F) is released from compression, and pushes the diaphragm up in the pressure stroke. The pressure of the diaphragm forces the fuel through outlet valve (J).

b. Disassembly (fig. 88).

- (1) Loosen holding screw at bottom of sediment cup, swing out holding bracket and remove cup, gasket, and strainer.
- (2) Take out screws holding bottom cover to pump body.
- (3) Unscrew valve cap nuts, and remove valve springs and valves.
- (4) Take out screws holding cover to pump body, and remove cover. Remove nuts holding diaphragm to push rod, and take off diaphragm.

ENGINE AND ACCESSORIES

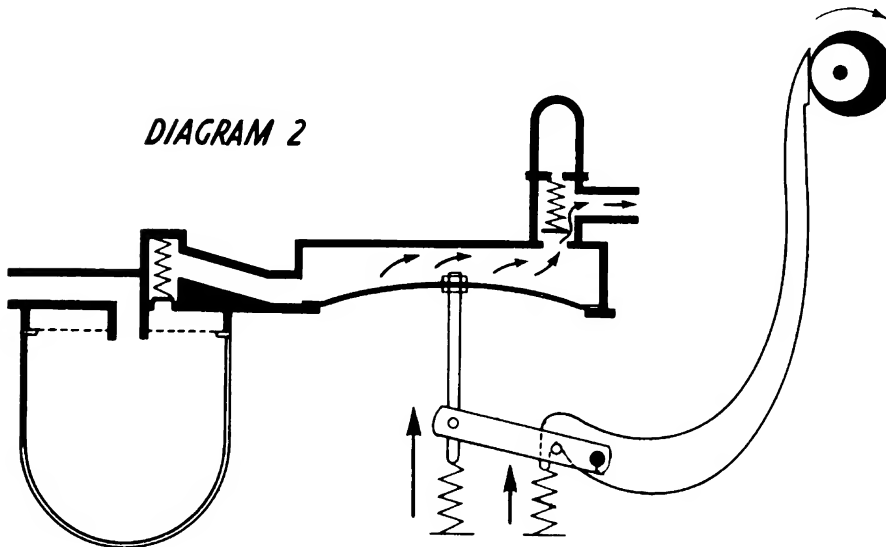
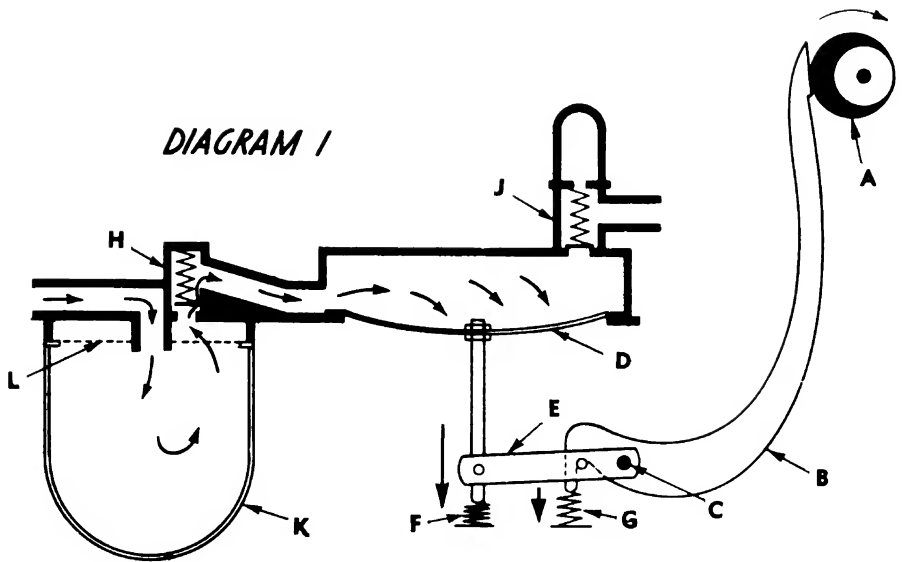

- A — CAM
- B — ARM, ROCKER
- C — PIVOT, ROCKER ARM
- D — DIAPHRAGM
- E — BAR

- F — SPRING, DIAPHRAGM
- G — SPRING, ROCKER ARM
- H — VALVE, INTAKE
- J — VALVE, OUTLET
- K — BOWL, SEDIMENT
- L — STRAINER, FUEL

RA PD 73529

Figure 87 — Fuel Pump Action Diagrams

ORDNANCE MAINTENANCE — GENERATING UNIT M7

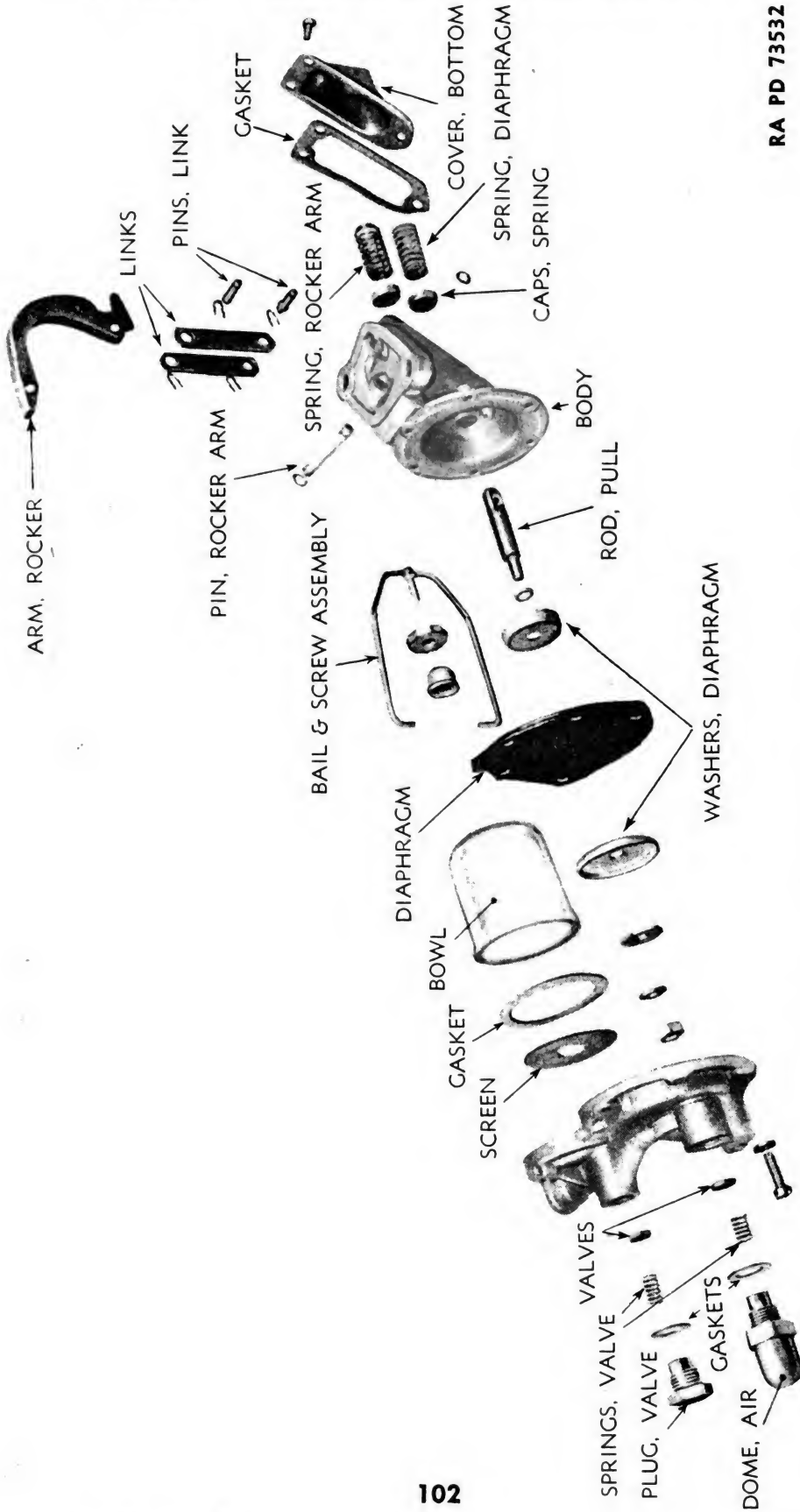

RA PD 73532

Figure 88 — Fuel Pump Assembly — Exploded View

ENGINE AND ACCESSORIES

c. Inspection. After the pump has been disassembled, it should be cleaned, and parts inspected.

(1) Replace all parts that show signs of wear or damage causing the pump to operate unsatisfactorily.

(2) Particularly note condition of diaphragm, and inspect inlet and outlet valves to make sure they are clean, and that springs seat valves properly.

d. Maintenance and Repair.

(1) **MAINTENANCE.**

(a) Examine pump and connections daily for leaks.

(b) Remove valve cap nuts at frequent intervals, and clean springs and valves.

(c) Remove, empty, and clean sediment cup.

(d) Remove and clean strainer and strainer gasket.

(e) Check tightness of bolts and screws.

(2) Repairs to pump are a matter of replacing defective parts.

e. Assembly. This procedure is the reverse of the procedure outlined in subparagraph **b**, above.

38. CARBURETOR DESCRIPTION (figs. 89, 90, and 91).

NOTE: Numbers and figures in parentheses correspond to those on figures 90 and 91.

a. The carburetor is of the downdraft-type. It employs a secondary Venturi to aid in complete vaporization of fuel. All air for fuel chamber ventilation and idling must come through the air filter, and air filter restrictions have a minimum influence on fuel-air ratio. It is designed with a vacuum controlled power jet and accelerating system. These auxiliary jet systems are to provide the extra fuel needed for certain operations.

b. The main discharge tube is centrally located directly above the Venturi. A metering well surrounds the upper portion of the discharge tube and is in the center of the fuel bowl. This concentration permits extremely high-angle operation in any direction. The removable double Venturi (19) measures the volume of air which passes through the carburetor.

c. Fuel, under normal fuel pump pressure, entering the float chamber through the fuel valve seat (11), is controlled by the float (14) which, moving on its axle (13), closes the needle valve (10) when the fuel reaches the proper level. At idling speeds, the throttle plate is almost closed, creating high suction at the edge of the plate. At this point the priming plug, or idle discharge orifice, is located. All fuel for part-throttle operation is ordinarily supplied through the main jet. In some cases this is supplemented by a bypass in the power jet valve.

ORDNANCE MAINTENANCE — GENERATING UNIT M7

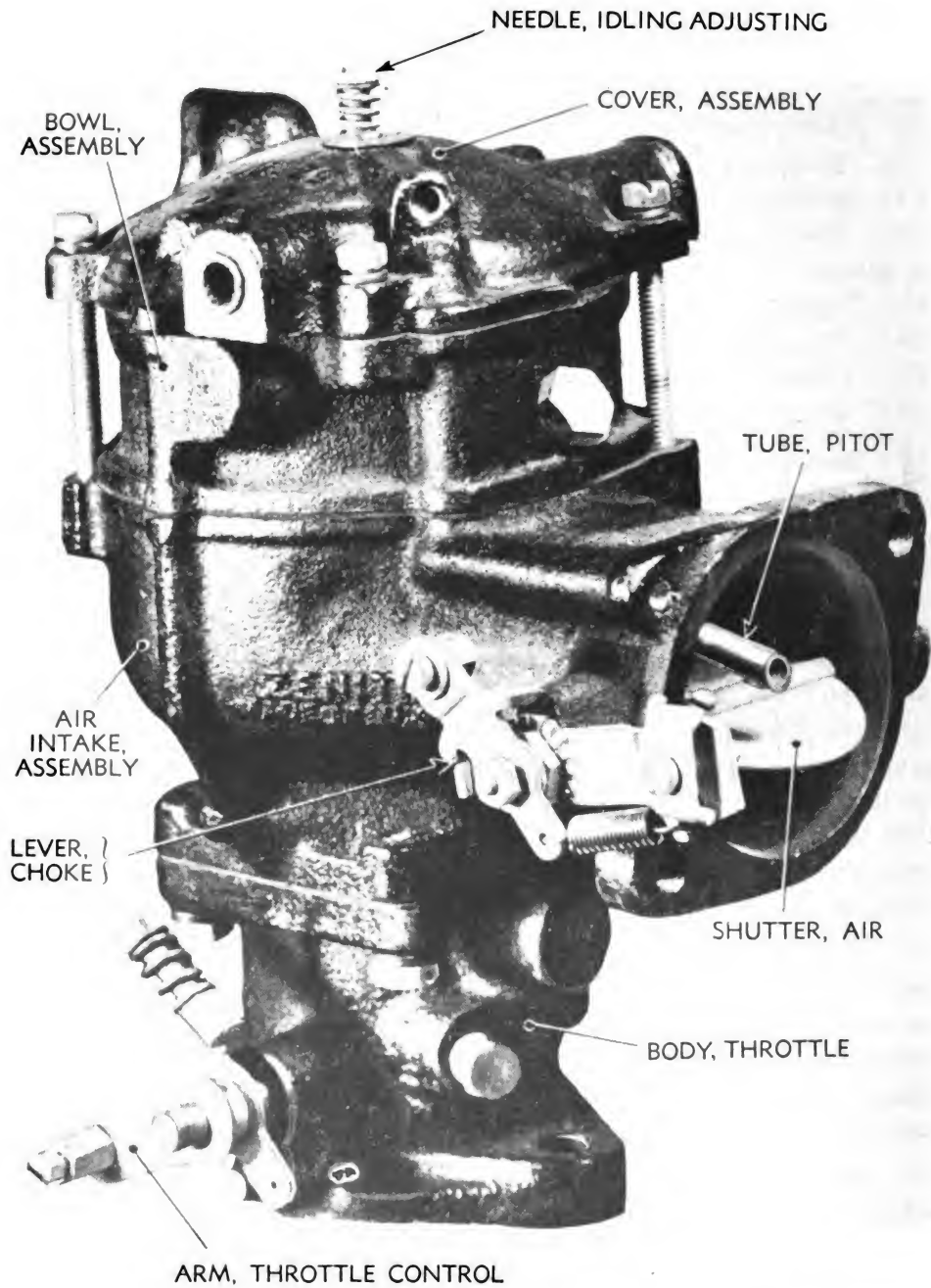

RA PD 73533

Figure 89 — Carburetor

ENGINE AND ACCESSORIES

Fuel from the float chamber floats through the main jet (16) into the metering well (9). Fuel for idling is drawn from this well through the metering orifice in the lower end of the idling jet (22). As fuel reaches the idling channel (E), it is mixed with air admitted from air intake channel (G) through permanent bleed (F), plus that admitted by the idling adjusting needle (23). The mixture passes through channel (E) to priming plug (20), at which point it is discharged into the air stream. Permanent bleed (F) prevents fuel from being siphoned into the manifold.

d. As the throttle is opened, the suction at the priming plug diminishes, but the increased volume of air entering the engine creates sufficient vacuum in the secondary Venturi (19) to draw fuel from the metering well (9) up and over into the discharge tube (17). Air from the float chamber, which is vented through a channel to the pitot tube (18) in the air intake, is admitted to the outer side of the metering well through the well vent (21). The manifold vacuum is communicated through opening (A) and channel (B) to the vacuum cylinder (D). Under normal part-throttle operating conditions, the vacuum piston and pump assembly (5) is held in the upper position as illustrated, and the power jet valve (3) is closed. When the throttle is opened wide, or when the load on the engine is increased to a point where the manifold vacuum drops below a predetermined point, the pump assembly drops, and holds the power jet valve (3) open. This permits fuel to flow through the power jet calibration (C) to supplement the main jet fuel in the well and provide a full power mixture. When the throttle position allows the manifold vacuum to rise above a predetermined point, the pump assembly is lifted and the power jet valve closed, permitting the carburetor to deliver an economy mixture again.

e. Quick opening of the throttle produces a sudden drop in the manifold vacuum, which allows the pump piston to be forced down by the pump spring. The downward movement of the piston closes pump check valve (4), opens refill check valve (6), closes air vent check valve (7), and discharges pump fuel through accelerating jet (8) into main discharge tube (17). When the pump stroke is completed, the air vent valve disk drops, opening air vent (7) and closing pump refill valve (6). Pump check valve (4) also opens (by gravity) to permit fuel to flow to the power jet or to refill the pump cylinder on the upward stroke of the pump. The air vent (7) supplies air from the float chamber to the accelerating jet to break suction on the accelerating and power jet system when the vacuum piston starts to lift the pump assembly.

ORDNANCE MAINTENANCE — GENERATING UNIT M7

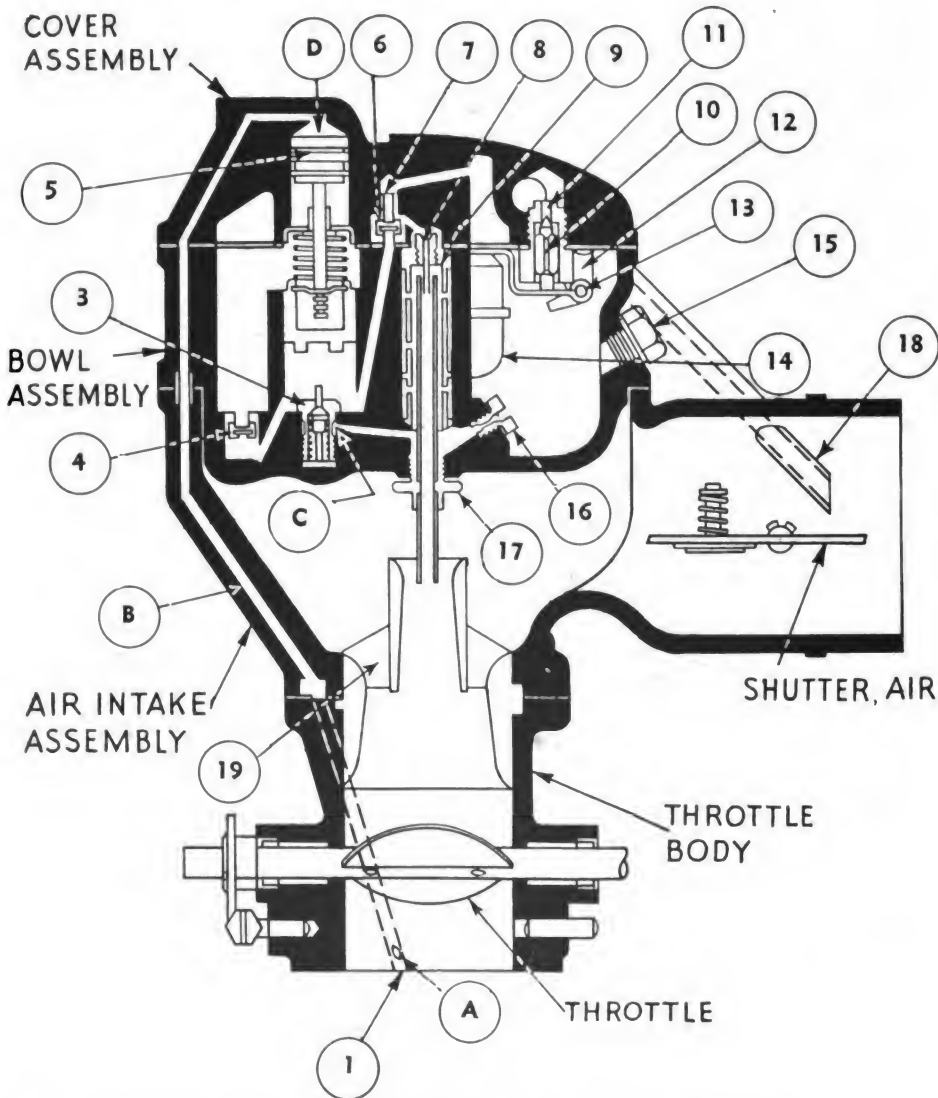

- | | |
|-------------------------------------|--------------------------------|
| A — MANIFOLD VACUUM OPENING | 9 — WELL, METERING |
| B — MANIFOLD VACUUM CHANNEL | 10 — VALVE, NEEDLE |
| C — POWER JET CALIBRATION | 11 — SEAT, FUEL VALVE |
| D — CYLINDER, VACUUM | 12 — BRACKET, FLOAT HINGE |
| 1 — CHANNEL, BY-PASS | 13 — AXLE, FLOAT |
| 3 — VALVE, POWER JET | 14 — FLOAT |
| 4 — PUMP CHECK VALVE | 15 — PLUG, BOWL ACCESS |
| 5 — VACUUM PISTON AND PUMP ASSEMBLY | 16 — JET, MAIN |
| 6 — VALVE, REFILL CHECK | 17 — TUBE, MAIN DISCHARGE |
| 7 — VALVE, AIR VENT CHECK | 18 — TUBE, PITOT |
| 8 — JET, ACCELERATING | 19 — VENTURI, REMOVABLE DOUBLE |

RA PD 73534

Figure 90 — Carburetor, Diagram 1

ENGINE AND ACCESSORIES

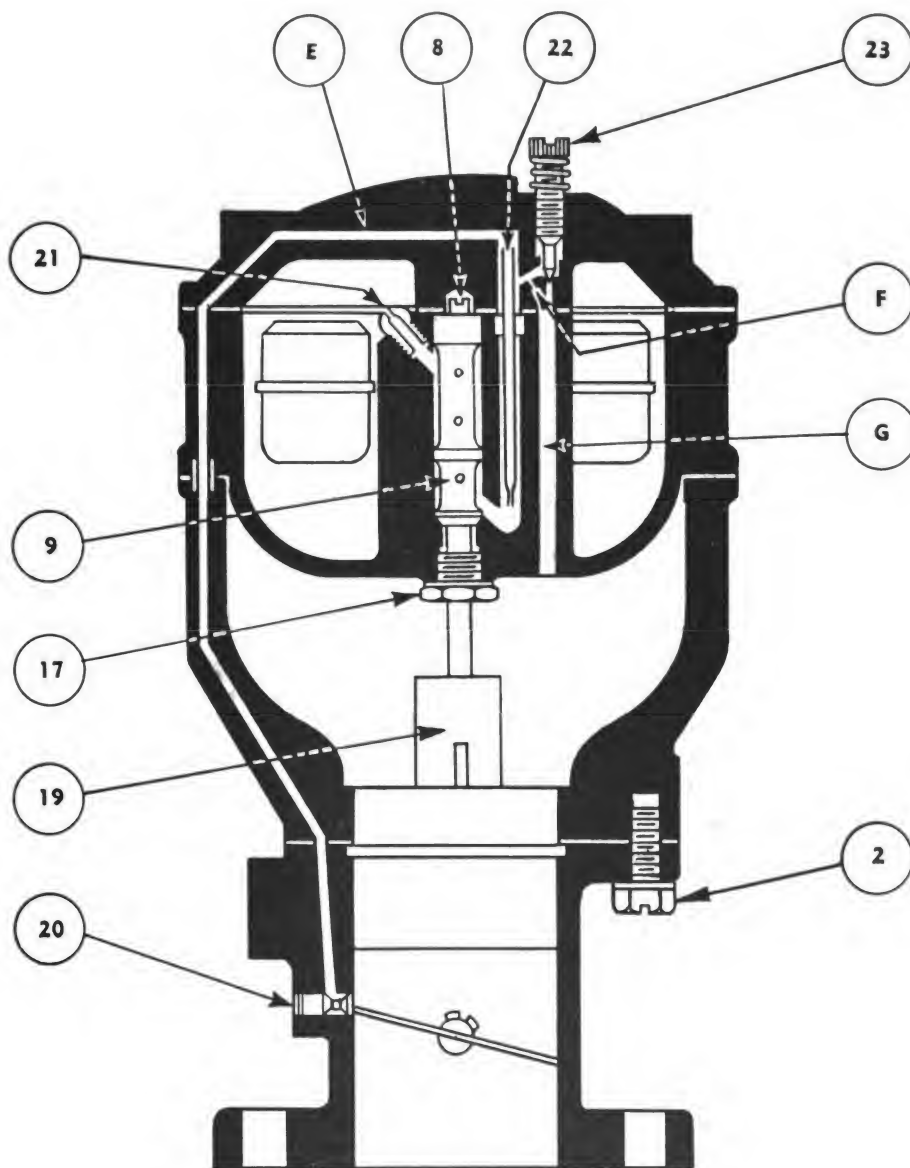

- E — IDLING CHANNEL
- F — PERMANENT BLEED
- G — AIR INTAKE CHANNEL
- 2 — SCREW, AIR INTAKE TO THROTTLE BODY
- 8 — JET, ACCELERATING
- 9 — WELL, METERING
- 17 — TUBE, MAIN DISCHARGE
- 19 — VENTURI, REMOVABLE DOUBLE
- 20 — PLUG, PRIMING
- 21 — VENT, WELL
- 22 — JET, IDLING
- 23 — NEEDLE, IDLING ADJUSTING

RA PD 73535

Figure 91 — Carburetor, Diagram 2

ORDNANCE MAINTENANCE — GENERATING UNIT M7

39. CARBURETOR DISASSEMBLY.

NOTE: The following special tools are required for complete disassembly:

Tool No. C161-5, Zenith.

Tool No. 161-123, Zenith.

Tool No. 161-121, Zenith.

a. Procedure.

(1) Unscrew idling adjusting screw at top of carburetor, and remove screw and spring.

(2) Take out the two long outside screws holding the bowl to the air intake assembly. Remove bowl (fig. 92), turn upside down, and take off gasket.

(3) Unscrew discharge tube, and remove tube and gasket (fig. 93).

(4) Turn the bowl right side up and remove the two short screws that hold the cover to the bowl, and remove cover and gasket.

(5) Lift pump assembly out of cover (fig. 94).

(6) Push float axle through the slotted end of the hinge bracket, and remove. Take out float assembly and fuel valve needle (fig. 95).

(7) Unscrew fuel valve seat, and remove seat and gasket.

(8) Insert tapered thread end of tool C161-5 into the valve body and screw in (counterclockwise) until tool is firmly attached to the body, then raise the sliding weight up sharply against the stop bar a few times to remove the port. Be careful to avoid screwing the tool too deeply into the valve body as it may damage the air vent check valve seat that is pressed into the cover directly above this point. If the hole in the valve body becomes enlarged, grind a little off the end of the tool so it will start to grip the body sooner.

(9) Lift idling jet out of the bowl casting (fig. 96).

(10) Unscrew well vent from the bowl casting, and remove.

(11) Remove metering well and accelerating jet. Unscrew accelerating jet from metering well (fig. 97).

(12) Carefully center tool C161-121 on valve head, and remove power jet valve and gasket.

(13) Unscrew bowl plug, and remove.

(14) Insert screwdriver through hole where plug was removed, loosen main jet, and remove (fig. 98).

(15) Insert taper thread end of tool C161-123 into the valve and screw in (counterclockwise) until the tool is firmly attached to the valve body, then strike the bent end with a hammer squarely and sharply a few times to pull the valve out. If tool pushes the valve disk out, be sure the disk is not left in the carburetor channel.

(16) Turn assembly upside down, remove cap screws connecting throttle body and air intake chamber. Remove throttle body (fig. 99).

ENGINE AND ACCESSORIES

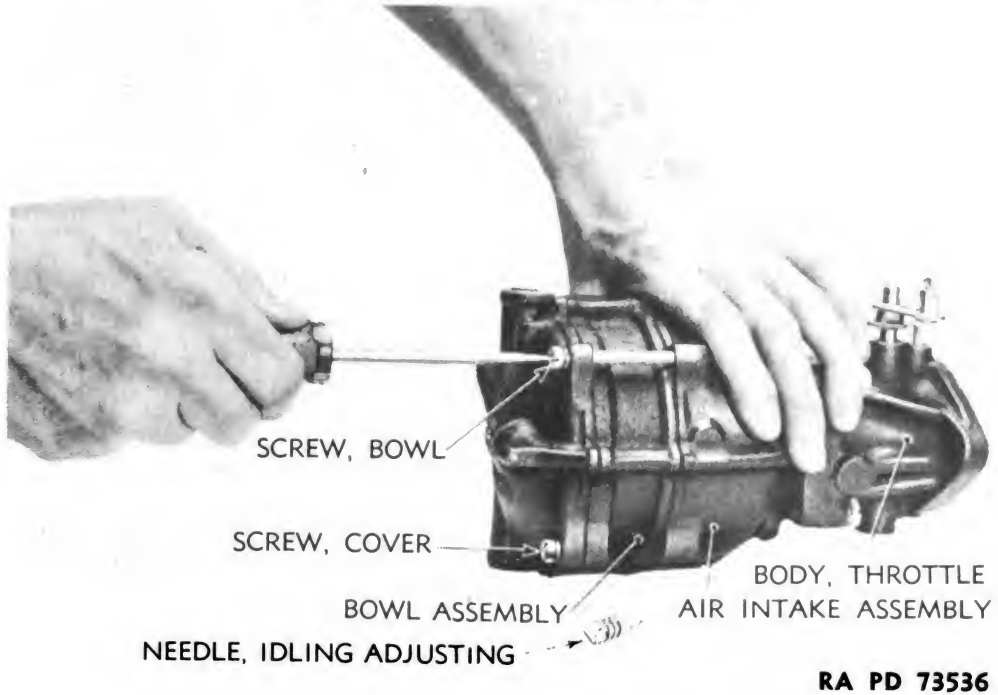

Figure 92 – Carburetor Bowl Assembly Removal

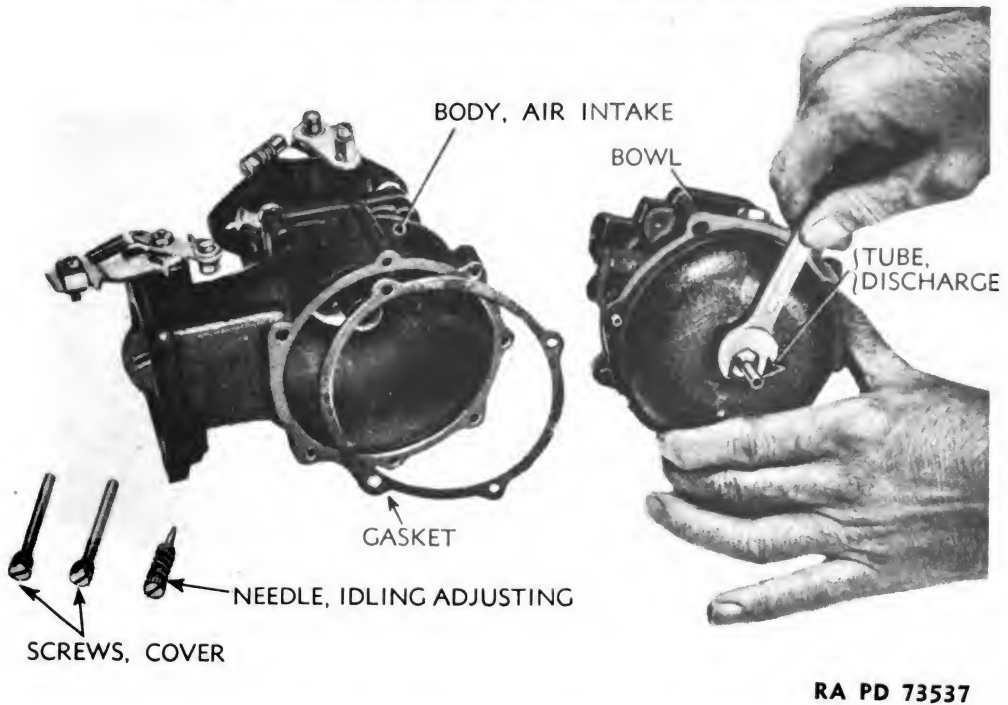
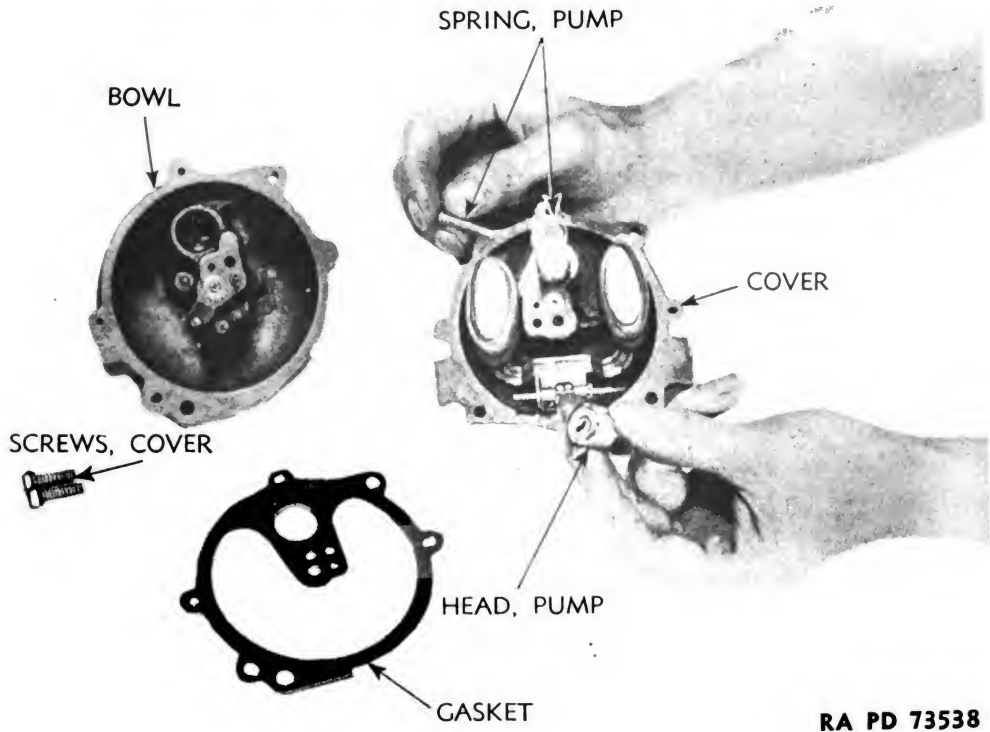

Figure 93 – Discharge Tube Removal

(17) File off the riveted ends of the screws holding throttle plate in shaft. Take out the screws attaching the plate. Slide plate through shaft, and remove. Pull shaft through body, and remove (fig. 100).

ORDNANCE MAINTENANCE — GENERATING UNIT M7



RA PD 73538

Figure 94 — Pump Assembly Removal

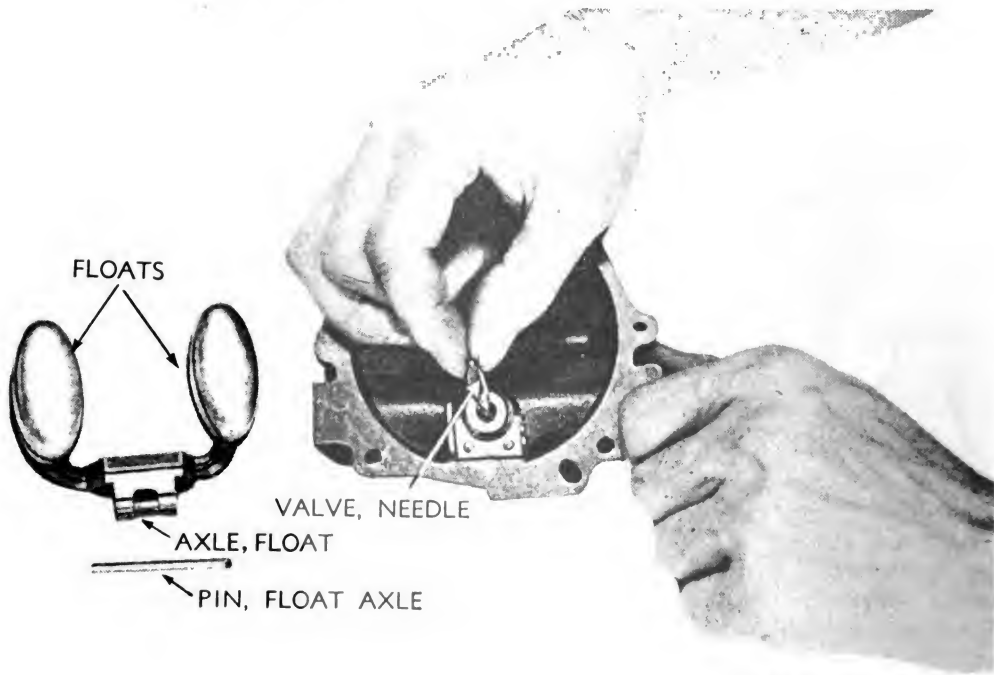

RA PD 73539

Figure 95 — Fuel Valve Needle Removal

ENGINE AND ACCESSORIES



RA PD 73540

Figure 96 — Idling Jet Removal

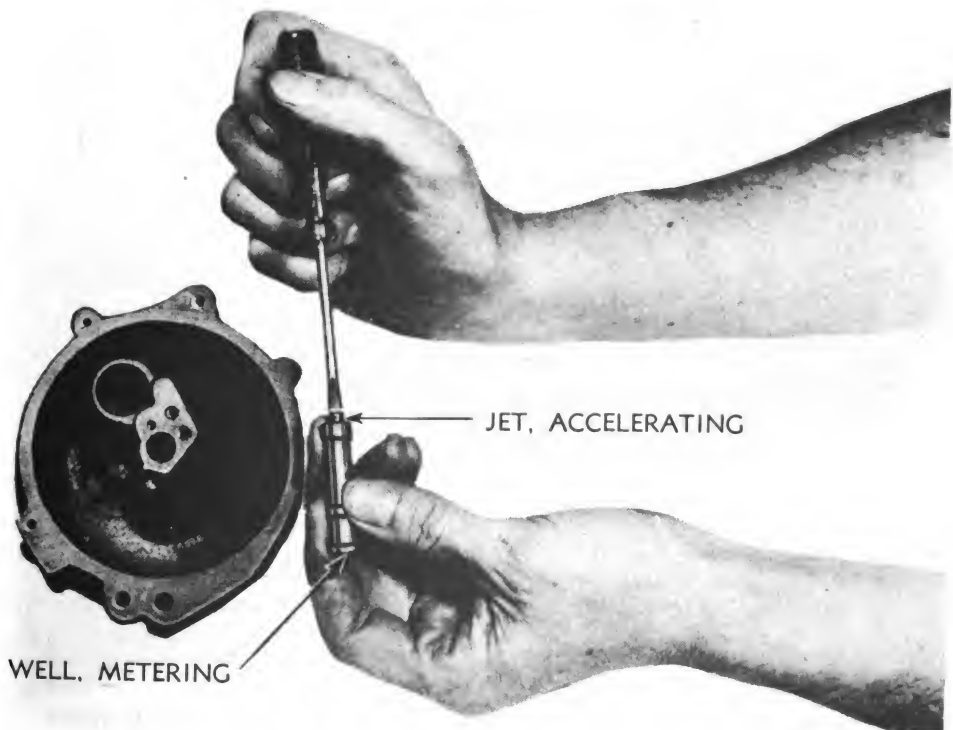

RA PD 73541

Figure 97 — Removing Accelerating Jet from Metering Well

ORDNANCE MAINTENANCE – GENERATING UNIT M7

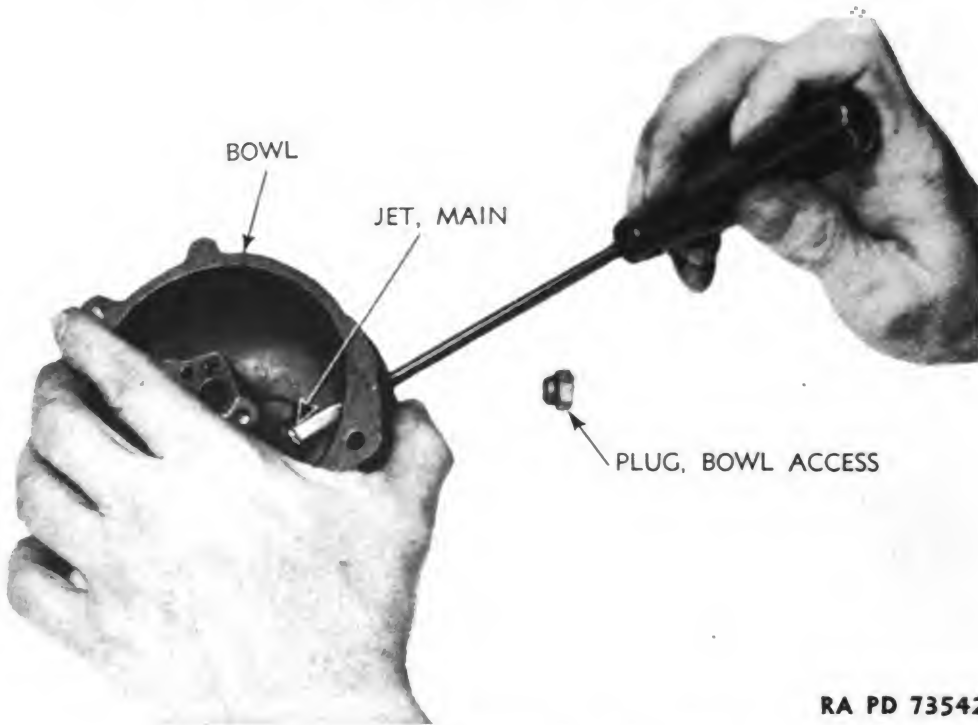

RA PD 73542

Figure 98 – Main Jet Removal

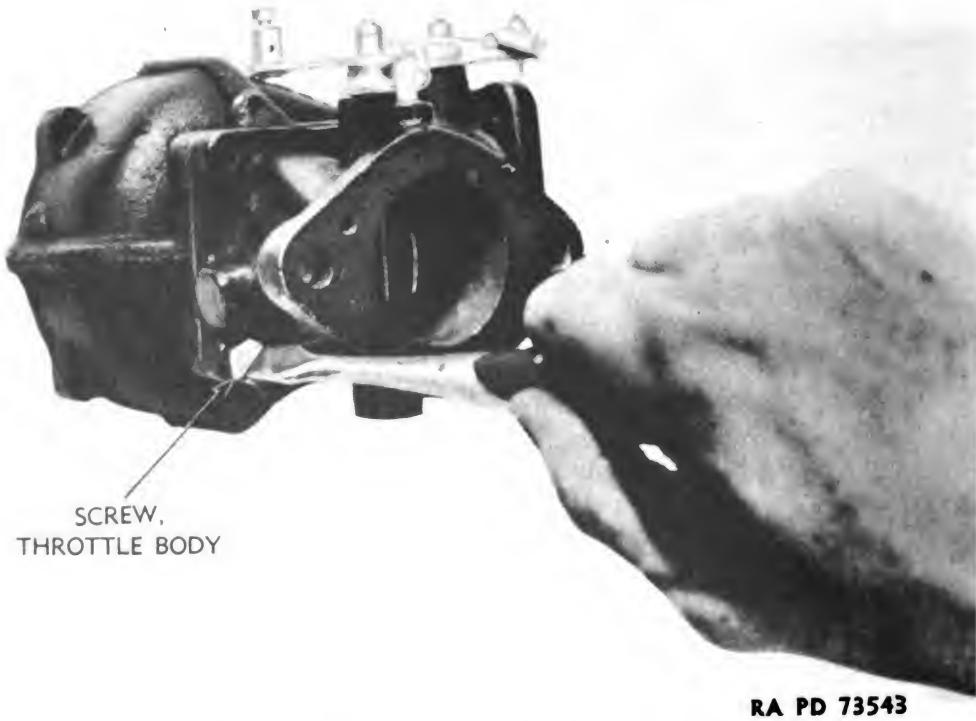

RA PD 73543

Figure 99 – Throttle Body Removal

ENGINE AND ACCESSORIES

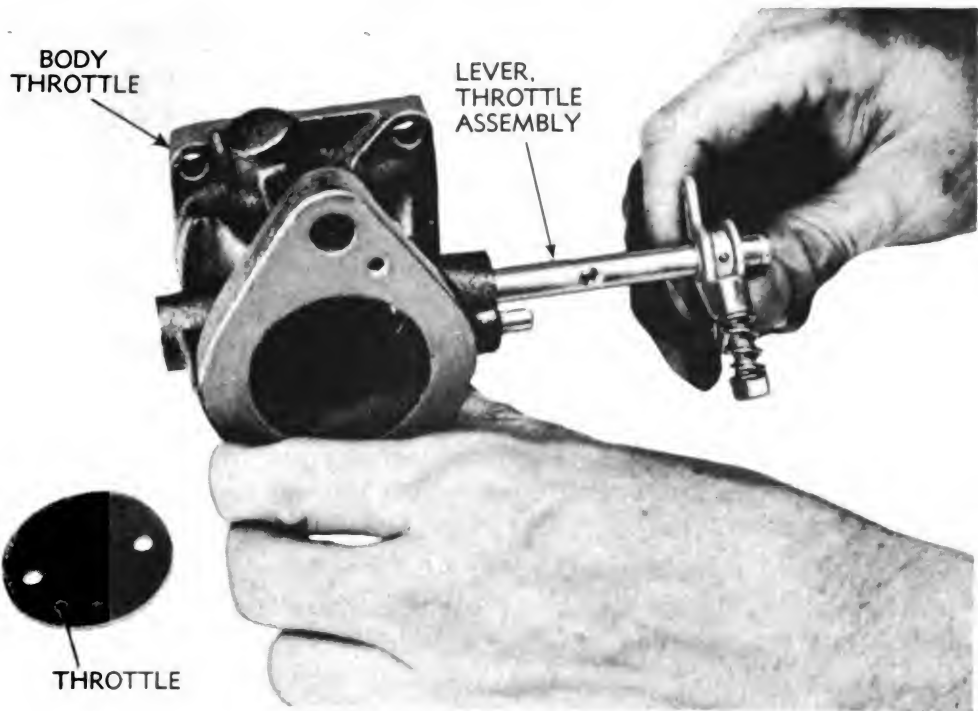

RA PD 73544

Figure 100 — Throttle Shaft Removal

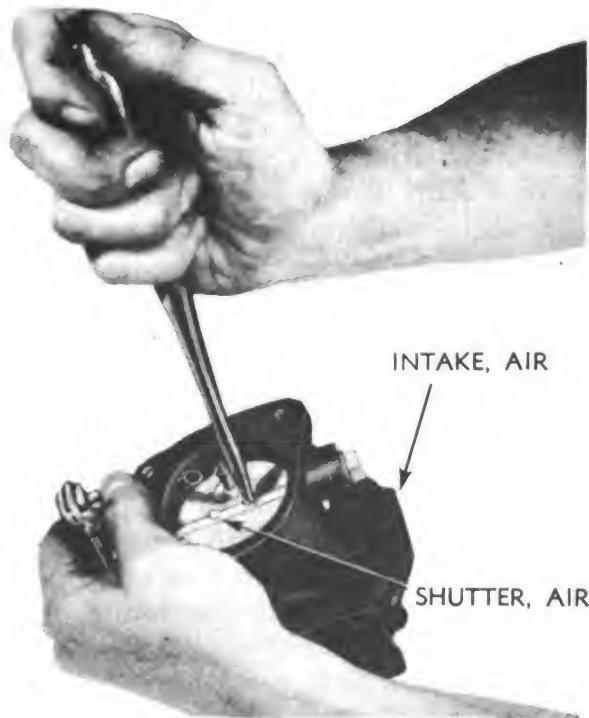

RA PD 73545

Figure 101 — Removing Air Shutter Retainer Screws

ORDNANCE MAINTENANCE – GENERATING UNIT M7

(18) File the riveted ends of the air shutter retainer screws and take out screws (fig. 101). Push air shutter through shaft and remove. Slide shaft out of throttle body with lever in position.

(19) Take out shaft hole plug, and remove plug and gasket.

40. CARBURETOR INSPECTION.**a. Procedure.**

(1) A carburetor, in which dirt and other foreign matter have been allowed to accumulate, will seldom function properly. Therefore, wash all parts in SOLVENT, dry-cleaning, and dry with compressed air.

(2) Inspect bowl body, air intake body, and throttle body for cracks and fractures. These are iron castings and may break. Blow out all air and jet holes with compressed air. Be certain air and jet holes are unobstructed.

(3) Inspect condition of solder which holds the halves of each float together. Look for cracks or breaks. Shake floats. If a sloshing sound is heard, indicating gasoline within a float, the float leaks, and must be replaced with a new one.

(4) Examine jets, Venturi tubes, valve seats, and tubes for cracks, fractures, or possible obstructions due to dirt or other foreign matter.

(5) Examine threads of all screws, plugs, nuts, and connections. Be sure drilled openings are free of dirt and foreign matter.

(6) Examine valves, washers, levers, float axle, hinge, and hinge bracket for breakage.

(7) Check all jet orifices with proper size drills. If oversize due to wear, replace with new jets. When replacing jets, make sure new jets have the same calibration numbers as the old.

41. CARBURETOR MAINTENANCE AND REPAIR.**a. Maintenance.**

(1) The carburetor should be removed, disassembled, and thoroughly cleaned in SOLVENT, dry-cleaning, at least once a year or every 500 hours of operation.

(2) All carburetor adjustments except idling are fixed, and for this reason the carburetor should not give any trouble, provided regular cleaning and inspection schedules are maintained. However, carburetor jets will wear in service, resulting in an overrich mixture and lack of engine efficiency. Then replacement or overhaul is desirable.

(3) Correct fuel level height is particularly important in obtaining greatest fuel economy. To obtain correct fuel level with normal pump pressure, the distance from the bottom of the float to the bot-

ENGINE AND ACCESSORIES

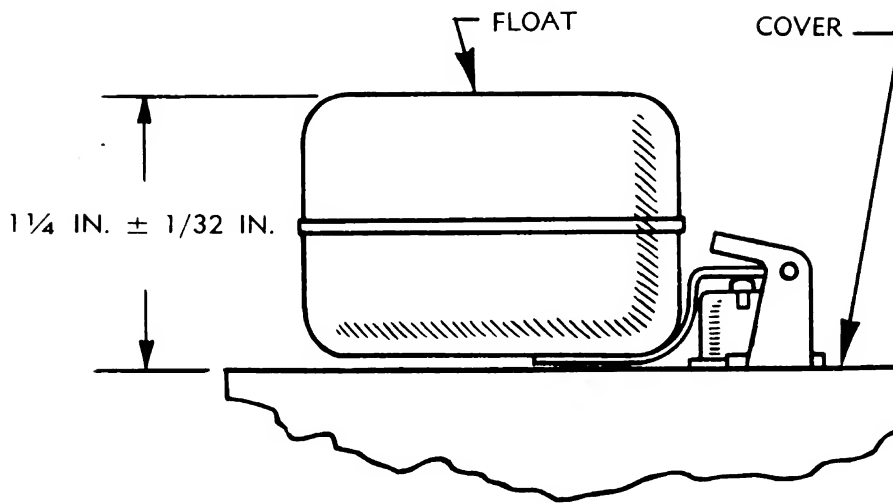

RA PD 73546

Figure 102 — Float Level Dimension

tom surface of the cover, as shown in figure 102, should be $1\frac{1}{4}$ inch plus or minus $\frac{1}{32}$ inch. A new and undamaged part will come within these limits.

(4) Uniform idling and part-throttle operation are very much dependent on the location of the priming plug hole in relation to the throttle plate. For this reason, throttle plates and bodies cannot be exchanged indiscriminately. If it is necessary to replace the throttle shaft or plate, back off throttle stop screw so that throttle plate can be completely closed. Holding the throttle in the closed position, scribe a line on the inside of the throttle body along the line of the throttle plate. Using the scribe line as a guide, replace throttle shaft or plate. If new plate shows a noticeable variation from the old one, select another new plate to get one that fits very close to the scribed line when installed.

b. Repair.

(1) Very few of the carburetor components can be repaired. Trouble of any kind except as noted below calls for replacement either of the complete carburetor or of the individual part.

(2) **FLOATS.** Floats cracked along the seam between the halves can be resoldered.

(3) **FUEL LEVEL.** To ensure the correct fuel level, with normal pump pressure, the floats should rest so that the distance from the bottom of the floats to the bottom surface of the cover, as shown in figure 102, is $1\frac{1}{4}$ inch plus or minus $\frac{1}{32}$ inch. If the float arm has been bent, or if for any other reason the floats do not take the proper level the arm may be bent slightly until the floats do take the correct level.

ORDNANCE MAINTENANCE - GENERATING UNIT M7

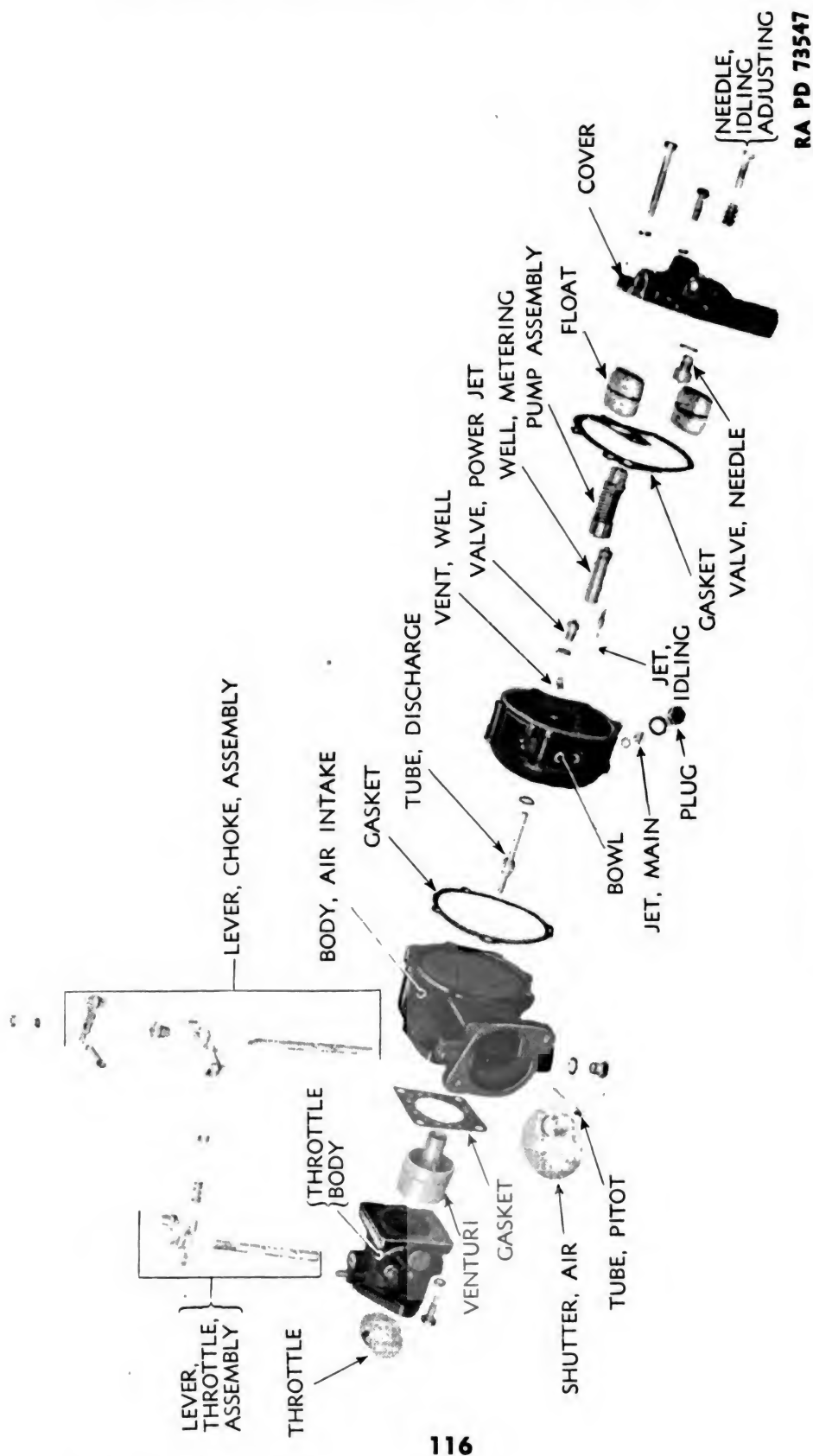

Figure 103 - Carburetor Assembly Details

ENGINE AND ACCESSORIES

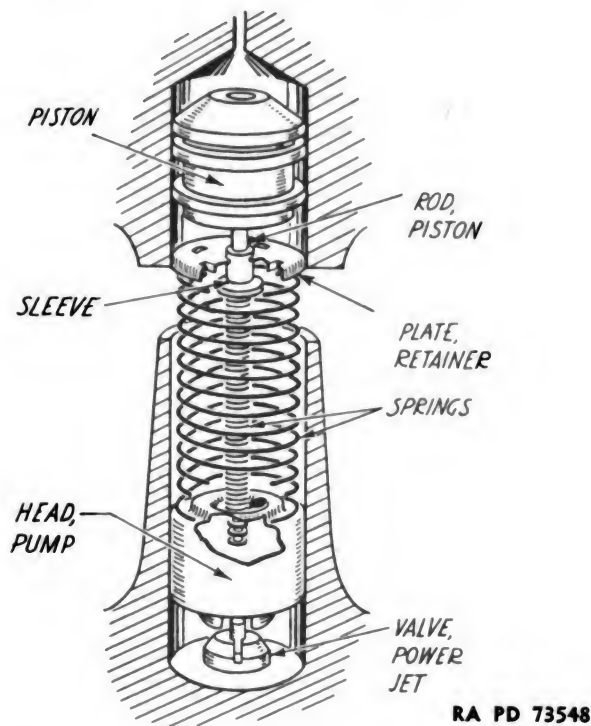

Figure 104 – Carburetor Pump Assembly Diagram

42. CARBURETOR ASSEMBLY (fig. 103).

NOTE: The following special tools are needed:

Tool No. C161-121, Zenith.

Tool No. C161-124, Zenith.

a. Procedure.

(1) Push shaft into throttle body. Insert throttle plate through shaft slot. When throttle plate is properly centered, install new screws to hold it in place. Peen over ends of screws, being careful not to spring the shaft.

(2) Slide air shutter shaft, with arm attached, into place. Insert shutter through shaft slot with relief valve up. Install new holding screws. Peen over ends of screws being careful not to spring the shaft.

(3) Screw hexagonal-head shaft hole plug and gasket into place.

(4) Place the Venturi in the throttle body, install gasket, carefully setting it in proper position so that the locating pin comes in the right place and the body holes are not closed off. Place intake body in position on throttle body, checking passages and locating pin. Turn upside down and install assembly screws. Tighten down evenly and securely.

(5) Install new pump check valve assembly, using tool C161-124

ORDNANCE MAINTENANCE — GENERATING UNIT M7

to hold the new valve in place, while using a hammer to drive the valve in.

(6) Install main jet, with new gasket, through bowl plug hole. Install bowl plug and new gasket.

(7) Install power jet valve and new gasket. Have tool No. C161-121 properly centered on the valve head.

(8) Install accelerating jet in the metering well using a small screwdriver while holding the metering well with the hand only. Install metering well and accelerating jet in the well channel. The metering well is designed to extend not more than 0.015 inch above the bowl casting to insure a good fit at that point when gasket and cover are in place.

(9) Screw well vent down in place.

(10) Set idling jet in place.

(11) To install pump refill check valve, place the valve body, head down, on a flat metal block; place the valve disk in the valve body; place the cover casting squarely over the valve, then strike the casting with a hammer to drive the cover down over the valve. Valve ends should be just flush with the casting.

(12) Screw fuel valve seat and new gasket into place. Insert needle.

(13) Place the float bracket in position in float hinge bracket and secure with wire pin float axle. The float should move freely on the axle. Hold the float level upside down as shown in figure 102 to observe relation of float to cover.

(14) Place piston rod and piston head in chamber. Secure in place with retainer plate. Slide sleeve and small spring over piston rod. Insert large spring into retainer plate flange. Attach brass pump head (fig. 104).

(15) Place the bowl to cover gasket in position on the bowl. Hold the cover assembly over the bowl, and guide the vacuum piston into the vacuum cylinder and the idling jet into its channel, being careful to avoid damage to float and other parts. Install cover to bowl assembly screws and lock washers. Tighten them evenly and securely.

(16) Screw discharge tube and new gasket into place in lower side of bowl.

(17) Place bowl to intake gasket in position on the bowl. Place the bowl assembly with gasket on the air intake. Be sure the channel bushings enter their respective channels. Install the assembly screws, and tighten evenly and securely.

(18) Place spring over idling adjusting screw, and install in tapped hole in cover.

ENGINE AND ACCESSORIES

RA PD 73549

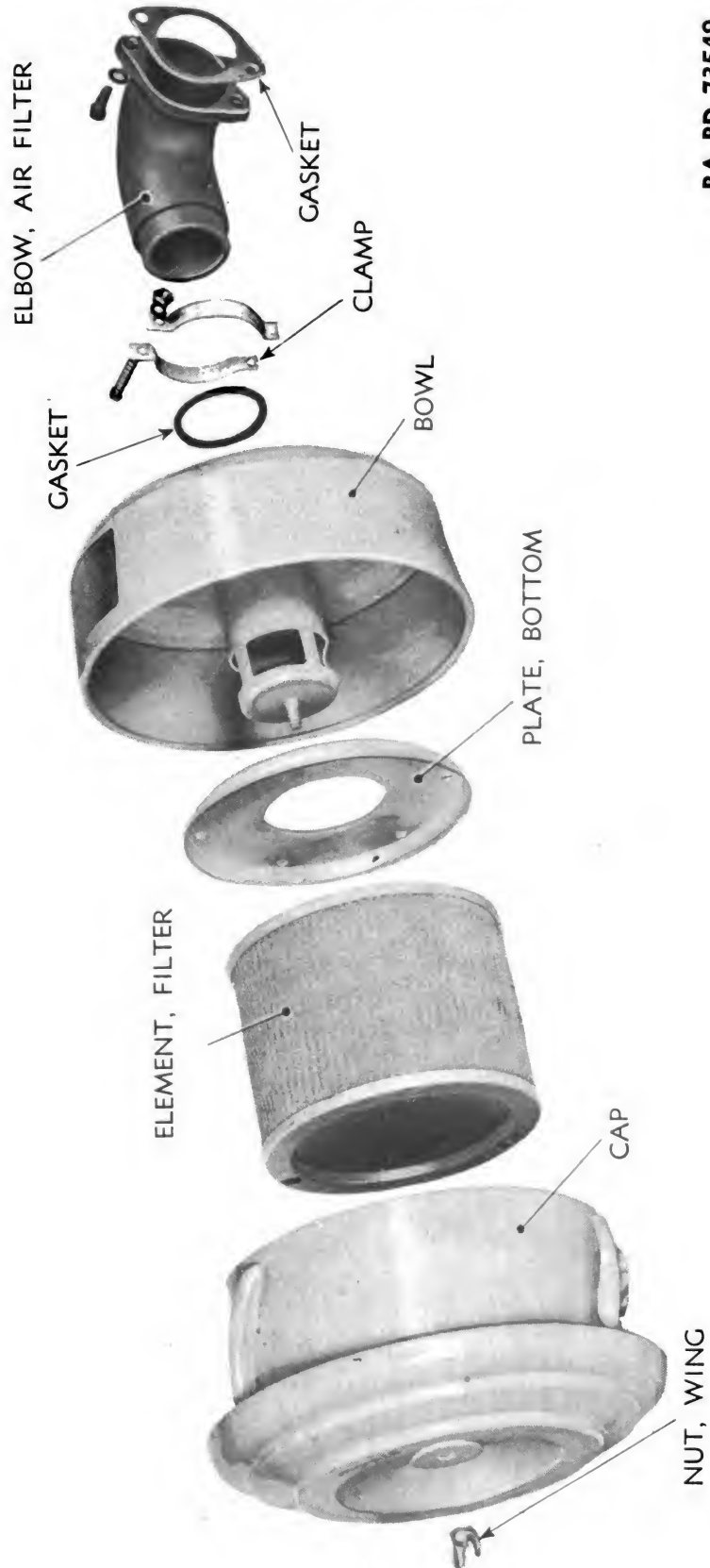
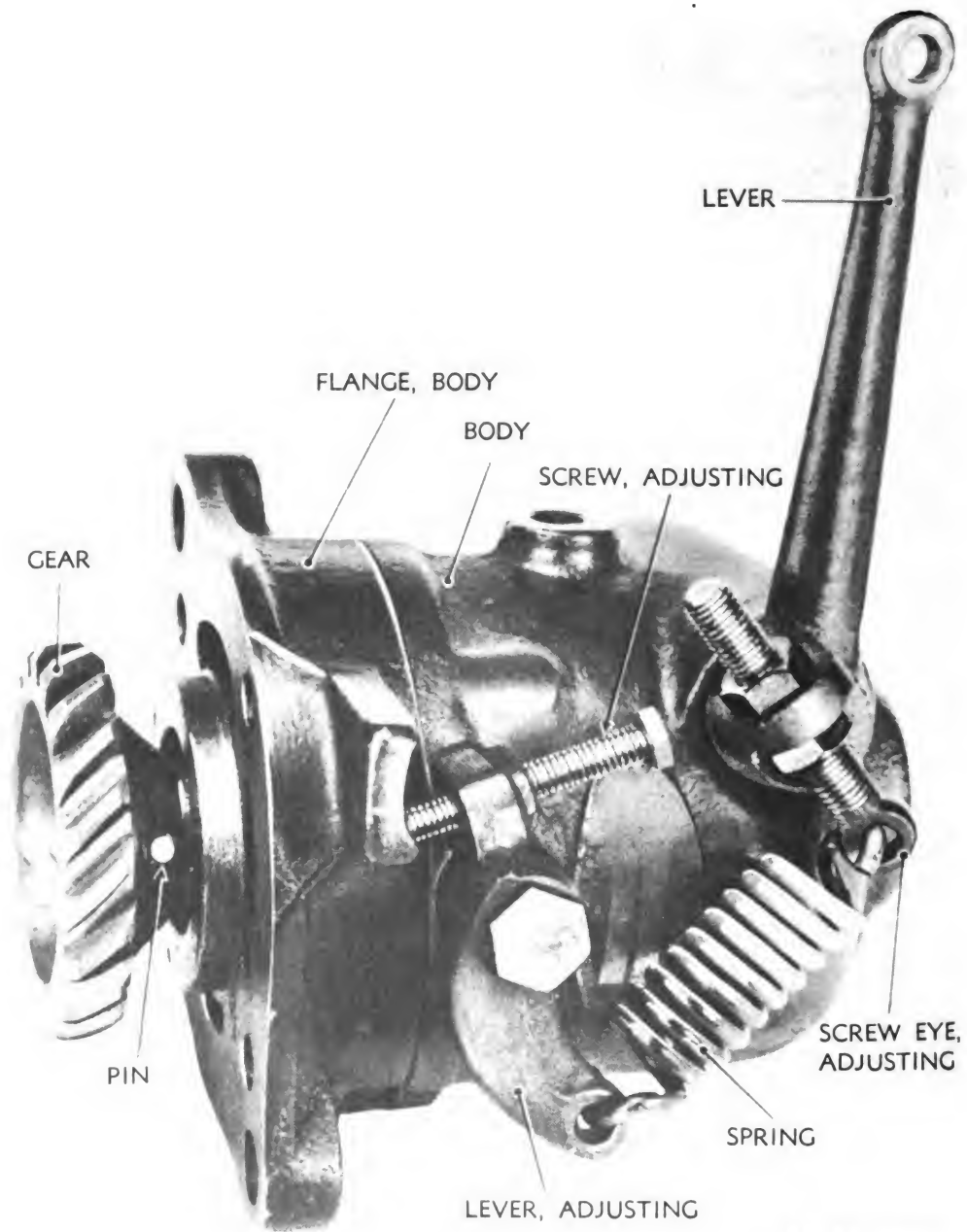

Figure 105 — Air Filter and Elbow Assembly

ORDNANCE MAINTENANCE — GENERATING UNIT M7



RA PD 73550

Figure 106 — Governor

ENGINE AND ACCESSORIES

43. AIR FILTER (fig. 105).

a. **Removal.** Loosen clamp bolts holding filter bowl flange to air filter elbow and remove clamp, gasket, and filter.

b. **Disassembly.** Unscrew the wing nut at the top of the cap and remove, in sequence, cap, filter element, and baffle plate.

c. **Inspection and Repair.**

(1) Examine element to see if it is bent. Solder screen to sheet metal if loose.

(2) Straighten baffle plate, cap, and bowl, if they are bent.

(3) Pour water into bowl to test for leakage. Solder any leaks.

d. **Assembly.**

(1) Slip baffle plate into position in the bowl.

(2) Fill bowl to bead level with used crankcase oil or OIL, engine, (crankcase grade).

(3) Set element in place on baffle plate.

(4) Bring cap down over element and clamp the assembly together, screwing the wing nut onto the bowl stud.

e. **Installation.** Set filter down on the flange of the air filter elbow. Set the collar clamp and gasket in place, and secure the filter to the elbow by tightening the clamp bolts.

f. **Servicing Air Filter.**

(1) **DAILY INSPECTION.**

(a) Check tightness of clamp bolts.

(b) Under extremely dusty conditions, change oil in bowl daily.

(2) **150-HOUR SERVICING.**

(a) Remove filter, disassemble, and empty oil from bowl.

(b) Clean element by swishing about in SOLVENT, dry-cleaning. Clean bowl, fill with used crankcase oil or OIL, engine, (crankcase grade).

44. GOVERNOR AND THROTTLE BOX DESCRIPTION.

a. The governor (fig. 106) is of the centrifugal "flyball" type. The governor spring force tends to hold the throttle valve in a wide-open position, and the weight force, opposing the spring, tends to close the valve.

b. The governor spring is located outside the governor case, with one end hooked to the speed adjusting lever and the other end an-

ORDNANCE MAINTENANCE — GENERATING UNIT M7

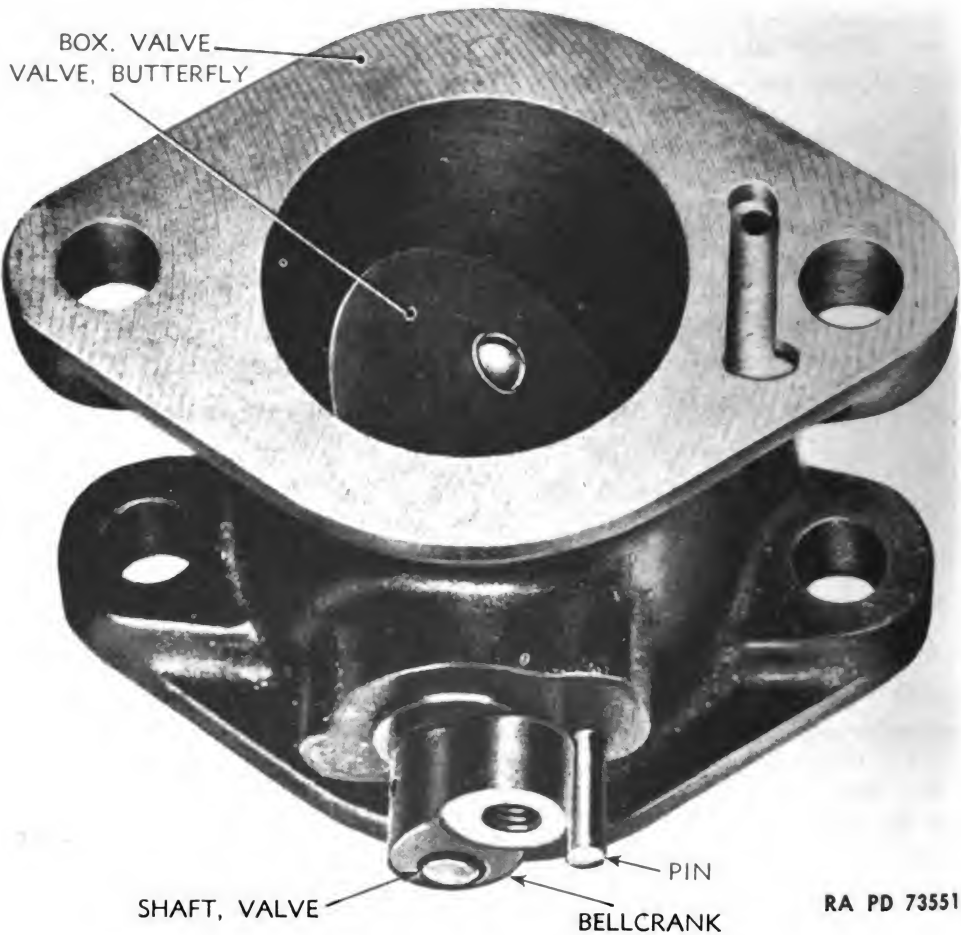

RA PD 73551

Figure 107 — Throttle Box

chored to the auxiliary adjusting screw eye on the rocker shaft. Increasing tension on the governor spring increases engine speed. Inside of the governor, the weights are hung on a weight spider fastened to the rotating drive shaft. As the weights revolve, centrifugal force tends to throw the mass of the weights outward. The weights pivot on the weight pins, converting the centrifugal force to a thrust against the thrust sleeve which moves longitudinally on the drive shaft.

c. Movement of the thrust sleeve is transmitted to the rocker shaft by means of the yoke, which contacts the thrust bearing pressed on the thrust sleeve.

d. When the engine is not running, the governor spring holds the throttle valve wide open. When the engine is started, the weights swing out and move the throttle valve towards the closed position. The weights continue to move out until the weight force and the opposing spring force are in balance. With the weight and spring forces

ENGINE AND ACCESSORIES

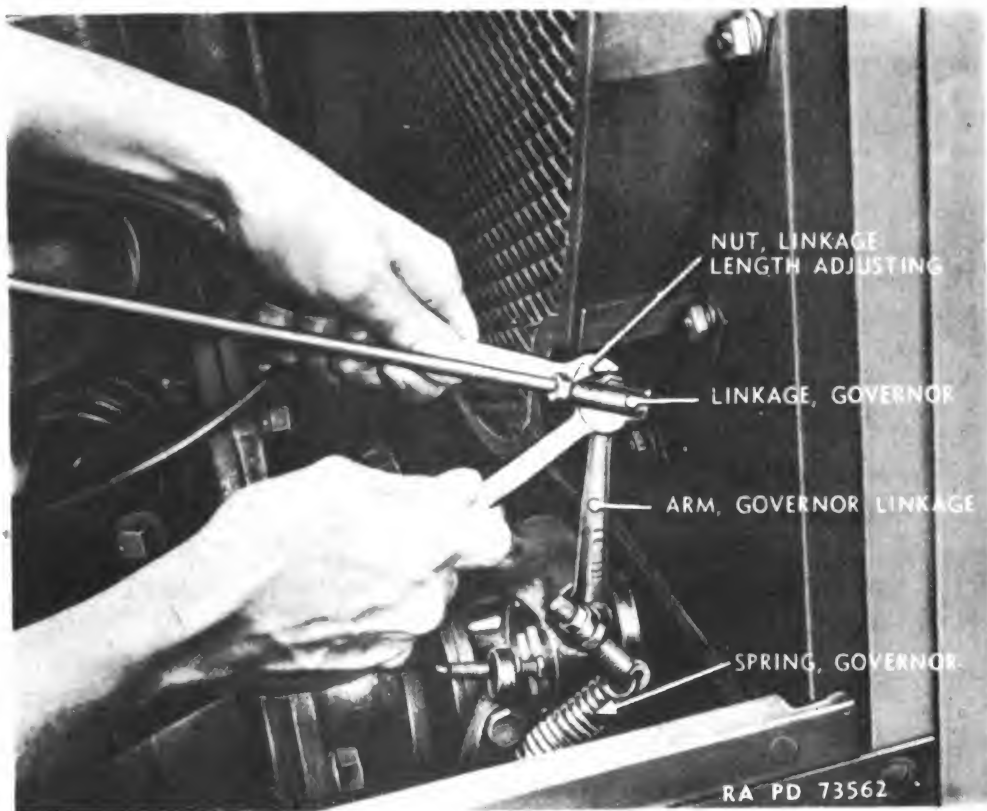

Figure 108 – Disconnecting Governor Linkage at Governor

in balance, the throttle will be set to maintain the predetermined governed speed.

e. If load is applied, the engine slows down and the spring force will open the throttle. If the load is thrown off, engine speed increases, and the increased weight force closes the throttle to maintain the governed revolutions per minute.

f. The throttle box (fig. 107) is of the conventional butterfly type, with the valve shaft mounted on ball bearings.

g. The connecting rod assembly uses “screw set” ball joints to overcome angularity and to eliminate friction.

45. GOVERNOR REMOVAL.

a. Procedure.

(1) Hold nut and take out screw fastening governor linkage to governor arm. *Do not disconnect at throttle box* (fig. 108).

(2) Remove nut holding oil line in compression fitting at the top of governor (fig. 21).

(3) Take out cap screws holding governor to housing (fig. 22), and remove governor.

ORDNANCE MAINTENANCE – GENERATING UNIT M7

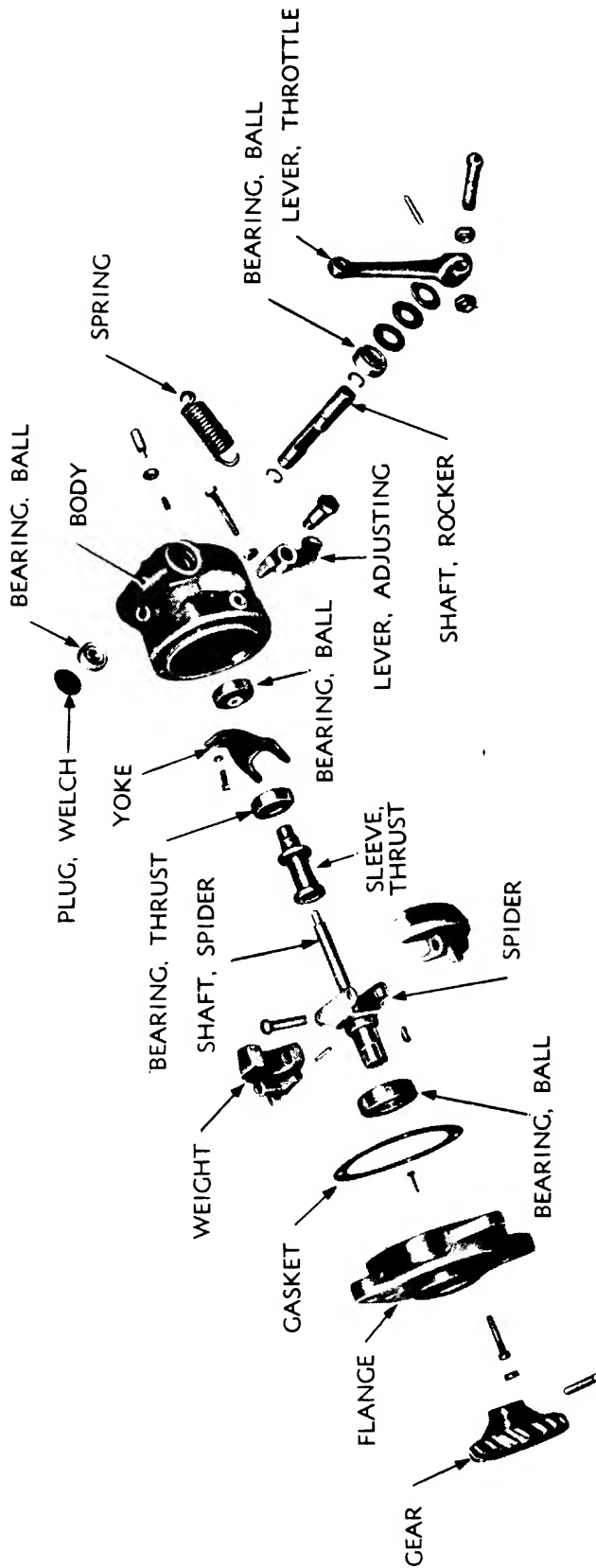

RA PD 73552

Figure 109 — Governor — Exploded View

ENGINE AND ACCESSORIES

46. GOVERNOR DISASSEMBLY (fig. 109).

a. Procedure.

- (1) Release tension from governor spring by loosening holding cap screw and lock nut. Remove shoulder screw, and remove spring.
- (2) Remove the four screws holding body to flange, and separate.
- (3) Take out the three round-head screws and washers inside the flange holding the bearing retainer to the flange.
- (4) Punch groove pin out through gear and shaft. Press gear from shaft (fig. 110). The bearing will be forced out of the casting seat in this operation.
- (5) Press bearing and sleeve from shaft (fig. 111).
- (6) Slide thrust sleeve and bearing off shaft.
- (7) Grind down the peened-over ends of the pins holding the weights to the spider, take out pins, and remove weights.
- (8) Drive groove pin through spider and shaft. Press spider from shaft.
- (9) Take out cap screws and lock washers, and remove yoke from rocker shaft.
- (10) Drive out taper pin holding lever to rocker shaft. Drive rocker shaft through lever, knocking out end bearing and welch plug (fig. 112). Reverse shaft, and use it for a punch to knock out the remaining bearing.

47. GOVERNOR INSPECTION AND REPAIR.

a. Individual parts of disassembled governor should be carefully washed in SOLVENT, dry-cleaning, before making the following inspections.

- (1) GASKET, FASTENING SCREWS, NUTS, AND WASHERS. These should be replaced if damaged.
- (2) GEAR. Inspect for wear or broken teeth, and replace if necessary.
- (3) BEARING AND SLEEVES. These should be inspected for excessive wear, and replaced if necessary.
- (4) SPRING. Check for rust spots or signs of corrosion. Replace, if corroded or if bent or broken.
- (5) WEIGHTS AND SPIDER. Weights should move freely on pivot pins, but they should not be too loose. Spider should not hug the weights, but should permit easy play. If spider is bent or damaged, it should be replaced.
- (6) SPIDER SHAFT. Inspect for wear or damage, and replace if necessary.
- (7) YOKE. Check for wear or damage, and replace if necessary.

ORDNANCE MAINTENANCE — GENERATING UNIT M7

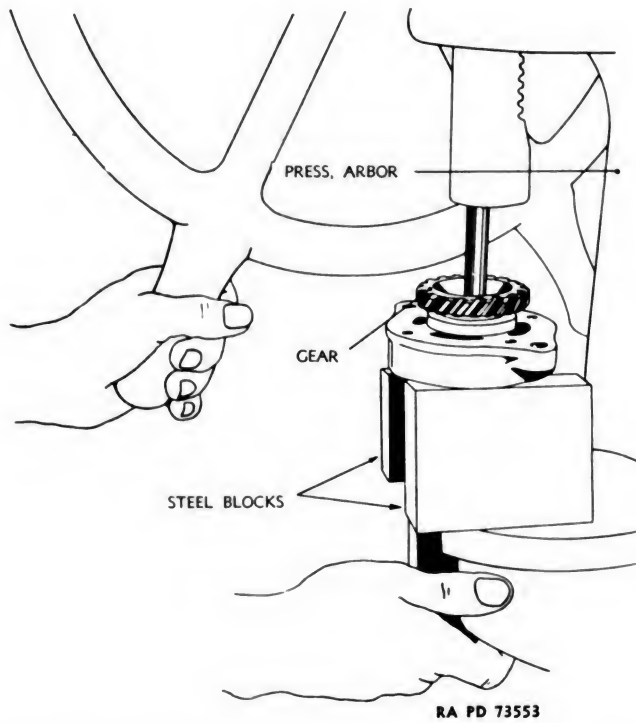

Figure 110 — Pressing Governor Drive Gear from Shaft

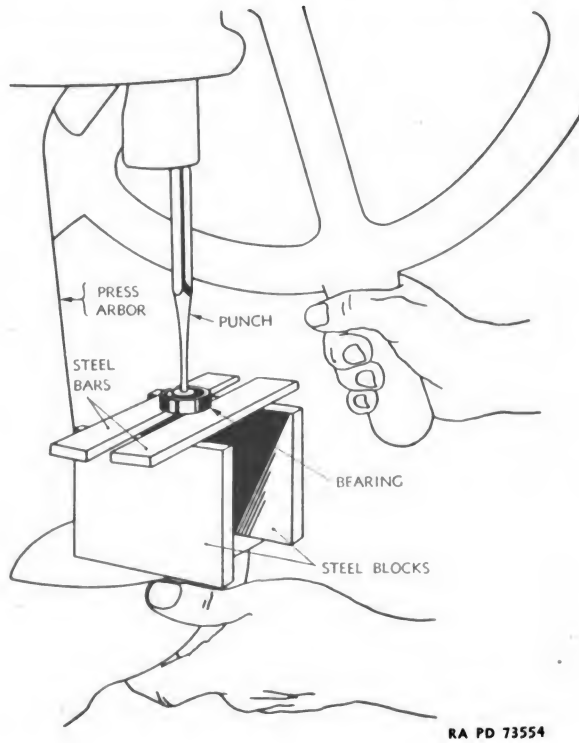

Figure 111 — Pressing Bearing and Sleeve from Shaft

ENGINE AND ACCESSORIES

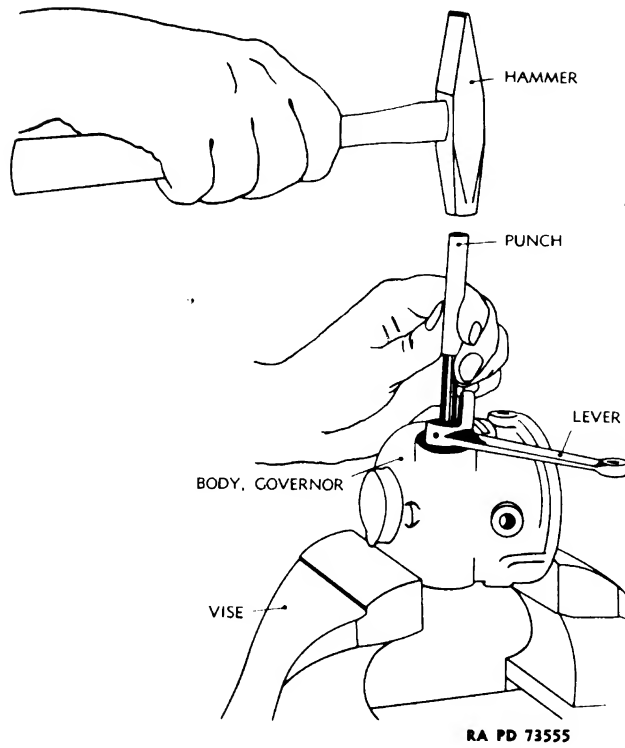

Figure 112 – Driving Rocker Shaft through Lever

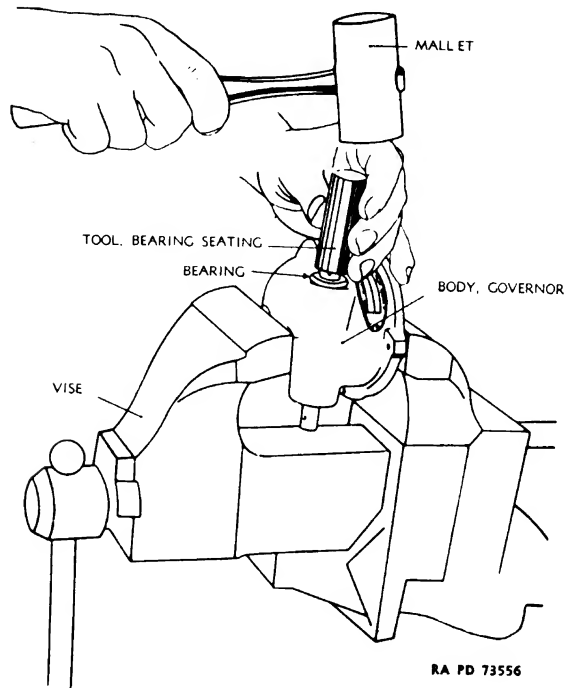

Figure 113 – Seating Bearings

ORDNANCE MAINTENANCE – GENERATING UNIT M7

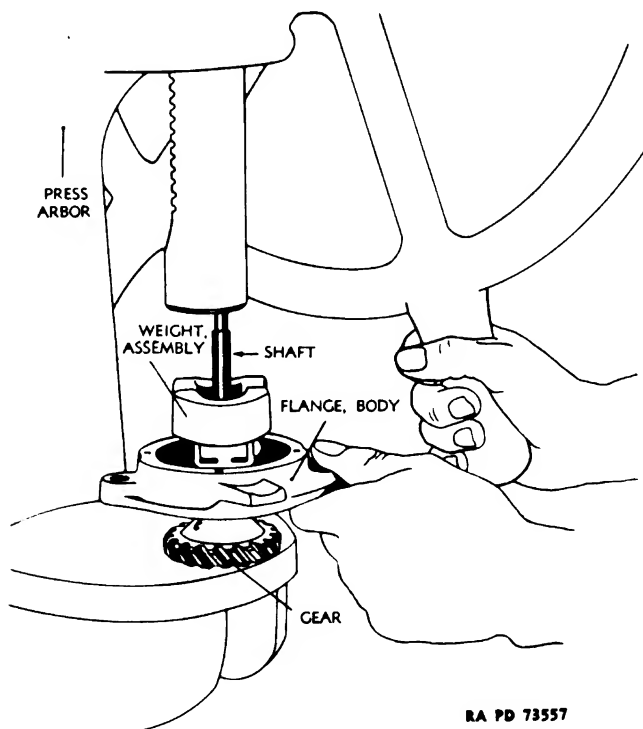

Figure 114 – Pressing Shaft into Drive Gear

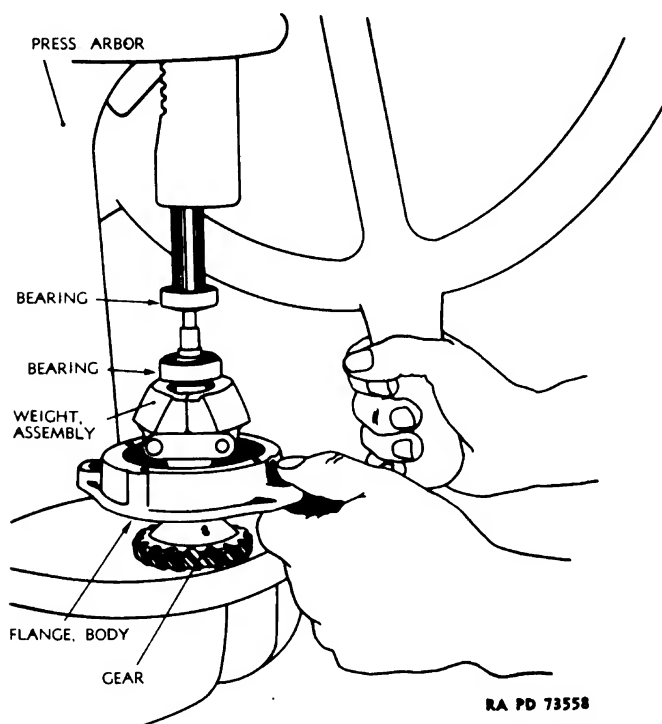
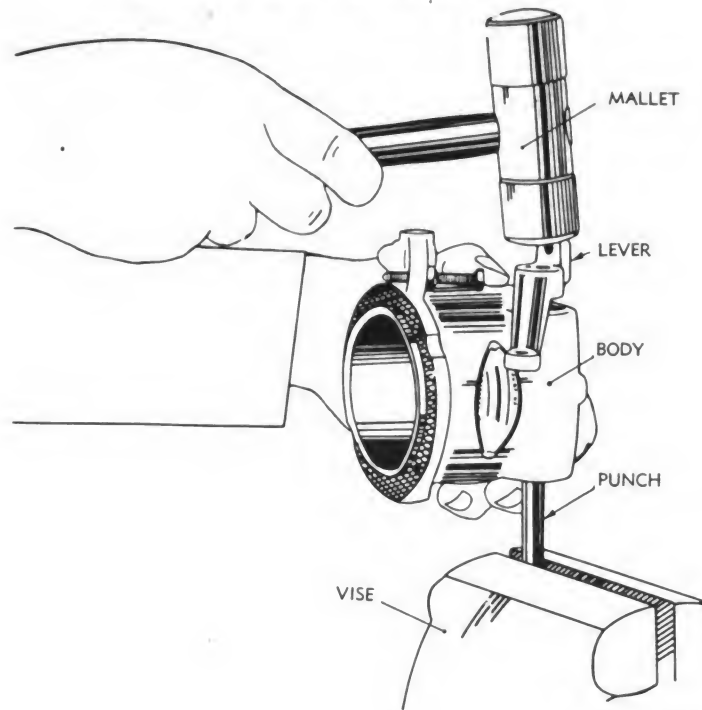

Figure 115 – End Bearing Installation

ENGINE AND ACCESSORIES



RA PD 73559

Figure 116 – Throttle Lever Installation

(8) **LEVER AND ROCKER ARM.** Inspect for damage, and replace if necessary.

(9) **GOVERNOR AND FLANGE BODY.** Inspect for cracks or breaks. Replace if defective.

48. GOVERNOR ASSEMBLY.

NOTE: The following special tool is required for assembly:

Bearing seating tool, Pierce governor.

a. Procedure.

(1) Put snap rings on rocker shaft. Install shaft in body without bearings, with the long end of the shaft toward the adjusting screw side. Install yoke on shaft with cap screws.

(2) Drive bearing on each end of shaft with letter side out. Seat bearings with mallet and governor bearing seating tool (fig. 113). Check rotation of shaft for friction. If bearings are correctly aligned, rocker shaft should be free enough so that the yoke will fall of its own weight.

(3) Tap oil seal into place using governor bearing seating tool and mallet. Oil seal must be seated sufficiently tight to prevent leakage, but should not be hammered down against the bearing, as this will place excessive friction on the rocker shaft.

ORDNANCE MAINTENANCE – GENERATING UNIT M7

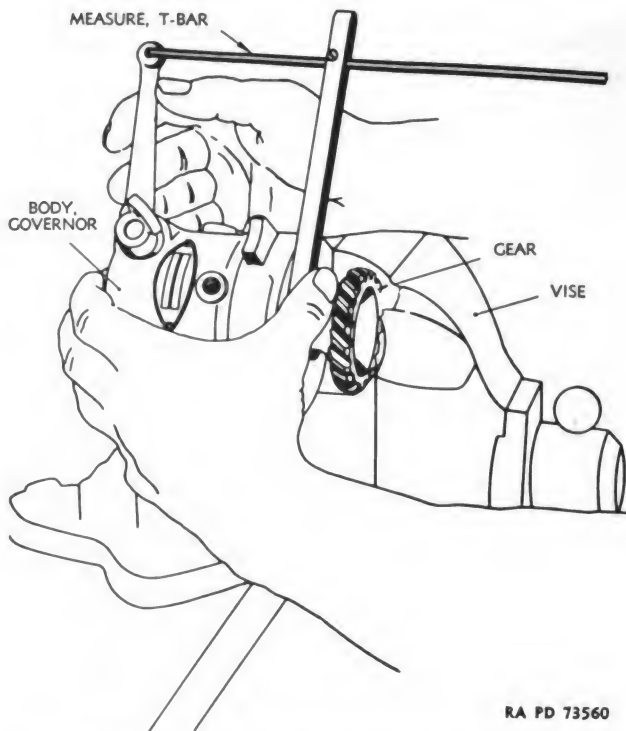

Figure 117 – Measuring Lever Distance from Body Flange

- (4) Press front spider bearing on shaft.
- (5) Press spider on shaft into position against bearing. Drill through spider and shaft with $\frac{1}{8}$ -inch drill, and pin with groove pin.
- (6) Position weights in spider. Secure with weight pins. Slide thrust sleeve and bearing on shaft, and check thrust sleeve travel when weights are moved from closed to open position. Exploding weights into wide-open position must move the thrust sleeve $\frac{1}{4}$ inch on the shaft. If the sleeve does not lift the required $\frac{1}{4}$ inch, grind the weight stop tips that contact the spider hub when the weights are in wide-open position. When thrust sleeve movement is satisfactorily regulated, rivet the weight pin ends.
- (7) Press shaft, bearings, and weight assembly into the governor flange. Care must be taken in pressing against end of drive shaft. Shaft is machined to very close tolerances, and can be easily sprung out of line. Use short interrupted strokes of the arbor press so that bearing can align itself. Fasten bearing with the three bearing retaining screws and lock washers. Open weights to wide-open position, and rotate drive shaft to see that the weight stop tips clear the head of the bearing retaining screws. If clearance is not available, it will be necessary to grind the weight stop tip.
- (8) Install Woodruff key in keyway of shaft, and press shaft into

ENGINE AND ACCESSORIES

gear (fig. 114). Drill through gear shank and spider shaft, and pin through with groove pin.

(9) Slide thrust sleeve with thrust bearing over shaft.

(10) Press bearing sleeve into ball bearing, and press this assembly on shaft with the bearing sleeve shoulder toward the weight assembly (fig. 115).

(11) Attach flange to body with the four fillister-head screws. Use a new gasket between flange and body.

(12) To install lever, back up the rocker shaft with a punch held in a vise (fig. 116), and tap on. Install lever with throttle rod end pointing toward the gear. Then, rotate so that the yoke in the body contacts the thrust bearing with the weights closed. Continue rotating in the same direction until the end of the lever is $3 \frac{3}{16}$ inches from the body flange (fig. 117).

(13) Set welch plug in position on governor body at end of rocker arm hole. Tap into place.

(14) Install adjusting lever in position on governor body with shoulder stud. Install spring by hooking one end through eye of throttle lever eye bolt and the other end through hole in adjusting lever.

49. GOVERNOR INSTALLATION.

a. Procedure.

(1) Set governor into housing, and attach with cap screws and lock washers.

(2) While holding nut, install screw attaching governor arm to linkage.

(3) Engage oil line in compression fitting at top of governor.

50. GOVERNOR ADJUSTMENT (fig. 118).

a. Before making speed adjustment, back out antisurge screw at back of governor until only a few threads are engaged, and lock with lock nut.

b. Adjust engine speed at adjusting lever cap screw. Increasing tension on the governor screw increases engine revolutions per minute.

c. Adjusting spring eye in the throttle lever regulates governor sensitivity. Shortening the effective length of this screw, moving the spring eye toward the rocker shaft, increases governor sensitivity. Moving the spring eye away from the rocker shaft broadens regulation.

d. To dampen load surge, lengthen screw a turn or two at a time, until surge is eliminated.

ORDNANCE MAINTENANCE – GENERATING UNIT M7

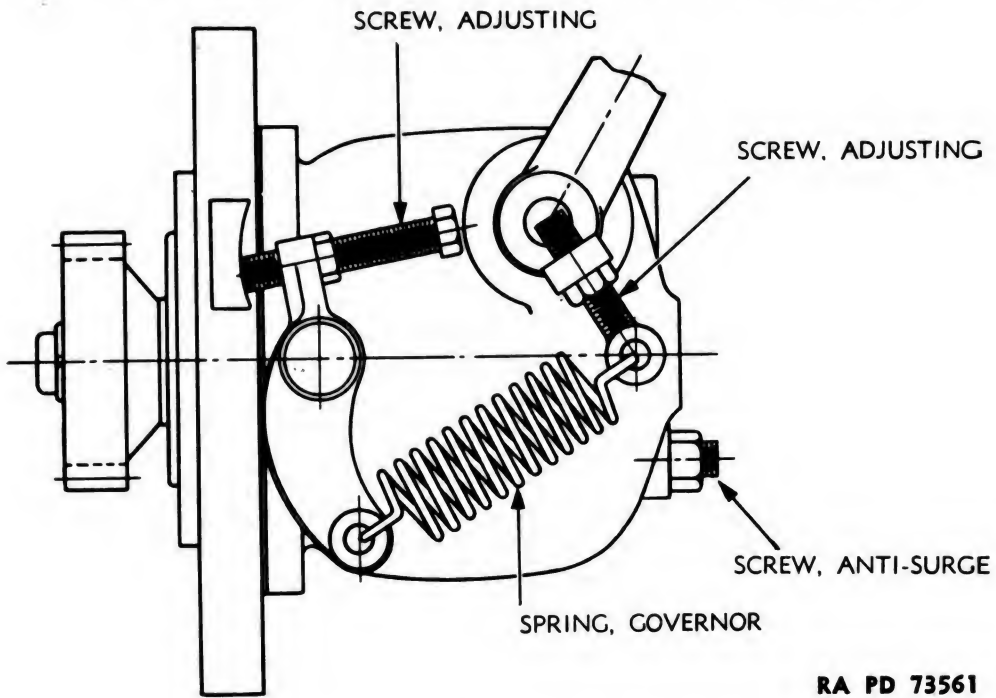

RA PD 73561

Figure 118 – Governor Adjusting Diagram

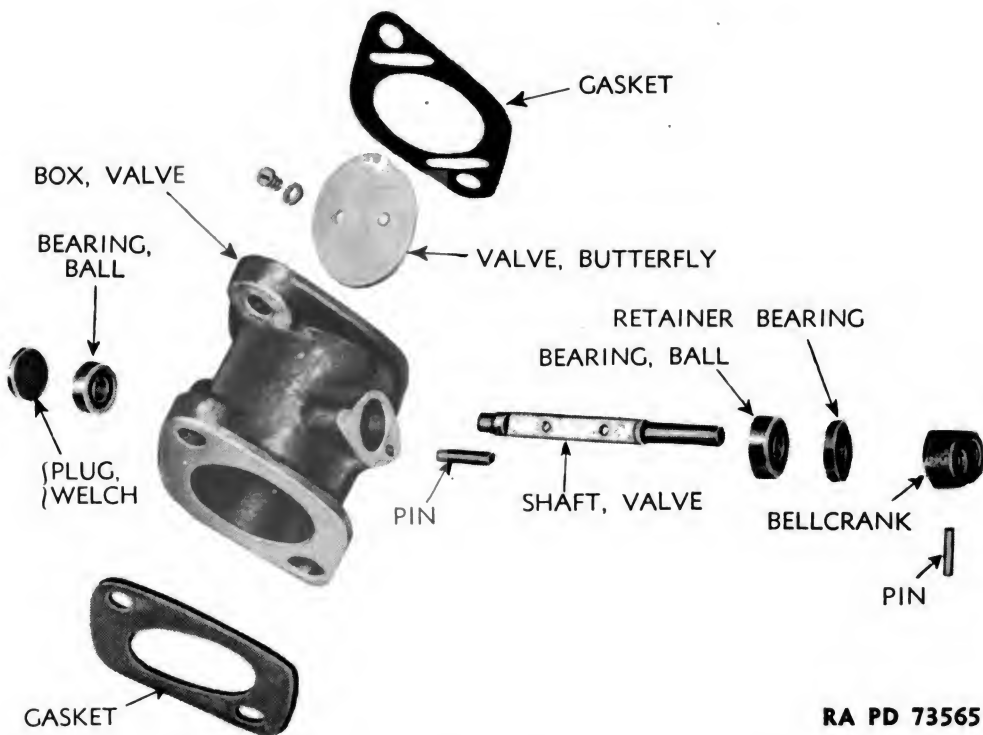

RA PD 73565

Figure 119 – Throttle Box – Exploded View

ENGINE AND ACCESSORIES

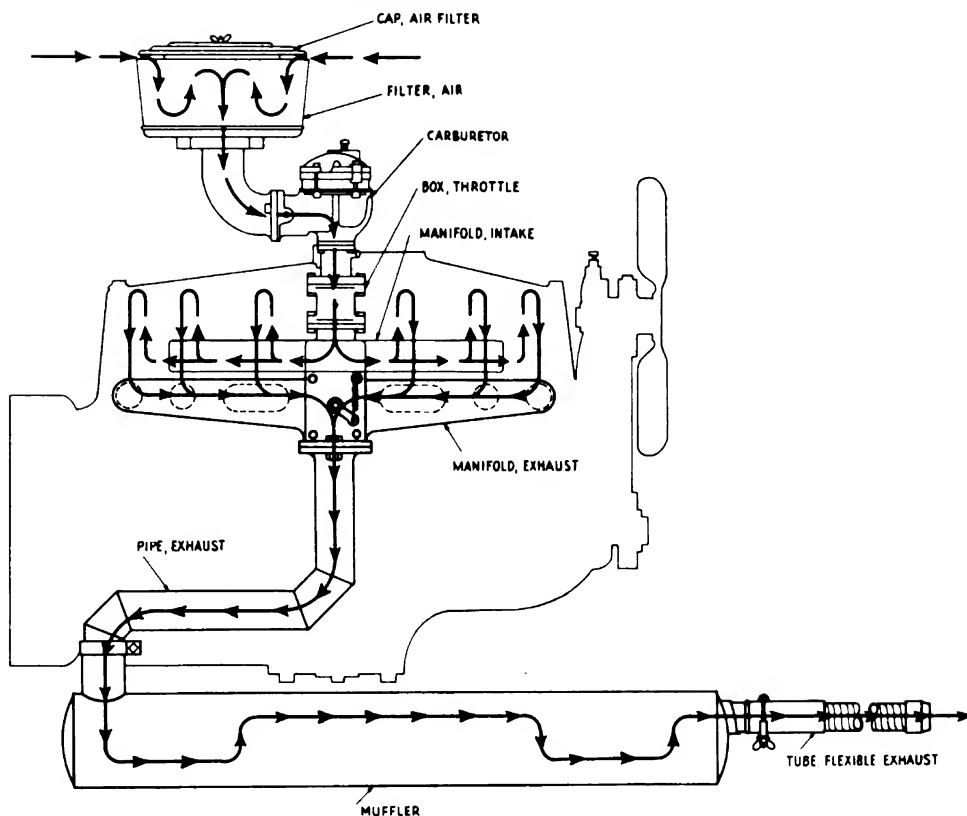

RA PD 73566

Figure 120 – Intake and Exhaust System Diagram – Broken Arrows, Intake Air – Solid Arrows, Exhaust Gas

e. No-load surge is controlled by antisurge screw at back of governor. To eliminate no-load surge, screw bumper in a turn or two at a time until surging stops. Do not screw in far enough to increase engine speed. Antisurge screw is used only to eliminate a no-load surge, and should not be turned in unless necessary.

51. THROTTLE BOX DISASSEMBLY (fig. 119).

a. Procedure.

(1) File down the peened-over ends of the butterfly valve screws. Take out the screws, and remove the butterfly valve.

(2) Drive out crank pin. Drive shaft through bell crank. This will knock out end bearing and welch plug. Reverse shaft, and use as punch to knock out remaining bearing and bearing retainer.

52. THROTTLE BOX INSPECTION AND REPAIR.

a. Wash parts in SOLVENT, dry-cleaning, and make the following inspections.

(1) Check valve shaft for alinement. If out of alinement, straighten or replace.

ORDNANCE MAINTENANCE — GENERATING UNIT M7

(2) Inspect bell crank and throttle body for cracks. If defective, replace.

(3) Inspect bearings for excessive wear, and replace if necessary.

53. THROTTLE BOX ASSEMBLY.

a. Procedure.

(1) Press into position the bearing and bearing retainer on the bell crank side of the casting. Install shaft, and press in remaining bearing. Install welch plug.

(2) Install butterfly valve using new screws. Before tightening screws, rotate valve to closed position, and tap with screwdriver so that it will center. Tighten screws and peen over ends so they will not back out. When upsetting screws, be sure to back up the valve shaft with a wood block to avoid springing shaft out of line.

(3) Slide bell crank into position on shaft. With valve in wide-open position, push bell crank against stop pin. In this position, drill through crank and shaft, and pin with groove pin.

Section IV

EXHAUST SYSTEM

	Paragraph
Description	54
Trouble shooting	55
Maintenance and repairs	56

54. DESCRIPTION.

a. Construction. The exhaust system (fig. 120) is made up of the exhaust section of the manifold, the muffler, the pipe connection between muffler and manifold, and the detachable flexible tube that is attached to the outside end of the muffler when the unit is in operation.

b. Functioning. The burned gases, resulting from the ignition of the mixture of gasoline and air in the cylinder are forced by the exhaust stroke of the pistons out of the cylinders, into the manifold, and away from the unit by way of the exhaust pipe, the muffler, and the exhaust tube.

ENGINE AND ACCESSORIES

55. TROUBLE SHOOTING.

a. Manifold.

(1) EXHAUST FUMES.

Possible Cause	Possible Remedy
Leaking manifold gasket.	Tighten or replace.
Blown-out manifold gasket.	Replace.
Cracked manifold.	Replace.

b. Muffler.

(1) EXHAUST FUMES, EXCESSIVE NOISE.

Loose connections.	Tighten connections.
Opened seams.	Replace muffler.
Corroded metal.	Replace muffler.
Burned-out muffler.	Replace muffler.

56. MAINTENANCE AND REPAIRS.

a. Manifold (fig. 17).

(1) The manifold should be frequently inspected for cracks. When engine troubles develop that might have been caused by manifold cracks not apparent, the manifold should be removed and thoroughly inspected. Position and extent of cracks will determine whether the cracks can be welded or the manifold should be replaced.

(2) Bolts should be checked periodically for tightness. Collar gasket should be checked for condition. A worn gasket should be replaced. Always replace gasket after manifold has been removed.

b. Exhaust Pipe.

(1) Examine exhaust pipe regularly for cracks. Test welded joints. If cracks are found, replace pipe. If welded joints are broken, reweld.

(2) Test regularly for tightness of connections with muffler and manifold. Clean out at regular intervals.

c. Muffler. No repairs can be made on the muffler. If inspection finds cracks or evidence of burning out, replace.

ORDNANCE MAINTENANCE – GENERATING UNIT M7

Section V

LUBRICATION SYSTEM

	Paragraph
Description	57
Trouble shooting	58
Oil filter	59
Oil pump	60

57. DESCRIPTION (figs. 121 and 122).

a. The engine oil system provides continuous lubrication by means of a submerged-type gear pump driven from the camshaft. From the oil sump at the bottom of the crankcase, the pump draws oil through a strainer screen, and delivers it under pressure to the main oil gallery, drilled in the cylinder block on the side opposite the camshaft. From here the oil is sent, still under pressure, to the main and connecting rod bearings, front camshaft bearing, and governor. The rear and center camshaft bearings, cylinder walls, pistons, and valve tappets are all lubricated by oil thrown from the ends of the main and connecting rod bearings.

b. A certain amount of the oil delivered to the gallery is taken off through a bypass, sent through the oil filter, and back to the sump.

c. The oil pressure is automatically controlled or regulated by a compression spring which controls a relief or bypass valve. This device is located in the base of the oil filter.

58. TROUBLE SHOOTING.

a. Excessive Oil Consumption.

Possible Cause	Possible Remedy
Improper grade of oil.	Use proper grade.
Oil level too high.	Drain to proper level.
Excessive oil pressure.	Adjust oil pump.
Oil leaks.	Tighten gaskets and oil line fittings.

b. Low Oil Pressure.

Improper grade of oil.	Use proper grade.
Lack of oil in crankcase.	Fill crankcase to proper level.
Relief valve stuck.	Remove valve, and service or replace.
Oil pump screen clogged.	Remove, and clean.
Oil pump worn.	Replace pump.

ENGINE AND ACCESSORIES

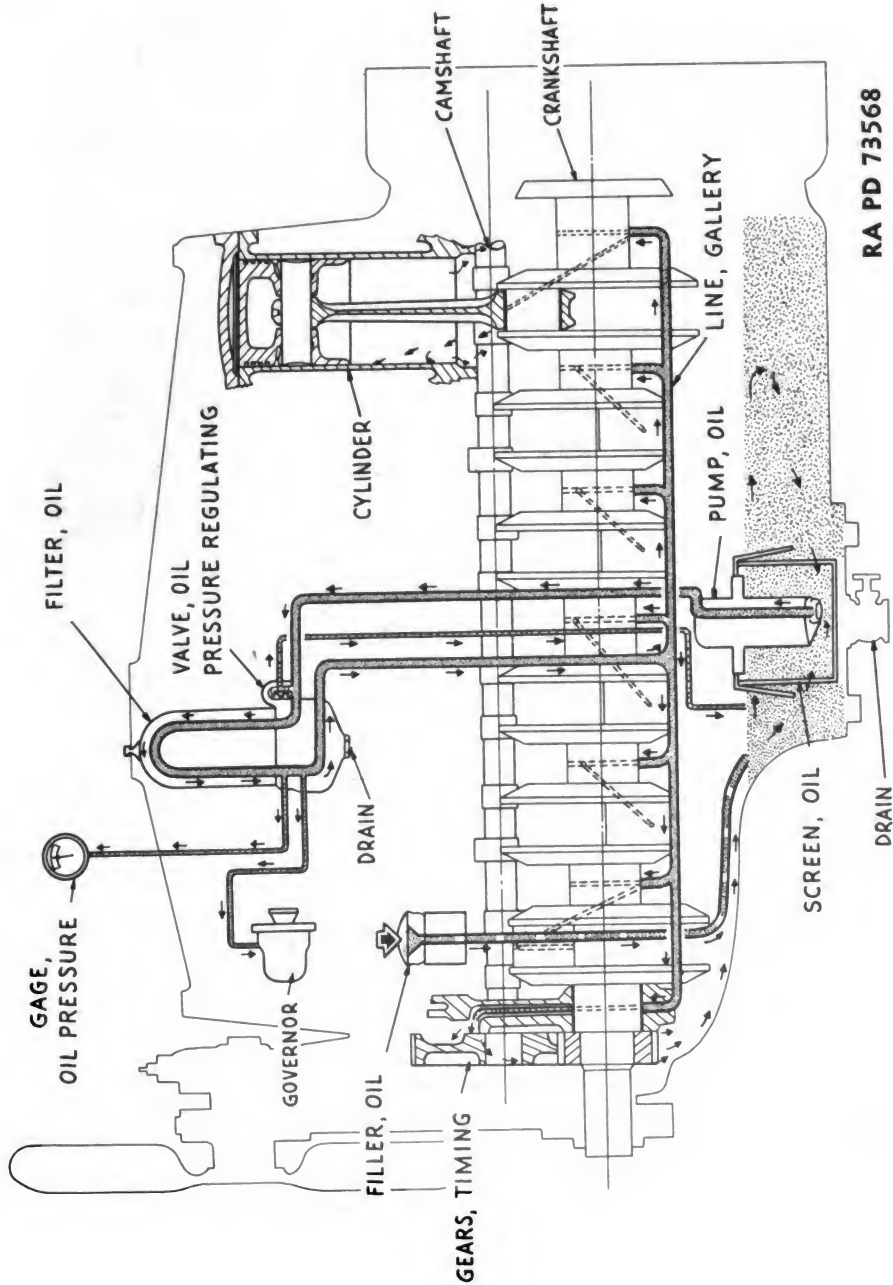

RA PD 73568

Figure 121 — Lubricating Oil System

ORDNANCE MAINTENANCE – GENERATING UNIT M7

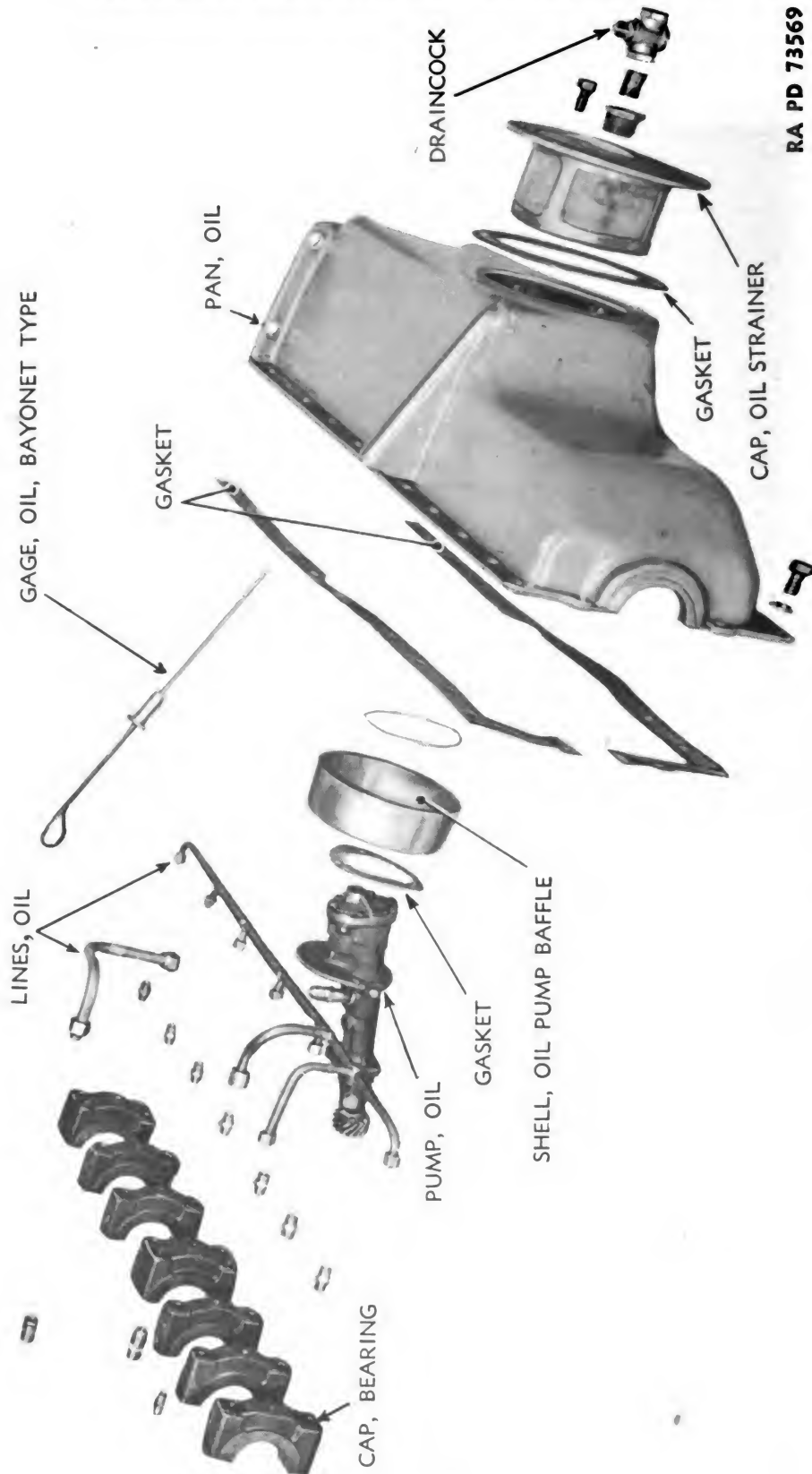

RA PD 73569

Figure 122 – Lubricating Oil System Details

ENGINE AND ACCESSORIES

RA PD 73570

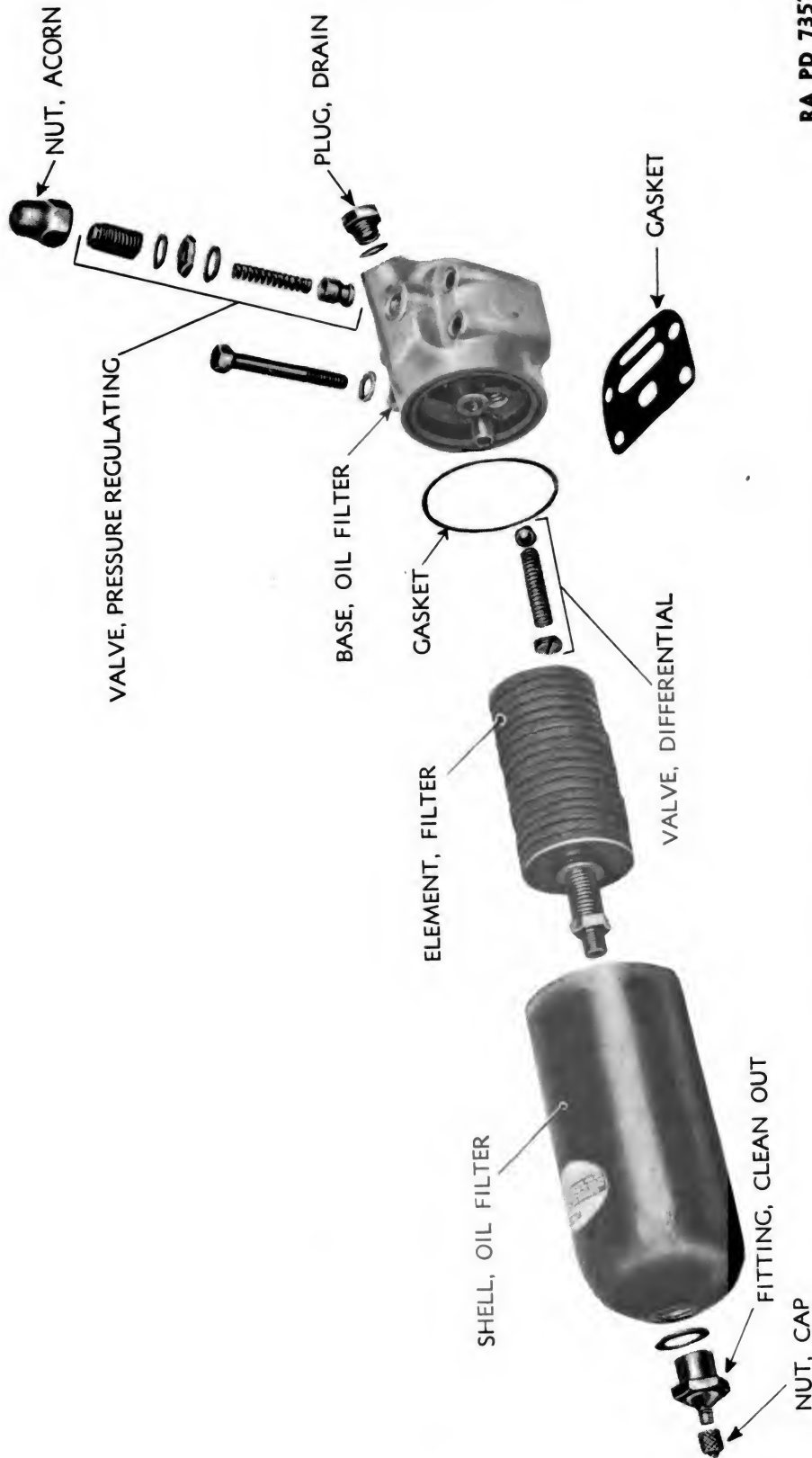

Figure 123 — Oil Filter Assembly — Exploded View

ORDNANCE MAINTENANCE – GENERATING UNIT M7

c. Discolored Oil.

Possible Cause	Possible Remedy
Clogged oil filter.	Service or replace filter.
Sludge in oil lines.	Remove and clean lines.
Sludge in oil pan.	Remove pan and clean.

59. OIL FILTER (fig. 123).

a. Description. The oil filter has a heavy-gage steel dome-shaped casing over a filter element made up of round felt pads about a center tube. The oil is pumped, under pressure, up through the filter pads. It comes out at the top and flows down through the filter tube, leaving dirt and other foreign substances on the bottom of the filter. A drain plug in the filter base allows sludge to be drained.

b. Removal. Take out four cap screws and lock washers holding filter base to engine block, and remove base and filter.

c. Disassembly.

(1) Unscrew hexagonal nut at top of shell, remove gasket, and take off casing.

(2) Unscrew element pipe at base, and lift off element.

(3) Remove acorn nut and gasket. Remove lock nut and gasket. Take out adjusting screw, and the spring will snap out. Turn filter base over, and the plunger will drop out.

(4) Take out screw, pull up spring, turn filter base upside down, and ball valve will shake out.

(5) Unscrew drain or sludge plug, and remove plug and gasket.

d. Inspection and Repair.

(1) Wash all parts thoroughly in SOLVENT, dry-cleaning, and dry with compressed air.

(2) Examine all springs for rust or signs of corrosion. Replace, if corroded, bent, or broken.

(3) Inspect screws, nuts, and valves for excessive wear, stripped threads, or breaks. Replace any faulty parts.

(4) Examine shell and filter base for cracks or breaks. Replace if necessary.

(5) Check gaskets, and replace if worn or damaged.

e. Assembly.

(1) Drop valve ball into tapped valve hole, follow with spring, and install spring holding screw.

(2) Screw down threaded end of element tube into center tapped hole of filter base.

ENGINE AND ACCESSORIES

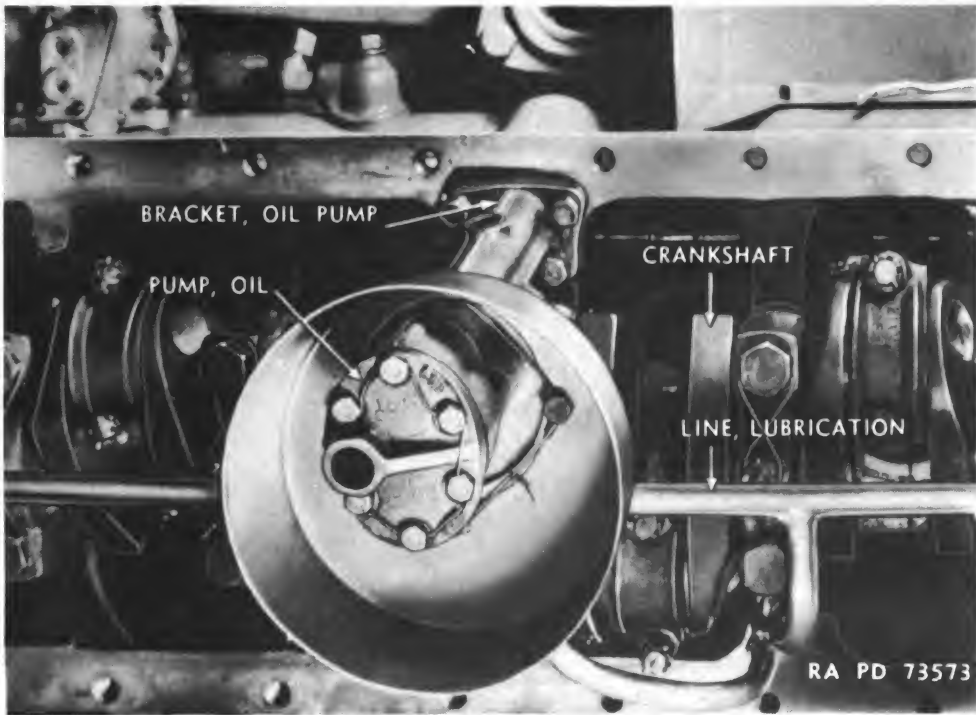

Figure 124 – Oil Pump

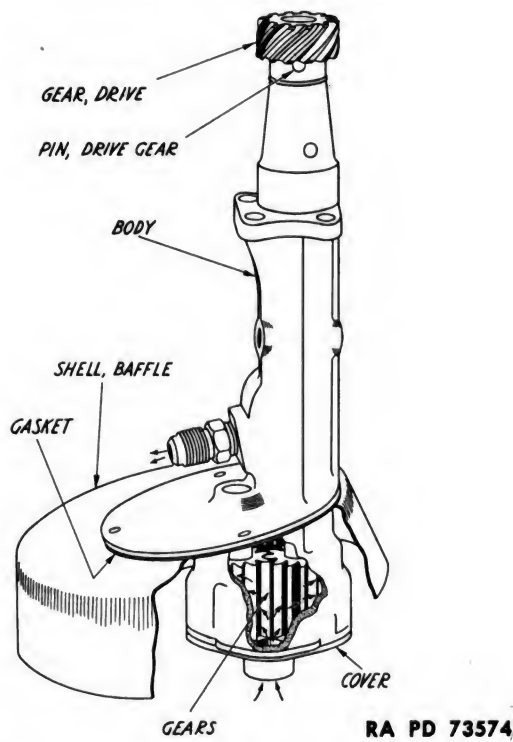

Figure 125 – Oil Pump Diagram

ORDNANCE MAINTENANCE — GENERATING UNIT M7

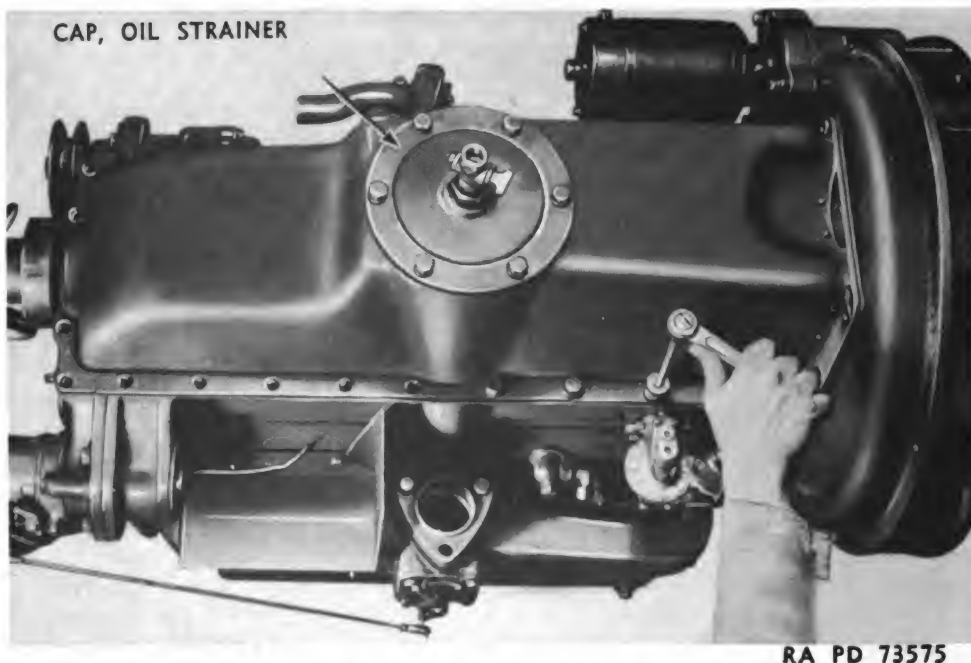

Figure 126 — Oil Pan Removal

(3) Bring filter shell down on element and base with gasket in place. Set gasket in place at top of shell, and screw on clean-out fitting with cap nut in place.

(4) Install drain plug and gasket at base of filter.

(5) Drop plunger into valve hole, hollow end up. Install spring on top of plunger. Hold gasket and lock nut on top of hole and install adjusting screw. Spin second gasket onto screw and cover with acorn nut.

f. Installation. Attach oil filter base to engine block over gasket with four cap screws.

g. Servicing.

(1) Take out sludge drain plug in bottom of filter and drain sludge.

(2) With sludge plug removed, remove cap nut from top of filter, and blow out the filter with compressed air.

(3) Remove clean-out fitting at top of shell, and remove shell. Scrape all sludge and foreign matter from the filter element with wood paddle.

h. Oil Pressure Regulating Valve (fig. 123).

(1) **REMOVAL.** Refer to procedure outlined in subparagraph c (3) above.

(2) **INSPECTION AND REPAIR.** Refer to procedure outlined in subparagraph d above.

ENGINE AND ACCESSORIES

(3) **ASSEMBLY.** Refer to procedure outlined in subparagraph e (5) above.

(4) **ADJUSTMENT.**

(a) Take off acorn nut and gasket, and loosen lock nut holding adjusting screw.

(b) The adjusting screw shall be turned until the oil pressure gage on the instrument panel registers 25 pounds pressure at 1,200 rpm. Tightening the screw increases the pressure, loosening the screw decreases pressure. **NOTE:** The oil pressure should not be changed or judged to be too high or too low until it is known that the proper weight of oil is being used, and the engine is warmed up to normal operating temperature. As the bearings become worn, more oil will escape around the bearings into the case, and this will lower the pressure slightly. It is not advisable to try to correct this slight loss of pressure by an adjustment of the pressure regulating valve because the extra amount of oil being thrown off by the worn bearings is already overoiling the cylinder walls.

60. OIL PUMP (figs. 124 and 125).

a. **Description.** The oil pump is of the positive spur gear type, and is submerged in the oil pan. It is gear-driven from the camshaft. In operation, oil is drawn from the oil pan, through the pump and to the main oil gallery in the cylinder block.

b. **Removal.**

- (1) Block unit up, high enough to remove oil pan.
- (2) Remove oil pan (par. 22 a (9)) (fig. 126).
- (3) Remove oil pump (par. 22 a (10)) (fig. 40).

c. **Disassembly** (fig. 127).

(1) Remove wire securing baffle shell cap screws together. Take out cap screws holding baffle shell to oil pump body, and remove baffle shell and gasket.

(2) Take out wire fastening cover plate cap screws together. Remove cap screws. Take out snap rings holding spur gears to shafts, and remove gears and idler shaft.

(3) File down peened-over end of drive gear pin, drive out pin, and slide gear and washer from shaft, and shaft from oil pump body.

d. **Inspection and Repair.**

(1) Check oil pump drive shaft for wear or damage. Replace if necessary.

(2) Try fit of oil pump drive shaft in body. It should be a free running fit without side play. Replace oil pump drive shaft or body if worn.

ORDNANCE MAINTENANCE — GENERATING UNIT M7

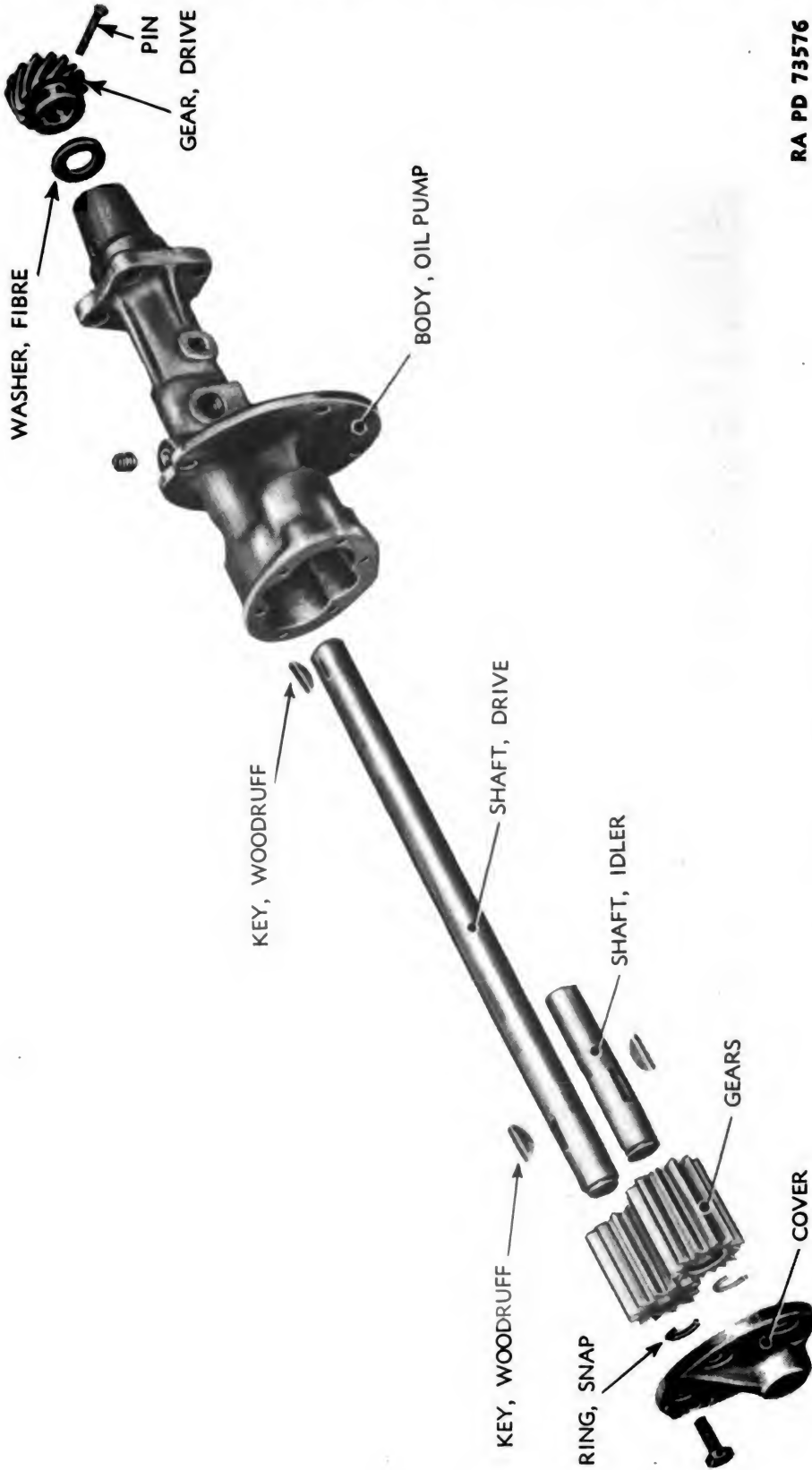

Figure 127 — Oil Pump Details

ENGINE AND ACCESSORIES

(3) Inspect condition of all oil pump gears. Replace damaged gears.

(4) Inspect condition of oil pump gear keys. Replace damaged keys.

e. Assembly.

(1) Press drive shaft up through pump body. Install new fiber washer over drive end. Insert Woodruff key in position in shaft slot. Press drive gear onto shaft until pin hole in gear collar lines up with hole through shaft. Insert new pin through gear and shaft and peen-over end.

(2) Place Woodruff key in position in drive shaft slot. Press gear over end of shaft, and secure with snap ring in shaft groove. Place Woodruff key in position in idler shaft, press on gear, and secure with snap ring in idler shaft groove. Insert idler shaft into pump body.

(3) Place oil pump cover in position, and secure to pump with cap screws. Wire the screw heads together.

(4) Place baffle shell in position over gasket on body plate. Secure with cap screws. Wire screw heads together.

f. Installation.

(1) Install oil pump (par. 24 a (14)).

(2) Attach oil pan (par. 24 a (16)).

Section VI

ELECTRICAL SYSTEM – BATTERY-CHARGING GENERATOR, REGULATOR, AND BATTERY

	Paragraph
Description	61
Trouble shooting	62
Generator disassembly	63
Generator inspection and repair	64
Generator assembly	65
Generator regulator	66
Battery description	67
Battery maintenance	68
Preparing new batteries for service	69
Battery repair	70

61. DESCRIPTION.

a. Battery-charging Generator Circuit (fig. 129).

(1) The battery-charging generator circuit consists of a generator, regulator, ammeter, battery, and connecting wires.

ORDNANCE MAINTENANCE — GENERATING UNIT M7

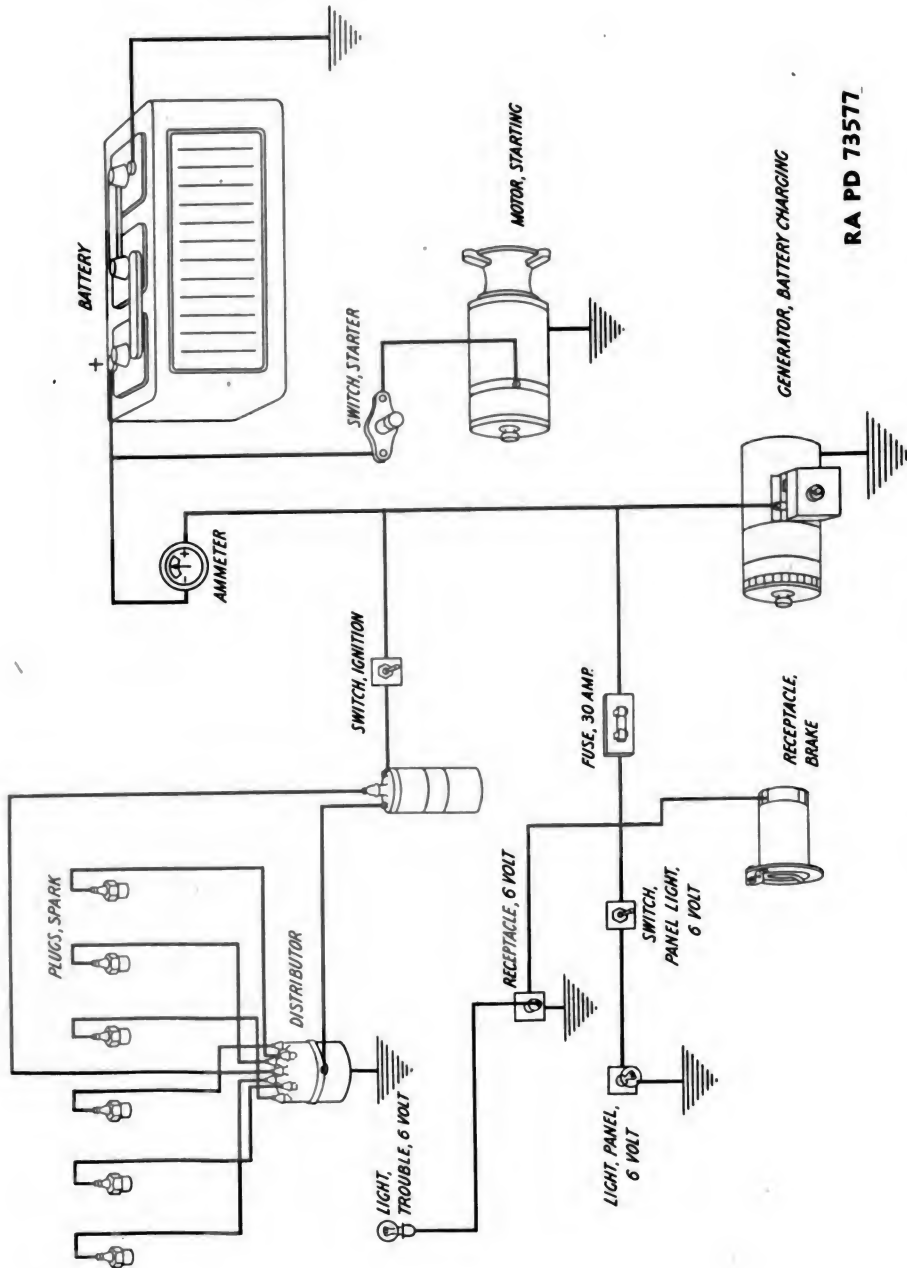

RA PD 73577

Figure 128 — Engine Electrical System

ENGINE AND ACCESSORIES

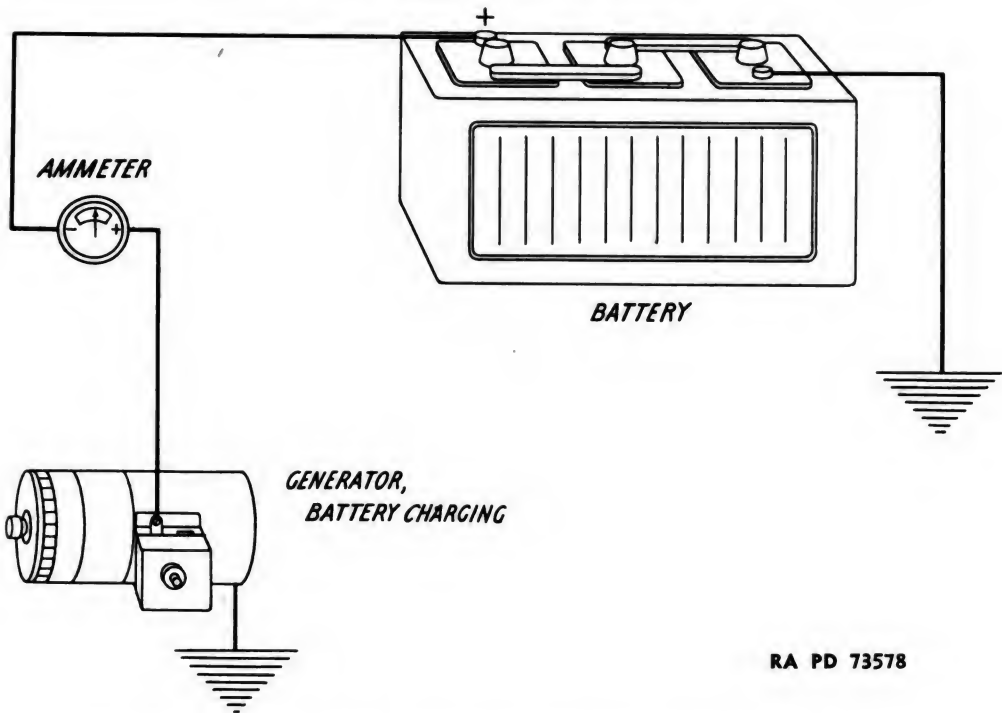

Figure 129 – Engine Electrical System – Generator Circuit

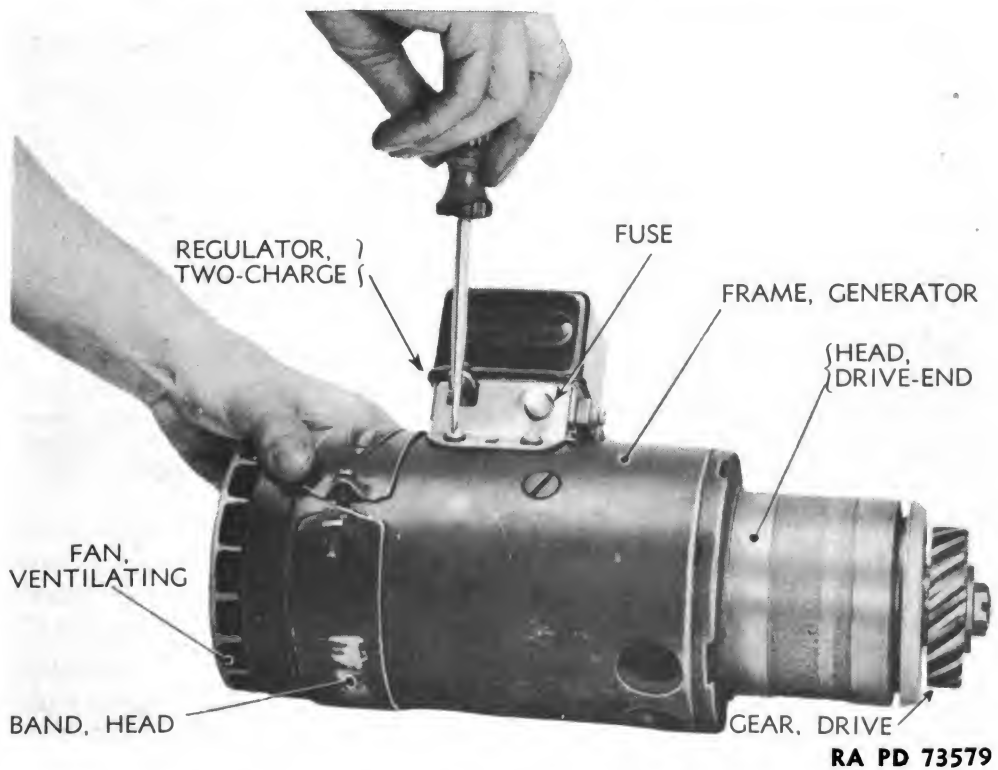
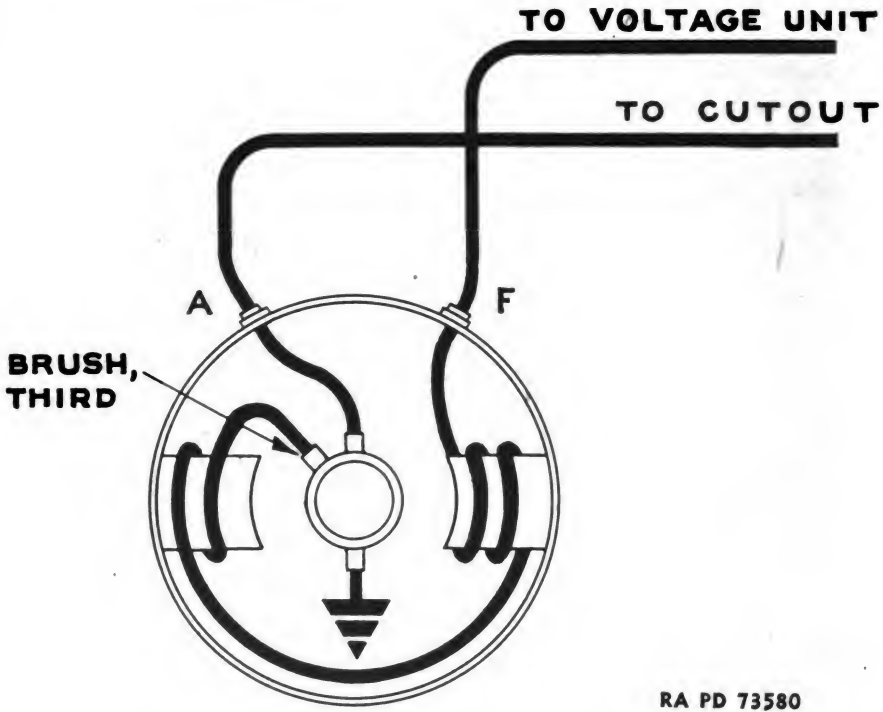

Figure 130 – Battery-charging Generator Regulator Removal

ORDNANCE MAINTENANCE — GENERATING UNIT M7



RA PD 73580

Figure 131 — Generator Wiring Diagram

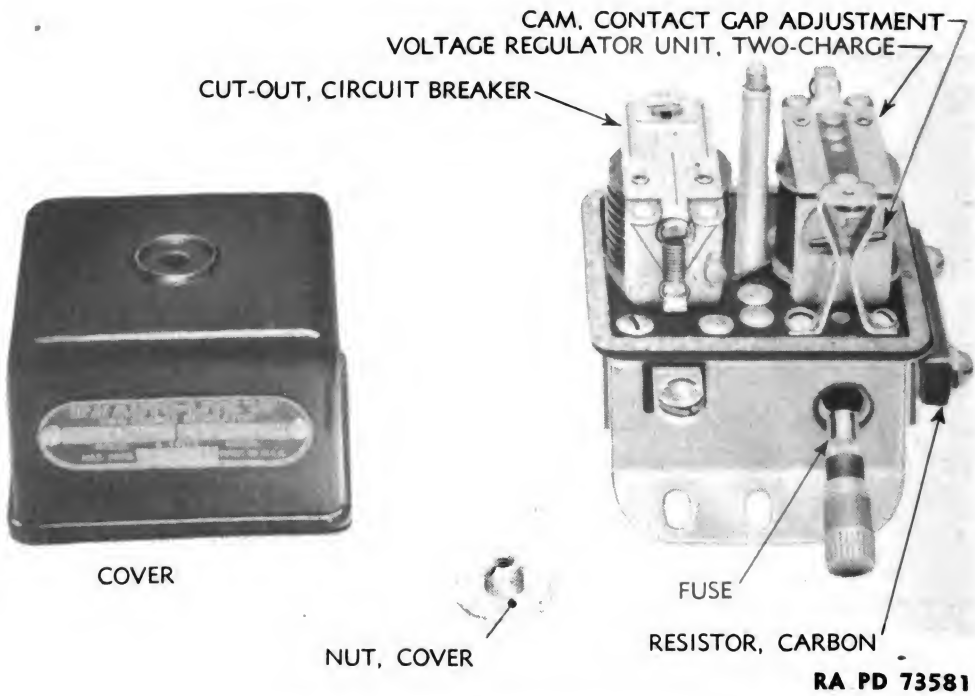

RA PD 73581

Figure 132 — Generator Regulator

ENGINE AND ACCESSORIES

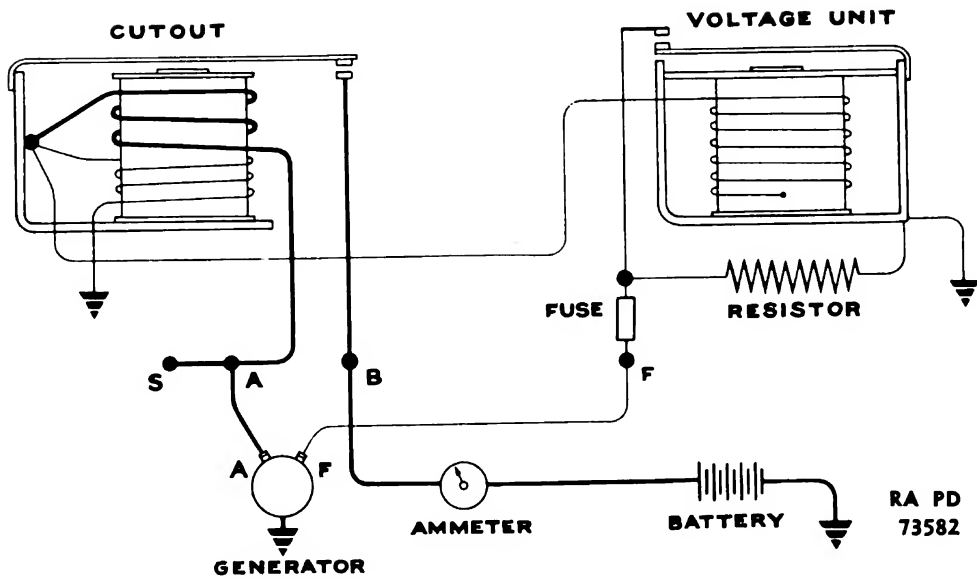

Figure 133 – Generator Regulator Wiring Diagram

(2) Its function is to convert a small amount of mechanical energy from the engine into electrical energy, and store it for future use. This electrical energy, produced by the generator, is carried from the generator through the wiring to the storage battery. In actual operation, some of the energy may be used directly from the generator.

b. Battery-charging Generator (figs. 130 and 131).

(1) The generator is a device for changing mechanical energy into electrical energy. It consists of four main subassemblies which are the frame and field, the armature, the commutator end plate, and the drive end head.

(2) The frame and field consist of the iron shell which supports the units, and also forms part of the magnetic circuit and the field coils which supply the magnetic field. The field coils are mounted on pole pieces which hold the coils in place, and also distribute the flux so that it flows evenly through the armature core and back through the frame. The armature is composed of the shaft, laminated iron core, the commutator, and the armature coils. The coils are wound in slots in the armature core, and the ends of the coils are clinched and soldered to the commutator bars. The commutator is composed of copper wedges insulated from each other and from the shaft. The drive end head provides the support for the ball bearing and also supplies the mounting flange. The commutator end plate also supports a ball bearing, and provides the support for the brush plates and arms. The brushes are mounted in these plates, and are held against the commutator by the brush springs and arms.

ORDNANCE MAINTENANCE — GENERATING UNIT M7

(3) To produce electrical energy, it is necessary to turn the armature. This causes the windings of the armature to cut the magnetic flux produced by the field coils. This cutting of a magnetic field by an electrical conductor produces a voltage in the armature conductors. The commutator and brushes are arranged so that the generated voltage is carried from the revolving armature to the armature terminal outside the generator. A small fraction of the current produced by the generator is bypassed through the field coils to produce the magnetic field. The output of the generator is determined by the strength of the field and by the speed of the armature in cutting through the field. Since the speed of the generator cannot be regulated, the control of the generator output is accomplished by changing the field current. This is done by the action of the generator regulator.

(4) The generator windings are cooled by the action of a centrifugal fan mounted on the commutator end of the armature shaft. This fan draws air into the generator through the openings on the under side of the frame. The air passes over the armature and field windings, and through the holes in the commutator end plate, where it is expelled by the fan.

c. Generator Regulator (figs. 132 and 133).

(1) The generator regulator is a combination circuit breaker and voltage regulator. The circuit breaker automatically opens and closes the circuit between generator and storage battery.

(2) The circuit breaker consists of an electromagnet and a set of contacts. The electromagnet has two windings; in one, a shunt coil, made of many windings, is connected across the generator; in the other, a series coil made of fewer turns of heavy wire, is connected in series with the generator output. The circuit breaker contacts consists of one movable contact mounted on an armature operated by the electromagnet, while the other is a stationary contact. These contacts are held open by an armature spring to prevent battery discharge through the generator.

(3) When the generator is not running, the contacts are open. When the generator is started, the voltage builds up at the generator terminal and in the shunt coil, since the shunt coil offers resistance to the current flow. As soon as the voltage reaches the value for which the circuit breaker is calibrated, there is sufficient magnetism created by the shunt coil to pull down the armature, closing the contacts, and automatically connecting the generator to the battery.

(4) With the contacts thus closed, the current which meets less resistance, in the series coil, flows from the generator to the battery, or in the same direction as the current in the shunt coil, so that the pull on the armature is increased by magnetism of the series coil.

ENGINE AND ACCESSORIES

(5) As the engine is stopping and the generator loses speed, the voltage falls. As soon as the generator voltage drops below the battery terminal voltage, the current flows from the battery to the generator, reversing the direction of current in the series coil. Then the magnetism created by the series coil is opposed to the magnetism created by the shunt coil. This reduces the magnetic pull on the armature, and the spring opens the contacts, disconnecting the generator from the battery.

(6) The voltage regulator operates on the principle of inserting a resistance in the generator field circuit when the generator voltage reaches a predetermined value. This consists of an electromagnet, a set of contacts, and a resistor, so arranged that the contacts are normally closed and the generator field circuit passes through the contacts to ground. When the contacts are opened, through the action of the electromagnet, the generator field circuit must pass through the resistor before going to ground. This is accomplished by connecting the electromagnet to the generator current at the circuit breaker. When the battery is low, it offers little resistance to the generator current, but as the battery approaches full charge and can not take the full generator current, the voltage is built up to the point at which the voltage regulator electromagnet is calibrated. The current flows through the electromagnet, opening the contacts and inserting the resistor in the generator field circuit. This cuts down the strength of the field, which reduces the generator output, and prevents the battery from being "overcharged."

(7) To meet battery characteristic changes resulting from temperature changes, a magnetic bypass is used. The magnetic bypass type of compensation operates by varying the amount of magnetic pull exerted on the armature at any given voltage, according to the temperature.

(8) The magnetic bypass is a small piece of nickel-iron across the top of the magnetic core of the electro-magnet. The magnetic conductivity of this bypass gradually increases as its temperature is reduced. Thus, at low temperatures, much of the magnetic pull of the core, which would normally affect the cutting-in of the field resistance, flows through this bypass instead of the regular armature. This results in a higher generator voltage being required to open the contacts and cut in the field resistance.

(9) At high temperatures the magnetic conductivity of the bypass is reduced, thus allowing the magnetic pull of the core to have full effect on the regulator armature and cut in the field resistance at a lower generator voltage.

ORDNANCE MAINTENANCE – GENERATING UNIT M7

62. TROUBLE SHOOTING.

a. Low or No Generator Output.

Possible Cause	Possible Remedy
Dry battery.	Refill cells (par 68).
Poor battery condition.	Replace battery.
Loose connections.	Tighten connections.
Dirty connections.	Clean and tighten connections.
Burned contacts on regulator.	Clean or repair contacts (par. 66 d (4)).

b. High Discharge Ammeter.

Regulator or circuit breaker closed.	Repair or adjust circuit breaker (par. 66 d (7)).
--------------------------------------	---

c. Noise at Engine Idle Speed.

Broken bearing.	Replace bearing (pars. 63 and 65).
Loose pole piece.	Tighten pole piece (par. 65).
Commutator damaged.	Repair commutator or replace armature (pars. 63 and 64).

d. Low Charging Rate.

Dirty commutator.	Clean commutator (par. 64 a (2) (c)).
Voltage regulator improperly adjusted.	Adjust regulator (par. 66 d).
High resistance in charging circuit.	Clean and tighten battery terminals, and check circuit for loose connections.
Third brush improperly adjusted.	Adjust for correct charging rate by moving brush holder in direction of armature rotation.

e. High Charging Rate.

Third brush improperly adjusted.	Adjust for lower charging rate by moving brush holder in direction opposite armature rotation.
----------------------------------	--

63. GENERATOR DISASSEMBLY (fig. 134).

a. Procedure.

(1) Take out the four screws holding the regulator to the generator. Take out the two screws holding generator leads to regulator, and remove leads and regulator.

(2) Unscrew bolt holding ends of head band cover strip together, and remove bolt and head band.

ENGINE AND ACCESSORIES

- (3) Take out cotter pin holding castellated shaft nut in place. Remove nut. Remove drive gear.
- (4) Take off shaft nut. Remove fan.
- (5) Take out screws holding the air deflector to the commutator head, and remove the deflector. Remove washers.
- (6) Take out screws attaching leads from field coils to brush holders, and remove leads.
- (7) Take out the frame screws, and remove the commutator end head.
- (8) Force back brush holder springs and spring clamps, and slide clamps and springs from posts. Take out screw attaching third brush-holding ring yoke to head, and remove yoke and brush-holding ring.
- (9) Separate drive end head and armature from body, and press out armature.
- (10) Take off cover plate. Press out head bearing.
- (11) Press out commutator end bearing.
- (12) Take out the two screws through the generator body to the pole pieces, and remove the field coils and pole pieces.

64. GENERATOR INSPECTION AND REPAIR.

a. Procedure.

(1) FIELD COIL TESTS.

(a) Place test prod leads on the two leads from one field coil. If the test lamp lights, the field coil has no open circuit. If lamp does not light, the field coil is open-circuited, and should be replaced. Proceed in the same manner to test the other field coil.

(b) Connect a field coil to a battery in series with a testing ammeter. Take a reading on ammeter. Repeat the procedure on the other field coil. If one field coil draws more current than the other, there is an internal short in the field coil that draws the most current, and it should be replaced.

(2) ARMATURE TESTS.

(a) Place one test prod lead on armature, and the other on one of the commutator bars (fig. 135). If test lamp lights, armature is grounded, and should be replaced. If test lamp does not light, armature is not grounded. Proceed to test each commutator bar in turn until all have been tested.

(b) Place armature on growler and, with a hack saw over armature core, rotate armature and test (fig. 136). If saw blade does not vibrate, armature has no shorts. If saw blade vibrates, armature is short-circuited. To determine whether armature windings or the commutator is shorted, clean out between commutator bars, and recheck armature. If the saw blade still vibrates, armature windings are short-circuited. Armature must be replaced.

ORDNANCE MAINTENANCE - GENERATING UNIT M7

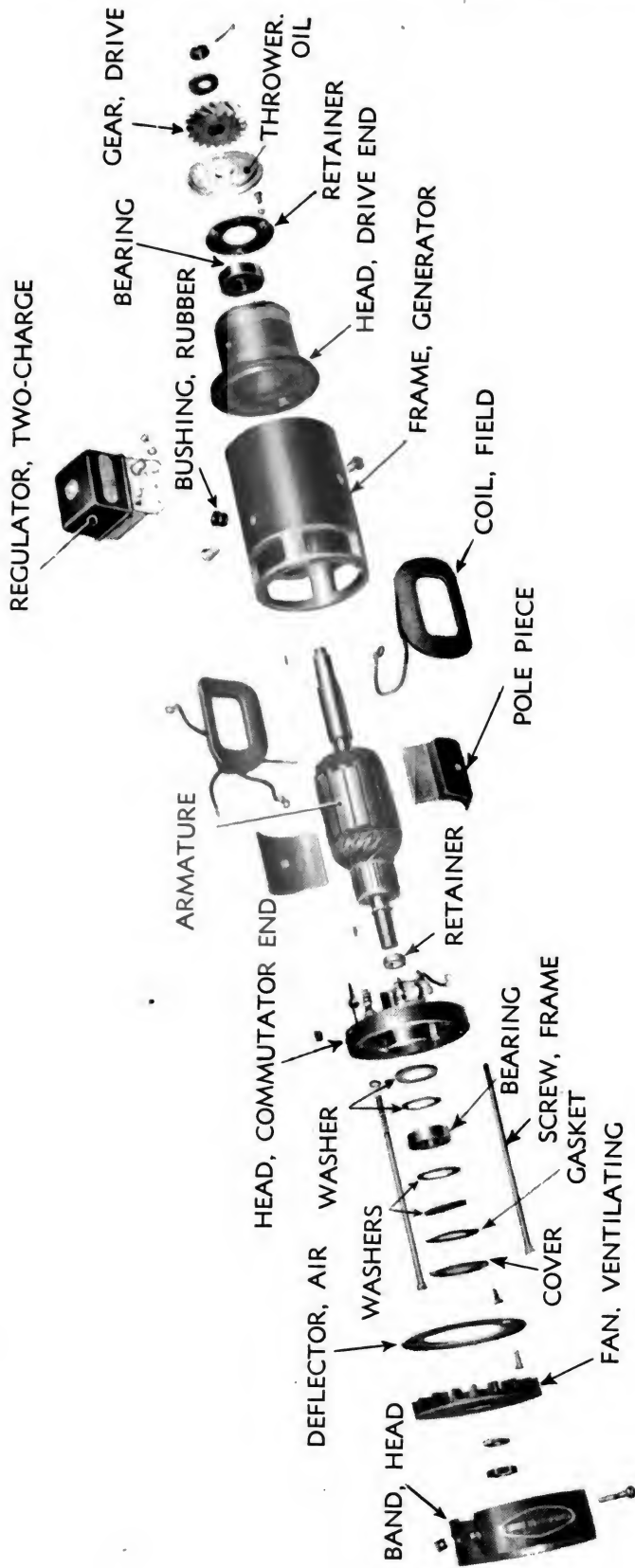

RA PD 73583

Figure 134 - Generator - Exploded View

ENGINE AND ACCESSORIES

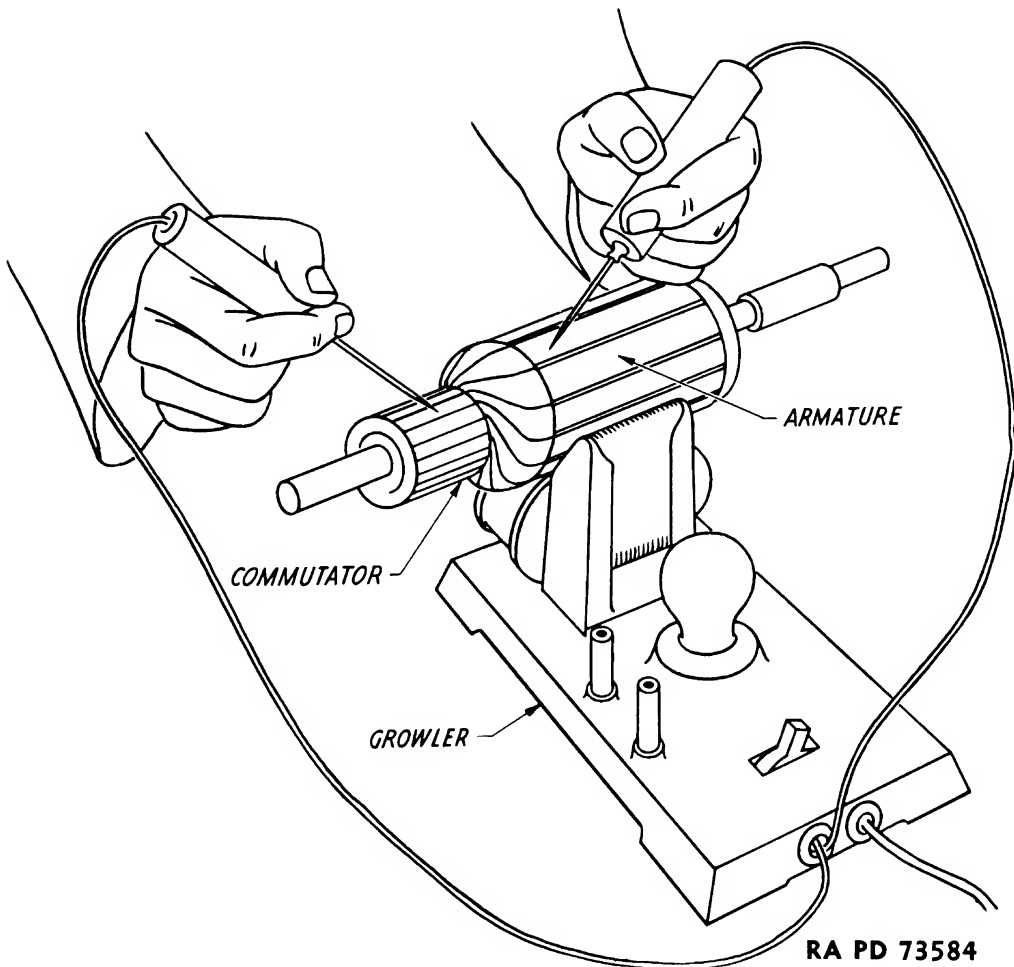

Figure 135 – Testing Commutator Bars

(c) Check the commutator for roughness, and if rough, turn it down on a lathe until it is thoroughly clean, after which dress with PAPER, flint, class B, No. 2/0. Undercut the mica (fig. 137), and again check armature on growler for shorts.

(d) Check armature to commutator leads. See that they are properly soldered to commutator.

(3) **GENERAL TESTS.**

(a) Check fit of armature shaft in commutator end bearing. If bearing is worn, replace it.

(b) Clean ball bearings in SOLVENT, dry-cleaning, and blow out with compressed air. Check bearings for wear or roughness. Replace if necessary.

(c) Check to see that brush springs have enough tension to hold brushes snugly against the commutator. Replace if necessary.

(d) Check brushes for wear and condition. Replace if worn to half their original length, or if broken.

ORDNANCE MAINTENANCE – GENERATING UNIT M7

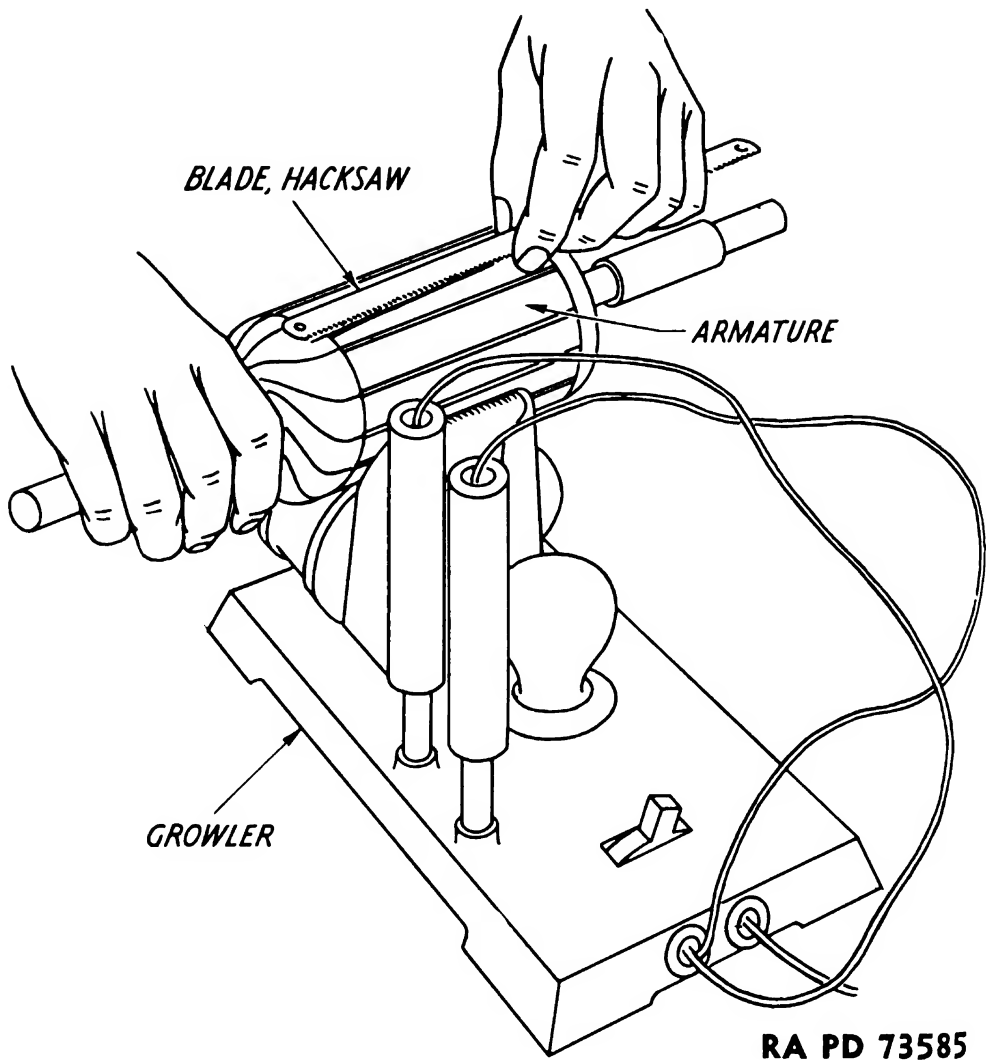

Figure 136 – Testing Armature for Shorts

65. GENERATOR ASSEMBLY (fig. 134).

a. Procedure.

(1) Press drive end head bearing on armature shaft, and press armature shaft into position in drive end head.

(2) Connect the field coils by soldering together the lead from each coil not attached to a lug. Attach the field coils to the frame by inserting a pole piece through each coil, and securing pole pieces and coils to the frame with flat-head screws. Bring the single unused wire from the one field coil up through the housing bushing hole. Carry one of the ends of the gray wire taped to the other field coil out through the same hole, and install the rubber bushing.

ENGINE AND ACCESSORIES

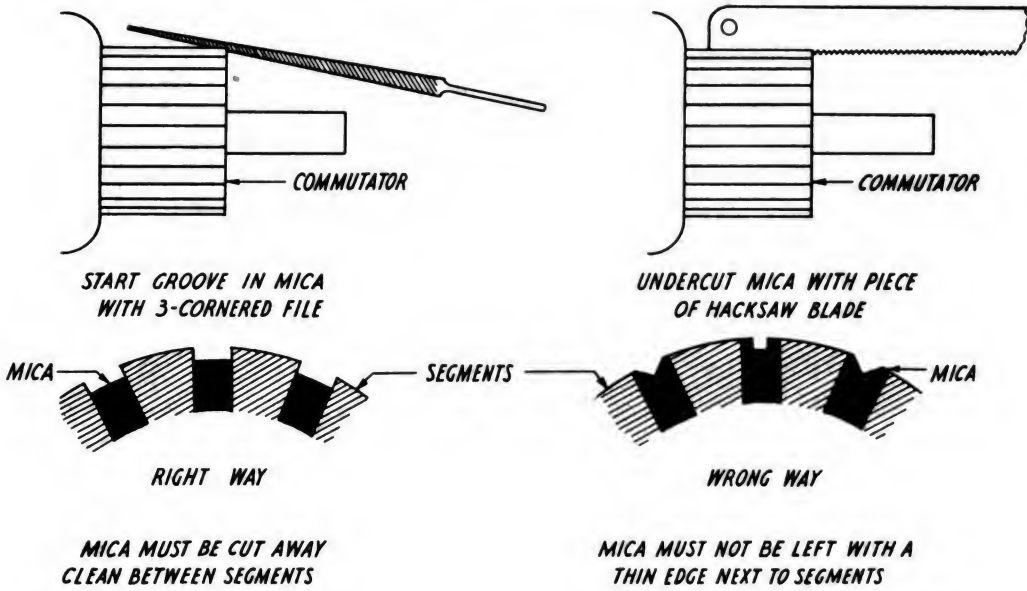

RA PD 73586

Figure 137 — Undercutting Commutators Mica



RA PD 73587

Figure 138 — Removing Regulator from Generator —
Taking Off Armature Connection

ORDNANCE MAINTENANCE – GENERATING UNIT M7

(3) Attach third brush-holding ring and ring yoke to head with screw through yoke. Install brush-holder springs and spring clips on commutator head posts. Hold back clips, and set brushes in place.

(4) Carry commutator end head over the commutator end of the armature and attach commutator end head, frame, and drive end head with the frame screws.

(5) To the brush holder that has no insulation between it and the ring, secure only the brush pigtail connection with screw. To the third, or adjustable brush holder, connect the brush connector and the black field lead with screw. To the remaining brush holder, attach its brush connection and the gray wire, which is the armature lead.

(6) Slide retainer into position on armature shaft. Install the felt and metal washers, and press the bearing into place in commutator end head.

(7) Slide metal and felt washers over armature shaft then the gasket and cover, and attach cover with screws. Install cover with flat-head screws. Install Woodruff key in shaft. Place air deflector and fan in position, and secure with nut.

(8) Place retainer in position over shaft at drive end, and secure to head with flat-head screws. Insert Woodruff key in shaft and slide oil thrower onto shaft. Press drive gear into position, install washer and castellated nut, and secure with cotter pin.

(9) To pole marked "A" (for armature), on bottom of regulator, connect the gray generator wire with screws. To pole "F" (for field), connect the black lead with screw. Secure regulator base to generator frame with round-head machine screws.

66. GENERATOR REGULATOR.

a. **Description and Operation** (par. 61 c).

b. **Removal** (par. 63 a (1)) (fig. 138).

c. **Disassembly.**

(1) Remove cover nut, and lift cover from regulator.

(2) Remove carbon resistor screws, and lift off carbon resistor (fig. 139).

(3) Unscrew fuse cap and remove fuse, fuse insulation, and fuse from regulator body.

d. **Inspection and Repair.**

(1) Examine for evidence of burning or abnormally high temperatures at the coils, contacts, insulation, external terminals, or other points.

(2) Examine for loose connections resulting from poor soldering.

(3) Examine for loose nuts on bottom of magnet cores, loose rivets, or screws. All nuts and screws must have lock washers.

ENGINE AND ACCESSORIES

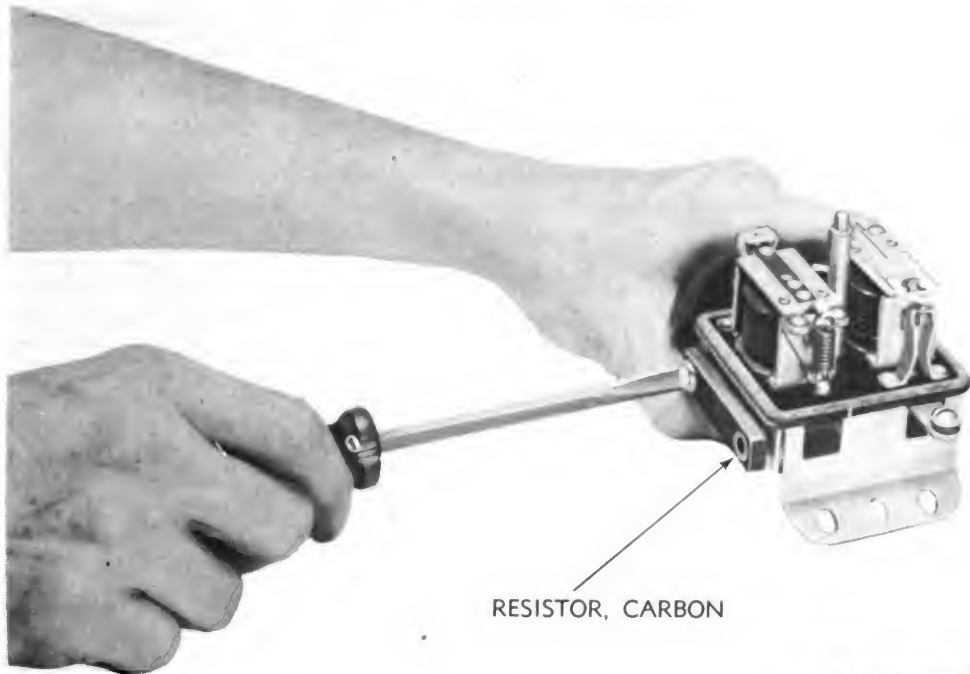

RA PD 73588

Figure 139 — Removing Carbon Resistor from Regulator

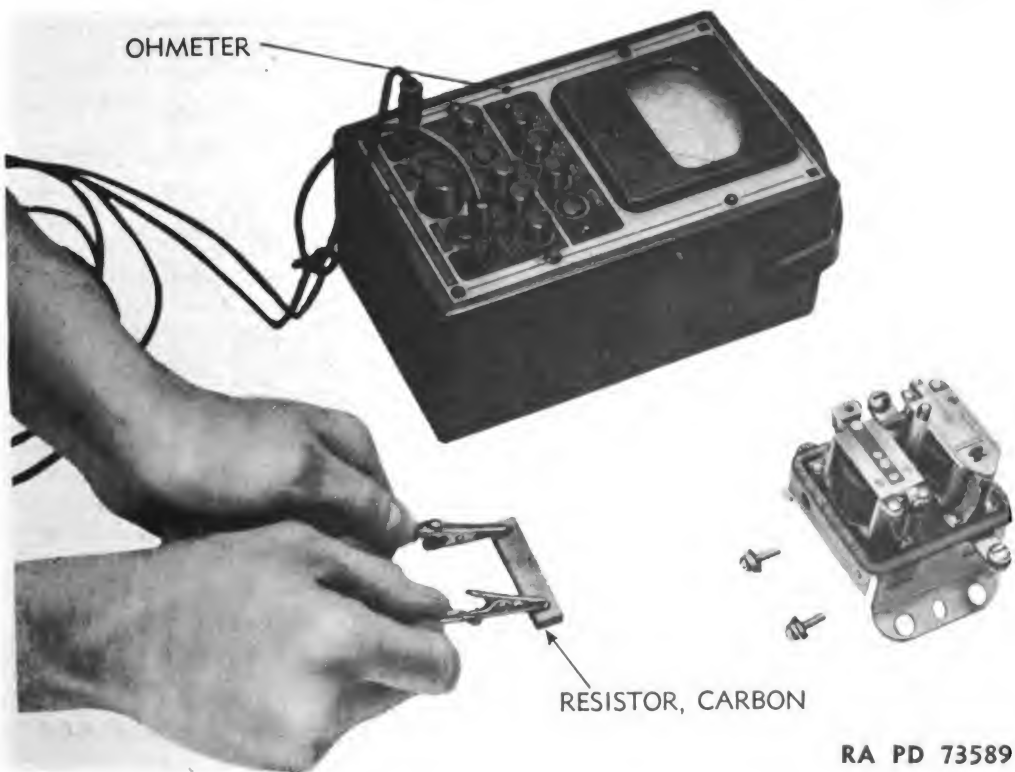

RA PD 73589

Figure 140 — Testing Carbon Resistor with Ohmmeter

ORDNANCE MAINTENANCE — GENERATING UNIT M7

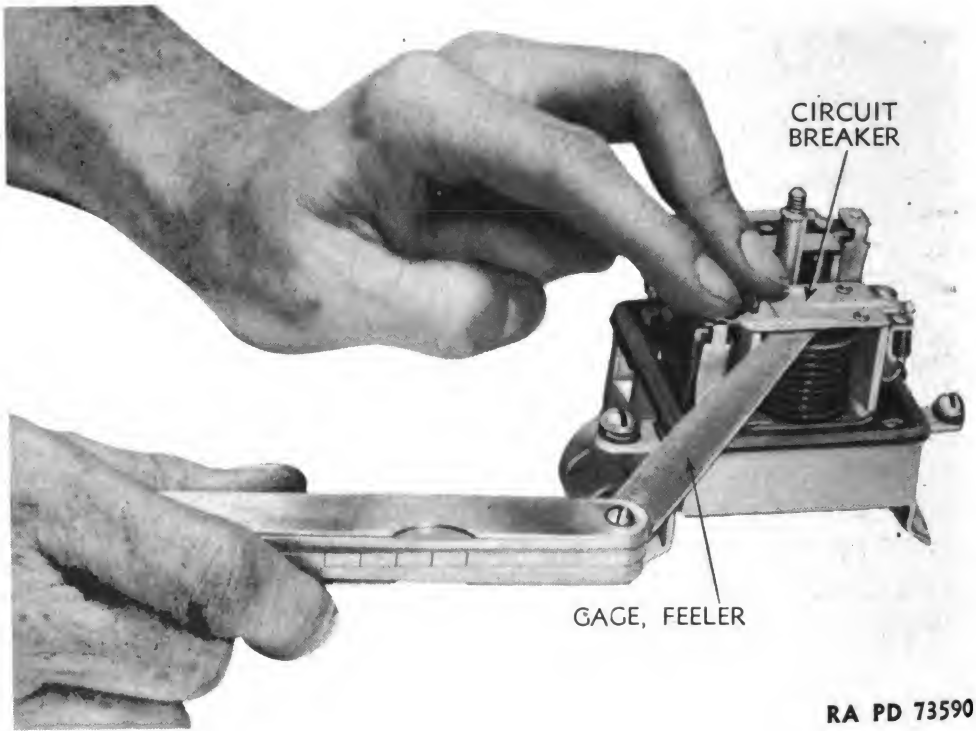

Figure 141 — Checking Circuit Breaker Armature Air Gap

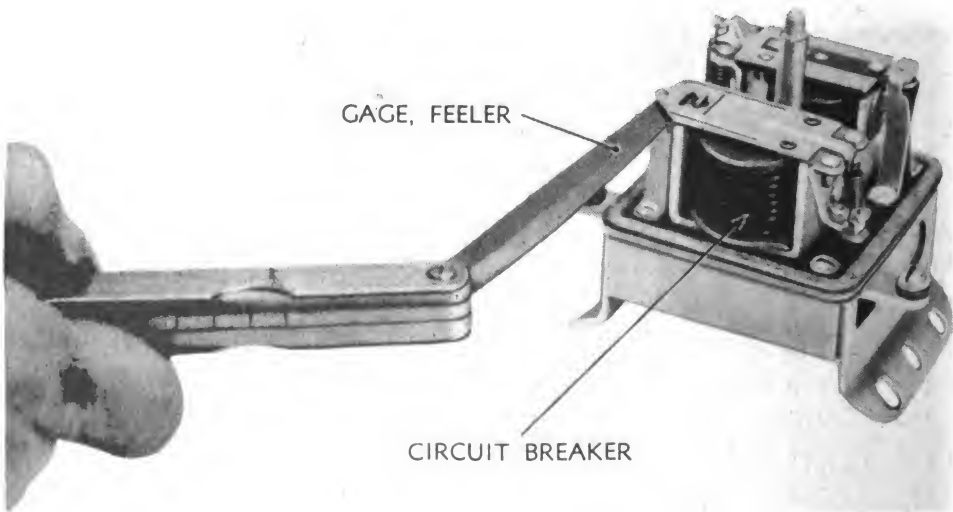

Figure 142 — Checking Circuit Breaker Contact Gap

ENGINE AND ACCESSORIES

(4) **CONTACTS.** Clean all contacts by filing, parallel with length of the armature, with a very fine file (ST-290) so that they are free from pits and burning. Clean points with **CARBON TETRACHLORIDE** to remove any dirt or grease. Pull a piece of clean linen tape between contacts to remove any residue.

(5) **CARBON RESISTOR.** Check resistance of the carbon resistor with an ohmmeter (fig. 140). It must read 7 ohms, plus or minus 5 percent. Replace if necessary.

(6) **CIRCUIT BREAKER ARMATURE AIR GAP.** Check circuit breaker armature gap (fig. 141). This check is made with contacts closed, and is adjusted by raising or lowering stationary contact. Adjust to 0.010 to 0.030 inch.

(7) **CIRCUIT BREAKER CONTACT GAP.** Check circuit breaker contact gap (fig. 142). It must be 0.015 to 0.045 inch. Adjust by bending armature stop.

(8) **REGULATOR ARMATURE AIR GAP** (fig. 143). Check regulator armature air gap. It must be 0.044 to 0.046 inch. Measure gap with regulator contact closed. Adjust by raising or lowering upper contact by expanding or contracting the bridge holding upper contact.

(9) Check regulator contact gap (fig. 144). It must have 0.005-inch minimum gap. Adjust by turning brass cam.

e. Assembly.

(1) Assemble fuse, fuse insulation, and fuse cap to regulator body.

(2) Assemble carbon resistor, carbon resistor screw insulating washers, and two screws to regulator body.

(3) Place gasket on regulator body, and assemble cover and cover nut to regulator body.

f. Battery-charging Generator Regulator Tests.

(1) **CHECK CIRCUIT BRAKER OPERATION.**

(a) Connect the circuit breaker, a voltmeter, potentiometer, a 12-volt battery, and a lamp in series, as illustrated per diagram in figure 145.

(b) Increase voltage from zero, and note voltage at which contact points close, as indicated by the lamp lighting.

(c) Voltage must be 6.5 to 7.25 volts. Adjust circuit breaker gap until voltmeter reading is within these limits (subpar. d (7), above).

(2) **CHECK REGULATOR OPERATION.**

(a) Connect the regulator, voltmeter, potentiometer, a 12-volt battery, and lamp in series as illustrated per diagram in figure 145.

(b) Increase voltage from zero, and note voltage at which contacts open as indicated by lamp dimming or going out.

ORDNANCE MAINTENANCE — GENERATING UNIT M7

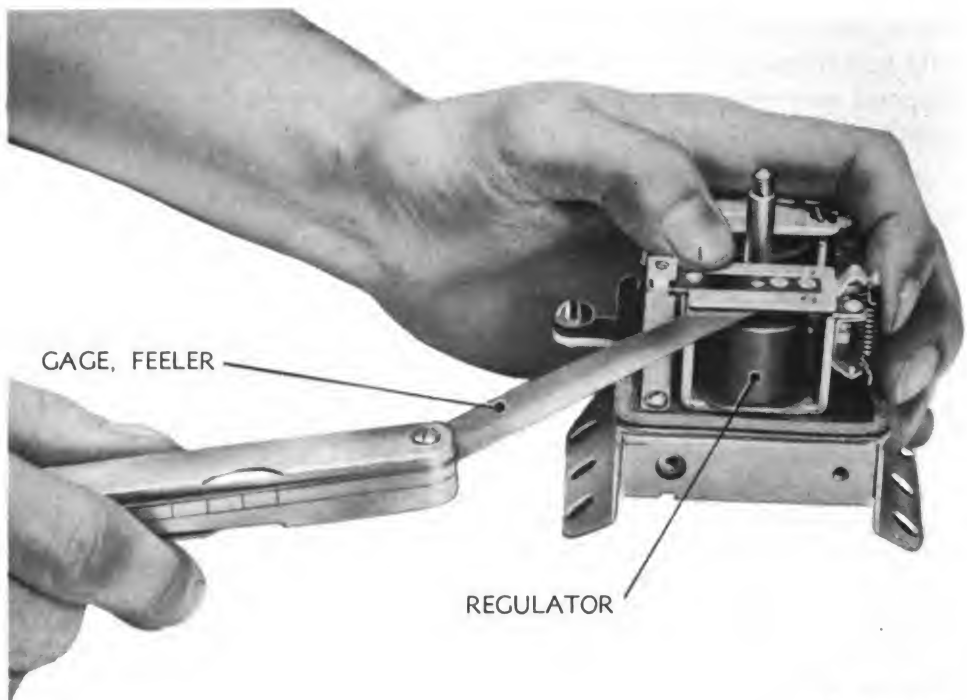

RA PD 73592

Figure 143 — Checking Regulator Armature Air Gap

(c) This voltage figure must be within the specifications, and at temperature shown in the following scale:

TEMPERATURE Degrees Fahrenheit	VOLTAGE		
	High	Low	Ideal
50	8.90	8.40	8.65
60	8.82	8.32	8.57
70	8.75	8.25	8.50
80	8.68	8.18	8.43
90	8.60	8.10	8.35
100	8.53	8.03	8.28
110	8.46	7.96	8.21

(d) Adjust the regulator contact gap by bending spring hanger until readings fall within above scale (step d, (8) above).

(e) Reduce voltage and check contact closing voltage as indicated by lamp lighting. This voltage reading must be from 1.2 to 2.4 volts below the contact opening voltage. Adjust gap by turning brass cam.

g. Installation.

(1) Attach generator field lead (black wire) to terminal marked "F" on bottom of regulator.

ENGINE AND ACCESSORIES

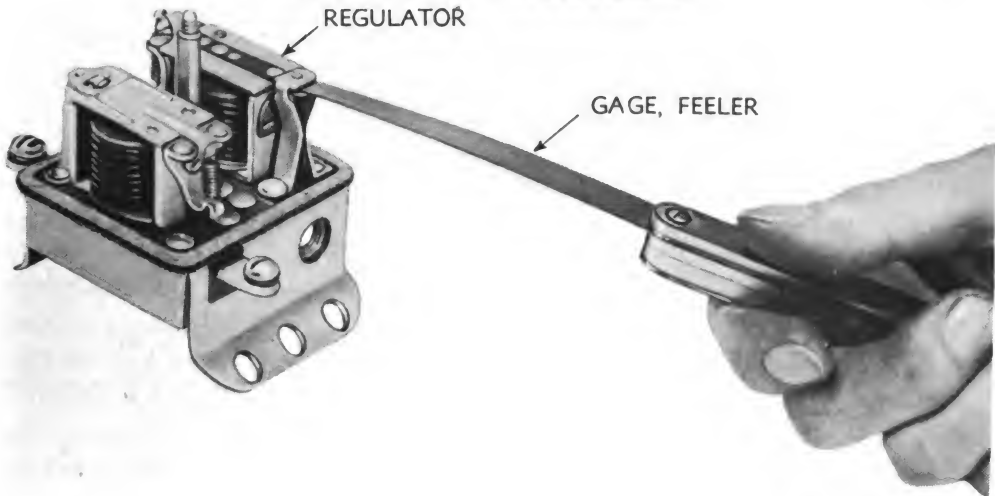

RA PD 73593

Figure 144 – Checking Regulator Contact Gap

- (2) Attach generator armature lead (gray wire) to terminal marked "A" on bottom of regulator.
- (3) Place regulator in position on generator.
- (4) Install the four mounting screws and lock washers.
- (5) Attach wire from "CG" post on terminal block to terminal marked "B" on engine side of battery regulator.

67. BATTERY DESCRIPTION.

a. The battery is a lead-acid, 3-cell, 6-volt model, with each cell containing 17 plates and delivering 2 volts. It has a capacity of 160 ampere-hours, when discharged at a 20-hour rate.

b. The container is made of rubber with the cells formed by partitions dividing the interior. The cells are closed by hard rubber covers sealed in place, with holes to provide for the cell terminals and a vent. Each negative group of plates, two of which are end plates, are permanently connected at the top to a metal strap carrying the projecting negative terminal. The positive plates, arranged alternately with the negative plates, are similarly connected in a group by a strap carrying the projecting positive terminals. Separators are placed between the adjacent positive and negative plates. The plates and separators rest on ribs molded in the bottom of the container. The exposed terminal posts of adjacent cells are joined, positive to negative, by outside connectors burned to the terminal posts on the tops of the cells, and connect the cells in series. Screw type vent plugs, which have small openings for the escape of gas, fit the openings in the center of each cell, and permit inspection of the inside of the cells and replenishment of the electrolyte or water. Circular rubber gaskets fit around the terminal posts in the covers and make the terminals leakproof.

ORDNANCE MAINTENANCE – GENERATING UNIT M7

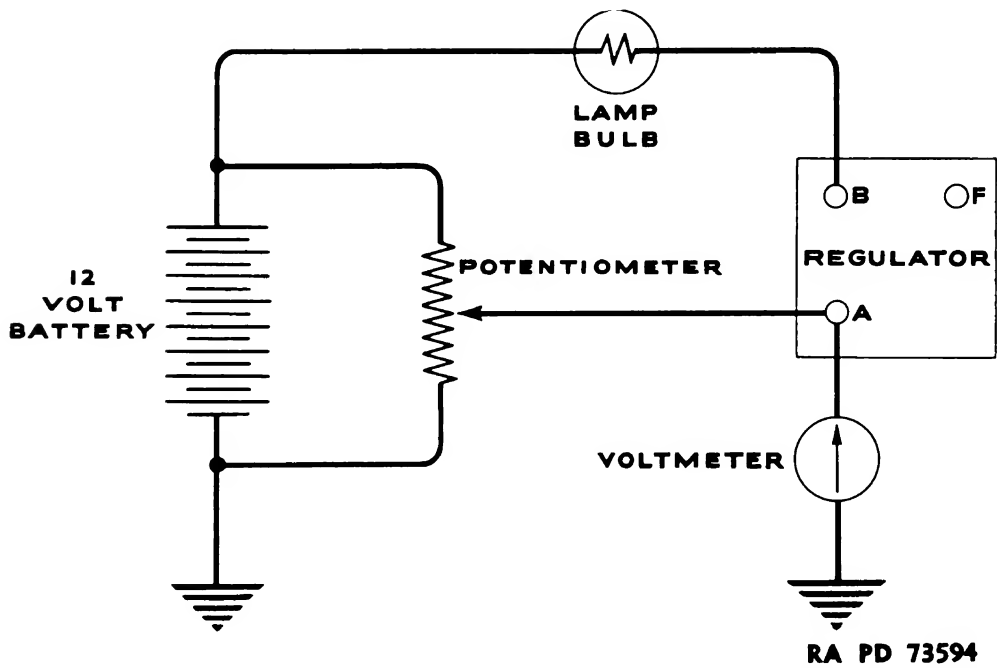

Figure 145 – Circuit Diagram for Testing Circuit Breaker Operation

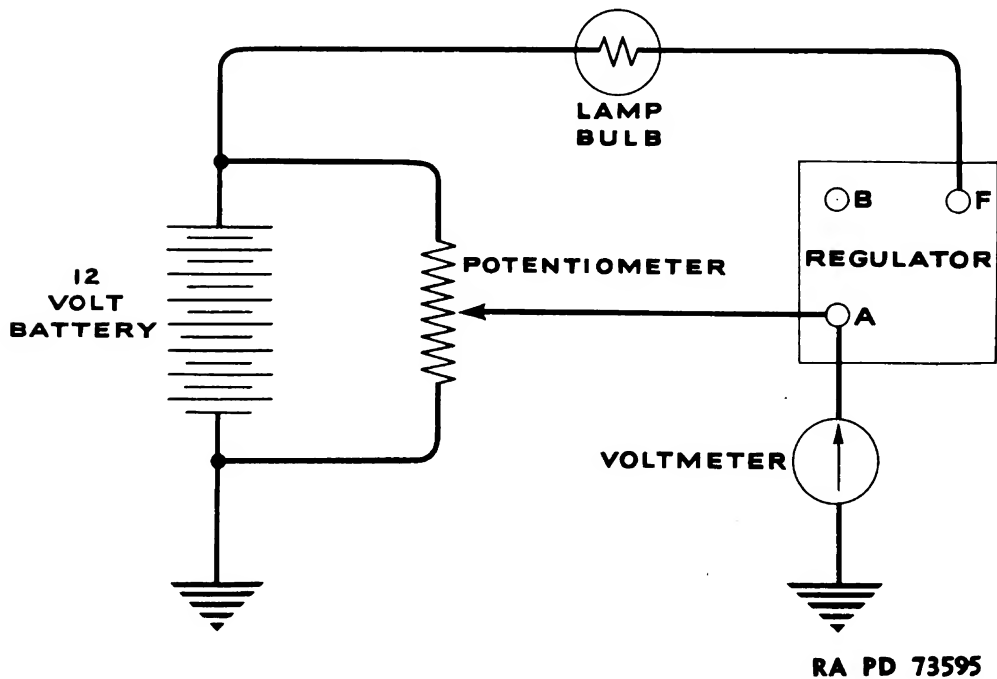

Figure 146 – Circuit Diagram for Testing Regulator Operation

c. The active materials in the lead-acid storage battery are as follows: The positive plate contains lead peroxide (chocolate brown color); the negative plate contains metallic lead in a finely divided

ENGINE AND ACCESSORIES

form, called sponge lead; the electrolyte is a solution of sulphur acid in water. During discharge, the active material in both the positive and negative plates reacts with the sulphuric acid of the electrolyte and is converted to lead sulphate. This action removes acid from the electrolyte and thus lowers its specific gravity. Both plates become converted in part to the same substance, lead sulphate, and the voltage delivered by the cell is reduced. The reverse action takes place when the cell is being charged. Acid is restored to the electrolyte, which increases the specific gravity of the electrolyte, and the plates are reconverted to the original materials. During both discharging and charging cycles, some of the water in the electrolyte decomposes into its elements, hydrogen and oxygen, which escape as gases from the solution. The quantity of gas released is much greater during charging than during discharging. These gases are explosive.

68. BATTERY MAINTENANCE.

a. Inspection. At least once a week, inspect the electrolyte level and terminals, and see that the battery is well secured. The electrolyte level should be kept $\frac{3}{8}$ inch above the separators. If the electrolyte appears too low in any cell, look for a leak in the container or sealing. The open-circuit voltage of a fully charged cell is approximately 2.12 volts. The terminal voltage of a discharged cell is 1.75 volts, when discharging at the normal rate. After discharging, the open-circuit voltage will rise to about 1.98 volts per cell. Actual values will vary with temperature.

b. Electrolyte.

(1) To maintain the level of the electrolyte, add distilled water. Boiling, filtering, and the use of "softening" materials or devices will not remove impurities from water that may injure the battery. Wipe top of battery and terminals dry after filling.

(2) Remove vent plugs, and test each cell with an accurate hydrometer. The reading for a fully-charged cell should be between 1.275 and 1.300. If any cells are below 1.225, place the battery on charge.

(3) Acid should never be added to the battery except to replace acid which has leaked out, been spilled, or been lost by overflushing. Adding acid to raise the specific gravity will not increase the state of charge. It will render hydrometer readings of no value, and shorten the life of the battery. When acid has been lost, add water and bring battery to a fully-charged state as indicated by no rise in the specific gravity of the electrolyte between successive readings during charge. Then empty the battery, and put in new electrolyte of 1.280 specific gravity. Continue charging at the normal rate, and after 1 hour, read the specific gravity. If it is below normal, withdraw some of the electrolyte and

ORDNANCE MAINTENANCE — GENERATING UNIT M7

replace with new electrolyte. If the specific gravity of the electrolyte is too high, remove electrolyte and replace with water. Continue charging, read the specific gravity, and repeat the adjustment at hourly intervals until the normal specific gravity is obtained. The battery must be charging and gassing during the entire adjustment procedure.

c. Charging.

(1) The charging rate of a battery depends upon the capacity of the battery and the charging method used. Continue charging until the battery is fully charged, as indicated by no rise in specific gravity in successive hydrometer readings. Take readings of specific gravity and voltage for each cell every hour. These readings should be recorded so as to eliminate under charging or over charging. The charging rate should not be too high, as evidenced by excessive gassing or temperature rise. The temperature of the battery should not be permitted to rise above 110 F (125 F in tropics). Mild gassing from a battery toward the end of charge is normal. Violent gassing or bubbling indicates excessive charging rates. After gassing starts, the charging rate should be approximately 1.0 ampere per positive plate (one cell). When placing a battery on charge, add distilled water to raise the electrolyte to the proper level ($\frac{3}{8}$ inch above separators), then replace the vent plugs.

CAUTION: The gas given off by storage batteries is a mixture of hydrogen and oxygen, and is highly explosive. Keep flames or sparks away from batteries on charge or discharge.

(2) **CONSTANT-CURRENT CHARGING.** A relatively high voltage d-c power source can be used for battery charging, if sufficient resistance is added to the circuit to limit the charging rate (current) to a safe value. The rise in battery voltage during charge is small compared to the voltage drop across the resistance, and the current remains practically constant throughout the charging period. When charging a number of batteries, several may be connected in series. The maximum number of cells that may be charged from a power source is the number obtained by dividing the voltage of the power source by 2.6. In series charging, the batteries must be carefully watched, and as each battery becomes fully charged it must be removed from the circuit.

(3) **CONSTANT-VOLTAGE CHARGING.** The time required for charging can be reduced by the use of a tapering current. If the power supply has a constant voltage of 2.50 volts per cell, this is accomplished automatically. The initial charging current drops rapidly as the battery charges. Be careful that the initial charging rate is not too high, as evidenced by excessive gassing, otherwise little attention is required for batteries on taper charge.

(4) **TRICKLE CHARGING.** Trickle charging is the continual application of a very low charging current. This method of maintaining the charge of batteries is not recommended for automotive type batteries.

ENGINE AND ACCESSORIES

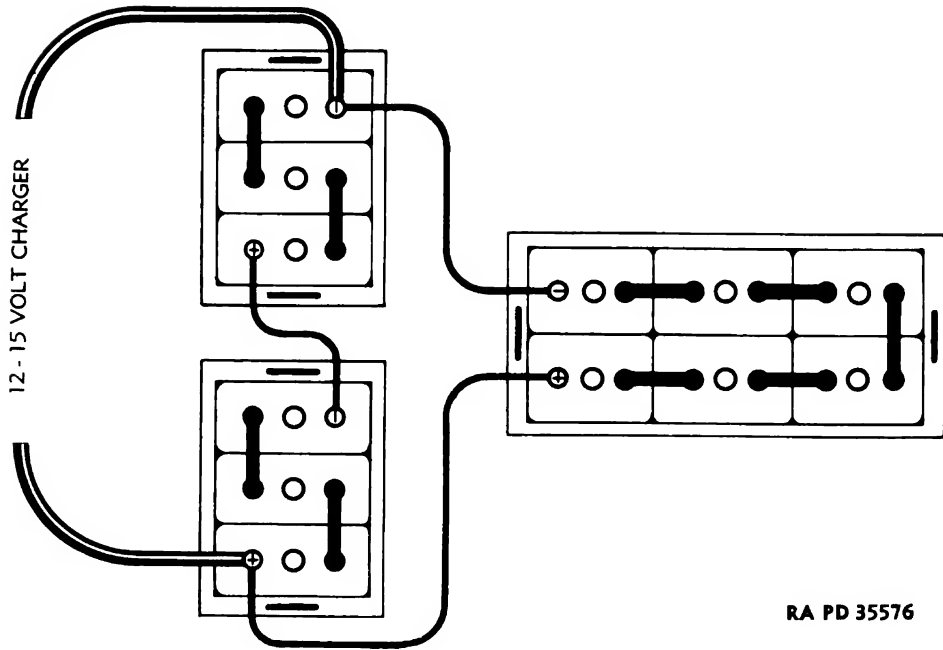

Figure 147 — Charging Two 6-volt Batteries and One 12-volt Battery in Parallel

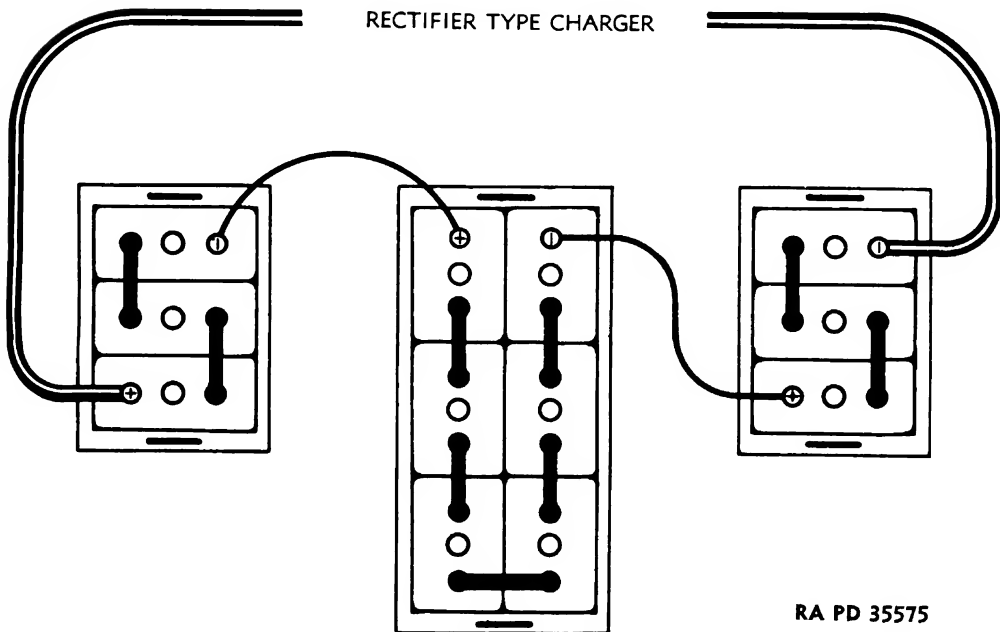

Figure 148 — Charging Two 6-volt Batteries and One 12-volt Battery in Series

ORDNANCE MAINTENANCE — GENERATING UNIT M7

d. **Battery Chargers.** Three types of battery chargers are likely to be encountered in ordnance establishments: Motor generator sets which operate from 110 volts alternating current; engine-driven generators; and rectifier-type chargers. The motor generator sets and the engine-driven generators have constant-potential-type generators. They generate at a voltage suitable for charging 12-volt batteries, and have connections for charging 6-volt batteries also. When using these chargers, the batteries are connected in parallel (fig. 147), and care must be taken to avoid overloading the generator. Reduce the generator voltage or limit the number of batteries being charged at one time to reduce the load on the charger. The rectifier-type chargers are of the constant-current type, and are generally limited to low values of current. The batteries are charged in series (fig. 148), and the voltage may be adjusted to suit the number of batteries being charged. Care must be taken when charging batteries in series to have only batteries of approximately the same capacity and condition on charge at the same time. It is possible when charging a strong and a weak battery that the stronger battery will act with the charger, and charge the weak battery with reversed polarity.

e. **Freezing.** A partially discharged battery may freeze in winter. Therefore, in cold weather, keep the battery fully charged. The freezing point of the electrolyte depends on its specific gravity. When fully charged, the electrolyte will remain liquid at extremely low temperatures. A fully-charged battery, if it stands idle long enough, will discharge slowly to a point where freezing may ensue. If the unit is stored for a long time without heat in very cold weather, take the battery to a place where it can be serviced. Water which has been added to a battery and has not been mixed with the electrolyte is likely to freeze if the battery is exposed to low temperature. When batteries have been frozen, they may be thawed by bringing them into a room kept at normal temperature (60 to 70 F). The battery may be serviceable if the freezing has not continued too far. In discharged batteries, the freezing points of electrolytes of various specific gravities are as follows:

Specific Gravity	Freezing Temperatures
1.220	-31 F (-35 C)
1.185	- 8 F (-22 C)
1.150	+ 5 F (-15 C)
1.100	+18 F (- 8 C)
1.000 (water)	+32 F (0 C)

f. **Heating.** Heating of the battery in service above 110 F (125 F in tropics) must be prevented. Watch the battery in warm weather and feel the top connectors. If these are warmer to the touch than the normal temperature of the human body, check the electrolyte with a thermometer. If the temperature reaches 130 F, the battery

ENGINE AND ACCESSORIES

may be ruined. Whenever the battery is found to be getting too warm on a run, check the voltage regulator, and cut down the charging rate if possible. If heating continues, check the whole electrical system.

g. Terminals. Check battery terminals and keep connections tight and clean. Clean with a solution of **AMMONIUM HYDROXIDE** or bicarbonate of soda in water and a wire brush. Wash afterwards with water. Lightly coat terminal with **COMPOUND**, rust-preventive, light, before tightening. Inspect ground strap and cables, and replace if worn or corroded. Corroded terminals are weakened and easily broken. The positive terminal is more susceptible to corrosion than the negative terminal, due to electrolytic action. Electrolytic action is greater at a loose connection than at a tight one. Loose terminals cause increased resistance, indicated by a decreased capacity and terminal voltage, while other indications show the battery to be normal.

h. Idle and Stored Batteries. Batteries should be stored fully charged, and filled with the proper amount of electrolyte. Keep them in a charged condition by periodically charging them every 30 days, or when the specific gravity of the electrolyte falls below 1.225. They will then be available for immediate use when needed.

i. Reversal of Polarity.

(1) Reversal of polarity may be indicated by loss of capacity and heating. If it is long continued, the plates may be destroyed.

(2) Reversal of polarity may occur from over discharging when a cell of low capacity is connected in series with cells of higher capacity. The high capacity cells will act to charge the low capacity cell, with the terminals connected in the wrong direction. The most common cause of reversal of polarity is charging the battery in the wrong direction.

(3) **REMEDY.** If the reversal is not extended over too long a period, the battery may be restored to normal condition by discharging to zero voltage, and recharging in the right direction. Care should be taken to prevent excessive heating and gassing.

j. Abnormal Sulphation.

(1) Abnormal sulphation, the hardening or crystallizing of lead sulphate in the plates and possibly on the separators in the cell, may result from prolonged insufficient charge or the addition of acid unnecessarily. It serves as an insulator on the plates and is not readily broken down when the battery is placed on charge. It causes loss of capacity, and if not corrected in time, will make the battery unfit for use.

(2) If a cell is not too badly sulphated, it may be put into condition by recharging. A high rate of charge should be used at the start. If the battery cannot be put into condition by recharging, discard it.

ORDNANCE MAINTENANCE — GENERATING UNIT M7

k. Mixing Electrolyte.

(1) Commercial sulphuric acid generally has a specific gravity of 1.835 or 1.400. This acid must be mixed with distilled water to make electrolyte of proper specific gravity for batteries. *Always pour the acid into the water* slowly, and stir to mix. The container should be made of glass, earthenware, lead-lined wood tank, or a similar vessel that is resistant to sulphuric acid and can stand the heat generated during mixing. Allow the electrolyte to cool below 90 F before using. As it cools, its specific gravity will rise slowly. The proportions of water and acid to use depend upon the gravity desired, and are approximately as follows:

PROPORTIONS BY VOLUME

Specific gravity desired	Using 1.400		Using 1.835		Freezing point
	specific gravity acid		specific gravity acid		
	Acid	Water	Acid	Water	
1.240	1	3/4	1	3 1/2	-51 F
1.275	1	1/2	1	2 3/4	-85 F
1.300	1	1/3	1	2 1/2	-95 F
1.340	1	1/7	1	2	-62 F
1.400	1	—	1	1 1/2	-33 F

(2) Sulphuric acid or battery electrolyte may cause painful burns if allowed to get on the hands or other parts of the body. Personnel engaged in the handling or mixing of electrolyte should be very careful to avoid injury. Wear goggles, rubber apron, rubber gloves, and rubber boots or rubber overshoes. In case of any accidental spillage on the body, preliminary first aid should consist of immediately flushing the affected areas of the skin with plenty of clean water, followed by a generous application of bicarbonate of soda solution. The sulphuric acid in the electrolyte does not evaporate, so always wash and neutralize spillage with AMMONIUM HYDROXIDE or bicarbonate of soda solution.

(3) When reading the specific gravity of electrolyte, correct the hydrometer reading for the temperature of the electrolyte. For each 10 degrees above 80 F, increase the hydrometer readings by adding 0.004; for each 10 degrees below 80 F, correct by subtracting 0.004. (The accurate correction is 0.00033 per degree F. The above corrections are close enough for the normal range of temperatures.) (fig. 149).

69. PREPARING NEW BATTERIES FOR SERVICE.

a. New batteries, if shipped wet, are always fully charged before shipping, and may be put into service immediately, although a freshening charge is recommended.

ENGINE AND ACCESSORIES

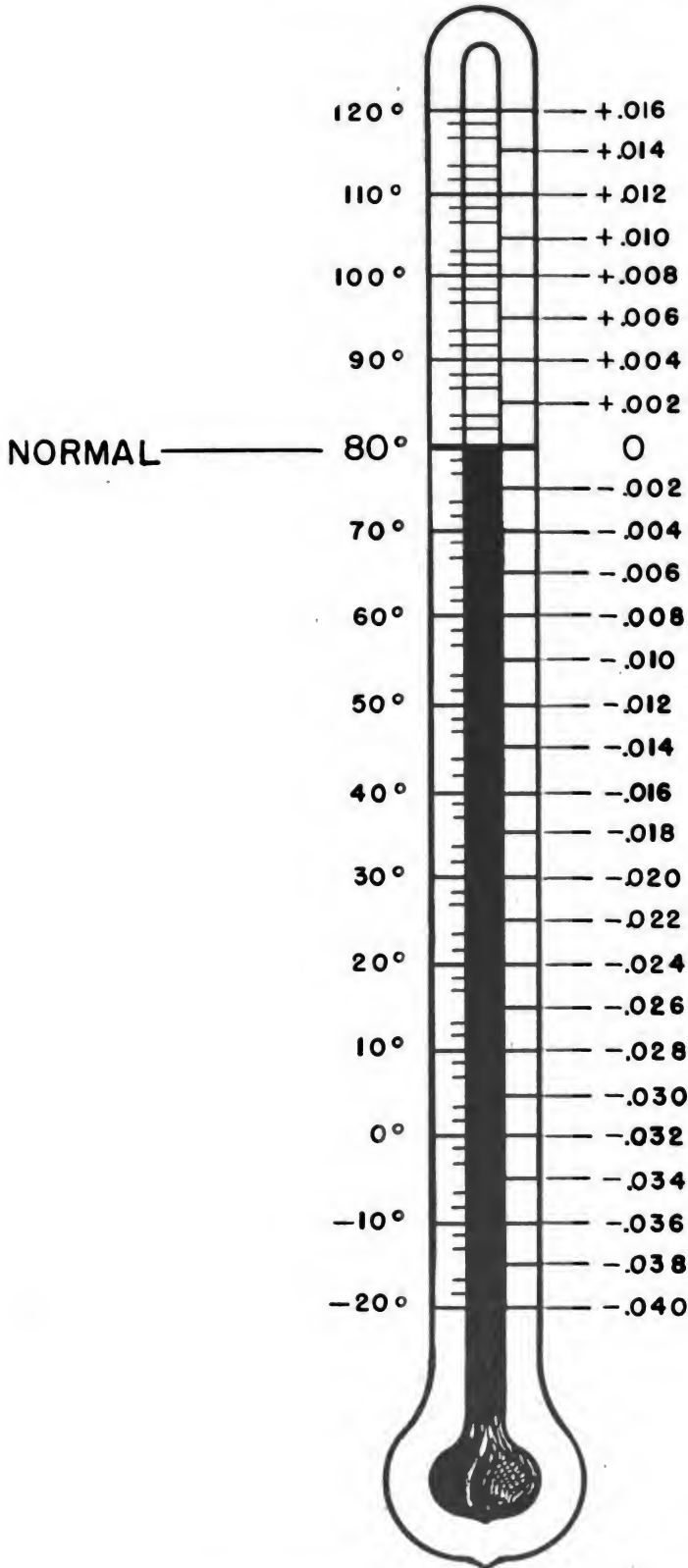

RA PD 5851

Figure 149 — Hydrometer Correction Chart

ORDNANCE MAINTENANCE — GENERATING UNIT M7

b. Batteries shipped without electrolyte in them are generally accompanied by instructions for putting them into service. In general, the following instructions apply:

(1) Batteries shipped dry charged must be filled with electrolyte, and given an initial charge before being put into service. Where the plugs are sealed for shipping and storing, they should not be removed until the battery is to be prepared for use.

(2) Fill each cell with electrolyte (1.270 specific gravity) to the proper level ($\frac{3}{8}$ inch above separators). Allow the battery to stand at least 1 hour after filling with electrolyte. If the level has fallen, add electrolyte to restore it. Replace vent plugs. The temperature of the electrolyte used for filling the cells should not exceed 90 F. If any electrolyte is spilled on the battery, remove it by wiping with a cloth dampened in a solution of bicarbonate of soda and water.

(3) Charge the batteries at their finishing rate (approximately 1 ampere per positive plate) before placing them in service. Continue charging until 4 consecutive hourly readings show no rise in specific gravity and voltage for the lowest cell. If the above charging rate is maintained, it will take at least 12 hours to complete the charge.

(4) Add only water to restore electrolyte level during charge. After completion of charge the specific gravity should be between 1.270 and 1.285 specific gravity, corrected to 77 F, and with the level of the electrolyte $\frac{3}{8}$ inch above the separators. If it is not within these limits, adjust by removing some electrolyte, and replacing with water or electrolyte as required. Charge the battery 1 hour to mix the electrolyte before testing again.

70. BATTERY REPAIR.

a. **General.** Normally, repair will not be attempted when replacement batteries can be obtained. When it is found that one or more cells are defective, and cannot be put in normal condition by charging, a battery may be repaired by replacing the damaged cells, using serviceable cells salvaged from otherwise unserviceable batteries. Such cells should be tested previously for serviceability.

b. Removal of Defective Cell From Battery.

(1) Drill out the connector over the top of the cells to disconnect the cells.

(2) Scrape away the sealing compound used to seal the covers to the container.

(3) Remove assembly of plates, separators, and cover from the cell as a unit and discard.

(4) Remove the electrolyte from the compartment with a syringe, and discard.

ENGINE AND ACCESSORIES

c. Installing a Salvaged Cell.

- (1) Remove salvaged cell. Follow procedure outlined in subparagraph **h**, above, except that electrolyte is not to be discarded.
- (2) Place the assembly of cell elements in the container, making sure the negative and positive poles are in correct position.
- (3) Place heated COMPOUND, battery-sealing, around top of covers, sealing them to the container.
- (4) Fuse the connectors to the terminal posts, connecting the cells in series.
- (5) Pour the electrolyte from the salvaged cell into vent opening until the tops of the separators are covered by approximately $\frac{3}{8}$ inch. If new electrolyte is used, it should not be over 1.200 specific gravity.
- (6) Charge the battery until fully charged, as indicated by no rise in the specific gravity of the electrolyte in four successive hourly readings. Adjust specific gravity of electrolyte (par. 69 **b** (4)).

Section VII

ELECTRICAL SYSTEM – IGNITION

	Paragraph
Description	71
Trouble shooting	72
Ignition coil	73
Distributor removal	74
Distributor disassembly	75
Distributor inspection and repair	76
Distributor assembly	77
Distributor tests and adjustments	78
Distributor installation	79
Spark plugs	80

71. DESCRIPTION.

a. The engine ignition system consists of an ignition coil, distributor, condenser, spark plugs, and connecting wires. Its function is to provide electric current for the operation of the engine.

b. The ignition coil is a self-contained unit consisting of an iron core around which are wound a few turns of heavy wire to form a primary circuit, and many turns of fine wire to form the secondary circuit. The core and wires are enclosed in a sealed case to form the complete coil. Its function is to step up the low voltage current of the primary circuit to the high voltage current of the secondary circuit, which is needed to produce a spark across the points of the spark plugs by which the explosive mixture in the cylinder is ignited.

ORDNANCE MAINTENANCE – GENERATING UNIT M7

c. The distributor consists of a housing in which is enclosed a pair of electrical contacts known as breaker points. A vertical shaft, driven by a gear on the engine camshaft, extends through the distributor housing. A cam is attached to this shaft within the housing, and is the means by which the breaker points are opened at proper intervals. Another contact, known as a rotor, is attached to the upper end of this shaft. A cap is attached to the top of the housing, and provides the means of connecting wires from the spark plugs to the distributor. It is important that the breaker points open at exactly the right instant to send the high tension current from the coil to the spark plug, causing ignition just when the piston is in the proper position. The function of the breaker points is to open the circuit in the primary of the ignition coil. This causes the field of magnetism around the core to collapse through the many turns of fine wire in the secondary. This collapse of field, which is "boosted" by the action of the condenser, causes a surge of high voltage current in the secondary. This high tension current travels from the coil to the distributor rotor, which is so positioned by the shaft holding the cam which actuates the breaker points, that the current must proceed through the proper connecting wire, to the spark plug which is in the cylinder that is ready for firing.

d. A condenser is mounted on the lower half of the distributor and its wire is attached to a terminal at the top of the distributor housing. Its function is to stop the flow of low tension current across the distributor points the instant the points are opened. This permits more rapid energization of the secondary windings in the coil, and at the same time prevents burning the distributor breaker points.

e. The spark plug consists of a metal shell within which is located an insulator having a central electrode stem. The shell is threaded at the lower end to permit screwing into the cylinder head. The lower end of the shell carries a fixed, bent electrode extending from the side of the shell inward toward the central electrode stem located in the insulator. These electrodes are separated by an air gap. The top end of the central electrode is where the wire from the distributor is attached.

72. TROUBLE SHOOTING.

a. Ignition Coil.

Possible Cause	Possible Remedy
(1) ENGINE FAILS TO FIRE.	
Excessive moisture on end of coil.	Wipe coil clean and dry.
Open circuit in primary or secondary circuit, or either circuit grounded outside of coil.	Check and tighten connections.
Windings grounded inside of coil.	Replace coil.

ENGINE AND ACCESSORIES

Possible Cause	Possible Remedy
Short-circuited turns in primary or secondary windings, or high voltage break-down in secondary windings.	Replace coil.
(2) ENGINE MISSES (WEAK SPARK).	
Internal short circuit in coil.	Replace ignition coil.
b. Distributor.	
(1) ENGINE WILL NOT START.	
Breaker points not closing.	Check and adjust breaker points. Replace, if necessary.
Breaker points worn.	Check breaker points, and replace, if necessary.
Breaker point lever grounded.	Replace breaker points.
Worn rotor or cap.	Examine and replace rotor or cap.
(2) ENGINE MISFIRES IN ONE OR MORE CYLINDERS.	
Broken cap or rotor.	Replace cap or rotor.
(3) ENGINE MISSES AT LOW SPEED.	
Breaker point gap too small.	Check and adjust gap (0.020 inch).
(4) ENGINE MISSES AT HIGH SPEED UNDER LOAD.	
Breaker lever spring tension spring weak.	Replace breaker points.
Breaker point gap too large.	Adjust gap (0.020 inch).
(5) WEAK SPARK AT PLUGS.	
Breaker cam worn.	Install new cam assembly.
Breaker contact points worn or pitted.	Examine, and replace contact points.
Condenser shorted or disconnected.	Test connection or replace condenser.
(6) TIMING INCORRECT OR IRREGULAR.	
Breaker cam loose or wobbly.	Replace bushings in distributor housing.
c. Spark Plug.	
(1) ENGINE MISSING SLIGHTLY; SLUGGISH OR IRREGULAR PERFORMANCE.	
Improper spark plug gap.	Adjust spark plug gap to 0.025 inch.
Loose leaky spark plug threads.	Tighten or replace plugs or gaskets.
Dirty spark plugs.	Clean and adjust spark plugs.

ORDNANCE MAINTENANCE — GENERATING UNIT M7

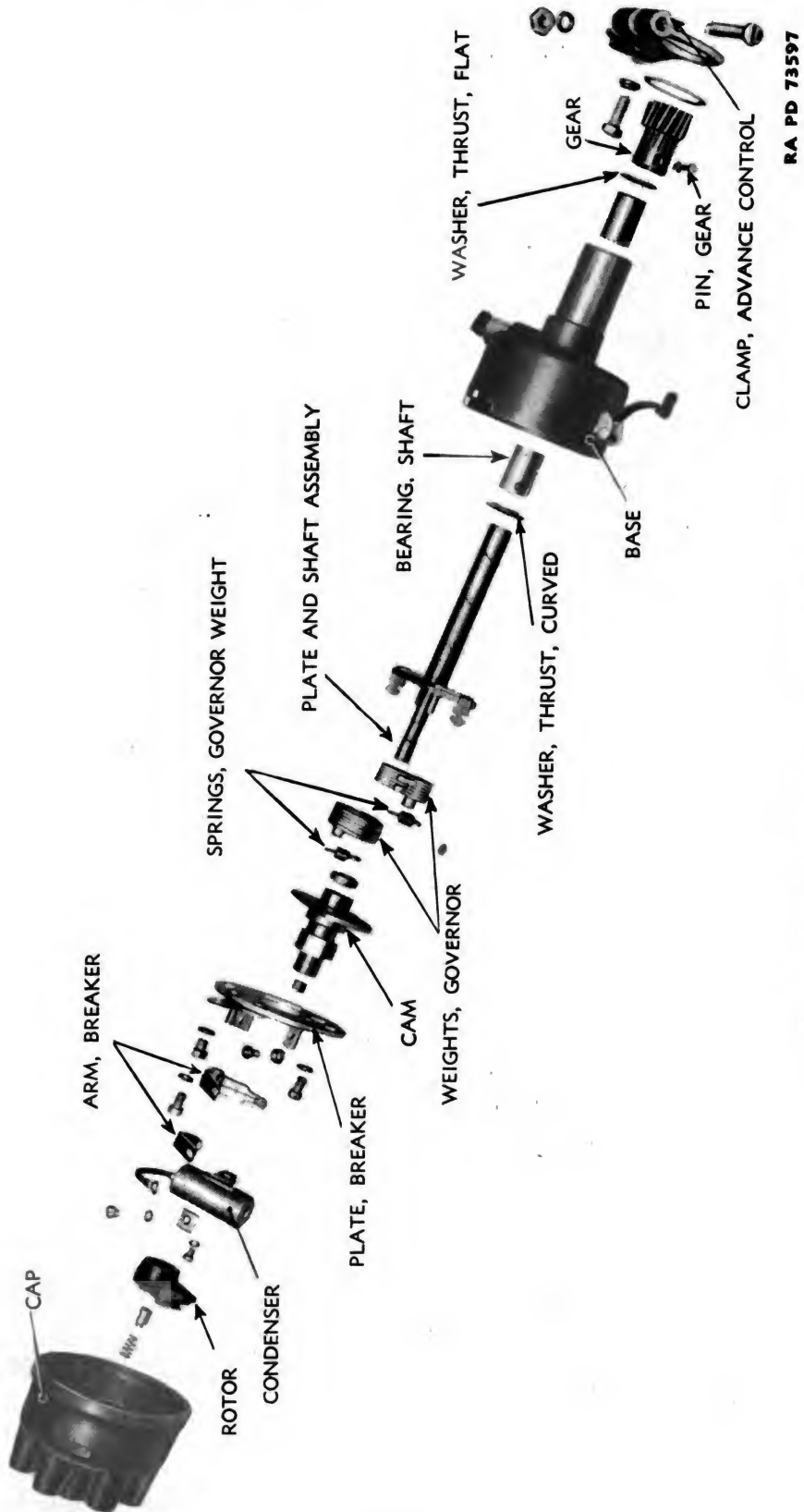

Figure 150 — Distributor — Exploded View

ENGINE AND ACCESSORIES

Possible Cause	Possible Remedy
(2) FAILURE TO GIVE SPARK.	
Insulation broken.	Replace spark plug.
Side electrode worn excessively.	Replace spark plug.
Plug carbonized at inner end.	Clean spark plug.
Insulation swollen, blistered, fused, or broken.	Replace spark plug.
Electrodes showing signs of disintegration.	Replace spark plug.
Leak around insulation, showing carbon streaks on outside.	Replace spark plug.
Moisture on outside of spark plugs.	Wipe dry.
Points forced into contact due to careless handling, when plug was installed.	Separate points, and adjust gap (0.025 inch).
(3) ENGINE MISSING AT LOW SPEED ONLY.	
Insulator cracked at point outside of engine.	Replace spark plug.

73. IGNITION COIL.

a. Inspection.

(1) Remove coil and place in coil tester. Check spark gap while running free and under load. If spark will jump a 1/4-inch gap under load, coil is suitable for further service.

NOTE: In the absence of coil testing equipment, compare performance with another coil known to be good. Replace coil, if performance is not equal to that of the ignition coil known to be good.

74. DISTRIBUTOR REMOVAL (figs. 26 and 27).

a. Procedure.

(1) Snap out lead connections from distributor cap. Loosen vertical cap screw in arm below distributor, and loosen horizontal bolt at right. Loosen iron collar below clamp, and remove distributor.

75. DISTRIBUTOR DISASSEMBLY (fig. 150).

a. Procedure.

(1) Snap down the two distributor cap springs, and lift the cap off the distributor.

(2) Lift rotor up from shaft and remove (fig. 151).

(3) Take out the two screws which hold breaker plate assembly to shaft and governor assembly. Lift breaker plate assembly out of base (fig. 152).

ORDNANCE MAINTENANCE — GENERATING UNIT M7

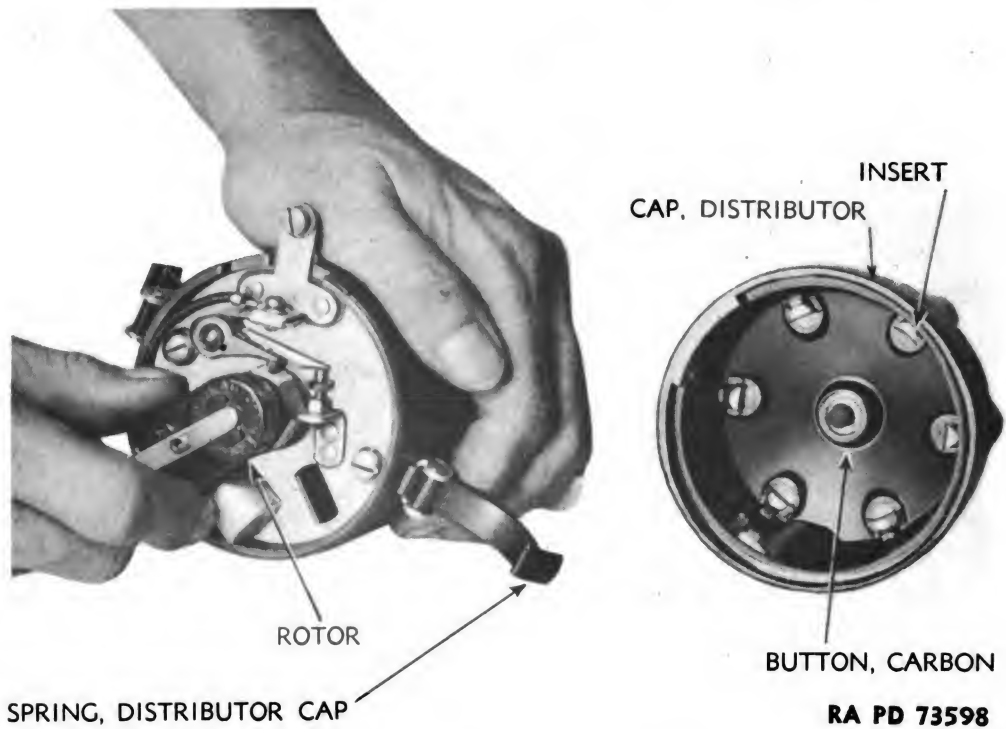

Figure 151 — Lifting Off Rotor

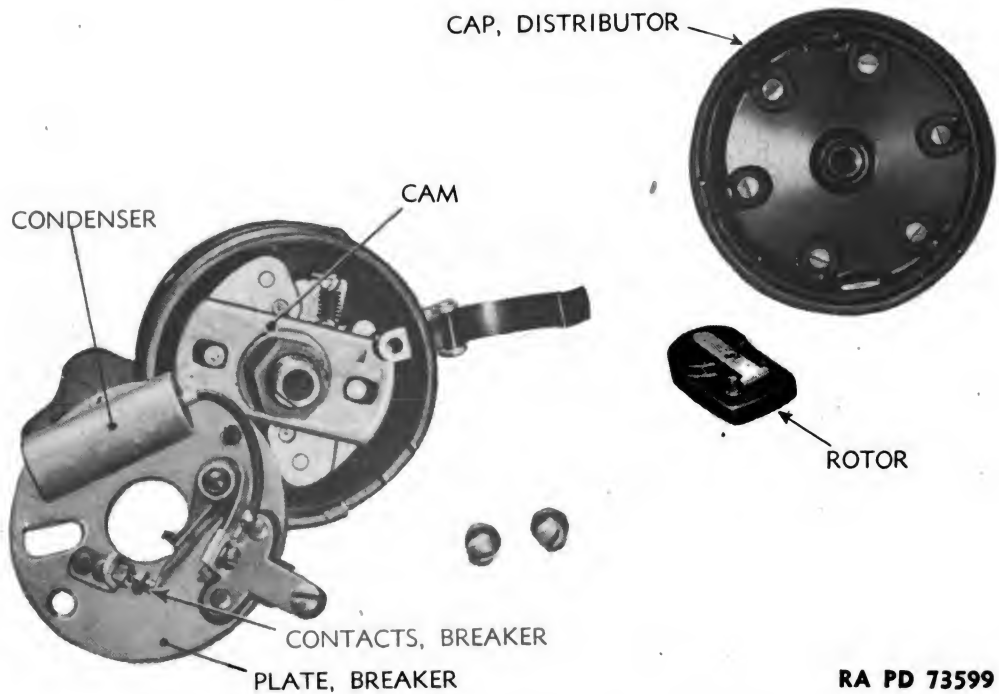
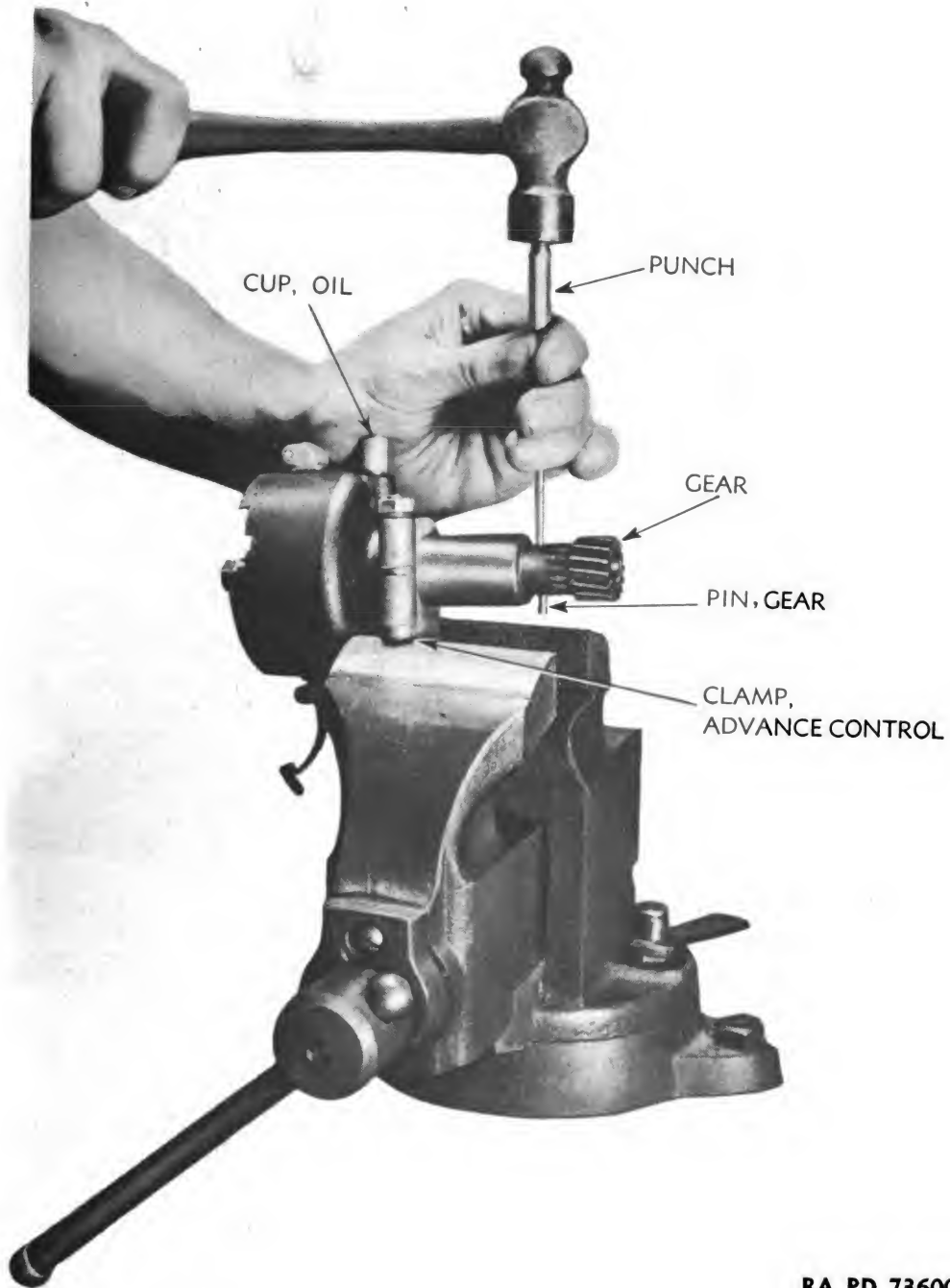

Figure 152 — Breaker Plate Assembly Removed

ENGINE AND ACCESSORIES



RA PD 73600

Figure 153 — Driving Out Distributor Gear Pin

ORDNANCE MAINTENANCE — GENERATING UNIT M7

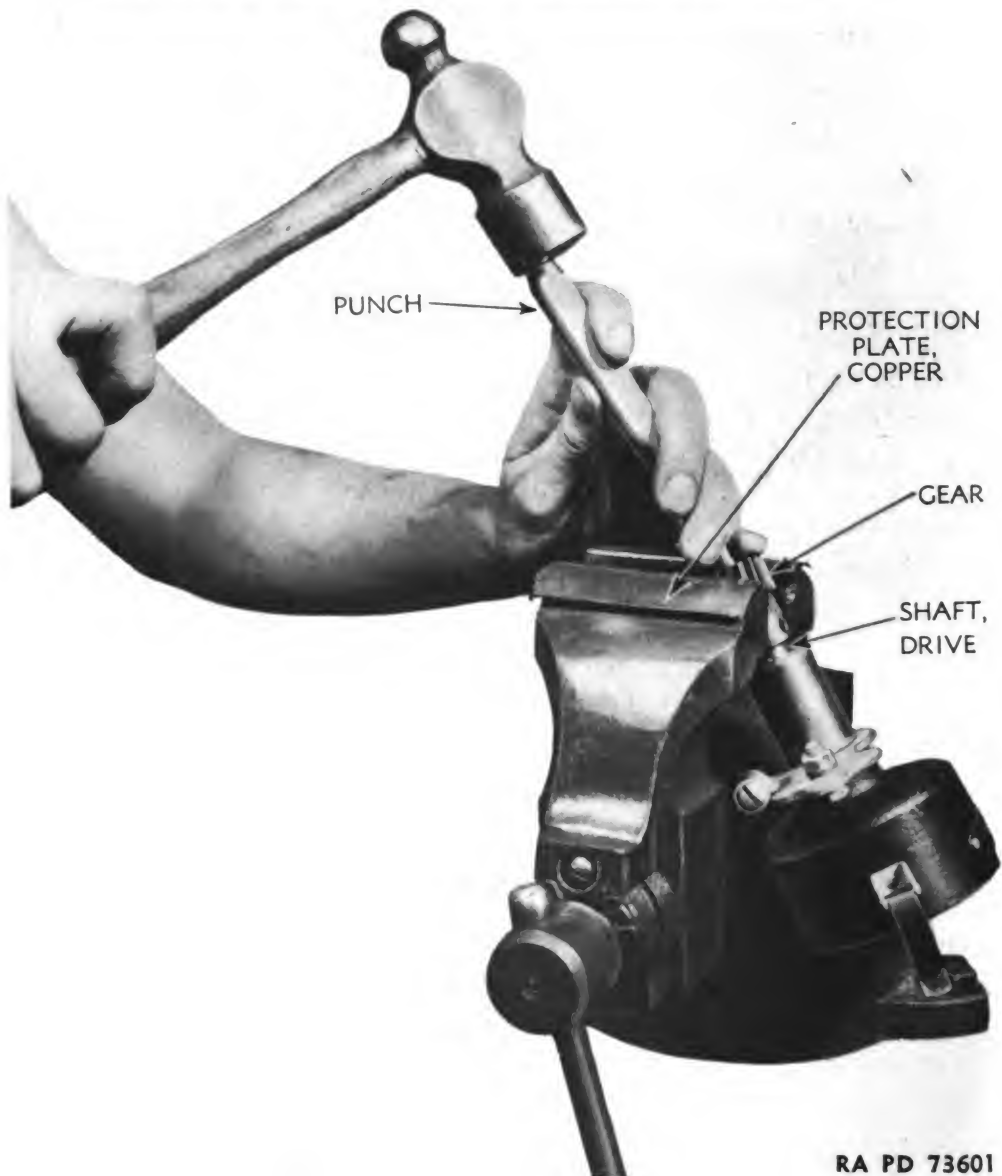
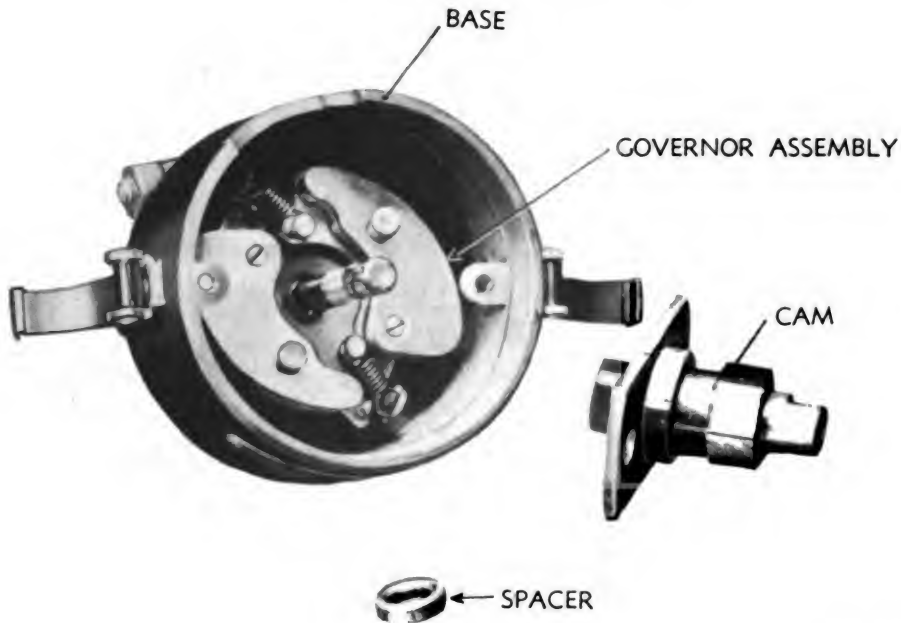

Figure 154 — Driving Distributor Shaft from Gear

- (4) File off one end of peened-over pin attaching gear to shaft, drive out pin (fig. 153), and drive shaft from gear (fig. 154). Remove gear and washer.
- (5) Lift cam from shaft and governor assembly (fig. 155).
- (6) Pull shaft and governor assembly out of base. Remove curved thrust washer.
- (7) Remove weight springs from governor and slide weights off pivots (fig. 156).
- (8) Remove stationary contact lock nut and stationary contact.

ENGINE AND ACCESSORIES



RA PD 73602

Figure 155 – Distributor Cam Removed

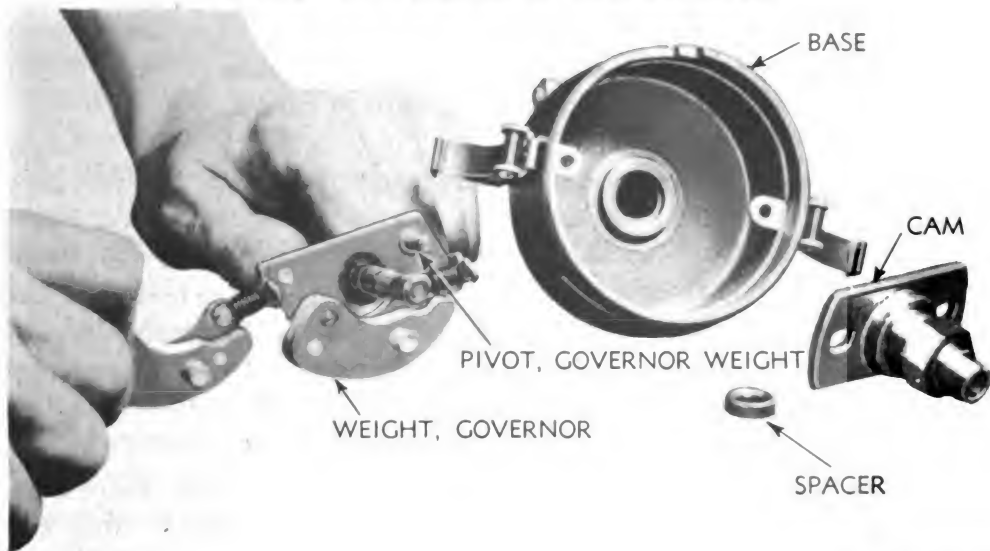

RA PD 73603

Figure 156 – Removing Distributor Weights

Remove condenser mounting screw and lock washer. Lift condenser from breaker plate (fig. 157).

(9) Remove breaker arm spring screw and breaker arm spring clip, and lift breaker arm from its pivot.

ORDNANCE MAINTENANCE — GENERATING UNIT M7

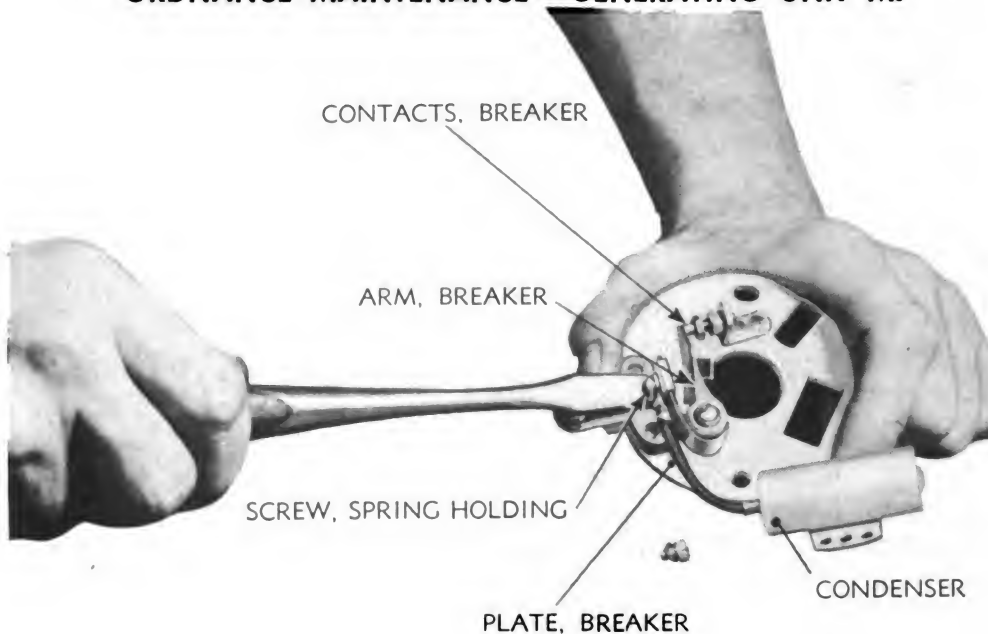

RA PD 73604

Figure 157 — Removing Condenser from Breaker Plate

76. DISTRIBUTOR INSPECTION AND REPAIR.

a. Distributor Cap.

(1) Visually inspect distributor cap for cracks, carbon streaks, and corroded high tension terminals. Replace cap, if any of these conditions are found.

(2) Inspect the inserts on inside of cap. After a distributor has had normal use, the vertical face of the inserts becomes slightly burned. Clean with CARBON TETRACHLORIDE. NOTE: Do not file. If the burning is excessive, replace the cap.

(3) Examine inserts for signs of burning on horizontal faces. If burning is noticeable at this point, it is an indication that gap between rotor and insert is too large. Replace both cap and rotor, if this condition is found.

b. Rotor. Inspect rotor for cracks, and replace, if any are found. Inspect contact for evidence of burning on top of metal strip. After normal use, the end of the metal strip will become slightly burned. Clean with CARBON TETRACHLORIDE. If evidence of burning is found on top of metal strip, replace rotor and cap.

c. Condenser.

(1) Check the condenser on an M1 Circuit Tester. Connect bare clip of low tension lead to a ground on engine; connect red clip to battery or starting switch terminal. Insert condenser in the clip on tester, and attach short test lead to condenser pigtail.

ENGINE AND ACCESSORIES

- (2) Place coil test switch at "test coil."
- (3) Turn on rotor switch.
- (4) Adjust variable spark gap to highest setting obtainable without missing.

(5) Move condenser test switch to "vehicle cord," and observe effect on high-tension output and on arcing at tester breaker contacts. Repeat test several times, changing position of condenser pigtail lead. If switching to "vehicle cord" does not result in arcing and spark does not miss, condenser is satisfactory. If arcing does occur or spark misses, condenser is not functioning normally and must be replaced. If moving condenser lead affects action, it indicates a faulty lead, and condenser must be replaced.

d. Breaker Contacts. Inspect the breaker contacts. If they are a grayish color and only slightly pitted, they need not be replaced. Make sure breaker arm turns freely on its pivot without excessive side play. Replace rough or pitted breaker contacts. If it is necessary to reinstall the old breaker contacts, hone them on a stone before reinstalling, to a smooth, flat surface. **NOTE:** Do not file.

e. Shaft and Governor. Clean the parts thoroughly in SOLVENT, dry-cleaning. Inspect governor weights and plate for wear. Inspect springs for distortion. Replace damaged parts. Pack pocket in the laminated weights with GREASE, general purpose (seasonal grade), and reassemble governor, making sure weight spring has the small loop on the weight pin.

f. Base.

(1) Clean the base thoroughly in dry-cleaning solvent, and inspect for evidence of breakage. Make sure the cap spring lugs are riveted tightly. Replace base if rivets are loose.

(2) Place shaft and governor in base and, with a dial indicator, measure side play of shaft. Clamp indicator to base with the point against shaft. Move shaft sideways and read indicator. If side play in any direction is over 0.005 inch, replace bearings.

(3) Drive bearings out of base and install new bearings (arbor press). Place bearing on the press, and press into base. Make the lower bearing flush with base; countersink upper bearing.

g. Cam. Clean cam and stop plate in dry-cleaning solvent. Inspect cam and weight slots for evidence of wear. Replace cam if worn or if slots do not have smooth, straight sides.

h. Breaker Plate. Clean breaker plate in dry-cleaning solvent, and inspect for stripped threads, bent breaker pivot, and bent or distorted primary terminal. With test lamp, check terminal for grounds. Touch one probe to plate, and other probe to the terminal. If lamp lights, the terminal is grounded, and plate must be replaced.

ORDNANCE MAINTENANCE – GENERATING UNIT M7

77. DISTRIBUTOR ASSEMBLY (fig. 150).

a. Procedure.

(1) Soak drive shaft bearings in OIL, engine (crankcase grade), and wipe drive shaft with same grade of oil. Install shaft and governor in base with the curved thrust washer between weight carrying plate and base.

(2) Place flat thrust washer and gear on bottom of the shaft and insert coupling pin. Peen the pin on both ends.

(3) With a dial indicator, measure end play of shaft. Limits are 0.003 to 0.010 inch. If end play exceeds 0.010 inch, remove coupling and install additional thrust washers

(4) Assemble cam and stop plate to shaft and governor.

(5) Assemble condenser and breaker contacts to breaker plate, and install screw holding breaker spring and condenser lead.

(6) Place breaker plate in base, and secure to base with hold-down screws. Place rotor on the shaft.

(7) Bend stationary contact bracket so that points make full surface contact. **NOTE:** Do not bend breaker arm. Use thin washer under arm to obtain alinement.

(8) Turn shaft to position breaker arm rubbing block on one of the lobes of cam, and adjust stationary contact so gap is 0.020 inch. Use feeler gage to measure gap (fig. 71). After adjusting gap, tighten the lock nut, and recheck.

(9) Turn shaft so rubbing block is on the flat side of cam. Using a spring scale, measure breaker arm spring tension. Hook the scale to breaker arm at contact end, and pull on a line perpendicular to contact surfaces. Take reading just as contacts separate. Loosen the spring holding screw and slide the end of the spring in or out, as necessary, to get a reading of 17 to 20 ounces.

(10) Add 6 to 8 drops of OIL, engine (crankcase grade), to the oiler. Add 1 or 2 drops only to breaker arm pivot and to governor weight pivots and slots. Apply 1 or 2 drops to the felt in top of cam. Wipe cam with GREASE, general purpose (seasonal grade).

78. DISTRIBUTOR TESTS AND ADJUSTMENTS.

a. Procedure.

(1) Place distributor on a distributor test fixture, and set controls to measure cam angle or dwell. Operate the distributor up and down the speed range, and note fluctuations in the meter. Excessive fluctuation is caused by a worn cam or sticking contact arm on its pivot. Adjust the reading to 41 degrees by changing contact point gap. Tighten the lock nut after each adjustment. (This operation can be done on the truck if only the M1 Ignition Circuit Tester is available.)

ENGINE AND ACCESSORIES

(2) Adjust the centrifugal advance. This operation can be done only on a fixture that will show the firing point in degrees, and the distributor speed in revolutions per minute.

(a) Run the distributor at 250 distributor revolutions per minute, and set dial at 0 degree.

(b) Increase speed up to 1,150 revolutions per minute, and note advance. Specifications are 6 distributor degrees. If maximum advance is not within specifications, reduce speed below 300 revolutions per minute, and note whether or not degrees indicator drops below zero. If an indication below zero is shown, stop distributor. Bend lugs on outer spring bracket slightly, and again check at 1,150 revolutions per minute. If advance is still not 6 degrees, stop distributor and relieve spring tension slightly by bending the outer spring bracket. Advance specifications at distributor revolutions per minute are as follows:

0°	at 300 rpm
1°	at 450 rpm
3°	at 725 rpm
5°	at 1,000 rpm
6°	at 1,150 rpm

79. DISTRIBUTOR INSTALLATION.

a. Procedure.

(1) Remove the number one spark plug. Close plug hole with thumb, and turn the engine over with the hand crank until the piston is at top dead center on the compression stroke. Compression can be felt and number one piston top dead center can be checked by a white spot showing on the flywheel when it is viewed through a 1-inch diameter peephole in the left side of the flywheel housing (fig. 72). While the distributor is off the unit, set the rotor at the number one firing position.

(2) Let distributor down into position in tachometer drive. Tighten bolt on iron collar below flange. Attach distributor arm to tachometer collar arm with cap screw and nut. Tighten horizontal bolt. NOTE: If the unit does not have a tachometer, the distributor drive, with gear attached, goes directly into the hole provided through the water pump drive housing to mesh with gear provided on the water pump drive.

(3) Time ignition (par. 27 a (9)).

80. SPARK PLUGS.

a. Spark Plug Inspection and Repair (100 Hour).

(1) Examine the manufacturer's symbols on spark plug porcelain. Replace spark plug with proper type, if wrong type is in use. Spark

ORDNANCE MAINTENANCE – GENERATING UNIT M7

plug should be Champion No. 1, common, or equivalent. This is a cold plug. Under no circumstances should a hot plug be used.

(2) Examine the electrodes. Replace plugs if electrodes are burned.

(3) Examine spark plug porcelains. Replace plugs if porcelains are cracked or broken. Note the color of the porcelain at center electrode tip. A dead white color indicates that the plug is running hot. Replace this plug with another of the same type. If after a period of running at normal speed, this plug also shows a dead white color or scaling, this is too hot a type plug, and must be replaced with a colder type. A light brown color indicates the plug is operating correctly. A glossy black deposit indicates an excessive amount of oil in the combustion chamber. Check piston rings and pistons. Correct the fault. A dull black deposit indicates a rich fuel mixture, weak ignition, improper spark plug gaps, or weak compression. Locate and correct the cause.

(4) Clean each spark plug in a sand blast spark plug cleaner. After doing so, file the oxide from between the points.

(5) Measure gap between electrode of each spark plug with a wire type feeler gage. Proper clearance is 0.025 inch. Bend electrode attached to metal base of spark plug until proper gap is obtained.

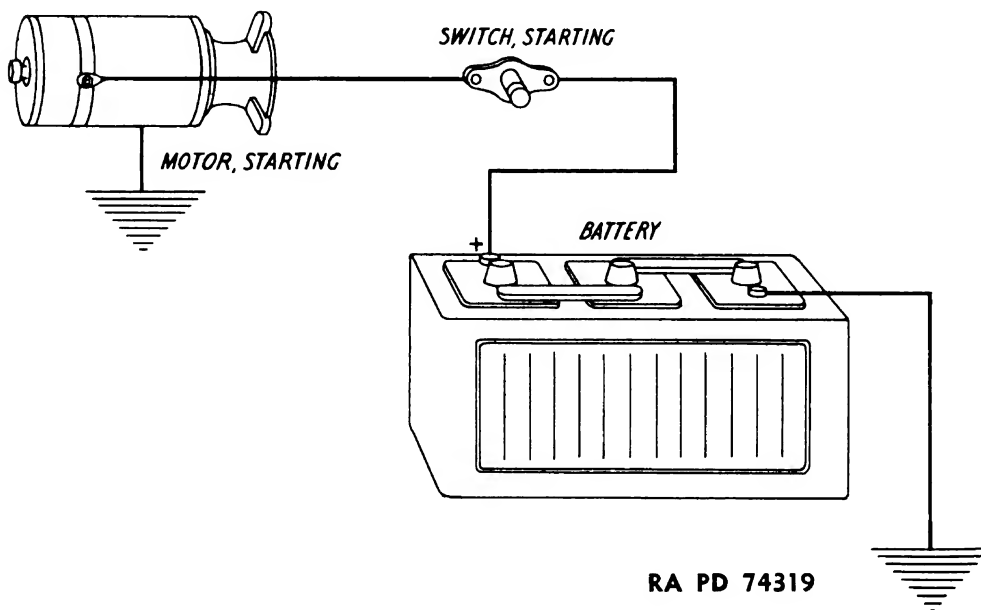

Figure 158 – Engine Starting System

ENGINE AND ACCESSORIES

Section VIII

ELECTRICAL SYSTEM – STARTING MOTOR

	Paragraph
Description	81
Trouble shooting	82
Disassembly	83
Inspection and repair	84
Assembly	85

81. DESCRIPTION.

a. **General.** The starting motor, the battery, and the starting switch on the instrument panel make up the engine starting system (fig. 158).

b. **Motor.** The starting motor (fig. 159) is of the four brush type with a Bendix drive. It is mounted on the flywheel housing at the lower left-hand side of the engine. The motor consists of a frame and field assembly, armature, and end plates. The four pole pieces and the four field coils are mounted in the frame. The field coils are connected in series. One lead of the coils is connected to an insulated terminal post, which passes through the frame. The other lead is connected to the brushes, which are held in brush holders in the commutator end plate. The commutator end plate is held to the frame.

c. **Drive.** The Bendix drive is mounted on the drive end of the armature. It gears the starting motor to the engine (fig. 159) when the starter switch is closed, and releases it when the engine is started. It consists of a gear mounted on a hollow spiral shaft, connected by splines to the armature shaft.

82. TROUBLE SHOOTING.

a. **Starting Motor Fails To Operate.**

Possible Cause	Possible Remedy
Battery discharged.	Recharge battery (par. 68 c).
Loose and dirty connections.	Clean and tighten connections.
Bendix gear jammed.	Free gear from flywheel.
Starting motor switch faulty.	Replace switch.
Bendix drive inoperative.	Remove starter, and repair or replace Bendix drive.

b. **Starting Motor Cranks Weakly.**

Battery weak.	Recharge battery (par. 68 c).
Loose or dirty connections.	Clean and tighten connections.

ORDNANCE MAINTENANCE – GENERATING UNIT M7

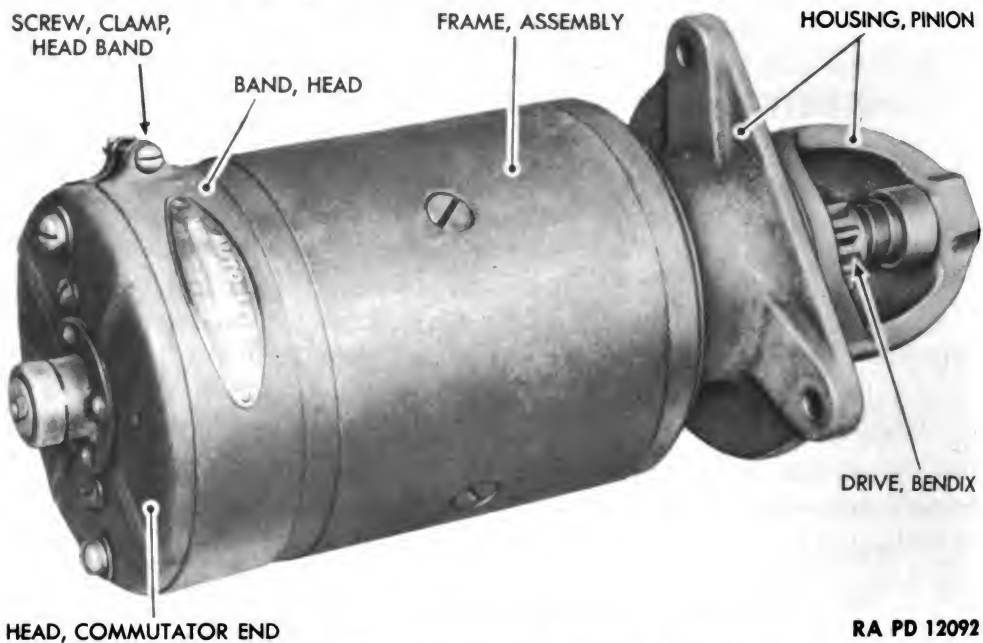

Figure 159 – Starting Motor Assembly

RA PD 12092

Possible Cause	Possible Remedy
Commutator dirty.	Clean commutator with SAND-PAPER, flint, Class B, No. 2/0.
Starting motor inoperative.	Remove, repair, or replace starting motor.
c. Bendix Drive Fails To Operate When Starting Motor Revolves.	
Dirty or gummy Bendix drive.	Remove starting motor. Clean drive.
Drive spring broken.	Remove starting motor, and replace drive spring.

83. DISASSEMBLY.

a. Procedure.

- (1) Loosen head band clamp screw, and lift off band.
- (2) Disconnect field coil lead to insulated brushes.
- (3) Remove the two frame screws (fig. 160). Hold up brushes, then pull commutator end head from the motor (fig. 161). Lift thrust washer from armature.
- (4) Lift off the pinion housing.
- (5) Pull the armature assembly out of the frame.
- (6) Remove shaft spring screw and head spring screw. Pull pinion assembly off armature shaft, and remove drive spring. Remove

ENGINE AND ACCESSORIES

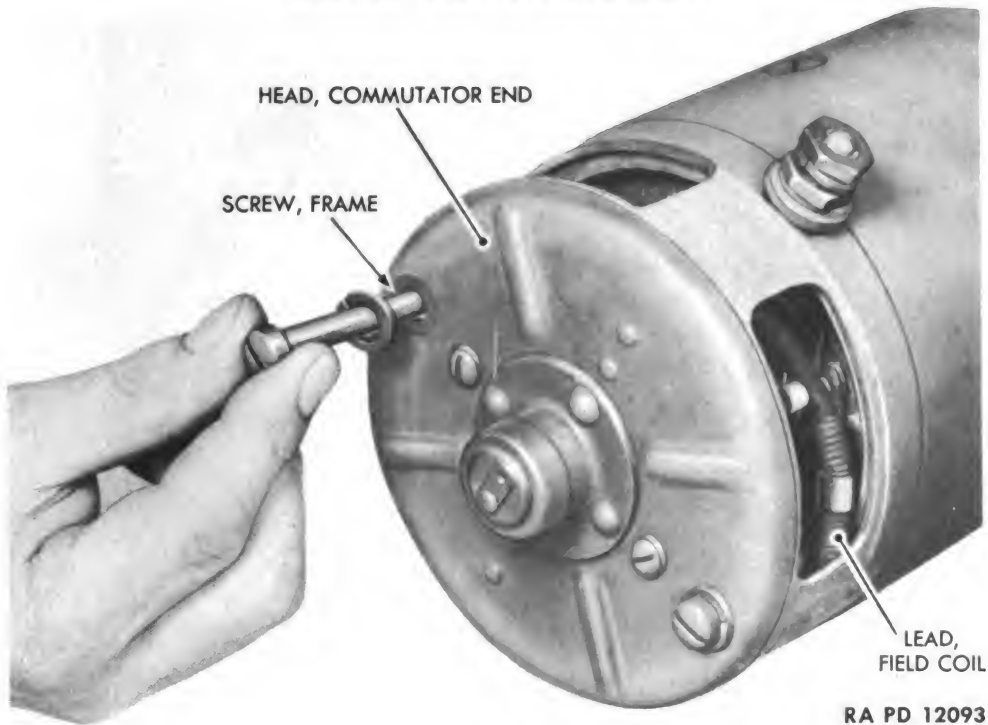

RA PD 12093

Figure 160 — Removing Frame Screw

dowel pin from head, and Woodruff key from armature shaft. Press head and intermediate bearing off armature.

(7) Remove brush screws. Remove brush lead ground screws. Lift out brushes and ground connectors. Pull brush-holder post clips off posts. Remove insulating washers, insulating bushings, brush springs, brush arms, spring insulators, and brush holder spacing insulators (figs. 162 and 163).

84. INSPECTION AND REPAIR.

a. Armature.

(1) **CLEAN COMMUTATOR.** If commutator is dirty or discolored, hold a piece of PAPER, flint, Class B, No. 2/0, against the commutator while turning armature slowly. Blow sand off commutator after dressing.

(2) **REPAIR OF ROUGH OR WORN COMMUTATOR.** If commutator is rough or worn, place armature in a lathe. Mount armature on bearing seats. Take as light a cut as possible to remove roughness. Do not undercut mica between commutator bars. **NOTE:** Lathe cutting tool must be sharp to avoid burring commutator. If burs are present after taking the cut, replace armature.

(3) **TEST ARMATURE FOR GROUNDS.** Hold one point of test lamp to the core or shaft (not on bearing surfaces). Touch each commuta-

ORDNANCE MAINTENANCE — GENERATING UNIT M7

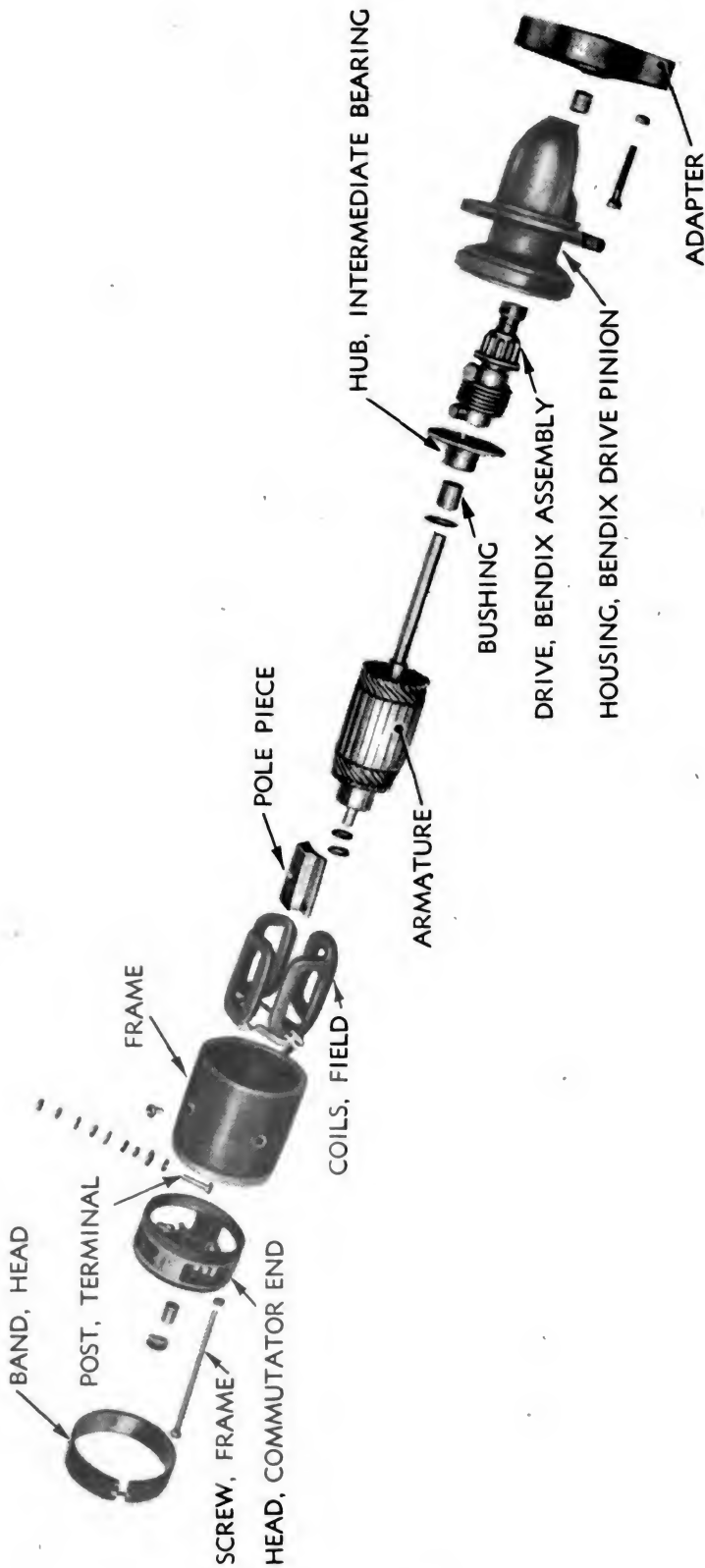

RA PD 74320

Figure 161 — Starting Motor — Exploded View

ENGINE AND ACCESSORIES

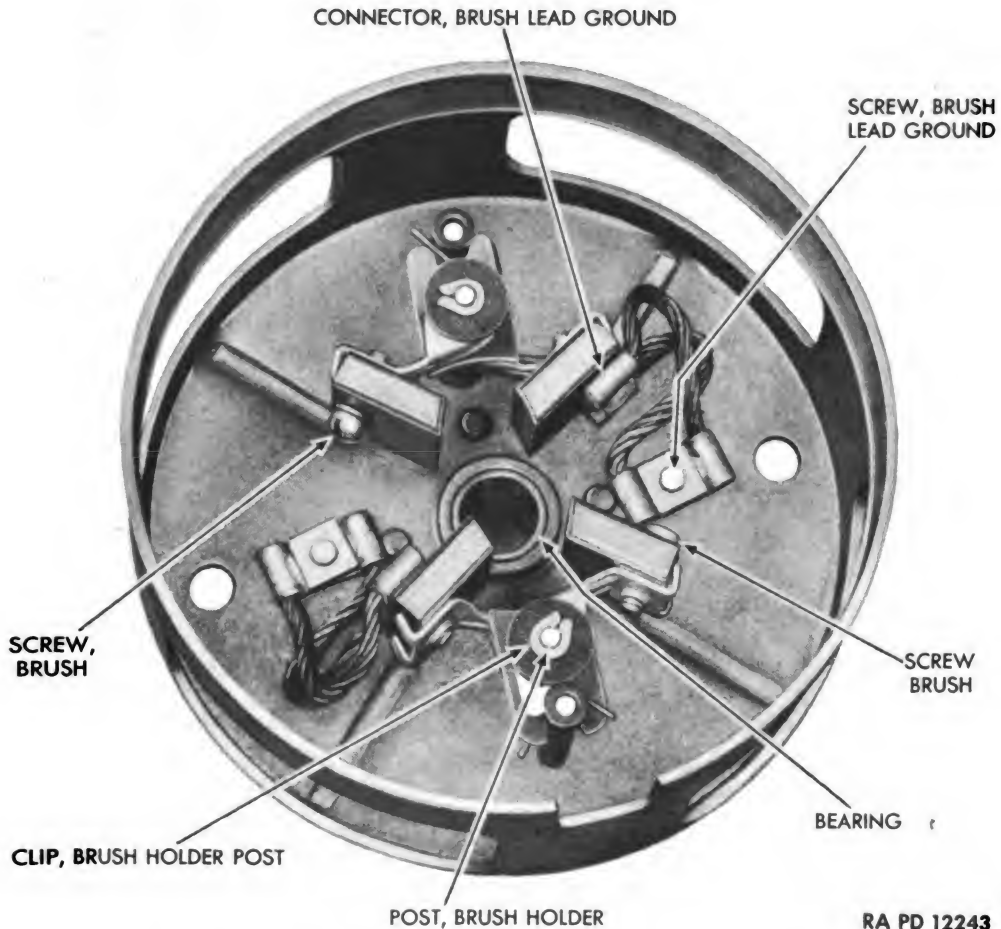

RA PD 12243

Figure 162 – Commutator End Head Assembly

tor segment with other point of test lamp (fig. 164). If lamp lights at any time, the winding is grounded. Replace armature if grounded.

(4) **TEST ARMATURE FOR SHORTS.** Place armature on a growler. Hold a thin strip of steel on the core. Rotate armature slowly by hand. If steel strip vibrates, armature is shorted. Replace armature if shorted.

b. Frame and Field.

(1) Test frame and field coils for shorts. Bend the two leads so that neither touches frame or field. Hold one point of test lamp on frame. Touch terminal post with other test lamp lead. If test lamp lights, a short circuit is present. To locate the short circuit, disassemble terminal post and repeat test. If test lamp still lights, short circuit is in field coil. If it no longer lights, the short circuit is in terminal post.

(2) Test field coil and leads for open circuit. Hold one point of test lamp on terminal post. Touch each lead, in turn, with the other

ORDNANCE MAINTENANCE - GENERATING UNIT M7

RA PD 12253

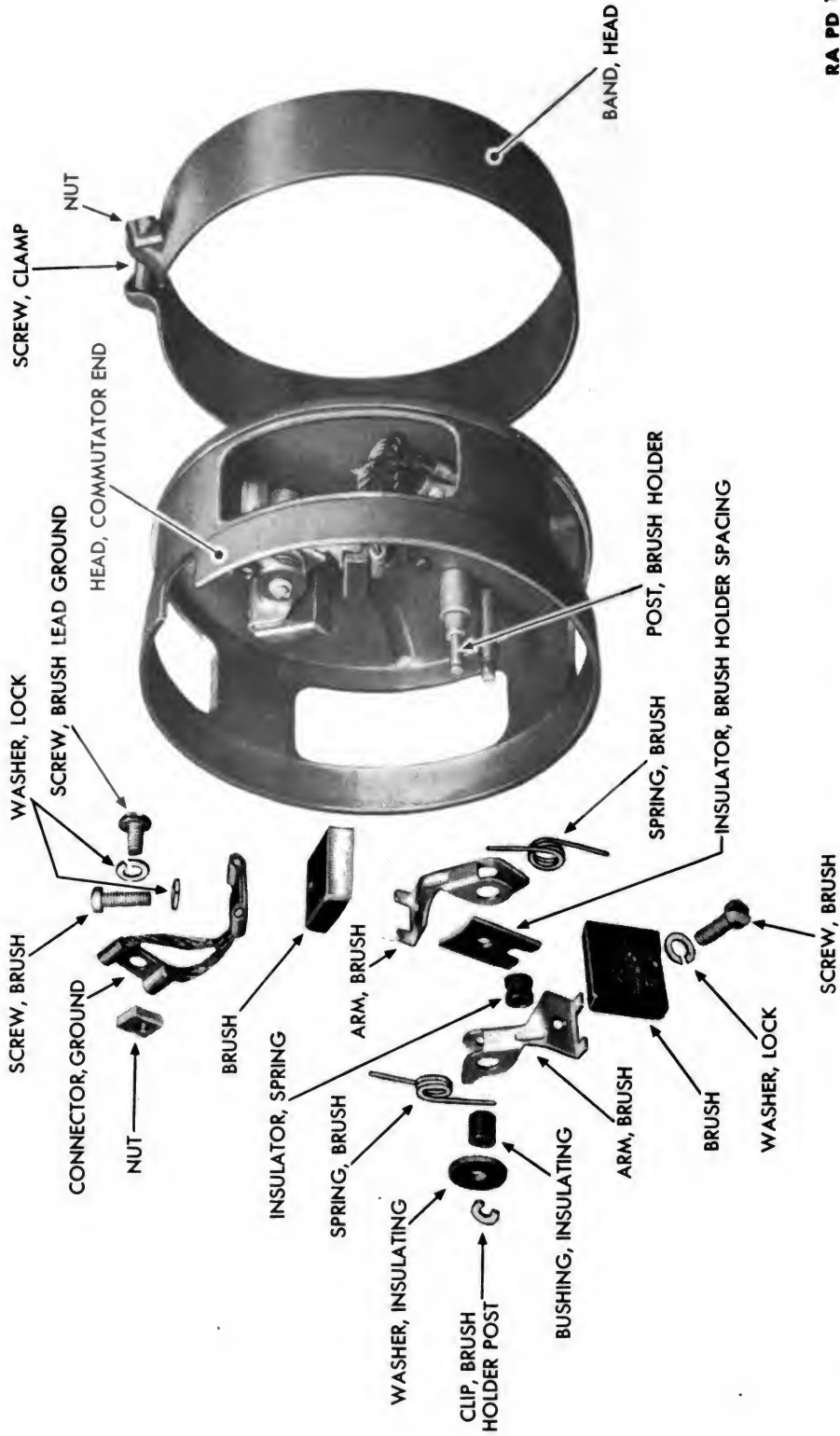

Figure 163 - Commutator End Head Assembly - Exploded View

ENGINE AND ACCESSORIES

point of test lamp. If test lamp fails to light in either instance, a field coil or lead is open.

(3) Repairing a short or open circuit in frame assembly.

(a) Disassemble frame assembly (fig. 165). Remove two nuts, insulating washer, and terminal post cover insulation from terminal post, and remove the four pole piece screws. Lift pole pieces and coils from frame. Lift terminal post frame insulation, insulating washer, and flat washer from terminal post.

(b) Repair shorted terminal post. Use two new insulating washers, new terminal post frame insulation, and new terminal post cover insulation on terminal post. Assemble frame assembly.

(c) Repair shorted field coil Replace field coils and assemble frame assembly.

(d) Repair open circuit. Melt solder on connections and disconnect the four field coils. Touch one point of test lamp to bare wire at one end of coil. Touch other point of test lamp to bare wire on other end of coil. Repeat test on each coil. Replace each coil on which test lamp fails to light. Connect field coils. Clean ends of all wires to be connected, clinch connections securely, and solder.

(e) Assemble frame assembly (figs. 165 and 166). Place the flat washer, insulating washer, and terminal post frame insulation on the terminal post. Place the field coils, insulation, and pole pieces in position in frame. Dip pole piece screws in VARNISH, shellac. Install the pole piece screws. Strike the frame a few sharp blows with a rawhide mallet as the screws are being tightened to aline pole pieces. Install terminal post cover insulation, insulating washer, lock washer, nut, second lock washer, and second nut on the terminal post.

c. Pinion Housing (fig. 167).

(1) Clean pinion housing in SOLVENT, dry-cleaning, and dry with compressed air.

(2) Examine pinion housing for fractures. Replace if broken.

(3) Fit armature shaft into the end bearing and check side play. If side play is more than barely perceptible, drive old bearing out and press in a new one. Press bearing flush with outer ends of bore in housing.

d. Bendix Drive and Intermediate Bearing Plate.

(1) Examine all parts to see if any are bent, broken, chipped, or worn. Replace damaged parts. Clean all parts in SOLVENT, dry-cleaning, and dry with compressed air.

(2) Inspect the intermediate bearing plate for wear or distortion. Fit intermediate bearing on armature shaft and check for side play. Replace intermediate bearing plate if side play is more than barely perceptible. Spin plate on shaft, and note if it is warped. Replace plate if it is not true.

ORDNANCE MAINTENANCE — GENERATING UNIT M7

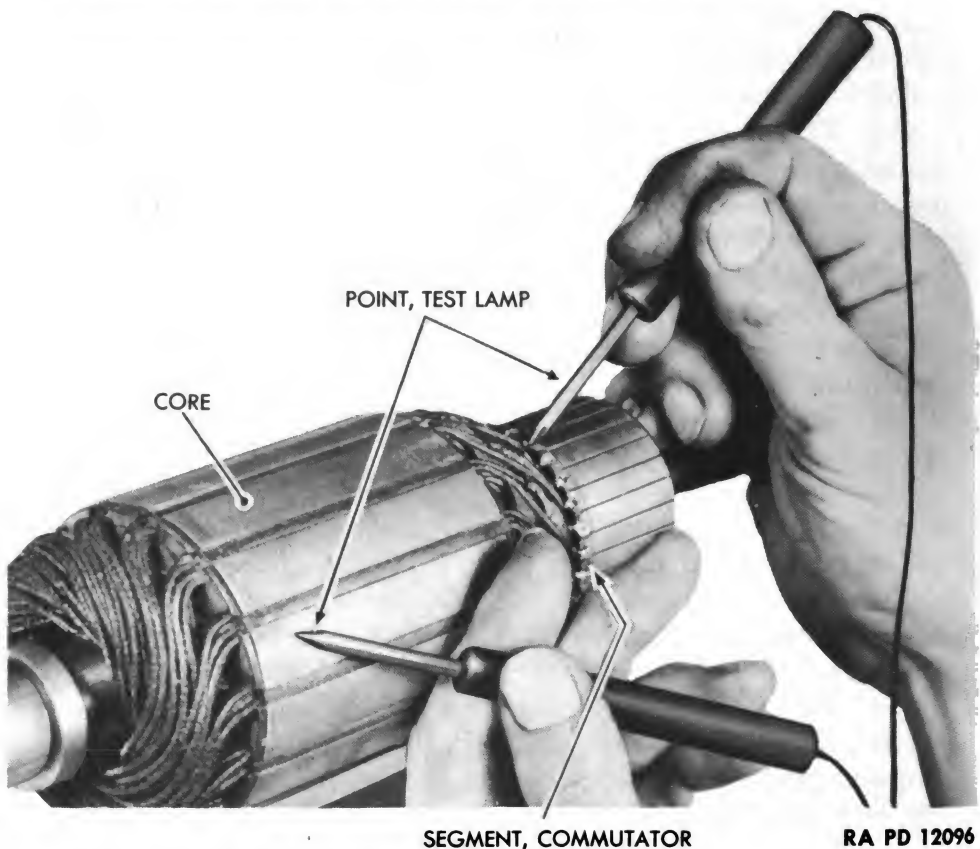

Figure 164 — Testing Armature for Ground

e. Commutator End Head.

(1) Clean commutator end head and all parts except brushes in SOLVENT, dry cleaning. Blow dry with compressed air.

(2) Inspect all parts for scoring, distortion, and breakage.

(3) If brushes are worn to less than half their original length, replace with new ones. Compare the old brush with a new one to determine the amount of wear.

(4) Fit armature shaft into bearing. If there is any perceptible side play, replace commutator end head.

85. ASSEMBLY.

a. Procedure.

(1) Install brush-holder spacing insulators, spring insulators, brush arms, brush springs, insulating bushings, and insulating washers in commutator head. Install brush holder post clips on posts.

(2) Place brushes and ground connectors in position in commutator head. Install brush lead ground screws. Install brush screws.

ENGINE AND ACCESSORIES

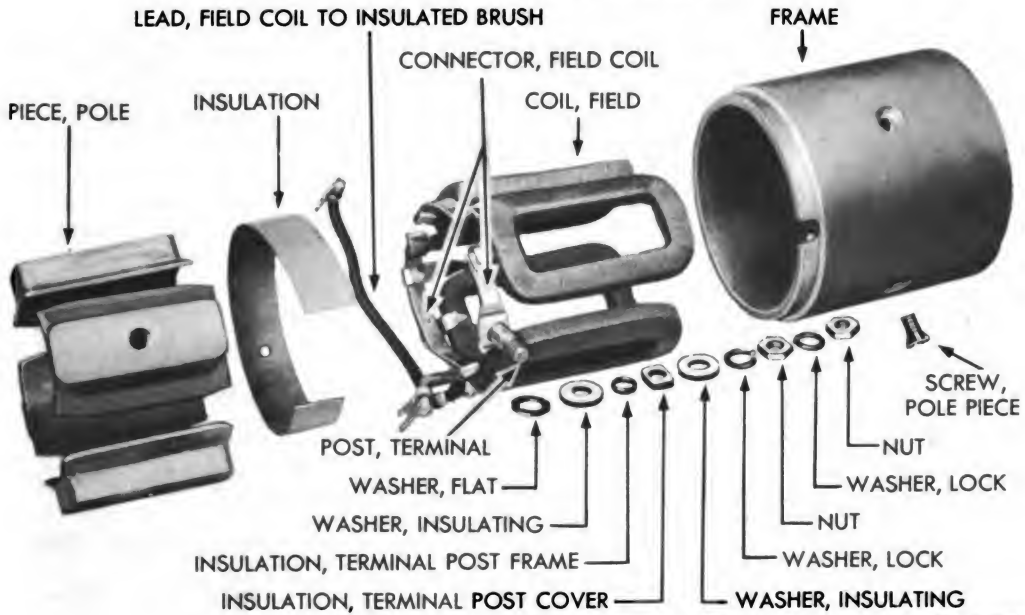

RA PD 12236

Figure 165 – Frame Assembly – Exploded View

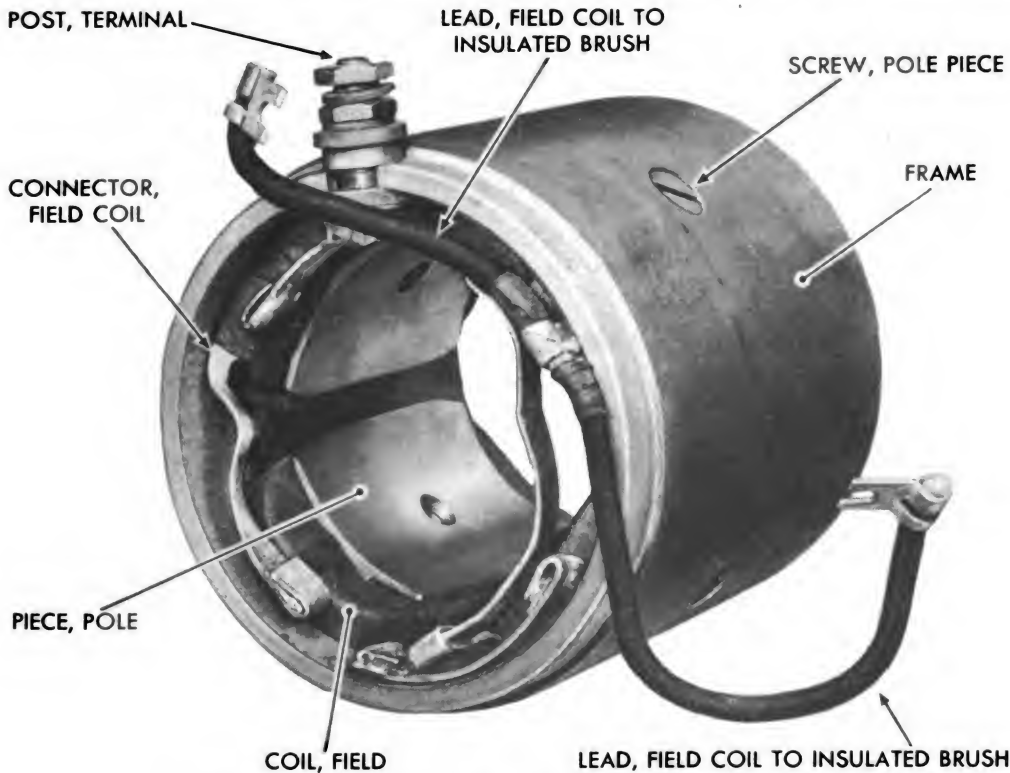

RA PD 12098

Figure 166 – Starting Motor Frame Assembly

(3) Soak all bearings in OIL, engine, SAE 10, and apply a light wipe of oil to armature shaft bearing seats.

(4) Assemble intermediate bearing plate on armature shaft.

ORDNANCE MAINTENANCE — GENERATING UNIT M7

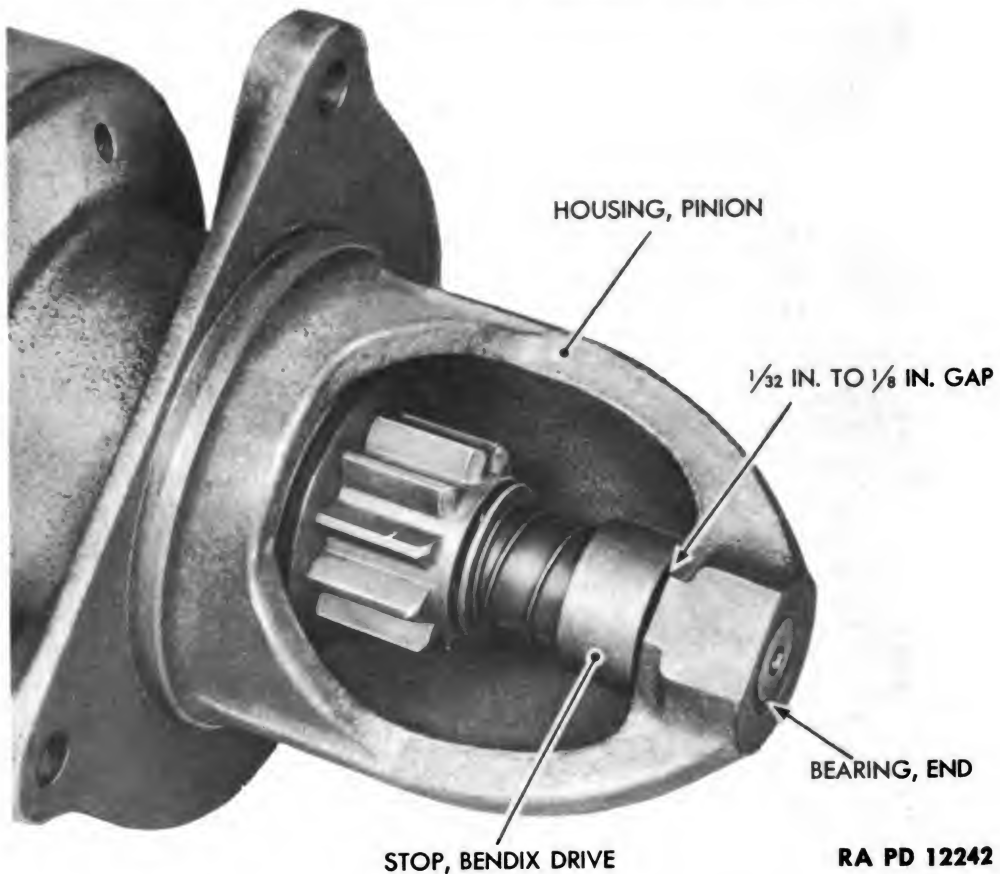

Figure 167 — Starting Motor Pinion Housing

- (5) Install dowel pin in Bendix head, and Woodruff key in armature shaft.
- (6) Press intermediate bearing plate and head on armature shaft.
- (7) Install drive spring on armature, and then install pinion assembly.
- (8) Install head spring screw and shaft spring screw, and tighten. Lock screws with special lock washers.
- (9) Assemble pinion housing over Bendix drive, and make sure intermediate bearing plate is tight against seat, with dowel pin in its proper place.
- (10) Place armature and pinion housing in frame and field assembly, and align pinion housing on dowel pin.
- (11) Place thrust washer on commutator end of armature shaft. Install commutator end head on armature shaft and against frame, and install frame screws. Strike the frame a few sharp blows with a rawhide hammer as the screws are tightened.
- (12) Connect brush leads to insulated brushes.

CHAPTER 4
ELECTRICAL GENERATING SYSTEM

Section I

GENERAL

	Paragraph
Description	86
Trouble shooting	87
200-ampere power receptacle.....	88
30-ampere power receptacle.....	89

86. DESCRIPTION (fig. 168).

a. General. The generating system functions through the use of two electrical generators. The smaller of the two generators is a d-c, stationary field-type generator known as an exciter. Its function is to furnish excitation (direct current) for field windings of the other generator. The other generator is an a-c revolving field-type generator known as an alternator. Its function is to deliver the electrical output of the unit.

b. Construction. The generating system is made up of the exciter (d-c generator), the alternator (a-c generator), a rheostat on the exciter line, a load switch, an ammeter for finding the amperage of the current delivered, a voltmeter for determining the voltage, a meter switch to connect each of the phases of the circuit with the ammeter, two 125-volt light sockets, a toggle switch and a lamp-dimming rheostat to control them, two power receptacles, T-slot receptacles, and fuses.

c. Functioning. The engine, directly coupled to the alternator shaft, turns the alternator rotor, and through a V-belt the exciter armature, or by direct connection on the alternator shaft in the case of the Hobart Bros. Co. unit. The exciter supplies the alternator field current as required by the load. The exciter field rheostat may be used to maintain constant alternator output voltage under varying loads. The load switch completes or interrupts the load circuit from the alternator to the two power receptacles. Five T-slot receptacles and two lamp sockets are fed from the line ahead of the load switch. The lamps are controlled by a toggle switch, and the illumination given is controlled by a dimming rheostat.

87. TROUBLE SHOOTING.

a. General. Three things can go wrong with the coils and leads of a generator. These are an open circuit, a short circuit, and a ground.

ORDNANCE MAINTENANCE — GENERATING UNIT M7

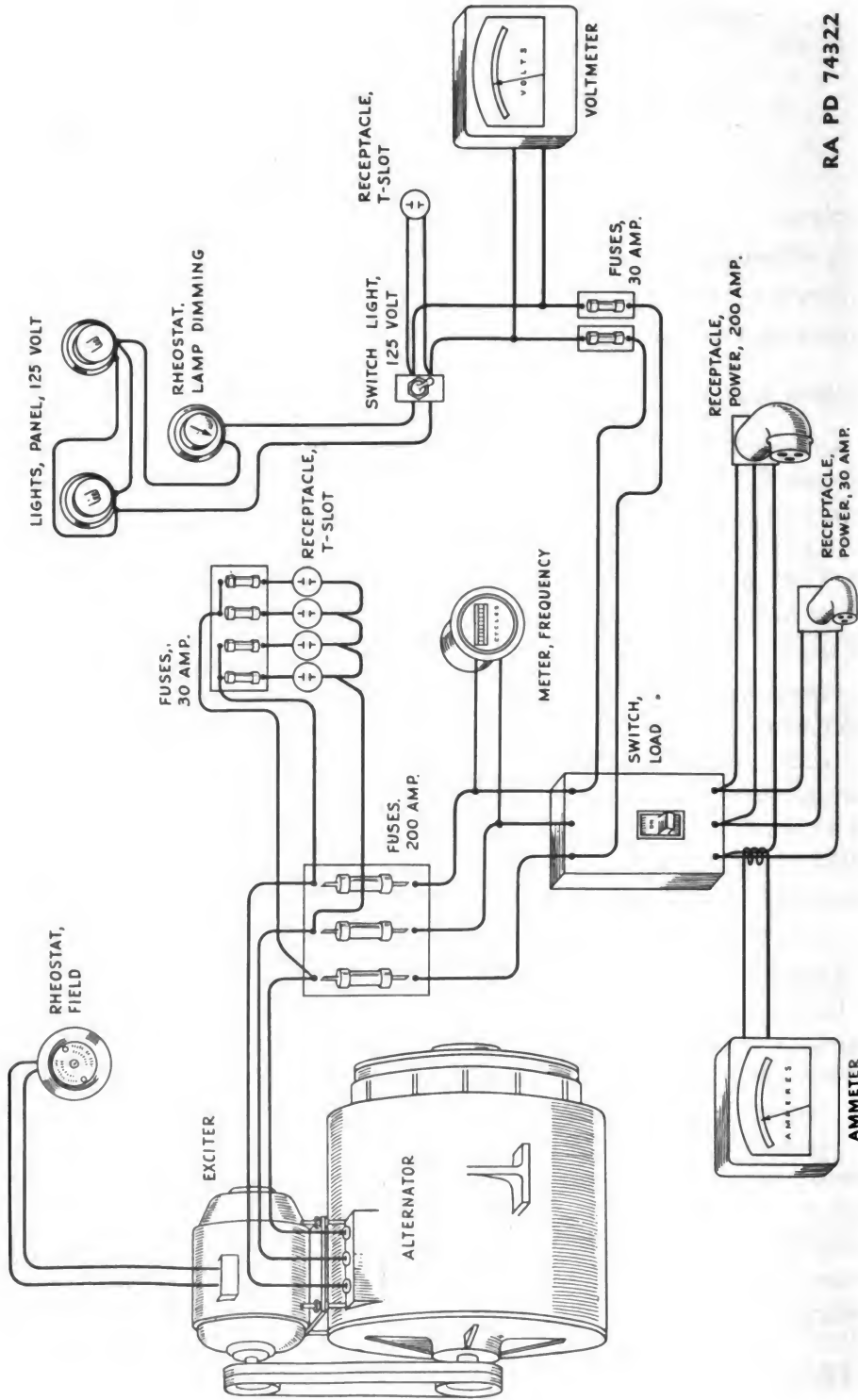

RA PD 74322

Figure 168 — Generating System

ELECTRICAL GENERATING SYSTEM

(1) **OPEN CIRCUIT.** An open circuit is caused by a break in a wire, or by the opening of a connection of two wires. This breaks the circuit because the current has no path to follow.

(2) **SHORT CIRCUIT.** A short circuit is caused by lack of insulation on two touching wires. This enables the current to take a "short cut" instead of traversing the route it is supposed to follow.

(3) **GROUND.** A ground is caused by lack of insulation on a wire or coil at point of contact with the framework of the generator. This allows the current to flow into the framework instead of following its proper course.

b. Test Lamp. Construct a test lamp by connecting in series, a lead, a battery, a lamp bulb, and another lead. Test operation of the test lamp by touching the points of the two leads together. The bulb should light.

c. Checking for an Open Circuit. Hold the point of one test lamp probe against the bare wire at one end of the coil or wire being tested. Place the point of the other probe against the bare wire at the other end of the coil or wire being tested. If the test lamp lights, a continuous circuit is indicated. If the test lamp fails to light, an open circuit exists in the coil or wire being tested.

d. Checking for a Short Circuit. Locating short circuits is more difficult than finding open circuits. No specific directions which will apply to all cases can be given. In general, loss of generator output and presence of excessive heat indicate a short circuit.

e. Checking for a Ground. Hold one probe of the test lamp against a bare lead to the coil or wire being tested. Touch other probe of test lamp against the frame of the generator. If the test lamp lights, a ground is present. If the lamp fails to light, absence of ground is indicated.

f. Trouble Shooting Chart.

(1) ARCING AT EXCITER BRUSHES.

Possible Cause	Possible Remedy
Dirt on commutator.	Clean commutator.
Worn brushes.	Replace brushes.
Brushes stuck in holders.	Remove, clean, and install brush holders and brushes.
Open circuit in armature coil in exciter.	Replace coil.
Open circuit in alternator lead to field rheostat.	Solder lead.

(2) ALTERNATOR FAILS TO GENERATE RATED AMPERES.

Unbalanced load on lines.	Balance load.
Defective wiring in circuit.	Replace or repair wiring.

ORDNANCE MAINTENANCE – GENERATING UNIT M7

Possible Cause	Possible Cause
Field rheostat incorrectly adjusted.	Adjust rheostat.
Dirt on exciter commutator.	Clean exciter commutator (par. 101).
Worn brushes on exciter.	Replace exciter brushes (par. 101).
Defective rotor.	Replace rotor (pars. 92 and 95).
Short circuit in revolving field coil.	Replace revolving field coil (par. 92).
Open circuit in revolving field coil.	Replace revolving field coil (par. 92).
Grounded revolving field coil.	Replace revolving field coil (par. 92).
Open circuit in field coil lead.	Solder field coil lead (par. 119).
Short circuit in field coil lead.	Replace field coil lead (par. 92).
Fuse burned out.	Replace fuse element.
Defective ammeter.	Replace ammeter.

(3) FAILS TO OPERATE AT PROPER FREQUENCY.

Engine speed too low.	Adjust engine speed (par. 50).
Engine speed too high.	Adjust engine speed (par. 50).

(4) ALTERNATOR DELIVERS NO VOLTAGE OR AMPERAGE.

Load switch off.	Put on load switch.
Dirt on commutator of exciter.	Clean commutator.
Exciter brushes stuck in holders.	Remove, clean, and install brush holder and brush (par. 101).
Worn exciter brushes.	Replace exciter brushes (par. 101).
Worn collector ring brushes.	Replace collector ring brushes (par. 95).
Open circuit in revolving field coil.	Replace revolving field coil (par. 92).
Open circuit in field coil lead.	Connect and solder field coil lead (par. 92).
Defective rotor.	Replace rotor (pars. 92 and 95).
Grounded revolving field coil.	Replace revolving field coil (par. 92).
Fuses blown out.	Replace fuse elements.
Open circuit in stator windings.	Replace body and stator (pars. 92 and 95).
Open circuit in wiring.	Test and repair or replace wiring.

ELECTRICAL GENERATING SYSTEM

(5) VOLTMETER SHOWS NO VOLTAGE.

Possible Cause	Possible Remedy
Defective voltmeter.	Replace voltmeter.
Fuses burned out.	Replace fuses.
Defective contacts in meter switch.	Repair contacts or replace meter switch.

(6) AMMETER REGISTERS TOO HIGH.

Defective ammeter.	Replace ammeter.
Improperly balanced load.	Balance load.
Unit overloaded.	Reduce load.

88. 200-AMPERE POWER RECEPTACLE (fig. 169).

a. Description. The 200-amp, three-pole power receptacle is the larger of the two power receptacles located on the left side of the unit. It is of gooseneck type, and is provided with a chained cover for protection when not in use.

b. Removal.

(1) Remove nuts and take off receptacle leads from the three studs at the bottom of the fuse panel.

(2) Take out stove bolts and nuts holding receptacle to side panel of housing, and remove receptacle. Chain, holding cover to housing, will come off with the removal of the lower left bolt.

c. Inspection and Repair.

(1) Check body and cover for cracks or stripped threads. Repair or replace defective parts.

(2) Remove shoe from nut by taking out four flat-head screws. Examine nut and shoe for cracks, and screws for stripped threads. Replace defective parts.

(3) Remove ring from body groove just inside rim, and pull out insulation, terminals, and plate. Examine all parts for cracks, chips, and breaks. Replace if defective. Examine soldered connections of terminals and cables. Resolder if loose.

d. Disassembly.

(1) Unscrew nut holding cover to body, and remove cover.

(2) Remove ring from body groove just inside rim, and pull out insulation, terminals with cables still connected, and plate.

(3) Play soldering torch on cable terminals, until the solder holding cables in terminals is loosened, then remove cables.

e. Assembly.

(1) Solder one of the three cables into the small cup at the back of each of the three terminals.

ORDNANCE MAINTENANCE – GENERATING UNIT M7

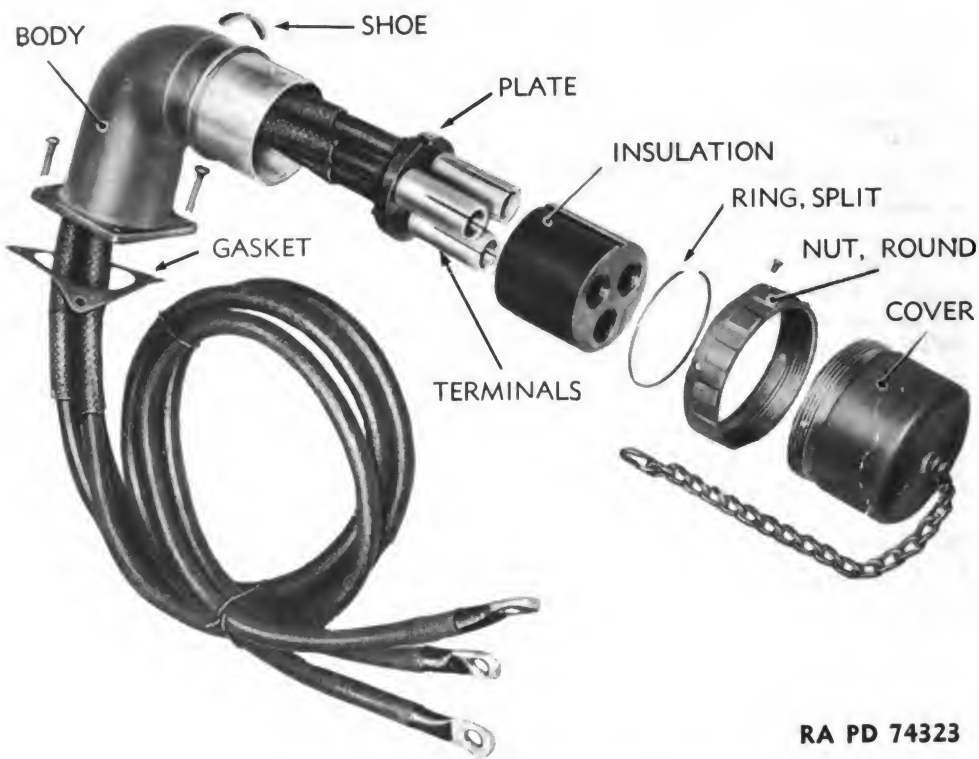

RA PD 74323

Figure 169 – 200-ampere Power Receptacle

(2) Push plate into terminal body, fitting rim groove to body indentation. Fit terminals into plate cover holes, wire end first, and draw wires out through gooseneck.

(3) Fit insulation into receptacle body, with groove running into body indentation. Secure with ring snapped into place just back of body rim.

(4) Put nut on body, and insert shoe, and fasten to nut.

f. Installation.

(1) Carry leads through hole in housing side panel, hold receptacle in position, secure with stove bolts and nuts. Under the lower left-hand bolt head, install the end link of the cap chain.

(2) Bring wires through iron collar back of receptacles, to fuse panel. Lead marked "A" goes to the right-hand stud. "B" lead attaches to the center stud. "C" lead attaches to the left stud. Secure leads with nuts.

89. 30-AMPERE POWER RECEPTACLE (fig. 170).

a. Description. The 30-amp, three-pole power receptacle is the smaller of the two-power receptacles located on the left side of the unit. It is of gooseneck type and is provided with a chained cap for protection, when not in use.

ELECTRICAL GENERATING SYSTEM

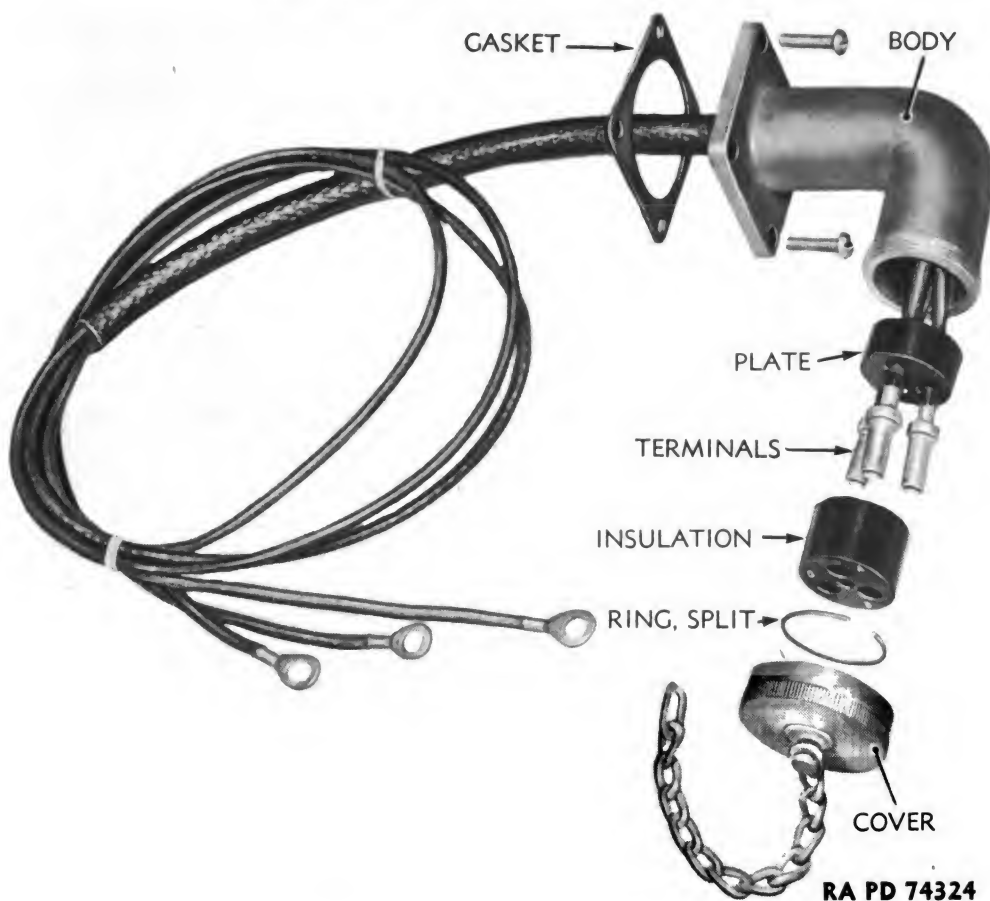

Figure 170 — 30-ampere Power Receptacle

b. Removal.

(1) Remove lock nuts and take off receptacle leads from the three studs on the fuse panel.

(2) Take out stove bolts and nuts holding receptacle to side panel of housing and remove receptacle. Chain, holding cap to housing, will come off with the removal of the lower left-hand bolt.

c. Inspection and Repairs.

(1) Check body and cover for cracks or stripped threads. Repair or replace any defective parts.

(2) Remove ring from body groove just inside rim, and pull out retainer terminals and insulation. Examine all parts for cracks, chips, or breaks. Replace defective parts. Examine soldered connections of terminals and cables. Resolder if loose.

d. Disassembly.

(1) Unscrew cover. Pry ring out of groove just back of body rim, remove ring and retainer behind it.

ORDNANCE MAINTENANCE – GENERATING UNIT M7

(2) Pull terminals and wires out of receptacle, then shake or pull out insulation block.

(3) Play soldering torch on each terminal until solder is melted and wire comes free.

e. Assembly.

(1) Solder one of the three cables into the small cup at the back of each of the three terminals.

(2) Push plate into terminal body, fitting rim groove to body indentation. Fit terminals into plate holes, wire end first, and draw wires out through gooseneck.

(3) Fit insulation around terminals, and secure in place by installing ring just back of body rim.

f. Installation.

(1) Carry leads through hole in housing side panel, hold receptacle in position, secure with stove bolts and nuts. Under the lower left-hand bolt head, install the end link of the cover chain.

(2) Bring wires through iron collar back of receptacle, through open clamp on side of alternator and the clip on the end of the alternator to fuse panel. Lead marked "A" goes to the right-hand stud. "B" lead attaches to the center stud. "C" lead attaches to the left stud. Secure leads with lock nuts.

Section II

ALTERNATOR

	Paragraph
Description	90
Removal	91
Disassembly	92
Inspection	93
Maintenance and repairs.....	94
Assembly	95
Installation	96

90. DESCRIPTION (fig. 171).

a. The alternator is an electric a-c generator connected to the engine by means of a flexible coupling. It is a semiprotected type and is self-ventilated. The rated output is 35-kva, 28-kw (80% power factor) 3-phase, 60-cycles, 125-v. The alternator weighs 420 pounds.

b. The alternator, in combination with the exciter, takes the mechanical energy of the engine and transforms it into electrical

ELECTRICAL GENERATING SYSTEM



RA PD 74325

Figure 171 — Alternator — Exciter Removed

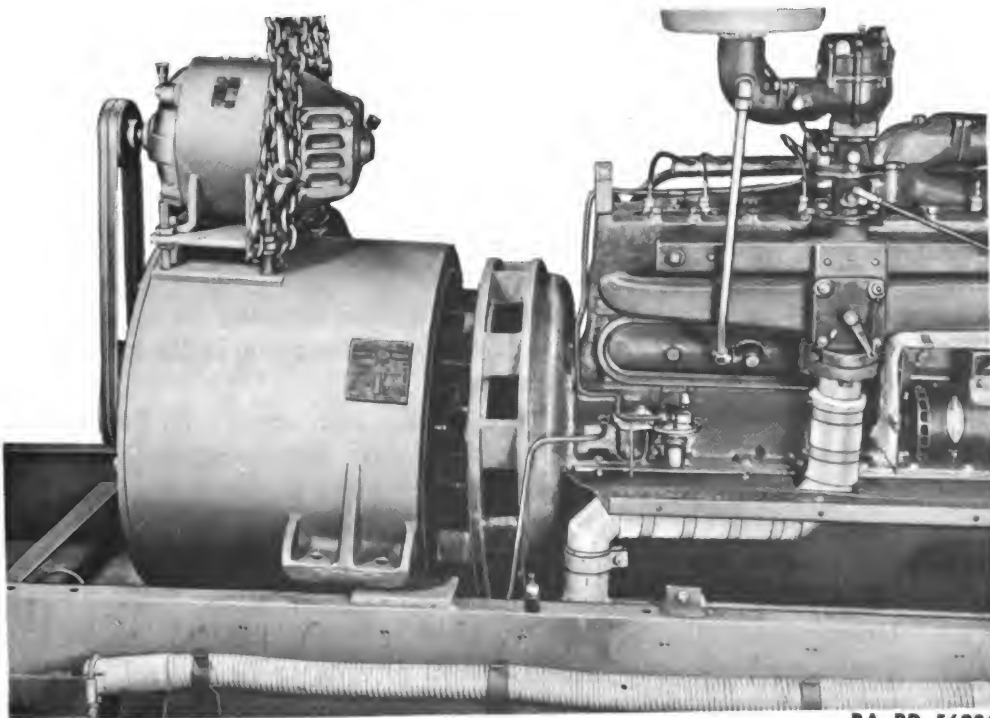

RA PD 56986

Figure 172 — Removing Alternator from Engine

ORDNANCE MAINTENANCE — GENERATING UNIT M7

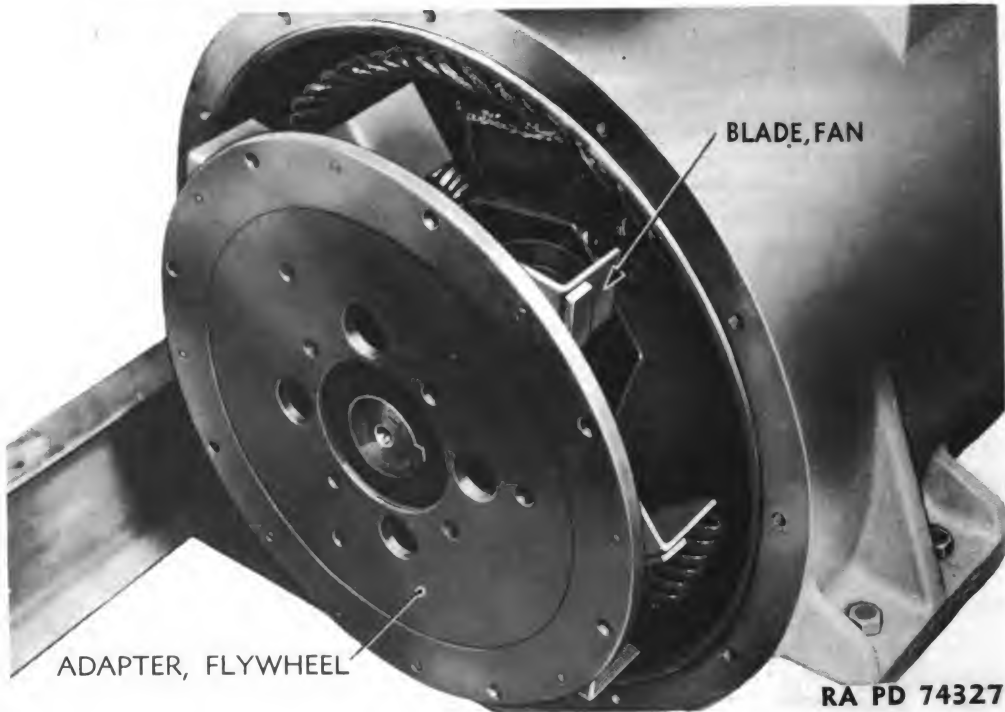

Figure 173 — Coupling End of Alternator, I.D.E. Co. Unit

energy by magnetic induction. When driven at its rated speed, the alternator, with its field energized by the exciter, produces a voltage at its terminals equivalent to that provided by the usual 125-volt lighting circuit. This voltage can be varied over a range of 90 to 150 volts by the use of the field rheostat.

91. REMOVAL.

a. All Units Except H. B. Co.

- (1) Remove housing (par. 11).
- (2) Remove expanded metal guard on bell housing.
- (3) Take out the eight bolts attaching bell housing to alternator housing (fig. 19). Remove wires tying flywheel coupling bolts together. Remove castellated nuts from these bolts.

(4) Remove nuts from alternator hold-down screws in flange at each side of alternator. Engage hoist chains with exciter support bracket on top of alternator (fig. 172). Bring alternator back until it is clear of adapter ring, then lift alternator up and off the frame. Move to one side and lower to the floor.

b. H. B. Co. Unit (fig. 174).

- (1) Unscrew nuts connecting leads to battery posts.
- (2) Trace alternator main leads from alternator to control panel, remove nuts and lock washers securing leads to panel, and remove. Trace remaining alternator leads to fuse terminals, remove nuts and lock washers securing leads to terminals, and remove leads.

ELECTRICAL GENERATING SYSTEM

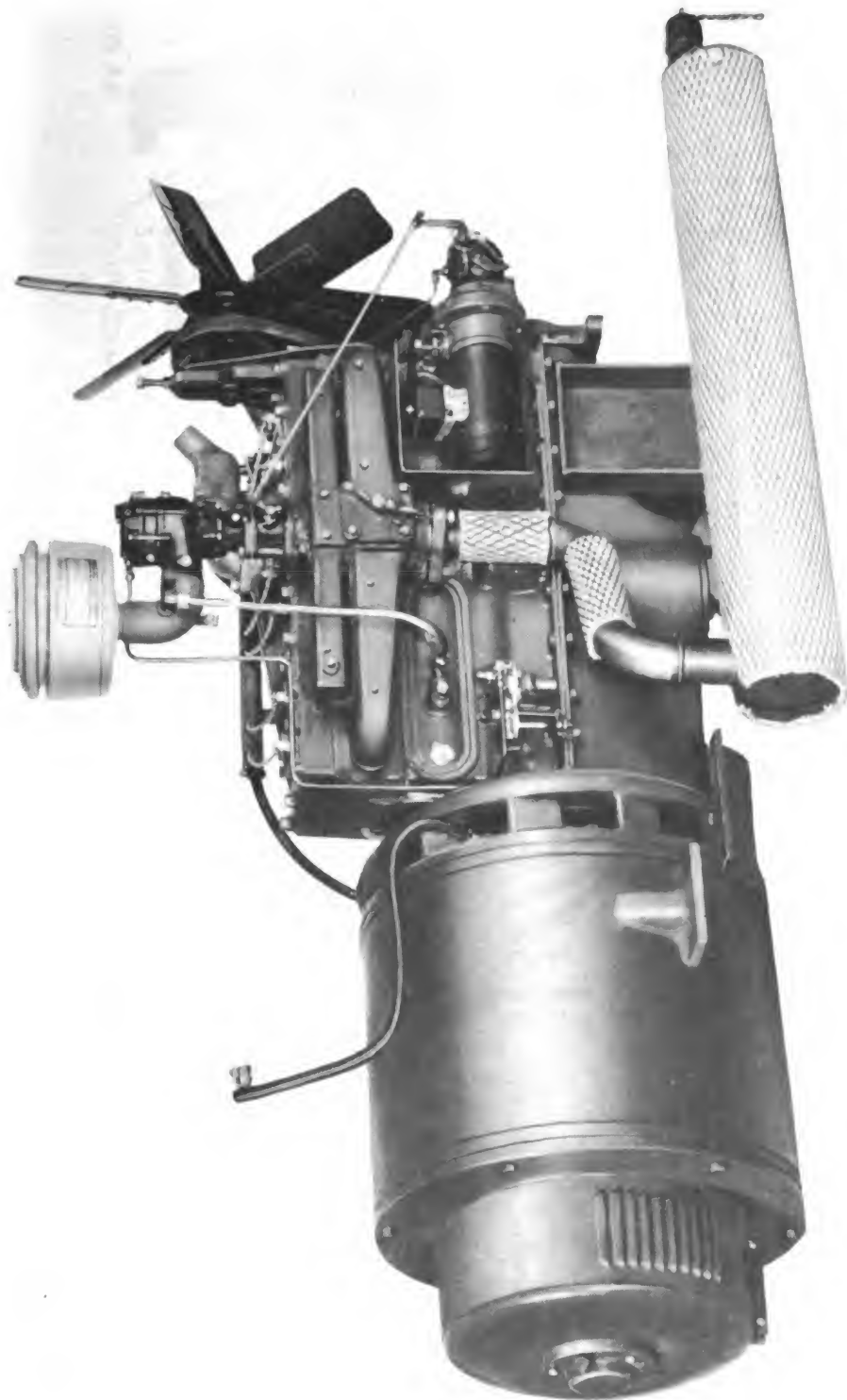

RA PD 74328

Figure 174 — Alternator and Exciter with Engine, H. B. Co. Unit

ORDNANCE MAINTENANCE — GENERATING UNIT M7

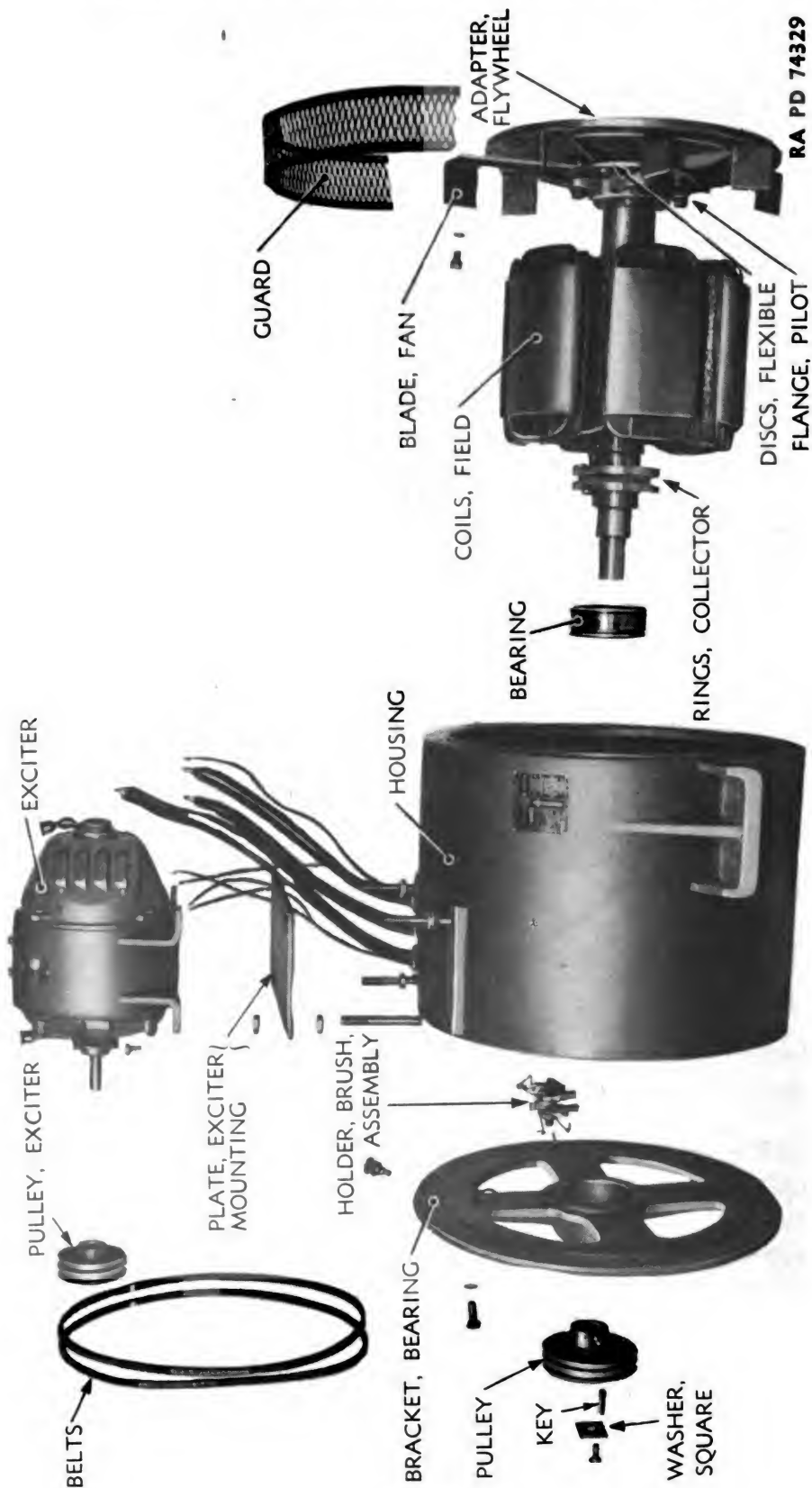
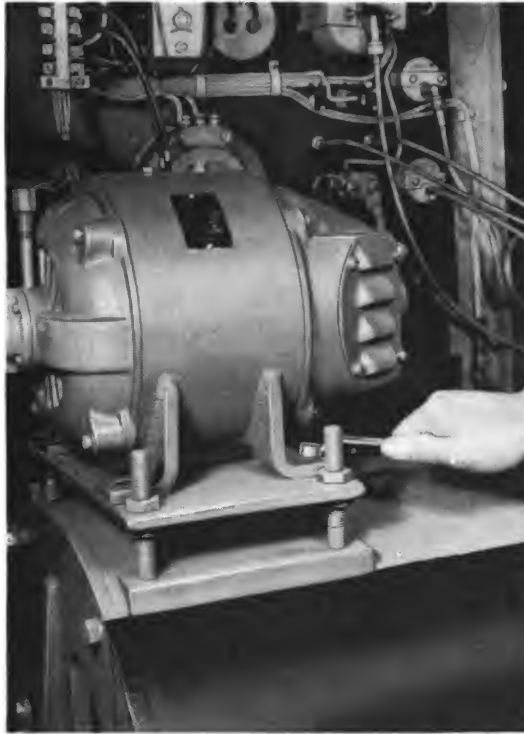

Figure 175 — Alternator — Exploded View

ELECTRICAL GENERATING SYSTEM

RA PD 56992

Figure 176 – Removing Exciter from Alternator

(3) Trace exciter leads to terminal block, take out connecting screws and lock washers, and remove leads.

(4) Remove nut and lock washer attaching brake receptacle housing rear plate. Remove nut and lock washer attaching lead, and remove lead.

(5) At starter button on instrument panel, remove nut and lock washer holding starting motor cable to panel, and remove cable.

(6) Loosen tachometer cable housing and disconnect tachometer lead.

(7) Trace lead from ignition coil to terminal block, unscrew connecting screw, and remove lead.

(8) Disconnect oil line flare tube fitting at gage and in oil filter base, and remove line.

(9) Trace heat indicator line from instrument panel to engine block, and disconnect bulb at end of line.

(10) Loosen clamping screw holding throttle and choke leads to carburetor. Loosen bolt through support bracket at top of engine, and remove leads from bracket.

(11) Open draincock in radiator outlet pipe. This will drain engine, radiator, and water lines.

ORDNANCE MAINTENANCE – GENERATING UNIT M7

(12) Loosen metal straps binding two hose sections in upper radiator water line and one hose section in lower radiator line by loosening bolts. Pull off hose.

(13) At point where flexible radiator overflow pipe enters compression fitting below draincock, remove pipe.

(14) Remove cap screws and lock washers attaching fan bracket to engine.

(15) Close shut-off cock on fuel line under fuel tank (fig. 83). Uncouple nut on engine side of shut-off cock, and remove line.

(16) Loosen manifold companion flange cap screws. Loosen manifold flange retaining screw. Remove exhaust pipe from manifold flanges.

(17) Remove nuts and lock washers from alternator hold-down screws in alternator flanges. Remove engine support cap screws, lock washers, and nuts.

(18) Block up and support engine and alternator to a level slightly above frame mounting level.

(19) Fix hoist chain hooks to the four lifting lugs on the frame. Carry frame forward to take alternator support flange bracket away from generator mounting flanges. Take out cap screws and lock washers holding flange bracket to frame, and remove bracket. Hoist frame and housing up, over, and down to one side.

(20) Take out cap screws and lock washers connecting engine flywheel housing to generator frame. Remove cap screws and lock washers attaching fan and coupling to flywheel.

(21) Adjust hoist chains about alternator. Bring alternator forward and away from engine. Be sure alternator is clear of engine before lifting.

92. DISASSEMBLY.**a. All Units Except H. B. Co. (fig. 175).**

(1) Remove belts connecting exciter and alternator. Take out cap screws holding exciter to adjustable plate on top of alternator, and remove exciter (fig. 176).

(2) Lift springs from commutator brushes, and remove brushes from holders. Loosen screws holding leads, and remove leads. Loosen lock nut on stud securing brush-holder assemblies to bearing bracket, and remove stud with brush holders in place.

(3) Clip off edges of punch holes holding square washer tight against the screw in the alternator shaft. Remove screw (fig. 177). Take off pulley (fig. 178).

(4) Take out cap screws holding bearing bracket to alternator housing. Remove key from shaft, and remove bracket (fig. 179).

ELECTRICAL GENERATING SYSTEM

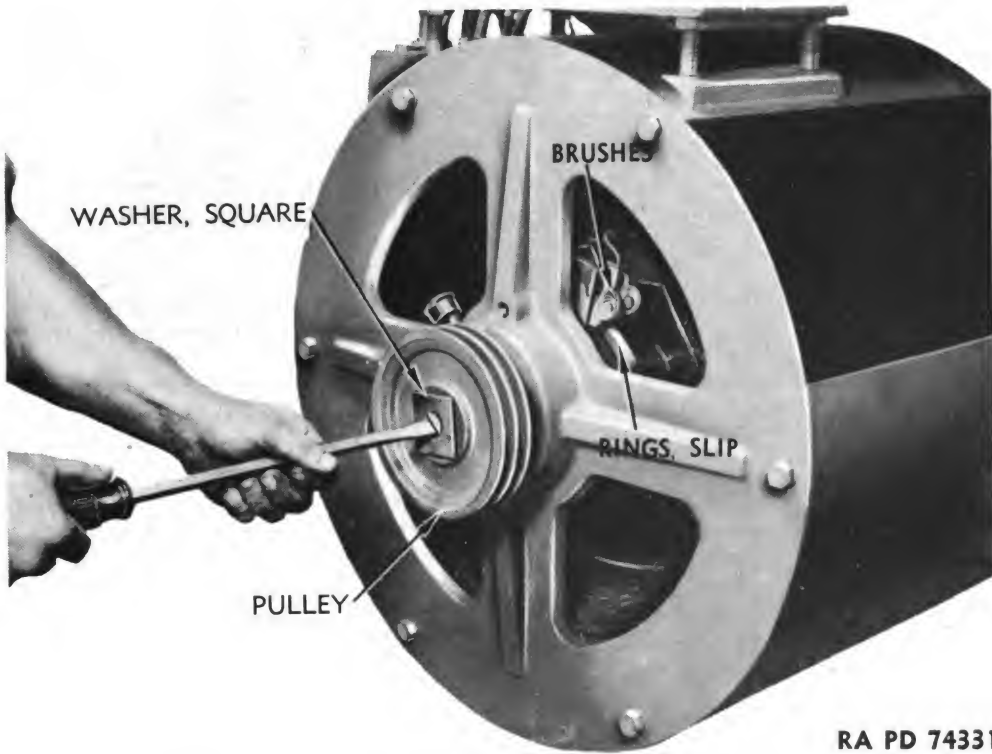

Figure 177 — Removing Alternator Shaft and Screw

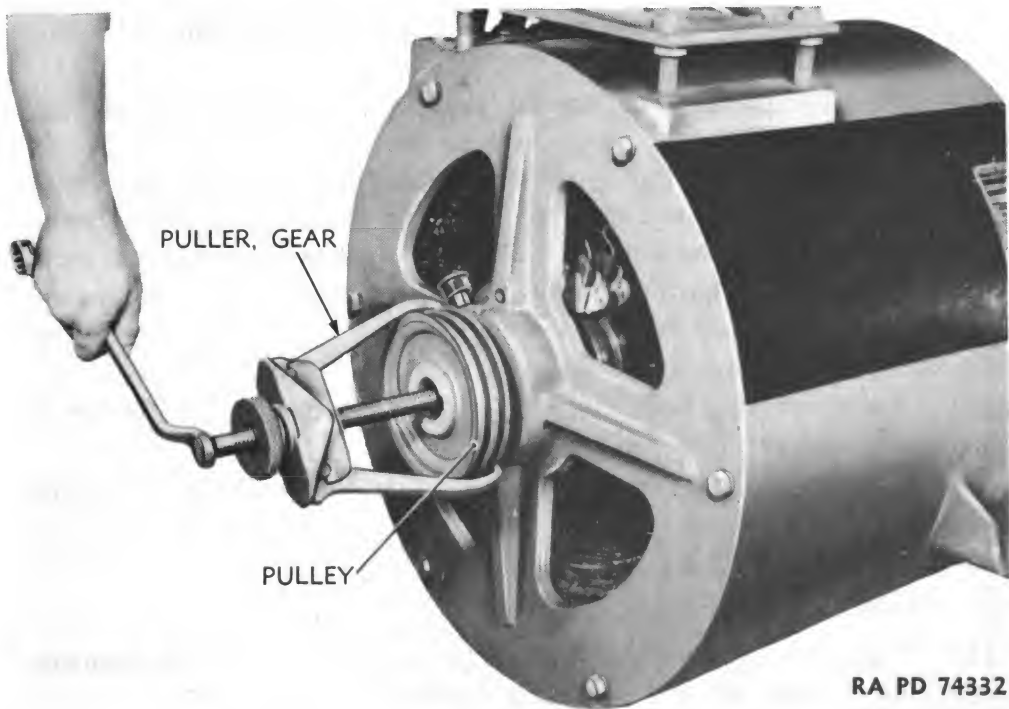
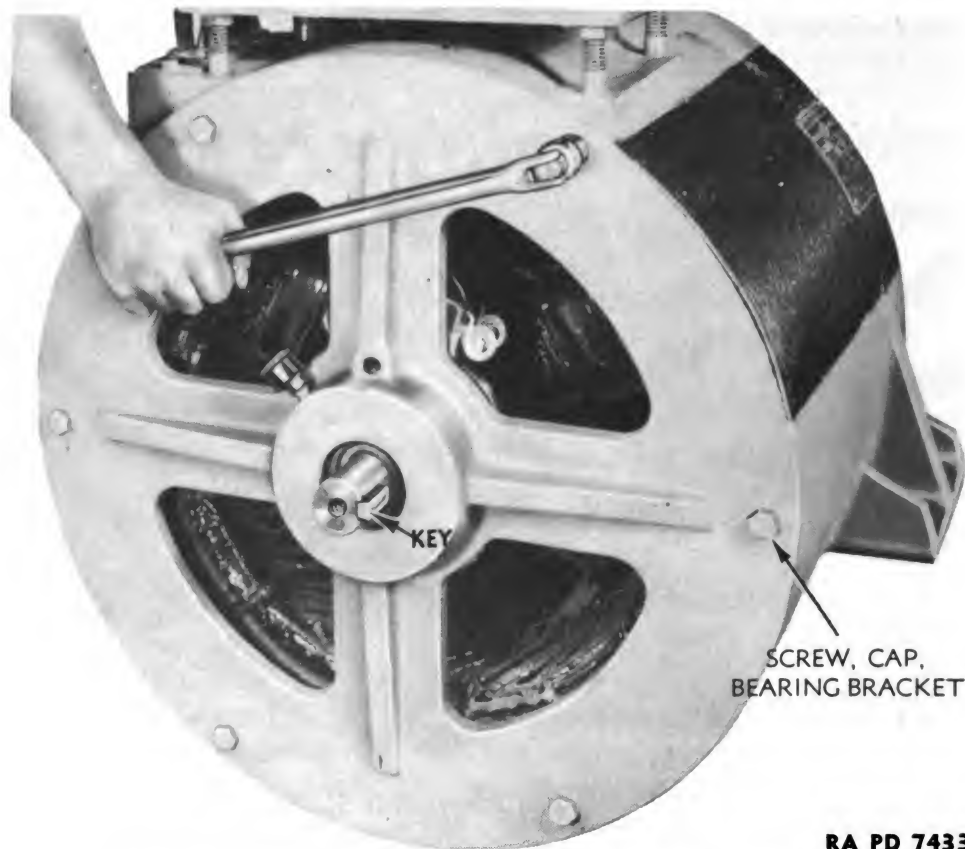

Figure 178 — Alternator Pulley Removal

ORDNANCE MAINTENANCE — GENERATING UNIT M7



RA PD 74333

Figure 179 — Alternator Bearing Bracket Removal

(5) Pull complete rotor assembly from alternator housing (fig. 180) from fan plate side.

(6) Take bearing from rotor shaft *being particularly careful to apply gear puller pressure only against the inner race* (fig. 181). Bearing may be seriously damaged if pressure is applied to the outer race.

(7) Take out socket-head set screws through collector ring flange (fig. 182). Remove screws holding collector rings together, remove leads, and remove rings (fig. 183).

(8) Take out nuts holding flywheel adapter to the flexible disks, and remove adapter (fig. 184).

(9) Take nuts from cap screws holding flexible disks to pilot flange, and remove disks (fig. 185).

(10) Press pilot flange from shaft (fig. 186).

b. H. B. Co. Units (fig. 187).

(1) Take out screws and nuts holding ends of exciter bearing bracket cover together, and remove cover and gasket.

(2) Take out three cap screws, and remove armature bearing cap and gasket (fig. 188).

ELECTRICAL GENERATING SYSTEM

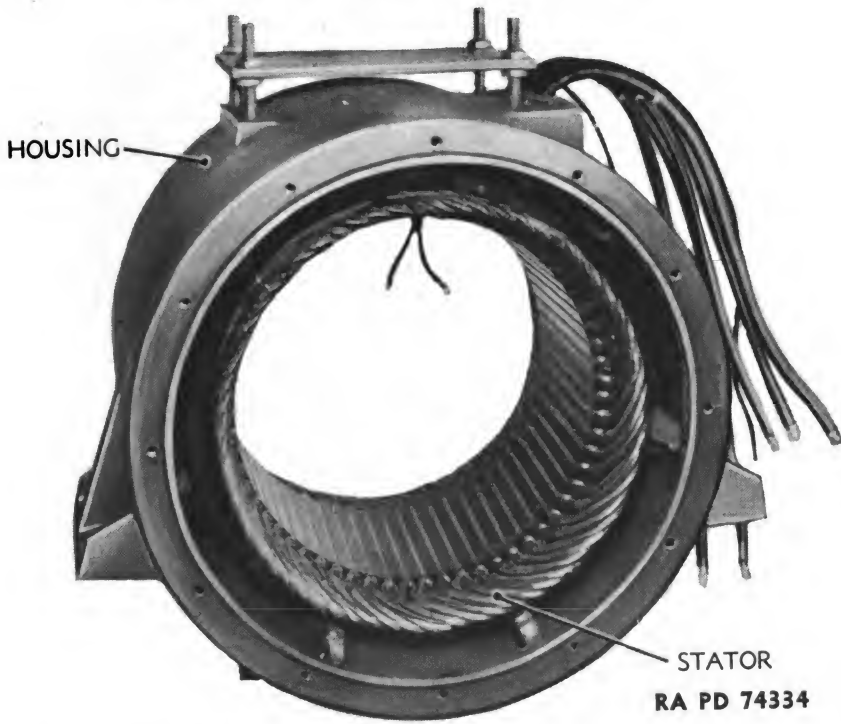

RA PD 74334

Figure 180 — Alternator Housing — Rotor Removed

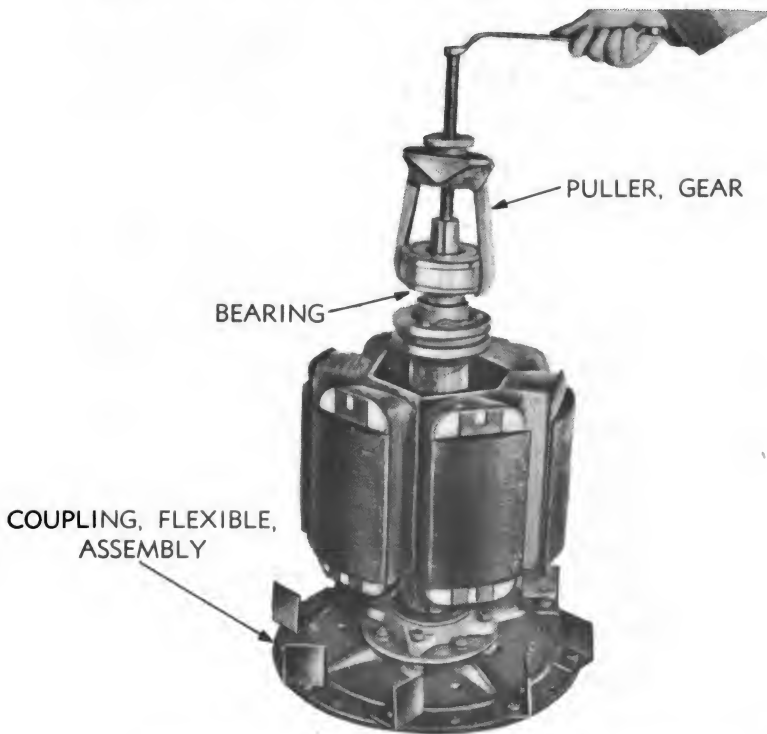

RA PD 74335

Figure 181 — Alternator Bearing Removal

ORDNANCE MAINTENANCE – GENERATING UNIT M7

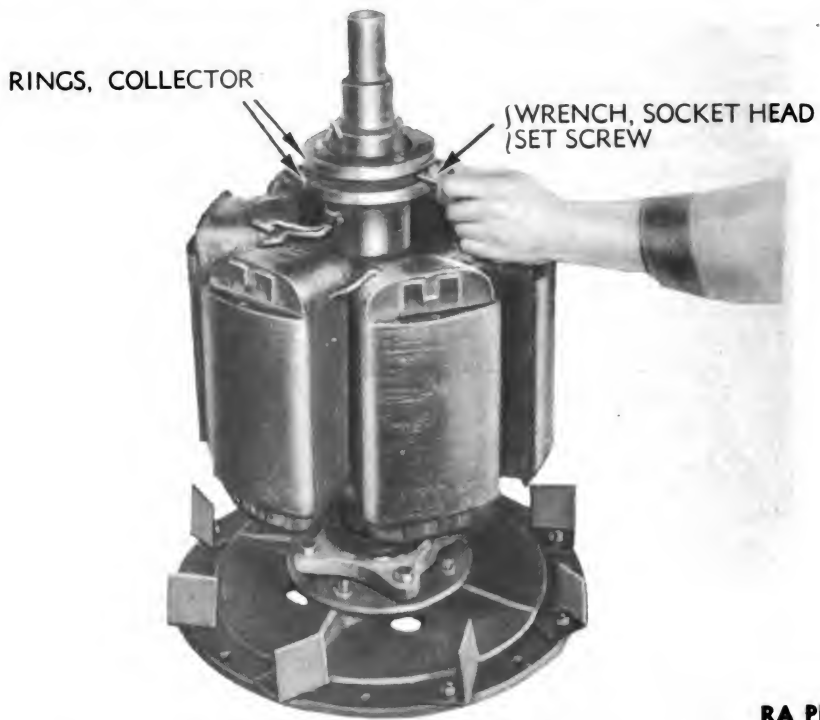

Figure 182 – Removing Collector Ring Flange Screws



Figure 183 – Collector Ring Removal

ELECTRICAL GENERATING SYSTEM

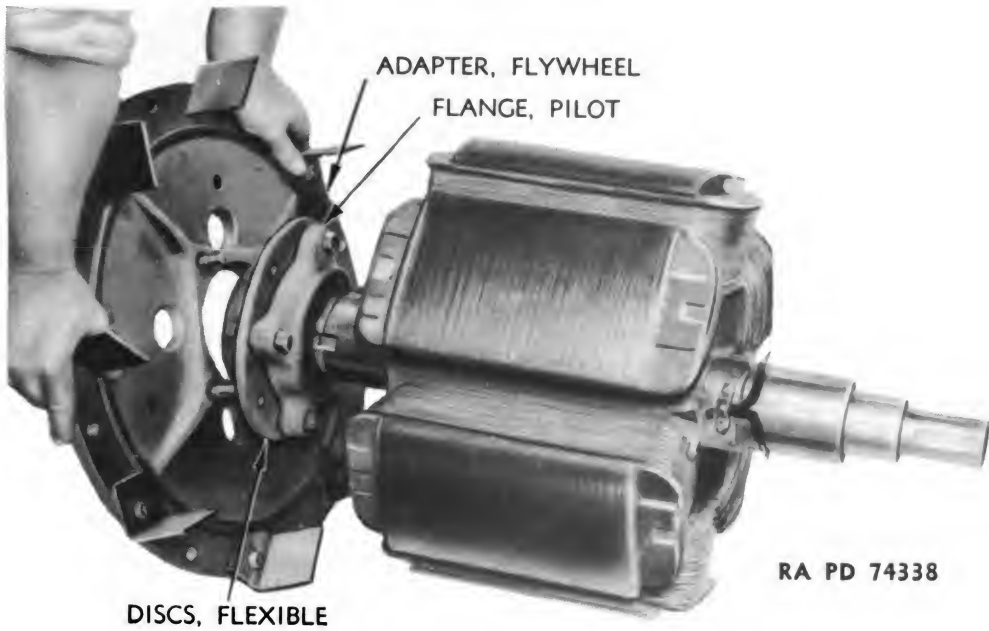

Figure 184 — Flexible Coupling Flywheel Adapter Removal

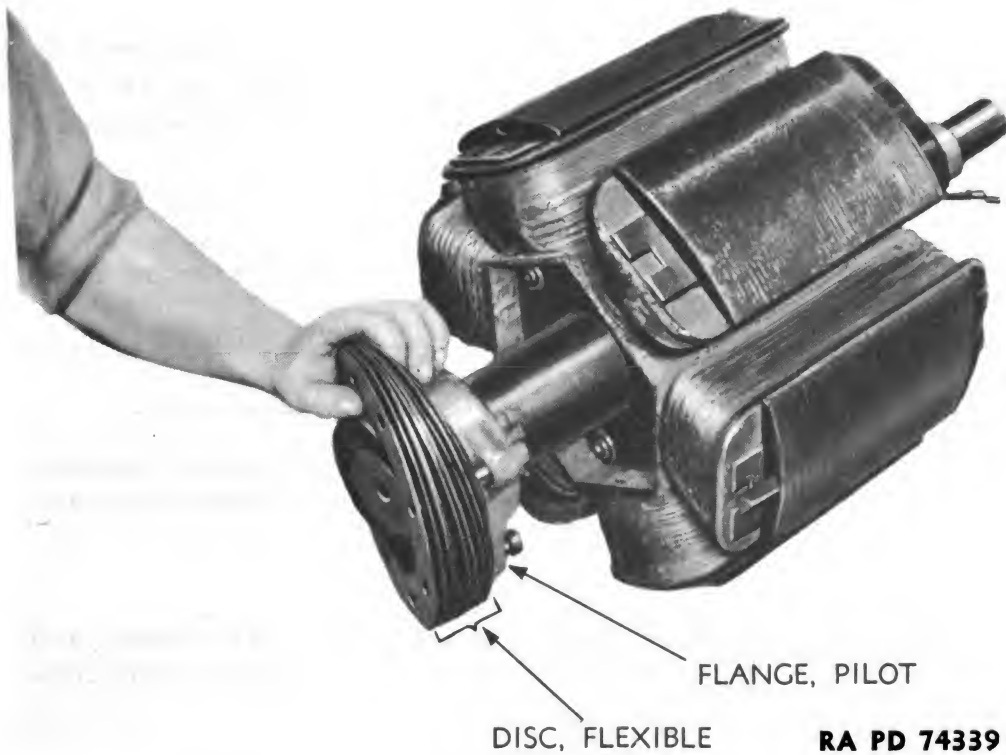

Figure 185 — Removing Coupling Flexible Disks

ORDNANCE MAINTENANCE — GENERATING UNIT M7

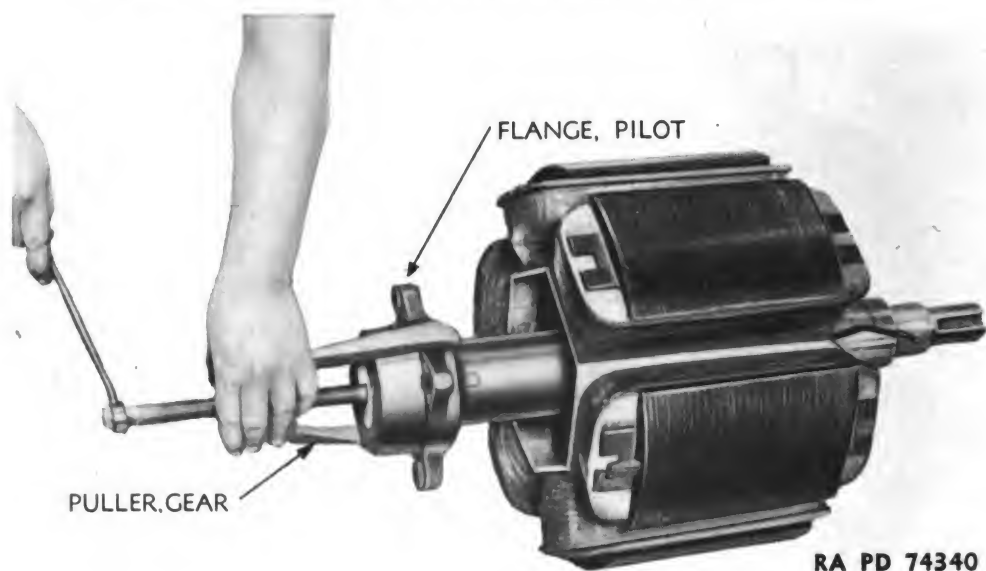

Figure 186 — Coupling Pilot Flange Removal

(3) Take out cap screws holding exciter bearing bracket to stator housing and remove bearing bracket (fig. 189).

(4) Take out cap screw attaching pole pieces to exciter field coil ring, and remove pole pieces and field coils (fig. 190).

(5) Disconnect leads. Loosen retaining screws holding rings to exciter bearing bracket, and remove brush holding rings (fig. 191).

(6) Take nut from end of shaft. Remove bearing. Take off grease retainer.

(7) Take out stator assembly and fan from coupling side of housing (fig. 192).

(8) Take out nuts holding flywheel adapter to the flexible disks, and remove adapter.

(9) Take nuts from cap screws holding flexible disks to pilot flange, and remove disks.

(10) Press pilot flange from shaft.

(11) Take out screws holding brush-holder assemblies together, and remove bushing, tension arm, spring, adjustable washer plate, and brush.

93. INSPECTION.

a. Clean metal parts by washing in SOLVENT, dry-cleaning, and dry with compressed air. Blow dirt from coils and windings with compressed air.

b. Inspect Rotor Assembly.

(1) Test revolving field coils for an open circuit by placing probes of a test lamp on the two slip rings. If lamp lights, no open

ELECTRICAL GENERATING SYSTEM

RA PD 74341

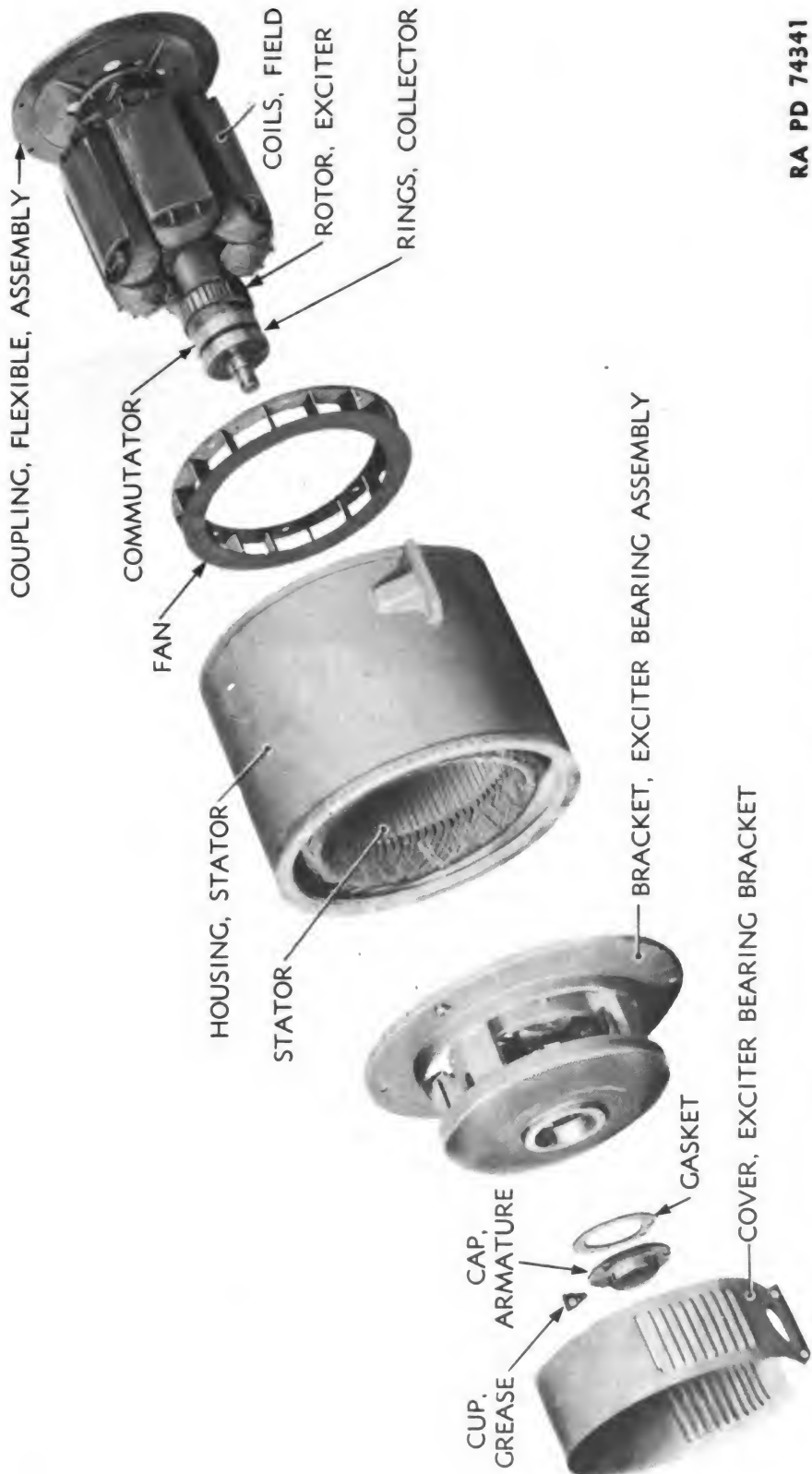

Figure 187 — Alternator and Exciter (H. B. Co. Unit) — Exploded View

ORDNANCE MAINTENANCE — GENERATING UNIT M7

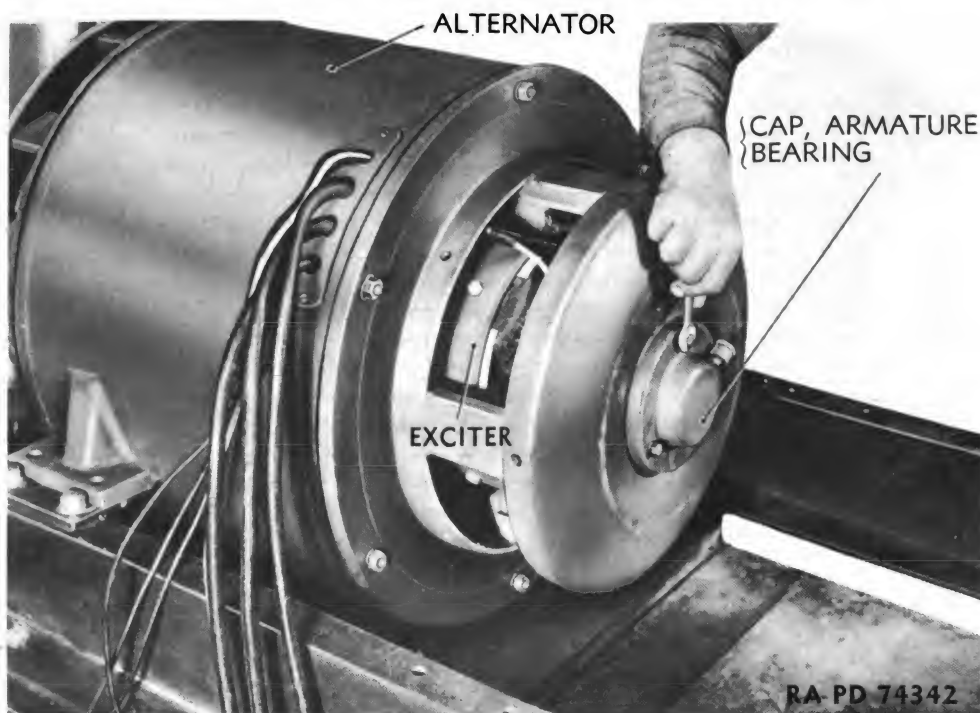

Figure 188 — Armature Bearing Cap Removal

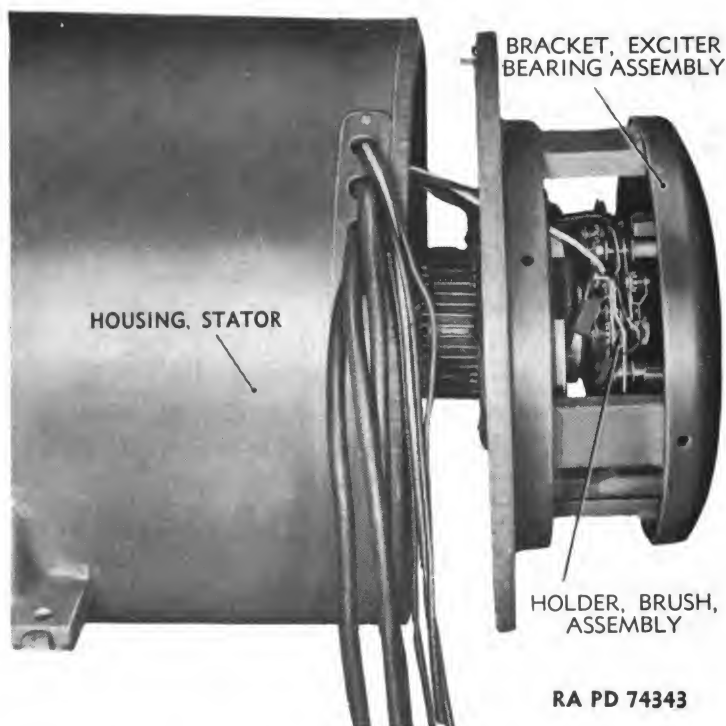
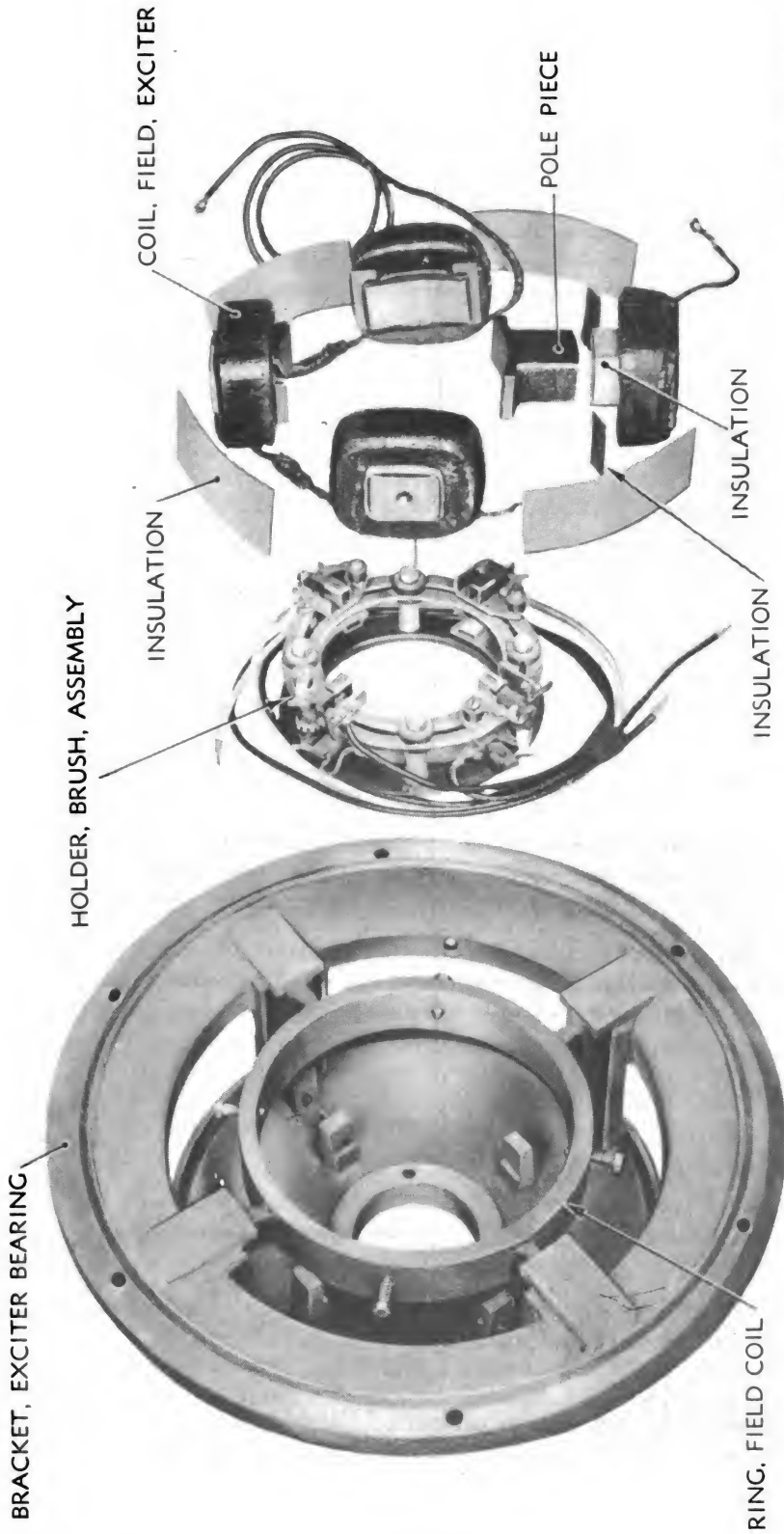

Figure 189 — Exciter Bearing Bracket Removal — H. B. Co. Unit

ELECTRICAL GENERATING SYSTEM



RA PD 74344

Figure 190 — Exciter Bearing Bracket with Coils and Brush-holder Ring Assembly Removed

ORDNANCE MAINTENANCE — GENERATING UNIT M7

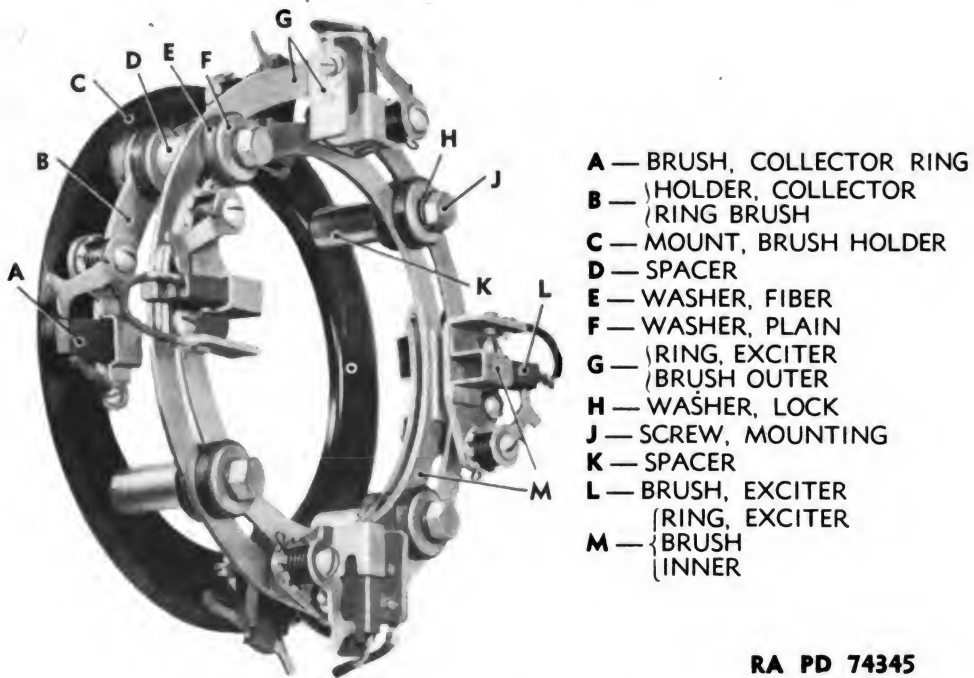

RA PD 74345

Figure 191 — Brush-holder Ring Assembly

circuit is present. If lamp fails to light, trace revolving field coil wires along armature shaft keyway under exciter armature. Remove tape from connections by which the two wires are joined to field coil leads. Repeat test lamp check with probes on the two exposed connections. If lamp now lights, but did not in the first test, open circuit is in the slip ring to revolving field coil wires or their connections. If the test lamp still fails to light, remove tape from the connections of field coil leads. Test each coil and each connection individually for an open circuit.

(2) Test revolving field coils for a ground by placing one probe of a test lamp on one slip ring. Place other probe on the armature shaft or paint-free portion of fan. If test lamp fails to light, no ground is present. If test lamp lights, disconnect both leads of each coil and repeat test on each. Place one probe on bare end of one of disconnected leads. Place other probe on armature shaft or fan. Similarly test each revolving field coil wire. Each time the test lamp lights, a grounded coil or wire is indicated.

(3) Test revolving field coils for a short circuit by connecting a 6-volt battery to the two slip rings. Using a 0- to 7½-volt voltmeter equipped with sharp probes, measure voltage drop across each coil. This is done by inserting one probe into one lead of a coil. Insert other probe into the other lead. Observe the reading of the voltmeter.

ELECTRICAL GENERATING SYSTEM

Repeat test on each of the coils, observing voltmeter each time. If any coil has a reading appreciably less than the others, a short circuit is indicated in that coil. **NOTE:** If the voltmeter hand moves in the wrong direction, reverse the probes.

(4) **H. B. CO. UNIT ONLY.** Test the exciter armature for a ground with test lamp. Place one probe on a commutator bar. Place the other probe on the armature shaft or paint-free portion of the fan. If lamp lights, a ground is indicated. Failure of the lamp to light shows no ground to be present.

(5) **H. B. CO. UNIT ONLY.** Test exciter armature for a short circuit by placing it in an armature growler. Turn on the growler. Move the steel strip slowly around the armature coils. Keep it parallel with the shaft. Turn off the growler and revolve the armature one-half turn in the growler. Turn on the growler, and test the other side of the armature. If the steel strip vibrates noticeably or is drawn to the laminations, a short circuit is indicated.

(6) **H. B. CO. UNIT ONLY.** Inspect the commutator bars. Look for burs which might short circuit two adjacent bars. Observe whether or not bars are scored.

(7) Inspect slip rings to see if they are scored. (This is a rare condition.) Examine slip ring separator to see if it has been broken due to improper disassembly.

(8) Examine alternator bearing to see if it is worn or broken. Examine balls and races to see if they are nicked or scored. Slide bearing on shaft. Grasp outer race and attempt to rock bearing on shaft. Presence of perceptible play indicates wear. If bearings are damaged, examine armature shaft to see if it is scored.

c. Inspect Body and Stator.

(1) Test stator windings for an open circuit with a test lamp. Place one probe on the tip of any one of the six main generator leads from stator. Touch each of the five remaining leads, one at a time, with the other probe. If lamp fails to light when any one of the leads is touched, an open circuit is indicated. If the lamp lights each time, no open circuit is indicated.

(2) Test the stator windings for a ground with a test lamp. Place one test lamp probe against an unpainted surface on the body. Place other probe against tip of any one of the six main generator leads. If lamp lights, a ground is indicated. If lamp fails to light no ground is present.

(3) Test stator windings for a short circuit with a stator growler. Place growler within body and stator so that steel strip is parallel and next to stator laminations. Turn on growler. Move growler slowly around entire inner circumference of stator. If stator windings have a short circuit, growler will "growl," due to vibration of the steel switch.

ELECTRICAL GENERATING SYSTEM

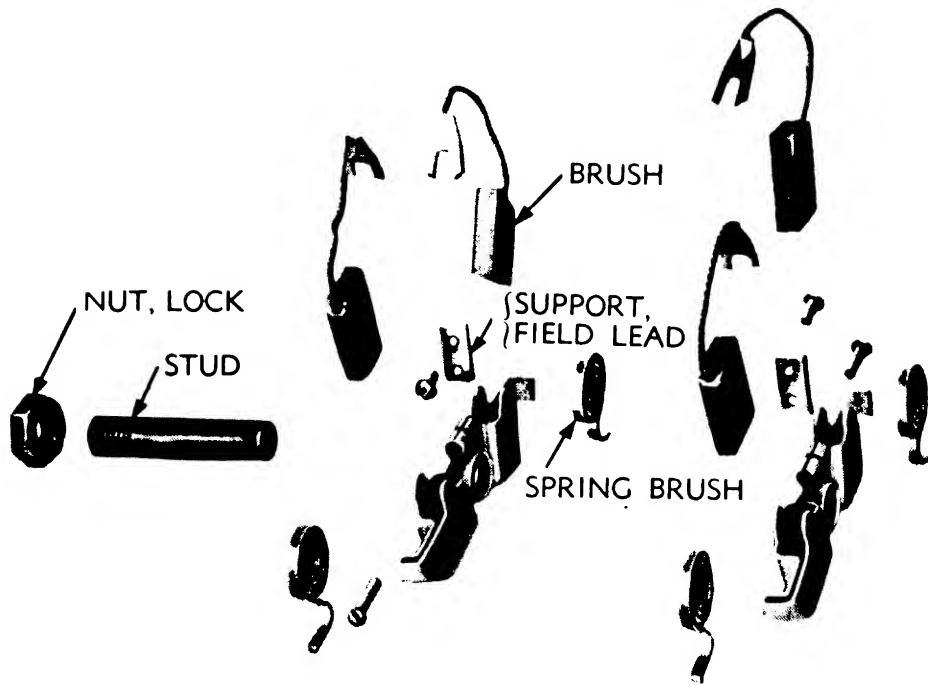

RA PD 74347

Figure 193 – Brush-holder Assembly – Exploded View

d. Inspect Exciter Bearing Bracket Assembly (H. B. Co. Unit only).

(1) Test exciter field coils for an open circuit with test lamp. Place one probe of test lamp on tip of exciter field coil to exciter brush wire. Touch other probe to the tip of main generator lead "1." If the lamp lights, no open circuit is present. If the lamp fails to light, an open circuit is indicated. In the presence of an open circuit, remove tape and cut connections of leads between coils. Test each coil individually. If the lamp fails to light, an open circuit is indicated.

(2) Test exciter field coils for ground with a test lamp. Hold one probe against a bare lead from the coil. Place other probe against the pole piece. If lamp lights, a ground is present. Failure of lamp to light indicates coil is free of grounds.

(3) Test exciter field coils for short circuits. This test is made with all coils connected in series. It can be made with coils installed in or removed from the exciter bearing bracket. Connect the six-volt battery to exciter field coil to commutator wire, and to main generator lead "1." Using a 0- to 7½-volt voltmeter equipped with sharp pointed probes, measure the voltage drop across each coil. Push one probe into one lead of a coil. Push other probe into other lead of same coil. Observe reading on the voltmeter. Repeat test on each of remaining three coils, observing reading on the voltmeter each time. If the reading on one coil is appreciably less than that of the other

ORDNANCE MAINTENANCE — GENERATING UNIT M7

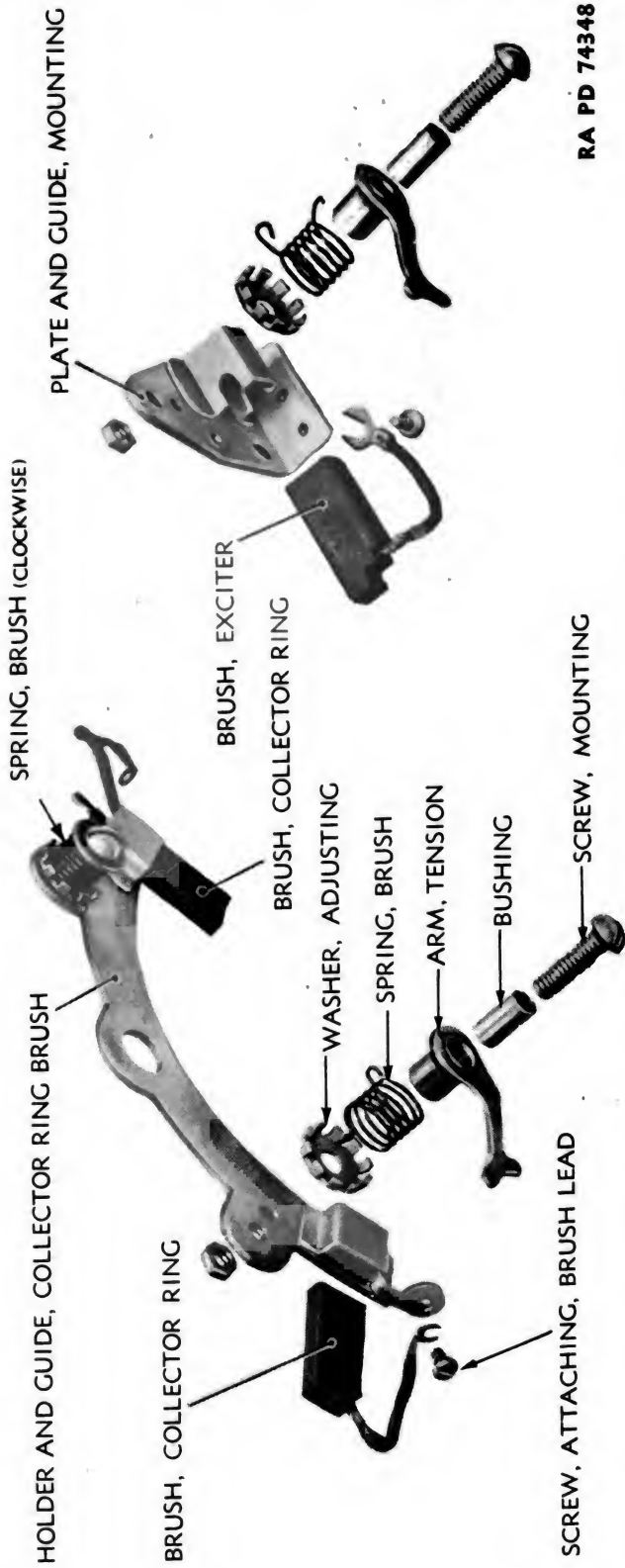

Figure 194 — Brush-holder Assembly (H. B. Co. Unit) — Exploded View

ELECTRICAL GENERATING SYSTEM

coils, a short circuit in that coil is indicated. If the reading is approximately equal on all coils, no short circuit is present. **NOTE:** If voltmeter hand moves in the wrong direction, reverse the probes.

(4) Inspect brushes to see if they are broken or worn. Measure length of each brush. Any brush that is $\frac{3}{4}$ inch or less in length must be replaced.

(5) Examine threads of all screws and tapped threads in screw holes to see if they are burred or stripped.

(6) Inspect brush tension arm springs to see if they are broken or weak.

(7) Examine all insulator spacers and bushings to see if they are broken.

(8) Inspect all metal parts to see if they are bent, worn, or broken.

e. Inspect Coupling End Generator Parts.

(1) Inspect driving flange to see if it is bent or broken. Observe keyway to see if it is square and free of burs. Examine threads of the Allen set screws and threads tapped in screw holes to see if they are burred or stripped. Examine welds to see if any have broken loose.

(2) Inspect armature shaft bearing bracket to see if it is broken. Examine threads in tapped screw holes and lubrication pipe nipple hole to see if they are burred or stripped. Inspect lubrication pipe nipple, elbow, and grease cup to see if they are broken, bent, plugged, or have damaged threads.

(3) Inspect grease retainer to see if it is bent or if welds have broken loose. Examine felt washer to see if it is torn, worn, or grease-soaked. Inspect the gasket to see if it is torn.

(4) Examine fan cover to see if it is bent or broken.

(5) Examine all screws and lock washers to see if they are broken. Note whether or not screw threads are burred or stripped.

94. MAINTENANCE AND REPAIRS.

a. Revolving Field Coils.

(1) In case of an open circuit in a revolving field coil, replace coil. Weigh coil to be discarded, and weigh the new coil. Use a new coil having the same weight as the one removed to preserve rotor assembly balance. In case the open circuit is in a connection, peel back insulation on the wire. Twist wires together and weld. Push boom over connection and wrap with black insulating tape. Paint tape with GLYPTAL, black.

(2) In case a revolving field coil is grounded, replace coil and all insulators. If a connection is grounded, replace old tape with new black insulating tape, and paint tape with GLYPTAL, black.

ORDNANCE MAINTENANCE — GENERATING UNIT M7

- J — RING WITH PLATE, EXCITER BRUSH, INNER, ASSEMBLY
- K — RING WITH PLATE, EXCITER BRUSH, OUTER, ASSEMBLY
- L — SPACER - 1-23/64"
- M — BRUSHES, COLLECTOR RING
- N — SPACER - 63/64"
- P — BUSHING, FIBER, LONG
- Q — SPACER - 37/64"

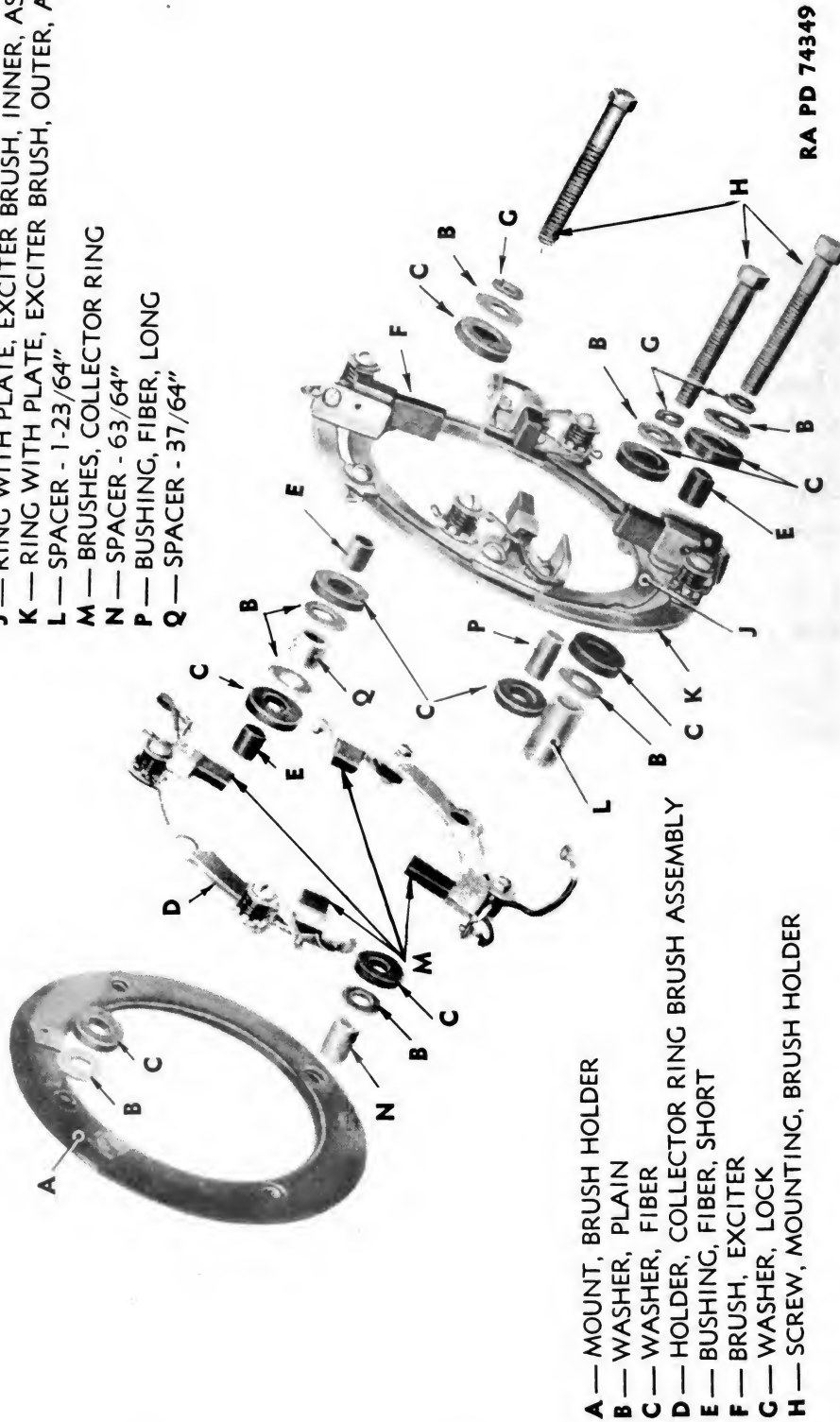

- A — MOUNT, BRUSH HOLDER
- B — WASHER, PLAIN
- C — WASHER, FIBER
- D — HOLDER, COLLECTOR RING BRUSH ASSEMBLY
- E — BUSHING, FIBER, SHORT
- F — BRUSH, EXCITER
- G — WASHER, LOCK
- H — SCREW, MOUNTING, BRUSH HOLDER

Figure 195 — Brush-holder Ring Assembly (H. B. Co. Unit) — Exploded View

ELECTRICAL GENERATING SYSTEM

(3) Replace short-circuited revolving field coils.

b. Exciter Armature (H. B. Co. Unit Only).

(1) Examine exciter armature if it has an open circuit. If the cause is a wire pulled loose from a commutator bar, solder wire into slot in bar. Turn commutator bars down on a lathe and undercut the mica as described below. If break cannot be located, replace armature.

(2) If exciter armature is grounded or short-circuited, replace.

c. Commutator Bars (H. B. Co. Unit Only). If commutator bars are scored, place armature assembly in a lathe. Take a cut from commutator bars. Make the cut as light as possible, but deep enough to remove all score marks. Hold a piece of PAPER, flint, Class B, No. 2/0 against the revolving commutator bars to remove cutting tool marks. Remove armature from lathe and undercut mica to a depth of 0.025 inch between commutator bars.

d. Slip Rings.

(1) If the slip rings are scored, place armature in lathe. Take a cut off each slip ring. Remove only enough metal to eliminate the score marks. Hold a piece of PAPER, flint, Class B, No. 2/0 against the revolving slip rings to remove cutting tool marks.

(2) If the slip ring separator is broken, melt the solder which secures the revolving field wire to outer slip ring, and pry wire from slip ring. Remove the six commutator ring screws. Tap threads in two screw holes in the commutator ring on opposite sides of shaft with $\frac{5}{16}$ -18 thread tap. Using a gear puller, pull the commutator ring from shaft. Lift slip ring and mica ring from shaft. Lift slip ring separator from shaft. Place a new slip ring separator in position on shaft. Place slip ring in position on the commutator ring with the mica in position between the two parts. Start assembly on shaft. Be sure screw holes line up. Tap commutator ring carefully on shaft. Install six commutator ring screws. Solder revolving field wire to outer slip ring.

e. Shaft. Replace armature shaft bearing if worn or broken. If shaft is scored due to bearing failure, smooth off ridges with a fine mill file. Do not attempt to eliminate score marks. Smooth it just enough so bearing can be pressed on. In case shaft is damaged enough to be undersize, replace armature assembly.

f. Fan. Straighten fan if bent. If welds have broken loose, re-weld. Be careful to preserve balance by using a very small amount of welding metal. Spot welds evenly.

g. Stator Windings.

(1) If stator windings have an open circuit, it may be due to a loose connection. If an open circuit is indicated in the stator, remove

ORDNANCE MAINTENANCE – GENERATING UNIT M7

old tape and loom from the connection which appears at fault. Examine welds. When the faulty connection is found, weld wires together. Cover all exposed connections with loom and tape with black insulating tape. Paint tape with GLYPTAL, black. If the open circuit is within a coil, replace stator.

(2) If stator windings are grounded, inspect all connections and lead wires for faulty insulation. Remove faulty insulation, replace loom and wrap the bared wire with black insulating tape. Paint tape with GLYPTAL, black. If ground cannot be located, it is probably in a coil and it will be necessary to replace stator.

(3) If stator windings are short-circuited, replace stator.

h. Exciter Field Coils (H. B. Co. Unit Only). Replace any exciter field coil having an open circuit, ground, or short circuit.

i. Brushes. Replace brushes if broken or worn to less than $\frac{3}{4}$ inch in length.

j. Brush Tension Arm Springs. Replace brush tension arm springs if they are broken or weak.

k. Metal Parts. Repair burred screw holes by running a thread tap through them. Straighten bent metal parts. Replace broken metal parts.

l. Insulator Spacers and Bushing. Replace all broken or doubtful insulator spacers and bushings.

m. Driving Flange. Replace pilot flange if it is bent, broken, or if the keyway is worn on edges. Remove burrs from keyway with a fine mill file.

n. Bearing Bracket. Replace armature shaft bearing bracket if broken. Repair damaged threads by running a thread tap through them. Replace damaged grease cup.

95. ASSEMBLY.

a. All Units Except H. B. Co.

(1) Press pilot flange on shaft, first inserting key in shaft.

(2) Attach set of flexible disks to pilot flange with cap screws and nuts.

(3) Attach flywheel adapter to flexible disk set with nuts over the adapter studs.

(4) Connect the collector rings with screws through rings and center flange. Attach ring assembly to shaft with socket-head screws through flange. Carry long lead from field coil through spaces between rings and shaft to tapped holes in outer edge of outside collector ring. Attach with round-head screws. Connect short lead to inner edge of inside collector ring with screw to tapped hole.

ELECTRICAL GENERATING SYSTEM

- (5) Press bearing on shaft.
- (6) Install complete brush holder assembly on bearing bracket by screwing stud into tapped hole in bearing bracket. Secure in place with lock nut (fig. 193).
- (7) Place bearing bracket in position, and secure to housing with cap screws.
- (8) Insert rotor assembly into housing with the bearing in position in the bearing bracket.
- (9) Install key in shaft slot. Force pulley into position on shaft. Place square washer in position at end of shaft at pulley. Secure with flat-head screw. Lock screw into place by punching hole in washer at each end of screw slot so that punched out metal will hold screw firmly.

b. H. B. Co. Unit (Alternator and Exciter).

- (1) Install coupling. Follow procedure given in subparagraph a (1), (2), and (3), above.
- (2) Assemble mounting screw and bushing through tension arm sleeve. Place spring on sleeve, and set spring adjusting washer over spring. Carry screw through brush holder and guide, or mounting plate and guide, and attach nut. Repeat this procedure for each brush holder (fig. 194).
- (3) Assemble brush-holder rings (fig. 195) by installing on each of the four mounting screws a plain washer and a fiber washer, then carry the cap screws through the exciter brush rings. On each of one pair of opposite screws install, below the exciter rings, a fiber washer, a plain washer, and a large size spacer ($1\frac{2\frac{3}{64}}{64}$ inch). On one of the other two screws, install below the exciter rings a short fiber bushing, a fiber washer, a plain washer, a short spacer ($\frac{3\frac{7}{64}}{64}$ inch), a metal washer, a fiber washer, a short fiber bushing, and a collector ring holder, spring side up, then a fiber washer and a metal washer. On the fourth cap screw, install below the exciter rings, a long fiber bushing, a fiber washer, a collector ring holder, spring side down, a fiber washer, a plain washer, and a medium spacer ($\frac{6\frac{3}{64}}{64}$ inch). This complete assembly is now screwed through to the brush-holder mount with the mounting screws.
- (4) Place brush-holder ring assembly in position in exciter bearing bracket, and secure with set screws to groove in brush-holder mount.
- (5) Place exciter field coils in position in field coil ring with connecting wires toward the small end of the bracket. Arrange insulation sheets behind wires. Insert pole pieces through coils with insulation rings in position. Secure coils with cap screws through field coil ring to pole pieces.

ORDNANCE MAINTENANCE – GENERATING UNIT M7

(6) Press grease retainer on shaft. Press roller bearing on shaft into position in exciter bearing bracket.

(7) Insert rotor into position in housing with fan assembly in place but not secured.

(8) Bring exciter bearing bracket into position at housing, and make the following wiring connections. Carry a lead from one exciter brush terminal to connection post "A1" on the terminal block. Carry a lead from the adjacent brush connection to post "A2" on the terminal block. Bring a lead from one collector ring brush holder terminal to post "A1" on the terminal block. Take a lead from the opposite collector ring brush terminal to exciter brush connected to "A2" on the terminal block. Take the short lead from the exciter field coil assembly and attach it to the exciter brush connection opposite the one to which the "A2" exciter lead is connected. Connect long lead from exciter field coil to terminal block post "F."

(9) Attach exciter bearing bracket to housing with cap screws.

(10) Screw nut on shaft end.

(11) Place cover and gasket in position, and attach exciter bearing bracket cover to bracket with screws.

96. INSTALLATION.

a. All Units Except H. B. Co. Install alternator. Reverse procedure specified in paragraph 91. (See paragraph 15 for housing installation.)

Section III

EXCITER

	Paragraph
Description	97
Removal (units other than H. B. Co.)	98
Disassembly	99
Inspection	100
Maintenance and repairs	101
Assembly	102
Installation	103

97. DESCRIPTION.

a. The exciter is a d-c generator connected to the alternator shaft by V-belts (except on H. B. Co. units). The exciter supplies direct, or excitation, current to the field coils of the alternator. The exciter weighs 160 lb and at 1,800 rpm the rated output is 1-kw, 6.25-v, 16-amp with 40 C temperature rise.

ORDNANCE MAINTENANCE — GENERATING UNIT M7

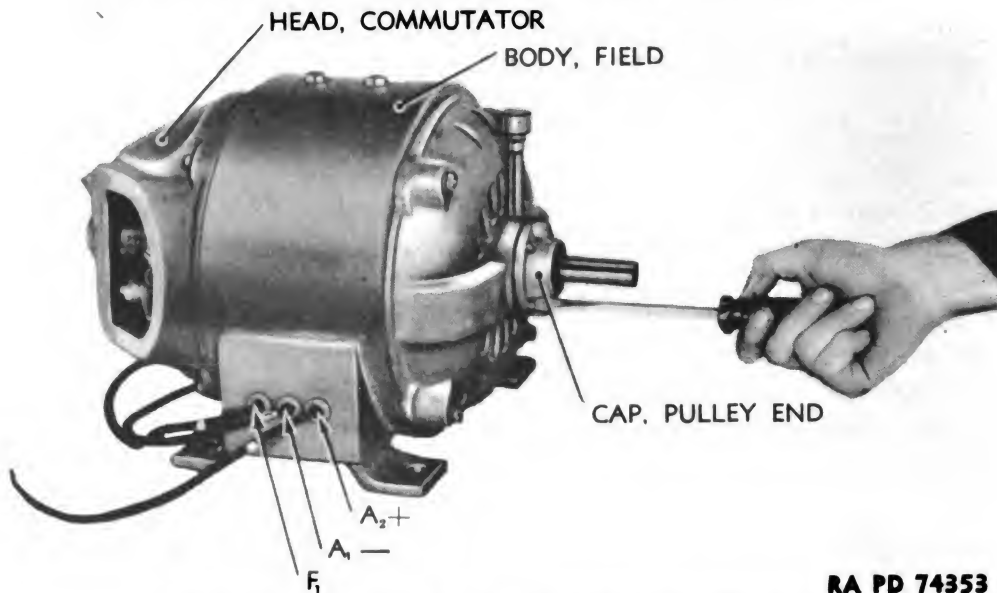

RA PD 74353

Figure 197 — Exciter Pulley End Cap Removal

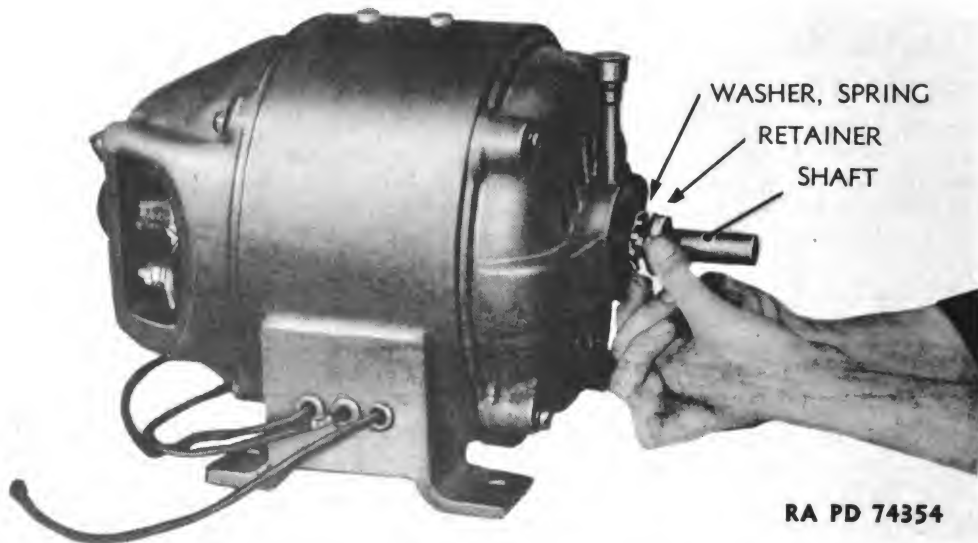

RA PD 74354

Figure 198 — Exciter Retainer Ring Removal

98. REMOVAL (Units Other Than H. B. Co.).

a. Procedure.

(1) Loosen hold-down clamp nuts and remove clamps. Loosen battery leads, and remove leads from battery posts. Remove battery and inside tray. Remove nuts from cap screws through battery tray flange, and lift tray off. Remove nuts from bolts through bottom of tool box, and remove box.

ELECTRICAL GENERATING SYSTEM

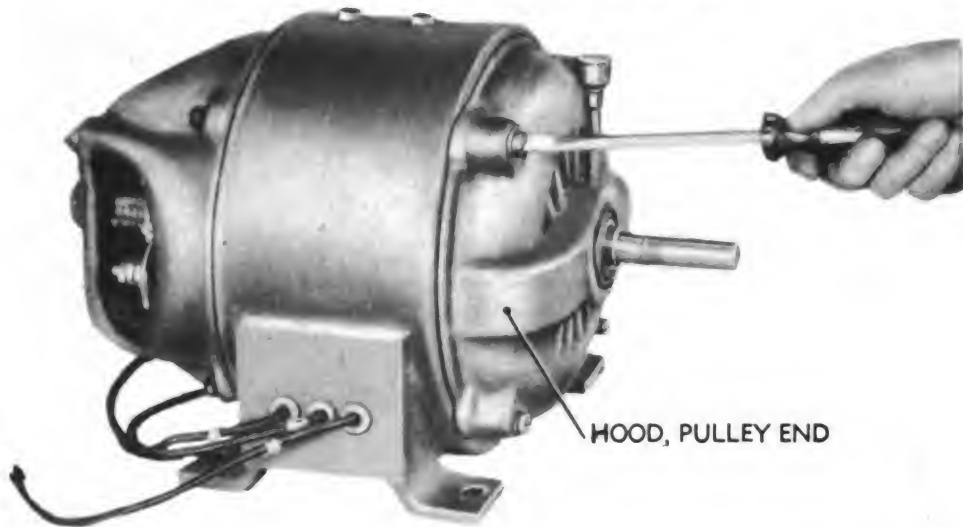

RA PD 74355

Figure 199 — Exciter Pulley End Hood Removal

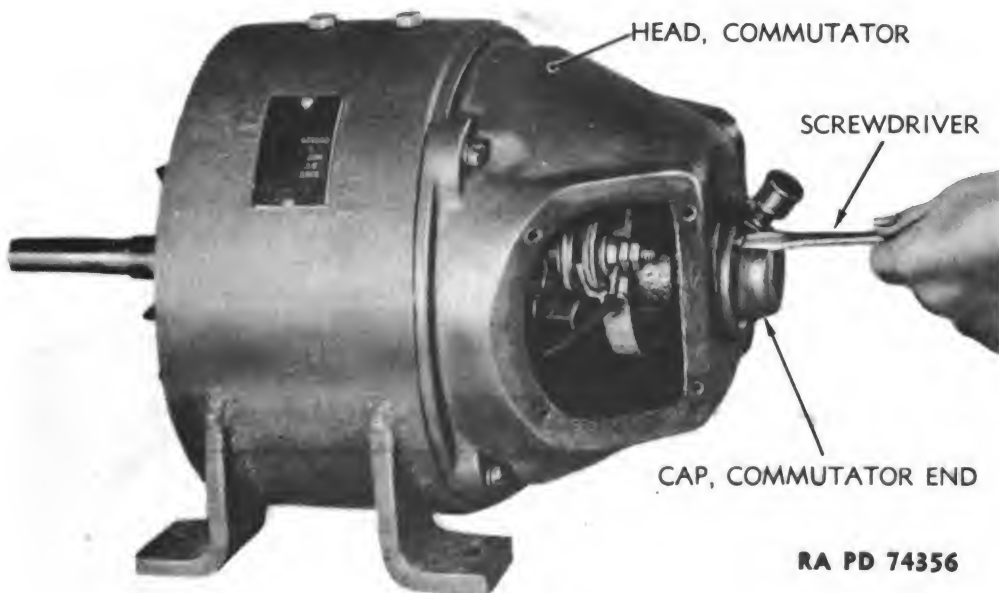

RA PD 74356

Figure 200 — Exciter Commutator End Cap Removal

- (2) Take off wing nuts and lock washers holding guard panel to uprights, and remove panel.
- (3) Trace exciter leads from exciter to terminal block, take out connecting screws, and remove leads.
- (4) Remove belts connecting exciter and alternator. Take out cap screws holding exciter to adjustable plate on top of alternator, and remove exciter.

ORDNANCE MAINTENANCE — GENERATING UNIT M7

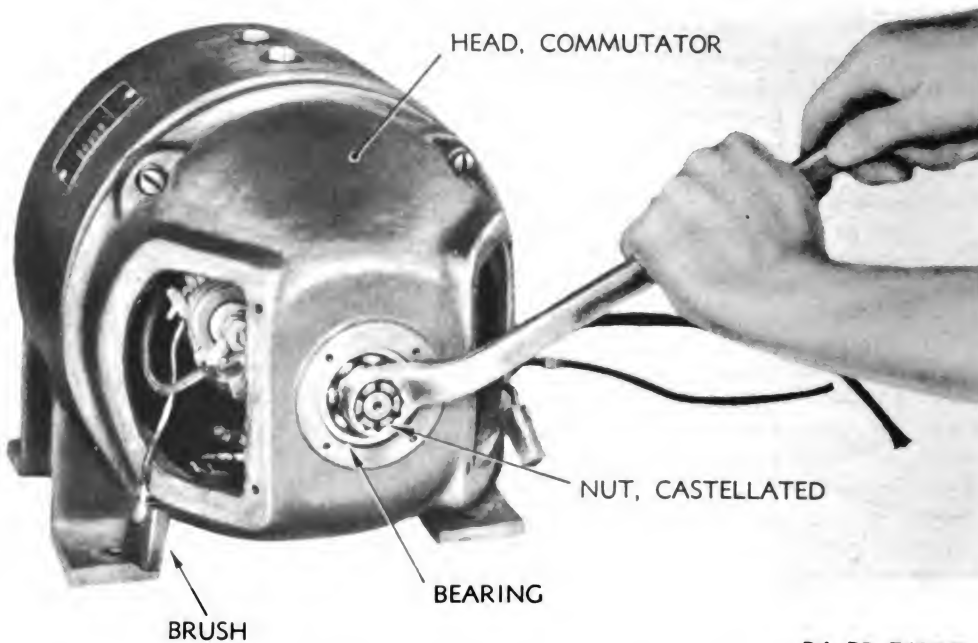

RA PD 74357

Figure 201 — Exciter Shaft End Nut Removal

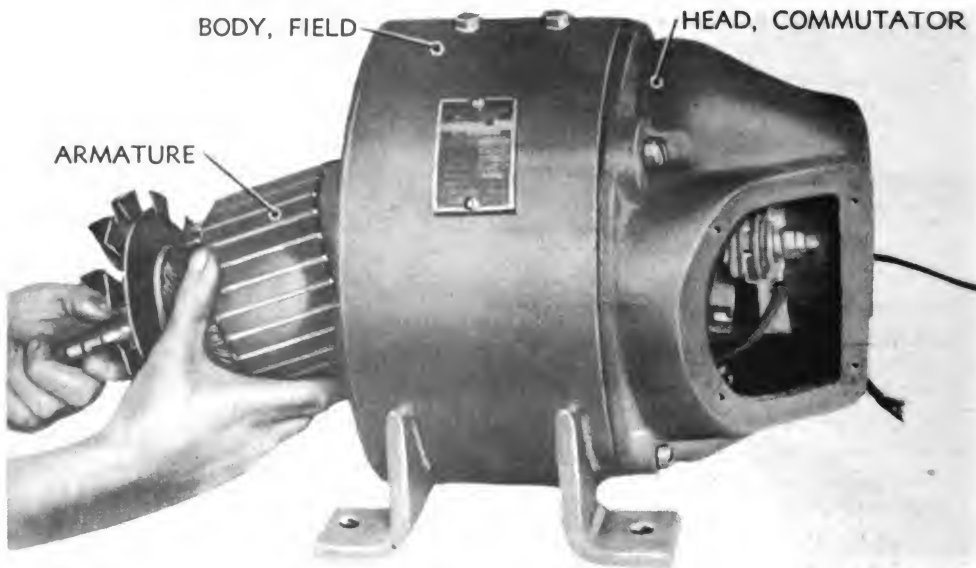

RA PD 74358

Figure 202 — Exciter Armature Removal

99. DISASSEMBLY (fig. 196).

a. Procedure.

- (1) Take out socket-head set screw through pulley shank, and press out pulley.
- (2) Take out screws holding end cover plates to commutator head.

ELECTRICAL GENERATING SYSTEM

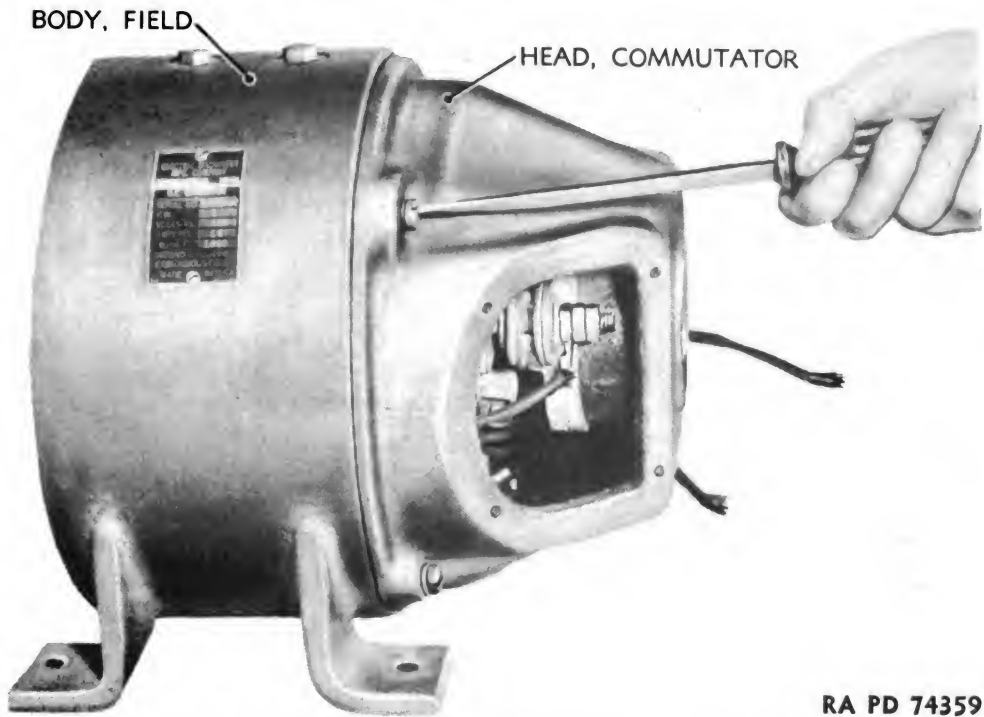

RA PD 74359

Figure 203 — Exciter Commutator Head Removal

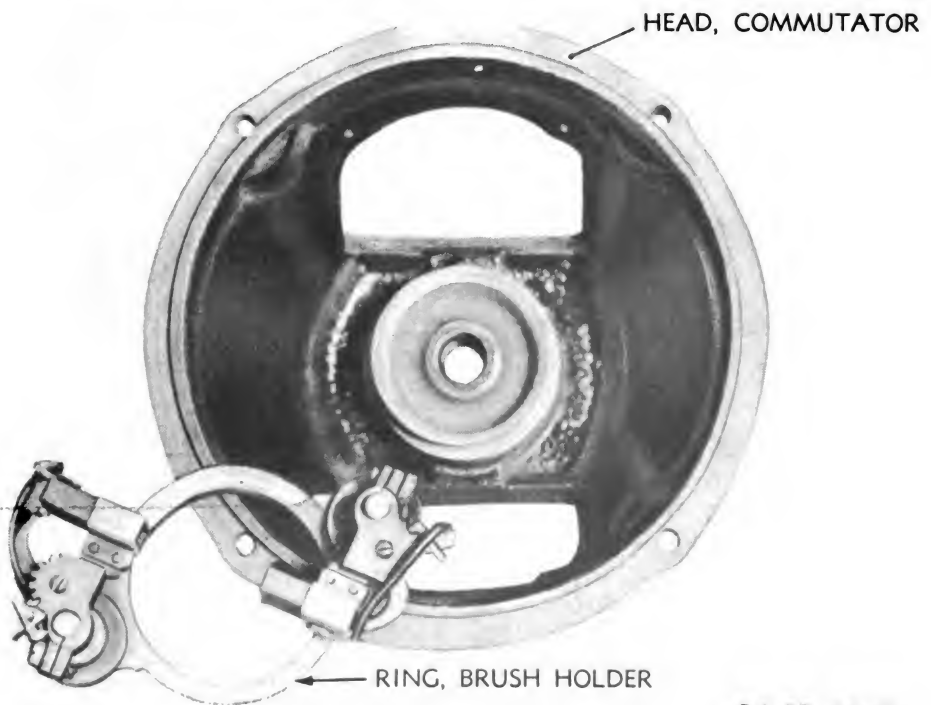

RA PD 74360

Figure 204 — Exciter Brush Holder Ring Removed

ORDNANCE MAINTENANCE — GENERATING UNIT M7

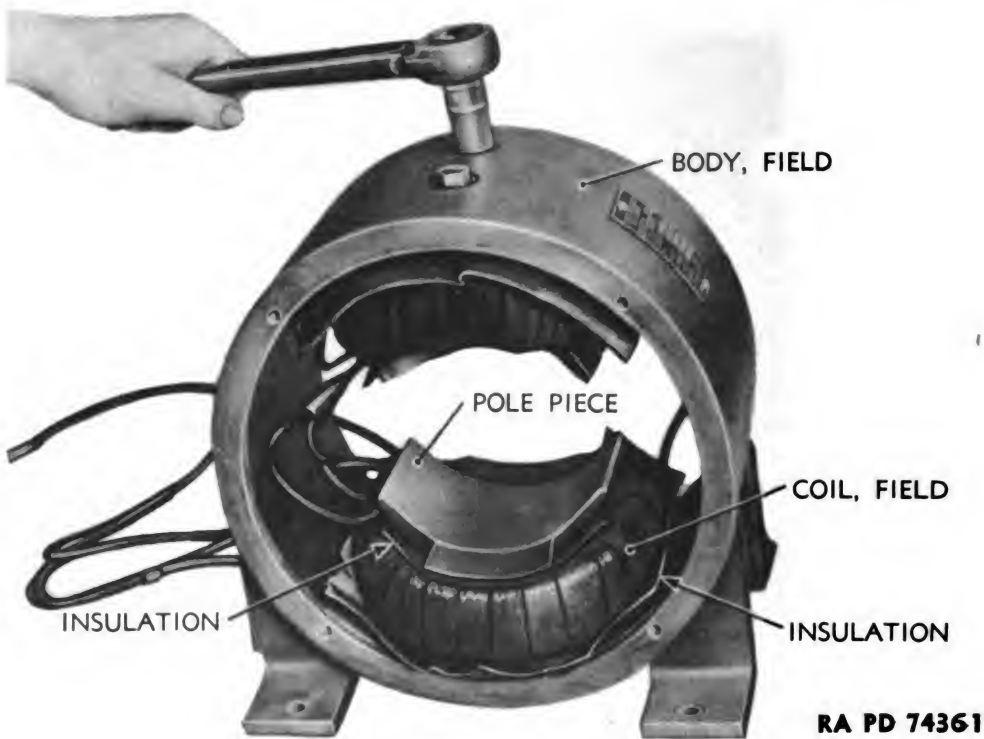

Figure 205 — Removing Exciter Field Coils

(3) Take out fillister-head screws, and remove cap (fig. 197). Slide retainer and spring washer from shaft (fig. 198).

(4) Take out four fillister-head screws, and remove pulley end hood (fig. 199).

(5) Take out fillister-head screws, and remove commutator end cap (fig. 200).

(6) Take out cotter pin securing castellated nut on end of armature shaft. Remove nut (fig. 201). Pull armature from commutator head (fig. 202).

(7) Take out the four fillister-head screws holding commutator head to field body, and remove commutator head (fig. 203).

(8) Take out nuts and washers holding field coil leads to brush-holder ring terminals. Take out fillister-head screws attaching brush-holder ring to commutator head, and remove ring (fig. 204).

(9) Press out bearings from commutator head and pulley end hood.

(10) Take out cap screws at top and bottom of field body (fig. 205), and remove field coils, pole pieces, and insulation (fig. 206).

ELECTRICAL GENERATING SYSTEM

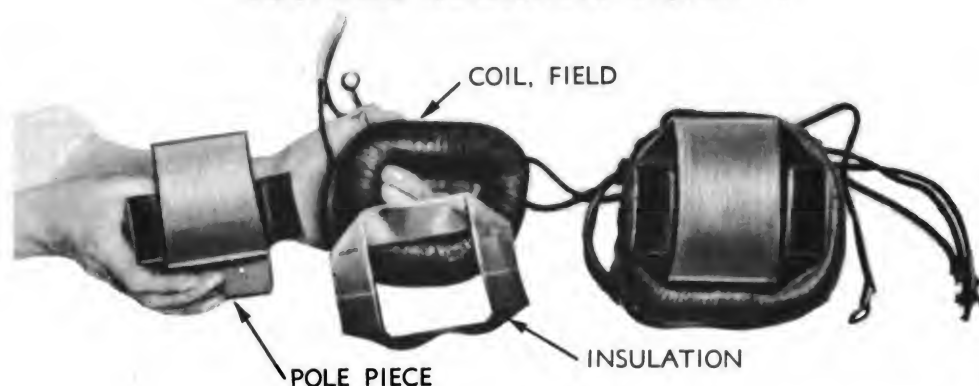

RA PD 74362

Figure 206 – Exciter Field Coil Assembly

100. INSPECTION.

a. Armature.

(1) **GROUND.** Place one probe of a test lamp on a commutator bar. Place the other probe on the armature shaft. If lamp lights, a ground is indicated. Failure of the lamp to light shows no ground to be present.

(2) **SHORT CIRCUIT.** Place armature in a growler. Turn on the growler. Move a steel strip or hacksaw blade slowly around the armature coils. Keep it parallel to the shaft. Turn off the growler and revolve the armature one-half turn in the growler. Turn on growler and test the other side of the armature. If the steel strip vibrates noticeably or is drawn to the laminations, a short circuit is indicated.

(3) **COMMUTATOR BARS.** Look for burrs which might short-circuit two adjacent bars. Observe whether or not bars are scored.

(4) **FAN.** Inspect fan to see if it is bent or damaged.

(5) **SHAFT.** Inspect shaft to see if it is scored. Examine screw threads for burring or stripping.

b. Coils.

(1) **OPEN CIRCUIT.** Place one probe of test lamp on tip of coil to exciter brush wire. Touch other probe to tip of alternator lead "1." If the lamp lights, no open circuit is present. If the lamp fails to light, an open circuit is indicated. If an open circuit is indicated, test each coil separately.

(2) **GROUND.** Hold one probe against a bare lead from the coil. Place other probe against the pole piece. If lamp lights, a ground is present. Failure of lamp to light indicates coil is free of grounds.

(3) **SHORT CIRCUIT.** This test is made with coils connected in series. It can be made with coils installed or removed. Connect a 6-volt battery to exciter coil to commutator wire and to alternator lead "1." Using a 0- to 7½-volt voltmeter equipped with sharp pointed probes,

ORDNANCE MAINTENANCE — GENERATING UNIT M7

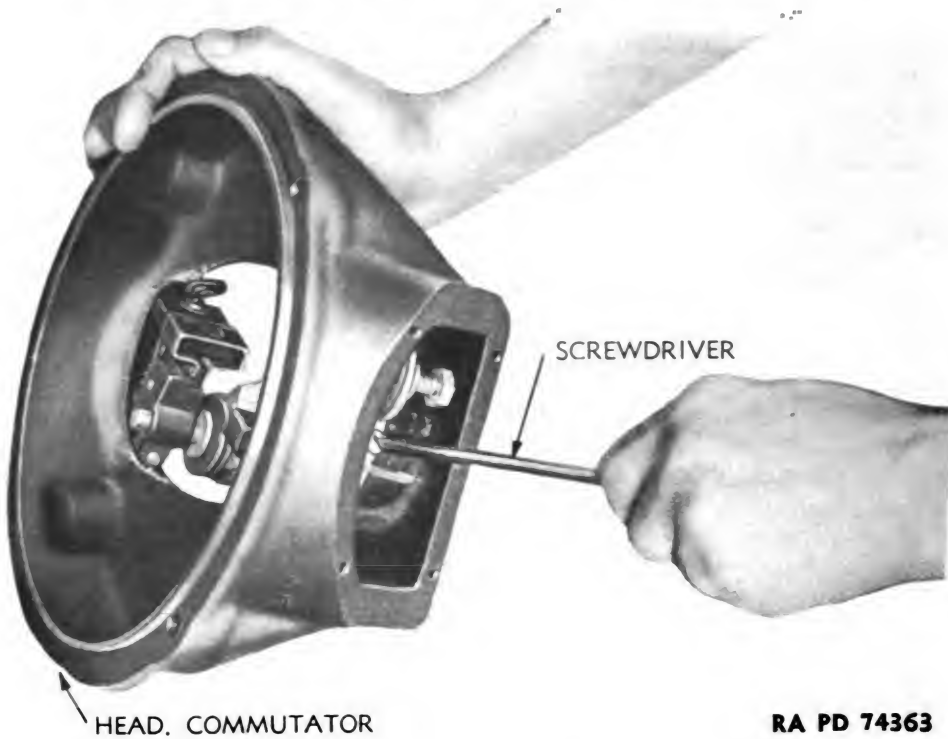

Figure 207 — Exciter Brush-holder Ring Insulation

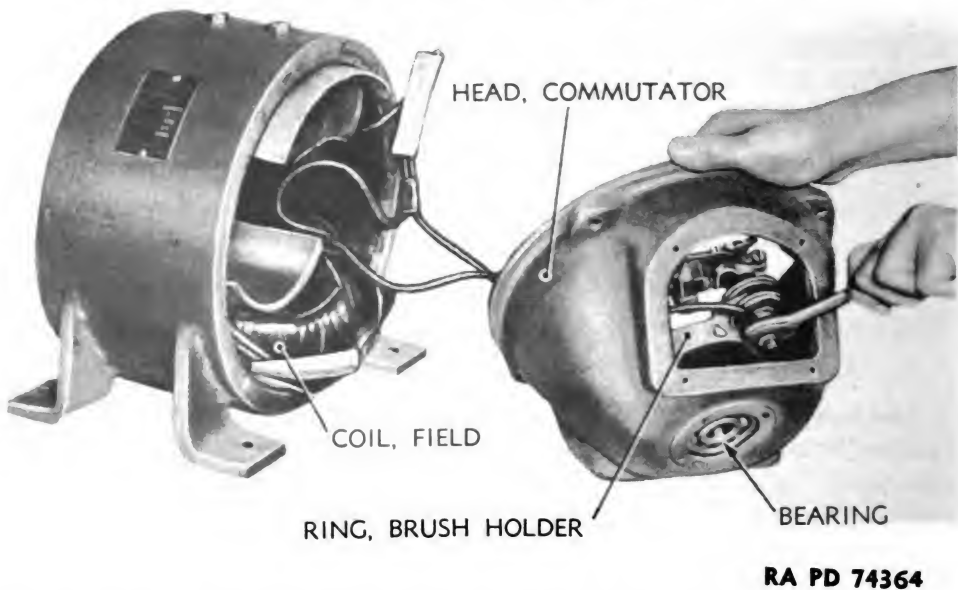

Figure 208 — Connecting Exciter Field Coil Leads to Brush Ring

measure the voltage drop across each coil. Push one probe into one lead of coil. Push other probe into other lead of same coil. Observe reading on voltmeter. Repeat test on other coil. If the reading on one

ELECTRICAL GENERATING SYSTEM

coil is appreciably less than the other, a short circuit in that coil is indicated. If the reading is approximately equal, no short circuit is indicated. **NOTE:** If voltmeter hand moves in the wrong direction, reverse the probes.

c. Brush-holder Ring Assembly. Check ring, holders, springs, screws, and nuts for damage or signs of wear. Inspect brushes for wear. they should not be less than $\frac{3}{4}$ inch long.

d. Bearings, Retainers, Washers. Inspect for broken or worn bearings. Inspect retainers to see if they are bent or if welds have broken loose. Examine felt washers to see if they are worn, torn, or grease-soaked.

e. Housing. Inspect field body, commutator head, pulley end hood, end caps and covers for casting breaks or cracks, loose welds, or stripped threads.

101. MAINTENANCE AND REPAIRS.

a. Armature.

(1) **OPEN CIRCUIT.** If the cause of the open circuit is a wire pulled loose from a commutator bar, solder wire into slot in bar. Turn commutator bars down on a lathe and undercut the mica as described below. If break cannot be located, replace armature.

(2) **SHORT CIRCUIT OR GROUND.** If armature is grounded or short circuited, replace.

(3) **SCORED COMMUTATOR BARS.** Place armature in a lathe. Take a cut from the commutator bars. Make cut as light as possible but deep enough to remove all score marks. Hold a piece of **PAPER**, flint, Class B, No. 2/0 against the revolving bars to remove cutting tool marks. Remove armature from lathe. Then undercut mica to a depth of 0.025 inch between commutator bars.

(4) **FAN.** Carefully straighten, if bent. If broken, weld. Be careful to preserve balance.

(5) **BEARINGS.** Replace worn or broken bearing.

(6) **SHAFT.** If shaft is scored due to bearing failure, smooth off ridges with a fine mill file. Do not attempt to eliminate score mark. Smooth just enough so bearing can be pressed on. In case shaft is damaged enough to be undersize, replace armature assembly.

b. Coils. Replace any coils having an open circuit, ground, or short circuit.

c. Brush-holder Ring Assembly.

(1) **BRUSH REPLACEMENT.** Take out screws and lock washers holding end cover plate, and remove plate. Loosen screw on brush-holder ring, and turn ring until screw holding pigtail connection is

ORDNANCE MAINTENANCE — GENERATING UNIT M7

accessible. Remove screw, hold back spring lever arm, and remove brush. Attach pigtail connection of new brush to screw above brush-holder screw. Lift spring lever arm, set brush in place in holder, and drop lever on brush. Turn brush-holder ring until line marked on ring coincides with casting rib. Tighten screw on brush-holder ring. Attach end plate with screws.

(2) **BRUSH SPRING REPLACEMENT.** Take out screws holding end plate to exciter. Loosen screw holding brush-holder ring in position, and turn until brush-holder screw is accessible. Loosen the three nuts on the brush-holder screw, and remove screw and brush-holder assembly from yoke of brush-holder ring. Take out the round-head brass screw holding together the spring, the tension lever arm, a brass sleeve, and the brush-holder arm. Slip round-head brass screw through hole in ratchet, and assemble tension lever arm, sleeve, and a new spring, and screw down securely into the brush-holder arm. Install the screw in the brush-holder yoke with two fiber insulators on each side. Tighten the nuts until the screw is held firmly to the yoke.

d. **Housing.** A cracked or broken field body, commutator head, pulley end hood, or end cap must be replaced. Reweld broken welds. Stripped threads may be repaired by running a threading tool of the proper size through the hole.

102. ASSEMBLY.

a. **Procedure.**

(1) Insert pole piece through each field coil with insulation sheet in between. Bring each coil assembly into place in field body with another insulation sheet between and secure to body with cap screws. Carry leads marked F1, A1-, and A2+ outside field body through holes provided.

(2) Press shaft bearing into commutator head and pulley end cap.

(3) Slip brush-holder ring onto commutator head flange, turn ring until line on ring coincides with line on head casting rib, and then secure ring to flange with fillister-head screws (fig. 207).

(4) Attach the commutator head to the field body with four fillister-head screws, first connecting field coil leads A1 and A2 to the brush-holder ring terminals (fig. 208).

(5) Slide retainer ring on the armature shaft, commutator end, and insert armature through field body and commutator head.

(6) Slide felt washer and gasket over the armature shaft, set pulley end hood in position, and attach to field body with fillister-head screws.

(7) Screw castellated end nut on shaft, and secure with cotter pin. Install commutator end cap with fillister-head screws.

(8) Slide spring washer and retainer ring over shaft. Install pulley end cap with fillister-head screws.

ELECTRICAL GENERATING SYSTEM

(9) Install the two commutator end covers with fillister-head screws.

(10) Install key in shaft slot. Press pulley into place on shaft. Secure pulley to shaft with socket-head set screw.

103. INSTALLATION.

a. Procedure.

(1) Place exciter on plate and alternator. Install cap screws attaching exciter to adjustable plate on top of alternator.

(2) Use holding nuts on exciter plate posts to adjust exciter pulley to the proper position for installing belts from alternator pulley to exciter pulley. Install exciter belts.

(3) Connect exciter lead with "A-1" on its identification collar to post marked "A-1" on the terminal block. Connect leads marked "A-2" and "F" with terminal block posts marked the same.

ORDNANCE MAINTENANCE — GENERATING UNIT M7
CHAPTER 5

INSTRUMENT PANEL AND INSTRUMENTS

Section I

INSTRUMENT PANEL

	Paragraph
Description	104
Removal	105
Disassembly	106
Inspection and repair	107
Assembly	108
Installation	109

104. DESCRIPTION (fig. 210).

a. The instrument panel is of sheet steel and is located behind the rear left-hand door of the unit, above the alternator. It is held in place against vertical supports welded to the center bow and the rear housing panel. The method of mounting varies somewhat with the different manufacturers. One method of mounting makes use of U-type steel clips bolted to brackets welded to the vertical supports (fig. 10), giving a spring action. In other cases, the panel is bolted directly to the supports.

b. The instrument panel brings together all the controls and gages necessary to the starting, stopping, and general operation and control of the unit (figs. 210 and 211), with the exception of the fuel gage. This is mounted on the instrument panel only on some make units. Figures 212 and 212A give a complete wiring diagram.

c. The general form of the instrument panel varies with the method of mounting and its manufacture. All of the panels illustrated vary in some details. On all units, the size of the central panel proper is the same, and the grouping of the instruments follows the same pattern.

105. REMOVAL.

a. Procedure.

(1) Trace alternator main leads from alternator to fuse panel, remove nuts securing leads, and remove leads. Trace remaining alternator leads to terminal block, take out connecting screws, and remove leads.

(2) Trace exciter leads from exciter to terminal block, take out connecting screws, and remove leads.

(3) Trace leads from 200-amp and 30-amp power receptacles to rear of instrument panel, and remove nuts and leads.

INSTRUMENT PANEL AND INSTRUMENTS

- A - AMMETER, BATTERY CHARGING
- B - GAGE, OIL PRESSURE
- C - GAGE, TEMPERATURE
- D - RECEPTICAL, LIGHT, 125 VOLT
- E - METER, FREQUENCY OR TACHOMETER
- F - SWITCH, IGNITION
- G - RECEPTICAL, LIGHT, 6 VOLT
- H - SWITCH, LIGHT, 6 VOLT
- J - THROTTLE
- K - CHOKE
- L - BUTTON, STARTER
- M - VOLT METER, AC
- N - RHEOSTAT, LOAD
- O - RECEPTICAL, LIGHT, 6 VOLT
- P - RHEOSTAT, LAMP DIMMING
- Q - SWITCH, METER
- R - AMMETER, AC
- S - SWITCH, LIGHT, 125 VOLT
- T - RECEPTICAL, 125 VOLT
- U - SWITCH, LOAD

RA PD 74365

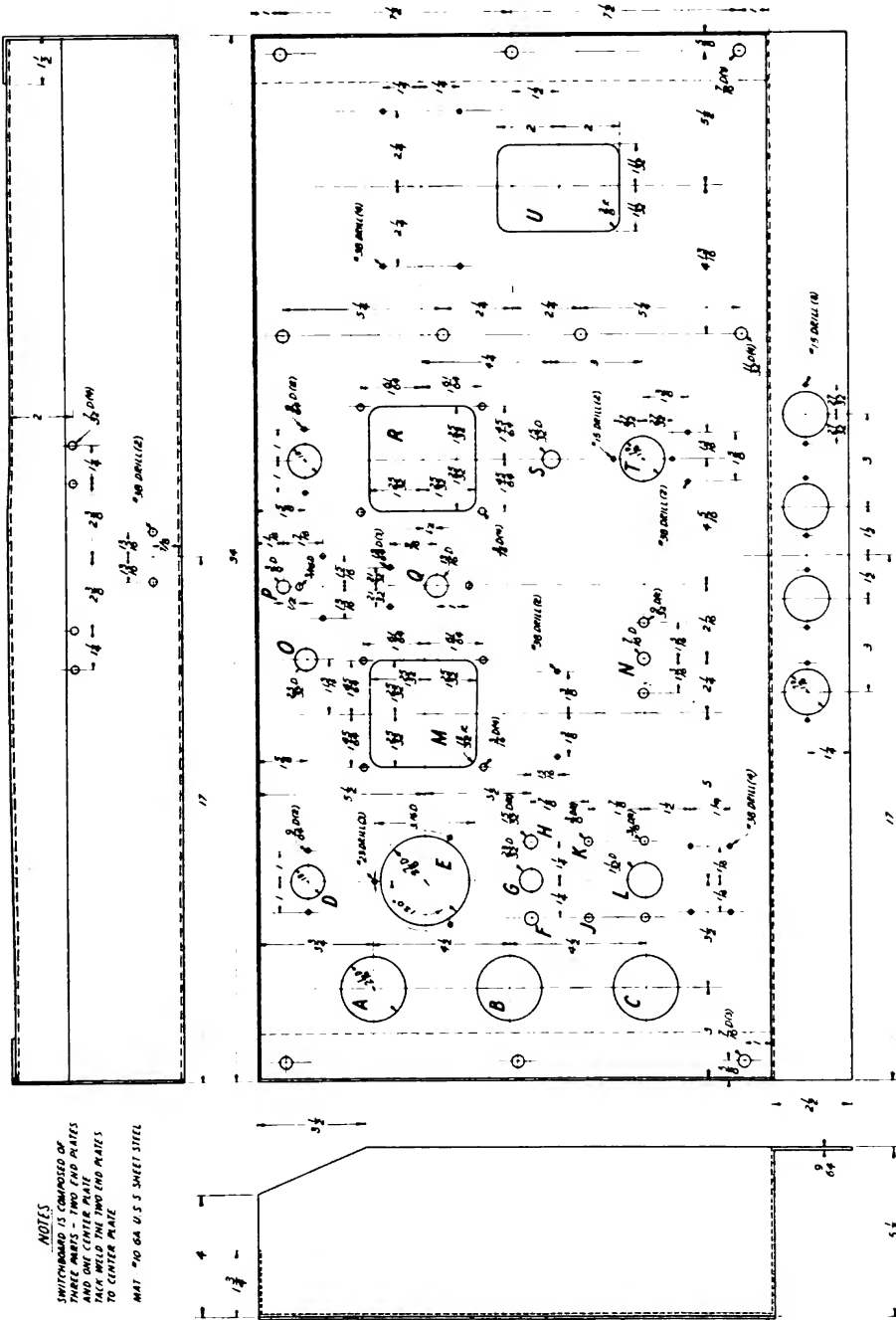

Figure 209 — Instrument Panel — Scale Drawing

INSTRUMENT PANEL AND INSTRUMENTS

- A — TRANSFORMER
- B — FUSE, 200 AMP.
- C — FUSE, 30 AMP.
- D — BLOCK, TERMINAL
- E — SWITCH, METER
- F — RHEOSTAT
- G — TACHOMETER
- H — AMMETER
- J — BATTERY CHARGING GAGE, OIL PRESSURE
- K — GAGE, TEMPERATURE
- L — THROTTLE
- M — BUTTON, STARTER
- N — EXCITER
- P — RHEOSTAT, FIELD
- Q — CHOKE
- R — SWITCH, LIGHT, 6 V.
- S — RECEPTACLE, 6 V.
- T — SWITCH, IGNITION

RA PD 74367

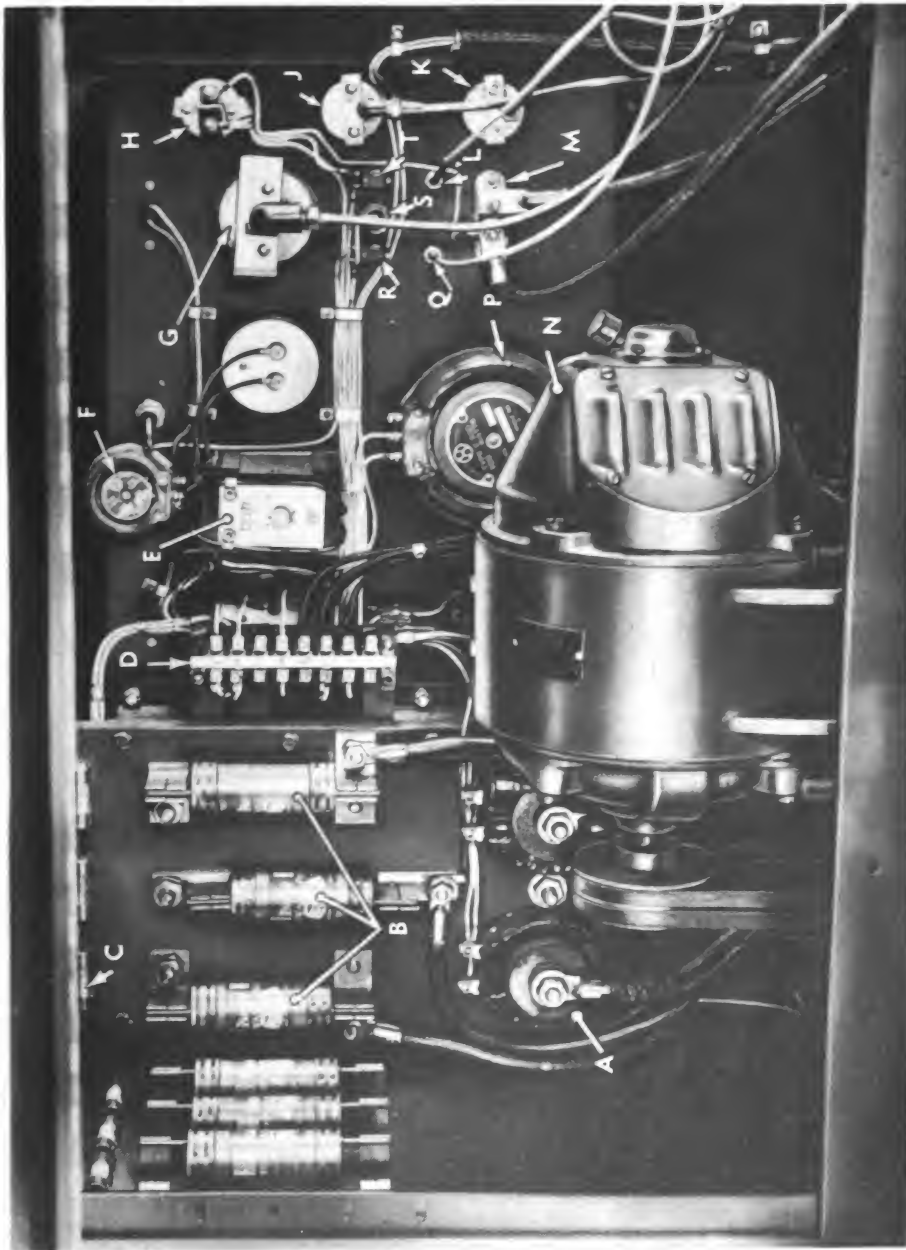
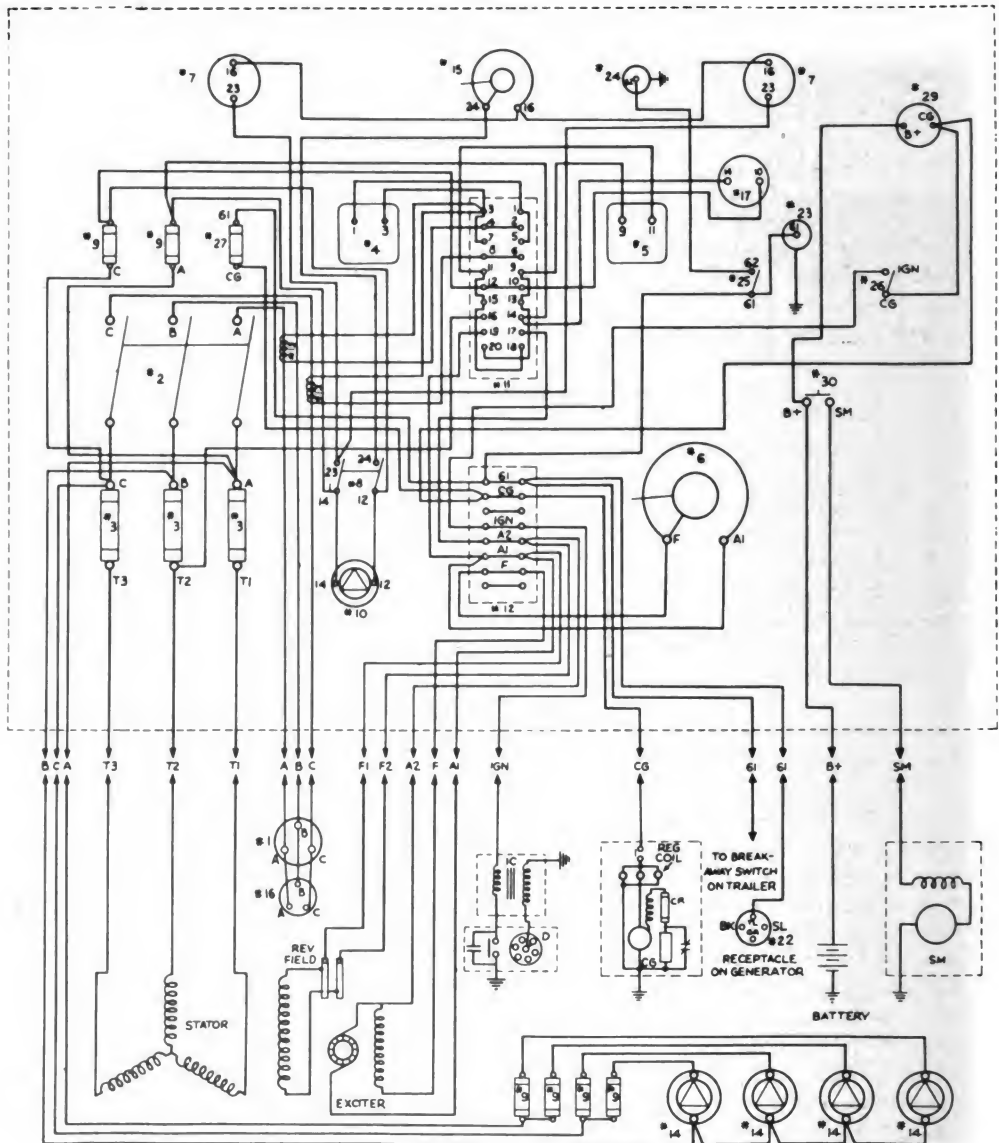

Figure 211 — Instrument Panel — Rear View

ORDNANCE MAINTENANCE – GENERATING UNIT M7



RA PD 15238

Figure 212 – Wiring Diagram

INSTRUMENT PANEL AND INSTRUMENTS

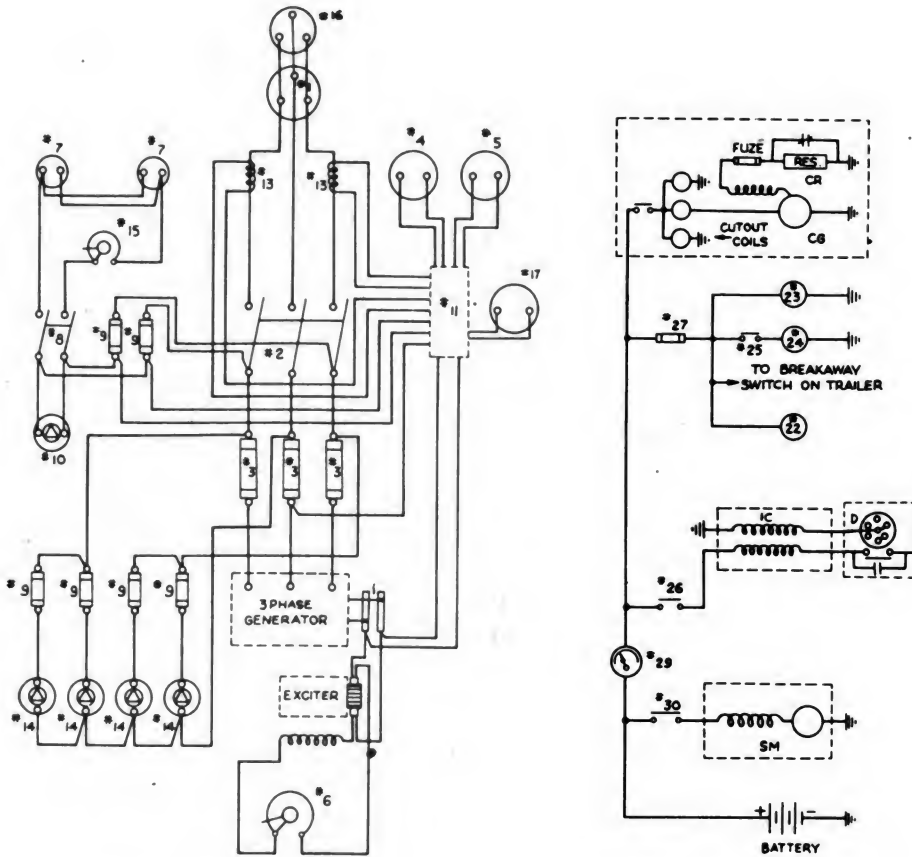

125 VOLT AC CIRCUIT

- 1- LOAD RECEPTACLE
- 2- LOAD SWITCH
- 3- FUSE-200 AMPS.
- 4- AMMETER
- 5- VOLTMETER
- 6- RHEOSTAT
- 7- LIGHTS
- 8- SWITCH, 125 V. LIGHTS
- 9- FUSES
- 10- RECEPTACLE, EXTENSION CORD
- 11- METER SWITCH
- 12- TERMINAL BLOCK
- 13- CURRENT TRANSFORMERS
- 14- RECEPTACLE, POWER TOOLS
- 15- RHEOSTAT, LIGHT DIMMING, 200 OHM, 1 TAPER, 1 AMP.
- 16- LOAD RECEPTACLE, 30 AMPS, C80109
- 17- FREQUENCY METER

6 VOLT BATT. CIRCUIT

- 22- RECEPT FOR BRAKES AND LIGHTS
- 23- RECEPT FOR EXTENSION CORD
- 24- LIGHT
- 25- LIGHT SWITCH
- 26- IGNITION SWITCH
- 27- FUZE
- 29- AMMETER
- 30- STARTER SWITCH
- C6- CHARGING GENERATOR
- CR- CHARGING VOLTAGE REGULATOR
- IC- IGNITION COIL
- D- DISTRIBUTOR
- SM- STARTER MOTOR

SMALL WIRE COLOR CODE

- LINE A - RED
- LINE B - GREEN
- LINE C - BLUE
- EXCITER - A1 BLACK
- +A2 WHITE
- 6 VOLTS YELLOW

RA PD 15238A

Figure 212A - Wiring Diagram

ORDNANCE MAINTENANCE — GENERATING UNIT M7

(4) Locate lead at fuel tank gage unit. Remove connecting screw and lead.

(5) Trace lead from brake receptacle to terminal block, and remove leads.

(6) At back of starter button on instrument panel, remove nuts holding leads to switch, and remove leads.

(7) Remove tachometer cable by unscrewing swivel nut from connector elbow at back of tachometer.

(8) Trace ignition coil and battery-charging generator leads to terminal block, unscrew connecting screw, and remove leads.

(9) Disconnect oil line flare tube fitting at oil pressure gage.

(10) Trace temperature indicator line from instrument panel to engine. Unscrew and remove temperature indicator bulb from cylinder head.

(11) Disconnect throttle and choke wires from carburetor.

(12) Remove instrument panel. (Omit this step when removing housing to work on engine or alternator.) **NOTE:** The procedure of actual panel removal will vary with the make of unit.

106. DISASSEMBLY.

a. Disassembly of the instrument panel includes removing all of the instruments, switches, and receptacles. Detailed information pertaining to the removal of these units is found in chapter V, section II, of this manual, and in section XVI of TM 9-618.

107. INSPECTION AND REPAIR.

a. Procedure.

(1) Visually inspect the panel for bent or broken places. Straighten bends. Weld cracks or breaks, and file down smooth.

(2) Inspect all welds, and if necessary, reweld.

108. ASSEMBLY.

a. Mount all instruments, switches, and receptacles on to instrument panel. Detailed information pertaining to the installation of these units is found in chapter V, section II, of this manual, and in section XVI of TM 9-618.

INSTRUMENT PANEL AND INSTRUMENTS

109. INSTALLATION.

a. Procedure.

- (1) Install instrument panel. NOTE: Method of installing panel will vary with make of unit.
- (2) Connect oil line at oil pressure gage fitting.
- (3) Bring lead from ignition coil to terminal block, and connect at post marked "IGN" on identification strip. Bring lead from battery-charging generator to terminal block, and connect at post marked "CG."
- (4) Connect tachometer cable (if tachometer is on panel).
- (5) Attach lead from starting motor to starter switch connection on rear of instrument panel.
- (6) Screw bulb on temperature indicator line into tapped hole in cylinder head.
- (7) Fasten throttle and choke wires through support bracket. Carry choke wire taut through binding post on choke arm, and tighten screw. Hold throttle valve lever forward, and connect wire to binding post on arm.
- (8) Connect lead from terminal marked "TA" on terminal block, to the fuel tank gage unit. (This applies only to those generating units equipped with electric fuel gage.)
- (9) Attach power receptacle leads to studs at bottom of instrument panel. Leads "A" go to the right stud. Leads "B" go to the center stud. Leads "C" go to the left stud.
- (10) Bring lead from brake receptacle to terminal block, and connect at screw marked "61."
- (11) Connect exciter lead with "A-1" on its identification collar to post marked "A-1" on the terminal block. Connect leads marked "A-2" and "F" with terminal block posts marked "A-2" and "F" respectively.
- (12) Connect alternator main lead marked "T-2" to middle fuse on junction box. Leads marked "T-1" and "T-3" connect to the other fuses, interchangeably. The two small, or field, leads of the generator go to the terminal block. Fasten lead "F-1" to terminal block post "A-1," and lead "F-2" to terminal block post "A-2."

ORDNANCE MAINTENANCE — GENERATING UNIT M7

Section II

INSTRUMENTS AND SWITCHES

	Paragraph
Trouble shooting	110
Battery-charging generator ammeter	111
Oil pressure gage	112
Temperature indicator gage	113
Electric fuel gage	114
Tachometer	115
Frequency meter	116
Voltmeter	117
Ammeter	118
Meter switch	119
Ignition switch	120
6-volt light switch	121
125-volt light switch	122
Starter switch	123
Load switch	124
Field rheostat	125
Lamp-dimming rheostat	126
Throttle control	127
Choke control	128
125-volt light receptacles	129
6-volt light receptacles	130
6-volt extension cord receptacle	131
T-slot receptacles	132
Terminal block	133
Fuse blocks	134

110. TROUBLE SHOOTING.

a. Fails to Register.

Possible Cause	Possible Remedy
Defective connection to instrument.	Repair connection.
Defective mechanism.	Replace mechanism or instrument.

b. Registers Incorrectly.

Out of adjustment.	Adjust or replace instrument.
Defective connection to instrument.	Repair connection.
Defective mechanism.	Replace mechanism or instrument.

INSTRUMENT PANEL AND INSTRUMENTS

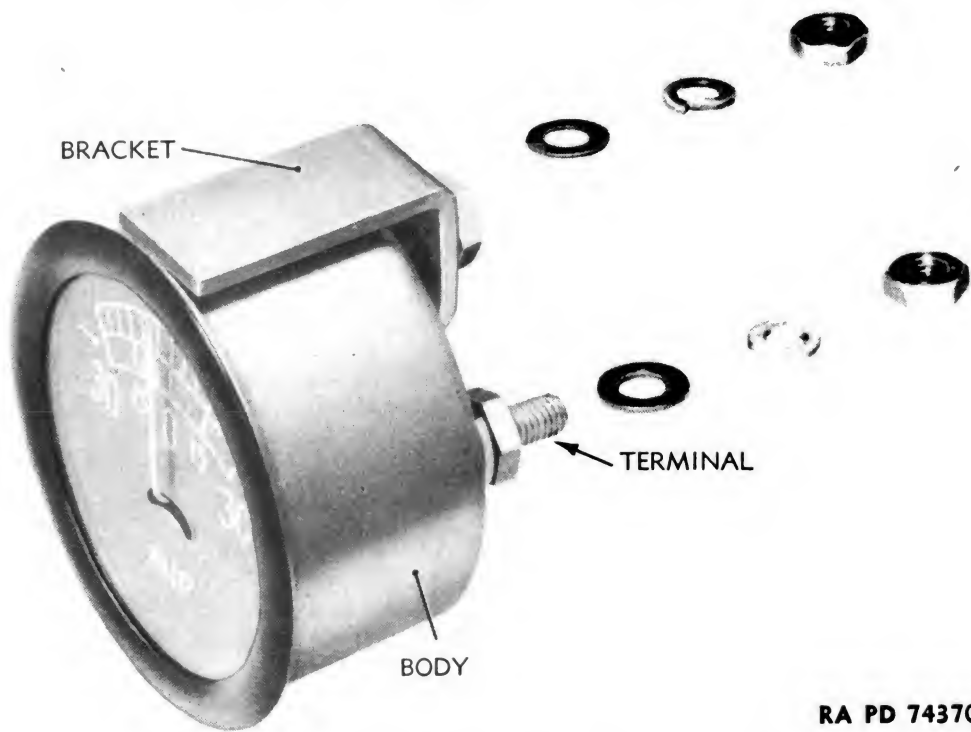

Figure 213 – Battery-charging Generator Ammeter

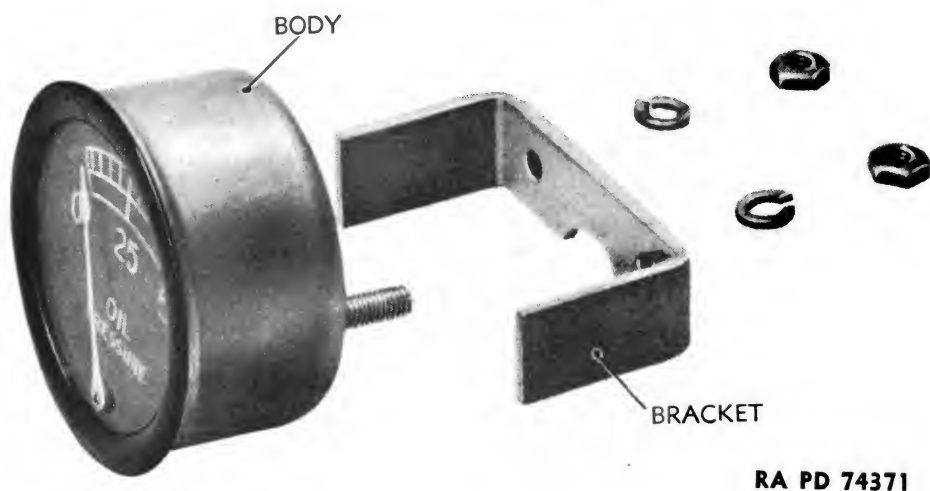

Figure 214 – Oil Pressure Gage

111. BATTERY-CHARGING GENERATOR AMMETER (fig. 213).

a. Description.

(1) Of standard automotive design, the battery-charging generator ammeter registers up to 30 amperes of current flow in either direction through it. Current passing through a coil sets up a magnetic field which

ORDNANCE MAINTENANCE — GENERATING UNIT M7

attracts or repels a piece of iron. The iron is linked to a hand which indicates the direction of the current (charge or discharge), and the amount of current in amperes.

(2) The function of the ammeter is to register rate of charge or discharge in engine battery circuit.

b. Removal.

(1) Remove nuts holding bracket against the rear of the panel, and remove bracket clips.

(2) Take off stop nuts attaching leads, and remove leads.

(3) Remove ammeter.

c. Disassembly.

(1) Remove nut and plain washer from each terminal.

(2) Pry bezel from ammeter case.

(3) Lift ammeter mechanism and porcelain insulators from case.

d. Inspection and Repair.

(1) Connect leads from posts of a 6-volt dry cell battery to terminal posts of ammeter. Note ammeter reading.

(2) Reverse leads on ammeter terminal posts. Observe ammeter reading.

(3) Repeat steps (1) and (2), above, using an ammeter known to be accurate. If readings between the two ammeters differ appreciably, replace ammeter mechanism.

(4) Replace glass in bezel, if broken.

(5) Replace insulators if damaged.

e. Assembly.

(1) Place the porcelain insulators on the terminal posts, and insert mechanism into case.

(2) Slide fiber insulator on terminal posts in back of case. On each post install terminal, flat washer and nut.

(3) Tap bezel and glass assembly in place with hammer.

f. Installation. Secure ammeter to instrument panel by fastening bracket over studs with nuts. Attach two wires marked "CG" to right connection, and wire marked "B+" to left connection.

112. OIL PRESSURE GAGE (fig. 214).**a. Description.**

(1) The oil pressure gage indicates the pressure at which the oil pump is forcing the oil through the oil lines. As the pump builds up pressure, oil is forced through the oil pressure gage line (copper tube) to the gage. As the oil is forced into the mechanism, which consist of a flattened crescent-shaped tube linked to the indicator hand, the tube

INSTRUMENT PANEL AND INSTRUMENTS

tends to straighten, thereby moving the hand across the dial. The gage indicates up to 50 pounds per square inch pressure.

(2) With the engine running at 1,200 rpm, the oil pressure gage should indicate 25 pounds pressure if the engine is fully warmed up.

b. Disassembly.

(1) With gage removed from panel, remove oil pressure gage line elbow from gage.

(2) Remove oil pressure gage nipple nut and flat washer from oil pressure gage nipple.

(3) Pry bezel and glass assembly from case.

(4) Lift movement from case.

c. Inspection and Repair.

(1) Clean parts of oil pressure gage in dry-cleaning solvent, and dry with compressed air.

(2) Check functioning of gage mechanism with that of a gage known to be good. Use a "T" connection. Replace gage, if defective.

(3) Replace glass in bezel, if broken.

(4) Inspect case, studs, threads, etc. Repair or replace if damaged.

d. Assembly.

(1) Place oil pressure gage mechanism in case, and tap bezel and glass assembly into case.

(2) Install oil pressure gage nipple flat washer and nut on oil pressure gage nipple.

113. TEMPERATURE INDICATOR GAGE (fig. 215).

a. **Description.** The temperature gage on the instrument panel indicates the temperature of the cooling water in the engine. This should be maintained at between 160 F and 190 F, by adjusting the radiator doors.

b. Removal.

(1) Unscrew temperature indicator bulb from cylinder head.

(2) Take off nuts holding bracket to panel, and remove gage.

c. **Disassembly.** The temperature gage should not be disassembled.

d. **Inspection and Repair.** With the gage attached to the temperature line, insert the bulb at the end of the line in a pan of boiling water. If the hand on the gage moves just past the 210 degree mark (212 F) the gage is indicating correctly. If the gage registers incorrectly, it should be replaced. Repairs should not be attempted.

e. Installation.

(1) Secure gage to instrument panel by fastening bracket over studs with nuts.

(2) Install bulb at end of gage line in tapped hole in cylinder head.

ORDNANCE MAINTENANCE — GENERATING UNIT M7

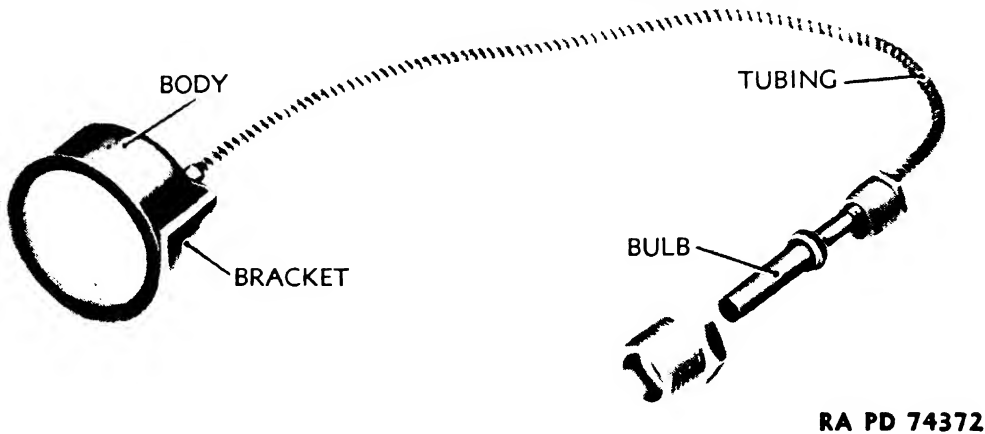

Figure 215 — Water Temperature Gage

114. ELECTRIC FUEL GAGE.

a. **Description.** The fuel gage is electrically connected to a float-operated unit in the fuel tank. This unit consists of a float arm and variable resistor. The resistor is connected in series with the fuel gage across the 6-volt battery circuit, and the reading of the gage is therefore dependent upon the fuel level of the tank. The capacity of the fuel tank is 26 gallons.

b. **Removal.** NOTE: Before removal, check performance (subparagraph c, below). Remove nuts, leads, and bracket from rear of gage at back of instrument panel, and remove gage.

c. **Disassembly and Inspection.** Repairs to the fuel gage should not be attempted. If action is faulty or the gage has been injured, a new gage should be installed. With the gage installed, performance may be checked by adding a known quantity of fuel to the tank, and noting the change in indication.

d. **Installation.**

(1) Secure gage to instrument panel by fastening bracket over gage studs with nuts.

(2) Attach two leads marked "IGN" to left connection, attach lead marked "TA" to right-hand connection, and secure each with a fiber washer and a nut.

115. TACHOMETER.

a. **Description.**

(1) The sweep hand on the tachometer indicates, on the large dial, the revolutions per minute of the engine in hundreds of revolutions. At the bottom of the dial is an odometer which records the total number of revolutions of the engine, also in hundreds of revolutions.

INSTRUMENT PANEL AND INSTRUMENTS

(2) The engine governor should be adjusted to maintain a constant running speed of 1,200 rpm.

b. Disassembly, Inspection, and Repair.

(1) The tachometer is not to be disassembled.

(2) If it is suspected that the action of the tachometer is faulty, it should be removed, and one known to be good installed. If the replacement tachometer indicates differently under the same conditions, the original instrument should not be used.

116. FREQUENCY METER.

a. Description.

(1) The frequency meter indicates the cycles of the alternating current generated. The meter consists of a number of reeds above an indicating scale and an electromagnetic coil, fastened to the base of the meter. Each reed is made to have a desired period of vibration. The reeds are then fastened in order, to the base, according to their vibration frequency, and given a final adjustment by hand. Any vibrations from the coil are transmitted to the reeds.

(2) The coil in the frequency meter is connected to a phase of the circuit and vibrates with the electrical impulses of the alternating current generated. Since each reed will vibrate appreciably with only one frequency, the reed having the same frequency as the current alternations will respond by vibrating through an arc, giving the appearance of a long line. At 60 cycles, which is the proper frequency with the engine at 1,200 rpm, the reed above the "60" line on the scale will show maximum vibration while adjacent reeds will be vibrating in a lesser degree.

b. Removal.

(1) Take off lock nuts and spring washers, and remove leads.

(2) Remove nuts and screws holding meter to panel, and remove meter.

c. Inspection and Repair.

(1) From an unvarying source of alternating current, 60 cycle and approximately 110 volts, connect leads to frequency meter terminals. Observe reading. Connect same leads to a frequency meter of known accuracy. Observe reading. Replace frequency meter being tested if readings differ appreciably from that of the known good frequency meter, or if frequency meter is damaged.

d. Installation.

(1) Attach meter to panel with screws, lock washers, and nuts.

(2) Bring leads marked "10" and "14" to rear of frequency meter. Attach to terminals, and secure with stop nuts.

ORDNANCE MAINTENANCE — GENERATING UNIT M7

NOTE: Some units have frequency meter hooked up with leads from voltmeter.

117. VOLTMETER.

a. Description. The a-c voltmeter on the instrument panel indicates the voltage of the exciter current and the voltage of the current generated by the unit, which is normally 125 volts. At this point on the dial is a red line. For procedure in obtaining these readings, see TM 9-618.

b. Removal.

(1) Hold elastic stop nuts on back of voltmeter, and unscrew the four corner bolts on face of voltmeter. On some units, removing these bolts will also release clips holding leads to panel.

(2) Take elastic stop nuts from the connections on the back of the voltmeter, remove leads and voltmeter.

c. Inspection and Repair. From an unvarying source of approximately 110-volt, 60-cycle alternating current, attach lead to each voltmeter terminal. Observe voltmeter reading. Connect another voltmeter known to be accurate across the voltmeter terminals. Observe the reading. If voltmeter being tested registers differently from the known good voltmeter, replace the voltmeter.

d. Installation.

(1) Place voltmeter in instrument panel, insert bolts through holes, install clips, if any, holding leads to panel, and install nuts.

(2) To the right connection post attach lead marked "11." To the left post attach lead "9," and install nuts.

e. Adjustment.

NOTE: With engine of unit not running, turn voltmeter adjusting screw to right or left until indicating hand points to zero.

118. AMMETER.

a. Description. The ammeter indicates the amperage of the current delivered in the phases of the circuit.

b. Removal.

(1) Hold elastic stop nuts on back of panel, and unscrew the four corner screws on the face of the ammeter. Removing these screws from some units will release a 3-wire clip held by each of the screws on the right side of the meter.

(2) Take elastic stop nuts from the terminals on the back of the ammeter, remove leads, and remove ammeter.

c. Inspection and Repair. From a source of approximately 30-amperes, 60-cycle alternating current, attach lead to each ammeter

INSTRUMENT PANEL AND INSTRUMENTS

terminal. Observe ammeter reading. Connect another ammeter known to be accurate across the ammeter terminals. Observe the reading. If ammeter being tested registers differently from the known good ammeter, replace the ammeter.

d. Installation.

(1) Place ammeter in instrument panel, insert bolts through holes, install clips (if any) holding leads to panel, and install nuts.

(2) Attach lead marked "1" to left terminal, and lead marked "3" to right with connecting nuts.

119. METER SWITCH (fig. 216).

a. Description. To check the voltage of the exciter, the amperage of the current being delivered to each of the three phases of the connected load, and the voltage between phases, the meter switch is provided. The method of checking the voltage and amperage is described in TM 9-618.

b. Removal.

(1) Remove elastic stop nuts from all connection posts, and remove all leads.

(2) Take out vertical screw through the shank of the knob, and remove knob.

(3) Unscrew four flat-head screws in faceplate, and remove plate. Remove front plate from face of panel by taking out three round-head screws from plate to hexagonal posts. The meter switch body can now be lifted from the rear of the panel.

c. Inspection and Repair.

(1) Inspect all parts of body for cracks or breaks. If any are found, replace switch.

(2) Slide out side panels (fig. 217). Inspect all contacts, fixed and movable for defects or for signs of burning. Replace any contacts not found in good condition (figs. 218 and 219).

(3) Install handle in position and rotate the handle to the various positions. At the same time rotate the handle of a meter switch known to be good. Compare the action of the cam on the two switches. If the rotation does not produce identical action of the movable contacts in the two switches, the switch being tested is at fault and should be replaced.

d. Installation.

(1) Replace side panels, and place connection block in position at rear of instrument panel with shaft projecting through panel. Carry connection plate over shaft on front of panel, and install switch with screws through plate, panel, and connection block.

ORDNANCE MAINTENANCE — GENERATING UNIT M7

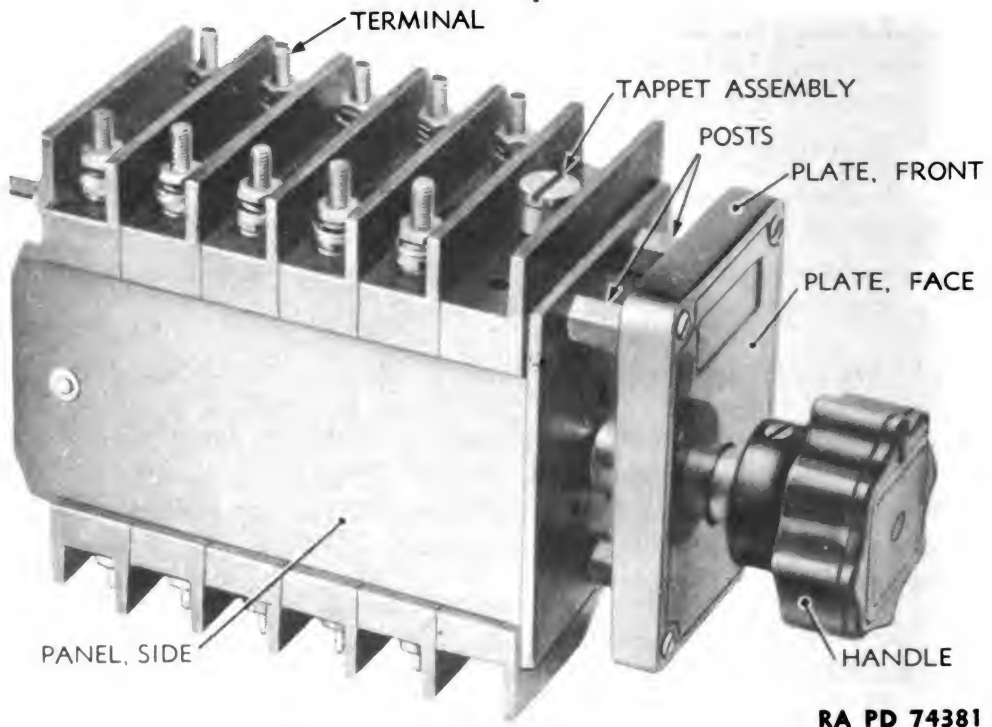

RA PD 74381

Figure 216 — Meter Switch

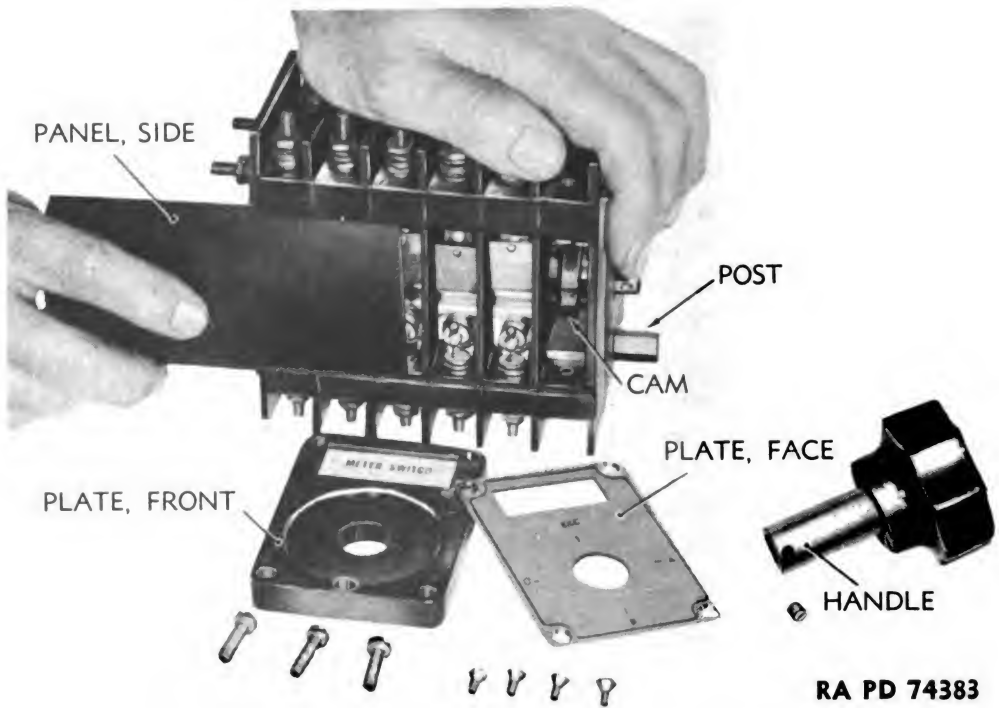

RA PD 74383

Figure 217 — Meter Switch Side Panel Removal

INSTRUMENT PANEL AND INSTRUMENTS

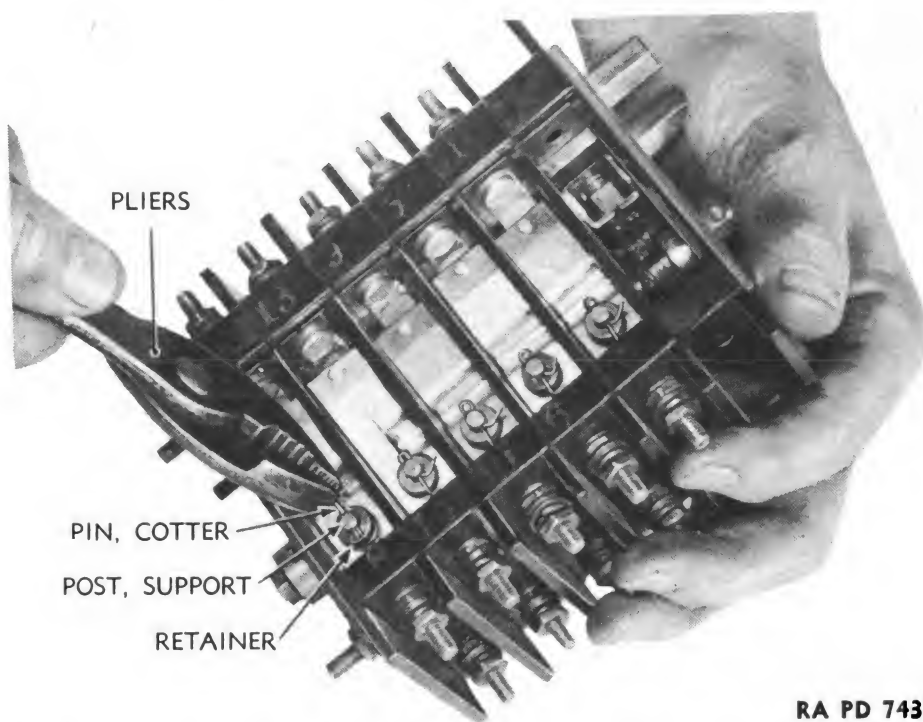

RA PD 74384

Figure 218 – Removing Cotter Pin from Movable Contact

(2) Cover mounting plate with faceplate, put name card and cover in proper position, and connect plates with corner screws. Slide knob over shaft with tapped pole through shank centered on hole in shaft. Secure knob to shaft with screw.

(3) Connect leads to connection posts marked identically with the leads by installing elastic stop nuts over the lead lugs.

120. IGNITION SWITCH.

a. Description. The ignition switch is toggle type, single pole, single throw. It controls the current in the ignition system and electric fuel gage.

b. Inspection and Repair. A faulty ignition switch cannot be repaired and must be replaced.

121. 6-VOLT LIGHT SWITCH.

a. Description. The 6-volt light switch is toggle type, single pole, single throw. It controls the 6-volt light which is used to furnish illumination when the unit is not running.

b. Inspection and Repair. This switch cannot be repaired, and if faulty, must be replaced.

ORDNANCE MAINTENANCE – GENERATING UNIT M7

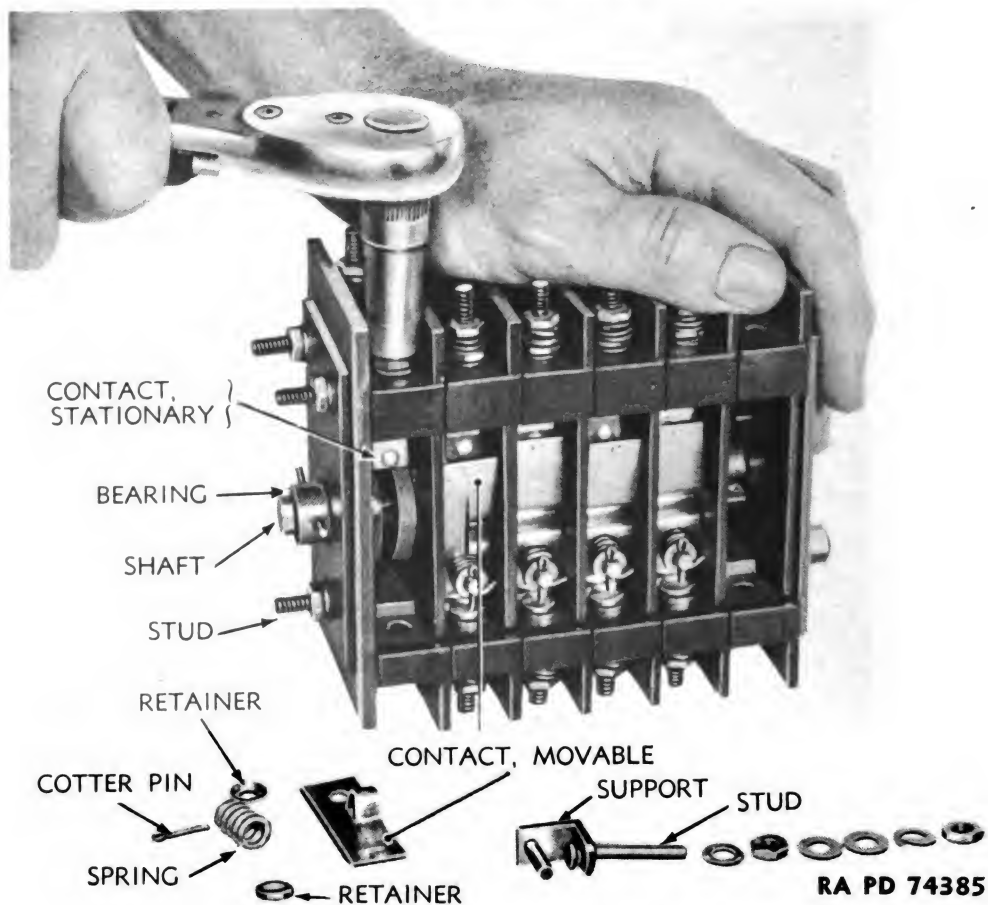

Figure 219 – Stationary Contact Removal

122. 125-VOLT LIGHT SWITCH.

a. **Description.** The 125-volt light switch is toggle type, double pole, single throw. This switch throws on the 125-volt lamps at the top of the panel.

b. **Inspection and Repair.** This switch cannot be repaired, and if faulty, must be replaced.

123. STARTER SWITCH (fig. 220).

a. **Description.** The engine starter, or cranking switch, is mounted on the left side of the instrument panel, directly below the throttle and choke knobs. It is a “push” switch of the conventional automotive type.

b. **Disassembly.**

(1) Remove starter switch.

(2) With starter switch removed from the panel, take out round-head screw which goes through one side plate (fig. 221), insulation

INSTRUMENT PANEL AND INSTRUMENTS

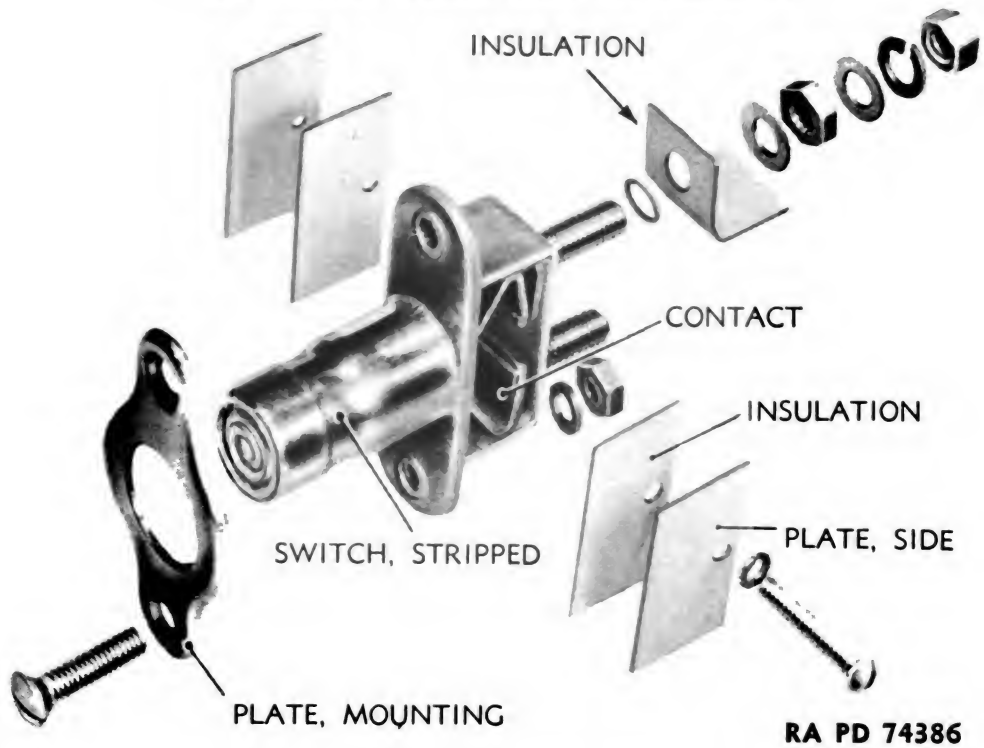

Figure 220 — Starter Switch — Exploded View

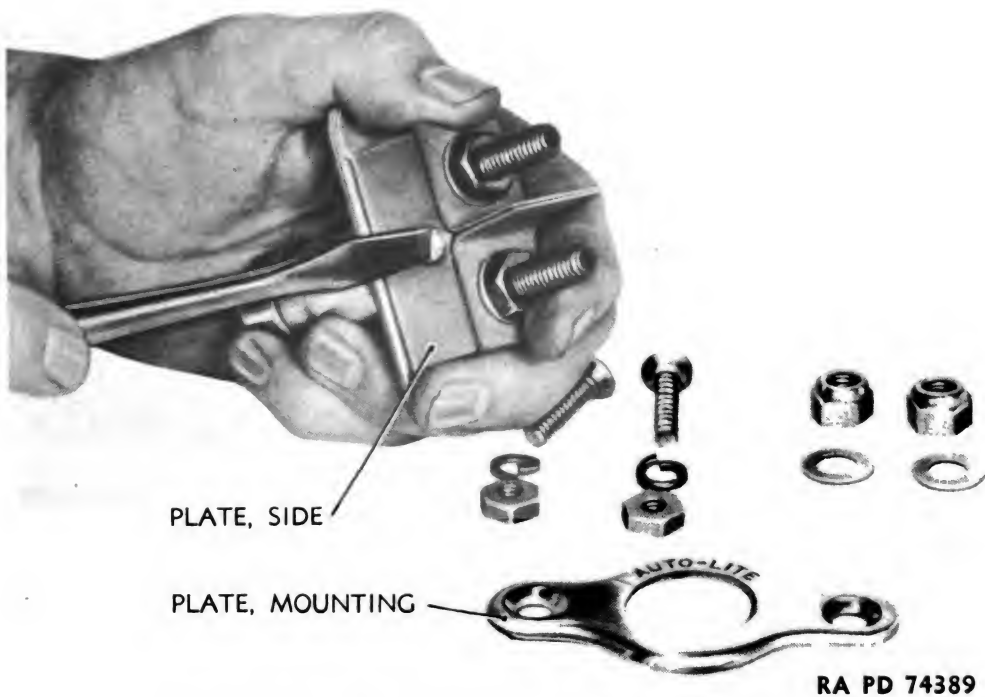

Figure 221 — Removing Starter Switch Side Plates

ORDNANCE MAINTENANCE — GENERATING UNIT M7

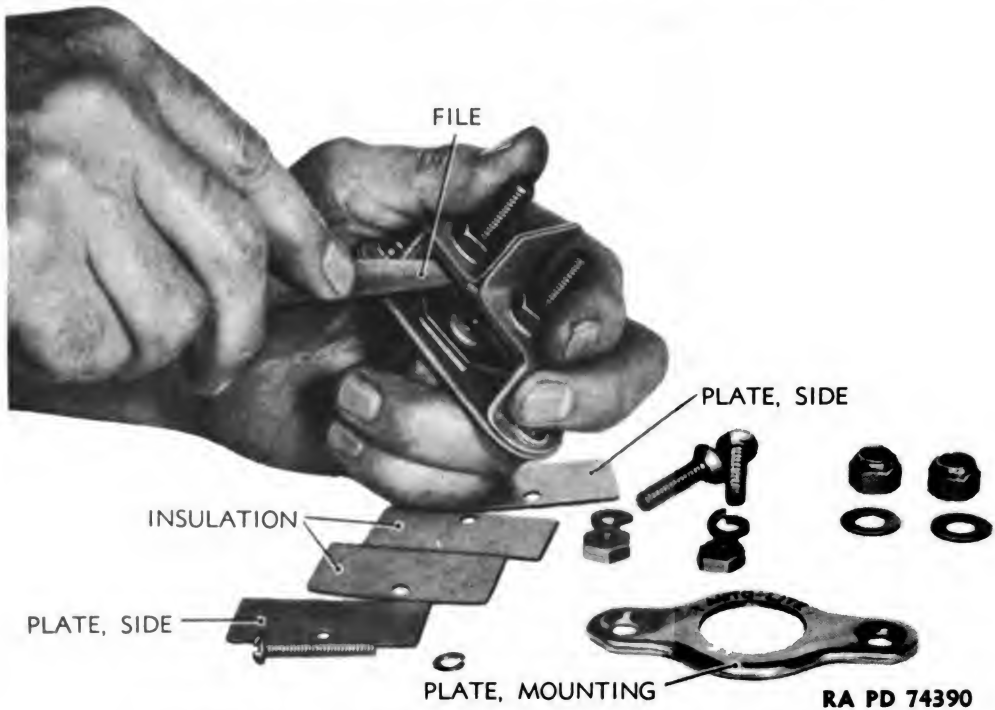

Figure 222 — Brightening Starter Switch Contacts



RA PD 74391

Figure 223 — Removing Field Rheostat Contact Assembly from Shaft

plates, and into a tapped hole in the opposite side plate. Remove plates.

c. Inspection and Repair.

(1) With plates removed, hold switch in hands, and push down on the switch plunger. Note whether or not the contact yoke makes

INSTRUMENT PANEL AND INSTRUMENTS

a good contact with the stud plates. If the spring does not work or if contacts are broken, replace switch.

(2) Observe the condition of the contact yoke and the stud plates. If they are not bright and clean, brighten them with a narrow file or with CLOTH, abrasive aluminum-oxide (fig. 222).

d. **Assembly.** Slide an insulation plate into position on each side of the switch body. Cover each of these with a side plate. Secure plates to body with round-head screw from untapped hole in one side plate to tapped hole in opposite plate.

124. LOAD SWITCH.

a. **Description.** The load switch, which controls the delivery of current to the power receptacles, is of the lever type. It is placed at the rear of the instrument panel with the switch lever projecting through to the front. When handle is in top position, the current is "ON." Bottom position is "OFF." Bolted to the back of the switch is a panel holding the three 200-amp fuses, three 30-amp fuses, and the two current transformers.

b. Removal.

(1) Take brass nuts from bottom of 200-amp fuse clips on the fuse panel, and remove leads.

(2) Take brass nuts from the three studs at the bottom of the fuse panel, and remove leads. Loosen screws at the top of the current transformers, and remove leads. Remove wood plugs and current transformers.

(3) Reach over the top of the front of the instrument panel and remove elastic stop nuts from six brass machine screws holding 30-amp fuse clips. Take off leads.

(4) Take four cap screws, washers, and nuts from each side of the fuse panel. Move panel and load switch out of position, turn sideways, and remove switch cover by taking out four machine screws.

(5) Take brass nut from top center stud on inside of switch, and remove load lead marked "B."

(6) Remove the brass nuts from the tops of the 200-amp fuse clips, and separate switch and fuse panel.

c. **Disassembly.** The switch should not be disassembled.

d. **Inspection and Repair.** This switch is not to be repaired. Mechanical troubles or any defects indicate the need for replacement.

e. Installation.

(1) Set fuse panel over back of switch with studs projecting through panel. Attach fuse panel to switch by screwing brass lock nuts on studs at the top of the three 200-amp fuse clips.

ORDNANCE MAINTENANCE – GENERATING UNIT M7

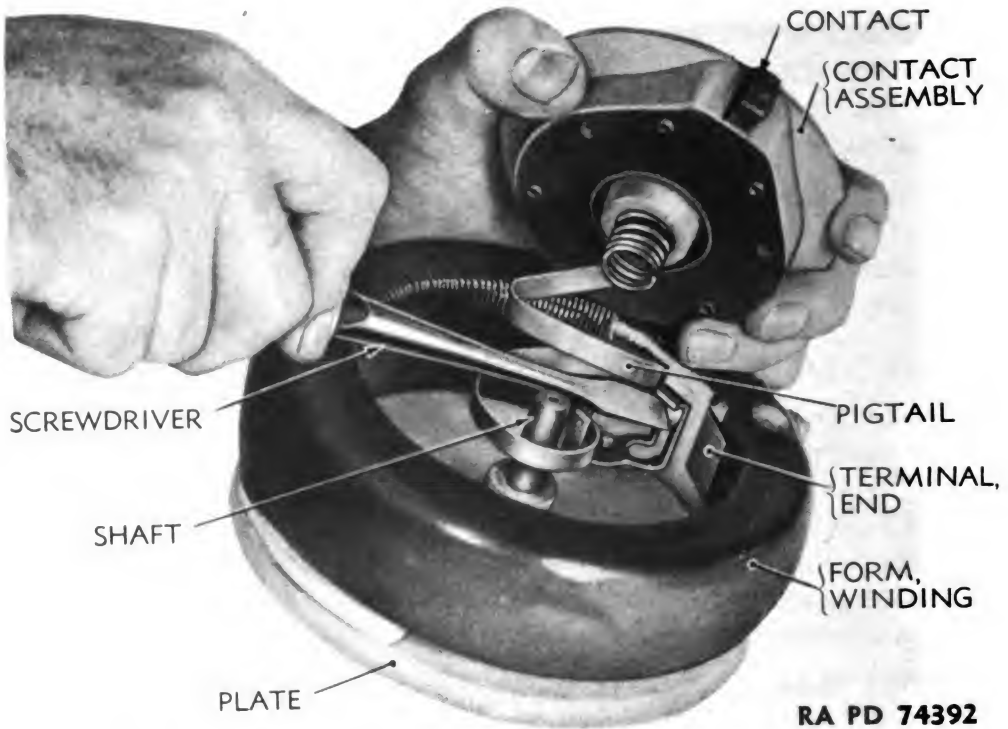

Figure 224 – Contact Assembly Removal

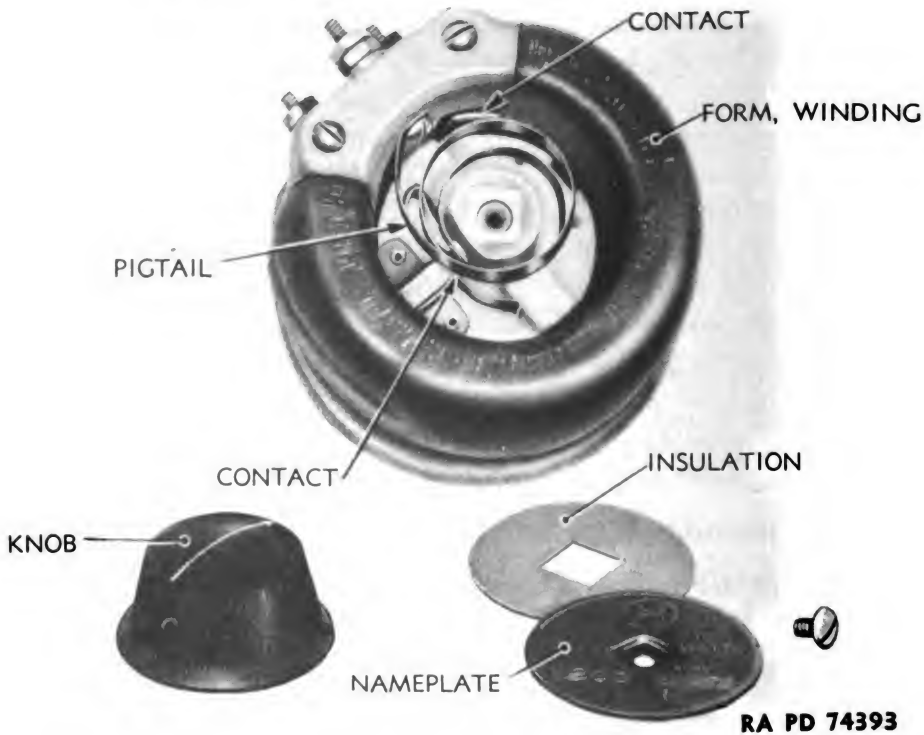

Figure 225 – Lamp-dimming Rheostat Disassembled

INSTRUMENT PANEL AND INSTRUMENTS

(2) Bring switch partly into position in back of instrument panel, and connect lead marked "B" to top center stud inside switch by installing brass nut.

(3) Place cover on switch, and secure by installing four screws through cover to switch.

(4) Bring switch into position at back of instrument panel, and install by connecting to brackets with four cap screws and nuts on each side of fuse panel.

(5) Reach over the top of the front of the instrument panel and attach leads to the 30-amp fuse clip bolts, securing the leads to the clip bolts with elastic stop nuts. To the first clip on the right attach lead marked "61." To the second clip, attach lead "CG." The third clip takes two leads, both marked "14." The fourth clip takes lead "A." To the fifth clip attach two leads marked "12," and to the last clip attach lead "C."

(6) On each of the two outside studs at the bottom of the fuse panel install a brass lock nut. On each stud place a current transformer, connection side up, secured in place with a wood plug. On top of each plug place a brass washer, and secure with another lock nut. To the left connector of each transformer attach a lead marked "3." To the right connector of the left-hand transformer attach lead "4." To the right connector of the right-hand transformer attach lead "8."

(7) On each of the three studs at the bottom of the fuse panel put a brass washer. To the left stud attach load leads marked "C," and secure with a plain brass washer, a star washer, and a brass lock nut. To the center cable attach load leads marked "B" over a brass washer, and follow with another brass washer, a star washer, and a brass lock nut. On the right-hand stud place a brass washer, attach load leads "A," and secure with another brass washer, a star washer, and a brass lock nut.

(8) To the bottom stud on the left-hand 200-amp fuse clip attach leads marked "T3." To the bottom stud on the center clip attach leads marked "T2." The third clip takes leads marked "T1." Secure each lead with two brass lock nuts.

125. FIELD RHEOSTAT.

a. **Description.** The field rheostat controls the output voltage of the unit. To increase the voltage of the current delivered, the knob is turned counterclockwise. The minimum voltage position is with the knob turned as far as possible clockwise. This is also starting and stopping position.

b. Removal.

(1) Disconnect leads from binding posts at rear of rheostat by removing nuts.

ORDNANCE MAINTENANCE – GENERATING UNIT M7

(2) Take out vertical screw holding rheostat knob to shaft, and remove knob.

(3) Take out two screws on the face of the instrument panel holding rheostat to panel. Remove rheostat.

c. Disassembly.

(1) Take out screw holding contact assembly to shaft (fig. 223).

(2) Lift up contact assembly, and remove screw attaching lug on end of pigtail to the winding form (fig. 224). Remove contact assembly and pigtail from the winding form.

d. Inspection and Repair. Check all parts for breaks or cracks. If winding form or contact case is cracked or broken, the rheostat must be replaced. Note the condition of windings, contacts, and pigtail. If they show signs of corrosion or are dirty, rub end terminal, contact, pigtail, and the exposed section of the windings with PAPER, flint, Class B, No. 2/0. The windings must be rubbed very lightly. Do not use CLOTH, abrasive, aluminum-oxide. When through, clean the rheostat carefully, and blow away all sand particles with compressed air.

e. Assembly.

(1) Bring contact assembly down into position over winding form, and attach lug at end of pigtail connection to winding form with round-head screw in side of winding form.

(2) Assemble contact assembly to shaft, and connect with round-head screw.

f. Installation.

(1) Attach rheostat tapped holes.

(2) Slip knob over rheostat shaft, and secure to shaft with vertical screw.

(3) Attach lead marked "A-1" to the left binding post of the rheostat, and secure with nut. Attach lead marked "F" to center post of rheostat, and install a wire jumper from center post to right post. Secure with nuts. NOTE: This applies when rheostat terminals are up. Check wiring with figure.

126. LAMP-DIMMING RHEOSTAT.

a. Description. The lamp-dimming rheostat, used to dim the 125-volt lamps, is centrally located at the top of the instrument panel.

b. Removal.

(1) Take off nuts from connections on rear of rheostat. Remove leads.

(2) Take out screw through rheostat knob, and slide knob off.

INSTRUMENT PANEL AND INSTRUMENTS

(3) Unscrew nut holding rheostat shaft sleeve against the face of the panel, and slide rheostat out at the back of the panel.

c. **Disassembly.** Take out fillister-head screw holding nameplate and insulation to shaft. Remove name plate and insulation (fig. 225).

d. **Inspection and Repair.** Check all parts for breaks or cracks. If winding form or porcelain center are broken, the rheostat must be replaced. Note the condition of windings, contacts, and pigtail. If they show signs of corrosion or are dirty, rub end terminal, contact, pigtail, and the exposed section of the windings with PAPER, flint, Class B, No. 2/0. The windings must be rubbed very lightly. Do not use CLOTH, abrasive, aluminum-oxide. When through, clean the rheostat carefully, and blow away all sand particles with compressed air.

e. **Assembly.** Place nameplate over the insulation ring, set in position on rheostat, and secure with fillister-head screw.

f. Installation.

(1) Install rheostat at back of panel with shaft projecting through panel. Secure in place with nut on shaft sleeve set tight against face of panel.

(2) Twist knob on shaft, and secure by tightening screw through knob against flatted part of shaft.

(3) Install two leads marked "16" to the left connection on the rheostat. Install lead marked "24" on the center post, and install a jumper from center post to right post. Secure with nuts. NOTE: This applies when rheostat terminals are up. Check wiring with figures 212 and 212 A.

127. THROTTLE CONTROL.

a. **Description.** The throttle knob is at the lower left in the control group on the left side of the instrument panel. This knob has a wire connection with a valve in the throttle body below the carburetor. Pulling out the knob reduces the amount of fuel mixture supplied the engine, and reduces engine speed.

b. Removal.

(1) Loosen clamping screws holding throttle wire and casing to carburetor, and remove wire. Loosen bolt through support bracket on top of engine, and remove wire from bracket.

(2) Unscrew nut from throttle knob casing on back of instrument panel, and remove nut. Remove knob, casing, and wire from the front of the instrument panel.

c. **Inspection and Repair.** The throttle control cannot be repaired, and if faulty, must be replaced.

ORDNANCE MAINTENANCE – GENERATING UNIT M7

d. Installation.

(1) Insert throttle wire and casing through instrument panel hole until rim of knob casing holds against front of panel. Carry nut over wire and screw on to threaded section of knob casing until the assembly is held securely in place.

(2) Fasten wire through support bracket on engine. Hold throttle lever on carburetor forward, bring wire through lever clamp, and tighten clamp.

128. CHOKE CONTROL.

a. Description. The choke knob is at the lower right in the control group on the left side of the instrument panel. This knob has a wire connection to a valve in the carburetor that regulates the carburetor air supply. Pulling out the knob cuts down on the air from into the carburetor.

b. Removal.

(1) Loosen clamping screws holding choke wire and casing to carburetor valve arm, and remove wire. Loosen bolt through support bracket on top of engine, and remove wire from bracket.

(2) Unscrew nut from choke knob casing on back of instrument panel, and remove nut. Remove knob, casing and wire from the front of the instrument panel.

c. Inspection and Repair. The choke control cannot be repaired, and if faulty, must be replaced.

d. Installation.

(1) Insert choke wire and casing through instrument panel hole until rim of knob casing holds against front of panel. Carry nut over wire, and screw on to threaded section of knob casing until the assembly is held securely in place.

(2) Fasten wire through support bracket on engine. Bring wire to carburetor, hold lever arm forward, and clamp wire to binding post on arm.

129. 125-VOLT LIGHT RECEPTACLES.

a. Description. At the top of the instrument panel are two 125-volt rubber-mounted light receptacles. They are controlled by the 125-volt light switch in the center of the panel, and the amount of the illumination given is regulated by the lamp-dimming rheostat set between them.

b. Removal.

(1) Trace lead "16" to lamp-dimming rheostat, remove nut, and remove lead. Trace lead "23" to 125-volt light switch, remove screw and lead.

INSTRUMENT PANEL AND INSTRUMENTS

(2) Hold screws, remove nuts at back of instrument panel, and remove receptacle.

c. Inspection and Repair. If inspection shows these receptacles to be damaged, they cannot be repaired, and must be replaced.

d. Installation.

(1) Bring receptacle to mounting holes in the front of the panel. Install with bolts through receptacle and panel with nuts at rear of panel.

(2) Connect receptacle lead "16" to the left connection of the lamp-dimming rheostat. Secure with nut. Connect receptacle lead "23" to the top left connection of the 125-volt light switch. Secure leads with screws.

130. 6-VOLT LIGHT RECEPTACLES.

a. Description. A 6-volt light receptacle is located at the top of the instrument panel for use in illuminating the panel at times when the unit is not being operated and the 125-volt circuit cannot be used. This light is controlled by the toggle switch at the upper right in the control group above the starter button.

b. Removal.

(1) Loosen horizontal screw through the body of the receptacle, and remove lead from center of back.

(2) Unscrew nut from the receptacle ring, and remove receptacle.

c. Inspection and Repair. If inspection shows this receptacle to be damaged, it cannot be repaired, and must be replaced.

d. Installation.

(1) Insert receptacle through panel until rim holds it in place. Install nut on back of receptacle.

(2) Insert lead wire "62" into connection hole at back of receptacle. Secure wire in place by tightening horizontal screw through body of receptacle.

131. 6-VOLT EXTENSION CORD RECEPTACLE.

a. Description. A receptacle to take the 6-volt trouble light carried in the tool box is provided at top center in the control group above the starter button.

b. Removal.

(1) Loosen horizontal screw through the body of the receptacle, and remove lead from center of back.

(2) Unscrew nut from the receptacle ring, remove receptacle.

c. Inspection and Repair. If inspection shows this receptacle to be damaged, it must be replaced.

ORDNANCE MAINTENANCE — GENERATING UNIT M7**d. Installation.**

(1) Insert receptacle through panel until rim holds it in place. Install nut on back of receptacle.

(2) Insert lead wire "61" into connection hole at back of receptacle. Secure wire in place by tightening horizontal screw through body of receptacle.

132. T-SLOT RECEPTACLES.

a. Description. One T-slot receptacle of the regular base receptacle type is provided on the instrument panel, and four on the apron below. The one on the panel is intended for use with 125-volt trouble light carried in the tool box. The receptacles on the apron are for electric tools.

b. Removal.

(1) Unscrew connector screws at back of receptacle, and take off leads.

(2) Take out the two screws holding the receptacle to the panel, and remove receptacle.

c. Inspection and Repair. If inspection shows a receptacle to be damaged, it cannot be repaired, and must be replaced.

d. Installation.

(1) Insert receptacle through hole from rear of instrument panel, alining tapped mounting holes in receptacle with mounting holes in panel. Secure receptacle to panel with screws through panel and receptacle.

(2) Attach lead marked "14" to one receptacle connection, lead marked "12" to the other. Secure with screws.

(3) Attach two leads marked "14" to one connection, one lead marked "9" to the other connection. Secure with screws. The end receptacle of the series will take only one "14" lead.

133. TERMINAL BLOCK.

a. Description. An eight-position terminal block in back of the instrument panel handles connections for both 6-volt and 125-volt circuits. A center label plate identifies the connection. The third and the eighth positions are unused. The block is mounted on arms welded to the load switch bracket.

b. Removal.

(1) Loosen screw connectors, and remove leads.

(2) Hold round-head screw at top left, remove nut at rear. Hold round-head screw at lower right, remove nut at rear, and remove block.

INSTRUMENT PANEL AND INSTRUMENTS

c. Inspection and Repair. If the block is cracked or broken, it cannot be repaired, and must be replaced.

d. Installation.

- (1) Install block with round-head screws and nuts.
- (2) Attach leads under the connection screws, marked identically with the labels on the wires.

134. FUSE BLOCKS.

a. Description. Two double fuse blocks are located on the under side of the instrument panel bottom ledge. These fuse blocks hold four 30-amp fuses connected with the four T-slot receptacles on the instrument panel apron.

b. Removal.

- (1) Take out screw connectors, and take off leads. Remove fuses.
- (2) Hold screw heads, and remove nuts. Remove fuse block.

c. Inspection and Repair. If blocks are cracked or broken, they cannot be repaired and should be replaced.

d. Installation.

- (1) Attach fuse block to panel with round-head screws and nuts.
- (2) To the connections nearest the T-slot receptacles, connect receptacle leads, one lead for each fuse. To one connection on the opposite end, connect lead "A" for one block, lead "B" for the other. In each fuse block, bridge this connection to the adjoining connection with a short wire.

ORDNANCE MAINTENANCE — GENERATING UNIT M7

CHAPTER 6
MISCELLANEOUS

Section I

LUBRICATION INSTRUCTIONS

	Paragraph
Introduction	135
Lubrication guide	136
Points to be serviced and/or lubricated by ordnance maintenance personnel	137
Reports and records	138

135. INTRODUCTION.

a. Lubrication is an essential part of preventive maintenance, determining to a great extent the serviceability of parts and assemblies. Materiel must be lubricated in accordance with the latest instructions contained in Technical Manuals and Ordnance Field Service Bulletins. Lubricating fittings are identified by a red circle, $\frac{3}{4}$ inch in diameter.

136. LUBRICATION GUIDE.

a. **General.** Lubrication instructions for this material are consolidated in a Lubrication Guide (fig. 226). These specify the points to be lubricated, the periods of lubrication, and the lubricant to be used. **NOTE:** The Lubrication Guide and notes set forth below cover both the Generating Unit M7 and Generator Trailer M7. They agree with the Lubrication Guide packed with the materiel which at the present time covers both of these items in one guide. Lubrication and maintenance of the Generator Trailer M7 is covered in TM 9-881.

b. **Notes.** The following notes apply to the Lubrication Guide (fig. 226). Any note reference in the Lubrication Guide itself is to the subparagraph below having the corresponding number. For lubrication and service below zero F, refer to OFSB 6-5.

(1) **FITTINGS.** Clean before applying lubricant. Lubricate until new lubricant is forced from the bearing, unless otherwise specified. **CAUTION:** Lubricate trailer points after washing.

(2) **INTERVALS.** Those indicated are for normal service. For extreme conditions of speed, heat, water, sand, mud, snow, rough roads, dust, etc., reduce interval on guide by one-third or one-half or more if conditions warrant.

MISCELLANEOUS

(3) **CLEANING.** SOLVENT, dry-cleaning, or OIL, fuel Diesel, will be used to clean or wash all parts. Use of gasoline for this purpose is prohibited. All parts will be thoroughly dry before relubrication.

(4) **AIR CLEANER.** Daily, check level and refill oil reservoir to bead level with used crankcase oil or OIL, engine, SAE 30 above + 32 F and SAE 10 + 32 F to zero F. Below zero F, remove oil, and operate dry. Every 150 hours, or daily, if operating in extreme dust conditions, remove entire assembly. Clean entire air cleaner and air pipes. Proper maintenance of air cleaners is essential to prolonged engine life.

(5) **CRANKCASE.** Drain only when engine is hot. Every 50 hours, drain, and refill to "FULL" mark on gage. Run engine a few minutes, and recheck oil level.

CAUTION: Be sure pressure gage indicates oil is circulating.

(6) **OIL FILTER.** Before draining crankcase oil, remove plug on filter which covers the oil reversing valve and, with the engine running, drain 2 quarts of oil. Stop engine and drain crankcase. After draining, remove filter shell, and scrape sludge from filter felts. Clean filter shell, and reassemble. Refill crankcase to "FULL" mark on gage. Run engine a few minutes, recheck level, and add oil to "FULL" mark.

(7) **FAN.** If grease-lubricated, remove plug and insert fitting to lubricate fan bearings. Replace plug. If oil-lubricated, use hand oiler.

(8) **DISTRIBUTOR.** Every 200 hours, wipe distributor breaker cam lightly with GREASE, general purpose, No. 1 above +32 F or No. 0 below +32 F; lubricate breaker arm pivot, wick under rotor, and governor weight pivots and slots, with 1 to 2 drops of OIL, engine, SAE 30 above +32 F; SAE 10 +32 F to zero F, and OIL, lubricating, preservative, light, below zero F.

(9) **BRAKE CABLES.** Every 6,000 miles, remove inner cables, clean and coat lightly with GREASE, general purpose, No. 0. Do not fill housings.

(10) **WHEEL BEARINGS.** Remove bearing cone assemblies from hub, and wash spindle and inside of hub. Inspect bearing races, and replace, if necessary. Wet the spindle and inside of hub and hub cap with wheel bearing grease to a maximum thickness of $\frac{1}{16}$ inch. only to retard rust. Wash bearing cones and grease seals. Inspect, and replace, if necessary. Lubricate bearings with wheel bearing grease with a packer or by hand, kneading lubricant into all spaces in the bearing. Use extreme care to protect bearings from dirt, and immediately reassemble, and replace wheel. The lubricant in the bearings is sufficient to provide lubrication until the next service period. Any excess might result in leakage into the brake drum.

(11) **OILCAN POINTS.** Every 50 hours or 1,000 miles, lubricate caster hanger bearing, water pump drive chain, hand brake ratchet,

ORDNANCE MAINTENANCE – GENERATING UNIT M7

KEY

LUBRICANTS

- OE—OIL, engine
Except crankcase
SAE 30 (above +32°F.)
SAE 10 (+32°F. to 0°F.)
PL (below 0°F.)
- CG—GREASE, general purpose
No. 1 (above +32°F.)
No. 0 (below +32°F.)
- WB—GREASE, general purpose, No. 2
- WP—GREASE, water pump
- GL—GREASE, lubricating, special
- PL—OIL, lubricating, preservative, light

CAUTION—Lubricate Dotted Arrow Points on Both Sides. Points on Opposite Side are Indicated by Dotted Short-Shaft Arrows.

Lubricant • Interval

- HAND BRAKE SHAFT BEARING CG 1
- LEVELING JACK CG 1
- ROCKER ARM GIB PLATE CG 1
GUIDE BEARINGS
- WHEEL BEARINGS WB 6
(Remove, clean and repack)
- SPRING HANGER GIB PLATE CG 1
GUIDE BEARINGS
- SPRING HANGER FULCRUM CG 1
PIN BEARING

Interval • Lubricant

- 1 CG LUNETTE SWIVEL
(Models so equipped)
- 1 CG LUNETTE SOCKET
(Models so equipped)
- 1 CG CASTER SUPPORT SWIVEL
AND ELEVATING WORM BRG.
- 1 CG CASTER WHEEL BEARINGS
- 1 CG HAND BRAKE SHAFT BEARING
- 1 CG HAND BRAKE SCREW BEARING
- 1 CG HAND BRAKE SHAFT BEARING

Serviced From Under Hood

- 200 GL GENERATOR SHAFT BEARING
(Refill cup, turn 1 full turn)
(For disassembly, Note 12)

- 200 GL EXCITER SHAFT BEARINGS
(Some models) (Refill
cups, turn 1 full turn)

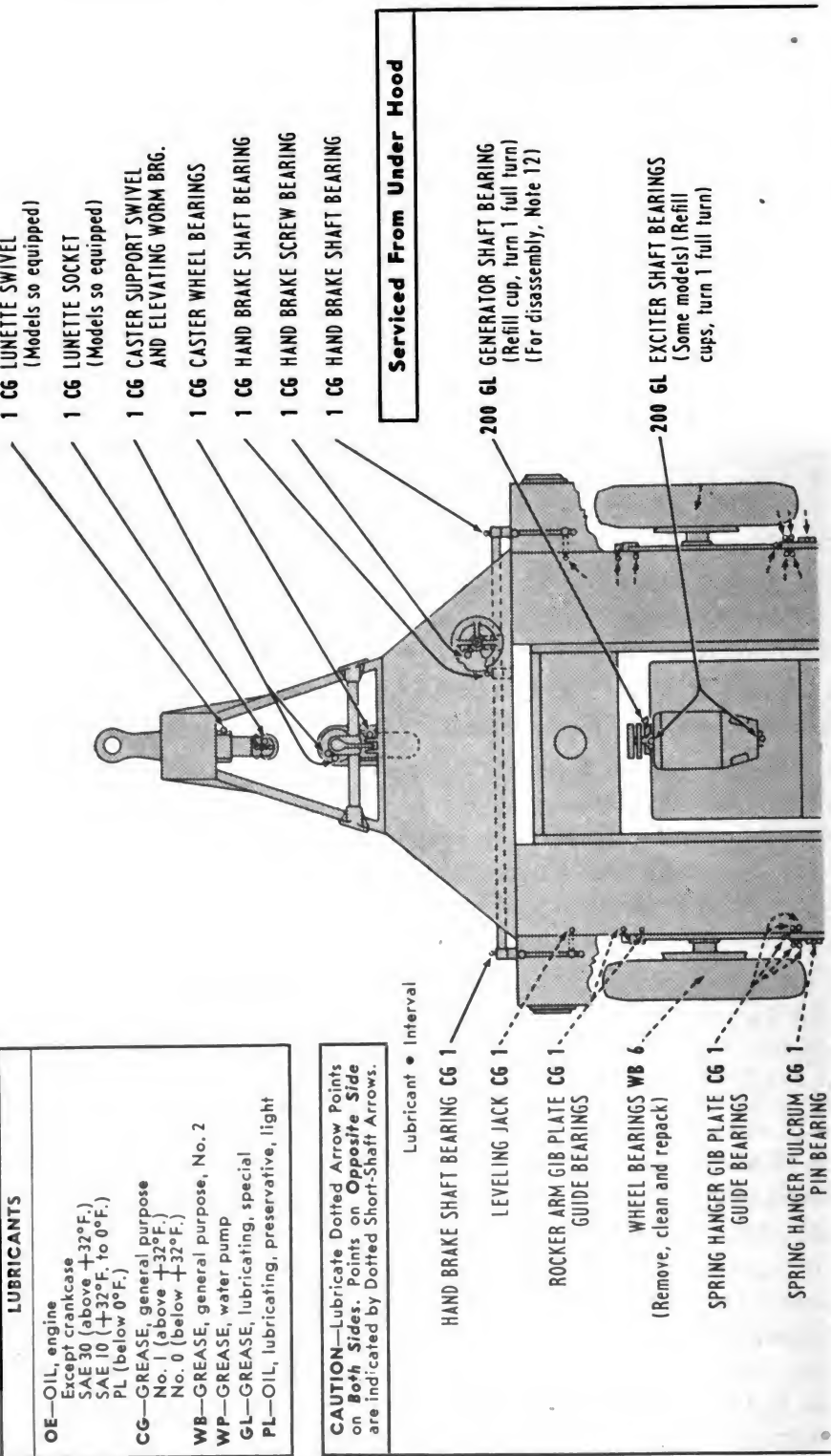

RA PD 84535

MISCELLANEOUS

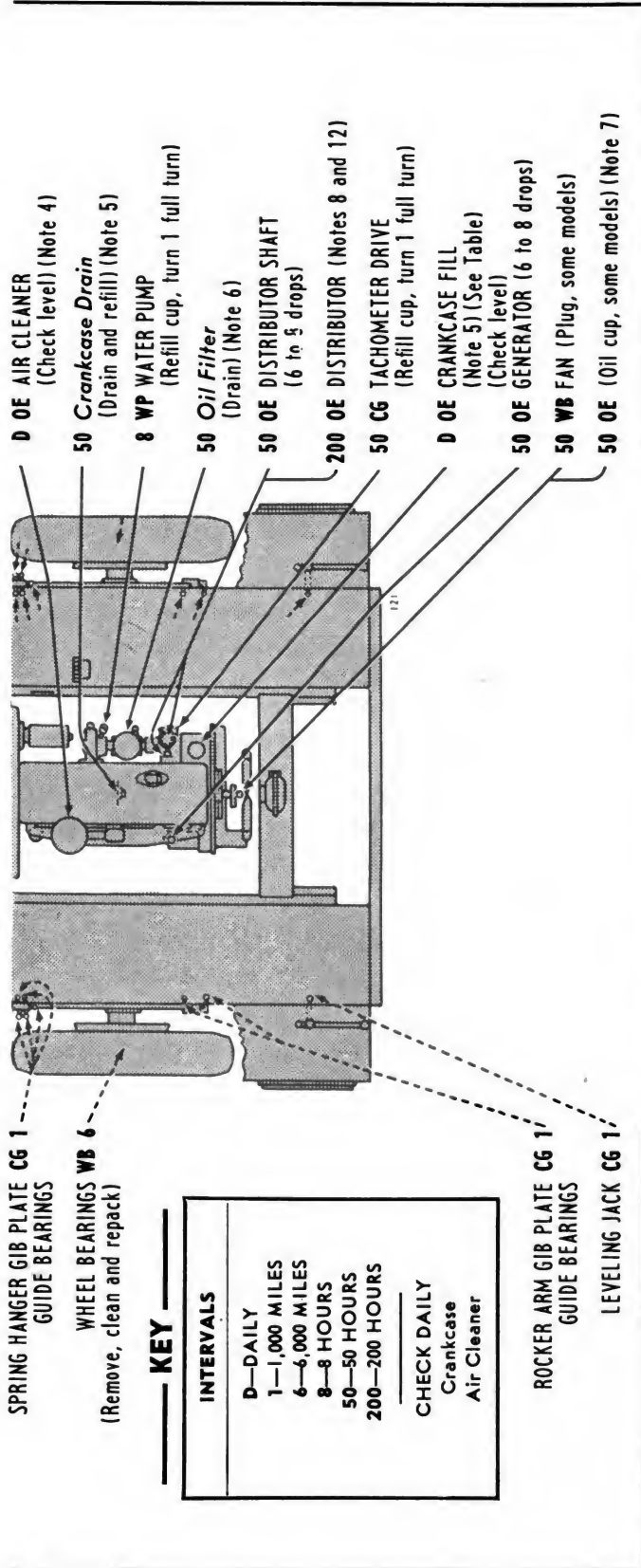

TABLE OF CAPACITIES AND LUBRICANTS TO BE USED

UNIT	CAPACITY (Approx.)	LOWEST EXPECTED AIR TEMPERATURE	
		+32° F. and above	+32° F. to 0° F.
Crankcase	7 qt.	OE SAE 30	OE SAE 10
		Refer to OFSB 6-5	

RA PD 84535A

Figure 226 — Lubrication Guide

ORDNANCE MAINTENANCE – GENERATING UNIT M7

linkage, tail gate hinges, hood hinges, and latches with OIL, engine, SAE 30 above +32 F; SAE 10 +32 F to zero F and OIL, lubricating, preservative, light, below zero F.

(12) POINTS TO BE SERVICED AND/OR LUBRICATED BY ORDNANCE MAINTENANCE PERSONNEL. Generator and exciter shaft bearings, starter, distributor (disassembly only) (par. 137).

(13) POINTS REQUIRING NO LUBRICATION SERVICE. Springs, governor, flexible coupling.

137. POINTS TO BE SERVICED AND/OR LUBRICATED BY ORDNANCE MAINTENANCE PERSONNEL.

a. **Generator and Exciter Shaft Bearings.** Yearly, or whenever the generator and/or exciter is disassembled, remove, clean, and re-pack the bearings with GREASE, lubricating, special.

b. **Starter.** Whenever starter is disassembled, clean, and coat bearings and seats with OIL, engine, SAE 10.

c. **Distributor.** Whenever distributor is disassembled, pack pockets in governor laminated weights with GREASE, general purpose, No. 1, above +32 F, and No. 0 below +32 F.

138. REPORTS AND RECORDS.

a. **Reports.** If lubrication instructions are closely followed, proper lubricants used, and satisfactory results are not obtained, a report will be made to the ordnance officer responsible for the maintenance of the materiel.

b. **Records.** A complete record of seasonal changes of lubricants will be kept in the Artillery Gun Book for the materiel.

Section II

CONSOLIDATED SERVICE DATA

	Paragraph
Fits and clearances	139
Wrench tensions	140

139. FITS AND CLEARANCES.

a. **Clearances.**

	Minimum	Maximum
Valve tappet clearance, intake	0.006 (engine hot)	—
Valve tappet clearance, exhaust	0.010 (engine hot)	—
Valve seat face width, intake and exhaust....	1/8 in.	5/32 in.
Valve seat diameter, intake	1 13/16 in.	—

MISCELLANEOUS

Clearances (cont'd)	Minimum	Maximum
Valve seat diameter, exhaust	1 $\frac{11}{16}$ in.	—
Valve stem clearance in guide, standard exhaust and intake	0.001	0.0015
Valve tappet clearance in guide.....	0.00075	0.001
Idler bearing clearance	0.001	0.0015
Cam bearing clearance	0.0015	0.0025
Crankshaft main bearing clearance	0.002	0.003
Bellhousing on chamfer	0.012	0.025
Connecting rod bearing	0.0015	0.002
Accessory or water pump drive shaft	0.0015	0.0025
Gear cover clearance around water pump shaft	0.006	0.015
Gear cover clearance around crankshaft.....	0.008	0.015
Oil pan clearance around crankshaft.....	0.008	0.015
Piston pin clearance	0.0002	0.0003
Piston ring to land clearance.....	0.0015	0.003
b. Gear Backlash.		
Accessory gear to idler.....	0.002	0.004
Idler gear to cam gear	0.001	0.002
Camshaft gear to crank gear.....	0.000	0.001
Oil pump gear to cam gear.....	0.008	0.010
c. Gap Settings.		
Piston ring gap.....	0.015	0.020
Spark plug electrodes	0.024	0.028
Distributor breaker points	0.019	0.021
d. End Thrust.		
Crankshaft end thrust	0.003	0.005
Connecting rod end clearance	0.005	0.010
Accessory shaft end clearance	0.001	0.003
e. Spring Tensions.		
Exciter brushes	12 oz	14 oz
Alternator	8 oz	—

140. WRENCH TENSIONS.

	Foot Pounds	Inch Pounds
Cylinder head screws (when using copper asbestos cylinder head gasket).....	60	720
Cylinder head screws (when using steel asbestos cylinder head gasket).....	75	900
Connecting rod nuts	63	756
Main bearings, center and rear	70	840
Main bearings, front and inter.	105	1,260

ORDNANCE MAINTENANCE – GENERATING UNIT M7

Section III

REFERENCES

	Paragraph
Standard nomenclature lists	141
Explanatory publications	142

141. STANDARD NOMENCLATURE LISTS.

- a. Unit, generating, M7..... SNL F-226
- b. Cleaning, preserving and lubricating materials;
recoil fluids, special oils, and miscellaneous
related items SNL K-1
- c. Major items of antiaircraft artillery..... SNL D-2
- d. Railway and antiaircraft artillery sighting
equipment and fire control instruments..... SNL F-2
- e. System, cable, M3..... SNL F-244

Current standard nomenclature lists are as tabulated here, An up-to-date list of SNL's is maintained as the "Ordnance Publications for Supply Index," now published in OFSB 1-1

142. EXPLANATORY PUBLICATIONS.

a. Fire Control.

- Instruction guide: Director M7 TM 9-2658
- Instruction guide: The instrument repairman.. TM 9-2602
- Instruction Guide: Height finder M1 TM 9-2623
- Ordnance maintenance: Director M7 TM 9-1658
- Ordnance maintenance: Height finder M1..... TM 9-1623
- Ordnance maintenance: Remote control
systems M2 TM 9-1642

b. Gun Materiel.

- 90-mm antiaircraft gun materiel M1 and
M1A1 TM 9-370
- 90-mm gun M1 and 90-mm antiaircraft gun
mount T2E1..... TM 9-371

MISCELLANEOUS

c. **Automotive Materiel.**

Automotive electricity	TM 10-580
Automotive lubrication	TM 10-540
Chassis, body, and trailer units	TM 10-560
Fuels and carburetion	TM 10-550
Generating unit M7	TM 9-618
Generator trailer M7 (to be superseded by TM 9-1881, when published)	TM 9-881
Military motor transportation	TM 10-505
Motor transport	FM 25-10
Motor transport inspection	TM 10-545
Motor vehicles	AR 850-15
Ordnance storage and shipment chart-group F	OSSC-F
Sheet metal work, body, fender, and radiator repairs	TM 10-450
Storage of motor vehicle equipment	AR 850-18
The blacksmith and the welder	TM 10-440
The internal combustion engine	TM 10-570
The machinist	TM 10-445

d. **Maintenance.**

Cleaning, preserving, lubricating, and welding materials and similar items issued by Ord- nance Department	TM 9-850
Detailed lubrication instructions for ordnance personnel	OFSB 6 series

e. **Miscellaneous.**

Chemical decontamination materials and equipment	TM 3-220
Defense against chemical attack	FM 21-40
Hand, measuring, and power tools	TM 10-590
Instruction guide: Welding—theory and application	TM 9-2852
List of publications for training	FM 21-6

ORDNANCE MAINTENANCE — GENERATING UNIT M7

INDEX

A	Page No.		Page No.
Accessories, engine		starting motor	194-196
installation	75	30-ampere power receptacle.....	204
removal	37-39	throttle box	135
Adjustment:		200-ampere power receptacle	201-202
distributor	184-185	water pump	85
governor	131-133		
oil pressure regulating valve.....	143	B	
valve tappets	74	Base, engine, inspection and repair..	183
voltmeter	256	Battery, maintenance	
Air cleaner, lubrication.....	273	abnormal sulphation	169
Allocation of maintenance.....	11-14	battery chargers	168
Alternator		charging	166
assembly	228-230	freezing	168
description	9, 204-206	idle and stored batteries.....	169
disassembly	210-216	heating	168-169
inspection	216-225	mixing electrolyte	170
installation	230	reversal of polarity.....	169
maintenance and repair.....	225-228	terminals	169
removal	206-210	(See also under Electrical system)	
Ammeter		Battery-charging generator	
description	256	regulator tests	161-162
inspection and repair.....	256-257	Battery test	76
installation	257	Bearing plate, intermediate,	
maintenance allocation.....	13	inspection and repair.....	193
removal	256	Bearings, camshaft, installation.....	63
Armature		Bearings, main, construction.....	24
inspection	189-191, 237	Bendix drive, inspection and repair..	193
maintenance and repair.....	239	Bracket assembly, exciter bearing,	
Assembly:		inspection	223-225
alternator	228-230	Breaker contracts, inspection and	
distributor	184	repair	183
engine	71-74	Breaker plate, inspection and repair	183
exciter	240-242	Bushings, inspection	52
fan	90		
fuel pump	103	C	
fuel system	117-118	Cables, battery, maintenance	
fuel tank	100	allocation	13
generator	156-158	Camshaft	
generator regular	161	inspection	61
governor	129-131	specifications	29
housing	21	Camshaft and idler shaft,	
instrument panel	248	construction	27
oil filter	141-142	Carbon, removal of in engine.....	62
oil pressure regulating valve.....	142	Carburetor	
oil pump	146	maintenance allocation	13
radiator	86-88	trouble shooting	93-94
		tune-up	78
		(See also under Fuel system)	

INDEX

C — Cont'd	Page No.	D
Choke control		Description
maintenance allocation	13	alternator
removal and installation.....	268	battery
Cleaning:		carburetor
engine parts	41-46	cooling system
fuel tank	98	electrical fuel gage.....
Coils, inspection	237-238	electrical generating system.....
Commutator bars, maintenance		electrical system
and repair	227	exciter
Commutator end head, inspection		exhaust system
and repair	194	engine
Condenser		fan
inspection and repair.....	182-183	frame
maintenance allocation.....	13	fuel pump
Connecting rods		fuel system
inspection	60	fuel tank
repair	67	generating unit M7.....
specifications	29	generator regulator
Consolidated service data		governor
fits and clearances.....	276-277	housing
wrench tensions	277	ignition
Construction:		instrument panel
engine	23-27	lubrication system
exhaust system	135	oil filter
electrical generating system.....	197	oil pump
Controls, description	9	radiator
Cooling system		starting motor
antifreeze	81	tachometer
daily and periodic inspection.....	80	temperature indicator gage.....
description	79	30-ampere power receptacle.....
fan	88-90	water pump
maintenance	80-81	
radiator	85-88	Differences among models of
reverse flush	80	generating units
trouble shooting	79-80	Dimensions of frame.....
water pump	84-85	Disassembly:
Coupling end parts (generator),		alternator
inspection	225	carburetor
Crankcase (and cylinder block)		distributor
inspection	52-60	engine
lubrication	273	exciter
Crankshaft		fan
inspection	60	fuel tank
specifications	29	generating units
Cylinder block (See Crankcase		generator
(and cylinder block))		generator regulator
		governor
		housing
		instrument panel

ORDNANCE MAINTENANCE — GENERATING UNIT M7

INDEX

D — Cont'd	Page No.		Page No.
Disassembly — Cont'd		removal	35-37
oil pump	143	accessories	37-39
radiator	86	repairs	62-67
starting motor	188-189	specifications	27-29
tachometer	255	trouble shooting	29-35
30-ampere power receptacle	203-204	tune-up	75-78
throttle box	133	Engine parts	
200-ampere power receptacle	201	cleaning	41-46
water pump	84-85	inspection	51-62
Distributor		Exciter	
lubrication	273	assembly	240-242
trouble shooting	175	description	9, 230
tune-up	76-78	disassembly	234-236
(See also under <i>Ignition</i>)		inspection	237-239
Distributor cap, inspection and		installation	242
repair	182	maintenance and repair	239-240
Distributor point, maintenance		removal	232-233
allocation	13	Exciter armature, maintenance	
E		and repair	227
Echelons, definition of	11-12	Exciter field coils, maintenance and	
Electrical system		repair	228
battery		Exhaust system	
description	163-165	description	135
maintenance	165-170	maintenance and repair	137
preparation for service	170-172	trouble shooting	137
repair	172-173	F	
description	145-151	Fan assembly	
generator		assembly	90
assembly	156-158	description	88
disassembly	152-153	disassembly	90
inspection and repair	153-155	inspection	90
generator regulator	158-163	lubrication	273
ignition	173-186	maintenance allocation	13
starting motor	187-197	maintenance and repair	90, 227
trouble shooting	152	Field coils, revolving, maintenance	
Electrolyte		and repair	225-227
inspection of level	165-166	Field equipment	
mixing	170	assembly and installation	266
Engine		description	265
assembly	71-74	disassembly	266
construction	23-27	inspection and repair	266
description	23	removal	265-266
disassembly	39-41	Filter, air, tune-up	78
installation	75		
accessories	75		
maintenance and repairs	41-67		

INDEX

F — Cont'd	Page No.	Page No.
Filter, oil		
assembly	141-142	
description	141	
inspection and repair.....	141	
installation	142	
oil pressure regulating valve..	142-143	
removal	141	
servicing	142	
Fits and clearances.....	276-277	
Flywheel, inspection	61	
Frame, description	15	
Frame and field coils, inspection and repair	191-193	
Frequency meter		
description	255	
inspection and repair.....	255	
installation	255-256	
removal	255	
Fuel pump		
assembly	103	
description	100	
disassembly	100	
inspection	103	
maintenance and repair.....	103	
Fuel system		
air filter	121	
carburetor		
assembly	117-118	
description	103-105	
disassembly	108-114	
inspection	114	
maintenance and repair....	114-115	
description	91	
fuel pump	102-103	
governor		
adjustment	131-133	
assembly	129-131	
description	121-123	
disassembly	125	
inspection and repair.....	125-129	
installation	131	
removal	123	
fuel pump	102-103	
throttle box		
assembly	135	
description	121-123	
disassembly	133	
inspection and repair.....	133-135	
trouble shooting	93-94	
Fuel tank		
assembly	100	
cleaning	98	
description	96	
disassembly	96	
installation	100	
removal	96	
repair	99-100	
testing	98	
Functioning:		
exhaust system	135	
generating system, electrical.....	197	
Fuse blocks, removal and installation	271	
G		
Gages		
electrical fuel, removal and installation	254	
fuel, maintenance allocation.....	13	
oil, maintenance allocation.....	13	
oil pressure		
assembly	253	
description	252-253	
disassembly	253	
inspection and repair.....	253	
temperature indicator, removal and installation	253	
Generating system, electrical		
description	197	
power receptacles		
30-ampere	202-204	
200-ampere	201-202	
trouble shooting	197-200	
Generating units		
disassembly	210-216	
removal	206-210	
Generator (See under Electrical system)		
Generator, battery-charging voltage regulator, maintenance allocation..	13	
Generator ammeter, battery-charging		
assembly	252	
description	251-252	
disassembly	252	
inspection and repair.....	252	
installation	252	
removal	252	
Generator body and starter, inspection	221	

ORDNANCE MAINTENANCE — GENERATING UNIT M7

INDEX

G — Cont'd	Page No.		Page No.
Generator regulator		carburetor	114
assembly	161	coupling end parts (regulator)....	225
battery-charging tests	161-162	engine parts	51-62
description and operation	158	exciter	237-239
disassembly	158	fan	90
inspection and repair	158-161	frame	15
installation	162-163	fuel pump	103
removal	158	generating unit M7.....	14
Governor (See under Fuel system)		generator	153-155
Guides, valve, replacement	63	generator body and stator.....	221
Guides, valve stem, inspection	60	generator regulator	158-161
		governor	125-129
H		ignition	182-183
Hose, radiator	88	ignition coil	177
Hose, water-cooling system, maintenance allocation	13	instrument panel	248
Housing		oil filter	141
assembly	21	oil pressure regulating valve.....	142
description	17	oil pump	143-146
disassembly	18	radiator	86
installation	21-22	rotor assembly	216-221
maintenance and repair	19	spark plugs	185-186
removal	17-18	starting motor	189-194
Housing, pinion, inspection and repair	193	tachometer	255
		voltmeter	256
I		temperature indicator gage.....	253
Ignition		30-ampere power receptacle.....	203
description	173-174	200-ampere power receptacle.....	201
distributor		water pump	85
assembly	184	Instrument panel	
disassembly	177-181	assembly	248
inspection and repair	182-183	description	242
installation	185	disassembly	248
removal	177	inspection and repair.....	248
tests and adjustments	184-185	installation	249
ignition coil	177	removal	242-248
spark plugs	185-186	Instruments and switches	
trouble shooting	174-177	ammeter	256-257
Ignition coil		battery-charging generator	
inspection	177	ammeter	251-252
trouble shooting	174-175	choke control	268
Ignition switch, description	259	electric fuel gage	254
Ignition timing	78	field equipment	265-266
Inspection (and repair)		frequency meter	255-256
alternator	216-225	fuse blocks	271
bracket assembly, exciter		ignition switch	259
bearing	223-225	lamp-dimming rheostat	266-267

INDEX

I — Cont'd	Page No.	M	Page No.
Instruments and switches—Cont'd		Maintenance (and repair)	
load switch	263-265	alternator	225-228
meter switch	257-259	battery	165-170
oil pressure gage.....	252-253	carburetor	114-115
125-volt light receptacles.....	268-269	commutator bars	227
125-volt light switch.....	260	cooling system	80-81
6-volt extension cord		engine	41-67
receptacles	269-270	exciter	239-240
6-volt light receptacles.....	269	exciter armature	227
6-volt light switch	259	exhaust system.....	137
starter switch	260-263	fan	90, 227
T-slot receptacles	270	fuel pump	103
tachometer	254-255	housing	19
temperature indicator gage.....	253	revolving field coils.....	225-227
terminal block	270-271	shaft	227
throttle control	267-269	slip rings	227
trouble shooting	250	water pump	85
voltmeter	256	Maintenance procedure, 750-hr...	61-62
		Meter switch	
		description	257
		inspection and repair.....	257
		installation	257-259
		removal	257
		Manifold	
		construction	27
		maintenance and repair.....	137
		trouble shooting	137
		Manifolds, intake and exhaust,	
		maintenance allocation.....	13
		Muffler	
		maintenance allocation	13
		maintenance and repair.....	137
		trouble shooting	137
		O	
		Oil filter, lubrication.....	273
		Oilcan points	273-276
		Operation of generator regulator.....	158
		P	
		Pipe, exhaust	
		allocation of maintenance.....	13
		maintenance and repair.....	137
		Piston pin, specifications.....	29
		Piston ring, replacement.....	65
		Pistons	
		construction	23
		inspection	60
		repair	67
		specifications	27

L

Lamp test, trouble shooting.....	199
Lamp-dimming rheostat,	
inspection and repair.....	267
Light receptacles	
125-volt	268-269
6-volt	269
Light switch	
125-volt	260
6-volt	259
Lines and fittings, oil, maintenance	
allocation	13
Load switch	
description	263
disassembly	263
inspection and repair.....	263
installation	263-265
removal	263
Lubrication	
lubrication guide	273-276
points serviced by ordnance	
personnel	276
reports and records.....	276
Lubrication system	
description	136
oil filter	141-143
oil pump	143-146
trouble shooting	136-140

ORDNANCE MAINTENANCE – GENERATING UNIT M7

INDEX

P – Cont'd	Page No.		Page No.
Power receptacle, 30-ampere		Ring gear, flywheel, replacement....	65
assembly	204	Rotor, inspection and	
description	202	repair	182, 216–221
disassembly	203–204	Rotor, distributor, maintenance	
inspection and repair.....	203	allocation	13
installation	204		
removal	203	S	
Power receptacle, 200-ampere		Shaft and governor, inspection	
assembly	201–202	and repair	183
disassembly	201	6-volt extension cord receptacle	
inspection and repair.....	201	installation	270
installation	202	removal	269
removal	201	Slip rings, maintenance and	
Pump, fuel		repair	227
maintenance allocation	13	Spark coil, maintenance	
trouble shooting	93	allocation	13
Pump, oil		Spark plugs	
assembly	146	inspection and repair.....	185–186
description	143	trouble shooting	175–177
disassembly	143	tune-up	76
inspection and repair.....	143–146	Specifications of engine.....	27–29
installation	146	Starter, maintenance allocation.....	13
removal	146	Starting motor	
Pump, water		assembly	194–196
assembly	85	description	187
description	84	disassembly	188–189
disassembly	84–85	inspection and repair	189–194
inspection	85	trouble shooting	187–188
R		Starter switch	
Radiator		assembly	263
assembly	86–88	description	260
description	85	disassembly	260–262
disassembly	86	inspection and repair.....	262–263
inspection and repair.....	86	Stator windings, maintenance	
installation	88	and repair	227–228
removal	85–86	Strainer, oil, maintenance	
Receptacles, light, maintenance		allocation	13
allocation	13	Studs, inspection	52
Repair (See Inspection (and repair))		Switch, lighting, maintenance	
Reports and records of lubrication..	276	allocation	13
Rheostat, field, maintenance		Switch, starting, maintenance	
allocation	13	allocation	13
Ring assembly, brush-holder		T	
inspection	239	Tachometer	
maintenance and repair.....	239–240	description	254–255
		disassembly, inspection and	
		repair	255
		maintenance allocation	13

