

✓ 1/4 ad  
4 W113  
.2  
TM  
1944

# TM 9-1767C

WAR DEPARTMENT TECHNICAL MANUAL

U.S. Dept. of Army

*ORDNANCE MAINTENANCE*

## Body, Chassis, and Winches for Tractor Truck M26, Component of 40-Ton Tank Transporter Trailer Truck M25



WAR DEPARTMENT

• 5 JANUARY 1944



*WAR DEPARTMENT TECHNICAL MANUAL*  
*TM 9-1767C*

---

*ORDNANCE MAINTENANCE*

Body, Chassis, and Winches  
for Tractor Truck M26,  
Component of  
40-Ton Tank Transporter  
Trailer Truck M25



---

*WAR DEPARTMENT*

*5 JANUARY 1944*

---

WAR DEPARTMENT  
WASHINGTON 25, D. C., 5 JANUARY 1944

TM 9-1767C, Ordnance Maintenance, Body, Chassis, and Winches for Tractor Truck M26, Component of 40-Ton Tank Transporter Trailer Truck M25, is published for the information and guidance of all concerned.

[ A.G. 300.7 (10 Aug 43)  
O.O.M. 461/(TM 9-) Rar. Ars. (6 Jan 44) ]

BY ORDER OF THE SECRETARY OF WAR:

G. C. MARSHALL,  
*Chief of Staff.*

OFFICIAL:

J. A. ULIO,  
*Major General,  
The Adjutant General.*

DISTRIBUTION: R 9(4); Bn 9(2); C 9(8).

(For explanation of symbols, see FM 21-6.)

U113  
2  
TM 9-1767C  
1944  
★ ★

# CONTENTS

		Paragraphs	Pages
CHAPTER	1. INTRODUCTION .....	1- 2	6- 7
CHAPTER	2. STEERING SYSTEM .....	3- 31	8- 33
SECTION	I. Description and operation of steering gear and hydraulic system .....	3	8- 10
	II. Steering gear hydraulic pump .....	4- 9	11- 14
	III. Steering gear hydraulic control valve .....	10- 15	15- 18
	IV. Steering hydraulic cylinder .....	16- 19	18- 20
	V. Steering gear .....	20- 25	20- 29
	VI. Drag link .....	26- 29	30- 31
	VII. Test and adjustment of steering system .....	30	31- 32
	VIII. Fits and tolerances .....	31	33
CHAPTER	3. BRAKE SYSTEM .....	32- 36	34- 37
SECTION	I. Description and data of brake system .....	32- 33	34- 35
	II. Service brake shoes .....	34- 36	36- 37
CHAPTER	4. PROPELLER SHAFT (PARKING) BRAKE .....	37- 40	38- 39
SECTION	I. Description and data of parking brake .....	37- 38	38
	II. Disassembly, cleaning, inspection, repair, and assembly of parking brake .....	39	38- 39
	III. Fits and tolerances .....	40	39
CHAPTER	5. FRONT-MOUNTED WINCH .....	41- 50	40- 53
SECTION	I. Description and data of front-mounted winch .....	41- 42	40- 42
	II. Disassembly of front-mounted winch into subassemblies .....	43	43- 44
	III. Disassembly, cleaning, inspection, repair, and assembly of front-mounted winch subassemblies .....	44- 47	45- 52
	IV. Assembly of front-mounted winch .....	48	52
	V. Test and adjustment of front-mounted winch .....	49	52
	VI. Fits and tolerances .....	50	53

# CONTENTS—Cont'd

		Paragraphs	Pages
CHAPTER	6. TANDEM WINCH ASSEMBLY.....	51- 70	54- 90
SECTION	I. Description and data.....	51- 52	54- 58
	II. Disassembly of tandem winch into subassemblies.....	53	59- 65
	III. Disassembly, cleaning, inspec- tion, repair, and assembly of tandem winch subassemblies.....	54- 67	65- 86
	IV. Assembly of tandem winch.....	68	87- 90
	V. Test and adjustment of tandem winch.....	69	90
	VI. Fits and tolerances.....	70	90
CHAPTER	7. VERTICAL LIFTING DEVICE.....	71- 73	91- 93
SECTION	I. Description and operation of vertical lifting device.....	71- 72	91
	II. Disassembly, cleaning, inspec- tion, repair, and assembly of vertical lifting device.....	73	91- 93
CHAPTER	8. FIFTH WHEEL.....	74- 81	94-100
SECTION	I. Description and data of fifth wheel.....	74- 75	94- 96
	II. Disassembly of fifth wheel into subassemblies.....	76	96
	III. Disassembly, cleaning, inspec- tion, repair and assembly of subassemblies.....	77- 78	96- 99
	IV. Assembly of fifth wheel.....	79	99
	V. Test and adjustment of fifth wheel.....	80	99-100
	VI. Fits and tolerances.....	81	100
CHAPTER	9. SPRINGS AND SHOCK ABSORBERS.....	82- 86	101-104
SECTION	I. Springs.....	82- 84	101-102
	II. Shock absorbers.....	85- 86	102-104

# CONTENTS - Cont'd

	Paragraphs	Pages
<b>CHAPTER 10. CAB</b> .....	87- 90	105-112
<b>SECTION I. Description and data of cab</b> .....	87	105
<b>II. Removal of cab</b> .....	88	105-110
<b>III. Cleaning, inspection, and repair of cab, tool boxes, doors, and shutters</b> .....	89	111-112
<b>IV. Installation of cab</b> .....	90	112
<b>CHAPTER 11. ELECTRIC LIGHTING SYTEM AND ACCESSORIES</b> .....	91-108	113-140
<b>SECTION I. Description and data of electric lighting system and accessories</b> .....	91	113-114
<b>II. Combination blinker and spotlight</b> .....	92- 96	115-123
<b>III. Siren with light</b> .....	97-101	123-127
<b>IV. Trailer wiring junction box</b> .....	102-103	127-130
<b>V. Low-pressure air indicator buzzer</b> .....	104-105	131-134
<b>VI. Windshield wipers</b> .....	106-107	134-139
<b>VII. Fits and tolerances</b> .....	108	139-140
<b>CHAPTER 12. FRAME</b> .....	109-111	141-142
<b>SECTION I. Description and data of frame</b> ..	109	141
<b>II. Testing of frame</b> .....	110	141-142
<b>III. Disassembly, cleaning, inspection, repair, and assembly of frame</b> .....	111	142
<b>CHAPTER 13. SPECIAL TOOLS AND EQUIPMENT</b> .....	112	143
<b>REFERENCES</b> .....		144-145
<b>INDEX</b> .....		146-151

**ORDNANCE MAINTENANCE — BODY, CHASSIS, AND WINCHES FOR TRACTOR TRUCK M26, COMPONENT OF 40-TON TANK TRANSPORTER TRAILER TRUCK M25**

**CHAPTER 1**

**INTRODUCTION**

	Paragraph
Scope .....	1
FSMWO and major unit assembly replacement record.....	2

**1. SCOPE.**

a. The instructions contained in this manual are for the information and guidance of personnel charged with the maintenance and repair of Tractor Truck M26. These instructions are supplementary to field and technical manuals prepared for the using arms. This manual does not contain information which is intended primarily for the using arms, since such information is available to ordnance maintenance personnel in 100-series TM's or FM's.

b. This manual contains a description of, and procedure for removal, disassembly, cleaning, inspection, repair and rebuilding, assembly, testing and adjustment, and installation of the steering gear, brakes, cab, winches, frame, springs, and electric lighting system and accessories of the Tractor Truck M26.

c. TM 9-767 contains operating and second echelon maintenance information for 40-ton Tank Transporter Trailer Truck M25, which includes Tractor Truck M26 and Semitrailer M15.

d. TM 9-1767A contains descriptive and maintenance procedure information as outlined in preceding subparagraph b above for the engine, engine accessories, ignition system, cooling system, engine lubrication system and clutch.

e. TM 9-1767B contains descriptive and maintenance procedure information as outlined in preceding subparagraph b above for the power train which consists of the transmission, auxiliary transmission, transfer case, declutch assembly for front axle, power take-off for the front winch, power take-off for the tandem winch assembly, propeller shafts and universal joints, front axle assembly, rear axle assembly, and wheels, hubs and tires.

f. TM 9-1767D contains descriptive and maintenance procedure information as outlined in preceding subparagraph b above for the Semitrailer M15.

g. Complete maintenance information on air brake system and electrical equipment is contained in the following manuals:

- TM 9-1825B — Electrical equipment.
- TM 9-1827A — Power brake system.

**INTRODUCTION****2. FSMWO AND MAJOR UNIT ASSEMBLY REPLACEMENT RECORD.**

**a. Description.** Every vehicle is supplied with a copy of AGO Form No. 478 which provides a means of keeping a record of each FSMWO completed or major unit assembly replaced. This form includes spaces for the vehicle name and U.S.A. Registration Number, instructions for use, and information pertinent to the work accomplished. It is very important that the form be used as directed and that it remain with the vehicle until the vehicle is removed from service.

**b. Instructions for Use.** Personnel performing modifications or major unit assembly replacements must record clearly on the form, a description of the work completed and must initial the form in the columns provided. When each modification is completed, record the date, hours and/or mileage, and FSMWO number. When major unit assemblies, such as engines, transmissions, transfer cases, are replaced, record the date, hours and/or mileage, and nomenclature of the unit assembly. Minor repairs and minor parts, and accessory replacements need not be recorded.

**c. Early Modifications.** Upon receipt by a third or fourth echelon repair facility of a vehicle for modification or repair, maintenance personnel will record the FSMWO numbers of modifications applied prior to the date of AGO Form No. 478.

**ORDNANCE MAINTENANCE – BODY, CHASSIS, AND WINCHES FOR TRACTOR TRUCK M26, COMPONENT OF 40-TON TANK TRANSPORTER TRAILER TRUCK M25**

**CHAPTER 2**

**STEERING SYSTEM**

**Section I**

**DESCRIPTION AND OPERATION OF STEERING GEAR AND HYDRAULIC SYSTEM**

Description and operation .....	Paragraph 3
---------------------------------	----------------

**3. DESCRIPTION AND OPERATION.**

**a. Description.** The steering system consists of a steering gear assembly which is bolted to the chassis frame and is connected to the front axle steering knuckles by a drag link. The steering gear is of the cam and lever type, to which has been added a hydraulic power system. The cam and lever principle consists of a special worm of variable ratio, which engages an internal lever on the side of the worm. The worm has a tapered groove which engages a tapered stud on the lever. The lever is an integral part of the cross shaft to which the steering arm is attached. The mechanism to transmit hydraulic power to the steering gears consists of a hydraulic pump and reservoir, valve, and power cylinder.

**b. Operation.** The hydraulic power is applied to the cross shaft through an extension of the lever which contacts a sliding block through a roller bearing. The sliding block is operated in either direction by the power cylinder and piston. The flow of oil to the cylinder is directed by the control valve. The oil is supplied by the hydraulic pump on the engine driven by an accessory shaft. The by-pass valve of the pump is set for a maximum pressure of 750 pounds per square inch. When the cam is turned to the right or left by turning the steering wheel, the stud of the lever is moved through the groove of the cam. The lever shaft is rotated and the steering arm moves in an angular direction. Whenever the effort at the steering wheel exceeds the preload of the control valve centering springs, the hydraulic system comes into operation automatically and assists the vehicle operator in turning. In addition to acting as a booster, the hydraulic system resists kick backs or shocks which might cause the operator to lose control of the vehicle. The spool in the valve moves axially with the camshaft, however, the two parts are restrained from axial movement by the pressure of the centering springs and the oil against the plungers. Both of these effects tend to center the spool and thus hold the valve in a neutral position, in which position there is a balance of pressure

## STEERING SYSTEM

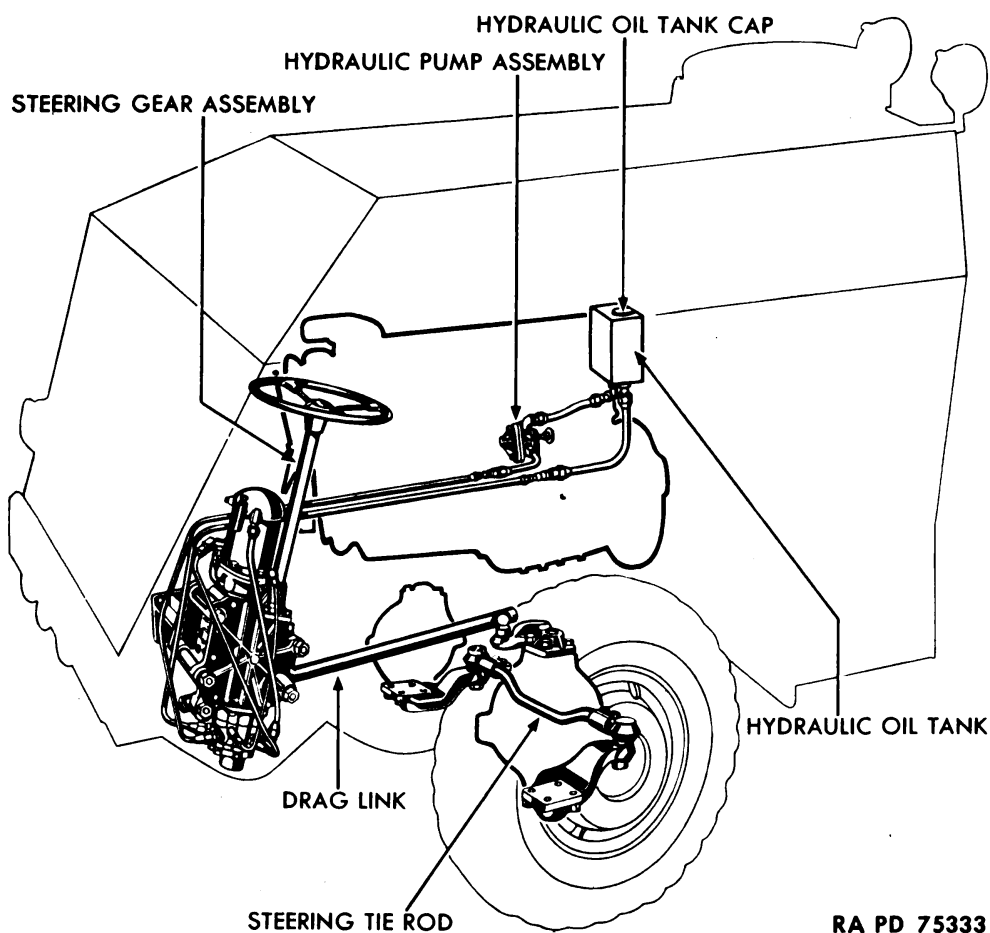

RA PD 75333

**Figure 1 – Hydraulic Steering System – Schematic View**

in the power cylinder. Whenever the effort at the steering wheel overcomes the preload of the centering springs, the valve spool is moved axially. Instantaneously the direction of oil flow is changed, causing an unbalance in the power cylinder. The immediate effect is hydraulic pressure in an end of the cylinder to actuate the piston which applies hydraulic power directly to the inner lever of the gear. Whenever the effort at the steering wheel is released, the valve spool is returned to the center position, and the pressure in the power cylinder becomes balanced. Shocks or kick-backs cause a similar function of the hydraulic system, thus preventing a kick-back at the steering wheel.

**ORDNANCE MAINTENANCE — BODY, CHASSIS, AND WINCHES FOR TRACTOR TRUCK M26, COMPONENT OF 40-TON TANK TRANSPORTER TRAILER TRUCK M25**

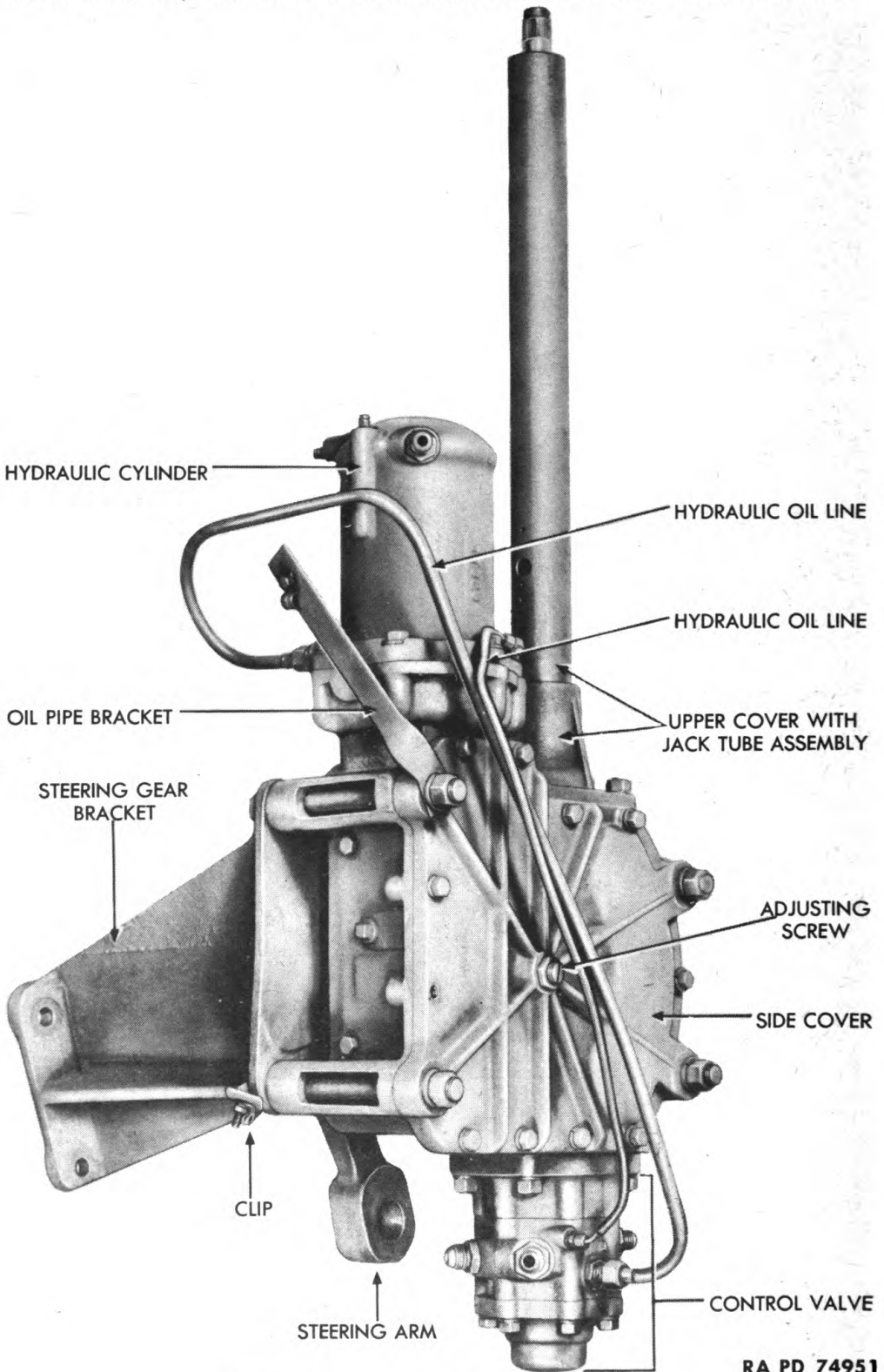

RA PD 74951

**Figure 2 — Steering Gear Assembly**

STEERING SYSTEM

Section II

STEERING GEAR HYDRAULIC PUMP

	Paragraph
Description and data .....	4
Test .....	5
Disassembly .....	6
Cleaning, inspection, and repair .....	7
Assembly .....	8
Test of rebuilt unit.....	9

4. DESCRIPTION AND DATA.

a. **Description** (fig. 3). The hydraulic pump is a rotor type pump mounted on the left side of the engine. The hydraulic pump housing has a cover secured by cap screws and contains the rotor mechanism and the by-pass valve. The pump drive shaft, which is driven by the engine, has the inner rotor secured to it by a key. This inner rotor has six lugs which revolve in seven grooves of the outer rotor. The outer rotor operates in a bushing contained in the housing. The by-pass valve is spring-loaded and is retained in the housing by a by-pass valve plug.

b. **Operation.** The hydraulic pump is in operation during the time the engine is running and is driven from the governor drive shaft through a flexible coupling on the end of the pump drive shaft. When the hydraulic oil, which is piped to the pump from the reservoir, reaches a pressure of 750 pounds per square inch, the by-pass valve automatically opens, and the oil by-passes the rotors so that the control valve on the end of the steering gear does not receive more oil under pressure.

c. **Data.**

Make .....	Bendix
Model .....	332872
Type .....	Rotor

5. TEST.

a. Disconnect the hydraulic oil line which connects pump to steering control valve and attach a gage to the line. The gage must be graduated from 500 to 1,000 pounds. Start engine and read gage; if reading is less than 750 pounds, remove pump (TM 9-767) and rebuild.

6. DISASSEMBLY.

a. **Remove Coupling** (fig. 3). Unscrew elbow (pump to reservoir) from hydraulic pump body. Remove two cap screws and nuts which hold flexible coupling to flexible coupling flange, and remove

**ORDNANCE MAINTENANCE — BODY, CHASSIS, AND WINCHES FOR TRACTOR TRUCK M26, COMPONENT OF 40-TON TANK TRANSPORTER TRAILER TRUCK M25**

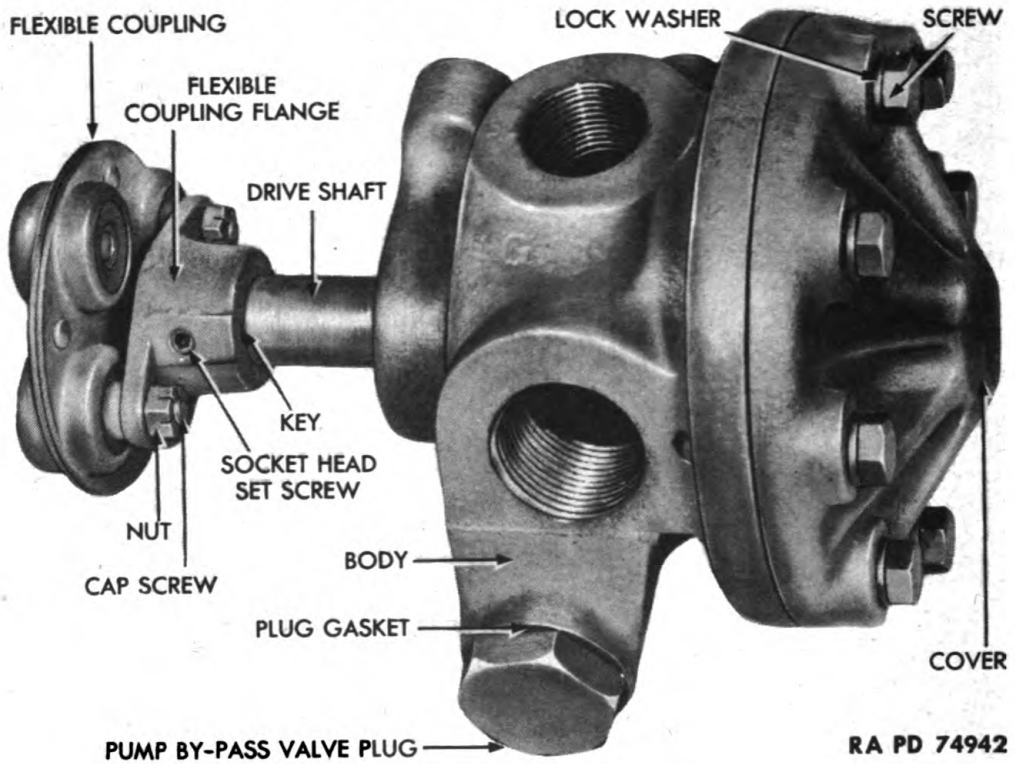

RA PD 74942

**Figure 3 — Hydraulic Pump**

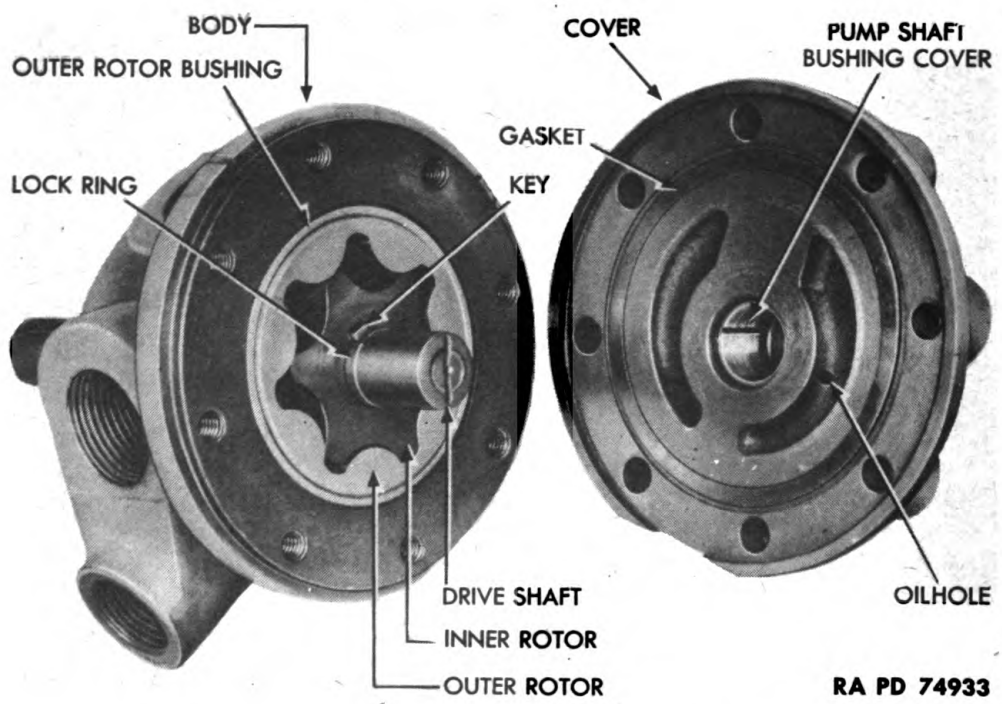

RA PD 74933

**Figure 4 — Hydraulic Pump-cover Removed**

## STEERING SYSTEM

coupling. Remove socket head set screw from flexible coupling. Remove socket head set screw from flexible coupling flange, remove the flange, and lift key from hydraulic pump drive shaft.

b. **Remove Cover and By-pass Valve** (figs. 3 and 4). Remove eight screws and lock washers which hold hydraulic pump cover to hydraulic pump body, and lift cover and gasket off body. Remove pump to steering gear pipe fitting from hydraulic pump body, then remove pump by-pass valve plug and plug gasket. Remove pump by-pass valve spring, plunger, and by-pass valve from hydraulic pump body (fig. 5).

c. **Remove Inner and Outer Rotors** (figs. 4 and 5). Remove key from hydraulic pump drive shaft by pushing shaft to rear. Remove lock ring from shaft, and pull shaft out of hydraulic pump body. Pull hydraulic pump inner rotor out of hydraulic pump outer rotor, and remove outer rotor bushing out of hydraulic pump body.

### 7. CLEANING, INSPECTION, AND REPAIR.

a. **Cleaning.** Remove all oil with dry-cleaning solvent, and dry with compressed air.

b. **Inspection and Repair.** Inspect hydraulic pump shaft bushings in the cover and body, and if surfaces are scored, press bushings out of cover or body, and replace. Press oil seals out of body and use new parts. Inspect outer rotor bushing in body and if scored, press out bushing and install new part. Inspect all threads for burs or cross threads, and straighten threads with thread die or tap, if necessary. Install key in drive shaft, and try inner rotor on key. There must be not over 0.003-inch clearance.

### 8. ASSEMBLY.

a. **Install Drive Shaft and By-pass Valve** (fig. 5). Install shaft in body and fasten with lock ring, then install key in drive shaft. Install by-pass valve, plunger, and by-pass valve spring in body. Install plug gasket and plug in body, then install pump to steering gear pipe fitting in body.

b. **Install Cover and Coupling** (fig. 5). Install gasket and cover on body, and fasten with eight screws and lock washers. Install key in drive shaft and install flexible coupling flange, then fasten with set screw. Install flexible coupling, and fasten with two cap screws and nuts. Screw elbow (pump to reservoir) in body.

### 9. TEST OF REBUILT UNIT.

a. The pump must be tested after installation (par. 5). If it does not test to 750 pounds, remove and rebuild, as the pump cannot be adjusted.

ORDNANCE MAINTENANCE — BODY, CHASSIS, AND WINCHES FOR TRACTOR TRUCK M26, COMPONENT OF .40-TON TANK TRANSPORTER TRAILER TRUCK M25

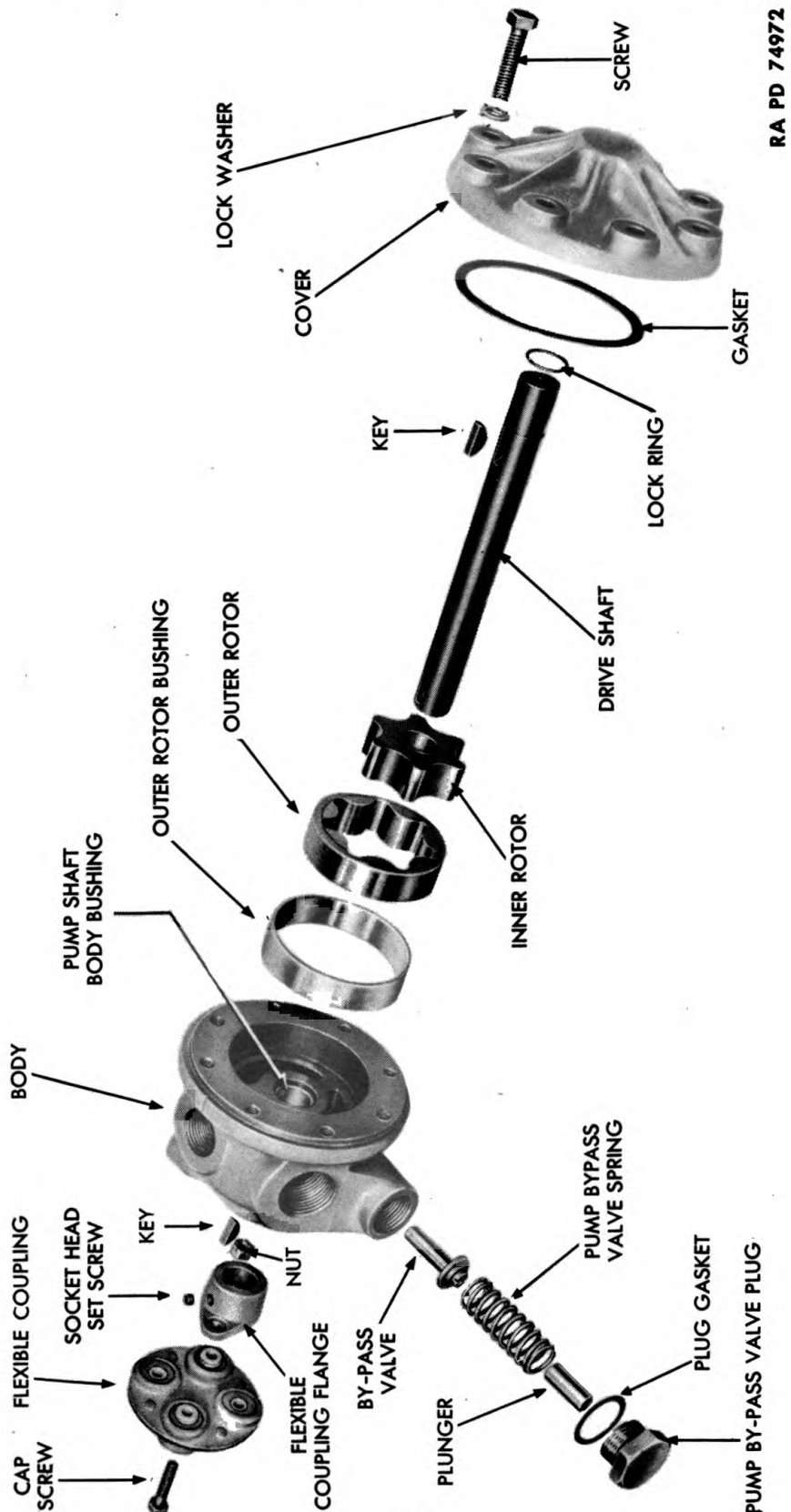

RA PD 74972

Figure 5 — Hydraulic Pump — Disassembled

STEERING SYSTEM

Section III

STEERING GEAR HYDRAULIC CONTROL VALVE

	Paragraph
Description and data .....	10
Test .....	11
Disassembly .....	12
Cleaning, inspection, and repair.....	13
Assembly .....	14
Test of rebuilt unit.....	15

10. DESCRIPTION AND DATA (figs. 6 and 7).

a. **Description.** The hydraulic control valve is a spring-loaded plunger type of valve which is secured to the bottom of the steering gear. The valve is connected to the hydraulic pump and to both ends of the hydraulic cylinder by pipes. Inside the housing are four pair of plungers separated from each other by coil springs, and in a central bore of the housing is a machined spool having three ground surfaces and two grooved sections. This spool fits over the lower end of the steering gear camshaft.

b. **Operation.** Hydraulic oil from the pump is piped to the control valve under a 750-pound per square inch pressure. Whenever effort at the steering wheel overcomes the preload of the plunger springs, the spool is moved axially with the camshaft, and the direction of oil flow is changed, causing an unbalance in the cylinder. This acts against the piston and causes it to move, thereby applying power to the inner lever of the steering gear. When no effort is applied at the steering wheel, the pressure of the plunger springs and the oil against the plungers tend to center the spool and hold the valve in its neutral position.

c. **Data.**

Make ..... Ross  
Model ..... 780

11. TEST.

a. The control valve must be tested with the steering gear on the vehicle. Remove oil line to hydraulic cylinder, and attach a pressure gage. Start engine and read gage. If pressure does not read 750 pounds, remove valve and rebuild.

**ORDNANCE MAINTENANCE — BODY, CHASSIS, AND WINCHES FOR TRACTOR TRUCK M26, COMPONENT OF 40-TON TANK TRANSPORTER TRAILER TRUCK M25**

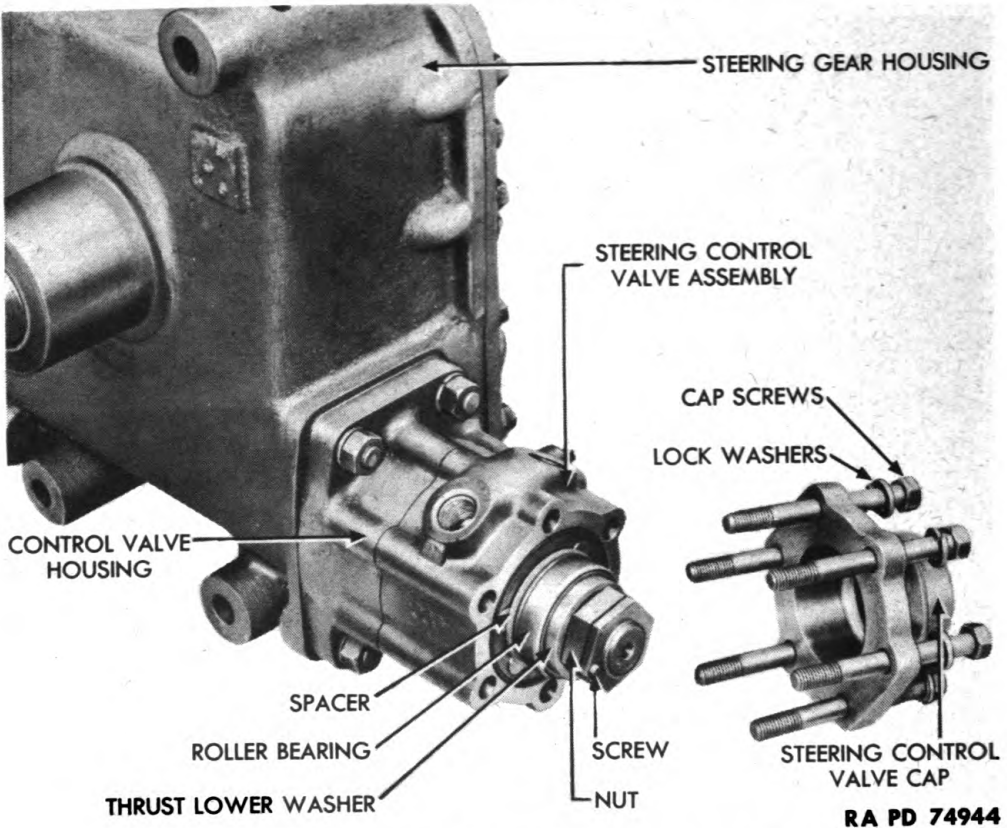

**Figure 6 — Steering Control Valve — Installed**

**12. DISASSEMBLY.**

a. **Remove Steering Control Valve** (figs. 6 and 7). Remove cap screws and lock washers that hold steering control valve cap on steering valve housing and remove cap. Remove screw from steering control valve cap nut. Then remove nut, camshaft valve lower thrust washers, control valve roller bearing, and spacer from worm shaft. Pull steering control valve assembly off steering gear, and remove remaining roller bearing and camshaft valve upper washer.

b. **Disassemble Steering Control Valve** (fig. 8). Remove eight steering control valve plungers and four steering control valve springs from valve, then remove spool from valve.

**13. CLEANING, INSPECTION, AND REPAIR.**

a. **Cleaning.** Remove all oil with dry-cleaning solvent, and dry with compressed air.

b. **Inspection and Repair.** Inspect machined surfaces for scoring, and replace part, if scored, as the close machining does not permit repair. Inspect four control valve springs; they must be of same

STEERING SYSTEM

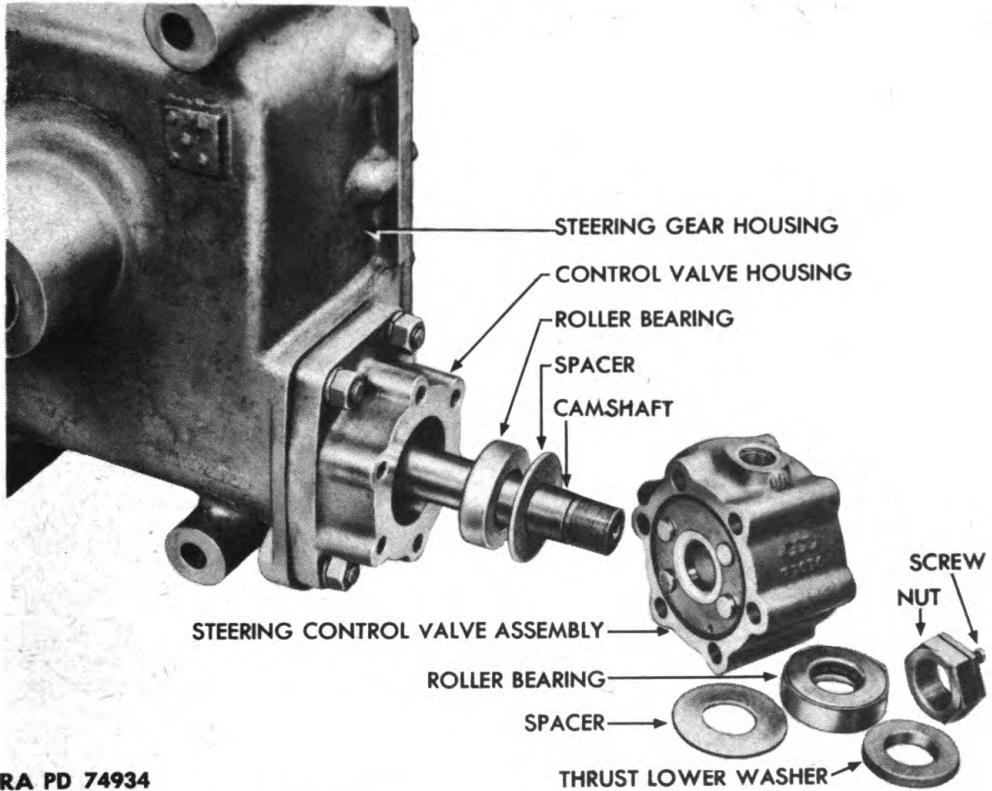

RA PD 74934

Figure 7— Steering Control Valve — Removed

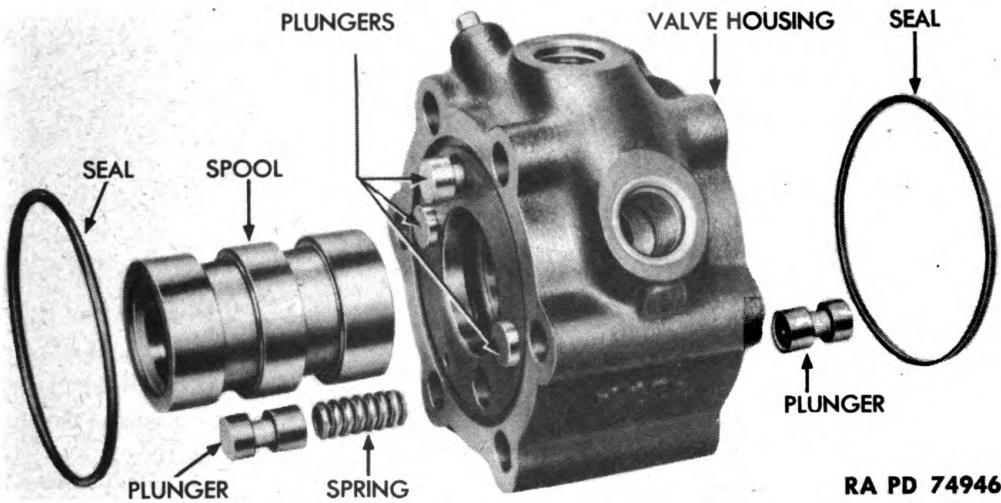

RA PD 74946

Figure 8 — Steering Control Valve — Disassembled

height. Remove and discard oil seals in valve housing, and use new parts. Install plunger in valve housing, and measure clearance which must be not over 0.001 inch. Install spool in valve housing, and measure clearance which must not be over 0.001 inch. Inspect seals

**ORDNANCE MAINTENANCE — BODY, CHASSIS, AND WINCHES FOR TRACTOR TRUCK M26, COMPONENT OF 40-TON TANK TRANSPORTER TRAILER TRUCK M25**

for breaks or brittleness, and use new parts if seals are broken or brittle. Inspect valve housing for fractures, and use new part if damaged.

**14. ASSEMBLY.**

a. **Assemble Control Valve** (fig. 8). Install two new seals in valve, then install spool in valve. Install eight plungers and four valve springs in valve.

b. **Install Steering Control Valve** (figs. 6 and 7). Install steering control valve assembly on steering gear, then install spacer, control valve thrust roller bearing, camshaft valve thrust lower washer, and nut on worm shaft. Install steering control valve cap nut on worm shaft, and install valve fillister head screw. Install steering control valve cap on steering control valve housing, and fasten with cap screws and lock washers.

**15. TEST OF REBUILT UNIT.**

a. **Test.** The control valve must be tested in the same manner as in paragraph 11.

---

**Section IV**

**STEERING HYDRAULIC CYLINDER**

	Paragraph
Description and data .....	16
Disassembly .....	17
Cleaning, inspection, and repair.....	18
Assembly .....	19

**16. DESCRIPTION AND DATA.**

a. **Description** (fig. 9). The steering hydraulic cylinder is a hollow steel casting that is secured to the top of the steering gear housing. Oil lines connect the control valve to the top and bottom of the cylinder. The hydraulic steering piston operates inside the cylinder, and the piston is secured on one end of the piston rod. The opposite end of the piston rod is secured to a slide block in which the steering lever bearing operates. The cam stud is mounted on roller bearings in the opposite end of the lever and engages the cam grooves.

b. **Operation.** Effort at the steering wheel operates the control valve which delivers hydraulic oil under pressure to either end of the cylinder, depending upon which direction the steering wheel was

**STEERING SYSTEM**

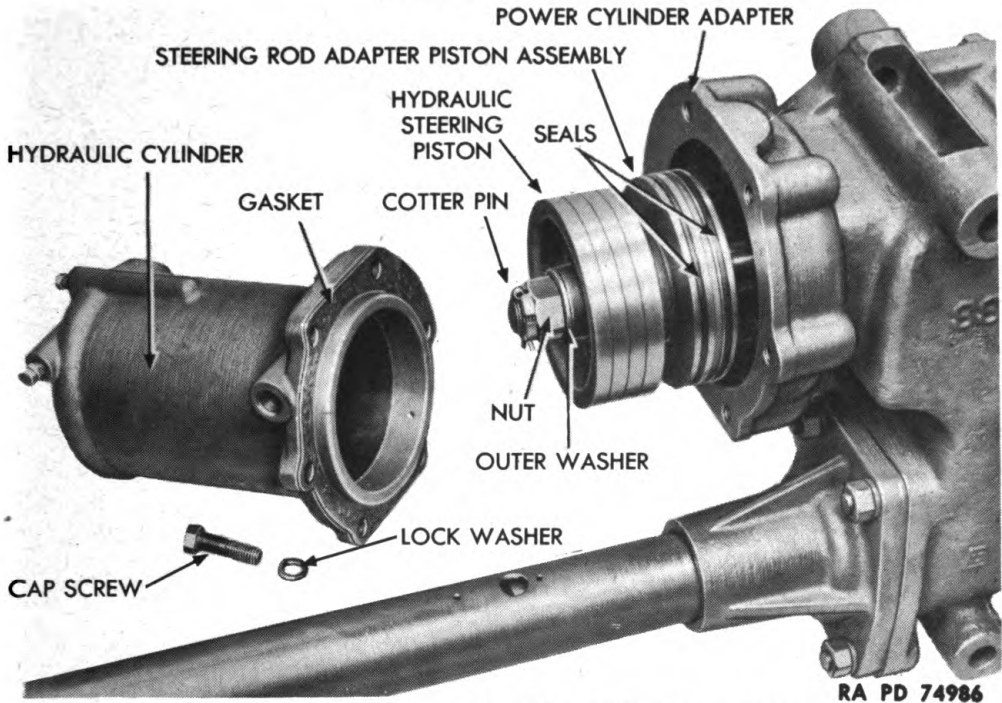

**Figure 9 – Steering Hydraulic Cylinder – Removed**

moved in. The oil pressure moves the piston, which applies power directly to the steering lever and the turn to the right or left is made. When the steering wheel is turned to bring the front wheels into a straight-ahead position, hydraulic power from the opposite end of the cylinder is transmitted to the piston and steering lever to assist in its movement.

**c. Data.**

Make ..... Ross  
Model ..... 780

**17. DISASSEMBLY.**

**a. Disassemble Piston** (figs. 9 and 16). Remove cap screws and lock washers that hold steering hydraulic cylinder, and remove cylinder with gasket. Remove cotter pin and nut from piston pin. Then remove piston pin outer washer, piston, piston pin inner washer, and steering rod adapter piston assembly from piston pin. Remove two steering power seals from piston, then remove oil seal.

**18. CLEANING, INSPECTION, AND REPAIR.**

**a. Cleaning.** Wash all metal parts with dry-cleaning solvent, and dry with compressed air.

**b. Inspection and Repair.** Inspect seals for breaks or brittleness, and use new parts, if seals are broken or brittle. Insert piston into

**ORDNANCE MAINTENANCE — BODY, CHASSIS, AND WINCHES FOR TRACTOR TRUCK M26, COMPONENT OF 40-TON TANK TRANSPORTER TRAILER TRUCK M25**

cylinder, and measure clearance. If clearance is over 0.002 inch, use new piston. Inspect machined surfaces for scores, and use new part, if scored, as the close fitting does not permit repair. Inspect inner and outer washers for scoring or burs, and, if found, smooth parts with crocus cloth. Use new oil seal in piston.

**19. ASSEMBLY.**

a. **Assemble Piston** (figs. 9 and 16). Install two steering power and oil seal rings on piston. Install steering rod adapter piston, inner washer, hydraulic steering piston, and piston pin outer washer on piston pin. Install nut and cotter pin on piston pin. Install cylinder with gasket on steering housing, and fasten with cap screws and lock washers.

---

**Section V**

**STEERING GEAR**

	Paragraph
Description and data .....	20
Removal .....	21
Disassembly .....	22
Cleaning, inspection, and repair.....	23
Assembly .....	24
Installation .....	25

**20. DESCRIPTION AND DATA** (fig. 2).

a. **Description.** The steering gear is of the cam and lever type for operation by the steering wheel and the hydraulic power system has been added to this. The cam is located in a housing at the lower end of the steering gear shaft. The steering lever shaft pivots in a bushing which is secured in the housing casting. The tapered stud in the lower end of the steering lever meshes with the tapered grooves of the cam. The housing has a cover which is secured by cap screws. The steering wheel is secured to the upper end of the cam and shaft. The hydraulic control valve is secured to the bottom of the steering gear housing, and the hydraulic cylinder is secured to the top of the housing. The steering lever shaft extends through the gear housing and has the steering Pitman arm secured to it.

b. **Operation.** The driver's effort at the steering wheel causes the stud on the steering lever shaft to move in the groove of the cam, thereby rotating the steering lever shaft and providing angular movement of the steering arm.

STEERING SYSTEM

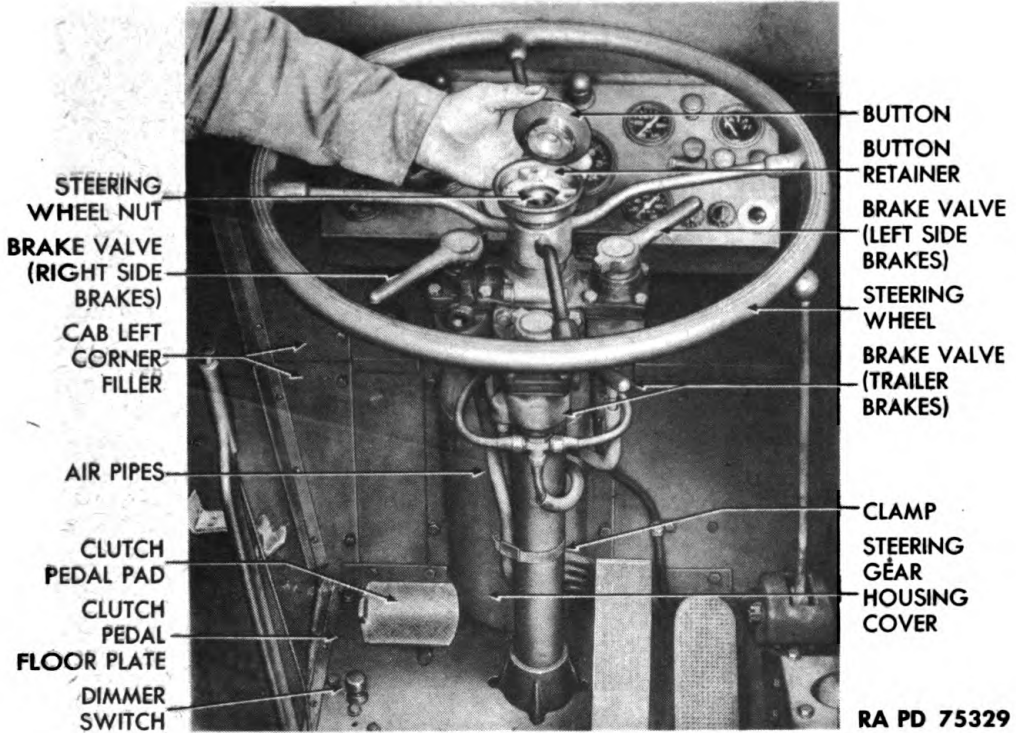

Figure 10 – Removing Steering Wheel Button

c. Data.

Make ..... Ross Gear  
Model ..... 780

21. REMOVAL.

a. **Remove Steering Wheel and Air Valves (fig. 10).** Remove button in center of steering wheel by pressing down on button while simultaneously turning button in either direction. Lift button off, remove three screws that hold button retainer, and remove retainer. Remove steering wheel nut, and pull wheel up and off column. Remove two bolts, nuts, and lock washers which hold right and left air valve bracket to steering column. Remove two bolts, nuts, and lock washers that hold trailer air valve bracket to steering column. Loosen clamp that holds air pipes to steering column, and lower valves to cab floor.

b. **Remove Steering Gear Housing Cover (fig. 10).** Remove cab left corner filler by removing five cap screws and lock washers and two nuts and lock washers from two bolts. Remove steering gear housing cover by removing five cap screws and lock washers, then remove bolt, nut, and lock washers that holds clutch pedal pad on clutch pedal and remove pad.

**ORDNANCE MAINTENANCE — BODY, CHASSIS, AND WINCHES FOR TRACTOR TRUCK M26, COMPONENT OF 40-TON TANK TRANSPORTER TRAILER TRUCK M25**

CLUTCH CROSS TUBE

CLUTCH PEDAL

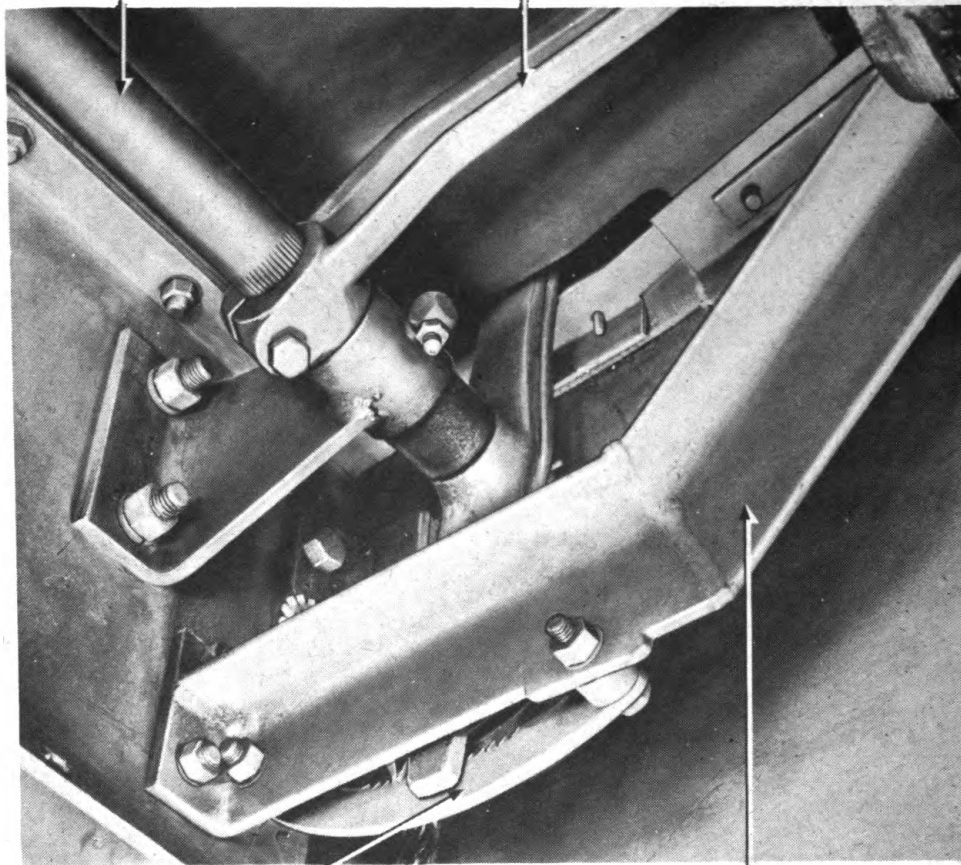

HAND BRAKE QUADRANT

DASH TO FRAME BRACKET

RA PD 75312

**Figure 11 — Dash to Frame Bracket**

c. **Remove Clutch Pedal Floor Plate and Steering Gear Bottom Cover** (figs. 10 and 11). Remove five cap screws and lock washers that hold clutch pedal floor plate to floor, and remove two cap screws that hold dimmer switch in place. Lift floor plate off floor and over clutch pedal. Remove bolts, nuts, and lock washers that hold steering gear bottom cover on frame and remove cover.

d. **Remove Dash to Frame Bracket** (fig. 11). Remove two bolts, nuts, and lock washers that hold left dash to frame bracket to frame, and remove bracket (with dash left filler plate and hand brake quadrant). Disconnect adjustable rod at clutch throw-out shaft and at clutch cross tube.

e. **Remove Steering Pitman Arm and Disconnect Hydraulic Lines** (fig. 12). Mark position of arm on lever shaft, remove cotter pin and nut that holds steering arm to drag link, and remove drag link from arm. Remove four bolts, nuts, and lock washers that hold

**STEERING SYSTEM**

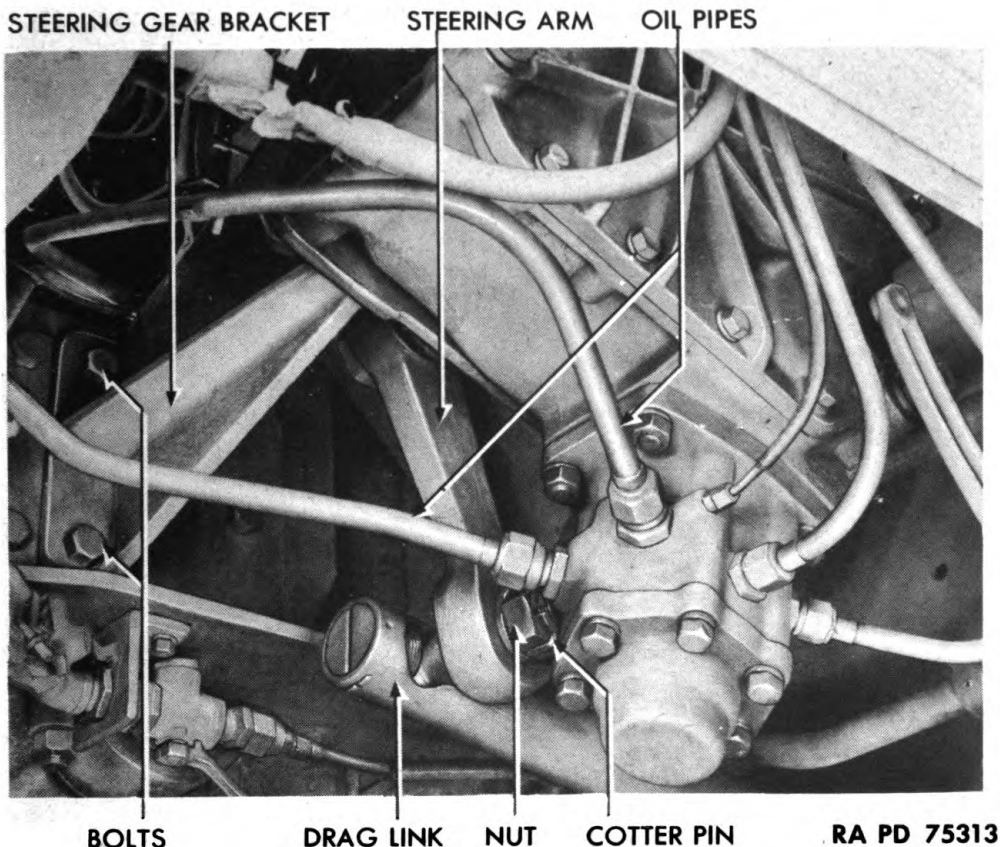

**Figure 12 — Steering Gear — Installed**

steering gear bracket to frame. Disconnect two oil pipes connected to steering gear housing, and catch hydraulic oil in clean container. Remove nut on steering gear housing that holds the hydraulic pipe clamp, loosen bolts holding pipes in clamp, and remove clamp.

f. **Remove Steering Gear** (fig. 13). Remove clamp (in cab) that holds pipes to steering column. Disconnect two pipes from left side brake valve and remove valve. Disconnect three pipes from trailer brake valve. Disconnect two pipes on right side brake valve. Loosen bolt and nut that holds speedometer cable to bracket on steering gear. Raise windshield armor plate shield, and attach loose chain around steering gear and to a chain hoist. Operate chain hoist through windshield opening in cab. Move steering gear to left until it clears the frame, and lower steering gear with steering gear bracket from chassis.

**22. DISASSEMBLY.**

a. **Remove Bracket** (fig. 2). Remove nut and lock washer which holds steering Pitman arm, and pull off arm. Remove bolts, nuts, and lock washers that hold steering bracket, and remove bracket. Remove tubing clip and oil pipe bracket. Unscrew four oil pipe nuts, and remove two oil pipes.

**ORDNANCE MAINTENANCE — BODY, CHASSIS, AND WINCHES FOR TRACTOR TRUCK M26, COMPONENT OF 40-TON TANK TRANSPORTER TRAILER TRUCK M25**

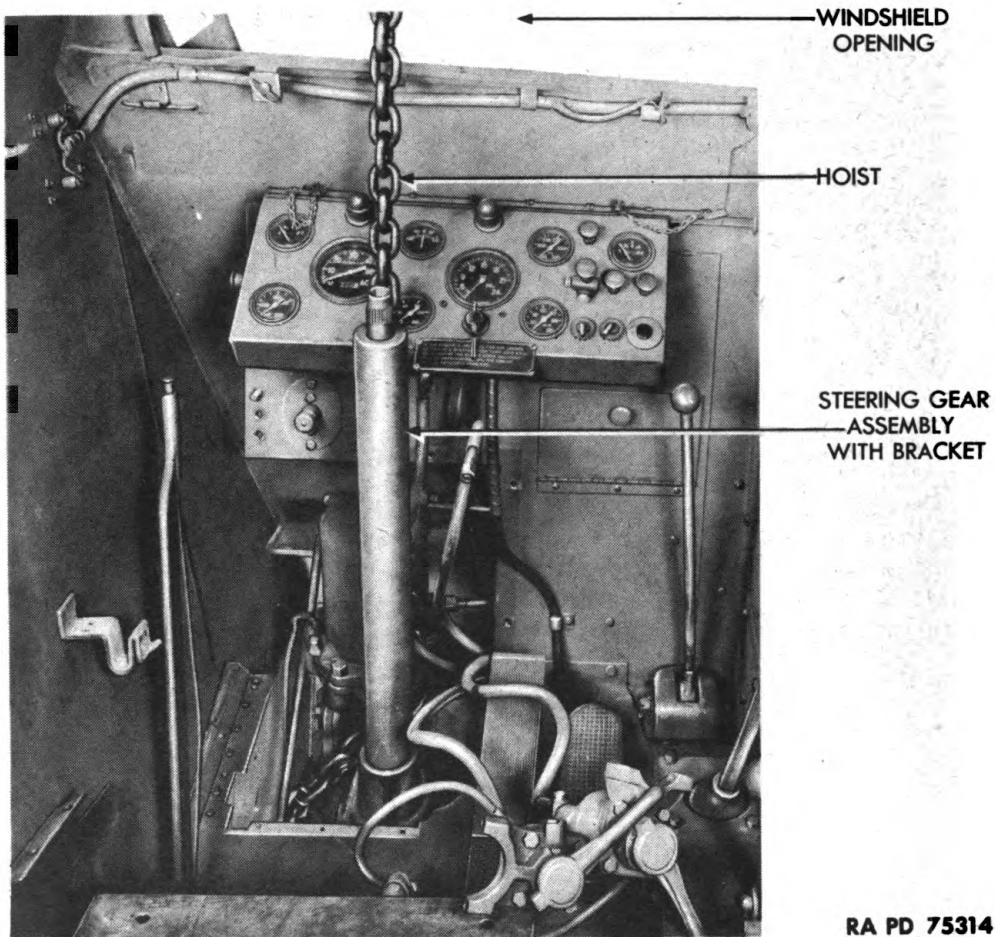

RA PD 75314

**Figure 13 — Removing Steering Gear with Bracket**

**b. Disassemble Housing (fig. 14).** Remove cap screws and lock washers that hold side cover on housing, and remove cover and cover gasket. Remove adjusting screw and lock nut. Lift steering lever shaft assembly out of housing.

**c. Remove Slides and Slide Block (fig. 14).** Remove two cotter pins, and pull pin out of slide block, then pull piston rod out of housing. Remove four cap screws and lock washers, and remove slides and slide block.

**d. Remove Upper Cover and Cam and Shaft (fig. 16).** Remove four nuts and lock washers that hold upper cover to steering housing, and remove upper cover with jack tube assembly. Remove gasket. Remove four nuts and lock washers that hold control valve housing to steering gear housing, and remove valve housing and gasket. Remove bushing and oil seal from housing. Remove cam and shaft.

STEERING SYSTEM

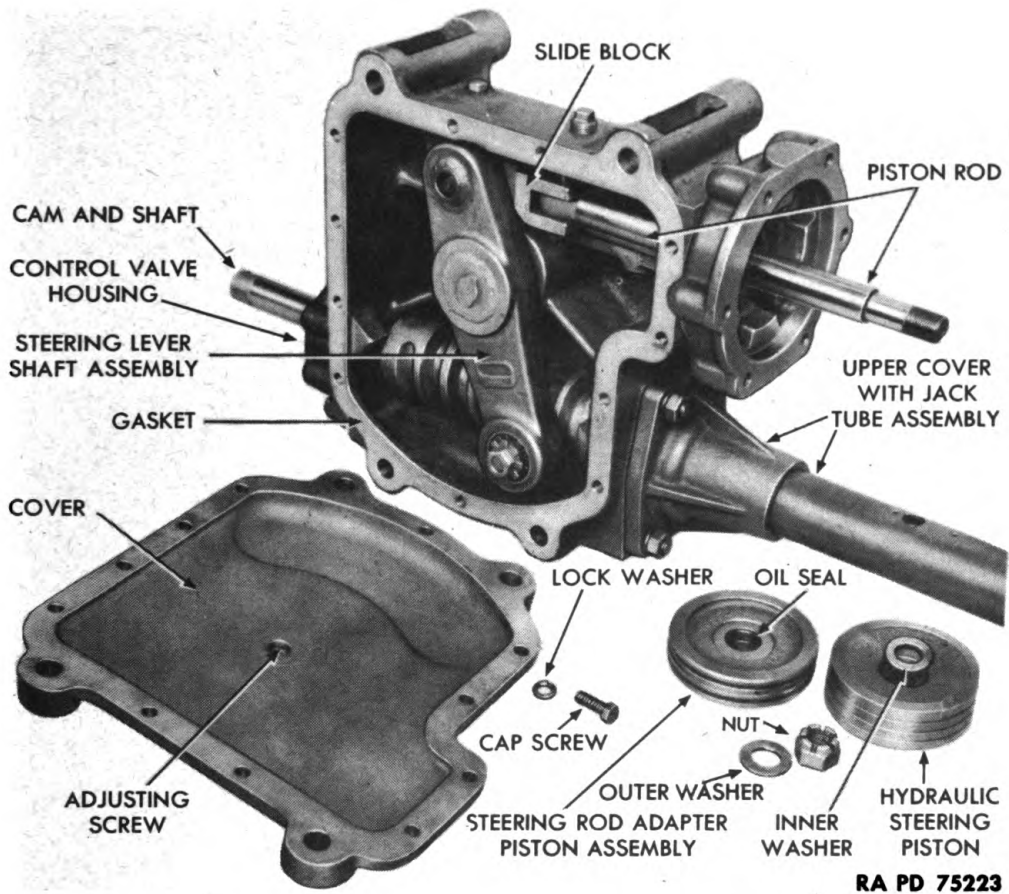

Figure 14 - Steering Gear Housing - Cover Removed

e. Remove Cylinder Housing and Lever Shaft Bushing (fig. 16). Remove nuts and lock washers that hold cylinder housing to gear housing, and remove cylinder housing and gasket. Press steering lever shaft bushing out of housing.

f. Disassemble Steering Lever Shaft (figs. 14 and 15). Straighten leg of washer, and remove nut and washer. Drive stud out of shaft, and remove rollers. Press cones out of shaft.

23. CLEANING, INSPECTION, AND REPAIR.

a. Cleaning. Wash all parts in dry-cleaning solvent, and dry with compressed air.

b. Inspection and Repair. Inspect machined surfaces for scoring. Light scores can be removed with crocus cloth, and heavy scores require replacement of a new part. Inspect threads for mashed or crossed threads, and straighten with thread die or tap. Insert

ORDNANCE MAINTENANCE — BODY, CHASSIS, AND WINCHES FOR TRACTOR  
TRUCK M26, COMPONENT OF 40-TON TANK TRANSPORTER TRAILER TRUCK M25

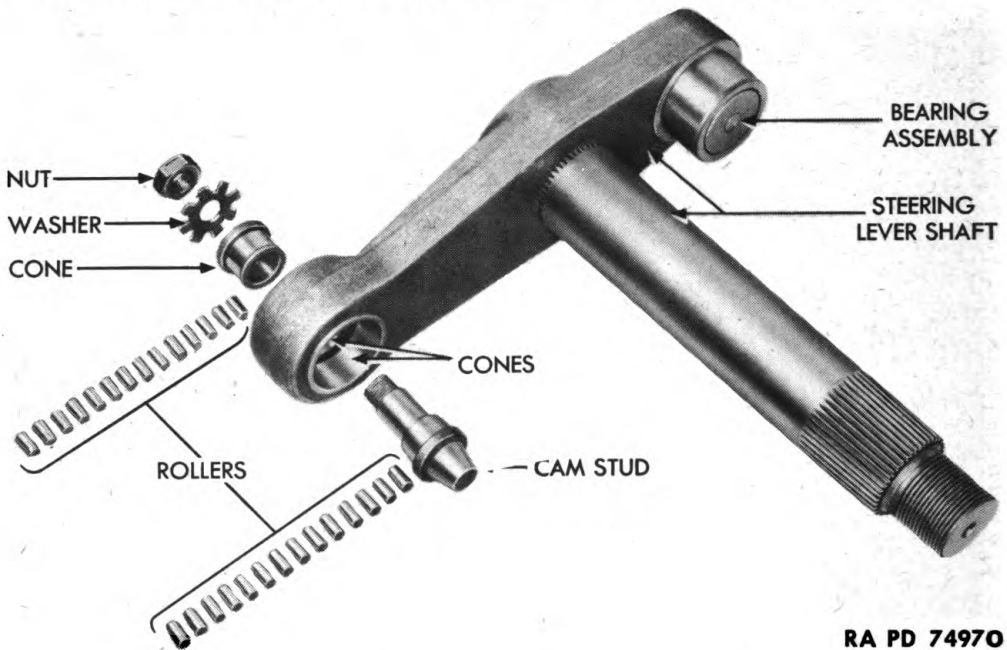

Figure 15 — Steering Lever Shaft — Disassembled

steering lever shaft in bushing and measure clearance. Use new bushing if clearance exceeds 0.003 inch. Inspect stud, cones, and roller for scoring or chipping, and replace part if scored or chipped. NOTE: *These parts must not be repaired.*

24. ASSEMBLY.

a. Assemble Steering Lever Shaft (fig. 15). Press cones in shaft, lay grease on cones, and install rollers. Drive stud onto shaft, and install washer and nut. Bend leg of washer against nut.

b. Assemble Steering Housing (figs. 14 and 16). Install cylinder housing and gasket on steering housing, and fasten with nuts and lock washers. Press two camshaft upper and lower bushings and steering lever shaft bushings in housing. Install worm and shaft.

c. Assemble Valve Housing (fig. 16). Install bushing and oil seal in control valve housing. Install control valve housing and gasket, and secure with four nuts and lock washers. Install slides and slide block, and fasten slides with four cap screws and lock washers. Install piston rod in housing, and attach piston rod to slide block with pin and two cotter pins. Install steering lever shaft assembly in housing.

d. Install Side Cover (fig. 16) Install side cover and cover gasket on housing, and fasten with cap screws and lock washers. Install adjusting screw and lock nut turning screw up snug; then tighten nut.

## STEERING SYSTEM

e. **Install Bracket.** Install two hydraulic oil pipes; then install oil pipe bracket and tubing clip. Install steering gear bracket, and fasten with bolts, nuts, and lock washers. Install steering Pitman arm, and fasten with lock washer and nut.

### 25. INSTALLATION.

a. **Install Steering Gear (fig. 13).** Attach steering gear assembly with bracket to a hoist, and raise gear assembly from bottom up into cab. Install four bolts, nuts, and lock washers that hold steering gear bracket to frame.

b. **Connect Speedometer Cable and Steering Gear Pipes (fig. 2).** Connect speedometer cable to bracket on steering gear. Connect two pipes to right side brake valve, and connect three pipes to trailer brake valve. Install left side brake valve, fasten with bolts, nuts, and lock washers, then connect two pipes. Install clamp on steering column around pipes. Install clamp on steering gear housing, then install hydraulic oil pipes in clamp and fasten with nut. Connect two oil pipes on steering gear housing.

c. **Connect Steering Arm and Clutch (fig. 12).** Fill hydraulic oil reservoir. Center steering gear, and turn front wheels in straight-ahead position. The ball on steering arm should line up with drag link. If it does not, the arm may be shifted on the splines of the lever shaft. Attach steering arm to drag link, and fasten with nut and cotter pin. Connect adjustable rod to clutch throw-out shaft and clutch cross tube. Install dash to frame bracket (with dash left filler plate and hand brake quadrant), and fasten with two bolts, nuts, and lock washers. Install steering gear bottom cover, and fasten with bolts, nuts, and lock washers.

d. **Install Clutch Pedal Pad and Dimmer Switch.** Install clutch pedal floor plate, and fasten with five cap screws and lock washers. Install dimmer switch, and fasten with two cap screws. Install clutch pedal pad, and fasten with bolt, nut, and lock washers.

e. **Install Housing Cover and Cab Left Corner Filler (fig. 10).** Install steering gear housing cover and fasten with five cap screws and lock washers. Fasten cab left corner filler by installing five cap screws and lock washers, also two nuts and lock washers.

f. **Install Air Pipes and Steering Wheel (fig. 10).** Install air pipes under clamp on steering column and tighten clamp. Connect trailer air valve to steering column with two bolts, nuts, and lock washers. Install steering wheel, and fasten with steering wheel nut. Install button retainer, and fasten with three screws. Install button.

g. **Bleed Hydraulic System.** Refer to TM 9-767.



STEERING SYSTEM

- |   |   |
|---|---|
| <b>A</b> —UPPER COVER WITH JACK TUBE ASSEMBLY | <b>Y</b> —LOCK WASHER                           |
| <b>B</b> —NUT                                 | <b>Z</b> —CAM (PART OF SHAFT)                   |
| <b>C</b> —LOCK WASHER                         | <b>AA</b> —SLIDE BLOCK                          |
| <b>D</b> —STEERING GEAR HOUSING               | <b>AB</b> —PIN                                  |
| <b>E</b> —NUT                                 | <b>AC</b> —COTTER PIN                           |
| <b>F</b> —LOCK WASHER                         | <b>AD</b> —CAP SCREW                            |
| <b>G</b> —STEERING ARM                        | <b>AE</b> —LOCK WASHER                          |
| <b>H</b> —STEERING BALL                       | <b>AF</b> —CAP SCREW                            |
| <b>J</b> —LOCK WASHER                         | <b>AG</b> —LOCK WASHER                          |
| <b>K</b> —NUT                                 | <b>AH</b> —SIDE COVER                           |
| <b>L</b> —CAM AND SHAFT                       | <b>AJ</b> —ADJUSTING SCREW                      |
| <b>M</b> —CONTROL VALVE HOUSING               | <b>AK</b> —LOCK NUT                             |
| <b>N</b> —LOCK WASHER                         | <b>AL</b> —STEERING LEVER SHAFT ASSEMBLY        |
| <b>P</b> —NUT                                 | <b>AM</b> —PISTON ROD                           |
| <b>Q</b> —STEERING CONTROL VALVE ASSEMBLY     | <b>AN</b> —STEERING ROD ADAPTER PISTON ASSEMBLY |
| <b>R</b> —SPACER                              | <b>AP</b> —PISTON PIN INNER WASHER              |
| <b>S</b> —CONTROL VALVE THRUST ROLLER BEARING | <b>AQ</b> —HYDRAULIC STEERING PISTON            |
| <b>T</b> —CAMSHAFT VALVE THRUST LOWER WASHER  | <b>AR</b> —PISTON PIN OUTER WASHER              |
| <b>U</b> —STEERING CONTROL VALVE CAP NUT      | <b>AS</b> —NUT                                  |
| <b>V</b> —VALVE FILLISTER HEAD SCREW          | <b>AT</b> —LOCK WASHER                          |
| <b>W</b> —CONTROL VALVE CAP                   | <b>AU</b> —CAP SCREW                            |
| <b>X</b> —CAP SCREW                           | <b>AV</b> —STEERING HYDRAULIC CYLINDER          |
|   | <b>AW</b> —SLIDE BLOCK BEARING PLATE GUIDES     |

RA PD 74937B

Legend for Figure 16

**ORDNANCE MAINTENANCE — BODY, CHASSIS, AND WINCHES FOR TRACTOR TRUCK M26, COMPONENT OF 40-TON TANK TRANSPORTER TRAILER TRUCK M25**

**Section VI**

**DRAG LINK**

	Paragraph
Description and data .....	26
Disassembly .....	27
Cleaning, inspection, and repair .....	28
Assembly .....	29

**26. DESCRIPTION AND DATA.**

a. **Description.** The drag link connects the steering gear to the left front steering knuckle and consists of a tube open at each end with seats for the ball of the steering arm at the steering gear and left steering knuckle. The seats are held tightly against the ball by plugs bearing against coil springs.

**27. DISASSEMBLY (fig. 17).**

a. At rear end of drag link, remove cotter pin, plug, spring seat, spring, and two ball seats. At front end of drag link, remove cotter pin, plug, two ball seats, spring, and spring seat.

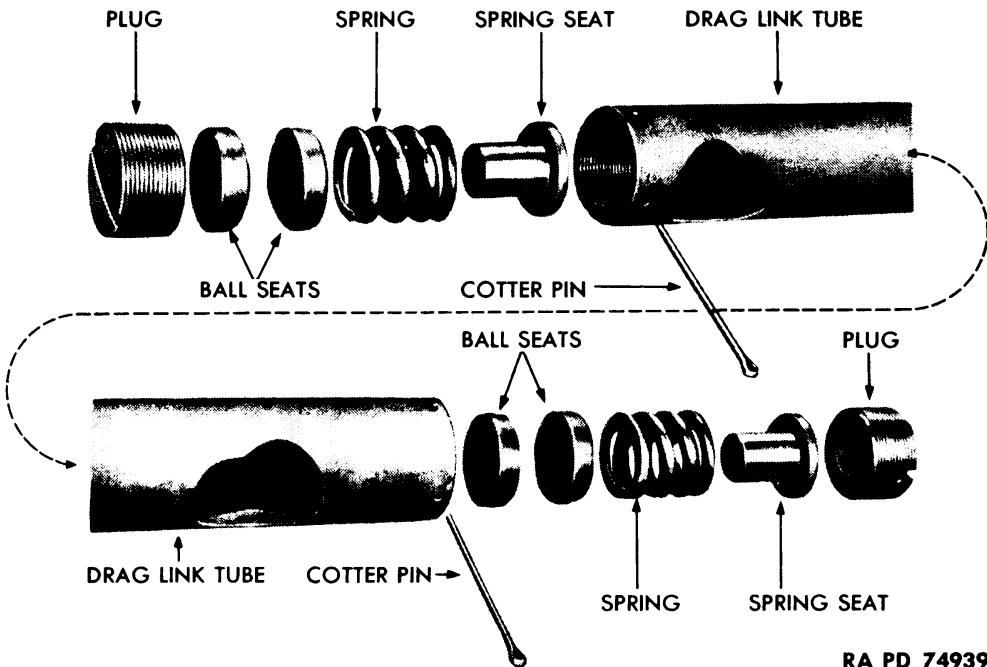

RA PD 74939

**Figure 17 — Drag Link — Disassembled**

## STEERING SYSTEM

### 28. CLEANING, INSPECTION, AND REPAIR.

a. **Cleaning.** Wash in dry-cleaning solvent, and dry with compressed air.

b. **Inspection and Repair.** Inspect ball seats for scoring and threads for burs. Remove burs on threads with thread die or tap. Remove any scores with crocus cloth. Inspect springs for breakage, then inspect spring coils which must be equidistant. **NOTE:** *Springs that are broken must be replaced.* Inspect tube for burs, and remove all burs with crocus cloth or file.

### 29. ASSEMBLY (fig. 17).

a. At front end of drag link, install spring seat, spring, two ball seats, plug, and cotter pins. At rear end of drag link, install two ball seats, spring, spring seat, plug, and cotter pin.

b. **Adjustment.** Center the steering gear; turn the front wheels in a straight-ahead position, and observe position of the steering arm, which should be in alinement with the drag link. If necessary, the arm may be shifted on the splines of the lever shaft.

---

## Section VII

### TEST AND ADJUSTMENT OF STEERING SYSTEM

Test and adjustment ..... 30

### 30. TEST AND ADJUSTMENT.

a. **Test.** Test the hydraulic pump to be certain it is delivering 750 pounds of pressure (par. 5). Check front wheel toe-in which must be  $\frac{1}{8}$  inch (TM 9-767). Check caster and camber of front wheels, caster must be 5 degrees, camber must be zero degrees (TM 9-1767B). Check inflation of front tires which must be 80 pounds. Check drag link adjustment.

b. **Adjust Steering System.** Adjust front wheel toe-in (TM 9-767), and adjust caster and camber of front wheels (TM 9-1767B). Adjust drag link.

c. **Hard Turning and Backlash.** There are two principal adjustments on this gear with a supplemental adjustment on the stud roller bearing unit in the lever shaft. The two principal adjustments are adjustment of roller thrust bearings on camshaft to eliminate hard turning of the steering wheel, and adjustment of the tapered stud in the cam groove to eliminate backlash at the steering wheel. The supplemental adjustment is the backlash at the ball on the steering arm and end play of the lever shaft.

**ORDNANCE MAINTENANCE — BODY, CHASSIS, AND WINCHES FOR TRACTOR TRUCK M26, COMPONENT OF 40-TON TANK TRANSPORTER TRAILER TRUCK M25**

d. **Disconnect Drag Link and Steering Column.** Disconnect drag link and steering gear bracket.

e. **Loosen Housing Side Cover Adjusting Screw (fig. 16).** Loosen lock nut, then loosen side cover adjusting screw.

f. **Hard Turning.**

(1) **REMOVE VALVE CAP (fig. 6).** Remove six cap screws which hold steering control valve cap to steering valve housing, and remove cap.

(2) **INSTALL ADJUSTING FLANGE TOOL.** Use a piece of  $\frac{3}{8}$ -inch flat steel stock and, using the valve cap as a template, drill bolt holes, and cut a hole in the center large enough to clear the thrust washer. Use three of the cap screws removed above, and install tool just made so that valve assembly is held tightly.

(3) **ADJUST BEARINGS (fig. 16).** Loosen screw in adjusting nut, and back off nut. Tighten nut until there is no perceptible drag at the steering wheel, and use a light grip on wheel. Tighten set screw, and remove adjusting flange tool. Install steering control valve cap, and secure with cap screws.

g. **Backlash at Steering Wheel, Backlash at Ball on Steering Arm, and End Play at Lever Shaft.**

(1) **SET STEERING WHEEL.** Turn steering wheel so that front wheels are in a straight-ahead position.

(2) **ADJUSTMENT (fig. 16).** Tighten side cover adjusting screw until a very slight drag is felt through midposition when turning the steering wheel, slowly, from one extreme to the other. Do not adjust in the end positions where backlash is normal and not objectionable. Hold adjusting screw and tighten lock nut. Recheck hard turning as in subparagraph c. Connect drag link.

h. **Aline Column.** Loosen brackets which hold steering gear to frame, and allow steering gear to move, then tighten bracket. Steering column must not be sprung in any direction from the free position. If the column has been permanently bent because of severe misalignment, the above test may not be reliable, and replacement of the jacket tube and camshaft will be necessary.

**STEERING SYSTEM**

**Section VIII**

**FITS AND TOLERANCES**

	<b>Paragraph</b>
Fits and tolerances .....	31

**31. FITS AND TOLERANCES.**

**a. Piston.**

Clearance in hydraulic cylinder.....	0.0005 to 0.0012 in.
Piston adapter fit in cylinder (clearance sealed with two synthetic rings).....	0.002 to 0.004 in.
Diameter .....	4.6868 to 4.6870 in.

**b. Steering Lever Shaft.**

Clearance of shaft in worm .....	Adjustable to zero
Diameter of rollers.....	0.0937 to 0.0939 in.

**c. Worm Shaft.**

Shaft diameter at bearings .....	1.746 to 1.747 in.
Diameter of shaft bushing .....	1.7485 to 1.750 in.

**d. Plungers.**

Diameter .....	0.5621 to 0.5623 in.
Clearance in steering control valve.....	0.0003 to 0.001 in.
Plunger spring tension .....	100 lb

**e. Spool.**

Diameter .....	1.8746 to 1.8748 in.
Clearance .....	0.0005 to 0.0012 in.

**ORDNANCE MAINTENANCE — BODY, CHASSIS, AND WINCHES FOR TRACTOR TRUCK M26, COMPONENT OF 40-TON TANK TRANSPORTER TRAILER TRUCK M25**

**CHAPTER 3**

**BRAKE SYSTEM**

**Section I**

**DESCRIPTION AND DATA OF BRAKE SYSTEM**

	Paragraph
Sources of information for description and operation.....	32
Data .....	33

**32. SOURCES OF INFORMATION FOR DESCRIPTION AND OPERATION.**

a. *The brake system consists of brake shoes operated by Bendix Westinghouse compressed air system. Description and maintenance of air system is covered in TM 9-1827A, Power Brake Systems. The brake shoe assemblies for the semitrailer are covered in TM 9-1767D, and the shoes for the rear wheels of the tractor truck are covered in this chapter.*

**33. DATA.**

**a. Air Brake Units.**

Make ..... Bendix-Westinghouse

Models:

Slack adjuster .....	220938
Air horn .....	217869
Low-pressure air indicator .....	215186
Air reservoirs .....	221393
Air manifold .....	212322
Air horn valve .....	217866
Air supply valve .....	221192
Foot-operated brake valve .....	216231
Hand-operated brake valve (tractor brakes).....	221303
Hand-operated brake valve (tractor brakes).....	215748
Relay valve .....	217383
Safety valve .....	205105
Single check valve .....	220306

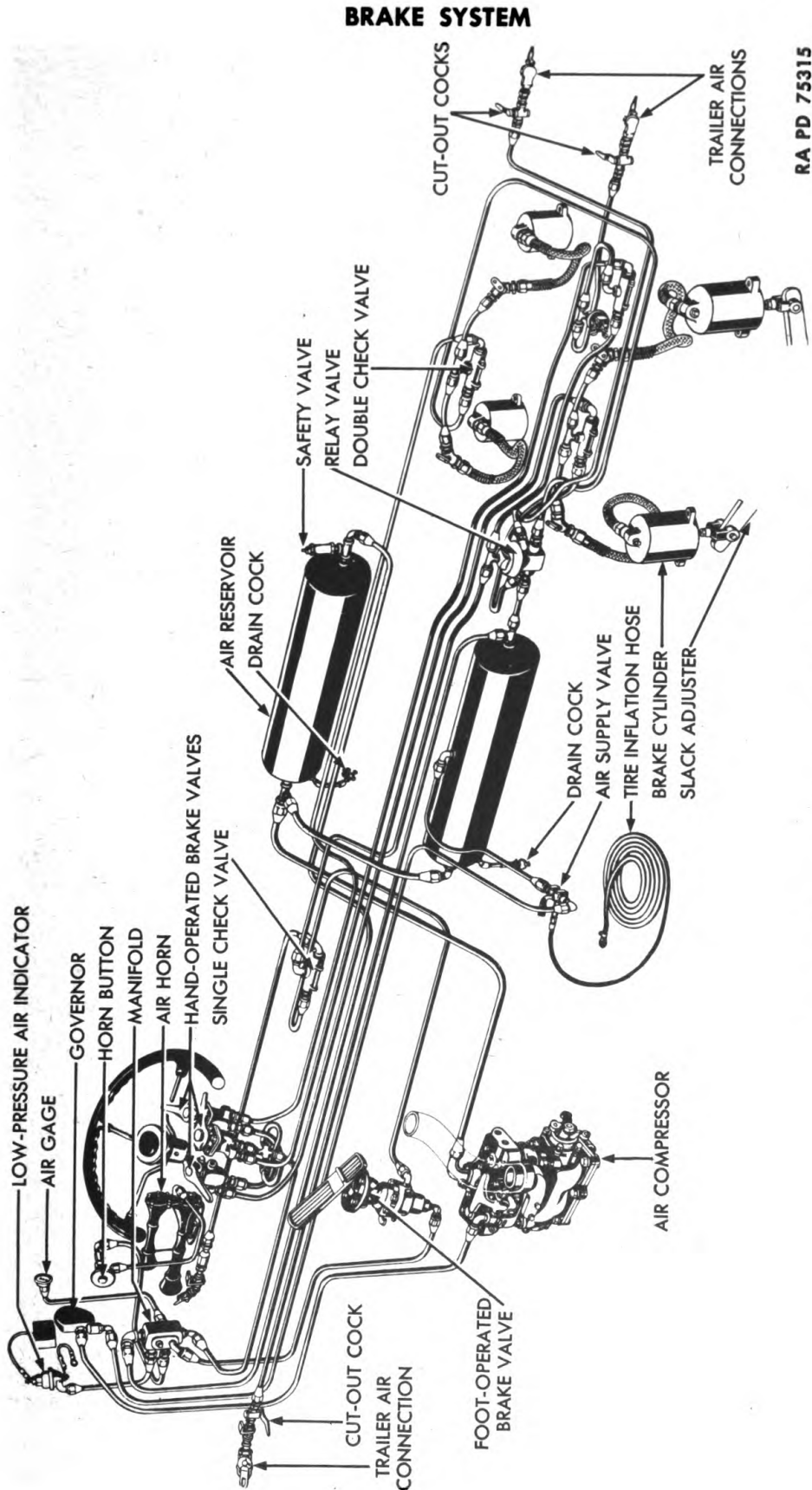

RA PD 75315

Figure 18 — Air System — Schematic View

**ORDNANCE MAINTENANCE — BODY, CHASSIS, AND WINCHES FOR TRACTOR TRUCK M26, COMPONENT OF 40-TON TANK TRANSPORTER TRAILER TRUCK M25**

**Section II**

**SERVICE BRAKE SHOES**

	Paragraph
Description and data.....	34
Disassembly, cleaning, inspection, repair, and assembly.....	35
Fits and tolerances.....	36

**34. DESCRIPTION AND DATA.**

**a. Description.** There are two brake shoes at each of the four rear wheels, and each shoe has two linings secured to it with bolts. The shoes are secured at one end with anchor pins operating in bushings in the shoes. The other end of the shoes have rollers secured to the shoe with pins, and the cam of the brake camshaft is located between the rollers. Two coil springs attached to the shoes hold the cam end of the shoes against the cam. The brake drum is secured to the wheel and houses the shoes.

**b. Operation.** Application of the brake control causes the brake cam to turn and expand the brake shoes against the inner face of the brake drum. Releasing of the brake control permits the coil springs to pull the shoes and linings away from the face of the drum.

**c. Data.**

Brake shoes .....	Kay-Brunner
Brake shoes — model .....	A6-F-263
Brake drums .....	Kay-Brunner

**35. DISASSEMBLY, CLEANING, INSPECTION, REPAIR, AND ASSEMBLY (fig. 19).**

**a. Disassembly.** Procedure for disassembly of brake shoe assemblies is given in TM 9-767. Remove four lining screws, lock washers, and nuts, which hold each of two lining sections to each of two shoes, and remove lining.

**b. Cleaning.** Wash all parts with dry-cleaning solvent to remove all dirt and grease. **CAUTION:** *See that solvent does not get on the brake lining.*

**c. Inspection and Repair.** Test fit of anchor pins in anchor pin bushings, and replace pins or bushing or both, if there is over 0.0005-inch play. Inspect coils of roller springs all of which must be equidistant. Replace brake lining which is worn down to lining bolts. Inspect lining for grease, and use new lining if there is grease present. Inspect rollers for scoring, and replace if necessary.

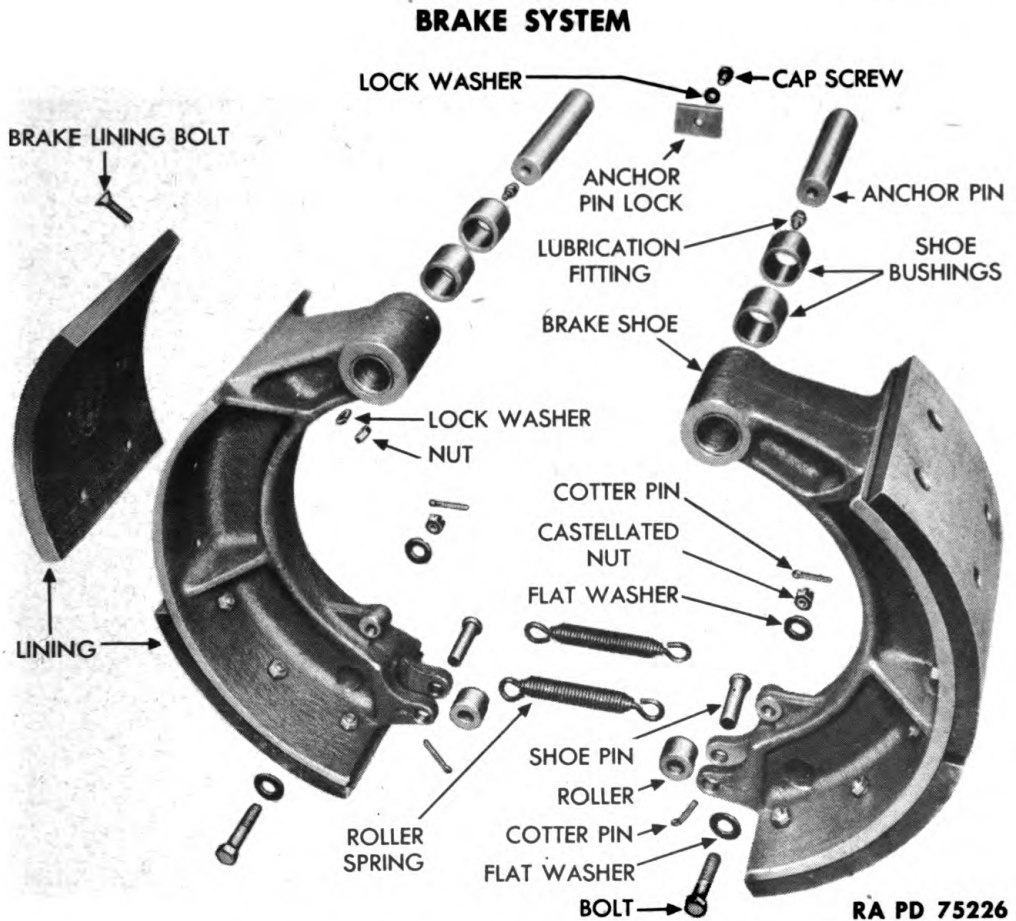

**Figure 19 – Service Brake Shoe – Disassembled**

d. **Assembly.** Install two lining sections on each brake shoe, and secure each section to shoe with four lining screws, lock washers, and nuts.

**36. FITS AND TOLERANCES.**

a. **Clearance Between Brake Lining and Drum.**

Heel .....	0.015 in.
Toe .....	0.005 in.

ORDNANCE MAINTENANCE — BODY, CHASSIS, AND WINCHES FOR TRACTOR  
TRUCK M26, COMPONENT OF 40-TON TANK TRANSPORTER TRAILER TRUCK M25

CHAPTER 4

**PROPELLER SHAFT (PARKING) BRAKE**

Section I

**DESCRIPTION AND DATA OF PARKING BRAKE**

	Paragraph
Description and operation .....	37
Data .....	38

**37. DESCRIPTION AND OPERATION (fig. 20).**

**a. Description.** The propeller shaft brake consists of a drum, two brake shoes with linings, and linkage to the lever at the tractor operator's seat. The drum is secured between two companion flanges at the rear of the transfer case. The two brake shoes with linings are secured at one end to an eccentric anchor pin, and the other ends of the shoes are held by an eye bolt, with eye bolt springs to hold the ends of the shoes apart. The operating lever in the cab is connected to a rod which extends to an actuating cam on the eye bolt.

**b. Operation.** Pulling back on the parking brake lever in the cab moves the actuating cam which in turn rotates the rocker on the eye bolt, causing the brake shoes to contact the drum. Releasing the brake allows the coil springs on the eye bolt to push the brake shoes away from the drum.

**38. DATA.**

Brake shoes — make ..... Vulcan and Cochin

Section II

**DISASSEMBLY, CLEANING, INSPECTION, REPAIR,  
AND ASSEMBLY OF PARKING BRAKE**

	Paragraph
Disassembly, cleaning, inspection, repair, and assembly.....	39

**39. DISASSEMBLY, CLEANING, INSPECTION, REPAIR, AND ASSEMBLY.**

**a. Disassembly (fig. 20).** Remove propeller shaft brake shoes (TM 9-767). Remove pad from eye bolt, then remove two cotter pins and cam pin which hold cam in rocker. Remove cam and eye bolt from the rocker, and remove remaining cam pin which holds eye bolt to cam.

**b. Cleaning.** Wash all parts in dry-cleaning solvent to remove all dirt and grease. **CAUTION:** *See that the solvent does not get on the brake lining.*

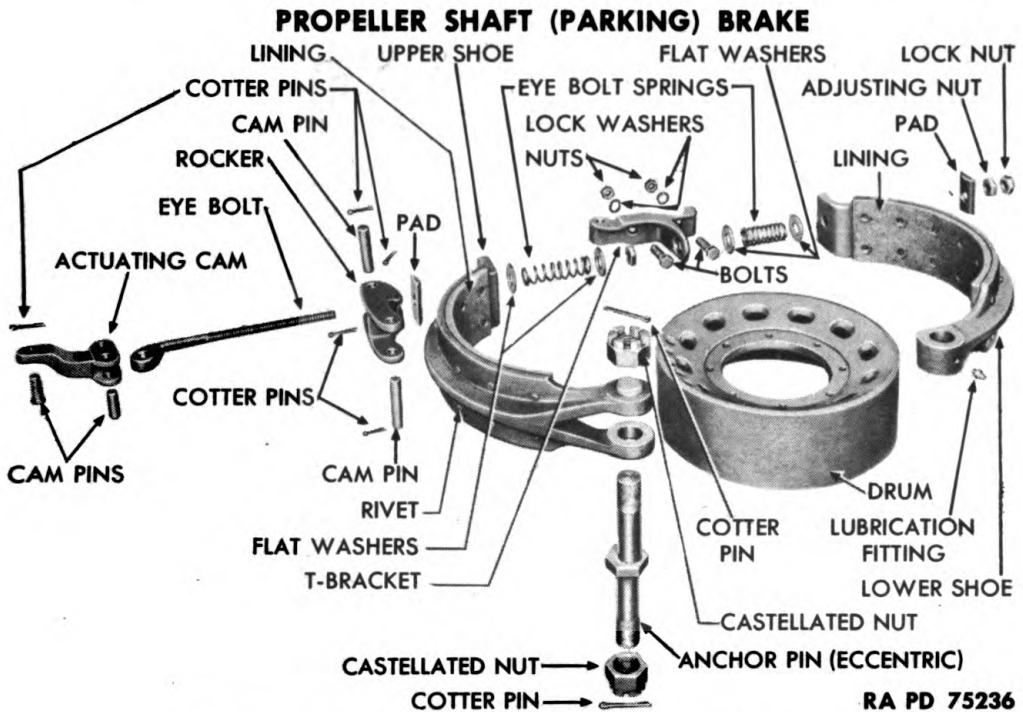

Figure 20 — Propeller Shaft Brake — Disassembled

c. **Inspection and Repair.** Install anchor pin in brake shoes, and replace pin or shoes or both, if side play of pin exceeds 0.005 inch. Inspect eye bolt springs for equal spacing of coils, and if coils are not equally spaced, use new spring. Inspect threads on eye bolt, anchor pin, and anchor pin castellated nuts, and straighten with die if mashed. Examine actuating cam for scoring, and remove scores with crocus cloth. Inspect brake lining; lining worn down to rivets must be replaced. Remove old lining from brake shoes by using brake lining riveting machine and forcing out 14 rivets which secure lining on shoes. Install new linings on shoes, using brake lining riveting machine to install 14 rivets which secure lining to brake shoe.

d. **Assembly (fig. 20).** Install eye bolt in cam securing it with one cam pin (without cotter pin holes), then install eye bolt and actuating cam in rocker with a second cam pin, locking both ends of cam pin with cotter pins. Install pad on one end of eye bolt. Adjust parking brake (TM-9-767).

### Section III

## FITS AND TOLERANCES

Fits and tolerances .....

Paragraph  
40

### 40. FITS AND TOLERANCES.

#### a. Clearance Between Brake and Shoe Lining and Drum.

Heel ..... 1/8 in.  
Toe ..... 1/8 in.

ORDNANCE MAINTENANCE — BODY, CHASSIS, AND WINCHES FOR TRACTOR  
TRUCK M26, COMPONENT OF 40-TON TANK TRANSPORTER TRAILER TRUCK M25

CHAPTER 5

FRONT-MOUNTED WINCH

Section I

DESCRIPTION AND DATA OF FRONT-MOUNTED WINCH

	Paragraph
Description and operation .....	41
Data .....	42

41. DESCRIPTION AND OPERATION.

a. **Description.** The front-mounted winch is secured to the front cross member of the frame. The worm gear and drum of the winch are keyed to the drum shaft, and the worm gear is mounted in a housing so that it meshes with the worm. The worm shaft and worm are made integral, and the shaft rotates on ball bearings mounted in the housing. Control of the front-mounted winch is connected to the side-mounted power take-off by means of a lever in the driving compartment. The automatic brake is mounted on the end of the worm shaft in a housing and consists of a brake band, which is wrapped around a disk that is keyed on the worm shaft.

b. **Operation.** Power for operating the winch is transmitted to the worm shaft of the winch by means of sprockets, chains, and drive shaft from the side-mounted power take-off. Shifting of the control lever in the cab meshes gears in the side-mounted power take-off on the auxiliary transmission. Cable can be pulled out or pulled in by this means. The automatic brake maintains a drag on the winch operation. The brake tends to loosen when cable is being pulled out, and to loosen when cable is being pulled in.

42. DATA.

Make .....	Gar Wood
Model .....	SM713K
Cable .....	$\frac{3}{4}$ in.
Length of cable .....	300 ft

FRONT-MOUNTED WINCH

RA PD 75334

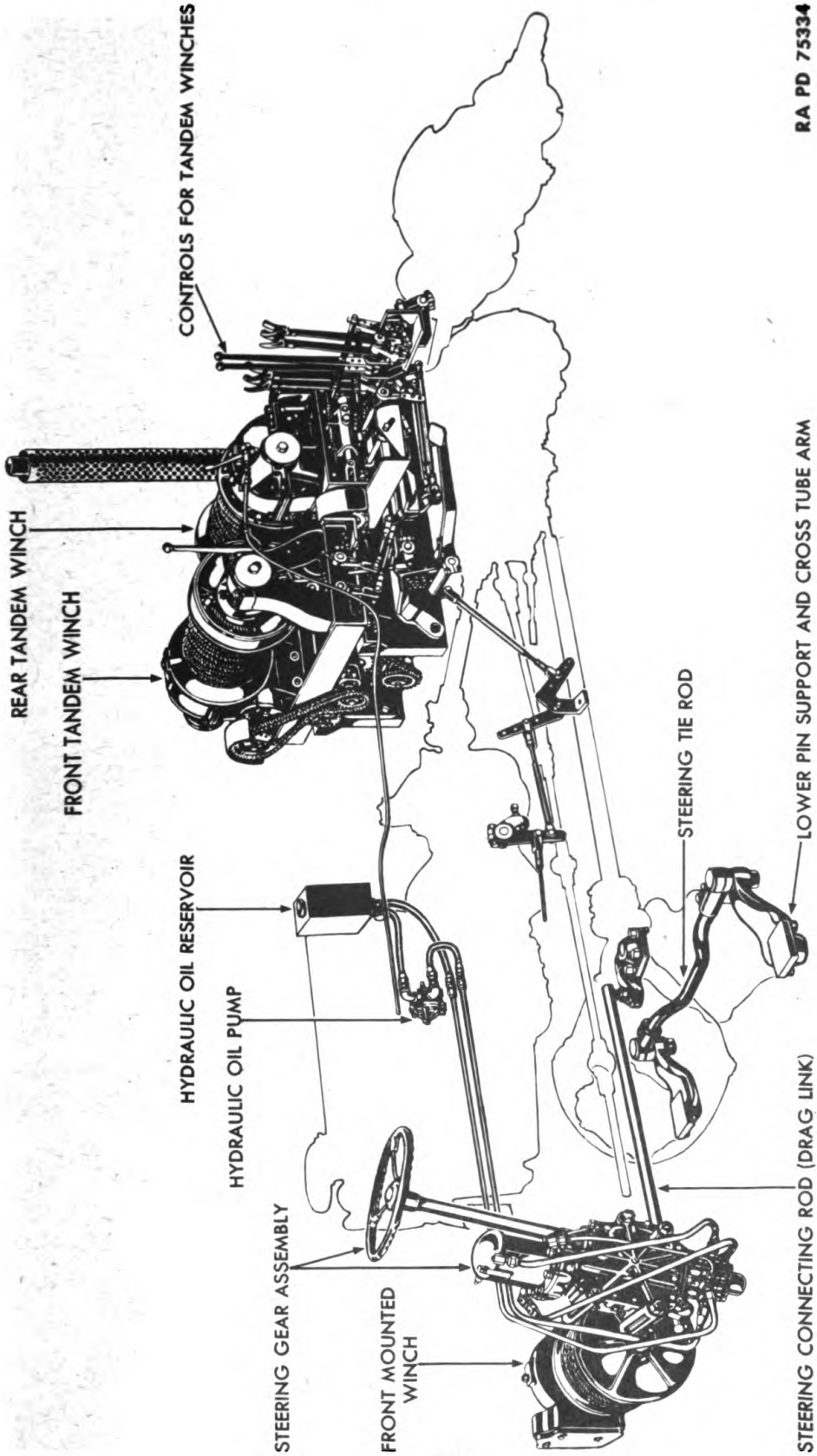
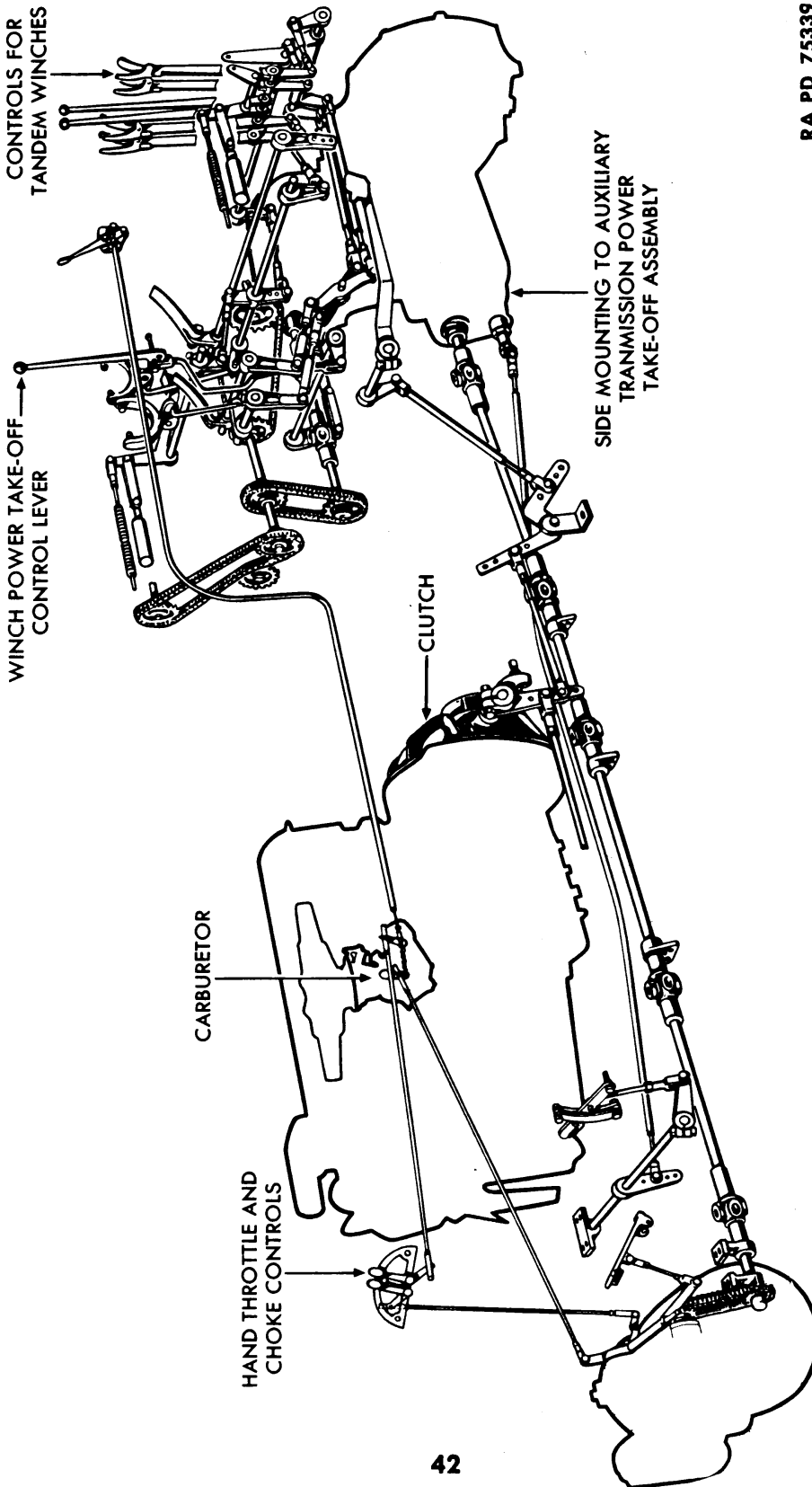

Figure 21 — Schematic View of Winches and Steering Mechanism

ORDNANCE MAINTENANCE — BODY, CHASSIS, AND WINCHES FOR TRACTOR TRUCK M26, COMPONENT OF 40-TON TANK TRANSPORTER TRAILER TRUCK M25



RA PD 75339

Figure 22 — Schematic View of Driving and Throttle Controls for Winches

FRONT-MOUNTED WINCH

Section II

DISASSEMBLY OF FRONT-MOUNTED WINCH INTO SUBASSEMBLIES

Paragraph

Disassembly ..... 43

43. DISASSEMBLY.

a. **Remove Cable and Drain Lubricant.** Remove cable from the drum, and lay it aside so that it will not kink, or wind cable onto another drum (TM 9-767). Remove drain plug from worm gear case, and drain lubricant into a clean container.

b. **Remove Worm Gear and Drum Assembly (fig. 23).** Remove bolts, nuts, and lock washers that secure worm gear case cover, and remove cover with bushings. Lift drum with drum shaft and worm gear out of gear case.

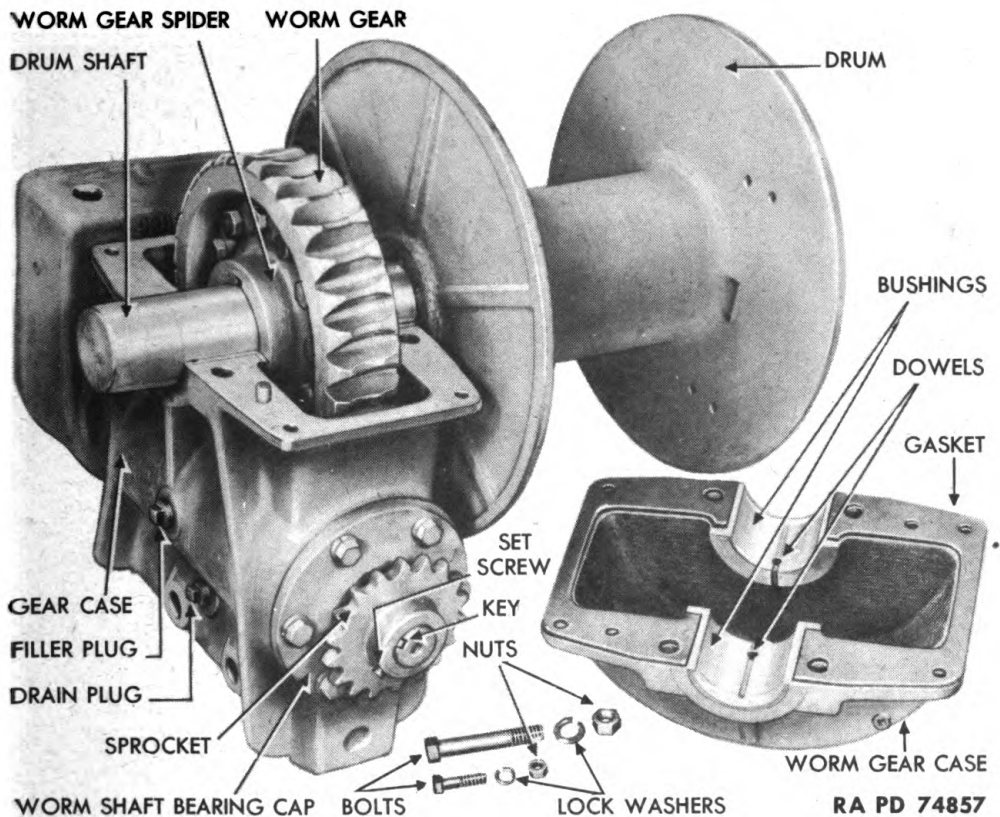
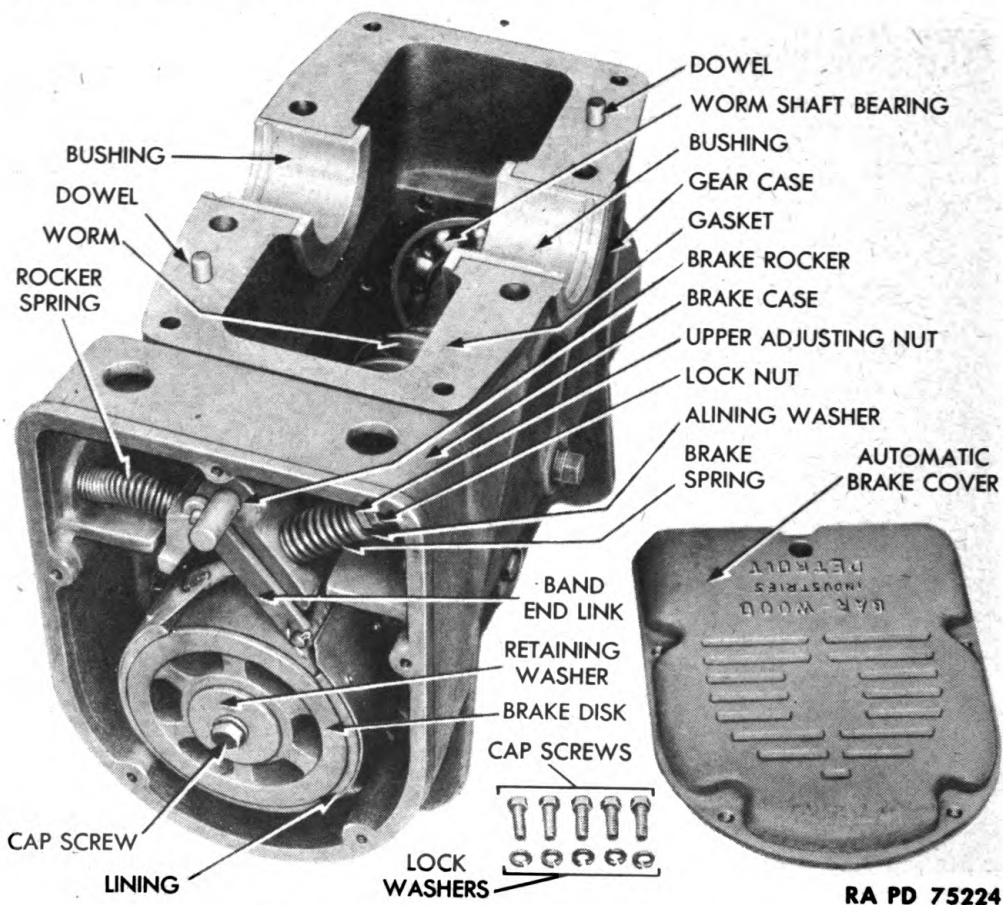

Figure 23 — Drum and Drum Shaft

**ORDNANCE MAINTENANCE – BODY, CHASSIS, AND WINCHES FOR TRACTOR TRUCK M26, COMPONENT OF 40-TON TANK TRANSPORTER TRAILER TRUCK M25**



**Figure 24 – Automatic Brake and Gear Case**

c. **Remove Automatic Brake Assembly (fig. 24).** Remove cap screws and lock washers that hold cover on brake case, and remove cover. Remove cap screw, lock washer, and retaining washer that hold brake disk, then pry off rocker spring. Use a puller, and remove brake disk with automatic brake as an assembly.

FRONT-MOUNTED WINCH

Section III

**DISASSEMBLY, CLEANING, INSPECTION, REPAIR, AND  
ASSEMBLY OF FRONT-MOUNTED WINCH  
SUBASSEMBLIES**

	Paragraph
Automatic brake .....	44
Gear case and worm .....	45
Drum and shaft .....	46
Drive shafts and universal joints .....	47

**44. AUTOMATIC BRAKE.**

a. **Disassembly** (fig. 25). Remove upper adjusting nut, lock nut, alining washer, and brake spring. Remove two cotter pins from welded pin and hand end pin, and remove two band end links. Remove brake rocker from brake band assembly, and clip spacer off band end. Remove lower adjusting nut and lock nut from band end.

b. **Cleaning, Inspection, and Repair.** Clean all parts except lining in dry-cleaning solvent. Inspect lining, and punch out rivets if worn thin to the level of the rivet heads. Remove lining and install new lining with new rivets. Inspect brake spring coils, and if they are not equally spaced, use new spring. Inspect brake rocker, band end links, and spacer for scores and burs. Remove all scores and burs with crocus cloth or file.

c. **Assembly** (fig. 25). Install lock nut and lower adjusting nut on band end, then install spacer and brake rocker on band end. Install two band end links, and fasten with band end pin and welded pin. Install cotter pins in band end and welded pins. Install brake spring, alining washer, lock nut, and upper adjusting nut.

**45. GEAR CASE AND WORM.**

a. **Disassembly.**

(1) **REMOVE BRAKE CASE AND WORM SHAFT SPROCKET** (fig. 26). Remove six cap screws and lock washers that hold brake case to lower half of gear case. Remove case, then remove case gasket. Remove set screw and sprocket from worm shaft, and remove key.

(2) **REMOVE WORM** (fig. 26). Remove cap screws and lock washers that hold worm shaft bearing cap, and remove cap and gasket. Press oil seal out of worm shaft bearing cup. Drive worm shaft bearings and worm shaft out of gear case, then press two ball bearings off worm shaft.

**ORDNANCE MAINTENANCE — BODY, CHASSIS, AND WINCHES FOR TRACTOR TRUCK M26, COMPONENT OF 40-TON TANK TRANSPORTER TRAILER TRUCK M25**

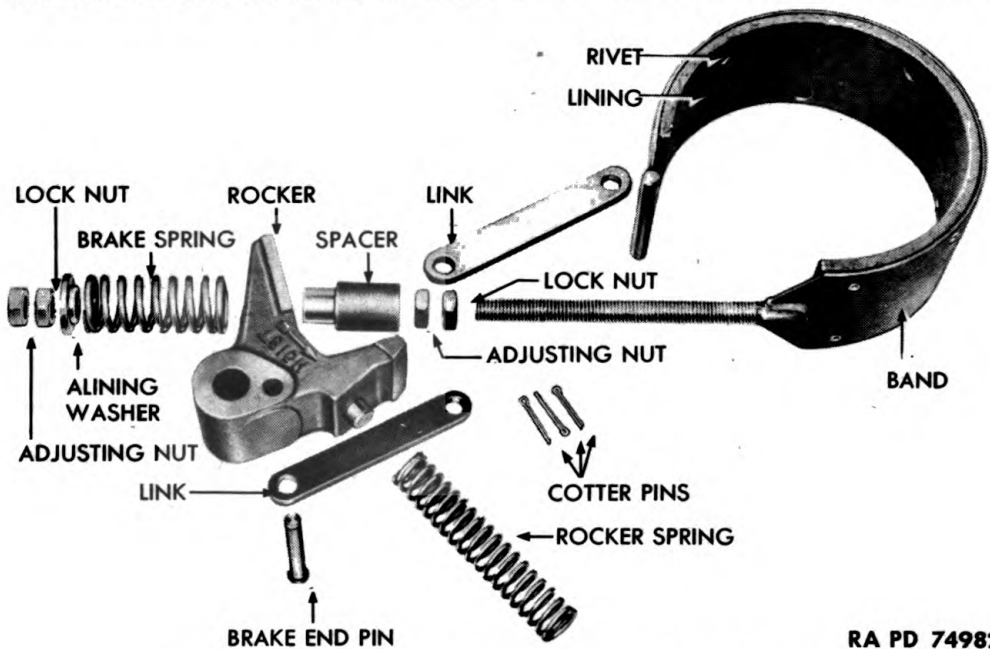

RA PD 74982

**Figure 25 — Automatic Brake — Disassembled**

**b. Cleaning, Inspection, and Repair.** Clean all parts in dry-cleaning solvent. Inspect brake case and gear case for breaks or fractures, and weld together all damaged parts. Discard oil seal and gasket and use new parts. Rotate ball bearings and inspect for noise, flat spots on balls, and chipping of balls and races. Use new bearings if any of these conditions are found. Inspect bushings for scoring, and replace any scored bushings.

**c. Assembly.**

(1) **INSTALL WORM** (fig. 26). Press bearings onto worm shaft, and press shaft bearings into gear case. Press oil seal into worm shaft bearing cap. Install gasket and bearing cap on case, and secure with cap screws and lock washers.

(2) **INSTALL BUSHINGS.** Place bushings on dowels in gear case and cover, and tap them firmly into position.

(3) **INSTALL WORM SHAFT SPROCKET AND BRAKE CASE.** Install key on worm shaft; then install sprocket and fasten with set screw. Install gasket and brake case on gear case, and fasten with six cap screws and lock washers.

**46. DRUM AND SHAFT** (fig. 27).

**a. Disassembly.** Tap drum shaft with worm gear out of drum, and remove two drum keys from shaft. Remove worm gear from worm gear spider by removing 12 bolts, nuts, and lock washers; then press spider off shaft. Remove clamp screw and clamp from drum.

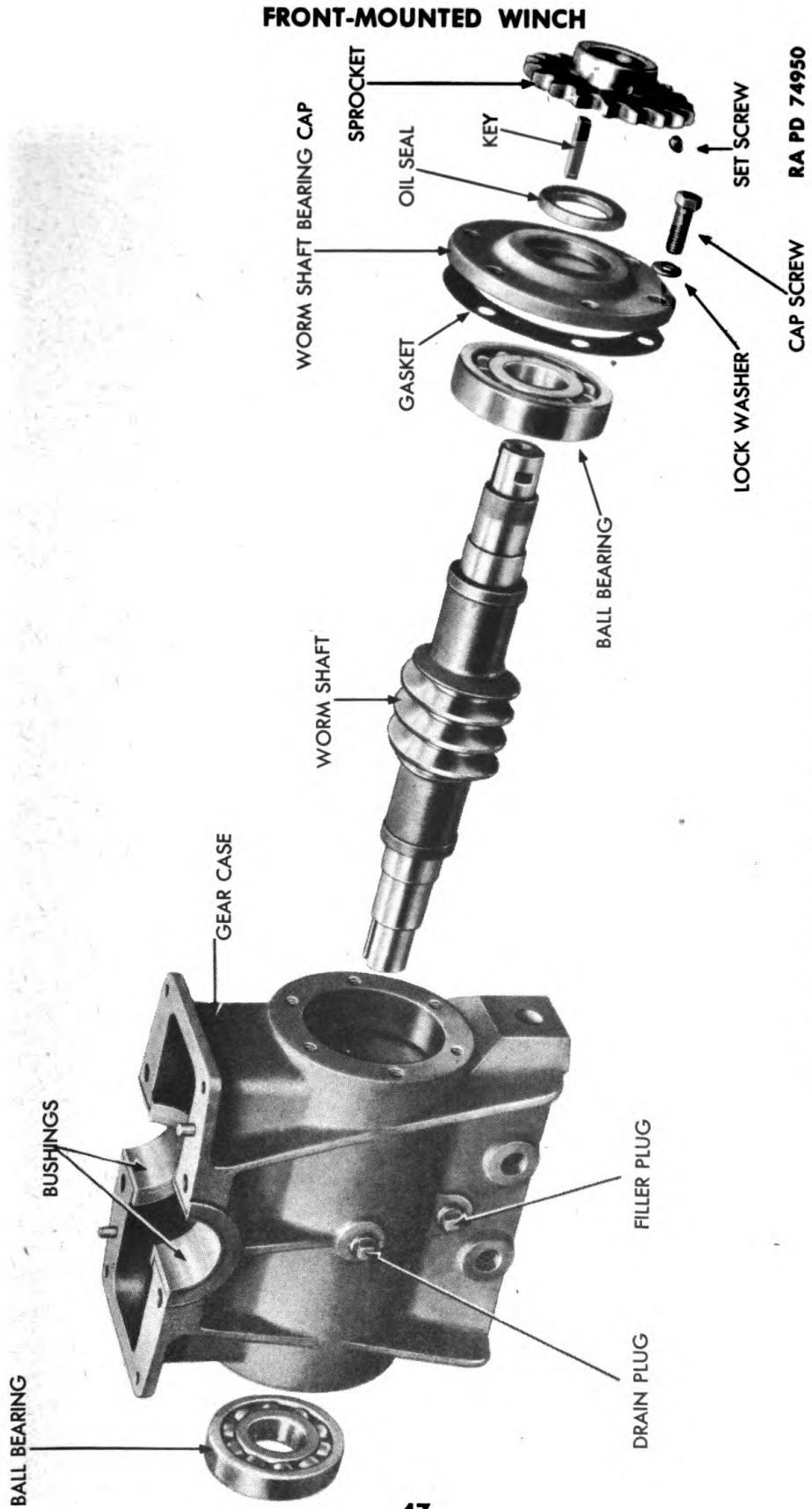

**Figure 26 — Gear Case and Worm — Disassembled**

**ORDNANCE MAINTENANCE — BODY, CHASSIS, AND WINCHES FOR TRACTOR TRUCK M26, COMPONENT OF 40-TON TANK TRANSPORTER TRAILER TRUCK M25**

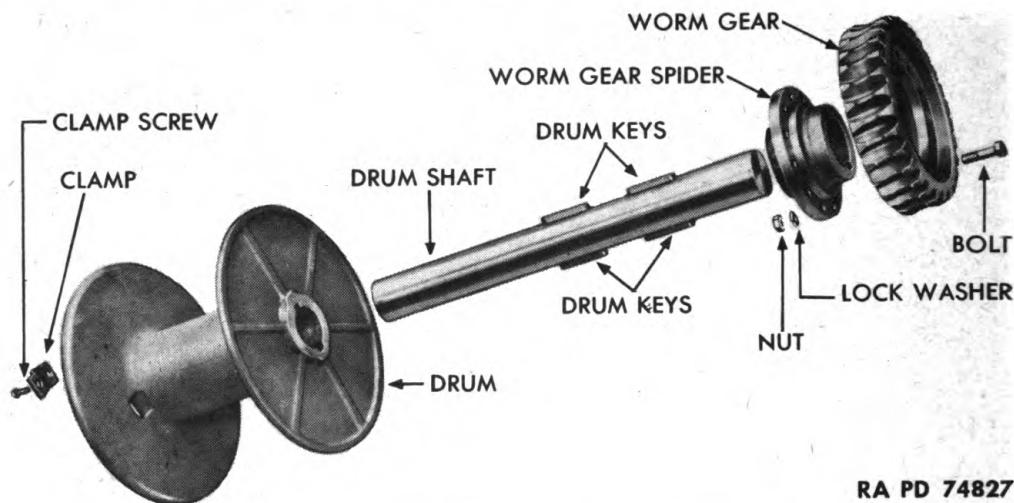

**Figure 27 — Drum and Shaft — Disassembled**

**b. Cleaning, Inspection, and Repair.** Clean all parts in dry-cleaning solvent. Inspect drum shaft for scoring and remove light scores with crocus cloth. Replace shaft if deeply scored. Inspect worm gear for scoring, and replace gear if damaged. Inspect drum keys for burrs and remove all burrs with a file.

**c. Assembly (fig. 27).** Press worm gear spider on drum shaft, and install worm gear on spider, securing with 12 bolts, nuts, and lock washers. Install two drum keys on shaft, and install shaft in drum. Install clamp and clamp screw on drum.

#### **47. DRIVE SHAFTS AND UNIVERSAL JOINTS.**

**a. Disassembly.**

(1) **DISASSEMBLE DRIVE SHAFTS (fig. 28).** Remove universal joint at power take-off by loosening set screw and sliding off rear drive shaft; then remove key from shaft. Loosen set screw that holds third universal joint to rear drive shaft, and remove shaft. Remove key from shaft, loosen set screw that holds third universal joint to center drive shaft, and remove universal joint and key from shaft. Loosen two set screws that hold two single bearing collars to center drive shaft, and remove bearings and collars from center drive shaft. Loosen set screw and key that holds second universal joint to center drive shaft, and remove universal joint and key from shaft. Remove key from rear end of front drive shaft. Remove set screw that holds first universal joint to double bearing, and remove universal joint and key from shaft.

(2) **DISASSEMBLE DOUBLE BEARING (fig. 29).** Loosen two bearing collar set screws, and pull double bearing shaft with sprocket out

FRONT-MOUNTED WINCH

RA PD 75338

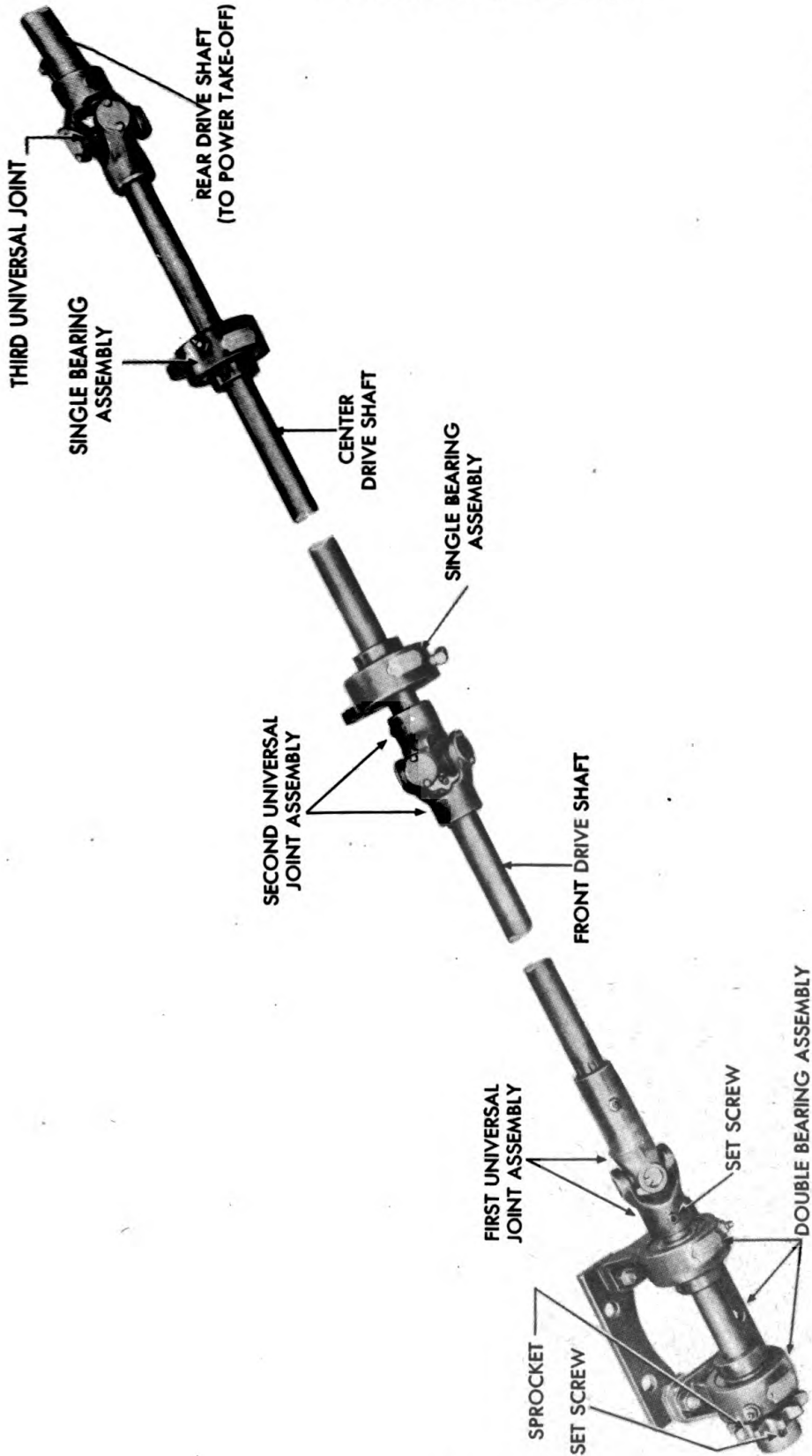

Figure 28 — Drive Shafts and Universal Joints

ORDNANCE MAINTENANCE — BODY, CHASSIS, AND WINCHES FOR TRACTOR  
TRUCK M26, COMPONENT OF 40-TON TANK TRANSPORTER TRAILER TRUCK M25

RA PD 75337

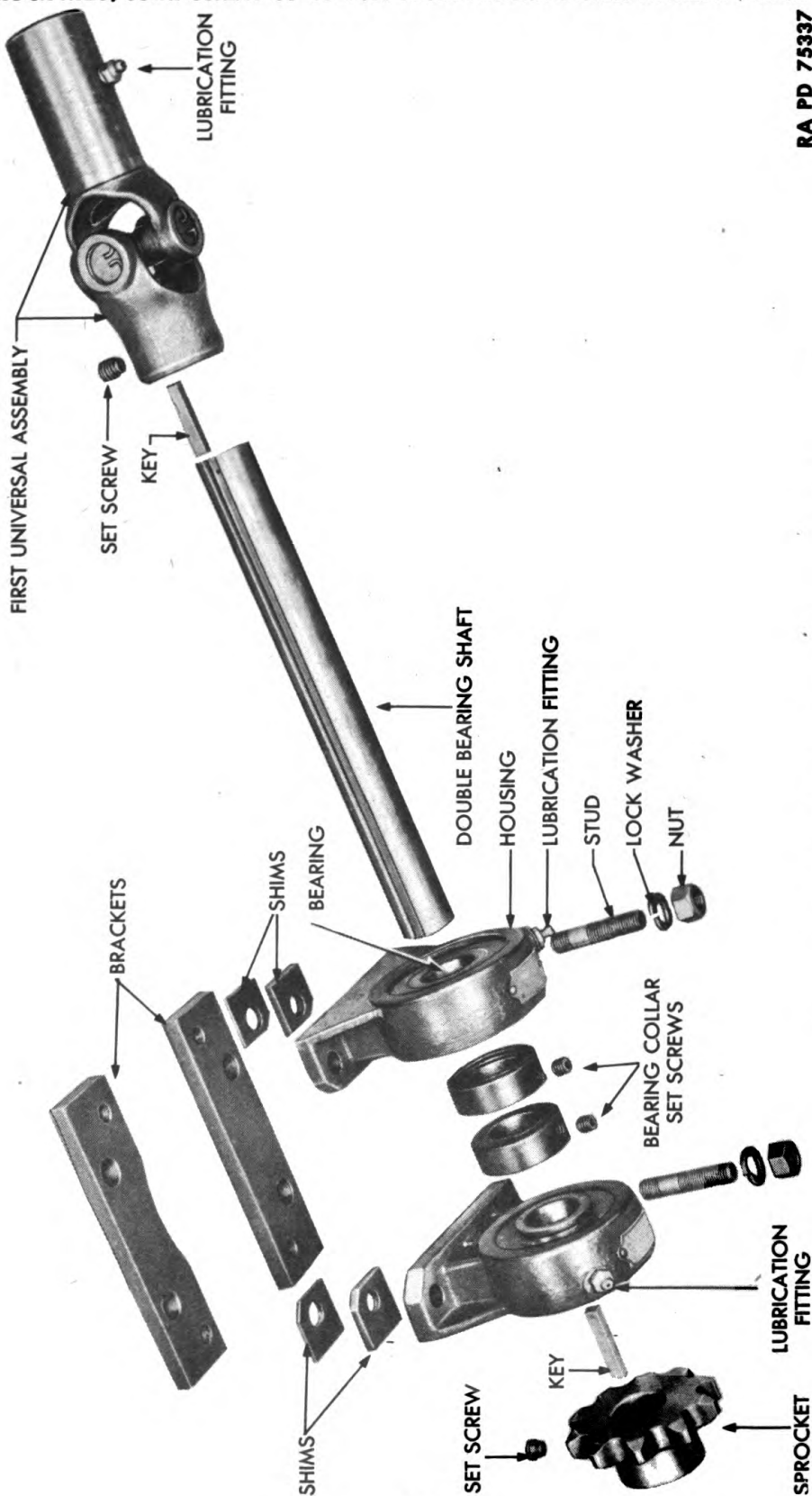
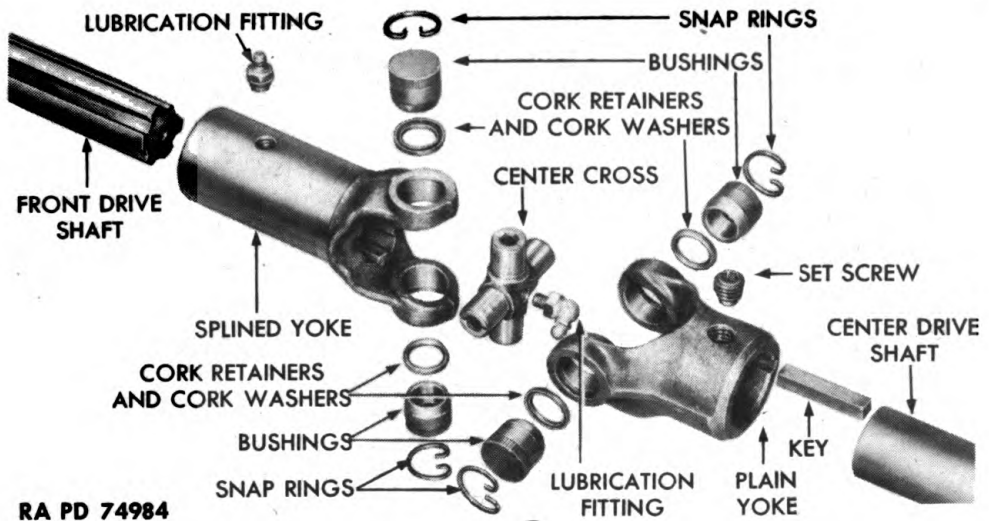

Figure 29 — Double Bearing — Disassembled

**FRONT-MOUNTED WINCH**



**Figure 30 – Universal Joint – Disassembled**

of bearings. Remove bearing collars; then loosen set screw that holds sprocket to shaft, and remove sprocket and key. Remove four studs, nuts, and lock washers that hold bearings to brackets, and remove two bearings with shims from brackets. Remove bearings from housings.

(3) **DISASSEMBLE UNIVERSAL JOINTS** (fig. 30). Remove four snap rings, and press on center cross so that four bushings are removed from center cross. Remove center cross from both yokes, and remove four cork washers and four cork retainers from cross. Remove set screw and lubrication fitting from yoke.

**b. Cleaning, Inspection, and Repair.** Clean all parts in dry-cleaning solvent. Inspect for scoring on machined surfaces, and replace any parts if necessary. Inspect threads for burrs and straighten with thread die or tap. Eliminate all light scores with crocus cloth. Inspect ball bearings by spinning slowly with the fingers. If the bearing is noisy or turns hard, replace with a new part. Housings can be satisfactorily welded or brazed, but parts that are under power strains cannot be repaired.

**c. Assembly.**

(1) **ASSEMBLE UNIVERSAL JOINTS** (fig. 30). Install lubrication fitting in yoke; then install four cork retainers and four cork washers on center cross. Install center cross in both yokes, install four bushings, and secure with snap rings.

(2) **ASSEMBLE DOUBLE BEARINGS** (fig. 29). Install two bearings and shims on brackets, and fasten with four nuts and lock washers. Install sprocket key and sprocket on double bearing shaft, and

**ORDNANCE MAINTENANCE — BODY, CHASSIS, AND WINCHES FOR TRACTOR TRUCK M26, COMPONENT OF 40-TON TANK TRANSPORTER TRAILER TRUCK M25**

fasten with set screw. Install two bearing collars at bearings, and insert shaft through bearings and collars. Tighten two bearing collar set screws. Install key and universal joint on double bearing shaft, and fasten with set screw.

(3) **ASSEMBLE DRIVE SHAFTS** (fig. 28). Install key on rear end of front drive shaft; then install key and second universal joint on center drive shaft. Fasten joint with set screw. Install bearings and collars on center drive shaft and fasten collars with set screws. Install key and third universal joint on center drive shaft, and fasten joint with set screw. Install rear drive shaft in third universal joint, and secure with set screw. Install key and universal joint for power take-off on rear drive shaft, and secure joint with set screw.

---

**Section IV**

**ASSEMBLY OF FRONT-MOUNTED WINCH**

Assemble front-mounted winch ..... Paragraph  
48

**48. ASSEMBLE FRONT-MOUNTED WINCH** (fig. 24).

a. **Install Automatic Brake.** Install automatic brake assembly and rocker spring. Install brake disk, and fasten with cap screw and lock washer. Adjust brake as instructed in TM 9-767. Place brake case cover in position, and secure with lock washers and cap screws.

b. **Install Brake Drum and Worm Wheel.** Place brake drum, worm wheel, and shaft assembly in position in gear case, and secure by installing gear case cover and gasket with bolts, lock washers, and nuts. Install drain plug, and fill gear case with correct grade of lubricant.

c. **Install Cable.** The cable can be more easily installed after winch has been assembled on truck tractor. Refer to TM 9-767 for procedure.

---

**Section V**

**TEST AND ADJUSTMENT OF FRONT-MOUNTED WINCH**

Test and adjustment ..... Paragraph  
49

**49. TEST AND ADJUSTMENT.**

a. The test of the winch can best be accomplished after installation on the truck tractor (TM 9-767). Add or subtract shims from under double bearing so that drive chain will have about 1/2-inch slack. Make sure that drive sprockets are in alignment; if not, move sprockets on drive shaft until they are in line.

FRONT-MOUNTED WINCH

Section VI

FITS AND TOLERANCES

	Paragraph
Fits and tolerances .....	50

**50. FITS AND TOLERANCES.**

Worm gear spider on drum shaft clearance .....	0.005 to 0.001 in.
Backlash between worm and worm gear .....	0.010 in.
Drum shaft clearance in bushing .....	0.001 to 0.0015 in.
Sprocket on drum shaft clearance .....	0.001 to 0.0015 in.
Drum on drum shaft .....	0.001 to 0.0015 in.
Drum keys in drum shaft .....	0.005 to 0.001 in.

**ORDNANCE MAINTENANCE — BODY, CHASSIS, AND WINCHES FOR TRACTOR TRUCK M26, COMPONENT OF 40-TON TANK TRANSPORTER TRAILER TRUCK M25**

**CHAPTER 6  
TANDEM WINCH ASSEMBLY**

**Section I**

**DESCRIPTION AND DATA**

	Paragraph
Description and operation .....	51
Data .....	52

**51. DESCRIPTION AND OPERATION.**

**a. Description.**

(1) **TANDEM WINCH** (figs. 31 and 32). The tandem winch assembly consists of a front (upper) and a rear (lower) winch secured to a mounting assembly which is fastened to the chassis frame at the rear of the cab.

(2) **MOUNTING.** The mounting assembly consists of a frame to which is attached the winch drum hand brake, winch sliding clutch, and winch gearshifting levers for the two winches. The drive chains with sprockets, chain tighteners, and remote controls for the engine throttle and engine clutch, are also secured to the frame assembly.

(3) **FRONT WINCH.** The front winch consists of a gear case, automatic brake, and drum shaft assemblies. The gear case assembly is secured to the base, and consists of a housing and cover in which the worm gear, worm shaft assembly, input shaft assembly, gears, and the shifting mechanism for the high, low, and reverse speeds are located. The worm gear is keyed to the drum shaft and rotates in bushings located in the gear case and end bearing frame. The worm and shaft is a one-piece forging on which is secured the high and low speed driven gears. The shaft rotates on ball bearings located in the gear case. The input shaft rotates on ball bearings secured in the gear case and has the high and low speed drive gears secured to it. The sliding clutch is located between these gears and is operated by the shift mechanism. The input shaft drive sprocket is located on the end of the input shaft, outside the gear case. A reverse idler gear is located between the input and worm shafts, and meshes with the input shaft clutch gear and the high speed gear on the worm shaft. This reverse idler gear is secured to the gear case by an idler gear pin. The shifting mechanism is mounted in a shifter cover which is bolted to the gear case. The shifting mechanism consists of a shift rod to which is secured a shift yoke which engages a slot in the sliding

**TANDEM WINCH ASSEMBLY**

clutch. The automatic brake assembly is contained in a housing, with cover secured to the gear case, and consists of a brake drum or disk secured to the worm shaft and a spring-loaded brake band around this drum. The drum shaft assembly consists of a shaft on which is secured the drum, winch head, and worm gear. A movable jaw clutch slides on keys in the drum shaft, and a brake band is on the end of the drum.

(4) **REAR WINCH.** The construction of the rear winch is the same as the front winch with the exception of the winch head.

**b. Operation.** Shifting of the power take-off lever meshes gears in the top mounted power take-off on the auxiliary transmission. A sprocket on the end of the power take-off shift drives the front and rear winch chain. Operation of the front or rear winch gearshift lever operates the shift yoke, which in turn moves the sliding clutch to attain high, low, or reverse speeds. Movement of the drum brake lever regulates the speed at which cable is paid out by applying a brake on the drum. Movement of the winch sliding clutch lever engages the drum and shift of either the front or rear winch with the drive chain, thereby applying the power from the drive chain to either winch.

**52. DATA.**

Make .....	Gar Wood
Model .....	Special 6G — 6G
Worm gear case assemblies (model no.) .....	22Y5603
Cable diameter .....	7/8 in.
Cable length .....	300 ft
Front tandem winch model .....	22Y5611
Rear tandem winch model .....	22Y5612



TANDEM WINCH ASSEMBLY

- |   |   |
|---|---|
| <p>A — POWER TAKE-OFF WINCH CONTROL LEVER<br/>         B — ADJUSTING YOKE<br/>         C — CLUTCH CONTROL ROD<br/>         D — BRAKE CONTROL ROD<br/>         E — LAYSHAFT TO REAR TANDEM WINCH CHAIN<br/>         F — QUADRANT<br/>         G — THROTTLE CONTROL LEVER<br/>         H — REAR TANDEM WINCH HAND CLUTCH LEVER<br/>         J — REAR TANDEM WINCH HAND BRAKE LEVER<br/>         K — REAR TANDEM WINCH HAND CONTROL LEVER<br/>         L — FRONT TANDEM WINCH HAND CONTROL LEVER<br/>         M — FRONT TANDEM WINCH HAND BRAKE LEVER<br/>         N — FRONT TANDEM WINCH HAND CLUTCH LEVER<br/>         P — NUT<br/>         Q — SET SCREWS<br/>         R — DOUBLE LEVER BRACKETS<br/>         S — OPERATING LEVERS<br/>         T — COLLARS<br/>         U — DOUBLE LEVER WINCH CONTROL ASSEMBLIES<br/>         V — REAR BASE ANGLE<br/>         W — HAND LEVER PIN</p> | <p>X — COTTER PIN<br/>         Y — BRAKE CONTROL SHAFT<br/>         Z — BRAKE CONTROL ROD<br/>         AA — BRAKE CONTROL LEVERS<br/>         AB — END PIN<br/>         AC — CLUTCH CONTROL ROD<br/>         AD — BRAKE CONTROL ROD<br/>         AE — ENGINE CLUTCH CONTROL FOOT LEVER<br/>         AF — ROCKER LEVERS<br/>         AG — ENGINE CLUTCH CONTROL SHAFT<br/>         AH — CLAMP BOLTS<br/>         AJ — WOODEN BLOCKS<br/>         AK — WINCH MOUNTING ASSEMBLY<br/>         AL — POWER TAKE-OFF CONTROL ROD<br/>         AM — DRIVE LINE TO LAYSHAFT CHAIN<br/>         AN — LAYSHAFT TO FRONT TANDEM WINCH CHAIN<br/>         AP — DRIVE SPROCKET<br/>         AQ — LAYSHAFT SPROCKET<br/>         AR — CHAIN TIGHTENER SPROCKET<br/>         AS — DRIVE SPROCKET FOR FRONT TANDEM WINCH</p> |
|---|---|

RA PD 74940B

Legend for Figure 31

**ORDNANCE MAINTENANCE – BODY, CHASSIS, AND WINCHES FOR TRACTOR TRUCK M26, COMPONENT OF 40-TON TANK TRANSPORTER TRAILER TRUCK M25**

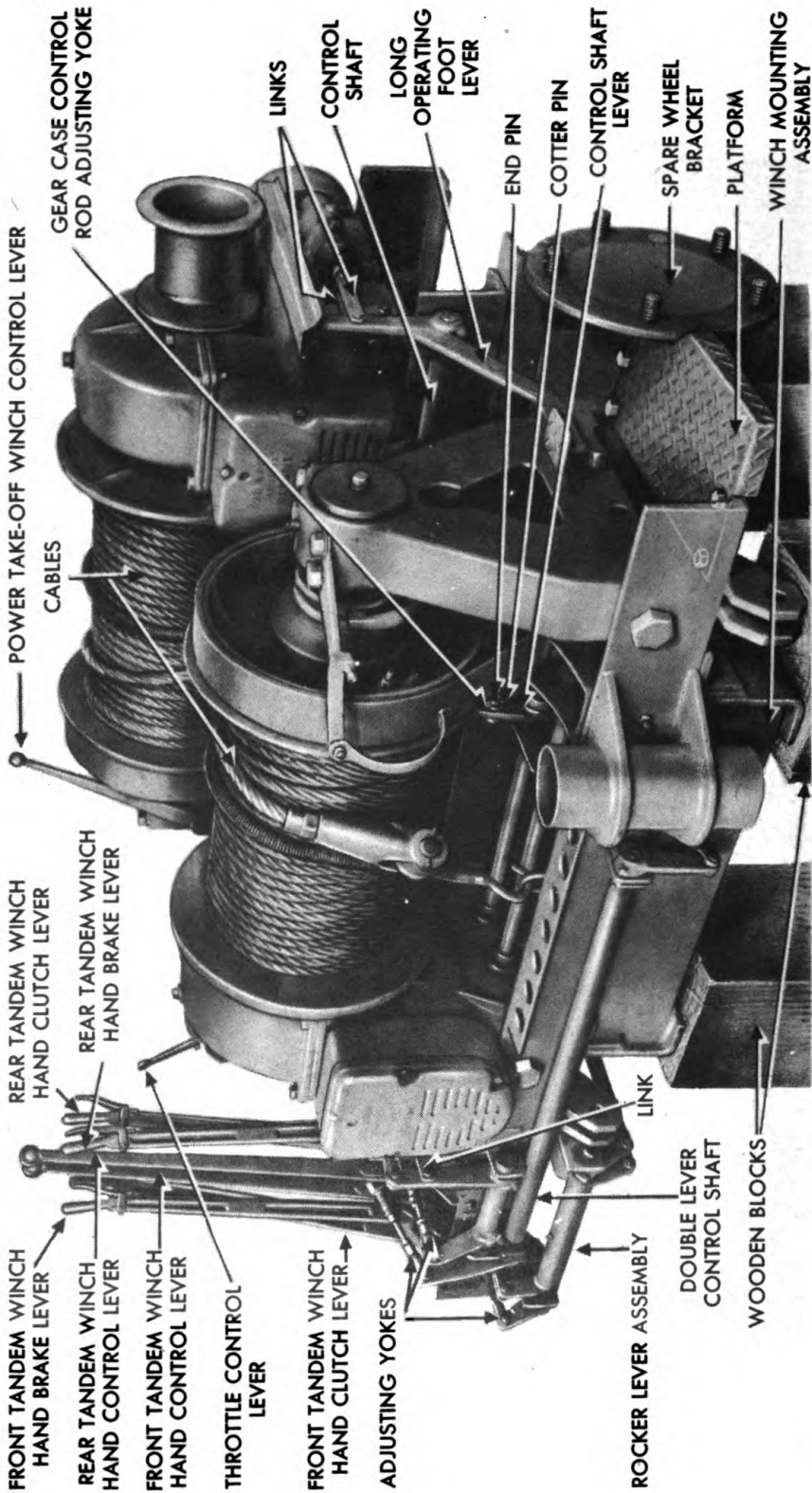

RA PD 74856

**Figure 32 – Tandem Winch Assembly – Rear View**

TANDEM WINCH ASSEMBLY

Section II

DISASSEMBLY OF TANDEM WINCH INTO  
SUBASSEMBLIES

	Paragraph
Disassembly .....	53

**53. DISASSEMBLY.**

a. **Remove Front Tandem Winch Double Lever Control Assembly** (figs. 31 and 32). The double lever winch control assembly (U, fig. 31) includes the front tandem winch hand brake and clutch levers and the bracket. Remove two end pins and cotter pins which hold adjusting yokes at the end of the control rods to control shaft lever and to rocker lever assembly at rear of rear tandem winch base rear angle. Remove four nuts, bolts, and lock washers which secure double lever bracket to base rear angle, and lift front winch double lever control assembly from angle.

b. **Remove Rear Tandem Winch Double Lever Control Assembly** (figs. 31 and 32). Rear tandem winch hand clutch, hand brake levers, and bracket (next to rear tandem winch) constitute the rear tandem winch double lever control assembly (U, fig. 31). Loosen set screw at top of rear winch brake control lever, and remove cotter pin and flat washer which hold brake control rod to control lever. Tap brake control lever partly off control shaft, and pull brake control rod from brake control lever. Remove cotter pin and end pin which secures adjusting yoke (at front end of clutch control rod) to clutch control lever. Disconnect brake control lever from adjusting yoke at front end of brake control rod in same manner. Remove four bolts, nuts, and lock washers which secure double lever bracket to rear tandem winch base rear angle, and lift two levers and bracket from angle.

c. **Remove Front and Rear Tandem Winch Hand Control (Gearshift) Levers** (figs. 31 and 32). Remove two cotter pins and end pins which hold adjusting yokes (at rear of operating rods) to operating levers (S, fig. 31). Remove two set screws on two collars between hand control levers. Remove cotter pin from one end of hand lever pin, and drive lever pin from levers and base rear angle. Remove two hand control (gearshift) lever assemblies and two collars. Remove two cotter pins and end pins which secure rocker (AF, fig. 31) and lever to links and adjusting yoke, at rear tandem winch gear case.

**ORDNANCE MAINTENANCE — BODY, CHASSIS, AND WINCHES FOR TRACTOR TRUCK M26, COMPONENT OF 40-TON TANK TRANSPORTER TRAILER TRUCK M25**

**d. Remove Front Tandem Winch Long Operating Foot Lever.** This lever is located at right side of assembly (fig. 32). Remove two cotter pins and end pins which hold lever to control rod adjusting yoke and to shift rod links. Loosen clamp bolt nut, and pull off lever.

**e. Remove Engine Clutch Foot Lever (fig. 31).** This lever is located at left side of front tandem winch. Loosen clamp bolt nut and pull lever from engine clutch control shaft. Remove Woodruff key from end of shaft.

**f. Remove Rear Winch Brake and Clutch Control Rods (fig. 31).** Remove cotter pin and end pin from adjusting yoke and rocker lever (AF, fig. 31) at front end of each rod, and remove two rods. Remove short clutch and brake control rods (C and D, fig. 31) by removing cotter pin and end pin from each end of each rod and its connecting control levers.

**g. Remove Power Take-off Winch Control Lever and Rod (figs. 31 and 32).** Remove lock pin from lever. Remove two cotter pins and end pins which secure lever to bracket and control rod, and remove control lever. Remove cotter pin and end pin which secures adjusting yoke at lower end of power take-off winch control rod (AL, fig. 31) to control shaft lever, and remove rod.

**h. Remove Chains (fig. 31).** Follow procedure given in TM 9-767 to remove tandem drive line to layshaft chain, layshaft to rear tandem winch chain, and layshaft to front tandem winch chain.

**i. Remove Gear Case Control Rod.** Remove two cotter pins and end pins which secure gear case control rod (fig. 32) to control shaft levers at each winch (this rod is located between two winches).

**j. Remove Spare Wheel Bracket and Platform (fig. 32).** Remove four bolts, nuts, and lock washers which hold spare wheel bracket to front tandem winch rear base angle (V, fig. 31) and to rear tandem winch front base angle. Remove bracket, then remove two bolts, nuts, and lock washers which secure platform to rear tandem winch rear base angle, and remove platform.

**k. Remove Front Tandem Winch (figs. 32 and 33).** Remove four bolts, nuts and lock washers which secure each side of winch to winch mounting assembly (fig. 32). Place a chain sling around ends of front tandem winch base angles, and attach a hoist to sling. Lift front tandem winch assembly from winch mounting assembly, and lower it onto wooden blocks to avoid damage to sprockets (fig. 33).

**l. Remove Rear Tandem Winch (fig. 32).** Remove four bolts, nuts, and lock washers which hold each side of rear tandem winch assembly to mounting assembly. Place a chain sling around ends of

TANDEM WINCH ASSEMBLY

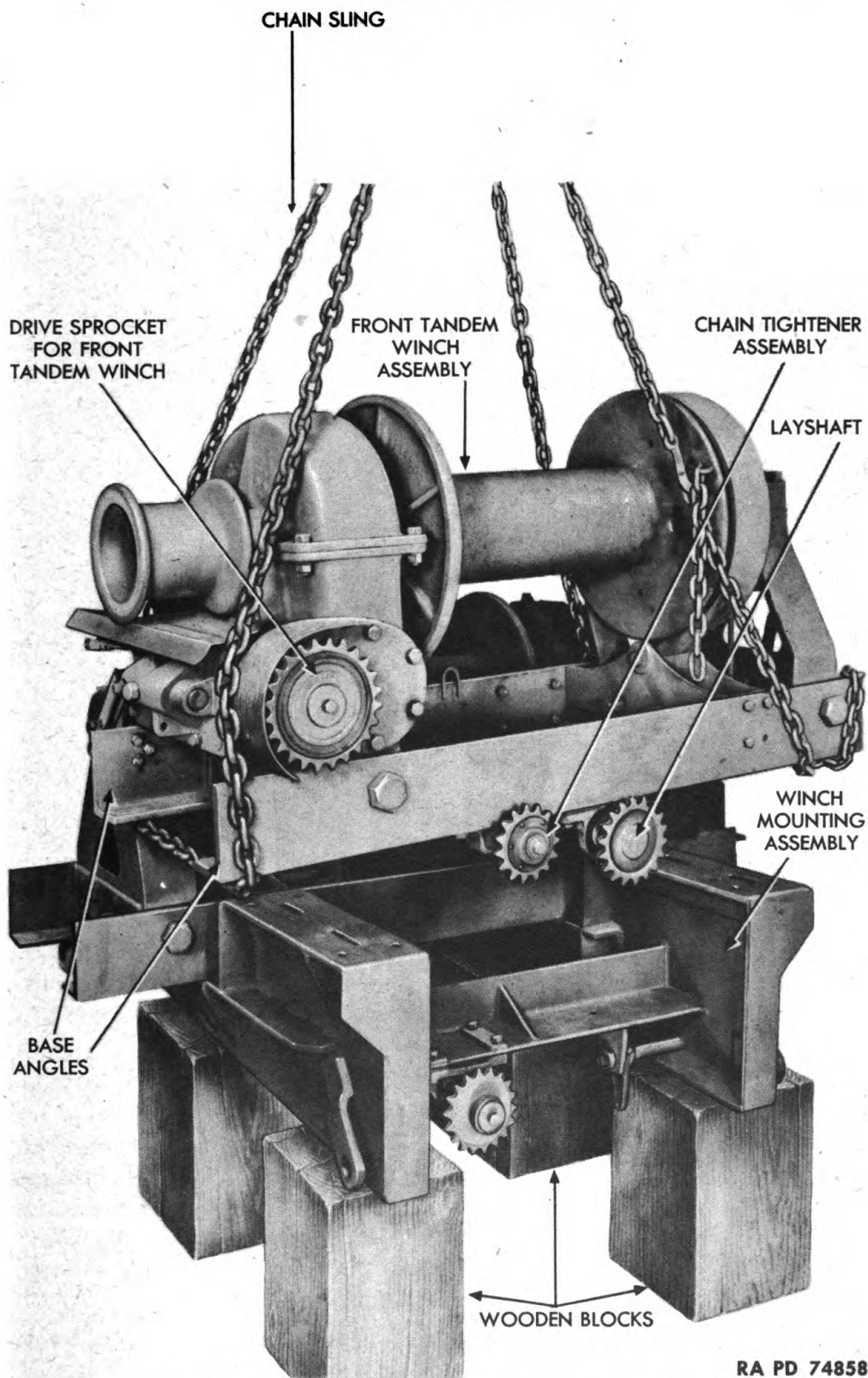

RA PD 74858

Figure 33 - Removing Front Tandem Winch

**ORDNANCE MAINTENANCE — BODY, CHASSIS, AND WINCHES FOR TRACTOR TRUCK M26, COMPONENT OF 40-TON TANK TRANSPORTER TRAILER TRUCK M25**

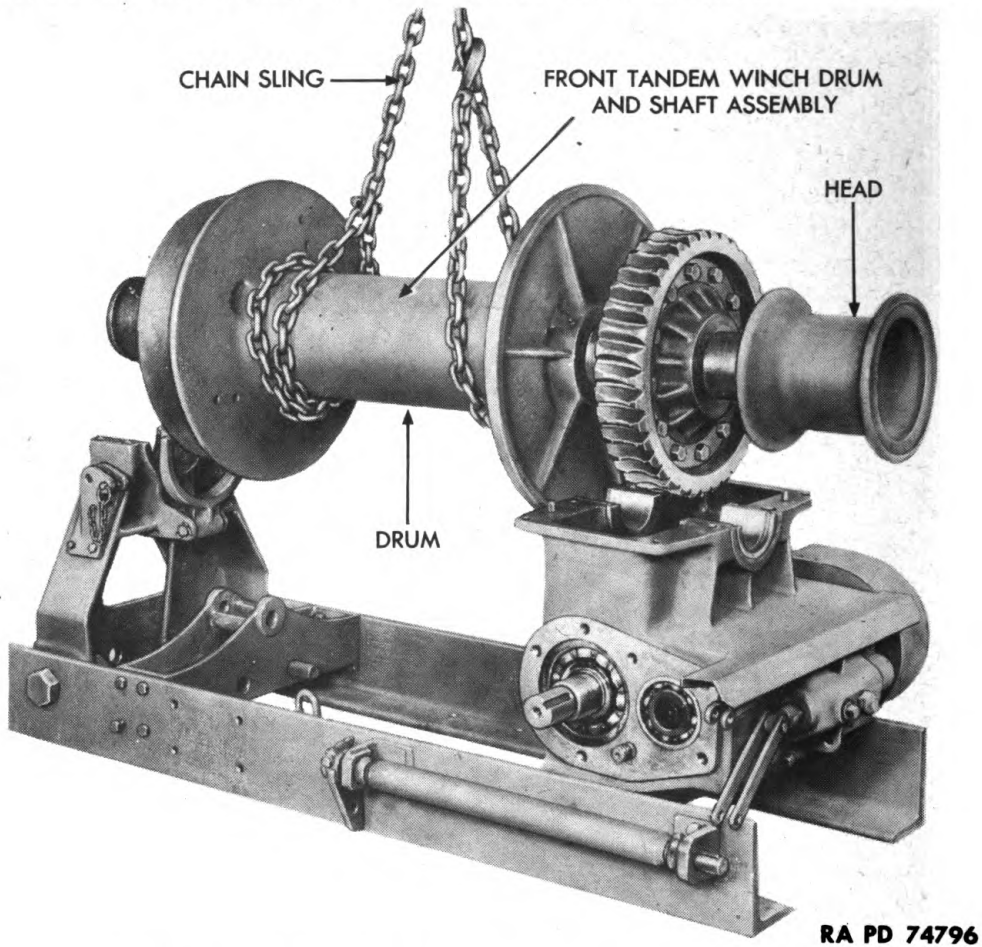

**Figure 34 — Removing Front Tandem Winch Drum and Shaft**

rear tandem winch base angles, and attach a hoist to sling. Lift rear tandem winch assembly from winch mounting assembly, and lower it onto wooden blocks to avoid damage to levers and brackets.

**m. Remove Layshaft and Chain Tightener.** Remove chain tightener assembly from front winch rear base angle by removing four bolts, nuts, and lock washers which secure chain tightener bracket to base angle (fig. 40). Remove layshaft assembly by removing two bolts, nuts, and lock washers which secure each of two single bearings to base angles. Lift layshaft with bearings attached, from angles and remove shims (fig. 39). Remove second chain tightener assembly by removing two bolts, nuts, and lock washers which secure clamps to front base angle and rear base angle (fig. 41).

**n. Remove Automatic Brake Assemblies.** Drain oil from gear case by removing drain plug from bottom of case. Remove five cap screws and lock washers which secure cover to case, and remove

TANDEM WINCH ASSEMBLY

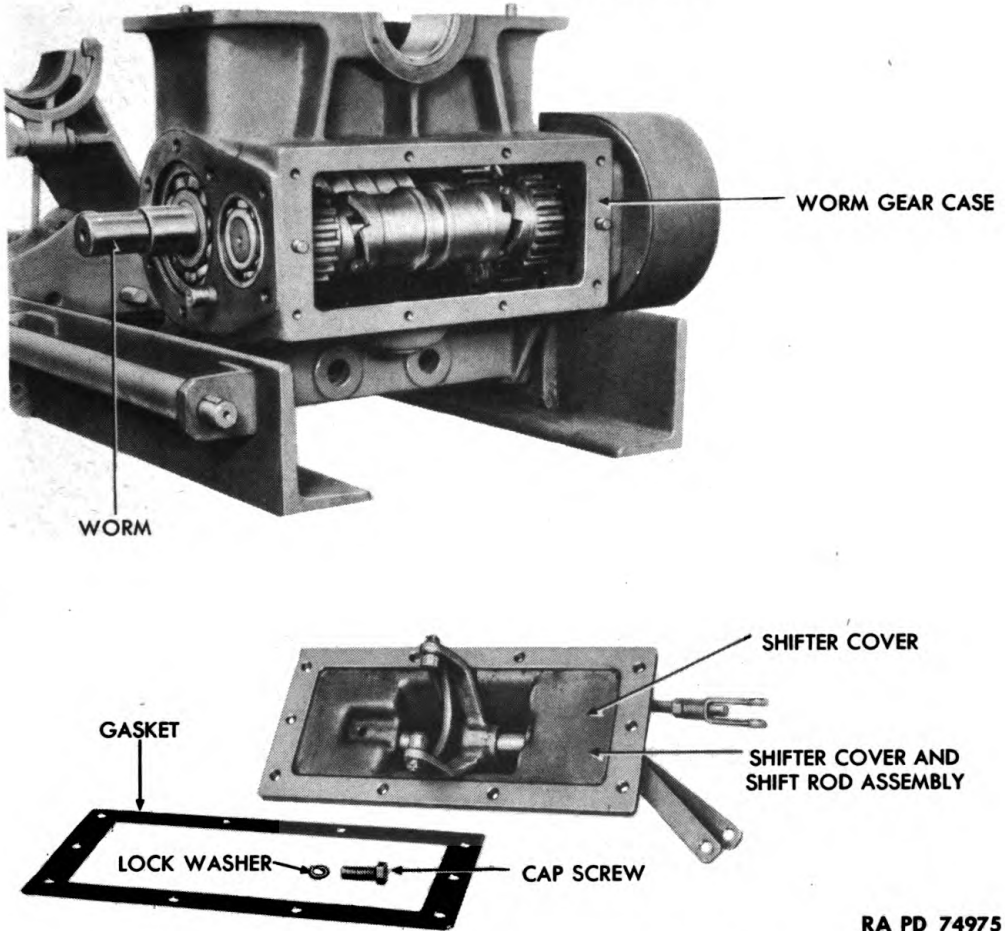

RA PD 74975

**Figure 35 – Shifter Cover and Shifter Rod Assembly – Removed**

cover (fig. 36). Loosen lock nut, adjusting nut, and alining washer on threaded end of brake band assembly, to release tension of brake spring (figs. 24 and 25). Remove brake band assembly from case by prying brake rocker (with assembled brake band) off rocker pin and brake disk. Remove rocker spring as brake assembly is removed from case. Remove brake disk by removing cap screw, lock washers, and retaining washer and prying off disk; then lift key from end of worm. Detach brake case from lower half of gear case by removing five cap screws and lock washers, then one nut and lock washer from inside brake case, and two cap screws and lock washers from outside case. Lift off brake case and gasket. **NOTE:** *Front and rear tandem winch automatic brake assemblies are removed in same manner.*

**o. Remove Drum Brake Band Assemblies (fig. 42).** Remove cotter pin from tight end pin at end of brake band assembly, and drive pin from brake band and brake anchor. Loosen set screws on two operating shaft collars and short brake operating lever, and pull brake operating shaft with operating lever attached from brake anchor

ORDNANCE MAINTENANCE — BODY, CHASSIS, AND WINCHES FOR TRACTOR  
TRUCK M26, COMPONENT OF 40-TON TANK TRANSPORTER TRAILER TRUCK M25

RA PD 74949

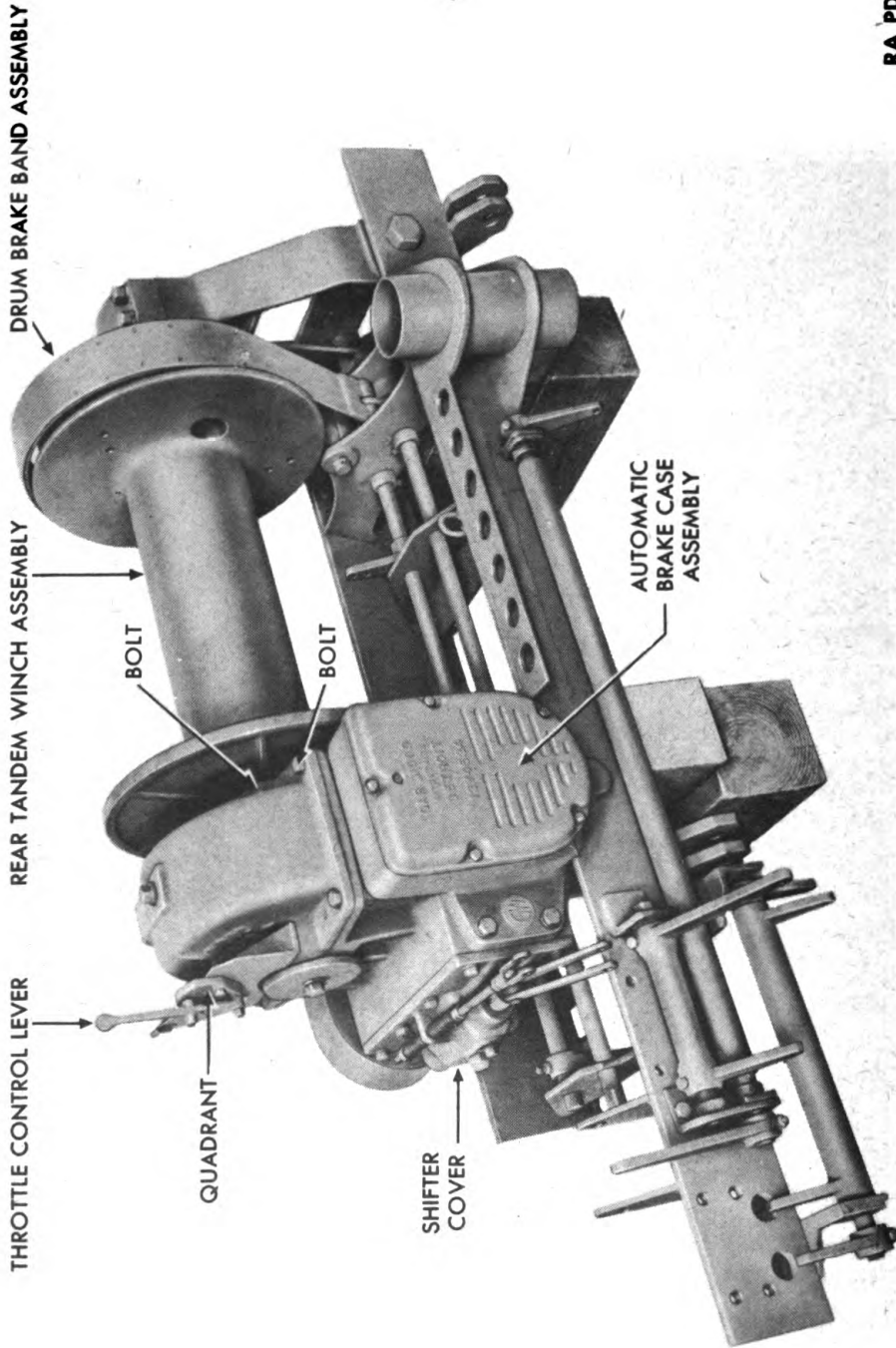

Figure 36 — Rear Tandem Winch

**TANDEM WINCH ASSEMBLY**

and end bearing frame. Remove collars, and lift drum brake band assembly from drum. **NOTE:** *Front and rear winch drum brake band assemblies are removed in same manner.*

p. **Remove Drum and Shaft Assemblies** (figs. 32 and 34). Remove four large bolts, nuts, and lock washers and four small bolts, nuts, and lock washers which secure gear case cover to gear case (fig. 32). Remove cover and two gaskets. Remove bearing frame cap (fig. 32) by removing four cap screws and lock washers which secure cap to end bearing frame, and remove cap. Wrap a chain sling around both sides of winch drum, and use a hoist to lift drum and shaft assembly from end bearing frame and gear case. Position chain sling so drum and shaft assembly can be lifted straight up (fig. 34). **NOTE:** *Front and rear winch drum and shaft assemblies are removed in same manner.*

q. **Remove Shifter Cover and Shift Rod Assemblies** (fig. 35). Remove two cap screws and lock washers which secure shield to cover, and remove shield (front tandem winch only). Remove remaining six cap screws and lock washers which secure cover to worm gear case, and remove shifter cover and shift rod assemblies. **NOTE:** *Front and rear tandem winch shifter cover and shift rod assemblies are removed in same manner.*

---

**Section III**

**DISASSEMBLY, CLEANING, INSPECTION, REPAIR, AND ASSEMBLY OF TANDEM WINCH SUBASSEMBLIES**

	Paragraph
Controls and linkage .....	54
Layshaft assembly .....	55
Layshaft to front tandem winch chain tightener assembly .....	56
Layshaft to rear tandem winch chain tightener assembly .....	57
Automatic brake case assemblies .....	58
Drum brake band assembly .....	59
Winch drum and shaft assembly .....	60
Shifter cover and shift rod assemblies .....	61
Gear case assembly .....	62
End bearing frame and clutch shift yoke assembly .....	63
Rear tandem winch base angles and controls .....	64
Winch mounting assembly .....	65
Double bearing assembly .....	66
Universal joint assembly .....	67

**54. CONTROLS AND LINKAGE.**

a. **Disassembly.** **NOTE:** *The two double lever winch control assemblies (AJ, fig. 37) are disassembled and assembled in same manner.*

ORDNANCE MAINTENANCE — BODY, CHASSIS, AND WINCHES FOR TRACTOR TRUCK M26, COMPONENT OF 40-TON TANK TRANSPORTER TRAILER TRUCK M25

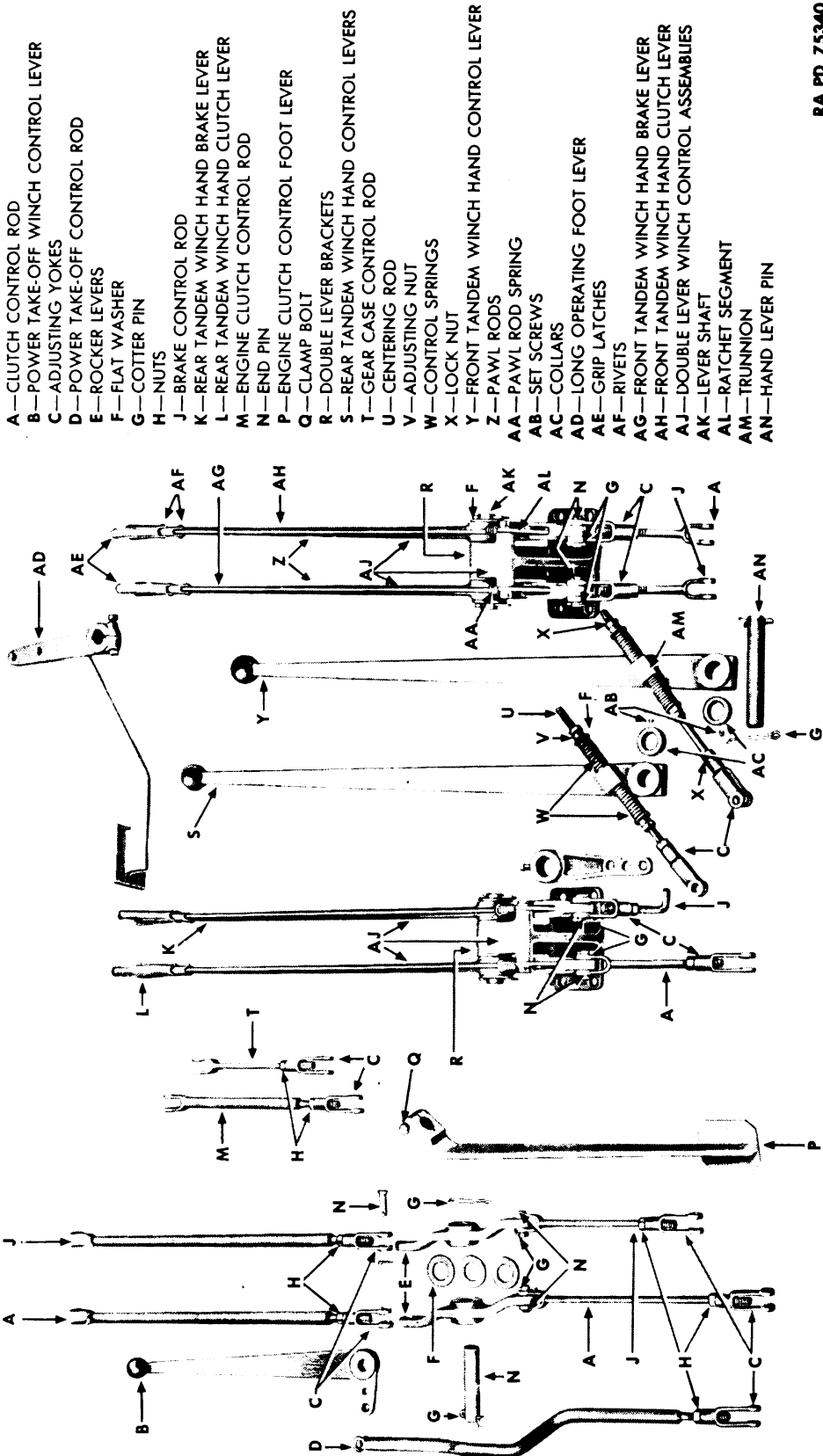

- A—CLUTCH CONTROL ROD
- B—POWER TAKE-OFF WINCH CONTROL LEVER
- C—ADJUSTING YOKES
- D—POWER TAKE-OFF CONTROL ROD
- E—ROCKER LEVERS
- F—FLAT WASHER
- G—COTTER PIN
- H—NUTS
- J—BRAKE CONTROL ROD
- K—REAR TANDEM WINCH HAND BRAKE LEVER
- L—REAR TANDEM WINCH HAND CLUTCH LEVER
- M—ENGINE CLUTCH CONTROL ROD
- N—END PIN
- P—ENGINE CLUTCH CONTROL FOOT LEVER
- Q—CLAMP BOLT
- R—DOUBLE LEVER BRACKETS
- S—REAR TANDEM WINCH HAND CONTROL LEVERS
- T—GEAR CASE CONTROL ROD
- U—CENTERING ROD
- V—ADJUSTING NUT
- W—CONTROL SPRINGS
- X—LOCK NUT
- Y—FRONT TANDEM WINCH HAND CONTROL LEVER
- Z—PAWL RODS
- AA—PAWL ROD SPRING
- AB—SET SCREWS
- AC—COLLARS
- AD—LONG OPERATING FOOT LEVER
- AE—GRIP LATCHES
- AF—RIVETS
- AG—FRONT TANDEM WINCH HAND BRAKE LEVER
- AH—FRONT TANDEM WINCH HAND CLUTCH LEVER
- AJ—DOUBLE LEVER WINCH CONTROL ASSEMBLIES
- AK—LEVER SHAFT
- AL—RATCHET SEGMENT
- AM—TRUNNION
- AN—HAND LEVER PIN

RA PD 75340

Figure 37 — Controls and Linkage Removed

## TANDEM WINCH ASSEMBLY

(1) **REMOVE ADJUSTING YOKES** (fig. 37). Remove two cotter pins and end pins which secure adjusting yokes (C) to two levers (U). Remove adjusting yokes and lock nuts from each control rod.

(2) **REMOVE RATCHET SEGMENT** (fig. 37). Remove four cap screws and lock washers which hold ratchet segment to double lever bracket, and remove two ratchet segments by depressing grip latch at top of each lever.

(3) **REMOVE LEVERS AND PAWL ROD** (fig. 37). Remove two cotter pins and flat washers from ends of lever shaft, and remove two levers from shaft. Drive shaft from bracket, then drive out two rivets which secure grip latch to lever and pawl rod end. Remove pawl rod, with two flat washers and pawl rod spring attached, from lever. Remove second pawl rod in same manner. Remove pawl rod end from rod, and remove two flat washers and spring.

(4) **DISASSEMBLE HAND CONTROL (GEARSHIFT) LEVER** (fig. 37). Remove cotter pin and flat washer which secures centering rod to lever, and remove rod from lever. Remove adjusting yoke and lock nut from end of centering rod. Then remove lock nut and adjusting nut at each end of centering rod, and remove two control springs from rod. Remove rod from trunnion. *NOTE: The front and rear tandem winch hand control levers are disassembled in the same manner.*

**b. Cleaning, Inspection, and Repair.** Clean all parts in dry-cleaning solvent. Inspect threads for crossed or mashed threads, and straighten any damaged threads with thread die. Inspect levers, shafts, and rods for bends, and straighten any bent units in a vise. Inspect rod end pins and yokes for burs, and remove any burs with a file.

### **c. Assembly.**

(1) **INSTALL PAWL ROD** (fig. 37). Position pawl rod spring with flat washer on each side of pawl rod, and install pawl rod end on pawl rod. Install pawl rod on lever, and install grip latch to pawl rod end and lever with two rivets. Before riveting pawl rod end, make sure that it is positioned on pawl rod correctly for operating of pawl rod in ratchet segment. Assemble and install second pawl rod in the same manner.

(2) **INSTALL LEVERS** (fig. 37). Drive lever shaft into double lever bracket, and install two levers on the shaft. Lock each lever in position by installing flat washer and cotter pin at end of shaft.

(3) **INSTALL RATCHET SEGMENTS** (fig. 37). Depress each grip latch, and place the two ratchet segments in position, securing them to the bracket by installing the four cap screws and lock washers. Install adjusting yoke and lock nut on ends of each control rod, and secure the two adjusting yokes to the lower end of each lever by installing a cotter pin.

**ORDNANCE MAINTENANCE — BODY, CHASSIS, AND WINCHES FOR TRACTOR TRUCK M26, COMPONENT OF 40-TON TANK TRANSPORTER TRAILER TRUCK M25**

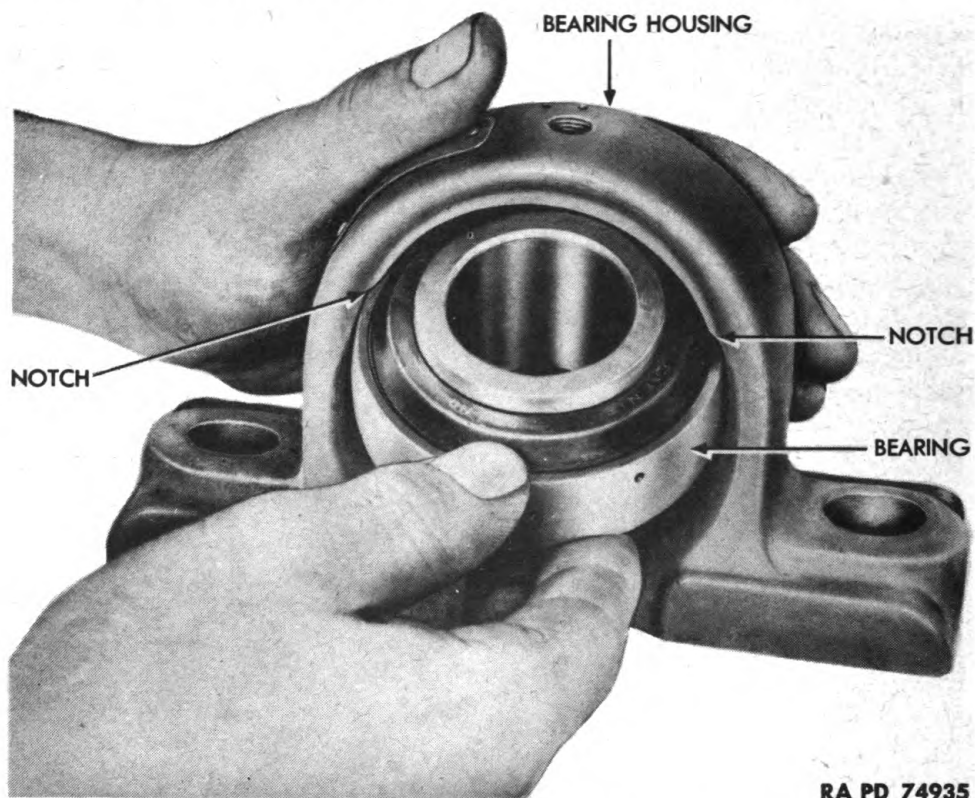

**Figure 38 — Removing Bearing from Housing**

(4) **INSTALL HAND CONTROL ROD** (fig. 37). First install centering rod (U) in the trunnion. Then install a control spring (W) on each end of the rod, and secure spring in place with a flat washer, adjusting nut, and lock nut. Position rod on hand control (gearshift) lever (S and T) and lock trunnion pin with a flat washer and cotter pin. Assemble second lever in same way.

## **55. LAYSHAFT ASSEMBLY.**

### **a. Disassembly.**

(1) **REMOVE END SPROCKETS** (fig. 39). Use a socket head set screw wrench to loosen set screw on two sprockets at each end of layshaft, and use a gear puller to remove two sprockets from ends of layshaft. Remove two keys from ends of layshaft.

(2) **REMOVE BEARINGS AND COLLARS** (fig. 38). Loosen set screw on lock collar which holds each bearing on layshaft, and remove two lock collars. Pull single bearing assemblies from layshaft. Remove bearings from their housings by turning bearing in housing so that it is at a right angle to its normal operating position and parallel with

## TANDEM WINCH ASSEMBLY

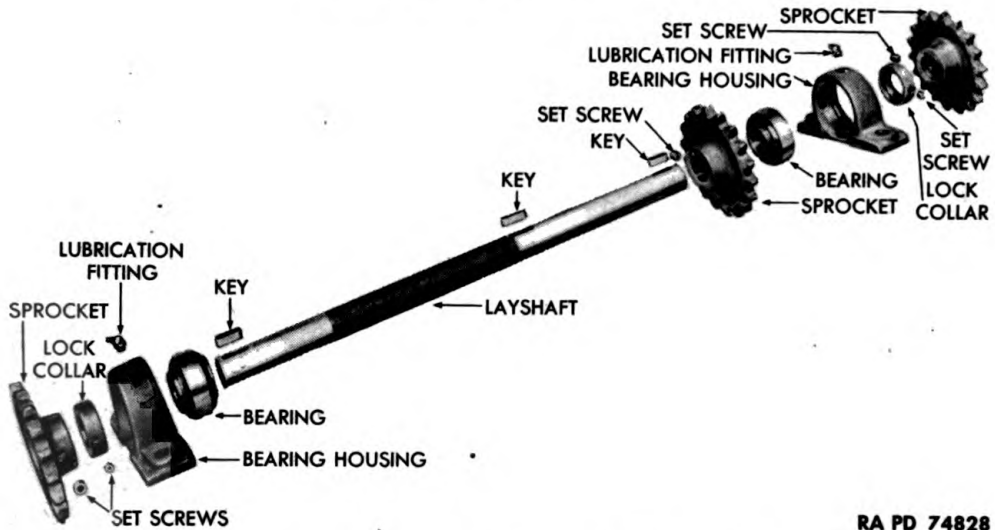

RA PD 74828

**Figure 39 — Layshaft — Disassembled**

bracket portion of housing (fig. 38). Bearing can then be pulled out of housing, past notches provided for its removal and installation.

(3) **REMOVE CENTER SPROCKET** (fig. 39). Loosen set screw on center sprocket. Press center sprocket from layshaft, and remove key.

**b. Cleaning, Inspection, and Repair.** Wash all parts in dry-cleaning solvent. If the parts are to be painted, wash them with soda ash solution. Inspect sprockets for scoring or breaks on teeth, and replace sprocket if deeply scored or broken. Rotate bearing, and inspect for rough or loose running. Replace bearing if necessary. Examine bearing housing for cracks or breaks, and replace if such condition is found. Measure fit of bearing on layshaft, and replace bearing, lay shaft, or both, if bearing is over 0.002 inch loose. Inspect set screws and set screw holes for damaged threads, and straighten with thread tap or replace set screws.

**c. Assembly.**

(1) **INSTALL BEARINGS AND LAYSHAFT DRIVE SPROCKET** (figs. 38 and 39). Install bearings in housing in same position as when removed, then turn bearings to their normal operating position. Install lubrication fitting on top of each bearing housing. Install key in keyway at center of layshaft, and press sprocket onto layshaft, then lock sprocket to shaft by installing set screw. Slide two single bearing assemblies on layshaft, install a lock collar next to each bearing, and secure with set screw in each lock collar.

(2) **INSTALL FRONT AND REAR WINCH DRIVE SPROCKETS.** Install key on end of layshaft, and press front winch drive sprocket on shaft. Then tighten set screw which locks sprocket to layshaft. Install rear winch drive sprocket on opposite end of layshaft in same manner.

ORDNANCE MAINTENANCE — BODY, CHASSIS, AND WINCHES FOR TRACTOR  
TRUCK M26, COMPONENT OF 40-TON TANK TRANSPORTER TRAILER TRUCK M25

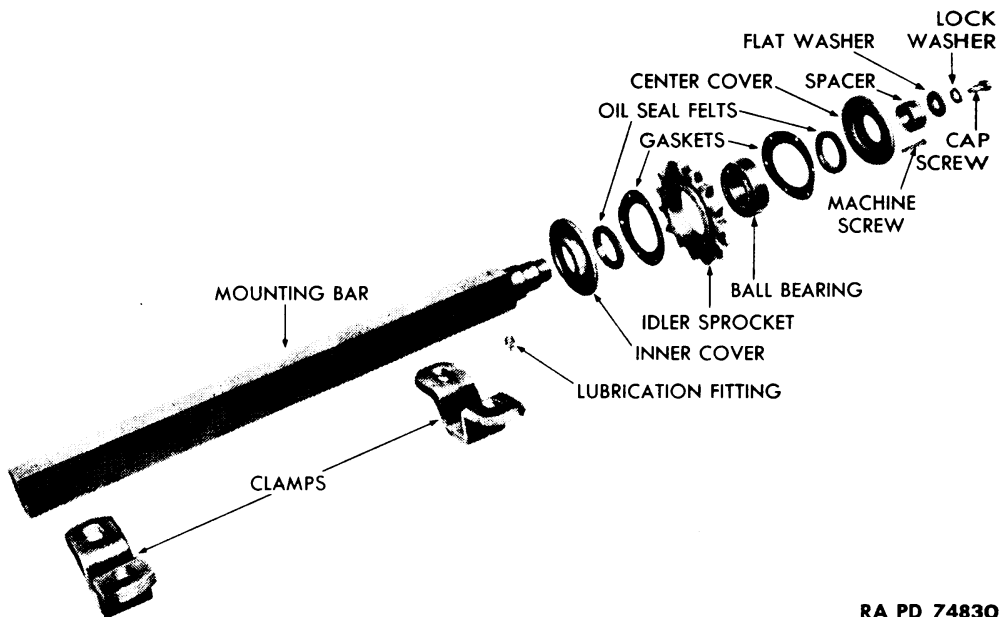

RA PD 74830

Figure 40 — Front Tandem Winch Chain Tightener — Disassembled

56. LAYSHAFT TO FRONT TANDEM WINCH CHAIN TIGHTENER ASSEMBLY.

a. **Disassembly** (fig. 40). Remove cap screw, lock washer, and flat washer from end of mounting bar. Then remove tightener sprocket assembly and spacer from end of bar. Remove six screws which hold inner and outer bearing oil seal covers on sprocket, and remove covers, oil seals, and gaskets. Press bearing from sprocket.

b. **Cleaning, Inspection, and Repair.** Wash all parts with dry-cleaning solvent. If nonbearing surfaces are to be painted, wash them with soda ash solution. Inspect sprocket teeth for breaks or deep scores, and replace sprocket if necessary. Test fit of spacer on end of bar, and replace spacer if over 0.006 inch loose. Rotate ball bearing, and inspect for flat spots on rollers and for rough running. Replace bearing if necessary. Test fit of bearing in sprocket, and replace if over 0.005 inch loose. Inspect screws for stripped threads, and straighten with a thread die. Discard oil seal felts and gaskets.

c. **Assembly** (fig. 40). Install new oil seal felt in inner and outer covers. Coat bearing with light engine oil, and press bearing into sprocket. Install covers and new gaskets on sprocket, and secure by installing six machine screws. Install flat washer, lock washer, and cap screw which secures sprocket assembly on bar, and tighten assembly securely.

TANDEM WINCH ASSEMBLY

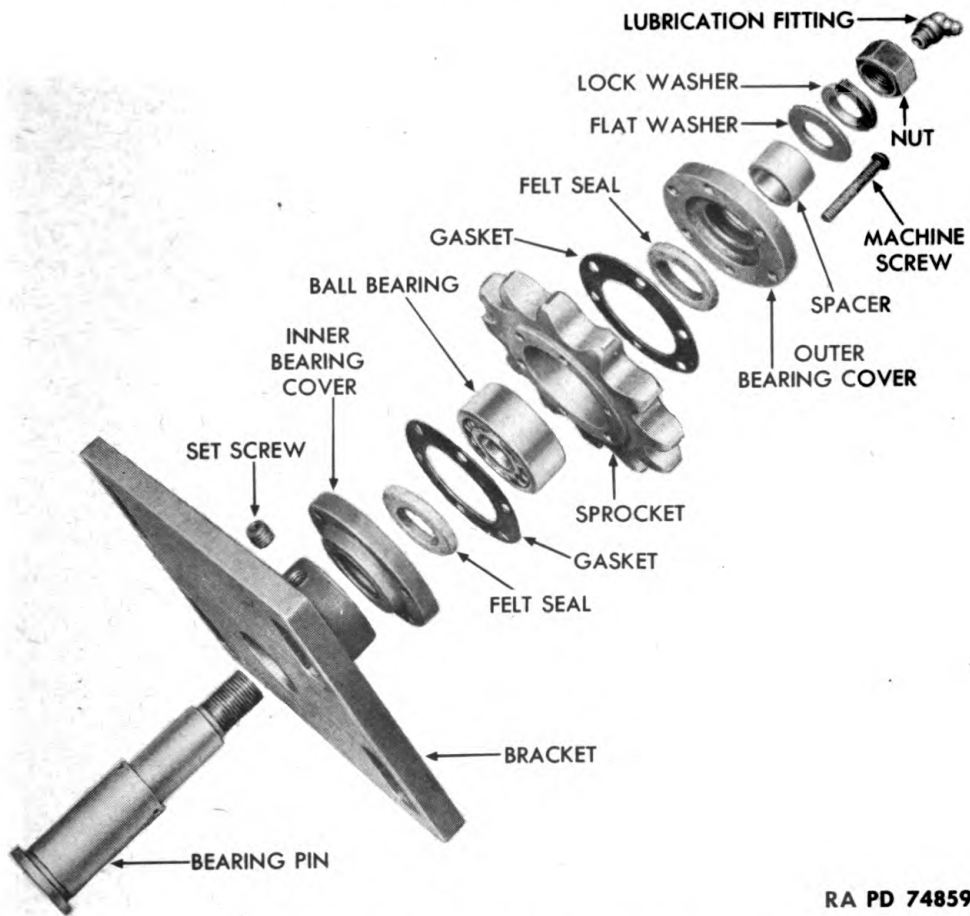

RA PD 74859

**Figure 41 – Rear Tandem Winch Chain Tightener – Disassembled**

**57. LAYSHAFT TO REAR TANDEM WINCH CHAIN TIGHTENER ASSEMBLY.**

a. **Disassembly** (fig. 41). Remove nut, lock washer, and flat washer from bearing pin. Remove set screw on bracket, and pull sprocket and spacer from bearing pin. Drive bearing pin from bracket. Remove six machine screws which secure inner and outer bearing covers to sprocket, and remove covers, felt seals, and gaskets. Remove felt oil seals from covers. Press ball bearing from sprocket.

b. **Cleaning, Inspection, and Repair.** Wash all parts with dry-cleaning solvent. Discard felt rings and gaskets. Inspect machine screws and covers for stripped threads, and straighten threads with die. Rotate bearing, and inspect for flat or damaged rollers and for loose running. Replace bearing if these conditions are noted. Replace sprocket if teeth are deeply scored or chipped. Measure fit of bearing in sprocket, and replace bearing or sprocket, or both, if there is over a 0.003-inch clearance.

ORDNANCE MAINTENANCE — BODY, CHASSIS, AND WINCHES FOR TRACTOR  
TRUCK M26, COMPONENT OF 40-TON TANK TRANSPORTER TRAILER TRUCK M25

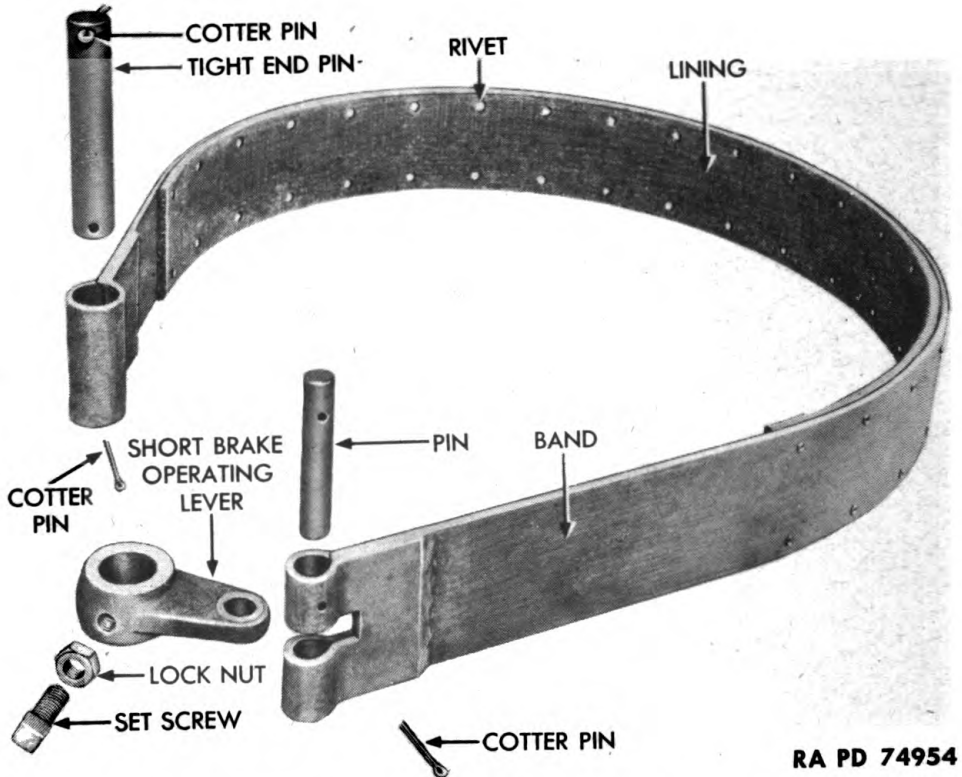

Figure 42 — Brake Band — Disassembled

c. Assembly (fig. 41). Coat ball bearing with light engine oil, and press bearing into sprocket. Install new felt seals in inner and outer covers. Install new gaskets, and secure covers on sprockets with six machine screws. Drive bearing pin into bracket, and press sprocket and bearing on pin. Install spacer, flat washer, lock washer, and nut on end of bearing pin. Tighten assembly securely. Install set screw on bracket.

### 58. AUTOMATIC BRAKE CASE ASSEMBLIES.

NOTE: The procedure for the disassembly, cleaning, inspection, repair, and assembly of the brake case assembly, on both the front and rear tandem winches, is the same as for the front-mounted winch automatic brake case assembly.

### 59. DRUM BRAKE BAND ASSEMBLY.

a. Disassembly (fig. 42). Remove cotter pin which holds tight end pin and short brake operating lever to brake band. Remove lock nut and set screw from end of short brake operating lever.

## TANDEM WINCH ASSEMBLY

b. **Cleaning, Inspection, and Repair.** Clean parts in dry-cleaning solvent, but do not get solvent on lining. Inspect brake lining; if worn down to level of rivet heads, remove rivets and install new lining. Inspect short brake operating lever and brake band for scoring and burs. Remove all burs and scores with crocus cloth.

c. **Assembly** (fig. 42). Install short brake operating lever, and secure to band with tight end pin and cotter pin. Install set screw and lock nut in end of short brake operating lever.

### 60. WINCH DRUM AND SHAFT ASSEMBLY (fig. 43).

a. **Disassembly.** *NOTE: The procedure for disassembly, cleaning, inspection, repair, and assembly of both front and rear tandem winch drum and shaft assemblies is the same.*

(1) **REMOVE DRUM SHAFT** (fig. 43). Remove cap screw, lock washer, retaining washer, and shims from head end of drum shaft, and pull off winch head. Winch head is used on front tandem winch only. Remove key from end of shaft, then remove cap screw, lock washer, retaining washer, and drum shaft shims from clutch end of shaft. Remove end bearing sleeve, frame thrust ring, and sliding clutch from shaft. Remove drum thrust ring from sliding clutch and two keys from shaft. Pull drum shaft with worm gear attached from drum.

(2) **REMOVE WORM GEAR** (fig. 43). Remove worm gear from spider by removing 12 bolts, nuts, and lock washers which secure gear to spider. Press spider from shaft, and remove keys from shaft. Remove two nuts which secure rope clamp to drum studs, and pull off clamp.

b. **Cleaning, Inspection, and Repair.** Wash all parts in dry-cleaning solvent. Inspect drum shaft, worm gear, and all machined surfaces for scoring, and replace part if scored. Measure fit of shaft in drum bushings, and if there is over 0.006-inch play, press bushings out of drum and replace bushings. Measure fit of end bearing sleeve on drum shaft, and replace bushing if there is over 0.003-inch play. Inspect sliding clutch, frame, and drum thrust rings for scoring. File out light scores, or replace part if deeply scored. Inspect braking surface of drum for scoring, and reface drum in a lathe if scored.

c. **Assembly.**

(1) **INSTALL SPIDER AND WORM GEAR.** Place spider keys in shaft keyways, and press spider onto shaft and keys. Place worm gear in position on spider, and secure with 12 bolts, lock washers, and nuts.

(2) **INSTALL WORM GEAR AND DRUM SHAFT ASSEMBLY.** Install drum shaft with worm gear attached through drum bushings. Install drum thrust ring, sliding clutch, frame thrust ring, and bearing sleeve

ORDNANCE MAINTENANCE — BODY, CHASSIS, AND WINCHES FOR TRACTOR  
TRUCK M26, COMPONENT OF 40-TON TANK TRANSPORTER TRAILER TRUCK M25

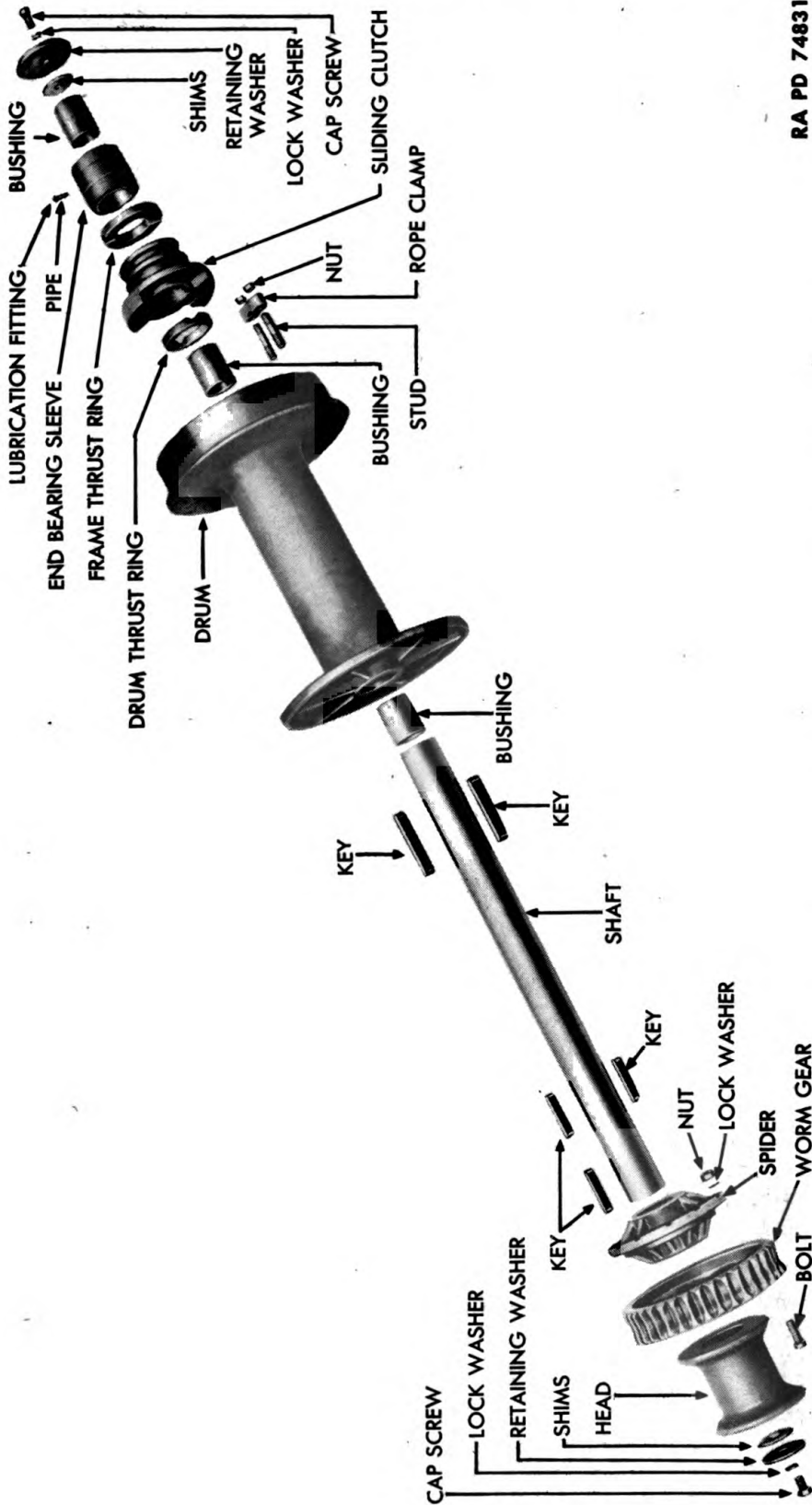

RA PD 74831

Figure 43 — Front Tandem Winch Drum and Shaft — Disassembled

**TANDEM WINCH ASSEMBLY**

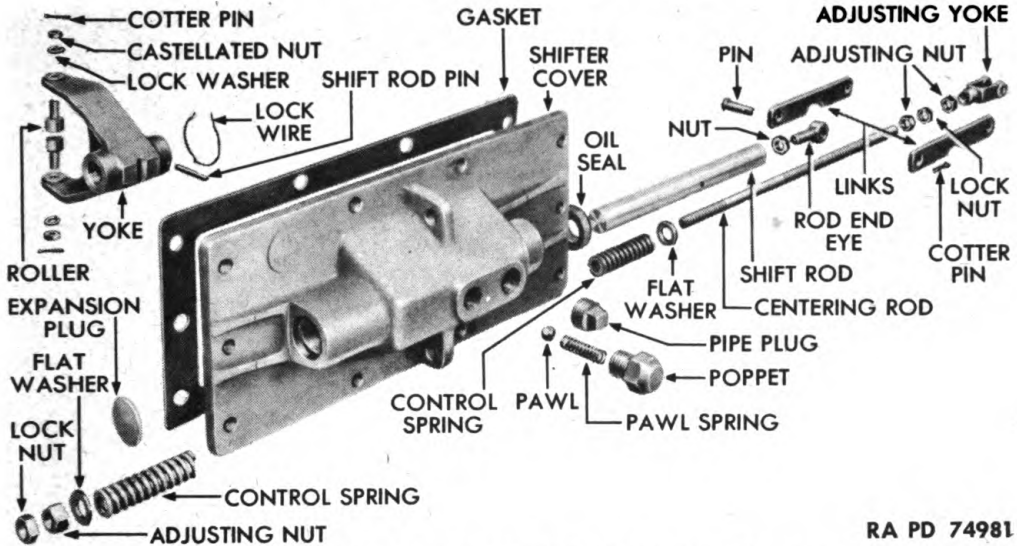

RA PD 74981

**Figure 44 – Shifter Cover and Shift Rod – Disassembled**

and bushing on drum shaft. Install winch head on worm gear end of drum shaft (there is no winch head on rear tandem winch).

(3) **INSTALL SHIMS** (fig. 43). Install drum shaft shims, retaining washer, lock washer, and cap screw at each end of drum shaft. Check end play which must not be over 0.008 inch. Remove or add shims if necessary.

(4) **INSTALL ROPE CLAMPS**. Install rope clamp on studs, and secure with two nuts.

**61. SHIFTER COVER AND SHIFT ROD ASSEMBLIES.**

**a. Disassembly.** NOTE: *Front and rear winch shifter cover and shift rod assemblies are removed in same manner.*

(1) **REMOVE LINKS AND CENTERING ROD** (fig. 44). Remove cotter pin and rod end pin which secures the two links to shift rod and remove links. Remove lock nut, adjusting nut, flat washer, and control spring from one end of centering rod, and remove rod from cover. Remove second control spring, flat washer, adjusting yoke, two adjusting nuts, and lock nut from rod.

(2) **REMOVE SHIFT ROD** (fig. 44). Remove poppet from cover and remove pawl spring from poppet, then turn shifter cover and allow pawl to drop out. Remove lock wire from shift rod pin, slide shift rod to one side, and drive shift rod pin from rod and yoke, working through poppet hole in cover. Pull shift rod out of shift yoke and cover, and remove yoke from cover. Remove rod end eye from shift rod.

(3) **REMOVE ROLLERS AND YOKE** (fig. 44). Remove cotter pins from castellated nuts which hold two rollers in position at ends of

ORDNANCE MAINTENANCE — BODY, CHASSIS, AND WINCHES FOR TRACTOR  
TRUCK M26, COMPONENT OF 40-TON TANK TRANSPORTER TRAILER TRUCK M25

RA PD 74891

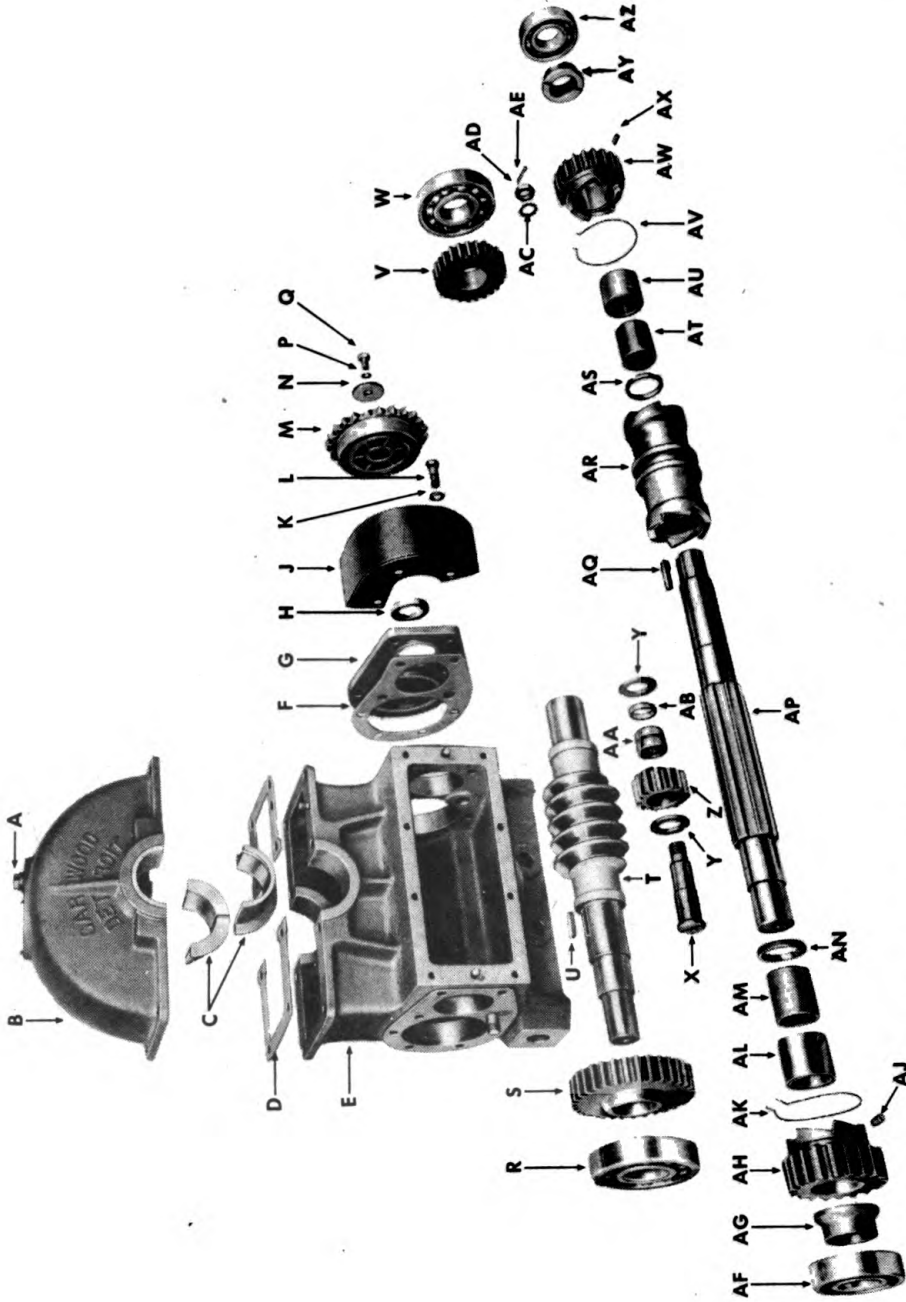

Figure 45 — Front Tandem Winch Gear Case — Disassembled

TANDEM WINCH ASSEMBLY

RA PD 74891B

- |  |                                      |
|--|--------------------------------------|
| <b>A</b> —FILLER PLUG  | <b>AA</b> —ROLLER BEARINGS           |
| <b>B</b> —COVER  | <b>AB</b> —IDLER GEAR BEARING SPACER |
| <b>C</b> —DRUM SHAFT BUSHINGS  | <b>AC</b> —LOCK WASHER               |
| <b>D</b> —GASKET   | <b>AD</b> —CASTELLATED NUT           |
| <b>E</b> —WORM GEAR CASE   | <b>AE</b> —COTTER PIN                |
| <b>F</b> —GASKET   | <b>AF</b> —BALL BEARING              |
| <b>G</b> —GEAR CASE END COVER  | <b>AG</b> —INPUT SHAFT THRUST COLLAR |
| <b>H</b> —OIL SEAL   | <b>AH</b> —CLUTCH GEAR (RIGHT HAND)  |
| <b>J</b> —SPROCKET SHIELD  | <b>AJ</b> —LOCK SCREW                |
| <b>K</b> —LOCK WASHER  | <b>AK</b> —LOCK WIRE                 |
| <b>L</b> —CAP SCREW  | <b>AL</b> —SLEEVE                    |
| <b>M</b> —SPROCKET ASSEMBLY (SPROCKET,<br>RIM, HUB, AND BUSHING—NOT<br>AVAILABLE SEPARATELY) | <b>AM</b> —BUSHING                   |
| <b>N</b> —RETAINER WASHER  | <b>AN</b> —CLUTCH GEAR SPACER        |
| <b>P</b> —LOCK WASHER  | <b>AP</b> —INPUT SHAFT               |
| <b>Q</b> —CAP SCREW  | <b>AQ</b> —KEY                       |
| <b>R</b> —BALL BEARING (BRAKE END)   | <b>AR</b> —SLIDING CLUTCH            |
| <b>S</b> —GEAR (33 TEETH)  | <b>AS</b> —CLUTCH GEAR SPACER        |
| <b>T</b> —WORM   | <b>AT</b> —BUSHING                   |
| <b>U</b> —KEY  | <b>AU</b> —SLEEVE                    |
| <b>V</b> —GEAR (25 TEETH)  | <b>AV</b> —LOCK WIRE                 |
| <b>W</b> —BALL BEARING (BLIND END)   | <b>AW</b> —CLUTCH GEAR (LEFT HAND)   |
| <b>X</b> —REVERSE IDLER PIN  | <b>AX</b> —LOCK SCREW                |
| <b>Y</b> —IDLER GEAR THRUST WASHER   | <b>AY</b> —INPUT SHAFT THRUST COLLAR |
| <b>Z</b> —REVERSE IDLER GEAR   | <b>AZ</b> —BALL BEARING              |

Legend for Figure 45

**ORDNANCE MAINTENANCE — BODY, CHASSIS, AND WINCHES FOR TRACTOR TRUCK M26, COMPONENT OF 40-TON TANK TRANSPORTER TRAILER TRUCK M25**

shift yoke; remove castellated nuts and drive rollers from yoke. Remove oil seal from cover, and discard oil seal.

b. **Cleaning, Inspection, and Repair.** Wash all parts in dry-cleaning solvent. Inspect links for bends and straighten in vise. Inspect centering rod for bends, and inspect threads for stripped or mashed threads. Straighten rod in vise, and straighten threads with die. Examine adjusting yoke and nuts for stripped threads, and straighten with die. Inspect control springs for breakage, bending, and coils that are unevenly spaced. Replace springs if any of these conditions are found. Examine shaft for scoring, and remove scores with crocus cloth. Inspect yoke rollers for scoring, and replace rollers if scored. Examine shifter cover for cracks and scores on its mounting surface. Remove scores with file, and weld together all cracks. Inspect pawl spring for bending or breakage and coils that are unequally spaced; replace spring if any of these conditions are found.

c. **Assembly.**

(1) **INSTALL YOKE ROLLERS AND YOKE** (fig. 44). Install new oil seal in cover. Drive two yoke rollers into ends of yoke, and lock each roller in position with a castellated nut and cotter pin. Position shift yoke in cover. Install rod and eye in end of shift rod, and slide shift rod through cover and yoke.

(2) **INSTALL SHIFT ROD PIN** (fig. 44). Slide shaft and yoke to one side so that shift rod pin can be driven through poppet holes in cover; then drive shift rod pin through yoke and rod, and lock pin with lock wire.

(3) **INSTALL PAWL AND CENTERING ROD** (fig. 44). Center yoke in cover, drop pawl in place, install pawl spring in poppet hole, and screw poppet into cover over pawl. Install two adjusting nuts, one lock nut, and adjusting yoke on one end of centering rod. Then place one flat washer and control spring on rod, and slide rod through hole in shifter cover. Install remaining control spring and flat washer over open end of rod, and install adjusting nut and lock nut. Turn adjusting nuts so that control springs hold centering rod securely in a centered position on cover. Secure two links to shift rod with a rod end pin and cotter pin.

## 62. GEAR CASE ASSEMBLY.

a. **Disassembly** (fig. 45). The gear case assemblies for the front and rear tandem winches are identical, except that the parts are in a reverse position, with the shifter cover and sliding clutch on opposite sides. The procedure in this paragraph applies to the front tandem winch gear case assembly, and the procedure can also be followed for the rear tandem winch gear case assembly.

## TANDEM WINCH ASSEMBLY

(1) **REMOVE SPROCKET GEAR CASE COVER AND SPROCKET SHIELD** (fig. 45). Remove cap screw, lock washer, and retaining washer from end of input shaft. Pull sprocket from shaft and remove key. Remove seven cap screws and lock washers, one cotter pin, castellated nut, and lock washer which hold gear case cover and sprocket shield to case. Remove shield end cover and gasket. **NOTE:** *Two of the gear case cover bolts on rear tandem winch secure throttle control lever, quadrant, and mounting plate.*

(2) **REMOVE REVERSE IDLER GEAR** (fig. 45). Drive reverse idler pin (X) out through inside of gear case, and remove pin with bearing attached. Remove two thrust washers, spacer, and reverse idler gear from reverse idler pin. Press bearing from idler gear.

(3) **REMOVE INPUT SHAFT** (fig. 45). Drive input shaft away from sprocket end of case until bearing at opposite end of shaft is out of case; then pull bearing off shaft. Remove thrust collar from input shaft, remove lock wire from lock screw on clutch gear (right-hand), and remove lock screw. Swing end of shaft out of case and remove clutch gear. Press bushing and sleeve from clutch gear (right-hand). Remove lock wire from lock screw on remaining clutch gear (left-hand), and remove lock screw. Remove input shaft from gear case, and remove ball bearing from end of shaft.

(4) **REMOVE SLIDING CLUTCH** (fig. 45). Remove thrust collar, clutch gear (left-hand) clutch gear spacer, and sliding clutch from shaft. Press bushing and sleeve from clutch gear (left-hand).

(5) **REMOVE WORM** (fig. 45). Drive worm (T) toward sprocket end of case, and remove ball bearing. Pull gear (25 teeth) from shaft, and remove key from worm. Pull worm forward through hole in case until remaining gear (33 teeth) is against inside of case at sprocket end. Drive gear and ball bearing from end of the worm, remove worm from case, and lift key from worm.

(6) **REMOVE CASE** (figs. 31 and 32). Remove control shaft from front tandem winch rear base angle by loosening clamp bolt on control shaft lever and removing lever and key from shaft. Remove three bolts, nuts, and lock washers which secure support bracket to base angle. Pull control shaft out to provide access to the pivot bolt, remove two pivot bolts and lock washers, and lift case from winch base angles.

**b. Cleaning, Inspection, and Repair.** Wash all parts in dry-cleaning solvent to remove all grease and dirt. If the gear case is to be painted, wash it in soda ash solution. Discard gaskets and oil seal. Inspect clutch gear bushings for scoring, and replace scored bushings. Examine worm and teeth of all gears for scoring, cracks, or breaks, and replace damaged gears. Measure fit of all gears on shafts, and if over 0.003 inch loose, replace either gear or shaft or both, as

**ORDNANCE MAINTENANCE — BODY, CHASSIS, AND WINCHES FOR TRACTOR TRUCK M26, COMPONENT OF 40-TON TANK TRANSPORTER TRAILER TRUCK M25**

required, to eliminate play. Rotate all bearings and inspect for loose running and flat spots on bearing balls. Replace bearing if necessary. Examine needles of reverse idler gear roller bearing for scoring. Rotate the bearing, and inspect for loose running, and replace bearing if loose or scored. Measure fit of sliding clutch, and replace if over 0.005 inch loose. Measure fit of bearing on reverse idler pin, replacing pin or bearing or both, if over 0.003 inch loose. If the sprocket shield is bent, straighten it with a ball peen hammer. Minor cracks in the gear case can be repaired by welding, and burs and scratches on mounting surfaces of gear case can be repaired by filing and rubbing down with crocus cloth.

**c. Assembly.**

(1) **INSTALL WORM** (fig. 45). Install key in gear (33 teeth) end of worm, and place worm in position in gear case. Press ball bearing and gear (33 teeth) onto end of worm, being sure ball bearing is positioned with part number side toward gear case. Install key on opposite end of worm, and press other gear (25 teeth) and bearing on worm, and into case.

(2) **INSTALL INPUT SHAFT** (fig. 43). Press bushing and sleeve into each clutch gear (AW). Install sliding clutch, clutch gear spacer, clutch gear (left-hand) (AW), and thrust collar on end of input shaft. Press ball bearing on end of shaft, then position input shaft in gear case. Slide parts just installed on end of input shaft into position, install lock screw in clutch gear (left-hand), and secure screw with lock wire. Hold open end of shaft out of case, and install remaining clutch gear (right-hand). Install lock screw on gear, and secure it with lock wire. Install thrust collar on input shaft, and press ball bearing on end of shaft and into case. *NOTE: Sliding clutch must be installed so that both ends mesh with clutch gear; if sliding clutch gets turned around, it will not mesh correctly.*

(3) **INSTALL REVERSE IDLER GEAR** (fig. 45). Press bearing into idler gear. Install gear, spacer, and two thrust washers on reverse idler pin. Drive reverse idler pin into case.

(4) **INSTALL SPROCKET AND SPROCKET SHIELD** (fig. 45). Cement new gasket to gear case and cover. Position cover and sprocket shield on case, securing cover and shield to case with seven cap screws and lock washers and one lock washer, castellated nut, and cotter pin which also secures reverse idler pin in case. Install key in end of input shaft, and press sprocket into position on shaft. Install retaining washer, lock washer, and cap screw over sprocket and in end of input shaft.

(5) **INSTALL WORM GEAR CASE** (figs. 31 and 32). Install worm gear case on winch base angles, and secure it with two pivot bolts,

**TANDEM WINCH ASSEMBLY**

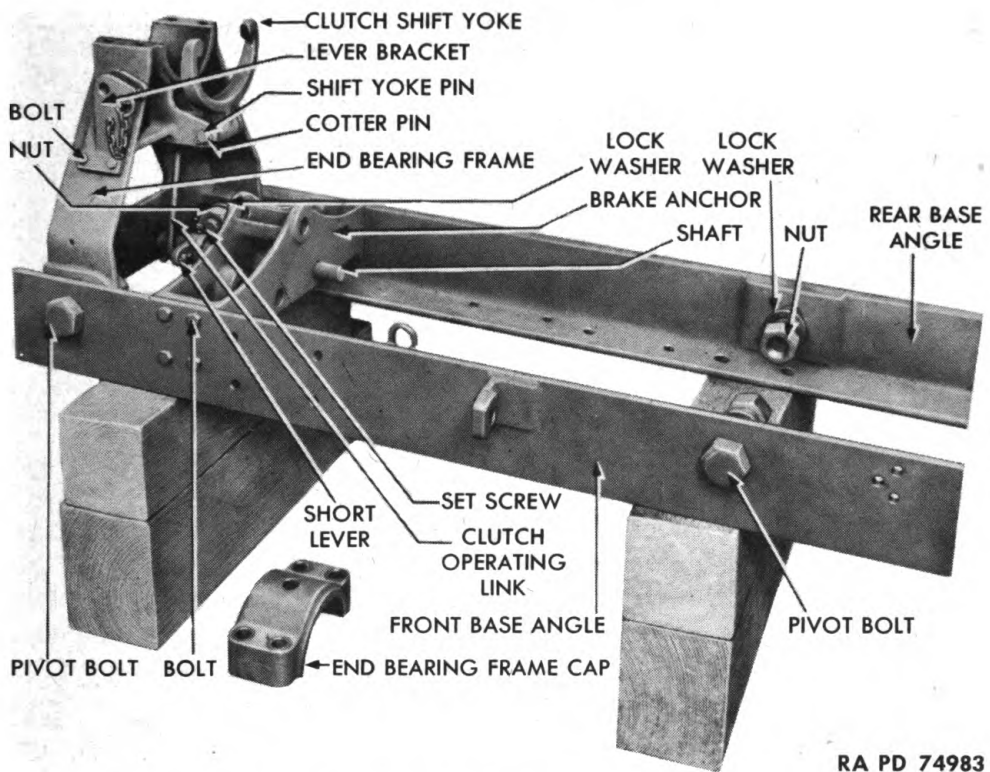

RA PD 74983

**Figure 46 – End Bearing Frame and Clutch Shift Yoke Assembly**

nuts, and lock washers. Install control shaft and bracket on rear base angle, securing bracket to angle with three bolts, nuts, and lock washers. Install key and control levers on end of shaft and tighten clamp bolt.

**63. END BEARING FRAME AND CLUTCH SHIFT YOKE ASSEMBLY.**

**a. Disassembly.**

(1) **REMOVE CLUTCH SHIFT YOKE** (fig. 46). Remove two cotter pins from shift yoke rod end pin, and remove pin. Remove cotter pin which holds yoke to clutch operating link, and remove cotter pin which secures link to clutch short operating lever. Remove yoke and link.

(2) **REMOVE CLUTCH SHORT OPERATING LEVER** (fig. 46). Loosen set screw on winch operating lever, and remove lever from end of clutch operating shaft. Loosen set screw on clutch short operating lever, and pull shaft from lever, end bearing frame, and brake anchor.

(3) **REMOVE END BEARING FRAME, BRAKE ANCHOR, AND LOWER BRACKET** (fig. 46). Remove two pivot bolts, nuts, and lock washers which secure end bearing frame to two winch base angles, and remove

**ORDNANCE MAINTENANCE — BODY, CHASSIS, AND WINCHES FOR TRACTOR TRUCK M26, COMPONENT OF 40-TON TANK TRANSPORTER TRAILER TRUCK M25**

frame. Remove brake anchor from base angles by removing eight bolts, nuts, and lock washers. Remove lever bracket from end bearing frame by removing three bolts, nuts, and lock washers.

**b. Cleaning, Inspection, and Repair.** Wash all parts in dry-cleaning solvent. If parts are to be painted, wash them in soda ash solution. Inspect all parts for cracks and breakage and weld, if cracked or broken. Inspect all nuts and bolts for stripped threads, and straighten threads with tap or die. Examine jaws of clutch shift yoke for scores, and replace the yoke if deeply scored; remove light scores with crocus cloth.

**c. Assembly.**

(1) **INSTALL LEVER BRACKET, BRAKE ANCHOR, AND END BEARING FRAME** (fig. 46). Install lever bracket on end bearing frame, and secure with three bolts, nuts, and lock washers. Install brake anchor on winch base angles with eight bolts, nuts, and lock washers. Place end bearing frame in position between angles, and secure frame to angles with two pivot bolts, nuts, and lock washers.

(2) **INSTALL CLUTCH SHORT OPERATING LEVER** (fig. 46). Slide clutch operating shaft through brake anchor, install short clutch operating lever on shaft, and slide shaft on through end bearing frame. Install winch operating lever on end of shaft, and tighten lever set screw. Tighten set screw which secures clutch short operating lever in position on operating shaft.

(3) **INSTALL CLUTCH SHIFT YOKE** (fig. 46). Secure clutch operating link to clutch short operating lever with a cotter pin, and in a similar manner, secure clutch shift yoke to link. Install rod end pin and two cotter pins which secure clutch shift yoke to end bearing frame.

**64. REAR TANDEM WINCH BASE ANGLES AND CONTROLS.**

**a. Disassembly.**

(1) **REMOVE WINCH DOUBLE LEVER** (fig. 46). Remove bolt, nut, and lock washer which secures lever bracket to base angle. Loosen set screw in collar at bracket end of double lever, and pull double lever, bracket, and collar from welded bracket. Remove bracket and two flat washers and collar from double lever.

(2) **REMOVE CLUTCH OPERATING SHAFT AND LEVERS** (fig. 46). Loosen clamp bolt nut on long operating lever on end of shaft and remove lever. Loosen set screws on two other levers and on three operating shaft collars. Remove short operating lever, then remove shaft, control lever, and collars.

**b. Cleaning, Inspection, and Repair.** Clean all parts in dry-cleaning solvent. Inspect double lever, bracket, and collar for fractures, and weld together if necessary. Inspect long operating lever,

**TANDEM WINCH ASSEMBLY**

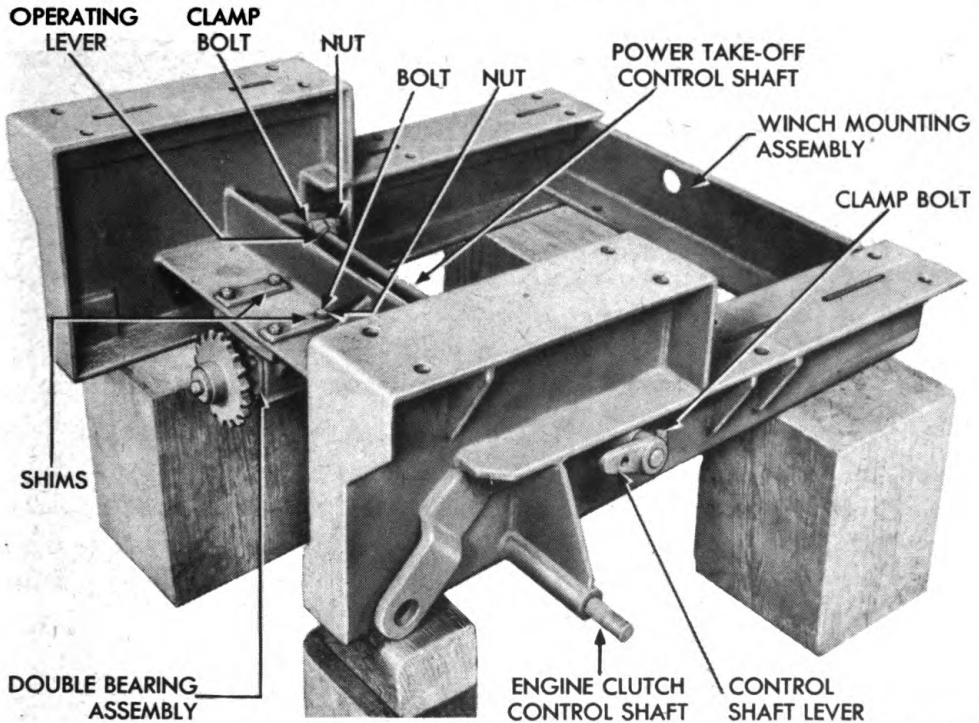

RA PD 74971

**Figure 47 – Winch Mounting Frame**

shaft, and collars for scoring and bending; straighten bent parts, and remove scores with crocus cloth.

**c. Assembly.**

(1) **INSTALL DOUBLE LEVER** (fig. 46). Install two flat washers at welded bracket end and collar at other end. Place bracket next to collar, and install parts in position on winch base angle. Secure bracket to angle by installing one cap screw, nut, and lock washer and one bolt, nut, and lock washer. Tighten collar set screw.

(2) **INSTALL CLUTCH OPERATING SHAFT AND LEVERS** (fig. 46). Install brake operating shaft; then slide collar, brake control lever, and two additional collars on shaft as it is being installed. Tighten set screws in collars and lever. Install short operating lever at clutch yoke end of shaft, and tighten set screw. Install long operating lever on other end of shaft, and tighten set screw.

**65. WINCH MOUNTING ASSEMBLY.**

**a. Disassembly.**

(1) **REMOVE DOUBLE BEARING** (fig. 47). Remove double bearing assembly from winch mounting assembly by removing four bolts, nuts, and lock washers and lifting off double bearing assembly and six shims.

**ORDNANCE MAINTENANCE — BODY, CHASSIS, AND WINCHES FOR TRACTOR TRUCK M26, COMPONENT OF 40-TON TANK TRANSPORTER TRAILER TRUCK M25**

(2) **REMOVE POWER TAKE-OFF CONTROL SHAFT** (fig. 47). Loosen set screw on collar on power take-off control shaft, and loosen clamp bolt on operating lever. Pull out shaft, and remove collar, lever, and key from shaft. Remove control shaft lever from end of shaft by loosening clamp bolt nut and tapping lever off. Remove key from shaft.

(3) **REMOVE ENGINE CLUTCH CONTROL SHAFT** (fig. 47). Loosen set screw on clutch control shaft collar, and loosen clamp bolt on control shaft lever. Pull shaft from winch mounting assembly, removing collar and lever as shaft is removed. Remove key from shaft.

**b. Cleaning, Inspection, and Repair.** Clean parts in dry-cleaning solvent. Inspect power take-off control shaft for burrs and scores. Remove burrs with file and scores with crocus cloth. Repeat procedure on engine clutch control shaft. Inspect operating lever for burrs and bending; remove burrs with file, and straighten any bends in vise.

**c. Assembly.**

(1) **INSTALL ENGINE CLUTCH CONTROL SHAFT AND CONTROL SHAFT LEVER** (fig. 47). Install key in end of engine clutch control shaft. Insert shaft in winch mounting assembly, installing control shaft lever as shaft is placed in position. Then install collar on inside end of shaft, and tighten collar set screw and lever clamp bolt nut. Install key in end of power take-off control shaft, and install control shaft lever on shaft. Tighten clamp bolt nut.

(2) **INSTALL OPERATING LEVER** (fig. 47). Place shaft in position in winch mounting assembly, installing operating lever on shaft as shaft is placed in position. Install collar on inside end of shaft, and tighten set screw to lock shaft in place.

**66. DOUBLE BEARING ASSEMBLY.**

**a. Disassembly.**

(1) **REMOVE SPROCKET** (fig. 48). Remove cap screw, lock washer, and retaining washer from end of bearing shaft, and remove sprocket.

(2) **REMOVE SHAFT** (fig. 48). Remove four cap screws and lock washers which hold each of two oil seal caps to bearing housing. Remove the two oil seal caps and gaskets. Press shaft out of the housing, carrying one ball bearing with it and leaving opposite bearing in housing.

(3) **REMOVE BEARING** (fig. 48). Remove bearing spacer from end of shaft, and pull off ball bearing. Drive remaining ball bearing out of housing.

**TANDEM WINCH ASSEMBLY**

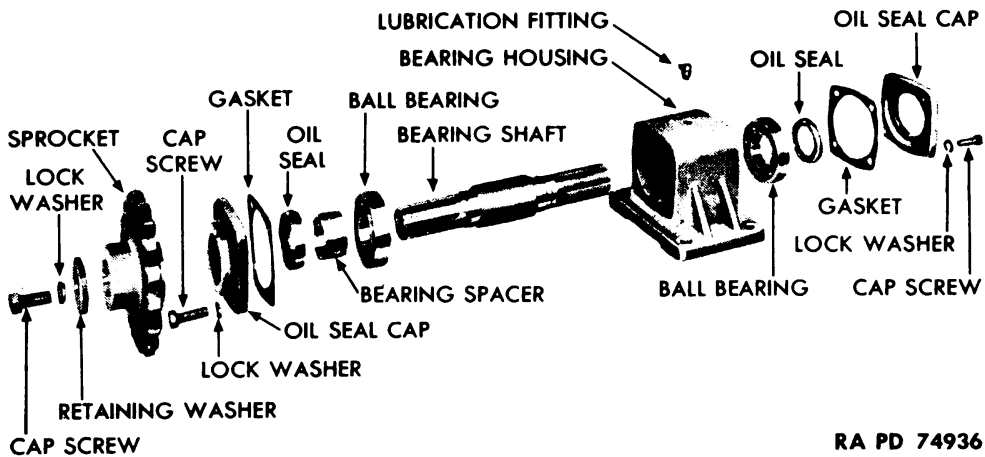

**Figure 48 – Double Bearing and Shaft – Disassembled**

b. **Cleaning, Inspection, and Repair.** Wash all parts in dry-cleaning solvent. Inspect bearing housing for cracks and for damage to machined surfaces. Test bearing for flat spots and rough running by rotating races by hand. Inspect splines on the bearing shaft for damage. Inspect cap screws for damaged threads. Minor burns and scratches on machined surfaces of the shaft and housing can be repaired by filing and rubbing down with crocus cloth. Remove oil seals from oil seal covers, and replace with new seals.

c. **Assembly.**

(1) **INSTALL BEARINGS** (fig. 48). Press one ball bearing on bearing shaft, then install shaft and bearing in bearing housing, and press ball bearing into position in housing. Press remaining ball bearing on opposite end of shaft and into bearing housing. Install bearing spacer on shaft, next to ball bearing just installed. Install a new oil seal in each oil seal cap.

(2) **INSTALL END COVERS** (fig. 48). Install new end cover gasket between each cover and bearing housing, and secure each cover to housing with four cap screws and lock washers.

(3) **INSTALL SPROCKET** (fig. 48). Install sprocket on shaft, then install retaining washer, securing it to end of shaft with a cap screw and lock washer.

**67. UNIVERSAL JOINT ASSEMBLY.**

a. **Disassembly** (fig. 49). Remove set screw with socket head wrench (screw holds plain yoke on drive shaft), then remove lubrication fitting from spline yoke. Pry eight snap rings out of two center crosses (both joints). Press on center cross in such a way that needle cup is pushed outward and can be removed, then remove eight needle cup assemblies. Remove retainers from needle cup assemblies, and

**ORDNANCE MAINTENANCE — BODY, CHASSIS, AND WINCHES FOR TRACTOR TRUCK M26, COMPONENT OF 40-TON TANK TRANSPORTER TRAILER TRUCK M25**

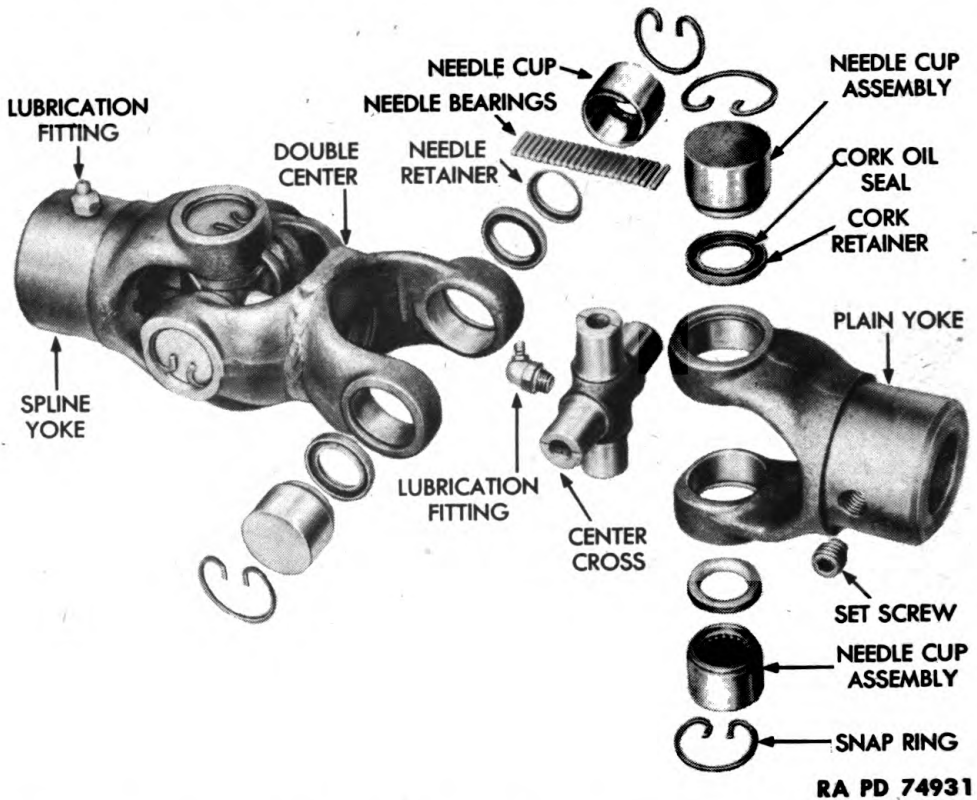

**Figure 49 — Tandem Winch Drive Shaft Universal Joint — Disassembled**

remove needle rollers. Remove eight cork oil seals and eight cork retainers from two center crosses. The double center is welded together and cannot be disassembled.

**b. Cleaning, Inspection, and Repair.** Remove grease from all parts with dry-cleaning solvent, and dry with compressed air or rags. Discard cork oil seals and cork retainers as new parts must be used to avoid lubrication leakage. Inspect machined surfaces for scoring, and examine needle rollers and needle cups for breaks or chips. Light scores can be removed with crocus cloth, and heavy scores require the use of a new part. Needle rollers or needle cups that are chipped or broken must be replaced.

**c. Assembly (fig. 49).** Install eight new cork oil seals and cork retainers on arms of two center crosses. Install center crosses so that they join double center, plain, and spline yokes together. Place a coating of grease in needle cups, install needle rollers in cups, then install retainers in cups. Carefully force needle cup assemblies on ends of center crosses, and fasten in place with retainers. Install set screw in plain yoke.

Section IV

**ASSEMBLY OF TANDEM WINCH**

Paragraph

Assembly ..... 68

**68. ASSEMBLY.**

a. **Install Universal Joint Assembly.** Install universal joint by positioning rear yoke on power take-off shaft and tightening set screw which secures yoke to shaft.

b. **Install Shifter Cover and Shift Rod** (figs. 35 and 36). Cement a new gasket to shifter cover, then position cover on worm gear case so that yoke rollers are in position on sliding clutch. Install eight cap screws and lock washers which secure cover to case, placing shield in position as two cap screws which also hold shield to cover are installed. **NOTE:** *Front and rear winch shifter cover and shift rods are installed in same manner.*

c. **Install Tandem Winch Drum and Shaft** (figs. 32 and 34). Wrap a chain sling around both sides of winch drum, and lift drum and shaft assembly onto end bearing frame and gear case. Position chain sling so that drum and shaft assembly can be held in a level position. Install bearing frame cap, securing it to bearing frame with four cap screws and lock washers. Install two new gaskets to gear case cover, and lift cover on gear case. Secure cover to case with four large bolts, nuts, and lock washers. **NOTE:** *Front and rear winch drums and shafts are installed in the same manner.*

d. **Install Drum Brake Band** (fig. 42). Position brake band around braking surface of drum, then install brake operating shaft through brake anchor and end bearing frame, installing two collars and short brake operating lever on shaft. Tighten set screws on collars and levers. Drive tight rod end pin through brake anchor and end of brake band, and lock rod end pin with a cotter pin at each end. **NOTE:** *Front and rear winch drum brake bands are installed in the same manner.*

e. **Install Tandem Winch Automatic Brake Case.** Position brake case on gear case, and secure it with five cap crews and lock washers, and one nut and lock washer which are installed inside brake case, and two cap screws and lock washers, which are installed from outside brake case. Install key on end of worm, and drive brake disk on worm. Install retaining washer, lock washer, and cap screw to lock drum in position on worm. Place rocker spring in position in case, and position brake band assembly over disk and into case, with rocker spring positioned over brake rocker. Tap brake band into place, and tighten adjusting nut and lock nut. Adjust brake as outlined in TM 9-767. Install throttle control lever, quadrant, and

**ORDNANCE MAINTENANCE — BODY, CHASSIS, AND WINCHES FOR TRACTOR TRUCK M26, COMPONENT OF 40-TON TANK TRANSPORTER TRAILER TRUCK M25**

mounting plate; then install case cover with five cap screws and lock washers. Remove filler plug from worm gear case, and refill with oil (TM 9-767). *NOTE: Front and rear winch automatic brakes are installed in the same manner.*

**f. Install Layshaft and Chain Tightener (fig. 40).** Install chain tightener assembly to rear winch base, securing with four bolts, nuts, and lock washers. Install layshaft assembly, positioning it under two base angles with shims in position between bearings and angles. Install two bolts, nuts, and lock washers which secure each of two single bearings to base angles. Install second chain tightener assembly in position under two base angles, with clamps in position over bar. Secure two clamps to angles by installing two bolts, nuts, and lock washers at each clamp.

**g. Install Rear Tandem Winch (fig. 32).** Place chain sling around ends of rear tandem winch base angles, lift winch into position on winch mounting assembly, and secure winch to mounting assembly by installing four bolts, nuts, and lock washers at each side. Remove chain sling.

**h. Install Front Tandem Winch (figs. 32 and 33).** Place chain sling around ends of front tandem winch base angles. Lift front tandem winch assembly in position on winch mounting assembly in front of rear tandem winch assembly, and secure right and left sides of winch to winch mounting assembly by installing four bolts, nuts, and lock washers at each side. Remove chain sling.

**i. Install Spare Wheel Bracket and Platform (fig. 32).** Place platform in position between rear tandem winch base angles at right side of winch. Install two bolts, nuts, and lock washers which secure platform to rear base angle. Place spare wheel bracket in position on front tandem winch base angle and rear tandem winch front base angle, and install four bolts, nuts, and lock washers. Two or three bolts also secure platform in position.

**j. Install Gear Case Control Rod (fig. 32).** Install gear case control rod in position on control shaft levers at each winch, between two winches. Secure rod to levers with two rod end pins and cotter pins.

**k. Install Chains (fig. 31).** Follow procedure given in TM 9-767 to install tandem drive line to layshaft, chain layshaft to rear tandem winch chain, and layshaft to front tandem winch chain.

**l. Install Power Take-off Winch Control Lever and Rod (figs. 31 and 32).** Secure adjusting yoke (at lower end of power take-off winch control rod) to control shaft lever by means of a rod end pin

**TANDEM WINCH ASSEMBLY**

and cotter pin. Attach control lever to bracket and control rod, with two rod end pins and cotter pins. Install lock pin in lever.

**m. Install Rear Winch Brake and Clutch Control Rods** (fig. 31). Place clutch and brake short control rods in position. Secure them to their connecting control levers by installing a rod end pin and cotter pin at each end of each rod. Secure front end of clutch and brake long control rods to bottom of rocker levers with two rod end pins and cotter pins.

**n. Install Foot Levers** (fig. 31). Install key on left end of engine clutch control shaft, drive engine clutch control foot lever into position on shaft, and tighten clamp bolt nut. Install front tandem winch foot operating lever on right side of assembly, and tighten clamp bolt nut. Secure lever to shift rod links and adjusting yoke at end of control rod by installing two rod end pins and cotter pins.

**o. Install Hand Control (Gearshift) Levers** (figs. 31 and 32). Install two front and rear tandem winch hand control (gearshift) levers, then secure rocker and lever to links and adjusting yoke (at rear tandem winch gear case) with two rod end pins and cotter pins. Drive hand lever pin through rear winch rear base angle, and as pin is installed, slide two collars and two hand control levers on pin. Install cotter pin in end of hand lever pin, and tighten set screws on two collars. Install two rod end pins and cotter pins which hold adjusting yokes at rear of operating rods to operating levers.

**p. Install Double Lever Winch Control** (figs. 31 and 32). Install double lever winch control assembly, which includes rear tandem winch hand clutch and brake levers and bracket. Secure double lever bracket (with two levers attached) to rear tandem winch rear base angle with four bolts, nuts, and lock washers. Connect brake control lever to adjusting yoke (at front end of brake control rod) with a rod end pin and cotter pin. Connect adjusting yoke (at front end of clutch control rod) to clutch control lever in the same manner.

**q. Install Brake Control Rod** (figs. 31 and 32). Position brake control rod on brake control lever, tap lever back into position on control shaft, and secure with flat washer and cotter pin. Tighten set screw at top of lever.

**r. Install Double Lever Winch Control** (figs. 31 and 32). Double lever winch control assembly includes front tandem winch hand brake and clutch levers and bracket. Place assembly in position on rear tandem winch rear base angle, and secure it with four bolts, nuts, and lock washers. Then install rod end pins and cotter pins which secure adjusting yokes, at end of control rods, to control shaft lever and rocker lever assembly at rear of base angle.

**ORDNANCE MAINTENANCE – BODY, CHASSIS, AND WINCHES FOR TRACTOR TRUCK M26, COMPONENT OF 40-TON TANK TRANSPORTER TRAILER TRUCK M25**

s. **Install Winch Cables.** Install winch cables on front and rear tandem winch drums (TM 9-767).

---

**Section V**

**TEST AND ADJUSTMENT OF TANDEM WINCH**

	Paragraph
Test and adjustment .....	69

**69. TEST AND ADJUSTMENT.**

a. Test the operation of the assembled tandem winch by operating the control, clutch, and brake hand levers with a load, to ascertain that positive gear engagement and operation of the winch clutches and brakes is present. Adjust winch controls, linkage, and chains (TM 9-767).

---

**Section VI**

**FITS AND TOLERANCES**

	Paragraph
Fits and tolerances .....	70

**70. FITS AND TOLERANCES.**

a. **Clearances.**

	Minimum	Maximum
Drum shaft in bushings.....	0.002 in.	0.004 in.
Sprockets on shafts.....	0.002 in.	0.003 in.
Brake disk on drum shaft.....	0.0015 in.	0.0025 in.
Layshaft in bearings.....	0.001 in.	0.002 in.
Single bearing in housing.....	0.002 in.	0.004 in.
Mounting bar in bearing.....	0.001 in.	0.002 in.
Chain tightener bearings on pin or shaft.....	0.001 in.	0.002 in.
Worm gear on shaft.....	0.0015 in.	0.003 in.
Shift rod in shifter cover.....	0.0015 in.	0.0035 in.
Double bearings on shaft.....	0.001 in.	0.0025 in.
Universal joint spline yoke on shaft.....	0.001 in.	0.0025 in.

CHAPTER 7  
**VERTICAL LIFTING DEVICE**

Section I

**DESCRIPTION AND OPERATION OF VERTICAL LIFTING DEVICE**

	Paragraph
Description and operation .....	71
Data .....	72

**71. DESCRIPTION AND OPERATION (fig. 50).**

**a. Description.** The vertical lifting device consists of two telescopic side supports and an A-frame which has a sheave mounted on the top of it. The vertical lifting device is carried on the tractor in a knocked-down condition and can be erected, as instructed in TM 9-767.

**b. Operation.** The vertical lifting device is used principally for the recovery of equipment which is on a lower plane than the tractor, which requires a vertical lift rather than a pull. It also makes it possible to raise the winch cable to a height which prevents the cable from becoming tangled with other equipment or from getting in the way of recovery operations. The cable from either of the tandem winches is placed on the sheave of the device.

**72. DATA.**

**a. Lifting Positions.**

Vertical

18 degrees forward of center

18 degrees back of center

Between 18 degrees back of center and vertical (two positions).

Section II

**DISASSEMBLY, CLEANING, INSPECTION, REPAIR, AND ASSEMBLY OF VERTICAL LIFTING DEVICE**

	Paragraph
Disassembly, cleaning, inspection, repair, and assembly.....	73

**73. DISASSEMBLY, CLEANING, INSPECTION, REPAIR, AND ASSEMBLY.**

**a. Disassembly (fig. 50).** Remove two angle pins which secure each side support to lower side support, and pull lower side supports out of upper side supports. Remove two pins which secure lower side

ORDNANCE MAINTENANCE — BODY, CHASSIS, AND WINCHES FOR TRACTOR  
TRUCK M26, COMPONENT OF 40-TON TANK TRANSPORTER TRAILER TRUCK M25

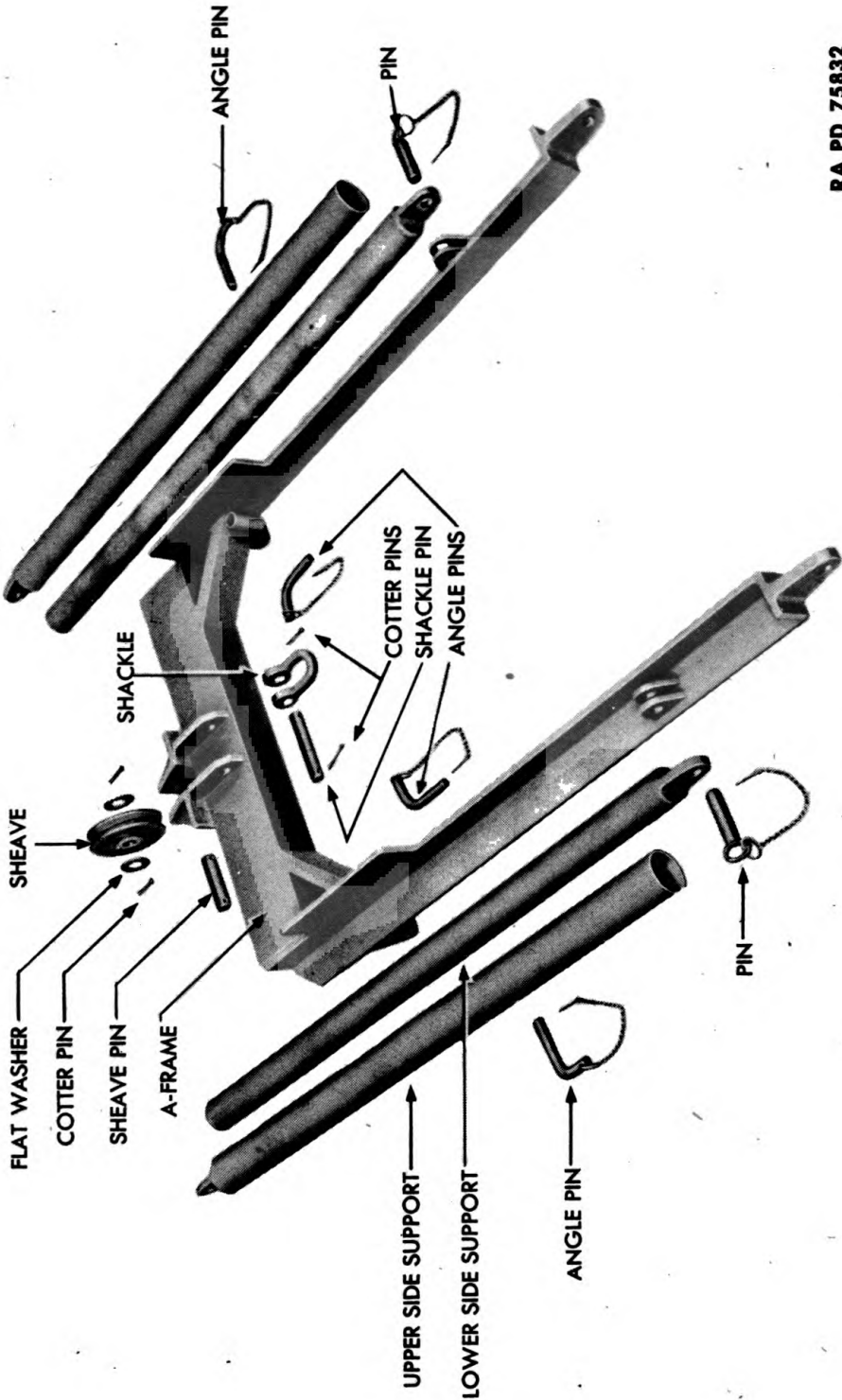

RA PD 75832

Figure 50 — Vertical Lifting Device — Disassembled

### VERTICAL LIFTING DEVICE

supports to A-frame, and remove lower supports. Remove cotter pin and drive sheave pin from A-frame, and lift off sheave and two flat washers. Remove cotter pin and drive shackle pin from A-frame, and remove shackle.

b. **Cleaning.** Wash all mud and dirt from all parts, using water. If parts are greasy, wash with dry-cleaning solvent. If assembly is to be painted, wash with soda ash solution. Refer to TM 9-850 or SNL K1.

c. **Inspection and Repair.** Inspect A-frame and supports to see that they are not bent or broken. Inspect all pins for breakage. All parts which cannot be repaired by welding or straightening must be replaced by new parts.

d. **Assembly (fig. 50).** Install sheave in A-frame by inserting sheave pin through A-frame and sheave, and secure sheave pin with cotter pins. Install shackle in A-frame in same manner. Install lower side supports on upper side supports, and secure by inserting two angle pins through upper and lower side supports. Insert two pins which secure lower side supports to A-frame. The A-frame is secured to the side supports only when vertical lifting device is in use.

ORDNANCE MAINTENANCE — BODY, CHASSIS, AND WINCHES FOR TRACTOR  
TRUCK M26, COMPONENT OF 40-TON TANK TRANSPORTER TRAILER TRUCK M25

CHAPTER 8  
FIFTH WHEEL

Section I

DESCRIPTION AND DATA OF FIFTH WHEEL

	Paragraph
Description and operation.....	74
Data .....	75

74. DESCRIPTION AND OPERATION (fig. 51).

a. **Description.** The fifth wheel assembly consists of two support brackets secured to the chassis frame. A ring is secured to the support brackets by a centrally located shaft, and a notched base is secured to the ring in the same manner. There are two jaws in the base which

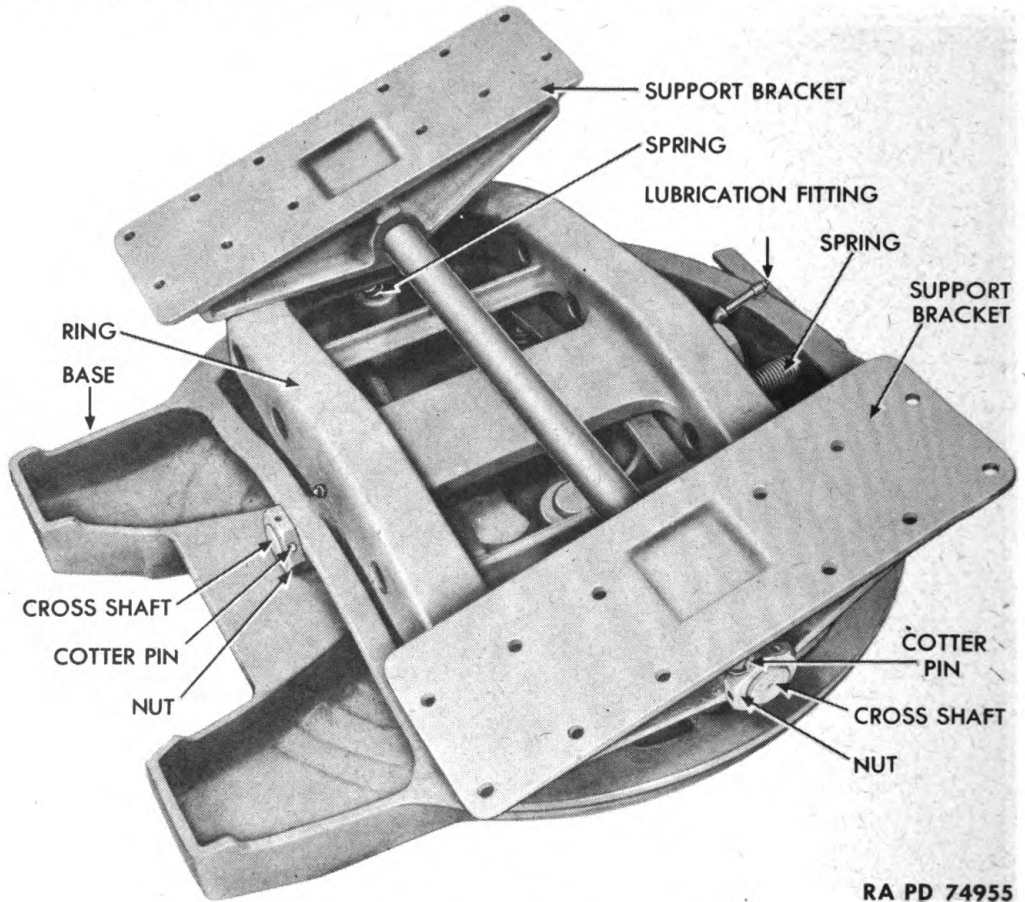
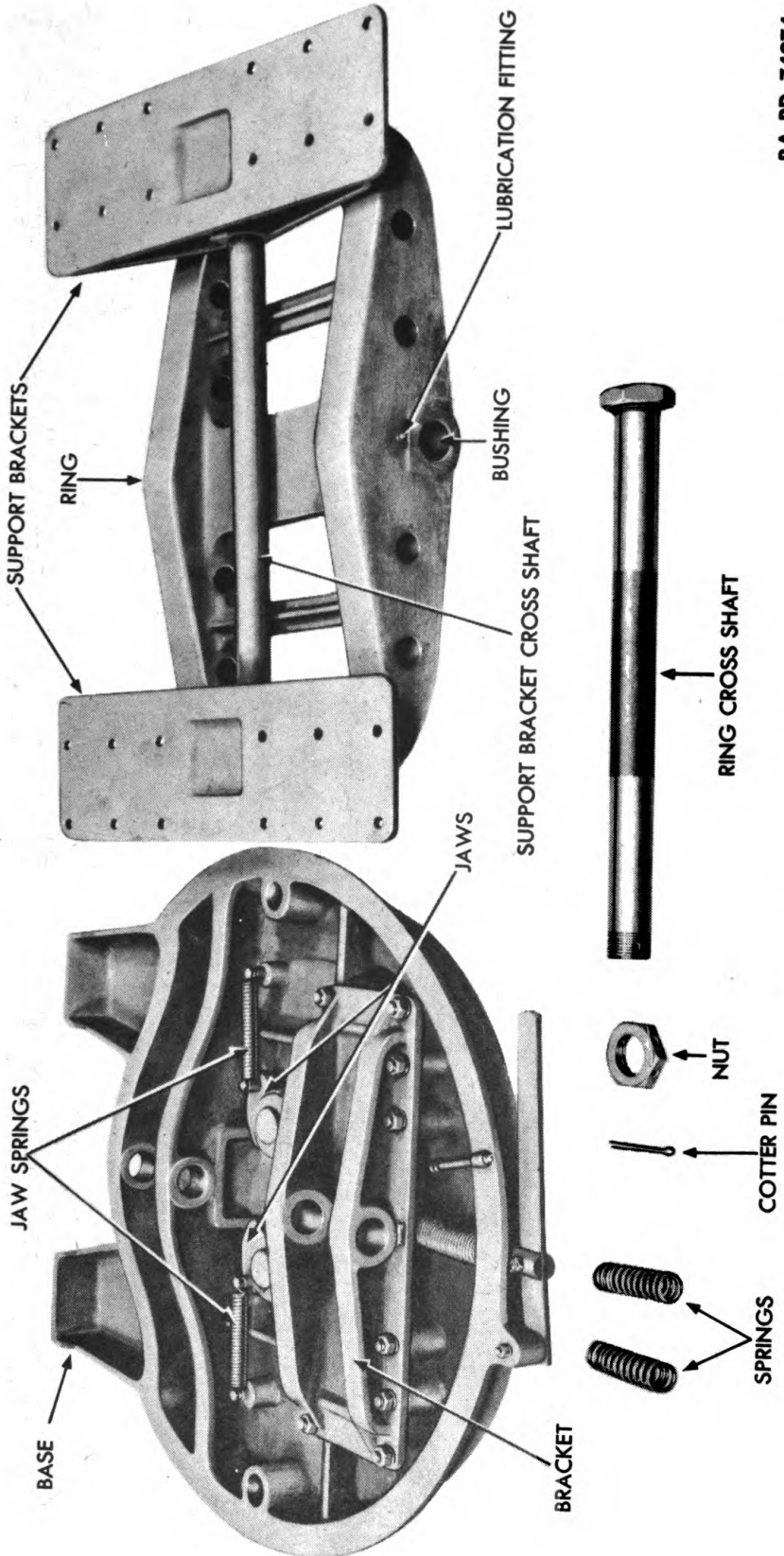

Figure 51 — Fifth Wheel Assembly

FIFTH WHEEL



RA PD 74974

Figure 52 — Support Brackets and Ring Assembly Removed from Fifth Wheel

**ORDNANCE MAINTENANCE — BODY, CHASSIS, AND WINCHES FOR TRACTOR TRUCK M26, COMPONENT OF 40-TON TANK TRANSPORTER TRAILER TRUCK M25**

are spring-loaded and controlled by a lever for securing the trailer kingpin.

b. **Operation.** Attaching the semitrailer to the tractor allows the ring and the base to swivel on their centrally located shafts, so that the kingpin of the trailer can drop into the notch in the base and be locked in place by the jaws. The lever releases the jaws for disconnecting the trailer from the tractor.

**75. DATA.**

Make ..... Fruehauf

---

**Section II**

**DISASSEMBLY OF FIFTH WHEEL INTO SUBASSEMBLIES**

Disassembly ..... Paragraph  
76

**76. DISASSEMBLY (figs. 51 and 52).**

a. Place fifth wheel assembly upside down on floor. Remove cotter pin from drilled nut and ring bracket cross shaft, then drive out cross shaft. Attach a chain and hoist to support bracket and ring assembly, and lift bracket and ring from balance of assembly. Remove two springs from base.

---

**Section III**

**DISASSEMBLY, CLEANING, INSPECTION, REPAIR, AND ASSEMBLY OF SUBASSEMBLIES**

Mounting brackets and ring assembly ..... Paragraph  
77  
Base assembly ..... 78

**77. MOUNTING BRACKETS AND RING ASSEMBLY.**

a. **Disassembly.**

(1) **REMOVE CROSS SHAFT AND MOUNTING BRACKETS.** Remove cotter pin which locks drilled nut to support bracket cross shaft, remove the nut, and drive out shaft. Lift the two brackets from ring.

b. **Cleaning, Inspection, and Repair.** Clean all parts in dry-cleaning solvent and if any parts are to be painted, wash them in soda ash solution (TM 9-850). Inspect four bushings in ring for scores, and test fit of cross shafts in bushings. If shafts are over 0.008 inch loose, or bushings are scored, replace bushings by driving out of

FIFTH WHEEL

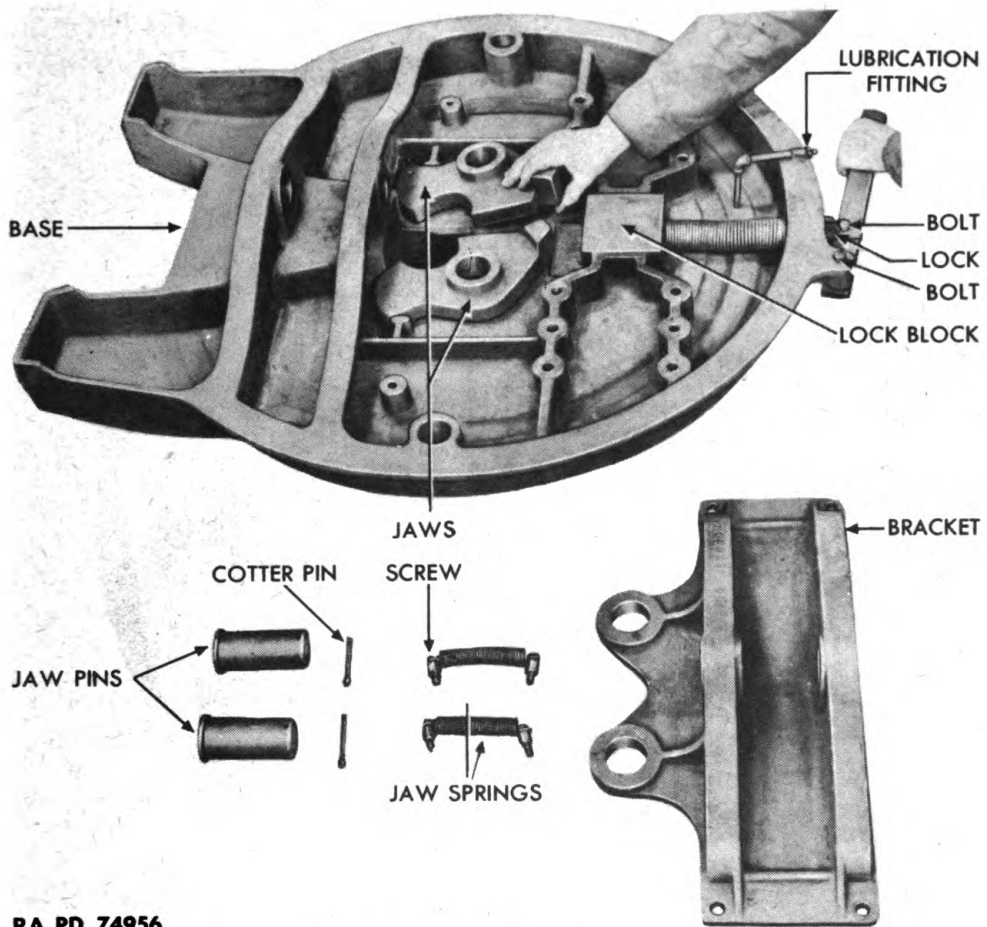

RA PD 74956

Figure 53 — Removing Jaws from Base

ring. Inspect ring and mounting brackets for fractures, and weld or replace part if necessary. Inspect cross shaft for scores, and replace shaft if damaged.

c. Assembly.

(1) **INSTALL CROSS SHAFT AND MOUNTING BRACKETS.** Use a hoist and lift ring into position on two brackets. Drive ring to bracket cross shaft through two brackets and ring. Install nut and cotter pin on end of shaft.

78. BASE ASSEMBLY.

a. Disassembly.

(1) **REMOVE BASE BRACKET** (figs. 53 and 54). Use a hoist and replace base assembly upside down on two wooden blocks. Remove 12 nuts and lock washers which hold base bracket to base. Drive bolts through plate and bracket, and lift off bracket.

**ORDNANCE MAINTENANCE — BODY, CHASSIS, AND WINCHES FOR TRACTOR TRUCK M26, COMPONENT OF 40-TON TANK TRANSPORTER TRAILER TRUCK M25**

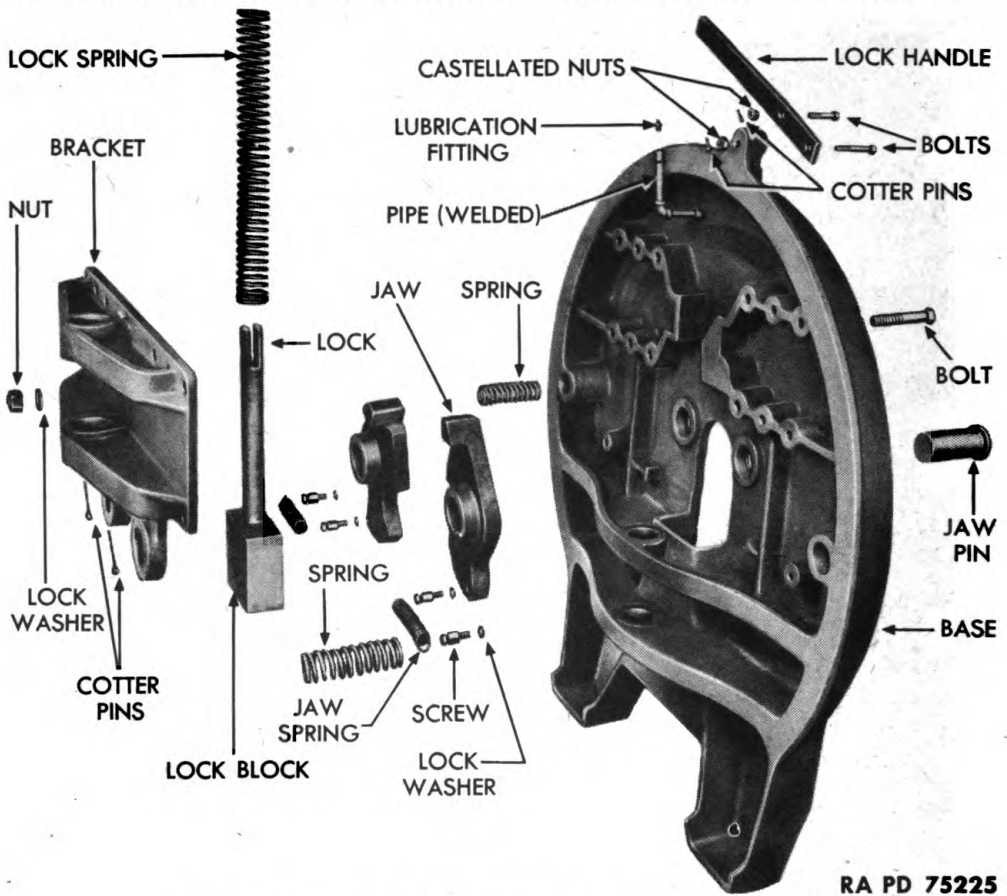

RA PD 75225

**Figure 54 — Fifth Wheel Base — Disassembled**

(2) **REMOVE JAWS** (fig. 53). Remove two spring screws which secure each of two jaw springs in position on base and jaws, and remove two springs. Remove cotter pin from each jaw pin, and drive jaw pins from jaws and base. Pull on lock handle and lift out jaws.

(3) **REMOVE LOCK HANDLE AND BLOCK** (fig. 54). To gain access to the bolt which holds the lock handle to the lock, place wooden block back of lock block and rod. Remove cotter pin, castellated nut, and bolt which holds handle to lock. Remove bolt, nut, and lock washer which secures handle to base, and remove handle. Remove block, lock, and lock spring.

**h. Cleaning, Inspection, and Repair.** Clean all parts in dry-cleaning solvent and if they are to be painted, wash in soda ash solution (TM 9-850). Inspect jaws for scores, burs, and fractures, and use new parts if necessary. Inspect lock spring, two jaw springs, and two ring to base springs for breakage. Make sure that all coils of each spring are equally spaced; if either condition is found, use new parts. Inspect base and bracket for fractures, and weld if necessary.

## FIFTH WHEEL

Inspect threads for crossed or mashed threads, and straighten with thread die or tap.

### c. Assembly.

(1) **INSTALL LOCK BLOCK AND HANDLE** (fig. 54). Install spring on lock block and rod, and use wooden block to wedge lock, with spring attached, through hole in base. Attach lock handle to rod by installing bolt, castellated nut, and cotter pin. Secure handle to base by installing a bolt, nut, and lock washers.

(2) **INSTALL JAWS** (fig. 54). Pull out handle, and place jaws in position. Lift handle end of base, and install jaw pins from top side of base, and secure jaw pins with cotter pins. Insert 12 bracket bolts through base from top side.

(3) **INSTALL BASE BRACKETS** (fig. 54). Lift bracket into position over bolts, then install 12 nuts and lock washers which secure bracket to base. Install two jaw springs by installing two springs and two spring screws and lock washers for each spring. One end of spring is secured to a jaw and other end to base.

---

## Section IV

### ASSEMBLY OF FIFTH WHEEL

	Paragraph
Assembly .....	79

#### 79. ASSEMBLY (figs. 51 and 52).

a. Position base assembly upside down on floor. Insert two springs in spring holes in sides of base. Attach a chain sling and hoist to support bracket and ring assembly, and lift it onto base. Drive cross shaft through support brackets and base bracket, then install drilled nut on end of bolt, and secure with cotter pin.

---

## Section V

### TEST AND ADJUSTMENT OF FIFTH WHEEL

	Paragraph
Test and adjustment .....	80

#### 80. TEST AND ADJUSTMENT (fig. 51).

a. Test operation of lock handle, and make sure that it opens jaws on fifth wheel assembly when lever is pulled out. Operate pick-

**ORDNANCE MAINTENANCE — BODY, CHASSIS, AND WINCHES FOR TRACTOR TRUCK M26, COMPONENT OF 40-TON TANK TRANSPORTER TRAILER TRUCK M25**

up plate, and make sure that it is free to turn on mounting brackets. There are no adjustments to be made on fifth wheel assembly.

---

**Section VI**

**FITS AND TOLERANCES**

	<b>Paragraph</b>
Fits and tolerances .....	<b>81</b>

**81. FITS AND TOLERANCES.**

Clearance of base on shaft .....	<b>0.004 to 0.006 in.</b>
Clearance of ring on shaft .....	<b>0.006 to 0.008 in.</b>
Clearance of jaws on pins .....	<b>0.003 to 0.005 in.</b>

CHAPTER 9  
**SPRINGS AND SHOCK ABSORBERS**

Section I  
**SPRINGS**

	Paragraph
Description and data .....	82
Disassembly, cleaning, inspection, repair, and assembly.....	83
Fits and tolerances .....	84

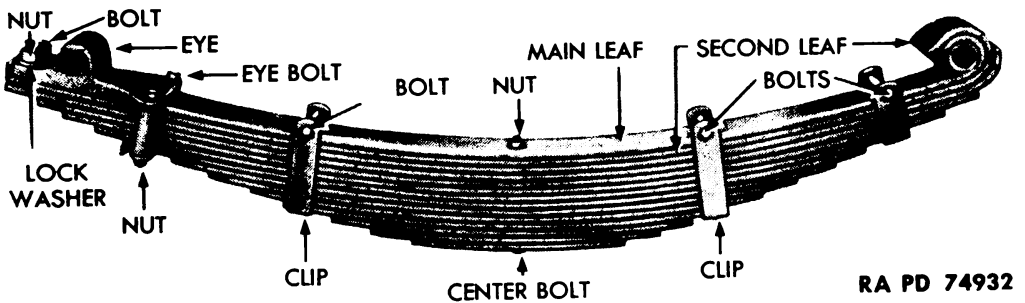

Figure 55 - Front Spring Assembly

**82. DESCRIPTION AND DATA.**

a. **Description** (fig. 55). The two front springs are semielliptic and consist of 14 leaves. Each spring is secured at the front end by a pin to a frame bracket, and at the rear end by a pin to a shackle.

b. **Data.**

Number of leaves ..... 14  
Make ..... U. S. Spring

**83. DISASSEMBLY, CLEANING, INSPECTION, REPAIR, AND ASSEMBLY.**

a. **Disassembly** (fig. 55).

(1) **REMOVE FRONT SPRING EYE.** Remove two bolts, nuts, and lock washers which secure eye to front end of spring leaves. Remove two eye clip bolts, nuts, and lock washers, and remove eye.

(2) **REMOVE FRONT SPRING LEAVES.** Remove 3 bolts, nuts, and lock washers which secure 3 spring clips to spring leaves, and remove center bolt, nut, and lock washer. Remove 12 lower leaves, and pull main leaf out of curved rear end of second leaf.

b. **Cleaning, Inspection, and Repair.** Wash all leaves, clips, bolts, nuts, and eye in dry-cleaning solvent, and remove all grease and dirt. Inspect all leaves for breakage, and replace broken leaves.

**ORDNANCE MAINTENANCE — BODY, CHASSIS, AND WINCHES FOR TRACTOR TRUCK M26, COMPONENT OF 40-TON TANK TRANSPORTER TRAILER TRUCK M25**

Examine clips for breakage, and replace if broken. Inspect bolts and nuts for stripped threads, and straighten with die or tap. Examine eye for breakage, and replace if broken. Examine eye bushing for scoring, and replace if scored.

**c. Assembly (fig. 55).**

(1) **INSTALL FRONT SPRING LEAVES.** Insert curved rear end of main leaf into curved end of second leaf, and position 2 leaves over other leaves, which must be assembled in order of size, with shortest leaf at bottom. Then insert center bolt through 14 leaves, and secure it with a nut and lock washer. Position 2 large clips around fourth to fourteenth leaves, and secure each clip with a bolt, nut, and lock washer. Secure top 6 leaves together with small clip, and install bolt, nut, and lock washer to tighten clip.

(2) **INSTALL FRONT SPRING EYE.** Place eye in position at front end of spring, and secure it to top seven leaves with two eye clip bolts, nuts, and lock washers. Install two bolts, nuts, and lock washers which secure eye to second and third leaves.

**84. FITS AND TOLERANCES.**

Shackle pin clearance in bushing.....	0.015 in.
Hanger pin clearance in bushing.....	0.015 in.

**Section II**

**SHOCK ABSORBERS**

Description and data .....	Paragraph 85
Disassembly, cleaning, inspection, repair, and assembly.....	86

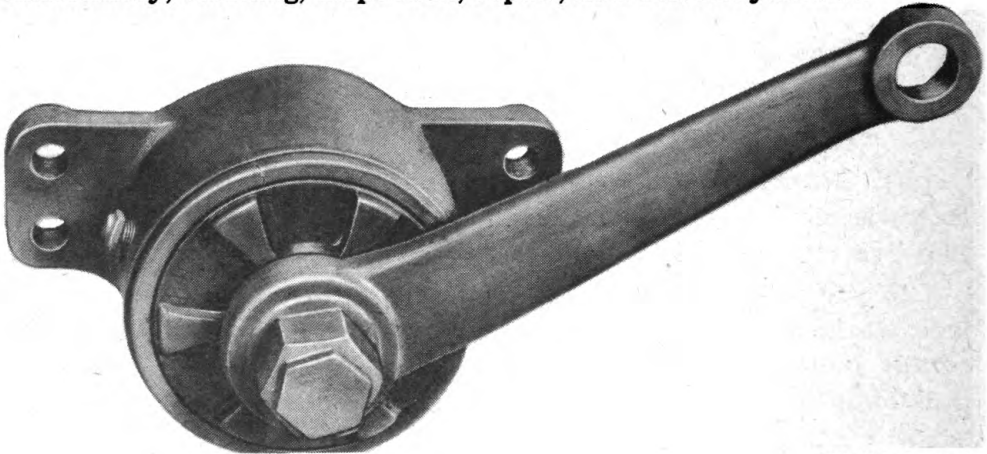

**RA PD 74977**

**Figure 56 — Front Shock Absorber**

**SPRINGS AND SHOCK ABSORBERS**

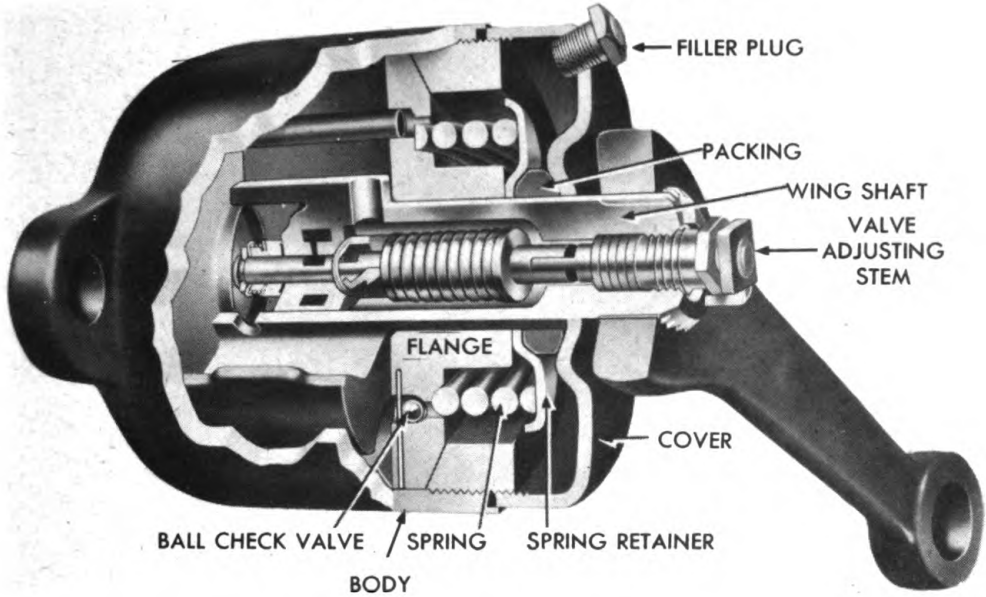

**Figure 57 — Shock Absorber — Cutaway View** RA PD 77083

**85. DESCRIPTION AND DATA.**

a. **Description.** A shock absorber is located at the right and left sides of the front of the vehicle, each being secured to the side of the chassis frame and connected by a drag link assembly to the front spring. The drag link assembly consists of a rod secured to the lever of the shock absorber at one end, the opposite end being a spring-loaded ball joint secured to the front spring by means of a ball stud. The shock absorber consists of a base cover and lever. The base and cover house the working chamber which is divided into two equal sections by a stationary wing. A moving wing in the base is secured to the shock absorber lever. In the stationary partition of the base are two automatic check valves, and the entire base is filled with shock absorber fluid. A needle and a replenishing valve or fluid is located in the cover.

b. **Operation.** When the vehicle spring is compressed, the moving wing is oscillated by the lever of the shock absorber. The two automatic check valves in the stationary partition of the base permit shock absorber fluid to flow freely in one direction, but they close completely the instant the flow of fluid is reversed. These check valves are also arranged so that they permit a retarded flow of fluid. When the vehicle spring is compressed, at the instant the lever is moved in the reverse direction (downward) caused by the spring recoil, the check valves close completely, stopping the flow of fluid with the result that the vehicle spring, during rebound, is under control in proportion to the shock resistance. The needle valve regulates the escape of the shock absorber fluid from the compression section of the shock absorber. The elimination of air is, by means

**ORDNANCE MAINTENANCE — BODY, CHASSIS, AND WINCHES FOR TRACTOR TRUCK M26, COMPONENT OF 40-TON TANK TRANSPORTER TRAILER TRUCK M25**

of the air vent, in the cover which divides the working chamber from the reserve chamber of the shock absorber. Replenishing valves located in the bottom of the flange permit the fluid in the auxiliary chamber to pass into the working chamber as required to keep the working chamber constantly full of fluid.

**c. Data.**

Make ..... Houdaille-Hershey  
 Model ..... G

**86. DISASSEMBLY, CLEANING, INSPECTION, REPAIR, AND ASSEMBLY.**

**a. Disassembly (fig. 57).**

- (1) Remove filler plug, and drain fluid from shock absorber.
- (2) Attach puller to lever with short piece of pipe resting on wing shaft, between wing shaft and puller screw, to avoid damage to adjusting valve. Pull lever from wing shaft.
- (3) Clamp body of shock absorber in vise, and loosen threaded cover in body, using hammer and punch to unscrew cover. Do not remove cover. Leave last two or three threads engaged with body, otherwise spring pressure will cause cover to fly out when threads are disengaged.
- (4) Place unit in hydraulic press with ram of press resting lightly against cover. Unscrew cover from body, and release hydraulic press slowly. Remove shock absorber from hydraulic press.
- (5) Turn shock absorber over, and tap on edge of bench to remove valves from inside body.

**b. Inspection.** Wash all parts and inside of body with dry-cleaning solvent. Inspect body for cracks and score marks. Replace, if damaged. Use new oil seals when assembling.

**c. Assembly.**

- (1) Install wing shaft in body. Install flange over wing shaft, entering dowel pin in hole. Tap flange in place.
- (2) Install new gasket around outside diameter of flange, and hold in place with flanged washer installed with rim downward.
- (3) Install spring, spring retainer, and oil seal packing over wing shaft. Place cover on spring retainer, and press down to body, using hydraulic press. Engage threads of cover with body, and tighten cover.
- (4) Install shock absorber lever to winch shaft, using hydraulic press. Install heavy shock absorber fluid, and install filler plug.
- (5) Inspection of level of shock absorber fluid can be made when shock absorber is on vehicle or after it has been removed. Remove filler plug. Level of shock absorber fluid must not be lower than 1/2 inch below filler plug opening, and shock absorber fluid can completely fill shock absorber without harm.

CHAPTER 10  
CAB

---

Section I

DESCRIPTION AND DATA OF CAB

Description and data .....	Paragraph 87
----------------------------	-----------------

87. DESCRIPTION AND DATA.

a. **Description.** The cab is of armor plate, welded together to provide a cover over the engine, radiator, and driving controls of the tractor. Doors for entrance into the cab are of armor plate with hinged windows of armor plate; windows on the sides and back of the cab are of armor plate; windows on the sides and back of the cab are also of armor plate and are hinged for opening or closing. Shutters over the windshield are hinged armor plate.

b. **Data.**

Construction .....	Armor plate welded
How attached .....	Bolted to chassis frame
Manufactured by .....	Pacific Car and Foundry Co.

---

Section II

REMOVAL OF CAB

Removal of cab .....	Paragraph 88
----------------------	-----------------

88. REMOVAL OF CAB.

a. **Preliminary Instructions** (figs. 58 and 59). Unlatch acetylene and oxygen tanks, and lift tanks off vehicle. Remove whiffle tree from back of cab (TM 9-767). Remove flood lights (TM 9-767). Remove wires A to L (fig. 58) at main junction block. **CAUTION: Tag all wires before removing from junction block.** Remove two bolts, nuts, and cotter pins which hold cab to front cross member of frame and are accessible from inside of radiator shutters.

b. **Disconnect Radiator Shutters and Front Ground Strap.** Remove cotter pin and clevis pin that hold radiator shutters to controls, and push shutter controls back and out of the way. Remove cap screw which holds front ground strap to frame front cross member.

**ORDNANCE MAINTENANCE — BODY, CHASSIS, AND WINCHES FOR TRACTOR TRUCK M26, COMPONENT OF 40-TON TANK TRANSPORTER TRAILER TRUCK M25**

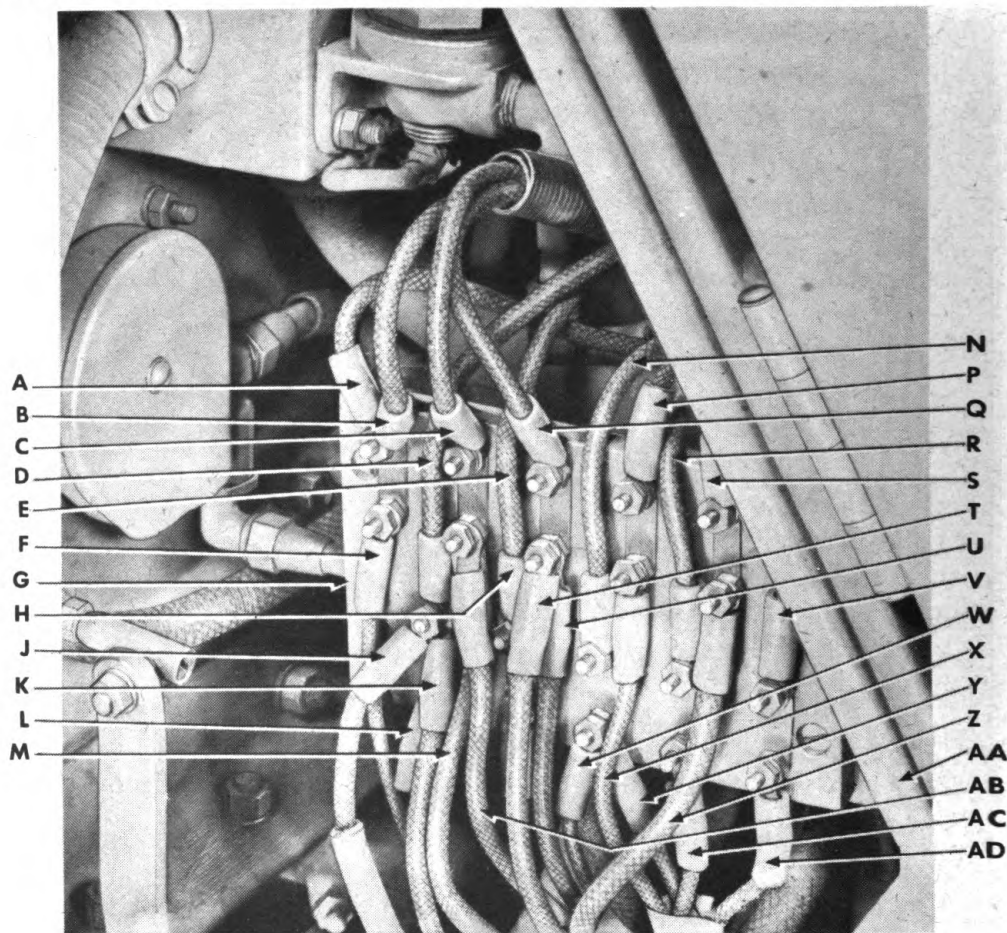

- A—SWITCH TO JUNCTION BLOCK HEAD LAMP WIRE
- B—JUNCTION BLOCK TO DIMMER SWITCH WIRE
- C—DIMMER SWITCH TO JUNCTION BLOCK (LOW BEAM ON HEAD LAMP)
- D—ALL BLACKOUT LIGHTS (LIGHT SWITCH TO JUNCTION BLOCK) EXCEPT BLACKOUT DRIVING LIGHT
- E—FLOODLIGHT SWITCH ON INSTRUMENT PANEL TO JUNCTION BLOCK
- F—SERVICE CLEARANCE LIGHT
- G—MAIN JUNCTION BLOCK
- H—FLOODLIGHT
- J—BLACKOUT MARKER LIGHT (RIGHT)
- K—BLACKOUT MARKER LIGHT (LEFT)
- L—BLACKOUT CLEARANCE LIGHT
- M—LOW BEAM ON HEADLIGHT (RIGHT)
- N—SPOTLIGHT REEL TO JUNCTION BLOCK, ALSO WINDSHIELD WIPER MOTORS

- P—BLACKOUT DRIVING LIGHT SWITCH
- Q—DIMMER SWITCH TO JUNCTION BLOCK (HIGH BEAM ON HEAD LAMP)
- R—SPOTLIGHT SWITCH
- S—SIREN MOTOR SWITCH TO JUNCTION BLOCK
- T—HIGH BEAM ON HEADLIGHT (RIGHT)
- U—HIGH BEAM ON HEADLIGHT (LEFT)
- V—SIREN LIGHT
- W—WINDSHIELD WIPERS, DOME LIGHT AND READING LIGHT
- X—BLACKOUT DRIVING LIGHT
- Y—SPOTLIGHT REEL
- Z—SIREN MOTOR
- AA—FRONT OF CAB (INSIDE RADIATOR DOOR)
- AB—LOW BEAM ON HEADLIGHT (LEFT)
- AC—SPOTLIGHT
- AD—SIREN LIGHT

NOTE—REMOVAL OF WIRES A TO L, INCLUSIVE, IS NECESSARY FOR REMOVAL OF CAB

RA PD  
74941

**Figure 58 — Main Junction Block Wiring**

CAB

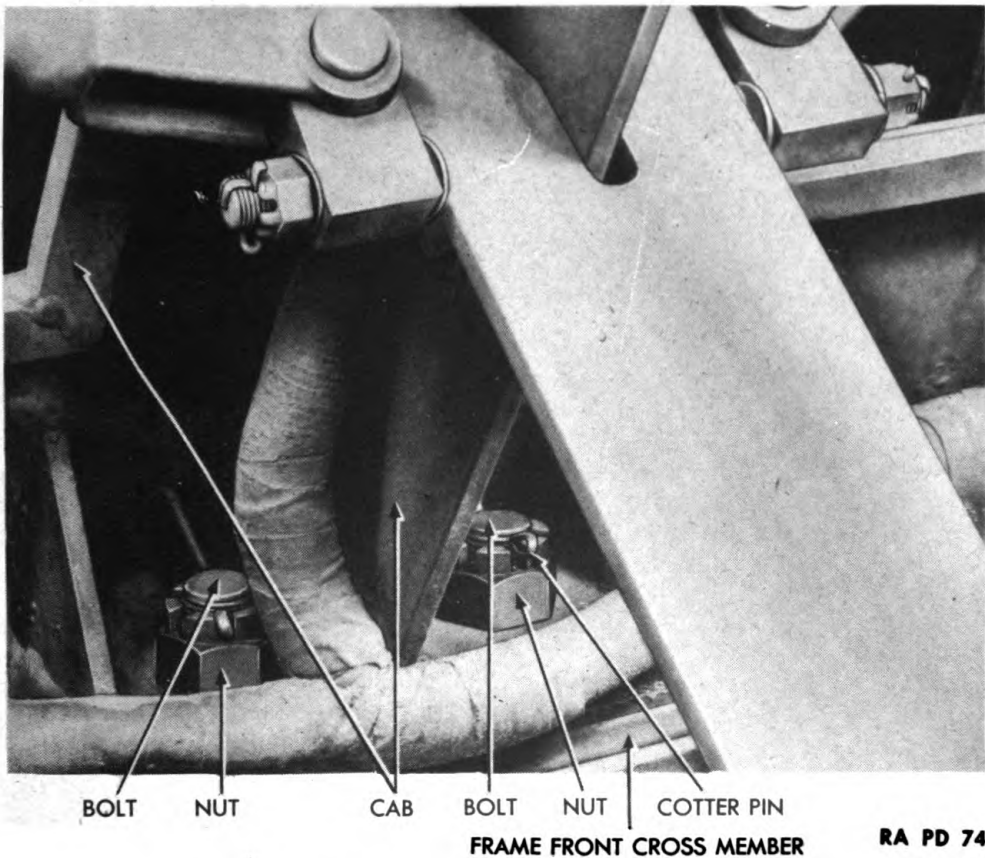

**Figure 59 – Cab Front Mounting Bolts**

c. **Disconnect Wheelhouse.** Remove one bolt, nut, and lock washer at rear corner of right wheelhouse strap; five bolts, nuts, and lock washers at rear edge of right wheelhouse; then seven bolts, nuts, and lock washers at inner edge of right wheelhouse (fig. 60). Remove screw holding right wheelhouse ground strap. Remove one bolt, nut, and lock washer at rear corner of left wheelhouse strap. Remove screw holding left wheelhouse ground strap.

d. **Disconnect Cab Angle Irons** (fig. 61). Remove (spare wheel side) five bolts, nuts, and lock washers; then remove (welding bottles side) five bolts, nuts, and lock washers that hold cab angle irons to cab (welding bottles side).

e. **Remove Cab Right Filler Strap** (fig. 62). Remove five bolts, nuts, and lock washers which hold cab right filler strap (at right of commander's seat); then repeat procedure on opposite side (at left of driver's seat).

f. **Remove Ammunition Box** (fig. 63). Remove four bolts, nuts, and lock washers which hold right ammunition box to cab right door frame.

ORDNANCE MAINTENANCE — BODY, CHASSIS, AND WINCHES FOR TRACTOR  
TRUCK M26, COMPONENT OF 40-TON TANK TRANSPORTER TRAILER TRUCK M25

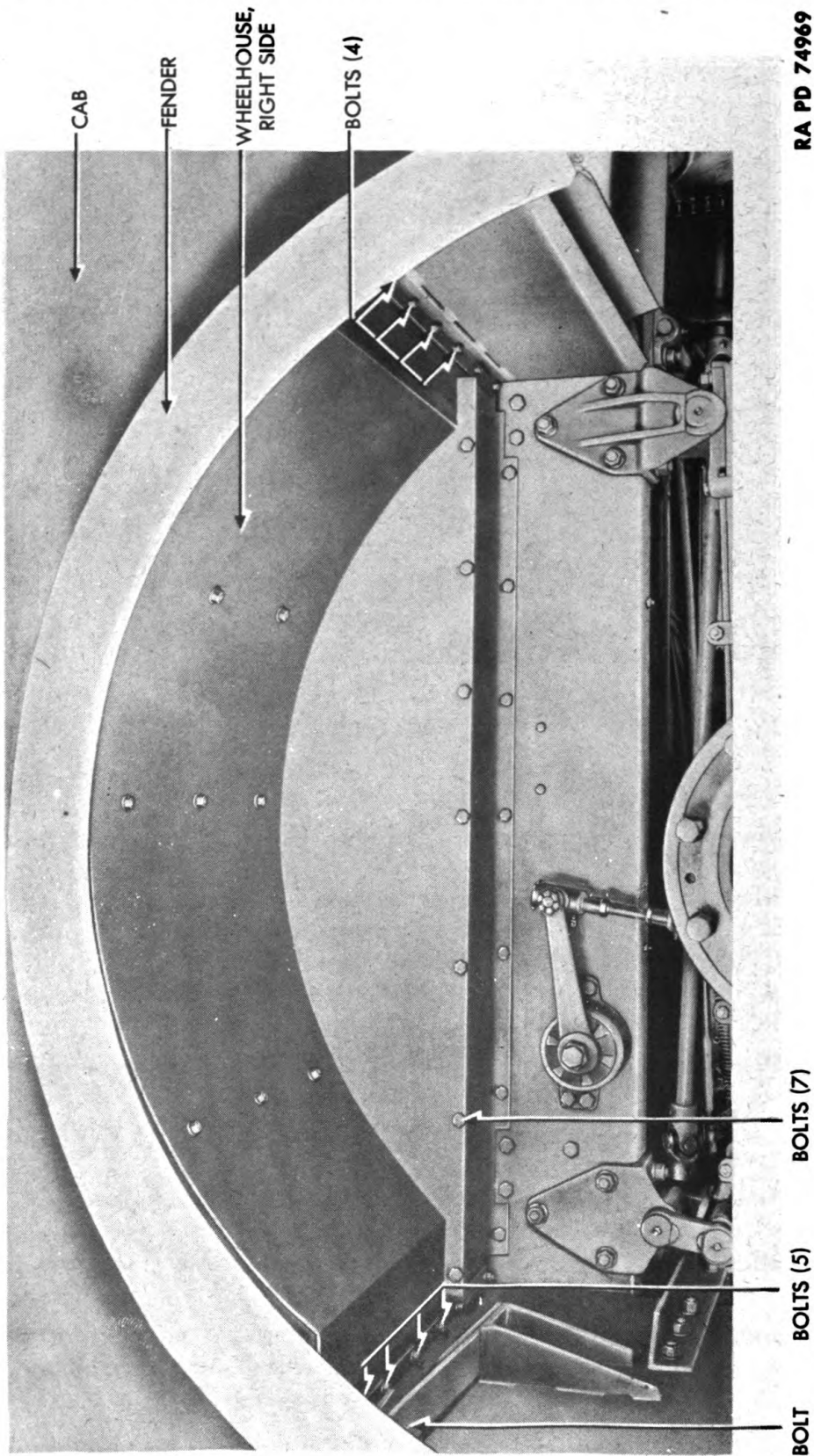

RA PD 74969

Figure 60 — Wheelhouse — Right Side

CAB

(LEFT REAR MOUNTING BRACKET)

(RIGHT REAR MOUNTING BRACKET)

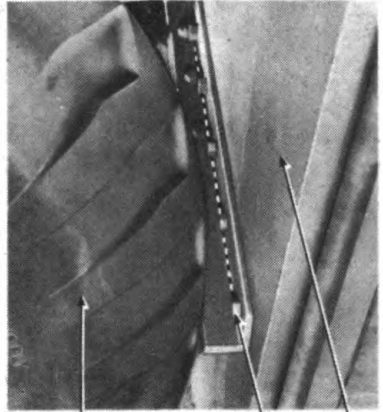
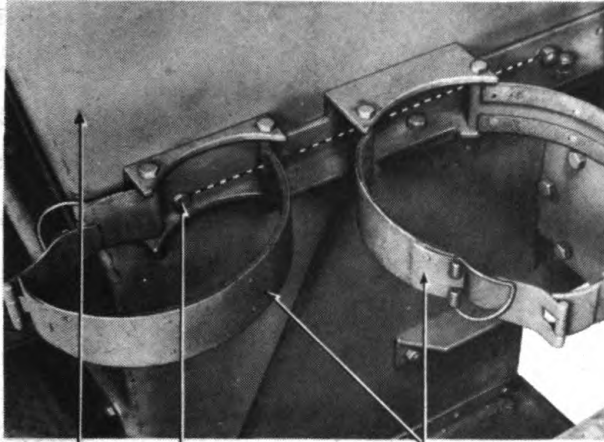

CAB BOLTS WELDING BOTTLE CLAMPS

SPARE WHEEL AND TIRE ASSEMBLY BOLTS CAB RA PD 74980

Figure 61 – Cab Rear Mounting Brackets

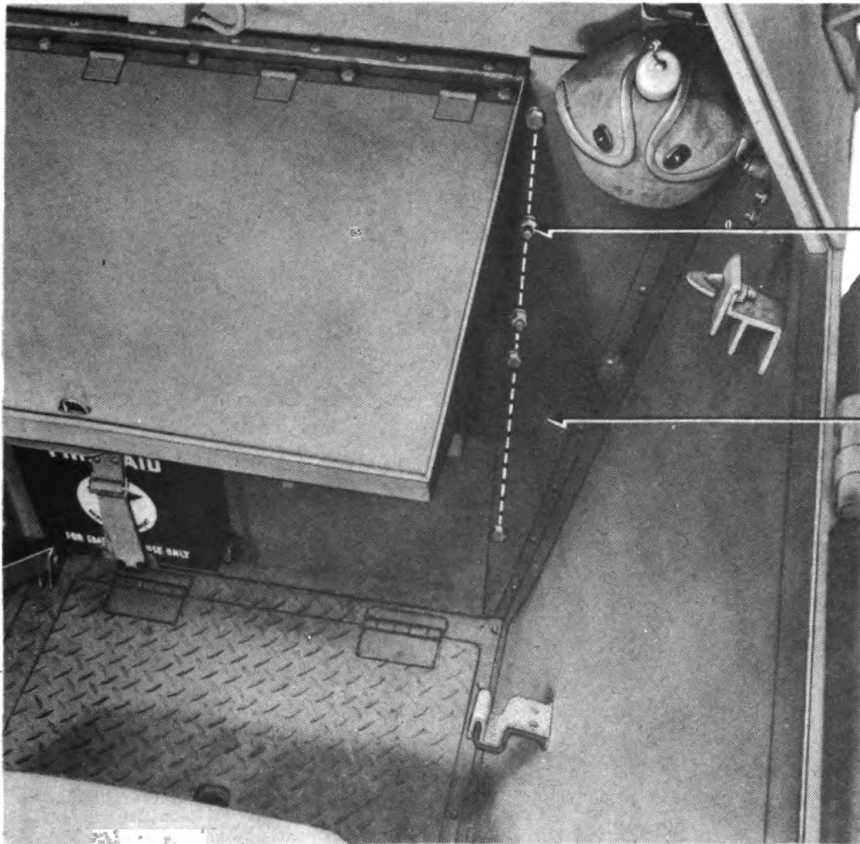

BOLTS

CAB FILLER STRIP, RIGHT

RA PD 74978

Figure 62 – Cab Right Filler Strip

**ORDNANCE MAINTENANCE — BODY, CHASSIS, AND WINCHES FOR TRACTOR TRUCK M26, COMPONENT OF 40-TON TANK TRANSPORTER TRAILER TRUCK M25**

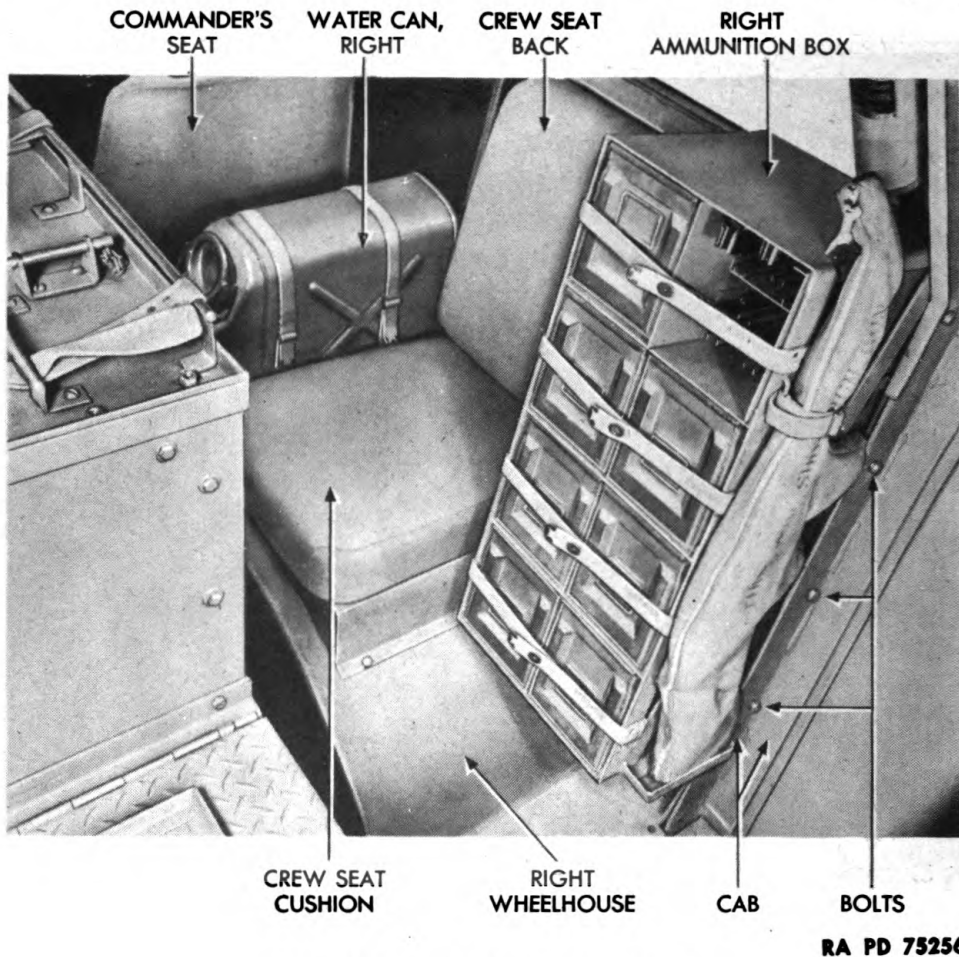

RA PD 75256

**Figure 63 — Right Side of Cab**

**g. Remove Crew and Commander's Seats (fig. 63).** Remove two bolts, nuts, and lock washers that hold crew seat back, and lift back up and off cab. Lift crew right seat cushion off its frame. Remove four bolts, nuts, and lock washers that hold commander's seat to cab (nuts are under wheelhouse and bolts inside cab). Remove right water can.

**h. Remove Right Wheelhouse (fig. 63).** Pry right wheelhouse up from cab. Lift wheelhouse up, and lay alongside engine out of way.

**i. Remove Cab (fig. 64).** Attach chain through cab at cab window, and attach loose chain to a hoist on right side. Repeat procedure on opposite side of cab, attaching chain to another hoist. Raise cab of chassis by having an operator on both sides of tractor to operate hoists.

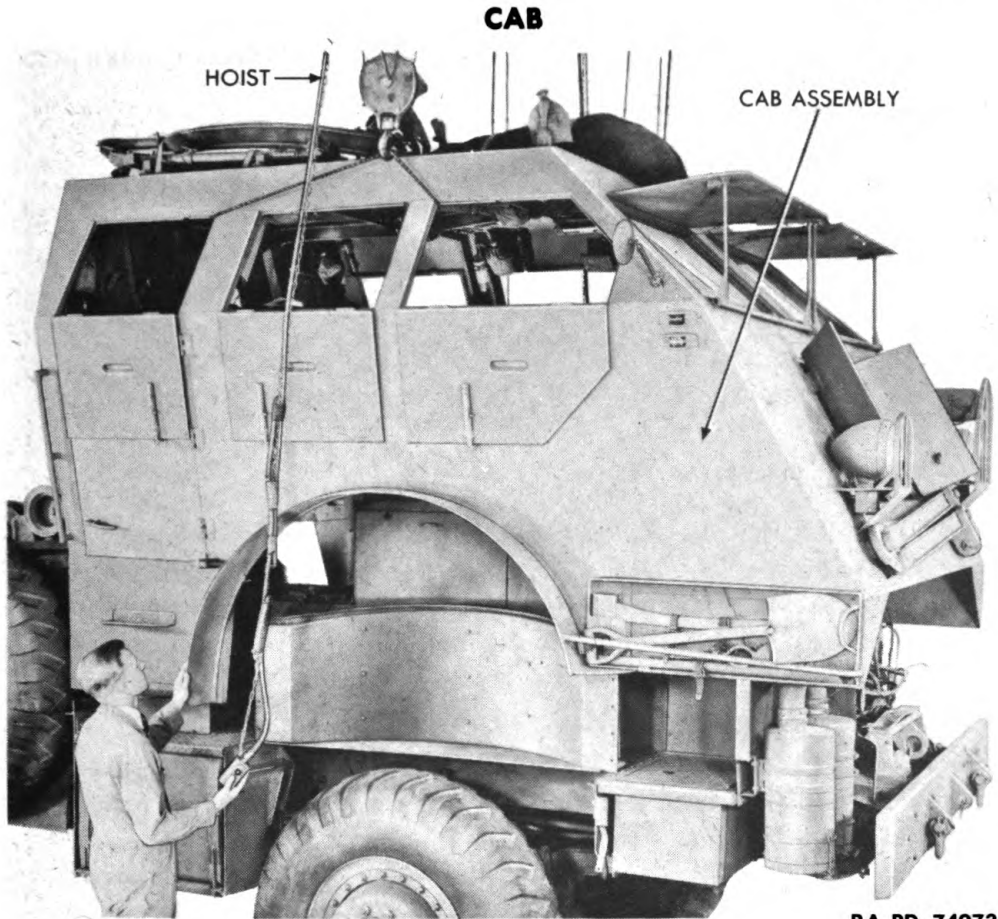

RA PD 74973

**Figure 64 – Removing Cab Assembly**

**Section III**

**CLEANING, INSPECTION, AND REPAIR OF CAB,  
TOOL BOXES, DOORS, AND SHUTTERS**

Cleaning, inspection, and repair..... Paragraph 89

**89. CLEANING, INSPECTION, AND REPAIR.**

a. **Cleaning.** Wash all parts in dry-cleaning solvent to remove grease; then if parts are to be painted, wash with soda ash solution. Refer to TM 9-850 or SNL K-1.

b. **Inspection and Repair.** Inspect cab and brackets for breaks or fractures, and weld together if necessary. The cab being of armor plate can be welded and also reinforced or patched with armor plate, which must be welded in place. Cab doors, radiator armor plate shutters, and cab armor plate windows can be welded if cracked and reinforced, or patched with armor plate if broken in combat (removal is covered in TM 9-767). Tool boxes and engine com-

**ORDNANCE MAINTENANCE — BODY, CHASSIS, AND WINCHES FOR TRACTOR TRUCK M26, COMPONENT OF 40-TON TANK TRANSPORTER TRAILER TRUCK M25**

partment covers are of sheet steel and can be straightened if bent, and welded if broken.

---

Section IV

**INSTALLATION OF CAB**

Installation .....	90
--------------------	----

**90. INSTALLATION.**

a. **Install Cab Wheelhouse and Seats.** Use two hoists and attach to cab at windows (fig. 64), and install cab on chassis. Install right wheelhouse. Install right water can; then install commander's seat, and fasten with four bolts, nuts, and lock washers. Install crew seat cushion, right, and then install crew seat back, right and left, and fasten with two bolts, nuts, and lock washers.

b. **Install Ammunition Box, Cab Filler Strip, and Angle Iron.** Install ammunition box, right, and fasten with four bolts, nuts, and lock washers (fig. 63). Install cab filler strips, right and left, and fasten with bolts, nuts, and lock washers (fig. 62). Install cab right angle iron and cab left angle iron (fig. 61), and fasten with bolts, nuts, and lock washers.

c. **Install Wheelhouse.** Install bolt, nut, and lock washer at rear corner of left wheelhouse strap. Install screw that holds right wheelhouse ground strap. Install seven bolts, nuts, and lock washers at inner edge of right wheelhouse (fig. 60); then install five bolts, nuts, and lock washers at rear edge of right wheelhouse. Install one bolt, nut, and lock washer at rear corner of right wheelhouse strap.

d. **Connect Wiring and Radiator Shutters.** Fasten front ground strap with screw. Connect shutter controls by installing clevis and cotter pin. Connect wires A to L (fig. 58) at main junction block; then install two bolts, nuts, and cotter pins that hold front of cab to frame. Install flood lights, whiffle tree, and welding tanks (TM 9-767).

CHAPTER 11  
**ELECTRIC LIGHTING SYSTEM AND ACCESSORIES**

Section I

**DESCRIPTION AND DATA OF ELECTRIC LIGHTING  
SYSTEM AND ACCESSORIES**

	Paragraph 91
--	-----------------

**91. DESCRIPTION AND DATA.**

a. **Description.** The electrical lighting system consists of the lights used for lighting the truck tractor for driving operation and visibility, and the lights used for signaling purposes. The electric accessories consist of the switches used for controlling the lights, the electric windshield wipers, and the wiring. All electric units are operated by the two storage batteries and are controlled by switches on the instrument panel or on the unit (TM 9-767). The wiring connecting the units and circuit used is shown on the wiring diagram (fig. 65).

b. **Data.**

Unit	Make	Model or Type
Windshield wipers	Owen-Dyneto	1939
Siren with light	Federal Electric	
Headlights	Guide	1004 K-12-16-162
Blackout driving light	Guide	551-3N
Floodlights	Dietz	600
Service tail and stop lights	Guide	3012C, Sealed beam
Blackout tail and stop lights	Guide	3012D, Sealed beam
Service clearance lights	Guide	
Blackout clearance lights	Guide	
Blackout marker lights	Guide	
Dome light	Yankee	404A
Starter button	Leece-Neville	10355
Dimmer switch	Delco-Remy	
Headlight switch	Cole-Hershey	8715X
Ignition switch	Clum	16709
Low pressure air indicator buzzer assembly	Keystone-Faraday	12-volt bus signal

**ORDNANCE MAINTENANCE — BODY, CHASSIS, AND WINCHES FOR TRACTOR  
TRUCK M26, COMPONENT OF 40-TON TANK TRANSPORTER TRAILER TRUCK M25**

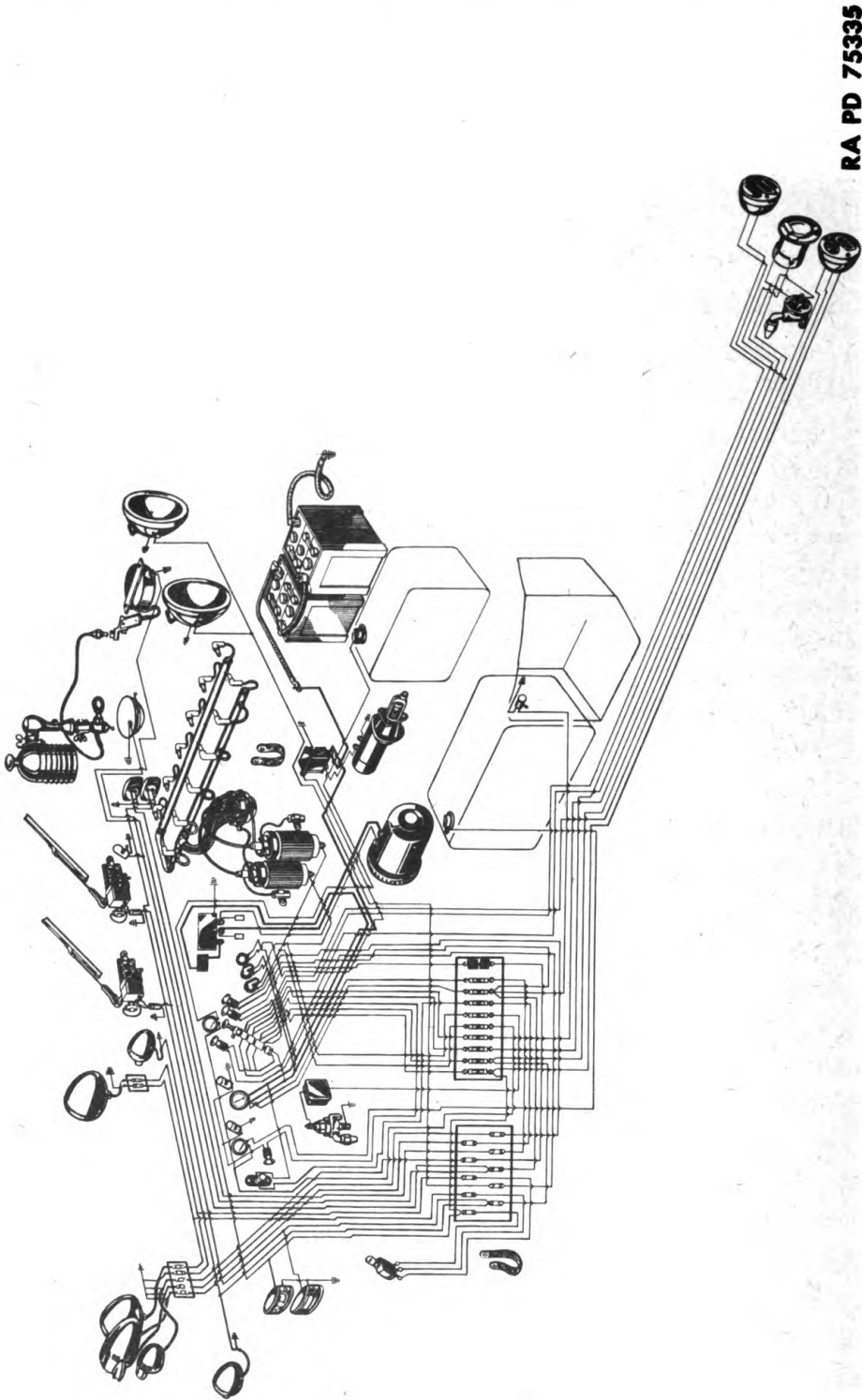

RA PD 75335

**Figure 65 — Wiring Diagram**

ELECTRIC LIGHTING SYSTEM AND ACCESSORIES

Section II

COMBINATION BLINKER AND SPOTLIGHT

	Paragraph
Description .....	92
Spotlight arm .....	93
Spotlight handle .....	94
Blinker and spotlight reel .....	95
Blinker and spotlight signal switch .....	96

92. DESCRIPTION.

a. **Description.** The blinker and spotlight consists of a spotlight with a removable shield, an arm shaft which extends through the roof of the cab, and a handle switch on the inside of the cab. The spotlight contains a sealed beam lighting unit secured to an arm, both of which are located on the top of the cab. A shaft connected to the arm extends through a bracket on the roof of the cab, and on the lower end of the shaft (inside of cab) is a handle containing a switch.

b. **Operation.** Turning the handle directs the spotlight in any direction desired, and the switch controls the operation of the light. When the light is used as a blinker, it is removed and attached to a reel with signal switch (TM 9-767).

93. SPOTLIGHT ARM.

a. **Disassembly** (figs. 66 and 67).

(1) **REMOVE SPOTLIGHT ARM SHAFT.** Remove set screw that holds cap on housing, and remove cap and rubber and steel washers from sleeve. Remove clamp screw and set screw which holds sleeve in housing, and pull sleeve out of housing off shaft.

(2) **REMOVE BEARING** (fig. 67). Remove clamp screw that holds bearing assembly in housing, and remove bearing. Pull arm shaft out of large end of housing, and lift washer off housing.

b. **Cleaning, Inspection, and Repair.** Clean all parts in dry-cleaning solvent. Inspect arm shaft and sleeve for bends or fractures, and replace parts if necessary. Inspect bearing assembly for easy operation without binding, and replace assembly if operation is difficult or if there is binding. Inspect housing and cap for fractures, and replace part if fractured. Straighten crossed or mashed threads with a thread die or tap.

c. **Assembly** (figs. 66, 67, and 68).

(1) **INSTALL ARM SHAFT AND BEARING.** Install washer on arm shaft, and push washer against base of gear. Insert shaft through large

**ORDNANCE MAINTENANCE — BODY, CHASSIS, AND WINCHES FOR TRACTOR TRUCK M26, COMPONENT OF 40-TON TANK TRANSPORTER TRAILER TRUCK M25**

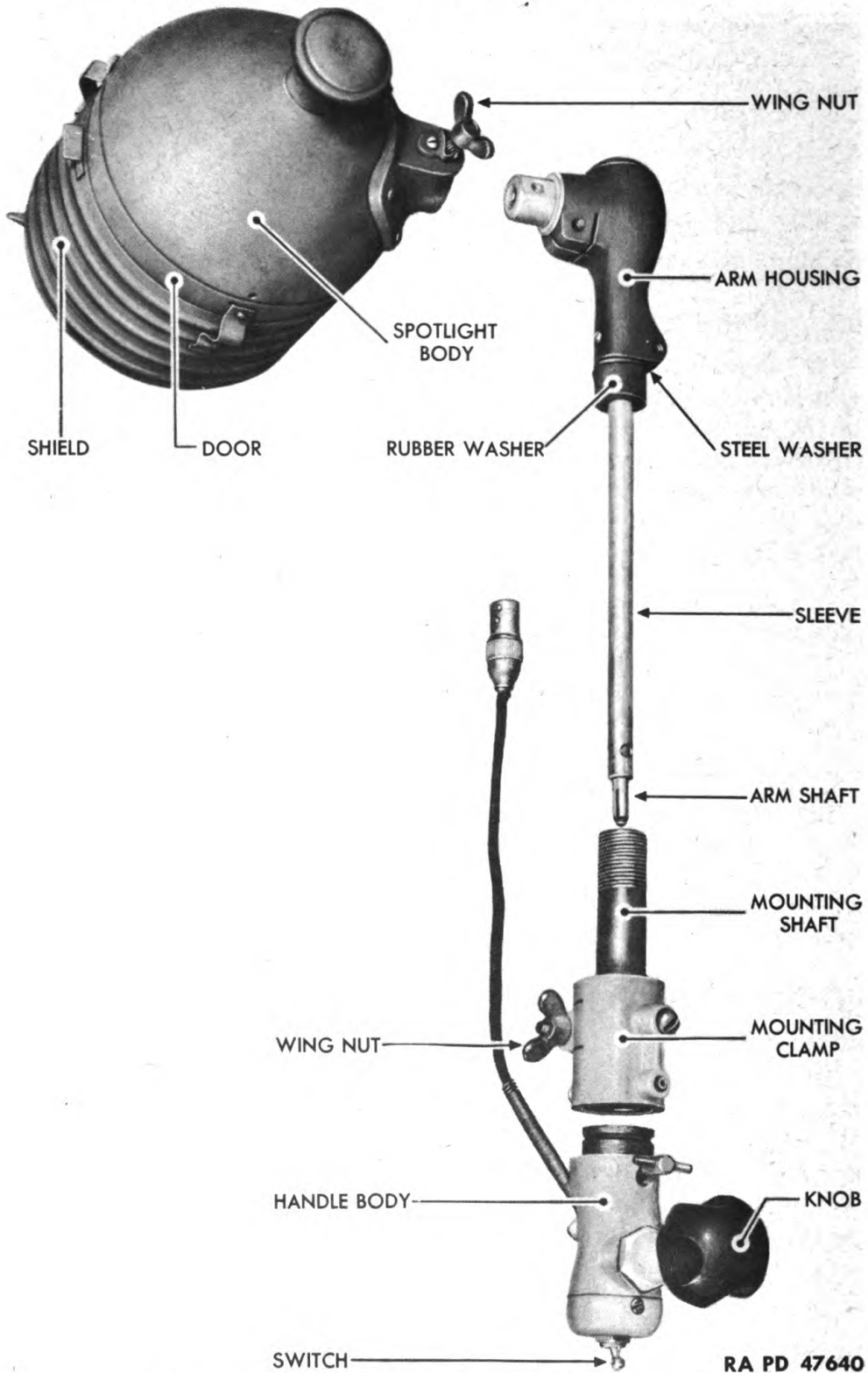

**Figure 66 — Spotlight — Partly Disassembled**

**ELECTRIC LIGHTING SYSTEM AND ACCESSORIES**

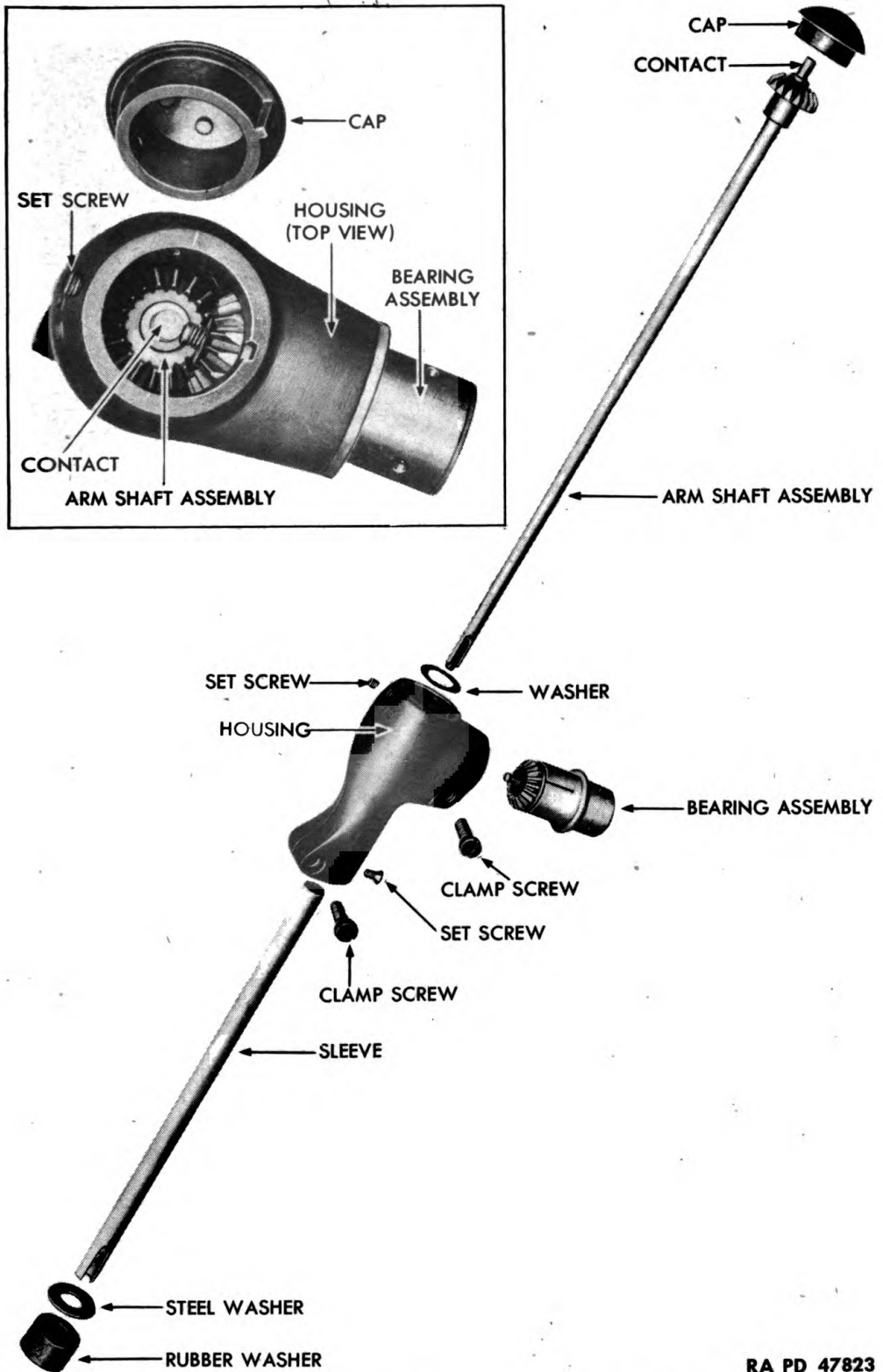

RA PD 47823

**Figure 67 – Spotlight Arm – Disassembled**

**ORDNANCE MAINTENANCE — BODY, CHASSIS, AND WINCHES FOR TRACTOR TRUCK M26, COMPONENT OF 40-TON TANK TRANSPORTER TRAILER TRUCK M25**

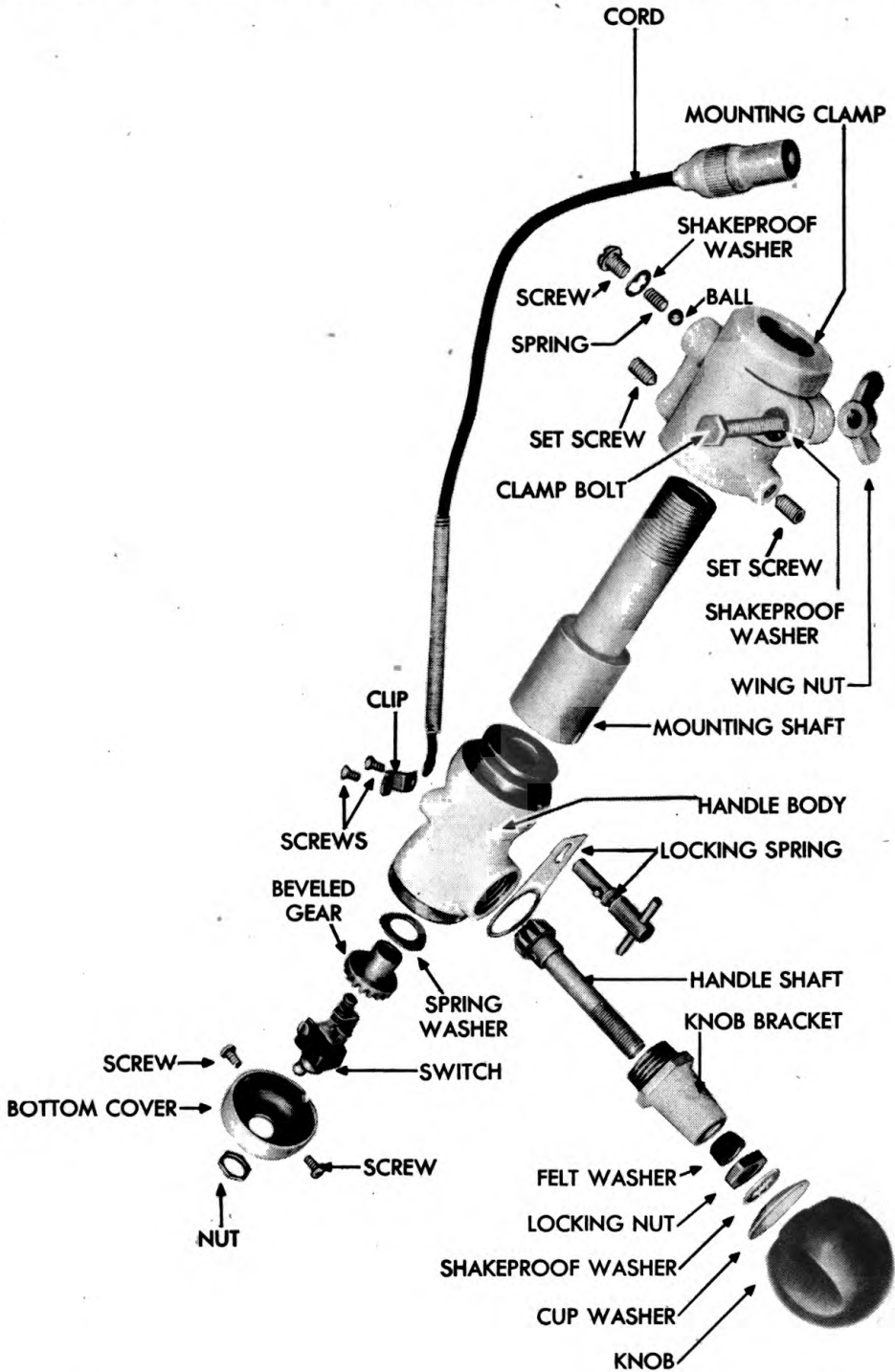

RA PD 75262

**Figure 68 — Spotlight Handle — Disassembled**

## ELECTRIC LIGHTING SYSTEM AND ACCESSORIES

end of housing, and push bearing assembly into housing, meshing gears of bearing assembly with gears on shaft assembly. Install clamp screw, pack housing with grease, and install cap. Fasten cap with set screw.

(2) **INSTALL SLEEVE.** Install sleeve over shaft and into housing. One end of sleeve has tapped hole near end of keyway. This end of sleeve must be inserted into the housing. Install set screw and clamp screw, then install steel washer and rubber washer over sleeve.

### 94. SPOTLIGHT HANDLE.

#### a. Disassembly (figs. 66, 67, and 68).

(1) **REMOVE COVER.** Pull mounting shaft and clamp from handle; then loosen two socket head set screws, and slide mounting clamp with shaft off handle. Remove screw, toothed washer spring, and ball from tapped hole in front side of clamp. Remove wing nut from clamp bolt, and slide shaft out from lower side. Remove switch nuts and two cover screws, and lift off cover.

(2) **REMOVE CORD FROM OPERATING HANDLE BODY.** Remove clip that holds cord to body of operating handle by taking out two screws; then push cord upward until terminal screw on switch base is accessible. Remove screw and cord from switch base, and pull cord back through handle body.

(3) **DISASSEMBLE HANDLE.** Remove knob and bracket from operating handle body by unscrewing knob bracket; then unscrew nut that locks knob onto shaft, and unscrew knob. Remove lock washers, cup washer, felt washer, and knob from shaft. Hold body of handle upright so that beveled gear and spring washer fall out, then take out clamp screw. Carefully pry out bearing assembly, and remove arm sleeve by taking out set screw and pulling sleeve off shaft.

b. **Cleaning, Inspection, and Repair.** Clean all parts with dry-cleaning solvent, and dry with compressed air. Inspect threads for burs, and straighten threads with thread die or tap. Examine teeth of handle shaft and beveled gear for breakage or chipping, and use new parts if teeth are broken or chipped. Inspect cord for breakage, and replace if broken. Inspect switch for breaks and corrosion, replace if necessary.

#### c. Assembly (figs. 66, 67, and 68).

(1) **INSTALL BEVELED GEAR.** Place spring washer on hub of beveled gear, then, holding handle body upside down, place beveled gear and spring washer in body, hub side of gear down.

(2) **ASSEMBLE KNOB TO BRACKET.** Insert beveled gear and shaft through bracket from threaded end. Install felt washer over shaft

**ORDNANCE MAINTENANCE — BODY, CHASSIS, AND WINCHES FOR TRACTOR TRUCK M26, COMPONENT OF 40-TON TANK TRANSPORTER TRAILER TRUCK M25**

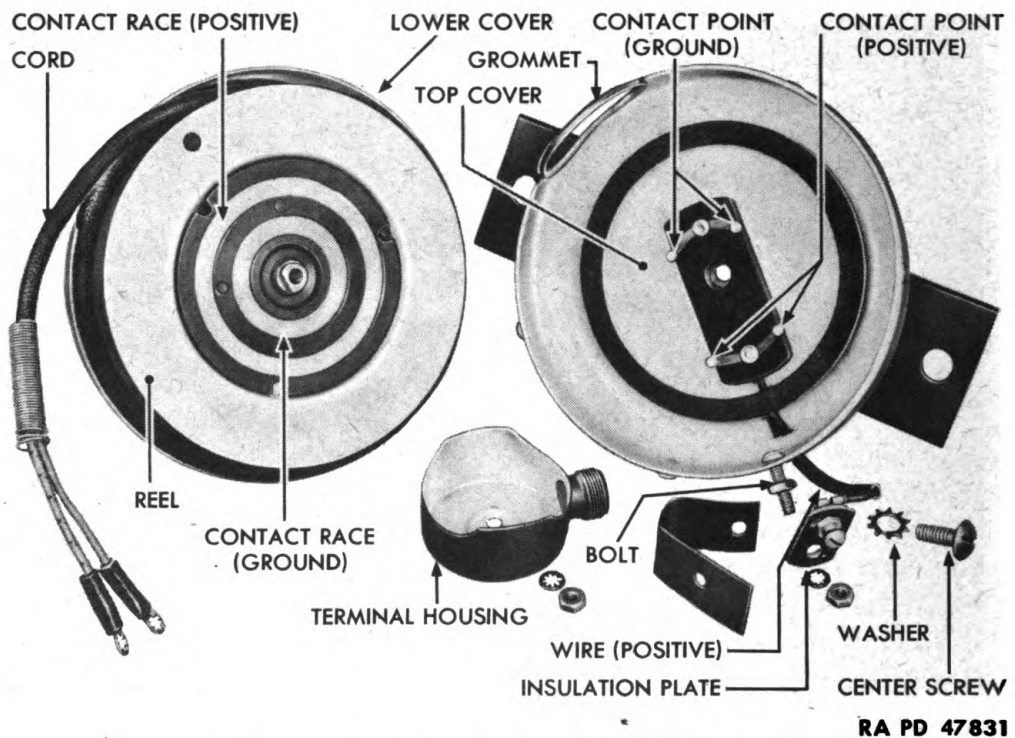

**Figure 69 — Signal Light Reel — Disassembled**

and into bracket, and install jam nut onto shaft. Screw nut down until there is about 0.003-inch end play so that gear will turn freely with minimum end play. Install lock washer and cup washer on shaft then, holding jam nut with wrench, screw knob down on shaft. Bracket should turn freely on shaft with very little end play.

(3) **INSTALL KNOB, CORD, AND SWITCH.** Install locking pin and locking spring onto handle body. Screw knob bracket into body. Insert cord through hole in body, and connect cord terminal to toggle switch body.

(4) **INSTALL BOTTOM COVER.** Pull cord down and bring switch body into position with contact plunger in center. Position slot in threaded part of switch toward side on which cord is installed; then install bottom cover, and pull switch through center hole. Fasten switch by installing switch nut, and install two cover screws. Place clip over cord and fasten to handle body with two screws.

(5) **ASSEMBLE CLAMP AND SHAFT.** Insert shaft through large end of clamp. Hold clamp with clamping screw side down, and drop ball and spring in larger tapped hole in top side. Install screw with toothed washer over spring; then, keeping shaft pushed all the way in, turn shaft until you feel ball fall into slot in shaft.

**ELECTRIC LIGHTING SYSTEM AND ACCESSORIES**

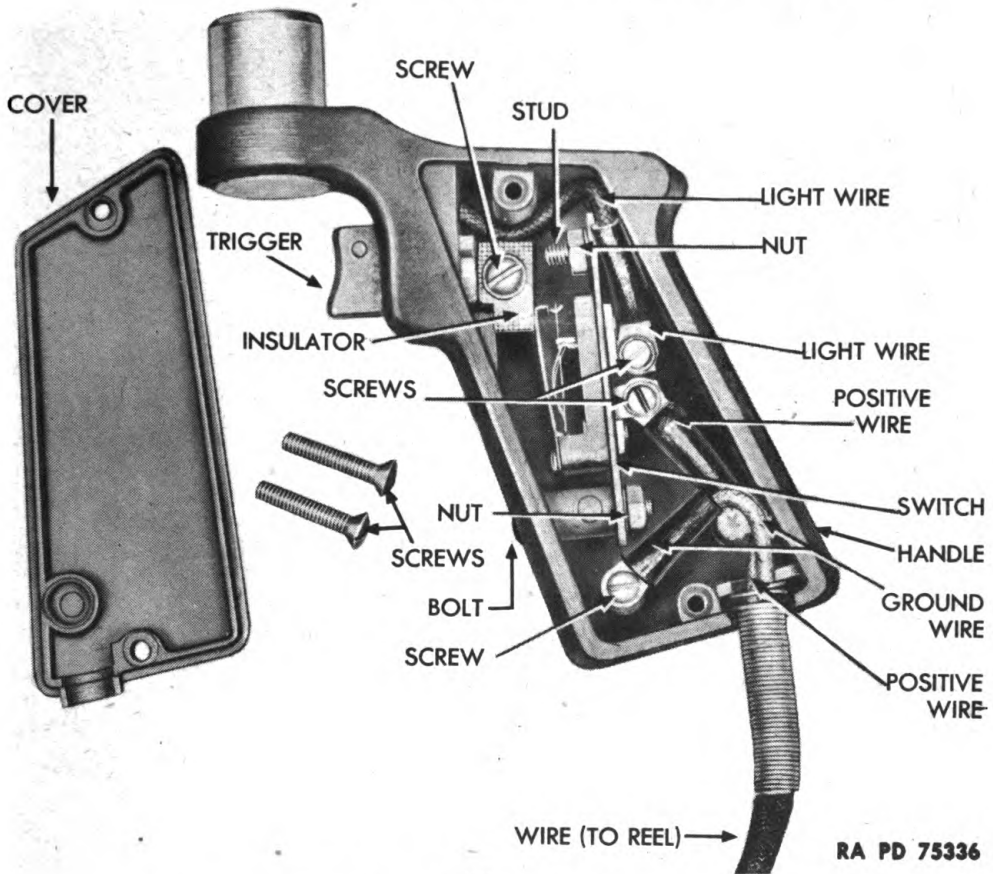

**Figure 70 — Signal Switch Assembly — Cover Removed**

**95. BLINKER AND SPOTLIGHT REEL.**

a. **Disassembly (fig. 69).** Remove center screw and star washer, and remove top cover from body. Allow reel to unwind, and remove metal grommet from cord outlet opening.

b. **Cleaning, Inspection, and Repair.** Inspect two contact races on upper surface of reel, and clean with fine sandpaper until contact surface is free from all foreign matter. Inspect contact points on top cover, and clean points with flint paper 2/0. Inspect positive and ground wire connections, and if connections are loose, tighten and resolder. Inspect cord for breaks or worn insulation, and replace cord.

c. **Assembly (fig. 69).** Wind wire on reel, being careful not to allow wiring to kink or twist, then wind reel about five turns to put tension on spring. Hold reel and lower cover together with spring under this tension, and shake assembly until spring stop falls into place. The action of this spring is similar to that of an ordinary window shade roller. Place metal grommet over wiring and in posi-

ORDNANCE MAINTENANCE — BODY, CHASSIS, AND WINCHES FOR TRACTOR  
TRUCK M26, COMPONENT OF 40-TON TANK TRANSPORTER TRAILER TRUCK M25

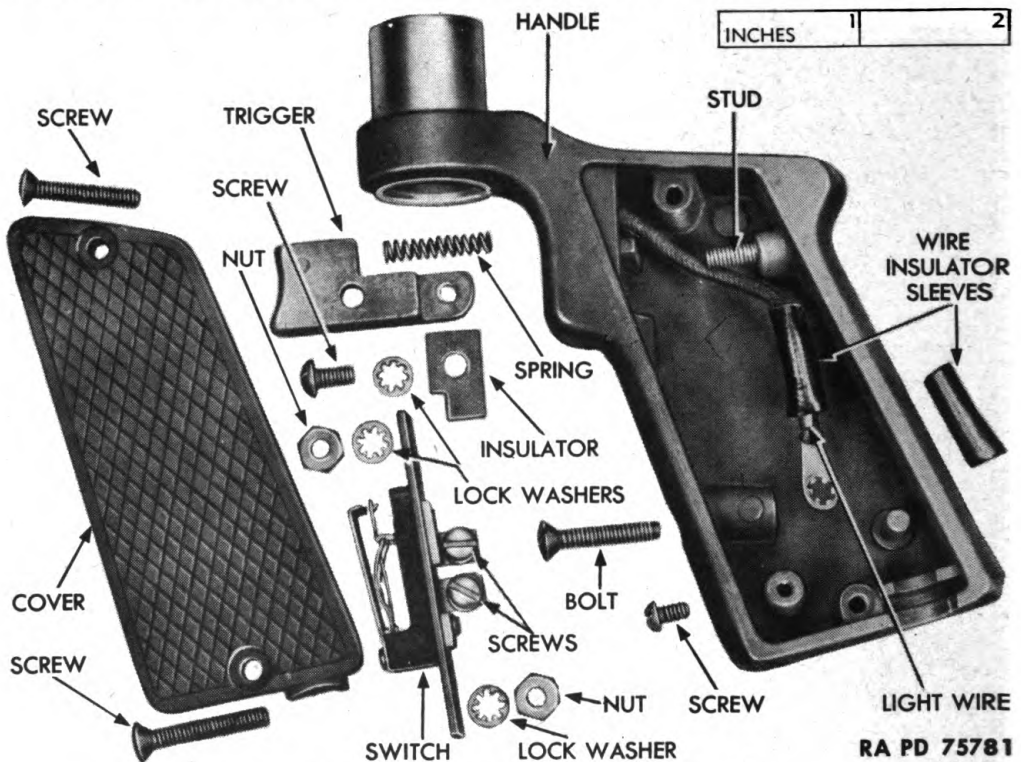

Figure 71 — Signal Switch — Disassembled

tion between two covers, and place covers together, fastening with screw and toothed washer through top cover and into reel.

96. BLINKER AND SPOTLIGHT SIGNAL SWITCH.

a. **Disassembly** (figs. 70 and 71). Remove two screws that hold cover to handle, and lift off cover. Remove screws and lock washers that hold ground and positive wires to handle, and remove wires. Remove screw and lock washer that holds light wire to handle, and remove wire. Remove screw and lock washer that holds insulator, and remove insulator. Lift trigger and spring out of handle. Remove nut and lock washer from bolt which holds switch, and remove bolt from handle. Remove nut and lock washer from stud which holds switch, and remove switch.

b. **Cleaning, Inspection, and Repair.** Clean all parts in dry-cleaning solvent. Inspect wires for breaks in insulation, and use new wiring if broken. Inspect insulator for cracks, and replace if necessary. Inspect trigger for breakage and scoring, and replace if broken or scored. Inspect operation of switch, and replace if broken. Inspect spring coils, and if they are not equally spaced, use new spring.

c. **Assembly** (figs. 70 and 71). Install switch on stud, and fasten

**ELECTRIC LIGHTING SYSTEM AND ACCESSORIES**

with nut and lock washer; then install bolt, nut, and lock washer that holds switch on handle. Install spring and trigger in handle, and install insulator. Fasten with screw and lock washer. Install light wire on handle, and fasten with screw and lock washer. Install ground and positive wires on handle, and fasten with screws and lock washers. Install cover on handle, and fasten with two screws.

---

**Section III**

**SIREN WITH LIGHT**

	<b>Paragraph</b>
Description .....	97
Disassembly into subassemblies .....	98
Disassembly, cleaning, inspection, repair, and assembly of subassemblies .....	99
Assembly .....	100
Test .....	101

**97. DESCRIPTION.**

**a. Description.** The siren with light consists of a base, body, motor, housing, wheel, light assembly, and two vents. The base is secured to the cab and siren body and is the means of mounting the siren and light. The siren motor is contained in the siren body, and secured to the front of the motor is a housing, which contains the siren wheel. This wheel is secured on the end of the siren motor armature. Mounted on the front of the siren housing is the siren light assembly to which two vents are secured. The siren light assembly contains a door, lens lamp, and base which are housed in the light body (TM 9-767).

**b. Operation.** Switches for operation of the siren light or siren are in the cab (TM 9-767). A flasher unit secured to the instrument panel at the switch causes a flashing operation of the light. The siren is operated by the pressing of the switch, which completes an electric circuit causing the siren motor and wheel to revolve.

**98. DISASSEMBLY INTO SUBASSEMBLIES (fig. 72).**

**a. Preliminary Instructions.** Remove and disassemble light assembly (TM 9-767).

**b. Remove Base Assembly.** Take out two cap screws that hold base to siren body, and remove base assembly.

**c. Remove Siren and Motor Assembly.** Push cord inward, and lift out siren and motor assembly from siren body.

ORDNANCE MAINTENANCE — BODY, CHASSIS, AND WINCHES FOR TRACTOR  
TRUCK M26, COMPONENT OF 40-TON TANK TRANSPORTER TRAILER TRUCK M25

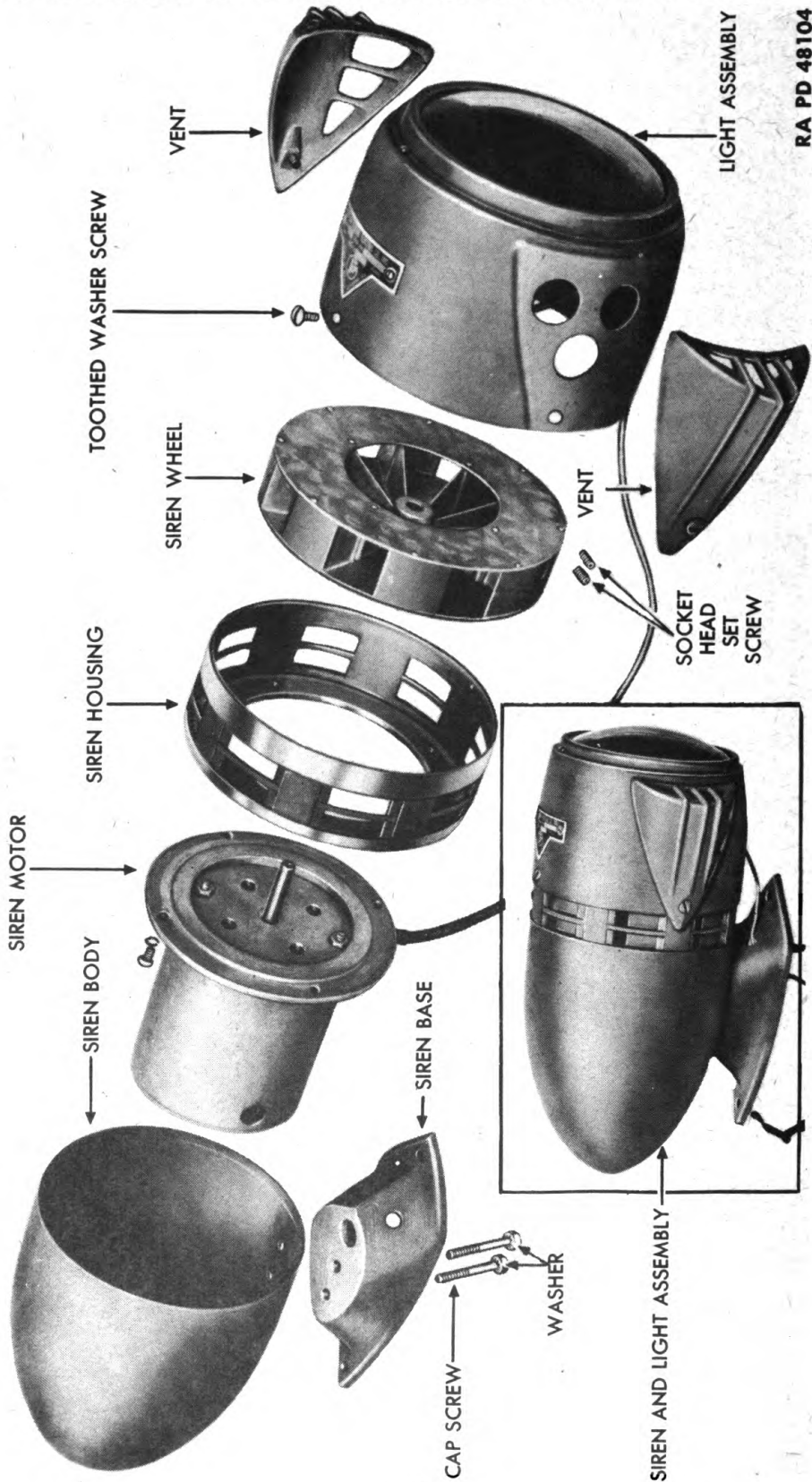

Figure 72 — Siren and Light Subassemblies

## ELECTRIC LIGHTING SYSTEM AND ACCESSORIES

d. **Remove Siren from Motor.** Loosen two socket head set screws that hold siren wheel to motor armature shaft, and take off wheel. Remove four screws that hold siren housing to motor body flange, and lift off housing.

### 99. DISASSEMBLY, CLEANING, INSPECTION, REPAIR, AND ASSEMBLY OF SUBASSEMBLIES.

#### a. Disassembly.

(1) **BASE ASSEMBLY.** Remove set screw that holds socket in sleeve of reflector base. Lift out plug in end of sleeve. Pull grommet out of sleeve of reflector base. Push wire inward and all the way. Pull out socket, and unsolder wire from socket.

(2) **SIREN MOTOR (fig. 74).** Remove two brush covers. Lift out brush assemblies. Remove rear end plate by taking out two attaching screws and toothed washers and lifting off. Remove armature from field housing by pushing out from rear end. Pull plate off armature shaft. Remove bolt holding field ground terminal to field housing. Unsolder field terminals from brush holders. Press out field coil and shoe assembly from rear of housing. Drive bearing out from outside of end plate. Remove lock nut and toothed washers from rear end bearing plate. Screw in end play adjusting screw. This pushes bearing out of recess. Lift out adjusting screw base.

b. **Cleaning, Inspection, and Repair.** Clean all parts in dry-cleaning solvent, and dry with compressed air. Inspect wiring for breaks or frayed insulation, and replace if necessary. Test armature for grounds on growler. Inspect electrical connections for corrosion, and remove with crocus cloth. Test field coils for shorts with test lamp. Inspect bearing for scoring, and use new bearing if scored.

#### c. Assembly (figs. 72 and 73).

(1) **INSTALL SOCKET IN REFLECTOR BASE.** Thread wire into hole in sleeve of reflector base and up through hole in reflector. Tie knot near front end of wire, and solder wire to lug at bottom of socket. Push socket down into hole in reflector, keeping wire pulled taut. When socket is down in place, fasten with set screw through reflector base sleeve. Install plug in end of sleeve.

(2) **INSTALL REFLECTOR AND BASE ASSEMBLY.** Place gasket around back of rim of reflector. Connect ground wire to reflector base with bolted, toothed washer, and nut. Thread lead wire through hole in under side of light body from inside. Install assembly in place on front of light body. Place lens and door on front of light body. Turn slightly clockwise until attaching screw holes match. Install screws and tighten.

(3) **ASSEMBLE SIREN MOTOR ASSEMBLY (fig. 74).** Place assembly over two studs inside field housing, with two short terminals to

**ORDNANCE MAINTENANCE — BODY, CHASSIS, AND WINCHES FOR TRACTOR TRUCK M26, COMPONENT OF 40-TON TANK TRANSPORTER TRAILER TRUCK M25**

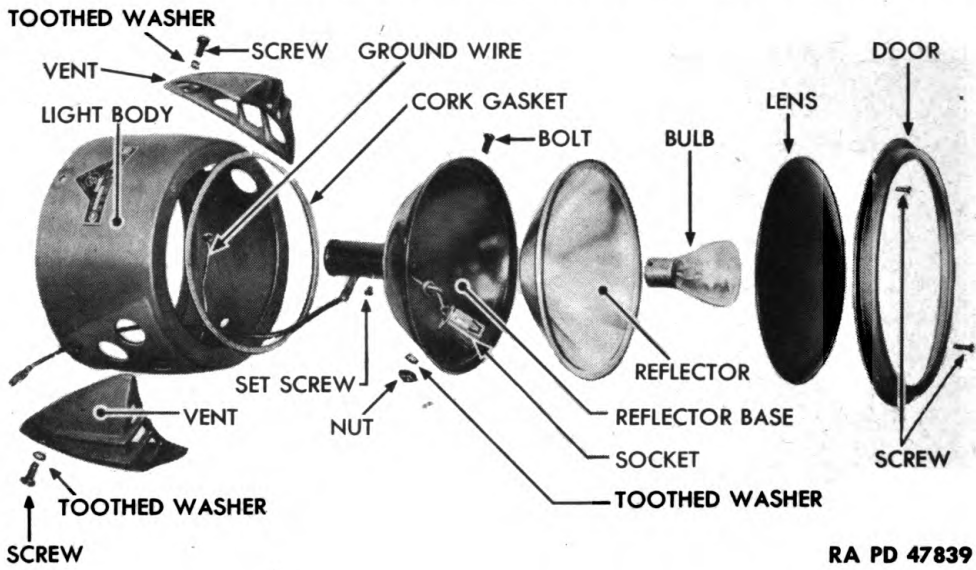

RA PD 47839

**Figure 73 — Siren Light — Disassembled**

rear end of housing, and press in. Solder terminals to brush holders. Bolt ground terminal to field housing with bolt, lock washer, and nut. Insert lead wire through hole in field housing.

(4) **INSTALL ARMATURE** (fig. 74). Install bearing in recess in rear end plate. (Bearing with smaller shaft opening goes into rear end plate.) **NOTE:** *Armature shaft is smaller at commutator end than at drive end.* Install rear end plate on field housing with two screws and toothed washers. Unscrew end play adjusting screw.

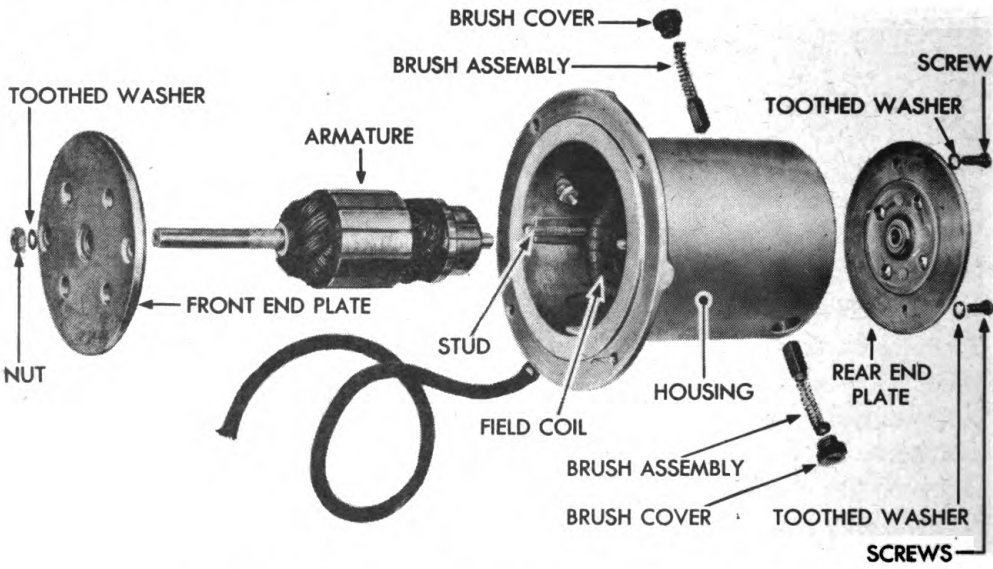

RA PD 48100

**Figure 74 — Siren Motor — Disassembled**

**ELECTRIC LIGHTING SYSTEM AND ACCESSORIES**

Insert armature through field coils from front end, commutator end first. Insert end of armature shaft into rear end plate. Install bearing with larger opening in front end plate.

(5) **INSTALL FRONT END PLATE** (fig. 74). Install front end plate over armature shaft, and cover two studs. Fasten plate down with two nuts and toothed washers. Adjust end play of armature. With lock nut backed off and adjusting screw loose, tap armature shaft at front end to seat rear bearing, and get all end play at rear end.

(6) **ADJUST ARMATURE** (fig. 74). Adjust adjusting socket head screw so that shaft turns freely with minimum end play. Tighten lock nut. Insert brushes into holders in field housing. Install brush covers and tighten.

**100. ASSEMBLY.**

a. **Install Siren (Wheel and Housing) on Motor** (fig. 74). Place siren housing on flange on front of motor. Fasten with four screws and toothed washers. Place siren wheel on motor shaft with closed side of wheel toward motor. Fasten wheel by tightening two set screws. Insert motor lead wire through front hole in siren body from inside, and install motor in body. Insert motor lead wire through front hole in base. Fasten base to body with two cap screws and toothed washers.

b. **Install Light Assembly.** Install light as instructed in TM 9-767.

**101. TEST.**

a. **Test Siren Motor.** Place siren and light assembly on electrical test bench, and connect siren to a 12-volt battery. If volume is not loud and clear, adjust as instructed in paragraph 99.

b. **Test Siren Light.** Connect light and flasher unit to a 12-volt battery, and if light does not flash, replace bulb or flasher unit or both.

---

**Section IV**

**TRAILER WIRING JUNCTION BOX**

	Paragraph
Description .....	102
Disassembly, cleaning, inspection, repair, and assembly.....	103

**102. DESCRIPTION.**

a. **Description.** The trailer wiring junction box is secured to the rear of the tractor frame and has a spring-operated cover over the opening to the terminals. This junction box consists of a housing

**ORDNANCE MAINTENANCE — BODY, CHASSIS, AND WINCHES FOR TRACTOR TRUCK M26, COMPONENT OF 40-TON TANK TRANSPORTER TRAILER TRUCK M25**

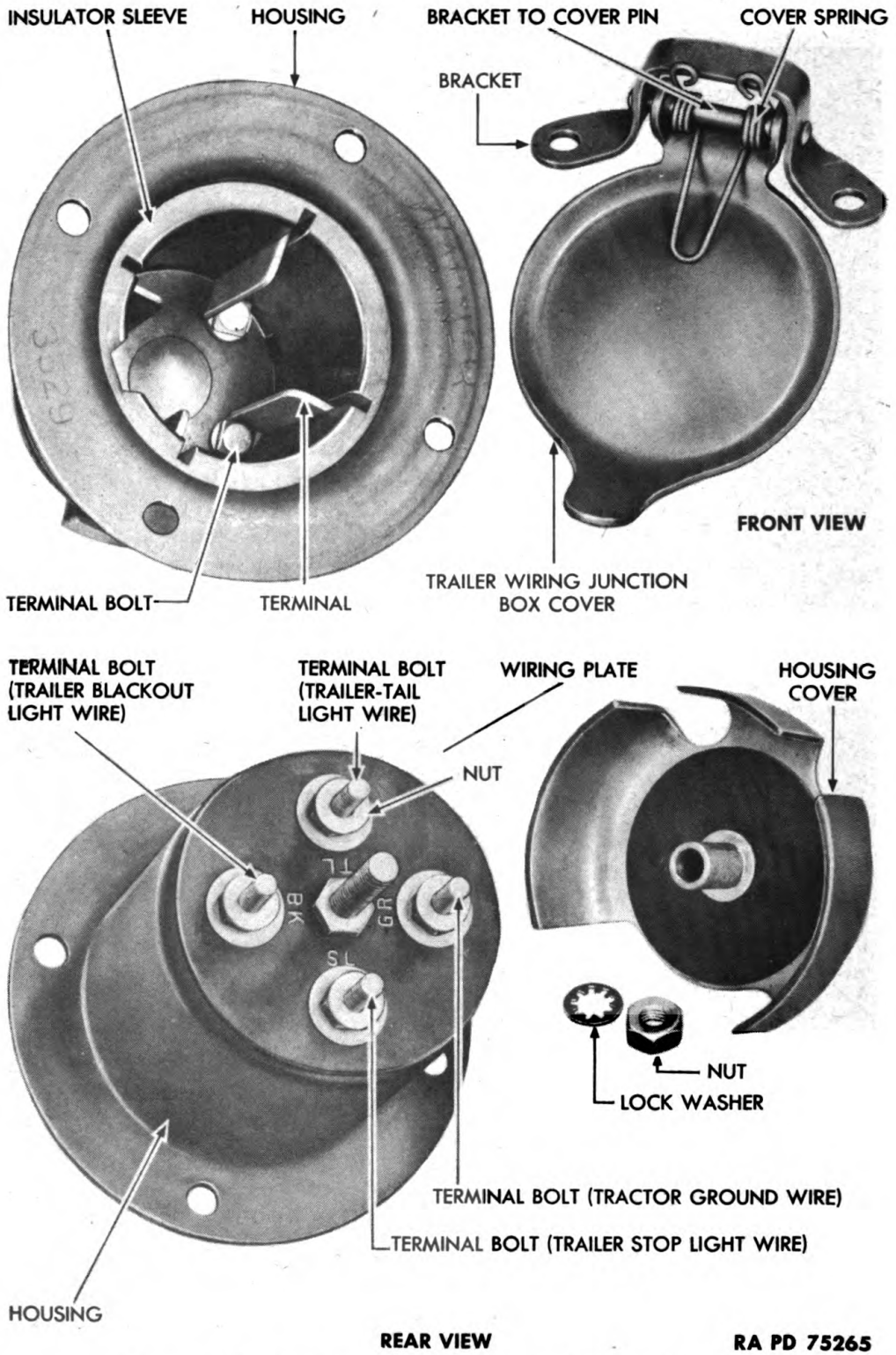

**Figure 75 — Trailer Wiring Junction Box and Cover**

**ELECTRIC LIGHTING SYSTEM AND ACCESSORIES**

RA PD 75274

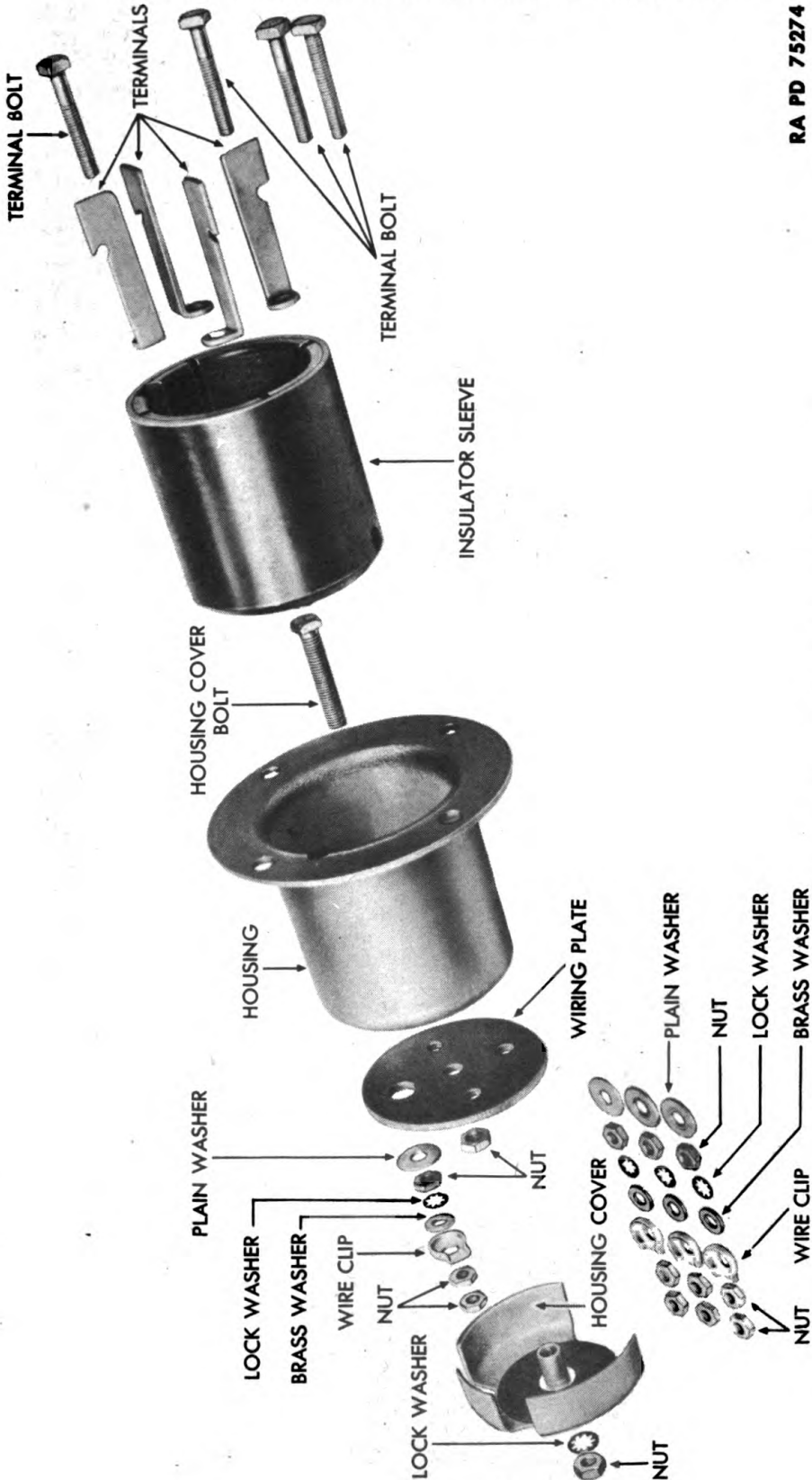

**Figure 76 — Trailer Wiring Junction Box — Disassembled**

**ORDNANCE MAINTENANCE — BODY, CHASSIS, AND WINCHES FOR TRACTOR TRUCK M26, COMPONENT OF 40-TON TANK TRANSPORTER TRAILER TRUCK M25**

containing an insulator sleeve in which are four terminals for the trailer blackout, taillight, and stop light wires. The fourth terminal is for a ground.

**103. DISASSEMBLY, CLEANING, INSPECTION, REPAIR, AND ASSEMBLY.**

**a. Disassembly.**

(1) **TRAILER WIRING JUNCTION BOX COVER** (fig. 75). Drive bracket to cover pin out of cover and bracket, and remove trailer wiring junction box cover from trailer wiring junction box along with cover spring and bracket.

(2) **DISASSEMBLE TRAILER WIRING JUNCTION BOX** (figs. 75 and 76). Remove a brass washer and a lock washer from each of four terminal bolts, then remove a nut and plain washer from each of four terminal bolts. Pull four terminals with terminal bolts out of insulator sleeve, and pull insulator sleeve out of housing. Remove nut from housing cover bolt, and remove wiring plate and housing cover bolt from housing.

**b. Cleaning, Inspection, and Repair.** Clean all parts in dry-cleaning solvent. Inspect all threads for burrs or cross threads, and straighten with a thread die or tap. Inspect all parts for cracks or breaks, and replace parts if damaged. Clean all contacts so that there is no corrosion.

**c. Assembly.**

(1) **TRAILER WIRING JUNCTION BOX COVER** (figs. 75 and 76). Install bracket to cover pin through one side of trailer wiring junction box cover and bracket, and install cover spring on pin. Push pin through opposite side of cover and bracket, then rivet pin onto cover.

(2) **TRAILER WIRING JUNCTION BOX** (figs. 75 and 76). Install housing cover bolt in housing, then install wiring plate on housing. Install nut on bolt. Install insulator sleeve in housing so that long lug on sleeve passes through large hole in plate. Install terminal bolt on terminal, and install terminal in insulator sleeve so that notched portion of terminal is in slot of insulator sleeve. Install plain washer on terminal bolt, then install nut on bolt. Repeat procedure on remaining three terminals, then install four lock washers and four brass washers on each of four terminal bolts.

**ELECTRIC LIGHTING SYSTEM AND ACCESSORIES**

**Section V**

**LOW-PRESSURE AIR INDICATOR BUZZER**

	Paragraph
Description and operation .....	104
Disassembly, cleaning, inspection, repair, and assembly.....	105

**104. DESCRIPTION AND OPERATION.**

a. **Description.** The low-pressure air indicator buzzer is secured to the dash and consists of two coils, contact arm, and terminals secured to a base. The internal parts are protected from dirt and water by a cover.

b. **Operation.** A low-pressure air indicator (TM 9-1827A, "Power Brake Systems (Bendix Westinghouse)") is electrically connected to the buzzer so that when the air pressure in the air reservoirs drops below 60 pounds, the coils in the buzzer are energized and thereby operate the contact arm, causing a buzzing sound.

**105. DISASSEMBLY, CLEANING, INSPECTION, REPAIR, AND ASSEMBLY.**

a. **Disassembly** (figs. 77, 78, and 79).

(1) **REMOVE CONTACT SCREW AND ADJUSTING ROD.** Remove two terminal screw nuts, lock washers, plain washers, and wire clamps from two terminal screws. Remove contact set screw and set screw lock nut, and remove contact screw. Remove spring tension adjusting rod set screw and adjusting rod thumb nut. Unhook spring from adjusting rod and remove rod.

(2) **REMOVE CONTACT ARM.** Unhook spring from contact arm and remove spring. Remove screw which holds contact spring bracket to terminal screw, and lift contact spring assembly from contact arm. Remove two screws from base which hold contact arm bracket to base, and lift contact arm with bracket assembly off base.

(3) **REMOVE CONTACT ARM BRACKET.** Remove upper screw from top of contact arm bracket, and remove adjusting screw (underneath upper screw). Remove lower screw from bottom of contact arm bracket, and remove contact arm from contact arm bracket.

(4) **REMOVE COILS AND CONTACT SCREW HOLDER.** Remove sealing wax from bottom of base by heating wax and scraping off, then unsolder coil wires from base (soldering iron). Remove two screws and lock washers that hold coils to base, and remove coils. Remove six screws which hold two terminal screws and one contact screw holder to base, and remove two terminal screws and contact screw holder.

**ORDNANCE MAINTENANCE — BODY, CHASSIS, AND WINCHES FOR TRACTOR TRUCK M26, COMPONENT OF 40-TON TANK TRANSPORTER TRAILER TRUCK M25**

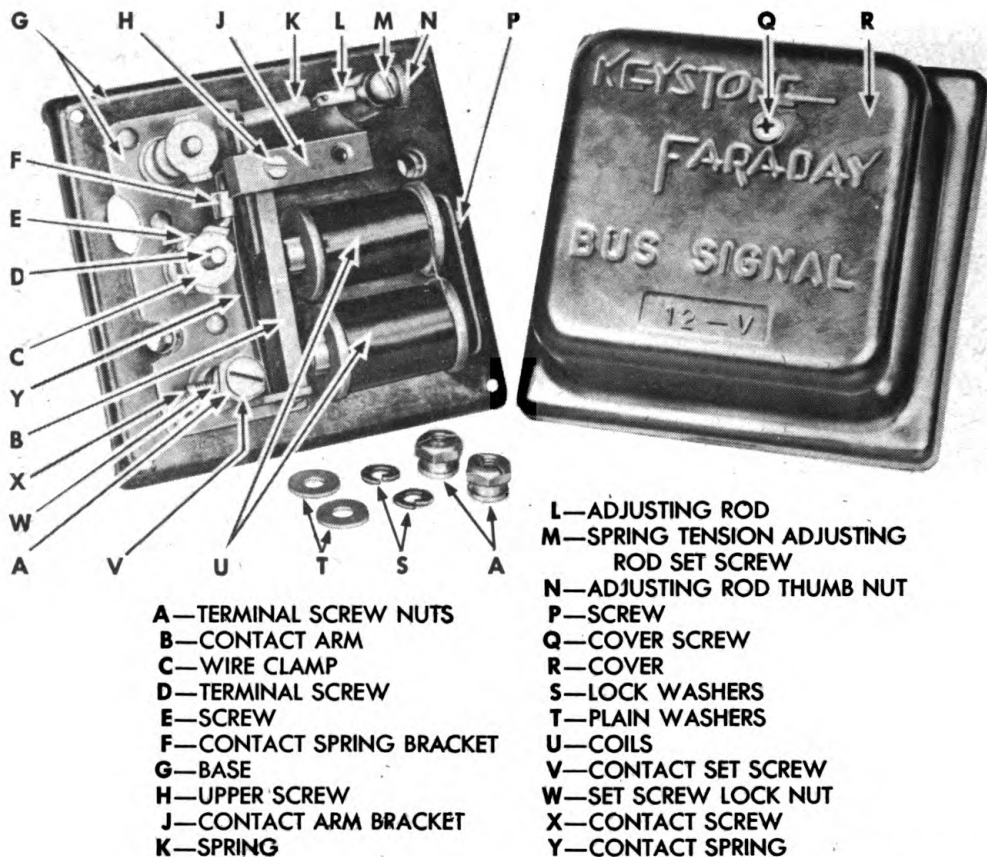

RA PD 75267

**Figure 77 — Low-pressure Air Indicator Buzzer — Top View**

**b. Cleaning, Inspection, and Repair.** Clean all parts in dry-cleaning solvent, and dry with compressed air. Remove any corrosion on terminals with crocus cloth. Inspect wires for breakage, frayed insulation, or corrosion, and use new wires, if damaged. Inspect threads for burs, and straighten threads with thread die or tap. Test coils in coil testing machine. Inspect springs which must have evenly spaced coils. Replace spring if coils are not equidistant.

**c. Assembly (figs. 77, 78, and 79).**

(1) **INSTALL COILS AND CONTACT SCREW HOLDER.** Install contact screw holder and two terminal screws on base, and fasten with six screws. Install coils on base, and fasten with two screws and lock washers. Solder coil wires to base (fig. 78), and install sealing wax on bottom of base.

(2) **INSTALL CONTACT ARM AND ADJUSTING SCREW.** Install contact arm on contact arm bracket, and install lower screw in bot-

**ELECTRIC LIGHTING SYSTEM AND ACCESSORIES**



RA PD 75101

**Figure 78 – Low-pressure Air Indicator Buzzer – Bottom View**

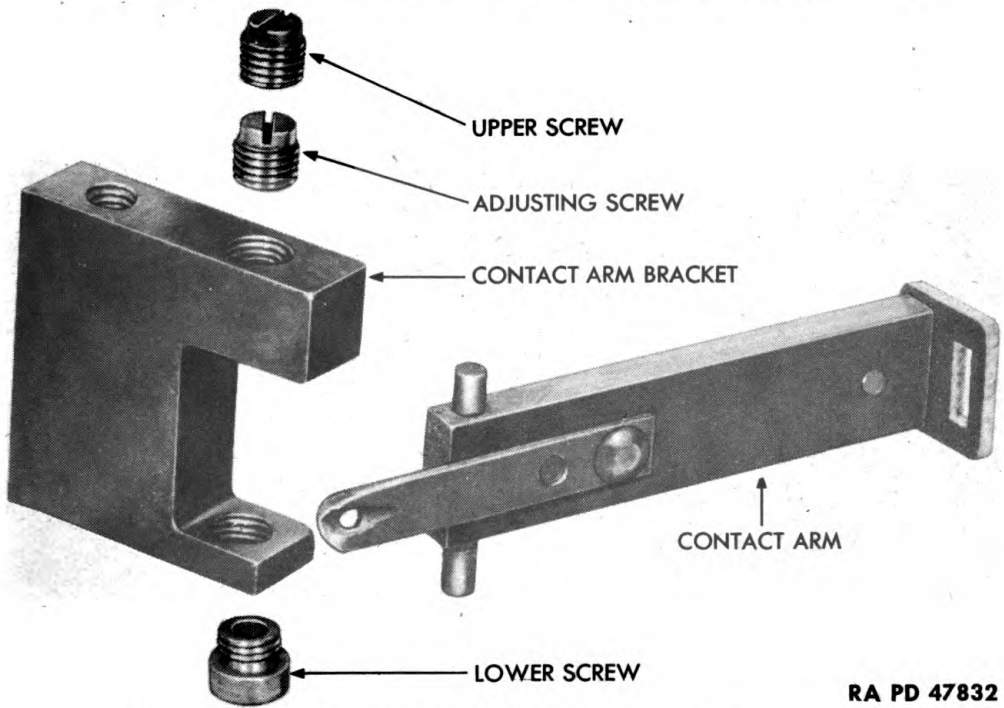

RA PD 47832

**Figure 79 – Contact Arm and Bracket – Disassembled**

**ORDNANCE MAINTENANCE — BODY, CHASSIS, AND WINCHES FOR TRACTOR TRUCK M26, COMPONENT OF 40-TON TANK TRANSPORTER TRAILER TRUCK M25**

tom of bracket. Install adjusting screw, then install contact arm with bracket on base. Fasten contact arm to base with two screws. Install contact spring assembly on contact arm, install contact spring bracket on terminal screw, and fasten with screw. Hook spring on contact arm.

(3) **INSTALL ADJUSTING ROD.** Install adjusting rod on base, and attach spring to rod. Install adjusting rod thumb nut, and install spring tension adjusting rod set screw. Install contact screw, contact screw set screw, and lock nut.

(4) **ADJUST BUZZER.** Attach buzzer to a 12-volt storage battery and adjust spring tension adjusting rod set screw and adjusting screw until buzzer has clear buzzing sound. Install upper screw on top of contact arm bracket. Install two wire clamps on two terminal screws.

---

**Section VI**

**WINDSHIELD WIPERS**

	Paragraph
Description .....	106
Disassembly, cleaning, inspection, repair, and assembly.....	107

**106. DESCRIPTION.**

a. **Description.** The two windshield wipers are secured to the right and left sides of the windshield lower frame. The windshield wiper consists of a body containing an electric motor, reduction gear, eccentric and gear, eccentric and sector, and the shaft and pinion. The windshield wiper arm and blade are secured to the shaft. Each windshield wiper has a switch.

b. **Operation.** Turning on the switch energizes the wiper motor, causing the worm on the armature shaft to rotate. The worm is in mesh with the eccentric and gear which in turn operates the eccentric and sector. The sector meshes with the pinion which is on the shaft, thereby operating the arm and wiper blade.

**107. DISASSEMBLY, CLEANING, INSPECTION, REPAIR, AND ASSEMBLY.**

a. **Disassembly** (figs. 80, 81 and 82).

(1) **REMOVE MOTOR HOUSING.** Remove two screws that hold motor housing to wiper body. Lift off housing.

(2) **REMOVE GEARS AND SHAFT.** Remove seven screws that hold gear cover to wiper body. Lift off cover. Remove shaft and pinion assembly by first taking off grease retaining cap at rear, then pushing

ELECTRIC LIGHTING SYSTEM AND ACCESSORIES

RA PD 47834

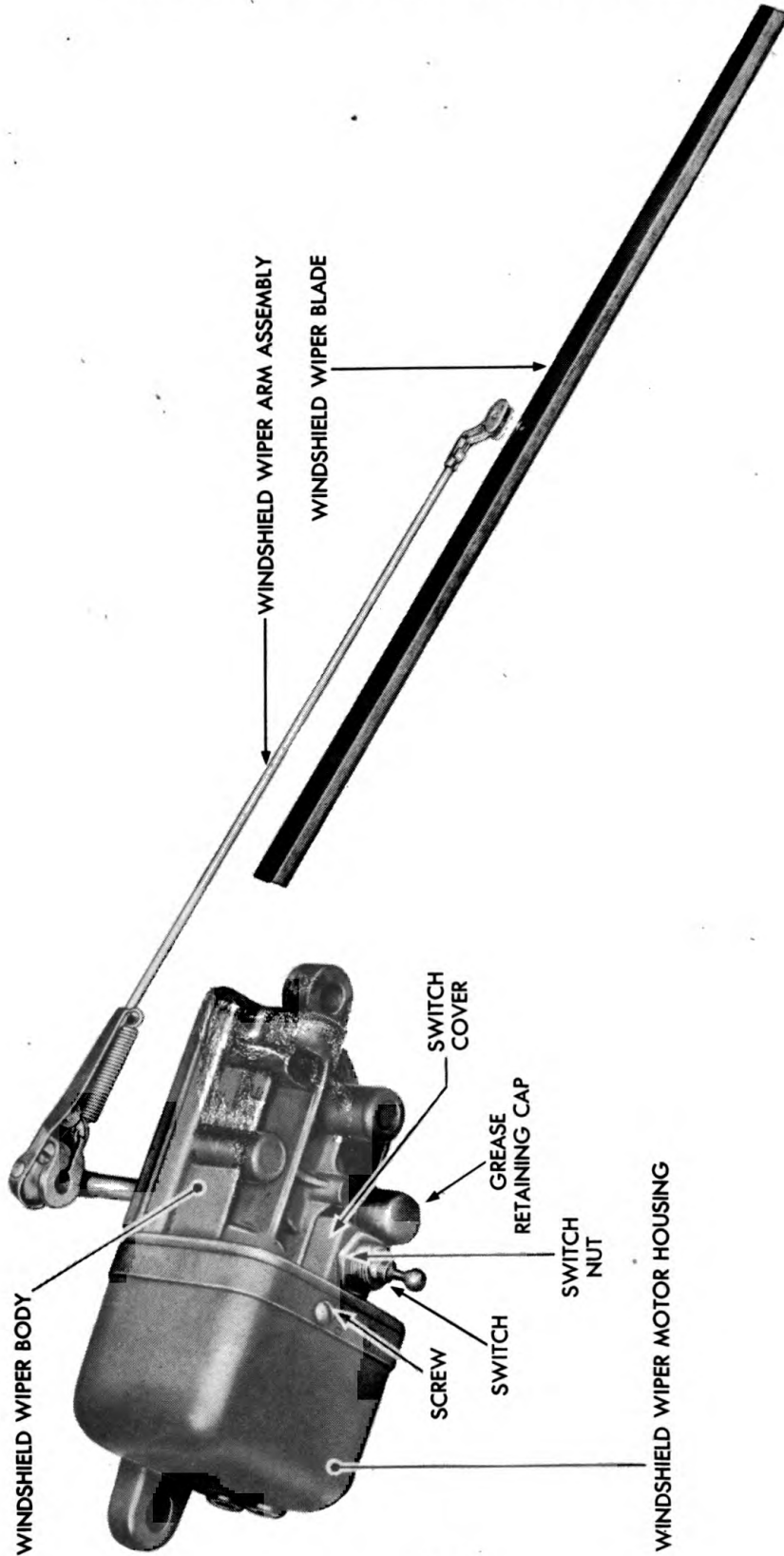
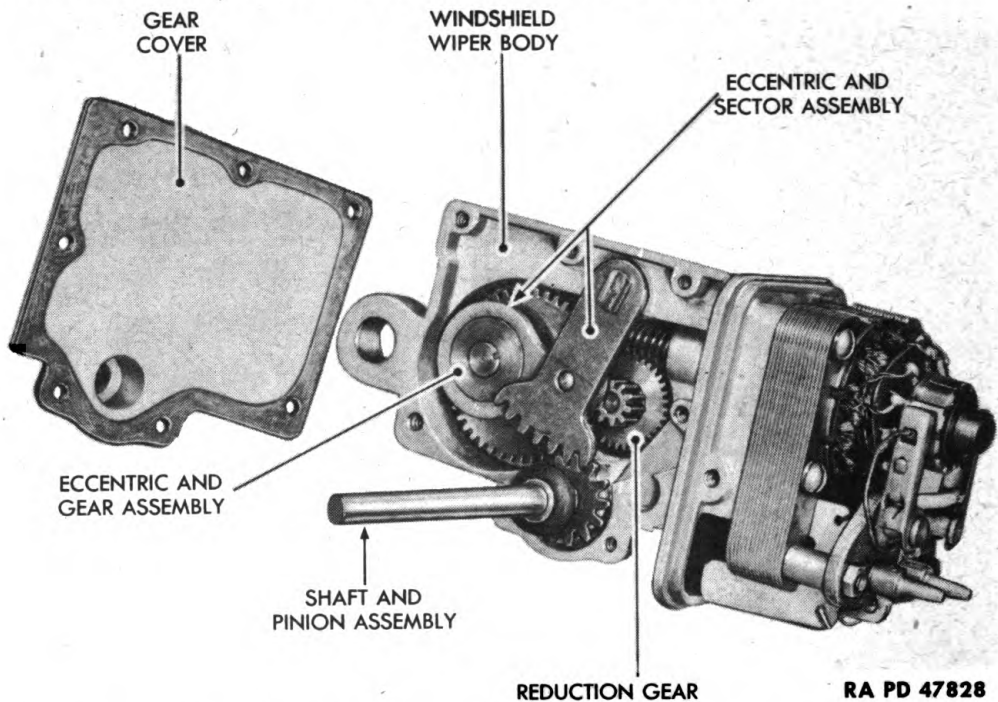

Figure 80 — Windshield Wiper Assembly

**ORDNANCE MAINTENANCE — BODY, CHASSIS, AND WINCHES FOR TRACTOR TRUCK M26, COMPONENT OF 40-TON TANK TRANSPORTER TRAILER TRUCK M25**



**Figure 81 — Windshield Wiper Motor Housing and Gear — Cover Removed**

shaft out from rear. Lift out eccentric and sector assembly. Lift out reduction gear, also eccentric and gear assembly.

(3) **REMOVE MOTOR.** Unsolder (from positive post and ground post) switch to positive post wire and switch wire to inner coil wire. Remove four screws and toothed washers. Lift entire motor (including shaft) off wiper body.

(4) **REMOVE ARMATURE AND BRUSH ARMS.** Remove armature, then unsolder brush lead (positive) and brush lead (ground). Remove two nuts that hold brush holder plate on studs. Lift off brush holder plate with brushes. Lift spacers off studs. Remove brush arms by springing outward and lifting off posts. Remove spring by removing spring retaining slip, and pulling out spring from brush arm.

(5) **REMOVE TOGGLE SWITCH.** Drive out rivets that hold switch cover to wiper body. Lift out switch assembly with switch to positive post wire and switch to inner coil wire. Remove switch nut, and take out switch body from switch cover. Remove switch insulator from positive wire. Unsolder switch to positive post wire and switch to inner coil wire from terminals on switch body.

b. **Cleaning, Inspection, and Repair.** Clean all parts in dry-cleaning solvent, but do not allow armature to soak in solvent.

**ELECTRIC LIGHTING SYSTEM AND ACCESSORIES**

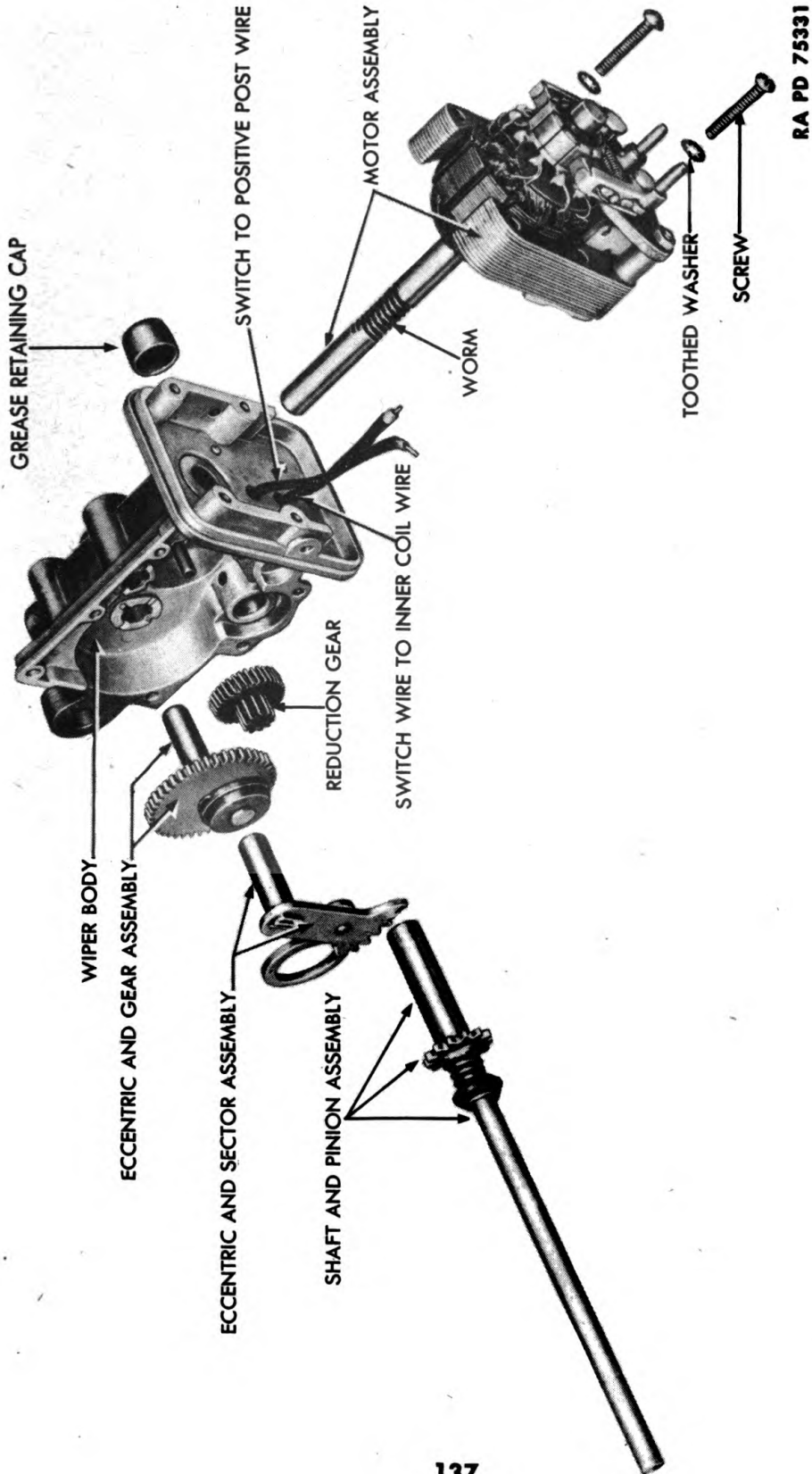

**Figure 82 — Windshield Wiper — Partly Disassembled**

**ORDNANCE MAINTENANCE — BODY, CHASSIS, AND WINCHES FOR TRACTOR TRUCK M26, COMPONENT OF 40-TON TANK TRANSPORTER TRAILER TRUCK M25**

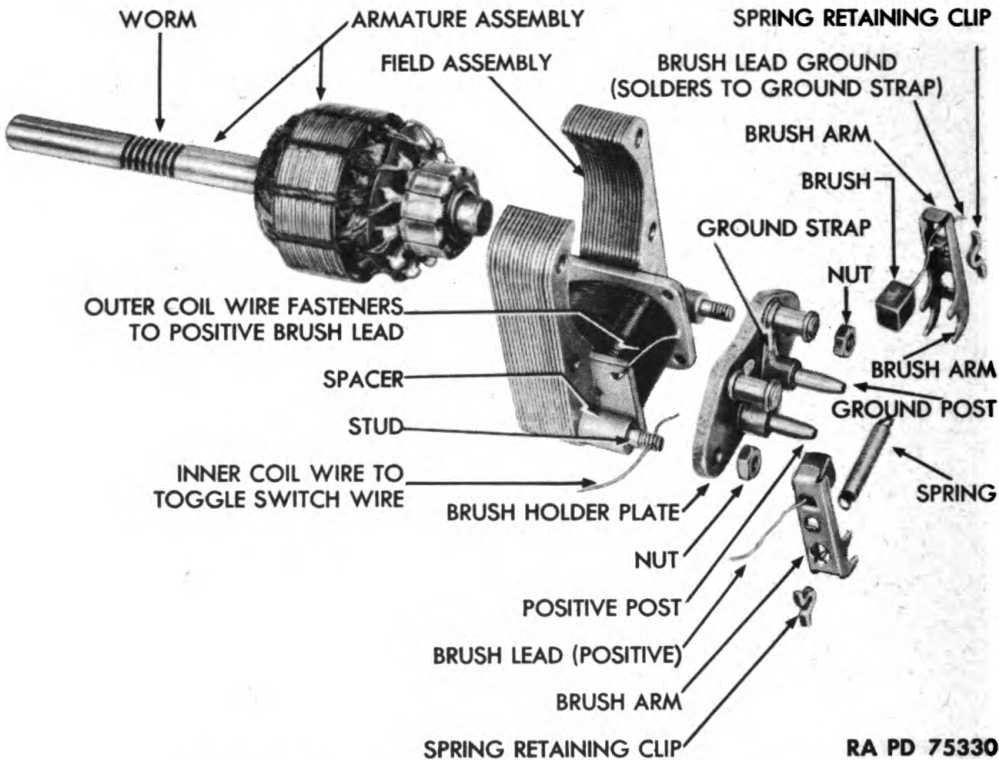

**Figure 83 — Windshield Wiper Motor — Disassembled**

Inspect armature on electric growler. Inspect motor housing and gear cover for breakage and fractures, replacing housing if cracked or broken. Inspect gears for broken or fractured teeth, and replace gears if teeth are damaged. Inspect wires for broken insulation and wire, and replace wire. Inspect brushes for scoring, and replace brushes if scored or worn short. Inspect armature commutator for scoring, and turn down in lathe if scored. Inspect springs for breaks and lack of tension, and replace springs if weak or broken.

**c. Assembly (fig. 83).**

(1) **INSTALL TOGGLE SWITCH.** Solder switch positive post wire and switch to inner coil wire on switch body terminals. Install switch insulator around positive wire. Place switch cover over switch body. Fasten with switch nut. Fasten switch cover to wiper body with two rivets, and upset ends of rivets.

(2) **INSTALL FIELD ASSEMBLY.** Place field assembly in position on wiper body. Fasten with four screws and lock washers.

(3) **INSTALL BRUSH HOLDER PLATE AND ARMATURE.** Place spacers on two studs in field assembly. Place brush holder plate on studs. Fasten with nuts. Insert armature shaft through field and

## ELECTRIC LIGHTING SYSTEM AND ACCESSORIES

into wiper body, so that commutator is directly over brush holder plate.

(4) **INSTALL BRUSHES.** Install brushes in brush holders. Install brush arms with brushes, on commutator and lower end of holders on brush holder supports. Install spring, and fasten with spring retaining clips. Insert outer coil wire through hole in brush holder plate. Solder end of this wire to positive brush lead. Solder ground brush lead to ground strap (between ground post and brush support).

(5) **CONNECT SWITCH.** Solder lower switch wire to inner coil wire. Solder upper switch wire to positive post.

(6) **INSTALL GEARS AND COVER.** Install reduction gear in body, meshing teeth in larger gear with worm on commutator shaft. Install eccentric and gear assembly in body, meshing gear with smaller reduction gear. Place ring of eccentric and sector assembly over eccentric of eccentric and gear assembly and shaft in hole in body. Install shaft and pinion assembly, meshing pinion with teeth in sector. Install gear cover, and fasten to body with seven screws. Install motor housing, and fasten with two screws.

---

### Section VII

## FITS AND TOLERANCES

	Paragraph
Fits and tolerances .....	108

### 108. FITS AND TOLERANCES.

a. **Electrical System Fits.** There are no allowable fits for electrical connections. Wiring connections must be as free of corrosion and as tight as possible. Fits of switch parts must be loose enough to assure free action, but not tight enough to bind.

b. **Electrical System Tolerances.** There are no specific tolerances. Wires that are not replaced must be cut long enough to connect the units. Accessories must have parts installed so that there is freedom of action.

**ORDNANCE MAINTENANCE — BODY, CHASSIS, AND WINCHES FOR TRACTOR TRUCK M26, COMPONENT OF 40-TON TANK TRANSPORTER TRAILER TRUCK M25**

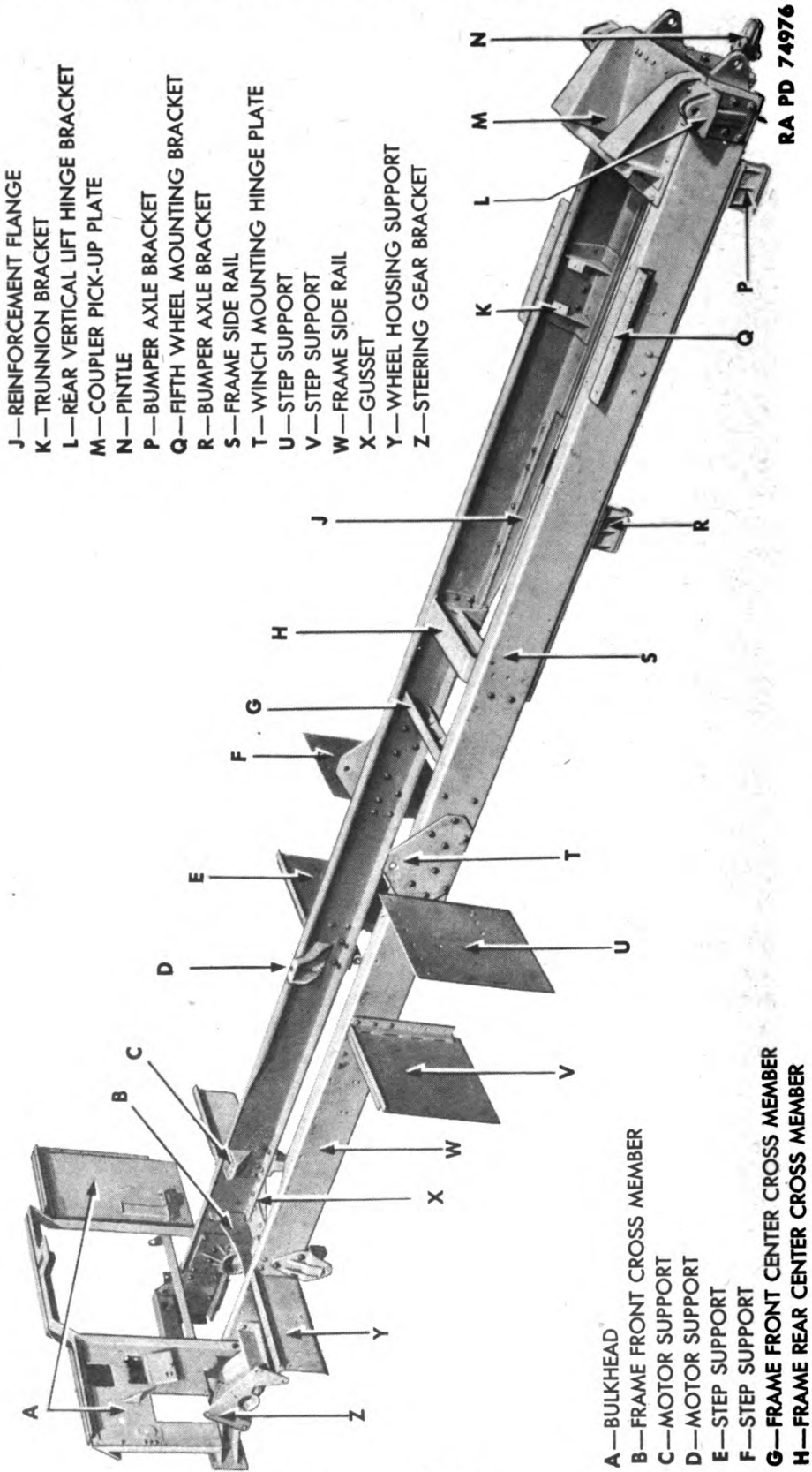

RA PD 74976

**Figure 84 — Frame Assembly — Left Rear Three-quarter View**

CHAPTER 12

FRAME

Section I

DESCRIPTION AND DATA OF FRAME

Description and data .....	Paragraph 109
----------------------------	------------------

109. DESCRIPTION AND DATA.

a. **Description.** The frame consists of channel steel side members and cross members which are riveted together. They are reinforced and strengthened by corner gussets which are riveted in place. Brackets for the units of the tractor are bolted to the frame.

b. **Data.**

Make ..... Pacific Car and Foundry Co.

Section II

TESTING OF FRAME

Test .....	Paragraph 110
------------	------------------

110. TEST.

a. **Preliminary Instructions** (fig. 85). The frame must be checked for alinement before removal from vehicle. Checking of alinement is done by means of centering gages.

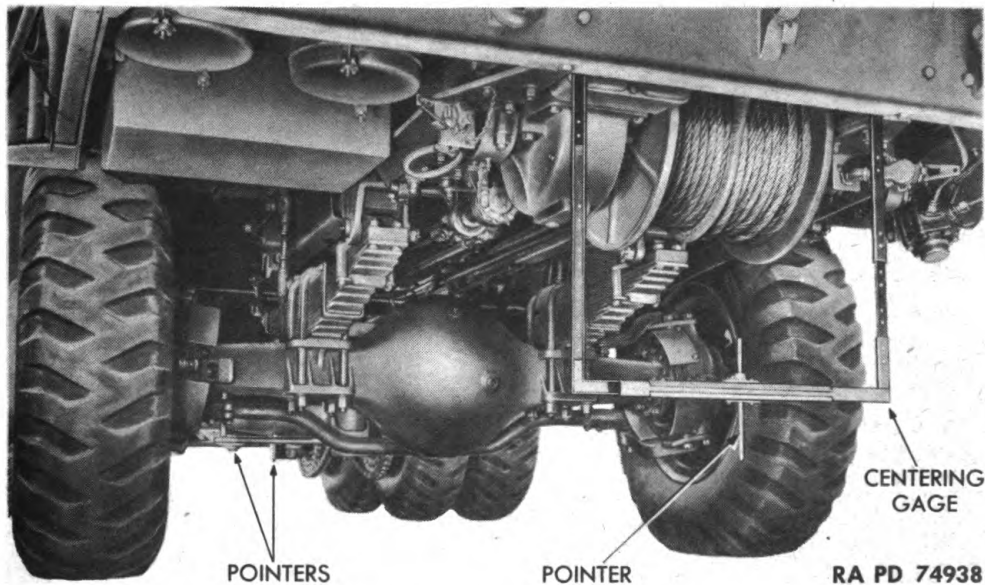

Figure 85 - Centering Gages on Frame

**ORDNANCE MAINTENANCE — BODY, CHASSIS, AND WINCHES FOR TRACTOR TRUCK M26, COMPONENT OF 40-TON TANK TRANSPORTER TRAILER TRUCK M25**

b. **Install Centering Gages.** Place vehicle on a level floor or on a combination frame straightener and wheel alinement machine. Install three centering gages on frame of vehicle. Place first centering gage near front end of frame, second centering gage near center of frame, and third centering gage near end of frame.

c. **Check Alinement.** Sight along the three centering gages and if the frame is straight, the three pointers will be in line. If pointers are not in line, then frame is bent. Straighten frame in frame straightening machine.

---

**Section III**

**DISASSEMBLY, CLEANING, INSPECTION, REPAIR, AND ASSEMBLY OF FRAME**

Paragraph

Disassembly, cleaning, inspection, repair and assembly..... 111

**111. DISASSEMBLY, CLEANING, INSPECTION, REPAIR, AND ASSEMBLY.**

a. **Disassembly.** The cross members and gussets of the frame are riveted and can be removed for replacement by cutting the rivets. The brackets are bolted to the frame and can be removed for replacement by removing the bolts, nuts, and lock washers (fig. 84).

b. **Cleaning.** Clean the dirt and mud from the frame with water and a brush. Remove grease with soda ash solution (TM 9-850).

c. **Inspection.** Inspect frame and brackets for cracks or fractures. Inspect bolt holes for out of round or elongated condition.

d. **Repair.** Frames that are cracked or fractured can be welded; braces or patches can be welded inside the frame at any weakened or broken places. Brackets or out of round holes can be welded, then drilled or bored to the proper size. Brackets that are broken can be removed by taking off the bolts, nuts, and lock washers which secure bracket to frame, then weld or replace bracket.

CHAPTER 13

**SPECIAL TOOLS AND EQUIPMENT**

	<b>Paragraph</b>
Special tools .....	112

41-R-2369-995



41-R-2302-610

RA PD 74930

**Figure 86 – Special Tools for Steering Gear**

**112. SPECIAL TOOLS.**

a. The special tools (fig. 86) are used for maintenance of the steering gear and are listed below.

Description	Federal Stock Number
Reamer, hand .....	41-R-2302-610
Remover, bushing and oil seal (steering gear) .....	41-R-2369-995

b. The special tools used for the maintenance of the front spring shackle and bracket bushings are listed below.

Remover, bushing, spring shackle bracket .....	41-R-2369-670
Remover, bushing, shackle, front and rear .....	41-R-2369-625

**ORDNANCE MAINTENANCE — BODY, CHASSIS, AND WINCHES FOR TRACTOR TRUCK M26, COMPONENT OF 40-TON TANK TRANSPORTER TRAILER TRUCK M25**

**REFERENCES**

**STANDARD NOMENCLATURE LISTS.**

Cleaning, preserving and lubricating materials; recoil fluids, special oils, and miscellaneous related items ..	SNL K-1
Ordnance maintenance sets .....	SNL N-21
Soldering, brazing and welding materials, gases and related items .....	SNL K-2
Tools, maintenance, for repair of automotive vehicles	SNL G-27
Tool-sets, for ordnance service command, automotive shops .....	SNL N-30
Tool-sets, motor transport .....	SNL N-19
Truck, trailer, 40-ton, tank recovery, M25 (T21) (composed of Truck, tractor, M26 (T25); Trailer, M15 (T28) .....	SNL G-160

Current Standard Nomenclature Lists are listed above.  
An up-to-date list of SNL's and other publications is maintained in the Index to Ordnance Publications... OFSB 1-1

**EXPLANATORY PUBLICATIONS.**

**General.**

List of publications for training .....	FM 21-6
Military motor vehicles .....	AR 850-15
Standard military motor vehicles .....	TM 9-2800

**Related Technical Manuals.**

40-ton tank transporter trailer truck M25 (T21) .....	TM 9-767
Ordnance maintenance: Engine for tractor truck M26, component of 40-ton tank transporter trailer truck M25 .....	TM 9-1767A
Ordnance maintenance: Power train for tractor truck M26, component of 40-ton tank transporter trailer truck M25 .....	TM 9-1767B
Ordnance maintenance: Semitrailer M15, component of 40-ton tank transporter trailer truck M25 .....	TM 9-1767D
Ordnance Maintenance: Power brake systems (Bendix-Westinghouse) .....	TM 9-1827A

## REFERENCES

**Automotive Materiel.**

Automotive electricity .....	TM 10-580
Electrical fundamentals .....	TM 1-455
Sheet metal work, body, fender, and radiator repairs..	TM 10-450
The motor vehicle .....	TM 10-510

**Care and Preservation.**

Automotive lubrication .....	TM 10-540
Basic maintenance manual .....	TM 38-250
Cleaning, preserving, lubricating, and welding materials and similar items issued by the Ordnance Department .....	TM 9-850
Explosives and demolitions .....	FM 5-25
Motor vehicle inspections and preventive maintenance services .....	TM 9-2810
Product guide .....	OFSB 6-2

**Decontamination.**

Chemical decontamination materials and equipment	TM 3-220
Decontamination of armored force vehicles.....	FM 17-59
Defense against chemical attack.....	FM 21-40

**Storage and Shipment.**

Ordnance field service storage and shipment Chart, group G major items .....	OSSC-G
Registration of motor vehicles .....	AR 850-1S
Rules governing the loading of mechanized and motorized army equipment, also, major caliber guns, for the United States Army and Navy, on open top equipment published by Operations and Maintenance Department of Association of American Railroads	
Storage of motor vehicle equipment .....	AR 850-18

**ORDNANCE MAINTENANCE — BODY, CHASSIS, AND WINCHES FOR TRACTOR TRUCK M26, COMPONENT OF 40-TON TANK TRANSPORTER TRAILER TRUCK M25**

**INDEX**

<b>A</b>	<b>Page No.</b>	<b>B</b>	<b>Page No.</b>
Adjustment (See Test and adjustment)		Base assembly	
Air brake units, data.....	34	assembly .....	99
Air pipes and steering wheel, installation .....	27	cleaning, inspection and repair .....	98-99
Assembly		disassembly .....	97-98
automatic brake assembly.....	45	Blinker and spotlight reel	
base assembly .....	99	assembly .....	121-122
controls and linkage.....	67-68	disassembly .....	121
double bearing assembly.....	85	Blinker and spotlight signal switch	
drag link .....	31	assembly .....	122-123
drive shafts and universal joints .....	51-52	disassembly .....	122
drum brake band assembly.....	73	Brake control rod, installation.....	89
fifth wheel .....	99	Brake system	
front-mounted winch .....	52	description and data.....	34
gear case and worm.....	46	service brake shoes.....	36-37
gear case assembly.....	80-81		
layshaft assembly .....	69	<b>C</b>	
layshaft to rear tandem winch chain tightener assembly.....	72	Cab	
mounting brackets and ring assembly .....	97	cleaning, inspection and repair....	111
parking brake .....	39	description and data.....	105
rear tandem winch base angles and control .....	83	installation .....	112
service brake shoes .....	37	removal .....	105-110
shifter cover and shift rod assembly .....	78	Cleaning	
siren with light.....	127	automatic brake .....	45
spotlight handle .....	119-120	base assembly .....	98-99
springs .....	102	cab .....	111
steering gear .....	26-27	controls and linkage.....	67
steering gear hydraulic control valve .....	18	double bearing assembly.....	85
steering gear hydraulic pump.....	13	drag link .....	31
steering gear hydraulic cylinder..	20	drive shafts and universal joints .....	51
tandem winch .....	87-90	drum brake band assembly.....	73
universal joint assembly.....	86	end bearing frame and clutch shift yoke assembly.....	82
vertical lifting device.....	93	gear case and worm.....	46
winch drum and shaft assembly .....	73-75	gear case assembly.....	79-80
winch mounting assembly.....	84	layshaft assembly .....	69
Automatic brake assembly		layshaft to rear tandem winch chain tightener assembly .....	71
assembly and disassembly.....	45	mounting brackets and ring assembly .....	96-97
removal .....	44, 62-63	parking brake .....	38
		rear tandem winch base angles and controls .....	82-83
		service brake shoes.....	36

INDEX

<b>C — Cont'd</b>	<b>Page No.</b>	<b>Description:</b>	<b>Page No.</b>
Cleaning — Cont'd		brake system .....	34
shifter cover and shift rod		cab .....	105
assembly .....	78	combination blinker and spotlight	115
springs .....	101-102	drag link .....	30
steering gear .....	25	electric lighting system and	
steering gear hydraulic control		accessories .....	113
valve .....	16	fifth wheel .....	94-96
steering hydraulic cylinder.....	19	frame .....	141
steering gear hydraulic pump.....	13	front-mounted winch .....	40
universal joint assembly.....	86	parking brake .....	38
vertical lifting device.....	93	service brake shoes.....	36
winch drum and shaft assembly..	73	shock absorbers .....	103
winch mounting assembly.....	84	springs .....	101
Clutch pedal floor plate,		steering gear .....	20
removal .....	22	steering gear and hydraulic	
Clutch pedal pad and dimmer		system .....	8
switch, installation .....	27	steering gear hydraulic control	
Combination blinker and spotlight		valve .....	15
blinker and spotlight reel....	121-122	steering hydraulic cylinder.....	18
blinker and spotlight signal		steering gear hydraulic pump.....	11
switch .....	122-123	tandem winch assembly.....	54-55
description .....	115	trailer wiring junction box....	127-130
spotlight arm .....	115-119	vertical lifting device.....	91
spotlight handle .....	119-120	windshield wipers .....	134
Controls and linkage			
assembly .....	67-68	Disassembly:	
cleaning, inspection and repair....	67	automatic brake .....	45
disassembly .....	65-67	base assembly .....	97-98
Cover and by-pass valve, removal..	13	controls and linkage.....	65-67
Cylinder housing and lever		double bearing assembly.....	84
shaft bushing, removal.....	25	drag link .....	30
		drive shafts and universal	
<b>D</b>		joints .....	48-51
Data:		drum and shaft.....	46
brake system .....	34	drum brake band assembly.....	72
cab .....	105	end bearing frame and clutch	
electric lighting system and		shaft yoke assembly.....	81-82
accessories .....	113	fifth wheel into subassemblies....	96
fifth wheel .....	96	front-mounted winch .....	43-44
front-mounted winch .....	40	gear case and worm.....	46
service brake shoes.....	36	gear case assembly.....	78-79
springs .....	101	layshaft assembly .....	68-69
steering gear .....	21	layshaft to front tandem winch	
steering gear hydraulic control		chain tightener assembly.....	70
valve .....	15	layshaft to rear tandem winch	
steering gear hydraulic pump.....	11	chain tightener assembly.....	71
steering hydraulic cylinder.....	19	mounting brackets and ring	
tandem winch assembly.....	55	assembly .....	96
vertical lifting device.....	91	parking brake .....	38

**ORDNANCE MAINTENANCE — BODY, CHASSIS, AND WINCHES FOR TRACTOR TRUCK M26, COMPONENT OF 40-TON TANK TRANSPORTER TRAILER TRUCK M25**

<b>D — Cont'd</b>	<b>Page No.</b>	<b>E</b>	<b>Page No.</b>
<b>Disassembly — Cont'd</b>		<b>Electric lighting system and accessories</b>	
rear tandem winch base angles		combination blinker and spotlight .....	115-123
and controls .....	82	description and data.....	113
service brake shoes.....	36	fits and tolerances.....	139
shifter cover and shift rod assemblies .....	75-78	low-pressure air indicator buzzer .....	131-134
siren light .....	125	siren with light.....	123-127
spotlight handle .....	119	trailer wiring junction box..	127-130
springs .....	101	windshield wipers .....	134-139
steering gear .....	23-25	<b>End bearing frame and clutch shift yoke assembly</b>	
steering gear hydraulic control valve .....	16	assembly .....	82
steering hydraulic cylinder.....	19	cleaning, inspection and repair....	82
tandem winch into sub-assemblies .....	59-65	disassembly .....	81-82
universal joint assembly.....	85-86	<b>Engine clutch foot lever, removal....</b>	<b>60</b>
vertical lifting device.....	91-93		
winch drum and shaft assembly..	73	<b>F</b>	
winch mounting assembly.....	83-84	<b>Fifth wheel</b>	
<b>Double bearing assembly</b>		assembly .....	99
assembly .....	85	description, and operation.....	94-96
disassembly .....	84	disassembly into subassemblies..	96
<b>Double lever winch control, installation .....</b>	<b>89</b>	fits and tolerances.....	100
<b>Drag link</b>		test and adjustment.....	99-100
assembly .....	31	<b>Fits and tolerances</b>	
cleaning, inspection and repair....	31	fifth wheel .....	100
description .....	30	front-mounted winch .....	53
disassembly .....	30	parking brake .....	39
<b>Drum shaft and by-pass valve, installation .....</b>	<b>13</b>	service brake shoes.....	37
<b>Drive shafts and universal joints</b>		springs .....	102
assembly .....	51-52	steering system .....	33
cleaning, inspection and repair....	51	tandem winch .....	90
disassembly .....	48-51	windshield wiper .....	139
<b>Drum and shaft</b>		<b>Frame</b>	
assembly .....	48	description and data.....	141
cleaning, inspection and repair....	48	disassembly, cleaning, inspection, repair and assembly.....	142
disassembly .....	46	testing .....	141-142
<b>Drum brake band assembly</b>		<b>Front-mounted winch</b>	
assembly .....	73	assembly .....	52
disassembly .....	72	description and operation.....	40
installation .....	87	disassembly into subassemblies	43-44
removal .....	63-64	fits and tolerances.....	53
		test and adjustment.....	52
		<b>Front tandem winch double lever control assembly, removal.....</b>	<b>59</b>

INDEX

<b>G</b>	<b>Page No.</b>	<b>L</b>	<b>Page No.</b>
Gear case assembly		Layshaft and chain tightener	
assembly .....	80-81	installation .....	88
cleaning, inspection and repair	79-80	removal .....	62
disassembly .....	78-79	Layshaft assembly	
Gear case and worm		assembly .....	69
assembly .....	46	cleaning, inspection and repair..	69
cleaning, inspection and repair...	46	disassembly .....	68-69
disassembly .....	45	Layshaft to front tandem winch	
Gear case control rod		chain tightener assembly.....	70
installation .....	88	Low-pressure air indicator buzzer	
removal .....	60	assembly .....	132-134
		cleaning, inspection and repair....	132
<b>I</b>		description and operation.....	131
Inspection and repair		disassembly .....	131
automatic brake .....	45		
base assembly .....	98-99	<b>M</b>	
cab .....	111-112	Mounting brackets and ring	
controls and linkage.....	67	assembly	
double bearing assembly.....	85	assembly .....	97
drag link .....	31	cleaning, inspection and	
drive shafts and universal joints..	51	repair .....	96-97
drum brake band assembly.....	73	disassembly .....	96
end bearing frame and clutch			
shift yoke assembly.....	82	<b>O</b>	
gear case and worm.....	46	Operation	
gear case assembly.....	79-80	combination blinker and	
layshaft assembly .....	69	spotlight .....	115
layshaft to front tandem winch		fifth wheel .....	96
chain tightener assembly.....	70	front-mounted winch .....	40
layshaft to rear tandem winch		parking brake .....	38
chain tightener assembly.....	71	service brake shoes.....	36
mounting bracket and ring		shock absorbers .....	103-104
assembly .....	96-97	steering gear .....	20
parking brake .....	39	steering gear and hydraulic	
rear tandem winch base angles		system .....	8-9
and controls .....	82-83	steering gear hydraulic control	
service brake shoes .....	36	valve .....	15
shifter cover and shift rod		steering gear hydraulic pump.....	11
assemblies .....	78	steering hydraulic cylinder.....	18-19
springs .....	101-102	tandem winch assembly.....	55
steering gear .....	25-26	vertical lifting device.....	91
steering gear hydraulic control			
valve .....	16-18	<b>P</b>	
steering hydraulic cylinder.....	19-20	Parking brake	
steering gear hydraulic pump.....	13	assembly .....	39
universal joint assembly.....	86	description and operation.....	38
vertical lifting device.....	93	disassembly and cleaning.....	38
winch drum and shaft assembly..	73	fits and tolerances.....	39
winch mounting assembly.....	84	inspection and repair.....	39

**ORDNANCE MAINTENANCE — BODY, CHASSIS, AND WINCHES FOR TRACTOR TRUCK M26, COMPONENT OF 40-TON TANK TRANSPORTER TRAILER TRUCK M25**

<b>P — Cont'd</b>	<b>Page No.</b>	<b>Page No.</b>
Power take-off winch control lever and rod		
installation .....	88-89	
removal .....	60	
<b>R</b>		
Rear tandem winch base angles and controls		
assembly .....	83	
disassembly .....	82	
inspection, cleaning, and repair .....	82-83	
Rear winch brake and clutch control rods, installation.....	89	
Rear tandem winch double lever control assembly, removal.....	59	
<b>S</b>		
Service brake shoes		
assembly .....	37	
description and data.....	36	
disassembly, cleaning, inspection and repair .....	36	
fits and tolerances.....	37	
Shifter cover and shift rod assemblies		
assembly .....	78	
cleaning, inspection and repair....	78	
disassembly .....	75-78	
installation .....	87	
removal .....	65	
Shock absorbers		
description and data.....	103-104	
disassembly, cleaning, inspection, repair, and assembly.....	104	
Siren with light		
assembly .....	127	
into subassemblies .....	125-127	
description .....	123	
disassembly .....	125	
into subassemblies .....	123-125	
Slides and slide block, removal.....	24	
Spare wheel bracket and platform		
installation .....	88	
removal .....	60	
Special tools and equipment.....	143	
Spotlight arm		
assembly .....	115-119	
cleaning, inspection and repair .....	115	
disassembly .....	115	
Spotlight handle		
assembly .....	119-120	
disassembly .....	119	
Springs		
assembly .....	102	
cleaning, inspection and repair .....	101-102	
description and data.....	101	
disassembly .....	101	
fits and tolerances.....	102	
Steering control valve		
assembly and installation.....	18	
removal and disassembly.....	16	
Steering gear		
assembly .....	26-27	
cleaning, inspection and repair	25-26	
description and data.....	20-21	
disassembly .....	23-25	
installation .....	27	
removal .....	21-23	
Steering gear and hydraulic system		
description .....	8	
operation .....	8-9	
Steering gear button cover, removal .....	22	
Steering gear housing cover, removal .....	21	
Steering gear hydraulic control valve		
assembly .....	18	
cleaning, inspection and repair .....	16-18	
description and data.....	15	
disassembly .....	16	
test .....	15	
Steering gear hydraulic pump		
cleaning, inspection and repair....	13	
description and data.....	11	
disassembly .....	11-13	
test .....	11	
of rebuilt unit.....	13	

INDEX

<b>S — Cont'd</b>	<b>Page No.</b>		<b>Page No.</b>
Steering hydraulic cylinder		Trailer wiring junction box	
assembly .....	20	description .....	127-130
cleaning, inspection and		disassembly, cleaning, inspection,	
repair .....	19-20	repair and assembly.....	130
data .....	19		
description .....	18	<b>U</b>	
disassembly .....	19	Universal joint assembly	
operation .....	18-19	assembly .....	86
Steering lever shaft		disassembly .....	85-86
assembly .....	26	installation .....	87
disassembly .....	25		
fits and tolerances.....	33	<b>V</b>	
Steering Pitman arm, removal....	22-23	Vertical lifting device	
Steering system		assembly .....	93
fits and tolerances.....	33	cleaning .....	93
test and adjustment.....	31-32	description and operation.....	91
Steering wheel and air valves,		disassembly .....	91-93
removal .....	21	inspection and repair.....	93
<b>T</b>		<b>W</b>	
Tandem winch (assembly)		Winch drum and shaft assembly	
assembly .....	87-90	assembly .....	73-75
data .....	55	cleaning, inspection and repair....	73
description and operation.....	54-55	disassembly .....	73
disassembly into subassemblies	59-65	Winch mounting assembly	
fits and tolerances.....	90	assembly .....	84
test and adjustment.....	90	cleaning, inspection and repair....	84
Tandem winch automatic brake		disassembly .....	83-84
case, installation .....	87-88	Windshield wipers	
Tandem winch drum and shaft,		assembly .....	138-139
installation .....	87	cleaning, inspection and	
Test and adjustment		repair .....	136-138
fifth wheel .....	99-100	description .....	134
front-mounted winch .....	52	disassembly .....	134-136
steering system .....	31-32	fits and tolerances.....	139
tandem winch .....	90	Worm gear and drum assembly,	
Testing:		removal .....	43
frame .....	141	Worm shaft, fits and tolerances.....	33
siren with light.....	127		
steering gear hydraulic control			
valve .....	15		
steering gear hydraulic pump.....	11		

# NOTES

A series of horizontal dotted lines for writing notes.

