

1/6/43
UICB
12
TM
1943

TM 9-1783C

WAR DEPARTMENT

U.S. Dept. of Army
TECHNICAL MANUAL

ORDNANCE MAINTENANCE
MEDIUM TRACTOR M1 (ALLIS-CHALMERS HD-7W)
ELECTRICAL SYSTEM, POWER TRAIN,
FRAME, AND TRACKS

26 JULY 1943



FOR ORDNANCE PERSONNEL ONLY

TECHNICAL MANUAL }
No. 9-1783C

U113
2
TM 9-1783C
1943
★ ★

TM 9-1783C

WAR DEPARTMENT
Washington, 26 July 1943

ORDNANCE MAINTENANCE

MEDIUM TRACTOR M1 (ALLIS-CHALMERS HD-7W)

**ELECTRICAL SYSTEM, POWER TRAIN,
FRAME, AND TRACKS**

Prepared under the direction of the
Chief of Ordnance

(with the cooperation of the Allis-Chalmers Manufacturing Company)

CONTENTS

	Paragraphs	Pages
CHAPTER 1. INTRODUCTION	1- 3	3
CHAPTER 2. MAINTENANCE ALLOCATION	4- 5	4- 11
CHAPTER 3. INSPECTION OF VEHICLE WHILE ASSEMBLED	6	12
CHAPTER 4. ELECTRICAL SYSTEM*	7- 12	13- 14
SECTION I. Description of system	7	13
SECTION II. Electrical accessories	8- 12	14
CHAPTER 5. FINAL DRIVES	13- 21	15- 61
CHAPTER 6. INSTRUMENTS	22- 23	62- 63
CHAPTER 7. POWER TAKE-OFF	24- 30	64- 86
CHAPTER 8. STABILIZER SPRING AND CRANK ASSEMBLY	31- 44	87-106
SECTION I. Stabilizer spring	31- 36	87- 92
SECTION II. Stabilizer crank assembly	37- 44	93-106
CHAPTER 9. STEERING CLUTCHES	45- 58	107-149
SECTION I. Clutch assemblies	45- 53	107-145
SECTION II. Steering clutch controls	54- 58	146-149
CHAPTER 10. TRACTOR BRAKES	59- 64	150-154

ORDNANCE MAINTENANCE — MEDIUM TRACTOR M1 (ALLIS-CHALMERS HD-7W)
ELECTRICAL SYSTEM, POWER TRAIN, FRAME, AND TRACKS

CONTENTS (Cont'd)

	Paragraphs	Pages
CHAPTER 11. TRANSMISSION AND GEARSHIFT		
MECHANISM	65- 77	155-215
SECTION I. General description	65	155
SECTION II. Trouble shooting for transmission gears and gearshift assembly	66	156-157
III. Transmission gears	67- 71	158-202
IV. Gearshift mechanism	72- 77	203-215
CHAPTER 12. TRUCK FRAME AND TRACK AS- SEMBLY	78-115	216-280
SECTION I. General description	78	216
II. Front idlers, truck wheels, and track support rollers	79- 92	217-247
III. Track release mechanism	93- 99	248-262
IV. Track assembly	100-108	263-273
V. Truck frame assembly	109-115	274-280
CHAPTER 13. WINCH	116-125	281-321
CHAPTER 14. MISCELLANEOUS ASSEMBLIES (COWL, ENGINE SPACER, ENGINE SUPPORT, FUEL TANK AND LINES, AND PINTLE ASSEMBLIES)	126-148	322-356
SECTION I. Cowl assembly	126-128	322-334
II. Engine spacer	129-134	335-343
III. Engine support	135-138	344-348
IV. Fuel tank and lines	139-143	349-351
V. Pintle assemblies	144-148	352-356
REFERENCES		357-358
INDEX		359-366

CHAPTER 1

INTRODUCTION

	Paragraph
Scope	1
Arrangement of manual	2
References	3

1. SCOPE.

a. The instructions contained in this manual are for the information and guidance of personnel charged with the maintenance and repair of the Medium Tractor M1 (Allis-Chalmers HD-7W). Information on the detailed construction of the tractor, disassembly and assembly procedure, inspection, maintenance and repair is contained in three Technical Manuals of the 1000-series, of which this is the third. These instructions are supplementary to those in the Field and Technical Manuals prepared for the using arms. This manual does not contain information which is intended primarily for the using arms, since such information is available to Ordnance maintenance personnel in 100-series Technical Manuals and Field Manuals.

b. This manual contains a description of, and procedure for maintenance and repair of the Medium Tractor M1 (Allis-Chalmers HD-7W) electrical system, power train, frame, and tracks.

c. TM 9-1783A contains instructions for maintenance and repair of Medium Tractor M1 (Allis-Chalmers HD-7W) engine.

d. TM 9-1783B contains instructions for maintenance and repair of Medium Tractor M1 (Allis-Chalmers HD-7W) engine accessories.

2. ARRANGEMENT OF MANUAL.

a. Specific and detailed instructions are given for inspecting, disassembling, repairing, and reassembling of each of the various component assemblies contained in the tractor. Illustrations, which show a large number of the actual maintenance operations, are provided throughout the entire text of the manual. Both text and illustrations should be studied by those doing the work on the tractor. Special tools needed for each assembly are listed at the end of each section for that particular assembly; fits and tolerances for parts are given in the proper place in assembly or adjustment procedure.

3. REFERENCES.

a. The references in the back of this book list all Technical Manuals, Standard Nomenclature Lists, and other publications relative to the materiel described herein.

**ORDNANCE MAINTENANCE — MEDIUM TRACTOR M1 (ALLIS-CHALMERS HD-7W)
ELECTRICAL SYSTEM, POWER TRAIN, FRAME, AND TRACKS**

CHAPTER 2

MAINTENANCE ALLOCATION

	Paragraph
Scope	4
Allocation of maintenance	5

4. SCOPE.

a. The scope of maintenance and repair by the crew and other units of the using arms is determined by the availability of suitable tools, availability of necessary parts, capabilities of the mechanics, time available, and the tactical situation. All of these are variable and no exact system of procedure can be prescribed.

5. ALLOCATION OF MAINTENANCE.

a. Indicated below are the maintenance duties for which tools and parts have been provided for the using arm personnel. Other replacements and repairs are the responsibility of ordnance maintenance personnel but may be performed by using arm personnel when circumstances permit, within the discretion of the commander concerned. Echelons and words as used in this list of maintenance allocations are defined as follows:

SECOND ECHELON: Line organization regiments, battalions, companies, detachments, and separate companies.

THIRD ECHELON: Ordnance light maintenance companies, ordnance medium maintenance companies, ordnance divisional maintenance battalions, and post ordnance shops.

FOURTH ECHELON: Ordnance heavy maintenance companies and service command shops.

FIFTH ECHELON: Ordnance base regiments, ordnance bases, arsenals, and manufacturers' plants.

SERVICE:

(Including preventive maintenance) (par. 23 a (1) and (2), AR 850-15 (10-6-42))
Consists of servicing, cleaning, lubricating, tightening bolts and nuts, and making external adjustments of subassemblies or assemblies and controls.

REPLACE:

(par. 23 a (4), AR 850-15 (10-6-42))
Consists of removing the part, subassembly or assembly, from the vehicles and replacing it with a new or reconditioned or rebuilt part, subassembly or assembly, whichever the case may be.

MAINTENANCE ALLOCATION

REPAIR:

(par. 23 a (3) and (5), in part, AR 850-15 (10-6-42)) Consists of making repairs to, or replacement of the part, subassembly or assembly that can be accomplished without completely disassembling the subassembly or assemblies, and does not require heavy welding, or riveting, machining, fitting, and/or alining or balancing.

REBUILD:

(par. 23 a (5) in part, and (6), AR 850-15 (10-6-42)) Consists of completely reconditioning and replacing in serviceable condition any unserviceable part, subassembly or assembly of the vehicle, including welding, riveting, machining, fitting, alining, balancing, assembling and testing.

	ECHELONS			
CLUTCH, MASTER, ASSEMBLY	2nd	3rd	4th	5th
Clutch assembly—service (adjust)	X			
Clutch assembly—replace	E	X		
Clutch assembly—repair (reline)		X		
Clutch assembly—rebuild			E	X
Control and linkage (external)—replace	X			
Control and linkage (internal)—replace		X		
Control and linkage (external and internal)—repair		X		
COOLING SYSTEM				
Connections, radiator to engine—service and replace	X			
Cooler, oil, assembly—replace	X			
Cooler, oil, assembly—repair		X		
Cooler, oil, assembly—rebuild			E	X
Cooling system—service (flush)	X			
Radiator assembly—replace	X			
Radiator assembly—repair		X		
Radiator assembly—rebuild			E	X
Shutter and controls, radiator—replace	X			
Shutter and controls, radiator—repair		X		
DRIVE, FINAL, ASSEMBLIES				
Drive, final, assemblies—replace	E	X		
Drive, final, assemblies—repair		X		
Drive, final, assemblies—rebuild			E	X
Sprockets, final drive—replace	E	X		
Sprockets, final drive—repair		X		
Sprockets, final drive—rebuild			E	X
ELECTRICAL SYSTEM				
Batteries—service, replace or recharge	X			
Batteries—repair		X		
Batteries—rebuild			E	X
Box, apparatus (generator control)—replace	X			

**ORDNANCE MAINTENANCE — MEDIUM TRACTOR M1 (ALLIS-CHALMERS HD-7W)
ELECTRICAL SYSTEM, POWER TRAIN, FRAME, AND TRACKS**

	ECHELONS			
	2nd	3rd	4th	5th
ELECTRICAL SYSTEM (Cont'd)				
Box, apparatus (generator control)—repair		X		
Cables, battery—replace	X			
Cables, battery—repair	E	X		
Conduits, fuses, and wiring, electrical—replace	X			
Conduits and wiring, electrical—repair	E	X		
Harness, wiring (all)—replace	X			
Harness, wiring (all)—repair	E	X		
Lamps (all)—service and replace	X			
Lamps (all)—repair		X		
Switches (all)—replace	X			
Switches (all)—repair		X		
ENGINE				
(General Motors Diesel 371)				
Bearings, connecting rod (inserts)—replace		E	E	X
Bearings, crankshaft (inserts)—replace		E	E	X
Belts—service (adjust) and replace	X			
Block assembly and cylinder sleeves—rebuild (re- condition)			E	X
Blower assembly—replace	X			
Blower assembly—repair		X		
Blower assembly—rebuild			E	X
Controls and linkage—replace	X			
Controls and linkage—repair		X		
Crankshaft—rebuild (recondition)			E	X
*Engine assembly—replace		X		
Engine assembly—repair		X		
Engine assembly—rebuild			E	X
Fan assembly—replace	X			
Fan assembly—repair		X		
Fan assembly—rebuild			X	
Filter, oil, assemblies—service (clean) and replace	X			
Filter, oil, assemblies—repair		X		
Flywheel assembly—replace or repair		X		
Flywheel assembly—rebuild (recondition)			E	X

NOTE: Operations allocated will normally be performed in the echelons indicated by "X." Operations allocated to the echelons as indicated by "E" may be accomplished by respective echelons in emergencies only.

*The second echelon is authorized to remove and reinstall engine and transmission assemblies, transfer units, controlled differential assembly, and other items marked by an asterisk. However, when it is necessary to replace an item marked by an asterisk with a new or rebuilt part, subassembly or unit assembly, the assembly marked by an asterisk may be removed from the vehicle by the second echelon *only after authority has been obtained from a higher echelon of maintenance.*

MAINTENANCE ALLOCATION

	ECHELONS			
	2nd	3rd	4th	5th
ENGINE (Cont'd)				
Gaskets (handhole cover, lower pan, manifold and valve cover)—replace	X			
Gear, timing, train—replace		X		
Generator assembly—replace	X			
Generator assembly—repair		X		
Generator assembly—rebuild			X	
Governor assembly—service (adjust), replace or repair		X		
Governor assembly—rebuild			E	X
Head, cylinder, assembly—replace or repair		X		
Head, cylinder, assembly—rebuild (recondition)			E	X
Heater, air box, assembly—replace	X			
Heater, air box, assembly—repair		X		
Heater, air box, assembly—rebuild			E	X
Housing, flywheel, assembly—replace		X		
Housing, flywheel, assembly—rebuild (recondition)			E	X
Injector assembly—replace	X			
Injector assembly—repair		X		
Injector assembly—rebuild			E	X
Lines and connections, oil (external)—replace	X			
Lines and connections, oil (external)—repair	E	X		
Lines and connections, oil (internal)—replace or repair		X		
Manifold, exhaust—replace	X			
Manifold, exhaust—repair		X		
Manifolds and connectors, fuel—replace	X			
Manifolds and connectors, fuel—repair	E	X		
Motor, starting, assembly—replace	X			
Motor, starting, assembly—repair		X		
Motor, starting, assembly—rebuild			X	
Pan, oil (lower)—service (clean) and replace	X			
Pan, oil (upper)—replace		X		
Pan, oil (lower or upper)—repair		X		
Pistons and rings—replace		E	E	X
Pump, fuel, assembly—replace	X			
Pump, fuel, assembly—repair		X		
Pump, fuel, assembly—rebuild			X	
Pump, oil, assembly—replace	E	X		
Pump, oil, assembly—repair		X		
Pump, oil, assembly—rebuild			X	
Pump, water, assembly—replace	X			
Pump, water, assembly—repair		X		
Pump, water, assembly—rebuild			X	
Rod, connecting, assembly—replace		E	E	X

**ORDNANCE MAINTENANCE — MEDIUM TRACTOR M1 (ALLIS-CHALMERS HD-7W)
ELECTRICAL SYSTEM, POWER TRAIN, FRAME, AND TRACKS**

	ECHELONS			
	2nd	3rd	4th	5th
ENGINE (Cont'd)				
Sleeve, cylinder—replace		E	E	X
Thermostat—replace	X			
Valve, clearance—service (adjust)	X			
EXHAUST SYSTEM				
Muffler and pipes—replace	X			
EXTINGUISHER, FIRE				
Extinguisher, fire (carbon dioxide, CO ₂)—replace	X			
Extinguisher, fire (carbon dioxide, CO ₂)—service (recharge) and repair		X		
Extinguisher, fire (carbon dioxide, CO ₂)—rebuild			E	X
Extinguisher, fire (carbon tetrachloride, CCl ₄)—service (refill) and replace	X			
Extinguisher, fire (carbon tetrachloride, CCl ₄)—repair		X		
Extinguisher, fire (carbon tetrachloride, CCl ₄)—rebuild			E	X
FRAME, TRUCK				
Crank, stabilizer, assemblies—replace	X			
Crank, stabilizer, assemblies—repair		X		
Crank, stabilizer, assemblies—rebuild			E	X
Frame, truck, components—replace	X			
Frame, truck, components—repair		X		
Frame, truck, components—rebuild			E	X
Idler, track front, assemblies—replace	X			
Idler, track front, assemblies—repair		X		
Idler, track front, assemblies—rebuild			E	X
Mechanism, track adjusting—service (adjust) and replace	X			
Mechanism, track adjusting—repair		X		
Mechanism, track adjusting—rebuild			E	X
Roller, track support, assemblies—replace	X			
Roller, track support, assemblies—repair		X		
Roller, track support, assemblies—rebuild			E	X
Spring, stabilizer, assembly—replace	X			
Spring, stabilizer, assembly—repair		X		
Spring, stabilizer, assembly—rebuild			E	X
Track assemblies—replace or repair	X			
Track assemblies—rebuild			E	X
Wheel, truck, assemblies—replace	X			
Wheel, truck, assemblies—repair		X		
Wheel, truck, assemblies—rebuild			E	X

MAINTENANCE ALLOCATION

	ECHELONS			
FUEL SYSTEM	2nd	3rd	4th	5th
Cleaners and connections, air—service (clean) and replace	X			
Cleaners and connections, air—repair		X		
Filters, fuel—service and replace	X			
Filters, fuel—repair		X		
Lines and connections, fuel—service (clean) and replace	X			
Lines and connections, fuel—repair	E	X		
Pump, air box heater, assembly—replace	X			
Pump, air box heater, assembly—repair		X		
Tank, fuel, assembly—service (clean) and replace . .	X			
Tank, fuel, assembly—repair		X		
GEAR TRAIN AND MAIN FRAME ASSEMBLY				
Bands, brake, steering clutch—service (adjust)	X			
Bands, brake, steering clutch—replace or repair (re-line)			X	
Case, power take-off, assembly—replace	X			
Case, power take-off, assembly—repair		X		
Case, power take-off, assembly—rebuild			X	
Clutch, steering, assemblies—service (adjust)	X			
Clutch, steering, assemblies—replace or repair		X		
Clutch, steering, assemblies—rebuild			E	X
Controls and linkage (external)—replace	X			
Controls and linkage (internal)—replace		X		
Controls and linkage (external or internal)—repair . . .		X		
Drawbar assembly—replace	X			
Drawbar assembly—repair		X		
Gear, bevel, assembly—service (adjust) and replace . .		X		
Guard, crankcase—replace	X			
Guard, crankcase—repair		X		
Hook, towing—replace	X			
Hook, towing—repair		X		
Pintle assemblies—replace	X			
Pintle assemblies—repair		X		
Pintle assemblies—rebuild			E	X
Spacer, engine support, assembly—replace or repair . .		X		
Support, engine, assembly—replace or repair		X		
Support, pintle—replace	X			
Support, pintle—repair		X		
Transmission components—replace or repair		X		
Transmission components—rebuild			E	X

INSTRUMENTS AND GAGES

Instruments and gages—replace	X			
Instruments and gages—repair		X		

**ORDNANCE MAINTENANCE — MEDIUM TRACTOR M1 (ALLIS-CHALMERS HD-7W)
ELECTRICAL SYSTEM, POWER TRAIN, FRAME, AND TRACKS**

	ECHELONS			
	2nd	3rd	4th	5th
INSTRUMENTS AND GAGES (Cont'd)				
Instruments and gages—rebuild			E	X
Meter, hour, assembly—replace	X			
Meter, hour, assembly—repair		X		
Meter, hour, assembly—rebuild			E	X
Odometer assembly—replace	X			
Odometer assembly—repair		X		
Odometer assembly—rebuild			E	X
METAL, SHEET				
Boxes, street plate and tool—replace	X			
Boxes, street plate and tool—repair		X		
Fenders and support assemblies—replace	X			
Fenders and support assemblies—repair		X		
Hood, top plate and doors—replace	X			
Hood, top plate and doors—repair		X		
Panel, dash and instrument, assembly—replace	X			
Panel, dash and instrument, assembly—repair		X		
Rack, luggage—replace	X			
Rack, luggage—repair		X		
Seat and seat frame—replace	X			
Seat and seat frame—repair		X		
VEHICLE ASSEMBLY				
Tractor, medium, M1 (Allis-Chalmers HD-7W)— service	X			
Tractor, medium, M1 (Allis-Chalmers HD-7W)— rebuild (with serviceable assemblies)			E	E
AUXILIARY EQUIPMENT				
Engine Preheater Assembly				
Preheater, engine, assembly—service (refill) and re- place	X			
Preheater, engine, assembly—repair		X		
Preheater, engine, assembly—rebuild			E	X
WINCH ASSEMBLY				
Band, worm shaft safety brake—service (adjust)	X			
Band, worm shaft safety brake—replace (reline)		X		
Bearings, drive shaft—replace	X			
Cable and hook assembly—replace	X			
Cable and hook assembly—repair		X		
Chain, winch drive—service and replace	X			
Chain, winch drive—repair		X		
Drum, worm shaft safety brake—replace	X			
Drum, worm shaft safety brake—repair		X		

MAINTENANCE ALLOCATION

	ECHELONS			
	2nd	3rd	4th	5th
WINCH ASSEMBLY (Cont'd)				
Pin, shear—replace	X			
Shaft, drive, assemblies (front and rear)—replace . .	X			
Shaft, drive, assemblies (front and rear)—repair . . .		X		
Shaft, drive, assemblies (front and rear)—rebuild . .			X	
Winch assembly—replace	X			
Winch assembly—repair		X		
Winch assembly—rebuild			E	X

**ORDNANCE MAINTENANCE — MEDIUM TRACTOR M1 (ALLIS-CHALMERS HD-7W)
ELECTRICAL SYSTEM, POWER TRAIN, FRAME, AND TRACKS**

CHAPTER 3

INSPECTION OF VEHICLE WHILE ASSEMBLED

Paragraph

Inspection of vehicle while assembled. 6

6. INSPECTION OF VEHICLE WHILE ASSEMBLED.

a. Inspection of Standing Vehicle.

(1) A majority of mechanical failures of vehicles are due to lack of lubrication of moving parts. Some are caused by lack of lubrication of these parts at specified intervals, and others by the loss of lubricant due to leaks in oil compartments. If vehicle has been standing idle, inspect the floor or ground underneath for evidence of leakage; a crack in a casting or a leak from a faulty gasket or oil seal can be detected by inspecting parts immediately above oil spots, which will indicate that oil has leaked out. Dust will collect more readily on oily parts of the vehicle; inspect these dusty spots to determine if cracks have developed in castings, or bolts have become loose. Any cracks should be repaired immediately and faulty oil seals or gaskets replaced to avoid resultant breakdown. If an oil compartment requires the addition of oil at frequent intervals, check to determine if the oil is leaking out or into another compartment. Inspect all compartments for proper oil level. Add oil where necessary.

(2) Carefully inspect the entire vehicle at intervals for worn parts, loose or missing bolts, cotter pins, etc. Replace worn bolts or pins and tighten those that have loosened. Check wires for loose connections, or spots where wires have rubbed, to make sure the insulation has not been rubbed off, exposing the wire to cause shorting. Replace or repair broken wires, or wrap parts of the wire where the insulation is worn off with friction tape, or like material. Inspect fuel lines for leaking connections, also for cracks or wear. Examine fuel tank for rusted or corroded spots. If rusted or corroded spots appear, test degree of corrosion or rust by tapping against these spots with the end of a steel rod. If spot is corroded nearly through, the rod will pierce a hole in the metal; repair if necessary by welding or brazing. Sandpaper rusted places and paint them to protect from further corrosion.

b. Inspect Vehicle in Motion. Start engine and test all tractor controls for operation and proper adjustment. Operate tractor in all gears and listen for unusual noises indicating improper functioning, or defective gears or bearings. Test winch and power take-off for operation and condition of cable. Turn lights on and check to see if all lamps light as they are turned on. Test stop light operation. Test tractor brakes. Check tool list against tool equipment in tractor to make sure no tools are missing.

CHAPTER 4

ELECTRICAL SYSTEM

Section I

DESCRIPTION OF SYSTEM

Paragraph

Description of system 7

7. DESCRIPTION OF SYSTEM.

a. A 12-volt electrical system is used. Two 6-volt storage batteries connected in series provide electrical energy for cranking engine and furnish current to the lighting equipment on the tractor.

b. Electrical energy drained from the batteries by the starter while cranking engine, or by the lighting system, is replaced by the generator mounted on the engine. The amount of electrical energy delivered to batteries by the generator is controlled by the voltage control unit mounted on the generator, and the rate of charge registers on the ammeter mounted in instrument panel on dash. For details of generator, voltage control unit, and starter, refer to TM 9-1783B.

c. All lights, with the exception of the panel light, are connected by wires to the main light switch mounted on left side of dash, which is in turn connected to the electrical supply. Convenient connectors are provided throughout the entire wiring system to facilitate disconnection or connection for disassembly or assembly of the tractor. The panel light is controlled by a separate switch. A push-button type switch is also provided for use of the air heater. A complete wiring diagram of the tractor can be found in TM 9-783B. No fuses are used in the wiring system. A thermal unit on the main light switch cuts off the current if a short or ground develops in any of the wiring system; this prevents burning out of lamps or burning of wires.

ORDNANCE MAINTENANCE — MEDIUM TRACTOR M1 (ALLIS-CHALMERS HD-7W)
ELECTRICAL SYSTEM, POWER TRAIN, FRAME, AND TRACKS

CHAPTER 4

ELECTRICAL SYSTEM (Cont'd)

Section II

ELECTRICAL ACCESSORIES

	Paragraph
Batteries	8
Light switch	9
Panel light	10
Service lights	11
Wiring of tractor	12

8. BATTERIES.

a. Refer to TM 9-783B for complete description and maintenance of batteries.

9. LIGHT SWITCH.

a. Refer to TM 9-783B for description and operating and replacement instructions.

10. PANEL LIGHT.

a. Refer to TM 9-783B for description and replacement instructions.

11. SERVICE LIGHTS.

a. Refer to TM 9-783B for maintenance information.

12. WIRING OF TRACTOR.

a. TM 9-783B contains a complete wiring diagram of tractor.

CHAPTER 5

FINAL DRIVES

	Paragraph
Description	13
Preventive maintenance	14
Trouble shooting	15
Removal	16
Disassembly	17
Inspection and repair of parts.....	18
Assembly	19
Installation	20
Special tools and equipment.....	21

13. DESCRIPTION.

a. Final Drive Gear Assembly.

(1) The final drive assembly is, in effect, a gear reduction unit which transfers the power of the engine from the transmission to the drive sprockets and tracks. The large gear is shrunk onto the hub to which the sprocket is bolted. Keys between hub and gear make turning of the gear on the hub impossible. The hub and gear rotate around the stationary axle on tapered roller bearings.

(2) Two seal assemblies, one on each side of the sprocket, guard against entrance of dirt and water, and prevent oil from escaping. Each seal assembly consists of two finely machined steel rings; one ring of each assembly turns with the sprocket, while the other is held stationary. A spring seal boot arrangement holds the flat surfaces of the two seal rings tightly against each other so that dirt or oil cannot pass between them, thus forming a seal.

(3) The gear case is filled with oil to a level even with the filler plug (fig. 21), and the rotation of the gear through the oil distributes oil to the final drive pinion, and to all bearings and other moving parts. The drain plug in the gear case is equipped with a small magnet to retain metal particles which might accumulate in the case from gears or other parts.

b. Final Drive Pinion Assembly.

(1) The final drive gear is driven by the final drive pinion and shaft. The shaft rotates on three ball bearings, one bearing located in the final drive gear case, one in the final drive spacer, and the other one in a cage bolted to the inside of the steering clutch compartment of the transmission case. The inner end of the pinion shaft is tapered and keyed to fit into the driven hub, which is bolted to the brake drum driven by the steering clutch and shaft.

**ORDNANCE MAINTENANCE — MEDIUM TRACTOR M1 (ALLIS-CHALMERS HD-7W)
ELECTRICAL SYSTEM, POWER TRAIN, FRAME, AND TRACKS**

(2) Oil from the final drive gear case is supplied to the pinion and bearings by the rotation of the final drive gear. An oil seal in the inner bearing cage prevents leakage of oil from the final drive assembly into the steering clutch compartment,

14. PREVENTIVE MAINTENANCE.

a. Lubrication. The oil level in the gear case must be kept even with the final drive filler plug. Use SAE 50 engine oil in summer and SAE 30 in winter. Drain oil from compartments after every 200 hours of operation; flush case and clean magnetic drain plug. Refill case with new lubricant.

b. Adjustment. The rear axle bearings require adjustment at periodic intervals. This is done by removing the sprocket guard and rear axle end cover, and tightening large nut on end of axle (par. 20 b (13) (b) or TM 9-783B). No other adjustments are required for final drive assembly.

15. TROUBLE SHOOTING.

a. Gear Case Leaking.

Possible Cause	Possible Remedy
Rear axle bearing loose.	Test bearings and adjust (par. 21 b (13) (b)).
Damaged gaskets.	Replace gaskets.
Worn or scored oil seal rings.	Replace rings.
Seal ring stuck on hub.	Remove and inspect; replace if damaged.
Damaged side plate.	Repair or replace side plate.
Cracks in gear case.	Repair or replace gear case.
Loose bolts.	Tighten bolts.

b. Noise in Final Drive.

Worn or damaged gears or bearings.	Disassemble and inspect; replace worn or damaged parts.
------------------------------------	---

c. Excessive Wear on Drive Sprockets.

Sand or grit on drive sprockets.	Inspect regularly and clean drive sprockets.
Tracks and rear axle bearings out of adjustment.	Adjust (par. 107)
Front idler out of line.	Aline front idler (par. 89)

16. REMOVAL.

a. Tools and Equipment Required.

Bar, drift, 18-in.

Chisel, 3/4-in.

Bar, pry

Hammer, 2-lb

FINAL DRIVES

Hammer, sledge	Wrench, hexagonal, $\frac{3}{8}$ -in.
Hoist, chain	Wrench, open-end, $\frac{9}{16}$ -in., with extension
Jack, hydraulic, 10-ton (2)	Wrench, open-end, $\frac{3}{4}$ -in.
Pipe, 2-in., 3-ft long	Wrench, open-end, $\frac{7}{8}$ -in.
Pliers	Wrench, open-end, $1\frac{1}{16}$ -in.
Puller assembly, final drive gear and case	Wrench, open-end, $1\frac{5}{16}$ -in.
Puller, assembly, final drive pinion	Wrench, open-end, $2\frac{1}{2}$ -in., with pipe extension
Rope	Wrench, open-end, $2\frac{3}{4}$ -in.
Screw, cap, $\frac{5}{8}$ - x 5-in.	Wrench, open-end, $3\frac{3}{4}$ -in.
F.T.U.S.S. (3)	Wrench, socket, $\frac{9}{16}$ -in.
Screwdriver, 10-in.	Wrench, socket, $\frac{3}{4}$ -in.
Tongs	Wrench, socket, $\frac{7}{8}$ -in.
Wrench, $1\frac{1}{4}$ -in.	Wrench, socket, $1\frac{5}{16}$ -in.
Wrench, 2-in.	Wrench, spanner
Wrench, box, $\frac{3}{4}$ -in.	Wrench, track-adjusting

b. Procedure. **NOTE:** The text outlines the removal of the final drive pinion assembly and continues with removal of the final drive gear and case assembly. However, either the final drive pinion assembly or the final drive gear and case assembly may be removed or installed without removing or installing the other. To remove the final drive pinion assembly only, perform the first seven steps. To remove only the final drive gear and case assembly, omit steps (1), (2), (4), (5), (6), (7), and (18) below. In the illustrations accompanying the text in both removal and installation procedures, the final drive pinion assembly removal is illustrated exactly as the work would be done, whether the pinion is removed for replacement, or as a necessary part of the work involved in the removal of the steering clutches (par. 47). The illustrations accompanying the latter part of the paragraph outlining the removal of the final drive gear and case assembly, after removal of the final drive pinion assembly show the pinion back in place as it would be if only the gear and case were to be removed, and not the pinion assembly. However, the procedure is exactly the same, whether pinion is in place or has been removed.

(1) REMOVE SEAT FRAME, FUEL TANK, AND STEERING CLUTCH COVERS.

Refer to paragraph 47 b, (1) through (6). Remove only the covers on the side from which pinion is to be removed, unless both pinion assemblies are to be removed (fig. 2).

ORDNANCE MAINTENANCE — MEDIUM TRACTOR M1 (ALLIS-CHALMERS HD-7W)
ELECTRICAL SYSTEM, POWER TRAIN, FRAME, AND TRACKS

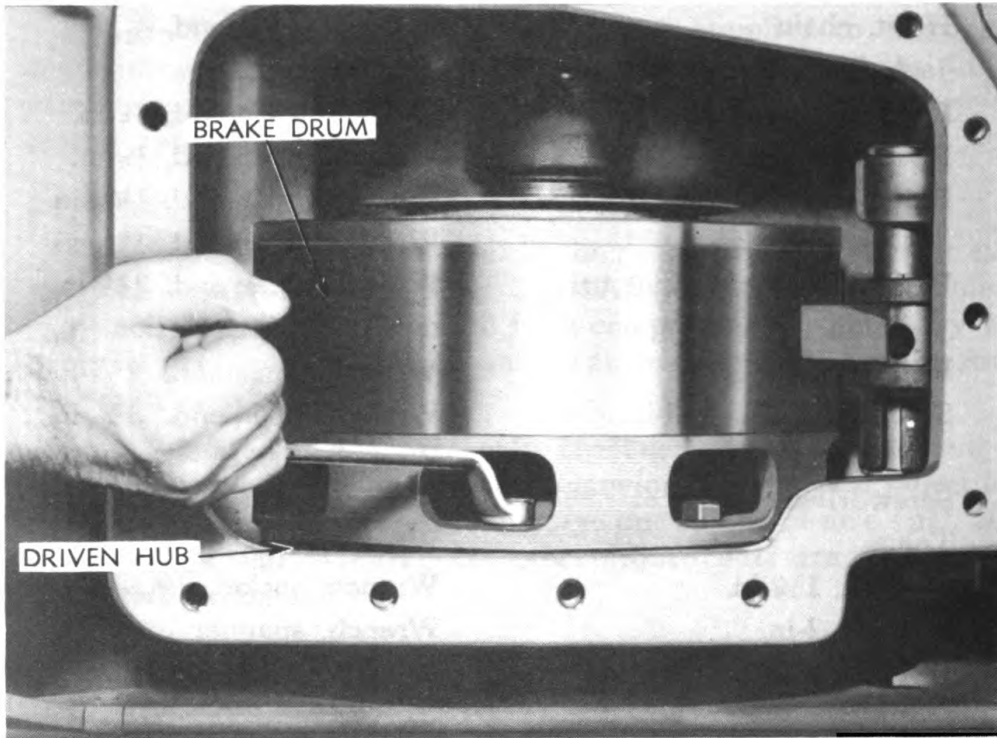

RA PD 41106

Figure 1 — Disconnecting Brake Drum from Driven Hub

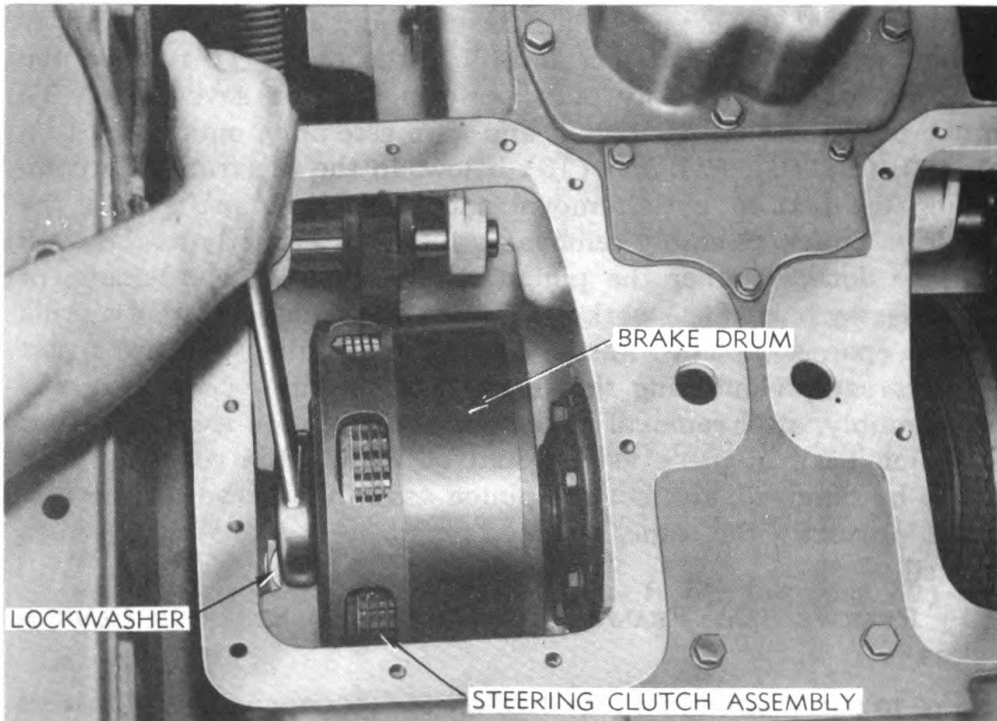

RA PD 41114

Figure 2 — Loosening Pinion Nut

FINAL DRIVES

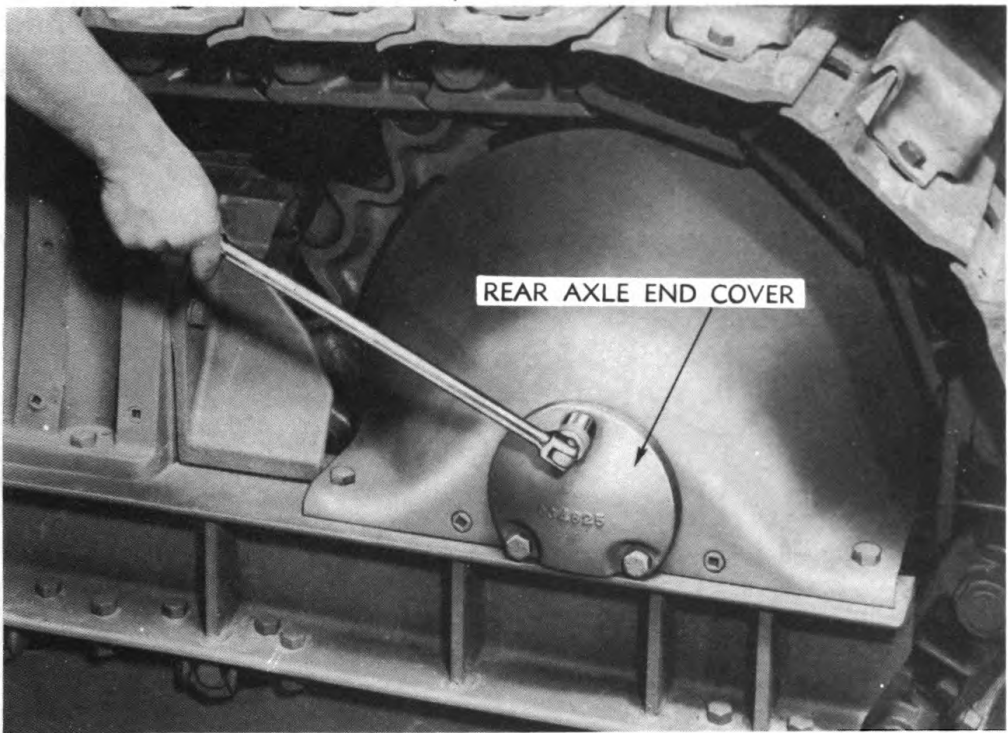

RA PD 41115

Figure 3 — Removing Rear Axle End Cover

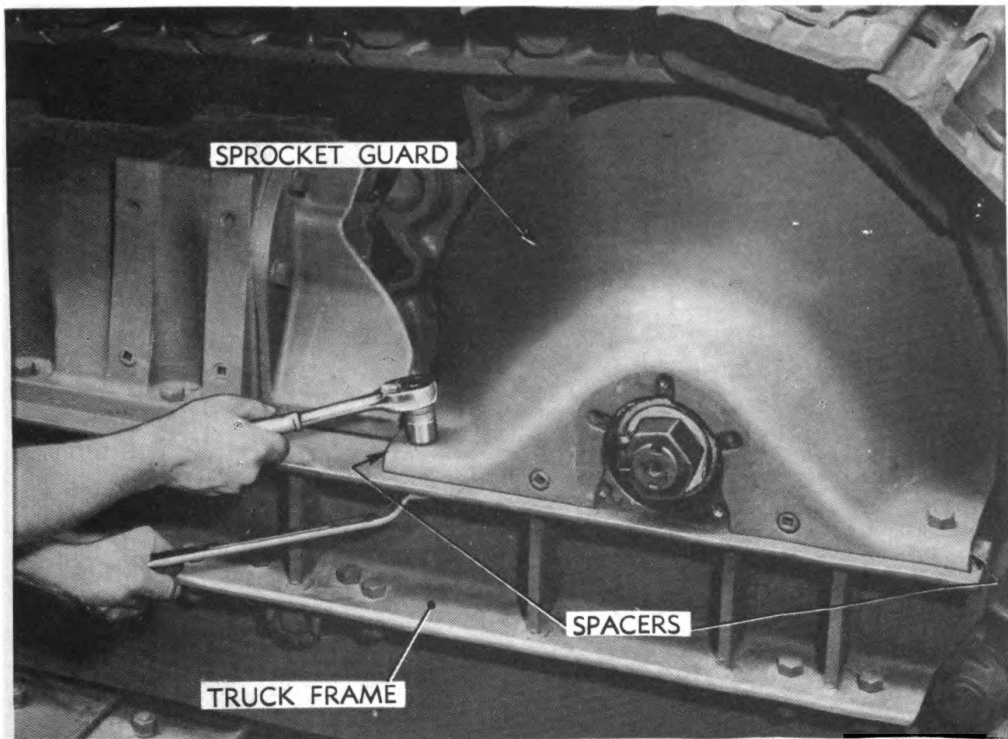

RA PD 41101

Figure 4 — Removing Sprocket Guard

**ORDNANCE MAINTENANCE — MEDIUM TRACTOR M1 (ALLIS-CHALMERS HD-7W)
ELECTRICAL SYSTEM, POWER TRAIN, FRAME, AND TRACKS**

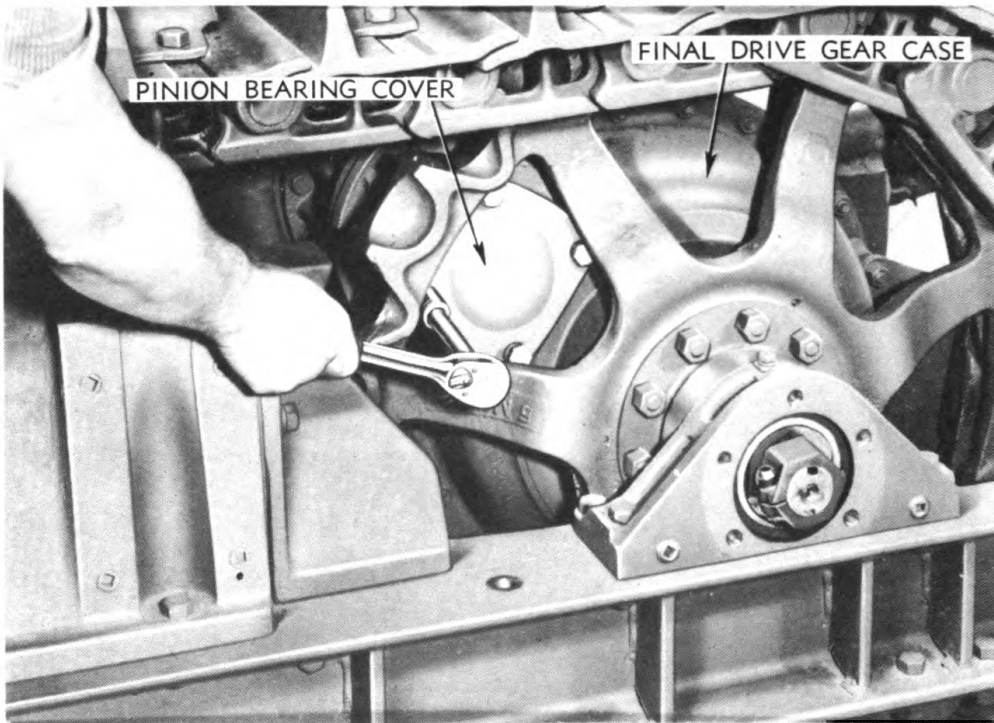

RA PD 41102

Figure 5 — Removing Outer Final Drive Pinion Bearing Cover

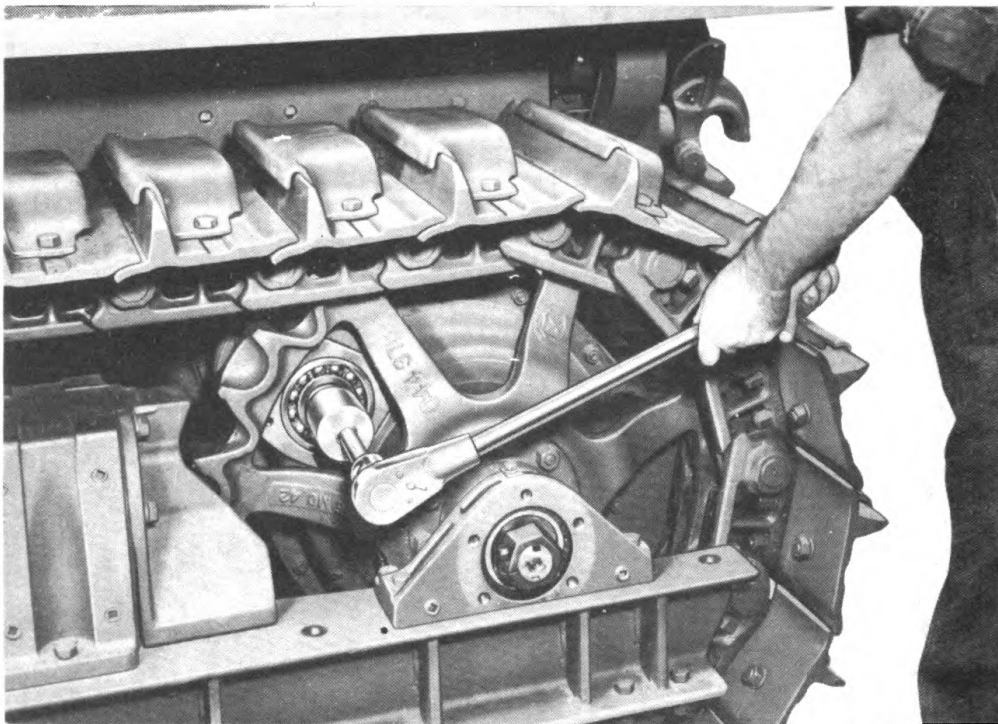

RA PD 41097

Figure 6 — Installing Adapter in Pinion Shaft

FINAL DRIVES**(2) DISCONNECT BRAKE DRUM FROM DRIVEN HUB AND LOOSEN PINION NUT.**Chisel, $\frac{3}{4}$ -in.Wrench, box, $\frac{3}{4}$ -in.

Hammer, 2-lb

Wrench, open-end, $2\frac{1}{2}$ -in.

Pipe, 2-in., 3-ft long

Remove the eight cap screws holding brake drum to driven hub ($\frac{3}{4}$ -in. box wrench). It will be necessary to roll tractor ahead or back, to rotate drum to remove these cap screws (fig. 1). This may be done with a bar through holes in brake drum. Slide clutch drum toward center of tractor and straighten lock on pinion nut holding driven hub to pinion shaft (hammer and chisel), and loosen nut ($2\frac{1}{2}$ -in. wrench with pipe extension). Turn nut off as far as possible until nut touches steering clutch shaft.

(3) REMOVE COVERS AND SPROCKET GUARD.Wrench, $\frac{3}{4}$ -in.Wrench, $\frac{15}{16}$ -in.Wrench, $\frac{7}{8}$ -in.

Remove three cap screws and take off rear axle end cover with $\frac{7}{8}$ -inch wrench (fig. 3). Remove the two bolts holding sprocket guard to truck frame ($\frac{7}{8}$ - and $\frac{15}{16}$ -in. wrenches) and remove guard and spacers between truck frame and guard (fig. 4). Clean all dirt from pinion bearing cover, sprocket, and other affected parts. Remove four cap screws and remove outer pinion bearing cover (fig. 5) from final drive case ($\frac{3}{4}$ -in. wrench).

(4) INSTALL PINION PULLER ASSEMBLY.

Pinion puller assembly, final drive.

Wrench, 2-in.

Wrench, open-end, $3\frac{3}{4}$ -in.

Screw $\frac{7}{8}$ -inch adapter of pinion puller assembly into threaded end of pinion with 2-inch wrench (fig. 6). With spacer, washer, and pedestal on puller bolt (fig. 7), screw bolt of puller tightly into adapter in pinion. Place pedestal against final drive case and screw large nut tightly against spacer and pedestal ($3\frac{3}{4}$ -in. wrench).

(5) REMOVE PINION AND BEARING.Wrench, $3\frac{3}{4}$ -in.

In loosening and pulling pinion with puller, one man should tighten large nut with $3\frac{3}{4}$ -inch wrench, while another operates sliding ram to drive against head of puller bolt. After pinion is loosened, remove nut and lock washer from inner end of pinion shaft; then pull pinion and shaft on out of case (fig. 8). Outer bearing will remain on shaft. Remove puller assembly from shaft.

(6) REMOVE DRIVEN HUB.

Bar, pry

Pry driven hub out of bearing cage and lift hub from steering clutch compartment (fig. 48). Pull Neoprene ring from inside of bearing cage (fig. 47).

ORDNANCE MAINTENANCE — MEDIUM TRACTOR M1 (ALLIS-CHALMERS HD-7W)
ELECTRICAL SYSTEM, POWER TRAIN, FRAME, AND TRACKS

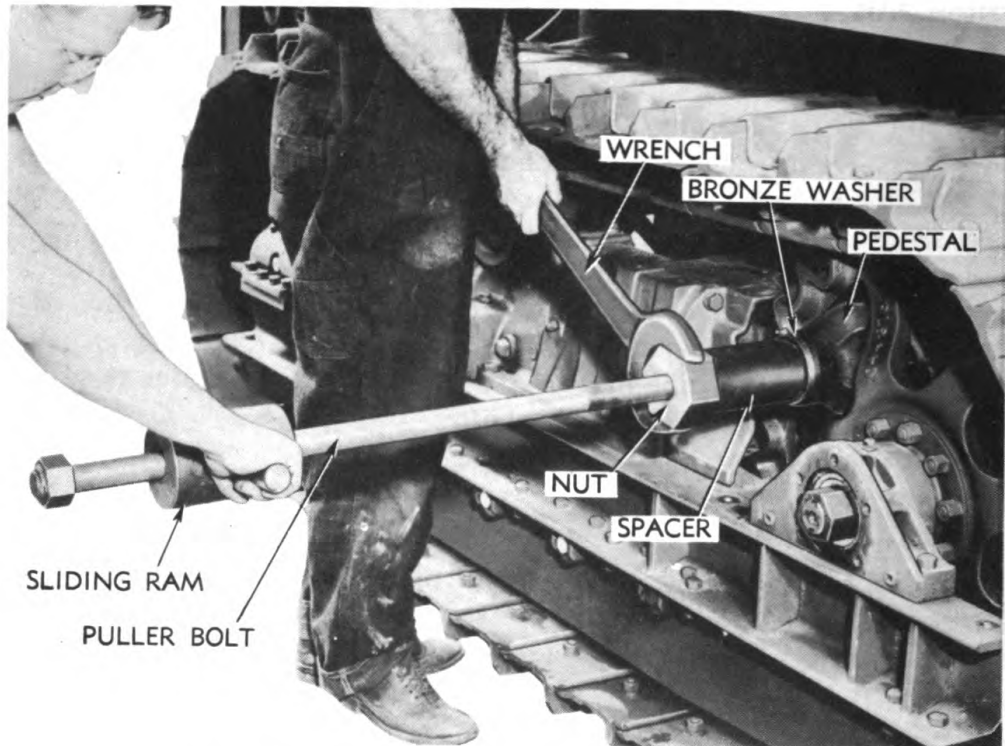

RA PD 41137

Figure 7 — Pulling Final Drive Pinion

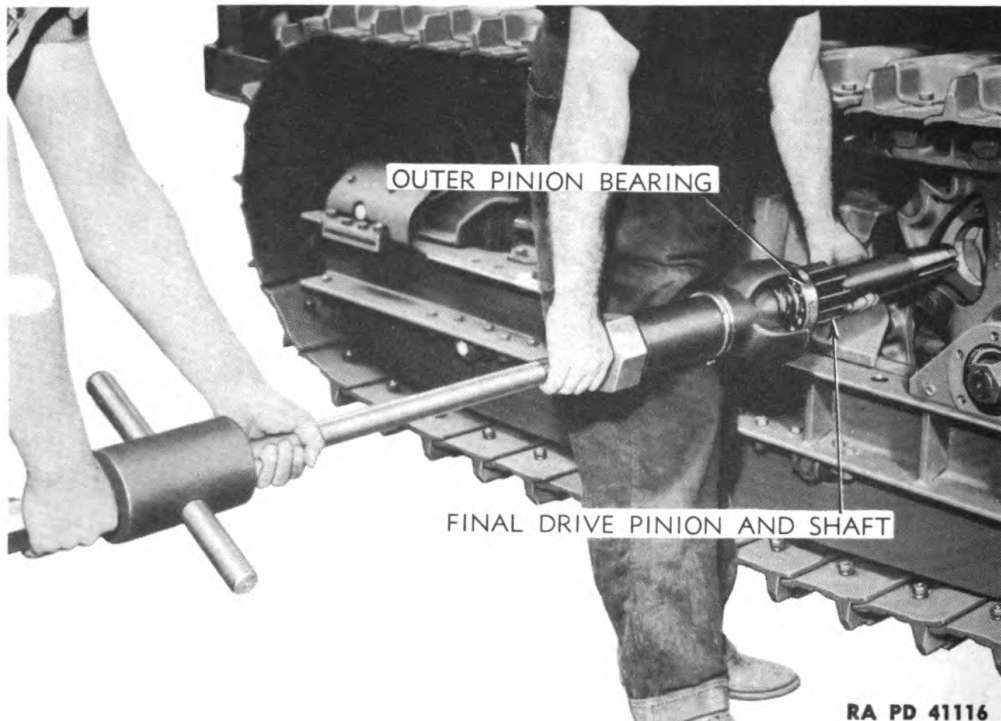

RA PD 41116

Figure 8 — Pinion Shaft and Bearing Removed

FINAL DRIVES

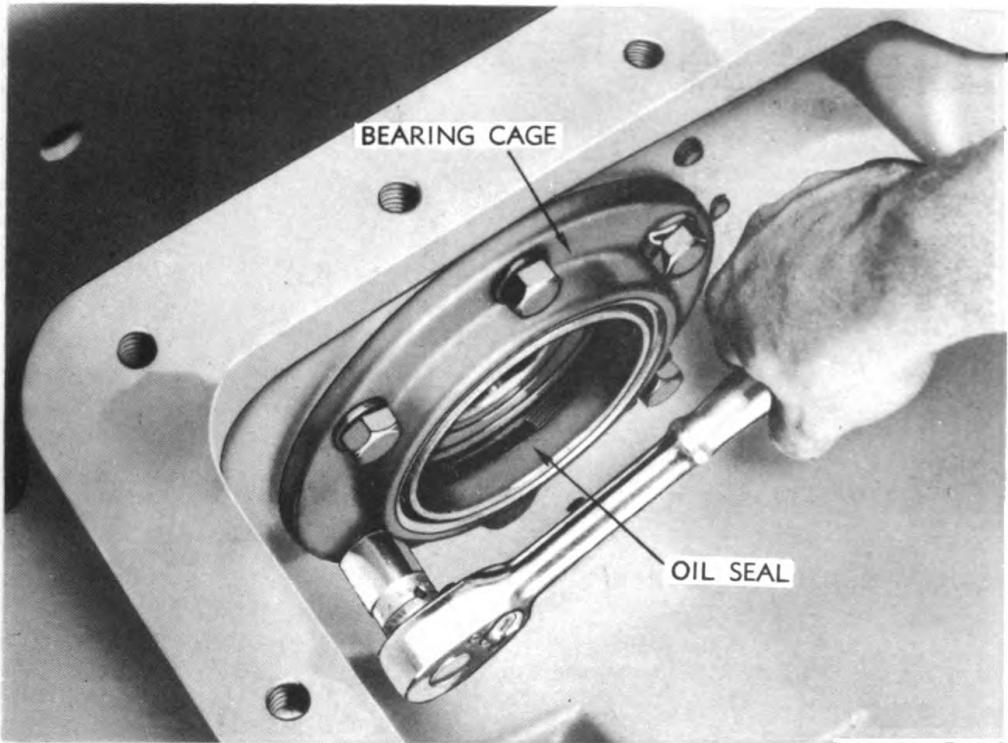

RA PD 41222

Figure 9 — Removing Bolts from Pinion Bearing Cage

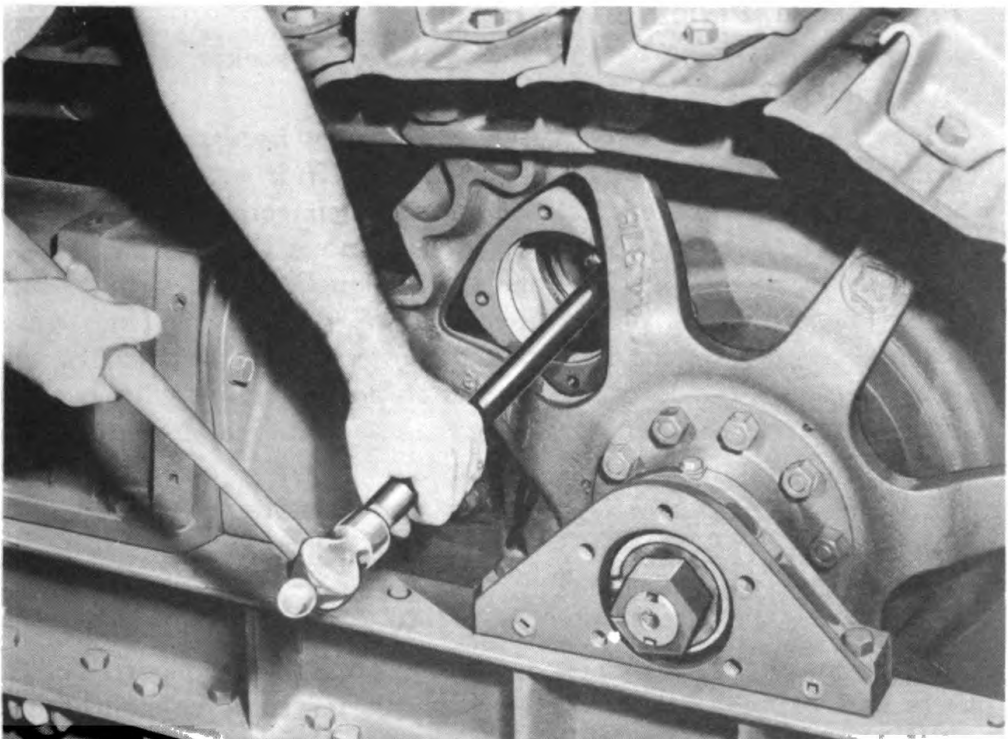

RA PD 41210

Figure 10 — Driving Out Pinion Bearing Cage

**ORDNANCE MAINTENANCE — MEDIUM TRACTOR M1 (ALLIS-CHALMERS HD-7W)
ELECTRICAL SYSTEM, POWER TRAIN, FRAME, AND TRACKS**

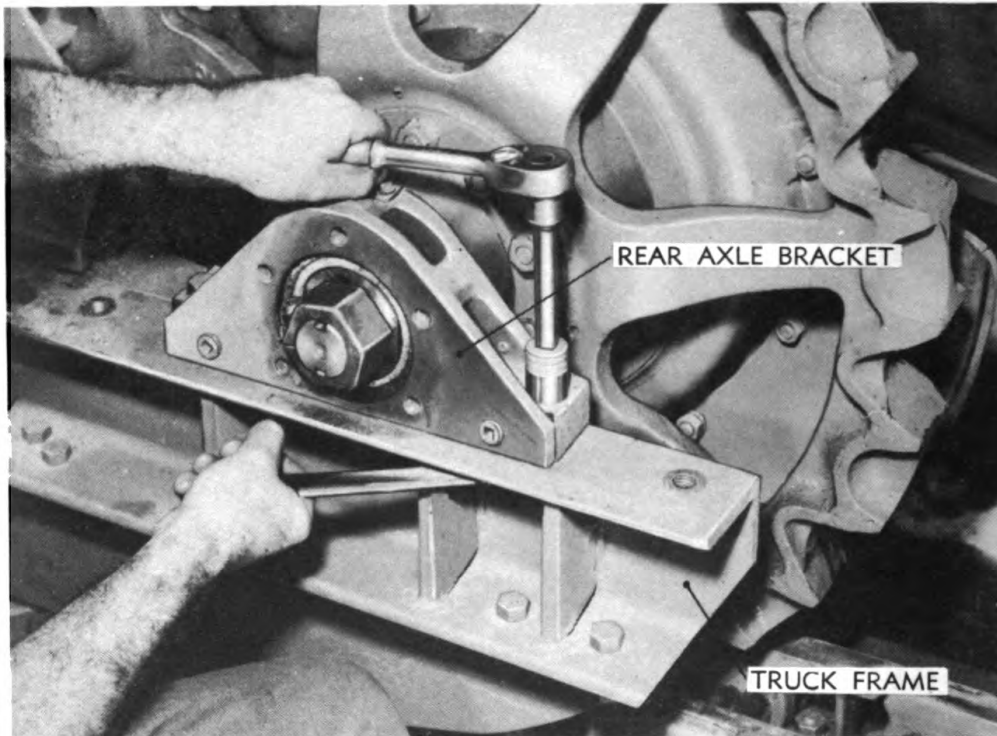

RA PD 18103

Figure 11 — Removing Bolts from Rear Axle Bracket

(7) REMOVE PINION SHAFT BEARINGS.

Bar, drift, 18-in.

Wrench, socket, $\frac{3}{4}$ -in.

Hammer, 2-lb

Unless bearings are to be removed, it is not necessary to remove bearing retainer. If bearings are to be removed, it will first be necessary to remove the steering clutches from their compartments. Refer to paragraph 47 b (7), (9), and (10). Remove the five cap screws holding inner pinion bearing cage to transmission case with $\frac{3}{4}$ -inch wrench (fig. 9). Drive pinion bearing cage and bearing from transmission case by inserting bar through pinion hole in final drive case and driving cage out into steering clutch compartment with bar and hammer (fig. 10). Lift out bearing cage assembly and spacer (figs. 45 and 46).

(8) DRAIN OIL FROM GEAR CASE AND UNCOUPLE TRACKS.

Bar, drift, 18-in.

Wrench, $\frac{7}{8}$ -in.

Hammer, sledge

Wrench, $1\frac{5}{16}$ -in.

Tongs

Wrench, track-adjusting

Locate master pin in track assembly. This pin is longer than the others and extends approximately one-quarter to three-eighths inch out of boss on side rails. Run tractor forward or backward until this pin comes to front of idler. Loosen tracks and remove master pin

FINAL DRIVES

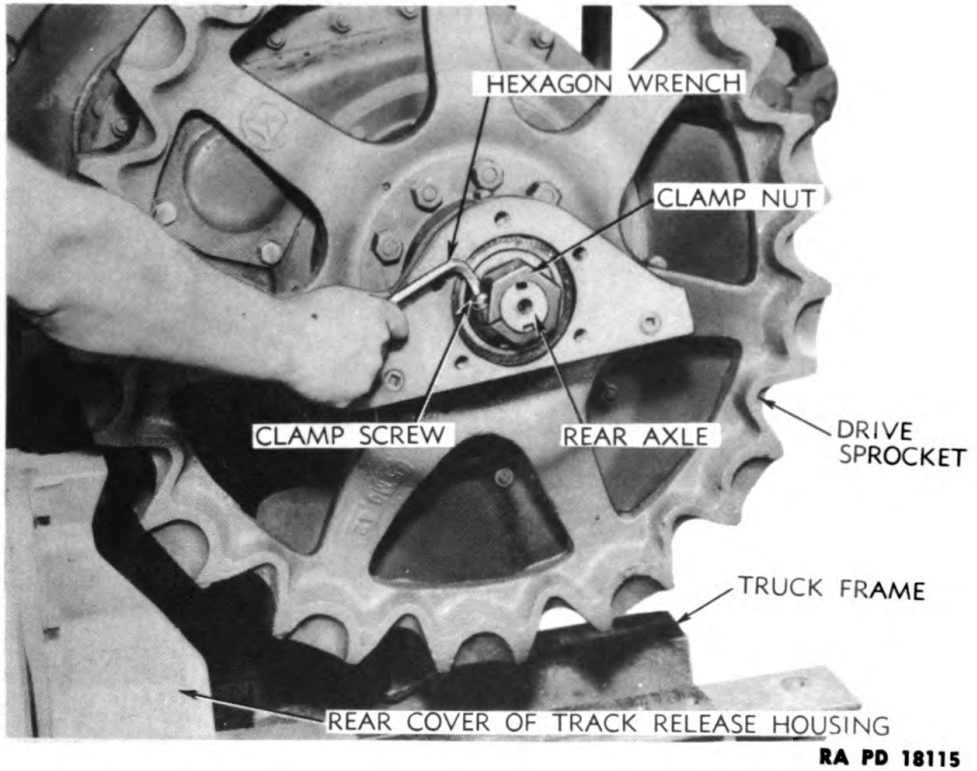

Figure 12 — Loosening Rear Axle Nut Clamp Screw

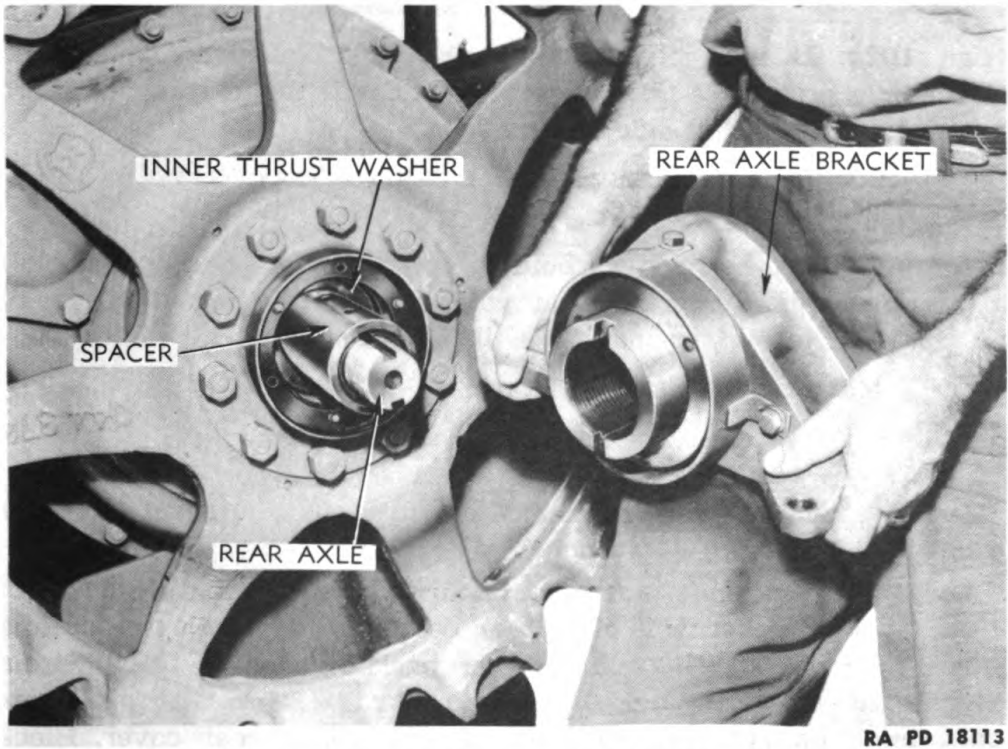
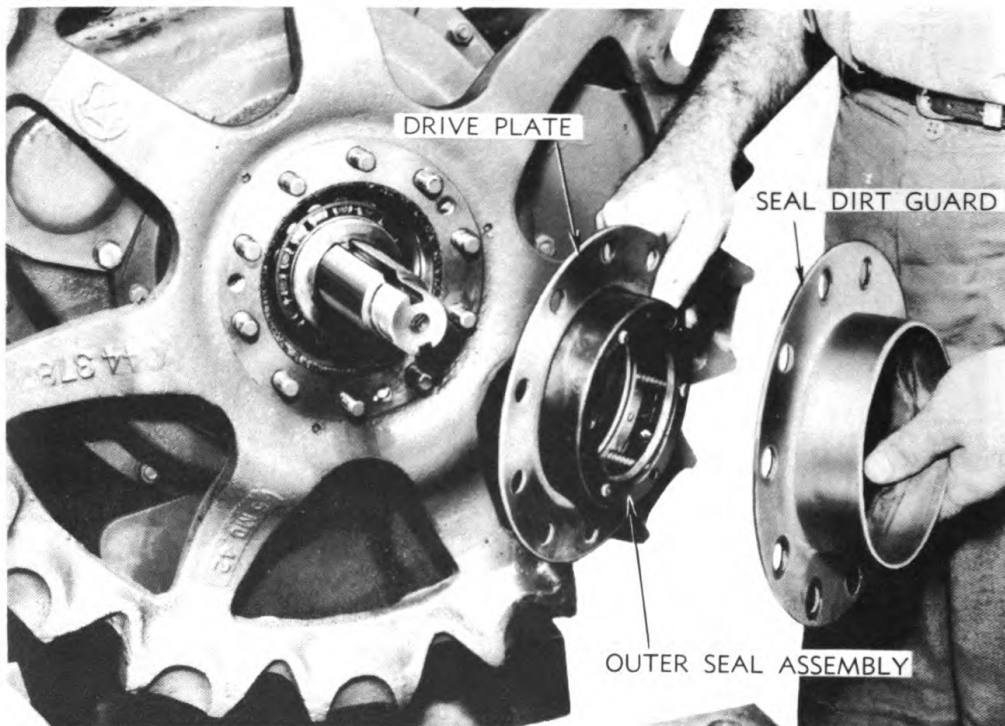

Figure 13 — Axle Bracket Removed

**ORDNANCE MAINTENANCE — MEDIUM TRACTOR M1 (ALLIS-CHALMERS HD-7W)
ELECTRICAL SYSTEM, POWER TRAIN, FRAME, AND TRACKS**



RA PD 18105

Figure 14 — Dirt Guard, Seal Drive Plate, and Outer Seal Follower Assembly Removed

(par. 102). Back tractor until track rolls off support roller and sprocket to ground or floor in rear. **NOTE:** In this description, final drive assembly on left side is removed.

(9) REMOVE CAP SCREWS FROM SPRING SEAT.

Wrench, $\frac{7}{8}$ -in.

Remove three cap screws holding spring seat to truck frame left top channel (fig. 89). Slide front idler forward so that when rear of tractor is jacked up, spring seat will not bind on track release yoke.

(10) RAISE REAR END OF TRACTOR.

Jack, hydraulic, 10-ton

Wrench, $\frac{15}{16}$ -in.

Wrench, $\frac{7}{8}$ -in.

(a) Remove the five bolts holding rear axle bracket to truck frame ($\frac{7}{8}$ - and $\frac{15}{16}$ -in. wrenches) (fig. 11).

(b) Place jack under left side of transmission case and raise tractor until track sprocket will clear rear cover of track release housing (fig. 12). Hold steering clutch lever back on side of tractor from which final drive is being removed, so that track sprocket can rotate until teeth on sprocket will clear track release rear cover. Block tractor securely.

FINAL DRIVES

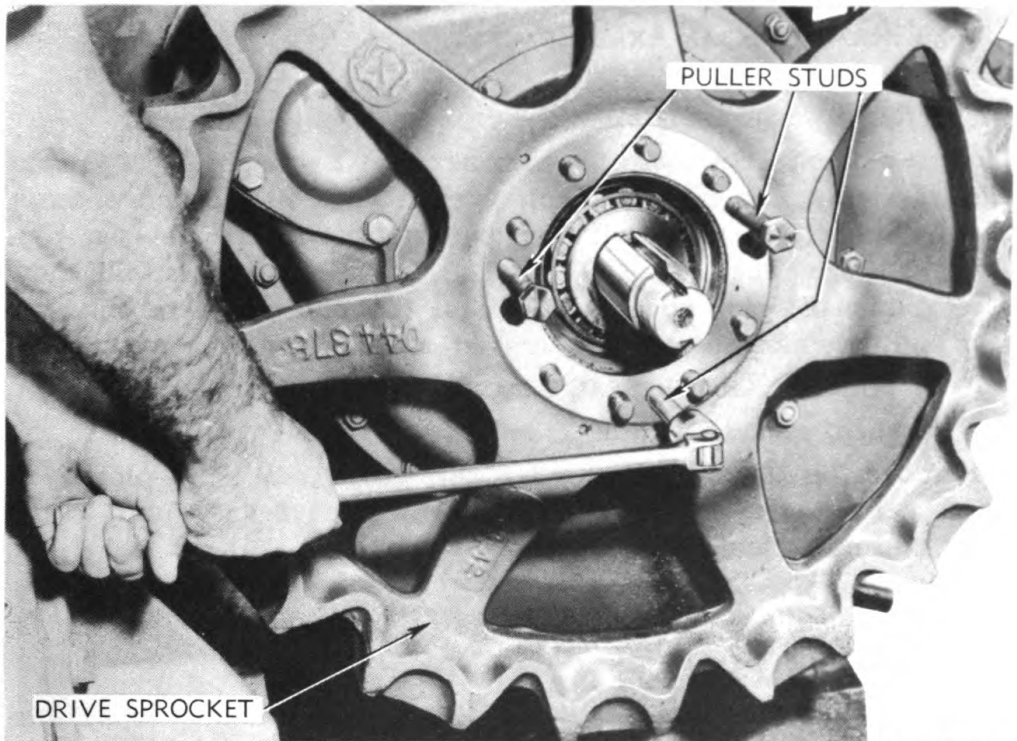

RA PD 18104

Figure 15 — Removing Drive Sprocket

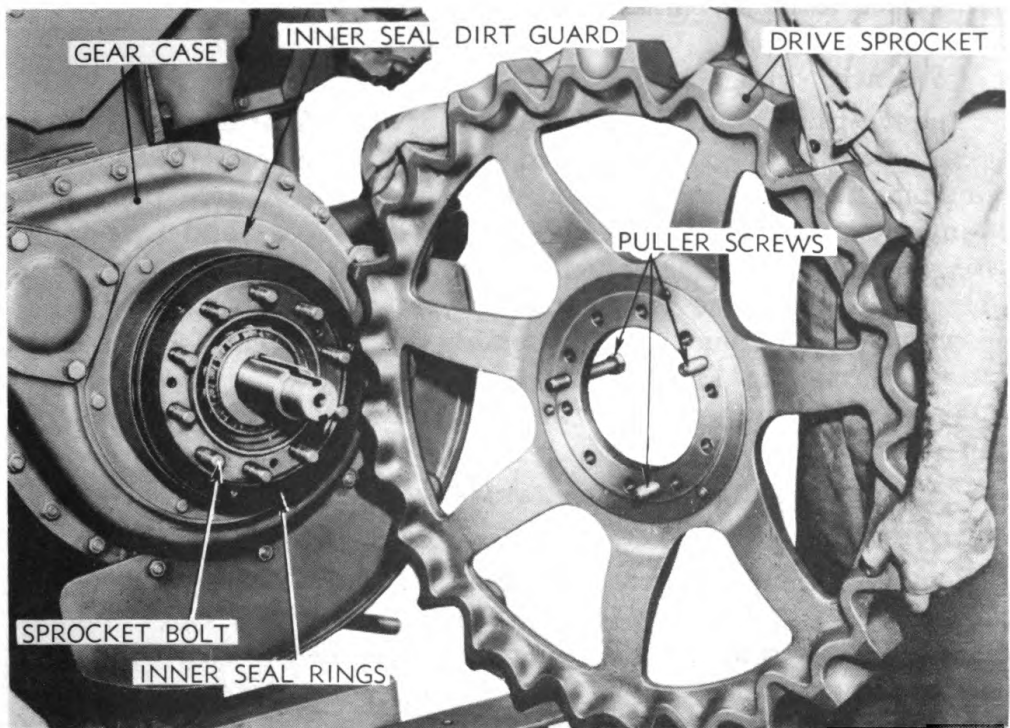

RAPD 41290

**ORDNANCE MAINTENANCE — MEDIUM TRACTOR M1 (ALLIS-CHALMERS HB-7W)
ELECTRICAL SYSTEM, POWER TRAIN, FRAME, AND TRACKS**

(11) REMOVE REAR AXLE BRACKET.

Bar, pry

Wrench, open-end, 2½-in.,
with pipe extension

Wrench, hexagonal, ⅜-in.

Loosen clamp screw with ⅜-inch hexagonal wrench (fig. 12) and remove clamp nut with 2½-inch wrench (fig. 60). Remove outer thrust washer (fig. 59). Pull rear axle bracket from axle (fig. 13). Remove spacer (fig. 13). NOTE: The following pictures will show outer pinion bearing cover in place as it would be were only the gear and case assembly to be removed, and not the pinion assembly.

(12) REMOVE OUTER SEAL ASSEMBLY.

Wrench, socket, 15/16-in.

Remove the 10 high nuts holding dirt guard, seal drive plate, and outer seal follower assembly to sprocket. Remove dirt guard, drive plate, and outer seal assembly (fig. 14).

(13) REMOVE DRIVE SPROCKET.

Screw, cap, ⅝- x 5-in.

Wrench, ⅞-in.

F. T. U.S.S. (3)

Install the three special puller cap screws in threaded holes provided in sprocket. Turn them in evenly, thus forcing sprocket from hub (fig. 15).

(14) REMOVE FINAL DRIVE GEAR CASE ASSEMBLY AND GEAR.Puller assembly, final drive
gear and case

Wrench, ⅞-in.

Wrench, 1¼-in.

Wrench, ¾-in. (2)

Remove the 5 bolts holding lower guard to final drive case (two ¾-in. wrenches). Remove guard (fig. 17). Remove the 19 bolts remaining in case, holding final drive gear case to side plate (two ¾-in. wrenches) (fig. 18). Install final drive gear and case puller assembly on two of the sprocket bolts in gear hub (fig. 19) (⅞-in. wrench). Tighten the puller stud against sprocket shaft end (1¼-in. wrench). Pull final drive assembly out until outer axle bearing is free on axle (fig. 19). Remove puller from hub. Remove gear case, outer axle bearing, and gear and hub assembly from shaft as one unit (fig. 20).

(15) REMOVE INNER SEAL ASSEMBLY.

Wrench, 9/16-in.

Remove the six cap screws holding inner seal dirt guard to gear case (fig. 16) and remove guard. Remove inner seal rings and seal drive assembly and lay seal rings and seal drive where they will not be damaged.

(16) REMOVE INNER BEARING.

Bar, pry

FINAL DRIVES

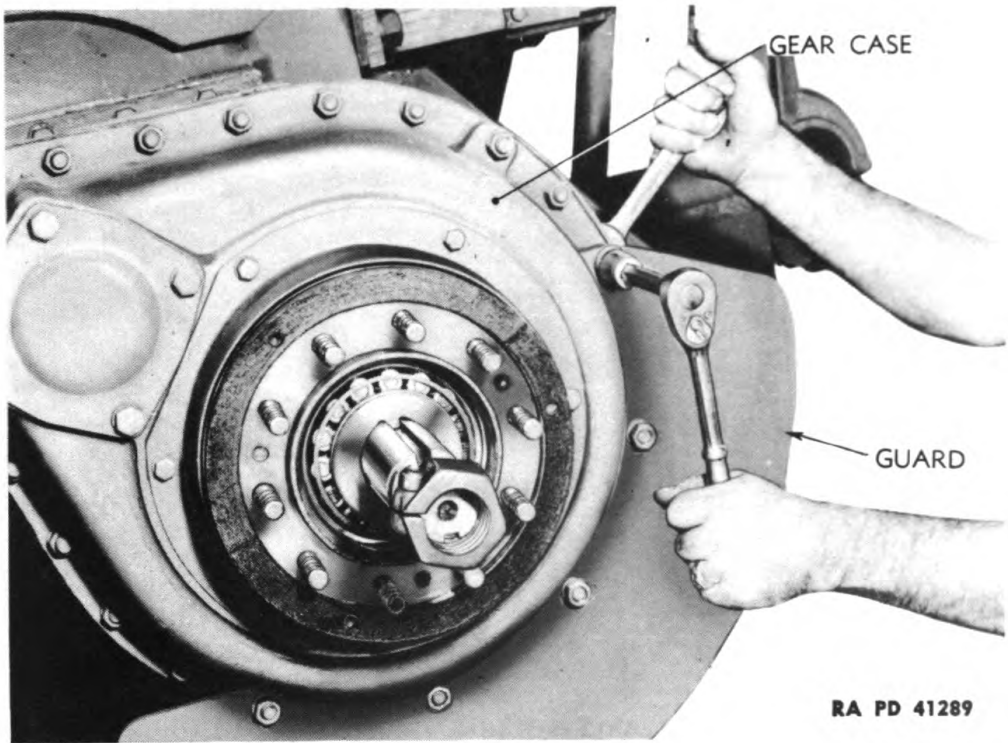

Figure 17 — Removing Lower Dirt Guard

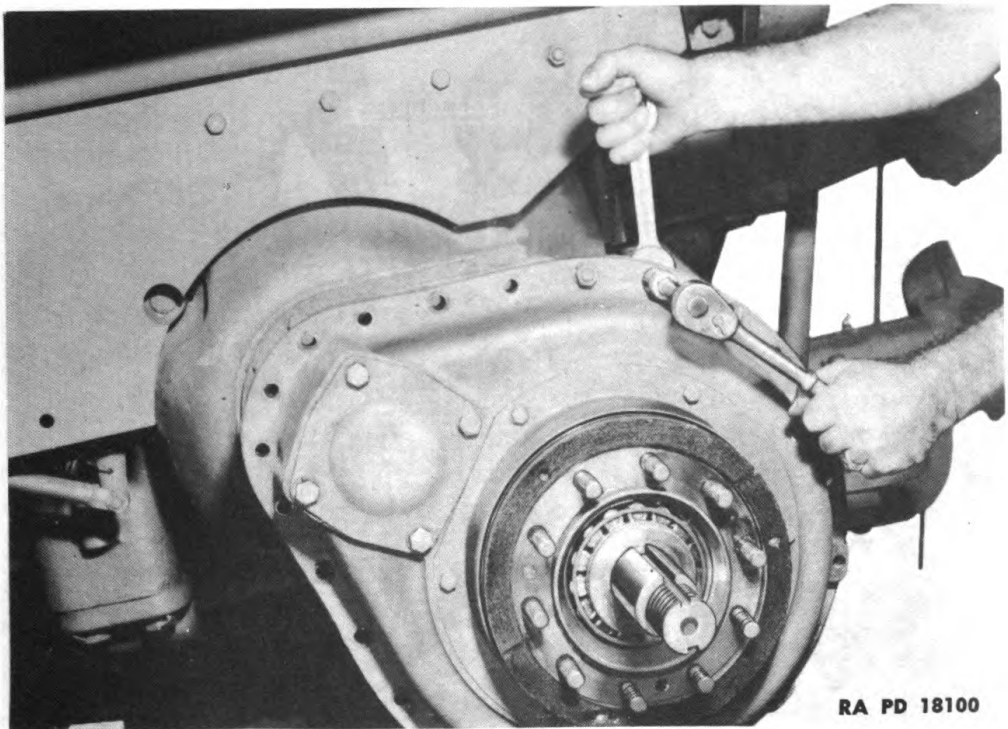

Figure 18 — Removing Gear Case Retaining Bolts

**ORDNANCE MAINTENANCE — MEDIUM TRACTOR M1 (ALLIS-CHALMERS HD-7W)
ELECTRICAL SYSTEM, POWER TRAIN, FRAME, AND TRACKS**

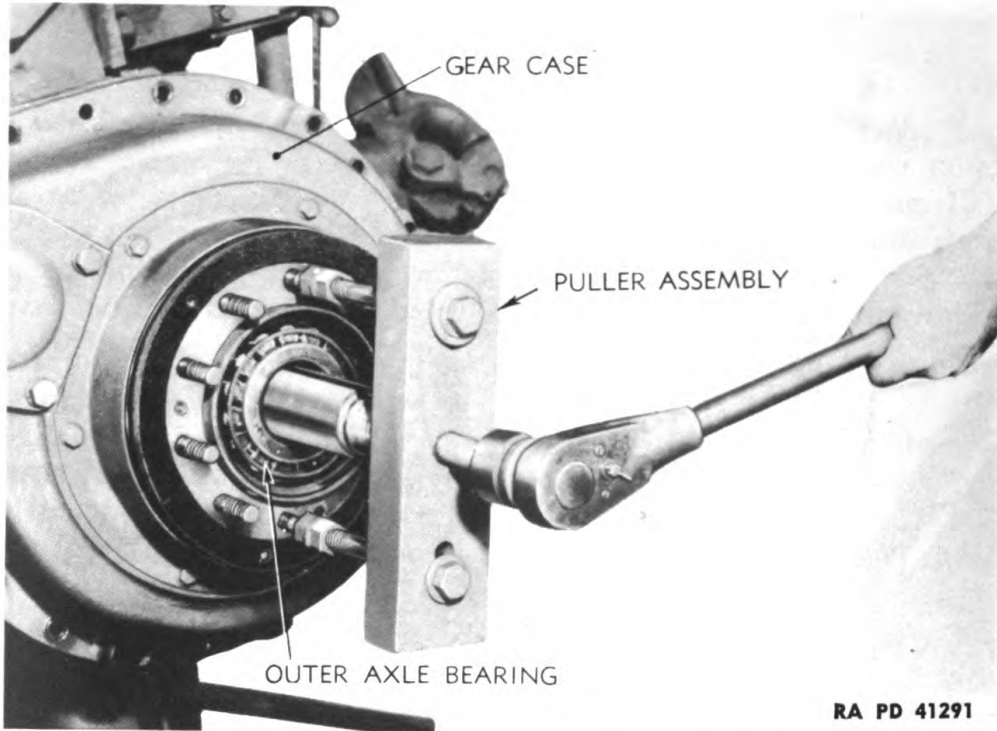

Figure 19 — Removing Final Drive Gear and Case Assembly

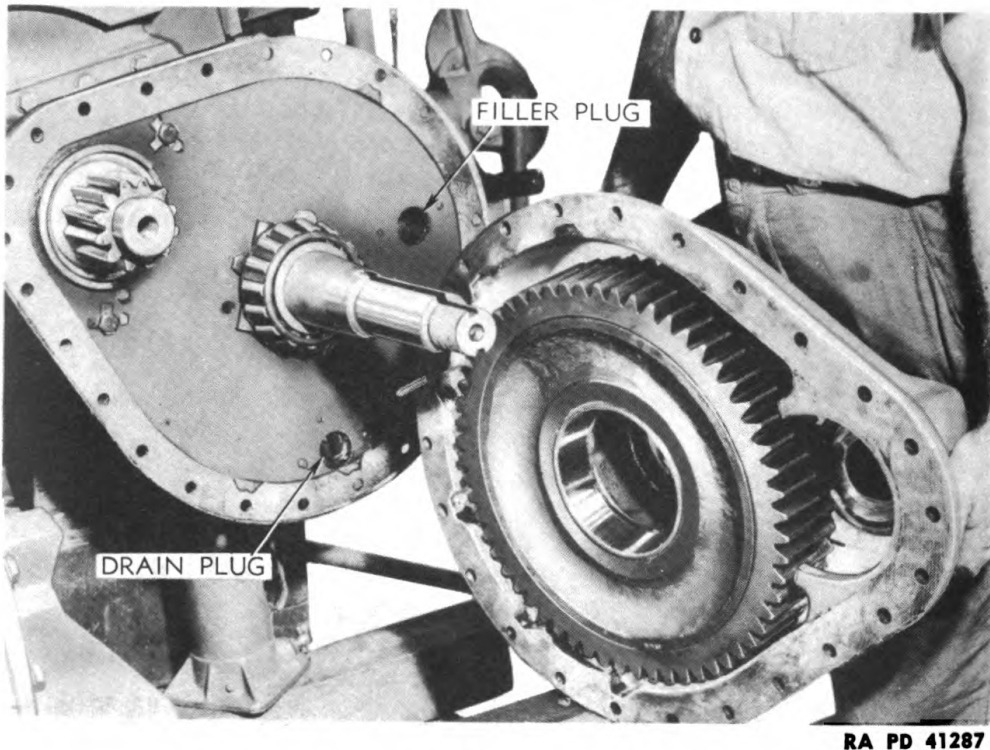
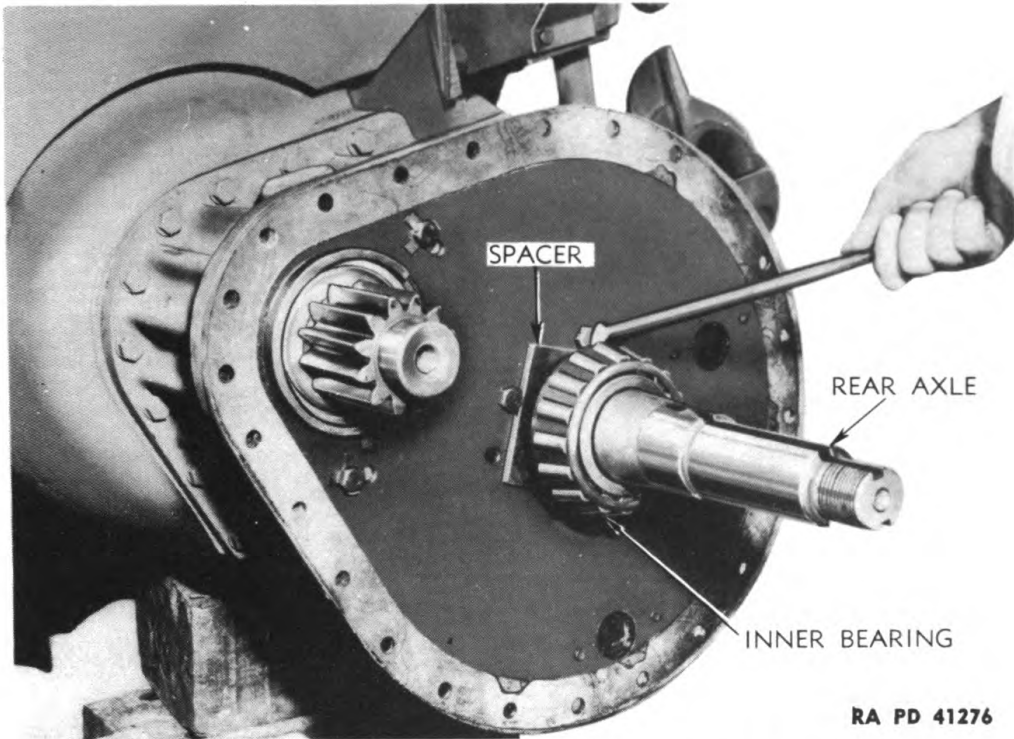

Figure 20 — Gear Case and Gear Removed

FINAL DRIVES



RA PD 41276

Figure 21 — Prying Inner Bearing from Axle Shaft

Pry inner bearing from position on axle shaft (fig. 21). Remove inner axle bearing and spacer.

(17) REMOVE SIDE PLATE.

Chisel, $\frac{3}{4}$ -in.

Wrench, socket, $\frac{3}{4}$ -in.

Hammer, 2-lb

Straighten locks with hammer and chisel and remove four cap screws and two bolts holding side plate to final drive spacer ($\frac{3}{4}$ -in. wrench) (fig. 22). Remove side plate (fig. 23).

(18) REMOVE FINAL DRIVE SPACER.

Jack, hydraulic, 10-ton (2)

Wrench, socket, $\frac{3}{4}$ -in.

Remove the 17 cap screws holding spacer to transmission case ($\frac{3}{4}$ -in. wrench). Using 2 hydraulic jacks, one against drawbar plate brace and spacer flange, and one against transmission case and flange of spacer on opposite side, force spacer off axle shaft (fig. 24).

17. DISASSEMBLY.

a. Tools Required.

Bar, soft

Press, arbor

Hammer, soft

Wrench, $\frac{9}{16}$ -in. (2)

Hammer, 2-lb

Wrench, $\frac{3}{4}$ -in.

Pliers

ORDNANCE MAINTENANCE — MEDIUM TRACTOR M1 (ALLIS-CHALMERS HD-7W)
ELECTRICAL SYSTEM, POWER TRAIN, FRAME, AND TRACKS

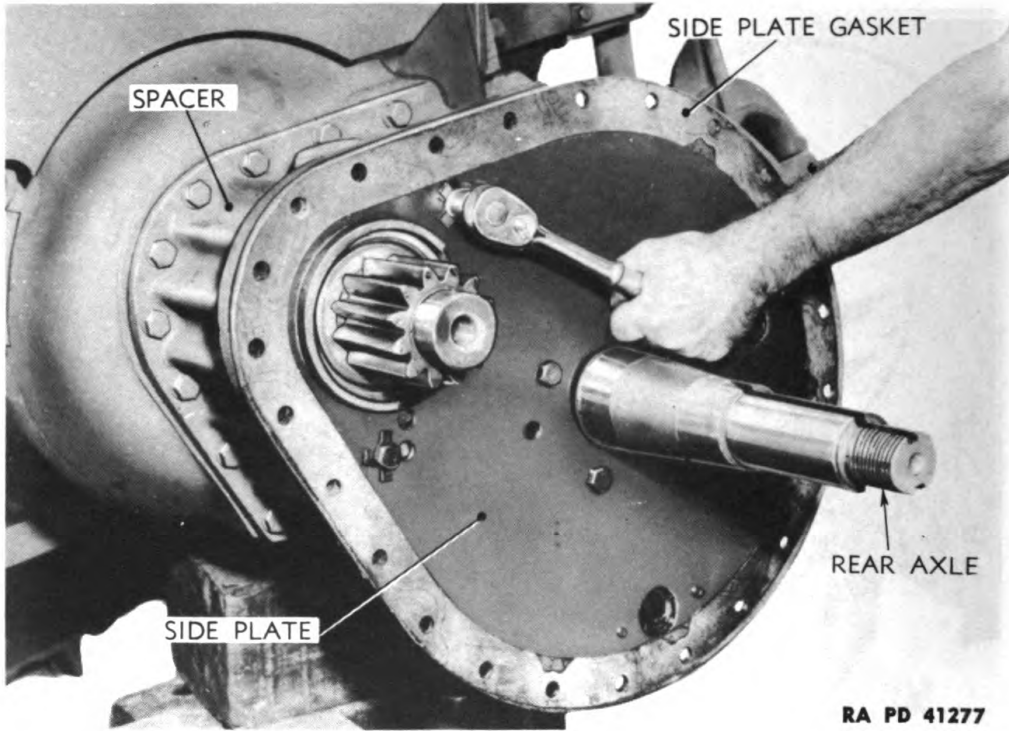

Figure 22 — Removing Side Plate Cap Screws

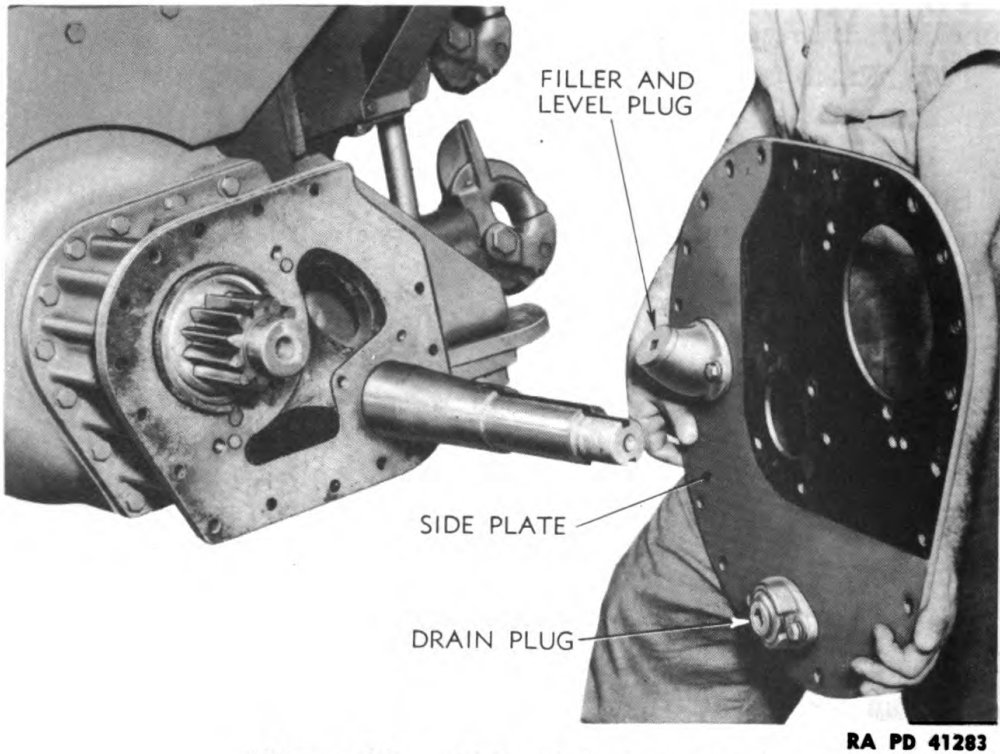
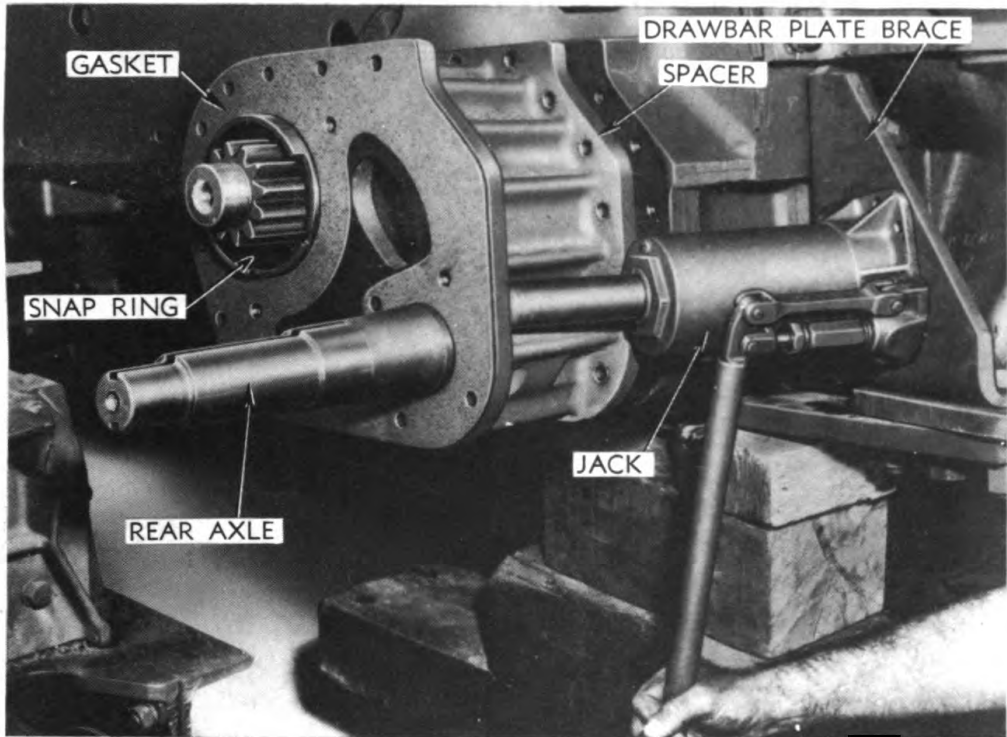

Figure 23 — Side Plate Removed

FINAL DRIVES



RA PD 41292

Figure 24 — Forcing Spacer off Axle Shaft

b. Procedure.

(1) DISASSEMBLE PINION ASSEMBLY.

Press, arbor

Place pinion shaft in press and press shaft out of outer pinion bearing.

(2) REMOVE SPROCKET BOLTS.

Hammer, soft

Wrench, $\frac{9}{16}$ -in. (2)

Pliers

Pull cotter pin (pliers) and remove the two bolts from clamp around final drive gear hub (two $\frac{9}{16}$ -in. wrenches) (fig. 25). Remove clamps. Drive sprocket bolts from gear hub with soft hammer (fig. 26).

(3) DISASSEMBLE OUTER SEAL ASSEMBLY.

Pliers

Remove the three cotter pins and remove outer seal boot assembly from drive plate (fig. 27). Remove seal boot from seal follower assembly. Remove washer from seal follower pins. Remove springs from follower pins (fig. 34).

(4) DISASSEMBLE REAR AXLE BRACKET.

Wrench, $\frac{9}{16}$ -in.

ORDNANCE MAINTENANCE — MEDIUM TRACTOR M1 (ALLIS-CHALMERS HD-7W)
ELECTRICAL SYSTEM, POWER TRAIN, FRAME, AND TRACKS

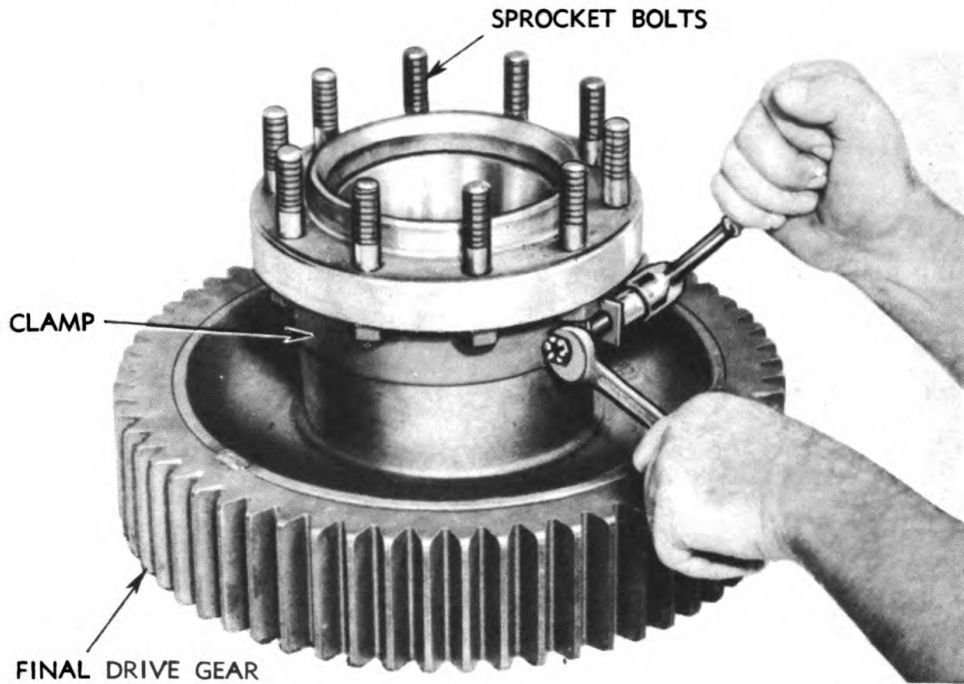

RA PD 41377

Figure 25 — Removing Clamp from Gear Hub

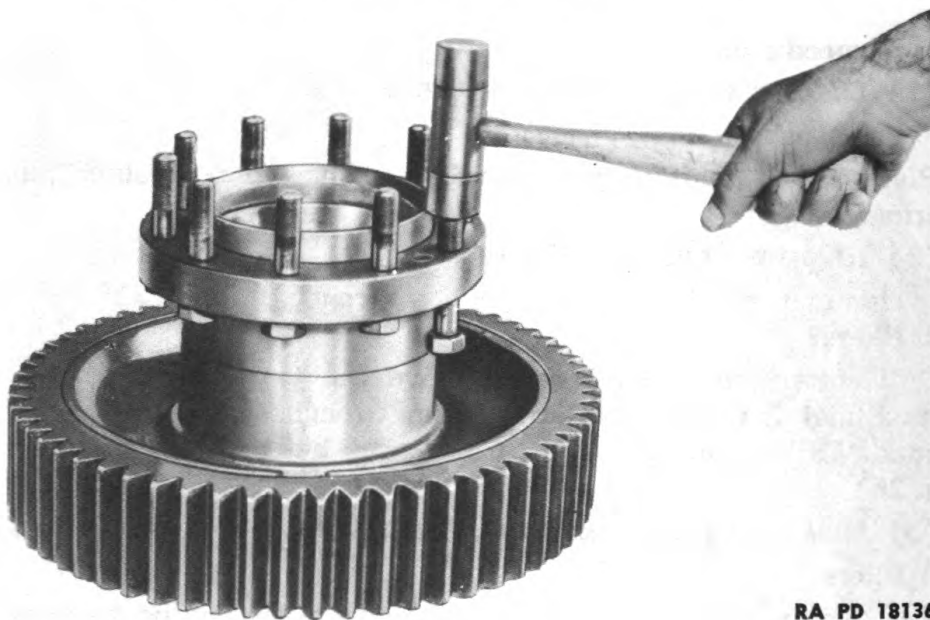

RA PD 18136

Figure 26 — Driving Sprocket Bolts out of Gear Hub Flange

Remove the three cap screws holding outer seal ring dirt shield to bracket (fig. 28). Remove shield. Remove seal rings and gasket (fig. 29)

FINAL DRIVES

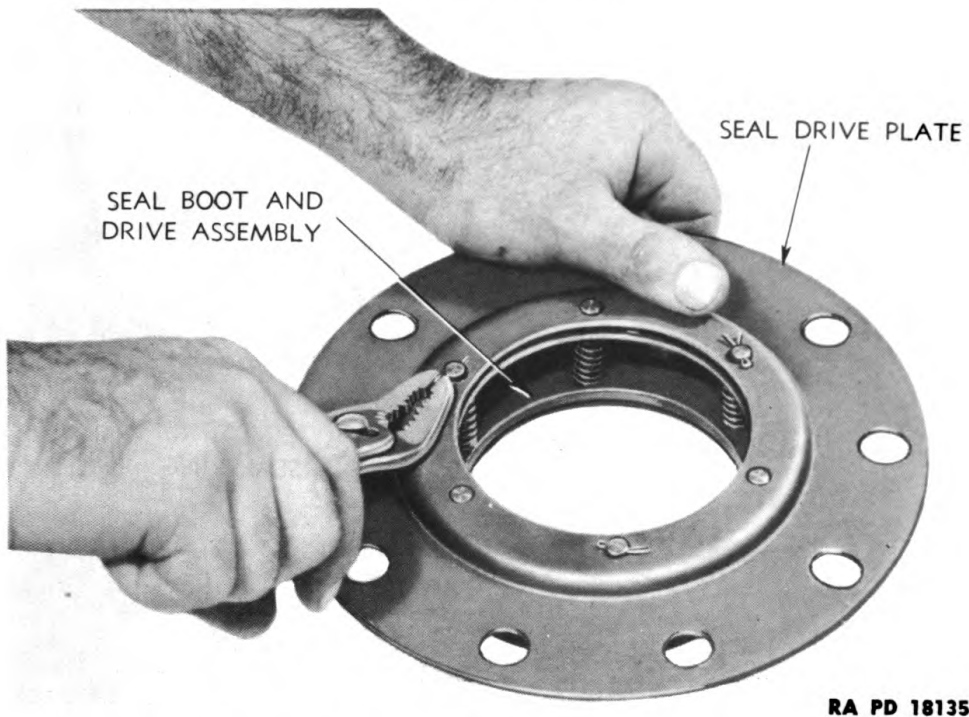

Figure 27 — Removing Outer Seal Drive Plate from Follower Assembly

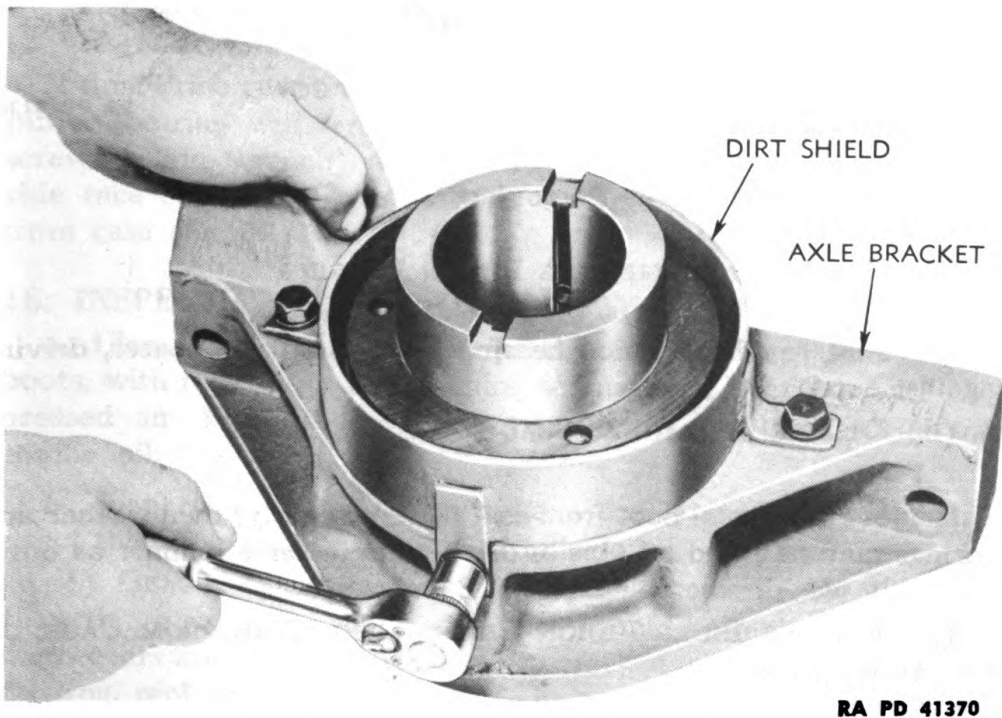

Figure 28 — Removing Outer Seal Ring Dirt Shield from Axle Bracket

**ORDNANCE MAINTENANCE — MEDIUM TRACTOR M1 (ALLIS-CHALMERS HD-7W)
ELECTRICAL SYSTEM, POWER TRAIN, FRAME, AND TRACKS**

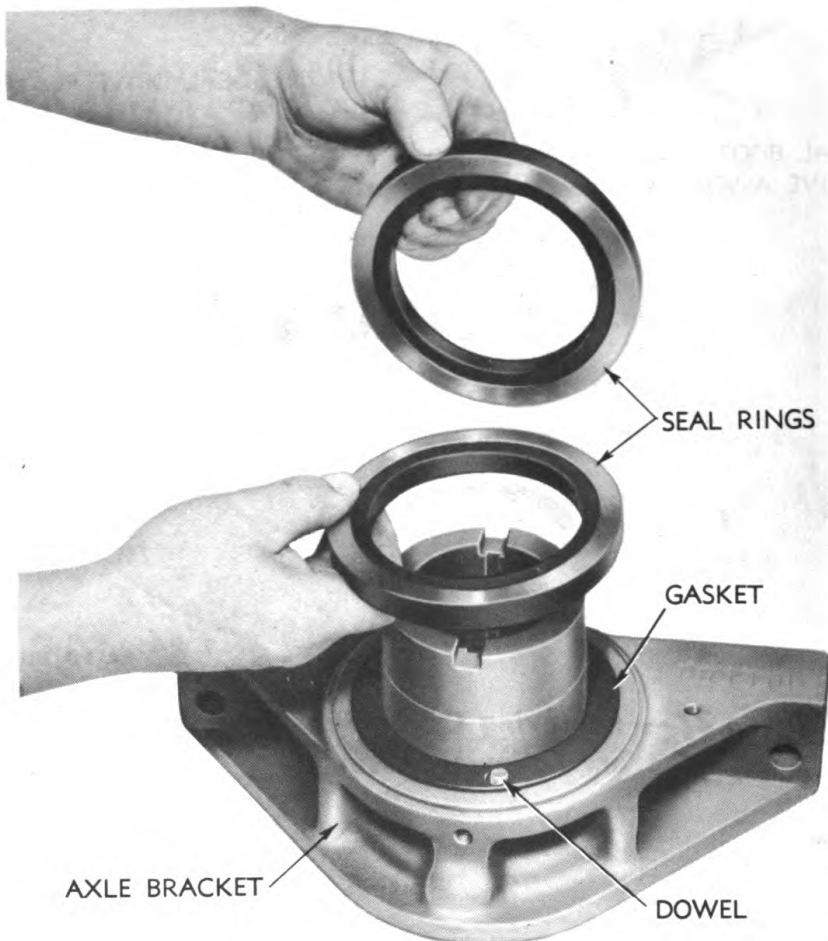

Figure 29 — Removing Outer Seal Rings

(5) REMOVE INTERMEDIATE PINION BEARING.

Bar, soft

Hammer, 2-lb

Drive intermediate pinion bearing from final drive spacer, driving against outer race of bearing.

(6) DISASSEMBLE INNER SEAL DRIVE ASSEMBLY.

Pliers

Remove inner seal boot from seal drive assembly; then washer and springs may be lifted off pins in drive plate in same manner as outer assembly was disassembled (step (3) above).

(7) REMOVE INNER PINION BEARING AND SEAL FROM CAGE.

Press, arbor

Place bearing cage in press, and press bearing from cage. Then turn cage over and press oil seal from other side of cage (figs. 38 and 39).

FINAL DRIVES

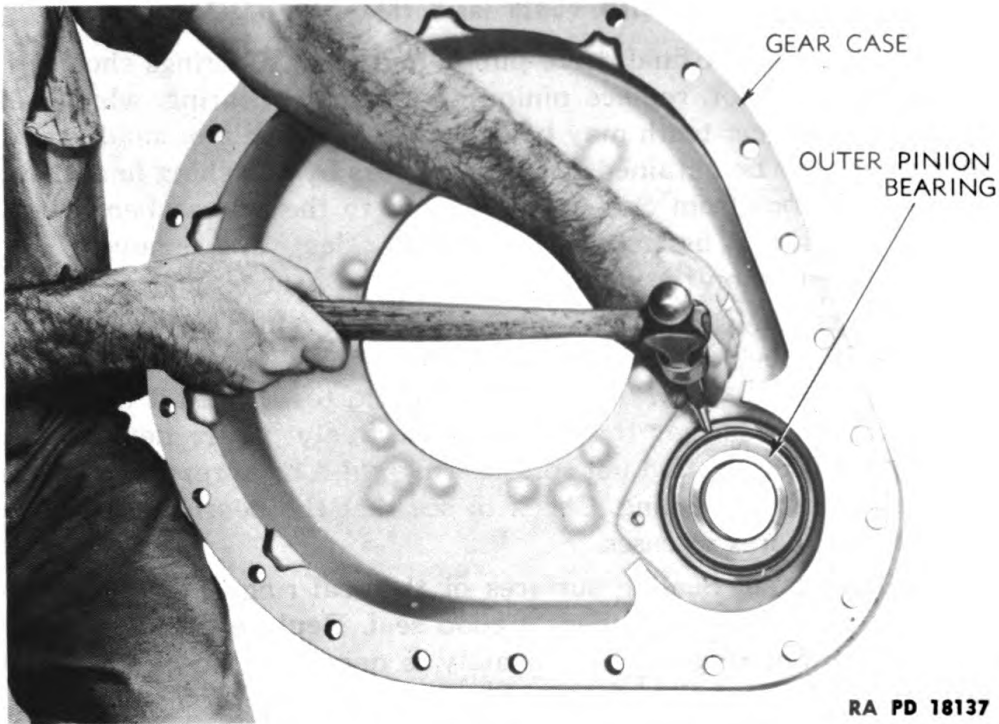

RA PD 18137

Figure 30 — Driving Outer Pinion Bearing from Case

(8) REMOVE OUTER PINION BEARING FROM GEAR CASE.

Bar, soft

Wrench, $\frac{3}{4}$ -in.

Hammer, 2-lb

If final drive gear and case assembly only were removed, the outer pinion bearing will remain in case. In this case, remove four cap screws ($\frac{3}{4}$ -in. wrench) and lift cover from case; then drive on outside race of bearing with soft bar and hammer to remove bearing from case (fig. 30).

18. INSPECTION AND REPAIR OF PARTS.

a. Cleaning Parts. Wash all parts, with the exception of the seal boots, with fuel oil, or dry-cleaning solvent, and blow dry with compressed air. Wash seal boots with a rag soaked with clean light engine oil.

b. Inspection. After all parts have been thoroughly cleaned, inspect them for damage or wear as follows:

(1) **GEARS.** Examine gears for cracks, checks, or broken teeth. If teeth are worn to a sharp edge, they should be replaced, if replacement gears are available. If gears are cracked, checked, or have teeth missing, replace. Inspect keyway where gear is shrunk onto hub to be sure key is tight in slots. It is necessary to replace gear and the hub it is shrunk onto, if either is defective, as each gear is individually

**ORDNANCE MAINTENANCE — MEDIUM TRACTOR M1 (ALLIS-CHALMERS HD-7W)
ELECTRICAL SYSTEM, POWER TRAIN, FRAME, AND TRACKS**

fitted to hub. Inspect final drive pinion and shaft. Bearings should fit snug on shaft, if not, replace pinion and shaft or bearing, whichever is worn. Rough gear teeth may be smoothed with a file or small stone. Extra wear may be obtained from worn gears by switching final drive gears and pinions from one side of tractor to the other when assembling final drive, if assemblies from both sides were removed. The wear will then be on the opposite sides of the gear teeth.

(2) **BEARINGS.** Rotate bearings slowly by hand and inspect to determine if rollers are out of round, chipped, or if they bind in any one spot. Lubricate with light engine oil and test to see if they spin freely. Replace bearings that do not roll freely or are defective in any way. **CAUTION:** Do not spin bearings with compressed air while drying them after cleaning. Check to see that the bearings fit snugly on shafts and bores in cases.

(3) **OIL SEALS.** Sealing surfaces of the seal rings should be perfectly flat and smooth to effect a good seal. Replace both seal rings of each, if either ring of the assembly is damaged. Check to see if any dowels that hold on drive seal rings are broken off or missing. Broken dowels may be drilled out of holes and new ones installed. If seal boots are dry and out of shape when time comes to install them, dip them in boiling water and they will resume their correct shape. Replace bent seal guards and drive plates. Replace twisted seal boot follower assemblies. Replace oil seal in final drive pinion bearing cage, if worn or damaged.

(4) **REAR AXLE BRACKET ASSEMBLIES.** Inspect bracket and spacer for wear. Replace worn or damaged parts. Inspect threads in rear axle nut and on axle. If threads are damaged in nut, replace nut. Sometimes threads are damaged by tightening nut to adjust rear axle bearings with the clamp screw too loose, allowing nut to spread and climb threads. If threads on rear axle are damaged to the extent that it is impossible to screw a nut onto the axle, the threads must be repaired, or the axle removed and replaced.

(5) **SPROCKET.** Inspect sprocket for cracks and general wear. If sprocket teeth are excessively worn, replace the sprocket. Extra wear may be obtained from worn sprockets by switching sprocket removed from left side to right side of tractor when assembling, and changing sprocket removed from right side of tractor to left side. Wear will then be on opposite side of sprocket teeth. Straighten sprocket guards if bent out of shape. Repair breaks by welding. If bolt holes are worn large, weld the holes shut, and redrill the holes to correct size.

(6) **GEAR CASE, SPACER, AND SIDE PLATE.** Replace broken gear case, spacer or side plate except in cases where only small cracks and breaks are evident. These may be repaired by welding. Clean magnetic drain plug and test magnetism of small magnet in plug.

FINAL DRIVES

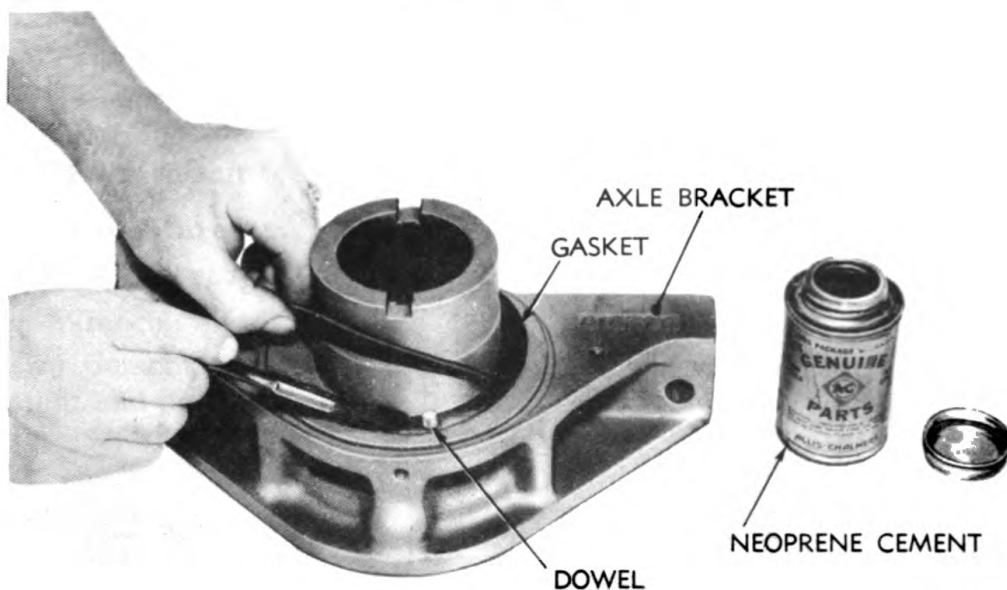

RA PD 41372

Figure 31 — Cementing Outer Seal Ring Gasket to Rear Axle Bracket

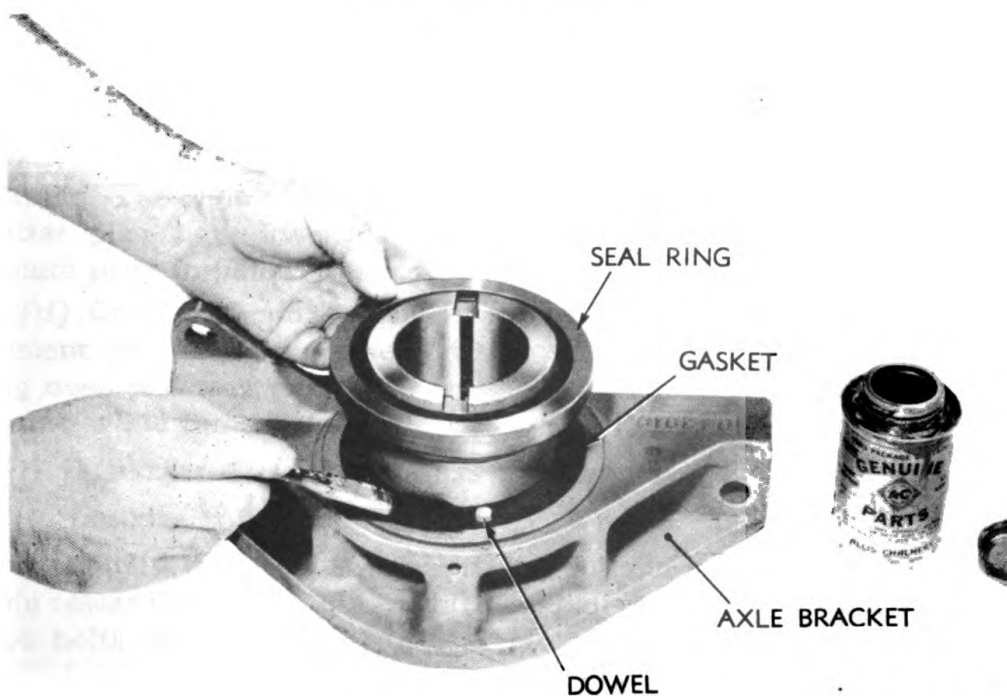

RA PD 41374

Figure 32 — Installing Outer Seal Ring on Bracket

The magnet must be strong enough to pick up small metal particles. Straighten lower dirt guard if bent, and repair if broken, by welding.

ORDNANCE MAINTENANCE — MEDIUM TRACTOR M1 (ALLIS-CHALMERS HD-7W)
ELECTRICAL SYSTEM, POWER TRAIN, FRAME, AND TRACKS

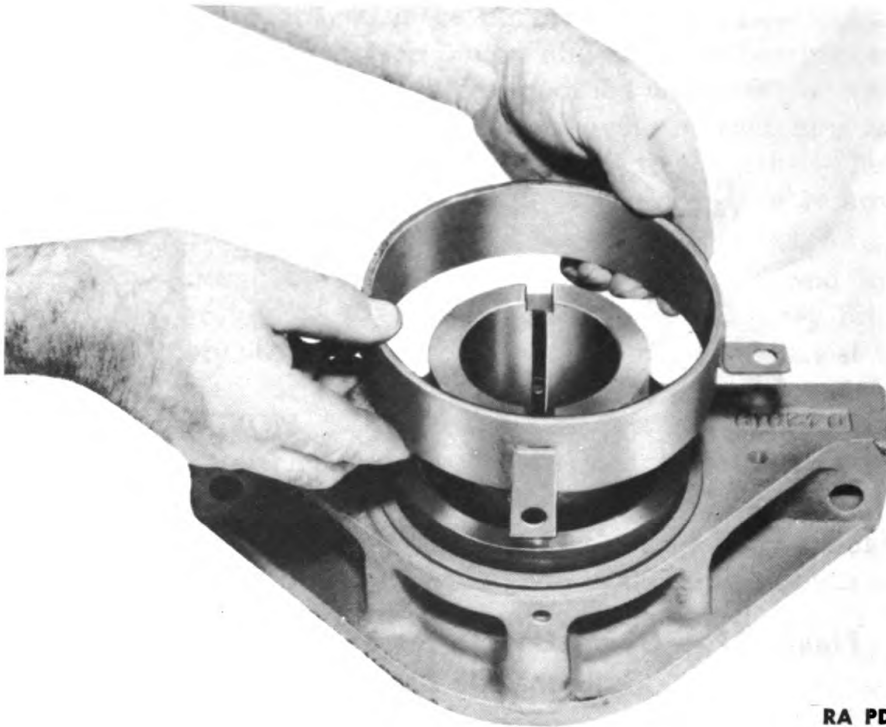

RA PD 41369

Figure 33 — Installing Outer Seal Dirt Guard on Bracket

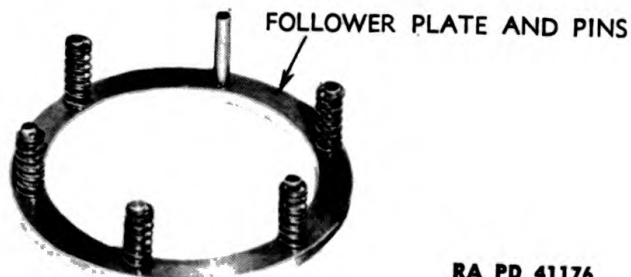

RA PD 41176

Figure 34 — Installing Springs on Follower Pins

FINAL DRIVES**19. ASSEMBLY.****a. Tools Required.**

Cement, Neoprene
 Cloth
 Hammer, soft

Pliers
 Press, arbor
 Wrench, $\frac{9}{16}$ -in. (2)

b. Procedure.**(1) ASSEMBLE REAR AXLE BRACKET ASSEMBLY.**

Wrench, $\frac{9}{16}$ -in.

(a) Cement both sides of outer seal ring gasket with Neoprene cement and place it on rear axle bracket over dowels (fig. 31). Install outer seal ring over dowels onto gasket (fig. 32). Place clean rag over seal face and put weight on it to hold seal ring in place while cement dries.

(b) Install outer seal ring dirt guard on rear axle bracket with three $\frac{3}{8}$ - x $\frac{3}{4}$ -inch cap screws with lock washers (fig. 33).

(2) ASSEMBLE OUTER SEAL FOLLOWER ASSEMBLY.

Pliers

(a) Install springs on each of follower pins (fig. 34). Install seal follower washer (fig. 35) above springs and onto pins in follower plate.

(b) Install seal boot over follower assembly and line up holes in boot with pins in follower plate (fig. 35). Cement boot to outer sides of follower washer and follower plate with Neoprene cement (fig. 35).

(c) Coat inner section of seal drive plate (fig. 36) with Neoprene cement. The ends of three pins in the follower plate have holes for cotter pins. Lay drive plate on follower assembly over pins and secure plate to follower assembly with cotter pins through three pins.

(d) Coat remaining outside flange of seal boot with Neoprene cement and install outer seal ring on dowels (fig. 37). Place clean rag over seal face and place weight on it to hold parts tightly together while cement dries.

(3) INSTALL SPROCKET BOLTS IN GEAR HUB.

Hammer, soft

Wrench, $\frac{9}{16}$ -in. (2)

Install the ten $\frac{5}{8}$ - x 3-inch sprocket bolts in gear hub flange from side toward gear (fig. 26). Install two half-clamps on gear hub using two bolts, nuts, and lock washers. Hold clamp up against heads of sprocket bolts, tighten nuts and install cotter pins through nuts and bolts (fig. 25). Clamp holds bolts in hub while sprocket is being installed.

(4) ASSEMBLE INNER SEAL DRIVE ASSEMBLY.

Pliers

Assemble inner seal drive assembly in same manner as outer seal (step (2) above). Install inner seal springs on pins in drive plate.

ORDNANCE MAINTENANCE — MEDIUM TRACTOR M1 (ALLIS-CHALMERS HD-7W)
ELECTRICAL SYSTEM, POWER TRAIN, FRAME, AND TRACKS

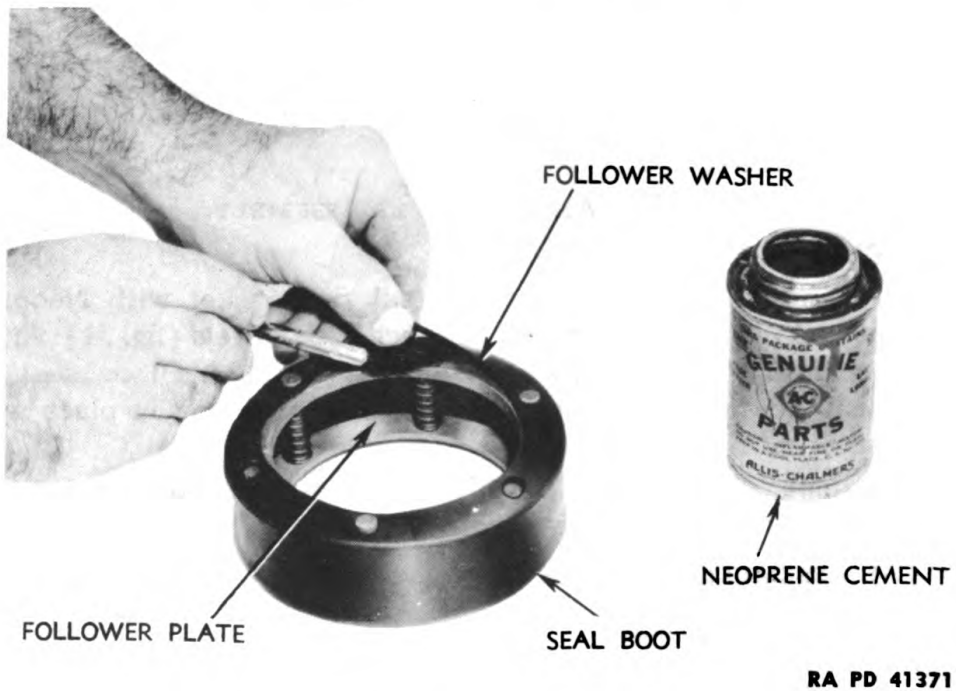

Figure 35 — Cementing Boot to Follower Assembly

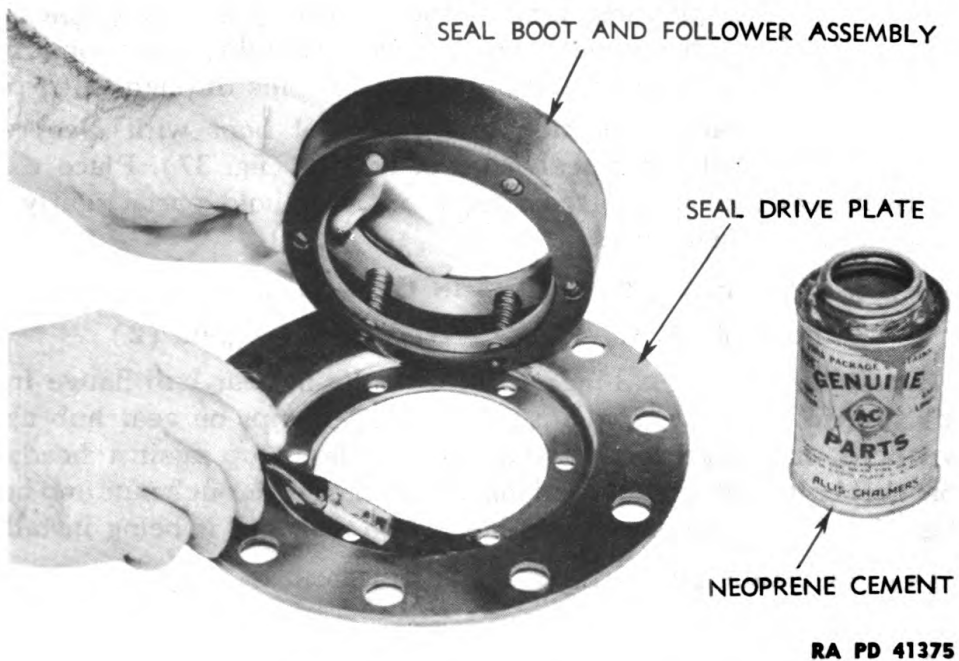
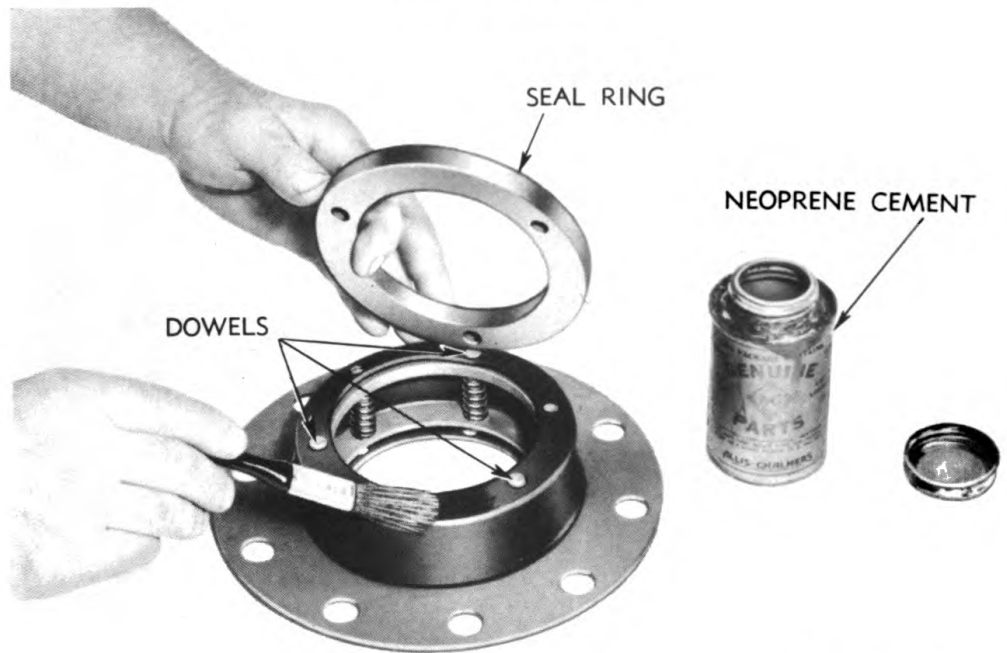

Figure 36 — Applying Cement to Seal Drive Plate

FINAL DRIVES



RA PD 41373

Figure 37 — Installing Seal Ring on Follower Assembly

Place washer over springs and pins. Hold assembly together with one hand and install rubber seal boot over assembly with holes in boot in line with pins. Apply Neoprene cement between drive plate and washer and inside of boot to cement boot to follower assembly.

(5) INSTALL INTERMEDIATE AND INNER PINION BEARINGS.

Press, arbor

Install intermediate pinion bearing into final drive spacer from end opposite snap ring, and press down against snap ring (fig. 24). Press inner pinion bearing into largest opening of bearing cage (fig. 38) and press oil seal into other side of cage (fig. 39) with sealing lip toward bearing just installed.

(6) INSTALL FINAL DRIVE BEARING CUPS IN GEAR HUB.

Press, arbor

Press final drive bearing cups into ends of final drive gear hub with beveled surfaces of cups facing toward outside of hub.

20. INSTALLATION.

a. Tools and Equipment Required.

- | | |
|-----------------------|-----------------------------------|
| Bar, brass | Hammer, soft |
| Bar, drift, 18-in. | Hardwood, block, 4- x 4- x 18-in. |
| Cement Neoprene | Jack, hydraulic, 10-ton |
| Chisel, 3/4-in. | Pipe, 2-in. x 4 ft |
| Hammer, 2-lb | |
| Hammer, sledge, 16-lb | |

**ORDNANCE MAINTENANCE — MEDIUM TRACTOR M1 (ALLIS-CHALMERS HD-7W)
ELECTRICAL SYSTEM, POWER TRAIN, FRAME, AND TRACKS**

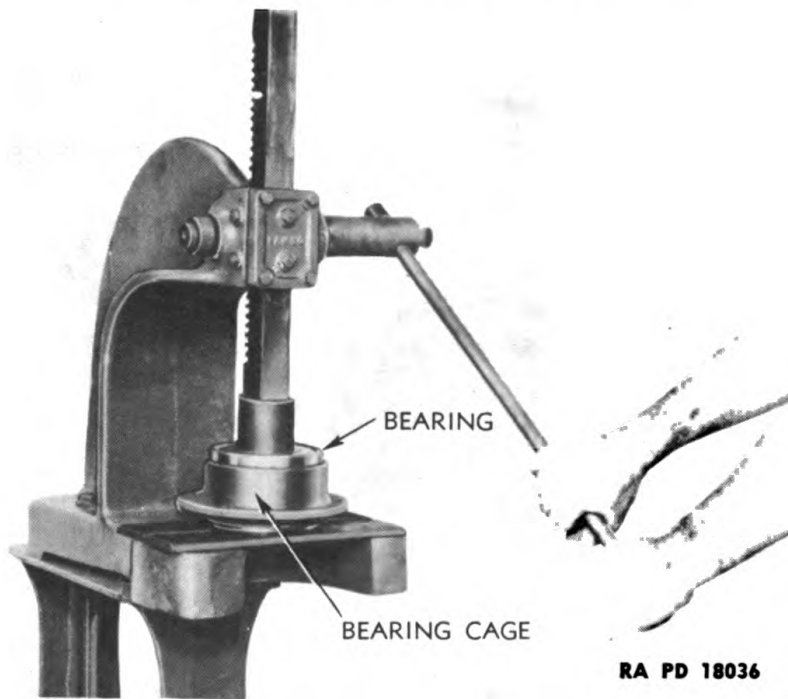

Figure 38 — Pressing Inner Pinion Bearing into Cage

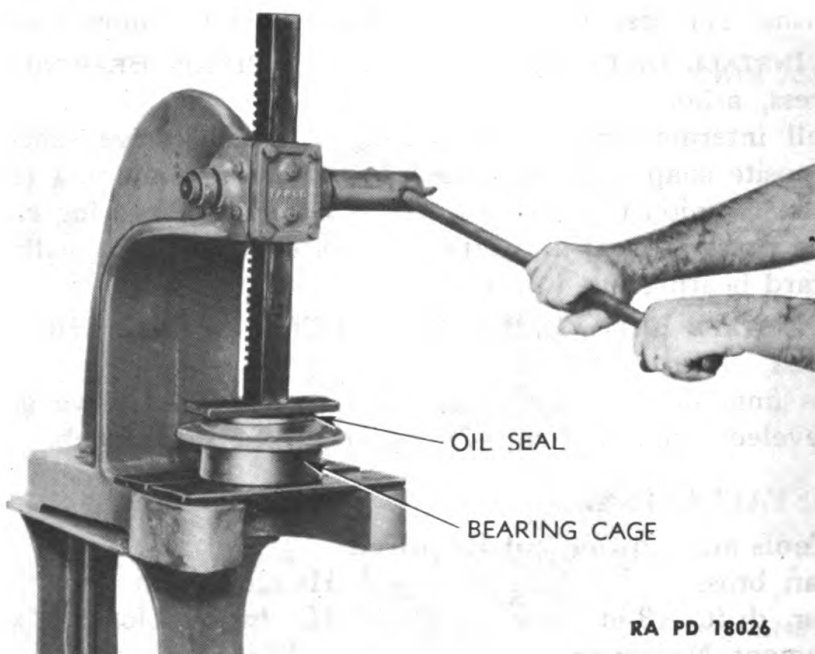
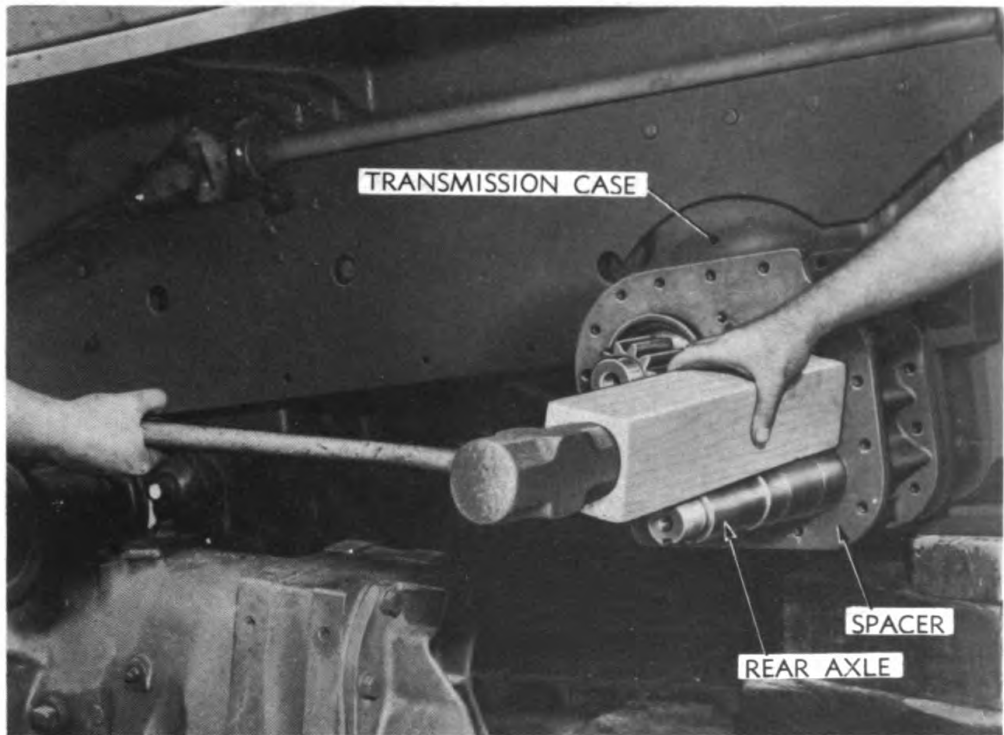

Figure 39 — Pressing Inner Oil Seal into Bearing Cage

FINAL DRIVES



RA PD 41288

Figure 40 — Installing Final Drive Spacer

- | | |
|------------------------------------|--|
| Puller assembly final drive pinion | Wrench, hexagonal, $\frac{3}{8}$ -in. |
| Shellac | Wrench, open-end, $\frac{3}{4}$ -in. |
| Wrench, 2-in. | Wrench, open-end, $\frac{15}{16}$ -in. |
| Wrench, $2\frac{1}{2}$ -in. | Wrench, socket, $\frac{3}{4}$ -in. |
| Wrench, box, $\frac{3}{4}$ -in. | Wrench, socket, $\frac{7}{8}$ -in. |
| | Wrench, socket, $\frac{15}{16}$ -in. |

b. Procedure.

(1) INSTALL FINAL DRIVE SPACER.

- | | |
|----------------------------------|------------------------------------|
| Hammer, sledge, 16-lb | Wrench, socket, $\frac{3}{4}$ -in. |
| Hardwood block, 4- x 4- x 18-in. | |

Shellac spacer gasket to transmission case. Install spacer over rear axle shaft, and drive into place with sledge hammer and wood block (fig. 40). Install the seventeen $\frac{1}{2}$ - x $1\frac{3}{4}$ -inch cap screws with lock washers to hold spacer to transmission case ($\frac{3}{4}$ -in. wrench).

(2) INSTALL SIDE PLATE.

- | | |
|----------------------------|--------------------------------|
| Chisel, $\frac{3}{4}$ -in. | Wrench, $\frac{3}{4}$ -in. (2) |
| Hammer, soft | |

Shellac side plate gasket on both sides and install on final drive spacer. Position side plate over axle shaft and pinion opening. Install

ORDNANCE MAINTENANCE — MEDIUM TRACTOR M1 (ALLIS-CHALMERS HD-7W)
ELECTRICAL SYSTEM, POWER TRAIN, FRAME, AND TRACKS

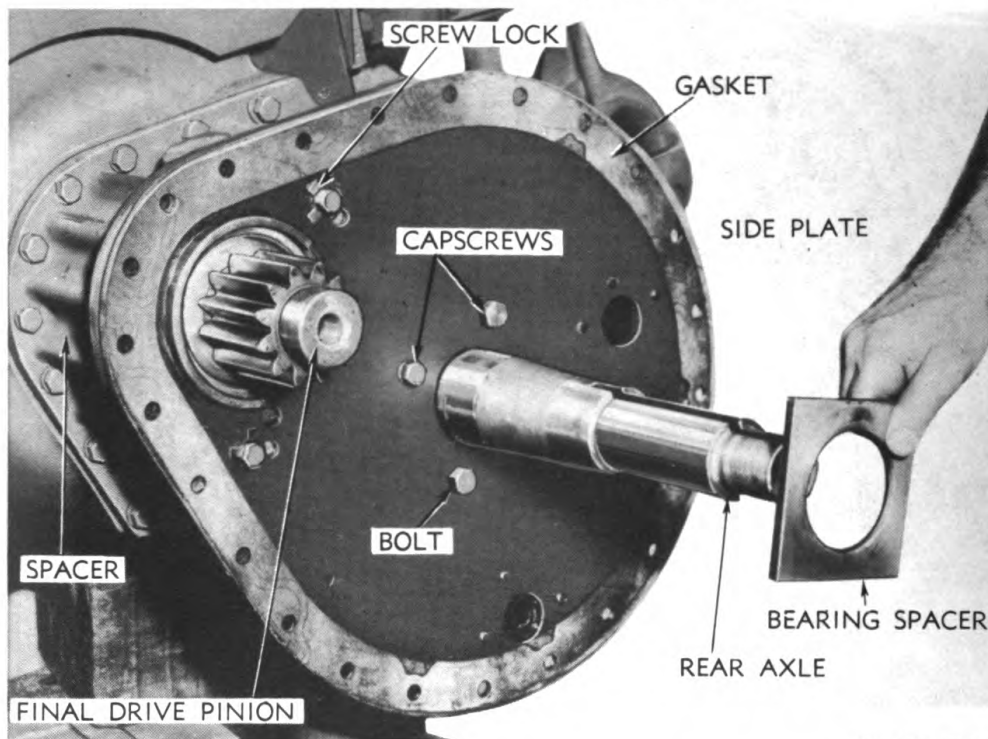

RA PD 41273

Figure 41 — Installing Spacer on Rear Axle Against Side Plate

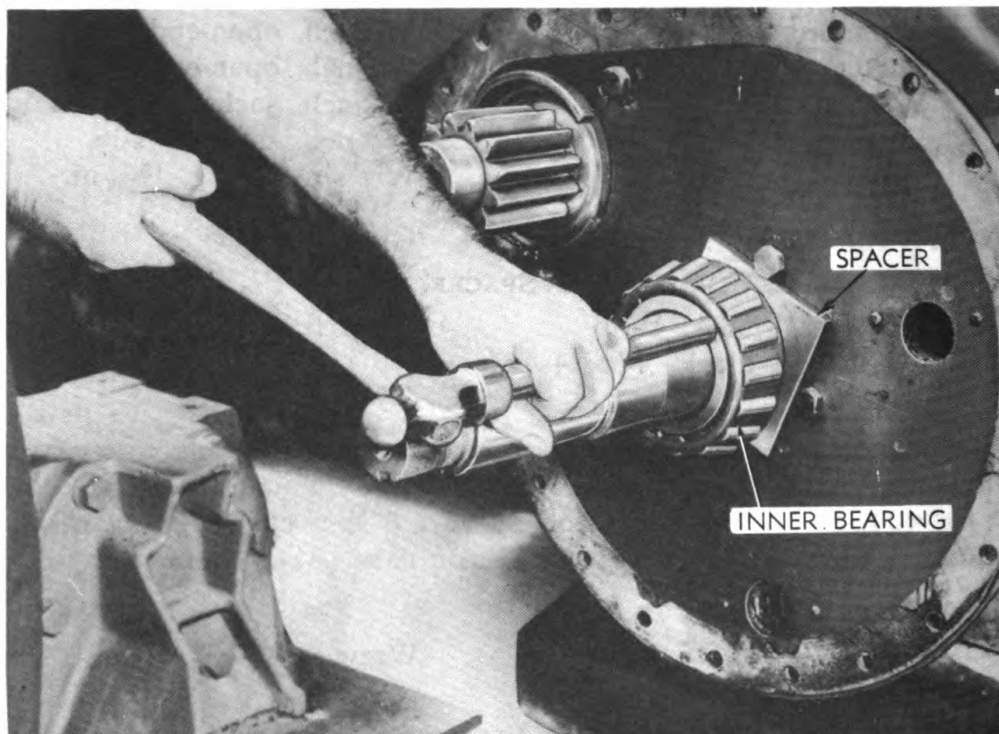

RA PD 18109

Figure 42 — Installing Inner Bearing on Rear Axle

FINAL DRIVES

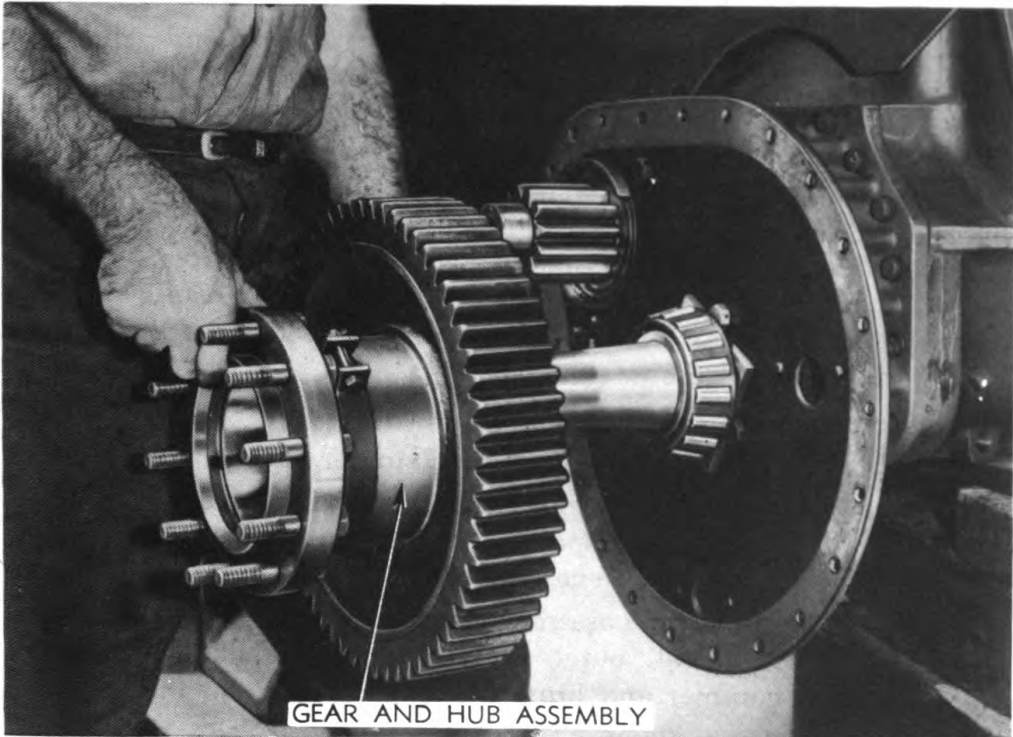

RA PD 41279

Figure 43 — Installing Final Drive Gear and Hub

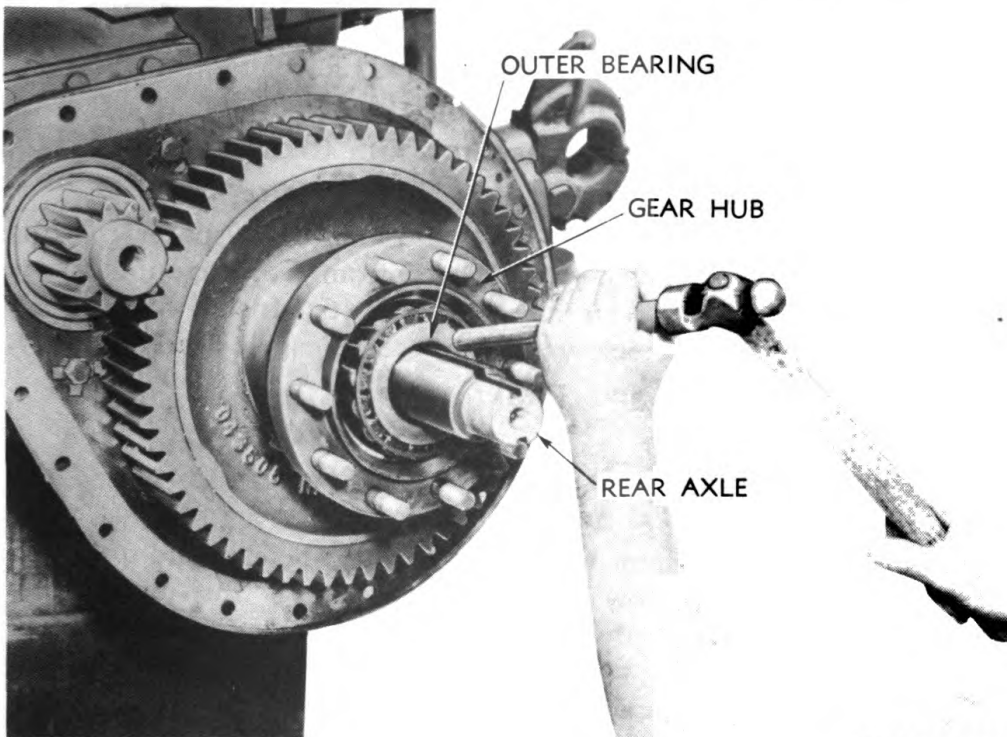

RA PD 18112

Figure 44 — Driving Outer Bearing into Place

**ORDNANCE MAINTENANCE — MEDIUM TRACTOR M1 (ALLIS-CHALMERS HD-7W)
ELECTRICAL SYSTEM, POWER TRAIN, FRAME, AND TRACKS**

the two 1/2- by 1-inch cap screws with screw locks near pinion holding side plate and gasket to final drive spacer (fig. 41). Bend locks over against heads of cap screws. Install two 1/2- by 1-inch cap screws in the two upper holes just above axle shaft and two 1/2- by 1 3/4-inch bolts with lock washers in the two holes below axle shaft (fig. 41). Position the heads of these cap screws and bolts when tightening them (two 3/4-in. wrenches) so that the spacer (figs. 41 and 42) may be installed to lock them from turning. Install the rear axle inner bearing spacer over shaft and place against side plate, locking the two cap screws and two bolts.

(3) INSTALL GEAR AND HUB ASSEMBLY.

Bar, brass
Hammer, 2-lb

(a) Install inner axle bearing, large end first, over axle shaft and drive into place against spacer with hammer and brass bar (fig. 42). Lubricate bearing with engine oil.

(b) Install gear and hub assembly over axle shaft (fig. 43). Lubricate with oil and install outer axle bearing over shaft and drive into place with hammer and brass bar (fig. 44).

(4) INSTALL GEAR CASE.

Shellac gear case gasket to side plate (fig. 22). Coat outer side of gasket with shellac. Install gear case, line up holes in case and side plate, and install ten 1/2- by 2 1/2-inch bolts and nine 1/2- by 1 1/2-inch bolts with lock washers to hold gear case to side plate (fig. 18), but do not tighten until outer pinion bearing has been installed, so that case can be lined up with pinion for installing bearing.

(5) INSTALL INNER PINION BEARING AND CAGE ASSEMBLY.

Hammer, soft
Wrench, socket, 3/4-in.

Install pinion bearing spacer (fig. 45) in final drive spacer, making sure that oil return cut-out portion is at bottom. Tap cage into place in transmission case with soft hammer (fig. 46). Install five 1/2- by 1 1/4-inch cap screws with lock washers to secure cage (3/4-in. wrench).

(6) INSTALL FINAL DRIVE PINION.

Bar, drift, 18-in.
Hammer, 2-lb
Wrench, 2-in.
Wrench, 2 1/2-in.

Puller assembly, final drive pinion

(a) Install puller adapter tightly in threaded hole in end of pinion shaft (2-in. wrench). Screw puller bolt with large nut and sliding ram on bolt tightly into adapter (2 1/2-in. wrench) and insert pinion into opening in final drive housing (fig. 8). Push pinion shaft through center bearing, through spacer between bearings, and through inner bearing. Outer pinion bearing may be installed on pinion before or after installation of pinion.

FINAL DRIVES

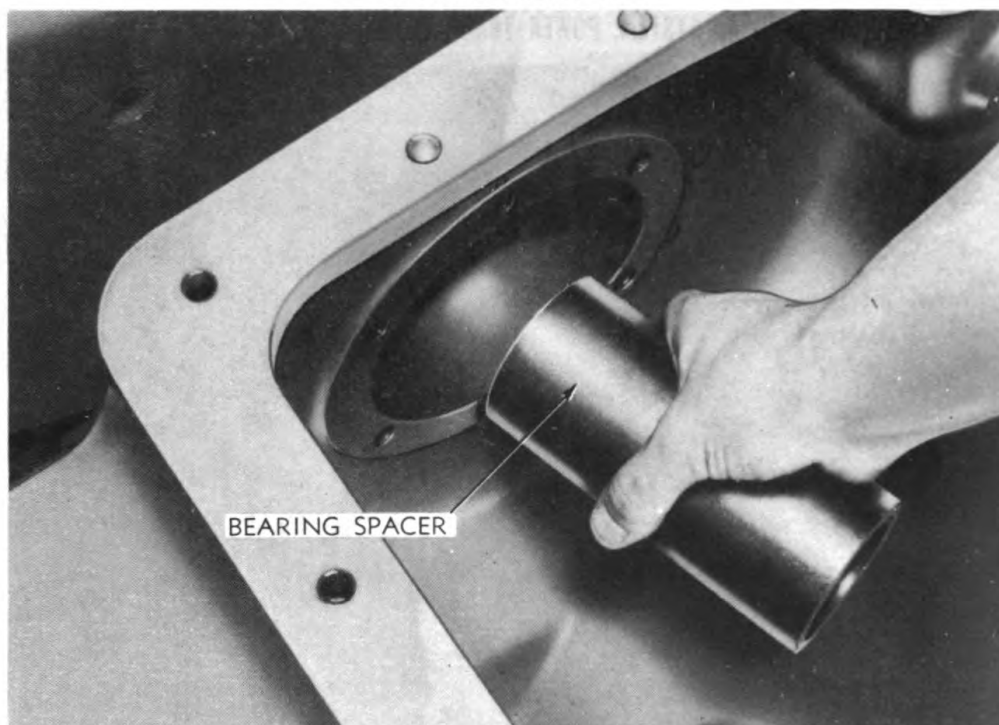

RA PD 41223

Figure 45 — Installing Pinion Bearing Spacer

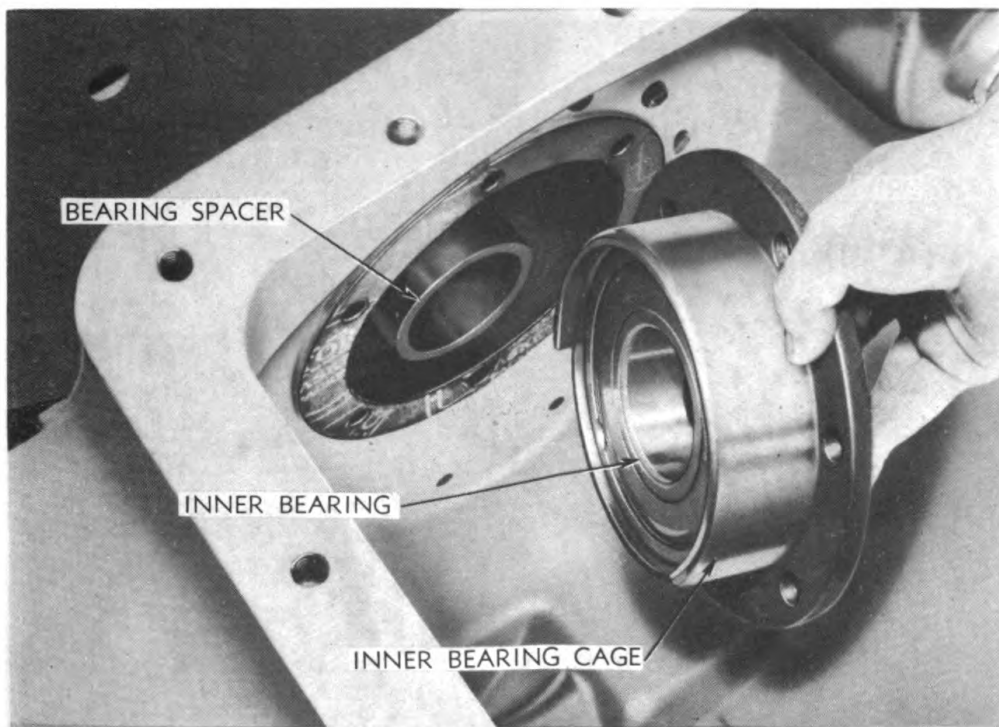

RA PD 41221

Figure 46 — Installing Pinion Bearing Cage and Bearing

ORDNANCE MAINTENANCE — MEDIUM TRACTOR M1 (ALLIS-CHALMERS HD-7W)
ELECTRICAL SYSTEM, POWER TRAIN, FRAME, AND TRACKS

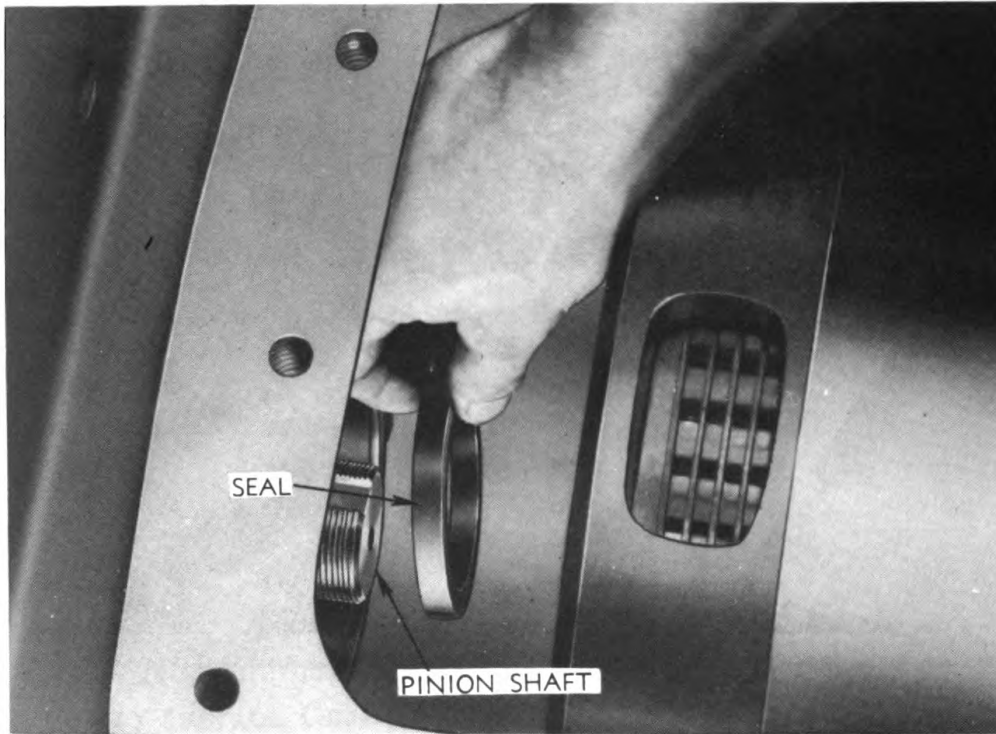

RA PD 41246

Figure 47 — Installing Duprene Seal

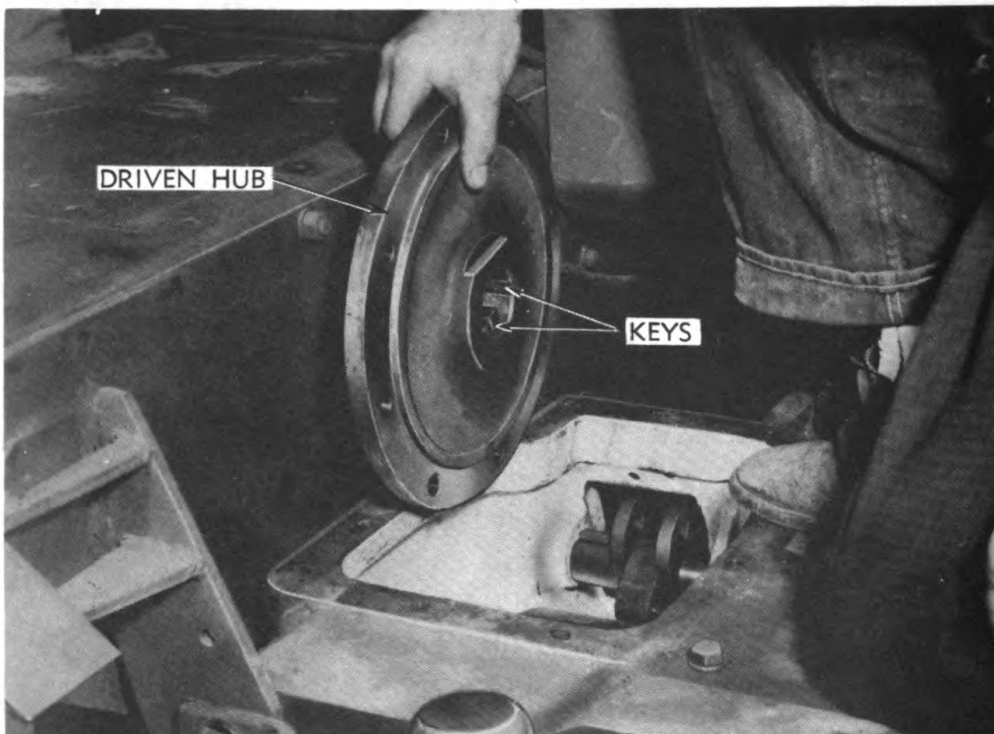

RA PD 41183

Figure 48 — Final Drive Driven Hub

FINAL DRIVES

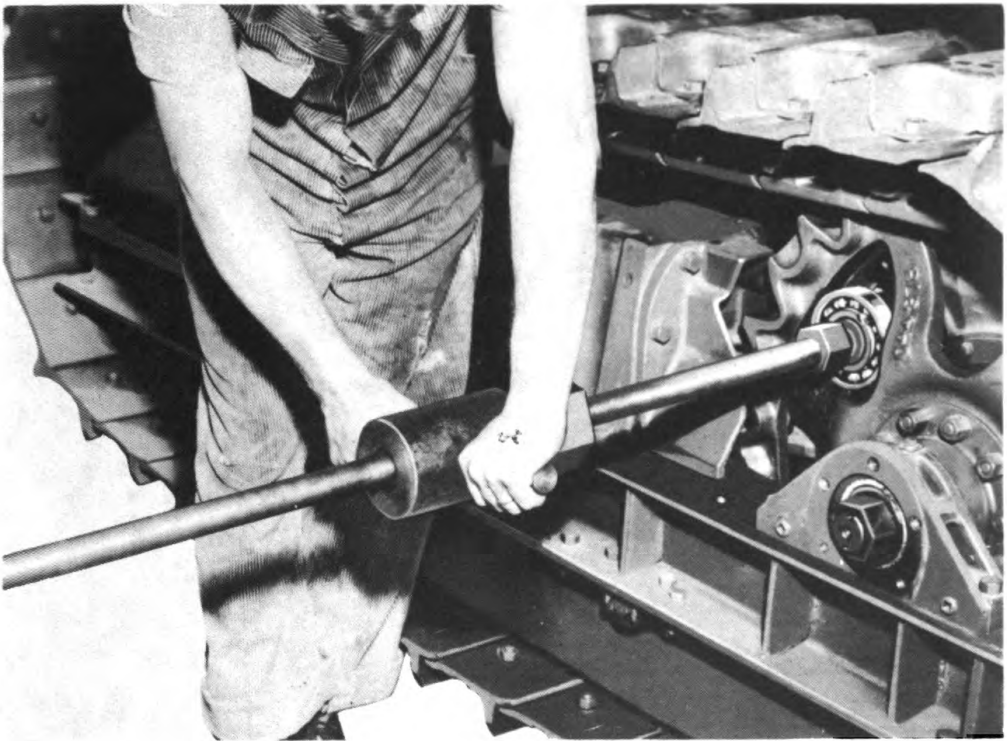

RA PD 41269

Figure 49 — Driving Pinion Shaft Through Bearings

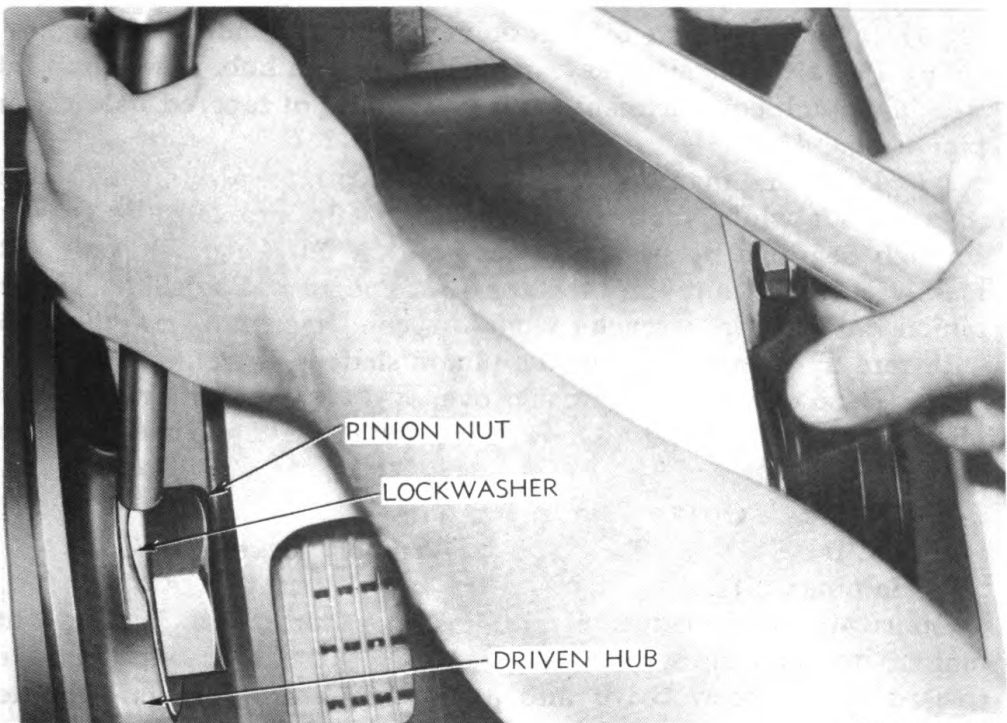

RA PD 41242

**ORDNANCE MAINTENANCE — MEDIUM TRACTOR M1 (ALLIS-CHALMERS HD-7W)
ELECTRICAL SYSTEM, POWER TRAIN, FRAME, AND TRACKS**

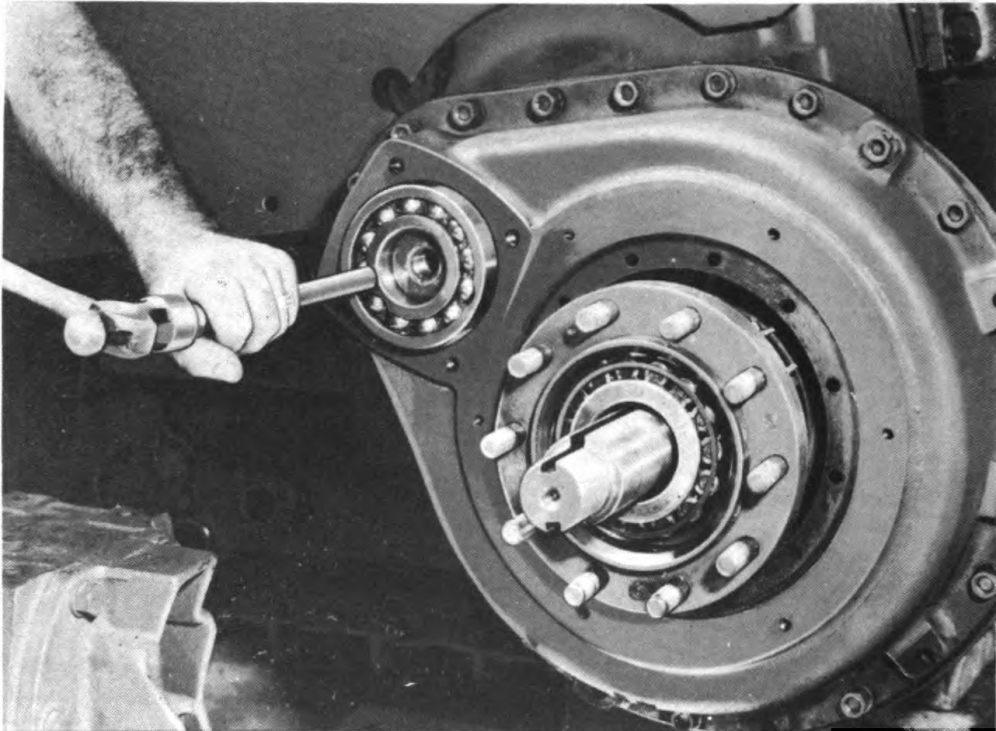

RA PD 41286

Figure 51 — Installing Outer Pinion Bearing

(b) Install Neoprene oil seal on inner end of pinion shaft (fig. 47).

(c) Place two straight keys in slots in driven hub. Lower hub into steering clutch compartment, with largest end of tapered hole toward pinion (fig. 48).

(d) Have one man hold hub with keys in hub in line with slots in pinion shaft while another man pushes shaft into hub. Force shaft through bearings by using the sliding ram on the puller bolt until lock washer and nut can be started on end of pinion shaft. Tighten pinion nut (2½-in. wrench) while a second man taps on puller bolt with ram to get a tight fit of the pinion shaft in driven hub (fig. 49).

(e) Bend edges of lock washer over two flat sides of nut with hammer and drift bar (fig. 50). Remove puller bolt and adapter from pinion.

(7) INSTALL OUTER PINION BEARING.

Bar, brass

Wrench, socket, ¾-in.

Hammer, 2-lb

Lubricate with engine oil and install outer pinion bearing onto pinion shaft and into gear case (fig. 51) with shielded side of bearing toward pinion gear. Drive into place with brass bar and hammer. Shellac gasket to cover and install cover with four ½- by 1½-inch cap screws with lock washers. Use ¾-inch wrench (fig. 5).

FINAL DRIVES

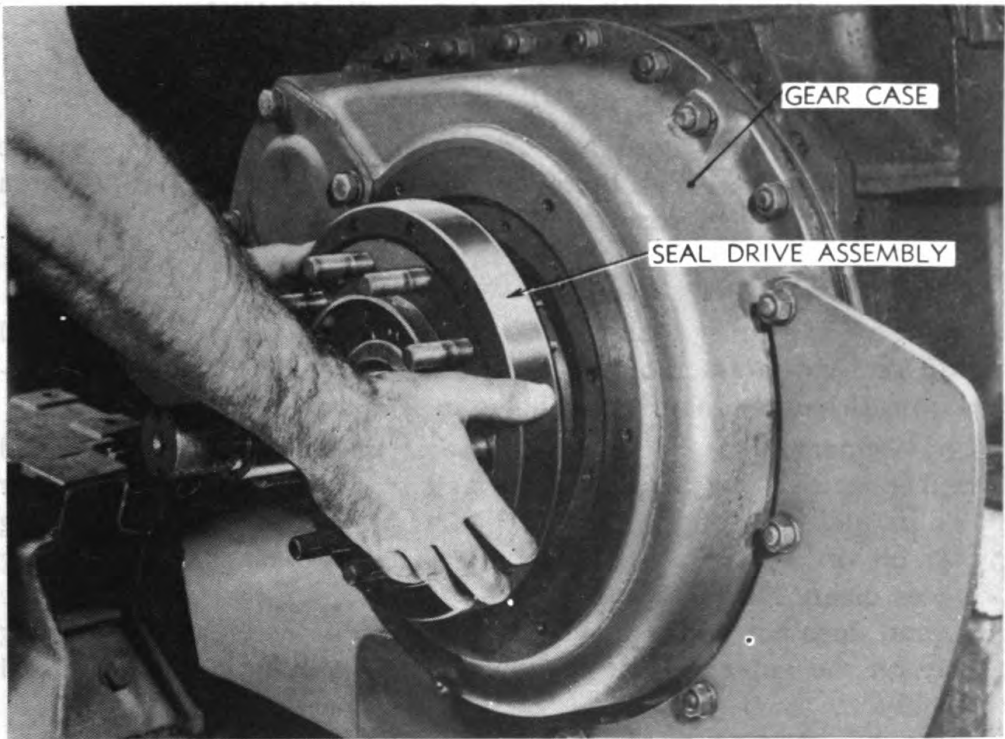

RA PD 41285

Figure 52 — Installing Inner Seal Drive Assembly

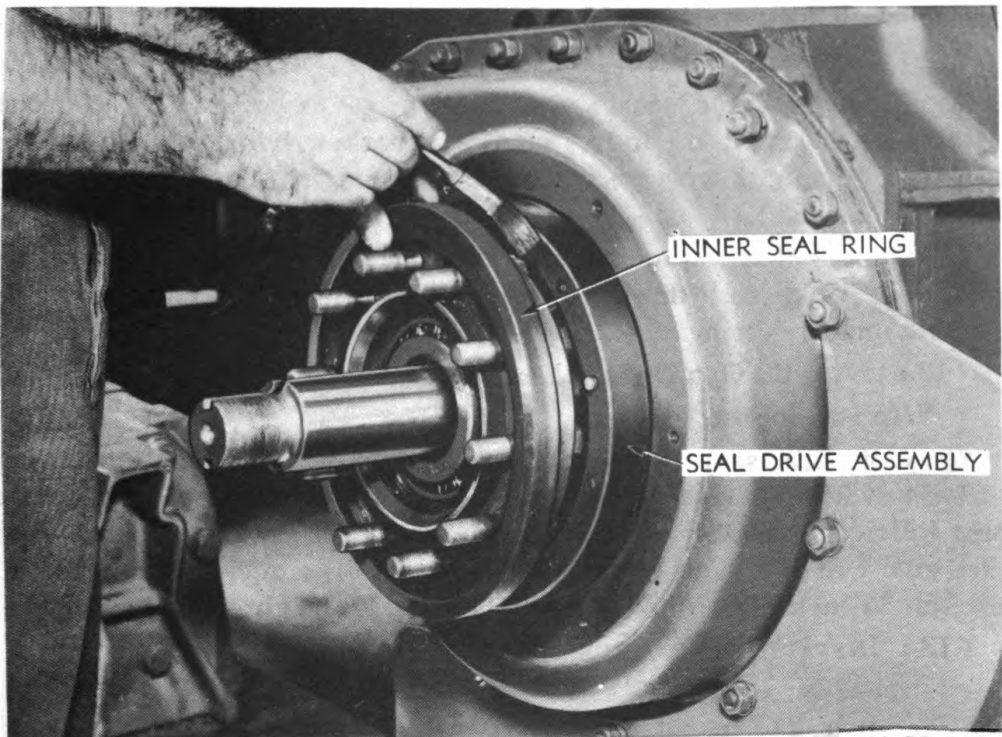

RA PD 18101

Figure 53 — Installing Inner Seal Ring on Seal Drive Assembly

**ORDNANCE MAINTENANCE — MEDIUM TRACTOR M1 (ALLIS-CHALMERS HD-7W)
ELECTRICAL SYSTEM, POWER TRAIN, FRAME, AND TRACKS**

(8) INSTALL DIRT GUARD.

Wrench, $\frac{3}{4}$ -in. (2)

Install lower dirt guard at bottom rear of final drive gear case with five $\frac{1}{2}$ - by $2\frac{3}{4}$ -inch bolts with lock washers (fig. 17). Tighten all bolts holding gear case to side plate (see fig. 18).

(9) INSTALL INNER SEAL ASSEMBLY.

(a) Coat the inner flange of seal boot with Neoprene cement and install seal drive assembly on gear case, being sure dowels projecting from drive assembly enter holes in gear case (fig. 52).

(b) Cement outer flange of seal boot with Neoprene cement and install inner seal ring, being sure dowels of seal drive assembly enter holes in seal ring (fig. 53). Install the other inner seal ring, using motor oil on sealing surface of both seal rings. Keep both bearing surfaces clean. **NOTE:** Be sure inner ring is properly located on the hub, and does not catch on surface of the hub. Test this by pushing gently on the outer seal ring, and note the spring action of the seal assembly.

(10) INSTALL INNER SEAL DIRT GUARD.

Wrench, socket, $\frac{9}{16}$ -in.

Bolt inner seal dirt guard to gear case with six $\frac{3}{8}$ - by $\frac{3}{4}$ -inch cap screws with lock washers (fig. 54).

(11) INSTALL DRIVE SPROCKET.

(a) Cement inner seal ring gasket to sprocket with Neoprene cement and install on inner side of sprocket, being sure holes in gasket are over dowels in sprocket. Coat outer side of gasket with cement (fig. 55).

(b) Install drive sprocket over shaft and onto bolts in gear hub (fig. 16). Make sure dowels on inner side of sprocket enter holes in outside inner seal ring.

(12) INSTALL OUTER SEAL ASSEMBLY.

Wrench, socket, $1\frac{5}{16}$ -in.

Cement outer seal drive plate gasket to outer race of hub bearing in bore of final drive sprocket (fig. 56). Install outer seal drive plate and follower assembly on sprocket bolts (fig. 57). Install outer seal dirt guard over follower and seal ring, and on sprocket bolts. Install the ten $\frac{5}{8}$ -inch high nuts on sprocket bolts and tighten.

(13) INSTALL REAR AXLE BRACKET ASSEMBLY.

Pipe, 2-in. x 4-ft

Wrench, hexagonal $\frac{3}{8}$ -in.

Wrench, $2\frac{1}{2}$ -in.

(a) Install inner thrust washer against outer axle bearing. Install bearing adjusting spacer over axle shaft (fig. 58).

FINAL DRIVES

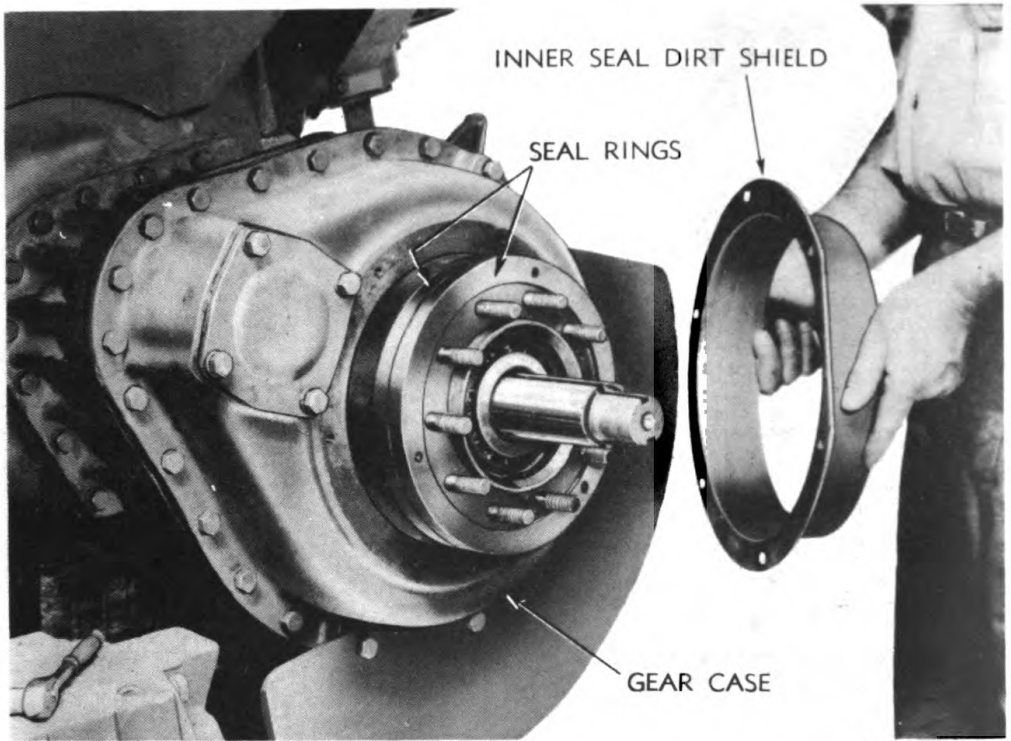

RA PD 41212

Figure 54 — Installing Inner Seal Dirt Guard

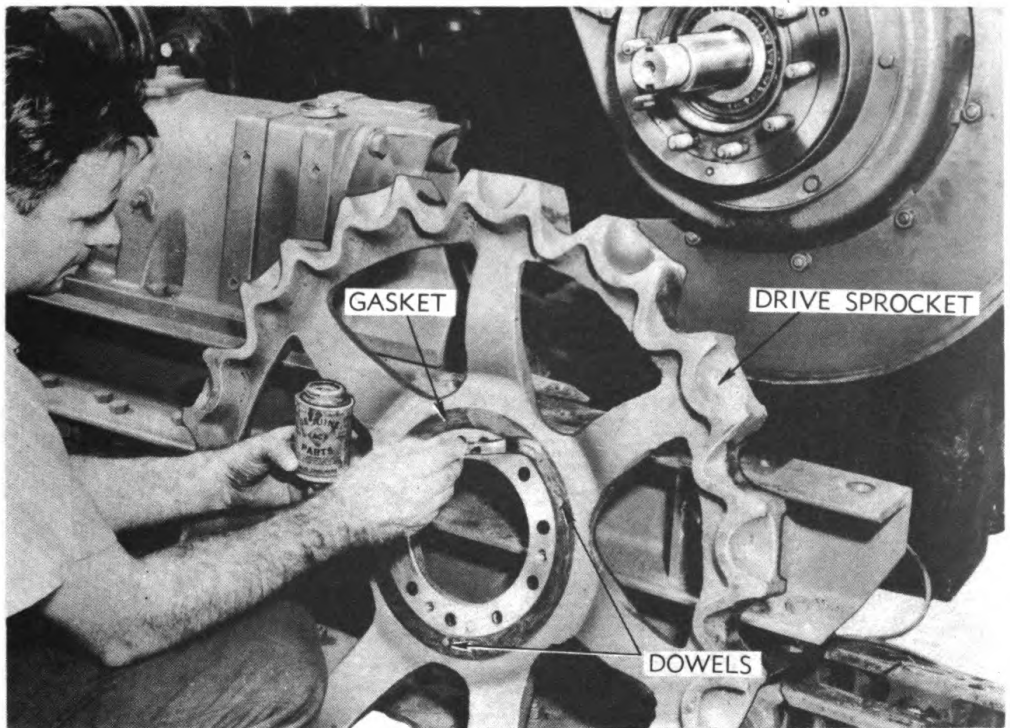

RA PD 18119

Figure 55 — Installing Seal Ring Gasket on Sprocket

**ORDNANCE MAINTENANCE — MEDIUM TRACTOR M1 (ALLIS-CHALMERS HD-7W)
ELECTRICAL SYSTEM, POWER TRAIN, FRAME, AND TRACKS**



RA PD 18117

Figure 56 — Installing Outer Seal Drive Plate Gasket

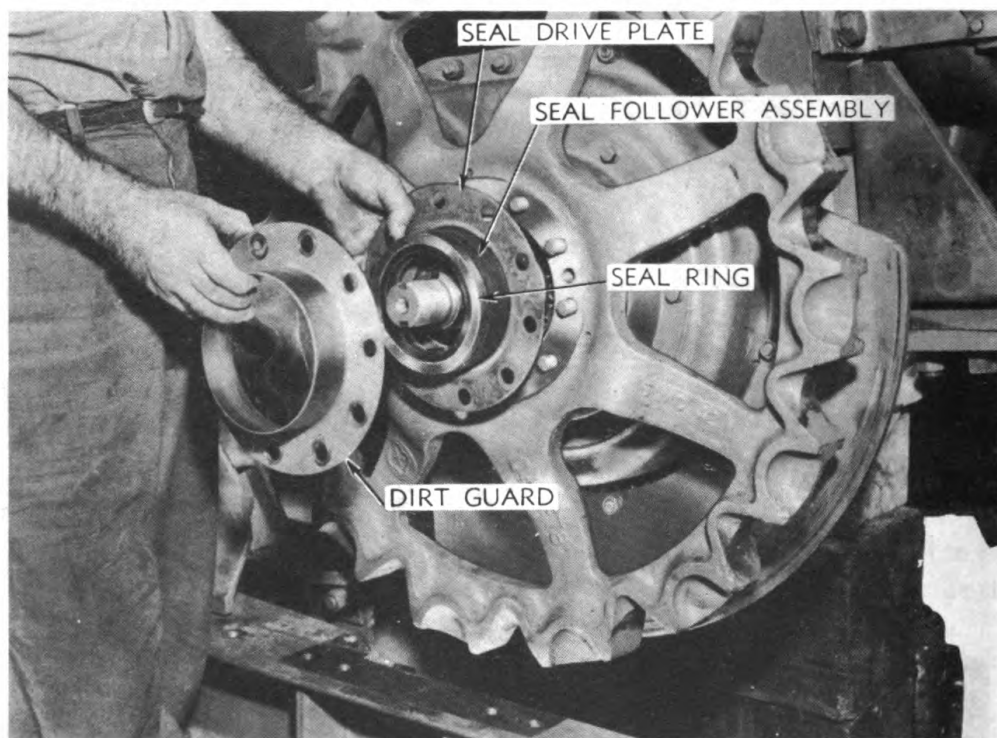

RA PD 18123

Figure 57 — Installing Outer Seal Drive Plate, Follower Assembly, and Dirt Guard

FINAL DRIVES

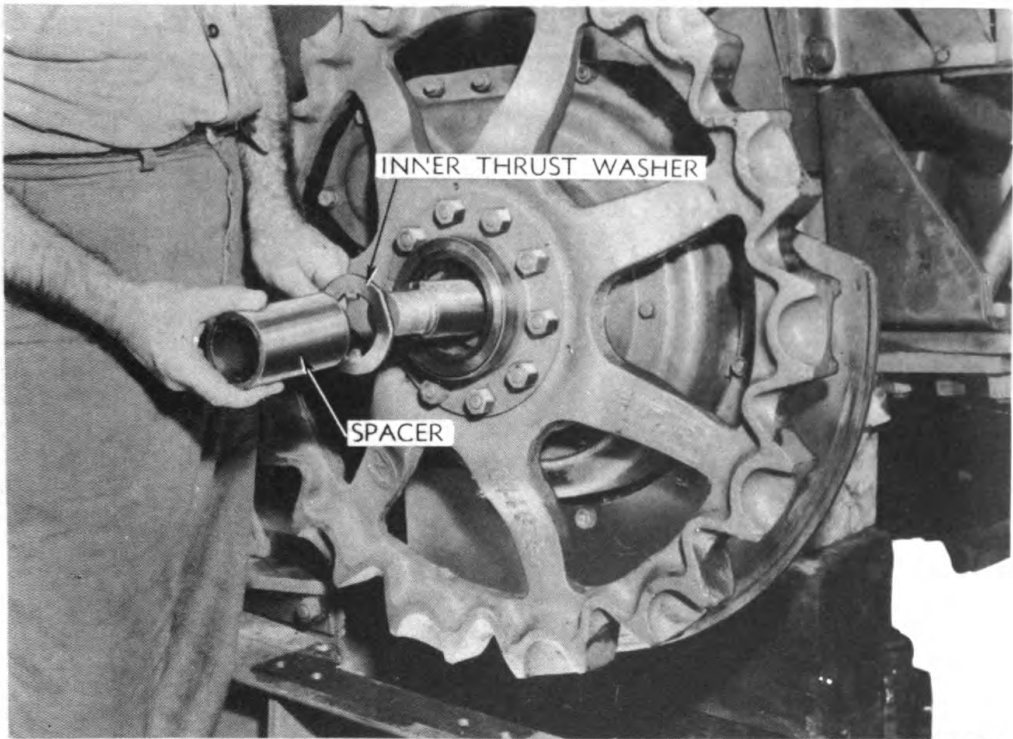

RA PD 18124

Figure 58 — Installing Thrust Washer and Bearing Spacer

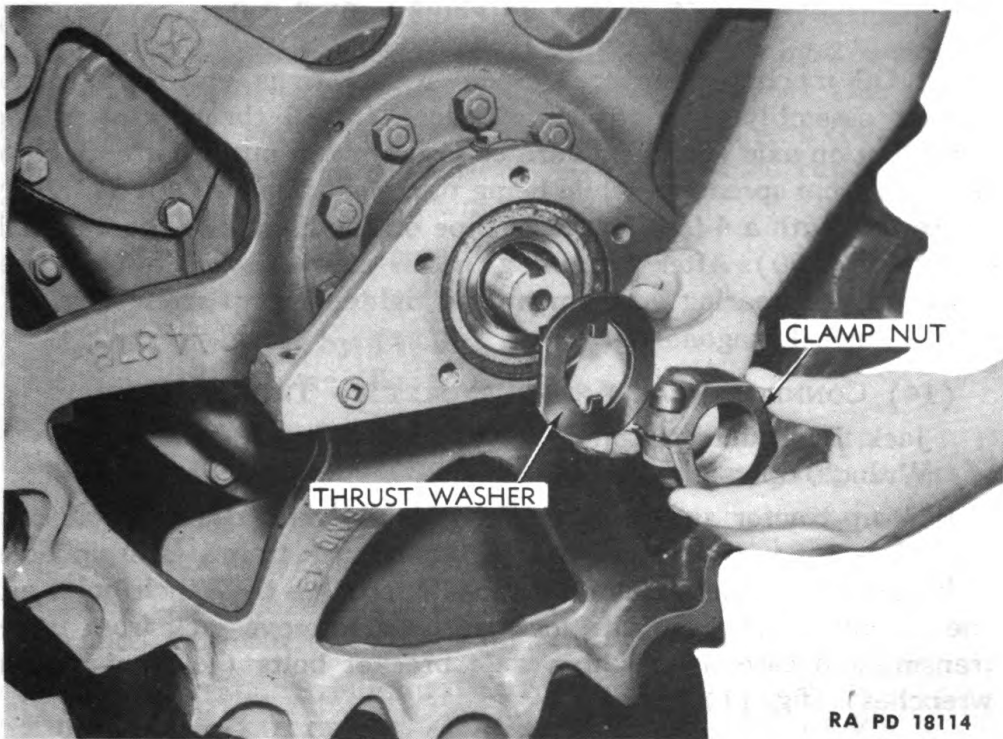

RA PD 18114

Figure 59 — Installing Thrust Washer and Clamp Nut

**ORDNANCE MAINTENANCE — MEDIUM TRACTOR M1 (ALLIS-CHALMERS HD-7W)
ELECTRICAL SYSTEM, POWER TRAIN, FRAME, AND TRACKS**

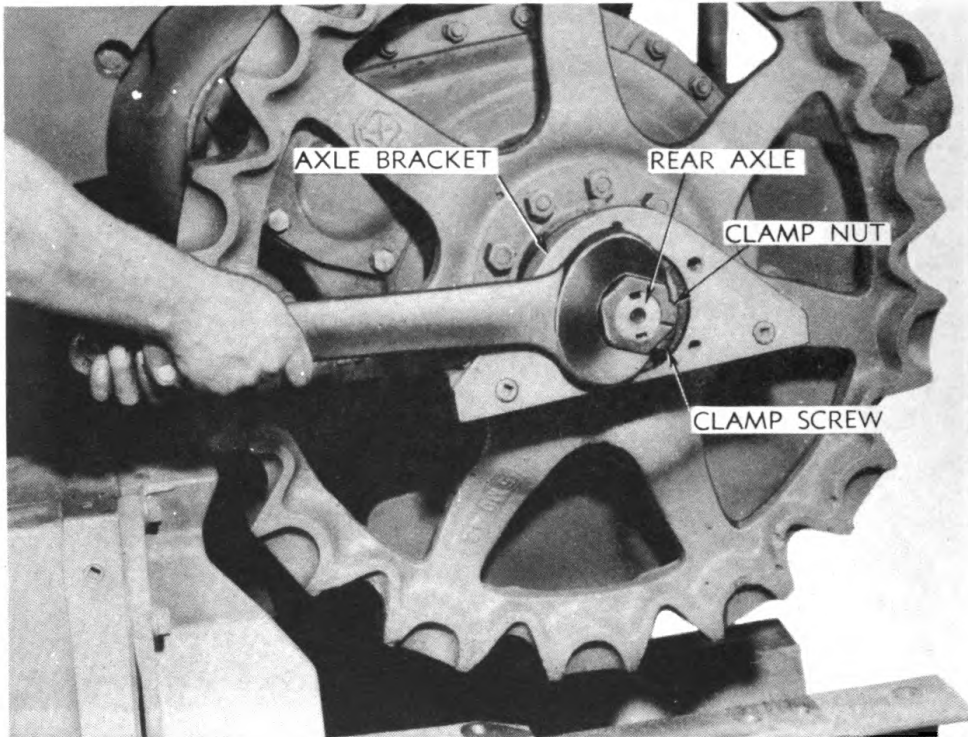

RA PD 18116

Figure 60 — Tightening Clamp Nut

(b) Oil machined surfaces of outer seal rings and install axle bracket assembly over adjusting spacer. Install thrust washer and clamp nut on axle (fig. 59). Turn clamp screw in nut in far enough to keep nut from spreading while being tightened. Tighten nut as tightly as possible with a 4-foot length of pipe on the handle of the 2½-inch wrench (fig. 60). After tightening in this manner, back nut off one-sixth turn for bearing adjustment and tighten clamp screw (fig. 12) with ⅜-inch hexagonal wrench.

(14) CONNECT REAR AXLE BRACKET TO TRUCK FRAME.

Jack, hydraulic, 10-ton

Wrench, socket, ⅞-in.

Wrench, open-end, 1⅝-in.

Jack up tractor and remove blocks from under transmission case. Lower tractor until axle bracket contacts truck frame. Line up holes in bracket and truck frame and install four ⅝- by 3-inch bolts and one ⅝- by 2-inch bolt with lock washers. Remove jack from under transmission case and tighten axle bracket bolts (⅞- and 1⅝-in. wrenches) (fig. 11).

(15) INSTALL SPROCKET GUARD AND END COVER.

Wrench, socket, ⅞-in.

Wrench, 1⅝-in.

FINAL DRIVES

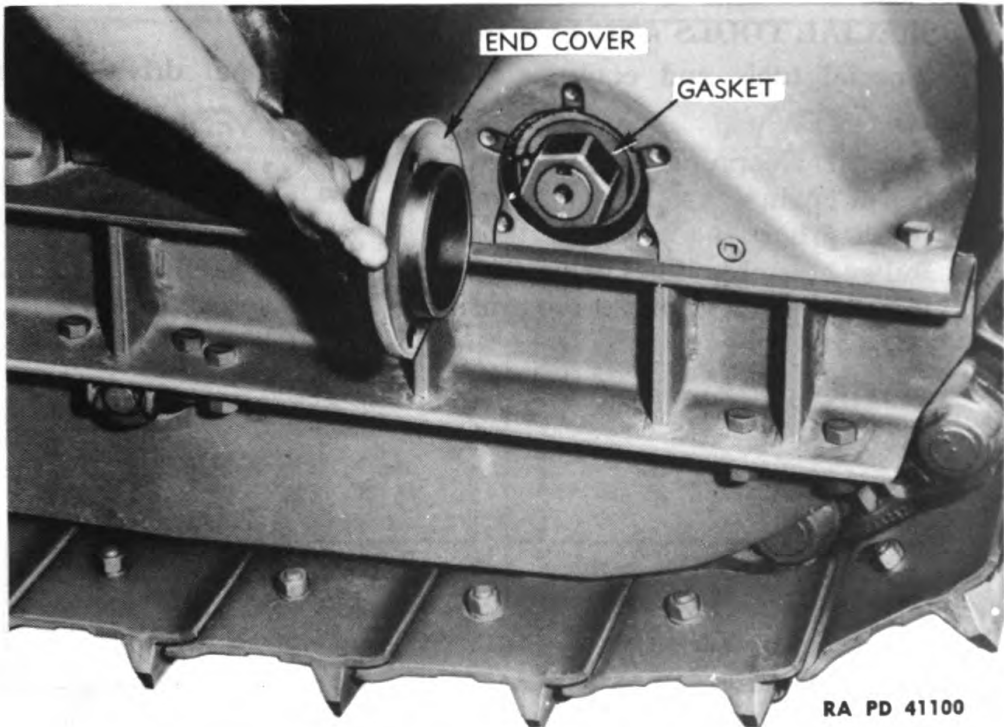

Figure 61 — Installing Rear Axle End Cover

(a) Install sprocket guard on truck frame with spacers placed between guard and truck frame. Install three $\frac{5}{8}$ - by $2\frac{1}{4}$ -inch bolts with lock washers, using $\frac{7}{8}$ - and $\frac{15}{16}$ -inch wrenches (fig. 4).

(b) Shellac gasket to bearing spacer and install end cover (fig. 61) to end of axle bracket with three $\frac{5}{8}$ - by $1\frac{3}{4}$ -inch cap screws with lock washers, using $\frac{7}{8}$ -inch wrench.

(16) INSTALL STABILIZER SPRING SEAT.

Wrench, socket, $\frac{7}{8}$ -in.

Install three $\frac{5}{8}$ - by $1\frac{1}{2}$ -inch cap screws to secure spring seat in place on truck frame (fig. 89).

(17) COUPLE AND ADJUST TRACKS.

Refer to paragraph 106 for procedure for coupling tracks, and paragraph 107 for adjusting tracks.

(18) FILL GEAR CASE WITH LUBRICANT.

Refer to TM 9-783B for lubrication specifications, and fill case with specified lubricant to level of filler plug.

(19) INSTALL STEERING CLUTCH THROW-OUT FORKS, COVERS, FUEL TANK, SEAL FRAME, AND POWER TAKE-OFF LINKAGE.

Refer to paragraph 51 b (9) through (21) on installation of steering clutches.

**ORDNANCE MAINTENANCE — MEDIUM TRACTOR M1 (ALLIS-CHALMERS HD-7W)
ELECTRICAL SYSTEM, POWER TRAIN, FRAME, AND TRACKS**

21. SPECIAL TOOLS AND EQUIPMENT.

a. Special tools and equipment required for final drive are as follows:

Cement, Neoprene

Hoist, chain

Press, arbor

Puller assembly, final drive gear and case (fig. 61A)

Puller assembly, final drive pinion

FINAL DRIVES

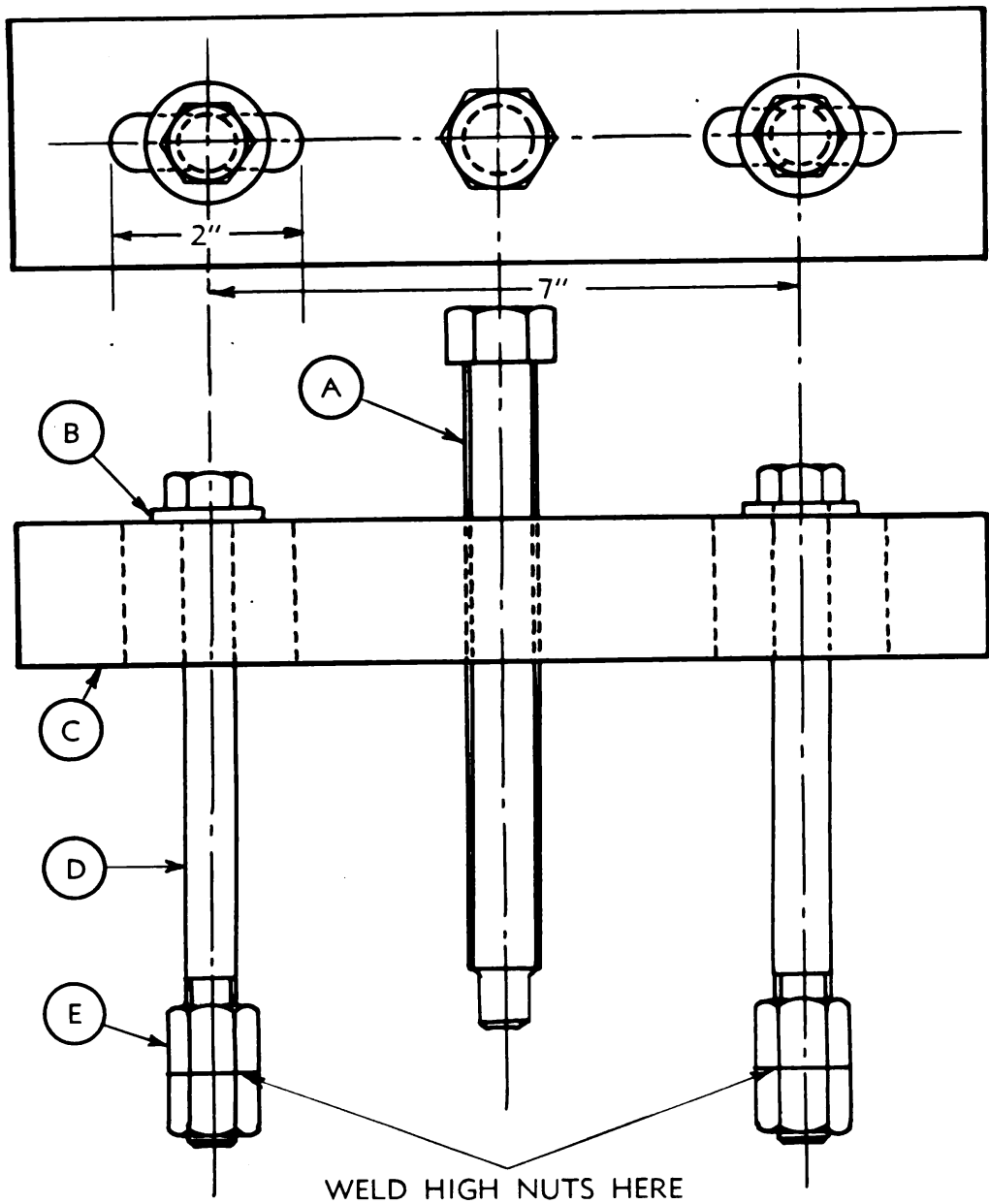

PARTS LIST

ITEM	QTY.	PART NAME
A	1	FULL THREAD PULLER STUD $\frac{7}{8}$ "-9 N.C. x 8"
B	2	PLAIN WASHER $\frac{5}{8}$ " x $1\frac{3}{8}$ " x 12 GA.
C	1	STEEL BAR $1\frac{3}{4}$ " x 3" x $11\frac{1}{2}$ "
D	2	BOLT $\frac{5}{8}$ "-18 N.F. x $7\frac{1}{2}$ "
E	4	HIGH NUT $\frac{5}{8}$ "-18 N.F.

RA PD 41443

Figure 61A — Drawing for Making Final Drive Gear and Case Puller Assembly

ORDNANCE MAINTENANCE — MEDIUM TRACTOR M1 (ALLIS-CHALMERS HD-7W)
ELECTRICAL SYSTEM, POWER TRAIN, FRAME, AND TRACKS

CHAPTER 6

INSTRUMENTS

	Paragraph
Purpose of instruments	22
Replacement of instruments	23

22. PURPOSE OF INSTRUMENTS.

a. Ammeter. The ammeter is a dial gage which registers the rate of charge delivered to the batteries by the generator while the engine is running, or discharge of current from the batteries when the engine is stopped (if lights or other electrical equipment is being used). If generator operation is normal, the needle swings toward the plus (+) side of the scale (unless batteries are fully charged, at which time the voltage control unit acts to prevent overcharging, and ammeter needle will register zero). When engine is not running, current used by electrical equipment on the tractor drains current from the batteries, the needle swings towards the minus (—) side of the scale, and registers rate of discharge from the battery. To check for causes of abnormal charge or discharge rate indicated by ammeter, refer to electrical system in TM 9-1783B.

b. Fuel Pressure Gage. The fuel pressure gage registers the pressure of the fuel delivered to the fuel injectors in the engine. Normal pressure at high idling speed is from 25 to 65 pounds. If pressure drops to below 25 pounds, it is an indication that the fuel system should be checked for clogging or defective units. Refer to "Fuel System" in TM 9-1783B for information concerning causes of low fuel pressure. If fuel pressure gage proves defective, it must be replaced.

c. Hour Meter. The hour meter is provided as a means of determining how many hours the engine and tractor have operated and when service or lubrication of the tractor or parts of tractor is necessary. Lubrication and service charts and instructions may be found in TM 9-783B. Instructions for operation and reading of the hour meter also appear in TM 9-783B.

d. Mile Meter. The dial on the mile meter is exactly the same, and is read in the same manner as the hour meter, except that it records number of miles the vehicle has traveled instead of number of hours of operation. The meter is driven by a cable from a spur gear in a housing on the front end of the lower transmission shaft.

e. Lubricating Oil Pressure Gage. This gage registers the pressure of the lubricating oil in pounds per square inch delivered to the

INSTRUMENTS

engine. Normal pressure is from 25 to 35 pounds at high idling speed after engine has reached operating temperature. If pressure drops below 25 pounds at operating engine speed, the engine should be stopped and cause of low pressure determined and corrected as explained in the "Lubrication System" section of TM 9-1783B. At closed throttle or low idling speed, oil pressure gage must not read less than 5 pounds.

f. Temperature Gage. The temperature gage registers the temperature of the cooling solution in the engine, and engine temperature. A flexible cable with a thermal tube on the end extends from the gage to the water outlet manifold on the engine. The tube at end of the cable is installed in the rear end of the manifold, and is immersed in the water passing through the manifold. As the water is heated by the engine, the expansion caused from heating is transmitted to the gage and actuates the needle on the gage. Normal operating temperature is from 160 F to 185 F. Refer to "Cooling System" in TM 9-1783B if engine temperature is not within this range.

23. REPLACEMENT OF INSTRUMENTS.

a. Refer to TM 9-783B for removal and installation instructions for all instruments named in above paragraph.

ORDNANCE MAINTENANCE — MEDIUM TRACTOR M1 (ALLIS-CHALMERS HD-7W)
ELECTRICAL SYSTEM, POWER TRAIN, FRAME, AND TRACKS

CHAPTER 7

POWER TAKE-OFF

	Paragraph
Description	24
Trouble shooting	25
Removal	26
Disassembly	27
Inspection and repair of parts.....	28
Assembly	29
Installation	30

24. DESCRIPTION.

a. Construction. The power take-off assembly is a reversible gear reduction unit bolted to the rear of the transmission case. The top shaft extends into the bevel gear compartment and is connected to the top transmission shaft by a splined coupling. This shaft and the lower power take-off shaft are mounted in tapered roller bearings. The drive sprocket is pressed onto the tapered end of power take-off shaft, and a key prevents sprocket from turning on shaft. A reverse idler gear makes it possible to turn power take-off shaft and winch drum in either direction. A sliding gear on the top shaft is controlled by the power take-off control lever, and changes the direction of rotation of the power take-off shaft.

b. Operation. The smaller gear on the reverse idler shaft is in constant mesh with the large driven gear on power take-off shaft. When the sliding or driving gear is meshed with the driven gear by moving control lever ahead, the power-take-off shaft and sprocket rotate in a clockwise direction. When control lever is pulled back, the sliding gear meshes with the reverse idler gear and the driven gear and power take-off shaft turn in a counterclockwise direction. When control lever is in neutral position, the sliding gear is not in mesh with either reverse idler gear or large driven gear and neither power take-off shaft nor drive sprocket turns.

25. TROUBLE SHOOTING.

a. Noise in Gear Box.

Possible Cause	Possible Remedy
Gears worn.	Replace gears.
Bearings loose.	Adjust bearings.
Assembly loose on transmission case.	Tighten cap screws.

POWER TAKE-OFF

b. Slips Out of Gear.

Possible Cause	Possible Remedy
Incorrect adjustment on shifter rod.	Adjust rod to obtain full gear mesh.
Worn shifter shaft at locking point.	Repair or replace shaft.
Lock spring and ball worn.	Replace spring and ball.
Pinion shaft bearings out of adjustment.	Adjust bearings.
Gears badly worn.	Replace gears.
Pinion shaft splines worn.	Replace shaft.
Shifter fork worn.	Repair or replace fork.

c. Oil Leaks Into Transmission.

Inner seal defective.	Replace seal.
Bearings out of adjustment.	Adjust bearings.

d. Oil Leaks Around Power Take-off Shaft.

Outer seal defective.	Replace seal.
Bearings out of adjustment.	Adjust bearings.

e. Excessive Wear on Gears.

Insufficient oil supply.	Fill to level of level plug.
Foreign material in oil.	Drain oil, flush case, and refill.
Bearings out of adjustment.	Adjust bearings.
Gears not in full mesh.	Replace worn parts and adjust shifter rod.

f. Power Take-off Shaft Wobbles.

Bearings loose.	Adjust bearings.
Shaft bent.	Replace shaft.

26. REMOVAL.

a. Tools Required.

Bar, pry	Wrench, open-end, $\frac{9}{16}$ -in.
Hammer, 2-lb	Wrench, open-end, $\frac{15}{16}$ -in.
Pliers	Wrench, socket, $\frac{9}{16}$ -in.
Punch, small	Wrench, socket, $\frac{7}{8}$ -in.
Wrench, $\frac{3}{4}$ -in.	Wrench, socket, $1\frac{5}{16}$ -in., with long extension
Wrench, $1\frac{1}{8}$ -in.	
Wrench, drain plug	

b. Procedure.

(1) REMOVE PINTLE BRACKET AND DRAIN OIL FROM CASE.

Wrench, drain plug	Wrench, open-end, $\frac{9}{16}$ -in.
--------------------	---------------------------------------

Refer to paragraph 147 for removal of pintle bracket, omitting subparagraph b (2). Remove drain plug from bottom of case and drain oil from case. Remove transmission drain plug and drain oil

ORDNANCE MAINTENANCE — MEDIUM TRACTOR M1 (ALLIS-CHALMERS HD-7W)
ELECTRICAL SYSTEM, POWER TRAIN, FRAME, AND TRACKS

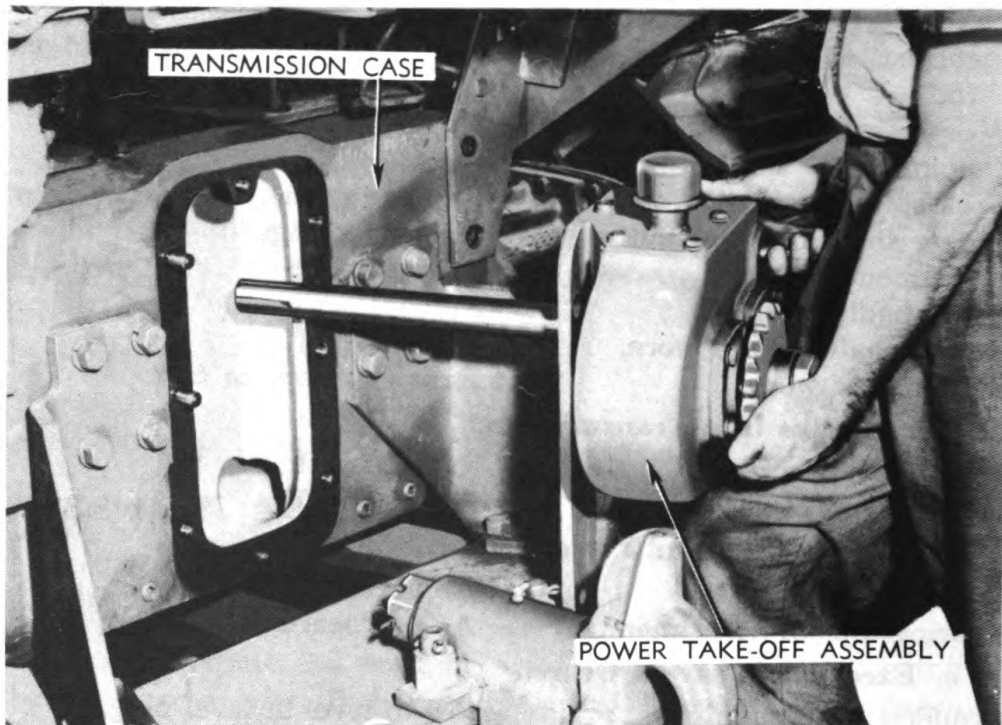

RA PD 41271

Figure 62 — Removing Power Take-off Assembly

from transmission case, so that the oil will not be lost when power take-off case is removed.

(2) REMOVE CONTROL LINKAGE.

Pliers

Wrench, $\frac{3}{4}$ -in.

Remove cotter pin from pin in shifter lever connected to shifter shaft (pliers) (fig. 108). Remove two cap screws holding shifter lever pivot bracket to top of transmission case ($\frac{3}{4}$ -in. wrench), and lay linkage up on top of transmission case. If any of the pins or links in control linkage are worn, they should be removed at this time for repair.

(3) REMOVE POWER TAKE-OFF ASSEMBLY FROM TRACTOR.

Bar, pry

Wrench, socket, $\frac{7}{8}$ -in.

Wrench, open-end, $\frac{15}{16}$ -in.

Remove five cap screws and two nuts on outside of case that hold case to tractor ($\frac{7}{8}$ - and $\frac{15}{16}$ -in. wrenches). The holes in transmission case, from which cap screws are to be removed, are shown in figure 62. Pry assembly loose from transmission case and remove from tractor (pry bar) (fig. 62). Splined coupling connecting pinion shaft to top transmission (fig. 158) may come off with case, or remain on end of top transmission shaft.

POWER TAKE-OFF

27. DISASSEMBLY.

a. Tools Required.

Bar, drift, brass	Puller, gear
Bar, drift, curved	Punch, 10-in.
Bar, pry	Punch, small
Chisel, 3/4-in.	Wrench, 9/16-in.
Hammer, 2-lb	Wrench, 1 7/8-in.
Press, arbor	

b. Procedure.

(1) REMOVE DRIVE SPROCKET FROM SPROCKET SHAFT.

Chisel, 3/4-in.	Punch, small
Hammer, 2-lb	Wrench, 1 7/8-in.
Puller, gear	

Remove cotter pin from nut with hammer and punch. Remove nut from shaft (1 7/8-in. wrench). Install a gear puller on sprocket and pull sprocket from shaft. Remove key from slot in shaft (fig. 63) by placing chisel at several points along side of key and close to shaft, tapping lightly with hammer until key is raised out of slot.

(2) REMOVE SHIFTER SHAFT ASSEMBLY.

Chisel, 3/4-in.	Punch, 10-in.
Hammer, 2-lb	Wrench, 9/16-in.

(a) Remove six cap screws (9/16-in. wrench) holding top cover to gear case (fig. 63).

(b) Straighten lock on cap screw clamping shifter fork to shifter shaft (hammer and chisel) and remove the cap screw (9/16-in. wrench) (fig. 64). Lift out spring and steel locking ball (fig. 87).

(c) Remove shaft and shifter fork by sliding shaft out of shifter fork and gear case (fig. 86).

(d) Drive oil seal out of case (hammer and punch) as shown in figure 65.

(3) REMOVE PINION SHAFT ASSEMBLY.

Bar, brass	Punch, 10-in.
Hammer, 2-lb	Wrench, 9/16-in.

(a) Remove four cap screws (9/16-in. wrench), and lift off retainer and shims (fig. 66).

(b) Drive on front end of pinion shaft (hammer and brass bar) (fig. 67). This will force out the rear pinion shaft bearing cup. Then slide shaft, with both bearings and pinion still on it, out the rear opening of case. Front bearing cup and oil seal will remain in case.

(c) Drive rear bearing off end of shaft with hammer and punch, slide pinion off shaft; then drive front bearing off long end of shaft (fig. 68).

ORDNANCE MAINTENANCE — MEDIUM TRACTOR M1 (ALLIS-CHALMERS HD-7W)
ELECTRICAL SYSTEM, POWER TRAIN, FRAME, AND TRACKS

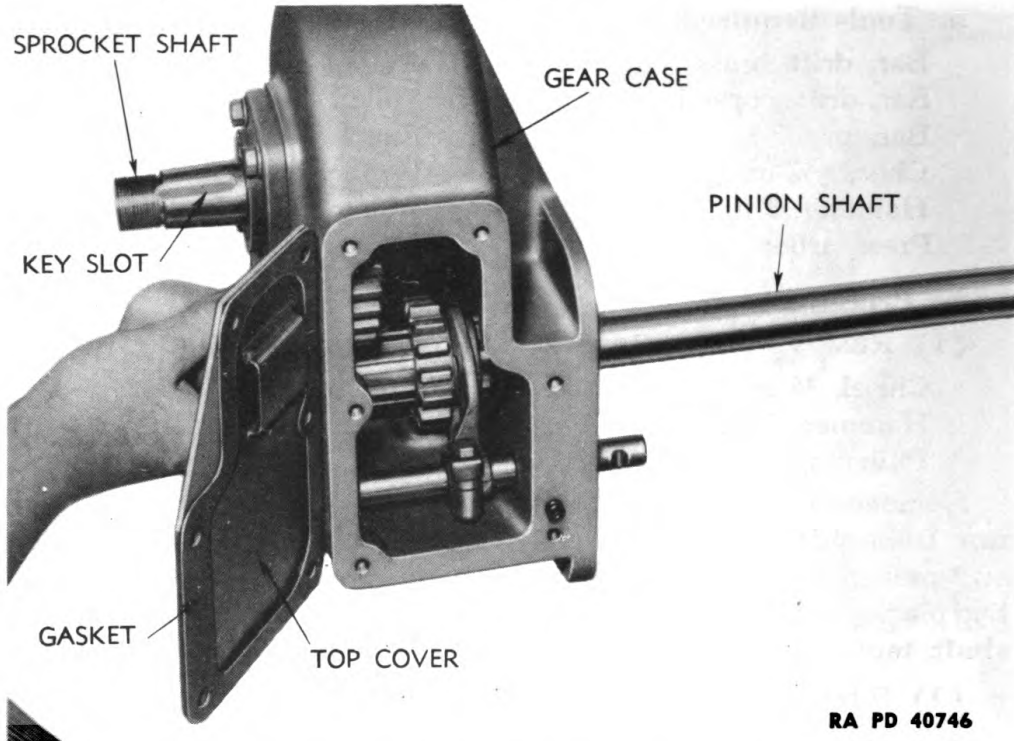

RA PD 40746

Figure 63 — Removing Top Cover

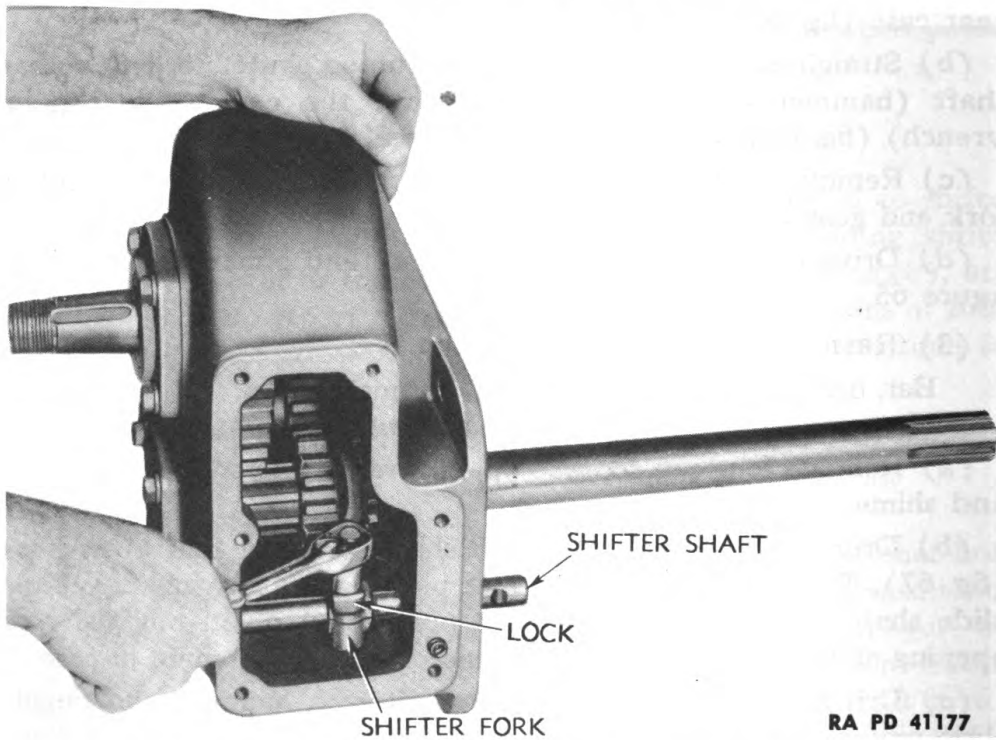

RA PD 41177

Figure 64 — Removing Clamp Bolt from Shifter Fork

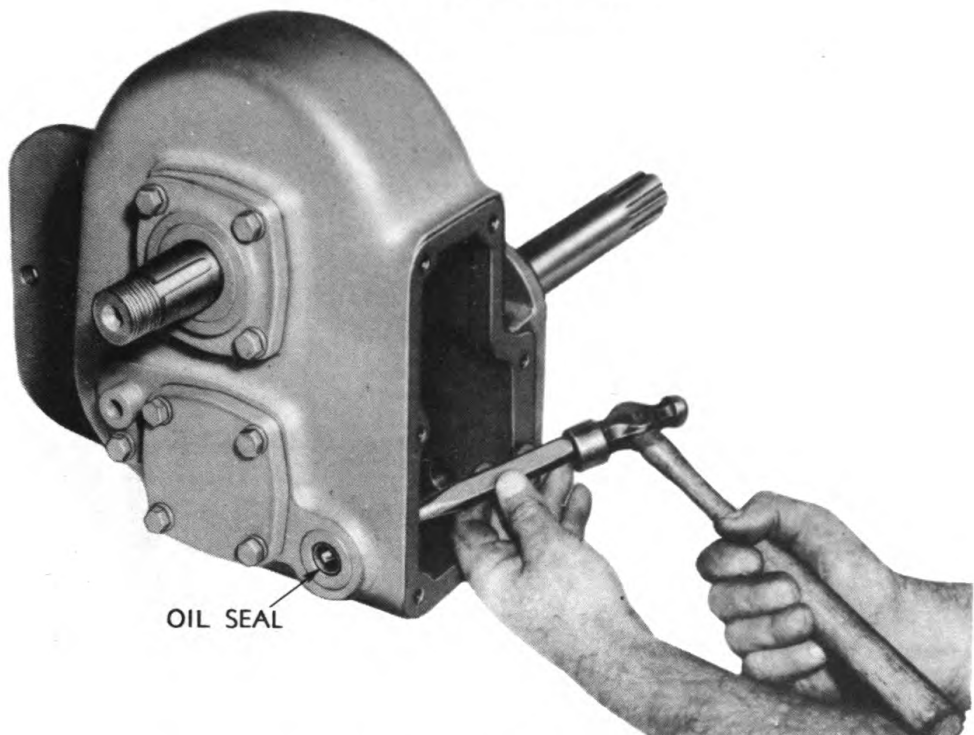
POWER TAKE-OFF

RA PD 41088

Figure 65 — Removing Oil Seal from Case

(d) Drive oil seal out of front of case (hammer and punch) (figs. 69 and 69A), then drive front bearing cup (hammer and punch) out of case, driving cup towards inside of case (fig. 70).

(4) REMOVE IDLER GEAR SHAFT ASSEMBLY.

Bar, drift, brass
Hammer, 2-lb

Wrench, $\frac{9}{16}$ -in.

Remove cap screw ($\frac{9}{16}$ -in. wrench) and idler gear shaft lock from rear of case (fig. 71). Drive idler gear shaft out rear end of case (brass bar and hammer) (fig. 72), lifting idler gear out of case as it is released from shaft.

(5) REMOVE SPROCKET SHAFT ASSEMBLY.

Bar, drift, curved
Bar, pry

Hammer, 2-lb
Wrench, $\frac{9}{16}$ -in.

(a) Remove four cap screws ($\frac{9}{16}$ -in. wrench), retainer, oil seal, and shims from rear of gear case (fig. 73). Oil seal remains in retainer.

(b) Using a curved drift bar along side of gear on inside of case, drive outer cup of rear bearing out of case. Lift up on shaft and pry front bearing, which will be under gear, off front end of shaft; then lift shaft and bearing out of case, and remove gear from case (fig. 74).

(c) Lift rear spacer and front bearing out of case; then pry front bearing cup out of case with pry bar (figs. 75 and 76).

ORDNANCE MAINTENANCE — MEDIUM TRACTOR M1 (ALLIS-CHALMERS HD-7W)
ELECTRICAL SYSTEM, POWER TRAIN, FRAME, AND TRACKS

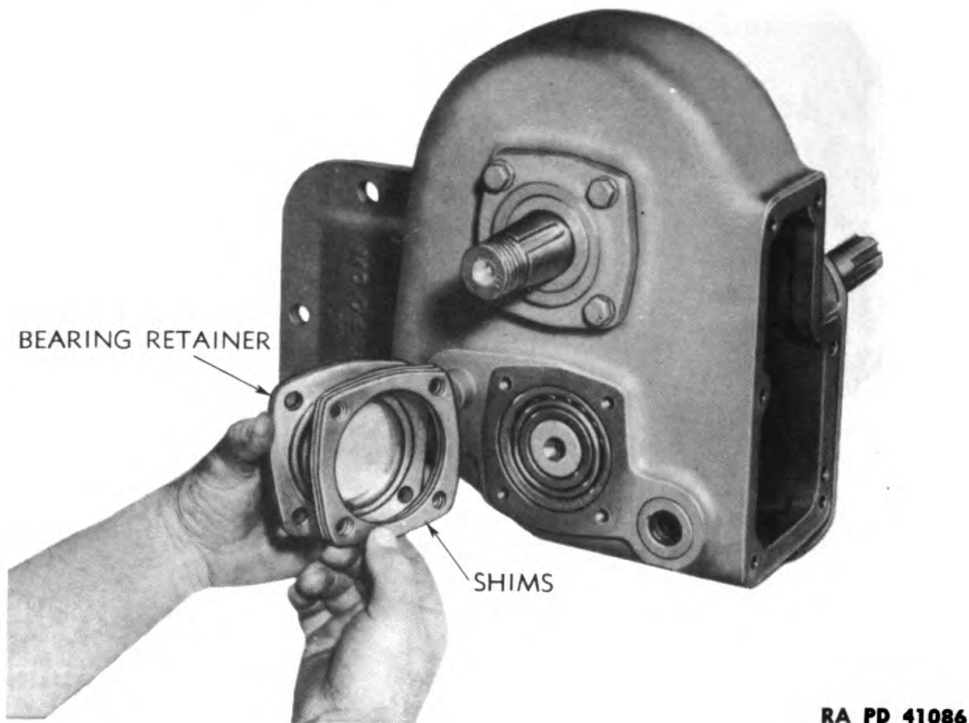

Figure 66 — Retainer and Shims Removed from Rear Pinion Bearing

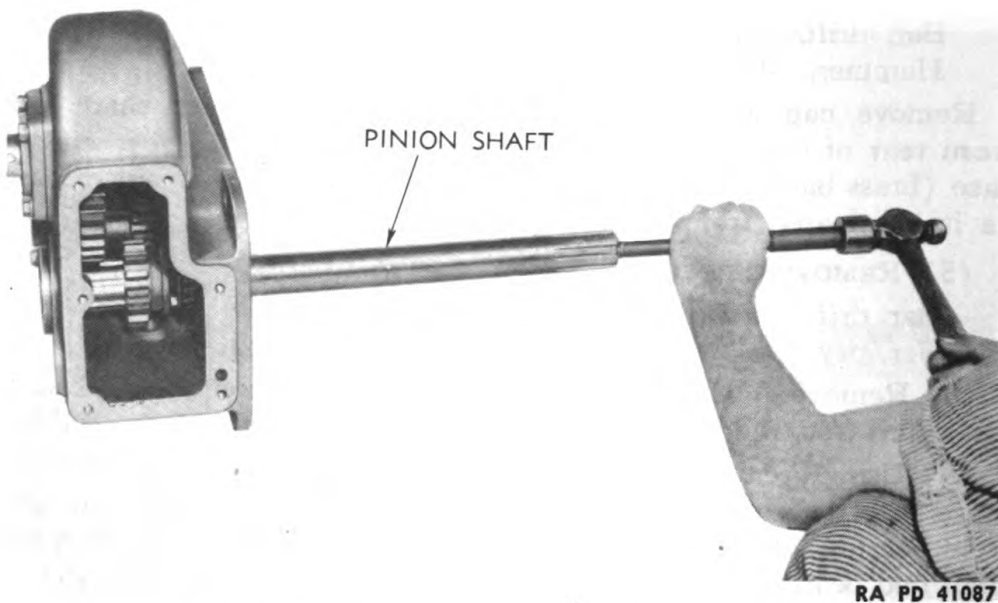

Figure 67 — Removing Pinion Shaft Assembly

POWER TAKE-OFF

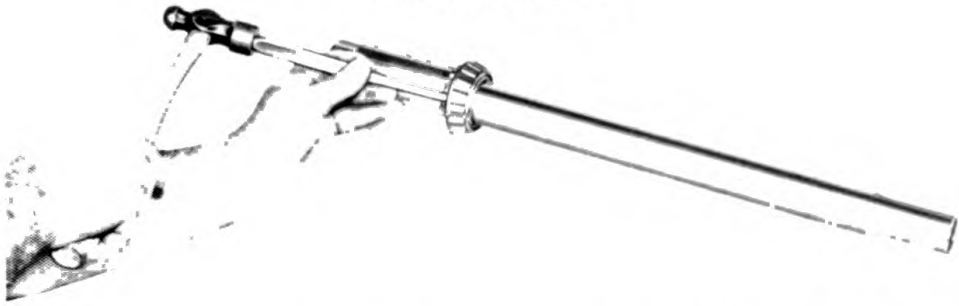

Figure 68 — Removing Pinion Bearing from Shaft RA PD 40731

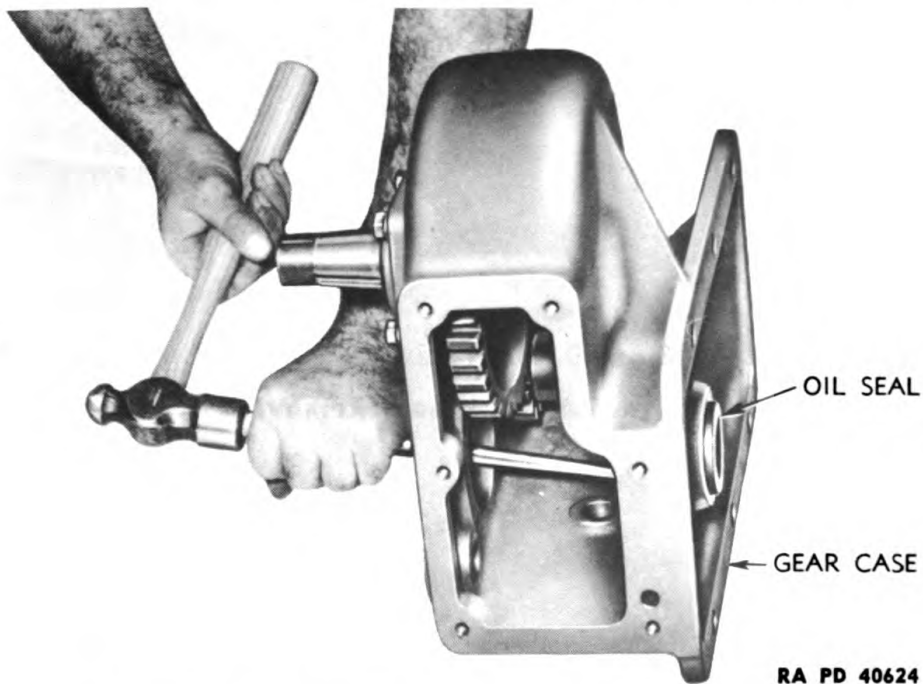

Figure 69 — Removing Pinion Shaft Oil Seal

(6) REMOVE BUSHINGS FROM IDLER GEAR.

Press, arbor

Check inner diameter of bushings in idler gear against outer diameter of idler shaft to determine if replacement is necessary. If worn to allow over 0.007-inch clearance, press the bushings out of the gear with an arbor press.

(7) REMOVE OIL SEAL FROM RETAINERS.

Hammer, 2-lb

Punch, 10-in.

Drive oil seal out of retainer removed from sprocket shaft (fig. 73).

28. INSPECTION AND REPAIR OF PARTS.

a. Clean Parts. Remove all old gaskets and wash all parts thor-

**ORDNANCE MAINTENANCE — MEDIUM TRACTOR M1 (ALLIS-CHALMERS HD-7W)
ELECTRICAL SYSTEM, POWER TRAIN, FRAME, AND TRACKS**

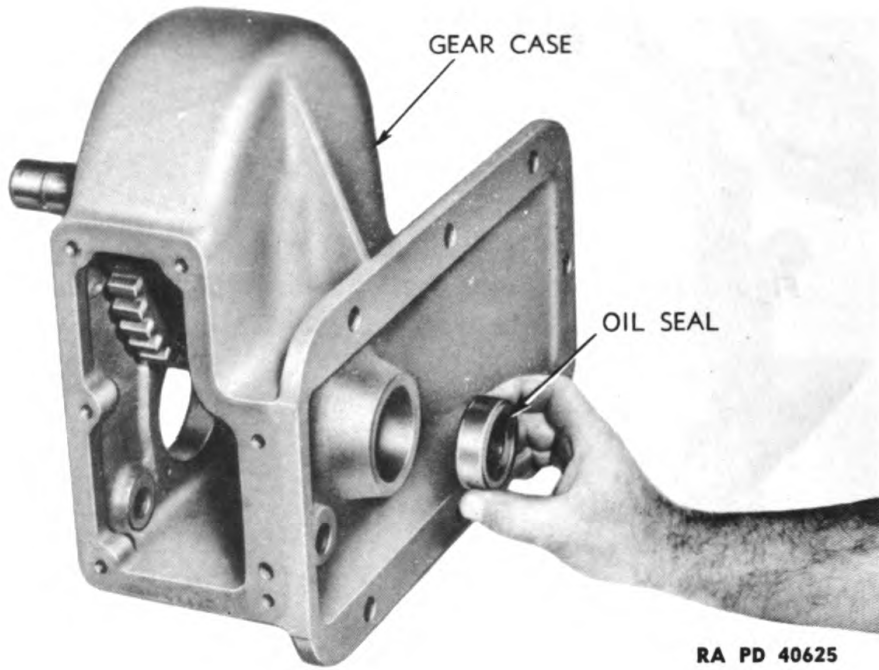

Figure 69A — Oil Seal Removed

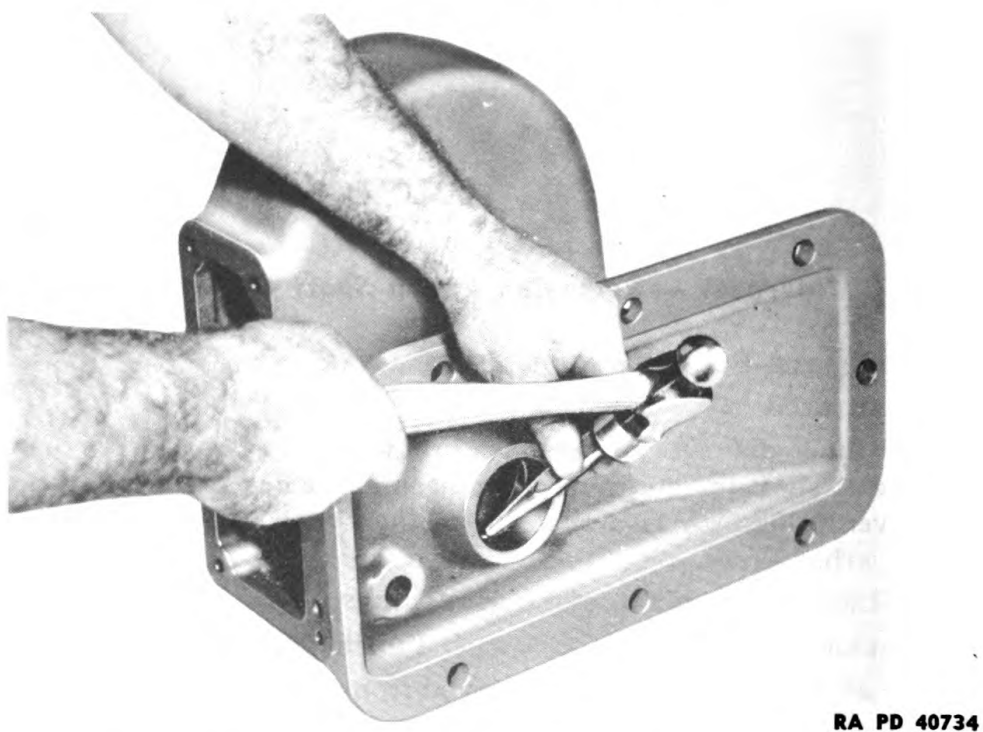
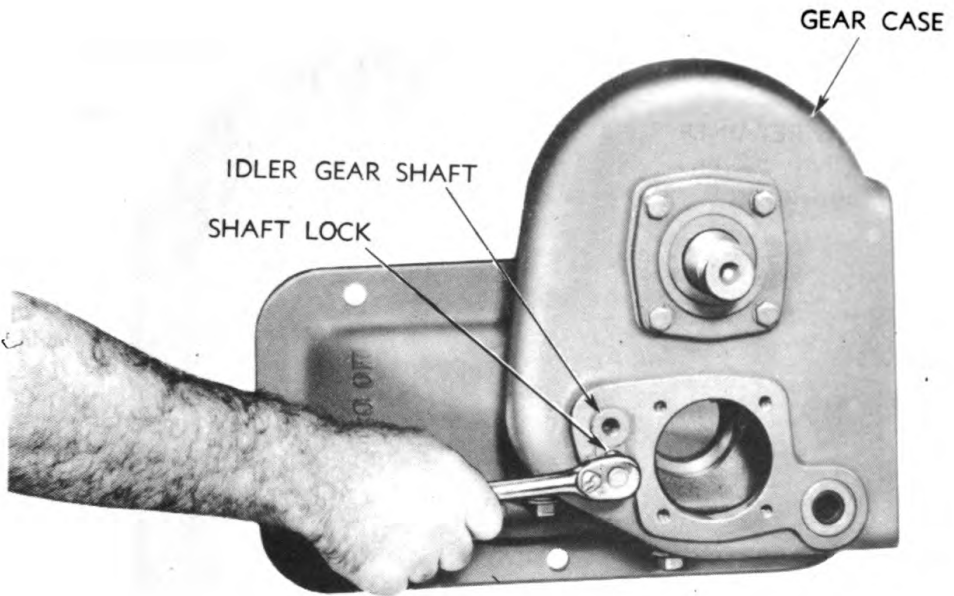

Figure 70 — Removing Rear Pinion Bearing Cup

POWER TAKE-OFF



RA PD 40631

Figure 71 — Removing Idler Gear Shaft Lock

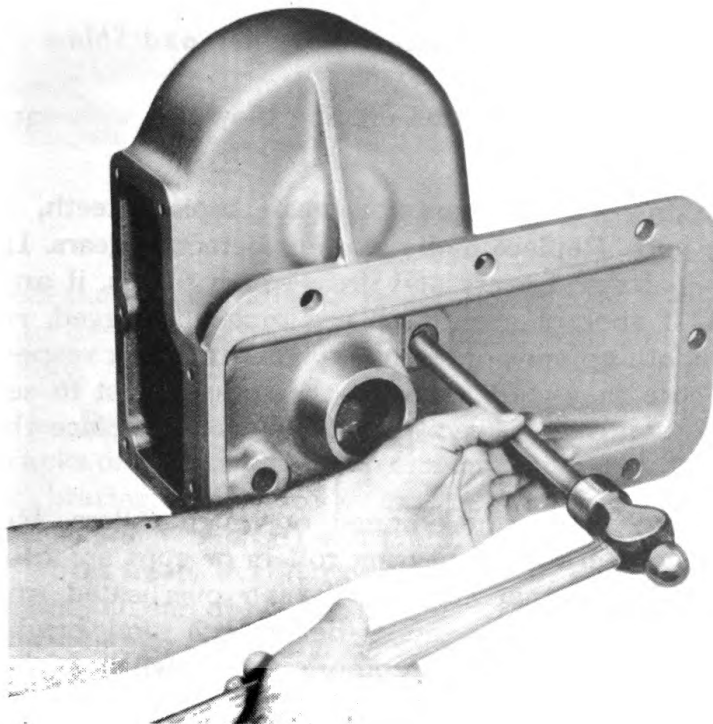

RA PD 40735

Figure 72 — Driving Idler Gear Shaft out of Case

**ORDNANCE MAINTENANCE — MEDIUM TRACTOR M1 (ALLIS-CHALMERS HD-7W)
ELECTRICAL SYSTEM, POWER TRAIN, FRAME, AND TRACKS**

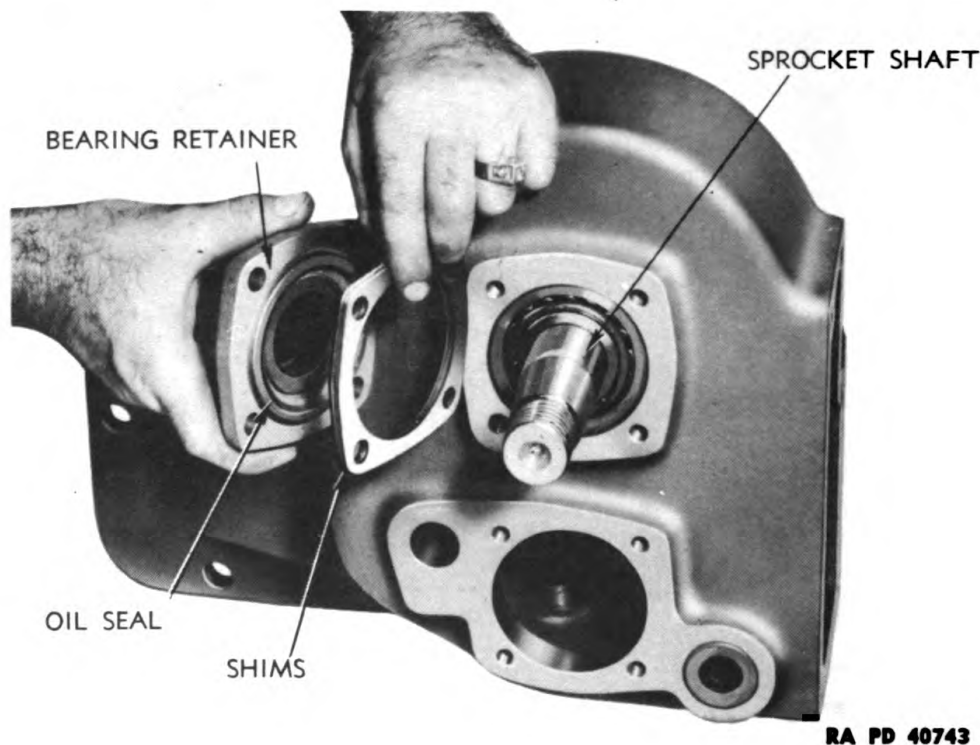

Figure 73 — Removing Sprocket Shaft Retainer and Shims

oroughly with dry-cleaning solvent, or fuel oil, and blow dry with compressed air.

b. Inspect Gears. Inspect all gears for wear, broken teeth, or cracks and checks in hubs. Replace badly worn or defective gears. Inspect the splines in shafts and gears and dress rough places, if any, with a file or stone. If ends of gear teeth are rough or jagged, replace the gears or smooth up ends of teeth. Try gears on their respective shafts to make sure they slide easily in the splines. Test to see that bearings fit snugly on their respective shafts. If loose replace the worn parts.

c. Bearings. Check bearings for chipped or rough rollers. Replace worn or defective bearings. If bearing rollers or cups are blue or dark colored, it indicates that they have been overheated and should be replaced. Bearing races must be smooth and bright. **CAUTION:** Do not spin bearings with compressed air when drying them after they have been cleaned.

d. Reverse Idler Gear Assembly. If bushing in reverse idler gear or idler gear shaft is worn, replace either bushing or shaft, or both, if

POWER TAKE-OFF

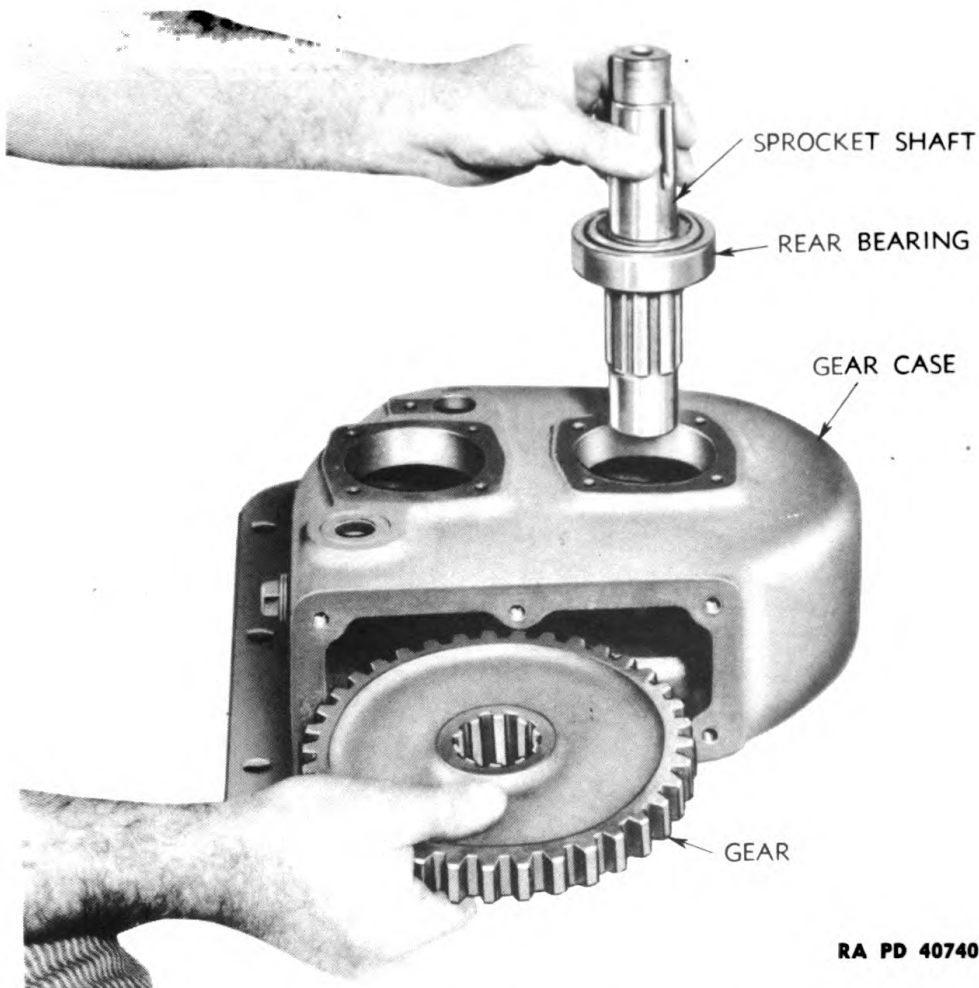

RA PD 40740

Figure 74 — Removing Gear and Shaft

necessary. If bushing is replaced, the new bushing must be pressed into the gear and reamed to fit shaft with enough clearance to rotate freely.

e. Replace Oil Seals if Worn or Damaged. Examine gear case for cracks or breaks. Small breaks or cracks may be repaired by welding or brazing. Shifter fork may be built up to original thickness by welding or brazing, if worn, and then ground flat and smooth so that it works freely in collar of sliding gear. Examine splined coupling and splines on end of pinion shaft and transmission shaft for wear. Replace coupling if worn badly. Be sure coupling slips onto either shaft easily before installing power take-off assembly.

f. Controls and Linkage. Replace worn pins in linkage. If holes in rod or levers are enlarged or elongated, they may be welded closed, and new holes drilled to fit new pin. Straighten bent rods or levers.

ORDNANCE MAINTENANCE — MEDIUM TRACTOR M1 (ALLIS-CHALMERS HD-7W)
ELECTRICAL SYSTEM, POWER TRAIN, FRAME, AND TRACKS

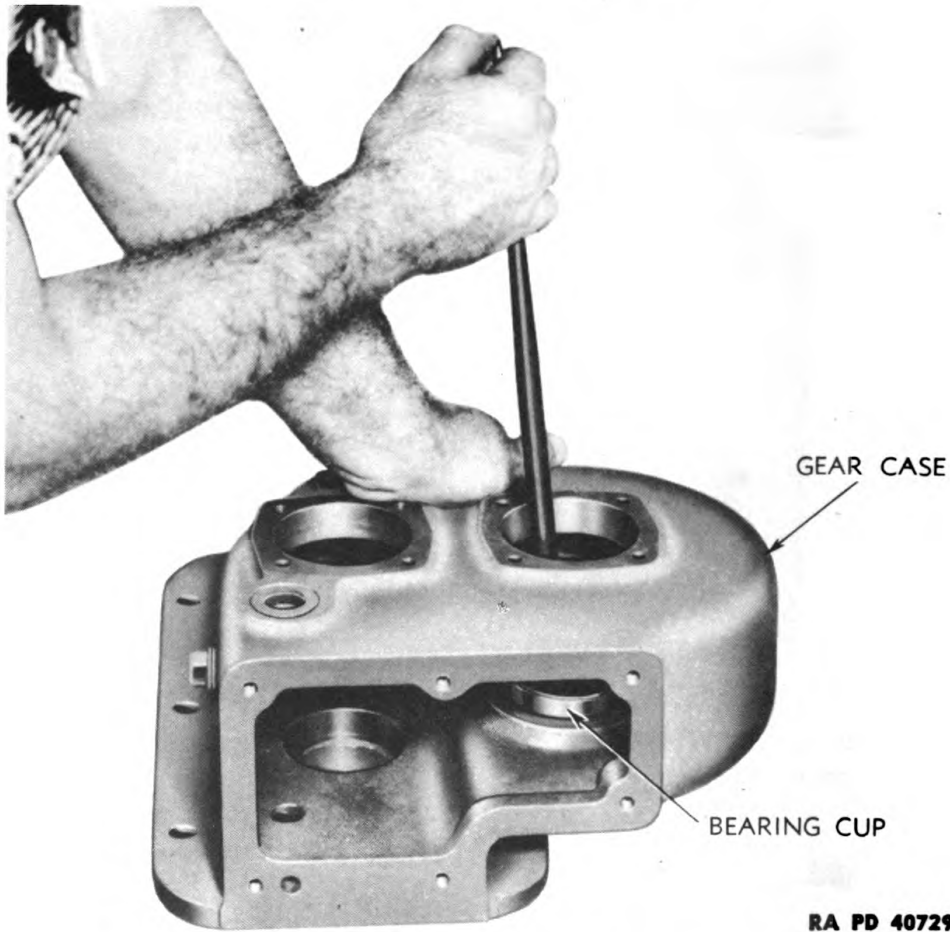

Figure 75 — Prying Front Bearing Cup out of Case

29. ASSEMBLY.

a. Tools Required.

Bar, drift, brass
Hammer, 2-lb
Hammer, soft
Press, arbor
Punch, brass, 10-in.

Reamer, expansion
Wrench, 1 $\frac{7}{8}$ -in.
Wrench, open-end, $\frac{9}{16}$ -in.
Wrench, socket, $\frac{9}{16}$ -in.

b. Procedure.

(1) INSTALL BUSHINGS IN IDLER GEAR.

Press, arbor

Reamer, expansion

Press bushings into gear with press; then ream bushings to allow 0.002-inch clearance between shaft and bushing.

(2) INSTALL LARGE GEAR AND SPROCKET SHAFT ASSEMBLY.

Bar, drift, brass
Hammer, 2-lb

Punch, brass, 10-in.
Wrench, $\frac{9}{16}$ -in.

POWER TAKE-OFF

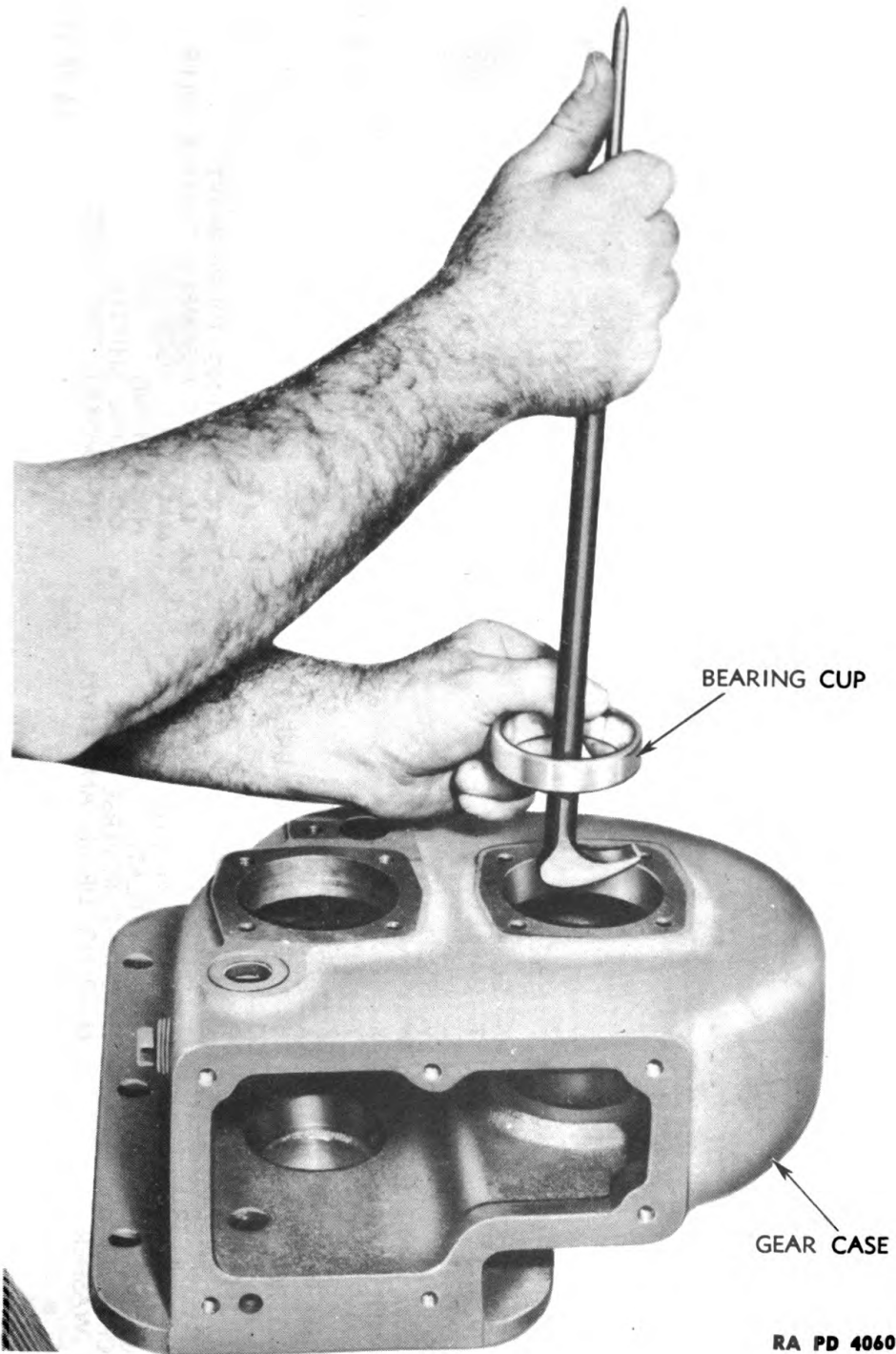

RA PD 40609

Figure 76 — Front Bearing Cup Removed

ORDNANCE MAINTENANCE — MEDIUM TRACTOR M1 (ALLIS-CHALMERS HD-7W)
ELECTRICAL SYSTEM, POWER TRAIN, FRAME, AND TRACKS

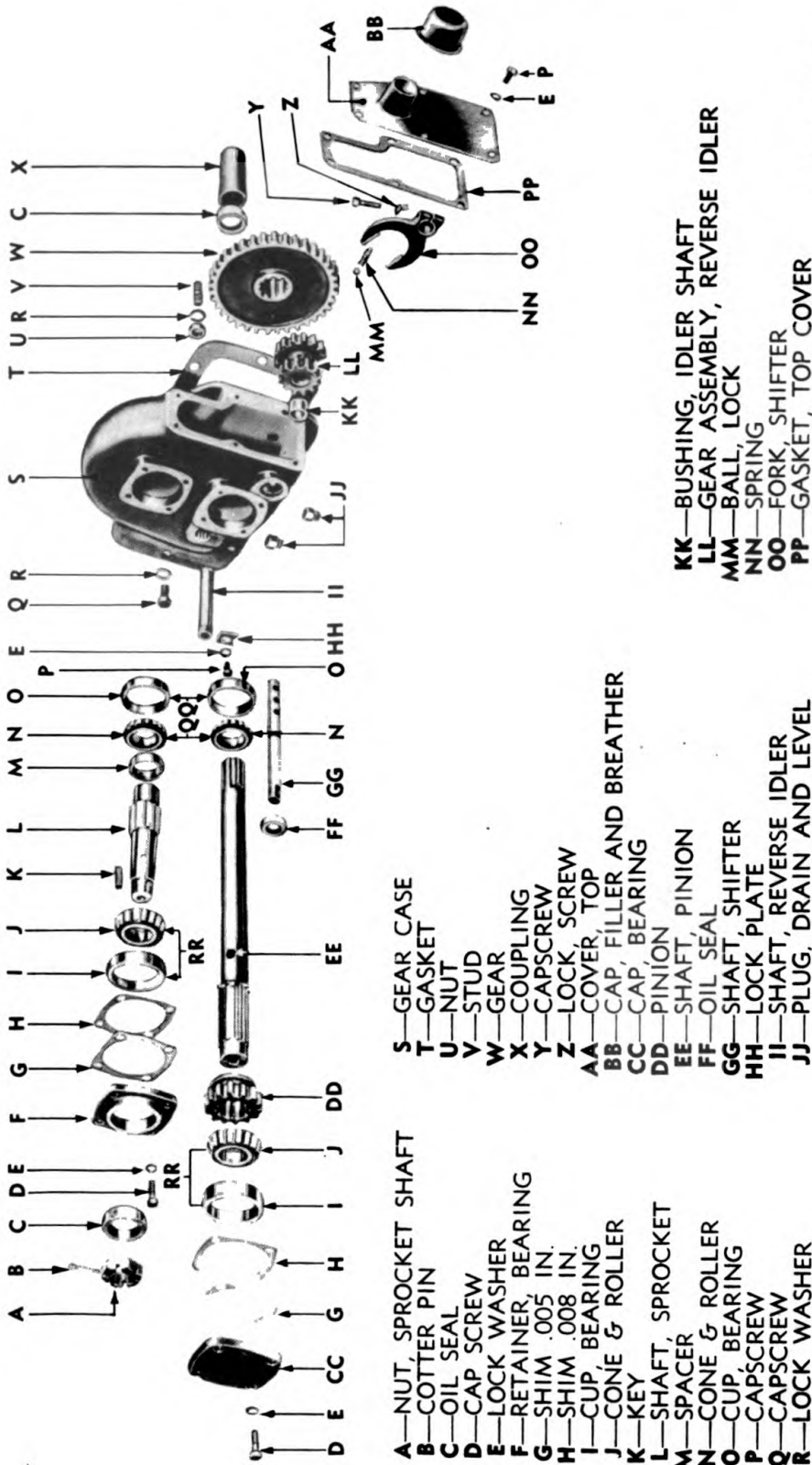

RA PD 59539

Figure 77 — Power Take-off Assembly — Exploded View

POWER TAKE-OFF

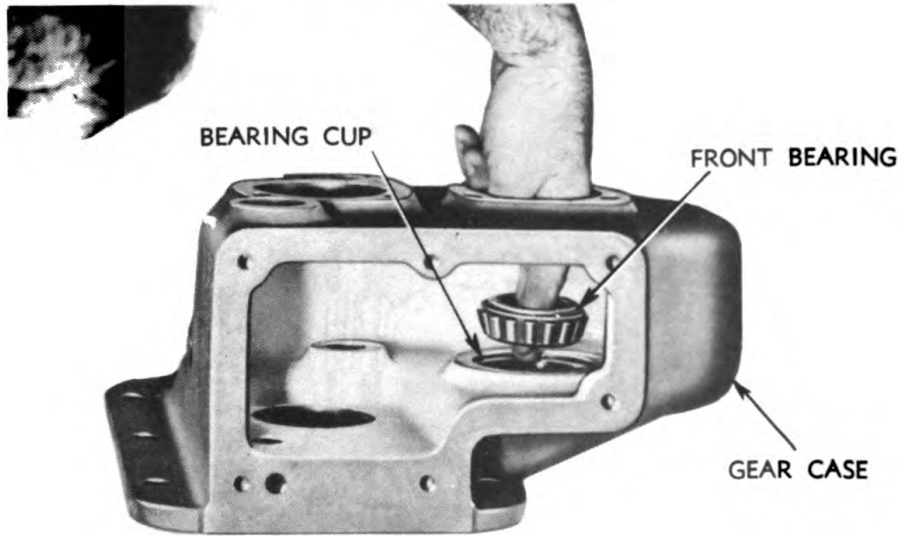

RA PD 40608

Figure 78 — Installing Front Sprocket Shaft Bearing

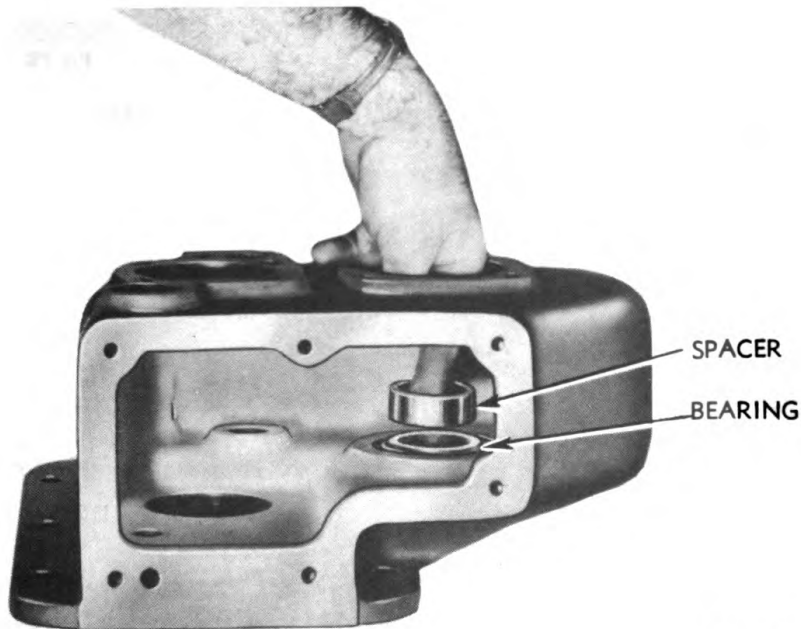

RA PD 40604

Figure 79 — Installing Spacer

(a) Tap front sprocket shaft bearing cup into position in bore below bearing shown being dropped into it in figure 78 (hammer and brass bar). Then drop bearing into cup as shown. Lubricate with light engine oil.

(b) Place spacer on top of bearing (fig. 79).

(c) Lay large gear in case on top of spacer as shown in figure 80,

ORDNANCE MAINTENANCE — MEDIUM TRACTOR M1 (ALLIS-CHALMERS HD-7W)
ELECTRICAL SYSTEM, POWER TRAIN, FRAME, AND TRACKS

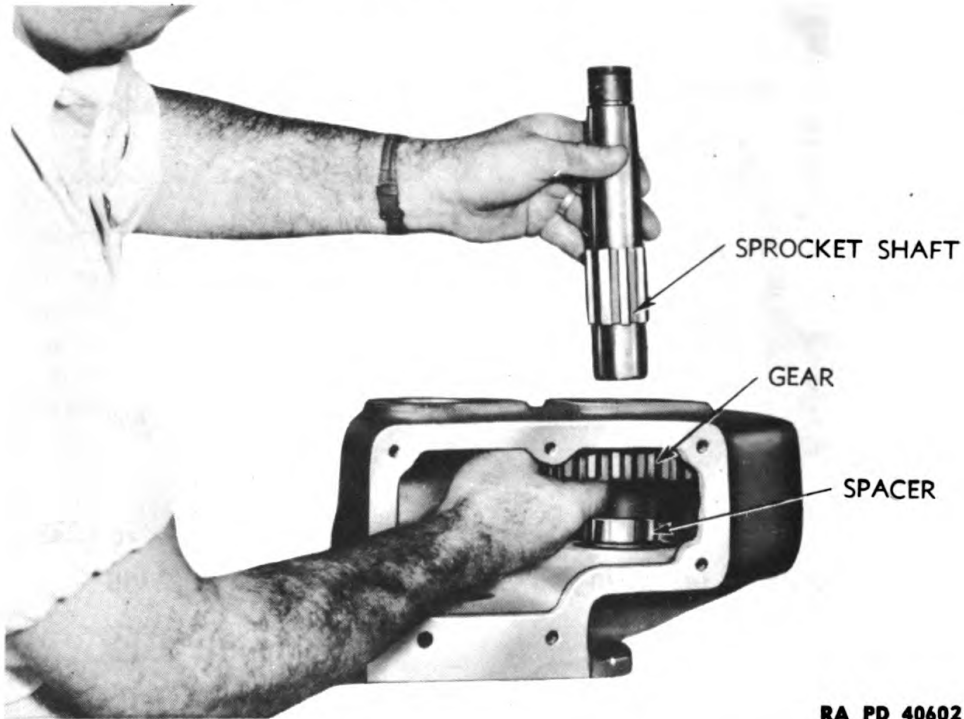

RA PD 40602

Figure 80 — Installing Gear and Shaft

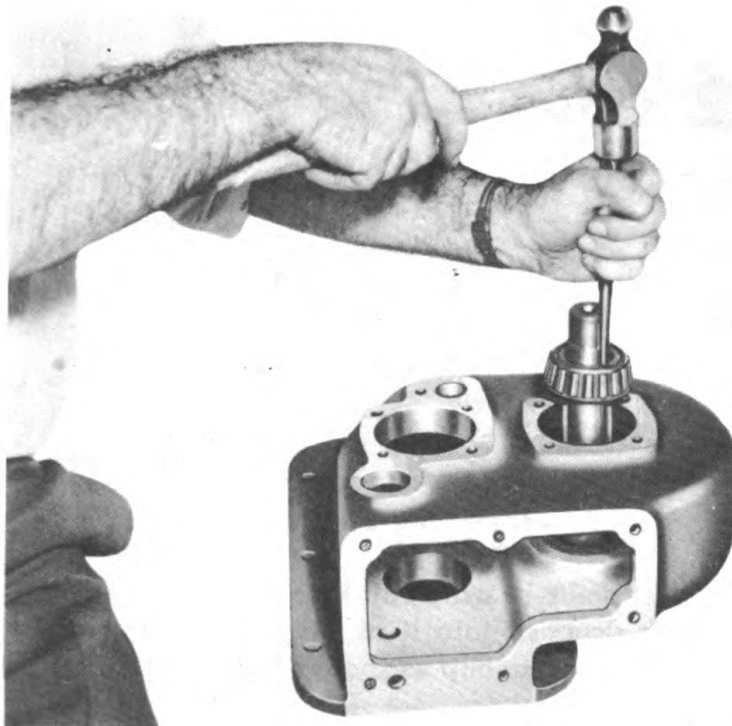

RA PD 40601

Figure 81 — Installing Rear Bearing on Shaft

POWER TAKE-OFF

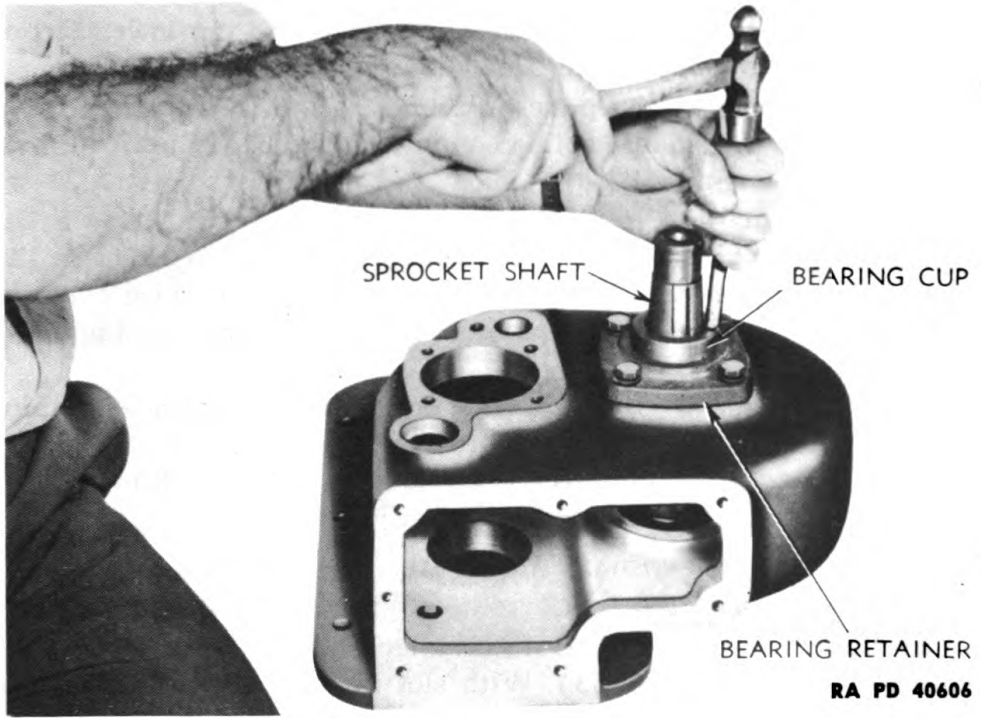

Figure 82 — Installing Rear Bearing Cup

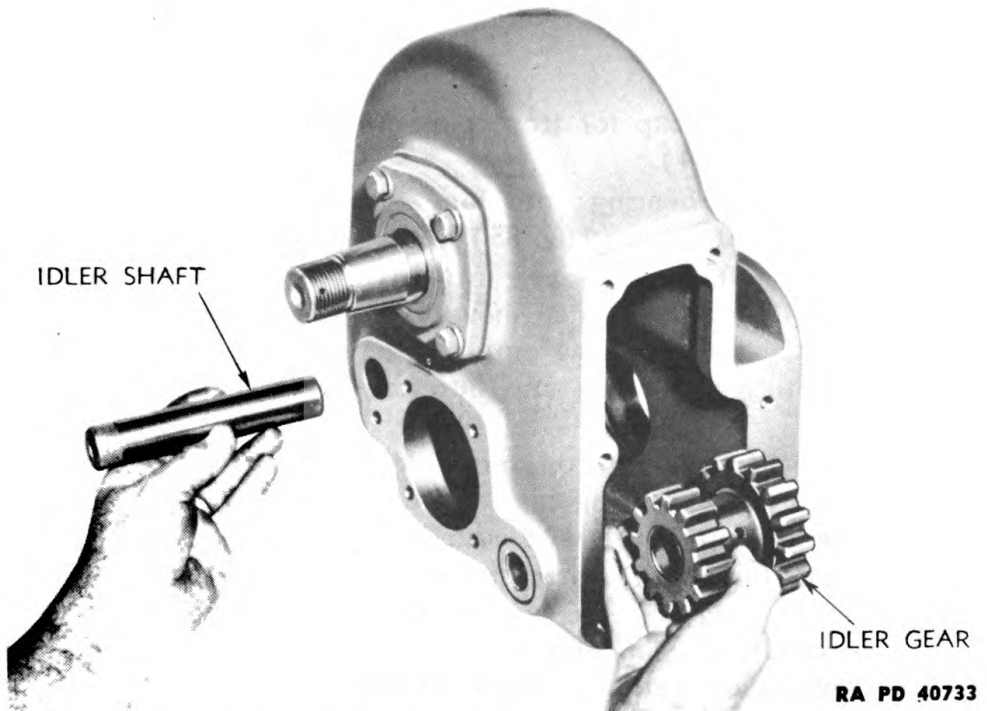

Figure 83 — Installing Idler Shaft and Gear

**ORDNANCE MAINTENANCE — MEDIUM TRACTOR M1 (ALLIS-CHALMERS HD-7W)
ELECTRICAL SYSTEM, POWER TRAIN, FRAME, AND TRACKS**

insert sprocket shaft through gear and spacer, and tap lower (front) end of shaft into front bearing.

(d) Driving with brass punch on inner race of bearing, drive rear bearing onto shaft against splined shoulder (fig. 81). Lubricate bearing with light engine oil.

(e) Lay shims and retainer formerly removed (fig. 73) on case and start at least two cap screws to hold shims and retainer in line; then start rear bearing cup through retainer and into place over rear bearing (fig. 82). By using this procedure, the oil seal in retainer will not be damaged.

(f) Adjust bearings by removing or adding shims under retainer for free rolling of the gear and shaft when turned by hand, but without end play of the shaft. Have all four cap screws drawn tightly ($\frac{9}{16}$ -in. wrench) when testing bearing adjustment.

(3) INSTALL IDLER SHAFT AND GEAR.

Hammer, soft

Wrench, $\frac{9}{16}$ -in.

(a) Lubricate bushing and insert idler gear into case in line with holes for idler shaft (fig. 83). With slot in shaft at rear, drive shaft through case and gear (soft hammer).

(b) Place lock in notch in shaft at rear of case, and secure lock to case with a $\frac{3}{8}$ - by $\frac{3}{4}$ -inch cap screw with lock washer ($\frac{9}{16}$ -in. wrench) (fig. 71).

(4) INSTALL PINION SHAFT ASSEMBLY.

Hammer, 2-lb

Wrench, socket $\frac{9}{16}$ -in.

Punch, brass, 10-in.

(a) Tap bearing cup for front pinion shaft bearing into bore in front of case (fig. 84).

(b) Press front bearing onto long (front) end of pinion shaft against shoulder of splines (fig. 85). Apply oil to bearing.

(c) Insert shaft through case from rear. Pinion and rear bearing go on shaft next, in order shown in figure 85. Place pinion on shaft first; then press bearing onto end of shaft and lubricate bearing. Then tap rear bearing cup into case over rear bearing (soft hammer).

(d) Soften leathers with oil and slide oil seal (figs. 69 and 69A) over long end of shaft, using care not to damage seal, and tap it into bore in case until it is flush with case.

(e) Install shims and bearing retainer on rear of case over outer pinion shaft bearing (fig. 66) using four $\frac{3}{8}$ - by $1\frac{1}{4}$ -inch cap screws with lock washer ($\frac{9}{16}$ -in. wrench). Adjust bearings by adding or removing shims under retainer. There should be no end play in shaft, but bearing adjustment should allow turning of shaft by hand. Test adjustment of bearings with all retainer cap screws tight.

POWER TAKE-OFF

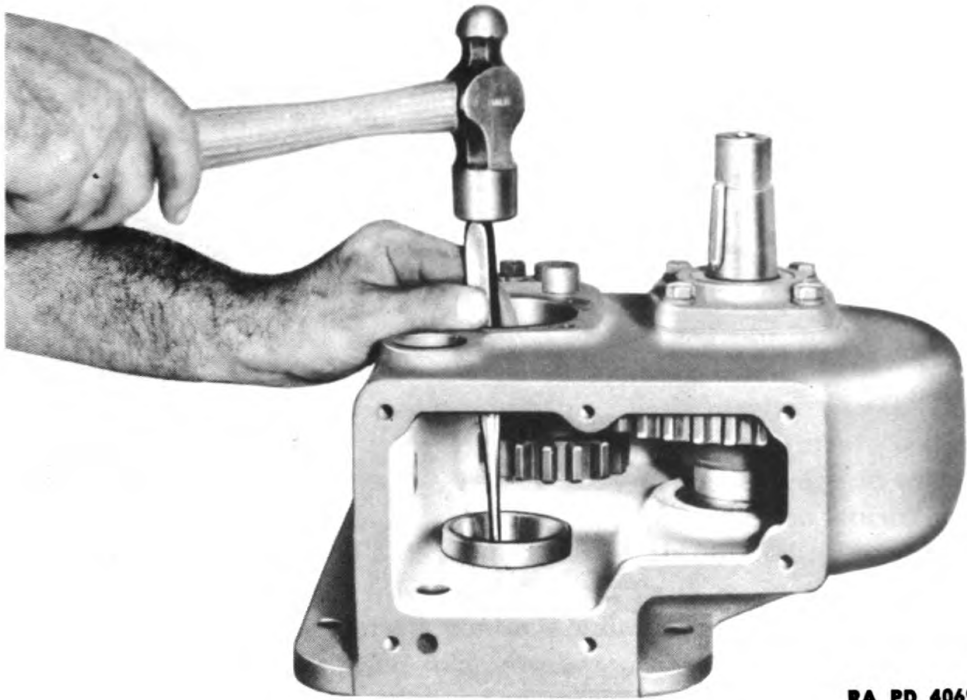

RA PD 40690

Figure 84 — Installing Front Pinion Shaft Bearing Cup

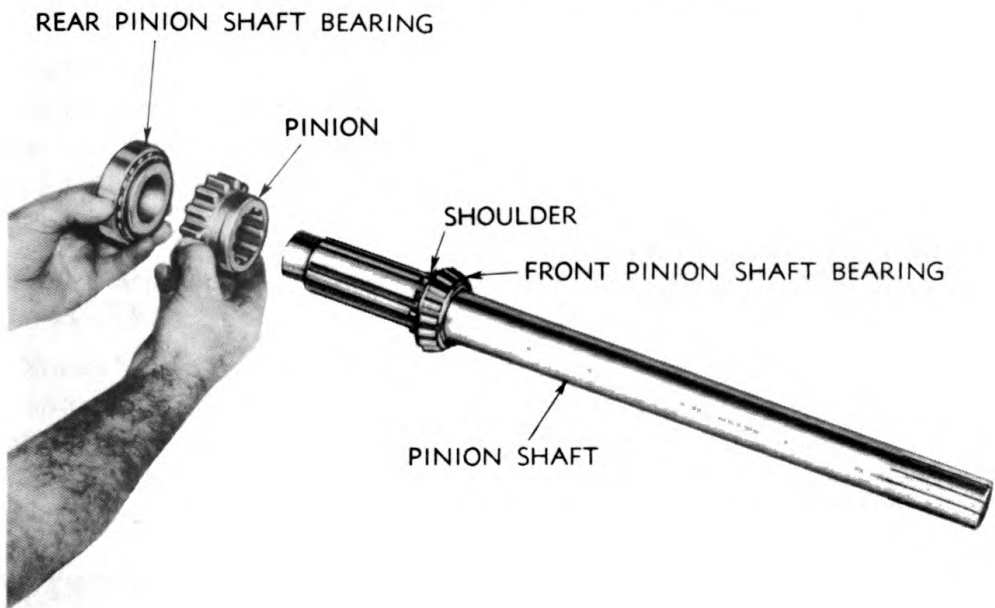

RA PD 40730

**Figure 85 — View Showing Relation of Gear and Bearings
on Pinion Shaft**

ORDNANCE MAINTENANCE — MEDIUM TRACTOR M1 (ALLIS-CHALMERS HD-7W)
ELECTRICAL SYSTEM, POWER TRAIN, FRAME, AND TRACKS

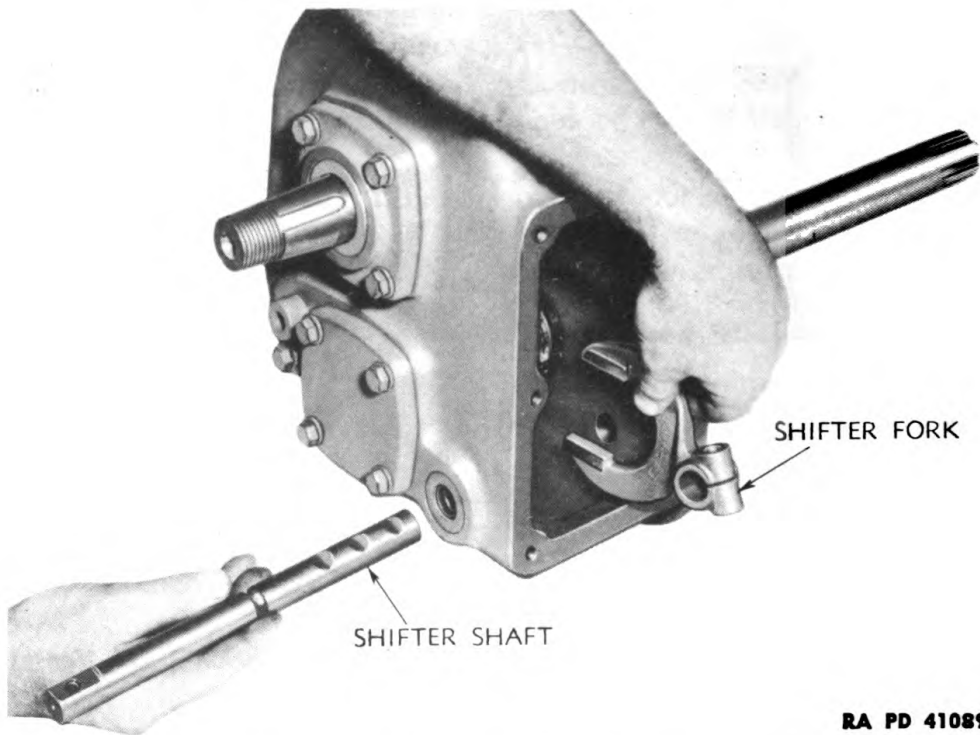

Figure 86 — Installing Shifter Shaft and Fork

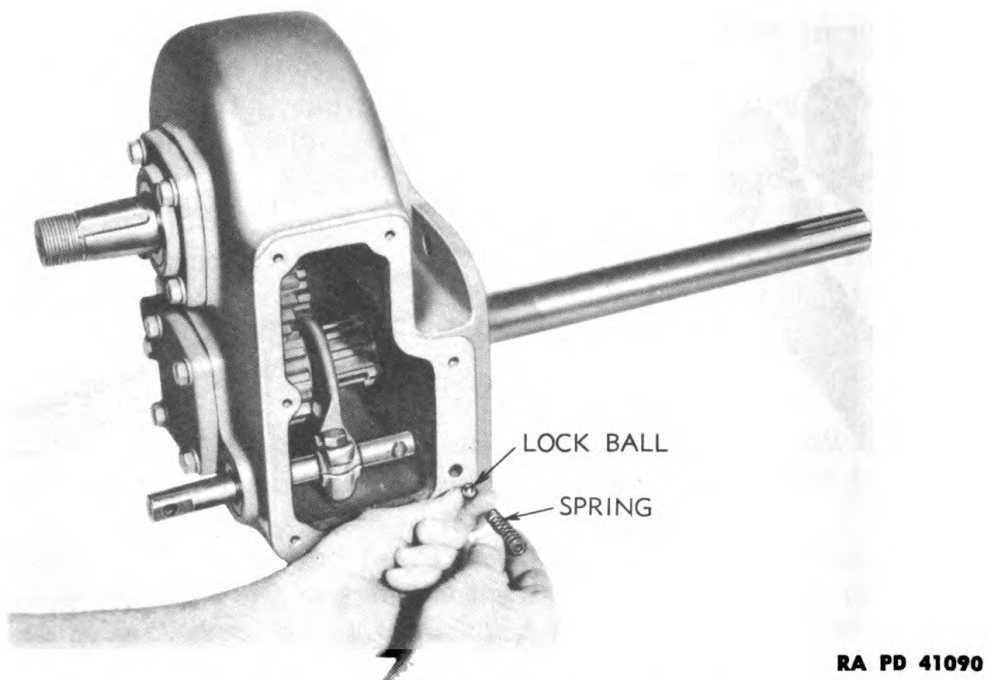

Figure 87 — Installing Shifter Lock Ball and Spring

POWER TAKE-OFF

(5) INSTALL SHIFTER SHAFT ASSEMBLY.

Hammer, soft

Wrench, $\frac{9}{16}$ -in.

(a) Apply oil to leather and tap shifter shaft oil seal into case (soft hammer) (fig. 65).

(b) Start end of shifter shaft into rear hole in case (fig. 86), hold shifter fork with fingers of fork in collar on sliding gear, and bore in fork in line with shifter shaft; then tap shaft through fork and into other side of case. Lubricate shaft with oil.

(c) Drop shifter lock ball, followed by spring, into hole in top of case above shaft (fig. 87). Hold down on top of spring; then move shifter shaft until ball drops into center notch of shifter shaft (fig. 86). Hold shaft in that position and locate sliding gear in neutral position. Install clamp bolt in shifter fork (cap screw must engage in groove in shaft) and tighten ($\frac{9}{16}$ -in. wrench). Hold down on spring and move shaft until lock ball drops into rear notch on shaft. Then move until lock ball drops into front notch. Observe if sliding gear meshes properly with the two gears it contacts when shaft shifted from one notch to the other. If sliding gear meshes more fully with one gear than with the other, adjust for equal mesh by loosening clamp bolt and tapping shifter fork in the direction necessary to equalize meshing of gears.

(6) INSTALL TOP COVER ON CASE.

Wrench, $\frac{9}{16}$ -in.

(a) If breather filler cap has not been washed previously, rinse in dry-cleaning solvent, shake solvent out of cap after cleaning, and install cap on cover.

(b) Shellac gasket to gear case and install cover with six $\frac{3}{8}$ - by $\frac{3}{4}$ -inch cap screws with lock washers.

(7) INSTALL DRIVE SPROCKET.

Hammer, 2-lb

Wrench, $1\frac{7}{8}$ -in.

Smooth any rough places on key with file; then tap key into slot in sprocket shaft. Tap sprocket onto shaft and key and start large nut. Turn nut onto shaft with $1\frac{7}{8}$ -inch wrench, tapping on sprocket at same time to force sprocket on as tightly as possible. Lock nut with cotter pin.

30. INSTALLATION.

a. Tools Required.

Pliers

Wrench, $\frac{9}{16}$ -in. (2)

Wrench, $\frac{3}{4}$ -in.

Wrench, open-end, $1\frac{5}{16}$ -in.

Wrench, open-end, $1\frac{1}{8}$ -in.

Wrench, socket, $\frac{7}{8}$ -in.

Wrench, socket, $1\frac{5}{16}$ -in., with long extension

**ORDNANCE MAINTENANCE — MEDIUM TRACTOR M1 (ALLIS-CHALMERS HD-7W)
ELECTRICAL SYSTEM, POWER TRAIN, FRAME, AND TRACKS**

b. Procedure.**(1) INSTALL POWER TAKE-OFF.**Wrench, open-end, $1\frac{5}{16}$ -in.Wrench, socket, $\frac{7}{8}$ -in.

Shellac power take-off case gasket to transmission case. Insert splined coupling over end of transmission top shaft. Install power take-off entering splines of long shaft into coupling on transmission top shaft. Install two $\frac{5}{8}$ -inch nuts and lock washers ($1\frac{5}{16}$ -in. wrench) and five $\frac{5}{8}$ - by $1\frac{1}{4}$ -inch cap screws ($\frac{7}{8}$ -in. wrench), to secure power take-off to transmission case.

(2) FILL POWER TAKE-OFF CASE WITH LUBRICANT.

Fill case with lubricant to level of level plug in case. Refer to TM 9-783B for lubrication specifications.

(3) CONNECT CONTROLS.

Pliers

Wrench, $\frac{3}{4}$ -in.

Install lever assembly by inserting pin on end of shifter lever (fig. 108) in hole in end of shifter shaft, and securing fulcrum lever bracket to top of transmission case with two $\frac{1}{2}$ - by $1\frac{1}{4}$ -inch cap screws with lock washers, using $\frac{3}{4}$ -inch wrench. Install cotter pin in pin through shifter shaft (pliers).

(4) INSTALL PINTLE BRACKET.

Refer to paragraph 148 b (1), (2), and (3).

CHAPTER 8

STABILIZER SPRING AND CRANK ASSEMBLY

Section I

STABILIZER SPRING

	Paragraph
Description	31
Removal	32
Disassembly	33
Inspection and repair	34
Assembly	35
Installation	36

31. DESCRIPTION.

a. The stabilizer spring assembly is made up of six spring leaves, of varied lengths, clamped and held together by U-bolt and a welded clamp. The spring supports part of the weight of the tractor and absorbs shocks when tractor is going over rough ground. A pivot shaft held in a bracket bolted to the transmission case extends through the welded bracket underneath the spring and into engine support. This allows the spring to pivot on this shaft as the truck frames oscillate up and down over uneven ground. The ends of the spring rest on spring seats bolted to the truck frames and the U-bolts hold the spring in line.

32. REMOVAL.

a. Tools and Equipment Required.

Bar, drift, 1- x 12-in.	Jack, hydraulic, 10-ton
Bar, drift, 1- x 18-in.	Wrench, $\frac{9}{16}$ -in.
Chain	Wrench, $\frac{3}{4}$ -in.
Chisel, $\frac{3}{4}$ -in.	Wrench, $\frac{7}{8}$ -in.
Hammer, 2-lb	Wrench, $\frac{15}{16}$ -in.
Hammer, 8-lb	Wrench, $1\frac{1}{16}$ -in.
Hammer, sledge, 16-lb	Wrench, track-adjusting
Hoist, chain	

b. Procedure.

(1) DISCONNECT TRACK.

Refer to paragraph 102 b (1) and (2). Slide front idler forward.

(2) REMOVE U-BOLT AND SPRING SEAT.

Jack, hydraulic, 10-ton	Wrench, $1\frac{1}{16}$ -in.
Wrench, $\frac{7}{8}$ -in.	

Jack up front of tractor until weight of tractor is off spring. Remove bottom nuts from U-bolt ($1\frac{1}{16}$ -in. wrench) (fig. 88). Remove the

ORDNANCE MAINTENANCE — MEDIUM TRACTOR M1 (ALLIS-CHALMERS HD-7W)
ELECTRICAL SYSTEM, POWER TRAIN, FRAME, AND TRACKS

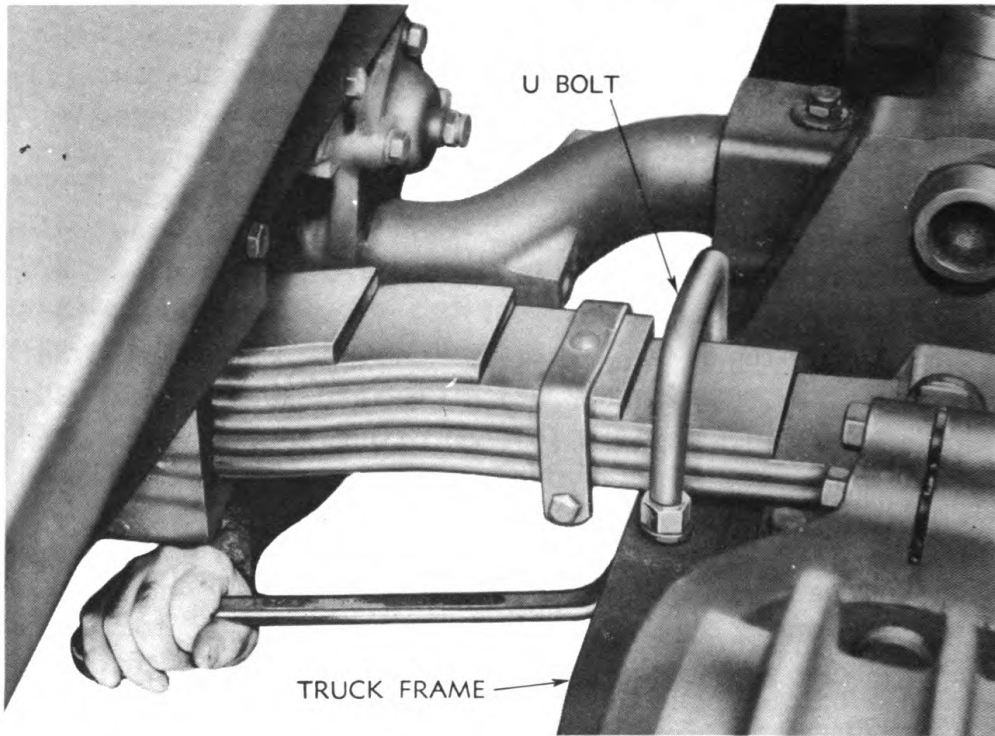

RA PD 41368

Figure 88 — Removing Spring U-bolt from Truck Frame

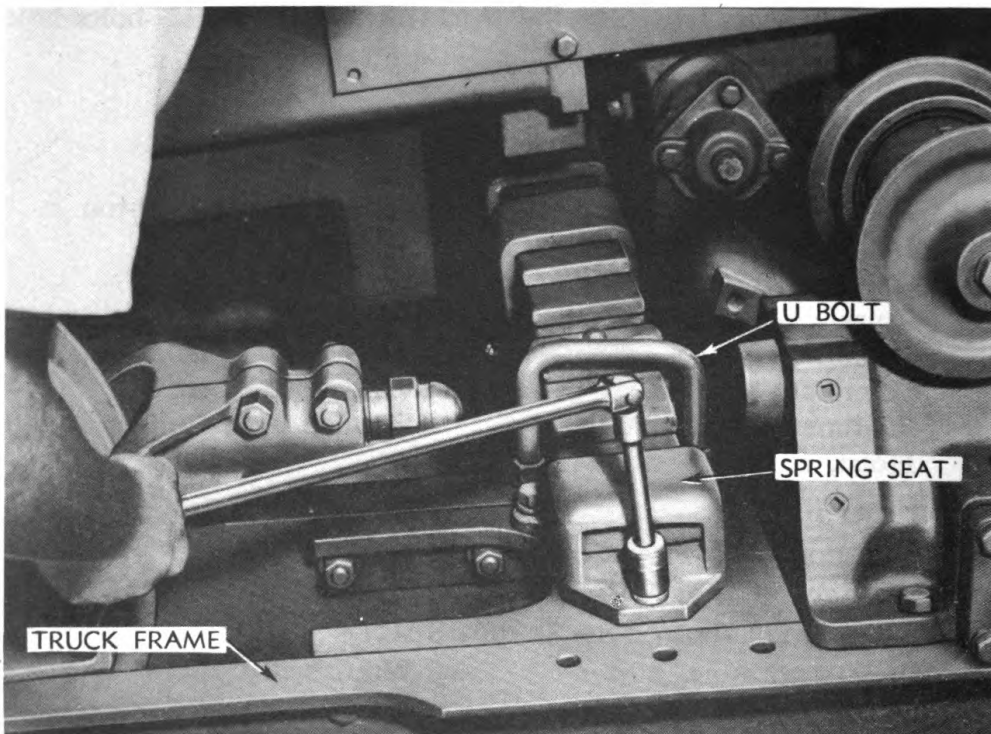

RA PD 18134

Figure 89 — Removing Stabilizer Spring Seat from Truck Frame

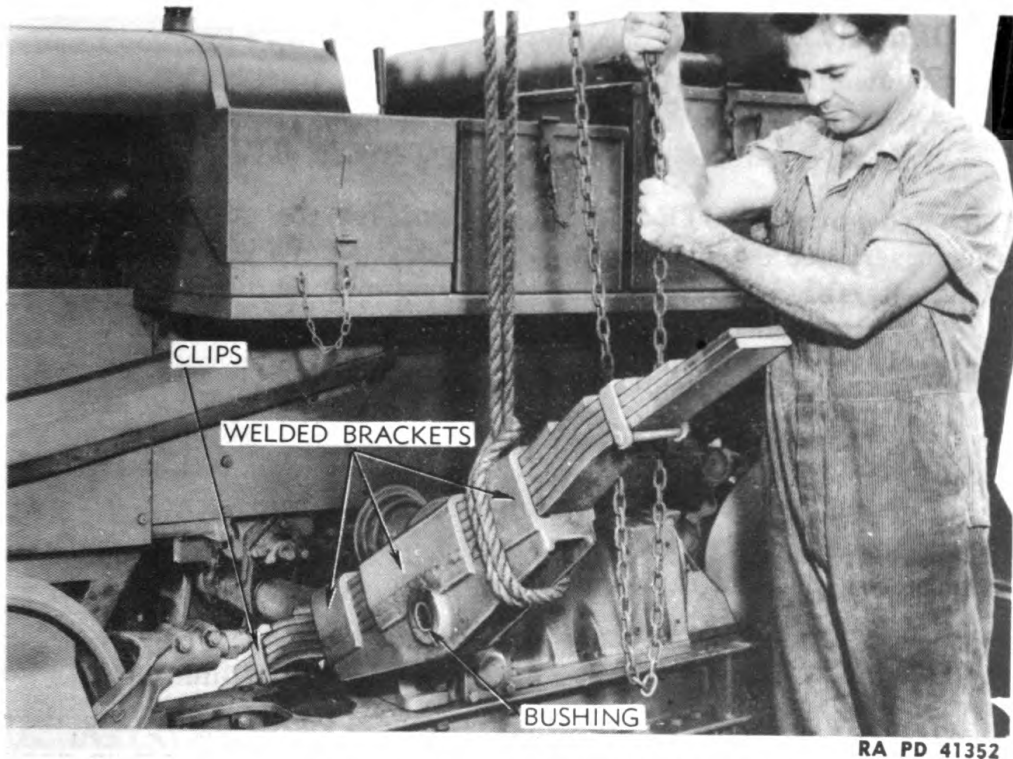
STABILIZER SPRING

RA PD 41352

Figure 90 — Removing Stabilizer Spring

three cap screws holding spring seat to truck frame ($\frac{7}{8}$ -in. wrench) (fig. 89) and remove spring seat and U-bolt from side of tractor with track disconnected.

(3) DRIVE PIVOT SHAFT OUT OF SPRING.

Bar, drift, 1- x 18-in.

Chisel, $\frac{3}{4}$ -in.

Hammer, 2-lb

Hammer, 8-lb

Wrench, $\frac{9}{16}$ -in.Wrench, $\frac{7}{8}$ -in.

(a) Remove four cap screws holding engine support bottom cover to engine support ($\frac{7}{8}$ -in. wrench) and remove bottom cover from tractor (fig. 282).

(b) Straighten lock on cap screw heads (hammer and chisel) and remove the two cap screws and washer (fig. 324) from front end of stabilizer spring pivot shaft ($\frac{9}{16}$ -in. wrench). Remove three cap screws at rear end of pivot shaft ($\frac{9}{16}$ -in. wrench). Using a long bar and hammer, drive stabilizer spring pivot shaft back out of spring (fig. 325). **NOTE:** Do not drive spring pivot shaft completely out of stabilizer bracket, but only far enough to release spring.

(4) REMOVE STABILIZER SPRING ASSEMBLY.

Hoist, chain

Rope

With the aid of chain hoist and rope, slide stabilizer spring toward side on which track was separated, and remove spring assembly from tractor (fig. 90).

**ORDNANCE MAINTENANCE — MEDIUM TRACTOR M1 (ALLIS-CHALMERS HD-7W)
ELECTRICAL SYSTEM, POWER TRAIN, FRAME, AND TRACKS**

33. DISASSEMBLY.**a. Tools and Equipment Required.**

Press, heavy	Wrench, $\frac{3}{4}$ -in. (2)
Welding or cutting equipment	Wrench, $1\frac{1}{8}$ -in.

b. Procedure. NOTE: Although parts for the stabilizer spring are not serviced separately, in case of emergency, when a complete spring assembly is not available, the spring may be disassembled and new leaves installed as follows:

(1) CUT WELDED JOINT IN BRACKET.

Torch, cutting, acetylene

Cut the welded joint on each side of the three sections of the stabilizer spring bracket and remove the three top center sections. Measure the location before cutting, so that the sections may be replaced and welded in the same position.

(2) DISASSEMBLE LEAVES.

Wrench, $\frac{3}{4}$ -in. (2)	Wrench, $1\frac{1}{8}$ -in.
--------------------------------	-----------------------------

(a) Place spring assembly in press to hold leaves tightly together and remove center bolt ($\frac{3}{4}$ -in. wrench). Cut welded joints in each welded bracket at ends of welded lower part of bracket.

(b) Remove clips from each end of second leaf (two $\frac{3}{4}$ -in. wrenches).

(c) Remove nuts from U-bolt clamps ($1\frac{1}{8}$ -in. wrench) and lift U-bolts and saddles off spring.

(d) Release press until pressure is relieved and spring leaves and heavy bracket may be separated.

(3) REMOVE PIVOT SHAFT BUSHING.

Press, heavy

Place spring assembly or bracket in press and, using suitable size shaft, press bushings from bracket.

34. INSPECTION AND REPAIR.

a. Spring Leaves. If necessary, bent leaves can be heated and formed to original shape to fit the other leaves. They should be tempered again if heated. New leaves may be made, in emergency, using broken pieces for pattern.

b. Pivot Shaft Bushing. If pivot shaft or bushing are badly worn, they should be replaced. Press old bushing out, install new one, and ream bushing to size that will allow pivot shaft to work freely in bushing. Replace broken or worn U-bolts, or spring seats.

STABILIZER SPRING

35. ASSEMBLY.

a. Tools and Equipment Required.

Hammer, 2-lb	Welding equipment, electric arc
Press, heavy	Wrench, $\frac{3}{4}$ -in.

b. Procedure.

(1) ASSEMBLE PIVOT SHAFT BRACKET AND SPRING LEAVES.

Press, heavy	Wrench, $\frac{3}{4}$ -in.
Welding equipment, electric arc	

(a) Lay leaves in proper order in press, with bolt holes in center of leaves in line and insert $\frac{1}{2}$ - by $5\frac{1}{2}$ -inch center bolt through holes.

(b) Lay pivot shaft bracket against bottom leaf with head of center bolt in recess in bracket. Lay upper part of pivot shaft bracket in position over leaves.

(c) Compress leaves and bracket. Install nut on center bolt and tighten ($\frac{3}{4}$ -in. wrench).

(d) Weld upper parts of bracket assembly to lower part and remove spring assembly from press.

36. INSTALLATION.

a. Tools and Equipment Required.

Bar, 3-ft	Wrench, $\frac{9}{16}$ -in.
Chain	Wrench, $\frac{3}{4}$ -in.
Hammer, 2-lb	Wrench, $\frac{7}{8}$ -in.
Hammer, 8-lb	Wrench, $1\frac{5}{16}$ -in.
Hammer, sledge, 16-lb	Wrench, $1\frac{1}{16}$ -in.
Hoist, chain	Wrench, track-adjusting
Jack, hydraulic, 10-ton	

b. Procedure.

(1) PLACE SPRING ASSEMBLY IN POSITION ON TRACTOR.

Chain	Jack, hydraulic, 10-ton
Hoist, chain	

Using chain hoist, lower stabilizer spring assembly onto side of tractor on which track was uncoupled. With jack and blocks, maneuver end of spring up underneath tractor until spring can be inserted through U-bolt, and into spring seat on truck frame on opposite side from which track was uncoupled.

(2) INSTALL PIVOT SHAFT.

Hammer, 2-lb	Wrench, $\frac{9}{16}$ -in.
Hammer, 8-lb	

Position spring so that hole in spring lines up with stabilizer spring pivot shaft in stabilizer bracket, and drive pivot shaft through spring with hammer. Install three $\frac{3}{8}$ - by $1\frac{1}{2}$ -inch cap screws with lock washers in flange on rear end of shaft ($\frac{9}{16}$ -in. wrench); then install

**ORDNANCE MAINTENANCE — MEDIUM TRACTOR M1 (ALLIS-CHALMERS HD-7W)
ELECTRICAL SYSTEM, POWER TRAIN, FRAME, AND TRACKS**

retaining washer at front end of shaft (fig. 324) with two $\frac{3}{8}$ - by $1\frac{1}{4}$ -inch cap screws with screw lock. Bend screw lock against heads of these two cap screws (hammer).

(3) INSTALL U-BOLT AND SPRING SEAT (figs. 88 and 89).

Wrench, $\frac{7}{8}$ -in.

Wrench, $1\frac{1}{16}$ -in.

Install U-bolt over spring and in truck frame (fig. 88), using two $\frac{3}{4}$ -inch hexagonal nuts ($1\frac{1}{16}$ -in. wrench). Install the spring seat (fig. 89) on truck frame with three $\frac{5}{8}$ - by $1\frac{1}{2}$ -inch cap screws with lock washers ($\frac{7}{8}$ -in. wrench). Remove jack from under tractor.

(4) INSTALL ENGINE SUPPORT BOTTOM COVER.

Wrench, $\frac{7}{8}$ -in.

Install bottom cover at bottom of engine support with four $\frac{5}{8}$ - by $1\frac{1}{2}$ -inch cap screws with lock washers.

(5) CONNECT TRACK.

Connect and adjust track as outlined in paragraphs 106 and 107.

CHAPTER 8

STABILIZER SPRING AND CRANK ASSEMBLY (Cont'd)

Section II

STABILIZER CRANK ASSEMBLY

	Paragraph
Description	37
Trouble shooting	38
Removal	39
Disassembly	40
Inspection of parts	41
Assembly	42
Installation	43
Special tools	44

37. DESCRIPTION.

a. The stabilizer crank assembly consists of the stabilizer link shaft, stabilizer links, and stabilizer cranks. The stabilizer link shaft is held rigid in the engine spacer by a setscrew on the left spacer bracket and a U-bolt in the bottom of the engine spacer (fig. 326). Two links are suspended from the stabilizer link shaft, and one end of each crank arm extends through each of these links. The other ends of the crank arms go through the track release housings. A cap screw and thrust washer in each end of the crank arms hold the cranks in place in links and track release housings.

b. The purpose of the stabilizer crank assembly is to hold truck frames and tracks in rigid alinement with the tractor, but still permit oscillation of the truck frames about the rear axle shaft so that the tracks may follow the ground when traveling over rough uneven ground, rocks, or other obstacles. As stated above, the stabilizer link shaft does not move, but the links oscillate on the link shaft and the cranks oscillate in both links and track release housings. This allows the front end of each track to raise or lower independent of the other, yet each truck frame and track is held in rigid alinement, cannot tip or toe in or out. Side thrust is taken on thrust collars and thrust washers at each end of crank arms.

38. TROUBLE SHOOTING.

a. Broken parts in the stabilizer crank assembly can easily be seen, and should be replaced. Worn or bent parts are generally indicated by the tracks running out of line. Check the following points of stabilizer assembly if tracks are out of line.

**ORDNANCE MAINTENANCE — MEDIUM TRACTOR M1 (ALLIS-CHALMERS HD-7W)
ELECTRICAL SYSTEM, POWER TRAIN, FRAME, AND TRACKS**

(1) WORN OR DAMAGED BUSHINGS IN STABILIZER LINKS AND ON LINKS OF TRACK RELEASE HOUSING.

Possible Cause	Possible Remedy
Worn or damaged oil seals.	Replace oil seals and worn or damaged bushings.

(2) TRACKS TOE OUT.

Loose cap screws in ends of cranks.	Replace cap screw locks.
Cap screw threads damaged.	Replace cap screws.
Worn thrust washers on crank arms and links.	Replace washers (par. 41).
Bent crank arms in stabilizer links or track release housing.	Straighten or replace crank arms.

(3) TRACKS TOE IN.

Worn thrust collars.	Replace thrust collars.
Worn crank arm bushings.	Replace bushings.
Bent crank arms.	Straighten or replace crank arms.

39. REMOVAL.

a. Tools Required.

Bar, 6-ft (2)	Wrench, 3/4-in.
Bar, drift, 1- x 18-in.	Wrench, 7/8-in.
Chisel, 3/4-in.	Wrench, 15/16-in.
Hammer, 2-lb	Wrench, 1 1/16-in.
Hammer, 8-lb	Wrench, box, 1 5/16-in.
Hammer, sledge, 16-lb	Wrench, open-end, 5/8-in.
Hoist, chain	Wrench, socket, 1 7/16-in.
Jack, hydraulic, 10-ton	Wrench, track-adjusting
Rope	

b. Procedure.

(1) UNCOUPLE TRACKS.

Refer to paragraph 102, uncouple left track, and roll it back off sprocket.

(2) REMOVE TRACK RELEASE HOUSING.

Refer to paragraph 95, and remove track release housing from left side of tractor.

(3) REMOVE STABILIZER LINK SHAFT.

Bar, 6-ft	Wrench, 3/4-in.
Chisel, 3/4-in.	Wrench, 1 1/16-in.
Hammer, 2-lb	Wrench, box, 1 5/16-in.
Hammer, 8-lb	Wrench, socket, 1 7/16-in.
Wrench, 5/8-in.	

STABILIZER CRANK ASSEMBLY

(a) Remove three cap screws from each link shaft cap ($\frac{3}{4}$ -in. wrench) (fig. 91), and remove link shaft caps from both ends of link shaft.

(b) Straighten lock washers with hammer and chisel and remove the cap screws (fig. 327) from both ends of link shaft ($1\frac{7}{16}$ -in. wrench). Remove shims, if any, from ends of shaft and mark them so they may be reinstalled at same end of shaft.

(c) Loosen lock nut ($1\frac{1}{16}$ -in. wrench) and turn setscrew in the left spacer bracket (fig. 92) out about one-quarter inch ($\frac{5}{8}$ -in. wrench).

(d) Remove the four cap screws holding master clutch cover to transmission case and floor plate ($\frac{3}{4}$ -in. wrench) and remove cover (fig. 180). NOTE: If steering clutch levers are in the way, pull the steering clutch levers back and fasten them in the disengaged position, or remove one of the clevis pins from each control rod.

(e) Position a $1\frac{5}{16}$ -inch box wrench on the rear nut on U-bolt in bottom of engine spacer housing under clutch shaft so that a 6-foot bar can be inserted through the hole from which cover was removed, to pry on the end of the wrench to loosen nut. Each time the wrench is pried over, the bar will have to be removed and wrench placed in position for loosening nut further, until wrench can be turned without the aid of the bar. After loosening rear nut, the front nut can be loosened easily. Back nuts off until U-bolt can be lowered about three-eighths inch. This will allow U-bolt to drop out of a groove in center of link shaft so that shaft may be removed.

(f) Install one of the cap screws previously removed from end of shaft back in the link shaft on the opposite side from which track release housing was removed. Tighten securely. Jack up front end of tractor until link shaft is just above track release housing on right side; then, using a long bar and hammer against the installed cap screw, remove shaft by driving it toward side on which the track release housing was removed (fig. 93).

(4) REMOVE STABILIZER CRANK AND LINK ASSEMBLY.

After link shaft has been driven out, the left-hand stabilizer crank and link assembly may be lifted from tractor (fig. 94).

(5) REMOVE RIGHT-HAND STABILIZER CRANK AND LINK ASSEMBLY.

Chisel, $\frac{3}{4}$ -in.

Wrench, socket, $1\frac{7}{16}$ -in.

Hammer, 2-lb

(a) Remove the four cap screws holding crank cap to outside of track release housing, and remove cap (fig. 247).

(b) Straighten the lock (hammer and chisel) and remove the cap screw, lock and thrust washers from stabilizer crank ($1\frac{7}{16}$ -in. wrench) (fig. 248). Slide crank out of track release housing.

ORDNANCE MAINTENANCE — MEDIUM TRACTOR M1 (ALLIS-CHALMERS HD-7W)
ELECTRICAL SYSTEM, POWER TRAIN, FRAME, AND TRACKS

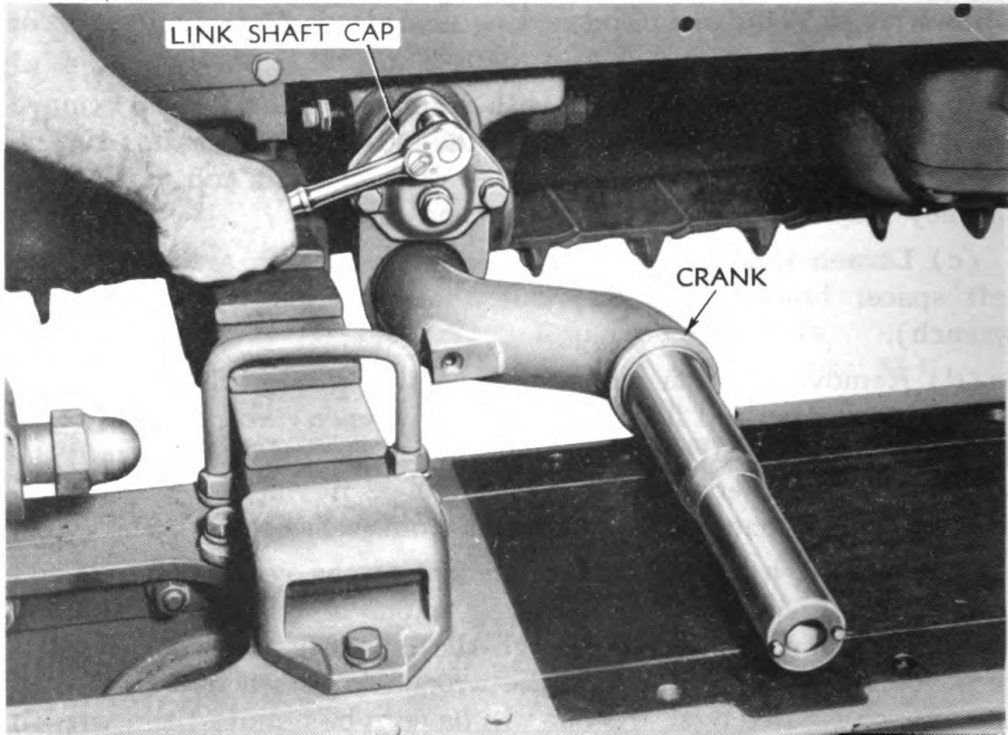

RA PD 18133

Figure 91 — Removing Stabilizer Link Shaft Cap

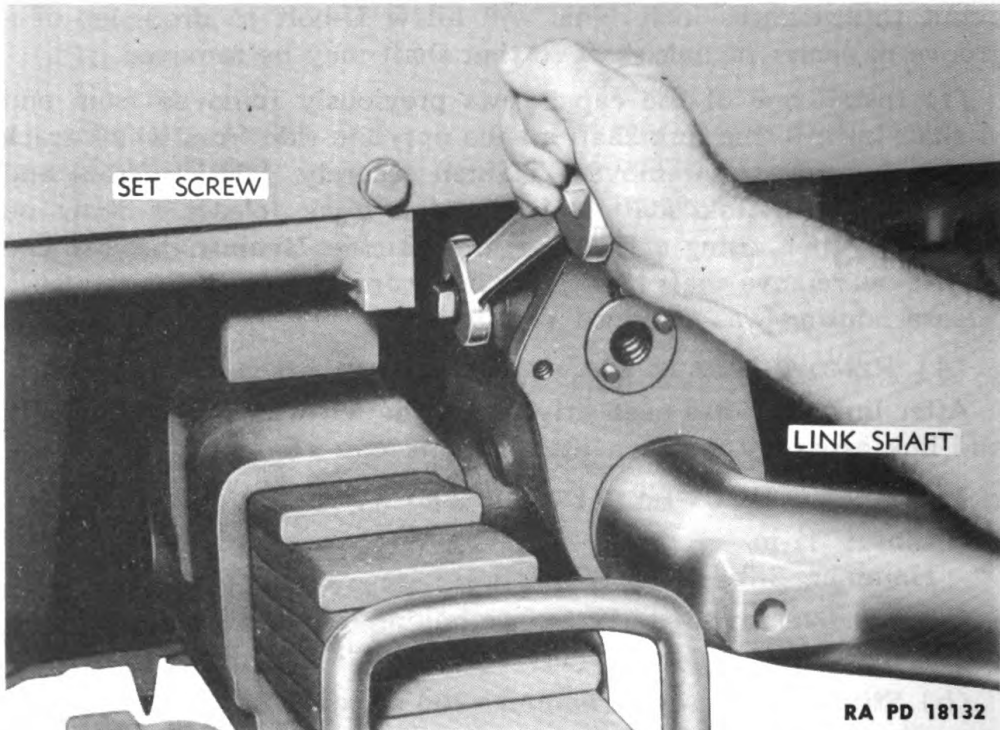

RA PD 18132

Figure 92 — Loosening Lock Nut on Link Shaft Setscrew

STABILIZER CRANK ASSEMBLY

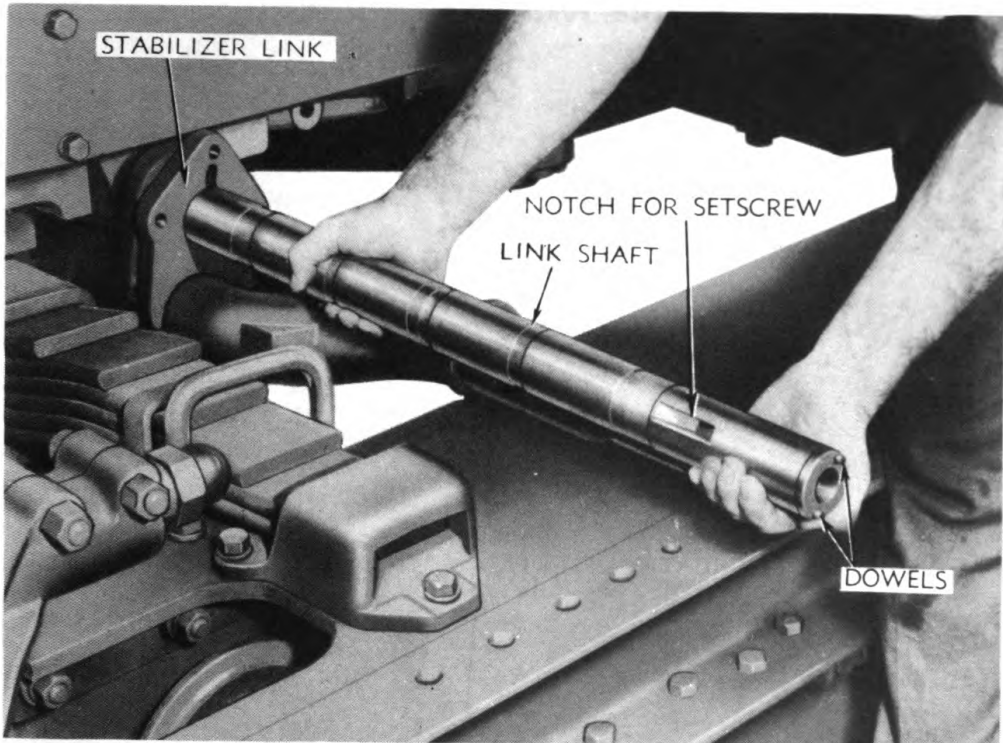

RA PD 18131

Figure 93 — Stabilizer Link Shaft Removed

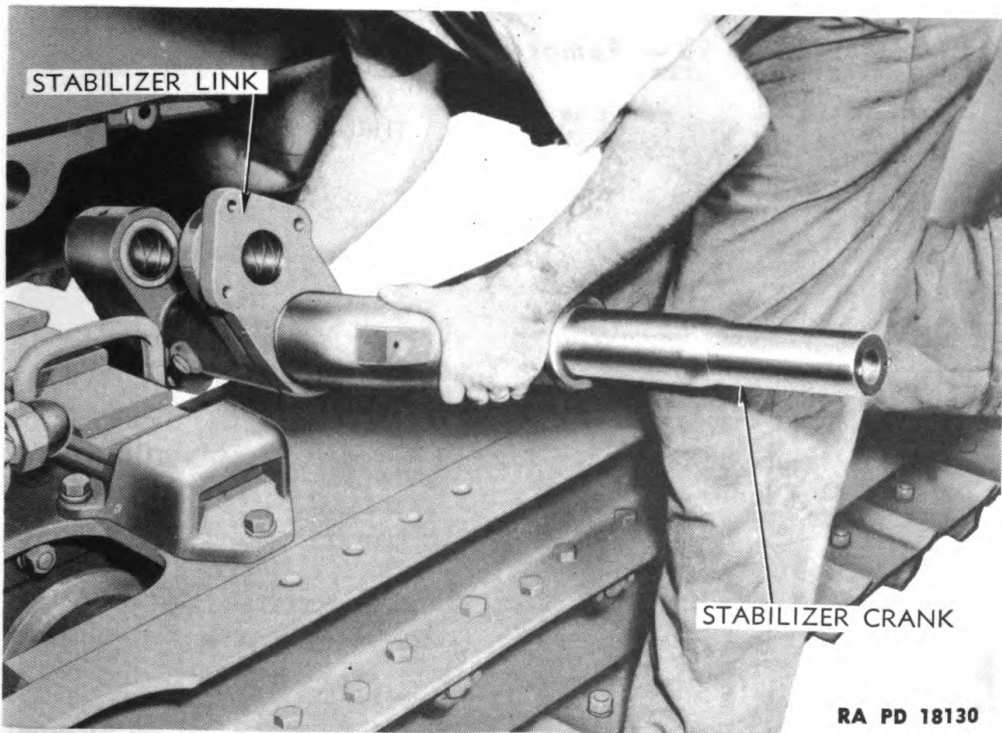

RA PD 18130

Figure 94 — Removing Left-hand Stabilizer Crank and Link Assembly

ORDNANCE MAINTENANCE — MEDIUM TRACTOR M1 (ALLIS-CHALMERS HD-7W)
ELECTRICAL SYSTEM, POWER TRAIN, FRAME, AND TRACKS

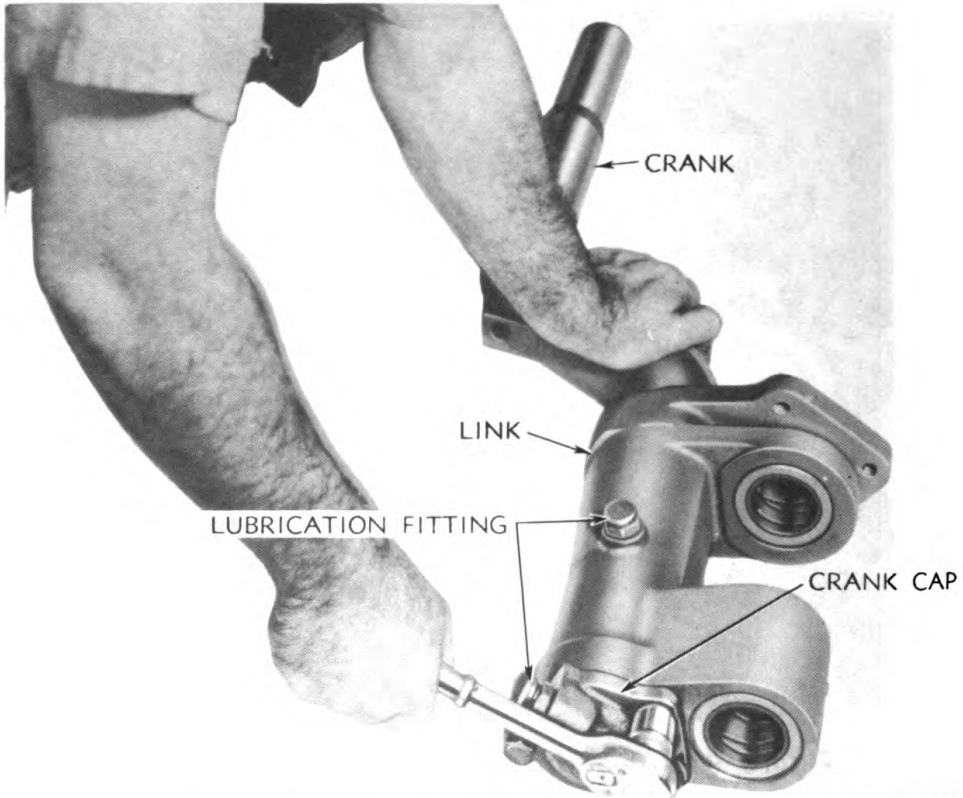

RA PD 41296

Figure 95 — Removing Inner Crank Cap

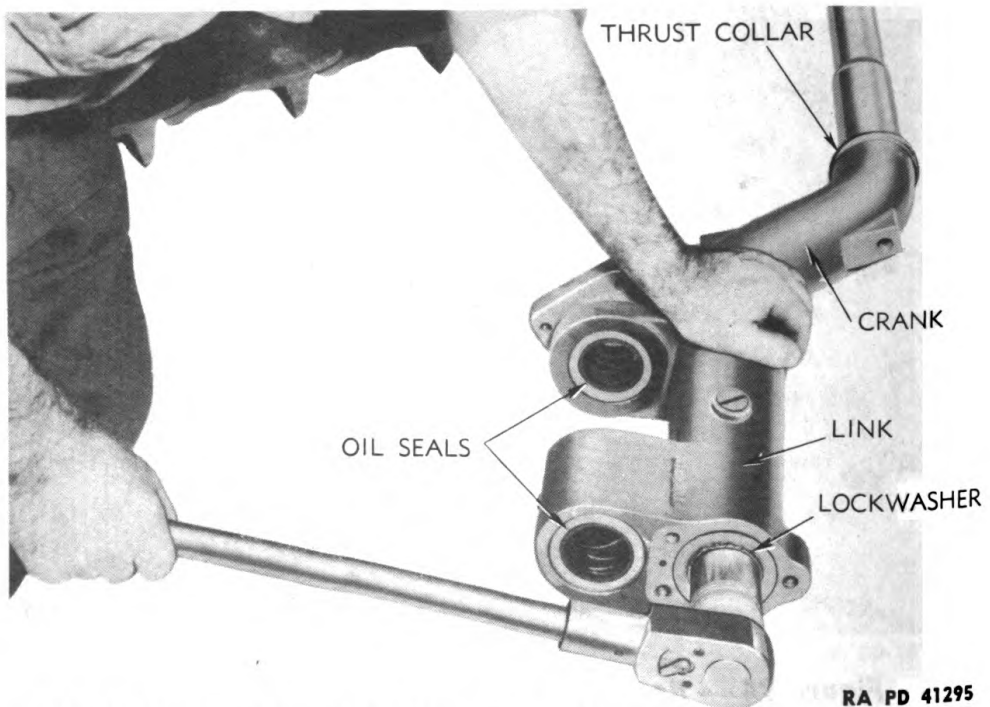

RA PD 41295

Figure 96 — Removing Cap Screw from Inner End of Crank

STABILIZER CRANK ASSEMBLY



RA PD 41294

Figure 97 — Link Removed from Crank

40. DISASSEMBLY.

a. Tools Required.

Bar, pry

Chisel, $\frac{3}{4}$ -in.

Hammer, 2-lb

Wrench, $\frac{3}{4}$ -in.

Wrench, socket, $1\frac{7}{16}$ -in.

b. Procedure.

(1) REMOVE CRANKS FROM LINKS.

Chisel, $\frac{3}{4}$ -in.

Hammer, 2-lb

Wrench, $\frac{3}{4}$ -in.

Wrench, socket, $1\frac{7}{16}$ -in.

(a) Remove crank caps from inner end of cranks by removing three capscrews from each ($\frac{3}{4}$ -in. wrench) (fig. 95).

(b) Straighten lock washers with hammer and chisel and remove capscrews from inner end of crank ($1\frac{7}{16}$ -in. wrench) (fig. 96). Lift thrust washers off ends of cranks (fig. 99).

(c) Slide links off cranks (fig. 97).

(2) REMOVE OIL SEALS FROM STABILIZER LINKS.

Bar, pry

Pry oil seals from link with pry bar (fig. 96). New oil seals will have to be installed, as those removed will not be usable.

(3) REMOVE BUSHINGS AND OIL SEALS FROM TRACK RELEASE SPRING HOUSINGS.

**ORDNANCE MAINTENANCE — MEDIUM TRACTOR M1 (ALLIS-CHALMERS HD-7W)
ELECTRICAL SYSTEM, POWER TRAIN, FRAME, AND TRACKS**

Refer to paragraph 96 for removal of these bushings and seals, and proceed as in paragraph b (4), if these bushings or seals are to be replaced.

41. INSPECTION OF PARTS.

a. Clean all parts thoroughly and inspect for cracks or breaks. Repair broken parts, if possible; replace those that cannot be repaired.

(1) STABILIZER LINKS AND CRANKS.

(a) Check link shaft and crank arms for degree of wear. Measure the diameter of the stabilizer link shaft, and diameter of journals on crank, with outside calipers. Original diameters are as follows:
 Diameter of link shaft. 2-in.
 Diameter of crank, outer journals. 2 $\frac{1}{8}$ -in.
 Diameter of crank, inner journals. 2 $\frac{7}{8}$ -in.

(b) The amount of wear on crank journals and link shaft may be determined by comparing measurements taken, to the above dimensions. The amount of wear on bushings in track release housing may be determined by comparing the measurement of the inside diameter of bushings measured with inside calipers, to above dimensions. Original clearance between link shaft and links and between crank journals and links or bushings is 0.003 inch. Replace parts that are worn to point where clearance between shaft and bushings exceeds 0.010 inch.

(2) **BUSHINGS.** Replacement of bushings in track release housing requires pressing the old ones out and pressing in new ones in their place. New bushings are slightly undersize, and will have to be reamed to give 0.003-inch clearance.

(3) **OIL SEALS.** Always install new oil seals when rebuilding the stabilizer crank assembly. The old ones, as a rule, will be damaged and worn when bushings or other parts require replacement. Examine all lubrication fittings and test to see that lubricant can pass in to lubricate shafts.

(4) **THRUST COLLARS.** Thrust collars are located against inner shoulders on cranks to take inward side thrust of truck frames (fig. 97); their original thickness is one-half inch. If worn more than 0.010 inch or scored, replace thrust collars.

(5) **THRUST WASHERS.** The round thrust washers at each end of cranks and link shaft measure 0.405 inch when new; replace these if worn more than 0.010 inch. The square thrust washers at outer ends of cranks measure $1\frac{3}{32}$ inch when new, and should be replaced if worn more than 0.010 inch. If dowel pins in link shaft or cranks (figs. 93 and 99) that engage thrust washers are broken off or missing, drill out broken pieces and install new ones.

STABILIZER CRANK ASSEMBLY

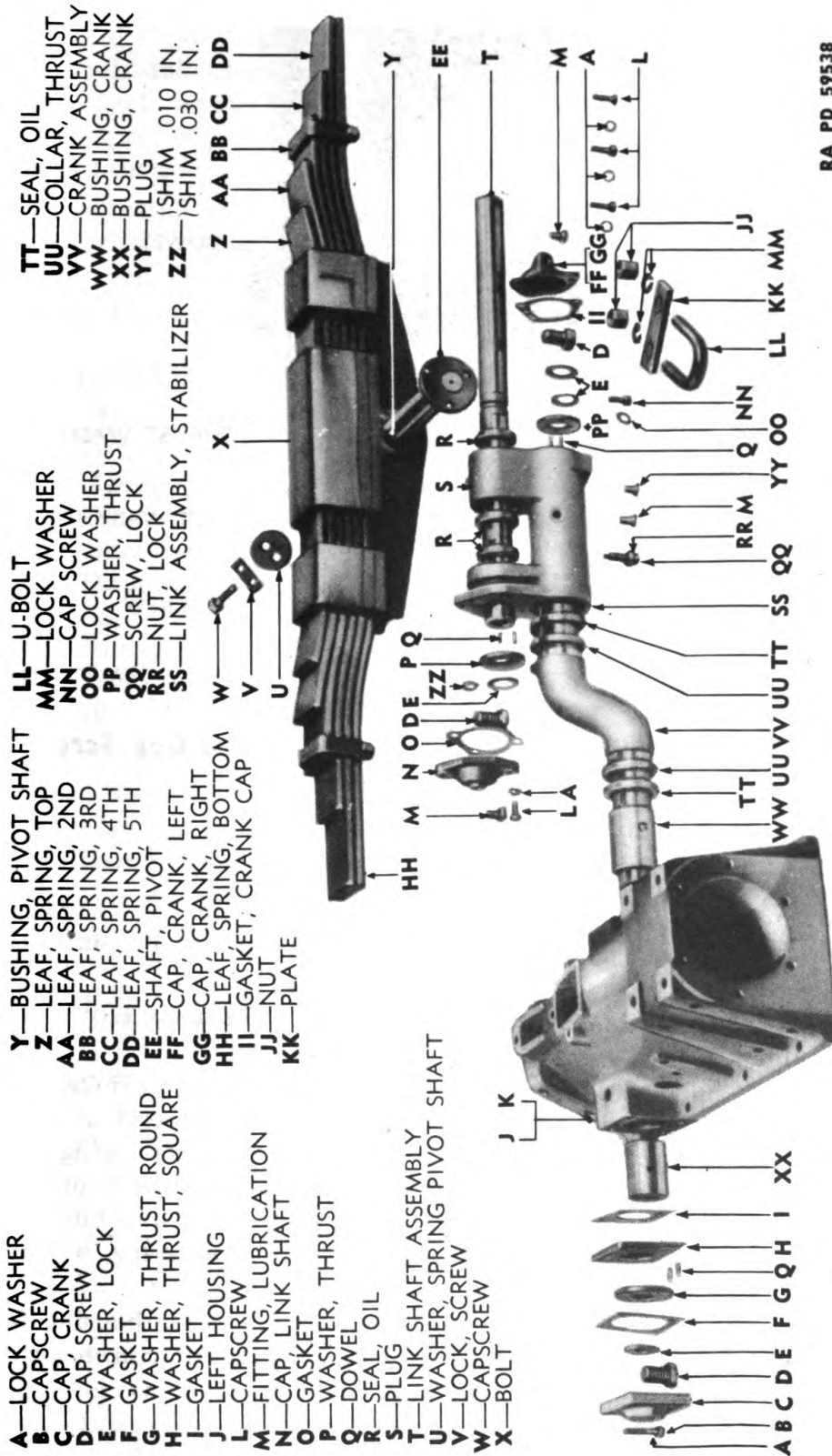

RA PD 59538

Figure 98 — Exploded View of Stabilizer Assembly

- A—LOCK WASHER
- B—CAPSCREW
- C—CAP, CRANK
- D—CAP, SCREW
- E—WASHER, LOCK
- F—GASKET
- G—WASHER, THRUST, ROUND
- H—WASHER, THRUST, SQUARE
- I—GASKET
- J—LEFT HOUSING
- K—CAPSCREW
- L—FITTING, LUBRICATION
- M—CAP, LINK SHAFT
- N—GASKET
- O—WASHER, THRUST
- P—DOWEL
- Q—SEAL, OIL
- R—PLUG
- S—LINK SHAFT ASSEMBLY
- T—WASHER, SPRING PIVOT SHAFT
- V—LOCK, SCREW
- W—CAPSCREW
- X—BOLT

- Y—BUSHING, PIVOT SHAFT
- Z—LEAF, SPRING, TOP
- AA—LEAF, SPRING, 2ND
- BB—LEAF, SPRING, 3RD
- CC—LEAF, SPRING, 4TH
- DD—LEAF, SPRING, 5TH
- EE—SHAFT, PIVOT
- FF—CAP, CRANK, LEFT
- GG—CAP, CRANK, RIGHT
- HH—LEAF, SPRING, BOTTOM
- II—GASKET, CRANK CAP
- JJ—NUT
- KK—PLATE

- LL—U-BOLT
- MM—LOCK WASHER
- NN—CAP, SCREW
- OO—LOCK WASHER
- PP—WASHER, THRUST
- QQ—SCREW, LOCK
- RR—NUT, LOCK
- SS—LINK ASSEMBLY, STABILIZER
- TT—SEAL, OIL
- UU—COLLAR, THRUST
- VV—CRANK ASSEMBLY
- WW—BUSHING, CRANK
- XX—BUSHING, CRANK
- YY—PLUG
- ZZ—SHIM .010 IN.
SHIM .030 IN.

- X
- Y
- Z
- AA
- BB
- CC
- DD
- EE
- FF
- GG
- HH
- II
- JJ
- KK
- LL
- MM
- NN
- OO
- PP
- QQ
- RR
- SS
- TT
- UU
- VV
- WW
- XX
- YY
- ZZ

ORDNANCE MAINTENANCE — MEDIUM TRACTOR M1 (ALLIS-CHALMERS HD-7W)
ELECTRICAL SYSTEM, POWER TRAIN, FRAME, AND TRACKS

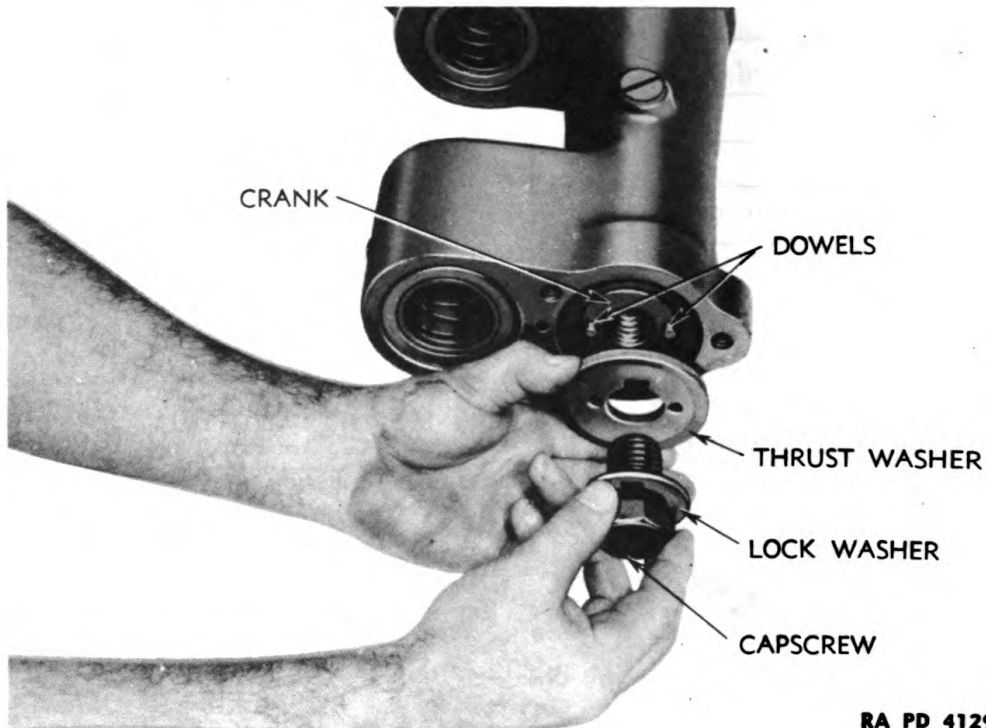

RA PD 41297

Figure 99 — Installing Inner Thrust Washer and Cap Screw in Crank and Link

42. ASSEMBLY.

a. Tools Required.

Hammer, soft
Hammer, 2-lb

Wrench, $\frac{3}{4}$ -in.
Wrench, socket, $1\frac{7}{16}$ -in.

b. Procedure.

(1) **INSTALL OIL SEALS IN LINKS AND TRACK RELEASE HOUSINGS.**
Hammer, soft

(a) Install oil seals in outer ends of crank openings in links; also in link arms at both ends of inner arm, and in inner end of outer arm (fig. 98). Tap them into place with lips of seals facing out. **NOTE:** These seals are installed opposite to all others on the tractor, since they serve to allow lubricant to be forced into bushings and out past seals and keep dirt and water from entering, as well as to hold lubricant in.

(b) Install oil seal in inside opening in track release housing for crank arm, in same manner as above, with lip of seal facing towards center of tractor.

(2) **ASSEMBLE CRANKS AND LINKS.**

Hammer, 2-lb
Wrench, $\frac{3}{4}$ -in.

Wrench, socket, $1\frac{7}{16}$ -in.

STABILIZER CRANK ASSEMBLY

(a) Slip thrust collar onto crank; then slide crank into link, taking care not to injure inner oil seal in link as crank is inserted (fig. 97).

(b) Install inner thrust washer on dowels in end of crank; then place lock washer on cap screw and install cap screw in end of crank (fig. 99). Tighten cap screw securely ($1\frac{7}{16}$ -in. wrench) and bend lock washer over against side of cap screw head with hammer.

(c) Install crank cap on link over cap screw with three $\frac{1}{2}$ - x $1\frac{3}{8}$ -inch cap screws with lock washers ($\frac{3}{4}$ -in. wrench), using gasket under cap (fig. 95).

(d) Repeat above operations for second crank and link assembly.

43. INSTALLATION.

a. Tools Required.

Bar, 6-ft (2)	Wrench, $\frac{3}{4}$ -in.
Hammer, 2-lb	Wrench, $\frac{7}{8}$ -in.
Hammer, 8-lb	Wrench, box, $1\frac{5}{16}$ -in.
Hammer, sledge, 16-lb	Wrench, open-end, $\frac{5}{8}$ -in.
Hammer, soft	Wrench, open-end, $1\frac{1}{16}$ -in.
Jack, hydraulic, 10-ton	Wrench, socket, $1\frac{5}{16}$ -in.
Ruler, 6-ft	Wrench, socket, $1\frac{7}{16}$ -in.
Scale, 6-in.	Wrench, track-adjusting
Wood block, 8- x 8- x 12-in.	

b. Procedure.

(1) INSTALL RIGHT-HAND CRANK AND LINK ASSEMBLY.

Hammer, soft	Wrench, socket, $1\frac{7}{16}$ -in.
Hammer, 2-lb	

(a) Install oil seal in inner opening for crank arm in track release housing (if oil seal was removed), and tap it into place with soft hammer, with lip of seal toward center of tractor.

(b) Slip thrust collar on crank; then insert crank arm into track release housing, taking care not to damage oil seal in housing.

(c) Install square thrust washer, then round thrust washer (fig. 250), on dowels in end of crank; place lock washer on cap screw and install cap screw in end of crank. Tighten cap screw securely with $1\frac{7}{16}$ -inch wrench and bend edge of lock washer over against flat side of cap screw head (hammer).

(2) INSTALL LINK SHAFT.

Hammer, 8-lb	Wrench, socket, $1\frac{7}{16}$ -in.
--------------	--------------------------------------

(a) Install one of the large cap screws removed from end of link shaft in the end of the shaft that has a notch cut in the side (fig. 93). Tighten securely with $1\frac{7}{16}$ -inch wrench. Start other end of shaft into outer side of left stabilizer link.

(b) With help of another man, place crank and link assembly in position under engine spacer with holes in link and engine spacer

ORDNANCE MAINTENANCE — MEDIUM TRACTOR M1 (ALLIS-CHALMERS HD-7W)
ELECTRICAL SYSTEM, POWER TRAIN, FRAME, AND TRACKS

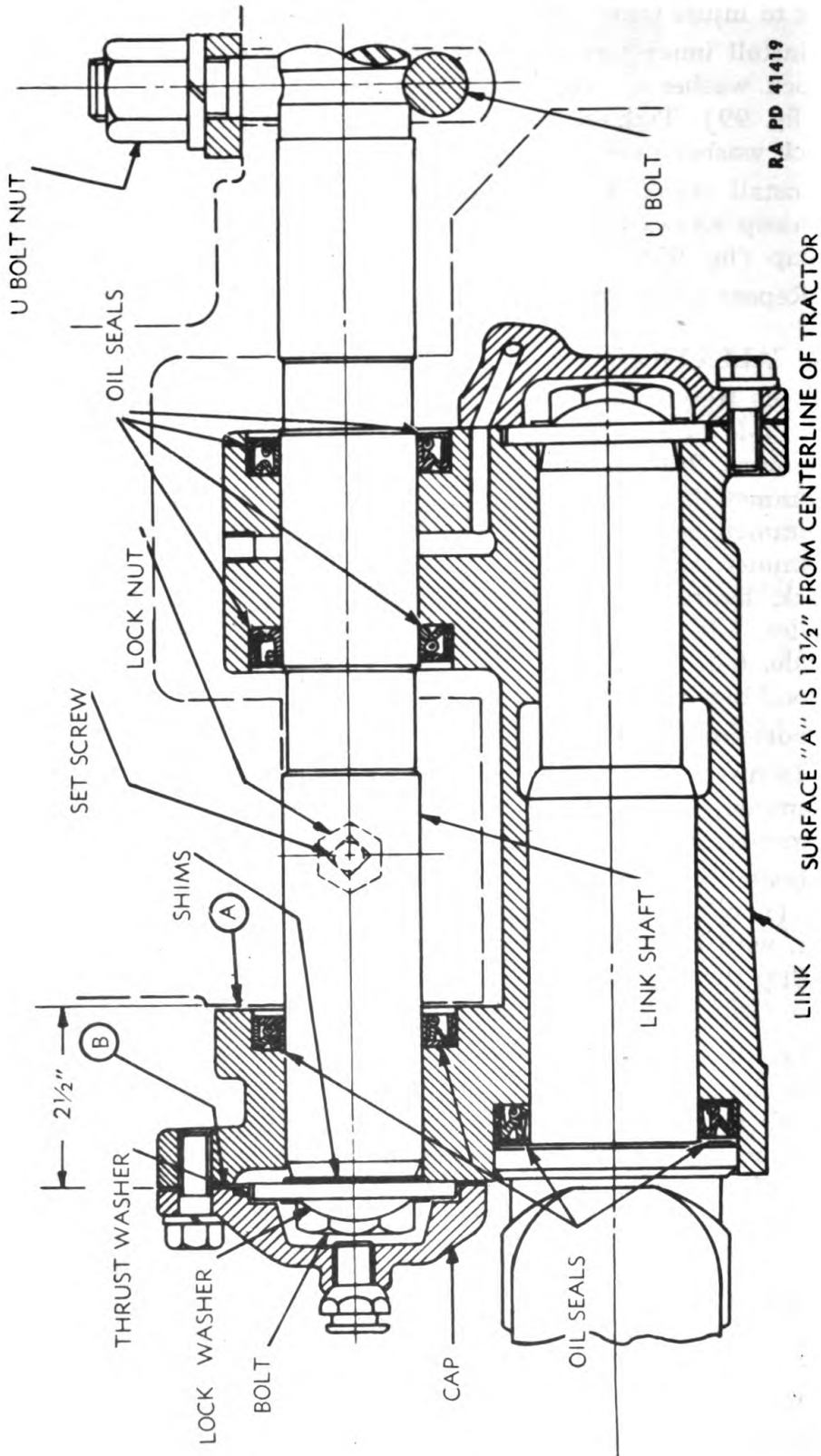

Figure 100 — Stabilizer Link Adjustment

STABILIZER CRANK ASSEMBLY

in line (fig. 93). Drive shaft through spacer and link (8-lb hammer), keeping notch in shaft in line with setscrew (fig. 92), so that setscrew will engage in notch when shaft is installed. Then turn crank and link on other side into position, and drive shaft through link and spacer on other side, so that ends of shaft are equal on both sides.

(3) ADJUST LINKS FOR ALINEMENT OF TRUCK FRAME.

Bar, 6-ft	Wrench, box, $1\frac{5}{16}$ -in.
Hammer, 2-lb	Wrench, open-end, $\frac{5}{8}$ -in.
Ruler, 6-ft	Wrench, open-end, $1\frac{1}{16}$ -in.
Scale, 6-in.	Wrench, socket, $1\frac{7}{16}$ -in.

(a) Refer to figure 100 and set the links so surface "B," the flat surface on the outer end of the link, is $2\frac{1}{2}$ inches from surface "A." With the link shaft turned and centered properly, tighten the setscrew (fig. 92). Turn setscrew all the way in against the bottom of the slot in shaft, and then back it out one-half turn ($\frac{5}{8}$ -in. wrench); tighten the lock nut to hold setscrew in this position ($1\frac{1}{16}$ -in. wrench).

(b) Remove cap screw from end of link shaft. If shims were removed from that end of shaft when shaft was removed, place them on dowels in end of shaft; then place thrust washer on dowels. Place lock washer on cap screw and install cap screw in end of shaft ($1\frac{7}{16}$ -in. wrench). Bend lock washer against side of cap screw head; then tap the shaft endwise just enough to bring the thrust washer up against outer face of link.

(c) With the two links in proper position with respect to the dimension from surface "B" to "A," add shims to the opposite end of the link shaft to make it exactly flush with the part of surface "B" which is contacted by the thrust washer. NOTE: On new assemblies it may be necessary to add a 0.010-inch shim extra to provide clearance at surfaces "A" and "B" to prevent binding the links on the spacer.

(d) With the proper number of shims in position, install the thrust washer, lock washer, and cap screw in end of shaft in same manner as on other end of shaft.

(e) By reaching through the clutch inspection hole with a $1\frac{5}{16}$ -inch box wrench, tighten nuts on U-bolt in bottom of engine spacer. After this operation has been accomplished, further tighten the rear nut by inserting a long bar through clutch inspection hole and prying on handle of wrench, using edge of clutch inspection hole as a fulcrum for the bar.

(f) Check position of links as shown (fig. 100), to make sure they are the same. Surface "A" should be $13\frac{1}{2}$ inches from centerline of tractor or outside face of link; surface "B" on one side should be 32 inches from corresponding surface of link on other side. Any wear at the various points in the stabilizer assembly must be cor-

**ORDNANCE MAINTENANCE — MEDIUM TRACTOR M1 (ALLIS-CHALMERS HD-7W)
ELECTRICAL SYSTEM, POWER TRAIN, FRAME, AND TRACKS**

rected and above measurements result, to insure perfect alinement of truck frames.

(4) INSTALL LINK SHAFT CAPS.

Wrench, $\frac{3}{4}$ -in.

Use gaskets under caps and install each cover on stabilizer links with three $\frac{1}{2}$ - by $1\frac{1}{2}$ -inch cap screws with lock washers (fig. 91).

(5) INSTALL TRACK RELEASE HOUSING AND CRANK CAP.

Refer to paragraph 99. Follow procedure outlined to install assembly that was removed. Lower front of tractor after housing is installed.

(6) COUPLE AND ADJUST TRACK.

Follow procedure outlined in paragraph 106 b (2). Adjust track as outlined in paragraph 107.

(7) INSTALL MASTER CLUTCH COVER.

Wrench, $\frac{3}{4}$ -in.

Install master clutch cover and gasket, using four $\frac{1}{2}$ - by $1\frac{1}{4}$ -inch cap screws with lock washers.

44. SPECIAL TOOLS.

- a. Special tools required for working on stabilizer assembly are:
Calipers, inside
Calipers, outside

CHAPTER 9 STEERING CLUTCHES

Section I

CLUTCH ASSEMBLIES

	Paragraph
Description	45
Trouble shooting	46
Removal	47
Disassembly	48
Inspection and repair of parts	49
Assembly	50
Installation	51
Adjustment	52
Special tools	53

45. DESCRIPTION.

a. Construction. The steering clutches (two) are of the multiple disk type, with 11 friction disks and 11 steel disks in each clutch assembly. Power is transmitted through these clutches to the final drives. The friction disks are of the molded type, with teeth on the outside circumference that engage splines in the brake drum, which encloses the clutch assembly. The steel disks, which alternate in arrangement with the friction disks, have teeth on the inside circumference that engage in splines in the steering clutch hub. The hub is mounted on a splined shaft that extends through both steering clutch hubs and the bevel gear hub. Ten springs in each steering clutch hub press the friction and steel disks tightly together to drive the tractor, and allow disks to be separated for steering (fig. 132).

b. Operation.

(1) The steering clutch shaft is driven by the bevel gear, and drives the steering clutch hubs and the steel disks, which turn with the hubs. When clutches are engaged, the springs in the clutch assembly press the steel disks and the friction disks tightly together, thus driving the brake drum, which is connected to the driven hub on the final drive pinion.

(2) The steering of the tractor is accomplished by pulling back on the steering lever and disengaging the steering clutch on the side toward which the turn is to be made. Pulling back on the steering lever forces ball bearings on the throw-out fork in the steering clutch compartment against the shifter plate of the steering clutch, and the shifter plate compresses the springs in the clutch. This allows the steel disks and friction disks to separate. The steel disks continue to turn,

**ORDNANCE MAINTENANCE — MEDIUM TRACTOR M1 (ALLIS-CHALMERS HD-7W)
ELECTRICAL SYSTEM, POWER TRAIN, FRAME, AND TRACKS**

but the friction disks and brake drum stop, or may be stopped, by applying the brake on that side. Power is thus applied to the track on the other side only, and causes the tractor to turn.

46. TROUBLE SHOOTING.

a. Steering Clutch Slips.

Possible Cause	Possible Remedy
Friction disks worn.	Replace disks.
Springs in clutch weak or have lost their tension.	Replace springs if free length is less than 3¼ inch.
Steel disks warped.	Replace disks.
Oil on clutch disks.	Wash clutches as outlined in TM 9-783B.
Steering clutch controls out of adjustment.	Adjust as outlined in paragraph 52.

b. Steering Clutches Shift on Clutch Shaft.

Spacers loose on clutch shaft.	Adjust as in paragraph 51.
Bevel gear hub bearings loose.	Adjust bearings to proper clearance.

c. Clutches Will Not Disengage.

Steering clutch controls out of adjustment.	Make proper adjustment on controls (par. 52).
Steering clutch throw-out bearings worn or broken.	Replace bearings and check to see that grease tube to bearing is in good condition.
Throw-out fork equalizer loose.	Tighten bolt; if lost, replace parts needed.
Ends of throw-out fork out of equalizer.	Replace fork in equalizer.

d. Short Life on Steering Clutches.

Clutches run with improper adjustments.	Adjust to proper clearances.
Improper brake adjustment.	Adjust brakes as outlined in paragraph 64.

47. REMOVAL.

a. Tools and Equipment Required.

Bar, pry	Puller, final drive pinion
Chisel, ¾-in.	Rope
Hammer, 2-lb	Screwdriver, 10-in.
Hoist, chain	Wrench, 2-in.
Pipe, 2-in., 3-ft long	Wrench, 2¾-in.
Pliers	Wrench, 3¾-in.

CLUTCH ASSEMBLIES

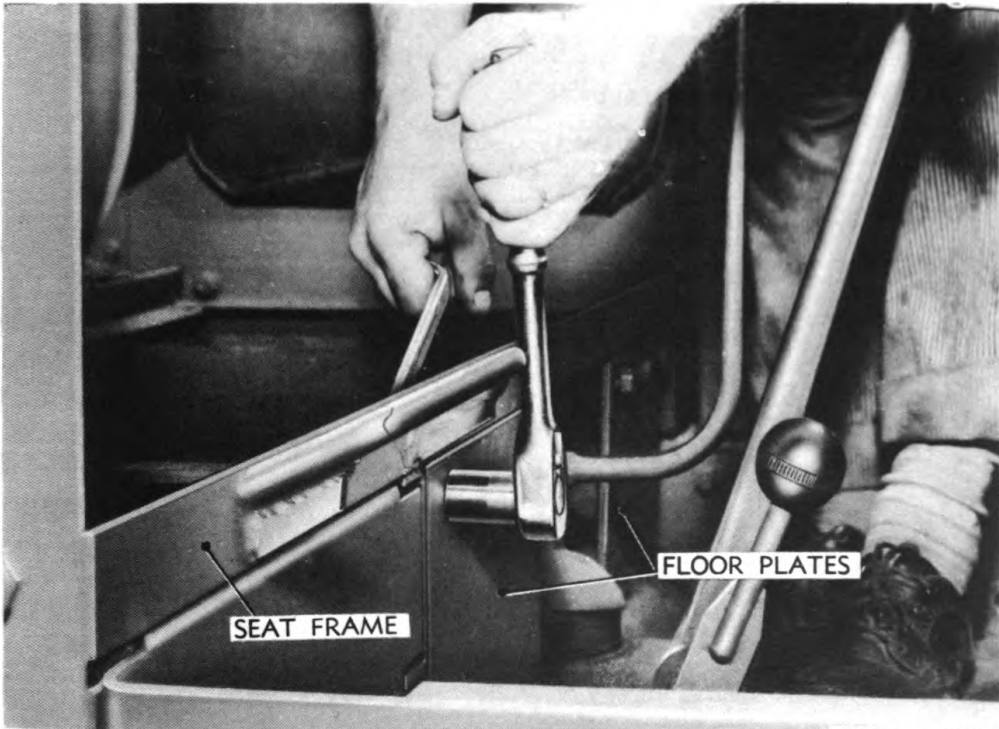

RA PD 41036

Figure 101 — Disconnecting Floor Plate from Seat Frame

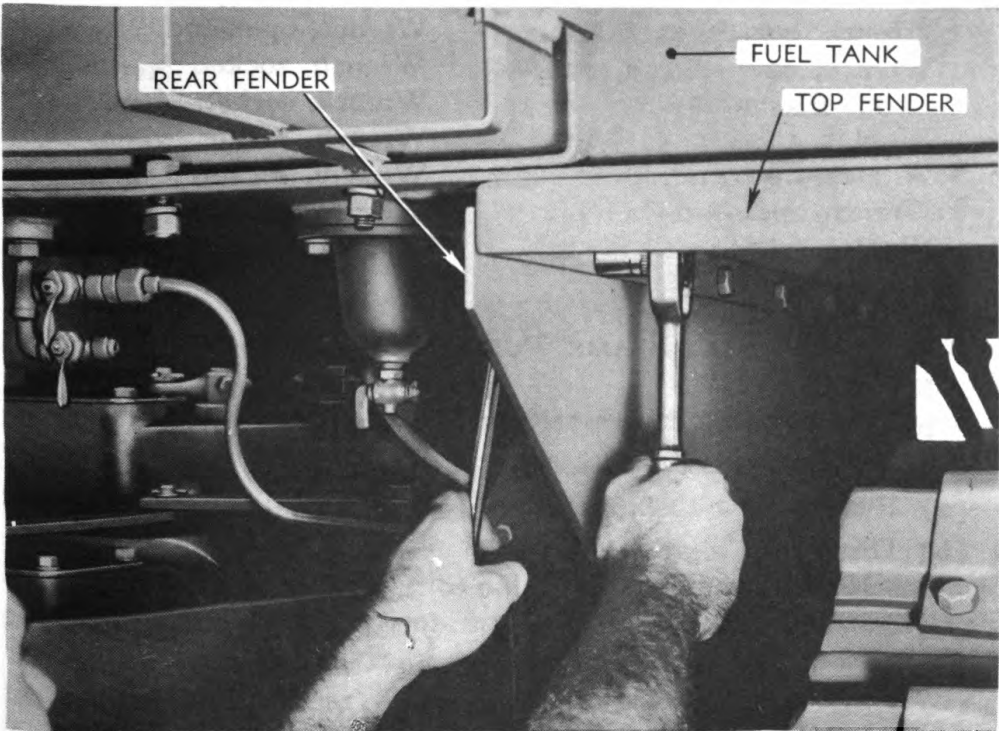

RA PD 41042

Figure 102 — Removing Bolts Holding Fuel Tank

**ORDNANCE MAINTENANCE — MEDIUM TRACTOR M1 (ALLIS-CHALMERS HD-7W)
ELECTRICAL SYSTEM, POWER TRAIN, FRAME, AND TRACKS**

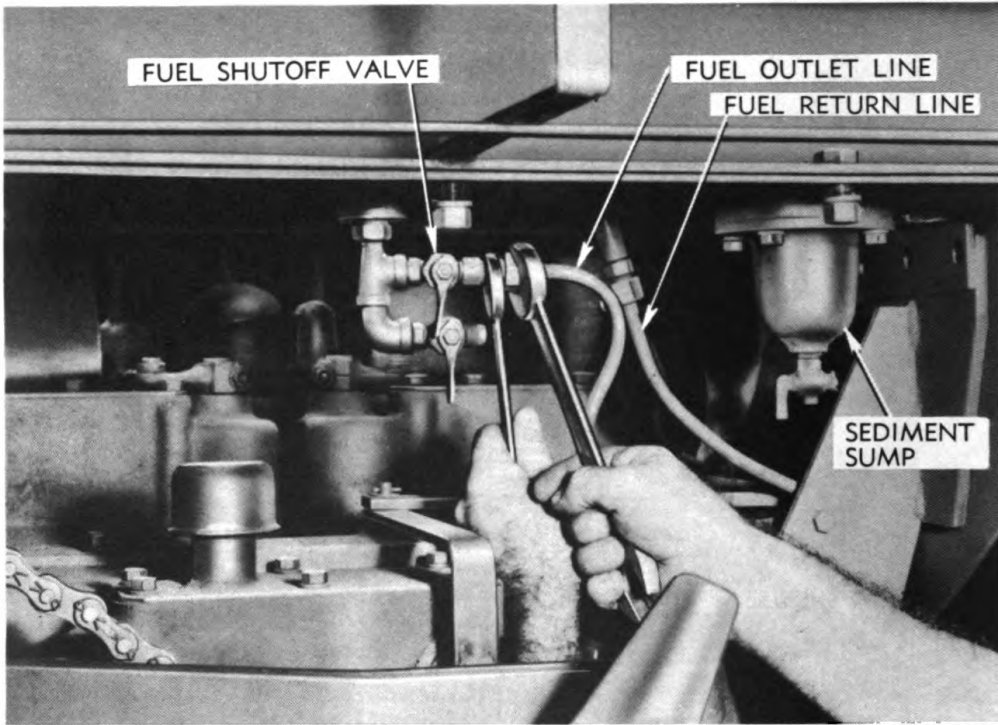

RA PD 41039

Figure 103 — Disconnecting Fuel Outlet Line

Wrench, box, $\frac{3}{4}$ -in.
Wrench, open-end, $\frac{9}{16}$ -in.,
with extension
Wrench, open-end, $1\frac{1}{16}$ -in.
Wrench, open-end, $\frac{3}{4}$ -in.
Wrench, open-end, $\frac{7}{8}$ -in.
Wrench, open-end, $1\frac{5}{16}$ -in.

Wrench, open-end, $2\frac{1}{2}$ -in.
Wrench, socket, $\frac{9}{16}$ -in.
Wrench, socket, $\frac{3}{4}$ -in.
Wrench, socket, $\frac{7}{8}$ -in.
Wrench, socket, $1\frac{5}{16}$ -in.
Wrench, spanner

b. Procedure.

(1) REMOVE SEAL FRAME, FUEL TANK, AND PACK CARRIER.

Hoist, chain
Rope
Wrench, open-end, $\frac{3}{4}$ -in.

Wrench, open-end, $\frac{7}{8}$ -in.
Wrench, socket, $\frac{3}{4}$ -in.

(a) Remove seat cushions.

(b) Disconnect seat frame (two $\frac{3}{4}$ -in. wrenches) as follows: Remove 10 bolts holding seat frame to right top fender, 6 bolts holding right and left floor plates to seat frame (fig. 101), and bolt holding brace to rear of preheater box.

(c) Remove 14 bolts holding fuel tank to rear and top fenders and 8 bolts holding street plate box to left top fender (two $\frac{3}{4}$ -in. wrenches) (fig. 102). Make sure fuel cock is shut off. Disconnect out-

CLUTCH ASSEMBLIES

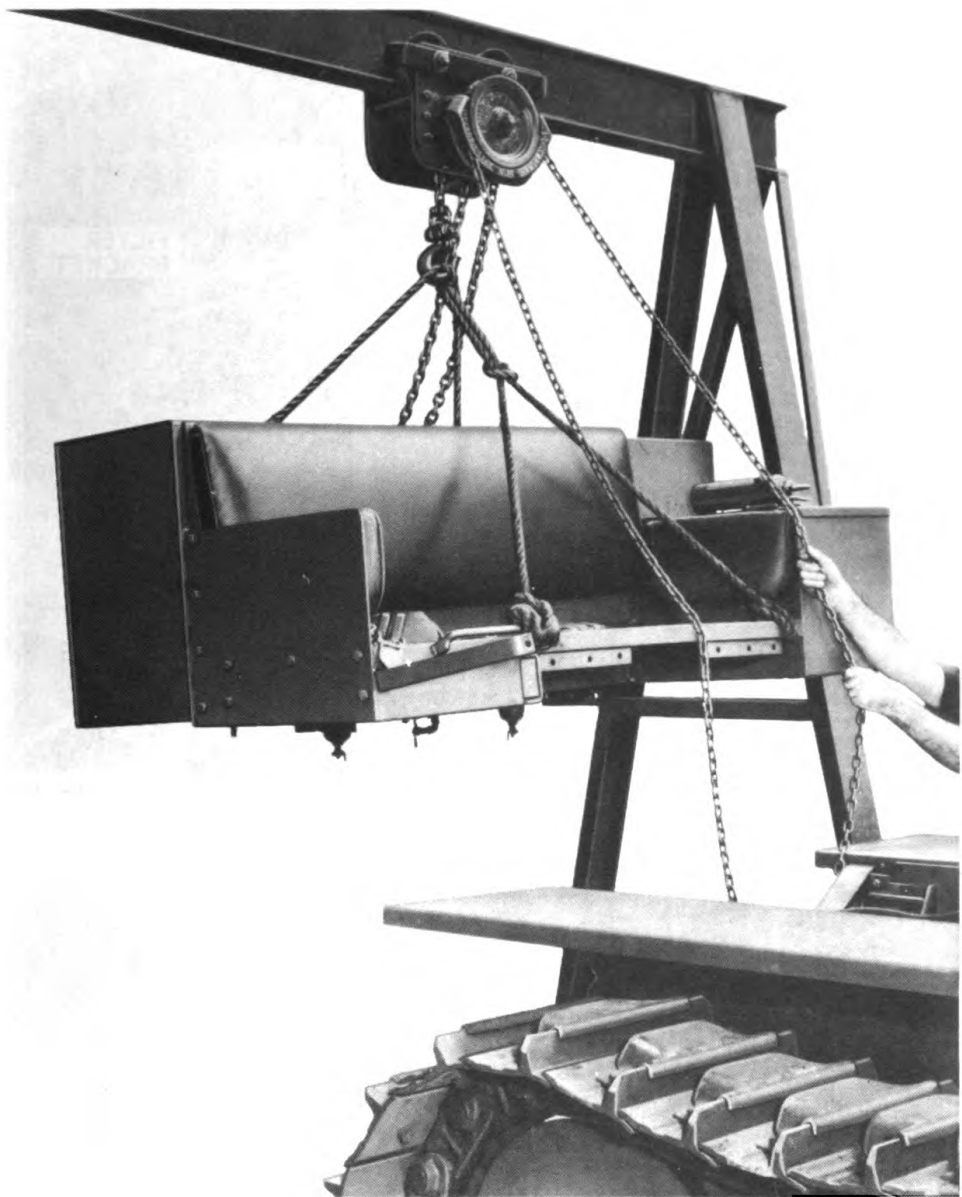

RA PD 41022

Figure 104 — Lifting off Seat Frame and Fuel Tank Assembly

let and fuel return lines at valve and under tank (fig. 103) ($\frac{3}{4}$ -in. and $\frac{7}{8}$ -in. wrenches).

(d) Remove the four bolts holding wire clips to bottom of pack carrier (two $\frac{3}{4}$ -in. wrenches), and remove plugs from sockets at rear of stop light by pushing in on them, turning them out of lock notches, and pulling them out of socket.

(e) Fasten rope around seat frame and fuel tank and, with aid of chain hoist, lift off assembly, consisting of the seat frame, fuel tank, pack carrier, and street plate box, as one unit (fig. 104).

ORDNANCE MAINTENANCE — MEDIUM TRACTOR M1 (ALLIS-CHALMERS HD-7W)
ELECTRICAL SYSTEM, POWER TRAIN, FRAME, AND TRACKS

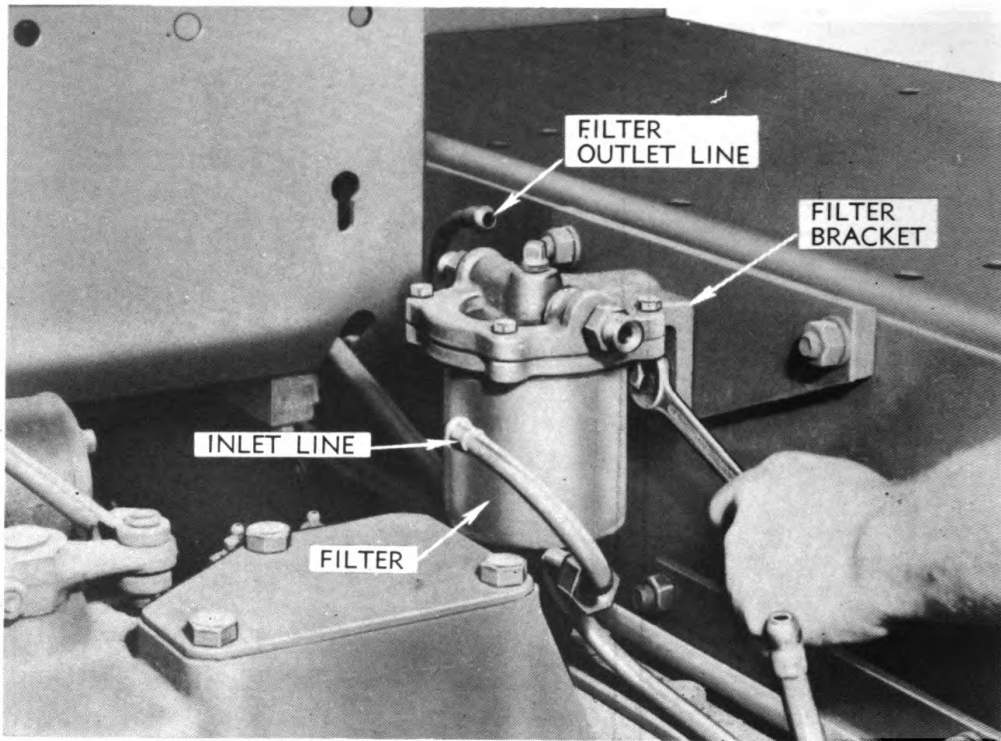

RA PD 40986

Figure 105 — Removing First Stage Fuel Filter

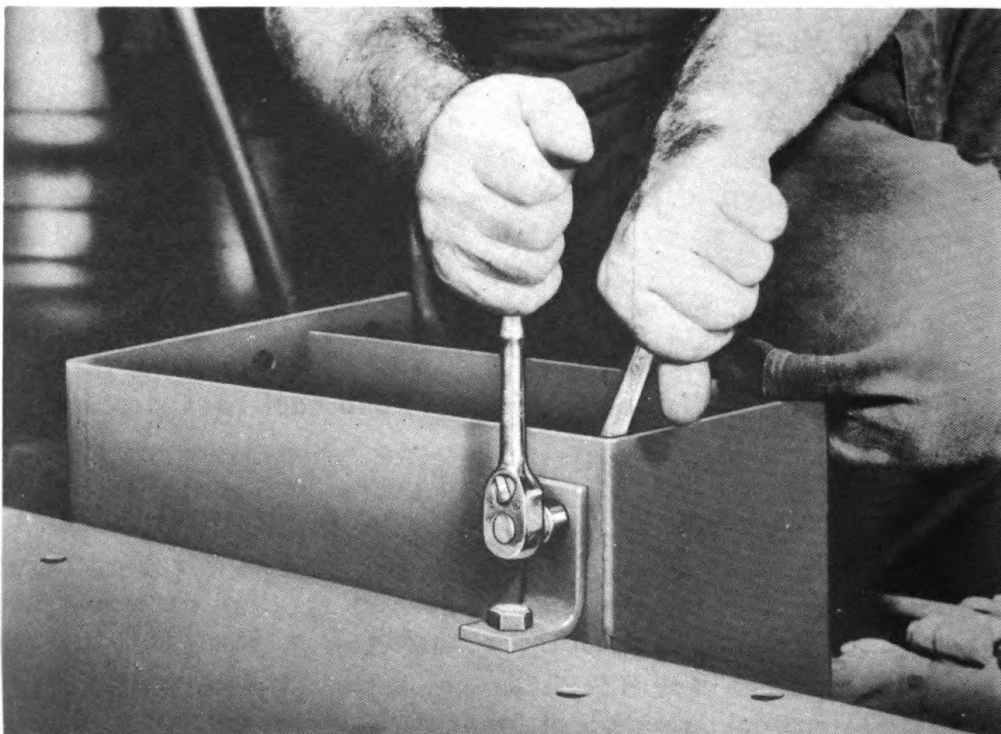

RA PD 41040

Figure 106 — Removing Tool Box

CLUTCH ASSEMBLIES

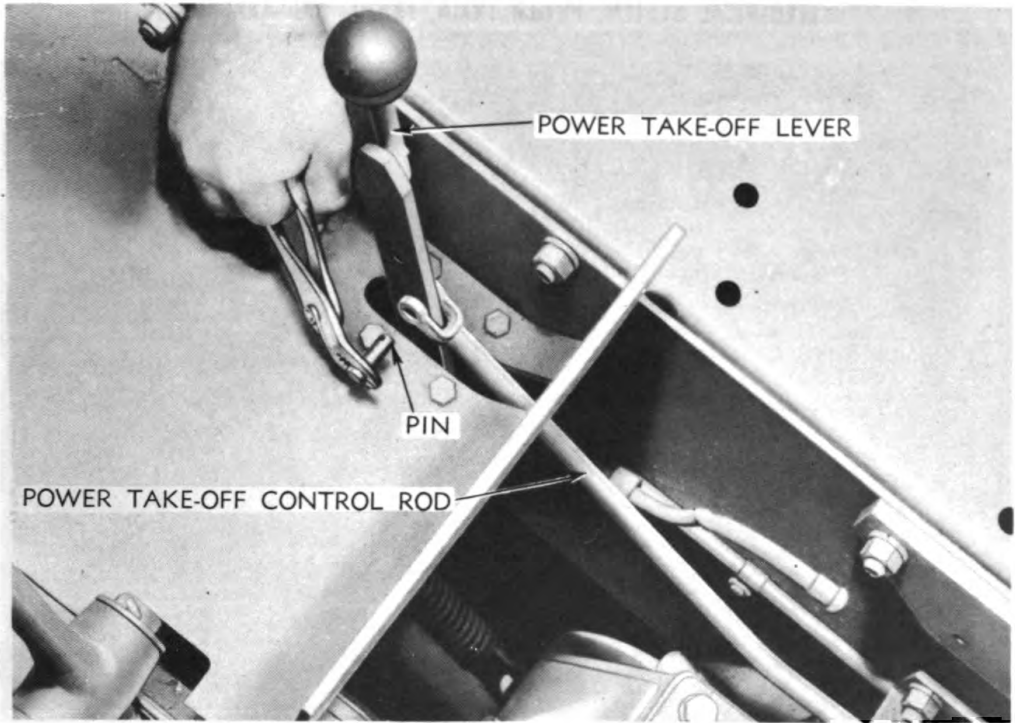

Figure 107 — Disconnecting Power Take-off Control Rod and Lever

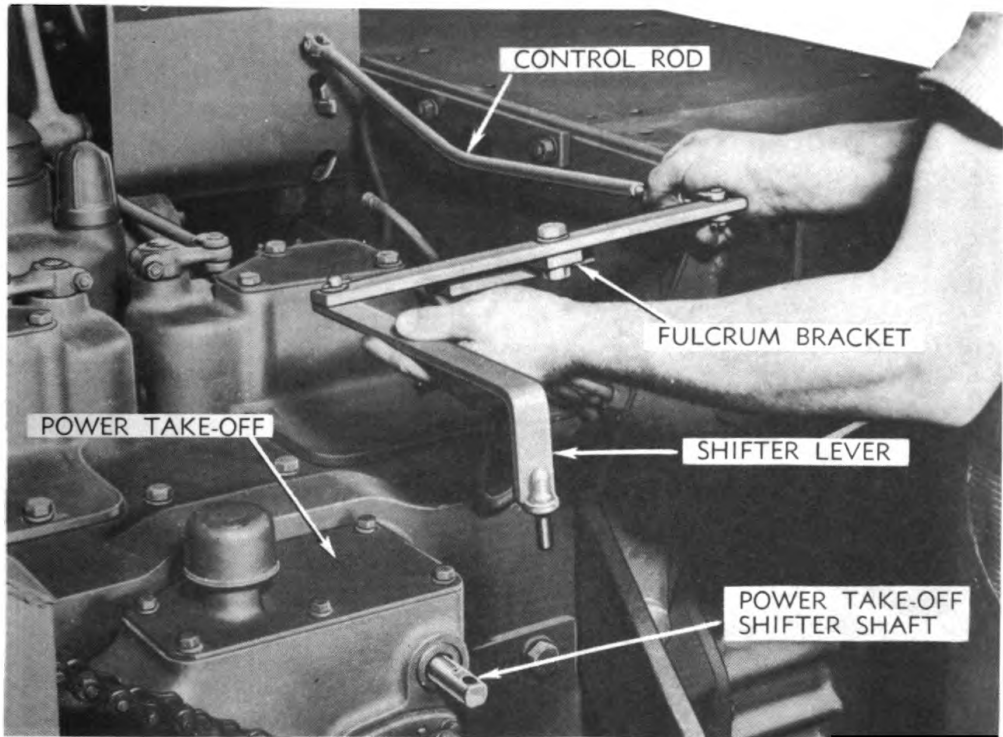
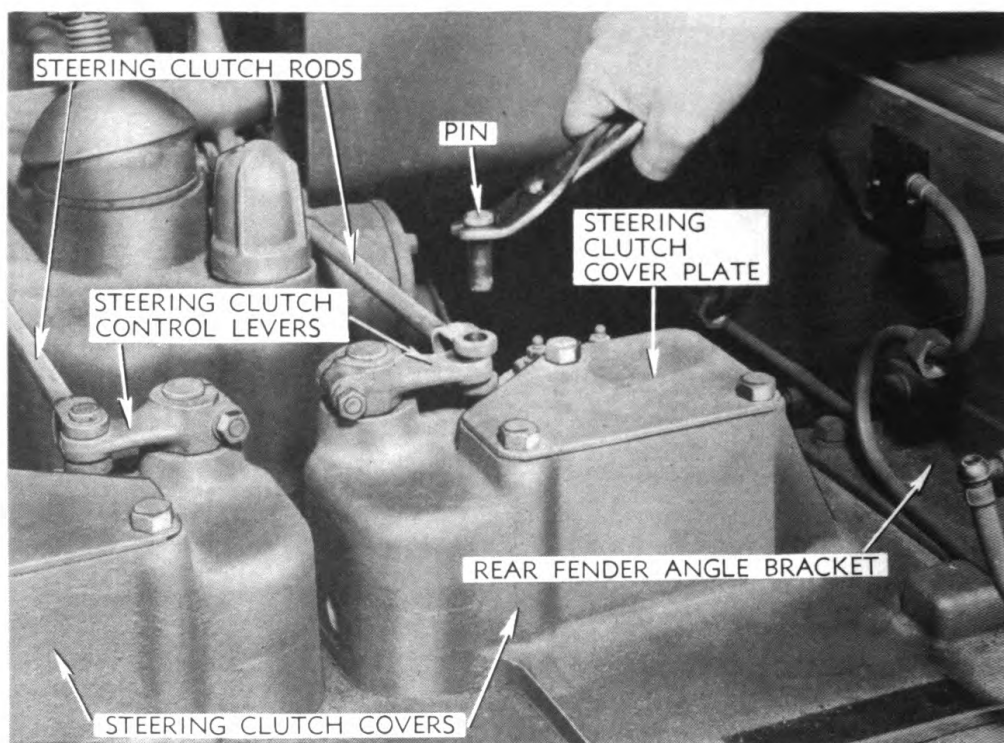

Figure 103 — Removing Power Take-off Control Linkage

ORDNANCE MAINTENANCE — MEDIUM TRACTOR M1 (ALLIS-CHALMERS HD-7W)
ELECTRICAL SYSTEM, POWER TRAIN, FRAME, AND TRACKS



RA PD 40972

Figure 109 — Disconnecting Steering Clutch Rod and Lever

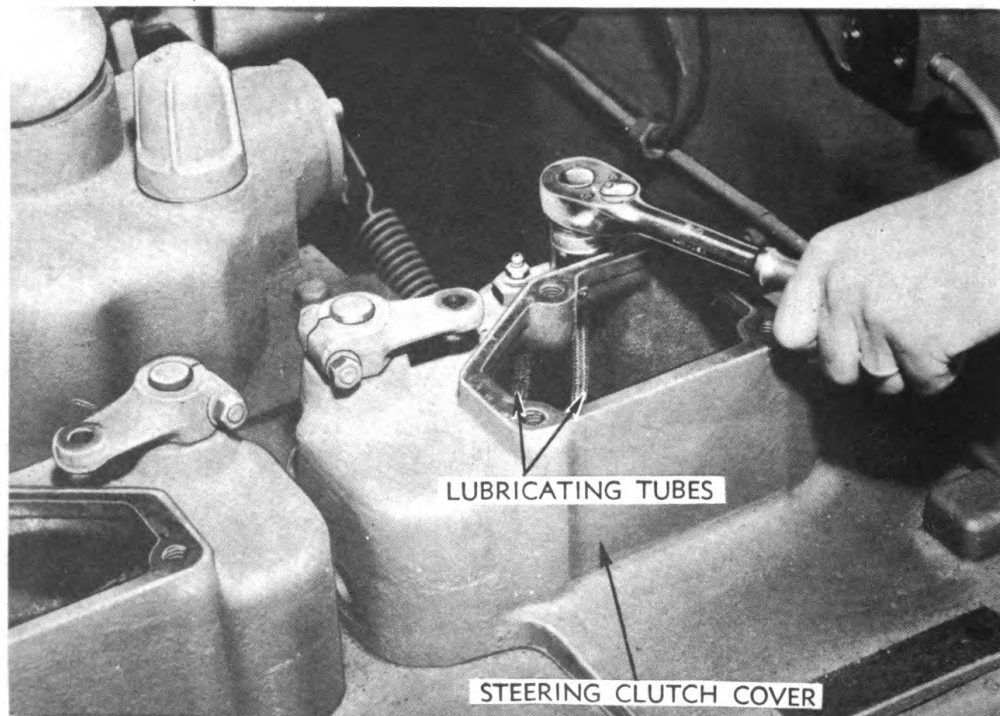

RA PD 41019

Figure 110 — Removing Jam Nuts from Lubricating Tubes

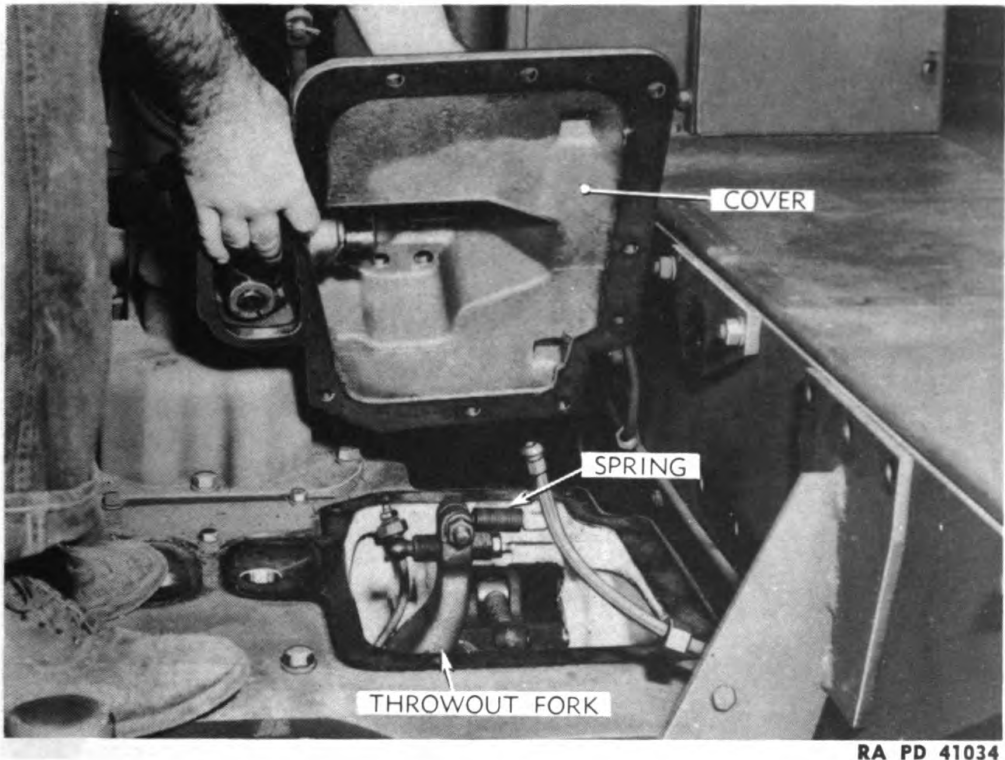
CLUTCH ASSEMBLIES

RA PD 41034

Figure 111 — Removing Steering Clutch Cover**(2) REMOVE FIRST STAGE FUEL FILTER.**Wrench, open-end, $\frac{3}{4}$ -in.Wrench, socket, $\frac{9}{16}$ -in.Wrench, open-end, $\frac{7}{8}$ -in.

Disconnect inlet and outlet fuel lines from first stage filter ($\frac{3}{4}$ - and $\frac{7}{8}$ -in. wrenches) (fig. 105). Remove the two cap screws holding filter to right fender, and remove filter assembly ($\frac{9}{16}$ -in. wrench).

(3) REMOVE TOOL BOX.Wrench, $\frac{9}{16}$ -in. (2)

Remove the remaining bolt holding tool box to left fender (fig. 106) and remove tool box.

(4) REMOVE POWER TAKE-OFF CONTROL LINKAGE.

Pliers

Wrench, $\frac{3}{4}$ -in.

Pull cotter pin and pin (fig. 107) (pliers) to disconnect control rod from power take-off control lever. Pull cotter pin and remove washer; then lift shifter lever pin out of power take-off shifter shaft (fig. 108). Remove the two cap screws holding lever fulcrum bracket to transmission case ($\frac{3}{4}$ -in. wrench), and remove lever assembly (fig. 108).

(5) REMOVE STEERING CLUTCH COVERS.

Pliers

Wrench, open-end, $\frac{11}{16}$ -in.Wrench, $\frac{3}{4}$ -in. (2)Wrench, socket, $\frac{15}{16}$ -in.

ORDNANCE MAINTENANCE — MEDIUM TRACTOR M1 (ALLIS-CHALMERS HD-7W)
ELECTRICAL SYSTEM, POWER TRAIN, FRAME, AND TRACKS

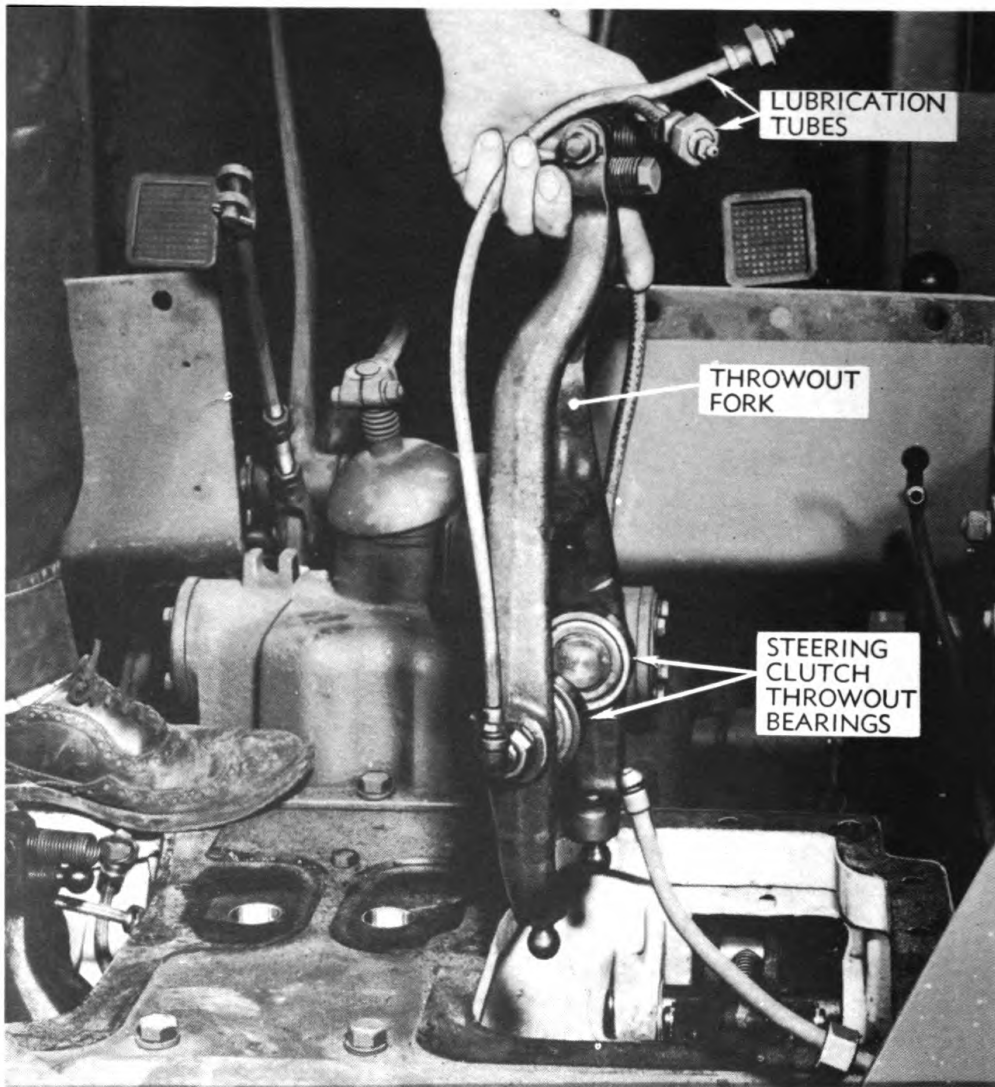

RA PD 41027

Figure 112 — Removing Steering Clutch Throw-out Fork Assembly

(a) Remove the pins from the steering clutch control rods and levers on each steering clutch cover (pliers) (fig. 109).

(b) Remove the six cap screws holding the top cover plates to the steering clutch covers ($\frac{3}{4}$ -in. wrench). Remove top plates.

(c) Remove three bolts and three cap screws with two $\frac{3}{4}$ -inch wrenches from each of the angle brackets on transmission and rear fenders (fig. 109), and remove the brackets.

(d) Hold $\frac{11}{16}$ -inch wrench on fittings under covers, and ($\frac{15}{16}$ -in. wrench) remove the jam nuts from top of lubricating tubes (fig. 110). Push tubes down out of covers.

CLUTCH ASSEMBLIES

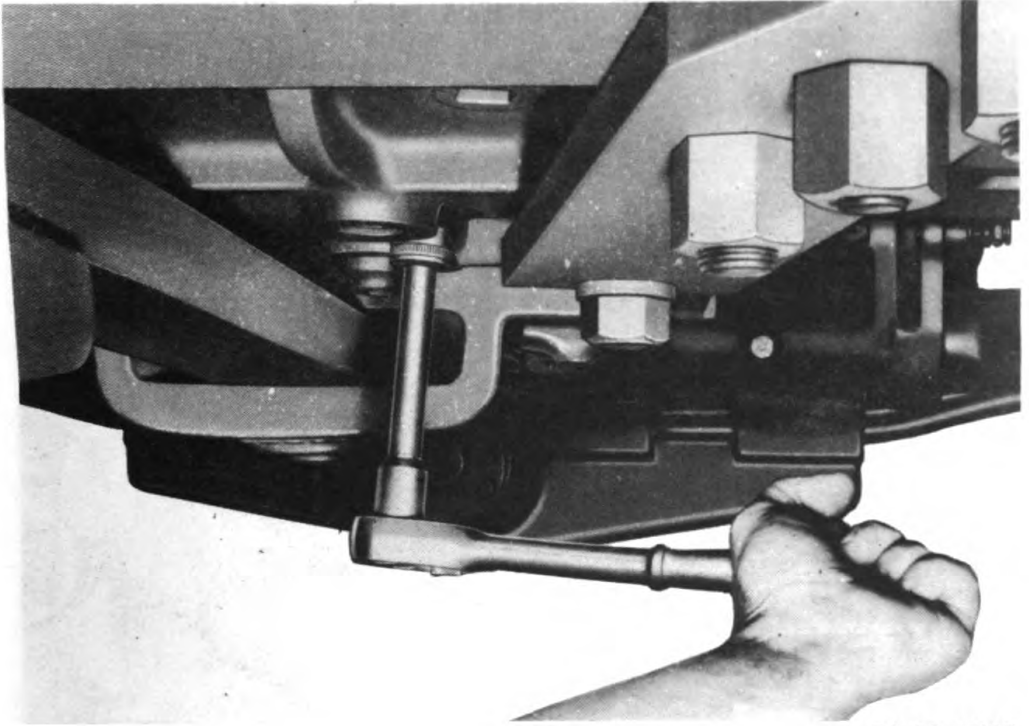

RA PD 41038

Figure 113 — Removing Steering Clutch Throw-out Fork Equalizer Bolt

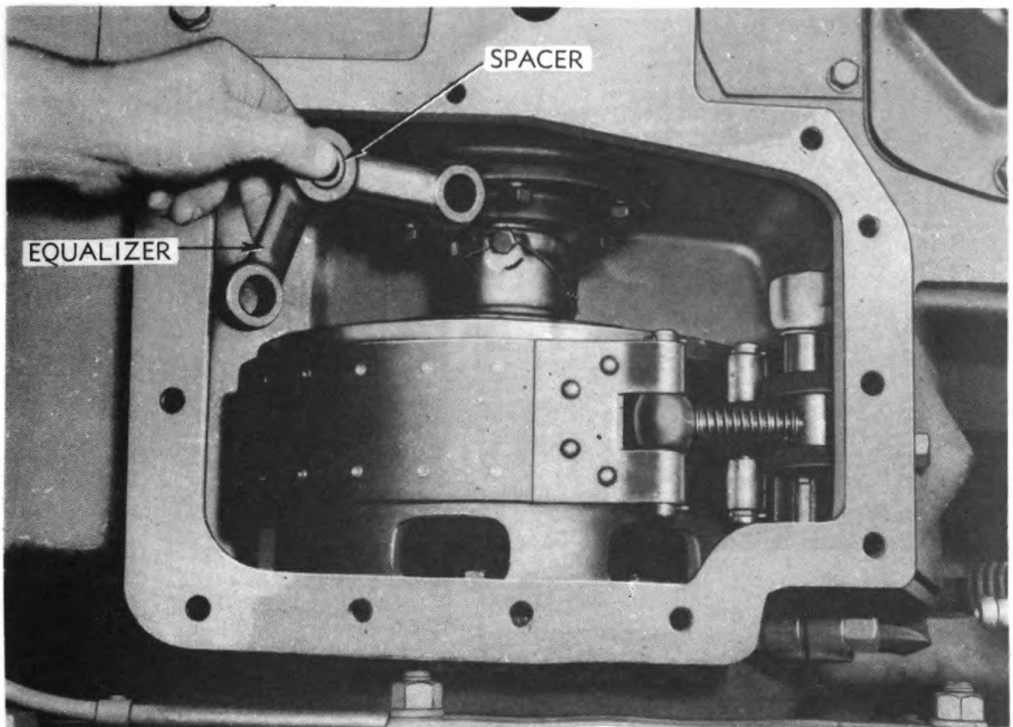

RA PD 41028

Figure 114 — Steering Clutch Throw-out Fork Equalizer Bar and Spacer

ORDNANCE MAINTENANCE — MEDIUM TRACTOR M1 (ALLIS-CHALMERS HD-7W)
ELECTRICAL SYSTEM, POWER TRAIN, FRAME, AND TRACKS

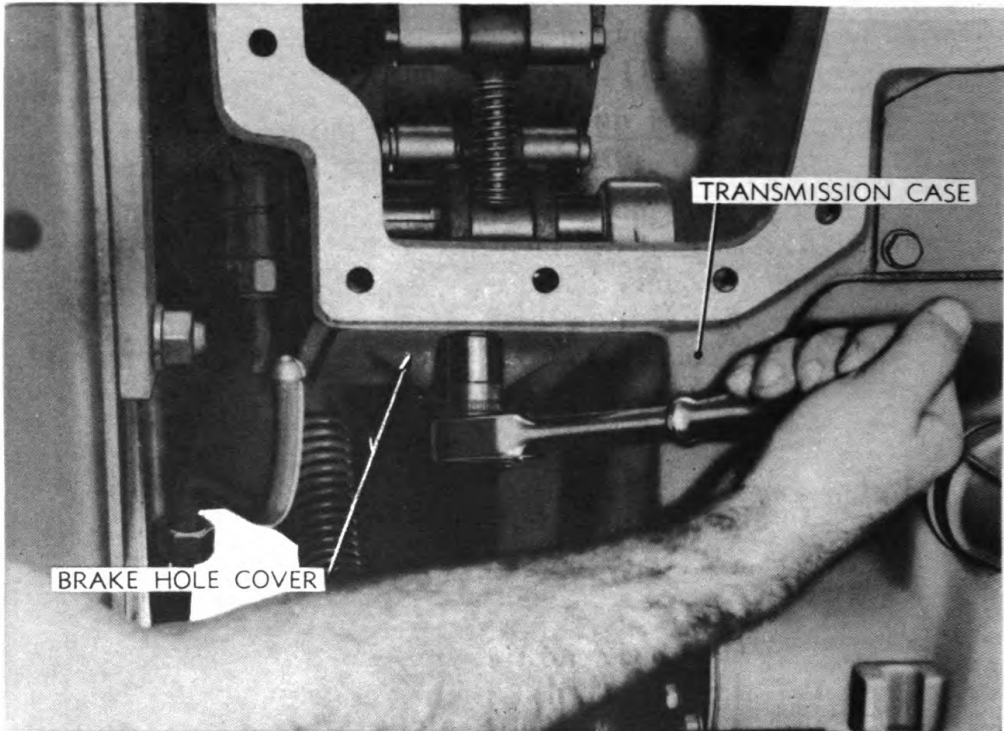

RA PD 41051

Figure 115 — Removing Brake Hole Cover

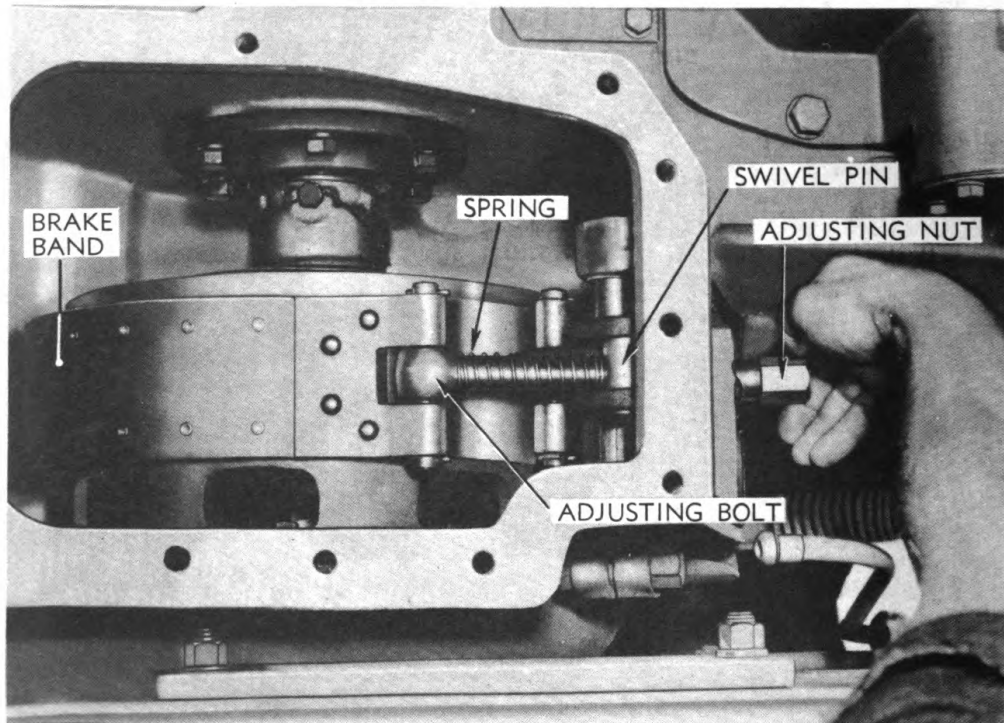

RA PD 40981

Figure 116 — Adjusting Nut Removed

CLUTCH ASSEMBLIES

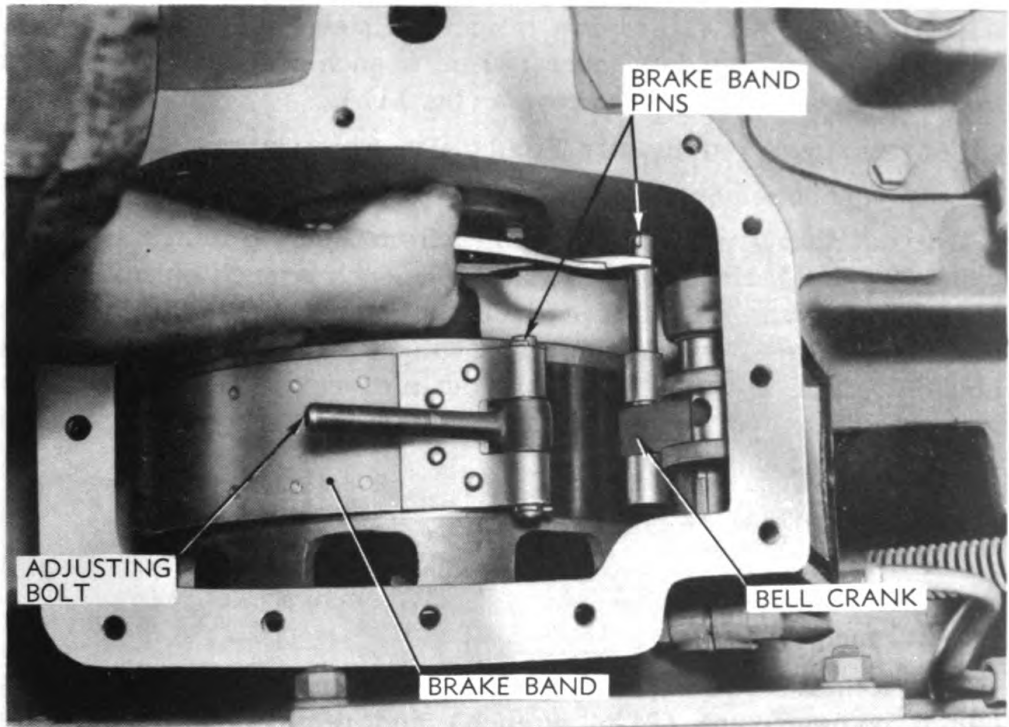

RA PD 41080

Figure 117 — Removing Brake Band Pin

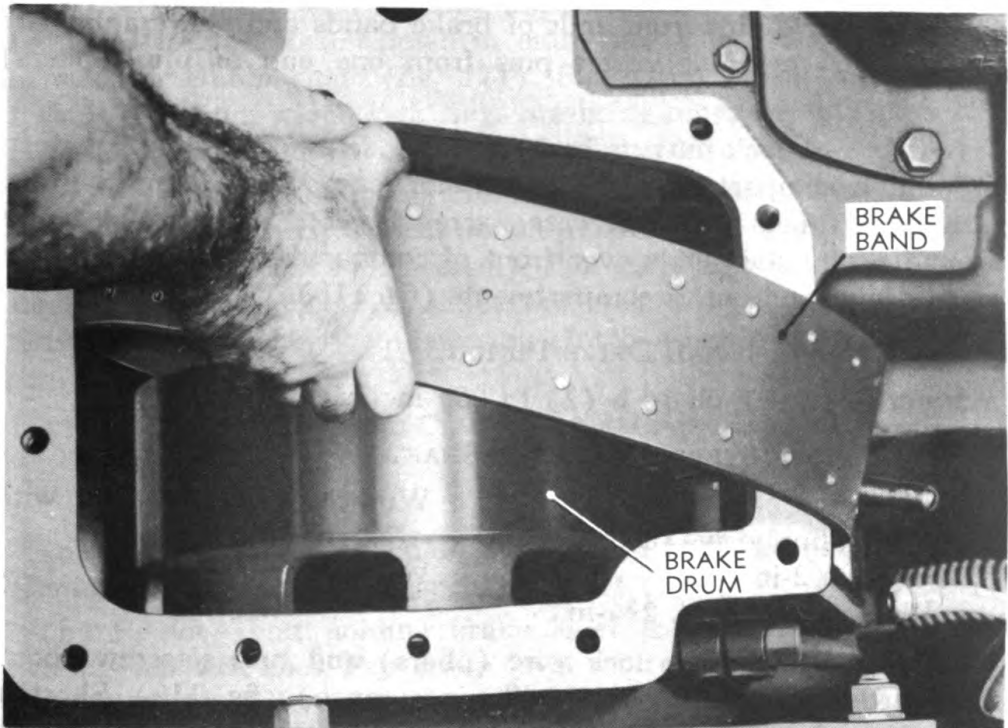

RA PD 41079

Figure 118 — Removing Brake Band

**ORDNANCE MAINTENANCE — MEDIUM TRACTOR M1 (ALLIS-CHALMERS HD-7W)
ELECTRICAL SYSTEM, POWER TRAIN, FRAME, AND TRACKS**

(e) Remove six cap screws from right steering clutch cover and five cap screws from left cover ($\frac{3}{4}$ -in. wrench), unhook the springs from covers, and remove the covers (fig. 111).

(6) REMOVE THROW-OUT FORKS AND EQUALIZERS.

Wrench, open-end, $1\frac{5}{16}$ -in. Wrench, socket, $\frac{7}{8}$ -in.

Lift out throw-out fork assemblies from steering clutch compartment (fig. 112). Have one man hold $1\frac{5}{16}$ -inch wrench on nut of bolt holding equalizer inside steering clutch compartment, while another man underneath transmission case with $\frac{7}{8}$ -inch wrench turns the bolt out of the nut (fig. 113). Lift out nut, lock washer, flat washer, spacer, and equalizer from compartment (fig. 114). Repeat for other side.

(7) REMOVE BRAKE BANDS.

Pliers	Wrench, open-end, $\frac{3}{4}$ -in.
Screwdriver, 10-in.	Wrench, socket, $\frac{3}{4}$ -in.
Wrench, $1\frac{5}{16}$ -in.	

(a) Remove two cap screws from each cover ahead of steering clutch compartment ($\frac{3}{4}$ -in wrench) and remove the brake hole covers (fig. 115). Remove the adjusting nuts from the adjusting bolts ($1\frac{5}{16}$ -in. wrench) (fig. 116). Pull adjusting bolts out of bell crank swivel pins.

(b) Remove pins from ends of brake bands and bell cranks with pliers, after removing cotter pins from one end of pins (pliers) (fig. 117).

(c) Loosen lock nuts on brake locating screws in bottom of steering clutch compartment of transmission case ($\frac{3}{4}$ -in. wrench) and turn screws nearly out of case (screwdriver). Turn brake bands around drum, start ends over front of compartment and turn bands off of drums and out of compartments (fig. 118).

(8) REMOVE FINAL DRIVE PINION.

Refer to paragraph 16 b (2) to (6) inclusive.

(9) REMOVE STEERING CLUTCH SHAFT.

Pliers	Wrench, socket, $\frac{9}{16}$ -in., with extension
Puller, final drive pinion	Wrench, spanner
Wrench, 2-in.	
Wrench, open-end, $2\frac{3}{4}$ -in.	

(a) Cut and remove lock wire (pliers) and turn setscrew about one-quarter inch out of spacer ($\frac{9}{16}$ -in. wrench) (fig. 119). Shorten the spacers by screwing the larger end of spacer onto the smaller end (spanner wrench) (fig. 120).

CLUTCH ASSEMBLIES

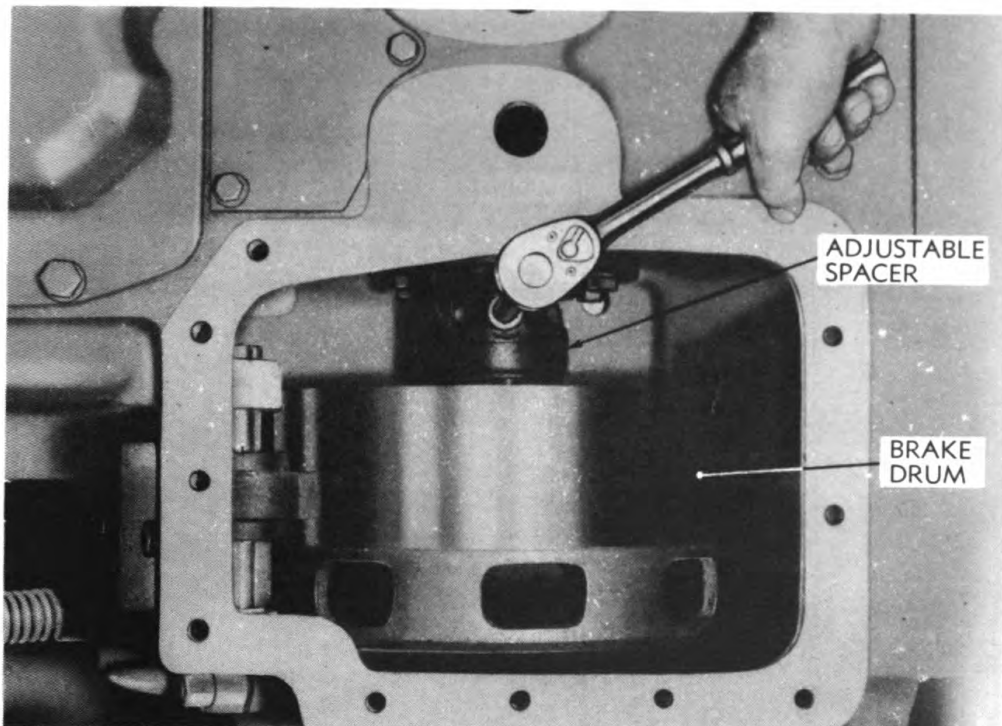

RA PD 41082

Figure 119 — Loosening Setscrew in Spacer

(b) Push drums and steering clutches as far as possible toward center of tractor. Reach down in and remove lock rings from ends of steering clutch shaft (fig. 121). Shaft may have to be moved toward side from which lock rings are being removed, and then back to other side, to remove lock rings on that side.

(c) Install puller adapter in threaded hole in end of steering clutch shaft (2 $\frac{3}{4}$ -in. wrench). Install pinion puller bolt into adapter through pinion bearing hole (2-in. wrench). Pull steering clutch shaft out of steering clutches (fig. 122), supporting weight of clutches as shaft is removed from them, then lowering clutch assemblies to bottom of compartments.

(10) REMOVE STEERING CLUTCH ASSEMBLIES.

Bar, pry

Wrench, $\frac{3}{4}$ -in. (2)

Pliers

(a) Remove yoke pin holding brake rod to brake pedal (pliers). Remove brake spring from spring support (fig. 123).

(b) Remove bolt holding brake lever to bell crank shaft with two $\frac{3}{4}$ -inch wrenches. Pry brake lever off bell crank shaft with pry bar (fig. 124), and turn bell crank one-half turn.

(c) Lift steering clutch assemblies and brake drums from compartments (fig. 125).

ORDNANCE MAINTENANCE — MEDIUM TRACTOR M1 (ALLIS-CHALMERS HD-7W)
ELECTRICAL SYSTEM, POWER TRAIN, FRAME, AND TRACKS

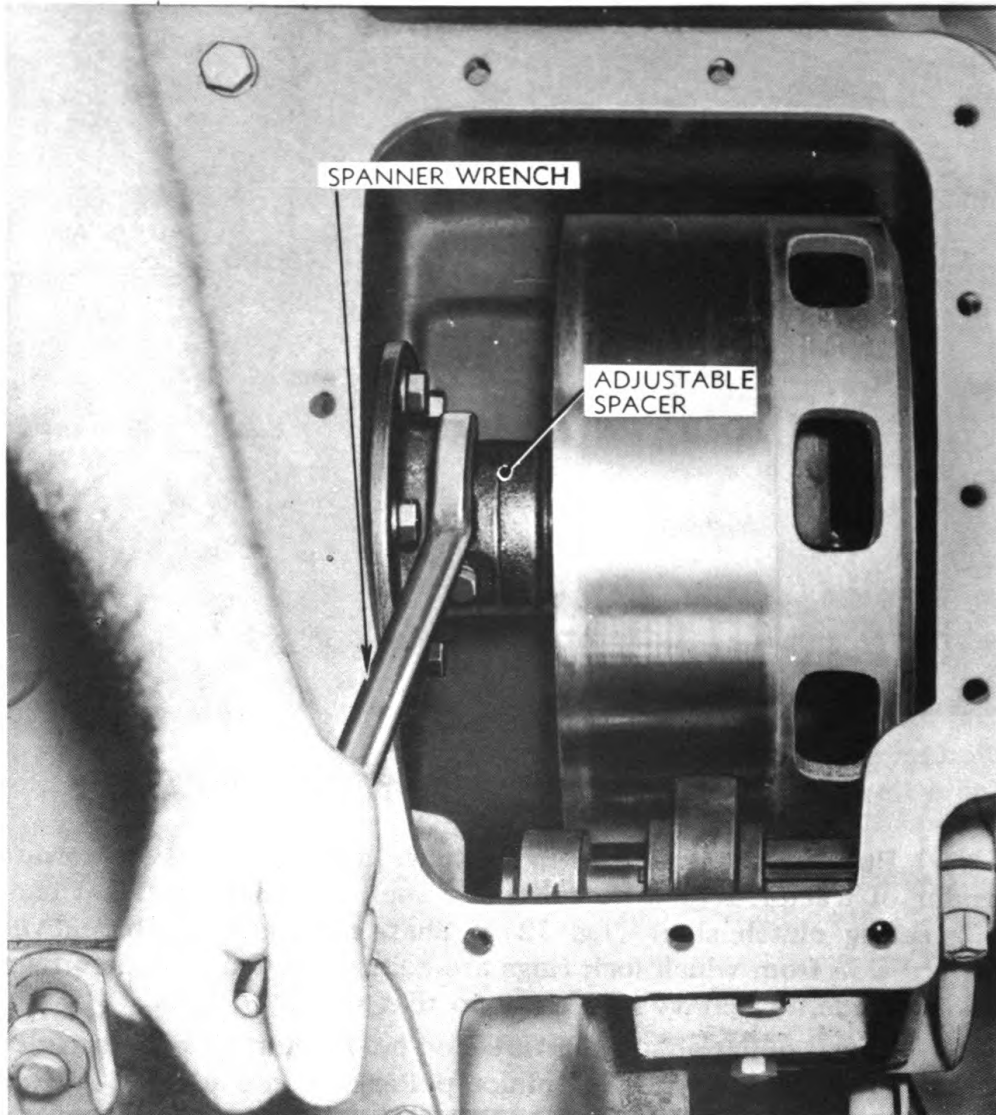

RA PD 41072

Figure 120 — Shortening Spacer

48. DISASSEMBLY.

a. Tools and Equipment Required.

- | | |
|--|---------------------------------|
| Pliers | Wrench, box, $\frac{3}{4}$ -in. |
| Nut, $\frac{1}{2}$ -in., SAE (3) | Wrench, stud |
| Stud bolt, $\frac{1}{2}$ - x 6-in., with 1 in.
of fine threads and 3 in. of
coarse threads (3) | |

b. Procedure.

(1) REMOVE BRAKE DRUM AND PRESSURE PLATE.

- | | |
|------------------------|--------------------------------|
| Pliers | Wrench, box $\frac{3}{4}$ -in. |
| Stud bolt, special (3) | Wrench, stud |

CLUTCH ASSEMBLIES

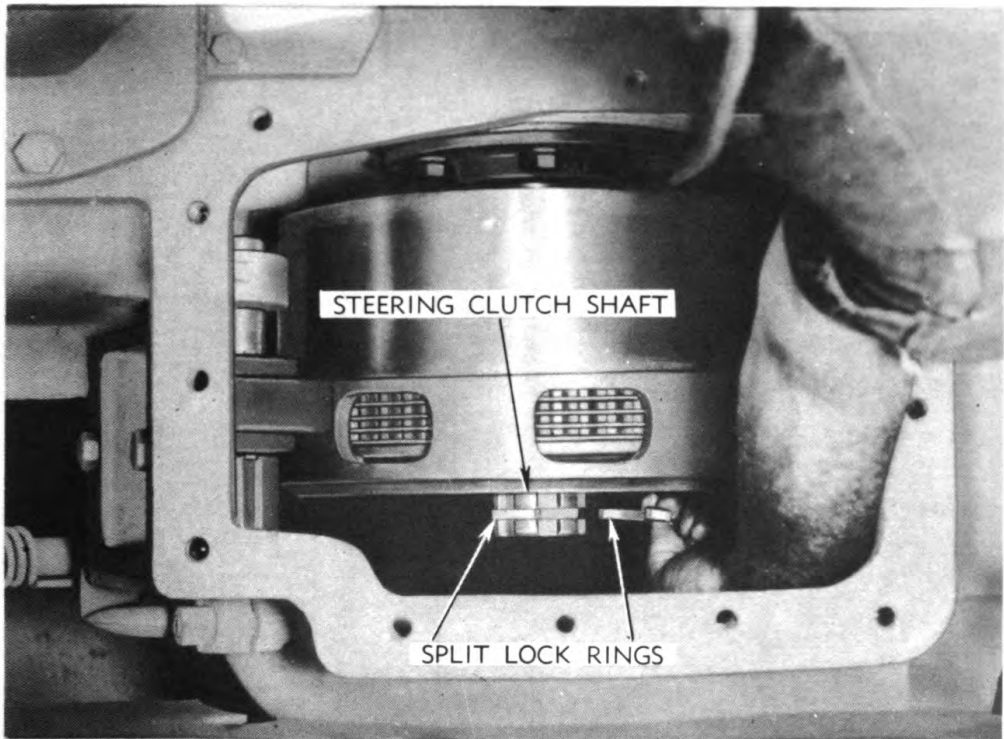

RA PD 41070

Figure 121 — Removing Split Lock Ring

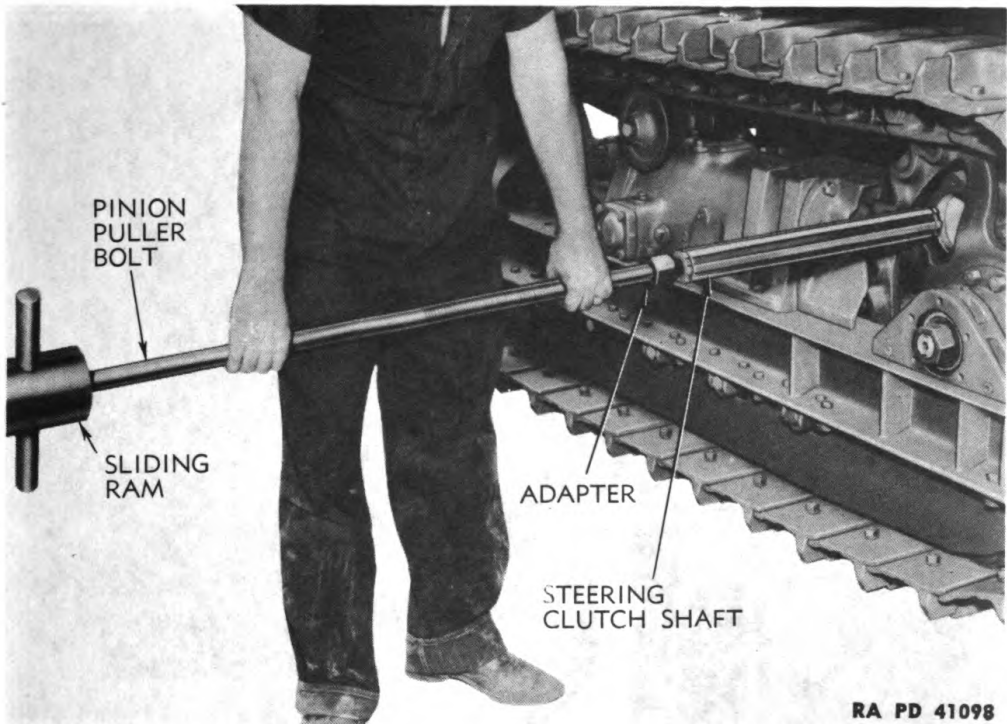

RA PD 41098

Figure 122 — Removing Steering Clutch Shaft

ORDNANCE MAINTENANCE — MEDIUM TRACTOR M1 (ALLIS-CHALMERS HD-7W)
ELECTRICAL SYSTEM, POWER TRAIN, FRAME, AND TRACKS

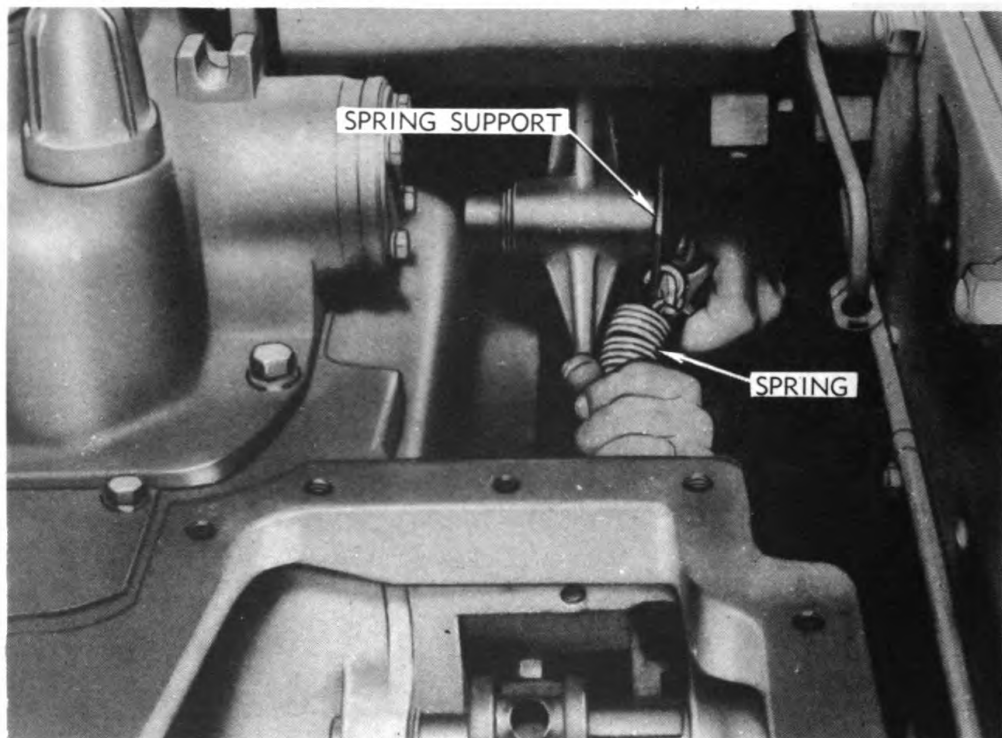

RA PD 41135

Figure 123 — Disconnecting Brake Spring

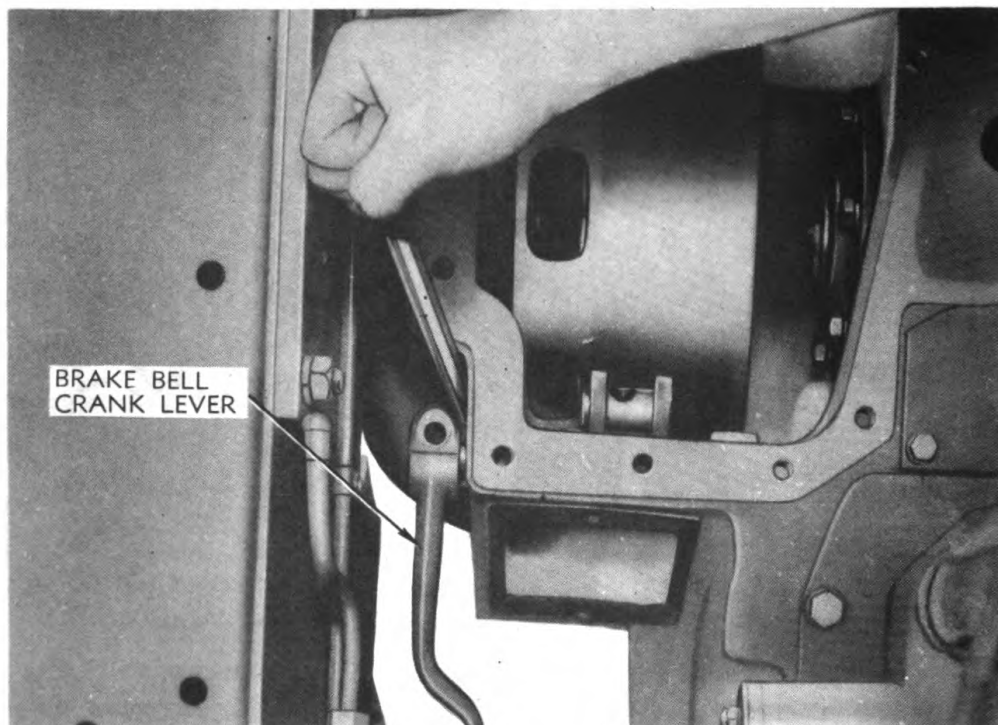

RA PD 41136

Figure 124 — Removing Brake Lever from Shaft

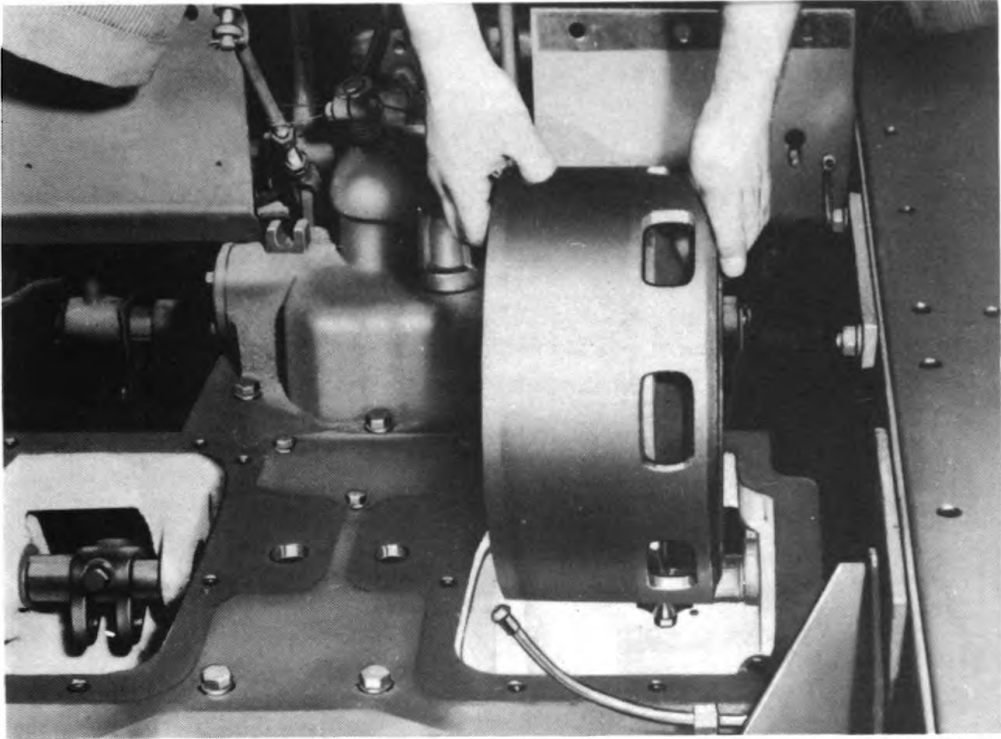
CLUTCH ASSEMBLIES

RA PD 41111

Figure 125 — Removing Steering Clutch Assembly

(a) Remove clutch assembly from brake drum (fig. 126). Cut and remove lock wire threaded through heads of cap screws (pliers). Remove three of the cap screws holding clutch assembly together (fig. 127).

(b) Install the three special studs in the holes from which the three cap screws were removed (stud wrench) (fig. 128). Install nuts on upper end of these studs and draw nuts down evenly ($\frac{3}{4}$ -in. wrench) until pressure of the clutch springs is relieved from the remaining cap screws (fig. 128).

(c) Remove the remaining seven cap screws ($\frac{3}{4}$ -in. wrench). Back nuts off on studs evenly until spring pressure is relieved ($\frac{3}{4}$ -in. wrench); then remove the studs (stud wrench).

(d) Lift pressure plate off clutch disks (fig. 129).

(2) REMOVE CLUTCH DISKS AND HUB.

Lift steel and friction disks from hub (figs. 130 and 131); then lift hub off springs and shifter plate (fig. 132).

(3) REMOVE SPRINGS AND OIL SLINGER FROM SHIFTER PLATE.

Lift insulating washers and springs off shifter plate (fig. 133); then remove spacers (fig. 134), then oil slinger (fig. 135) from

**ORDNANCE MAINTENANCE — MEDIUM TRACTOR M1 (ALLIS-CHALMERS HD-7W)
ELECTRICAL SYSTEM, POWER TRAIN, FRAME, AND TRACKS**

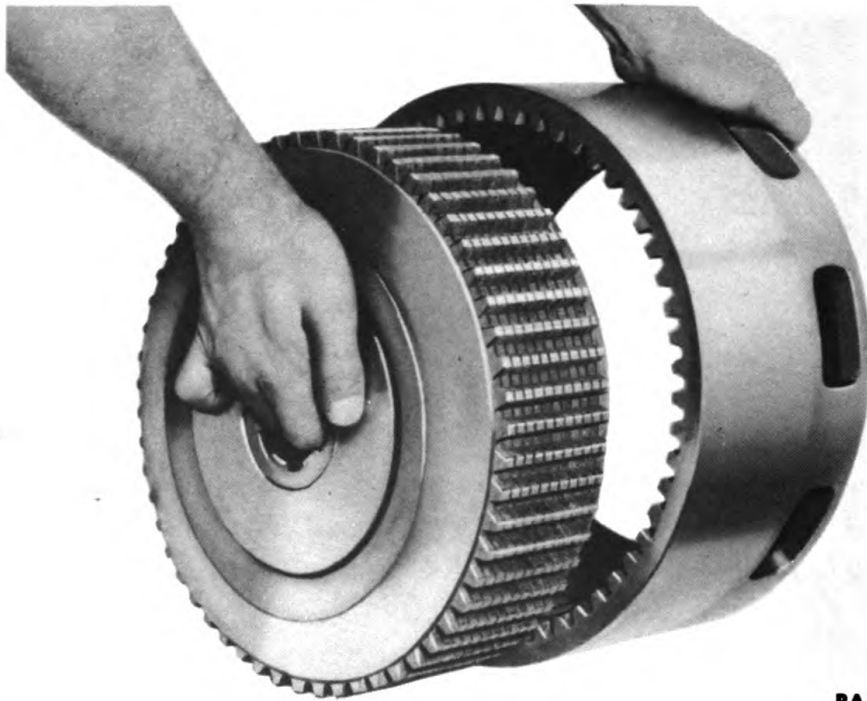

RA PD 41140

Figure 126 — Removing Clutch Assembly from Brake Drum

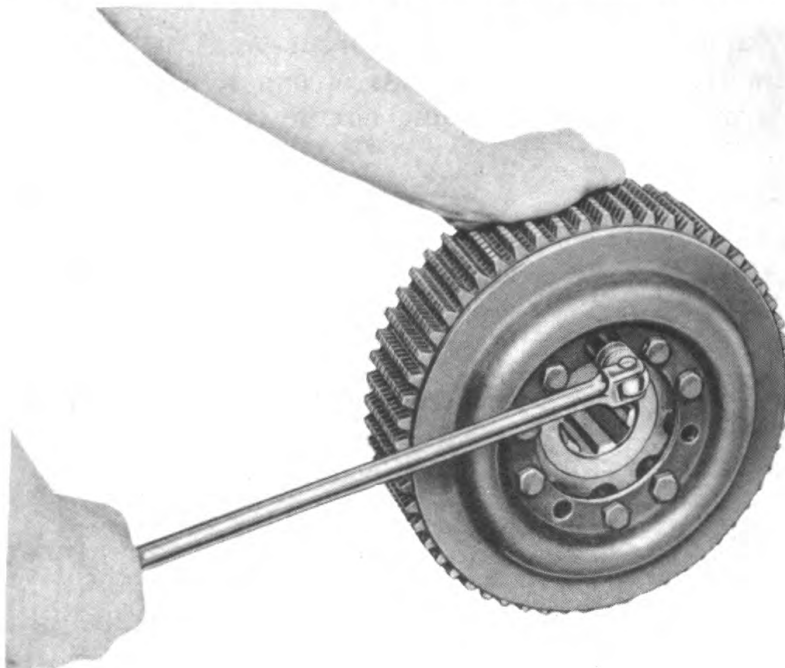

RA PD 41069

Figure 127 — Removing Cap Screws from Clutch to Install Studs

CLUTCH ASSEMBLIES

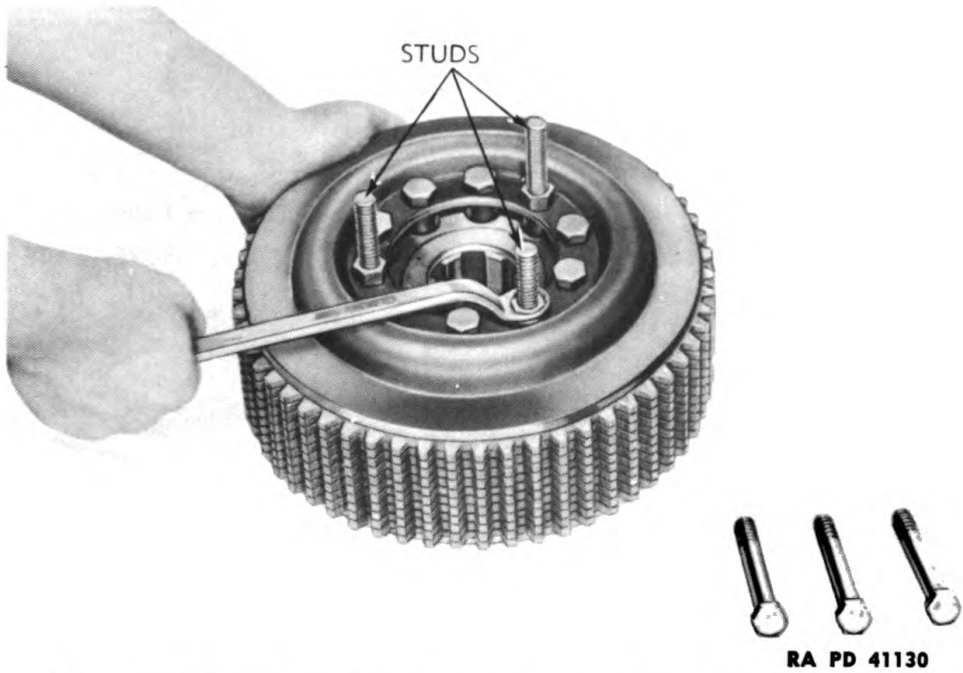

Figure 128 — Relieving Pressure on Cap Screws with Special Stud Bolts

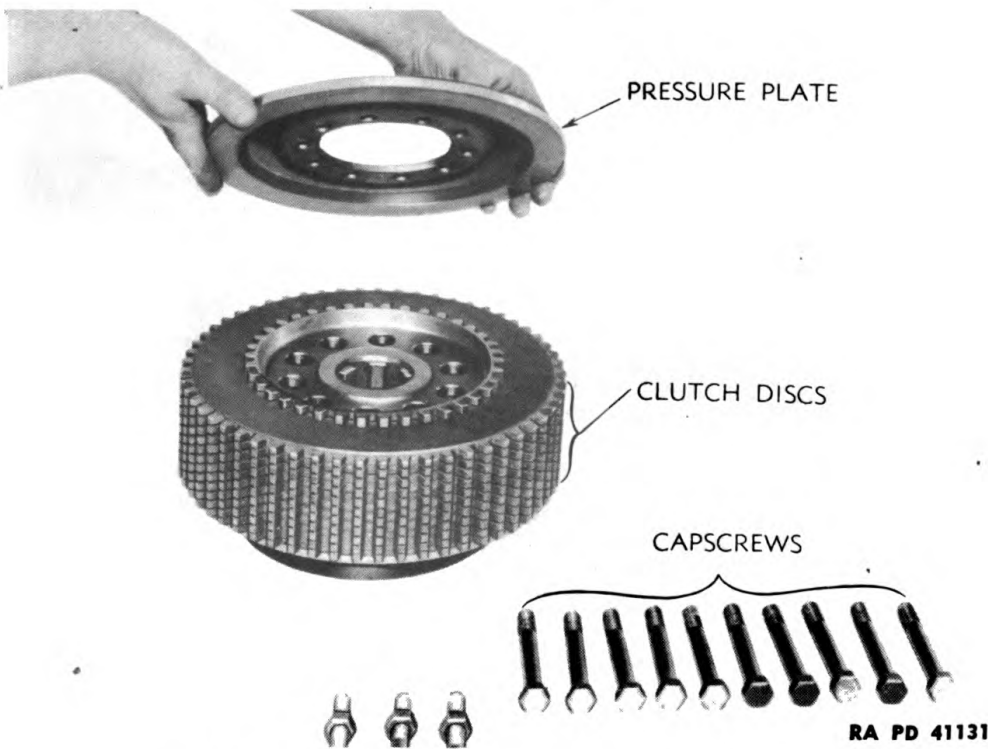

Figure 129 — Removing Pressure Plate

ORDNANCE MAINTENANCE — MEDIUM TRACTOR M1 (ALLIS-CHALMERS HD-7W)
ELECTRICAL SYSTEM, POWER TRAIN, FRAME, AND TRACKS



Figure 130 — Removing Steel Disk from Hub



Figure 131 — Removing Friction Disk from Hub

CLUTCH ASSEMBLIES

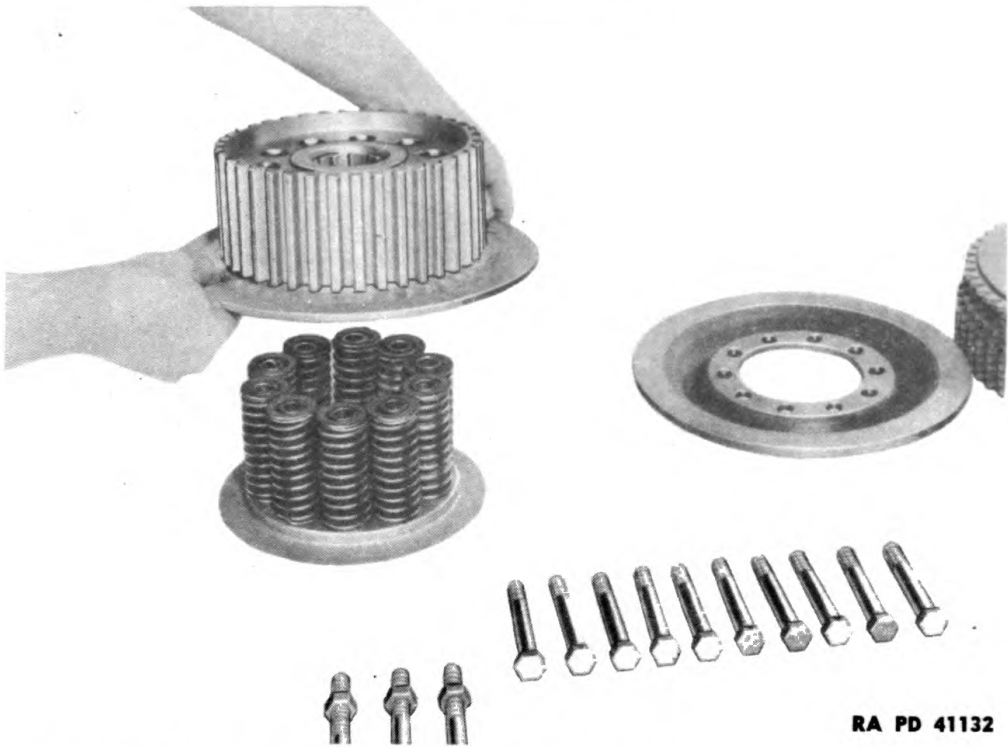

Figure 132 — Removing Hub from Springs and Shifter Plate

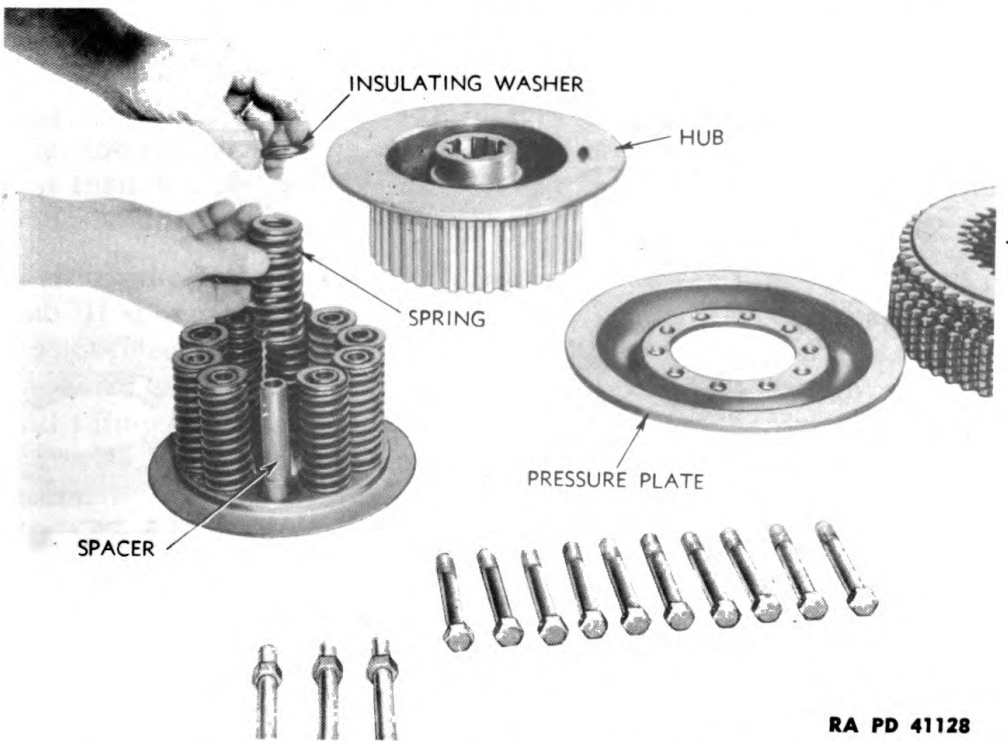

Figure 133 — Removing Springs and Insulating Washers from Shifter Plate

ORDNANCE MAINTENANCE — MEDIUM TRACTOR M1 (ALLIS-CHALMERS HD-7W)
ELECTRICAL SYSTEM, POWER TRAIN, FRAME, AND TRACKS



Figure 134 — Removing Spacers from Shifter Plate

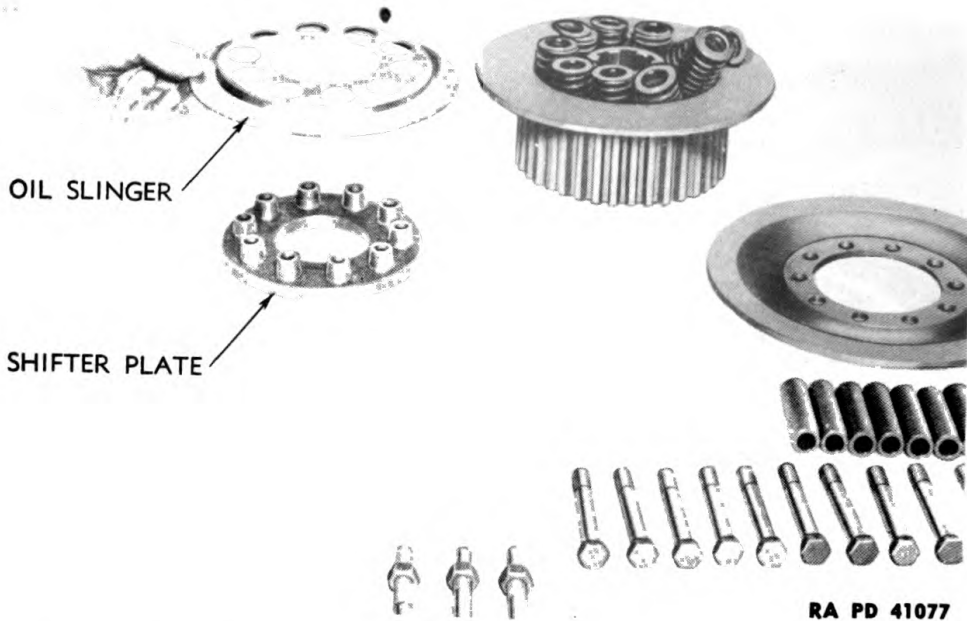
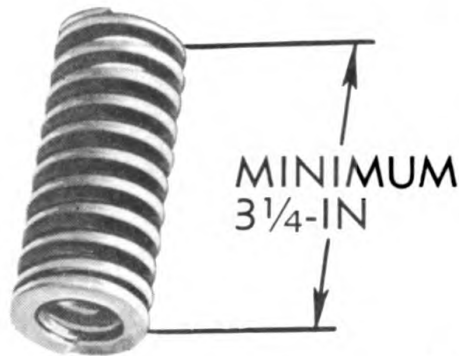

Figure 135 — Removing Oil Slinger from Shifter Plate

CLUTCH ASSEMBLIES



RA PD 41439

Figure 136 — Free Length of Clutch Spring

49. INSPECTION AND REPAIR OF PARTS.

a. Cleaning. Wash all parts thoroughly with dry-cleaning solvent and blow off dry with compressed air. Discard all broken or cracked parts.

b. Clutch Disks. Replace all friction disks that are worn or glazed from having been soaked with oil, or overheated from slipping.

Replace those disks which have worn or missing teeth. Inspect steel disks, and replace any with badly worn teeth or scored surfaces. Lay each disk separately on a good flat surface to check for warping; replace warped disks.

c. Springs. Measure free length of spring by standing it upright and measuring over-all length of spring. If this length is $3\frac{1}{4}$ inches (fig. 136) or greater, the spring may be used again. If spring measures less than $3\frac{1}{4}$ inches, this is an indication that it has lost its tension and should be replaced.

d. Brake Drums and Hub. Inspect splines in brake drum and on hub. If splines are badly worn, the parts should be replaced. If outside surface of brake drum where brake band contacts it is grooved or scored, surface can be smoothed by putting brake drum in a lathe and turning it down. Do not take off more than one-sixteenth inch of material. Extend the cut only to the edge of the ventilating holes in drum. If refacing and smoothing of drum requires that more than one-sixteenth inch of material be removed, replace the drum. The outside diameter of a brake drum when new is $12\frac{3}{4}$ inches and the minimum allowable diameter after turning down is $12\frac{11}{16}$ inches. **NOTE:** Measurements are to be made on the brake surface of the drum contacted by the brake band.

e. Shifter Plate and Pressure Plate. Check both these plates for warpage; discard if warped. Face of shifter plate should be smooth and flat.

**ORDNANCE MAINTENANCE — MEDIUM TRACTOR M1 (ALLIS-CHALMERS HD-7W)
ELECTRICAL SYSTEM, POWER TRAIN, FRAME, AND TRACKS**

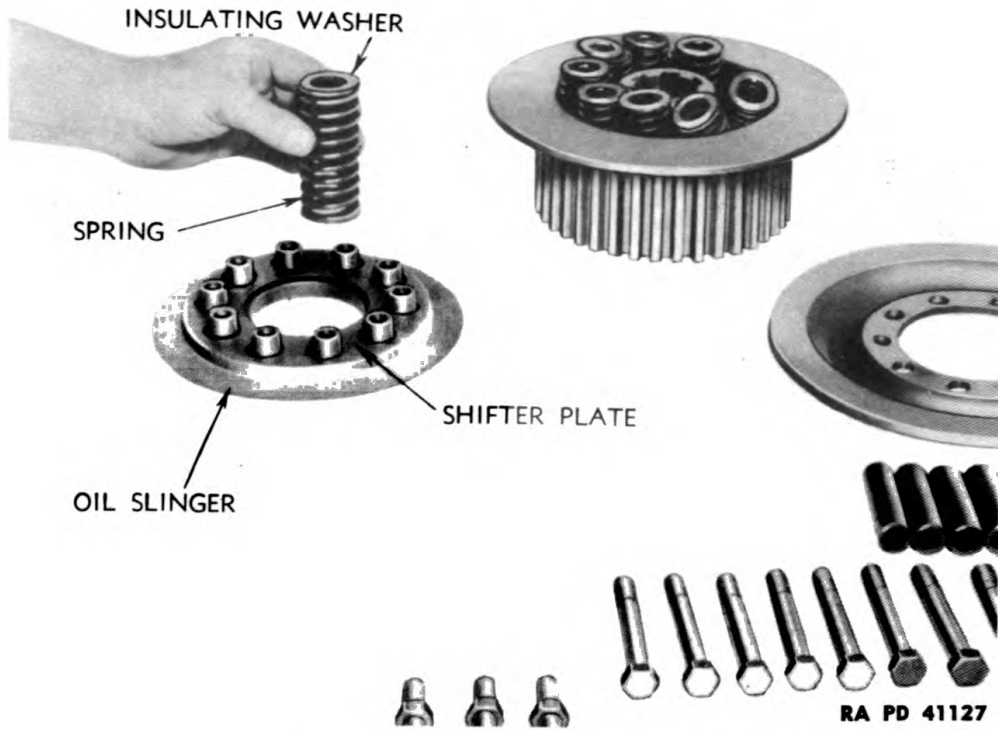
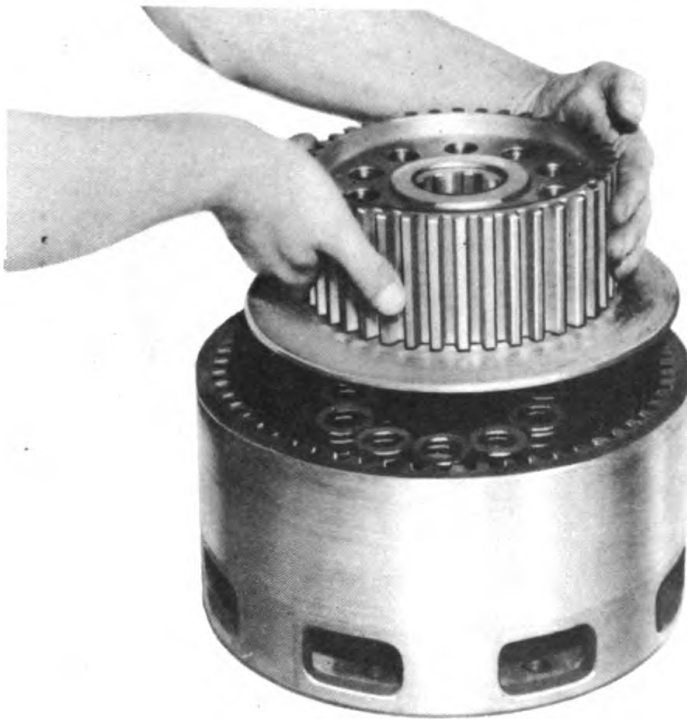

Figure 137 — Installing Spring and Insulating Washer



Figure 138 — Installing Brake Drum over Shifter Plate and Springs

CLUTCH ASSEMBLIES



RA PD 41141

Figure 139 — Installing Hub in Drum over Springs

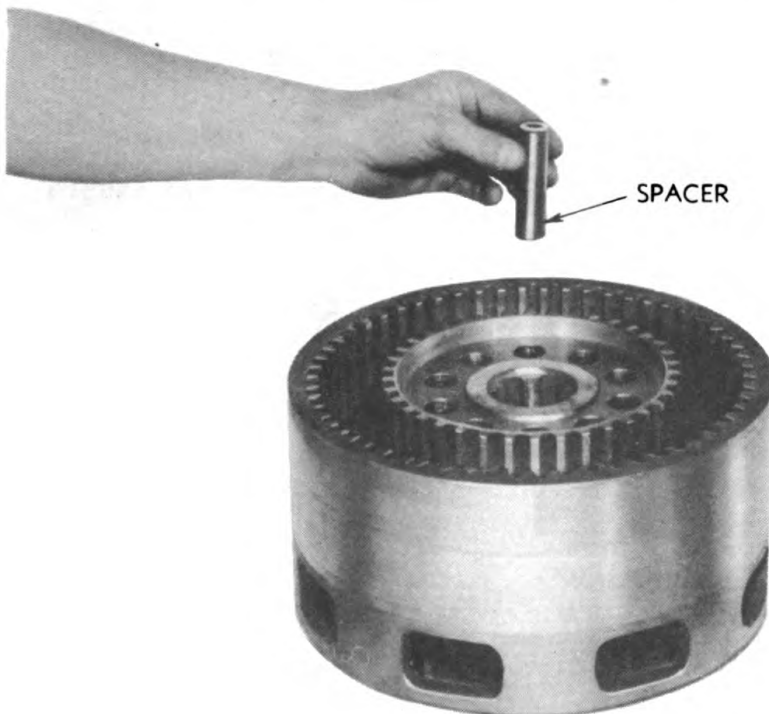

RA PD 41138

Figure 140 — Installing Spacers in Hub

ORDNANCE MAINTENANCE — MEDIUM TRACTOR M1 (ALLIS-CHALMERS HD-7W)
ELECTRICAL SYSTEM, POWER TRAIN, FRAME, AND TRACKS



RA PD 41104

Figure 141 — Installing Pressure Plate on Clutch Disks

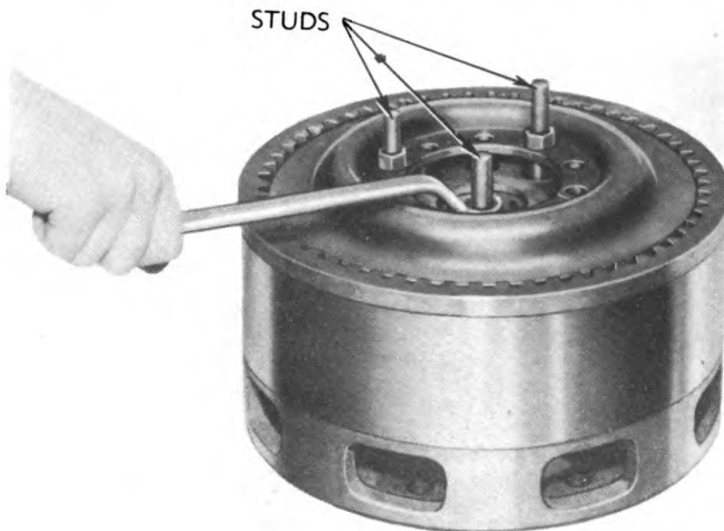

RA PD 41103

Figure 142 — Compressing Springs to Install Cap Screws

CLUTCH ASSEMBLIES

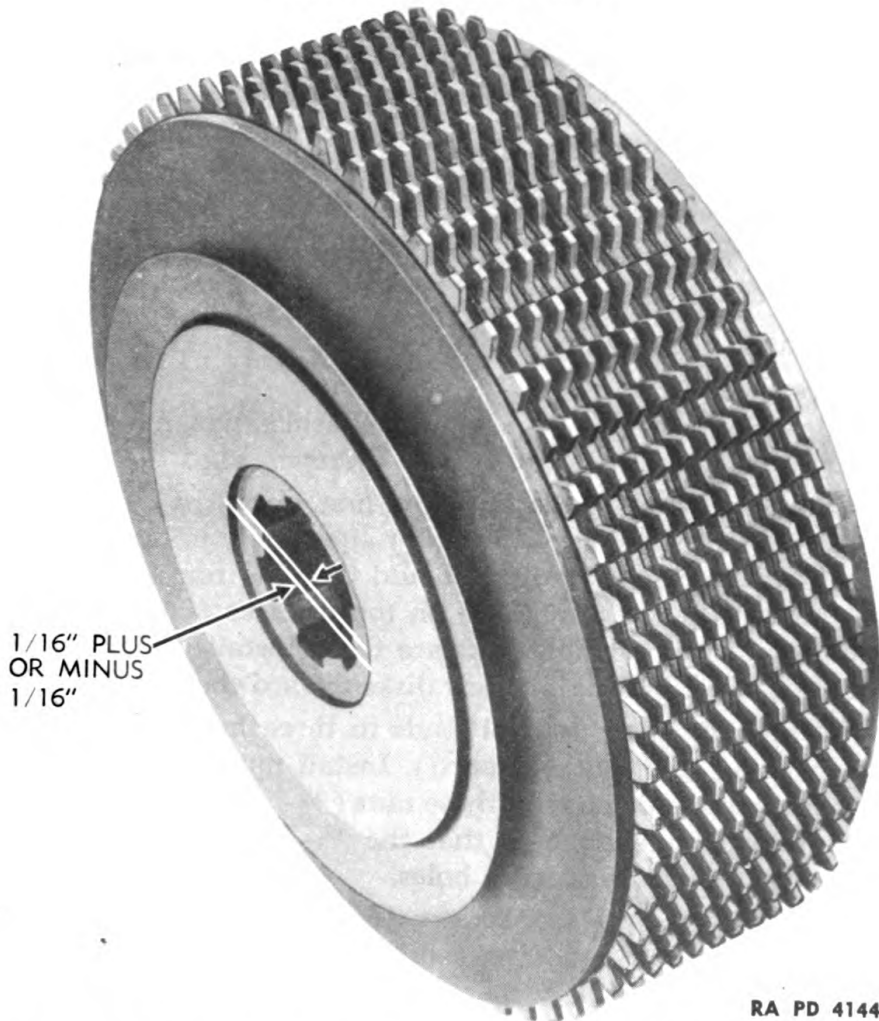

Figure 143 — View Showing Relative Position of Shifter Plate with End of Hub

f. Steering Clutch Shaft. Check clutch shaft to make sure it is straight and that splines and shaft are not worn to the point of making it unserviceable.

g. Inspection of Throw-out Fork Assembly (par. 57).

50. ASSEMBLY.

a. Tools Required.

Nut, 1/2-in., SAE (3)

Pliers

Scale, 6-in.

Stud bolt, special (3)

(par. 48)

Wire

Wood block, 2-x 6-x 6-in.

Wrench box, 3/4-in.

Wrench, stud

b. Procedure.

(1) **ASSEMBLE CLUTCH HUB.**

(a) Place shifter plate on wood block with face down. Install oil

**ORDNANCE MAINTENANCE — MEDIUM TRACTOR M1 (ALLIS-CHALMERS HD-7W)
ELECTRICAL SYSTEM, POWER TRAIN, FRAME, AND TRACKS**

slinger on shifter plate; then set a spring on each threaded projection on shifter plate (fig. 137). Lay an insulating washer on top of each spring.

(b) Lower brake drum over springs, oil slinger, and shifter plate (fig. 138).

(c) Install hub over springs and inside brake drum (fig. 139). Drop a spacer inside each spring (fig. 140).

(2) INSTALL CLUTCH DISCS AND PRESSURE PLATE.

Pliers	Wire
Scale, 6-in.	Wrench, box, $\frac{3}{4}$ -in.
Stud bolt, special (3)	Wrench, stud

(a) Starting with a friction disk first, install 11 friction disks (fig. 131) and 11 steel disks (fig. 130) alternately in brake drum and on hub. Total thickness of disks should then be from $2\frac{3}{32}$ inches to $3\frac{3}{32}$ inches. Install pressure plate on top of disks (fig. 141). **NOTE:** If a number of new friction disks are to be installed, first install the used friction disks placing the new disks toward the top.

(b) Screw the three special studs in three holes in shifter plate as shown in fig. 142 (stud wrench). Install nuts on these bolts and draw pressure plate down with these nuts ($\frac{3}{4}$ -in. wrench) until springs are compressed far enough so that the $\frac{1}{2}$ - by $3\frac{3}{4}$ -inch cap screws can be started in the remaining holes.

(c) After tightening cap screws ($\frac{3}{4}$ -in. wrench), remove the 3 stud bolts and install cap screws in their place. Tighten all 10 cap screws securely (fig. 127); then thread wire through the heads of cap screws and twist ends together (pliers). Remove clutch assembly from brake drum.

(3) CHECK POSITION OF SHIFTER PLATE AND HUB.

Scale, 6-in.

(a) After clutch has been assembled, the end of the hub must be in a certain relation to the face of the shifter plate (fig. 143). With scale, measure the distance from the face of the shifter plate to the end of the splined hub. This distance must be $\frac{1}{16}$ inch, plus or minus $\frac{1}{16}$ inch (fig. 143). In other words, the end of the hub may be flush with shifter plate, one-eighth inch in from face of shifter plate, or at any point in between.

(b) If hub projects through shifter plate, the pressure plate must be removed and either an extra friction disk or steel disk added to those already installed. The thickness of a new friction disk is 0.1875 inch (plus or minus 0.005 in.), and that of a new steel disk is 0.093 inch (plus or minus 0.009 in.). If hub projects through shifter plate 0.093 inch or less, add a steel disk; if it projects more than 0.093 inch,

CLUTCH ASSEMBLIES

add a friction disk. Reassemble clutch and check to make sure the assembled clutch is within these limits.

(c) If end of splined hub is more than one-eighth inch below face of shifter plate, a steel or friction disk must be removed to bring assembled clutch within limit. If distance from face of shifter plate to hub is between $\frac{1}{8}$ inch and $\frac{3}{16}$ inch, remove a steel disk; if distance is from $\frac{3}{16}$ inch to $\frac{1}{4}$ inch, remove a friction disk. Reassemble clutch and check to make sure assembled clutch is within these limits. As clutch disks wear, the shifter plate moves out from end of hub.

(4) INSTALL CLUTCH ASSEMBLY IN BRAKE DRUM.

Install clutch in brake drum with shifter plate facing open side of drum (fig. 126).

51. INSTALLATION.

a. Tools and Equipment Required.

Bar, 6-ft	Wrench, 2 $\frac{3}{4}$ -in.
Bar, brass	Wrench, box, $\frac{3}{4}$ -in.
Bar, drift, 18-in.	Wrench, deep socket, $\frac{15}{16}$ -in.
Hammer, 2-lb	Wrench, open-end, $\frac{9}{16}$ -in.
Hoist, chain	Wrench, open-end, $\frac{11}{16}$ -in.
Pliers	Wrench, open-end, $\frac{3}{4}$ -in.
Puller, final drive pinion	Wrench, open-end, $\frac{7}{8}$ -in.
Rope	Wrench, open-end, $\frac{15}{16}$ -in.
Ruler or scale, 12-in.	Wrench, socket, $\frac{9}{16}$ -in.
Screwdriver, 8-in.	Wrench, socket, $\frac{3}{4}$ -in.
Wire, lock	Wrench, socket, $\frac{7}{8}$ -in., with extension
Wrench, 2-in.	Wrench, spanner
Wrench, 2 $\frac{1}{2}$ -in.	

b. Procedure.

(1) SET CLUTCHES IN COMPARTMENTS.

Lower clutch and drum assemblies into compartments in transmission case with attaching flanges of brake drums toward outside of tractor (fig. 125).

(2) INSTALL STEERING CLUTCH SHAFT.

Puller, final drive pinion assembly	Wrench, 2-in.
Rope	Wrench, 2 $\frac{3}{4}$ -in.

(a) Install bolts of pinion puller in end of steering clutch shaft as described in paragraph 47 b (9) (c), and insert shaft through opening for final drive pinion (fig. 122). Hold clutch assembly suspended with rope and insert shaft through clutch assembly.

(b) Next install an adjustable spacer (fig. 144) on shaft with cap screw in spacer toward center of tractor; then push shaft through bevel gear hub, after alining splines on shaft with splines in hub. As

**ORDNANCE MAINTENANCE — MEDIUM TRACTOR M1 (ALLIS-CHALMERS HD-7W)
ELECTRICAL SYSTEM, POWER TRAIN, FRAME, AND TRACKS**

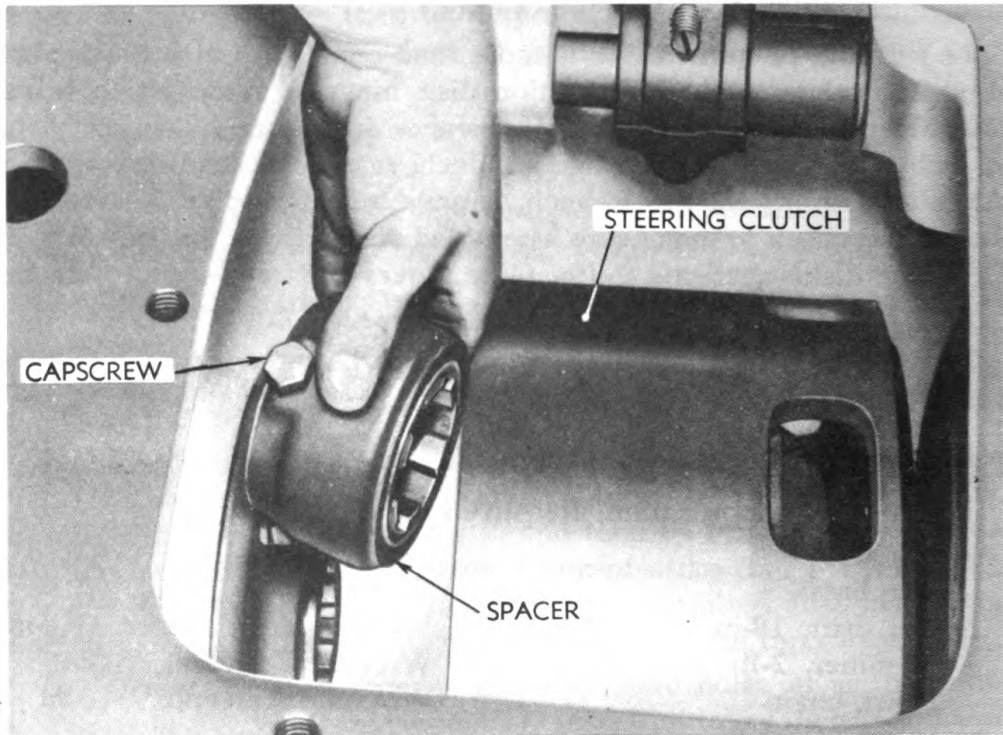

RA PD 41110

Figure 144 — Installing Adjustable Spacer

shaft comes out other side of bevel gear hub, install another spacer on shaft; then lift second clutch with rope, and push shaft through it.

(c) Remove pinion puller bolt and adapter from shaft (2 and 2 $\frac{3}{4}$ -in. wrenches).

(3) INSTALL LOCK RINGS.

To secure enough clearance to install lock rings on ends of steering clutch shaft, it may be necessary to shorten the adjustable spacers. Drive clutch shaft to the right far enough to allow lock rings on right end of shaft to be placed in groove (fig. 121). Insert rings. Shove clutch shaft back to the left as far as possible, and install lock rings in groove at left end of shaft. Be sure rings enter and are covered by recesses in end of steering clutch hubs.

(4) ADJUST SPACERS.

Pliers

Wire, lock

Wrench, socket, $\frac{9}{16}$ -in.

Wrench, spanner

Steering clutches must now be adjusted (spanner wrench) so that there is equal distance between shifter plates and bevel gear hub bearing retainers. Screw in or out on spacers until distances "A" (fig. 145) are equal and spacers are tight. Then tighten setscrews (screws should engage in the bottom of a spline on steering clutch

CLUTCH ASSEMBLIES

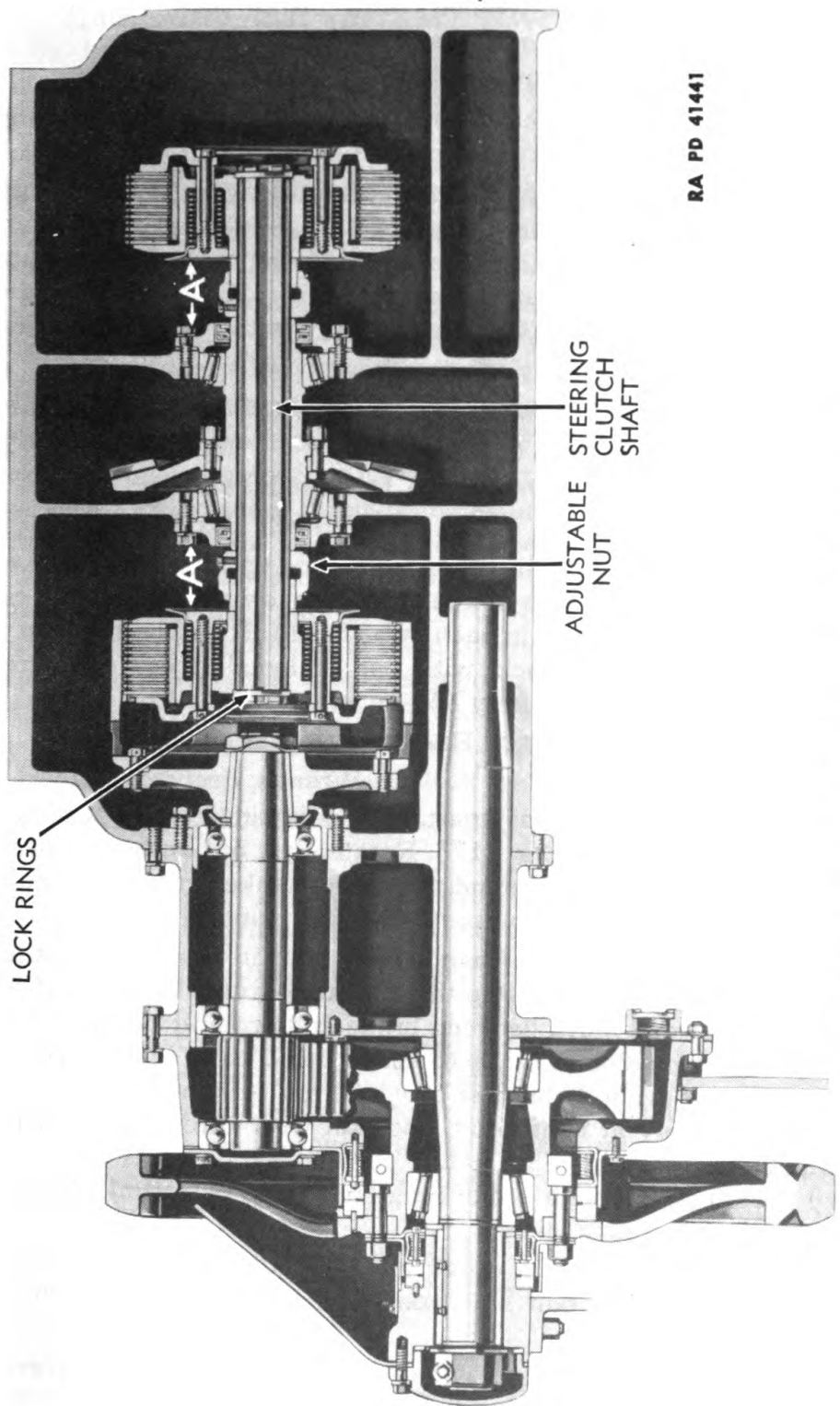

RA PD 41441

Figure 145 — Spacing Steering Clutch Assemblies

**ORDNANCE MAINTENANCE — MEDIUM TRACTOR M1 (ALLIS-CHALMERS HD-7W)
ELECTRICAL SYSTEM, POWER TRAIN, FRAME, AND TRACKS**

shaft) in spacers ($\frac{9}{16}$ -in. wrench) and install lock wire (pliers) through heads of setscrews and around spacers.

(5) INSTALL BRAKE LEVERS.

Hammer, 2-lb

Wrench, $\frac{3}{4}$ -in. (2)

Pliers

(a) Turn brake bell crank into position (fig. 117) and install brake lever on shaft over key (fig. 124). Tap lever on with hammer, and install the clamp bolt in lever (two $\frac{3}{4}$ -in. wrenches). Connect brake spring to lever and spring support (fig. 123). Install yoke pin holding brake rod to brake lever, and secure with cotter pin (pliers).

(b) Repeat above operations on other side of tractor.

(6) INSTALL FINAL DRIVE PINION ASSEMBLY.

Refer to paragraph 20, b (6), (7).

(7) CONNECT BRAKE DRUMS TO DRIVEN HUBS.

Bar, 6-ft

Wrench, box, $\frac{3}{4}$ -in.

Slide brake drums against driven hubs; line up holes in drums with holes in driven hub; attach brake drums to driven hubs with eight $\frac{1}{2}$ - by $1\frac{3}{8}$ -inch cap screws in each hub (fig. 1). It will be necessary to roll tractor forward, or back, with bar to install these cap screws. Tighten the cap screws securely ($\frac{3}{4}$ -in. wrench).

(8) INSTALL AND CONNECT BRAKE BAND ASSEMBLIES.

Pliers

Wrench, deep socket, $1\frac{5}{16}$ -in.

(a) Spread ends of bands apart, with adjusting bolt ends of bands towards front of tractor (fig. 117). Rotate ends of bands opposite the ends with adjusting bolts around and under brake drums until adjusting bolt is at top front of compartment and pointing forward.

(b) Check to determine if bands were bent in process of installing them on drums, by compressing them around drums by hand. If bent, insert a small wood block between brake and drum at bend, and press on band at both sides of block to spring band back into shape, so it will fit curve of drum. If band is bent and not reshaped, the band will contact drum only at bent point, and will wear through at this point very quickly.

(c) Install pin through end of brake band and bell crank (fig. 117), and install cotter pin (pliers).

(d) Install swivel pin in upper part of bell crank (fig. 116). Slip spring onto adjusting bolt and insert end of adjusting bolt through swivel pin.

(e) Install adjusting nut on end of adjusting bolt ($1\frac{5}{16}$ -in. wrench). Adjust brakes after tractor is assembled.

(9) INSTALL EQUALIZER BAR.

Wrench, open-end, $1\frac{5}{16}$ -in.

Wrench, socket, $\frac{7}{8}$ -in.

CLUTCH ASSEMBLIES

Place spacer in equalizer bar and hold it in bottom of steering clutch compartment over hole at inner edge of brake drum, with off-set arms toward drum (fig. 114). Have man under tractor insert bolt $\frac{5}{8}$ - by $3\frac{1}{4}$ inches up through hole in case and spacer. Install flat washer, lock washer and nut on bolt, and have man underneath tighten bolt with wrench ($\frac{7}{8}$ -in. wrench) (fig. 113), while man on top holds nut ($\frac{15}{16}$ -in. wrench). Repeat for other side.

(10) INSTALL THROW-OUT FORKS ASSEMBLIES.

Lower throw-out forks into steering clutch compartment so that ball pivots on lower legs of forks set in slots of equalizers (fig. 112).

(11) INSTALL STEERING CLUTCH COVERS.

Pliers

Wrench, $\frac{3}{4}$ -in. (2)

Install gasket and steering clutch cover in position on each compartment. See that ball end of throw-out adjusting screw enters hollow of thrust pin on each cover (fig. 146). Install rear fender angle brackets in place on covers (fig. 109). Install the six $\frac{1}{2}$ - by $1\frac{1}{2}$ -inch bolts with lock washers through angles and rear fenders, but do not tighten. Install the six $\frac{1}{2}$ - by $1\frac{3}{4}$ -inch cap screws with lock washers holding fender brackets to clutch covers ($\frac{3}{4}$ -in wrench). Install the eight $\frac{1}{2}$ - by $1\frac{1}{2}$ -inch cap screws with lock washers holding clutch covers to transmission case ($\frac{3}{4}$ -in. wrench). Tighten all bolts and cap screws on covers and brackets (two $\frac{3}{4}$ -in. wrenches). Hook return spring (fig. 111) onto dowel in case above each throw-out fork (pliers). Install brake hole covers and gaskets (fig. 115) with two $\frac{1}{2}$ - by $1\frac{1}{8}$ -inch cap screws with lock washers ($\frac{3}{4}$ -in. wrench).

(12) CONNECT CONTROL RODS.

Pliers

Connect steering clutch control level rods to lever assemblies on top of each steering clutch cover with yoke pin and cotter pin (fig. 109).

(13) CONNECT LUBRICATING TUBES.Wrench, $\frac{15}{16}$ -in.Wrench, open-end, $\frac{11}{16}$ -in.

Insert lubricating tubes up through holes in covers (fig. 110) and secure with four special jam nuts. Hold $\frac{11}{16}$ -inch wrench on connection under covers while tightening jam nuts on lubricating tubes ($\frac{15}{16}$ -in. wrench), to prevent twisting tubes. Pump lubricant through fittings to make sure throw-out bearings will be lubricated, and tubes will not be broken.

(14) ADJUST STEERING CLUTCHES.

Refer to paragraph 52. Adjust clutches as outlined therein.

(15) INSTALL TOP COVERS.Wrench, $\frac{3}{4}$ -in.

Install top cover plates (fig. 109) and gaskets in position and secure with one $\frac{1}{2}$ - by $5\frac{1}{4}$ -inch cap screw and two $\frac{1}{2}$ - by $\frac{3}{4}$ -inch cap screws with lock washers on each cover.

**ORDNANCE MAINTENANCE — MEDIUM TRACTOR M1 (ALLIS-CHALMERS HD-7W)
ELECTRICAL SYSTEM, POWER TRAIN, FRAME, AND TRACKS**

(16) INSTALL POWER TAKE-OFF CONTROL LINKAGE.

Pliers
Wrench, $\frac{3}{4}$ -in.

(a) Install lever assembly (fig. 108) on tractor with two $\frac{1}{2}$ - by $1\frac{3}{4}$ -inch capscrews with lock washers holding power take-off control bracket to right steering clutch cover ($\frac{3}{4}$ -in. wrench).

(b) Insert control arm end in shifter shaft of power take-off and secure with flat washer and cotter pin (pliers). Connect front rod to front lever on right side of floor plate (fig. 107) with pin and cotter pin (pliers).

(17) INSTALL PRIMARY FUEL FILTER.

Wrench, open-end, $\frac{9}{16}$ -in.
Wrench, open-end, $\frac{3}{4}$ -in.
Wrench, open-end, $\frac{7}{8}$ -in.

(a) Install filter bracket on right rear fender with two $\frac{3}{8}$ - by 1-inch SAE cap screws with lock washers ($\frac{9}{16}$ -in. wrench) (fig. 105).

(b) Connect inlet and outlet lines to primary fuel filter (fig. 105) ($\frac{3}{4}$ - and $\frac{7}{8}$ -in. wrenches).

(18) INSTALL TOOL BOX.

Wrench, $\frac{9}{16}$ -in. (2)

Install tool box on left rear fender with a $\frac{3}{8}$ - by 1-inch bolt with lock washer (fig. 106).

(19) INSTALL SEAT FRAME, FUEL TANK, AND PACK CARRIER.

Hoist, chain
Rope
Wrench, $\frac{3}{4}$ -in. (2)

(a) Using chain hoist and rope, lower fuel tank, street plate box, pack carrier, and seat frame into position as a unit (fig. 104).

(b) All bolts, nuts, and lock washers should be installed before they are tightened. Install twelve $\frac{1}{2}$ - by 1-inch bolts with lock washers holding fuel tank to street plate box on left top fender. Install three $\frac{1}{2}$ - by $1\frac{1}{2}$ -inch bolts with lock washers holding fuel tank to left rear fender. Install the three $\frac{1}{2}$ - by $1\frac{1}{4}$ -inch bolts with lock washers holding tool box to left floor plates and seat frame. Install the four $\frac{1}{2}$ - by $1\frac{1}{4}$ -inch bolts with lock washers, holding fuel tank to right top fender (fig. 102). Install one $\frac{1}{2}$ - by $1\frac{1}{2}$ -inch bolt with lock washer holding fuel tank and wire clip to inside corner of right top fender. Install ten $\frac{1}{2}$ - by 1-inch bolts with lock washers holding seat frame to right top fender. Install two $\frac{1}{2}$ - by 1-inch bolts with lock washers holding brace between seat frame and preheater box. Install the three $\frac{1}{2}$ - by $1\frac{1}{4}$ -inch bolts with lock washers holding seat frame to right floor plate (fig. 101). Tighten all nuts (two $\frac{3}{4}$ -in. wrenches).

(20) INSTALL SEAT CUSHIONS.

Install seat cushions on seat frame.

CLUTCH ASSEMBLIES

(21) ADJUST BRAKES.
Refer to paragraph 64.

52. ADJUSTMENT.

a. Tools Required.

Pliers	Wrench, open-end, $\frac{3}{4}$ -in.
Ruler or scale, 12-in.	Wrench, socket, $\frac{3}{4}$ -in.

b. Procedure (refer to fig. 146).

(1) Check for adjustment. (Check each clutch separately.)
Ruler or scale, 12-in.

(a) Place one end of a ruler or scale against the dash so it projects horizontally past the top of the steering clutch lever.

(b) Push the lever forward as far as it will go; at this point the bottom end of the lever strikes a stop on the gear shifter housing, and prevents it from going too far forward.

(c) Pull the lever back until the lost motion is taken up. This can easily be felt by a definite increase in the pull required to release the clutch.

(d) Observe the measurement of the distance between the dash and the top of the lever when it is in its forward position, and also the distance when the lever is pulled back to the position where the lost motion is all taken up. The free motion, or difference between these two measurements, should not be less than 3 inches and not more than $5\frac{1}{2}$ inches. As the steering clutches wear, the free motion of the levers becomes less. If the free motion of the lever is less than 3 inches, it is an indication that adjustment is necessary.

(2) ADJUST FREE TRAVEL OF THRUST PIN.

Pliers	Wrench, open-end, $\frac{3}{4}$ -in.
Ruler or scale, 12-in.	

(a) With steering clutch lever ahead as far as it will go, the shoulder of thrust pin should contact boss on steering clutch control bracket. When steering clutch lever is pulled back to end of its free travel, where disengagement of clutch begins, top of throw-out fork and thrust pin should move out and there should be $\frac{3}{16}$ -inch clearance between shoulder of thrust pin and boss on steering clutch control bracket.

(b) If thrust pin shoulder does not move back against boss on bracket when lever is ahead against stop, loosen jam nut on adjusting rod ($\frac{3}{4}$ -in. wrench) and remove yoke pin (pliers). Turn adjusting rod out of yoke end (counterclockwise) one-half turn and replace pin. Test to see if shoulder of thrust pin contacts boss on bracket, if necessary, turn rod out of yoke end until contact is established.

ORDNANCE MAINTENANCE — MEDIUM TRACTOR M1 (ALLIS-CHALMERS HD-7W)
ELECTRICAL SYSTEM, POWER TRAIN, FRAME, AND TRACKS

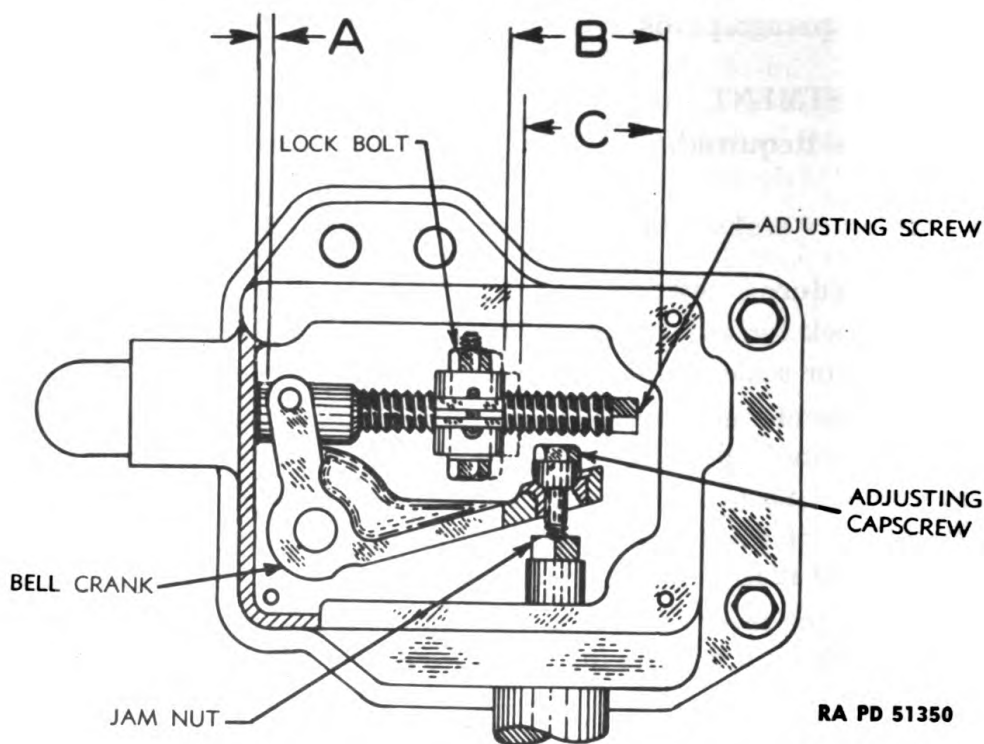

Figure 146 — Steering Clutch Adjustments

(c) Check to see if thrust pin moves out as soon as lever is pulled back. There should be no free travel of lever before thrust pin begins to move out. If there is, the adjusting rod should be screwed into yoke end (clockwise) until free lever travel is eliminated.

(3) ADJUST FREE MOTION OF THRUST PIN AND TOP OF THROW-OUT FORK.

Ruler or scale, 12-in.

Wrench, $\frac{3}{4}$ -in. (2)

Pull steering clutch lever back to end of its free travel where pressure is felt, and disengagement of clutch begins. Hold lever in that position and, with ruler or scale, check clearance between control bracket and shoulder of thrust pin. If it is less than $\frac{3}{16}$ inch, loosen lock bolt (two $\frac{3}{4}$ -in. wrenches) and turn adjusting screw out (counterclockwise) until $\frac{3}{16}$ -inch clearance is obtained ($\frac{3}{4}$ -in. wrench). If it is more than $\frac{3}{16}$ inch, turn adjusting screw in. Tighten lock bolt. Top of steering clutch lever should now have approximately 5-inch free travel before disengagement of clutch begins. Be sure jam nut on adjusting rod is tightened and cotter pin is in yoke pin before installing inspection covers. **NOTE:** This adjustment is very important, and it should be done carefully. If there is no clearance

CLUTCH ASSEMBLIES

at this point, it is possible for the clutch throw-out bearings to ride against the shifter plate even though the steering clutch levers are adjusted as specified.

53. SPECIAL TOOLS.

a. Tools and equipment required other than ordinary hand tools are:

Hoist, chain

Wrench, spanner

Puller, final drive pinion

ORDNANCE MAINTENANCE — MEDIUM TRACTOR M1 (ALLIS-CHALMERS HD-7W)
ELECTRICAL SYSTEM, POWER TRAIN, FRAME, AND TRACKS

CHAPTER 9

STEERING CLUTCHES (Cont'd)

Section II

STEERING CLUTCH CONTROLS

	Paragraph
Description	54
Trouble shooting	55
Disassembly of steering clutch controls.....	56
Inspection and repair of parts.....	57
Assembly of steering clutch controls.....	58

54. DESCRIPTION.

a. Steering levers are mounted on shafts protruding from the transmission gear shifter housing. The steering levers are connected to rods running to the bell crank levers on the steering clutch covers. Pulling back on a steering lever operates an adjustable bell crank arrangement in the steering clutch cover that moves the throw-out fork and bearings on the throw-out fork in the steering clutch compartment towards the shifter plate of the steering clutch assembly. The bearings roll on and bear against the shifter plate to compress the steering clutch springs and disengage the clutch.

55. TROUBLE SHOOTING.

a. Clutch Fails to Disengage When Lever Is Pulled Back.

Possible Cause	Possible Remedy
Throw-out fork bearings damaged.	Replace bearings, check adjustments, and check grease tube for leaks.
Rod broken between lever and bell crank in steering clutch cover.	Repair or replace rod.
Controls out of adjustment.	Adjust as explained in TM 9-783B, or in paragraph 52 of this manual.

b. Steering Lever Sticks and Will Not Return to Forward Position.

Spring on control rod broken.	Replace spring.
Thrust pin sticking in steering clutch cover.	Remove pin and examine for cause of sticking; repair if possible; if not, replace pin.

STEERING CLUTCH CONTROLS

Possible Cause	Possible Remedy
Control linkage binding.	Controls may be binding in linkage, or may be bent, or clogged with dirt or mud.
c. Controls Work Abnormally Hard.	
Splines in brake drum may be worn and ridged.	Examine and replace necessary parts.
Controls binding or jammed.	Examine for bent or broken parts.

56. DISASSEMBLY OF STEERING CLUTCH CONTROLS.

a. Tools and Equipment Required.

Bar, pry	Wrench, $\frac{9}{16}$ -in. (2)
Hammer, soft	Wrench, $\frac{7}{8}$ -in.
Pliers	Wrench, open-end, $\frac{7}{16}$ -in.
Press, arbor	Wrench, open-end, $\frac{3}{4}$ -in. (2)

b. Procedure (fig. 146).

(1) DISASSEMBLE STEERING LEVER ASSEMBLY.

Press, arbor

Place lever in press and, using arbor of suitable size, press bushing from lever.

(2) DISASSEMBLE STEERING CLUTCH COVER.

Bar, pry	Wrench, $\frac{9}{16}$ -in. (2)
Pliers	

(a) Remove clamp bolt from top lever (two $\frac{9}{16}$ -in. wrenches). Pry lever off pivot shaft (pry bar), and remove half-moon key (pliers).

(b) Push pivot shaft out of cover toward bottom of case; roller bearings and spacer will come out with shaft. Pull thrust pin from cover. Remove cap screw ($\frac{9}{16}$ -in. wrench) and tap lever off bottom of pivot pin (hammer).

(c) Press oil seal and outer bearing races out of pivot shaft opening (arbor press).

(3) DISASSEMBLE THROW-OUT FORK ASSEMBLY.

Hammer, soft	Wrench, open-end, $\frac{7}{16}$ -in.
Pliers	Wrench, open-end, $\frac{3}{4}$ -in. (2)
Wrench, $\frac{7}{8}$ -in.	

(a) Unscrew lubricating tube out of pipe elbows ($\frac{7}{16}$ -in. wrench), and unscrew pipe elbows out of bearing pins (pliers) (fig. 147).

(b) Remove nuts from end of bearing pins ($\frac{7}{8}$ -in. wrench) and tap pins out of arms of fork with soft hammer (fig. 147). Bearings and spacers will remain on pins.

(c) Remove spacers and drive pins out of bearings (hammer).

(d) Loosen clamp bolt (two $\frac{3}{4}$ -in. wrenches) and turn adjusting screw out of top of fork ($\frac{3}{4}$ -in. wrench).

**ORDNANCE MAINTENANCE — MEDIUM TRACTOR M1 (ALLIS-CHALMERS HD-7W)
ELECTRICAL SYSTEM, POWER TRAIN, FRAME, AND TRACKS**

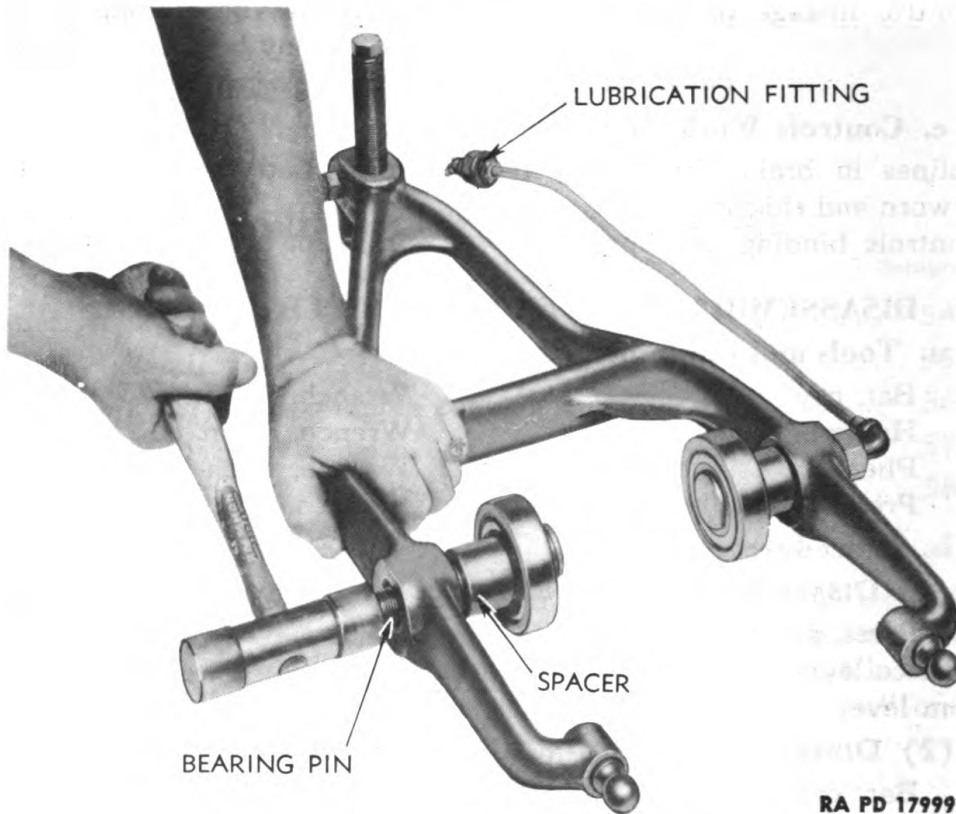

Figure 147 — Removing Bearing Pin from Throw-out Fork

57. INSPECTION AND REPAIR OF PARTS.

a. Steering Clutch Cover Assembly. Clean all parts thoroughly and inspect for broken or damaged parts. Replace pivot shaft, if worn, and replace bearings if they do not roll freely. Clean socket for thrust pin and check thrust pin to make sure it slides easily in its opening. Replace oil seal if damaged. Inspect the adjusting screw to make sure the threads on screw are in good condition.

b. Throw-out Fork Assembly. Wash all parts in dry-cleaning solvent. Inspect lubricating tubes and pipe fittings to make sure they are not cracked or broken. If either shows evidence of lubricant having oozed out of any part of the tube, discard and install new ones. Inspect bearings. Rotate bearings slowly by hand and determine if bearings appear rough, or bind in any one spot. Examine balls and races for signs of chipping, roughness, or overheating. If bearing races or balls are blue or discolored from heat, discard them. Oil with light engine oil and spin bearings to make sure they rotate freely. **CAUTION:** Do not spin bearings with compressed air when drying after cleaning them.

STEERING CLUTCH CONTROLS**58. ASSEMBLY OF STEERING CLUTCH CONTROLS.****a. Tools Required.**

Hammer, 2-lb	Wrench, $\frac{9}{16}$ -in. (2)
Hammer, soft	Wrench, $\frac{7}{8}$ -in.
Pliers	Wrench, open-end, $\frac{7}{16}$ -in.
Press, arbor	

b. Procedure.**(1) ASSEMBLE THROW-OUT FORK ASSEMBLY (fig. 147).**

Hammer, soft	Wrench, $\frac{7}{8}$ -in.
Pliers	Wrench, open-end, $\frac{7}{16}$ -in.

(a) Screw adjusting screw into top of fork with ball end so it will be towards center of tractor when fork is installed.

(b) Tap pins through bearings (hammer); then slip spacers onto pins and drive pins through arms of fork. Install lock washers and nuts, and tighten securely ($\frac{7}{8}$ -in. wrench).

(c) Screw pipe elbows into ends of bearing pins (pliers). Screw lubricating tubes into elbows ($\frac{7}{16}$ -in. wrench). Install lubrication fittings in upper ends of tubes, if they were removed ($\frac{7}{16}$ -in. wrench).

(2) ASSEMBLE STEERING CLUTCH COVER (fig. 146).

Hammer, 2-lb	Wrench, $\frac{9}{16}$ -in. (2)
Press, arbor	

(a) Press bearing races into pivot pin opening from each end of opening for pivot pin (arbor press), so that ends of bushings are flush with opening.

(b) Tap key into slot in bottom end of pivot pin, then tap lower lever onto pin and key (hammer). Install cap screw through lever and tighten ($\frac{9}{16}$ -in. wrench).

(c) Place a roller bearing on pivot pin, then add spacer and second roller bearing. Insert pin and bearings up through opening in cover and block under end of pin; then slip oil seal over top of pin and tap into opening above top bearing (hammer).

(d) Install half-moon key into slot in top end of pivot pin and tap top lever onto pin (hammer). Install clamp bolt in lever and tighten (two $\frac{9}{16}$ -in. wrenches).

(e) Slip thrust pin into place in cover with socket end of thrust pin towards open side of cover.

(3) PRESS BUSHING INTO STEERING LEVER.

Press, arbor

Press new bushings into lever and ream, if necessary, for a free fit on shaft.

ORDNANCE MAINTENANCE — MEDIUM TRACTOR M1 (ALLIS-CHALMERS HD-7W)
ELECTRICAL SYSTEM, POWER TRAIN, FRAME, AND TRACKS

CHAPTER 10

TRACTOR BRAKES

	Paragraph
Description	59
Trouble shooting	60
Removal	61
Inspection and repair	62
Installation	63
Adjustment	64

59. DESCRIPTION.

a. The brakes are of the mechanical type, operated by foot pedals. One-piece steel bands, lined with seven sections of molded or woven lining, encircle the brake drums enclosing the steering clutch assemblies. Bell cranks mounted on shafts in the steering clutch compartments are activated by linkage from the brake pedals to compress the brake bands around the brake drum. The brake bands, when not in use, are supported at the bottom by the brake locating screws, and held away from the brake drum by springs in the linkage. This allows brake drums to rotate inside the brake bands with a slight clearance. An adjusting screw provides a means of adjusting brakes. Locks on the brake pedal assemblies make it possible to set the brakes in engaged position for parking purposes.

60. TROUBLE SHOOTING.

a. Brakes Do Not Hold.

Possible Cause	Possible Remedy
Brake lining worn.	Replace lining.
Improper brake adjustment.	Adjust brakes.
Oil on brakes.	Wash brakes and check to determine source of oil.
Brake band broken.	Replace band.
Broken controls or linkage.	Replace broken parts.

b. Brakes Get Hot.

Brakes adjusted too tight.	Adjust brakes to proper clearances.
Return spring broken.	Replace spring.
Brakes do not disengage completely (brakes stick).	Free up controls and lubricate with light oil.

TRACTOR BRAKES

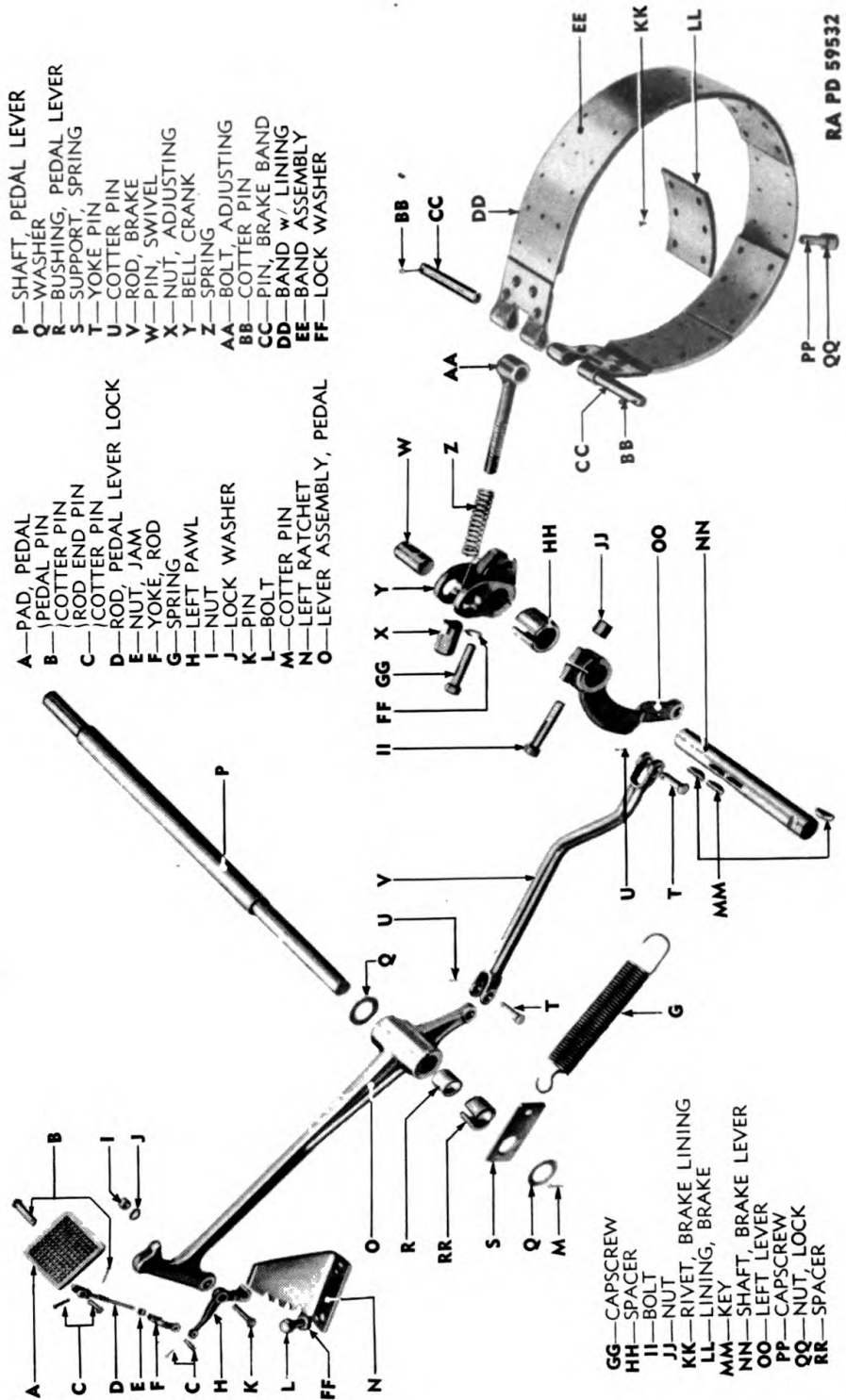

Figure 148 — Brake Assembly — Exploded View

**ORDNANCE MAINTENANCE — MEDIUM TRACTOR M1 (ALLIS-CHALMERS HD-7W)
ELECTRICAL SYSTEM, POWER TRAIN, FRAME, AND TRACKS**

c. Brake Lining Wears Fast.

Possible Cause	Possible Remedy
Improper brake adjustment.	Adjust to proper clearance.
Brake controls bind and hold brake on.	Free up controls and lubricate with light oil.
Brake drums scored.	Machine face of drums or replace drums (par. 49).
Operator does not handle brakes according to instructions.	Instruct operator on proper use of brakes.

d. Brake Pedals Work Up and Down When Tractor Is in Motion.

Driven hub on final drive pinion shaft warped, causing brake drum to run out of line.	Machine face of brake drums or replace drums.
Worn or damaged brake drums.	Repair or replace.
Final drive pinion bearings worn or broken.	Replace bearings.
Loose driven hub on pinion.	Tighten pinion nut.
Driven hub not square on pinion shaft.	Install correctly.

61. REMOVAL.

a. Tools and Equipment Required.

Hoist, chain	Wrench, open-end, 7/8-in.
Pliers	Wrench, open-end, 15/16-in.
Rope	Wrench, socket, 9/16-in.
Screwdriver, 10-in.	Wrench, socket, 3/4-in.
Wrench, open-end, 9/16-in.	Wrench, socket, 7/8-in.
Wrench, open-end, 11/16-in.	Wrench, socket, 15/16-in.
Wrench, open-end, 3/4-in.	

b. Procedure.

(1) REMOVE BRAKE BAND ASSEMBLIES FROM TRACTOR.

Refer to paragraph 47 **b** (1) through (7).

62. INSPECTION AND REPAIR.

a. Brake Drums. After removing brake band assemblies, inspect both brake drums to make sure they are smooth. If lining on bands is worn to the point where the heads of the rivets have contacted the drums, the drums will probably be scored. The drums may be chucked in a lathe and machined smooth, if not scored too deeply (par. 49).

b. Brake Lining. Wash brake bands and linings with dry-cleaning solvent. If linings seem brittle and are glazed, replace them. The

TRACTOR BRAKES

original thickness of the lining is $\frac{5}{16}$ inch. If lining is worn to the point where in a short time the heads of rivets will be rubbing on drum, remove the old lining from the band, discard it, and reline the band. Remove old lining by punching out the rivets, and install the new lining, either with the use of a brake lining machine, or a brake rivet anvil and punch set.

c. Brake Bands and Linkage. Inspect all linkage and bands for general condition. Replace badly worn pins and linkage where necessary. Make sure rivets in ends of bands are tight. Straighten bent or twisted bands.

63. INSTALLATION.

a. Tools and Equipment Required.

- | | |
|---|--|
| Hoist, chain | Wrench, open-end, $\frac{1}{16}$ -in. |
| Pliers | Wrench, open-end, $\frac{3}{4}$ -in. |
| Rope | Wrench, open-end, $\frac{7}{8}$ -in. |
| Ruler or scale, 12-in. | Wrench, open-end, $\frac{15}{16}$ -in. |
| Screwdriver, 8-in. | Wrench, socket, $\frac{9}{16}$ -in. |
| Wrench, deep socket, $\frac{15}{16}$ -in. | Wrench, socket, $\frac{3}{4}$ -in. |
| Wrench, open-end, $\frac{9}{16}$ -in. | Wrench, socket, $\frac{7}{8}$ -in. |

b. Procedure. Refer to paragraph 51 b (8) through (21). After installing clutches, adjust as outlined in next paragraph.

64. ADJUSTMENT.

a. Tools Required.

- | | |
|----------------------------|---|
| Screwdriver, 8-in. | Wrench, deep socket, $\frac{15}{16}$ -in. |
| Wrench, $\frac{3}{4}$ -in. | |

b. Procedure. NOTE: The brake locating screw located in the bottom of the steering clutch and brake compartment requires adjustment only when the brakes have been removed and are again installed. After this screw has been adjusted, it is not necessary to readjust it in subsequent adjustments of the brakes. The screw supports the weight of the band to prevent the brake band assembly from sagging onto the brake drum and wearing the lining on the top part of the band.

(1) ADJUST BRAKE LOCATING SCREW (only after installation of brakes.)

- | | |
|--------------------|----------------------------|
| Screwdriver, 8-in. | Wrench, $\frac{3}{4}$ -in. |
|--------------------|----------------------------|

Loosen lock nut on screw from underneath steering clutch compartment of transmission case ($\frac{3}{4}$ -in. wrench). With screwdriver, turn screw into case until it pushes brake band against brake drum. Screw will then be tight. Then back screw out one-half turn and tighten lock nut. This will allow a slight clearance between band and drum.

ORDNANCE MAINTENANCE — MEDIUM TRACTOR M1 (ALLIS-CHALMERS HD-7W)
ELECTRICAL SYSTEM, POWER TRAIN, FRAME, AND TRACKS

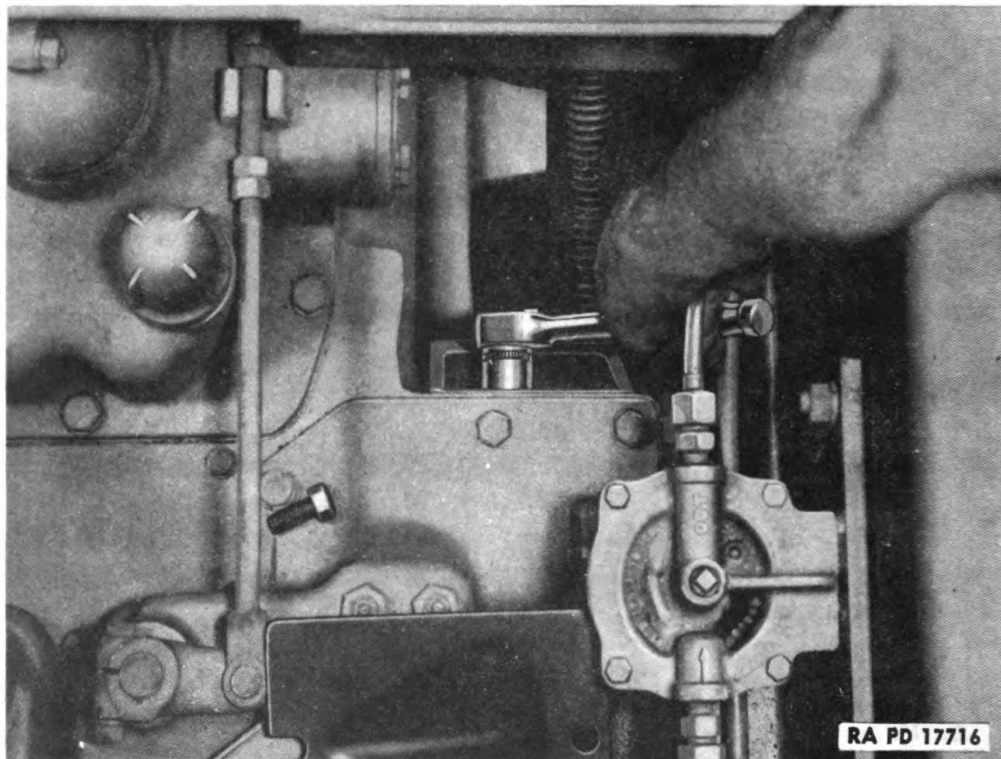

Figure 149 — Adjusting Brakes

(2) ADJUST BRAKE BANDS.

Wrench, deep socket, $1\frac{5}{16}$ -in.

Tighten the brake bands by turning the brake band adjusting nut in a clockwise direction. This nut is reached through the brake hole in front of steering clutch compartment (fig. 149). The brake bands are in correct adjustment when pawl on pedal lever lacks 1 inch of striking master clutch inspection covers on engine spacer, when pedals are depressed as far as possible to apply brakes. **NOTE:** The tractor should be in motion when making this test. The rear of the adjusting nut is formed with a circular notch which fits over the bell crank to hold nut from coming loose while tractor is in operation. Therefore it should be turned one-half turn at a time, while adjusting brakes, so the notch will again be in proper position. It is desirable to maintain the maximum free travel of pedal to insure as much clearance as possible between brake bands and drums, which in turn results in less heat and longer wear on brake linings.

CHAPTER 11

TRANSMISSION AND GEARSHIFT MECHANISM

Section I

GENERAL DESCRIPTION

Paragraph

General description 65

65. GENERAL DESCRIPTION.

a. Construction. The transmission gears, gearshift assembly, bevel gear and pinion, and steering clutches are all contained in a large casting called the transmission case. This case acts as the main frame of the tractor; it is divided into five compartments. The front compartment houses the master clutch controls; the center compartment houses the transmission gears and gearshift assembly; and the center rear compartment houses the bevel gear and pinion. The steering clutches are in separate compartments on each side of the bevel gear compartment in rear of case. The engine is connected to the front of the transmission case by the engine spacer. The final drive cases are bolted to the sides of the case, the power take-off and pintle assemblies to the rear, and the stabilizer assembly is bolted to and supports the front end of case. The gearshift mechanism consists of sliding shafts controlled by the gearshift lever. Forks, the ends of which fit into collars on three sliding gears in the transmission, are bolted to these shafts.

b. Operation. Power is delivered by the engine to the transmission, through the clutch shaft and gear. The desired speed or power is obtained by shifting the gearshift lever into different positions. Shifting of the lever determines which sliding gear meshes with gear to turn the bevel pinion and shaft at the proper speed. This action, in turn, drives the bevel gear and final drive gears through the steering clutches. For low speeds, small pinion gears mesh with larger gears and the result is more pull at the same governed engine speed. To increase the speed, larger pinion gears mesh with smaller gears and the speed of the tractor is increased, but pull is decreased in direct proportion to the increased speed. For driving tractor in reverse, another gear is brought into play which reverses the direction of the bevel pinion and shaft.

CHAPTER 11

TRANSMISSION AND GEARSHIFT MECHANISM (Cont'd)

Section II

**TROUBLE SHOOTING FOR TRANSMISSION GEARS
AND GEARSHIFT ASSEMBLY**

Paragraph

Trouble shooting 66

66. TROUBLE SHOOTING.

a. Gears Disengage While Tractor Is in Operation.

Possible Cause	Possible Remedy
Shifting lever does not have enough travel to move shifter shafts into locking position.	Adjust lever so shafts can lock.
Gear shifter locks worn or springs weak.	Repair or replace worn parts or weak springs.

b. Gears Not in Full Mesh While in Operation.

Shifter fork locks worn.	Repair or replace.
Shifter fork worn or damaged.	Repair or replace.
Shifter controls not properly adjusted.	Adjust controls for proper mesh.
Worn or broken bearings.	Replace bearings.

c. Gears Hard to Shift.

Oil in transmission too heavy.	Drain and fill with oil of recommended weight for prevailing temperature.
Worn shifting controls.	Repair or replace worn parts.
Insufficient clearance between clutch release bearing carrier and clutch brake.	Adjust to proper clearance.
Lining on master clutch brake worn out.	Replace lining.
Lining torn loose on master-clutch disk (clutch will not disengage fully).	Replace clutch disk assembly.
Burred gears.	Repair or replace.

d. Gear or Bearing Failure.

Tractor has been operated with insufficient amount of oil in transmission case.	Rebuild transmission and fill to proper level with correct oil.
---	---

TROUBLE SHOOTING FOR TRANSMISSION GEARS AND GEARSHIFT ASSEMBLY

Possible Cause	Possible Remedy
Wrong kind of oil has been used.	Rebuild transmission and refer to manufacturer's recommendations on oil to be used.
Dirt or other foreign material in oil.	Drain oil from case regularly, flush case and refill with clean oil.
Operator continually clashes gears in shifting.	This can result in small metal pieces being broken off gears and lodging in gears or bearings. Make sure gears are stopped before attempting to shift into another gear.
e. Noise in Transmission.	
Bevel gear and bevel pinion gear not in proper mesh.	Adjust for proper mesh (par. 70).
Bevel gear hub bearings out of adjustment.	Adjust as outlined (par. 70).
Bearing worn or failed.	Replace bearing.
Gears badly worn.	Replace gears.
Bevel pinion shaft worn or twisted.	Replace shaft and pinion.
Reverse idler or top transmission shaft worn or twisted.	Replace damaged parts.
Foreign material in oil.	Drain, flush, and fill with clean oil.
Broken or damaged transmission case.	Repair or replace.
Gears clash because of improper spacing on shafts.	Check spacing of gears and adjust spacing where needed.
Tooth broken off gear.	Replace damaged gear.
Oil level very low.	Add oil to bring level up to "FULL" mark on bayonet gage.

**ORDNANCE MAINTENANCE — MEDIUM TRACTOR M1 (ALLIS-CHALMERS HD-7W)
ELECTRICAL SYSTEM, POWER TRAIN, FRAME, AND TRACKS**

CHAPTER 11

TRANSMISSION AND GEARSHIFT MECHANISM (Cont'd)

Section III

TRANSMISSION GEARS

	Paragraph
Description	67
Removal and disassembly of transmission and gears.....	68
Inspection and repair of parts.....	69
Assembly and installation of transmission gears.....	70
Special tools	71

67. DESCRIPTION.

a. Transmission Gears. The transmission gear system is of the selective speed type and is designed to furnish the proper gear reduction for varying load requirements. The clutch shaft, supported by the pilot bearing in the flywheel at the front end and a ball bearing at the rear end, transmits the power from the engine through a set of gears to the top transmission shaft. The power take-off is connected by a splined coupling to this top shaft. There are two sliding gears on the top shaft and one on the bevel pinion shaft. Each of these gears may be brought into mesh and held in mesh with a different mating gear by means of the gear shift lever and mechanism (sec. IV) to obtain the desired speed for the power required. The low and reverse pinion on the top shaft may be engaged with the reverse idler gear on the reverse idler gear shaft to allow for backing the tractor and load.

b. Bevel Pinion and Gear. The bevel pinion on the end of the lower or bevel pinion shaft is cast integral with this shaft and extends into the bevel gear compartment at rear of transmission case. Teeth on the bevel pinion and gear are cut in a spiral shape and made in matched sets. Both pinion and gear must be replaced if replacement of either is necessary. The bevel gear is mounted on a hub through which the splined steering clutch shaft extends. The bevel gear and hub rotate on tapered roller bearings. The steering clutch shaft, splined to engage in the splines inside of the bevel gear hub, drives the steering clutches, which in turn drive the final drive pinion and gear and drive sprockets.

c. Clutch Shaft. The master clutch driven disk hub is splined and engages in splines on the front end of the master clutch shaft. The master clutch brake assembly (in halves) clamps around the

TRANSMISSION GEARS

clutch shaft and is used as a means of stopping the rotation of the transmission gears for shifting into another gear. This is accomplished by forcing the clutch release bearing carrier against the rotating brake with the clutch lever, after the clutch has been disengaged.

d. **Mile Meter.** A worm gear is located on the front end of the bevel pinion shaft to drive the mile meter gear assembly contained in the mile meter housing. The mile meter housing takes the place of the front bevel pinion shaft bearing retainer. An enclosed flexible cable extends from this housing through a hole in the transmission case to the mile meter in the dash.

68. REMOVAL AND DISASSEMBLY OF TRANSMISSION AND GEARS.

a. Tools and Equipment Required.

Bar, 6-ft	Wrench, open-end, 1/2-in.
Bar, pry	Wrench, open-end, 9/16-in., with extension
Chisel, 3/4-in.	Wrench, open-end, 11/16-in.
Hammer, 1/2-lb	Wrench, open-end, 3/4-in.
Hammer, 2-lb	Wrench, open-end, 7/8-in.
Hardwood block, (2)	Wrench, open-end, 15/16-in.
Hoist, chain	Wrench, open-end, 1-in.
Jack, hydraulic, 10-ton	Wrench, open-end, 17/16-in.
Pipe, 2-in., 3-ft long	Wrench, open-end, 2 1/2-in.
Pliers	Wrench, open-end, 2 3/4-in.
Press, arbor	Wrench, open-end, 3 3/4-in.
Puller, final drive pinion	Wrench, socket, 1/2-in.
Punch, small	Wrench, socket, 9/16-in.
Punch, 10-in.	Wrench, socket, 3/4-in.
Punch, 24-in.	Wrench, socket, 7/8-in., with extension
Rope	Wrench, socket, 15/16-in.
Screwdriver, 6-in.	Wrench, socket, 1-in.
Screwdriver, 10-in.	Wrench, socket, 1 1/8-in.
Steel disk, 1/2-in. thick	Wrench, socket, 15/16-in., with long extension
Wrench, 3/8-in.	Wrench, spanner
Wrench, 7/16-in.	
Wrench, 5/8-in.	
Wrench, 2-in.	
Wrench, box, 3/4-in.	

b. Procedure.

(1) REMOVE ENGINE FROM TRACTOR.

Refer to TM 9-783B or TM 9-1783A for removal procedure.

(2) REMOVE STEERING CLUTCH ASSEMBLIES.

Refer to paragraph 47, and follow procedure outlined.

(3) REMOVE GEARSHIFTER ASSEMBLY.

Wrench, 3/4-in. (2)

ORDNANCE MAINTENANCE — MEDIUM TRACTOR M1 (ALLIS-CHALMERS HD-7W)
ELECTRICAL SYSTEM, POWER TRAIN, FRAME, AND TRACKS

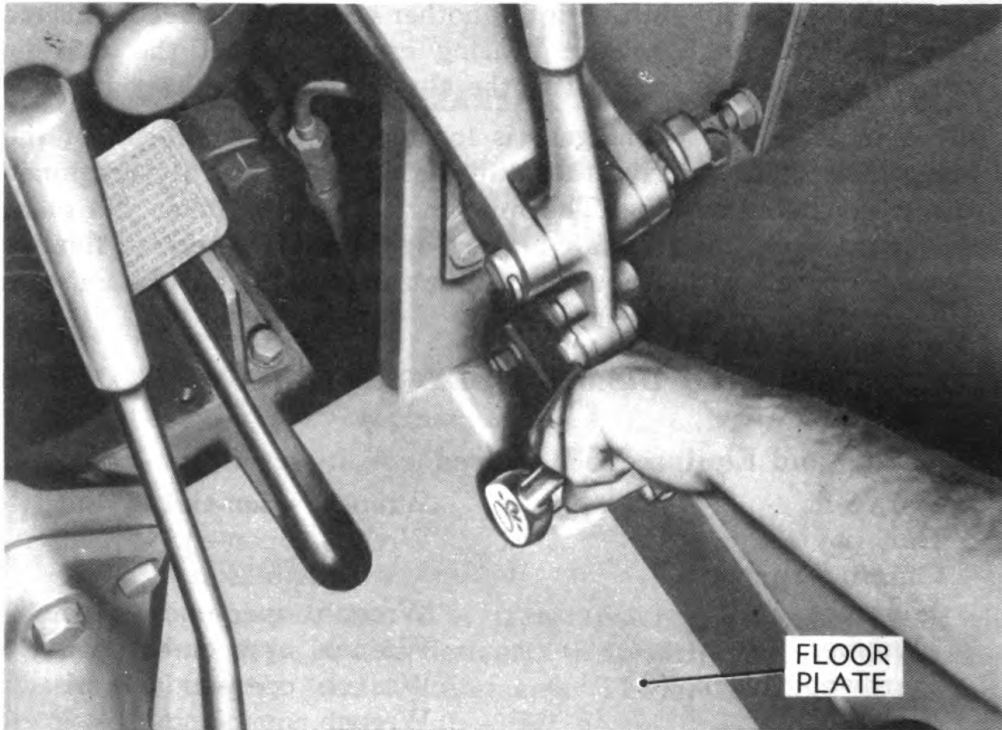

RA PD 41155

Figure 150 — Removing Floor Plate

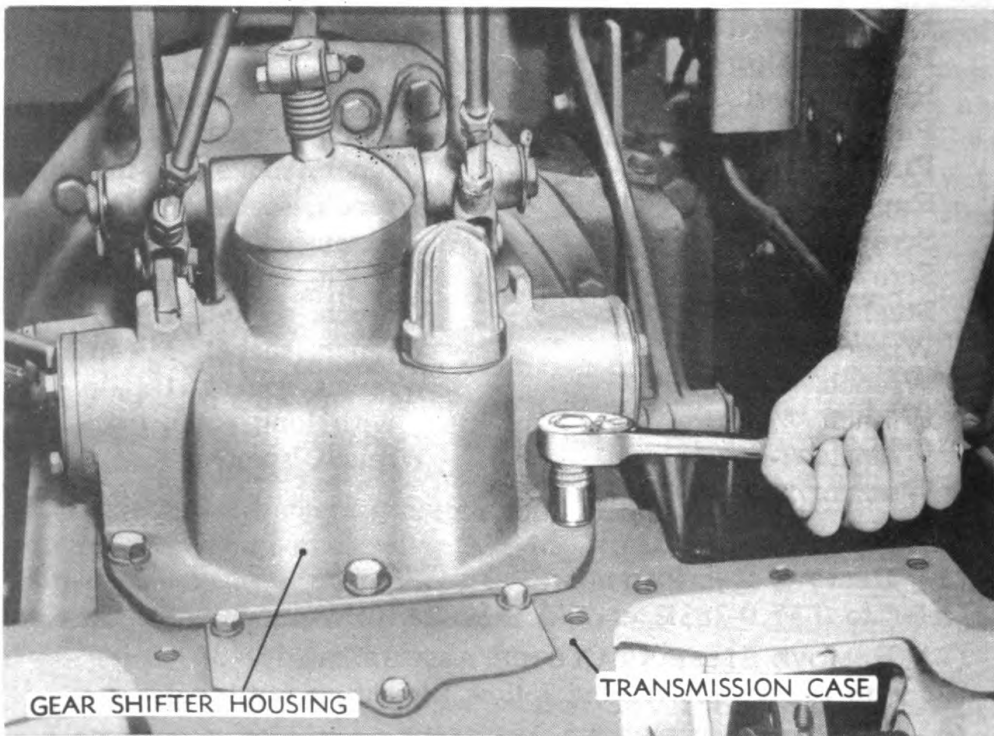

RA PD 41112

Figure 151 — Removing Cap Screws from Gearshifter Housing

TRANSMISSION GEARS

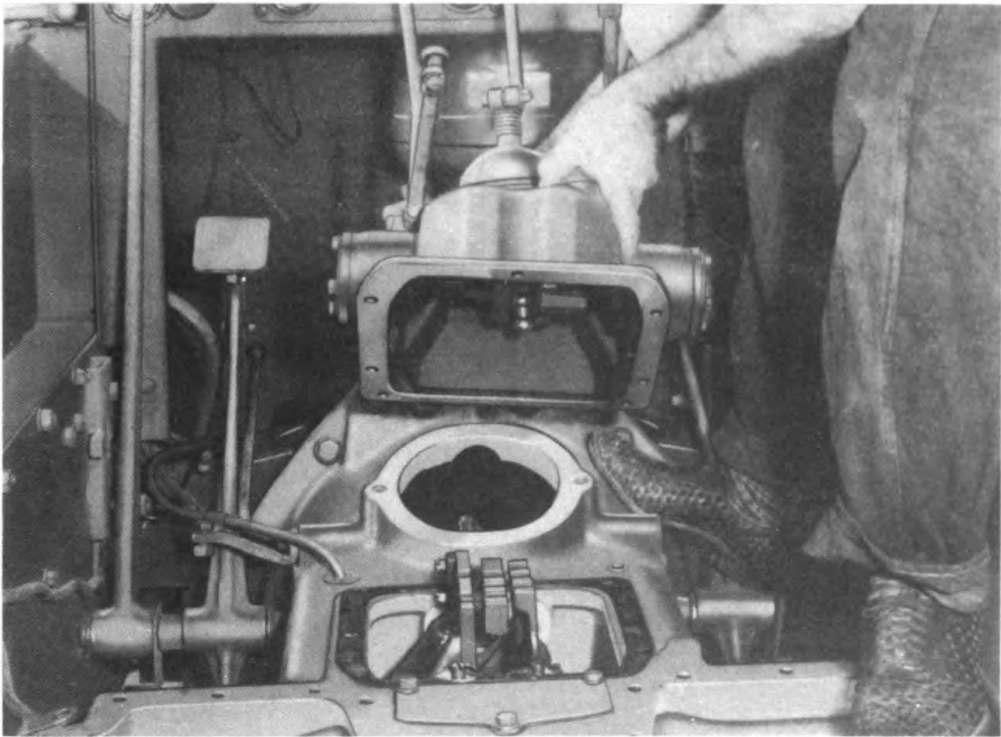

RA PD 41118

Figure 152 — Gearshifter Housing Removed

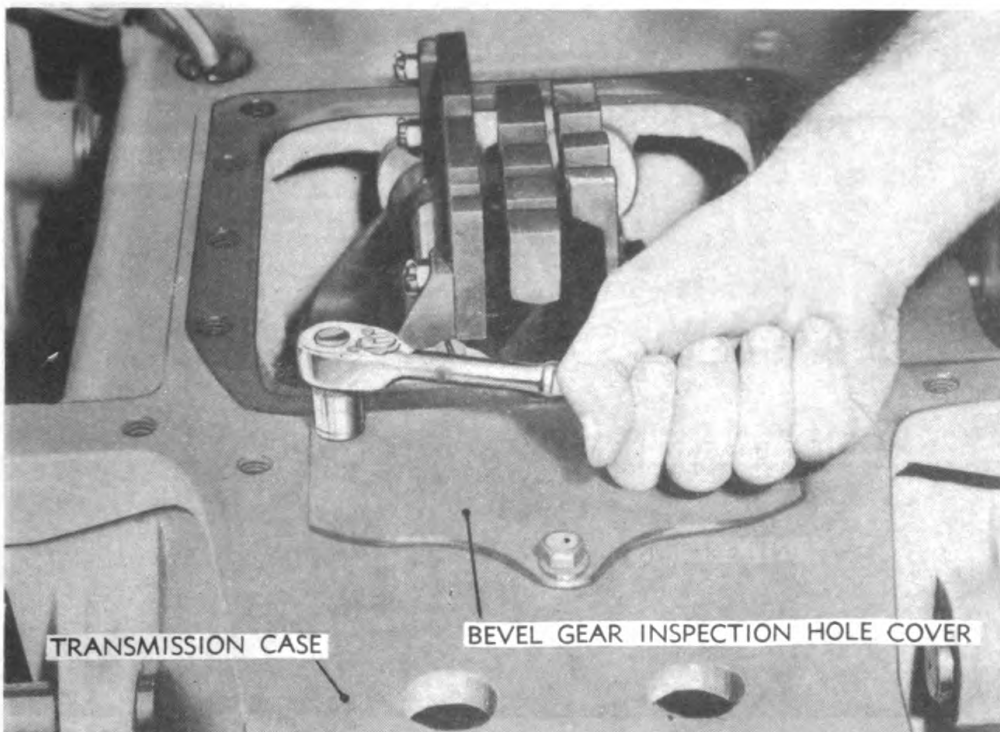

RA PD 41150

Figure 153 — Removing Bevel Gear Inspection Hole Cover

ORDNANCE MAINTENANCE — MEDIUM TRACTOR M1 (ALLIS-CHALMERS HD-7W)
ELECTRICAL SYSTEM, POWER TRAIN, FRAME, AND TRACKS

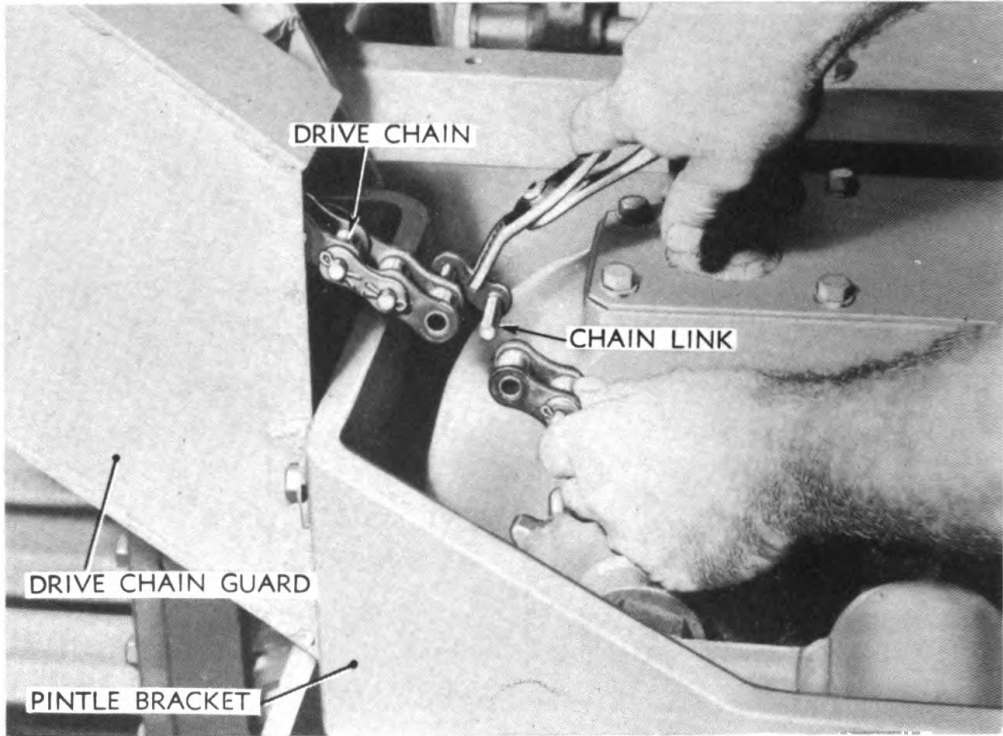

RA PD 41108

Figure 154 — Disconnecting Winch Drive Chain

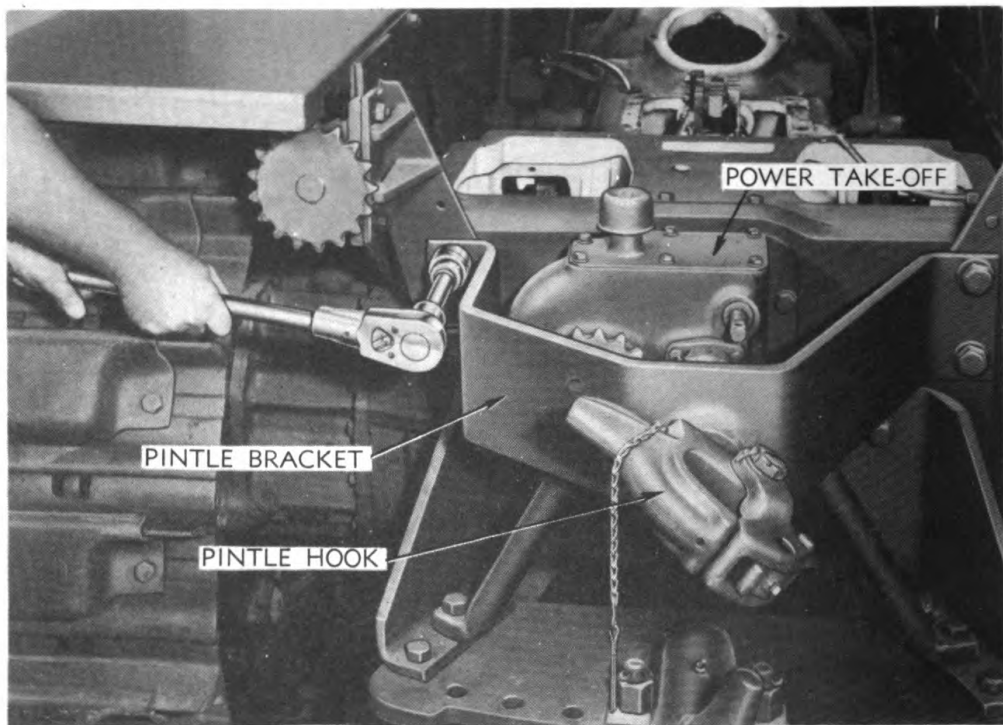

RA PD 41058

**Figure 155 — Removing Cap Screws Holding Pintle Bracket
to Transmission Case**

TRANSMISSION GEARS

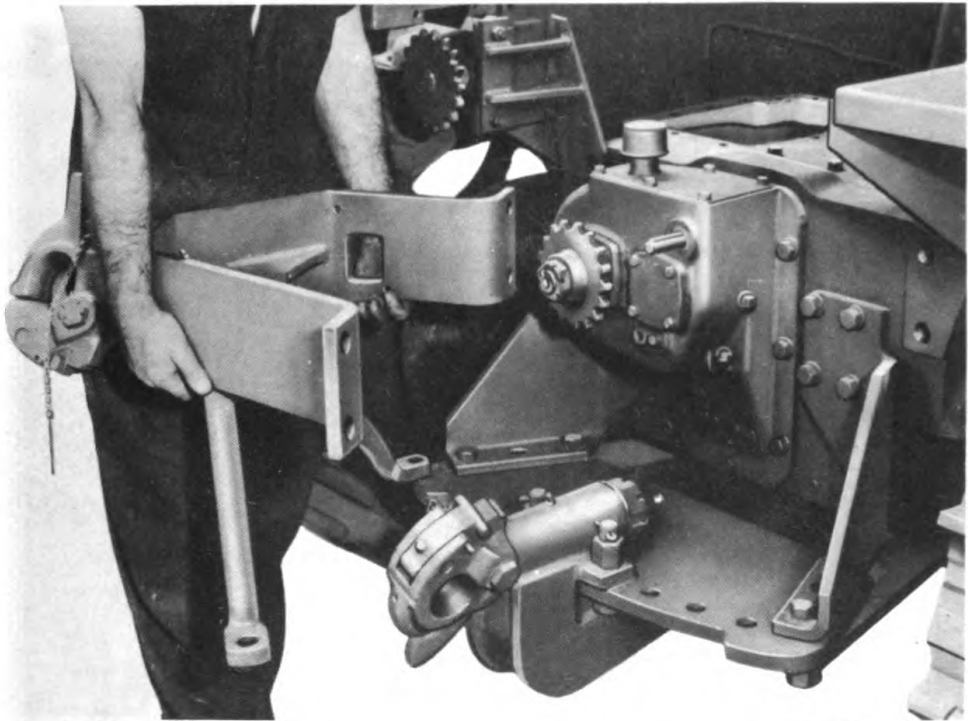

RA PD 41157

Figure 156 — Pintle Bracket Removed

(a) Remove two bolts holding right floor plate to right rear fender (fig. 150). Remove two cap screws holding left floor plate to left rear fender (two $\frac{3}{4}$ -in. wrenches). Remove floor plates.

(b) Remove the seven cap screws holding gearshifter assembly to transmission case ($\frac{3}{4}$ -in. wrench) and remove gearshifter assembly (figs. 151 and 152).

(4) REMOVE BEVEL GEAR INSPECTION HOLE COVER.

Wrench, $\frac{9}{16}$ -in.

Remove the three cap screws holding bevel gear inspection hole cover to transmission cover and remove cover (fig. 153).

(5) REMOVE WINCH DRIVE CHAIN AND PINTLE BRACKET.

Hammer, $\frac{1}{2}$ -lb

Pliers

Punch, small

Wrench, $\frac{9}{16}$ -in. (2)

Wrench, socket $1\frac{1}{8}$ -in.

Wrench, socket, $1\frac{5}{16}$ -in.,
with long extension

(a) Remove cotter pins from one link of drive chain (pliers). Disconnect chain by removing link (fig. 154). Drive link out with punch and hammer.

(b) Remove the two bolts holding drive chain guard to left top fender and two bolts holding guard to pintle bracket (two $\frac{9}{16}$ -in. wrenches) and remove guard. Remove chain from sprockets.

ORDNANCE MAINTENANCE — MEDIUM TRACTOR M1 (ALLIS-CHALMERS HD-7W)
ELECTRICAL SYSTEM, POWER TRAIN, FRAME, AND TRACKS

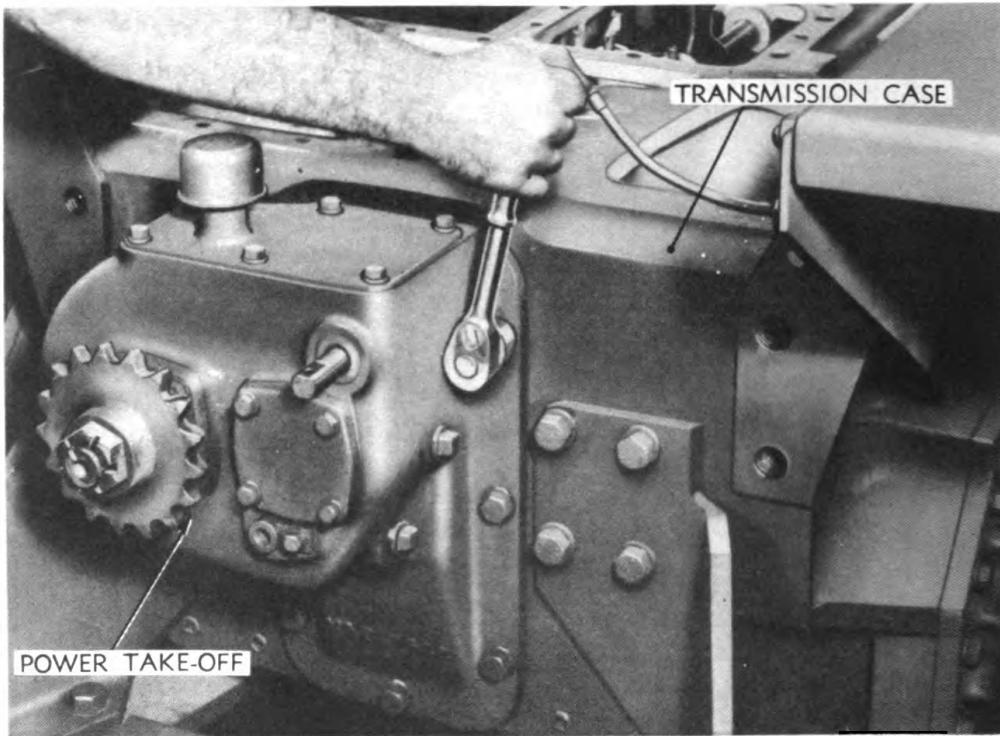

RA PD 41160

Figure 157 — Removing Cap Screws from Power Take-off

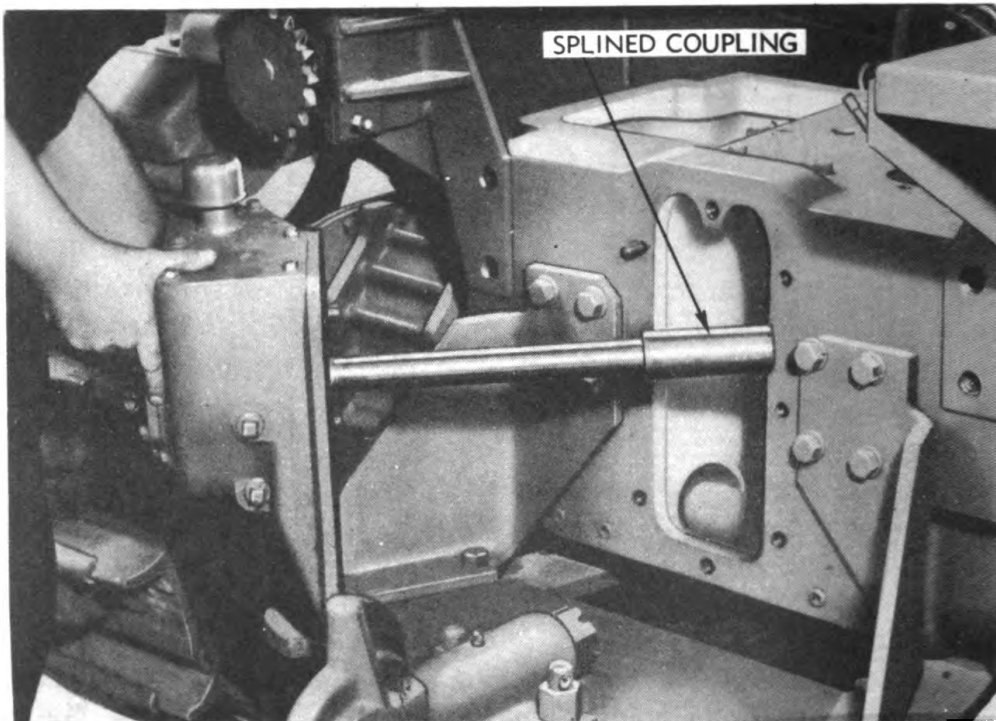

RA PD 41095

Figure 158 — Power Take-off Assembly Removed

TRANSMISSION GEARS

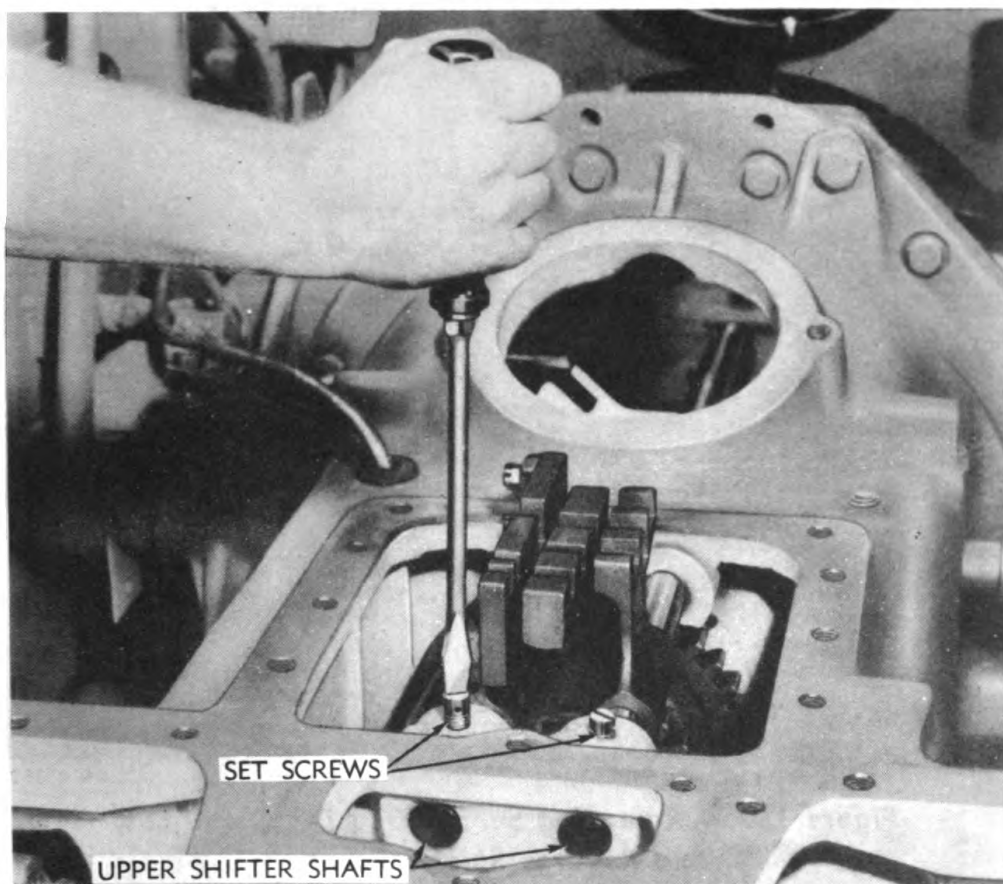

RA PD 41154

Figure 159— Removing Shifter Shaft Setscrews

(c) Remove the four cap screws holding pintle bracket to rear of transmission case ($1\frac{5}{16}$ -in. wrench) and two bolts holding legs of bracket to drawbar plate ($1\frac{1}{8}$ - and $1\frac{5}{16}$ -in. wrenches), and remove pintle bracket from tractor (figs. 155 and 156).

(6) REMOVE POWER TAKE-OFF GEAR CASE.

Wrench, open-end, $1\frac{5}{16}$ -in. Wrench, socket, $\frac{7}{8}$ -in.

Remove the five cap screws ($\frac{7}{8}$ -in. wrench) and two nuts ($1\frac{5}{16}$ -in. wrench) on bolts holding power take-off to transmission case and pull assembly from tractor, (figs. 157 and 158).

(7) REMOVE SHIFTER SHAFTS AND FORKS.

Hammer, 2-lb Screwdriver, 10-in.
Pliers Wrench, socket, $\frac{3}{4}$ -in.
Punch, 24-in.

(a) Cut lock wire (pliers) and remove the two setscrews (fig. 159) holding the two upper shifter shafts in transmission case (screwdriver). Insert long punch through bevel gear compartment from rear opening and drive the two top shafts forward, thus forcing the

ORDNANCE MAINTENANCE — MEDIUM TRACTOR M1 (ALLIS-CHALMERS HD-7W)
ELECTRICAL SYSTEM, POWER TRAIN, FRAME, AND TRACKS

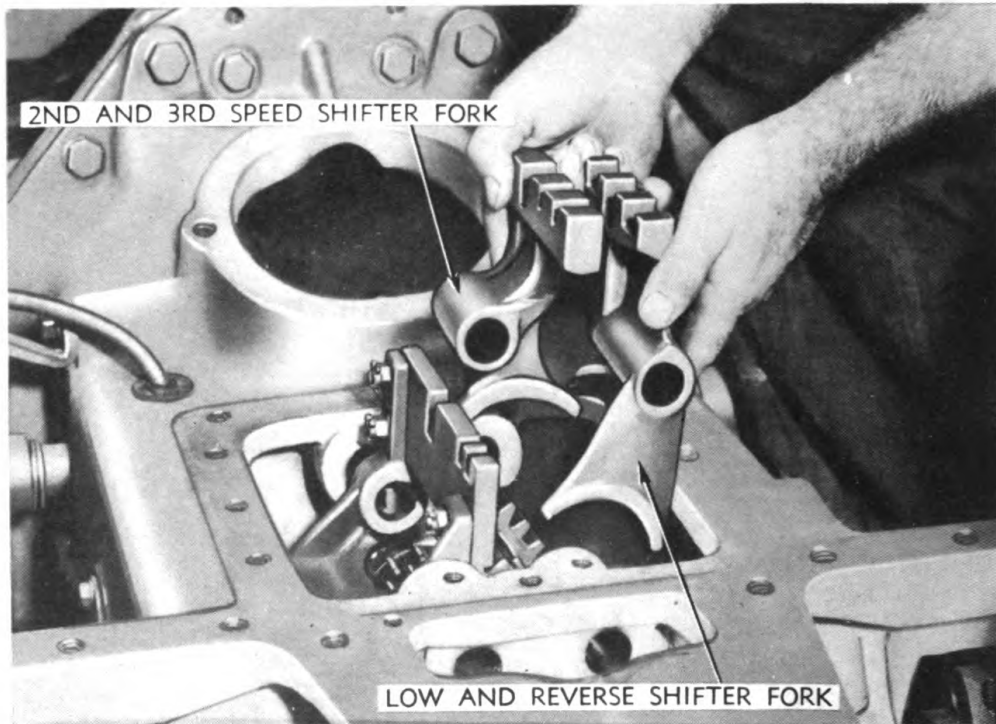

RA PD 41153

Figure 160 — Removing Second and Third, and Low and Reverse Shifter Forks

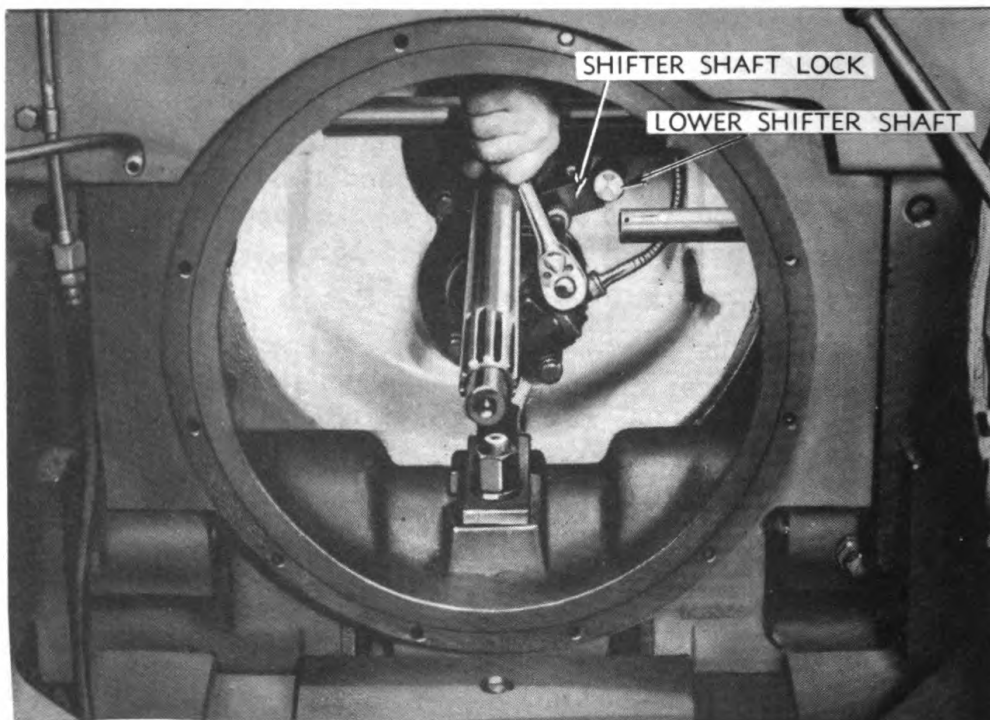

RA PD 41117

Figure 161 — Removing Shifter Shaft Lock

TRANSMISSION GEARS

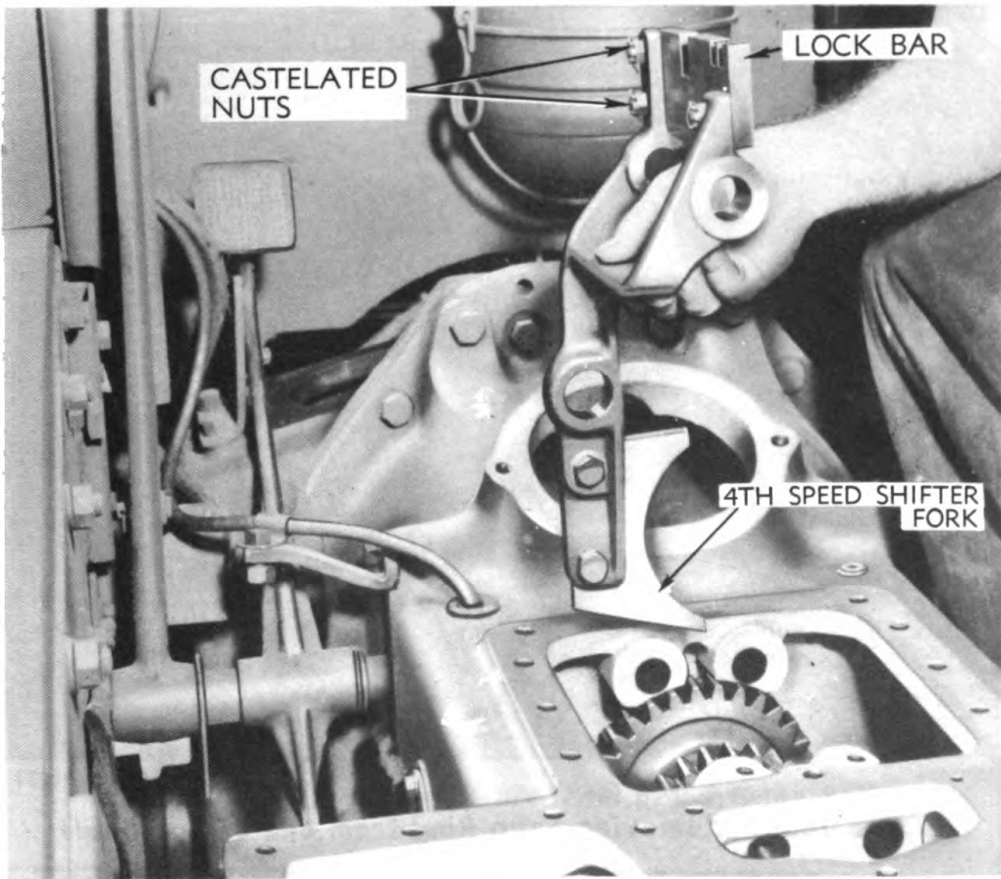

RA PD 41120

Figure 162 — Removing Fourth Speed Shifter Fork

shaft cover cups out into master clutch compartment (hammer and punch). Remove the two shafts and two cover cups.

(b) Lift the second and third speed and low and reverse shifter forks from transmission case (fig. 160).

(c) Remove the cap screw holding lower shifter shaft lock (fig. 161) to transmission case inside master clutch compartment ($\frac{3}{4}$ -in. wrench). Pull lower shifter shaft from transmission case through master clutch compartment.

(d) Lift fourth speed shifter fork from transmission case (fig. 162).

(8) REMOVE TRANSMISSION TOP SHAFT.

Bar, pry

Pliers

(a) Remove snap ring from rear end of transmission top shaft (pliers) (fig. 163).

(b) Pull top shaft assembly toward rear of tractor until front ball bearing and washer are exposed. Remove bearing and washer from shaft by using small pry bar (fig. 164). Continue to pull shaft back and lift the reducer gear, the second and third speed pinion, and the low and reverse pinion from transmission case (fig. 193) as

ORDNANCE MAINTENANCE — MEDIUM TRACTOR M1 (ALLIS-CHALMERS HD-7W)
ELECTRICAL SYSTEM, POWER TRAIN, FRAME, AND TRACKS

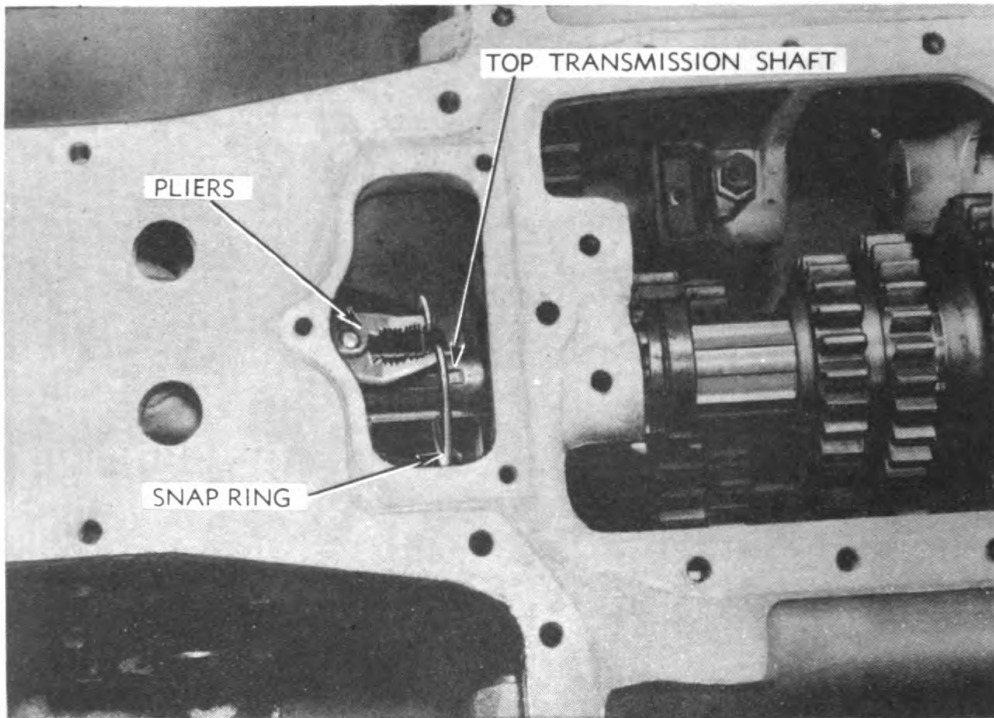

RA PD 41091

Figure 163 — Removing Snap Ring from End of Top Shaft

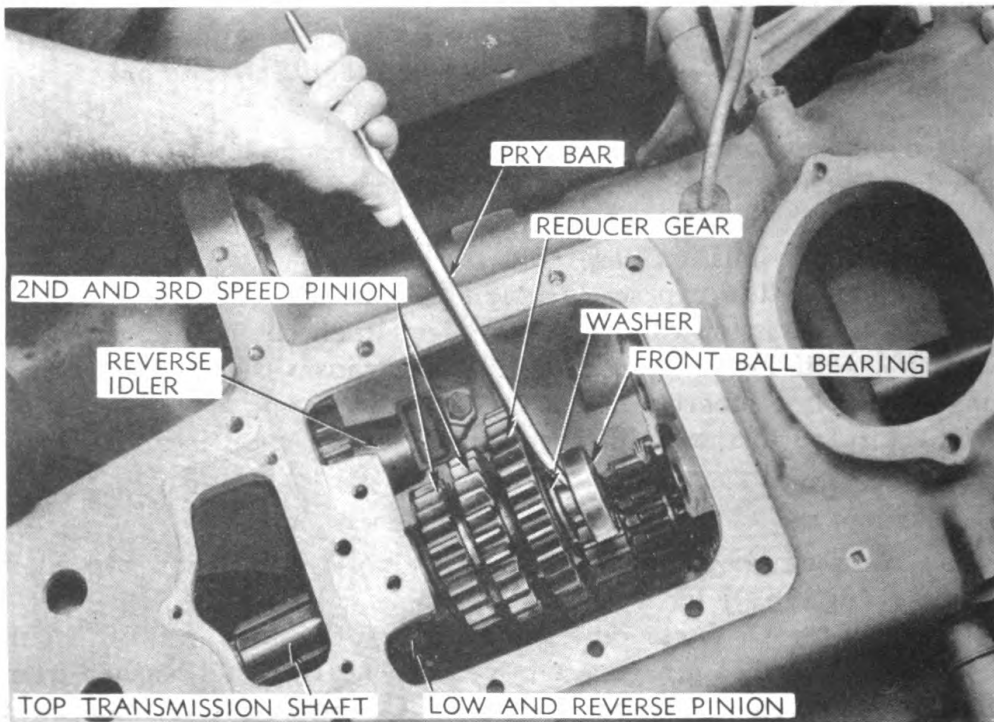

RA PD 41096

Figure 164 — Prying Bearing from End of Top Shaft

TRANSMISSION GEARS

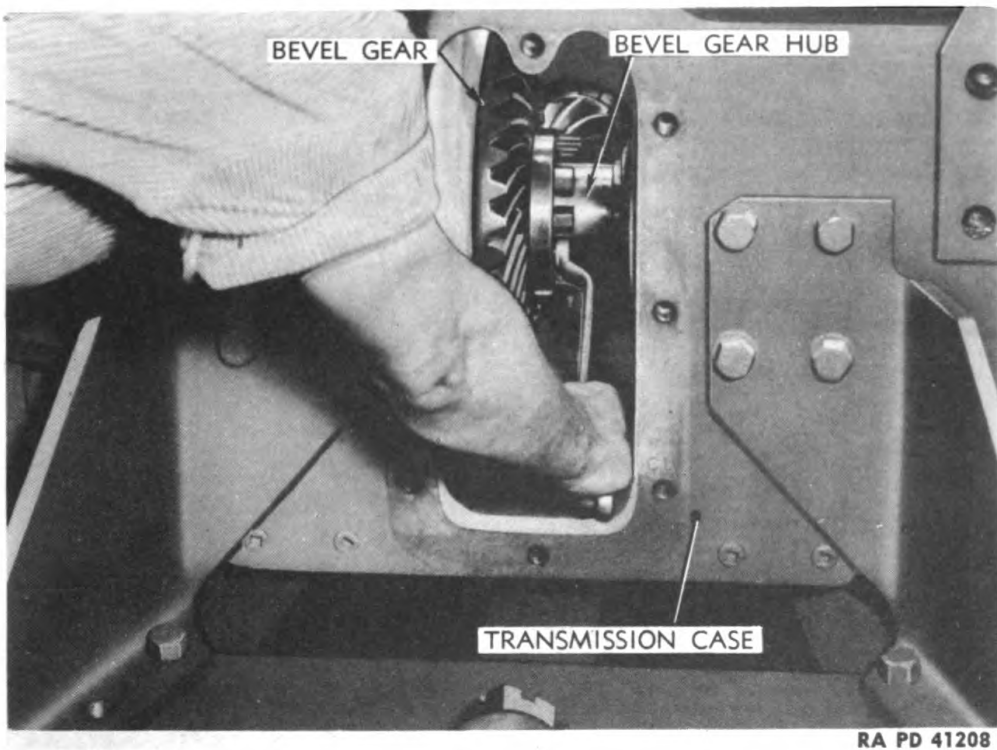

Figure 165 — Removing Nuts from Bevel Gear Bolts

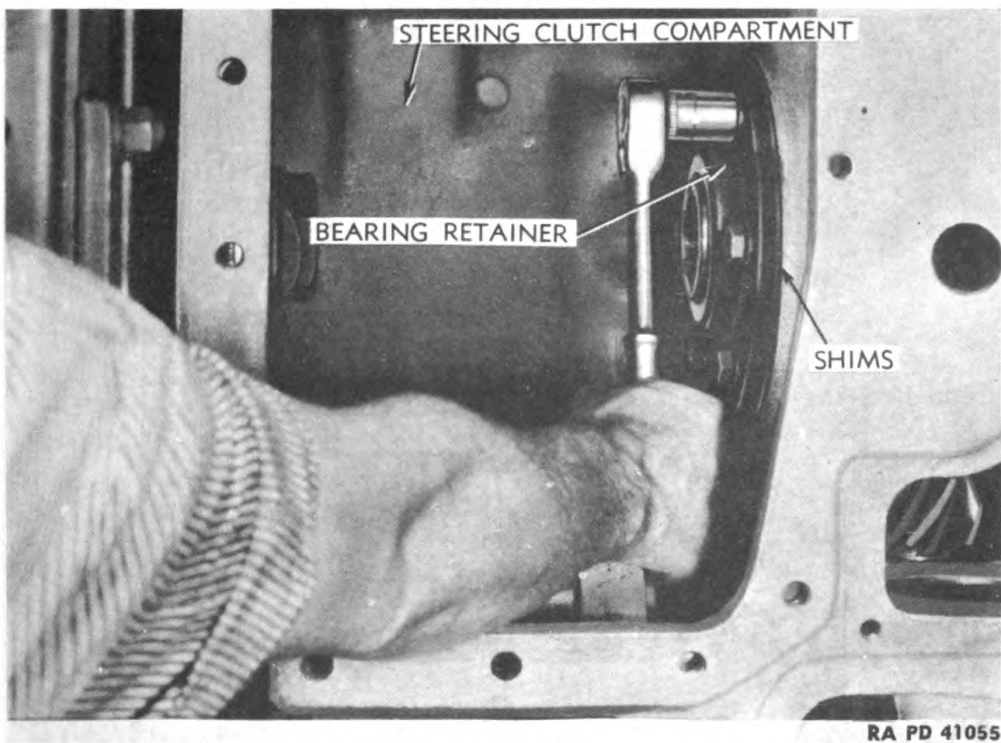
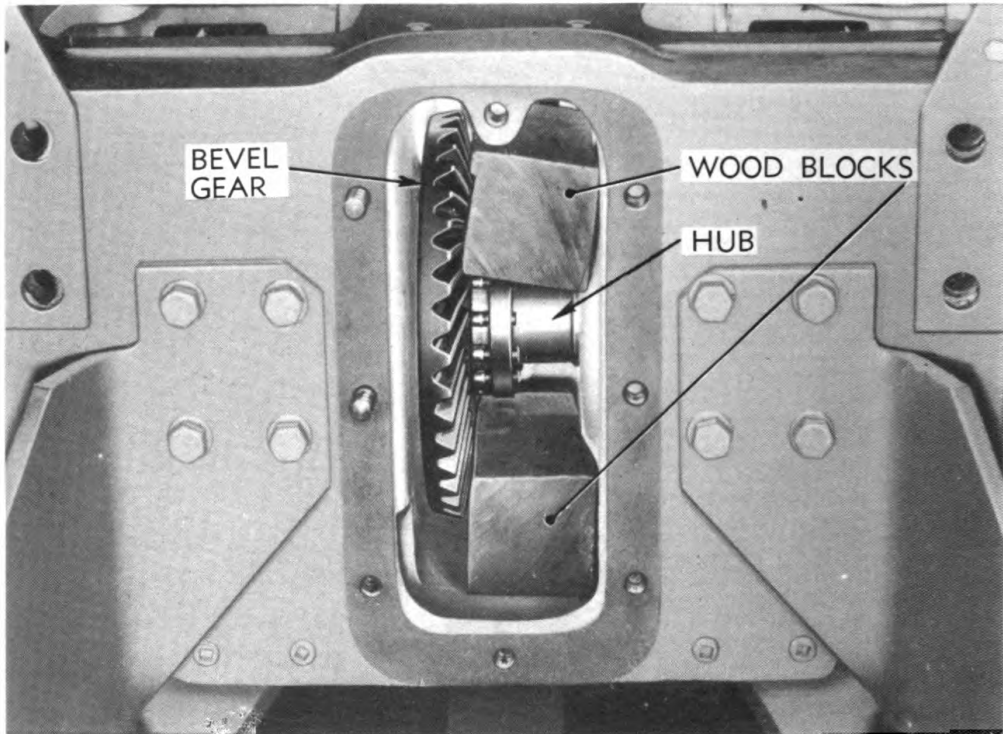

Figure 166— Removing Bearing Retainer

ORDNANCE MAINTENANCE — MEDIUM TRACTOR M1 (ALLIS-CHALMERS HD-7W)
ELECTRICAL SYSTEM, POWER TRAIN, FRAME, AND TRACKS



RA PD 41062

Figure 167 — Position of Blocks for Removing Bevel Gear

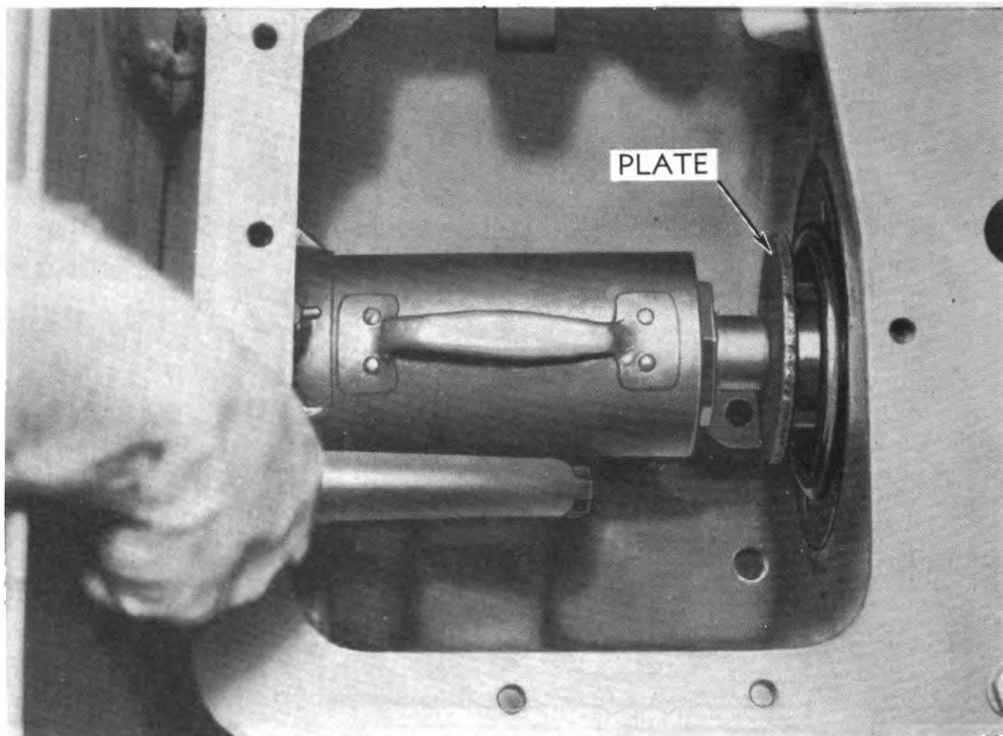

RA PD 41059

Figure 168 — Forcing Bevel Gear Off Hub

TRANSMISSION GEARS

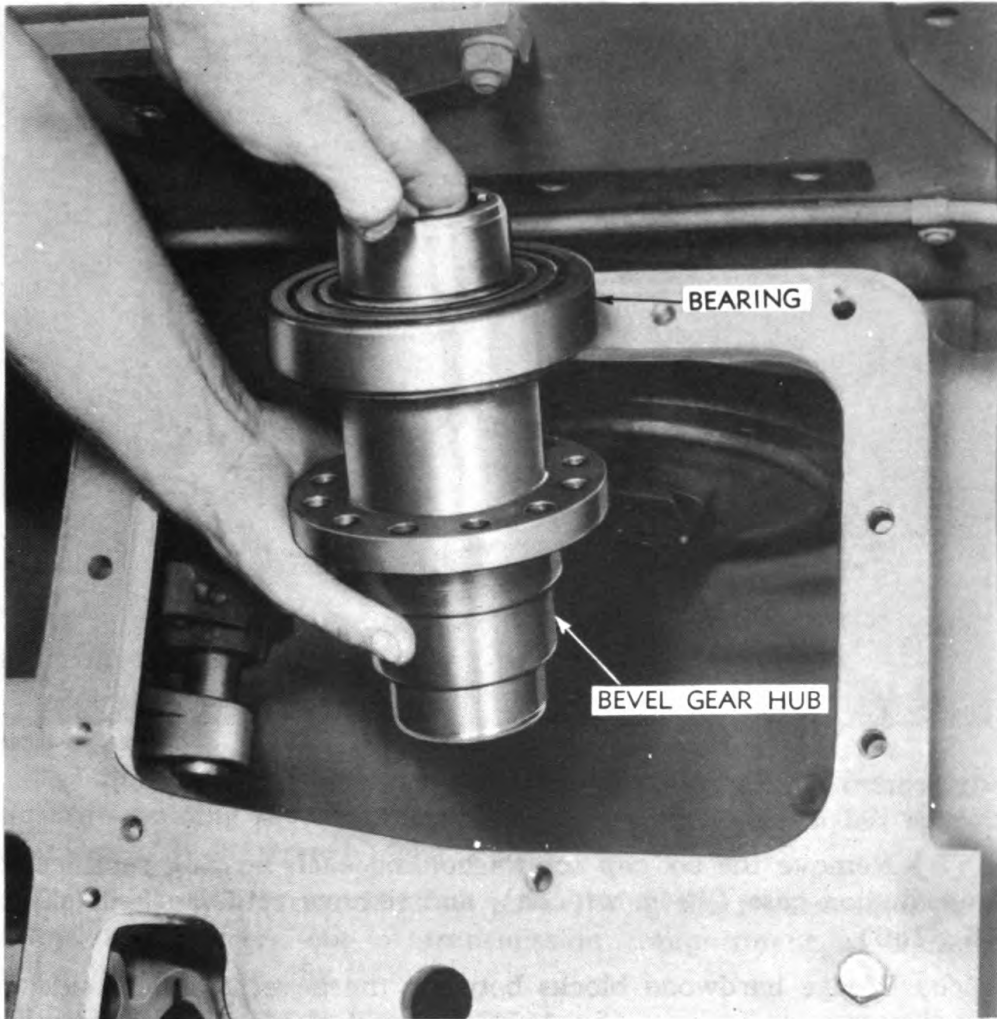

RA PD 41056

Figure 169 — Removing Bevel Gear Hub

they are released from shaft. Remove top shaft and rear ball bearing through rear bevel gear compartment.

(9) REMOVE BEVEL GEAR AND HUB.

Chisel, $\frac{3}{4}$ -in.

Hammer, 2-lb

Hardwood block (2)

Jack, hydraulic, 10-ton

Press, arbor

Punch, brass, 10-in.

Steel disk, $\frac{1}{2}$ -in. thick

Wrench, box, $\frac{3}{4}$ -in.

Wrench, socket, $\frac{3}{4}$ -in.

(a) Straighten the nut locks (hammer and chisel) and remove the 12 high nuts ($\frac{3}{4}$ -in. wrench) holding bevel gear to bevel gear hub (fig. 165).

**ORDNANCE MAINTENANCE — MEDIUM TRACTOR M1 (ALLIS-CHALMERS HD-7W)
ELECTRICAL SYSTEM, POWER TRAIN, FRAME, AND TRACKS**

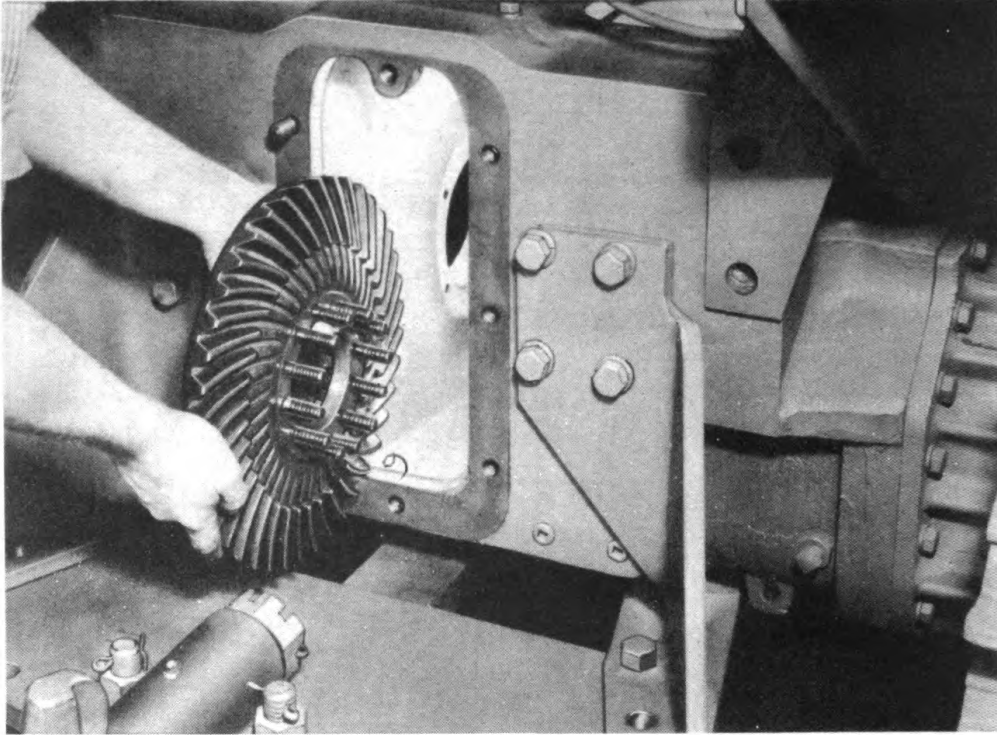

RA PD 41054

Figure 170 — Removing Bevel Gear

(b) Remove the six cap screws holding each bearing retainer to transmission case ($\frac{3}{4}$ -in. wrench), and remove retainers and shims (fig. 166).

(c) Wedge hardwood blocks between the bevel gear and side of bevel gear compartment (fig. 167). Using steel plate with hydraulic jack against bevel gear hub in left steering clutch compartment (fig. 168), press bevel gear hub off bolts in bevel gear hub flange and out into right steering clutch compartment. The bearing cup in right-hand side of case will be pushed out with hub, and bearing will be lifted out of case with hub (fig. 169). The left-hand bearing cup will remain in case.

(d) Remove bevel gear and left-hand bearing cone from case (fig. 170).

(e) Remove bearing cup from left-hand side of case with brass punch and hammer.

(f) Press bearing off hub with arbor press (fig. 171).

(10) REMOVE REVERSE IDLER GEAR.

Chisel, $\frac{3}{4}$ -in.
Hammer, 2-lb

Wrench, socket, $\frac{7}{8}$ -in., with
extension

TRANSMISSION GEARS

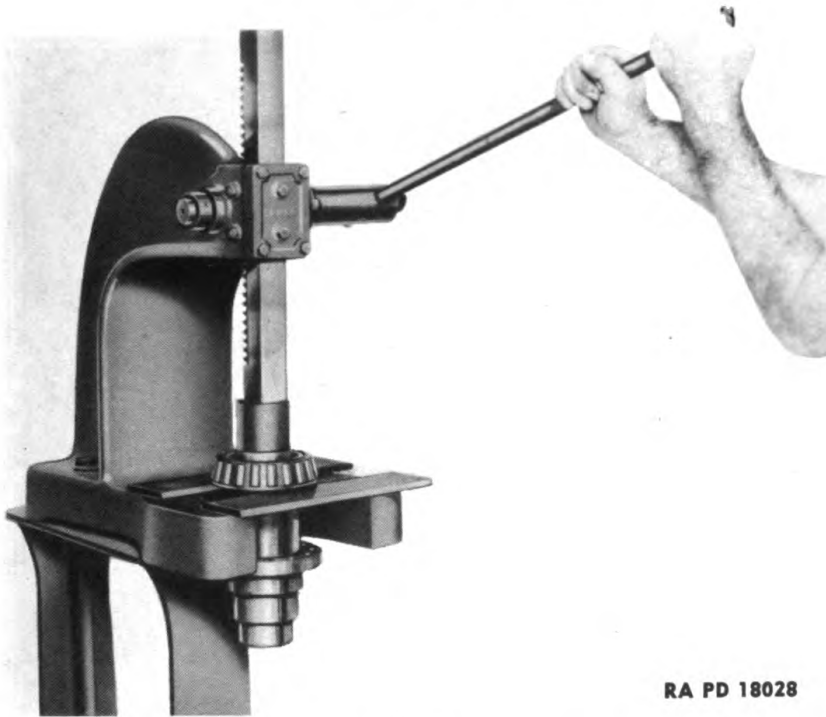

RA PD 18028

Figure 171 — Pressing Hub Out of Bearing

(a) Straighten the nut lock (hammer and chisel) and remove the setscrew holding reverse idler gear shaft in the boss on left side of gear case ($\frac{7}{8}$ -in. wrench) (fig. 172).

(b) Pull shaft forward out of case, lifting the reverse idler gear, shims, and spacers out of transmission compartment as shaft is pulled out of case (fig. 173).

(11) REMOVE MILE METER HOUSING.

Pliers

Wrench, socket, $\frac{3}{4}$ -in.

Disconnect mile meter cable from housing cap, using pliers (fig. 174). Remove the four cap screws holding mile meter housing to case ($\frac{3}{4}$ -in. wrench) (fig. 175), and remove housing.

(12) REMOVE BEVEL PINION AND SHAFT.

Chisel, $\frac{3}{4}$ -in.

Pliers

Hammer, 2-lb

Punch, 10-in.

Hardwood block

Wrench, open-end, $1\frac{7}{16}$ -in.

Remove snap ring and shims (fig. 189) from front end of bevel pinion shaft bearing. Straighten the nut lock (hammer and chisel) and remove the nut from front end of bevel pinion shaft ($1\frac{7}{16}$ -in. wrench) (fig. 176). Remove nut lock and spacer from shaft. Using hardwood block and hammer, drive bevel pinion shaft from inside master clutch compartment through gears and out into bevel gear

ORDNANCE MAINTENANCE — MEDIUM TRACTOR M1 (ALLIS-CHALMERS HD-7W)
ELECTRICAL SYSTEM, POWER TRAIN, FRAME, AND TRACKS

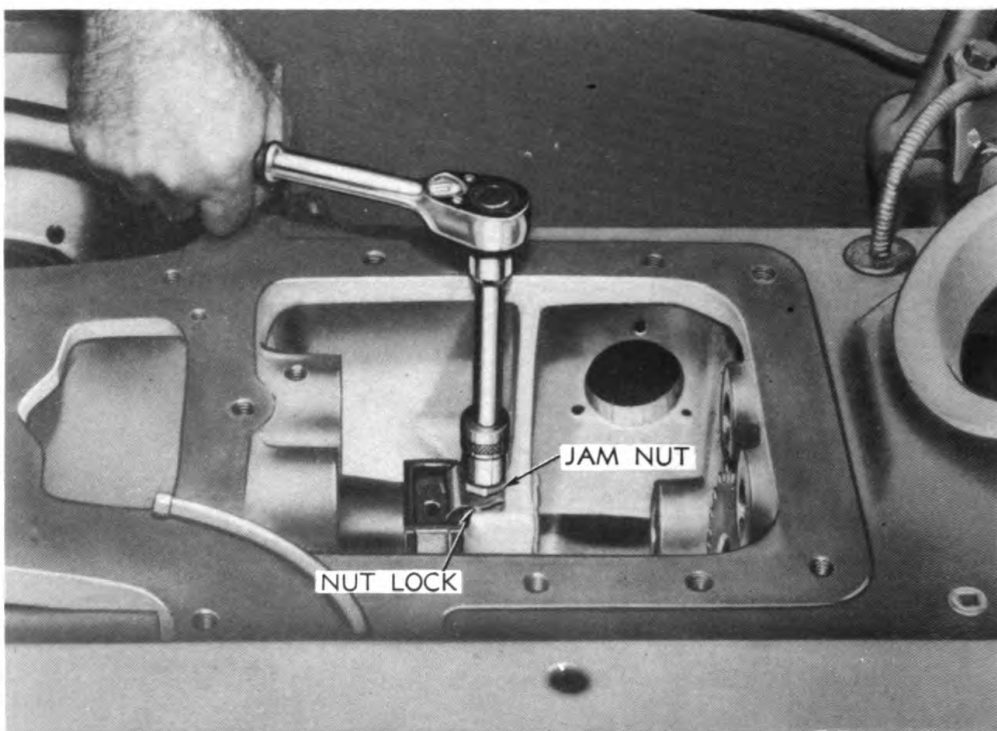

RA PD 41230

Figure 172 — Removing Setscrew from Reverse Idler Gear Shaft

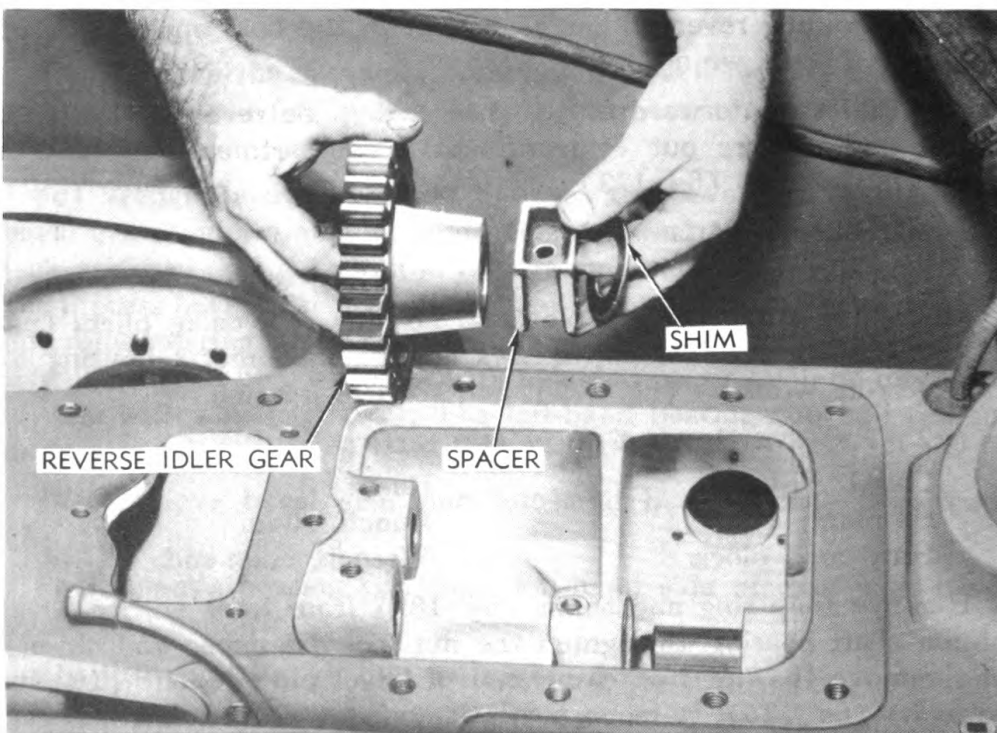

RA PD 41227

Figure 173 — Removing Reverse Idler Gear, Spacer, and Shim

TRANSMISSION GEARS

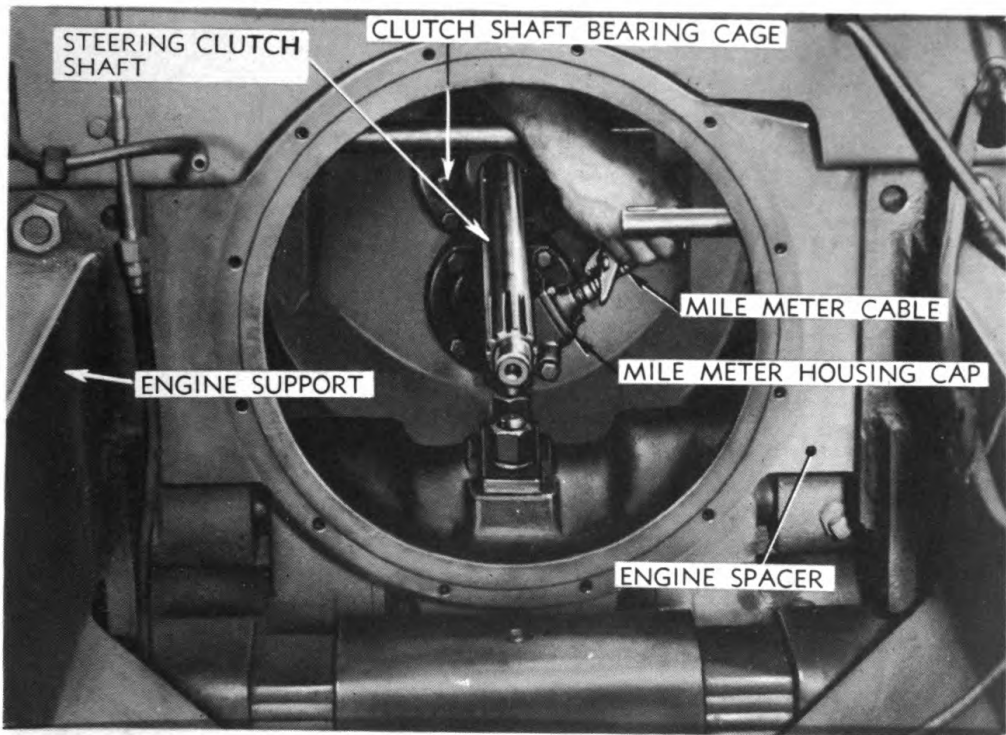

RA PD 41060

Figure 174 — Disconnecting Mile Meter Cable

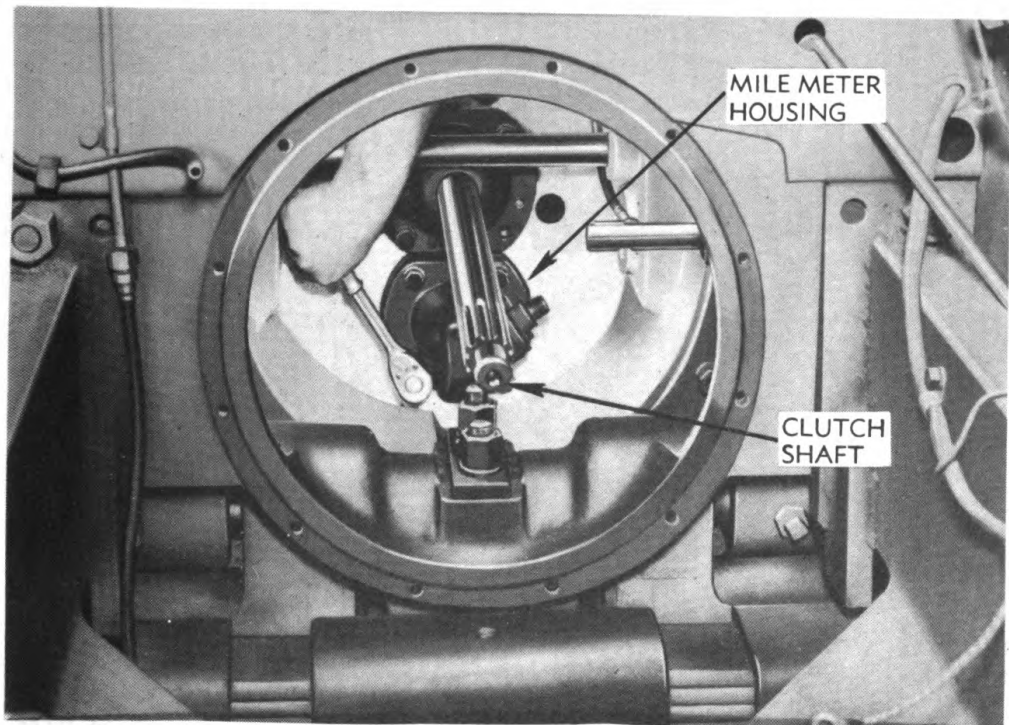

RA PD 41200

Figure 175 — Removing Mile Meter Housing

ORDNANCE MAINTENANCE — MEDIUM TRACTOR M1 (ALLIS-CHALMERS HD-7W)
ELECTRICAL SYSTEM, POWER TRAIN, FRAME, AND TRACKS

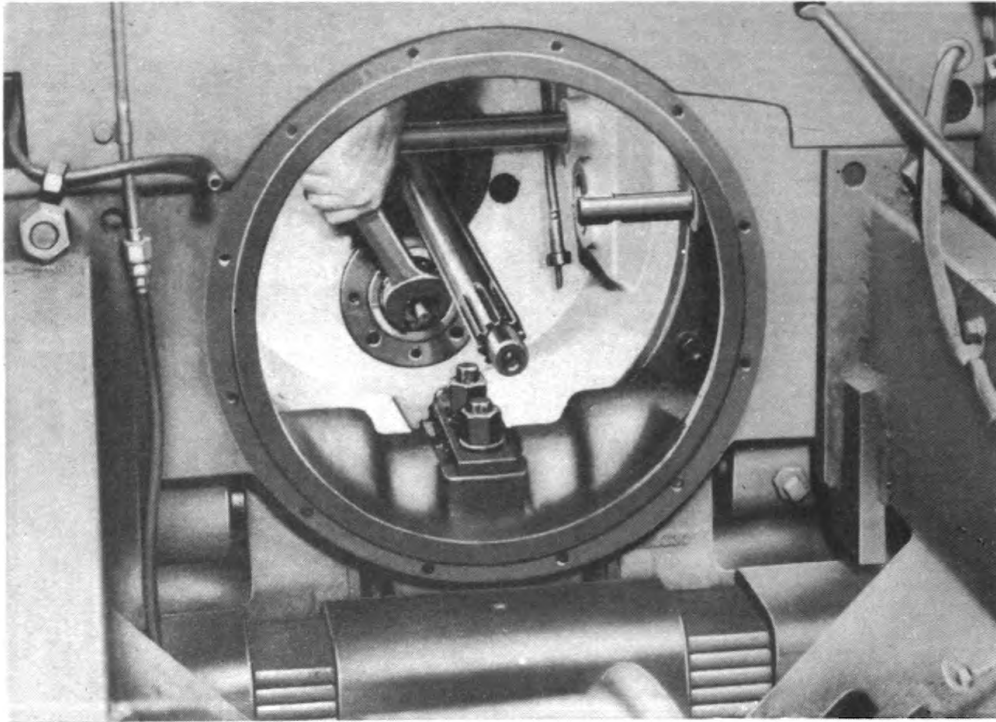

RA PD 41194

Figure 176 — Removing Pinion Shaft Nut

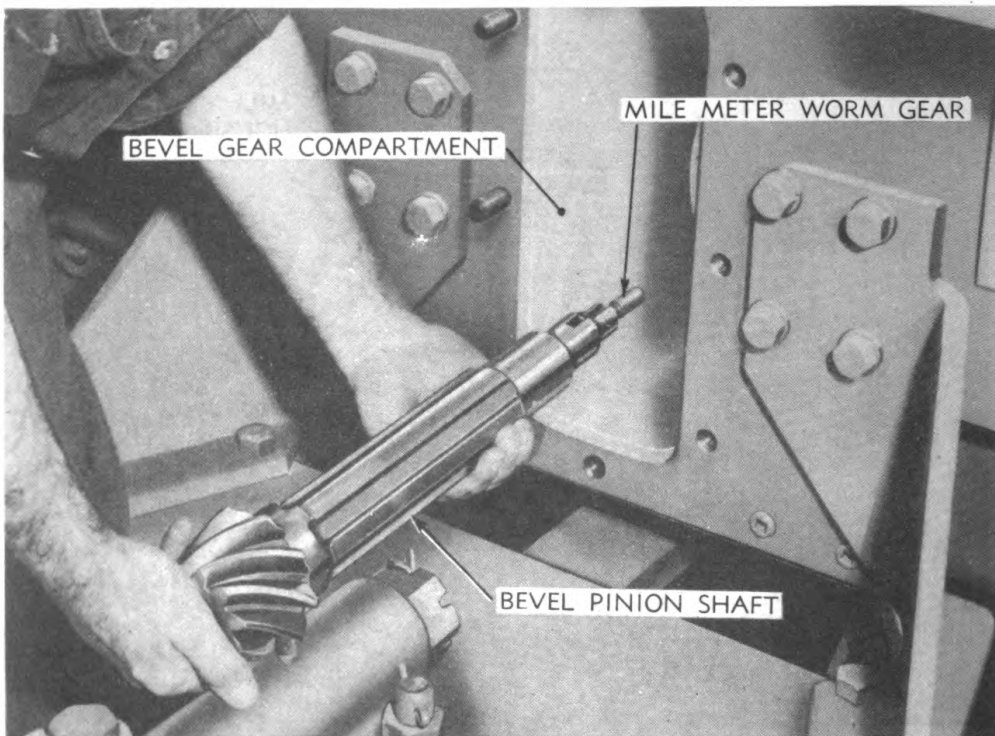

RA PD 41195

Figure 177 — Bevel Pinion and Shaft Removed

TRANSMISSION GEARS

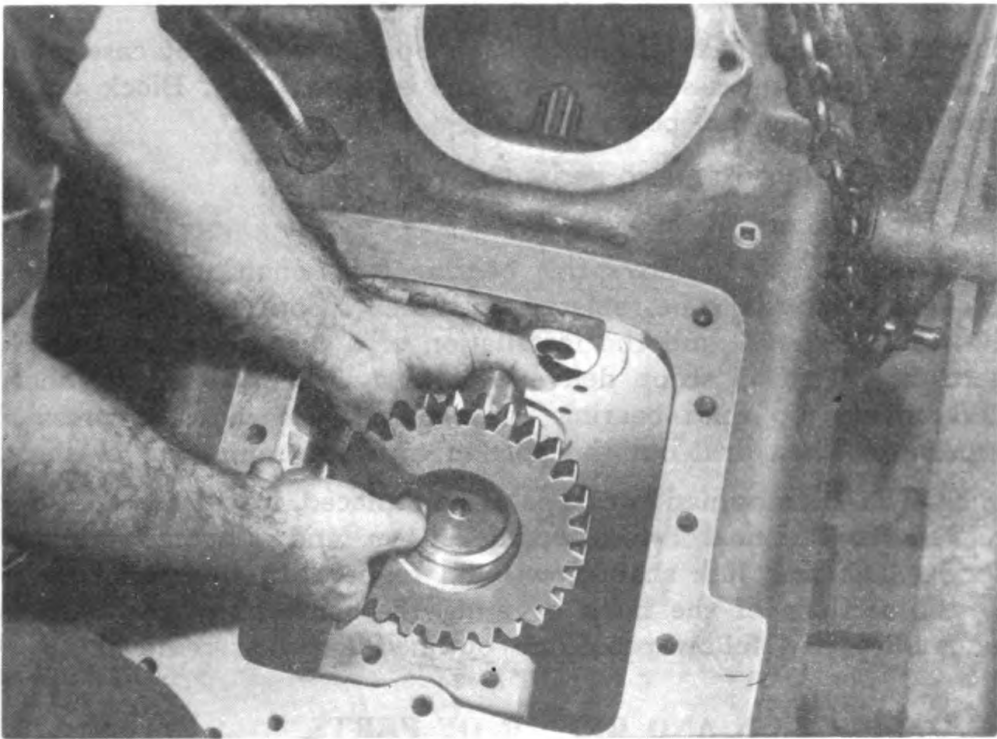

RA PD 41192

Figure 178 — Removing Clutch Shaft Assembly

compartment. Lift the bevel pinion and shaft from rear of bevel gear compartment (fig. 177). Lift the gears from transmission case. The front pinion bearing may be removed by driving it forward into master clutch compartment with hammer and brass punch.

(13) REMOVE MASTER CLUTCH SHAFT.

Bar, 6-ft

Jack, hydraulic, 10-ton

Wrench, socket, $\frac{3}{4}$ -in.

Wrench, socket, $\frac{7}{8}$ -in.

Wrench, socket, $\frac{15}{16}$ -in.

Wrench, socket, 1-in.

Wrench, socket, $1\frac{1}{8}$ -in.

(a) Remove clutch shaft bearing cage by removing four cap screws ($\frac{3}{4}$ -in. wrench) and sliding it forward off end of shaft (fig. 174).

(b) Disconnect fenders and cowl from engine support and spacer by removing two cap screws from side of tractor holding front end of rear fenders to engine support (fig. 331), one cap screw holding right side of cowl to engine support, and one cap screw holding left side of cowl and battery cable to engine spacer ($\frac{3}{4}$ -in. wrench).

(c) Block up under front of winch to hold winch and engine support in position. Remove the 18 bolts holding transmission case to engine spacer, using $\frac{7}{8}$ -, $\frac{15}{16}$ -, 1-, and $1\frac{1}{8}$ -inch wrenches. Use jack under front end of transmission case to raise front end of case about 1 inch above engine spacer, prying spacer away from case at same time with bar, until enough clearance is obtained to lift master

**ORDNANCE MAINTENANCE — MEDIUM TRACTOR M1 (ALLIS-CHALMERS HD-7W)
ELECTRICAL SYSTEM, POWER TRAIN, FRAME, AND TRACKS**

clutch shaft and gear assembly from opening at top of case from which gear-shifter assembly was removed (fig. 178). Block under case to hold it in that position.

(14) REMOVE BEARING FROM CLUTCH SHAFT.

Press, arbor

NOTE: Do not remove this bearing from shaft unless bearing is damaged and is to be replaced, as the oil scoop (fig. 183) will be cut off in removal and the installation of a new oil scoop will be necessary. This oil scoop delivers oil to a drilled passage in shaft to lubricate top shaft bearing. Press bearing off in arbor press if necessary. Then drill out the portion of scoop remaining in shaft.

NOTE: If transmission case is to be replaced, it will be necessary to remove the final drives, engine spacer and support, stabilizer spring, stabilizer link shaft, cowl, and fenders. In this event, refer to the sections of the book covering the removal of the various assemblies, and follow procedure outlined for their removal.

69. INSPECTION AND REPAIR OF PARTS.

a. Transmission Gears. Clean and inspect all gears for general wear. Check to see if gears have been meshing fully with their mating gears. If ends of gear teeth are burred, smooth teeth with a small stone or file. If gears are badly worn, splines or teeth are damaged or broken, discard them and replace with new gears.

b. Bearings and Shafts. Clean bearings and shafts thoroughly and inspect shafts for wear; bearings must fit snugly on shafts. Bearing balls, rollers, or races must be smooth and bright; bearings with chipped or rough balls, rollers, or races must be replaced. If bearings are blue or discolored, it is an indication that they have been overheated, and are unfit for further use; replace with new ones. Oil bearings with light engine oil after cleaning and inspecting them, and spin bearings. Bearings should roll smoothly and quietly. **CAUTION:** Do not spin bearings with compressed air when drying them after cleaning. Inspect shafts for straightness and see that splined sliding gears slide easily on splines in shafts. Inspect threaded ends of bevel pinion shaft to make sure threads are not damaged. Place shaft in lathe and retrace threads, if threads are merely burred, so that nut will not start on. Also inspect threads in nut.

c. Bevel Gear and Pinion. Inspect bevel gear and pinion for worn or broken teeth. If teeth on gears are worn to a sharp edge, replace with new bevel gear and bevel pinion and shaft. The bevel pinion and gear must both be replaced if it is necessary to replace either, as these are matched sets of gears. Examine bevel gear hub

TRANSMISSION GEARS

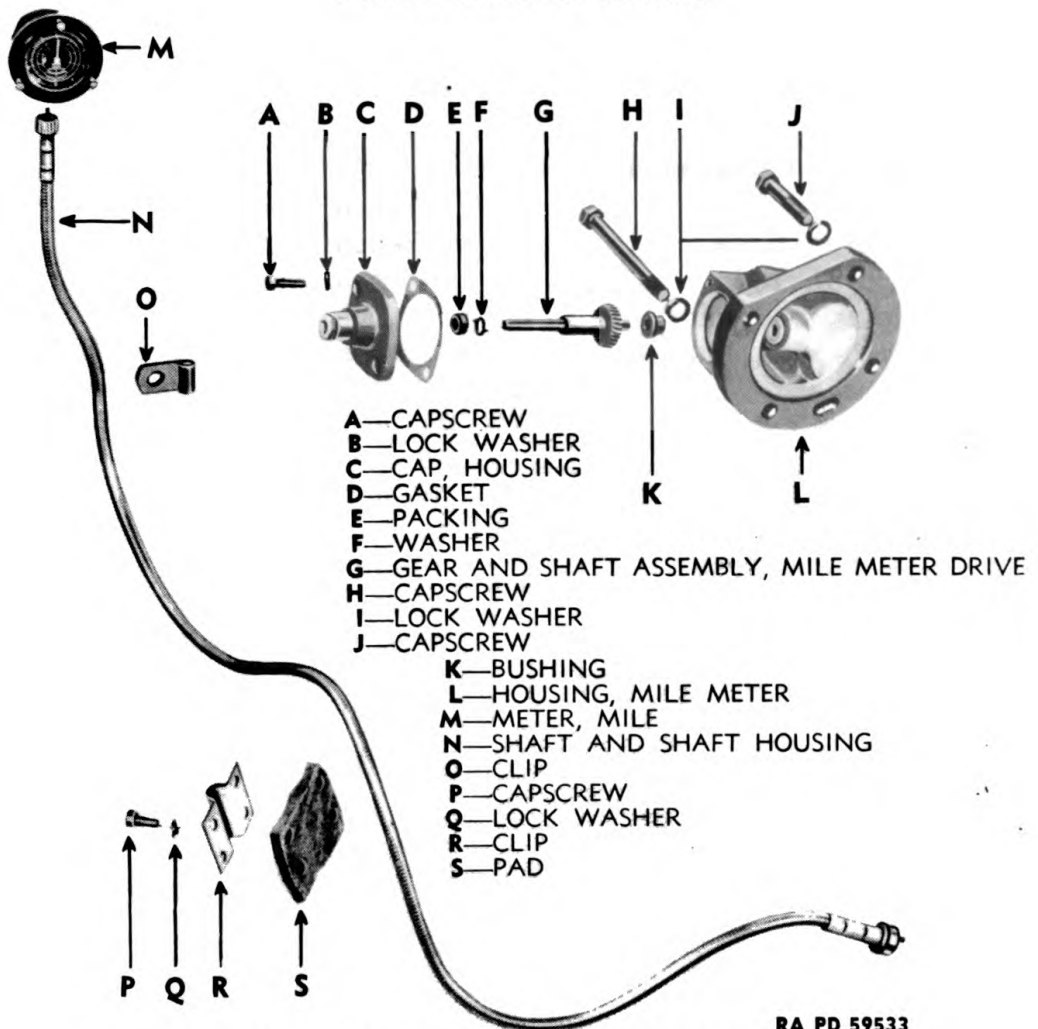

RA PD 59533

Figure 179 — Mile Meter Assembly — Exploded View

and bearings. Remove all burrs from shoulders on hub so bearings and gear may fit tightly against shoulders when installed.

d. Transmission Case. Clean case thoroughly and inspect for cracked or broken places; small cracks or breaks may be repaired by welding. Replace any bushings that are worn. Test all mounting bolts to make sure all bolts are tightened securely and none are missing. Check condition of master clutch controls, shafts, and linkage; replace all worn bushings, pins, or shafts.

e. Mile Meter and Housing. If worm on front end of bevel pinion shaft, or gear in housing is worn or broken, remove the two bolts from cover on mile meter housing and lift out parts (fig. 179). Replace the necessary parts by removing worm from end of shaft, and screw in new worm to replace the one which was worn or damaged. Install parts when reassembling cable drive gear in order shown in figure 179.

**ORDNANCE MAINTENANCE — MEDIUM TRACTOR M1 (ALLIS-CHALMERS HD-7W)
ELECTRICAL SYSTEM, POWER TRAIN, FRAME, AND TRACKS**

70. ASSEMBLY AND INSTALLATION OF TRANSMISSION GEARS.

a. Tools and Equipment Required.

Bar, 6-ft	Wrench, 5/8-in.
Bar, drift, brass	Wrench, 2-in.
Bar, drift, 18-in.	Wrench, 2 3/4-in.
Calipers, 2-in., inside	Wrench, box, 3/4-in.
Calipers, 6-in., outside	Wrench, deep socket, 1 5/16-in.
Gage, dial	Wrench, engine cranking
Hammer, 2-lb	Wrench, open-end, 1/2-in.
Hammer, soft	Wrench, open-end, 9/16-in. (2)
Hardwood block	Wrench, open-end, 1 1/16-in.
Hoist, chain	Wrench, open-end, 3/4-in.
Jack, hydraulic, 10-ton	Wrench, open-end, 7/8-in.
Pliers	Wrench, open-end, 1 5/16-in.
Press, arbor	Wrench, open-end, 1 1/8-in.
Puller, final drive pinion	Wrench, open-end, 1 7/16-in.
Punch, 10-in.	Wrench, open-end, 2 1/2-in.
Punch, small	Wrench, socket, 1/2-in.
Rope	Wrench, socket, 9/16-in.
Ruler or scale, 12-in.	Wrench, socket, 3/4-in., with extension
Scale, 6-in., with 1/64-in. graduations	Wrench, socket, 7/8-in., with extension
Screwdriver, 6-in.	Wrench, socket, 1 5/16-in.
Screwdriver, 8-in.	Wrench, socket, 1-in.
Screwdriver, 10-in.	Wrench, socket, 1 1/8-in.
Shellac	Wrench, socket, 1 5/16-in., with long extension
Steel plate, 1/2-in. thick	Wrench, spanner
Wire, lock	
Wrench, 3/8-in.	
Wrench, 7/16-in.	

b. Procedure.

(1) ASSEMBLE CLUTCH SHAFT ASSEMBLY.

Hammer, 2-lb	Punch, small
Press, arbor	

(a) Press bearing onto clutch shaft with arbor press (fig. 182).

(b) After bearing is pressed on, install a new oil scoop (par. 68 b (14)) in shaft (fig. 183). Push or tap the new scoop all the way into the hole in side of shaft (fig. 183), with lip of scoop facing in direction shown, (toward direction of rotation of shaft). Insert a punch into hole in gear end of shaft, and bend inner end of scoop to hold it in place. Use care not to shear off end of scoop with punch. Lubricate bearing with light engine oil.

TRANSMISSION GEARS

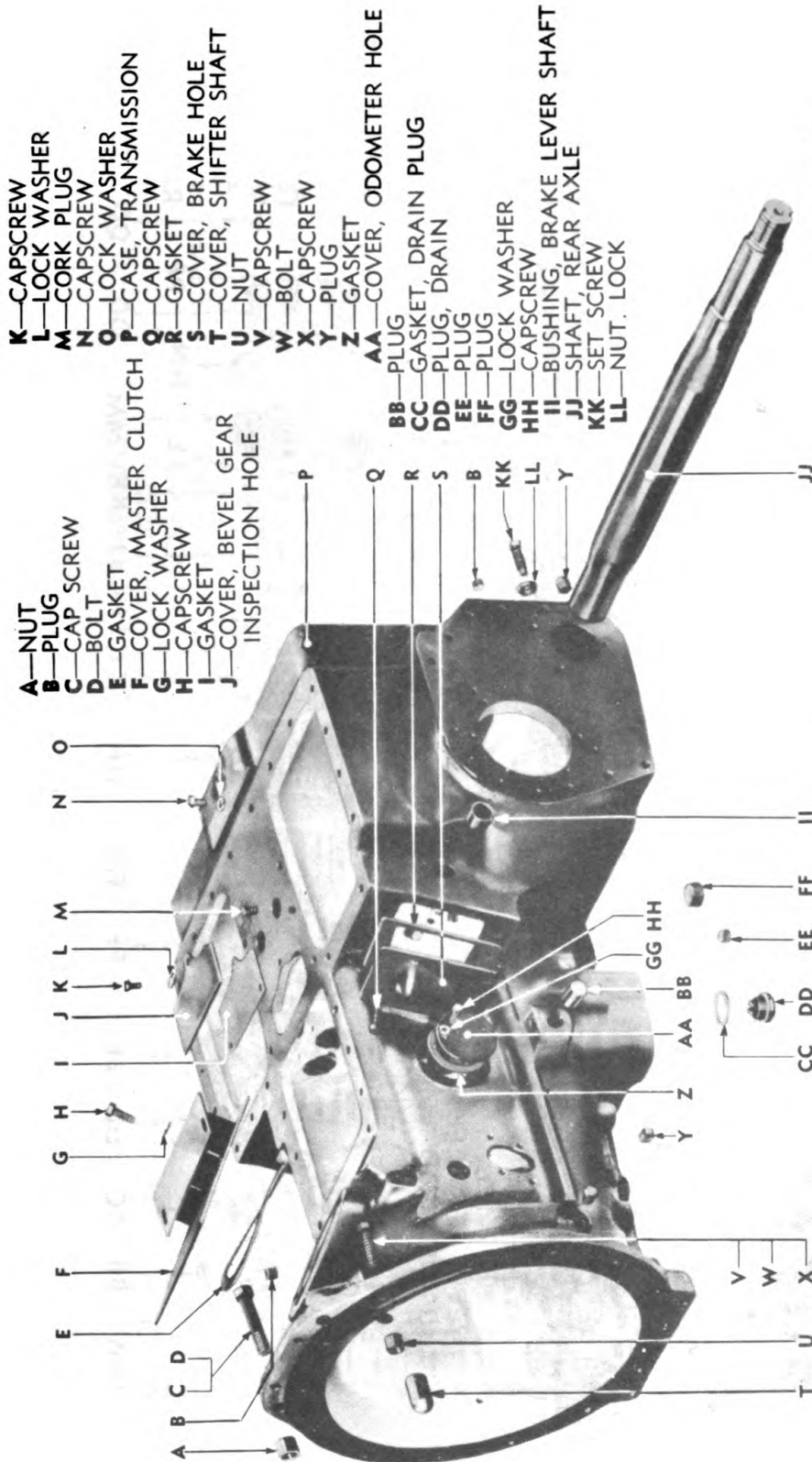

- A—NUT
- B—PLUG
- C—CAP SCREW
- D—BOLT
- E—GASKET
- F—COVER, MASTER CLUTCH
- G—LOCK WASHER
- H—CAPSCREW
- I—GASKET
- J—COVER, BEVEL GEAR INSPECTION HOLE
- K—CAPSCREW
- L—LOCK WASHER
- M—CORK PLUG
- N—CAPSCREW
- O—LOCK WASHER
- P—CASE, TRANSMISSION
- Q—CAPSCREW
- R—GASKET
- S—COVER, BRAKE HOLE
- T—COVER, SHIFTER SHAFT
- U—NUT
- V—CAPSCREW
- W—BOLT
- X—CAPSCREW
- Y—PLUG
- Z—GASKET
- AA—COVER, ODOMETER HOLE
- BB—PLUG
- CC—GASKET, DRAIN PLUG
- DD—PLUG, DRAIN
- EE—PLUG
- FF—PLUG
- GG—LOCK WASHER
- HH—CAPSCREW
- II—BUSHING, BRAKE LEVER SHAFT
- JJ—SHAFT, REAR AXLE
- KK—SET SCREW
- LL—NUT, LOCK

RA PD 59535

Figure 180 — Transmission Case and Covers

ORDNANCE MAINTENANCE — MEDIUM TRACTOR M1 (ALLIS-CHALMERS HD-7W)
ELECTRICAL SYSTEM, POWER TRAIN, FRAME, AND TRACKS

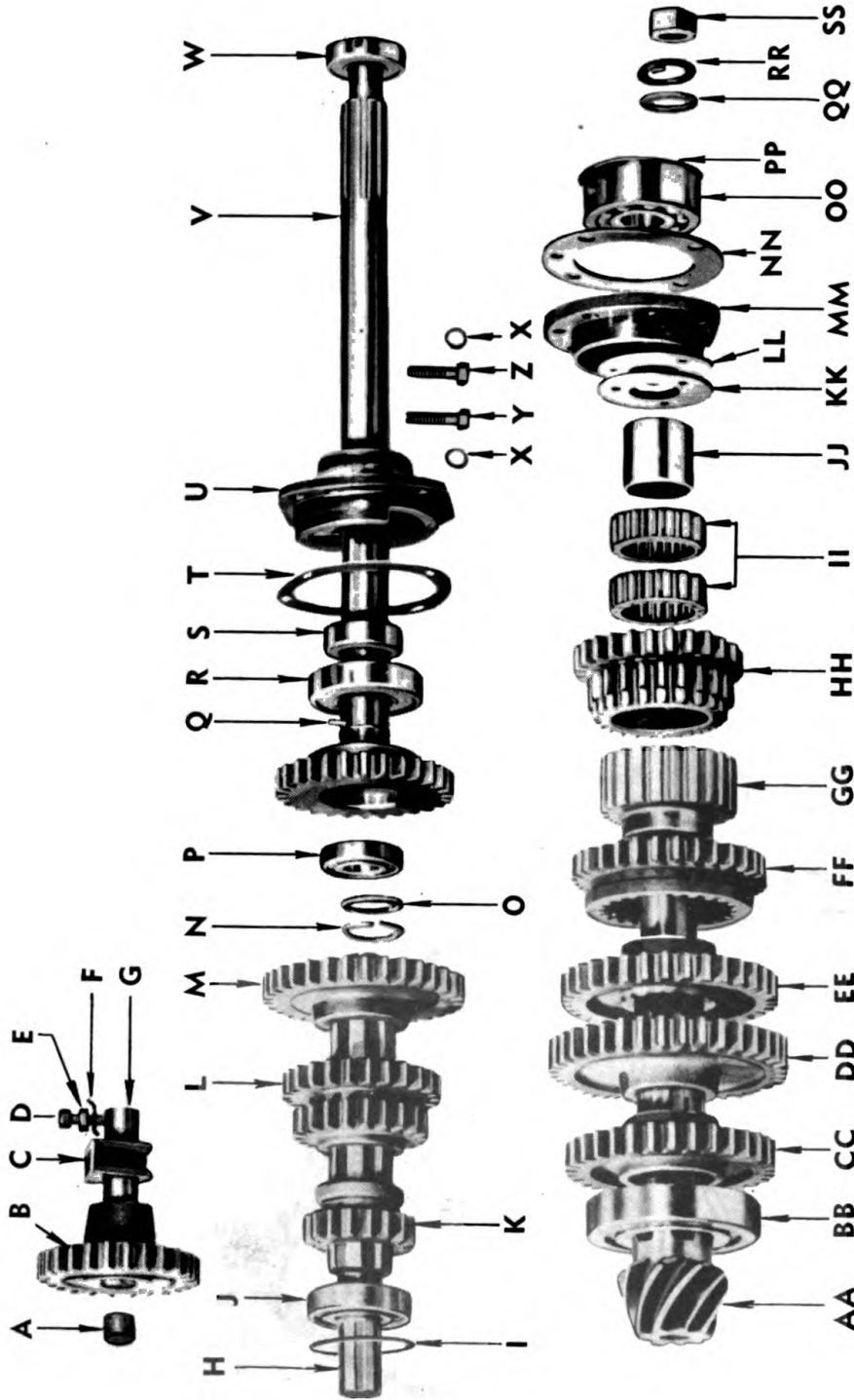

RA PD 17348

Figure 181 — Transmission Gears, Shafts, and Bearings

TRANSMISSION GEARS

- | | |
|---------------------------------------|---|
| A —BUSHING, REVERSE IDLER GEAR | X —LOCK WASHER |
| B —GEAR, REVERSE IDLER | Y —CAPSCREW |
| C —SPACER | Z —CAPSCREW |
| D —SCREW, SET | AA —PINION AND SHAFT, BEVEL |
| E —JAM NUT | BB —BEARING, REAR PINION SHAFT |
| F —NUT LOCK | CC —GEAR, REVERSE |
| G —SHAFT, REVERSE IDLER GEAR | DD —GEAR, LOW |
| H —SHAFT, TOP | EE —GEAR, 2ND |
| I —RING, SNAP | FF —GEAR, 3RD |
| J —BEARING, REAR TOP SHAFT | GG —HUB, 3RD GEAR |
| K —PINION, LOW AND REVERSE | HH —GEAR, IDLER |
| L —PINION, 2ND AND 3RD SPEED | II —BEARING, IDLER GEAR |
| M —GEAR, REDUCER | JJ —RACE, IDLER GEAR BEARING |
| N —RING, SNAP | KK —WASHER |
| O —WASHER | LL —GASKET |
| P —BEARING, FRONT TOP SHAFT | MM —CAGE, FRONT BEVEL PINION BEARING |
| Q —SCOOP, OIL | NN —(SHIM, 0.005 IN. |
| R —BEARING, CLUTCH SHAFT |)SHIM, 0.010 IN. |
| S —OIL SEAL | OO —BEARING, FRONT BEV. |
| T —GASKET | PP —RING, SNAP |
| U —CAGE, BEARING | QQ —WASHER |
| V —SHAFT AND GEAR, CLUTCH | RR —LOCK WASHER |
| W —BEARING, CLUTCH PILOT | SS —NUT |

RA PD 173488

Legend for Figure 181, Transmission Gears, Shafts, and Bearings

ORDNANCE MAINTENANCE — MEDIUM TRACTOR M1 (ALLIS-CHALMERS HD-7W)
ELECTRICAL SYSTEM, POWER TRAIN, FRAME, AND TRACKS

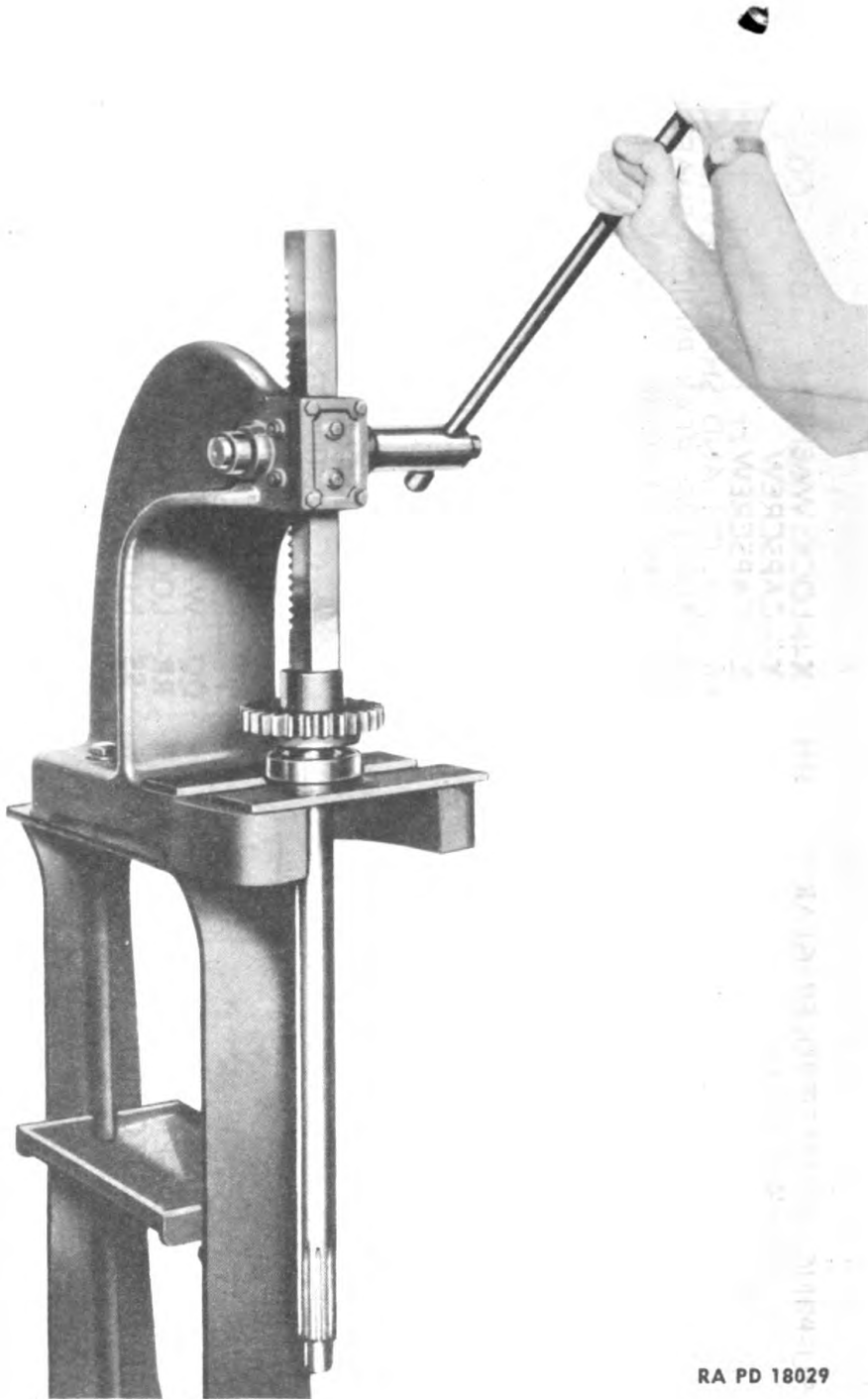

RA PD 18029

Figure 182 — Pressing Clutch Shaft into Bearing

TRANSMISSION GEARS

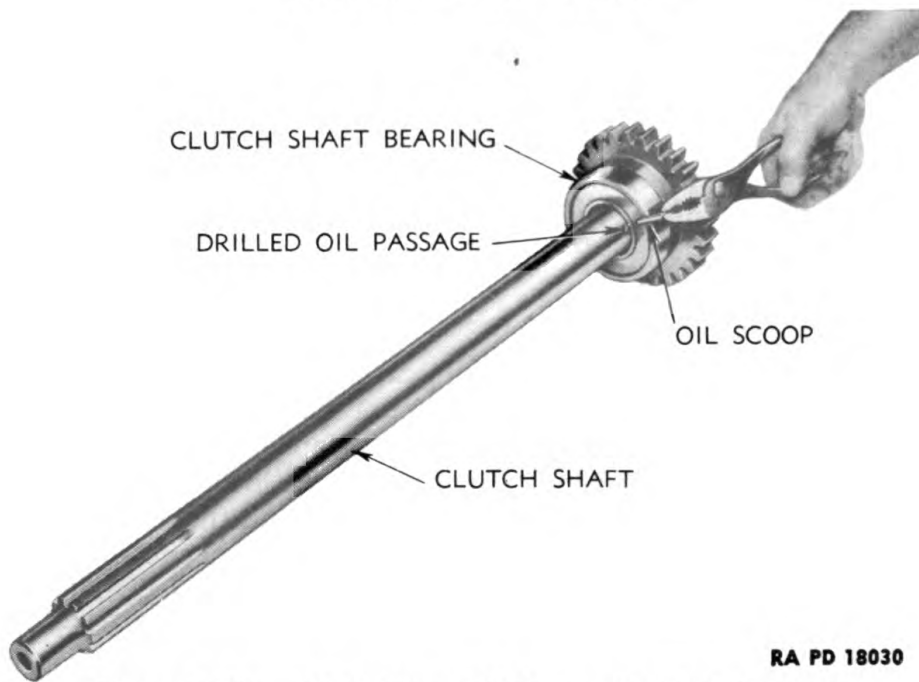

Figure 183 — Installing Oil Scoop in Clutch Shaft

(2) INSTALL CLUTCH SHAFT ASSEMBLY.

Hammer, soft
Jack, hydraulic, 10-ton

Wrench, socket, $\frac{3}{4}$ -in.

(a) With front end of transmission case raised above spacer (par. 68 b (13)) (fig. 178), insert end of shaft through opening for gear-shifter housing, and through top hole in front of transmission gear compartment.

(b) Install oil seal in bearing cage, if seal was previously removed, by tapping it into cage with soft hammer. Lip of seal should face open end of cage. Slip seal and cage over end of master clutch shaft (open side towards gear end of shaft), taking care not to injure oil seal, and slide it back on shaft to opening in front of transmission case. Tap cage into place in bore of case (soft hammer) (fig. 174) and secure with three $\frac{1}{2}$ - by $1\frac{3}{8}$ -inch cap screws with lock washers ($\frac{3}{4}$ -in. wrench). A fourth cap screw which goes in lower left hole will be installed later.

(3) CONNECT ENGINE SPACER TO TRANSMISSION CASE.

Jack, hydraulic, 10-ton
Wrench, socket, $\frac{7}{8}$ -in.
Wrench, socket, $\frac{15}{16}$ -in.

Wrench, socket, 1-in.

Wrench, socket, $1\frac{1}{8}$ -in.

Lower front end of transmission case with hydraulic jack until bolt holes in engine spacer and transmission case line up. Do not tighten any of the following bolts until all are installed: Install two $\frac{3}{4}$ - by 4-inch bolts with high nuts in top holes of spacer; install two $\frac{5}{8}$ - by 3-inch bolts with high nuts in next hole down on each side of spacer; install ten (five on each side) $\frac{5}{8}$ - by $2\frac{1}{2}$ -inch bolts with

**ORDNANCE MAINTENANCE — MEDIUM TRACTOR M1 (ALLIS-CHALMERS HD-7W)
ELECTRICAL SYSTEM, POWER TRAIN, FRAME, AND TRACKS**

high nuts at sides of spacer; install a $\frac{5}{8}$ - by $3\frac{1}{2}$ -inch bolt with high nut on each side in the two smaller lower holes; install two $\frac{3}{4}$ - by $3\frac{3}{4}$ -inch bolts with high nuts in bottom holes. Tighten all bolts with above wrenches. Remove jack from underneath tractor and blocks from underneath winch.

(4) CONNECT REAR FENDERS AND COWL TO ENGINE SUPPORT AND SPACER.

Wrench, $\frac{3}{4}$ -in.

(a) Install the two $\frac{1}{2}$ - x 1-inch cap screws with lock washers holding right rear fender to engine support (fig. 331), and three cap screws of same size holding left rear fender to engine support.

(b) Install the $\frac{1}{2}$ - x 1-inch cap screws and lock washers holding right side of cowl to engine support (fig. 321) and the $\frac{1}{2}$ - x $1\frac{1}{4}$ -inch cap screw and lock washer holding battery ground cable and cowl to left side of engine spacer. **NOTE:** Paragraphs 70 b (1) through (4) apply only when clutch shaft has been removed. All other gears and shafts in transmission can be removed or installed without this procedure.

(5) INSTALL BEVEL PINION SHAFT AND GEARS.

(a) Lubricate with oil and start rear pinion shaft roller bearing into bottom bore in rear of transmission compartment from rear. Insert end of bevel pinion shaft (fig. 177) through bearing and a little way into transmission compartment.

(b) Lubricate splines in gears and place the gears on shaft in the following order and in position named, pushing shaft through farther as each gear is installed. Install reverse gear (32 teeth) (fig. 184) on shaft with long part of hub toward master clutch compartment; low speed gear (37 teeth) with long part of hub toward bevel gear compartment; second gear (33 teeth) with long part of hub toward master clutch compartment; third gear and hub (29 teeth and 22 teeth) with long part of hub toward bevel gear compartment. Install idler gear and bearing assembly (26 teeth and 22 teeth) (figs. 185, 186, 187) with smaller gear toward bevel gear compartment. Push shaft forward; then install thrust washer with machined surface toward gear and bevel side towards front of shaft.

(6) INSTALL PINION SHAFT BEARINGS.

Bar, drift, brass

Press, arbor

Hammer, 2-lb

Punch, 10-in.

Hardwood block

Wrench, open-end, $1\frac{7}{16}$ -in.

(a) Drive pinion shaft and rear bearing into place with hammer and hardwood block, supporting front end of shaft in line with center of front hole.

(b) Using arbor press, press front pinion shaft bearing into bearing cage with snap ring groove in outer bearing race towards front of

TRANSMISSION GEARS

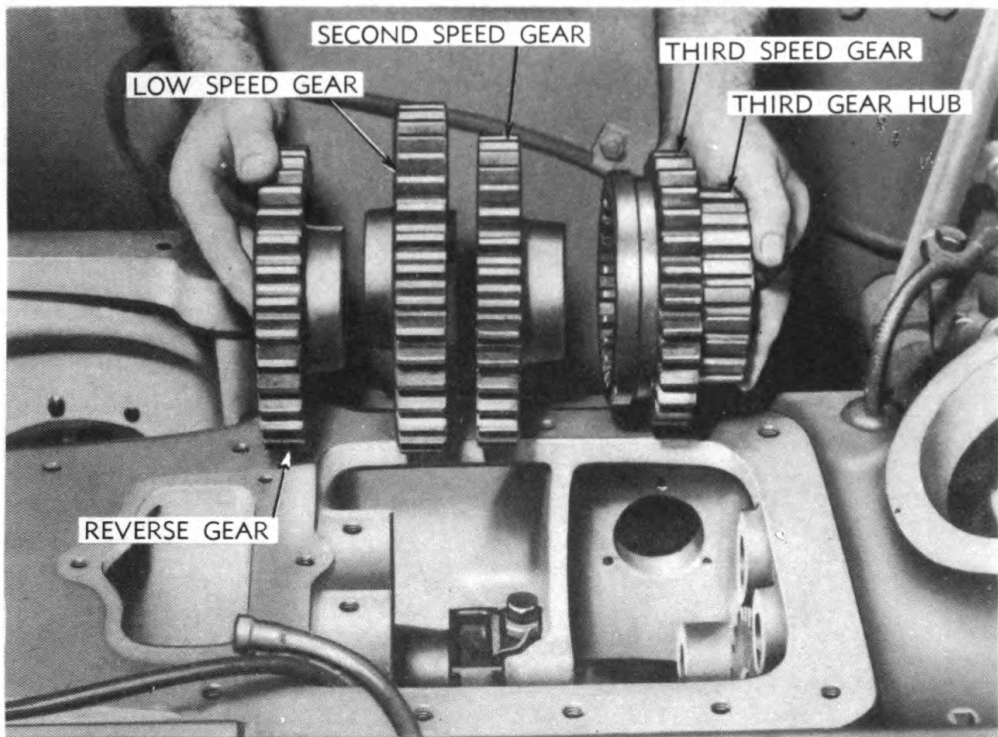

RA PD 41186

Figure 184 — Bevel Pinion Shaft Gears in Order of Installation

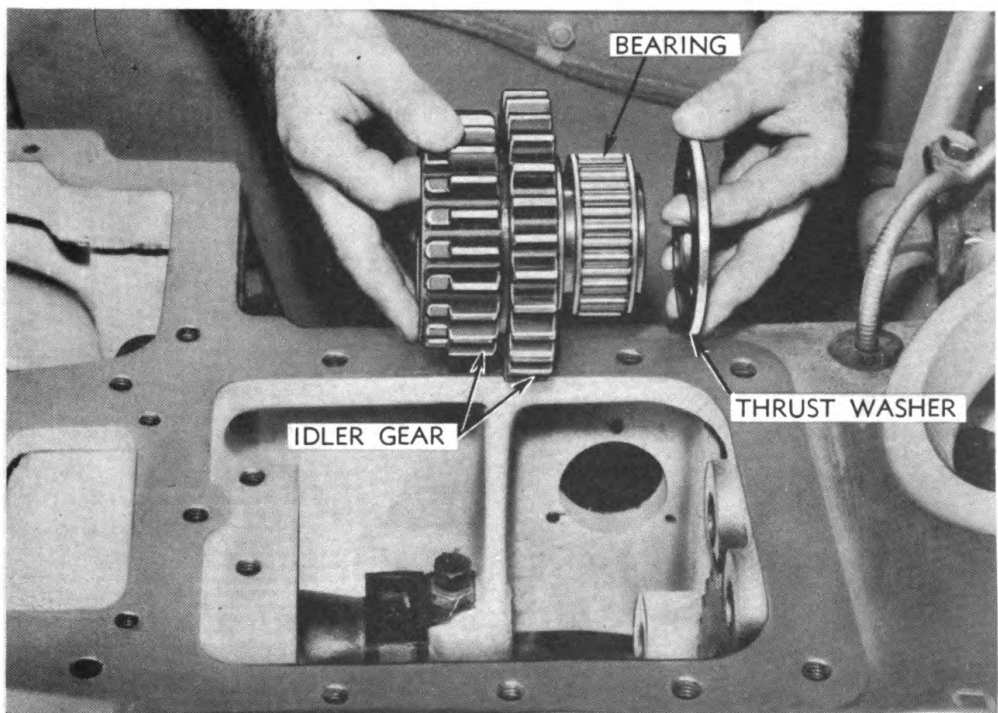

RA PD 41189

Figure 185 — Idler Gear and Bearing in Order of Installation

ORDNANCE MAINTENANCE — MEDIUM TRACTOR M1 (ALLIS-CHALMERS HD-7W)
ELECTRICAL SYSTEM, POWER TRAIN, FRAME, AND TRACKS

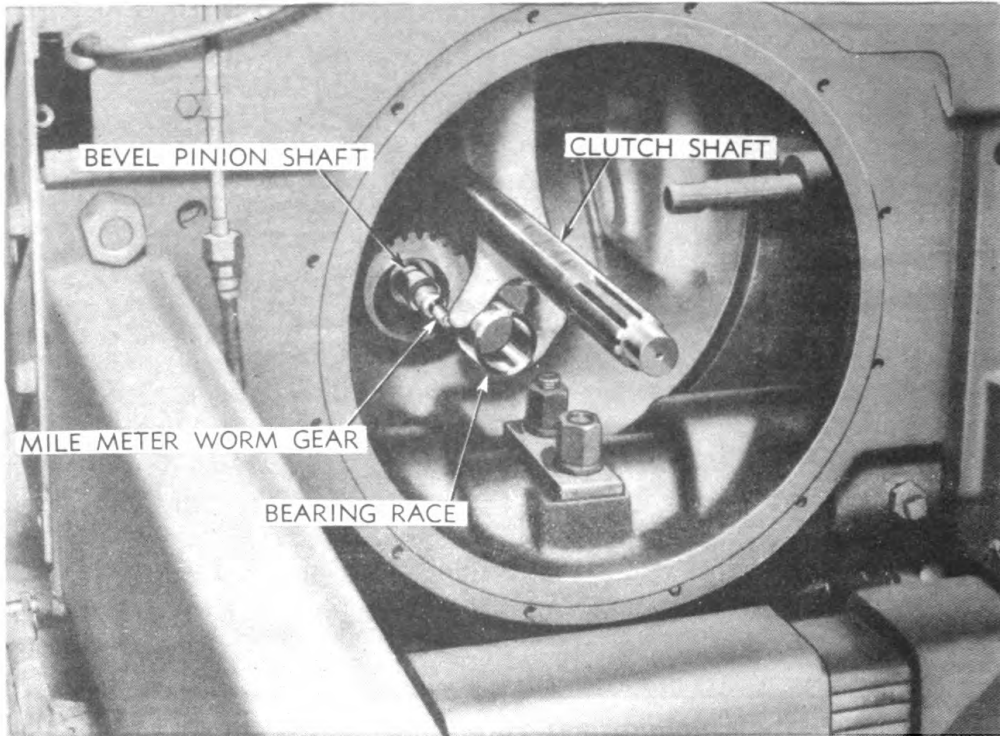

RA PD 41234

Figure 186 — Installing Inner Bearing Race

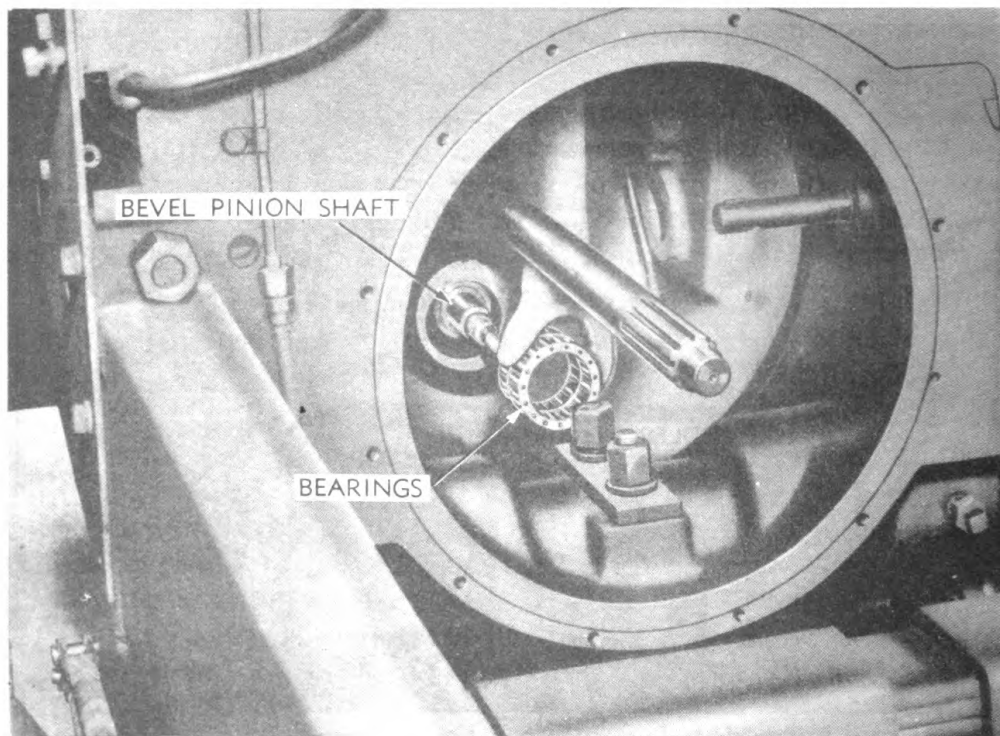

RA PD 41235

Figure 187 — Installing Roller Bearing

TRANSMISSION GEARS

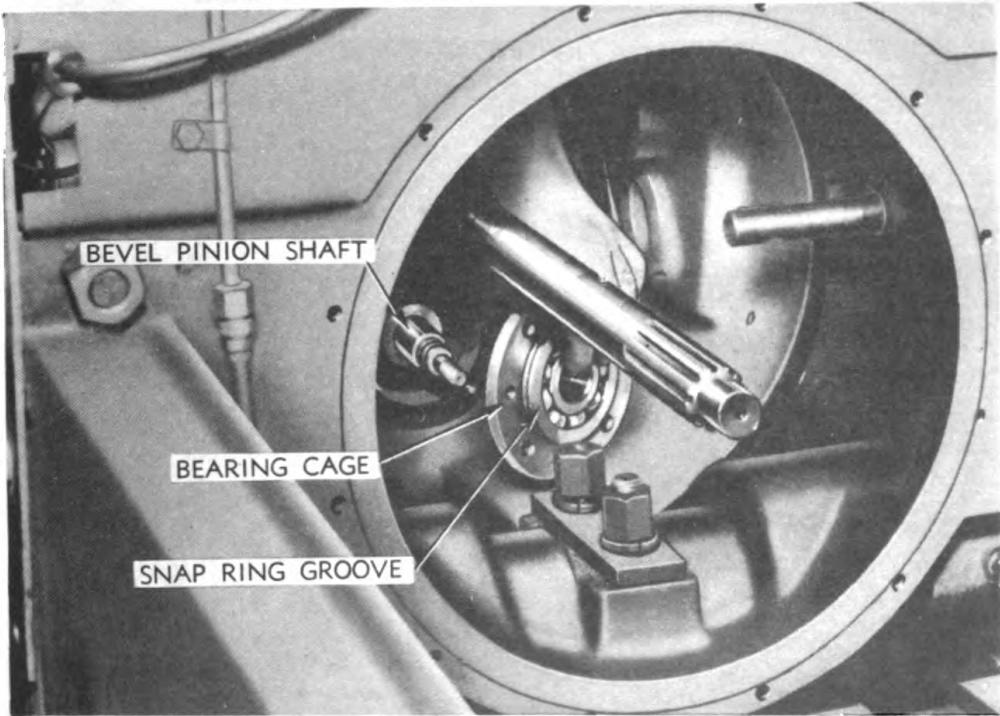

RA PD 41213

Figure 188 — Installing Front Bearing and Bearing Cage

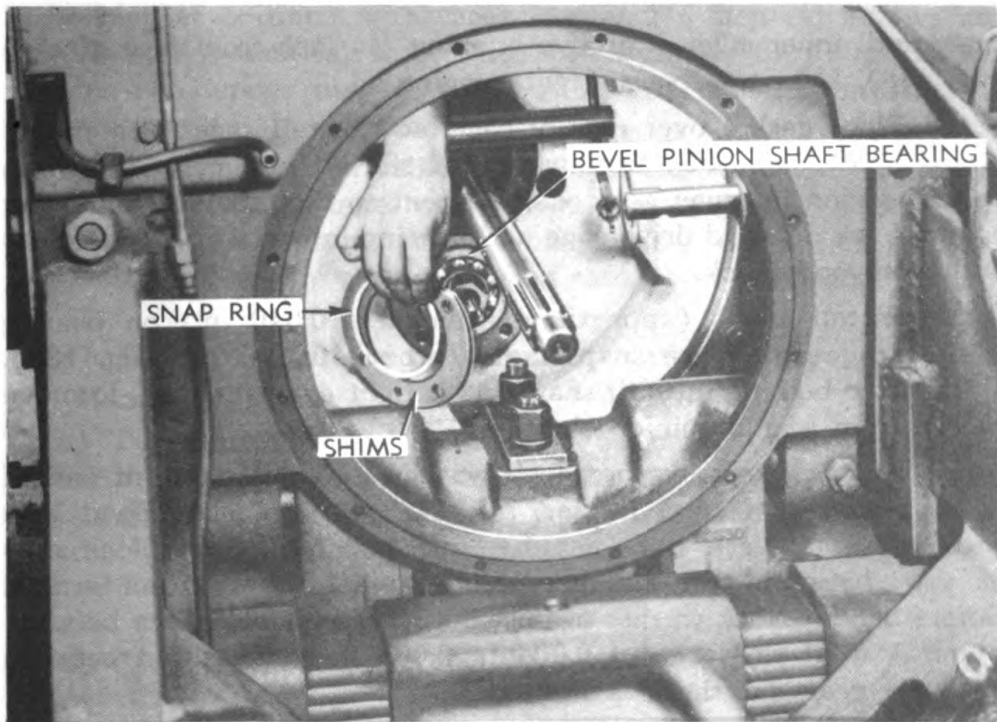

RA PD 41191

Figure 189 — Installing Shims and Snap Ring

**ORDNANCE MAINTENANCE — MEDIUM TRACTOR M1 (ALLIS-CHALMERS HD-7W)
ELECTRICAL SYSTEM, POWER TRAIN, FRAME, AND TRACKS**

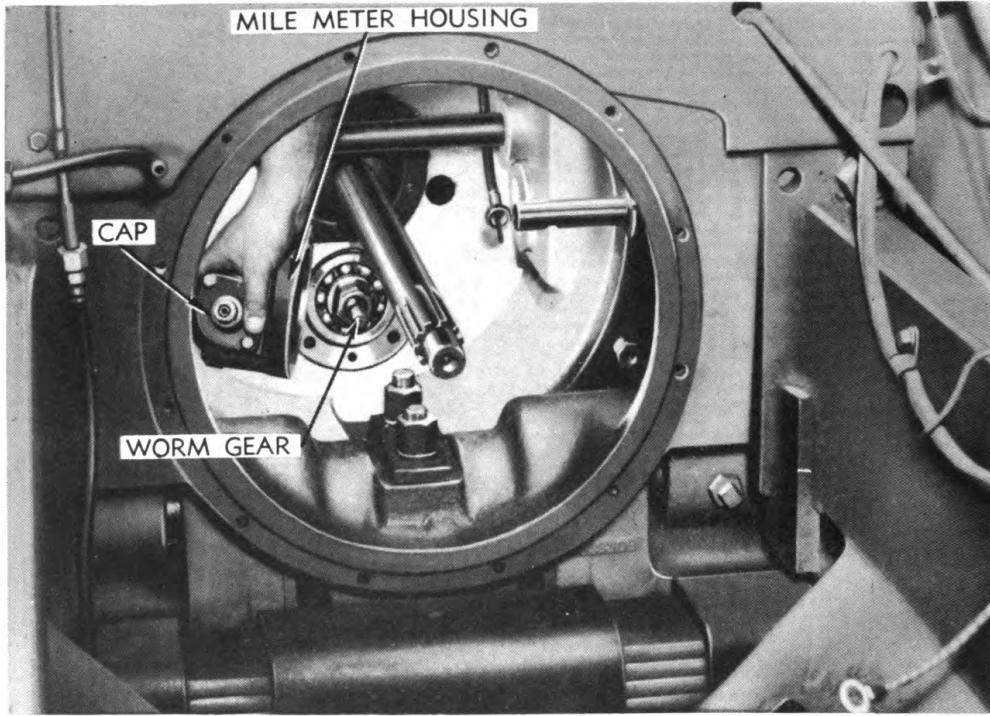

RA PD 41196

Figure 190 — Installing Mile Meter Housing

cage, until inner edge of groove is about $\frac{1}{32}$ inch from face of cage (fig. 188). Lubricate bearing with engine oil.

(c) Place gasket over rear of cage, and install cage over end of pinion shaft (fig. 188) until cage has started into case. Block up behind pinion in bevel gear compartment so that shaft and bearing cannot back out, and drive cage and bearing into place with hammer and hardwood block.

(d) Install shims (approximate thickness 0.040 in.) on bearing against cage and place snap ring in groove in bearing (fig. 189). Then drive bearing in until snap ring is tight against shims. Remove blocks from rear of pinion shaft.

(e) Install spacer, washer, lock washer, and nut on front end of bevel pinion shaft and tighten nut ($1\frac{7}{16}$ -in. wrench). Bend lock washer over to lock nut (hammer and punch). Wood block may be used between case and gear teeth to hold shaft from turning. Before bending lock washer against nut, check for clearance between gears. A total clearance of 0.004 to 0.005 inch, measured between any two gears on shaft, is desired.

(7) INSTALL MILE METER HOUSING AND CONNECT CABLE.

Pliers

Wrench, $\frac{3}{4}$ -in.

TRANSMISSION GEARS

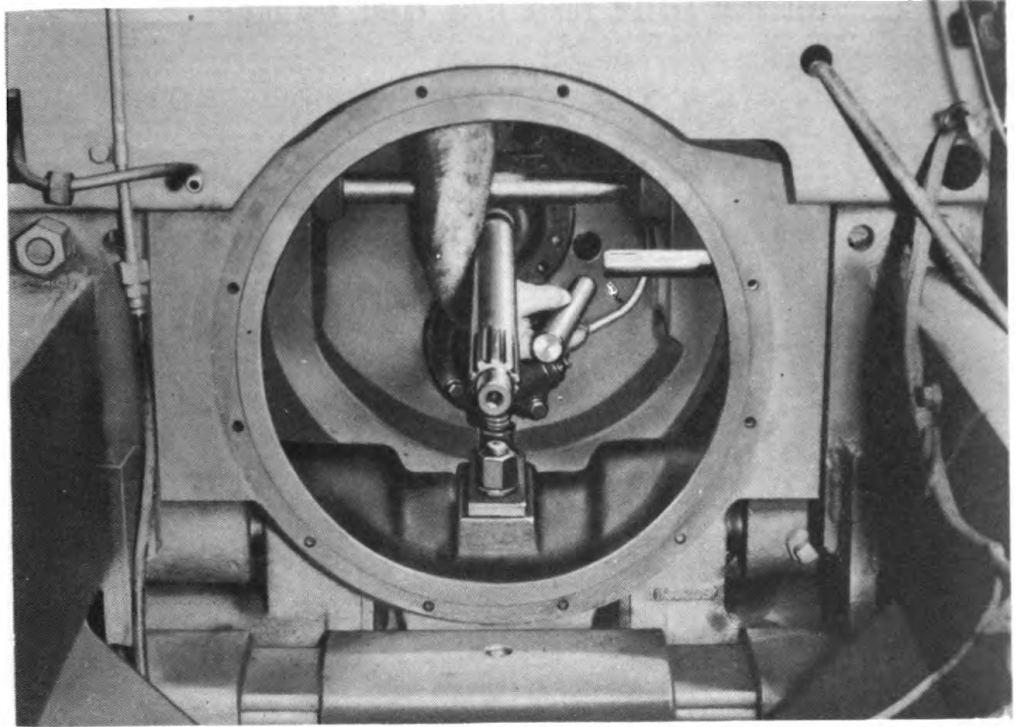

RA PD 41107

Figure 191 — Installing Reverse Idler Gear Shaft

(a) Install mile meter housing assembly (with oil return hole in housing at bottom) with three $\frac{1}{2}$ - by $2\frac{1}{2}$ -inch cap screws and one $\frac{1}{2}$ - by $5\frac{1}{4}$ -inch cap screw with lock washers (fig. 190). NOTE: Tighten cap screws just tight enough so that there is pressure on lock washers ($\frac{3}{4}$ -in. wrench).

(b) Insert mile meter cable into master clutch compartment, connect end of cable to mile meter drive (fig. 174), and tighten lock nut. Install rubber grommet on cable housing, and insert grommet in opening in left side of transmission case where cable goes through the case.

(8) ADJUST MILE METER DRIVE GEAR AND WORM.

Hammer, 2-lb

Wrench, $\frac{3}{4}$ -in.

(a) Turn upper end of drive cable back and forth with fingers to see if there is any backlash in meter drive gear. There should be a slight backlash, or gear and worm will bind and shear gear. Clearance can be obtained by tapping housing down and to the left with a hammer. When clearance is correct, tighten cap screws in housing ($\frac{3}{4}$ -in. wrench).

(b) Connect upper end of cable to mile meter.

(9) INSTALL REVERSE IDLER GEAR.

Pliers

Wrench, socket, $\frac{3}{4}$ -in.

Wrench, open-end, $\frac{7}{8}$ -in.

ORDNANCE MAINTENANCE — MEDIUM TRACTOR M1 (ALLIS-CHALMERS HD-7W)
ELECTRICAL SYSTEM, POWER TRAIN, FRAME, AND TRACKS .

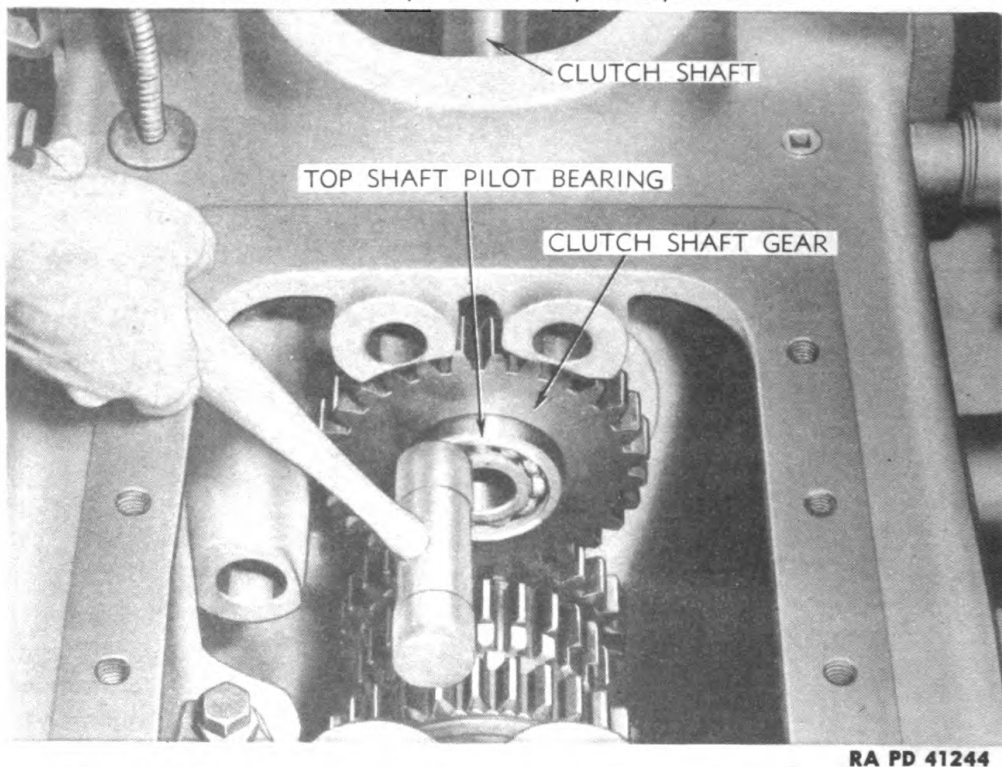

RA PD 41244

Figure 192 — Installing Top Shaft Pilot Bearing in Clutch Shaft Gear

Lubricate shaft with oil; install reverse idler gear shaft (fig. 191) through lower shifter shaft hole in master clutch compartment; slide shaft back through clutch compartment until it is just even with front end of idler gear recess. Install idler gear with long end toward shaft (fig. 173) and push shaft through gear and on into case. Install setscrew, jam nut, and nut lock (fig. 172); tighten setscrew to hold shaft ($\frac{3}{4}$ -in. wrench). Tighten jam nut ($\frac{7}{8}$ -in. wrench) and bend nut lock to hold nut (pliers).

(10) INSTALL TOP SHAFT PILOT BEARING.

Hammer, soft

Tap the top shaft pilot bearing into recess in clutch shaft gear (fig. 192). Lubricate bearing with engine oil.

(11) INSTALL TOP SHAFT AND GEARS.

Bar, drift, brass

Hammer, rawhide

(a) Insert top shaft into top hole at rear of transmission gear case from bevel gear compartment. As shaft is inserted into gear compartment, install the following items in the following order on shaft: low and reverse pinion gear (17 teeth) with shifter collar to front of case; second and third pinion gear (21 and 25 teeth) with smaller gear to rear of case; reducer gear (32 teeth) with long

TRANSMISSION GEARS

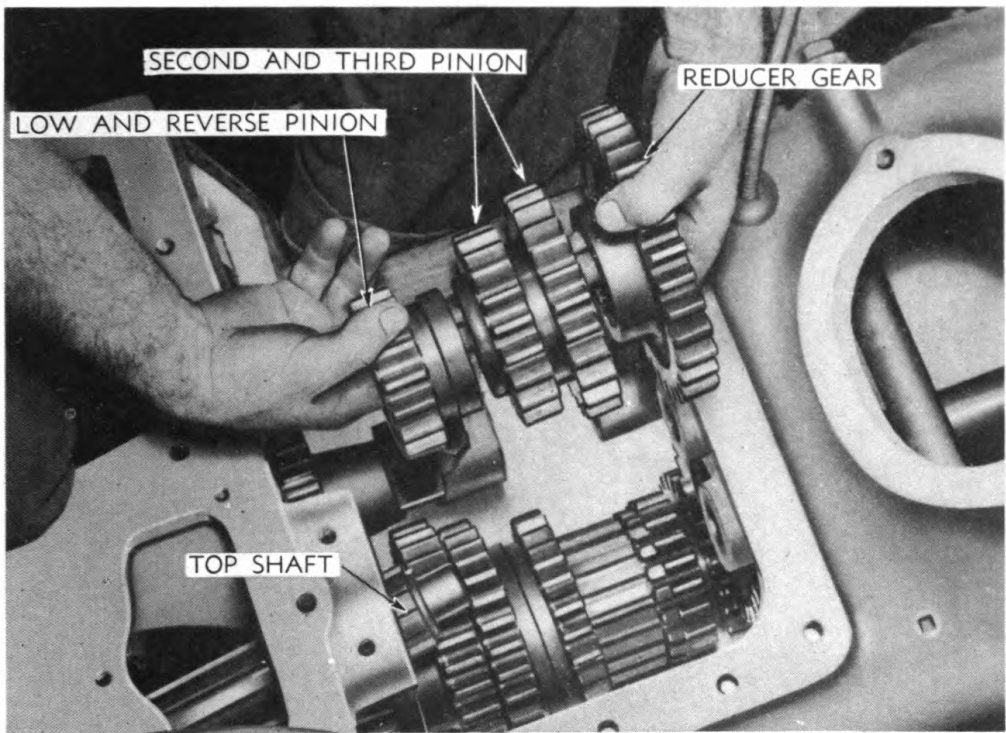

RA PD 41147

Figure 193 — Top Shaft Gears in Order of Installation

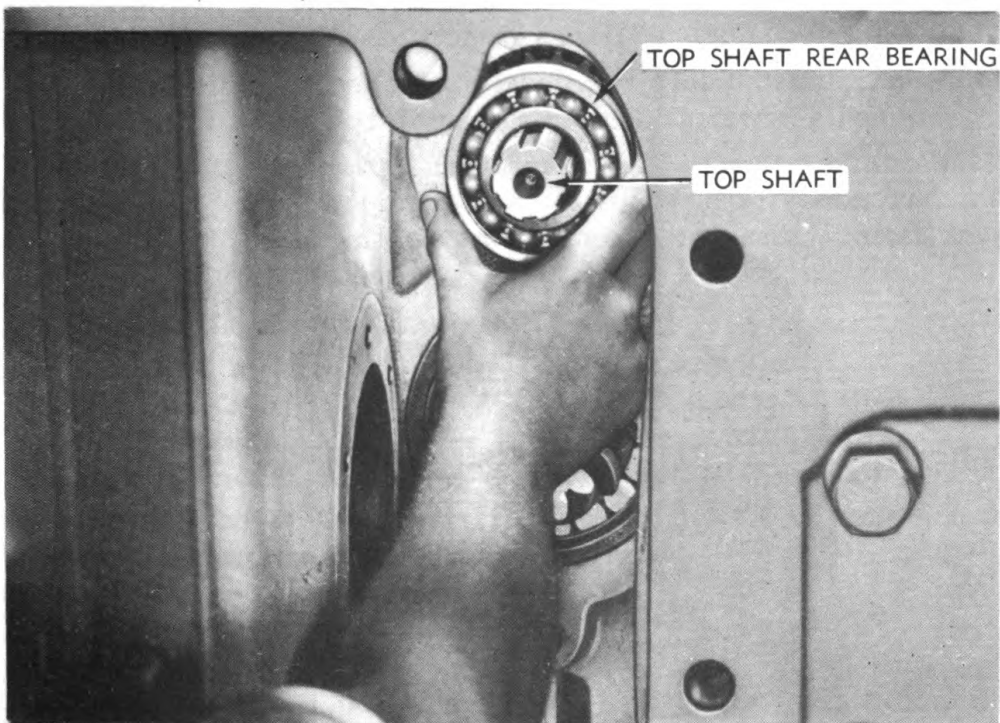

RA PD 41217

Figure 194 — Installing Rear Top Shaft Bearing

ORDNANCE MAINTENANCE — MEDIUM TRACTOR M1 (ALLIS-CHALMERS HD-7W)
ELECTRICAL SYSTEM, POWER TRAIN, FRAME, AND TRACKS

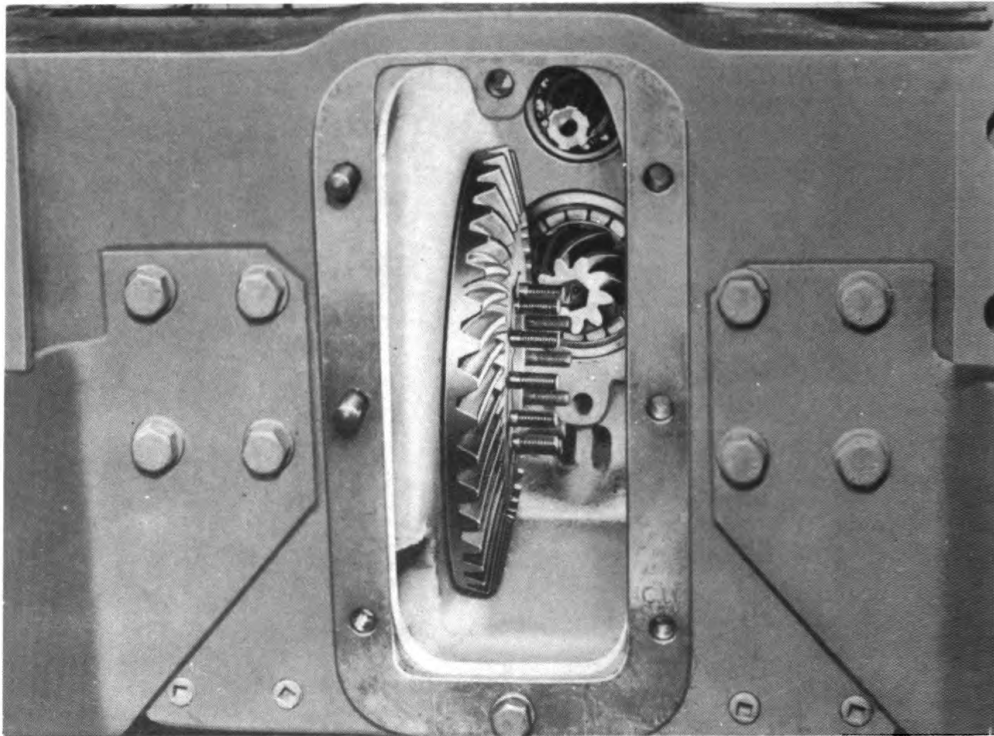

RA PD 41215

Figure 195 — Bevel Gear and Bolts

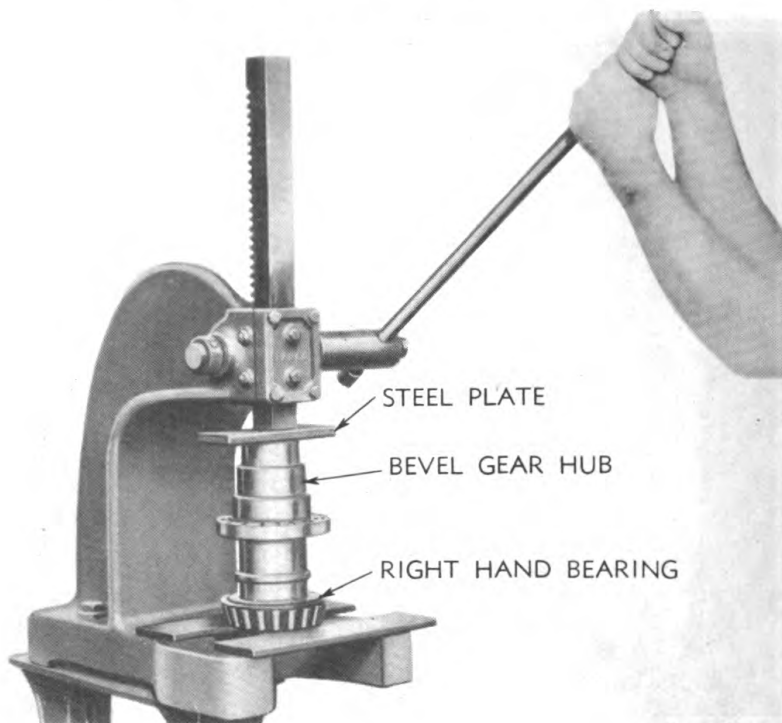

RA PD 41381

Figure 196 — Pressing Bearing onto Bevel Gear Hub

TRANSMISSION GEARS

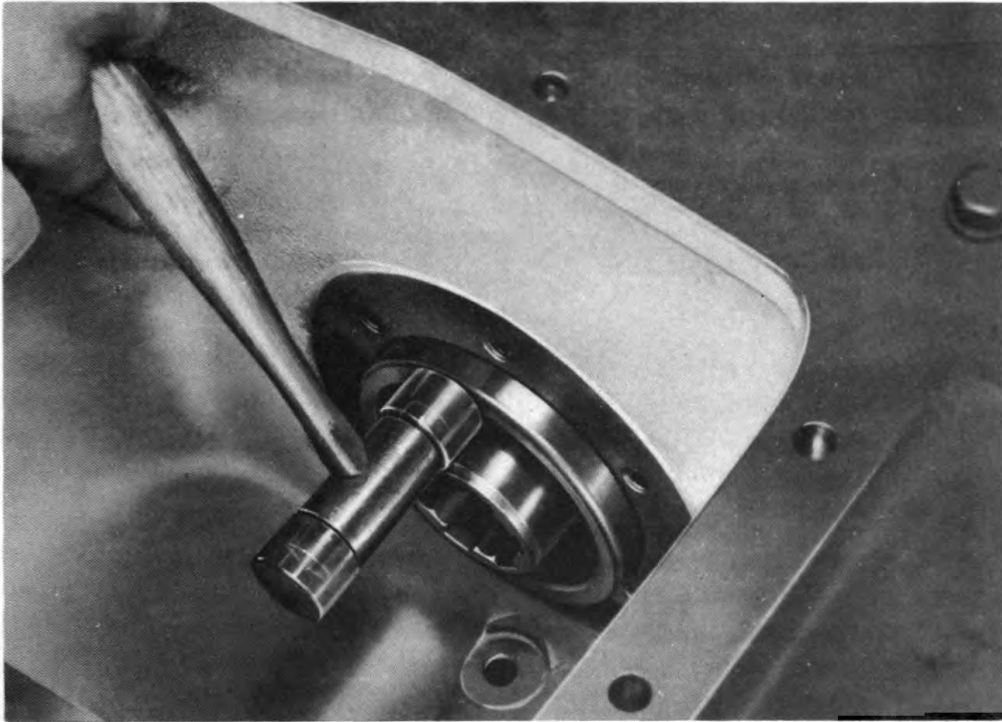

RA PD 41218

Figure 197 — Installing Bevel Gear Hub Bearing Cup

end of hub to rear of case; and thrust washer with flat face towards gear, and bevel side toward front of case (fig. 193).

(b) Line up front end of top shaft with pilot bearing in clutch shaft gear (fig. 192), and drive into place with rawhide hammer.

(c) Lubricate and install rear bearing on rear end of top shaft (fig. 194), and tap into place in transmission case (brass bar and hammer), until the snap ring groove in case is cleared. Install snap ring in groove behind bearing.

(12) INSTALL BEVEL GEAR AND HUB.

Bar, drift, brass

Hammer, 2-lb

Hammer, soft

Jack, hydraulic, 10-ton

Press, arbor

Steel plate, 1/2-in. thick

Wrench, box, 3/4-in.

Wrench, socket, 3/4-in.

(a) Install bevel gear bolts in gear from side opposite teeth (hammer). Place bevel gear in compartment with teeth of gear toward right-hand side of tractor (fig. 195).

(b) Place bevel gear hub and bearing in arbor press (fig. 196), and press end of hub into right-hand bearing roller assembly against narrow shoulder on hub.

(c) Insert hub with bearing roller assembly installed through hole in right-hand side of bevel gear compartment from steering clutch

**ORDNANCE MAINTENANCE — MEDIUM TRACTOR M1 (ALLIS-CHALMERS HD-7W)
ELECTRICAL SYSTEM, POWER TRAIN, FRAME, AND TRACKS**

compartment (fig. 169), and through bevel gear. Line up holes in hub with bolts in gear.

(d) Block gear in compartment and place a steel plate $\frac{1}{2}$ inch thick against right end of hub. Place hydraulic jack between steel plate and outer wall of right steering clutch compartment (fig. 168), and press hub over bolts through gear and onto bolts in gear. Install six nut locks and twelve $\frac{1}{2}$ -inch high nuts on bolts (fig. 165). Do not tighten these bolts.

(e) Lubricate bearings, then tap right-hand bearing cup into bore in case over bearing roller with soft hammer (fig. 197). Install shims and bearing retainer over right-hand bearing and secure it to case with six $\frac{1}{2}$ - by $1\frac{3}{4}$ -inch cap screws with lock washers ($\frac{3}{4}$ -in. wrench) (fig. 198).

(f) Install left-hand bearing roller assembly on left end of bevel gear hub (hammer and drift bar), and tap bearing cup into bore in case over bearing roller assembly in same manner as the right-hand assembly. Install shims and bearing retainer in same manner.

(g) Tighten bevel gear bolts securely, drawing gear tightly against flange on hub ($\frac{3}{4}$ -in. box wrench) (fig. 165); then bend nut locks against nuts with hammer and drift bar to prevent nuts from loosening (fig. 199).

(13) ADJUST BEVEL GEAR HUB BEARINGS.

Wrench, socket, $\frac{3}{4}$ -in.

See that bevel gear is not tight against pinion; then add or remove shims from between bearing retainers and case (fig. 198) until bearings are adjusted to the point where bearings are snug but bevel gear can be rotated freely. All retainer cap screws must be tight when test is made.

(14) ADJUST BEVEL PINION TO BEVEL GEAR.

Calipers, 2-in., inside

Scale, 6-in., with $\frac{1}{64}$ -in.

Calipers, 6-in., outside

graduations

NOTE: The bevel gear and pinion are matched sets; both should be replaced if necessary to replace either. These are spiral gears and require more accurate adjustment than gears with straight teeth. The correct position for setting the spiral bevel pinion has been determined on the gear lapping machine at the factory. The correct distance from the center of the bevel gear hub to the small end of the pinion is etched on the small end of the pinion (fig. 200). Theoretically this distance is 4.322 inches, but actually varies for each matched set of gears. In all cases, however, the distance etched on the pinion should be used. Adjust gears as follows:

TRANSMISSION GEARS

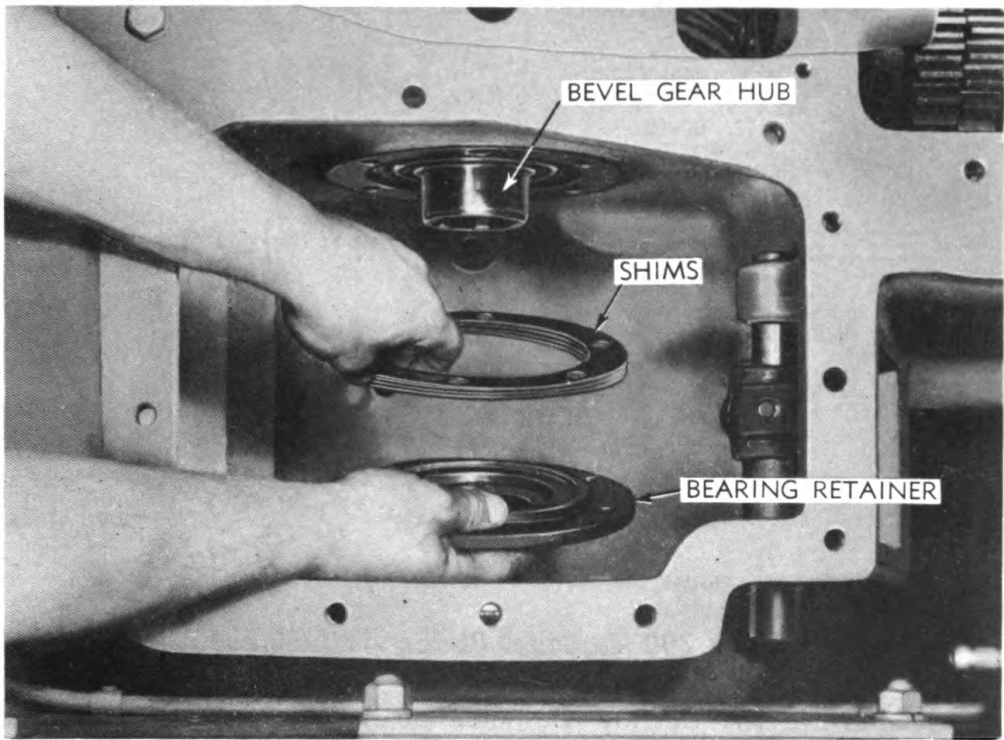

RA PD 41061

Figure 198 — Installing Bevel Gear Hub Bearing Retainer and Shims

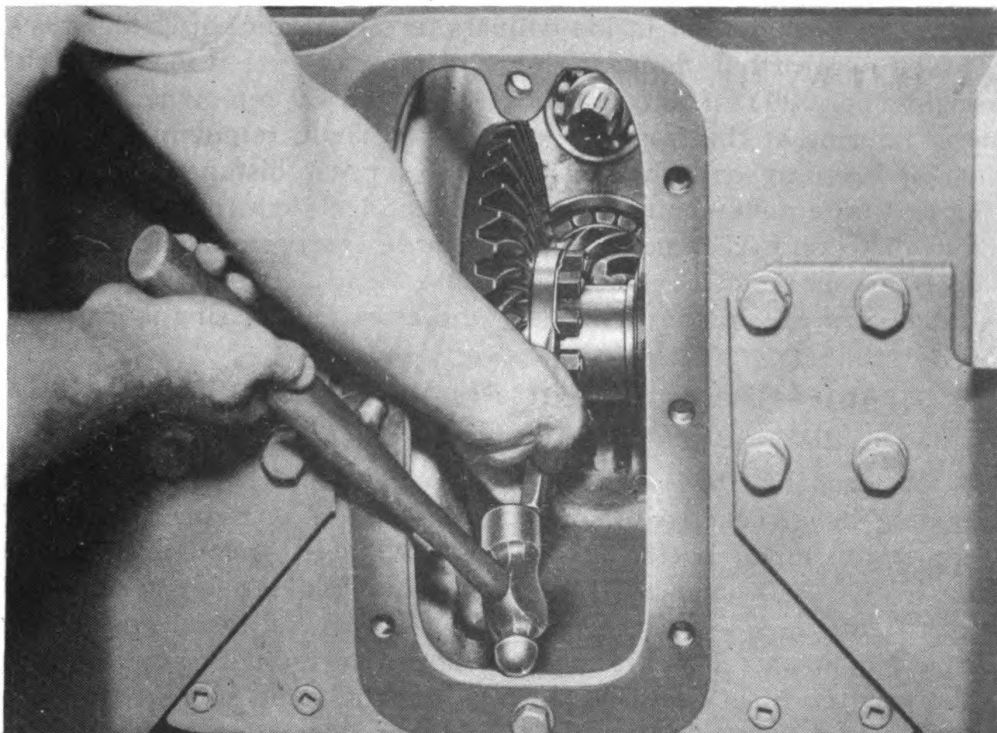

RA PD 41219

Figure 199 — Locking Bevel Gear Nut Locks

ORDNANCE MAINTENANCE — MEDIUM TRACTOR M1 (ALLIS-CHALMERS HD-7W)
ELECTRICAL SYSTEM, POWER TRAIN, FRAME, AND TRACKS

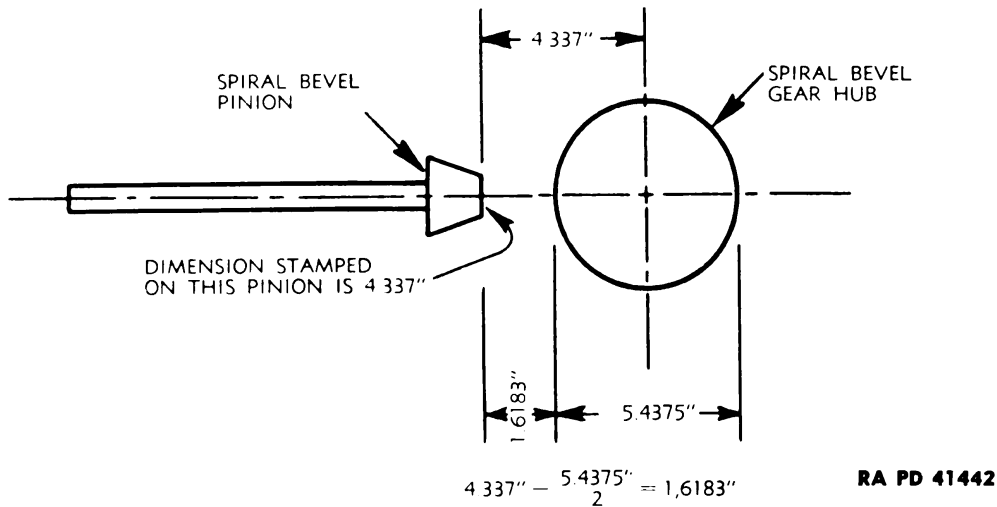

FIGURE 200—BEVEL PINION ADJUSTMENT

Figure 200 — Bevel Pinion Adjustment

(a) Measure the outside diameter of the flange of bevel gear hub to which bevel gear attaches. Use outside calipers. Divide this distance by two. The result will be the distance from center of bore of hub to outside of hub flange.

(b) Subtract this distance from the dimension etched on the end of the bevel pinion. Set inside calipers to dimension obtained. Check between edge of hub flange and end of pinion to see if measurement is right (fig. 200); if not, it can be corrected by removing the mile meter housing at the front of bevel pinion shaft, removing the snap ring; and adding or removing shims to correct distance. The snap ring and mile meter housing must be installed each time after being removed to add or remove shims, in order to position pinion shaft before measurement is checked. Be sure to adjust for a slight backlash between mile meter drive gear and worm, as housing is installed for last time (par. 70 b (8)).

(15) ADJUST BEVEL GEAR TO PINION.

Gage, dial

Wrench, socket, 3/4-in.

A backlash of 0.007 inch to 0.011 inch should be allowed when adjusting bevel gear to pinion; this should be at tightest point. If there is too much backlash, remove a sufficient number of shims from back of left-hand bearing retainer, and put the shims removed under right-hand bearing retainer. This moves the bevel gear closer to the pinion and decreases the backlash. Reverse above procedure if there is too little backlash. Always use the same shims that were removed from one side to add to the other side, so as not to change bearing adjustment.

TRANSMISSION GEARS

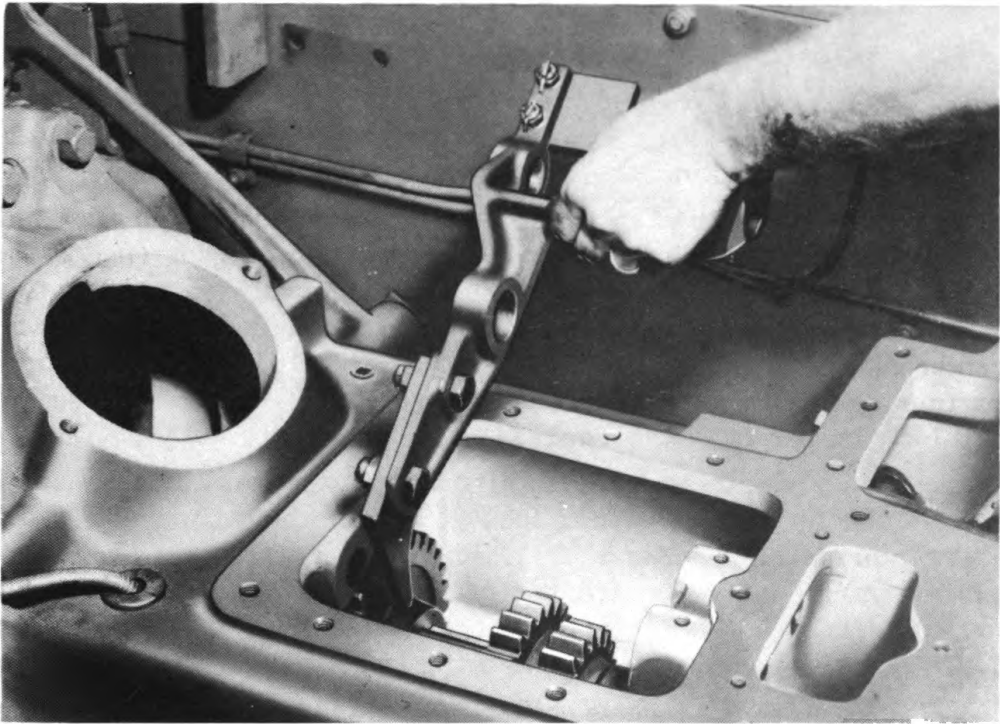

RA PD 41266

Figure 201 — Installing Fourth Speed Shifter Fork

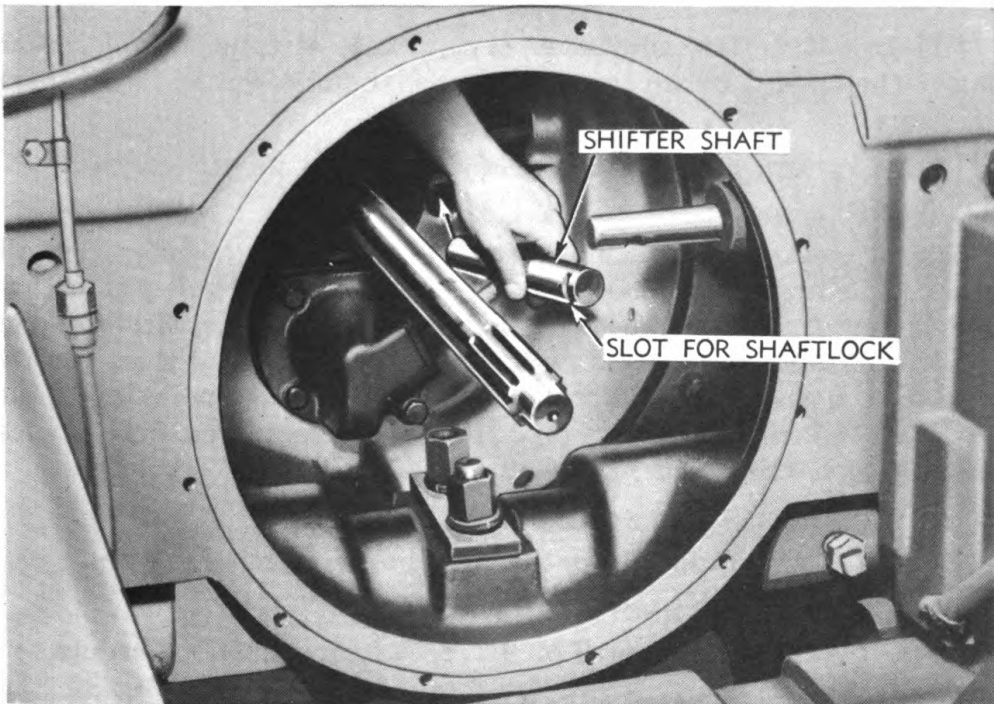

RA PD 41268

Figure 202 — Installing Lower Shifter Shaft

**ORDNANCE MAINTENANCE — MEDIUM TRACTOR M1 (ALLIS-CHALMERS HD-7W)
ELECTRICAL SYSTEM, POWER TRAIN, FRAME, AND TRACKS**

(16) INSTALL SHIFTER SHAFTS AND FORKS.

Hammer, soft	Wire, lock
Pliers	Wrench, socket, 3/4-in., with extension
Screwdriver, 10-in.	

(a) Lower the fourth speed shifter fork into transmission case and engage fork in the shifter collar of the third speed gear (fig. 201). Slide lower shifter shaft from master clutch compartment through hole in case (fig. 202), through shifter fork, and into support at center of case. Install shaft lock in place (fig. 161) in clutch compartment, and in slot of shaft. Secure with 1/2- by 1 3/4-inch cap screw and lock washer (3/4-in. wrench).

(b) Lower the second and third speed shifter fork into case, and engage the fork in the shifter fork groove of the second and third speed pinion (figs. 193 and 203). Slide left upper shifter shaft into place through master clutch compartment, into case, and through both fourth speed shifter fork, and second and third speed shifter forks. Lock in place with setscrew, using large screwdriver (fig. 159).

(c) Place low and reverse shifter fork into case with fork engaging shifter collar of low and reverse pinion (figs. 193 and 204). Slide shaft into place from master clutch compartment, through case and shifter fork. Lock in place with setscrew (screwdriver) (fig. 159). Install lock wire through both shaft setscrews (pliers).

(d) Install shifter shaft cover cups in case at front end of shifter shafts (hammer). Lubricate all shifter shafts and shifter fork collars on gears.

(17) INSTALL GEAR SHIFTER HOUSING ASSEMBLY.

Wrench, socket, 3/4-in.

Shellac gasket to attaching face of gearshifter housing. Set all gears in neutral position. Lower housing into place, being sure that lower end of gearshift lever is in proper alignment with slots in shifter forks. Secure housing with three 1/2- by 1 3/8-inch cap screws with lock washers (two in front corners and one at rear) and four 1/2- by 1 1/2-inch cap screws with lock washers in remaining holes in sides of housing (figs. 151 and 152).

(18) INSTALL STEERING CLUTCHES.

Refer to paragraph 51 for installation procedure.

(19) INSTALL ENGINE IN TRACTOR.

Refer to TM 9-783B or TM 9-1783A for outlined procedure.

(20) INSTALL POWER TAKE-OFF ASSEMBLY AND PINTLE BRACKET ASSEMBLY.

Refer to paragraph 30 for installation of power take-off assembly,

TRANSMISSION GEARS

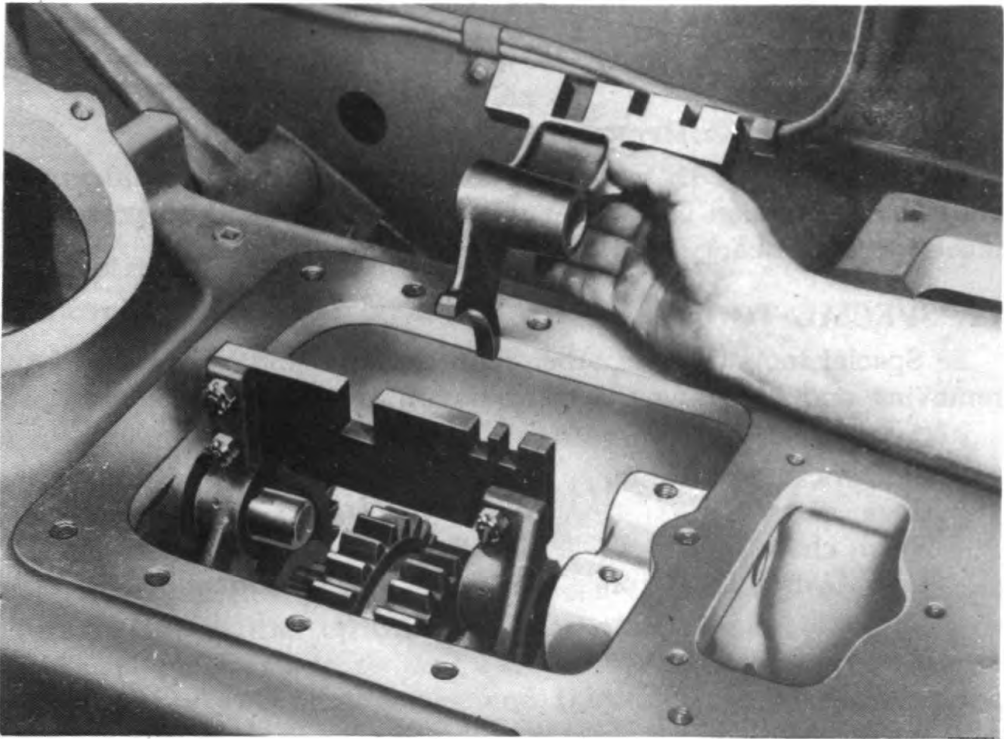

RA PD 41272

Figure 203 — Installing Second and Third Speed Shifter Fork

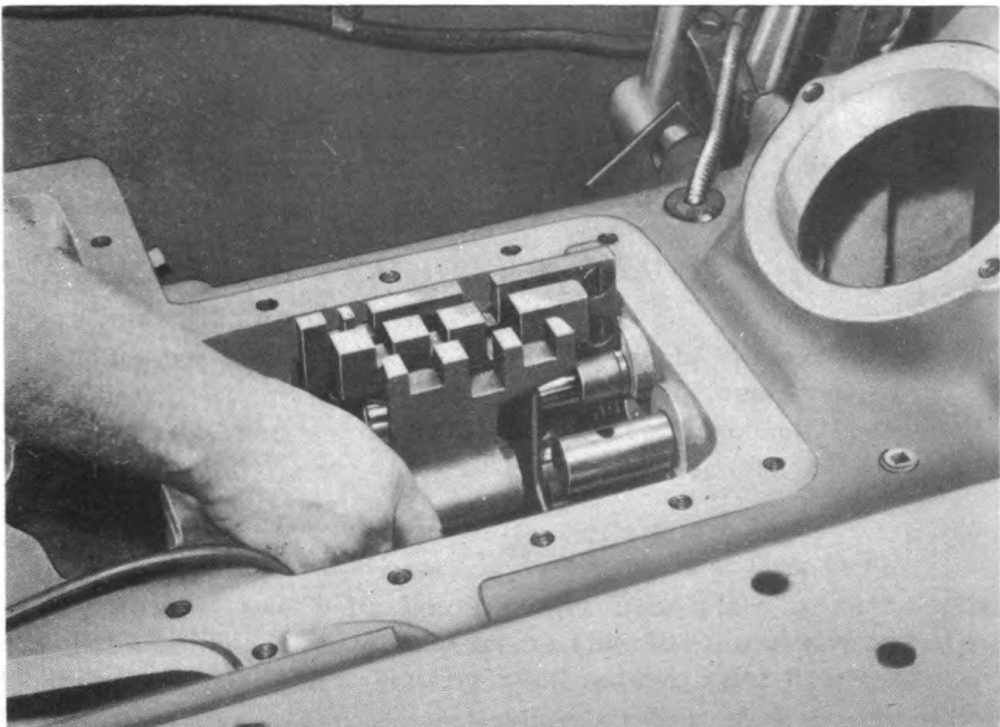

RA PD 41260

Figure 204 — Installing Low and Reverse Shifter Fork

**ORDNANCE MAINTENANCE — MEDIUM TRACTOR M1 (ALLIS-CHALMERS HD-7W)
ELECTRICAL SYSTEM, POWER TRAIN, FRAME, AND TRACKS**

and paragraph 147 for installation of pintle bracket and winch drive chain.

(21) FILL OIL COMPARTMENTS.

Refer to TM 9-783B for lubrication instructions and specifications, and fill transmission and power take-off compartments to prescribed levels with lubricant. Lubricate all controls and linkage.

71. SPECIAL TOOLS.

a. Special tools or tools other than regular hand tools needed for removing and installing the transmission gears are as follows:

Calipers, inside, 2-in.	Press, arbor
Calipers, outside, 6-in.	Puller, final drive pinion
Gage, dial	Steel plate, 1/2-in. thick
Hoist, chain	Wrench, engine cranking
Jack, hydraulic, 10-ton	Wrench, spanner

CHAPTER 11

TRANSMISSION AND GEARSHIFT MECHANISM (Cont'd)

Section IV

GEARSHIFT MECHANISM

	Paragraph
Description of gearshift mechanism.....	72
Removal of gearshift mechanism.....	73
Disassembly of gearshifter housing assembly.....	74
Inspection and repair of parts.....	75
Assembly of gearshifter housing assembly.....	76
Installation of gearshift mechanism.....	77

72. DESCRIPTION OF GEARSHIFT MECHANISM.

a. The gearshift mechanism provides a means of shifting two sliding gears on the top transmission shaft and one sliding gear on the bevel pinion shaft, so that each of these gears will mesh with either one or two other gears, and thus increase or decrease the speed or power, or change the direction of travel of the tractor. The gearshift lever extends through the gearshifter housing, and the lower end of the lever engages in notches in the lock bar on the fourth speed shifter fork arm and the upper parts of the other two shifter forks. Moving the lever to its different positions selects the shifter fork that will be moved to mesh the correct gears for the desired direction or speed of travel. The lower ends of the shifter forks fit in collars on the sliding gears. The gears are held in the desired position by these shifter forks, which in turn are held by the locking mechanism.

73. REMOVAL OF GEARSHIFT MECHANISM.

a. Tools Required.

Hammer, 2-lb	Wrench, $\frac{9}{16}$ -in.
Pliers	Wrench, open-end, $\frac{3}{4}$ -in.
Punch, curved	Wrench, socket, $\frac{3}{4}$ -in.

b. Procedure.

(1) REMOVE FLOOR PLATES.

Wrench, open-end, $\frac{3}{4}$ -in. Wrench, socket, $\frac{3}{4}$ -in.

(a) Remove two bolts holding right floor plate to rear fender, two bolts holding plate to seat frame (fig. 101), and one cap screw holding it to gearshifter housing, then remove right floor plate.

(b) Remove two cap screws holding left floor plate to rear fender, two bolts holding plate to seat frame, and one cap screw holding it to gearshifter housing; then remove left floor plate.

ORDNANCE MAINTENANCE — MEDIUM TRACTOR M1 (ALLIS-CHALMERS HD-7W)
ELECTRICAL SYSTEM, POWER TRAIN, FRAME, AND TRACKS

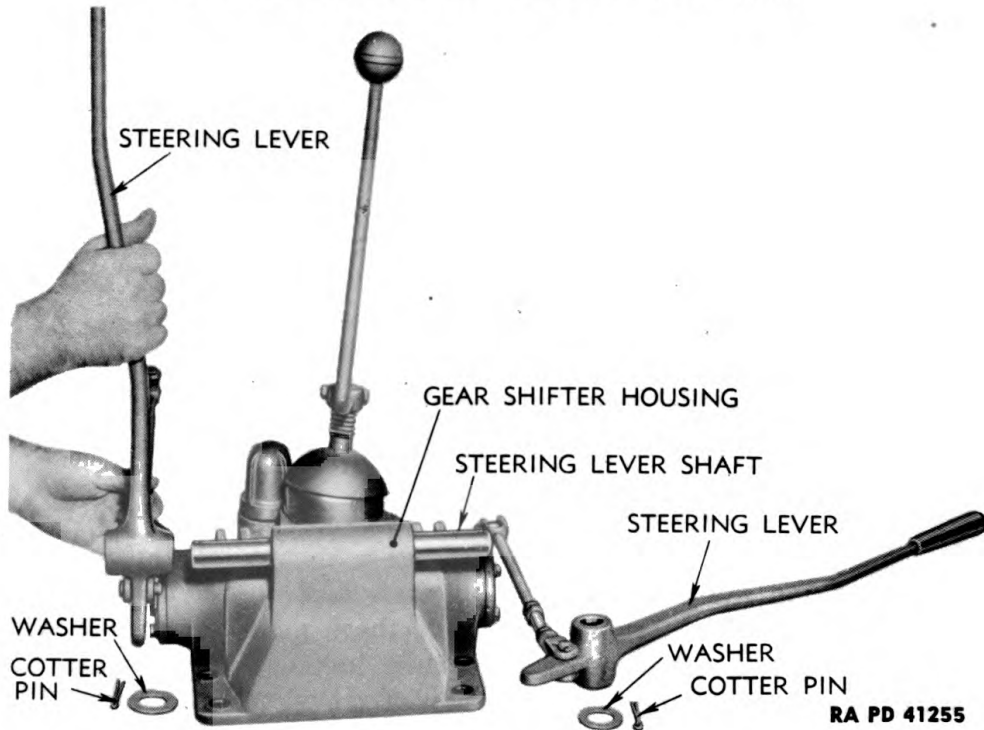

RA PD 41255

Figure 205 — Removing Steering Levers

(2) REMOVE GEARSHIFTER HOUSING ASSEMBLY.

Wrench, socket, $\frac{3}{4}$ -in.

Remove the seven cap screws holding gearshifter housing to transmission case, and lift gearshifter housing assembly from tractor (figs. 151 and 152).

(3) REMOVE SHIFTER FORKS.

Hammer, 2-lb

Pliers

Punch, curved

Wrench, $\frac{9}{16}$ -in.

Wrench, $\frac{3}{4}$ -in.

(a) Remove two cap screws with $\frac{3}{4}$ -inch wrench, and remove master clutch inspection hole cover just ahead of gearshifter housing.

(b) Remove three cap screws with $\frac{9}{16}$ -inch wrench, and lift cover from bevel gear inspection hole just behind gearshifter housing (fig. 153).

(c) Cut lock wire (pliers) and remove the two setscrews holding the two upper shifter shafts in transmission case (screwdriver) (fig. 159).

(d) With hammer and curved punch or rod inserted through bevel gear inspection hole, drive the two top shifter shafts forward to force the shifter shaft cover cups at front ends of shafts out into

GEARSHIFT MECHANISM

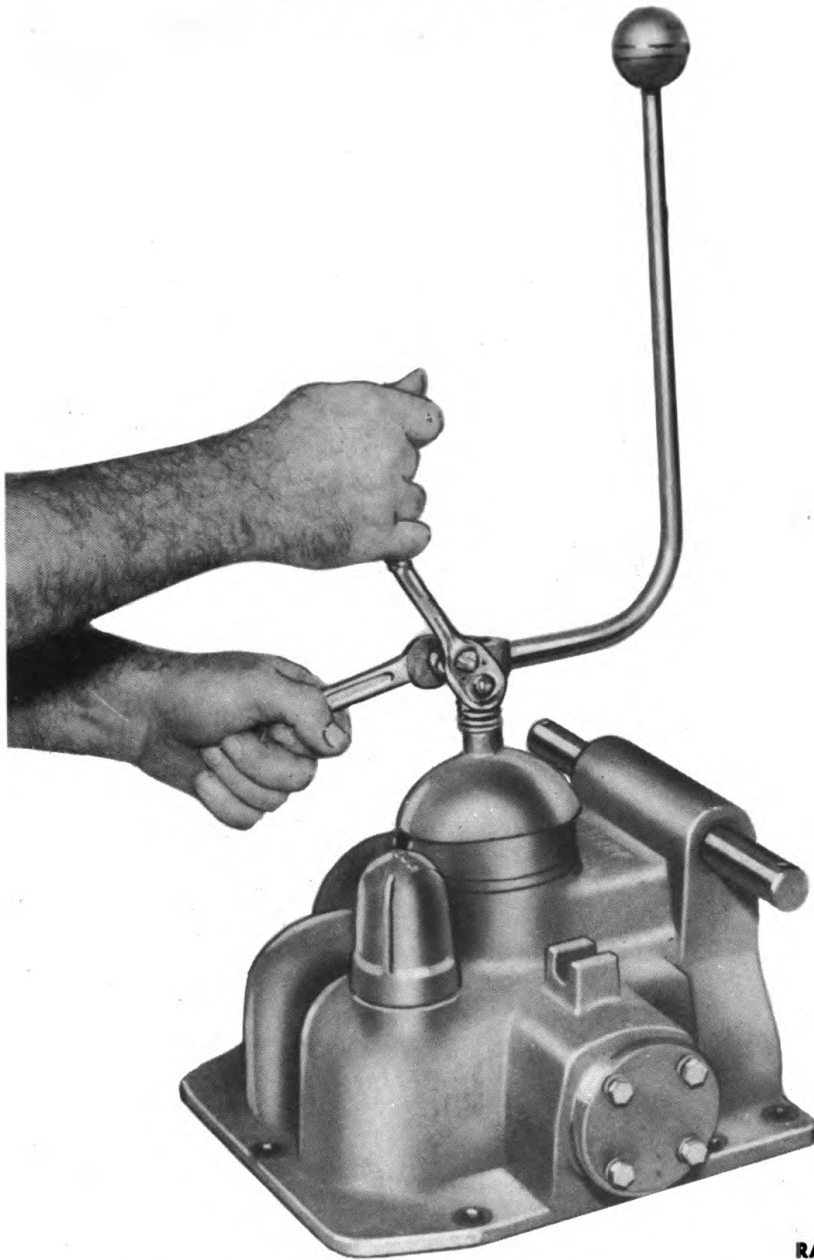

RA PD 41253

Figure 206 — Loosening Lever Extension Clamp Bolt

master clutch compartment; then slide the shafts out the front end of transmission compartment.

(e) Lift the second and third speed and low and reverse shifter forks from compartment (fig. 160.)

(f) Reach through clutch inspection hole and remove the cap screw holding fourth speed shifter shaft lock ($\frac{3}{4}$ -in. wrench) (fig. 161); then slide shifter shaft out into master clutch compartment, and lift fourth speed shifter fork out of case (fig. 162).

ORDNANCE MAINTENANCE — MEDIUM TRACTOR M1 (ALLIS-CHALMERS HD-7W)
ELECTRICAL SYSTEM, POWER TRAIN, FRAME, AND TRACKS

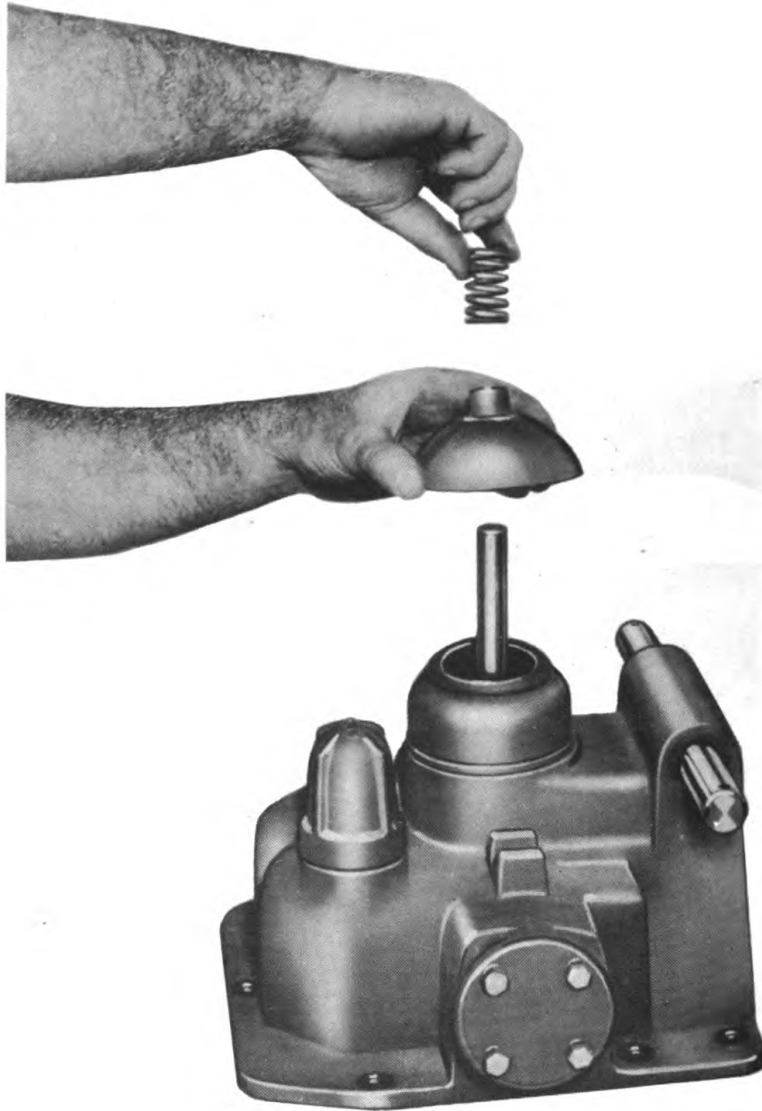

RA PD 41237

Figure 207 — Removing Spring and Cover

74. DISASSEMBLY OF GEARSHIFTER HOUSING ASSEMBLY.

a. Tools Required.

Hammer, 1/2-lb

Pliers

Pliers, long nosed

Punch, small

Wrench, 1/2-in.

Wrench, 9/16-in. (2)

Wrench, 3/4-in. (2)

b. Procedure.

(1) REMOVE STEERING LEVERS.

Pliers

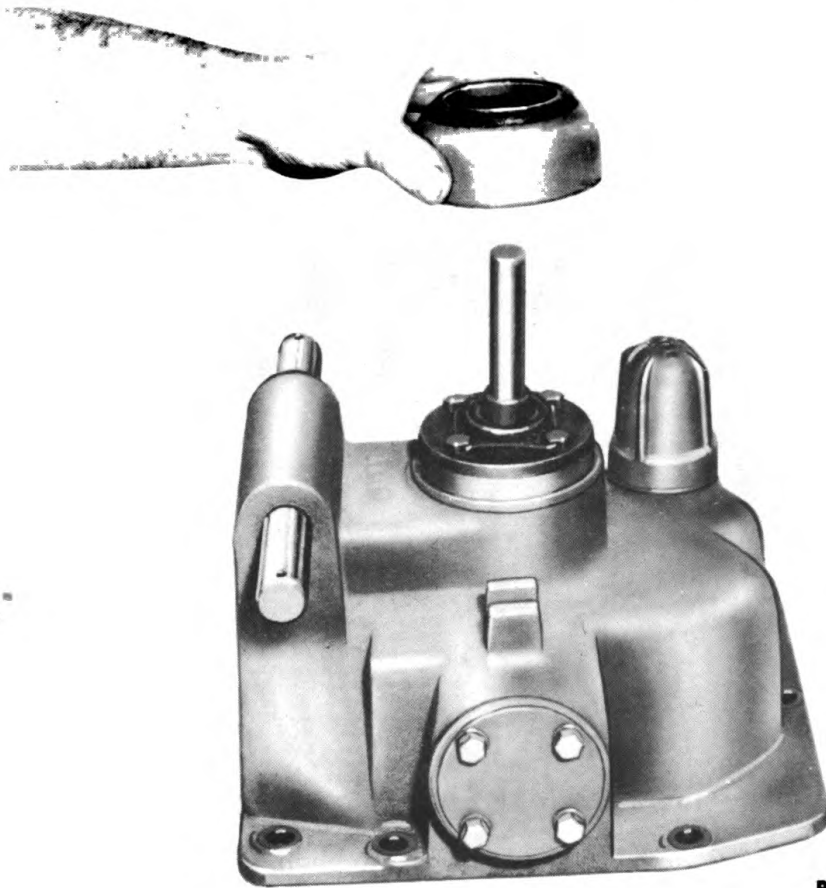
GEARSHIFT MECHANISM

RA PD 41245

Figure 208 — Removing Dust Cap

Pull cotter pins (pliers) and remove washers and levers from shaft (fig. 205).

(2) REMOVE GEARSHIFT LEVER.

Hammer, 1/2-lb

Wrench, 1/2-in.

Pliers

Wrench, 9/16-in. (2)

Punch, small

(a) Loosen clamp bolt in lever extension with two 9/16-inch wrenches (fig. 206). Remove extension from lever; then lift spring and cover from dust cap (fig. 207).

(b) Tap dust cap off clamp ring with hammer and punch (fig. 208).

(c) Cut lock wire (pliers) and remove four cap screws from clamp plate (1/2-in. wrench); lift off clamp plate and Neoprene boot (figs. 209 and 210).

(d) Lift off clamp ring assembly and gearshift lever assembly (fig. 211).

(3) REMOVE SHIFTER LOCK.

Wrench, 1/2-in.

ORDNANCE MAINTENANCE — MEDIUM TRACTOR M1 (ALLIS-CHALMERS HD-7W)
ELECTRICAL SYSTEM, POWER TRAIN, FRAME, AND TRACKS

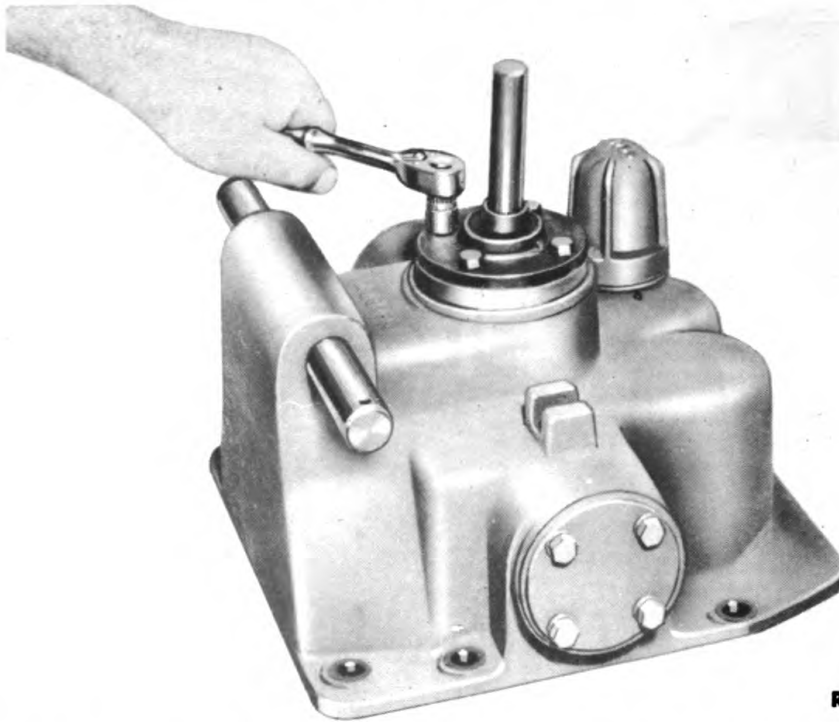

RA PD 41252

Figure 209 — Removing Cap Screws from Clamp Ring Assembly

(a) Remove the four cap screws from each shifter guide plate with $\frac{1}{2}$ -inch wrench (fig. 212), and remove the two shifter guides from housing (fig. 213).

(b) Remove shifter lock from gearshifter housing (fig. 214).

(4) DISASSEMBLE SHIFTER LOCK.

Pliers, long nosed

Remove snap ring holding plunger in end of shifter lock, using long nosed pliers (fig. 215), and remove plunger and spring. Repeat for other side.

(5) DISASSEMBLE FOURTH SPEED SHIFTER FORK ASSEMBLY.

Pliers

Wrench, $\frac{3}{4}$ -in. (2)

Wrench, $\frac{9}{16}$ -in.

(a) Pull cotter pins from the three castellated nuts holding lock bar to upper part of shifter fork arm (pliers), and remove nuts ($\frac{9}{16}$ -in. wrench). Remove lock bar (fig. 162).

(b) Pull cotter pins (pliers) and remove the two bolts holding shifter fork to lower end of arm (two $\frac{3}{4}$ -in. wrenches); then remove shifter fork.

75. INSPECTION AND REPAIR OF PARTS.

a. **Lever Assembly.** Inspect parts of the lever assembly after cleaning it for general wear or breakage. Straighten lever if bent

GEARSHIFT MECHANISM

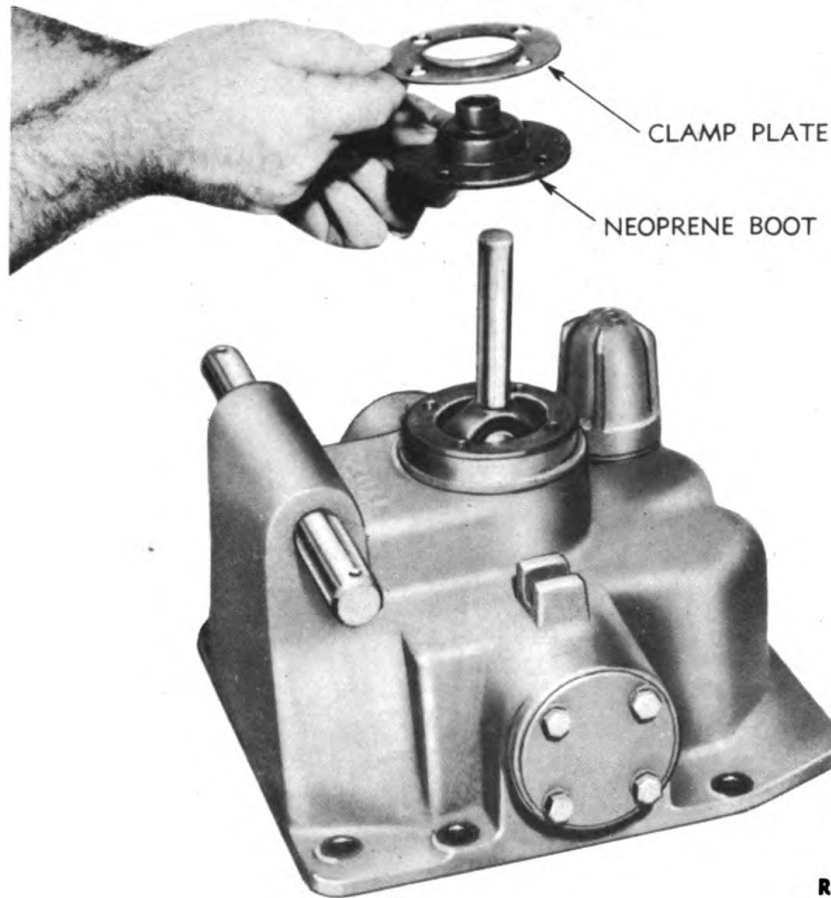

RA PD 41247

Figure 210 — Removing Clamp Plate and Boot

out of its original shape and replace or repair lever, if broken, by welding. Worn lower end of lever or pivot shaft in lever assembly may be built up in emergency and ground to original size and shape on an emery wheel. Replace felt seal in dust cap and inspect parts of the dust cap and cover to make sure that parts are in such condition that they will effectively keep dust and other foreign material from entering.

b. Shifter Fork Assemblies. Clean and examine all the shifter forks. Replace or repair forks cracked, bent, or badly worn. The wearing surfaces on sides of forks, where the gears contact against them, should be smooth and flat. If the contacting surfaces are worn unevenly, it is an indication that the fork is bent. If fork is bent, the gear controlled by that fork will not be shifted into full mesh with its mating gears and will cause uneven wear on the gear teeth; this may also result in the gears slipping out of mesh. The original thickness of the wearing parts of the shifter forks is 0.485 to 0.495 inch. Replace worn locking parts or broken plunger springs in locking mechanism. Before assembling, make sure the gearshifter

**ORDNANCE MAINTENANCE — MEDIUM TRACTOR M1 (ALLIS-CHALMERS HD-7W)
ELECTRICAL SYSTEM, POWER, TRAIN, FRAME, AND TRACKS**

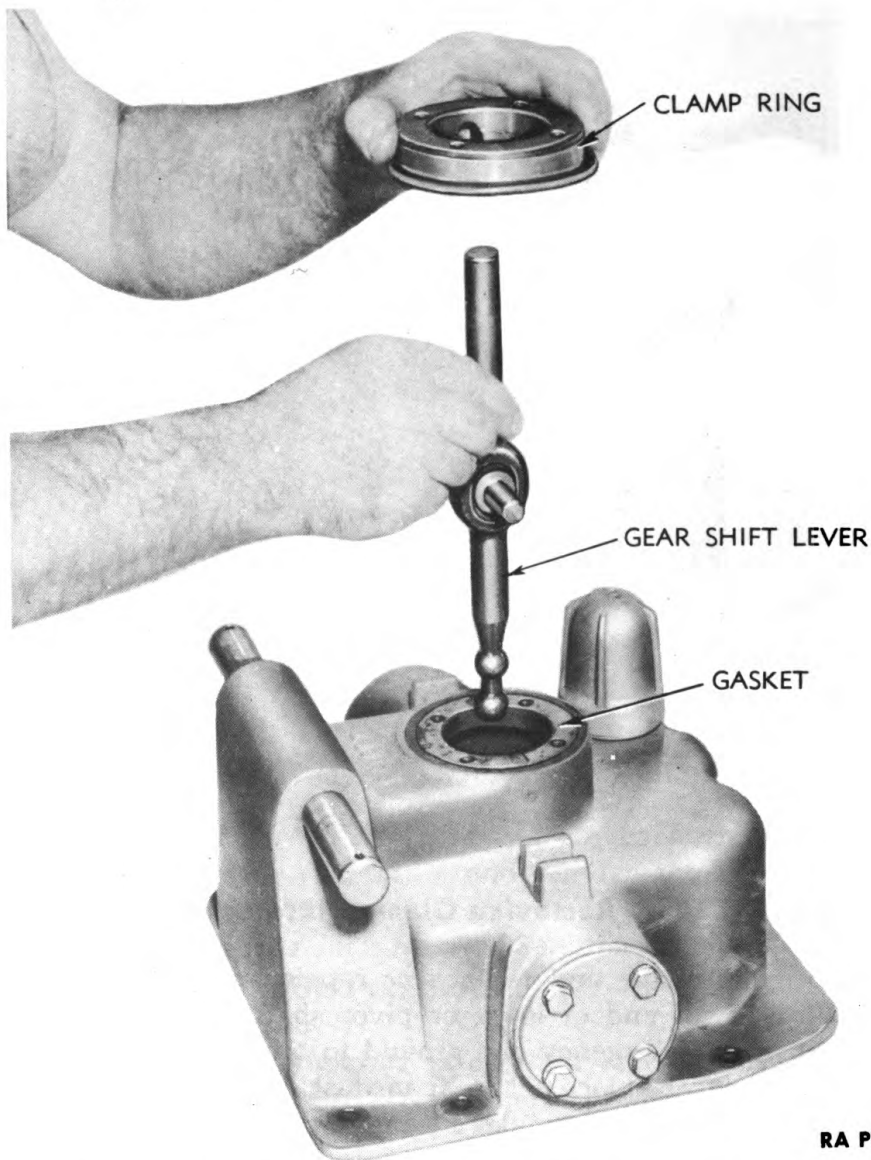

RA PD 41258

Figure 211 — Removing Clamp Ring and Gearshifter Lever

lock works freely, and also that forks slide freely on the shifter shafts.

76. ASSEMBLY OF GEARSHIFTER HOUSING ASSEMBLY.

a. Tools Required.

Hammer, 1/2-lb

Pliers

Pliers, long nosed

Shellac

Wrench, 1/2-in.

Wrench, 9/16-in. (2)

Wrench, 3/4-in. (2)

GEARSHIFT MECHANISM

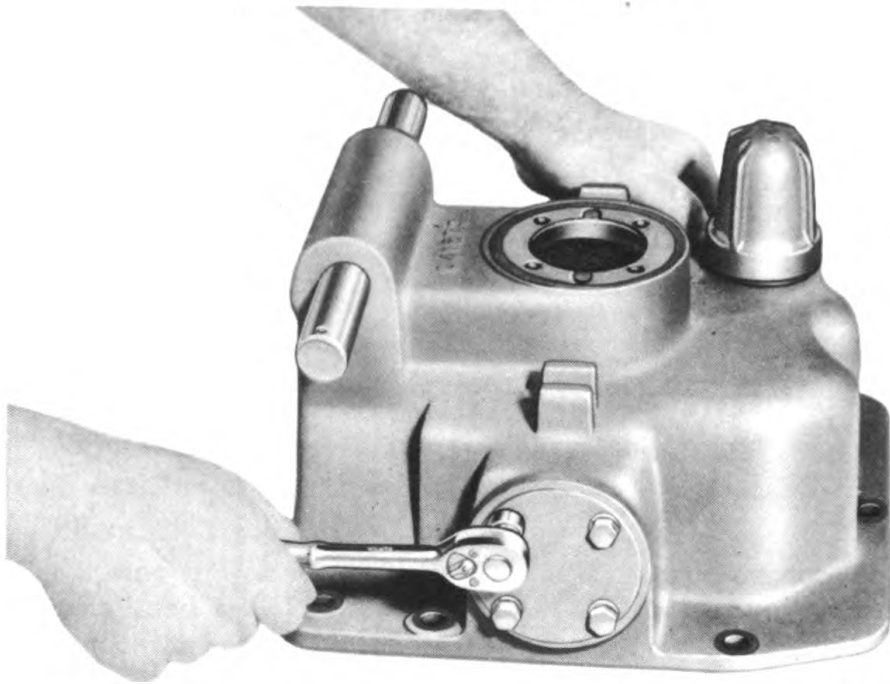

RA PD 41261

Figure 212 — Removing Shifter Guide Plate

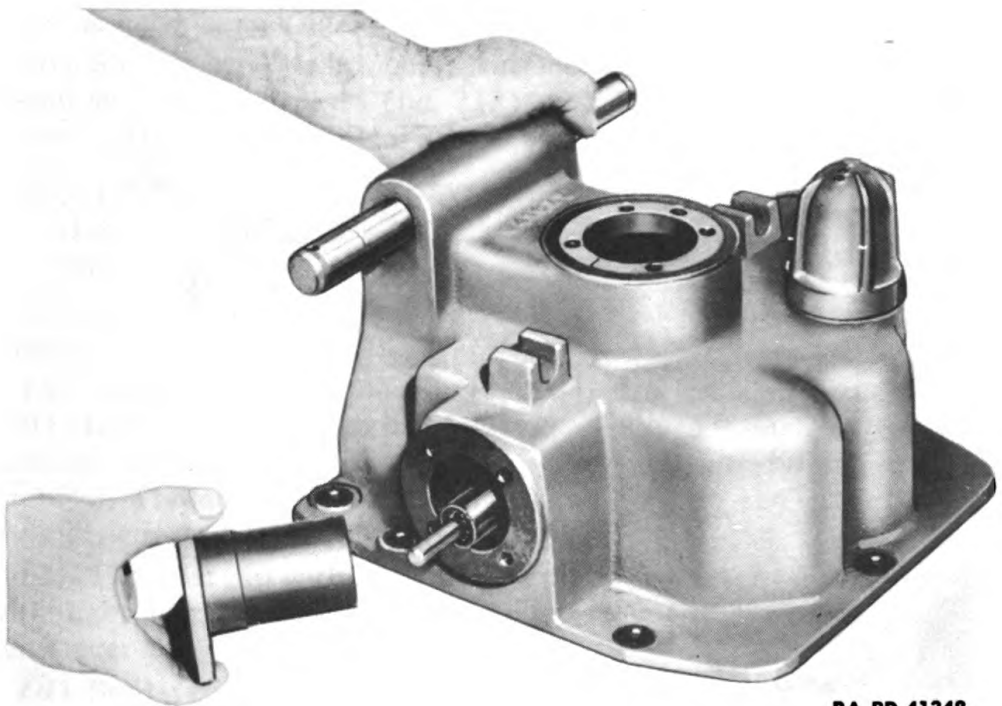

RA PD 41248

Figure 213 — Removing Shifter Guide

ORDNANCE MAINTENANCE — MEDIUM TRACTOR M1 (ALLIS-CHALMERS HD-7W)
ELECTRICAL SYSTEM, POWER TRAIN, FRAME, AND TRACKS

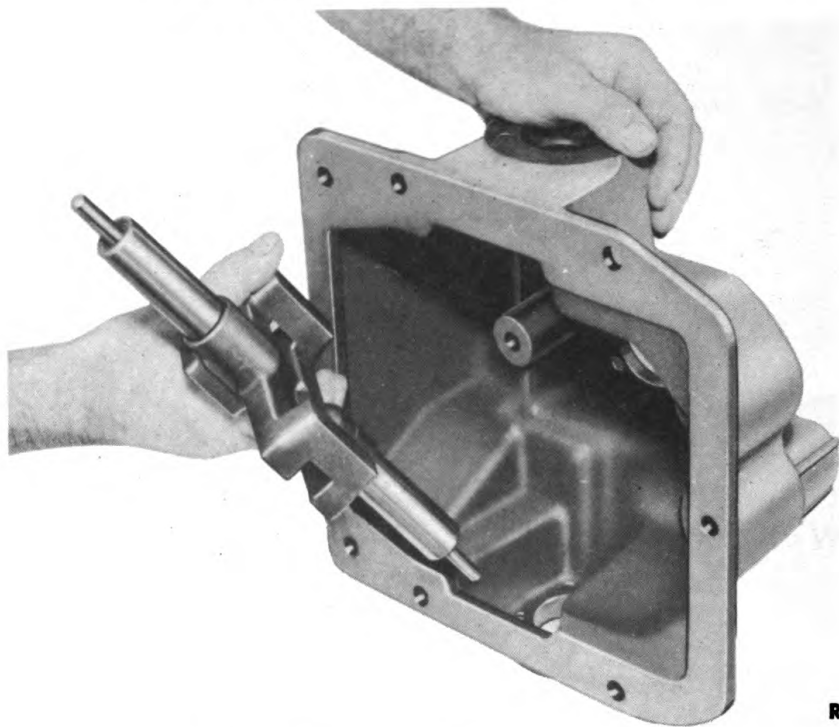

RA PD 41249

Figure 214 — Removing Shifter Lock

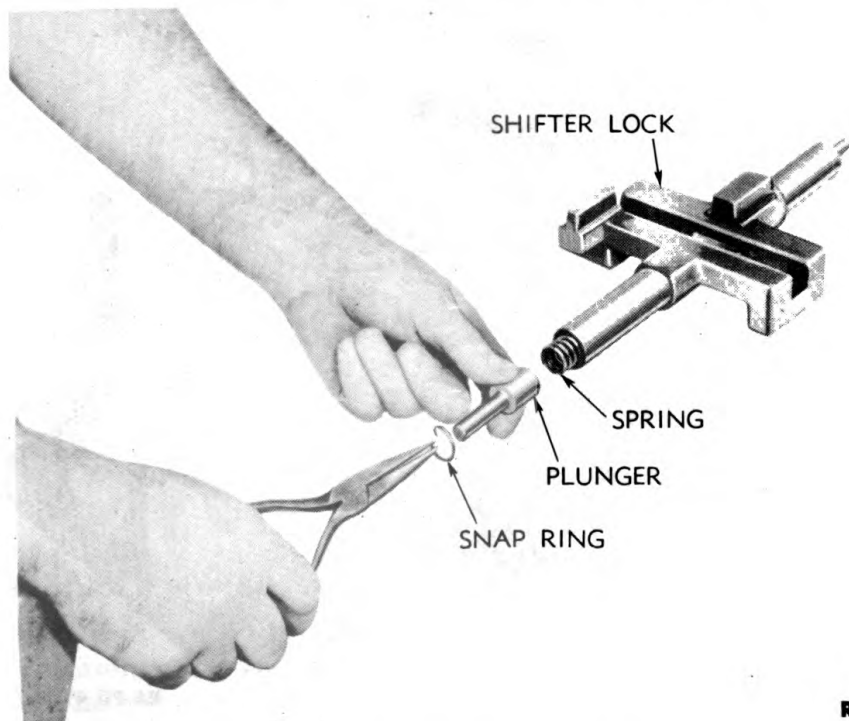

RA PD 41251

Figure 215 — Removing Shifter Lock Plunger and Spring

**ORDNANCE MAINTENANCE — MEDIUM TRACTOR M1 (ALLIS-CHALMERS HD-7W)
ELECTRICAL SYSTEM, POWER TRAIN, FRAME, AND TRACKS**

77. INSTALLATION OF GEARSHIFT MECHANISM.**a. Tools Required.**

Hammer, 2-lb	Wrench, $\frac{9}{16}$ -in.
Pliers	Wrench, open-end, $\frac{3}{4}$ -in.
Screwdriver, 10-in.	Wrench, socket. $\frac{3}{4}$ -in.
Shellac	

b. Procedure.**(1) INSTALL SHIFTER SHAFTS AND FORKS.**

Hammer, 2-lb	Screwdriver, 10-in.
Pliers	Wrench, socket, $\frac{3}{4}$ -in.

(a) Lower the fourth speed shifter fork into transmission case and engage fork in the shifter collar of third speed gear (fig. 201). Slide lower shifter shaft from master clutch compartment through hole in case (fig. 202), through shifter fork, and into support at center of case. Install shaft lock in place (fig. 161) in clutch compartment, and in slot in shifter shaft. Secure with $\frac{1}{2}$ - by $1\frac{3}{4}$ -inch cap screw with lock washer ($\frac{3}{4}$ -in. wrench).

(b) Lower the second and third speed shifter fork into case and engage the fork in the shifter collar of second and third speed pinion (figs. 193 and 203). Slide left upper shifter shaft into place, through clutch inspection hole, into case and through forks; lock in place with setscrew, using large screwdriver (fig. 159).

(c) Place low and reverse shifter fork into case with fork engaging shifter collar of low and reverse pinion (figs. 193 and 204). Slide shaft into place through case and shifter fork; lock in place with setscrew (screwdriver). Install lock wire through both shaft setscrews (pliers).

(d) Install shifter shaft cover cups in case at front end of shifter shafts (hammer). Lubricate all shifter shafts.

(2) INSTALL GEARSHIFTER HOUSING ASSEMBLY.

Wrench, $\frac{3}{4}$ -in.

Shellac gasket to attaching face of gearshifter housing. Set all gears in neutral position. Lower housing into place, being sure that lower end of gearshift lever is in proper alignment with slots in shifter forks (fig. 152). Secure housing with three $\frac{1}{2}$ - by $1\frac{3}{8}$ -inch cap screws with lock washers (two in front corners and one at rear), and four $\frac{1}{2}$ - by $1\frac{1}{2}$ -inch cap screws with lock washers in remaining holes in sides of housing (fig. 151).

(3) INSTALL BEVEL GEAR INSPECTION HOLE COVER.

Wrench, $\frac{9}{16}$ -in.

Install cover with gasket over bevel gear inspection hole with three $\frac{3}{8}$ - by $\frac{3}{4}$ -inch cap screws with lock washers (fig. 153).

GEARSHIFT MECHANISM**(4) INSTALL FLOOR PLATES.**

Wrench, $\frac{3}{4}$ -in. (2)

(a) Install left floor plate, securing it to rear fender with two $\frac{1}{2}$ - by $1\frac{1}{4}$ -inch cap screws, to seat frame with two $\frac{1}{2}$ - by $1\frac{1}{4}$ -inch bolts, and to gearshifter housing with one $\frac{1}{2}$ - by $1\frac{1}{4}$ -inch cap screw. Use lock washers on all bolts and cap screws.

(b) Install right floor plate in same manner, using bolts to secure it to right rear fender instead of cap screws at that point (fig. 150).

ORDNANCE MAINTENANCE — MEDIUM TRACTOR M1 (ALLIS-CHALMERS HD-7W)
ELECTRICAL SYSTEM, POWER TRAIN, FRAME, AND TRACKS

CHAPTER 12

TRUCK FRAME AND TRACK ASSEMBLY

Section I

GENERAL DESCRIPTION

	Paragraph
General description	78

78. GENERAL DESCRIPTION.

a. The truck frame and track assembly consists of the truck frame, truck wheels, track support rollers, front idlers, track release mechanism, and track assembly. The truck frames pivot on the rear axle and are held in line with the drive sprockets by the stabilizer assembly. The weight of the tractor is carried on five truck wheels under each truck frame, except when crossing ditches, logs, rocks, or the like, at which time some weight is imposed on the front idlers or drive sprockets. The track assembly is driven by the drive sprocket, and the position of the front idler determines the amount of normal track tension. The ends of the front idler shaft are mounted in a sliding bracket called the release yoke. An adjusting screw on this track release yoke provides a means of adjusting tension of track by moving the front idler forward or back. If rocks, tree limbs, or other objects should be caught in the track, a spring and bell crank arrangement in the track release housing allows front idler to move back and relieve excess tension which might cause breakage. The support rollers, mounted on the track release housings, support the upper part of the track between front idlers and sprockets.

CHAPTER 12
TRUCK FRAME AND TRACK ASSEMBLY (Cont'd)
Section II

**FRONT IDLERS, TRUCK WHEELS, AND
 TRACK SUPPORT ROLLERS**

	Paragraph
Description	79
Trouble shooting	80
Removal of front idler	81
Removal of truck wheel	82
Disassembly of front idler or truck wheel assemblies.....	83
Removal of track support roller.....	84
Disassembly of track support roller.....	85
Inspection of parts in front idler, truck wheel, and track support rollers	86
Assembly of front idler or truck wheel assemblies.....	87
Assembly of track support roller	88
Installation of front idler	89
Installation of truck wheel	90
Installation of track support roller	91
Special tools	92

79. DESCRIPTION.

a. The front idlers, truck wheels, and track support rollers rotate on tapered roller bearings, and have positive oil seals. This type of seal consists of a steel seal plate and a steel seal ring with their flat sealing surfaces held tightly against each other by a spring-loaded Neoprene boot. Two types of seal boot assemblies are used (par. 87 b (8), and fig. 230). One sealing ring is held stationary; the other turns with the wheel. These seal ring assemblies on each end of the shaft thus form a tight seal, preventing leakage of oil from wheel, or entrance of dirt or water into the assembly. The track support rollers have a different type of spring-loaded oil seal. Mounting brackets are pressed onto the ends of the front idler and truck wheel shafts. Support rollers are supported by brackets in the center between the flanges. The first, third, and fifth truck wheels on each truck frame are single-flanged; the second and fourth are double-flanged (fig. 278). Support rollers are single-flanged. **NOTE:** These positive seal assemblies must be lubricated by changing the oil with the flushing lubricator included with tractor. Under no condition should a pressure gun be used.

**ORDNANCE MAINTENANCE — MEDIUM TRACTOR M1 (ALLIS-CHALMERS HD-7W)
ELECTRICAL SYSTEM, POWER TRAIN, FRAME, AND TRACKS**

80. TROUBLE SHOOTING.**a. Front Idlers.**

Possible Cause	Possible Remedy
(1) OIL LEAKING FROM WHEELS.	
Oil seals damaged.	Replace oil seal assemblies.
(2) WHEEL WOBBLING.	
Shaft bent or broken.	Replace shaft.
Bearings damaged.	Replace bearings.
(3) FLANGES ON WHEEL WEARING.	
Wheel out of alignment with track.	Aline wheel by adjusting shims between idler shaft brackets and track release yoke (par. 89 b (4)).

b. Truck Wheels.

(1) OIL LEAKING FROM WHEEL.	
Oil seals damaged.	Replace oil seal assemblies.
(2) FLANGES ON WHEEL WORN.	
Bolts in mounting bracket loose or missing.	Tighten loose bolts or replace missing bolts.
Tracks out of line.	Aline track and front idler.
Truck frame bent.	Straighten or replace frame.
(3) TRUCK WHEEL DOES NOT TURN.	
Bearings damaged or broken, thus locking wheel.	Replace or rebuild truck wheel.
Truck wheel frozen, due to damaged oil seals.	Replace oil seals.
Shaft broken.	Replace or rebuild truck wheel.
No lubricant in wheel.	Lubricate as specified in TM 9-783B. Wheel will require rebuilding if it has been run without oil.

c. Track Support Rollers.

(1) OIL LEAKING FROM WHEEL.	
Oil seals damaged.	Replace oil seal assemblies.
(2) WHEEL WOBBLING.	
Bolts in mounting bracket loose.	Tighten mounting bolts.
Shaft bent or broken.	Replace shaft and other necessary parts.
Bearings worn or broken.	Rebuild roller.

FRONT IDLERS, TRUCK WHEELS, AND TRACK SUPPORT ROLLERS

(3) FLANGES ON ROLLER WEARING.

Possible Cause	Possible Remedy
Tracks run too loose.	Adjust tracks.
Track out of line.	Aline track.
Truck frame bent or broken.	Straighten or replace frame.
Stabilizer assembly worn.	Replace worn stabilizer parts.

(4) ROLLER DOES NOT TURN.

Roller frozen due to lack of lubricant.	This will require that roller be rebuilt, as bearings and oil seals will be damaged.
Mud frozen around roller.	Apply heat to thaw mud and clean dirt from around roller.

81. REMOVAL OF FRONT IDLER.

a. Tools Required.

Bar, drift, 1- x 12-in.	Wrench, $1\frac{5}{16}$ -in.
Hammer, sledge, 16-lb	Wrench, socket, $\frac{3}{4}$ -in.
Tongs	Wrench, track-adjusting
Wrench, $\frac{7}{8}$ -in.	

b. Procedure.

(1) UNCOUPLE TRACK.

Refer to paragraph 102 for uncoupling procedure.

(2) REMOVE IDLER GUARDS.

Wrench, $\frac{3}{4}$ -in.

Remove two cap screws holding each guard to idler shaft brackets (fig. 279), remove guards from both sides of idler wheel.

(3) REMOVE IDLER FROM TRUCK FRAME.

Wrench, $\frac{3}{4}$ -in.

Remove four cap screws connecting ends of track release yoke to idler shaft brackets, and slide idler brackets and wheel off front end of truck frame (fig. 279).

82. REMOVAL OF TRUCK WHEEL.

a. Tools Required.

Wood block, 8- x-8- x 12-in. (2)	Wrench, $1\frac{5}{16}$ -in.
Wrench, $\frac{7}{8}$ -in.	Wrench, track-adjusting

b. Procedure.

(1) LOOSEN TRACKS.

Wrench, $\frac{7}{8}$ -in.	Wrench, track-adjusting
Wrench, $1\frac{5}{16}$ -in.	

**ORDNANCE MAINTENANCE — MEDIUM TRACTOR M1 (ALLIS-CHALMERS HD-7W)
ELECTRICAL SYSTEM, POWER TRAIN, FRAME, AND TRACKS**

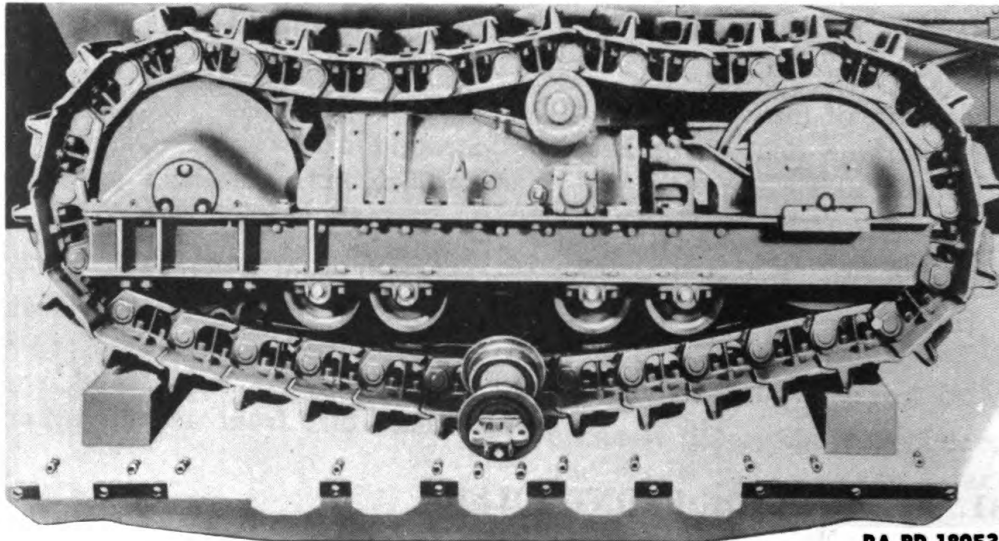

RA PD 18053

Figure 216 — Truck Wheel Removed

Loosen clamp bolts holding track-adjusting screw in track release yoke (fig. 264) ($\frac{7}{8}$ - and $\frac{15}{16}$ -in. wrenches). Turn screw as far as possible into track release yoke to allow track to sag.

(2) DRIVE TRACTOR ONTO BLOCKS.

Wood block, 8- x 8- x 12-in. (2)

Place one block under front of track. Drive tractor forward onto block until block is slightly back of front idler; then place second block under rear of track, and back tractor onto this block. Stop tractor with blocks directly under idler and drive sprocket. Track will sag to ground between blocks (fig. 216).

(3) REMOVE TRUCK WHEEL GUARD.

Wrench, $\frac{7}{8}$ -in.

Wrench, $\frac{15}{16}$ -in.

Remove the nine nuts from bolts holding outside truck wheel guard to truck frame, and remove the guard (fig. 216).

(4) REMOVE TRUCK WHEEL ASSEMBLY.

Wrench, $\frac{7}{8}$ -in.

Wrench, $\frac{15}{16}$ -in.

Remove four bolts holding truck wheel brackets to truck frame. Tap brackets with hammer or pry down with a small bar. The truck wheel assembly will drop down out of frame (fig. 216) and can be removed. **NOTE:** In some cases it may be necessary to loosen bolts holding inside truck wheel guard. One or all of the truck wheels can be removed in this manner.

**FRONT IDLERS, TRUCK WHEELS, AND
TRACK SUPPORT ROLLERS**

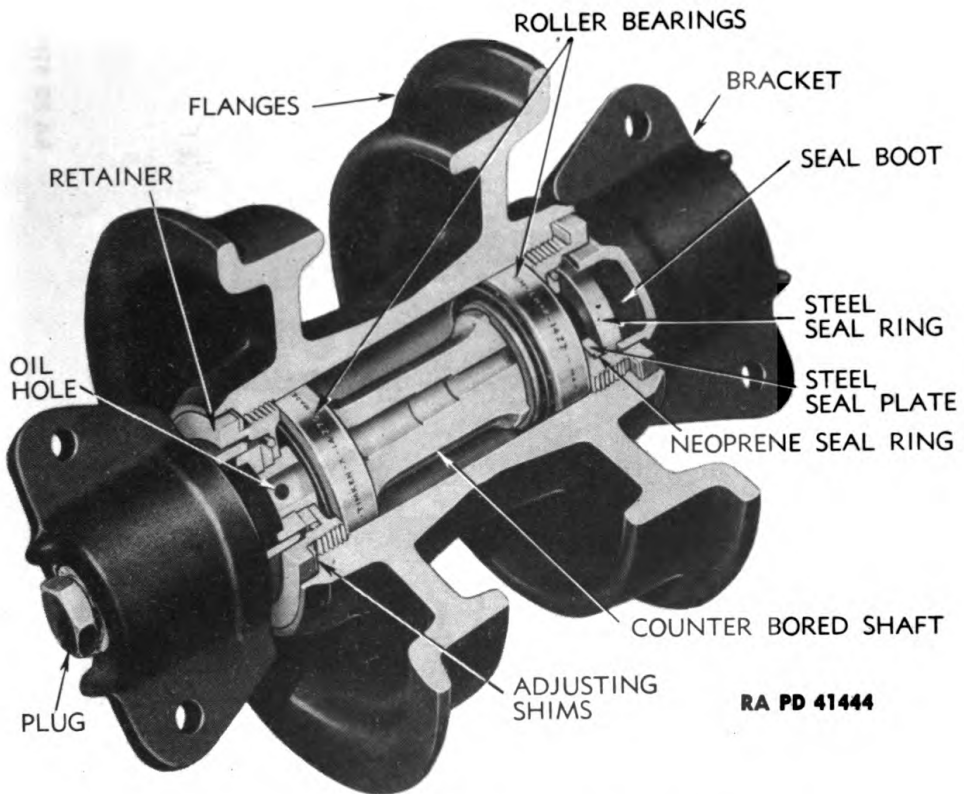

Figure 217 — Cutaway Truck Wheel Assembly

83. DISASSEMBLY OF FRONT IDLER OR TRUCK WHEEL ASSEMBLIES (fig. 217).

a. Tools and Equipment Required.

- | | |
|---|------------------------------|
| Hammer, 2-lb | Wrench, $\frac{9}{16}$ -in. |
| Hammer, 4-lb | Wrench, $\frac{7}{8}$ -in. |
| Press and equipment, truck wheel, special | Wrench, $1\frac{5}{16}$ -in. |
| Punch, center | Wrench, adjustable |
| Wood block | Wrench, plug, truck wheel |

b. Procedure. NOTE: Because of the positive type oil seals and bearings used in the positive seal front idlers, truck wheels, and track support rollers, they must be carefully and correctly disassembled and assembled when repairs are made. All repair work must be done in a clean place where all parts of these assemblies can be kept absolutely clean during assembly. Figure 217 shows a positive seal truck wheel cut away to show the relation of parts. The front idler, except for the difference in size and shape of wheel and brackets, is

ORDNANCE MAINTENANCE — MEDIUM TRACTOR M1 (ALLIS-CHALMERS HD-7W)
ELECTRICAL SYSTEM, POWER TRAIN, FRAME, AND TRACKS

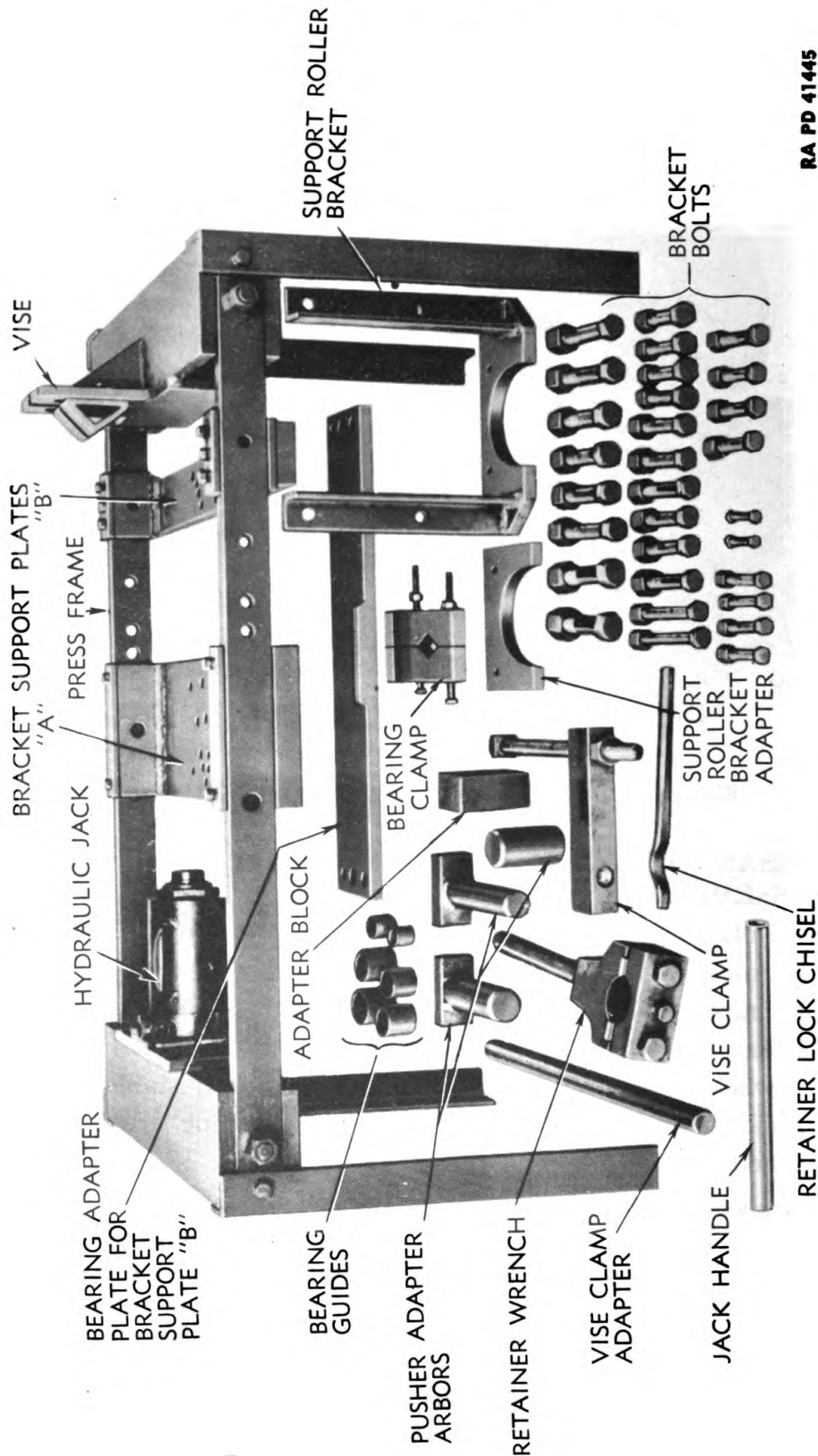

RA PD 41445

Figure 218 — Special Truck Wheel Press and Equipment

**FRONT IDLERS, TRUCK WHEELS, AND
TRACK SUPPORT ROLLERS**

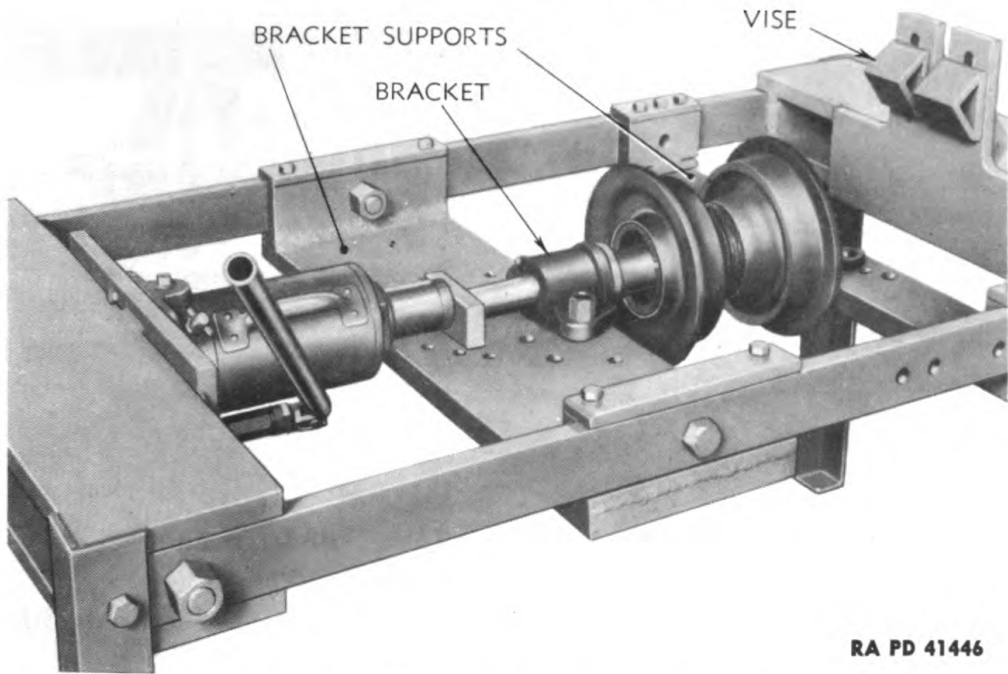

Figure 219 — Truck Wheel Installed in Press

of exactly the same construction. Figure 218 shows a special press and tool equipment, available from the manufacturer of the tractor for disassembling and assembling either a front idler, truck wheel, or

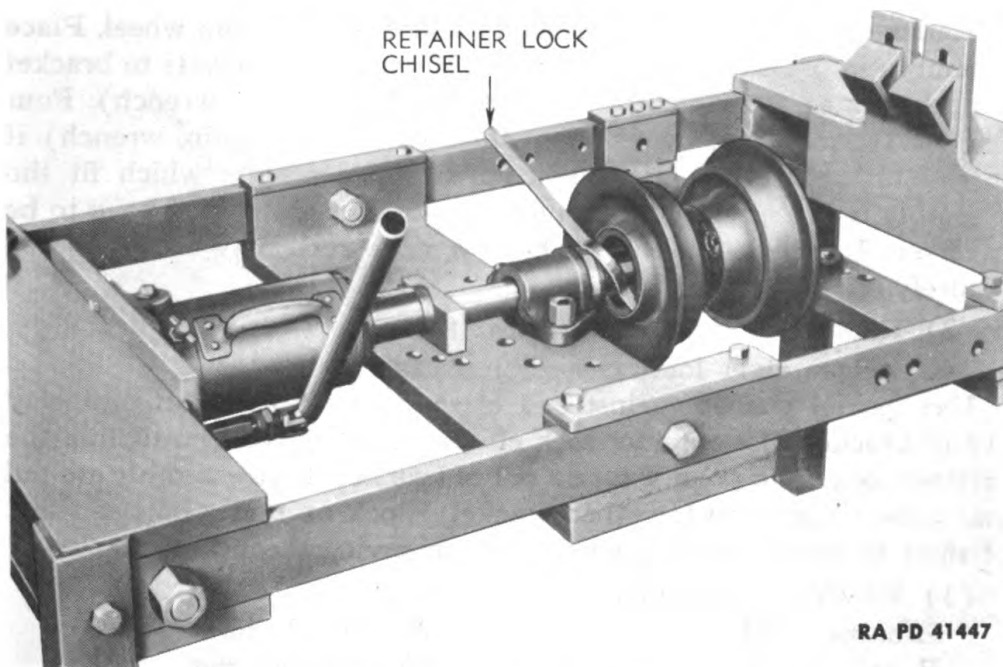
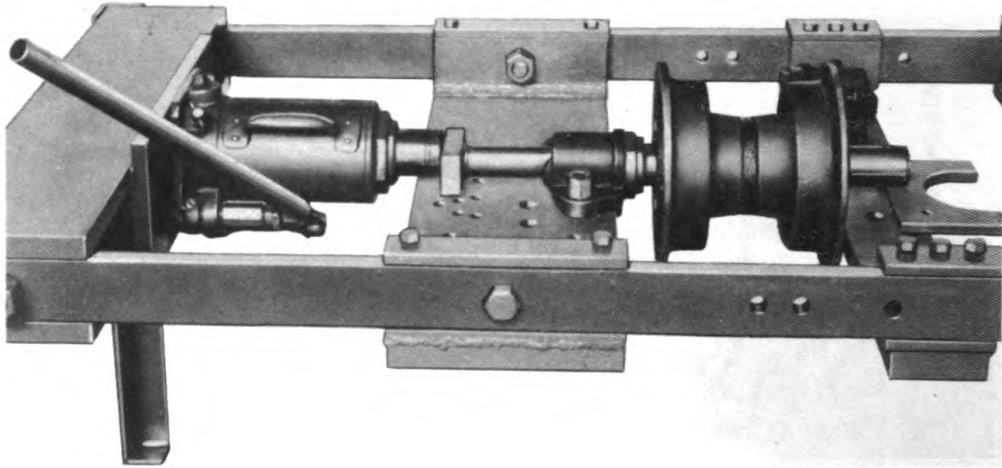

Figure 220 — Straightening Retainer Lock

**ORDNANCE MAINTENANCE — MEDIUM TRACTOR M1 (ALLIS-CHALMERS HD-7W)
ELECTRICAL SYSTEM, POWER TRAIN, FRAME, AND TRACKS**



RA PD 41448

Figure 221 — Pressing Second Bracket from Shaft

track support roller. This press accommodates wheels for three different sizes of tractors.

Proceed as follows to disassemble truck wheel or front idler (procedure for both is exactly the same, with exception of the removal of retainers).

(1) PLACE ASSEMBLY IN PRESS.

Wrench, $\frac{7}{8}$ -in.

Wrench, plug, truck wheel

Wrench, $\frac{15}{16}$ -in.

Remove shaft plug (plug wrench) and drain oil from wheel. Place assembly in press as shown in figure 219 and bolt brackets to bracket support plates with four $\frac{5}{8}$ - by 3-inch bolts ($\frac{15}{16}$ -in. wrench). Four $\frac{5}{8}$ - by $3\frac{3}{4}$ -inch and two $\frac{5}{8}$ - by $3\frac{1}{4}$ -inch bolts ($\frac{15}{16}$ -in. wrench) if disassembling front idler, use holes in support plate which fit the assembly being serviced. In some cases support plates will have to be reversed. Use high nuts on all bolts and be sure they are tightened securely.

(2) REMOVE BRACKETS FROM SHAFT.

Chisel, retainer lock

Hammer, 2-lb

Use special pusher against end of shaft and press shaft part way out of bracket. Use retainer lock chisel (fig. 220) and straighten the retainer lock, then press shaft on out of bracket. Turn assembly around and repeat operation for other bracket. Block up under opposite end of shaft to keep assembly level while removing second bracket.

(3) REMOVE RETAINERS.

Hammer, 4-lb

Wrench, $\frac{3}{4}$ -in.

Punch, center

Wrench, retainer

Wrench, $\frac{9}{16}$ -in.

**FRONT IDLERS, TRUCK WHEELS, AND
TRACK SUPPORT ROLLERS**

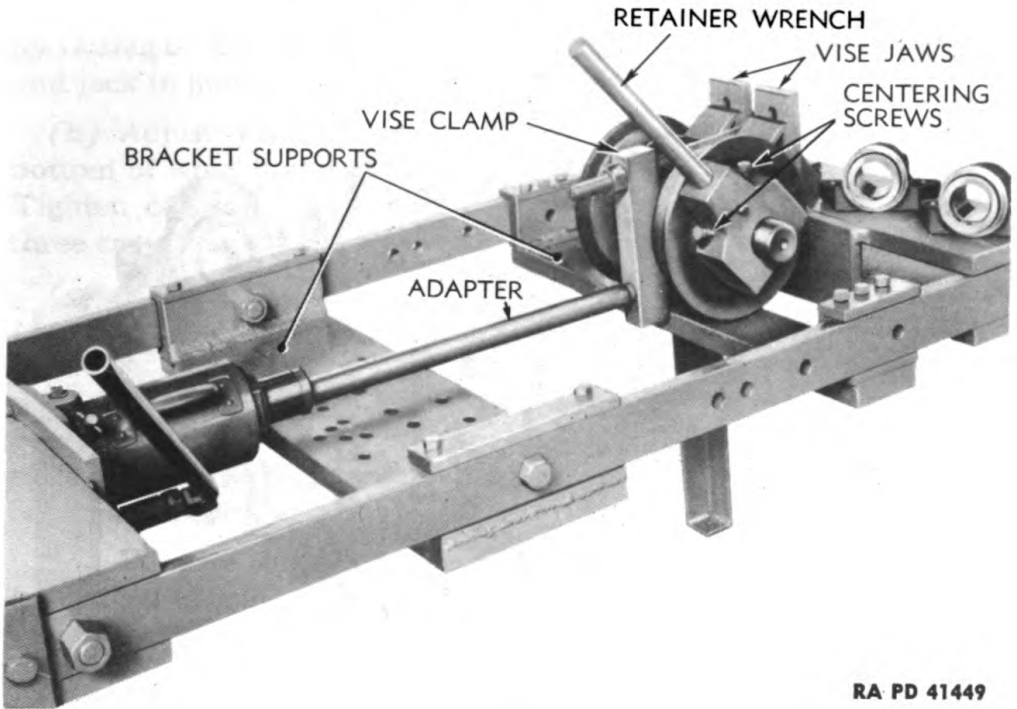

RA PD 41449

Figure 222 — Truck Wheel Installed in Vise

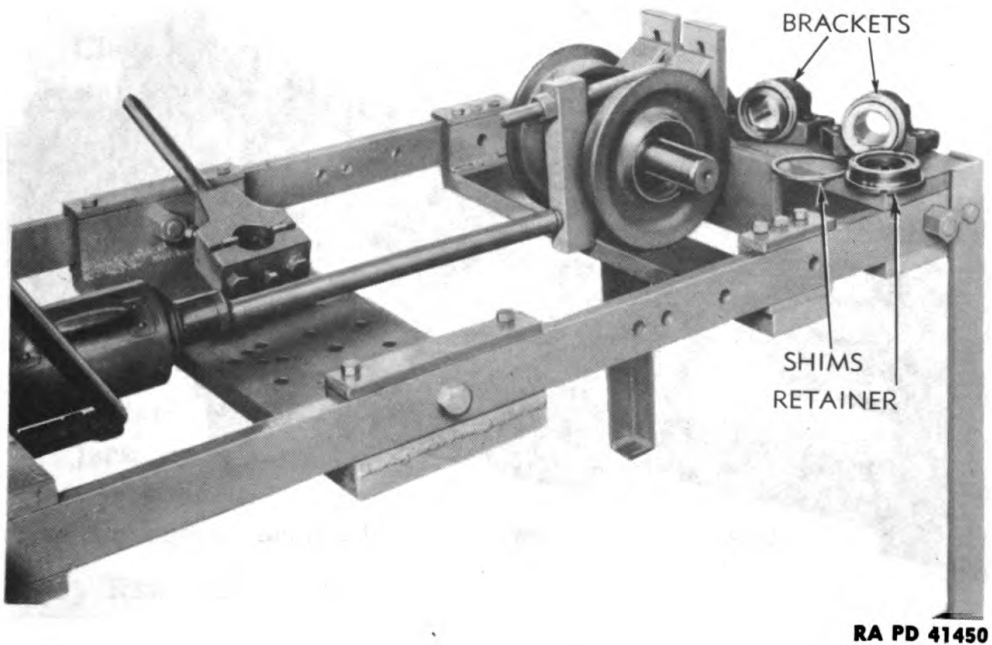

RA PD 41450

Figure 223 — Brackets, Retainer, and Shims Removed

**ORDNANCE MAINTENANCE — MEDIUM TRACTOR M1 (ALLIS-CHALMERS HD-7W)
ELECTRICAL SYSTEM, POWER TRAIN, FRAME, AND TRACKS**

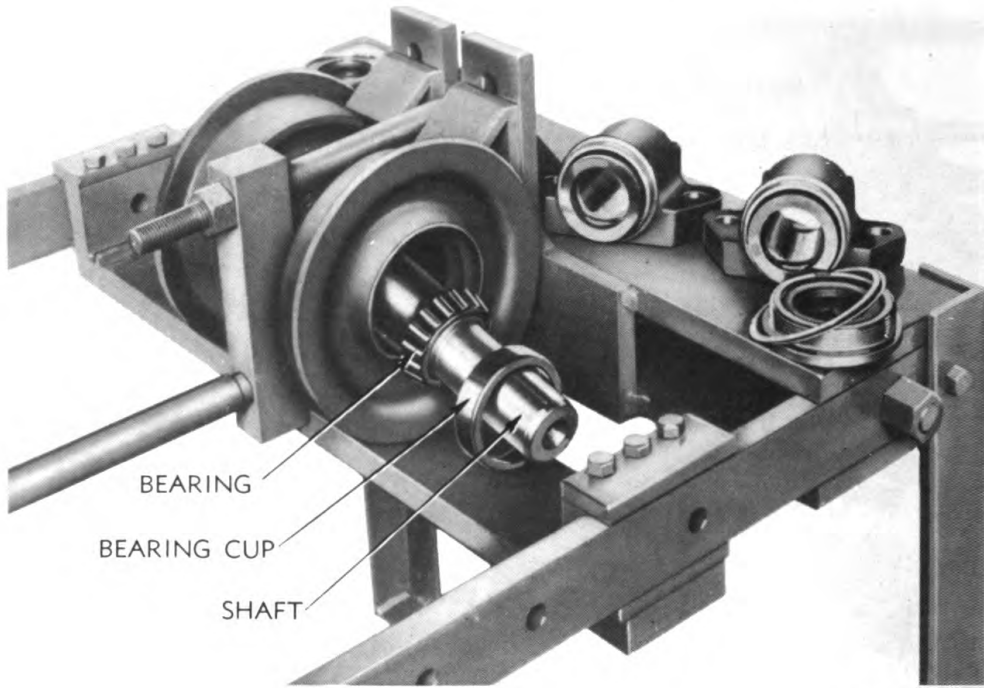

RA PD 41451

Figure 224 — Shaft and Bearing Removed

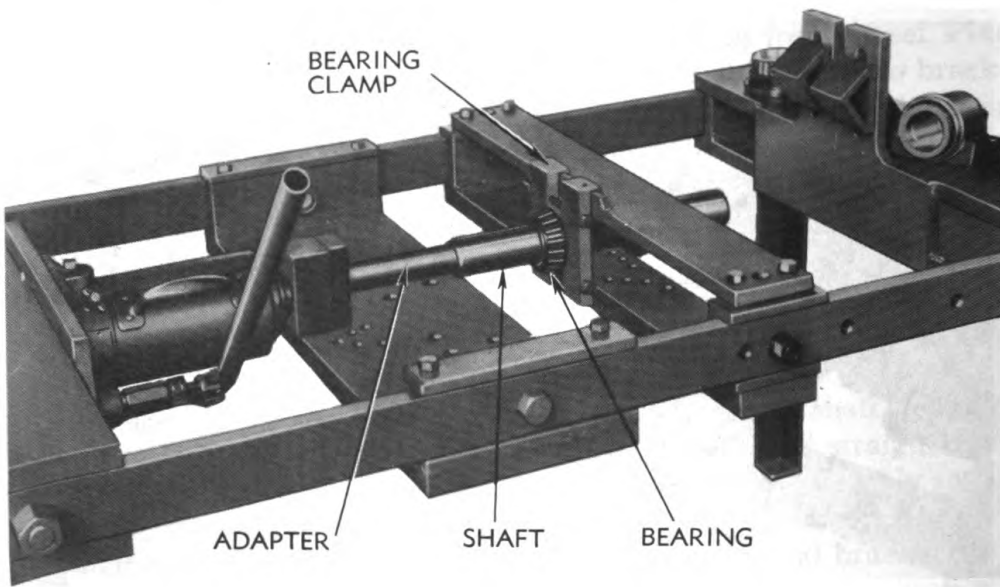

RA PD 41452

Figure 225 — Removing Bearings from Shaft

FRONT IDLERS, TRUCK WHEELS, AND TRACK SUPPORT ROLLERS

(a) Install truck wheel in vise (fig. 222). Adjust vise to fit wheel by raising or lowering jaws and adjusting vise clamp, then use adapter and jack to hold wheel.

(b) Adjust retainer wrench as follows: Loosen two cap screws in bottom of wrench and adjust lugs on wrench to fit into retainer slots. Tighten cap screws ($\frac{9}{16}$ -in. wrench). Center wrench on shaft with three cap screws in side of wrench head.

(c) Mark each retainer and flange with center punch so that retainers can be assembled in their original position. Use the heavy hammer on handle of retainer wrench to loosen retainers; then remove retainers. NOTE: The front idler will not require the use of the retainer wrench, as the retainers are held in with six cap screws in each retainer. Remove these cap screws ($\frac{3}{4}$ -in. wrench) and remove retainers (fig. 223).

(d) Remove shims with their respective retainers so they may be assembled in same end of wheel.

(4) REMOVE SHAFT AND BEARING ASSEMBLIES.

Chisel, retainer lock Wood block
Hammer, 2-lb

Using hammer and wood block, drive against one end of shaft, removing shaft, bearings, and one bearing cup (fig. 224). Use retainer lock chisel as punch, and drive other bearing cup out of wheel.

(5) REMOVE BEARINGS FROM SHAFT.

Clamp, bearing

Install bearing clamp on press (fig. 225) and press shaft out of bearings.

84. REMOVAL OF TRACK SUPPORT ROLLER.

a. Tools Required.

Jack, hydraulic Wrench, $\frac{7}{8}$ -in.

b. Procedure.

(1) RAISE TRACK FROM ROLLER.

Jack, hydraulic

Set jack on track release housing and jack track up off support roller far enough to clear flanges of roller (fig. 226).

(2) REMOVE ROLLER ASSEMBLY.

Wrench, $\frac{7}{8}$ -in.

Remove the two cap screws holding roller bracket to support bracket (fig. 226) and lift off roller assembly.

FRONT IDLERS, TRUCK WHEELS, AND TRACK SUPPORT ROLLERS

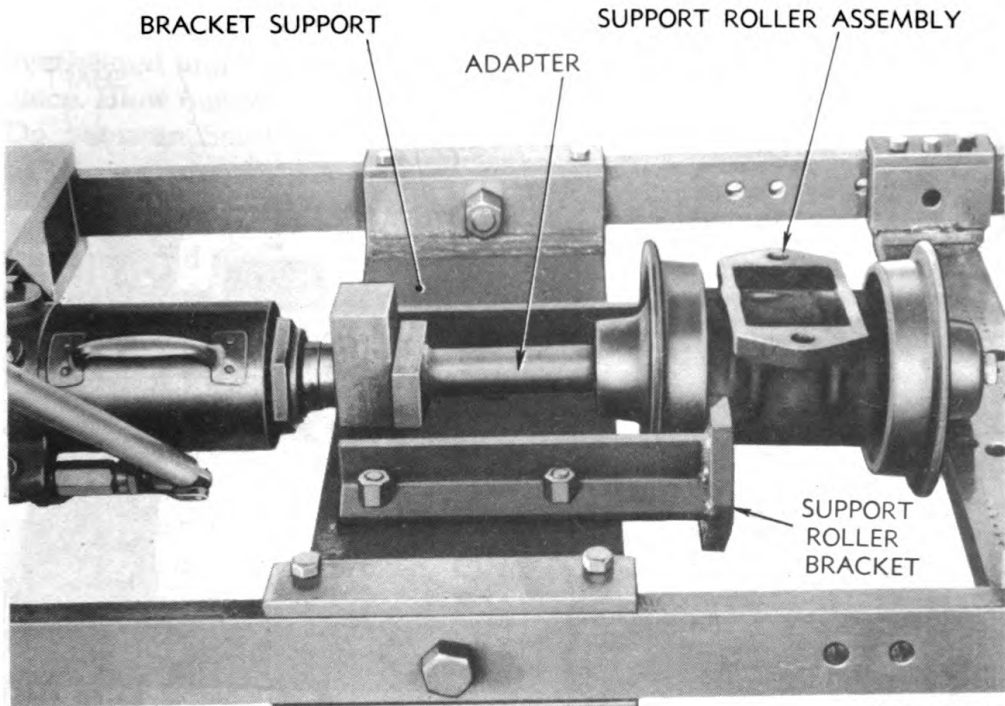

RA PD 41453

Figure 227 — Track Support Roller Installed in Press

(b) Reverse support roller in press; block up under end of shaft from which roller has been removed to keep assembly level; and press shaft out of other roller.

(3) REMOVE BEARING RETAINERS AND SHIMS.

Hammer, 2-lb

Screwdriver, 10-in.

Punch, center

Place support roller bracket in vise of press (par. 83 b (3)), mark position of retainer on bracket with center punch and hammer, and remove six screws from the retainers in each end of roller bracket (screwdriver). Keep shims with retainer with which they were removed so parts may be assembled in their original position (fig. 229).

(4) REMOVE SHAFT AND BEARING ASSEMBLIES.

Use same procedure as outlined in paragraph 83 b (4) and (5).

(5) REMOVE OIL SEALS.

Hammer, 2-lb

Punch, drift, small

Tap oil seals from bearing retainers.

86. INSPECTION OF PARTS IN FRONT IDLER, TRUCK WHEEL, AND TRACK SUPPORT ROLLERS.

a. Front Idler.

(1) **SHAFTS AND BEARINGS.** Clean and inspect bearing rollers and cups for chipping, roughness, wear, and discoloration. Bearing races,

**ORDNANCE MAINTENANCE — MEDIUM TRACTOR M1 (ALLIS-CHALMERS HD-7W)
ELECTRICAL SYSTEM, POWER TRAIN, FRAME, AND TRACKS**

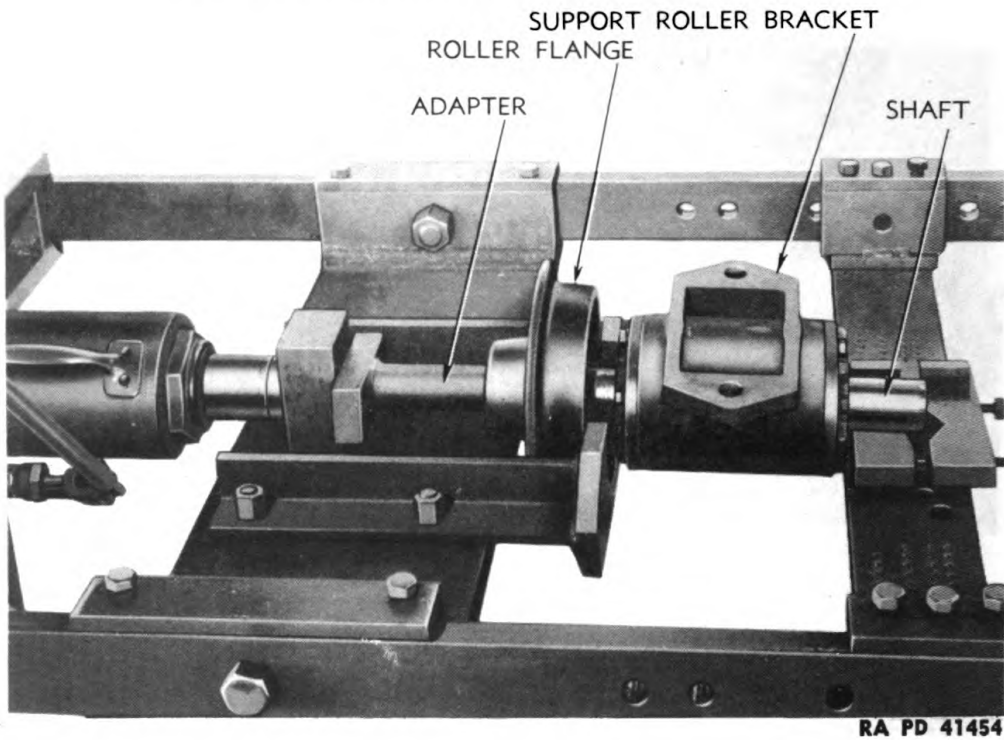

Figure 228 — Pressing Shaft out of Rollers

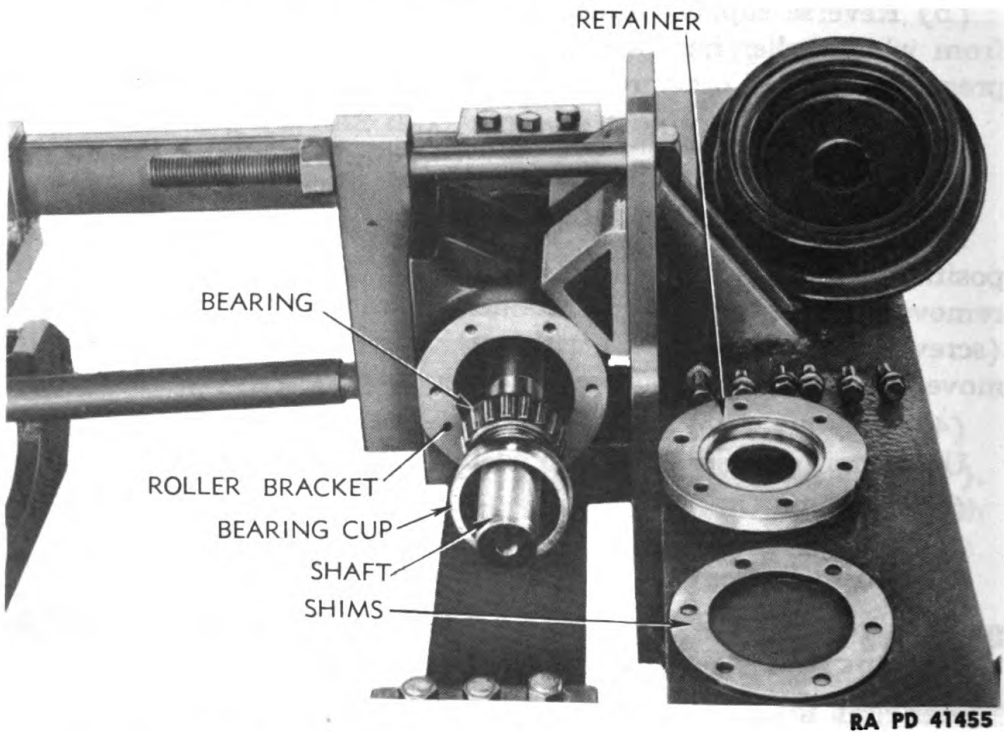

Figure 229 — Retainers, Shaft, and Bearings Removed

FRONT IDLERS, TRUCK WHEELS, AND TRACK SUPPORT ROLLERS

cups, and rollers must have a bright polished surface and be perfectly smooth. Blue or dark-colored parts indicate that bearings have been overheated and are unfit for further use. If shaft is worn or bent, replace. Blow out oil passages in shaft with compressed air. **CAUTION:** Do not spin bearings with compressed air when drying them after they have been cleaned.

(2) **SEAL PLATES AND SEAL RING ASSEMBLIES.** Clean and inspect seal rings and plates for scoring or roughness. The contacting surfaces of the seal rings and seal plates must be perfectly flat and smooth to insure a perfect seal against entrance of dirt, or leakage of oil. Clean grooves in seal plates so that new Neoprene seal rings may be installed. Discard worn or damaged parts.

(3) **BRACKETS AND RETAINERS.** Clean grooves in brackets for Neoprene seal boots. Be sure all old cement and particles of Neoprene are scraped out of these grooves. Discard brackets or retainers that are damaged or broken. Clean inside of retainers with emery cloth or sandpaper to remove all rust and paint. Discard damaged oil seals in track support roller retainers. Remove broken bolts from idler brackets, by drilling into broken piece, inserting screw extractor into drilled hole, and screwing broken piece out.

(4) **NEOPRENE SEAL BOOTS.** The Neoprene seal boots may be used again when assembling if they are not softened or damaged in any way. Unless noncorrosive oil that is not injurious to the boots has been used in rollers, the seal boot is apt to have been rendered unfit for further service.

(5) **IDLER WHEELS AND ROLLER FLANGES.** Replace worn roller flanges or rollers, and broken or badly worn idlers. Do not do any welding on hubs of idlers, or truck wheels, and track support rollers, unless shaft and bearing assemblies are first removed from them. The heat will damage the bearings and oil seal assemblies, especially the Neoprene seal boot and Neoprene seal ring, and cause rollers to leak and wear out quickly.

87. ASSEMBLY OF FRONT IDLER OR TRUCK WHEEL ASSEMBLIES.

a. Tools Required.

Cement, Neoprene

Hammer, 1/2-lb

Hammer, 2-lb

Hammer, 4-lb

Pliers

Press and equipment, truck
wheel, special

Screwdriver, 2-in.

Wood block

Wrench, 3/4-in.

Wrench, adjustable

Wrench, plug, truck wheel

**ORDNANCE MAINTENANCE — MEDIUM TRACTOR M1 (ALLIS-CHALMERS HD-7W)
ELECTRICAL SYSTEM, POWER TRAIN, FRAME, AND TRACKS**

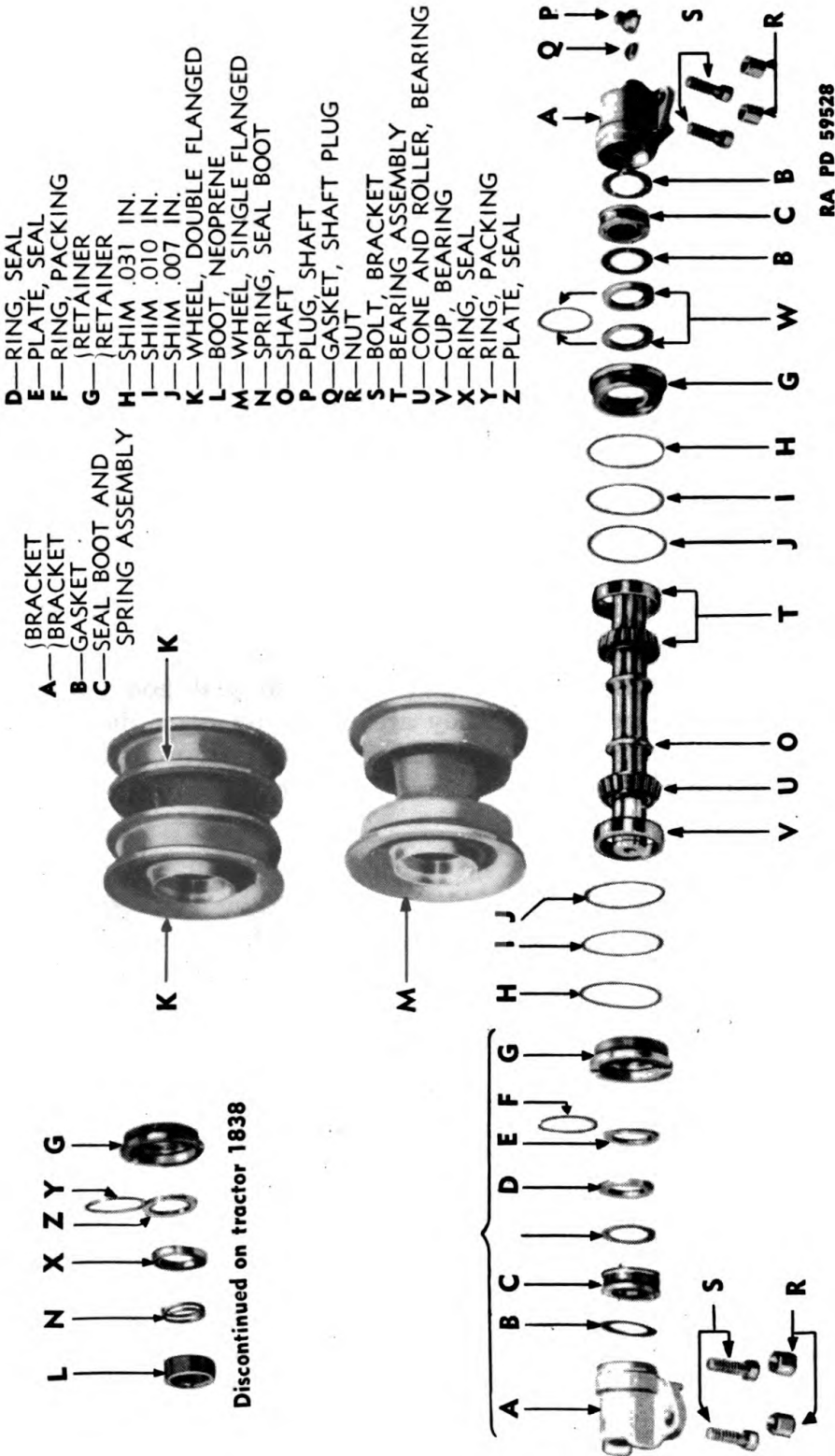

RA PD 59528

Figure 230 — Truck Wheel Assembly — Exploded View

FRONT IDLERS, TRUCK WHEELS, AND TRACK SUPPORT ROLLERS

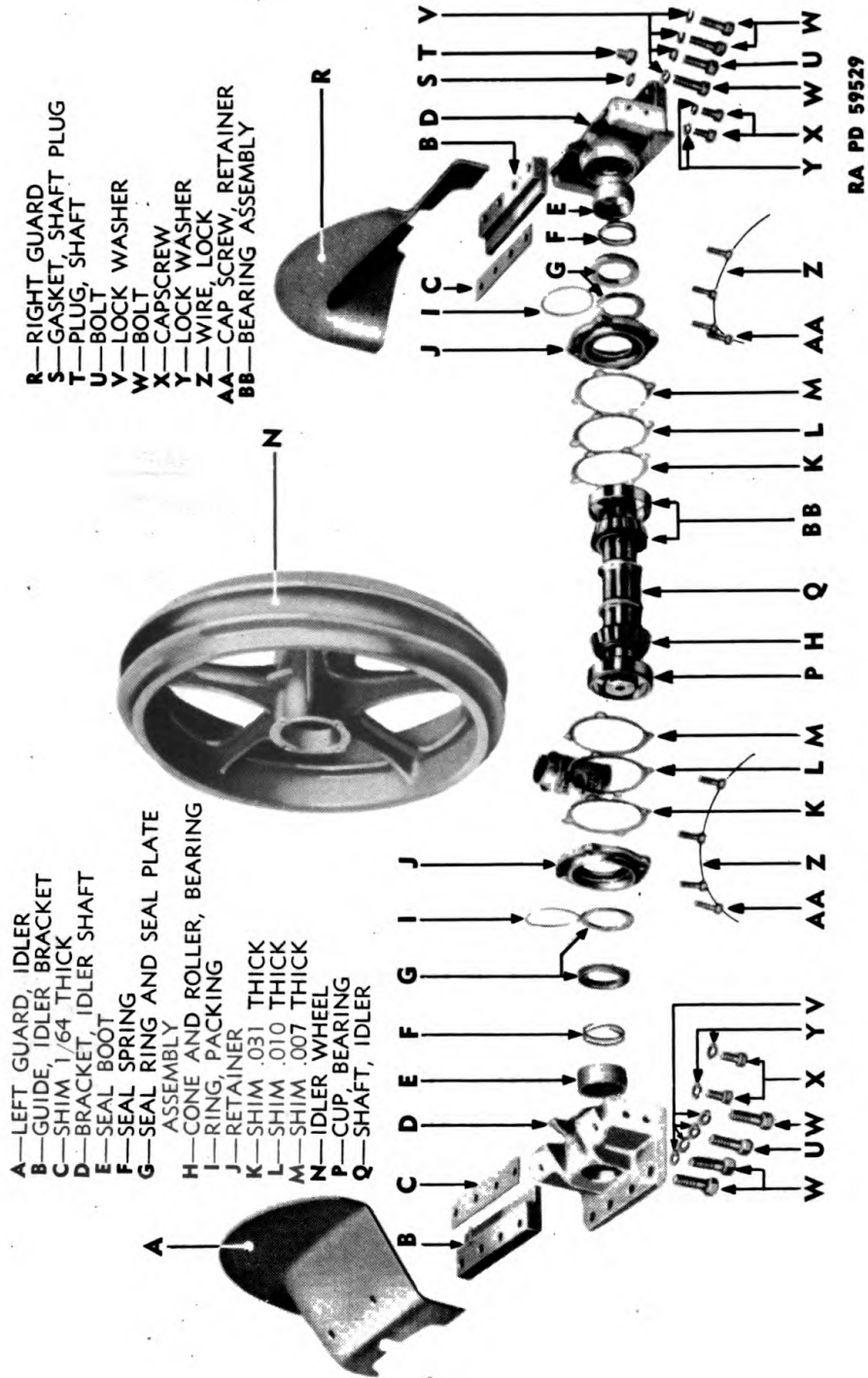
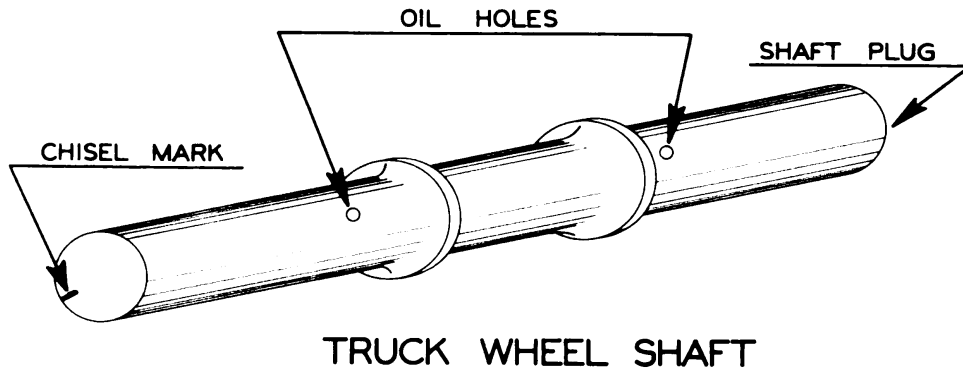
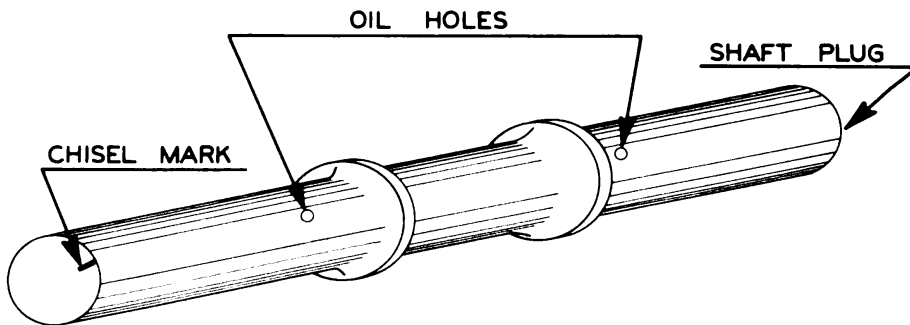

Figure 231 — Front Idler Assembly — Exploded View

ORDNANCE MAINTENANCE — MEDIUM TRACTOR M1 (ALLIS-CHALMERS HD-7W)
ELECTRICAL SYSTEM, POWER TRAIN, FRAME, AND TRACKS



TRUCK WHEEL SHAFT



IDLER SHAFT

RA PD 41456

Figure 232 — Shafts Marked for Assembly Purpose

b. Procedure. CAUTION: Thoroughly wash and clean all parts before assembling. Make sure that oil passages in shaft are open. If a new shaft is to be installed in truck wheel or front idler, use a chisel and mark the shaft on the end opposite the shaft plug (fig. 232). These marks are to be used as a guide when pressing the brackets on shaft, so that oilholes in shaft will be on the top side when the assembly is reinstalled on the tractor. Have mark at top when pressing brackets onto the shaft.

(1) INSTALL BEARINGS.

- Clamp, bearing
- Guide, bearing

Wrench, $\frac{9}{16}$ -in.

Select bearing guide that will fit inside the inner race of the bearing and adjust jaws of bearing clamp so that bearing guide will slip through between them (figs. 233 and 234). Start bearing on end of shaft, place guide in inner race of bearing from small end of bearing, and press bearing onto shaft. Reverse shaft and repeat operation for other bearing.

**FRONT IDLERS, TRUCK WHEELS, AND
TRACK SUPPORT ROLLERS**

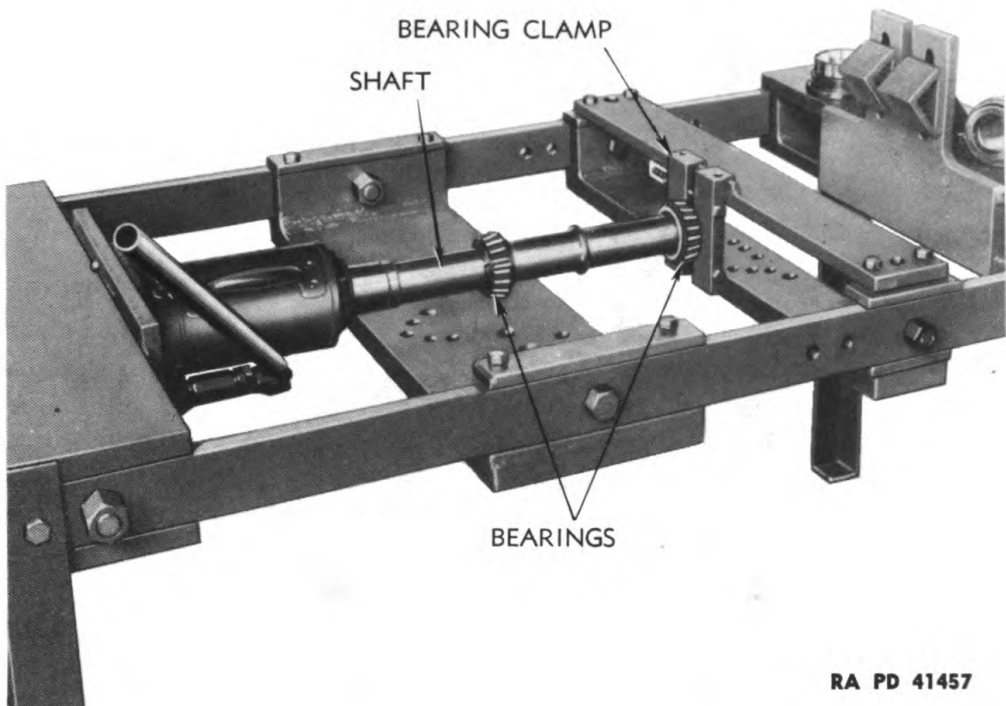

RA PD 41457

Figure 233 — Bearing in Installation Position

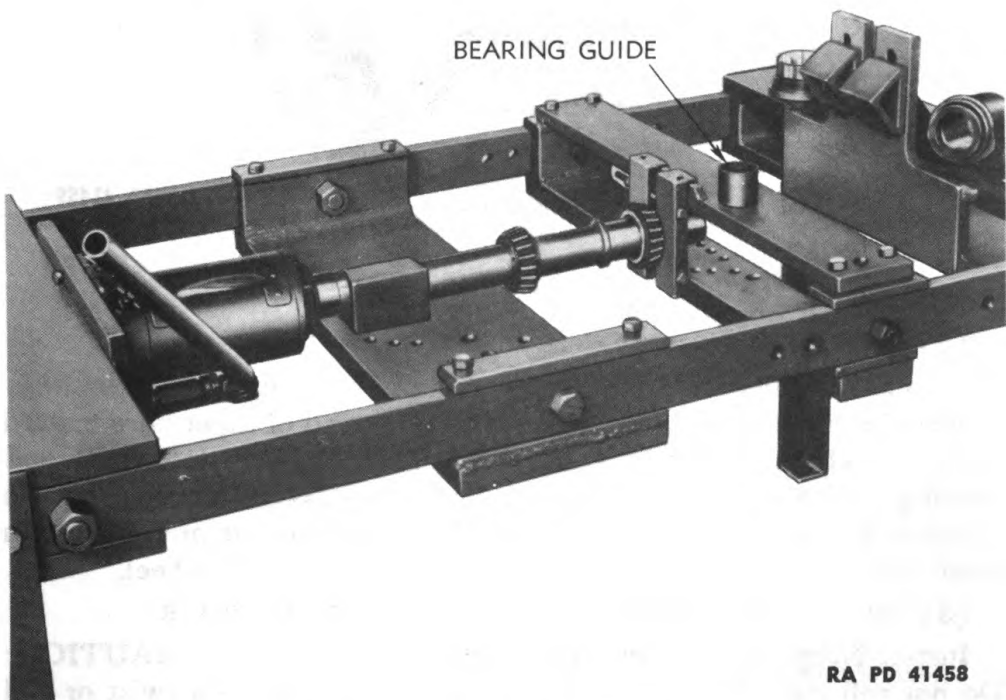

RA PD 41458

Figure 234 — Installing Bearings on Shaft

**ORDNANCE MAINTENANCE — MEDIUM TRACTOR M1 (ALLIS-CHALMERS HD-7W)
ELECTRICAL SYSTEM, POWER TRAIN, FRAME, AND TRACKS**

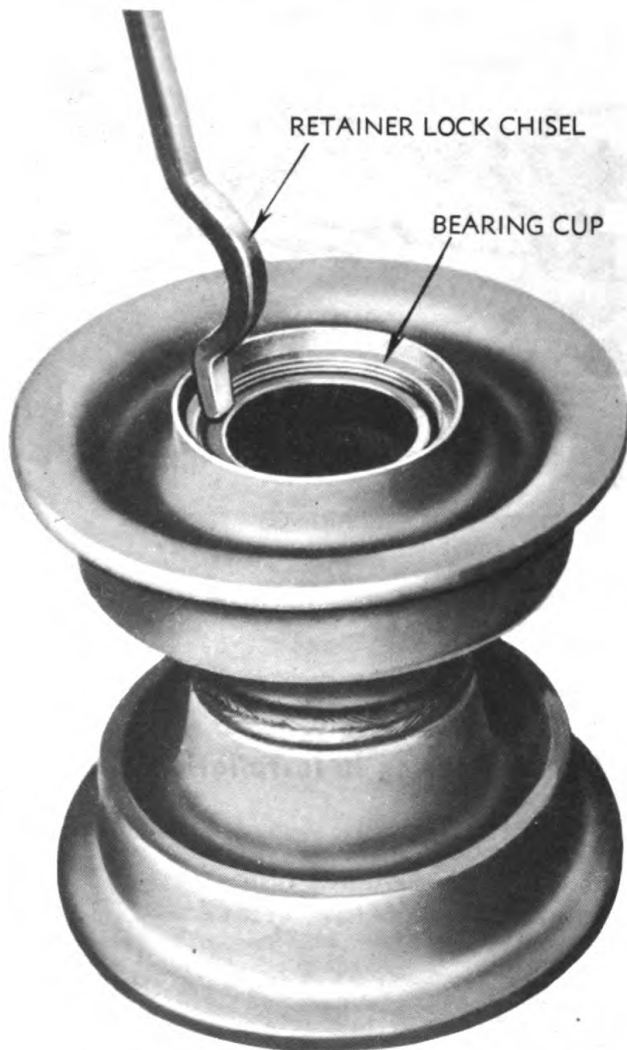

RA PD 41459

Figure 235 — Installing Bearing Cup

(2) INSTALL BEARING CUPS.

Chisel, retainer lock

Hammer, 2-lb

Install one bearing cup in wheel with large end of taper bore toward inside of wheel (hammer and chisel) (fig. 235). Install shaft and bearing assemblies through wheel, and install other bearing cup in opposite end of wheel in same manner. Coat bearings and cups with clean engine oil before inserting shaft and bearings in wheel.

(3) INSTALL NEOPRENE PACKING RING IN SEAL PLATE.

Install Neoprene packing ring in groove in seal plate. **CAUTION:** Do not roll ring into groove, as this is likely to leave a twist or roll in the ring and cause a leak. Ring *must* lie in groove evenly without being twisted (par. 86 a (2)).

**FRONT IDLERS, TRUCK WHEELS, AND
TRACK SUPPORT ROLLERS**

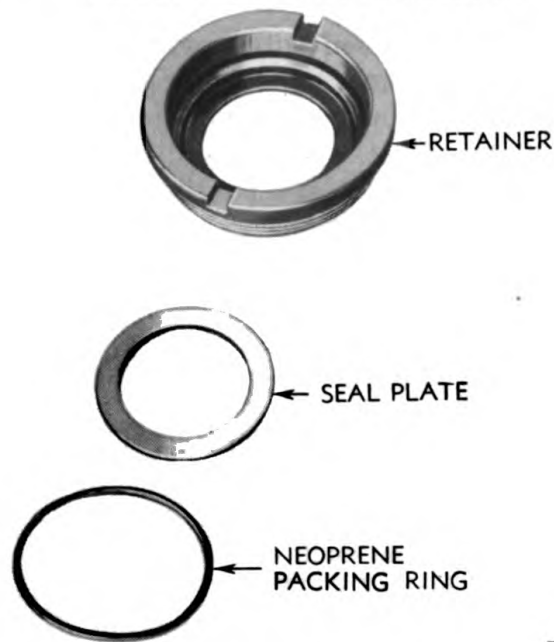

RA PD 41460

Figure 236 — Retainer, Seal Plate, and Neoprene Packing Ring

(4) INSTALL SEAL PLATES IN RETAINERS.

Hammer, 1/2-lb

Wood block

Using a block of wood, press seal plates into retainers, with chamfer on inner bore of plates toward threaded end of retainers. It may be

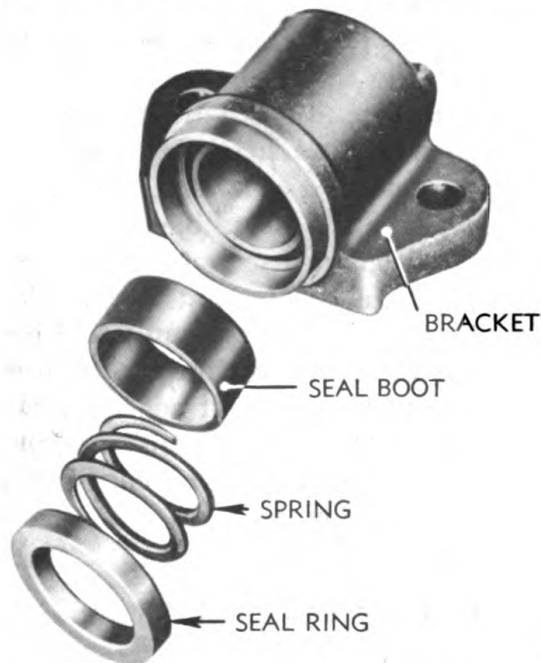

RA PD 41461

Figure 237 — Truck Wheel Bracket, Seal Ring, and Boot Assembly

**ORDNANCE MAINTENANCE — MEDIUM TRACTOR M1 (ALLIS-CHALMERS HD-7W)
ELECTRICAL SYSTEM, POWER TRAIN, FRAME, AND TRACKS**

necessary to tap block of wood with hammer to properly seat seal plates in retainers. Use clean engine oil on Neoprene ring when installing the seal plates and be careful not to damage, mar, or scratch surfaces of seal plates. Check after installing to determine if they seat properly in retainers and are parallel with the back walls of retainers. There should be a slight spring back when seal plate is pressed tight against back wall of retainer.

(5) INSTALL RETAINERS.

Hammer, 4-lb
Wrench, $\frac{3}{4}$ -in.

Wrench, retainer

Place truck wheel in vise of press. Install shims and retainer (sub-par. b (9) below) over end of shaft, using same number and thickness of shims removed with the retainer being installed. If shims have been mixed up, use one each of the three thicknesses furnished, $\frac{1}{32}$, 0.010, and 0.007 inch. **CAUTION:** Make sure shims seat on shoulder of retainer and do not get into threads or between retainer and bearing. Tighten retainers securely by using heavy hammer on handle of retainer wrench (fig. 222).

(6) ADJUST BEARINGS.

Hammer, 4-lb
Wood block

Wrench, $\frac{3}{4}$ -in.

Using hard wood block and hammer, drive first on one end of shaft and then on the other to position the bearing cups against retainers. Test for proper preloading of bearings by grasping end of shaft in hands and turning shaft (fig. 238). There should be a slight drag if bearings are properly adjusted. Shims may have to be removed from under retainers or added to get this adjustment; to do this, remove retainer from one end of wheel, add or remove estimated number of shims required and reassemble. **CAUTION:** Never remove an excessive amount of shims from one end of the wheel; that is, the total thickness of shims in one end of the wheel must not vary from those in the other end by more than 0.020 inch in truck wheel, or 0.030 inch in front idler. Install shims in both ends to avoid this, if necessary. Always test preloading of bearings, as in preceding step, after adjusting shims. **NOTE:** If assembling front idler, use same procedure except that retainer is held by cap screws ($\frac{3}{4}$ -in. wrench) instead of being screwed into wheel.

(7) LOCK RETAINERS.

Chisel, retainer lock
Hammer, 2-lb

Pliers

Lock retainers by driving a section of the edge of wheel hub into the two slots provided in the retainer (fig. 239). Remove wheel from

FRONT IDLERS, TRUCK WHEELS, AND TRACK SUPPORT ROLLERS

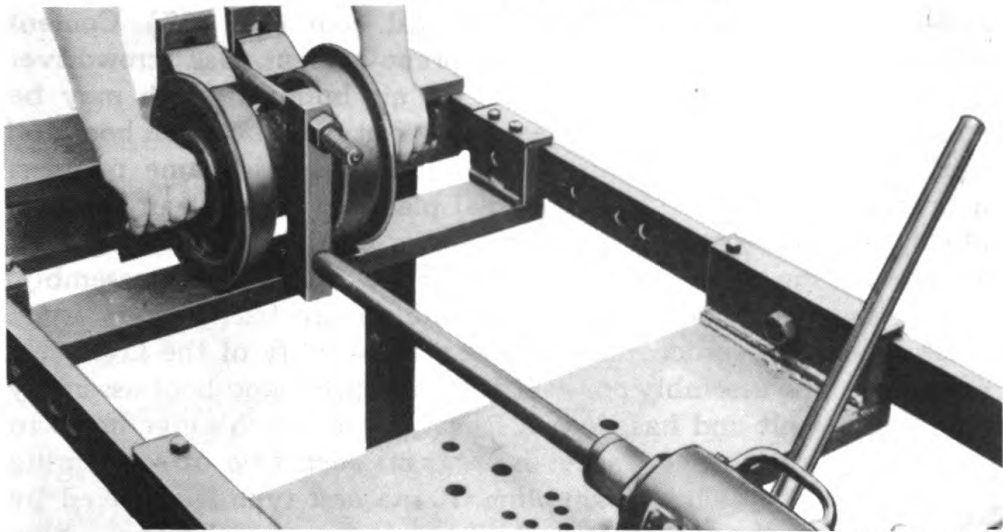

RA PD 41462

Figure 238 — Testing Bearing Adjustment

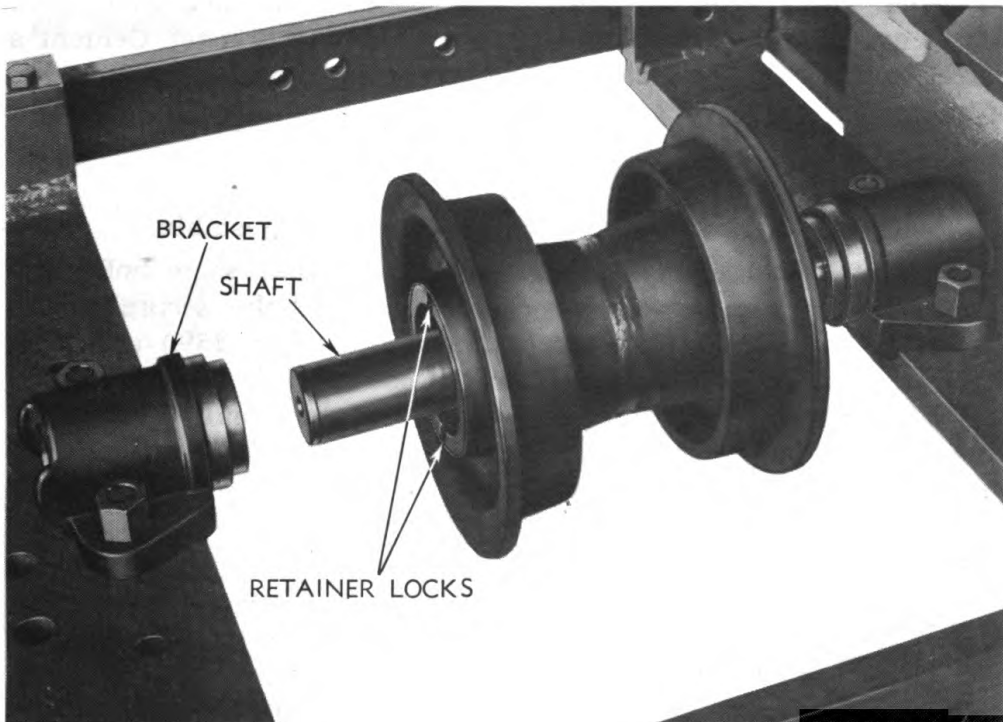

RA PD 41472

Figure 239 — Preparing to Install Bracket on Shaft

vis. **NOTE:** If assembling front idler, lock cap screws in retainer with wire through heads of cap screws (pliers).

(8) ASSEMBLE SEAL RING, BOOT, AND BRACKET.

Screwdriver, 2-in.

**ORDNANCE MAINTENANCE — MEDIUM TRACTOR M1 (ALLIS-CHALMERS HD-7W)
ELECTRICAL SYSTEM, POWER TRAIN, FRAME, AND TRACKS**

Install seal spring inside Neoprene seal boot (fig. 237). Cement boot into groove in bracket with Neoprene cement. Use screwdriver when cementing boot and work out all air bubbles which may be trapped in groove under boot to assure a tight bond between boot and metal. Cement seal ring onto other end of boot in same manner. Set bracket on bench with face of seal plate up, lay a clean cloth on seal ring, and place a weight on top to hold assembly firmly together. Allow to dry for at least an hour. Repeat for other bracket assembly. **NOTE:** Two types of seal boot assemblies are used in the truck wheels. The above procedure outlines the assembly of the first type. The second type assembly consists of a seal spring and boot assembly which is one unit and has dowels in each side which enter holes in bracket and seal ring. A gasket is used on each side of seal spring and boot assembly when assembling. If the first type is replaced by the second type, the second type shaft brackets and seal plates, which have holes for entrance of dowels in them, must also be used. To assemble the second type, cement a gasket to one outer side of seal boot and spring assembly with Neoprene cement; then coat outer side of gasket with cement, and place assembly in bracket. Cement a gasket to other side of seal boot and spring assembly, coat outer side of gasket with cement, and lay seal ring on assembly. Place weight on assembled parts and allow the cement to dry.

(9) INSTALL BRACKET ASSEMBLIES.

Scale or ruler, 18-in.

Wrench, adjustable

(a) Bolt bracket to press bracket support, using same holes and bolts used for disassembly of wheel. Tighten bolts securely with adjustable wrench. Install truck wheel in press (fig. 239) and start shaft into bracket, making sure that the chisel mark on end of shaft is up. Place proper blocking between end of shaft and end plate of press (fig. 240). Clean and lubricate machined surfaces of seal ring and seal plate and press first bracket ("A," fig. 242) onto shaft until the measurement between the face of the retainer and the machined shoulder of the bracket is $\frac{3}{16}$ inch (plus or minus $\frac{1}{32}$ in.) if assembling truck wheel, or $\frac{3}{32}$ inch (plus or minus $\frac{1}{32}$ in.) if assembling front idler (fig. 241). **CAUTION:** If the outside face of the retainer is worn, the amount of wear must be taken into consideration and added to the dimensions given above. The amount of wear can be determined by measuring the thickness of the retainer before it is assembled into the wheel. A new truck wheel retainer is $1\frac{1}{16}$ inches thick; a new front idler retainer is $1\frac{3}{16}$ inches thick.

(b) Remove blocking between end of shaft and press end plate, and bolt second bracket ("B," fig. 242) securely to narrow bracket support. Block between "B" bracket and end plate of press and, using suitable adapter between end of shaft and jack, press shaft into "B" bracket in

**FRONT IDLERS, TRUCK WHEELS, AND
TRACK SUPPORT ROLLERS**

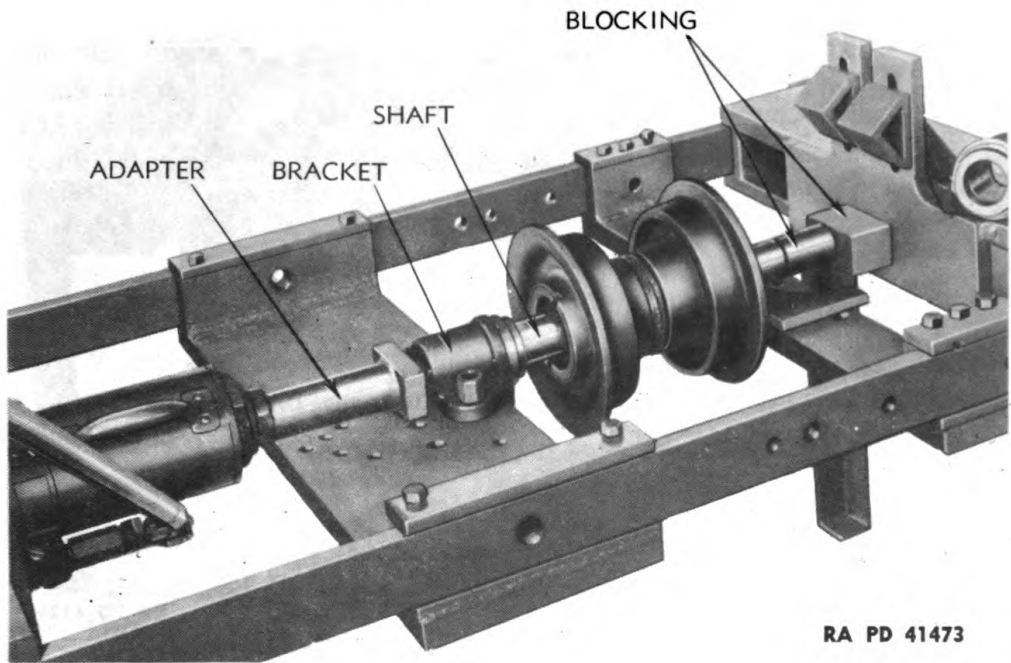

RA PD 41473

Figure 240 — Installing Bracket on Truck Wheel

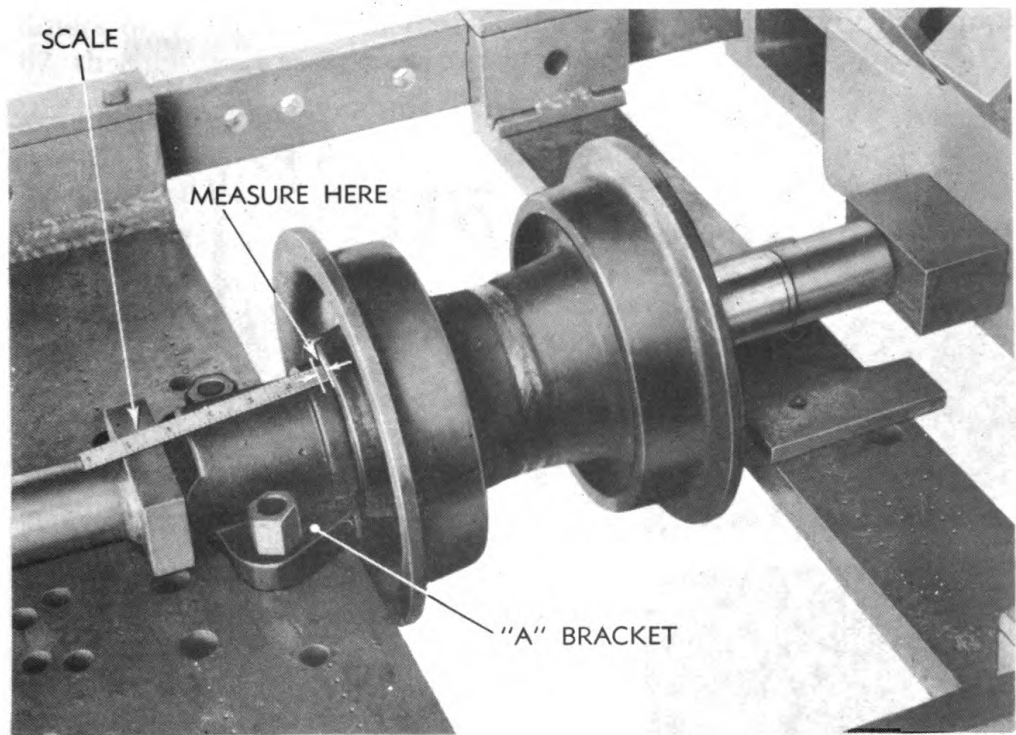

RA PD 41390

Figure 241 — Measuring Position of Bracket

241

**ORDNANCE MAINTENANCE — MEDIUM TRACTOR M1 (ALLIS-CHALMERS HD-7W)
ELECTRICAL SYSTEM, POWER TRAIN, FRAME, AND TRACKS**

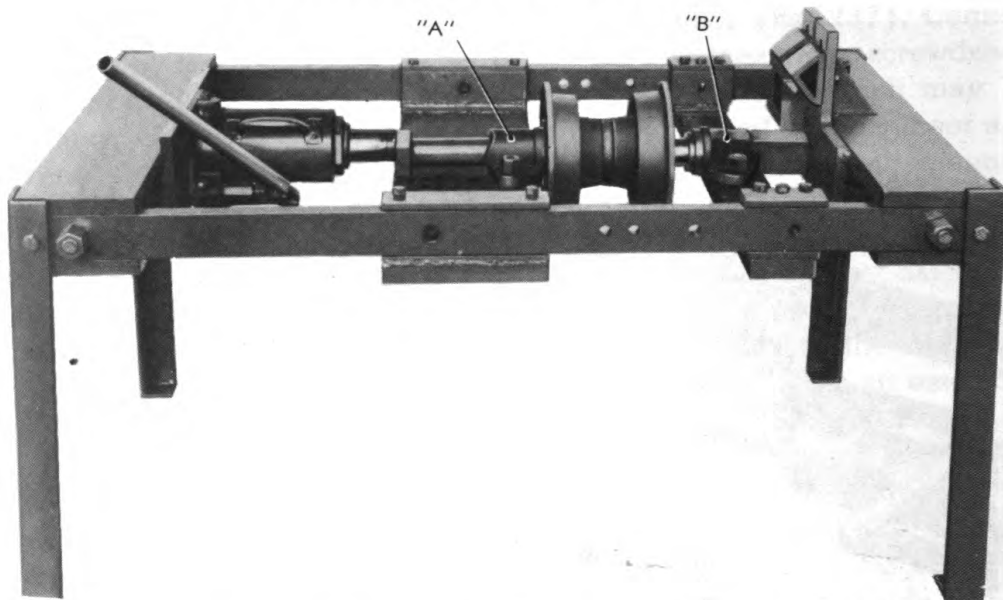

RA PD 41393

Figure 242 — Installing Second Bracket

same manner as first one. **CAUTION:** Be sure that adapter used between end of shaft and jack contacts end of shaft rather than bracket "A." Press "B" bracket onto shaft just far enough so that

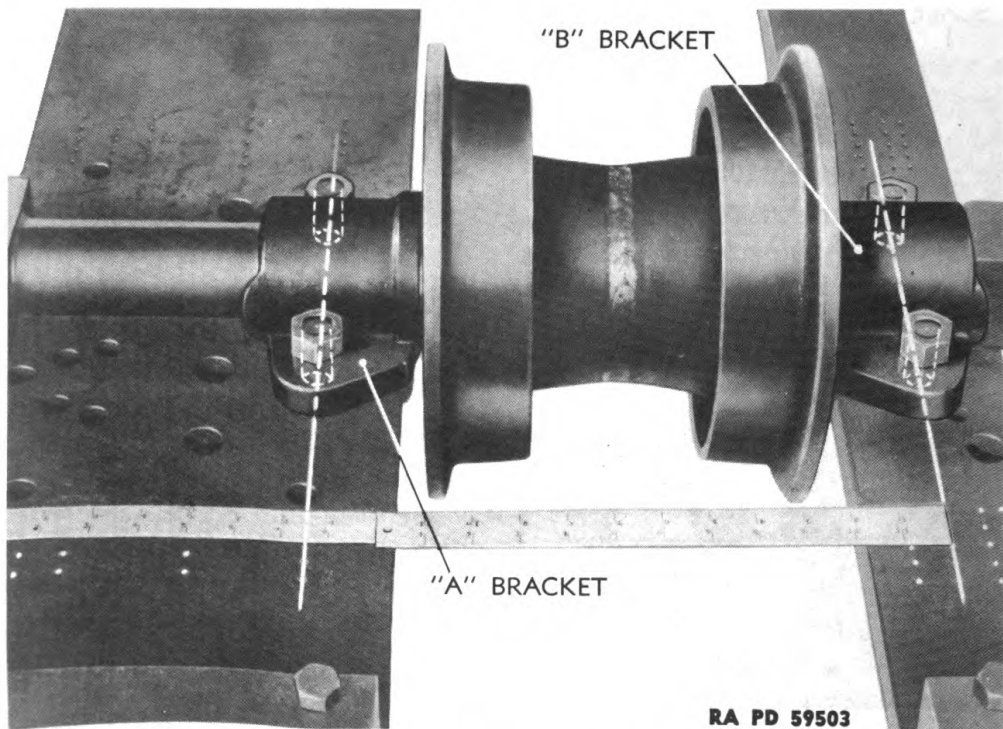

RA PD 59503

Figure 243 — Spacing for Brackets

FRONT IDLERS, TRUCK WHEELS, AND TRACK SUPPORT ROLLERS

the distance between the bolt holes in the "A" bracket and those in the "B" bracket will coincide with the spacing of the holes in the truck frame channels, to which the truck frame will be bolted (figure 243). This distance is 11³/₄ inches (center-to-center of holes) for truck wheels, and 15³/₈ inches for front idlers. Take this measurement at both sides of truck wheel and press "B" bracket on shaft so that the average of the two measurements will be as close as possible to the correct dimension.

(10) FILL WHEEL WITH LUBRICANT.

Wrench, plug, truck wheel

Fill truck wheel or front idler with lubricant (see lubrication guide, TM 9-783B) and install shaft plug with gasket in end of shaft.

88. ASSEMBLY OF TRACK SUPPORT ROLLER.

a. Tools and Equipment Required.

Hammer, 2-lb

Wrench, adjustable

Press and equipment, truck wheel, special

Wrench, plug, truck wheel

Screwdriver, 10-in.

b. Procedure. NOTE: The assembly of the track support roller differs only slightly from that of the truck wheel. Study paragraph 87, then proceed as follows to assemble track support roller:

(1) ASSEMBLE BEARINGS AND SHAFT.

Install bearings, shaft, and bearing cups as described in paragraph 87 b (1) and (2).

(2) INSTALL RETAINERS.

Screwdriver, 10-in.

Install retainers on support roller, using same shims that were removed with them, and on the same end of wheel from which they were removed. Bolt each retainer to support roller bracket with special countersunk screws. If original shims were lost or mixed, use from 0.003- to 0.047-inch of shims between each retainer and support roller. Tighten the retainer cap screws securely and check the bearing adjustment. The bearings are properly adjusted when the shaft will turn freely, but without end play, when turned by hand. If necessary, remove retainer and add or remove shims from one end to obtain the proper adjustment.

(3) INSTALL OIL SEALS IN RETAINERS.

Chisel, retainer lock

Hammer, 2-lb

After proper bearing adjustment has been made and retainer screw locked in place, install the oil seals in the retainers, using the retainers

ORDNANCE MAINTENANCE — MEDIUM TRACTOR M1 (ALLIS-CHALMERS HD-7W)
ELECTRICAL SYSTEM, POWER TRAIN, FRAME, AND TRACKS

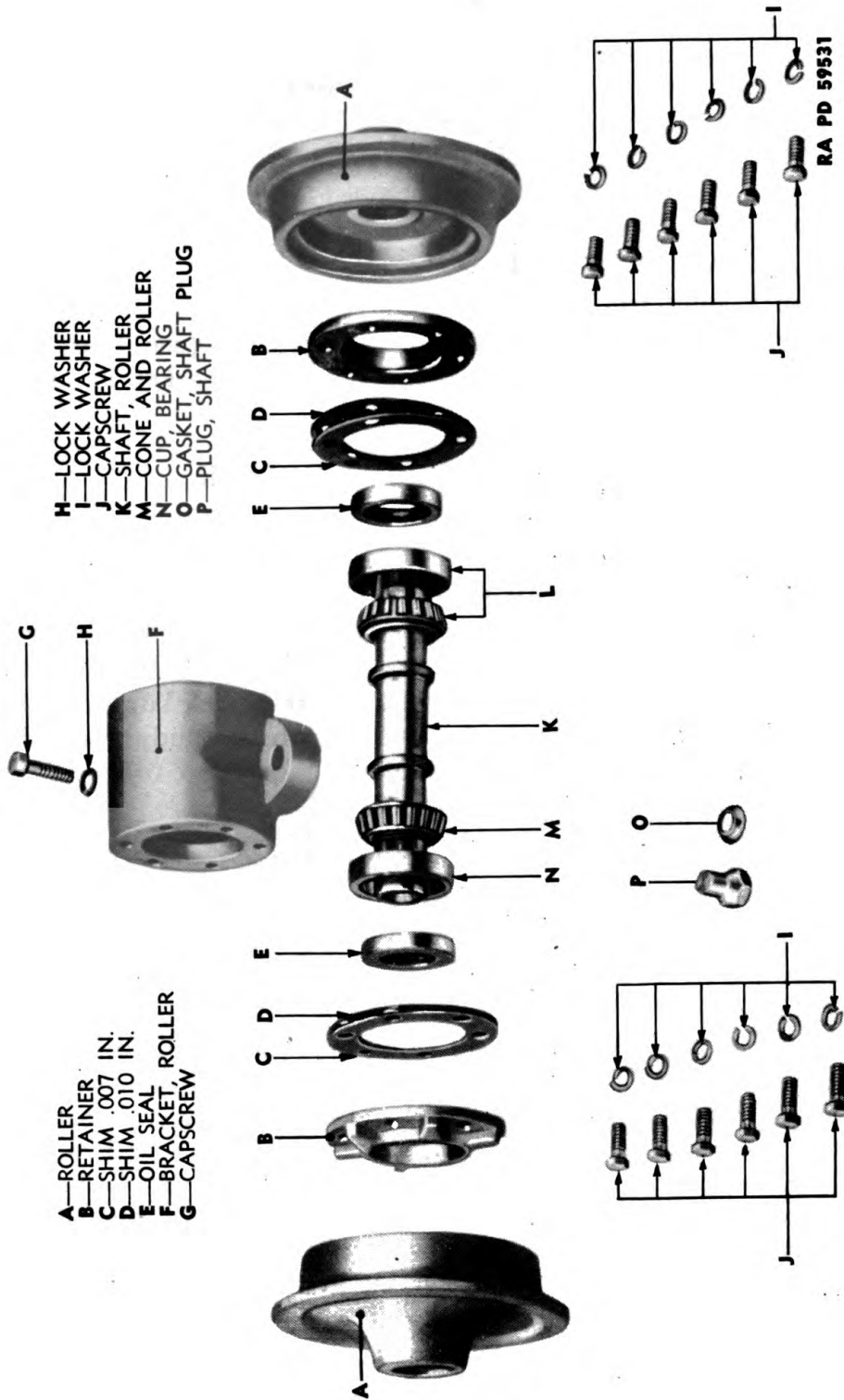
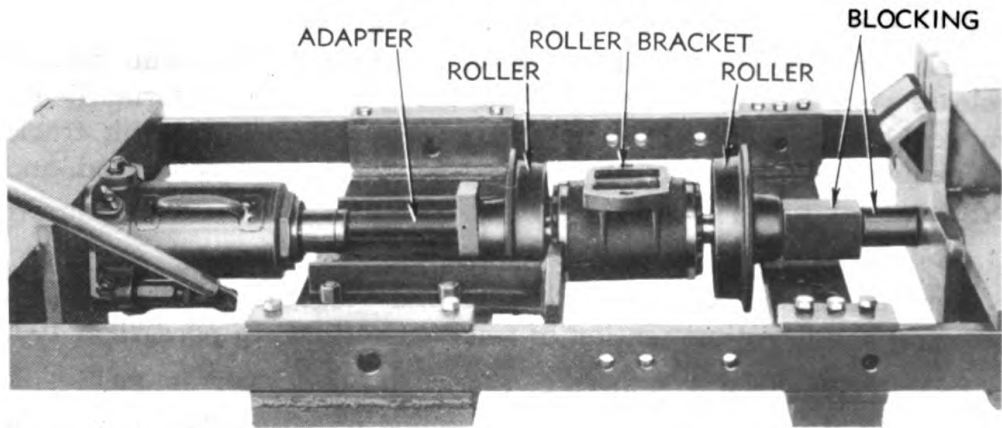

Figure 244 — Track Support Roller — Exploded View

**FRONT IDLERS, TRUCK WHEELS, AND
TRACK SUPPORT ROLLERS**



RA PD 59504

Figure 245 — Installing Rollers on Shaft

lock chisel and hammer to drive them into place. **NOTE:** Install oil seals with lip of seal pointing toward outside of retainer.

(4) INSTALL ROLLERS.

Start the two rollers on the ends of the shaft and place support roller in press (fig. 245). Block between one roller and the end plate of the press; use an adapter between the jack and the other roller, which will contact the roller rather than the shaft; and press both rollers on the shaft until faces of roller hubs are flush with ends of shaft.

(5) LUBRICATE ROLLER.

Wrench, plug, truck wheel

Fill roller with lubricant (TM 9-783B) and install shaft plug with copper gasket in end of shaft.

89. INSTALLATION OF FRONT IDLER.

a. Tools Required.

Bar, 6-ft

Hammer, sledge, 12-lb

Wrench, $\frac{7}{8}$ -in.

Wrench, $1\frac{5}{16}$ -in.

Wrench, socket, $\frac{3}{4}$ -in.

Wrench, track-adjusting

b. Procedure.

(1) INSTALL IDLER BRACKET GUIDES.

Wrench, $\frac{7}{8}$ -in.

Set idler assembly on truck frame with plug in idler shaft to the outside (fig. 279). Bolt idler bracket guides to lower side of idler shaft brackets with two $\frac{5}{8}$ - by 2-inch cap screws with lock washers. Use shims between brackets and guides to allow clearance for idler assembly to slide freely on truck frame.

**ORDNANCE MAINTENANCE — MEDIUM TRACTOR M1 (ALLIS-CHALMERS HD-7W)
ELECTRICAL SYSTEM, POWER TRAIN, FRAME, AND TRACKS**

(2) CONNECT IDLER TO TRACK RELEASE YOKE.

Install two 1/2- by 1 3/4-inch cap screws through each arm of track release yoke and into idler brackets, using same shims formerly removed between idler bracket and yoke to aline idler with track. Alinement will have to be checked after track is connected and adjusted (step (4) below).

(3) COUPLE AND ADJUST TRACKS.

Run track into place and couple ends together as outlined in paragraph 106. Adjust tension of track as outlined in paragraph 107.

(4) CHECK TRACK ALINEMENT AND ALINE FRONT IDLER.

Observe if inside of track rail is rubbing on either flange on front idler. If it is, the idler should be alined. Remove cap screws and take some of the shims between front idler brackets and track release yoke from the side on which rail is rubbing; add them to the side on which the rail is not rubbing, until idler is in alinement, and there is clearance between each flange and inside of rail.

(5) INSTALL IDLER GUARDS.

Wrench, 3/4-in.

Hold idler guard in place on bracket and install the two 1/2- by 1-inch cap screws through guard and onto bracket (3/4-in. wrench). Repeat on other side of idler.

90. INSTALLATION OF TRUCK WHEEL.

a. Tools and Equipment Required.

Wrench, 7/8-in.

Wrench, track-adjusting

Wrench, 15/16-in.

b. Procedure.

(1) INSTALL TRUCK WHEEL.

Wrench, 7/8-in.

Wrench, 15/16-in.

With tractor blocked up as explained and shown in paragraph 82 and figure 216, place truck wheel in position in truck frame, inserting inside end (end without plug) into notch in inside truck wheel guard. Hold brackets of wheel up against frame and bolt brackets to frame with two 5/8- by 1 5/8-inch bolts with high nuts in each bracket. One or all five truck wheels may be installed in this manner; remove inner truck wheel guard if installing all five. Install the front and rear wheels (single-flanged) first, rolling them toward front idler and drive sprocket; then the second and fourth wheels (double-flanged); and the center wheel (single-flanged) last.

(2) INSTALL TRUCK WHEEL GUARD.

Wrench, 7/8-in.

Wrench, 15/16-in.

FRONT IDLERS, TRUCK WHEELS, AND TRACK SUPPORT ROLLERS

Install outer truck wheel guard on truck frame with ten $\frac{3}{4}$ - by 2-inch bolts with high nuts. Tighten bolts holding inner truck wheel guard.

(3) ADJUST TRACKS.

Drive tractor off blocks and adjust tracks as outlined in paragraph 107.

91. INSTALLATION OF TRACK SUPPORT ROLLER.

a. Tools Required.

Jack, hydraulic

Wrench, $\frac{7}{8}$ -in.

b. Procedure.

Set jack on track release housing and raise center of track high enough to set support roller in place on housing (fig. 226). Have end of roller with plug turned to outside. Bolt to track release housing with two $\frac{5}{8}$ - by $2\frac{1}{4}$ -inch cap screws with lock washers ($\frac{7}{8}$ -in. wrench).

92. SPECIAL TOOLS.

a. Special tools required for repair of front idlers, truck wheels, and track support rollers are:

Press and equipment, truck wheel, including:

Adapters, assorted

Press assembly

Bolts, assorted

Pusher assemblies, assorted

Bracket, support roller

Wrench, retainer

Chisel, retainer lock

ORDNANCE MAINTENANCE — MEDIUM TRACTOR M1 (ALLIS-CHALMERS HD-7W)
ELECTRICAL SYSTEM, POWER TRAIN, FRAME, AND TRACKS

CHAPTER 12

TRUCK FRAME AND TRACK ASSEMBLY (Cont'd)

Section III

TRACK RELEASE MECHANISM

	Paragraph
Description	93
Trouble shooting	94
Removal	95
Disassembly	96
Inspection and repair of parts.....	97
Assembly	98
Installation	99

93. DESCRIPTION.

a. The track release mechanism is designed to relieve strain on track idler and sprocket shafts if rocks, limbs, or other foreign material should get caught in the track, or if mud should freeze in the track. A bell crank arrangement with a coil spring behind it holds the front idler in its forward position, but permits it to move back against the bell crank, compressing the coil spring, to relieve excess track tension when something becomes lodged in the track. As soon as the track has freed itself from the object, the coil spring returns the bell crank and idler to their original positions. The bell crank and spring assemblies operate in oil, which fills the housing to a level even with the level plug on the side of the housing (fig. 249).

b. A yoke in front of the track release housing that is bolted to the front idler brackets has an adjusting screw, the ball on the rear end of which fits into the sliding cross head in the front end of the release spring housing. A seal in the housing around the cross head prevents the entrance of dirt or loss of oil from the housing. Tracks are adjusted by turning this screw in or out of the track release yoke to loosen or tighten them.

94. TROUBLE SHOOTING.

a. Mechanism Inoperative.

Possible Cause	Possible Remedy
Crosshead tight in housing.	Remove, clean, and lubricate with engine oil.

TRACK RELEASE MECHANISM

Possible Cause	Possible Remedy
Water or mud frozen in housing.	Remove housing, apply heat to housing to thaw ice or mud, and drain oil and water. Clean housing thoroughly and fill with new oil. Inspect seals to determine the reason for dirt or water entering the housing.
b. Tracks Run Out of Line.	
Bushings for stabilizer crank worn.	Replace bushings.
c. Front Idler Out of Alinement.	
Bolts in yoke and idler brackets loose or broken.	Tighten or replace bolts.
Shims lost out of one side between yoke and idler brackets.	Install new shims and aline idler (par. 89 b (4)).
d. Tracks Become Loose.	
Threads on adjusting screw in yoke damaged.	Replace adjusting screw.
Mud or dirt in slot in yoke makes it impossible to tighten clamp around adjusting screw.	Clean dirt or mud from slot and tighten clamp bolts.

95. REMOVAL.

a. Tools and Equipment Required.

Bar, 6-ft (2)	Rope
Bar, drift, 1- x 18-in.	Tongs
Chisel, 3/4-in.	Wrench, 7/8-in.
Hammer, 2-lb	Wrench, 15/16-in.
Hammer, sledge, 16-lb	Wrench, 1 7/16-in.
Hoist, chain	Wrench, track-adjusting

b. Procedure. NOTE: The track release assembly can be removed from the tractor without disconnecting the tracks. However, disconnecting the track and rolling it back off the sprocket allows better use of a chain hoist, and makes the work easier.

(1) DISCONNECT TRACK.

Disconnect and roll track off sprocket as outlined in paragraph 102. Slide front idler ahead to end of truck frame (fig. 279).

(2) REMOVE HOUSING BOLTS.

Wrench, 7/8-in.	Wrench, 15/16-in.
-----------------	-------------------

Remove the eight bolts holding release spring housing to truck frame (fig. 246).

**ORDNANCE MAINTENANCE — MEDIUM TRACTOR M1 (ALLIS-CHALMERS HD-7W)
ELECTRICAL SYSTEM, POWER TRAIN, FRAME, AND TRACKS**

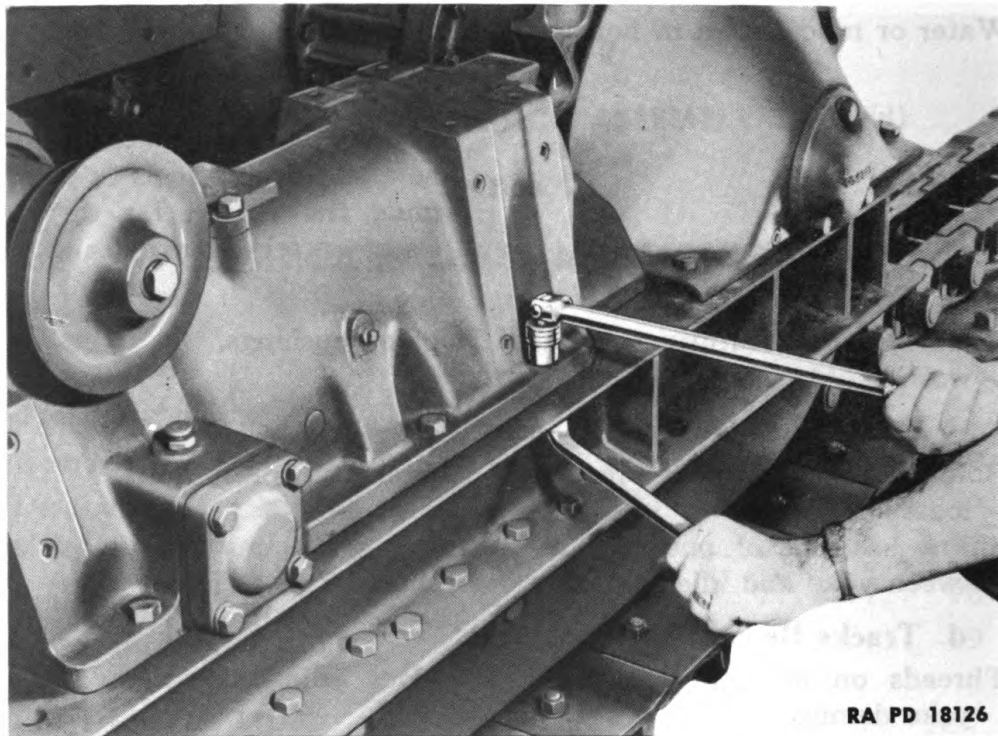

Figure 246 — Removing Bolts Holding Track Release Housing

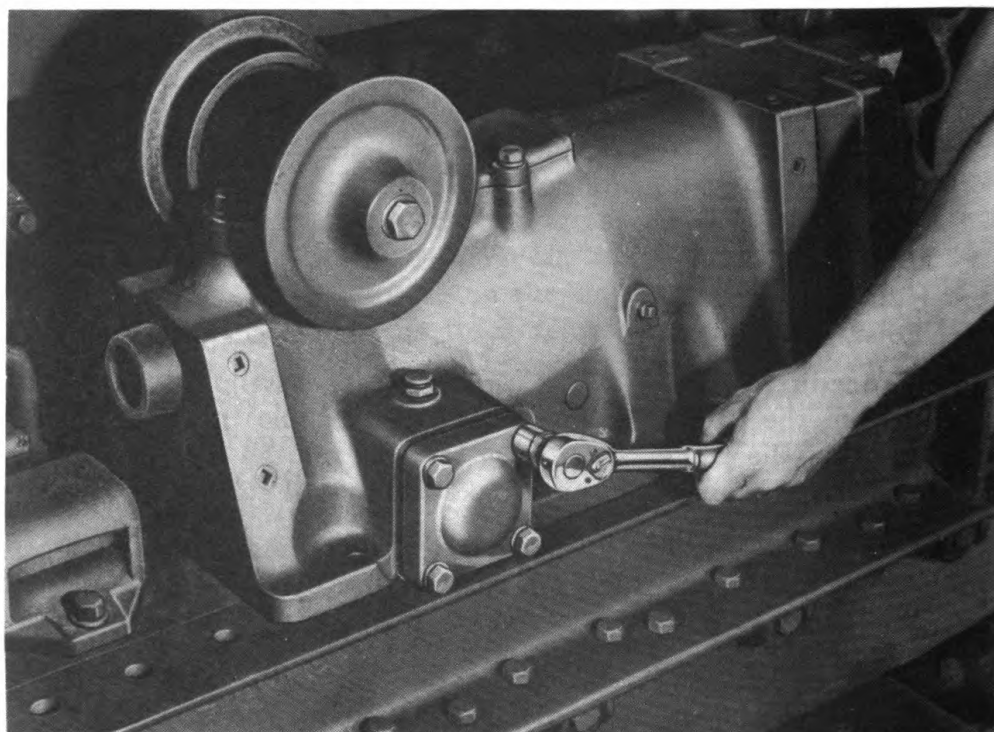
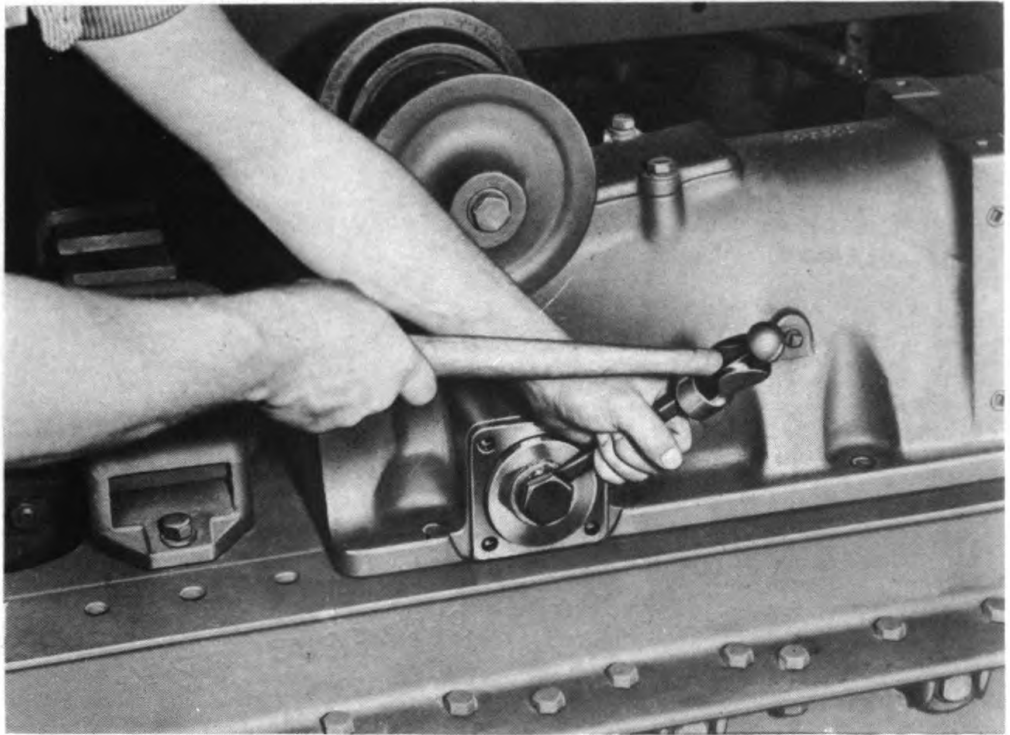

Figure 247 — Removing Stabilizer Crank End Cap

RA PD 18125

TRACK RELEASE MECHANISM



RA PD 18129

Figure 248 — Straightening Lock Washer to Remove Cap Screw

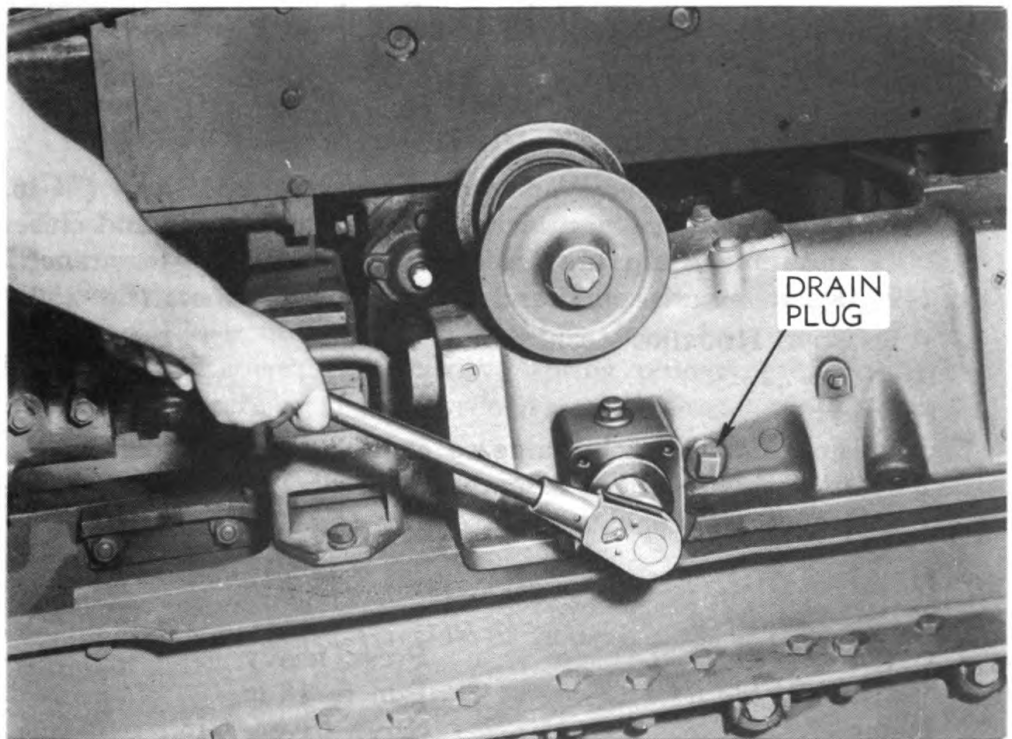

RA PD 18128

Figure 249 — Removing Cap Screw from End of Stabilizer Crank

**ORDNANCE MAINTENANCE — MEDIUM TRACTOR M1 (ALLIS-CHALMERS HD-7W)
ELECTRICAL SYSTEM, POWER TRAIN, FRAME, AND TRACKS**

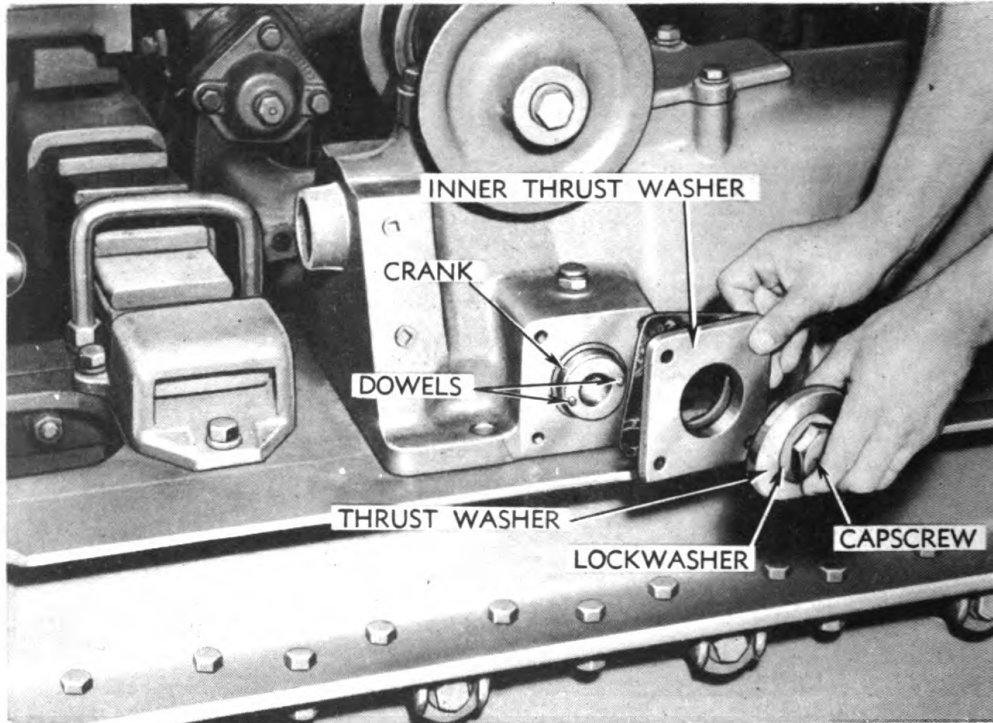

RA PD 18127

Figure 250 — Cap Screw and Thrust Washers Removed from Stabilizer Crank

(3) REMOVE STABILIZER CRANK END CAP AND CAP SCREW.

Chisel, 3/4-in.

Wrench, 3/4-in.

Hammer, 2-lb

Wrench, 1 7/16-in.

Remove four cap screws and remove crank end cap (3/4-in. wrench) (fig. 247). Straighten lock washer with hammer and chisel (fig. 248), and remove cap screw from end of crank (1 7/16-in. wrench) (fig. 249). Remove both round and square thrust washers (fig. 250).

(4) REMOVE HOUSING ASSEMBLY.

Bar, 6-ft (2)

Rope

Hoist, chain

Pry housing out on track frame so chain hoist will clear fender. Attach rope or chain sling to assembly, move housing out, off stabilizer crank, and remove housing assembly (fig. 251).

96. DISASSEMBLY.

a. Tools Required.

Bar, 3-ft

Press, heavy

Bar, drift, 18-in.

Punch, 18-in.

Hammer, 2-lb

Screwdriver, 6-in.

Hammer, sledge, 8-lb

Wrench, 3/4-in.

Hammer, sledge, 12-lb

Wrench, socket, 7/8-in.

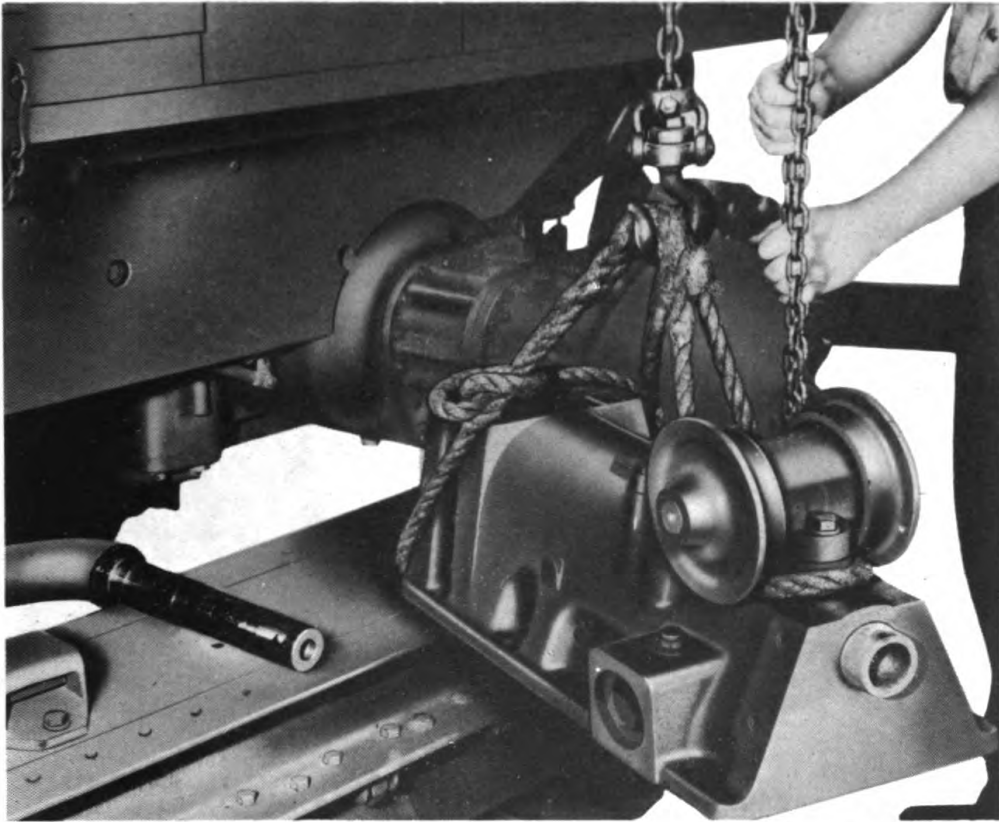
TRACK RELEASE MECHANISM

RA PD 18118

Figure 251 — Removing Track Release Housing**b. Procedure.****(1) REMOVE REAR COVER AND SPRING.**Wrench, $\frac{3}{4}$ -in.Wrench, socket, $\frac{7}{8}$ -in.

Drain oil from housing. Remove six cap screws from rear cover and remove cover (fig. 252). NOTE: All six cap screws must be unscrewed evenly at the same time, until tension on spring in housing is relieved ($\frac{7}{8}$ -in. wrench). Pull spring from housing (fig. 253), after removing cover; then remove spring plunger (fig. 254). Remove two cap screws ($\frac{3}{4}$ -in. wrench), and remove top cover (fig. 255).

(2) REMOVE BELL CRANK ASSEMBLY.

Bar, drift, 18-in.

Hammer, sledge, 12-lb

Using a sledge and drift bar, drive bell crank shaft toward inside of housing, and out of bell crank (fig. 256) far enough to remove bell crank assembly from inside of housing (fig. 257). Drive pin out of bell crank and push rods (hammer and punch).

(3) REMOVE CROSSHEAD AND SEAL.

Bar, 3-ft

Screwdriver, 6-in.

Hammer, sledge, 8-lb

ORDNANCE MAINTENANCE — MEDIUM TRACTOR M1 (ALLIS-CHALMERS HD-7W)
ELECTRICAL SYSTEM, POWER TRAIN, FRAME, AND TRACKS

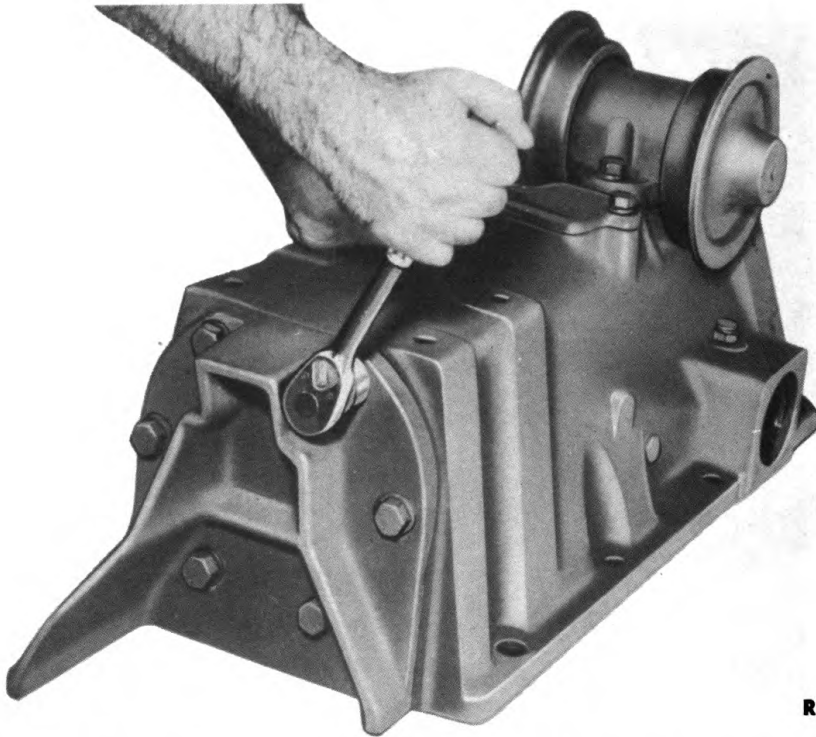

RA PD 41302

Figure 252 — Removing Rear Cover from Track Release Housing

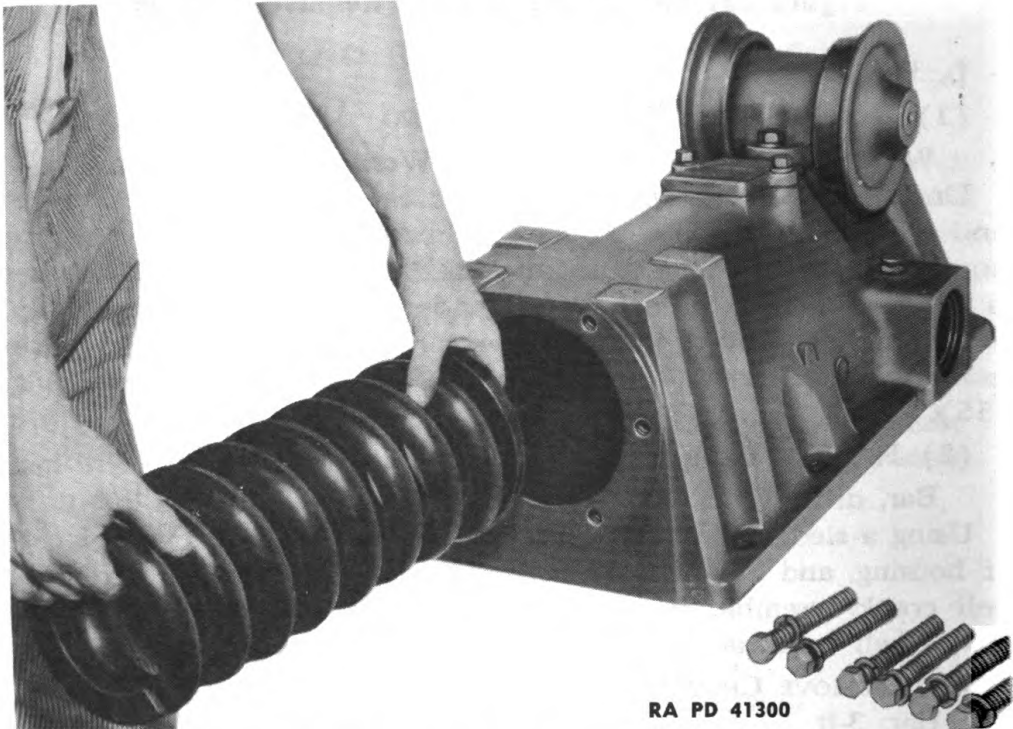

RA PD 41300

Figure 253 — Removing Spring from Housing

TRACK RELEASE MECHANISM

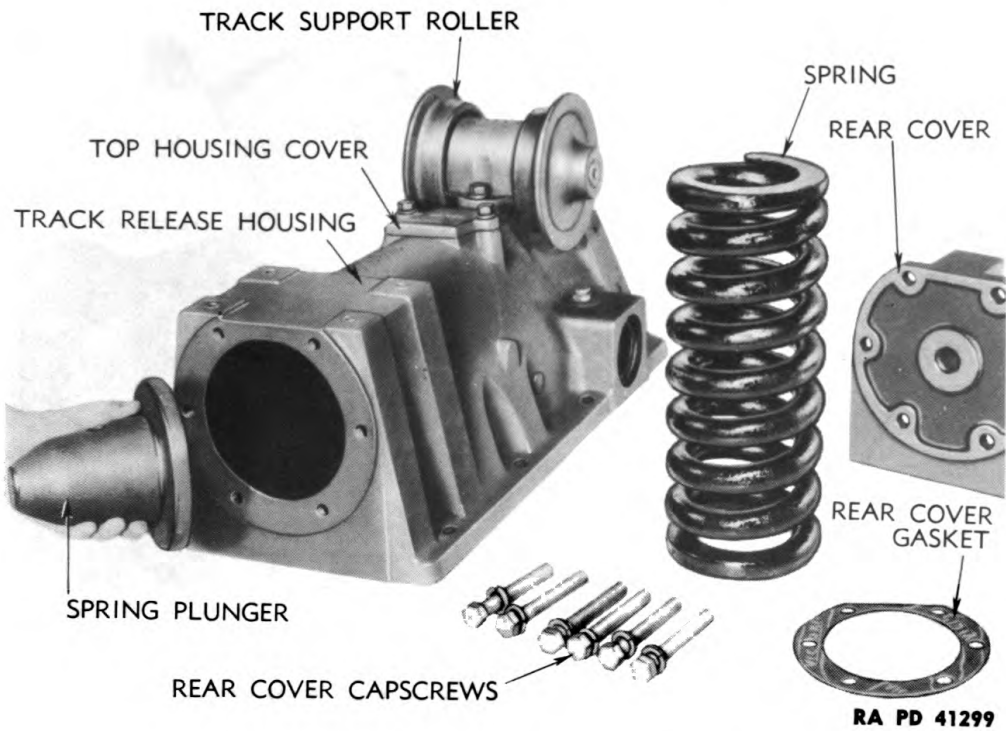

Figure 254 — Removing Spring Plunger

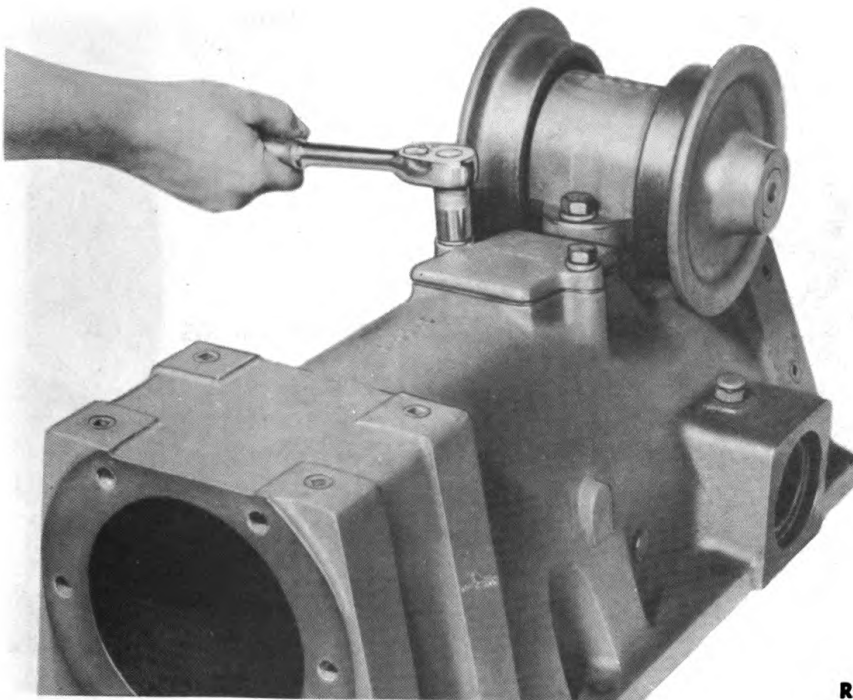

Figure 255 — Removing Top Cover

**ORDNANCE MAINTENANCE — MEDIUM TRACTOR M1 (ALLIS-CHALMERS HD-7W)
ELECTRICAL SYSTEM, POWER TRAIN, FRAME, AND TRACKS**

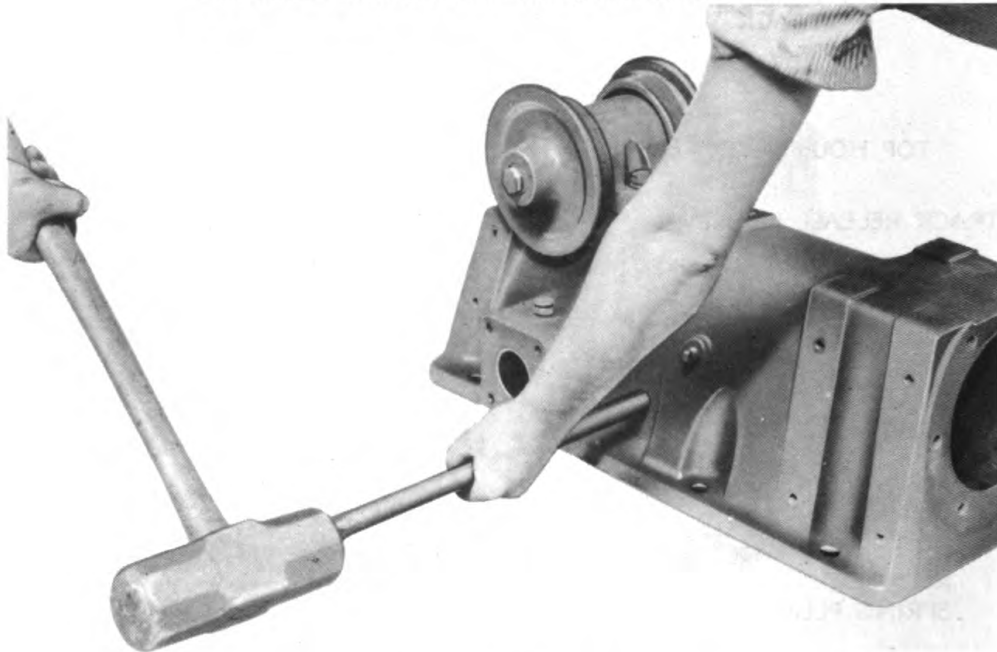

Figure 256 — Driving Shaft out of Bell Crank RA PD 41306

Drive crosshead out front of housing (hammer and bar) (fig. 258) and remove seal ring from crosshead (screwdriver) (fig. 259).

(4) REMOVE STABILIZER CRANK SEAL AND BUSHINGS.

Hammer, 2-lb
Press, heavy

Punch, 18-in.

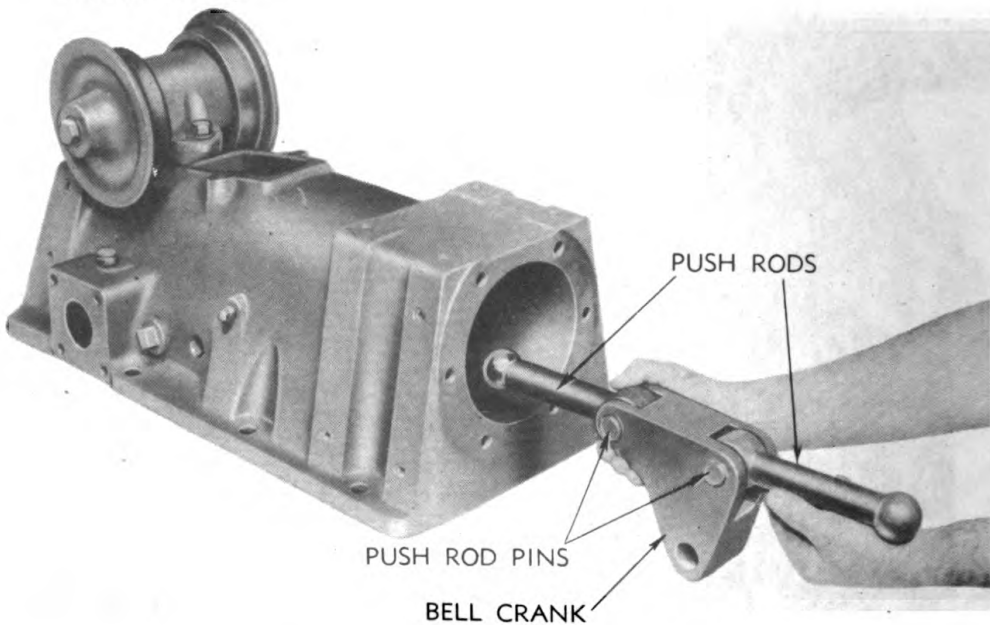
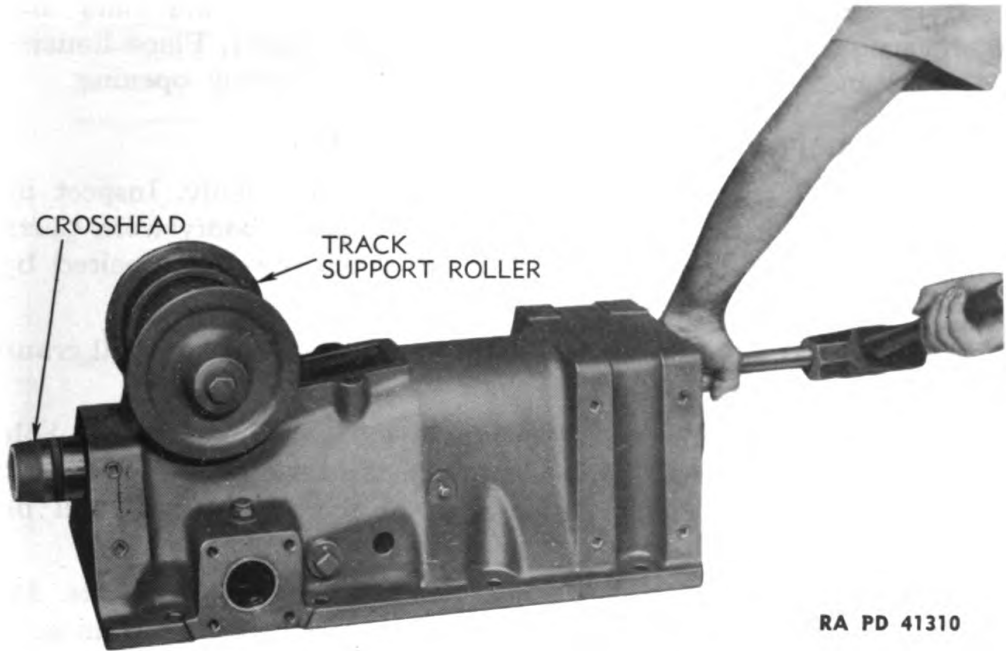

Figure 257 — Removing Bell Crank Assembly RA PD 41307

TRACK RELEASE MECHANISM



RA PD 41310

Figure 258 — Driving Crosshead out of Track Release Housing

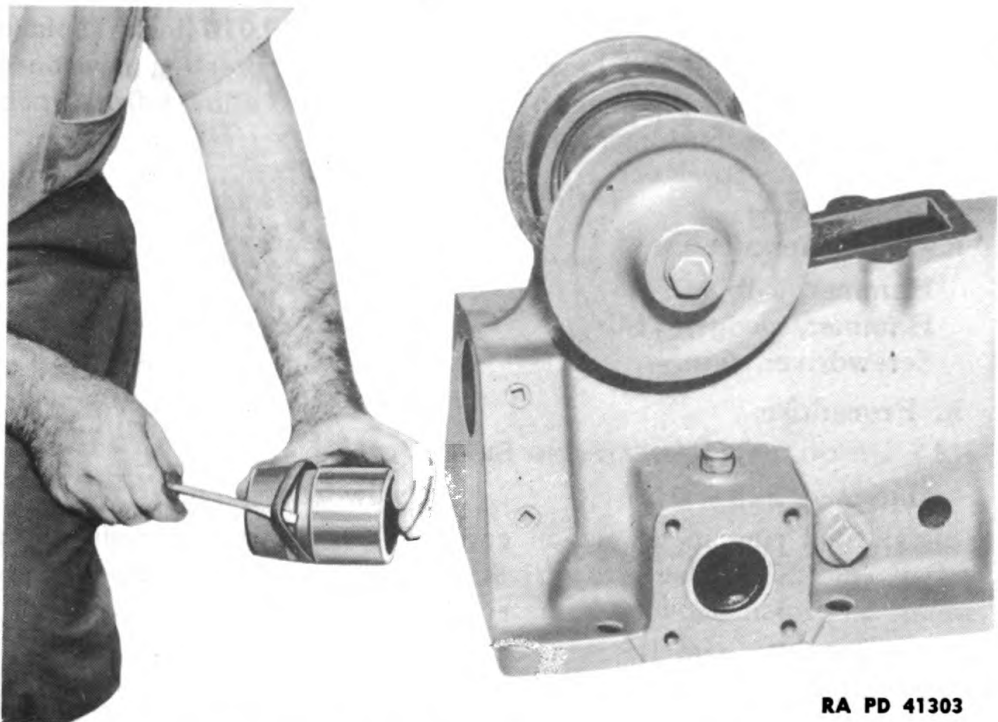

RA PD 41303

Figure 259 — Removing Seal Ring from Crosshead

**ORDNANCE MAINTENANCE — MEDIUM TRACTOR M1 (ALLIS-CHALMERS HD-7W)
ELECTRICAL SYSTEM, POWER TRAIN, FRAME, AND TRACKS**

If necessary to replace stabilizer crank oil seal from inner side of housing, drive old one out (hammer and punch). Place housing in press and press bushings from both sides of crank opening.

97. INSPECTION AND REPAIR OF PARTS.

a. Clean all parts and wash housing out thoroughly. Inspect all parts for wear or breakage. Discard all broken or badly worn parts. Small cracks or holes in housing or end cover may be repaired by welding.

b. Bell Crank Assembly. If bell crank pin or holes in bell crank or push rods are badly worn, replace them.

c. Crosshead. Replace seal in crosshead if damaged. Clean hole in housing for crosshead and test to make sure crosshead does not bind in opening. If the hole is rough or scored, the seal will be damaged in operation.

d. Track Release Yoke. Inspect yoke for cracks or twists. Inspect adjusting screw to make sure the threads are not damaged; replace if damaged. Clean dirt from slot in yoke so clamp bolts can draw yoke clamp tight around adjusting screw.

e. Stabilizer Crank Bushings. Measure inside diameter of bushings. Original diameter of bushing in outer side of housing is $2\frac{1}{8}$ inches; of inner bushing it is $2\frac{7}{8}$ inches. If worn to point where clearance between crank and bushings exceeds 0.010 inch, replace them by pressing out old bushings in press and pressing new ones into place. Ream new bushings after installation to allow a 0.003-inch clearance between bushings and crank journals.

98. ASSEMBLY.

a. Tools Required.

Hammer, 2-lb

Hammer, sledge, 12-lb

Screwdriver, 6-in.

Shellac

Wrench, $\frac{3}{4}$ -in.

Wrench, socket, $\frac{7}{8}$ -in.

b. Procedure.

(1) INSTALL CROSSHEAD AND SEAL.

Hammer, 2-lb

Screwdriver, 6-in.

Install seal ring in groove in crosshead and install crosshead in housing (fig. 261). Use screwdriver to start seal into housing while tapping on crosshead with hammer.

(2) ASSEMBLE AND INSTALL BELL CRANK ASSEMBLY.

Hammer, sledge, 12-lb

Install push rods in bell crank with pins (fig. 257) and place bell crank in housing with step on bell crank towards front of housing,

ORDNANCE MAINTENANCE — MEDIUM TRACTOR M1 (ALLIS-CHALMERS HD-7W)
ELECTRICAL SYSTEM, POWER TRAIN, FRAME, AND TRACKS

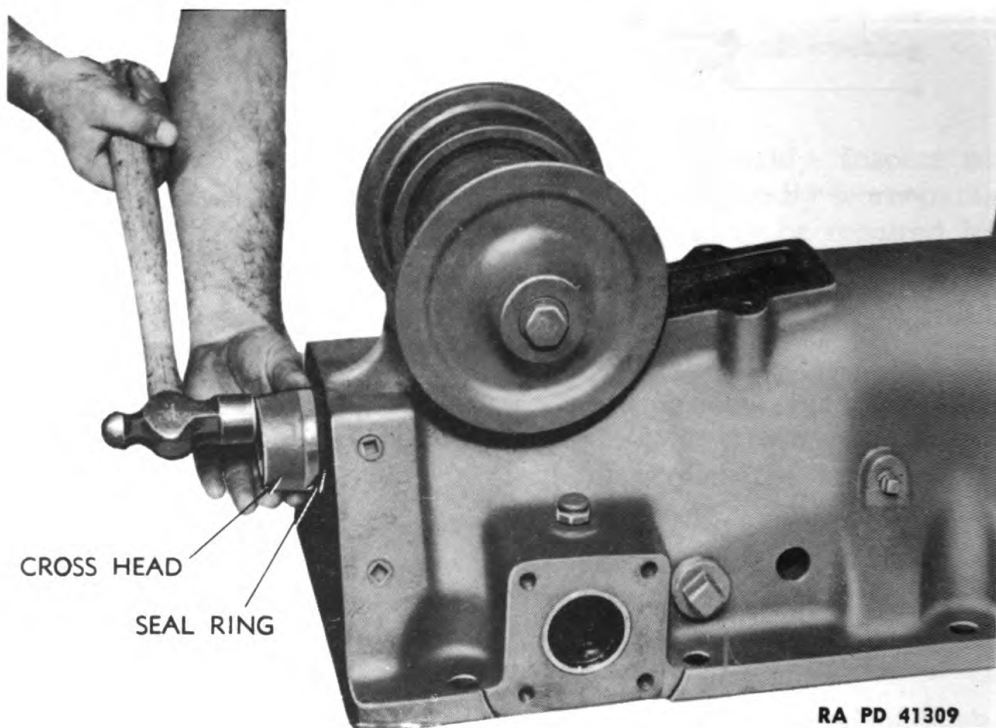

Figure 261 — Installing Crosshead and Seal

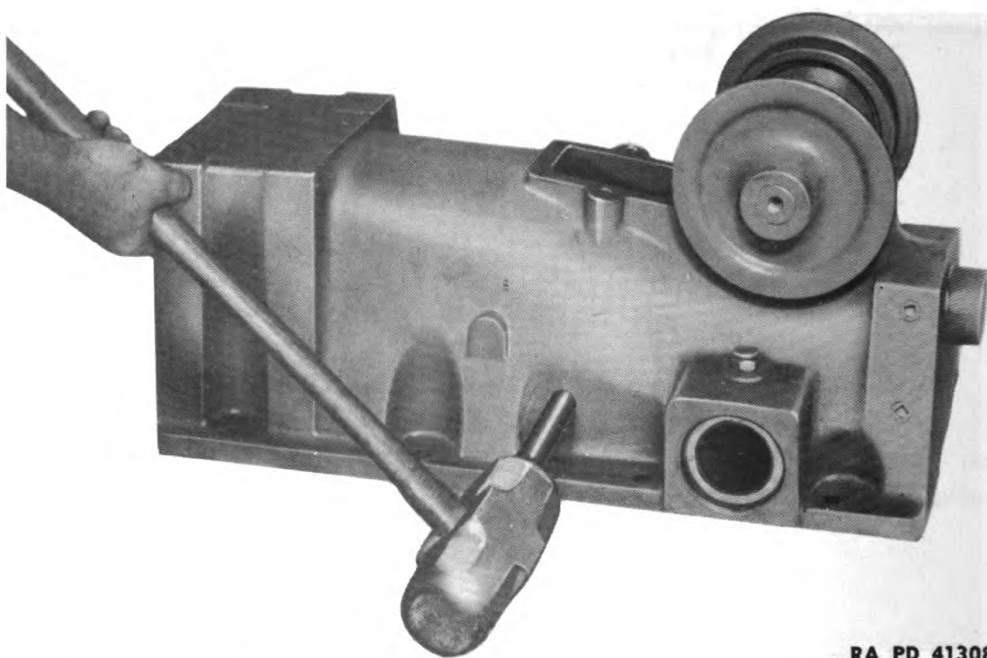
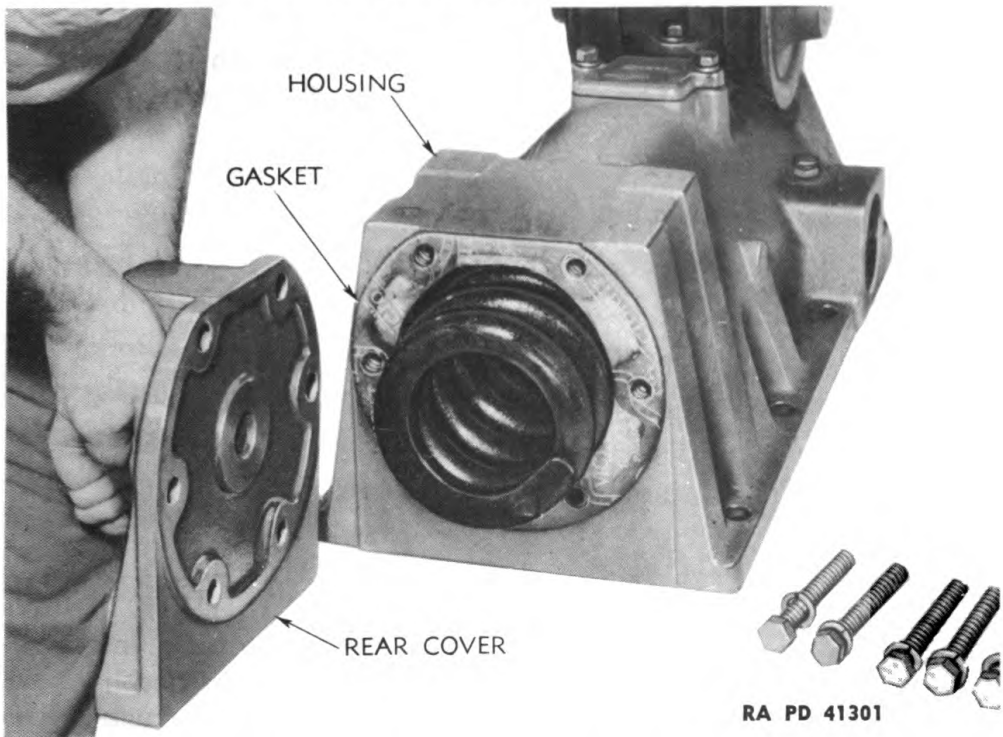

Figure 262 — Driving Bell Crank Shaft into Housing

TRACK RELEASE MECHANISM**Figure 263 — Installing Rear Cover**

and hole in bell crank for shaft at bottom. Drive bell crank shaft through inside hole in housing. Line up hole in bell crank with shaft, and drive shaft through bell crank into hole in other side. Be careful not to swell end of shaft while driving on it. If end of shaft is swelled, it is apt to crack the boss on the case when the swelled end is driven into the case. Drive shaft in until the end is flush with the case.

(3) INSTALL SPRING PLUNGER, SPRING, AND REAR COVER.

Wrench, socket, $\frac{7}{8}$ -in.

Install spring plunger into case, placing end of push rod on bell crank into socket of plunger. Insert spring (fig. 253) into housing and against plunger. Shellac gasket to rear of housing (fig. 263) and start all six $\frac{5}{8}$ - by 5-inch cap screws with lock washers through rear cover and into housing. Draw cap screws up evenly to compress spring, and draw cover up against housing.

(4) INSTALL OIL SEAL FOR STABILIZER CRANK.

Hammer, 2-lb

Tap oil seal into inner opening for stabilizer crank with lip of seal pointing away from housing.

(5) INSTALL TOP COVER.

Wrench, $\frac{3}{4}$ -in.

**ORDNANCE MAINTENANCE — MEDIUM TRACTOR M1 (ALLIS-CHALMERS HD-7W)
ELECTRICAL SYSTEM, POWER TRAIN, FRAME, AND TRACKS**

Shellac gasket to housing, and install top cover on housing (fig. 255) with two 1/2- by 1 3/4-inch cap screws with lock washers.

99. INSTALLATION.**a. Tools and Equipment Required.**

Bar, 6-ft (2)	Rope
Chisel, 3/4-in.	Wrench, 7/8-in.
Hammer, 2-lb	Wrench, 15/16-in.
Hammer, sledge, 16-lb	Wrench, 1 7/16-in.
Hoist, chain	Wrench, track-adjusting

b. Procedure.**(1) INSTALL ASSEMBLY ON TRUCK FRAME.**

Bar, 6-ft (2)	Wrench, 7/8-in.
Hoist, chain	Wrench, 15/16-in.
Rope	

Using chain hoist and rope, lower track release housing into position for inserting the stabilizer crank through hole in housing (fig. 251), and maneuver assembly into proper position on truck frame (fig. 249). Take care not to damage oil seal on inside of housing. Install the eight 5/8- by 2 1/4-inch bolts holding track release housing to truck frame (fig. 246).

(2) INSTALL WASHERS AND CAP SCREW.

Chisel, 3/4-in.	Wrench, 1 7/16-in.
Hammer, 2-lb	

Shellac gasket to housing, and install square thrust washer over shaft and bushing. Install outer thrust washer on dowels in end of stabilizer crank. Place lock washer on cap screw, and screw cap screw tightly into end of crank with prong on washer engaging in slot in outer thrust washer (1 7/16-in. wrench). Bend lock washer over head of cap screw with hammer and chisel (fig. 248).

(3) INSTALL END CAP.

Wrench, 3/4-in.

Shellac gasket to outside of square thrust washer and install stabilizer crank cap with four 1/2- by 2 1/4-inch cap screws with lock washers (fig. 247).

(4) CONNECT TRACK.

Move idler back, and engage end of adjusting screw in cross head in track release housing. Connect track and adjust as outlined in paragraphs 106 and 107.

(5) LUBRICATE RELEASE ASSEMBLY.

Fill track release housing to level of level plug with SAE 50 engine oil.

CHAPTER 12
TRUCK FRAME AND TRACK ASSEMBLY (Cont'd)
Section IV
TRACK ASSEMBLY

	Paragraph
Description	100
Trouble shooting	101
Removal	102
Disassembly	103
Inspection and repair	104
Assembly	105
Installation	106
Adjustment	107
Special tools	108

100. DESCRIPTION.

a. The track rail assembly consists of 34 pairs of side bars connected by hardened steel pins to form the track rail or chain. The rear ends of each pair of side bars are pressed onto hardened steel bushings; then the front ends of the next pair of side bars are connected to them with a pin through the bushing and pressed into the side bars. The bushings are free to turn on the pins, to allow track rails to hinge. An 18-inch grouser shoe is bolted to each pair of side bars with four specially hardened steel bolts. Street plates, one to each grouser shoe, are provided to allow travel on hard surfaced roads without injuring the road. A master pin, easily identified because it is $\frac{3}{4}$ inch longer than the others, is provided for separating tracks for removal.

101. TROUBLE SHOOTING.

a. Tracks Run Out of Line.

Possible Cause	Possible Remedy
Twisted or broken truck frame.	Repair or replace parts needed.
Stabilizer assembly worn.	Replace needed parts.

b. Excessive Wear on Pins, Bushings, and Rails.

Rear axle bearings loose.	Adjust bearings.
Rear axle bracket worn or damaged.	Repair or replace parts needed.
Stabilizer crank or bushings in track release housing badly worn.	Replace bushings or crank.
Stabilizer link bushings worn.	Replace bushings.
Bolts in end of stabilizer crank and link shaft loose.	Tighten bolts; replace bolts if damaged.

ORDNANCE MAINTENANCE — MEDIUM TRACTOR M1 (ALLIS-CHALMERS HD-7W)
ELECTRICAL SYSTEM, POWER TRAIN, FRAME, AND TRACKS

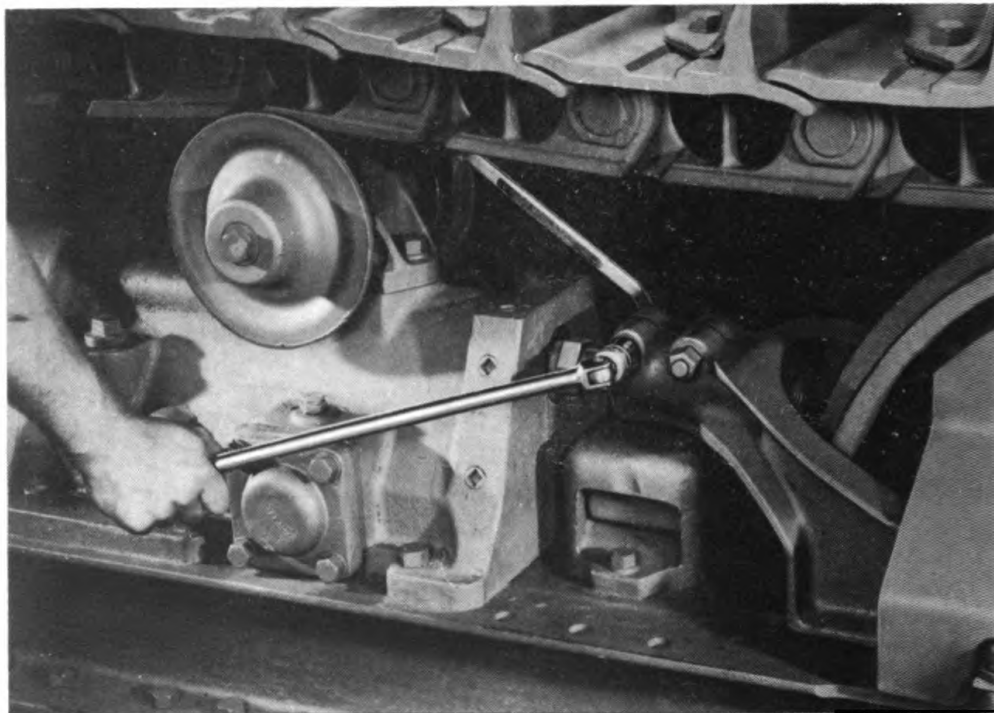

RA PD 17623

Figure 264 — Loosening Clamp Bolts in Track Release Yoke

Possible Cause	Possible Remedy
Front idler running out of line.	Adjust front idler by adding or removing shims (par. 89).
Track frame damaged or broken.	Repair or replace parts needed.
Badly worn truck wheels.	Repair or replace truck wheels.

c. Parts of Tracks Worn.

Worn pins and bushings, but rails in good condition.	Pins and bushings can be turned 180 degrees for further wear; if badly worn, replace them.
Badly worn pins, bushings, and rails.	Replace track rail assembly.

102. REMOVAL.

a. Tools Required.

Bar, drift, 1- x 12-in.	Wrench, 7/8-in.
Hammer, sledge, 16-lb	Wrench, 15/16-in.
Tongs	Wrench, track-adjusting

b. Procedure.

(1) LOCATE MASTER PIN AND LOOSEN TRACK.

Wrench, 7/8-in.	Wrench, track-adjusting
Wrench, 15/16-in.	

TRACK ASSEMBLY

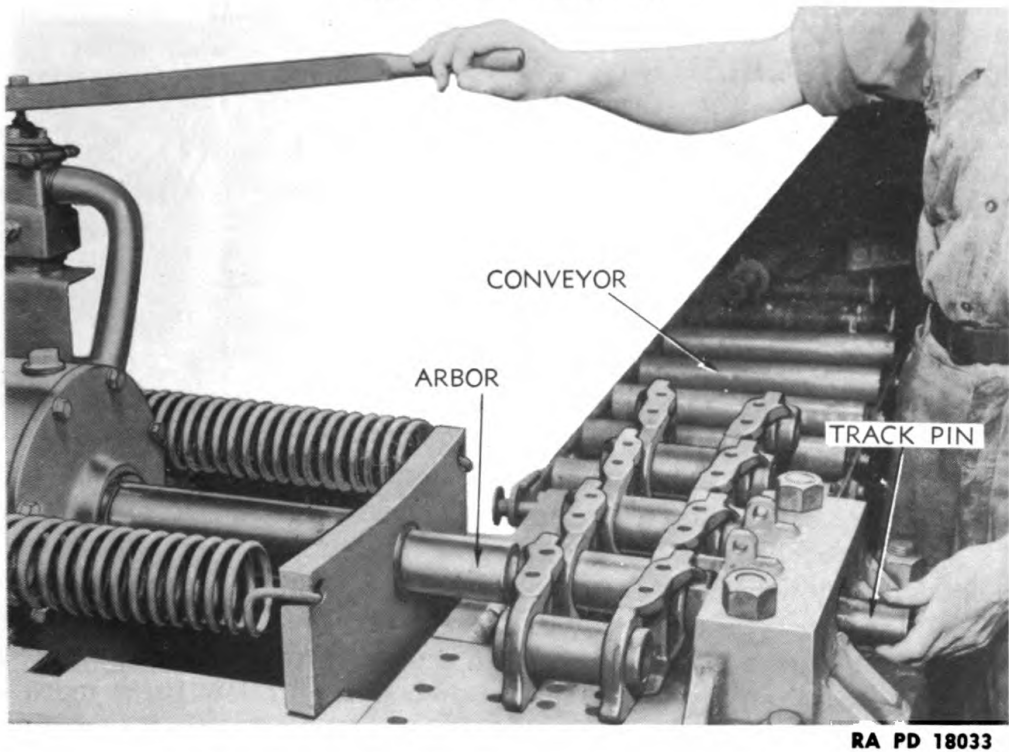

RA PD 18033

Figure 265 — Pressing Pin out of Track

The master pin can be identified because it is longer than the others, and the ends protrude about $\frac{3}{8}$ inch out of boss on side bars, whereas the ends of others are flush with boss. Drive tractor forward until the master pin is at a point between front and bottom of front idler. Loosen tracks by loosening clamp bolts in track release yoke ($\frac{7}{8}$ - and $\frac{15}{16}$ -in. wrenches) (fig. 264) and screwing adjusting screw into yoke (track-adjusting wrench) (fig. 272).

(2) REMOVE MASTER PIN.

Bar, drift, 1- x 12-in.

Tongs

Hammer, sledge, 16-lb

Hold end of drift bar against center of outside end of master pin with tongs, and drive pin out of track. Strike as hard as possible with sledge hammer while starting pin out of track, as the fewer blows necessary, the less chance there is of swelling end of pin. Remove the two bushing spacers from track link from which master pin was removed.

(3) REMOVE TRACK.

Back tractor until end of track falls from sprocket; then lay a heavy plank or other support ahead of front end of track, and drive tractor off track onto plank.

ORDNANCE MAINTENANCE — MEDIUM TRACTOR M1 (ALLIS-CHALMERS HD-7W)
ELECTRICAL SYSTEM, POWER TRAIN, FRAME, AND TRACKS

103. DISASSEMBLY.

a. Tools Required.

Bar, pry	Wrench, $\frac{7}{8}$ -in. (2)
Press, hydraulic, track pin	Wrench, socket, $\frac{13}{16}$ -in.

b. Procedure.

(1) REMOVE STREET PLATES AND GROUSER SHOES.

Bar, pry	Wrench, socket, $\frac{13}{16}$ -in.
Wrench, $\frac{7}{8}$ -in. (2)	

Remove two bolts holding each street plate to grouser shoes (two $\frac{7}{8}$ -in. wrenches), and remove plates. Remove grouser shoes by holding end of pry bar between flat side of nuts on track shoe bolts and side bar to keep nuts from turning; turn bolts out of nuts with $\frac{13}{16}$ -inch wrench. **NOTE:** If only pins and bushings are to be removed, it may not be necessary to remove the grouser shoes. This will depend on the type of track pin press used. The following pictures were taken while removing pins from a track with a stationary press that required the removal of the grouser shoes. Follow press manufacturer's instructions for removal of pins and bushings.

(2) REMOVE PINS FROM TRACK.

Press, hydraulic, track pin

Lay track on conveyor of press with holes in side bars up. Line pin in track with ram of press and, using suitable adapter, press pin out of track (fig. 265). Slide track assembly ahead on conveyor, and repeat for each pin.

(3) REMOVE TRACK PIN BUSHINGS.

Press, hydraulic, track pin

Place bushing fixture on press plunger, and press bushing out of side bar on one side (fig. 266); then turn other side bar in same position in press and press bushing out of second side bar (fig. 267).

104. INSPECTION AND REPAIR.

a. Pins and Bushings. Inspect pins and bushings for wear. If bushings in tracks are cracked or pieces broken out, replace bushings. If bushings are badly worn, the pins are likely to be worn also to the point where replacement is necessary. Longer life can be obtained from track pins and bushings if they are removed and turned 180 degrees from their original position, before they are worn to the point where the bushings begin to break.

b. Track Rails. If bosses for pins on side bars show evidence of having contacted the flanges of truck wheels or track, this may be due to the side bars being worn or truck wheels and support rollers being worn; replace either, or both, if necessary. Inspect all side bars

TRACK ASSEMBLY

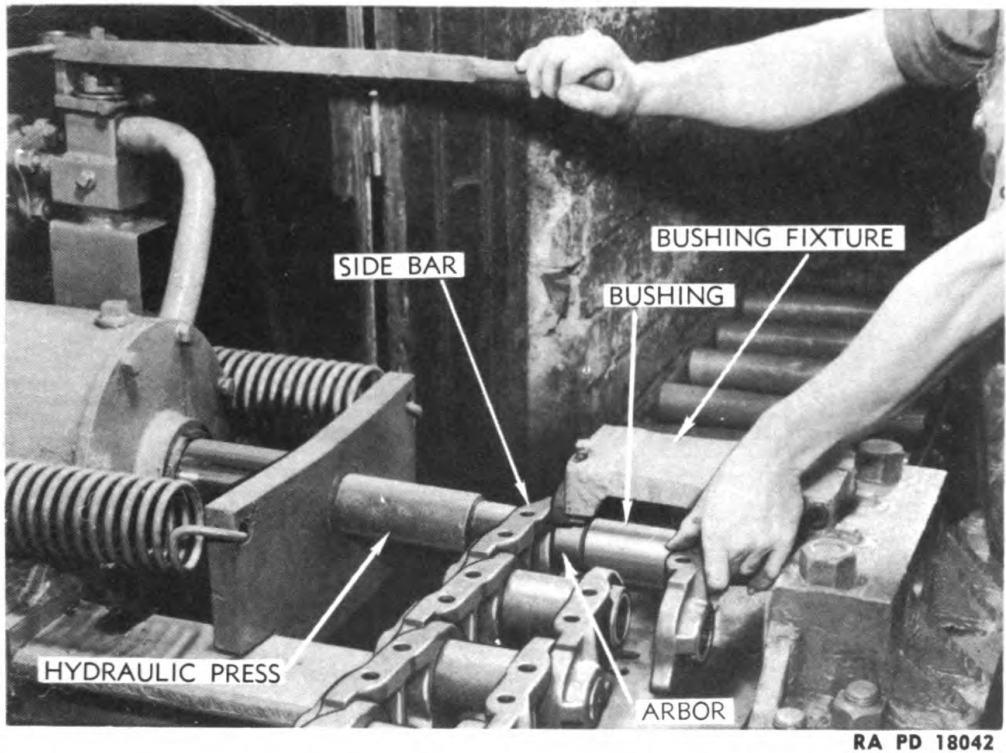

Figure 266 — Removing Track Pin Bushing — Operation No. 1

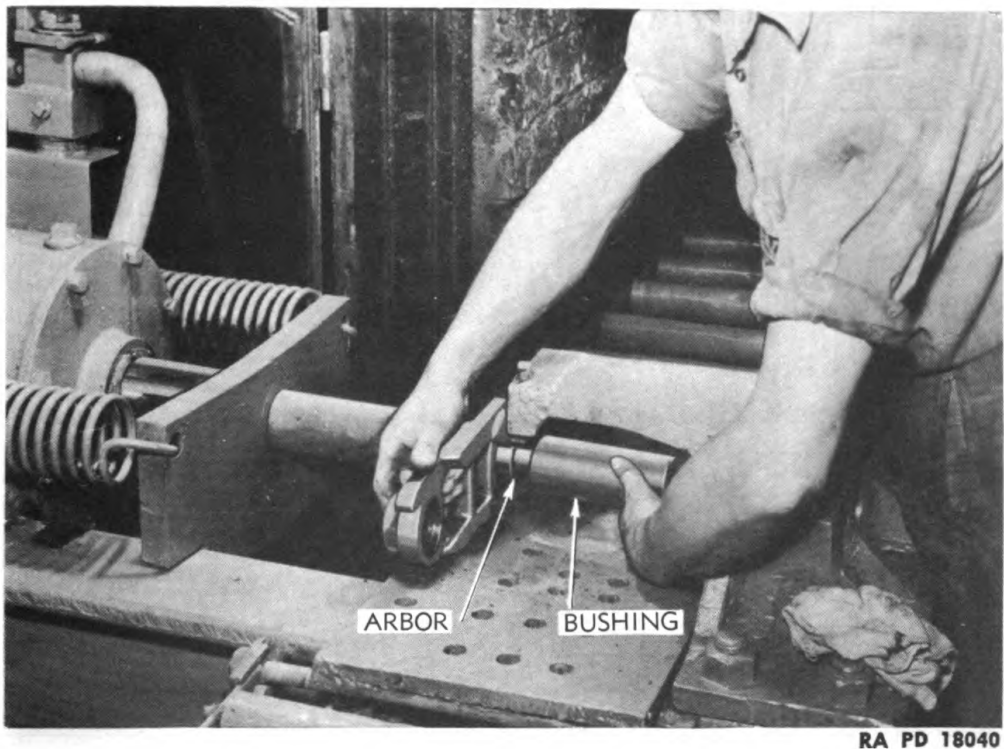
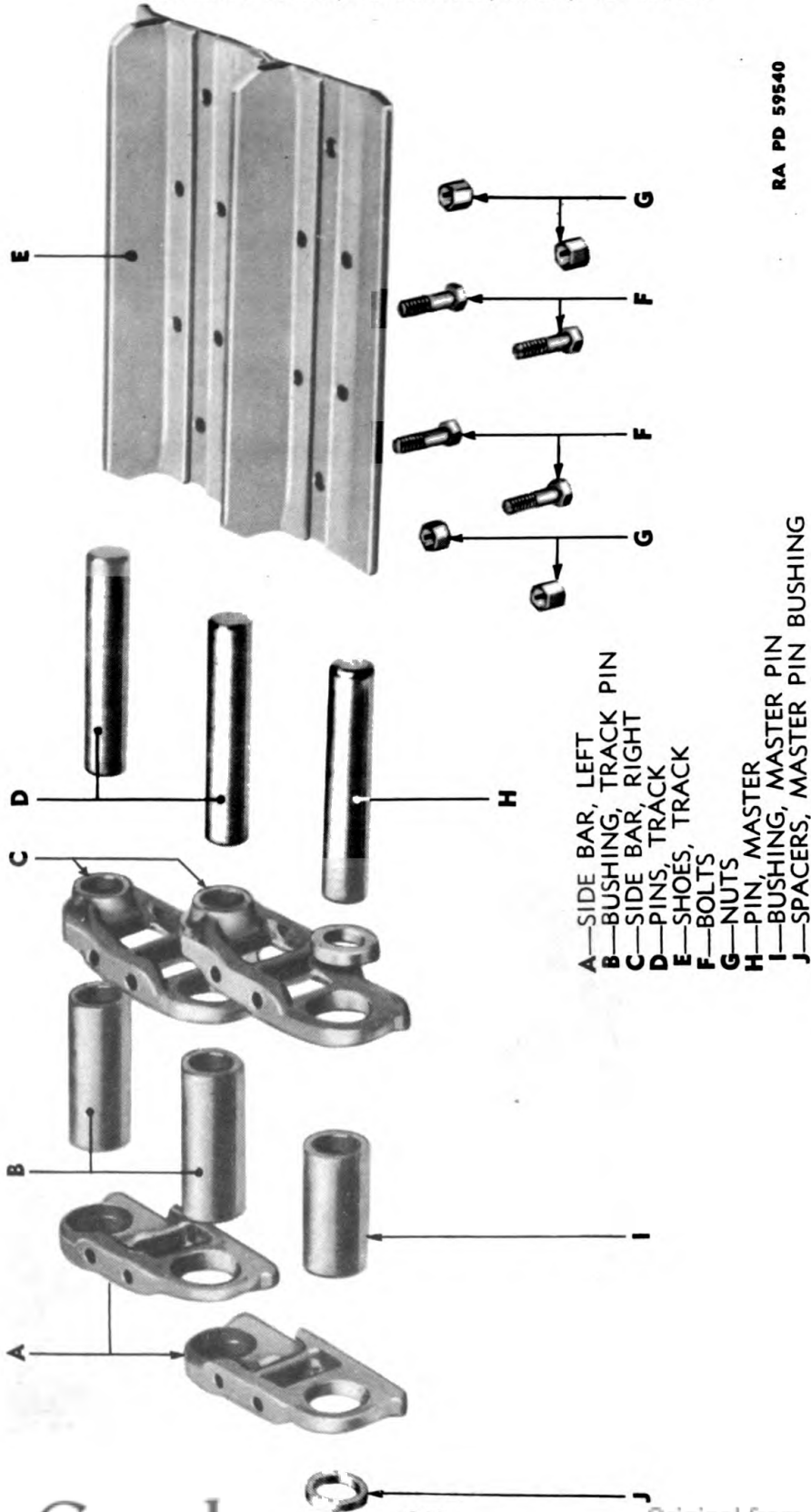

Figure 267 — Removing Track Pin Bushing — Operation No. 2

ORDNANCE MAINTENANCE — MEDIUM TRACTOR M1 (ALLIS-CHALMERS HD-7W)
ELECTRICAL SYSTEM, POWER TRAIN, FRAME, AND TRACKS



RA PD 59540

Figure 268 — Parts in Track Assembly

TRACK ASSEMBLY

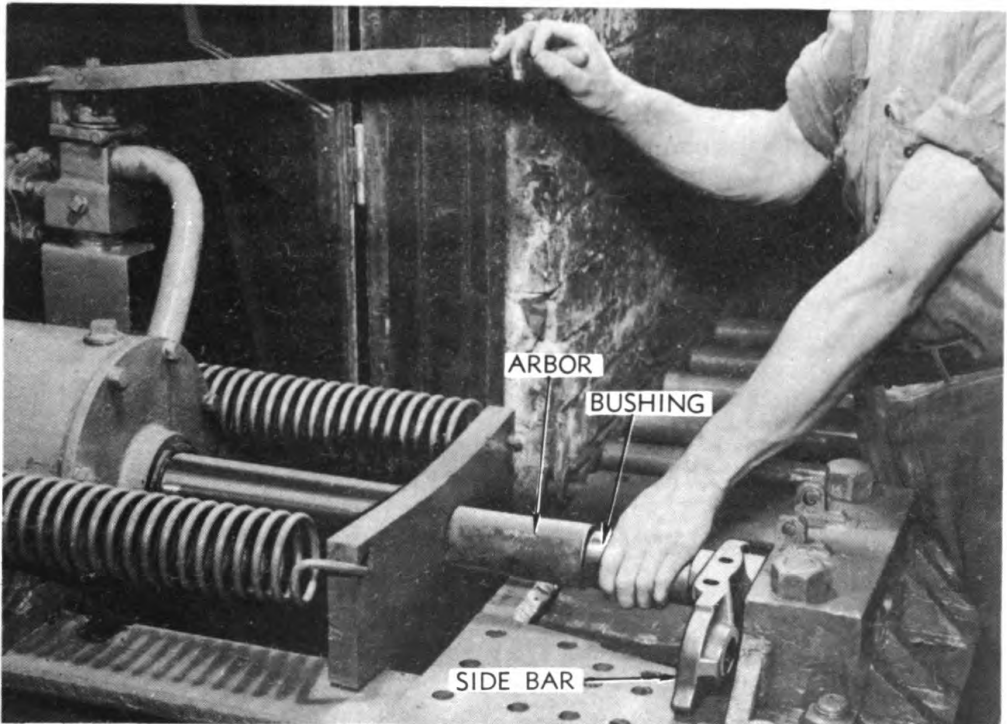

RA PD 18039

Figure 269 — Pressing Bushing into Side Bar

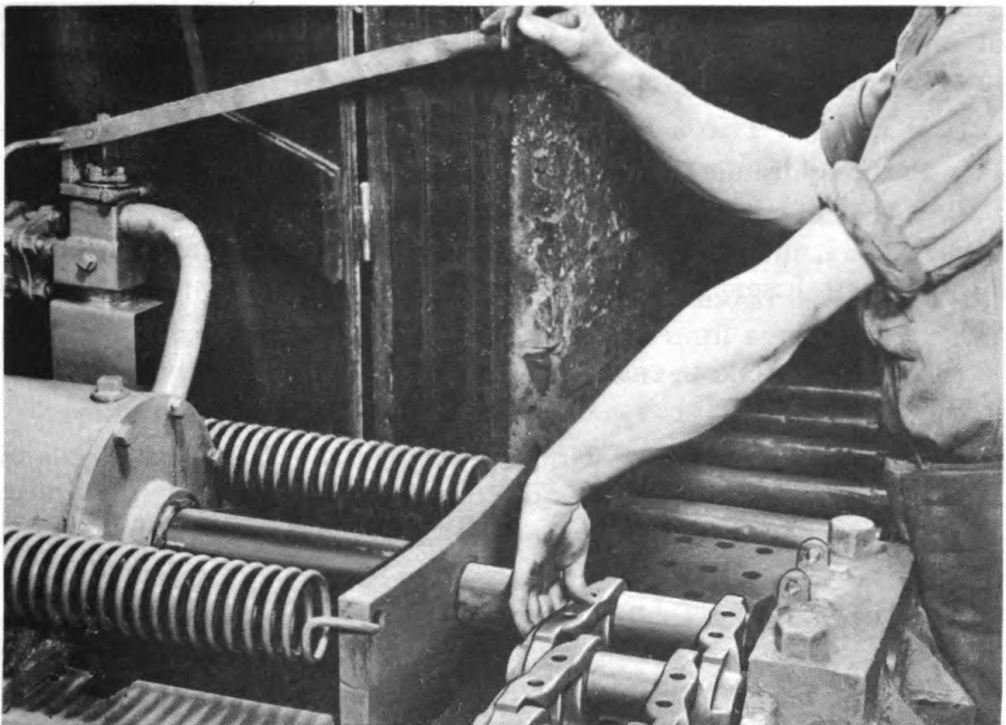

RA PD 18204

Figure 270 — Pressing Second Side Bar onto Bushing

**ORDNANCE MAINTENANCE — MEDIUM TRACTOR M1 (ALLIS-CHALMERS HD-7W)
ELECTRICAL SYSTEM, POWER TRAIN, FRAME, AND TRACKS**

to be sure none is cracked, so as to cause breakdown later on. If tractor has been operated for any length of time with bolts holding grouser shoes loose, the holes in side bars and shoes will be elongated, and bolts will be worn. In this event, new bolts must be installed; they will have to be checked and tightened often, as the elongated holes will cause even new bolts to loosen.

c. Grouser Shoes and Street Plates. Replace street plates that are worn out or broken. Bent street plates or shoes can be straightened. Replace worn bolts.

105. ASSEMBLY.

a. Tools Required.

Bar, pry

Wrench, $\frac{7}{8}$ -in. (2)

Press, hydraulic, track pin

Wrench, socket, $1\frac{3}{16}$ -in.

b. Procedure.

(1) ASSEMBLE SIDE BARS AND BUSHINGS.

Press, hydraulic, track pin

Place one side bar against face of press plate and press one end of bushing into larger hole in side bar (fig. 269), then lay assembled side bar and bushing in position on assembled part of track (fig. 270), and press mating side bar onto other end of bushing. Other end of side bar will be pressed onto protruding ends of preceding bushing at same time. Press side bars together until holes in side bars will line up with holes in grouser shoe.

(2) INSTALL TRACK PINS.

Press, hydraulic, track pin

With track rails connected by bushings, roll track along on conveyor rollers, and press pins through side bars and bushings (fig. 271). Adjust press assembly so an equal amount of the pins will extend out each side.

(3) INSTALL GROUSERS.

Bar, pry

Wrench, socket, $1\frac{3}{16}$ -in.

Install grousers on links with lug on grouser toward pin bosses of outside links. Bolt in place, with four special bolts with high nuts, each grouser and rail. Tighten all bolts as tightly as possible, using bar between side of nut and side bar, and turning bolt into nut.

(4) INSTALL STREET PLATES.

Wrench, $\frac{7}{8}$ -in. (2)

Install street plate on each grouser with lip of plate hooked over lug on grouser. Install two bolts with lock washers in each; tighten securely.

TRACK ASSEMBLY

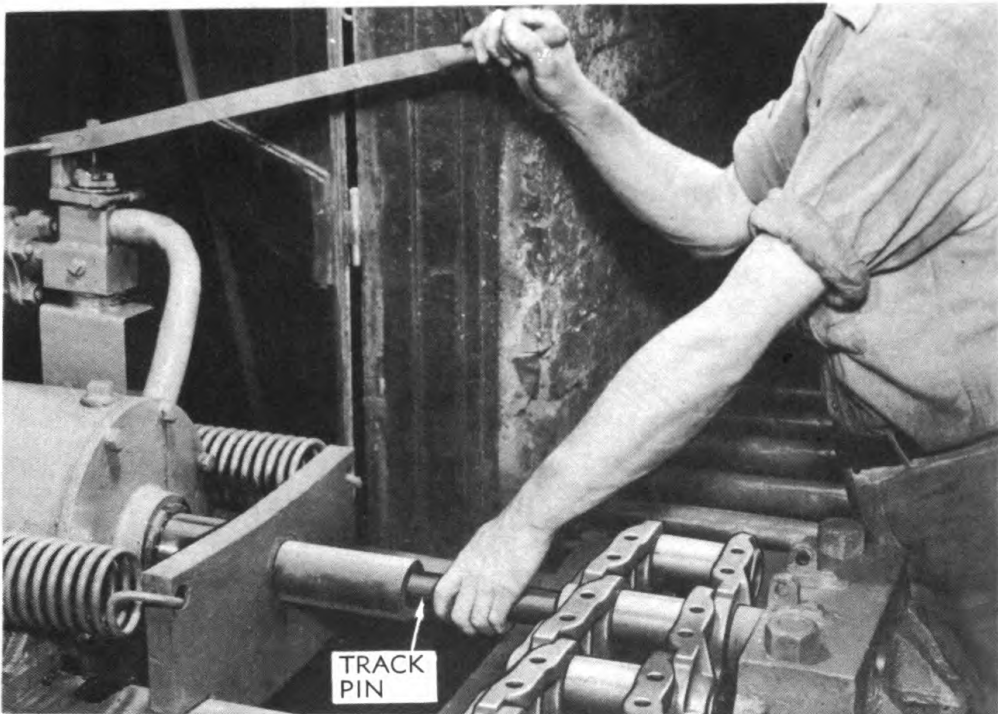

RA PD 18032

Figure 271 — Installing Track Pins in Rails

106. INSTALLATION.

a. Tools Required.

Bar, 6-ft

Hammer, sledge, 16-lb

Wood block, 8- x 8- x 12-in.

Wrench, $\frac{7}{8}$ -in.

Wrench, $1\frac{5}{16}$ -in.

Wrench, track-adjusting

b. Procedure.

(1) RUN TRACTOR ONTO TRACK.

Lay track assembly down behind and in line with sprocket. These tracks are not reversible, so be sure the correct end is laid next to the sprocket (fig. 274). Back tractor onto track until sprocket is within 3 feet of running off end of track.

(2) CONNECT TRACK.

Bar, 6-ft

Hammer, sledge, 16-lb

Wood block, 8- x 8- x 12-in.

Raise front end of track and lay wood block under tip of second grouser. Insert bar through rear end of track and raise end of track onto sprocket. Drive tractor forward slowly while one man holds track on sprocket, and guides it over support roller and front idler. Line up holes in two ends of track, install master pin bushing spacers in outside links, and drive master pin into place, leaving an equal length of the master pin extending from both side bars.

ORDNANCE MAINTENANCE — MEDIUM TRACTOR M1 (ALLIS-CHALMERS HD-7W)
ELECTRICAL SYSTEM, POWER TRAIN, FRAME, AND TRACKS

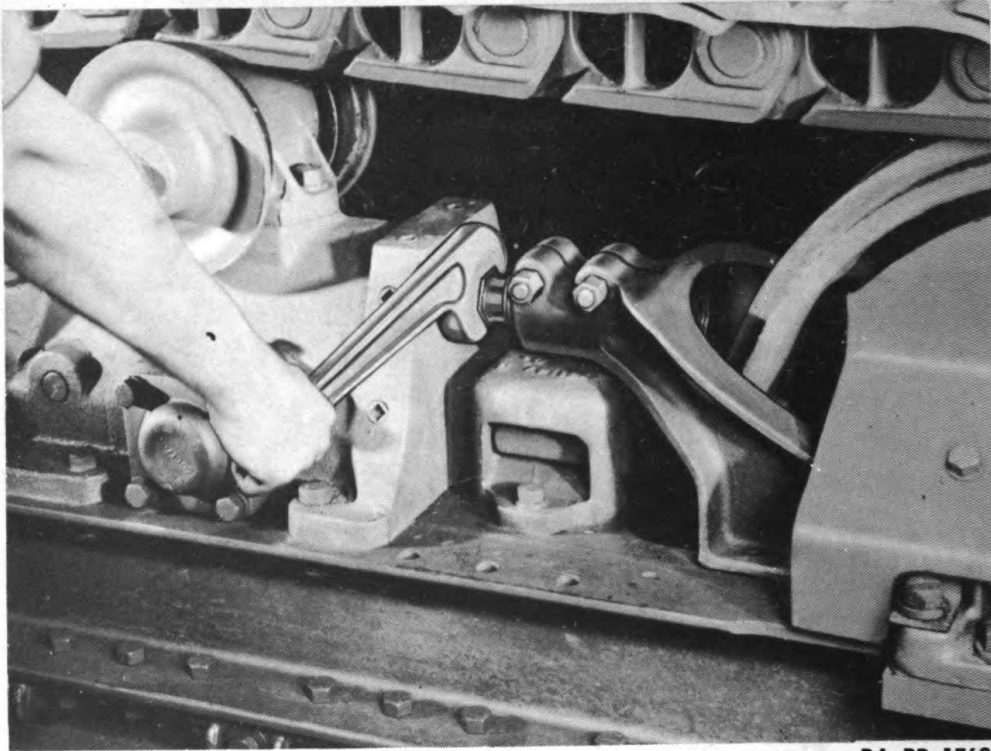

RA PD 17624

Figure 272 — Adjusting Track

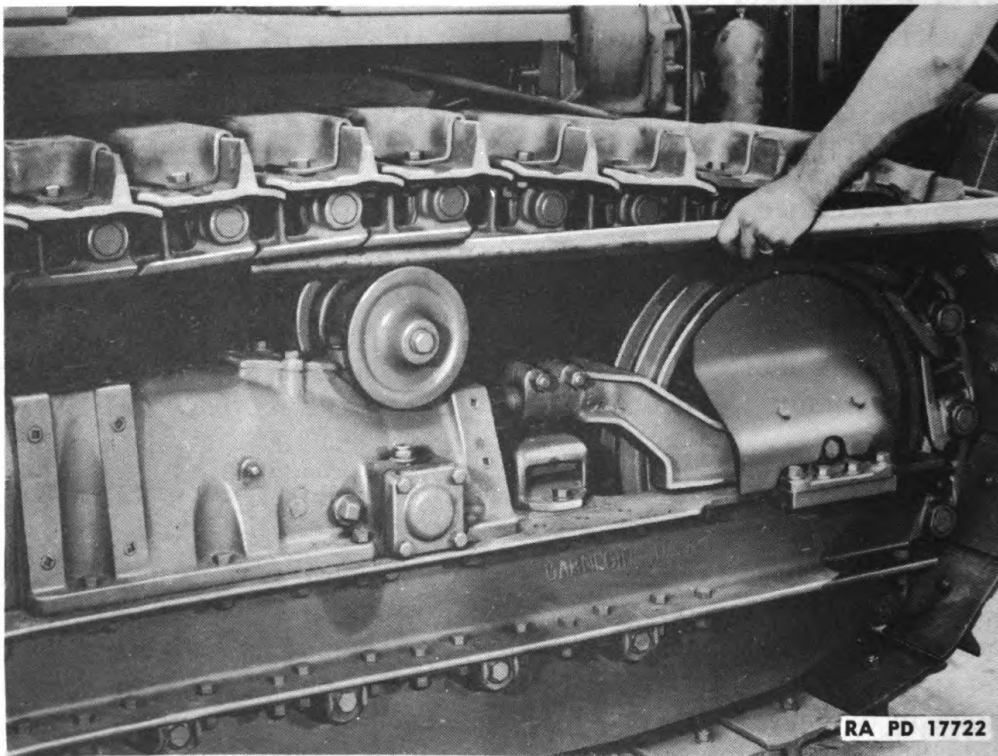

RA PD 17722

Figure 273 — Testing Track Adjustment

TRACK ASSEMBLY

(3) ADJUST TRACK.

Adjust track as outlined in paragraph 107.

107. ADJUSTMENT.

a. Tools Required.

Bar, 6-ft

Wrench, $\frac{7}{8}$ -in.

Wrench, $\frac{15}{16}$ -in.

Wrench, track-adjusting

b. Procedure.

(1) ADJUST TENSION OF TRACK.

Bar, 6-ft

Wrench, $\frac{7}{8}$ -in.

Wrench, $\frac{15}{16}$ -in.

Wrench, track-adjusting

Turn the adjusting screw out of the yoke (fig. 272) to force the front idler ahead, and tighten the track. Turn screw into the yoke to allow the idler to move back and loosen the track (track-adjusting wrench). Track is properly adjusted when it can be lifted about 2 inches off support roller with bar (fig. 273). Drive tractor back and forth a few times after making adjustment; this gives idlers a chance to move out if brackets are binding on truck frame; then check adjustment with bar. If driving the tractor back and forth makes no change in track tension, tighten the clamp bolts in track release yoke ($\frac{7}{8}$ - and $\frac{15}{16}$ -in. wrenches).

(2) CHECK TRACK ALINEMENT.

Observe if inside of track rail is rubbing on either flange of front idler. If it is, the idler should be alined as outlined in paragraph 89 b (4).

108. SPECIAL TOOLS.

a. A track pin press is the only special equipment necessary to repair the track assembly.

ORDNANCE MAINTENANCE — MEDIUM TRACTOR M1 (ALLIS-CHALMERS HD-7W)
ELECTRICAL SYSTEM, POWER TRAIN, FRAME, AND TRACKS

CHAPTER 12
TRUCK FRAME AND TRACK ASSEMBLY (Cont'd)

Section V
TRUCK FRAME ASSEMBLY

	Paragraph
Description	109
Trouble shooting	110
Removal	111
Disassembly	112
Inspection and repair	113
Assembly	114
Installation	115

109. DESCRIPTION.

a. The truck frame consists of two side channels bolted to a heavy center section. A bracket is bolted to the rear of the outer channel for truck frame to pivot on rear axle and allow truck frame to oscillate. The truck frame is held in alinement with tractor by the stabilizer assembly. The truck wheels are mounted under the truck frame and guards are bolted to the lower flanges of the outside channels to protect the truck wheels. The track release mechanism and front idler are also mounted on the truck frame.

110. TROUBLE SHOOTING.

a. **Excessive Wear on Track and Truck Wheels.**

Possible Cause	Possible Remedy
Truck frame bent or twisted.	Straighten or replace frame.
Worn stabilizer cranks or bushings.	Replace cranks or bushings.
Worn rear axle bracket and bushings.	Replace bracket and bushings.
Dirt guards broken or lost.	Replace damaged or missing parts; keep bolts tight to prevent loss of guards.

111. REMOVAL.

a. **Tools and Equipment Required.**

Bar, 6-ft (2)	Rope
Bar, drift, 1- x 12-in.	Tongs
Bar, drift, 1- x 18-in.	Wood blocks, assorted
Chisel, 3/4-in.	Wrench, 7/8-in.
Hammer, 2-lb	Wrench, 15/16-in.
Hammer, sledge, 16-lb	Wrench, 1 1/16-in.
Hoist, chain	Wrench, 1 7/16-in.
Jack, hydraulic, 10-ton	Wrench, track-adjusting

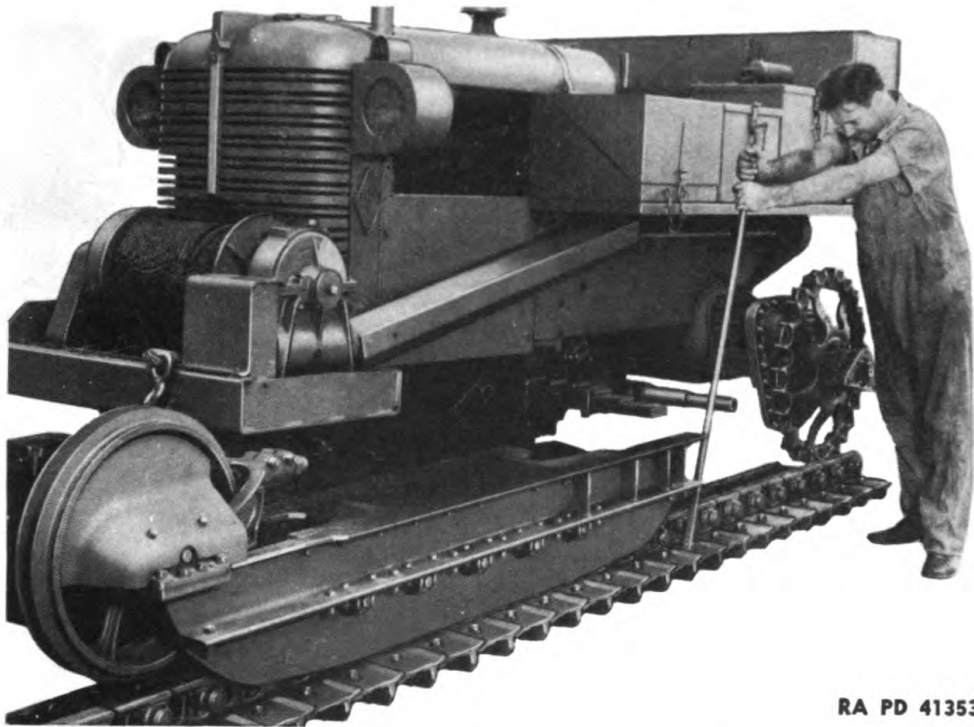
TRUCK FRAME ASSEMBLY

RA PD 41353

Figure 274 — Rolling Truck Frame Assembly Forward**b. Procedure.****(1) UNCOUPLE TRACK.**

Refer to Paragraph 102 b (1) and (2).

(2) PREPARE TO REMOVE TRUCK FRAME.

Jack, hydraulic, 10-ton

Wood block, assorted

Raise front end of tractor with jack until weight is taken off stabilizer spring. Block up under front of tractor, and raise rear end of tractor on side from which truck frame is to be removed until weight is taken off rear axle bracket. Block in that position.

(3) REMOVE REAR AXLE END COVER AND SPROCKET GUARD.

Wrench, $\frac{7}{8}$ -in.

Wrench, $\frac{15}{16}$ -in.

Remove the three cap screws ($\frac{7}{8}$ -in. wrench) and remove rear axle end cover (fig. 3). Remove sprocket guard by removing the two bolts holding it to truck frame ($\frac{7}{8}$ - and $\frac{15}{16}$ -in. wrenches) (fig. 4). Remove the four bolts holding rear axle bracket to truck frame ($\frac{7}{8}$ - and $\frac{15}{16}$ -in. wrenches).

(4) REMOVE STABILIZER SPRING SEAT AND U-BOLT.

See paragraph 32 for removal of spring seat and U-bolt.

(5) REMOVE TRACK RELEASE HOUSING FROM TRUCK FRAME.

See paragraph 95 for removal of track release housing.

ORDNANCE MAINTENANCE — MEDIUM TRACTOR M1 (ALLIS-CHALMERS HD-7W)
ELECTRICAL SYSTEM, POWER TRAIN, FRAME, AND TRACKS

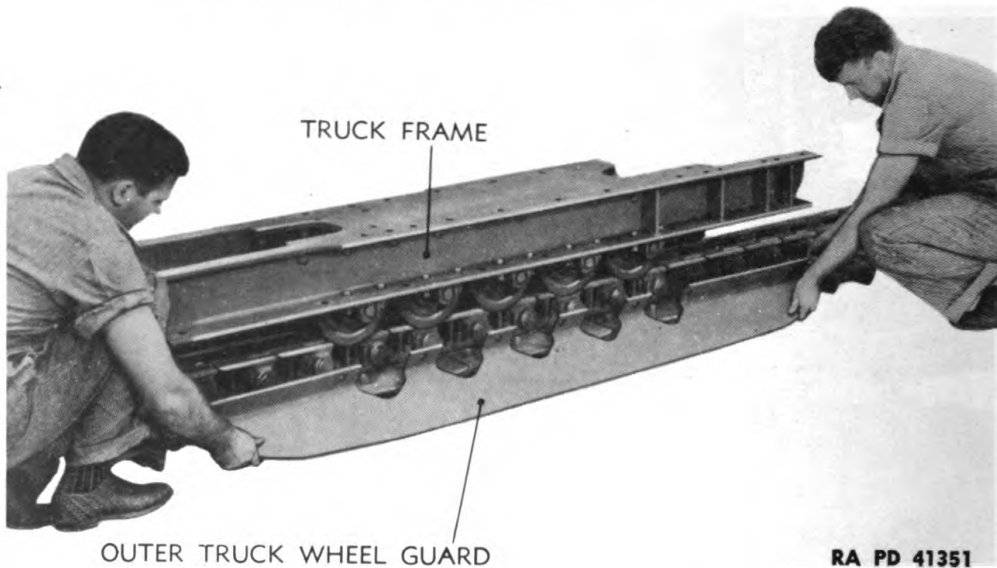

Figure 275 — Truck Wheel Guard Removed

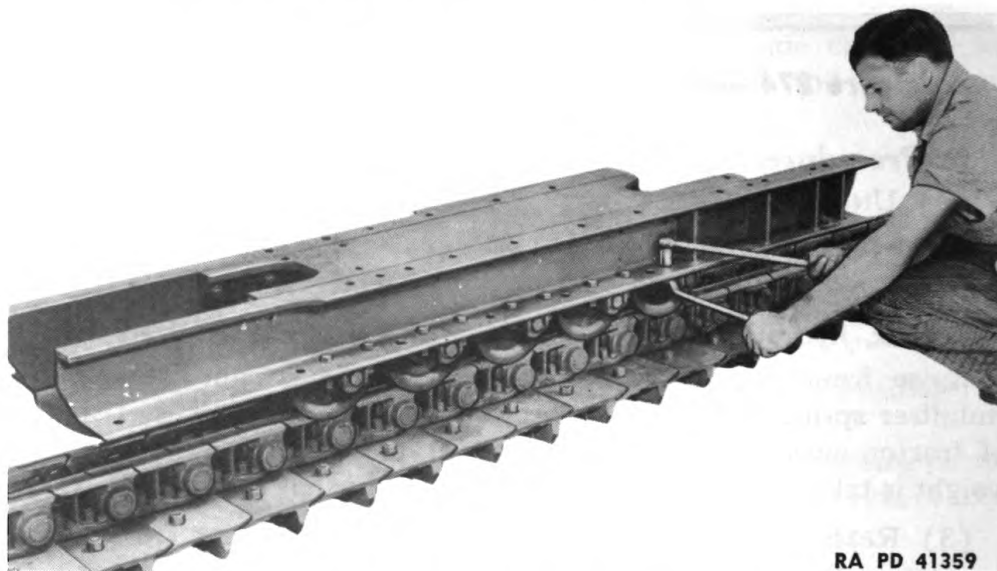

Figure 276 — Removing Truck Wheel Bolts

(6) ROLL TRUCK FRAME ASSEMBLY AHEAD.

Bar, 6-ft

Roll truck frame assembly forward and clear of tractor (fig. 274). Slide front idler off front end of truck frame and roll it out of the way.

112. DISASSEMBLY.

a. Tools Required.

Wrench, $\frac{7}{8}$ -in.

Wrench, $\frac{15}{16}$ -in.

TRUCK FRAME ASSEMBLY

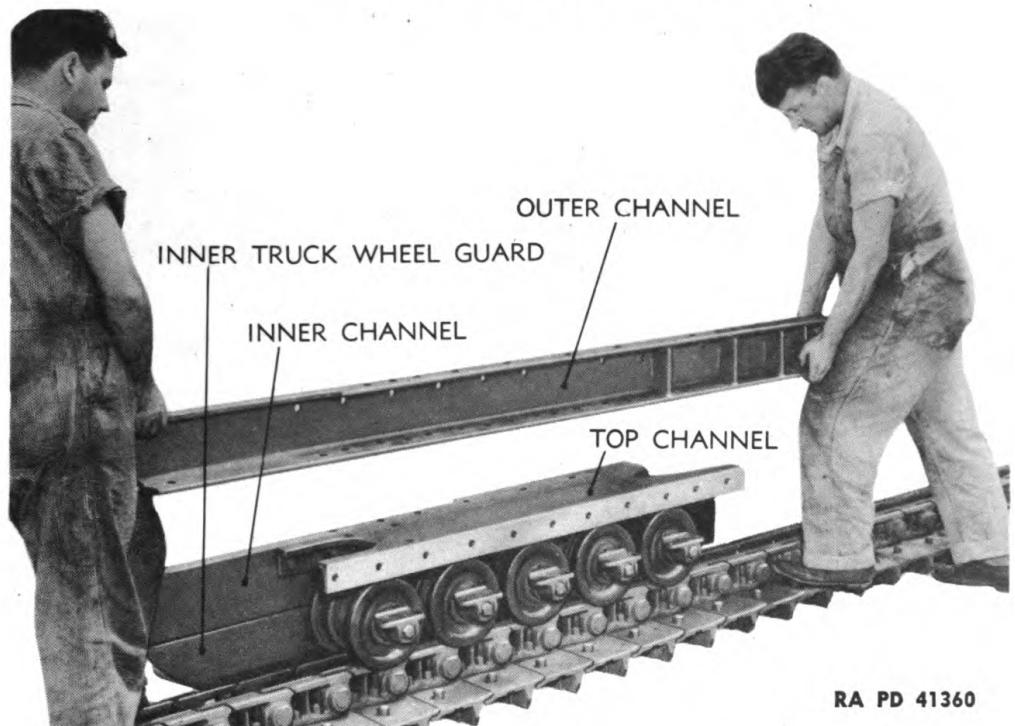

RA PD 41360

Figure 277 — Outer Channel Removed from Truck Frame

b. Procedure.

(1) REMOVE TRUCK WHEEL GUARDS.

Wrench, $\frac{7}{8}$ -in.

Wrench, $\frac{15}{16}$ -in.

Remove nine bolts to remove outer truck wheel guard (fig. 275), or seven bolts to remove inner truck wheel guard.

(2) REMOVE OUTER CHANNELS.

Wrench, $\frac{7}{8}$ -in.

Wrench, $\frac{15}{16}$ -in.

(a) Remove 10 bolts on each side from truck wheel brackets and channels ($\frac{7}{8}$ - and $\frac{15}{16}$ -in. wrenches) (fig. 276).

(b) Remove 10 bolts to remove outer channel from top channel and 9 bolts to remove inner channel ($\frac{7}{8}$ - and $\frac{15}{16}$ -in. wrenches) (fig. 277).

113. INSPECTION AND REPAIR.

a. Clean all parts thoroughly. Repair broken parts by welding, and straighten bent or twisted parts. Check straightness of channels with a tight string or straight edge. Straighten channels if bent in press. Straighten truck wheel guards to fit outer channels, and repair or replace broken guards.

114. ASSEMBLY.

a. Tools Required.

Wrench, $\frac{7}{8}$ -in.

Wrench, $\frac{15}{16}$ -in.

ORDNANCE MAINTENANCE — MEDIUM TRACTOR M1 (ALLIS-CHALMERS HD-7W)
ELECTRICAL SYSTEM, POWER TRAIN, FRAME, AND TRACKS

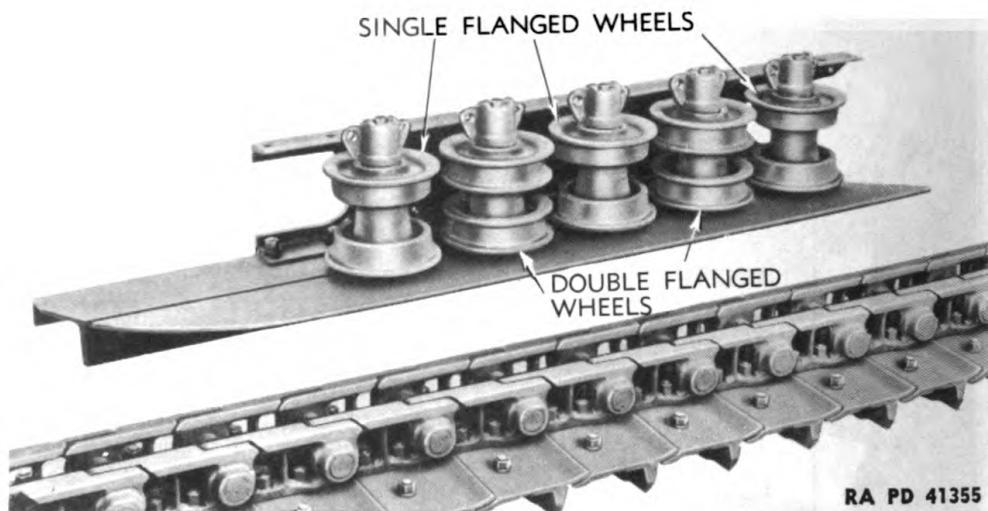

Figure 278 —Arrangement of Truck Wheels in Truck Frame

b. Procedure.

(1) INSTALL OUTER CHANNELS ON TOP CHANNEL.

Wrench, $\frac{7}{8}$ -in.

Wrench, $\frac{15}{16}$ -in.

Bolt inner channel to inner side of top channel with nine $\frac{5}{8}$ - by 2-inch bolts, and outer channel with ten bolts of the same size (fig. 277). Use $\frac{7}{8}$ - and $\frac{15}{16}$ -inch wrenches.

(2) INSTALL TRUCK WHEELS.

Wrench, $\frac{7}{8}$ -in.

Wrench, $\frac{15}{16}$ -in.

Turn frame on side and install the five truck wheels in frame. Install single-flanged wheels at front, center, and rear; install double-flanged wheels in Number 2 and Number 4 positions (fig. 278). Secure brackets of truck wheels to lower flanges of outer channels with two $\frac{5}{8}$ - by 2-inch bolts and high nuts ($\frac{7}{8}$ - and $\frac{15}{16}$ -in. wrenches). NOTE: Be sure truck wheels are installed so shaft plugs in wheels will be to the outside when assembled (fig. 278).

(3) INSTALL TRUCK WHEEL GUARDS.

Wrench, $\frac{7}{8}$ -in.

Wrench, $\frac{15}{16}$ -in.

Turn frame and truck wheels right side up, and install truck wheel guards on lower flange on outer channels with seven $\frac{5}{8}$ - by 2-inch bolts with high nuts for inner guard ($\frac{7}{8}$ - and $\frac{15}{16}$ -in. wrenches), and ten $\frac{5}{8}$ - by 2-inch bolts for outer guard (fig. 275).

115. INSTALLATION.

a. Tools and Equipment Required.

Bar, 6-ft (2)

Chisel, $\frac{3}{4}$ -in.

Hammer, 2-lb

Hammer, sledge, 16-lb

TRUCK FRAME ASSEMBLY

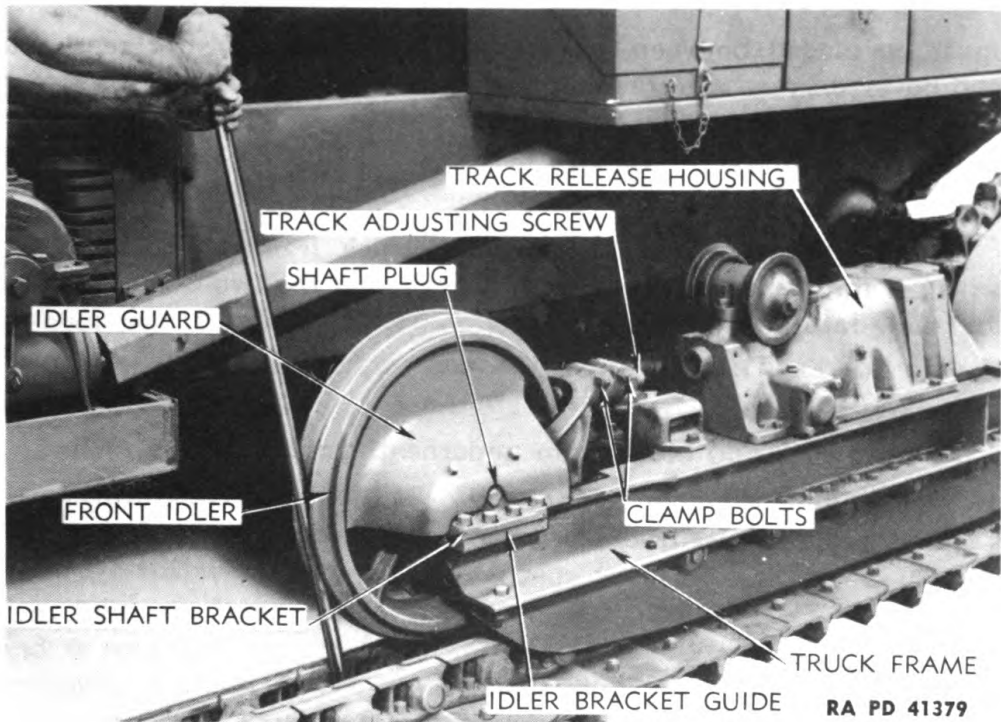

Figure 279 — Installing Front Idler on Truck Frame

- | | |
|------------------------------|------------------------------|
| Hoist, chain | Wrench, $\frac{15}{16}$ -in. |
| Jack, hydraulic, 10-ton | Wrench, $\frac{11}{16}$ -in. |
| Rope | Wrench, $\frac{17}{16}$ -in. |
| Wood block, 8- x 8- x 12-in. | Wrench, track-adjusting |
| Wrench, $\frac{7}{8}$ -in. | |

b. Procedure.

(1) CONNECT TRUCK FRAME TO REAR AXLE.

- | | |
|----------------------------|------------------------------|
| Wrench, $\frac{7}{8}$ -in. | Wrench, $\frac{15}{16}$ -in. |
|----------------------------|------------------------------|

Roll truck frame on tracks back into position, lining up holes in rear end of truck frame with holes in rear axle bracket. Install four 5- by 3-inch and one $\frac{5}{8}$ - by 2-inch bolts through rear axle bracket and truck frame ($\frac{7}{8}$ - and $\frac{15}{16}$ -in. wrenches) (fig. 11). Install high nuts on bolts and tighten.

(2) INSTALL TRACK RELEASE HOUSING.

Refer to paragraph 99 for installation of track release housing.

(3) INSTALL STABILIZER SPRING SEAT AND U-BOLT.

Refer to paragraph 36 for installation of stabilizer spring seat and U-bolt.

(4) INSTALL SPROCKET GUARD AND REAR AXLE END COVER.

- | | |
|----------------------------|------------------------------|
| Wrench, $\frac{7}{8}$ -in. | Wrench, $\frac{15}{16}$ -in. |
|----------------------------|------------------------------|

Install sprocket guard on truck frame with two $\frac{5}{8}$ - by 2 $\frac{1}{4}$ -inch bolts with lock washers ($\frac{7}{8}$ - and $\frac{15}{16}$ -in. wrenches) (fig. 4). Spacers

**ORDNANCE MAINTENANCE — MEDIUM TRACTOR M1 (ALLIS-CHALMERS HD-7W)
ELECTRICAL SYSTEM, POWER TRAIN, FRAME, AND TRACKS**

must be placed between guard and truck frame. Install rear axle end cover on rear axle bracket with two $\frac{5}{8}$ - by $1\frac{1}{4}$ -inch cap screws with lock washers ($\frac{7}{8}$ -in. wrench).

(5) INSTALL FRONT IDLER.

Bar, 6-ft

Roll idler on track until it reaches truck frame; then lift it up with bar until idler bracket guides engage over the two outer channels and slide into position (fig. 279).

(6) LOWER TRACTOR.

Jack, hydraulic, 10-ton

Remove jack and block from underneath tractor.

(7) COUPLE TRACKS.

Couple and adjust tracks as outlined in paragraphs 106 and 107.

CHAPTER 13

WINCH

	Paragraph
Description	116
Trouble shooting	117
Removal of winch assembly	118
Removal of winch lay shaft and control levers	119
Disassembly of winch and controls	120
Inspection and repair of parts	121
Assembly of winch and controls	122
Installation of winch lay shaft and control levers	123
Installation of winch assembly	124
Adjustments of winch and controls	125

116. DESCRIPTION.

a. The winch is a Model T 4B Gar Wood heavy-duty type winch, and is mounted on the front end of the tractor. The winch drum, equipped with bronze bushings, is mounted on a heavy shaft to which a gear is keyed on one end, and a sliding jaw clutch on the other. The gear is driven by a worm mounted on the ball bearings in the gear case. A drive shaft with universals is connected to this worm, and extends back along the side of the tractor to the rear, where a roller chain from the power take-off sprocket connects to the sprocket on the end of the shaft.

b. The winch drum is turned by engaging the jaw clutch on the winch drum shaft with the jaws on the end of the drum, then shifting the power take-off control lever into the desired position for reeling or unreeling cable, and engaging the master clutch. When the jaw clutch is disengaged, the drum turns freely. Two control levers are mounted on the right fender; one operates the winch jaw clutch, the other the winch drum brake used when unreeling cable. An automatic safety brake is mounted on the front end of the winch worm shaft. This brake automatically engages to hold the load being pulled when the master clutch is disengaged. The winch is supplied with 300 feet of 5/8-inch cable. The drum, however, has a capacity of 675 feet. For further specifications, refer to TM 9-783B.

117. TROUBLE SHOOTING.

a. Oil Leakage.

Possible Cause	Possible Remedy
Ball bearings on worm shaft worn.	Replace ball bearings.
Cracked case.	Repair or replace case.

ORDNANCE MAINTENANCE — MEDIUM TRACTOR M1 (ALLIS-CHALMERS HD-7W)
ELECTRICAL SYSTEM, POWER TRAIN, FRAME, AND TRACKS

Possible Cause	Possible Remedy
Oil seal in worm shaft bearing cap worn.	Replace oil seal.
Oil seal in brake case worn.	Replace oil seal.
b. Winch Fails to Hold Load.	
Automatic brake spring too loose.	Adjust brake spring.
Brake lining worn or defective.	Inspect and replace lining if necessary.
Oil on brake lining.	Clean oil from linings and determine source of oil.
c. Winch Brake Overheats.	
Automatic brake out of adjustment.	Adjust automatic brake.
d. Winch Drum Wobbles.	
Drum shaft bent.	Straighten or replace drum shaft.
e. End Frame and Gear Case Wobble.	
Large bolts holding each unit to winch base may be loose.	Tighten bolts.
Drum shaft may be bent.	Straighten or replace drum shaft.
f. Sliding Clutch Does Not Engage.	
Clutch sticks.	Free clutch.
Clutch jumps out of engagement.	Adjust linkage on clutch control rod.

118. REMOVAL OF WINCH ASSEMBLY.

a. Tools Required.

Hoist, chain	Wrench, socket, $\frac{9}{16}$ -in.
Pliers	Wrench, socket, $\frac{3}{4}$ -in.
Rope	Wrench, socket, $\frac{7}{8}$ -in.
Wrench, open-end, $\frac{9}{16}$ -in.	Wrench, socket, $1\frac{1}{16}$ -in., with extension
Wrench, open-end, $\frac{3}{4}$ -in.	Wrench, socket, $1\frac{7}{16}$ -in., with extension
Wrench, open-end, 1-in.	
Wrench, open-end, $1\frac{5}{16}$ -in.	

b. Procedure.

(1) DISCONNECT WINCH CONTROL RODS.

Pliers

Remove the yoke pins holding winch clutch and brake control rods to control levers under right top fender (fig. 280).

(2) REMOVE WINCH DRIVE SHAFT GUARD.

Wrench, open-end, $\frac{9}{16}$ -in.	Wrench, socket, $\frac{9}{16}$ -in.
Wrench, open-end, $\frac{3}{4}$ -in.	Wrench, socket, $\frac{3}{4}$ -in.

WINCH

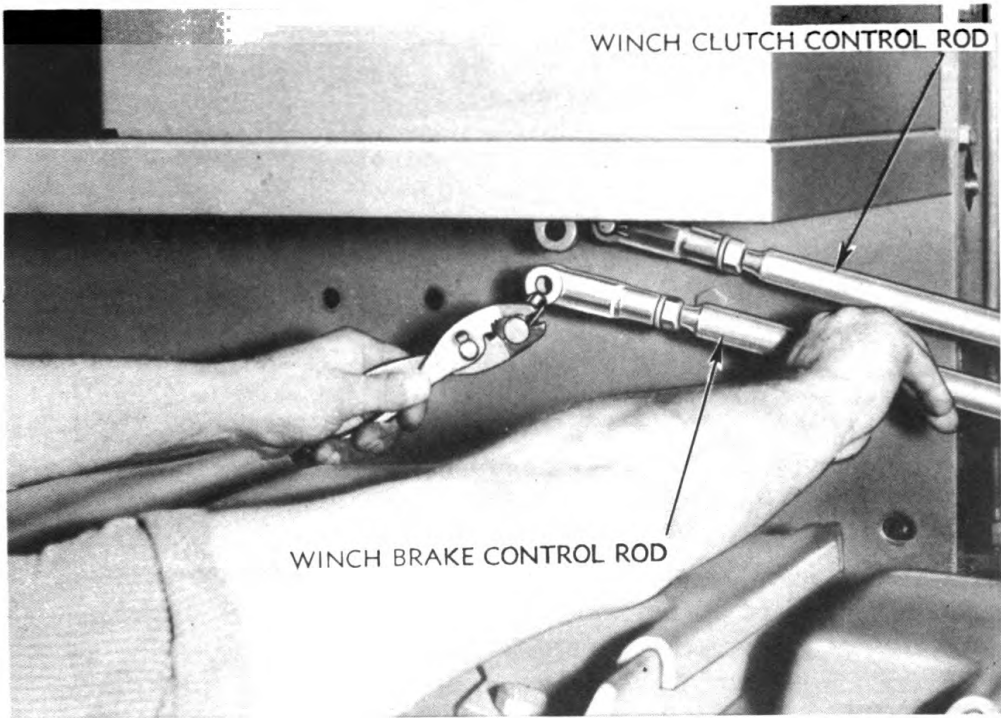

RA PD 41207

Figure 280 — Disconnecting Control Rods from Hand Lever

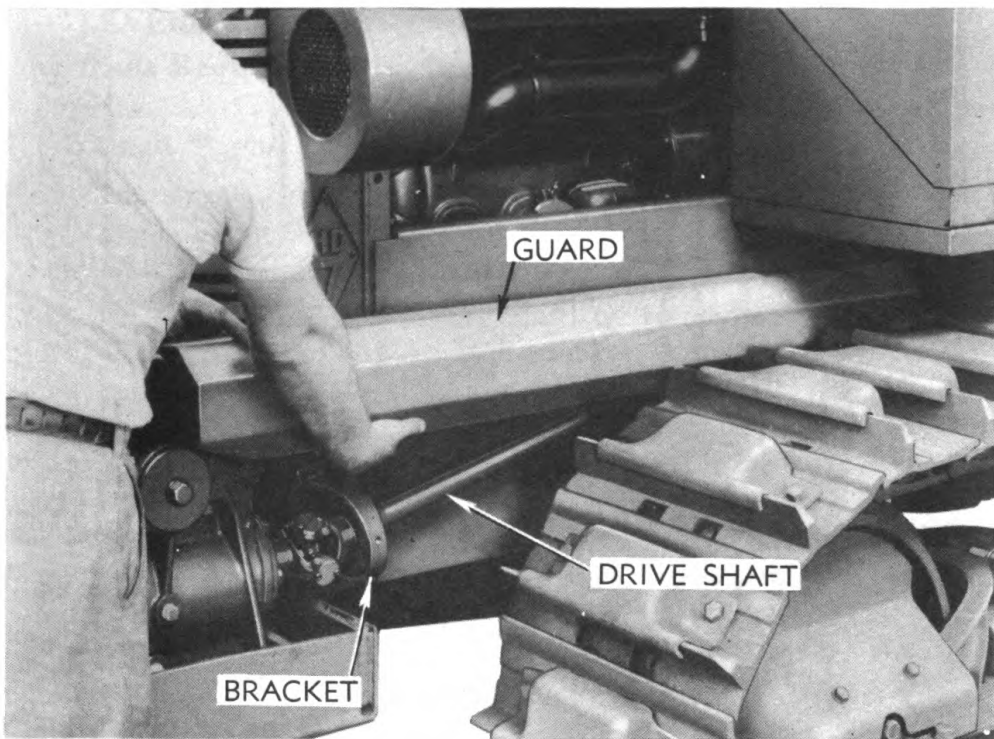

RA PD 17693

Figure 281 — Removing Winch Drive Shaft Guard

**ORDNANCE MAINTENANCE — MEDIUM TRACTOR M1 (ALLIS-CHALMERS HD-7W)
ELECTRICAL SYSTEM, POWER TRAIN, FRAME, AND TRACKS**



RA PD 40778

Figure 282 — Removing Engine Support Bottom Cover

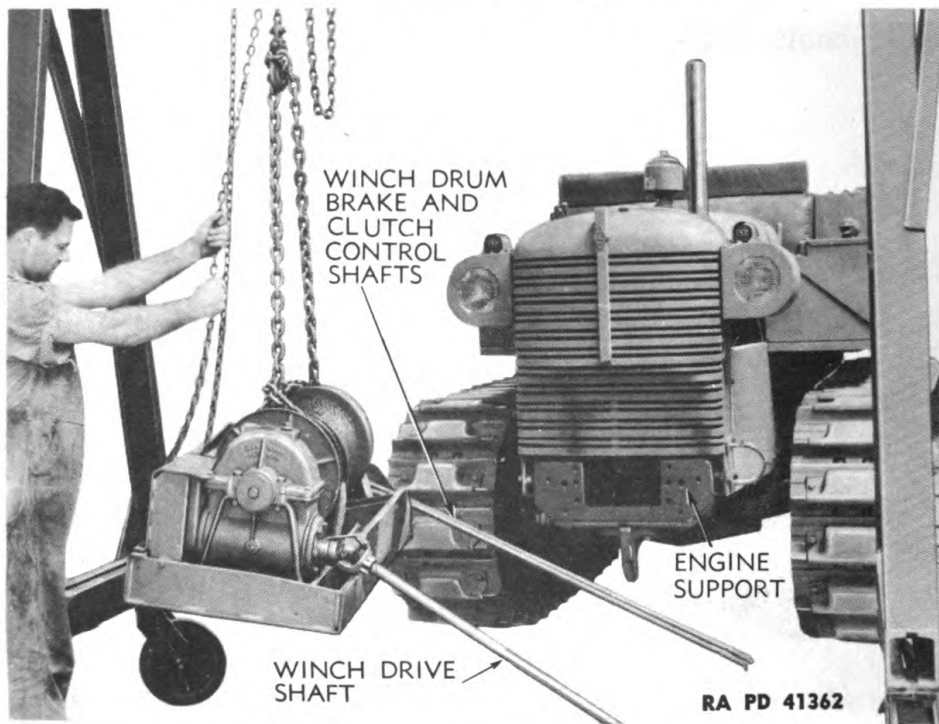

RA PD 41362

Figure 283 — Winch Assembly Removed from Tractor

WINCH

Remove three cap screws holding front of guard to bracket on radiator ($\frac{9}{16}$ -in. wrench). Remove three bolts from rear of guard (two $\frac{9}{16}$ - and two $\frac{3}{4}$ -in. wrenches). Remove guard (fig. 281).

(3) REMOVE ENGINE SUPPORT BOTTOM COVER.

Wrench, socket, $\frac{7}{8}$ -in.

Remove four cap screws holding engine support bottom cover to engine support. Remove cover (fig. 282).

(4) REMOVE WINCH.

Hoist, chain

Rope

Wrench, open-end, 1-in.

Wrench, open-end, $1\frac{5}{16}$ -in.

Wrench, socket, $1\frac{1}{16}$ -in.,
with extension

Wrench, socket, $1\frac{7}{16}$ -in.,
with extension

Fasten rope or chain around winch assembly, hook chain or rope into hook of hoist, and take up slack in chain. Have one man hold 1-inch and $1\frac{5}{16}$ -inch wrenches on nuts of bolts holding winch assembly to front of tractor while another man, working through opening made by removal of engine support cover, turns the 11 bolt out of nuts with $1\frac{1}{16}$ -inch and $1\frac{7}{16}$ -inch wrenches. After removing these bolts, pull winch assembly forward away from tractor (fig. 283). Rear end of winch drive shaft will slip out of slip joint of universal joint on lay shaft.

119. REMOVAL OF WINCH LAY SHAFT AND CONTROL LEVERS.

a. Tools Required.

Pliers

Wrench, $\frac{9}{16}$ -in. (2)

Wrench, $\frac{3}{4}$ -in. (2)

b. Procedure.

(1) REMOVE WINCH LAY SHAFT.

Wrench, $\frac{9}{16}$ -in. (2)

Wrench, $\frac{3}{4}$ -in. (2)

(a) Remove lay shaft sprocket guard by removing the four bolts holding it to rear fender and pintle bracket (two $\frac{9}{16}$ -in. wrenches)

(b) Remove two bolts and nuts holding lay shaft rear bearing bracket to rear fender bracket (two $\frac{3}{4}$ -in. wrenches). Remove two bolts and nuts holding lay shaft front bearing bracket underneath the top fender (two $\frac{3}{4}$ -in. wrenches), and remove lay shaft assembly from tractor. NOTE: When removing rear lay shaft, any shims that are removed should be saved and position noted for reinstallation in original positions.

(2) REMOVE WINCH CONTROL LEVER ASSEMBLY.

Pliers

Wrench, $\frac{9}{16}$ -in. (2)

Wrench, $\frac{3}{4}$ -in. (2)

(a) Disconnect control rods from bottom of winch drum brake and clutch control levers by removing pins at rear end of rods.

**ORDNANCE MAINTENANCE — MEDIUM TRACTOR M1 (ALLIS-CHALMERS HD-7W)
ELECTRICAL SYSTEM, POWER TRAIN, FRAME, AND TRACKS**

with pliers (fig. 280), unless winch assembly has been removed and control rods removed with it.

(b) Remove the two bolts holding lever bracket to side of cowl (two $\frac{3}{4}$ -in. wrenches), and remove the bracket and lever assembly as a unit.

120. DISASSEMBLY OF WINCH AND CONTROLS.

a. Tools and Equipment Required.

Bar, drift, $\frac{3}{4}$ - x 18-in.	Wood block
Bar, drift, 3-ft	Wrench, 1-in.
Bar, drift, brass	Wrench, box, 1½-in.
Bar, pry	Wrench, box, 1⅝-in.
Chisel, $\frac{3}{4}$ -in.	Wrench, hexagonal, $\frac{3}{16}$ -in.
Disk, steel, $\frac{5}{16}$ -in. thick, 3-in. diam	Wrench, open-end, $\frac{3}{8}$ -in.
File, flat	Wrench, open-end, $\frac{7}{16}$ -in. (2)
Hammer, 2-lb	Wrench, open-end, $\frac{9}{16}$ -in.
Hammer, soft	Wrench, open-end, $\frac{11}{16}$ -in.
Hoist, chain	Wrench, open-end, $\frac{3}{4}$ -in.
Pliers	Wrench, open-end, $\frac{15}{16}$ -in.
Press, arbor	Wrench, open-end, 1½-in.
Punch, 10-in.	Wrench, open-end, 1⅝-in.
Punch, short	Wrench, socket, $\frac{7}{16}$ -in.
Punch, small	Wrench, socket, $\frac{9}{16}$ -in.
Remover, stud	Wrench, socket, $\frac{3}{4}$ -in., with extension
Rope	Wrench, socket, $\frac{7}{8}$ -in.
Screwdriver, 4-in.	
Screwdriver, 10-in.	

b. Procedure.

(1) PREPARE TO DISASSEMBLE WINCH.

Hoist, chain	Wrench, $\frac{3}{4}$ -in.
Rope	

With the aid of the chain hoist, raise the winch assembly and set it up on some large flat blocks with the base of the winch resting on the blocks. Disengage sliding jaw clutch (if engaged) from jaws on winch drum; have another man hold winch drum brake loose with lever and unreel cable from drum. Then remove cable clamp from drum flange by removing the two nuts ($\frac{3}{4}$ -in. wrench), and pull end of cable out of flange.

(2) REMOVE WINCH DRIVE SHAFT AND CONTROL RODS (fig. 283).

Chisel, $\frac{3}{4}$ -in.	Pliers
Hammer, 2-lb	

(a) Using hammer, tap end of universal joint off winch worm shaft and key while another man pulls on drive shaft. Remove key

WINCH

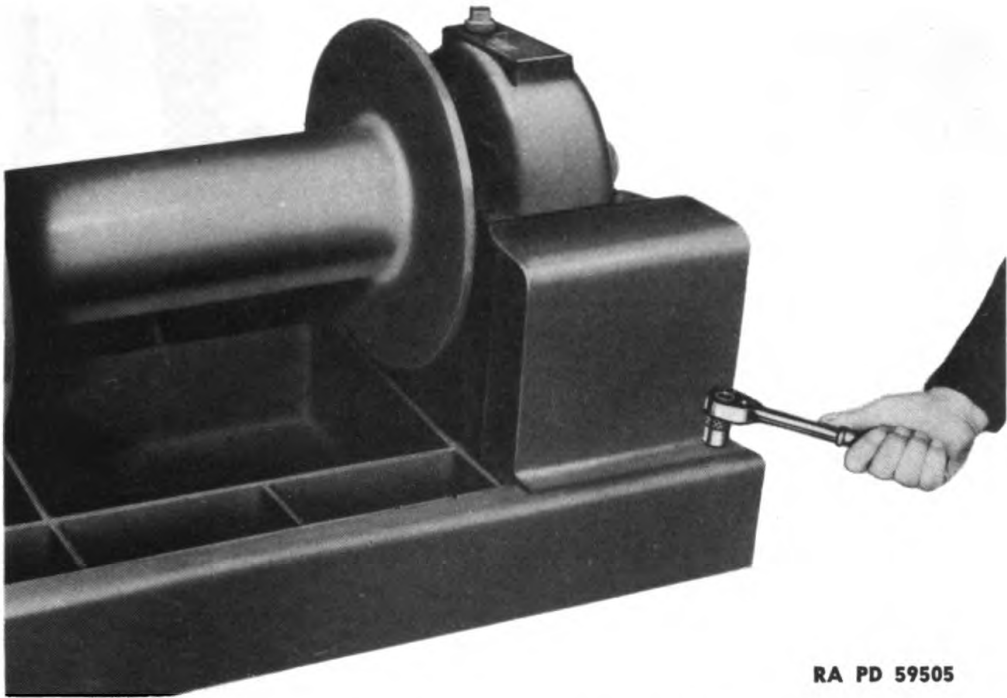

RA PD 59505

Figure 284 — Removing Bolts Holding Automatic Brake Guard

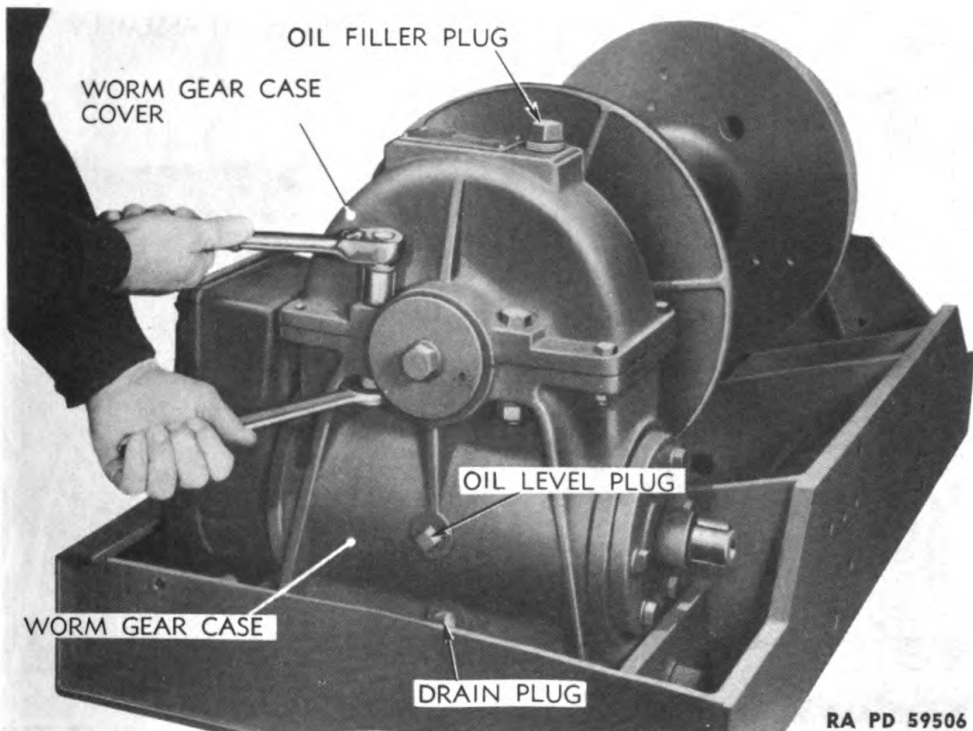

RA PD 59506

Figure 285 — Removing Bolts from Gear Case and Cover

ORDNANCE MAINTENANCE — MEDIUM TRACTOR M1 (ALLIS-CHALMERS HD-7W)
ELECTRICAL SYSTEM, POWER TRAIN, FRAME, AND TRACKS

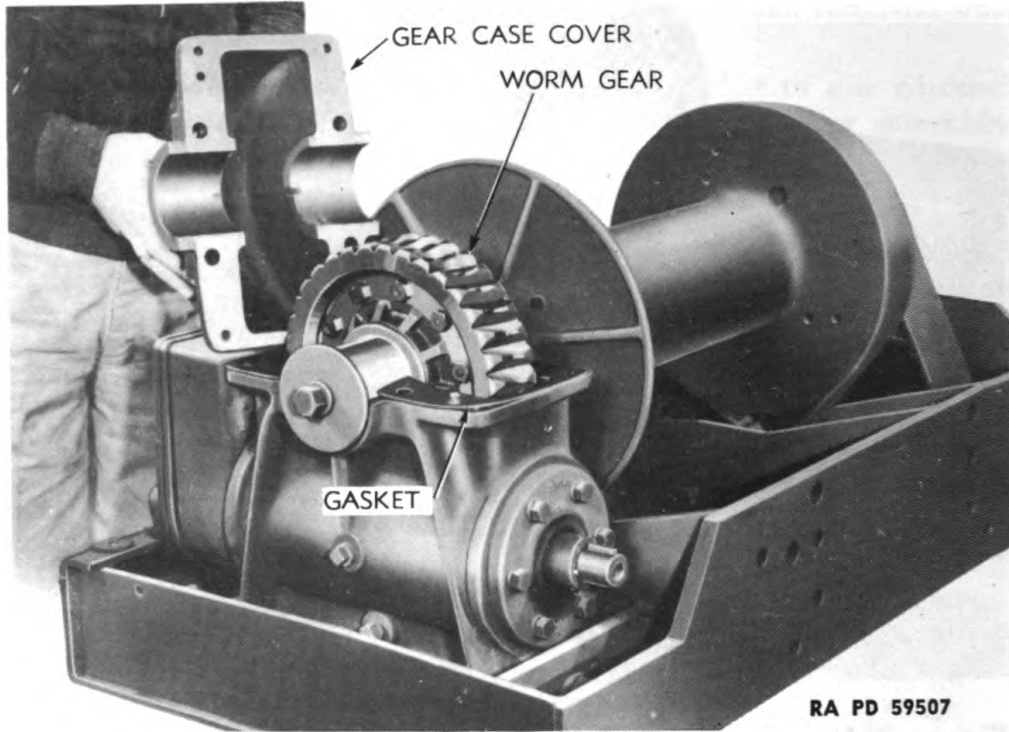

Figure 286 — Gear Case Cover Removed

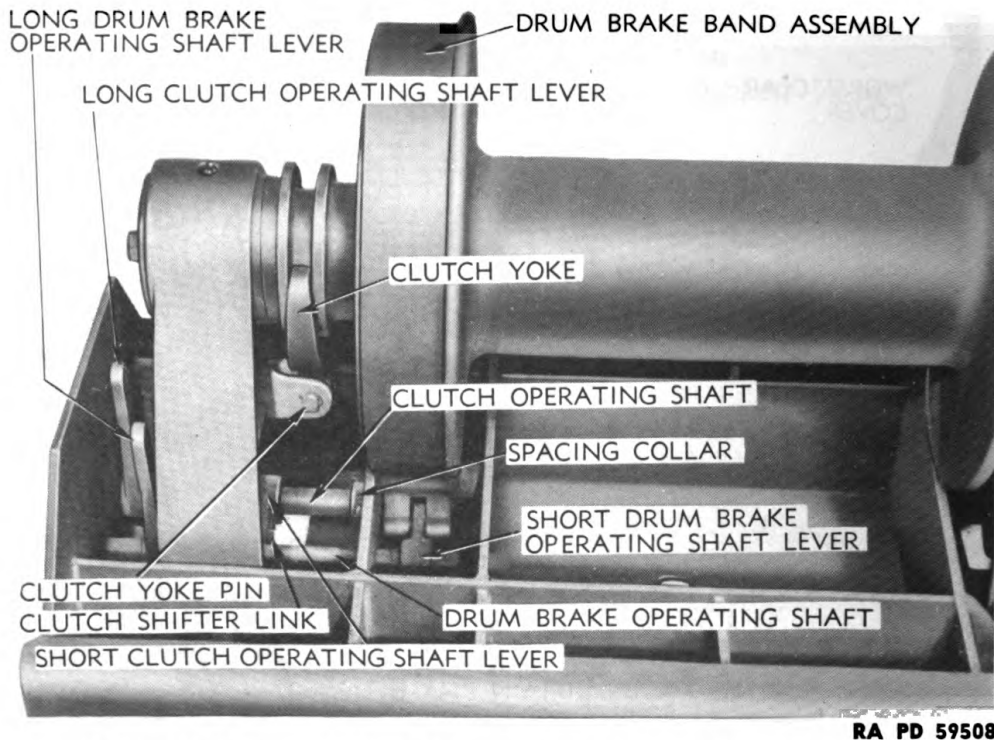

Figure 287 — Sliding Clutch and Drum Brake Controls

WINCH

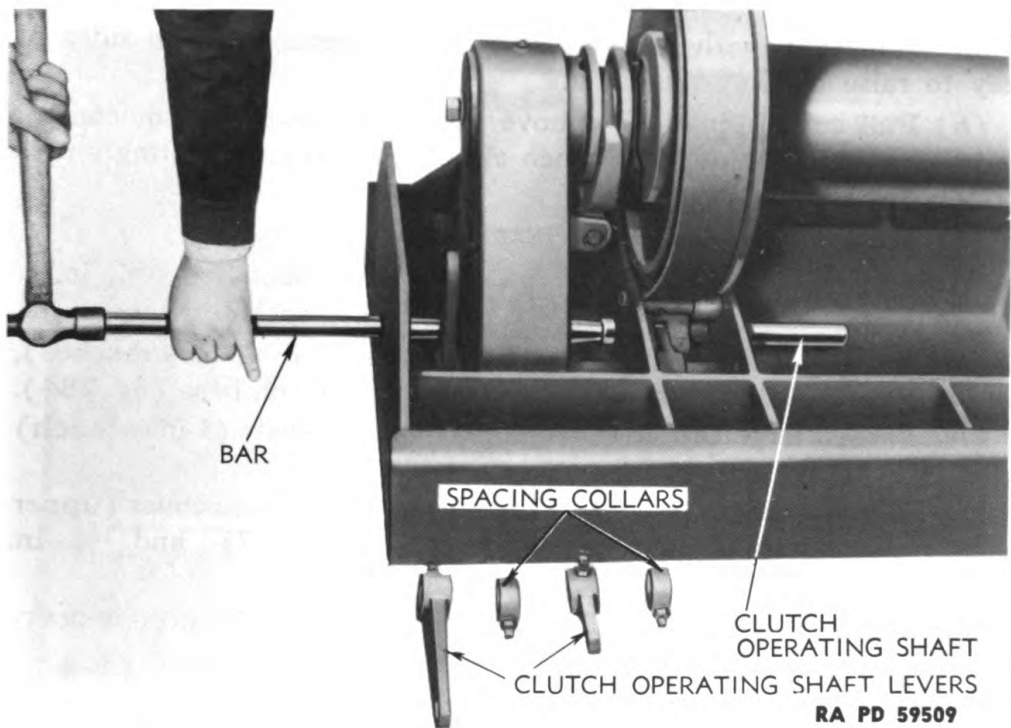

Figure 288 — Removing Clutch Operating Shaft

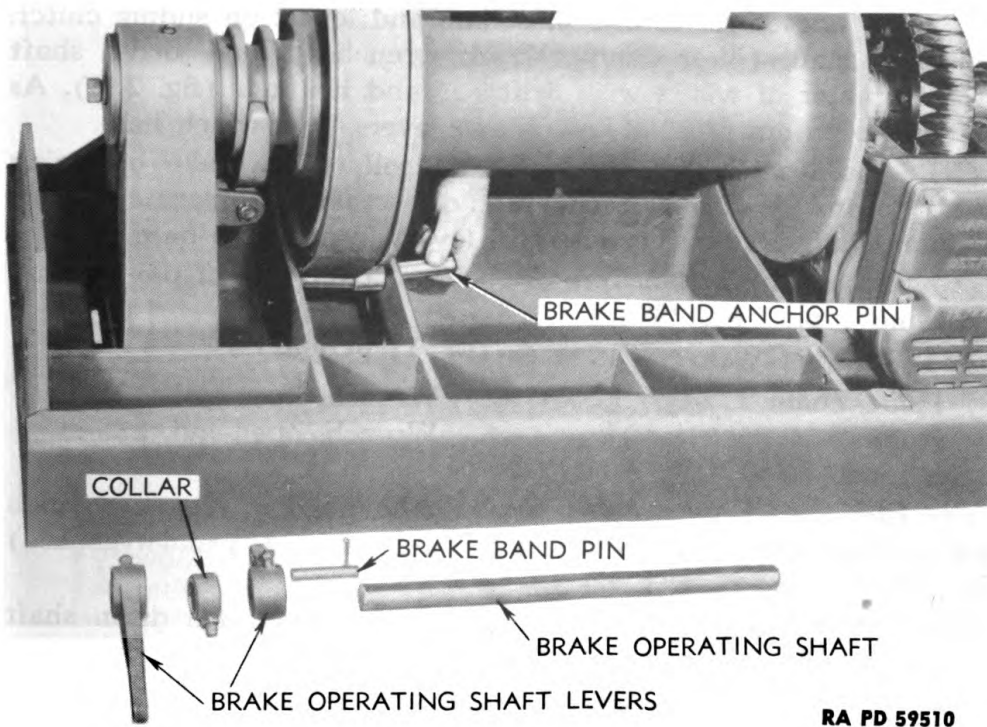

Figure 289 — Removing Brake Band Anchor Pin

**ORDNANCE MAINTENANCE — MEDIUM TRACTOR M1 (ALLIS-CHALMERS HD-7W)
ELECTRICAL SYSTEM, POWER TRAIN, FRAME, AND TRACKS**

from worm shaft with hammer and chisel, driving on both sides of key to raise the key out of slot.

(b) Pull cotter pins and remove pins from yoke ends of control rods; also remove pins from winch clutch and brake operating levers (pliers). Remove rods.

(3) REMOVE COVER FROM GEAR CASE.

Wrench, $\frac{9}{16}$ -in. (2)

Wrench, 1-in.

Wrench, open-end, $\frac{15}{16}$ -in.

Wrench, socket, $\frac{7}{8}$ -in.

(a) Remove four cap screws and two bolts (two $\frac{9}{16}$ -in. wrenches), and remove guard from front of gear case and winch base (fig. 284).

(b) Loosen large cap screws in ends of drum shaft (1-in. wrench) (fig. 292).

(c) Remove the six remaining bolts holding gear case cover (upper half of gear case) to gear case housing (two $\frac{9}{16}$ -, $\frac{7}{8}$ -, and $\frac{15}{16}$ -in. wrenches) and lift off cover (figs. 285 and 286).

(4) REMOVE WINCH SLIDING CLUTCH AND DRUM BRAKE OPERATING SHAFTS.

Bar, drift, $\frac{3}{4}$ - x 18-in.

Hammer, 2-lb

Pliers

Punch, 10-in.

Wrench, open-end, $\frac{3}{8}$ -in.

Wrench, open-end, $\frac{11}{16}$ -in.

(a) Remove cotter pin from lower end of clutch shifter link (pliers) and remove end of link from lever on operating shaft (fig. 287). Loosen set screws in collars and levers on sliding clutch operating shaft ($\frac{3}{8}$ -in. and $\frac{11}{16}$ -in. wrenches), and drive shaft towards center of winch with drift bar and hammer (fig. 288). As shaft is driven out, lift the collars and levers from winch base.

(b) Loosen setscrews in levers and collars on brake operating shaft ($\frac{3}{8}$ - and $\frac{11}{16}$ -in. wrenches), and drive shaft out in same manner as clutch shaft. Remove collars and levers from winch base.

(c) Remove cotter pin from drum brake band anchor pin (pliers) and remove pin (fig. 289).

(5) REMOVE WINCH DRUM SHAFT ASSEMBLY.

Hoist, chain

Rope

Wrench, 1-in.

Wrench, open-end, $1\frac{1}{2}$ -in.

Wrench, open-end, $1\frac{5}{8}$ -in.

(a) Remove the two large pivot bolts holding end frame to winch base at right-hand side of winch ($1\frac{1}{2}$ - and $1\frac{5}{8}$ -in. wrenches) (fig. 290).

(b) Fasten rope around winch drum and lift winch drum shaft assembly and end frame up and out of winch base with chain hoist (fig. 291).

(c) Remove cap screw from clutch end of shaft with 1-inch wrench (fig. 292) and slide end frame, outer thrust ring, and sliding clutch

WINCH

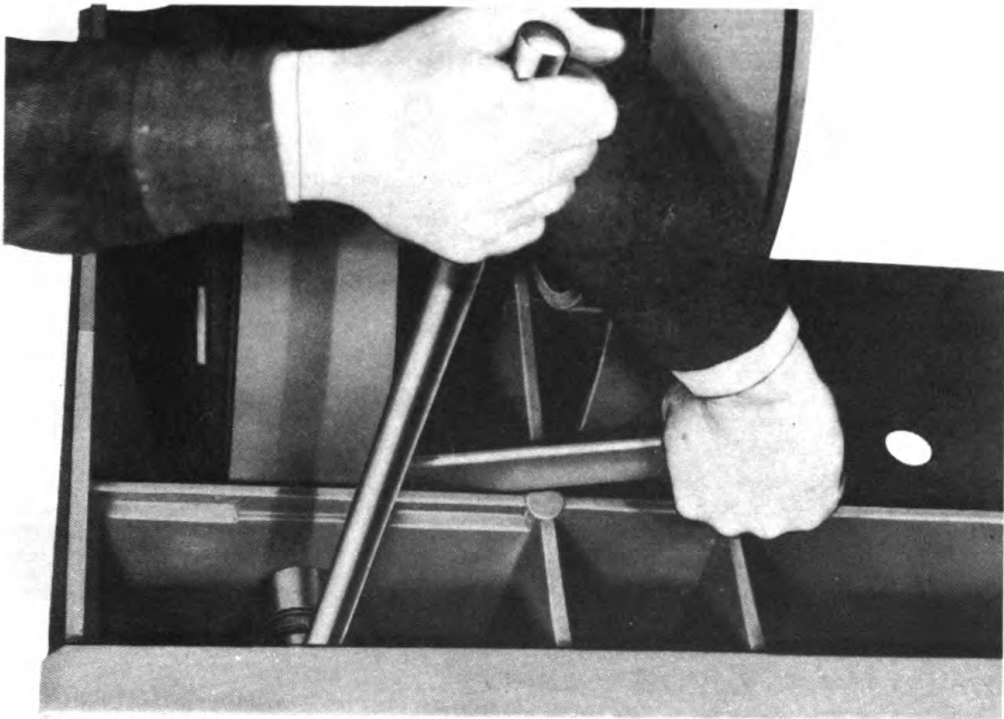

RA PD 59511

Figure 290 — Removing End Frame Pivot Bolts

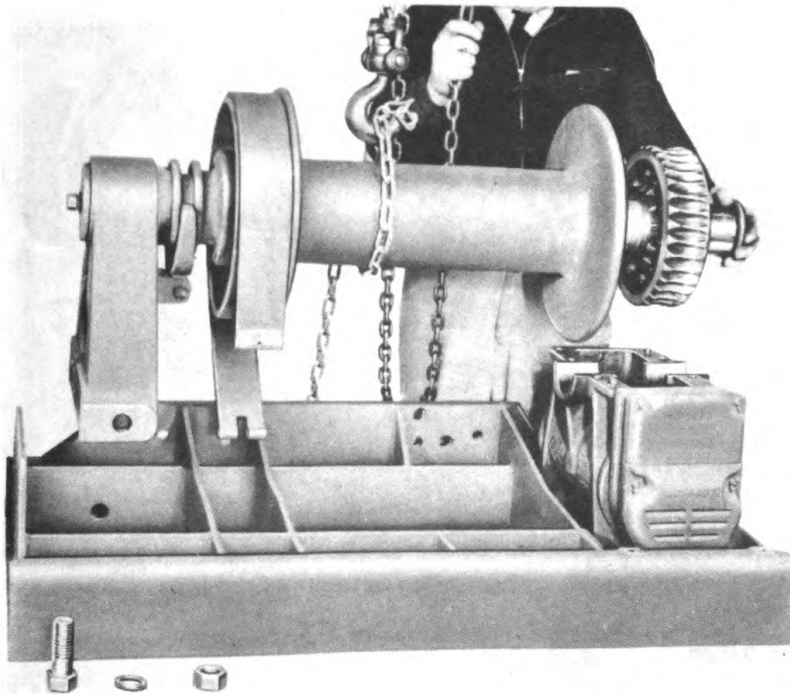

RA PD 59512

Figure 291 — Lifting Drum Shaft Assembly from Winch

ORDNANCE MAINTENANCE — MEDIUM TRACTOR M1 (ALLIS-CHALMERS HD-7W)
ELECTRICAL SYSTEM, POWER TRAIN, FRAME, AND TRACKS

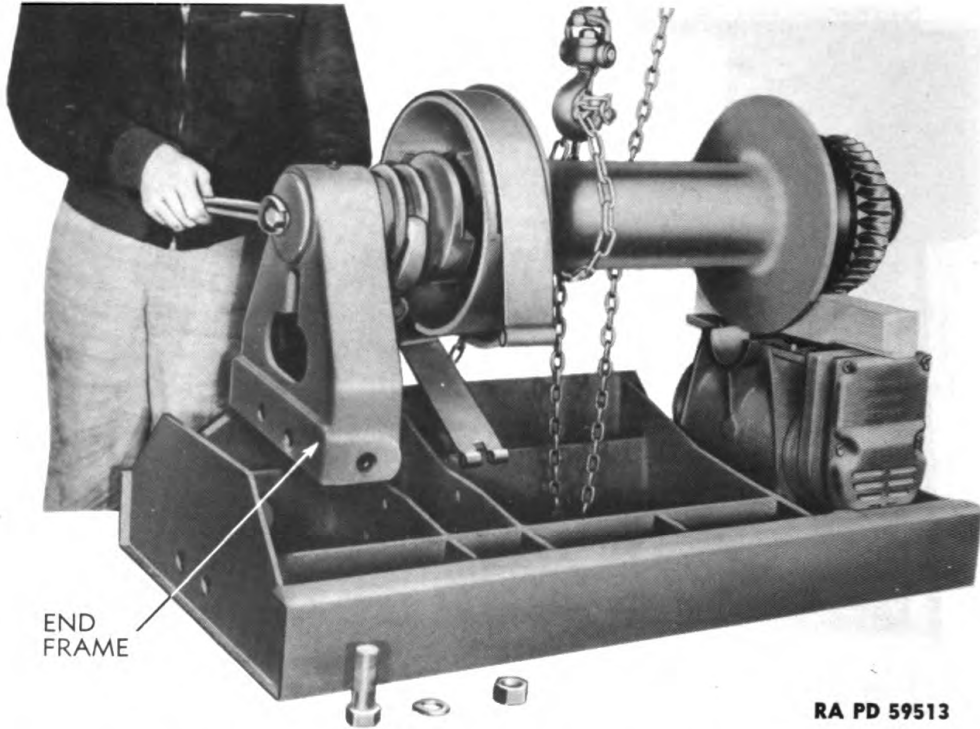

Figure 292 — Removing Cap Screw from End of Drum Shaft

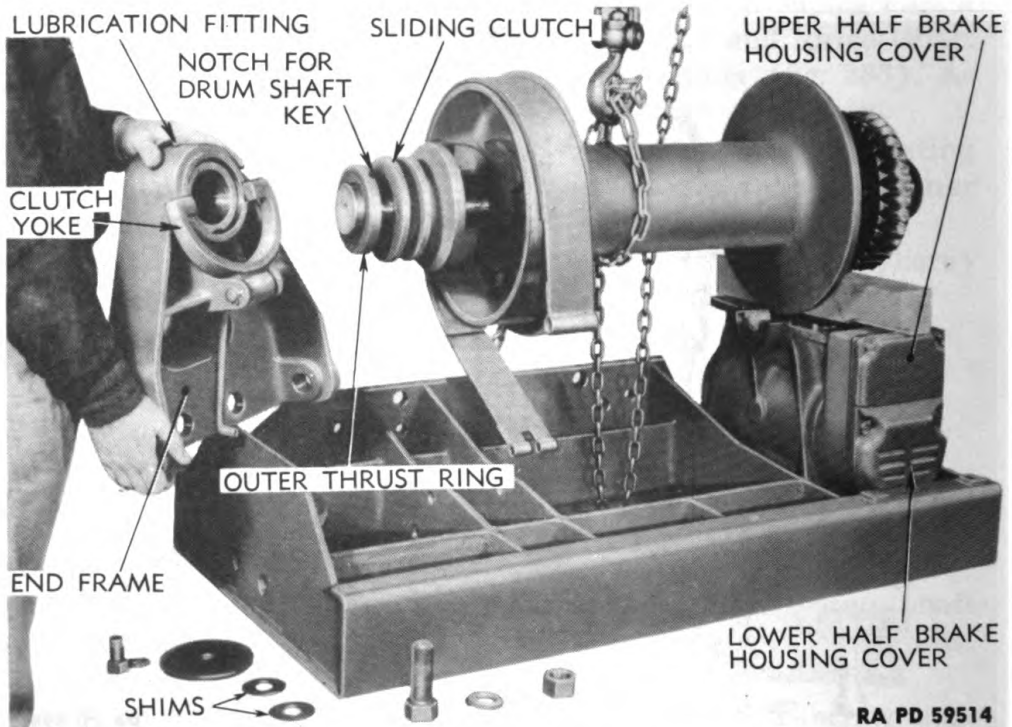

Figure 293 — End Removed from Drum Shaft

WINCH

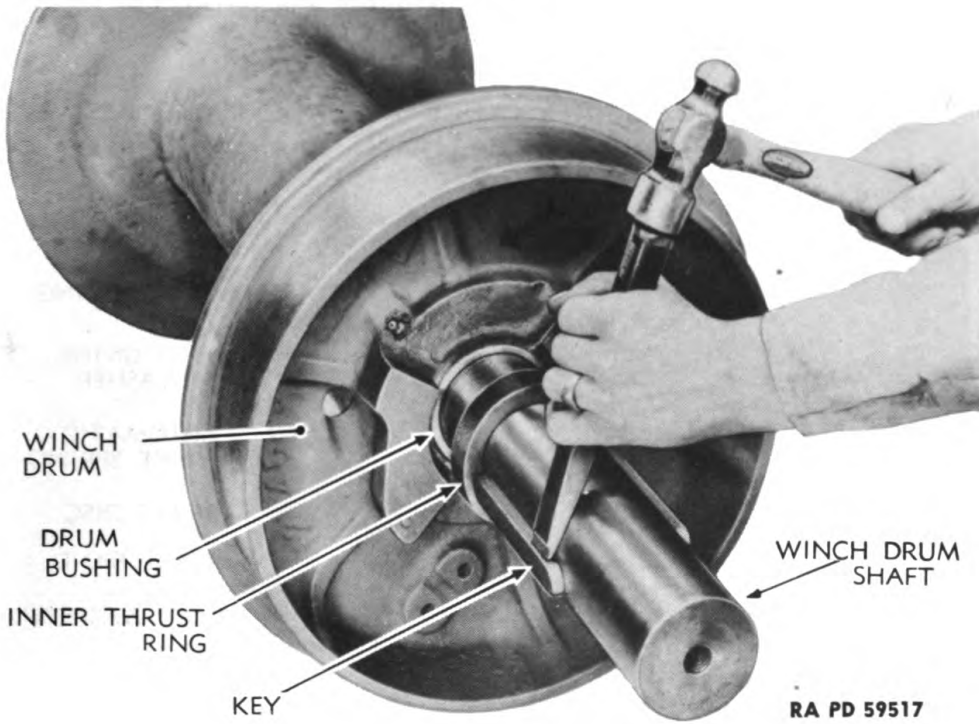

Figure 294 — Removing Drum Shaft Keys from Drum Shaft

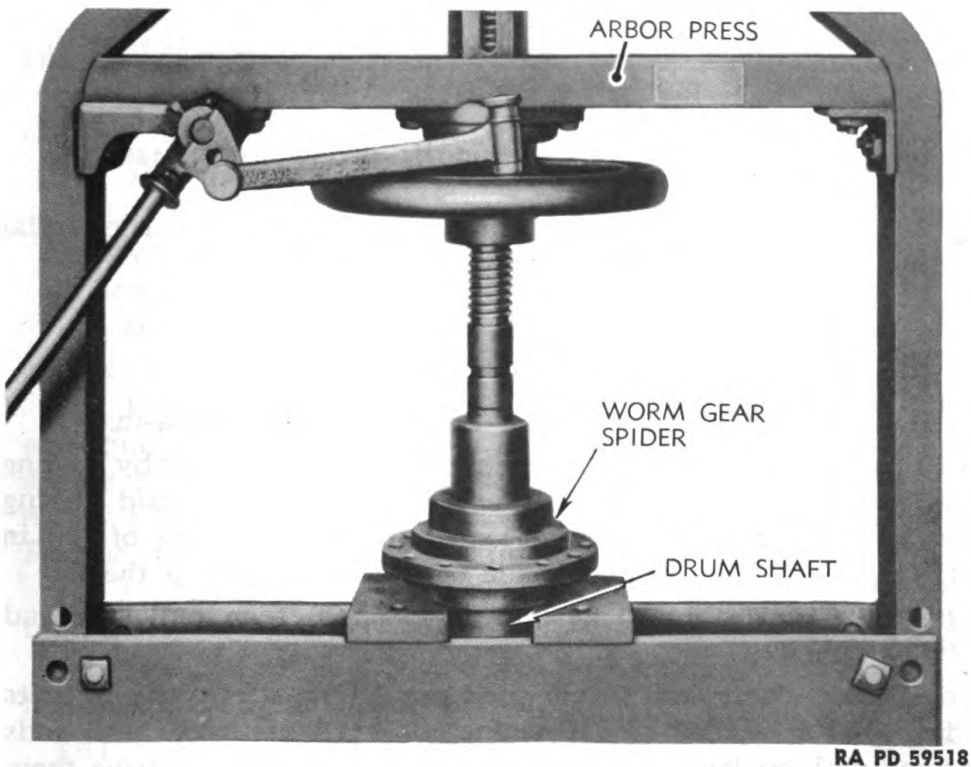

Figure 295 — Removing Worm Gear Spider from Drum Shaft

ORDNANCE MAINTENANCE — MEDIUM TRACTOR M1 (ALLIS-CHALMERS HD-7W)
ELECTRICAL SYSTEM, POWER TRAIN, FRAME, AND TRACKS

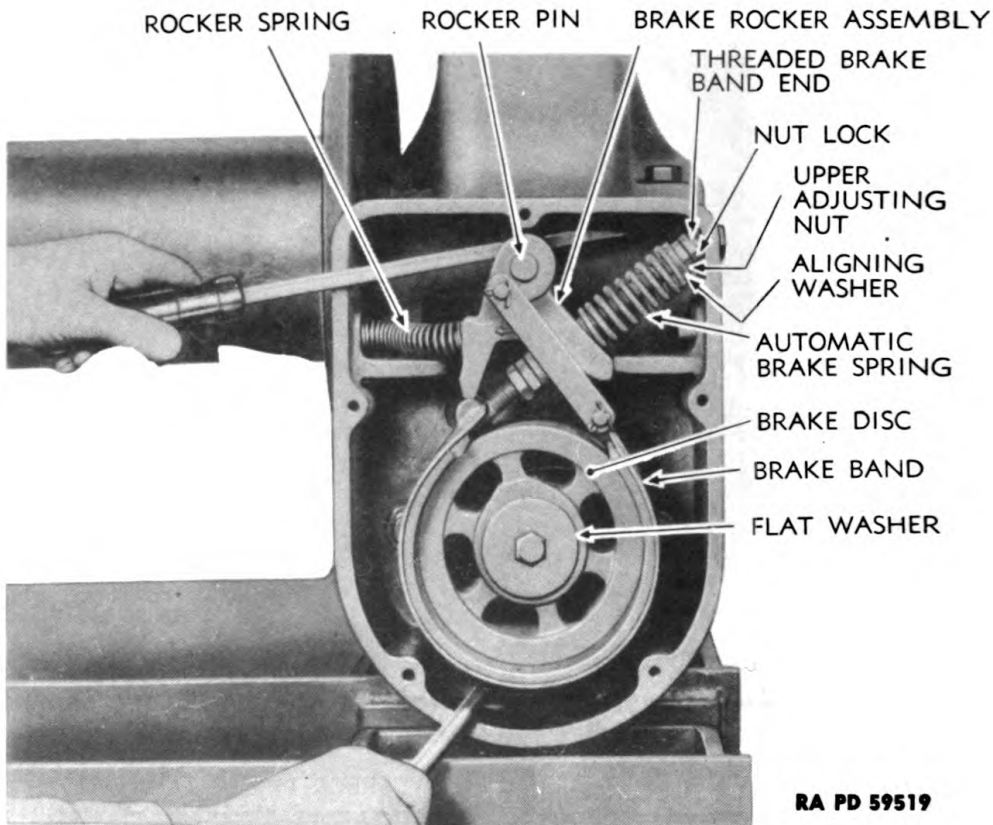

Figure 296 — Removing Automatic Brake Band Assembly

(fig. 293) toward end of shaft so clutch yoke will slide out of collar on clutch when end frame is removed.

(6) DISASSEMBLE DRUM SHAFT ASSEMBLY.

Chisel, $\frac{3}{4}$ -in.

File, flat

Hammer, soft

Press, arbor

Punch, 10-in.

Wrench, socket, $\frac{3}{4}$ -in.

(a) Remove the two keys from clutch end of drum shaft by holding chisel close to shaft on sides of keys at several points, and driving on chisel with hammer until keys are raised up and out of slot in shaft (fig. 294). File off burs made on keys in removing them.

(b) Slide inner thrust ring off end of shaft; then pull gear and shaft from drum.

(c) Clamp drum shaft in vise, and remove nuts from the 10 bolts holding gear to spider ($\frac{3}{4}$ -in. wrench). Tap bolts back until ends are flush with spider (soft hammer); then use punch to drive them on out. Use care not to damage threads. Tap gear off spider.

WINCH

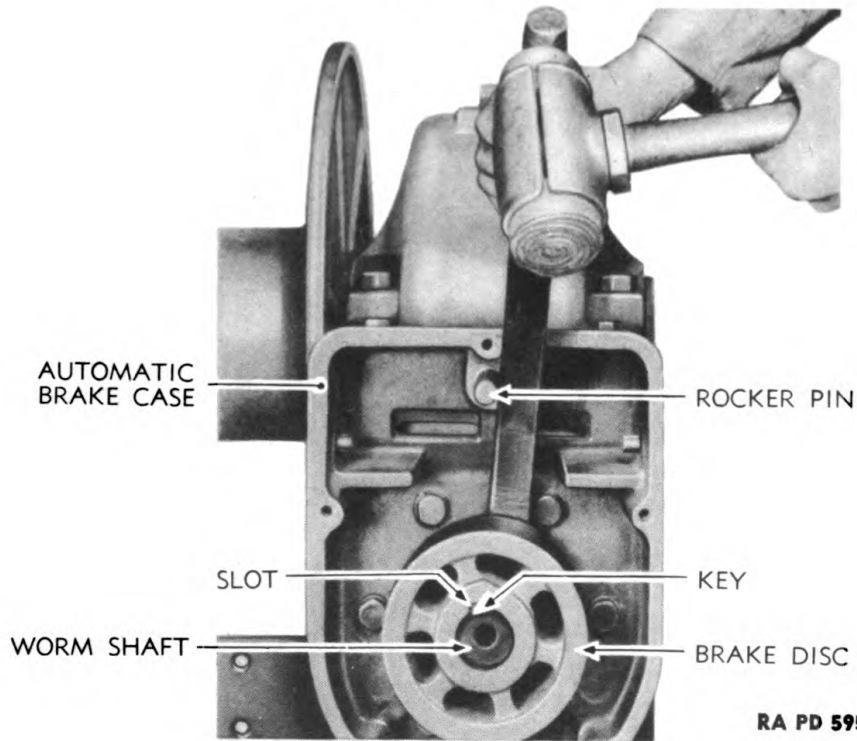

Figure 297 — Removing Brake Disk

(d) Place shaft in arbor press, and press shaft out of spider (fig. 295).

(e) Remove the two keys from slots in shaft (chisel and hammer) as in step (6) (a) above.

(7) REMOVE AUTOMATIC BRAKE ASSEMBLY FROM GEAR CASE.

Bar, pry

Pliers

Screwdriver, 10-in.

Wrench, open-end, $\frac{7}{16}$ -in. (2)

Wrench, socket, $\frac{3}{4}$ -in., with extension

(a) Remove drain plug (fig. 285) from gear case ($\frac{5}{8}$ -in. wrench) and drain oil from case. Replace plug after oil is drained.

(b) Remove brake housing cover (fig. 293). Loosen lock nut and adjusting nut (two $\frac{7}{16}$ -in. wrenches) (fig. 296), pull cotter pin from anchor pin (pliers), and pry brake rocker assembly and band off rocker pin and brake disk with a large screwdriver and pry bar. Rocker spring will come off at the same time.

(c) Remove the cap screw ($\frac{3}{4}$ -in. wrench) and large washer from the center of brake disk and pry brake disk off shaft (fig. 297).

(d) Use $\frac{3}{4}$ -inch wrench and remove six cap screws holding brake housing to gear case; remove brake housing.

(8) REMOVE WORM SHAFT ASSEMBLY.

Hammer, 2-lb

Punch, short

Wood block

Wrench, $\frac{3}{4}$ -in.

ORDNANCE MAINTENANCE — MEDIUM TRACTOR M1 (ALLIS-CHALMERS HD-7W)
ELECTRICAL SYSTEM, POWER TRAIN, FRAME, AND TRACKS

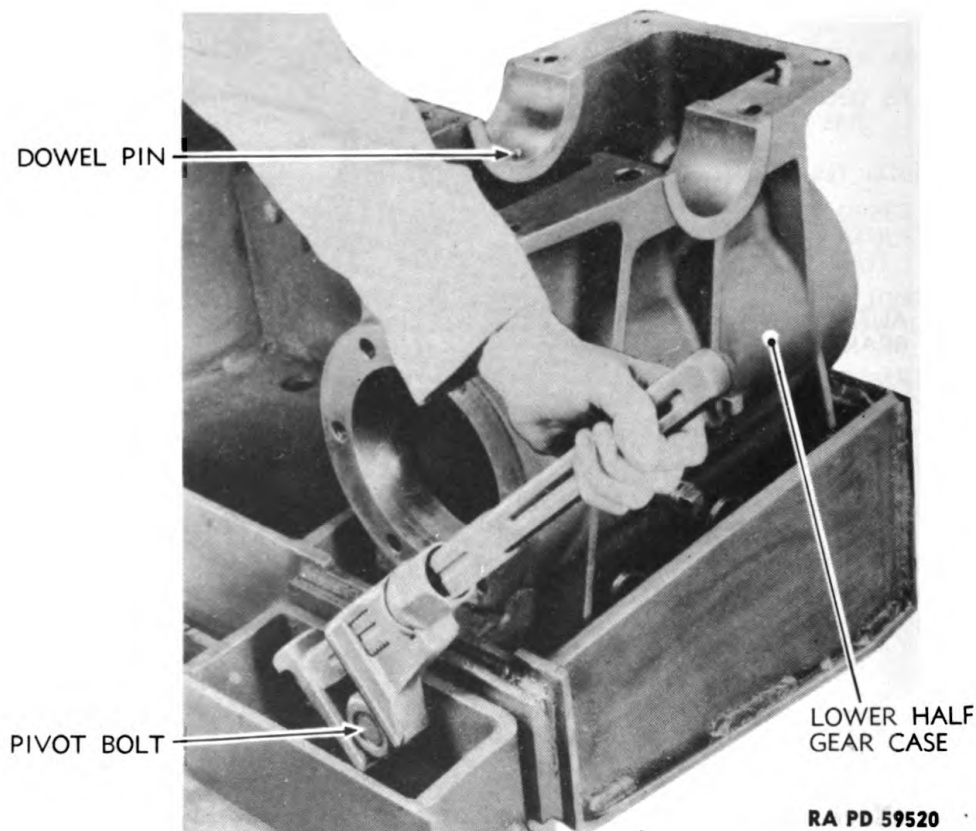

Figure 298 — Removing Worm Gear Case

(a) Remove six cap screws and remove rear worm shaft bearing retainer ($\frac{3}{4}$ -in. wrench). Slip spacer off end of shaft.

(b) Use wood block against rear end of shaft, and drive shaft assembly out of gear case. This will remove front worm shaft bearing and cup. Remove worm shaft assembly from gear case (fig. 304); then drive rear bearing cup from case with hammer and short punch.

(9) REMOVE WORM GEAR CASE FROM WINCH BASE.

Wrench, adjustable, $1\frac{1}{2}$ -in.

Remove two large pivot bolts holding gear case to winch base (fig. 298). Lift case from base.

(10) DISASSEMBLE WORM SHAFT ASSEMBLY.

Chisel, $\frac{3}{4}$ -in.

Press, arbor

Hammer, 2-lb

Remove key from slot in brake end of shaft in same manner as in subparagraph b (2) (a) above. Remove spacer from drive end of shaft. Place shaft in arbor press and press shaft out of one bearing; then reverse ends and press shaft out of bearing on other end.

WINCH

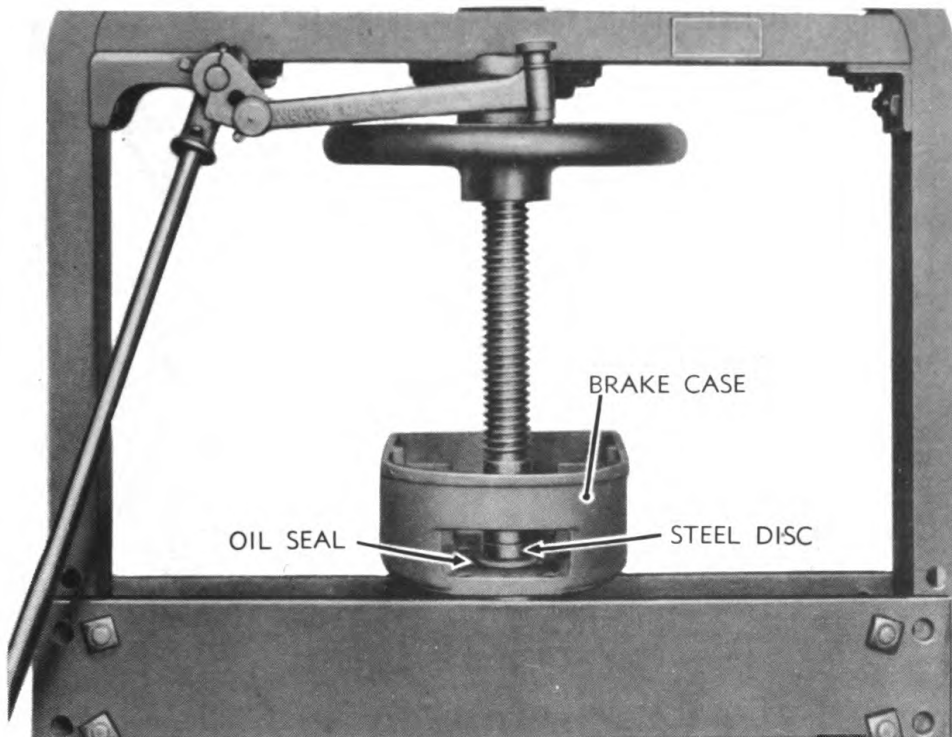

RA PD 59521

Figure 299 — Removing Oil Seal from Brake Housing

(11) REMOVE WORM SHAFT OIL SEALS.

Disk, steel, $\frac{5}{16}$ -in. thick, Press, arbor
3-in. diam

Place automatic brake housing in press (fig. 299); place steel disk over oil seal and press seal from housing. Remove oil seal from rear worm shaft bearing retainer in same manner.

(12) REMOVE BUSHINGS FROM WINCH DRUM.

Bar, drift, 2-ft Screwdriver, 4-in.
Hammer, 2-lb Wrench, $\frac{3}{4}$ -in. (2)

Remove lock screws from edges of bushings (screwdriver). Insert bar through drum and, with end of bar against inner end of bushing, drive bushing out of drum; repeat for second bushing. Cable clamp studs may be removed from drum by screwing two $\frac{1}{2}$ -inch nuts on studs, tightening them against each other, and turning studs out with $\frac{3}{4}$ -inch wrench.

(13) DISASSEMBLE AUTOMATIC BRAKE AND DRUM BRAKE ASSEMBLIES (figs. 300 and 301).

Brake lining machine Wrench, open-end, $\frac{7}{16}$ -in.
Pliers

NOTE: Do not disassemble unless certain parts are to be replaced, or lining is to be replaced. Inspect carefully.

**ORDNANCE MAINTENANCE — MEDIUM TRACTOR M1 (ALLIS-CHALMERS HD-7W)
ELECTRICAL SYSTEM, POWER TRAIN, FRAME, AND TRACKS**

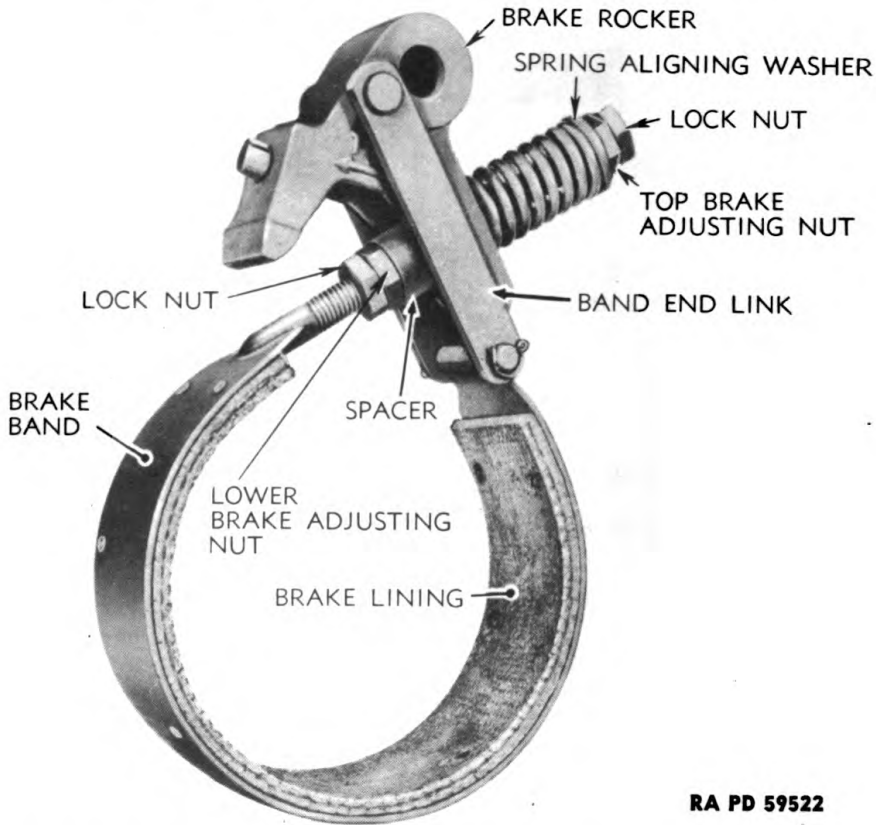

RA PD 59522

Figure 300 — Automatic Winch Worm Safety Brake Assembly

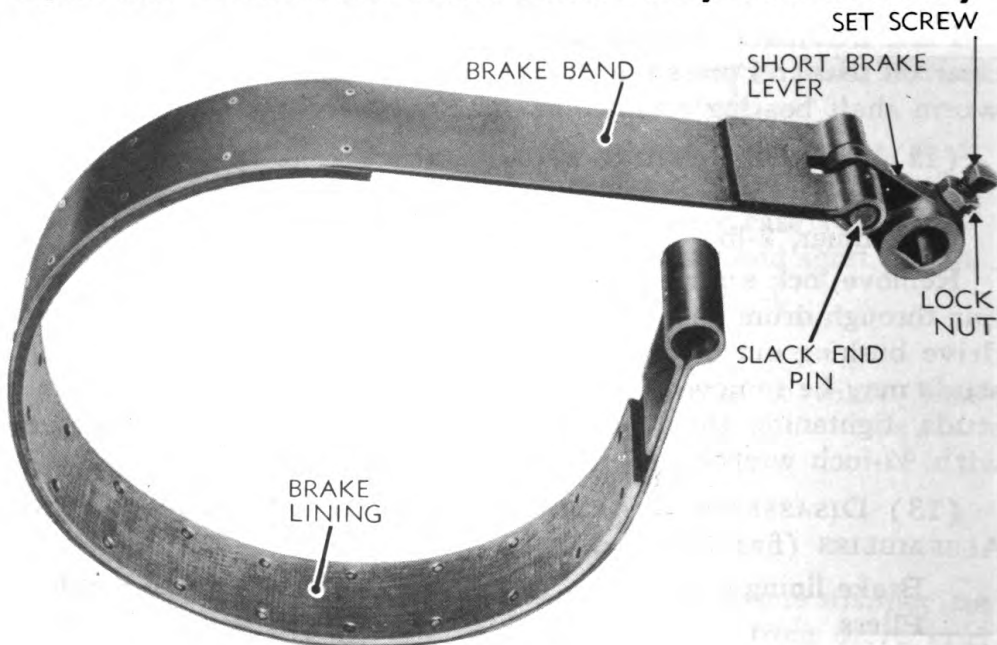

RA PD 59523

Figure 301 — Winch Drum Brake Band Assembly

WINCH

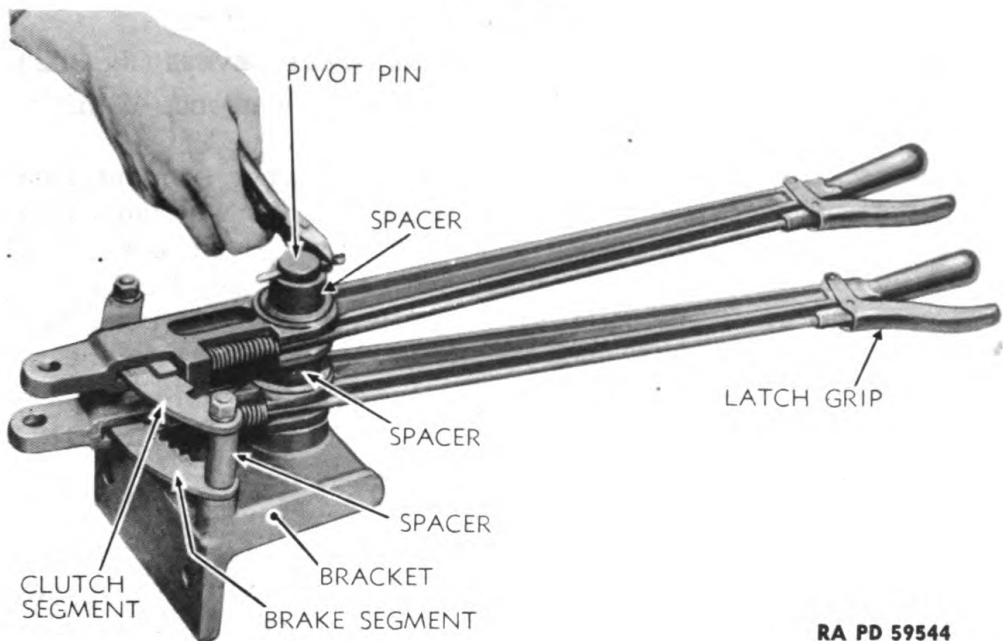

RA PD 59544

Figure 302 — Removing Levers from Bracket

(a) Remove both nuts ($\frac{7}{16}$ -in. wrench), spring aligning washer, and spring from threaded end of band. Pull cotter pins from pins in rocker and end of band (pliers), and remove pins and links.

(b) Remove rocker and spacer from threaded end of band. Remove lower adjusting and lock nuts.

(c) Punch rivets out of lining and bands with punch tool of brake lining machine to remove lining from band. Remove lining from drum brake band in same manner.

(14) REMOVE BEARING FROM END FRAME.

Wrench, socket, $\frac{7}{16}$ -in.

Remove grease fitting from bearing in end frame and remove bearing from end frame.

(15) DISASSEMBLE CONTROL LEVER ASSEMBLY (fig. 302).

Bar, drift, brass

Remover, stud

Hammer, 2-lb

Wrench, $\frac{9}{16}$ -in.

Pliers

(a) Pull cotter pin from pivot pin with pliers. Remove spacer and flat washer from pin.

(b) Remove nuts from the two studs on which brake ratchet segments are installed ($\frac{9}{16}$ -in. wrench). Lift lever assemblies and segments off pivot pin.

(c) Drive pivot pin out of bracket with hammer and drift bar. Studs may be removed from bracket with a stud remover.

**ORDNANCE MAINTENANCE — MEDIUM TRACTOR M1 (ALLIS-CHALMERS HD-7W)
ELECTRICAL SYSTEM, POWER TRAIN, FRAME, AND TRACKS**

(16) DISASSEMBLE WINCH CLUTCH AND BRAKE LEVERS (fig. 302).

Hammer, 2-lb
Punch, small

Wrench, open-end, $\frac{3}{8}$ -in.

Squeeze grip latch on lever and remove ratchet segment from lower part of lever. Remove rod end from grip latch or latch from lever by cutting heads off rivets and punching rivets out (small punch and hammer). Rod end may then be unscrewed from rod or rod assembly lifted out of lower end of lever. Remove pawl from lower end of rod with $\frac{3}{8}$ -inch wrench. Procedure is the same for either rod.

(17) DISASSEMBLE WINCH DRIVE AND LAY SHAFTS (fig. 312).

Hammer, 2-lb
Punch, small

Wrench, hexagonal, $\frac{3}{16}$ -in.

(a) Remove bearings from lay shaft by removing the hexagon-recessed setscrews holding bearings in place on shaft ($\frac{3}{16}$ -in. hexagonal wrench), and tapping bearings out of slots in brackets after turning bearings sideways one-quarter turn (hammer).

(b) Remove universals from shafts by removing hexagon-recessed setscrew ($\frac{3}{16}$ -in. hexagonal wrench), and sliding universals off shafts and keys. Tap off with hammer if necessary.

(c) Remove drive sprocket on rear end of lay shaft by removing the two hexagon-recessed setscrews from sprocket ($\frac{3}{16}$ -in. hexagonal wrench), then tapping sprocket off key and shaft (hammer).

(18) DISASSEMBLE UNIVERSAL JOINTS.

Screwdriver

Remove retaining screws and covers from ends of universal joint bushings (screwdriver), and jar parts out of each side of joint (fig. 311).

121. INSPECTION AND REPAIR OF PARTS.

a. Cleaning and Inspection. Clean all parts thoroughly, washing them with dry-cleaning solvent. Inspect all parts for cracks, breaks, or other damage. If cast parts are broken and pulled out of shape, replace them with new parts. Small cracks or breaks may be repaired by welding or brazing.

b. Gear Case. Inspect gear case after cleaning it. See that oil grooves and passages in bushings are not clogged. Replace dowel pins that are damaged, or, if pins are broken off, drill the broken pieces out and install new dowels.

c. End Frame. Repair broken parts in end frame, if any, or replace assembly. Test wear on end frame bearing by trying it on drum shaft. If there is excessive play between bearing and shaft, replace bearing.

WINCH

d. Drum Assembly. Inspect drum for cracks or breaks; repair or replace, if necessary. Be sure studs in cable clamp are in good shape.

e. Worm Gear and Drum Shaft. Replace worm gear if teeth are scored, cracked, or broken. Inspect worm gear spider; replace worn or damaged bolts or spider. Replace damaged or worn keys in drum shaft. If shaft is bent or damaged, replace shaft or, if a heavy press is available, the shaft can be straightened.

f. Worm Shaft Assembly. Examine worm teeth for scoring, chipping, or breaks. If teeth are worn to a sharp edge, replace the gear. Due to the pressure on the worm and gear, the teeth on both must be smooth. Replace worm if chipped or cracked teeth are found. Clean ball bearings and rotate slowly by hand. If balls or races are rough, pitted, or discolored, replace the bearing. Discolored or blue bearings indicate overheating, which makes a bearing unfit for further use. Oil bearings with light engine oil and test to see that they roll smoothly; if they do not, replace the bearings. Examine oil seals in brake housing and worm shaft bearing retainer. If worn or damaged, remove seals as explained in paragraph 120 **b** (11), and install as outlined in paragraph 122 **b** (2) and (4).

g. Automatic Safety Brake Assembly. Examine brake disk. If scored, place disk in lathe and smooth brake surface. If linings are worn nearly to rivet heads, replace lining on brake band. Use a brake lining machine to punch out the rivets to remove lining, and install a new lining of the original thickness and of the special kind provided for winch brakes with the same machine. If lining is not worn, but is grease-soaked, wash grease out of lining with a dry-cleaning solvent. Inspect and replace lining on winch drum brake in same manner. Make sure all brake pins and linkage work freely. Replace worn brake pins and linkage. Make sure the threads on band end and in adjusting nuts are not damaged.

h. Main Frame. Repair any cracks or breaks in main frame by welding. Replace frame if twisted out of shape. Straighten clutch and brake control shafts if bent. Replace spacing collars, if threads in collars or on setscrews are damaged.

i. Cable. Replace cable end if broken. If cable is frayed in any one place or strands are broken, replace with new cable. Take care not to take hold of a frayed cable with bare hands, as hands can be cut or easily pierced by doing so.

j. Controls. Examine control lever assemblies to make sure pawls and ratchet segments are not worn to the point where corners are rounded off and will not hold, and that the springs in lever rods are not broken. Replace any of these parts that are worn or broken.

ORDNANCE MAINTENANCE — MEDIUM TRACTOR M1 (ALLIS-CHALMERS HD-7W)
ELECTRICAL SYSTEM, POWER TRAIN, FRAME, AND TRACKS

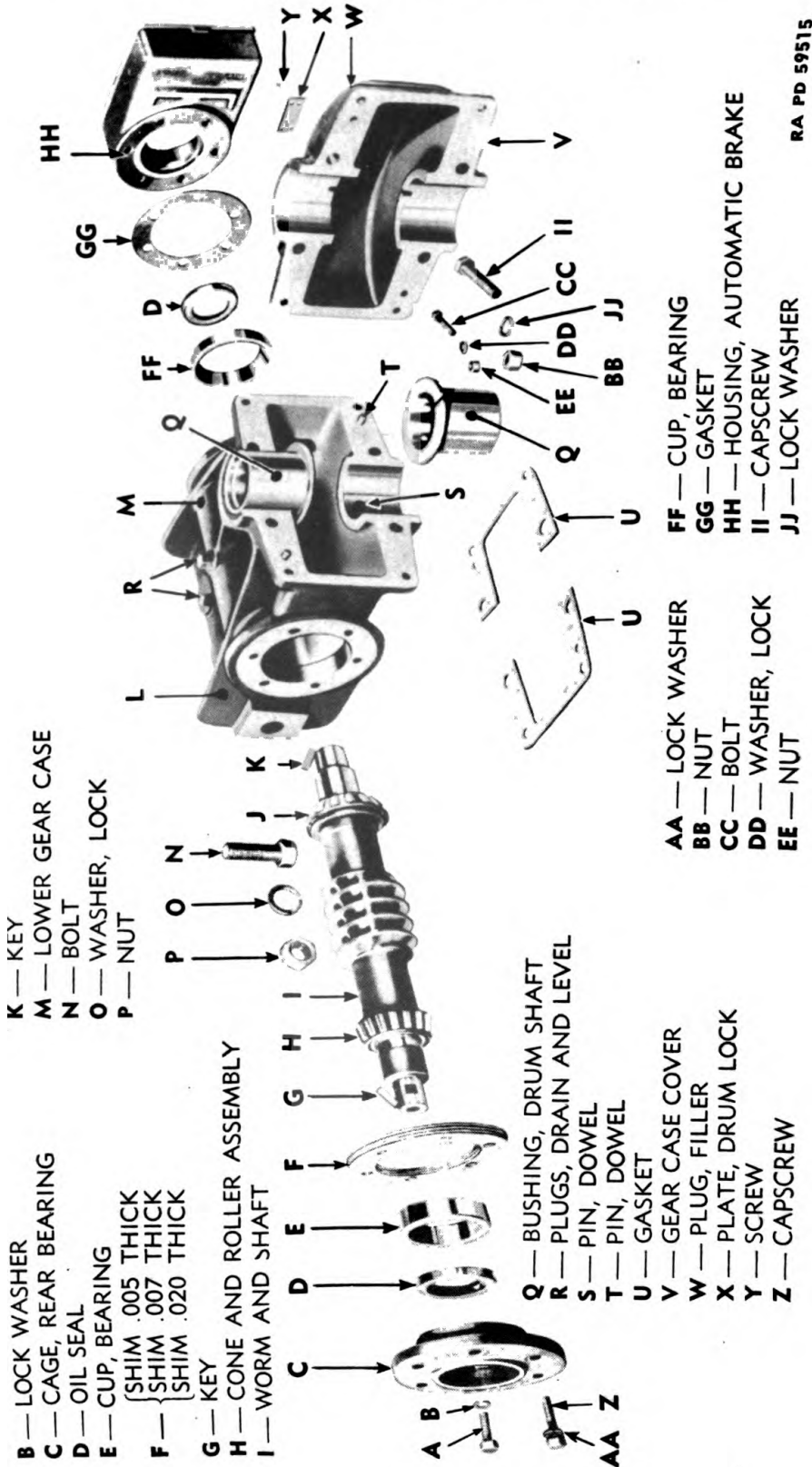

RA PD 59515

Figure 303 — Gear Case and Worm Shaft Assembly — Exploded View

122. A

plugs
two
for
er

from r
assembly
lock
of r

WINCH

k. Drive Shafts. If universals on drive shaft or lay shaft can be rattled considerably, replace the entire universal joint assembly. Inspect lay shaft bearings as in subparagraph f above. Straighten shafts, if bent, in a press. Repair worn keyways in shafts and replace damaged shaft keys.

122. ASSEMBLY OF WINCH AND CONTROLS.

a. Tools and Equipment Required.

File, flat	Wrench, deep socket, $\frac{7}{16}$ -in.
Hammer, $\frac{1}{2}$ -lb	Wrench, hexagonal, $\frac{3}{16}$ -in.
Hammer, 2-lb	Wrench, hexagonal, $\frac{1}{4}$ -in.
Hammer, ball peen	Wrench, open-end, $\frac{3}{8}$ -in.
Hardwood block	Wrench, open-end, $\frac{7}{16}$ -in. (2)
Hoist, chain	Wrench, open-end, $\frac{9}{16}$ -in.
Pliers	Wrench, open-end, $\frac{5}{8}$ -in.
Press, arbor	Wrench, open-end, $\frac{11}{16}$ -in.
Punch, 10-in.	Wrench, open-end, $\frac{3}{4}$ -in.
Punch, center	Wrench, open-end, $\frac{15}{16}$ -in.
Rope	Wrench, open-end, 1 $\frac{1}{2}$ -in.
Screwdriver, 4-in.	Wrench, open-end, 1 $\frac{5}{8}$ -in.
Shellac	Wrench, socket, $\frac{9}{16}$ -in.
White lead	Wrench, socket, $\frac{3}{4}$ -in.
Wrench, 1-in.	Wrench, socket, $\frac{7}{8}$ -in.
Wrench, box, 1 $\frac{1}{2}$ -in.	Wrench, stud
Wrench, box, 1 $\frac{5}{8}$ -in.	

b. Procedure.

(1) INSTALL WORM GEAR HOUSING.

Install worm gear housing into left end of winch base, with both oil plugs toward outside of base (fig. 285). Line up holes and install two large pivot bolts with lock washers through base and gear housing. Leave these two bolts loose until winch drum and shaft are installed to aline bushings in top of case.

(2) INSTALL WORM SHAFT REAR BEARING RETAINER.

Hammer, 2-lb	Wrench, $\frac{3}{4}$ -in.
Punch, 10-in.	

Install seal in rear bearing retainer with lip of seal toward attaching flange. Install rear bearing race (punch and hammer) with largest inside diameter away from seal. Install shims that were removed from rear bearing retainer in disassembly and rear bearing retainer assembly on rear end of gear case with six $\frac{1}{2}$ -inch cap screws with lock washers ($\frac{3}{4}$ -in. wrench). NOTE: Apply white lead to threads of these cap screws to insure oilproof seal. Do not tighten these bolts until after automatic brake housing is installed.

(3) ASSEMBLE AND INSTALL WORM SHAFT ASSEMBLY.

Hammer, 2-lb	Punch, 10-in.
Press, arbor	

ORDNANCE MAINTENANCE — MEDIUM TRACTOR M1 (ALLIS-CHALMERS HD-7W)
ELECTRICAL SYSTEM, POWER TRAIN, FRAME, AND TRACKS

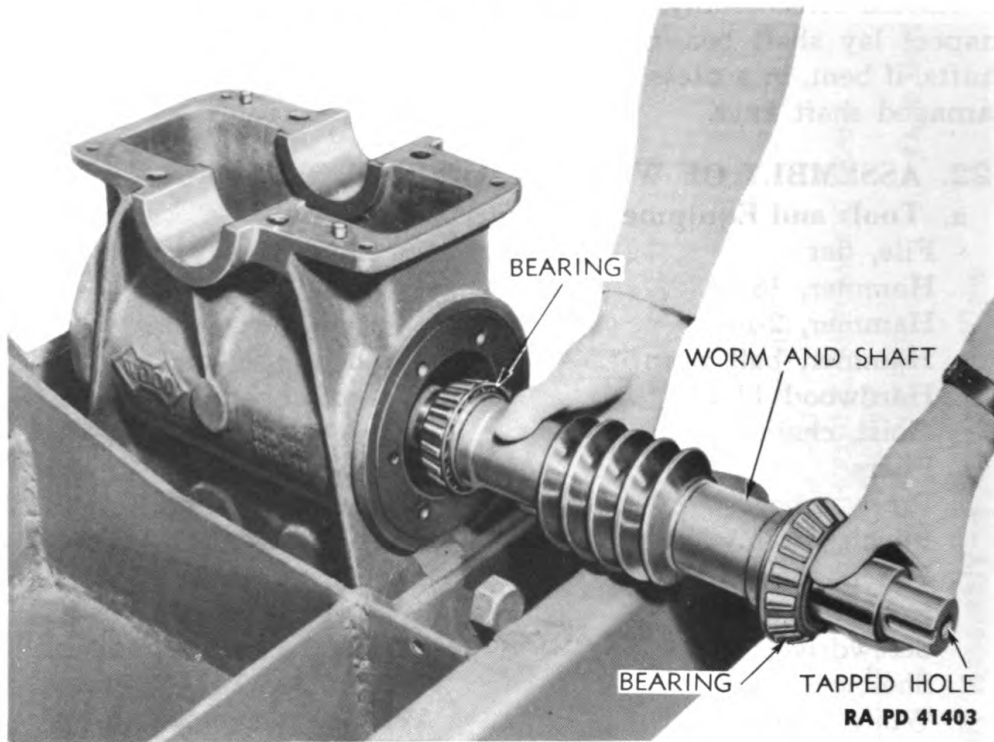

Figure 304 — Installing Worm Shaft Assembly in Gear Case

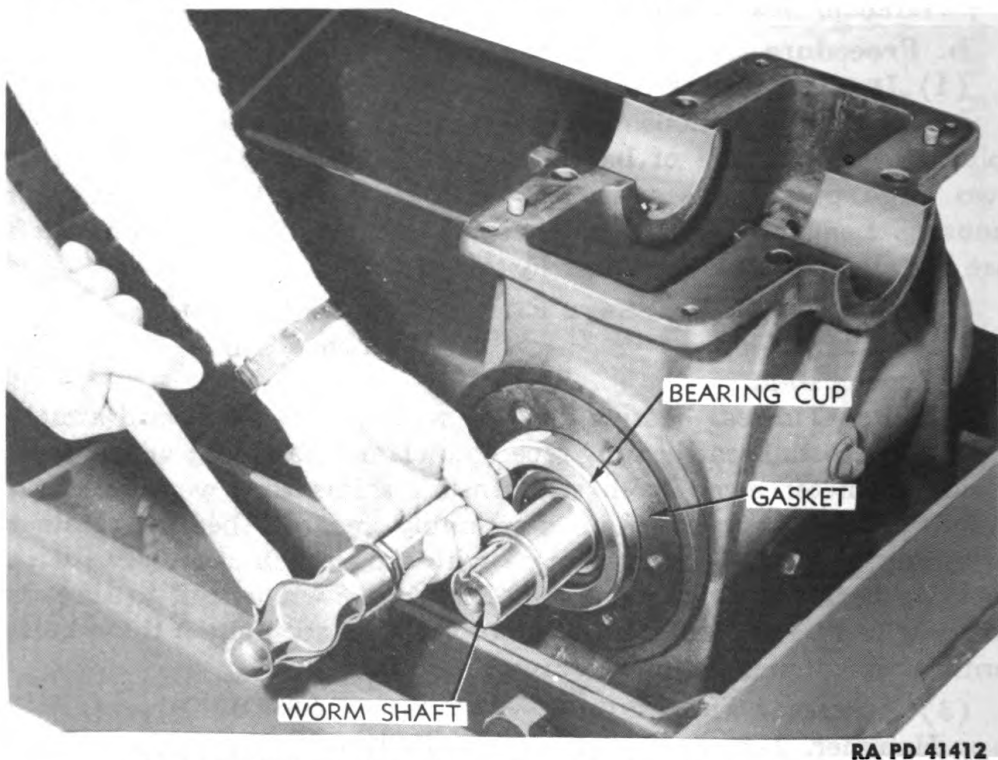
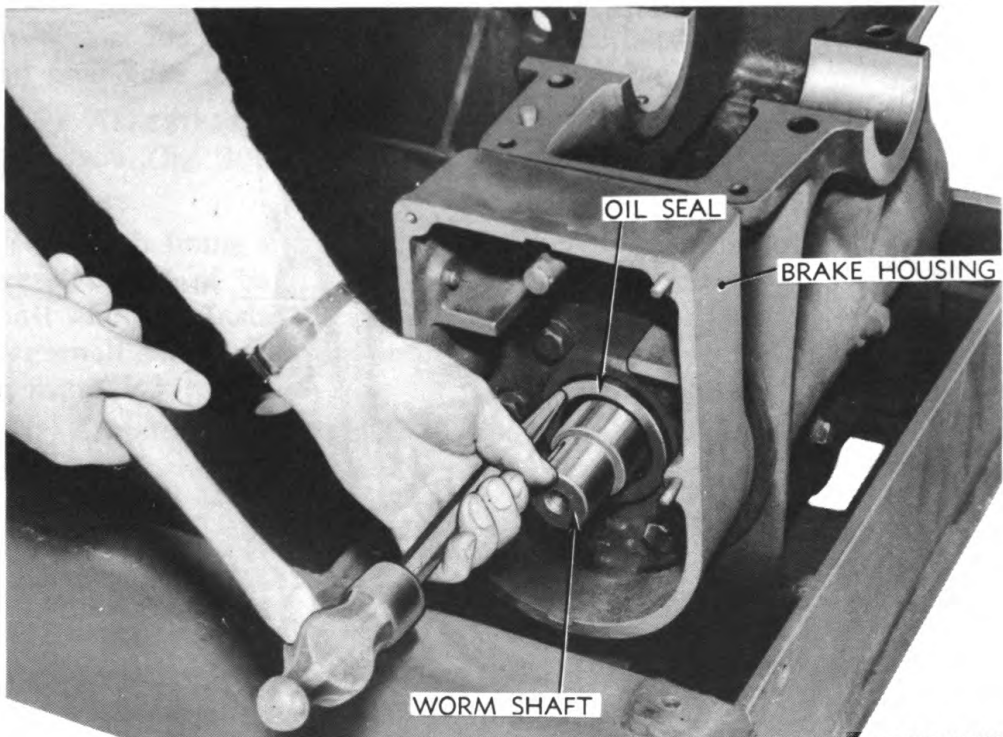

Figure 305 — Installing Front Outer Bearing Cup

WINCH



RA PD 41409

Figure 306 — Installing Oil Seal in Brake Housing

(a) Press bearing roller assemblies onto worm shaft with arbor press, with smallest outside diameter of bearing toward ends of shaft.

(b) Install worm shaft and bearings in gear case, with 1/2-inch tapped hole in end of shaft toward front of housing (fig. 304), being sure not to injure oil seal as shaft is inserted through rear bearing retainer. Tap front bearing cup into front of gear case over front bearing (hammer and punch) (fig. 305).

(4) INSTALL AUTOMATIC BRAKE HOUSING.

Hammer, 2-lb

Wrench, socket, 3/4-in.

Punch, 10-in.

Shellac gasket to gear case and install brake housing over front of worm shaft. Secure housing to gear case with six 1/2-inch cap screws with lock washers, using a gasket compound or white lead on threads, and tighten cap screws evenly (3/4-in. wrench). Install front oil seal in brake housing with lip of seal toward worm gear case (punch and hammer).

(5) ADJUST WINCH WORM SHAFT BEARINGS.

Wrench, 3/4-in.

Adjust winch worm shaft bearings so the shaft will turn freely but there will be no end play in shaft or bearings when rear retainer

ORDNANCE MAINTENANCE — MEDIUM TRACTOR M1 (ALLIS-CHALMERS HD-7W)
ELECTRICAL SYSTEM, POWER TRAIN, FRAME, AND TRACKS

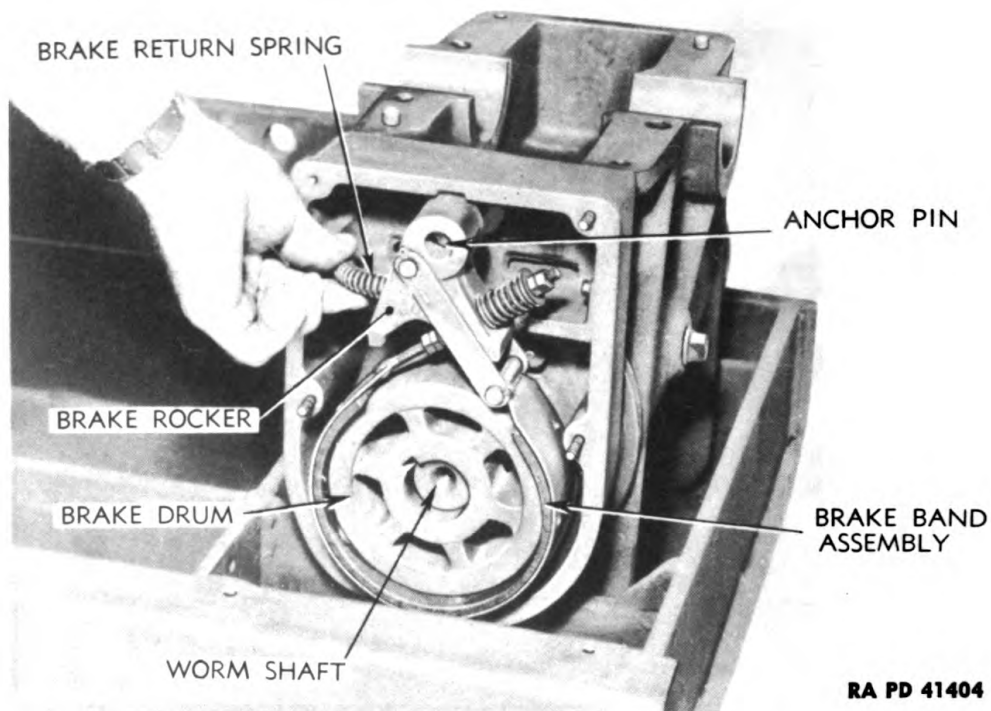

Figure 307 — Installing Brake Return Spring

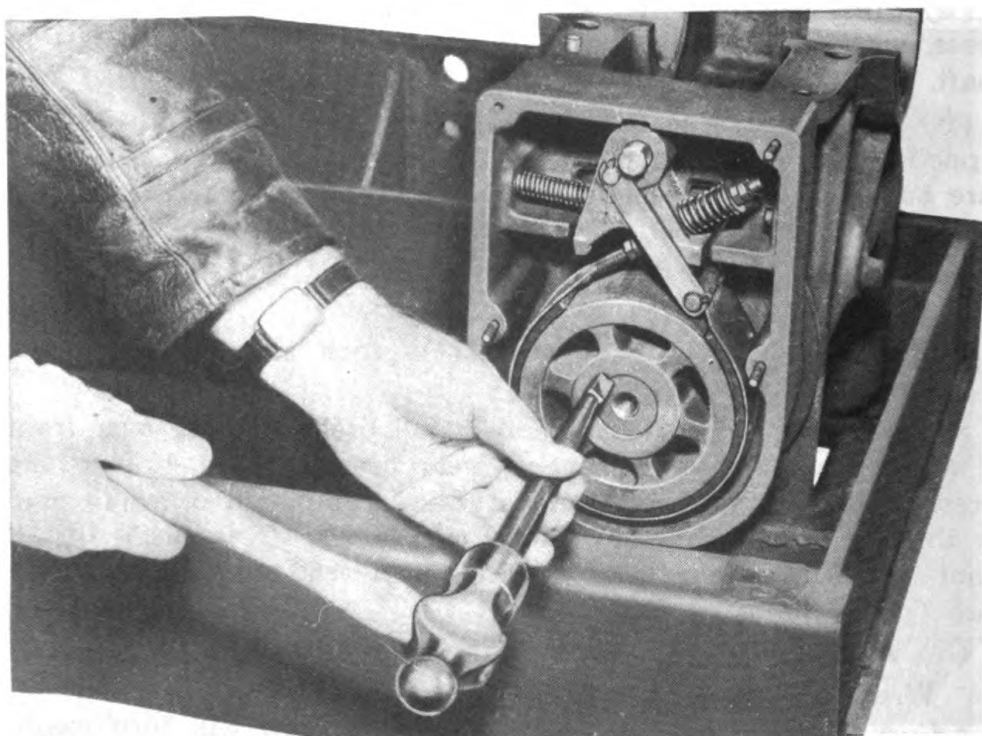

Figure 308 — Installing Key in Drum and Worm Shaft

RA PD 41410

WINCH

cap screws are tight. Add or remove shims between bearing retainer and gear case to obtain correct adjustment.

(6) ASSEMBLE AUTOMATIC WINCH WORM SAFETY BRAKE ASSEMBLY (fig. 300).

Pliers

Wrench, open-end, $\frac{7}{16}$ -in.

(a) With lining installed on band, screw lower adjusting nuts on threaded end of band ($\frac{7}{16}$ -in. wrench). Slip spacer on next, with small end up. Install brake rocker on threaded end of band and over small end of spacer, then brake spring, washer, and upper adjusting nuts ($\frac{7}{16}$ -in. wrench).

(b) Install band end links with pin through lower part of links and brake band, and another pin through upper end of links and brake rocker. Secure pins with cotter pins (pliers).

(7) INSTALL AUTOMATIC BRAKE ASSEMBLY.

Hammer, 2-lb

Punch, 10-in.

Pliers

Wrench, $\frac{3}{4}$ -in.

(a) Lay brake drum on bench with recessed side and fins down. Place brake assembly around drum in position shown in figure 307. Install drum and brake band assembly in housing together, starting drum onto worm shaft and brake rocker onto anchor pin at the same time. Have keyway in worm shaft in line with keyway in brake drum (fig. 308).

(b) With drum and brake rocker started onto worm shaft and anchor pin, install return spring with one end of spring over lug on brake rocker and other end over lug in side of brake housing (fig. 307). Push drum and brake assembly all the way onto worm shaft and anchor pin until face of drum hub is flush with end of worm shaft.

(c) Drive key into slot in drum and shaft (fig. 308) so that key does not project beyond end of shaft; then place a lock washer and flat washer on the $\frac{1}{2}$ -inch cap screw and install the cap screw in front end of shaft and tighten ($\frac{3}{4}$ -in. wrench).

(d) Install cotter pin in end of anchor pin (pliers).

(8) INSTALL BUSHINGS IN WINCH DRUM.

Hammer, 2-lb

Wood block

Screwdriver, 4-in.

Using wood block against bushings, drive a bushing into each end of drum. These bushings have threaded half holes in their outer ends. These must line up with similar threaded half holes in winch drum when installing the bushings so that when the bushings are in place, the two half holes will be together, and a locking screw may be installed to prevent bushings from turning (fig. 309). Install locking screw (screwdriver).

WINCH**(9) ASSEMBLE DRUM SHAFT ASSEMBLY.**

File, flat

Punch, center

Hammer, 2-lb

Wrench, deep socket, $\frac{7}{16}$ -in.

Pliers

Wrench, socket, $\frac{3}{4}$ -in.

Press, arbor

(a) Install two keys in slots on gear end of drum shaft, tapping them into place (hammer). Lock keys by burring edge of keyway against key (center punch and hammer). File off any burs on key (flat file).

(b) Coat end of shaft with white lead for lubrication and start worm gear spider onto shaft with flange side of spider to the inside (fig. 309). Press spider onto shaft (arbor press) until hub of spider is centered on keys (fig. 310).

(c) Install worm gear on spider with wide rim towards outside. Install 12 bolts through gear and spider (fig. 310), and install and tighten nuts as tightly as possible ($\frac{3}{4}$ -in. wrench). Use special bolts provided, as substitute bolts are likely to shear and damage to gear will result.

(d) Slip one drum shaft bushing onto long end of shaft with thrust flange towards gear. Slip other drum shaft bushing onto gear end of shaft with thrust flange towards gear (fig. 303). Place lock washer and large flat washer on cap screw and screw cap screw into gear end of shaft, but do not tighten it.

(e) Slip drum shaft into drum from end opposite brake drum. Install drum inner thrust ring on drum shaft next to brake drum with key notches facing out (fig. 309). Install two keys in slots in end of drum shaft; then slip sliding clutch onto shaft with clutch jaws facing drum (fig. 293). Slip second thrust ring onto shaft with key notches toward drum.

(f) Install end frame bearing in top of end frame, with slot on outside of bearing engaging dowel in hole for bearing and threaded hole opposite slot in line with hole in top of end frame. Install lubrication fitting in bearing through hole in top of end frame ($\frac{7}{16}$ -in. wrench) (fig. 293).

(g) Install sliding clutch yoke in bracket on inside of end frame with yoke pin (fig. 293). Secure yoke pin with cotter pins (pliers).

(h) Slide clutch close to end of drum shaft; then engage fingers of clutch yoke in collar of clutch, and slide end frame assembly onto shaft. Install large cap screw with lock washer (fig. 292) and large flat washer in end of shaft, but do not tighten.

(10) INSTALL DRUM SHAFT ASSEMBLY.

Hoist, chain

Wrench, open-end, $1\frac{1}{2}$ -in.

Rope

Wrench, open-end, $1\frac{5}{8}$ -in.

(a) Place drum brake band assembly on drum in position shown in figure 291.

**ORDNANCE MAINTENANCE — MEDIUM TRACTOR M1 (ALLIS-CHALMERS HD-7W)
ELECTRICAL SYSTEM, POWER TRAIN, FRAME, AND TRACKS**

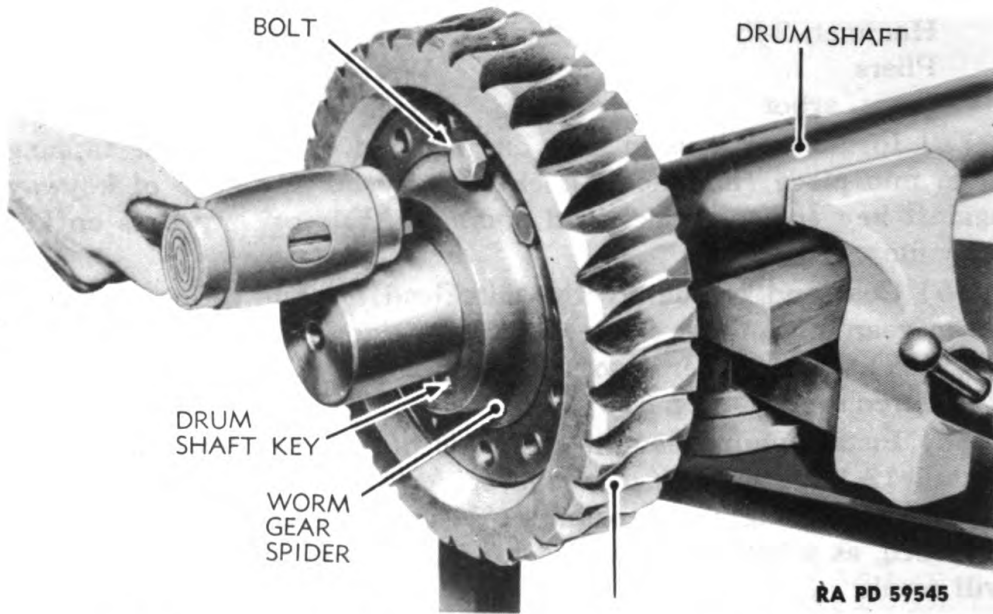

Figure 310 — Installing Worm Gear onto Worm Gear Spider

(b) Fasten rope around drum and lift assembly into position over winch base (fig. 291). Lower assembly into base, and worm gear into gear case. Make sure holes in bushings on gear end of drum shaft engage dowels in bushing recesses in gear case. Mesh worm gear teeth in worm.

(c) Install the two pivot bolts securing end frame to winch base (fig. 290), using 1½- and 1⅝-inch wrenches.

(11) INSTALL COVER ON GEAR CASE.

Wrench, open-end, 9/16-in.

Wrench, socket, 9/16-in.

Wrench, open-end, 15/16-in.

Wrench, socket, 7/8-in.

Place cover on gear case (fig. 286) using new gaskets. Install two 5/8-inch bolts with lock washers on each side of cover near drum shaft (7/8- and 15/16-in. wrenches), and a 3/8-inch bolt with lock washer in each rear corner of cover (two 9/16-in. wrenches) (fig. 285). Bolts will be installed in front corners when guard is put on.

(12) ADJUST AUTOMATIC BRAKE.

Refer to paragraph 125. Adjust brake; then install covers with four wing nuts.

(13) TIGHTEN CAP SCREWS IN ENDS OF DRUM SHAFT AND GEAR CASE PIVOT BOLTS.

Wrench, 1-in.

Wrench, box, 1⅝-in.

Wrench, box, 1½-in.

(a) When winch was disassembled, shims were removed from between large washer and one end of drum shaft; these shims provide

WINCH

clearance for free rolling of drum and for removing end thrust of shaft. Add or remove shims (fig. 293) from back of washer until excessive end thrust of shaft is eliminated, and shaft will roll freely when cap screws are tightened (fig. 292).

(b) Tighten pivot bolts holding gear case to winch base ($1\frac{1}{2}$ - and $1\frac{5}{8}$ -in. wrenches).

(14) INSTALL AUTOMATIC BRAKE GUARD.

Wrench, open-end, $\frac{9}{16}$ -in. Wrench, socket, $\frac{9}{16}$ -in.

Install guard at front of automatic brake with four $\frac{3}{8}$ -inch cap screws and two $\frac{3}{8}$ -inch bolts with lock washers (fig. 284).

(15) INSTALL BRAKE OPERATING SHAFT (fig. 289).

Hammer, 2-lb Wrench, open-end, $\frac{3}{8}$ -in.
Pliers Wrench, open-end, $1\frac{1}{16}$ -in.
Punch, 10-in.

(a) Insert end of brake operating shaft (longer of the two flat-sided shafts) through front hole in right-hand end of winch base and slip the long brake operating lever on the shaft. Push shaft in farther, through end frame, and slip set collar on shaft; then push shaft on through next cross member. Install short brake lever on end of brake band in rear of drum and install cotter pin. Then slip lever onto shaft. Push shaft farther in until outer end of shaft is flush with outer side of winch base.

(b) Holding shaft in this position, set long brake operating lever against outer side of end of frame and collar against inner side of end frame; tighten setscrews in both ($\frac{3}{8}$ - and $1\frac{1}{16}$ -in. wrenches). Set short brake operating lever on shaft below center of face of brake drum and tighten setscrew ($\frac{3}{8}$ - and $1\frac{1}{16}$ -in. wrenches).

(c) Install brake band anchor pin in other end of brake band and cross member of winch base, and secure with cotter pin (fig. 289).

(16) INSTALL AND CONNECT CLUTCH OPERATING SHAFT.

Hammer, 2-lb Wrench, open-end, $\frac{3}{8}$ -in.
Pliers Wrench, open-end, $1\frac{1}{16}$ -in.
Punch, 10-in.

(a) Insert end of clutch operating shaft through remaining hole in end of winch base and slip the longer of the two clutch operating levers on shaft; parts are shown in figure 288. Push shaft in farther, through end of frame, and install a collar, then the short clutch operating lever; then a second collar. Leave outer end of shaft flush with end of base.

(b) Hold shaft in above position, set long clutch operating lever 1 inch from end of base, and tighten setscrew. Set collars, one against inner side of end frame, the other against cross member of base; tighten setscrews ($\frac{3}{8}$ - and $1\frac{1}{16}$ -in. wrenches).

**ORDNANCE MAINTENANCE — MEDIUM TRACTOR M1 (ALLIS-CHALMERS HD-7W)
ELECTRICAL SYSTEM, POWER TRAIN, FRAME, AND TRACKS**

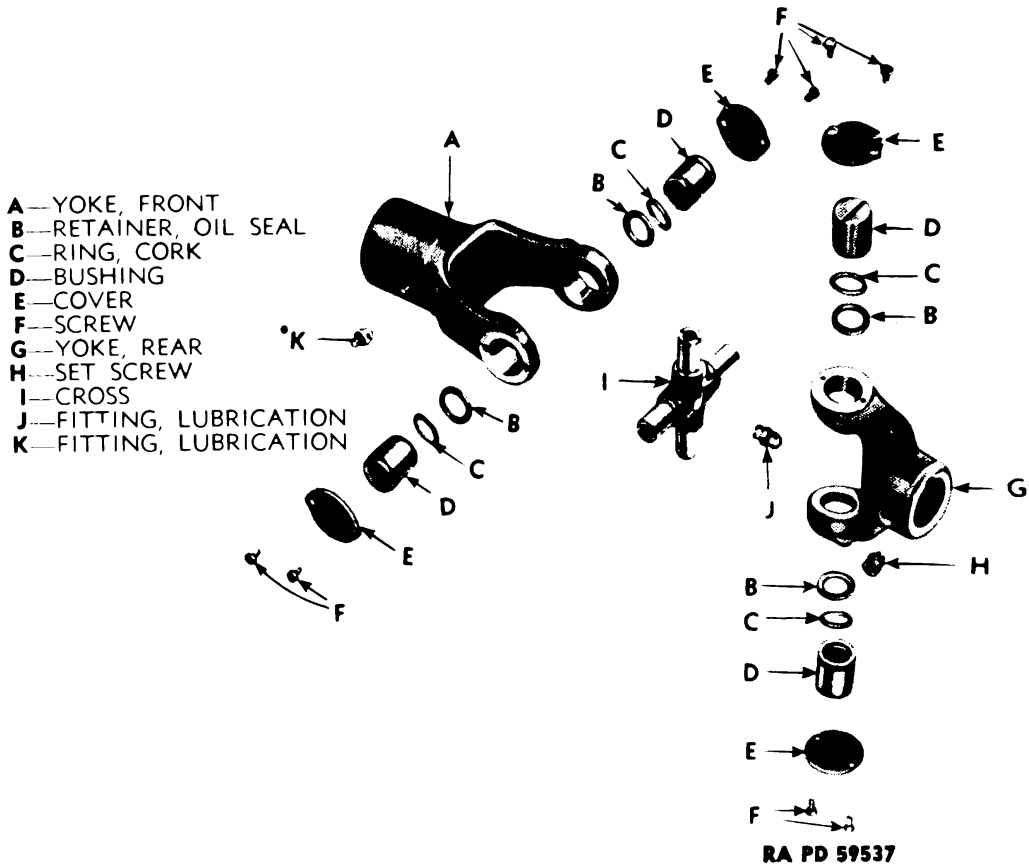

Figure 311 — Lay Shaft Universal Joint — Exploded View

(c) Install link rod (fig. 287) in arm of clutch yoke from rear of arm and short brake lever on shaft, and install cotter keys in each end of link (pliers).

(d) Set short lever on shaft so linkage works freely, and tighten setscrew ($\frac{3}{8}$ - and $\frac{1}{16}$ -in. wrenches).

(17) LUBRICATE WINCH ASSEMBLY.

Wrench, open-end, $\frac{7}{16}$ -in.

Wrench, open-end, $\frac{5}{8}$ -in.

(a) Remove filler plug and oil level plug from gear case (fig. 285) and make sure drain plug is tight ($\frac{5}{8}$ -in. wrench). Pour lubricant into filler hole of gear case (see lubrication chart, TM 9-783B) until it reaches level of level plug. Install level plug and filler plug.

(b) Install all lubrication fittings that have been removed ($\frac{7}{16}$ -in. wrench) and lubricate all parts of winch assembly as specified on lubrication chart.

(18) ASSEMBLE DRIVE SHAFT AND LAY SHAFT ASSEMBLIES.

Hammer, $\frac{1}{2}$ -lb

Wrench, hexagonal, $\frac{3}{16}$ -in.

Hammer, 2-lb

Wrench, open-end, $\frac{7}{16}$ -in.

Pliers

WINCH

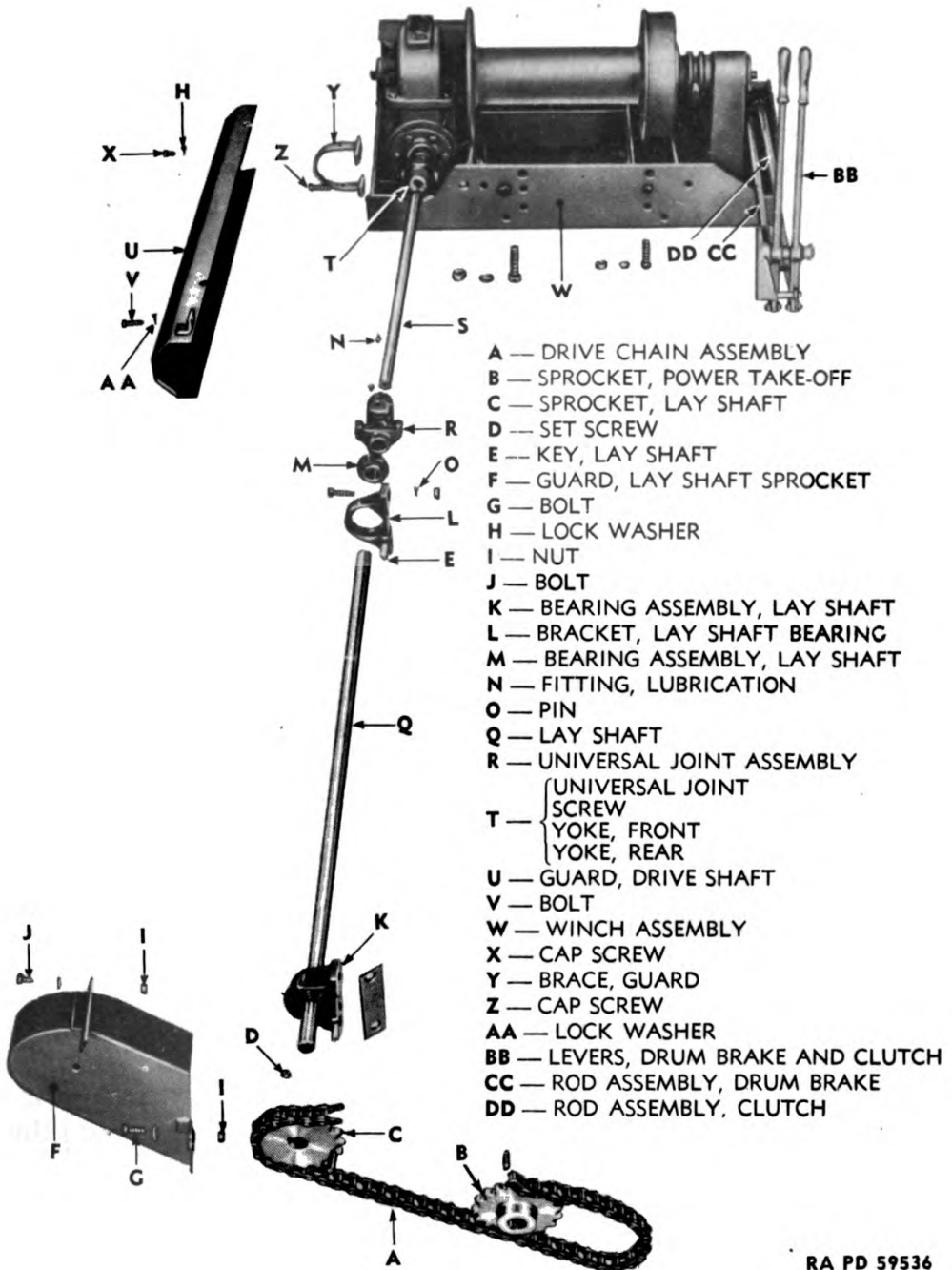

RA PD 59536

Figure 312 — Winch Drive Shaft Assemblies — Exploded View

**ORDNANCE MAINTENANCE — MEDIUM TRACTOR M1 (ALLIS-CHALMERS HD-7W)
ELECTRICAL SYSTEM, POWER TRAIN, FRAME, AND TRACKS**

(a) Assemble universal joints (fig. 311). Place cross of joint into one yoke. Install oil seal in retainer and install a seal and retainer on each arm of cross with cork side toward the outside. Then install a bushing on each arm of cross, tapping into place with light hammer. Install covers on outside of each end of yoke behind each bushing (screwdriver). Install lubrication fittings where tapped holes are provided ($\frac{7}{16}$ -in. wrench). Place second yoke of universal on other two arms of cross and install oil seals and bushings in same manner as for first yoke. Lubricate joint through fittings with chassis grease.

(b) Install lay shaft bearings in bearing brackets by inserting bearing through slot in side of bracket and turning bearing in line with bracket. **NOTE:** Hole in outer race of bearing must be in line with groove in bracket when assembled. Install a bearing and bracket assembly on each end of lay shaft with long sides of inner bearing races facing each other. Then tap key into slot in rear end of shaft and tap drive sprocket onto shaft and key (end of sprocket hub with tapped hole toward the inside), until face of sprocket is flush with end of shaft. Install and tighten hexagon-recessed setscrew in sprocket hub ($\frac{3}{16}$ -in. hexagonal wrench).

(c) Install key in slot in other end of shaft and tap nonsplined end of universal joint onto shaft and key.

(d) Install key in slot in nonsplined end of drive shaft and tap one end of front universal joint onto shaft and key.

(19) ASSEMBLE CONTROL LEVER ASSEMBLIES (fig. 313).

Hammer, ball peen

Wrench, open-end, $\frac{3}{8}$ -in.

Pliers

Wrench, open-end, $\frac{7}{16}$ -in.

Wrench, $\frac{9}{16}$ -in.

Wrench, stud

(a) Screw two studs into lever bracket with stud wrench.

(b) Tap pivot pin into bracket. Drive rivet in and peen edges. Rivet latch grip to lever.

(c) Install brake pawl (with tapered end) on end of brake lever rod having fewest threads. Tighten with $\frac{3}{8}$ -inch wrench. Insert upper end of rod through square pawl slide. Slip a flat washer, then a spring, then another flat washer over end of rod. Screw rod end onto other end of rod ($\frac{7}{16}$ -in. wrench).

(d) Slide rod assembly up through pawl slide until rivet can be inserted through latch grip and rod end. Be sure point of pawl is away from lever. Peen end of rivet (hammer).

(e) Install brake ratchet segment (with tapered notches) by squeezing latch grip, then inserting segment in slot in brake lever. Install segment in direction so that notches will fit taper end of pawl.

(f) Install assembly on lever bracket with lever on pivot pin and studs in lever bracket engaging holes in ratchet segment. Install spacers on studs and pivot pin.

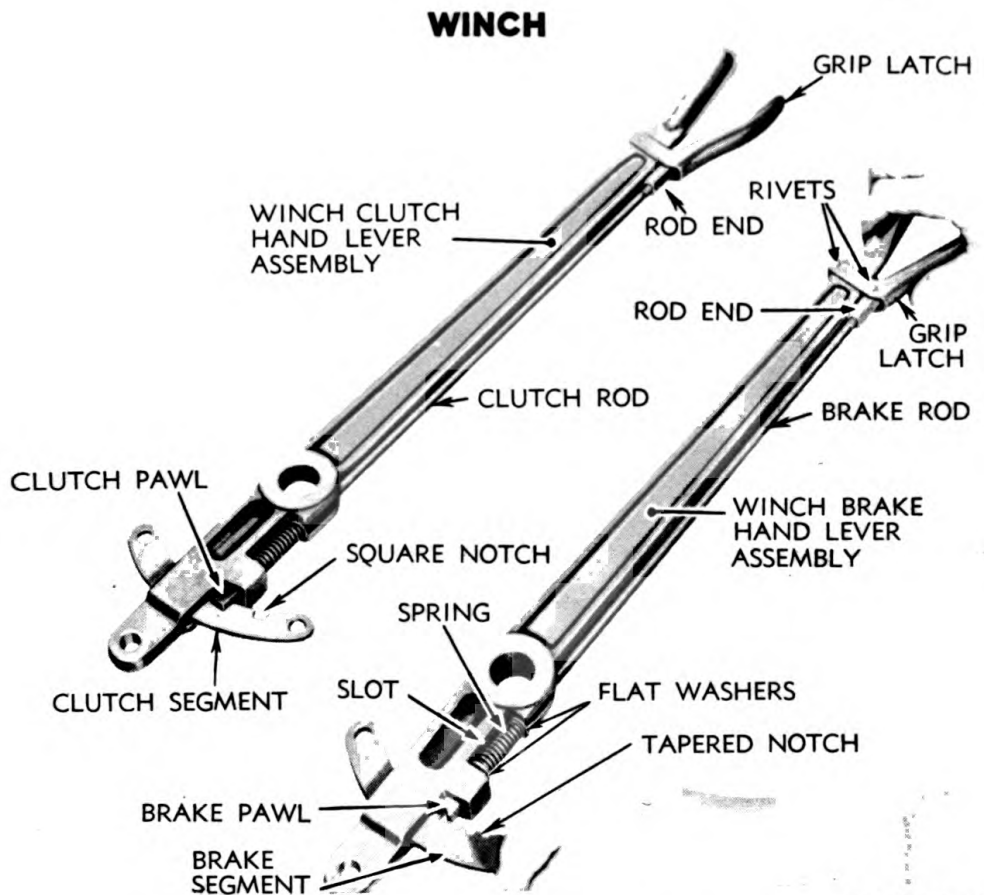

RA PD 59542

Figure 313 — Installing Brake Ratchet Segment

- (g) Assemble winch clutch control lever in same manner.
- (h) Install clutch lever assembly on lever bracket; install lock washers and nuts on studs ($\frac{9}{16}$ -in. wrench), then flat washer, spacer and cotter pin to hold levers on pivot pin (pliers).

(20) INSTALL WINCH CABLE.

Wrench, socket, $\frac{3}{4}$ -in.

NOTE: Winch must be installed on tractor before cable can be wound on drum, as power is required for winding.

(a) Insert cable end through one of the holes in drum flange, passing it through from inner side and under drum.

(b) Clamp cable end under cable clamp and tighten nuts on the rope clamp studs (fig. 314).

(c) Extend cable, being careful to avoid kinking, and anchor hook end to some object so that strain can be put on cable when winding. Never anchor to any object by passing winch cable around the object and securing hook end of cable to cable itself. This will fray the cable.

(d) Push power take-off lever ahead, engage clutch, and start winding. Winch cable must always be wound on drum from under

ORDNANCE MAINTENANCE — MEDIUM TRACTOR M1 (ALLIS-CHALMERS HD-7W)
ELECTRICAL SYSTEM, POWER TRAIN, FRAME, AND TRACKS

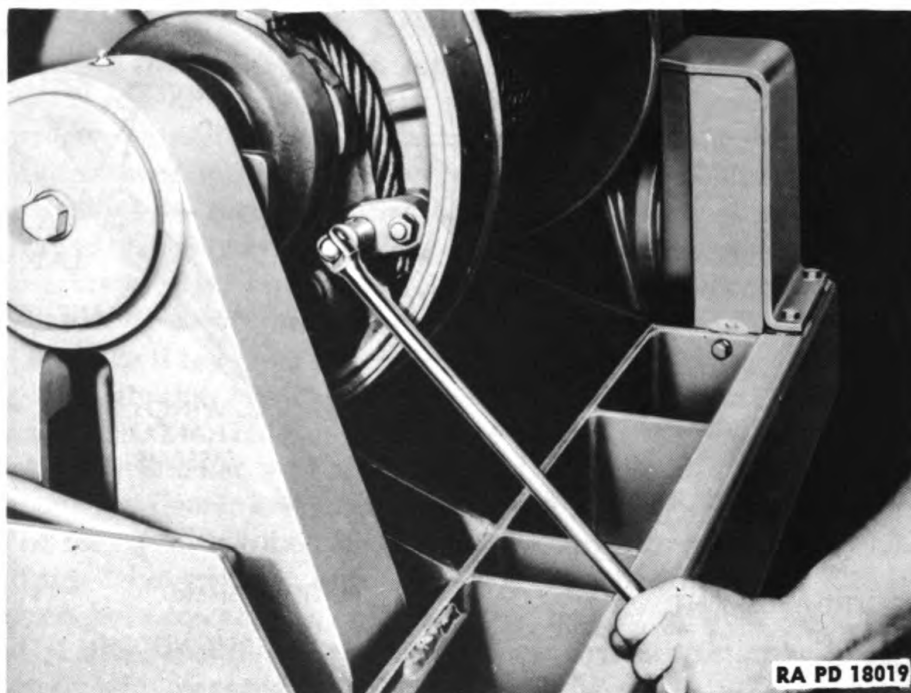

Figure 314 — Installing Cable on Drum

side; never wind it over drum. To overwind cable will put strain on equipment. When cable is fully payed out, and power take-off lever ahead, cable will underwind when engine clutch is engaged. If power take-off lever is pulled back, cable will overwind. This must be avoided. NOTE: Cable should not be wound onto winch drum too rapidly without a load, as cable may kink. In winding up cable, one person, and preferably two, should feed cable onto drum, keeping one coil laid tightly against the one before it until the cable is wound up.

123. INSTALLATION OF WINCH LAY SHAFT AND CONTROL LEVERS.

a. Tools Required.

Hammer, 2-lb

Wrench, $\frac{9}{16}$ -in. (2)

Wrench, $\frac{3}{4}$ -in. (2)

Wrench, hexagonal, $\frac{1}{8}$ -in.

Wrench, hexagonal, $\frac{3}{16}$ -in.

b. Procedure.

(1) INSTALL WINCH LAY SHAFT ASSEMBLY.

Wrench, $\frac{3}{4}$ -in. (2)

Wrench, hexagonal, $\frac{3}{16}$ -in.

Place lay shaft in position against left rear fender. Swing front end of shaft (with universal joint attached) out away from tractor so drive chain may be placed on sprocket. Swing front end of shaft back against tractor and install assembly on tractor with two bolts

WINCH

through each bearing bracket and rear fender (two $\frac{3}{4}$ -in. wrenches). **NOTE:** Correct and equal amount of shims must be placed between fender and brackets while installing to allow slight slack in drive chain. Line up sprocket with sprocket on power take-off by sliding shaft forward or back through outboard bearings, and tighten hexagon-recessed setscrews in inner bearing races ($\frac{3}{16}$ -in. hexagonal wrench). Install drive chain over sprockets (fig. 154) and adjust tension of chain as explained above.

(2) INSTALL SPROCKET GUARD.

Wrench, $\frac{9}{16}$ -in. (2)

Install sprocket guard on rear fender and pintle bracket over drive sprocket with four $\frac{3}{8}$ - by $1\frac{1}{4}$ -inch bolts with lock washers (fig. 154).

124. INSTALLATION OF WINCH ASSEMBLY.

a. Tools and Equipment Required.

Hammer, 2-lb	Wrench, open-end, $\frac{7}{16}$ -in.
Hoist, chain	Wrench, open-end, $\frac{3}{4}$ -in.
Pliers	Wrench, open-end, $1\frac{1}{16}$ -in.
Rope	Wrench, open-end, $1\frac{7}{16}$ -in.
Wrench, $\frac{7}{8}$ -in.	Wrench, socket, 1-in.
Wrench, hexagonal, $\frac{1}{4}$ -in.	Wrench, socket, $1\frac{5}{16}$ -in.

b. Procedure.

(1) SWING WINCH ASSEMBLY INTO POSITION.

Hammer, 2-lb	Rope
Hoist, chain	Wrench, hexagonal, $\frac{1}{4}$ -in.

(a) Using chain hoist, lift winch and swing it into position to bolt to front of tractor (fig. 283). **NOTE:** If drive shaft is connected to winch worm shaft, insert the shaft through the drive shaft guard bracket on left side of radiator. If drive shaft has been disconnected from winch, install it before bolting winch to tractor.

(b) With winch in position for installation, insert the end with the universal joint on it through drive shaft guard bracket and tap end of universal onto end of winch worm shaft. Install and tighten hexagon-recessed setscrew in universal joint against shaft ($\frac{1}{4}$ -in. hexagonal wrench). Then guide rear (splined) end of shaft into slip joint on universal on front end of lay shaft as winch is pushed back against the tractor.

(2) INSTALL BOLTS HOLDING WINCH ASSEMBLY TO TRACTOR.

Wrench, open-end, $1\frac{1}{16}$ -in.	Wrench, socket, 1-in.
Wrench, open-end, $1\frac{7}{16}$ -in.	Wrench, socket, $1\frac{5}{16}$ -in.

Install the eight $\frac{3}{4}$ -inch bolts with lock washers (1- and $1\frac{1}{16}$ -in. wrenches) and three 1-inch bolts with lock washers ($1\frac{5}{16}$ - and $1\frac{7}{16}$ -in. wrenches), holding winch to engine support (par. 118 b (4)).

**ORDNANCE MAINTENANCE — MEDIUM TRACTOR M1 (ALLIS-CHALMERS HD-7W)
ELECTRICAL SYSTEM, POWER TRAIN, FRAME, AND TRACKS**

(3) CONNECT CLUTCH AND BRAKE CONTROL RODS.

Pliers

Connect yoke ends of winch clutch and winch drum brake control rods to lower ends of control levers underneath right top fender (fig. 280); connect other ends of rods to levers on winch clutch and brake operating shafts. Use pins and secure with cotter pins.

(4) INSTALL ENGINE SUPPORT BOTTOM COVER.

Wrench, $\frac{7}{8}$ -in.

Install engine support bottom cover with four $\frac{5}{8}$ - by $1\frac{1}{2}$ -inch cap screws with lock washers (fig. 282).

(5) INSTALL LUBRICATION FITTINGS AND LUBRICATE WINCH ASSEMBLY.

Wrench, open-end, $\frac{7}{16}$ -in.

Install lubrication fittings where not previously installed; lubricate entire winch assembly, drive shaft, and control assemblies. Refer to lubrication chart in TM 9-783B for lubrication instructions.

(6) ADJUST WINCH CONTROLS.

Adjust winch controls as described in paragraph 125.

125. ADJUSTMENTS OF WINCH AND CONTROLS.

a. Adjustment of Control Levers. Adjustment of the control levers is made by shortening or lengthening the rods connected to the levers on the sliding clutch and winch drum brake operating shafts, and the hand control levers on the right fender (fig. 280).

(1) TOOLS REQUIRED.

Pliers

Wrench, open-end, $\frac{3}{4}$ -in.

(2) PROCEDURE.

(a) ADJUST WINCH DRUM BRAKE.

Pliers

Wrench, open-end, $\frac{3}{4}$ -in.

The brake is adjusted properly when band is loose on drum with lever in released position and lower end of lever lacks from $\frac{1}{2}$ - to $\frac{3}{4}$ -inch contacting stop at end of ratchet segment when in engaged position with band drawn tightly around drum. If brake is too loose, shorten rod by removing pin from end of rod (pliers), loosening lock nut against rod yoke end, and turning yoke end clockwise on rod ($\frac{3}{4}$ -in. wrench). Connect rod yoke end to lever with pin, secure pin with cotter pin, and tighten lock nut against yoke end. Test for action, and adjust further if necessary. If brake is too tight, lengthen rod by turning yoke end counterclockwise on rod.

(b) ADJUST SLIDING CLUTCH.

Pliers

Wrench, open-end, $\frac{3}{4}$ -in.

WINCH

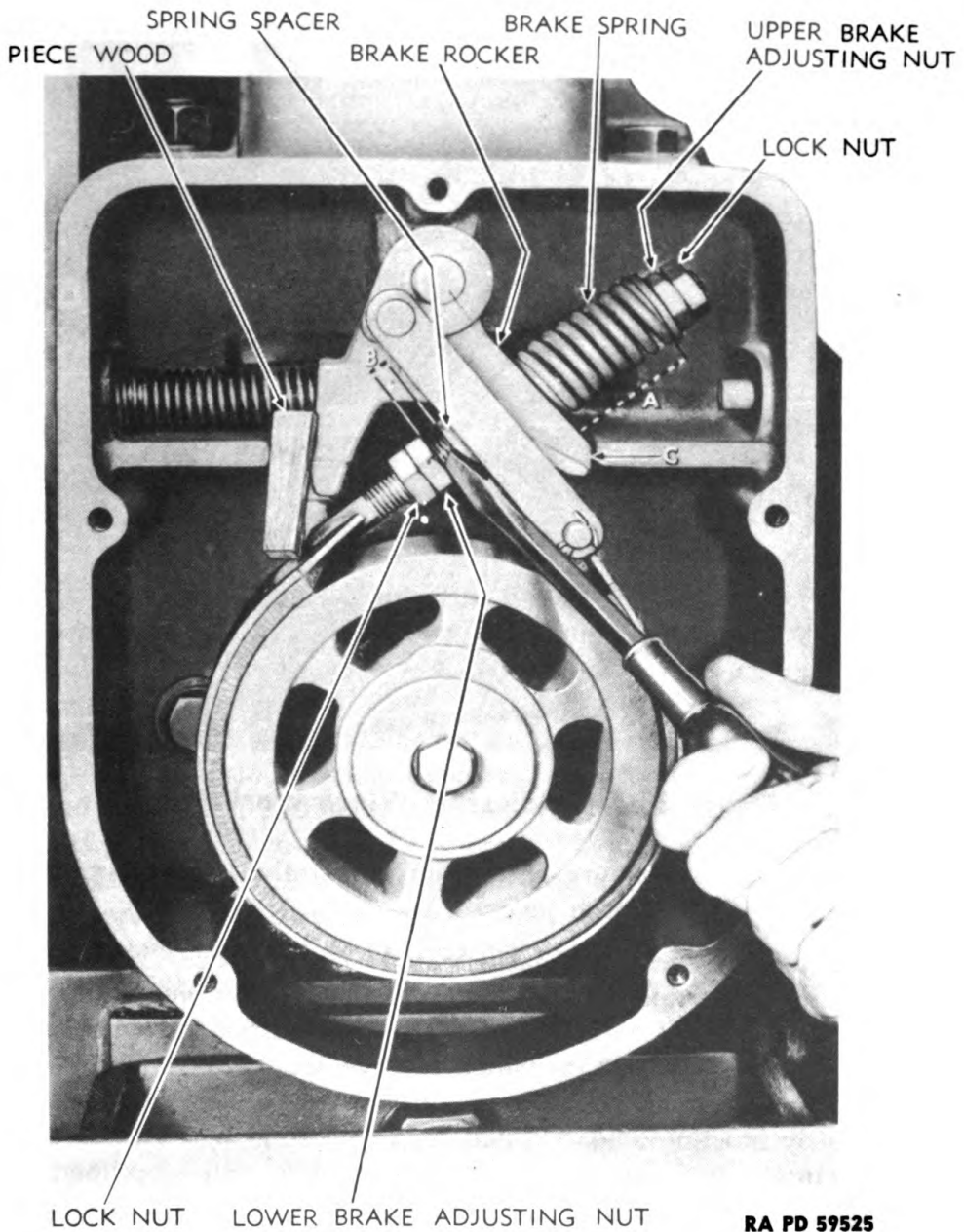

Figure 315 — Checking Adjustment of Automatic Winch Brake

Adjust clutch control rod in same manner as winch drum brake rod. When clutch lever is pushed forward (engaged position) and locked in position, the jaws of sliding clutch should engage fully with jaws on winch drum. When lever is pulled back (disengaged position), the jaws of clutch should disengage completely from winch drum jaws. Shortening the rod makes the jaws mesh deeper, and lengthening the rod causes clutch jaws to move farther away from

**ORDNANCE MAINTENANCE — MEDIUM TRACTOR M1 (ALLIS-CHALMERS HD-7W)
ELECTRICAL SYSTEM, POWER TRAIN, FRAME, AND TRACKS**

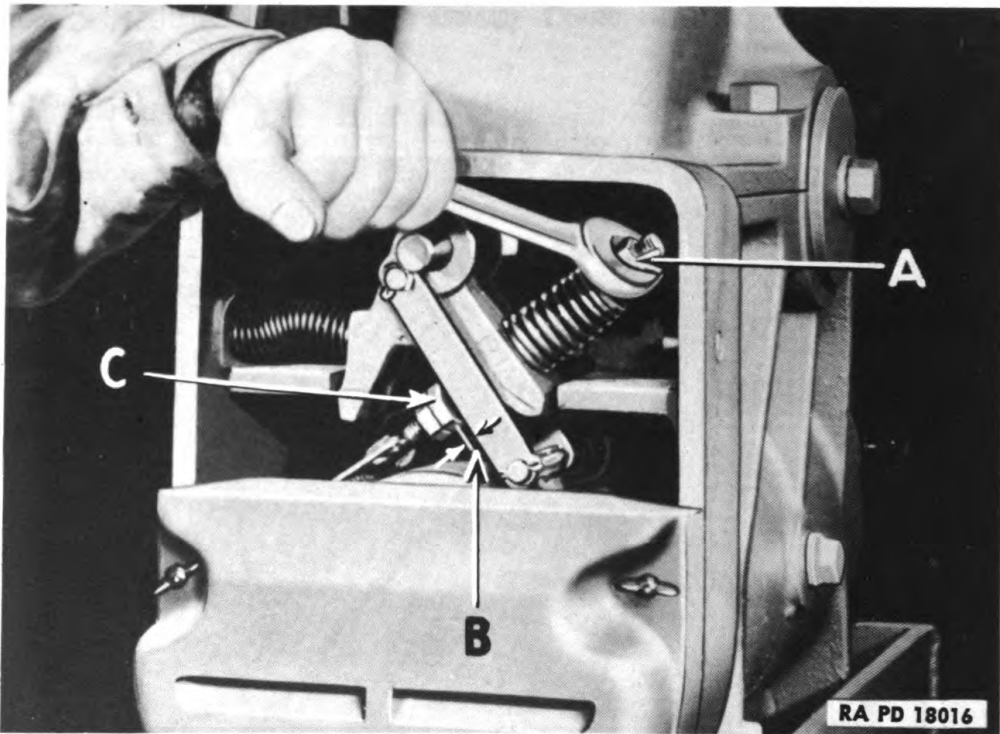

Figure 316 — Adjusting Winch Work Brake

winch drum jaws. Be sure cotter pin is installed in yoke pin when rod is connected to clutch lever.

b. Adjustment of Automatic Winch Worm Brake. The action of the automatic brake is such that brake should automatically apply enough drag on brake disk to hold the load suspended when engine clutch is disengaged. When winch is reversed by power, the brake should allow drum to turn for unwinding cable. Test holding power of brake by hoisting a load. Then start lowering load and disengage engine clutch. If properly adjusted, the brake will stop load from coming down more than 2 inches after engine clutch is disengaged, and will hold it suspended.

(1) TOOLS REQUIRED.

Pliers

Scale

Screwdriver, 10-in.

Wrench, open-end, $\frac{7}{16}$ -in. (2)

Wrench, open-end, $\frac{9}{16}$ -in.

Wrench, socket, $\frac{9}{16}$ -in.

(2) PROCEDURE.

(a) Remove guard from in front of brake housing by removing four cap screws and two bolts (two $\frac{9}{16}$ -in. wrenches) (fig. 284).

(b) Remove upper half of brake cover by removing two wing nuts (pliers).

WINCH

(c) If brake is being installed after having been removed, wedge rocker over so that rocker holds contact at "C," figure 315. Slack off top lock nut and adjusting nut about one-eighth inch and adjust top adjusting nut ($\frac{7}{16}$ in. wrench) (fig. 316) to make length of brake spring $1\frac{5}{8}$ inches in this position (dimension "A"). Tighten lock nut against top adjusting nut until there is a $\frac{1}{8}$ -inch clearance between spring spacer and lower adjusting nut. Test brake to see if it will hold load, if it does not, increase brake spring tension as outlined in following steps.

(d) Loosen lock nuts above top brake adjusting nut and lock nut below lower brake adjusting nut (two $\frac{7}{16}$ -in. wrenches). Tighten top adjusting nut one-half turn (fig. 316); tighten lock nut against it to maintain location (two $\frac{7}{16}$ -in. wrenches).

(e) With no load on winch, wedge rocker over so that rocker holds contact at "C" (fig. 314). Use screwdriver to hold spring spacer up into rocker as far as it will go.

(f) Dimension "B," which is the space between spring spacer and lower adjusting nut, should then be about $\frac{1}{8}$ inch. Tighten or loosen (whichever is necessary) lower adjusting nut ($\frac{7}{16}$ -in. wrench) until dimension "B" is about $\frac{1}{8}$ inch; then maintain location of lower brake adjusting nut by tightening lock nut against it (two $\frac{7}{16}$ -in. wrenches).

(g) Test winch. If brake does not stop load and hold it, tighten top adjusting nut again, by one-half turn. Then retest winch. Keep repeating this procedure until brake holds load.

(h) If brake overheats during hoisting operation, slightly decrease dimension "B" until overheating ceases. To decrease dimension "B," back off lock nut of lower adjusting nut; then turn lower adjusting nut clockwise by one-half turn, and tighten lock nut against it (two $\frac{7}{16}$ -in. wrenches).

(i) If brake overheats in winch lowering operation, slightly decrease tension of brake spring until overheating ceases. First back off lock nut of top brake adjusting nut and then back off top adjusting nut one-half turn. Lock position of top adjusting nut by tightening lock nut against it.

(j) Test brakes by running winch with no load in lowering operation position. If overheating is not corrected, repeat procedure until overheating is stopped.

(k) To determine whether overheating is caused by hoisting or lowering operations, run winch first in hoisting operation, then in lowering operation. In hoisting operation, brake should not heat even if run continuously. In lowering operation, there should be no excessive heating, although brake will become hot to touch. NOTE: Smoking of brake does not necessarily indicate improper adjustment, as oil on brake disk or lining will smoke until burned off, and oil will burn off at much lower temperatures than will harm lining. If lining chars, heating is excessive and adjustment should be loosened.

ORDNANCE MAINTENANCE — MEDIUM TRACTOR M1 (ALLIS-CHALMERS HD-7W)
ELECTRICAL SYSTEM, POWER TRAIN, FRAME, AND TRACKS

CHAPTER 14

MISCELLANEOUS ASSEMBLIES (COWL, ENGINE
SPACER, ENGINE SUPPORT, FUEL TANK AND
LINES, AND PINTLE ASSEMBLIES)

Section I

COWL ASSEMBLY

	Paragraph
General	126
Removal of cowl assembly	127
Installation of cowl assembly.....	128

126. GENERAL.

a. The cowl provides convenient locations for engine controls and instruments. The oil bath air cleaner and radiator shutter control lever are located underneath the cowl. The light switch, mile meter, hour meter, air heater pump, fuel and air shut-off control, and throttle lever are mounted in the dash. The instrument panel is located in the center of the dash. The dash light, temperature gage, oil pressure gage, fuel pressure gage, and ammeter are mounted in the instrument panel. All these accessories can be quickly and easily detached from the dash or instrument panel when replacement is necessary. The replacement of these accessories is covered in TM 9-783B.

127. REMOVAL OF COWL ASSEMBLY.

a. Tools and Equipment Required.

Bar, pry	Wrench, 1/2-in.
Hoist, chain	Wrench, open-end, 7/16-in.
Pliers	Wrench, open-end, 9/16-in.
Pliers, battery	Wrench, open-end, 5/8-in.
Rope	Wrench, open-end, 1 1/16-in.
Screwdriver, 1/8-in.	Wrench, open-end, 3/4-in.
Screwdriver, 6-in.	Wrench, open-end, 7/8-in.
Tape, friction	Wrench, socket, 9/16-in.
Wrench, 3/8-in.	Wrench, socket, 3/4-in.

b. Procedure. NOTE: Refer to section V in TM 9-1783A for illustrations showing location of items to be disconnected or removed in the first six steps in this chapter.

(1) REMOVE ENGINE HOOD.

Bar, pry	Wrench, open-end, 9/16-in.
----------	----------------------------

COWL ASSEMBLY

Loosen three bolts at corners of hood. **NOTE:** Remove nut from left rear hood, which is reached from inside battery box. Pry bolts out of clips and remove hood.

(2) REMOVE WINCH DRIVE SHAFT GUARD.Wrench, $\frac{9}{16}$ -in. (2)Wrench, $\frac{3}{4}$ -in. (2)

Remove the three cap screws holding guard to front bracket ($\frac{9}{16}$ -in. wrench) (fig. 281) and three bolts holding it to left rear fender ($\frac{9}{16}$ - and $\frac{3}{4}$ -in. wrenches). Remove the two bolts and one cap screw holding left rear fender to cowl.

(3) REMOVE FRONT FENDERS.Wrench, $\frac{3}{4}$ -in. (2)

Remove the one bolt and three cap screws holding right front fender to radiator and rear fender, and three bolts and two cap screws holding left front fender; then remove fenders.

(4) DISCONNECT OIL AND FUEL LINES.Wrench, open-end, $\frac{3}{4}$ -in.Wrench, open-end, $\frac{7}{8}$ -in.

(a) Disconnect lubricating oil pressure gage line from engine beneath blower.

(b) Disconnect return fuel line from fitting underneath right side of cowl.

(c) Disconnect inlet fuel line at fuel pump. Disconnect outlet fuel line at fuel pump and bottom of third stage filter, and remove line.

(d) Disconnect fuel line at top of second stage filter and from top of third stage filter, and remove line. Disconnect fuel oil pressure gage line at top of third stage filter.

(5) REMOVE AIR INTAKE ELBOW.

Pliers

Wrench, $\frac{9}{16}$ -in.

Screwdriver, 6-in.

Loosen hose clamp (screwdriver) and push hose onto air intake elbow. Remove the four cap screws holding air intake elbow to air inlet housing ($\frac{9}{16}$ -in. wrench); disconnect fuel and air shut-off rod from long shut-off lever at rear of engine, and from lever on top of governor housing (pliers). Remove air intake elbow from air inlet housing.

(6) DISCONNECT WIRES AND CONTROLS.

Pliers

Wrench, $\frac{3}{4}$ -in.

Screwdriver, 6-in.

Wrench, open-end, $\frac{7}{16}$ -in.Wrench, $\frac{3}{8}$ -in.Wrench, open-end, $\frac{9}{16}$ -in.Wrench, $\frac{1}{2}$ -in.Wrench, open-end, $1\frac{1}{16}$ -in.Wrench, $\frac{5}{8}$ -in.

(a) Disconnect throttle control rod from short shut-off lever at rear of engine by removing the pin from rod yoke and lever (pliers).

**ORDNANCE MAINTENANCE — MEDIUM TRACTOR M1 (ALLIS-CHALMERS HD-7W)
ELECTRICAL SYSTEM, POWER TRAIN, FRAME, AND TRACKS**

(b) Disconnect thermo gage tube from water outlet manifold ($\frac{11}{16}$ -in. wrench), and remove clip holding line to engine rear lifter bracket ($\frac{5}{8}$ -in. wrench).

(c) Disconnect air heater fuel line at check valve ($\frac{7}{16}$ - and $\frac{9}{16}$ -in. wrenches). Remove clip from cylinder block end plate, holding line to engine, by removing cap screws ($\frac{9}{16}$ -in. wrench).

(d) Remove two cap screws holding heater cover ($\frac{1}{2}$ -in. wrench), and disconnect coil wire.

(e) Disconnect starter rod from starter switch by removing pin from front end of rod (pliers). Disconnect battery cable from starter switch ($\frac{3}{4}$ -in. wrench) tape end of cable; then remove other end from battery terminal ($\frac{9}{16}$ -in. wrench).

(f) Disconnect wire leading to ammeter from voltage control unit (screwdriver). Disconnect headlight wires by pulling the wires from the 2-way connectors which will be found near the generator. Remove the two cap screws holding wiring harness clips to left side of engine support ($\frac{9}{16}$ -in. wrench).

(g) Remove the pin from the front end of the radiator shutter control rod when it is connected to shutter lever (pliers).

(7) REMOVE BATTERIES.

Pliers, battery

Wrench, socket, $\frac{9}{16}$ -in.

Remove the eight nuts and lift off the two battery hold-down brackets ($\frac{9}{16}$ -in. wrench) (fig. 317). Disconnect the negative cable, and the connecting cable, from the battery posts (battery pliers); remove batteries from box (fig. 318).

(8) REMOVE BOLTS HOLDING BATTERY BOX TO COWL.

Wrench, $\frac{3}{4}$ -in. (2)

Remove the four bolts from inside battery box holding cowl to battery box (fig. 319). One man should hold the nuts inside cowl while another turns bolts out of nuts.

(9) DISCONNECT WIRES FROM LIGHT SWITCH.

Screwdriver, $\frac{1}{8}$ -in.

Wrench, $\frac{1}{2}$ -in.

Screwdriver, 6-in.

Wrench, $\frac{3}{4}$ -in. (2)

(a) Remove knob from switch by loosening setscrew in side of knob ($\frac{1}{8}$ -in. screwdriver), and screwing knob off shaft. Remove setscrew ($\frac{1}{2}$ -in. wrench), depress latch button, and slide blackout control assembly from shaft. Remove mounting nut holding switch in cowl ($\frac{3}{4}$ -in. wrench), and remove two bolts holding wiring harness clips to cowl. Switch may be pushed out of cowl and lowered to remove wires (fig. 320).

(b) Disconnect following wires from switch (screwdriver), tagging each one as it is removed, with the letters marked on the switch designating the terminal from which it was removed:

COWL ASSEMBLY

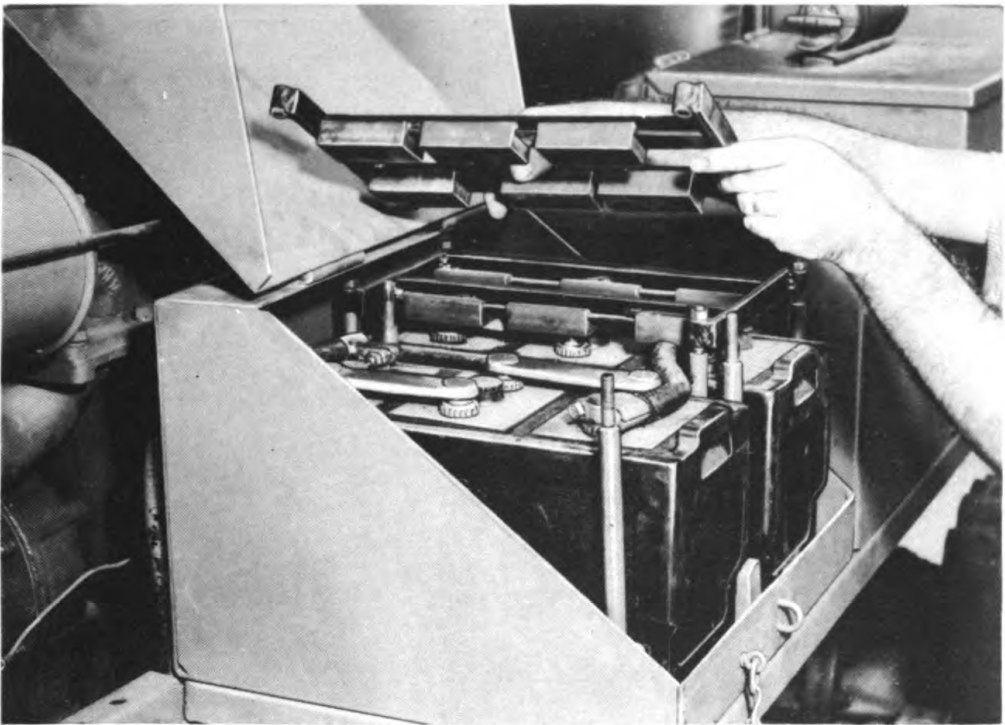

RA PD 41363

Figure 317 — Removing Battery Hold-down Brackets

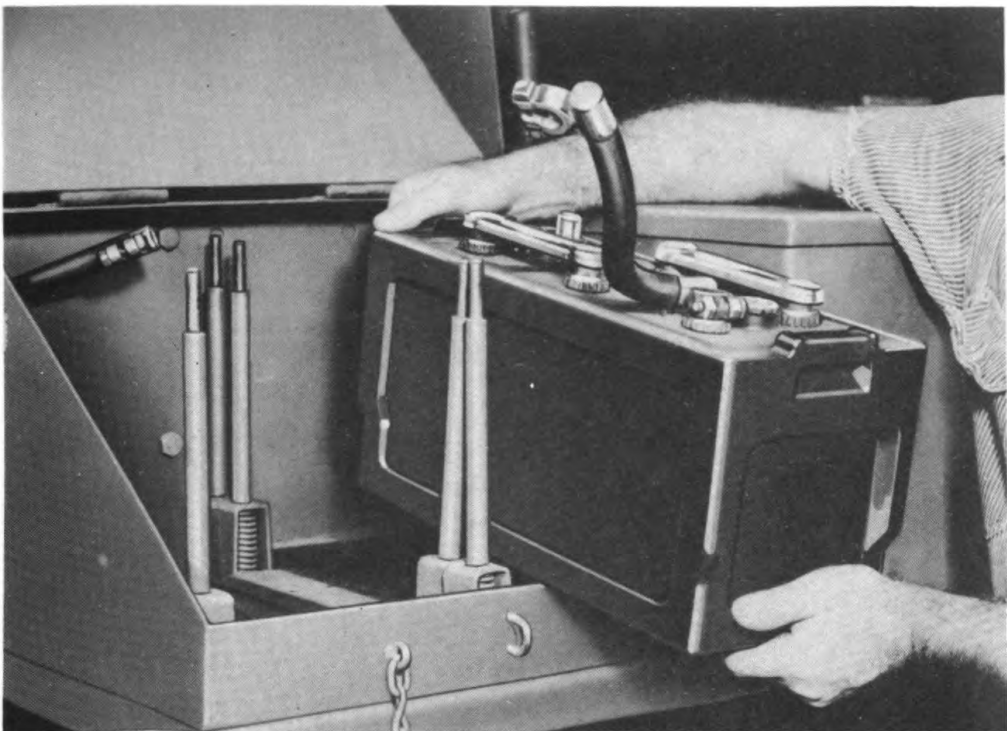

RA PD 41365

Figure 318 — Removing Batteries

325

**ORDNANCE MAINTENANCE — MEDIUM TRACTOR M1 (ALLIS-CHALMERS HD-7W)
ELECTRICAL SYSTEM, POWER TRAIN, FRAME, AND TRACKS**

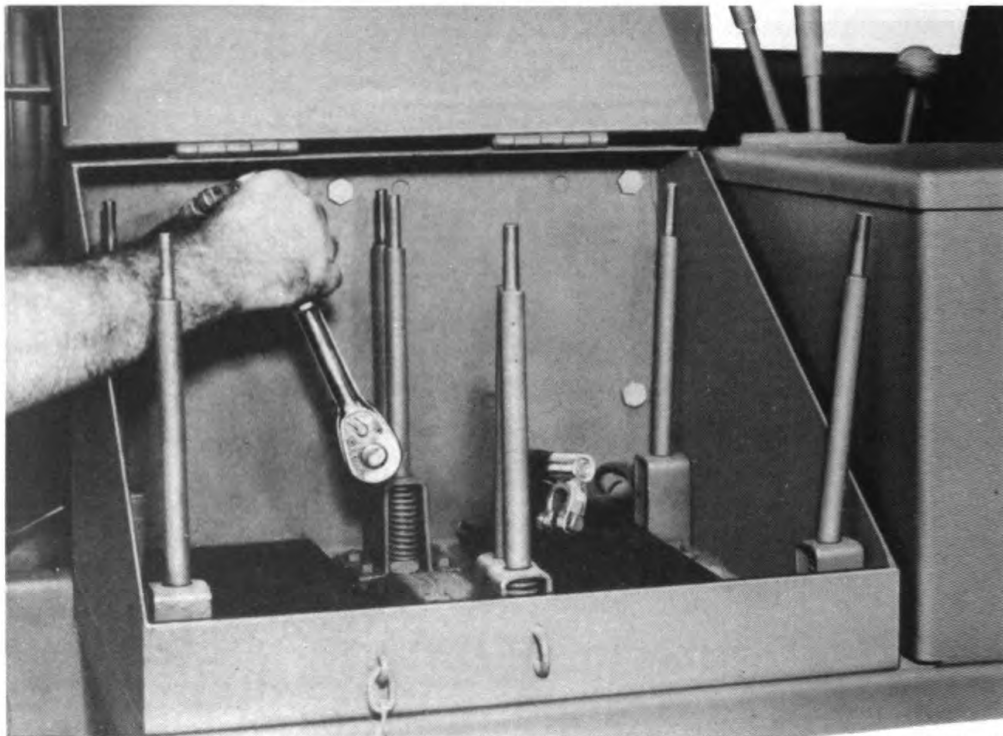

RA PD 41361

Figure 319 — Removing Bolts Holding Battery Box to Cowl

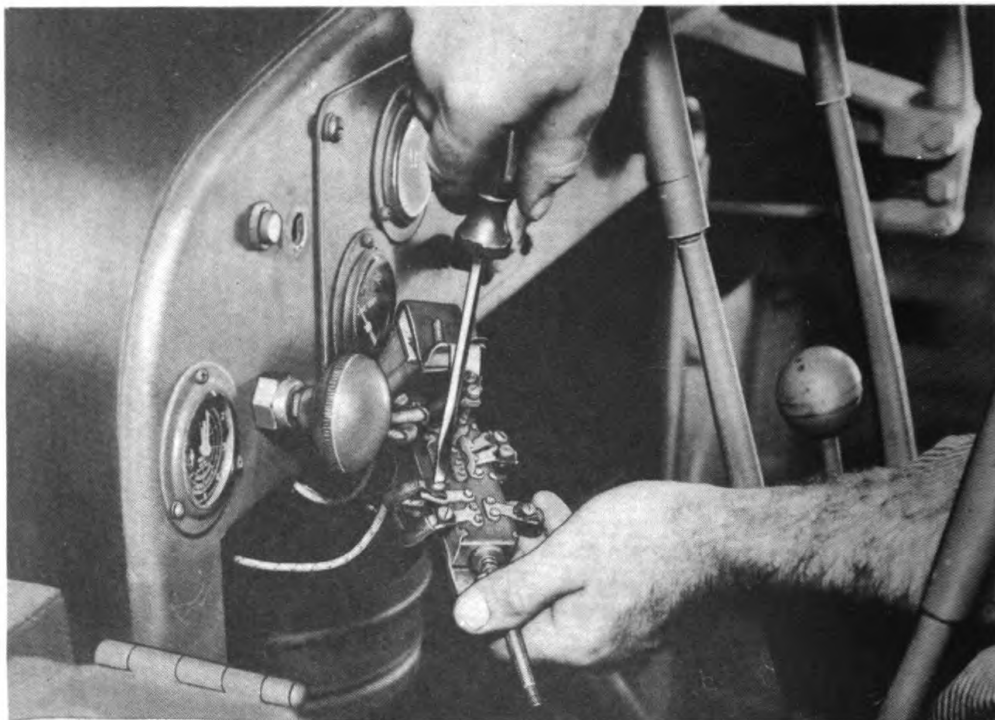

RA PD 41383

Figure 320 — Disconnecting Wires from Light Switch

COWL ASSEMBLY

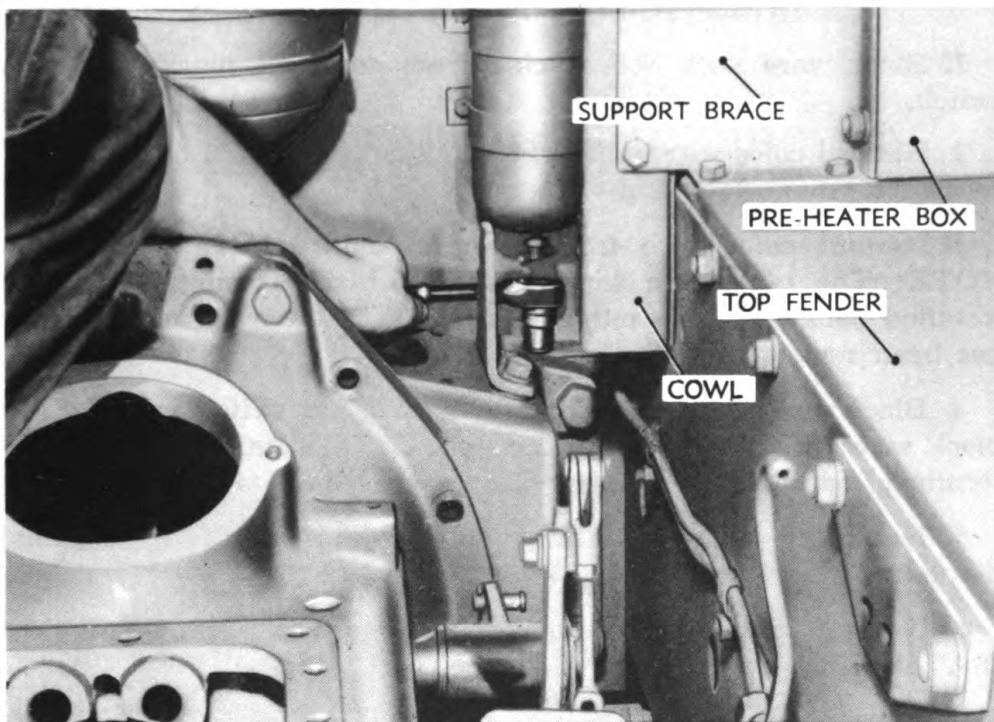

RA PD 41199

Figure 321 — Removing Cap Screws Holding Cowl to Engine Support

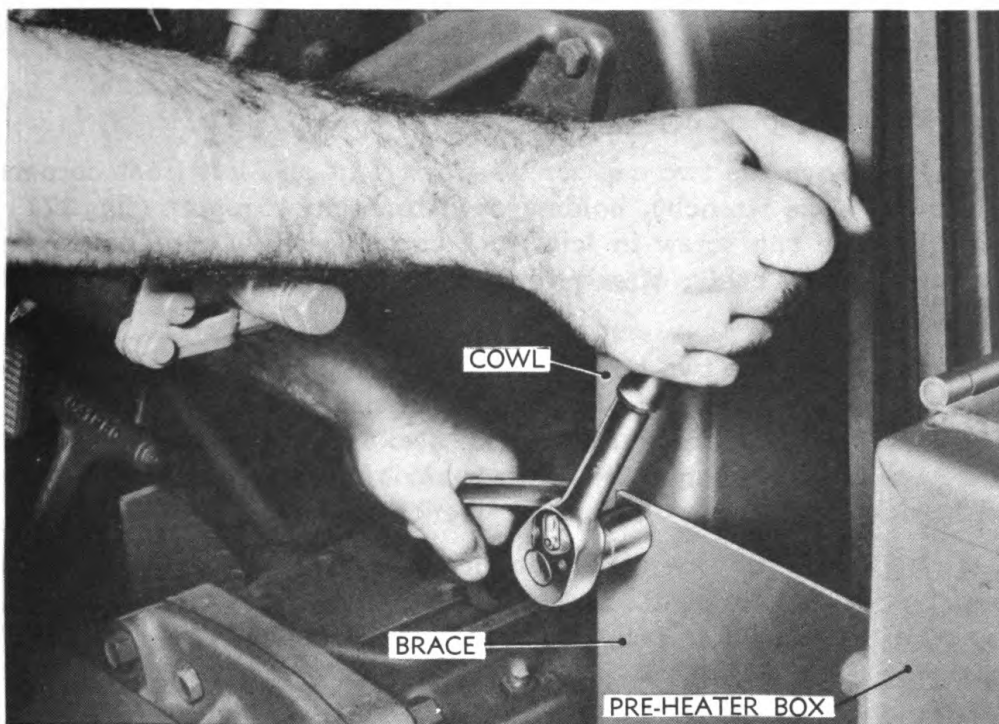

RA PD 41357

Figure 322 — Removing Bolts from Preheater Box Brace

**ORDNANCE MAINTENANCE — MEDIUM TRACTOR M1 (ALLIS-CHALMERS HD-7W)
ELECTRICAL SYSTEM, POWER TRAIN, FRAME, AND TRACKS**

1. Black wire with red tracing from terminal marked "S" on switch.
2. Natural color wire with red tracing from terminal marked "BS" on switch.
3. Natural color wire from terminal marked "HT" on switch. **NOTE:** The two white wires with two black tracings should be installed back on the terminal marked "HT" after the natural wire has been removed.
4. Black wire from terminal marked "BHT" on switch. **NOTE:** The black wire with two white tracings should be installed back on the terminal marked "BHT" after the black wire has been removed.
5. Natural color wire with green cross tracings from terminal marked "SS" on right side of switch.
6. Natural color wire with green tracings from terminal marked "SA" on right side of switch.

(10) DISCONNECT MILE METER CABLE.

Pliers

Disconnect mile meter cable from mile meter underneath left side of cowl, and pull from underneath cowl.

(11) REMOVE COWL RETAINING BOLTS.

Wrench, open-end, $\frac{3}{4}$ -in.

Wrench, socket, $\frac{3}{4}$ -in.

Wrench, open-end, $\frac{7}{8}$ -in.

(a) Remove the two cap screws from right and left front corners of cowl ($\frac{3}{4}$ -in. wrench), holding cowl to engine support (fig. 321). **NOTE:** The cap screw in left front corner of cowl also holds the battery ground cable; after removing, pull cable through cowl and remove grommet.

(b) Remove the two bolts holding right top fender and preheater box support brace to cowl ($\frac{3}{4}$ -in. wrench) (figs. 321 and 322). **NOTE:** The top one of these bolts also holds the air heater fuel inlet line clip. Disconnect line from main inlet line at union at lower right side of cowl ($\frac{3}{4}$ - and $\frac{7}{8}$ -in. wrenches).

(c) Remove the four bolts holding front support brace to right top fender and preheater box (two $\frac{3}{4}$ -in. wrenches). Two of the bolts go in preheater box, and two in top fender. The brace will remain on the cowl.

(d) Remove the two bolts holding both right rear and top fender to cowl, and two more bolts holding only right rear fender to cowl.

COWL ASSEMBLY

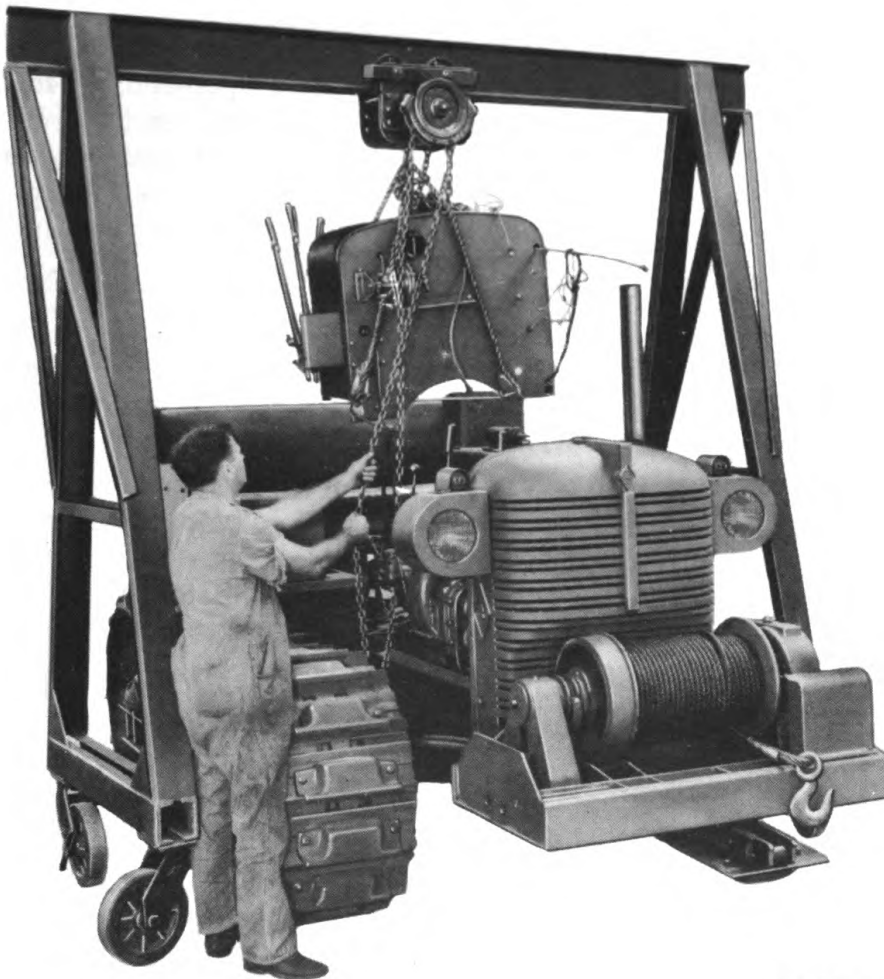

RA PD 41345

Figure 323 — Removing Cowl Assembly from Tractor

(12) DISCONNECT WINCH CONTROL RODS.

Pliers

Remove 2 yoke pins holding winch control rods to lower ends of winch clutch and winch brake control levers (fig. 280).

(13) LIFT OFF COWL.

Bar, pry

Hoist, chain

Rope

Wrench, socket, $\frac{3}{4}$ -in.

Remove the two cap screws ($\frac{3}{4}$ -in. wrench) holding right rear fender to engine support (fig. 331) and pry right rear fender (pry bar) away from engine support, to allow clearance enough for cowl to clear fuel return line as it is being hoisted from transmission case. Lift cowl off with chain hoist and rope.

**ORDNANCE MAINTENANCE — MEDIUM TRACTOR M1 (ALLIS-CHALMERS HD-7W)
ELECTRICAL SYSTEM, POWER TRAIN, FRAME, AND TRACKS**

128. INSTALLATION OF COWL ASSEMBLY.**a. Tools Required.**

Hoist, chain	Wrench, open-end, $\frac{7}{16}$ -in.
Pliers	Wrench, open-end, $\frac{1}{2}$ -in.
Pliers, battery	Wrench, open-end, $\frac{9}{16}$ -in.
Rope	Wrench, open-end, $1\frac{1}{16}$ -in.
Screwdriver, $\frac{1}{8}$ -in.	Wrench, open-end, $\frac{3}{4}$ -in.
Screwdriver, 6-in.	Wrench, open-end, $\frac{7}{8}$ -in.
Wrench, $\frac{3}{8}$ -in.	Wrench, socket, $\frac{9}{16}$ -in.
Wrench, $\frac{5}{8}$ -in.	Wrench, socket, $\frac{3}{4}$ -in.

b. Procedure.**(1) LOWER COWL INTO POSITION.**

Hoist, chain	Wrench, $\frac{3}{4}$ -in. (2)
Rope	

Lower cowl into position on tractor (chain hoist), taking care not to damage fuel return lines; also see that radiator shutter control rod enters into its position in left top side of radiator shell. Install the two $\frac{1}{2}$ - by 1-inch cap screws with lock washers holding right rear fender to engine support (two $\frac{3}{4}$ -in. wrenches).

(2) CONNECT WINCH CONTROL RODS.

Pliers

Connect winch clutch and brake control rods to control levers on right top fender with pins secured by cotter pins (fig. 280).

(3) INSTALL COWL BOLTS.

Wrench, $\frac{3}{4}$ -in. (2)	Wrench, open-end, $\frac{7}{8}$ -in.
--------------------------------	--------------------------------------

(a) Install the two $\frac{1}{2}$ - by $1\frac{1}{4}$ -inch bolts with lock washers holding right rear fender and top fender to cowl and two $\frac{1}{2}$ - by 1-inch bolts with lock washers holding rear fender to cowl (two $\frac{3}{4}$ -in. wrenches).

(b) Install the two $\frac{1}{2}$ - by 1-inch bolts with lock washers holding right top fender and preheater support brace (fig. 322) to cowl (two $\frac{3}{4}$ -in. wrenches). **NOTE:** Install the clip on the air heater fuel inlet line under the top bolt and connect main inlet line to lower end of union at lower right side of cowl ($\frac{7}{8}$ -in. wrench).

(c) Install four $\frac{1}{2}$ - by 1-inch bolts with lock washers holding front support brace to right front fender and preheater box (two $\frac{3}{4}$ -in. wrenches). Two of these bolts go in top fender and two in preheater box.

(d) Install the $\frac{1}{2}$ - by 1-inch cap screws with lock washers holding right-hand corner of cowl to engine support ($\frac{3}{4}$ -in. wrench) (fig. 321). Install grommet in hole in battery box, and insert small end of battery ground cable through grommet. Install the $\frac{1}{2}$ - by $1\frac{1}{4}$ -inch

COWL ASSEMBLY

cap screw with lock washer holding left corner of cowl through battery ground cable, and into engine support ($\frac{3}{4}$ -in. wrench).

(4) CONNECT MILE METER CABLE.

Pliers

Connect mile meter cable to mile meter on left top side of cowl.

(5) CONNECT WIRES TO LIGHT SWITCH AND INSTALL SWITCH IN DASH OF COWL.

Screwdriver, $\frac{1}{8}$ -in.

Wrench, $\frac{3}{4}$ -in. (2)

Screwdriver, 6-in.

Wrench, open-end, $\frac{1}{2}$ -in.

Wrench, $\frac{9}{16}$ -in. (2)

(a) CONNECT WIRES AS FOLLOWS:

1. Natural color wire with green tracings to terminal marked "SW" on right side of switch.

2. Natural color wire with green cross tracings to terminal marked "SS" on right side of switch.

3. Black wire to terminal marked "BHT" on left side of switch over the black wire with two white tracings.

4. Natural color wire to terminal marked "HT" on left side of switch over two white wires with two black tracings.

5. Natural color wire with red tracing to terminal marked "BS" on left side of switch.

6. Black wire with red tracings goes to terminal marked "S" on left side of switch.

(b) Install the two $\frac{3}{8}$ - by 1-inch bolts with lock washers holding wiring harness clip to left side of cowl (two $\frac{9}{16}$ -in. wrenches).

(c) Insert switch through hole in dash, and install mounting nut to hold switch ($\frac{3}{4}$ -in. wrench). Depress latch button of blackout control assembly and slide it onto shaft of switch. Install and tighten setscrew in blackout control assembly ($\frac{1}{2}$ -in. wrench). Screw knob onto shaft and tighten setscrew ($\frac{1}{8}$ -in. screwdriver).

(6) INSTALL WINCH DRIVE SHAFT GUARD.

Wrench, $\frac{9}{16}$ -in. (2)

Wrench, $\frac{3}{4}$ -in. (2)

Install the two $\frac{1}{2}$ - by 1-inch bolts with lock washers and $\frac{1}{2}$ - by 1-inch cap screw with lock washer holding left rear fender to cowl (two $\frac{3}{4}$ -in. wrenches). Install winch drive shaft guard over winch drive shaft, and install the three $\frac{3}{8}$ - by $\frac{1}{2}$ -inch cap screws with lock washers holding guard to front bracket. Install the two $\frac{3}{8}$ - by 1-inch bolts with lock washers in the two lower holes (two $\frac{9}{16}$ -in. wrenches), and one $\frac{1}{2}$ - by $1\frac{1}{4}$ -inch bolt with lock washer in top hole holding guard to left rear fender. **NOTE:** The clip holding wiring harness to left rear fender must also be installed on the upper bolt (two $\frac{3}{4}$ -in. wrenches).

**ORDNANCE MAINTENANCE — MEDIUM TRACTOR M1 (ALLIS-CHALMERS HD-7W)
ELECTRICAL SYSTEM, POWER TRAIN, FRAME, AND TRACKS**

(7) INSTALL BOLTS HOLDING COWL TO BATTERY BOX.Wrench, $\frac{3}{4}$ -in. (2)

Install the four $\frac{1}{2}$ - by 1-inch bolts with lock washers inside battery box holding cowl to battery box.

NOTE: For illustrations for the balance of the cowl assembly, see TM 9-1780A.

(8) CONNECT OIL GAGE LINE.Wrench, open-end, $\frac{7}{8}$ -in.

Connect lubricating oil pressure gage line to fitting in engine block underneath blower.

(9) CONNECT FUEL LINES.Wrench, open-end, $\frac{3}{4}$ -in.Wrench, open-end, $\frac{7}{8}$ -in.

(a) Connect fuel line from return fuel manifold on engine fitting on end of fuel return line underneath right side of cowl.

(b) Connect main inlet fuel line to inner fitting on fuel pump.

(c) Install fuel line, connecting one end to outer fitting on fuel pump and other end to bottom fitting on second stage fuel filter.

(d) Install fuel line, connecting one end to top fitting on second stage fuel filter and other end to fitting at side of third stage fuel filter.

(e) Connect line from fuel oil pressure gage to top fitting on third stage fuel filter.

(10) INSTALL AIR INTAKE ELBOW.

Pliers

Wrench, $\frac{9}{16}$ -in.

Screwdriver, 6-in.

Install air intake elbow and gasket on air inlet housing with four $\frac{3}{8}$ - by $1\frac{1}{4}$ -inch cap screws with lock washers ($\frac{9}{16}$ -in. wrench). Install the yoke pin and cotter pin connecting rear end of fuel and air shut-off rod to long shut-off lever on throttle shaft on front of cowl and also install yoke pin and cotter pin holding front fuel shut-off rod to shut-off lever on top of governor control housing (pliers). Connect hose on air intake elbow with air tube and tighten the two hose clamps (screwdriver).

(11) CONNECT THROTTLE CONTROL ROD.

Pliers

Connect throttle control rod to short shut-off lever on throttle shaft on front of cowl.

(12) CONNECT THERMO GAGE LINE.Wrench, $\frac{5}{8}$ -in.Wrench, open-end, $1\frac{1}{16}$ -in.

Insert thermo gage tube in rear end of water outlet manifold and tighten the tube nut ($1\frac{1}{16}$ -in. wrench). Install the $\frac{7}{16}$ - by $1\frac{1}{2}$ -inch cap screw with lock washer holding thermo gage line clip to rear engine lifter bracket ($\frac{5}{8}$ -in. wrench).

COWL ASSEMBLY**(13) CONNECT AIR HEATER.**Wrench, $\frac{3}{8}$ -in.Wrench, open-end, $\frac{7}{16}$ -in.Wrench, $\frac{1}{2}$ -in.Wrench, socket, $\frac{9}{16}$ -in.

(a) Connect air heater coil wire to coil ($\frac{3}{8}$ -in. wrench) and install the air heater cover with two $\frac{5}{16}$ - by $2\frac{7}{8}$ -inch cap screws with lock washers ($\frac{1}{2}$ -in. wrench). Secure the air heater fuel check valve clip to air heater cover with the lower cap screw.

(b) Connect air heater fuel line to check valve ($\frac{7}{16}$ - and $\frac{9}{16}$ -in. wrenches), attach clip on fuel line to lower left bolt on rear cylinder block end plate, and install the $\frac{3}{8}$ -inch nut and lock washer on bolt ($\frac{9}{16}$ -in. wrench).

(14) CONNECT WIRES.

Screwdriver, 6-in.

Wrench, $\frac{3}{4}$ -in.Wrench, $\frac{9}{16}$ -in. (2)

(a) Connect ammeter wire and starter cable to starter switch post ($\frac{3}{4}$ -in. wrench). Connect other wire from ammeter to voltage control on top of generator (screwdriver).

(b) Insert headlight wires into 2-way connectors at end of headlight wire leading from cowl.

(c) Install two $\frac{3}{8}$ - by $\frac{1}{2}$ -inch cap screws with lock washers through wire harness clips and into left side of engine support (two $\frac{9}{16}$ -in. wrenches).

(15) CONNECT STARTER ROD.

Pliers

Install starter rod over pin on starter switch, and install cotter pin.

(16) CONNECT SHUTTER CONTROL ROD.

Pliers

Install yoke pin and cotter pin holding shutter control rod to radiator shutter lever.

(17) INSTALL FRONT FENDERS.Wrench, $\frac{3}{4}$ -in. (2)

Install the one $\frac{1}{2}$ - by 1-inch bolt and three $\frac{1}{2}$ - by 1-inch cap screws with lock washers holding right front fender; and three $\frac{1}{2}$ - by 1-inch bolts and two $\frac{1}{2}$ - by $1\frac{1}{4}$ -inch cap screws with lock washers holding left front fender. **NOTE:** The top rear bolt also holds the clip on the cable leading from battery to starting motor.

(18) INSTALL HOOD.Wrench, open-end, $\frac{9}{16}$ -in.

Lower hood over exhaust pipe and into position on cowl and radiator shell; tap the hold-down bolts into clips at each corner of hood, and tighten. **NOTE:** The bolt holding the left rear corner of the hood is located inside the battery box.

**ORDNANCE MAINTENANCE — MEDIUM TRACTOR M1 (ALLIS-CHALMERS HD-7W)
ELECTRICAL SYSTEM, POWER TRAIN, FRAME, AND TRACKS**

(19) INSTALL BATTERIES.

Pliers, battery

Wrench, $\frac{9}{16}$ -in.

Install rear battery in box with the positive post toward cowl and install ground cable on the positive post (battery pliers). **NOTE:** This battery is the one that had connecting cable left on. Install second battery with the negative post toward cowl and install starter cable to this negative post. Install the connecting cable on the positive post of the front battery. Install the two battery hold-down brackets, using $\frac{3}{8}$ -inch nuts on the battery hold-down bolts ($\frac{9}{16}$ -in. wrench). Refer to section **XV** in **TM 9-783B**.

CHAPTER 14

**MISCELLANEOUS ASSEMBLIES (COWL, ENGINE SPACER,
ENGINE SUPPORT, FUEL TANK AND LINES, AND
PINTLE ASSEMBLIES) (Cont'd)**

Section II

ENGINE SPACER

	Paragraph
Description	129
Removal	130
Disassembly	131
Inspection of parts	132
Assembly	133
Installation	134

129. DESCRIPTION.

a. The engine spacer, located between the engine and transmission, is in effect an adapter which connects the engine to the transmission case. The engine support also bolts to the spacer for the support of the front end of engine and radiator.

130. REMOVAL.

a. Tools and Equipment Required.

Bar, 5-ft	Wrench, 5/8-in.
Bar, drift, 1- x 18-in.	Wrench, 15/16-in.
Bar, pry	Wrench, 1-in.
Chain	Wrench, 1 1/8-in.
Chisel, 3/4-in.	Wrench, open-end, 1/2-in.
Hammer, 2-lb	Wrench, open-end, 9/16-in.
Hammer, 8-lb	Wrench, open-end, 11/16-in.
Hoist, chain	Wrench, open-end, 3/4-in.
Jack, hydraulic, 10-ton	Wrench, open-end, 7/8-in.
Rope	Wrench, open-end, 15/16-in.
Screwdriver, 6-in.	Wrench, socket, 1/2-in.
Screwdriver, 8-in.	Wrench, socket, 9/16-in.
Wood block, 2- x 10- x 36-in. (2)	Wrench, socket, 3/4-in.
Wrench, 3/8-in.	Wrench, socket, 15/16-in.
Wrench, 7/16-in.	Wrench, socket, 1 7/16-in.
	Wrench, socket, 1 1/2-in.

b. Procedure.

(1) REMOVE ENGINE.

Refer to section XI in TM 9-783B or section V in TM 9-1780A for removal procedure.

ORDNANCE MAINTENANCE — MEDIUM TRACTOR M1 (ALLIS-CHALMERS HD-7W)
ELECTRICAL SYSTEM, POWER TRAIN, FRAME, AND TRACKS

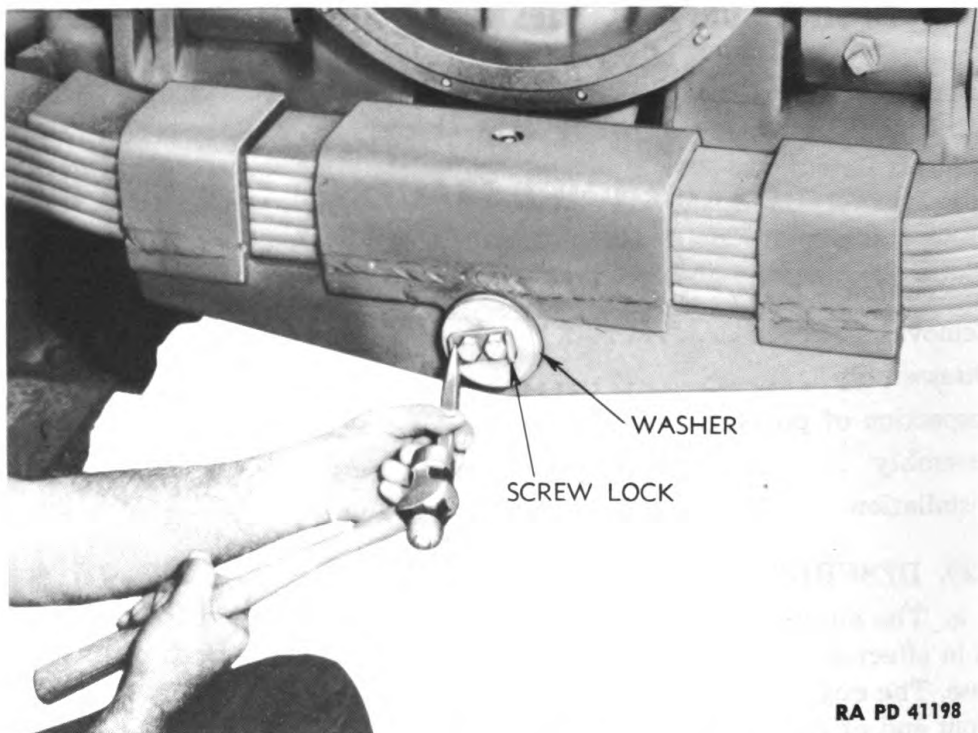

RA PD 41198

Figure 324 — Straightening Locks to Remove Washer Cap Screws

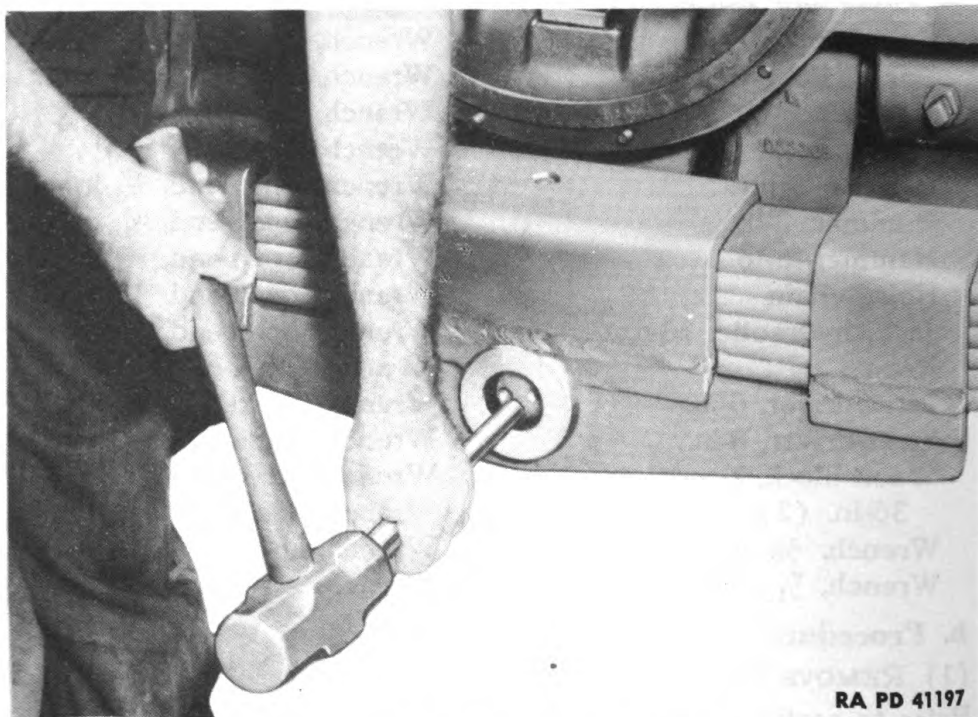

RA PD 41197

Figure 325 — Driving Pivot Shaft out of Stabilizer Spring

ENGINE SPACER

(2) REMOVE WINCH AND ENGINE SUPPORT ASSEMBLIES.

Refer to paragraph 136 b (3) and (4) for removal procedure.

(3) DISCONNECT AND RAISE FRONT END OF COWL AND FENDER ASSEMBLIES.

Hoist, chain	Wrench, socket, $1\frac{5}{16}$ -in.
Rope	Wrench, socket, 1-in.
Wrench, $\frac{3}{4}$ -in. (2)	Wrench, socket, $1\frac{1}{8}$ -in.
Wrench, socket, $\frac{7}{8}$ -in.	

(a) Remove the six cap screws holding rear fender angle brackets to right and left steering clutch covers (fig. 109).

(b) Remove the six bolts holding welded bracket assemblies to rear and top fender. Loosen remaining two bolts, one at bottom of each bracket, to act as a pivot when front end of top deck assembly is raised up to clear engine spacer.

(c) Using chain hoist, raise front end of top deck assembly high enough to obtain clearance between engine spacer and top deck to remove spacer (fig. 326). NOTE: Top deck assembly as referred to in this paragraph includes seat, fuel tank, street plate box, cowl, pack rack, engine preheater box, tool box, and battery box.

(d) Remove all but the 2 top bolts (fig. 326) of the 18 bolts holding spacer to transmission case ($\frac{7}{8}$ -, $1\frac{5}{16}$ -, and $1\frac{1}{8}$ -in. wrenches).

(4) REMOVE STABILIZER SPRING PIVOT SHAFT.

Bar, drift, 1- x 18-in.	Jack, hydraulic, 10-ton
Chisel, $\frac{3}{4}$ -in.	Wrench, $\frac{9}{16}$ -in.
Hammer, 8-lb	Wrench, $\frac{3}{4}$ -in.

(a) Using hydraulic jack under front end of transmission case just back of spacer, raise tractor until weight is removed from stabilizer spring pivot shaft (fig. 324).

(b) Straighten the locks on the two cap screws holding washer to front end of spring pivot shaft (hammer and chisel) and remove the two cap screws ($\frac{3}{4}$ -in. wrench). Remove the three cap screws holding spring pivot shaft to rear end of engine spacer ($\frac{9}{16}$ -in. wrench). Drive spring pivot shaft toward rear of tractor, and out of spacer (drift bar and hammer) (fig. 325).

(5) REMOVE STABILIZER LINK SHAFT.

Bar, 5-ft	Wrench, $\frac{3}{4}$ -in.
Chisel, $\frac{3}{4}$ -in.	Wrench, 1-in.
Hammer, 2-lb	Wrench, socket, $1\frac{5}{16}$ -in.
Hammer, 8-lb	Wrench, socket, $1\frac{7}{16}$ -in.

(a) Loosen the two nuts on the U-bolt holding link shaft tightly in spacer ($1\frac{5}{16}$ -in. wrench) (fig. 326).

(b) Remove the end caps from both ends of link shaft (fig. 91) by removing three cap screws from each. ($\frac{3}{4}$ -in. wrench).

**ORDNANCE MAINTENANCE — MEDIUM TRACTOR M1 (ALLIS-CHALMERS HD-7W)
ELECTRICAL SYSTEM, POWER TRAIN, FRAME, AND TRACKS**

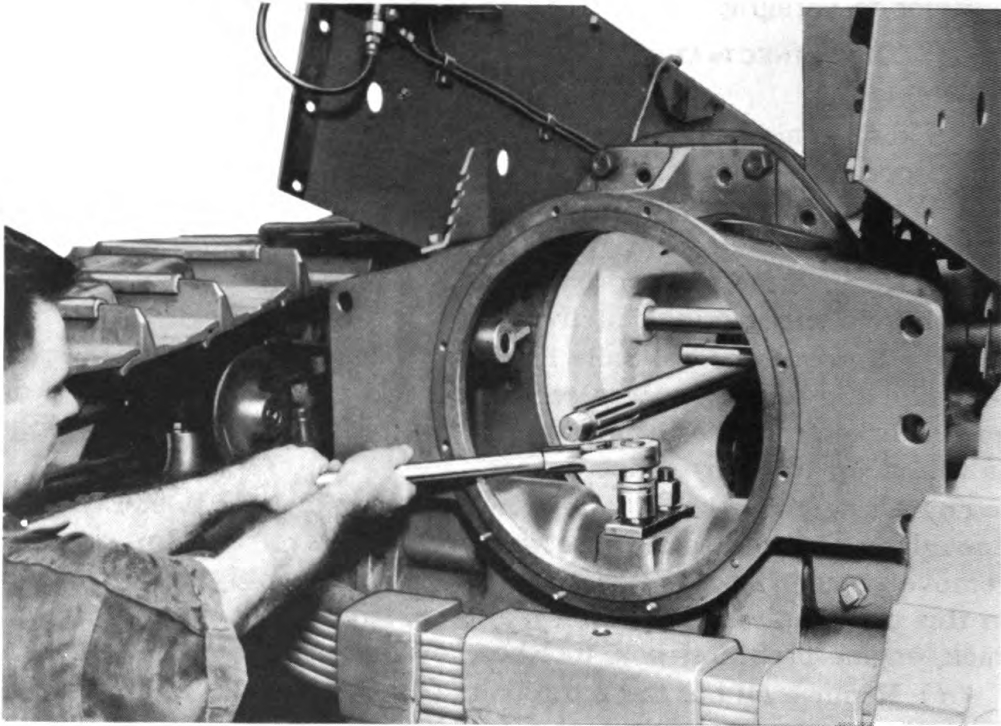

RA PD 41263

Figure 326 — Loosening U Bolt in Engine Spacer

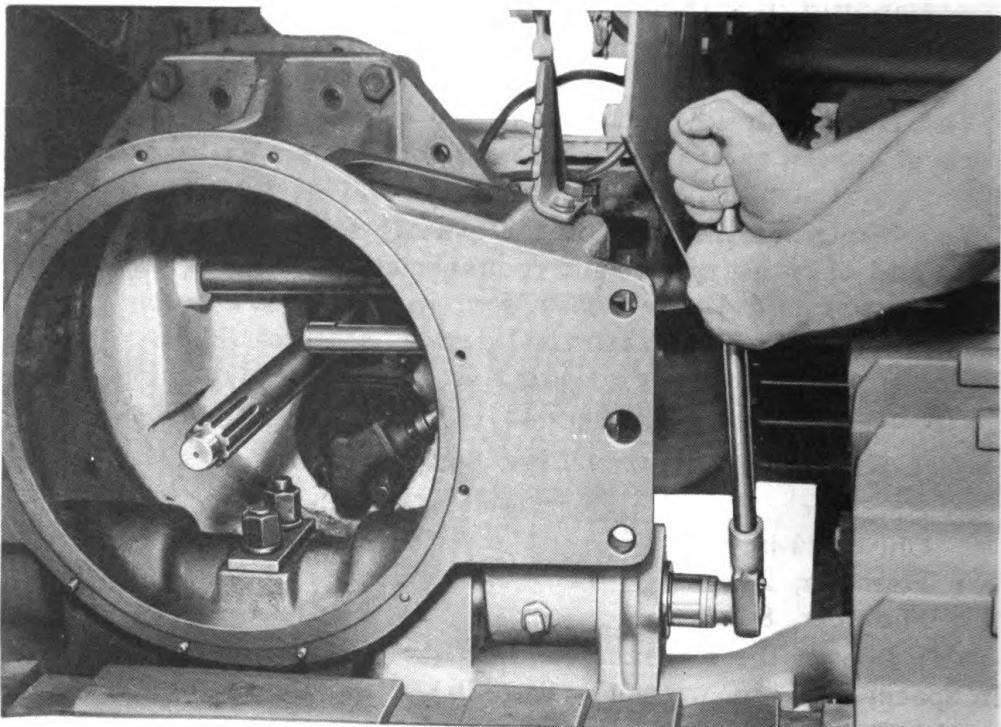

RA PD 41267

Figure 327 — Removing Cap Screw from End of Link Shaft

ENGINE SPACER

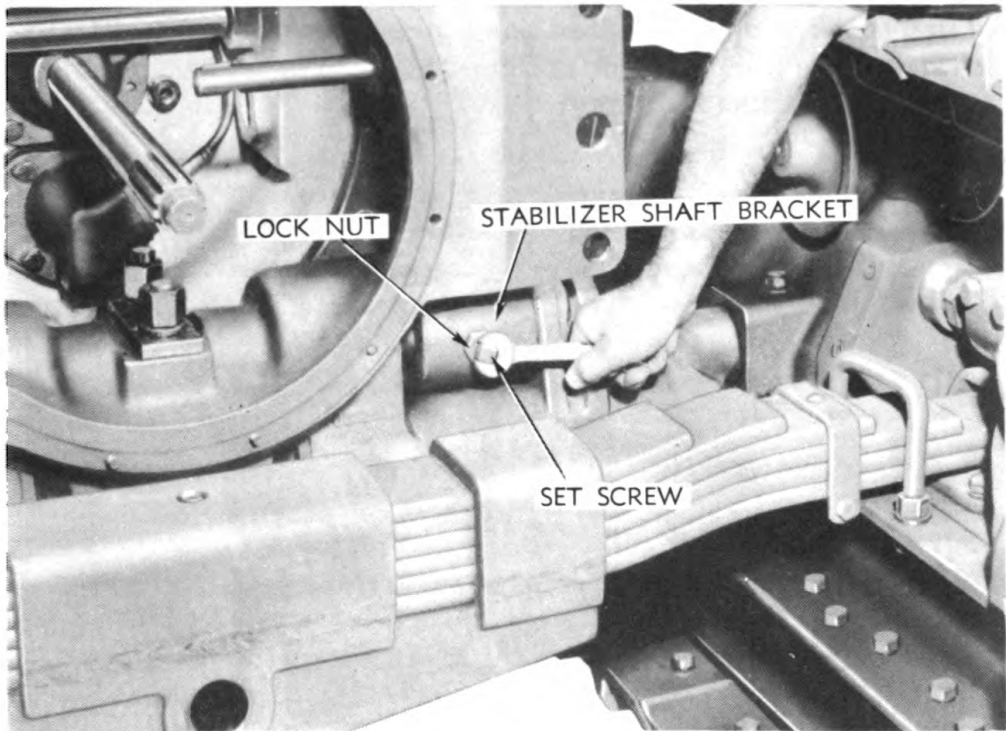

RA PD 41236

Figure 328 — Loosening Setscrew in Link Shaft Bracket

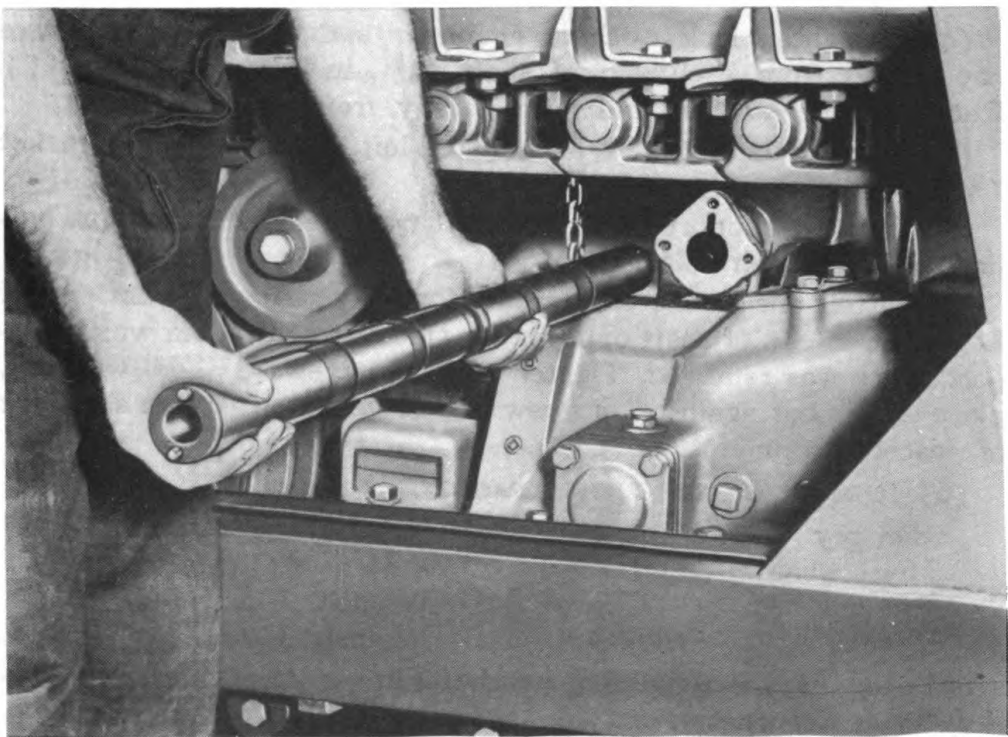

RA PD 41262

Figure 329 — Stabilizer Link Shaft Removed

ORDNANCE MAINTENANCE — MEDIUM TRACTOR M1 (ALLIS-CHALMERS HD-7W)
ELECTRICAL SYSTEM, POWER TRAIN, FRAME, AND TRACKS

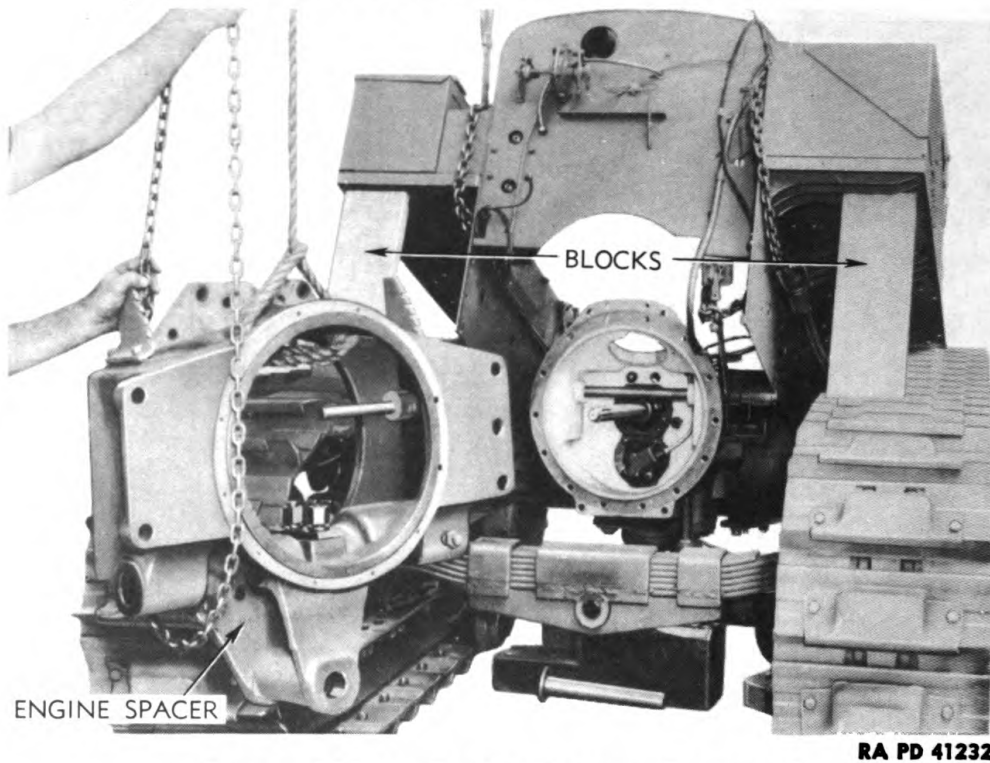

Figure 330 — Engine Spacer Removed

(c) Straighten lock washers (hammer and chisel) and remove cap screws from each end of shaft ($1\frac{7}{16}$ -in. wrench) (fig. 327). Remove thrust washers and shims, if any, from ends of shaft.

(d) Loosen the setscrew in front of left stabilizer shaft bracket ($\frac{3}{4}$ -in. wrench) (fig. 328).

(e) Remove support roller from left track release housing as outlined in paragraph 84.

(f) Install one of the cap screws, formerly removed from end of link shaft, in end of shaft opposite to side of tractor from which support roller was removed. Tighten this cap screw ($1\frac{7}{16}$ -in. wrench), place end of bar against cap screw and drive stabilizer link shaft out of spacer (hammer) (fig. 329).

(6) REMOVE SPACER FROM TRACTOR.

Bar, pry
Hoist, chain
Pliers
Rope

Wood block, 2- x 10- x
36-in. (2)
Wrench, 1-in.
Wrench, $1\frac{1}{8}$ -in.

(a) Remove the remaining two bolts in top of engine spacer (1- and $1\frac{1}{8}$ -in. wrenches).

(b) Remove cotter pin and yoke pin from clutch control rod and lever at left side of spacer (pliers).

ENGINE SPACER

(c) Block between top fenders and track as shown in figure 330 to hold top deck up. Remove rope from top deck, fasten it around spacer and, with aid of chain hoist, pry spacer from front end of transmission case and lift it from tractor (fig. 330).

131. DISASSEMBLY.

a. Removal of the clutch control shafts and linkage from the spacer assembly is described in paragraph 68. Although these steps describe removal with spacer in tractor, the removal procedure for these parts will be the same with spacer removed.

132. INSPECTION OF PARTS.

a. Clean and examine spacer and parts of clutch controls. Replace spacer if broken or cracked. Welding of a broken spacer will not be successful because it is apt to throw transmission shafts and engine out of alinement. Inspect linkage, shafts, bushings, and throw-out yoke for wear. Replace worn or damaged parts. Ream new yoke shaft bushings, if installed, so yoke shafts slip freely in bushings.

133. ASSEMBLY.

a. For installation of clutch control parts in spacer, refer to paragraph 70. Parts may be installed either before or after installation of spacer assembly.

134. INSTALLATION.

a. Tools and Equipment Required.

Bar, drift, 1- x 18-in.	Wrench, engine cranking
Bar, pry	Wrench, open-end, 1/2-in.
Chain	Wrench, open-end, 9/16-in. (2)
Hammer, 2-lb	Wrench, open-end, 5/8-in.
Hammer, 8-lb	Wrench, open-end, 1 1/16-in.
Hoist, chain	Wrench, open-end, 3/4-in.
Rope	Wrench, open-end, 7/8-in.
Scale, 6-in.	Wrench, open-end, 1 5/16-in.
Screwdriver, 6-in.	Wrench, socket, 1/2-in.
Screwdriver, 8-in.	Wrench, socket, 9/16-in.
Shellac	Wrench, socket, 3/4-in.
Wrench, 3/8-in.	Wrench, socket, 7/8-in.
Wrench, 7/16-in.	Wrench, socket, 1 1/8-in.
Wrench, 1 5/16-in.	Wrench, socket, 1 5/16-in.
Wrench, 1-in.	Wrench, socket, 1 7/16-in.
Wrench, 1 1/16-in.	Wrench, socket, 1 1/2-in.

b. Procedure.

(1) CONNECT SPACER TO TRANSMISSION CASE.

Hoist, chain	Wrench, socket, 1 5/16-in.
Rope	Wrench, socket, 1-in.
Wrench, socket, 7/8-in.	Wrench, socket, 1 1/8-in.

**ORDNANCE MAINTENANCE — MEDIUM TRACTOR M1 (ALLIS-CHALMERS HD-7W)
ELECTRICAL SYSTEM, POWER TRAIN, FRAME, AND TRACKS**

(a) Using chain hoist and rope, lower engine spacer into position for installation.

(b) Line up holes in spacer with holes in transmission case and install the two $\frac{3}{4}$ - by 4-inch bolts in two upper holes at top of spacer (fig. 326). Start nuts on these bolts. Next install two $\frac{5}{8}$ - by 3-inch bolts below and between the first two installed. Then install two $\frac{3}{4}$ - by $3\frac{3}{4}$ -inch bolts in two lowest holes, and two $\frac{5}{8}$ - by $3\frac{1}{2}$ -inch bolts between these. Install ten $\frac{5}{8}$ - by $2\frac{1}{2}$ -inch bolts in remaining holes. Start high nuts on all bolts and tighten securely, using $\frac{7}{8}$ - and $1\frac{5}{16}$ -inch wrenches on $\frac{5}{8}$ -inch bolts and 1- and $1\frac{1}{8}$ -inch wrenches on the $\frac{3}{4}$ -inch bolts. Remove rope and chain hoist. **NOTE:** Do not tighten nuts on any of the bolts until all bolts are installed.

(2) INSTALL STABILIZER LINK SHAFT.

Bar, drift, 1- x 18-in.

Wrench, $\frac{3}{4}$ -in.

Hammer, 2-lb

Wrench, open-end, $\frac{5}{8}$ -in.

Hammer, 8-lb

Wrench, open-end, $1\frac{1}{16}$ -in.

Scale, 6-in.

Wrench, socket, $1\frac{7}{16}$ -in.

(a) Remove cap screw previously installed in one end of shaft. Screw it tightly into opposite end of shaft ($1\frac{7}{16}$ -in wrench).

(b) Start end of shaft without cap screw into stabilizer link on side of tractor from which track support roller was removed. Turn shaft so slot near end (fig. 93) will line up with setscrew (fig. 328) when installed. Raise stabilizer link until holes in link line up with holes in link shaft brackets on bottom of spacer; then drive shaft with hammer through link, bracket, and spacer far enough so that stabilizer link on other side of tractor may be raised in line with shaft, and shaft started into it. **CAUTION:** Use extreme care not to damage oil seals in stabilizer links while driving shaft through them; then drive shaft through link and bracket until groove at center of shaft is in line with U-bolt in spacer (fig. 326).

(c) Refer to paragraph 43 and adjust stabilizer links and shaft; tighten U-bolt (fig. 326) as outlined in subparagraph b (3) below; then install the link shaft cap gaskets and caps (fig. 91), using three $\frac{1}{2}$ - by $1\frac{3}{8}$ -inch cap screws with lock washers at each end ($\frac{3}{4}$ -in. wrench).

(3) INSTALL STABILIZER SPRING PIVOT SHAFT.

Chisel, $\frac{3}{4}$ -in.

Wrench, $\frac{9}{16}$ -in.

Hammer, 2-lb

Wrench, $\frac{3}{4}$ -in.

Lower the hydraulic jack until the hole in the stabilizer spring lines up with hole in engine spacer; then drive spring pivot shaft through spacer and spring. Install the three $\frac{3}{8}$ - by $1\frac{1}{2}$ -inch cap screws with lock washers holding spring pivot shaft to rear end of engine spacer ($\frac{9}{16}$ -in. wrench); then install washer at front end of shaft with

ENGINE SPACER

two $\frac{1}{2}$ - by $1\frac{1}{4}$ -inch cap screws and nut lock ($\frac{3}{4}$ -in. wrench) (fig. 324). Bend ends of nut lock over heads of cap screws with hammer and chisel, and remove jack from underneath the tractor.

(4) LOWER FRONT END OF TOP DECK ASSEMBLY.

Hoist, chain

Rope

Using chain hoist and rope, raise front end of top deck, remove blocking, and lower assembly into place. **NOTE:** Top deck assembly as referred to here includes seat, fuel tank, street plate box, cowl, pack rack, engine preheater box, tool box, and battery box.

(5) SECURE TOP DECK TO TRANSMISSION CASE.

Wrench, $\frac{3}{4}$ -in. (2)

Install six $\frac{1}{2}$ -inch cap screws with lock washers in rear fender angle brackets on steering clutch covers. Install six $\frac{1}{2}$ -inch bolts with lock washers through welded bracket assemblies at rear of tractor.

(6) INSTALL WINCH AND ENGINE SUPPORT.

Refer to paragraph 138 for installation procedure.

(7) INSTALL ENGINE AND RADIATOR ASSEMBLY.

Refer to TM 9-783B or TM 9-1780A for installation of these two units.

(8) INSTALL TRACK SUPPORT ROLLER.

Refer to paragraph 91 for installation of roller.

ORDNANCE MAINTENANCE — MEDIUM TRACTOR M1 (ALLIS-CHALMERS HD-7W)
ELECTRICAL SYSTEM, POWER TRAIN, FRAME, AND TRACKS

CHAPTER 14

MISCELLANEOUS ASSEMBLIES (COWL, ENGINE SPACER,
ENGINE SUPPORT, FUEL TANK AND LINES, AND
PINTLE ASSEMBLIES)(Cont'd)

Section III

ENGINE SUPPORT

	Paragraph
Description	135
Removal	136
Inspection and repair	137
Installation	138

135. DESCRIPTION.

a. The engine support is a heavy one-piece welded assembly bolted to the engine spacer for support of the engine, radiator assembly, and winch. The lower part of the engine support is designed to protect the engine from damage from stumps or rocks when tractor is operated in wooded or rocky terrain. A section of this lower part, called the engine support bottom cover, is removable to give access to the engine from beneath. A large pull hook is provided on the bottom side of the engine support for towing purposes.

136. REMOVAL.

a. Tools and Equipment Required.

Bar, pry	Wrench, open-end, 1/2-in.
Chain	Wrench, open-end, 9/16-in.
Hoist, chain	Wrench, open-end, 1 1/16-in.
Rope	Wrench, open-end, 3/4-in.
Screwdriver, 6-in.	Wrench, open-end, 7/8-in.
Screwdriver, 8-in.	Wrench, open-end, 1 5/16-in.
Wrench, 3/8-in.	Wrench, socket, 1/2-in.
Wrench, 7/16-in.	Wrench, socket, 9/16-in.
Wrench, 5/8-in.	Wrench, socket, 3/4-in.
Wrench, 1 5/16-in.	Wrench, socket, 1 5/16-in.
Wrench, 1-in.	Wrench, socket, 1 1/2-in.

b. Procedure.

(1) REMOVE RADIATOR AND ENGINE FROM TRACTOR.

Refer to TM 9-783B or TM 9-1780A for removal procedure.

(2) REMOVE WINCH ASSEMBLY (ONLY IF ENGINE SUPPORT IS TO BE REPLACED).

ENGINE SUPPORT

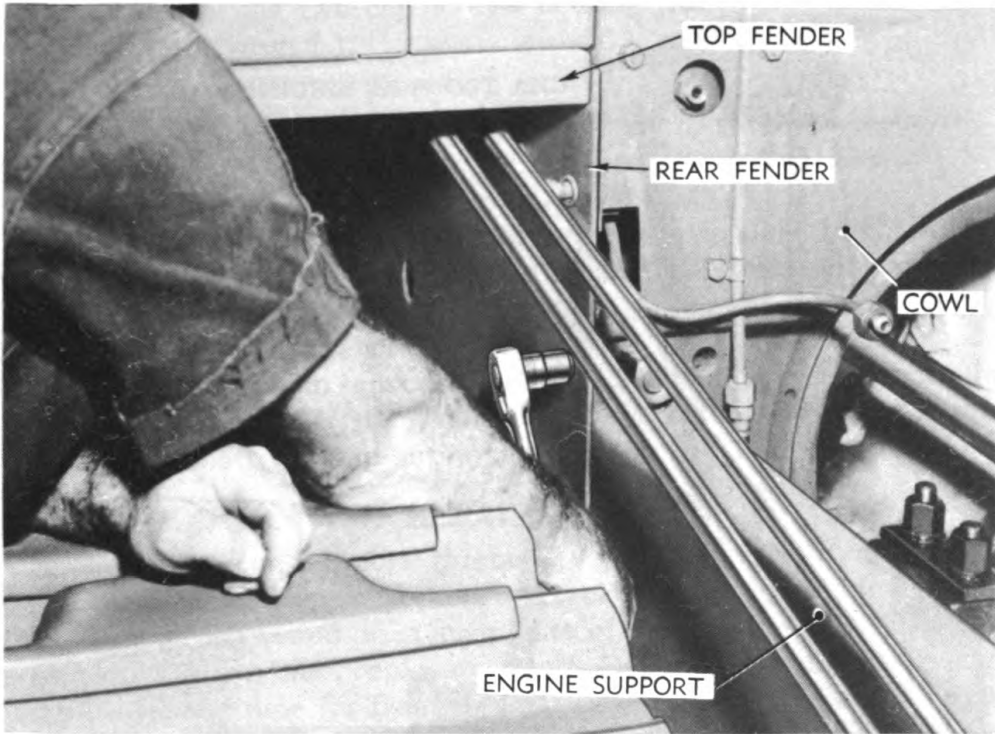

RA PD 41206

Figure 331 — Disconnecting Rear Fenders from Engine Support

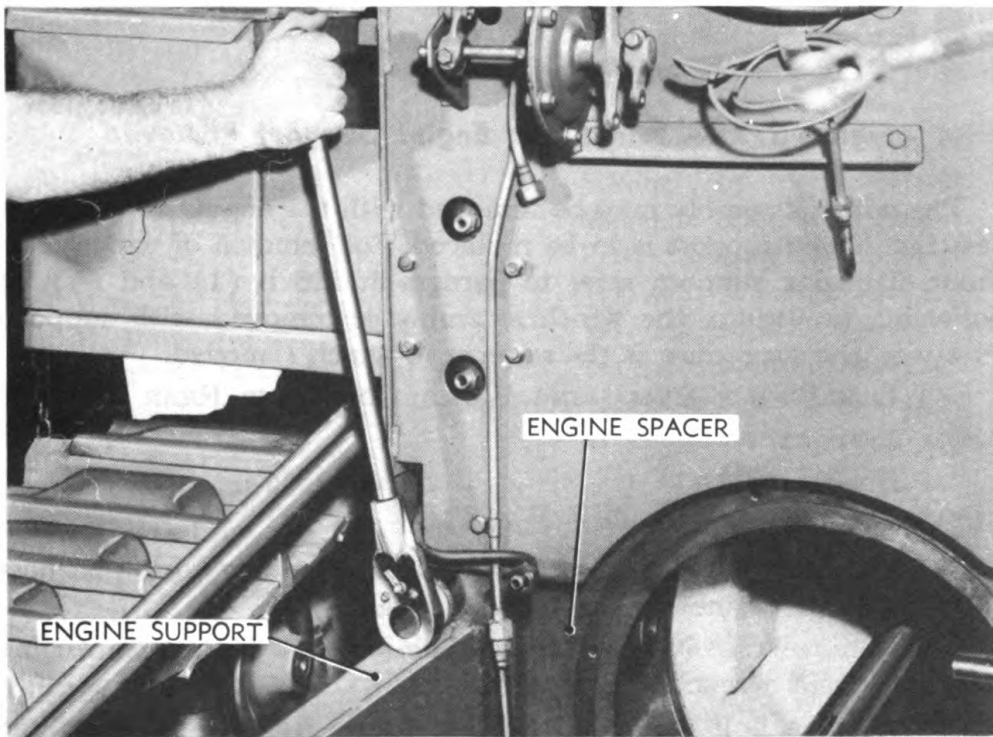

RA PD 41184

Figure 332 — Disconnecting Support from Engine Spacer

**ORDNANCE MAINTENANCE — MEDIUM TRACTOR M1 (ALLIS-CHALMERS HD-7W)
ELECTRICAL SYSTEM, POWER TRAIN, FRAME, AND TRACKS**

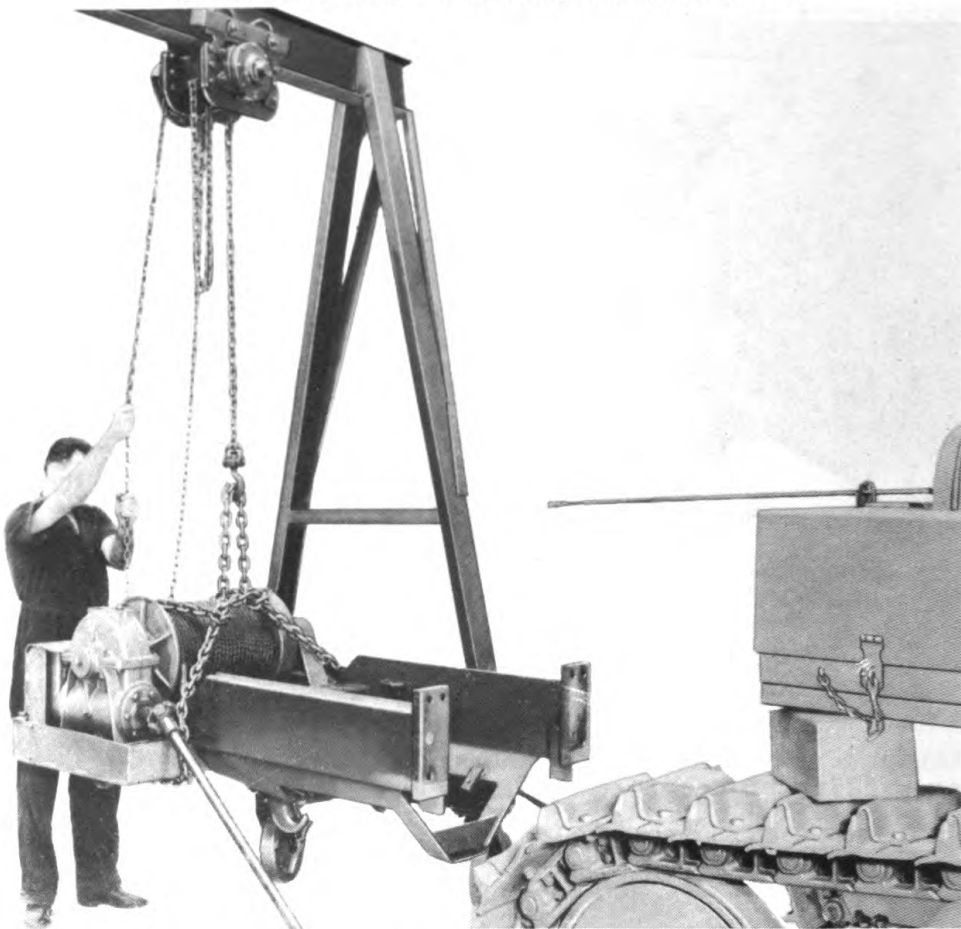

RA PD 41204

Figure 333 — Winch and Engine Support Removed

The winch assembly may be removed with the engine support, unless the engine support is to be replaced. For removal of winch from front of engine support, refer to paragraph 118 b (1) and (4). In following procedure, the winch assembly is removed with support; however, the procedure is the same with winch removed.

(3) DISCONNECT REMAINING WIRES, COWL AND REAR FENDERS FROM SUPPORT.

Pliers

Wrench, $\frac{3}{4}$ -in.

Wrench, $\frac{9}{16}$ -in. (2)

(a) Remove the two cap screws from clips holding wiring harness to left side of engine support ($\frac{9}{16}$ -in. wrench).

(b) Remove the five cap screws holding rear fenders to engine support ($\frac{3}{4}$ -in. wrench) (fig. 331).

(c) Remove bolt from clip holding lubricating oil pressure line to cowl (two $\frac{9}{16}$ -in. wrenches). Push line over so it will not interfere with removal of the engine support.

ENGINE SUPPORT

(d) Remove the two cap screws holding front corners of cowl to support ($\frac{3}{4}$ -in. wrench).

(4) REMOVE ENGINE SUPPORT AND WINCH ASSEMBLIES.

Chain	Wrench, socket, $1\frac{5}{16}$ -in.
Hoist, chain	Wrench, socket, $1\frac{1}{2}$ -in.
Wrench, open-end, $1\frac{5}{16}$ -in.	

(a) Fasten chain around assembly and take up slack in chain with chain hoist to support weight while attaching bolts are removed.

(b) Remove the two bolts ($1\frac{5}{16}$ - and $1\frac{1}{2}$ -in. wrenches) and two cap screws ($1\frac{5}{16}$ -in. wrench) holding engine support to engine spacer (fig. 332). Using chain hoist, lift winch and engine support assemblies away from tractor (fig. 333). As assembly is pulled away from spacer, winch drive shaft will slip out of slip joint on lay shaft universal joint.

137. INSPECTION AND REPAIR.

a. Clean engine support thoroughly and examine it closely for cracks or breaks. Repair broken or cracked parts by welding unless the assembly is twisted or in such state of destruction that this is not possible; in which case, replace support. Be sure the brackets welded to the sides of frame for front support of engine are welded securely. Straighten pull hook, if twisted; weld, if broken.

138. INSTALLATION.

a. Tools and Equipment Required.

Bar, pry	Wrench, open-end, $\frac{1}{2}$ -in.
Chain	Wrench, open-end, $\frac{9}{16}$ -in.
Hoist, chain	(2)
Rope	Wrench, open-end, $1\frac{1}{16}$ -in.
Screwdriver, 6-in.	Wrench, open-end, $\frac{3}{4}$ -in.
Screwdriver, 8-in.	Wrench, open-end, $\frac{7}{8}$ -in.
Shellac	Wrench, open-end, $1\frac{5}{16}$ -in.
Wrench, $\frac{3}{8}$ -in.	Wrench, socket, $\frac{1}{2}$ -in.
Wrench, $\frac{7}{16}$ -in.	Wrench, socket, $\frac{9}{16}$ -in.
Wrench, $\frac{5}{8}$ -in.	Wrench, socket, $\frac{3}{4}$ -in.
Wrench, $1\frac{5}{16}$ -in.	Wrench, socket, $\frac{7}{8}$ -in.
Wrench, 1-in.	Wrench, socket, $1\frac{5}{16}$ -in.
Wrench, engine cranking	Wrench, socket, $1\frac{1}{2}$ -in.

b. Procedure.

(1) LIFT SUPPORT AND WINCH INTO PLACE.

Chain	Hoist, chain
-------	--------------

Using chain hoist, place engine support in position for installation. Engage rear end of winch drive shaft in slip joint of winch lay shaft underneath left top fender as support is moved into place if winch is being installed with support. If not, install winch after support is installed (par. 124).

**ORDNANCE MAINTENANCE — MEDIUM TRACTOR M1 (ALLIS-CHALMERS HD-7W)
ELECTRICAL SYSTEM, POWER TRAIN, FRAME, AND TRACKS**

(2) CONNECT ENGINE SUPPORT TO SPACER.Wrench, $\frac{3}{4}$ -in.Wrench, socket, $1\frac{5}{16}$ -in.Wrench, open-end, $1\frac{5}{16}$ -in.Wrench, socket, $1\frac{1}{2}$ -in.

Line up holes in rear of engine support with holes in engine spacer. Install two 1- by 4-inch bolts with high nuts in top holes of support and spacer (fig. 332), and two 1- by $3\frac{1}{4}$ -inch cap screws with lock washers in the bottom holes of support and spacer. Tighten bolts ($1\frac{5}{16}$ - and $1\frac{1}{2}$ -in. wrenches) and cap screws ($1\frac{1}{2}$ -in. wrench) securely.

(3) CONNECT COWL AND REAR FENDERS TO SUPPORT.Wrench, $\frac{9}{16}$ -in. (2)Wrench, socket, $\frac{3}{4}$ -in.

(a) Bolt cowl to engine support with $\frac{1}{2}$ - by 1-inch cap screw with lock washer in right front corner of cowl (fig. 321), and $\frac{1}{2}$ - by $1\frac{1}{4}$ -inch cap screw with lock washer through battery ground cable and in left front corner of cowl ($\frac{3}{4}$ -in. wrench).

(b) Bolt front end of rear fenders to engine support with two $\frac{1}{2}$ - by 1-inch cap screws with lock washers on right side, and three on left side ($\frac{3}{4}$ -in. wrench).

(c) Secure lubricating oil pressure gage line to front of cowl with a $\frac{3}{8}$ - by $\frac{3}{4}$ -inch bolt with lock washer through clip on line and cowl (two $\frac{9}{16}$ -in. wrenches).

(d) Attach wiring harness to left side of support with two $\frac{3}{8}$ - by $\frac{3}{4}$ -inch cap screws through clips on harness and into support ($\frac{9}{16}$ -in. wrench).

(4) INSTALL ENGINE AND RADIATOR ASSEMBLY.

Refer to TM 9-783B or TM 9-1780A for installation procedure.

CHAPTER 14

**MISCELLANEOUS ASSEMBLIES (COWL, ENGINE SPACER,
ENGINE SUPPORT, FUEL TANK AND LINES, AND
PINTLE ASSEMBLIES) (Cont'd)**

Section IV

FUEL TANK AND LINES

	Paragraph
Description of fuel tank.....	139
Maintenance for fuel tank.....	140
Removal of fuel tank.....	141
Installation of fuel tank.....	142
Fuel lines	143

139. DESCRIPTION OF FUEL TANK.

a. The fuel tank is made up of sections of sheet steel with welded joints, and has a capacity of 120 gallons of fuel. There are baffle plates inside the tank welded to front and back sides. These baffles extend from the top of the tank to within nine-sixteenths inch of the bottom. The baffles prevent fuel from quickly running from one end of the tank to the other as the tractor is in operation, and also act as braces to reinforce the sides of tank. Other brace irons reinforce the tank in other places. Two sediment sumps with drain cocks are provided on the bottom of the tank to catch and drain dirt, sediment, or water from the fuel tank. A shut-off valve, also on bottom of tank, provides a means for shutting off fuel.

140. MAINTENANCE FOR FUEL TANK.

a. Every precaution should be taken to prevent entrance of dirt or foreign material into the tank while filling with fuel, and sediment sump should be drained regularly to drain water and sediment out of tank. Inspect tank at regular intervals for rusted or corroded spots, sand these spots smooth, and paint them. Repair leaks in tanks by welding or brazing, using prescribed precautions against fire or explosion while repairing. Flush tank periodically with clean fuel to keep tank clean. See that filler cap locks securely in place.

141. REMOVAL OF FUEL TANK.

a. Tools Required.

Hoist, chain

Rope

Wrench, $\frac{9}{16}$ -in.

Wrench, open-end, $\frac{5}{8}$ -in.

Wrench, open-end, $\frac{3}{4}$ -in.

Wrench, open-end, $\frac{13}{16}$ -in.

Wrench, open-end, $\frac{7}{8}$ -in.

Wrench, socket, $\frac{3}{4}$ -in.

**ORDNANCE MAINTENANCE — MEDIUM TRACTOR M1 (ALLIS-CHALMERS HD-7W)
ELECTRICAL SYSTEM, POWER TRAIN, FRAME, AND TRACKS**

b. Procedure.

(1) REMOVE CUSHIONS.

Wrench, open-end, $1\frac{3}{16}$ -in.

Remove seat cushions. Remove nuts from bolts through clips at bottom of back cushions, and lift back cushions out of frame.

(2) REMOVE PACK CARRIER.

Wrench, $\frac{3}{4}$ -in. (2)

(a) Pull wires out of sockets at rear of rear lights.

(b) Remove two bolts at top of pack carrier, and six bolts at bottom of pack carrier holding it to fuel tank, and lift off pack carrier.

(3) DISCONNECT FUEL LINES FROM TANK.

Wrench, open-end, $\frac{3}{4}$ -in. Wrench, open-end, $\frac{7}{8}$ -in.

Hold fittings with $\frac{3}{4}$ -inch wrench and disconnect outlet and return fuel lines from shut-off valve, and return line at bottom of tank (fig. 103).

(4) REMOVE TANK FROM TRACTOR.

Hoist, chain

Wrench, $\frac{3}{4}$ -in. (2)

Rope

(a) Remove four remaining bolts holding tank to rear of top fenders and four bolts holding right-hand end of tank to end of seat frame. Open lid of box on left top fender and remove the four bolts holding tank to box.

(b) Fasten rope sling around tank, and use chain hoist to lift tank from tractor.

(5) REMOVE SEDIMENT SUMPS AND SHUT-OFF VALVE.

Wrench, $\frac{9}{16}$ -in. Wrench, open-end, $\frac{5}{8}$ -in.

If fuel tank is to be repaired or replaced, remove sediment sumps from bottom of tank by removing four cap screws from each ($\frac{9}{16}$ -in. wrench). Remove valve from tank with $\frac{5}{8}$ -inch wrench.

142. INSTALLATION OF FUEL TANK.

a. Tools and Equipment Required.

Hoist, chain

Wrench, open-end, $\frac{3}{4}$ -in.

Rope

Wrench, open-end, $1\frac{3}{16}$ -in.

Shellac

Wrench, open-end, $\frac{7}{8}$ -in.

Wrench, $\frac{9}{16}$ -in.

Wrench, socket, $\frac{3}{4}$ -in.

Wrench, open-end, $\frac{5}{8}$ -in.

b. Procedure.

(1) INSTALL SEDIMENT SUMPS AND SHUT-OFF VALVE (IF THEY WERE REMOVED).

Wrench, $\frac{9}{16}$ -in.

Wrench, open-end, $\frac{5}{8}$ -in.

ORDNANCE MAINTENANCE — MEDIUM TRACTOR M1 (ALLIS-CHALMERS HD-7W)
ELECTRICAL SYSTEM, POWER TRAIN, FRAME, AND TRACKS

CHAPTER 14

MISCELLANEOUS ASSEMBLIES (COWL, ENGINE SPACER,
ENGINE SUPPORT, FUEL TANK AND LINES, AND
PINTLE ASSEMBLIES) (Cont'd)

Section V

PINTLE ASSEMBLIES

	Paragraph
Description	144
Removal of pintle drawbar assembly	145
Installation of pintle drawbar assembly	146
Removal of pintle bracket assembly	147
Installation of pintle bracket assembly	148

144. DESCRIPTION.

a. Two pintle assemblies provide hitches for towing vehicles requiring either a low or high hitch. The lower pintle is on the drawbar of the tractor, and the upper pintle is on a bracket which is bolted to the drawbar plate and rear of transmission case. The upper pintle is held stationary in line with center of tractor; the lower pintle may be held in center of tractor or, by removing two bolts from pintle drawbar and drawbar plate, it may be moved sidewise in either direction to several different pulling angles, if desired. The pintles are free to rotate in the drawbar and bracket, so that hitch on trailed vehicle will not be twisted when traveling over rough terrain. Safety pins in the pintles prevent latch of hook from opening while tractor is in operation.

145. REMOVAL OF PINTLE DRAWBAR ASSEMBLY.

a. Tools Required.

- | | |
|-----------------|-----------------------------|
| Bar, 3-ft | Punch, small |
| Chisel, 3/4-in. | Wrench, open-end, 2 1/2-in. |
| Hammer, 2-lb | Wrench, socket, 1 5/16-in. |

b. Procedure.

(1) REMOVE PINTLE FROM DRAWBAR.

- | | |
|--------------|-----------------------------|
| Bar, 3-ft | Punch, small |
| Hammer, 2-lb | Wrench, open-end, 2 1/2-in. |

Remove cotter pin from nut (hammer and punch). Hold nut with 2 1/2-inch wrench and, with bar through pintle hook, turn shaft out of nut. Remove washer, and pull pintle from drawbar.

PINTLE ASSEMBLIES

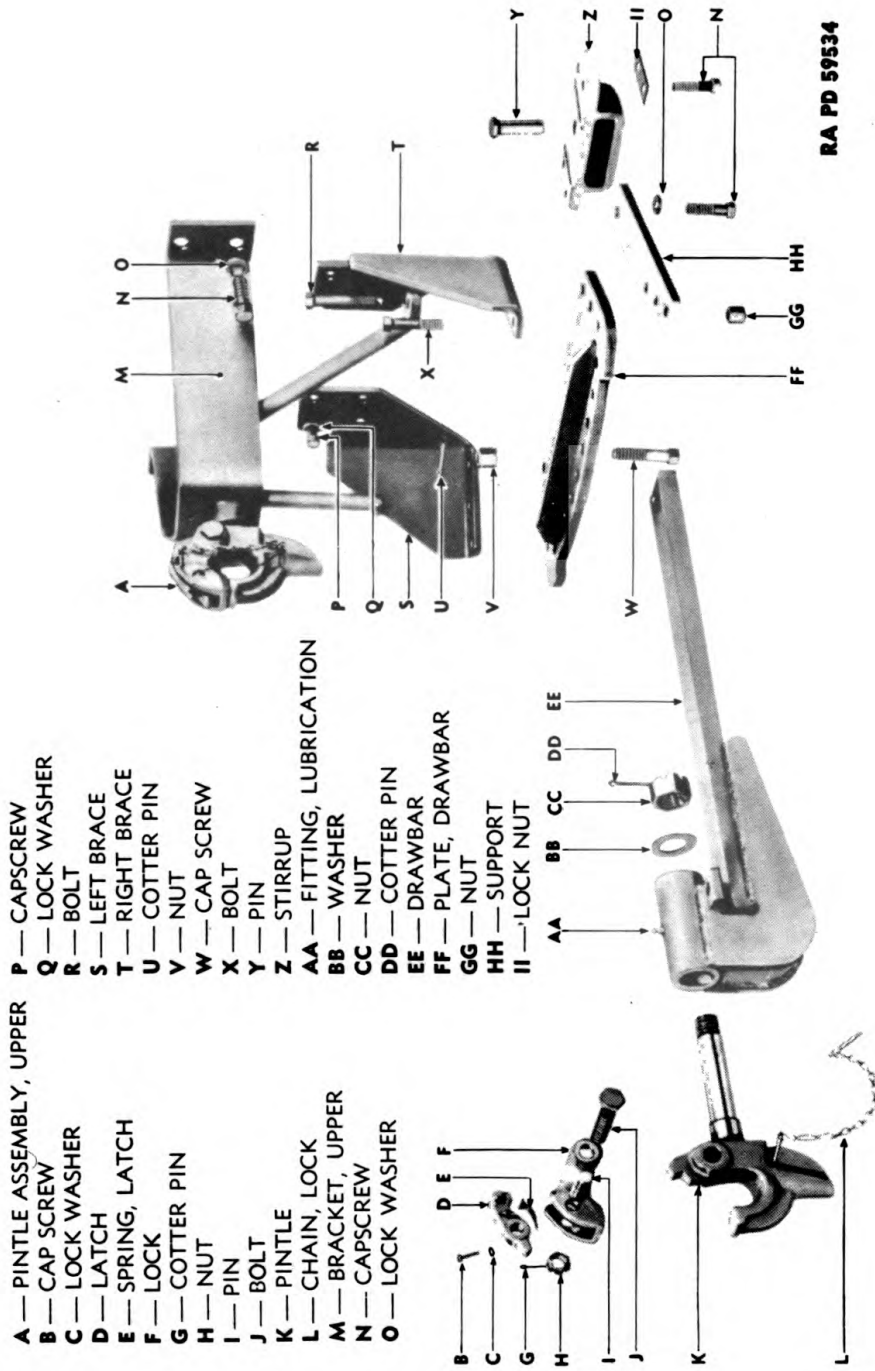

RA PD 59534

Figure 334 — Pintle Assemblies — Exploded View

**ORDNANCE MAINTENANCE — MEDIUM TRACTOR M1 (ALLIS-CHALMERS HD-7W)
ELECTRICAL SYSTEM, POWER TRAIN, FRAME, AND TRACKS**

(2) REMOVE DRAWBAR (fig. 334).

Chisel, $\frac{3}{4}$ -in.

Wrench, socket, $1\frac{5}{16}$ -in.

Hammer, 2-lb

Wrench, $1\frac{7}{16}$ -in.

Remove cotter pins and two bolts holding drawbar to drawbar plate (pliers); remove the bolts ($1\frac{5}{16}$ - and $1\frac{7}{16}$ -in. wrenches). Straighten screw locks on cap screws holding drawbar stirrup at front end of drawbar to bottom of transmission case (hammer and chisel). Remove the four cap screws from stirrup ($1\frac{5}{16}$ -in. wrench). Remove drawbar and stirrup from tractor. Remove front drawbar pin to separate drawbar and stirrup.

146. INSTALLATION OF PINTLE DRAWBAR ASSEMBLY.

a. Tools Required.

Bar, 3-ft

Wrench, $1\frac{7}{16}$ -in.

Chisel, $\frac{3}{4}$ -in.

Wrench, open-end, $2\frac{1}{2}$ -in.

Hammer, 2-lb

Wrench, socket, $1\frac{5}{16}$ -in.

Pliers

b. Procedure.

(1) INSTALL DRAWBAR.

Chisel, $\frac{3}{4}$ -in.

Wrench, $1\frac{7}{16}$ -in.

Hammer, 2-lb

Wrench, open-end, $2\frac{1}{2}$ -in.

Pliers

Wrench, socket, $1\frac{5}{16}$ -in.

Insert front end of drawbar into stirrup and insert front drawbar pin. Place drawbar in position on drawbar plate. Using new screw locks, secure stirrup on front end of drawbar to bottom of transmission case with four 1- by 3-inch cap screws ($1\frac{5}{16}$ -in. wrench). Bend screw locks around cap screw heads (hammer and chisel). Install two 1- by 4-inch cap screws with lock washers in rear end of drawbar and drawbar plate ($1\frac{5}{16}$ - and $1\frac{7}{16}$ -in. wrenches). Install cotter pins through bolts (pliers).

(2) INSTALL PINTLE.

Bar, 3-ft

Wrench, open-end, $2\frac{1}{2}$ -in.

Pliers

Insert shaft into drawbar. Place washer on shaft and start nut. Hold nut with $2\frac{1}{2}$ -inch wrench and turn shaft into nut with bar through pintle hook. Install cotter pin through nut and shaft (pliers).

147. REMOVAL OF PINTLE BRACKET ASSEMBLY.

a. Tools Required.

Bar, 3-ft

Wrench, $\frac{9}{16}$ -in. (2)

Hammer, 2-lb

Wrench, $1\frac{1}{8}$ -in.

Pliers

Wrench, open-end, $2\frac{1}{2}$ -in.

Punch, small

Wrench, socket, $1\frac{5}{16}$ -in.,
with long extension

PINTLE ASSEMBLIES

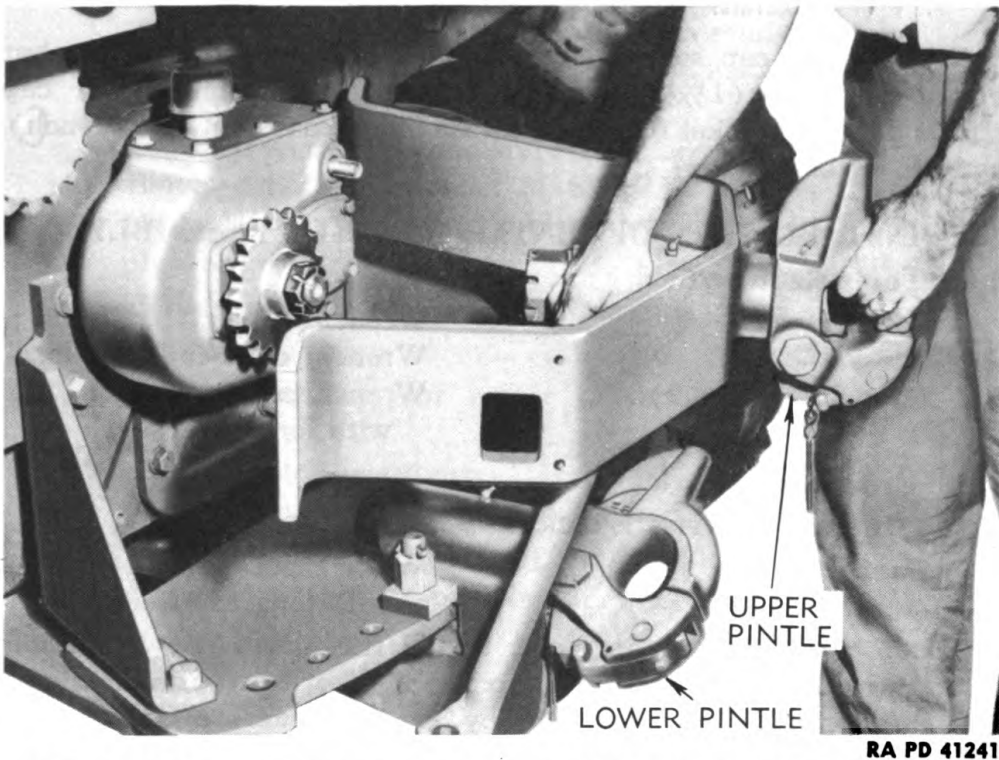

RA PD 41241

Figure 335 — Removing Pintle and Pintle Bracket Assembly

b. Procedure.

(1) **REMOVE WINCH DRIVE SHAFT SPROCKET GUARD.**

Wrench, $\frac{9}{16}$ -in. (2)

Remove four bolts holding guard to pintle bracket and top fender.

(2) **REMOVE PINTLE.**

Bar, 3-ft

Hammer, 2-lb

Punch, small

Wrench, open-end, 2½-in.

Remove cotter pin from pintle nut (hammer and punch). Hold nut with 2½-inch wrench, insert bar through pintle hook, and turn shaft out of nut. Remove washer and pull pintle from bracket. It is not necessary to remove pintle from bracket before removing bracket, unless desired.

(3) **DISCONNECT WINCH DRIVE CHAIN.**

Hammer, 2-lb

Pliers

Punch, small

Wrench, open-end, 2½-in.

Remove cotter pins from both pins of one chain link (pliers). Hold 2½-inch wrench back of chain and drive this link out of chain (hammer and punch). Remove chain from sprockets.

(4) **REMOVE BRACKET.**

Wrench, 1⅛-in.

Wrench, socket, 1⅝-in.,
with long extension

**ORDNANCE MAINTENANCE — MEDIUM TRACTOR M1 (ALLIS-CHALMERS HD-7W)
ELECTRICAL SYSTEM, POWER TRAIN, FRAME, AND TRACKS**

Remove two cap screws holding lower bracket arms to drawbar plate and brace ($1\frac{1}{8}$ - and $1\frac{5}{16}$ -in. wrenches). Remove four cap screws holding bracket to rear of transmission case ($1\frac{5}{16}$ -in. wrench), and lift off bracket.

148. INSTALLATION OF PINTLE BRACKET ASSEMBLY.

a. Tools Required.

Bar, 3-ft

Pliers

Wrench, $\frac{9}{16}$ -in. (2)

Wrench, $1\frac{1}{8}$ -in.

Wrench, open-end, $2\frac{1}{2}$ -in.

Wrench, socket, $1\frac{5}{16}$ -in.,
with long extension

b. Procedure.

(1) INSTALL PINTLE BRACKET.

Wrench, $1\frac{1}{8}$ -in.

Wrench, socket, $1\frac{5}{16}$ -in.,
with long extension

Install pintle bracket in place. Install the four 1- by 3-inch cap screws with lock washers holding pintle bracket to transmission case ($1\frac{5}{16}$ -in. wrench), and two $\frac{7}{8}$ - by $4\frac{1}{2}$ -inch bolts and high nuts holding pintle bracket to drawbar plate ($1\frac{1}{8}$ - and $1\frac{5}{16}$ -in. wrenches).

(2) INSTALL WINCH DRIVE CHAIN.

Pliers

Install drive chain over sprockets. Install connecting link in chain and place keeper on link pins. Secure with two cotter pins in link pins (pliers).

(3) INSTALL DRIVE CHAIN GUARD.

Wrench, $\frac{9}{16}$ -in. (2)

Install sprocket guard with two $\frac{3}{8}$ - by $1\frac{1}{4}$ -inch bolts with flat washers and lock washers in pintle bracket, and two $\frac{3}{8}$ - by 1-inch bolts with flat washers and lock washers in left top fender (two $\frac{9}{16}$ -in. wrenches).

(4) INSTALL PINTLE.

Bar, 3-ft

Pliers

Wrench, open-end, $2\frac{1}{2}$ -in.

Insert shaft of pintle in bracket. Place washer on shaft and start nut. Hold nut with $2\frac{1}{2}$ -inch wrench and turn shaft into nut; tighten with bar inserted through pintle. Install cotter pin through nut and shaft (pliers).

REFERENCES

STANDARD NOMENCLATURE LISTS.

Cleaning, preserving, and lubricating materials; recoil fluids, special oils, and miscellaneous related items	SNL K-1
Current Standard Nomenclature Lists are listed above. An up-to-date list of SNL's is maintained as the "Ordnance Publications for Supply Index"	OPSI
Soldering, brazing and welding material, gases and related items	SNL K-2
Tools, maintenance, for repair of automotive vehicles	SNL G-27
Tool-sets, motor transport.	SNL N-19
Tractor, medium, M1 (Allis-Chalmers HD-7W)	SNL G-125

EXPLANATORY PUBLICATIONS.

List of publications for training.	FM 21-6
Automotive Materiel.	
Automotive electricity.	TM 10-580
Electrical fundamentals	TM 1-455
Sheet metal work, body, fender, and radiator repairs	TM 10-450
The motor vehicle.	TM 10-510
Care and Preservation.	
Automotive lubrication.	TM 10-540
Cleaning, preserving, lubricating, and welding materials and similar items issued by the Ordnance Department.	TM 9-850
Detailed lubrication instructions for ordnance materiel	OFSB 6-series
Explosives and demolitions.	FM 5-25
Fire prevention, safety precautions, accidents. . .	TM 10-360
Motor transport inspections.	TM 10-545
Product guide.	OFSB 6-2
Decontamination.	
Chemical decontamination materials and equipment	TM 3-220
Decontamination of armored force vehicles. . .	FM 17-59
Defense against chemical attack.	FM 21-40
Maintenance and Repair.	
Echelon system of maintenance.	TM 10-525
Maintenance and repair.	TM 10-520
Ordnance maintenance procedure: Materiel inspection and repair.	TM 9-1100

**ORDNANCE MAINTENANCE — MEDIUM TRACTOR M1 (ALLIS-CHALMERS HD-7W)
ELECTRICAL SYSTEM, POWER TRAIN, FRAME, AND TRACKS**

Related Technical Manuals.

- Medium tractor M1 (Allis-Chalmers HD-7W) TM 9-783B
- Ordnance maintenance: Medium tractor M1
(Allis-Chalmers HD-7W) Diesel engine (GM
3-71 RC 14)..... TM 9-1783A
- Ordnance maintenance: Medium tractor M1
(Allis-Chalmers HD-7W) engine accessories. TM 9-1783B
- Registration of motor vehicles..... AR 850-10
- Rules governing the loading of mechanized and
motorized army equipment, also, major calibre
guns, for the United States Army and Navy,
on open top equipment. Published by Opera-
tions and Maintenance Department of Associ-
ation of American Railroads.
- Storage of motor vehicle equipment..... AR 850-18

Storage and Shipment.

- Ordnance storage and shipment chart—Group
G—major items OSSCG

INDEX

A	Page No.	B	Page No.
Accessories of electrical system..	14	Bearing retainers and shims, re- moval	229
Adjustments:		Bell crank assembly	
bevel gear hub bearings	196	assembly and installation..	258-261
clutch assemblies	143	inspection and repair	258
final drives	16	removal	253
free travel of thrust pin... 143-144		Bevel gear and hub	
links for alinement of truck		installation	195-196
frame	105-106	removal	171-172
mile meter drive gear and worm	191	Bevel gear hub bearings, adjust- ment	196
spacers	138-140	Bevel gear inspection hole cover	
track assembly	273	installation	214
tractor brakes	153-154	removal	163
winch and controls		Bevel pinion and gear	
automatic winch worm		description	158
brake	320-321	inspection and repair	178-179
control levers	318-320	installation	186
Air intake elbow		Brake band (assemblies)	
installation	332	adjustment	154
removal	323	installation	140
Ammeter, description	62	removal	120
Assembly:		Brake bands and linkage, inspec- tion and repair	153
clutch assemblies	135-137	Brake drum (and hub)	
engine spacer	341	inspection and repair	131
final drives	41-43	removal	122-125
front idler	231-243	Brake levers, installation	140
power take-off	76-85	Brake operating shaft, installation	311
stabilizer crank assembly..	102-103	Brakes (See Tractor brakes)	
stabilizer spring	91	Bushings	
steering clutch controls	149	installation in idler gear.....	76
track assembly	270	removal from idler gear	71
track release mechanism... 258-262			
transmission gears	180-202		
truck frame assembly.....	277-278		
truck wheel assembly	231-243		
Automatic brake assembly			
adjustment	310		
disassembly	297-299		
inspection and repair.....	301		
removal from gear case.....	295		
Automatic brake guard, installa- tion	311		
Automatic brake housing, installa- tion	305		
Automatic winch worm safety			
brake			
adjustment	320-321		
assembly	307		
Auxiliary equipment, maintenance			
duties by echelons.....	10-11		

C

Clutch assemblies	
adjustment	143-145
assembly	135-137
description	107-108
disassembly	122-125
inspection and repair of	
parts	131-135
installation	137-143
removal	108-121
special tools	145
trouble shooting	108
Clutch controls (See Steering clutch controls)	

**ORDNANCE MAINTENANCE — MEDIUM TRACTOR M1 (ALLIS-CHALMERS HD-7W)
ELECTRICAL SYSTEM, POWER TRAIN, FRAME, AND TRACKS**

C—Cont'd	Page No.	Page No.
Clutch disks (and hub)		
assembly	135-136	
inspection and repair	131	
installation	136	
removal	125	
Clutch shaft (assembly)		
assembly	180	
description	158-159	
installation	185	
Control lever (assemblies)		
adjustment	318-320	
assembly	314-315	
disassembly	299	
Controls and linkage, inspection and repair	75	
Cooling system, maintenance du- ties by echelons	5	
Cowl assembly		
installation	330-334	
removal	322-329	
Crosshead and seal		
inspection and repair	258	
installation	258	
removal	253-256	
D		
Description:		
clutch assemblies	107-108	
electrical system	13	
engine spacer	335	
engine support	344	
final drives	15-16	
front idlers	217	
fuel tank	349	
gearshift mechanism	203	
pintle assemblies	352	
power take-off	64	
stabilizer crank assembly	93	
stabilizer spring	87	
steering clutch controls	146	
track assembly	263	
track release mechanism	248	
track support rollers	217	
tractor brakes	150	
transmission and gearshift mechanism	155	
truck frame assembly....	216, 274	
truck wheels	217	
winch	281	
Disassembly:		
clutch assemblies	122-125	
engine spacer	341	
final drives	31-37	
front idlers	221-227	
gearshifter housing assembly	206-208	
inner seal drive assembly.....	36	
outer seal assembly.....	33	
power take-off	67-71	
stabilizer crank assembly...	99-100	
stabilizer spring	90	
steering clutch controls....	147-148	
track release mechanism...	252-258	
track support roller	228-229	
truck frame assembly.....	276-277	
Drawbar (See Pintle drawbar as- sembly)		
Drive shaft (and lay shaft as- semblies)		
assembly	312-314	
inspection and repair	303	
Drive sprocket		
installation	54	
removal	28	
from sprocket shaft	67	
Driven hub, removal	21	
Drum brake operating shafts, re- moval	290	
Drum shaft assembly		
assembly	309	
installation	309-310	
E		
Electrical system		
accessories	14	
description	13	
maintenance duties by echelons	5-6	
End frame, inspection and repair.	300	
Engine hood, removal	322-323	
Engine preheater assembly, main- tenance duties by echelons.....	10	
Engine spacer		
assembly	341	
description	335	
disassembly	341	
inspection of parts	341	
installation	341-343	
removal	335-341	

INDEX

E—Cont'd	Page No.		Page No.
Engine support		special tools	247
description	344	trouble shooting	218
inspection and repair	347	Fuel pressure gage, description..	62
installation	347-348	Fuel tank and lines	
removal	344-347	description	349
Engine support bottom cover		fuel lines	351
installation	92, 318	installation	350-351
removal	285	maintenance	349
Equalizer bar, installation....	140-141	removal	349-350
Exhaust system, maintenance du-			
ties by echelons	8	G	
		Gear and hub assembly, installa-	
F		tion	48
Final drive bearing cups, installa-		Gear case	
tion in gear hub	43	inspection and repair... 38-39,	300
Final drive gear assembly		installation	48
description	15	of cover	310
removal	28	removal of cover	290
Final drive pinion assembly		trouble shooting	16
description	15-16	Gear shifter housing assembly	
installation	48-52	assembly	210-213
removal	120	installation	200, 214
Final drive spacer		disassembly	206-208
installation	45	removal	204
removal	31	Gear train and main frame as-	
Final drives		sembly, maintenance duties by	
assembly	41-43	echelons	9
description	15-16	Gearshift lever assembly	
disassembly	31-37	installation	213
inspection and repair of parts	37-39	removal	207
installation	43-59	Gearshift mechanism	
maintenance	16	assembly of gearshifter housing	
removal	16-31	assembly	210-213
special tools and equipment... 60		description	203
trouble shooting	16	disassembly of gearshifter hous-	
First stage fuel filter, removal..	115	ing assembly	206-208
Floor plates, installation.....	215	inspection and repair of	
Fourth speed shifter fork assembly		parts	208-210
assembly	213	installation	214-215
disassembly	208	removal	203-205
Front idler		(See also Transmission and gear-	
alinement	246	shift mechanism)	
assembly	231-243	Grouser shoes (See Street plates	
description	217	and grouser shoes)	
disassembly	221-227		
inspection of parts.....	229-231	I	
installation	245-246	Idler bracket guides, installation.	245
removal	219	Idler gear shaft assembly, removal	69
		Idler guards, installation	246

ORDNANCE MAINTENANCE — MEDIUM TRACTOR M1 (ALLIS-CHALMERS HD-7W)
ELECTRICAL SYSTEM, POWER TRAIN, FRAME, AND TRACKS

I—Cont'd	Page No.	M	Page No.
Idler shaft and gear, installation.	82	Maintenance	
Inner bearing, removal.....	28-31	final drives	16
Inner pinion bearings		fuel tank	349
installation	42, 48	Master clutch assembly, maintenance duties by echelons	5
removal from cage	36	Master clutch cover, installation.	106
Inner seal assembly		Master clutch shaft, removal.	177-178
installation	54	Master pin, removal	265
removal	28	Mile meter cable, disconnect....	328
Inner seal dirt guard, installation.	54	Mile meter drive gear and worm, adjustment	191
Inner seal drive assembly		Mile meter (housing)	
assembly	42-43	description	159
disassembly	36	inspection and repair	179
Inspection (See also Inspection and repair)		installation	190-191
engine spacer	341	removal	173
vehicle, assembled	12		
Inspection and repair		N	
clutch assemblies	131-135	Neoprene packing ring, installation	
engine support	347	in seal plate	236
final drives	37-39	Neoprene seal boots, inspection..	231
gearshift mechanism	208-210		
power take-off	71-75	O	
stabilizer crank assembly.....	100	Oil seals	
stabilizer spring	90	inspection and repair.....	38, 100
steering clutch control parts	148-149	installation	261
track assembly	266-270	in retainers	243-245
track release mechanism	258	removal	
tractor brakes	152-153	from retainers	71
truck frame assembly	277	from stabilizer links.....	99-100
Instruments (and gages)		Oil slinger and springs, removal	
maintenance duties by echelons	10	from shifter plate	125
purpose	62-63	Operation	
replacement	63	clutch assemblies	107-108
Intermediate pinion bearing		power take-off	64
installation	43	transmission and gearshift mechanism	155
removal	36	Outer channels	
L		installation	278
Lever assembly, inspection and repair	208-209	removal	277
Link shaft, installation	103-105	Outer pinion bearing	
Lock rings, installation	138	installation	52
Lubricating oil pressure gage, description	62-63	removal from gear case.....	37
Lubrication:		Outer seal assembly	
final drives	16	assembly	41
track release assembly	262	disassembly	33
winch assembly	312	installation	54
		removal	28

INDEX

P	Page No.	P	Page No.
Pinion assembly, disassembly	33	Replace defined	4
Pinion puller assembly, installation	21	Reverse idler gear (assembly)	
Pinion shaft assembly		inspection and repair	74-75
installation	82	installation	191-192
removal	67-69	removal	172-173
Pinion shaft bearings		Roller (assembly)	
installation	186-190	lubrication and installation . . .	245
removal	24	removal	227
Pins and bushings, inspection and		Roller flanges, inspection	231
repair	266		
Pintle bracket assembly		S	
installation	356	Seal frame, removal	110-111
removal	354-356	Seal ring, assembly	239-240
Pintle drawbar assembly		Seat cushions, installation	142
installation	354	Sediment sumps and shut-off valve	
removal	352-354	installation	350-351
Pivot shaft, installation	91-92	removal	350
Pivot shaft bracket and spring		Service defined	4
leaves, assembly	91	Shaft and bearing assemblies, re-	
Pivot shaft bushing, inspection and		moval	227, 229
repair	90	Shifter lock assembly, assembly	
Power take-off assembly		and installation in housing	213
assembly	76-85	Shifter shafts and forks	
description	64	installation	200, 214
disassembly	67-71	removal	165-167
inspection and repair of parts	71-75	Shifter shaft assembly	
installation	85-86	installation	85
removal	65-66	removal	67
trouble shooting	64-65	Side bars and bushings, assembly .	270
Power take-off control linkage, re-		Side plate	
moval	115	inspection and repair	38-39
Power take-off gear case, removal .	165	installation	45-48
Pressure plate, installation	136	removal	31
Preventive maintenance (See		Sliding clutch (See Winch sliding	
Maintenance)		clutch)	
Primary fuel filter, installation . . .	142	Spacers, adjustment	138-140
		(See also Engine spacer)	
R		Special tools	
Rear axle bracket assembly		clutch assemblies	145
assembly	41	final drives	60
disassembly	33-34	front idlers, truck wheels, and	
inspection and repair	38	track support rollers	247
installation	54-58	stabilizer crank assembly	106
removal	28	track assembly	273
Rear axle end cover and sprocket		transmission gears	202
guard		Sprocket bolts	
installation	279-280	installation in gear hub	41
removal	275	removal	33
Rebuild and repair defined	5		

ORDNANCE MAINTENANCE — MEDIUM TRACTOR M1 (ALLIS-CHALMERS HD-7W)
ELECTRICAL SYSTEM, POWER TRAIN, FRAME, AND TRACKS

S—Cont'd	Page No.	Page No.
Sprocket guard (and end cover)		
installation	58-59, 317	
removal	21	
Stabilizer crank assembly		
assembly	102-103	
description	93	
disassembly	99-100	
inspection of parts	100	
installation	103-106	
removal	94-95	
special tools	106	
trouble shooting	93-94	
Stabilizer crank seal and bushings		
inspection and repair	258	
removal	256-258	
Stabilizer link shaft		
installation	342	
removal	337-340	
Stabilizer spring		
assembly	91	
description	87	
disassembly	90	
inspection and repair	90	
installation	91-92	
removal	87-89	
Stabilizer spring pivot shaft		
installation	342-343	
removal	337	
Stabilizer spring seat, removal....	275	
Steering clutch controls		
assembly	149	
description	146	
disassembly	147-148	
inspection and repair of		
parts	148-149	
trouble shooting	146-147	
Steering clutch cover		
assembly	149	
disassembly	147	
inspection	148	
installation	141	
removal	115-120	
Steering clutch shaft		
inspection and repair	135	
installation	137-138	
removal	120-121	
Steering lever assembly		
disassembly	147	
removal	206-207	
Street plate and grouser shoes		
inspection and repair	270	
installation	270	
removal	266	
Support roller bracket, installation	228	

T

Temperature gage, description ...	63
Throw-out fork assembly	
assembly	149
disassembly	147-148
inspection and repair	148-149
installation	141
removal	120
Thrust pin, adjustment for free	
travel	143-144
Tool box	
installation	142
removal	115
Top cover installation	261-262
on case	85
Top shaft pilot bearing, installation	192
Track assembly	
adjustment	273
assembly	270
description	263
disassembly	266
inspection and repair	266-270
installation	271-273
removal	264-265
special tools	273
trouble shooting	263-264
Track pin bushings, removal....	266
Track pins, installation	270
Track rails, inspection and re-	
pair	266-270
Track release assembly, lubrication	262
Track release housing	
installation	106, 279
removal	94
Track release mechanism	
assembly	258-262
description	248
disassembly	252-258
inspection and repair of parts..	258
installation	262

INDEX

T—Cont'd	Page No.		Page No.
Track release mechanism—Cont'd		transmission gears and gearshift	
removal	249-252	assembly	156-157
trouble shooting	248-249	truck frame assembly	274
Track support rollers		winch	281-282
assembly	243-245	Truck frame assembly	
description	217	assembly	277-278
disassembly	228-229	description	274
inspection of parts	231	disassembly	276-277
installation	247	inspection and repair	277
removal	227	installation	278-280
special tools	247	maintenance duties by echelons	8
trouble shooting	218-219	removal	274-276
Tracks		trouble shooting	274
adjustment	247, 273	Truck wheel guard	
alinement	246	installation	246-247, 278
Tractor brakes		removal	220, 277
adjustment	153-154	Truck wheels	
description	150	assembly	231-243
inspection and repair	152-153	description	217
installation	153	disassembly	221-227
removal	152	inspection of parts	231
trouble shooting	150-152	installation	246-247
Transmission and gearshift mechanism		removal	219-220
description	155	special tools	247
gearshift mechanism	203-215	trouble shooting	218
transmission gears	158-202		
trouble shooting	156-157	U	
Transmission gears		U-bolt and spring seat	
assembly and installation ..	180-202	installation	92
description	158-159	removal	87-89
inspection and repair of		Universal joints	
parts	178-179	assembly	314
removal and disassembly ..	159-178	disassembly	300
special tools	202		
Transmission top shaft (and gears)		W	
installation	192-195	Winch	
removal	167-171	adjustments of winch and con-	
Trouble shooting:		trols	318-321
clutch assemblies	108	assembly of winch and con-	
final drives	16	trols	303-316
front idlers	218	description	281
power take-off	64-65	disassembly of winch and con-	
stabilizer crank assembly ...	93-94	trols	286-300
steering clutch controls ...	146-147	inspection and repair of parts	300-303
track assembly	263-264	installation	
track release mechanism ...	248-249	winch assembly	317-318
tractor brakes	150-152	winch lay shaft and control	
		levers	316-317

**ORDNANCE MAINTENANCE — MEDIUM TRACTOR M1 (ALLIS-CHALMERS HD-7W)
ELECTRICAL SYSTEM, POWER TRAIN, FRAME, AND TRACKS**

W—Cont'd	Page No.	Page No.	
Winch—Cont'd		Winch drum brake, adjustment.. 318	
removal		Winch drum shaft assembly	
winch assembly	282-285	disassembly	294-295
winch lay shaft and control		removal	290-294
levers	285-286	Winch lay shaft and control levers	
trouble shooting	281-282	installation	316-317
Winch and controls (See Winch)		removal	285-286
Winch assembly		Winch sliding clutch	
installation	317-318	adjustment	318-320
lubrication	312	removal	290
maintenance duties by echelons	10-11	Winch worm shaft bearings, ad-	
removal	282-285	justment	305-307
Winch cable	315-316	Worm gear and drum shaft, in-	
Winch clutch and brake levers,		spection and repair	301
disassembly	300	Worm gear case, removal from	
Winch control lever assembly, re-		winch case	296
moval	285-286	Worm gear housing, installation..	303
Winch drive and lay shafts, dis-		Worm shaft assembly	
assembly	300	assembly and installation..	303-305
Winch drive chain and pintle		disassembly	296
bracket, removal	163-165	inspection and repair	301
Winch drive shaft and control rods,		installation	316-317
removal	286-290	removal	295-296
Winch drive shaft guard		Worm shaft oil seals, removal...	297
installation	331	Worm shaft rear bearing retainers,	
removal	282-285, 323	installation	303

[A.G. 062.11 (7 Apr 43)
O.O. 461/41163 O.O. (19 May 43)]

BY ORDER OF THE SECRETARY OF WAR:

G. C. MARSHALL,
Chief of Staff.

OFFICIAL:

J. A. ULIO,
Major General,
The Adjutant General.

DISTRIBUTION: R 9(4); Bn 9(2); C 9(8)

(For explanation of symbols, see FM 21-6)

RAPD22SEP43-42M

366

PUBLICATIONS DIVISION, RARITAN ARSENAL.

NOTES

A series of horizontal dashed lines for writing notes, spanning the width of the page.

