

U.S. Dept. of Army
U113
12
TM
1943

TM 9-1787A

WAR DEPARTMENT

U.S. Dept. of Army
TECHNICAL MANUAL

ORDNANCE MAINTENANCE

HEAVY TRACTOR M1
(Allis-Chalmers HD-10W) ENGINE

FEBRUARY 6, 1943

Success
gift
you are

TECHNICAL MANUAL }
 No. 9-1787A }

WAR DEPARTMENT
 Washington, February 6, 1943

U113
 2
 TM 9-1787-
 1943

ORDNANCE MAINTENANCE
HEAVY TRACTOR M1
(Allis-Chalmers HD-10W) ENGINE ★ ★

Prepared under the direction of the
 Chief of Ordnance
 (with the cooperation of the Allis-Chalmers Manufacturing Company)

CONTENTS

	Paragraphs	Pages
SECTION I. Introduction	1-3	2-3
II. Description and data.....	4-5	4-12
III. Allocation of maintenance duties by echelons	6	13-21
IV. Engine Inspection and trouble shoot- ing on vehicle	7-8	22-28
V. Removal of engine from vehicle.....	9	29-40
VI. Removal of accessories from engine..	10	41-57
VII. Disassembly of engine.....	11-13	58-89
VIII. Inspection and repair of engine.....	14	90-94
IX. Assembly of engine.....	15-16	95-130
X. Installation of accessories on engine..	17-22	131-144
XI. Installation of engine in tractor.....	23-24	145-152
XII. Special tools and equipment.....	25-26	153-154
XIII. Storage and shipment.....	27-28	155-156
XIV. Fits and tolerances.....	29-30	157-161
XV. References	31-32	162-163
INDEX		164-171

Section I

INTRODUCTION

	Paragraph
Scope.....	1
Content and arrangement of manual.....	2
References	3

1. SCOPE.

a. The instructions contained in this manual are for the information and guidance of the personnel charged with the maintenance and repair of the Heavy Tractor M1 (Allis-Chalmers HD-10W). Information on the detailed construction of the unit, disassembly and assembly procedure, inspection, maintenance, and repair is contained in four technical manuals of which this is the first.

(1) This manual covers a description of the Heavy Tractor M1 (Allis-Chalmers HD-10W) Engine. It defines the various maintenance terms and allocates the maintenance operations to their proper echelons. The procedure for removing the engine from the tractor, removal of accessories from the engine, disassembly, inspection, trouble shooting, repair and assembly of sub-assemblies, installation of accessories, and the installation of the engine in the tractor.

(2) The second manual (TM 9-1787B) contains a description of and procedure for the removal, disassembly, inspection, trouble shooting, repair, assembly and installation of the master clutch and the various units outlined in the fuel and air system, cooling system, electrical system, lubrication system, exhaust manifold and muffler, governor and controls, and engine and air heaters.

(3) The third manual (TM 9-1787C) contains a description of and procedure for the disassembly, inspection, trouble shooting, repair and assembly of the power train, frame assembly, and seats.

(4) The fourth manual (TM 9-1787D) contains a description of all the equipment listed for the Heavy Tractor M1 (Allis-Chalmers HD-10W).

2. CONTENT AND ARRANGEMENT OF MANUAL.

a. Section II contains a description of the engine. It includes a table of data. Section III defines the various maintenance terms used in this manual and allocates the various maintenance operations to the proper echelons. Engine inspection and trouble shooting are covered in section IV. Sections V to XI outline procedure for removing the engine from the tractor, removal of accessories from the engine, disassembly,

INTRODUCTION

repair, and assembly of subassemblies, installation of accessories, and the installation of the engine in the tractor. New and worn clearances and fits for component parts of the engine and special tools required in repair are listed in sections XII and XIV. Storage and shipment and references to other technical manuals pertaining to this engine and the tractor in which it is used comprise the remaining sections.

3. REFERENCES.

a. A list of references pertaining to this manual will be found in section XV.

Section II

DESCRIPTION AND DATA

	Paragraph
Description	4
Tabulated data	5

4. DESCRIPTION (figs. 1 through 5).

a. This engine is a water-cooled, 4-cylinder, 2-cycle Diesel. It differs from the conventional 4-cycle engine in that it requires only 2 strokes of the piston, one up and one down, to complete an operating cycle instead of 4 strokes as in the 4-cycle engine. In the 2-cycle engine, intake and exhaust occur together when the piston is at the bottom

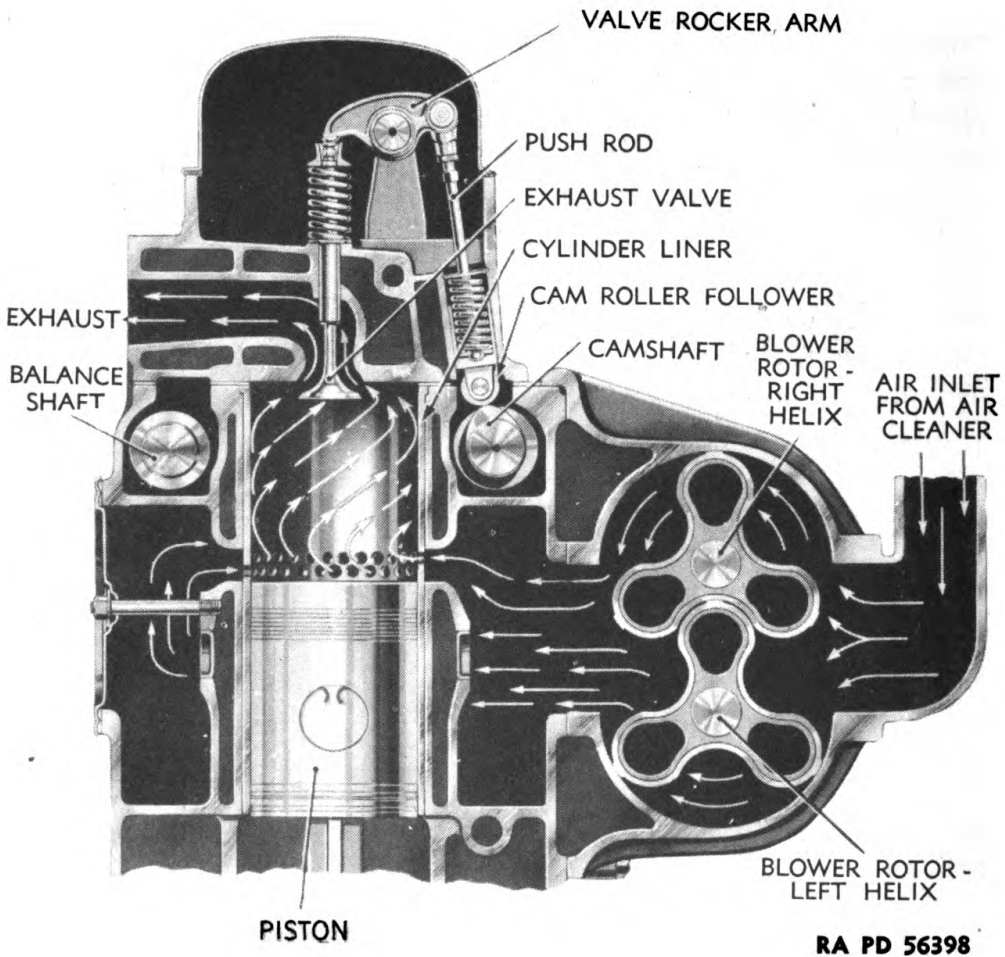

RA PD 56398

Figure 1 — Cross Section of Engine Showing Circulation of Air

DESCRIPTION AND DATA

RA PD 58118

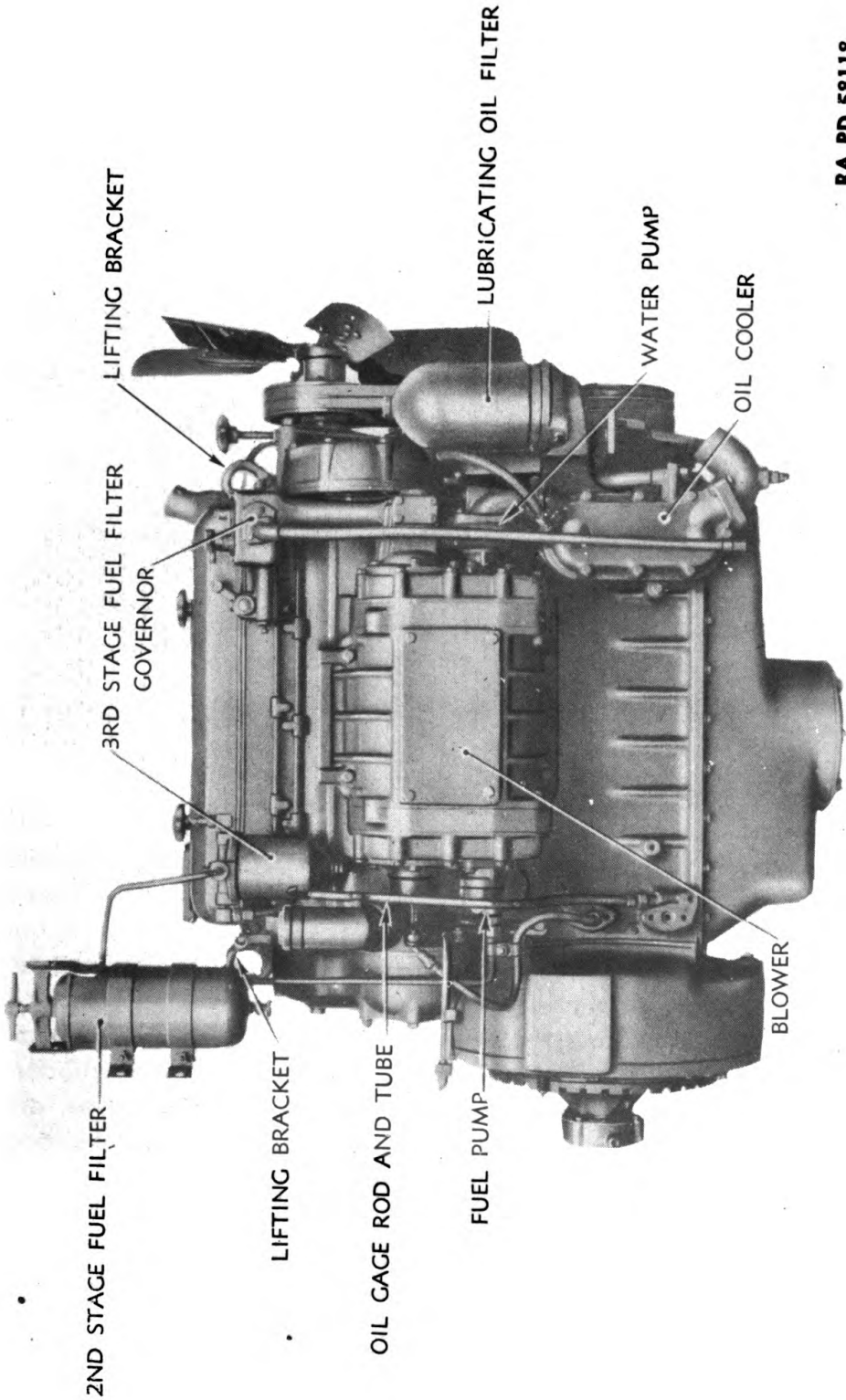
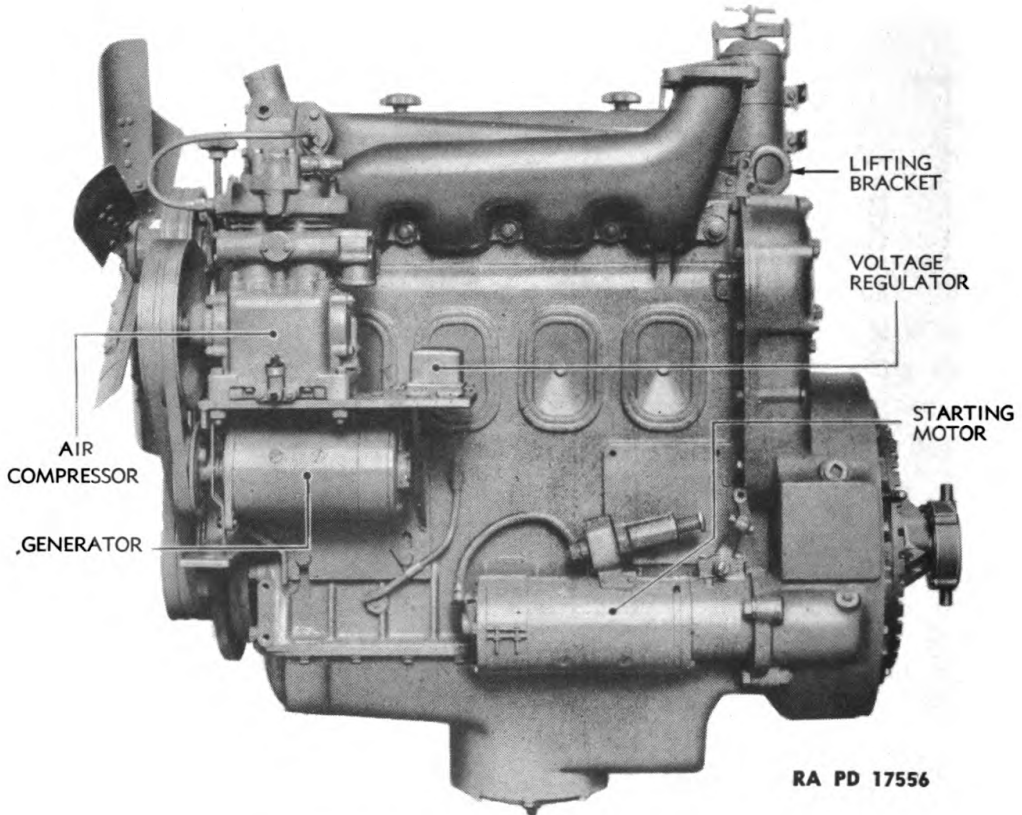

Figure 2 — Engine — Right Side

ORDNANCE MAINTENANCE — HEAVY TRACTOR M1 (Allis-Chalmers HD-10W) ENGINE



RA PD 17556

Figure 3 — Engine — Left Side

of its stroke; every upstroke is a compression stroke; every downstroke delivers power. Thus the intake and exhaust strokes of the 4-cycle engine are eliminated. The 2-cycle engine exhausts burned gases and fills its cylinders with fresh air, not by the pumping action of the engine itself, but by means of a rotary blower mounted on the right side of the engine and driven from the engine crankshaft. As the piston nears the end of its power stroke, the exhaust valves (2 for each cylinder) in the cylinder head open to allow the burned gases to escape, and the piston uncovers the intake ports in the lower part of the cylinder wall (64 holes in each cylinder liner) to permit fresh air from the blower to rush in, forcing burned gases out through the exhaust valves and filling the cylinder with a new charge of fresh air (fig. 1). As the piston rises on the compression stroke, it closes off the intake ports, the exhaust valves close, and the charge of air is compressed into $\frac{1}{16}$ of its former volume. This compression causes the air to become extremely hot. A charge of fuel oil is injected into this hot compressed air by the injector just before the piston reaches the top of its stroke. The fuel is ignited by the hot air and burns. The expansion caused

DESCRIPTION AND DATA

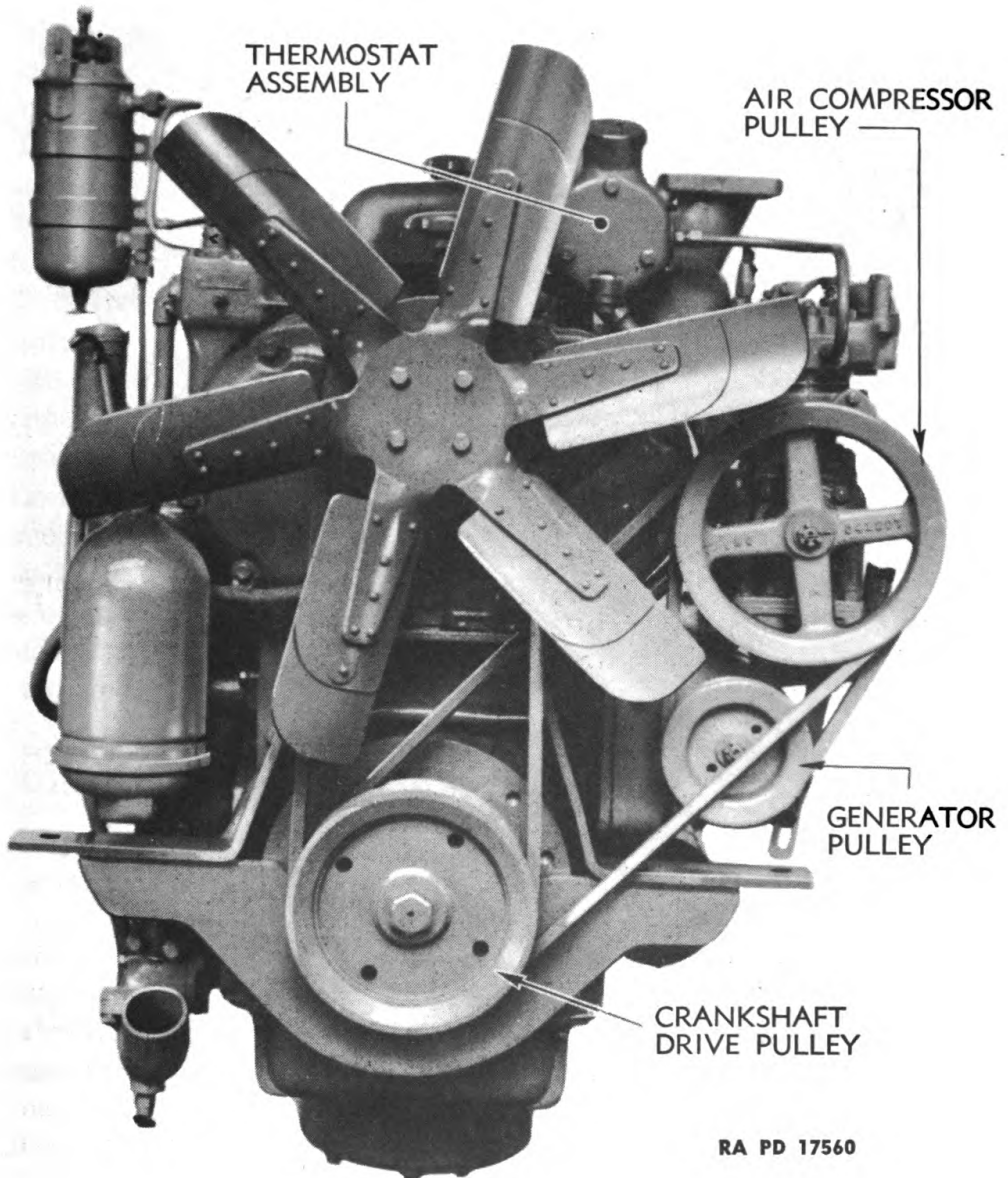

RA PD 17560

Figure 4 — Engine — Front View

by the combustion of the gases formed forces the piston down on its power stroke.

b. Basic engine parts are readily accessible. On the right-hand side of the engine, as viewed from the operator's seat, is located the blower, engine governor, fuel pump, second and third stage fuel filters, lubricating oil filter and cooler, and water pump. The air compressor, starting motor, air heater, and electric generator are mounted on the left-hand side.

ORDNANCE MAINTENANCE—HEAVY TRACTOR M1 (Allis-Chalmers HD-10W) ENGINE

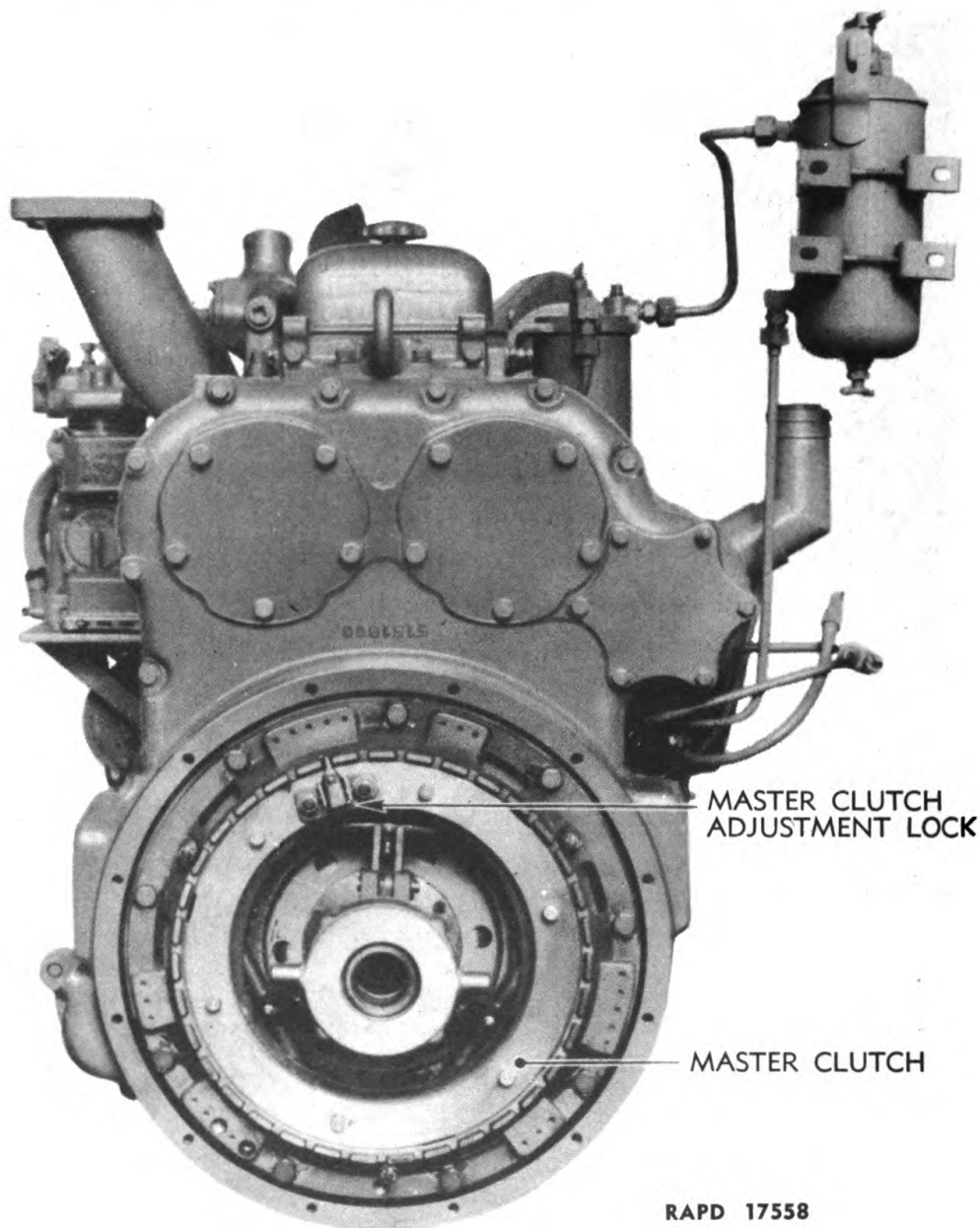

RAPD 17558

Figure 5 — Engine — Rear View

c. The fuel pump and water pump are driven by the lower blower rotor shaft. The fan and air compressor are driven by V-belts from a pulley on the crankshaft, and the generator is driven by a V-belt from the air compressor pulley.

d. The flywheel housing and timing gear cover are bolted directly to the rear end of the cylinder block. Engine lifter brackets are provided, attached to the top of the cylinder head, to assist in the removal or installation of the engine.

DESCRIPTION AND DATA**5. TABULATED DATA.****a. Engine and Accessories.**

Number used 1
 Make General Motors
 Type Diesel
 Model and Series RC 14, series 4-71
 Dimensions:
 Length $38\frac{7}{8}$ in.
 Height $41\frac{1}{16}$ in.
 Width $24\frac{5}{8}$ in.
 Weight:
 With accessories 1,865 lb
 Without accessories (estimated) 1,300 lb
 Horsepower 110 hp at 2,000 rpm
 Maximum engine speed 2,000 rpm
 Number of cycles (Diesel) 2
 Method of starting (Diesel) Electric starter
 Type of injection system (Diesel) Unit injection
 Number of cylinders 4
 No. 1 cylinder location At front
 Bore $4\frac{1}{4}$ in.
 Stroke 5 in.
 Firing order 1-3-4-2
 Piston displacement 284 cu in.
 Compression ratio 16 to 1
 Type of oil system Wet sump
 Oil pump:
 Make and model General Motors
 Oil filter type Full-flow
 Make and model AC Spark Plug Company
 Rocker arm or valve clearance adjustment:
 Hot:
 Exhaust 0.010 in.
 Cold:
 Exhaust 0.012 in.

b. Fuel System.

Number of tanks 1
 Location At rear of vehicle
 Capacity of tanks 160 gal
 Fuel pump:
 Make and model General Motors
 Pressure at outlet end of fuel pump (approx.) 25 lb
 Fuel filter type Cartridge

ORDNANCE MAINTENANCE — HEAVY TRACTOR M1 (Allis-Chalmers HD-10W) ENGINE

Make and model:

- First stage Commercial Filters Corporation, AS 4¼ BDV
- Second stage AC Spark Plug Company, Economy B 500
- Third stage AC Spark Plug Company, type T

Air cleaner:

- Number 2
- Make and model United Specialties Company, CT 85-9665
- Type (oil bath, mesh) Oil bath with screen and precleaners

Governor:

- Make Handee
- Type Centrifugal
- Setting Spring tension

c. Cooling System.

- Cooling medium Water
- Type of radiator Fin and tube
- Capacity 9¾ gal
- Fans 1
 - Diameter 20 in.
 - Number of blades 6

Water pump:

- Number 1
- Make and model General Motors
- Type Centrifugal

Thermostat:

- Type Bypass
- Location Engine water outlet manifold
- Limits (open and closed) 185 F – 158 F

d. Clutch.

- Make and model Rockford
- Number of plates 1
- Adjustments Adjusting ring in mounting plate
 - Free travel to floorboard Hand-operated over center type

e. Transmission and Transfer Case.

- Make and model Allis-Chalmers
- Type Spur gear

Number of speeds:

- Forward 6
- Reverse 2

Transfer case:

- Make and model Allis-Chalmers
- Speeds Controlled by transmission

DESCRIPTION AND DATA

f. Axles.

Rear axle:

Make and modelAllis-Chalmers
 Type.....Dead axle pressed into transmission case

g. Brake System.

Manufacturer and model.....Allis-Chalmers
 TypeBand

h. Steering System.

MakeAllis-Chalmers
 Type of steering.....Lever-actuated steering clutches

i. Tracks.

TypeSteel, pin and bushing
 Number of grousers per track.....32
 Size of each grouser.....9⁵/₁₆ x 20 in.
 Tension of trackNone
 Weight of each2,080

j. Electrical System.

Battery:

Make and model.....Exide XHM-25; Auto-lite 625 HSR
 Voltage12 volts
 Filling level for electrolyte.....Controlled by nonoverflow caps

Hydrometer readings:

Fully charged1.280
 Half charged1.250
 Discharged1.200
 Terminal groundedPositive

Generator:

Make and model.....Delco-Remy 5888
 Voltage12 volts
 DriveV-belt

Output:

Cold.....16 to 18 amp at 16.1 to 16.5 volts at 2,400 rpm
 Hot.....11 to 13 amp at 15.1 to 15.5 volts at 2,400 rpm

Electric system regulators:

Cut-out relay:

Air gap0.015 in.
 Point opening0.020 in.
 Closing voltage12.9-13.9 volts

ORDNANCE MAINTENANCE — HEAVY TRACTOR M1 (Allis-Chalmers HD-10W) ENGINE

Voltage regulator:

Air gap	0.045 in.
Point setting	0.015 in.
Voltage setting	12.0 in.
Point opening (180 F)	14.1 to 14.7 volts

Starting motor:

Make	Delco-Remy 1108714
Type	12 volt
Drive	Dyer-gear

k. Direction of Rotation (Viewed from Operator's Seat):

Crankshaft	Counterclockwise
Starting motor	Clockwise
Generator	Counterclockwise
Fuel pump	Clockwise
Fan	Counterclockwise
Water pump	Clockwise
Oil pump	Counterclockwise
Blower	Counterclockwise
Air compressor	Counterclockwise

l. Ratio of Accessory Drive to Crankshaft Speed:

Starting motor	9.27 to 1
Generator	1.7 to 1
Fuel pump	1.94 to 1
Water pump	1.94 to 1
Oil pump	1.39 to 1
Blower	1.94 to 1
Air compressor	0.933 to 1

Section III

**ALLOCATION OF MAINTENANCE DUTIES
BY ECHELONS**

Paragraph

Organization maintenance 6

6. ORGANIZATION MAINTENANCE.

a. Scope. The scope of maintenance and repair by the crew and other units of the using arms is determined by the availability of suitable tools, availability of necessary parts, capabilities of the mechanics, time available, and the tactical situation. All of these are variable and no exact system of procedure can be prescribed.

b. Allocation of Maintenance. Indicated below are the maintenance duties for which tools and parts have been provided for the using arm personnel. Other replacements and repairs are the responsibility of ordnance maintenance personnel but may be performed by using arm personnel when circumstances permit, within the discretion of the commander concerned. Echelons and words as used in this list of maintenance allocations are defined as follows:

SECOND ECHELON: Line organization regiments, battalions, companies, detachments, and separate companies.

THIRD ECHELON: Ordnance light maintenance companies, ordnance medium maintenance companies, ordnance divisional maintenance battalions, and post ordnance shops.

FOURTH ECHELON: Ordnance heavy maintenance companies, and service command shops.

FIFTH ECHELON: Ordnance base regiments, ordnance bases, arsenals, and manufacturers' plants.

SERVICE: (Including preventive maintenance): Refer to AR 850-15, paragraph 23 a (1) and (2). Consists of servicing, cleaning, lubricating, tightening bolts and nuts, and making external adjustments of subassemblies or assemblies and controls.

REPLACE: Refer to AR 850-15, paragraph 23 a (4). Consists of removing the part, subassembly or assembly from the vehicles and replacing it with a new or reconditioned or rebuilt part, subassembly or assembly, whichever the case may be.

ORDNANCE MAINTENANCE — HEAVY TRACTOR M1 (Allis-Chalmers HD-10W) ENGINE

REPAIR: Refer to AR 850-15, paragraph 23 a (3) and (5), in part. Consists of making repairs to, or replacement of the part, subassembly or assembly, that can be accomplished without completely disassembling the subassembly or assemblies, and does not require heavy welding, or riveting, machining, fitting and/or alining or balancing.

REBUILD: Refer to AR 850-15, paragraph 23 a (5) in part, and (6). Consists of completely reconditioning and replacing in serviceable condition any unserviceable part, subassembly or assembly of the vehicle, including welding, riveting, machining, fitting, alining, balancing, assembling and testing.

NOTE: Operations allocated will normally be performed in the echelon indicated by "X." Operations allocated to the echelons as indicated by "E" may be accomplished by respective echelons in emergencies only.

	ECHELONS			
ENGINE CLUTCH ASSEMBLY	2nd	3rd	4th	5th
Clutch assembly—service (adjust)	X			
Clutch assembly—replace	E	X		
Clutch assembly—repair (reline)		X		
Clutch assembly—rebuild			E	X
Control and linkage (external)—replace	X			
Control and linkage (internal)—replace		X		
Control and linkage (external and internal)—repair		X		
COOLING SYSTEM				
Connections, radiator—service and replace	X			
Radiator assembly—replace	X			
Radiator assembly—repair		X		
Radiator assembly—rebuild			E	X
Shutter assembly and controls, radiator—replace	X			
Shutter assembly and controls, radiator—repair		X		
ELECTRICAL SYSTEM				
Batteries—service, replace or recharge	X			
Batteries—repair		X		
Batteries—rebuild			E	X
Conduits and wiring, electrical—replace	X			
Conduits and wiring, electrical—repair	E	X		
Lamps (all)—service and replace	X			

ALLOCATION OF MAINTENANCE DUTIES BY ECHELONS

	ECHELONS			
	2nd	3rd	4th	5th
ELECTRICAL SYSTEM—Cont'd				
Lamps (all)—repair		X		
Switches (all)—replace	X			
Switches (all)—repair		X		
ENGINE ASSEMBLY				
Bearings, connecting rod (inserts)—replace		E	E	X
Bearings, crankshaft (inserts)—replace		E	E	X
Belts, air compressor, fan, and generator—adjust or replace	X			
Block assembly and cylinder sleeves—rebuild (recondition)			E	X
Blower assembly—replace	X			
Blower assembly—repair		X		
Blower assembly—rebuild			E	X
Controls and linkage, engine—replace	X			
Controls and linkage, engine—repair		X		
Cooler and primary filter assembly, oil—service and replace	X			
Cooler and primary filter assembly, oil—repair		X		
Crankshaft—rebuild (recondition)			E	X
*Engine assembly—replace		X		
Engine assembly—repair		X		
Engine assembly—rebuild			E	X
Fan assembly—service and replace	X			
Fan assembly—repair		X		
Filter assembly, oil secondary—service and replace	X			
Filter assembly, oil secondary—repair		X		
Flywheel assembly—replace or repair		X		
Flywheel assembly—rebuild (recondition)			E	X
Gaskets (handhole cover, lower pan, manifold and valve cover)—replace	X			
Gear train, timing—replace		X		
Generator assembly—service and replace	X			

*The second echelon is authorized to remove and reinstall the engine and transmission assemblies, transfer unit controlled differential assembly, and other items marked by asterisk. However, when it is necessary to replace an item marked by an asterisk with a new or rebuilt part, subassembly or unit assembly, the assembly marked by asterisk will not be removed from the vehicle by the **second echelon** until authorization is received from a higher echelon.

ORDNANCE MAINTENANCE — HEAVY TRACTOR M1 (Allis-Chalmers HD-10W) ENGINE

ENGINE ASSEMBLY—Cont'd	ECHELONS			
	2nd	3rd	4th	5th
Generator assembly—repair		X		
Generator assembly—rebuild			X	
Governor assembly—service (adjust) and replace		X		
Governor assembly—rebuild			E	X
Head assembly, cylinder—replace	X			
Head assembly, cylinder—repair		X		
Head assembly, cylinder—rebuild (recondition) . .			E	X
Heater assembly, air box—replace	X			
Heater assembly, air box—repair		X		
Heater assembly, air box—rebuild			E	X
Housing assembly, flywheel—replace		X		
Housing assembly, flywheel—rebuild (recondition)			E	X
Injector assembly—replace	X			
Injector assembly—repair		X		
Injector assembly—rebuild			E	X
Lines and connections, oil (external)—replace . . .	X			
Lines and connections, oil (external)—repair . . .	E	X		
Lines and connections, oil (internal)—replace or repair		X		
Manifold, exhaust—replace	X			
Manifold, exhaust—rebuild (recondition)			E	X
Manifolds and connectors, fuel—replace	X			
Manifolds and connectors, fuel—repair	E	X		
Motor, starting—replace	X			
Motor, starting—repair		X		
Motor, starting—rebuild			X	
Pan, crankcase oil (lower)—service and replace . .	X			
Pan, crankcase oil (upper)—replace	E	X		
Pan, crankcase oil (lower or upper)—repair		X		
Pistons and rings—replace		E	E	X
Pump assembly, fuel—replace	X			
Pump assembly, fuel—repair		X		
Pump assembly, fuel—rebuild			X	
Pump assembly, oil—replace	E	X		
Pump assembly, oil—repair		X		
Pump assembly, oil—rebuild			X	

ALLOCATION OF MAINTENANCE DUTIES BY ECHELONS

	2nd	ECHELONS		
		3rd	4th	5th
ENGINE ASSEMBLY—Cont'd				
Pump assembly, water—replace	X			
Pump assembly, water—repair		X		
Pump assembly, water—rebuild			X	
Rod assembly, connecting—replace		E	E	X
Sleeve, cylinder—replace		E	E	X
Thermostat—replace	X			
Valve clearance—service (adjust)	X			
EXHAUST SYSTEM				
Muffler and pipes—replace	X			
FIRE EXTINGUISHING SYSTEM				
Extinguisher, fire (CARBON TETRACHLORIDE, CC14)—service (refill) and replace	X			
Extinguisher, fire (CARBON TETRACHLORIDE, CC14)—repair		X		
Extinguisher, fire (CARBON TETRACHLORIDE, CC14)—rebuild			E	X
FINAL DRIVE ASSEMBLIES				
Final drive assemblies—replace		X		
Final drive assemblies—repair		X		
Final drive assemblies—rebuild			E	X
Sprockets, final drive—replace	X			
Sprockets, final drive—repair		X		
Sprockets, final drive—rebuild (recondition)			E	X
FRAME ASSEMBLY TRUCK				
Crank assemblies, stabilizer—replace	X			
Crank assemblies, stabilizer—repair		X		
Frame components, truck—replace	X			
Frame components, truck—repair		X		
Frame components, truck—rebuild			E	X
Idler assemblies, track front—replace	X			
Idler assemblies, track front—repair		X		
Idler assemblies, track front—rebuild			E	X
Roller assemblies, track support—replace	X			
Roller assemblies, track support—repair		X		
Roller assemblies, track support—rebuild			E	X
Spring assembly, stabilizer—replace	X			

ORDNANCE MAINTENANCE — HEAVY TRACTOR M1 (Allis-Chalmers HD-10W) ENGINE

	2nd	ECHELONS		
		3rd	4th	5th
FRAME ASSEMBLY TRUCK—Cont'd				
Spring assembly, stabilizer—repair		X		
Spring assembly, stabilizer—rebuild			E	X
Track adjusting mechanism—service (adjust) and replace	X			
Track adjusting mechanism—repair		X		
Track adjusting mechanism—rebuild			E	X
Track assemblies—replace or repair	X			
Track assemblies—rebuild			E	X
Wheel assemblies, truck—replace	X			
Wheel assemblies, truck—repair		X		
Wheel assemblies, truck—rebuild			E	X

FUEL SYSTEM

Cleaners and connections, air—service and replace	X			
Cleaners and connections, air—repair		X		
Filters, fuel oil—service and replace	X			
Filters, fuel oil—repair		X		
Lines and connections, fuel oil—service and replace	X			
Lines and connections, fuel oil—repair	E	X		
Pump assembly, air box heater—replace	X			
Pump assembly, air box heater—repair		X		
Tank assembly, fuel—service and replace	X			
Tank assembly, fuel—repair		X		

GEAR TRAIN AND MAIN FRAME ASSEMBLY

Bands, steering clutch brake—service (adjust) . . .	X			
Bands, steering clutch brake—replace or reline . . .		X		
Case assembly, power take-off—replace	X			
Case assembly, power take-off—repair		X		
Case assembly, power take-off—rebuild			X	
Clutch assemblies, steering—service (adjust) . . .	X			
Clutch assemblies, steering—replace or repair . . .		X		
Clutch assemblies, steering—rebuild			E	X
Controls and linkage (steering clutch, transmission, and power take-off) (external)—replace	X			
Controls and linkage (steering clutch, transmission, and power take-off) (internal)—replace		X		

ALLOCATION OF MAINTENANCE DUTIES BY ECHELONS

GEAR TRAIN AND MAIN FRAME ASSEMBLY—Cont'd	2nd	ECHELONS			
		3rd	4th	5th	
Controls and linkage (steering clutch, transmission, and power take-off) (external or internal)—repair		X			
Drawbar assembly—replace	X				
Drawbar assembly—repair		X			
Gear assembly, bevel—service (adjust) and replace		X			
Hook, towing—replace	X				
Hook, towing—repair		X			
Pintle assemblies—replace	X				
Pintle assemblies—repair		X			
Pintle assemblies—rebuild			E	X	
Spacer assembly, engine support—replace or repair		X			
Support assembly, engine—replace or repair		X			
Support bottom cover, engine—replace	X				
Support bottom cover, engine—repair		X			
Support, pintle—replace	X				
Support, pintle—repair		X			
Transmission components—replace or repair		X			
Transmission components—rebuild			E	X	
INSTRUMENTS AND GAGES					
Instruments and gages—replace	X				
Instruments and gages—repair		X			
Instruments and gages—rebuild			E	X	
Meter assembly, hour—replace	X				
Meter assembly, hour—repair		X			
Meter assembly, hour—rebuild			E	X	
Odometer assembly—replace	X				
Odometer assembly—repair		X			
Odometer assembly—rebuild			E	X	
SHEET METAL GROUP					
Boxes, street plate and tool—replace	X				
Boxes, street plate and tool—repair		X			
Dash and instrument panel assembly—replace	X				
Dash and instrument panel assembly—repair		X			
Fenders and support assemblies—replace	X				

ORDNANCE MAINTENANCE — HEAVY TRACTOR M1 (Allis-Chalmers HD-10W) ENGINE

SHEET METAL GROUP—Cont'd	ECHELONS			
	2nd	3rd	4th	5th
Fenders and support assemblies—repair		X		
Hood top plate and doors—replace	X			
Hood top plate and doors—repair		X		
Rack, luggage—replace	X			
Rack luggage—repair		X		
Seat and seat frame—replace	X			
Seat and seat frame—repair		X		
VEHICLE ASSEMBLY				
Tractor, heavy M1 (Allis-Chalmers HD-10W)— service		X		
Tractor, heavy M1 (Allis-Chalmers HD-10W)— rebuild (with serviceable assemblies)			X	E
AUXILIARY EQUIPMENT				
AIR BRAKE CONTROL ASSEMBLY				
Compressor assembly, air—service and replace	X			
Compressor assembly, air—repair		X		
Compressor assembly, air—rebuild			E	X
Governor assembly, air pressure—service (adjust) and replace	X			
Governor assembly, air pressure—repair		X		
Governor assembly, air pressure—rebuild			E	X
Lines and connections, air—replace or repair	X			
Linkage and controls—replace	X			
Linkage and controls—repair		X		
Tank assembly, air—replace	X			
Tank assembly, air—repair		X		
Valve assemblies, air brake—replace	X			
Valve assemblies, air brake—repair		X		
Valve assemblies, air brake—rebuild (recondition)			E	X
ELECTRIC BRAKE CONTROL ASSEMBLY				
Controller assembly, electric—replace	X			
Controller assembly, electric—repair		X		
Controller assembly, electric—rebuild			E	X
Resistance assembly, load control—replace	X			
Resistance assembly, load control—repair		X		
Socket assembly, outlet—replace	X			

ALLOCATION OF MAINTENANCE DUTIES BY ECHELONS

ELECTRIC BRAKE CONTROL ASSEMBLY—Cont'd	2nd	ECHELONS		
		3rd	4th	5th
Socket assembly, outlet—repair		X		
Wiring—replace or repair	X			
ENGINE PREHEATER ASSEMBLY				
Engine preheater assembly—service (refill) and replace	X			
Engine preheater assembly—repair		X		
Engine preheater assembly—rebuild			E	X
WINCH ASSEMBLY				
Band, worm shaft safety brake—service (adjust) . .	X			
Band, worm shaft safety brake—replace or reline . .		X		
Bearings, drive shaft—replace	X			
Cable and hook assembly—replace	X			
Cable and hook assembly—repair		X		
Chain, winch drive—service and replace	X			
Chain, winch drive—repair		X		
Drum, worm shaft safety brake—replace	X			
Drum, worm shaft safety brake—repair		X		
Pin, shear—replace	X			
Shaft assemblies, drive (front and rear)—replace .	X			
Shaft assemblies, drive (front and rear)—repair . .		X		
Shaft assemblies, drive (front and rear)—rebuild .			X	
Winch assembly—replace	X			
Winch assembly—repair		X		
Winch assembly—rebuild			E	X

Section IV

ENGINE INSPECTION AND TROUBLE SHOOTING ON VEHICLE

	Paragraph
Inspection	7
Trouble shooting	8

7. INSPECTION.

a. Periodic inspection of the engine is a necessary part of maintenance. Serious breakdowns and delay can often be avoided if regular careful inspections are made and minor defects or irregularities corrected before they can develop into cause for extensive repair.

b. General Inspection.

(1) Make a complete inspection of engine for loose or missing bolts, nuts, or cap screws. Check all control linkages for wear, absence of cotter pins in yoke pins, and operation of controls.

(2) Check engine assembly for leaking gaskets. Observe if any fuel or oil lines have been leaking at connections or are cracked or broken. Inspect water lines and hoses for general condition. A water hose may look perfect, but can be rotted on inside. Rotten hoses may be detected by squeezing them. If they yield readily to pressure, replace them.

(3) Inspect fan, air compressor, and generator belts for wear or signs of breakage. Inspect all electric wiring for bare or broken wires, loose connections, loose clips, etc. Check muffler for broken or cracked supports, and punctured or rusted spots. Check exhaust manifold for leaking gaskets or cracks.

(4) Remove covers from generator and starting motor. Observe if assemblies are greasy and dirty, and commutators or brushes worn or scored, and if degree of wear or general condition warrants reconditioning.

(5) Remove handhole covers from engine. Observe if air intake ports in cylinder liners are clogged. If sludge and carbon is building up in air box compartment or air intake ports in cylinder liners are partially closed by carbon, this sludge and carbon should be removed. Inspection can be made for condition of pistons, rings, and cylinder liners by looking through these ports while engine is turned by hand-cranking.

(6) Remove lubricating oil filter and inspect metal filter elements and deposits in base of filter. Metal chips either on screens or in base of filter indicate corroded bearings or possibly small broken pieces of piston rings.

ENGINE INSPECTION AND TROUBLE SHOOTING ON VEHICLE

c. Inspection with Engine Running.

(1) Start engine and let it run until operating temperature is reached. Listen for indications of uneven operation or unusual noises. Hold fingers under end of air box drain tube. If tube is open, air escaping will be felt. If tube is not open, remove it and clean the opening in the engine as well as the tube. It is important that this tube be kept open to allow excess or unburned fuel collected in air box to drain out through this tube. Check water pump for leaks.

(2) Open throttle lever to "STOP" notch. Observe instruments. Oil pressure gage should register a minimum of 25 pounds pressure. Fuel pressure gage should register a minimum of 20 pounds. Ammeter should register charge (unless battery is fully charged). Air pressure gage should register approximately 100 to 105 pounds. Read instructions pertaining to these instruments thoroughly (see TM 9-787A).

(3) Stop engine and remove air inlet housing from blower. Inspect blower housing and rotors. If rotors can be shaken considerably, it indicates worn blower drive coupling or blower drive shaft. Excessive backlash in blower timing gears is usually indicated by signs of rotor lobes rubbing their entire length. A worn bearing will cause rotor to rub on end plate. Leaking oil seals are usually indicated by the presence of oil on the blower rotors.

(4) General condition of valves, pistons, rings, and cylinder liners can be determined with a compression tester. This tester replaces an injector for testing compression of each cylinder. High compression is vitally necessary for efficient operation of a Diesel engine.

(5) Make an inspection, with engine running, of all fuel, oil, and air line connections. Leaking connections should be tightened or necessary repairs made.

(6) Check operation of air heater and air heater fuel pump. Check operation and adjustment of clutch. Remove rocker arm cover from engine and check adjustments of valves and injectors. Refer to paragraphs 20, 21, 22, and 23.

d. Summary of Inspection. Notes should be taken from above inspections and carefully analyzed. A general tune up of engine while installed should be made. If engine cannot be put in normal operating condition by this tune up method, a report should be made to the commanding officer regarding repairs necessary.

8. TROUBLE SHOOTING.

a. The following list has been made to aid the maintenance personnel in locating the cause of irregular engine operation. Detailed procedure for correcting the various disorders is outlined in the main text of the book.

ORDNANCE MAINTENANCE — HEAVY TRACTOR M1 (Allis-Chalmers HD-10W) ENGINE

b. Fails to Start.

Probable Cause	Probable Remedy
Battery too low to turn engine over fast enough.	Charge battery or install battery that will crank engine at least 80 rpm.
Starting motor shift lever out of adjustment.	Adjust lever.
Starting motor switch defective.	Replace switch.
Poor electrical connections.	Clean switch and tighten connections.
Fuel and air shut-off controls out of adjustment.	Correct control rod adjustment.
Insufficient fuel to injectors.	Inspect fuel supply, fuel shut-off valve, fuel filters, fuel pump and lines.
Cold weather.	Use air heater and preheater.
Fuel shut-off lever on governor loose on shaft.	Adjust lever and tighten clamp bolt.
Oil in engine too heavy.	Use correct weight oil. See War Department Lubrication Guide No. 36 in TM 9-787A.

c. Lack of Power.

Poor compression.	See paragraph f below.
Injectors out of time.	Time injectors (par. 21).
Injectors not equalized.	Equalize injectors (par. 22).
Fuel and air shut-off controls out of adjustment.	Make proper adjustments.
Improper fuel.	Obtain proper fuel.
Insufficient fuel.	Inspect fuel supply, fuel shut-off valve, fuel filters, fuel pump and lines.
Fuel filters clogged.	Replace filter elements.
Defective transfer pump.	Replace or repair.
Air cleaner clogged.	Remove cups, clean and refill cups, and swab out air intake pipe.
Precleaners clogged.	Service precleaners.
Air intake holes in cylinder liners clogged.	Remove cylinder head and hand-hole covers, and clean port holes.
One or more cylinders misfiring.	Locate and correct cause.

d. Excessive Black Smoke from Exhaust.

Improper fuel.	Obtain proper fuel.
Air cleaner clogged.	Clean central passage in air cleaner.

ENGINE INSPECTION AND TROUBLE SHOOTING ON VEHICLE

Probable Cause	Probable Remedy
Precleaner clogged.	Remove and clean. If defective, replace.
Too much or too heavy oil in air cleaner.	Fill with proper weight and amount of oil.
Air box handhole cover gaskets leaking.	Tighten or install new gaskets.
Insufficient air supply.	Inspect air supply system.
Air box drain plugged.	Open drain.
Injectors out of time.	Time injectors (par. 21).
Injectors not equalized.	Equalize injectors (par. 22).
Defective injector.	Repair or replace injector.
Worn rings, piston, or liners.	Replace.
e. Excessive Blue Smoke.	
Insufficient fuel to injectors.	Inspect fuel supply to injectors.
Injectors not equalized.	Equalize the injectors.
Cylinder misfiring.	Locate and correct cause.
Defective injectors.	Repair or replace.
f. Engine Detonates (Knocks).	
Injector out of time.	Time injector (par. 21).
Injectors not equalized.	Equalize injectors (par. 22).
Incorrect valve clearance.	Adjust valves for 0.010-inch clearance (par. 23).
g. Poor Compression.	
Valves not seating.	Recondition valves or replace.
Valve seats worn, pitted or cracked.	Recondition valve seats; if cracked, replace.
Piston rings weak, broken, stuck or worn.	Replace; correct cause of sticking.
Bent valve.	Replace valve.
Valve sticking.	Recondition or replace.
Broken valve spring.	Replace spring.
Improper valve clearance adjustment.	Adjust to 0.010-inch clearance (par. 23).
Excessive valve guide wear.	Replace valve guide.
Leaking cylinder head gasket.	Replace.
Worn cylinder liners.	Replace.
Worn pistons.	Replace.
h. Excessive Piston and Cylinder Liner Wear.	
Wrong grade of oil.	Change to oil of suitable grade and viscosity as specified in War Department Lubrication Guide No. 36 in TM 9-787A.

ORDNANCE MAINTENANCE—HEAVY TRACTOR M1 (Allis-Chalmers HD-10W) ENGINE

Probable Cause

Probable Remedy

Carbon building up on pistons and rings.

Sometimes caused by engine running too cold, wrong kind of lubricating oil, or wrong fuel.

Dirty containers used for lubricating oil.

Lubricating oil should be kept in a clean place, and clean containers used when filling engine with oil.

Oil used over the recommended length of time.

Change oil at the recommended intervals.

Lack of oil.

Keep the oil at the recommended level.

Piston rings improperly fitted to piston and cylinder liner.

Install new rings and fit properly.

Piston rings stuck or broken.

Replace rings.

Foreign materials entering engine.

Service and inspect air cleaners and precleaners.

Loose connections in air system.

Inspect gaskets and hose connections in air system.

Loose valve cover.

Any dirt entering the valve deck is washed down into the crankcase oil. Tighten cover.

Improper fuel.

Change to proper grade of fuel.

i. Burned Piston Heads.

Piston pin bushings loose in connecting rods, closing off oil to spray tip in upper part of rod that sprays oil on pistons.

Replace with new bushings with proper fit.

Engine has been allowed to run at slow idling speed with no oil pressure.

Set idling speed of engine to run at 450 rpm to maintain oil pressure of not less than 5 pounds.

Clogged connecting rod spray tips.

Clean tips.

Low oil pressure.

Check for cause of low oil pressure and correct.

j. Bearing Failure.

Lack of oil.

Maintain proper oil level.

Foreign materials entering engine.

Use clean oil containers when filling engine with oil, and see that air hose connections and gaskets on engine are in good condition.

Engine has been overheated.

Maintain normal operating temperature of 160 F to 180 F.

Restrictions in oil passages.

Clean engine oil passages.

ENGINE INSPECTION AND TROUBLE SHOOTING ON VEHICLE

Probable Cause	Probable Remedy
Crankshaft bearing journal rough or out of round.	Grind or replace crankshaft.
Crankshaft out of alinement.	Replace shaft.
Bent connecting rod.	Straighten rod or replace.
Low oil pressure.	Do not operate engine with low oil pressure. Oil pressure should be 5 pounds at idling speed; at full throttle, 25 to 35 pounds.
Bearings worn.	Replace bearings.
Bearing insert bent.	Replace inserts.
 k. Burned Valves and Seats.	
Insufficient valve clearance.	Adjust to 0.010-inch clearance (par. 23).
Weak valve springs.	Replace springs.
Valves sticking in guides.	Clean stems and guides, replace necessary parts.
Valve seats too wide.	Grind to $\frac{3}{32}$ -inch width.
Engine operating temperature too high.	See TM 9-787A, section XIII, Cooling System.
Unsuitable fuel.	Use a fuel with the recommended specifications.
Excessive carbon deposits around seat and valve heads.	Clean and recondition. Replace, if necessary.
Warped valve head.	Replace valve.
 l. Valves Sticking.	
Engine runs too cold, causing deposits of gummy substances.	Operate at temperature of 160 F to 180 F.
Insufficient clearance between valve stem and guide.	Ream guide for proper clearance.
Weak valve springs.	Replace springs.
Broken valve springs.	Replace springs.
Valve stems scored or carboned.	Replace or clean valves.
Gummy deposits on valves from inferior fuel.	Clean and use proper grade of fuel.
 m. Excessive Oil Consumption.	
Piston rings worn or broken.	Install new rings.
Crankcase gasket leaking.	Replace gasket.
Rear crankshaft oil seal leaking.	Replace seal.
Crankshaft wick allowing too much oil through to clutch shaft pilot bearing.	Replace wick.

ORDNANCE MAINTENANCE -- HEAVY TRACTOR M1 (Allis-Chalmers HD-10W) ENGINE

Probable Cause	Probable Remedy
Defective crankshaft seals.	Replace seals.
Leaking blower gasket.	Replace gasket.
Leaking blower oil seals.	Replace seals.
Cylinder liners worn.	Replace liners.
Excessive ring gap.	Replace rings.
Engine overheating.	See TM 9-787A, section XIII, Cooling System.
Rings not seating.	Replace rings.
Stuck oil rings, clogged drain slots.	Replace rings; clean drain slots.
Oil level too high.	Maintain proper oil level.

Section V

REMOVAL OF ENGINE FROM VEHICLE

Paragraph

Removal of engine..... 9

9. REMOVAL OF ENGINE.

a. Equipment.

- | | |
|--------------------------------|---|
| HAMMER, 2-lb | WRENCH, box, $\frac{9}{16}$ -in., with
90 deg offset |
| HOIST, chain | WRENCH, open-end, $\frac{3}{8}$ -in. |
| PLIERS | WRENCH, open-end, $\frac{7}{16}$ -in.
(2) |
| PUNCH, large | WRENCH, open-end, $\frac{9}{16}$ -in. |
| PUNCH, small | WRENCH, open-end, $\frac{5}{8}$ -in. |
| ROPE | WRENCH, open-end, $\frac{11}{16}$ -in. |
| SCREWDRIVER, 10-in. | WRENCH, open-end, $\frac{7}{8}$ -in. |
| WRENCH, $\frac{1}{2}$ -in. | WRENCH, socket, $\frac{5}{8}$ -in. |
| WRENCH, $\frac{3}{4}$ -in. (2) | |
| WRENCH, $\frac{15}{16}$ -in. | |
| WRENCH, 1-in. | |

b. Procedure.

- (1) DRAIN COOLING SYSTEM AND CRANKCASE.
PLIERS

Open drain cocks in lower connector elbow and water pump. Remove drain plug from crankcase.

- (2) REMOVE PRECLEANERS AND HOOD.
WRENCH, $\frac{7}{16}$ -in. (2) WRENCH, open-end, $\frac{9}{16}$ -in.

Loosen clamp bolts ($\frac{7}{16}$ -in. wrenches) and lift precleaners off pre-cleaner extension tubes. Loosen bolts at each corner of hood ($\frac{9}{16}$ -in. wrench), pry bolts out of clips, and lift hood off over exhaust tail pipe and precleaner elbows.

- (3) REMOVE BOTH FRONT FENDERS.
WRENCH, $\frac{3}{4}$ -in. (2)

Remove 4 bolts in right fender and 3 bolts and 1 cap screw in left fender, and remove fenders.

- (4) REMOVE WINCH DRIVE SHAFT GUARD AND GUARD SUPPORT BRACKET.

- | | |
|---------------------------------|---------------|
| WRENCH, $\frac{9}{16}$ -in. (2) | WRENCH, 1-in. |
| WRENCH, $\frac{3}{4}$ -in. (2) | |

Remove winch drive shaft guard by removing the 3 bolts at rear of guard ($\frac{3}{4}$ - and $\frac{9}{16}$ -in. wrenches) and 3 cap screws at front ($\frac{9}{16}$ -in. wrench); and remove the 2 cap screws, holding bracket to radiator shell (1-in. wrench), and remove bracket. Remove the 2 corresponding cap screws on right side, holding radiator shell to engine support.



Figure 6 — Removal of Precleaners

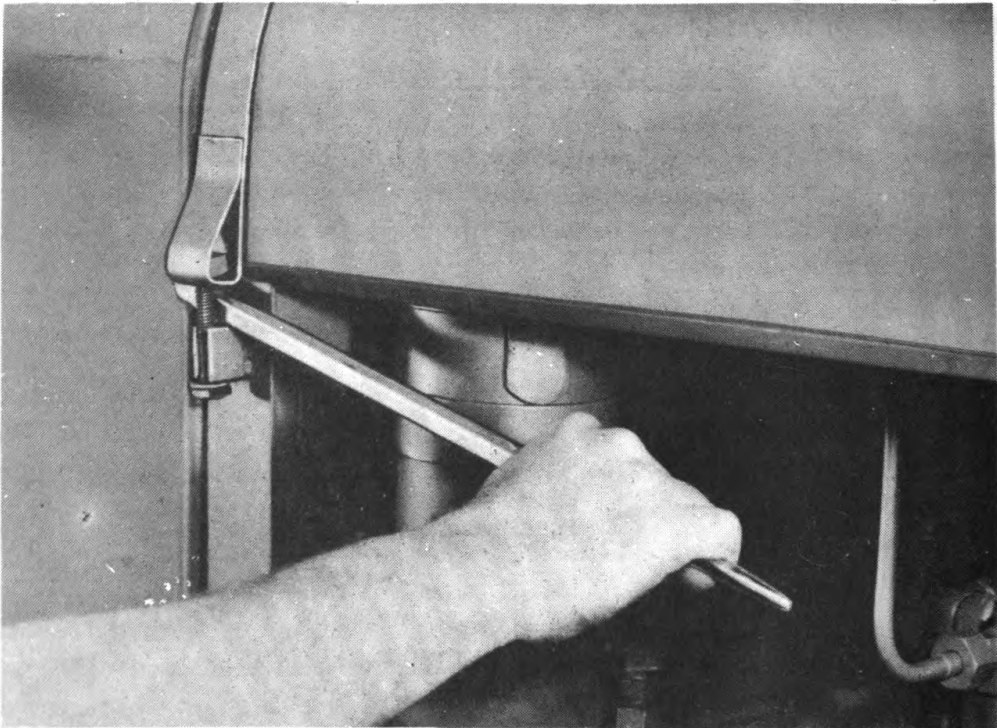

Figure 7 — Hood Clamp Removal

REMOVAL OF ENGINE FROM VEHICLE

RA PD 17807

Figure 8 — Front Fender Removal**(5) DISCONNECT WIRES AND UPPER RADIATOR HOSE.****PLIERS****SCREWDRIVER, 10-in.**

Disconnect ground terminal from battery post (pliers). Disconnect headlight wires at connector. This connector can be found near generator. Loosen lower clamp of top radiator hose and remove hose from thermostat housing.

(6) REMOVE ENGINE SUPPORT BOTTOM COVER.**WRENCH, 7/8-in.**

Remove the 6 cap screws, holding cover to engine support. It may be necessary to pry cover from support.

(7) DISCONNECT LOWER WATER CONNECTION.**WRENCH, 1/2-in.**

Remove the 2 cap screws, holding connection to oil cooler inlet.

(8) REMOVE RADIATOR GRILL.**HAMMER, 2-lb****WRENCH, 1-in.****HOIST, chain****WRENCH, socket, 5/8-in.,****PUNCH, large****with 6-in. extension****ROPE**

ORDNANCE MAINTENANCE — HEAVY TRACTOR M1 (Allis-Chalmers HD-10W) ENGINE

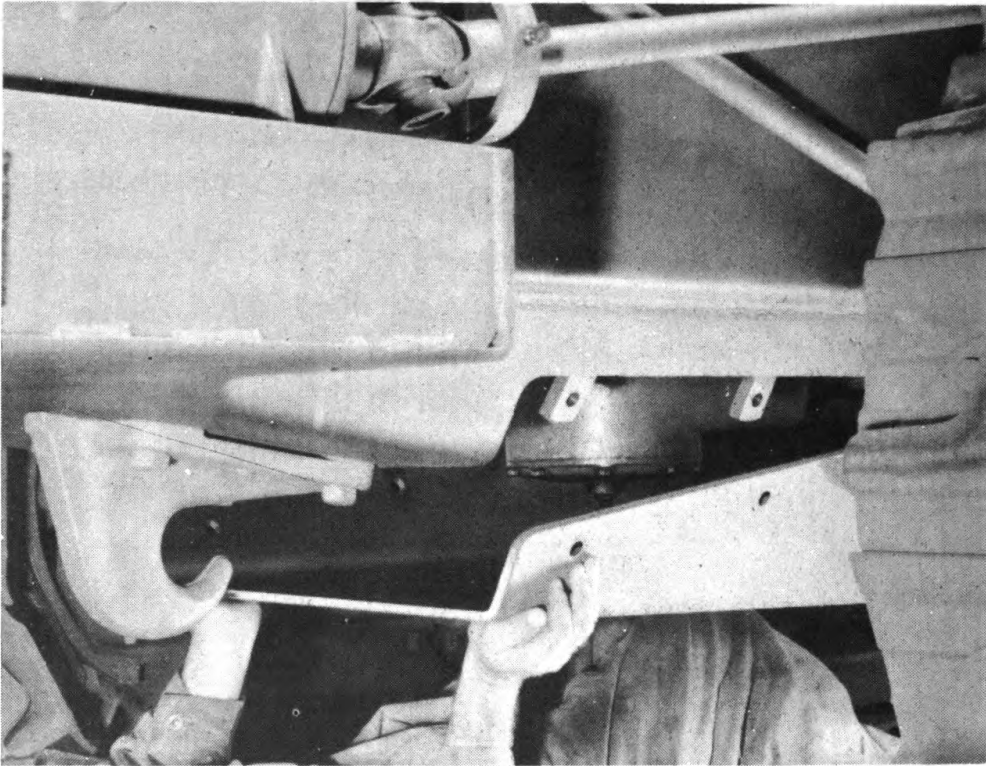

RA PD 17626

Figure 9 — Engine Support Bottom Cover Removal

Remove the 4 nuts on each side from bolts, holding grill to radiator ($\frac{5}{8}$ -in. wrench). Loosen the 2 remaining cap screws, holding radiator shell to engine support (1-in. wrench), and tilt top of radiator back until radiator touches fan. Drive out the T-head bolts from which nuts were removed (hammer, punch), taking care not to damage threads, and lift out grille (rope, chain hoist). **NOTE:** The lower bolts on left-hand side should be removed last as grille will have to be shifted to the left to allow this bolt to pass under flange on winch drum.

(9) REMOVE FAN ASSEMBLY.

PLIERS

WRENCH, $\frac{3}{4}$ -in.

Remove pin from radiator shutter control rod (pliers) and pull top of radiator as far forward as possible. Remove the 3 cap screws, holding bracket of fan assembly to balance weight cover of engine ($\frac{3}{4}$ -in. wrench); remove belts from pulley and lift out fan assembly.

(10) LIFT OUT RADIATOR ASSEMBLY.

HOIST, chain

WRENCH, 1-in.

Remove the 2 cap screws previously loosened on each side at bottom of radiator shell (1-in. wrench). Place rope around radiator under headlights. Lift out radiator assembly (chain hoist). Disengage shutter control rod as radiator is lifted out.

REMOVAL OF ENGINE FROM VEHICLE

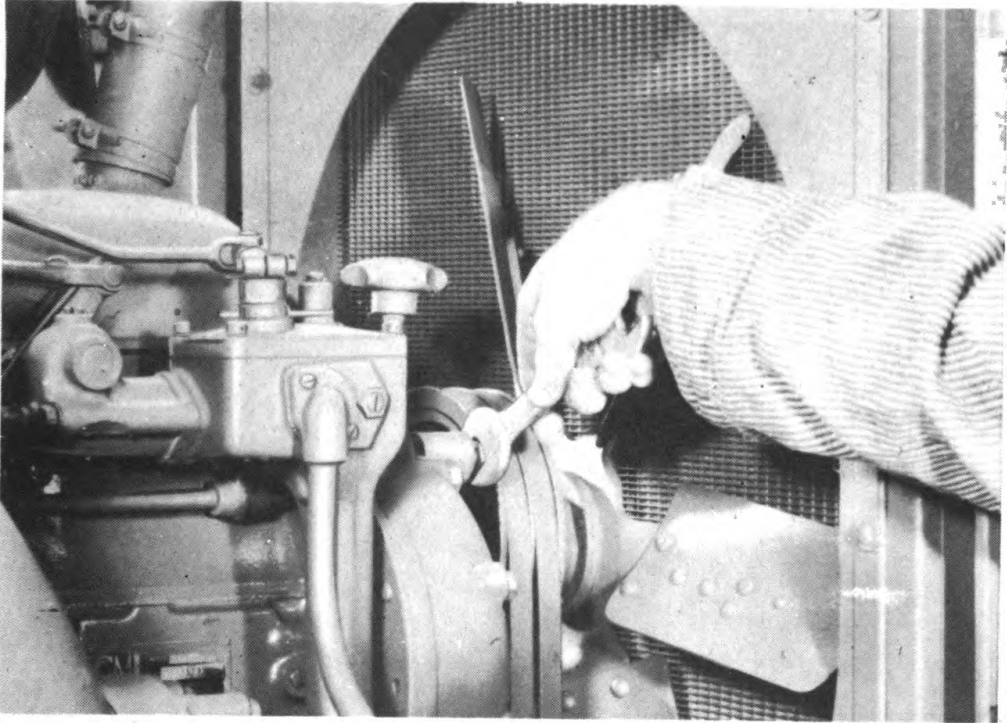

Figure 10 — Fan Assembly Removal

RA PD 17715

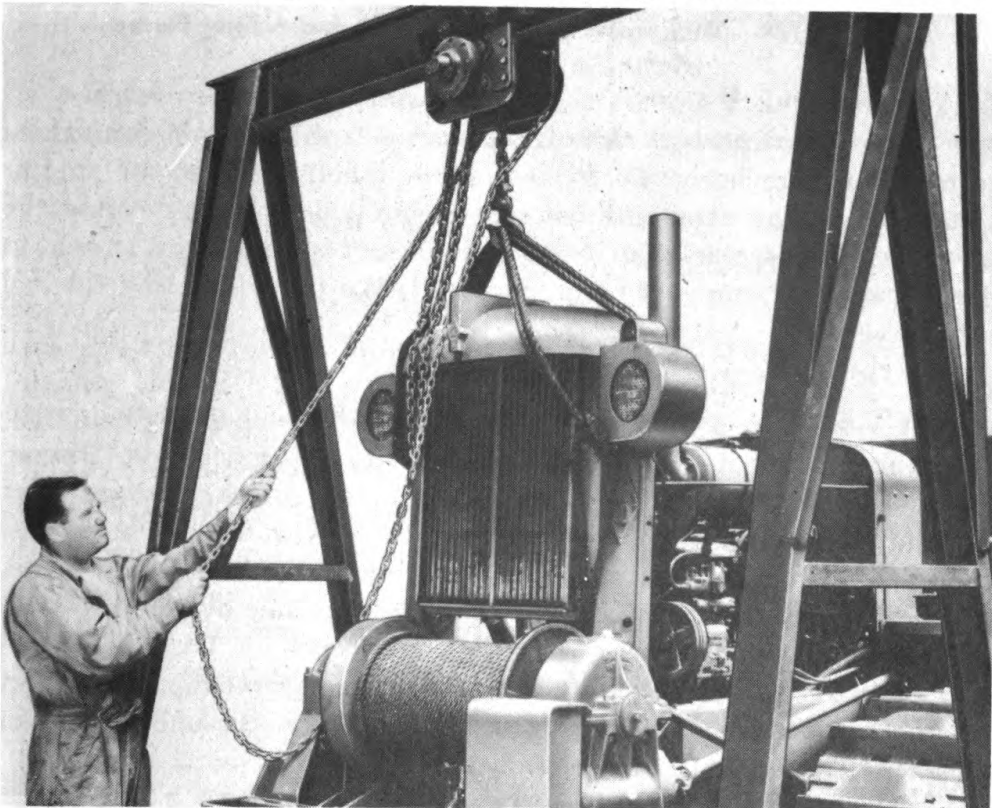
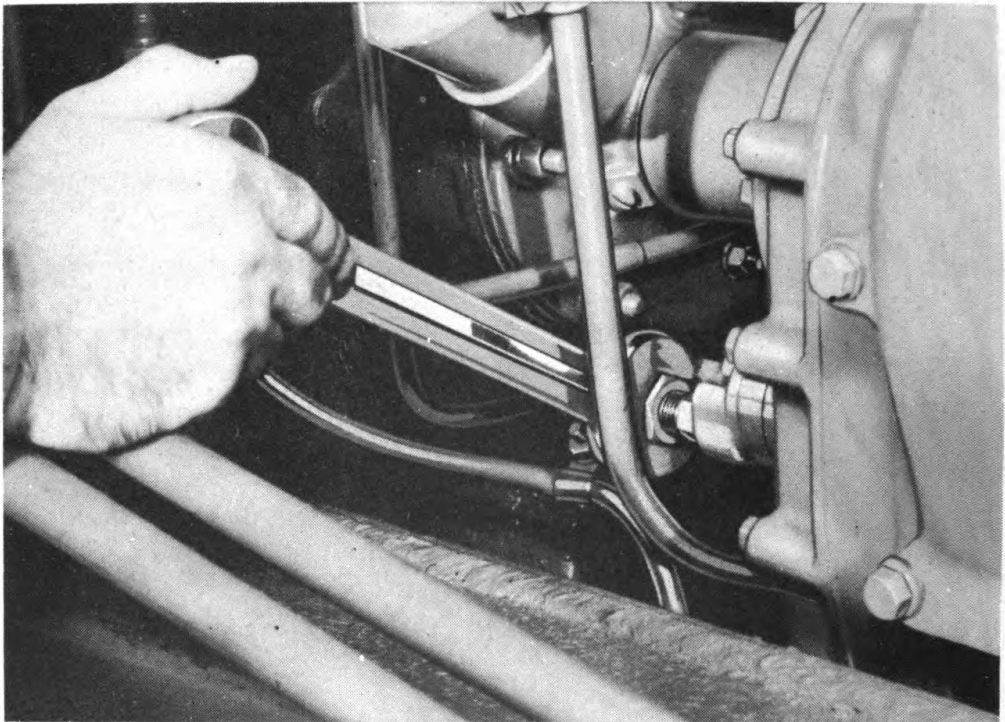

Figure 11 — Lifting Out Radiator Assembly

RA PD 17645



RA PD 17611

Figure 12 — Disconnecting Fuel Lines from Fuel Pump

(11) **DISCONNECT CONTROL RODS.** Disconnect throttle control shaft lever to governor rod by removing cotter pin and yoke pin connecting the rod to the governor. Disconnect shut-off bell crank to air shutter shaft lever rod by removing cotter pin and yoke pin connecting the rod to the air shutter shaft lever. Disconnect shut-off bell crank to governor rod by removing cotter pin and yoke pin connecting the rod to the governor.

(12) **DISCONNECT FUEL LINES.**

WRENCH, open-end, $\frac{3}{4}$ -in.

WRENCH, open-end, $\frac{7}{8}$ -in.

Shut off fuel supply by closing fuel shut-off cock under tank. Disconnect fuel pressure gage line from fitting at top of third stage filter ($\frac{3}{4}$ - and $\frac{7}{8}$ -in. wrenches), taking care not to twist flexible hose. Disconnect line from second stage to third stage filter ($\frac{3}{4}$ - and $\frac{7}{8}$ -in. wrenches). Disconnect flexible engine oil pressure line at union to steel tubing on right side of cowl ($\frac{3}{4}$ - and $\frac{7}{8}$ -in. wrenches). Disconnect fuel pump discharge line from second stage filter ($\frac{7}{8}$ -in. wrench). Disconnect fuel pump inlet and fuel return lines from connections under front of cowl on engine support ($\frac{7}{8}$ -in. wrench).

(13) **REMOVE THERMO GAGE TUBE.**

WRENCH, open-end, $1\frac{1}{16}$ -in.

REMOVAL OF ENGINE FROM VEHICLE

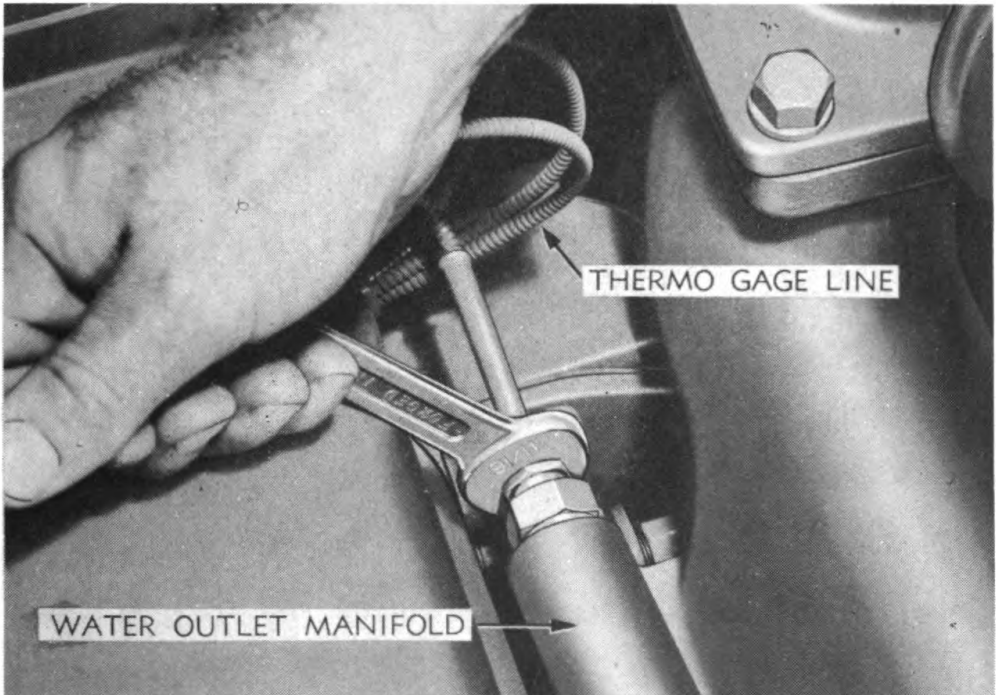

RA PD 56393

Figure 13 — Removing Thermo Gage Tube from Water Outlet Manifold

Loosen and remove thermo gage tube from rear end of water manifold.

(14) REMOVE AIR INTAKE ELBOW.

CLOTH, large

WRENCH, $\frac{9}{16}$ -in.

SCREWDRIVER, 10-in.

Loosen front hose clamp (screwdriver) and remove 4 cap screws, holding elbow ($\frac{9}{16}$ -in. wrench). Remove elbow. Stuff large cloth into air intake housing to prevent any foreign matter from entering.

(15) DISCONNECT AIR HEATER FUEL LINE.

WRENCH, open-end, $\frac{7}{16}$ -in.

WRENCH, open-end, $\frac{9}{16}$ -in. (2)

Disconnect air heater fuel line at rear of check valve underneath air heater ($\frac{9}{16}$ - and $\frac{7}{16}$ -in. wrenches). Remove nut, holding fuel line clip to flywheel housing (two $\frac{9}{16}$ -in. wrenches).

(16) REMOVE AIR HEATER COVER AND DISCONNECT COIL WIRE.

WRENCH, $\frac{1}{2}$ -in.

WRENCH, open-end, $\frac{3}{8}$ -in.

Remove 2 cap screws, holding air heater cover ($\frac{1}{2}$ -in. wrench), remove cover, disconnect wire from bottom of coil ($\frac{3}{8}$ -in. wrench), and reinstall cover ($\frac{1}{2}$ -in. wrench).

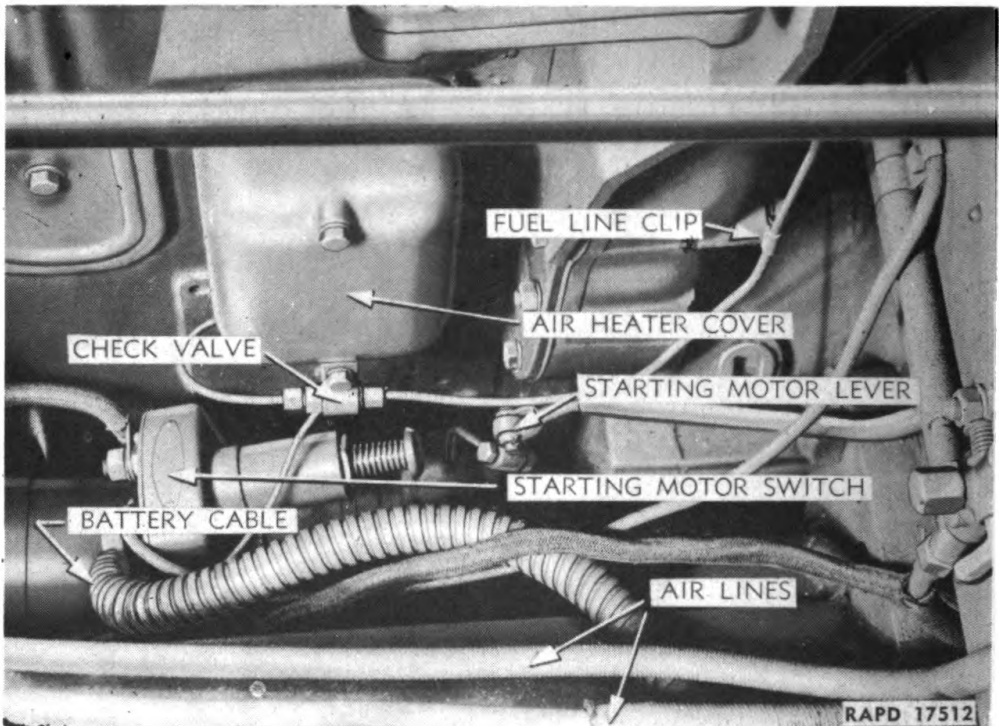

Figure 14 — Wires, Lines, and Controls To Be Disconnected

(17) DISCONNECT STARTING MOTOR.

PLIERS

WRENCH, 3/4-in.

Disconnect battery cable from starting motor switch terminal. Tape end of battery cable to prevent its contacting metal. Lift ammeter and electric trailer brake control wire from terminal. Remove pin from starting motor lever and rod (fig. 14).

(18) DISCONNECT WIRE FROM VOLTAGE REGULATOR.

SCREWDRIVER, 10-in.

Disconnect wire running from voltage regulator to ammeter.

(19) REMOVE AIR LINES.

WRENCH, 7/16-in.

WRENCH, open-end, 5/8-in.

WRENCH, 1/2-in.

WRENCH, open-end, 7/8-in.

Disconnect the 2 air lines from fittings on top of air compressor (5/8- and 7/8-in. wrenches) and remove bolts from clip, holding lines to air compressor bracket (7/16- and 1/2-in. wrenches).

(20) ENGAGE MASTER CLUTCH.

The master clutch must be engaged so that throwout bearing will clear clutch shaft when engine is moved ahead to be lifted out of tractor.

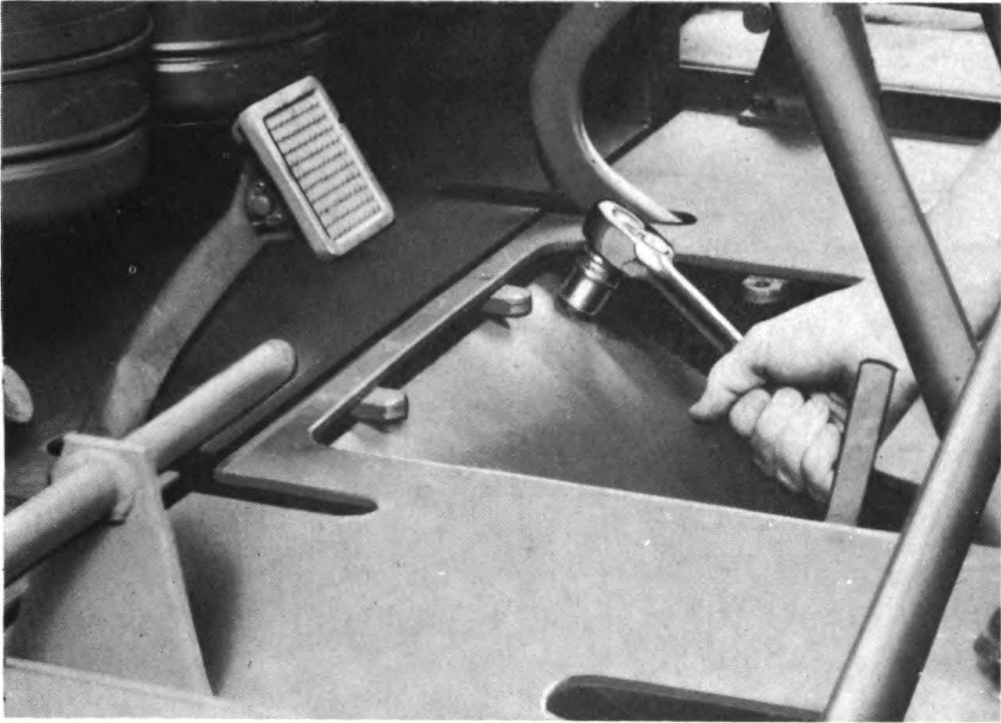
REMOVAL OF ENGINE FROM VEHICLE

RA PD 17638

Figure 15 — Clutch Inspection Cover Removal**(21) REMOVE CLUTCH INSPECTION HOLE COVER.****PLIERS****WRENCH, $\frac{3}{4}$ -in.**

Remove 2 cap screws and lift off floor plate over inspection hole cover ($\frac{3}{4}$ -in. wrench). Remove 4 cap screws from cover over master clutch inspection hole ($\frac{3}{4}$ -in. wrench). Remove cover, pull cotter pin (pliers), and remove yoke pin from end of master clutch control rod.

(22) REMOVE NUT FROM RELEASE BEARING LUBRICATING TUBE.**WRENCH, $\frac{15}{16}$ -in.**

Remove nut from release bearing lubricating tube on top of clutch housing and push lubricating tube down into clutch compartment. Prevent tube from turning or twisting while removing nut (fig. 16).

(23) DISCONNECT ENGINE FROM SPACER.**PUNCH, small****WRENCH, box, $\frac{9}{16}$ -in., with 90 deg offset**

Remove the 10 cap screws, holding engine to spacer. **NOTE:** The 2 bottom cap screws may be most easily removed with a 90 degree offset, box socket wrench. The offset wrench can be placed between the fly-wheel housing and equalizer spring to remove the cap screws. Turn wrench with punch through opposite end of wrench.

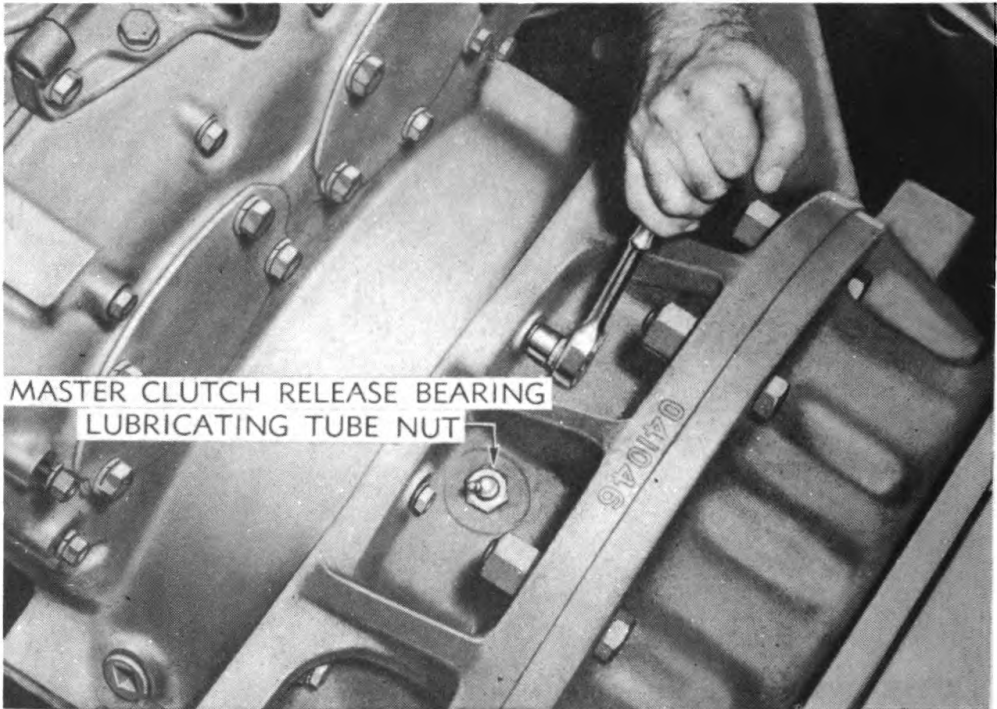

RA PD 56394

Figure 16 — Location of Engine-to-Spacer Cap Screws

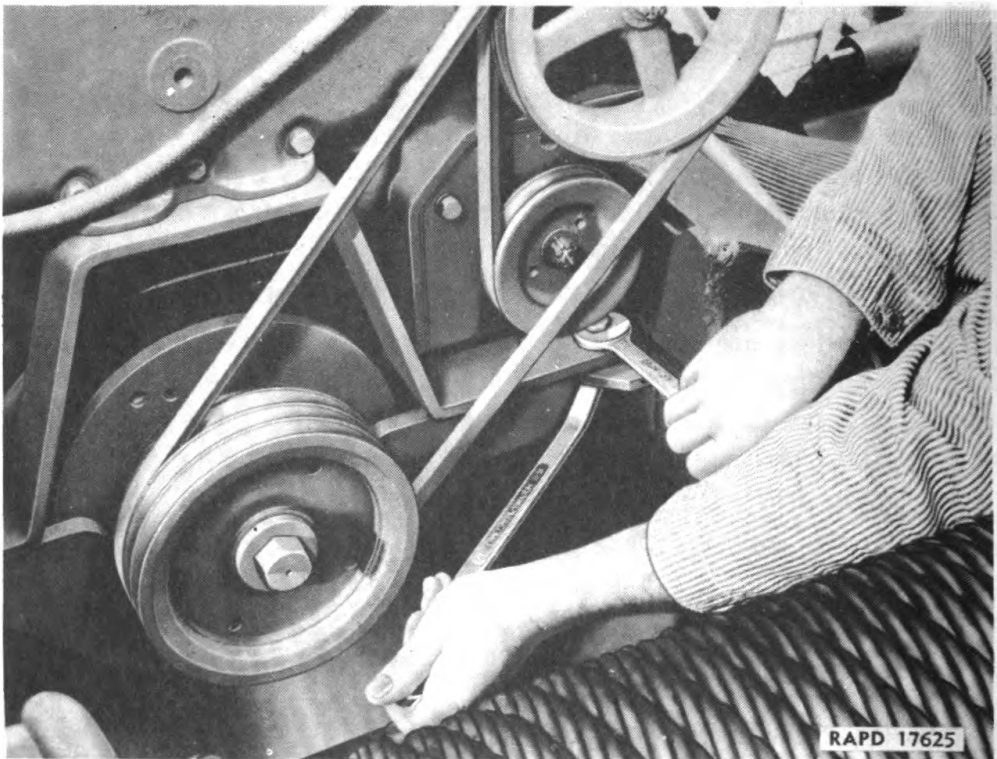
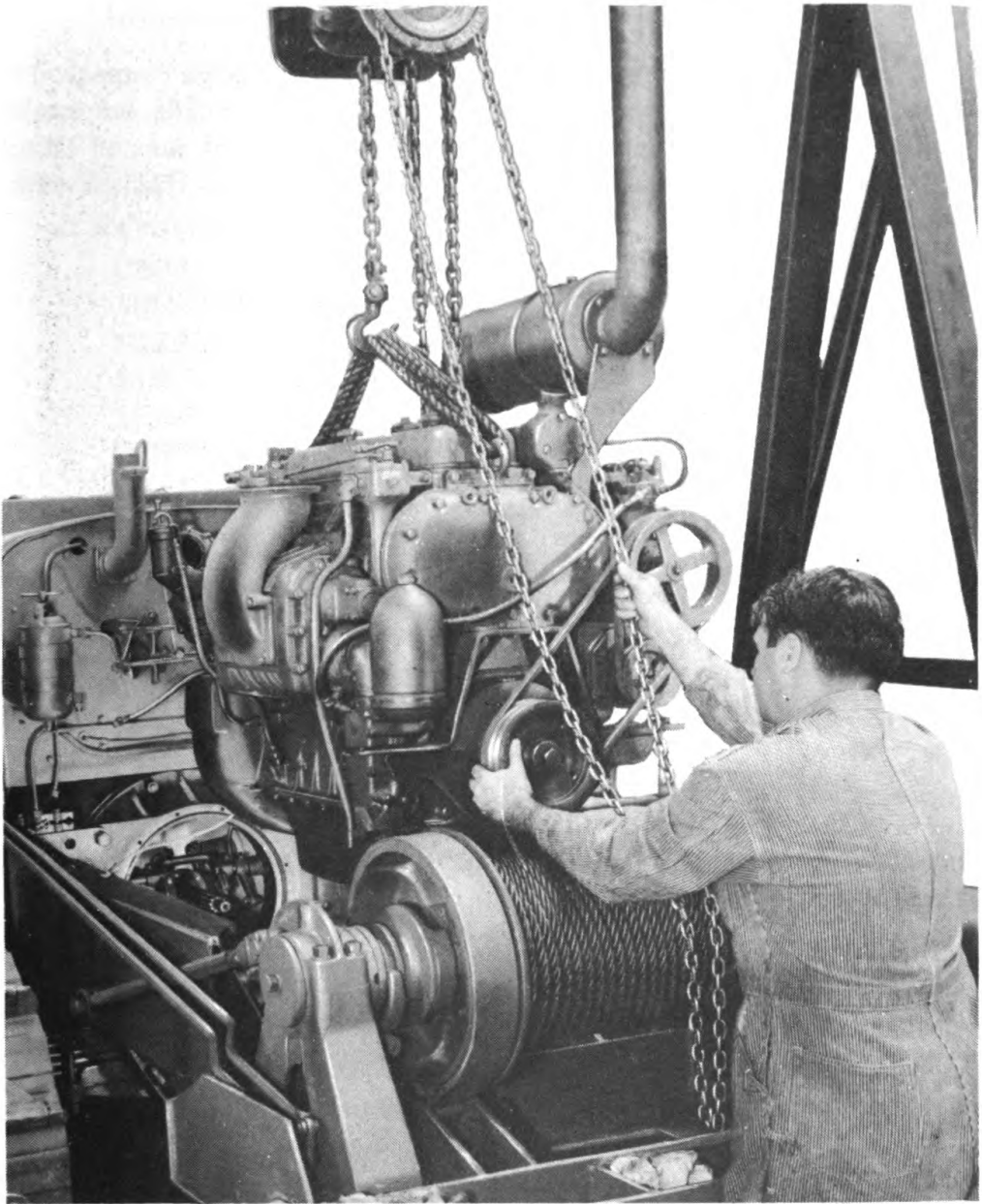

Figure 17 — Removing Bolts from Front Engine Support

REMOVAL OF ENGINE FROM VEHICLE

RA PD 17649

Figure 18 — Lifting Engine from Tractor**(24) REMOVE BOLTS FROM FRONT ENGINE SUPPORT.****HOIST**, chain**WRENCH**, $\frac{7}{8}$ -in.**ROPE****WRENCH**, $\frac{15}{16}$ -in.

Remove the 2 bolts from the front engine support ($\frac{7}{8}$ - and $\frac{15}{16}$ -in. wrenches), lift motor slightly, and take out the shims from between support and hanger. **CAUTION:** Shims removed must be reinstalled when engine is reinstalled. Wire them to tractor.

ORDNANCE MAINTENANCE — HEAVY TRACTOR M1 (Allis-Chalmers HD-10W) ENGINE

(25) LIFT ENGINE FROM TRACTOR.

HOIST, chain

ROPE

Engine can now be removed by a chain hoist and rope connected to lifter brackets. Raise engine high enough to take weight off engine supports; then slide engine forward far enough so that master clutch throwout bearing clears end of clutch shaft. Engine may then be lifted from tractor.

Section VI

REMOVAL OF ACCESSORIES FROM ENGINE

Paragraph

Removal of accessories from engine 10

10. REMOVAL OF ACCESSORIES FROM ENGINE.**a. Equipment.**

CHISEL, $\frac{5}{8}$ -in.	WRENCH, open-end, $\frac{7}{16}$ -in.
HAMMER, 2-lb	WRENCH, open-end, $\frac{1}{2}$ -in.
PLIERS	WRENCH, open-end, $\frac{9}{16}$ -in.
PULLER, fan drive pulley	WRENCH, open-end, $\frac{3}{4}$ -in.
SCREWDRIVER, 8-in.	WRENCH, open-end, $\frac{7}{8}$ -in.
SCREWDRIVER, 10-in.	WRENCH, socket, $\frac{1}{2}$ -in.
STAND, engine	WRENCH, socket, $\frac{9}{16}$ -in., with 6-in. extension
WRENCH, $\frac{5}{8}$ -in.	WRENCH, socket, $\frac{7}{8}$ -in., with 18-in. extension
WRENCH, $\frac{13}{16}$ -in.	
WRENCH, $\frac{15}{16}$ -in.	
WRENCH, $\frac{15}{16}$ -in.	

b. Procedure.**(1) REMOVE STARTING MOTOR.**

WRENCH, $\frac{15}{16}$ -in.	WRENCH, socket, $\frac{7}{8}$ -in., with 18-in. extension
------------------------------	--

Remove 2 cap screws and 1 bolt, holding starting motor to flywheel housing assembly ($\frac{7}{8}$ - and $\frac{15}{16}$ -in. wrenches). Jar starting motor loose and remove it.

(2) REMOVE GENERATOR.

SCREWDRIVER, 8-in.	WRENCH, $\frac{5}{8}$ -in.
WRENCH, $\frac{1}{2}$ -in.	

Remove cap screw, holding generator to slotted adjusting arm ($\frac{1}{2}$ -in. wrench). Disconnect generator from generator voltage regulator to generator wires (screwdriver). Remove cap screw in belt adjusting link. Remove 2 cap screws, holding generator to compressor support bracket ($\frac{5}{8}$ -in. wrench). Remove generator drive belt from generator pulley and lift off generator.

(3) REMOVE AIR COMPRESSOR.

WRENCH, $\frac{5}{8}$ -in.

Disconnect the inlet and outlet water lines from the compressor head. Remove the 2 upper cap screws, holding compressor support bracket to cylinder block. Loosen the 2 lower cap screws, holding compressor support bracket, remove drive belt from pulley, and lift air compressor assembly off engine. Remove the 2 lower cap screws.

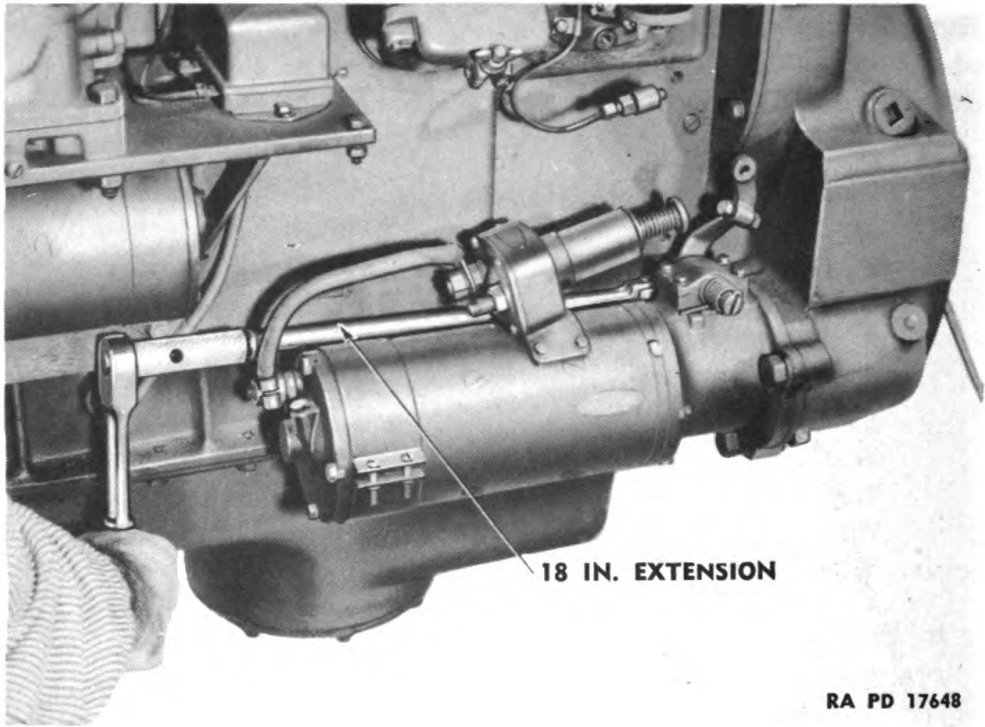

RA PD 17648

Figure 19 — Starting Motor Assembly Removal

(4) REMOVE PREHEATER INLET ELBOW.

WRENCH, socket, $\frac{9}{16}$ -in., with 6-in. extension

Open hinged cover and remove cap screw, holding preheater inlet elbow to cylinder block. Remove elbow.

(5) REMOVE AIR HEATER.

WRENCH, socket, $\frac{9}{16}$ -in.

Remove air heater cover. Remove special cap screw, holding air heater assembly to cylinder block. Lift off air heater assembly. Remove remaining handhole covers.

(6) REMOVE AIR BOX DRAIN TUBE AND ELBOW.

WRENCH, open-end, $\frac{1}{2}$ -in.

WRENCH, open-end, $\frac{3}{4}$ -in.

Disconnect drain tube from elbow ($\frac{3}{4}$ -in. wrench). Remove elbow ($\frac{1}{2}$ -in. wrench) (fig. 20).

(7) MOUNT ENGINE ON ENGINE STAND.

With above accessories removed, the engine can be mounted on a stand similar to the one shown. This will facilitate the remaining work to be done on engine.

REMOVAL OF ACCESSORIES FROM ENGINE

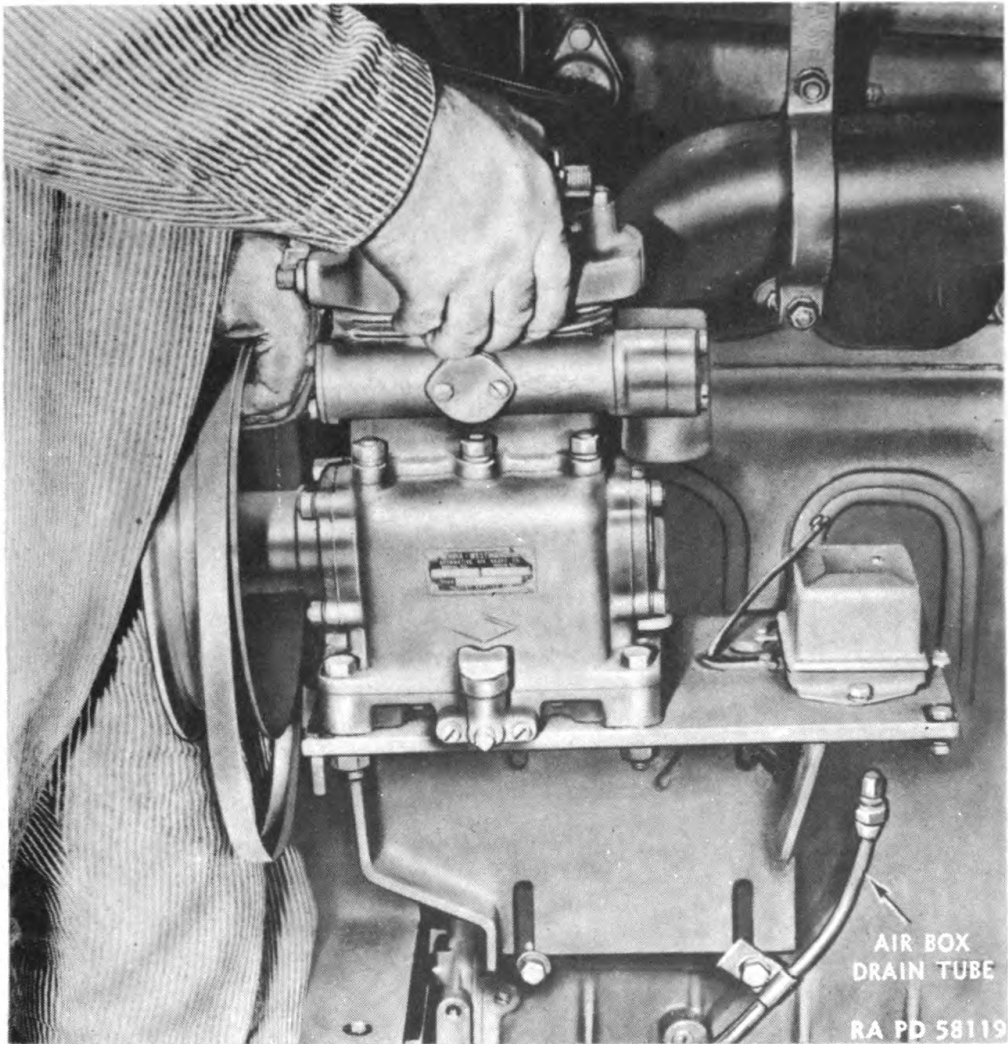

Figure 20 — Air Compressor Assembly Removal

(8) REMOVE MUFFLER AND MANIFOLD ASSEMBLY.

WRENCH, $\frac{9}{16}$ -in. (2)

WRENCH, $\frac{5}{8}$ -in.

Remove the 2 bolts, holding the bottom of each muffler support to the cylinder block end plates. **NOTE:** The front bolts are threaded into the end plates. Loosen the 5 stud nuts, holding exhaust manifold to cylinder block. Lift off muffler and manifold assembly.

(9) REMOVE MASTER CLUTCH ASSEMBLY.

CHISEL, $\frac{5}{8}$ -in.

WRENCH, $\frac{3}{4}$ -in.

HAMMER, 2-lb

Straighten the screw locks on 9 special cap screws, holding master clutch assembly (hammer and chisel), and remove the cap screws ($\frac{3}{4}$ -in. wrench). Lift off master clutch assembly.

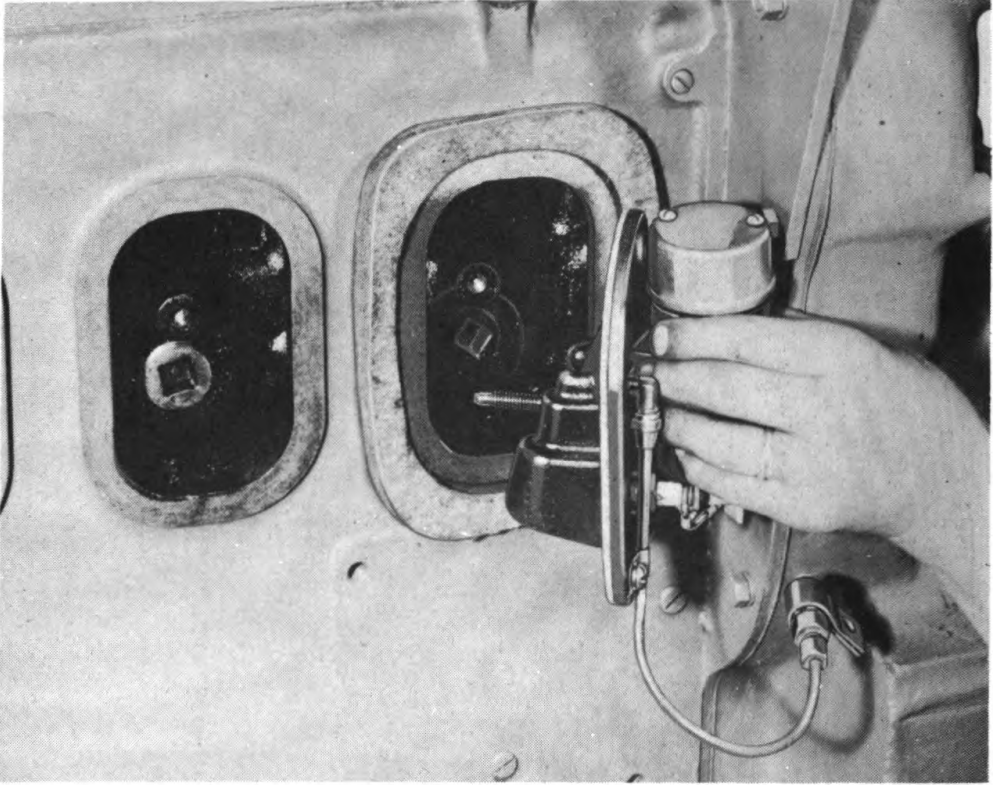

RA PD 17639

Figure 21 — Air Heater Burner Unit Removal

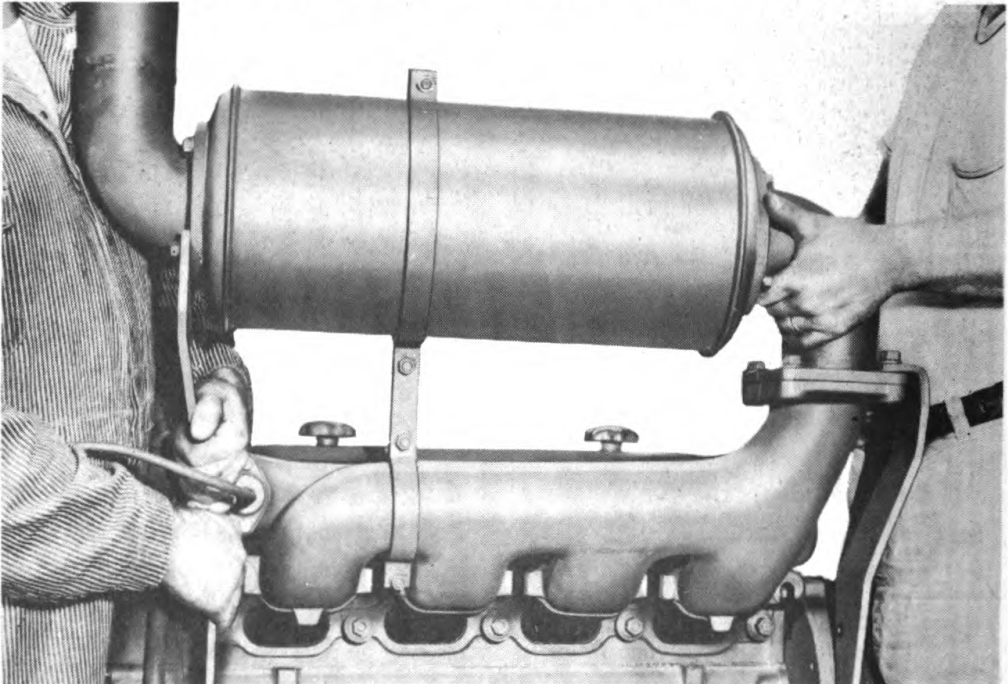

RA PD 17650

Figure 22 — Exhaust Manifold and Muffler Assembly Removal

REMOVAL OF ACCESSORIES FROM ENGINE

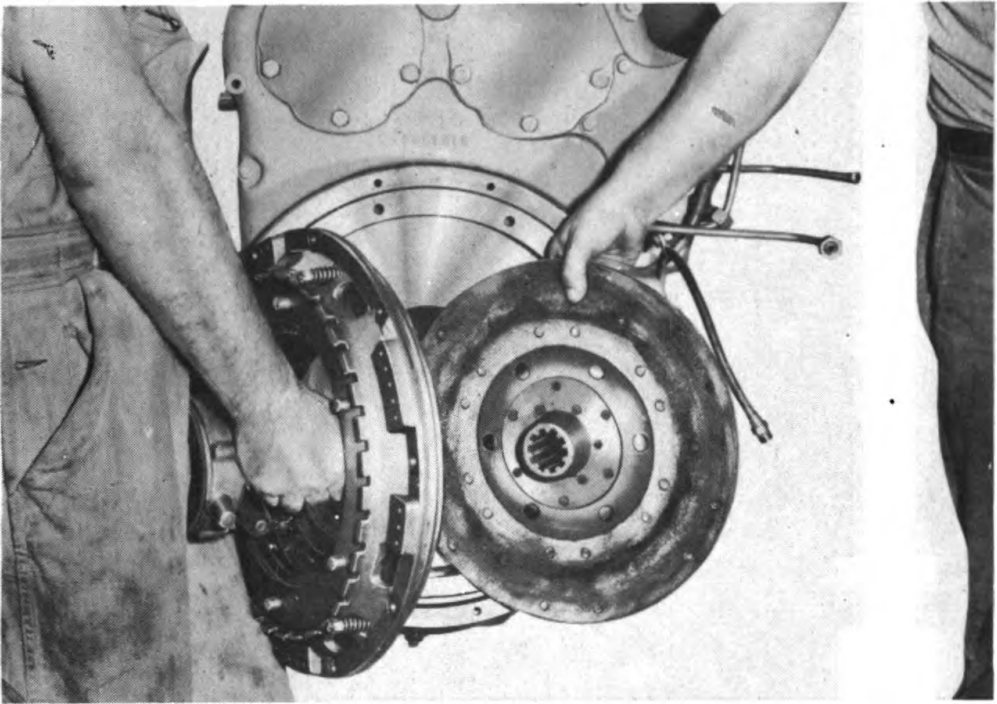

RA PD 17848

Figure 23 — Master Clutch Assembly Removal

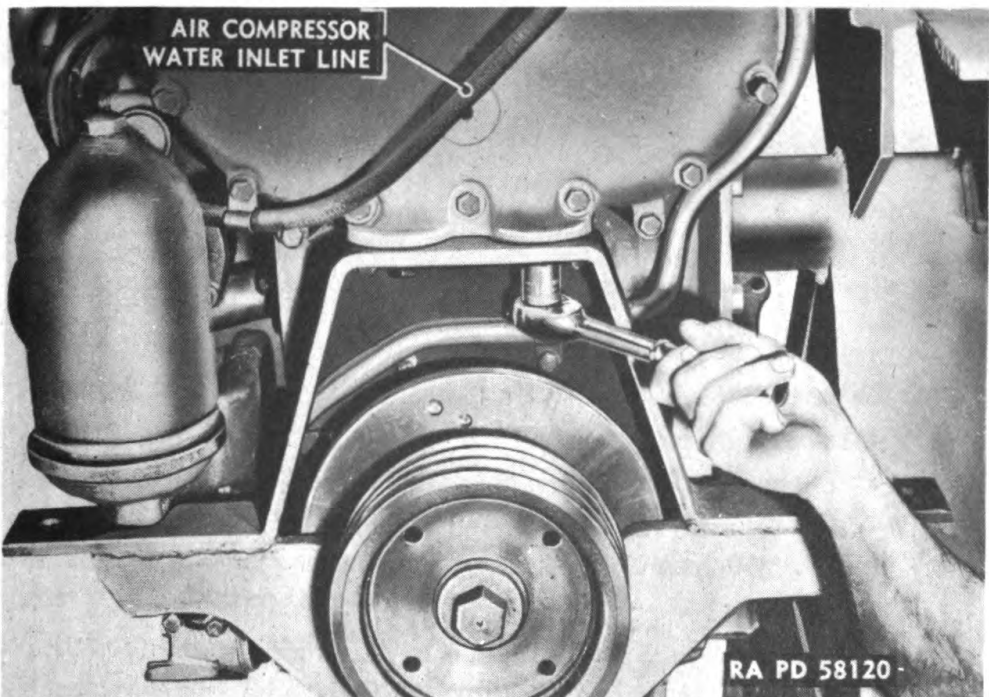

RA PD 58120

Figure 24 — Engine Front Hanger Removal

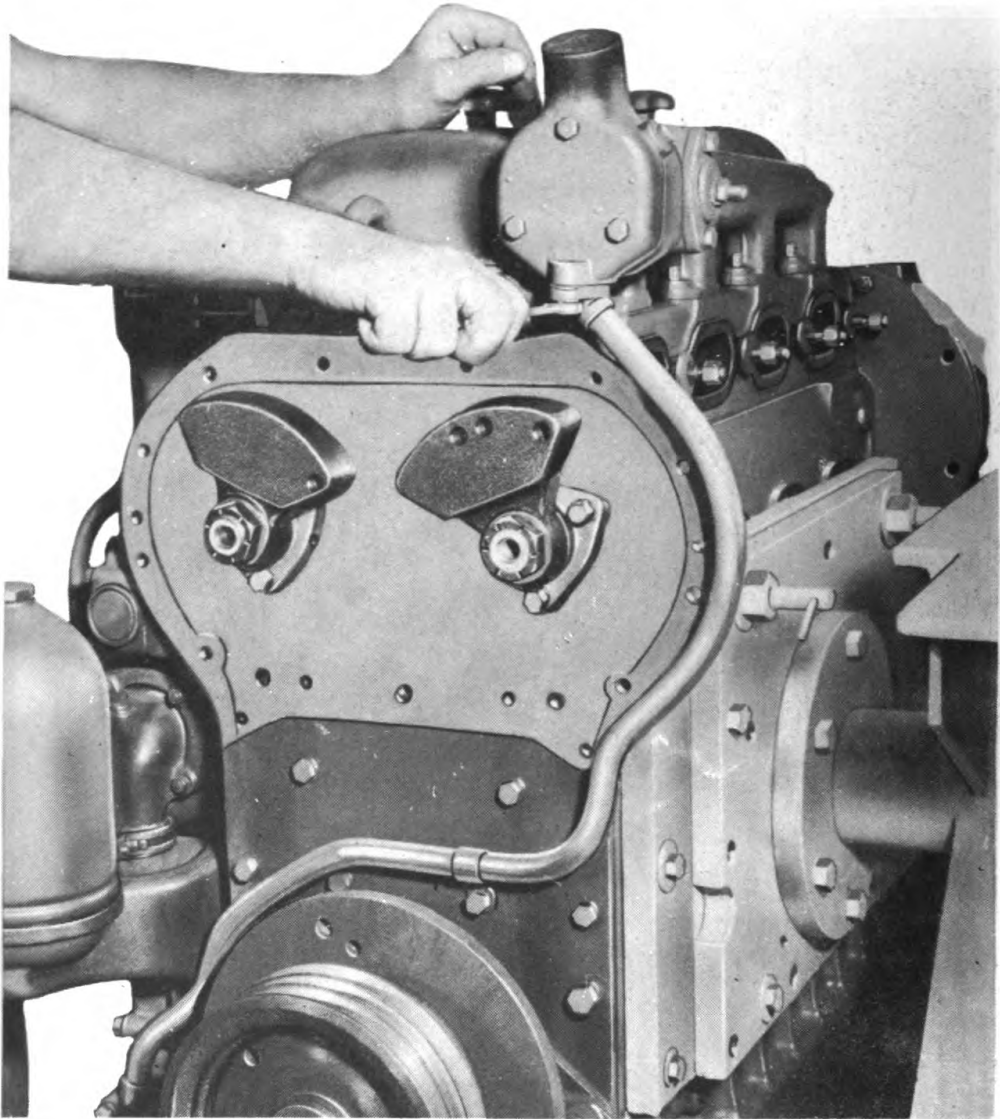

RA PD 17742

**Figure 25 — Disconnecting Water Bypass Tube from
Thermostat Housing**

(10) REMOVE ENGINE FRONT HANGER.

WRENCH, $\frac{7}{8}$ -in.

Remove 2 cap screws, holding engine support bracket to balance weight housing. Lift off engine front hanger.

(11) REMOVE WATER BYPASS TUBE ASSEMBLY.

WRENCH, $\frac{1}{2}$ -in.

WRENCH, $\frac{9}{16}$ -in.

Remove 2 cap screws, holding water bypass tube assembly to thermostat housing and 2 cap screws, holding it to oil cooler ($\frac{1}{2}$ -in. wrench). Remove cap screw, holding bypass tube clip to front of engine ($\frac{9}{16}$ -in. wrench) and lift off water bypass tube assembly.

REMOVAL OF ACCESSORIES FROM ENGINE

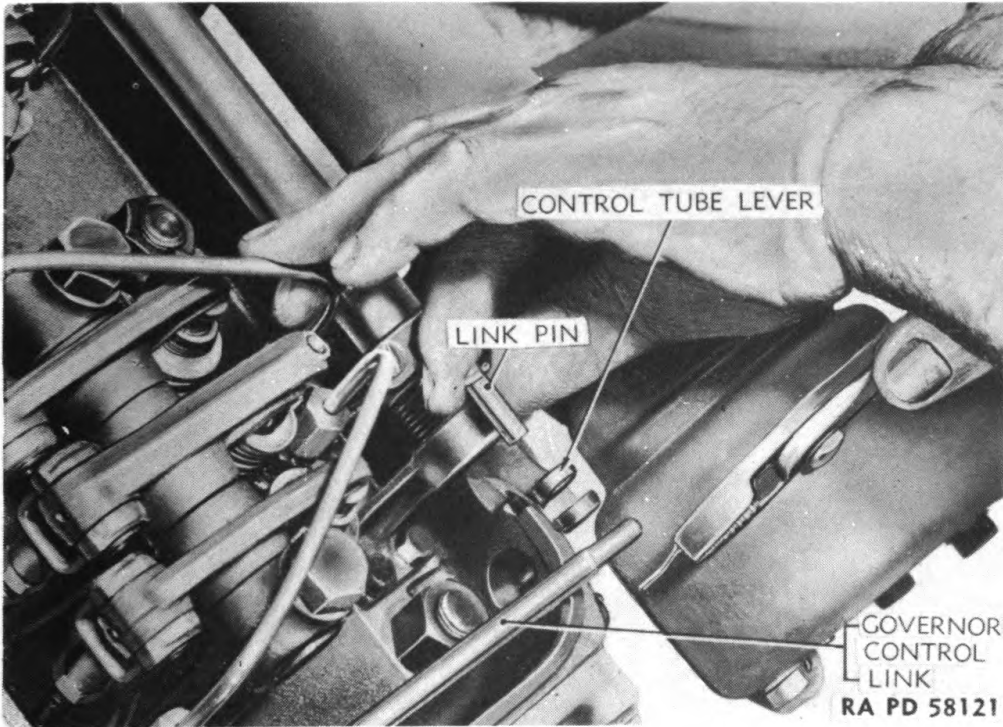

Figure 26 — Disconnecting Control Link from Control Tube Lever

(12) REMOVE WATER OUTLET MANIFOLD.

WRENCH, $\frac{9}{16}$ -in.

Remove air compressor water outlet line from manifold. Remove eight $\frac{3}{8}$ -inch nuts and lock washers from studs, securing manifold to cylinder head. Remove manifold and gasket.

(13) REMOVE CONTROL HOUSING ASSEMBLY.

(a) Disconnect Control Link.

PLIERS

Remove rocker arm cover. Remove link pin, holding control link to control tube lever.

(b) Remove Control Housing Cover Assembly.

SCREWDRIVER, 10-in.

Remove 4 fillister head screws holding control housing cover assembly to governor housing. Remove cover assembly.

(c) Remove Control Link.

PLIERS

Remove clip and washer, holding control link on differential lever pin. Remove control link.

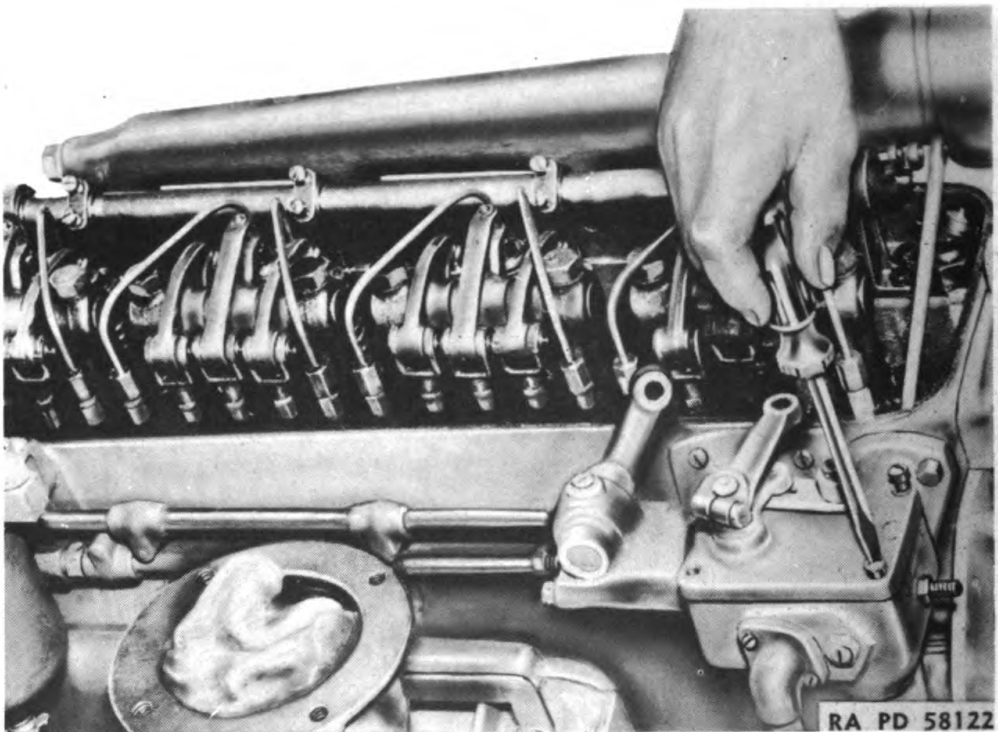

Figure 27 — Control Housing Cover Assembly Removal

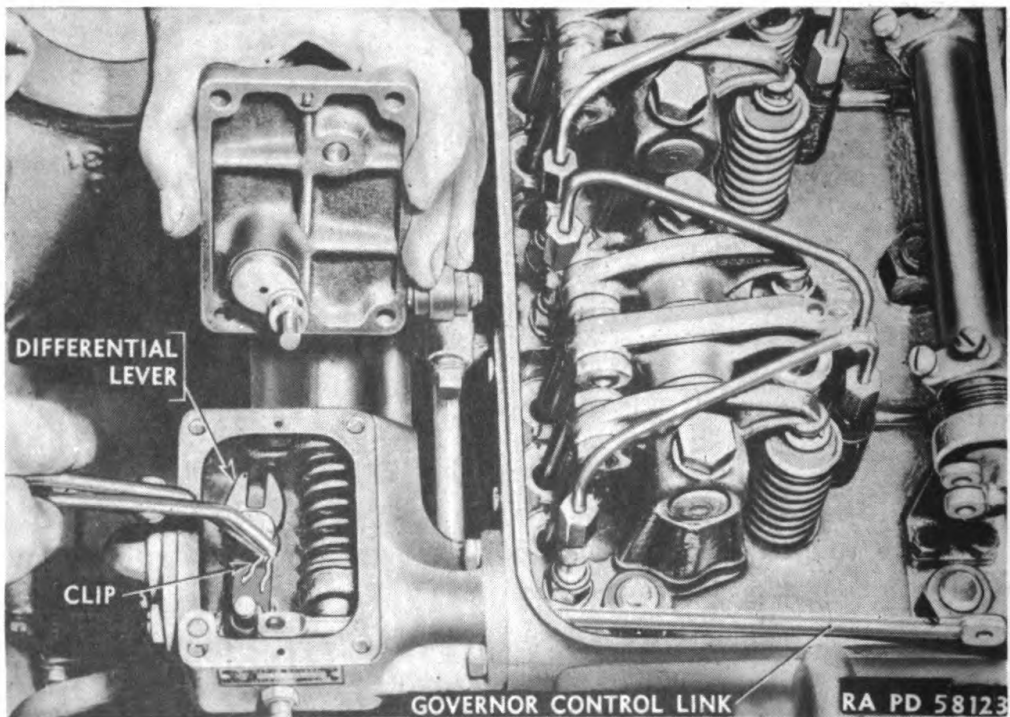
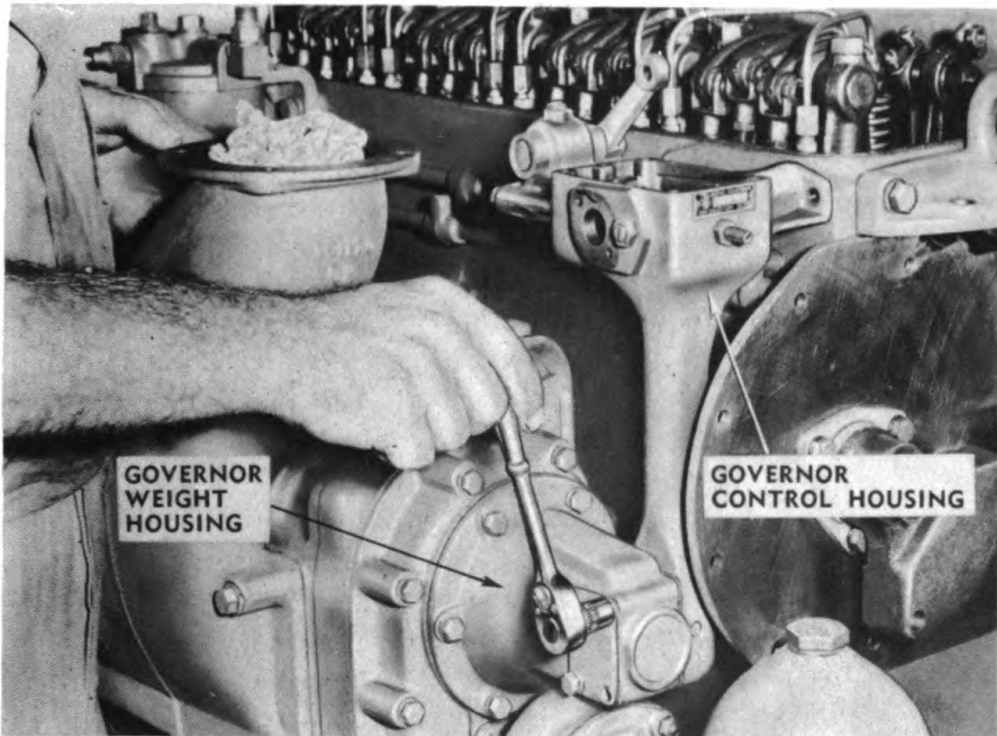

Figure 28 — Removing Clip from Differential Lever Pin

REMOVAL OF ACCESSORIES FROM ENGINE

RA PD 17849

Figure 29 — Control Housing Removal**(d) Remove Governor Breather Pipe.****SCREWDRIVER, 10-in.**

Remove 2 screws, holding governor breather pipe to control housing. Lift governor breather pipe out of clip, holding pipe to oil cooler housing.

(e) Remove Control Housing Assembly.**WRENCH, open-end, $\frac{7}{16}$ -in.**

Remove 2 cap screws at upper end, holding assembly to cylinder head and 4 cap screws at lower end, holding assembly to governor weight housing. Lift off control housing assembly.

(14) REMOVE OIL COOLER AND FILTER.**WRENCH, $\frac{1}{2}$ -in.****WRENCH, socket, $\frac{9}{16}$ -in.**

Disconnect oil cooler housing from water pump. Remove 8 cap screws, holding oil cooler housing ($\frac{1}{2}$ -in. wrench), and remove housing and oil cooler element. Remove 7 cap screws, holding oil filter and cooler adapter to cylinder block ($\frac{9}{16}$ -in. wrench). Lift off adapter and oil filter. **NOTE:** Cooler element lifts out of housing after housing is removed.

(15) REMOVE BLOWER DRIVE SHAFT.**PLIERS, long nose****WRENCH, open-end, $\frac{9}{16}$ -in.****SCREW, cap, $\frac{5}{16}$ x 4-in.****(2)**

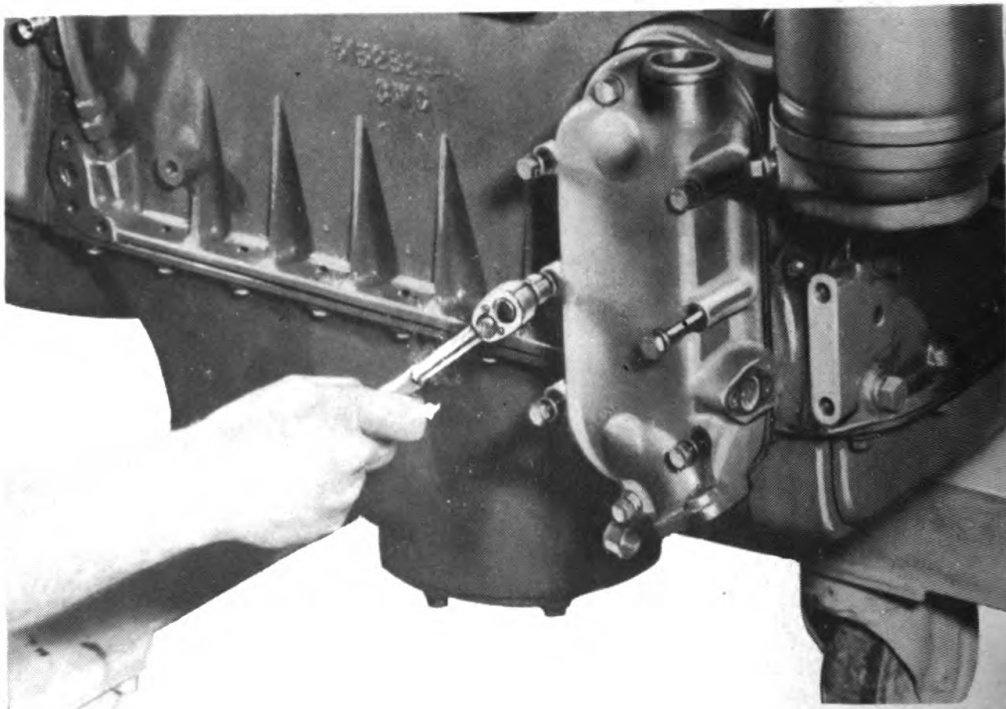

RA PD 17828

Figure 30 — Oil Cooler Housing Removal

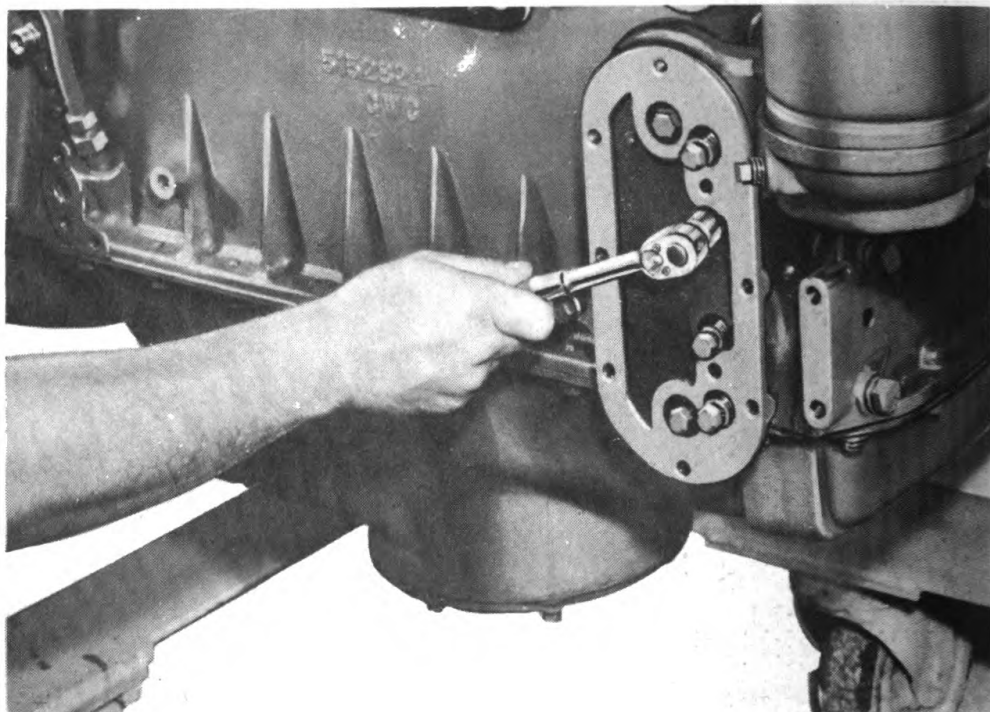

RA PD 17872

Figure 31 — Oil Filter and Cooler Adapter Removal

REMOVAL OF ACCESSORIES FROM ENGINE

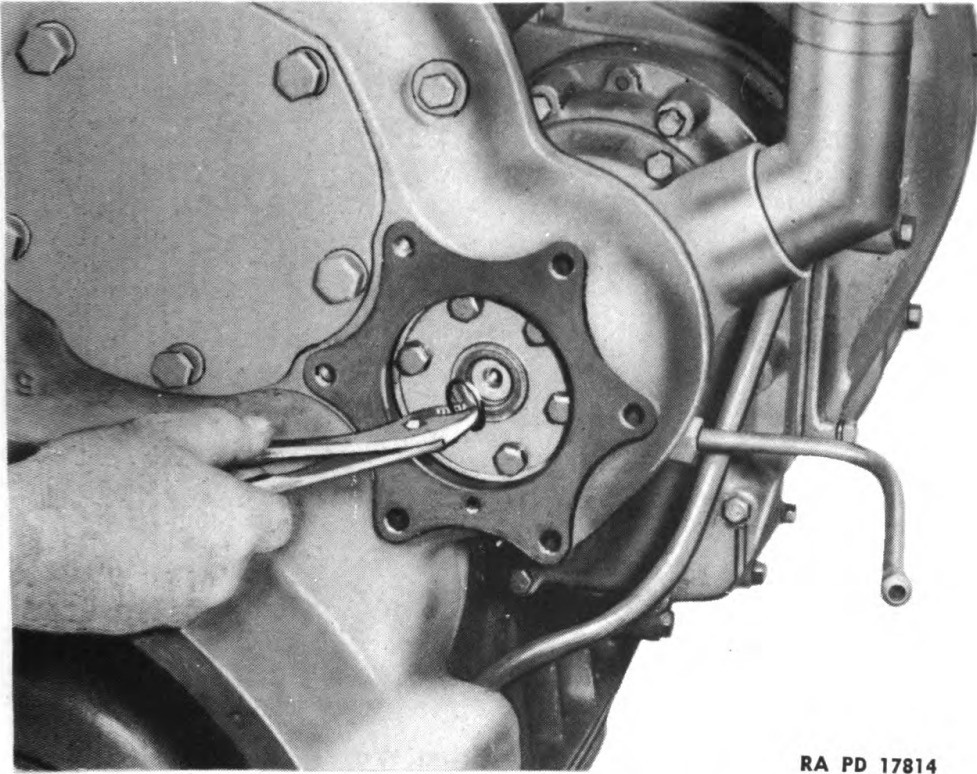

RA PD 17814

Figure 32 — Blower Drive Shaft Retainer Ring Removal

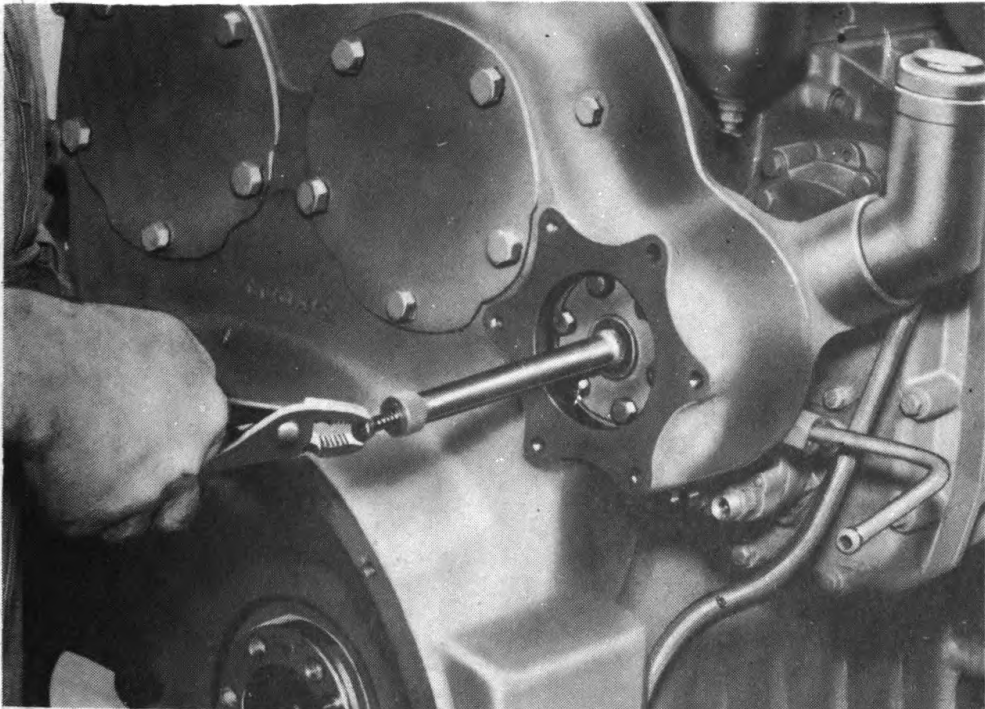

RA PD 17829

Figure 33 — Blower Drive Shaft Removal

ORDNANCE MAINTENANCE — HEAVY TRACTOR M1 (Allis-Chalmers HD-10W) ENGINE

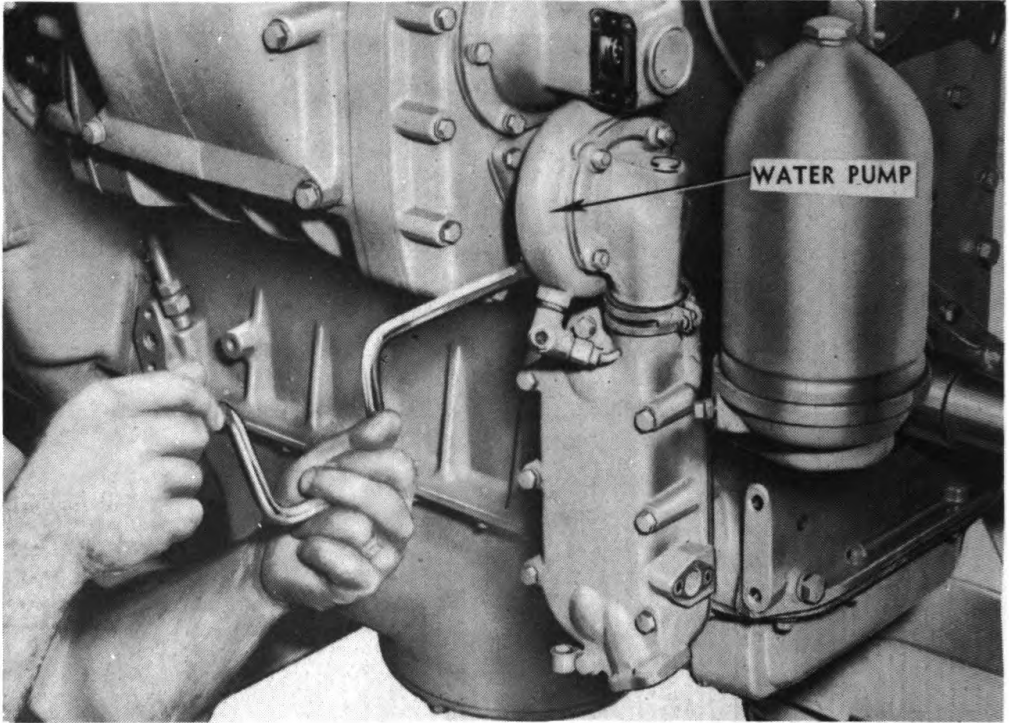

RA PD 17810

Figure 34 — Removing Cap Screws from Water Pump Outlet Packing Flange

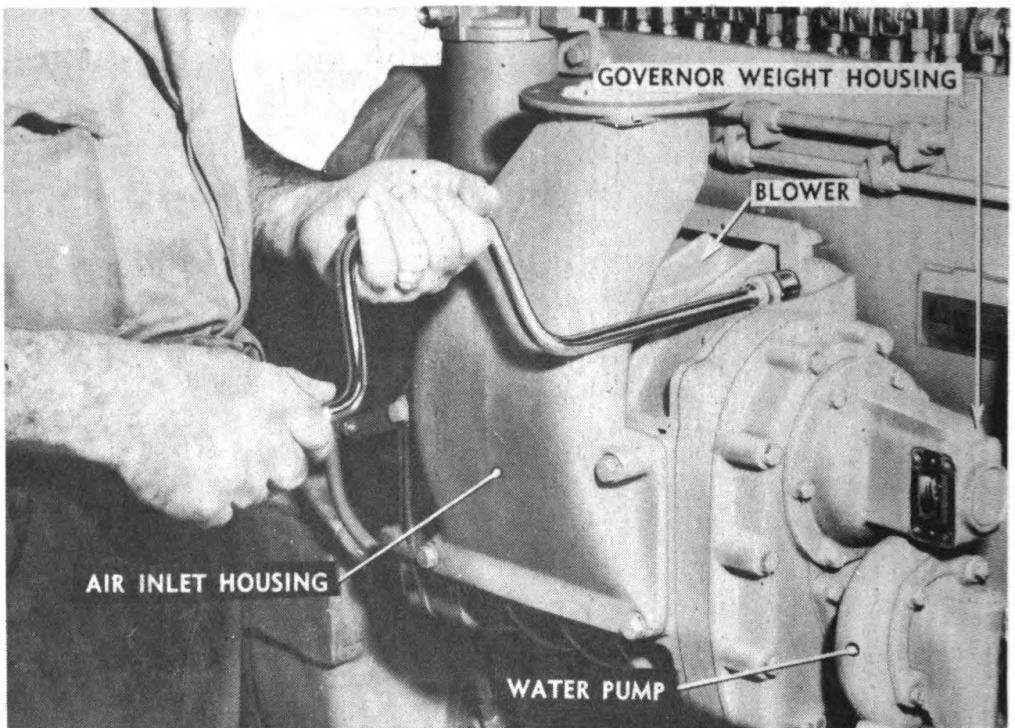

RA PD 17811

Figure 35 — Removing Cap Screws Holding Blower to Cylinder Block

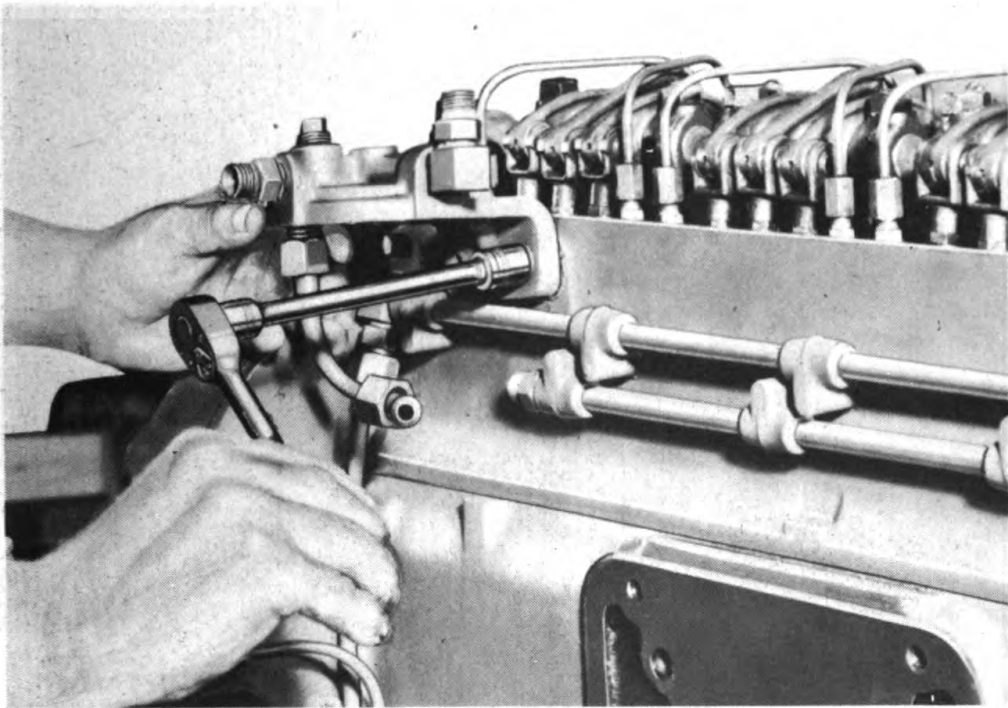
REMOVAL OF ACCESSORIES FROM ENGINE

RA PD 17844

Figure 36 — Third Stage Fuel Filter Head Removal

Remove 4 bolts and 2 cap screws, holding flywheel housing star cover ($\frac{9}{16}$ -in. wrenches), and remove cover. Remove blower drive shaft retainer ring (pliers). Insert cap screw in end of drive shaft and pull out shaft.

(16) REMOVE BLOWER, WATER AND FUEL PUMP, AND GOVERNOR WEIGHT HOUSING AS ONE UNIT.

WRENCH, $\frac{5}{8}$ -in.

WRENCH, socket, $\frac{1}{2}$ -in.

Loosen 2 cap screws, holding water pump outlet packing flange to cylinder block ($\frac{1}{2}$ -in. wrench). Remove 4 cap screws, holding blower to cylinder block ($\frac{5}{8}$ -in. wrench). Remove throttle control pull-back spring bracket when upper cap screws are removed. Lift off blower assembly with governor weight housing, water pump, and fuel pump attached.

(17) REMOVE THIRD STAGE FUEL FILTER.

WRENCH, $\frac{5}{8}$ -in.

WRENCH, open-end, $\frac{7}{8}$ -in.

WRENCH, open-end, $\frac{3}{4}$ -in.

Remove special cap screw, holding filter housing to filter head ($\frac{5}{8}$ -in. wrench), and remove filter housing and element. Disconnect fuel line from fuel manifold ($\frac{7}{8}$ - and $\frac{3}{4}$ -in. wrenches). Take out 2 cap screws, holding filter head to cylinder head ($\frac{5}{8}$ -in. wrench), and remove filter head.

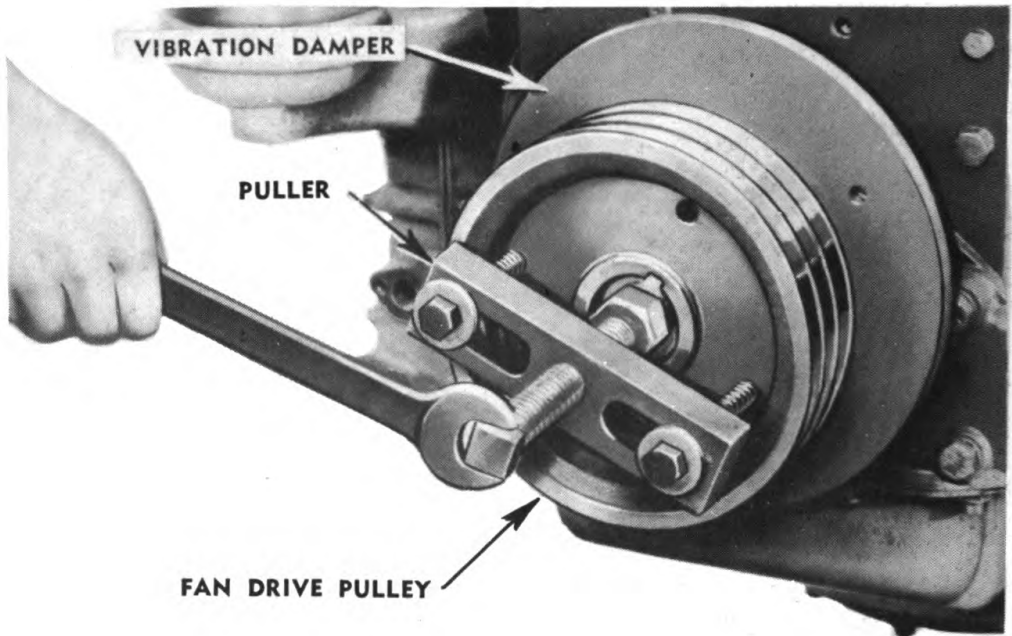

RA PD 17850

Figure 37 — Fan Drive Pulley Removal

(18) REMOVE FAN DRIVE PULLEY AND VIBRATION DAMPER.

PLIERS

WRENCH, 7/8-in.

PULLER, fan drive pulley

WRENCH, 1 5/16-in.

Remove cap screw from end of crankshaft, remove washer, and re-install cap screw (1 5/16-in. wrench). Install puller bolts in tapped holes in pulley and screw center bolt in against head of cap screw, forcing pulley off crankshaft (7/8-in. wrench). Remove puller assembly from fan drive pulley, install puller bolts in 2 tapped holes in vibration damper, and pull damper and front damper cone from crankshaft. Remove Woodruff key from crankshaft (pliers).

(19) REMOVE OIL GAGE ROD AND TUBE ASSEMBLY.

WRENCH, open-end, 7/16-in.

Remove cap screw holding assembly at top (7/16-in. wrench). Disconnect tube at lower end and remove tube assembly.

(20) REMOVE FUEL RETURN LINE.

WRENCH, open-end, 7/8-in.

Disconnect fuel return line from fitting at rear of fuel manifold. Remove clip on fuel return line from bolt on lower side of lower drive gear housing.

(21) REMOVE BLOWER DRIVE ASSEMBLY.

WRENCH, 9/16-in.

WRENCH, open-end, 7/16-in.

REMOVAL OF ACCESSORIES FROM ENGINE

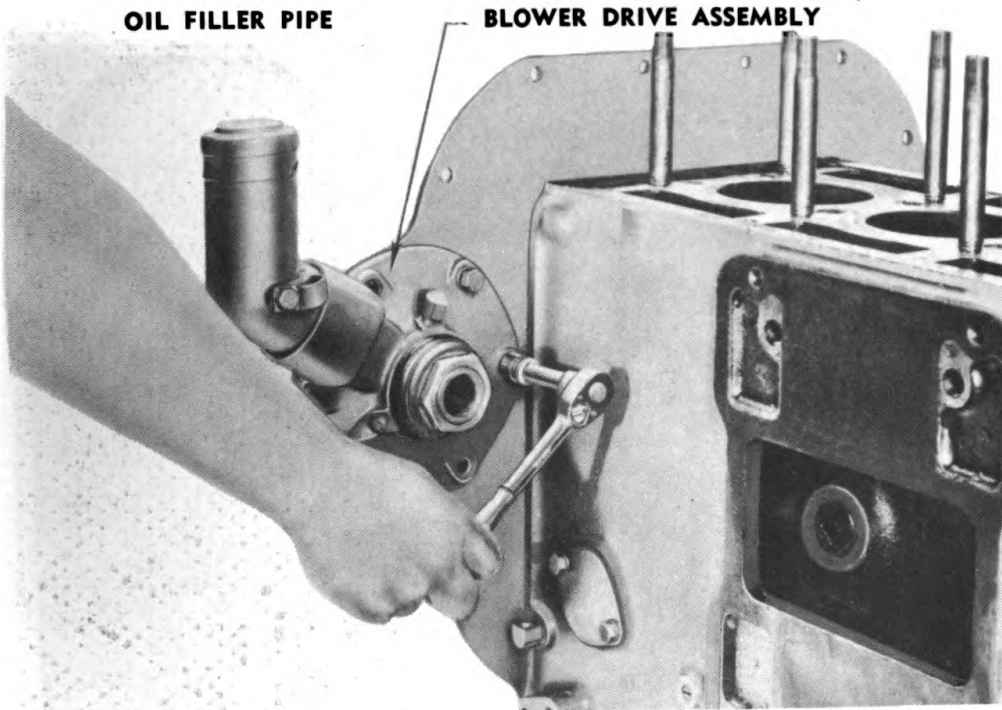

RA PD 17823

Figure 38 — Blower Drive Assembly Removal

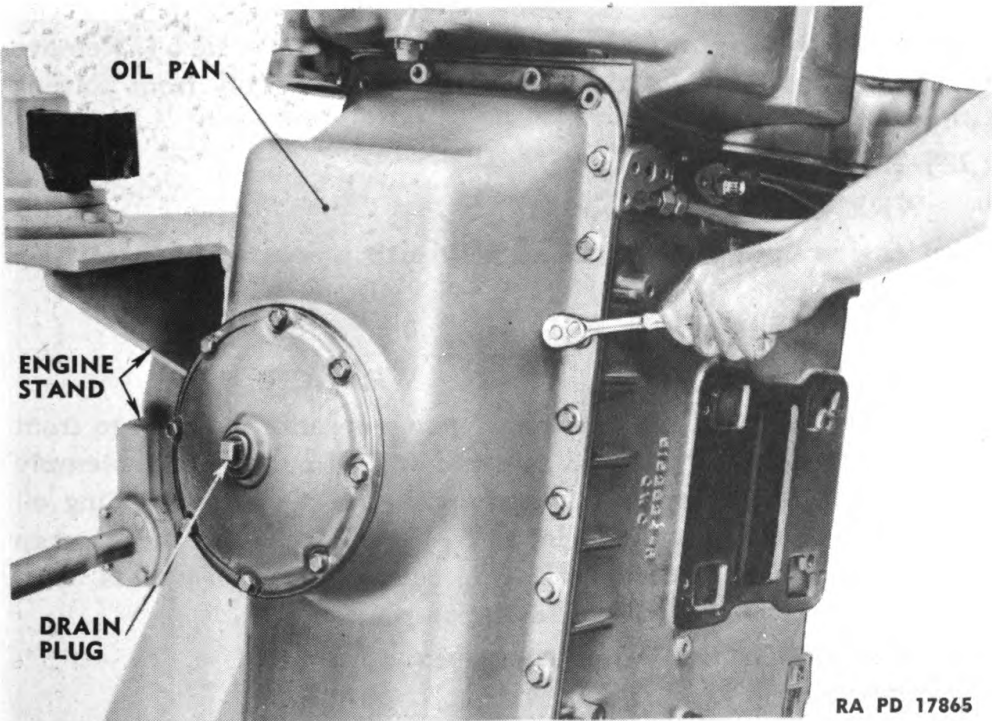

RA PD 17865

Figure 39 — Oil Pan Cap Screws Removal

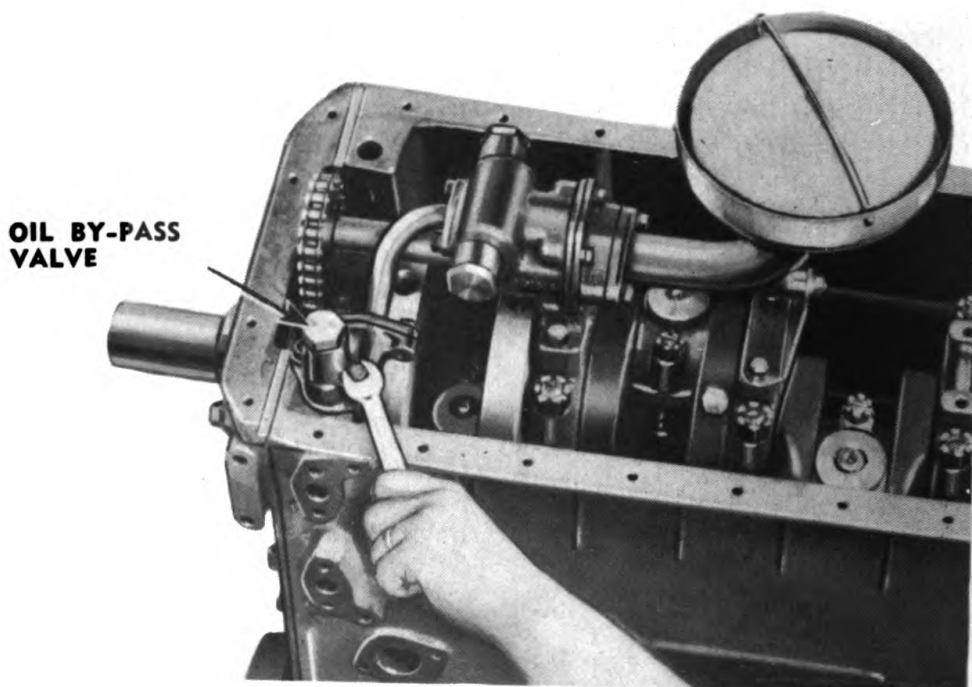

RA PD 17832

Figure 40 — Oil Bypass Valve Assembly Removal

Remove the blower drive bearing oil line ($\frac{7}{16}$ -in. wrench). Remove 4 bolts and 2 cap screws, and pull blower drive assembly from housing ($\frac{9}{16}$ -in. wrench).

(22) REMOVE OIL PAN.

WRENCH, socket, $\frac{1}{2}$ -in.

Turn engine upside down. Remove 26 cap screws, holding oil pan and remove oil pan.

(23) REMOVE OIL PUMP ASSEMBLY.

WRENCH, $\frac{1}{2}$ -in.

WRENCH, $\frac{9}{16}$ -in.

Remove the 2 cap screws holding oil pump sprocket support to front main bearing cap and the 2 stud nuts holding oil pump body assembly to No. 2 main bearing cap ($\frac{9}{16}$ -in. wrench), the cap screw holding oil pump inlet bracket to oil pump inlet ($\frac{1}{2}$ -in. wrench), and the two cap screws ($\frac{1}{2}$ -in. wrench) holding oil pump outlet pipe to oil bypass valve assembly ($\frac{9}{16}$ -in. wrench). Remove oil pump assembly.

(24) REMOVE BYPASS VALVE ASSEMBLY.

WRENCH, $\frac{1}{2}$ -in.

Remove the 2 cap screws, holding oil pump bypass valve assembly to cylinder block and lift off bypass valve assembly.

REMOVAL OF ACCESSORIES FROM ENGINE

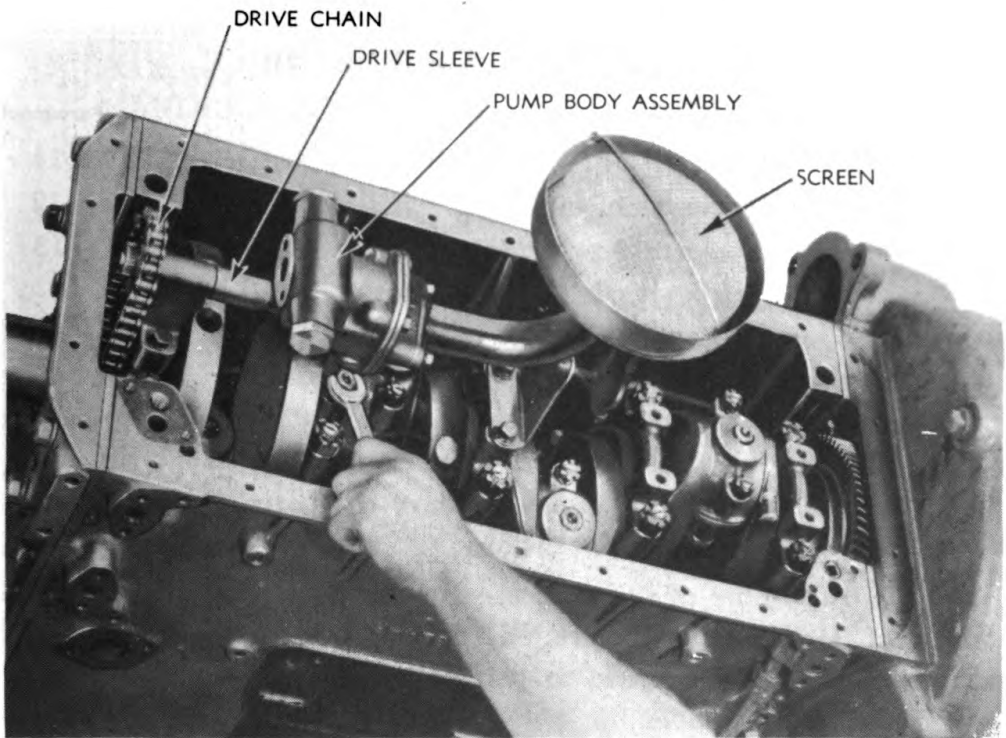

RA PD 56399

Figure 41 — Oil Pump Assembly Removal

(25) REMOVE OIL PUMP DRIVE.

Remove the oil pump drive sprocket and shaft assembly by maneuvering it into its lowest position on front main bearing cap. Lift off oil pump drive chain from sprocket and remove sprocket and shaft assembly.

Section VII

DISASSEMBLY OF ENGINE

	Paragraph
General	11
Disassembly into subassemblies.....	12
Disassembly of subassemblies.....	13

11. GENERAL.

a. It is very important to have the proper tools and equipment before attempting repair operations on this engine. It is also important that the shop in which the work is to be done be clean and, especially in assembling, that all precautions be taken to have the parts *thoroughly* clean when they are put back in the engine.

NOTE: A number of the tools used in this manual are not standard equipment. Observe the illustrations closely and improvise tools and equipment that may be used to perform the operations for which no special tools are available.

b. Have plenty of pans or boxes available so that bolts, nuts, and small parts removed in disassembling may be kept separate with the subassembly from which they are removed to avoid confusion and loss of time in assembling the engine. Clean and examine parts as they are disassembled and make a list of parts needing replacement.

c. Do not disassemble subassemblies that show no need of repair. The text outlines complete disassembly of each subassembly. Follow this procedure if complete disassembly is necessary, otherwise use only the portions of the text pertaining to the subassemblies in need of repair.

d. Section XIV contains a list of fits and tolerances for new engines and also gives the maximum allowable worn clearances. When rebuilding and reassembling engine, the new clearances should be used as a guide. The worn clearances are only to indicate amount of wear allowed before rebuilding or replacing a particular part.

e. In assembling, *always* use new gaskets throughout the engine. This will insure against any leaks when engine is put back in operation. Use lock washers on bolts and cap screws where specified. Cap screws entering cast parts as a rule have coarse threads. Those entering the cylinder block end plates have fine threads. Be sure all bolts and cap screws are tightened firmly.

DISASSEMBLY OF ENGINE**12. DISASSEMBLY INTO SUBASSEMBLIES.****a. Equipment.**

BAR, pry	WRENCH, open-end, $\frac{3}{4}$ -in.
HANDLE, socket, flex, 18-in.	WRENCH, open-end, $\frac{7}{8}$ -in.
PLIERS	WRENCH, socket, $\frac{1}{2}$ -in.
PULLER, main bearing cap	WRENCH, socket, $\frac{9}{16}$ -in.,
REMOVER & REPLACER,	with extension
cylinder liner	WRENCH, socket, $\frac{5}{8}$ -in.
SCREW, cap, $\frac{7}{16}$ x 3-in. (2),	WRENCH, socket, $\frac{11}{16}$ -in.
with $2\frac{1}{2}$ -in. threads	WRENCH, socket, $\frac{3}{4}$ -in.
SCREWDRIVER, 10-in.	WRENCH, socket, $\frac{13}{16}$ -in.,
WRENCH, $\frac{1}{2}$ -in.	with extension
WRENCH, $\frac{9}{16}$ -in.	WRENCH, socket, $\frac{15}{16}$ -in.,
WRENCH, $\frac{5}{8}$ -in.	with 6-in. extension
WRENCH, $1\frac{1}{2}$ -in.	

b. Procedure.**(1) REMOVE CYLINDER HEAD ASSEMBLY.**

HANDLE, socket, flex, 18-in.	WRENCH, socket, $\frac{15}{16}$ -in.,
WRENCH, $\frac{5}{8}$ -in.	with 6-in. extension

Remove rocker arm cover. Remove the 4 cap screws, holding the front and rear engine lifter brackets to balance weight cover and flywheel housing ($\frac{5}{8}$ -in. wrench). Using $\frac{15}{16}$ -inch socket with extension, remove the 10 cylinder head stud nuts, and lift cylinder head from engine. Lay cylinder head on its side or on blocks so injector tips and cam followers will not be damaged. Remove cylinder head gasket.

(2) FLYWHEEL PILOT BEARING REMOVAL.

WRENCH, $\frac{3}{4}$ -in.	WRENCH, $\frac{13}{16}$ -in.
----------------------------	------------------------------

Back out center stud on puller tool so puller fingers will collapse and will be able to be inserted through inner race of bearing. Set tool up against rear face of flywheel (fig. 79) and turn clockwise on inner stud so that puller fingers will expand and bear against inner face of bearing inner race ($\frac{3}{4}$ -in. wrench). If necessary, hold center stud from turning and screw puller nut clockwise ($\frac{13}{16}$ -in. wrench), pulling bearing out of flywheel.

(3) REMOVE FLYWHEEL.

PLIERS	WRENCH, socket, $\frac{5}{8}$ -in.
SCREW, cap, $\frac{7}{16}$ x 3-in. (2),	WRENCH, socket, $\frac{13}{16}$ -in.,
with $2\frac{1}{2}$ -in. thread	with extension

Cut lock wire (pliers) and remove the 6 cap screws holding flywheel to crankshaft flange ($\frac{13}{16}$ -in. wrench). Insert the 2 special cap screws in threaded puller holes in flywheel and force flywheel from crankshaft ($\frac{5}{8}$ -in. wrench).

ORDNANCE MAINTENANCE — HEAVY TRACTOR M1 (Allis-Chalmers HD-10W) ENGINE

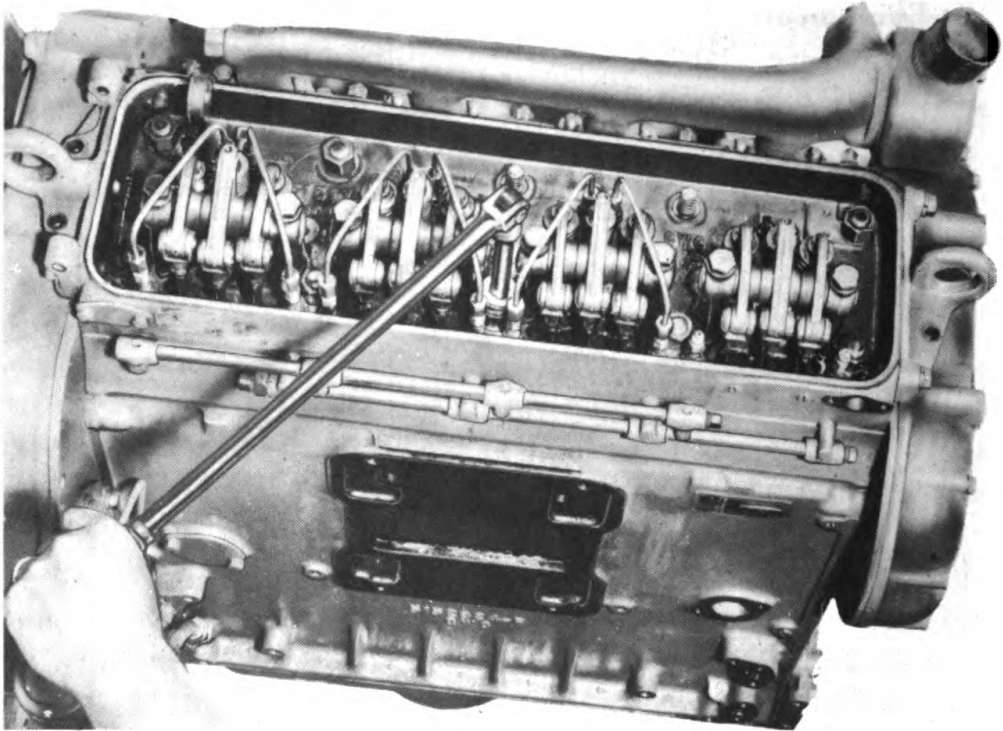

RA PD 17835

Figure 42 — Removal of Cylinder Head Stud Nuts

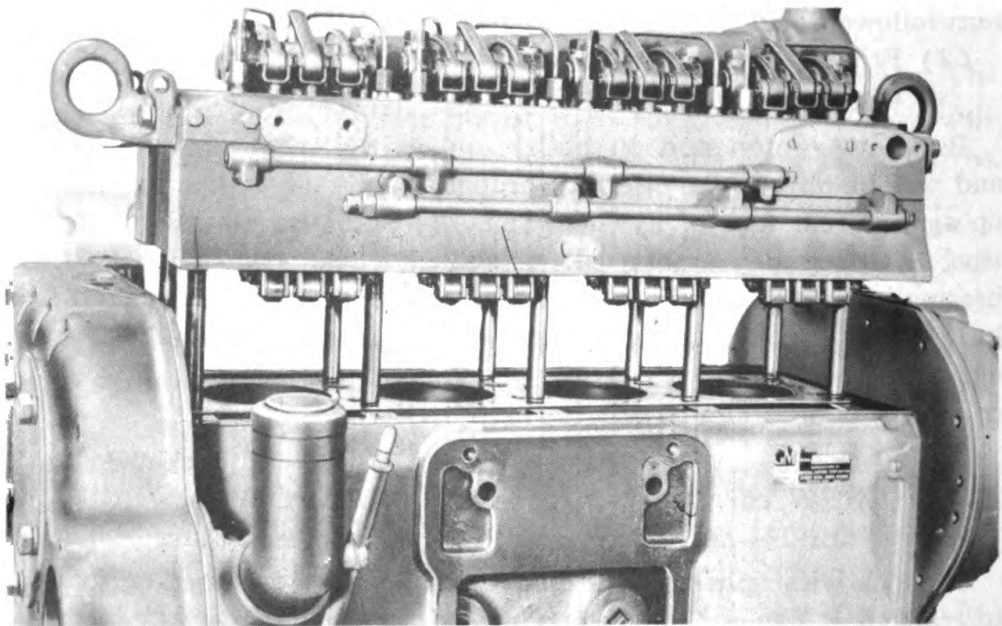

RA PD 17869

Figure 43 — Cylinder Head Removal

DISASSEMBLY OF ENGINE

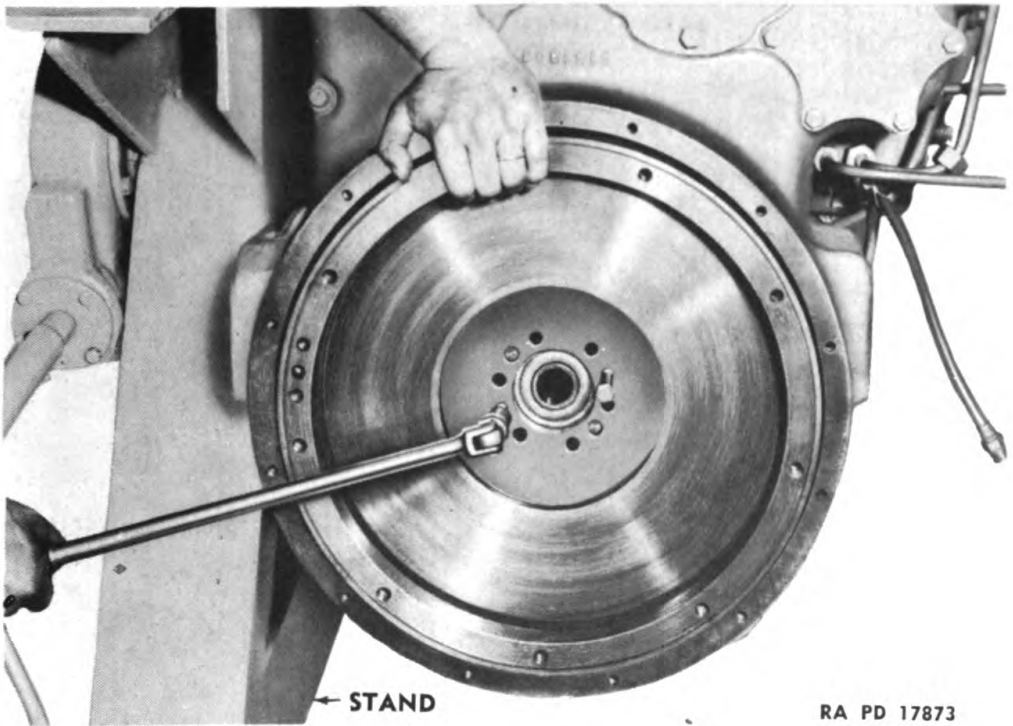

Figure 44 — Flywheel Removal

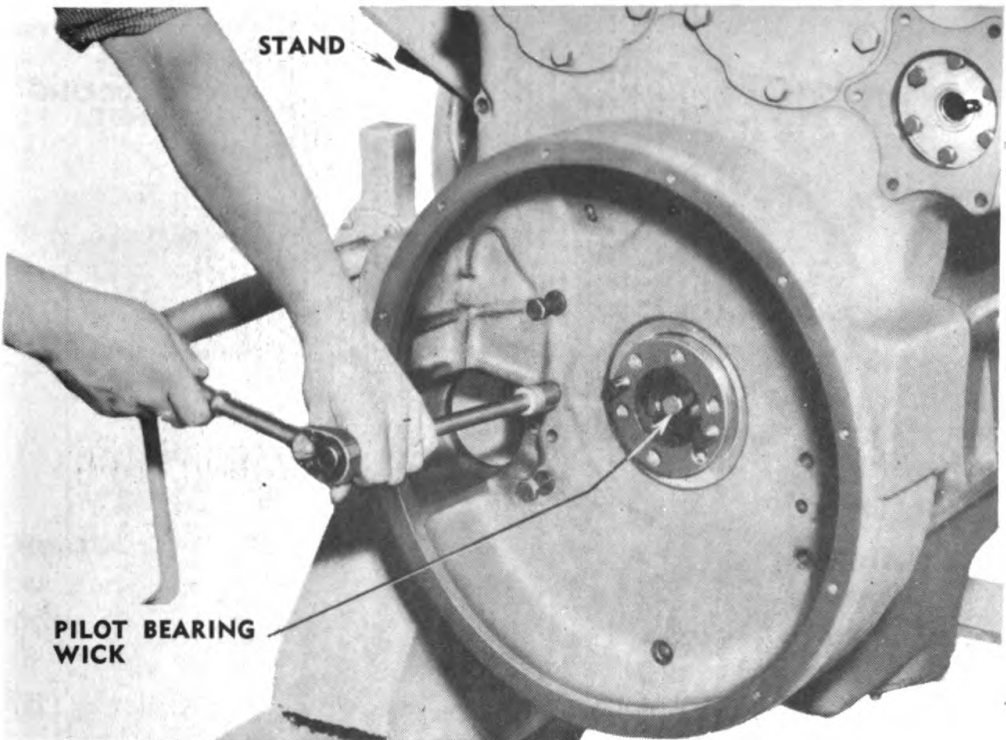
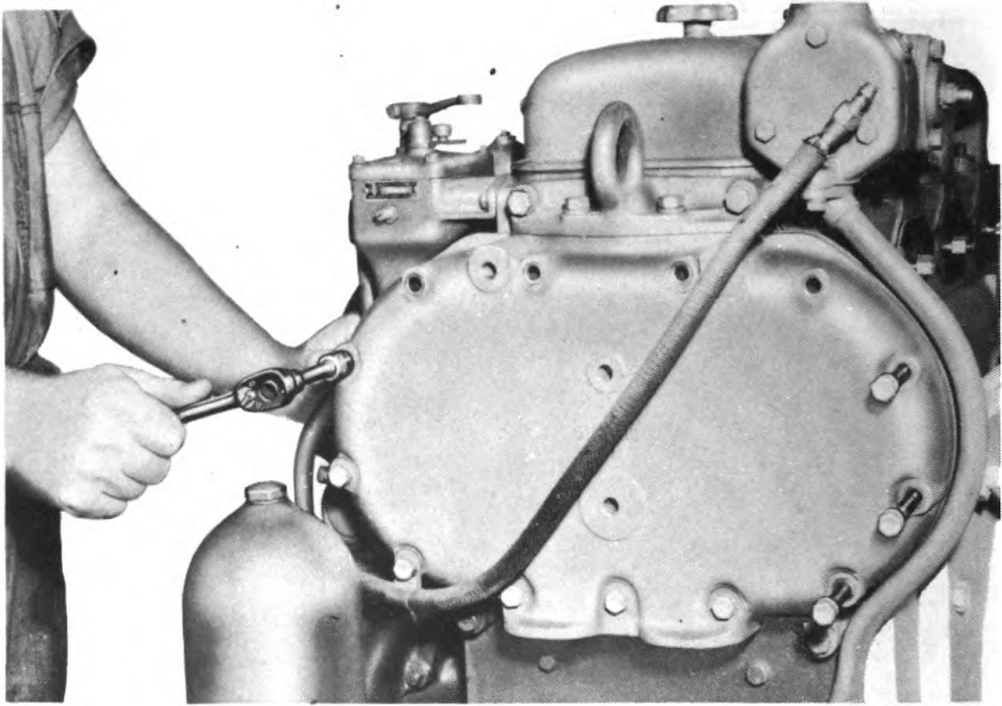

Figure 45 — Removing Cap Screws from Flywheel Housing

ORDNANCE MAINTENANCE — HEAVY TRACTOR M1 (Allis-Chalmers HD-10W) ENGINE



RA PD 17718

Figure 46 — Balance Weight Cover Removal

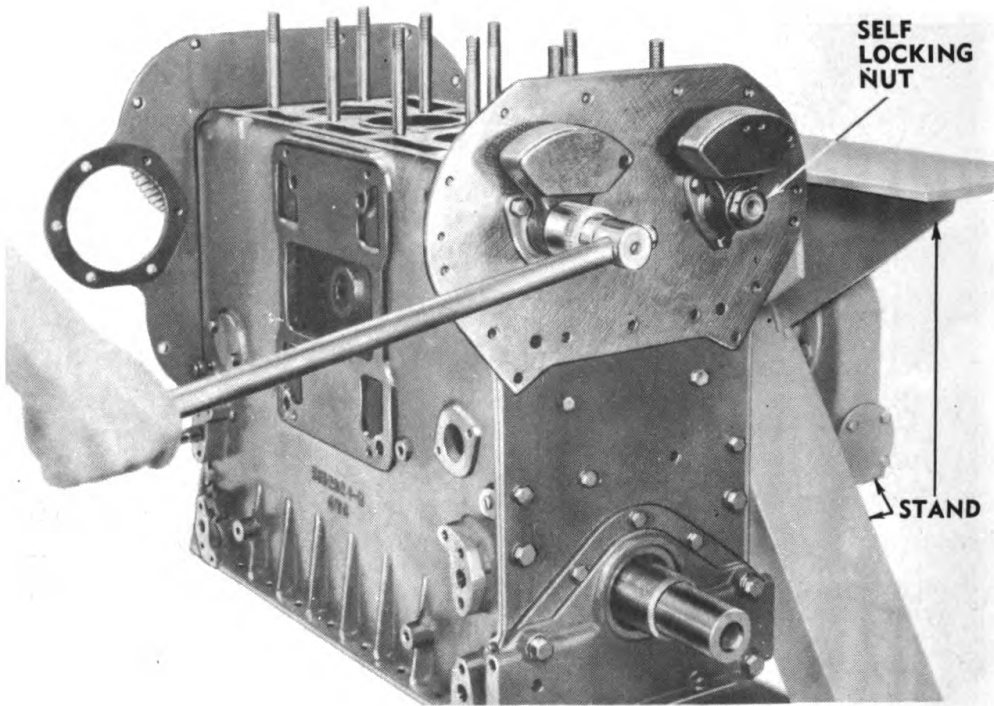

RA PD 17822

Figure 47 — Balance Weight Removal

DISASSEMBLY OF ENGINE

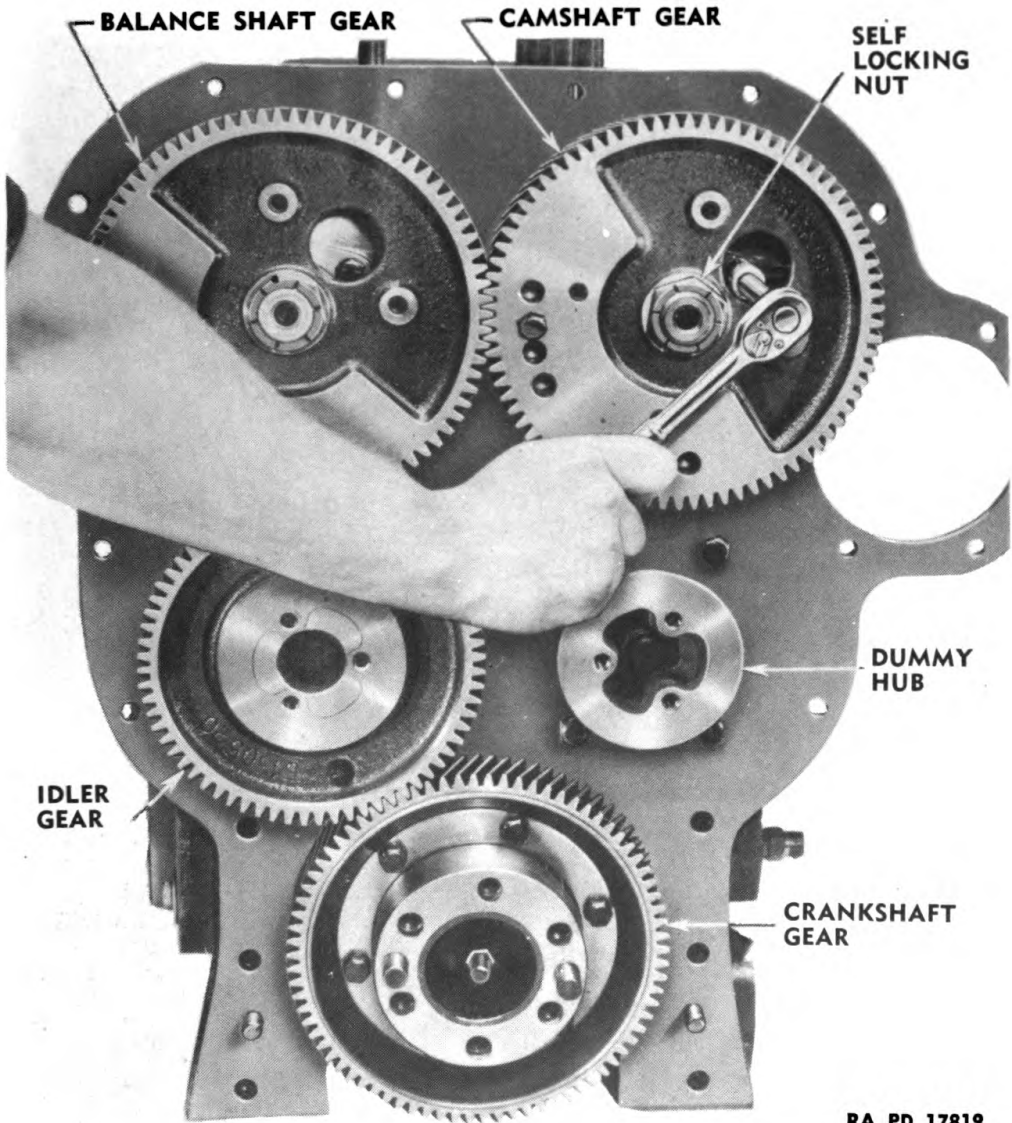

RA PD 17819

Figure 48 — Removing Cap Screw from Rear Camshaft End Bearing

(4) REMOVE FLYWHEEL HOUSING.

WRENCH, $\frac{9}{16}$ -in. (2)

WRENCH, $\frac{3}{4}$ -in.

Remove the 6 cap screws and 4 bolts, holding housing to rear cylinder block end plate ($\frac{9}{16}$ -in. wrenches). Remove the 12 cap screws inside housing (3 on each side at top and 3 on each side of crankshaft). Use both $\frac{9}{16}$ - and $\frac{3}{4}$ -inch wrenches. Remove flywheel housing.

(5) REMOVE BALANCE WEIGHT COVER.

WRENCH, $\frac{9}{16}$ -in.

Remove 13 cap screws, holding balance weight cover and remove cover.

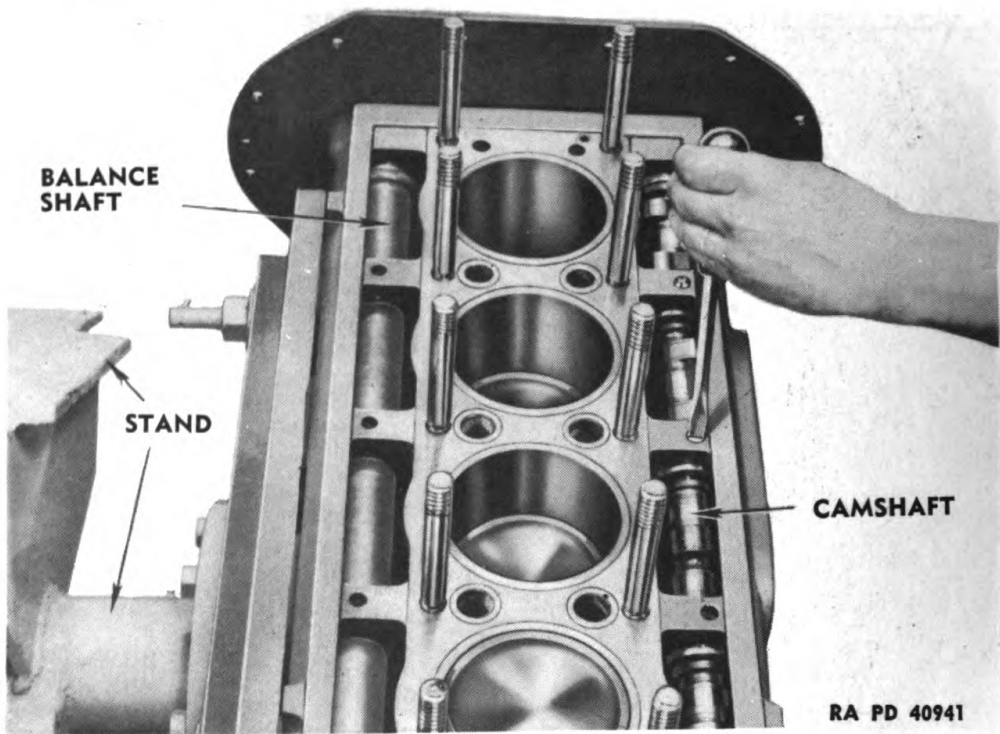

Figure 49 — Removing Lock Screws from Intermediate Camshaft Bearings

(6) REMOVE CAMSHAFT AND BALANCE SHAFT ASSEMBLIES.

(a) Remove Front Balance Weights.

BAR, pry

WRENCH, 1½-in.

Place a folded cloth between the teeth of camshaft and balance shaft gears. Remove self-locking nuts, holding balance weights on shafts (1½-in. wrench) and pry balance weights off shafts (pry bar).

(b) Loosen Bearings.

SCREWDRIVER, 10-in.

WRENCH, socket, ⅞-in.,
with extension.

Remove 3 cap screws, holding rear bearing of each shaft to rear cylinder block end plate (⅞-in. wrench). Cap screws are removed through large holes in camshaft and balance shaft gears. Remove the 3 camshaft intermediate bearing lock bolts, holding camshaft intermediate bearings in place (screwdriver).

(c) Remove Cam Shaft and Balance Shaft.

Slide camshaft and balance shaft out of cylinder block. Rear bearings and intermediate bearings will remain on shaft.

(d) Remove Front Bearings.

WRENCH, ⅞-in.

DISASSEMBLY OF ENGINE

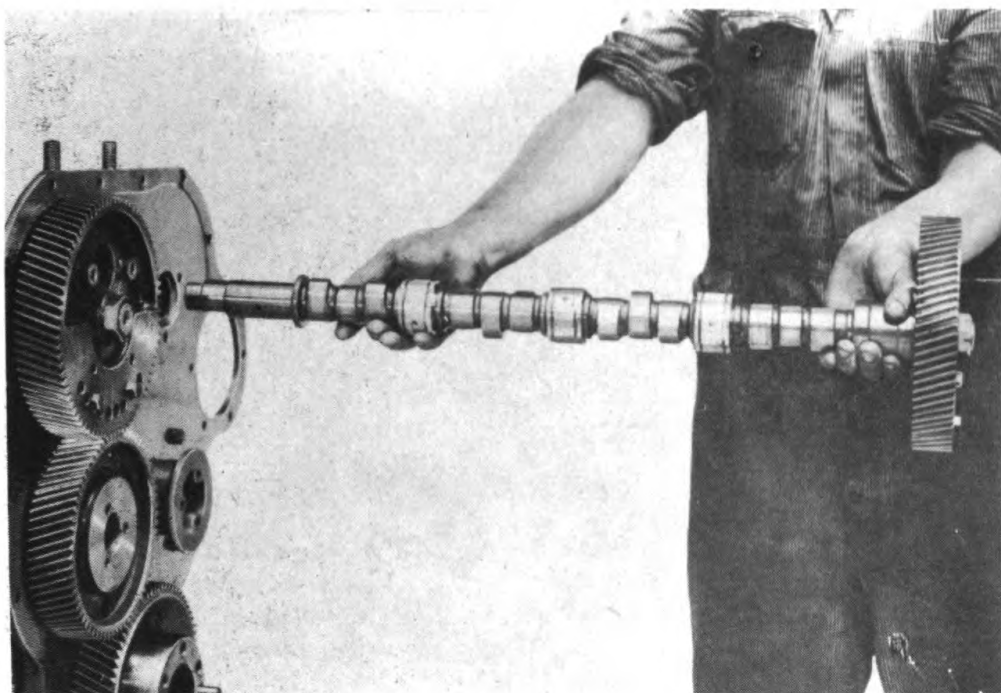

RA PD 40963

Figure 50 — Removing Camshaft Assembly from Cylinder Block

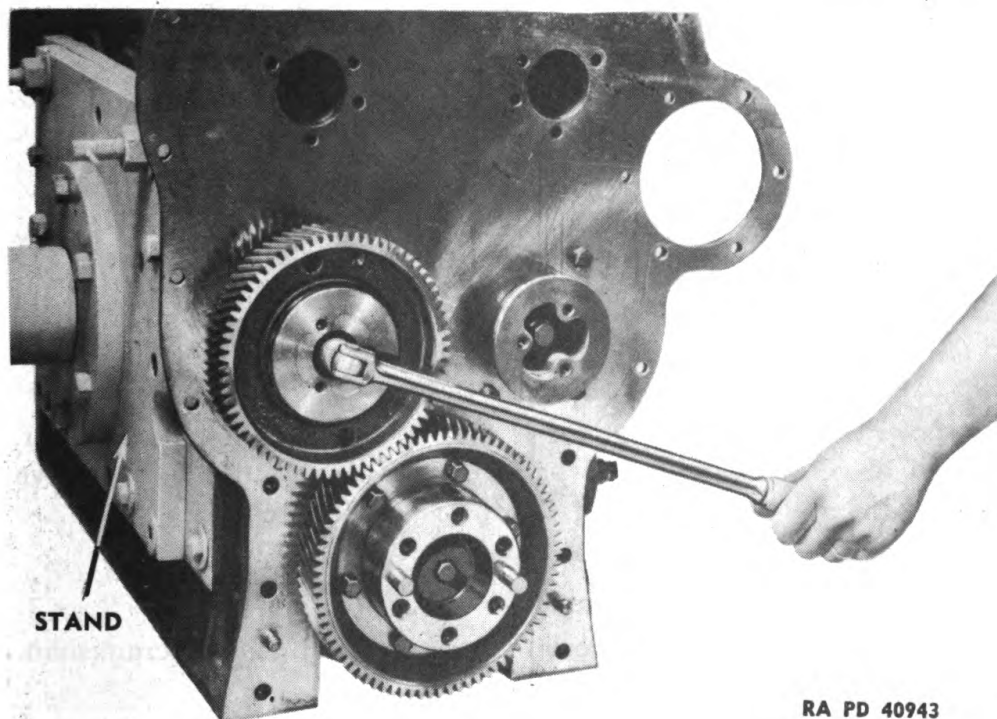

RA PD 40943

Figure 51 — Idler Gear Assembly Removal

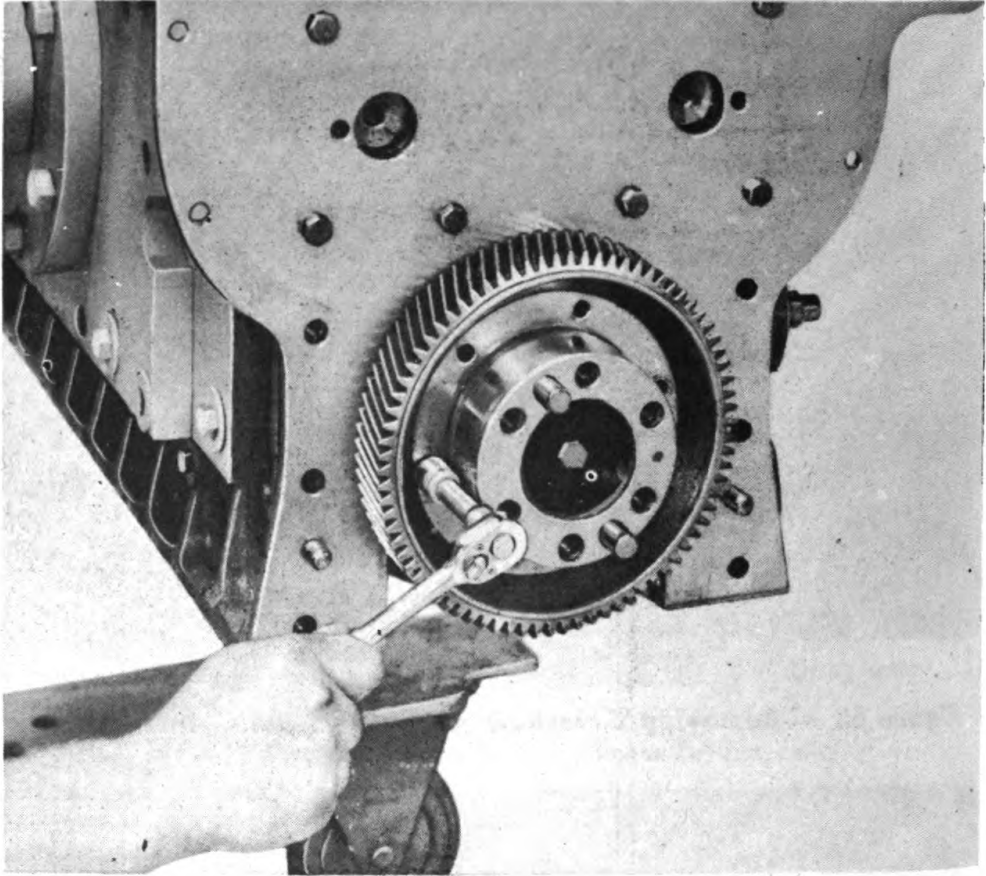

RA PD 40910

Figure 52 — Crankshaft Gear Removal

Remove 3 cap screws from each front bearing and pull bearings out of cylinder block.

(7) REMOVE IDLER GEAR ASSEMBLY.

WRENCH, socket, $\frac{3}{4}$ -in.

Remove cap screw from center of idler gear hub. Lift off idler gear, hub and dowel assembly, and spacer. Remove cap screw and remove spacer and dowel assembly next to idler gear assembly.

(8) REMOVE CRANKSHAFT GEAR.

WRENCH, socket, $\frac{9}{16}$ -in.

Remove 6 cap screws, remove oil slinger, and pry gear off crankshaft.

(9) REMOVE CRANKSHAFT FRONT COVER ASSEMBLY.

WRENCH, $\frac{9}{16}$ -in.

WRENCH, $\frac{3}{4}$ -in.

Remove 7 cap screws, holding front cover assembly and remove front cover assembly.

DISASSEMBLY OF ENGINE

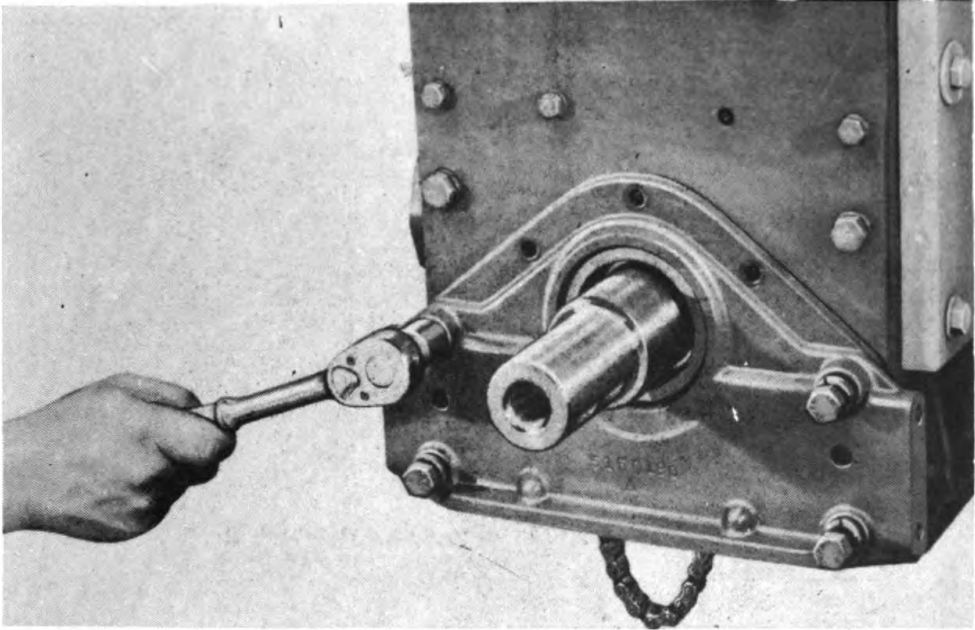

RA PD 40909

Figure 53 — Crankshaft Front Cover Assembly Removal

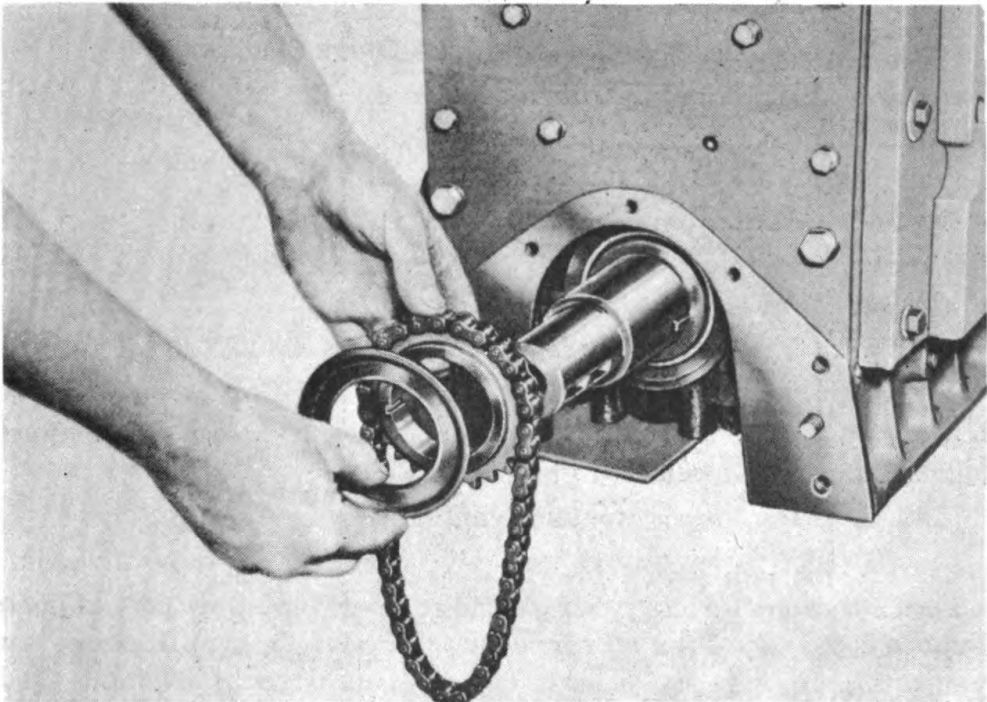

RA PD 40934

Figure 54 — Oil Slinger and Oil Pump Drive Sprocket and Chain

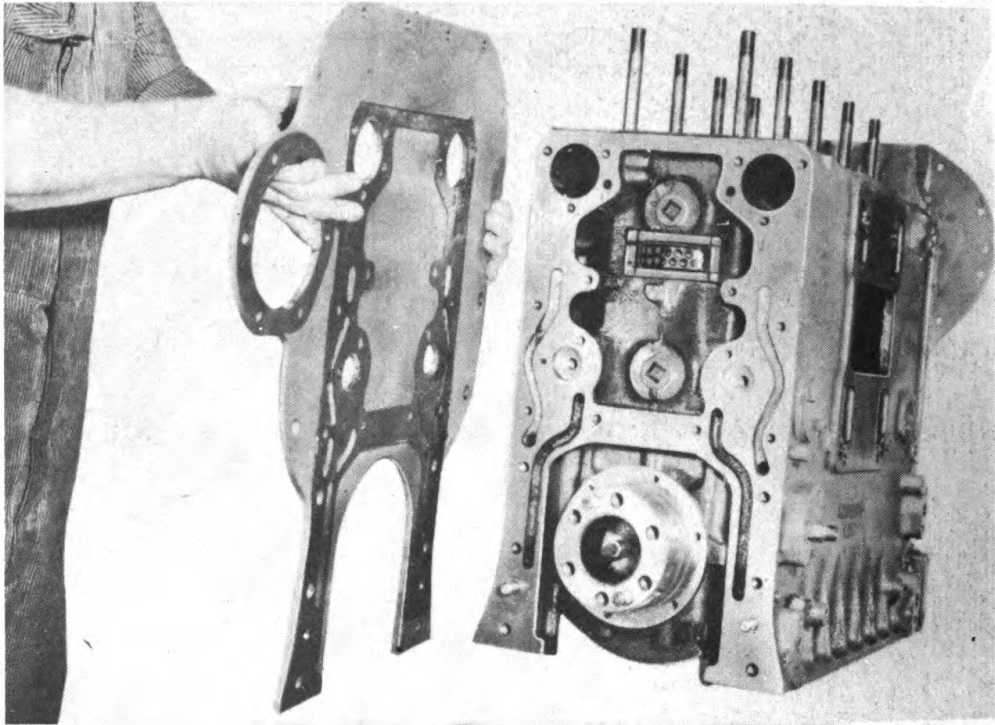

RA PD 40932

Figure 55 — Rear Cylinder Block and Plate Removal

(10) REMOVE OIL SLINGER AND PUMP DRIVE SPROCKET.

Remove rear vibration damper cone, oil slinger, oil pump drive sprocket and chain.

(11) REMOVE REAR CYLINDER BLOCK END PLATE.

WRENCH, $\frac{9}{16}$ -in.

Remove 6 cap screws, holding cylinder block end plate to cylinder block; pull cylinder block end plate off dowels.

(12) REMOVAL OF FRONT CYLINDER BLOCK END PLATE.

WRENCH, $\frac{9}{16}$ -in.

WRENCH, $\frac{3}{4}$ -in.

Remove 8 cap screws, holding front cylinder block end plate to cylinder block, and pull end plate off dowels.

(13) REMOVE PISTON AND CONNECTING ROD ASSEMBLIES.

PLIERS

WRENCH, socket, $1\frac{1}{16}$ -in.

Turn engine with end up. Scrape the carbon from upper part of liners. Remove cotter pins from all connecting rod bolts (pliers). Remove nuts from one connecting rod bearing cap ($1\frac{1}{16}$ -in. wrench). Remove bearing cap and push piston and rod assembly out of cylinder. After removing piston and rod, install lower half of bearing back on rod. Repeat for remaining piston and rod assemblies.

DISASSEMBLY OF ENGINE

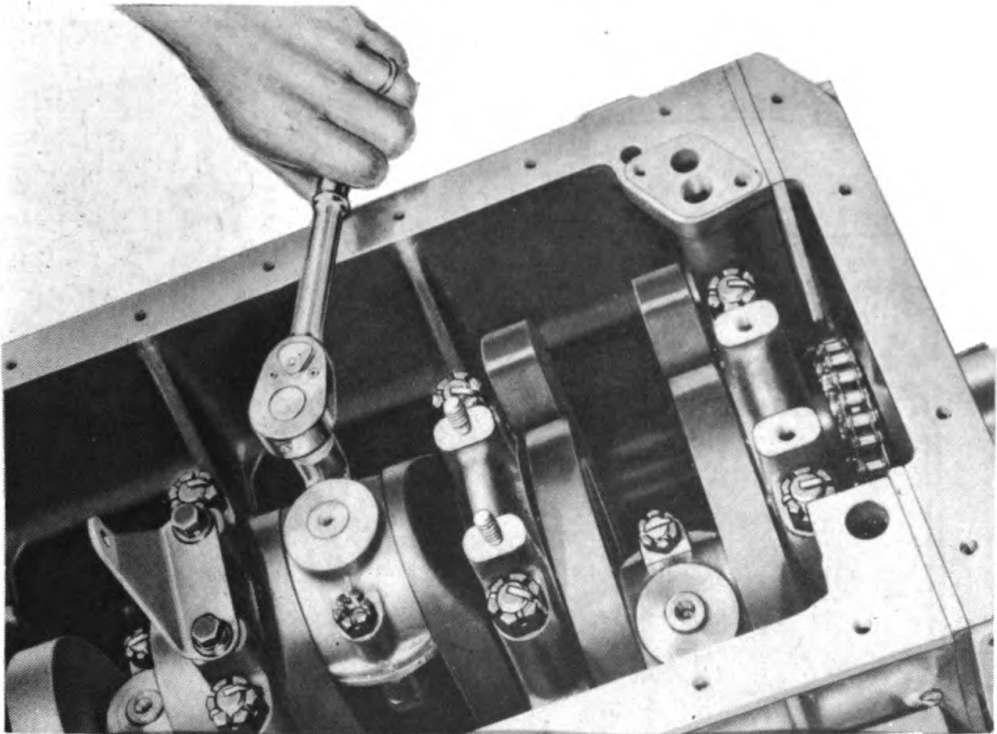

RA PD 17825

Figure 56 — Connecting Rod Bearing Cap Removal

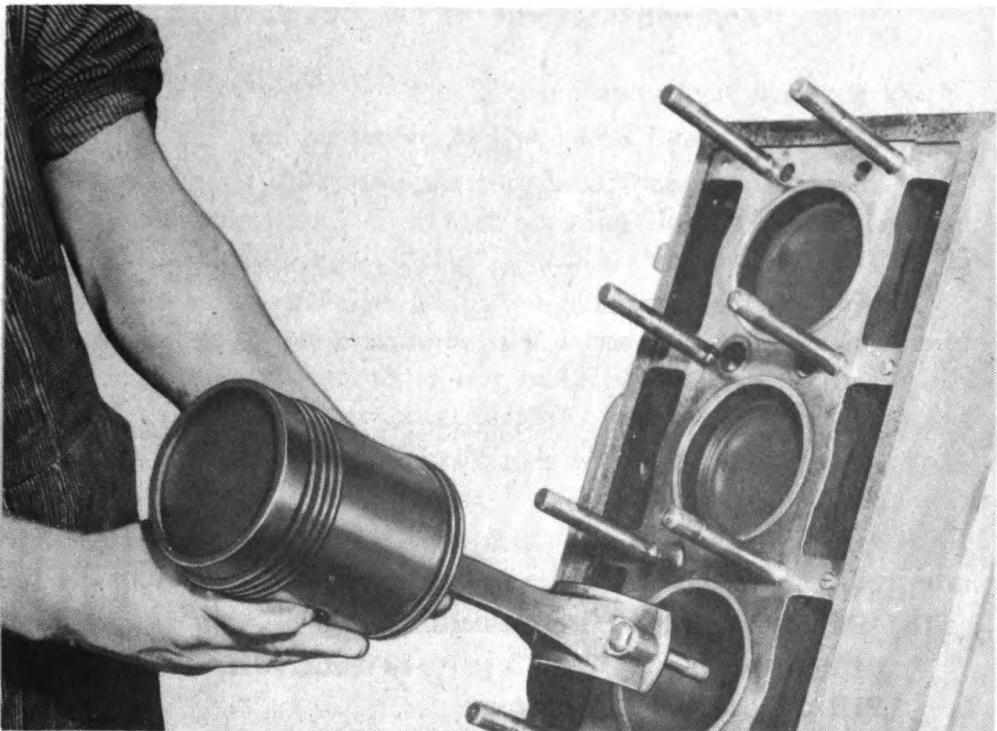

RA PD 40915

Figure 57 — Connecting Rod and Piston Assembly Removal

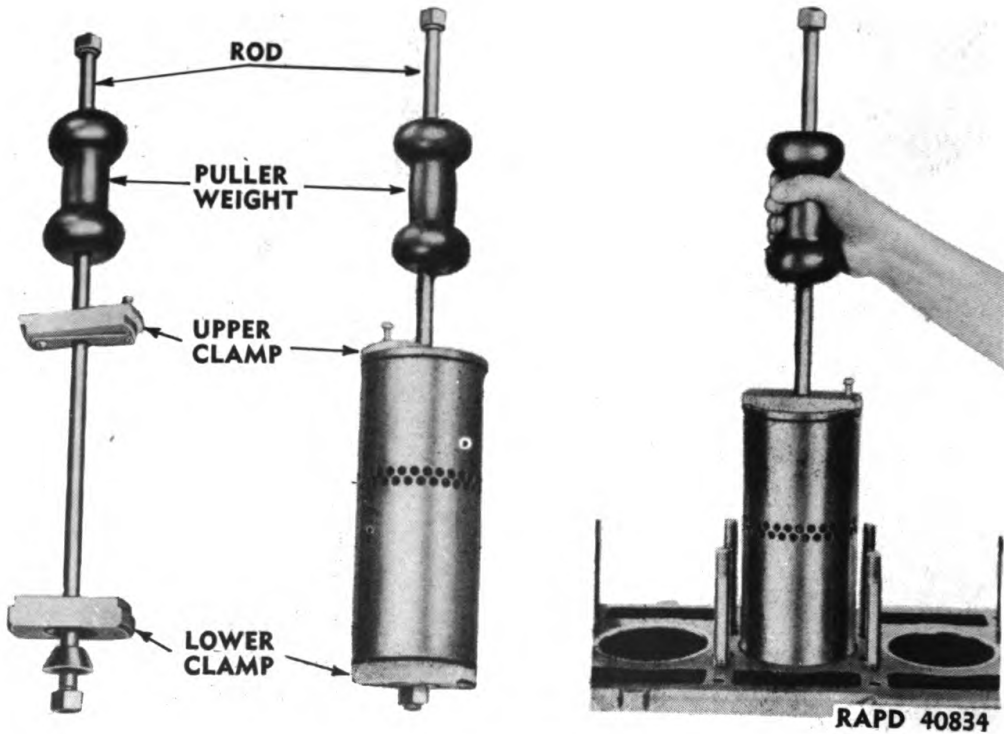

Figure 58 — Cylinder Liner Removal

(14) REMOVE CYLINDER LINERS.

REMOVER and REPLACER, cylinder liner

The liners are a loose fit and may slide out with piston when removing pistons. If not, install and use the cylinder liner remover and replacer (fig. 58) as follows:

(a) Turn engine right side up. Slip the lower puller clamp up the puller rod and off its tapered seat, and cock clamp on rod so it will slide down through liner. When rod is dropped down through liner, clamp will drop back onto its seat in a horizontal position.

(b) Slide the upper puller clamp down against the top edges of the liner.

(c) With tool so mounted, strike the upset head on upper end of puller rod a sharp blow with the puller weight, thus releasing the liner.

(15) REMOVE CRANKSHAFT ASSEMBLY.

PLIERS

WRENCH, socket, $1\frac{5}{16}$ -in.

PULLER, main bearing cap

Turn engine bottom side up. Remove the cotter pins (pliers) and nuts ($1\frac{5}{16}$ -in. wrench) from the main bearing studs. Install puller tool

DISASSEMBLY OF ENGINE

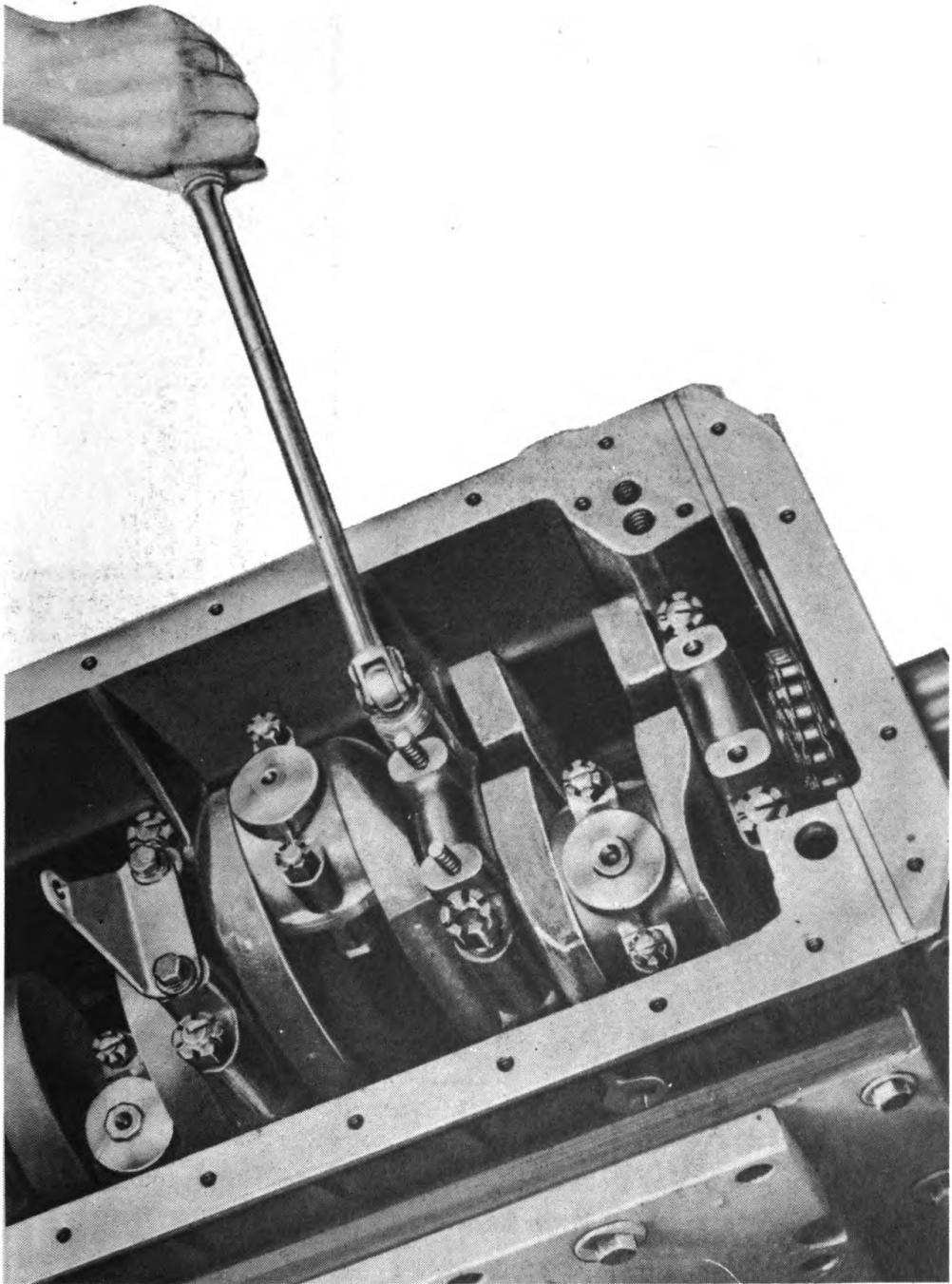

RA PD 17831

Figure 59 — Main Bearing Cap Stud Nut Removal

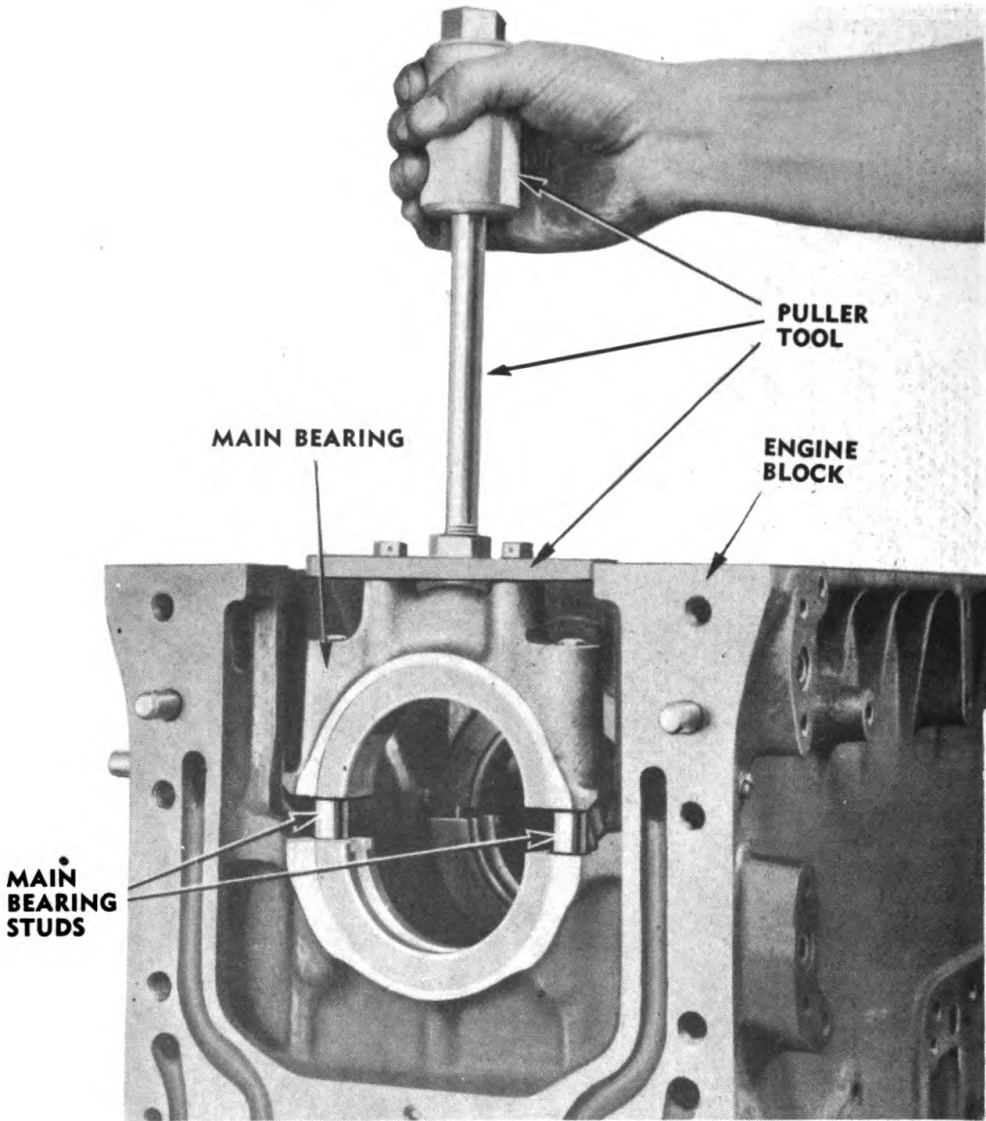

RA PD 40835

Figure 60 — Main Bearing Cap Removal

to caps and jar caps from position (fig. 60). Remove main bearing caps. Lift crankshaft from block. Remove upper main bearing shells from crankcase.

13. DISASSEMBLY OF SUBASSEMBLIES.

a. Lay parts for each subassembly together and separate from other subassemblies in following procedure:

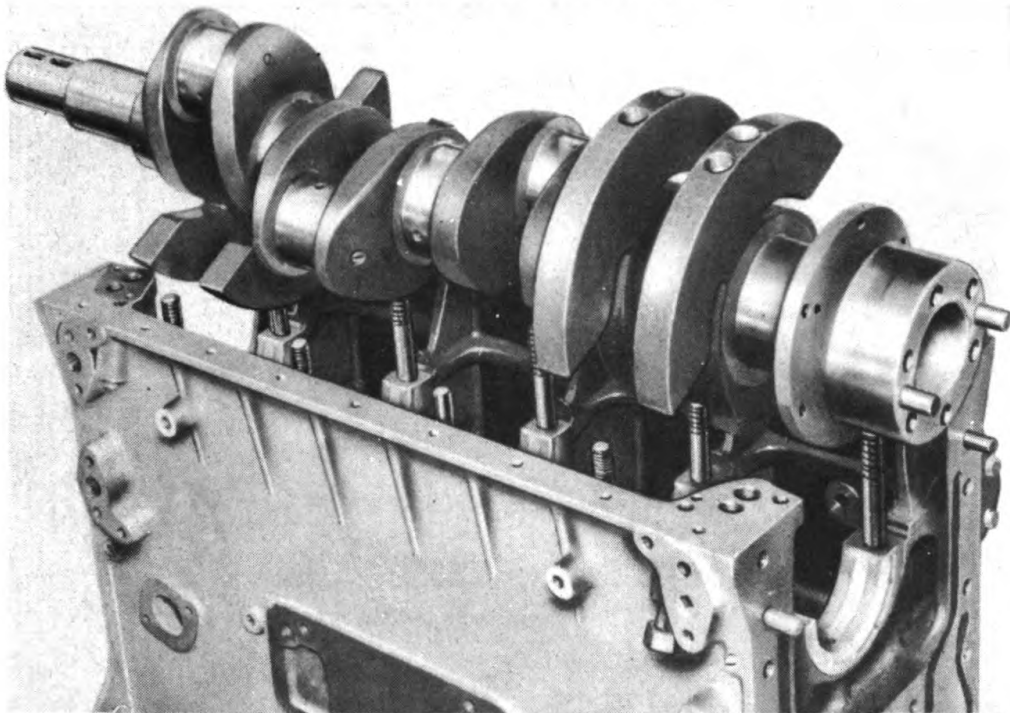
DISASSEMBLY OF ENGINE

RA PD 40908

Figure 61 — Crankshaft Removed from Crankcase**b. Equipment.**

CHISEL, 1/2-in.

CHISEL, 7/8-in.

HAMMER, 1/2-lb

HAMMER, 2-lb

PAN or BOX, for parts (10)

PLIERS

PLIERS, long-nosed

PRESS, hydraulic

PULLER, flywheel pilot bearing

PUNCH, large

PUNCH, small

REMOVER, injector copper tube

REMOVER & REPLACER, piston pin bushing, set

REMOVER & REPLACER, piston ring

REMOVER, push rod

REMOVER, valve insert

REMOVER, valve spring compressor and injector

REMOVER, valve stem guide

SCREWDRIVER, 8-in.

SCREWDRIVER, 10-in.

SPREADER, spring

VISE

WRENCH, 7/16-in.

WRENCH, 1/2-in.

WRENCH, 3/4-in.

WRENCH, 13/16-in.

WRENCH, 1 1/4-in.

WRENCH, 1 1/2-in.

WRENCH, deep socket, 7/16-in.

WRENCH, filter cap

WRENCH, open-end, 1/2-in.

WRENCH, open-end, 3/4-in.

WRENCH, open-end, 7/8-in.

WRENCH, open-end, 1 7/8-in.

WRENCH, socket, 9/16-in.

ORDNANCE MAINTENANCE — HEAVY TRACTOR M1 (Allis-Chalmers HD-10W) ENGINE

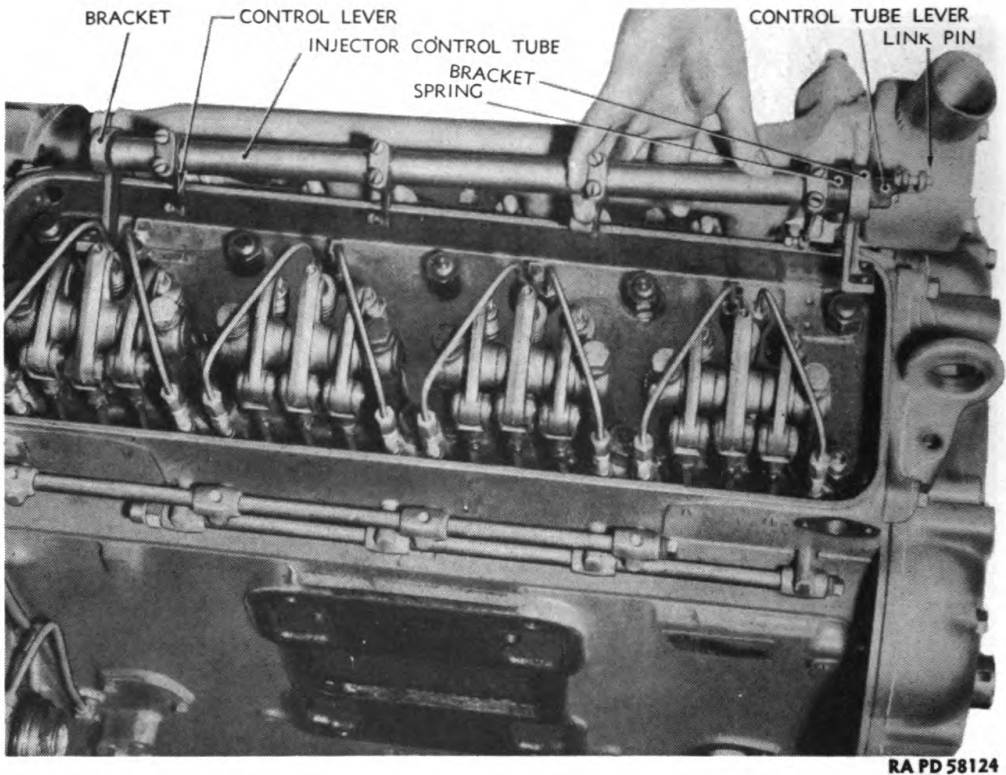

RA PD 58124

Figure 62 — Injector Control Tube Assembly Removal

c. Disassembly of Cylinder Head.

(1) REMOVE INJECTOR CONTROL TUBE ASSEMBLY.

HAMMER, ½-lb
PRESS, hydraulic
PUNCH, small

SCREWDRIVER, 10-in.
WRENCH, 7/16-in.

Remove 2 cap screws, holding bracket on each end to cylinder head (7/16-in. wrench). Lift assembly from head. Remove rear bracket from tube, loosen adjusting screws in rack control levers (screwdriver), and slide control levers and spring from tube. Drive groove pin from control tube lever (hammer and punch) and remove lever and front bracket assembly from tube. Press bearings from brackets (hydraulic press).

(2) REMOVE INJECTOR FUEL LINES.

WRENCH, open-end, ½-in.

Unscrew connector nuts at each end of lines and remove all lines. Place shipping caps on fittings from which lines were removed.

(3) REMOVE ROCKER ARM ASSEMBLIES.

WRENCH, ¾-in.

WRENCH, open-end, ½-in.

Loosen push rod lock nuts (½-in. wrench). Remove the 2 bolts, holding the rocker arm shaft brackets (¾-in. wrench) to the cylinder

DISASSEMBLY OF ENGINE

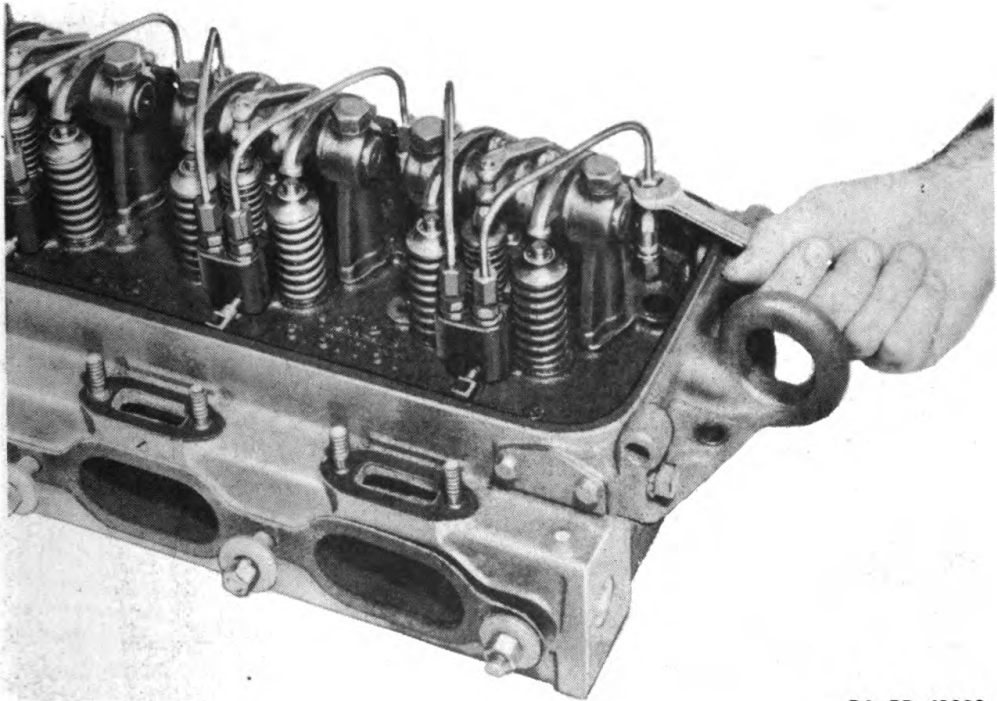

RA PD 41322

Figure 63.— Injector Fuel Line Removal

head, and remove the brackets from the shaft. Slide the shaft from the rocker arms and fold the arms back. Unscrew rocker arms from push rods. **CAUTION:** When removing the rocker arm shaft, fold back the 3 rocker arms and shaft just far enough so shaft can be pulled endwise; do not force the rocker arms back with shaft in place and impose a load on the rocker arm push rod.

(4) REMOVE INJECTORS.

REMOVER, valve spring compressor and injector

WRENCH, socket, $\frac{9}{16}$ -in.

Remove nut and bevel washer from each clamp stud ($\frac{9}{16}$ -in. wrench). Lift off injector clamps. Use injector remover to remove injectors.

(5) REMOVE PUSH RODS AND CAM FOLLOWER ASSEMBLIES.

PLIERS, long-nosed

WRENCH, open-end, $\frac{1}{2}$ -in.

REMOVER, push rod

WRENCH, socket, $\frac{7}{16}$ -in.

Using a $\frac{7}{16}$ -inch socket wrench, remove the 2 cap screws and lock washers, holding the cam roller guide to the cylinder head. Remove the guide. Insert push rod remover against push rod and between jam nut and spring retainer washer. Tighten jam nut against tool to compress spring ($\frac{1}{2}$ -in. wrench). Remove lock wire holding upper spring seat in place, from groove (pliers) and lift out push rod, spring, and spring

ORDNANCE MAINTENANCE — HEAVY TRACTOR M1 (Allis-Chalmers HD-10W) ENGINE

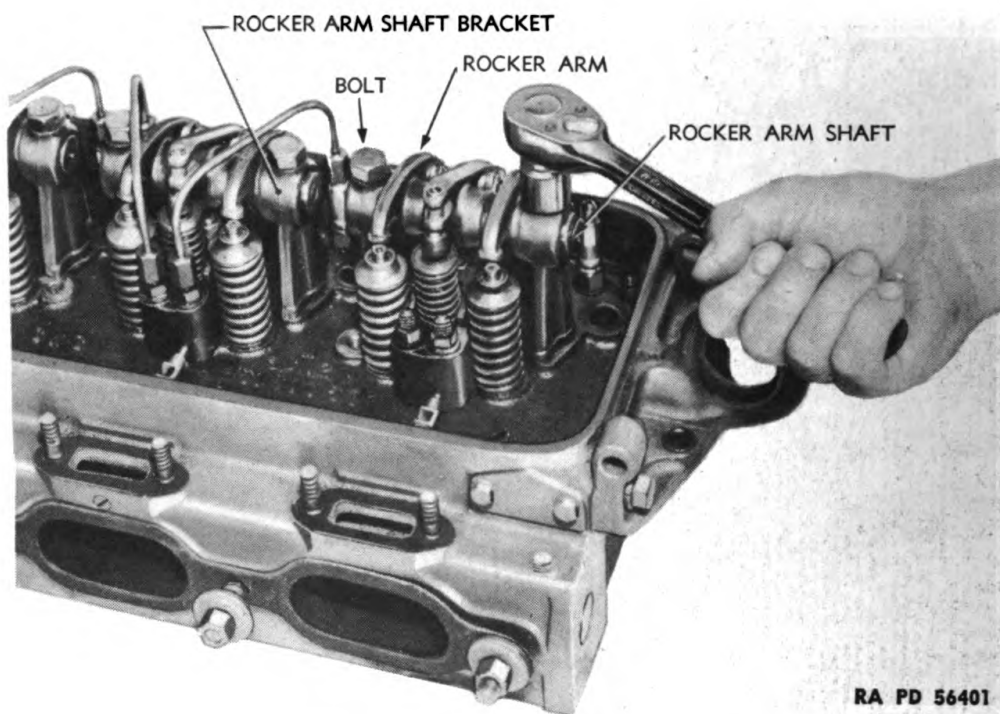

Figure 64 — Removal of Rocker Arm Bracket Bolts

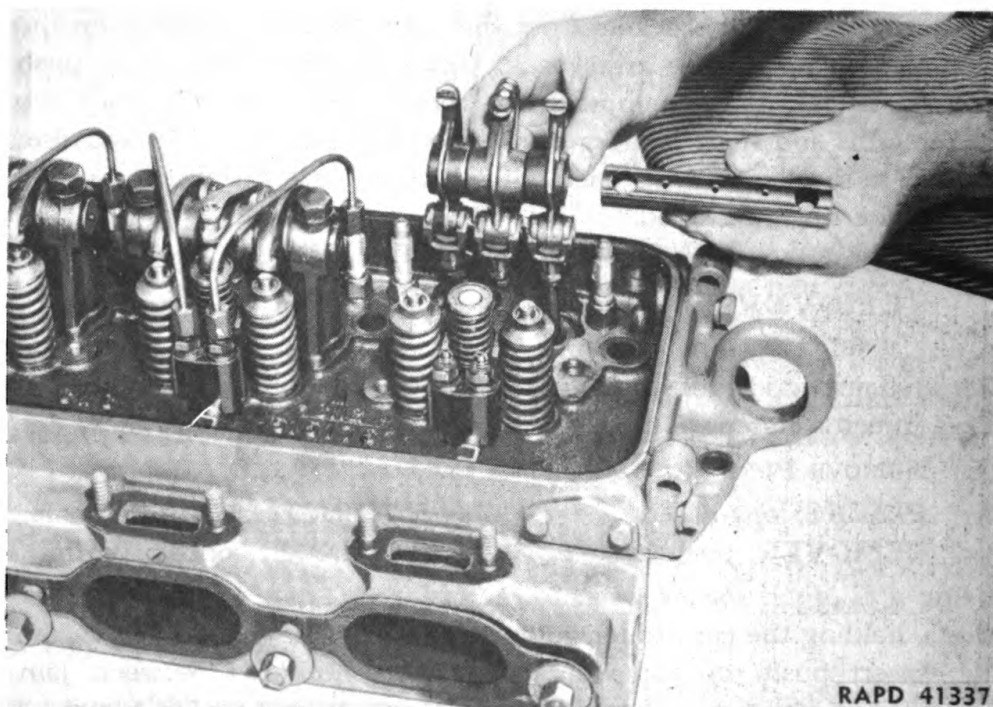
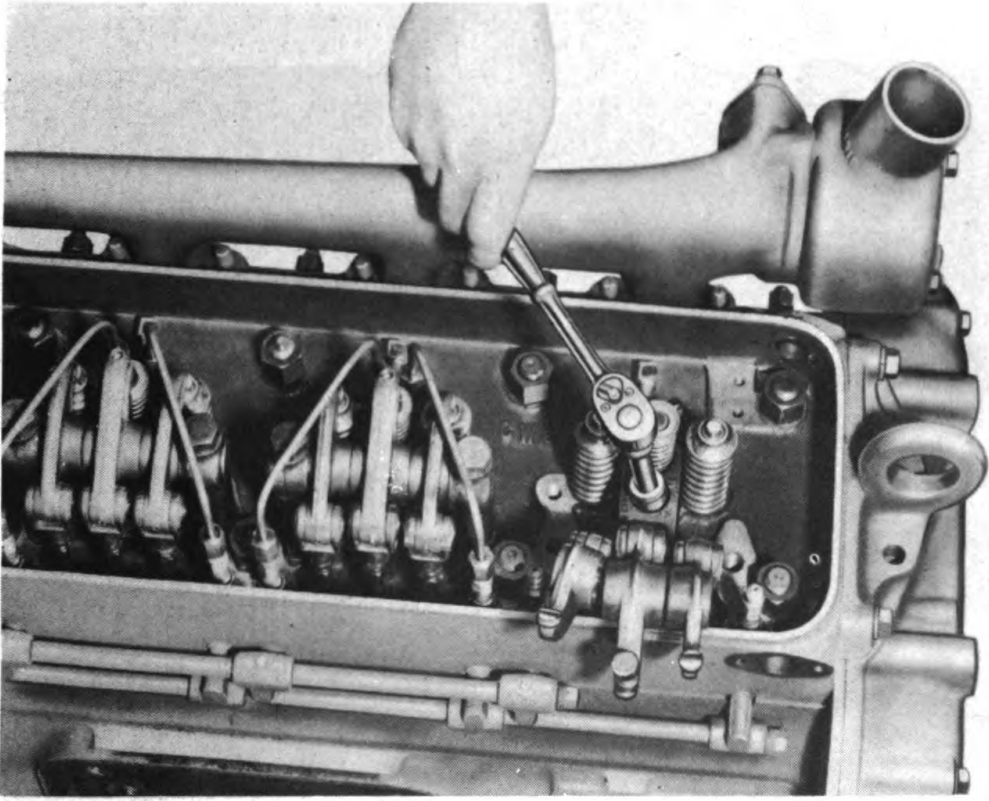

Figure 65 — Rocker Arm Shaft Removal

DISASSEMBLY OF ENGINE



RA PD 17804

Figure 66 — Injector Clamp Nut Removal

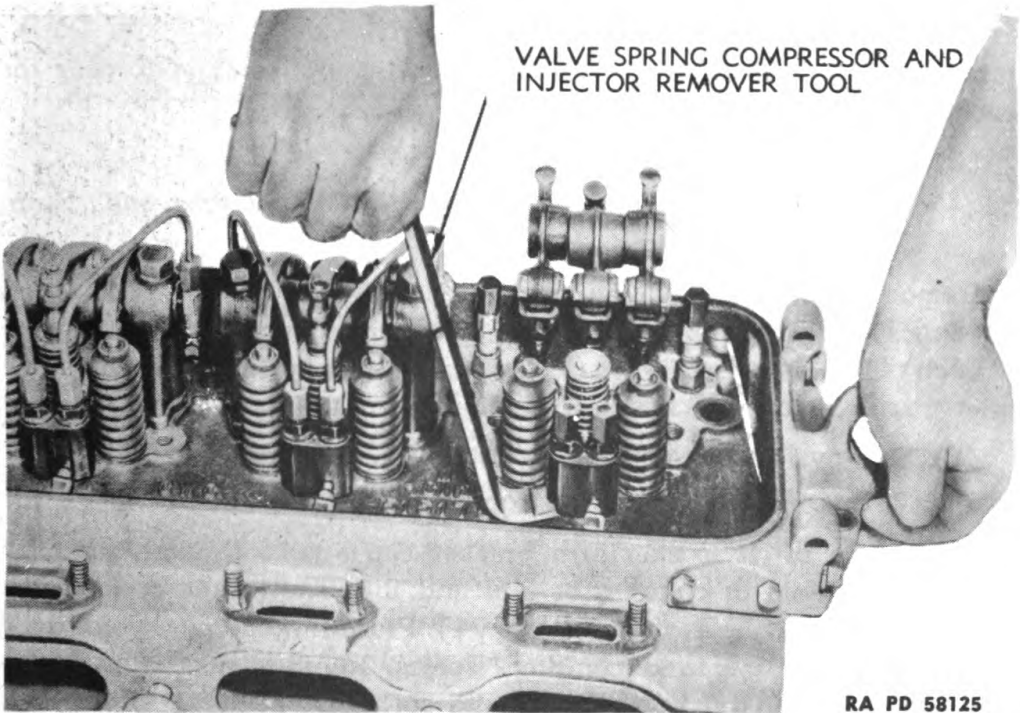

RA PD 58125

Figure 67 — Injector Removal

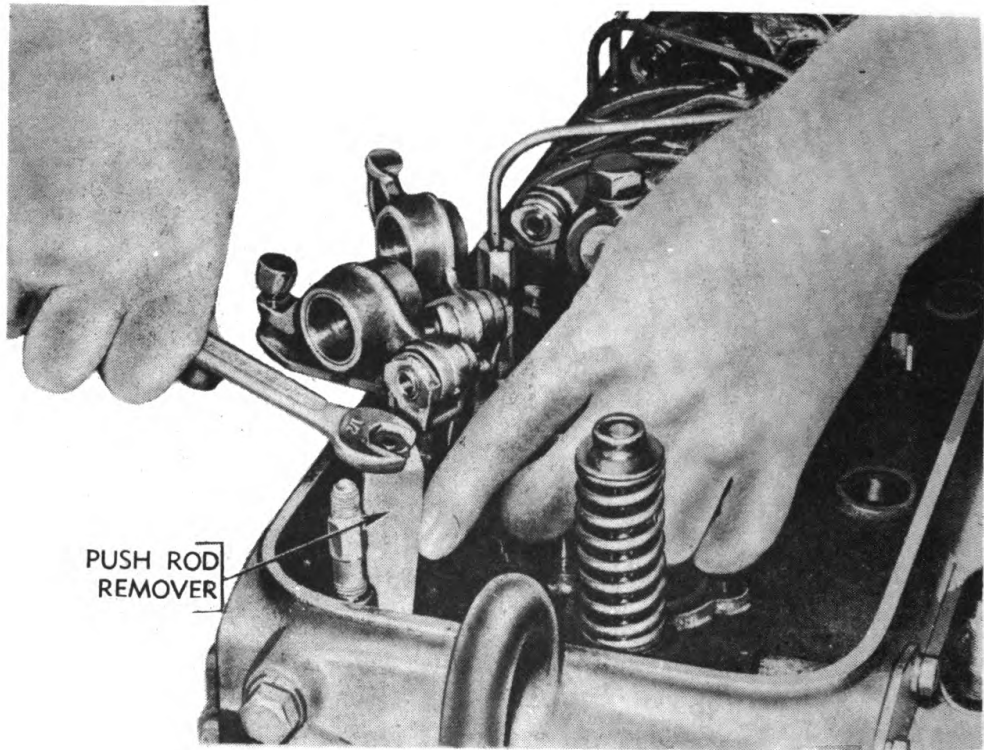

RA PD 58126

Figure 68 — Push Rod Remover Installation

retainers. Insert finger and lift out cam follower assembly. Repeat for each push rod.

(6) REMOVE FUEL MANIFOLD.

WRENCH, filter cap

WRENCH, open-end, $\frac{7}{8}$ -in.

WRENCH, open-end, $\frac{3}{4}$ -in.

Remove return fuel manifold restriction unit ($\frac{3}{4}$ - and $\frac{7}{8}$ -in. wrenches). Remove 4 fuel manifold connector jam nuts (filter cap wrench). Remove connectors. Pull out fuel return manifold. Remove inlet manifold in same manner.

(7) REMOVE EXHAUST VALVES.

REMOVER, valve spring compressor and injector

Install one of the rocker arm bracket cap screws through remover bushing and hole in compressor tool and into one of the rocker arm bracket cap screw holes in head (fig. 74). Place forked end of tool over valve spring retainer and compress spring. Remove the valve locks. Let spring up and remove retainer and spring. Repeat for all springs. Then turn head on side and remove valves.

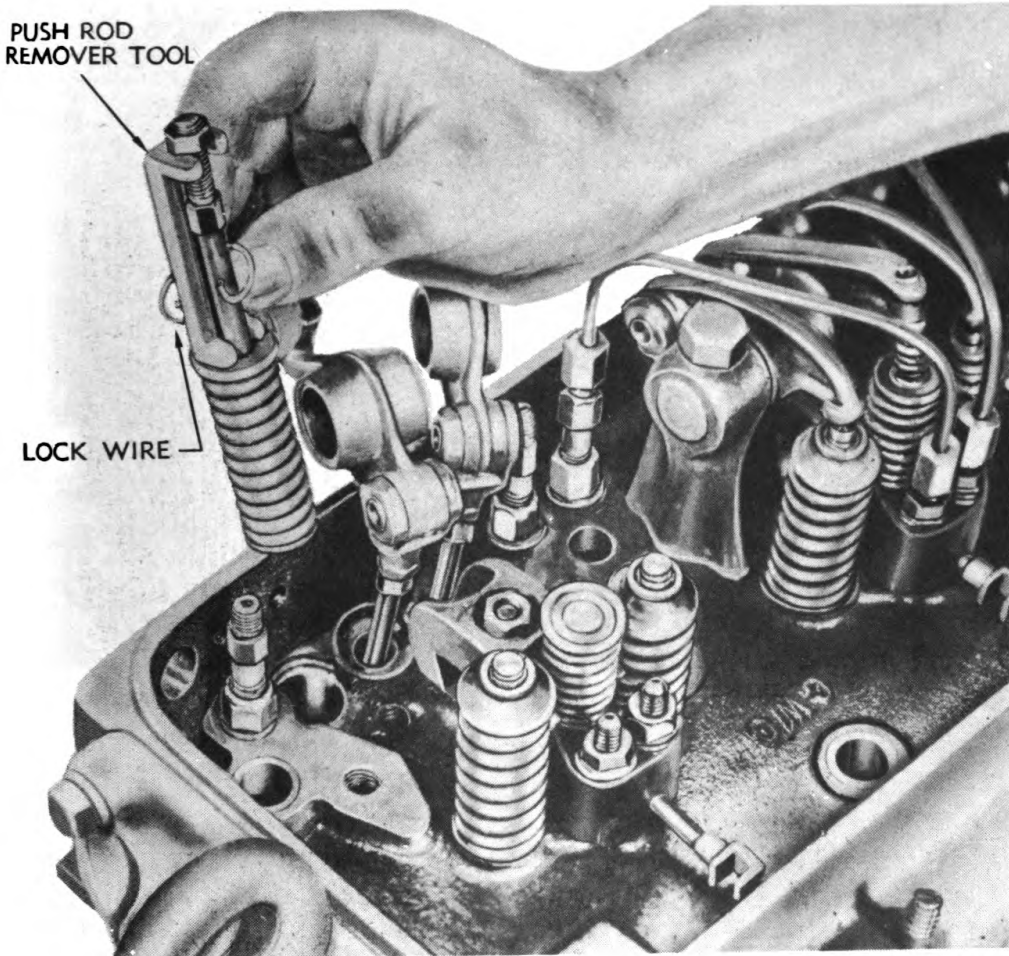
DISASSEMBLY OF ENGINE

RA PD 58127

Figure 69 — Push Rod Assembly Removal**(8) REMOVE VALVE GUIDES.****HAMMER, 2-lb****REMOVER, valve stem guide**

Turn head bottom side up and support it with blocks at each end. Drive guides from head with special tool and hammer.

(9) REMOVE VALVE SEAT INSERTS.**REMOVER, valve insert**

Insert collet of tool inside of valve insert so that lip at bottom of collet flange is flush with bottom side of valve insert. While holding collet in this position, expand it by turning nut at top of tool. *Be sure* that flange of collet is firmly entered just below insert. Slide tool body over top of collet with recessed hexagonal head screw of body in line with slot below threads on collet. Turn screw in to engage slot and

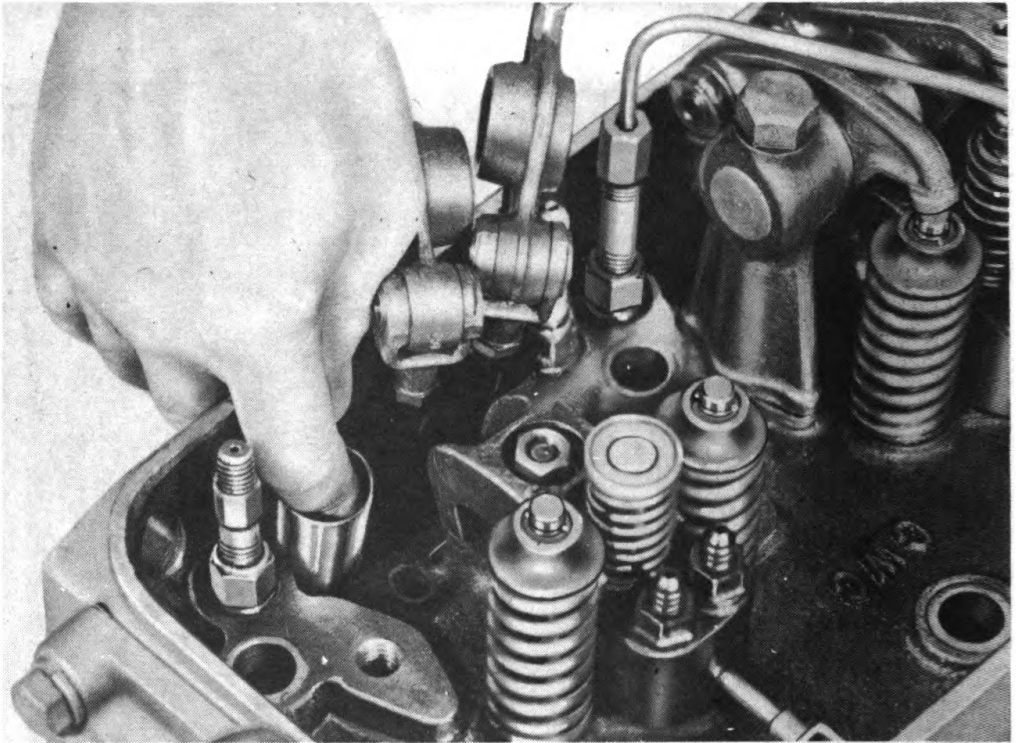

RA PD 40916

Figure 70 — Cam Follower Assembly Removal

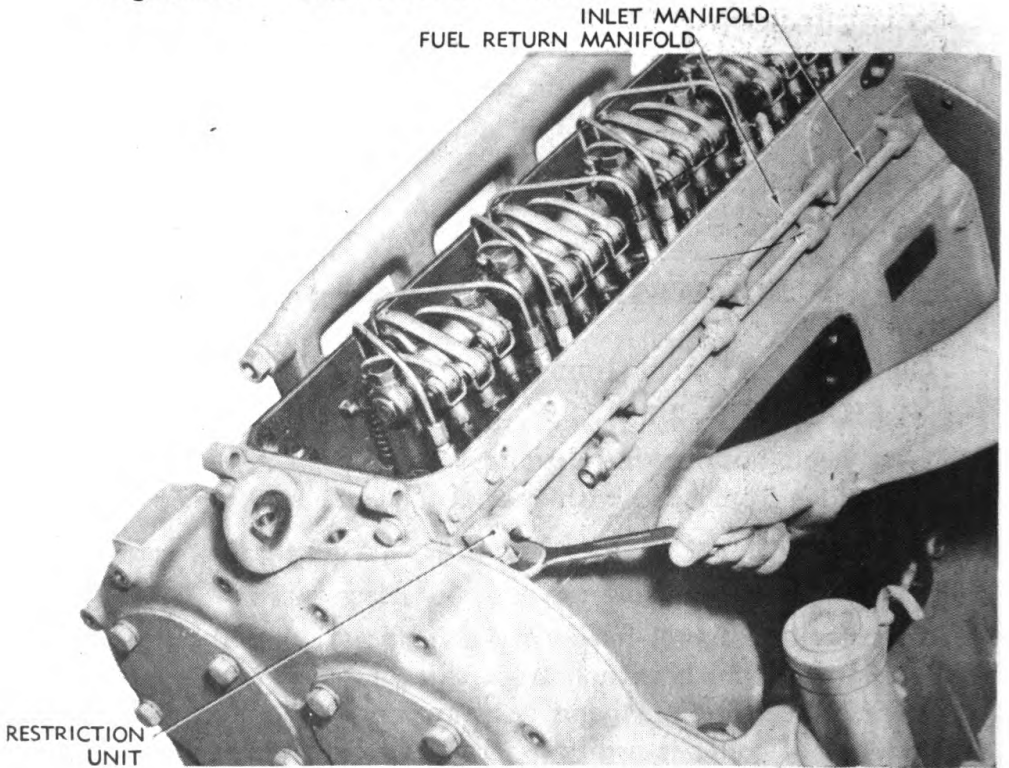

RA PD 56402

Figure 71 — Removing Fitting from Restriction Unit

DISASSEMBLY OF ENGINE

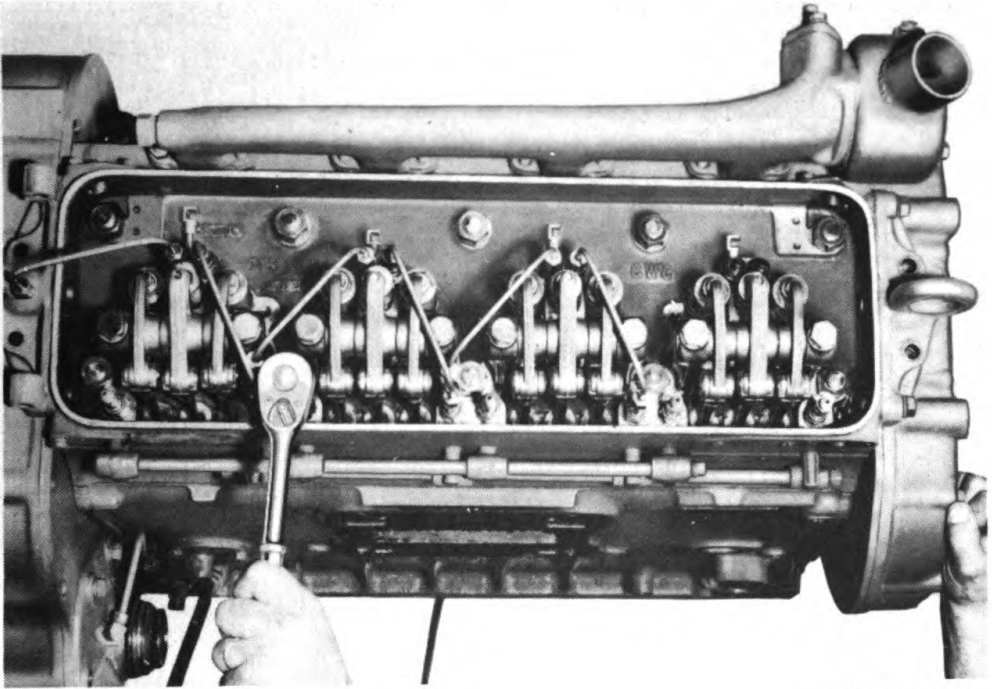

RA PD 17854

Figure 72 — Fuel Connector Removal

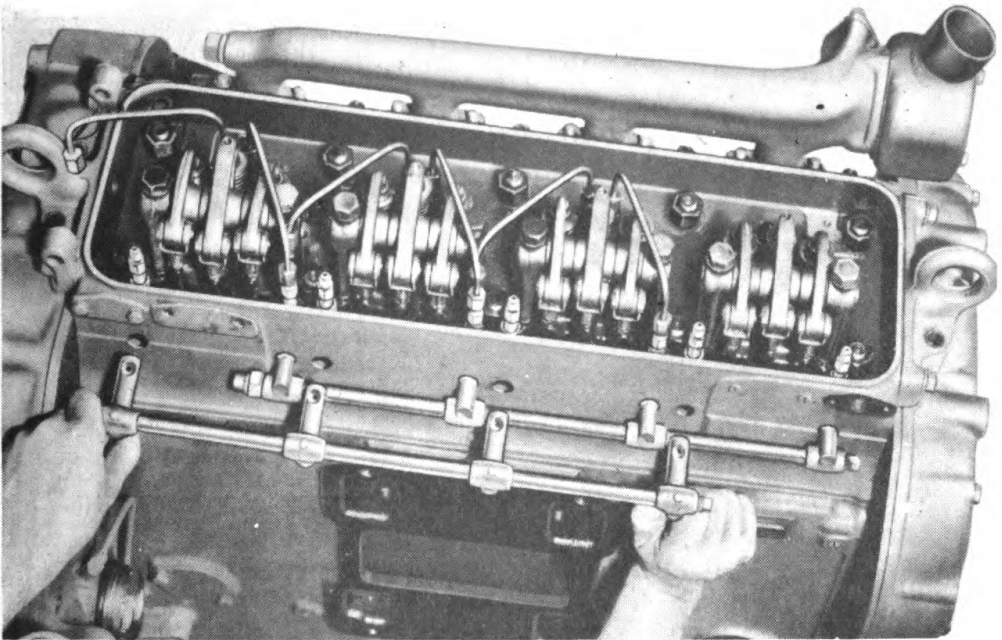

RA PD 17833

Figure 73 — Fuel Return Manifold Removal

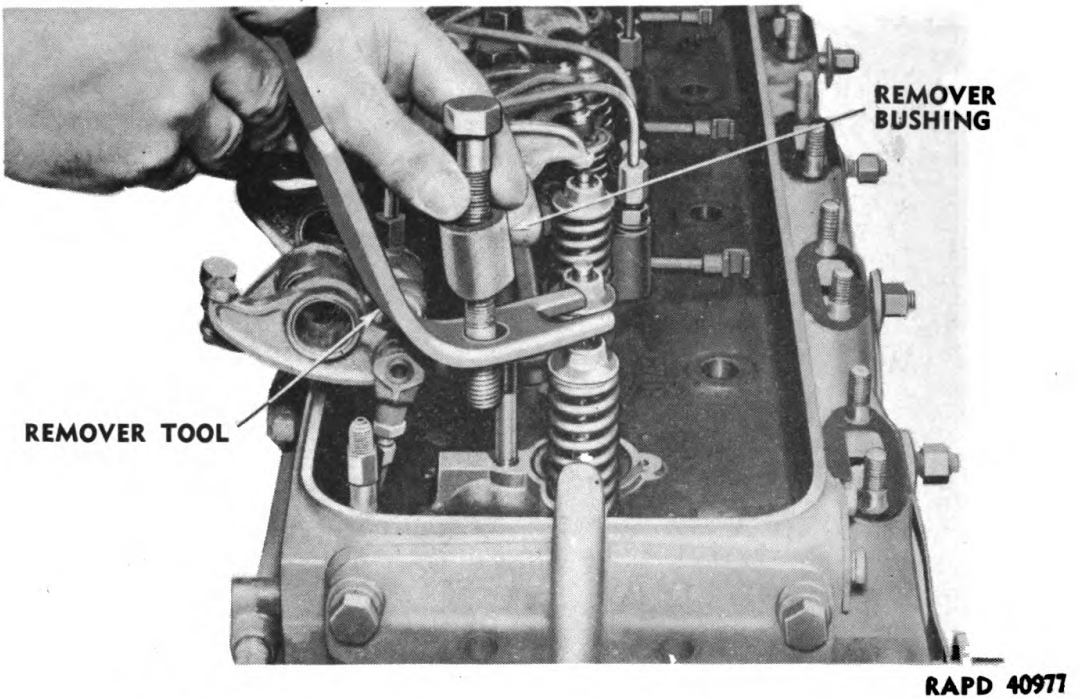

Figure 74 — Valve Spring Compressor Tool Installation

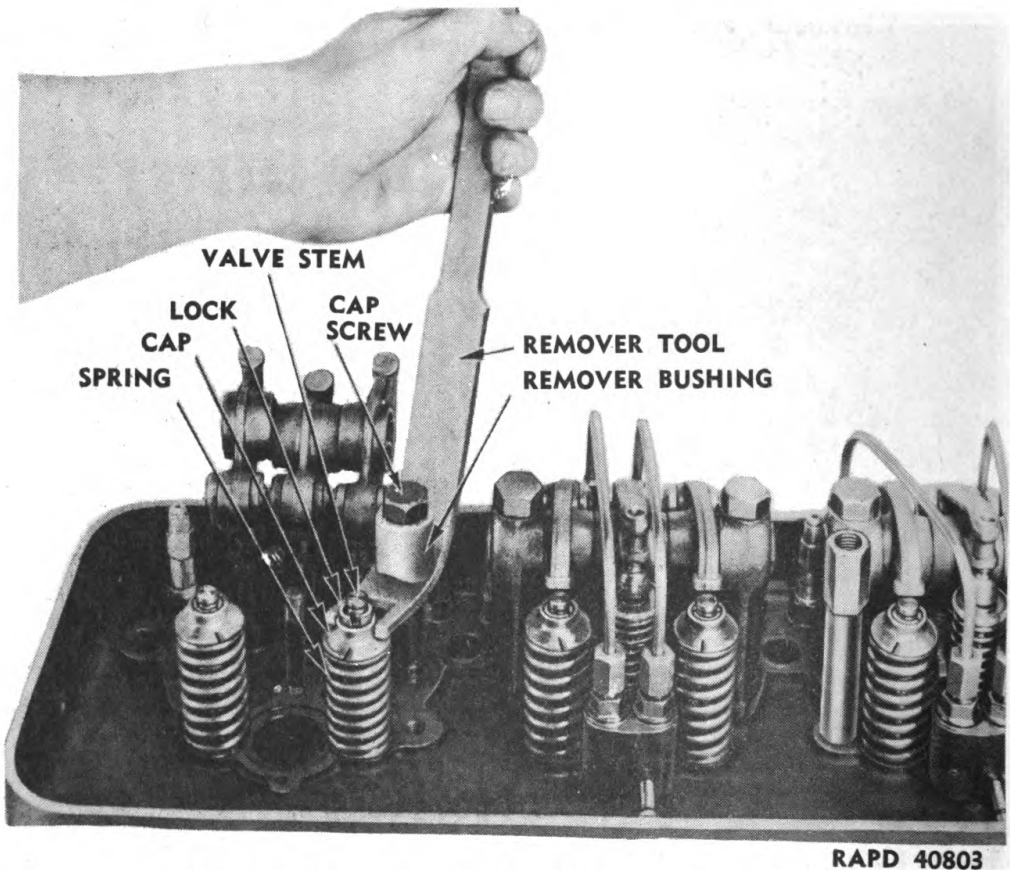
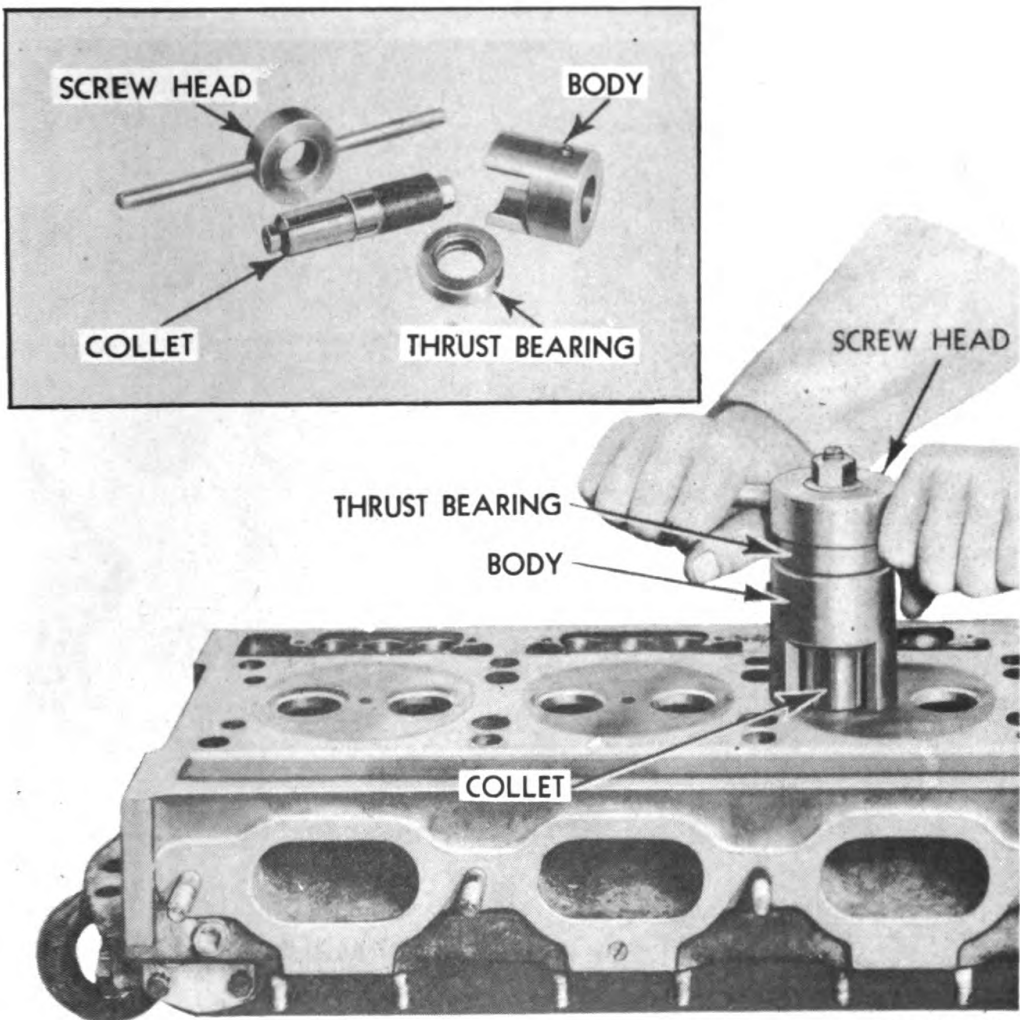

Figure 75 — Removal of Valve Spring Locks

DISASSEMBLY OF ENGINE



RA PD 40804

Figure 76 — Valve Seat Insert Removal

lock screw on collet relative to body. Put thrust bearing over top of collet and on top of body. Start screw head onto collet and continue to turn until valve insert is pulled from cylinder head.

(10) REMOVE INJECTOR COPPER TUBES.

HAMMER, 2-lb

WRENCH, 3/4-in.

REMOVER, injector copper tube, set

Screw threaded tool into upper end of copper tube (3/4-in. wrench). Turn cylinder head over and, using special punch, drive tube out through top of cylinder head (2-lb hammer).

d. Remove Flywheel Ring Gear.

CHISEL, 7/8-in.

HAMMER, 2 lb

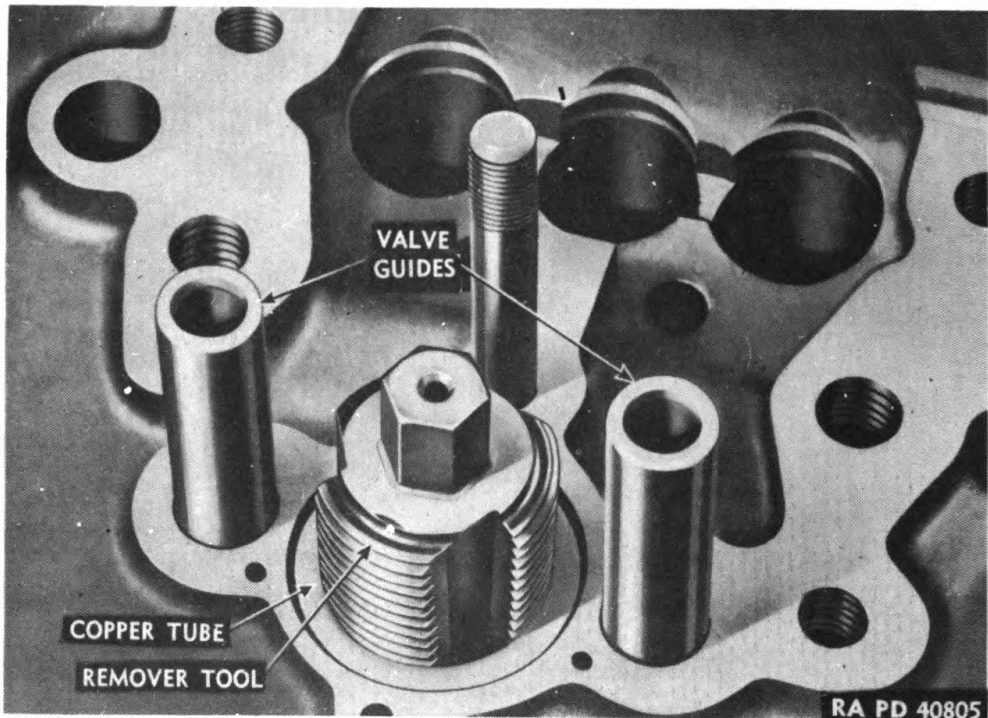

Figure 77 — Injector Tube Remover Installed

Cut damaged gear from flywheel with chisel. Hold chisel in gear between two of the teeth. Strike chisel sharply with hammer until gear expands enough to be driven from flywheel.

e. Disassemble Flywheel Housing.

HAMMER, 2-lb

PUNCH, large

Drive rear crankshaft oil seal out of housing with punch and hammer.

f. Disassemble Camshaft and Balance Shaft Assemblies.

PLIERS

SCREWDRIVER, 8-in.

PRESS, hydraulic

WRENCH, 1½-in.

Pry snap rings from intermediate camshaft bearings (screwdriver). These bearings are in two halves held by the snap rings. Remove self-locking nuts (1½-in. wrench) and press shafts from gears (hydraulic press). Remove Woodruff keys from shafts (pliers). Slide rear bearings from shafts.

g. Disassemble Crankshaft Front Cover Assembly.

HAMMER, 2-lb

PUNCH, large

DISASSEMBLY OF ENGINE

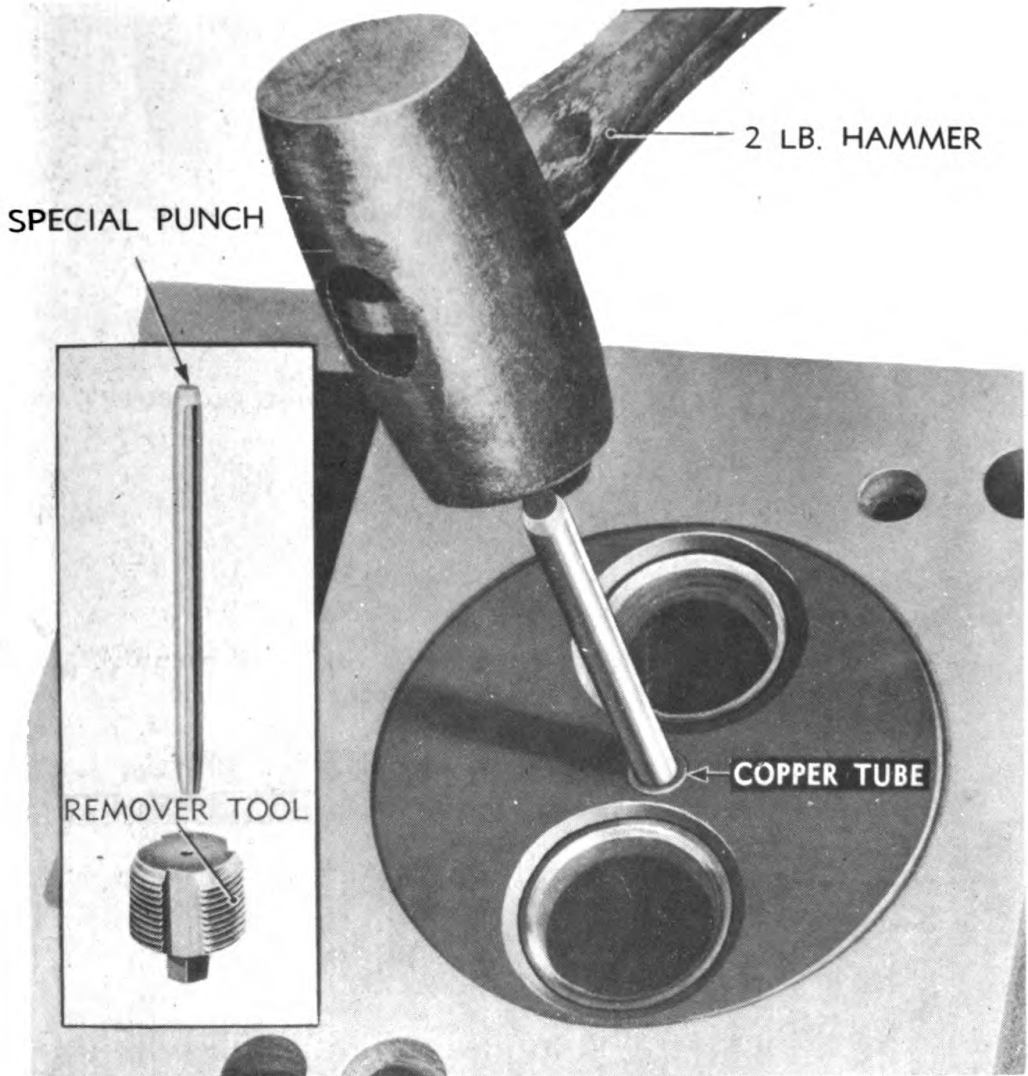

RA PD 56403

Figure 78 — Driving Out Injector Tube

Drive front crankshaft oil seal out of front cover with punch and hammer.

h. Disassemble Piston and Connecting Rod Assemblies.

(1) REMOVE PISTON PIN.

PLIERS, long nose

Remove lock ring, holding steel retainer cap at end of pin. Jar retainer and piston pin from connecting rod and piston.

(2) REMOVE PISTON RINGS.

REMOVER and **REPLACER**, piston ring

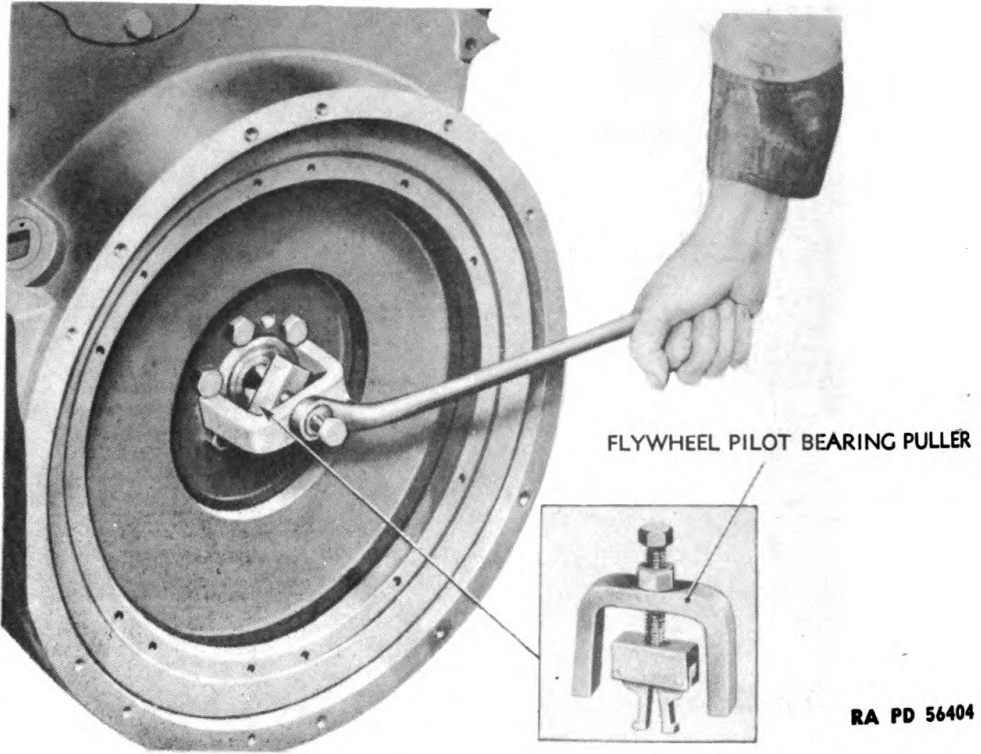

Figure 79 — Clutch Shaft Pilot Bearing Removal

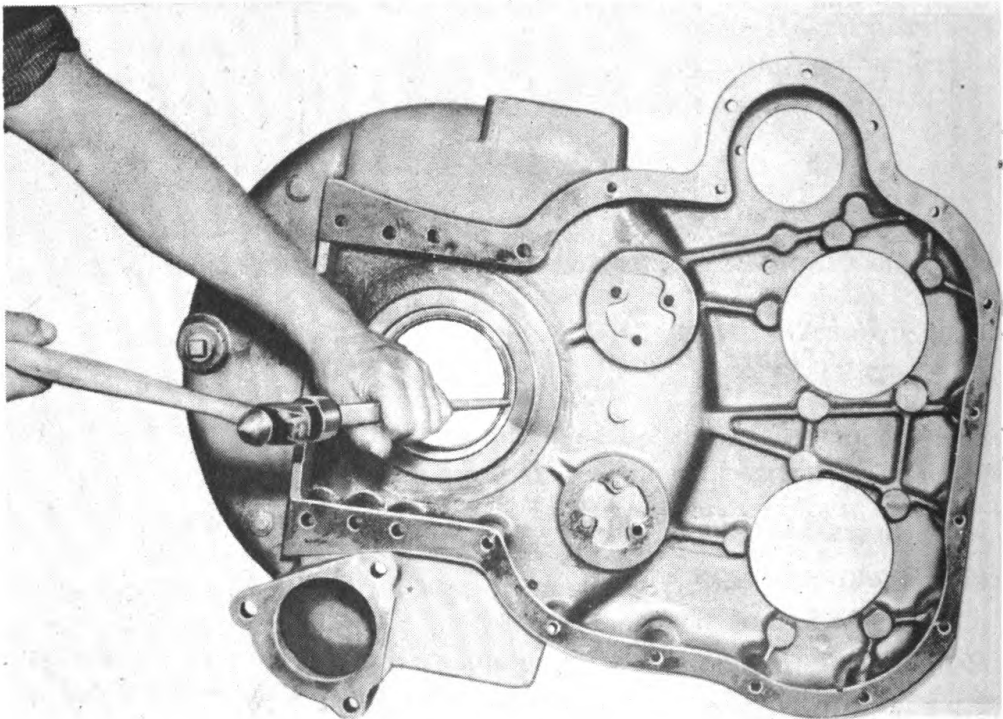

Figure 80 — Rear Crankshaft Oil Seal Removal

DISASSEMBLY OF ENGINE

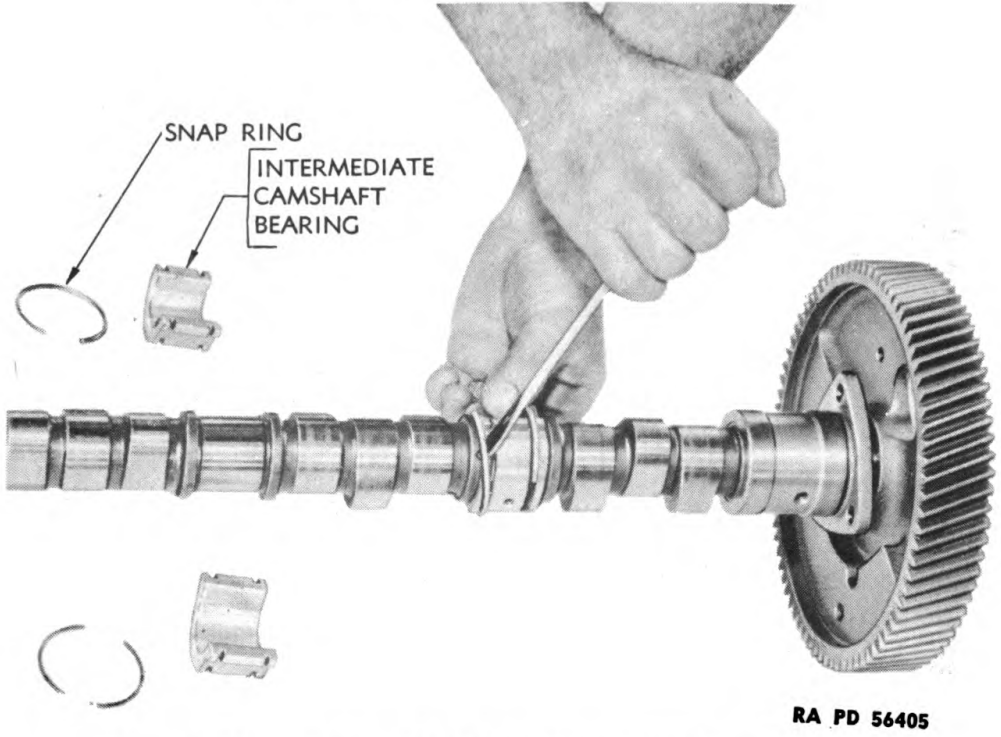

Figure 81 — Removing Snap Ring from Camshaft Intermediate Bearing

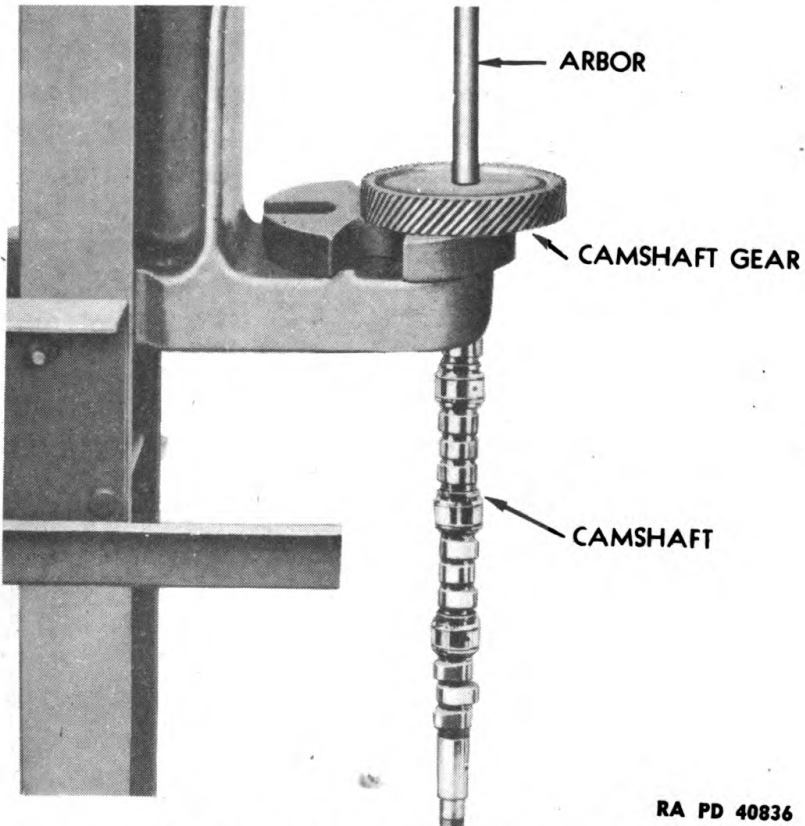
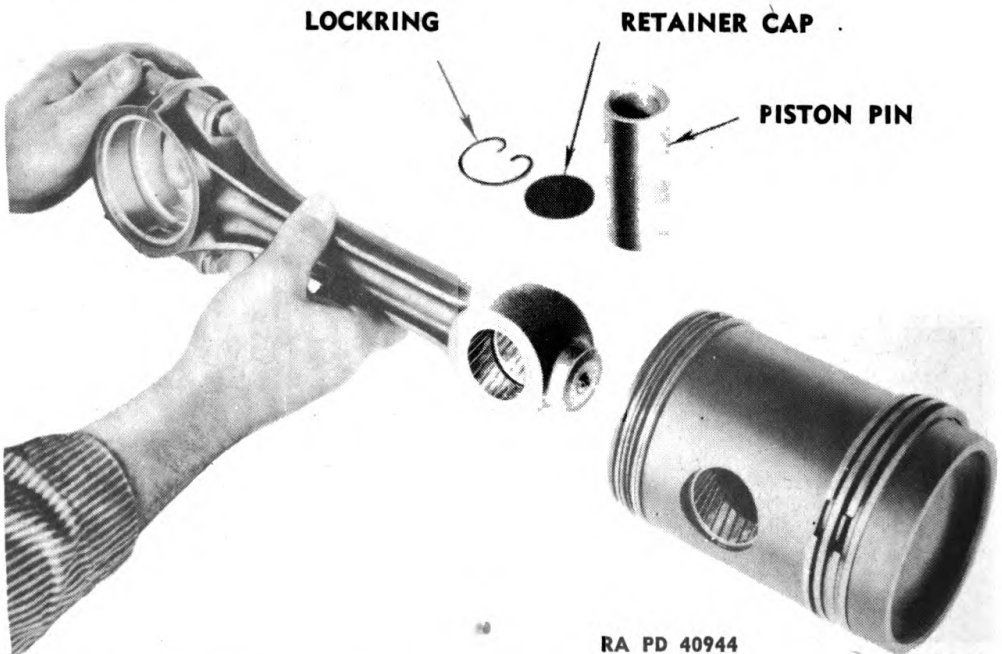

Figure 82 — Pressing Camshaft from Gear



RA PD 40948

Figure 83 — Removing Lock Ring from Piston



RA PD 40944

Figure 84 — Connecting Rod Removed from Piston

DISASSEMBLY OF ENGINE

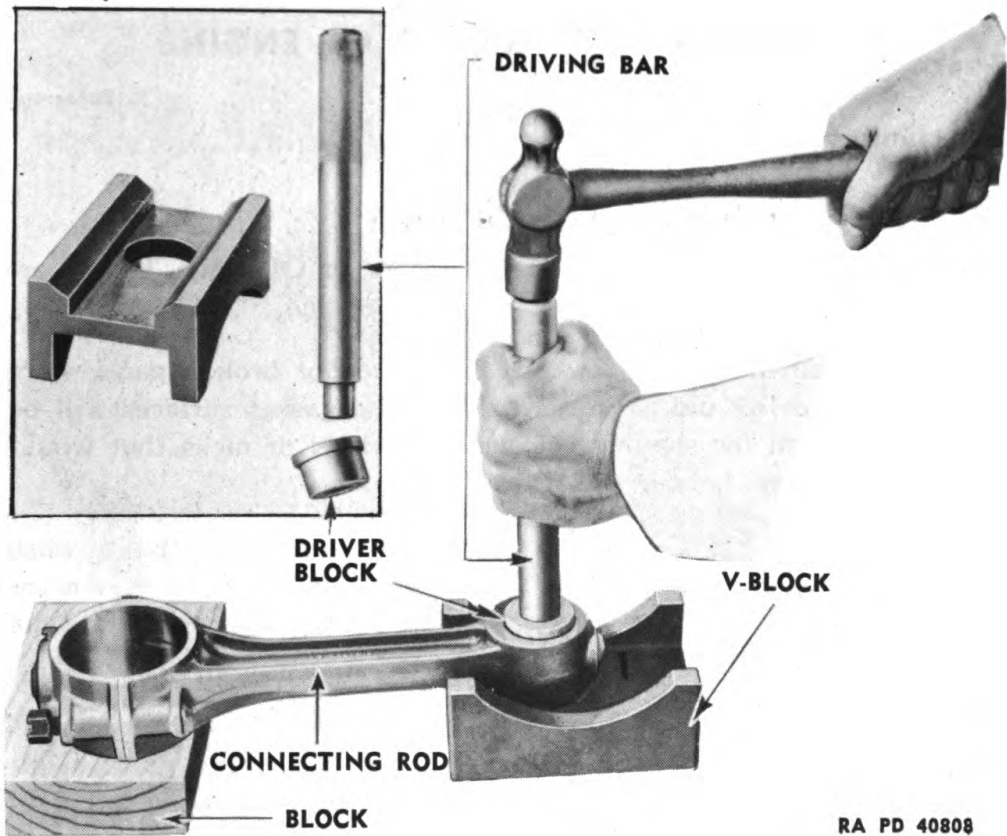

RA PD 40808

Figure 85 — Connecting Rod Bushing Removal

Remove rings as shown in figure 112. Care must be taken not to overstress the piston rings by spreading the ends more than necessary to slip rings off the piston.

(3) REMOVE BUSHING FROM CONNECTING ROD.

HAMMER, 2-lb

REMOVER and REPLACER,
piston pin bushing

Rest lower end of connecting rod on block and place upper end of V-block (fig. 85) with holes in block and rod in alignment. Drive bushings from connecting rod as shown.

i. Disassemble Crankshaft.

PLIERS

WRENCH, socket, $\frac{9}{16}$ -in.

Remove keys remaining in crankshaft, if any (pliers). Unscrew pilot bearing oil wick holder from crankshaft ($\frac{9}{16}$ -in. wrench).

Section VIII

INSPECTION AND REPAIR OF ENGINE

Paragraph

Inspection and repair of parts..... 14

14. INSPECTION AND REPAIR OF PARTS.

a. **Cleaning Solutions.** CLEANER, engine, or OIL, fuel, Diesel, are the only cleaning solutions to be used on this engine.

b. **Inspection of Parts.** Discard all cracked or broken parts, worn bolts, etc. Scrape all old gaskets from parts so gasket surfaces will be clean and smooth for assembly. Remove all burs or nicks that would prevent a tight seal between surfaces.

c. Refer to section XV and check to see if parts are so badly worn that replacement is necessary. If a part is worn almost to the maximum allowable limit, replace that part to prevent engine failure after a short operating period.

d. **Cylinder Block.** Clean entire block thoroughly with live steam and blow off dry with compressed air. Remove plugs from ends of oil galleries and blow out all oil passages, using CLEANER, engine, or OIL, fuel, Diesel, under air pressure. Install these plugs immediately after cleaning, using COMPOUND, joint and thread, to insure against leakage. Inspect for conditions that would render block unfit for further use.

e. **End Plates.** Clean and inspect cylinder block end plates for burs or damaged marks on surfaces. Both surfaces must be smooth and flat.

f. **Cylinder Liners.** Check cylinder liners for roundness and general condition. Clean all air intake ports in liners. Measure each cylinder liner bore with a gage similar to the one shown in figure 86. Check for wear, to see if it is out of round (egg shaped), or tapered (larger at one end than the other). If the dimensions are not within the limits specified in section XV, replace the liner with a new one.

g. **Pistons.** Clean the pistons by slushing in CLEANER, engine, and rinsing in hot water. Clean the ring grooves with a broken piston ring ground flat on the end. Check piston for roundness; 0.001 inch out of round is allowable. Insert piston in cylinder liner. Using thin feeler ribbon, check clearance between piston and liner crosswise of the pin. If more than 0.007 inch clearance exists, replace piston or liner or

INSPECTION AND REPAIR OF ENGINE

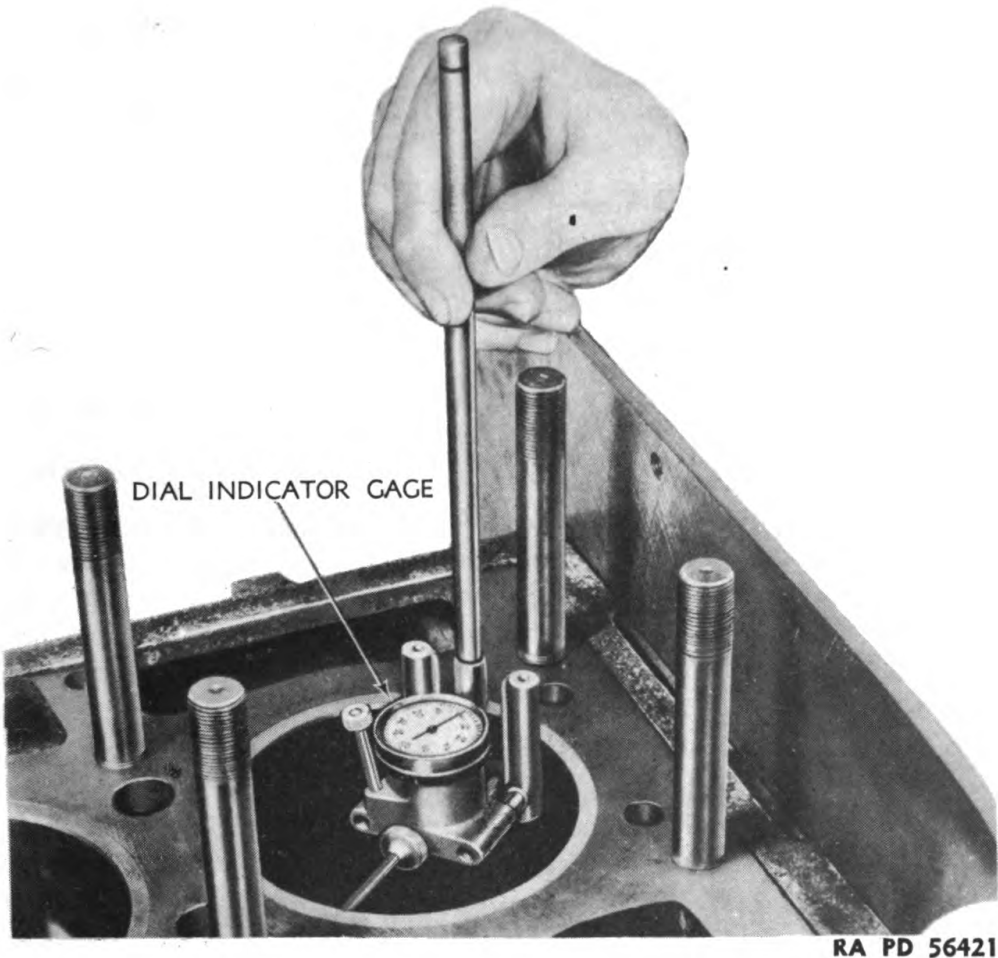

RA PD 56421

Figure 86 — Measuring Cylinder Liners for Wear

both. Check rings and ring grooves for wear. See section XV. Inspect piston pins and bushings for wear. Replace if beyond maximum allowable wear. It is usually advisable to install new rings. New rings should *always* be used if new pistons are installed. For installation of piston pin bushings in connection rod, see paragraph 16 b (2).

h. Crankshaft and Bearings.

(1) Clean and inspect crankshaft for signs of scoring, overheating, or abnormal wear. If there is any indication of any of these, replace crankshaft. Blow out all oil passages in crankshaft with air. Measure all main and connecting rod journals and crankpins in several places on the circumference to determine the smallest diameter in case journals or crankpins are worn out of round.

(2) Measure the thickness of the main bearing and connecting rod shells (figs. 87 and 88). Bearing shells have a thickness of $\frac{5}{32}$ inch at a point 90 degrees from the parting line. The two shells do not form

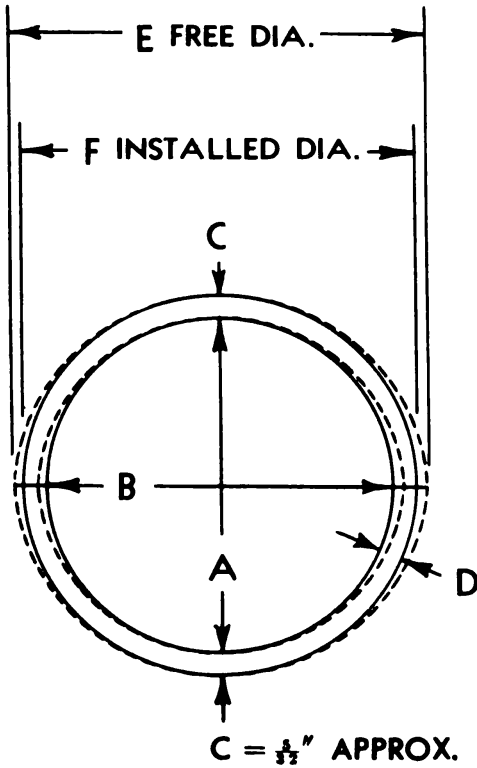

"A" IS .001" SMALLER THAN "B"
 "C" IS .0005" THICKER THAN "D"
 "E" IS .030" GREATER THAN "F"

RAPD 40810

Figure 87 — Bearing Shell Dimensions

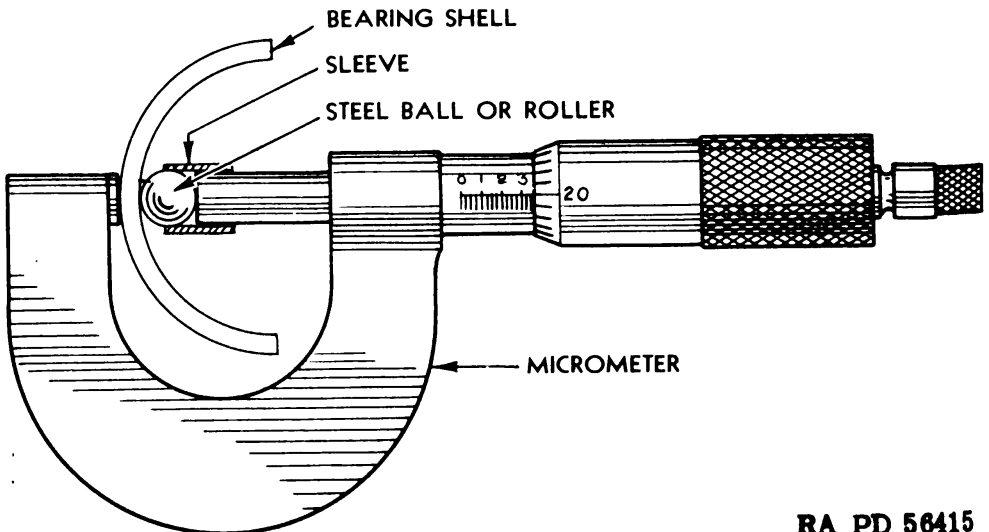

RA PD 56415

Figure 88 — Measuring Bearing Shell Thickness

INSPECTION AND REPAIR OF ENGINE

a true circle when not installed, and when measured for inside diameter, should be installed in their caps and block, with caps bolted firmly in place. The shells may be measured with micrometers at the points marked "C" (fig. 87), and any variation from $\frac{5}{32}$ inch will indicate the amount of wear on the shell being measured. Clearance between bearing shells and journals is 0.002 inch to 0.004 inch and should not exceed 0.008 inch. Discard any shells showing signs of chipping, pitting, scoring, corrosion, or overheating. All load is carried on the lower half of the main bearings and upper half of the connecting rod bearings. It is not always necessary, therefore, to replace the other half if it is not worn or damaged.

(3) Replace the crankshaft oil seals in flywheel housing and front cover. These seals must be in perfect condition or oil leaks will develop.

i. Camshaft and Balance Shaft Assemblies.

(1) Examine all bearings and journals for good bearing surfaces and wear. Examine both faces of the camshaft and balance shaft thrust shoulders and thrust end bearings, and if either is scored, replace the affected parts. If both faces are smooth, they are satisfactory for further use. Should any of the bearings show damage or scoring or be worn so clearances exceed limits given in section XV, install new bearings. Examine cam surfaces for wear or scoring. Replace shaft if cams are scored. Examine and clean all oilholes and passages.

(2) Examine the gears on both shafts, and also the idler and crankshaft gears. Worn gears or bearings cause excessive backlash and noisy operation. Inspect for wear and remove burrs on gears. When assembling engine, test clearances between gears, and if not within prescribed limits, replace those necessary.

j. Idler Gear Assembly.

(1) Inspect the journal on gear hub for scoring and check the diameter. Check inside diameter of gear bearing also for scoring. The clearance between bearing in the gear and the journal should be from 0.002 inch to 0.003 inch and should not exceed 0.006 inch. If the clearance exceeds 0.006 inch, replace either the gear and bearing assembly or the gear hub, or both, depending on which part is worn.

(2) Examine the face of the steel washer, the flange of the gear hub, and both thrust faces for scoring and wear. Replace worn parts. End play of the idler gear assembly is from 0.003 inch to 0.006 inch and should not exceed 0.008 inch. NOTE: The idler gear bearing is not removable; therefore, in case of bearing failure, the entire gear assembly must be replaced.

k. Exhaust Valves.

(1) Clean carbon from valves and guides. The valves may be cleaned

ORDNANCE MAINTENANCE — HEAVY TRACTOR M1 (Allis-Chalmers HD-10W) ENGINE

on a wire buffer, but it is necessary to ream carbon from guides with guides in head. This is done with a special valve guide cleaning tool (fig. 103). Rotate tool in guides until gum, carbon, or other foreign material is removed. Check clearance between valve stems and guides. If clearance exceeds 0.005 inch, replace either worn valves or guides, or both. Replace valves with bent stems.

(2) **VALVE, VALVE GUIDE, AND VALVE SEAT RECONDITIONING.** The exhaust valves may be refaced if stems are not worn or bent or valve heads badly burned. Use a valve refacing grinder. If badly grooved, replace with new ones. If refaced, the seating surface should be ground to a 45 degree angle. Valve seats and guides must be installed in the head for reconditioning.

1. Injector Tubes. No repair is possible on these tubes. If defective, replace.

Section IX

ASSEMBLY OF ENGINE

	Paragraph
Assembly of subassemblies	15
Assembly of engine	16

15. ASSEMBLY OF SUBASSEMBLIES.

a. Equipment.

- | | |
|--|--|
| BAR, pry | REMOVER, valve spring, compressor and injector |
| DRIVER, valve insert | REPLACER, pilot bearing |
| FIXTURE, clamping | SCREWDRIVER, 8-in. |
| GAGE, feeler (set) | SCREWDRIVER, 10-in. |
| HAMMER, 1/2-lb | TOOL, grinder, valve seat |
| HAMMER, 2-lb | TOOL, indicator, valve seat (set) |
| INJECTOR, tube drive and flanger | TOOL, replacer, valve guide |
| PIN, piston, bushing reamer and fixture | VALVE, lapper |
| PIN, piston, bushing remover and removing and replacer (set) | WRENCH, 7/16-in. |
| PLIERS, long-nosed | WRENCH, 1/2-in. |
| PRESS, hydraulic | WRENCH, 9/16-in. |
| PUNCH, small | WRENCH, 3/4-in. |
| REAMER, injector, bevel seat (set) | WRENCH, deep socket, 7/16-in. |
| REAMER, injector tube (set) | WRENCH, filter cap |
| REAMER, valve stem guide (2) | WRENCH, open-end, 1/2-in. |
| REMOVER, push rod | WRENCH, open-end, 3/4-in. |
| | WRENCH, open-end, 7/8-in. |
| | WRENCH, open-end, 1 7/8-in. |
| | WRENCH, socket, 9/16-in. |

b. Procedure. Some subassemblies are assembled in the engine assembly process and cannot be assembled previous to their installation. The following assemblies, however, may be assembled or partially assembled before their installation in assembling the engine.

(1) ASSEMBLE CRANKSHAFT.

- | | |
|--------------|------------------|
| PUNCH, small | WRENCH, 9/16-in. |
|--------------|------------------|

Install a new oil wick in wick retainer. This should be done by sticking one end of a small piece of wire through end of wick and drawing it through oil wick holder and crankshaft after wick holder has been screwed into end of crankshaft. Remove the wire and, with a small punch, stuff part of the protruding ends of the wick into the crank-

ORDNANCE MAINTENANCE—HEAVY TRACTOR M1 (Allis-Chalmers HD-10W) ENGINE

shaft until the wick is tight in each end. Then cut the wick at each end, leaving about $\frac{3}{8}$ inch sticking out from each end.

(2) ASSEMBLE PISTON AND CONNECTING ROD ASSEMBLIES.**(a) Install Piston Pin Bushings in Connecting Rod.****HAMMER, 2-lb****PIN, piston, bushing remover and replacer (set)**

Start bushings in rod with the joint in bushing towards top of rod. Drive each bushing in (fig. 85) until outer end of bushing is flush with outer edge of rod. Use same setup as was used for removing bushings. An oil space of approximately $\frac{3}{16}$ inch will be left between bushings for passage of oil to spray jet at upper end of rod.

(b) Ream Bushings.**PIN, piston, bushing reamer and fixture**

Figure 89 shows how the connecting rod is placed on the fixture preparatory to reaming. Figure 90 shows the actual reaming operation. Install lower end of rod on arbor of fixture (bearing shells removed) and draw bearing cap tight. Slide rear reamer guide bushing into rear guide boss of fixture with the hollow end facing the slot which is to receive the upper end of the connecting rod. Drop top of rod into slot so that it rests on boss of fixture bed. Install front reamer guide bushing on reamer and insert reamer into front guide boss and turn clockwise with uniform motion. Do not crowd reamer too hard, as better results will be obtained by moderate pressures when turning. After reaming, inspect for good bearing fit in the bushings. This can be done by giving a standard piston pin a very light coating of **PRUSSIAN BLUE**, and sliding it through the bushing. Point of contact can thus be easily checked. Check for proper clearance (sec. XV).

(c) Connect Rod to Piston.**PLIERS, long-nosed**

Install one piston pin retainer cap and lock ring in either end of piston pin bore. The two ears on the lock ring should be bent in before installing so that when the lock ring is in place these ears will exert an inward pressure on the pin cap, thus preventing the leakage of oil around the cap. Place upper end of connecting rod between piston bosses in line with pinholes. Lubricate pin with **OIL**, engine, and slide pin into piston and rod bores. **NOTE:** Pin should slip readily into position without forcing if fits are correct. Install second piston pin retainer cap and lock ring in piston at exposed end of pin, making sure lock ring ears are bent as indicated above to hold retainer cap tight.

(3) ASSEMBLE FLYWHEEL ASSEMBLY.**(a) Install Flywheel Ring Gear.****HAMMER, 2-lb**

ASSEMBLY OF ENGINE

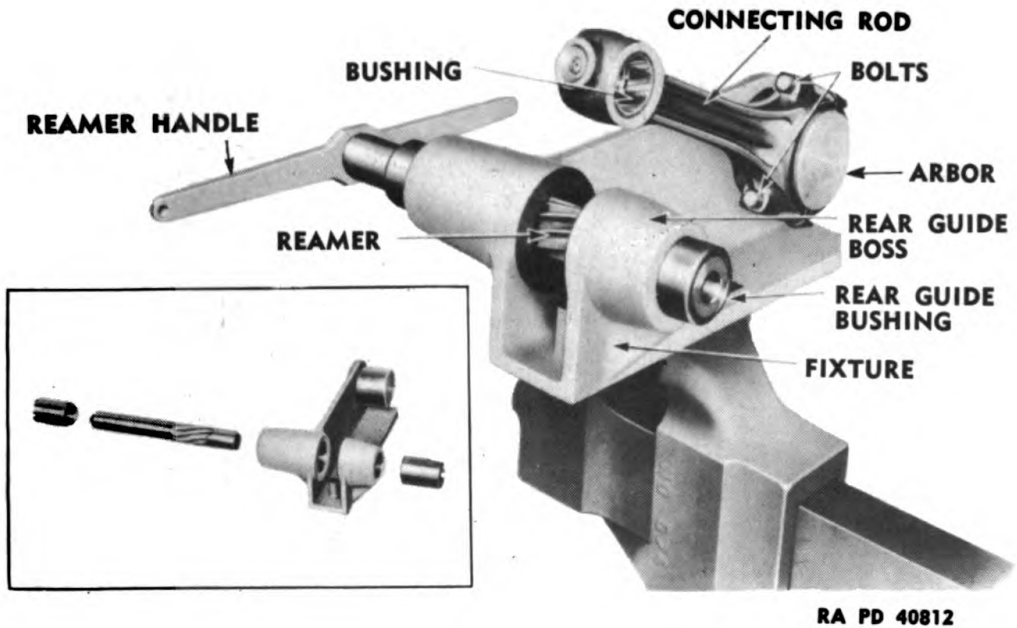

Figure 89 — Preparation for Reaming Piston Pin Bushing

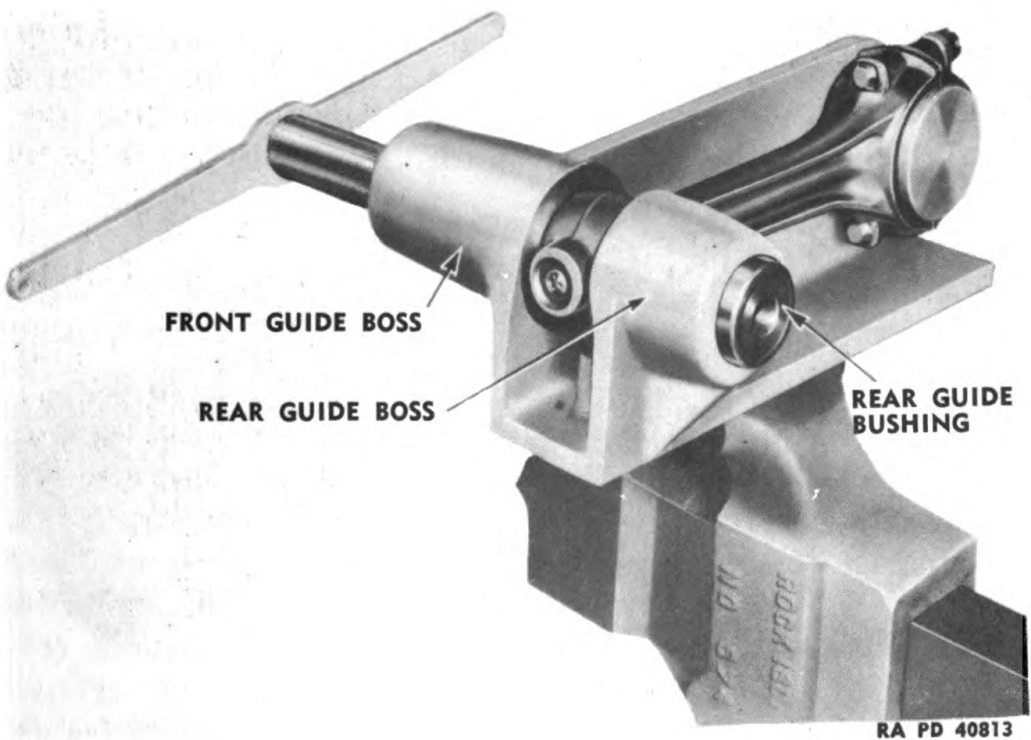
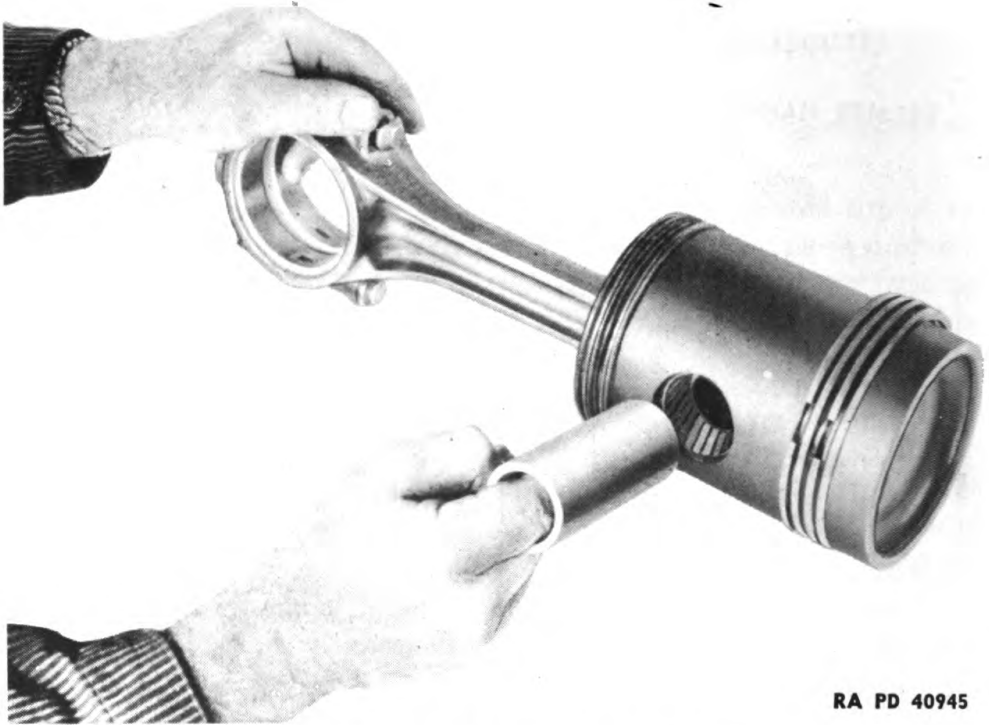
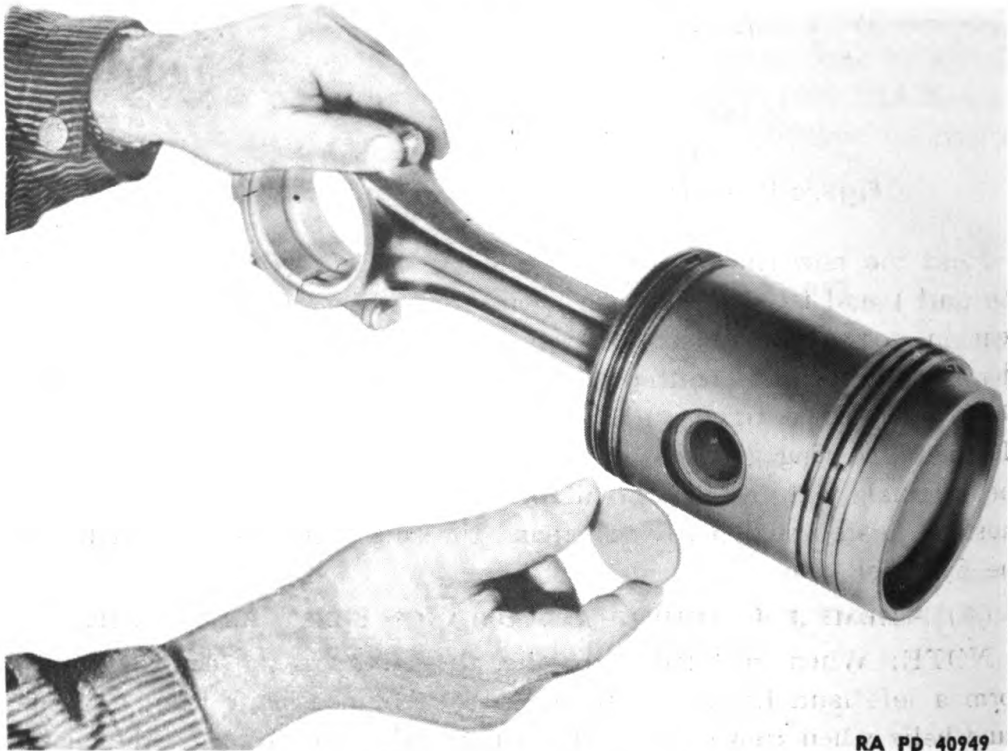

Figure 90 — Reaming Piston Pin Bushing



RA PD 40945

Figure 91 — Piston Pin Installation



RA PD 40945

Figure 92 — Piston Pin Retainer Cap Installation

ASSEMBLY OF ENGINE

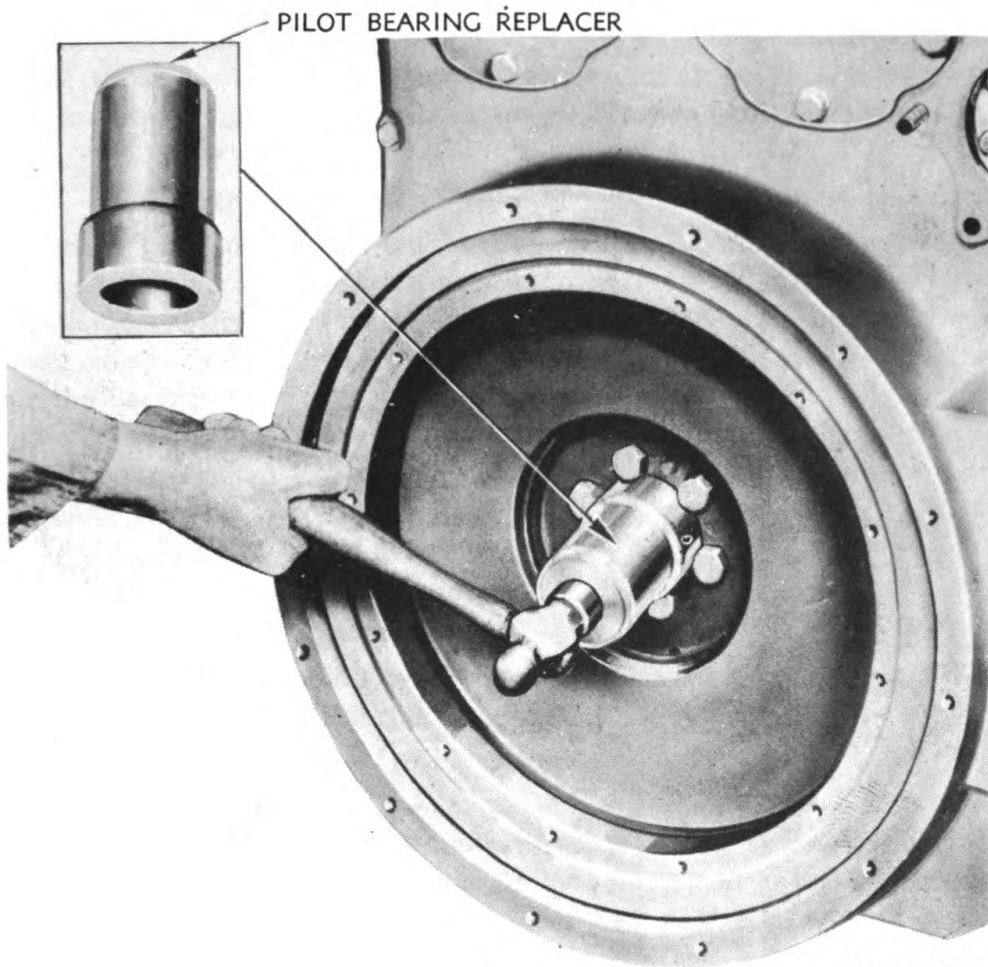

RA PD 58128

Figure 93 — Installing Pilot Bearing in Flywheel

Heat the new ring gear evenly to 450 degrees (red heat visible in the dark) and have flywheel at room temperature (70 F). Then place gear in position on flywheel so that, when flywheel is installed, the chamfered end of the teeth on the ring gear will face the cylinder block. Drive gear down tight against shoulder on flywheel. Let cool in air. **NOTE:** The ring gear should not be subjected to too much heat, as the original heat treatment will be destroyed. On the other hand, it must be heated sufficiently to expand the ring and make a tight fit on the flywheel.

(4) ASSEMBLE CAMSHAFT AND BALANCE SHAFT ASSEMBLIES.

NOTE: When installed in engine, the teeth on the camshaft gear form a left-hand helix, and those on the balance shaft form a right-hand helix when viewed from the rear. Weights are bolted to the backs of both gears. If these weights were removed, *be sure* they are installed

ORDNANCE MAINTENANCE — HEAVY TRACTOR M1 (Allis-Chalmers HD-10W) ENGINE

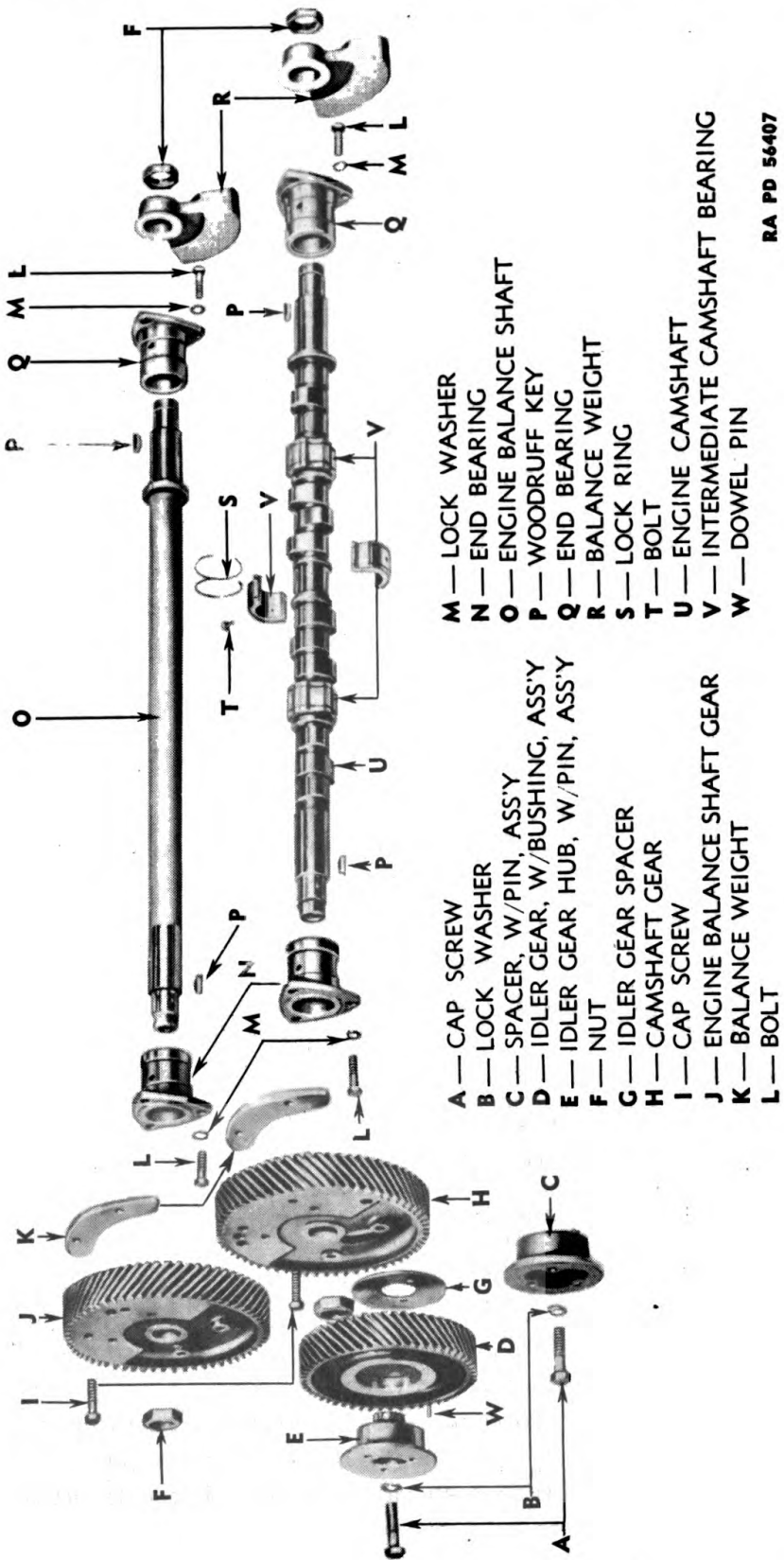

Figure 94 — Camshaft and Balance Shaft Assemblies — Exploded View

RA PD 56407

ASSEMBLY OF ENGINE

on the gears before gears are installed in engine. The camshaft and balance shaft end bearings for the rear or gear end of shafts are plain, while those for the front end are grooved. Keep these notes in mind when assembling. Refer to figure 94 for relative position of parts.

(a) Install Gears on Shafts.**HAMMER, 1/2-lb****PRESS, hydraulic**

Slip a plain nonthrust end bearing (no oil grooves in bushing) on each shaft with flanged end towards gear. Gears go on the shaft ends which do not have thrust shoulders. Install Woodruff keys in slots in ends of shafts (hammer) and press gear with right-hand helical teeth on the balance shaft and gear with left-hand helical teeth on the camshaft. Flat finished face of gears must be away from bearings. Slots in bore of gears must line up with keys on shafts. Screw nuts on shafts by hand to be tightened later when shafts are installed.

(b) Install Intermediate Camshaft Bearings.**SCREWDRIVER, 8-in.**

The 3 intermediate bearings are in halves. Lubricate with OIL, engine (crankcase grade), and place each bearing in position and snap lock rings into grooves in the bearings to hold them together in place.

(5) INSTALL OIL SEAL IN FLYWHEEL HOUSING.**HAMMER, 2-lb**

If crankshaft oil seal was removed from housing, install the new one with lip or edge of seal towards engine. It may be tapped into place by tapping all the way around it with a hammer to drive it in evenly, or a flat piece of metal may be used. This flat piece must be the same diameter as the seat or it may damage the seal retainer.

(6) INSTALL OIL SEAL IN CRANKSHAFT FRONT COVER.**HAMMER, 2-lb**

This seal is installed in the same manner as the seal installed in flywheel housing (see above).

(7) ASSEMBLE INJECTOR CONTROL TUBE ASSEMBLY.**HAMMER, 1/2-lb****PRESS, hydraulic**

Press bearings into control tube brackets. One end of control tube has a hole in it. Install one bracket on this end of control tube with offset of bracket away from shaft. Install control tube lever on shaft next with offset away from shaft and arm pointing toward the side of the shaft which has the adjusting screw holes. Install groove pin through lever and tube (hammer). Next place spring on tube from opposite end and slip the 4 rack control levers onto the tubes with pins on levers pointing away from the bracket already installed. These levers should slide on and rotate freely on tube. If not, inspect for burrs on shaft. Place second bracket on other end of shaft.

ORDNANCE MAINTENANCE — HEAVY TRACTOR M1 (Allis-Chalmers HD-10W) ENGINE

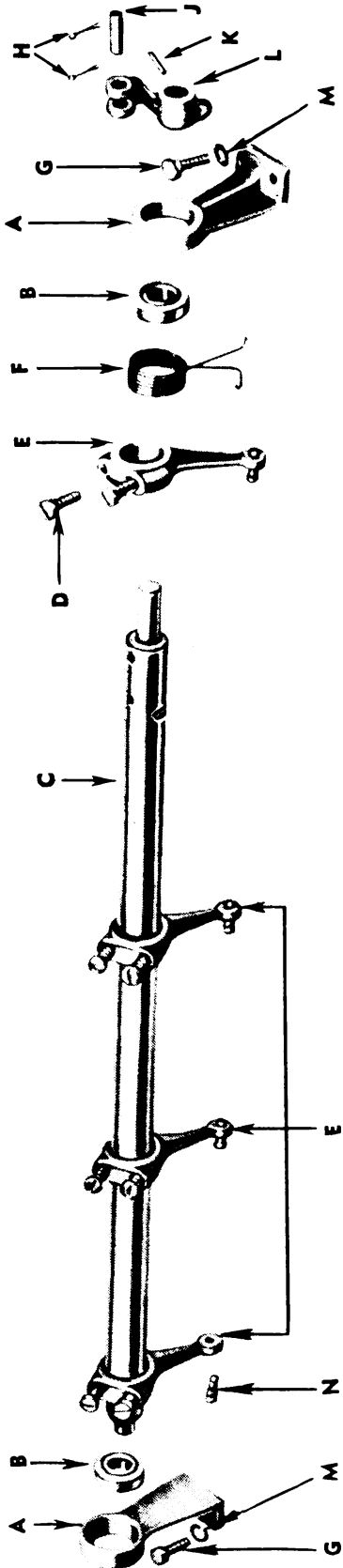

- A — CONTROL TUBE BRACKET
- B — BALL BEARING
- C — INJECTOR CONTROL TUBE
- D — CAPSCREW
- E — RACK CONTROL LEVER
- F — CONTROL SHAFT RETURN SPRING
- G — CAPSCREW
- H — COTTER PIN
- J — LINK PIN
- K — GROOVE PIN
- L — INJECTOR CONTROL TUBE LEVER
- M — LOCK WASHER
- N — RACK CONTROL LEVER PIN

RA PD 58129

Figure 95 — Injector Control Tube Assembly — Exploded View

ASSEMBLY OF ENGINE

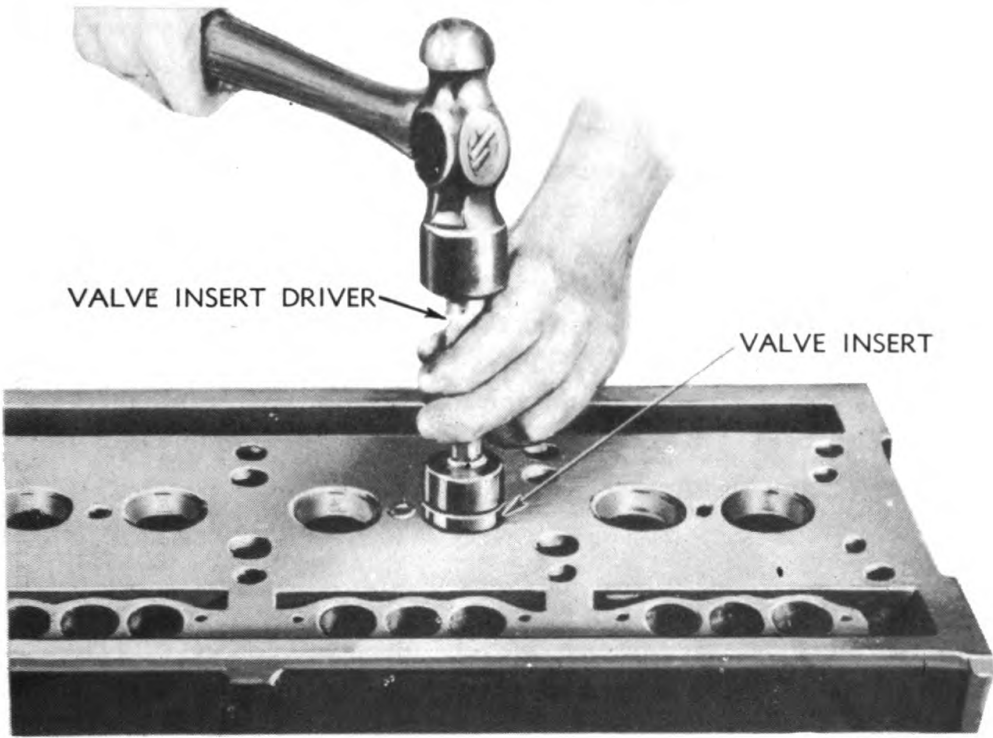

RA PD 58254

Figure 96 — Installation of Valve Seat Inserts

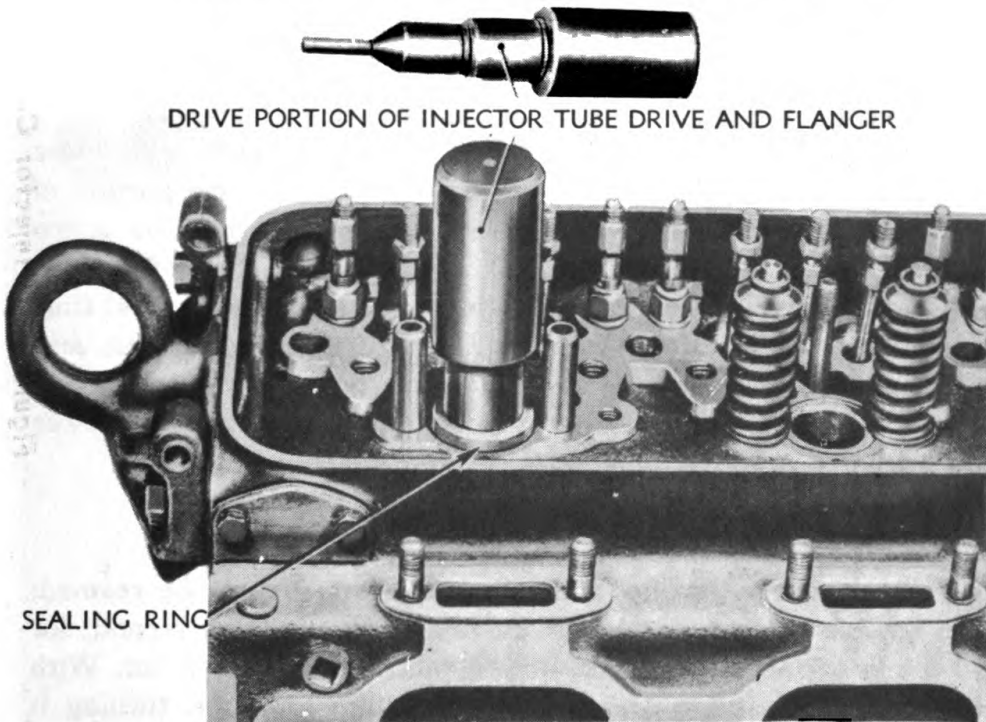

RA PD 58255

Figure 97 — Special Tool for Installing Injector Tube

ORDNANCE MAINTENANCE — HEAVY TRACTOR M1 (Allis-Chalmers HD-10W) ENGINE

(8) ASSEMBLE CYLINDER HEAD ASSEMBLY.

(a) *Install Valve Seat Inserts.*

DRIVER, valve insert

HAMMER, 2-lb

Particular care must be exercised when installing valve seat inserts. They are installed with a drive-shrink fit, and must be started in place true with counterbore in head. See that cylinder head is perfectly clean, particularly the counterbore for inserts. Immerse cylinder head for 30 minutes in water at temperature of 180 F to 200 F. Place head bottom side up on bench, and lay on insert in counterbore, valve side up. Drive insert into counterbore. **NOTE:** This operation must be done quickly while the head is hot, and the insert must not be allowed to become heated before it is driven into place.

(b) *Install Injector Copper Tubes.*

HAMMER, 2-lb

INJECTOR, tube, drive and flanger

Support head, right side up, on 2 blocks. Install a new seal ring on injector copper tube, insert drive portion of injector tube drive and flanger into tube, and drive tube into injector opening in cylinder head (hammer). The flange at upper end of tube will seat on ring and into counterbore when tube is in position.

(c) *Flare End of Injector Tube.*

FIXTURE, clamping

INJECTOR, tube, drive and flanger

HAMMER, 2-lb

WRENCH, 3/4-in.

Using the 2 hold-down bolts provided in feet of clamping fixture tool, attach clamp to top of cylinder head through block stud holes (3/4-in. wrench). Screw-in clamp must be over top of drive portion of injector tube drive and flanger (fig. 98). Loosen lock nuts on screw thread and turn screw down against top of drive portion of tool so that injector tube is firmly seated in cylinder head and against seal ring. Fix screw thread in position with lock nuts. Turn head on side and install flanging portion of injector drive and flanger over lower end of drive portion and upset injector tube into counterbore at lower side of cylinder head (hammer).

(d) *Ream Injector Tube for Injector Nut and Spray Tip.*

REAMER, injector tube (set)

After injector tube has been installed in head, it must be reamed; first, to receive the injector body nut and spray tip; and second, for good seating of the bevel on the lower end of the injector nut. With head right side up, insert the reamer down into the tube, turning it at the same time. This will ream the tube to the proper size to receive the injector nut and spray tip.

ASSEMBLY OF ENGINE

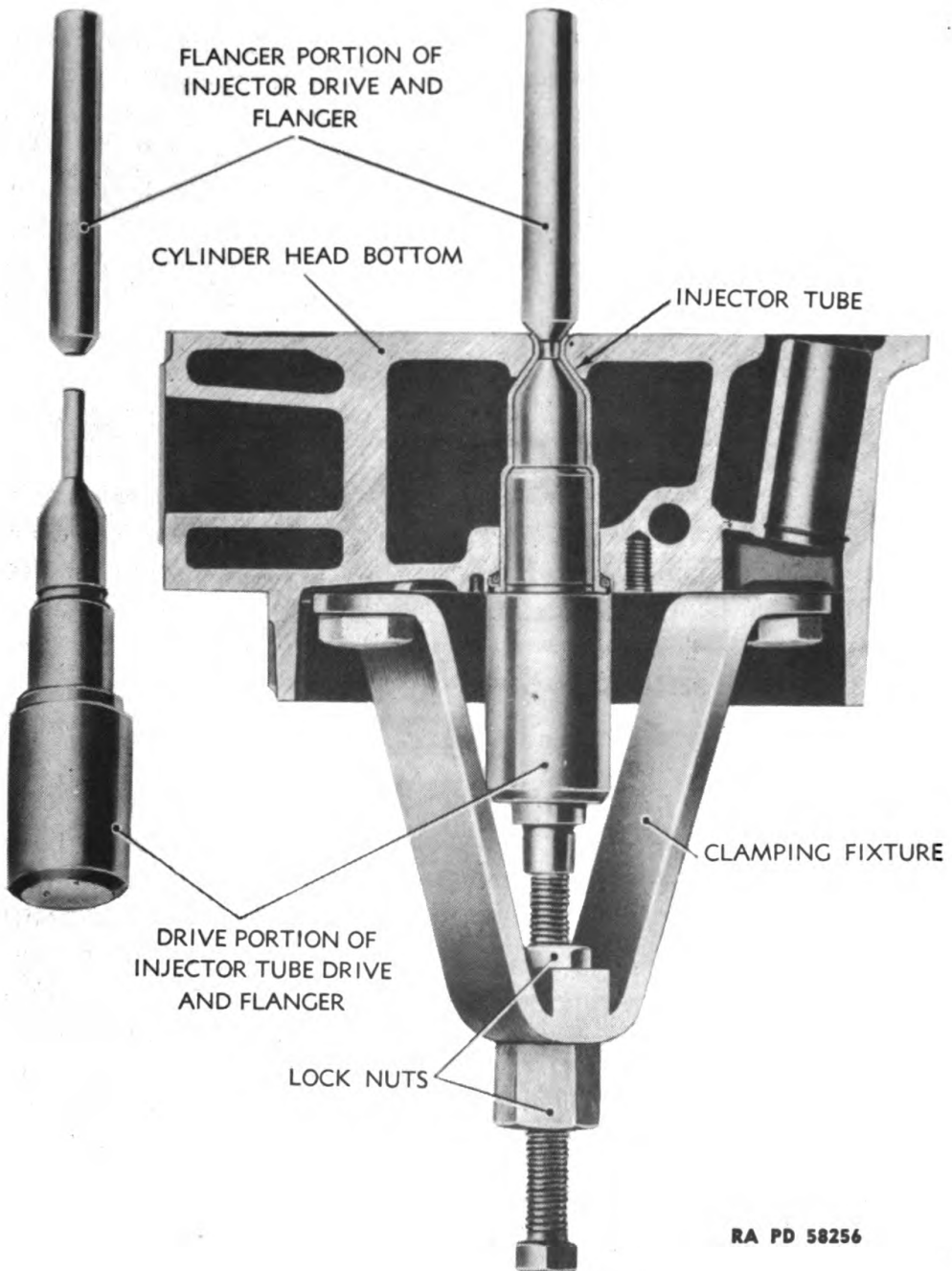

Figure 98 — Injector Tube Installation

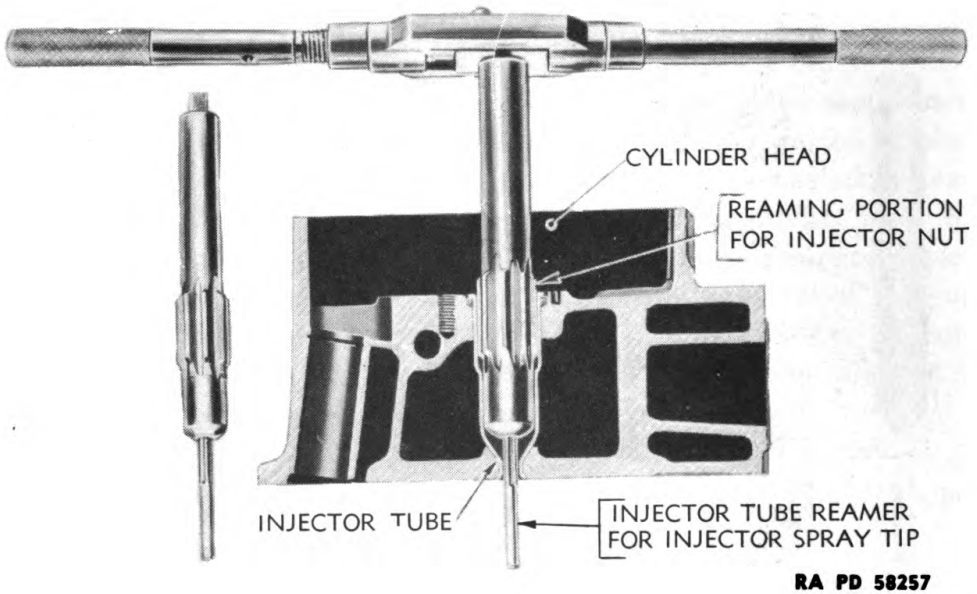

Figure 99 — Reaming Injector Tube

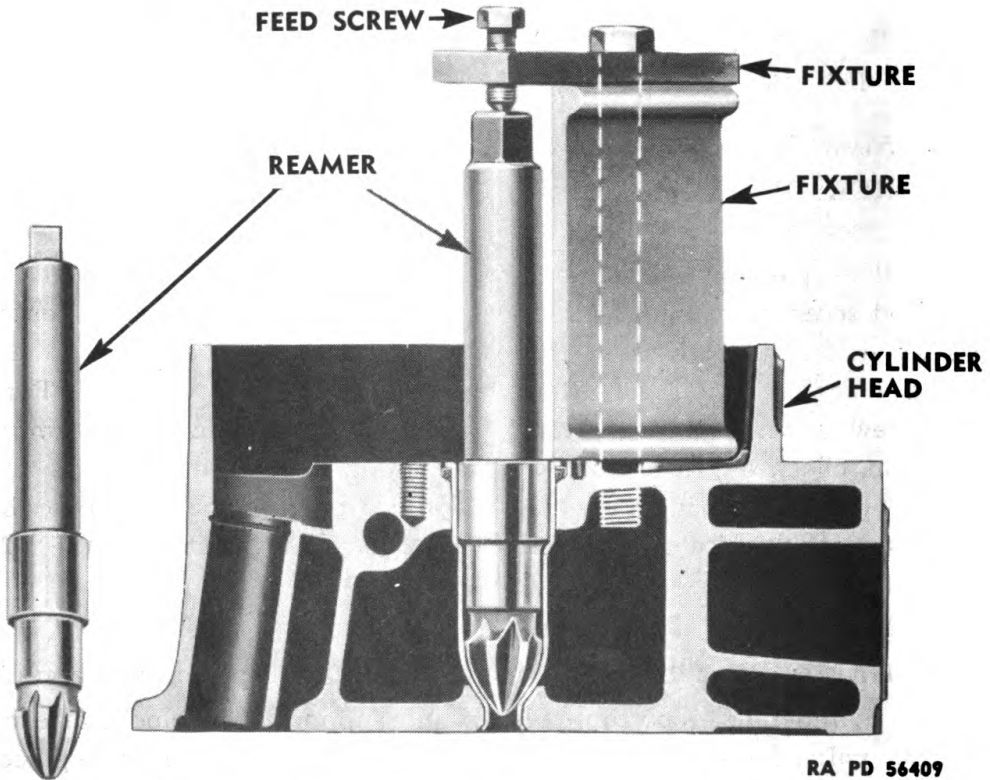

Figure 100 — Reaming Bevel Seat in Injector Tube

ASSEMBLY OF ENGINE

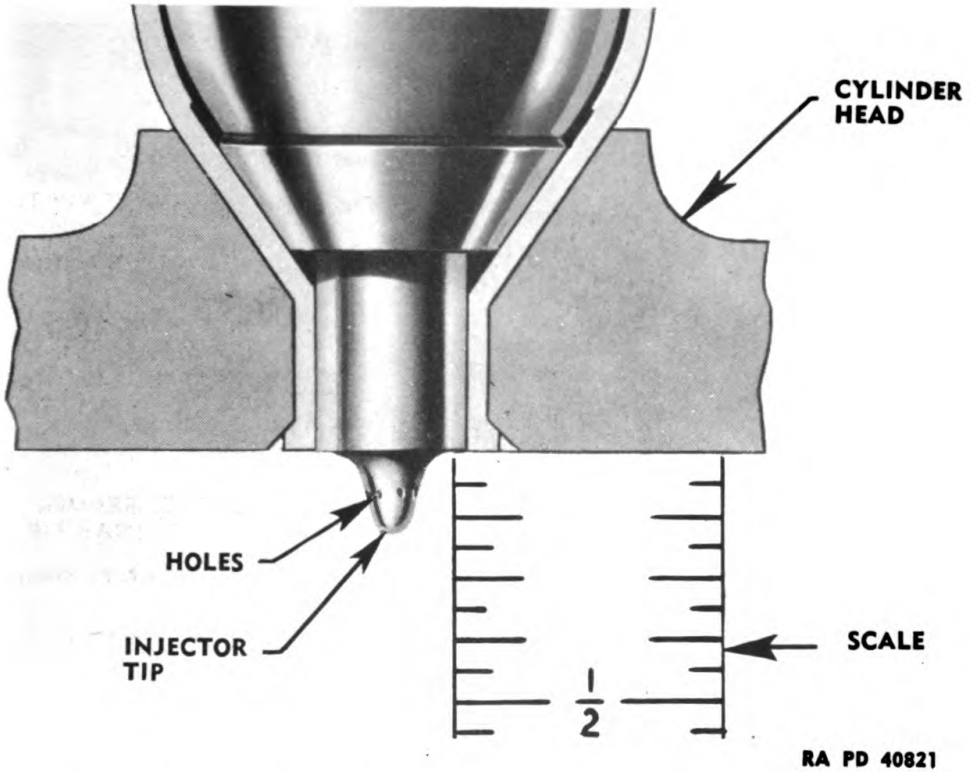

Figure 101 — Checking Location of Injector Spray Tip

(e) *Ream Bevel Seat in Tube.*

REAMER, injector bevel
seat (set)

WRENCH, $\frac{3}{4}$ -in.

Install reamer into injector tube. Set fixture on cylinder head so that feed screw in overhanging portion of fixture is directly over center of reamer. Fasten fixture in this position with a cap screw into the tapped hole for rocker arm shaft bracket bolt ($\frac{3}{4}$ -in. wrench). Turn feed screw down *finger-tight only* (see fig. 100). During the reaming operation, check depth of cut by installing an injector in the tube and measuring as shown in figure 101. Shoulder on injector tip should be just flush with surface of head. Check for good seating with PRUSSIAN BLUE, after reaming.

(f) *Install Valve Guides.*

HAMMER, 2-lb

TOOL, replacer, valve guide

Turn cylinder head bottom side up and support it on blocks at each end. Set valve guide in bore in cylinder head. Place collar on replacer tool against shoulder of tool and insert tool in valve guide. Drive valve guide into cylinder head as far as collar on tool allows. This will correctly position guide.



Figure 102 — Installation of Valve Guides

(g) *Ream Valve Guides.*

REAMER, valve stem guide (2)

Valve guides must be reamed in place after they are installed. Use the roughing reamer first and make a finish cut with the finishing reamer (fig. 103).

(h) *Grind Valve Seats.*

TOOL, grinder, valve seat
TOOL, indicator, valve seat
(set)

TOOL, valve lapping

ASSEMBLY OF ENGINE

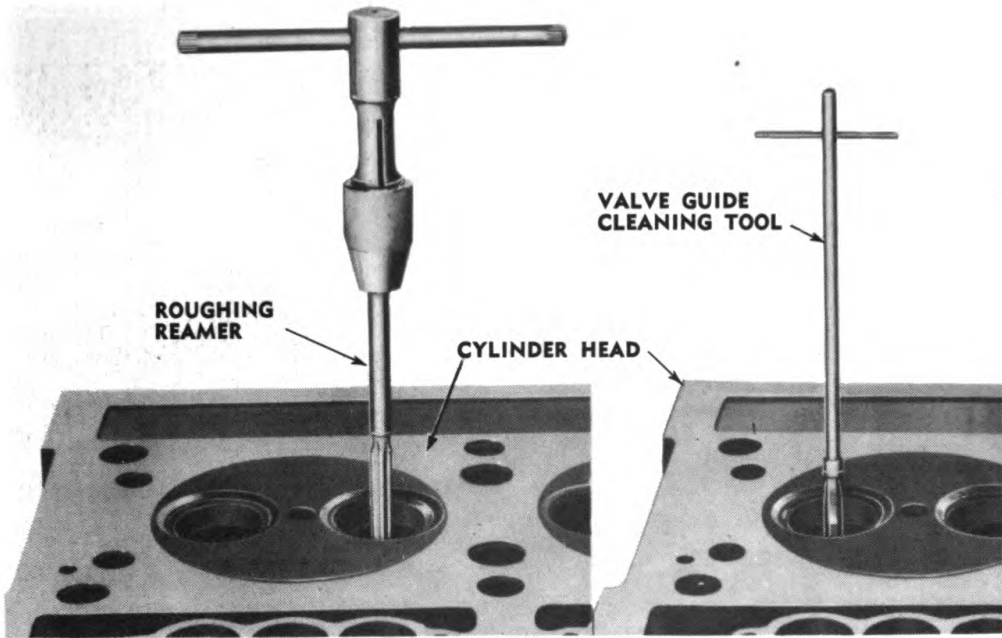

RA PD 40824

Figure 103 — Reaming and Cleaning Valve Guides

The width of the valve seats is $\frac{3}{32}$ inch. New or reused inserts must be refaced with a grinding wheel such as the one shown in figure 104. The ordinary method of reaming valve seats is ineffective on this engine because of the very hard valve insert material. Use the 45-degree grinding wheel for refacing the valve seats and the 70-degree wheel for narrowing the seats to the standard $\frac{3}{32}$ -inch width. After dressing the valve seats with the grinding wheel, use the dial indicator to check to see if valve seats are concentric with the valve guides. The grinding wheel may occasionally have to be dressed to maintain the desired seat angle with the dressing tool provided with the grinding set (fig. 106). After grinding the valve seats, put valves in place and lap valve and seat to produce a perfect seat with the valve lapping tool. After lapping, wipe a thin film of PRUSSIAN BLUE, on seats and bounce the valve on the seat to check for perfect seating.

(i) Install Push Rods and Cam Follower Assemblies.

PLIERS, long-nosed
 REMOVER, push rod
 SCREWDRIVER, 10-in.

WRENCH, open-end, $\frac{1}{2}$ -in.
 WRENCH, socket, $\frac{7}{16}$ -in.

If cam follower spring and spring seats have been removed from push rod, remove lock nut from upper end of push rod and install over the rod the lower spring seat, the cam follower spring, and the upper

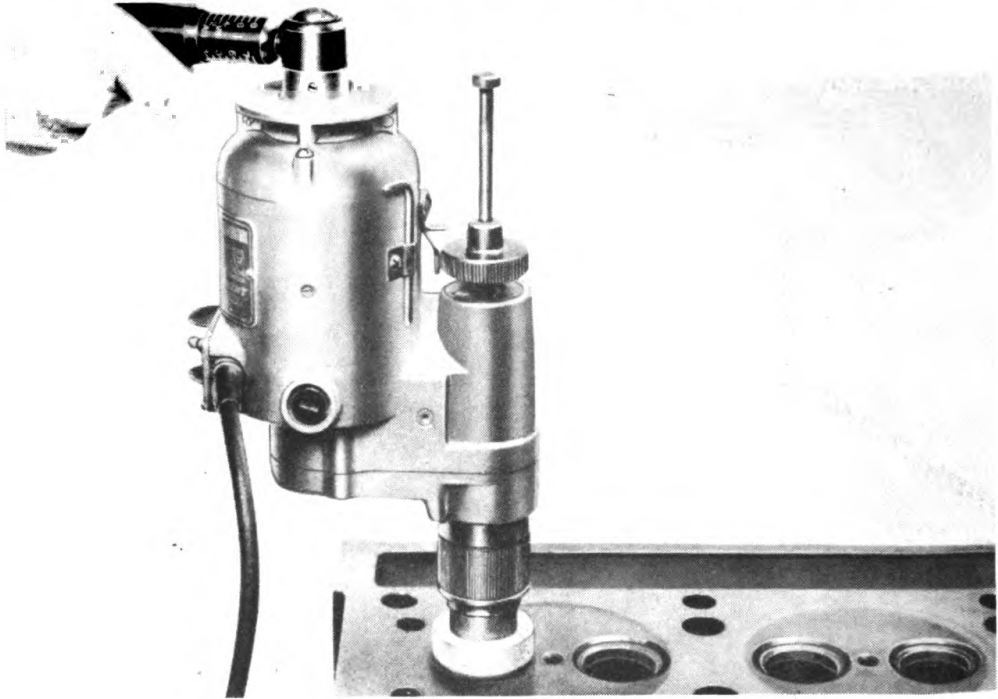

RA PD 40825

Figure 104 — Grinding Valve Seats

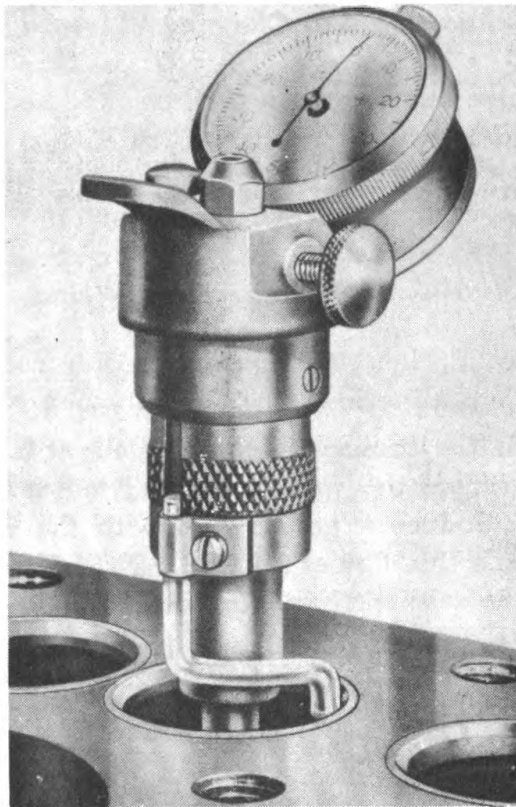

RA PD 40826

Figure 105 — Checking Valve Seats for Concentricity with Valve Guide

ASSEMBLY OF ENGINE

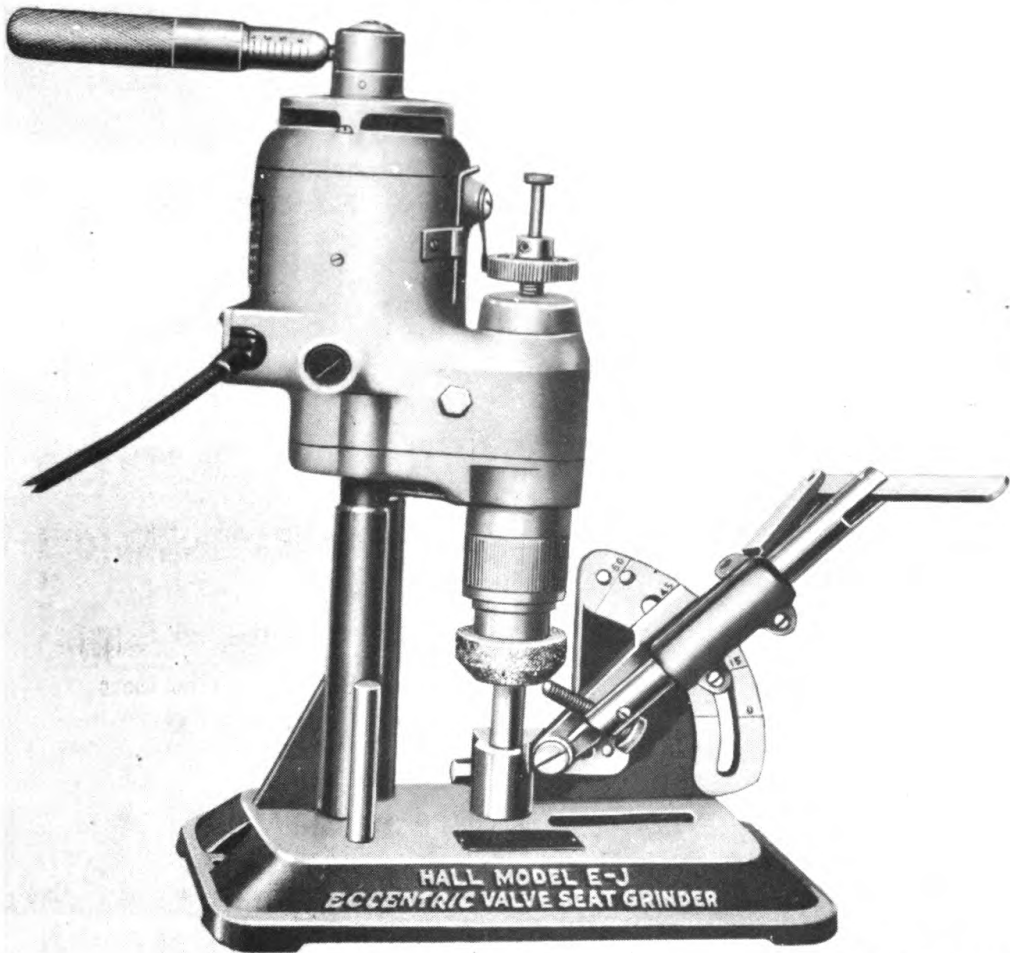

RA PD 40827

Figure 106 — Dressing Grinding Wheel

spring seat. Place the cam roller guide in position and fasten with 2 cap screws with lock washers using a $\frac{7}{16}$ -inch socket wrench. Drop a cam follower assembly into each push rod hole in cylinder head, making sure that the roller is down and the oilhole at the bottom of the cam follower is away from the valves, so it will not be covered by the cam roller guide. Place push rod remover on push rod above upper spring seat and screw down push rod nut to compress the spring ($\frac{1}{2}$ -in. wrench). Lower into cam follower assembly and install lockwire in groove in the cylinder head inside the push rod hole (pliers, screwdriver). Loosen nut ($\frac{1}{2}$ -in. wrench) and remove push rod remover tool. Repeat for remaining cam follower assemblies.

(j) *Install Valve Assemblies.*

REMOVER, valve spring, compressor and injector

Clean cylinder head, valves, and seats, and insert valves in guides. Turn cylinder head right-side up on a clean bench to hold valves in



RA PD 56410

Figure 107 — Lapping Valve and Seat

place. Place valve springs and spring caps on valves. Install compressor tool, depress springs (figs. 74 and 75), and install valve spring seat locks.

(k) Install Injector.

WRENCH, socket, $\frac{9}{16}$ -in.

Insert injectors in position in copper tubes with dowel in injector body registering with hole in cylinder head. Place clamp over stud, centering the side arms of the clamp on machined recesses in injector body. Place special beveled washer (beveled side down) over bolt in clamp recess and install nut. Tighten nut firmly with wrench, using 8-inch handle.

(1) INSTALL ROCKER ARM ASSEMBLIES.

WRENCH, $\frac{3}{4}$ -in.

Screw valve and injector rocker arms onto push rods. **NOTE:** The injector rocker arms differ from the valve rocker arms in that the

ASSEMBLY OF ENGINE

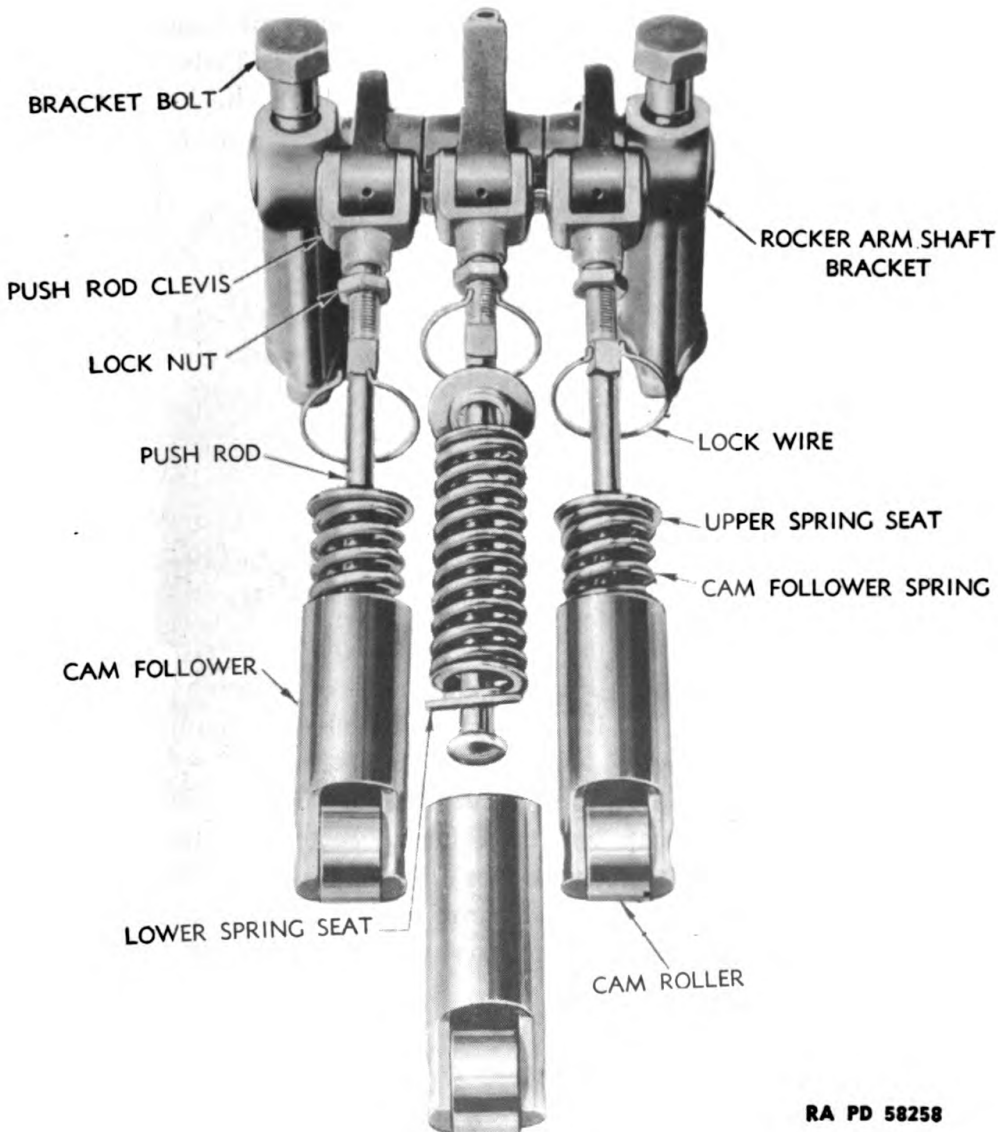

RA PD 58258

Figure 108 — Rocker Arm and Cam Follower Assembly — Partially Exploded

injector rocker arms are fitted with a hardened ball stud and a ball seat. There are also left and right valve rocker arms. The boss on one side of exhaust valve rocker arm is longer on one side than on the other. The side with longer boss goes towards the injector rocker arm. Screw rocker arms onto push rods until one or two threads of push rod project above clevis in rocker arm. This is necessary to prevent piston from hitting valves when engine is turned to adjust valves. Do

ORDNANCE MAINTENANCE — HEAVY TRACTOR M1 (Allis-Chalmers HD-10W) ENGINE

not tighten push rod lock nuts. Then lubricate rocker arm shaft with OIL, engine, crankcase grade, and slide it through rocker arms. Place a bracket on each end of shaft (machined side of bracket towards rocker arm) and install rocker arm bracket bolts. Tighten firmly, at the same time holding the brackets together with the hand to allow about 0.006-inch clearance measured between one outside rocker arm and bracket.

(m) *Install Injector Control Tube Assembly.*

WRENCH, $\frac{7}{16}$ -in.

Set assembly in position in cylinder head, at the same time engaging pins of rack control levers in slots in injector control racks. Secure assembly in place with two $\frac{1}{4}$ - x $\frac{7}{8}$ -inch cap screws with lock washers. Check to see that tube rotates freely in bearing.

(n) *Install Fuel Manifolds.*

WRENCH, deep socket,
 $\frac{7}{16}$ -in.

WRENCH, open-end, $\frac{3}{4}$ -in.
WRENCH, open-end, $\frac{7}{8}$ -in.

WRENCH, filter cap

Insert fuel return manifold in top row of holes in side of cylinder head. Install 4 fuel connectors from top of head in holes corresponding with manifold inlets ($\frac{7}{16}$ -in. wrench). Beveled bottom end of fuel connectors should register with tapered seats in fuel manifold inlets. Tighten connectors firmly; then install connector jam nuts with new copper washers (filter cap wrench). Install restriction unit on rear of manifold ($\frac{3}{4}$ -in. and $\frac{7}{8}$ -in. wrenches). Install fuel intake manifold in same manner except no restriction unit is required. Place shipping caps on fuel connectors to prevent dirt from entering.

16. ASSEMBLY OF ENGINE.

a. Equipment.

BAR, small

WRENCH, 1 $\frac{1}{2}$ -in.

COMPRESSOR, piston ring

WRENCH, open-end, $\frac{1}{2}$ -in.

FILE, fine mill

WRENCH, open-end, $\frac{9}{16}$ -in.

GAGE, feeler (set)

WRENCH, socket, $\frac{9}{16}$ -in.,
with 6-in. extension

HAMMER, soft

WRENCH, socket, $\frac{5}{8}$ -in.

HAMMER, 2-lb

WRENCH, socket, 1 $\frac{1}{16}$ -in.,

PLIERS

with 8-in. handle

REMOVER and REPLACER,
piston ring

WRENCH, socket, $\frac{3}{4}$ -in.

SCREWDRIVER, 10-in.

WRENCH, socket, 1 $\frac{3}{16}$ -in.,
with 18-in. handle

SEAL, oil, flywheel housing
expander

WRENCH, socket, 1 $\frac{5}{16}$ -in.,
with 18-in. handle

WRENCH, $\frac{3}{4}$ -in.

ASSEMBLY OF ENGINE

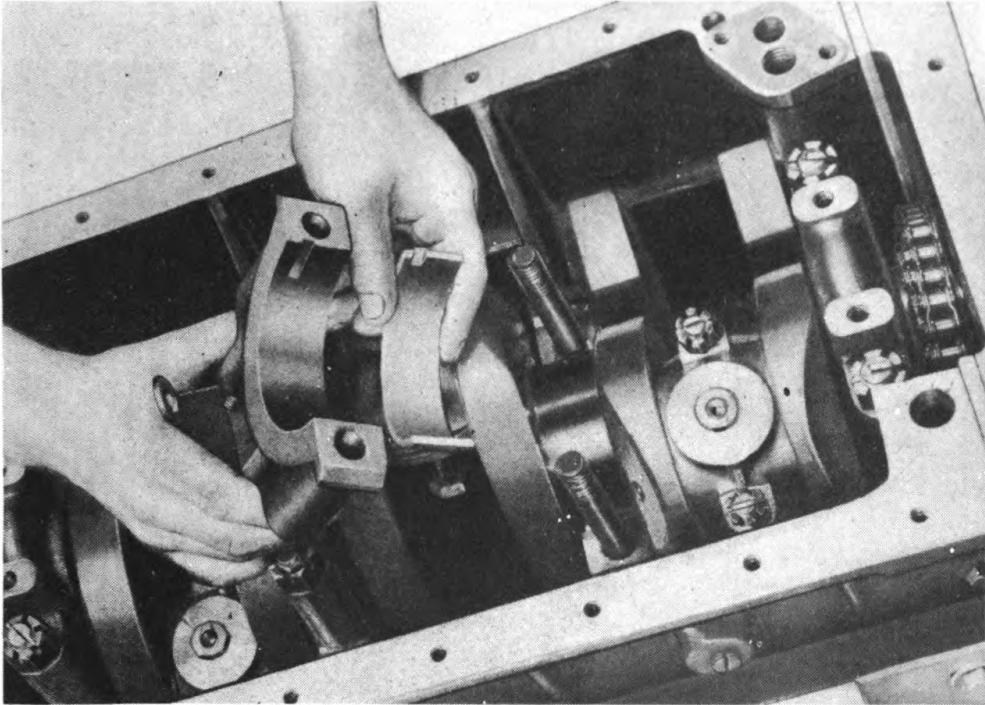

RA PD 17830

Figure 109 — Installing Bearing Shell in Main Bearing Cap

b. Procedure.

(1) INSTALL CRANKSHAFT IN CYLINDER BLOCK.

HAMMER, 2-1⁵

**WRENCH, socket, $\frac{15}{16}$ -in.,
with 18-in. handle**

With cylinder block turned bottom side up on engine stand, and all oil passage plugs tight in place in cylinder block and crankshaft, install upper halves of main bearing shells in crankcase. Upper halves are grooved for oil and are marked "UPPER" and will be positioned correctly in crankcase by tang at parting line. Thrust washers go in rear bearing. (Blower opening is on right side when cylinder block is viewed from the rear.) Lubricate bearings with engine oil, and lay crankshaft in position with flywheel flange towards rear of block. Place lower main bearing shells in main bearing caps and lubricate the same as upper main bearing shells were lubricated. Install caps on main bearing stud bolts with tang and bearing cap identification number to the right (blower side). Attach with special main bearing stud nuts and tighten firmly ($\frac{15}{16}$ -in. wrench). Rap bearing caps sharply with hammer to position them firmly after drawing the nuts tight; then check all nuts for tightness again. Secure nuts with cotter pins.

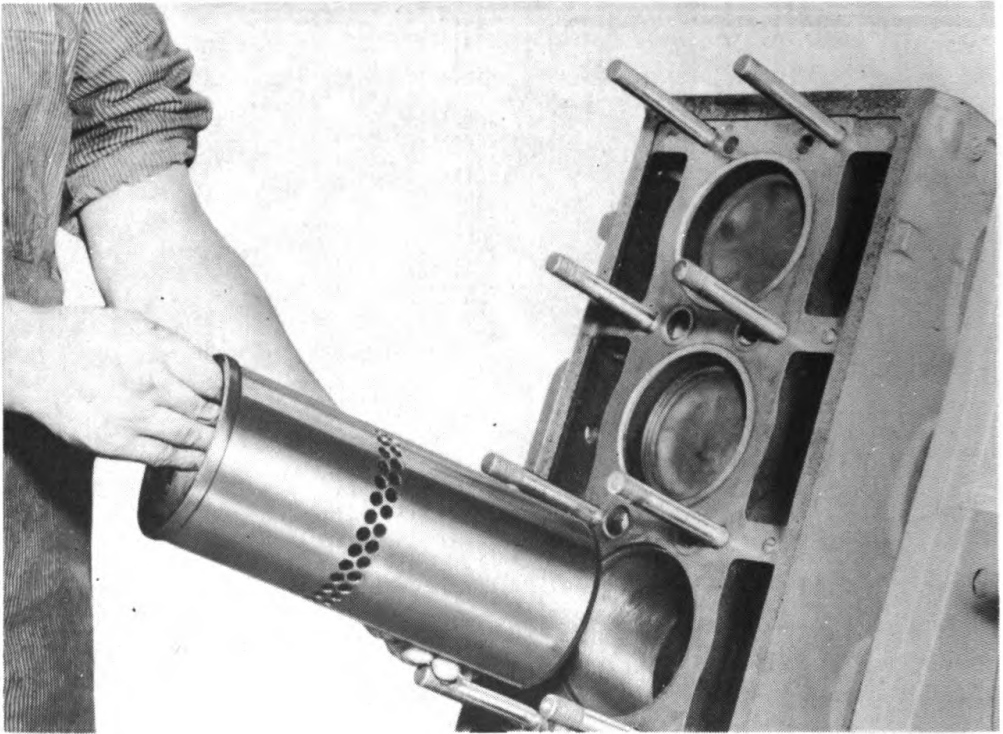

RA PD 40933

Figure 110 — Installing Cylinder Liner in Block

(2) INSTALL CYLINDER LINERS IN BORE OF CYLINDER BLOCK.

Turn engine right side up. Be sure cylinder liner and shoulder recesses in cylinder block are clean. Install cylinder liners in cylinder block by dropping them into cylinder bores. **NOTE:** The top of liners will project 0.002 inch to 0.004 inch above cylinder block face.

(3) FIT AND INSTALL PISTON RINGS ON PISTON.

FILE, fine mill
GAGE, feeler (set)

REMOVER and **REPLACER**,
piston ring

Fit rings in cylinder liner in which they will operate to obtain correct ring gap before installing them on piston. Use a piston and push ring squarely into liner and about 2 inches below top of liner, and check ring gap with feeler gages. Correct compression ring gap is 0.020 inch to 0.025 inch; oil ring gap, 0.010 inch to 0.020 inch. File ends of rings if necessary to obtain this gap clearance. Install compression rings in 4 upper piston grooves. Oil rings with expanders go in 2 lower grooves with all scraper edges down and chamfered section in upper part of groove (fig. 113). Install rings with gaps in rings and expanders staggered around the piston. Use the special piston ring tool to install rings on pistons, expanding them only enough for them to pass over

ASSEMBLY OF ENGINE

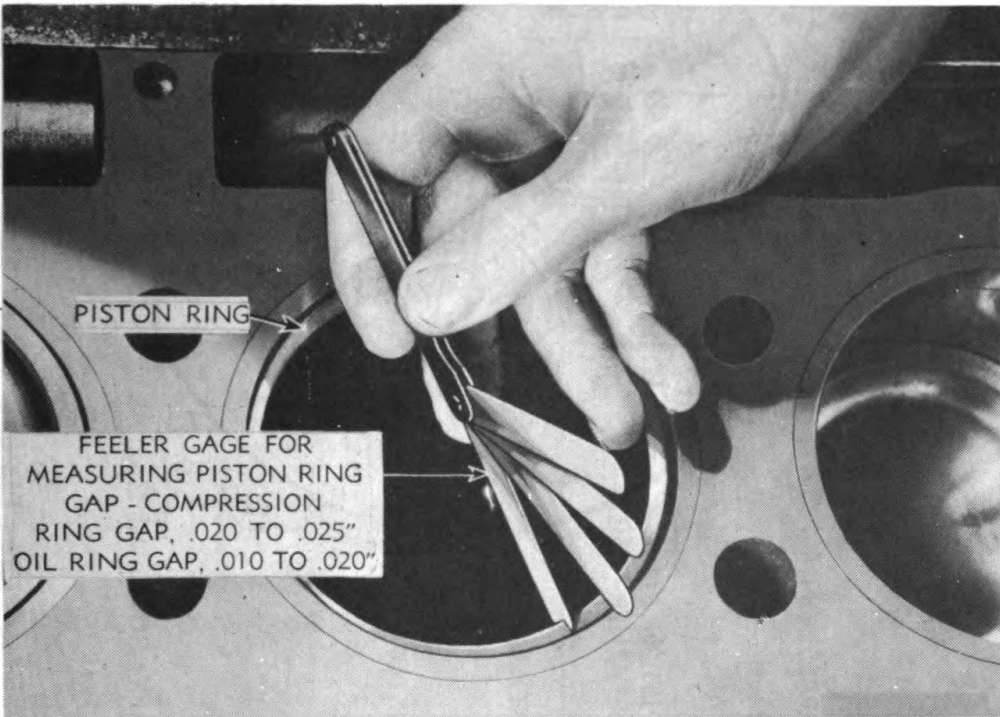

RA PD 56413

Figure 111 — Checking Piston Ring Gap

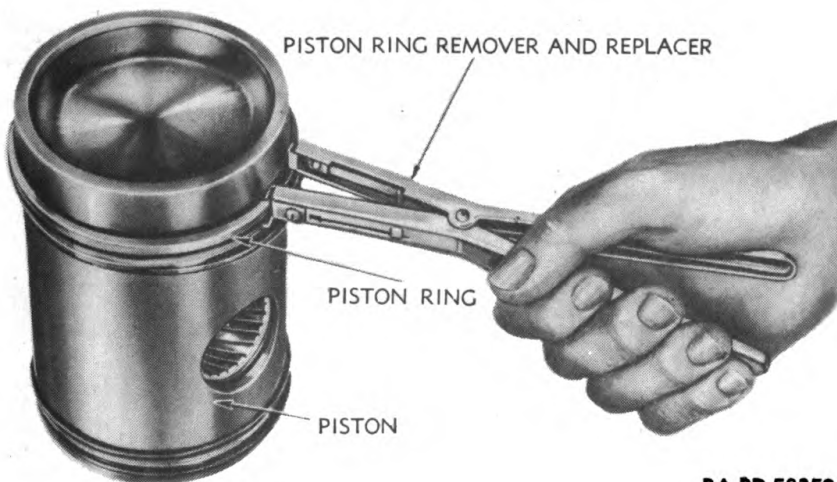

RA PD 58259

Figure 112 — Installing Rings on Piston

PROPER ASSEMBLY OF THREE PIECE OIL RINGS

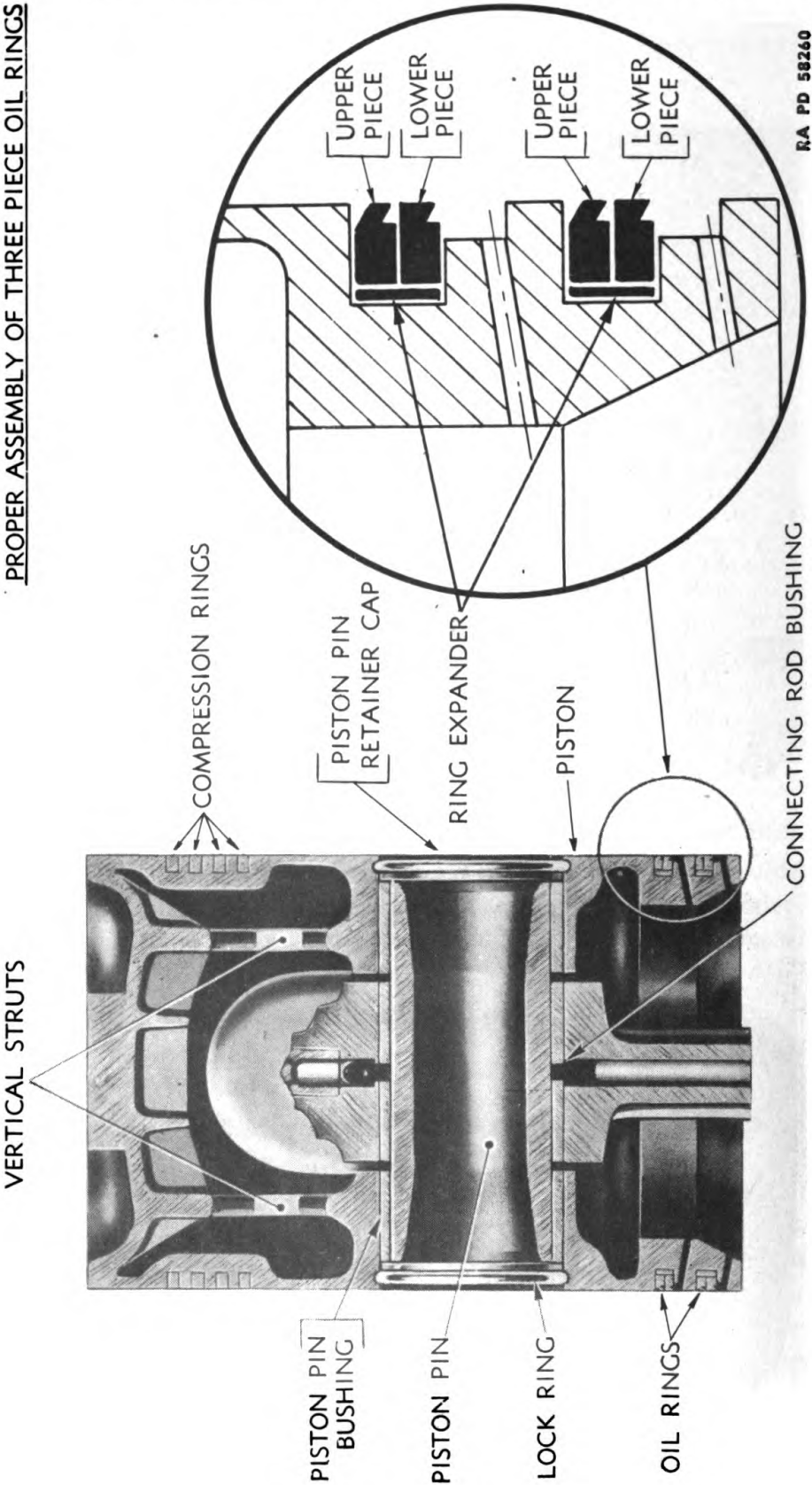
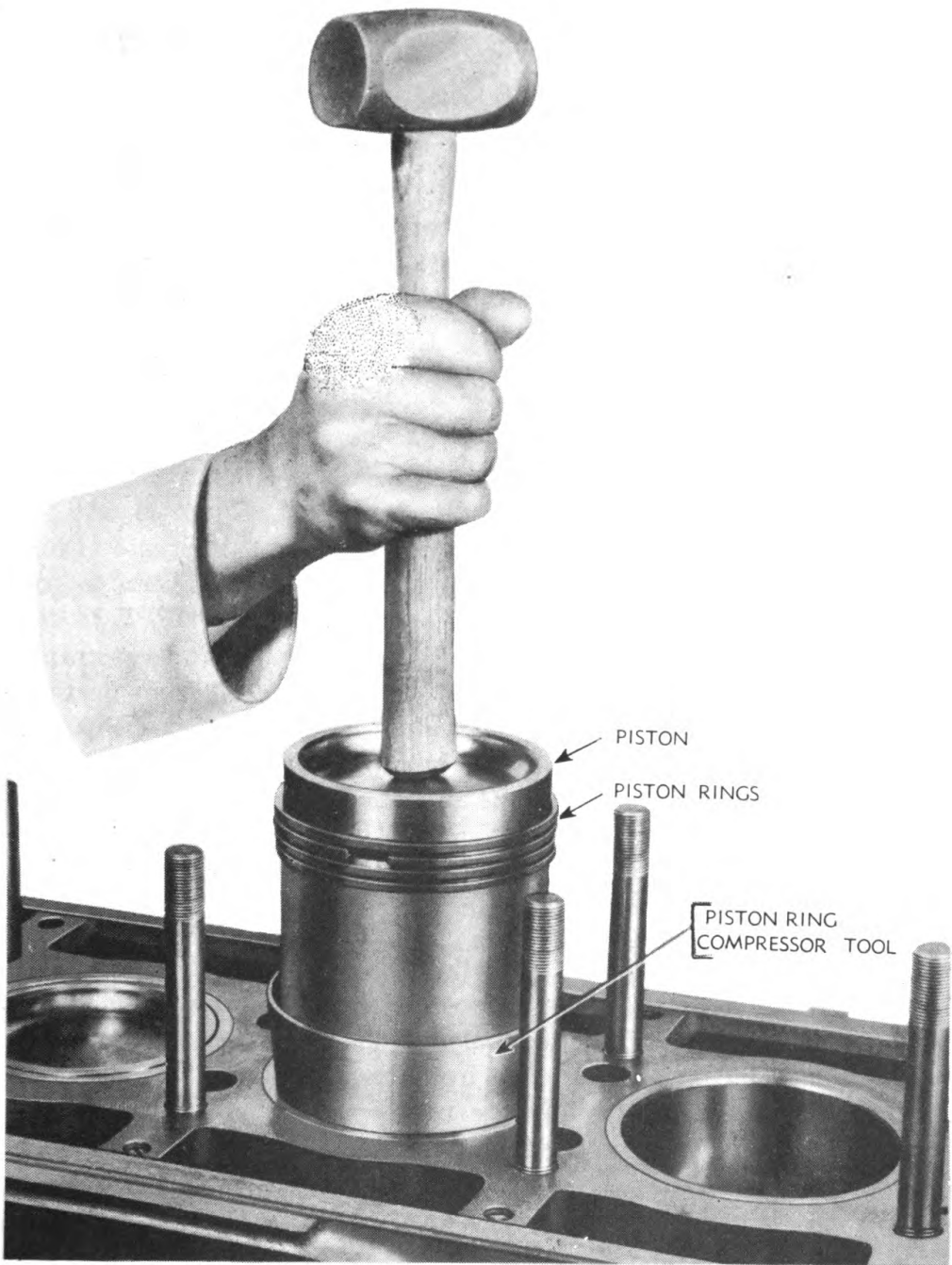

Figure 113 — Piston in Cross Section Showing Piston Pin and Piston Ring Details

ASSEMBLY OF ENGINE



RA PD 58261

Figure 114 — Piston and Connecting Rod Assembly Installation

ORDNANCE MAINTENANCE — HEAVY TRACTOR M1 (Allis-Chalmers HD-10W) ENGINE

piston. Install rings fitted to each liner on piston for that cylinder identified by the number on the connecting rod.

(4) INSTALL PISTON AND CONNECTING ROD ASSEMBLIES.

COMPRESSOR, piston ring **WRENCH**, socket, $\frac{1}{16}$ -in.,
HAMMER, soft with 8-in. handle
PLIERS

NOTE: The lower end of the connecting rod, as well as the caps, are stamped on one side — 1, 2, 3, etc. These numbers identify the caps with the rods and the cylinder from which the rod was removed. The connecting rods should be installed in the same cylinders from which they were removed. The side of the rod containing grooves to position bearing shells and on which the number is stamped goes toward the right or blower side of engine when installed. Slide the piston ring compressor tool over the lower end of the piston skirt, with flared end toward top of piston (fig. 114). Turn the piston and rod assembly so that the numbers on connecting rod are toward the blower side of the engine. Tap on upper end of piston with wood block or handle of hammer to drive piston into cylinder. Wipe clean and lubricate crankshaft connecting rod journal. Install upper half of connecting rod bearing shell in connecting rod (upper shell is marked "UPPER" and has only short grooves at each parting line). Position rod on crankshaft. Install lower half of bearing shell (grooves for oil from parting-line-to-parting-line) in cap with tang of shell in groove of cap. Put cap and shell in place. Install special bolts in cap and rod and tighten. Use $\frac{1}{16}$ -inch wrench, with 8-inch handle to tighten nuts. Secure nuts with cotter pins (pliers).

(5) INSTALL FRONT CYLINDER BLOCK END PLATE.

WRENCH, $\frac{9}{16}$ -in. **WRENCH**, $\frac{3}{4}$ -in.

Shellac new end plate gasket to cylinder block. Then shellac outside of gasket. Place front end plate in position on the 2 dowels in block. Insert the grooved camshaft and balance shaft end bearings through plate and into block. **NOTE:** The front camshaft and balance shaft end bearings are grooved while the rear ones are not. Attach each bearing to block with three $\frac{3}{8}$ - x $1\frac{1}{4}$ -inch cap screws with lock washers. Then install six $\frac{3}{8}$ - x 1-inch ($\frac{9}{16}$ -in. wrench) and two $\frac{1}{2}$ - x $1\frac{1}{8}$ -inch cap screws ($\frac{3}{4}$ -in. wrench) with lock washers in mid-section of end plate and block.

(6) INSTALL REAR CYLINDER BLOCK END PLATE.

WRENCH, $\frac{9}{16}$ -in.

Shellac new gasket to rear end of cylinder block. Then shellac outside of gasket. Place end plate in position on dowels with hole for blower drive support towards blower side. Lubricate bearings and

ASSEMBLY OF ENGINE

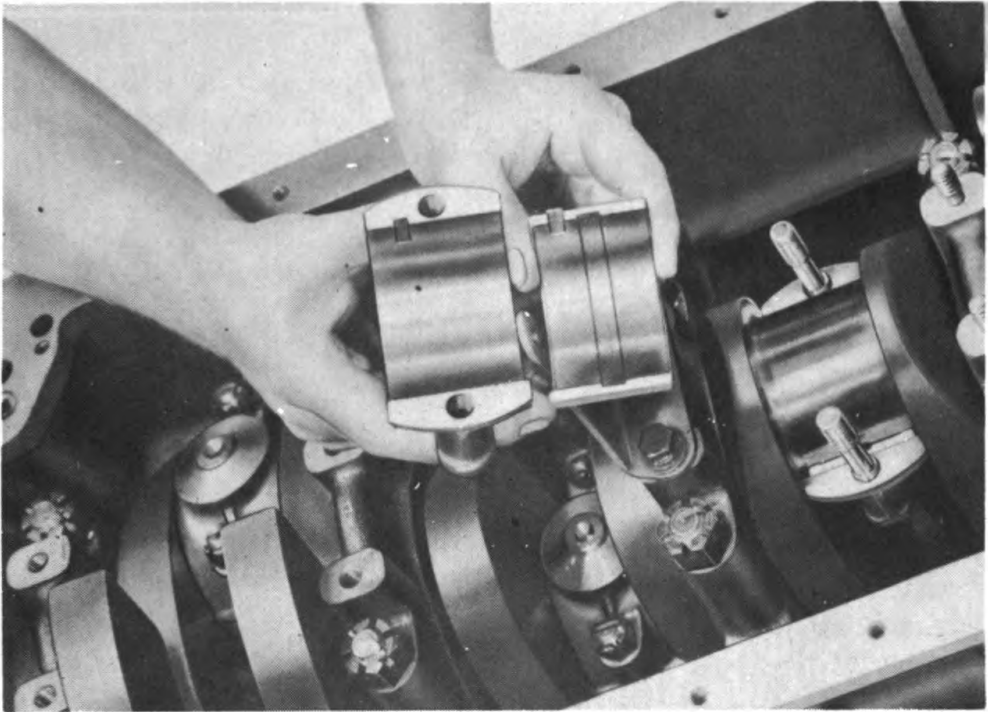

RA PD 17821

Figure 115 — Installing Bearing Shell in Connecting Rod Bearing Cap

insert camshaft and balance shaft assemblies (use care not to damage cams) into their respective bores in block (camshaft to blower side) to aline holes for these assemblies in end plate with bores in block before installing cap screws in end plate. Then install six $\frac{3}{8}$ - x 1-inch cap screws with lock washers in mid-section of end plate and block. Install these cap screws one above and two below the hole for idler gear hub; and one above and two below the hole for the dummy hub opposite.

(7) INSTALL CAMSHAFT ASSEMBLY.

SCREWDRIVER, 10-in.

WRENCH, socket, $\frac{9}{16}$ -in.,
with 6-in. extension

The camshaft assembly was inserted into the bore in block in preceding step. Now install the three $\frac{3}{8}$ - x $1\frac{1}{4}$ -inch cap screws with lock washers to secure the rear end bearing to block. These can be installed through the large hole in camshaft gear. Tighten them firmly. Turn camshaft intermediate bearings until locking holes in bearings aline with holes in top of cylinder block, and install the locking screws.

(8) INSTALL BALANCE SHAFT ASSEMBLY.

WRENCH, socket, $\frac{9}{16}$ -in., with 6-in. extension

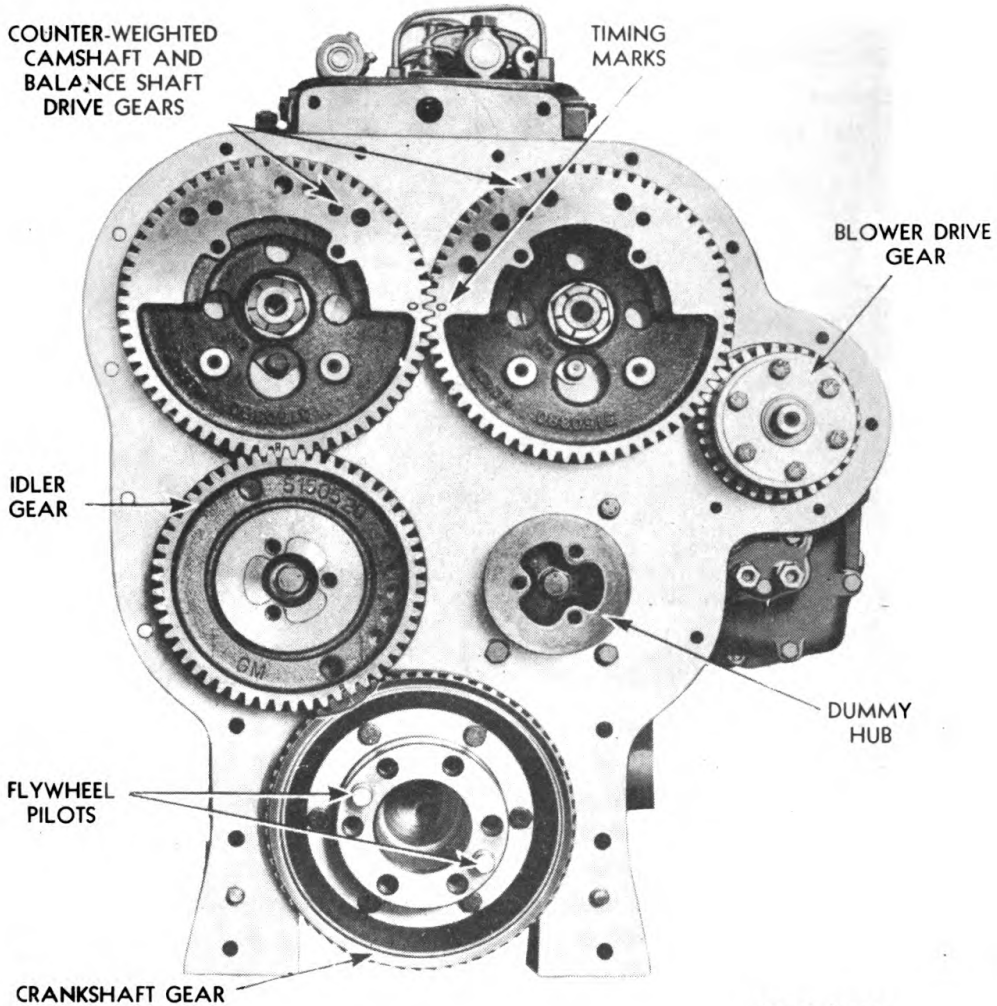

RA PD 40831

Figure 116 — Timing Marks on Gears

An "O" is stamped on both camshaft and balance shaft gears just below the teeth. If necessary, pull balance shaft and gear partly out of block, and rotate both gears so that the "O" on the camshaft gear and the "O" on the balance shaft gear are together when balance shaft gear is again meshed with camshaft gear (fig. 116). Secure rear balance shaft end bearing to end plate and block with three $\frac{3}{8}$ - x $1\frac{1}{4}$ -inch cap screws with lock washers.

(9) INSTALL BALANCE WEIGHTS.

GAGE, feeler

WRENCH, $1\frac{1}{2}$ -in.

Place Woodruff keys in slots in front end of camshaft and balance shaft. Slip balance weights on shaft. Place folded cloth between camshaft and balance shaft gears, install and tighten self locking nuts on

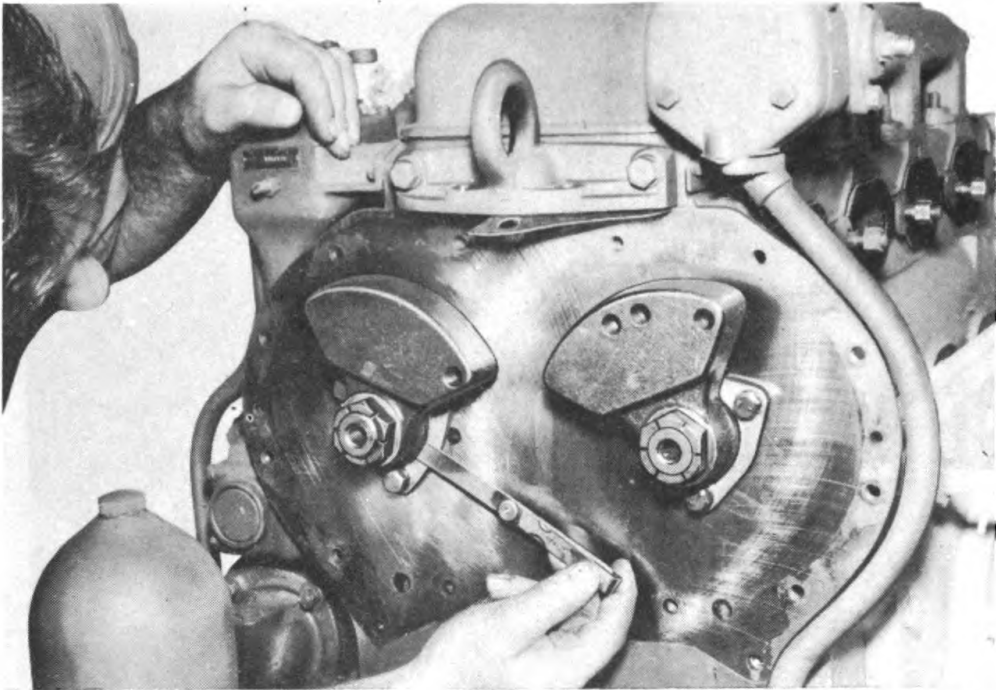
ASSEMBLY OF ENGINE

RA PD 17729

Figure 117 — Checking End Clearance on Balance Weights

both ends of both shafts. Check end clearance between end bearings and balance weights. This should not exceed 0.012 inch. If more than that, install new end bearings.

- (10) **INSTALL CRANKSHAFT GEAR AND OIL SLINGER ON CRANKSHAFT.**
WRENCH, socket, $\frac{9}{16}$ -in.

Slip crankshaft gear on flange at rear end of crankshaft. Line up cap screw holes. Holes are drilled so gear can be installed only in the correct position. Place oil slinger in position against gear. Bolt gear and slinger in place with six $\frac{3}{8}$ - x $1\frac{1}{8}$ -inch cap screws with lock washers.

- (11) **INSTALL IDLER GEAR ASSEMBLY AND DUMMY HUB.**

BAR, small

WRENCH, socket, $\frac{3}{4}$ -in.

Refer to figure 116. Revolve camshaft and balance shaft gears until "O's" on the gears are together. Turn crankshaft with small bar and dowels in end of crankshaft until the "R" on crankshaft gear is to the left. Apply a small amount of **GREASE**, general purpose, (seasonal grade), to one face of the idler gear spacer and set it against cylinder block end plate, with hole in steel washer in line with oilhole. Grease is to hold spacer in place until hub and gear are installed. Set idler gear on crankshaft gear with "R" on tooth of one gear opposite "R" between

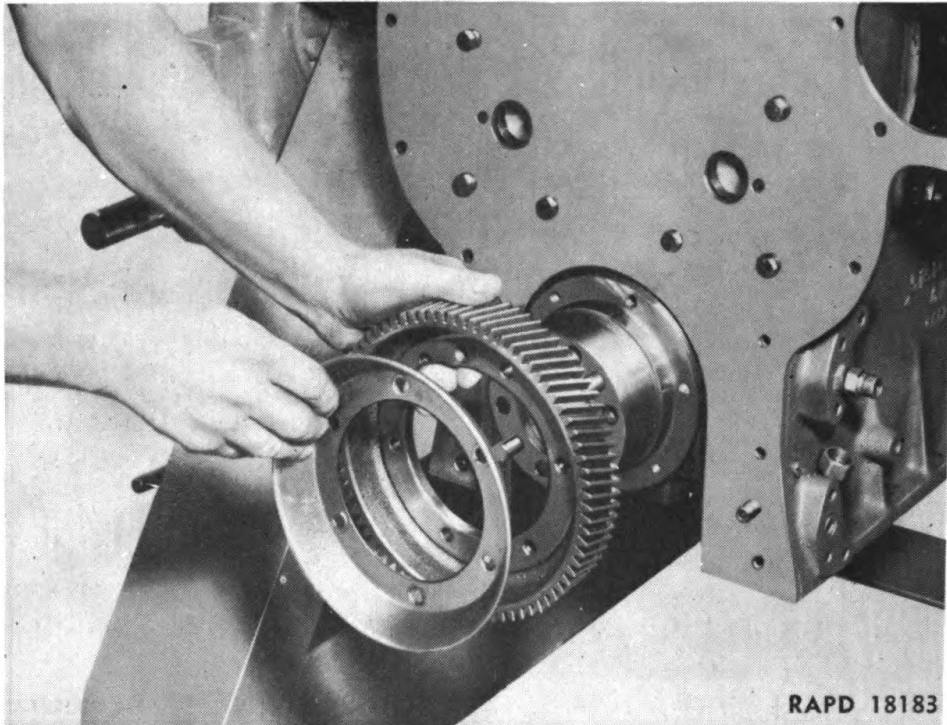

Figure 118 — Crankshaft Gear and Oil Slinger Installation

2 teeth of the other. Then turn crankshaft and gear to roll idler gear into mesh with balance shaft gear so other "R" on idler gear lines up with "R" on balance shaft gear (fig. 116). Lubricate bearing surfaces with OIL, engine, crankcase grade, and slide idler gear hub into place through idler gear so hollow pins on hub enter hole in idler gear spacers end plate. Lock hub in place with $\frac{1}{2}$ - x 2-inch cap screw with lock washers. Push cylinder liners back down if they raised when crankshaft was turned. Install dummy hub similar to the idler gear hub in hole on opposite side of end plate with a $\frac{1}{2}$ - x 2-inch cap screw with lock washer.

(12) INSTALL FLYWHEEL HOUSING (fig. 122).

SEAL, oil, flywheel housing
expander

WRENCH, socket, $\frac{9}{16}$ -in.

WRENCH, socket, $\frac{3}{4}$ -in.

WRENCH, open-end, $\frac{9}{16}$ -in.

Shellac new gaskets to rear cylinder block end plate, idler gear hub, and dummy hub. Set oil seal expander tool on dowels in end of crankshaft. Slide flywheel housing squarely towards cylinder block so oil seal starts squarely over expander tool (use care not to damage seal) and holes in housing engage dowels "A" in cylinder block. Push housing up against end plate and install cap screws and bolts as follows:

ASSEMBLY OF ENGINE

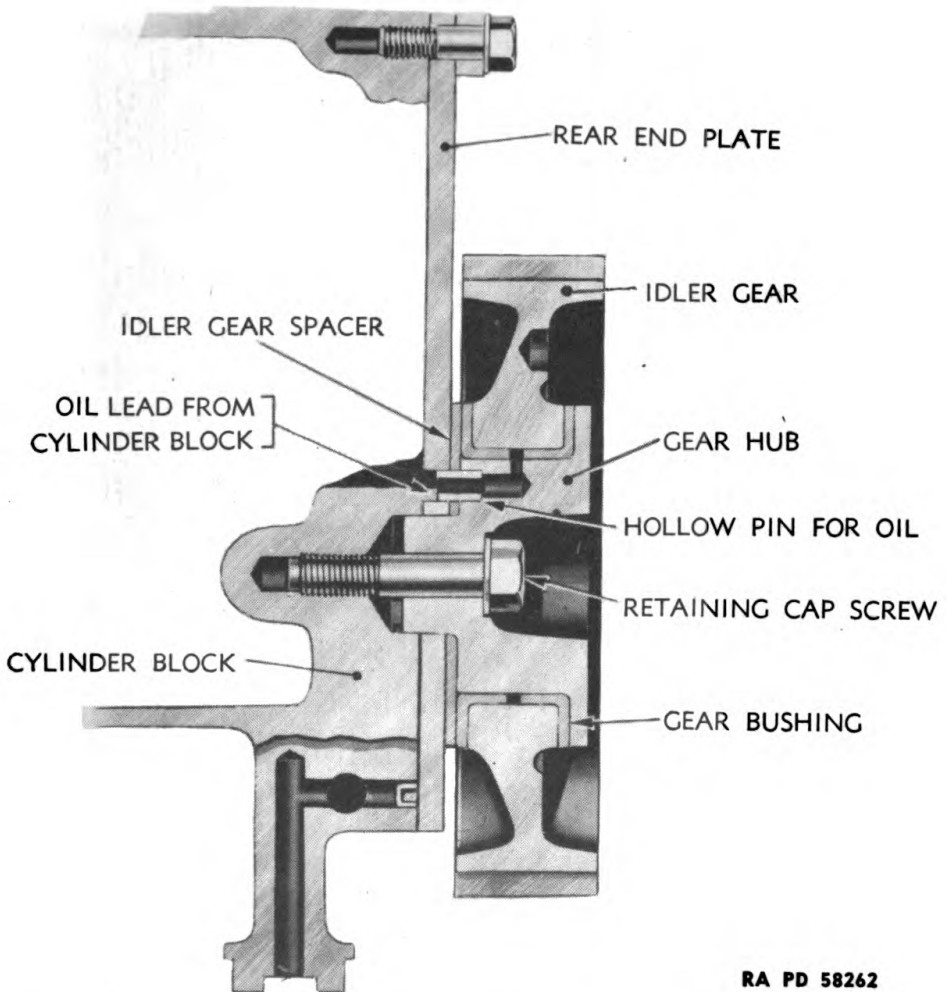

RA PD 58262

Figure 119 — Relative Position of Parts in Idler Gear Assembly

(a) Use $\frac{3}{4}$ -inch wrench for six $\frac{1}{2}$ - x $3\frac{1}{4}$ -inch coarse thread cap screws with lock washers "B" (housing to block, three on each side of crankshaft inside housing).

(b) Use $\frac{9}{16}$ -inch wrench for three $\frac{3}{8}$ - x $1\frac{1}{8}$ -inch coarse thread cap screws with lock washers "C" into idler gear hub.

(c) Use $\frac{9}{16}$ -inch wrench for three $\frac{3}{8}$ - x $1\frac{1}{8}$ -inch coarse thread cap screws with lock washers "D" into dummy hub.

(d) Use $\frac{9}{16}$ -inch wrench for two $\frac{3}{8}$ - x 1-inch coarse thread cap screws with lock washers "E" entered from the front of rear end plate into flywheel housing in the lower hole of each side of block.

(e) Use $\frac{9}{16}$ -inch wrench for three $\frac{3}{8}$ - x $3\frac{1}{4}$ -inch fine thread cap screws and one $\frac{3}{8}$ - x $4\frac{1}{2}$ -inch bolt with lock washers "F" at top of housing and end plate (bolt goes in hole on left side).

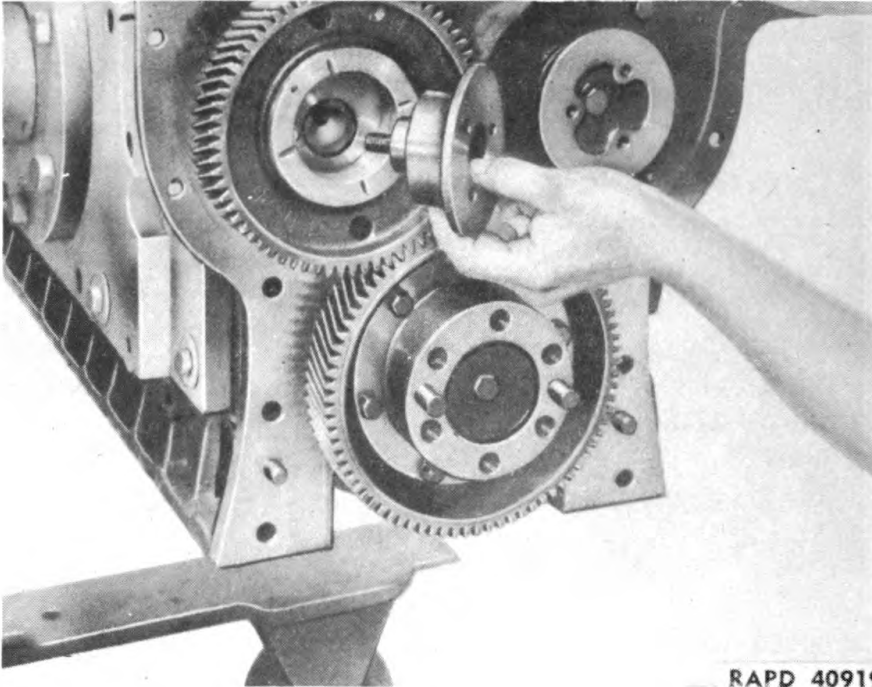

Figure 120 — Idler Gear Assembly Installation

(f) Use $\frac{9}{16}$ -inch wrench for one $\frac{3}{8}$ - x $3\frac{3}{4}$ -inch fine thread bolt with lock washers "H" above blower drive opening.

(g) Install one $\frac{3}{8}$ - x $4\frac{1}{4}$ -inch fine thread bolt with lock washer "G" in lower hole of left side of housing and end plate.

(h) Install two $\frac{3}{8}$ - x $4\frac{3}{4}$ -inch fine thread bolts with lock washers "J" in remaining holes on left side of housing. (These bolts also go through muffler rear support later on.) NOTE: Do not install bolts on cover to blower drive assembly until blower assembly has been installed.

(13) INSTALL FLYWHEEL ASSEMBLY.

PLIERS

WRENCH, socket, $1\frac{3}{16}$ -in.,
with 18-in. handle

Lift flywheel into place over dowels projecting from rear flywheel flange. Holes are so spaced that flywheel cannot be installed in wrong position. Attach with 6 special cap screws. Tighten firmly ($1\frac{3}{16}$ -in. wrench) and lock with wire through cap screw heads (pliers).

(14) INSTALL PILOT BEARING.

HAMMER, 2-lb

REPLACER, pilot bearing

Lubricate bearing with OIL, engine, crankcase grade. Shielded side of bearing must be facing the outside away from the flywheel. Start

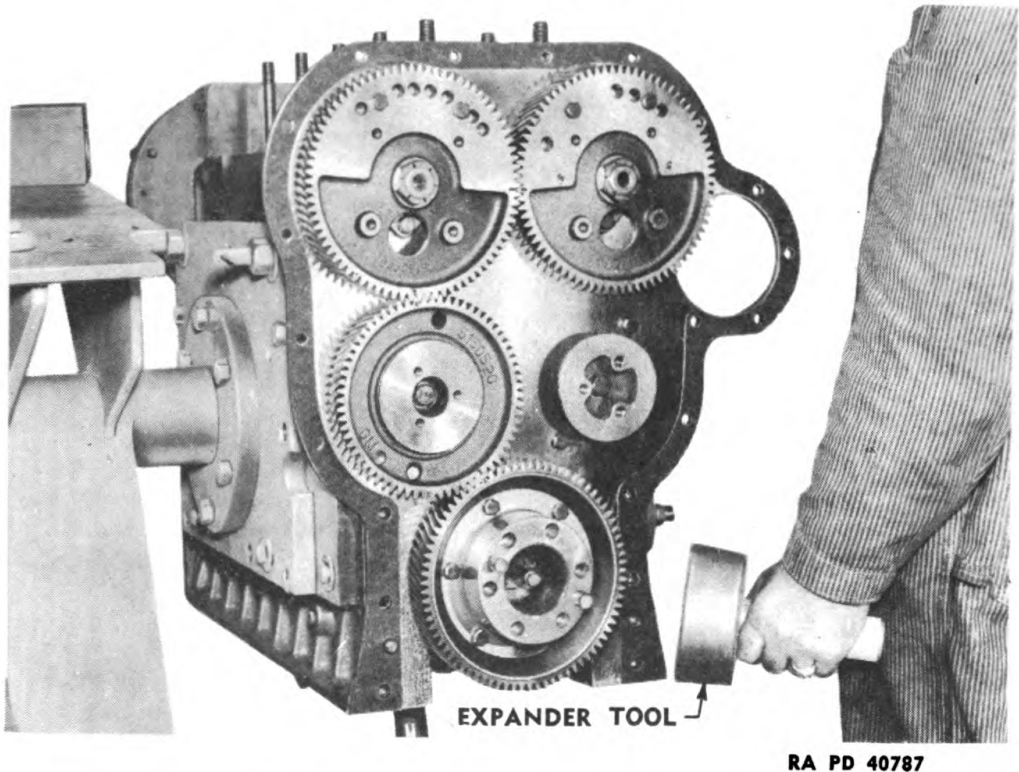
ASSEMBLY OF ENGINE

RA PD 40787

Figure 121 — Flywheel Housing Oil Seal Expander Installation

bearings squarely into bore of flywheel by hand. Place tool on outer face of bearing (fig. 93) and drive bearing in flush with outer face of flywheel.

(15) INSTALL BALANCE WEIGHT COVER.

WRENCH, socket, $\frac{9}{16}$ -in.

Shellac new gasket to balance weight cover. Place cover in position and attach as follows:

(a) Install two $\frac{3}{8}$ - x $3\frac{1}{2}$ -inch coarse thread cap screws with lock washers on either side of lower center hole.

(b) Install one $\frac{3}{8}$ - x $2\frac{7}{8}$ -inch fine thread cap screw with lock washer in lower center hole.

(c) Install two $\frac{3}{8}$ - x $3\frac{1}{2}$ -inch fine thread cap screws with lock washers on extreme left side of cover.

(d) Install two $\frac{3}{8}$ - x $1\frac{7}{8}$ -inch coarse thread cap screws with lock washers on lower flange of cover.

(e) Install eight $\frac{3}{8}$ - x $2\frac{7}{8}$ -inch fine thread cap screws with lock washers in remaining holes in cover.

(16) INSTALL OIL PUMP DRIVE SPROCKET ON CRANKSHAFT.

HAMMER, soft

Tap Woodruff key in rear slot in front end of crankshaft. Place oil pump drive chain on drive sprocket. Use soft hammer to tap sprocket

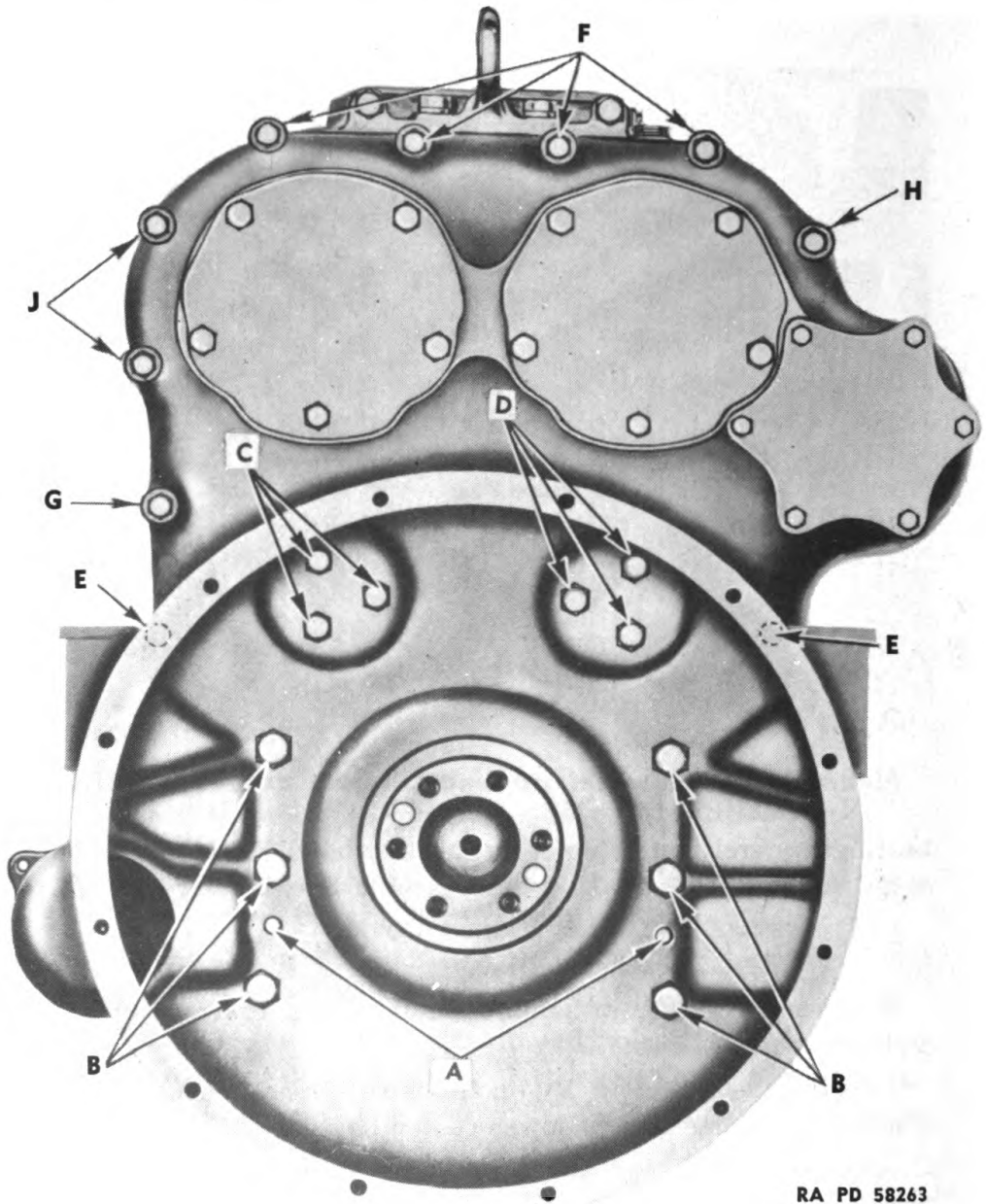

RA PD 58263

Figure 122 — Location of Bolts In Flywheel Housing

into position on crankshaft and on key. NOTE: Chamfered edge of oil pump drive sprocket is toward front of engine when installed on crankshaft.

(17) INSTALL CRANKSHAFT FRONT COVER ASSEMBLY.

WRENCH, $\frac{9}{16}$ -in.

WRENCH, $\frac{3}{4}$ -in.

Slip front oil slinger over crankshaft and against oil pump drive sprocket with edge pointing away from engine. Place front cover over

ASSEMBLY OF ENGINE

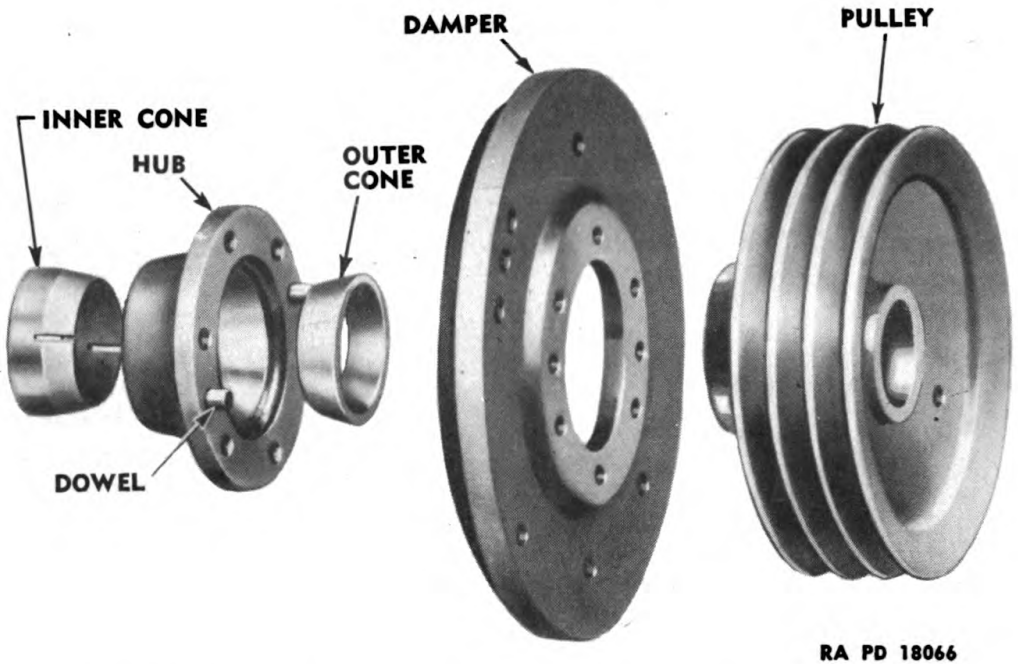

RA PD 18066

Figure 123 — Relative Location of Parts on Front End of Crankshaft

crankshaft and against cylinder block end plate and secure to block with four $\frac{1}{2}$ - x $2\frac{1}{4}$ -inch coarse thread cap screws with lock washers in lower part ($\frac{3}{4}$ -in. wrench) and three $\frac{3}{8}$ - x $\frac{3}{4}$ -inch fine thread cap screws with lock washers in upper part. Slip inside vibration damper cone over shaft (with beveled end away from engine) and through front oil seal against front oil slinger.

(18) INSTALL CYLINDER HEAD.

WRENCH, socket, $1\frac{5}{16}$ -in., with 6-in. extension and 18-in. handle

Clean all dirt or foreign material from top of cylinder block and out of cylinders. Shellac new cork oil sealing gaskets to cylinder head. Install new cylinder head gasket (gasket surface next to head is marked "TOP" and the bead around openings for combustion chamber goes toward cylinder head). Use no shellac or gasket cement on cylinder head gasket, but coat upper surface of cork gasket with shellac or gasket cement. Install lifter brackets on each end of head temporarily, but do not tighten cap screws. Set head in position. Remove lifter brackets and install cylinder head stud nuts. Tighten nuts firmly and evenly, beginning at center of head and working towards ends.

(19) INSTALL ENGINE LIFTER BRACKETS.

WRENCH, socket, $\frac{5}{8}$ -in.

Bend new gaskets to fit around bottom and inside of lifter brackets. Install each bracket to cylinder head and housings with four $\frac{7}{16}$ - x

ORDNANCE MAINTENANCE—HEAVY TRACTOR M1 (Allis-Chalmers MD-10W) ENGINE

1½-inch coarse thread cap screws with lock washers. Draw all 4 cap screws evenly so bracket will be tight against both head and housing. Use no gasket cement on gaskets.

(20) INSTALL INJECTOR FUEL LINES.

WRENCH, open-end, ½-in.

Remove shipping caps from fittings. Place connector nuts at each end of lines. Install and tighten all lines and connect fuel manifolds to injectors.

Section X

INSTALLATION OF ACCESSORIES ON ENGINE

	Paragraph
General	17
Installation of accessories on engine	18
Inspection, cleaning, and testing fuel injectors	19
Injector timing	20
Injector equalizing	21
Valve clearance adjustment	22

17. GENERAL.

a. In the following procedure, the accessories are assumed to be assembled exactly as they were when they were removed in paragraph 10. In some cases two or more assemblies are installed as one assembly. TM 9-1787B outlines installation procedure for each assembled accessory with engine in tractor. Removal and installation in some instances requires additional operations when the engine has not been removed from the tractor.

18. INSTALLATION OF ACCESSORIES ON ENGINE.

a. Equipment.

- | | |
|---|---|
| BAR, pry | WRENCH, open-end, 5/16-in. |
| CAN, oil (filled with OIL,
lubricating, engine,
SAE 30) | WRENCH, open-end, 7/16-in. |
| CHAIN, or rope | WRENCH, open-end, 5/8-in. |
| CHISEL, 1/2-in. | WRENCH, open-end, 3/4-in. |
| GAGE, feeler | WRENCH, open-end, 7/8-in. |
| GAGE, injector timing | WRENCH, open-end, 15/16-in. |
| HAMMER, 1/2-lb | WRENCH, socket, 7/16-in. |
| HAMMER, 2-lb | WRENCH, socket, 3/4-in. |
| HAMMER, soft | WRENCH, socket, 1/2-in.,
with 8-in. extension |
| HOIST, chain | WRENCH, socket, 9/16-in.,
with 6-in. extension |
| PLIERS, long-nosed | WRENCH, socket, 5/8-in.,
with 6-in. extension |
| SCREWDRIVER, 8-in. | WRENCH, socket, 7/8-in.,
with 16-in. extension |
| SCREWDRIVER, 10-in. | WRENCH, socket, 15/16-in.,
with 24-in. handle |
| SHELLAC | |
| WRENCH, 1/2-in. | |
| WRENCH, 9/16-in. | |
| WRENCH, 13/16-in. | |

b. Procedure.

(1) INSTALL OIL PUMP ASSEMBLY.

- WRENCH, 9/16-in.

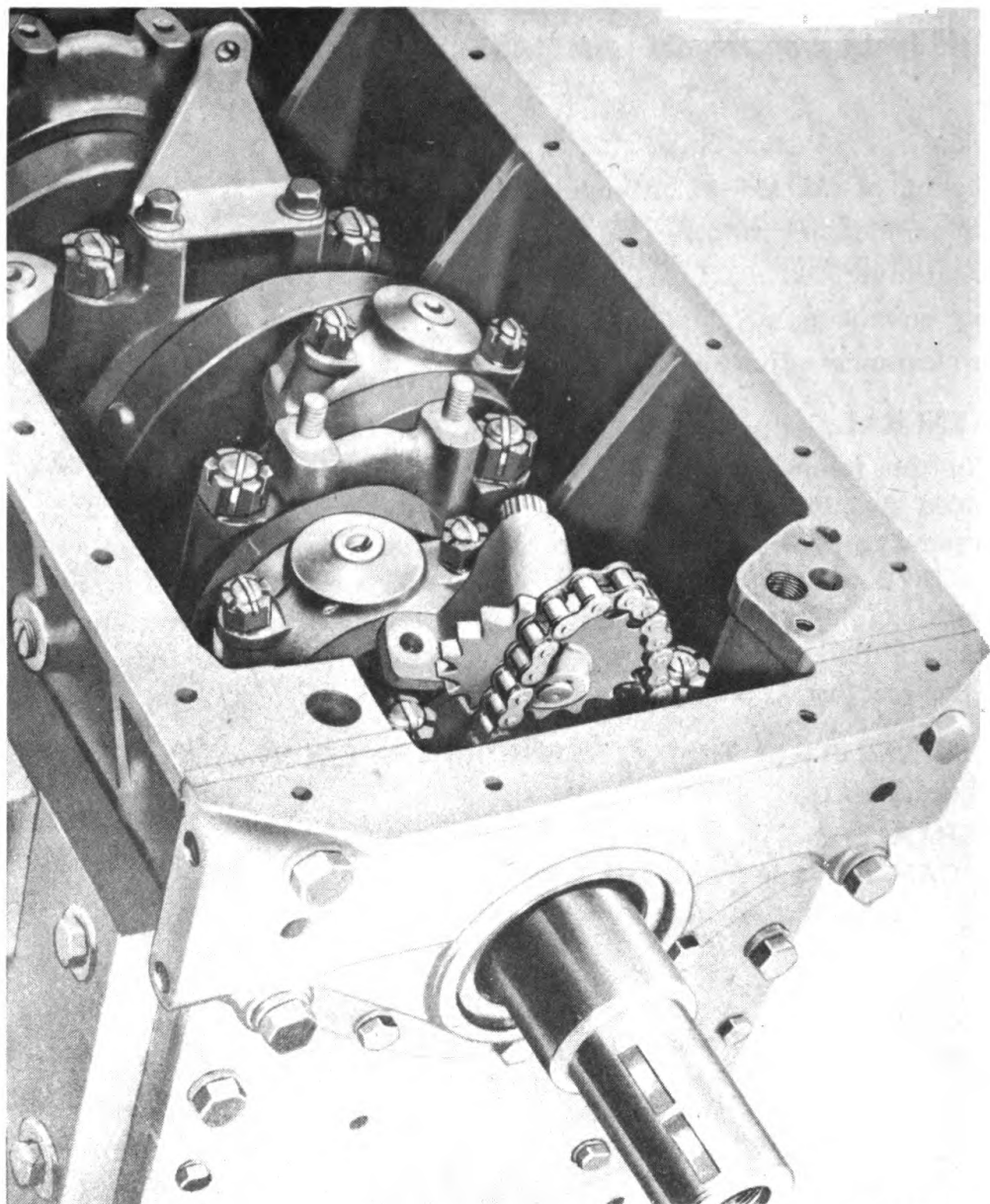

RA PD 17875

Figure 124 — Position of Oil Pump Sprocket Shaft Assembly for Installation

Turn engine bottom side up on stand. First maneuver oil pump sprocket into chain with support bracket in position on front main bearing cap (fig. 124). Do not install cap screws in this bracket until oil pump is in place. Place drive sleeve on pump drive shaft and place pump assembly in position, engaging drive sleeve on splined end of sprocket shaft. Secure assembly with two $\frac{3}{8}$ -inch nuts on the 2 studs in No. 2 main bearing cap, two $\frac{3}{8}$ - x 1-inch cap screws with lock washers in pump sprocket support, and two $\frac{3}{8}$ - x $\frac{3}{4}$ -inch cap screws

INSTALLATION OF ACCESSORIES ON ENGINE

with lock washers holding inlet bracket to No. 3 main bearing cap. Aline oil pump sprocket shaft and oil pump drive gear shaft as nuts and cap screws are tightened to prevent binding in either. A little slack should be allowed in chain. Too much slack in oil pump drive chain may be taken up by installing an equal amount of shims, made from shim stock between sprocket shaft bracket, pump body, and inlet support bracket and the bearing caps to which they are mounted; however, if slack is excessive, a new chain should be installed (fig. 41).

(2) INSTALL OIL PUMP OUTLET PIPE AND BYPASS VALVE ASSEMBLY.

WRENCH, $\frac{1}{2}$ -in.

Shellac new gaskets to pipe flange and valve body. Install assembly with one $\frac{5}{16}$ - x 1-inch and one $\frac{5}{16}$ - x $1\frac{3}{4}$ -inch cap screw with lock washers in valve body and two $\frac{5}{16}$ - x $\frac{3}{4}$ -inch cap screws with lock washers in pipe flange (fig. 40).

(3) INSTALL OIL PAN.

WRENCH, socket, $\frac{1}{2}$ -in.

Clean gasket surfaces of oil pan and cylinder block. Shellac gasket to cylinder block, and place oil pan in position. Install 26 $\frac{5}{16}$ - x 1-inch cap screws with lock washers to secure oil pan to cylinder block (fig. 39).

(4) INSTALL BLOWER DRIVE ASSEMBLY.

WRENCH, $\frac{9}{16}$ -in.

Place blower drive assembly in position in rear cylinder block end plate. The blower drive gear does not need to be timed with camshaft gear. Secure the assembly to end plate with two $\frac{3}{8}$ - x $1\frac{3}{16}$ -inch fine thread cap screws with lock washers in the 2 threaded holes in end plate. (See fig. 38).

(5) INSTALL OIL PIPE AND GAGE ROD TUBE ASSEMBLIES.

WRENCH, open-end, $\frac{7}{16}$ -in.

Connect blower drive bearing oil pipe assembly to fittings in cylinder block and blower drive support. Insert upper end of oil gage rod tube assembly through clip. Connect lower end of tube to base of cylinder block with fitting.

(6) INSTALL BLOWER ASSEMBLY (WITH FUEL PUMP, WATER PUMP, AND GOVERNOR WEIGHT HOUSING ATTACHED).

WRENCH, $\frac{5}{8}$ -in.

WRENCH, socket, $\frac{1}{2}$ -in.

Clean gasket surface and shellac gasket to cylinder block. Place blower assembly in position and attach with four $\frac{7}{16}$ - x 2-inch cap screws with plain washers ($\frac{5}{8}$ -in. wrench). Attach throttle control pull-back spring bracket when installing upper 2 cap screws. **CAUTION:** Use care in tightening cap screws. Do not draw them too tight. Then connect water pump outlet packing flange to cylinder block with two

ORDNANCE MAINTENANCE—HEAVY TRACTOR M1 (Allis-Chalmers HD-10W) ENGINE

$\frac{5}{16}$ - x $1\frac{1}{8}$ -inch cap screws with lock washers ($\frac{1}{2}$ -in. wrench) (figs. 34 and 35).

(7) INSTALL BLOWER DRIVE SHAFT.

PLIERS, long-nosed **WRENCH**, open-end, $\frac{9}{16}$ -in. (2)

Insert blower drive shaft through blower drive (longest splined end towards blower) and into blower drive gear hub, until retainer ring (pliers) can be inserted in groove in blower drive coupling cam. Install cover over blower drive with four $\frac{3}{8}$ - x 5-inch bolts and two $\frac{3}{8}$ - x 1-inch cap screws with lock washers (figs. 32 and 33).

(8) INSTALL OIL FILTER AND COOLER ADAPTER.

WRENCH, socket, $\frac{9}{16}$ -in.

Shellac both cooler adapter gaskets in place, and then shellac other side of gaskets. Place oil cooler adapter in position and attach with four $\frac{3}{8}$ - x $1\frac{3}{8}$ -inch cap screws, two $\frac{3}{8}$ - x $1\frac{1}{8}$ -inch cap screws, and one $\frac{3}{8}$ - x $1\frac{3}{4}$ -inch cap screw with lock washers (fig. 31).

(9) INSTALL OIL COOLER.

WRENCH, socket, $\frac{1}{2}$ -in., with 8-in. extension

Shellac new gaskets to adapter and oil cooler housing; then shellac outside surfaces of both gaskets. Place element in housing, and place element and housing in position against adapter bracket. Slip water pump oil cooler hose connection in place at the same time. Attach element and housing with eight $\frac{5}{16}$ - x $2\frac{7}{8}$ -inch cap screws with lock washers. Tighten hose connection clamp. **NOTE:** It may be necessary to remove water pump side outlet elbow to insert upper cap screw (fig. 30).

(10) INSTALL GOVERNOR CONTROL HOUSING.

WRENCH, socket, $\frac{7}{16}$ -in.

Set control housing assembly in place. Enter fork into weight housing at bottom of assembly from rear of governor weight housing. Use new gaskets on each side of governor weight housing and between top of governor and cylinder head. *Be sure* front thrust washer is between thrust bearing and fork when installing this unit. Install the four $\frac{1}{4}$ - x $2\frac{1}{4}$ -inch cap screws holding bottom of governor control housing and governor weight housing cover and the two $\frac{1}{2}$ - x $\frac{3}{4}$ -inch cap screws at top of governor control housing to cylinder head. If governor weight housing has been removed from the blower while these assemblies were off the engine, the 6 cap screws holding it to the blower should be loosened while installing governor control housing to assure proper alignment. Tighten cap screws in governor weight and governor control housings evenly (fig. 29).

(11) INSTALL GOVERNOR BREATHER PIPE.

SCREWDRIVER, 10-in.

INSTALLATION OF ACCESSORIES ON ENGINE

Shellac new gasket to breather pipe. Slide lower end of breather pipe through clip attached to oil cooler. Bolt upper end to governor with two (No. 10) 24- x $\frac{5}{8}$ -inch fillister head cap screws with lock washers.

(12) INSTALL GOVERNOR CONTROL LINK.**PLIERS**

Insert link through opening in cylinder head and slip over differential lever pin of governor control assembly. Lock in place with washer and clip. Install cotter pin and link pin through control tube lever and governor control link (figs. 26 and 28).

(13) INSTALL CONTROL HOUSING COVER ASSEMBLY.**SCREWDRIVER, 10-in.**

Shellac gasket in place. Position cover so pin in governor shut-off lever assembly engages slot in differential lever. Attach cover with four $\frac{1}{4}$ - x $\frac{7}{8}$ -inch fillister head cap screws with lock washers (fig. 27).

(14) INSTALL MASTER CLUTCH ASSEMBLY.**CHISEL, $\frac{5}{8}$ -in.****WRENCH, open-end, $1\frac{5}{16}$ -in.****HAMMER, 2-lb****WRENCH, socket, $\frac{3}{4}$ -in.**

Place drive disk assembly against flywheel, with oil slinger toward engine. **NOTE:** Lubricating flywheel pilot bearing with OIL, lubricating engine, (crankcase grade), at this point will facilitate connecting clutch shaft. If clutch cam grease fittings have not previously been lubricated, lubricate them before engine is installed in tractor with GREASE, general purpose, (seasonal grade). Place master clutch assembly in position against drive disk assembly. Attach with 9 special $\frac{1}{2}$ - x $1\frac{1}{4}$ -inch cap screws ($\frac{3}{4}$ -in. wrench) with screw locks. Tighten firmly and evenly. Lock screw locks with chisel and hammer. Place sliding block over yoke pin on release bearing carrier lug. Connect lubricating tube to this lug ($1\frac{5}{16}$ -in. wrench) (fig. 16).

(15) CONNECT FUEL RETURN LINE.**WRENCH, open-end, $\frac{7}{8}$ -in.**

Connect fuel return line to fitting at rear of upper fuel manifold. Attach clip on fuel return line to bolt on lower side of blower drive gear housing.

(16) INSTALL THIRD STAGE FUEL FILTER ASSEMBLY.**WRENCH, $\frac{5}{8}$ -in.****WRENCH, $\frac{9}{16}$ -in.**

Attach fuel filter head to cylinder head with 2 coarse thread cap screws, $\frac{3}{8}$ - x 1-inch, with lock washers. Connect fuel filter outlet line to fittings at rear of fuel filter head and to lower fuel manifold. Place fuel filter element in fuel filter housing. Make sure gasket is in proper position, and attach housing to fuel filter head with special cap screw with lock washer (fig. 36).

ORDNANCE MAINTENANCE—HEAVY TRACTOR M1 (Allis-Chalmers HD-10W) ENGINE**(17) INSTALL ENGINE FRONT HANGER.****WRENCH, $\frac{7}{8}$ -in.**

Bolt hanger to balance weight cover with two $\frac{5}{8}$ - x 2-inch cap screws with lock washers.

(18) INSTALL WATER OUTLET MANIFOLD.**WRENCH, $\frac{9}{16}$ -in.**

Shellac new gaskets to water manifold, shellac gasket surfaces of cylinder head, set manifold on studs and secure with eight $\frac{3}{8}$ -inch nuts and lock washers.

(19) INSTALL WATER BYPASS TUBE ASSEMBLY (fig. 25).**WRENCH, $\frac{1}{2}$ -in.****WRENCH, $\frac{9}{16}$ -in.**

Shellac gaskets in place on thermostat housing and oil cooler. Connect lower end of tube to oil cooler with two $\frac{5}{16}$ - x $1\frac{1}{2}$ -inch cap screws with lock washers ($\frac{1}{2}$ -in. wrench), and upper end to thermostat housing with two $\frac{5}{16}$ - x 1-inch cap screws with lock washers. Bolt tube to front cylinder block end plate with one course thread cap screw $\frac{3}{8}$ - x 1-inch with lock washer ($\frac{9}{16}$ -in. wrench).

(20) INSTALL EXHAUST MANIFOLD AND MUFFLER ASSEMBLY.**WRENCH, socket, $\frac{5}{8}$ -in., with 6-in. extension**

Remove nuts and special washers from studs in head. Install new exhaust manifold gaskets on head. Install new exhaust manifold gaskets on studs (no gasket cement necessary), place manifold and muffler assembly on studs and install the washers and nuts. Tighten these nuts evenly. Install bolts holding muffler supports to cylinder block end plates (fig. 22).

(21) INSTALL VIBRATION DAMPER AND FAN DRIVE PULLEY.**BAR, pry****WRENCH, socket, $1\frac{5}{16}$ -in.,****HAMMER, 2-lb****with 24-in. handle****HAMMER, soft**

Install Woodruff key in crankshaft (hammer). Slide damper on crankshaft with slot in damper registering with key (hub toward engine). Tap back onto rear cone (hammer). Place front cone on crankshaft next. Then set two Woodruff keys in slots in crankshaft. Tap in place with hammer and drive fan pulley onto crankshaft with hammer and block of wood. Place special washer on the 1- x $2\frac{1}{4}$ -inch cap screw, hold flywheel from turning with pry bar, and install and tighten cap screw as tight as possible, forcing entire vibration damper and cones and fan drive pulley assembly tightly together.

(22) REMOVE ENGINE FROM STAND.**CHAIN, or rope****HOIST, chain**

Fasten rope or chain in engine lifter brackets. Take weight of engine off stand with chain hoist and remove bolts or clamps holding engine

INSTALLATION OF ACCESSORIES ON ENGINE

to engine stand. Remaining accessories can now be installed on left side of engine while hanging from chain hoist or resting on blocks.

(23) INSTALL STARTING MOTOR.

WRENCH, open-end, $1\frac{5}{16}$ -in.

WRENCH, socket, $\frac{7}{8}$ -in.,
with 16-in. extension

Position starting motor in starting motor boss. Attach with 2 coarse thread cap screws, $\frac{5}{8}$ - x $1\frac{1}{2}$ inches, with lock washers, and one fine thread cap screw, $\frac{5}{8}$ - x $2\frac{1}{4}$ inches, with lock washers and nut (fig. 19).

(24) INSTALL HANDHOLE COVERS.

WRENCH, $\frac{9}{16}$ -in.

Place handhole covers on front 2 handholes in cylinder block. Gaskets should be with covers. Attach each cover with $\frac{3}{8}$ - x $2\frac{1}{4}$ -inch handhole cover cap screw with washer and gasket.

(25) INSTALL ENGINE PREHEATER INLET ELBOW.

WRENCH, socket, $\frac{9}{16}$ -in., with 6-in. extension

Place engine preheater inlet elbow in third handhole from front of engine. Gasket should be with adapter. Attach with a $\frac{3}{8}$ - x 1-inch cap screw with lock washer.

(26) INSTALL ENGINE AIR HEATER.

WRENCH, socket, $\frac{9}{16}$ -in.

Place engine air heater in rear handhole. Gasket should be with heater. Attach with $\frac{3}{8}$ - x $2\frac{1}{4}$ -inch handhole cover cap screw with washer and gasket (fig. 21).

(27) INSTALL DRAIN TUBE (fig. 20).

WRENCH, $\frac{9}{16}$ -in.

WRENCH, open-end, $\frac{3}{4}$ -in.

Install air box drain tube elbow beneath second handhole ($\frac{9}{16}$ -in. wrench). Attach air box drain tube to elbow ($\frac{3}{4}$ -in. wrench).

(28) INSTALL AIR COMPRESSOR ASSEMBLY.

WRENCH, open-end, $\frac{5}{8}$ -in.

WRENCH, socket, $\frac{5}{8}$ -in.

Start two $\frac{7}{16}$ - x $1\frac{1}{4}$ -inch cap screws with lock washers in lower air compressor attaching holes. Place air box drain tube clip on rear cap screw as it is installed. Lower air compressor assembly into position on these two cap screws and install 2 more cap screws with lock washers in upper holes of compressor bracket. Do not tighten cap screws until compressor drive belt is installed. Place generator drive belt in inner groove of compressor pulley. Place compressor drive belt in inner groove of crankshaft pulley and outer groove of compressor pulley. Slide air compressor assembly upward, taking care to keep it square, until one side of compressor drive belt may be depressed $1\frac{1}{4}$ inches, between pulleys. Tighten cap screws with compressor assembly square with cylinder block ($\frac{5}{8}$ -in. socket wrench). Connect water outlet line from

ORDNANCE MAINTENANCE — HEAVY TRACTOR M1 (Allis-Chalmers HD-10W) ENGINE

water manifold to outer air compressor water line fitting ($\frac{5}{8}$ -in. open-end wrench). Connect water inlet line from water pump to air compressor water line fitting. Fasten water line clip to balance weight cover with cap screw (figs. 20 and 24).

(29) INSTALL GENERATOR.**WRENCH**, $\frac{1}{2}$ -in.**WRENCH**, socket, $\frac{5}{8}$ -in.

Place generator in position and attach to air compressor support bracket with a $\frac{7}{16}$ - x $1\frac{3}{4}$ -inch cap screw with lock washer at front and rear of generator ($\frac{5}{8}$ -in. socket wrench). Place generator drive belt in groove of generator pulley. Attach generator belt adjusting link to generator with a $\frac{5}{16}$ - x $\frac{3}{4}$ -inch cap screw with plain washer. Attach link to air compressor support bracket with a $\frac{5}{16}$ - x $\frac{7}{8}$ -inch bolt with lock washer. Pull generator down until one side of generator drive belt may be depressed 1 inch. Tighten cap screws firmly ($\frac{1}{2}$ -in. wrench).

(30) INSTALL GENERATOR VOLTAGE REGULATOR.**SCREWDRIVER**, 8-in.**WRENCH**, $\frac{7}{16}$ -in.

Install unit on air compressor support bracket and secure with two $\frac{1}{4}$ - x $\frac{5}{8}$ -inch cap screws and lock washers ($\frac{7}{16}$ -in. wrench). Connect 2 wires from generator, with "F" terminal on generator connected to "F" terminal of generator voltage regulator, and "GEN" terminal of control unit connected to other generator terminal (8-in. screwdriver).

19. INSPECTION, CLEANING, AND TESTING FUEL INJECTORS.

a. Inspection. For instructions on inspection, cleaning and testing fuel injectors, see TM 9-1787B.

20. INJECTOR TIMING.

a. The timing of an injector consists of properly locating the top of the injector plunger follower in relation to the injector body when it is at the top of its stroke (fig. 127). This distance is 1.484 inches, and a special tool called timing gage (in the injector service kit) is used to make the proper adjustment. The injector must always be timed and equalized before the engine is operated. The following procedure should be used to time the injectors.

(1) EQUIPMENT.**GAGE**, timing**WRENCH**, open-end, $\frac{5}{16}$ -in.**SCREWDRIVER**, small**WRENCH**, open-end, $\frac{1}{2}$ -in.**(2) PROCEDURE.****(a)** *Pull Fuel Shut-Off to "Off" Position.*

Do not allow the engine to start. Crank engine with starting motor until the exhaust valves of the cylinder on which the injector is to be

INSTALLATION OF ACCESSORIES ON ENGINE

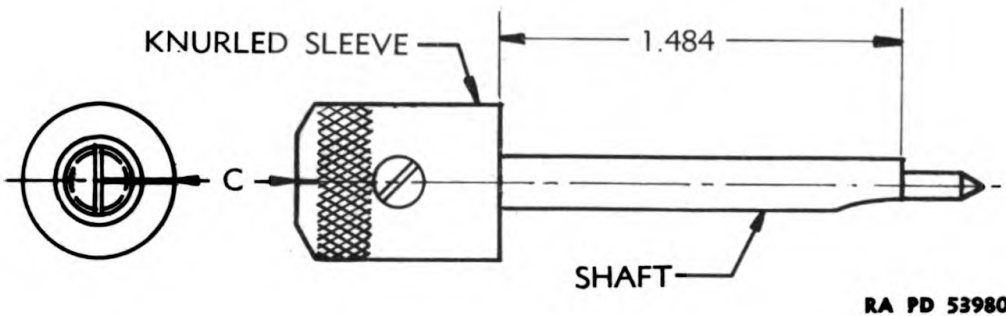
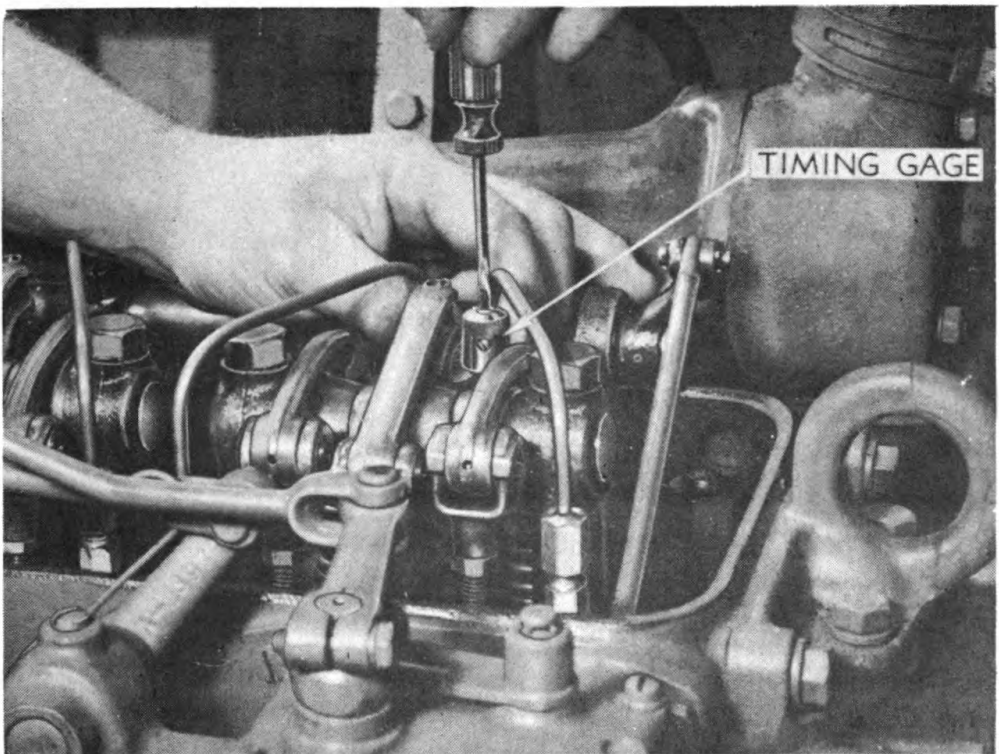

Figure 125 — Injector Timing Gage



RA PD 56386

Figure 126 — Injector Timing

timed are fully opened. When the rocker arms have depressed the exhaust valves, the injector may be timed.

(b) *Set Timing Gage in Position* (figs. 125 and 126).

GAGE, timing

SCREWDRIVER, small

Place the timing gage in the timing hole in the injector body. The knurled head or sleeve should be turned to the left as far as possible. Hold the gage vertical with a firm downward pressure by a small

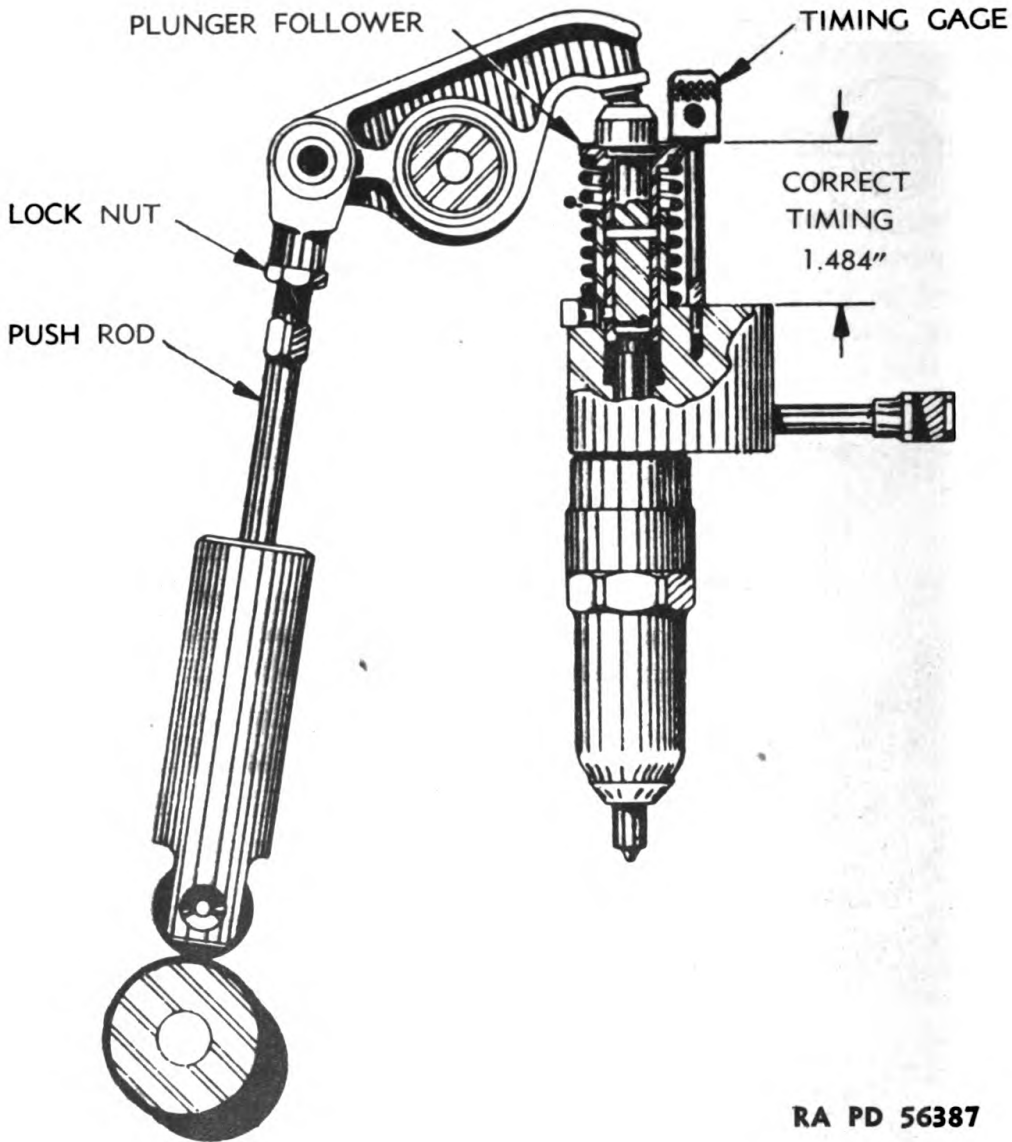

RA PD 56387

Figure 127 — Correct Timing of Injector

screwdriver engaged in the slot in the top of the timing gage shaft. Make certain that the shoulder at the lower end of the timing gage shaft rests squarely on the injector body and is not resting on the copper gasket under the fuel line fitting in the injector.

(c) *Check Present Setting* (fig. 127).

GAGE, timing

Rotate the knurled sleeve to the right until the lower shoulder of the sleeve rests squarely on the edge of the follower guide. If the top of the shaft and the sleeve are not flush and the marks "C" on the sleeve

INSTALLATION OF ACCESSORIES ON ENGINE

and shaft are not in line, the push rod must be lengthened or shortened to obtain the proper adjustment.

(d) *Adjust Push Rod.*

WRENCH, open-end, $\frac{5}{16}$ -in WRENCH, open-end, $\frac{1}{2}$ -in.

Loosen the lock nut on the push rod. Adjust the rocker arm by turning the push rod to the right to shorten it, which will allow the injector plunger follower to come up. Turning the push rod to the left will lengthen the push rod and will push the plunger follower guide down. When the timing marks line up, with a small allowance for a slight change which occurs when the lock nut is tightened, the sleeve should also be flush with the top of the timing shaft. Tighten the lock nut on the push rod. The timing marks should now be exactly in line. If they are not in line, change the adjustment slightly until the marks line up when the lock nut is tight.

21. INJECTOR EQUALIZING.

a. This operation consists of properly adjusting all injector control racks to obtain an equal fuel injection from each injector. Accurate timing of the injectors is essential before they are equalized. The injectors must be timed and equalized every time any part of the engine is worked on which might affect the position of the injector or rocker arm assembly. Equalizing is accomplished by the following procedure.

(1) **EQUIPMENT.**

PLIERS

SCREWDRIVER

(2) **PROCEDURE.**

(a) *Push Fuel Shut-Off Forward (Open).*

Push fuel shut-off all the way forward, and pull throttle back (open) as far as possible.

(b) *Loosen Adjusting Screws.*

SCREWDRIVER

Loosen all adjusting screws on the rack control levers, and be sure the levers are free on the control tube and that the control tube rotates freely in the bearings.

(c) *Disconnect Governor Control Link.*

PLIERS

Remove link pin from governor control link and control tube lever. All injector control racks should move freely and the injector control tube assembly should return to the "no injection" position, injector rack out, when the governor control link is disconnected.

(d) *Adjust for Control Rack and Gear Clearance (fig. 129).*

SCREWDRIVER

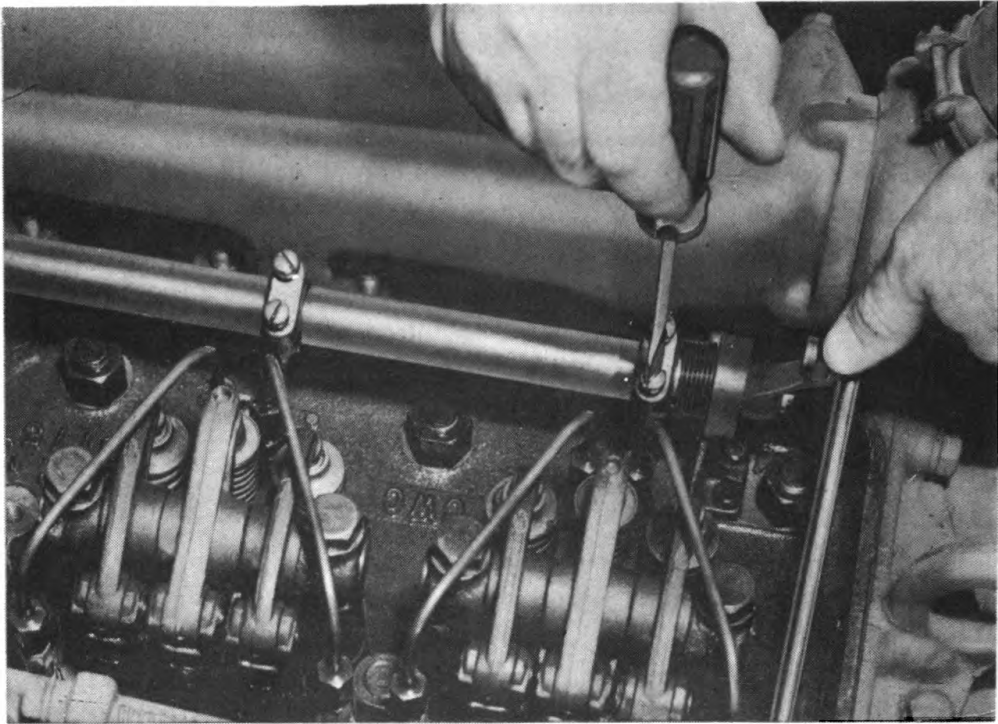

RA PD 17664

Figure 128 — No. 1 Control Rack Adjustment

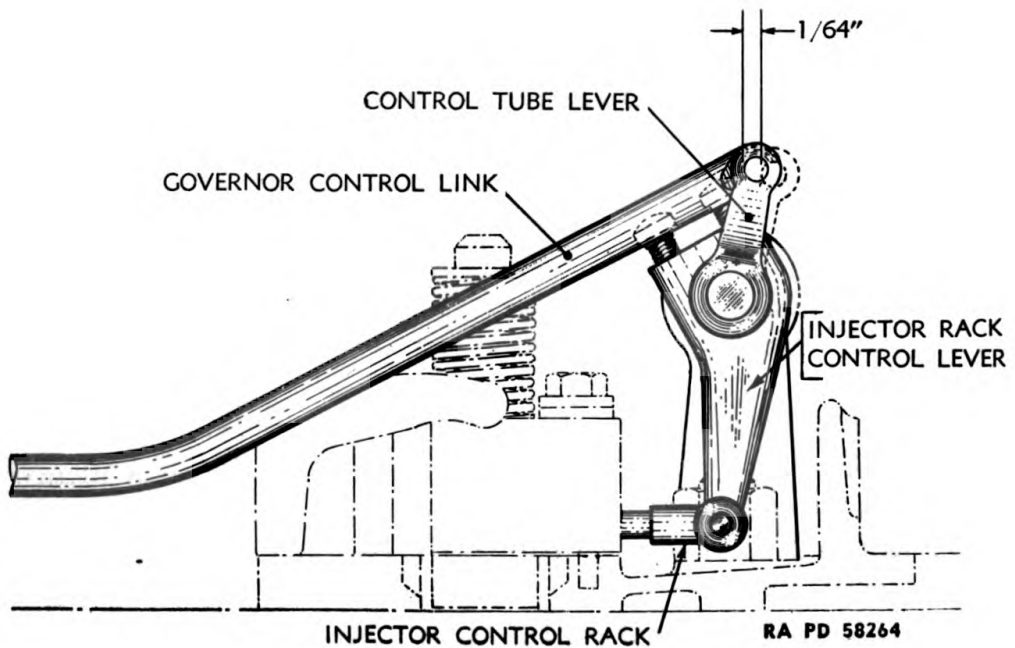

RA PD 58264

Figure 129 — Clearance for Control Rack and Gear

INSTALLATION OF ACCESSORIES ON ENGINE

Hold the throttle lever on the top of the governor in full-load position and turn the lower adjusting screw for No. 1 injector in until the hole for the pin in the control tube lever is $\frac{1}{64}$ inch out of line with the hole in the governor control link (fig. 128). Turn the upper adjusting screw down and tighten both screws lightly so that the $\frac{1}{64}$ -inch spacing is maintained.

(e) *Adjust Remaining Rack Control Levers.*

Hold No. 1 rack control lever against No. 1 injector control rack in its "IN" position and adjust the remaining rack control levers until the lugs on all rack control levers just contact the inner faces of the slots in the injector control racks. CAUTION: The adjusting screws will be damaged if drawn too tightly. If they are just screwed down firmly, they will not loosen.

(f) *Connect Governor Control Link.*

Install link pin in governor control link and control tube lever, and secure with cotter pin. Install rocker arm cover, start engine, and test for proper operation.

22. VALVE CLEARANCE ADJUSTMENT.

a. General. Correct valve clearance is important because of high compression pressure developed in a Diesel engine. Too little clearance causes a loss of compression, "missing", and eventual burning of the valves and valve seats. Too much clearance results in noisy engine operation. The correct valve clearance is 0.010 inch at operating temperature. The valve clearance is adjusted by turning the push rod in the rocker arm clevis, which changes the length of the rod. Turn the push rod to the left to decrease valve clearance (lengthen rod), and to right to increase clearance (shorten rod). The following procedure should be used to adjust the valve clearance correctly.

(1) **EQUIPMENT.**

GAGE, feeler

WRENCH, open-end, $\frac{1}{2}$ -in.

WRENCH, open-end, $\frac{5}{16}$ -in.

(2) **ADJUSTMENT** (fig. 130).

(a) *Rotate Engine Until Injector Is at Bottom of Stroke.*

Rotate the engine with the starting motor until the injector plunger is fully depressed (injector rocker arm down).

(b) *Adjust Clearance Between Rocker Arm and Push Rod.*

GAGE, feeler

WRENCH, open-end, $\frac{1}{2}$ -in.

WRENCH, open-end, $\frac{5}{16}$ -in.

Use the 0.010-inch feeler gage and adjust each push rod until the gage will just pass between the valve stem and the rocker arm.

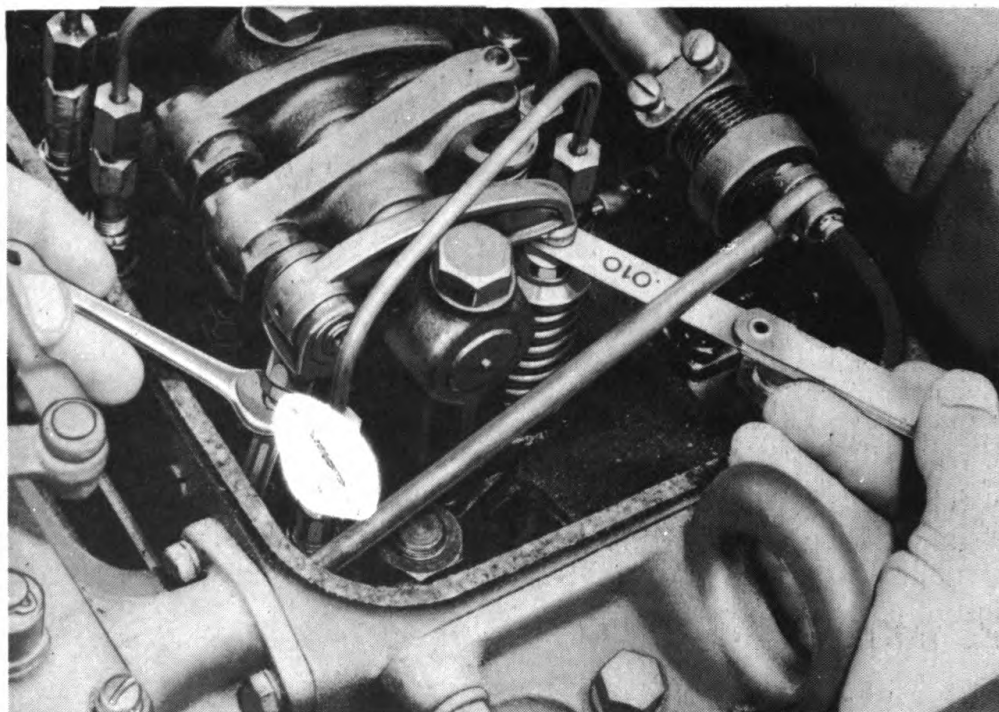

RA PD 17491

Figure 130 — Valve Clearance Adjustment

(c) *Tighten Lock Nut.*

WRENCH, open-end, $\frac{5}{16}$ -in.

WRENCH, open-end, $\frac{1}{2}$ -in.

Hold push rod and tighten lock nut. Check again to see if 0.010-inch feeler gage can be inserted between the valve stem and rocker arm. A slight drag should be felt on feeler gage.

(d) *Repeat Above Steps for Each Cylinder.*

Section XI

INSTALLATION OF ENGINE IN TRACTOR

Paragraph

General 23
Installation of engine in tractor 24

23. GENERAL.

a. Before installing engine back into tractor, wash dirt and grease from the engine support and master clutch compartment. At the same time inspect the engine support assembly, engine spacer, and master clutch compartment and assemblies included in them, and if any repair work is necessary on them, do it before engine is installed. Check engine spacer and engine support bolts to see that all are tight and none are missing. Check bolts holding winch assembly to engine support, tighten or replace them if necessary. Also inspect wiring and fuel lines on tractor for necessary repairs or replacement.

24. INSTALLATION OF ENGINE IN TRACTOR.

a. Equipment.

- | | |
|---|--|
| BAR, pry | WRENCH, open-end, 7/16-in. |
| GAGE, injector timing | (2) |
| HOIST, chain | WRENCH, open-end, 1/2-in. |
| PLIERS | WRENCH, open-end, 9/16-in. |
| ROPE | (2) |
| SCALE, or ruler | WRENCH, open-end, 5/8-in. |
| SCREWDRIVER, 8-in. | WRENCH, open-end, 11/16-in. |
| SCREWDRIVER, 10-in. | WRENCH, open-end, 3/4-in. |
| WRENCH, 1-in. | WRENCH, open-end, 7/8-in. |
| WRENCH, box socket, 9/16-in.,
with 90-deg offset | WRENCH, open-end, 15/16-in. |
| WRENCH, engine cranking | WRENCH, socket, 9/16-in. |
| WRENCH, fan adjusting | WRENCH, socket, 3/4-in. |
| WRENCH, open-end, 5/16-in. | WRENCH, socket, 5/8-in.,
with 6-in. extension |
| WRENCH, open-end, 3/8-in. | |

b. Procedure.

(1) LOWER ENGINE INTO PLACE.

- | | |
|--------------|------|
| HOIST, chain | ROPE |
|--------------|------|

NOTE: Master clutch must be engaged in order to install engine. Using chain hoist and rope, lower engine into position until the hole in clutch release bearing carrier lines up with end of clutch shaft. Start engine back onto shaft (fig. 18).

ORDNANCE MAINTENANCE—HEAVY TRACTOR M1 (Allis-Chalmers HD-10W) ENGINE

(2) LINE UP SPLINES.

WRENCH, engine cranking

Line up the splines on the clutch shaft with the splines in driven member of master clutch. Crankshaft will have to be turned to do this, using cranking wrench. Line up sliding blocks on release bearing carrier with slots in throwout yoke. Push engine back until sliding blocks engage yoke and clutch shaft enters driven member hub.

(3) CONNECT ENGINE TO SPACER.

WRENCH, box socket, $\frac{9}{16}$ -in.,
with 90-deg offset

WRENCH, socket, $\frac{9}{16}$ -in.

Start the ten $\frac{3}{8}$ - x 2-inch cap screws with lock washers holding fly-wheel housing to engine spacer (two $\frac{9}{16}$ -in. wrenches). Tighten them securely before removing chain hoist and chain (fig. 16).

(4) INSTALL SHIMS UNDER FRONT ENGINE HANGER.

HOIST, chain

WRENCH, $\frac{7}{8}$ -in.

ROPE

WRENCH, $\frac{15}{16}$ -in.

Use shims taken out when engine was removed. Crowd as many shims as possible between front engine hanger end and engine support without raising engine. Then raise front of engine with chain hoist and add one more shim to each side (these shims are $\frac{1}{32}$ in. thick). Install the two $\frac{5}{8}$ - x 2-inch bolts with lock washers holding engine hanger and shims to engine support bracket (fig. 17).

(5) CONNECT RELEASE BEARING LUBRICATING TUBE.

WRENCH, open-end, $1\frac{1}{16}$ -in.

WRENCH, open-end, $1\frac{5}{16}$ -in.

Insert release bearing lubricating tube through hole in spacer and secure with $\frac{5}{8}$ -inch S.A.E. jam nut (fig. 16).

(6) CONNECT INNER CLUTCH ROD.

PLIERS

Connect inner clutch rod to sub lever with pin and cotter pin.

(7) MASTER CLUTCH ADJUSTMENT.

BAR, pry

WRENCH, $\frac{9}{16}$ -in.

PLIERS

WRENCH, $\frac{3}{4}$ -in. (2)

(a) Turn Clutch to Adjusting Position.

Disengage clutch and revolve the clutch until the adjusting lock is located near the inspection hole.

(b) Disengage Adjusting Lock.

Hinge adjusting lock back out of slot in back plate.

(c) Turn Adjusting Ring.

BAR, pry

INSTALLATION OF ENGINE IN TRACTOR

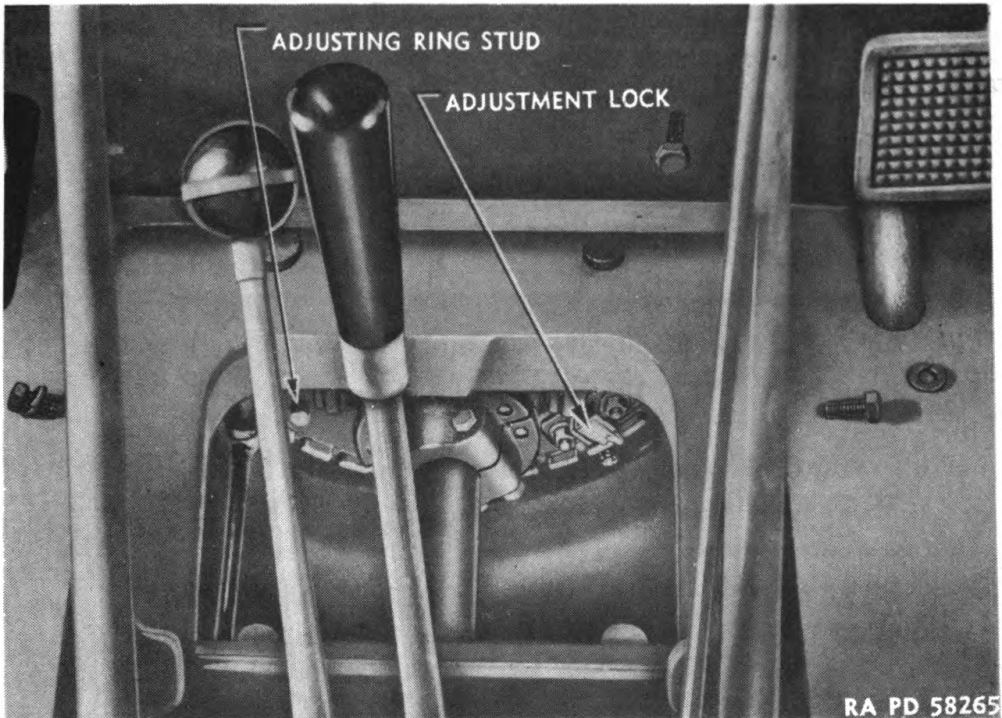

Figure 131 — Master Clutch Adjusting Lock

Pry on the studs on adjusting ring to turn ring. To tighten clutch, turn adjusting ring clockwise; to loosen it, turn the ring counterclockwise. Turn ring in desired direction a notch at a time and test pull required on lever to engage clutch until desired pull is obtained. Engagement of the master clutch when in proper adjustment requires a pull of from 50 to 55 pounds on the control lever when the engine is idling or from 60 to 65 pounds when the engine is stopped. It should engage with the snap and the lever will lock into position with an overcenter action.

(d) Lock Ring in Place.

Engage adjusting lock in notch in back plate.

(8) CLUTCH BRAKE ADJUSTMENT.

PLIERS

RULER or scale

WRENCH, open-end, $\frac{9}{16}$ -in.

WRENCH, socket, $\frac{3}{4}$ -in.

(a) Remove Locking Wire.

PLIERS

Cut wire running through head of lock screw and around the clutch shaft.

(b) Loosen Bolts.

WRENCH, open-end, $\frac{9}{16}$ -in.

WRENCH, socket, $\frac{3}{4}$ -in.

ORDNANCE MAINTENANCE — HEAVY TRACTOR M1 (Allis-Chalmers HD-10W) ENGINE

Loosen lock screw. Loosen bolts that clamp the two halves of clutch brake to clutch shaft.

(c) *Engage Master Clutch.*

(d) *Adjust Clearance.*

Move brake assembly ahead on shaft until space between clutch throw-out assembly and brake measures $1\frac{1}{16}$ inch to $1\frac{1}{8}$ inches.

(e) *Tighten Bolts, Install Wire.*

PLIERS

WRENCH, socket, $\frac{3}{4}$ -in.

WRENCH, open-end, $\frac{9}{16}$ -in.

Tighten bolts clamping brake assembly to shaft. Then tighten lock screw and install lock wire through head of lock screw and around shaft.

(9) **INSTALL MASTER CLUTCH INSPECTION COVER.**

WRENCH, socket, $\frac{3}{4}$ -in.

Install master clutch inspection cover and gasket with four $\frac{1}{2}$ - x $1\frac{1}{4}$ -inch cap screws with lock washers.

(10) **INSTALL AIR INTAKE ELBOW.**

SCREWDRIVER, 10-in.

WRENCH, $\frac{9}{16}$ -in.

Remove large cloth from blower intake. Install air intake elbow and gasket to top of air intake housing with four $\frac{3}{8}$ - x 1-inch cap screws and lock washers ($\frac{9}{16}$ -in. wrench). Slide hose coupling into position on air cleaner outlet pipe and tighten clamps (screwdriver).

(11) **CONNECT CONTROL ROD.**

PLIERS

Connect shut-off bell crank to air shutter shaft lever rod by installing yoke pin and cotter pin connecting the rod to the air shutter shaft lever. Connect shut-off bell crank to governor rod by installing yoke pin and cotter pin connecting the rod to the governor.

(12) **CONNECT AIR LINES.**

WRENCH, open-end, $\frac{5}{8}$ -in.

WRENCH, open-end, $\frac{7}{8}$ -in.

Connect air line from air reservoir to left side of compressor ($\frac{7}{8}$ -in. wrench). Connect air governor line to compressor on right side ($\frac{5}{8}$ -in. wrench).

(13) **CONNECT STARTING MOTOR.**

PLIERS

WRENCH, $\frac{3}{4}$ -in.

Connect the starting motor control rod to starter lever with pin and cotter pin (pliers). Connect battery cable, electric trailer brake cable, and ammeter wire to starting motor switch terminal ($\frac{3}{4}$ -in. wrench).

(14) **CONNECT AIR HEATER.**

WRENCH, $\frac{1}{2}$ -in.

WRENCH, open-end, $\frac{7}{16}$ -in.

WRENCH, open-end, $\frac{3}{8}$ -in.

WRENCH, open-end, $\frac{9}{16}$ -in. (2)

INSTALLATION OF ENGINE IN TRACTOR

Connect air heater fuel line at check valve at bottom of unit (two $\frac{9}{16}$ -in. wrenches). Connect coil wire to coil terminal ($\frac{3}{8}$ -in. wrench). Install air heater cover with two $\frac{5}{16}$ - x $2\frac{7}{8}$ -inch cap screws with lock washers (12-in. wrench). Install air heater fuel line clip to flywheel housing on bolt already in housing ($\frac{7}{16}$ -in. wrench).

- (15) **CONNECT WIRES TO VOLTAGE REGULATOR.**
SCREWDRIVER, 10-in.

Connect wire from wiring harness to voltage regulator terminal and tighten screw.

- (16) **CONNECT FUEL LINES.**
WRENCH, open-end, $\frac{3}{4}$ -in. WRENCH, open-end, $\frac{7}{8}$ -in.

Connect fuel pump inlet line to connection at right side of cowl on engine support ($\frac{3}{4}$ - and $\frac{7}{8}$ -in. wrenches). Connect fuel return line to fitting on right side of cowl on engine support ($\frac{3}{4}$ - and $\frac{7}{8}$ -in. wrenches). Install the fuel pump discharge line by connecting to fuel pump and second stage fuel filter ($\frac{7}{8}$ -in. wrench). Install fuel line between second stage fuel filter and third stage fuel filter ($\frac{7}{8}$ -in. wrench). Connect fuel oil pressure line to third stage fuel filter ($\frac{7}{8}$ -in. wrench).

- (17) **CONNECT LUBRICATING OIL PRESSURE GAGE LINE.**
WRENCH, open-end, $\frac{7}{8}$ -in.

Connect the lubricating oil pressure gage line to connection at right rear of engine. Install clip holding gage line to the line between the fuel pump and secondary filter.

- (18) **CONNECT THROTTLE CONTROL ROD.**
PLIERS

Connect throttle control rod to control bracket arm on the cowl with yoke pin and cotter pin.

- (19) **INSTALL THERMO GAGE TUBE.**
WRENCH, open-end, $1\frac{1}{16}$ -in.

Install thermo gage tube in rear of water manifold and tighten jam nut (fig. 13).

- (20) **LOWER RADIATOR INTO POSITION.**
HOIST, chain WRENCH, 1-in.
ROPE

Lower radiator assembly into position on front of engine support. Start the 2 front lower $\frac{3}{4}$ - x $1\frac{3}{4}$ -inch cap screws with lock washers holding radiator to engine support, but do not tighten. Remove chain hoist and rope (fig. 11).

- (21) **INSTALL FAN ASSEMBLY AND CONNECT RADIATOR SHUTTER CONTROL ROD.**
PLIERS WRENCH, $\frac{3}{4}$ -in.
WRENCH, fan adjusting

ORDNANCE MAINTENANCE—HEAVY TRACTOR M1 (Allis-Chalmers HD-10W) ENGINE

Tilt radiator forward, lay belts in fan pulley and install fan assembly on balance weight cover with three $\frac{1}{2}$ - x $2\frac{1}{4}$ -inch cap screws with lock washers ($\frac{3}{4}$ -in. wrench). Adjust belts so one side of belts can be depressed 1 inch between pulley ($\frac{3}{4}$ -in. wrench and fan adjusting wrench). Install pin through control rod and radiator shutter lever and secure with cotter pin (pliers) (fig. 10).

(22) INSTALL RADIATOR GRILLE.**HAMMER**, 2-lb**HOIST**, chain**PUNCH**, long**WRENCH**, socket, $\frac{5}{8}$ -in.,

with 6-in. extension

Tilt radiator back until it touches fan. Set grille in position and install the eight T-head bolts with lock washers holding radiator grille to shell (punch, hammer, $\frac{5}{8}$ -in. wrench). Install lower left-hand bolt first, as grille will have to be shifted to left so this bolt will pass flange of winch drum.

(23) CONNECT TOP RADIATOR HOSE.

Shellac lower end of hose and place over thermostat housing outlet and fasten clamp.

(24) INSTALL CAP SCREWS HOLDING RADIATOR.**WRENCH**, 1-in.

Install the 2 remaining $\frac{3}{4}$ - x $1\frac{3}{4}$ -inch cap screws with lock washers on right side of radiator. Do not tighten.

(25) INSTALL WINCH DRIVE SHAFT GUARD BRACKET.**SCREWDRIVER**, 10-in.**WRENCH**, 1-in.

Install bracket in position and install two $\frac{3}{4}$ - x 2-inch cap screws with lock washers through it into engine support on left side of radiator. Tighten radiator bolts on both sides (1-in. wrench). Tighten hose clamps on top hose (screwdriver).

(26) INSTALL LOWER WATER CONNECTION.**WRENCH**, $\frac{1}{2}$ -in.

Shellac new gasket to oil cooler inlet and install lower water connection with two $\frac{5}{16}$ - x 1-inch cap screws with lock washers.

(27) INSTALL ENGINE SUPPORT BOTTOM COVER.**WRENCH**, $\frac{7}{8}$ -in.

Install engine support bottom cover and secure with six $\frac{5}{8}$ - x $1\frac{1}{2}$ -inch cap screws with lock washers. See that crankcase drain plug is tight in place (fig. 9).

(28) CONNECT HEADLIGHT WIRES.

Connect headlight wires at connectors near generator.

ORDNANCE MAINTENANCE — HEAVY TRACTOR M1 (Allis-Chalmers HD-10W) ENGINE

(36) INSTALL PRECLEANERS.

WRENCH, $\frac{7}{16}$ -in. (2)

Install precleaners on air intake elbows and tighten clamp bolts (fig. 6).

(37) OPERATE ENGINE FOR RUN-IN PERIOD.

(a) Start engine and let run for 10 hours on the following run-in schedule:

1 hour at $\frac{1}{2}$ throttle.....With no load

2 hours at $\frac{2}{3}$ throttle.....With light load (2nd gear)

5 hours at $\frac{3}{4}$ throttle.....With light load (4th gear)

(b) Check to see that lubricating oil pressure, fuel pressure, and temperature stay within normal range during the above run-in period.

Section XII

SPECIAL TOOLS AND EQUIPMENT

	Paragraph
Introduction	25
Special tools	26

25. INTRODUCTION.

a. The overhaul of this engine and its accessories requires the use of the below mentioned tools. Most of these tools are not standard equipment. The illustrations in the manual should be used as a guide for improvising tools to perform operations for which no special tools are available. The tool numbers listed below are those of the Kent-Moore Organization, General Motors Building, Detroit, Michigan.

26. SPECIAL TOOLS.

TOOLS AND ASSEMBLY REQUIRED	DESCRIPTION
Blower:	
J-1471	Blower drive coupling spring expander
J-1682-C	Blower service tool set
J-1698	Blower clearance feeler set
Connecting rod:	
J-1686	Connecting rod bushing reamer and fixture
Cylinder:	
J-1687	Cylinder liner air port carbon remover
KMO-913	Cylinder checking gage
J-1918	Cylinder liner remover and replacer
J-1319-A	Cylinder compression gage
Engine:	
J-1926	Engine stand
Fan drive pulley:	
J-1905	Fan drive pulley puller
Flywheel:	
J-1904	Flywheel removing tool (set of 2)
J-1914	Flywheel pilot bearing puller
J-1359	Flywheel housing oil seal expander
J-1910	Flywheel pilot bearing replacer
Fuel pump:	
J-1580	Fuel pump tool set
KMO-326-A	Fuel pump wrench
Governor:	
J-1652	Governor spring retainer nut wrench

ORDNANCE MAINTENANCE—HEAVY TRACTOR M1 (Allis-Chalmers HD-10W) ENGINE

TOOLS AND ASSEMBLY
REQUIRED

DESCRIPTION

Injector:

J-1229	Injector tube drive and flanger
J-1229-5	Clamping fixture
J-1231-A	Injector tube reamer set
J-1231-5	Feeding fixture
J-1238	Injector nut wrench
J-1241	Injector service set
J-1261-A	Injector body vise jaws with popping tool
J-1290	Injector spring lifter
J-1291-A	Injector bushing cleaner and spray tip remover
J-1330	Injector valve lapping block
J-1891	Injector tube remover set
KMO-240	Injector filter cap wrench

Main bearing:

J-1472	Main bearing cap puller
--------	-------------------------

Piston:

KMO-231	Piston ring compressor
KMO-232	Piston ring remover and replacer
J-1513	Piston pin bushing remover and replacer set

Push rod:

J-1244	Push rod remover (set of 6)
J-1922	Push rod lock nut wrench

Valve:

J-1641-A	Valve insert remover
J-1736	Valve insert driver
.341	Valve stem guide reamer (finishing)
KMO-239	Valve lapper
J-129-2	Valve stem guide reamer (roughing)
J-1227	Valve spring compressor and injector remover
KMO-122	Valve guide cleaner
J-1641	Valve insert remover
KMO-167-D	Valve seat grinder set

Section XIII

STORAGE AND SHIPMENT

	Paragraph
Preparation for storage and shipment.....	27
Packing.....	28

27. PREPARATION FOR STORAGE AND SHIPMENT.

a. When the engine is to be stored or shipped, special precautions should be taken to protect the engine against rust accumulation, corrosion of the wearing surfaces, and gumming of the fuel system.

b. Prepare the engine for storage or shipment as follows:

(1) Start engine and run at 800 to 1,200 revolutions per minute under no load for 15 minutes. Shut down engine.

(2) Thoroughly drain all fuel lines, fuel filters, fuel pump, and injector.

(3) Disconnect fuel supply line to fuel pump and remove injectors from engine. Use an oil can to fill the injectors with OIL, lubricating, preservative, medium. While turning the engine over with the starting motor, and with the throttle wide open, suck OIL, lubricating, preservative, medium, into the fuel pump until the lines to the injectors are full of oil. At the same time, spray approximately 1 pint of OIL, lubricating, preservative, medium, into the air intake. NOTE: Starter should be used for 30 second intervals only, with 2 minute rest periods if more than 30 seconds are required to accomplish this injection procedure. This will avoid damage to starting motor from overheating.

(4) Drain oil from fuel pumps, filters, and injectors. Install injectors. Reconnect fuel lines to fuel pump. Attach manila tag, which reads "Use only Diesel fuel oil, U. S. Army Specification 2-102, latest revision."

(5) Drain lubricating oil system. Attach red tag to crankcase oil fill cap which reads "This engine has been prepared for shipment. Use only OIL, engine, U. S. Army Specification 2-104, latest revision, for operation."

(6) Remove rocker arm cover and thoroughly clean interior of cover, rocker arm and the control rack. Spray with OIL, lubricating, preservative, medium, while the crankshaft is being rotated, so that the entire surface of the rocker arm, control rack, and the protruding ends of the valve stems will be coated thoroughly. Spray the interior of the cover and replace.

(7) After the engine has cooled, remove grease and dirt from the exterior of the engine and apply a light film of COMPOUND, rust-preventive, light, to all exposed threaded surfaces, using a brush, and being careful not to coat rubber parts. Seal engine air cleaners, breathers,

ORDNANCE MAINTENANCE—HEAVY TRACTOR M1 (Allis-Chalmers HD-10W) ENGINE

exhaust, exhaust expansion joints, and openings of all electrical units with waterproof tape. Rust appearing on any part before storage will be removed with sandpaper and the metal either painted or lightly coated with COMPOUND, rust-preventive, light.

28. PACKING.

a. Shipment by Rail or Truck. If an engine is to be shipped by truck or box car, it should first be placed on and fastened to a suitable skid frame. The weight of the engine should rest on the flywheel housing, oil pan, and front engine hanger. A circular notch should be cut in the cross member of the skid to distribute the weight around the bottom of the flywheel housing. The oil filler pipe and oil gage tube should be removed and wired to engine. The blower air inlet housing, muffler and muffler clamp should be removed and wired to the skid floor to prevent breakage of these units in case engine should be upset. All openings in blower, exhaust manifold, etc., should be covered with self-sealing tape to prevent direct entry of dirt or moisture. The engine should then be fastened to floor or sides of skids with bolts and reinforcing steel strap securely nailed. After skid containing engine has been placed on floor of truck or box car, the sides and ends of skid should be toe-nailed to floor and blocks nailed at each end of skid to prevent skid from sliding if sudden stops or starts are made. If car or truck is open at top, the engine should be covered with water-proofed paper.

b. Export Shipment. If engine is to be shipped by boat, it must first be placed in a crate. Floor of crate should be of material $1\frac{1}{8}$ inches or more thick, with two 2- x 4-inch skids. The cross members at rear of crate, above and below flywheel housing, should have circular notches cut in them to fit the flywheel housing, and securely nailed in place to the two rear corner posts of crate. Blocks should be cut to fit between floor of crate and front engine hanger, and wedge-shaped blocks inserted under each end of oil pan. Remove same accessories and fasten engine to crate as in a of this paragraph. Place waterproof paper under engine so complete envelope is formed. Cover engine with water-proofed paper, and nail sides and tops of crate to skid. Nail reinforcing steel strap around crate.

Section XIV

FITS AND TOLERANCES

	Paragraph
General	29
Specifications	30

29. GENERAL.

The fits and tolerances listed below cover all parts of the engine and its accessories. Allowable worn clearances are tabulated as well as the tolerances for new engines. When rebuilding an engine, use the new clearances and dimensions as a guide and use the worn clearances to determine if a worn part is usable or should be replaced. Fits and tolerances for engine accessories may be found in TM 9-1787B.

30. SPECIFICATIONS.

a. Crankcase and Cylinder Block.

Cylinder bore	4.6275 in.—4.6265 in.
Cylinder liner:	
Type	Dry
Inside diameter	4.2507 in.—4.2492 in.
Out of round.....	0.001 in. (not over)
Taper	0.001 in. (not over)
Fit of liner in cylinder bore.....	Loose (0.000 in.—0.002 in.)

b. Crankshaft.

Out of alinement—not over.....	0.003 in.
Thrust taken	At rear bearing
Main bearing journals:	
Diameter	3.499 in.—3.500 in.
Out of round.....	0.0003 in. (not over)
Taper	0.0005 in. (not over)
Crank pin bearing journals:	
Diameter	2.749 in.—2.750 in.
Out of line with main journals.....	0.0005 in. (not over)
Out of round	0.0003 in. (not over)
Taper	0.0005 in. (not over)

c. Main Bearings.

Number of main bearings	5
Bearing diameter	3.502 in.—3.503 in.
Bearing clearance	0.002 in.—0.004 in.

ORDNANCE MAINTENANCE — HEAVY TRACTOR M1 (Allis-Chalmers HD-10W) ENGINE

Worn limit0.008-in. (not over)
 ShimsNone

d. Camshaft and Bearings.

Number of camshaft bearings5
 Shaft bearing diameter1.498 in.—1.4985 in.
 Reamed bearing sizes:
 Front and rear1.501 in.—1.500 in.
 Intermediate1.502 in.—1.501 in.
 End bearing clearance with shaft0.0015 in.—0.003 in.
 Worn limit0.005 in. (not over)
 Intermediate bearing clearance with shaft0.0025 in.—0.004 in.
 Worn limit0.006 in.
 End clearance0.008 in.—0.012 in.
 Worn limit0.016 in. (not over)
 Thrust takenAt rear

e. Balance Shaft and Bearings.

Balance shaft diameter1.498 in.—1.4985 in.
 Bearing diameter1.500 in.—1.501 in.
 Bearing clearance0.0015 in.—0.003 in.
 Worn limit0.005 in. (not over)
 End clearance0.008 in.—0.012 in.
 Worn limit0.016 in. (not over)

f. Connecting Rods.

Length, center to center10.126 in.—10.124 in.
 Bushing bore (in rod)1.7501 in.—1.7500 in.
 Bushing inside diameter1.5020 in.—1.5015 in.
 Bore for bearing—lower end3.0630 in.—3.0625 in.
 Bearing inside diameter2.7530 in.—2.7520 in.
 Bearing clearances:
 Diameter0.002 in.—0.004 in.
 Worn limit—not over0.008 in.
 Side clearance0.004 in.—0.012 in.
 ShimsNone

g. Pistons.

Clearance top of skirt0.007 in.—0.006 in.
 Worn limit0.010 in. (not over)

FITS AND TOLERANCES

Clearance bottom of skirt.....	0.007 in.—0.006 in.
Worn limit.....	0.010 in. (not over)
Out of round.....	0.001 in. (not over)
Ring location:	
Compression	Above pin
Oil	Below pin
Weight, balanced within.....	0.02 lb
Piston bore for piston pin bushing.....	1.688 in.—1.6875 in.
Piston pin bushing:	
Length	0.880 in.—0.870 in.
Inside diameter	1.5013 in.—1.5022 in.
Piston pin outside diameter	1.5000 in.—1.4998 in.
Piston pin clearance.....	0.0013 in.—0.0024 in.
Worn limit	0.010 in. (not over)

h. Piston Rings.

Compression rings:

Gap	0.020 in.—0.025 in.
Ring width	0.124 in.—0.1235 in.
Thickness	0.170 in.—0.158 in.
Clearance in grooves:	
Top ring	0.011 in.—0.0125 in.
Worn limit	0.030 in. (not over)
2nd ring	0.008 in.—0.0105 in.
Worn limit	0.020 in. (not over)
3rd and 4th rings.....	0.006 in.—0.0085 in.
Worn limit	0.015 in. (not over)

Oil rings:

Gap	0.010 in.—0.020 in.
Width	2 pieces
Thickness	0.145 in.—0.155 in.
Clearance in groove.....	0.004 in.—0.008 in.
Worn limit	0.012 in.

i. Valves and Valve Mechanism.

Exhaust valve location.....	In cylinder head
Exhaust valves:	
Number (in each cylinder).....	2
Material	Silchrome

ORDNANCE MAINTENANCE—HEAVY TRACTOR M1 (Allis-Chalmers HD-10W) ENGINE

Clearance between stem and guide.....	0.001 in.—0.003 in.
Worn limit	0.005 in. (not over)
Length overall.....	6.4375 in.
Seat angle	45 deg
Stem diameter	0.3425 in.—0.3415 in.
Clearance diameter head.....	1 ⁹ / ₁₆ in.
Valve clearance, hot.....	0.010 in.
Valve lift	0.375 in.

Valve springs:

Free length	2 ³ / ₈ in.
Load, valve closed.....	44 lbs at 2 ³ / ₁₆ in.
Load, valve open.....	135.5 to 144.5 lbs at 1 ⁵ / ₆₄ in.

Rocker arm and shaft:

Shaft clearance.....	0.001 in.—0.0025 in.
Worn limit.....	0.006 in. (not over)

Cam follower and bore:

Clearance	0.001 in.—0.003 in.
Worn limit.....	0.006 in. (not over)

Follower spring:

Free length.....	2 ³¹ / ₃₂ in.
Load, valve closed.....	60 lbs at 2 ²⁷ / ₆₄ in.
Load, valve open.....	134.5 to 144.5 lbs at 2 ⁷ / ₆₄ in.

Cam follower roller:

Maximum radial movement.....	0.0005 in.—0.0016 in.
Worn limit.....	0.005 in. (not over)

j. Timing Gears.

Type

Helical

Pressure angle:

Early models	41 deg
Later models	19 deg

Backlash

0.003 in.—0.005 in.

 Worn limit.....

0.010 in. (not over)

Idler gear:

Teeth:

Early models	54
Later models	68

FITS AND TOLERANCES

Diameter, inside bushing	2.7490 in.—2.7495 in.
Hub diameter	2.7465 in.—2.746 in.
Bearing clearance inside bushing to hub.....	0.0025 in.—0.0035 in.
Worn limit.....	0.006 in. (not over)
End clearance between gear and hub.....	0.003 in.—0.006 in.
Worn limit.....	0.008 in. (not over)
Camshaft gear:	
Teeth:	
Early models62
Later models78
Balance shaft gear:	
Teeth:	
Early models62
Later models78
Blower drive gear:	
Teeth:	
Early models32
Later models40
Hub end clearance with bushing.....	0.003 in.—0.006 in.
Worn limit	0.010 in. (not over)
Clearance in bushing with hub.....	0.001 in.—0.002 in.
Backlash	0.001 in.—0.0015 in.
Worn limit	0.004 in.

Section XV

REFERENCES

	Paragraph
Standard nomenclature lists.....	31
Explanatory publications	32

31. STANDARD NOMENCLATURE LISTS.

- a. Cleaning, preserving and lubricating materials, re-coil fluids, special oils, and miscellaneous related items SNL K-1
 - b. Tractor, heavy, M1 (Allis-Chalmers HD-10W).. SNL G-98
- Current Standard Nomenclature Lists are as tabulated here. An up-to-date list of SNL's is maintained as the "Ordnance Publications for Supply Index" OPSI

32. EXPLANATORY PUBLICATIONS.

- a. **Automotive Materiel.**
 - Heavy tractor M1 (Allis-Chalmers HD-10W).. TM 9-787A
 - Military motor vehicles..... AR 850-15
 - Motor transport FM 25-10
 - Ordnance maintenance: Heavy tractor M1 (Allis-Chalmers HD-10W) engine accessories..... TM 9-1787B
 - Ordnance maintenance: Heavy tractor M1 (Allis-Chalmers HD-10W) equipment..... TM 9-1787D
 - Ordnance maintenance: Heavy tractor M1 (Allis-Chalmers HD-10W) power train, frame assembly and seats..... TM 9-1787C
- b. Cleaning, preserving, lubricating, and welding materials and similar items issued by the Ordnance Department TM 9-850
- c. **Diesels.**
 - Diesel engines TF 9-159
 - Diesel engines and fuels FS 10-37
 - Diesel engines and fuels..... TM 10-575
 - Engine of the Diesel tractor..... TF 9-171
 - Power train of the Diesel tractor..... TF 9-172
 - The electrical system of the Diesel tractor... TF 9-169

REFERENCES

- The fuel system of the Diesel tractor TF 9-170
- The track and suspension system of the Diesel tractor TF 9-173
- d. Inspection and Maintenance.**
- Echelon system of maintenance TM 10-525
- Fire prevention, safety precautions, accidents . . . TM 10-360
- First echelon of maintenance FS 10-53
- Inspection of motor vehicles FS 10-58
- Motor transport inspections TM 10-545
- Second echelon of maintenance FS 10-54
- The motor vehicle driver, first echelon maintenance TF 11-558
- e. Lubrication FS 10-39**
- f. Miscellaneous.**
- Automotive electricity TM 10-580
- Electrical fundamentals TM 1-455
- List of publications for training, including training films and film strips FM 21-6
- The internal combustion engine TM 10-570
- g. Storage and Shipment.**
- Rules governing the loading of mechanized and motorized Army equipment, also, major calibre guns for the United States Army and Navy, on open top railroad equipment — published by Operations and Maintenance Department of Association of American Railroads.
- Storage of motor vehicle equipment AR 850-18

INDEX

A	Page No.		Page No.
Accessories		Balance shaft assemblies	
data on	9	assemble	99-101
fits and tolerances.....	157-161	disassemble	84
general discussion of.....	131	inspection and repair.....	93
injector timing		install	121-122
equalizing	141-143	Balance shaft gear, teeth.....	161
timing	138-141	Balance weight cover	
inspection, cleaning and testing		install	127
injectors	138	remove	63
installation of on engine....	131-138	Balance weights, install.....	122-123
removal of from engine.....	41-57	Battery, data on.....	11
valve clearance adjustment.	143-144	Bearing failure, cause and remedy	26-27
Accessory drive, ratio of to crank-		Bearing shells, measuring clearance	
shaft speed	12	of	91-93
Adjustment:		Bearings, main and connecting rod,	
clutch brakes	147-148	measuring	91
master clutch	146-147	Bevel seat, reaming in injector tube	107
valve clearance	143-144	Black smoke, excessive, from ex-	
Air box drain tube and elbow, re-		haust	24-25
moval	42	Blower	
Air brake control assembly data on	20	remove	53
Air cleaner, data on.....	10	rotary	6
Air compressor (assembly)		special tools and equipment.....	153
install	137-138	Blower assembly (with accessories	
remove	41	attached), install on engine..	133-134
Air compressor crankcase, filling		Blower drive assembly	
with oil	151	install	133
Air heater		remove	54-56
connect	148-149	Blower drive gear, fits and toler-	
remove	35	ances	161
cover	42	Blower drive shaft	
Air heater fuel line, disconnect....	35	install on engine.....	134
Air intake elbow		remove	49-53
install	148	Bolts, remove from front engine	
remove	35	support	39
Air lines, connect.....	148	Brake system, data on.....	11
Assembly of engine.....	114-130	Burned piston heads, cause and	
precautions in	58	remedy	26
subassemblies	95-114	Burned valves and seats, cause and	
Auxiliary equipment, data on... 20-21,		remedy	27
Axles, data on.....	11	Bushings	
		reaming	96
		remove from connecting rod.....	89
		Bypass valve assembly	
		install on engine.....	133
		remove	56

B

Backlash (timing gears).....	160
Balance shaft and bearings, fits and	
tolerances	158

INDEX

C	Page No.	Page No.	
Cam follower and bore, fits and tolerances	160	filling	151
Cam follower assemblies		maintenance	14
install	109-111	Crank pin bearing journal, fits and tolerances	157
remove	75-78	Crankcase	
Cam follower roller, fits and tolerances	160	draining	29
Camshaft and balance shaft assemblies		filling with oil.....	151
assemble	99-101	fits and tolerances.....	157
disassemble	84	Crankshaft	
inspection and repair.....	93	assemble	95-96
remove	64-66	disassemble	89
Camshaft and bearings, fits and tolerances	158	fits and tolerances.....	157
Camshaft assembly, install.....	121	install crankshaft gear and oil slinger	123
Camshaft gear teeth.....	161	install in cylinder block.....	115
Cleaning (See Inspection and repair of engine)		install oil pump drive sprocket on	127-128
Cleaning solutions	90	remove	70-72
Clearance, valve, adjustment..	143-144	Crankshaft and bearings, cleaning and inspection	91-93
Clutch (assembly)		Crankshaft front cover assembly	
brakes, adjustment	147-148	disassemble	84-85
data on	10	install	128-129
maintenance	14	oil seal in.....	101
Clutch inspection hole cover, removal	37	remove	66
Coil wire, disconnect.....	35	Crankshaft gear	
Compression in valves, poor.....	25	install	123
Compression rings, fits and tolerances	157	remove	66
Compression stroke	6	Crankshaft speed, ratio of accessory drive to	12
Connecting rods		Cut-out relay, data on.....	11
fits and tolerances.....	158	Cycle, operating	4-7
remove bushing from.....	89	Cylinder, special tools and equipment	153
special tools and equipment.....	153	Cylinder block	
(See also Piston and connecting rod assemblies)		cleaning and inspection.....	90
Control housing (cover) assembly		fits and tolerances.....	157
install	135	install crankshaft in.....	115
remove	47-49	install cylinder liners in bore of..	116
Control rod(s)		Cylinder head (assembly)	
connect	148	assemble	104
disconnect	34	disassemble	74-83
Cooler adapter, install.....	134	install	129
Cooling system		remove	59
data on	10	Cylinder liners	
draining	29	checking and cleaning.....	90
		fits and tolerances.....	157
		install in bore of cylinder block.	116
		remove	70

ORDNANCE MAINTENANCE — HEAVY TRACTOR M1 (Allis-Chalmers HD-10W) ENGINE

D	Page No.		Page No.
Data, tabulated		description	4-8
axles	11	disassembly	58-89
brake system	11	general discussion of.....	58
clutch	10	into subassemblies	59-72
cooling system	10	of subassemblies	72-89
direction of rotation.....	12	fits and tolerances.....	157-161
electrical system	11-12	inspection and repair of parts..	90-94
engine and accessories.....	9	inspection on vehicle.....	22-23
fits and tolerances (See Fits and tolerances)		installation of in vehicle....	145-152
fuel system	9-10	maintenance duties, allocation of	
ratio of accessory drive to crank-shaft speed	12	by echelons	13-21
steering system	11	parts, location	7
tracks	11	removal of from vehicle.....	29-40
transmission and transfer case...	10	special tools and equipment.	153-154
Definitions of echelons and maintenance terms	13-14	storage and shipment.....	155-156
Description of engine		trouble shooting on vehicle....	24-28
basic parts, location.....	7	Engine air heater, install.....	137
operating cycle	4-7	Engine assembly, maintenance...	15-17
parts for removal or installation of engine	8	Engine clutch assembly, maintenance	14
special tools and equipment.	153-154	Engine front hanger	
V-belts, function	8	install	136
Detonating engine, cause and remedy	25	shims under	146
Dimensions of engine.....	9	remove	46
Direction of rotation, data on.....	12	Engine lifter brackets	
Drain tube, install.....	137	install	129-130
Draining cooling system and crank-case	29	location and function.....	8
Driving hub, install.....	124	Engine preheater assembly, data on.	21
		Engine preheater inlet elbow, install	137
		Engine running, inspection with...	23
		Engine stand	
		mounting engine on.....	42
		remove engine from.....	136-137
		Engine support bottom cover	
		install	150
		remove	31
		Equalizing fuel injectors..	141-143, 151
		Equipment and special tools..	153-154
		Exhaust, excessive black smoke	
		from	24-25
		Exhaust manifold, install on engine.	136
		Exhaust system, maintenance.....	17
		Exhaust valves	
		cleaning	93-94
		remove	78
		fits	159
		Export shipment of engine.....	156

E

Echelons, definition of.....	13
Electric brake control assembly, data on	20-21
Electrical system	
data on	11-12
maintenance	14-15
End plates, cleaning and inspection	90
Engine	
accessories	
installation of on.....	131-134
removal of from.....	41-57
assembly of	114-130
subassemblies	95-114
data, tabulated	9-12

INDEX

F	Page No.		Page No.
Failure		Front engine support, remove bolts	
bearing	26-27	from	39
engine starting	24	Front fenders	
Fan assembly		install	151
install	149-150	remove	29
remove	32	Fuel filter, third stage (See Third	
Fan drive pulley		stage fuel filter assembly)	
install	136	Fuel injectors (See Injector(s))	
remove	54	Fuel lines, disconnect	34
Fans, data on	10	Fuel manifolds	
Fenders (See Front fenders)		install	114
Filling cooling system	151	remove	78
Final drive assemblies, maintenance	17	Fuel pump	
Fire extinguishing system	17	data on	9-10
Fits and tolerances		how driven	8
balance shaft and bearings	158	special tool	153
camshaft and bearings	158	Fuel return line	
connecting rods	158	connect	135
crankcase and cylinder block	157	remove	54
crankshaft	157	Fuel system	
general discussion of	157	data on	9-10
main bearing	157-158	maintenance	18
piston rings	159		
pistons	158-159	G	
timing gears	160-161	Gages, data on	19
valve and valve mechanism	159-160	Gaskets, use of new in assembling ..	58
Flaring end of injector tube	104	Gear train and main frame assem-	
Flywheel		bly, data on	18-19
remove	59	Generator	
special tools and equipment	153	data on	11
Flywheel assembly		how driven	8
assemble	96-99	install on engine	138
install	126	remove	41
Flywheel housing		Generator voltage regulator, install	
disassemble	84	on engine	130
install	124-126	Governor	
oil seal in	101	data on	10
remove	63	special tools	153
Flywheel pilot bearing, remove	59	Governor breather pipe, install on	
Flywheel ring gear, remove	83-84	engine	134-135
Follower spring, fits and tolerances ..	160	Governor control housing, install on	
Frame assembly truck, mainte-		engine	134
nance	17-18	Governor control link	
Front cylinder block end plate		connect	143
install	120	disconnect	141
remove	68	install on engine	135
Front engine hanger, install shims		Governor weight housing, remove as	
under	146	one unit	53
		Grinding valve seats	108-109

ORDNANCE MAINTENANCE—HEAVY TRACTOR M1 (Allis-Chalmers HD-10W) ENGINE

H	Page No.		Page No.
Handhole covers, install on engine.	137	injector tubes	94
Headlight wires, connect.....	150	parts, inspection of.....	90
Hood		pistons	90-91
install	151	Instruments, data on.....	19
remove	29		
Hydrometer readings, data on.....	11	K	
		Knocking in engine, cause and remedy	25
I			
Idler gear assembly		L	
inspection and repair.....	93	Lifter brackets, engine, location and function	8
install	123-124	Lubricant used in preparing engine for storage or shipment.....	155
remove	66	Lubricating oil pressure gage line, connect	149
teeth	160		
Injector control tube assembly		M	
assemble	101	Main bearings, fits and toler- ances	157-158
install	114	Maintenance duties, allocation of by echelons	
remove	74	auxiliary equipment	20-21
Injector copper tubes		air brake control assembly....	20
install	104	electric brake control assem- bly	20-21
remove	83	engine preheater assembly....	21
Injector fuel lines		winch assembly	21
install	130	cooling system	14
remove	74	definitions of echelons and terms	13-14
Injector tube(s)		electrical system	14-15
defective	94	engine assembly	15-17
reaming	104	engine clutch assembly.....	14
Injector(s)		exhaust system	17
equalize	141-143, 151	final drive assemblies.....	17
install	112	fire extinguishing system.....	17
remove	75	frame assembly truck.....	17-18
special tools and equipment....	154	fuel system	18
timing	138-141	gear train and main frame assembly	18-19
Inner clutch rod, connect.....	146	instruments and gages.....	19
Inspection		scope of	13
before installing engine in ve- hicle	145	sheet metal group.....	19-20
engine in vehicle.....	22-23	vehicle assembly	20
fuel injectors, reference on.....	138	Manifold assembly, remove.....	43
Inspection and repair of engine		Master clutch (assembly) adjustment	146-147
camshaft and balance shaft assem- blies	93		
cleaning solutions	90		
crankshaft and bearings.....	91-93		
cylinder block	90		
cylinder liners	90		
end plates	90		
exhaust valves	93-94		
idler gear assembly.....	93		

INDEX

M—Cont'd	Page No.		Page No.
Master clutch (assembly)—Cont'd		Operating cycle	4-7
engage	36	Organization maintenance (See	
install on engine.....	135	Maintenance duties, allocation of	
remove	43	by echelons)	
Master clutch inspection cover, in-			
stall	148	P	
Mounting engine on engine stand...	42	Packing engine for shipment.....	156
Muffler and manifold assembly		Parts of engine, inspection of.....	90
install	136	Periodic inspection of engine.....	22
remove	43	Pilot bearing, install.....	126-127
N		Piston and connecting rod assemblies	
Number, tool	153-154	assemble	96
Nut, remove from release bearing		disassemble	85-89
lubricating tube	37	install	120
		remove	68
O		Piston and cylinder liner wear, ex-	
Oil consumption, excessive, cause		cessive, cause and remedy....	25-26
and remedy	27-28	Piston heads, burned, cause and	
Oil cooler		remedy	26
install	134	Piston rings	
remove	49	fit and install on piston.....	116-120
Oil filter, install on engine.....	134	fits and tolerances.....	157
Oil gage rod and tube assembly		Piston(s)	
install	133	checking and cleaning.....	90-91
remove	54	fit and install piston rings on	116-120
Oil pan		fits and tolerances.....	158-159
install on engine.....	133	function of in operating cycle...	6
remove	56	special tools and equipment....	154
Oil pipe and gage rod tube assem-		Power in engine, lack of, cause and	
blies, install on engine.....	133	remedy	24
Oil pump assembly		Precautions in assembly.....	58
install on engine.....	131-133	Precleaners	
remove	56	install	152
Oil pump drive, remove.....	56-57	remove	29
Oil pump drive sprocket, install on		Preheater assembly, engine, data on	21
crankshaft	127-128	Preheater inlet elbow, remove.....	42
Oil pump outlet pipe and bypass		Pressure cycle	160
valve assembly, install on engine	133	Push rod(s)	
Oil rings, fits and tolerances.....	157	install	109-111
Oil seal		remove	75-78
install in crankshaft cover.....	101	special tools and equipment....	154
install in flywheel housing.....	101	R	
Oil slinger and crankshaft gear, in-		Radiator (assembly)	
stall on crankshaft.....	123	install cap screws holding.....	150
Oil slinger and pump drive sprocket,		lift out	32
remove	68	lower into position.....	149

ORDNANCE MAINTENANCE—HEAVY TRACTOR M1 (Allis-Chalmers HD-10W) ENGINE

R—Cont'd

Page No.

Page No.

Radiator grille
 install 150
 remove 31-32
 Radiator hose, upper, disconnect.. 31
 Radiator shutter control rod, connect 149-150
 Rail, shipment of engine by..... 156
 Ratio of accessory drive to crankshaft speed 12
 Reaming:
 bushings 96
 injector tube 104
 bevel seat in..... 107
 valve guides 108
 Rear axle, data on..... 11
 Rear cylinder block end plate
 install 120-121
 remove 68
 Rebuild defined 14
 Reconditioning valve, valve guide, and valve seat..... 94
 Regulators, data on..... 11
 Release bearing lubricating tube
 connect 146
 remove nut from..... 37
 Repair defined 14
 (See also Inspection and repair of engine)
 Replace defined 13
 Rocker arm and shaft, fits and tolerances 160
 Rocker arm assemblies
 install 112-114
 remove 74-75
 Rocker arm or valve clearance adjustment, data on..... 9
 Rotary blower 6
 Rotation, direction of, data on.... 12
 Run-in period of engine..... 152
 Running engine, inspection while.. 23
 Rust-preventive used in preparing engine for storage or shipment 155-156

S

Service defined 13
 Sheet metal group, data on..... 19-20
 Shims, install under front engine hanger 146
 Shipment (See Storage and shipment)

Smoke, excessive, cause and remedy
 black, from exhaust..... 24-25
 blue 25
 Spacer
 connect engine to..... 146
 disconnect engine from..... 37
 Special tools and equipment.. 153-154
 Splines on clutch, lining up..... 146
 Starting motor
 connect 148
 data on 12
 disconnect 36
 install 137
 remove 41
 Starting the engine..... 151
 run-in period 152
 Steering system, data on..... 11
 Sticking valves, cause and remedy. 27
 Storage and shipment .
 packing 156
 preparation for 155-156

T

Tabulated data (See Data, tabulated)
 Testing
 engine (run-in period) 152
 fuel system, reference for..... 138
 Thermo gage tube
 install 149
 remove 34-35
 Thermostat, data on..... 10
 Third stage fuel filter assembly
 install on engine..... 135
 remove 53
 Throttle control rod..... 149
 Timing, injector 138-141
 Timing gears, fits and tolerances 160-161
 Tolerances (See Fits and tolerances)
 Top radiator hose, connect..... 150
 Tracks, data on..... 11
 Transfer case, data on..... 10
 Transmission, data on..... 10
 Trouble shooting engine on vehicle
 bearing failure 26-27
 black smoke from exhaust, excessive 24-25
 blue smoke, excessive..... 25
 compression, poor 25
 failure to start..... 24
 general discussion of..... 23

INDEX

T—Cont'd	Page No.		Page No.
Trouble shooting engine on vehicle—Cont'd		lift engine from.....	40
oil consumption, excessive....	27-28	remove engine from.....	29-40
piston and cylinder liner wear, excessive	25-26	trouble shooting engine on....	24-28
piston heads, burned.....	26	Vehicle assembly, data on.....	20
power, lack of.....	24	Vibration damper	
valves and seats, burned.....	27	install	136
valves sticking	27	remove	54
Truck, shipment of engine by....	156	Voltage regulator	
Two-cycle engine	4-7	connect wires to.....	149
(See also Engine)		data on	12
		disconnect wires from.....	36
		W	
		Water bypass tube assembly	
		install	136
		remove	46
		Water connection, lower	
		disconnect	31
		install	150
		Water outlet manifold	
		install	136
		remove	47
		Water pump	
		data on	10
		how driven	8
		remove	53
		Weight of engine, data on.....	9
		Wires	
		connect to voltage regulator....	149
		disconnect from voltage regulator	36
		headlight, disconnect at connector	31
		Winch assembly, data on.....	21
		Winch drive shaft guard	
		install	151
		bracket	150
		remove	29

[A.G. 062.11 (12-21-42)
O.O. 461/30243 (2-6-43)]

BY ORDER OF THE SECRETARY OF WAR:

OFFICIAL:

J. A. ULIO,
Major General,
The Adjutant General.

G. C. MARSHALL,
Chief of Staff.

DISTRIBUTION: R 9(2); IBn 9(1); IC 9(4)

(For explanation of symbols, see FM 21-6)

