

TM 9-765

WAR DEPARTMENT

U.S. Dept. of Army
TECHNICAL MANUAL

**BOMB SERVICE TRUCK M6
(Chevrolet)**

AUGUST 13, 1942

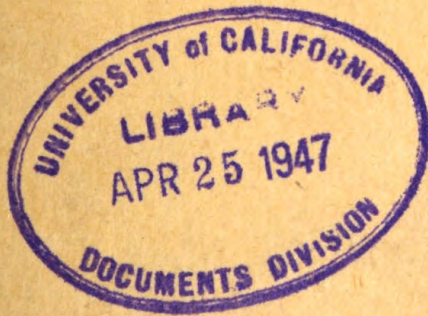

Book well
gift
from me

TECHNICAL MANUAL
No. 9-765

11113
-12
TM 9-765
1942

WAR DEPARTMENT
Washington, August 13, 1942

★ ★
BOMB SERVICE TRUCK M6 (Chevrolet)

Prepared under the direction of the
Chief of Ordnance

(With the cooperation of the Chevrolet Motor Division, General Motors Corporation)

PART ONE—Operating Instructions

SECTION		Paragraphs	Pages
I:	Introduction	1- 3	4- 7
II:	Operation and controls	4- 7	8- 18
III:	Inspection	8-14	19- 22
IV:	Lubrication	15-19	23- 29
V:	General care and preservation ..	20-21	30
VI:	Painting	22-27	31- 33
VII:	Tools and equipment on vehicle	28-29	34
VIII:	Operations under unusual condi- tions	30-30A	35- 39
IX:	Materiel affected by gas	31-34	40- 42

PART TWO—Organization Maintenance

		Paragraphs	Pages
X:	Scope of maintenance operations	35-37	43- 47
XI:	Front axle	38-41	48- 54
XII:	Rear axle	42-45	55- 59
XIII:	Body	46-50	60- 69
XIV:	Brake system	51-63	70-101
XV:	Clutch	64-68	102-110
XVI:	Cooling system	69-84	111-124
XVII:	Battery and starting system...	85-90	125-131
XVIII:	Generator and controls	91-95	132-140

BOMB SERVICE TRUCK M6 (Chevrolet)

PART TWO—Organization Maintenance (Continued)

	Paragraphs	Pages
XIX: Ignition system	96-102	141-151
XX: Lighting and wiring systems	103-109	152-161
XXI: Engine	110-122	162-195
XXII: Exhaust system	123-126	196-198
XXIII: Frame	127-129	199-201
XXIV: Fuel system	130-136	202-212
XXV: Instruments and gages	137-142	213-218
XXVI: Propeller shafts	143-148	219-226
XXVII: Chassis sheet metal	149-152	227-230
XXVIII: Springs and shock absorbers	153-158	231-238
XXIX: Steering gear	159-162	239-246
XXX: Transfer case	163-166	247-250
XXXI: Transmission	167-170	251-257
XXXII: Wheels, wheel bearings, tires	171-174	258-267
XXXIII: Storage of vehicle		268
XXXIV: References	175-176	269-270
INDEX		271-280

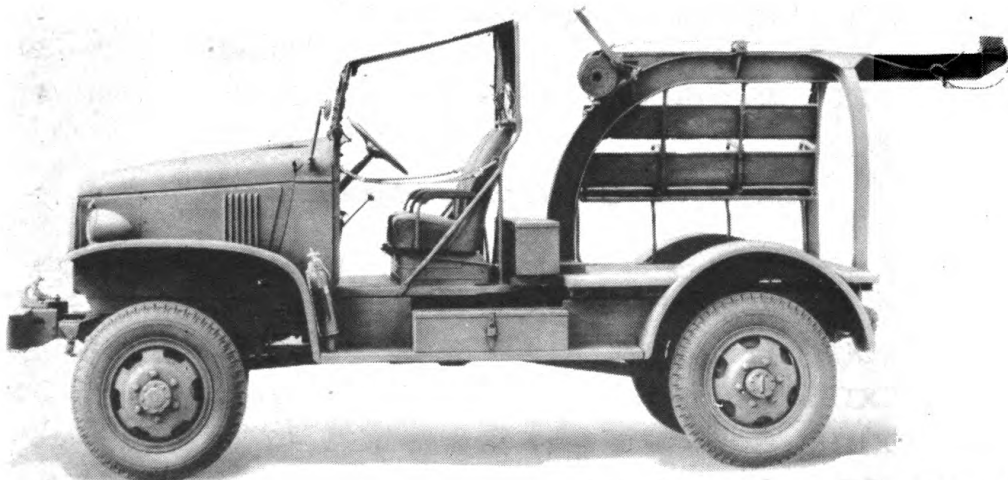

RA PD 32201

Figure 1—Chevrolet Bomb Service Truck—Left Side

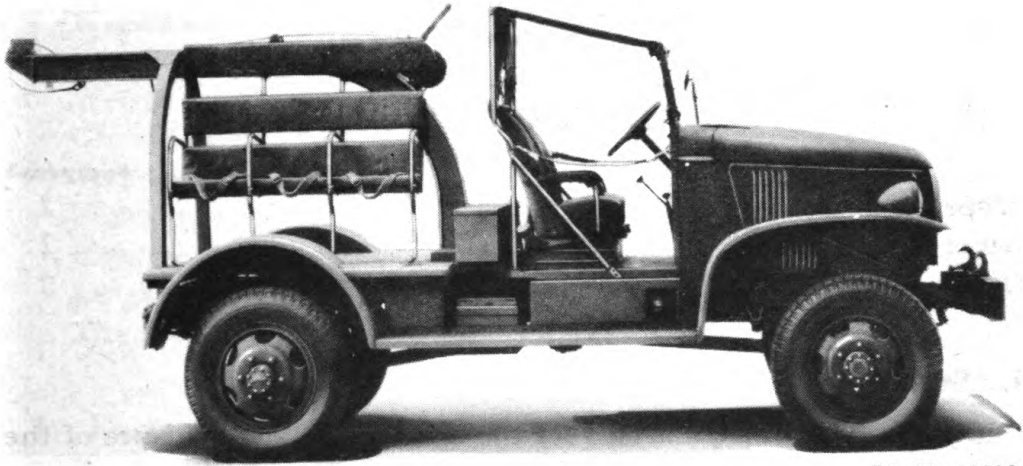

RA PD 32202

Figure 2—Chevrolet Bomb Service Truck—Right Side



RA PD 32203

Figure 3—Chevrolet Bomb Service Truck—Left Front

BOMB SERVICE TRUCK M6 (Chevrolet)

PART ONE — OPERATING INSTRUCTIONS

Section I

INTRODUCTION

	Paragraph
Scope	1
General description	2
Data	3

1. SCOPE.

a. This manual is published for the information and guidance of the using arms and services.

b. In addition to a description of the CHEVROLET 4 x 4 MODEL G-7128 BOMB SERVICE TRUCK M6, this manual contains technical information required for the identification, use and care of the materiel.

c. Disassembly, assembly and such repairs as may be handled by using arms personnel will be undertaken only under the supervision of an officer or the chief mechanic.

d. In all cases where the nature of the repair, modification, or adjustment is beyond the scope or facilities of the unit, the responsible ordnance service should be informed in order that trained personnel with suitable tools and equipment may be provided or proper instructions issued.

2. GENERAL DESCRIPTION.

a. The bomb service truck is used to load, unload and tow bomb trailers. It is powered by a six-cylinder valve-in-head engine. A single plate dry disk clutch with a diaphragm spring is used.

b. A selective sliding gear type transmission supplies four forward speeds and one reverse speed.

c. In order to provide a drive to the front axle as well as an auxiliary low speed, a two-speed transfer case is mounted back of the transmission.

d. Tubular drive shafts with needle type universal joints are used between the transfer case and axles as well as between the transfer case and transmission.

e. The frame, constructed of heavy channel steel, supports the open type body and platform on which a hoist for loading and unloading the bomb trailer is mounted.

INTRODUCTION

3. DATA.

a. General.

Wheelbase	125 in.
Weight (shipping)	6040 lb
Weight (road)	6325 lb
Ground clearance	18 $\frac{1}{8}$ in.
Tread (center to center of tracks)	60 $\frac{5}{16}$ in.
Width over-all	72 in.
Height over-all	91 $\frac{7}{8}$ in.
Length over-all	220 $\frac{3}{8}$ in.
Tire pressure	55 lb

b. Engine.

Number of cylinders	6
Firing order	1-5-3-6-2-4
Bore and stroke	3 $\frac{9}{16}$ x 3 $\frac{1}{8}$
Piston displacement	235.5 cu in.
Compression ratio	6.62 to 1
Rated horsepower (at 3100 rpm)	93
Weight of engine and clutch ass'y.	574 lb

c. Fuel, Oil, and Cooling Capacities.

Fuel capacity	Main tank, 30 gal Auxiliary tank, 18 gal
Oil capacity, engine	5 qt
Transmission	5 $\frac{1}{2}$ pt
Transfer case	4 pt
Front axle	13 $\frac{1}{2}$ pt
Rear axle	14 pt
Cooling system	17 $\frac{1}{4}$ qt
Cruising range	250 miles

BOMB SERVICE TRUCK M6 (Chevrolet)

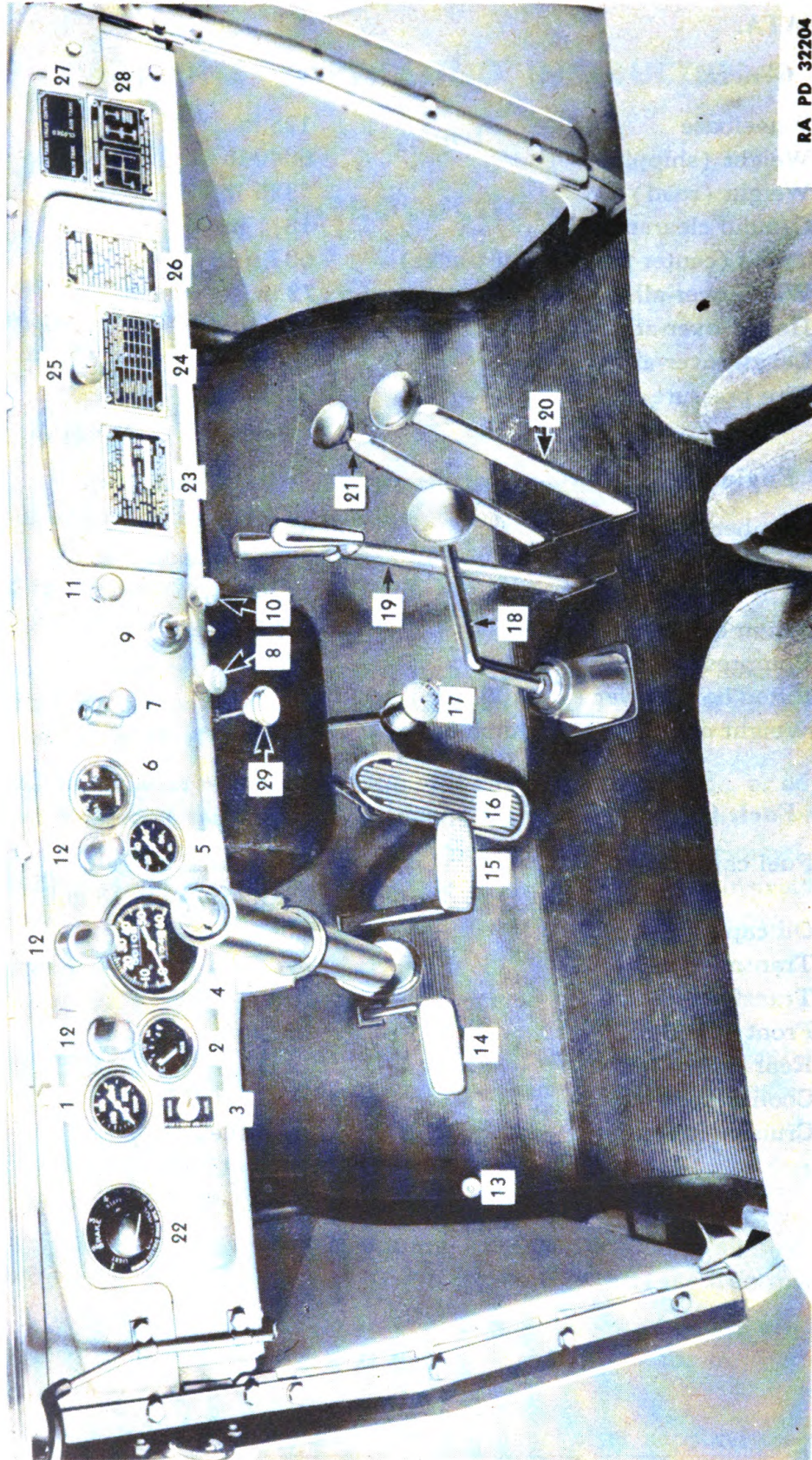

Figure 4 — Driver's Compartment

INTRODUCTION

- | | |
|--------------------------------------|--|
| 1—Temperature Gage Indicator | 16—Accelerator |
| 2—Fuel Gage | 17—Starter Switch Pedal |
| 3—Fuel Gage Gas Tank Selector Switch | 18—Transmission Gearshift Lever |
| 4—Speedometer | 19—Hand Brake Lever |
| 5—Oil Pressure Gage | 20—Transfer Case Shifting Lever |
| 6—Ammeter | 21—Front Axle Control Lever |
| 7—Lighting Switch | 22—Trailer Electric Brake Load Control |
| 8—Carburetor Choke | 23—Serial Number and Load Data Plate |
| 9—Ignition Switch | 24—Maximum Permissible Road Speeds Plate |
| 10—Hand Throttle | 25—Glove Compartment Lock |
| 11—Panel Light Switch | 26—Cooling System Draining Caution Plate |
| 12—Panel Lights | 27—Gas Tank Valve Control Plate |
| 13—Headlight Dimmer Switch | 28—Shifting Diagram Plate |
| 14—Clutch Pedal | 29—Ventilator Control Lever |
| 15—Brake Pedal | |

RA PD 32204A

Nomenclature for Figure 4—Driver's Compartment

BOMB SERVICE TRUCK M6 (Chevrolet)

Section II

OPERATION AND CONTROLS

	Paragraph
General information on instruments and controls	4
Prestarting inspection	5
Starting the engine	6
Operating the vehicle	7

4. GENERAL INFORMATION ON INSTRUMENTS AND CONTROLS.

a. It is of definite importance that the driver of one of these vehicles be thoroughly familiar with the various controls and their proper use. Even the experienced driver should study the controls shown in figures 4, 5, 6, 7, 8, 9, and 10 as there are a number which are not ordinarily found on standard vehicles.

b. Figure 4 illustrates the controls, instruments and instruction plates and their location. In the following instructions we will refer to this illustration by the key number of the control or instrument being discussed so that the reader may easily follow the instructions.

c. **Temperature Indicator No. 1** indicates the temperature of the liquid in the cooling system at all times. The dial of the instrument indicates temperature in degrees Fahrenheit. The driver should watch this instrument closely for any indication of excessive temperature. Whenever the indicator hand shows over 180 degrees, the driver should immediately investigate the cause of the excessive temperature. Continuing to drive an over-heated engine may cause permanent damage to its working parts.

d. **Fuel Gage No. 2** registers the amount of fuel in either the main tank or the auxiliary tank, according to the position of the gas tank gage selector switch No. 3, when the ignition switch is also turned on. The gage has gradations for empty, $\frac{1}{4}$, $\frac{1}{2}$, $\frac{3}{4}$ and full.

e. **Fuel Gage Gas Tank Selector Switch No. 3.** When it is desired to check the quantity of fuel in the main tank, the switch lever should be up, and when checking the auxiliary tank the switch lever should be down. The position of this switch should coincide with the position of the gasoline tank selector valve shown in figure 5.

f. **Speedometer No. 4** indicates the speed at which the vehicle is being driven. The odometer registers the total number of miles the vehicle has been driven.

OPERATION AND CONTROLS

g. **Oil Pressure Gage No. 5** indicates the oil pressure in the lubrication system. The driver should watch this instrument closely and, if the indicator hand drops to zero, the engine should be stopped immediately and the cause of oil pressure failure investigated and corrected before continuing to run the engine.

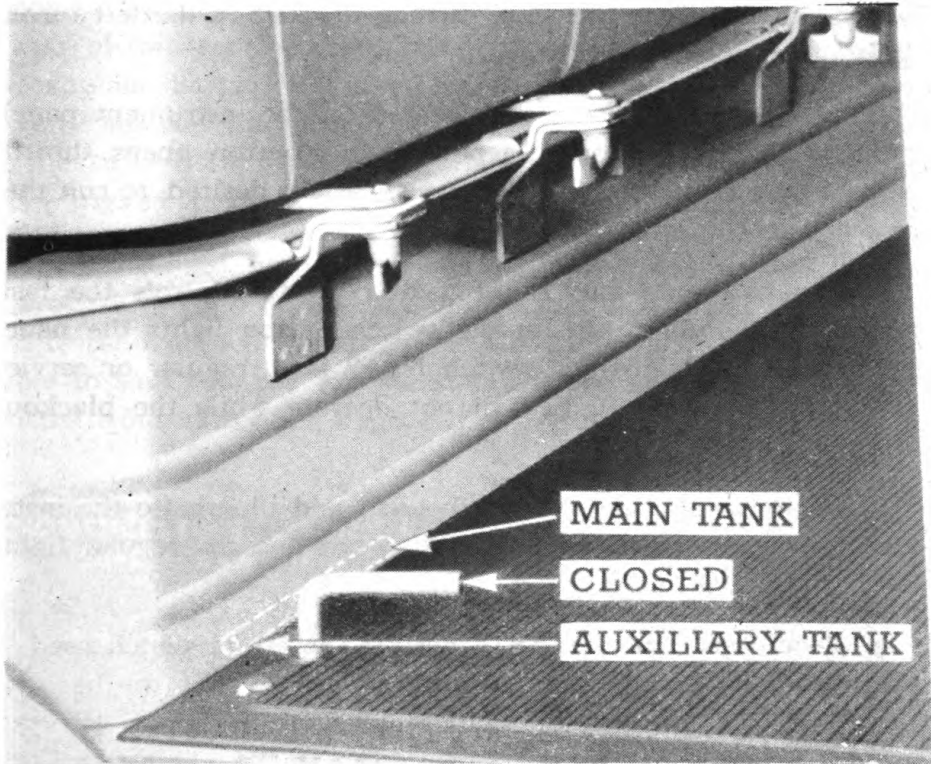

RA PD 32205

Figure 5—Gasoline Tank Selector Lever

h. **Ammeter No. 6** is used to indicate whether the battery is being charged or discharged when the vehicle is in operation. If the ammeter shows discharge at all times, the cause should be investigated and corrected; otherwise the battery will be discharged.

i. **Lighting Switch No. 7** controls the lighting circuits. When the lighting switch is pulled out to the first position, it turns on the blackout head lamps and taillight and, in addition, this position permits turning on the blackout stop lamp when the brakes are applied. To turn on the regular headlights, depress the blackout button on top of the switch and pull the control button out to the second position. In this position, circuits are established to the regular tail and stop lights. When the lighting switch button is pulled out to the third position, it closes circuits for the service stop light during daylight driving.

j. **Carburetor Choke Control No. 8** is used when starting a cold engine. Pulling out this control button shuts off the air to the carburetor

BOMB SERVICE TRUCK M6 (Chevrolet)

providing a rich mixture. The choke button should be pushed in when the engine starts. If the engine is warm, the use of the choke is unnecessary.

k. Ignition Switch No. 9 is operated by turning the ignition switch key. Turning the key to the right turns on the ignition by closing the ignition primary circuit, while turning the key to the left turns off the ignition by opening the primary circuit.

l. Hand Throttle No. 10 is located on the instrument panel to the right of the ignition switch; pulling this button opens throttle. This control may be used when starting or, if it is desired, to run the engine at a constant speed.

m. Instrument Panel Light Switch No. 11 controls the instrument panel lights. Pulling out on the switch button lights the panel lights only when the main light switch No. 7 is in regular or service lights position. The panel lights will not operate while the blackout lights are on.

n. Panel Lights No. 12 are hooded and illuminate the instruments when the panel light switch is pulled out and the regular light switch is in service light position.

o. Headlight Dimmer Switch No. 13 is a foot switch used to select the headlight beam (upper or lower) desired after the headlights are turned on, by depressing the switch button with the foot. Always use the lower beam when passing approaching vehicles. This is an important highway safety rule.

p. Clutch Pedal No. 14 is used to disengage the engine from the transmission when shifting gears. The clutch should never be engaged quickly when the vehicle is in gear. Driving with foot on pedal will cause wear of clutch facings and throw out bearing. There should be one inch of free travel of the clutch pedal before the clutch starts to disengage.

q. Brake Pedal No. 15. Pressing on the brake pedal applies the hydraulic brakes at all four wheels and also operates the electric brake control unit for the trailer brakes.

r. Accelerator No. 16 is used in driving to control the speed of the engine.

s. Starter Switch Pedal No. 17. Pressing down on pedal with foot engages the starter and flywheel gears and also closes the starter switch, completing the electrical circuit between battery and starter. Rotation of starter cranks the engine. When the engine starts, the foot should be removed from pedal immediately.

OPERATION AND CONTROLS

t. **Transmission Gear Shift Lever No. 18** is used to select various gear ratios provided in the transmission. There are four forward speeds and one reverse speed. Reverse gear can only be engaged when latch on gear shift lever is raised. Lever positions for the various gears will be discussed in paragraph 7.

u. **Hand Brake Lever No. 19** is used to control the parking brake at the rear of the transfer case. Pulling the hand brake lever toward the rear applies the parking brake, while pushing it forward releases the brake. Whenever the vehicle is parked, the lever should be pulled toward the rear as far as possible. Before moving the vehicle lever should be pushed forward to the fully released position.

v. **Transfer Case Shifting Lever No. 20** is used to select either high, low or neutral speed ranges in the transfer case. The shifting lever is linked to the front axle control lever No. 21 in such a way that it is impossible to shift into the low speed in the transfer case without the drive to the front axle being engaged.

NOMENCLATURE: 1½-TON 4x4 BOMB SERVICE TRUCK M-6 SUPPLY ARM OR SERVICE MAINTAINING TRUCK	
ORDNANCE DEPT. U. S. ARMY	
MAKE AND MODEL—CHEVROLET—1942—67128	
MFG. SERIAL NUMBER	<input type="text"/>
ORDNANCE SERIAL NUMBER	<input type="text"/>
CONTRACT—W-374-ORD.-1281	
GROSS WEIGHT	6990 LBS.
MAXIMUM PAY LOAD AND DRIVER	2000 LBS.
MAXIMUM TRAILED LOAD	14000 LBS.
DATE OF DELIVERY	<input type="text"/>
OCTANE RATING OF GASOLINE	70-72
ENGINE LUBRICATION RECOMMENDED	
WINTER S.A.E. 10, SUMMER S.A.E. 30; FOLLOW INSTRUCTION	
BOOK FOR ALL GENERAL LUBRICATION; ALSO	
FOR EXTREME CLIMATIC CONDITIONS	

RA PD 32206

Figure 6—Identification Plate

w. **Front Axle Control Lever No. 21** permits engaging or disengaging the front axle drive through the transfer case. When the lever is pushed forward, the front drive is engaged, and when it is pulled toward

BOMB SERVICE TRUCK M6 (Chevrolet)

the rear, it is disengaged. NOTE: The front axle drive should be disengaged when operating on hard-surfaced roads.

x. **Trailer Electric Brake Load Control No. 22.** An electrical control unit for trailer brakes is actuated by the brake foot pedal No. 15 and operates in conjunction with the regular service brakes. The load control unit No. 22 has four positions for light, medium, medium-heavy and heavy loads designated by numbers 1, 2, 3 and 4. If the load on the trailer is light, the load control should be set at No. 1; if the load is heavy, the control should be set at No. 4. In other words, the load control should be set in accordance with the weight of the load on the trailer.

y. **Serial Number and Load Data Plate No. 23.** This plate gives the serial number of the truck and the load data. Figure 6 illustrates a sample of the serial number and load data plate.

z. **Maximum Permissible Road Speeds Plate No. 24.** This plate gives the maximum permissible road speeds at which the vehicle shall be driven in the various gear positions with the transfer case in high or low gear. Figure 7 shows an enlarged view of this plate.

TRANSMISSION IN	TRANSFER CASE IN	
	HIGH RANGE	LOW RANGE
DIRECT	48	24
THIRD	28	14
SECOND	14	7
FIRST	6	3
REVERSE	6	3

RA PD 32207

Figure 7—Road Speed Plate

aa. **Glove Compartment Lock No. 25.** Pressing in on center of glove compartment knob with the lock unlocked releases the glove compartment door latch and permits opening the door. The glove compartment door may be locked with the key supplied with the vehicle.

OPERATION AND CONTROLS

ab. **Cooling System Draining Caution Plate No. 26** gives the driver important instructions regarding draining the cooling system.

ac. **Gas Tank Valve Control Plate No. 27** indicates the position in which the gasoline tank control valve should be according to whether fuel is to be drawn from the main tank or the auxiliary tank. The fuel gage gas tank selector switch No. 3 should be placed in position corresponding to the tank being used.

ad. **Shifting Diagram Plate No. 28** and also figure 8 give the driver instructions on the various shifting lever positions.

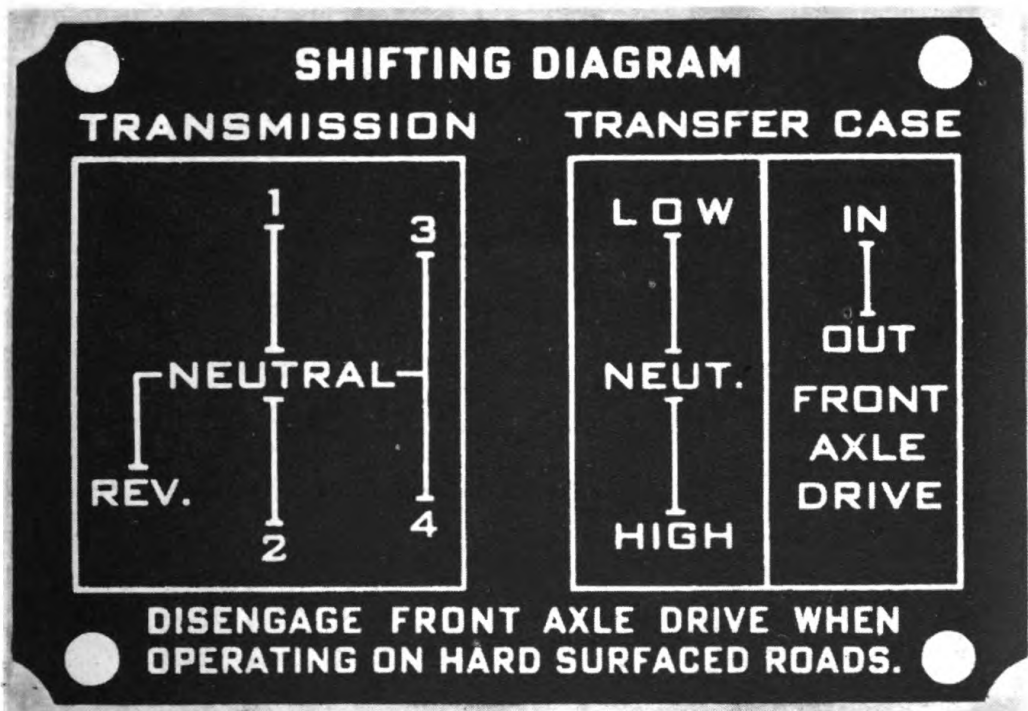

RA PD 32208

Figure 8—Shifting Diagram

ae. **Ventilator Control Lever No. 29** is used to open and close the cowl ventilator. Pushing the lever forward opens the ventilator, while pulling it toward the rear closes the ventilator.

af. **Windshield Wiper Switches No. 1** (fig. 9), are used to turn the windshield wipers on and off. The further out these switches are pulled the faster the wiper blades operate.

BOMB SERVICE TRUCK M6 (Chevrolet)

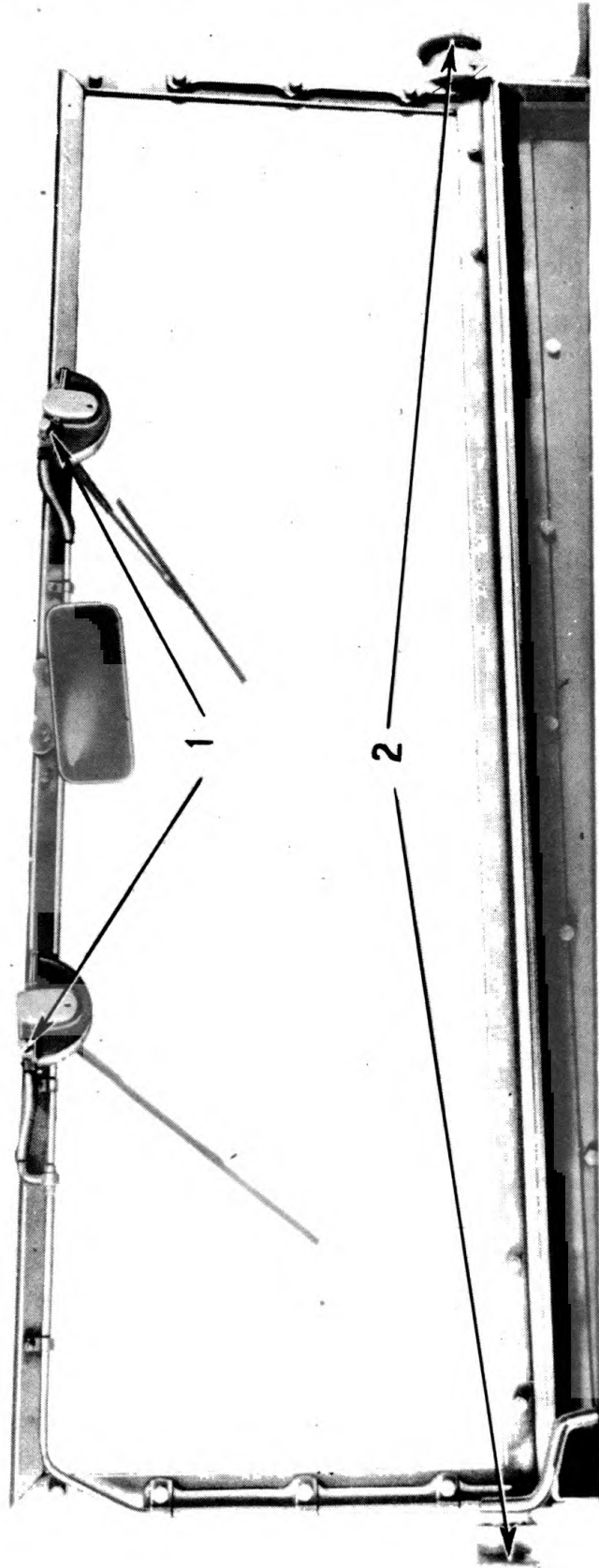

RA PD 32209

Figure 9 – Windshield and Wiper Controls

OPERATION AND CONTROLS

ag. **Windshield Quadrant Clamp Screws No. 2** (fig. 9) are used to clamp the windshield in position. Loosening these screws will permit laying the windshield down horizontally over hood of truck.

ah. **Water Bypass Shut-off Cock.** The water bypass shut-off cock (fig. 10) is located between the water temperature indicator adapter and the steam relief tube leading to the radiator, and should be kept closed except when the air temperature is above 60 degrees and the truck is operating on extreme grades. The purpose of this shut-off cock is to prevent the cooling liquid from bypassing the thermostat under cold operating conditions and thereby preventing proper operating temperature of the engine being maintained. A metal caution tag wired to the shut-off cock reads as follows: "This shut-off cock is to be kept closed. Open only when operating in air temperatures above 60 F on extreme grades."

5. PRESTARTING INSPECTION.

Before the engine is started, the prestarting inspection outlined in section III must be performed.

6. STARTING THE ENGINE.

- a. Place transmission in neutral. See shifting diagram plate.
- b. Pull hand throttle out about $\frac{3}{8}$ inch.
- c. Insert ignition key and turn to "on" position.
- d. Pull out on choke button to obtain correct mixture. In warm weather or with a warm engine this may not be necessary.
- e. Step on starter pedal to crank engine; release pedal as soon as engine starts.
- f. Push in on choke and hand throttle to obtain a smooth idling speed. In cold weather the engine should run several minutes before attempting to move the vehicle or run the engine at high speed.
- g. Make sure oil gage and ammeter register normal conditions.
- h. When starting a cold engine, it will be noted that the oil pressure gage on the instrument panel will register a high oil pressure. As the engine warms up, the pressure will drop until it reaches a point where changes to higher speeds will raise the pressure very little if at all.
- i. If the oil pressure registers abnormally high after the engine is thoroughly warmed up, an inspection should be made to ascertain whether the oil lines and passages are plugged.

BOMB SERVICE TRUCK M6 (Chevrolet)

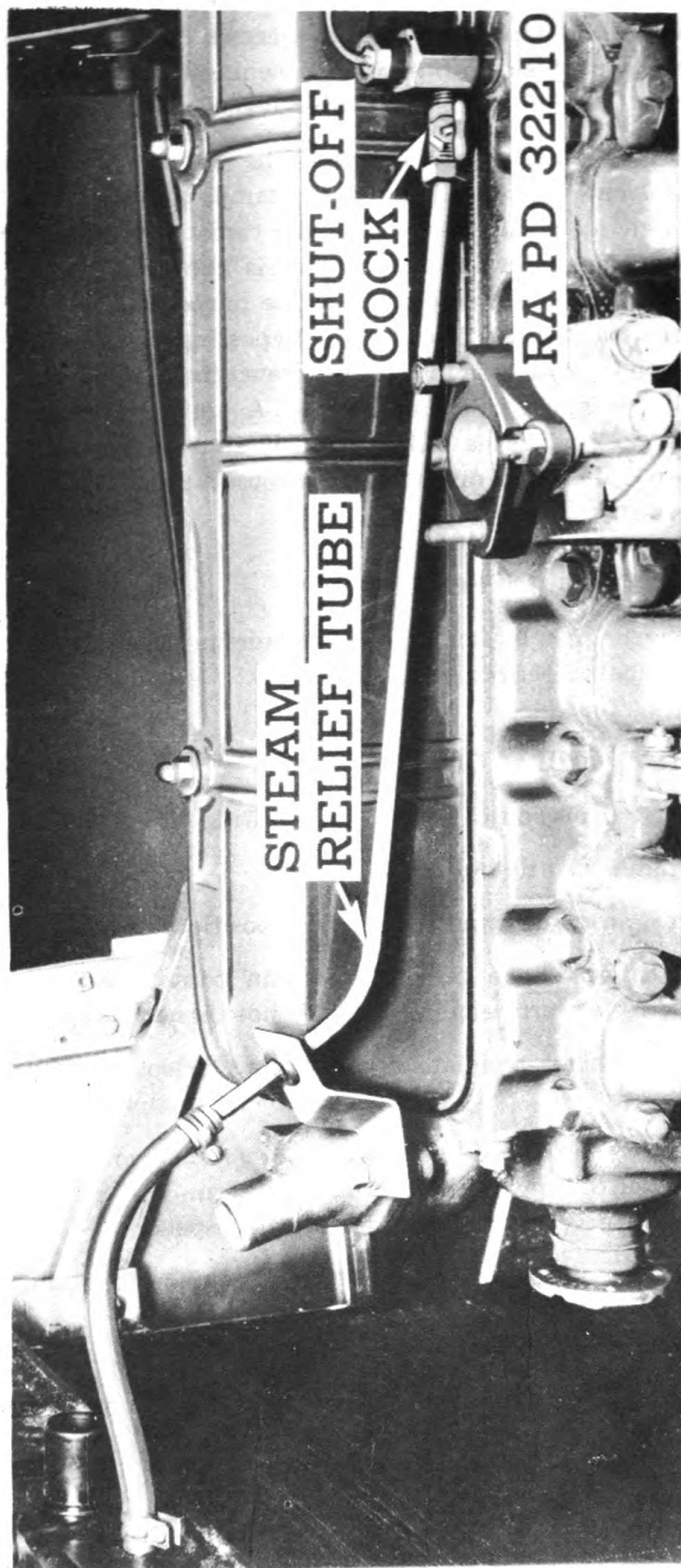

Figure 10—Steam Relief Tube

OPERATION AND CONTROLS**7. OPERATING THE VEHICLE.****a. Starting the Truck.**

- (1) Push clutch pedal downward to disengage the clutch.
- (2) Shift transfer lever into either high or low speed position. See shifting diagram plate.
- (3) Move transmission gear shift lever to the left and forward into first gear position.
- (4) Release the hand brake lever.
- (5) Step down on accelerator pedal to speed up the engine. Engage clutch slowly and push accelerator pedal down as necessary to pick up the load and prevent stalling the engine as the truck starts to move.
- (6) As truck speed increases, release accelerator pedal, depress the clutch pedal, move the gear shift lever to neutral and then to the next higher speed. Step down on accelerator and engage clutch as explained above. Repeat this operation until transmission is in high gear.

b. Shifting Front Axle Drive Gears in Transfer Case.

- (1) The transfer case may be operated in either high or low speed range when the front axle is engaged, but cannot be operated in low speed range when the front axle is disengaged.
- (2) To engage the front axle, first, shift the transfer case into neutral, then engage the front axle by moving front axle shift lever forward. Then place the transfer case shifting lever in the high or low speed position.
- (3) To disengage the front axle, shift the transfer case into neutral, then disengage the front axle by moving front axle shift lever toward the rear.

c. Shifting Transfer Case from High to Low Speed.

- (1) This shift should not be attempted except when the vehicle is being operated at low speeds or at a standstill. Front axle must be engaged for this shift.
- (2) Depress the clutch pedal and move transfer case shift lever to neutral position.
- (3) Engage clutch pedal and accelerate engine to approximately twice that of vehicle speed.
- (4) Depress clutch pedal again and move shift lever forward (without applying excessive pressure) into low speed position. Then release clutch and accelerate engine.

BOMB SERVICE TRUCK M6 (Chevrolet)

(5) This method of shifting is termed double-clutching. A little practice will enable driver to make shift smoothly and efficiently.

d. Shifting Transfer Case from Low to High Speed.

(1) This shift may be accomplished at any time, regardless of vehicle speed.

(2) Release accelerator, depress clutch pedal and move shift lever to neutral position.

(3) Release clutch pedal and accelerate engine to synchronize engine speed with that of vehicle.

(4) Depress clutch pedal and move shift lever toward rear into high speed position.

e. Shifting to Lower Speed in Transmission.

(1) The transmission should always be shifted to the next lower speed before engine begins to labor or before vehicle speed is reduced appreciably. Shifting to lower speed is accomplished as follows:

(2) Depress the clutch pedal quickly, maintaining the same pressure on accelerator. Move gear shift lever to neutral and at the same instant engage the clutch.

(3) Again depress the clutch pedal and move the gear shift lever to the next lower speed. Engage the clutch slowly and at the same time accelerate the engine speed to synchronize it with that of the vehicle.

(4) It is advisable to use the same transmission gear going downhill as would be required to climb the same hill. This is a safety rule followed by all good drivers in hilly territory.

f. Shifting into Reverse.

(1) Before attempting to shift into reverse, the truck must be brought to a complete stop.

(2) Push clutch pedal downward to disengage clutch.

(3) Raise latch on gear shift lever and move lever to left as far as possible, then toward the rear. See shifting diagram plate.

(4) Engage clutch and accelerate the engine in the same manner as previously explained in paragraph 7 a.

g. Stopping the Truck.

(1) With trailer electric brake load control on the instrument panel set in proper position according to trailer load, remove foot from accelerator pedal and apply brakes by pressing down on foot pedal.

(2) When speed of truck has been reduced to idling speed of engine, disengage the clutch and move transmission gear shift lever into neutral position.

(3) When truck has come to a complete stop, release clutch pedal.

Section III

INSPECTION

	Paragraph
Purpose	8
Prestarting inspection	9
Inspection during operation	10
Inspection at the halt	11
Inspection daily after operation	12
Periodic inspection every 1000 miles of operation	13
Periodic inspection after 6000 miles of operation	14

8. PURPOSE.

a. To insure mechanical efficiency and normal service, it is necessary that motor vehicles be systematically inspected at regular intervals in order that the necessary tightening and adjustments or repairs be made before they result in serious damage.

b. Information or suggestions regarding design which might affect durability, efficiency and economy, or the safety and comfort of the operator, should be forwarded to the office of the Chief of Ordnance through proper channels. Such action is encouraged in order that improvements can be made on vehicles in the future.

9. PRESTARTING INSPECTION.

a. Before starting, check the crankcase oil level with the dip stick. If oil level is down to the low mark, add oil.

b. Check cooling system solution. Add water or antifreeze as required.

c. Check hose connections for leaks. Tighten if necessary.

d. Check fan belt for correct tension. If necessary, adjust according to instructions in section XVI.

e. Check tire inflation. Inflate to 55 pounds.

f. Check fuel supply. Replenish if necessary.

g. Check clutch pedal for normal free travel of 1 inch to 1¼ inches. If necessary adjust according to instructions in paragraph 67.

h. Check brake condition by depressing pedal, making sure that it does not go more than half way to floor. If necessary, adjust according to instructions in paragraph 54.

BOMB SERVICE TRUCK M6 (Chevrolet)

- i. Check horn. If it fails to blow, the necessary repairs should be made.
- j. Check lights. Any troubles should be repaired according to instructions in section **XX**.
- k. Check to see that fire extinguisher is in place.
- l. Check tools. Shortages should be reported and replacement made

10. INSPECTION DURING OPERATION.

- a. The driver should always be alert to detect any abnormal conditions in the operation of the vehicle. Any indications of trouble should be investigated and corrected before proceeding.
- b. Watch the temperature indicator for signs of overheating.
- c. Watch the oil gage to make sure that the oil pump is working.
- d. Note the ammeter reading for electrical charging rate.
- e. Occasionally check the supply of gas in the main and auxiliary tanks.

11. INSPECTION AT THE HALT.

- a. Check for oil or gas leaks and make the necessary corrections.
- b. Check amount of solution in cooling system. Add water or anti-freeze as required.
- c. Check oil level in motor. Add oil if down to "add oil" mark.
- d. Check tires. Inflate to 55 pounds.
- e. Clean windshield and headlights.

12. INSPECTION DAILY AFTER OPERATION.

- a. These inspections should be made at the end of a run in order that the vehicle can be put in condition and ready for use in the least possible time.
- b. Check hand and service brake condition. Report, if repairs or adjustment are required.
- c. Check the engine for smooth idling and any abnormal noises at different engine speeds. Report any abnormal condition.
- d. Check operation of windshield wipers. Report any trouble.

INSPECTION

- e. Check to see that fire extinguisher is in place. If it has been used, it should be replaced or refilled.
- f. Check horn. Report any trouble to service personnel.
- g. Check lights: head, tail, stop and blackout. If any repairs are required, report to service personnel.
- h. Check and tighten wheel and axle flange bolts.
- i. Check and tighten steering gear housing to frame bolts.
- j. Check all steering connections. Report any looseness.
- k. Check all tires, including spare. Any damaged tires should be changed or reported.
- l. Check cooling system for leaks. Any leaks should be repaired or reported.
- m. Check fan belt. See paragraph 77 for adjustment instructions.
- n. Check engine oil. Add oil if down to "add oil" mark.
- o. Check for oil leaks. Any leaks should be corrected or reported.
- p. Check for fuel leaks. Any leaks should be corrected or reported.

13. PERIODIC INSPECTION EVERY 1000 MILES OF OPERATION.

- a. Make routine prestarting and halt inspection, and the following:
- b. Check front axle lubricant level. See section IV of this manual.
- c. Check rear axle lubricant level. See section IV of this manual.
- d. Check transfer case lubricant level. See section IV of this manual.
- e. Check transmission lubricant level. See section IV of this manual.
- f. Inspect gas tanks and fuel lines for leaks. If leaks are found, the necessary tightening or repairs should be made.
- g. Check brake lines for fluid leak. It is essential that all leaks be corrected at once.
- h. Check brake master cylinder for sufficient fluid. Add fluid as required.

BOMB SERVICE TRUCK M6 (Chevrolet)

- i. Check brake pedal for excessive travel and adjust brakes if necessary. See paragraph 54.
- j. Check steering gear adjustment. If adjustment is necessary, follow instructions in paragraph 161.
- k. Check steering tie rod and connecting rod ends for correct adjustment and proper locking. If necessary, adjust according to instructions in section **XXIX** of this manual.
- l. Tighten steering gear to frame anchorage.
- m. Tighten wheel to hub bolt nuts.
- n. Tighten axle flange bolts.
- o. Tighten spring to axle U bolts.
- p. Tighten all propeller shaft universal joint U bolt nuts.
- q. Add distilled water to battery.
- r. Test all electrical units and tighten connections. See sections **XVII** to **XX** of this manual.
- s. Road test car.
- t. Tighten transfer case to frame bolts.

14. PERIODIC INSPECTION AFTER 6000 MILES OF OPERATION.

- a. Make all inspections referred to under "Prestarting," "Halt," and "1000 Mile Inspection."
- b. Inspect wheel bearings. Adjust and lubricate if necessary.
- c. Inspect and adjust brakes. See section **XIV** of this manual for instructions.
- d. Inspect and fill shock absorbers. See section **XXVIII**.
- e. Inspect driving units for backlash or looseness. Tighten or repair if necessary.
- f. Tune engine completely. See paragraph 116.
- g. Drain and flush cooling system.
- h. Check electrical system and wiring, and make necessary adjustments.

Section IV

LUBRICATION

	Paragraph
Introduction	15
Schedules	16
Methods	17
Detailed lubrication instructions	18
Records	19

15. INTRODUCTION.

Lubrication is an essential part of preventive maintenance, determining to a great extent the serviceability of parts and assemblies. Lubrication, or the lack of it, influences materially repairs and operations and is one of the most important factors affecting dependable service and useful vehicle life. Vehicles must be lubricated in accordance with the latest lubrication instructions. Refer to the general instruction section (OFSB 6-1) for additional lubrication information and to the Product Guide (OFSB 6-2) for the latest approved lubricants.

16. SCHEDULES.

Lubrication instructions are consolidated and charted in schedules for each make of vehicle. Figures 11 and 12 are lubrication charts for the bomb service truck and bomb lift truck. In general, the chassis and slow-motion parts should be lubricated every seven days or 50 hours of vehicle operation. The crankcase oil should be checked frequently and changed after not more than 1000 miles of operation or more often during prolonged periods of cross-country driving, hard pulls, or idling. Gear lubricants should be checked weekly and changed seasonally, unless operating mileage requires more frequent changes. Severe operating conditions may necessitate immediate action. For detailed information see section VIII. All breathers in housings and gear cases should be examined frequently to check that they are clean and free.

a. Records. A complete record of lubrication will be kept for every vehicle. Responsible personnel will execute a check sheet at regular intervals to indicate the actual mileage and date at which each component received such attention as prescribed.

b. Supplies. Lubricants and application equipment should conform to the recommendations of responsible manufacturers or the supply services concerned. Refer to OFSB 6-2 for the Product Guide. During field service, it may not be possible to supply a complete assortment of lubricants called for by the schedule to meet the recommendations and it will

BOMB SERVICE TRUCK M6 (Chevrolet)

be necessary to make the best use of those available, subject to inspection by the motor officer concerned in consultation with responsible ordnance personnel.

17. METHODS.

Lubricants are applied to vehicles by employing the equipment provided by the Tables of Basic Allowances.

a. Application. Refer to OFSB 6-10 for general automotive lubricating instructions.

b. NOTE: Friction and vibration tend to develop squeaks, groans, and improper fitting of rubber chassis parts, instrument panel accessories, and engine mounts. Lubricants such as mineral oil, castor oil, or greases must not be used by reason of their tending to swell or rot the rubber. A suitable lubricating material can be made by mixing colloidal graphite with ethylene glycol or glycerine, and adding enough water to prevent rapid drying before the solution has penetrated. The solution can be applied with an ordinary spray, but a needle spray will be needed to force the lubricant between parts having close clearance. Rubber parts which are used to keep other parts from slipping or rotating should not be lubricated.

18. DETAILED LUBRICATION INSTRUCTIONS.

a. Manifold Heating Control. Manifold heating control assemblies are automatically operated but the gate valve on the intake manifold requires lubrication every 500 miles. Apply GREASE, graphite, light, to keep hinge from rusting.

b. Front Wheel Bearings. Front wheel bearings must be lubricated at intervals shown on figure 11.

(1) Remove wheel and bearings. Wash bearings and interior of hubs.

(2) Pack GREASE, general purpose, No. 2, into bearings only and replace.

(3) Tighten adjustment nut until wheel binds. Back off nut slightly until wheel spins freely without side play.

(4) Lock nut in place.

c. Rear Wheel Bearings. Rear axle is full floating type and the axle shaft must be removed to adjustment bearings.

(1) Unscrew axle shaft flange stud nuts which hold axle and remove axle, oil seal and retainer.

(2) Release two lock nuts which hold bearings. Remove, wash, dry and pack with GREASE, general purpose, No. 2.

LUBRICATION

(3) Replace bearing and tighten lock nut until wheel binds. Back off nut $\frac{1}{8}$ turn or sufficiently to permit wheel to turn freely without play.

(4) Replace second lock nut, tighten and test adjustment.

d. Bomb Lift Truck. The truck is equipped with eight Oilite bearings, which require periodic attention. Oilite bearings are impregnated with oil at the time of manufacture, but oil must be replenished as it is used.

(1) Oil sparingly every two months.

(2) When truck is disassembled, remove shaft from bearings and wash shaft and bearings in OIL, engine, SAE 10. Permit bearings to absorb all the oil they will take. Do not wipe away surface oil.

e. Bomb Lift Hydraulic Cylinder. Refill every six months with OIL, engine, SAE 10. **CAUTION:** Do not confuse with hydraulic brake equipment. Brake or recoil fluid will damage the bomb lift mechanism.

(1) To refill cylinder, lower platform, remove plug and fill until oil is level with top of panel rod.

(2) To remove cylinder, extract the five cotters and remove the two retaining pins. Tighten cylinder packing nuts at first evidence of leaking.

19. RECORDS.

A complete record of lubrication servicing will be kept for the materiel.

BOMB SERVICE TRUCK M6 (Chevrolet)

**TRUCK, BOMB SERVICE. M6
(CHEVROLET)**

MFR'S. STARTING SERIAL No.—14NQ10-1684. Located on plate on dash.

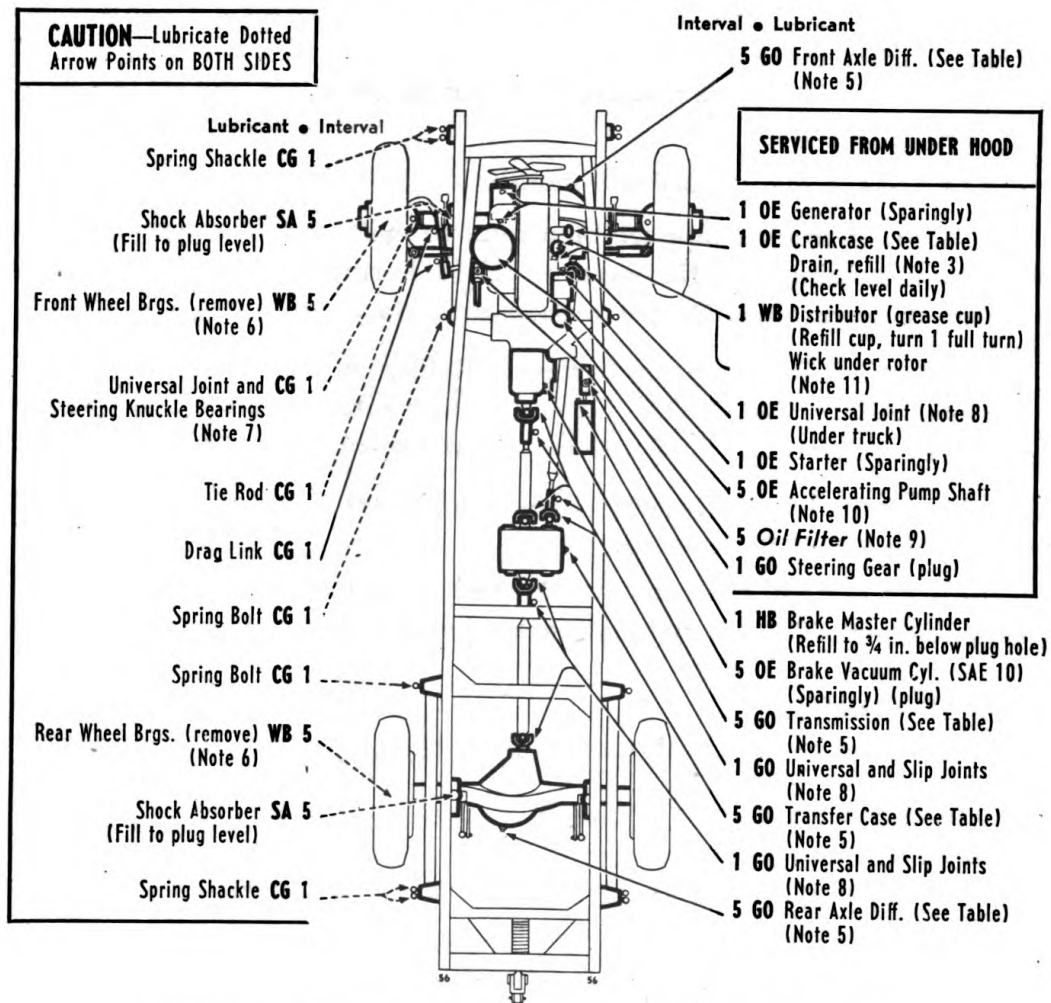

NOTE—See Fig. 12 for lubrication of WINCH and BOMB LIFT TRUCK

KEY

LUBRICANTS	
<p>OE—OIL, Engine Crankcase grade</p> <p>GO—LUBRICANT, Gear, Universal Seasonal grade</p> <p>CG—GREASE, General Purpose No. 1 (above +32°) No. 1 or No. 0 (+32° to +10°) No. 0 (below +10°)</p>	<p>WB—GREASE, General Purpose No. 2</p> <p>HB—FLUID, Brake, Hydraulic</p> <p>SA—SHOCK ABSORBER FLUID, Light</p>

INTERVALS
1—1,000 MILES
5—5,000 MILES
CHECK DAILY
Crankcase
Air Cleaners

RA PD 43319

Figure 11—Lubrication Chart—Chassis

LUBRICATION

MFR'S. STARTING SERIAL No.—14NQ10-1684. Located on plate on dash.

TABLE OF CAPACITIES WITH RECOMMENDATIONS AT TEMPERATURES SHOWN

	Capacity	Above +32°	+32° to +10°	+10° to -10°	BELOW -10°
Crankcase	5 qt	OE SAE 30	OE SAE 30 or 10	OE SAE 10	Refer to OFSB 6-11
Transmission	2¾ qt	GO SAE 90	GO SAE 90 or 80	GO SAE 80	
Differential (front)	6¾ qt				
Differential (rear)	7 qt				
Transfer Case	2 qt				

NOTES Additional Lubrication and Service Instructions on individual Units and Parts NOTES

COLD WEATHER: For Lubrication and Service below -10°, refer to OFSB 6-11.

- FITTINGS**—Clean before applying lubricant. Lubricate until new grease is forced from the bearing. **CAUTION:** Lubricate chassis points after washing truck.
- AIR CLEANERS**—(Engine) Check level and refill oil cup to bead level daily with O.E. Drain, clean and refill every 100 to 1000 miles, depending on operating conditions. Every 2000 miles, also remove air cleaner and wash all parts. (Brake Vacuum Cylinder) Every 6 months, wash curled hair, dry and oil with OE.
- CRANKCASE**—Drain only when engine is hot. Refill to FULL mark on gage. Run engine a few minutes and recheck oil level. **CAUTION:** Be sure pressure gage indicates oil is circulating. See Table.
- INTERVALS** indicated are for normal service. For extreme conditions of speed, heat, water, mud, snow, rough roads, dust, etc., change crankcase oil and lubricate more frequently.
- GEAR CASES** — Check level every 1000 miles, add lubricant if necessary. Check with truck on level ground. Drain, flush and refill at end of first 1000 miles; thereafter as indicated at points on guide. When draining, drain immediately after operation.
- WHEEL BEARINGS** (Front and rear) —Remove wheel, clean and repack bearings.
- UNIVERSAL JOINTS** (Front wheels) —Remove level plug in rear of joint and fill through fitting, located on bottom of joint housing, to level of plug opening.
- UNIVERSAL JOINTS AND SLIP JOINTS**—Apply lubricant to joint until it overflows at relief valve, and to slip joint until lubricant is forced from end of slip joint.
- OIL FILTER** — Remove drain plug every 1000 miles to drain water or sludge. Renew filter element every 5000 miles or when oil becomes dirty. After renewing element, refill crankcase to FULL mark on gage. Run engine a few minutes and recheck oil level.
- ACCELERATING PUMP SHAFT**— Remove air cleaner so carburetor is accessible. Remove cover and saturate felt ring on carburetor pump lever shaft.
- DISTRIBUTOR** — Wipe distributor breaker cam lightly with CG and lubricate breaker arm pivot with OE sparingly every 1000 miles.
- OIL CAN POINTS**—Lubricate throttle and spark control rod ends, clevises, hinges, latches and pintle with OE every 1000 miles.
- POINTS REQUIRING NO LUBRICATION** — Springs, Shock Absorber Links, Fan, Water Pump, Pedal Shaft, Clutch Pilot Bearing.
- POINTS TO BE LUBRICATED BY ORDNANCE MAINTENANCE PERSONNEL**—Clutch Release Bearing.

RA PD 43319A

Nomenclature for Figure 11—Lubrication Chart—Chassis

BOMB SERVICE TRUCK M6 (Chevrolet)

**WINCH AND BOMB LIFT TRUCK
(CHEVROLET)**

TRUCK STARTING SERIAL No.—14NQ10-1684. Located on plate on dash.

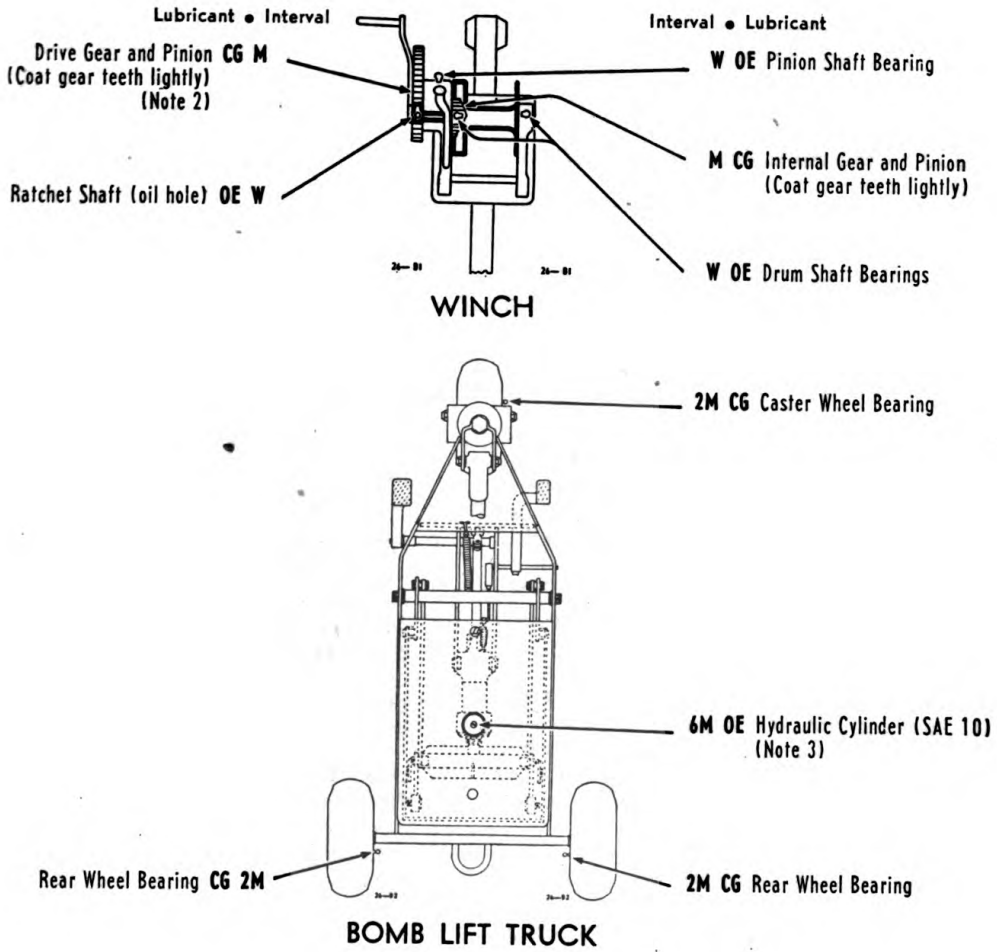

NOTE—See Fig. 11 for lubrication of TRUCK

KEY

LUBRICANTS	
OE —OIL, Engine Crankcase grade	CG —GREASE, General Purpose No. 1 (above +32°) No. 1 or No. 0 (+32° to +10°) No. 0 (below +10°)

INTERVALS
W —WEEKLY
M —MONTHLY
2M —2 MONTHS
6M —6 MONTHS

RA PD 43320

Figure 12—Lubrication Chart—Winch and Bomb Lift

LUBRICATION

MFR'S. STARTING SERIAL NO.—14NQ10-1684. Located on plate on dash.

NOTES Additional Lubrication and Service Instructions on Individual Units and Parts NOTES

COLD WEATHER: For Lubrication and Service below—10°, refer to OFSB 6-11.

1. FITTINGS—Clean before applying lubricant. Lubricate until new grease is forced from the bearing. CAUTION: Lubricate after washing truck.
2. DRIVE GEAR AND PINION—Remove hand crank shaft by removing cotter pin in shaft lock pin, clean and coat with CG monthly.
3. HYDRAULIC CYLINDER—With platform in lowered position, remove fill plug and fill hydraulic cylinder with OE SAE 10 until oil is level with top of piston rod.
4. OIL CAN POINTS—Lubricate bomb lift truck handle bearings, hydraulic jack pedal shaft bearings, lift clevises and linkage, with OE every 2 months, and winch support beam sheaves with OE weekly.
5. POINTS REQUIRING NO LUBRICATION—Caster Pivot Bearing.

RA PD 43320A

Nomenclature for Figure 12—Lubrication Chart—Winch and Bomb Lift

BOMB SERVICE TRUCK M6 (Chevrolet)

Section V

GENERAL CARE AND PRESERVATION

	Paragraph
Records	20
Cleaning	21

20. RECORDS.

a. **Use.** An accurate record must be kept of each motor vehicle issued by the Ordnance Department. For this purpose the Ordnance Motor Book (O. O. Form No. 7255), generally called "Log Book," is issued with each vehicle and must accompany it at all times. This book furnishes a complete record of the vehicle, from which valuable information concerning operation and maintenance costs, etc., are obtained, and organization commanders must insist that correct entries are made. This book will habitually be kept in a canvas cover to prevent its being injured or soiled.

b. The page bearing a record of assignment must be destroyed prior to entering the combat zone. All other reference which may be posted regarding the identity of the organization must also be deleted.

21. CLEANING.

a. Grit, dirt, and mud are the sources of greatest wear to a vehicle. If deposits of dirt and grit are allowed to accumulate, particles will soon find their way into bearing surfaces, causing unnecessary wear, and if the condition is not remedied, will soon cause serious difficulty. When removing engine parts or any other units, in making repairs and replacements, or if in the course of inspection working joints or bearing surfaces are to be exposed, all dirt and grit that might find its way to the exposed surfaces must first be carefully removed. The tools must be clean, and care must always be taken to eliminate the possibilities of brushing dirt or grit into the opening with the sleeve or other part of the clothing. To cut oil-soaked dirt and grit, hardened grit, or road oil, use SOLVENT, dry cleaning, applied with rags (not waste) or a brush. The vehicle is so designed that the possibility of interfering with its proper operation by careless application of cleaning water is very small. However, care should be taken to keep water from the power unit, as it might interfere with proper ignition and carburetion.

b. Oil holes which have become clogged should be opened with a piece of wire. Wood should never be used for this purpose, as splinters are likely to break off and permanently clog the passages. Particular care should be taken to clean and decontaminate vehicles that have been caught in a gas attack. See section IX for details of this operation.

Section VI

PAINTING

	Paragraph
General	22
Preparing for painting	23
Painting metal surfaces	24
Paint as a camouflage	25
Removing paint	26
Painting lubricating devices	27

22. GENERAL.

a. Ordnance materiel is painted before issue to the using arms, and one maintenance coat per year will ordinarily be ample for protection. With but few exceptions this materiel will be painted with **ENAMEL**, synthetic, olive drab, lusterless. The enamel may be applied over old coats of long oil enamel and oil paint previously issued by the Ordnance Department if the old coat is in satisfactory condition for repainting.

b. Paints and enamels are usually issued ready for use and are applied by brush or spray. They may be brushed on satisfactorily when used unthinned in the original package consistency or when thinned no more than 5 percent by volume with **THINNER**. The enamel will spray satisfactorily when thinned with 15 percent by volume of **THINNER**. (Linseed oil must not be used as a thinner since it will impart a luster not desired in this enamel.) If sprayed, it dries hard enough for repainting within 1/2 hour and dries hard in 16 hours.

c. Certain exceptions to the regulations concerning painting exist. Items which require a crystalline finish will not be painted with **ENAMEL**, olive drab.

d. Complete information on painting is contained in **TM 9-850**.

23. PREPARING FOR PAINTING.

a. If the base coat on the materiel is in poor condition, it is more desirable to strip the old paint from the surface than to use sanding and touchup methods. After stripping, it will then be necessary to apply a primer coat.

b. **PRIMER**, ground, synthetic, should be used on wood as a base coat for synthetic enamel. It may be applied either by brushing or spraying. It will brush satisfactorily as received or after the addition of not more

BOMB SERVICE TRUCK M6 (Chevrolet)

than 5 percent by volume of **THINNER**. It will be dry enough to touch in 30 minutes and hard in 5 to 7 hours. For spraying, it may be thinned with not more than 15 percent by volume of **THINNER**. Lacquers must not be applied to the **PRIMER**, ground, synthetic, within less than 48 hours.

c. **PRIMER**, synthetic, rust inhibiting, for bare metal, should be used on metal as a base coat. Its use and application is similar to that outlined in paragraph b above.

d. The success of a job of painting depends partly on the selection of a suitable paint, but also largely upon the care used in preparing the surface prior to painting. All parts to be painted should be free from rust, dirt, grease, kerosene, oil, and alkali, and must be dry.

24. PAINTING METAL SURFACES.

If metal parts are in need of cleaning, they should be washed in a liquid solution consisting of half pound of **SODA ASH** in 8 quarts of warm water, or an equivalent solution, and then rinsed in clear water and wiped thoroughly dry. Wood parts in need of cleaning should be treated in the same manner, but the alkaline solution must not be left on for more than a few minutes and the surfaces should be wiped dry as soon as they are washed clean. When automotive equipment is in fair condition and only marred in spots, the bad places should be touched with **ENAMEL**, synthetic, olive drab, lusterless, and permitted to dry. The whole surface will then be sandpapered with **PAPER**, flint, No. 1, and a finish coat of **ENAMEL**, synthetic, olive drab, lusterless, applied and allowed to dry thoroughly before the materiel is used. If the equipment is in bad condition, all parts should be thoroughly sanded with **PAPER**, flint, No. 2, or equivalent, given a coat of **PRIMER**, ground, synthetic, and permitted to dry for at least 16 hours. They will then be sandpapered with **PAPER**, flint, No. 00, wiped free from dust and dirt, and final coat of **ENAMEL**, synthetic, olive drab, lusterless, applied and allowed to dry thoroughly before the materiel is used.

25. PAINT AS A CAMOUFLAGE.

Camouflage is now a major consideration in painting ordnance vehicles, with rust prevention secondary. The camouflage plan at present employed utilizes three factors: Color, gloss and stenciling.

a. **Color.** Vehicles are painted with **ENAMEL**, synthetic, olive drab, lusterless, which was chosen to blend in reasonably well with the average landscape.

PAINING

26. REMOVING PAINT.

After repeated paintings, the paint may become so thick as to crack and scale off in places, presenting an unsightly appearance. If such is the case, remove the old paint by use of a lime-and-lye solution (see TM 9-850 for details) or **REMOVER**, paint and varnish. It is important that every trace of lye or other paint remover be completely rinsed off and that the equipment be perfectly dry before repainting is attempted. It is preferable that the use of lye solutions be limited to iron or steel parts. If used on wood, the lye solution must not be allowed to remain on the surface for more than a minute before being thoroughly rinsed off and the surface wiped dry with rags. Crevices or cracks in wood should be filled with putty and the wood sandpapered before refinishing. The surfaces thus prepared should be painted according to directions in paragraph 23.

27. PAINTING LUBRICATING DEVICES.

Oil cups, grease fittings, oil holes, and similar lubricating devices, as well as a circle about three-fourths of an inch in diameter at each point of lubrication will be painted with **ENAMEL**, red, water resisting, in order that they may be readily located.

BOMB SERVICE TRUCK M6 (Chevrolet)

Section VII

TOOLS AND EQUIPMENT ON VEHICLE

	Paragraph
Equipment furnished	28
Care of equipment	29

28. EQUIPMENT FURNISHED.

The items listed below are furnished and will be found in the tool box on the left running board or the tool box on the platform directly behind the driver's seat unless otherwise noted:

- | | |
|----------------------------------|---|
| Bag, tool | Screwdriver, $\frac{5}{16}$ -in. |
| Box, tool, assembly | Screwdriver, 6-in. |
| Can, oil | Wrench, adjustable, 11-in. |
| Chain, tire, assembly | Wrench, open-end, adjustable, 8-in. (Crescent type) |
| Crank, starting | Wrench, double, open-end, $\frac{3}{8} \times \frac{7}{16}$ -in. |
| Gun, lubrication extension | Wrench, double, open-end, $\frac{1}{2} \times \frac{1}{3} \frac{9}{2}$ -in. |
| Gun, lubrication, type C | Wrench, double, open-end, $\frac{9}{16} \times \frac{1}{4}$ -in. |
| Hammer, ball peen, 16-oz. | Wrench, double, open-end, $\frac{5}{8} \times \frac{2}{3} \frac{5}{2}$ -in. |
| Handle, auto jack | Wrench, double, open-end, $\frac{3}{4} \times \frac{7}{8}$ -in. |
| Handle, wheel bearing nut wrench | Wrench, spark plug |
| Handle, wheel wrench | Wrench, wheel |
| Iron, tire changing | Wrench, wheel bearing nut |
| Jack, auto assembly | |
| Padlock & chain assembly (2) | |
| Pliers, combination, 16-in. | |
| Screwdriver, $\frac{3}{2}$ -in. | |
| Screwdriver, $\frac{1}{4}$ -in. | |

29. CARE OF EQUIPMENT.

An accurate record of all tools and accessories should be kept in order that their location and condition may be known at all times. Items which have been lost or rendered unserviceable should be replaced immediately. Clean all tools and equipment, condition (if necessary), and treat against rust or deterioration, before returning them to their location.

Section VIII

OPERATIONS UNDER UNUSUAL CONDITIONS

	Paragraph
Cold weather operation	30
High temperature operation	30A

30. COLD WEATHER OPERATION.

a. The operation and maintenance of automotive vehicles at low temperatures involve factors which do not exist at normal temperatures. Operators and maintenance personnel must spend more time in protective maintenance. Failure to give this extra service will result in actual damage, unnecessary and untold expenses, and also failure to start.

b. "Low temperatures" have been divided into 2 ranges: -10 F to -30 F, and below -30 F. Engine and lubricants undergo changes in physical properties below -30 F. In many cases, accessories, equipment for supplying heat to engine, fuel and intake air are required.

c. The following is a list of things that the operator should be familiar with before operating a vehicle in cold weather.

(1) **GASOLINE.** The formation of ice crystals from small quantities of water in the fuel sometimes causes considerable trouble. The following precautions should be followed to keep water out of the fuel tank:

(a) Strain gasoline through a suitable strainer. **CAUTION:** a positive metallic contact must be maintained between the fuel container and gasoline tank unless fuel tank and container are independently grounded.

(b) Keep fuel tank as full as possible.

(c) Add ½ pint of denatured alcohol to a tank of gasoline to absorb moisture that might condense.

(d) Store gasoline in clean drums.

(e) Never pump gasoline drums dry: allow about 4 inches of fuel to remain.

(2) **CRANKCASE OIL.** Engine lubrication at temperature above -10 F is covered in section IV of this manual and in the lubrication guide. For temperatures below -10 F, one of the following measures must be taken according to facilities available:

BOMB SERVICE TRUCK M6 (Chevrolet)

(a) Keep vehicle in heated inclosure, if possible, when it is not being operated.

(b) When the engine is stopped, drain the crankcase oil while it is still hot and store it in a warm place until vehicle is to be operated again. If a warm place is not available, heat the oil before putting it in the crankcase. (Do not get the oil too hot. Heat only to a point where the bare hand can be inserted without burning.) **TAG THE VEHICLE IN A CONSPICUOUS PLACE IN THE CAB TO WARN PERSONNEL THAT THE CRANKCASE IS EMPTY.**

(c) Cover the engine with a tarpaulin. About three hours before the engine is to be started place fire pots under the tarpaulin. A Van Prag, Primus type, or other types of blow torches or kerosene lanterns may be used. With due consideration for fire hazards involved, the flame may be applied direct to the oil pan.

(d) Dilute crankcase oil with gasoline. The table below shows the quantities of diluent to be added to the oil prescribed on the lubrication guides for use at -10 F. The quantities of diluents will form mixtures for satisfactory starting at temperatures indicated.

	-10 F to -30 F	Below -30 F
Gasoline	½ qt to each 4½ qt of engine oil	1 qt to each 5 qt of engine oil

1 When the crankcase oil is first diluted, turn the engine over several times to mix oil and diluent thoroughly.

2 Check oil level frequently.

(3) **COOLING WATER.**

(a) Ethylene glycol (Prestone) is prescribed for use as antifreeze solution. If ethylene glycol is not available, other materials may be used. The following table gives three permissible materials and the quantity to be added to prevent freezing at indicated temperatures.

OPERATIONS UNDER UNUSUAL CONDITIONS

Freezing Point	Pints Ethylene Glycol (Prestone) Per gallon of System Capacity	Pints Glycerine Grade A, U.S.P. Per gallon of System Capacity	Pints Denatured Alcohol Per gallon of System Capacity
10 F	2	3	2½
0 F	2½	3½	3
-10 F	3	3½	3½
-20 F	3½	4	4
-30 F	4	5	5
-40 F	4½	—	5½
-50 F	4½	—	6
-60 F	5	—	6½
-70 F	5	—	—

(b) Precautions.

- 1 Do not use alcohol if other materials are available.
- 2 Flush out the radiator and cylinder head separately before adding antifreeze material.
- 3 Do not mix antifreeze solutions.
- 4 Check cooling system for leaks.
- 5 If hot water heater is added to cooling system, add about one gallon to the original volume of the cooling system.
- 6 Check thermostat.
- 7 Use radiator cover to accelerate and maintain engine operating temperatures.
- 8 Check adjustment and weakness of fan belt. Replace rubber fan belt with fiber, leather or synthetic belts below -20 F.
- 9 Make sure that water pump is in good operating condition.

(4) BATTERY AND ALL ELECTRICAL PARTS.

(a) Keep battery fully charged with hydrometer reading between 1.275 and 1.300. A fully discharged battery will freeze and rupture at 5 F.

(b) Clean and repair all electrical wiring accessories (spark plugs, ignition coil and distributor) to prevent undue resistance. Make sure all connections are tight.

(c) Set spark plug gap 0.005 inch less than that recommended for operation under normal conditions.

BOMB SERVICE TRUCK M6 (Chevrolet)

(d) Check generator, starter brushes, commutators and bearings. See that the commutators and brushes are clean.

(e) Be sure that no heavy grease or dirt is on the starter throwout mechanism.

(5) GEAR LUBRICANTS.

Below -15 F dilute lubricants prescribed for use at -10 F with 10 percent gasoline. If circumstances preclude dilution of lubricants, heat gear cases with a blowtorch. Play the torch lightly under the entire gear case; do not concentrate the heat in one spot.

(6) CHASSIS AND OTHER LUBRICANTS.

(a) Chassis, wheel-bearing, and other lubricants prescribed for use at -10 F will furnish satisfactory lubrication as low as -30 F . For sustained temperatures below -30 F use grease comparable to GREASE, lubricating, special, or GREASE, O. D. No. 00. Use OIL, engine, crankcase grade, in steering gear housing.

(b) Commercial brake and shock absorber fluids remain fluid at temperatures encountered.

(7) SPECIAL OPERATING PRECAUTIONS.

(a) Full choke is necessary to secure the air-fuel ratio required for cold weather starting. Check the butterfly valve to see that it closes all the way and otherwise functions properly.

(b) Check fuel pump.

(c) Below $+10\text{ F}$ remove oil from the air cleaners. Below -30 F remove the air cleaner.

(d) Inspect vehicle frequently.

(e) Remove or bypass oil filters at temperatures below -30 F .

(f) Disconnect oil-lubricated speedometer cables at the drive end for operating vehicles at temperatures of below -30 F .

(g) Remove and clean sediment bulb, strainer, etc., in the fuel system at frequent intervals.

(h) Retune engine frequently.

(i) Before starting the engine pull the choke all the way out and leave it partially pulled out until the engine has warmed up. Turn the

OPERATIONS UNDER UNUSUAL CONDITIONS

engine as rapidly as possible with the starter and release starting pedal as soon as the engine fires. After the engine has started, idle it until it has warmed up sufficiently to run smoothly. Do not race the engine immediately after starting.

(j) To stop the engine, first increase the engine speed and then turn off the ignition and release the throttle at the same time.

d. Cold Weather Accessories. The following list of cold weather accessories is given only as a suggestion and may be employed at the discretion of officers in charge of the materiel.

(1) Tarpaulins, tents, or collapsible sheds are useful for covering vehicles, particularly the engines.

(2) Fire pots, Primus type, or Van Prag blowtorches, ordinary blowtorches, oil stoves, or kerosene lanterns can be used for heating vehicles.

(3) Extra batteries and facilities for changing batteries quickly are aids in starting.

(4) Steel drums and suitable metal stands are useful for heating crankcase oil.

(5) Insulation of the fuel line will help prevent ice formation inside the line.

(6) Small quantities of denatured alcohol, about one-half pint to a tank of fuel, will reduce difficulties from water in gasoline.

(7) Radiator covers can be improvised locally and help to keep the engine running at normal temperatures.

30a. HIGH TEMPERATURE OPERATION.

To prevent overheating, the following things should be checked:

- a. The cooling system should be kept clean and full.
- b. The fins in the radiator should be kept free from bugs and foreign material that might affect free circulation of air.
- c. The fan belt should be properly adjusted.
- d. A gear reduction should never be used which requires the engine to labor at low engine speeds as this will cause overheating due to lack of sufficient water and air circulation.
- e. Under severe conditions it may be advisable to remove the hood side panels, providing less restriction to the flow of air.
- f. Watch the temperature indicator, and if the needle goes into the red band investigate the cause.

BOMB SERVICE TRUCK M6 (Chevrolet)

Section IX

MATERIEL AFFECTED BY GAS

	Paragraph
Protective measures	31
Cleaning	32
Decontamination	33
Special precautions for automotive materiel	34

31. PROTECTIVE MEASURES.

a. When materiel is in constant danger of gas attack, unpainted metal parts will be lightly coated with engine oil. Instruments are included among the items to be protected by oil from chemical clouds or chemical shells, but ammunition is excluded. Care will be taken that the oil does not touch the optical parts of instruments or leather or canvas fittings. Materiel not in use will be protected with covers as far as possible. Ammunition will be kept in sealed containers.

b. Ordinary fabrics offer practically no protection against mustard gas or lewisite. Rubber and oilcloth, for example, will be penetrated within a short time. The longer the period during which they are exposed, the greater the danger of wearing these articles. Rubber boots worn in an area contaminated with mustard gas may offer a grave danger to men who wear them several days after the bombardment. Impermeable clothing will resist penetration more than an hour, but should not be worn longer than this.

32. CLEANING.

a. All unpainted metal parts of materiel that have been exposed to any gas except mustard and lewisite must be cleaned as soon as possible with SOLVENT, dry cleaning, or ALCOHOL, denatured, and wiped dry. All parts should then be coated with OIL, engine.

b. Ammunition which has been exposed to gas must be thoroughly cleaned before it can be fired. To clean ammunition use AGENT, decontaminating, noncorrosive, or if this is not available, strong soap and cool water. After cleaning, wipe all ammunition dry with clean rags. **NOTE:** Do not use dry powdered AGENT, decontaminating (chloride of lime), as flaming occurs through the use of chloride of lime on liquid mustard.

33. DECONTAMINATION.

For the removal of liquid chemicals (mustard, lewisite, etc.) from materiel, the following steps should be taken:

MATERIEL AFFECTED BY GAS**a. Protective Measures.**

(1) For all of these operations a complete suit of impermeable clothing and a service gas mask will be worn. Immediately after removal of the suit, a thorough bath with soap and water (preferably hot) must be taken. If any skin areas have come in contact with mustard, if even a very small drop of mustard gets into the eye, or if the vapor of mustard has been inhaled, it is imperative that complete first-aid measures be given within 20 to 30 minutes after exposure. First-aid instructions are given in TM 9-850 and FM 21-40.

(2) Garments exposed to mustard will be decontaminated. If the impermeable clothing has been exposed to vapor only, it may be decontaminated by hanging in the open air, preferably in sunlight for several days. It may also be cleaned by steaming for 2 hours. If the impermeable clothing has been contaminated with liquid mustard, steaming for 6 to 8 hours will be required. Various kinds of steaming devices can be improvised from materials available in the field.

b. Procedure.

(1) Commence by freeing materiel of dirt through the use of sticks, rags, etc., which must be burned or buried immediately after this operation.

(2) If the surface of the materiel is coated with grease or heavy oil, this grease or oil should be removed before decontamination is begun; SOLVENT, dry cleaning, or other available solvents for oil should be used with rags attached to ends of sticks.

(3) Decontaminate the painted surfaces of the materiel with bleaching solution made by mixing one part AGENT, decontaminating (chloride of lime), with one part water. This solution should be swabbed over all surfaces. Wash off thoroughly with water, then dry and oil all surfaces.

(4) All unpainted metal parts and instruments exposed to mustard or lewisite must be decontaminated with AGENT, decontaminating, non-corrosive, mixed one part solid to fifteen parts solvent (ACETYLENE TETRACHLORIDE). If this is not available, use warm water and soap. Bleaching solution must not be used, because of its corrosive action. Instrument lenses may be cleaned only with PAPER, lens, tissue, using a small amount of ALCOHOL, ethyl. Coat all metal surfaces lightly with OIL, engine.

(5) In the event AGENT, decontaminating (chloride of lime), is not available, materiel may be temporarily cleaned with large volumes of hot water. However, mustard lying in joints or in leather or canvas webbing

BOMB SERVICE TRUCK M6 (Chevrolet)

is not removed by this procedure and will remain a constant source of danger until the materiel can be properly decontaminated. All mustard washed from materiel in this manner lies unchanged on the ground, necessitating that the contaminated area be plainly marked with warning signs before abandonment.

(6) The cleaning or decontaminating of materiel contaminated with lewisite will wash arsenic compounds into the soil, poisoning many water supplies in the locality for either men or animals.

(7) Leather or canvas webbing that has been contaminated should be scrubbed thoroughly with bleaching solution. In this event this treatment is insufficient; it may be necessary to burn or bury such materiel.

(8) Detailed information on decontamination is contained in FM 21-40, TM 9-850, and TC 38, 1941, Decontamination.

34. SPECIAL PRECAUTIONS FOR AUTOMOTIVE MATERIEL.

a. When vehicles have been subjected to gas attack with the engine running, the air cleaner should be serviced by removing the oil, flushing with SOLVENT, dry cleaning, and refilling with the proper grade of oil.

b. Instrument panels should be cleaned in the same manner as outlined for instruments.

c. Contaminated seat cushions will be discarded.

d. Washing the compartments thoroughly with bleaching solution is the most that can be done in the field. Operators should constantly be on the alert, when running under conditions of high temperatures, for slow vaporization of the mustard or lewisite.

e. Exterior surfaces of vehicles will be decontaminated with bleaching solution. Repainting may be necessary after this operation.

PART TWO—ORGANIZATION MAINTENANCE

Section X

SCOPE OF MAINTENANCE OPERATIONS

	Paragraph
Scope	35
Definition of terms	36
Allocation of repair	37

35. SCOPE.

The scope of maintenance and repairs by the crew and other units of the using arm is determined by the ease with which the project can be accomplished, the amount of time available, the nature of the terrain, weather conditions, temperatures, concealment, shelter, proximity to hostile fire, the equipment available, and the skill of the personnel. All of these are variable and no exact system of procedure can be prescribed.

36. DEFINITION OF TERMS.

The definitions given below are included in order that the operation name may be correctly interpreted by those doing the work.

a. **Service** consists of cleaning, lubricating, tightening bolts and nuts, and making external adjustments of subassemblies or assemblies and controls.

b. **Repair** consists of making repairs to, or replacement of a part, subassembly or assembly that can be accomplished without completely disassembling the subassembly or assembly, and does not require heavy welding or riveting, machining, fitting, and/or alining.

c. **Replace** consists of removing the part, subassembly or assembly from the vehicle and replacing it with a new or reconditioned or rebuilt part, subassembly or assembly, whichever the case may be.

d. **Rebuild** consists of completely reconditioning and placing in serviceable condition any unserviceable part, subassembly or assembly of the motor vehicle including welding, riveting, machining, fitting, alining, assembling and testing.

37. ALLOCATION OF REPAIR.

The operations herein may be performed by personnel of the using arms without supervision of ordnance maintenance personnel. Additional and more complicated maintenance operations (removal and reinstallation of the engine, transmission, and front axle group assemblies) may also be accomplished by the using arms, provided proper authority is received from ordnance maintenance personnel before the work is started.

FRONT AXLE

Alinement—Adjust for toe-in

Axle shaft—Replace

BOMB SERVICE TRUCK M6 (Chevrolet)**REAR AXLE**

Axle shaft—Replace

Differential (3rd member) assembly—Replace

BODY

Bows—Replace

Fenders—Replace

Running boards—Replace

Seats—Replace

Top—Replace

Windshields—Replace assemblies

Wipers—Replace

BRAKES

Hydrovac—Replace assembly

Brakes—Adjust; replace lines

Brake cylinders—Replace assembly

Master cylinder—Replace assembly

Shoes—Replace assembly

CLUTCH

Clutch—Adjust

Clutch—Replace assembly

COOLING SYSTEM

Fan belt—Adjust or replace

Fan and water pump—Replace assemblies

Hose and pipe—Replace

Radiator—Clean, flush, or replace

Thermostat—Replace

ELECTRICAL SYSTEM

Battery—Replace, charge and service

Cables—Replace assemblies

Coils and condensers—Replace assemblies

Distributor—Replace assembly; replace and adjust points

Generator—Replace assembly

Horn and relay—Replace assemblies

Lights—Adjust or replace assemblies

Regulator—Replace assembly

Spark plugs—Replace

Starter—Replace assembly

Switches—Replace assemblies

ENGINE

Gaskets—Replace (carburetor, cylinder head, fuel pump, manifolds, oil pan, valve cover, water pump)

SCOPE OF MAINTENANCE OPERATIONS

Motor tune-up
Valve adjustment

EXHAUST SYSTEM

Manifolds—Replace assemblies
Muffler—Replace assembly
Pipes—Replace

FUEL SYSTEM

Air cleaner—Clean or replace assembly
Carburetor—Replace assembly
Filter—Clean or replace assembly
Lines—Repair or replace
Pump—Replace assembly
Tanks—Clean or replace assemblies

INSTRUMENTS

Gages—Replace assemblies
Meters—Replace assemblies

LUBRICATION SYSTEM

Filter—Replace cartridge
Lines—Replace
Oil pan—Clean or replace
Oil pump screen—Clean or replace assembly

SHOCK ABSORBERS AND SPRINGS

Center and shackle bolts—Replace
Shock absorbers—Service and replace assembly; replace linkage
Springs—Adjust or replace assemblies

STEERING GEAR

Steering gear—Adjust or replace assembly
Steering connecting rod—Adjust or replace assembly
Tie rod—Adjust or replace assembly

TRANSMISSION

Shift levers—Replace
Shift lever cover—Replace

WHEELS

Bearings—Adjust and replace
Grease retainers—Replace
Tires and tubes—Replace
Wheels—Replace

MISCELLANEOUS

Cleaning
Lubricating
Painting
Tire chains—Repair

BOMB SERVICE TRUCK M6 (Chevrolet)

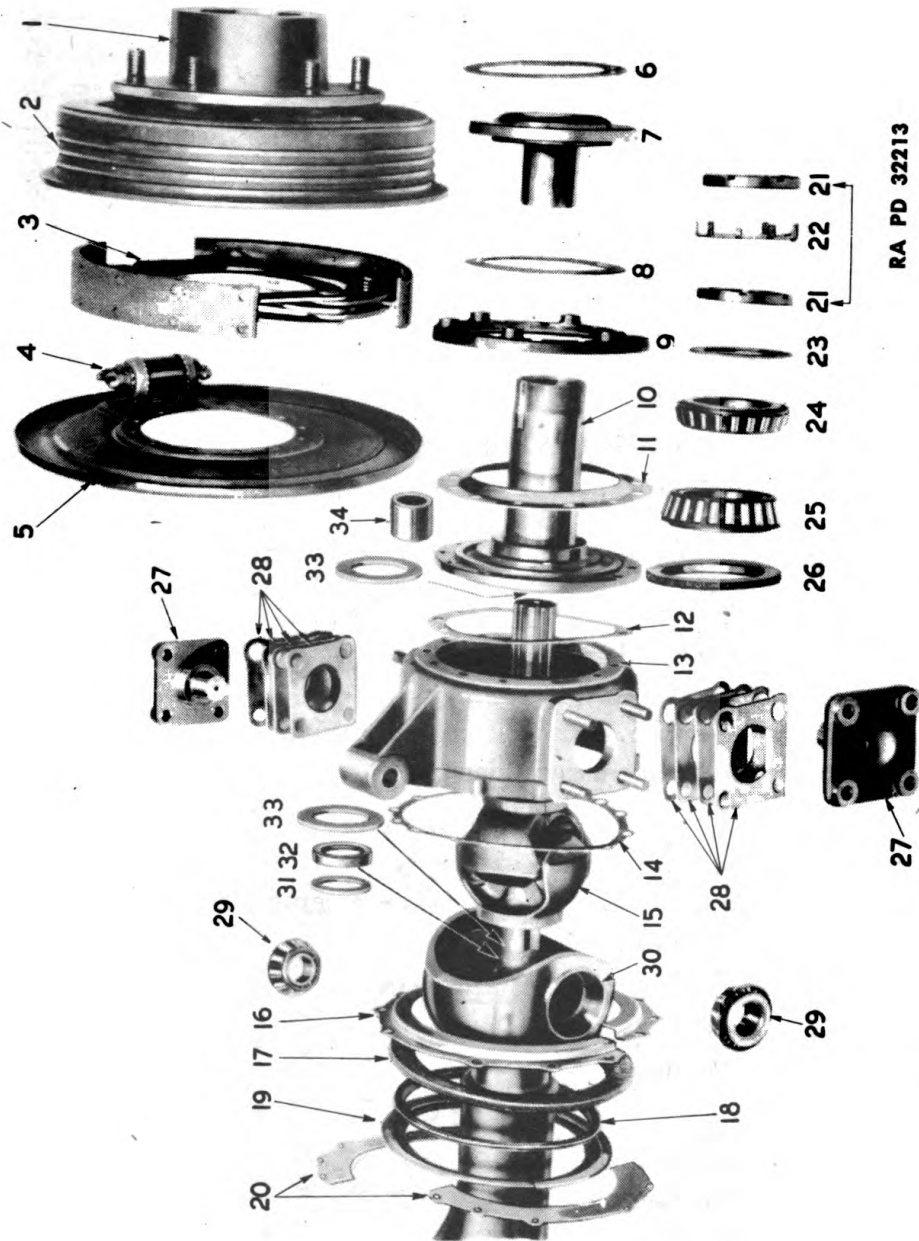

Figure 13—Front Wheel Hub and Steering Control Parts

SCOPE OF MAINTENANCE OPERATIONS

- | | |
|--|---|
| 1—Front Wheel Hub | 18—Housing Outer End Seal (Spring Loaded) |
| 2—Front Brake Drum Assembly | 19—Retainer (Spring Loaded Oil Seal) |
| 3—Front Brake Anchor Plate and Shoe Assembly | 20—Housing Outer End Seal Inner Retainer |
| 4—Wheel Cylinder Assembly | 21—Front Wheel Hub Bearing Adjusting Nut |
| 5—Front Brake Flange Plate | 22—Front Wheel Hub Nut Lock |
| 6—Front Axle Drive Flange Bolt Lock | 23—Front Wheel Hub Nut Washer |
| 7—Front Axle Drive Flange | 24—Roller Bearing and Cone (Outer) |
| 8—Front Wheel Hub Drive Flange Gasket | 25—Roller Bearing and Cone (Inner) |
| 9—Front Brake Shoe Anchor Plate Spacer | 26—Front Wheel Bearing Oil Seal |
| 10—Steering Knuckle | 27—Front Axle Trunnion |
| 11—Front Wheel Hub Inner Oil Deflector | 28—Steering Knuckle Bearing Shim |
| 12—Steering Knuckle Support Gasket | 29—Steering Knuckle Roller Bearing and Cone |
| 13—Steering Knuckle Support | 30—Steering Knuckle Bearing Outer Race |
| 14—Housing Outer End Seal Retainer Gasket | 31—Axle Shaft Oil Seal Shim |
| 15—Axle Shaft and Universal Joint Assembly | 32—Axle Shaft Oil Seal |
| 16—Housing Outer End Seal Retainer | 33—Thrust Washer |
| 17—Housing Outer End Seal (Felt and Rubber) | 34—Steering Knuckle Bushing |

RA PD 32213A

Nomenclature for Figure 13—Front Wheel Hub and Steering Control Parts

BOMB SERVICE TRUCK M6 (Chevrolet)

Section XI

FRONT AXLE

	Paragraph
Description	38
Trouble shooting	39
Maintenance and adjustments	40
Unit replacement	41

38. DESCRIPTION.

The front axle assembly is a front wheel driving unit, consisting of a banjo-type housing, on which there is provision for mounting specially designed steering knuckles and a conventional type differential. The front wheels are driven by axle shafts equipped with constant velocity type universal joints which are enclosed in the steering knuckle support housing.

39. TROUBLE SHOOTING.

Symptom	Probable remedy
a. Hard Steering.	
(1) Lack of lubrication.	(1) Lubricate tie rod ends, steering gear and steering connecting rod.
(2) Steering gear out of adjustment (loose or tight).	(2) Readjust (see paragraph 161).
(3) Improper toe-in.	(3) Adjust at tie rod end.
(4) Improper tire pressure.	(4) Inflate both front and rear tires to 55 pounds.
(5) Bent frame.	(5) Report to higher authority.
(6) Excessive caster.	(6) Report to higher authority.
(7) Shackle bolts too tight.	(7) Readjust.
b. Lubricant Leaks.	
(1) Leaks at steering knuckle support.	(1) Report to higher authority.
(2) Leaks at differential.	(2) Replace carrier gasket.

FRONT AXLE

Symptom	Probable remedy
c. Shimmy.	
(1) Steering knuckle arm bushings loose or worn.	(1) Readjust or report if they need replacement.
(2) Tie rod loose.	(2) Tighten or replace worn parts.
(3) Insufficient toe-in.	(3) Readjust.
(4) Improper tire inflation.	(4) Inflate to recommended pressure.
(5) Front wheel bearings loose.	(5) Adjust.
(6) Steering knuckle support trunion bearings loose.	(6) Adjust to a load of 4½ to 6 pounds.
(7) Steering gear loose.	(7) Adjust.
(8) Improper caster.	(8) Report.
(9) Spring set.	(9) Report.
d. Wandering.	
(1) Front wheel bearings out of adjustment.	(1) Readjust.
(2) Bent axle.	(2) Report.
(3) Tight steering gear.	(3) Readjust.
(4) Spring center bolt sheared and axle shifted.	(4) Replace center bolt.
(5) Improper toe-in.	(5) Adjust.
e. Noisy Differential.	
(1) Gears or bearings need replacement.	(1) Report to higher authority.

40. MAINTENANCE AND ADJUSTMENTS.

a. Axle Shaft Replacement.

(1) TOOLS REQUIRED:

Chisel, cold

Clamp, wheel cylinder, J-718-C
(KM)

Hammer

Jack, 41-J-73-5

Pliers, brake spring, 41-P-1579

Wrench, front wheel nut, J-1663
(KM)

Wrench, socket, 5/8-in.

Wrench, wheel stud nut

(2) REMOVE DRIVE FLANGE. Refer to paragraph 174 a (2).

BOMB SERVICE TRUCK M6 (Chevrolet)

(3) **REMOVE HUB.** Remove the adjusting nut, roller bearing and cone assembly; then remove the wheel hub.

(4) **REMOVE RETRACTING SPRING.** Install the wheel cylinder clamp (fig. 14) and remove the brake shoe retracting spring, using brake spring pliers.

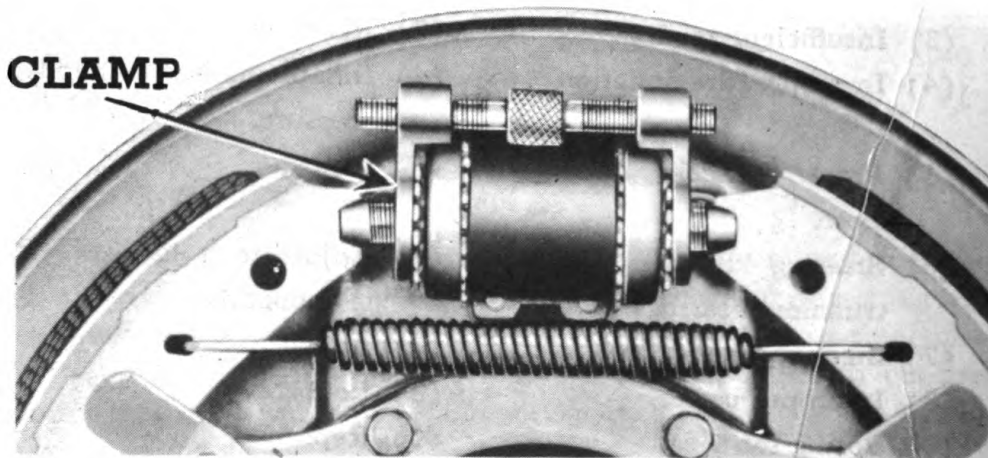

RA PD 32214

Figure 14—Brake Wheel Cylinder Clamp

(5) **REMOVE ANCHOR PLATE.** Using $\frac{5}{8}$ -inch wrench or socket, remove the six cap screws that attach the brake shoe anchor plate to the steering knuckle. Remove the anchor plate.

(6) **REMOVE ANCHOR PLATE SPACER.** With a $\frac{5}{8}$ -inch socket wrench, remove the 12 cap screws which attach the brake shoe anchor plate spacer, inner oil deflector, brake flange plate and steering knuckle to the steering knuckle support. Remove the spacer and oil deflector.

(7) **REMOVE FLANGE PLATE.** Slide the brake flange plate off the steering knuckle and support it with a piece of wire. This procedure saves removing the brake line hose and bleeding the brakes after performing these operations.

(8) **REMOVE STEERING KNUCKLE.** The steering knuckle can then be removed from its support.

(9) **REMOVE AXLE SHAFT.** Pull the axle shaft from the housing, supporting it throughout its full length to prevent damaging the oil seal in the end of the housing (fig. 15). **NOTE:** The right and left axle shafts are not interchangeable as they are of different lengths.

FRONT AXLE

(10) **INSTALL AXLE SHAFT.** Pack the universal joint with LUBRICANT, general purpose, No. 2, according to instructions given in paragraph 174. Push the axle shaft into the housing, rotating it slightly to pick up the splines in the differential side gear. **NOTE:** When installing the shaft, it must be supported to prevent damaging the oil seal.

RA PD 32215

BRAKE FLANGE PLATE.

AXLE SHAFT

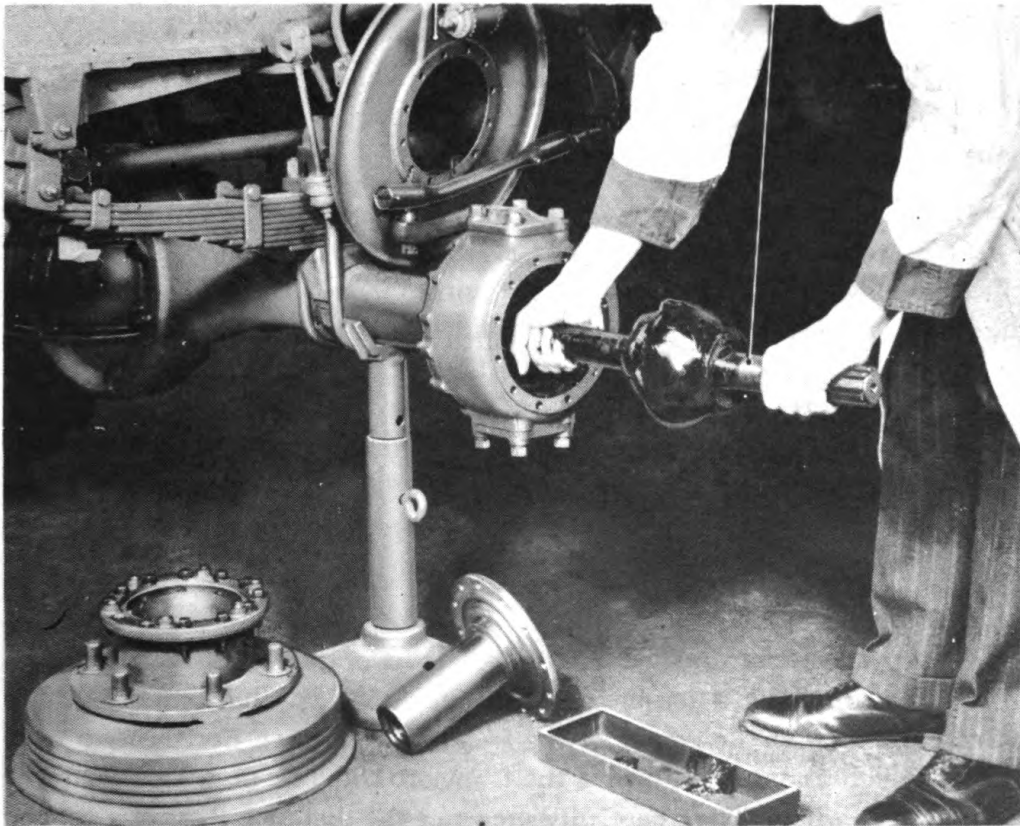

Figure 15—Front Axle Shaft Removal

(11) **INSTALL STEERING KNUCKLE.** Lubricate the axle shaft where it contacts the bushing and thrust washer in the steering knuckle. Using a new gasket, install the steering knuckle with the keyway at the top.

(12) **INSTALL FLANGE PLATE.** The brake flange plate, oil deflector and shoe anchor plate spacer should be installed. Space two of the anchor support bosses on the spacer equally with reference to the wheel cylinder. Install the 12 cap screws and washers and tighten them securely.

(13) **INSTALL ANCHOR PLATE.** Install the brake shoe anchor plate and bolt it to the spacer. Using the special pliers, replace the brake shoe retracting spring. Remove the wheel cylinder clamp.

BOMB SERVICE TRUCK M6 (Chevrolet)

(14) **INSTALL AND ADJUST BEARINGS.** Install the wheel hub and bearings. Adjust the bearings according to instructions given in paragraph 174 of this manual.

b. Tie Rod Replacement and Adjustment.**(1) TOOLS REQUIRED:**Wrench, open-end, $\frac{3}{4}$ -in.

Wrench, open-end, 1-in.

(2) **REMOVAL.** With a 1-inch end wrench, remove tie rod attaching bolts from the steering arms and remove the tie rod.

(3) **INSTALLATION.** The tie rod is made with a bend to clear the differential. The right end is threaded with a coarse thread to screw into the right tie rod end and left end is threaded with a fine thread for making toe-in adjustment. When installing the tie rod, loosen the two pinch bolts, using a $\frac{3}{4}$ -inch wrench. The end should then be screwed into the right tie rod end until there is a minimum of $\frac{1}{8}$ -inch clearance between the lower rib on the differential on the left side and the tie rod on a full left turn. After checking and setting this clearance, install the retaining bolt in the right end.

(4) **ADJUSTMENT.** Adjust the left tie rod end to provide 0-inch to $\frac{1}{8}$ -inch toe-in, using a toe-in scale for checking. To check toe-in, mark a fine chalk line at the center of the tread of both tires. Set the two tires so that the chalk mark is toward the front of the truck on a line with the center of the wheel. Then carefully measure the distance from the center of one chalk line to the other. Now revolve the wheels so that the chalk lines are facing the back of the car and on center with the wheel. Again measure the distance between the chalk marks. For the correct toe-in setting the difference between the measurements obtained should be between 0-inch and $\frac{1}{8}$ -inch, with the shorter distance, if any, at the front. If difficulty is experienced in securing proper toe-in, it may be necessary to disconnect the tie rod from the right steering arm and screw the end either on or off the tie rod one turn. Then screw the left tie rod end on or off the rod to secure the proper toe-in. Recheck the four tie rod end pinch bolts to make certain they are tight.

(5) **LOCKING RETAINING BOLT.** Install lock nut on the tie rod to steering arm retaining bolts. Pull down, wrench tight, and back off one-third to one-half turn. Lock the nut with a cotter pin.

FRONT AXLE

41. UNIT REPLACEMENT.

When damaged in the field, the axle assembly should be replaced as a unit (fig. 16).

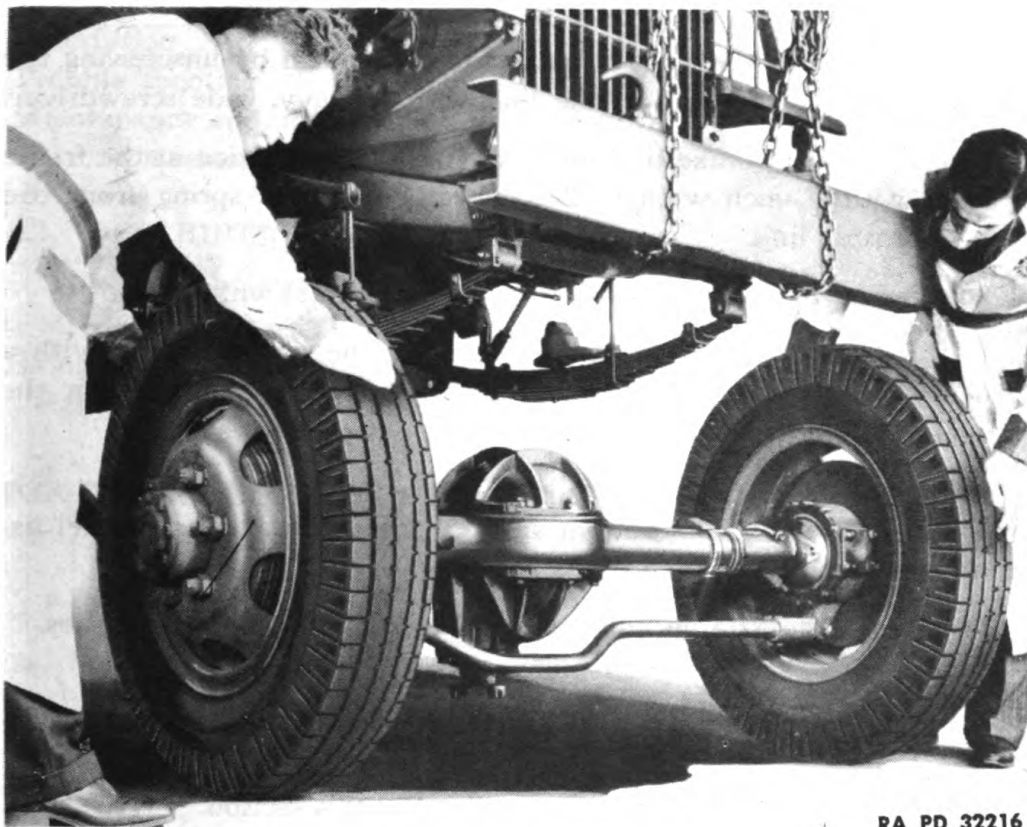

RA PD 32216

Figure 16—Front Axle Assembly Removal

a. Tools Required:

Jack, 41-5-73-5

Jacks, stand, two

Screwdriver, wide

Wrench, open-end, $\frac{9}{16}$ -in.

Wrenches, open-end or box,
 $\frac{5}{8}$ -in. and $\frac{7}{16}$ -in.

Wrench, open-end or box,
 $\frac{15}{16}$ -in.

Wrench, wheel stud

b. Removal.

(1) Set unit on a level spot and loosen the six wheel stud nuts on each wheel.

(2) Place jacks under the frame just back of each wheel and lift up front end of vehicle.

BOMB SERVICE TRUCK M6 (Chevrolet)

(3) Split the front universal joint by removing the four U bolt retaining nuts (fig. 105) with a $\frac{9}{16}$ -inch end wrench, and removing the two U bolts. Tape the two trunnion bearings in place to prevent them from falling off the trunnion yoke. This will save time in reassembly. Slide the U joint back on its slip joint and lower the end of the drive shaft assembly to the floor.

(4) Disconnect the drag link from the third arm by unscrewing the adjusting plug in the end of the link with a heavy, wide screwdriver.

(5) Disconnect brake lines by removing the connection at the frame bracket with $\frac{7}{16}$ -inch wrench. Disconnect brake line spring from the shock absorber link.

(6) Support the axle assembly at the differential with a jack.

(7) Remove the four retaining nuts from the spring U bolts with a $\frac{5}{8}$ -inch wrench. Disconnect shock absorber attaching plate from the U bolts and move shock absorber link up out of the way.

(8) Remove the jack, carefully allowing the heavy side of the axle assembly to settle to the bottom and roll the entire axle and wheel assembly out from under the truck.

(9) Block the axle up and remove the tire and wheel assemblies.

c. Installation.

(1) Replace the axle assembly in reverse order to removal.

(2) Check and adjust toe-in as outlined in this section.

(3) It will be necessary to bleed all brake wheel cylinders after installing a new assembly. Refer to paragraph 56 for this operation.

REAR AXLE

Section XII

REAR AXLE

	Paragraph
Description	42
Trouble shooting	43
Maintenance and adjustment	44
Unit replacement	45

42. DESCRIPTION.

The rear axle is of the single-reduction, full floating, hypoid type with a straddle mounted pinion gear and a high traction type differential. Being of the full floating type, the axle shafts can be removed with the weight of the vehicle on its wheels.

43. TROUBLE SHOOTING.

Symptom	Probable remedy
a. Axle Noises.	
(1) Wheel bearings.	(1) Adjust bearings. If necessary to replace, report to higher authority.
(2) Noisy on drive.	(2) Ring gear and pinion adjusted too tight. Report to higher authority.
(3) Axle noisy on coast.	(3) Report to higher authority.
b. Backlash.	
(1) Loose axle shaft flange.	(1) Replace terneplate gasket. Tighten and lock cap screws.
(2) Excessive clearance at axle shaft splines.	(2) Replace worn differential, gears, worn shafts or both.
(3) Excessive pinion and ring gear clearance.	(3) Report to higher authority.
c. Grease Leakage.	
(1) Grease on brake linings.	(1) Inspect and replace oil seal if necessary.

BOMB SERVICE TRUCK M6 (Chevrolet)

- | | |
|---------------------------|--|
| (2) At axle shaft flange. | (2) Inspect and replace oil seal if necessary. Check face of flange for roughness. |
|---------------------------|--|

44. MAINTENANCE AND ADJUSTMENT.

a. Axle Shaft Replacement.

(1) TOOLS REQUIRED:

Chisel, cold	Hammer
Wrench, socket, $\frac{3}{4}$ -in.	

(2) With a cold chisel and hammer bend the lugs of the lock plate away from the bolt heads.

(3) Remove the eight cap screws with a $\frac{3}{4}$ -inch socket or end wrench. Remove lock plate.

(4) Install two of the cap screws in the threaded holes provided in the axle shaft flange. By turning these cap screws alternately, the axle shaft may be removed (fig. 17). Remove the terneplate gasket.

(5) To replace, first install a new terneplate gasket on the axle shaft and push the shaft into place, turning it slightly to pick up the splines in the differential side gears.

(6) Using a new lock plate install the eight cap screws in the flange and, tightening them alternately, draw them up tight. Then bend the tangs of the lock plate against the heads of the cap screws.

b. Third Member (Differential) Replacement.

(1) TOOLS REQUIRED:

Wrench, $\frac{9}{16}$ -in.	Wrench, $\frac{3}{4}$ -in.
-----------------------------	----------------------------

(2) Place vehicle on level ground and set the brakes.

(3) Drain the differential.

(4) Remove the axle shaft cap screws and pull out the shafts far enough to clear the differential side bearings.

(5) Split the rear U joint and lower the propeller shaft to the floor. The trunnion bearings can be left in place and held with tape (fig. 108).

(6) Remove the cap screws and lock washers that retain the third member assembly to the banjo housing.

(7) The third member assembly can then be removed by pulling back and out.

(8) Replacement is the reverse of removal.

REAR AXLE

RA PD 32217

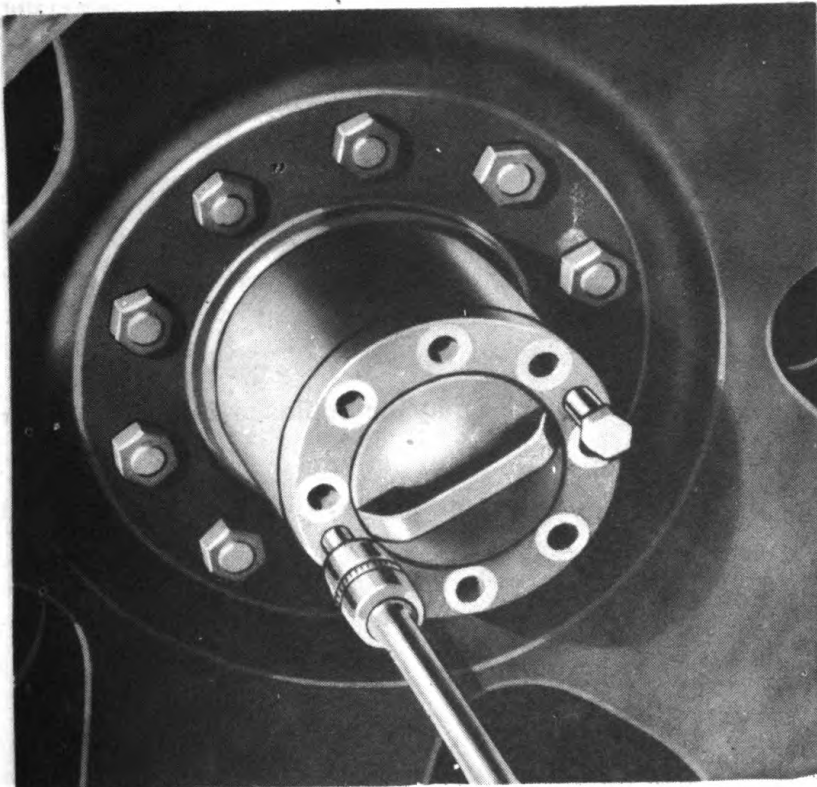
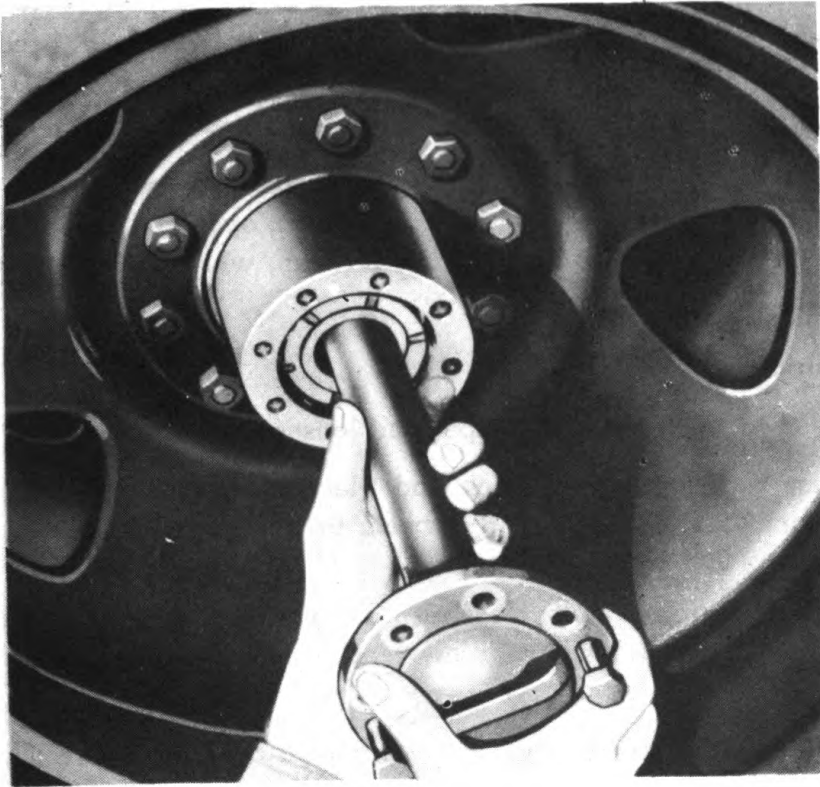

Figure 17 - Rear Axle Shaft Removal

BOMB SERVICE TRUCK M6 (Chevrolet)**45. UNIT REPLACEMENT.**

The complete rear axle assembly should be replaced if it becomes damaged (fig. 18).

a. Tools Required:

Jack, 41-J-73-5

Jacks, stand, two

Wrench, $\frac{7}{8}$ -in.

Wrench, $\frac{5}{8}$ -in.

Wrench, open-end, $\frac{9}{8}$ -in.

Wrench, open-end, $\frac{15}{8}$ -in.

Wrench, wheel hub nut

b. Removal.

(1) Set the vehicle on a level spot and loosen the wheel hub nuts.

(2) Raise the rear of the truck and place a stand jack under the frame on each side. Remove both wheels to provide clearance at the fenders.

(3) With a $\frac{9}{8}$ -inch wrench, disconnect the rear U joint and lower the shaft to the floor. Tape the trunnion bearings in place to keep them from falling off.

(4) Disconnect the brake line from the master cylinder where it joins the line running across the axle to the wheel cylinders.

(5) Place the hydraulic jack under the differential, centering the load.

(6) Using a $\frac{15}{8}$ -inch wrench, remove the eight (four on each side) spring U bolt attaching nuts. Move the shock absorber link and bracket up out of the way.

(7) By steadying the load, the assembly can be wheeled out from under the vehicle.

c. Installation.

(1) A new rear axle assembly may be replaced in reverse order to removal.

(2) It will be necessary to bleed all brakes after replacing the unit.

REAR AXLE

RA PD 32218

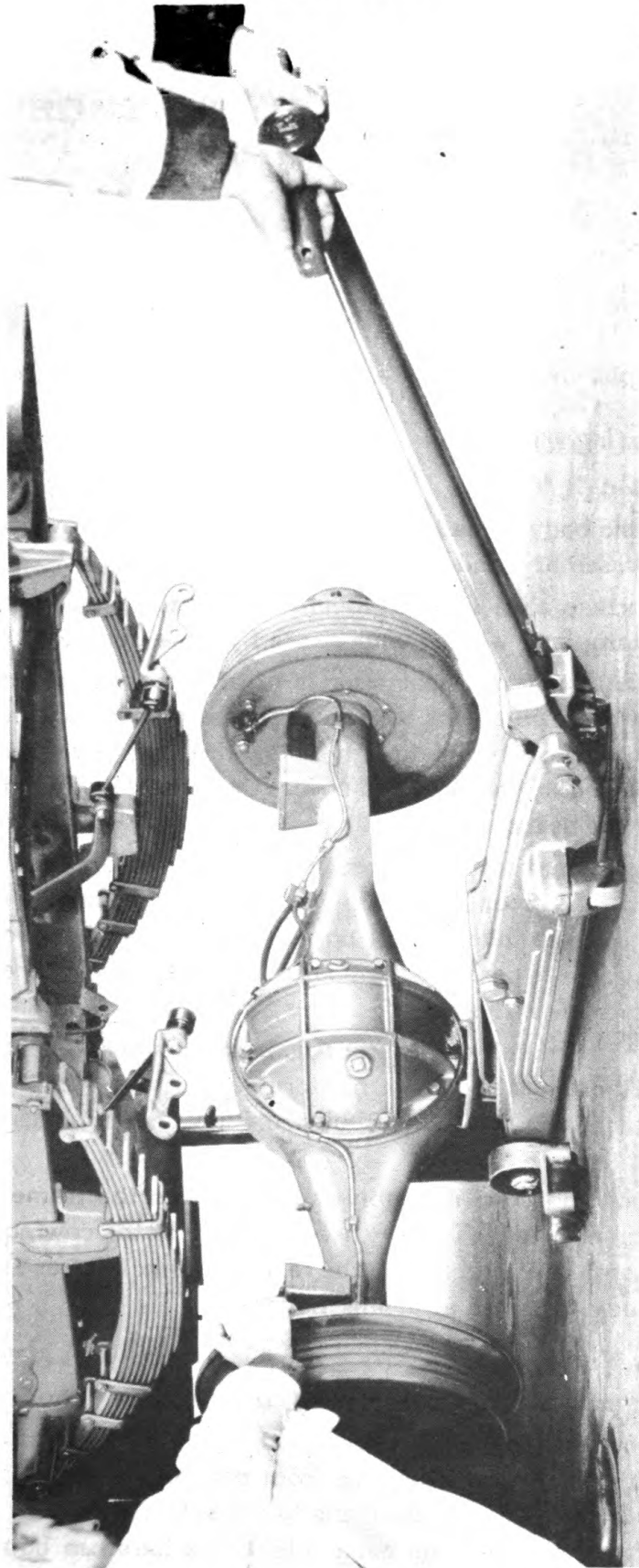

Figure 18—Rear Axle Assembly Removal

BOMB SERVICE TRUCK M6 (Chevrolet)

Section XIII

BODY

	Paragraph
Construction	46
Maintenance	47
Hoist operation	48
Hoist repairs	49
Windshield replacement	50

46. CONSTRUCTION.

a. Basic Body.

(1) The basic body is made up of three sections: the cowl, front floor and seat riser assembly, and the platform.

(2) The flatface cowl is of all-metal construction, made up of individual steel stampings welded and riveted into a complete assembly.

(3) The front floor and seat riser is of all-metal construction. The seat riser is welded to the floor. A removable front floor board is used to provide access to chassis units directly below the floor. A removable seat riser cover is placed on the riser and covers the gas tank which is located directly below the seats.

(4) The platform, back of the seat riser, is made of oak mounted on four cross sills. The floor boards are spaced with sufficient clearance between the boards to take care of normal swelling of the wood due to moisture. These spaces between the boards are covered with special steel wear irons to provide a tight platform.

(5) The cowl is bolted to the front floor at each side, and the upper floor board is then installed. The platform is then bolted to the back end of the front floor with eight bolts, making a complete floor and cowl assembly.

(6) The floor and cowl assembly is attached to the frame brackets by eight bolts on each side. Two of these bolts are at the cowl, two at the front floor and seat riser, and four in the rear platform. Figures 19, 20, and 21 show the body to frame attaching bolts.

b. Driver's Compartment.

(1) The driver's compartment is covered by a canopy top.

(2) The top frame consists of tubular uprights, the bottom of which is attached to the back corners of the front platform assembly. Tubular braces run forward and down, attaching to the side of the front platform at the front of the seat riser on each side. Cross bars run between the two upright supports at the top of the seats and at the top of the uprights.

BODY

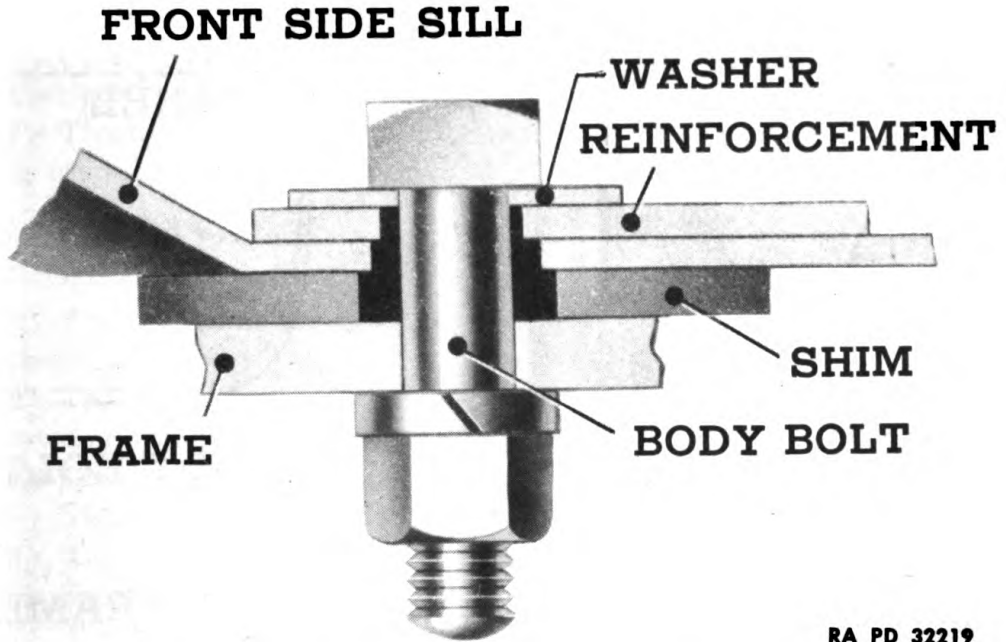

RA PD 32219

Figure 19—Forward Cowl and Dash Attaching Bolt

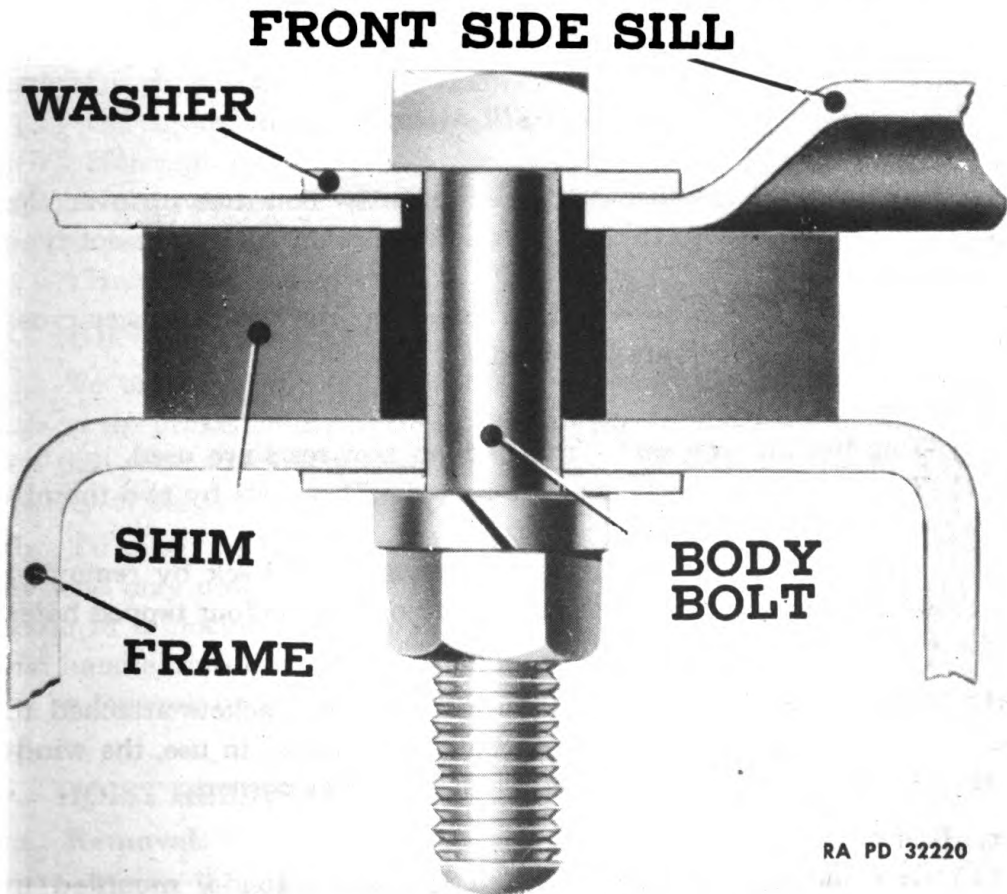

RA PD 32220

Figure 20—Rear Cowl and Dash Attaching Bolt

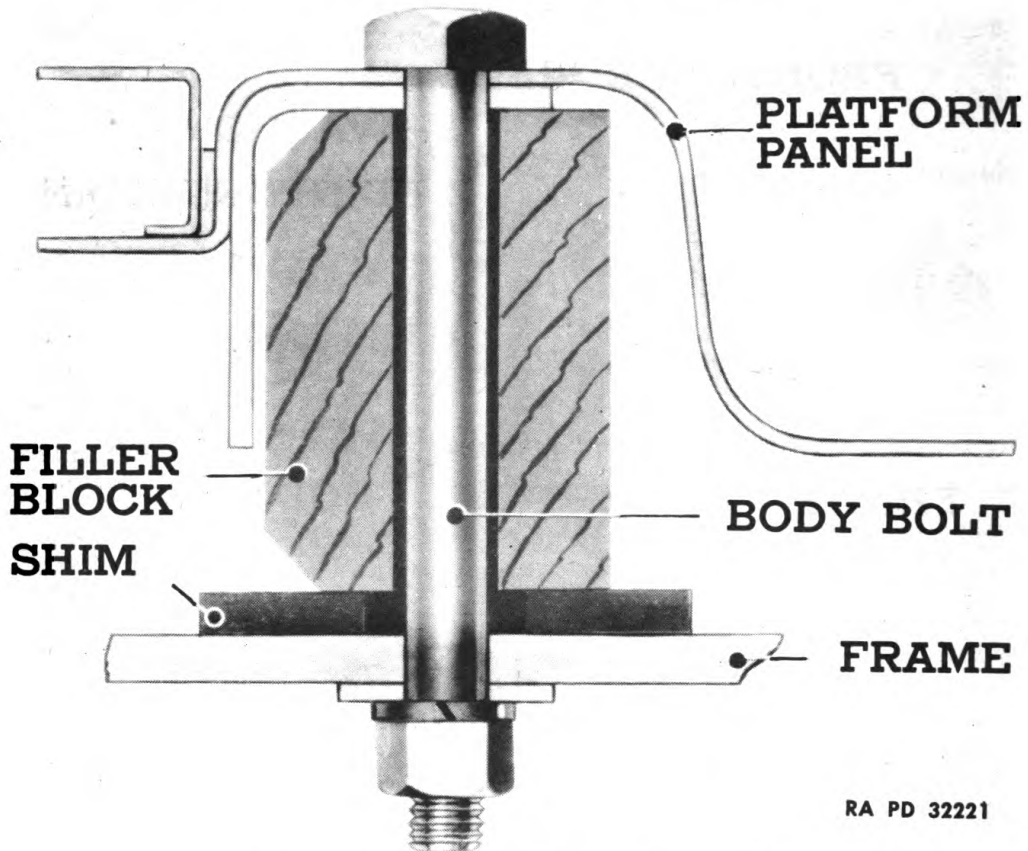
BOMB SERVICE TRUCK M6 (Chevrolet)

RA PD 32221

Figure 21 – Side Sill Attaching Bolt

(3) The canopy attached to the lower cross bar runs up over the upper bar and is attached to the windshield frame by 10 lift-the-dot type fasteners.

(4) The canopy can be rolled up and supported at the lower cross bar by four straps which are provided.

c. Seats.

(1) Two bucket-type seats with padded arm rests are used.

(2) The seats are attached to the seat riser brackets by two thumbscrews on each seat.

(3) The driver's seat is adjustable forward and back by removing the thumbscrews and installing them in any one of the four tapped holes in the seat brackets.

d. Windshield. The windshield is mounted in brackets attached to the cowl and dash assembly. When the canopy is not in use, the windshield can be adjusted by hand screws at the lower corners.

e. Body.

(1) One end of a specially formed I beam is rigidly mounted to the platform back of the driver's compartment. This I beam curves

BODY

back to form a horizontal hoist support. Braces attached at the back corners of the platform support the I beam at the back of the body.

(2) A three-place seat is mounted on the platform to the right of the hoist support.

(3) The hoist shown in figure 22 is mounted on the I beam section and is used for loading bombs on the bomb trailer.

47. MAINTENANCE.

a. Tightening.

(1) The body, like the rest of the vehicle, requires a certain amount of attention.

(2) The following things should be checked at the end of 1000 miles of travel and every 2000 miles thereafter.

(3) Check and adjust body to frame bracket bolts.

(4) Tighten cowl sill to platform sill screws.

(5) Tighten platform to sill bolts.

(6) Tighten platform wear iron bolts.

(7) Tighten windshield to adjusting support bolts.

(8) Tighten canopy top support bolts at platform.

b. Lubrication.

(1) The following points should be lubricated with OIL, engine:

(2) Oil cups at each end of hoist drum shaft.

(3) Oil cup on hoist reduction gear.

(4) Hoist ratchet pawl shaft.

(5) Hoist crankshaft (Remove crank gear shaft retainer and lubricate through retainer hole).

(6) Hoist cable pulley shaft.

48. HOIST OPERATION.

a. To unwind the cable from the drum raise the ratchet pawl, pull back on the brake handle to check the cable from uncoiling on the drum, then pull the cable out the desired distance to pick up the load. The capacity of the hoist is two tons.

b. To raise the load, lower the ratchet pawl and release the brake. The load may now be raised to the desired height by turning the hoist handle in a clockwise direction. To lower the load, while holding the hoist handle, raise the ratchet pawl and apply the brake. The load may now be lowered by turning the hoist handle in a counterclockwise direction.

49. HOIST REPAIRS.

a. Removal.

(1) TOOLS REQUIRED:

Wrench, open-end, $\frac{9}{16}$ -in.

Wrench, open-end, $\frac{1}{8}$ -in.

BOMB SERVICE TRUCK M6 (Chevrolet)

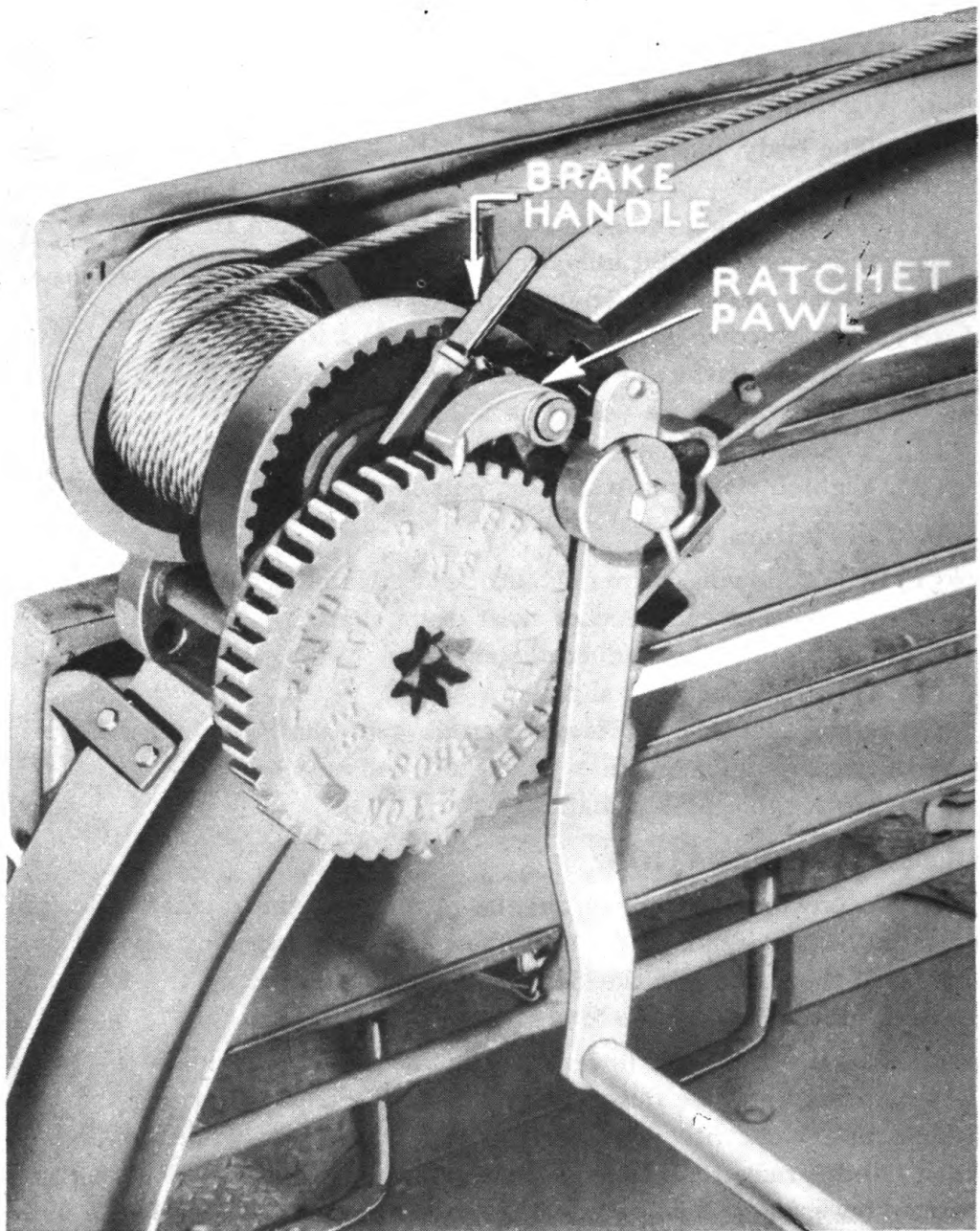

RA PD 32222

Figure 22—Bomb Handling Hoist

BODY

(2) Pull out the cable and with a $\frac{9}{16}$ -inch wrench remove the U bolt cable to drum anchor.

(3) Using a $\frac{5}{8}$ -inch wrench remove the two short and two long mounting bolts.

b. Disassembly.

(1) **TOOLS REQUIRED:**

Pliers

Wrench, open-end, $\frac{5}{8}$ -in.

Wrench, open-end, $\frac{9}{16}$ -in.

(2) Unwind and disconnect the cable from the drum. Use $\frac{9}{16}$ -inch open-end wrench to loosen U clamp.

(3) Remove cotter pin from crank gear shaft and remove retainer and shaft.

(4) Remove cotter pin from reduction gear retainer; remove the retainer and slide the reduction gear out of its bearing.

(5) Using a $\frac{5}{8}$ -inch wrench remove the nuts from the through bolts and remove the support brackets from the drum.

(6) Remove the brake shoe and ratchet pawl pivot pin.

(7) Figure 23 shows an exploded view of the hoist assembly parts.

c. Inspection.

(1) Wash all parts in clean SOLVENT, dry cleaning.

(2) Inspect the gears for worn, broken, chipped or cracked teeth.

(3) Inspect shafts and bearings for wear or scoring.

(4) Check condition of brake lining.

(5) Any worn or damaged parts should be replaced.

d. Reassembly.

(1) **TOOLS REQUIRED:**

Pliers, combination, 6-in.

Wrench, open-end, $\frac{9}{16}$ -in.

Wrench, open-end, $\frac{5}{8}$ -in.

(2) Assemble the brake lever, brake shoe and ratchet pawl to the support bracket.

(3) Lubricate with OIL, engine, seasonal grade, and install the pivot pin and lock it in place with cotter pin.

(4) Assemble the hoist drum to the support brackets, install the through bolts, and with a $\frac{3}{8}$ -inch wrench tighten the nuts securely.

(5) Lubricate the drum bearings with OIL, engine, seasonal grade.

(6) Lubricate the reduction gear shaft with OIL, engine, seasonal grade and assemble it to the support bracket.

(7) Install the reduction gear retainer and lock it in place with a cotter pin.

BOMB SERVICE TRUCK M6 (Chevrolet)

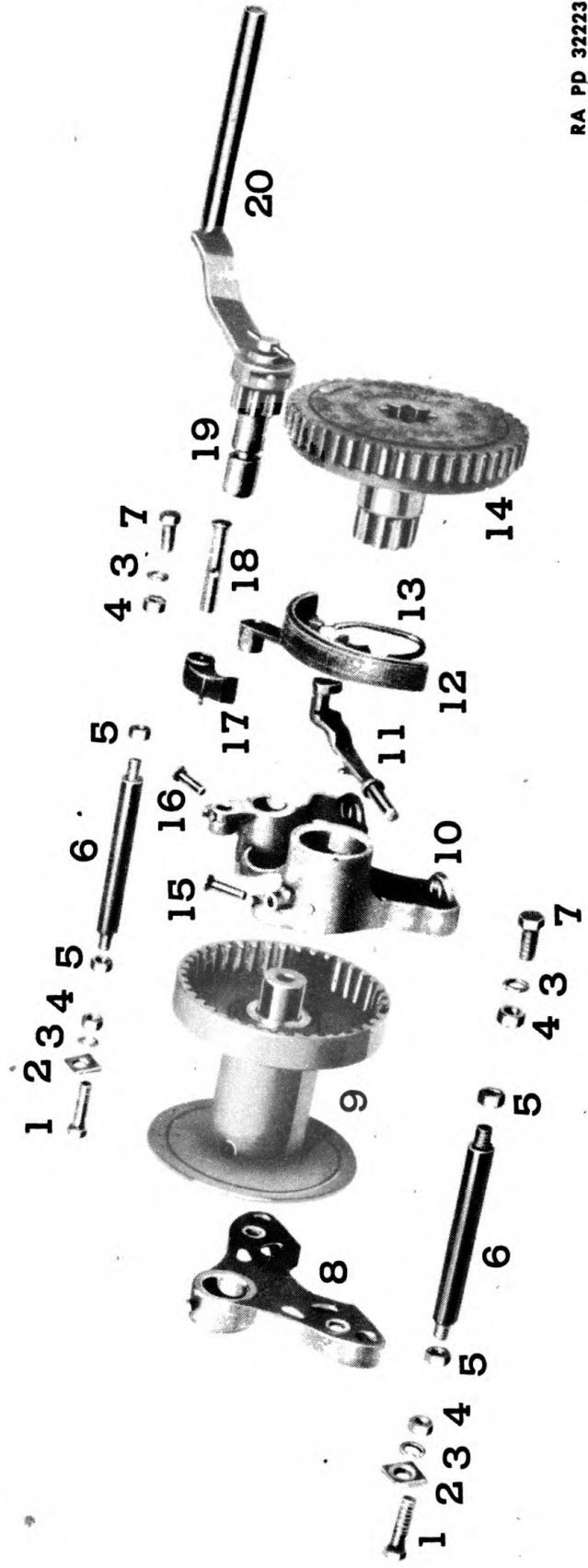

RA PD 32223

Figure 23—Bomb Handling Hoist Parts

BODY

- | | |
|--|--|
| 1 —Mounting bolt (long) | 11 —Brake lever |
| 2 —Spacer (mounting bolt) | 12 —Brake shoe |
| 3 —Lockwasher | 13 —Spring (brake shoe) |
| 4 —Nut (mounting bolt) | 14 —Reduction gear |
| 5 —Nut (through bolt) | 15 —Retainer (reduction gear) |
| 6 —Through bolt | 16 —Retainer (crank gear shaft) |
| 7 —Mounting bolt (short) | 17 —Ratchet pawl |
| 8 —Drum support | 18 —Pivot pin |
| 9 —Drum | 19 —Crank gear and shaft |
| 10 —Drum support (reduction gear end) | 20 —Crank handle |

RA PD 32213A

Nomenclature for Figure 23—Bomb Handling Hoist Parts

BOMB SERVICE TRUCK M6 (Chevrolet)

(8) Lubricate crank gear shaft with oil, engine, seasonal grade and install it to the support bracket. Install retainer and lock it in place with a cotter pin.

(9) Reassemble hoist to support and tighten mounting bolts with $\frac{1}{8}$ -inch wrench.

(10) Using a $\frac{9}{16}$ -inch wrench install U clamp which anchors cable to drum.

(11) Lubricate cable and wind it on the drum.

50. WINDSHIELD REPLACEMENT.

a. Assembly Removal.

(1) **TOOL REQUIRED:**

Wrench, open-end, $\frac{1}{2}$ -in.

(2) Unfasten the canopy at windshield top.

(3) Disconnect the windshield wiper hose at the left side of windshield.

(4) Remove the windshield hand adjusting screws and flat washers on each side.

(5) Using a $\frac{1}{2}$ -inch end wrench remove the three bolts which attach one of the windshield hinge brackets to the windshield support.

(6) Remove the windshield assembly.

b. Windshield Glass Removal.

(1) **TOOLS REQUIRED:**

Screwdriver

Wrench, open-end, $\frac{7}{8}$ -in.

(2) Disconnect the windshield wiper motor hose from the suction pipe.

(3) **SUCTION PIPE.** Remove the screws which attach the suction pipe mounting clips to the windshield frame.

(4) Using a $\frac{7}{8}$ -inch, open-end wrench remove the hexagon head bolts on each side of the windshield frame which retain the frame header.

(5) Remove the header.

(6) Remove glass from frame.

(7) Clean the inside of windshield frame to remove all rust.

c. Windshield Glass Installation.

(1) **TOOLS REQUIRED:**

Screwdriver

Wrench, open-end, $\frac{7}{8}$ -in.

(2) Place a piece of channel filler around the edge of the windshield glass with the soapstone side out.

(3) At each corner, pinch the surplus material together and cut surplus material off. This provides a smooth joint.

BODY

(4) Brush the inside of frame channel freely with OIL, engine, SAE 10. This will enable the channel filler to slip freely into place.

(5) Push the glass with filler into the channel until it is firmly seated.

(6) Install windshield frame header and retaining bolts.

(7) Trim off the edges of the filler with a sharp knife.

(8) After the glass is in place, the oil softens the filler, causing it to swell, thereby making a watertight seal. It takes approximately 24 hours for the oil to expand the filler; therefore, waterleak tests should not be made until this expansion has taken place.

(9) Using a screwdriver, assemble suction pipe, wiper motor hoses, and retaining clip screws.

d. Windshield Assembly Installation.

(1) **TOOL REQUIRED:**

Wrench, open-end, 1/2-in. •

(2) Place the windshield assembly in the windshield frame.

(3) Place the windshield hinge bracket that was removed in disassembly in position and install the three bolts; using a 1/2-inch open-end wrench tighten bolts.

(4) Replace the windshield hand adjusting screws and washers.

(5) Connect the windshield wiper hose at left side of windshield.

(6) Pull canopy into place and fasten to windshield header.

BOMB SERVICE TRUCK M6 (Chevrolet)

Section XIV

BRAKE SYSTEM

	Paragraph
General description	51
Functioning	52
Trouble shooting	53
Brake adjustment	54
Parking brake adjustment	55
Bleeding hydraulic system	56
Hydraulic brake tubing	57
Master cylinder	58
Wheel cylinder	59
Brake shoe replacement	60
Parking brake band replacement	61
Hydrovac booster system	62
Trailer electric brake control	63

51. GENERAL DESCRIPTION.

The braking system combines hydraulically operated service brakes, a hydrovac booster system, a mechanically operated parking brake and electrically controlled trailer brake. In order to understand the operation of the hydraulic brake system, it is necessary to have a thorough knowledge of the various parts and their functions and to know what takes place throughout the system during application and release of the brakes. The brake construction at the front wheel is shown in figure 24.

52. FUNCTIONING.

Pressure applied to the brake pedal is transmitted from the push rod to the piston in the master cylinder, then into the pipe lines and into the wheel cylinders. This pressure forces the pistons in the wheel cylinders outward, expanding the brake shoes against the drum. As the pedal is further depressed, higher pressure is built up within the hydraulic system, causing the brake shoes to exert greater force against the brake drums. As the pedal is released, the hydraulic pressure is relieved and the brake shoe retracting springs draw the shoes together, pressing the wheel cylinder pistons inward and forcing the fluid out of the wheel cylinders back into the lines toward the master cylinder.

BRAKE SYSTEM

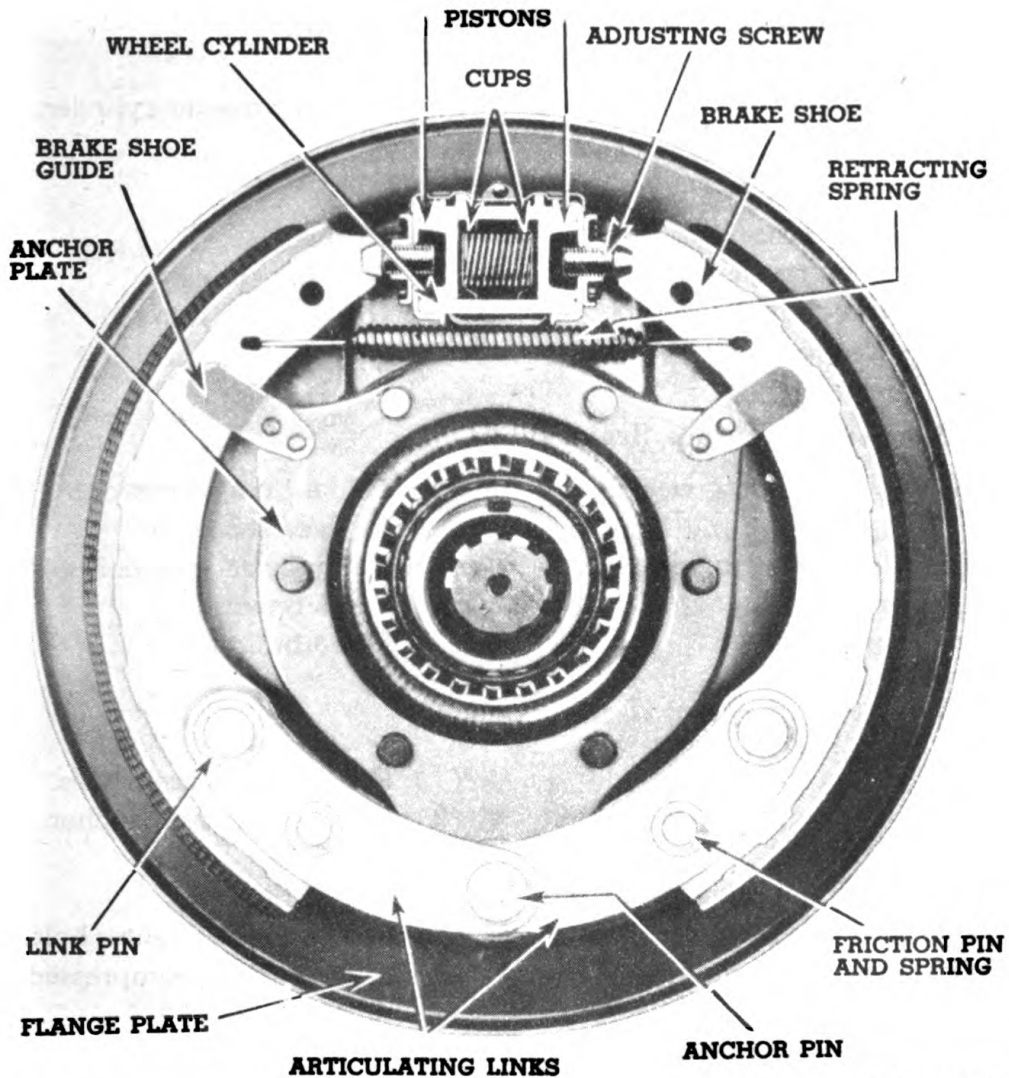

RA PD 32224

Figure 24—Brake Construction—Front Wheel

53. TROUBLE SHOOTING.

Symptom	Probable remedy
<p>a. Brake Pedal.</p> <p>(1) Pedal "spongy." Air in lines.</p>	<p>(1) Bleed brakes.</p>
<p>b. Brakes Drag.</p> <p>(1) Mineral oil in system.</p>	<p>(1) Wash out lines and cylinder and replace rubber parts.</p>

BOMB SERVICE TRUCK M6 (Chevrolet)

Symptom	Probable remedy
(2) Improper toeboard clearance.	(2) Adjust.
(3) Dirt in master cylinder.	(3) Replace master cylinder.
c. One Brake Drags.	
(1) Loose wheel bearing.	(1) Adjust.
(2) Weak retractor spring.	(2) Replace spring.
(3) Brake shoes adjusted too close to drum.	(3) Readjust.
d. Necessary to Pump Brake Pedal.	
(1) Normal lining wear.	(1) Brake lining worn out. Replace shoes.
(2) Fluid low in master cylinder.	(2) Fill master cylinder and bleed brakes.
(3) Air in line.	(3) Bleed brakes.
e. Brakes Uneven.	
(1) Oil on lining.	(1) Replace with new shoes.
(2) Shoes tight on brake anchor.	(2) Free up shoes on anchor.
(3) Tires improperly inflated.	(3) Inflate tires.
(4) Spring center bolt sheared.	(4) Replace spring center bolt.
(5) Dust between drum and shoe.	(5) Blow out with compressed air.
f. Excessive Pedal Pressure, Poor Brakes.	
(1) Oil on lining.	(1) Replace brake shoes.
(2) Full area of lining not contacting drum.	(2) Sand shoes so linings contract drum properly.
(3) Scored brake drum.	(3) Turn drum, or replace it. If lining is scored, shoes should be replaced.
g. Hydrovac Booster Fails to Operate.	
(1) Dirty air cleaner.	(1) Clean according to paragraph 62 d.
(2) Vacuum line leaks.	(2) Find location and correct.
(3) Vacuum valve sticking.	(3) Remove and clean valve. Replace worn or damaged parts.

BRAKE SYSTEM

Symptom	Probable remedy
(4) Lack of lubricant in vacuum cylinder.	(4) Lubricate. See section IV.
(5) Worn parts in hydrovac unit.	(5) Replace unit.

54. BRAKE ADJUSTMENT.

a. Tools Required:

Jack, 41-5-73-5

Screwdriver, 5½-in.

Stands, jack, four

Wrench, open-end, ⅝-in.

(1) The brakes can be adjusted without the removal of the wheels, as the front brake flange plates have openings with spring snap covers, through which the adjustment may be reached. The rear brakes are adjusted by turning an adjusting pinion on the inside of the flange plate.

(2) Raise the truck and place jack stands front and rear so that all four wheels rotate freely.

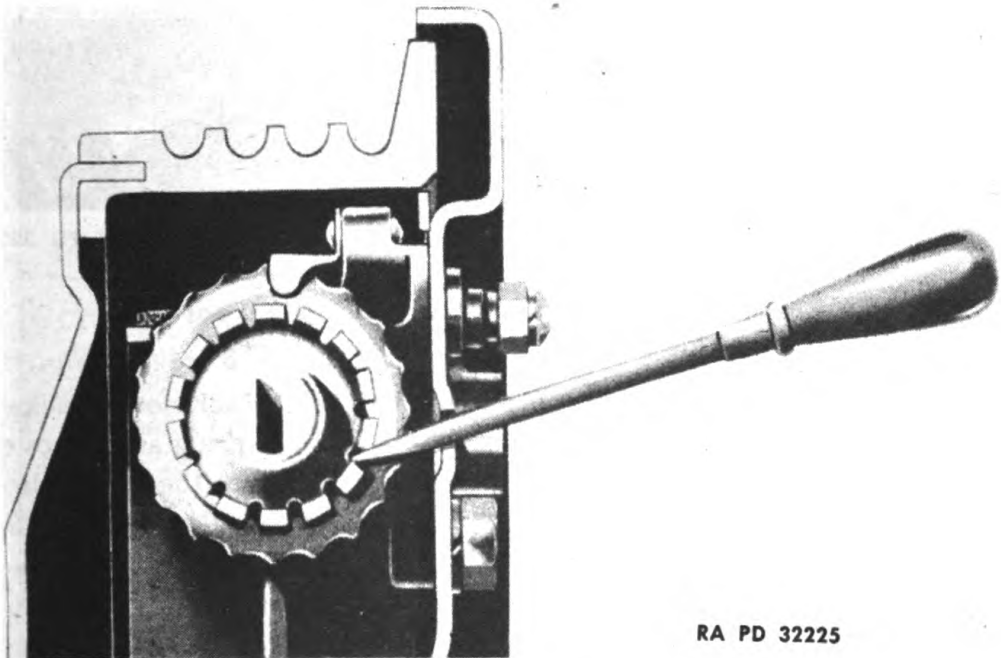

RA PD 32225

Figure 25—Adjusting Brakes—Front Wheel

(3) Remove the adjusting hole covers from the front flange plates and insert a screwdriver through the adjusting hole and engage the teeth on the adjusting cover of the wheel cylinder (fig. 25).

BOMB SERVICE TRUCK M6 (Chevrolet)

(4) Turn the adjusting cover in a clockwise direction, looking at the end of the cylinder, until the shoes cause a slight drag on the drum.

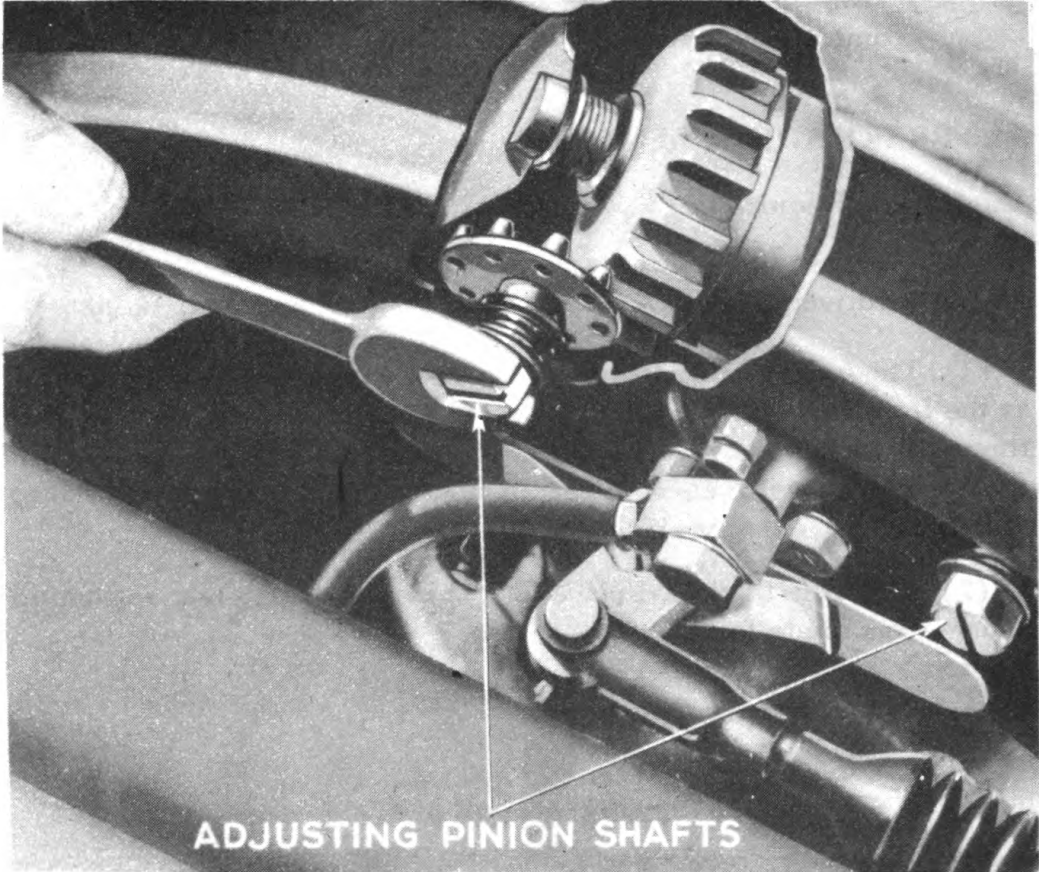

RA PD 32226

Figure 26—Adjusting Brakes—Rear Wheel

(5) Turn the adjusting cover back four notches. Each notch backed off will be indicated by a faint click of the cover lock spring as the cover is turned. This backing off of the adjusting cover moves the brake shoe away from the drum to insure proper running clearance of the shoes in the drum.

(6) Replace the adjusting hole covers.

(7) To adjust the rear brakes, use a $\frac{5}{8}$ -inch open-end wrench to turn the adjusting pinion (fig. 26). Turn the pinion in a clockwise direction until shoe causes a slight drag on the drum.

(8) Turn the adjusting pinion back two-thirds of a turn or four sides of the hexagon on pinion shaft to provide running clearance.

BRAKE SYSTEM

b. Toeboard Clearance.

(1) TOOLS REQUIRED:

Pliers, 6-in.

Wrench, $\frac{9}{16}$ -in.

(2) Toeboard clearance very seldom needs to be adjusted. The pedal stop, which is located in the brake main cylinder, is permanent. Before attempting to adjust toeboard clearance be certain that the pedal returns to the full released position freely, with no binding, and that the pedal retracting spring has not lost its tension.

(3) Loosen the check nut on the rear of the clevis on the master cylinder push rod, using a $\frac{9}{16}$ -inch wrench.

(4) Remove clevis pin and turn the clevis attached to the master cylinder push rod (fig. 27), in the proper direction to secure $\frac{1}{4}$ -inch toeboard clearance, measurement being taken between pedal arm and underside of toe-pan.

(5) Tighten the check nut against the clevis.

55. PARKING BRAKE ADJUSTMENT.

a. Tools Required:

Gage, clearance

Wrench, open-end, $\frac{7}{16}$ -in.

Pliers, 6-in.

Wrench, open-end, $\frac{5}{8}$ -in.

b. Procedure.

(1) The parking brake adjustment should be checked each time the hydraulic service brakes are adjusted.

(2) Set hand brake lever in fully released position, then detach pull-rod (3) (fig. 28).

(3) Remove rear anchor screw lock wire at (1) and turn the adjusting screw to secure 0.010-inch to 0.015-inch clearance between the brake band and drum underneath brake anchor.

(4) Lock the anchor adjusting screw with a lock wire.

(5) Loosen lower shoe adjustment lock nut (6) on figure 28, using $\frac{7}{16}$ -inch open-end wrench.

(6) Turn the adjusting screw (7) to secure 0.020-inch between the lower end of the band and drum. Tighten adjusting screw lock nut (6).

BOMB SERVICE TRUCK M6 (Chevrolet)

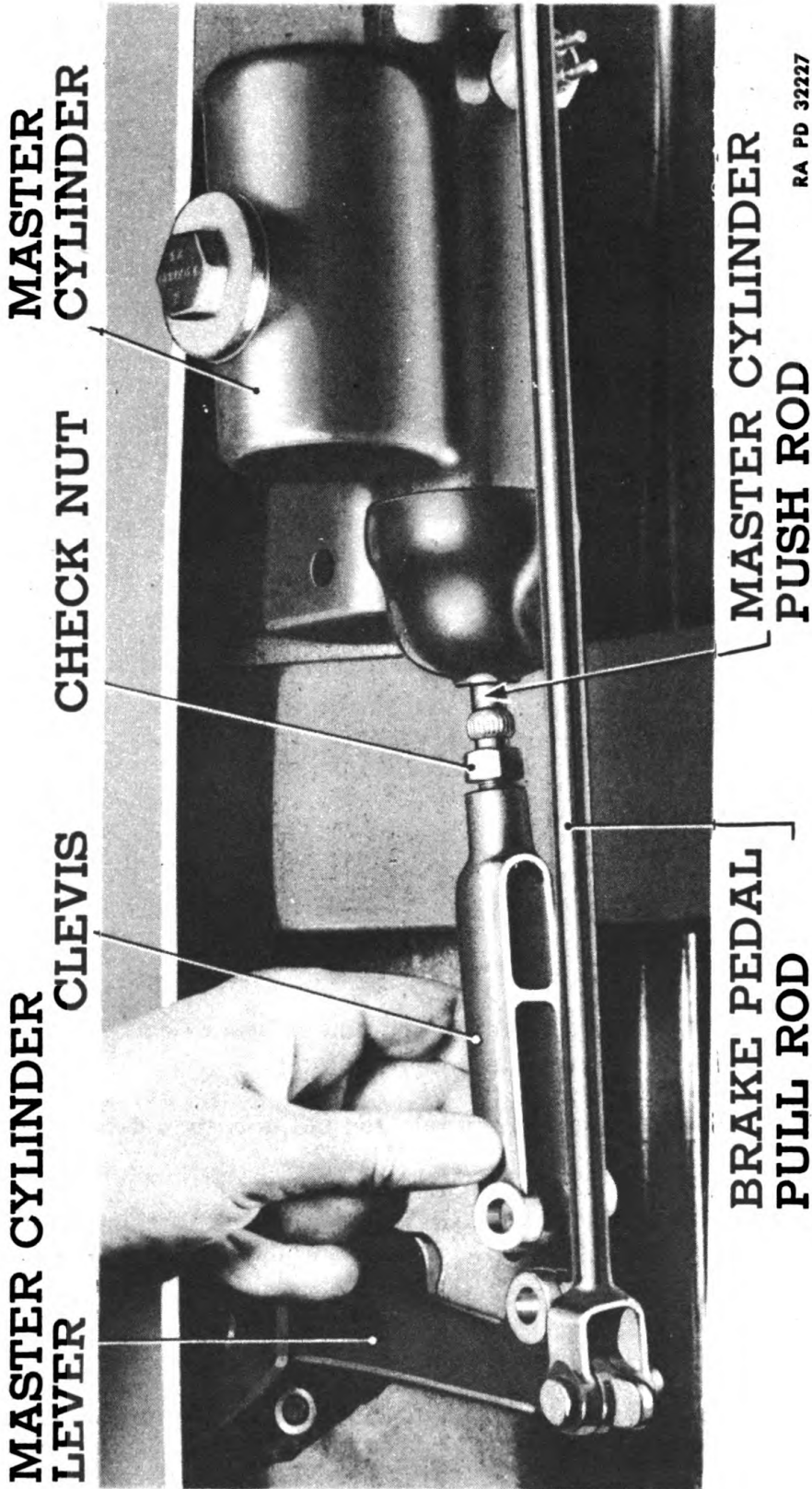

Figure 27 - Adjusting Foot Pedal Toeboard Clearance

BRAKE SYSTEM

(7) With a $\frac{5}{8}$ -inch open-end wrench loosen lock nut on large adjusting bolt and back it off until it is free of the adjusting nut. See No. 10 on figure 28.

(8) Turn adjusting nut on adjusting bolt (5) to secure 0.020-inch clearance between upper end of band and the drum. Then tighten the lock nut securely while holding the adjusting nut to prevent upsetting adjustment.

(9) Lubricate all of sectional surfaces of the brake control linkage and anchor bolts with OIL, engine.

56. BLEEDING HYDRAULIC SYSTEM.

a. Tools Required:

Filler, master cylinder,
41-F-2980

Jar, bleeder

Tube, bleeder, J-747 (KM)

Wrench, open-end, $\frac{5}{16}$ -in.

Wrench, open-end, $\frac{3}{8}$ -in.

Wrench, open-end, $\frac{7}{8}$ -in.

b. The hydraulic brake system must be bled whenever a pipe line has been disconnected or when a leak has allowed air to enter the system. A leak in the system may sometimes be evident through the presence of a "spongy" brake pedal. Air trapped in the system is compressible and prevents all pressure applied to the brake pedal from being transmitted to the brake shoes. The system must be **ABSOLUTELY** free from air at all times. **NOTE:** Before bleeding the wheel cylinder lines on vehicles equipped with the hydrovac booster system, it is first necessary to bleed the hydrovac unit. This procedure is explained in paragraph 62.

c. After the hydrovac unit has been bled, proceed with bleeding the wheel cylinder lines. The longest pipe line of the brake system should be bled first. The proper sequence for bleeding is: left rear, left front, right rear, and lastly, right front. See bleeding diagram (fig. 40). During bleeding operations, the master cylinder must be kept at least half full of hydraulic brake fluid. The master cylinder filler (fig. 29) automatically maintains the correct fluid level in the master cylinder during bleeding.

d. **Procedure.** Carefully clean all dirt from around the master cylinder filler plug.

(1) Remove filler plug, using a $\frac{7}{8}$ -inch open-end wrench. Install adapter and automatic filler. Open automatic valve in the filler.

BOMB SERVICE TRUCK M6 (Chevrolet)

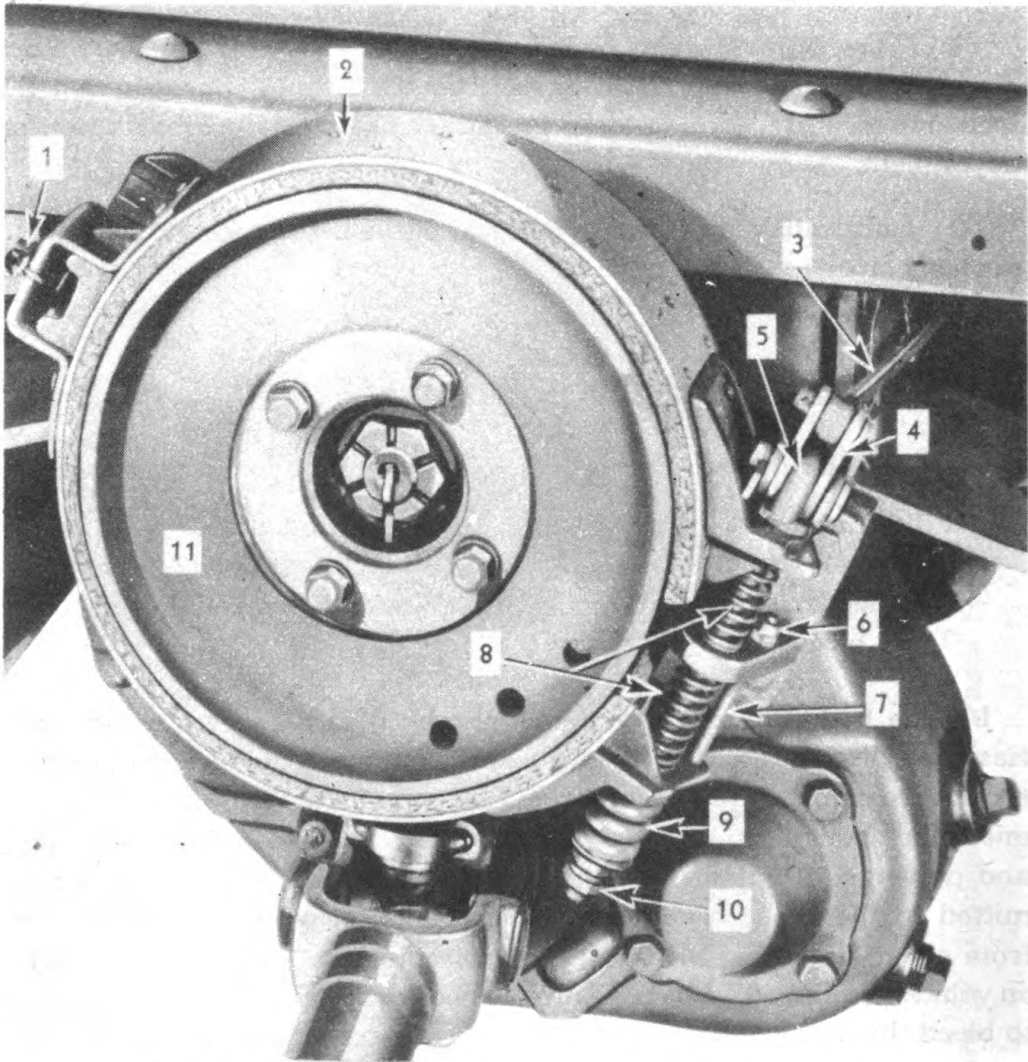

- 1 — BRAKE ANCHOR
- 2 — BRAKE BAND WITH LINING
- 3 — BRAKE PULL ROD
- 4 — OPERATING CAM
- 5 — ADJUSTING BOLT
- 6 — ADJUSTING SCREW LOCK NUTS (LOWER SHOE)
- 7 — ADJUSTING SCREW (LOWER SHOE)
- 8 — SPRINGS (SHOE RELEASE)
- 9 — SPRING (UPPER SHOE ADJUSTING)
- 10 — ADJUSTING BOLT NUTS (UPPER SHOE)
- 11 — BRAKE DRUM

RA PD 32228

Figure 28—Parking Brake Construction

BRAKE SYSTEM

(2) Remove bleeder valve screw, using $\frac{5}{16}$ -inch open-end wrench. Attach bleeder drain (fig. 30), keeping the end of the drain hose below the surface of the fluid in the jar.

(3) Unscrew bleeder valve in wheel cylinder one-half to three-quarters turn, using $\frac{3}{8}$ -inch open-end wrench.

(4) Depress the foot pedal by hand, allowing it to return slowly. Continuing this pumping action forces the fluid through the lines and out at the bleeder drain, carrying with it any air in the system. When bubbles cease to appear at the end of the bleeder drain hose shut off the bleeder valve and remove the drain hose.



Figure 29—Master Cylinder Filler

(5) Replace and tighten the screw at the end of the bleeder valve.

(6) After bleeding operation has been completed at all wheels, fill the master cylinder reservoir approximately full, and replace the filler

BOMB SERVICE TRUCK M6 (Chevrolet)

plug, using a $\frac{7}{8}$ -inch open-end wrench. NOTE: Fluid withdrawn in the bleeding operation should not be used again. Only approved brake fluid should be used, and never oil.

57. HYDRAULIC BRAKE TUBING.

a. The hydraulic brake tubing is a double layer, flexible steel tubing, treated to resist corrosion and also to stand up under the high pressures which are developed when applying the brakes.

(1) The important thing in connection with making up hydraulic brake pipes is the proper flaring of the ends of the tubing for the compres-

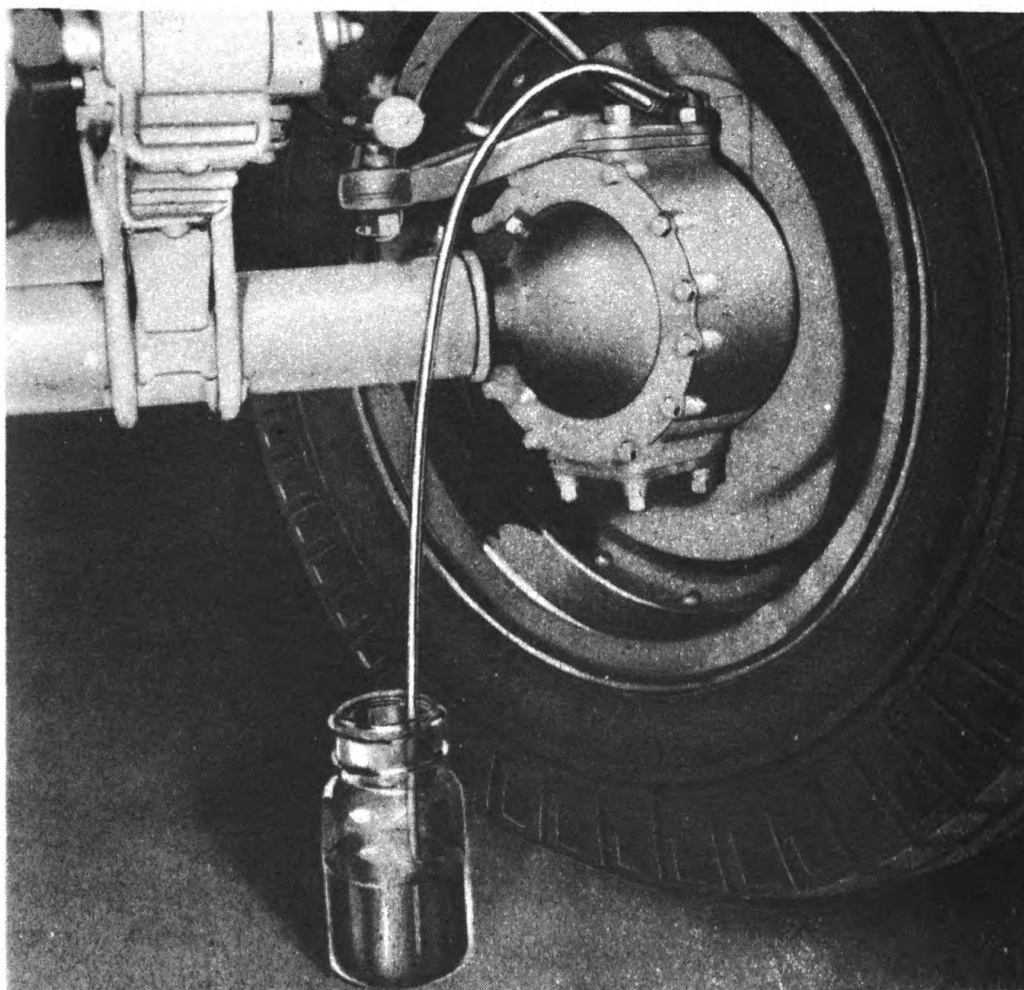

RA PD 32230

Figure 30—Bleeding Wheel Cylinder

sion couplings. Unless the tubing is properly flared, the couplings will leak and the brake will become ineffective.

(2) This safety steel tubing *must* be double-lap-flared in order to produce a strong, leak-proof joint.

BRAKE SYSTEM

(3) The brake-flaring tool (fig. 31) is used to form the double-lap flare.

b. Directions.

(1) TOOLS REQUIRED:

Cutter, tube, 41-C-2825
Tool, brake tube, flaring,
J-1280 (KM)

Wrench, open-end, $\frac{7}{8}$ -in.
Wrench, open-end, $\frac{1}{2}$ -in.

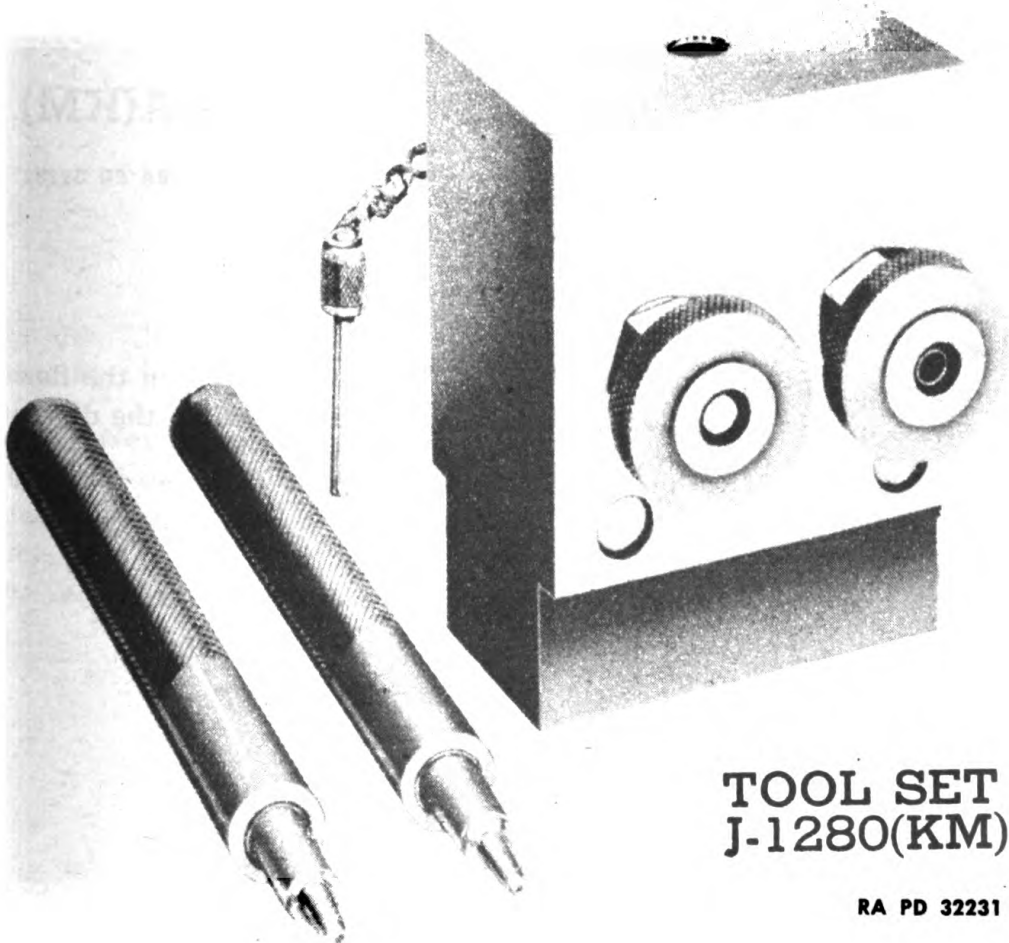

**TOOL SET
J-1280(KM)**

RA PD 32231

Figure 31—Brake Tube Flaring Tool

(2) Cut the tubing to the desired length, using tube cutter to prevent flattening the tubing (fig. 32). Square off the end with a fine-cut mill file, then ream the sharp edges with the reamer blade provided on the tube cutter. The reamer blade can be seen in figure 32.

BOMB SERVICE TRUCK M6 (Chevrolet)

(3) Place new inverted flared tube nuts on the tubing. Dip end of tubing to be flared in hydraulic brake fluid. This lubrication results in

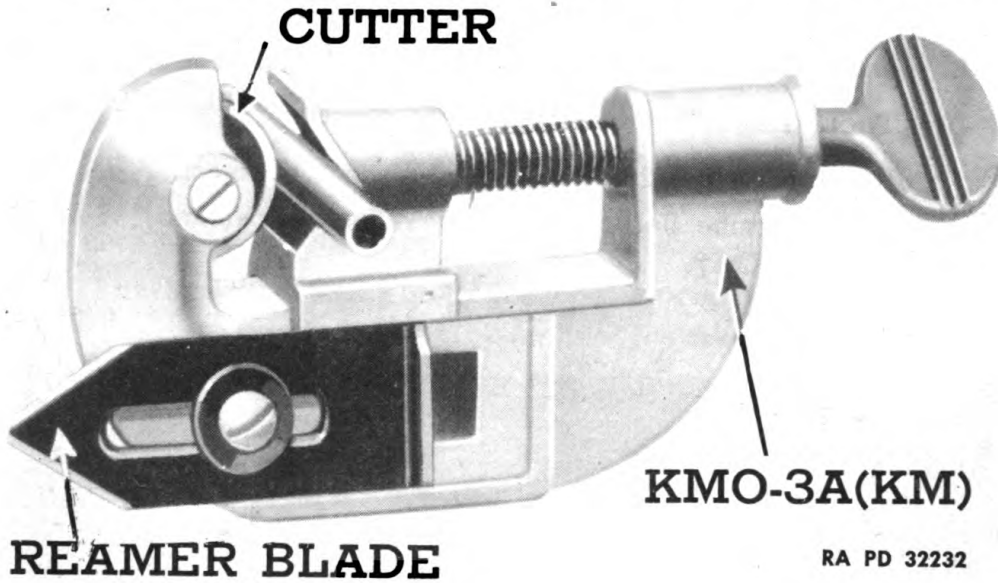

Figure 32—Brake Tube Cutting Tool

a better formation of the flare. Loosen the clamping nuts on the flaring tool and insert finished end of the tubing in the channel of the die until it bears against the stop pin (fig. 33).

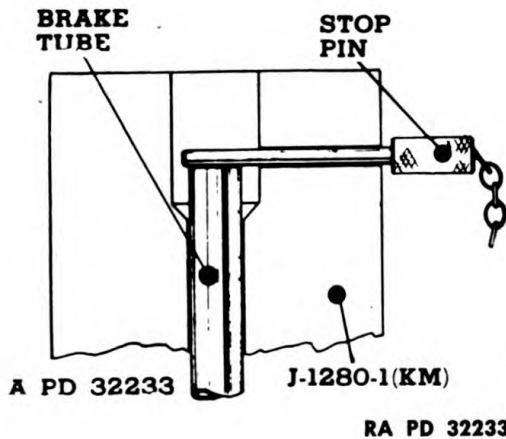

Figure 33—Installing Tube to Proper Depth in Tool

(4) Tighten the clamping nuts by hand and place the fixture in a bench vise. Then tighten down the clamping nuts firmly with a wrench and remove the stop pin from the die. The tubing is now firmly gripped in the die and ready for the first flare-forming operation.

BRAKE SYSTEM

(5) Using the flare-forming tool (J-1280-2) having the concave die, insert the forming tool in the die and strike firm blows, using a one-pound hammer, until the shoulder of the tool contacts the top of

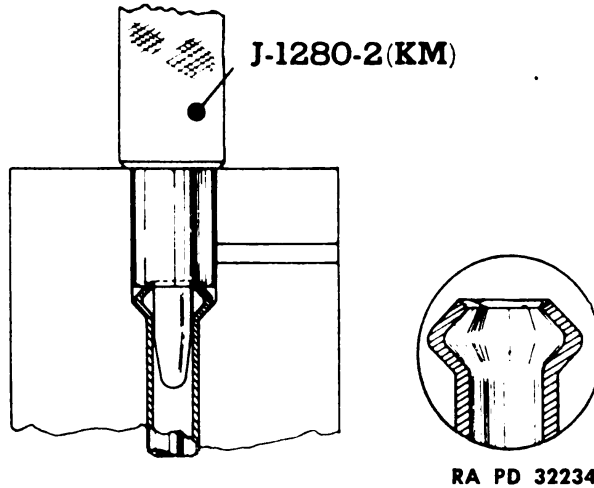

Figure 34—First Flare Forming Operation

the die. The cross section drawing (fig. 34) shows the first step in forming the double-lap flare.

(6) Next, using the flare-forming tool (J-1280-3) having the 46-degree die at its lower end, insert the tool in the die and strike firm blows, using a one-pound hammer, until the shoulder of the tool contacts the top of the die. The cross section drawing (fig. 35) shows the second and final forming operation in making a double-lap flare.

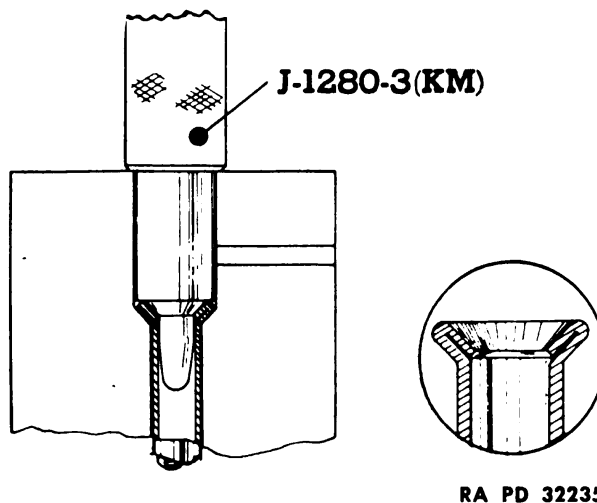
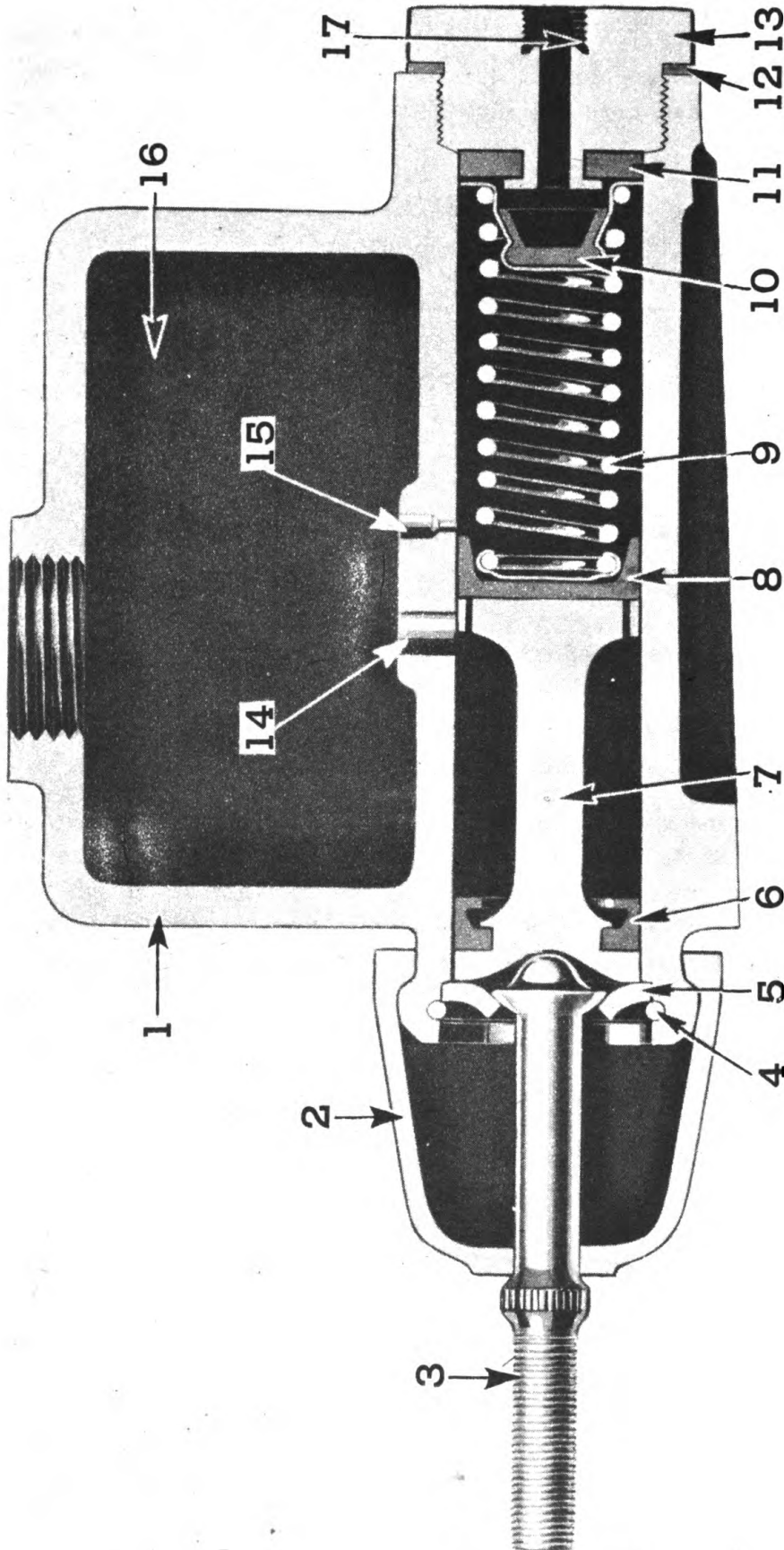

Figure 35—Final Flare Forming Operation

Original from

UNIVERSITY OF CALIFORNIA

BOMB SERVICE TRUCK M6 (Chevrolet)



RA PD 32236

Figure 36—Master Cylinder Cross Section

BRAKE SYSTEM

- | | |
|------------------------|----------------------|
| 1—Master cylinder body | 10—Valve |
| 2—Dust boot | 11—Valve seat |
| 3—Pedal link | 12—End plug gasket |
| 4—Snap ring | 13—End plug |
| 5—Link retainer | 14—Inlet port |
| 6—Secondary piston cup | 15—Compensating port |
| 7—Piston | 16—Reservoir |
| 8—Primary piston cup | 17—Outlet |
| 9—Return spring | |

RA PD 32236A

Nomenclature for Figure 36—Master Cylinder Cross Section

BOMB SERVICE TRUCK M6 (Chevrolet)

c. Brake Hose Replacement.

(1) To allow for frame movement, flexible brake hose is used at each of the front wheels and also between the main pipe line and the line leading to the rear wheels. To prevent the brake hose at the front from contacting the wheel, a clamp is connected onto the hose and a spring attached from it to the shock absorber link. The composition of the brake hose is such that it permits a great amount of flexing action without destroying the brake fluid seal, thus preventing air leaks or loss of fluid.

(2) When replacing a brake hose, care must be taken to make certain that the hose is seating properly in the couplings; otherwise leaks will cause the brakes to become ineffective. This can be checked by applying pressure to the brake foot pedal and at the same time carefully inspecting the surface surrounding the hose joint for any signs of leaks. If even the smallest of bubbles appears, it will be necessary to tighten the connection further. If proper seal cannot be obtained by tightening the fitting, then replace the coupling as outlined in paragraph 57 c.

58. MASTER CYLINDER.

a. Description.

(1) The piston in the master cylinder (fig. 36) receives mechanical pressure from the push rod and exerts pressure on the fluid in the lines, building up the hydraulic pressure which moves the wheel cylinder pistons. The primary cup is held against the piston by the piston return spring, which also retains the return valve against its seat. The spring maintains a slight pressure in the lines and in the wheel cylinders to prevent the possible entrance of air into the system. The secondary cup, which is secured to the opposite end of the piston, prevents the leakage of fluid into the rubber boot.

(2) Holes in the piston head allow the fluid to flow from the annular space around the piston into the space between the primary cup and the check valve, thereby keeping sufficient fluid in the lines at all times. The compensating port (15) allows pressure to equalize between reservoir and cylinder, and must be kept clean and open, as fluid expands or contracts with temperature changes. Holes in the valve cage allow the fluid to flow through the cage and around the lip of the rubber valve cup and out into the lines during brake application. When the brake is released, the valve is forced off its seat, permitting the fluid to return to the master cylinder. The push rod assembly is held in the opposite end of the housing by means of a snap ring. The rubber

BRAKE SYSTEM

boot that fits around the push rod and over the end of the housing prevents dirt or any other foreign matter from entering the master cylinder.

b. Servicing. The level of the fluid in the master cylinder should be inspected at least once a month or every 1000 miles. For proper level, the master cylinder reservoir should be approximately full. Any noticeable loss indicates a leak in the system which should be located and stopped.

c. Unit Replacement.

(1) TOOLS REQUIRED:

Filler, master cylinder, 41-F-2980	Wrench, box, $\frac{5}{8}$ -in.
Jar, bleeder	Wrench, open-end, $\frac{7}{16}$ -in.
Tube, bleeder, J-747 (KM)	

(2) The master cylinder assembly should be removed and replaced as a unit when any part of it is damaged.

(3) Remove clevis pin from master cylinder link to idler lever.

(4) Disconnect brake pipe from master cylinder end plug with a $\frac{7}{16}$ -inch wrench, and raise end, so fluid cannot run out.

(5) Remove wires from stop light switch.

(6) Remove the two nuts which attach the master cylinder to the frame bracket, using $\frac{5}{8}$ -inch box wrench.

(7) Install a new assembly, reconnect, and refill with fluid. Bleed the brake system.

59. WHEEL CYLINDER.

a. The wheel cylinder (fig. 24) contains two pistons, their purpose being to transmit the pressure evenly to each of the two brake shoes. The adjusting covers serve two purposes: first, to cover the ends of the cylinder and prevent the entrance of dirt and foreign matter into the cylinder; and second, to serve as a means of adjusting the brake shoes to the proper drum clearance, since they are threaded to receive the slotted adjusting screws which fit the webs of the brake shoes.

b. Unit Replacement.

(1) TOOLS REQUIRED:

Filler, master cylinder, 41-F-2980	Stand, jack
Jack, 41-J-73-5	Tube, bleeder, J-747 (KM)
Jar, bleeder	Wrench, open-end, $\frac{7}{16}$ -in.
Pliers	Wrench, open-end, $\frac{1}{2}$ -in.
Screwdriver	Wrench, open-end, $\frac{5}{8}$ -in.
	Wrench, wheel stud nut

BOMB SERVICE TRUCK M6 (Chevrolet)

(2) Place the vehicle on a level spot. In order to remove the hydraulic brake wheel cylinder, the vehicle must be jacked up and the wheel removed, using wheel stud nut wrench.

(3) Remove brake drum and hub. See paragraph 174 a (2) to (7).

(4) Disconnect lead pipe or hose from the wheel cylinder, using $\frac{5}{8}$ -inch open-end wrench.

(5) Disconnect brake shoe retracting spring with brake spring pliers.

(6) The two cap screws which hold the cylinder to the brake flange plate must be removed before the cylinder can be taken from the flange plate, using a $\frac{1}{2}$ -inch open-end wrench.

(7) Install a new wheel cylinder assembly, reconnect and bleed system.

60. BRAKE SHOE REPLACEMENT.

a. Tools Required:

Clamps, wheel cylinder,
J-718-C (KM)
Filler, master cylinder,
41-F-2980
Jack, 41-J-73-5
Pliers, 6-in.
Pliers, brake spring,
41-P-1579

Screwdriver, 8-in.
Stands, jack, four
Tube, bleeder, J-747 (KM)
Wrench, open-end, $\frac{7}{8}$ -in.
Wrench, open-end, $\frac{9}{8}$ -in.
Wrench, open-end $\frac{5}{8}$ -in.
Wrench, wheel stud nut

b. Inspection.

(1) Place vehicle on level spot, jack up vehicle and place on four jack stands.

(2) Using wheel stud nut wrench, remove stud nuts and take off all wheels.

(3) Remove drums and hubs. See paragraph 174 a (2) to (7).

(4) After removal of the brake drums and before disassembly of the shoes from the anchor plate, all linings should be inspected for wear, improper alignment causing uneven wear, and oil or grease on linings.

(5) If any of the conditions listed in (4) above exist, it will be necessary to replace the shoes.

BRAKE SYSTEM

(6) If, in checking the linings, it is noticed that they have the appearance of being glazed, remember that this is a normal condition with the hard type lining used. Do not use a wire brush or any abrasive on the lining to destroy this glazed surface as it is essential for proper operation.

c. Brake Shoe Removal.

(1) Satisfactory performance can be obtained by replacing only the forward shoes when the reverse linings do not show excessive wear. Tests have shown that in most cases the reverse lining will outlast two sets of forward linings. This is true of both front and rear wheel brakes. Shoes should be changed in sets, that is, both forward shoes on front wheels, or both forward and reverse shoes on front wheels. The same is true on the rear wheels.

(2) After drums and hubs are removed, install wheel cylinder clamps (fig. 37) to keep the wheel cylinder pistons in place and prevent leakage of brake fluid while replacing shoes.

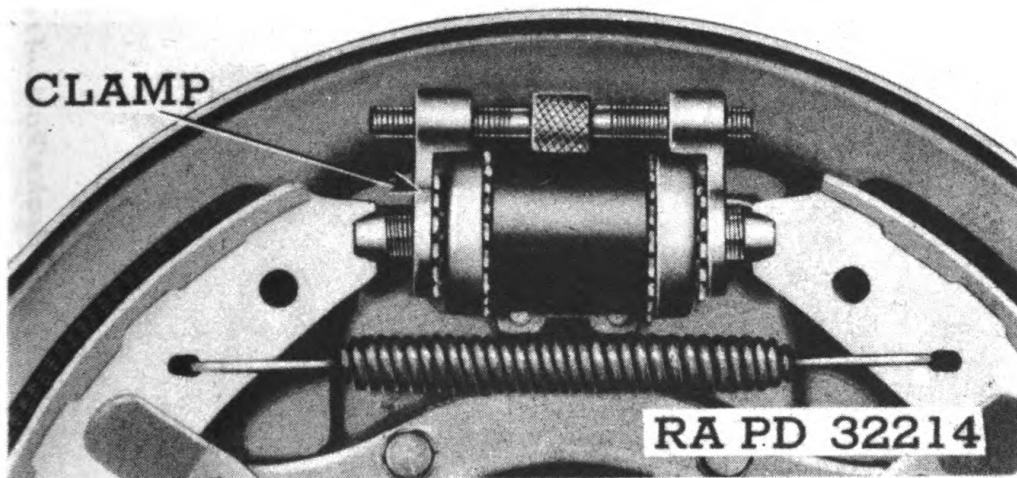

Figure 37—Brake Wheel Cylinder Clamp

(3) Remove brake shoe retracting springs, using special brake spring pliers.

(4) Remove the brake shoe anchor pin lock and pin—one on front brakes, two on rear.

(5) Remove articulating link friction spring pin lock, pin and spring. Disassemble articulating links from shoes by removing pin lock and pin. Figure 38 shows a layout of the front wheel brake parts and figure 39 the rear brake parts.

BOMB SERVICE TRUCK M6 (Chevrolet)

RA PD 32238

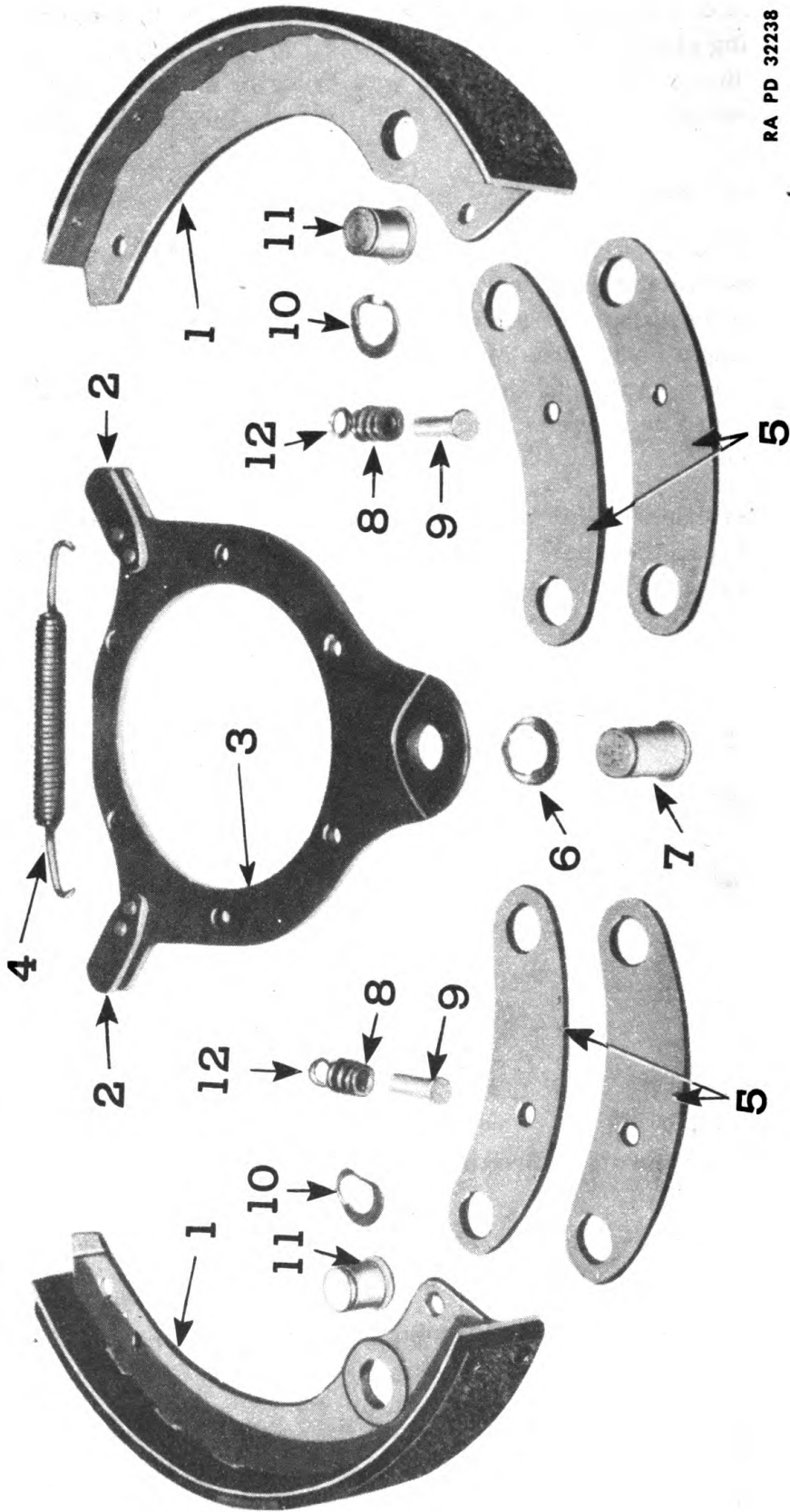

Figure 38 — Brake Parts—Front Wheel

BRAKE SYSTEM

- 1—Brake shoe
- 2—Brake shoe guide
- 3—Anchor plate
- 4—Retracting spring
- 5—Articulating links
- 6—Anchor pin lock
- 7—Anchor pin
- 8—Articulating link friction spring
- 9—Friction spring pin
- 10—Articulating link pin lock
- 11—Articulating link pin
- 12—Friction spring pin lock

RA PD 32238A

Nomenclature for Figure 38—Brake Parts—Front Wheel

BOMB SERVICE TRUCK M6 (Chevrolet)

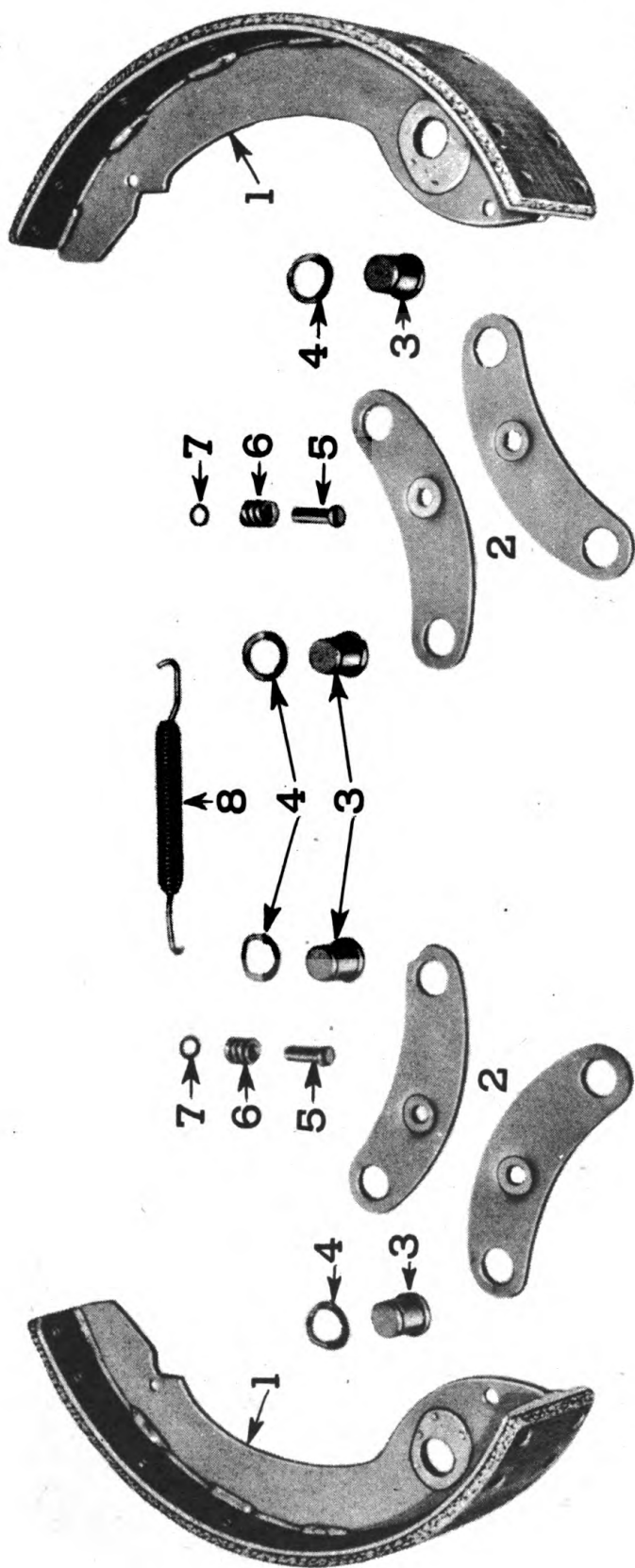

RA PD 32239

Figure 39 — Brake Parts—Rear Wheel

BRAKE SYSTEM

- | | |
|--------------------------------|--|
| 1—Brake shoe and lining | 5—Articulating link friction spring pin |
| 2—Brake shoe articulating link | 6—Articulating link friction spring |
| 3—Articulating link pin | 7—Articulating link friction spring lock |
| 4—Articulating link pin lock | 8—Brake shoe retracting spring |

RA PD 32239A

Nomenclature for Figure 39—Brake Parts—Rear Wheel

BOMB SERVICE TRUCK M6 (Chevrolet)

d. Installation.

- (1) Reassemble articulating links, pins, friction springs and locks to new brake shoes and assemble shoes to anchor plate.
- (2) Check fit of shoe in the brake shoe guide riveted to the anchor plate. The shoe should be free without excessive side movement.
- (3) Install brake shoe retracting spring and remove wheel cylinder clamp.
- (4) Replace wheels and hubs and adjust the wheel bearings as outlined in paragraph 174.

61. PARKING BRAKE BAND REPLACEMENT.

a. Disassembly.

(1) **TOOLS SUPPLIED:**

- | | |
|-----------------|---------------------------------------|
| Gage, clearance | Wrench, open-end, $\frac{7}{16}$ -in. |
| Pliers, 6-in. | Wrench, open-end, $\frac{5}{8}$ -in. |

- (2) Remove the lock nut, lockwasher, adjusting nut flat washer and spring from the large adjusting bolt, using a $\frac{5}{8}$ -inch wrench (5) and (10) (fig. 28).
- (3) Remove cotter key and clevis pin from operating cam and adjusting bolt (4) (fig. 28). Remove adjusting bolt and shoe springs.
- (4) Remove nuts from lower shoe adjustment screw (6) (fig. 28) and remove the screw and lower shoe spring, using a $\frac{7}{16}$ -inch open-end wrench.
- (5) Remove rear anchor screw lock wire (1) (fig. 28) and remove the screw. Then slide the band assembly off the anchor.

b. Reassembly.

- (1) After replacement, the brake band should be formed as necessary to conform to the shape of the drum.
- (2) Reassemble the brake to its mounting and adjust it according to instructions given in paragraph 55.

62. HYDROVAC BOOSTER SYSTEM.

a. Description. The hydrovac booster system is installed to make available to the driver a greater pressure on the hydraulic brake system than he could possibly exert by his foot pressure on the brake pedal. This greatly increases the driver's ability to stop quickly when driving at high speeds or when heavily loaded on steep grades. In other words, the hydrovac booster system is an auxiliary power unit that applies additional force

BRAKE SYSTEM

to the hydraulic brake system. The hydrovac unit is a combined hydraulic and vacuum booster system, using the vacuum created in the engine intake manifold as an operating force. It is a self-contained unit and is placed between the regular master cylinder and the main line leading to the wheel cylinders. The hydrovac unit is so constructed that in case of engine failure and consequent loss of vacuum, the hydraulic fluid from the master cylinder bypasses the hydrovac unit and the brakes will function with the regular hydraulic system.

b. Bleeding Hydrovac Unit.

(1) TOOLS REQUIRED:

Filler, master cylinder	Tube, bleeder, J-747 (KM)
Jar, bleeder	Wrench, open-end, 1/2-in.

(2) To bleed the entire brake system, the hydrovac unit must be bled at all three bleeder valves before attempting to bleed at the wheel cylinders. The bleeder valves are bled in the order shown in figure 40. After the hydrovac bleeding process is completed, the wheel cylinders are bled in accordance with instructions previously given for bleeding brakes.

(3) After bleeding the wheel lines, start the engine and operate the hydrovac unit several times by depressing the brake pedal. Stop the engine and again bleed No. 3 bleeder valve on the hydrovac slave cylinder

c. Lubrication. The hydrovac power cylinder should be lubricated every 20,000 miles or after six months service (whichever occurs first) with OIL, engine, SAE 10. Remove the pipe plug (using a 1/2-inch open-end wrench) from the cylinder at the relay valve end of the unit and also the 1/8-inch pipe plug at the center plate, and inject two ounces of OIL, engine, SAE, in each opening. Replace lubrication plugs.

d. Maintenance. The outside of the hydrovac unit should be cleaned thoroughly and inspected every six months. All hose connection clamps should be tightened and all pipe fittings and hydraulic connections checked for looseness. The air cleaner should be removed, disassembled and cleaned at least twice a year. If the truck is operating under dirty conditions, the air cleaner should be cleaned more frequently. Remove the cover screw and remove the cleaning element and wash thoroughly in SOLVENTS, dry cleaning. Allow to dry, then dip the element in OIL, engine, light, and let it drain. Clean all dirt from the inside of the air cleaner housing and reassemble. A layout of the air cleaner parts is shown in figure 41.

e. Unit Removal.

(1) TOOLS REQUIRED:

Screwdriver, 6-in.	Wrench, open-end, 7/16-in.
	Wrench, open-end, 9/16-in.

(2) Disconnect at the hydrovac unit the hydraulic brake lines which lead to the master cylinder and wheel cylinder, using a 7/16-inch open-end wrench.

BOMB SERVICE TRUCK M6 (Chevrolet)

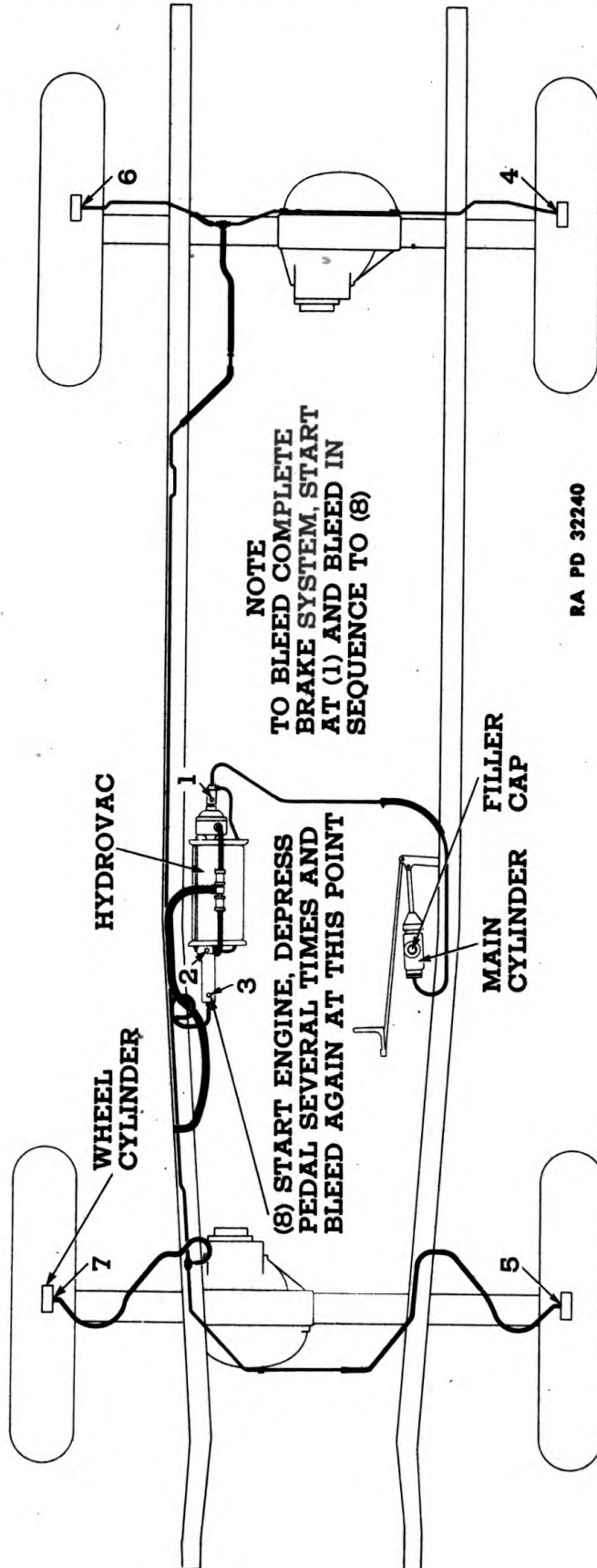
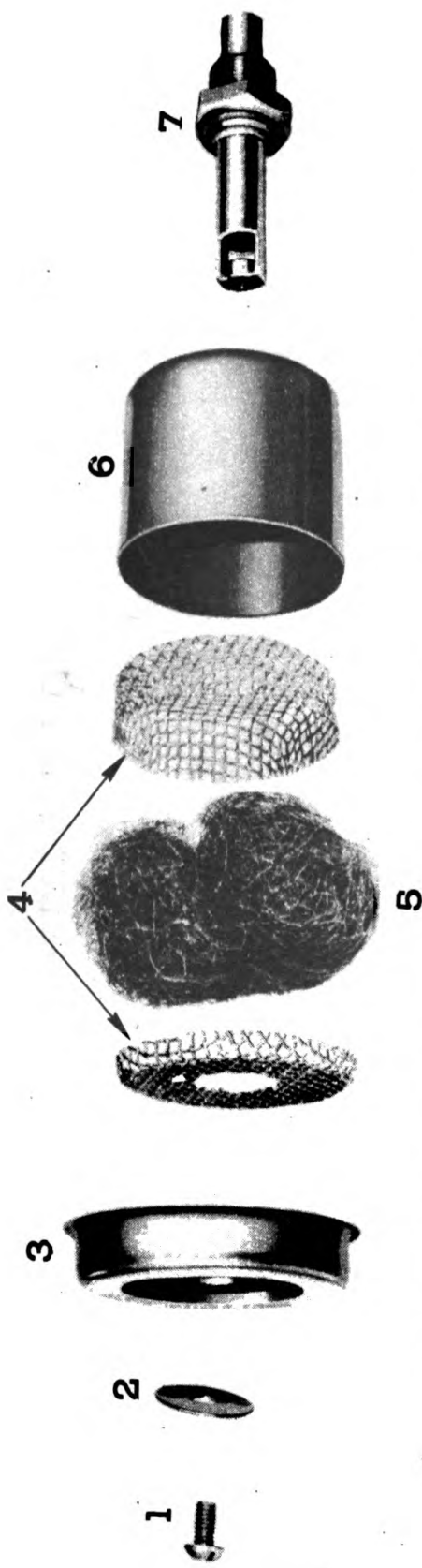

Figure 40—Brake Bleeding Diagram

BRAKE SYSTEM



- 1 — COVER SCREW
- 2 — FLAT WASHER
- 3 — AIR CLEANER COVER
- 4 — ELEMENT RETAINER
- 5 — FILTER ELEMENT
- 6 — AIR CLEANER BODY
- 7 — CORE AND SUPPORT

RA PD 32241

Figure 41 — Hydrovac Air Cleaner Parts

BOMB SERVICE TRUCK M6 (Chevrolet)

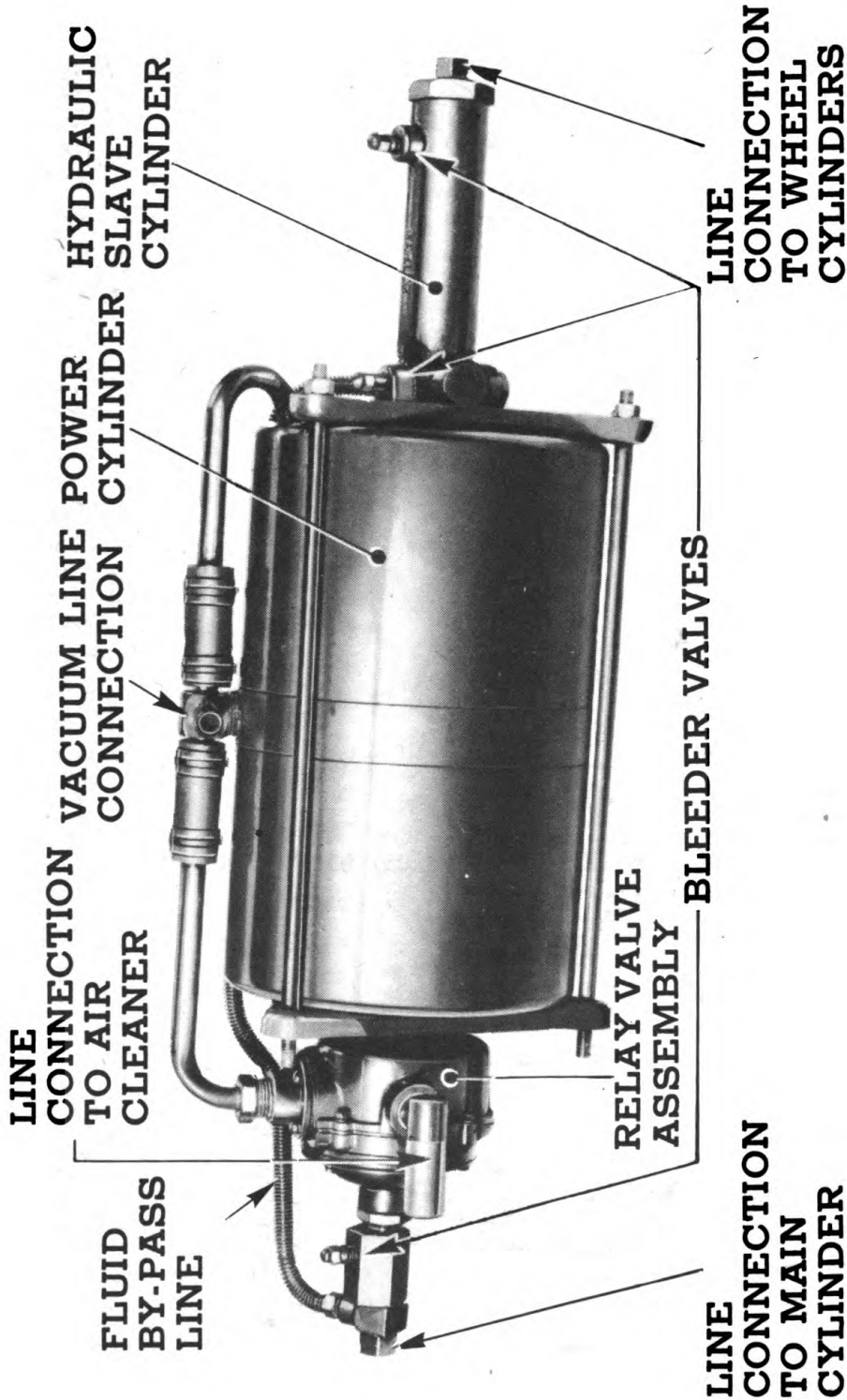

RA PD 32242

Figure 42 — Hydrovac Assembly

BRAKE SYSTEM

(3) Remove the hose connections to the air cleaner and the vacuum line, using a screwdriver.

(4) Remove the bolts which retain the hydrovac unit to the frame side rail, using a $\frac{9}{16}$ -inch open-end wrench. Remove the hydrovac booster unit (fig. 42).

f. Unit Installation.

(1) Reassemble hydrovac unit to the frame side rail and tighten bolts and nuts securely.

(2) Connect air cleaner and vacuum line hose connection.

(3) Connect hydraulic lines from master cylinders and wheel cylinder.

(4) Bleed entire hydraulic braking system according to instructions already given in this section.

g. Vacuum Line Check Valve. The vacuum line check valve is mounted on the dash in a rubber support fitting. The purpose of this valve is to trap the vacuum in the hydrovac unit in the event the engine stalls so that at least one application of the hydrovac braking system be made after the engine stops. Ordinarily this valve requires no attention; however, if the valve sticks, it should be disassembled and cleaned or replaced. The parts are shown in figure 43.

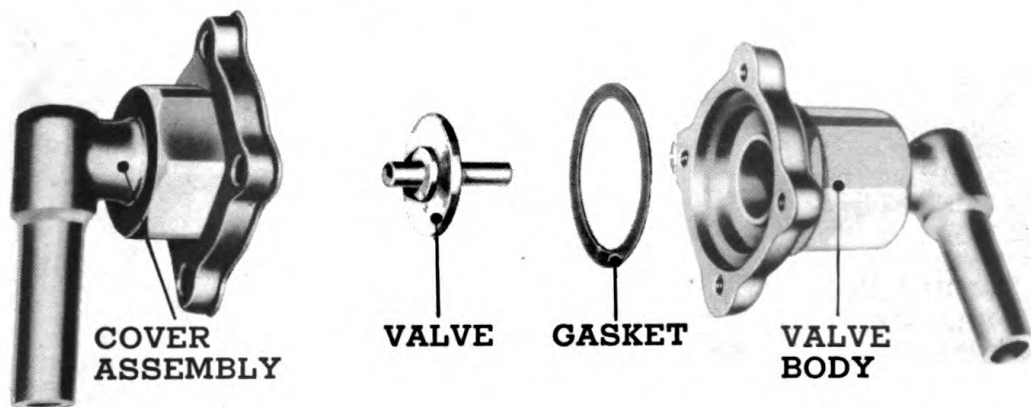

RA PD 32243

Figure 43—Hydrovac Vacuum Valve Parts

63. TRAILER-ELECTRIC BRAKE CONTROL.

a. An electric control unit for the trailer-brakes is mounted under the driver compartment floor boards as shown in figure 44. The control unit is connected by an adjustable rod clamped to the foot brake pedal pull rod, so that when the truck foot brakes are applied, the trailer-brakes also are applied. A stop light switch also is incorporated in this unit which controls both truck and trailer stop lights according to main light switch position.

BOMB SERVICE TRUCK M6 (Chevrolet)

b. A load control unit mounted on the instrument panel has four positions for light, medium, medium-heavy, and heavy loads, designated by the numbers 1, 2, 3 and 4. If the load in the trailer is light, the load control should be set at No. 1; if it is heavy, it should be set at No. 4. In other words, the load control should be set in accordance with the weight of the load in the trailer.

c. **Servicing Electric Control Unit.** Adjustment of the switch pull rod should be made as follows:

(1) **TOOLS REQUIRED:**

Pliers, 6-in.

Screwdriver, 5 1/2-in.

Sandpaper, No. 00

Wrench, open-end, 9/16-in.

(2) Remove clevis pin from front clevis at clamp.

(3) Place control unit operating arm in full off position (toward rear).

(4) Adjust clevis so that with operating arm in full off position and foot brake pedal in released position, clevis pin can be inserted without altering either the arm or pedal position.

(5) Cotter-pin the clevis pin and tighten clevis lock nut, using a 9/16-inch open-end wrench. The switch blade and contacts should be cleaned occasionally with No. 00 sandpaper. Figure 45 shows a view of the control unit with cover removed.

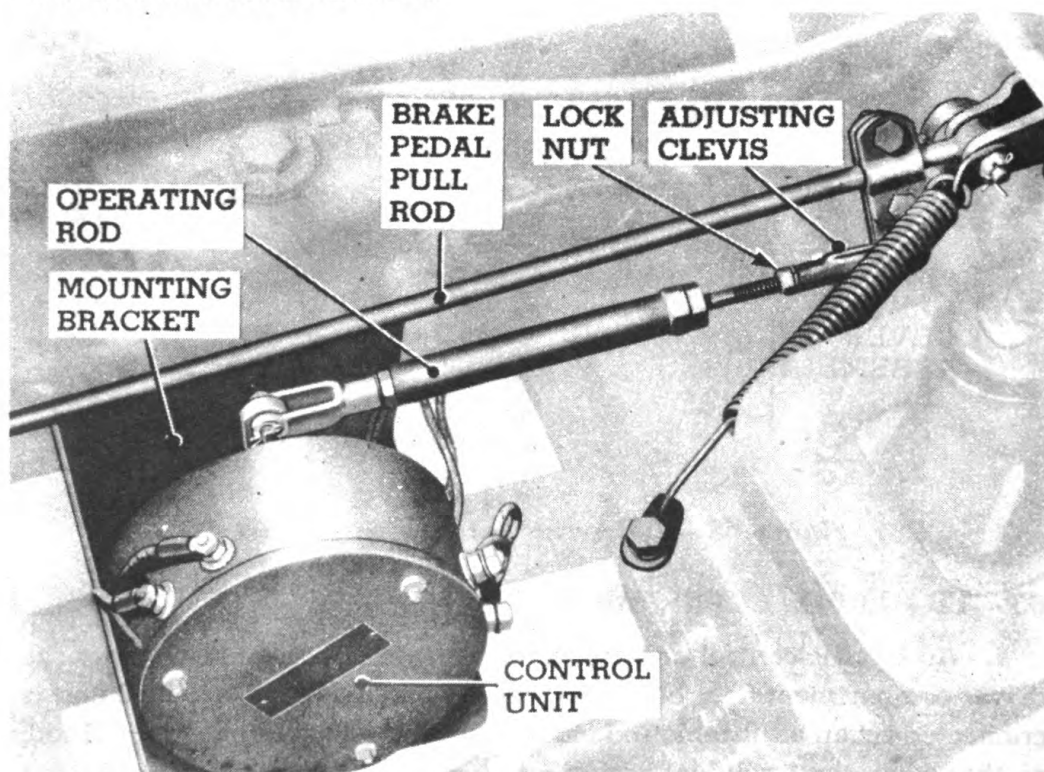

RA PD 32224

Figure 44—Electric Trailer Brake Adjustment

BRAKE SYSTEM

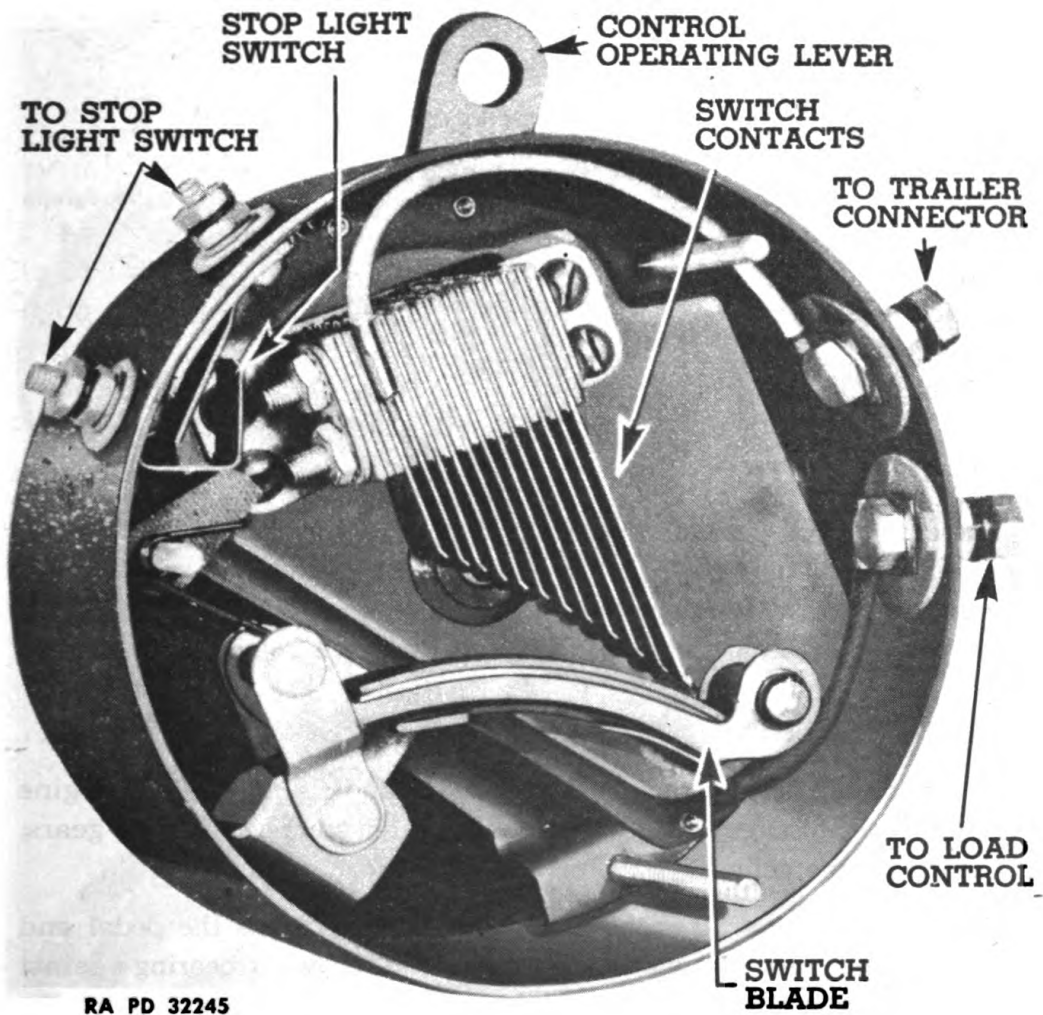

RA PD 32245

Figure 45—Electric Trailer Brake Construction

BOMB SERVICE TRUCK M6 (Chevrolet)

Section XV

CLUTCH

	Paragraph
Description	64
Operation	65
Trouble shooting	66
Pedal adjustment	67
Overhaul	68

64. DESCRIPTION.

The clutch is of the single plate dry disk type, incorporating a spring-mounted disk hub (fig. 46). The engagement pressure is supplied by a single diaphragm type spring. The clutch is controlled by the clutch pedal, connecting link, throwout fork, and throwout bearing.

65. OPERATION.

a. The clutch provides a means of engaging and disengaging the engine from the transmission and other drive units for starting, shifting gears, and stopping the vehicle.

b. The driver depresses the clutch pedal, which pulls the pedal end of the throwout fork backward. This forces the throwout bearing against the diaphragm spring, forcing the center of the spring forward. This disengages the clutch. The clutch should always be engaged slowly, as quick engagement places abnormal strain on all parts of the driving unit.

c. Comparatively light pressure is required for clutch disengagement; therefore, the driver should never drive with his foot on the pedal as this will cause clutch slippage and premature wear.

66. TROUBLE SHOOTING.

Symptom	Probable remedy
a. Slipping.	
(1) Improper pedal adjustment.	(1) Adjust pedal free travel.
(2) Disk oil soaked.	(2) Replace clutch disk.
(3) Sticking pressure plate.	(3) Check fit of drive lugs on pressure plate in slots in cover. (Replace pressure plate if necessary).

CLUTCH

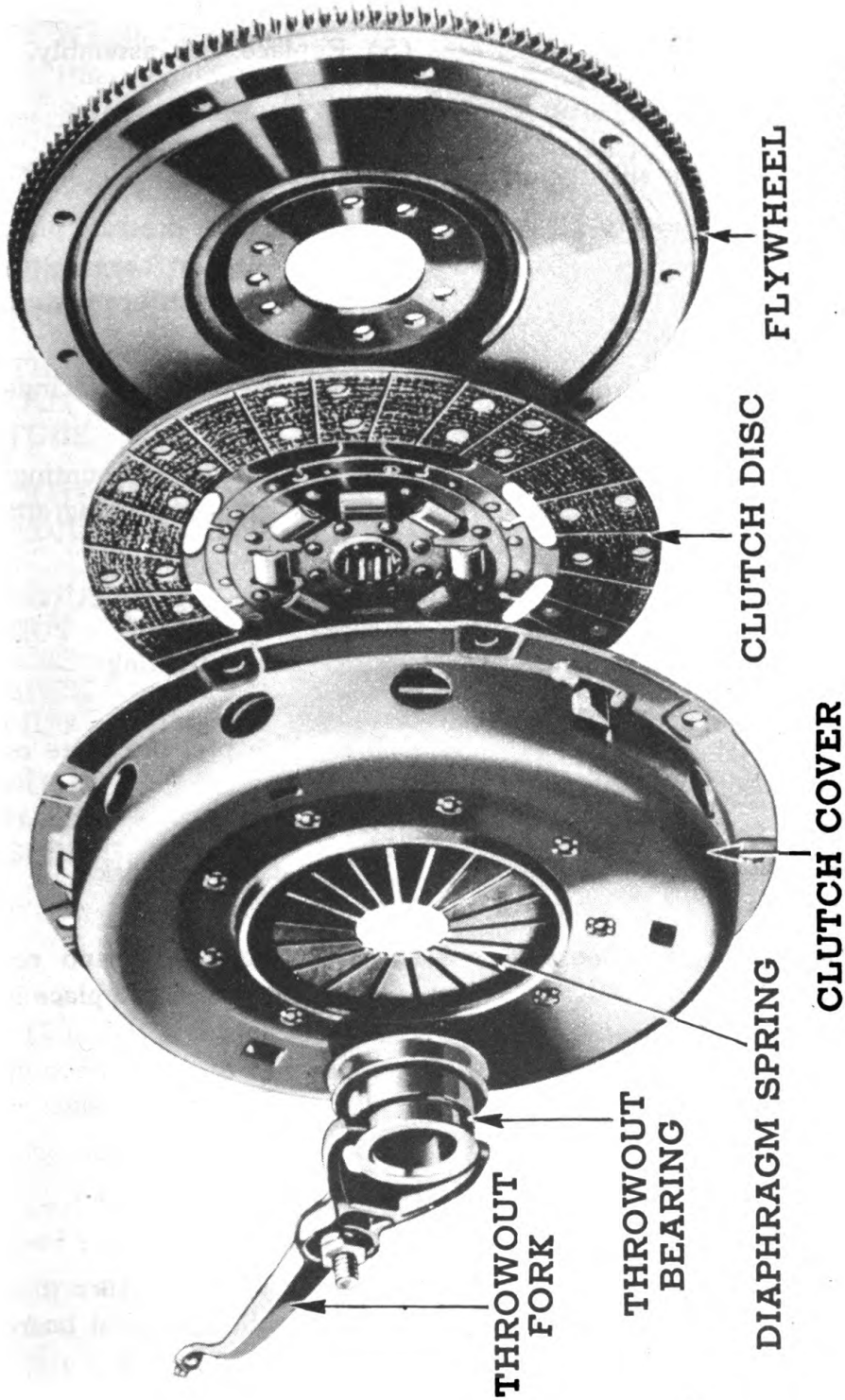

RA PD 32246

Figure 46 - Lay-out of Clutch Parts

BOMB SERVICE TRUCK M6 (Chevrolet)

Symptom	Probable remedy
(4) Weak clutch spring.	(4) Replace spring and cover assembly.
(5) Torn disk facings.	(5) Replace disk assembly.
b. Grabbing.	
(1) Disk linings slightly oily.	(1) Replace disk.
(2) Sticking pressure plate.	(2) Check fit of pressure plate drive lugs in cover slots. (Replace pressure plate if necessary).
(3) Abnormally flat glazed facings.	(3) Replace disk and facings.
(4) Loose engine mountings.	(4) Adjust engine mountings as instructed in paragraph 122.
c. Rattling.	
(1) Weak retracting springs.	(1) Replace retracting springs.
(2) Excessive clearance at pressure plate driving lugs.	(2) Replace pressure plate or cover.
(3) Broken clutch disk cushion springs.	(3) Replace clutch disk.
(4) Throwout fork loose on ball.	(4) Check ball stud and retaining spring. (Replace if necessary).

67. PEDAL ADJUSTMENT.

a. Tool Required:

Wrench, open-end, $\frac{5}{8}$ -in.

b. Normal clutch facing wear permits the clutch pedal to return to a point closer to the pedal stop. The free travel before the throwout bearing contacts the spring should be between 1 inch and $1\frac{1}{4}$ inches.

c. To make this adjustment, loosen the adjusting lock nut (fig. 47) with $\frac{5}{8}$ -inch wrench and turn adjusting nut until $1\frac{1}{4}$ -inch free travel is obtained. Tighten lock nut.

CLUTCH

68. OVERHAUL.

a. Removal.

(1) TOOLS REQUIRED:

Handle, ratchet
Pliers, comb., 6-in.
Screwdriver, 6-in.
Socket, $\frac{7}{16}$ -in.
Socket, $\frac{9}{16}$ -in.

Tool, clutch pilot, K-411
(KM)
Wrench, open-end, $\frac{5}{8}$ -in.
Wrench, open-end, $\frac{3}{4}$ -in.
Wrench, socket, $\frac{1}{2}$ -in.

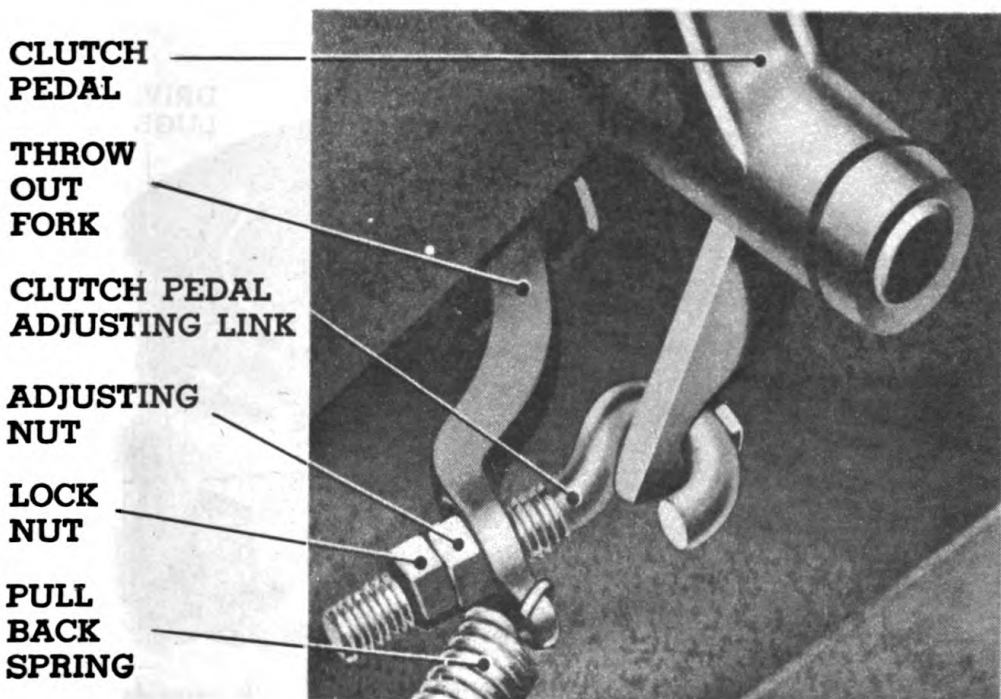

RA PD 32247

Figure 47—Clutch Free Pedal Travel Adjustment

(2) The transmission must be removed before the clutch can be removed. Refer to transmission removal, section XXXI, of this manual for detailed instructions.

(3) Remove the throwout bearing from the fork.

(4) Disconnect pull back spring and with a $\frac{5}{8}$ -inch open-end wrench remove the adjusting link from the clutch fork.

(5) Remove the clutch fork by pressing it away from its mounting with a screwdriver until the fork snaps loose from the ball.

(6) The spring retainer may be removed from the fork by prying it out of the groove, one end at a time.

(7) Using a $\frac{3}{4}$ -inch wrench remove the throwout fork mounting ball stud from the clutch housing.

BOMB SERVICE TRUCK M6 (Chevrolet)

(8) Install the clutch pilot tool, No. K-411, to support the clutch during disassembly.

(9) Using a $\frac{9}{16}$ -inch socket and ratchet handle loosen the nine clutch to flywheel bolts one turn at a time (to prevent cover distortion) until the diaphragm spring pressure is released.

(10) Remove the clutch cover assembly and disk from the clutch housing.

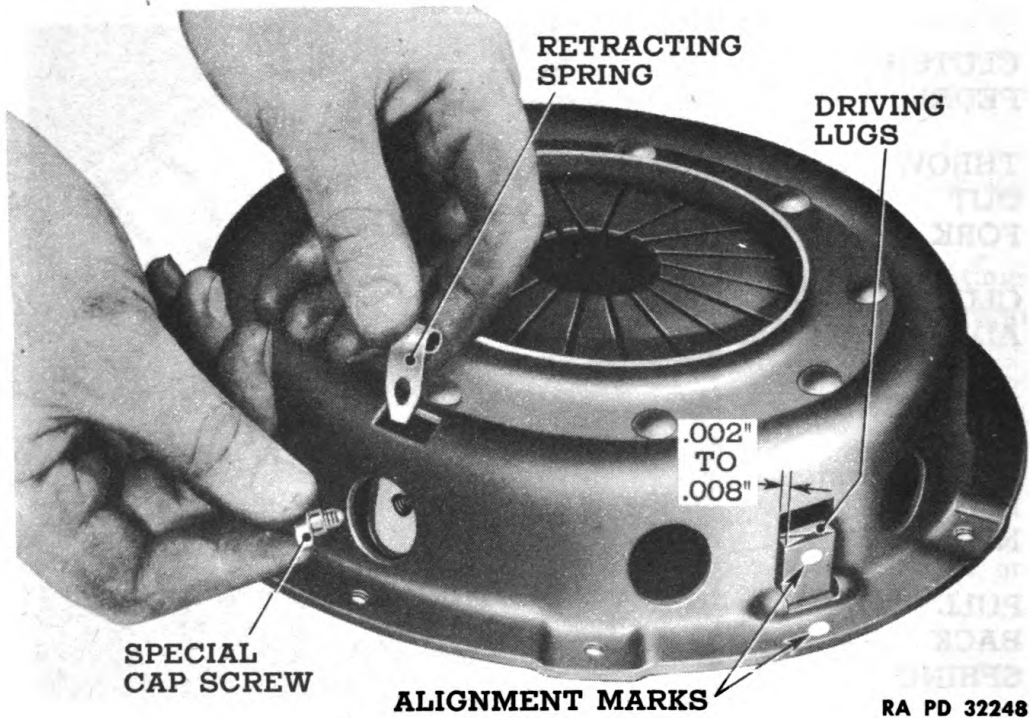

Figure 48—Retracting Spring Removal

(11) With a $\frac{7}{16}$ -inch socket and ratchet handle remove the three clutch pressure plate retracting springs and remove the pressure plate from the clutch cover assembly (fig. 48).

(12) The clutch cover, diaphragm spring, and two pivot rings are riveted together and serviced as an assembly.

b. Inspection.

(1) Wash all parts (except the throwout bearing and disk) in SOLVENT, cleaning.

(2) Inspect the pressure plate and flywheel for scores or cracks which would affect normal clutch operation.

(3) Check the three pressure-plate drive lugs for excessive wear or burs. Check their fit in the cover. They should have from 0.002-inch to 0.008-inch clearance (fig. 48).

CLUTCH

(4) Check the throwout bearing for roughness and free fit on the extension of the transmission main drive gear bearing retainer. This is a permanently lubricated bearing and must not be washed as the SOLVENT, cleaning, would cut the lubricant and it would be thrown out into the clutch.

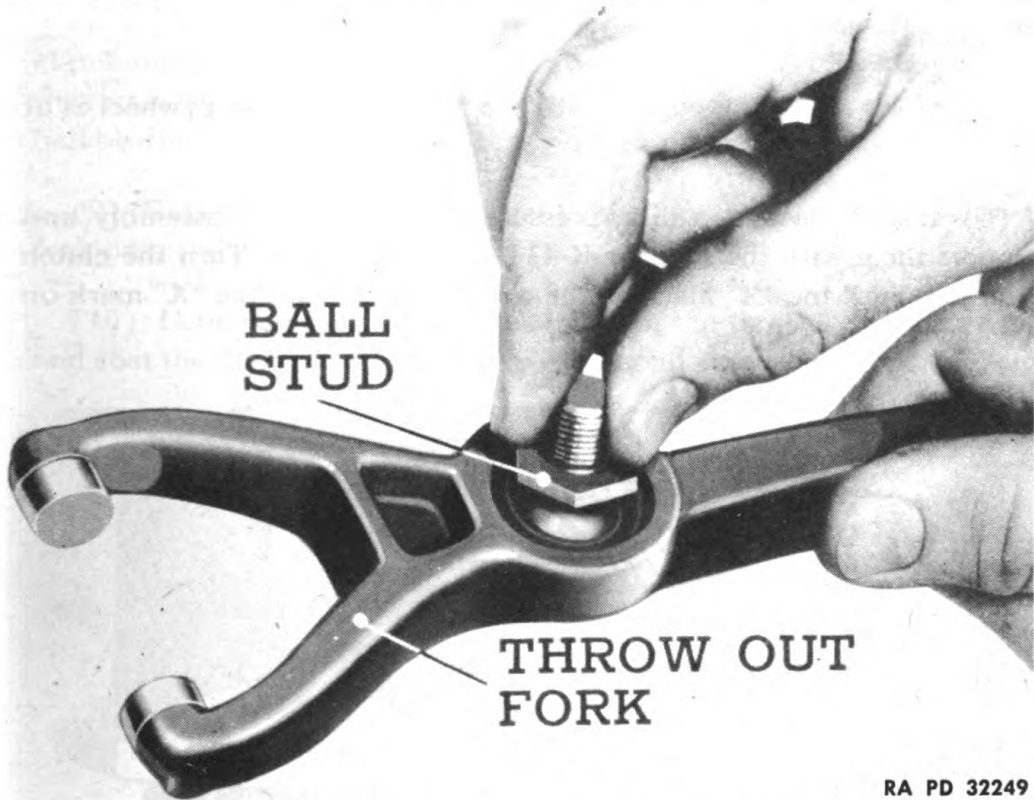

RA PD 32249

Figure 49—Checking Fit of Ball in Throwout Fork

(5) Check fit of the ball stud in the throwout fork (fig. 49). This should be snug without side play.

(6) Inspect the clutch disk for worn, loose or oil-soaked facings, and for broken disk springs or rivets loose on hub. Check to see that the splines are not excessively worn and that they move freely on the splines of the clutch gear. If the splines are worn, the disk should be replaced.

c. Clutch Reassembly.

(1) TOOLS REQUIRED:

Handle, ratchet
Pliers, 6-in.
Screwdriver, 6-in.
Socket, $\frac{7}{16}$ -in.

Socket, $\frac{9}{16}$ -in.
Tool, clutch pilot, K-411 (KM)
Wrench, open-end, $\frac{5}{8}$ -in.
Wrench, open-end, $\frac{3}{4}$ -in.

(2) With a $\frac{3}{4}$ -inch wrench replace the throwout fork mounting ball in the clutch housing.

BOMB SERVICE TRUCK M6 (Chevrolet)

(3) Install the pressure plate in the cover assembly, making sure to mate the "O" mark on the pressure plate lug with the "O" mark on the cover (fig. 48). This is necessary to maintain proper balance.

(4) With a $\frac{7}{16}$ -inch socket and ratchet handle install the three pressure plate retracting springs. The clutch is now ready to be reassembled to the engine.

(5) Hand crank the engine until the "X" mark on the flywheel is at the bottom.

(6) Install the clutch disk, pressure plate, and cover assembly and support them with the number K-411 clutch pilot tool. Turn the clutch assembly until the "X" mark on the cover lines up with the "X" mark on the flywheel (fig. 50).

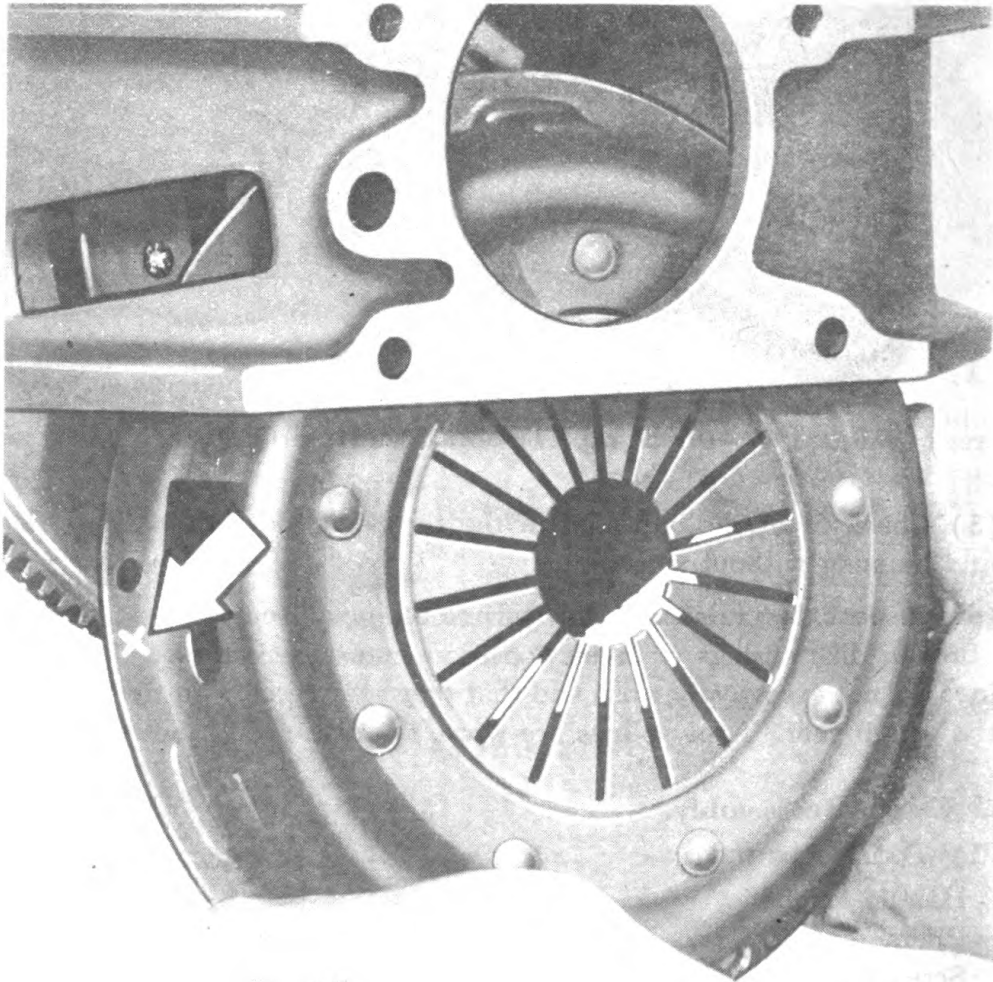

RA PD 32250

Figure 50—Alining Cover Assembly with Flywheel

CLUTCH

(7) Install the nine bolts with a $\frac{9}{16}$ -inch ratchet wrench tighten them each a turn at a time to prevent distorting the cover as the spring pressure is being taken up. Remove the pilot tool.

(8) Pack the ball seat in the fork with a small amount of GREASE, general purpose, No. 2. Install a new spring retainer in the groove in the clutch fork if the old retainer is worn or damaged. **NOTE:** Make certain the retainer is installed with the high side of the retainer up, away from the ball bearing, and the open end of the retainer on the horizontal.

(9) Replace the fork in position in the clutch housing and snap the fork onto the ball.

(10) Lubricate the recess on the inside of the throwout bearing collar and coat the throwout fork groove with a small amount of GREASE, gen-

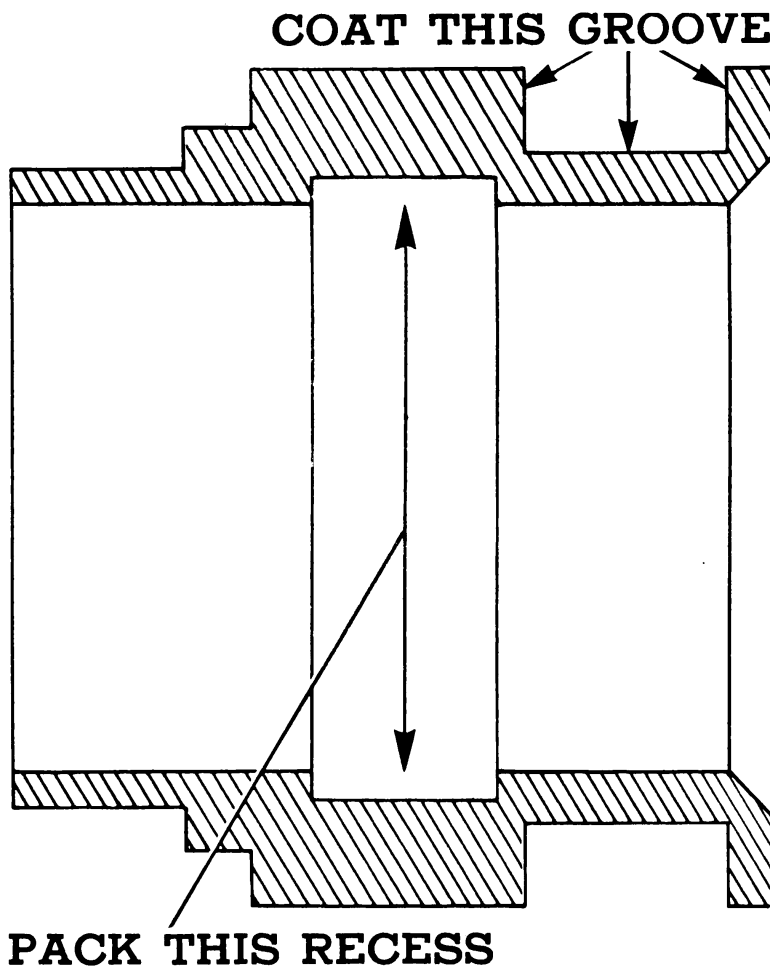

RA PD 32251

Figure 51—Throwout Bearing Collar Lubrication

BOMB SERVICE TRUCK M6 (Chevrolet)

eral purpose No. 2 (fig. 51). Then install the throwout bearing on the throwout fork. **CAUTION:** Be careful not to use too much lubricant.

(11) Using a $\frac{5}{8}$ -inch open-end wrench install the adjustment link and pull back spring.

(12) Install the transmission as explained in section **XXXI** of this manual.

(13) Adjust the clutch pedal as explained, in paragraph 67.

Section XVI

COOLING SYSTEM

	Paragraph
Description	69
Inspection	70
Trouble shooting	71
Draining cooling system	72
Filling cooling system	73
Radiator pressure filler cap	74
Fan shroud	75
Fan blades	76
Fan belt	77
Water pump	78
Steam relief tube	79
Water bypass shut-off cock	80
Thermostat	81
Radiator core	82
Care of cooling system	83
Antifreeze	84

69. DESCRIPTION.

- a. The cooling system consists of a radiator, fan shroud, fan, thermostat, centrifugal water pump, fan belt, hoses and connections (fig. 52).
- b. **Cooling Capacity.** Cooling capacity is 17¼ quarts.

70. INSPECTION.

a. Tools Required:

- | | |
|---------------|-----------------------------|
| Screwdriver | Wrench, open-end, ½-in. |
| Socket, ¾-in. | Wrench, torque, J-1313 (KM) |

b. All hose connections should be examined frequently and replaced if they show signs of disintegration.

c. Cylinder head bolts should be checked to see that they are tight (75 to 80 pounds pull on torque wrench) and that there are no leaks around the cylinder head.

d. The fan belt should be inspected and if it is worn, cracked or oil soaked, it should be replaced.

BOMB SERVICE TRUCK M6 (Chevrolet)

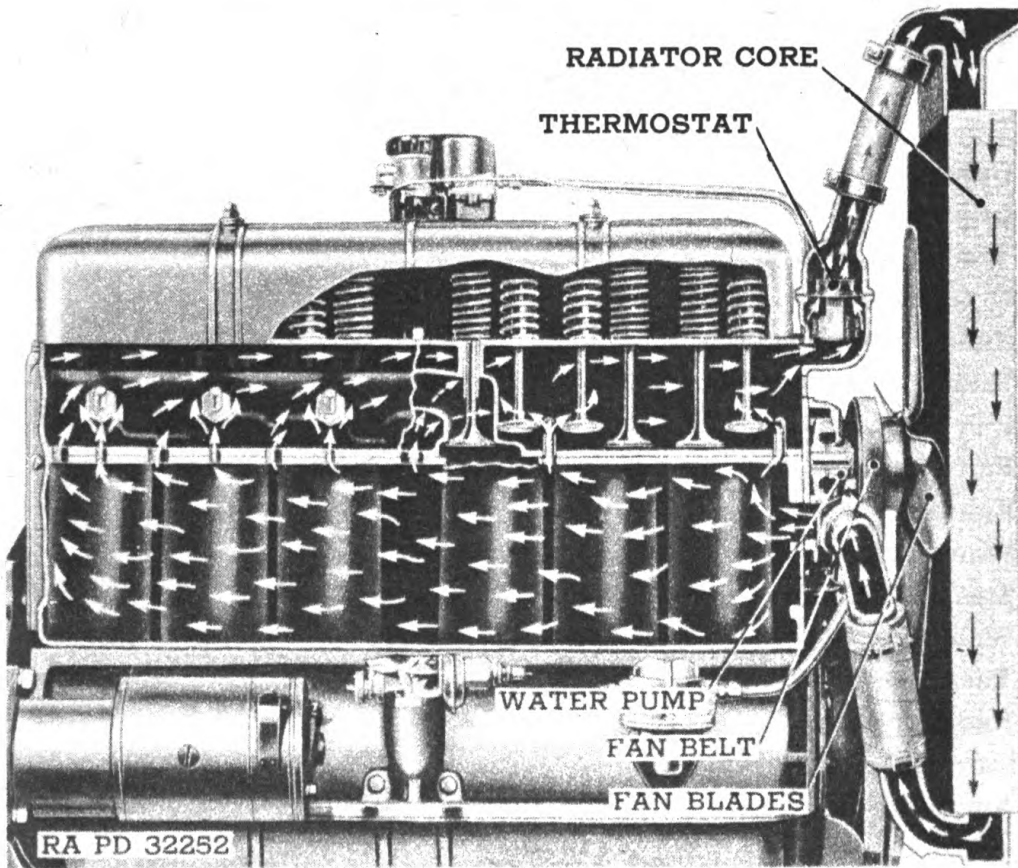

Figure 52—Circulation Diagram of Cooling System

e. The belt is in correct adjustment when it can be pushed $\frac{3}{4}$ -inch below a straight line midway between the fan and radiator pulleys.

71. TROUBLE SHOOTING.

Symptom	Probable remedy
a. Overheating.	
(1) Lack of water.	(1) Refill system.
(2) Fan belt loose.	(2) Adjust or replace.
(3) Fan belt worn or oil soaked.	(3) Replace belt.
(4) Thermostat sticking closed.	(4) Replace thermostat.
(5) Water pump inoperative.	(5) Replace pump.
(6) Cooling system clogged.	(6) Flush and clean system.
(7) Incorrect ignition or valve timing.	(7) Retime engine.
(8) Brakes dragging.	(8) Adjust brakes.

COOLING SYSTEM

b. Overcooling.

- | | |
|--------------------------------------|--------------------------|
| (1) Thermostat sticking open. | (1) Replace thermostat. |
| (2) Water bypass shut-off cock open. | (2) Close shut-off cock. |

c. Loss of Cooling Liquid.

- | | |
|--|---------------------------------------|
| (1) Loose hose connections. | (1) Tighten all hose connections. |
| (2) Damaged hose connections. | (2) Replace hose. |
| (3) Leaky water pump. | (3) Repack or report for replacement. |
| (4) Leak in radiator core. | (4) Repair or replace core. |
| (5) Pressure cap not seating properly. | (5) Install new gasket. |
| (6) Leaks at cylinder head gasket. | (6) Tighten or replace gasket. |
| (7) Leaky cylinder expansion plug. | (7) Tighten. |
| (8) Leaky cylinder block drain cock. | (8) Tighten. |

72. DRAINING COOLING SYSTEM.

a. To drain the radiator, open the valve located at the bottom of the radiator on the right side.

b. To drain the cylinder block, open the valve located on left side of motor at the rear cylinder (fig. 53).

73. FILLING COOLING SYSTEM.

a. **CAUTION:** When cooling system has been drained, run motor at idling speed while filling radiator to prevent air pockets from forming in the cooling system.

(1) Never pour cold water in the radiator if the water in the cooling system is boiling or scalding hot, as the cold water may crack the cylinder head.

BOMB SERVICE TRUCK M6 (Chevrolet)

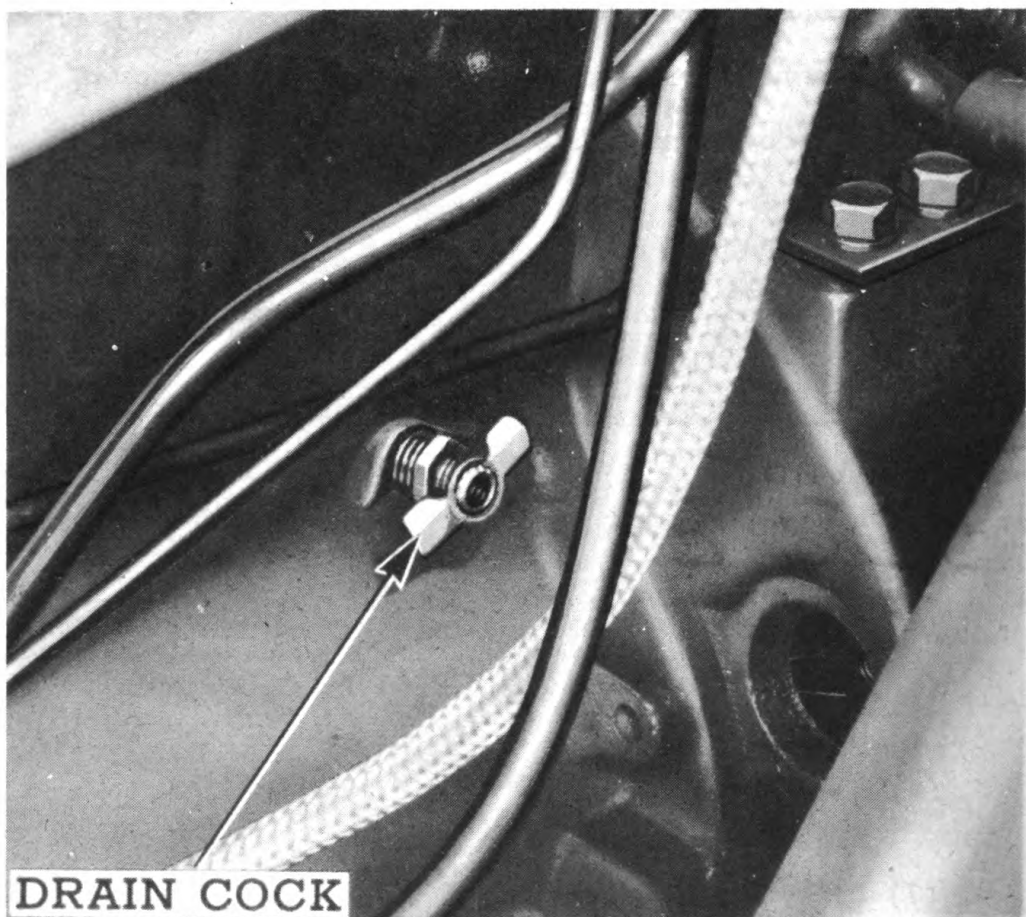

RA PD 32253

Figure 53—Cylinder Block Drain Cock

(2) When using antifreeze, never fill the radiator full. Leave about 1 inch of air space between top of water and top of radiator to allow for expansion of the antifreeze. This will prevent loss of antifreeze.

(3) Close valve at bottom of radiator.

(4) Close valve on left side of motor at rear cylinder.

(5) Fill radiator with clean water or, during cold weather, with an antifreeze solution.

h. Replace Filler Cap. Be sure that the filler cap gasket is in good condition and that the cap is tight on the radiator neck.

74. RADIATOR PRESSURE FILLER CAP (fig. 54).

a. Description. The radiator is sealed by a pressure cap which maintains a slight pressure on the cooling liquid. The pressure cap consists of a special filler cap into which is built a spring-loaded valve. The over-

COOLING SYSTEM

flow pipe in the radiator filler neck is located above the valve seat so that no liquid or air can escape when the cap is in position. When the pressure in the cooling system rises to $3\frac{1}{4}$ to $4\frac{1}{4}$ pounds per square inch, the valve opens and relieves the pressure in the cooling system through the overflow pipe.

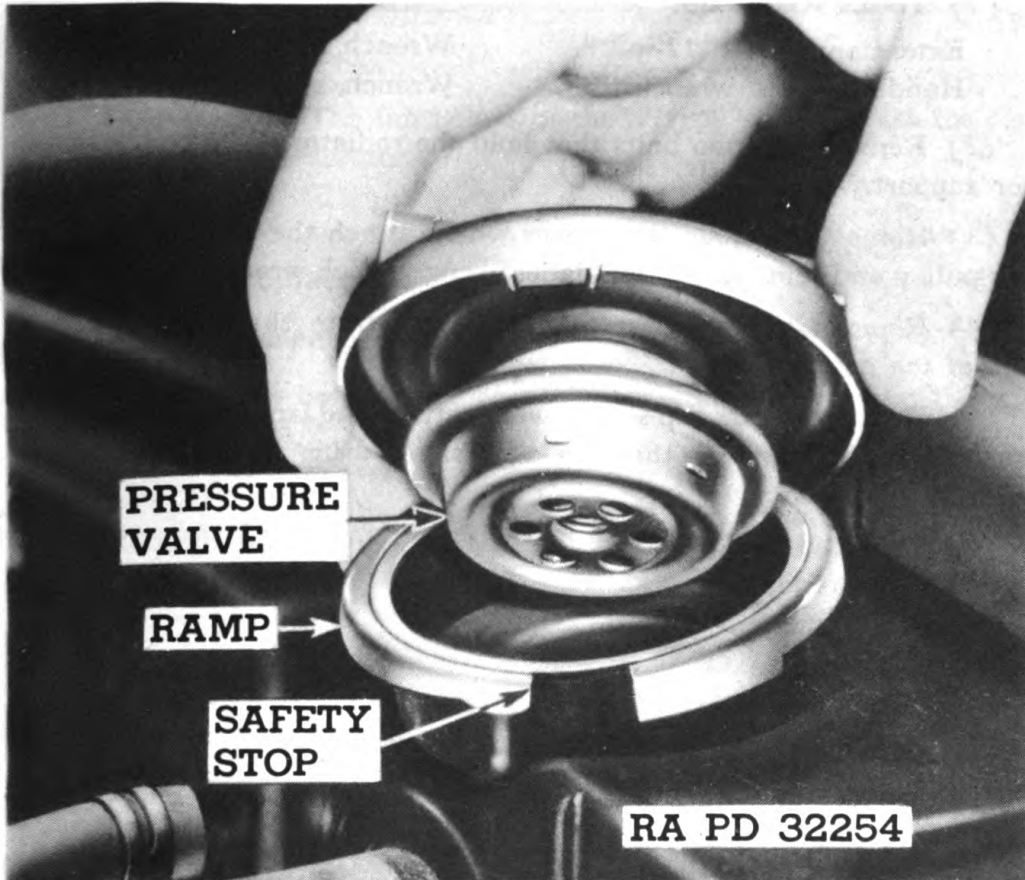

Figure 54—Radiator Pressure Cap

b. Removing Pressure Cap.

- (1) Turn the cap to the left until the bayonets on the cap come in contact with the safety stop.
- (2) Pause at this point for a few seconds to allow any pressure or steam to pass off through the overflow pipe.
- (3) After the pressure has been relieved, press cap down and turn it to the left as far as it will go.
- (4) Lift cap off of filler neck.

c. Replacing Pressure Cap. When replacing pressure cap, be sure that the fiber gasket is in a satisfactory condition so that it forms a seal between the cap and the radiator filler neck.

BOMB SERVICE TRUCK M6 (Chevrolet)**75. FAN SHROUD.**

a. **Description.** The radiator is equipped with a fan shroud which is mounted to the radiator by six bolts, three on each side of the radiator.

b. Fan Shroud Removal.**(1) TOOLS REQUIRED:**

Extension, socket, 12-in.

Wrench, open-end, $\frac{7}{16}$ -in.

Handle, socket wrench.

Wrench, socket, $\frac{1}{2}$ -in.

(2) Remove the two bolts that hold the radiator brace to the radiator support.

(3) Remove the four cap screws which attach the fan blades to the fan pulley and remove the fan blades, using $\frac{7}{16}$ -inch wrench.

(4) Remove the head lamp wiring loom from the clips along the top of the radiator.

(5) Remove the six cap screws which attach the fan shroud and radiator core to the support (three on each side), using $\frac{1}{2}$ -inch socket and 12-inch extension.

(6) Push the fan shroud to one side and slip it past the bolt which attaches the radiator support, lift the brace and lift the fan shroud upward and out.

c. Fan Shroud Replacement.

(1) Lift brace and slip fan shroud into place.

(2) Replace the six cap screws which attach the fan shroud and radiator core to the support.

(3) Replace the four cap screws which attach the fan blades to the fan pulley.

(4) Replace the head lamp wiring loom in the clips along the top of the radiator.

(5) Install the radiator brace rod in place with the two bolts which attach the radiator brace rod to the radiator support.

76. FAN BLADES.

a. **Description.** The fan blade assembly is 18 inches in diameter and has four blades.

b. Fan Blade Replacement.**(1) TOOLS REQUIRED:**Wrench, $\frac{1}{2}$ -in.Wrench, $\frac{7}{16}$ -in.

COOLING SYSTEM

(2) Remove the four cap screws which attach the fan blade assembly to the pulley.

(3) Remove the fan blade assembly.

(4) **REPLACING FAN BLADES.** Install the four cap screws through the fan assembly and bolt it to the fan pulley.

77. FAN BELT.

a. **Description.** The fan belt is of the V type and it drives the fan, water pump and generator.

b. **Adjustment.**

(1) **TOOL REQUIRED:**

Wrench, open-end, 1/2-inch.

(2) Loosen the bolt at the generator mounting bracket and the end of the slotted brace.

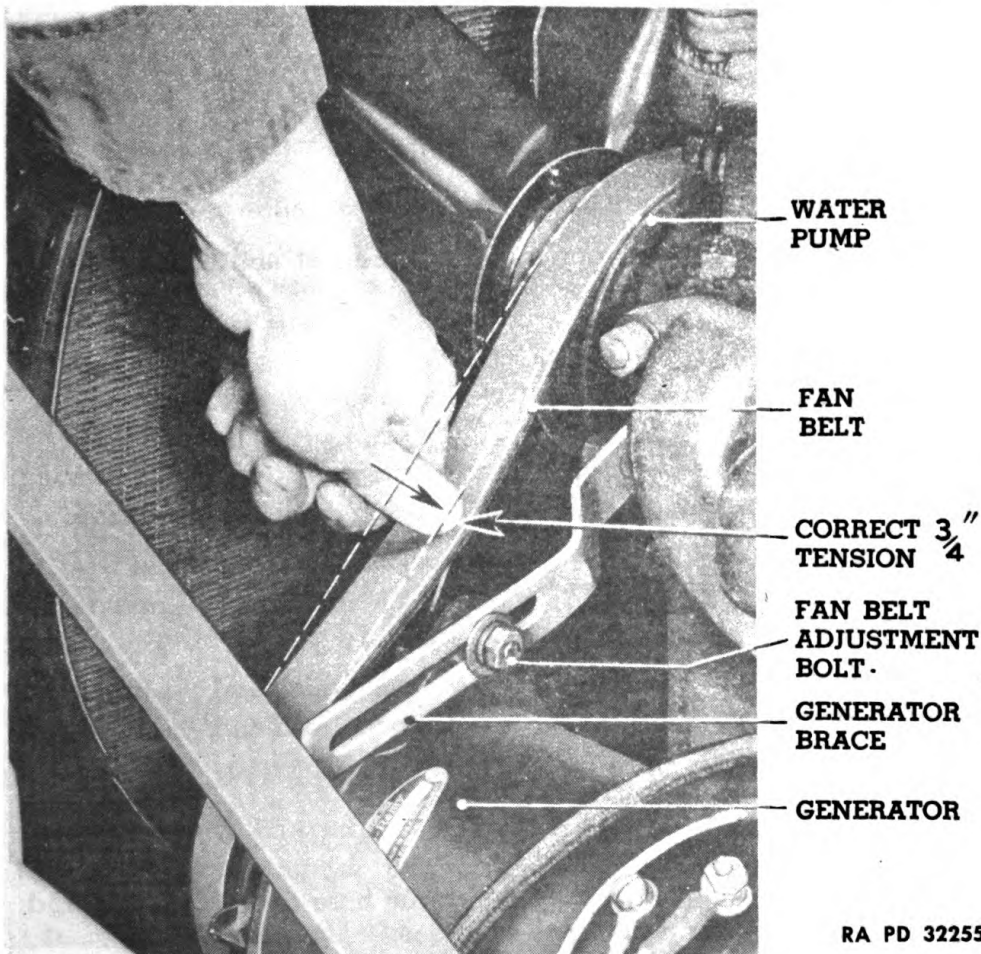

RA PD 32255

Figure 55—Fan Belt Adjustment

BOMB SERVICE TRUCK M6 (Chevrolet)

(3) Rock the generator on its mounting bracket. Moving the generator away from the engine tightens the belt. Moving the generator toward the engine loosens the belt. The correct adjustment is obtained when the belt can be depressed $\frac{3}{4}$ -inch from normal as shown in figure 55.

(4) Tighten the bolt at the generator mounting bracket and the end of the slotted brace and recheck for proper tension.

c. Fan Belt Removal.

(1) **TOOL REQUIRED:**

Wrench, open-end, $\frac{1}{2}$ -in.

(2) Loosen bolt in generator mounting bracket and the end of slotted brace and push generator toward engine.

(3) Remove fan belt from generator pulley.

(4) Remove fan belt from crankshaft pulley.

(5) Slip fan belt over fan blades.

d. Fan Belt Replacement.

(1) Slip fan belt over fan blades.

(2) Slip fan belt over crankshaft pulley.

(3) Slip fan belt over generator pulley.

(4) Adjust fan belt.

(5) Tighten bolts in generator mounting bracket and end of slotted brace.

78. WATER PUMP.

a. **Description.** The water pump is of the centrifugal ball bearing type. The water pump needs no lubrication during the life of the pump.

b. Water Pump Replacement.

(1) **TOOLS REQUIRED:**

Screwdriver

Wrench, open-end, $\frac{7}{16}$ -in.

Wrench, open-end, $\frac{1}{2}$ -in.

Wrench, open-end, $\frac{5}{8}$ -in.

(2) **REMOVING WATER PUMP.**

(a) Drain the radiator.

(b) Loosen the hose clamps that clamp the hose to water pump and elbow.

(c) Slide hose away from water pump.

COOLING SYSTEM

(d) Loosen the bolt in the slotted end of the generator brace and mounting bracket to loosen fan belt. Remove belt from water pump pulley.

(e) Remove the four cap screws which attach the pump to the cylinder block and remove the pump and fan blades as an assembly by turning it as it is removed (fig. 56).

(3) REPLACING WATER PUMP.

(a) Install new gasket between water pump and cylinder block and place pump and fan blade assembly in position.

(b) Install the four cap screws that hold the pump to the cylinder block.

(c) Install the fan belt over the three pulleys and adjust to proper tension.

(d) Slide the hose connection over the water pump opening and tighten the hose clamps.

(e) Close both drain cocks, fill the radiator and make sure there are no water leaks.

79. STEAM RELIEF TUBE (fig. 57).

a. The steam relief tube is a tube from the top of the radiator to the left side of the cylinder head. It is for the purpose of relieving any air pockets that may be caused by steam or surging of water when the vehicle is descending steep grades.

b. Care of Steam Relief Tube.

(1) TOOLS REQUIRED:

Screwdriver

Wrench, open-end, $\frac{5}{8}$ -in.

(2) The steam relief tube requires no attention other than keeping it from leaking. If leaks occur at front end of tube, tighten or replace hose connections. If leak occurs at rear of tube, tighten packing nut to shut-off valve.

80. WATER BYPASS SHUT-OFF COCK (fig. 57).

a. **Purpose.** The purpose of the shut-off cock is to prevent the cooling liquid from bypassing the thermostat under cold operating conditions.

b. **CAUTION.** Always keep the water shut-off bypass closed when the air temperature is below 60 F, unless the vehicle is descending steep grades.

BOMB SERVICE TRUCK M6 (Chevrolet)

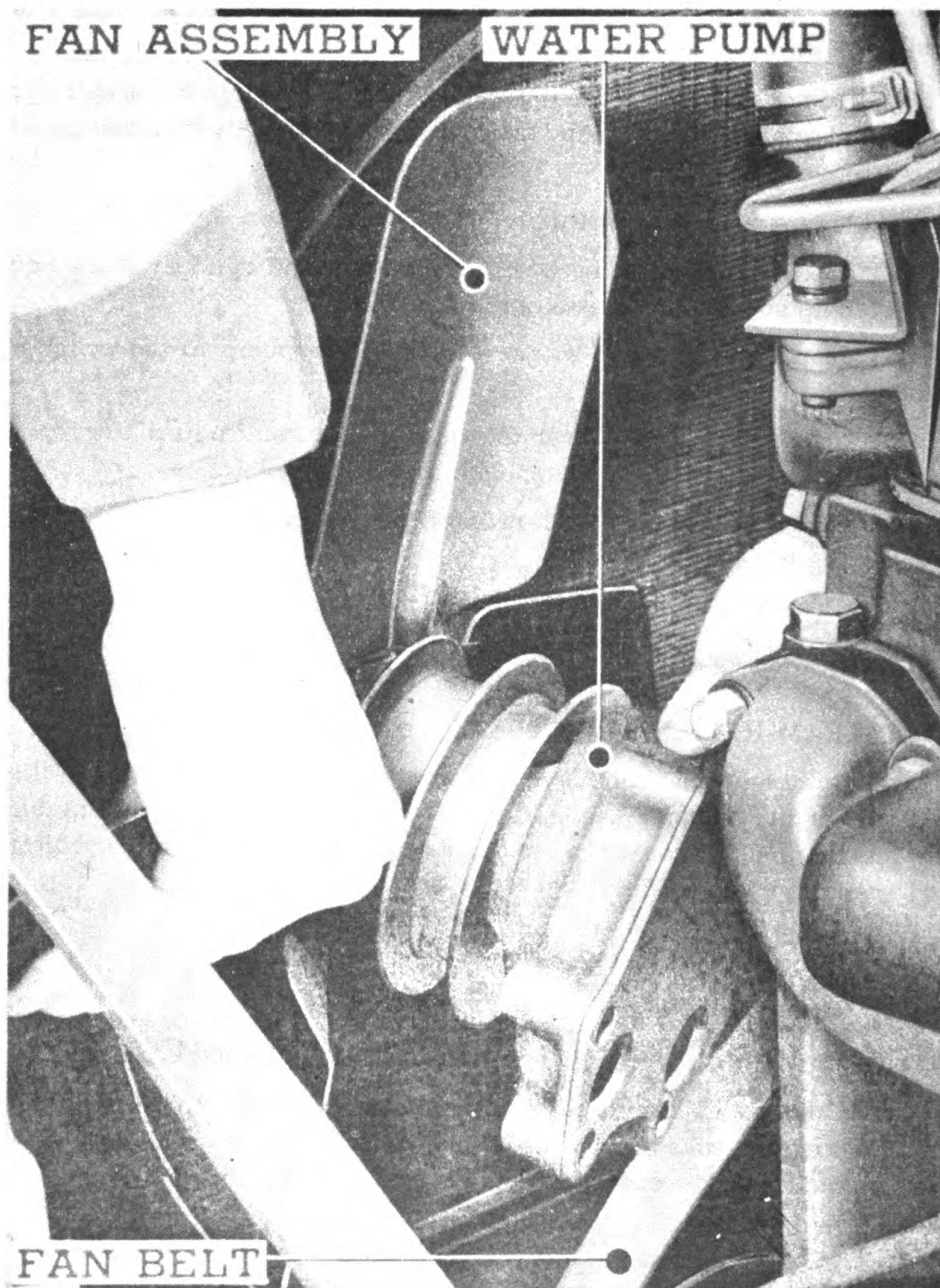

RA PD 32256

Figure 56—Water Pump Removal

COOLING SYSTEM

81 THERMOSTAT.

a. **Description.** A bellows-type thermostat is located in the water outlet passage in the cylinder head. It is set to start opening at about 143 degrees and is fully open at 170 degrees. The engine should not be operated without a thermostat.

b. Thermostat Replacement.

(1) TOOLS REQUIRED:

Screwdriver

Wrench, open-end, $\frac{9}{16}$ -in.

(2) REMOVING THERMOSTAT.

(a) Drain radiator.

(b) Loosen upper hose clamps with screwdriver.

(c) Remove cap screws which attach the water outlet connection to the cylinder head, using a $\frac{9}{16}$ -inch wrench.

(d) Remove water outlet connection.

(e) Remove water outlet connection gasket.

(f) Remove thermostat.

(3) REPLACING THERMOSTAT.

(a) Install thermostat, exposed parts of bellows to front and rear.

(b) Install new gasket.

(c) Install water outlet connection.

(d) Install hose connection and hose clamps.

82. RADIATOR CORE.

a. **Description.** The radiator core is of the tube and fin construction and is made of copper. The core is supported in steel anchorage and bolted in a support that is bolted in turn to the front cross member through a rubber cushion.

b. Radiator Core Removal.

(1) TOOLS REQUIRED:

Extension, socket, 12-in.

Wrench, open-end, $\frac{7}{16}$ -in.

Handle, socket wrench

Wrench, socket, $\frac{1}{2}$ -in.

Screwdriver

(2) Drain the radiator.

(3) Remove all hose connections.

BOMB SERVICE TRUCK M6 (Chevrolet)

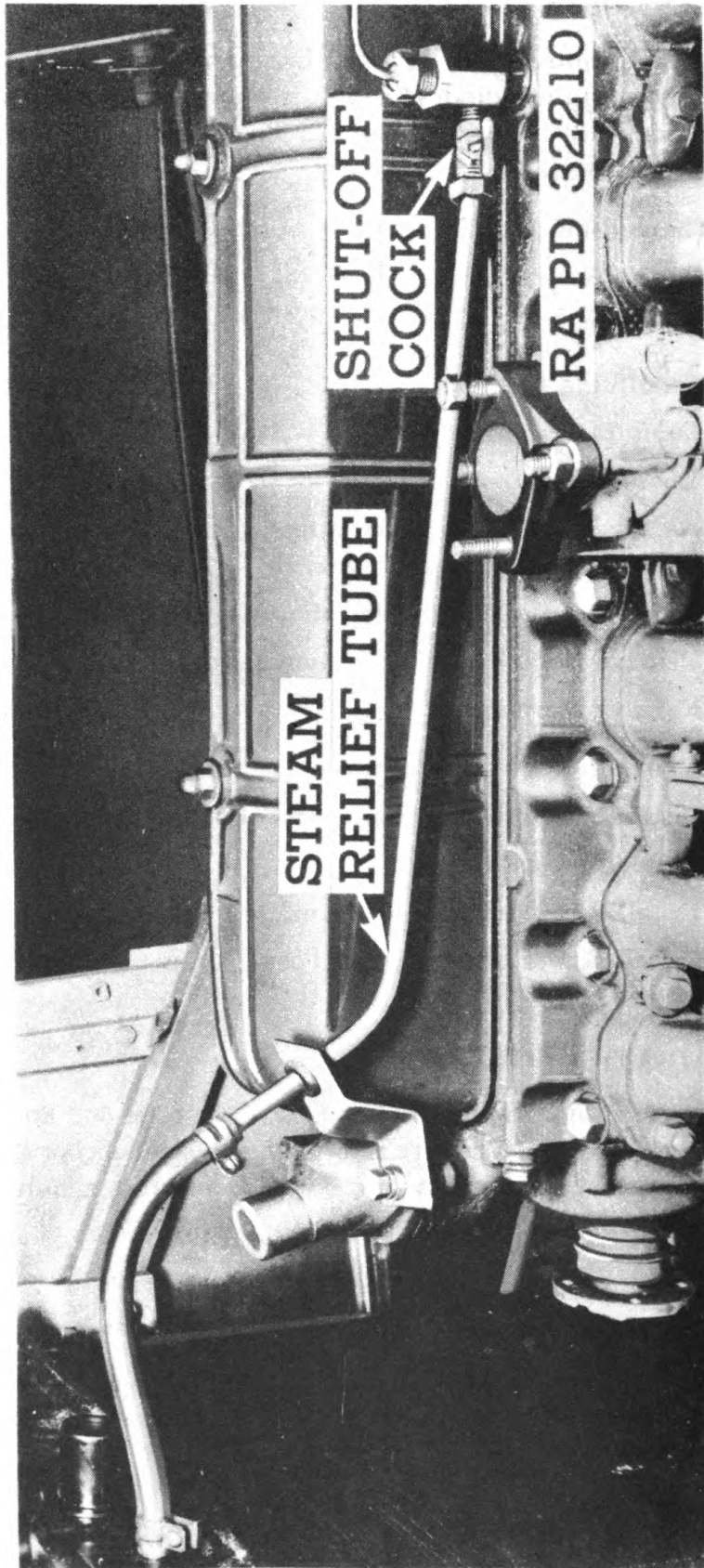
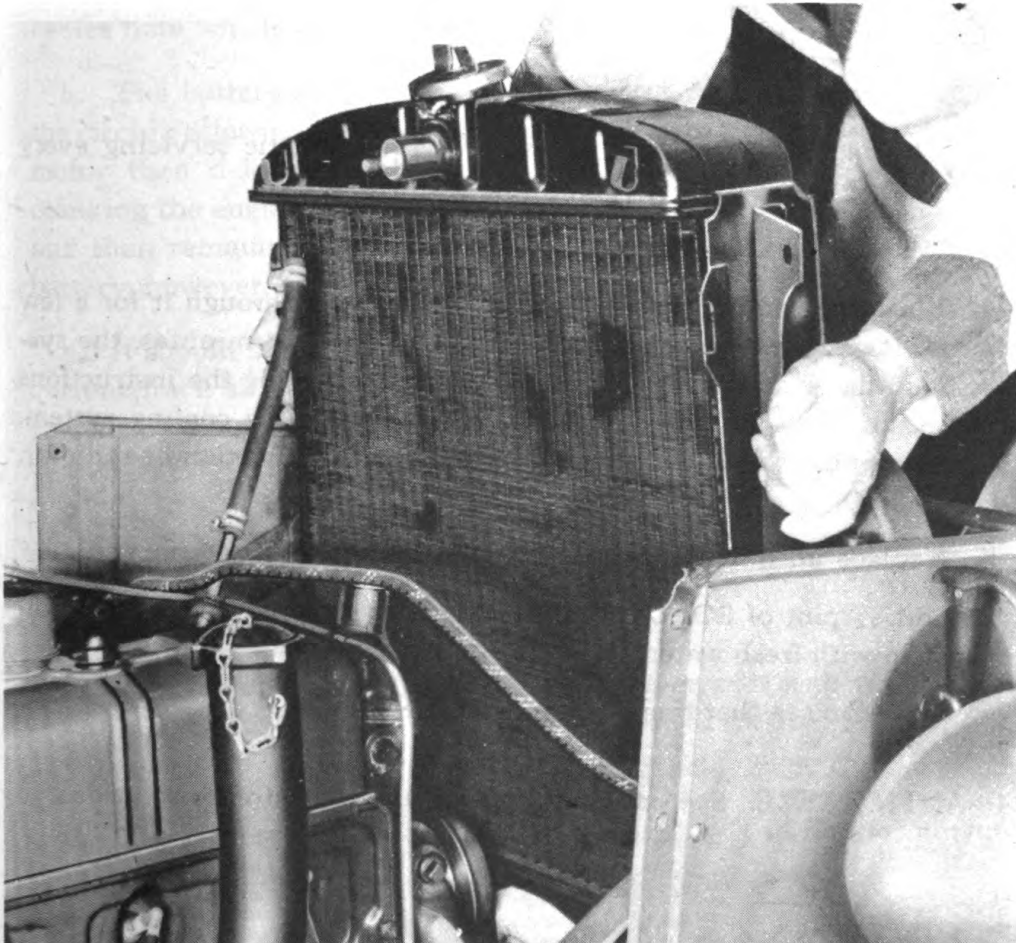

Figure 57 — Steam Relief Tube

COOLING SYSTEM

- (4) Remove the two bolts which attach the radiator brace to the radiator support.
- (5) Loosen nuts on brace rod at the dash.
- (6) Remove the fan blades.
- (7) Remove the head lamp wiring loom from the clips along the top of the radiator.
- (8) Remove the six cap screws (three on each side) that hold the fan shroud and radiator to the support.
- (9) Raise the brace rod and push the fan shroud to one side, slipping it past the bolt which attaches the radiator support brace.
- (10) Lift fan shroud up and out.
- (11) Remove radiator core in the same manner as the fan shroud (fig. 58).

**Figure 58—Radiator Core Removal**

RA PD 32258

Original from

UNIVERSITY OF CALIFORNIA

BOMB SERVICE TRUCK M6 (Chevrolet)

c. Replacing Radiator Core.

- (1) Lift the brace rod and slip the radiator core in place.
- (2) Slip the fan shroud in place.
- (3) Install the six cap screws through the fan shroud and radiator core to the support.
- (4) Replace head lamp wiring loom in clips along the top of the radiator.
- (5) Replace the fan blades.
- (6) Replace the brace to the radiator support.
- (7) Replace all hose connections and clamps.
- (8) Tighten nuts on brace rods at dash.
- (9) Refill cooling system.
- (10) Check to see that there are no water leaks.

83. CARE OF COOLING SYSTEM.

a. Tool Required:

Screwdriver

b. The cooling system should be given a systematic servicing every 6000 miles or about twice a year, in the spring and fall.

c. Drain the cooling system.

d. Flush the cooling system by letting water run through it for a few minutes. If the water does not run clear in a couple of minutes, the system should be flushed with a flushing solution, following the instructions that are furnished with the solution. When flushing the cooling system, the flushing hose should be attached to the lower connection of radiator. Remove flush.

e. Replace all hose connections that show signs of deterioration.

f. Add $\frac{1}{2}$ pint of SOLUTION, rust preventive, when filling the cooling system with fresh water.

g. Check to see that there are no water leaks.

84. ANTIFREEZE. See paragraph 30 for use of antifreeze solutions.

Section XVII

BATTERY AND STARTING SYSTEM

	Paragraph
Description	85
Inspection and maintenance	86
Trouble shooting	87
Battery	88
Starting motor	89
Starting motor switch	90

85. DESCRIPTION.

a. In the starting system, there are three units: the battery, the starting switch and the starting motor. Important. Some vehicles are positive grounded and some negative grounded. Before removing battery or cables note which system is used and install parts accordingly.

b. The battery supplies the electric energy and the switch completes the circuit, allowing the electric energy to flow to the starting motor. The motor then delivers mechanical energy and does the actual work of cranking the engine. The starting equipment is used for a short time only and then remains idle until it is again needed to start the engine. The battery, however, performs other functions.

c. It should be noted that the starting motor draws a large amount of current for a short period of time, whereas the generator replaces this current by charging the battery at a lower rate for a much longer period of time.

86. INSPECTION AND MAINTENANCE.

a. Tools Required:

Hydrometer, battery,
18-H-1240
Pliers

Tester, volt-ampere,
17-T-5550
Wrench, $\frac{9}{16}$ -in.

b. The battery should be checked once a week to obtain maximum service.

c. To check the battery and fill it with distilled water, lift off the inspection cover and remove the vent caps from the battery.

BOMB SERVICE TRUCK M6 (Chevrolet)

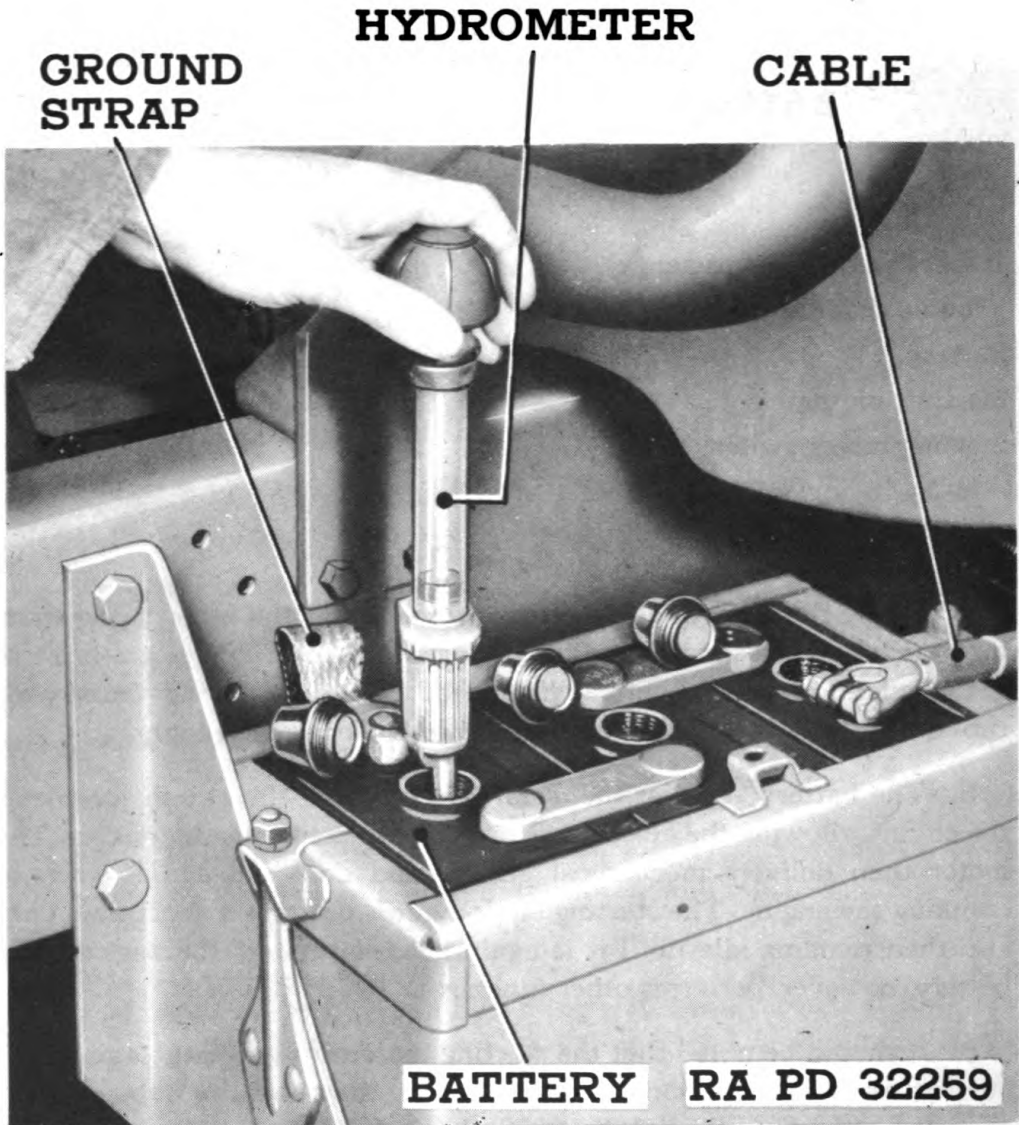

Figure 59—Specific Gravity Test of Battery

d. Check the specific gravity of each cell with a reliable hydrometer (fig. 59). A fully charged battery will show a reading of 1.275 to 1.300. A completely discharged battery will show a reading of approximately 1.150.

e. Should the reading be below 1.240, the battery should be recharged and the cause of the partially discharged condition investigated and corrected.

f. After testing the battery, it should be filled with distilled water to a level $\frac{1}{4}$ -inch above the plates.

g. The battery must be kept tight in its hanger at all times.

BATTERY AND STARTING SYSTEM

h. The battery terminals must be kept tight and free of corrosion.

i. To clean the cable terminals, remove them from the battery, scrape all corrosion from the inside of the terminal and then wash them off in a strong ammonia and water solution, plain water, or baking soda solution.

j. At regular intervals, the cover band should be removed from the starting motor and the commutator and brushes inspected. If the commutator is dirty, it may be cleaned with No. 00 sandpaper. Then blow out the dust. Never use emery cloth to clean commutator.

87. TROUBLE SHOOTING.

a. Discharged Battery.

Symptom	Probable remedy
(1) Loose or dirty terminals.	(1) Clean and tighten terminals.
(2) Generator not charging.	(2) Test as directed in paragraph 92.
(3) Leak in wiring.	(3) Check wiring for short circuit.
(4) Excessive use of starting motor, due to hard starting.	(4) Tune engine as directed in paragraph 116.
(5) Dead cell in battery.	(5) Replace battery.
(6) Worn out battery.	(6) Replace battery.
(7) Regulator not working.	(7) Check regulator.

b. Slow Starter Speed.

(1) Discharged battery.	(1) Recharge or replace battery.
(2) Loose or dirty terminals on battery and ground.	(2) Clean and tighten terminals.
(3) Worn brushes.	(3) Replace brushes.
(4) Sticking brushes.	(4) Clean brushes.
(5) Dirty or burned commutator.	(5) Clean commutator.
(6) Worn drive end bushing.	(6) Replace starting motor.
(7) Burned starter switch points.	(7) Replace switch.

BOMB SERVICE TRUCK M6 (Chevrolet)**88. BATTERY.**

a. Description. The battery in this truck is a 19-plate 6-volt battery having a rated capacity of 150 ampere hours. The battery is mounted in a hanger located outside the frame side rail just to the rear of the cab step on the right side of the truck (fig. 59). A removable metal cover attached by two screws protects the battery from mud and dirt. It also provides access for inspection and filling the battery with distilled water.

b. Battery Removal.**(1) TOOLS REQUIRED:**

Battery	Screwdriver
Knife	Wrench, $\frac{9}{16}$ -in.
Pliers	

(2) Remove screws on inspection cover and remove cover, using $\frac{9}{16}$ -inch wrench.

(3) Loosen the nuts on battery cable clamp bolts with $\frac{9}{16}$ -inch wrench.

(4) Spread ends of battery cable clamps to loosen them from the battery terminal and remove the cables from the battery terminals.

(5) Loosen the two nuts on the ends of the battery retainer cover and remove the battery retainer cover, using a $\frac{9}{16}$ -inch wrench.

(6) Lift battery out of the battery hanger.

c. Battery Replacement.

(1) Place the battery in position in the battery hanger. Be sure that the correct battery terminal is grounded.

(2) Install the battery retainer cover and the two nuts and lock washers.

(3) Scrape the inside of the battery cable clamps and install the battery cables on the battery terminals.

(4) Tighten battery cable clamp nuts securely.

(5) Install inspection cover and screws.

89. STARTING MOTOR.**a. Description.**

(1) The starting motor is located on the right side of the engine at the rear.

(2) The starting motor incorporates a manual shift drive mechanism which assures positive engagement of the starting motor pinion with the flywheel until the engine is started (fig. 60).

BATTERY AND STARTING SYSTEM

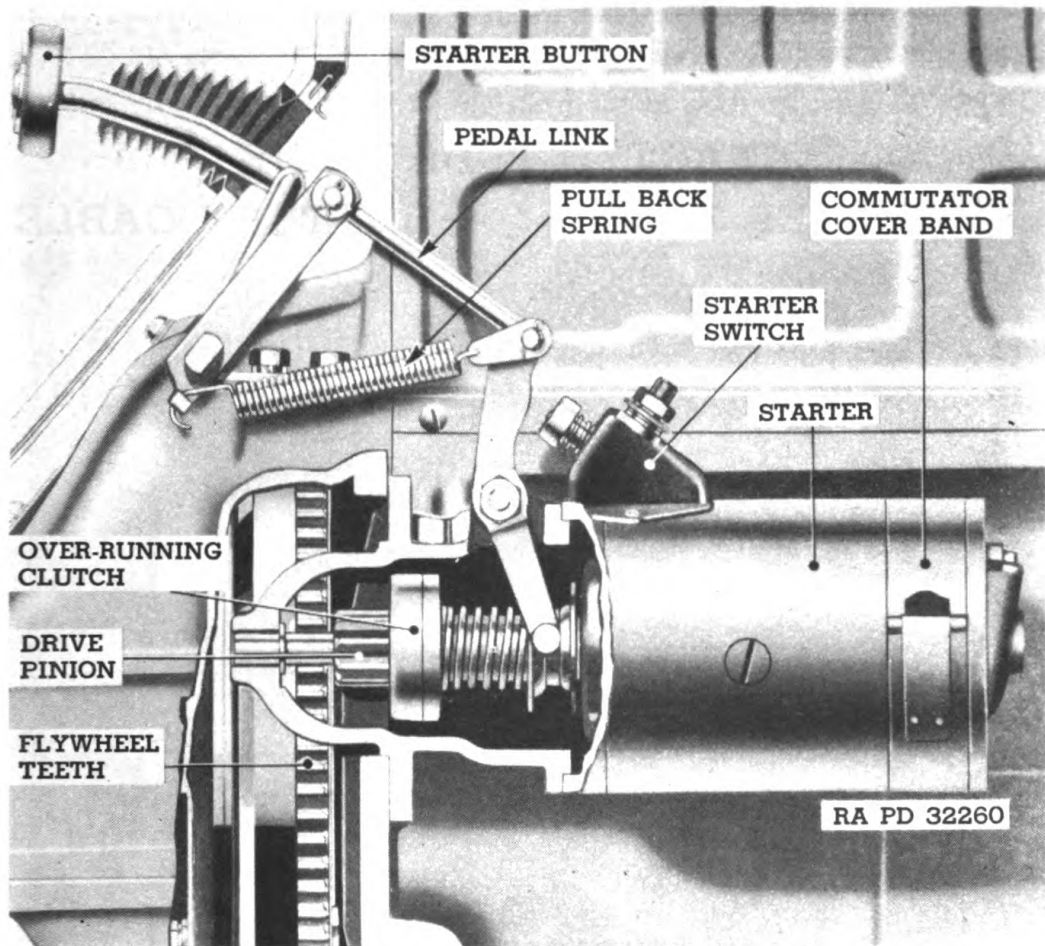

Figure 60—Cross Section of Starting Motor

(3) The starter pedal is connected to the manual shift drive mechanism by a series of linkage which also operates the starting switch.

b. Starting Motor Removal.

(1) TOOLS REQUIRED:

Pliers	Wrench, starter, $\frac{3}{4}$ -in. KMO-126 (KM)
Screwdriver	
Wrench, $\frac{11}{16}$ -in.	

(2) Disconnect battery terminals from battery.

(3) Remove nut and lockwasher from starting switch with a $\frac{11}{16}$ -inch wrench. Then remove ammeter wire and battery cable from the switch.

(4) Remove pedal pull-back spring.

(5) Remove cotter key and pin from linkage at point where front end of pull-back spring hooked on.

BOMB SERVICE TRUCK M6 (Chevrolet)

(6) Remove the two cap screws that hold the starting motor to the clutch housing with a $\frac{3}{4}$ -inch starter wrench.

(7) Remove starting motor from clutch housing (fig. 61).

STARTER PEDAL LINK

AMMETER WIRE

BATTERY CABLE

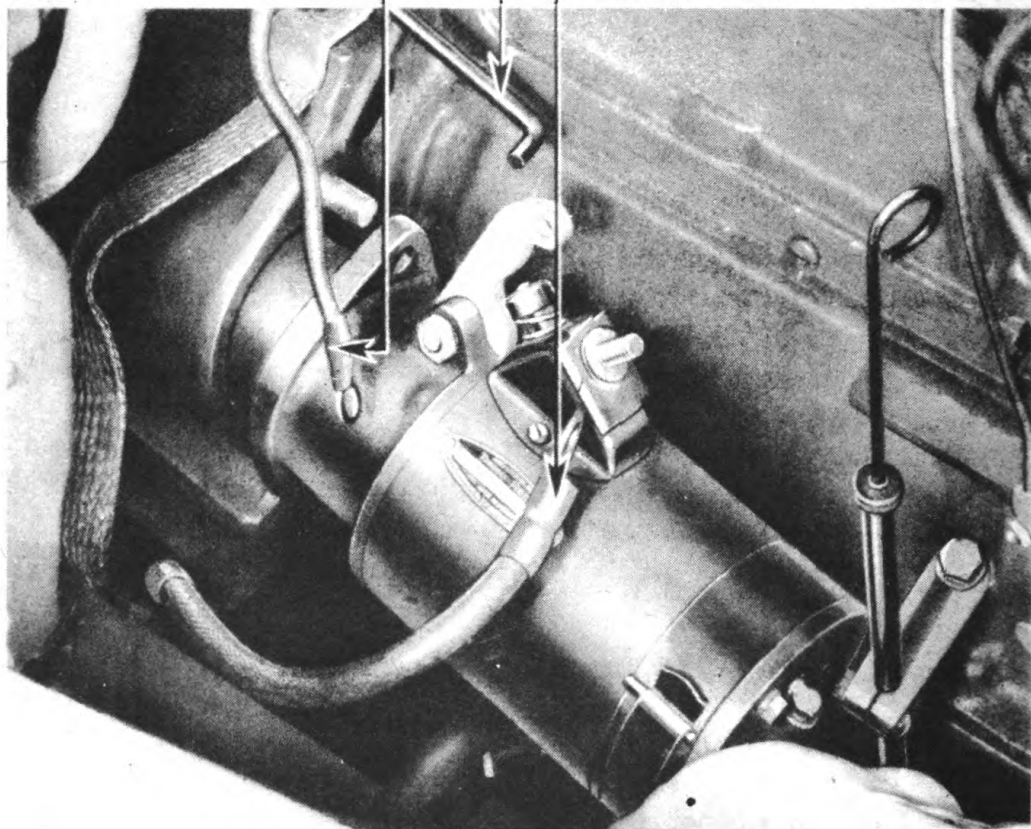

Figure 61—Starting Motor Removal

RA PD 32261

(8) Remove the two screws that attach the starting switch to the starting motor.

c. Starter Installation.

(1) TOOLS REQUIRED:

Pliers

Screwdriver

Wrench, $\frac{11}{16}$ -in.

Wrench, starter, $\frac{3}{4}$ -in. KMO-126 (KM)

(2) Install starting switch in position on starting motor with two screws and lockwasher.

(3) Place starting motor in position in clutch housing.

(4) Install the two cap screws and lockwashers that hold the starting motor to the clutch housing.

BATTERY AND STARTING SYSTEM

(5) Connect starting pedal linkage and insert pin and cotter key.
NOTE: Be sure that the two insulators are on each side of the contact bars before installing the switch on the motor.

(6) Install the ammeter wire and battery cable on the starting switch with the nut and lockwasher.

(7) Connect battery terminals onto battery.

90. STARTING MOTOR SWITCH.

a. Description.

(1) The starting switch is designed to carry the heavy current required by the starting motor without loss and without heating.

(2) The contacts are mounted loosely and are arranged to provide a wedging action, thus insuring a good connection when the contacts are brought together and also giving the contacts a wiping action which tends to keep them clean.

b. Starting Motor Switch Removal.

(1) TOOLS REQUIRED:

Screwdriver

Wrench, $\frac{1}{8}$ -in.

(2) Disconnect battery terminals from battery.

(3) Remove nut and lockwasher from terminal and remove battery cable, using a $\frac{1}{8}$ -inch wrench. Tape terminal to prevent short circuits.

(4) Remove the two screws that hold the starting switch to starting motor.

c. Switch Installation.

(1) Install the starting switch in position on the starting motor and install the two screws that hold the switch to the starter. **NOTE:** Be sure that the two insulators are on each side of the contact bars before installing the switch on the motor.

(2) Install ammeter wire and the battery cable on the terminal and lock with the nut and lockwasher.

(3) Connect battery terminals onto battery.

BOMB SERVICE TRUCK M6 (Chevrolet)

Section XVIII

GENERATOR AND CONTROLS

	Paragraph
Description	91
Testing and maintenance	92
Trouble shooting	93
Generator	94
Regulator unit	95

91. DESCRIPTION.

a. The function of the generating system may be summed up as follows: It converts a small amount of mechanical energy from the engine into electrical energy which is carried through the wiring to the battery, where it is stored for future use. In actual operation some of the energy may be used directly from the generator, but for explanatory purposes, it is assumed to flow from the generator to the battery and then be drawn from the battery. The generating circuit diagram is shown in figure 62.

b. The regulator unit does three things:

- (1) It keeps the battery from discharging through the generator when the engine is not running.
- (2) It keeps the generator from overcharging the battery.
- (3) It keeps the generator from building up excessive current which would burn up the generator.

92. TESTING AND MAINTENANCE.

The following tests may be made to determine whether or not the units are operating normally. If not, the checks will indicate whether the generator or regulator is at fault.

a. Tools Required:

Screwdriver	Wrench, 1/2-in.
Tester, volt-ampere, 17-T-5550	Wrench, 3/16-in.

b. Fully Charged Battery and a Low Charging Rate.

- (1) This indicates normal current regulator operation. To check the

GENERATOR AND CONTROLS

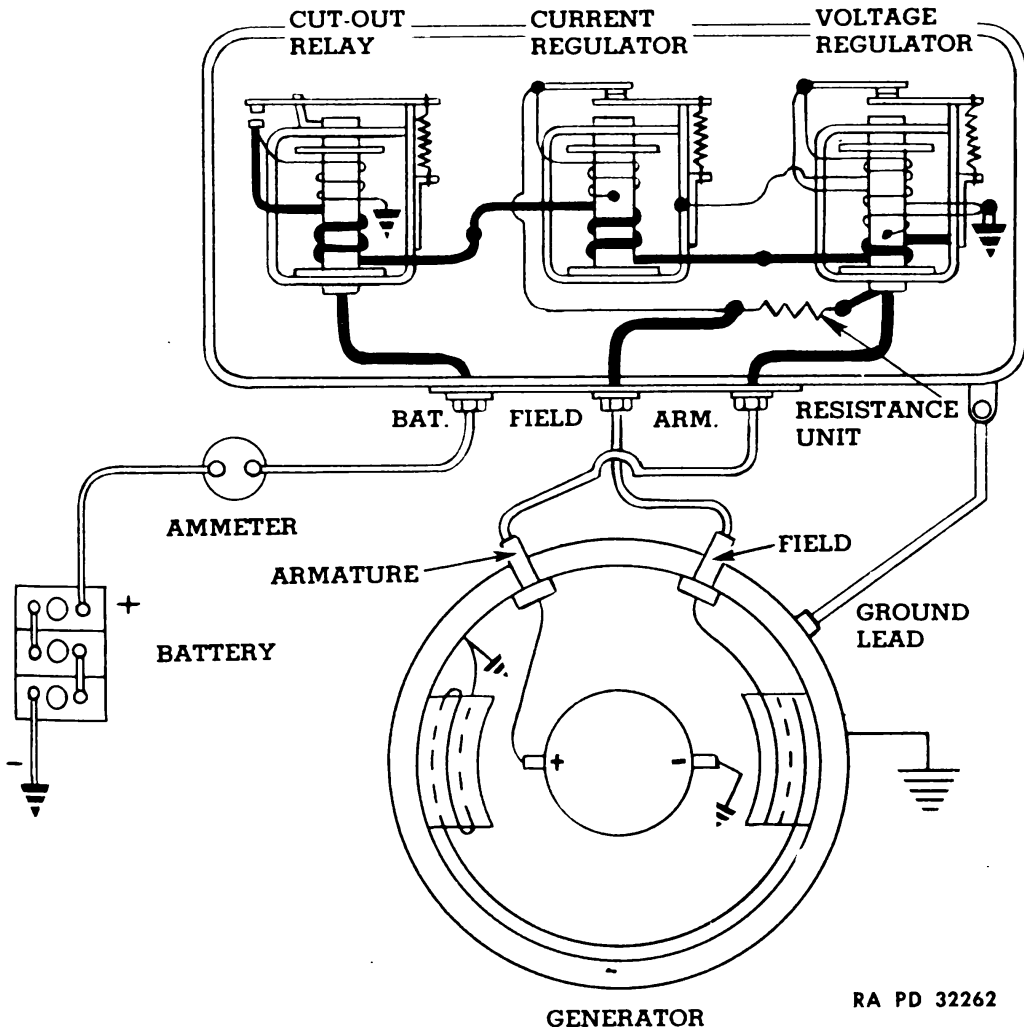

Figure 62—Generator Circuit Diagram

current regulator, remove the battery wire from the battery terminal of the regulator.

(2) Connect the positive lead of an ammeter to the battery terminal of the regulator and the negative lead to the battery wire with the ignition switch in the "off" position (fig. 63).

(3) Step on the starting switch and crank the engine for about 15 seconds. Then start the engine and, with it running at medium speed, turn on the lights and other electrical accessories, and note quickly the generator output on test ammeter, which should be the value for which the current regulator is set.

(4) Now turn off the lights and other electrical accessories and allow the engine to continue running. As soon as the generator has replaced in the battery the current used in cranking, the voltage regulator, if operating properly, will taper the output down to a few amperes.

BOMB SERVICE TRUCK M6 (Chevrolet)

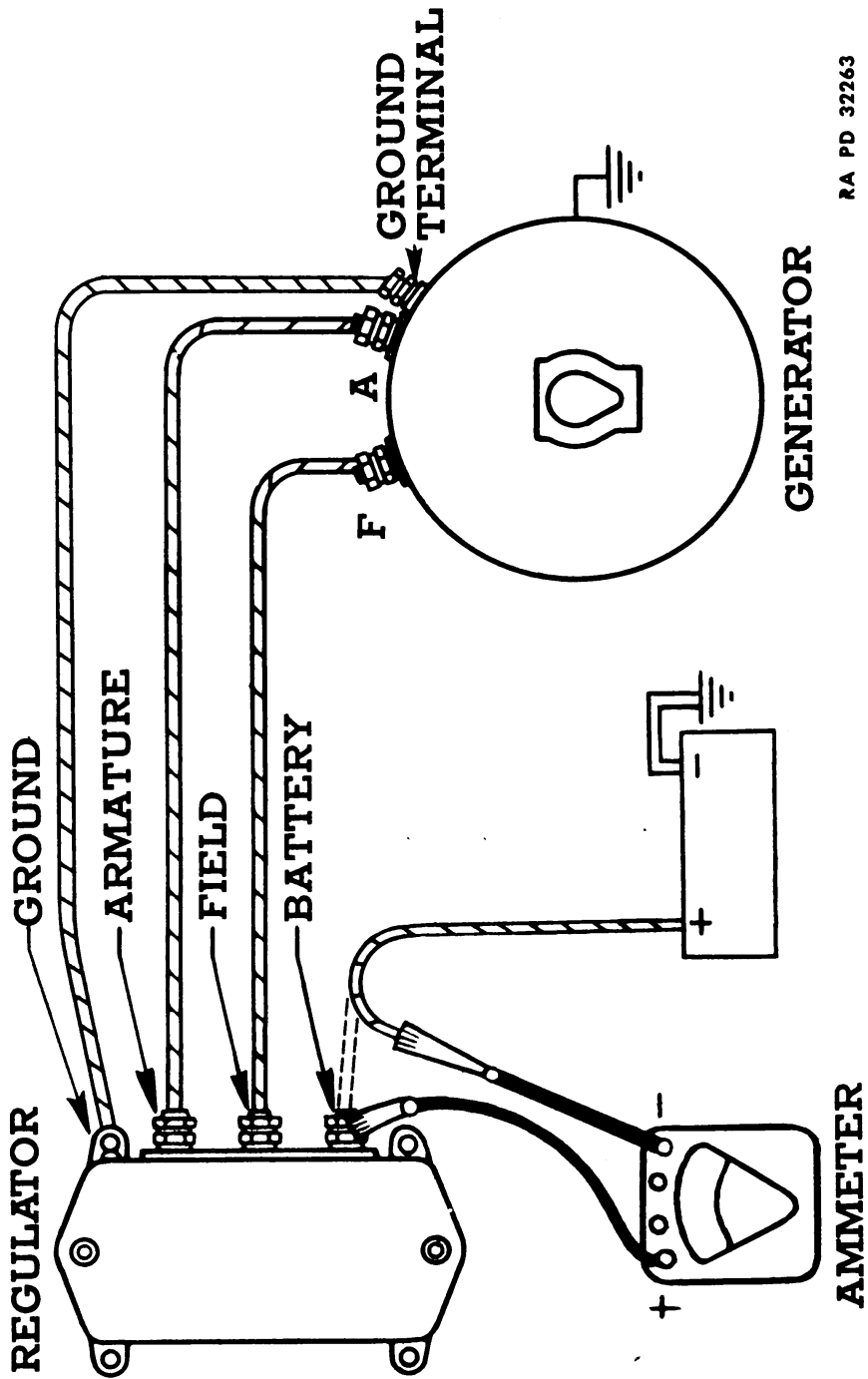

RA PD 32263

Figure 63—Checking Charging Rate with Fully Charged Battery

GENERATOR AND CONTROLS

c. Fully Charged Battery and a High Charging Rate.

(1) Disconnect the field wire from the field terminal of the regulator. This opens the generator field circuit and the output should immediately drop off. If it does not, the generator and field wires are shorted together in the wiring harness.

(2) If the output drops off to zero with the field lead disconnected, the trouble has been isolated in the regulator. Reconnect the field lead on the field terminal of the regulator.

(3) Remove the regulator cover and depress the voltage regulator armature manually to open the points. If the output now drops off, the voltage regulator unit has been failing to reduce the output as the battery came up to charge and voltage regulator replacement is indicated.

(4) If separating the voltage-regulator or current-regulator contacts does not cause the output to drop off, the field circuit within the regulator is shorted and the regulator should be replaced.

d. A Low Battery and a Low or No Charging Rate.

(1) Check the circuit for loose connections, corroded battery terminals, loose or corroded ground strap. The high resistance resulting from these conditions will prevent normal charge from reaching the battery. If the entire charging circuit is in good condition, then either the regulator or generator is at fault.

(2) With a jumper wire, connect the field and armature terminals together (fig. 64). Increase the generator speed and check the output. If the output increases, the regulator requires attention. If the output does not increase, a further check is necessary.

(3) If generator output remains at a few amperes with the field and armature terminals connected together, the generator is at fault and should be checked.

(4) If the generator does not show any output at all, either with or without the field and armature terminals connected together, short the armature terminals on the generator to ground with a screwdriver or a pair of pliers, with the generator operating at medium speed. If spark does not occur, the trouble has been isolated in the generator, and the generator should be replaced. If a spark does occur, it is likely the generator is building up current which cannot flow to the battery because of burnt cut-out points, points not closing, open voltage winding, or too high voltage setting of the cut-out. Use a voltmeter to test generators whenever one is available, as less than seven volts (required for operation) may give a spark and false information.

BOMB SERVICE TRUCK M6 (Chevrolet)

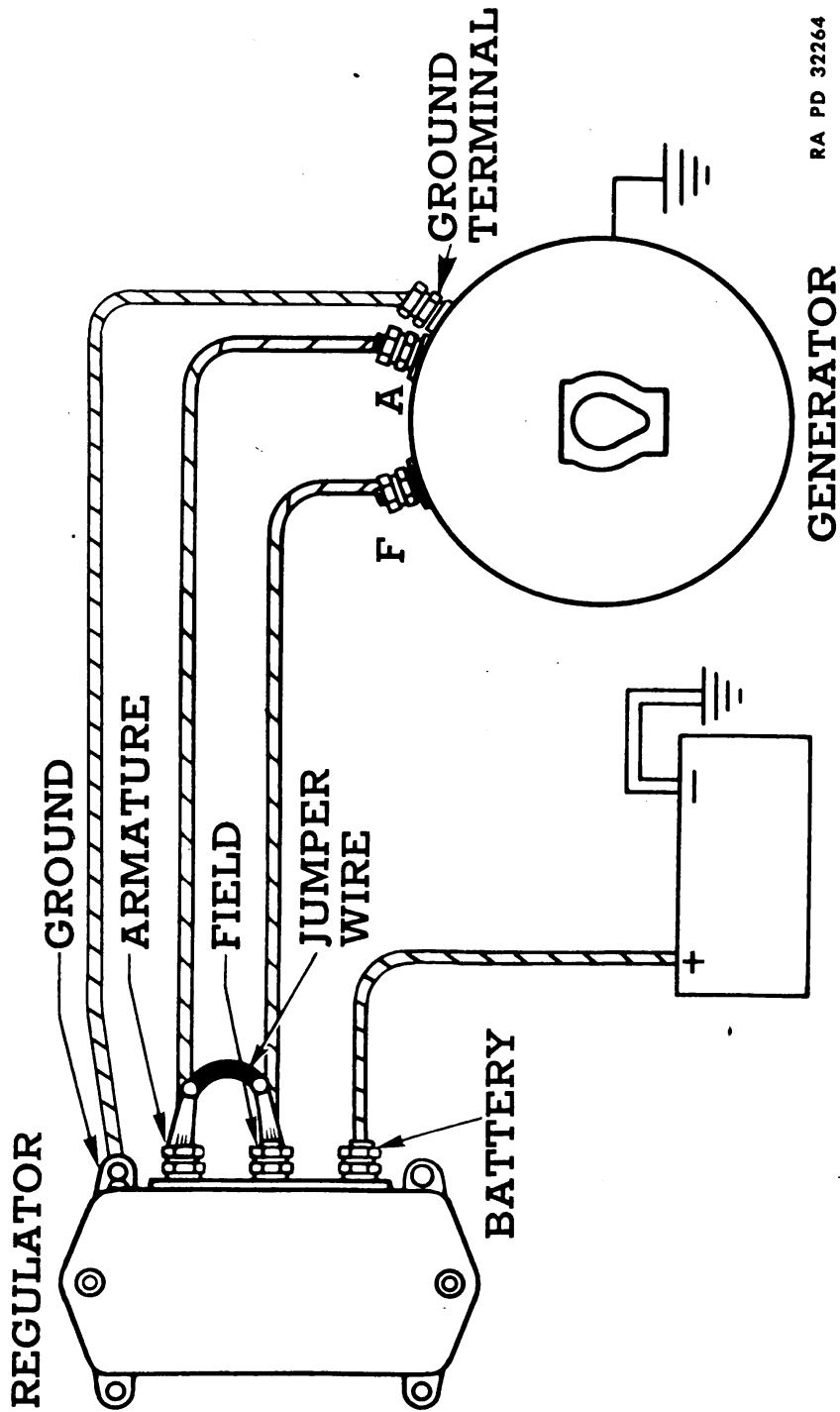

RA PD 32264

Figure 64 — Checking Charging Rate with Low Charged Battery

GENERATOR AND CONTROLS

e. **Maintenance.** At regular intervals, the generator cover band should be removed and the commutator and brushes inspected. If the commutator is dirty, it may be cleaned with No. 00 sandpaper and then the dirt blown out. Never use emery cloth to clean commutator.

93. TROUBLE SHOOTING.

Symptom	Probable remedy
a. Low Generator Charging Rate.	
(1) Dirty commutator.	(1) Clean commutator.
(2) Loose fan belt.	(2) Adjust fan belt. See paragraph 77.
(3) Voltage regulator out of adjustment.	(3) Replace unit.
(4) High resistance in charging circuit.	(4) Clean and tighten battery terminals and check circuit for loose connections.
(5) Worn brushes.	(5) Replace brushes.
(6) Weak brush springs.	(6) Replace springs.
b. Too High Generator Charging Rate.	
(1) Current regulator out of adjustment.	(1) Replace unit.
(2) Dead cell in battery.	(2) Replace battery.

94. GENERATOR.

a. Description.

(1) The generator is a two-brush, shunt-wound machine which is attached to the left side of the engine at the front by a brace and bracket with bolts and nuts (fig. 65).

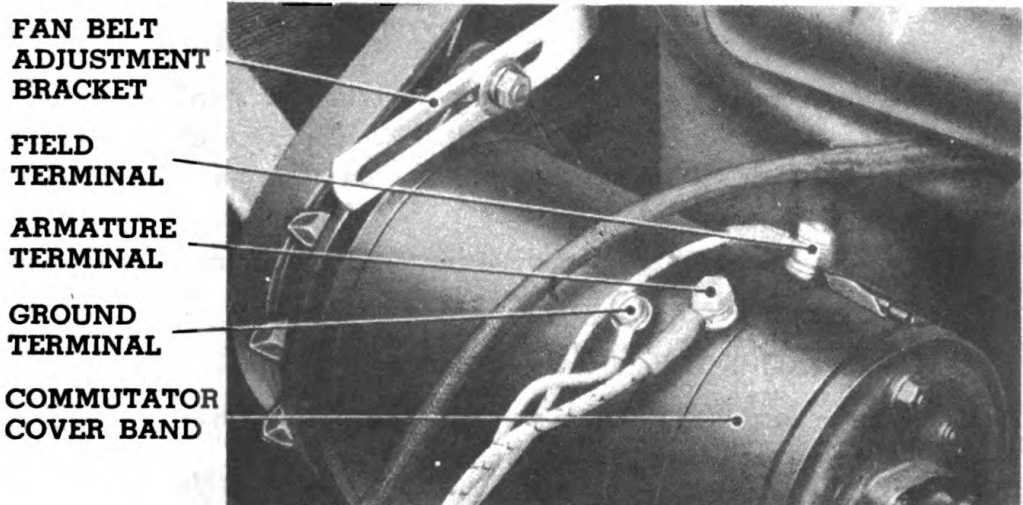

RA PD 32265

Figure 65—Generator Assembly

BOMB SERVICE TRUCK M6 (Chevrolet)

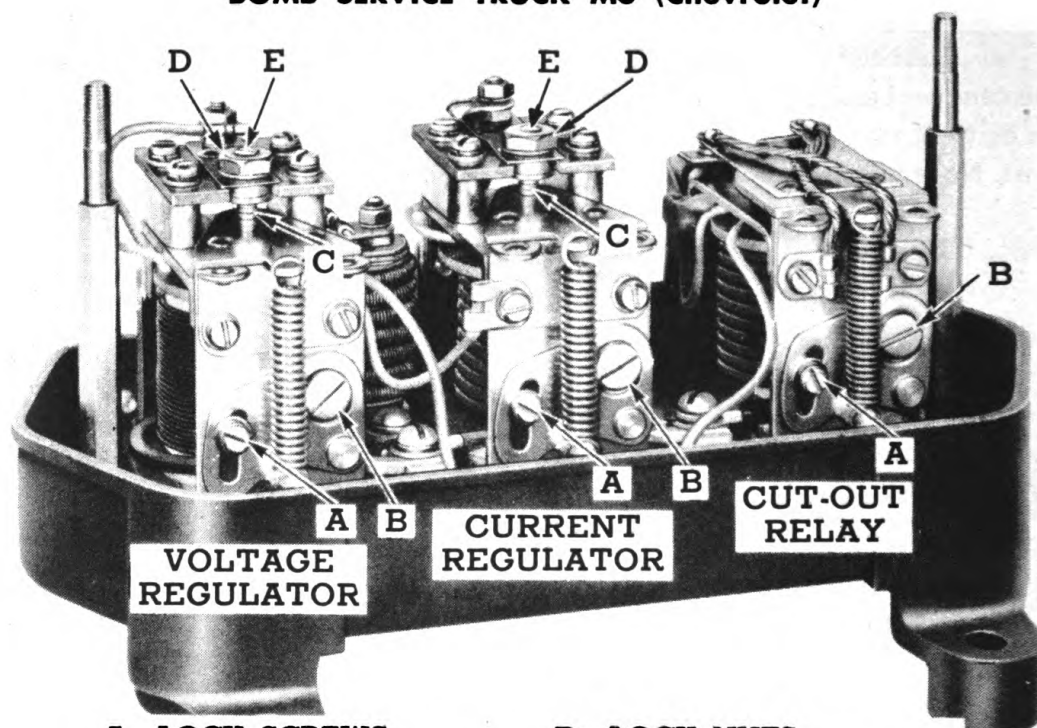

A—LOCK SCREWS
B—ECCENTRIC SCREWS
C—POINT OPENING

D—LOCK NUTS
E—CONTACT SCREWS

RA PD 32266

Figure 66—Generator Circuit Regulator

- (2) The generator is driven by the fan belt.
- (3) It is cooled by a fan located in back of the generator pulley.

b. Replacement.

(1) TOOLS REQUIRED:

Screwdriver

Wrenches, 1/2-in., two

(2) Disconnect the two wires from the two terminals and the ground connection on the top of the generator. **NOTE:** Identify each wire with a tag so that each wire will be put back on the same terminal from which it was removed.

(3) Remove the cap screw from the slotted brace on top of generator.

(4) Push generator toward engine.

(5) Remove fan belt from the generator pulley.

(6) Remove the two bolts, nuts and lockwashers at each end of bracket on bottom of generator, using two 1/2-inch wrenches.

(7) Remove the generator.

(8) To install a new generator, place generator in position on the

GENERATOR AND CONTROLS

bracket and install the two bolts, nuts and lockwashers through bracket and generator.

- (9) Install fan belt on the generator pulley.
- (10) Install cap screw through slotted brace and bolt it to the generator.
- (11) Adjust fan belt tension. See paragraph 77.
- (12) Connect the two wires to the generator on the same terminals they were removed from, and connect the third wire to the ground.

95. REGULATOR UNIT.

a. Description.

(1) The generator is controlled by a regulator unit which contains a voltage regulator, current regulator and cut-out relay (fig. 66). The unit is fastened to the left side of the dash.

(2) The voltage regulator controls the generator voltage and does not allow it to rise above a value determined by the voltage regulator setting.

(3) The current regulator controls the maximum generator output (amperage) and does not allow the output to exceed the value determined by the current regulator setting.

(4) The cut-out relay is an automatic switch which automatically closes the circuit between the generator and battery when the generator voltage rises above that of the battery, and automatically opens the circuit between the generator and battery when the generator voltage falls below that of the battery.

(5) The terminals of the regulator unit are marked and care should be used in making connections; otherwise serious damage to the regulator may result.

b. Replacement. NOTE: The Regulator unit cover is marked "POS-GROUND" or "NEG-GROUND." Be sure that the unit being installed is marked the same as the unit that was removed.

(1) TOOL REQUIRED:

Wrench, 1/2-in.

(2) Disconnect the three wires from the terminals on the regulator unit. NOTE: Identify each wire with a tag so that they can be connected to the same terminals from which they were removed.

BOMB SERVICE TRUCK M6 (Chevrolet)

(3) **CAUTION:** Tape the wire removed from the battery terminal of the regulator to prevent accidental short circuit during regulator replacement operations.

(4) Remove the four bolts that attach the regulator unit to the dash and remove the unit, using a 1/2-inch wrench.

(5) Install the unit in place on the dash with the four screws.

(6) Install the three wires on the terminals, making sure that they are attached to same terminals from which they were removed.

Section XIX

IGNITION SYSTEM

	Paragraph
Description	96
Trouble shooting	97
Distributor	98
Condenser	99
Automatic spark control	100
Spark plugs	101
Ignition coil	102

96. DESCRIPTION.

The power in a gasoline engine is derived from burning a gas and air mixture in the engine cylinders. In order to ignite this gas, the electric spark is made to jump a small gap inside the cylinder. The ignition system furnishes this spark. The spark must occur in each cylinder at exactly the proper time and the sparks in the various cylinders must follow each other in the proper order. To accomplish this, the following parts are used: the battery which furnishes the electrical energy; the ignition coil which transforms the battery current to high tension current which will jump the gap in the spark plug; the mechanical breaker which opens and closes the primary circuit at the proper time; the distributor which delivers the spark to the proper cylinders; the spark plug which provides the gap in the engine cylinder; the wiring which connects the various units; the ignition switch for disconnecting the battery when it is desired to stop the engine. See figure 67.

97. TROUBLE SHOOTING.

Symptom	Probable remedy
a. Hard Starting.	
(1) Distributor points burned or corroded.	(1) Clean or replace points and check cause.
(2) Points out of adjustment.	(2) Adjust to 0.018 inch.
(3) Spark plug gaps out of adjustment.	(3) Adjust to 0.040 inch.
(4) Spark plug wires loose or corroded in distributor cap.	(4) Clean wire and cap terminals.

BOMB SERVICE TRUCK M6 (Chevrolet)

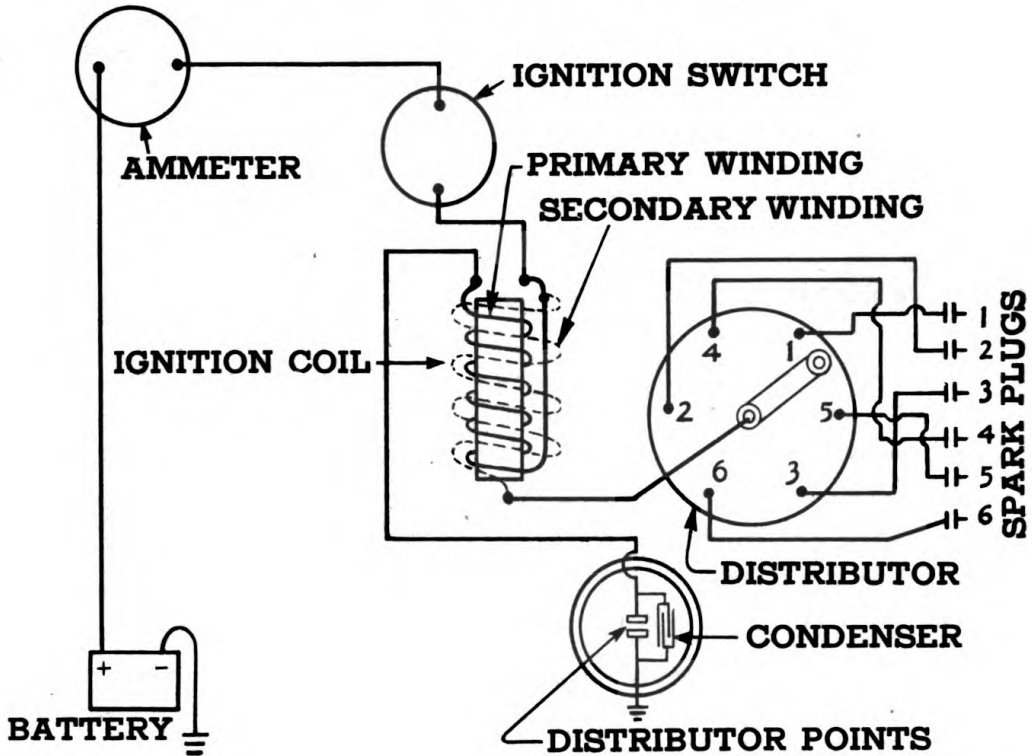

RA PD 32267

Figure 67—Ignition Circuit

- | | |
|--|---|
| (5) Loose connections in primary circuit. | (5) Tighten all connections in primary circuit. |
| (6) Corroded battery terminals and ground terminals. | (6) Clean and tighten terminals. |
| (7) Series resistance in condenser circuit. | (7) Clean all connections in condenser circuit. |
| (8) Low capacity condenser. | (8) Replace condenser. |
- b. Failure to Start.**
- | | |
|---|--------------------------------|
| (1) Disconnected distributor or coil wires. | (1) Connect wires. |
| (2) Corroded battery and/or ground terminals. | (2) Remove, clean and tighten. |
| (3) Ignition coil faulty. | (3) Replace. |
| (4) Fuel trouble. | (4) See section XXIV. |
| (5) Wet spark plugs. | (5) Remove and dry thoroughly. |
| (6) Distributor points burned. | (6) Replace points. |
| (7) Shorted condenser. | (7) Replace condenser. |

IGNITION SYSTEM

98. DISTRIBUTOR.

a. Description. The ignition distributor is mounted on the right side of the engine and is driven from the camshaft by spiral gears. Spark control is entirely automatic, being operated by centrifugal weights pivoted on a plate which is an integral part of the shaft and connected to the breaker arm. This mechanism advances the timing automatically as the engine speed increases.

b. Maintenance.

(1) Keep the grease cup filled with GREASE, medium cup. Turn down the cup one turn every 1000 miles.

(2) Add a trace of petrolatum to the breaker cam and add a few drops of OIL, engine, light, in the wick in the top of the cam under the rotor every 1000 miles.

(3) The distributor cap should be removed at regular intervals and the contacts, rotor and cap examined. Look for carbon lines between contacts on cap.

(4) Check the high tension wiring for frayed or damaged insulation and poor connections at the caps or plugs. Any damaged parts should be replaced and loose connections tightened.

(5) Contact points that are burned or pitted should be replaced or dressed down with a fine-cut ignition point file. The file should not be used on other metals and should not be allowed to become greasy or dirty.

(6) Never use emery cloth to clean contact points.

(7) Oxidized points may be caused by bad condenser, high resistance or loose connections in condenser circuit, oil or dirt on the contact surfaces, or high voltage regulator setting. Check for these conditions where burned contact points are experienced.

c. Breaker Point Adjustment.

(1) **TOOLS REQUIRED:**

Gage, feeler, .018-in.

Screwdriver

(2) The contact points are fixed on their mounts and are controlled by an eccentric screw moving the mounting plate. To adjust the gap of these points, proceed as follows:

(3) Remove the distributor cap and rotor.

(4) Hand crank the engine until the breaker arm cam follower is on the peak of the cam. The contact points are then opened the maximum distance.

BOMB SERVICE TRUCK M6 (Chevrolet)

(5) Loosen the lock screw on the stationary mount (the screw nearest the point) and turn the eccentric adjusting screw to the right or left, increasing or decreasing the gap to 0.018 inch (fig. 68). Tighten lock screw and check gap adjustment, and replace rotor and distributor cap.

(6) **NOTE:** If new points are installed, adjust the gap to 0.020 inch to 0.022 inch to compensate for initial wear on the fiber cam follower.

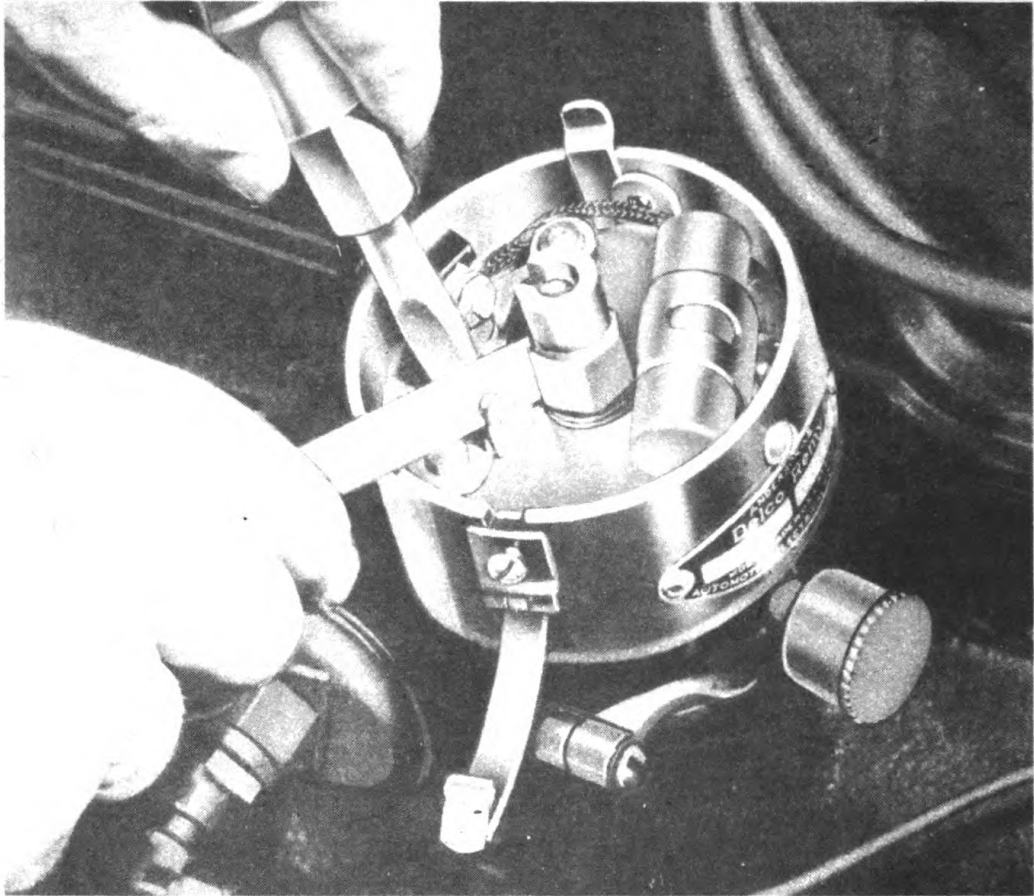

RA PD 32268

Figure 68—Distributor Point Adjustment

d. Breaker Point Replacement.

(1) **TOOLS REQUIRED:**

Gage, feeler, .018-in.

Screwdriver

Wrench, ignition, $\frac{5}{16}$ -in.

(2) To remove breaker points, first remove the distributor cap and rotor.

(3) Using a $\frac{5}{16}$ -inch ignition wrench, loosen nut on terminal on inside of distributor housing and lift movable breaker arm up until it is out of housing.

IGNITION SYSTEM

(4) Remove the lock screw (screw nearest breaker point), from the stationary breaker point, and remove the point.

(5) To install breaker points, first install stationary contact point and movable contact point.

(6) Adjust point gap to 0.018 inch. See (5) above.

(7) Install rotor and distributor cap.

e. Distributor Replacement.

(1) TOOLS REQUIRED:

Light, timing, KMO-318 (KM) Screwdriver

(2) To remove distributor, first remove distributor cap.

(3) With point of screwdriver or a piece of chalk, put a mark on outside of housing at right angles to motor. This is important as housing must be replaced in the same position.

(4) Also scratch a mark on the rim of the housing at a point opposite the center of the metal tip at the outside of the rotor. This also is important as the rotor must be in this position when the distributor is replaced.

(5) With a screwdriver, loosen the distributor clamp screw, which is located between the distributor and the cylinder block.

(6) Thread distributor assembly up and out of cylinder block.

(7) To install distributor, if the engine has not been turned or hand cranked since removing the distributor, the distributor can be replaced as follows:

(8) Thread distributor part way into the cylinder block. Set distributor body in the same position that it was in before it was removed and hold it with one hand.

(9) While holding distributor body, turn rotor one tooth of the gear (about $\frac{1}{4}$ inch) in a clockwise direction from the mark that was scratched on the edge of the rim and push assembly down in position. **NOTE:** Be sure that marks line up and both the rotor and the housing are in the same position they were in before they were removed.

(10) Tighten distributor clamp screw and install distributor cap.

(11) Time engine as follows:

(12) Attach timing light to No. 1 spark plug.

(13) Start engine and run it at idling speed.

BOMB SERVICE TRUCK M6 (Chevrolet)

(14) Loosen distributor clamp bolt and rotate the distributor body clockwise or counterclockwise until the steel ball in the flywheel lines up with the pointer on the flywheel housing (fig. 69).

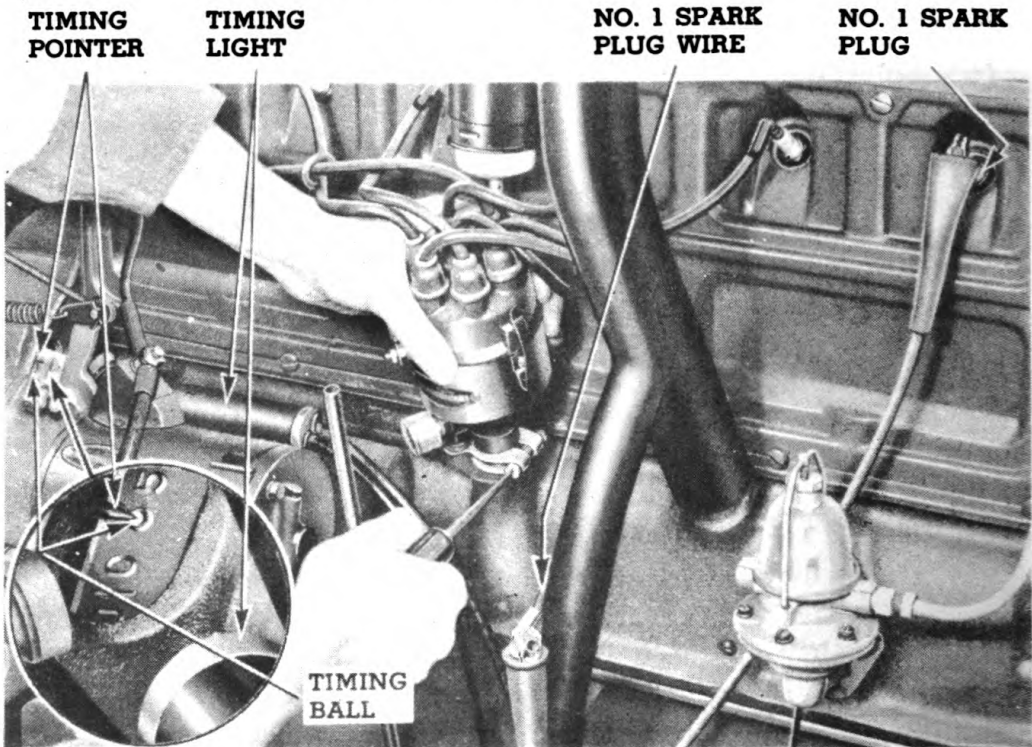

RA PD 32269

Figure 69—Setting Engine Timing

(15) Tighten distributor clamp screw.

f. Retiming Distributor.

(1) **TOOLS REQUIRED:**

Light, timing, KMO-318 (KM) Wrench, $\frac{9}{16}$ -in.
Screwdriver

(2) If the engine has been turned or hand cranked while distributor was removed, it will be necessary to time the distributor as follows:

(3) Remove No. 1 spark plug with special spark plug wrench.

(4) Remove valve cover with $\frac{9}{16}$ -inch wrench.

(5) With engine crank, hand crank engine until the second valve (No. 1 intake valve) closes. Then continue to hand crank engine about one-half turn until the piston comes to the top of the No. 1 cylinder. This can be determined by turning the flywheel until the steel ball appears at the indicator opening in the flywheel housing on the right-hand side of the engine.

IGNITION SYSTEM

(6) Now turn engine until the steel ball is about $\frac{1}{2}$ inch beyond the indicator, to a line stamped on the flywheel between the letters U/C.

(7) With engine in this position, install distributor cap on distributor and trace the wire from the No. 1 spark plug and scratch a mark on the edge of distributor housing directly under the terminal of the distributor cap that leads to No. 1 cylinder.

(8) Remove distributor cap and install assembly as follows:

(9) Start the assembly in cylinder block.

(10) Hold assembly in one hand with the primary terminal in the position shown in figure 70.

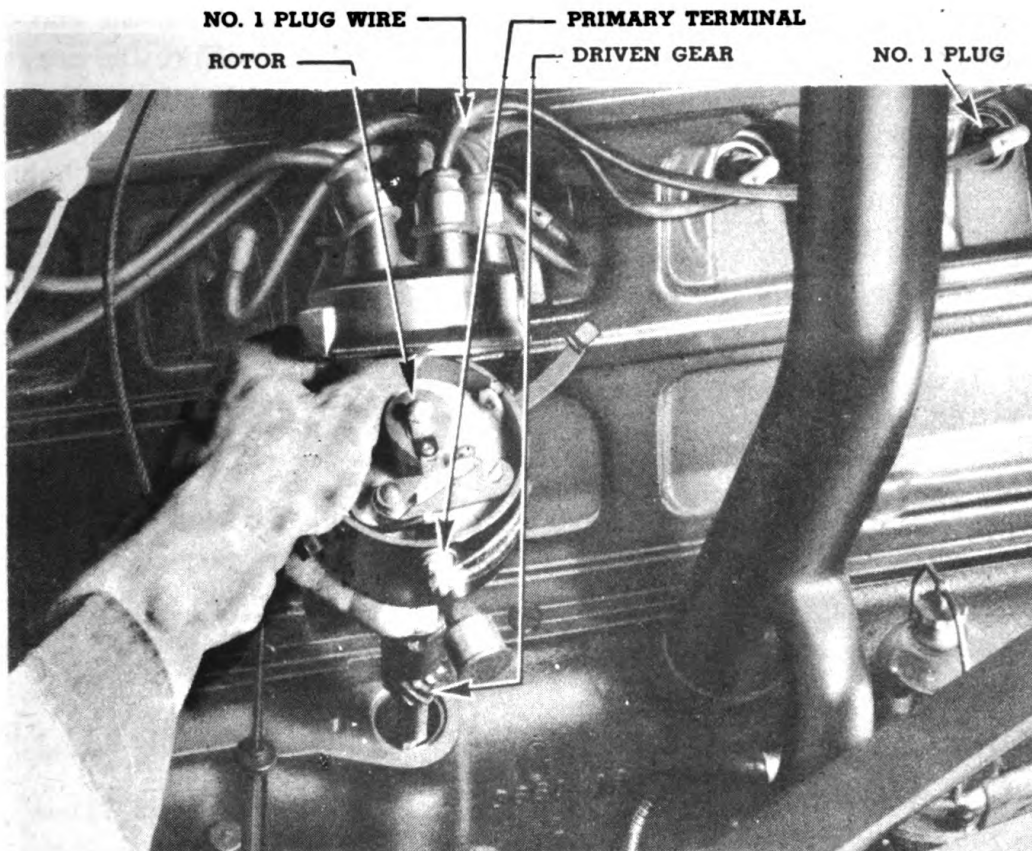

RA PD 32270

Figure 70—Distributor Installation

(11) With other hand, turn rotor one tooth or about $\frac{1}{4}$ inch clockwise from the mark opposite the No. 1 wire terminal and push assembly down into cylinder block. **NOTE:** When assembly is in place, the center

BOMB SERVICE TRUCK M6 (Chevrolet)

of the metal tip at edge of rotor should be lined up with the mark opposite the No. 1 terminal of the distributor cap.

(12) Tighten clamp screw on clamp which is between the distributor and cylinder block and install distributor cap.

(13) Time ignition. See instructions in subparagraph e (11).

99. CONDENSER.

a. **Purpose.** The condenser, which is located within the distributor body, is provided to permit a rapid collapsing of the lines of force built up around the windings of the ignition coil and to protect the breaker points from arcing and burning.

b. **Testing.** Remove the high tension terminal from the distributor and support it with an insulated handle screwdriver so that the end of the terminal is about $\frac{3}{8}$ inch from the cylinder block. Turn the engine with the starting motor and if the spark developed is slightly reddish in color instead of deep blue, then the condenser should be replaced. Remove and test condenser for shorting, with test lamp. If lamp lights, condenser is shorted and must be replaced.

c. Replacement.

(1) TOOLS REQUIRED:

Screwdriver

Wrench, ignition, $\frac{5}{16}$ -in.

(2) Remove distributor cap and rotor.

(3) With a $\frac{5}{16}$ -inch ignition wrench, loosen nut on terminal on inside of housing and lift off the end of condenser lead.

(4) With a screwdriver, remove the screw from the clamp that attaches the condenser to the plate.

(5) To install condenser, reverse the above procedure.

100. AUTOMATIC SPARK CONTROL.

a. **Description.** Automatic spark advance is accomplished by the use of two centrifugal weights pivoted on a plate which is an integral part of the distributor shaft. These weights are connected to the distributor cam by springs. The inner end of the weights rests against the lobes of the distributor cam base. As the engine speed increases, the weights have a tendency to swing out toward the distributor body. This action moves the distributor cam in a clockwise direction, advancing

IGNITION SYSTEM

the spark (fig. 71), right view. As the engine speed decreases, the springs pull the weights back to their original position, retarding the spark (fig. 71), left view.

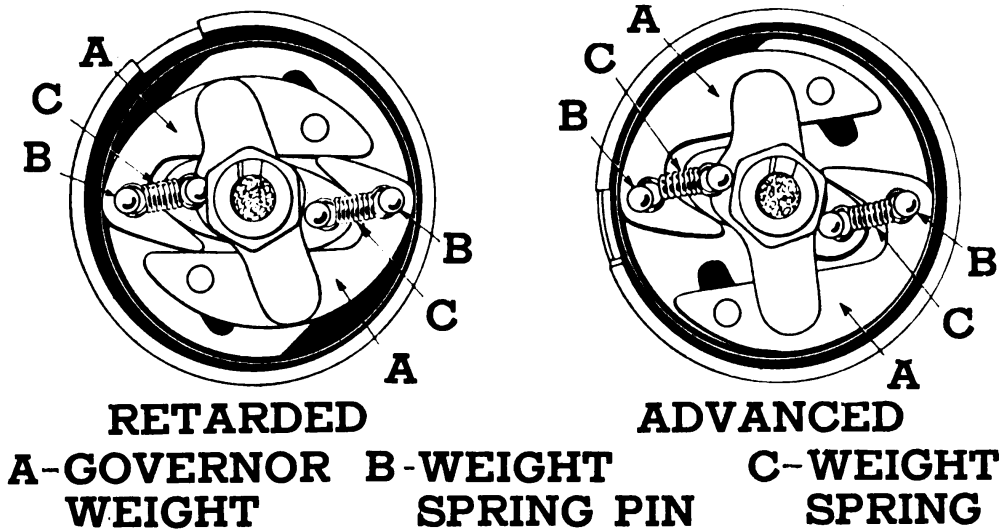

RA PD 32271

Figure 71—Mechanical Breaker Mechanism

b. To check the operation of the automatic spark control:

(1) Remove distributor cap and with fingers try to turn rotor in a counterclockwise direction. It should not move. It should be resting against the stop.

(2) Now turn rotor in a clockwise direction. It should turn about 1/4 inch before it hits a stop. When you let go of the rotor, the spring tension should return the rotor to its original position.

(3) If the automatic spark control does not operate as outlined above, the distributor should be replaced.

101. SPARK PLUGS.

a. **Tools Required:**

Gage, spark plug

Wrench, spark plug, 5/8-in.

b. The spark plugs are 10 millimeter A-C-104. They are of one piece construction.

c. When installing spark plugs, use a new gasket and screw the plug in finger tight. Then tighten with a spark plug wrench one-half turn more, just making a good seat on gasket. If a torque wrench is used, the plugs should not be tightened over 15 foot pounds maximum.

BOMB SERVICE TRUCK M6 (Chevrolet)

- d. Keep plugs clean. Always use correct heat range A-C-104.
- e. Keep spark plug gaps adjusted to 0.040 inch.
- f. Use a round feeler gage when setting spark plug gaps (fig. 72).

102. IGNITION COIL.

a. The ignition coil is filled with transformer oil and is hermetically sealed to prevent the entrance of moisture. A large porcelain insulator is used at the secondary terminal to provide effective insulation.

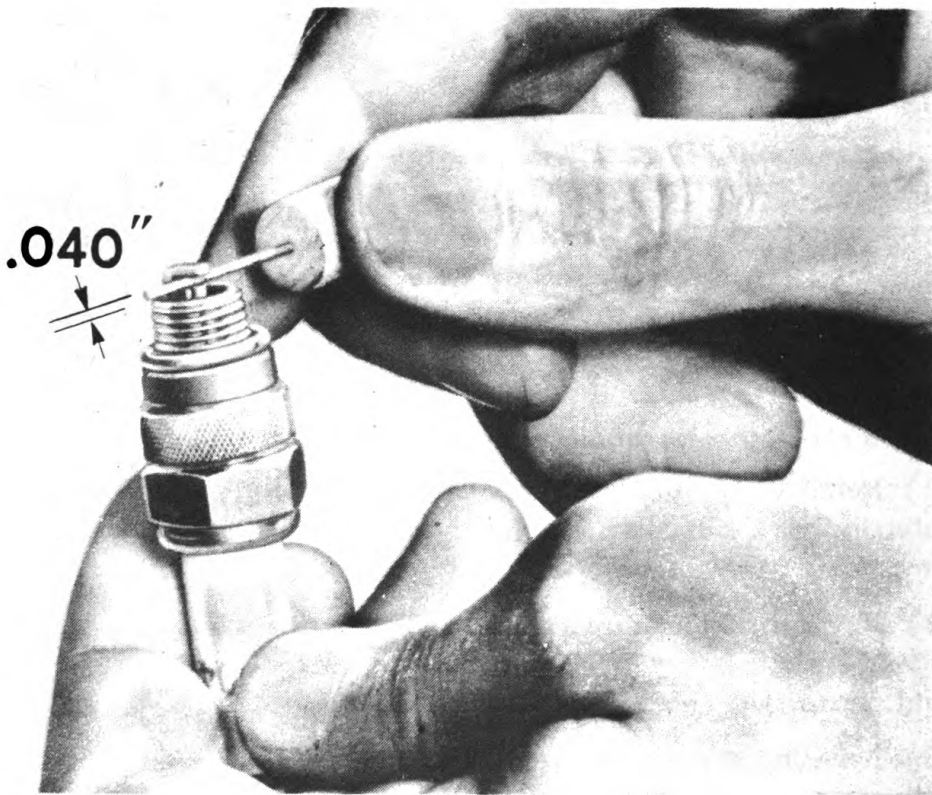

RA PD 32272

Figure 72—Setting Spark Plug Gap

b. **Coil Testing.** Coil tests can only be made on coil testing equipment; therefore, the instructions of the equipment manufacturer should be followed.

c. Coil Removal.

(1) TOOLS REQUIRED:

Screwdriver

Wrench, $\frac{3}{8}$ -in.

(2) With a $\frac{3}{8}$ -inch wrench, remove nuts and lockwashers on the two terminals on top of the coil and remove wires. **NOTE:** Tag wires "pos." and

IGNITION SYSTEM

“neg.” so they can be put back on the same terminals from which they were removed. **THIS IS IMPORTANT.**

(3) Pull high tension wire off of terminal at bottom of coil.

(4) With screwdriver, remove the two screws on each side of the coil which attach the coil to the cylinder block.

d. Coil Replacement.

(1) Mount coil on right side of motor with the two screws and lockwashers.

(2) Push high tension wire on terminal at bottom of coil.

(3) Attach wires to the two terminals on top of the coil. Make sure to put the wires on the same terminals from which they were removed.

BOMB SERVICE TRUCK M6 (Chevrolet)

Section XX

LIGHTING AND WIRING SYSTEMS

	Paragraph
Description	103
Trouble shooting on headlights	104
Main light switch	105
Head lamps	106
Head lamp aiming	107
Blackout head lamp	108
Blackout tail and stop lamp	109

103. DESCRIPTION.

a. The lights are controlled by switches within easy reach of the driver. The lighting circuits are protected by an overload circuit breaker which clicks on and off in the event of a short circuit in the wiring. In addition, the wiring to the fuel gage and horn is protected by circuit breakers of the same type.

b. A simplified wiring diagram of the electrical system is shown in figure 73. By studying this diagram the reader can gain an understanding of the circuits which operate the various units and lights in the system.

c. For convenience in servicing, the wiring on this truck is made up in three separate wiring harnesses, namely, chassis rear wiring harness, chassis front wiring harness and body wiring harness. These harnesses connect to a common junction block located on the front of the dash on the left side of the truck. Figures 74, 75, and 76 show these wiring harness connections to the junction block followed by an explanation of the wiring hookup.

d. Chassis Front Wiring Harness (fig. 74).

Terminal No.	Connects to	Wire Size No.	Wire Color
1	Blackout head lamp	16	Natural with green tracer
2	No connection this harness		
3	Head lamp upper beam	12	Natural with black cross tracer
4	Horn	14	Natural with black tracer
5	Horn	14	Natural with red tracer
6	Head lamp lower beam	14	Natural with green tracer

BOMB SERVICE TRUCK M6 (Chevrolet)

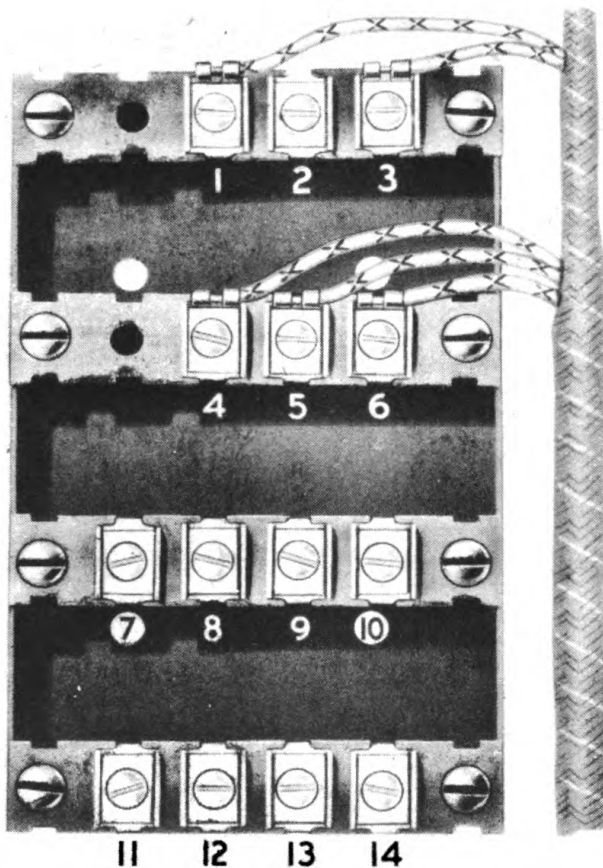

RA PD 32274

Figure 74—Chassis Front Wiring Harness Junction Block

e. Chassis Rear Wiring Harness (fig. 75).

Terminal No.	Connects to	Wire Size No.	Wire Color	
1	Blackout tail lamps	16	Natural with green tracer	
2	Electric brake controller	12	Natural with red tracer	
3, 4, 5 & 6	No connection with this harness			
7		Main gas tank gage unit	16	Natural with red tracer
8		Auxiliary gas tank gage unit	16	Natural with black tracer
9		"T" terminal on trailer connector	14	Black
10	Service tail lamp, and "BATT" on dimmer switch	16	Natural with black cross tracer	
11	Service stop lamp	14	Natural	

LIGHTING AND WIRING SYSTEMS

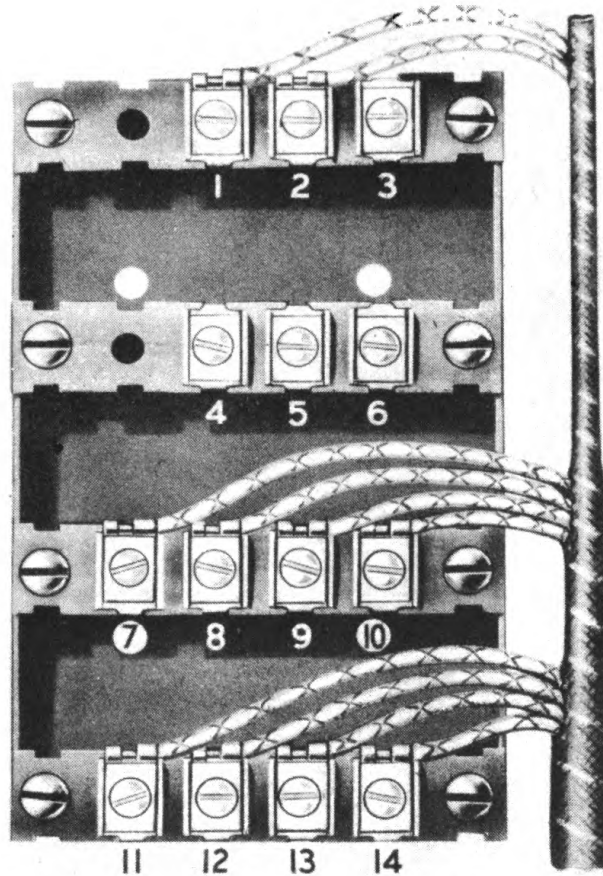

RA PD 32275

Figure 75—Chassis Rear Wiring Harness Junction Block

Terminal No.	Connects to	Wire Size No.	Wire Color
12	Blackout stop lamp	16	Natural with green cross tracer
13	Brake control stop light switch and service stop light switch	14	Natural
14	Brake control stop light switch, service stop light switch, and "S" terminal on trailer connector	14	Natural with black tracer

f. Body Wiring Harness (fig. 76).

Terminal No.	Connects to	Wire Size No.	Wire Color
1	Electric brake load regulator	12	Natural with red tracer

BOMB SERVICE TRUCK M6 (Chevrolet)

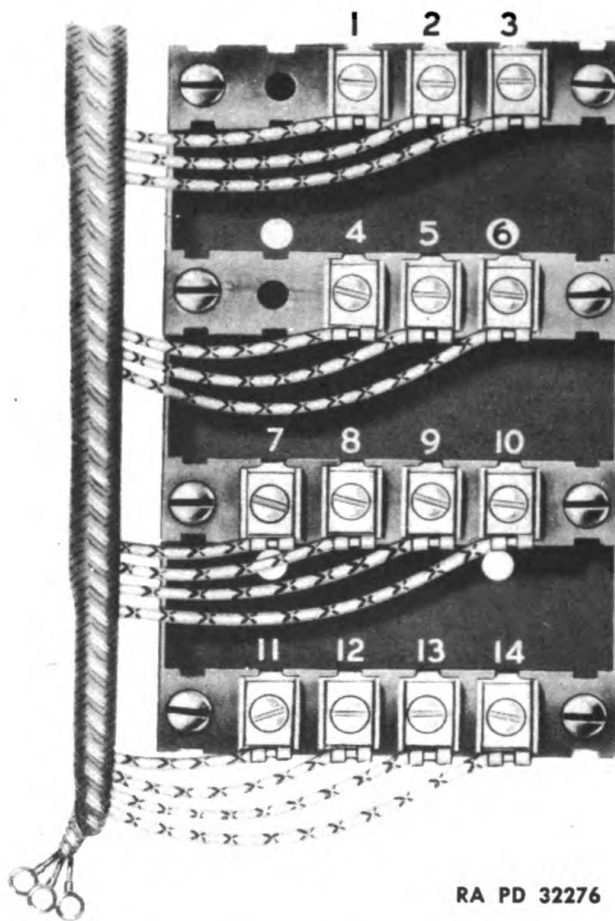

RA PD 32276

Figure 76—Body Wiring Harness Junction Block

Terminal No.	Connects to	Wire Size No.	Wire Color
2	Terminal "BHT" on lighting switch	16	Natural with green tracer
3	Dimmer switch bright (upper beam) terminal	12	Natural with black cross tracer
4	Horn button	14	Natural with black tracer
5	Horn circuit breaker	14	Natural with red tracer
6	Dimmer switch dim (lower beam) terminal	14	Natural with green tracer
7	Main tank terminal on gas tank gage selector switch	16	Natural with black cross tracer
8	Auxiliary tank terminal on gas tank gage selector	16	Natural with black tracer
9	Lighting switch "TT" terminal (trailer taillight)	14	Black

LIGHTING AND WIRING SYSTEMS

10	Lighting switch "HT" terminal (head and tail) also instrument light switch	12	Black with red cross tracer
11	Lighting switch "S" terminal (service stop light)	16	Natural
12	Lighting switch "BS" terminal (blackout stop light)	16	Natural with green cross tracer
13	Lighting switch "SW" terminal (stop light switch)	14	Natural
14	Lighting switch "SS" terminal (trailer connector)	14	Natural with black tracer

104. TROUBLE SHOOTING ON HEADLIGHTS.

Symptom	Probable remedy
a. LIGHTS BURN DIM	
(1) Loose connections.	(1) Tighten connections at junction terminal blocks and at ground connection on both fender skirt and dimmer switch.
(2) Burned switch contacts.	(2) Replace lighting or dimmer switch.
(3) Corroded battery terminals.	(3) Clean and tighten battery terminals.

105. MAIN LIGHT SWITCH.

a. This switch has four positions. When the switch button is all the way in, all lights are turned off. Pulling the switch out to the first position turns on the blackout head lamp, the blackout tail lamps and also connects the circuit for the blackout stop lamp on the right side of the truck, the circuit being completed through the stop light switch when the brakes are applied.

b. To turn on the main headlights, it is necessary to push down on the blackout button, and while holding it down, pull the switch button out to the main headlight position. When the lighting switch button is pulled all the way out, all lights are turned off and connections are made for the use of the service stop light during daylight driving.

BOMB SERVICE TRUCK M6 (Chevrolet)

c. The lighting switch is shown in figure 77. Each terminal is marked for the convenience of the repairman when replacing a switch or body wiring harness. The connection table gives the color wire which should be connected to each terminal.

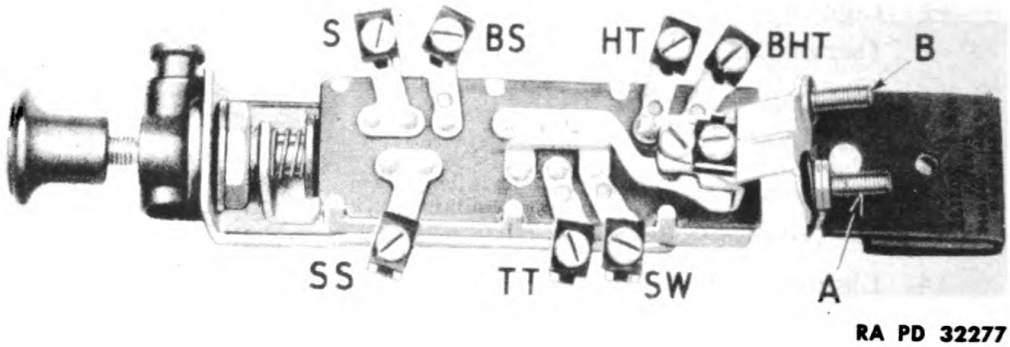

Figure 77 – Main Light Switch

d. Lighting Switch Connections.

Terminal Marking	Wire Size No.	Wire Color	Connects to
S	16	Natural	Service stop junction
B.S.	16	Natural with green cross tracer	Blackout stop junction
H.T.	12	Natural with black and red cross tracer	To head and tail junction
B.H.T.	16	Natural with green tracer	Blackout head and tail
B	12	Natural with red tracer	To ammeter
S.S.	14	Natural with black tracer	To stop light S.W. junction
S.W.	14	Natural	To stop S.W. feed junction

106. HEAD LAMPS.

a. Head lamps (fig. 78) are the “sealed beam” type; that is, reflector bulb and lens are a complete unit and can only be replaced as a unit. The lower beam filament is positioned slightly to one side of the focal point in the reflector. This results in deflecting the lower beam to

LIGHTING AND WIRING SYSTEMS

the right side to illuminate the side of the road when meeting other vehicles on the highway.

b. Sealed Beam Unit Replacement.

(1) TOOLS REQUIRED:

Screwdriver, small

Wrench, open-end, 1/2-in.

Wrench, open-end, 7/16-in.

(2) Remove the three brackets to fender attaching bolts, using a 7/16-inch wrench, and turn the head lamp on the fender.

(3) Loosen the lens rim clamp screw, using a small screwdriver, and remove the rim.

(4) Remove the three screws attaching the retainer ring to the lamp body and remove the ring.

(5) Pull the "sealed beam" unit out of the lamp body and disconnect the wiring connector from the rear of the unit.

(6) Install a new unit by reversing the above operation. **NOTE:** By following this procedure, it will not be necessary to reaim the head lamp when replacing a "sealed beam" unit.

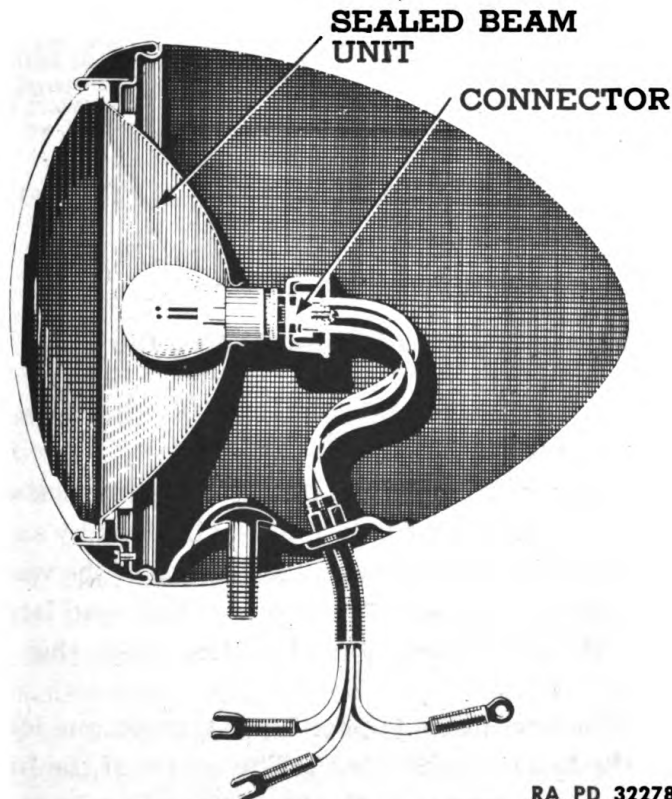

RA PD 32278

Figure 78—Head Lamp Construction

LIGHTING AND WIRING SYSTEMS

(6) If the aim is incorrect, loosen the nut on the mounting bolt, using a $\frac{3}{4}$ -inch wrench, and move the head lamp body on its ball and socket joint until the beam is aimed as described above. Then tighten the nut on the mounting bolt. The other head lamp should be aimed in the same manner.

(7) No further adjustment is needed for the traffic (lower) beam.

(8) The illumination output of head lamps is affected by a low battery, corroded battery terminals, loose connections in the lighting circuits and loose or dirty head lamp ground connections. Possibly the commonest cause of reduced illumination is dirty head lamp lenses. This being the case, it is good policy to keep head lamp lenses clean at all times.

108. BLACKOUT HEAD LAMP.

a. The blackout head lamps are mounted on the front fenders. A dowel hole in the fender assures proper positioning of the lamp.

b. Bulb Replacement.

(1) TOOL REQUIRED:

Screwdriver

(2) To replace a bulb in one of these lamps, remove the lamp rim retaining screw with screwdriver, then pull the rim out at the bottom and raise it upward to release the stamped catch in the cover from the slot in the top of the lamp body. The bulb is a standard 6-8 volt, 3 candlepower, single contact bayonet base.

109. BLACKOUT TAIL AND STOP LAMP.

a. The blackout tail and stop lamp mounted on the right side of the truck chassis contains two sealed units, one for stop signal and the other for the tail signal. Each consists of a housing, a bulb soldered to the housing, a filter and lens. When the lamp bulb in one of these units burns out, the complete unit must be replaced. To replace a unit, remove the two screws which attach the lamp rim to the body, and pull the unit out of its socket in the lamp body. The new unit is installed by reversing the above operation.

b. **Blackout Tail, Service Tail and Stop Lamp.** The blackout tail, service tail and stop lamp is mounted on the left side of the truck chassis. It is constructed in the same manner as the blackout tail and stop lamp, the difference being in the service tail and stop lamp unit, which contains a double filament bulb, 3 candlepower for the tail light and 21 candlepower for stop light, and a lens made of ruby glass. The operation for replacing a unit is the same as for the blackout tail and stop lamp.

BOMB SERVICE TRUCK M6 (Chevrolet)

Section XXI

ENGINE

	Paragraph
General description	110
Data	111
Trouble shooting	112
Manifolds	113
Cylinder head	114
Valve adjustment procedure	115
Engine tune-up	116
Engine oiling system	117
Oil pan replacement	118
Oil pump replacement	119
Engine removal	120
Engine installation	121
Engine mountings	122

110. GENERAL DESCRIPTION.

The heavy-duty engine shown in figures 80, 81 and 82 is a four-cycle, six-cylinder-in-line, valve-in-head type. The engine number is stamped on a machined surface on the right side of the block just back of the distributor. The cylinders are numbered from the fan, or front end of the engine. The engine runs in a clockwise direction, figured from the front or cranking location.

111. DATA.

Model	Chevrolet "235"
Number of cylinders	6
Firing order	1-5-3-6-2-4
Bore and stroke	$3\frac{9}{16}$ -in. x $3\frac{1}{8}$ -in.
Piston displacement	235.5 cu in.
Compression ratio	6.62 to 1
Maximum brake horsepower (3100 rpm)	93
Rated hp (SAE)	30.4
Weight of engine and clutch	574
Torque, foot pounds	192

ENGINE

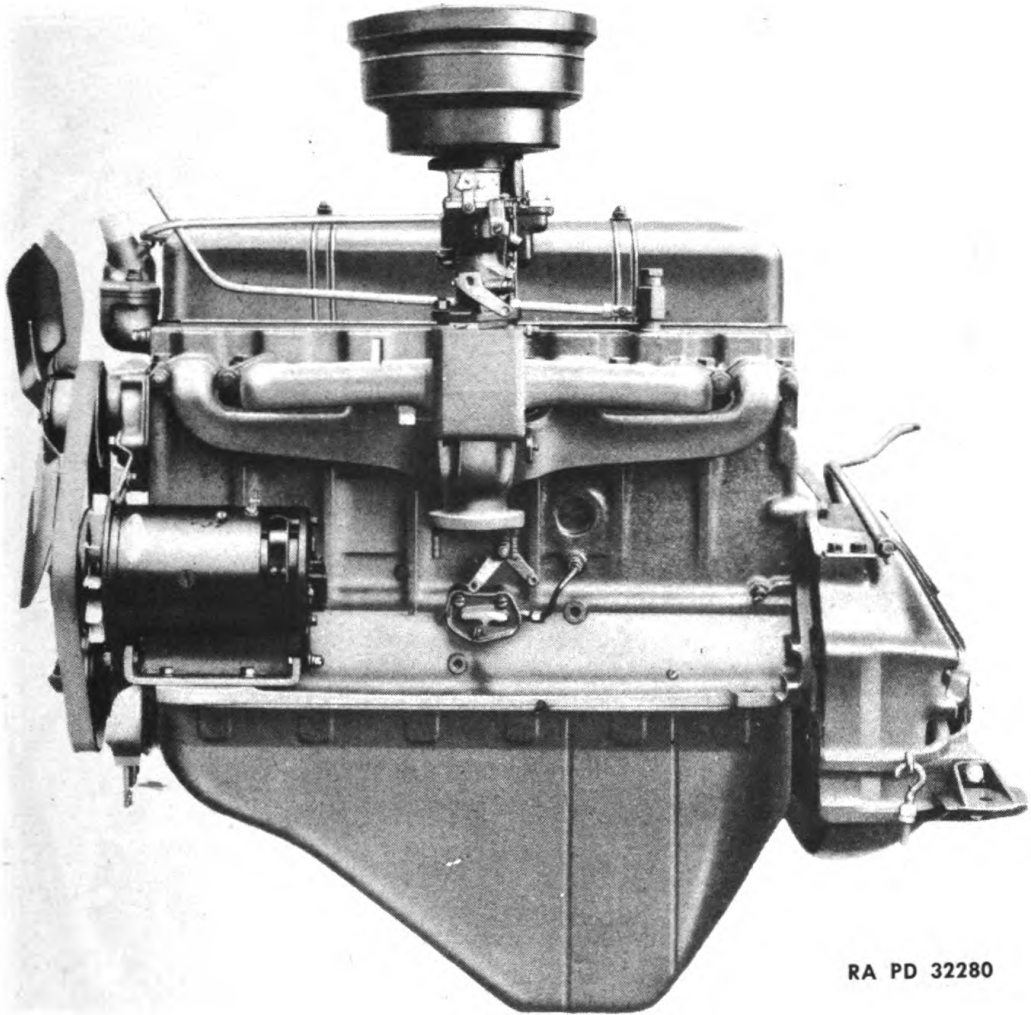

RA PD 32280

Figure 80—Engine—Left Side

Oil capacity	5 qt
Oil filling location	Breather, right side
Oil gage rod	Right side, back of distributor
Oil drain location	Bottom, rear of pan
Cooling system capacity	17¼ qt
Cooling system drains (2)	Bottom, right of radiator and left rear side of block

BOMB SERVICE TRUCK M6 (Chevrolet)

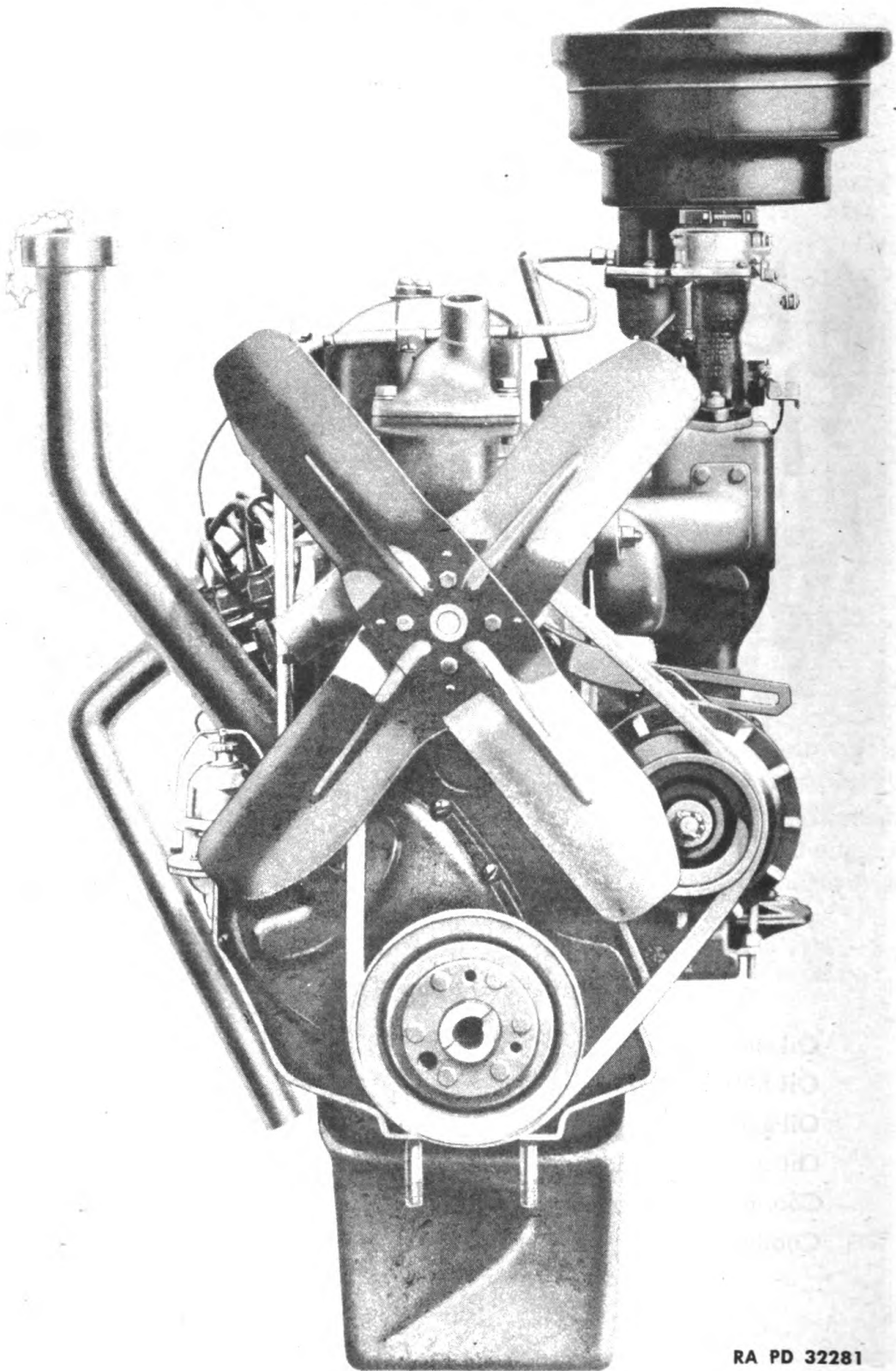

RA PD 32281

Figure 81 – Engine – Front

ENGINE

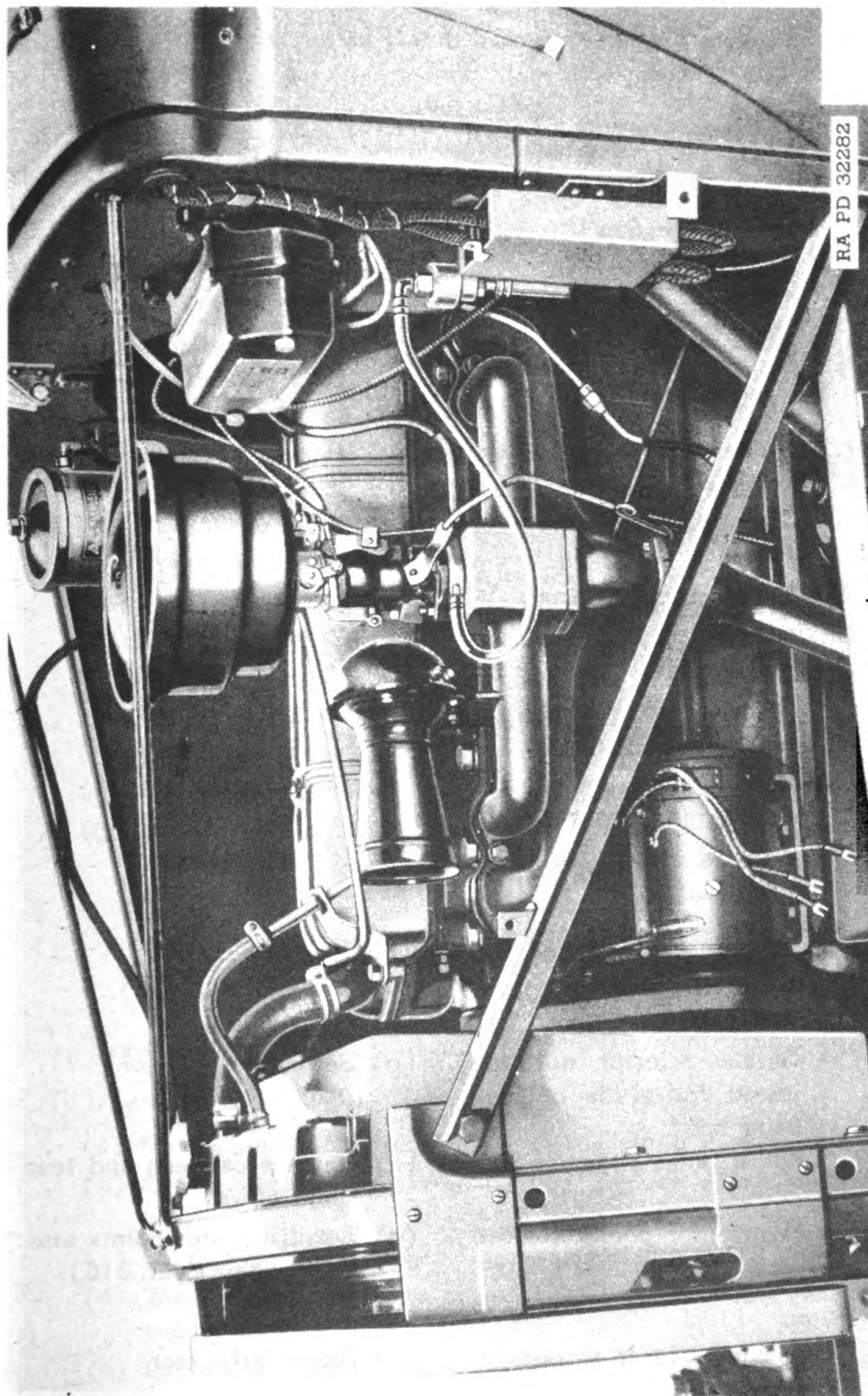

Figure 82—Engine—In Chassis

BOMB SERVICE TRUCK M6 (Chevrolet)

112. TROUBLE SHOOTING.

a. The engine should be watched closely for any indications of trouble. Different types of trouble may be encountered, as follows:

Symptom	Probable remedy
b. Lack of Power.	
(1) Poor compression	
(a) Incorrect valve lash.	(a) Adjust valve lash (par. 115).
(b) Leaky valves.	(b) Remove cylinder head and have valves ground, or report to higher authorities.
(c) Valve stems or lifters sticking.	(c) Report to higher authorities.
(d) Valve springs weak or broken.	(d) Report.
(e) Valve timing incorrect.	(e) Report.
(f) Leaking cylinder head gasket.	(f) Tighten or replace.
(g) Piston rings broken, worn or stuck.	(g) Report.
(h) Poor fit between pistons, rings and cylinders.	(h) Report.
(i) Exhaust system partly restricted.	(i) Replace or clean.
(2) Poor ignition	
(a) Ignition not properly timed.	(a) Retime (par. 116).
(b) Octane selector not adjusted for grade of fuel being used.	(b) Set octane selector.
(c) Spark plugs defective.	(c) Replace or clean and test spark plugs.
(d) Distributor points not set correctly.	(d) Set distributor points and time engine (par. 116).
(3) Lack of fuel	
(a) Dirt or water in carburetor.	(a) Clean carburetor.
(b) Gas lines partly plugged.	(b) Clean gas lines.

ENGINE

Symptom	Probable remedy
(c) Dirt in gas tank.	(c) Clean gas tank.
(d) Air leaks in gas line.	(d) Tighten and check gas lines.
(e) Fuel pump not functioning properly.	(e) Replace or repair fuel pump.
 (4) Improper fuel—air ratio	
(a) Air cleaner dirty.	(a) Clean air cleaner (par. 136).
(b) Carburetor choke partly closed.	(b) Adjust or replace choke mechanism.
 (5) Overheating	
(a) Cooling system troubles.	(a) See paragraph 71 a.
(b) Improper grade and viscosity of oil being used.	(b) Change to correct oil.
(c) Fuel mixture too lean.	(c) Adjust carburetor.
(d) Restricted air cleaner.	(d) Clean air cleaner (par. 136).
(e) Valves not timed properly.	(e) Report.
(f) Defective ignition system.	(f) See paragraph 116.
(g) Transfer case in four wheel drive on hard surface roads.	(g) Shift transfer case to two wheel drive.
(h) Dragging brakes.	(h) Adjust brakes (See par. 54).

c. Excessive Oil Consumption.**(1) Leaking oil**

(a) Oil pan drain plug loose.	(a) Tighten drain plug.
(b) Oil pan retainer bolts loose.	(b) Tighten oil pan bolts.
(c) Oil pan gaskets damaged.	(c) Replace pan gaskets.
(d) Timing gear cover loose or gasket damaged.	(d) Tighten timing gear cover or replace gaskets.
(e) Oil return from timing gear case to block restricted causing leak at crankshaft fan pulley hub.	(e) Remove oil pan and clean oil return passages.

BOMB SERVICE TRUCK M6 (Chevrolet)

Symptom	Probable remedy
(f) Push rod or rocker arm cover gaskets damaged or covers loose.	(f) Tighten push rod and rocker arm covers, or replace gaskets.
(g) Fuel pump loose or gasket damaged.	(g) Tighten fuel pump or replace gasket.
(h) Rear main bearing leaking oil into clutch housing.	(h) Report.
 (2) Burning oil	
(a) Broken piston rings.	(a) Report.
(b) Rings not correctly seated to cylinder walls.	(b) Report.
(c) Piston rings worn excessively or stuck in ring grooves.	(c) Report.
(d) Piston ring oil return holes clogged with carbon.	(d) Report.
(e) Excessive clearance between piston and cylinder walls due to wear or their being improperly fitted.	(e) Report.
(f) Cylinder walls scored, tapered or out-of-round.	(f) Report.

d. Popping, Spitting, and Spark Knock.

(1) Overheated intake manifold	
(a) Manifold heat control spring not properly installed.	(a) Adjust according to paragraph 116.
(b) Manifold heat control valve sticking.	(b) Free up heat control valve.
 (2) Ignition trouble	
(a) Loose wiring connections.	(a) Tighten all wire connections.
(b) Defective wiring.	(b) Replace defective wiring.
(c) Defective spark plugs.	(c) Clean or replace spark plugs. See paragraph 116.
 (3) Poor carburetion	
(a) Lean combustion mixture.	(a) Clean and adjust carburetor.

ENGINE

Symptom	Probable remedy
(b) Dirt in carburetor.	(b) Clean carburetor.
(c) Restricted gas supply to carburetor.	(c) Clean gas lines and check for restrictions.
(d) Leaking carburetor or intake manifold gaskets.	(d) Tighten carburetor to manifold and manifold to head bolts, or replace gaskets.
(e) Carburetor metering rod hole cover not in place.	(e) Replace metering rod hole cover.
 (4) Valve trouble	
(a) Valves adjusted too close.	(a) Adjust valve lash.
(b) Valves sticking.	(b) Lubricate and free up or report.
(c) Exhaust valve head thin and overheating.	(c) Report.
(d) Weak valve springs.	(d) Report.
(e) Valves timed early.	(e) Report.
 (5) Cylinder head	
(a) Excessive carbon deposits in combustion chamber.	(a) Remove head and clean carbon.
(b) Cylinder head water passages partly clogged, causing hot spot in combustion chamber.	(b) Remove cylinder head and clean water passages.
(c) Partly restricted exhaust ports in cylinder head.	(c) Remove cylinder head and clean exhaust ports.
(d) Cylinder head gasket blown between cylinders.	(d) Replace cylinder head gasket.
 (6) Spark plugs	
(a) Spark plugs glazed.	(a) Clean or replace spark plugs.
(b) Wrong heat range plug being used.	(b) Change to correct spark plugs.
 (7) Exhaust system	
(a) Exhaust manifold or muffler restricted, causing back pressure.	(a) Clean or replace manifold and muffler.

BOMB SERVICE TRUCK M6 (Chevrolet)

Symptom

Probable remedy

e. Rough Engine Idling.

(1) Poor carburetion

- | | |
|---|--|
| (a) Improper idling adjustment. | (a) Adjust according to instructions in paragraph 135. |
| (b) Carburetor float intake needle valve not seating. | (b) Replace or report. |

(2) Air leaks

- | | |
|--|---|
| (a) Carburetor to manifold gasket leaks. | (a) Tighten carburetor to manifold bolts or replace gasket. |
| (b) Manifold to head gasket leaks. | (b) Tighten manifold to head bolts or replace gasket. |
| (c) Air leaks in the windshield wiper vacuum line. | (c) Check for leaks and repair. |
| (d) Air leaks in the hydrovac lines. | (d) Check hydrovac lines and correct leaks. |

(3) Valves

- | | |
|----------------------------------|---|
| (a) Improper lash adjustment. | (a) Check and adjust valves according to instructions in paragraph 116. |
| (b) Valves not seating properly. | (b) Report. |

(4) Cylinder head

- | | |
|------------------------------|-----------------------------------|
| (a) Cracks in exhaust ports. | (a) Replace cylinder head. |
| (b) Head gasket leaks. | (b) Replace cylinder head gasket. |

f. Engine Noises.

(1) It is often very difficult to determine the exact cause of certain engine noises. If unusual noises develop which the driver is unable to definitely trace and correct, the vehicle should not be driven until an experienced officer or mechanic has checked the vehicle and given instructions regarding its use or repairs.

(2) When any motor noise develops, quickly check for low or no oil pressure and abnormally high temperature indicator reading. Check for sufficient oil in the motor and sufficient solution in the cooling system.

g. MANY OF THE TROUBLES REFERRED TO UNDER TROUBLE SHOOTING WOULD BE LOCATED AND CORRECTED WITH A NORMAL MOTOR TUNE. REFER TO THE MOTOR TUNING INSTRUCTION IN THIS SECTION.

ENGINE

113. MANIFOLDS.

a. The intake manifold is designed to assist in the vaporizing and equal distribution of the fuel to all cylinders. The manifold has an intake heating chamber cast integrally with it. This heating chamber is open at the bottom for attaching to the exhaust manifold.

b. The exhaust manifold has been designed to dispose of the exhaust gases with a minimum of back pressure or restriction. The exhaust manifold has a large opening at the center top where the intake manifold bolts to it. The two manifolds are placed together with a gasket between them and bolted into one unit, and will not be disassembled unless one of the two manifolds or the gasket between them requires replacement.

c. A thermostatically controlled valve is mounted in the exhaust manifold to control automatically the amount of hot exhaust gases to be directed into the intake heat chamber. When the engine is cold, the valve directs a large portion of the gases to the intake manifold (fig. 83 left). As the

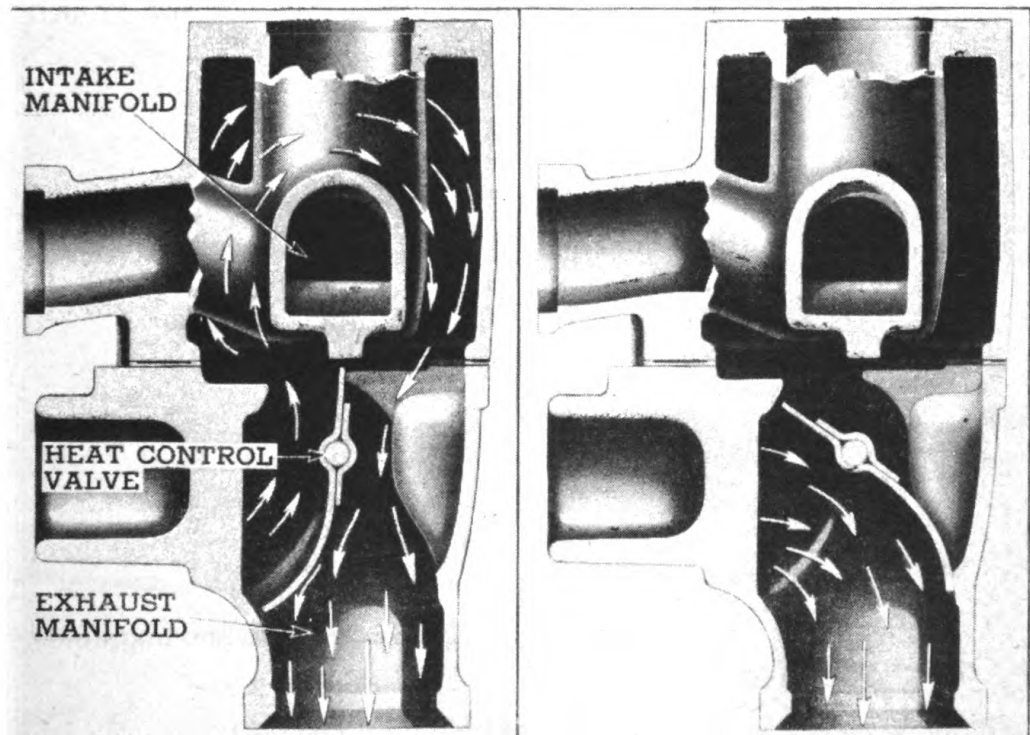

RA PD 32283

Figure 83—Manifold Heat Control Valve

engine warms up the valve gradually closes and these hot gases are deflected away from the intake manifold (fig 83 right). This automatic control aids in the warming up of the engine and yet prevents overheating of the fuel mixture.

BOMB SERVICE TRUCK M6 (Chevrolet)

d. The tension of the thermostat spring is very important for proper engine operation. The spring should be wound up just enough for the end to slip over the pin in the manifold. This is approximately one-half turn of the spring at 70 F.

e. Manifold Removal.**(1) TOOLS REQUIRED:**

Pliers, combination, 6-in.	Wrench, open-end, $\frac{3}{8}$ -in.
Screwdriver, 4-in.	Wrench, open-end, $\frac{7}{16}$ -in.
Wrench, manifold, $\frac{9}{16}$ -in. (double hex.) 41-W-635	Wrench, open-end, $\frac{9}{16}$ -in.

(2) Using a $\frac{9}{16}$ -inch manifold wrench remove two nuts which attach exhaust pipe to manifold.

(3) CARBURETOR REMOVAL.

(a) Remove the air cleaner.

(b) Disconnect the gas line at carburetor with a $\frac{9}{16}$ -inch and $\frac{1}{2}$ -inch wrench.

(c) Disconnect the windshield wiper tube.

(d) Disconnect the throttle rod.

(e) Disconnect the horn wires.

(f) Disconnect the hydrovac control vacuum line.

(g) Disconnect the choke and hand throttle wires.

(h) Remove the two $\frac{9}{16}$ -inch nuts that attach the carburetor.

(i) Lift carburetor off.

(4) With a $\frac{9}{16}$ -inch manifold wrench remove the two nuts and loosen the six cap screws which attach the manifold to the cylinder head.

(5) Remove manifolds and gaskets.

f. Manifold Replacement.

(1) To assure a perfect seal between the cylinder head and manifolds, new gaskets should be used.

(2) Install the manifold gaskets and manifold (fig. 84).

(3) With a $\frac{9}{16}$ -inch manifold wrench install the bolts and nuts and tighten them evenly and securely.

(4) CARBURETOR INSTALLATION.

(a) Place gasket and carburetor on manifold.

(b) Install the two $\frac{9}{16}$ -inch carburetors to manifold nuts and tighten them evenly.

ENGINE

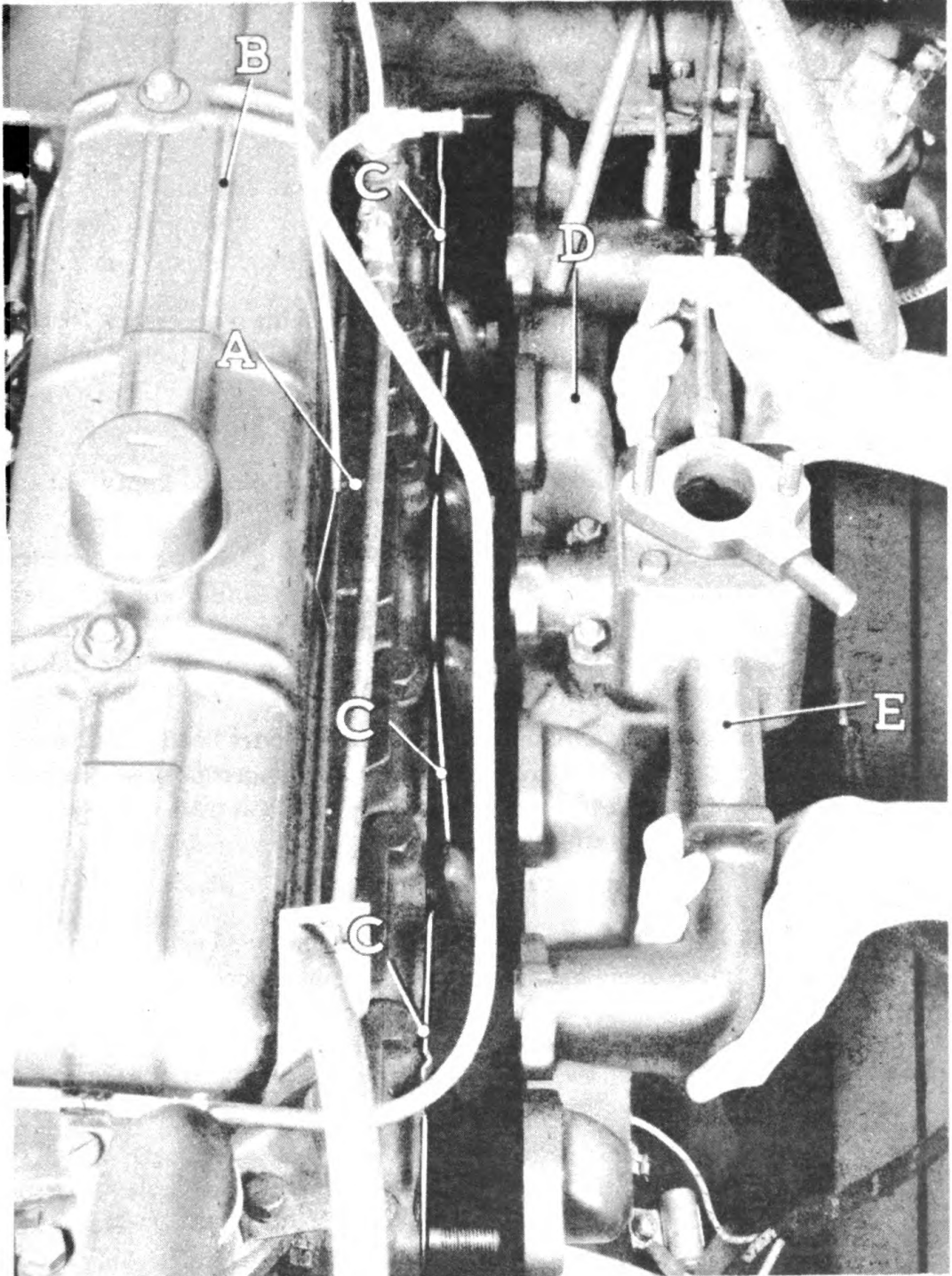

A—CYLINDER HEAD
B—ROCKER ARM COVER
C—MANIFOLD GASKET

D—EXHAUST MANIFOLD
E—INTAKE MANIFOLD

RA PD 32284

Figure 84—Manifold Replacement

BOMB SERVICE TRUCK M6 (Chevrolet)

- (c) Connect the throttle rod.
- (d) Connect the windshield wiper tube.
- (e) Connect gas feed line with a $\frac{9}{16}$ -inch and $\frac{1}{2}$ -inch end wrench.
- (f) Connect the horn wires.
- (g) Connect the hand throttle and choker wires.
- (h) Connect the hydrovac control line.
- (i) Install air cleaner.

(5) Fit exhaust pipe to manifold, using new packing if necessary. Install the retaining nuts and tighten them securely with a $\frac{9}{16}$ -inch manifold wrench.

(6) MANIFOLD GASKET LEAKS.

(a) It is important that the manifold attaching bolts be kept tight as leaks affect the operation of the vehicle.

(b) Leaks caused by loose connections or faulty gaskets between the carburetor and manifold, or between the intake manifold and cylinder head will admit air to the fuel mixture. This deprives two or more cylinders of their proper mixture, making it too lean. This will result in rough motor idling, lack of power, overheating and burned valves.

(c) Leaks between the exhaust manifold and cylinder head, or between the exhaust manifold and exhaust pipe produce dangerous gases in the motor and driving compartments. The gaskets will soon burn or blow out and the leak will become a fire hazard.

114. CYLINDER HEAD.

a. Description. The cylinder head of a valve-in-head engine plays an important part in its operation. It contains the inlet ports, exhaust ports, valve seats, valve assemblies, spark plugs, combustion chambers and necessary water passages to maintain the proper temperature of these important parts.

b. Removal.

(1) TOOLS REQUIRED:

- | | |
|--|---|
| Pan, drain | Wrench, open-end, $\frac{3}{8}$ -in. |
| Pins, guide, cylinder head,
N-344 (KM), two | Wrench, open-end, $\frac{7}{16}$ -in. |
| Pliers, combination, 6-in. | Wrench, open-end, $\frac{1}{2}$ -in. |
| Screwdriver, 4-in. | Wrench, open-end, $\frac{9}{16}$ -in. |
| Socket, $\frac{3}{4}$ -in. | Wrench, open-end, $1\frac{1}{8}$ -in. |
| Wrench, manifold, 41-W-635 | Wrench, spark plug, $\frac{5}{8}$ -in. |
| | Wrench, torque, cylinder head,
J-1313 (KM) |

ENGINE

- (2) Remove the air cleaner.
- (3) Disconnect the lower end of throttle rod.
- (4) With a $\frac{9}{16}$ -inch manifold wrench disconnect the manifold from the engine.
- (5) Pull the manifold and carburetor assembly to the left until it clears the cylinder head and block up the manifold to support its weight.
- (6) Drain cooling system.
- (7) Remove rocker arm cover with a $\frac{9}{16}$ -inch open-end wrench.
- (8) Remove spark plug wires.
- (9) Remove spark plugs with a $\frac{5}{8}$ -inch spark plug wrench.
- (10) Remove push rod cover retaining screws and remove the cover.
- (11) Remove thermostat housing with a $\frac{9}{16}$ -inch open-end wrench.
- (12) Disconnect steam relief tube with a $\frac{5}{8}$ -inch open-end wrench.
- (13) Disconnect hose from steam relief tube and remove tube.
- (14) Disconnect temperature indicator with a $\frac{1}{2}$ -inch open-end wrench and remove the fitting from the cylinder head with $1\frac{1}{8}$ -inch open-end wrench.
- (15) Disconnect oil line to rocker arm connector with a $\frac{3}{8}$ -inch open-end wrench.
- (16) With a $\frac{9}{16}$ -inch open-end wrench remove four bolts and two nuts which retain the rocker arm assembly and remove the rocker arms.
- (17) Remove the 12 valve push rods.
- (18) Remove 15 cylinder head bolts with a torque wrench and $\frac{3}{4}$ -inch socket.
- (19) Remove cylinder head and gasket.

c. Valve Grinding. Correct valve seats must be maintained if the engine is to render satisfactory performance. Special equipment is required for properly conditioning the valves and seats; therefore, this work should not be attempted unless the equipment is available.

d. Because of the construction of the valve-in-head engine, the head and valve mechanism can be taken to a 3rd or 4th echelon shop for valve conditioning.

e. Carbon Removing.**(1) TOOLS REQUIRED:**

Drill, electric, and carbon brush Scraper, carbon

- (2) Whenever the cylinder head is removed, the carbon should be cleaned out before installing the cylinder head.
- (3) Scrape the carbon from the heads of the pistons.
- (4) Clean the carbon from the combustion chambers and valve ports.

BOMB SERVICE TRUCK M6 (Chevrolet)

f. Rocker Arm and Shaft Assemblies.

(1) The valve-in-head engine requires the use of valve tappets, which ride the lobes of the camshaft, push rods, rocker arms, and rocker arm shafts to operate the valves. In order to obtain correct clearance between rocker arms and valve stems, an adjusting screw with a ball end is used at the push rod end of the rocker arm. The ball seats in push rod head. It is important that correct adjustment be maintained to keep this mechanism normally quiet and provide correct opening and closing of the valves. Three intake and three exhaust rocker arms are mounted on each of the two shafts.

(2) Sludge and gum formation in the shafts and rocker arms may restrict the normal lubrication to the rocker arms and valves. Any time the rocker arm and shaft assemblies have been removed they should be disassembled and thoroughly cleaned.

(3) To remove the rocker arms from the shafts it is only necessary to remove the hairpin locks, the springs, and rocker arms.

(4) Clean all the sludge or gum formation from the inside and outside of shafts. Clean the oil holes and passages in the shafts and rocker arms.

(5) There are three each of four different rocker arms used—right- and left-hand exhaust and right- and left-hand intake. It is important that these be installed in the correct positions. For identification each type rocker arm carries a different number stamped on the side (fig. 85). The proper locations of the rocker arms according to number are as follows:

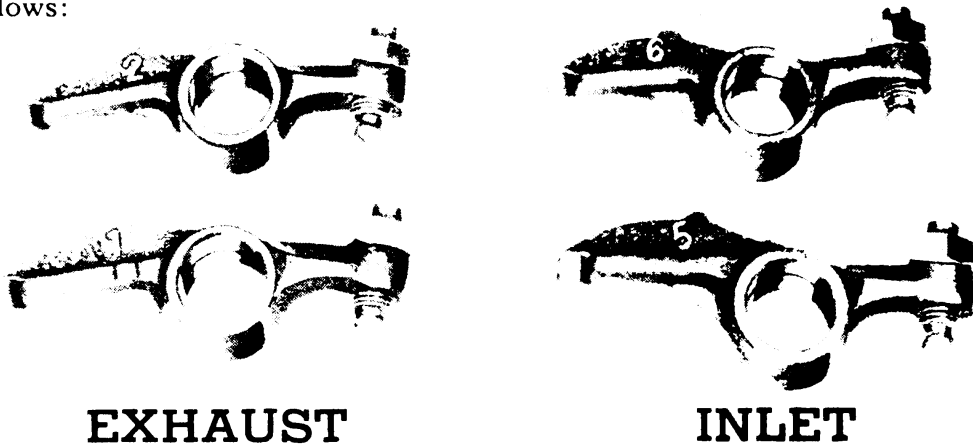

RA PD 32285

Figure 85—Rocker Arm Identification

No. on Rocker Arm	Type Rocker Arm	For Cylinder	Part No.
1	L.H. Exhaust	1-3-5 Exhaust	839459
2	R.H. Exhaust	2-4-6 Exhaust	839460
5	L.H. Intake	2-4-6 Intake	839463
6	R.H. Intake	1-3-5 Intake	839464

ENGINE

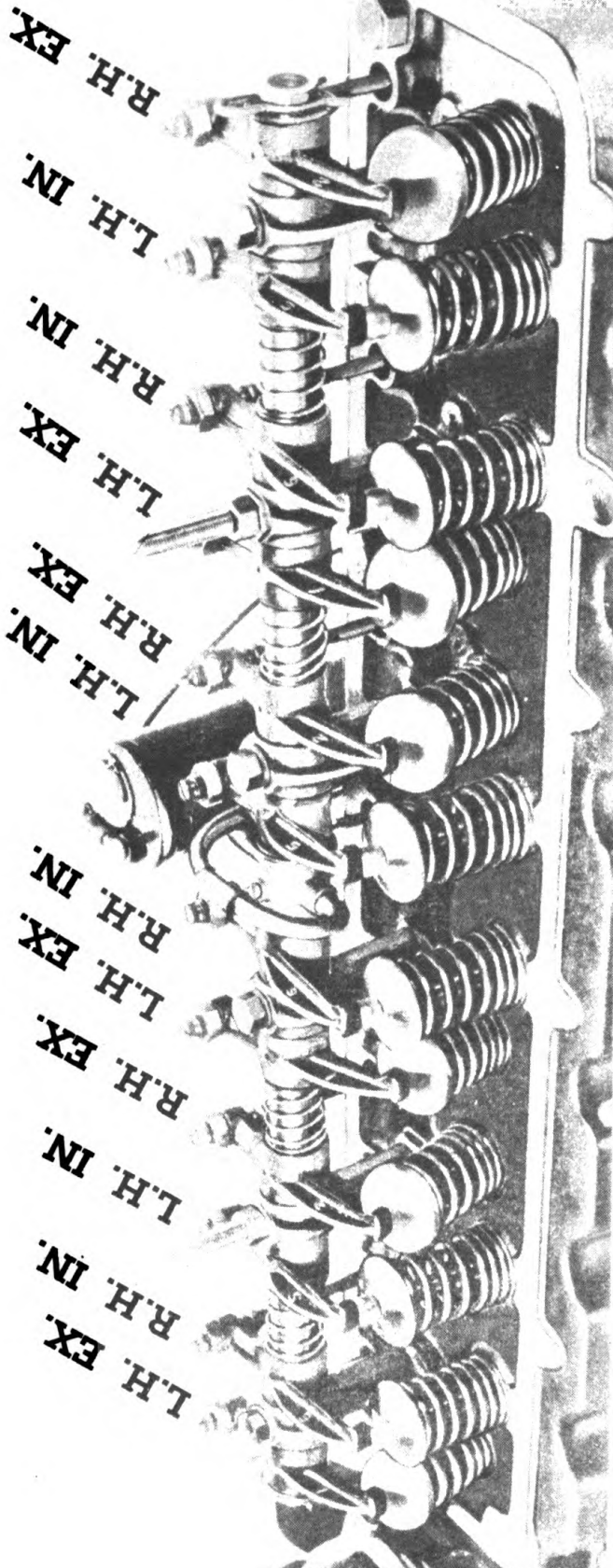

RA PD 32286

Figure 86—Rocker Arm Location

BOMB SERVICE TRUCK M6 (Chevrolet)

(6) One end of each shaft is plugged; the open end of the shafts should be placed at the center. The rear shaft has a stamped steel baffle in the forward end. This is to evenly distribute oil to both shafts. Figure 86 shows the position of all rocker arms on the shafts.

g. Cylinder Head Replacement.**(1) TOOLS REQUIRED:**

Use tools listed in **b (1)** of this paragraph.

(2) Install new cylinder head gasket with the markings "This side up," as shown in figure 87, up and on the camshaft side of the engine.

(3) Install the guide pins in the front and rear holes on the manifold side to line up and hold the gasket in place while installing the cylinder head (fig. 87).

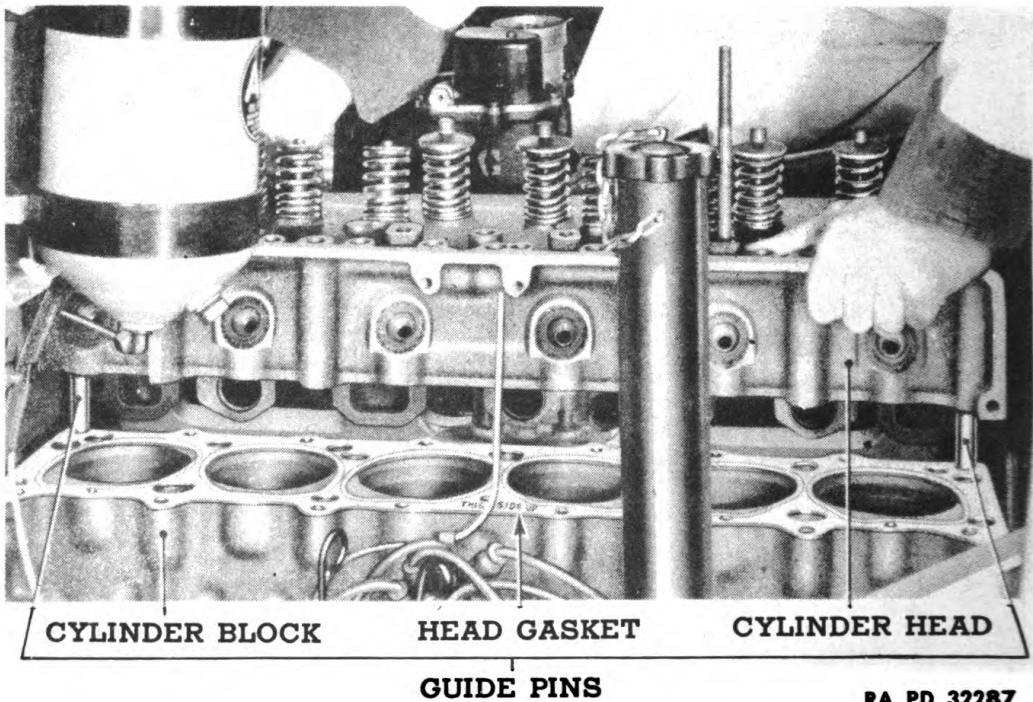

Figure 87—Cylinder Head Installation

(4) Install the cylinder head and 15 cylinder head bolts. Using a $\frac{3}{4}$ -inch socket and cylinder head torque wrench, tighten the bolts evenly a little at a time in the order shown in figure 88. They should be tightened to 75 to 80 pounds with the torque wrench. Following this sequence the correct tightening of the bolts is important to prevent water leaks into the cylinders and compression leaks between cylinders or into the water jacket.

(5) Install rocker arm shafts with connector assembly between them (fig. 89); install four bolts and two nuts which retain the shaft assemblies

RA PD 32288

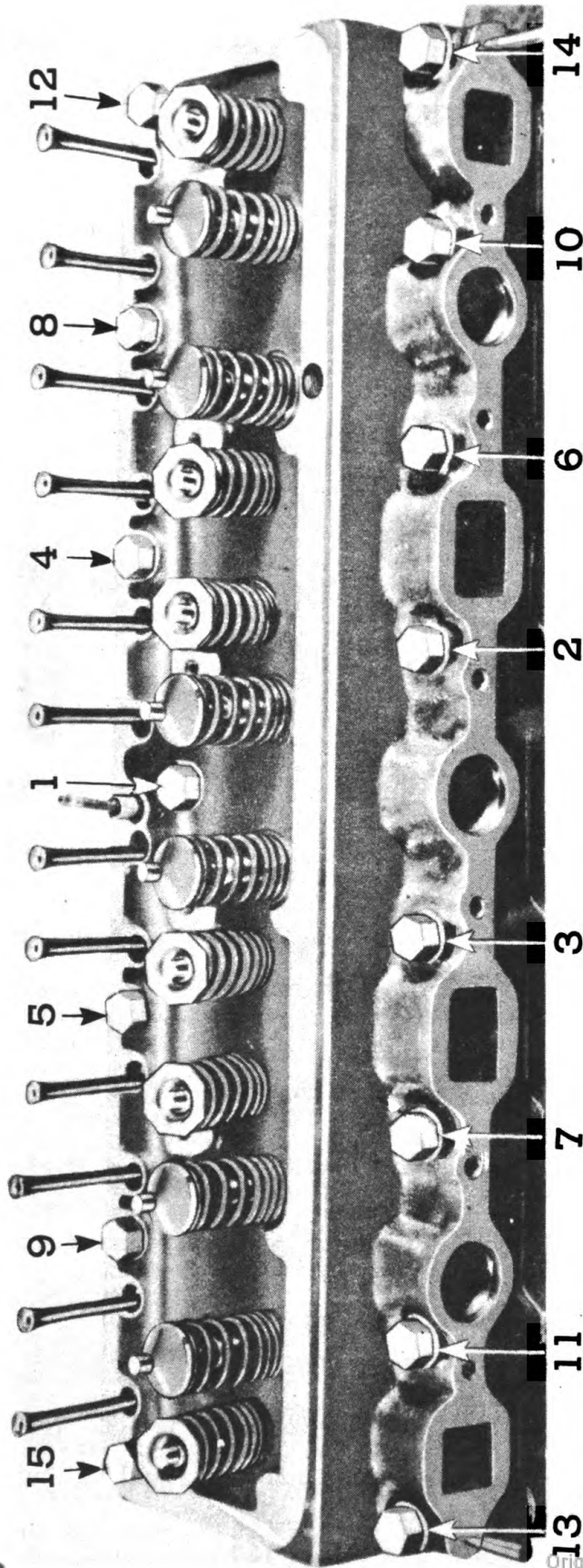
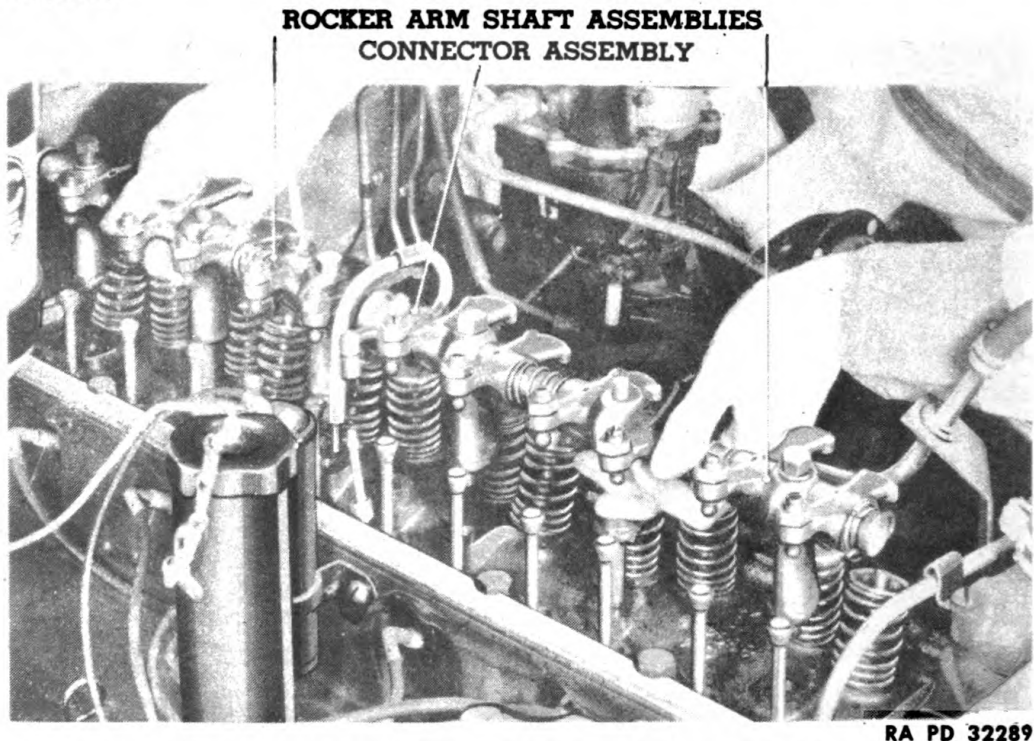

Figure 88 — Bolt Tightening Diagram

BOMB SERVICE TRUCK M6 (Chevrolet)

and tighten them securely with a $\frac{9}{16}$ -inch open-end wrench. Attach rocker arm oil line to connector assembly and tighten with a $\frac{3}{8}$ -inch wrench.



RA PD 32289

Figure 89—Installing Rocker Arms and Shafts

(6) Install oil pressure gage fitting and tighten with a $1\frac{1}{8}$ -inch wrench.

(7) With a $\frac{5}{8}$ -inch wrench install steam relief tube and hook up hose at radiator end.

(8) Hook up temperature indicator, using a $\frac{1}{2}$ -inch open-end wrench.

(9) Install thermostat housing and tighten with a $\frac{9}{16}$ -inch open-end wrench.

(10) Install push rod cover and, using a screwdriver, tighten the screws securely.

(11) Install spark plugs using a $\frac{5}{8}$ -inch plug wrench. (See tightening instructions in par. 116).

(12) Install spark plug wires.

(13) Install rocker arm cover and tighten with a $\frac{9}{16}$ -inch open-end wrench.

(14) Fill cooling system.

(15) Install carburetor and manifolds and tighten the bolts with a $\frac{9}{16}$ -inch manifold wrench.

ENGINE

- (16) Connect throttle control rod.
- (17) Replace air cleaner.

115. VALVE ADJUSTMENT PROCEDURE.

a. Tools Required:

Gage, feeler
Screwdriver

Thermometer, KMO-296 (KM)
Wrench, open-end, $\frac{5}{8}$ -in.

b. Before adjusting valve clearance, the engine must be thoroughly warmed up to normalize the expansion of all parts and stabilize the oil temperature. This is very important because during the warm-up period the valve clearance varies considerably.

c. Covering the radiator with a blanket will not materially hasten the warming-up process because even with the water temperature quickly raised to 185 F, it does not change the rate at which the oil temperature increases.

d. The actual temperature of the oil is not as important as the stabilization of the oil temperature. The expansion or contraction of the valves, rocker arm supports, push rods, cylinder head and cylinder block are

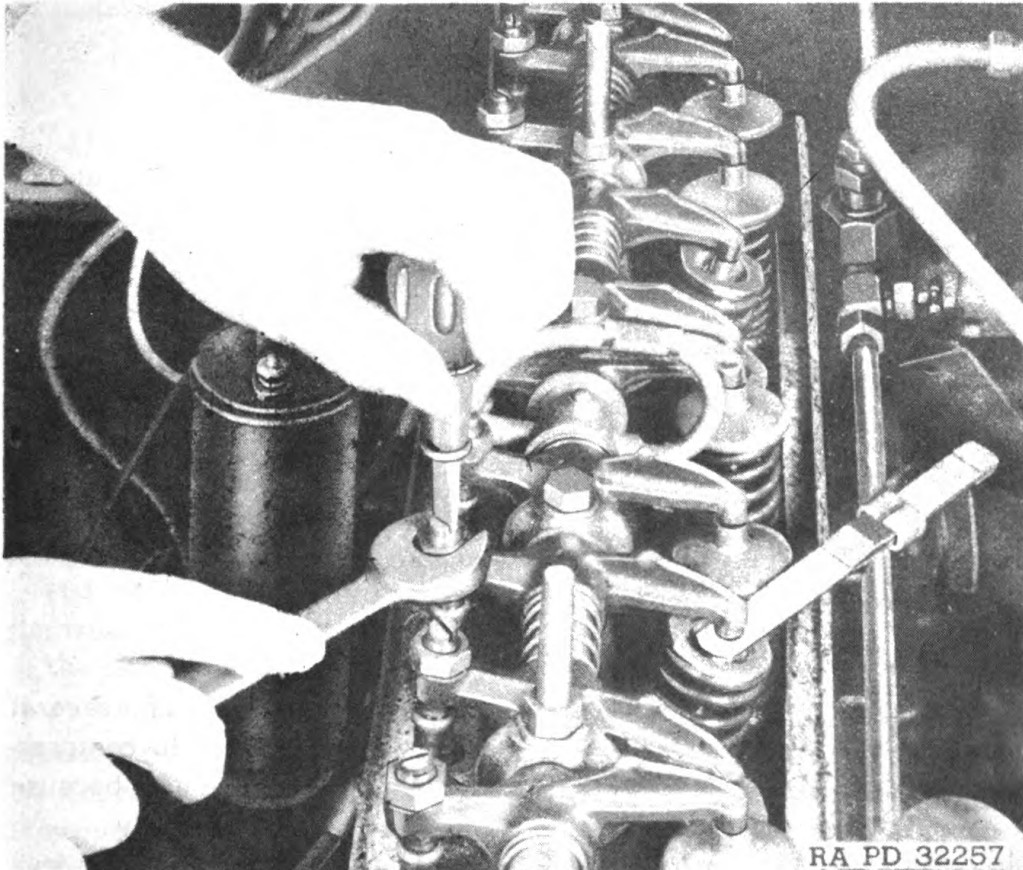

RA PD 32257

Figure 89A—Valve Adjustment

BOMB SERVICE TRUCK M6 (Chevrolet)

relative to this oil temperature. Hence, after the oil temperature is stabilized, these parts have stopped expanding and no change in valve adjustment takes place.

e. To normalize the engine, run it at a fast idle (approximately 600 rpm) and check the oil temperature with a thermometer at the overflow pipe on the valve rocker shaft connector. **WHEN A CONSTANT OIL TEMPERATURE IS REACHED FOR A PERIOD OF FIVE MINUTES, THE ENGINE IS NORMALIZED AND READY FOR VALVE ADJUSTMENT.**

f. If a thermometer is not available for checking oil temperature, the engine should be run at a fast idle for 30 minutes, or the valves may be adjusted immediately upon returning from a trip.

g. **Adjustment.** Before adjusting the valve clearance, lubricate valve stems to insure free movement of the valves in their guides. Adjust the valve clearance as follows (fig. 89A):

Normal operation	Heavy-duty operation
Intake 0.006 in. to 0.008 in.	0.010 in.
Exhaust 0.013 in. to 0.015 in.	0.020 in.

h. On severe truck operations it is advisable to adjust the valves to the high setting.

116. ENGINE TUNE-UP.

a. Tools Required:

Feeler, 0.040 in.	Screwdriver
Gage, compression, 41-G-124	Set, feeler
Light, timing, neon, KMO-318 (KM)	Tester, volt-ammeter, 17-T- 5550
Scale, check, distributor point	Wrench, spark plug, 5/8-in.

b. One of the most important operations in the maintenance of the engine is proper engine tune-up. This operation, more than any other, determines whether or not the engine delivers the maximum in performance and economy. Only by accurately making the following checks and adjustments can the performance and economy that has been built into the engine be obtained.

c. Compression.

(1) Before making any checks on an engine it should be run for several minutes to warm it up and lubricate the valve mechanism. The compression of the engine should be checked first when tuning an engine because an engine with uneven compression cannot be tuned successfully.

(2) Remove all spark plugs with a 5/8-inch spark plug wrench. The ignition should be turned off, with the throttle valve in the open position.

ENGINE

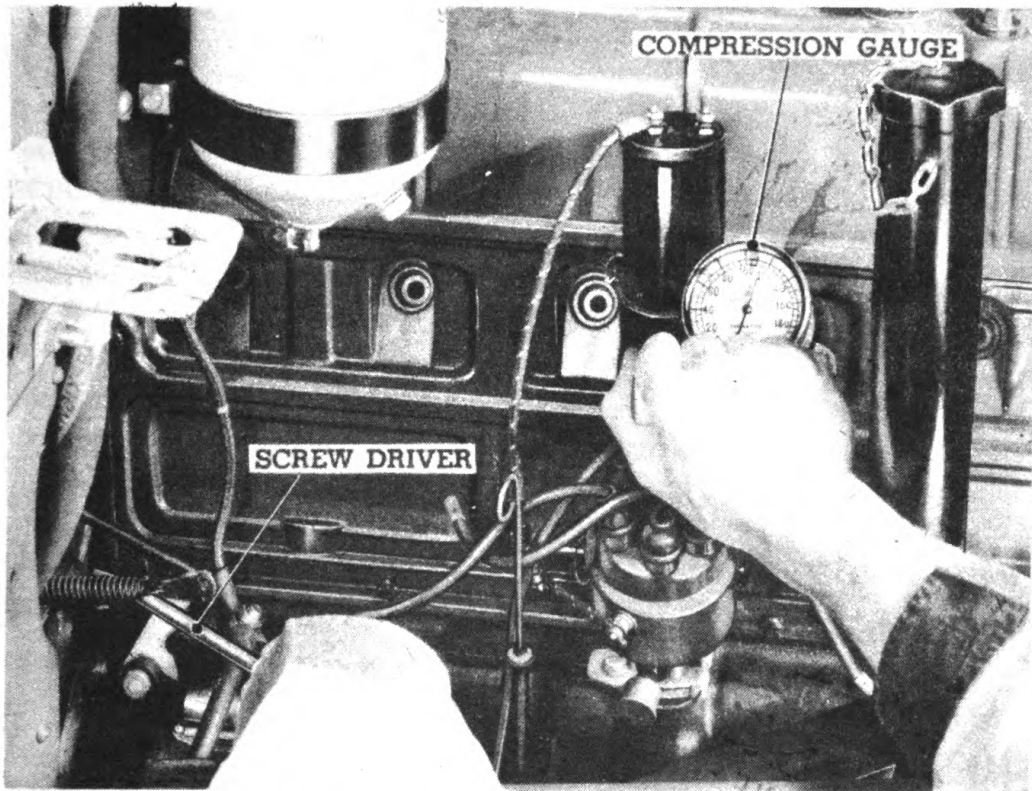

Figure 90—Compression Check

RA PD 32290

(3) Insert the compression gage in a spark plug hole and hold it tightly (fig. 90). Crank the engine with the starting motor until the gage reaches its highest reading, which requires only a few turns of the engine. Repeat the same test on all cylinders and make a note of the compression on each cylinder.

(4) The compression on all cylinders should be 110 pounds or better, and all cylinders should read alike, within 5 to 10 pounds, for satisfactory engine performance.

(5) Should there be a low compression reading on two adjacent cylinders, it indicates a possible inter-cylinder leak, usually caused by a leak at a cylinder head gasket.

(6) If the compression readings are low or vary widely, the cause of the trouble may be determined by injecting a liberal supply of oil on top of the pistons of the low reading cylinders.

(7) Crank the engine over several times and then take a second compression test. If there is practically no difference in the readings when compared with the first test, it indicates sticky or poorly seating valves. However, if the compression reading on the low reading cylinders is about uniform with the other cylinders, it indicates compression loss past the pistons and rings.

BOMB SERVICE TRUCK M6 (Chevrolet)

(8) The cause of low or uneven compression must be corrected before proceeding with an engine tune-up job.

d. Spark Plugs.

(1) Clean the spark plugs thoroughly, using an abrasive type cleaner. If the porcelains are badly glazed or blistered, the spark plugs should be replaced. All spark plugs must be of the same make and heat range.

(2) Adjust the spark plug gaps at 0.040 inch, using a round feeler gage. Refer to figure 72. **DO NOT BEND THE CENTER ELECTRODE.**

(3) Care must be used when installing the 10 millimeter spark plugs, or the setting of the gap may be upset. If a torque wrench is used when installing the plugs, the proper torque is 15 foot pounds. If a torque wrench is not available, the following procedure should be followed.

(4) Install a new gasket on the plug, screw the plug in finger tight and then tighten with a wrench $\frac{1}{2}$ - to $\frac{3}{4}$ -turn.

e. Battery Test.

(1) Connect the negative terminal of a voltmeter to the starting switch terminal and the positive terminal of the voltmeter to a good ground.

(2) Close the starting motor switch and crank the engine for 15 seconds. If the starting motor cranks the engine over at a good rate of speed with the voltmeter reading 5 volts or better, it indicates a satisfactory starting circuit, which includes the condition of the battery, terminals and cables. However, if the cranking speed is slow, or the voltmeter reading is under 5 volts, the starting motor, battery, and battery cable terminals should be checked individually to locate the source of the trouble. See section XVII.

f. Distributor.

(1) Remove the spark plug wires from the distributor cap and examine the terminals for corrosion. The wires should also be checked for damaged insulation and for being oil soaked.

(2) Remove the distributor cap and check the cap and distributor rotor for cracks or burned contacts.

(3) Check the automatic advance mechanism by turning the distributor cam in a clockwise direction as far as possible, then release the cam and see if the springs return it to its retarded position. If the cam does not return readily, the distributor must be disassembled and the cause of the trouble corrected.

(4) Examine the distributor points. Dirty points should be cleaned, and pitted or worn points should be replaced. Check the points for alinement and aline them if necessary.

(5) Hand crank the engine until the cam follower rests on the peak of

ENGINE

the cam. Adjust the point gap to 0.018 inch, using a feeler gage (fig. 68). This operation must be performed very accurately because it affects point dwell or how long points stay together. Hand crank the engine until the cam follower is located between the cams. Hook the end of a point scale over the movable point and pull steadily on the spring scale until the points just start to open. At this point the reading on the scale should be between 17 and 21 ounces.

(6) Set the octane selector at "zero" on the scale. Reassemble distributor cap and spark plug wires. Make sure that the terminals of the primary wire from the ignition coil to the distributor are clean and tight.

g. Coil and Condenser. The ignition coil and condenser should be checked, following the instructions given in section XIX.

h. Fuel Pump. Remove the filter bowl and screen, and wash them thoroughly in SOLVENT, cleaning. When reassembling, make sure that the cork gasket is in good condition and properly seated. Tighten all fuel pump connections.

i. Carburetor Air Cleaner.

(1) Remove the air cleaner from the carburetor. Remove the wing nut from the top and remove the cover. Remove the filter element assembly. CAUTION: Do not pry this part loose if it sticks. It must be removed by hand because you may damage the filter element flange, which must lie flat against the body to insure a tight seat at this point to prevent air leaks when the cover is assembled.

(2) Empty the oil out of the cleaner and clean out all oil and accumulated dirt. Wash body with SOLVENT, cleaning, and wipe dry. Wash filter element by slushing up and down in SOLVENT, cleaning. Dry thoroughly, either with an air hose or by letting it stand until dry. Fill the body of the cleaner with two pints of OIL, engine, SAE 50.

(3) It is not necessary to reoil the filter element as this is done automatically when the car is driven.

(4) Reassemble the filter element to the body of the cleaner, being sure that the flange sits flat against the top flange of the body.

(5) Reassemble the cover, making sure that the gasket is clean and in good condition over its entire surface so that a tight seal is obtained at this point. Put on wing nut.

(6) Reassemble the cleaner to the carburetor. The cleaner must be put on tight so that it rests against the carburetor to assure a good seat at this point. Tighten clamp.

j. Valve Cover Air Cleaner. Remove the air cleaner and wash it thoroughly by slushing it back and forth in SOLVENT, dry cleaning. Dry thoroughly and dip it in OIL, engine, SAE 50. Allow the excess oil to

BOMB SERVICE TRUCK M6 (Chevrolet)

drain off, wipe body of cleaner dry and reinstall on valve cover. **CAUTION:** Make sure vent is not restricted. This vent aids crankcase ventilation.

k. Carburetor.

(1) The only adjustments that should be attempted by using arms are for the throttle stop screw and idling adjusting screw. See paragraph 135 for adjusting instructions.

(2) If any other service is required, the carburetor should be removed and sent to the responsible ordnance service for repairs. See paragraph 113 e (3) for instructions regarding carburetor removal.

l. Manifold Heat Valve. Unhook the thermostatic spring from its anchor pin and check the adjustment. Proper adjustment requires only one-half turn of the spring to slip it over its anchor pin. Should the thermostatic spring be distorted in any way it should be replaced.

m. Ignition Timing. With the octane selector set at "zero" attach one wire of the neon timing light to No. 1 spark plug and the other wire to the No. 1 spark plug wire. Mark the steel ball imbedded in the flywheel with a piece of chalk. Start the engine and run it at idling speed. Loosen distributor clamp and rotate distributor body clockwise or counterclockwise until the steel ball in the flywheel lines up with the pointer on the flywheel housing (fig. 69). Tighten the distributor clamp screw.

n. Valve Adjustment.

(1) Start the engine and while it is warming up, the cylinder head bolts, rocker arm shaft support bolts and nuts, and the manifold bolts and nuts should be tightened. Where torque wrenches are available the cylinder head bolts should be tightened to 75 to 80 foot pounds, and the rocker arm shaft support bolts to 25 to 30 pounds.

(2) Normalize the engine and adjust the valves according to the procedure given in paragraph 115.

(3) Install the rocker arm cover, using a new gasket and check for oil leaks.

o. Idling Adjustment. Adjust the carburetor idle and throttle stop screws in combination with each other to secure the best idling performance (fig. 100). Idling speed should be set at 500 to 550 revolutions per minute.

p. Cooling System. Tighten all hose connections and examine for any indications of water leaks. Check the fan belt for cracks, oil soaking and for proper tension and adjust it if necessary. See section XVI.

q. Road Test. After the completion of the above operations, the truck should be road-tested for performance. During this time the octane selector should be adjusted for the grade of fuel being used. For peak

ENGINE

performance and maximum gasoline economy, the octane selector should be set to produce a slight "ping" upon accelerating at wide-open throttle.

117. ENGINE OILING SYSTEM.

a. Lubrication for the engine is supplied by a positively driven gear pump that is equipped with a spring loaded bypass valve which controls the maximum pressure at high speeds and when the engine oil is apt to be heavy and sluggish during cold weather starting.

b. The engine oiling system provides positive pressure lubrication to the main bearings and camshaft bearings. The connecting rod bearings are lubricated by means of dippers on the rods which dip into troughs in the oil pan at low speeds, and by oil nozzles at higher speeds. Cylinder walls and piston pins are lubricated by the oil spray. Oil for the valve mechanism is pumped up to the hollow rocker arm shafts.

c. **Main and Camshaft Bearing Lubrication.** The oil flow is from the pan, through the pump screen and oil pump to the block fitting pipe, and then to the oil manifold, thence through drilled passages in the bearing support webs in the cylinder block, to the four main bearings. The oil then passes through grooves in the bearings to the drilled passages in the cylinder block webs and to the camshaft bearings. In this manner full pressure feed lubrication is supplied to all main and camshaft bearings.

d. **Timing Gear Lubrication.** Lubrication for the timing gears is supplied by conducting the oil from the front camshaft bearing, through a milled slot in the back of the engine front end plate, to a nozzle which is so aimed that the oil stream effectively lubricates the timing gears.

e. **Connecting Rod Bearing Lubrication.**

(1) Oil for the connecting rods passes from the cylinder block fitting to the oil manifold, through a drilled passage in the cylinder block and to the oil distributor. As the oil pressure builds up, the oil distributor valve opens and releases the oil into a drilled passage in the block, this passage connecting with the short pipe that fits into the main supply pipe in the oil pan. From the main supply pipe the oil passes to the oil manifold in the oil pan, where it is distributed to the six oil nozzle pipes.

(2) The six oil troughs in the oil pan are adjusted to the proper height so that the connecting rod dippers will dip into the oil and supply lubrication for the lower speeds.

(3) As the engine speed is increased and the oil pressure is built up, the oil streams from the nozzles rise and are intercepted by the dippers, forcing the oil into the connecting rod bearings under high pressure. The cylinder walls, pistons, and piston pins are lubricated by the oil spray thrown off by the connecting rods.

f. **Valve Mechanism Lubrication.** Oil for lubrication of the valve mechanism is tapped off at the oil manifold and is carried by a pipe which

BOMB SERVICE TRUCK M6 (Chevrolet)

passes through the water jacket to a fitting between the two hollow rocker arm shafts, where it is distributed to all rocker arm bearings. A bleeder hole in each rocker arm supplies oil for lubrication of the valve stems and push rod sockets.

118. OIL PAN REPLACEMENT.

a. Tools Required:

Handle, speed	Wrench, open-end, $\frac{3}{8}$ -in.
Screwdriver	Wrench, open-end, $1\frac{1}{4}$ -in.
Socket, $\frac{1}{2}$ -in.	

b. Remove oil pan drain plug with a $1\frac{1}{4}$ -inch open-end wrench and drain oil from pan.

c. Remove oil gage rod.

d. Remove oil gage rod guide tube clamp at bottom of cylinder block and loosen clamp on right side of oil pan. Remove guide tube.

e. Remove the oil pan attaching screws with a screwdriver and a $\frac{1}{2}$ -inch speed wrench.

f. Bump the oil pan to break it loose from the gasket and lower the pan, being careful not to damage the oil screen or oil troughs in the pan.

g. When installing the pan, new gaskets and end corks should be used.

h. Work oil pan up into position over the suction screen. Install screws and tighten them securely with a screwdriver and a $\frac{1}{2}$ -inch speed wrench.

i. Install lower end of the oil gage tube in the bracket on right side of oil pan and the upper end of tube in bracket at bottom of cylinder block. Tighten the clamp screws securely.

j. Install oil gage rod.

k. Tighten drain plug with $1\frac{1}{4}$ -inch open-end wrench.

l. Refill oil pan with OIL, engine, seasonal grade.

119. OIL PUMP REPLACEMENT.

a. Tools Required:

Wrench, open-end, $\frac{1}{2}$ -in.	Wrench, open-end, $\frac{1}{8}$ -in.
Wrench, open-end, $\frac{5}{8}$ -in.	

b. Remove oil pan as described in paragraph 118.

c. Disconnect the oil pump suction and feed lines from the oil pump with an $\frac{1}{8}$ -in. open-end wrench.

d. With a $\frac{5}{8}$ -inch open-end wrench loosen the lock nut, and remove oil pump lock bolt with a $\frac{1}{2}$ -inch open-end wrench.

e. Turn slightly and pull the oil pump out of the bracket.

ENGINE

- f. To install the new oil pump, first install the pump in its bracket.
- g. Install the lock bolt, making sure it enters the hole in pump body, and tighten it securely with a $\frac{1}{2}$ -inch open-end wrench, then tighten lock nut with a $\frac{5}{8}$ -inch open-end wrench.
- h. Connect oil lines to pump and tighten them securely with an $\frac{11}{16}$ -inch open-end wrench.
- i. Replace oil pan.

120. ENGINE REMOVAL.

a. Tools Required:

Bolt, eye, engine lifting, J-770
(KM)

Handle, ratchet

Hoist

Pan, drain

Pliers, combination, 6-in.

Screwdriver, 6-in.

Socket, $\frac{9}{16}$ -in.

Socket, $\frac{5}{8}$ -in.

Wrench, head bolt, $\frac{3}{4}$ -in.

Wrench, open-end, $\frac{3}{8}$ -in.

Wrench, open-end, $\frac{7}{16}$ -in.

Wrench, open-end, $\frac{1}{2}$ -in.

Wrench, open-end, $\frac{9}{16}$ -in.

Wrench, open-end, $1\frac{1}{4}$ -in.

- b. Drain radiator and cylinder block.
- c. Remove hood and side panels with a screwdriver and $\frac{7}{16}$ -inch open-end wrench.
- d. Remove the radiator, front end sheet metal, and fenders as a unit as described in paragraph 151.
- e. With a $\frac{9}{16}$ -inch open-end wrench remove the battery cable and ammeter wire from the starter switch terminal. Tape the end of the battery cable wire to prevent the possibility of shorts.
- f. Remove the ignition wire from the top of coil with a $\frac{3}{8}$ -inch wrench.
- g. Disconnect the two oil filter lines at the connectors with a $\frac{1}{2}$ -inch wrench.
- h. Disconnect the gasoline feed line from the fuel pump using a $\frac{1}{2}$ -inch and a $\frac{9}{16}$ -inch open-end wrench.
- i. Remove the right engine side pan with a $\frac{1}{2}$ -inch wrench and screwdriver.
- j. Disconnect the wiring from the generator with a $\frac{7}{16}$ -inch open-end wrench.
- k. Disconnect the wires from horn with a $\frac{7}{16}$ -inch open-end wrench and remove the horn.
- l. Disconnect carburetor end of choke and throttle cables.
- m. Remove the air cleaner.

BOMB SERVICE TRUCK M6 (Chevrolet)

- n. Disconnect oil pressure gage line with a $\frac{7}{16}$ -inch wrench and disconnect temperature indicator.
- o. Disconnect the hydrovac booster vacuum line.
- p. Remove the two exhaust manifolds to pipe bolts with a $\frac{9}{16}$ -inch wrench.
- q. Remove left engine side pan with a $\frac{1}{2}$ -inch open-end wrench and screwdriver.
- r. Remove the floor and toeboards.
- s. With a $\frac{9}{16}$ -inch open-end wrench split the universal joint back of the transmission by removing the nuts and lockwashers from the U clamps which retain the trunnion bearings.
- t. With a $\frac{9}{16}$ -inch ratchet wrench remove transfer case control levers and emergency brake lever attaching screws on right side of transmission.
- u. Disconnect power plant brace rod at transmission end with a $\frac{9}{16}$ -inch wrench.
- v. Disconnect pull back spring at left rear corners of transmission.



RA PD 32291

Figure 91—Engine Assembly Removal

- w. With a $\frac{9}{16}$ -inch open-end wrench drain the transmission lubricant.
- x. With a $1\frac{1}{4}$ -inch open-end wrench drain the oil pan.

ENGINE

y. Disconnect the accelerator rod from the bell crank on left side of engine.

z. With a $\frac{9}{16}$ -inch open-end wrench remove the three cap screws which attach the clutch and brake pedal shaft assembly to the clutch housing.

aa. Remove the starting motor cross shaft with a $\frac{9}{16}$ -inch open-end wrench by removing the bolts from the brackets and disconnecting the link and spring from the starting motor gear shifter lever.

ab. With a $\frac{9}{16}$ -inch speed wrench remove the transmission cover and place a piece of cardboard on top of the transmission to prevent dirt falling into it during engine removal.

ac. Remove the bolts from the rear engine mountings with a $\frac{5}{8}$ -inch ratchet wrench and remove the front engine mounting with a $\frac{9}{16}$ -inch ratchet wrench.

ad. With a $\frac{3}{4}$ -inch head bolt wrench remove the third cylinder head bolt from the rear on the left side and install the engine lifting eyebolt.

ae. Connect a hoist to the eyebolt and raise the engine clutch and transmission from the chassis as a unit (fig. 91).

121. ENGINE INSTALLATION.

a. Tools Required:

Use tools listed in paragraph 120 a.

b. With a $\frac{3}{4}$ -inch head bolt wrench remove the third cylinder head bolt from the rear on the left side and install the engine lifting eyebolt.

c. Connect a hoist to the lifting eyebolt and raise the engine, clutch and transmission assembly. Swing it over the chassis and guide the engine assembly into place.

d. Install the engine mounting bolts and nuts with a $\frac{9}{16}$ -inch and a $\frac{5}{8}$ -inch wrench. Tighten engine mountings and lock securely. See paragraph 122 b (1).

e. Install the transmission cover and tighten the retaining bolts with a $\frac{9}{16}$ -inch speed wrench.

f. Install the starter cross shaft and bolt the brackets securely with a $\frac{9}{16}$ -inch wrench. Hook up the starting motor gear shifter link.

g. Place the clutch and brake pedal shaft with pedals in position; install the three retaining bolts, and tighten them with a $\frac{9}{16}$ -inch wrench.

h. Install the accelerator rod and attach it to the bell crank on the left side of engine.

i. Hook brake pedal pull back spring to clip at left rear transmission cover bolt.

BOMB SERVICE TRUCK M6 (Chevrolet)

j. Adjust power plant brace rod to correct length so that bolt will just drop through end of adjusting link and bracket at transmission cover. Install nut and tighten securely with a $\frac{9}{16}$ -in open-end wrench.

k. Install transfer case control levers, emergency brake lever, and attaching bracket to right side of transmission. Tighten the retaining bolts with a $\frac{9}{16}$ -inch ratchet wrench.

l. Place the universal joint in position, install the U clamps, lock-washers, and nuts. Tighten securely with a $\frac{9}{16}$ -inch ratchet wrench.

m. Install the floor and toeboards.

n. Install left engine side pan with a $\frac{1}{2}$ -inch open-end wrench and screwdriver.

o. Install exhaust pipe to manifold and tighten with a $\frac{9}{16}$ -inch open-end wrench.

p. Connect the hydrovac booster vacuum line.

q. Connect oil pressure gage line with a $\frac{7}{16}$ -inch open-end wrench.

r. Connect windshield wiper vacuum line.

s. Connect choke and throttle cables with a screwdriver.

t. Install horn. Tighten bolts with a $\frac{7}{16}$ -inch open-end wrench and attach horn wires.

u. Attach generator wires and tighten nut with a $\frac{7}{16}$ -inch open-end wrench.

v. Install right engine side pan and tighten screws with a $\frac{1}{2}$ -inch wrench and screwdriver.

w. Attach gasoline supply line to fuel pump with $\frac{9}{16}$ -inch and $\frac{1}{2}$ -inch open-end wrenches.

x. Attach oil filter lines at the connectors and tighten securely with a $\frac{1}{2}$ -inch open-end wrench.

y. Attach the ignition wire to the top of coil and tighten with a $\frac{3}{8}$ -inch wrench.

z. Attach the battery cable and ammeter wire to starter motor terminal and tighten with a $\frac{9}{16}$ -inch open-end wrench.

aa. Reinstall the radiator front end sheet metal and fenders as a unit as described in section XXVII.

ab. Reinstall air cleaner.

ac. Reinstall hood and side panels.

ad. Refill oil pan and transmission. Lubricate the universal joint that was disassembled.

122. ENGINE MOUNTINGS.

a. The engine is attached to the frame by three rubber cushioned

ENGINE

mountings to prevent engine vibrations from being transmitted to the cab. One of the mountings is at the front and attaches to the center of the frame front cross member. The other two mountings are located at the sides of the engine and attach to the clutch housing and to frame brackets.

b. Front Engine Mounting Removal.

(1) TOOLS REQUIRED:

Jack, roller, 41J-73-5	Socket, 1/2-in.
Handle, ratchet	Socket, 9/16-in.
Pliers	Wrench, open-end, 7/16-in.
Screwdriver	

(2) Drain the cooling system.

(3) Remove the upper and lower radiator hose.

(4) Remove the fan blades using a 7/16-inch open-end wrench.

(5) Loosen the rear motor mountings using a 7/8-inch wrench.

(6) Remove the motor mounting to frame cross member bolt nuts with a 1/2-inch ratchet wrench, and the front end plate to motor mounting bolt nuts with a 9/16-inch ratchet wrench.

(7) Jack the front end of the motor up about two inches, being careful not to damage the oil pan.

(8) Remove the old motor mounting.

c. Front Engine Mounting Installation.

(1) Install the round head mounting bolts through the mounting top plate.

(2) Place the mounting oil shield over the top plate and place the two pieces over the bolts in the engine front end plate.

(3) Place the rubber mounting over the bolts with the large end of the two bushings toward the engine front end plate.

(4) Install the nuts on the two center bolts which are attached to the engine front end plate. Tighten the nuts securely with a 9/16-inch wrench; install cotter pins.

(5) Install mounting, retainer and lower front end of engine so that bolts pass through holes in frame front cross member.

(6) Install washers and nuts and tighten with a 1/2-inch wrench.

(7) Tighten rear mounting bolts.

d. Side Engine Mounting Removal.

(1) TOOLS REQUIRED:

Jack, roller, 41J-73-5	Wrench, open-end, 7/8-in.
------------------------	---------------------------

BOMB SERVICE TRUCK M6 (Chevrolet)

(2) Remove the upper and lower mounting bolts on each mounting, using a $\frac{7}{8}$ -inch wrench.

(3) Place the jack under the transmission and raise the back end of the motor slightly to clear the motor mountings.

(4) Remove the mountings.

e. Side Engine Mounting Installation.

(1) Bolt the side of the mounting with the wider plate to the engine support bracket.

(2) Lower the jack until the mounting just touches the frame bracket.

(3) Line up the dowel in the mounting lower plate with the dowel hole in the frame bracket.

(4) Install the lower spacer, lockwasher and bolt.

(5) Remove the jack.

(6) Tighten both bolts with a $\frac{7}{8}$ -inch open-end wrench.

f. Power Plant Brace Rod.

(1) **DESCRIPTION.** To control the fore and aft movement of the power plant in its mountings when the hand brake is applied, a brace rod is used between the transmission and frame second cross member. The rear end of the brace attaches to a bracket on the frame cross member while the front end is fitted with an adjusting eyebolt. The adjusting eyebolt attaches to a bracket mounted on the right side of the transmission by two cover bolts (fig. 92).

(2) **ADJUSTMENT.**

(a) **TOOLS REQUIRED:**

Wrench, open-end, $\frac{9}{16}$ -in.

Wrench, open-end, $\frac{5}{8}$ -in.

(b) Locate vehicle on level floor.

(c) Remove the brace rod to transmission bracket bolt with a $\frac{9}{16}$ -inch open-end wrench.

(d) Loosen the adjusting eyebolt lock nut with a $\frac{5}{8}$ -inch open-end wrench.

(e) Turn adjusting eye to shorten or lengthen the rod so that the attaching bolt will just drop through adjusting eye and transmission bracket.

(f) Tighten lock nut with $\frac{5}{8}$ -inch wrench.

(g) Install flat washer and nut. Tighten nut with a $\frac{9}{16}$ -inch wrench and install cotter pin.

ENGINE

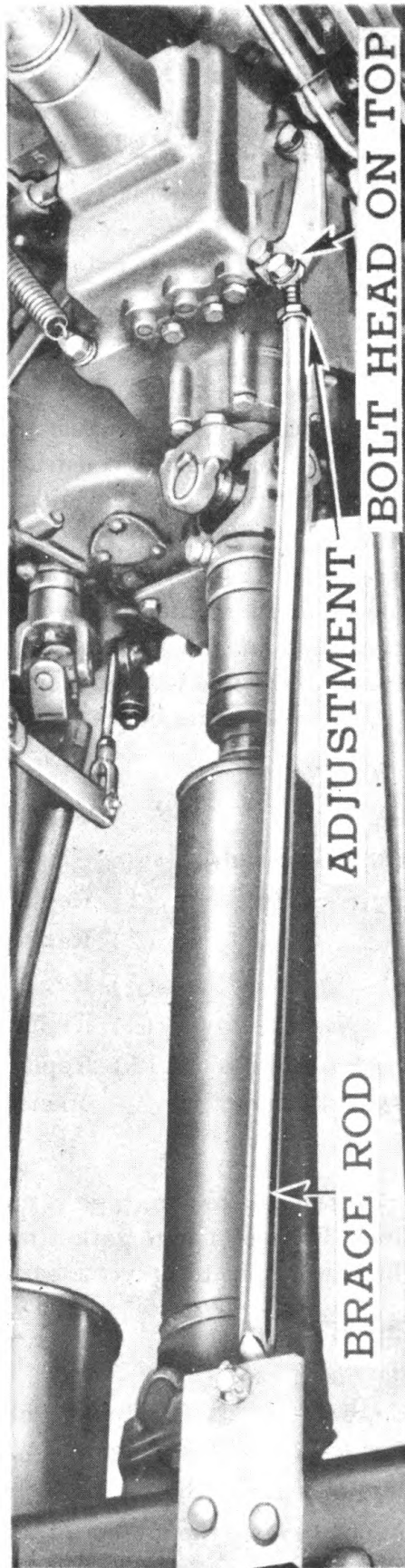

RA PD 32292

Figure 92—Power Plant Brace Rod

BOMB SERVICE TRUCK M6 (Chevrolet)

Section XXII

EXHAUST SYSTEM

	Paragraph
Description	123
Trouble shooting	124
Maintenance	125
Unit replacement	126

123. DESCRIPTION.

a. The exhaust system consists of an exhaust pipe, muffler and tail pipe (fig. 93). The muffler is of integral construction, employing the reverse flow and diffusion principles to obtain quiet operation.

b. The exhaust pipe from the manifold slides into the muffler inlet tube and is held in place by a clamp. Small projections on the exhaust pipe locate the proper depth in the muffler. The muffler is attached to the transfer case support by a strap and clamp assembly. The tail pipe slides over the muffler outlet tube where it is held by a clamp. The outer end of the tail pipe is supported by a strap and bolt attached to the frame.

124. TROUBLE SHOOTING.

Symptom	Probable remedy
a. Rattling and unusual sounds.	
(1) Opened seams in muffler.	(1) Replace unit.
(2) Corroded metal.	(2) Replace unit.
(3) Loose baffle.	(3) Replace unit.
(4) Loose flange.	(4) Tighten or replace gasket.
(5) Dents and breaks from flying stones, ruts, and stumps.	(5) Replace if metal is opened.

125. MAINTENANCE.

Keep muffler tail pipe open. Make sure pipe is not closed as this will affect engine performance. Exhaust flange gasket nuts, strap and clamp bolts must be kept tight at all times to prevent leaks.

126. UNIT REPLACEMENT.

a. Tools Required:

Pliers, combination, 6-in.	Wrench, box, $\frac{9}{16}$ -in.
Screwdriver, 8-in.	Wrench, open-end, $\frac{1}{2}$ -in.

b. With a $\frac{1}{2}$ -inch wrench remove the tail pipe clamp.

c. With a $\frac{1}{2}$ -inch wrench remove the muffler to tail pipe support.

EXHAUST SYSTEM

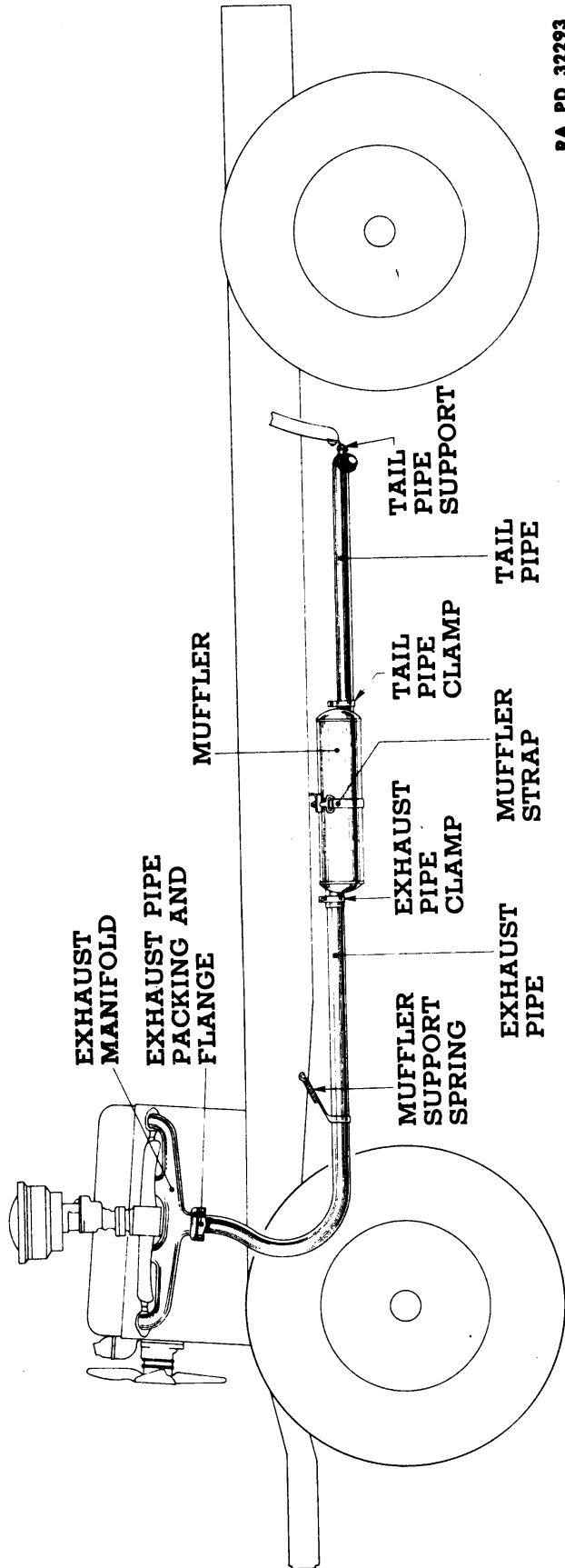

Figure 93—Exhaust System

BOMB SERVICE TRUCK M6 (Chevrolet)

- d. Remove the tail pipe.
- e. With a $\frac{9}{16}$ -inch wrench remove the exhaust pipe to manifold stud nuts.
- f. Disconnect the muffler support spring.
- g. With a $\frac{1}{2}$ -inch wrench remove the muffler strap clamp.
- h. Remove muffler and exhaust pipe.
- i. Remove exhaust pipe to muffler clamp with a $\frac{1}{2}$ -inch wrench.
- j. Disconnect the muffler from exhaust pipe.
- k. The assembly would be the reverse from disassembly except that all clamp bolts should be left loose until the parts are in correct relation to each other.
- l. Slight rotation of the muffler may be necessary to line up the inlet and outlet tubes properly.
- m. Make sure the pipes are properly fitted to the muffler and tighten the clamps, brackets and exhaust pipe to manifold bolts.

Section XXIII

FRAME

	Paragraph
Frame	127
Pintle (tow) and pull hooks	128
Bumper	129

127. FRAME.

The frame design features simplicity and great strength, yet provides accessibility for servicing (fig. 94). Frame side rails and cross members are constructed of channel steel rigidly riveted together. Braces and brackets are used to maintain proper longitudinal position of the side rails relative to each other and at the same time provide additional resistance to twisting.

128. PINTLE (TOW) AND PULL HOOKS.

a. A pintle (tow) hook is provided at the rear and two pull hooks at the front. The pintle is held in place between the rear frame cross member and an additional support brace by means of two heavy steel bushings. Machined collars on the bushings bear against a strong coil spring, providing a means of absorbing the starting shock.

b. Pintle hook installation.

(1) **TOOLS REQUIRED:**

Wrench, open-end, 3/4-in.

Wrench, socket, 2 1/4-in.

(2) Install the pintle hook support over the pintle hook shaft.

(3) Place one of the bushings over the shaft so that the shorter end of the bushing pilots through the bracket.

(4) Place the spring over the shaft and bushing so that it rests against the bushing shoulder.

(5) Place the other bushing over the shaft so that the short end pilots into the spring and the shoulder rests against the spring.

(6) Install the washer and nut and tighten the nut with a 2 1/4-inch socket wrench.

(7) Place the pintle hook and bracket assembly against the frame cross member. Install the eight bolts, washers, and nuts. Tighten securely with a 3/4-inch wrench.

(8) Back off the pintle hook shaft nut until the bushings cease turning with the pintle.

BOMB SERVICE TRUCK M6 (Chevrolet)

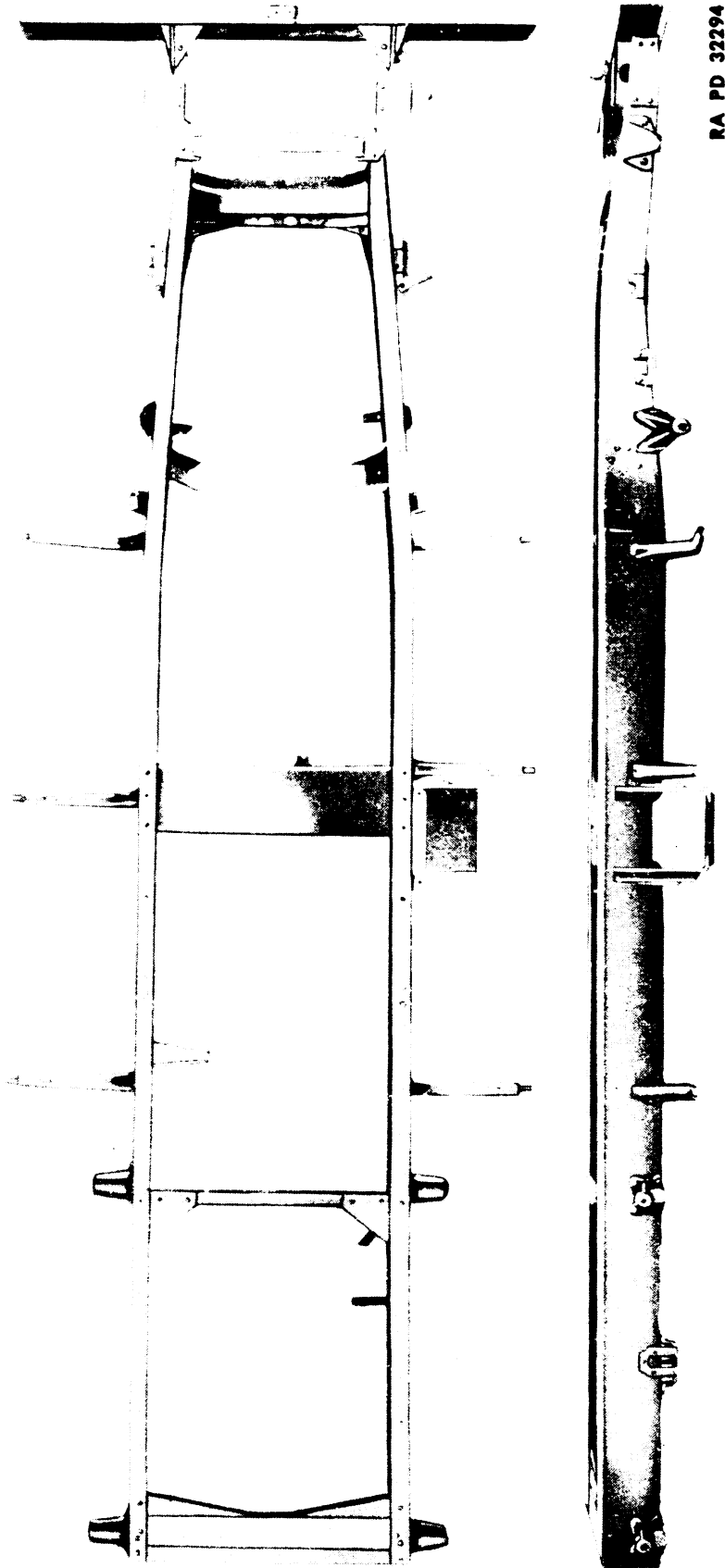

Figure 94—Frame

FRAME

(9) Install cotter pin. **NOTE:** The pintle hook may be shifted $1\frac{3}{4}$ inches further back from the rear cross member by changing ends with both bushings.

129. BUMPER.

A bumper of extremely heavy channel steel is provided and mounted at the front of the frame, supported by strong braces and brackets.

BOMB SERVICE TRUCK M6 (Chevrolet)

Section XXIV

FUEL SYSTEM

	Paragraph
Description	130
Trouble shooting	131
Fuel tanks	132
Fuel pump	133
Fuel filter	134
Carburetor	135
Air cleaner	136

130. DESCRIPTION.

a. The fuel system consists of a main tank, auxiliary tank, a transfer and shut-off valve, fuel filter, fuel pump, carburetor, air cleaner, throttle control and engine manifold. Short, flexible lines are used to prevent breakage from vibration at main anchored fuel lines.

b. **Operation.** Transfer and shut-off valve selects the tank to be used for the supply of fuel (fig. 5).

c. **Capacity.** Total capacity of the system is 48 gallons.

131. TROUBLE SHOOTING.

Symptom	Probable remedy
a. Excessive Fuel Consumption.	
(1) Improper carburetor adjustment.	(1) (a) Adjust idling and stop screws. (b) Synchronize metering rod with throttle valve. See metering rod adjustment instructions.
(2) Dirty air cleaner.	(2) Clean air cleaner.
(3) Fuel leaks.	(3) Check carburetor, fuel pump, fuel tank and all lines and connections for leaks.
(4) Sticking controls.	(4) Free up controls and lubricate linkage.
(5) Excessive idling.	(5) Stop engine when vehicle will not be moving for long periods.

FUEL SYSTEM

Symptom	Probable remedy
(6) Improper engine temperatures.	(6) Refer to section XVI of this manual.
(7) Dragging brakes.	(7) Refer to section XIV of this manual.
(8) Tires, under-inflated.	(8) Inflate to recommended pressure.
(9) Engine improperly tuned.	(9) Tune engine. See par. 116.
(10) Vehicle overloaded.	(10) Load only to rated capacity.
b. Fast Idling.	
(1) Improper adjustment.	(1) Adjust idling and throttle stop screws.
(2) Carburetor controls sticking.	(2) Free up controls and lubricate linkage.
c. Will Not Idle Below 15 Miles per Hour.	
(1) Low speed jet or idle passages plugged with dirt.	(1) Replace carburetor.
d. Engine Misses on Acceleration.	
(1) Improper spark plug gap adjustment.	(1) Adjust.
(2) Improper valve adjustment.	(2) Adjust.
(3) Accelerating pump jet plugged.	(3) Clean.
(4) Accelerating pump check valves sticking or leaking.	(4) Replace carburetor.

132. FUEL TANKS.

a. A main tank and an auxiliary tank are used. The main tank capacity is 30 gallons. Auxiliary tank capacity is 18 gallons.

b. Main Fuel Tank. Two steel straps around the top of the tank fasten into two support braces extending beneath the tank. These braces in turn are attached to the frame side rail on the right side. On the left side of the tank, the two steel straps are attached to an "ell" section brace which in turn is attached at its center to a bracket on the frame left side rail by one bolt. This provides a three-point mounting for the tank and protects it from distortion when the vehicle is being driven over rough terrain.

BOMB SERVICE TRUCK M6 (Chevrolet)**c. Replacement.****(1) TOOLS REQUIRED:**

Screwdriver

Wrench, open-end, 1/2-in.

Wrench, open-end, 3/8-in.

Wrench, open-end, 1/16-in.

(2) To remove the tank, disconnect the filler at the coupling.**(3)** Disconnect gasoline line and wires to fuel gage, using 1/16-inch, 3/8-inch, 1/2-inch open-end wrenches.**(4)** Remove the bolts which attach the braces to the frame side rails. Then, by moving the tank toward the center and dropping the outer edge slightly, the tank may be lowered and removed with the straps still in place attached to the braces. Use a 1/16-inch open-end wrench for this operation.

d. Auxiliary Fuel Tank. Two steel straps around the top of the tank fasten into two support braces extending beneath the tank. To remove the tank, remove seats by taking off the four wing nuts from the seat adjuster bolts. Remove the 14 metal screws from seat riser cover panel and remove panel. Disconnect gasoline line, using a 1/16-inch open-end wrench, and then disconnect wires to fuel gage. Remove the nuts and lock washers from bottom of hold-down straps. The tank may then be lifted out.

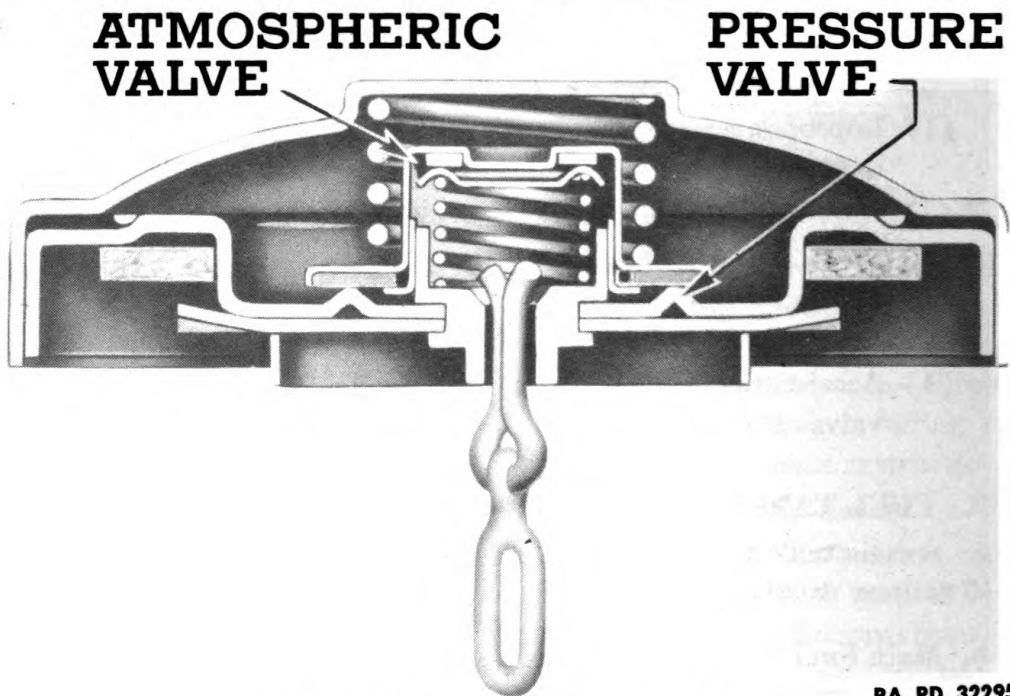
**Figure 95—Fuel Tank Filler Cap**

e. Filler Cap. The fuel tank filler cap is of the pressure type, equipped with spring-loaded pressure and atmospheric valve as shown in the cross section (fig. 95).

FUEL SYSTEM

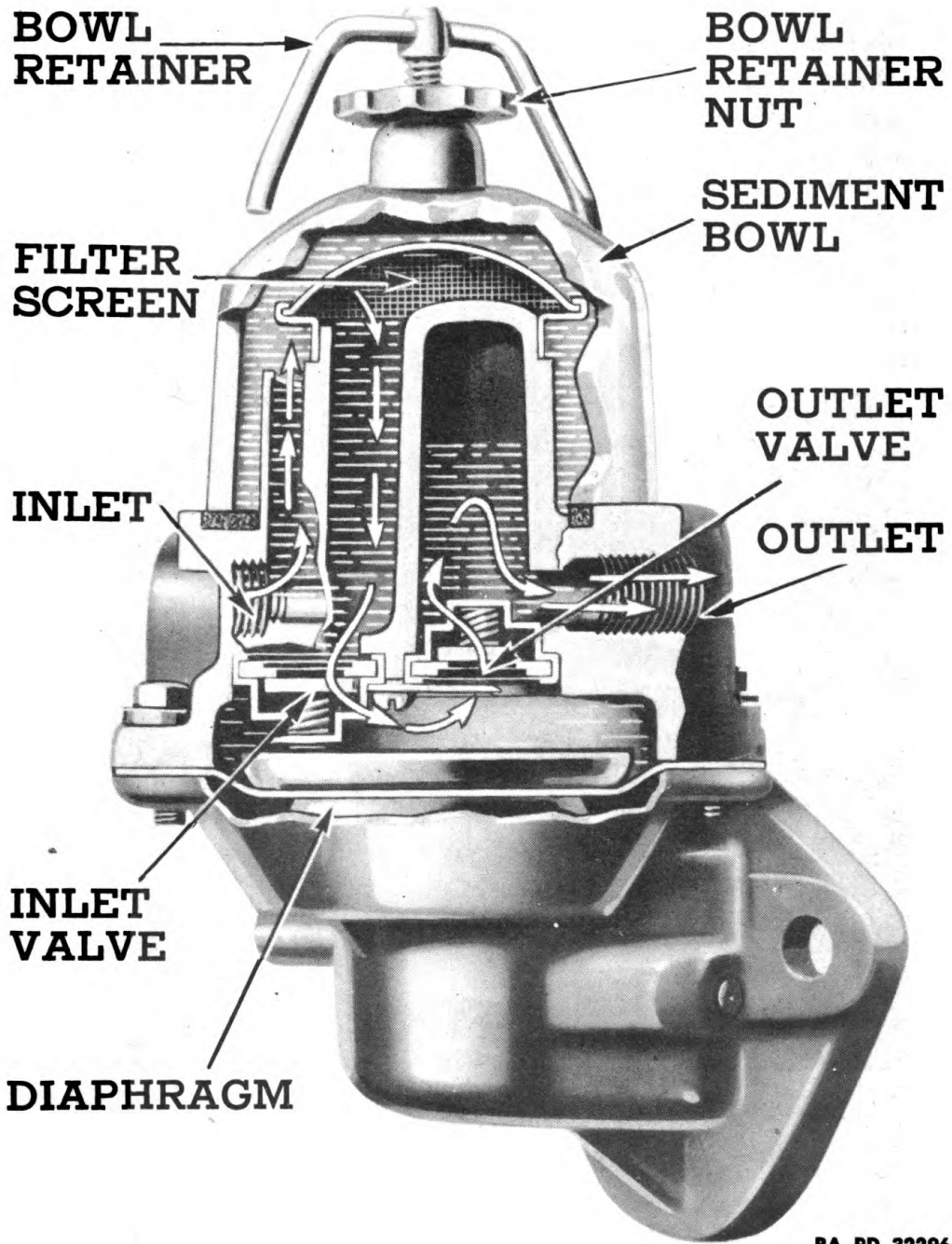

RA PD 32296

BOMB SERVICE TRUCK M6 (Chevrolet)**133. FUEL PUMP.**

a. The diaphragm-type fuel pump (fig. 96) is mounted on the right side of the crankcase and operated from an eccentric on the camshaft. The diaphragm is composed of several layers of specially treated cloth which is impervious to gasoline and benzol. The cloth material is held between two metal disks and is pushed upward by a pump spring, and downward by the arm on camshaft. This diaphragm, in its downward movement, causes a vacuum in the pump chamber and fuel is drawn in through the glass bowl and strainer to fill this vacuum. The upward movement of the diaphragm forces fuel to the carburetor. A lever and spring located on the rear side of the fuel pump body is used to fill the fuel pump and carburetor bowl in the event the truck should run out of gasoline or the filler bowl is removed for cleaning (fig. 97).

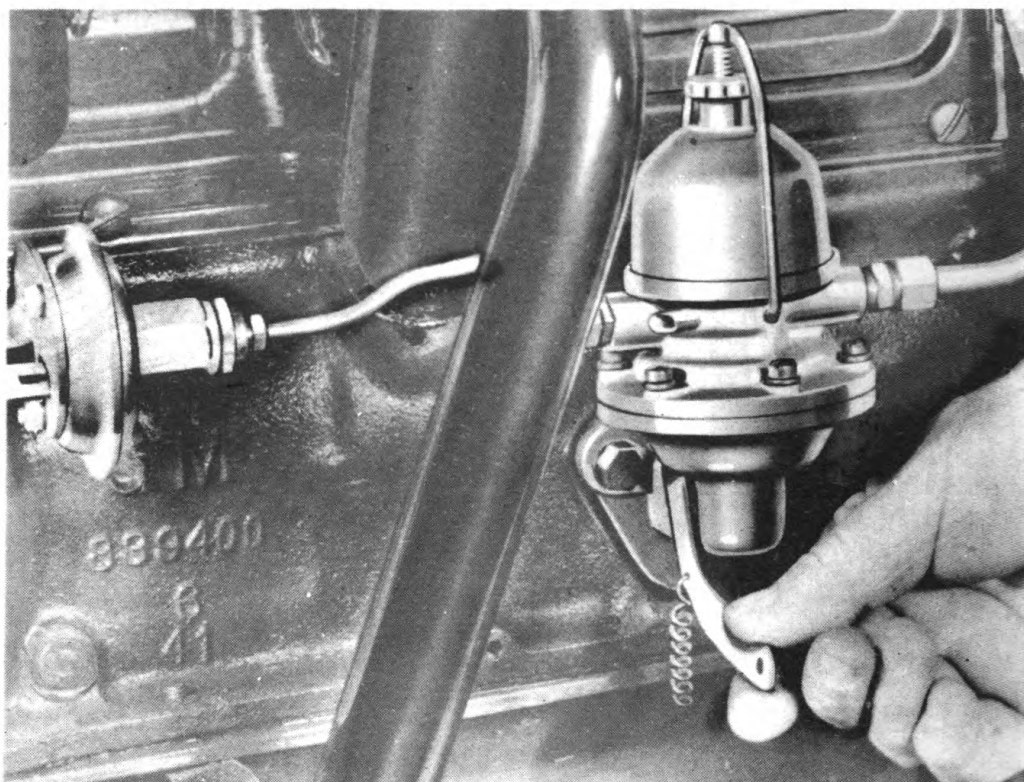

RA PD 32297

Figure 97—Filling Carburetor Bowl

b. **Maintenance.** The pump requires no adjustment. Working parts are lubricated from the engine oil which comes through the opening in the crankcase. Fuel line connector fittings should be checked regularly for leaks. Body screws retaining the diaphragms must be kept tight to prevent air and fuel leaks, and the mounting bolts must be tight. The glass filter bowl is clamped to the cover assembly, making it a simple matter to detect

FUEL SYSTEM

the presence of sediment in the fuel pump. Sediment bowl should be checked and cleaned when necessary.

c. Replacement.

(1) TOOLS REQUIRED:

Wrench, box, 1/2-in.

Wrench, open-end, 9/16-in.

Wrench, open-end, 1/2-in.

(2) When pump fails to function properly, it should be replaced, following the procedure indicated:

(3) Disconnect fuel lines at pump, using a 9/16-inch open-end wrench; also a 1/2-inch open-end wrench.

(4) Take out the two bolts that hold the fuel pump assembly to crank-case, using a 1/2-inch box wrench.

(5) When installing pump, replace gasket.

134. FUEL FILTER.

a. A fuel filter of the multiple disk type is mounted on the outside of the right frame side rail in line with the driver compartment floor boards, and located between the gasoline tank and fuel pump. This is an added precaution against water or dirt reaching the carburetor.

b. Maintenance.

(1) TOOLS REQUIRED:

Pan, parts washing

Wrench, open-end, 5/8-in.

(2) A drain plug in the bottom of the filter bowl may be removed to drain dirt and water from the filter. A shut-off valve is located in the gasoline line between the gasoline tank and filter as shown in figure 98.

(3) To drain water or dirt from the filter bowl, close the shut-off valve in the gasoline line. Then remove the drain plug and drain off any water or dirt in the bowl. Open the shut-off valve for a second or two to flush out the bowl. Close the valve and replace the drain plug. Then again open the shut-off valve in the gasoline line.

(4) To clean the filter element, close the shut-off valve. Then remove the cover bolt, using a 5/8-inch open-end wrench, and remove the bowl and filter element (fig. 99).

(5) Wash all parts of the filter in clean gasoline. The filter element should be slushed back and forth in clean gasoline to remove any particles of dirt that might be lodged between the plates of the element.

(6) Reassemble the filter, making sure the gaskets are in good condition. Then open the shut-off valve.

BOMB SERVICE TRUCK M6 (Chevrolet)

135. CARBURETOR.

a. **Description** (fig. 100). The Carter Model W 1 downdraft carburetor used on this truck embodies a principle employing three venturis, one located above and two below the level of the fuel in the float chamber.

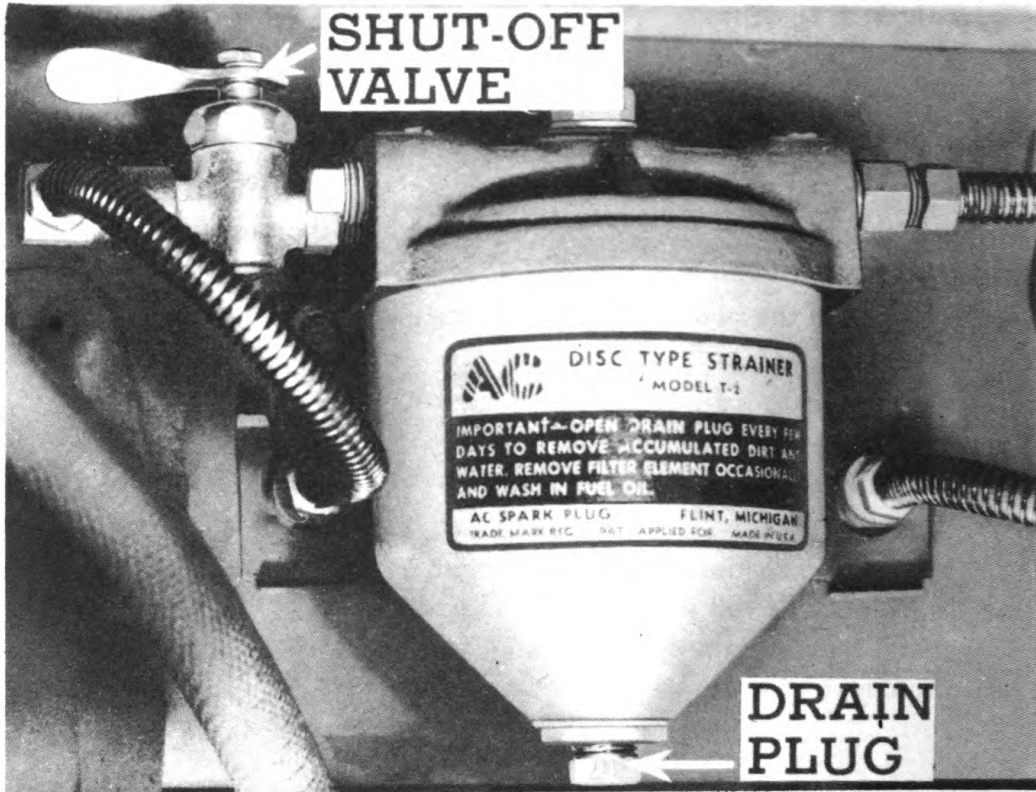

RA PD 32298

Figure 98—Fuel Filter

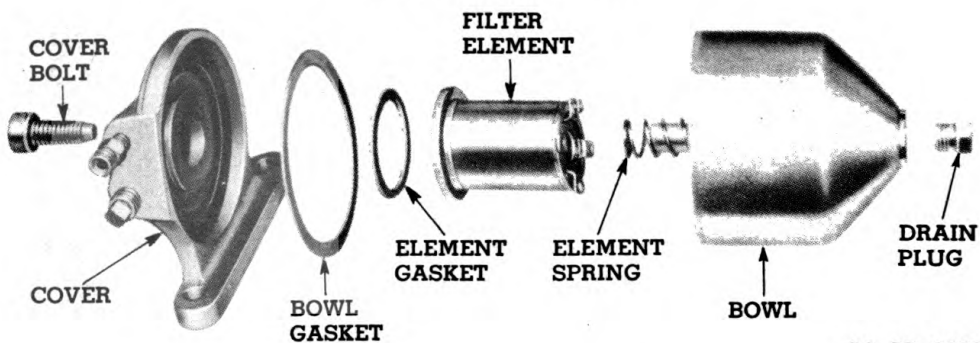

RA PD 32299

Figure 99—Fuel Filter Parts

This triple venturi has the effect of increasing the suction on the first or primary venturi, causing the nozzle to start delivering fuel at very low air speeds. The nozzle enters the primary venturi at an angle, discharging upwardly against the air stream. This angle secures an even flow of proportioned and finely atomized fuel.

FUEL SYSTEM

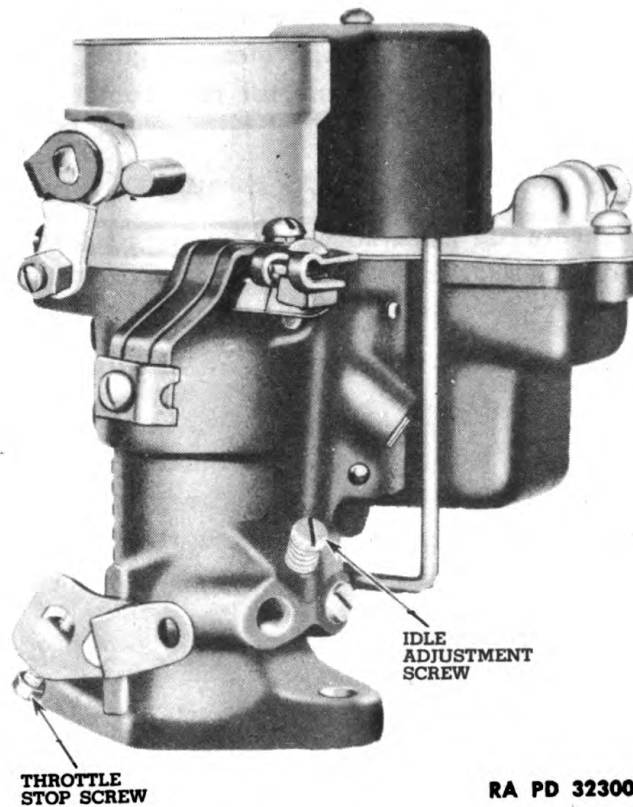

RA PD 32300

Figure 100—Carburetor

b. Maintenance and Replacement.

(1) TOOLS REQUIRED:

Gage, metering rod, Part #600996	Wrench, open-end, 1/2-in.
Screwdriver	Wrench, open-end, 9/16-in.

(2) The carburetor needs very little attention if properly installed and adjusted. Check carburetor to manifold attachment and if an air leak appears, tighten the two nuts that attach carburetor to manifold, using a $\frac{9}{16}$ -inch open-end wrench, and making sure gaskets are in good condition.

(3) **IDLING.** To adjust the idling mixture, proceed as follows: Open the idle adjustment screw (fig. 100) one and one half turns. Start the engine and let it run at idling speed. Then adjust the idle and throttle stop screws in combination with each other to secure the best idling performance. Idling speed should be set at 500 to 550 revolutions per minute.

(4) **CHOKE.** The choke wire control should be checked to see that the choke valve is fully open with the button against the panel, and fully closed with the button fully out. To adjust, remove air cleaner and with a screwdriver set choke control at choke valve arm.

BOMB SERVICE TRUCK M6 (Chevrolet)

(5) **METERING ROD.** To properly synchronize the metering rod with the throttle valve, proceed as follows: Refer to figure 101. Remove the metering rod and disconnect the connector rod from the throttle valve lever.

(6) Back off throttle stop screw until throttle valve is closed tightly.

(7) Install metering rod gage, allowing the metering rod pivot pin on the lever to rest on the gage, metering rod gage, Chevrolet part number 600996.

(8) Bend connector rod at throttle valve end until connector rod will enter hole in the lever freely.

(9) Remove metering rod gage. Assemble metering rod and metering rod hole cover washer. Install metering rod anti-rattle spring. Install connector rod and readjust the throttle stop screw three-quarters turn after contacting stop to open throttle valve slightly.

c. Replacement. When carburetor fails to function properly and does not respond to minor adjustments, replacement should be made following the procedure indicated:

(1) Remove air cleaner.

(2) Disconnect control linkage and choke cable.

(3) Disconnect fuel line at carburetor, using $\frac{9}{16}$ -inch and $\frac{1}{2}$ -inch open-end wrenches.

(4) Remove the two carburetor mounting stud nuts, using a $\frac{9}{16}$ -inch open-end wrench.

(5) Lift carburetor from manifold.

(6) Replace unit and refer to paragraph on adjustments.

136. AIR CLEANER.

a. Description. The air which is taken into the carburetor to mix with the fuel is thoroughly cleaned in passing through an air cleaner of the oil bath type. This cleaner is filled to the oil level mark with an oil of not less than SAE 50 viscosity in summer months and a lighter oil in winter. Viscosity of the oil used in winter months will be governed by the temperature.

b. Maintenance.

(1) **TOOLS REQUIRED:**

Pan, parts washing

Screwdriver, 5 $\frac{1}{2}$ -in.

(2) Servicing of this cleaner is an important operation and must be

FUEL SYSTEM

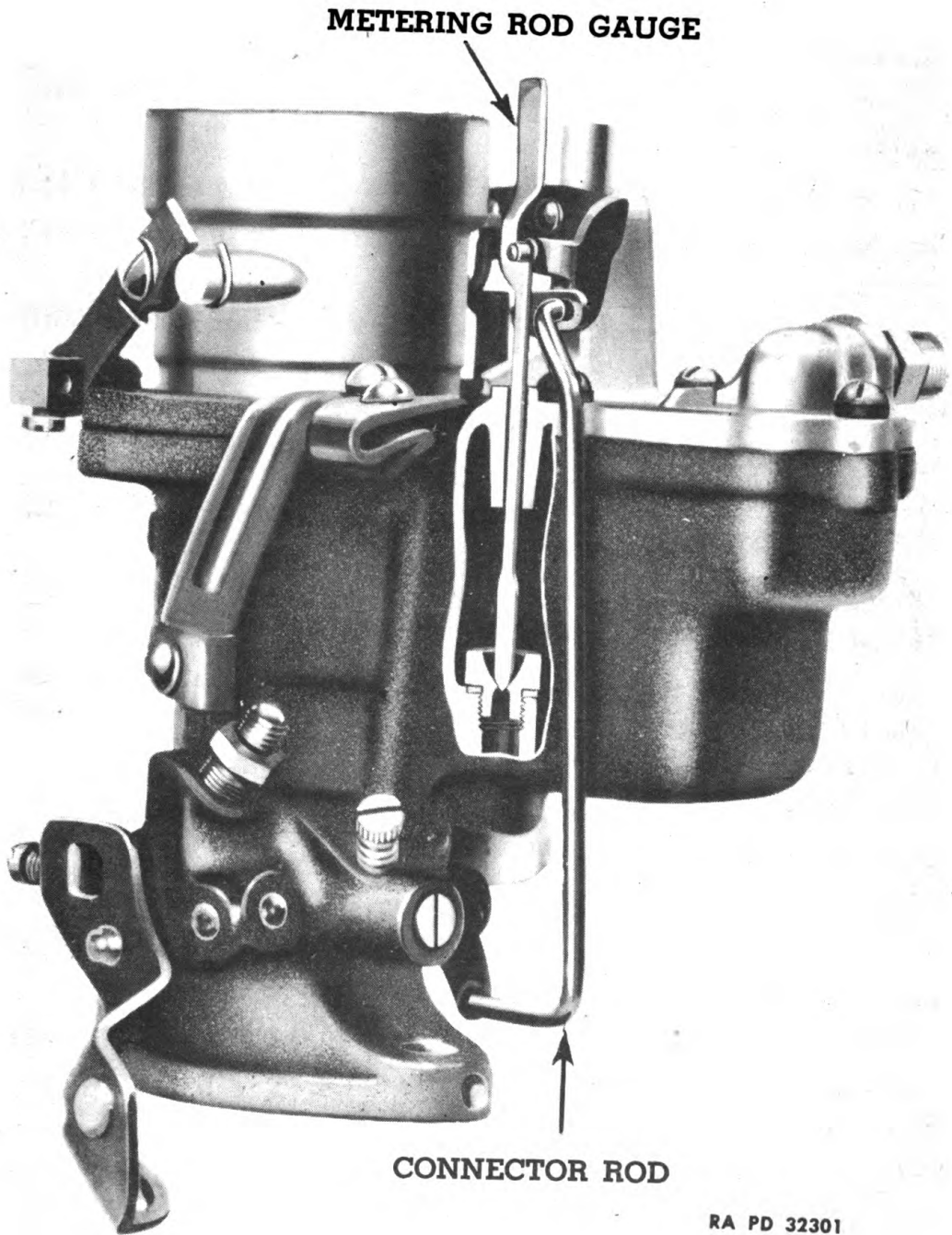

Figure 101—Metering Rod Adjustment

BOMB SERVICE TRUCK M6 (Chevrolet)

performed as follows: Remove the air cleaner from the carburetor. Remove the wing nut from the top and remove the cover. Remove the filter element assembly. **CAUTION:** Do not pry this part loose if it sticks. It must be removed by hand because you may damage the filter element flange, which must lie flat against the body to insure a tight seat at this point to prevent air leaks when the cover is assembled.

(3) Empty the oil out of the cleaner and clean out all oil and accumulated dirt.

(4) Wash body with clean **SOLVENT**, dry cleaning, and wipe dry.

(5) Wash filter element by slushing up and down in **SOLVENT**, cleaning.

(6) Dry thoroughly either with an air hose or by letting it stand until dry.

(7) Fill the body of the cleaner with two pints of **OIL**, engine, **SAE 50**.

(8) It is not necessary to reoil the filter element as this is done automatically when the truck is driven.

(9) Reassemble the filter element to the body of the cleaner, being sure that the flange sets flat against the top flange of the body.

(10) Reassemble the cover, making sure that the gasket is clean and in good condition over its entire surface so that a tight seat is obtained at this point. Put on wing nut.

(11) Reassemble the cleaner to the carburetor. The cleaner must be put on tight and set down so that it rests against the carburetor to assure a good seat at this point. Tighten clamp.

Section XXV

INSTRUMENTS AND GAGES

	Paragraph
Instrument cluster	137
Temperature indicator	138
Fuel gage	139
Oil pressure gage	140
Ammeter	141
Speedometer	142

137. INSTRUMENT CLUSTER (fig. 102).

The instrument cluster includes a temperature indicator, fuel gage, oil pressure gage, ammeter and speedometer.

138. TEMPERATURE INDICATOR.

a. The driver should watch this instrument closely for any indication of excessive temperature. If indicator does not register, replace with new unit.

b. Replacement.

(1) TOOLS REQUIRED:

Wrench, open-end, $\frac{3}{8}$ -in.

Wrench, open-end, $\frac{3}{4}$ -in.

(2) Drain cooling system and remove temperature indicator fitting at adapter at rear of motor, using a $\frac{3}{4}$ -inch open-end wrench, and remove indicator from dash, using a $\frac{3}{8}$ -inch wrench. Replace with new unit.

139. FUEL GAGE.

a. The gasoline gage is composed of four units: the indicating unit which is mounted on the instrument panel, a tank unit mounted in the main gasoline tank, a tank unit mounted in the auxiliary gasoline tank, and a selector switch mounted on the instrument panel. This circuit is shown in figure 103. The electrical current that operates these instruments passes through the ignition switch and therefore the gasoline gage will operate only when the ignition switch is on.

b. If trouble is experienced with either the tank or dash unit, replacement of the unit is the only remedy.

BOMB SERVICE TRUCK M6 (Chevrolet)

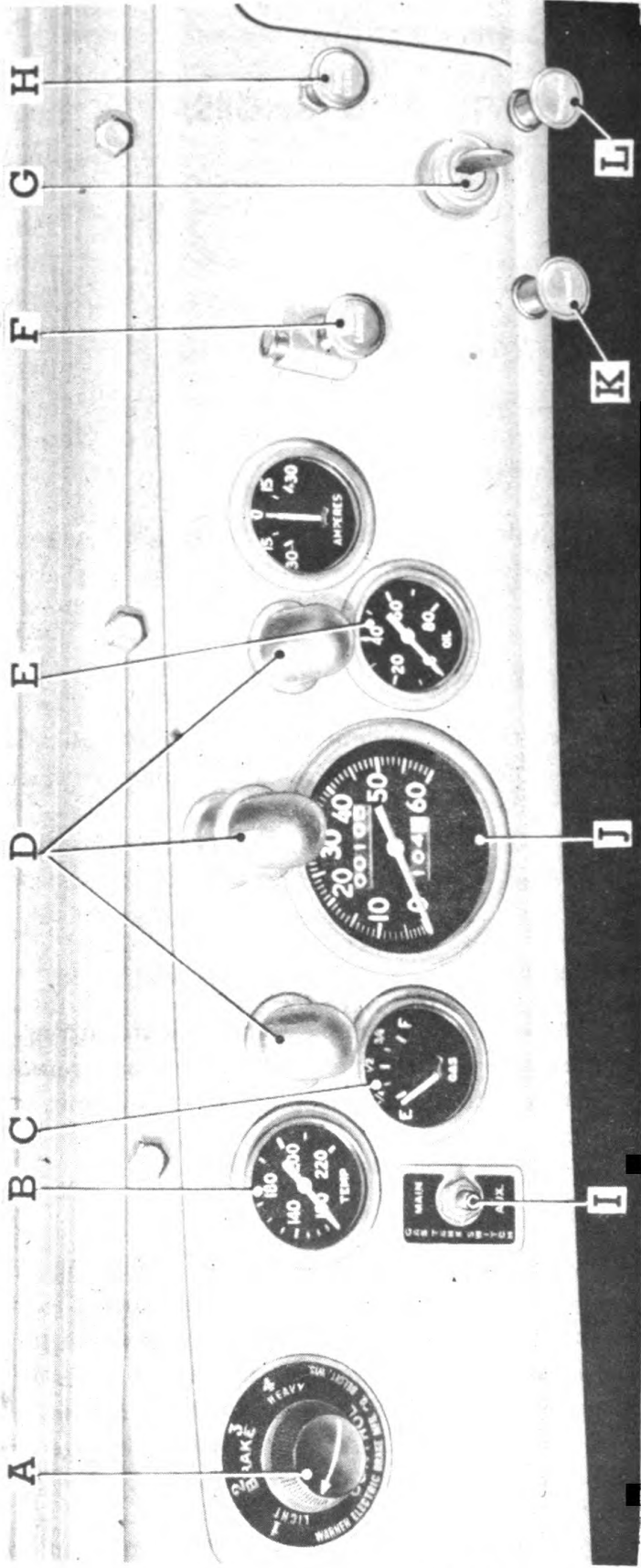

- A — TRAILER ELECTRIC BRAKE LOAD CONTROL
- B — TEMPERATURE INDICATOR
- C — FUEL GAGE
- D — PANEL LIGHTS
- E — OIL PRESSURE GAGE
- F — LIGHTING SWITCH
- G — IGNITION SWITCH
- H — PANEL LIGHT SWITCH
- I — FUEL GAGE GAS TANK SELECTOR SWITCH
- J — SPEEDOMETER
- K — CARBURETOR CHOKE
- L — HAND THROTTLE

Figure 102—Instrument Panel

RA PD 32302

INSTRUMENTS AND GAGES

c. Testing.

(1) TOOLS REQUIRED:

Screwdriver

Tester, gas gage, KMO-204 (KM) Wrench, open-end, $\frac{3}{8}$ -in.

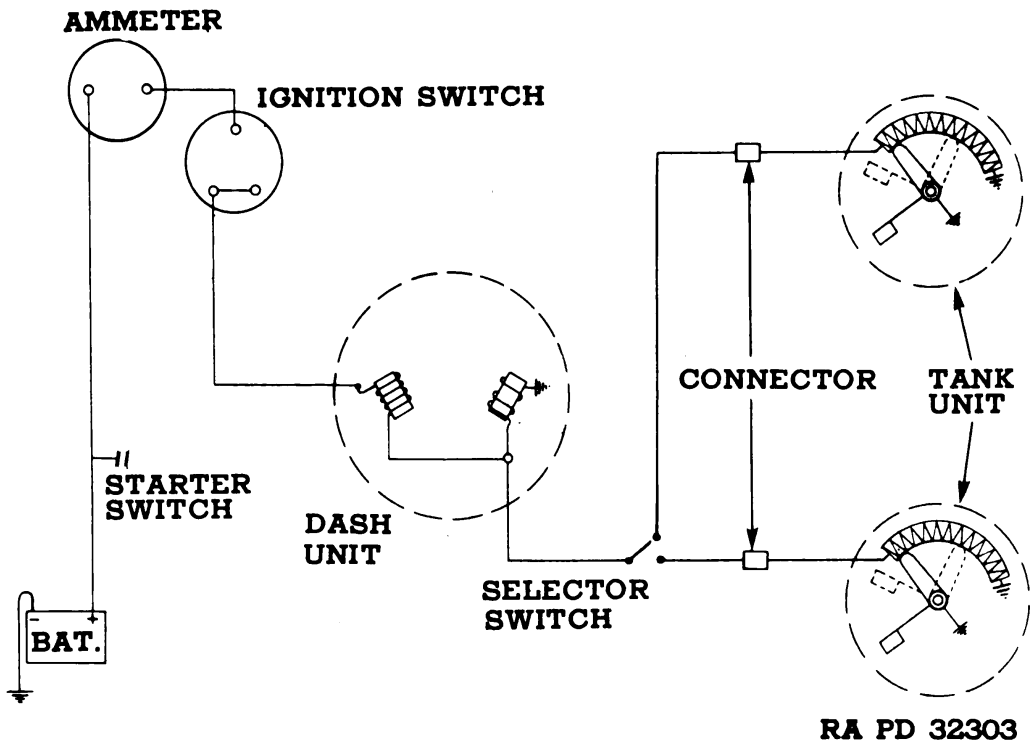

Figure 103—Fuel Gage Circuits

(2) The following is a procedure for locating trouble in the gasoline gage, using KMO-204 gas gage tester.

(3) With ignition switch off, disconnect tank wire from back of dash unit. This is the larger terminal.

(4) Attach the RED wire of the tester to this terminal and BLACK wire to a good ground.

(5) Turn ignition switch on, move tester arm up and down. Dash unit should register FULL and EMPTY, if it is all right. If so, turn ignition switch off and reconnect tank wire.

(6) If dash unit does not register at all on above test, before replacing it make certain that it is getting current from the ignition switch. This can be quickly tested by connecting a 6-volt lamp from ignition terminal (left-hand terminal on back of dash unit) to ground.

BOMB SERVICE TRUCK M6 (Chevrolet)

(7) If dash unit is all right, next check the wiring between dash and tank units as follows:

(8) Disconnect tank unit wire near the gas tank at the connection or terminal junction block.

(9) Attach the **RED** wire of the tester to the connection running to the dash and the **BLACK** wire to ground.

(10) If on this test dash unit reads **EMPTY** at all times or the reading is noticeably lower than during the check at the dash unit, look for shorts or leaks in the wiring between dash and tank. Leaks are most liable to occur at terminal junctions. If dash unit reads above **FULL** at all times or if it reads higher at **EMPTY** and **FULL** than reading obtained when checking at the dash, look for poor connection or break in the wiring. Be sure contacts are clean.

(11) If dash unit and wiring check all right, remove tank and take out tank unit. Clean away all dirt that has collected around tank unit terminal, as road dirt, particularly calcium chloride, causes an electrical leak that will cause an error in reading.

(12) After cleaning thoroughly, connect tank unit to the wire leading to dash, grounding the tank unit with a short piece of wire from the outer edge to any part of the truck. Turn ignition switch on and move the float arm up and down. If this unit is all right, the dash unit will give corresponding **EMPTY** and **FULL** readings.

(13) If tank unit is all right, reinstall in the tank; if not, replace with a new tank unit but first repeat above test before installing in the tank.

(14) **NOTE:** Always check tank units for freedom of movement of the float arm by raising it to various positions and observing that it will fall to the **EMPTY** position in every instance.

140. OIL PRESSURE GAGE.

a. The gage indicates the oil pressure in the lubrication system. The driver should watch this instrument closely and if the indicator hand drops to zero, the engine should be stopped immediately and the cause of oil pressure failure investigated and corrected before continuing to run the engine.

(1) When starting a cold engine, it will be noted that the oil gage on the instrument panel registers a high oil pressure. As the engine warms up, the pressure will drop until it reaches a point where changes to higher speeds will raise the pressure very little if at all.

INSTRUMENTS AND GAGES

(2) If the oil pressure registers abnormally high after the engine is thoroughly warmed up, an inspection should be made to ascertain whether the oil lines and passages are plugged. If indicator hand does not leave zero or does not return to zero and oil pressure is all right, replace pressure gage.

h. Replacement.

(1) TOOLS REQUIRED:

Wrench, open-end, $\frac{3}{8}$ -in.

Wrench, open-end, $\frac{9}{16}$ -in.

(2) Disconnect pressure line at gage; loosen and remove mounting screws; remove instrument from rear and replace with new one.

141. AMMETER.

a. Description. The electro-magnetic type ammeter is used to indicate whether the battery is being charged or discharged when the vehicle is in operation. If the ammeter shows discharge at all times, the cause should be investigated and corrected; otherwise the battery will be discharged. After electrical system has been checked and ammeter found not registering, it should be replaced.

h. Replacement.

(1) TOOLS REQUIRED:

Wrench, open-end, $\frac{3}{8}$ -in.

(2) Disconnect wires at terminals and loosen and remove mounting nuts, using a $\frac{3}{8}$ -inch open-end wrench. Remove instrument to front and replace with new one.

142. SPEEDOMETER.

a. Description. The speedometer indicates the speed at which the vehicle is being driven. The odometer registers the total number of miles the vehicle has been driven. The speedometer is driven by a flexible drive cable which is connected into the transfer case.

BOMB SERVICE TRUCK M6 (Chevrolet)**b. Replacement.****(1) TOOLS REQUIRED:**

Jack

Pliers

(2) Jack up one rear wheel of vehicle and with transfer case in rear wheel drive only, start engine and shift transmission into gear. Disconnect speedometer housing at head and check to see if cable is turning. If cable does not turn, trouble is at gears, or cable is broken, but if cable turns, trouble is in speedometer and unit should be replaced. Remove cable housing from speedometer head using pliers. Loosen and remove wing nuts; remove instrument from front and replace with new one.

Section XXVI

PROPELLER SHAFTS

	Paragraph
Description—propeller shaft	143
Description—universal joints	144
Trouble shooting	145
Propeller shaft assembly removal	146
Propeller shaft assembly overhaul	147
Propeller shaft assembly replacement	148

143. DESCRIPTION—PROPELLER SHAFT.

a. Three tubular propeller shafts are used on the bomb service truck. One shaft provides the drive line from the transmission to the transfer case, one from the transfer case to the rear axle and the third from the transfer case to the front axle. The propeller shafts from the transfer case to the front and rear axles are dimensionally the same and are therefore interchangeable. The drive line is shown in figure 104.

b. Each of these three shafts has a splined end welded into one end of the shaft. This provides a means of installing a slip joint. The other end of the shaft has a universal joint yoke welded into it. These three shafts, when fitted with the permanent and slip type universal joints, make up the drive shaft assemblies.

144. DESCRIPTION—UNIVERSAL JOINTS.

The six universal joints are of the needle bearing type (fig. 105). The yokes have drilled passages to the trunnions, and a central lubrication fitting on each yoke provides lubricant to all four trunnion bearings. A special adapter is furnished with the tool kit, which should be placed on the lubrication gun for lubricating these joints. On the yoke, opposite the lubrication fitting, a relief valve is used to prevent overlubrication and damage to the cork trunnion bearing seals. Each of the three slip joints is fitted with a lubrication fitting on the splined yoke to provide sufficient lubricant to assure free movement of the slip joint on the spline. A plug is staked in the joint end of the splined yoke to retain the lubricant and keep dirt out of the splines. A small hole is drilled in the plug to relieve trapped air. A cork seal and screw cap is used at the other end of the splined yoke to retain the lubricant and prevent dirt from entering at this point (fig. 106).

BOMB SERVICE TRUCK M6 (Chevrolet)

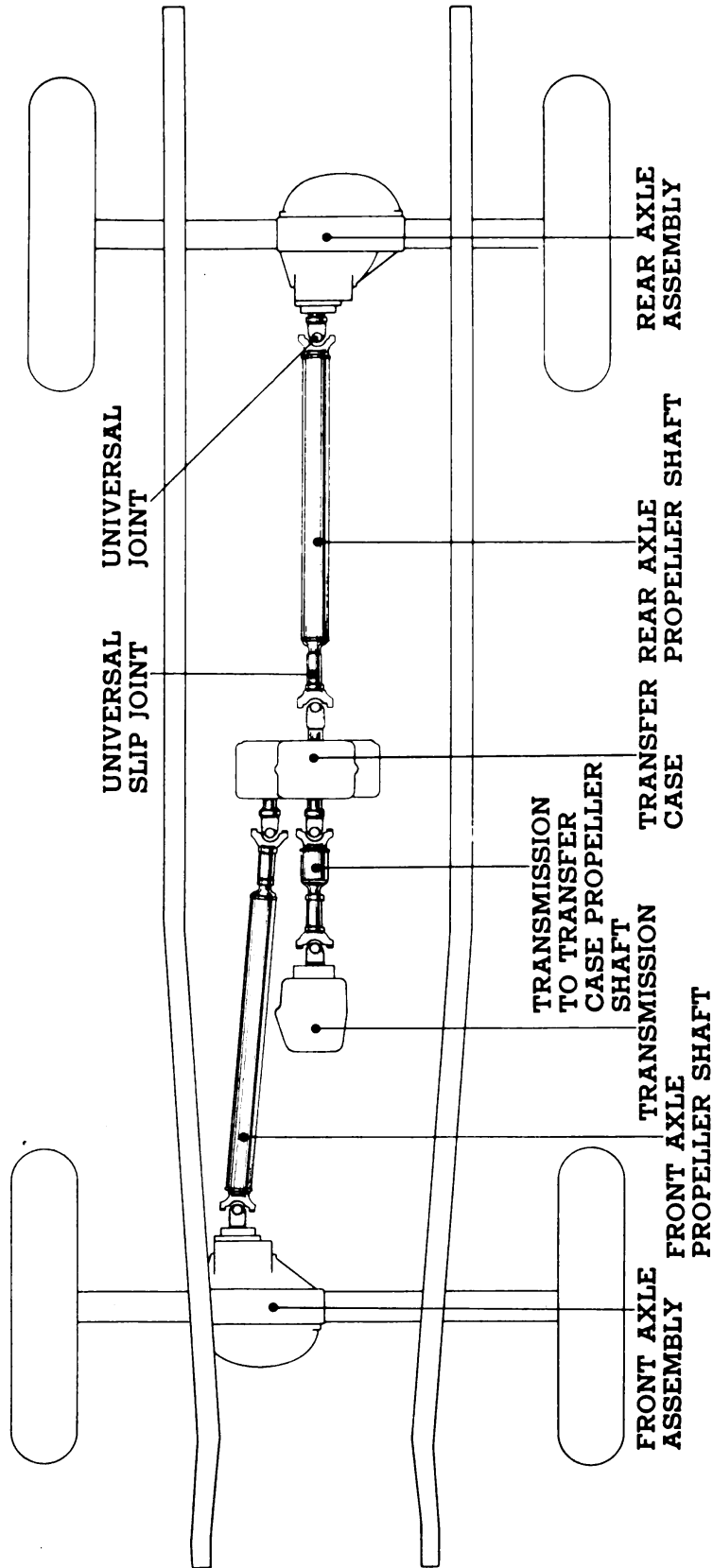

RA PD 32304

Figure 104—Propeller Shaft Drive Line

PROPELLER SHAFTS

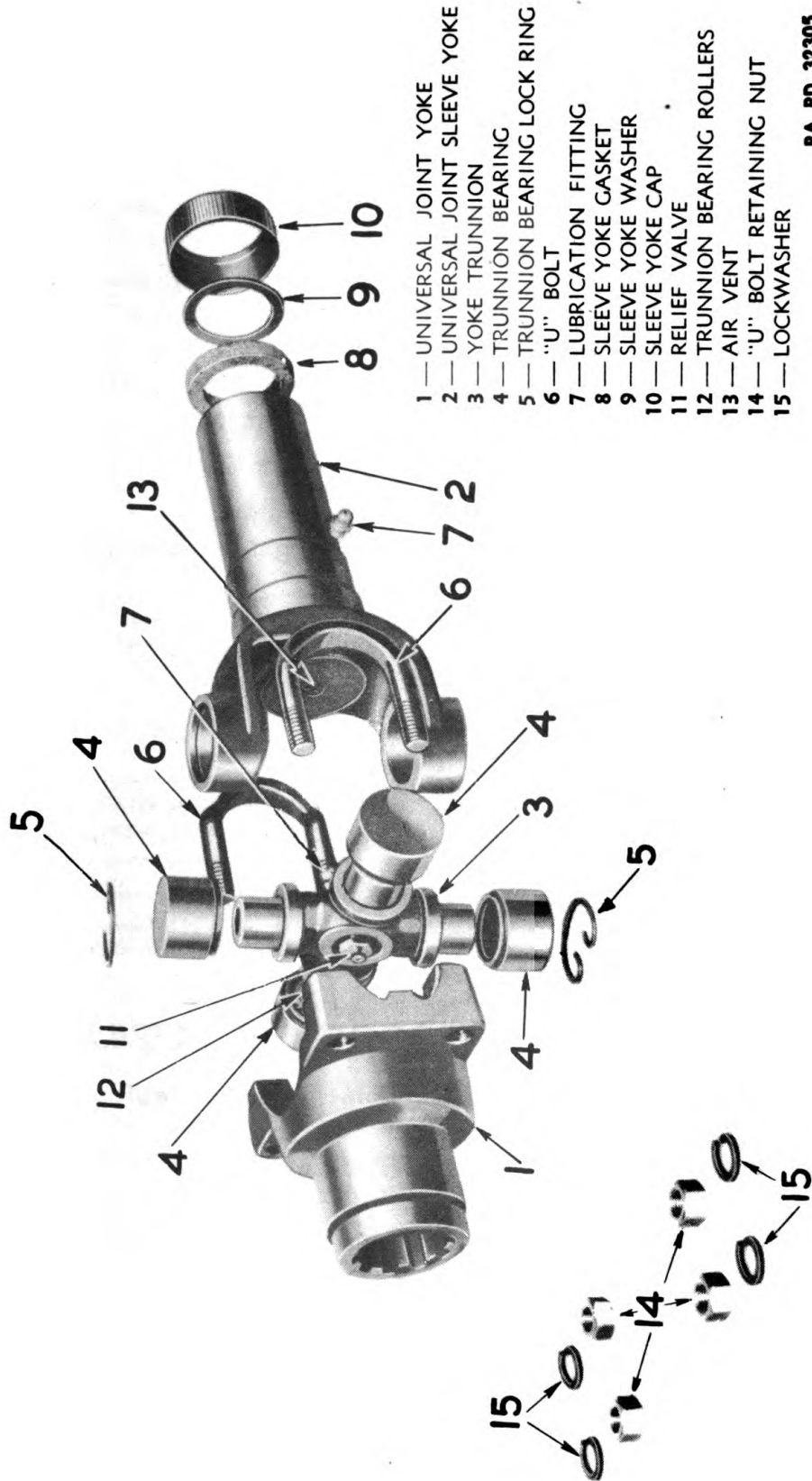

- 1 — UNIVERSAL JOINT YOKE
- 2 — UNIVERSAL JOINT SLEEVE YOKE
- 3 — YOKE TRUNNION
- 4 — TRUNNION BEARING
- 5 — TRUNNION BEARING LOCK RING
- 6 — "U" BOLT
- 7 — LUBRICATION FITTING
- 8 — SLEEVE YOKE GASKET
- 9 — SLEEVE YOKE WASHER
- 10 — SLEEVE YOKE CAP
- 11 — RELIEF VALVE
- 12 — TRUNNION BEARING ROLLERS
- 13 — AIR VENT
- 14 — "U" BOLT RETAINING NUT
- 15 — LOCKWASHER

RA PD 32305

Figure 105—Universal Joint

BOMB SERVICE TRUCK M6 (Chevrolet)

145. TROUBLE SHOOTING.

Symptom	Probable remedy
a. Vibration.	
(1) Bent propeller shaft.	(1) Replace shaft.
(2) Shaft improperly assembled.	(2) It is important that the slip joint be installed on the splines of the propeller shaft with the sleeve yoke in the same plane as the yoke welded to the opposite end of the shaft.
(3) Universal joints badly worn.	(3) Replace or overhaul universal joints.
b. Excessive Backlash.	
(1) Worn universal joints.	(1) Replace.
(2) Universal joint U clamps loose.	(2) Tighten U clamps.

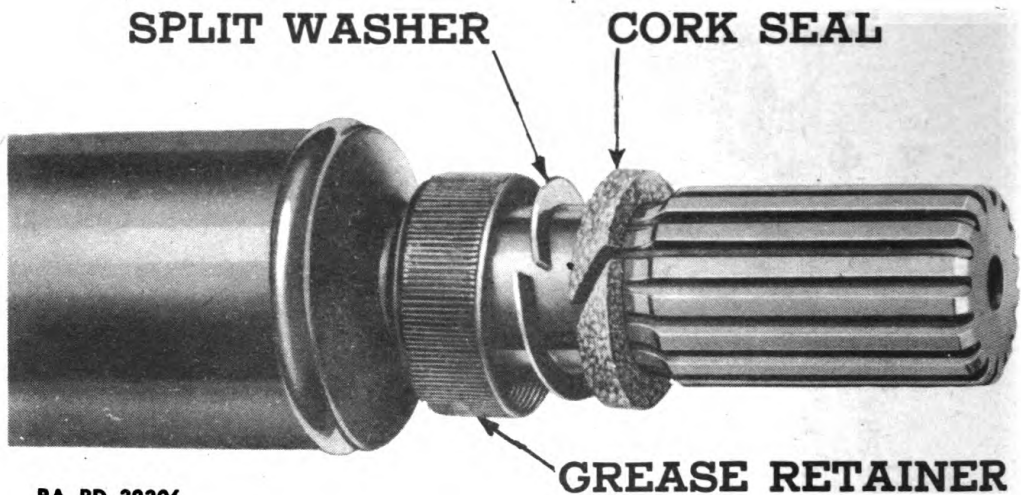

Figure 106—Universal Slip Joint Lubricant Seal

146. PROPELLER SHAFT ASSEMBLY REMOVAL.

a. Tool Required:

Wrench, open-end, $\frac{9}{16}$ -in.

b. Any one of the three propeller shafts may be removed by removing the nuts and washers from the U clamps on both joints and removing the clamps (fig. 107).

c. Remove the U clamp nuts and remove lockwashers and U clamps.

d. Slip the spline joint onto the shaft and pull the assembly out.

PROPELLER SHAFTS

NOTE: It is good practice when splitting these needle bearing universal joints to leave the bearings on the trunnions, holding them in place with a piece of tape wrapped endwise over the bearings and trunnions. This will keep the needle bearings clean and in place (fig. 108).

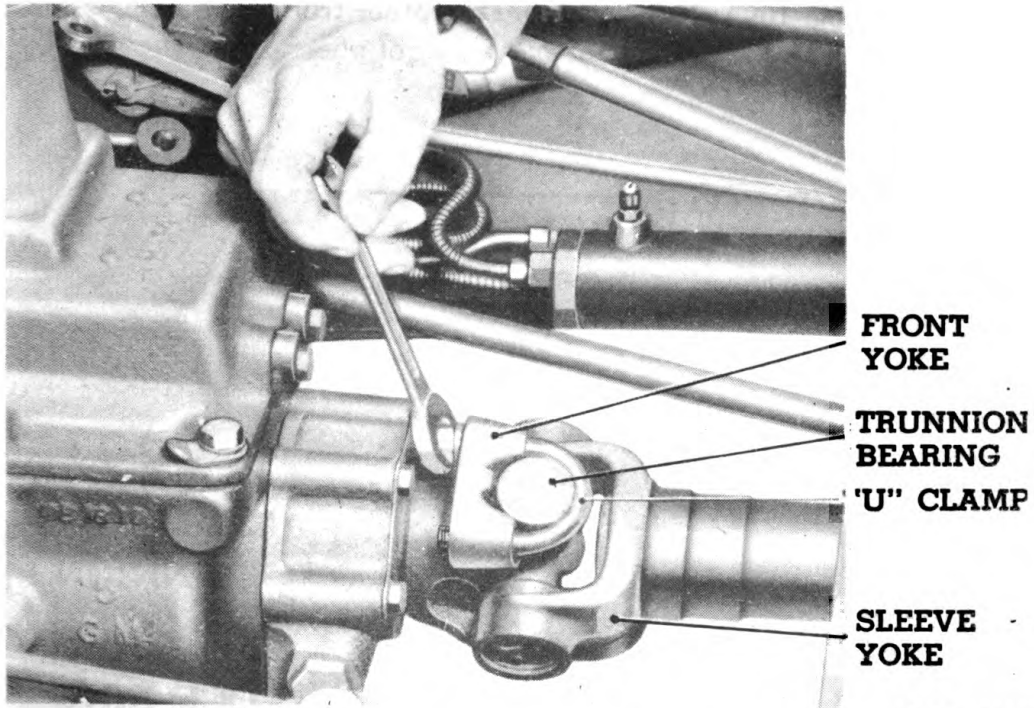

Figure 107 – Disconnecting Universal Joint

RA PD 32307

147. PROPELLER SHAFT ASSEMBLY OVERHAUL.

a. Disassembly.

(1) TOOLS REQUIRED:

Drift, brass, $\frac{3}{4}$ -in.

Hammer

Pliers, combination, 6-in.

Wrench, chain grip, J-987 (KM)

Wrench, open-end, $\frac{7}{16}$ -in.

(2) The slip joint may be disassembled from the propeller shaft by unscrewing the seal retainer with a chain grip wrench and pulling the universal joint assembly off the splines on the propeller shaft.

(3) When necessary to replace a cork seal in the grease retainer, push it out of the retainer and as it is split (fig. 106), it may be removed from the propeller shaft.

(4) Remove the two loose trunnion bearings which were taped in place when splitting the universal.

(5) Remove the lubrication fitting with a $\frac{7}{16}$ -inch open-end wrench.

BOMB SERVICE TRUCK M6 (Chevrolet)

(6) Remove the two trunnion bearing lock rings from the ends of the yoke with 6-inch combination pliers.

(7) Clamp the yoke in a bench vise; using a brass drift and hammer, drive on one of the trunnion bearings until the trunnion just strikes the lower yoke (fig. 109). This will drive the other trunnion bearing almost out. It can be carefully removed with a pair of pliers.

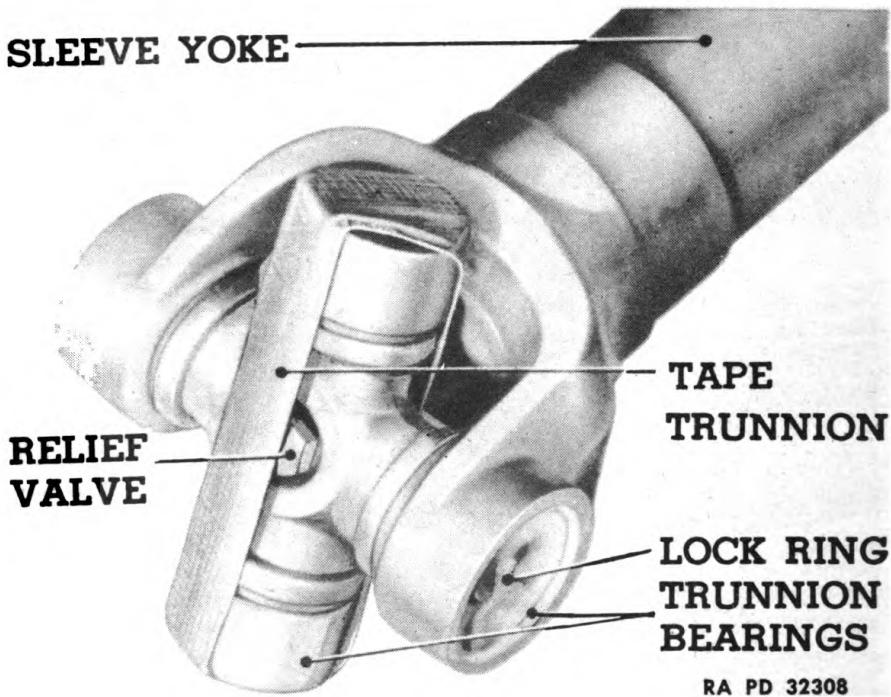

Figure 108—Trunnion Bearings Held in Place with Tape

(8) Turn the yoke over, clamp the other side in the vise and drive on the end of the trunnion pin until the other bearing is removed.

(9) Slide the trunnion into one side of the yoke and tip the other side away from the yoke and lift it out of place.

b. Cleaning and Inspection.

(1) Wash all parts in SOLVENT, dry cleaning.

(2) Inspect the needle bearing, bearing cage, trunnion cork seal and splines for wear.

(3) Replace all damaged parts.

PROPELLER SHAFTS

c. Reassembly.

- (1) Assemble the 27 needle bearings to each bearing cage, using light cup grease to hold them in place.
- (2) Install the trunnion in the yoke.

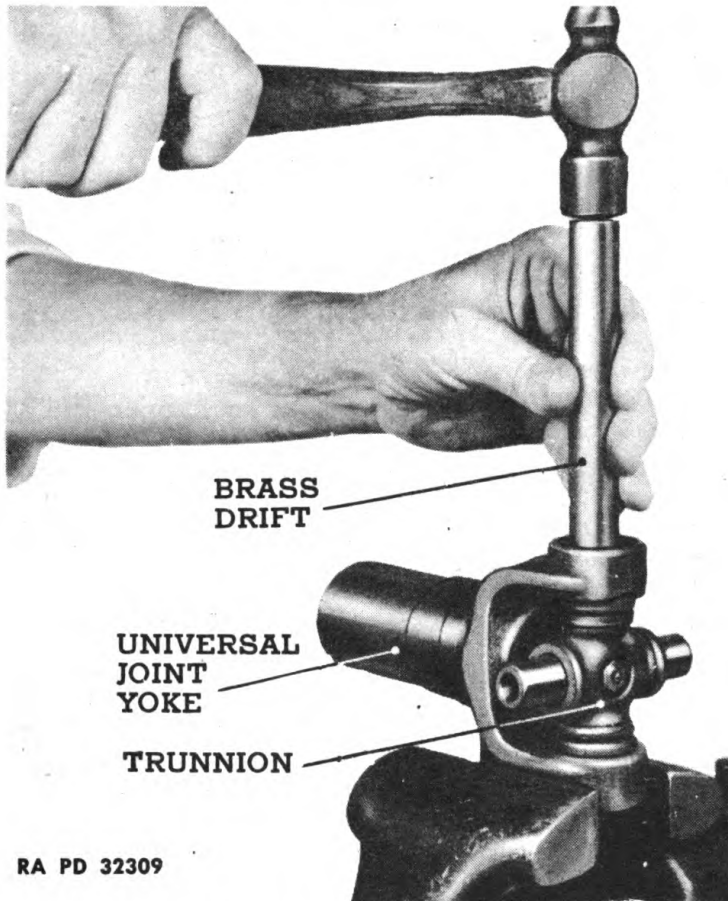

Figure 109—Trunnion Removal

- (3) Start one trunnion bearing into the yoke and start the yoke into the bearing to hold the needle bearings in place.
- (4) Using the bench vise as a press, force the bearing in flush with the yoke.
- (5) Start the other trunnion bearing into the yoke and enter the trunnion pin into it to hold the needles in place and press the bearing in flush with the yoke.
- (6) Drive or press one trunnion bearing in far enough to install the lock ring.
- (7) Drive or press the other bearing in and install the lock ring with a pair of pliers.

BOMB SERVICE TRUCK M6 (Chevrolet)

(8) Hold the joint in one hand and strike the yoke a light blow on each side to seat the trunnion bearings against the lock rings.

(9) Check to see that the bearings are seated against the lock rings as this provides normal clearance and prevents overheating.

(10) Install the slip joint onto the propeller shaft, making sure that the yoke of the slip joint is in the same plane with the yoke of the joint welded in the opposite end of the shaft. Install and tighten the oil seal retainer with the chain grip wrench.

(11) Install the four loose trunnion bearings to the trunnions and tape them to hold them in place.

148. PROPELLER SHAFT ASSEMBLY REPLACEMENT.

a. Tools Required:

Gun, grease

Wrench, open-end, $\frac{9}{16}$ -in.

b. Place the propeller shaft assembly in position under the truck.

c. Remove the tape from the trunnion bearings on one joint; install the U clamps, washers, and nuts and tighten.

d. Remove the tape from the trunnion bearings on the other joint and slide the joint into place.

e. Install U clamps, lockwashers, and nuts. Tighten securely with a $\frac{9}{16}$ -inch wrench.

f. See section IV for lubrication of universal joints.

Section XXVII

CHASSIS SHEET METAL

	Paragraph
Description	149
Front end sheet metal ASSEMBLY removal	150
Front end sheet metal ASSEMBLY replacement	151
Front fender removal	152

149. DESCRIPTION.

a. The major parts covered in this section are front and rear fenders, running boards, hood, and hood side panels.

b. To facilitate manufacturing and service operations, the radiator core, radiator shell, radiator guard, radiator support, fan shroud, front fenders, head lamps, and their bracings are assembled into a unit. This unit is called the front and sheet metal assembly.

c. This assembly is attached to the front frame cross member at the front and to the running boards and cowl at the rear.

d. Diagonal braces running from a bracket on each side of the radiator support to the front end of the side sill assembly adequately brace the radiator support. The radiator support is attached to the frame cross member through a rubber mounting. This method of mounting prevents frame distortions from being transmitted to the front end sheet metal assembly when the vehicle is being driven over uneven terrain. Removing this assembly provides access to the engine for removal or major service operations.

150. FRONT END SHEET METAL ASSEMBLY REMOVAL.

a. Tools Required:

- | | |
|---------------------------------------|--------------------------------------|
| Screwdriver | Wrench, open-end, $\frac{5}{8}$ -in. |
| Wrench, open-end, $\frac{7}{16}$ -in. | Wrench, open-end, $\frac{7}{8}$ -in. |
| Wrench, open-end, $\frac{1}{2}$ -in. | Wrench, open-end, $\frac{1}{2}$ -in. |
| Wrench, open-end, $\frac{9}{16}$ -in. | |

b. Remove the hood brace rod anchor screws at the cowl and the hood hinge pins with a screwdriver, and remove the hood.

c. Remove the hood side panels with a $\frac{7}{16}$ -inch open-end wrench and screwdriver.

BOMB SERVICE TRUCK M6 (Chevrolet)

d. With a $\frac{7}{16}$ -inch wrench disconnect the radiator brace rod from the radiator support and disconnect it from the cowl with a $\frac{5}{8}$ -inch wrench. Remove the brace rod.

e. Drain the cooling system and remove drain cock.

f. With a screwdriver disconnect the radiator hose at top and bottom of radiator.

g. Disconnect the electrical wiring at the junction block on each side and the blackout wires at bayonet connectors.

h. With a screwdriver and $\frac{1}{2}$ -inch open-end wrench remove the fender to running board and fender to cowl bolts on each side.

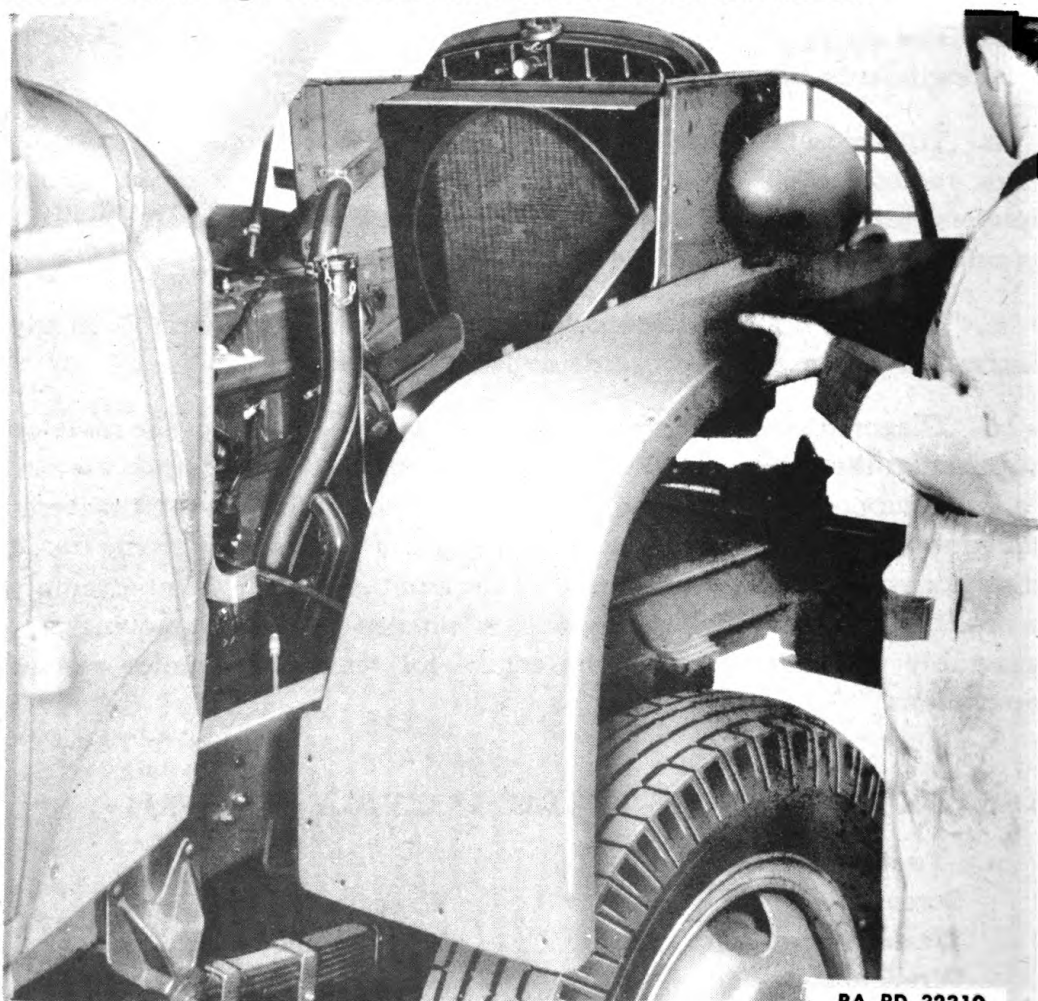

Figure 110—Front End Sheet Metal Removal

i. With $\frac{7}{8}$ -inch and $1\frac{1}{8}$ -inch open-end wrenches remove the bolts which attach the radiator support diagonal braces to the frame.

j. Using a $\frac{5}{8}$ -inch wrench remove the nuts from the lower radiator anchorage to frame cross member bolts and remove the bolts.

CHASSIS SHEET METAL

k. Slide the front end sheet metal assembly forward until the fan shroud clears the fan blades and then lift the assembly off the chassis (fig. 110).

l. If any of the individual items of this assembly require repairs or replacement they can be removed from the assembly very easily.

151. FRONT END SHEET METAL ASSEMBLY REPLACEMENT.

a. **Tools Required:** Use tools listed in paragraph 150 a.

b. Place the sheet metal assembly on the frame and slide it back into position, making sure the shroud clears the fan to prevent damaging the fan, shroud, or radiator core.

c. Line up the holes in the radiator anchorage, rubber mounting, and frame cross member. Install the bolts and nuts, and with a $\frac{5}{8}$ -inch open-end wrench tighten the nuts.

d. Using a screwdriver and $\frac{1}{2}$ -inch wrench install and tighten the fender to cowl and fender to running board bolts.

e. Replace the electrical wiring at the junction blocks and bayonet connections.

f. Install the bolts which attach the diagonal braces to frame and with $\frac{7}{8}$ -inch and $\frac{1}{2}$ -inch wrenches tighten them securely.

g. Install the upper and lower radiator hose and clamps. Tighten the clamps securely.

h. Fill the cooling system and check for leaks.

i. Install the radiator brace rod and with a $\frac{7}{16}$ -inch wrench tighten the brace rod to radiator anchorage bolts. With a $\frac{5}{8}$ -inch wrench adjust and tighten the brace rod to cowl retaining nuts.

j. Using a $\frac{7}{16}$ -inch open-end wrench and screwdriver, install and tighten the hood side panels.

k. Replace the hood; install the hood hinge pins and hood brace rod to cowl screws.

152. FRONT FENDER REMOVAL.

a. **Tools Required:**

Screwdriver

Wrench, open-end, $\frac{7}{16}$ -in.

Wrench, open-end, $\frac{1}{2}$ -in.

Wrench, open-end, $\frac{9}{16}$ -in.

BOMB SERVICE TRUCK M6 (Chevrolet)

- b. Raise the hood and insert pin in hood brace to lock the hood up.
- c. Disconnect electrical wiring at junction block and blackout wire at bayonet connector.
- d. With a $\frac{7}{16}$ -inch end wrench and screwdriver remove the front and rear hood side panels.
- e. With a $\frac{1}{2}$ -inch end wrench and screwdriver remove the fender to running board and fender to cowl bolts.
- f. Using a $\frac{1}{2}$ -inch wrench remove the bolts which attach the fender to the radiator guard.
- g. Remove the fender and skirt assembly.
- h. The skirt may be removed from the fender by removing the stove bolts with a $\frac{9}{16}$ -inch wrench and screwdriver.
- i. For headlight removal, replacement, and adjustment see section **XX** of this manual.
- j. The fender replacement is the reverse of removal.

Section XXVIII

SPRINGS AND SHOCK ABSORBERS

	Paragraph
Description	153
Trouble shooting	154
Front springs	155
Rear springs	156
Spring shackles and attaching parts	157
Shock absorber	158

153. DESCRIPTION.

a. **Front Springs.** The eight leaf front springs are of the semielliptic type, 40 inches long and 2 inches wide. Bronze bushings are pressed into the eye at each end as a bearing for the shackle pin and eyebolt. A Berlin eye is formed at the rear of the second leaf as a safety measure in the event the top leaf should break. The spring is shackled at the front.

b. **Rear Springs.** The rear springs are also of the semielliptic type, having 10 leaves and being $45\frac{1}{2}$ inches long and $2\frac{1}{2}$ inches wide. Bronze bushings are pressed into the eye on each end as in the front springs. The spring is shackled at the rear.

c. **Shackles and Eyebolts.** The shackles at the front of the front springs and the rear of the rear springs are interchangeable as are the shackle pins, eyebolts, lock bolts and nuts.

d. **Shock Absorbers.** Double acting, opposed cylinder shock absorbers are used at the front and rear of the vehicle. They should be kept filled with light shock absorber fluid.

154. TROUBLE SHOOTING.

Symptom	Probable remedy
a. Hard Riding.	
(1) Insufficient lubrication.	(1) Lubricate.
(2) Broken shackle pin.	(2) Replace shackle pin.
(3) Broken spring eye.	(3) Replace spring.
(4) Broken spring hanger.	(4) Replace hanger.
(5) No shock absorber action.	(5) Refill or replace.
(6) Weak shock absorber valves.	(6) Replace shock absorber.
(7) Shock absorber leaks.	(7) Replace shock absorber.

BOMB SERVICE TRUCK M6 (Chevrolet)

NOTE: Overloading and uneven load distribution are possible causes of hard riding.

Symptom	Probable remedy
b. Over-flexibility.	
(1) Broken spring leaves.	(1) Replace spring.
(2) Excessive lubrication.	(2) Wash with solvent.
(3) Shock absorber low on fluid.	(3) Refill.
c. Improper Steering.	
(1) Wandering.	(1) Spring center bolt sheared and axle shifted. Replace center bolt and relocate in seat.
d. Excessive Noise.	
(1) Worn shackle pin.	(1) Replace shackle pin.
(2) Worn bushing.	(2) Replace bushing.
(3) Loose spring clips.	(3) Tighten clips.
(4) Broken spring eye.	(4) Replace spring.
(5) Broken leaves.	(5) Replace spring.
(6) Broken shackle pin.	(6) Replace shackle pin.

155. FRONT SPRINGS.

a. Spring Removal.

(1) TOOLS REQUIRED:

Hammer

Jack

Punch, 1/2-in.

Stand, jack

Wrench, open-end, 1 1/8-in.

Wrench, open-end, 1 1/16-in.

Wrench, open-end, 7/8-in.

(2) Raise front of truck and support at the frame with jack stand.

(3) Remove the lock bolt and nut from the eyebolt at the rear of the spring.

(4) Disconnect the rear end of the spring from the frame hanger by driving the pin (eyebolt) out of the hanger and spring eye.

(5) Remove the lock bolt and nut from the lower shackle pin at the front end of the spring.

(6) Drive out the shackle pin to disconnect the front end of the spring from the shackle.

(7) Remove the four U bolt nuts and lockwashers from the two U bolts retaining the center of the spring to the axle.

SPRINGS AND SHOCK ABSORBERS

(8) Move the shock absorber link and bracket that was disconnected from the top of the spring by the removal of the U bolts, up out of the way.

(9) The spring can now be lifted off the axle.

b. Spring Replacement.

(1) Place spring in position on the spring saddle, being sure that the safety eye on the second leaf is toward the rear of the truck.

(2) Place shock absorber bracket in position on top of the spring.

(3) Install U bolts, lockwashers and retaining nuts.

(4) Install pin at rear of spring and shackle pin at the front, being sure to line up the groove for the lock bolt. Install lock bolts and nuts.

(5) Lubricate the pins through fittings.

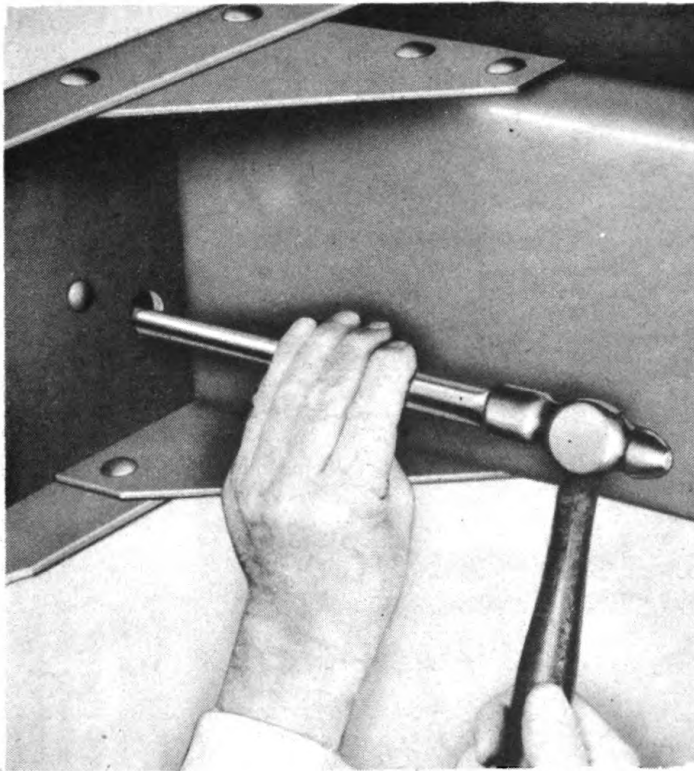

RA PD 32311

Figure 111—Shackle Pin Removal

156. REAR SPRINGS.

a. Spring Removal.

(1) TOOLS REQUIRED:

Hammer

Jack

Punch, 1/2-in.

Stand, jack

Wrench, open-end, 9/16-in.

Wrench, open-end, 1 1/8-in.

Wrench, open-end, 7/8-in.

BOMB SERVICE TRUCK M6 (Chevrolet)

- (2) Raise rear end of truck and support the frame with jack stand.
- (3) Remove lock bolt and nut from the eyebolt at the front of the spring.
- (4) Drive the pin out through the hole provided in the frame side rail (fig. 111). **NOTE:** When removing the pin from the right spring, it may be necessary to loosen the gas tank straps and slide the tank forward slightly to provide clearance between the back of the tank and the frame cross member.
- (5) Remove lock bolt from lower shackle pin at the rear of the spring.
- (6) Drive out the shackle pin.

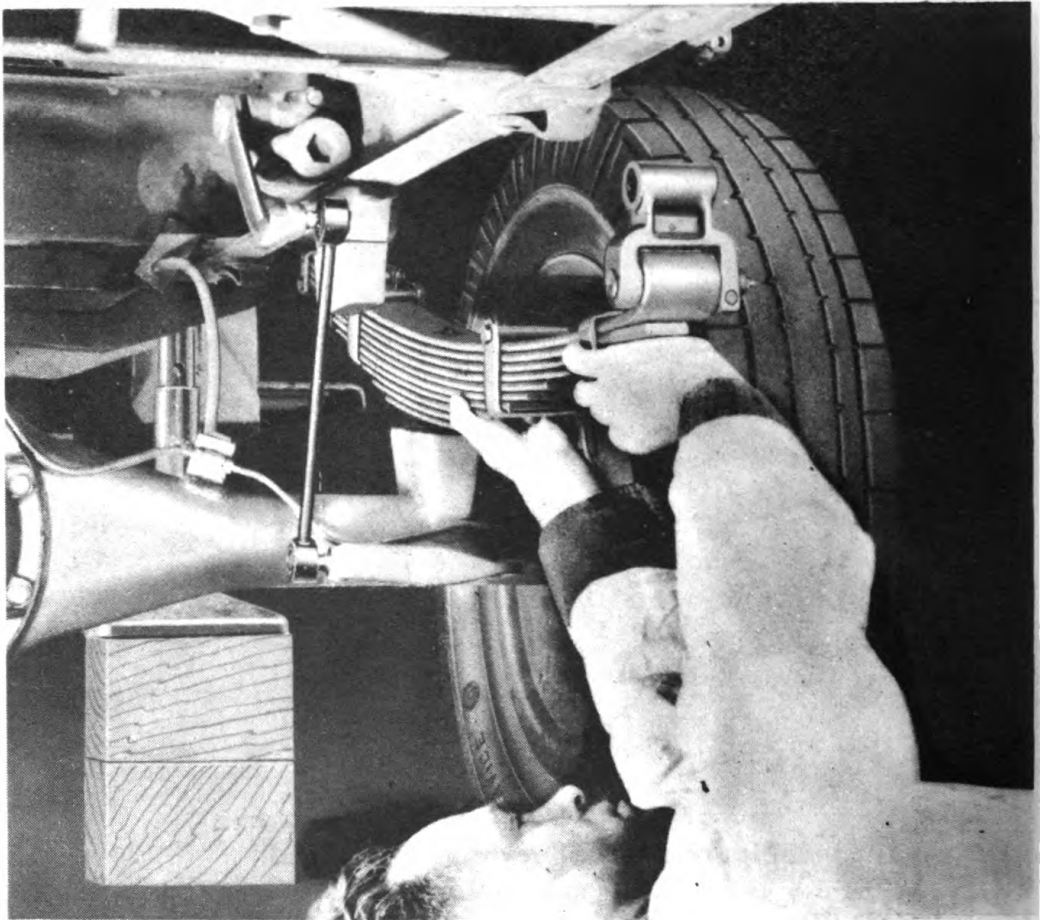

RA PD 32312

Figure 112—Installing Rear Spring

- (7) Disconnect the spring from its seat on the housing by removing the two U bolts.
- (8) Move shock absorber arm and link up out of the way.
- (9) Remove spring.

SPRINGS AND SHOCK ABSORBERS

c. Spring Replacement.

- (1) Place spring in position on axle seat aligning dowel pin with hole in seat (fig. 112).
- (2) Move shock absorber bracket into place and install the two U bolts, U bolt lockwashers and nuts.
- (3) Drive pin through frame hanger and eye at front of spring, lining up the lock bolt groove.
- (4) Install lock bolt.
- (5) Drive shackle pin into place at the rear of the spring and install lock bolt.

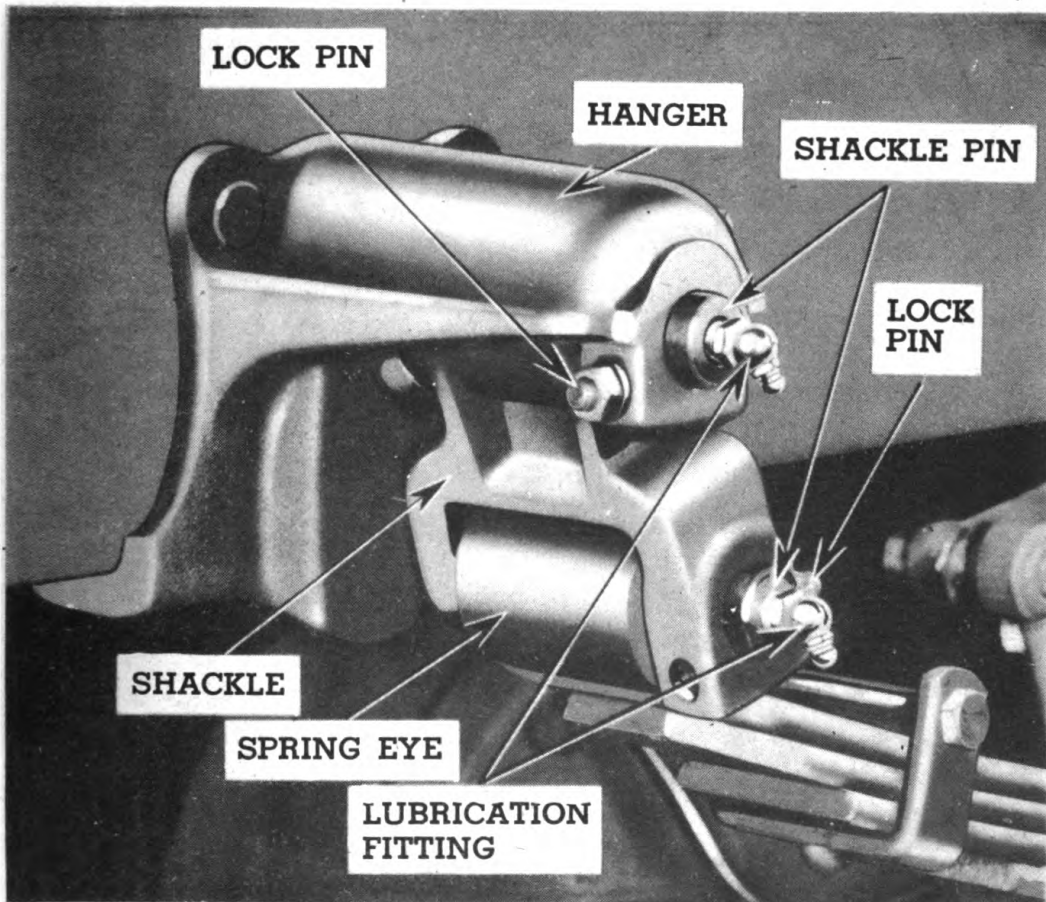

RA PD 32313

Figure 113—Spring Shackle

- (6) Lubricate pins and lower truck to ground. **NOTE:** Be sure to relocate gas tank and tighten straps if it was moved during right spring replacement.

BOMB SERVICE TRUCK M6 (Chevrolet)

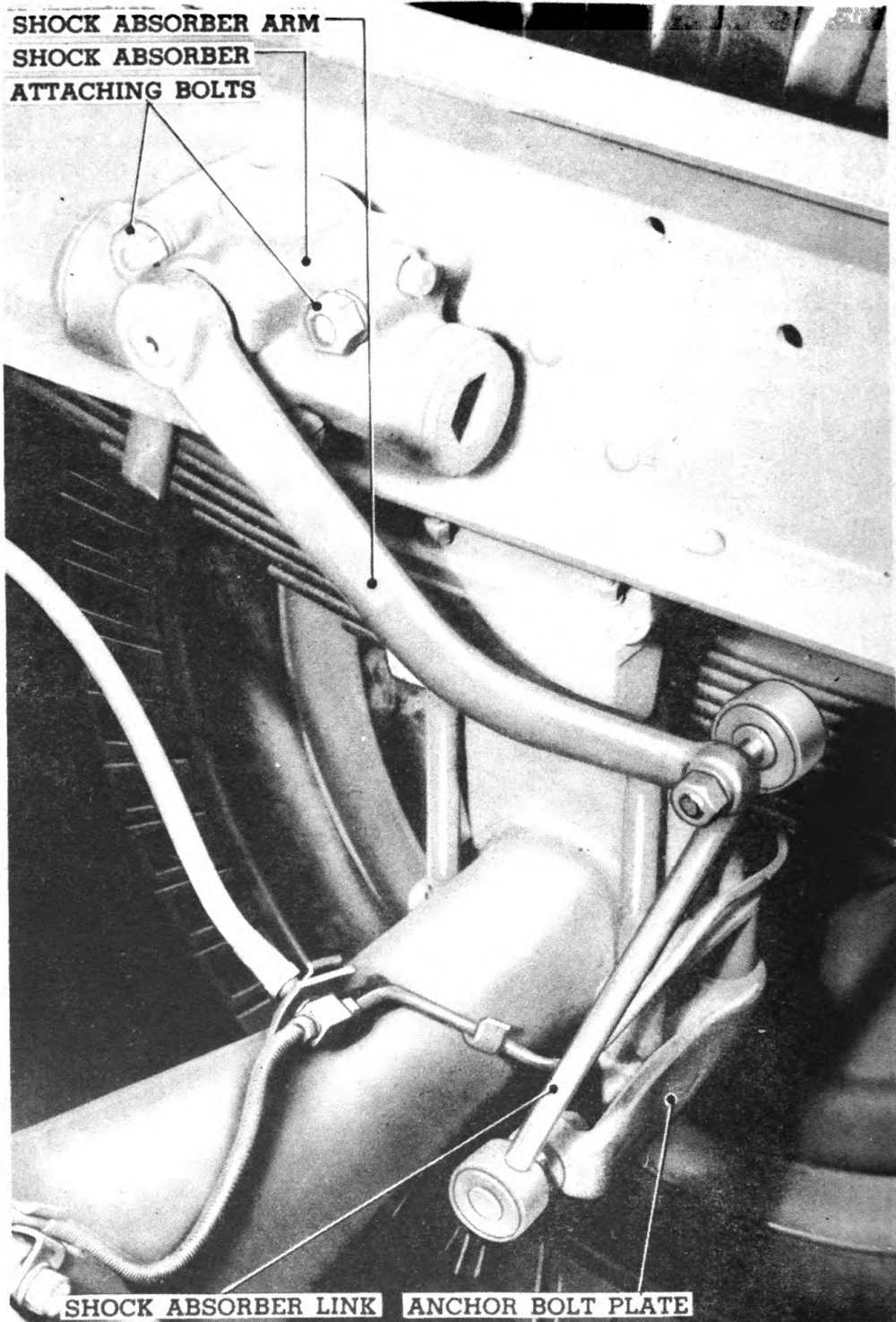

RA PD 32314

Figure 114—Shock Absorber

SPRINGS AND SHOCK ABSORBERS

157. SPRING SHACKLES AND ATTACHING PARTS (fig. 113).

a. Eyebolt Replacement.

(1) Replace eyebolt on front springs as outlined in paragraph 155 a (1) to (4).

(2) Replace eyebolt on rear springs as outlined in paragraph 155 a, (1) to (4)—Rear spring removal.

b. Shackle Replacement.

(1) Disconnect spring eye from shackle by removing lock bolt and driving the pin out as outlined in paragraphs 155 a, 156 a, (1), (2), (5) and (6) under Spring Removal.

(2) Remove lock bolt from upper shackle pin and drive the pin out through the opening provided in the frame.

(3) The shackle can now be removed from the frame hanger.

(4) To install a new hanger, reverse the removal procedure.

158. SHOCK ABSORBER (fig. 114).

a. Checking Operation.

(1) TOOLS REQUIRED:

Pliers

Wrench, open-end, $\frac{1}{8}$ -in.

(2) Remove nut and lockwasher from bottom of connecting link.

(3) Remove connecting link from anchor.

(4) Move connecting link up and down slightly to determine tightness of bushings or wear in link pins or link pin holes.

(5) Check link or bushing wear by twisting link with pliers or by prying link connection with screwdriver. Outward appearances of bushing or linkage will usually disclose excessive wear.

(6) Replace link if parts are faulty.

(7) Pull shock absorber arm down with a steady but hard pull. If arm comes down easily part way, then moves slowly the rest of the way, there is not enough fluid in the shock absorber. See d below.

(8) When operating properly, the shock absorber arm requires a steady hard push or pull to move the arm to top or bottom.

(9) If shock absorber does not operate as outlined in the above paragraph, replace the shock absorber.

BOMB SERVICE TRUCK M6 (Chevrolet)

- (10) Replace any shock absorber that leaks fluid. See **b** and **c** below.
- (11) If shock absorber "grunts" or is noisy, it should be replaced.

b. Removing Shock Absorber.**(1) TOOLS REQUIRED:**Wrench, open-end, $\frac{1}{8}$ -in.Wrench, open-end, $\frac{1}{16}$ -in.

- (2) Remove nut and lockwasher from lower end of shock absorber connecting link.
- (3) Remove connecting link from anchor.
- (4) Remove the two nuts and lockwashers from the shock absorber attaching bolts which are inside the frame channel.
- (5) Remove shock absorber.

c. Replacing Shock Absorber.**(1) TOOLS REQUIRED:**Wrench, open-end, $\frac{1}{8}$ -in.Wrench, open-end, $\frac{1}{16}$ -in.

- (2) Place shock in place on frame.
- (3) Install the two nuts and bolts on the shock absorber attaching bolts which are on the inside of the frame channel.
- (4) Install the connecting link in the anchor and install the nut and lockwasher.

d. To Fill Shock Absorbers With Fluid.**(1) TOOLS REQUIRED:**

Injector, fluid, KMO-1026 (KM)

Wrench, open-end, $\frac{1}{2}$ -in.

- (2) Clean all dirt from around filler plug.
- (3) Remove filler plug.
- (4) With fluid injector, fill to capacity with light shock absorber fluid.
- (5) Work arm up and down by bouncing car while adding fluid, or disconnect link at axle and operate arm up and down while filling. **CAUTION:** Shock absorber must not be filled completely full but approximately 10 percent air space must be provided, as over-filling may result in blowing out the cover gasket. After filling to capacity, extract a quantity of fluid equal to 10 percent of the amount the absorber will hold.
- (6) Replace filler plug, using new gasket.

Section XXIX

STEERING GEAR

	Paragraph
Description	159
Trouble shooting	160
Maintenance and adjustment	161
Unit replacement	162

159. DESCRIPTION.

a. The steering gear is of the recirculating ball type, having a reduction ratio of 23.6 to 1. A ball nut with two separate circuits of ball bearings operates on the helical groove machined in the main shaft. The rack teeth of the ball nut mesh with the sector teeth of the pitman shaft, to which is attached the pitman arm. When the steering wheel is turned, the helical grooves on the main shaft cause the ball bearings to climb up or down the path carrying with them the ball nut. The rack teeth on the ball nut cause the sector teeth on the pitman shaft to follow them, thus turning the pitman shaft and moving the pitman arm.

b. The steering connecting rod is of the ball and socket type, having identical ball seats, springs and adjusting plugs on the ends. The safety plugs in each end, however, are of different lengths.

c. The steering wheel is of the three-spoke type, having a diameter of 20 inches. The wheel is serrated to the main shaft and held in place with a retaining nut.

160. TROUBLE SHOOTING.

Symptom	Probable remedy
a. Hard Steering.	
(1) Lack of lubrication.	(1) Lubricate steering gear, tie rod ends and steering connecting rod ball joints.
(2) Tie rod and bolts too tight.	(2) Readjust.
(3) Under-inflated tires.	(3) Inflate to proper pressure (55 lbs.).
(4) Improper steering gear adjustment.	(4) Readjust. See paragraph 161.
(5) Improper caster, camber and toe-in.	(5) Check and correct or report to higher authority.

BOMB SERVICE TRUCK M6 (Chevrolet)

Symptom	Probable remedy
b. Loose Steering.	
(1) Improper steering gear adjustment.	(1) Adjust according to instructions in paragraph 161.
(2) Loose ball joints.	(2) Readjust.
(3) Worn steering arm bushings.	(3) Replace bushings.
c. Shimmy.	
(1) Loose steering.	(1) See paragraph h above.
(2) Wheel balance.	(2) See section XXXII.
(3) Improper toe-in.	(3) Refer to section XI.
d. Side Pull.	
(1) Improper camber or caster.	(1) Report to higher authority.
(2) Unequal tire inflation.	(2) Inflate to correct pressure (55 lbs.).
(3) Dragging brakes.	(3) Readjust according to instructions given in paragraph 54.
(4) Tight wheel bearing.	(4) Readjust. See paragraph 174.
(5) Improper tracking.	(5) Report to higher authority.
e. Wander or Weaving.	
(1) Improper caster.	(1) Report to higher authority.
(2) Excessive tightness in system.	(2) Check and readjust or lubricate.
(3) Improper toe-in.	(3) Refer to paragraph 40.
f. Road Shock.	
(1) Improper steering connecting rod adjustment.	(1) Readjust end plugs according to instructions in paragraph 161.
(2) Incorrect shock absorber action.	(2) See paragraph 158.
(3) Steering gear improperly adjusted.	(3) Readjust.

161. MAINTENANCE AND ADJUSTMENT.

a. Locating Source of Trouble.

- (1) Disconnect the steering connecting rod from the pitman arm. The

STEERING GEAR

steering gear is designed to have no backlash through the center position and but slight backlash at each end of travel. Turn the steering wheel and if any excessive binding or looseness is found, the trouble may be assumed to be in the steering gear. An easy way to check for proper steering gear adjustment is with the use of a checking scale. The pull at the wheel rim through the center position should be between 2 and 2 1/2 pounds.

(2) If the steering gear is found to be correctly adjusted, then it will be necessary to check wheel alinement, wheel bearing adjustment, steering knuckle adjustment and tire inflation.

b. **Steering Gear Adjustment.** There are two adjustments to the steering gear and they **MUST** be made in the order shown in the following paragraphs.

(1) **TOOLS REQUIRED:**

Pliers	Wrench, 1/2-in.
Scale, checking, J-544 (KM)	Wrench, 5/8-in.
Screwdriver	Wrench, 1 1/8-in.
Screwdriver, offset	Wrench, open-end, 2 3/4-in.

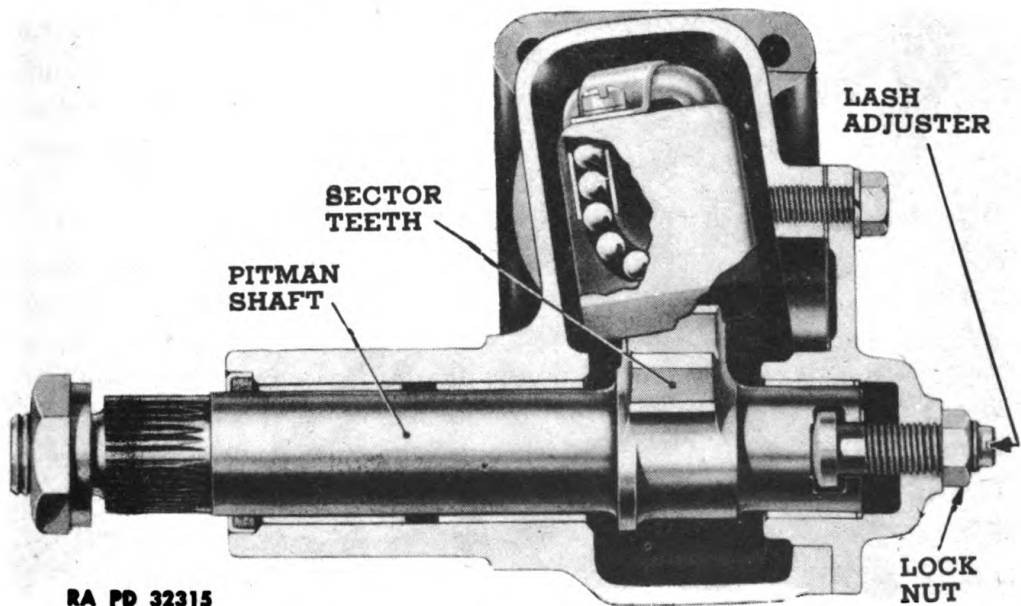

RA PD 32315

Figure 115—Pitman Shaft Adjustment

(2) **Disconnect** steering connecting rod from the pitman arm by removing the end plug with a wide screwdriver and pulling the socket off the pitman arm ball.

(3) **Loosen** the mast jacket to instrument panel bracket with a 1/2-inch wrench, making sure there is no bind due to the anchorage.

BOMB SERVICE TRUCK M6 (Chevrolet)

(4) With a $\frac{5}{8}$ -inch wrench, loosen the lock nut (fig. 115), and turn the lash adjuster a few turns in a counterclockwise direction with an offset screwdriver. This removes the worm bearing load imposed by close meshing of rack and sector teeth. Turn steering wheel slowly in one direction until stopped by gear. Then back away one turn. **CAUTION:** Do not turn steering wheel hard against stops when steering connecting rod is disconnected, as damage to the ball guides may result.

(5) Using checking scale, measure the pull at the rim of wheel required to keep wheel in motion. This should be between 1 and $1\frac{1}{2}$ pounds. **NOTE:** When making this check, it is important that the line of the scale be kept at right angles to the spoke of the wheel (fig. 116). If the pull necessary to move the wheel does not lie between the above limits, it will be necessary to adjust the worm bearings.

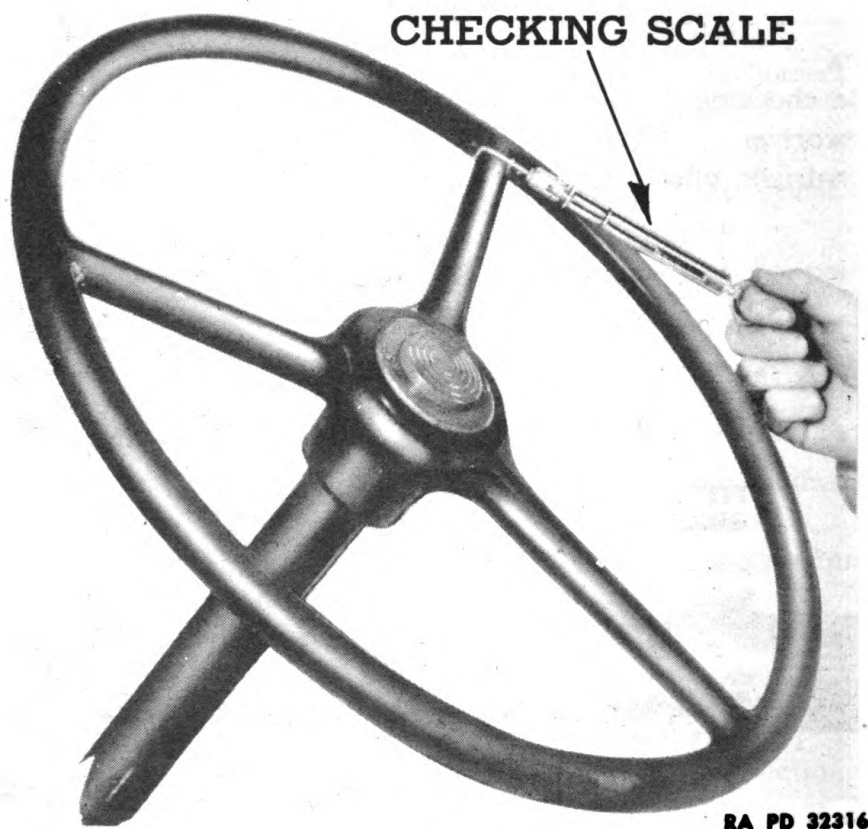

Figure 116—Checking Steering Gear Adjustment

(6) Loosen worm bearing thrust screw lock nut (fig. 117) with a $2\frac{3}{4}$ -inch wrench and turn worm bearing thrust screw until there is no end play in worm. Check the pull at wheel rim as outlined in b (5) above, readjusting, if necessary, to obtain proper pull as it must be between the limits specified after lock nut is tightened. If the gear feels "lumpy" after

STEERING GEAR

Figure 117—Worm Shaft Adjustment

adjustment of worm bearings, there is probably damage in the bearings due to severe impact or to improper adjustment, and the assembly must be torn down for replacement of damaged parts. In this event, replace the steering gear assembly as a unit.

(7) Check alinement of assembly by tightening the mounting bolt nuts on the mast jacket clamp to instrument panel with a $\frac{1}{2}$ -inch wrench. Then check the pull at the wheel rim and if it has increased over the previous reading, then the steering column was sprung in tightening it to the instrument panel. If this condition is encountered, it will be necessary to again loosen the mounting bolt nuts in the mast jacket clamp and loosen the steering gear to frame side rail mounting bolts with a $1\frac{1}{8}$ -inch wrench. Then shift the assembly slightly to line up the steering column. Again tighten all mounting bolts and recheck rim pull.

(8) Locate center of sector shaft travel by turning the steering wheel gently from one stop to the other, while counting the number of steering wheel turns. Then turn wheel back one-half the number of turns and mark the wheel at top or bottom with a piece of tape. Turn lash adjuster (fig. 115), clockwise to take out all lash in gear teeth, and tighten lock nut with a $\frac{5}{8}$ -inch wrench. Check pull at wheel rim with checking scale as before, taking the highest reading of the checking scale as the wheel is turned through center position. This should be

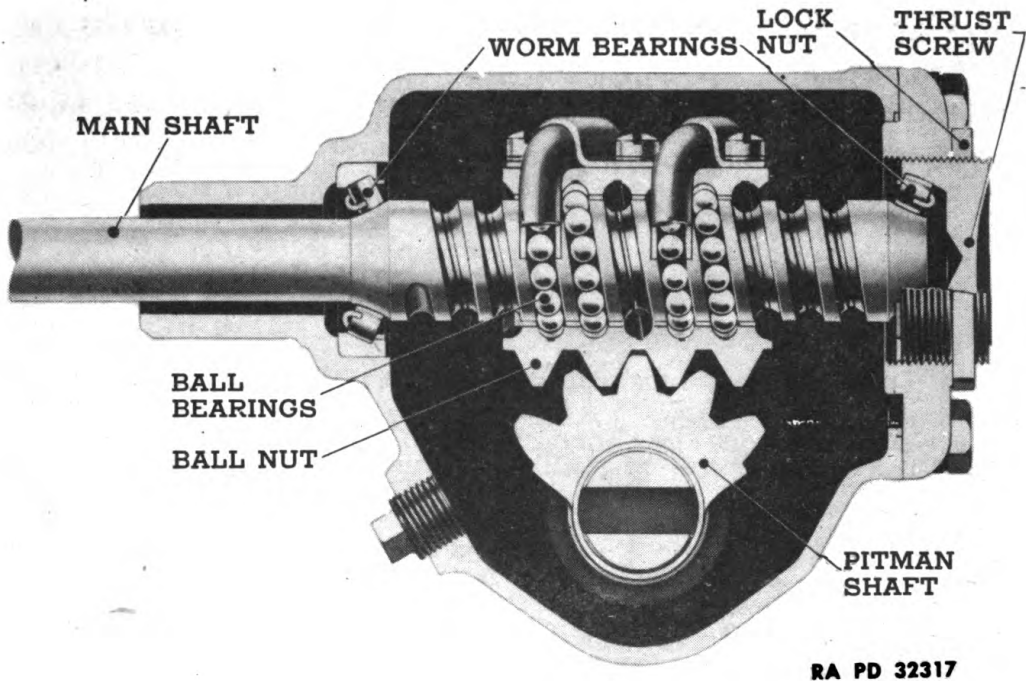
BOMB SERVICE TRUCK M6 (Chevrolet)

between 2 and 2½ pounds. Readjust, if necessary, to obtain proper pull. Tighten lock nut and recheck pull.

(9) Reassemble steering connecting rod to pitman arm and adjust according to instructions given in this section.

c. Steering Connecting Rod Replacement.

(1) Remove cotter pins from adjusting plugs in each end of rod.

(2) With a wide screwdriver remove adjusting plugs, safety plugs, tension springs and ball seats.

(3) The steering connecting rod can then be removed from the third arm and pitman arm.

(4) To replace, install one ball seat in the offset end of the steering connecting rod and place that end over the ball on the third arm. The other ball seat, spring, short safety plug and adjusting plug should be installed in the order mentioned.

(5) At the pitman arm end, install the spring, long safety plug and one ball seat in the end of the rod. Then place the rod in position over the ball of the pitman arm. Install the remaining ball seat and adjusting plug. Figure 118 shows a layout of the steering connecting rod parts.

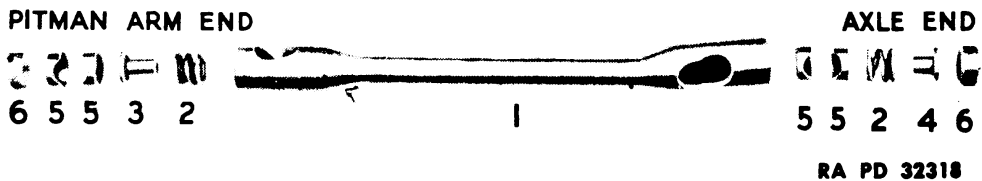

Figure 118—Steering Connecting Rod

(6) To adjust the ball joints, screw end plugs in tight and back off one-half to one full turn. Lock the plugs with new cotter pins.

162. UNIT REPLACEMENT.

If the steering gear is damaged, it should be replaced as a unit.

a. Tools Required:

- | | |
|-------------------------------------|-----------------------------|
| Pliers | Scale, checking, J-544 (KM) |
| Puller, pitman arm, J-1376-G (KM) | Screwdriver |
| Puller, steering wheel, J-1618 (KM) | Wrench, ½-in. |
| | Wrench, 1 ⅛-in. |
| | Wrench, 1 ¼-in. |

b. Remove the two screws that retain the horn button and remove button and horn button spring.

STEERING GEAR

c. Remove steering wheel retaining nut with a 1¼-inch wrench. Screw steering wheel puller adapter on end of shaft and assemble steering wheel puller J-1618 to steering wheel. Turning the puller screw will remove the wheel. Remove wheel key and upper bearing tension spring.

d. With a ½-inch wrench remove the nuts from the mast jacket to instrument panel clamp.

e. Remove the floor and toeboards. Then remove the clevis pin from brake pedal pull rod at master cylinder. The pedal may then be pulled back to provide clearance for removing the gear.

f. Remove the horn wire terminal plate from the mast jacket by removing the two attaching screws.

g. Disconnect steering connecting rod from pitman arm. With a 1¼-inch wrench remove pitman arm nut and then remove pitman arm, using arm puller J-1376-G (fig. 119).

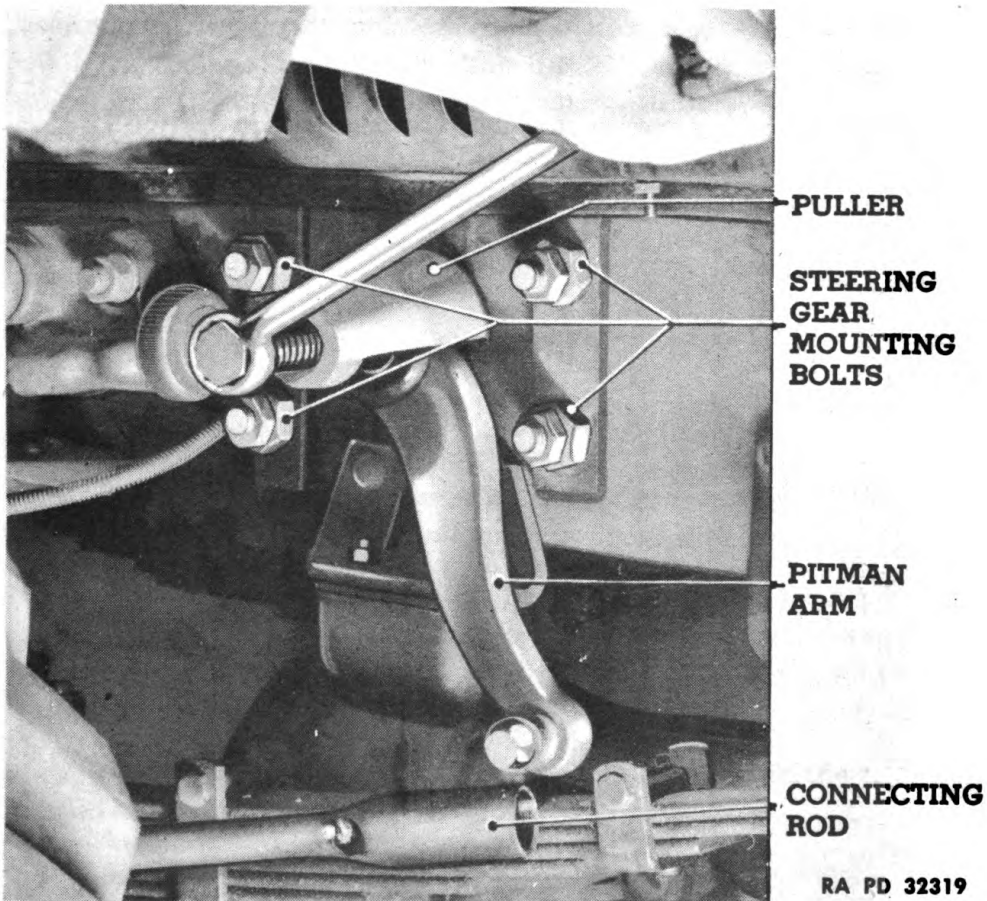

RA PD 32319

Figure 119—Pitman Arm Removal

h. With a 1⅛-inch wrench remove the four steering gear to frame mounting bolts and remove the gear through the left door of the truck.

BOMB SERVICE TRUCK M6 (Chevrolet)

i. Install the new steering gear assembly in place and install the mounting bolts. Leave the bolts loose enough so that the gear assembly can be moved to align the steering column at the instrument panel.

j. Line up steering column so that there will be no bind on the shaft after installing retaining bracket. Install bracket and tighten the two clamp retaining nuts with a $\frac{1}{2}$ -inch wrench. Tighten the four steering gear to frame mounting bolts with a $1\frac{1}{8}$ -inch wrench.

k. With the checking scale, check to make sure the adjustment is within 2 to $2\frac{1}{2}$ pounds pull as outlined under paragraph 161 b (8) of this section. If it is not, then a bind has been put on the shaft when installing the assembly.

l. Line up marks on pitman arm and end of sector shaft and install pitman arm. Tighten pitman arm nut with a $1\frac{1}{4}$ -inch wrench. Install steering connecting rod and adjust according to instructions given in this section.

m. Replace horn wire terminal plate, steering wheel, and horn button. Replace brake pedal pull rod and install floor and toeboards.

n. Lubricate steering gear according to instructions in section IV.

Section XXX

TRANSFER CASE

	Paragraph
Description	163
Trouble shooting	164
Unit replacement	165
Shifter shaft control rod adjustment.....	166

163. DESCRIPTION.

a. The transfer case is a two-speed gear box mounted in the frame between the transmission and rear axle. It provides a drive for the front and rear axles.

b. Two shift levers in the driver's compartment, to the right of the transmission lever, provide a means of selecting the transfer case drive desired. The lever to the left provides *high, neutral* or *low* range while the lever to the right provides a means of shifting to *four* wheel or *two* wheel drive. See figure 4 for shift lever positions.

c. The shift lever linkage is so designed that the transfer case can be shifted to four wheel or two wheel drive when the transfer case is in high gear; however, when the transfer case is in low speed range, the vehicle must be in four wheel drive.

d. The transfer case low speed gear reduction is 1.94 to 1.

164. TROUBLE SHOOTING.

a. The most common abuses the transfer case is subjected to are excessive use of four wheel drive and improper gear shifting.

b. The vehicle should normally be used in two wheel drive. Four wheel drive should only be used when more power or traction is required than would be possible with two wheel drive. The operator should follow the gear shifting instructions given in paragraph 7.

c. Any unusual or abnormal noise which is traced to the transfer case should be investigated.

Symptom	Probable remedy
d. Noise.	
(1) Transfer case loose in frame.	(1) Tighten the eight bolts that hold the transfer case to frame bracket.

BOMB SERVICE TRUCK M6 (Chevrolet)

Symptom	Probable Remedy
(2) Insufficient lubricant.	(2) Add lubricant as instructed in section IV.
(3) Broken bearing caps.	(3) Report to higher authorities.
(4) Loose bearing caps.	(4) Tighten bearing cap Retaining screws.
(5) Front axle engaged on hard surface roads.	(5) Shift into two wheel drive.
(6) Worn bearings.	(6) Report.
(7) Worn or damaged gears.	(7) Report.
(8) Worn or loose speedometer gears.	(8) Report.
 e. Lubricant Leaks.	
(1) Transfer case vent plugged up.	(1) Replace vent.
(2) Loose bearing retainer bolts.	(2) Tighten bolts.
(3) Damaged bearing retainer gaskets.	(3) Report.
(4) Cracked transfer case.	(4) Replace transfer case assembly.
(5) Filler or drain plug not properly installed.	(5) Install properly.
(6) Cover bolts loose.	(6) Tighten cover bolts.
(7) Drive flange seals damaged due to improper installation or foreign material.	(7) Report.
(8) Drive flange retaining nuts not properly tightened.	(8) Tighten nuts securely and install new cotter pins.
 f. Slipping Out of Gear.	
(1) Shift lock springs weak or broken.	(1) Report.
(2) Shift lock balls sticking.	(2) Report.
(3) Improperly adjusted shifter shaft pull rods.	(3) Adjust pull rods.
(4) Misalignment of the main shaft extension.	(4) Report.

TRANSFER CASE

165. UNIT REPLACEMENT.

a. Removal.

(1) TOOLS REQUIRED:

- | | |
|-------------------------|----------------------------|
| Gun, grease | Pliers, combination, 6-in. |
| Jack, roller, 41-J-73-5 | Wrench, open-end, 1/2-in. |
| Pan, drain | Wrench, open-end, 9/16-in. |

(2) Place drain pan under the transfer case and remove filler and drain plugs with a 9/16-inch wrench. After lubricant has drained out, install filler and drain plugs.

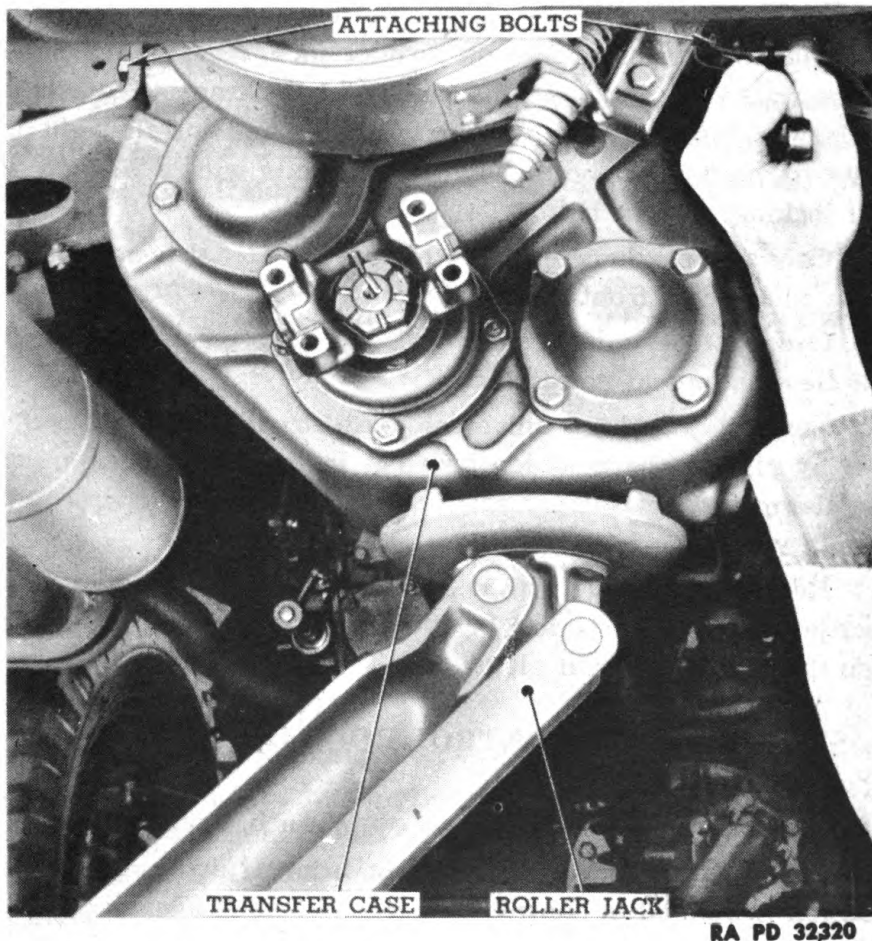

Figure 120—Transfer Case Removal

(3) With a 9/16-inch ratchet wrench remove the nuts and lockwashers from the U clamps which retain the universal joint trunnion bearings to all three propeller shaft driving flanges. NOTE: It is good practice when splitting these needle bearing universal joints to leave the bearings on the trunnions, holding them in place with a piece of tape wrapped endwise over the bearings and trunnion. This will keep the needle bearings clean and in place (fig. 108).

BOMB SERVICE TRUCK M6 (Chevrolet)

(4) Remove the cotter pins and clevis pins; disconnect the shifter pull rods at the transfer case end.

(5) With a pair of pliers disconnect the speedometer cable from the speedometer driven gear.

(6) Place a roller jack under the transfer case, from right side of truck, and raise the jack to support the unit (fig. 120). Remove the locking wire and the eight cap screws that attach the transfer case to the frame brackets using a $\frac{3}{4}$ -inch wrench. Support the transfer case while the jack is being lowered. Pull the jack and transfer case out from under the truck.

b. Replacement.

(1) Place the transfer case on a roller jack. Run it under the truck from the right side and raise the jack until the transfer case is in position. Using a taper punch, line up the holes and install eight transfer cases to frame bracket bolts. Tighten the bolts with a $\frac{3}{4}$ -inch wrench. Install locking wire in bolts.

(2) Connect speedometer cable to speedometer driven gear in transfer case idler shaft front retainer.

(3) Connect the shifter shaft pull rods to the shifter shafts and install clevis pins and cotter pins.

(4) Connect the three universal joints to the transfer case driven flanges by placing the trunion bearings in the bearing seats, installing the U clamps, lockwashers, and nuts. Tighten securely with a $\frac{9}{16}$ -inch open-end wrench.

(5) Remove filler plug with a $\frac{9}{16}$ -inch wrench and fill transfer case to correct level. Refer to section IV of this manual. Install filler plug and tighten the filler and drain plugs.

166. SHIFTER SHAFT CONTROL ROD ADJUSTMENT.

a. Tools Required:

Pliers, combination, 6-in.

Wrench, open-end, $\frac{5}{8}$ -in.

b. Remove cotter pin and clevis pin from adjusting eye at transfer case shifter shaft end of control rod.

c. With a $\frac{5}{8}$ -inch wrench, loosen adjusting eye lock nut.

d. Shift transfer case shifter shaft into gear so that lock ball drops into groove in shaft holding shaft in position.

e. Place shift lever in position to correspond with the gear to which the transfer case was shifted.

f. Turn adjusting eye until shaft is correct length for clevis pin to drop through adjusting eye and shifter shaft.

g. Tighten adjusting eye lock nut with a $\frac{5}{8}$ -inch wrench.

h. Install clevis pins and cotter pins.

Section XXXI

TRANSMISSION

	Paragraph
Description	167
Trouble shooting	168
Cover replacement	169
Transmission replacement	170

167. DESCRIPTION.

a. The selective sliding gear type transmission used in the bomb service truck incorporates four forward speeds and one reverse speed. Provision is made on the left side of the case for mounting a power take-off when a winch or hoist is to be used.

b. The transmission is bolted to the clutch housing and becomes a part of the unit power plant assembly. The emergency brake and transfer case shift levers are mounted on the right side of the transmission.

c. Transmission Gear Reduction.

- (1) Low or first: 7.06 to 1.
- (2) Second: 3.48 to 1.
- (3) Third: 1.71 to 1.
- (4) High is direct drive.
- (5) Reverse: 6.98 to 1.

168. TROUBLE SHOOTING.

a. **General.** Before deciding that major service will be required, an accurate check should be made to determine that the trouble is in the transmission. The vehicle should be driven at various speeds and special attention given to the speed, gear ratio, and power applied when the condition being investigated is most pronounced. If it cannot be definitely isolated in any one unit, it may be advisable to jack up the rear wheels and, with the transfer case in high and two wheel drive, reproduce the driving conditions which produced the most noise, and check the drive line to isolate the noise.

Symptom	Probable remedy
b. Noises.	
(1) Insufficient lubricant.	(1) Fill to correct level according to instructions in section IV.

BOMB SERVICE TRUCK M6 (Chevrolet)

Symptom	Probable remedy
(2) Bent shifter forks.	(2) Replace cover assembly.
(3) Universal joint front yoke retainer cap screw loose.	(3) Tighten securely.
(4) Worn or broken bearings.	(4) Replace transmission or report to higher authorities.
(5) Badly worn gears.	(5) Replace transmission or report.
(6) Gear teeth chipped.	(6) Replace transmission or report.
(7) Worn reverse idler gear bushing.	(7) Replace transmission or report.

c. Jumping Out of Gear.

(1) Transmission to clutch housing bolts loose.	(1) Tighten bolts.
(2) Worn gears.	(2) Replace transmission or report.
(3) Shift lock springs weak or broken.	(3) Replace transmission cover or report.
(4) Bent shifter fork.	(4) Replace transmission cover or report.
(5) Misalignment of transmission.	(5) Report.

d. Difficulty in Shifting to Low or Reverse.

(1) Worn or bent gear shift interlock guide plate.	(1) Replace transmission cover or report.
(2) Worn reverse lock sleeve on lower end of gear shift lever.	(2) Replace gear shift lever or sleeve.

169. COVER REPLACEMENT.

a. Removal.

(1) **TOOLS REQUIRED:**

Handle, speed

Screwdriver, 6-in.

Pliers, combination, 6-in.

Socket, $\frac{9}{16}$ -in.

(2) Remove the gear shift lever by installing the gear shift lever

TRANSMISSION

remover as shown in figure 120A. Turn the remover until the lugs engage the slots in the lever retainer. Push down on the remover and turn it slightly to the left. This disengages the lugs and the lever assembly can be raised out of the cover.

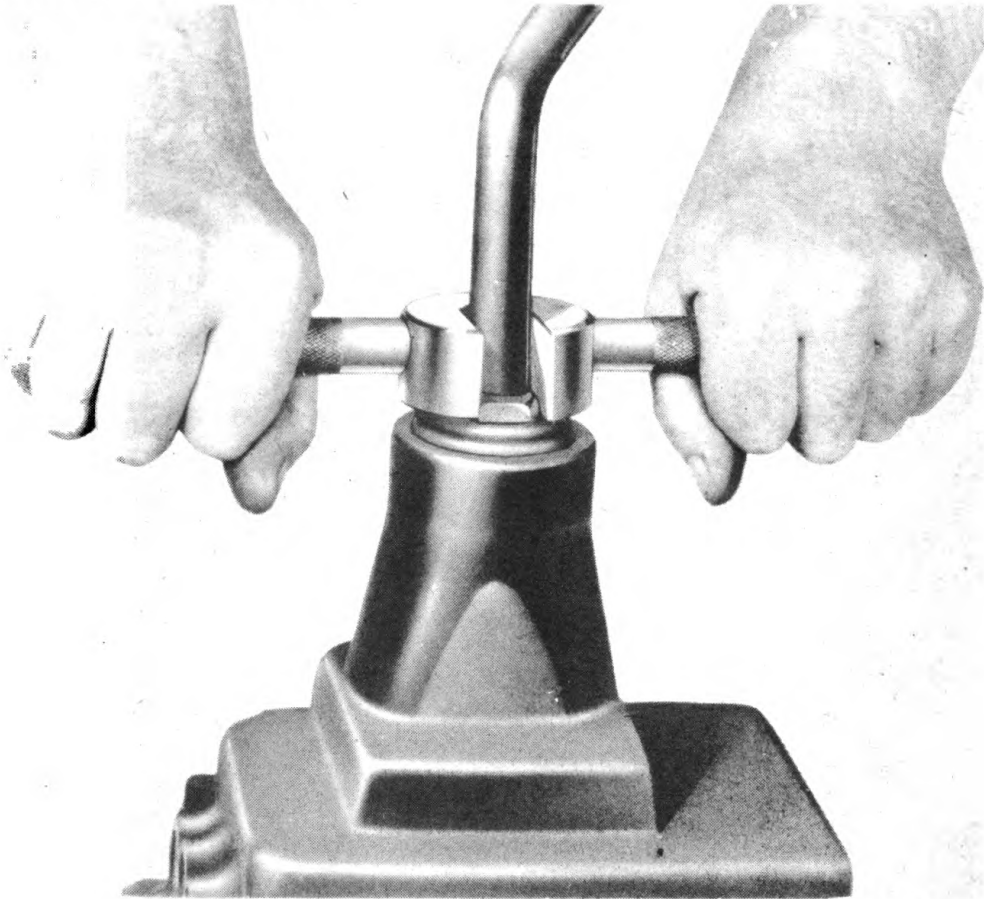

RA PD 32237

Figure 120A—Removing Gear Shift Lever

- (3) Remove floor board screws with a screwdriver and remove floor board.
- (4) Remove brake pedal pull back spring from transmission cover.
- (5) With a $\frac{9}{16}$ -inch speed wrench remove the six cap screws which retain the transmission cover and lift cover off transmission.

b. Cover Installation.

- (1) Make sure the shifter forks in the cover are in neutral position.
- (2) Place the transmission gears in neutral position.
- (3) Lower the cover straight down on the transmission, being careful not to tip the cover. This places the shifting forks in the grooves of their respective gears (fig. 121).

BOMB SERVICE TRUCK M6 (Chevrolet)

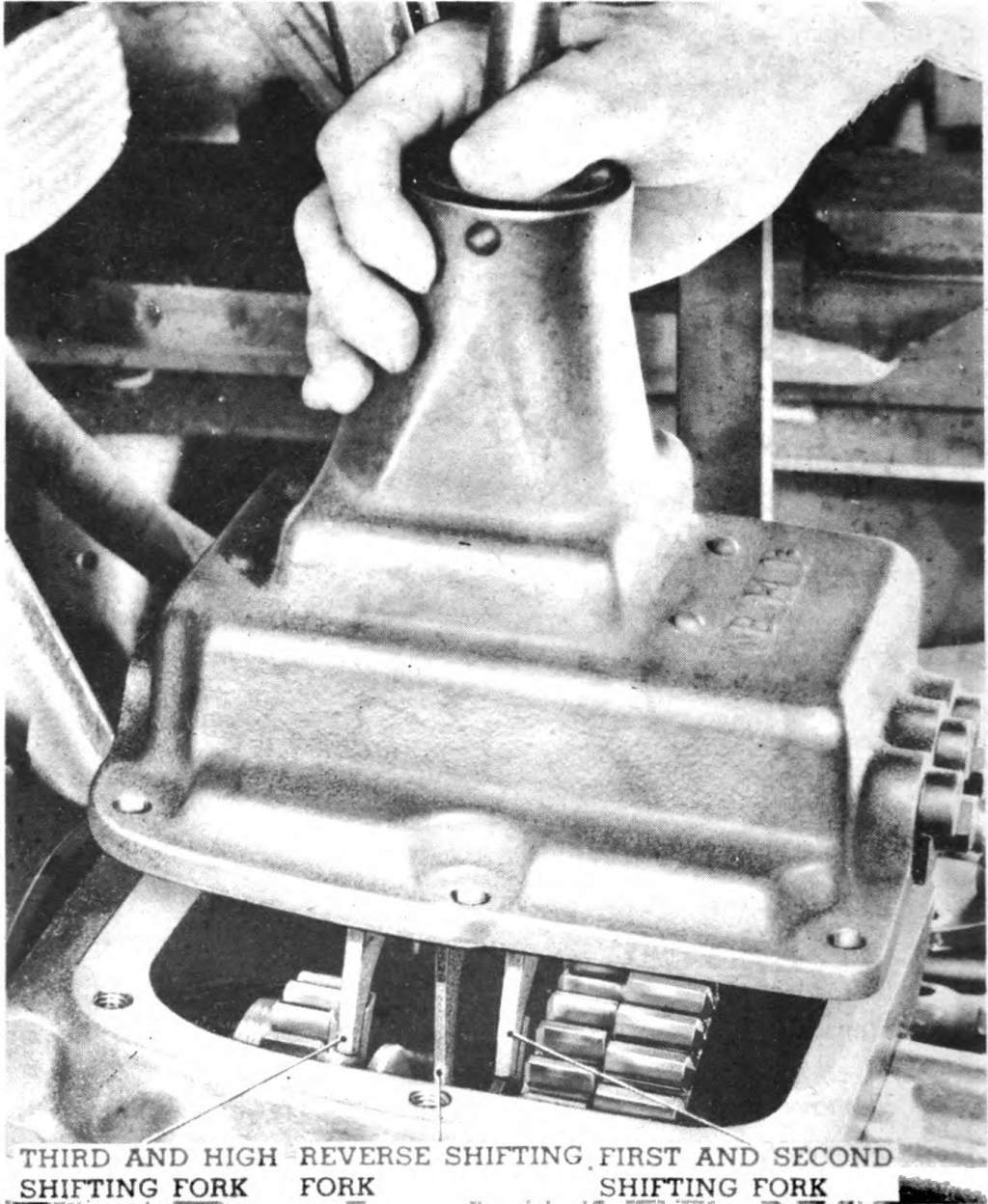

THIRD AND HIGH REVERSE SHIFTING FIRST AND SECOND
SHIFTING FORK FORK SHIFTING FORK

RA PD 32321

Figure 121—Installing Transmission Cover

TRANSMISSION

- (4) Install the six cap screws which retain the cover and tighten with a $\frac{9}{16}$ -inch speed wrench.
- (5) Install the gear shift lever, making sure the lower end of the lever enters the slots in the forks. Place the gear shift lever remover in position as shown in figure 120A. Press down on the tool and turn it to the right to lock the lever in position.
- (6) Check the gear shift to all gear positions.
- (7) Hook brake pull back spring to clip at left rear cover belt.
- (8) Install floor boards and replace attaching screws.

170. TRANSMISSION REPLACEMENT.

a. Removal.

(1) TOOLS REQUIRED:

Handle, ratchet	Socket, $\frac{1}{2}$ -in.
Pan, drain	Socket, $\frac{9}{16}$ -in.
Pliers, combination, 6-in.	Socket, $\frac{3}{4}$ -in.
Screwdriver, 6-in.	Wrench, open-end, $\frac{9}{16}$ -in.

- (2) Remove floor board screws and floor board.
- (3) Remove transmission drain plug with a $\frac{9}{16}$ -inch wrench, drain transmission and install plug.
- (4) With a $\frac{9}{16}$ -inch speed wrench remove transfer case control levers and emergency brake lever attaching bolts on right side of transmission.
- (5) Disconnect power plant brace rod at transmission end with a $\frac{9}{16}$ -inch wrench.
- (6) Disconnect pull back spring at left rear corner of transmission.
- (7) Remove the nuts and lock washers from the U clamps which retain the trunnion bearings to the front yoke of the universal joint with a $\frac{9}{16}$ -inch open-end wrench. Then remove the U clamps. Slide the rear yoke of the joint back on the splines of the propeller shaft.
- (8) It is good practice when splitting these needle bearing universal joints to have the bearings on the trunnions, holding them in place with a piece of tape wrapped endwise over the bearings. This prevents dirt getting into the bearings and keeps them in place.
- (9) Remove the screws which retain the flywheel underpan and remove the pan.
- (10) With a $\frac{3}{4}$ -inch ratchet wrench remove the two bottom attaching bolts by reaching in through the bottom of the clutch housing. Remove the two upper attaching bolts.
- (11) Slide the transmission back to clear the splines in the clutch

BOMB SERVICE TRUCK M6 (Chevrolet)

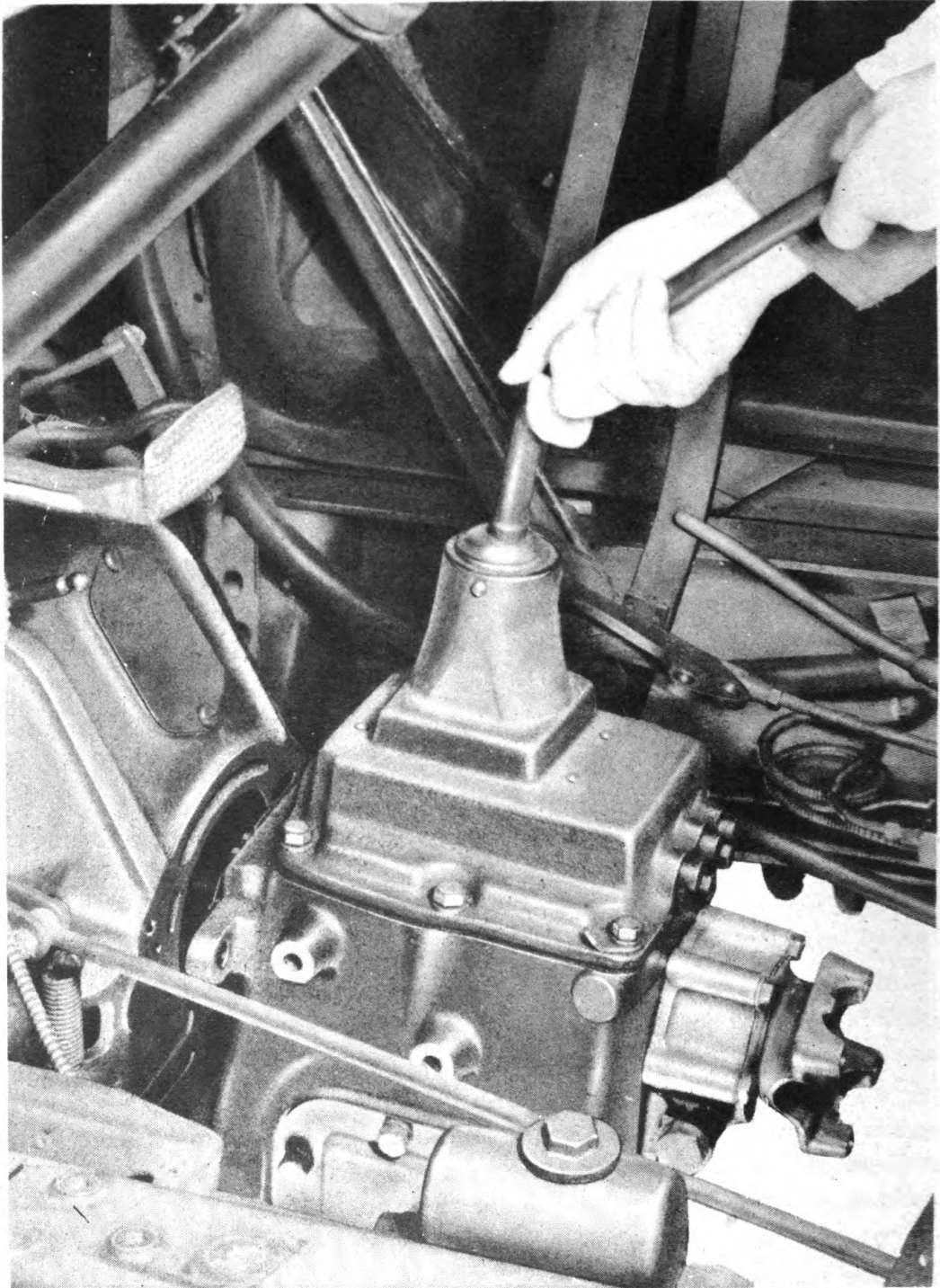

RA PD 32322

Figure 122—Transmission Removal

TRANSMISSION

disk and lower the transmission to the floor (fig. 122). **NOTE:** It is very important that the weight of the transmission be supported until the end of the clutch gear splines are out of the splines in the clutch disk.

b. Transmission Installation.

(1) TOOLS REQUIRED:

Handle, ratchet	Socket, 1/2-in.
Pan, drain	Socket, 9/16-in.
Pliers, combination, 6-in.	Socket, 3/4-in.
Screwdriver, 6-in.	Wrench, open-end, 9/16-in.

- (2) Clean the machined surface of transmission and clutch housing.
- (3) Place the transmission under the truck and raise the transmission until the main drive gear shaft lines up with splines in clutch. Work transmission forward into place, being careful not to release the weight of the transmission until it is up against the clutch housing.
- (4) Install the two upper transmissions to clutch housing bolts. Install the two lower transmissions to clutch housing bolts and tighten all bolts securely with a 3/4-inch ratchet wrench.
- (5) Install the clutch housing underpan and tighten the screws securely.
- (6) Place the propeller shaft slip joint in position against the flange. Install the U clamps, lockwashers, and nuts. Tighten the nuts securely with a 9/16-inch open-end wrench.
- (7) Hook up the brake pedal pull back spring.
- (8) Attach the power plant brace rod and tighten the attaching bolt with a 9/16-inch wrench.
- (9) Replace the emergency brake lever and transfer case shift levers, install the retaining bolts and tighten them with a 9/16-inch wrench.
- (10) Fill the transmission case to correct level. See section IV. Lubricate universal joint which was disassembled.
- (11) Replace floor boards and install the retaining screws.

BOMB SERVICE TRUCK M6 (Chevrolet)

Section XXXII

WHEELS, WHEEL BEARINGS, TIRES

	Paragraph
Description	171
Trouble shooting	172
Wheel and tire replacement	173
Wheel bearings	174

171. DESCRIPTION.

a. Single wheels, front and rear, are normally used on this vehicle; however, provision is made for the installation of dual wheels either front or rear as the occasion may demand.

b. The wheels are held in place by inner and outer retaining nuts. When single wheels are installed, the outer nut should be kept tightened against the inner nut to prevent loss.

c. The wheel size is 20 x 7 and the tire size 7.50 x 20. Tire pressure, front and rear, is 55 pounds.

d. Timken roller bearings are used at the front wheels and Hyatt roller bearings of the barrel type are used at the rear wheels.

172. TROUBLE SHOOTING.

Symptom	Probable remedy
a. Hard Steering.	
(1) Tires under-inflated.	(1) Inflate to 55 pounds.
(2) Wheel bearings out of adjustment.	(2) Readjust.
(3) Wheel bearing scored or seized.	(3) Replace.
(4) Lack of lubrication.	(4) Lubricate steering gear, steering connecting rod and tie rod fittings.
(5) Steering knuckle bearings improperly adjusted.	(5) Report to higher authority.
(6) Improper steering adjustment.	(6) See steering adjustment, section XXIX.
b. Air Leakage.	
(1) Tube leaks.	(1) Check for slow leaks in tube.

WHEELS, WHEEL BEARINGS, TIRES

Symptom	Probable remedy
(2) Valve cap missing.	(2) Install new cap.
(3) Valve core loose.	(3) Tighten.
(4) Valve core damaged.	(4) Replace core.
c. Uneven Tire Wear.	
(1) Irregular.	(1) Interchange tires to compensate.
(2) Side wear.	(2) (a) Check for improper camber. (b) Underinflation. (c) Sharp turns at high speeds. (d) High crown roads.
(3) Excessive wear.	(3) Check for improper toe-in.

173. WHEEL AND TIRE REPLACEMENT.

(1) **TOOLS REQUIRED:**

a. Removal.

Irons, tire

Screwdriver, heavy

Jack, 41-J-73-5

Wrench, wheel hub nut

(2) Set truck on a level spot and loosen the wheel retaining nuts.

(3) Raise truck and remove the retaining nuts with the hub nut wrench.

(4) Remove wheel and tire assembly.

(5) Deflate tire **COMPLETELY**.

(6) Force one side of the clamp ring toward the center of the wheel until it drops into the groove in the wheel.

(7) Insert a heavy screwdriver into the recess in the clamp ring and pry this side of the ring out over the edge of the wheel.

(8) Work the ring off with tire irons and remove the tire and tube assembly.

b. Replacement.

(1) When replacing tire, make sure the clamp ring is seated against the rim of the wheel throughout its whole circumference before inflating the tire. Install wheel retaining nuts and tighten them evenly with a wheel hub nut wrench.

(2) The wheel retaining nuts should be checked frequently to keep them tight, as there may be a tendency for them to loosen during operation.

BOMB SERVICE TRUCK M6 (Chevrolet)

174. WHEEL HEARINGS.

a. Adjustment—Front and Rear Wheels.

(1) TOOLS REQUIRED:

Chisel, cold

Hammer

Jack, 41-J-73-5

Wrench, speed, $\frac{5}{8}$ -in.

Wrench, speed, $\frac{3}{4}$ -in.

Wrench, wheel bearing nut

Wrench, wheel stud nut

(2) Place vehicle on level ground and apply parking brake. Loosen the six wheel stud nuts on the wheel that is to be worked on with the wheel stud nut wrench.

(3) Raise the truck with the jack until the wheel clears the ground.

(4) Remove the six wheel stud nuts that were previously loosened and remove the wheel.

(5) With a cold chisel and hammer, bend the lugs of the lock plate away from the bolt heads.

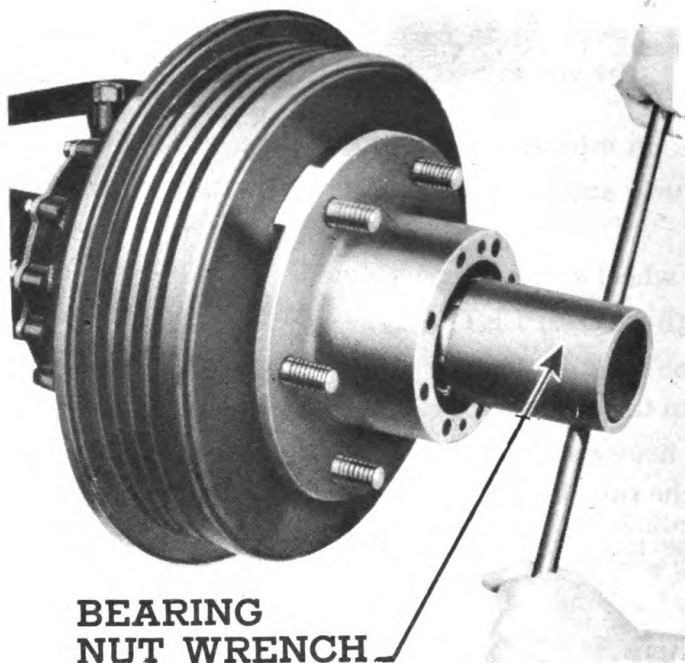

RA PD 32323

Figure 123—Removing Wheel Bearing Outer Nut

(6) With a $\frac{3}{4}$ -inch wrench remove the cap screws which attach the drive flange on the front wheel hub or with a $\frac{5}{8}$ -inch wrench remove the cap screws which retain the rear wheel hub.

WHEELS, WHEEL BEARINGS, TIRES

(7) If the flange or axle shaft is tight, it may be removed by installing two of the drive flange or axle shaft cap screws in the tapped holes in the flange or shaft. By turning these cap screws alternately, the drive flange or axle shaft may be removed (fig. 17).

(8) Raise the tang which locks the outer lock nut and remove the nut, using bearing nut wrench (fig. 123). Then remove the nut lockwasher.

(9) Using the special wrench and a T handle, pull the inner nut up snugly (wrench tight). Then back the nut off a distance equal to that between two adjacent flange bolt holes, which is equal to 45 degrees. Aline nearest slot in nut with short tang on locking washer and bend the tang down.

(10) Install outer lock nut. Then tighten the nut securely, using the special wrench, and bend down long tang on locking washer into slot in nut.

(11) Place a new terneplate gasket on the drive flange or axle shaft and install the flange, making sure to line up the bolt holes in the flange with those in the gasket as shown in figure 124.

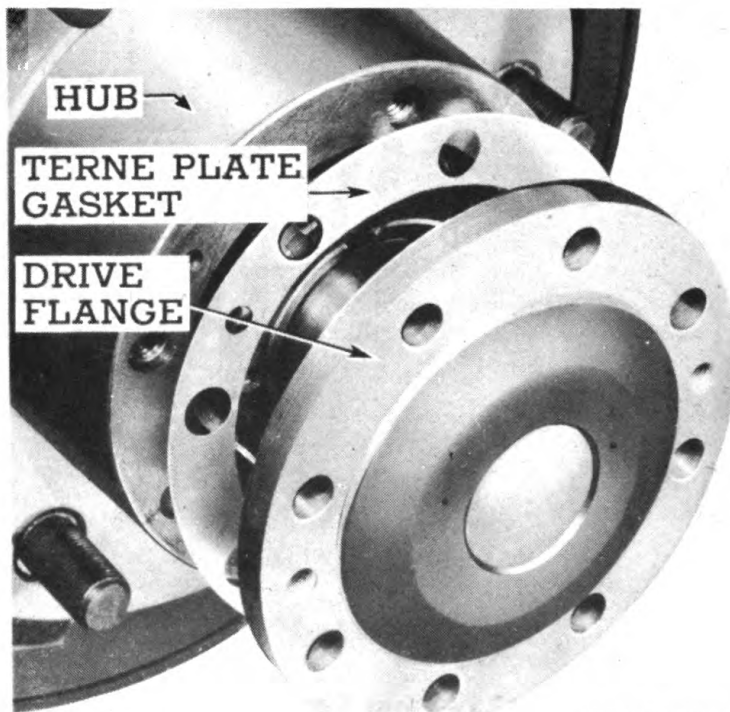

RA PD 32324

Figure 124—Installing Drive Flange

(12) Install the eight cap screws through a new lock plate and tighten them securely with a $\frac{5}{8}$ -inch or $\frac{3}{4}$ -inch wrench. Where tension wrenches are available, these cap screws should be tightened to a torque load of 95 to 115 foot pounds.

(13) Bend the tangs of the lock plate against the cap screw heads.

BOMB SERVICE TRUCK M6 (Chevrolet)

b. Wheel Bearing Replacement—Front.

(1) TOOLS REQUIRED:

- | | |
|--------------------------------------|--|
| Chisel | Puller, inner bearing, J-918-G (KM) |
| Driver, oil seal, J-1672 (KM) | Punch, drift |
| Driver, outer bearing, J-1660-3 (KM) | Wrench, speed, 3/4-in. |
| Hammer | Wrench, wheel bearing nut, J-1663 (KM) |
| Handle, driver, J-1660-1 (KM) | Wrench, wheel stud nut |
| Jack, 41-J-73-5 | |

(2) Proceed as outlined in a (2) to (8) of this paragraph.

(3) Remove the bearing adjusting nut.

(4) Remove spacer washer, roller bearing and cone assembly, and wheel hub. Install wheel cylinder clamp.

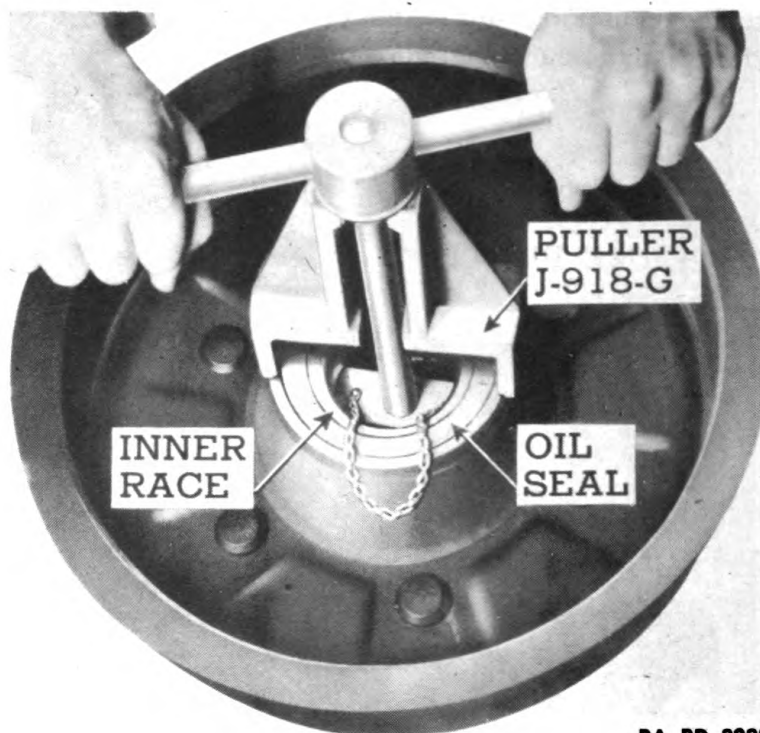

RA PD 32325

Figure 125—Inner Bearing Removal

(5) Using puller, remove the inner bearing and oil seal. The puller is installed by tilting the plate with chain attached, so that it may be slipped through the inner race of the bearing and then raised up behind the outer race. The plate is then held in this position by the chain while threading the puller shaft into the tapped hole. The puller body is then located against the inner end of the hub and the puller handle installed (Fig. 125).

WHEELS, WHEEL BEARINGS, TIRES

(6) Drive the outer bearing outer race from the hub, using a long drift punch through the inner end of the hub so that it contacts the back of the race.

(7) Wash the bearings and the inside of the hub with SOLVENT, dry cleaning.

(8) Inspect the bearings and replace any that are worn, scored, or checked. When in doubt, it is a good policy to use new parts.

(9) Replace outer races of both the inner and outer bearings, using driver J-1660-3 (KM), to either drive or press them in place (fig. 126).

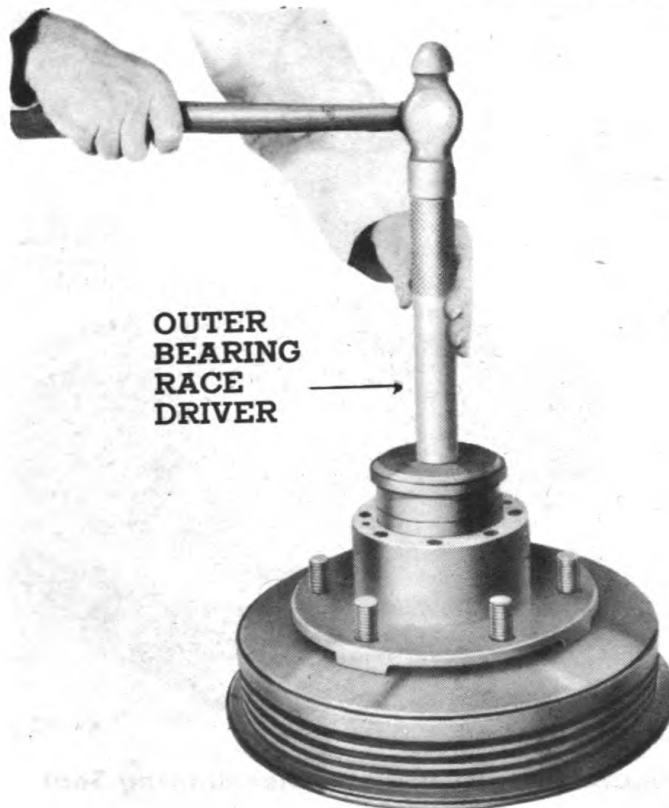

RA PD 32326

Figure 126—Replacing Outer Race

NOTE: The bearing surface of both races should be facing away from the center of the hub.

(10) Hand pack the inner bearing roller assembly with GREASE, general purpose, No. 2. Refer to section IV for instructions.

(11) Coat the outside of seal lightly with sealing compound, place it on driver J-1672 (KM), and drive it into the hub until it contacts the bearing outer race (fig. 127).

(12) For prelubrication, a light coating of OIL, engine, seasonal grade, should be rubbed on the inner oil seal.

BOMB SERVICE TRUCK M6 (Chevrolet)

(13) Install the hub on the steering knuckle. Then hand pack the outer bearing roller assembly with **GREASE**, general purpose, No. 2 or its equivalent and install it in the hub. Install spacer washer and adjusting nut.

(14) Adjust the bearings according to instructions given in paragraph 174.

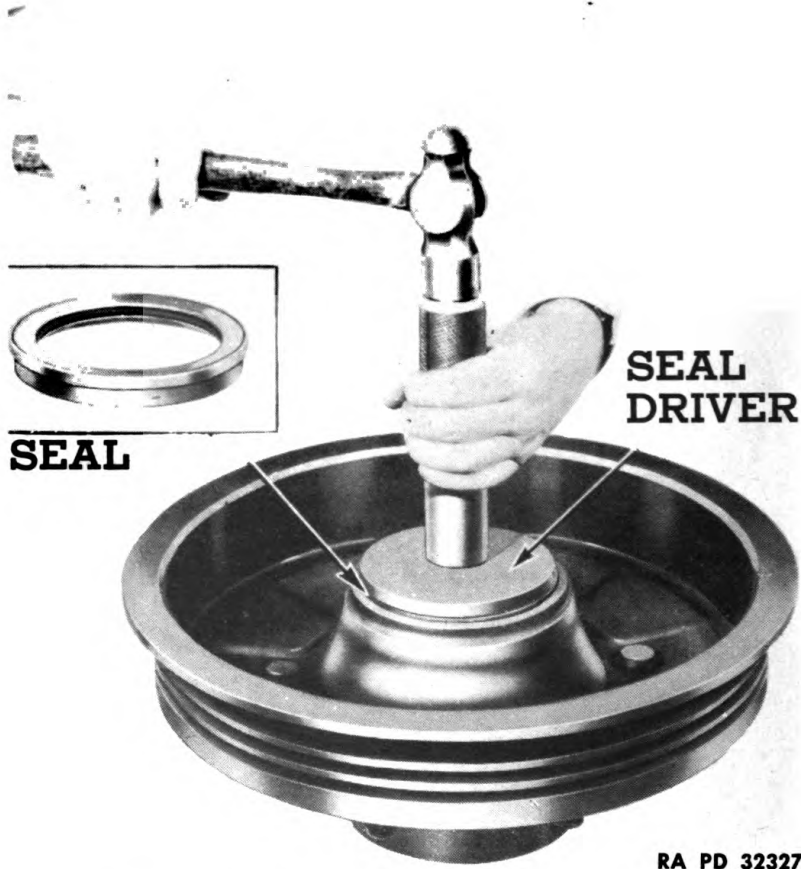

RA PD 32327

Figure 127—Replacing Inner Bearing Seal

c. Wheel Bearing Replacement—Rear.

(1) TOOLS REQUIRED:

Clamp, brake wheel cylinder,
J-718C (KM)

Chisel

Driver, inner bearing, J-872-4
(KM)

Jack, 41-J-73-5 (KM)

Hammer

Pliers

Puller, inner bearing, J-918-G
(KM)

Punch, drift

Remover, outer bearing, and
replacer, J-872-1 (KM)

Replacer, oil seal, J-872-2
(KM)

Wrench, speed, $\frac{5}{8}$ -in.

Wrench, wheel bearing nut,
J-870 (KM)

Wrench, wheel stud nut

WHEELS, WHEEL BEARINGS, TIRES

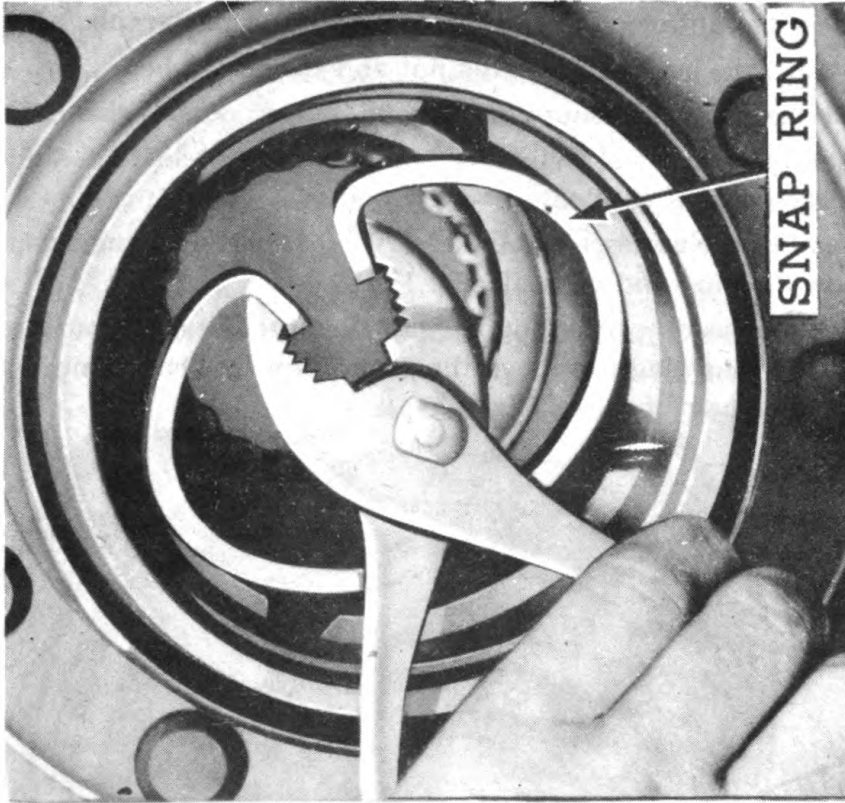

RA PD 32328

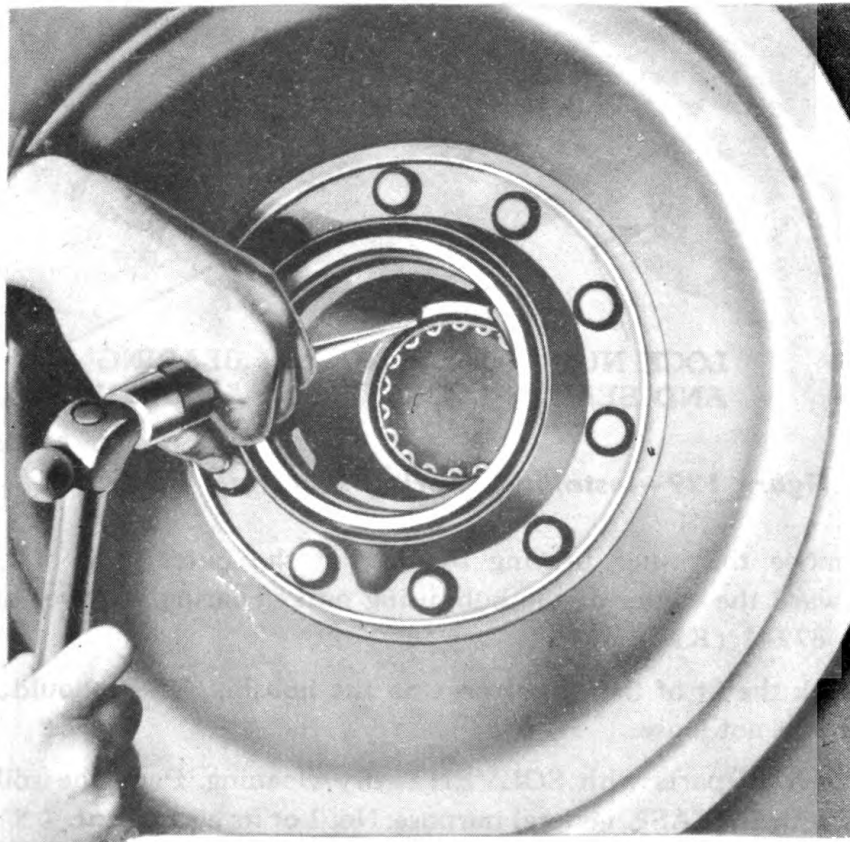
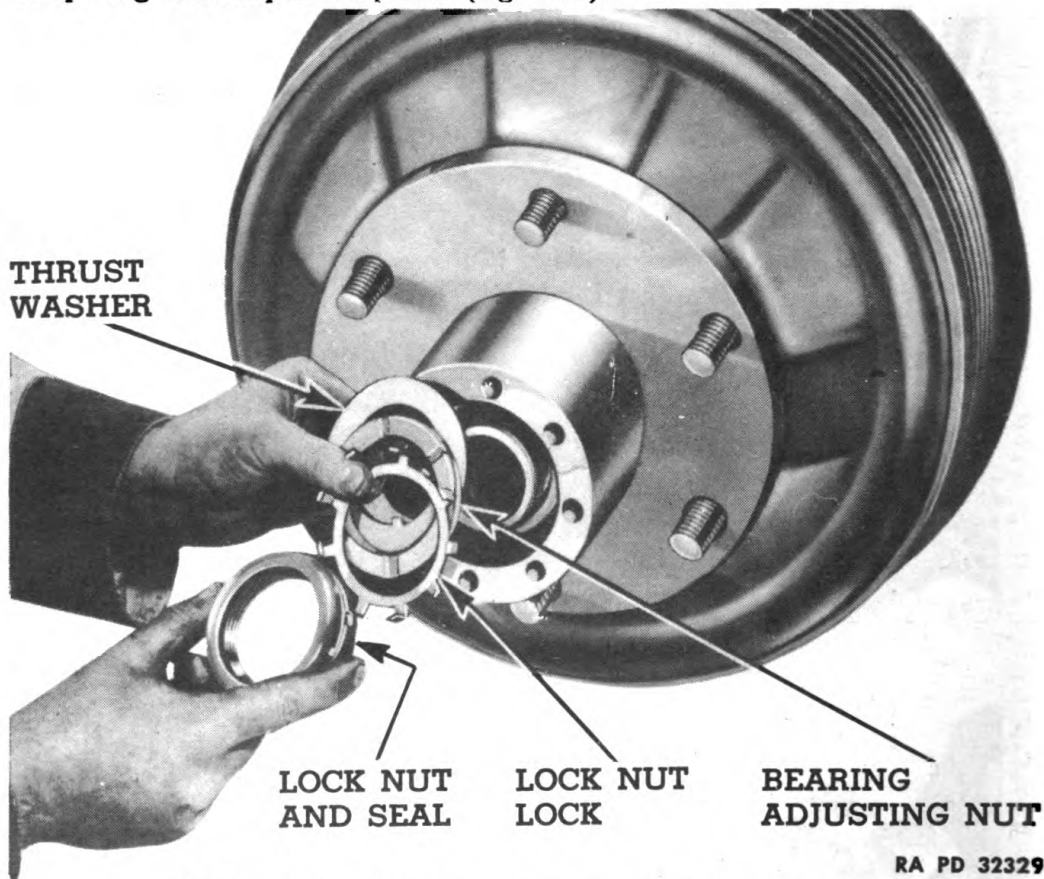

Figure 128—Removing Outer Bearing Snap Ring

BOMB SERVICE TRUCK M6 (Chevrolet)

- (2) Proceed as outlined in 174 a (2) to (8) of this paragraph.
- (3) Remove the bearing adjusting nut and spacer washer.
- (4) Remove hub and drum assembly.
- (5) Install brake wheel cylinder clamp to prevent loss of fluid in case the brake pedal is accidentally depressed.
- (6) Install puller as described under 174 b (5) of this paragraph and remove inner bearing and oil seal (fig. 125).
- (7) With the inside of the hub up, tap the outer bearing outer race away from the snap ring to relieve the tension on it. Then remove the snap ring with a pair of pliers (fig. 128).



RA PD 32329

Figure 129—Installing Bearing Adjusting Nuts

- (8) Remove the outer bearing by driving the outer race of the bearing toward the center of the hub, using outer bearing remover and replacer J-872-1 (KM).
- (9) Check the fit of the inner races on the housing. They should be free to turn but not loose.
- (10) Wash all parts with SOLVENT, dry cleaning. Pack the roller assemblies with GREASE, general purpose, No. 2 or its equivalent.
- (11) Install the outer bearing snap ring in the hub.

WHEELS, WHEEL BEARINGS, TIRES

(12) Place the outer bearing outer race in the wheel hub with the wide side of the race down. Press the bearing firmly against the snap ring, using outer wheel bearing race remover and replacer J-872-1 (KM) (fig. 126).

(13) Place outer race of inner bearing in hub with wide side of the race down. Use driver J-872-4 (KM) to press the race against its seat.

(14) Hand pack the inner bearing with LUBRICANT, general purpose, No. 2 and place it in the inner bearing outer race. Install the oil seal, using the oil seal replacer J-872-2 (KM). Press the seal down against the bearing in an arbor press. Lock the seal in place by prick punching at three equally spaced places.

(15) Install wheel hub and drum assembly. Hand pack the outer bearing and install it in the end of hub, turning the hub to properly line up the bearings.

(16) Install the thrust washer and adjusting nut (fig. 129).

(17) Adjust bearing as outlined, paragraph 174.

BOMB SERVICE TRUCK M6 (Chevrolet)

Section XXXIII

STORAGE OF VEHICLE

This information is not available at the present time.

Section XXXIV

REFERENCES

	Paragraph
Standard Nomenclature Lists	175
Explanatory Publications	176

175. STANDARD NOMENCLATURE LISTS:

- a. Bomb service truck M6 SNL G-85, Vol. 1V.
- b. Cleaning, preserving and lubricating materials, recoil fluids, special oils, and similar items of issue SNL K-1

Current Standard Nomenclature Lists are as tabulated here. An up-to-date list of SNL's is maintained as the "Ordnance Publications for Supply Index" OPSI

176. EXPLANATORY PUBLICATIONS:

- a. **Automotive Materiel.**
 - Automotive brakes TM 10-565
 - Fuels and carburetion TM 10-550
 - The internal combustion engine TM 10-570
- b. **Automotive Electricity.**
 - Automotive electricity TM 10-580
 - Electrical fundamentals TM 1-455

c. **Cleaning, Preserving, Lubricating, and Welding Materials and Similar Items**

Issued by the Ordnance Department TM 9-850

BOMB SERVICE TRUCK M6 (Chevrolet)

d. Explosives and Demolition FM 5-25

e. Hand Grenades FM 23-30

f. Maintenance.

Automotive lubrication	TM 10-540
Camouflage	FM 5-20
Defense against chemical attack	FM 21-40
Detailed lubrication instructions	OFSB 6 series
Echelon system of maintenance	TM 10-525
Fire prevention, safety	TM 10-360
Military motor transportation	TM 10-505
Military motor vehicles	AR 850-15
Motor transport	FM 25-10
Motor transport inspections	TM 10-545
Storage of motor vehicle equipment	AR 850-18
Tune-up and adjustment	TM 10-530

INDEX

A	Page No.	B—Cont'd	Page No.
Accelerating pump shaft, lubrication	27	Bleeding	
Accelerator, description	10	hydraulic brakes	77-80
Accessories, cold weather	39	hydrovac	95
Adjustment of:		Body	60-69
brakes	73-88	construction	60-63
hydraulic	77-88	lubrication	63
parking	75-76	maintenance	63
service	73-75	repair	44
breaker points	143-144	tightening	63
carburetor	209-210	Body wiring harness	155-157
choke	209	Bomb lift, hydraulic cylinder (See Cylinder, hydraulic)	
clutch pedal	104	Bomb lift truck (See Truck, bomb lift)	
fan belt	117-118	Brake hose, replacement	86
idling	186, 209	Brake pedal	10
metering rod	210	Brakes	
shifter shaft control rod	250	dragging, causes of	71-72
steering gear	241-244	repair	44
valves	181-182, 186	Brake shoe replacement	88-94
wheel bearings	260-261	Brake system	70-100
Air cleaner		adjustment	73-100
carburetor		hydraulic	77-94
description	210	hydrovac booster	94-98
lubrication	27	parking	75-76
maintenance	210-212	service	73-75
tune-up	185	trailer electric	98-100
valve cover		description	70
lubrication	27	functioning	70
tune-up	185-186	parts listed	91-93
Air leakage, tires	258-259	trailer electric	98-100
Ammeter	9, 217	trouble shooting	71-73
Automatic spark control	148-149	Brake (hydraulic) tubing, installa- tion	80-86
checking operation	149	Breaker points	143-145
description	148-149	adjustment	143-144
Automotive materiel, special precau- tions for	42	replacement	144-145
Auxiliary fuel tank	204	Bumper	201
Axles (See Front axle and Rear axle)			
		C	
B		Camouflage, paint as	32
Backlash, remedies for		Carbon removal	175
rear axle	55	Carburetor	208-210
universal joints	222	description	208
Battery and starting system	125-131	idling adjustment	209
cold weather operation	37-38	maintenance	209-210
description	125, 128	replacement	210
replacement	128	tune-up	185-186
starting motor	128-131	Carburetor air cleaner (See Air cleaner)	
testing	184	Care and preservation	30
trouble shooting	127	Chassis sheet metal	227-230
Bearings, lubrication	187-188		
Blackout lights	161		

BOMB SERVICE TRUCK M6 (Chevrolet)

C—Cont'd	Page No.	C—Cont'd	Page No.
Chassis sheet metal—Cont'd		Controls—Cont'd	
description	227	generator (See Generator)	
front end assembly		glove compartment lock	12
removal	227-229	hand throttle	10
replacement	229	headlight dimmer switch	10
front fender	229-230	identification plate	12
lubrication chart	26, 27	instrument panel light switch	10
Chassis wiring harness		lighting switch	9
front	152	maximum road speeds plate	12
rear	154-155	panel lights	10
Checking shock absorbers	237-238	serial number and load data plate	12
Choke		shifting diagram plate	13
adjustment	209	speedometer	8
description	9-10	starter switch pedal	10
Cleaning	30	temperature indicator	8
after gas attack	40	trailer electric brake load	12
propeller shaft assembly	224	transfer case shifting lever	11
Clutch	102-110	transmission gear shift lever	11
description	102	ventilator control lever	13
inspection	106-107	water bypass shut-off cock	15
overhaul	105-110	windshield quadrant clamp screws	15
pedal		windshield wiper switches	13
adjustment	104	Cooling system	111-124
description	10	capacity	5
release bearings, lubrication	27	description	111
repair	44	draining plate	13
trouble shooting	102-104	draining	113
Coil (See Ignition coil)		fan blades	116-117
Cold weather operation	35-39	fan belt	117-118
battery	37-38	fan shroud	116
cooling water	36-37	filling	113-114
crankcase oil	35-36	inspection	111-112
electrical parts	37-38	radiator core	121-124
gasoline	35	radiator pressure filler cap	114-115
gear lubricants	38	repair	44
special precautions	38-39	steam relief tube	119
Compression, engine	182-184	thermostat	121
ratio	5	trouble shooting	112-113
Condenser	148	tune-up	186
Contact points (See Breaker points)		water bypass shut-off cock	119
Controls, instruments and	8-15	water pump	118-119
accelerator	10	Cooling water, cold weather	36-37
ammeter	9	Crankcase, lubrication	27
brake pedal	10	Crankcase oil, cold weather	35-36
choke	9-10	Cruising range	5
clutch pedal	10	Cylinder head	174-181
cooling system draining plate	13	carbon removal	175
front axle control lever	11-12	description	174
fuel gage and gas tank selector		removal	174-175
switch	8	replacement	178-181
gear shift lever	11	valve grinding	175

INDEX

C—Cont'd	Page No.	D—Cont'd	Page No.
Cylinder, hydraulic, lubrication	25, 29	Description of:—Cont'd	
Cylinder, hydraulic brake		ignition system	141
master		instrument cluster	213
description	86-87	instruments	8-15
replacement	87	lighting and wiring system	152-157
servicing	87	manifolds	171-172
wheel		master cylinders (brake)	86-87
description	87	oiling system, engine	187-188
replacement	87-88	oil pressure gage	216-217
Cylinders		pintle hook	199
bore and stroke	5	power plant brace rod	194
firing order	5	propeller shafts	219
numbering	5	pull hooks	199
		radiator core	121
		radiator pressure filler cap	114-115
		rear axle	55
		regulator unit	139
		slip joints	219
		speedometer	217
		springs	231
		starting motor	128-129
		switch	131
		starting system	125
		steam relief tube	119
		steering gear	239
		thermostat	121
		transfer case	247
		universal joints	219
		water pump	118
		wheels	258
		windshield	62
		wiring system	152-157
		Discharged battery	127
		Distributor	143-148
		breaker points	
		adjustment	143-144
		replacement	144-145
		description	143
		lubrication	27
		replacement	145-146
		retiming	146-148
		tune-up	184-185
		Double-clutching	17-18
		Drive gear and pinion, lubrication	29
		Driver's compartment	60-63
		E	
		Electrical system	
		cold weather operation	37-38
		repair	44
		(See also Lighting and wiring system)	

D

E

BOMB SERVICE TRUCK M6 (Chevrolet)

E—Cont'd	Page No.
Engine	162-194
cylinder head	174-181
carbon removal	175
description	174
removal	174-178
rocker arm and shaft assem- blies	176-178
replacement	178-181
rocker arm and shaft assem- blies	178-180
data, tabulated	5, 162-163
description, general	162
installation	191-192
manifolds	171-174
description	171-172
gasket leaks	174
removal	172
replacement	172-174
misses, remedies, for	203
mountings	192-194
noises, remedies for	170
oiling system	187-188
oil pan, replacement	188
oil pump, replacement	188-189
removal	189-191
repair	44-45
starting	151
trouble shooting	166-170
lack of power	166-167
idling rough	170
noises	170
popping, spitting, spark knock	168-169
tune-up	182-187
valve adjustment	181-182
Equipment on vehicle	34
Exhaust system	196-198
description	196
maintenance	196
repair	45
replacement	196-198
trouble shooting	196
Eye bolt, replacement	237

F

Fan belt	117-118
Fan blades	116-117
Fan shroud	116
Fenders (See Chassis sheet metal)	
Filler cap, fuel tank	204
Filling shock absorbers	238

F—Cont'd	Page No.
Fittings, lubrication	
chassis	27
truck	29
Frame	199-201
bumper	201
description	199
pintle and pull hooks	199-200
Front axle	48-54
adjustment	49-52
description	48
control lever	11-12
drive gears, shifting	17
maintenance	49-52
oil capacity	5
parts listed	47
repair	43
replacement	53-54
shaft, replacement	49-52
tie rod, replacement	52
trouble shooting	48-49
Front wheel bearings, lubrication ..	24
Fuel	
capacity	5
consumption, excessive	202-203
Fuel filter	207
Fuel gage	213-216
description	8, 213-215
testing	215-216
Fuel pump	206-207
description	206
maintenance	206-207
replacement	207
tune-up	207
Fuel system	202-212
air cleaner	210-212
ammeter	217
carburetor	208-210
description	202
fuel filter	207
fuel pump	206-207
repair	45
tanks	203-204
trouble shooting	202-203
Fuel tanks	203-204

G

Gages (See Instruments and gages)	
Gas, materiel affected by	40-42
automotive	42
cleaning	40
decontamination	40-42

INDEX

G—Cont'd	Page No.	I	Page No.
Gasket, manifold, leaks	174	Identification plate	12
Gasoline		Idling	
cold weather	35	adjustment	209
tank gage selector switch	35	fast, remedies for	203
Gear cases, lubrication	27	rough, remedies for	170
Gear shift lever	11	Ignition coil	150-151
Gear reduction, transmission	251	Ignition harness	152-157
Generator and controls	132-140	body	155-157
charging rate too high or low	137	chassis front	152
description	132, 137-138	chassis rear	154-155
maintenance	137	Ignition system	141-151
regulator unit	139-140	automatic spark control	148-149
replacement	138-139	coil	150-151
testing	132-135	condenser	148
trouble shooting	137	description	141
Glove compartment lock	12	distributor	143-148
Grabbing clutch, causes of	104	breaker points	
Grease leakage, rear axle, causes of	55-56	adjustment	143-144
Grinding valves	175	replacement	144-145
Ground clearance	5	description	143
		replacement	145-146
		retiming	146-148
		spark plugs	149-150
		timing	146-148
		trouble shooting	141-142
		Ignition timing, tune-up	186
		Inspection	19-22
		after operation	20-21
		at halt	20
		battery	125-127
		clutch	106-107
		cooling system	111-112
		daily	20-21
		during operation	20
		hoist	65
		periodic	21-22
		prestarting	19-20
		propeller shafts	224
		starting system	125-127
		Instrument panel light switch	10
		Instruments and gages	213-218
		description	213
		(See also Controls)	
		fuel gage	213-216
		description	213-215
		testing	215-216
		oil pressure gage	216-217
		repair	45
		speedometer	217-218
		temperature indicator	8, 213
		Intervals, lubrication	27

H

Hand throttle	10
Hard riding, causes of	231-232
Hard steering, causes of	239, 258
Headlights	157-161
aiming	160-161
description	158-159
dim, causes of	157
dimmer switch	10
sealed beam unit, replacement	159
Height	5
High temperature operation	39
Hoist, bomb handling	
inspection	65
installation and reassembly	65-69
operation	63
parts listed	67
removal and disassembly	63-65
repairs	63-65
Hood (See Chassis sheet metal)	
Hydraulic brakes, adjustment	77-88
bleeding	77-80
master cylinder	86-87
tubing	80-86
Hydrovac booster system	94-97
bleeding	95
description	94-95
failure to operate	72-73
lubrication	95
maintenance	95
replacement	95-98

BOMB SERVICE TRUCK M6 (Chevrolet)

J	Page No.	M	Page No.
Jumping out of gear, causes of	252	Maintenance and adjustment	
		air cleaner	210-212
		battery	125-127
		body	63
		carburetor	209-210
		air cleaner	210-212
		distributor	143
		exhaust system	196
		front axle	49-52
		fuel filter	207
		fuel pump	206-207
		hydrovac booster	95
		rear axle	56
		starting system	125-127
		steering gear	240-241
		Maintenance operations	43-47
		Manifold heating control	
		lubrication	24
		valve, tune-up	186
		Manifolds	171-174
		description	171-174
		replacement	172-174
		Maximum road speeds plate, descrip- tion	12
		Metal surfaces, painting	32
		Metering rod, adjustment	210
		Missing engine, causes of	203
		N	
		Noises, causes and remedies	
		axle	55
		differential	49
		engine	170
		rear axle	55
		springs	232
		transmission	251-252
		O	
		Oil can points	27, 29
		Oil capacity	5
		Oil filter	27
		Oiling system, engine	187-188
		Oil pan, replacement	188
		Oil pressure gage	216-217
		Oil pump, replacement	188-189
		Operation	8-18
		cold weather	35-39
		controls	8-15
		hoist	63
		prestarting inspection	15
		shifting	17-18
L			
Leaks			
air, tires	258-259		
gasket, manifold	174		
lubricant			
front axle	48		
transfer case	248		
steam relief tube	119		
water	113		
Lighting and wiring systems	152-161		
blackout lights	161		
description	152-157		
headlights	158-161		
aiming	160-161		
description	158-159		
dim	157		
main light switch	157-158		
Light switch			
instrument panel	9, 10		
main	157-158		
Log book	30		
Loose steering, remedies for	240		
Lubricant leaks			
front axle	48		
transfer case	248		
Lubricating system	187-188		
camshaft bearing	187		
connecting rod-bearing	187		
main bearing	187		
repair	45		
timing gear	187		
valve mechanism	187-188		
Lubrication	23-29		
body	63		
bomb lift hydraulic cylinder	25		
bomb lift truck	25		
charts	26-29		
cold weather	35-36, 38		
front wheel bearings	24		
hydrovac booster	95		
manifold heating control	24		
methods	24		
rear wheel bearings	24-25		
records	23, 25		
schedules	23		
supplies	23-24		
wheel bearings	24-25		

INDEX

O—Cont'd	Page No.
Operation—Cont'd	
starting engine	15
starting truck	17
Overhaul propeller shaft assem- bly	223-224
Overheating, causes of	112-113

P

Paint(ing)	31-33
camouflage	32
general instructions	31
lubricating devices	33
metal surfaces	32
preparation for	31-32
removing	32
Panel lights	10
Parking brake, adjustment	75-76
Pintle hook	199
Piston displacement	5
Popping, remedies for	168-169
Power, lack of	166-167
Power plant brace rod	194
Prestarting inspection	
engine	15
truck	19-20
Primer, ground, synthetic	31-32
Primer, synthetic, rust inhibiting	32
Propeller shafts	219-226
cleaning	224
description	219
inspection	224
overhaul	223-224
reassembly	225-226
removal	222-223
replacement	226
trouble shooting	222
Pull hooks	199-201

R

Radiator core	121-124
Radiator pressure filler cap	114-115
Rear axle	55-58
adjustment	56
description	55
differential, replacement	56
maintenance	56
oil capacity	5
repair	44
replacement	58
shaft, replacement	56
Rear wheel bearing, lubrication	24-25
Rebuild, definition	43

R—Cont'd	Page No.
Records	
lubrication	23, 25
use	30
Regulator unit	139-140
Repair, allocation of	43-47
body	44
brakes	44
clutch	44
cooling system	44
definition	43
electrical system	44
engine	44-45
exhaust system	45
front axle	43
fuel system	45
hoist	63-65
instruments	45
lubricating system	45
rear axle	44
shock absorbers	45
springs	45
steering gear	45
transmission	45
Replacement (removal and)	
ammeter	217
axle shaft, front	49-52
battery	128
blackout lights, bulb	161
brake hose	86
brake shoe	88-94
breaker points	144-145
carburetor	210
chassis front end assembly	227-229
clutch	105-110
condenser	148
cylinder head	178-181
cylinders, brake	87-88
definition	43
differential	56
engine	189-192
engine mountings	192-194
exhaust system	196-198
eye bolt	237
fan belt	118
fan blades	116-117
fan shroud	116
front axle	53-54
front fender	229-230
front springs	232-233
fuel tank, main	204
generator	138-139
headlights, sealed beam unit	159

BOMB SERVICE TRUCK M6 (Chevrolet)

R—Cont'd	Page No.	S—Cont'd	Page No.
Replacement (removal and)—Cont'd		Service brakes—Cont'd	
hydrovac booster	95-98	toeboard clearance	75
ignition coil	150-151	Service, definition	43
manifolds	172-174	Shackles, replacement	237
master cylinder, brake	87	Shifter shaft control rod, adjust- ment	250
oil pan	188	Shifting	17-18
oil pressure gage	217	Shifting diagram plate	13
oil pump	188-189	Shifting difficulties	252
pintle hook	199	Shimmy, remedies for	49, 240
propeller shafts	222-226	Shock absorbers (See Springs and shock absorbers)	
radiator core	121-124	Side pull, remedies for	240
radiator pressure filler cap	115	Slipping clutch	102-104
rear axle	58	Slipping out of gear	248
shaft	56	Slip joints	
rear springs	233-235	description	219
regulator unit	139-140	lubrication	27
rocker arms	176-180	Slow starter speed	127
shock absorbers	238	Spark knock, remedies for	168-169
speedometer	218	Spark plugs	149-150
starting motor	129-131	tune-up	184
switch	131	Speedometer	8, 217-218
steering gear	244-246	Spitting, remedy for	168-169
connecting rod	244	Springs and shock absorbers	231-238
temperature indicator	213	description	231
thermostat	121	eye bolt, replacement	237
tie rod	52	front springs	232-233
tires	259	removal	232-233
transfer case	249-250	replacement	233
transmission	255-257	rear springs	233-235
cover	252-255	removal	233-234
water pump	118-119	replacement	235
wheel bearings	262-267	repair	45
front	262-264	shackles, replacement	237
rear	264-267	shock absorbers	237-238
wheel cylinder, brake	87-88	checking	237
wheels	259	filling	238
windshield	68-69	replacement	238
Reverse, shifting into	18	trouble shooting	231-232
Road shock, remedies for	240	Starter switch pedal	10
Road test	186-187	Starting	
Rocker arms and shafts		engine	15
installation	178-180	failure	142
location of	176-177	hard	141-142
removal	176-178	Starting motor	128-131
Running boards (See Chassis sheet metal)		switch	131
S		Starting system (See Battery and starting system)	
Serial number and load data plate	12	Steam relief tube	119
Service brakes			
adjustment	70-73		
description	70		

BOMB SERVICE TRUCK M6 (Chevrolet)

T—Cont'd	Page No.	V	Page No.
Trouble shooting—Cont'd		Vacuum line check valve	98
rear axle	55-56	Valve adjustment	181-182
road shock	240	tune-up	186
shifting difficulties	252	Ventilator control lever	13
shimmy	49, 240	Vibration (propeller shaft)	222
slipping clutch	102-104		
slipping out of gear	248	W	
springs	231-232	Wandering, remedies for	232
start, failure to	142	Water bypass shut-off cock	15, 119
starting system	127	Water pump	118-119
steering gear	239-240	Weaving, remedies for	240
transfer case	247-248	Weight	5
transmission	251-252	Wheel(s), wheel bearings, tires	258-267
universal joints	222	base, length	5
vibration (propeller shaft)	222	bearings	
wandering	49, 240	adjustment	260-261
weaving	240	replacement	
wheels	258-259	front	262-264
Truck, bomb lift		rear	264-267
lubrication	15, 28, 29	description	258
starting	17	lubrication	24-25
Tubing, brake	80-86	repair	45
Tune-up, engine	182-187	replacement	259
battery test	184	trouble shooting	258-259
compression	182-184	Wheel cylinder (brake)	87-88
condenser	185	Winch, lubrication	28, 29
cooling system	186	Windshield	
fuel pump	185	description	62
ignition coil	185	quadrant clamp screw	15
manifold heat valve	186	replacement	68-69
road test	186-187	wiper switches	13
spark plugs	184	Wiring system	152-157
U		body harness	155-157
Universal joints		chassis front harness	152
description	219	chassis rear harness	154-155
lubrication	27		
trouble shooting	222		

[A. G. 062.11 (8-13-42)
O.O. 461 20000 O.O. (8-13-42)]

BY ORDER OF THE SECRETARY OF WAR:

G. C. MARSHALL, *Chief of Staff.*

OFFICIAL:

J. A. ULIO,
Major General,
The Adjutant General.

DISTRIBUTION:

IC 9(4)

For explanation of these symbols see FM 21-6.

