



UNIVERSITY OF CALIFORNIA

*1/4 wd U113
TM
1944*

TM 9-768

US WAR DEPARTMENT TECHNICAL MANUAL

U.S. Dept. of Army

45-TON TANK TRANSPORTER TRUCK-TRAILER M19

RESTRICTED DISSEMINATION OF RESTRICTED MATTER—
The information contained in restricted documents and the essential characteristics of restricted material may be given to any person known to be in the service of the United States and to persons of undoubted loyalty and discretion who are cooperating in Government work, but will not be communicated to the public or to the press except by authorized military public relations agencies. (See also paragraph 23b, AR 380-5, 15 March 1944.)

WAR DEPARTMENT

• 25 OCTOBER 1944

THE UNIVERSITY OF CALIFORNIA
LIBRARY

THE UNIVERSITY OF CALIFORNIA
LIBRARY

WAR DEPARTMENT TECHNICAL MANUAL
TM 9-768

This manual supersedes:

- a. WDTB ORD 91, dated 13 May 1944, and WDTB ORD 103, dated 10 June 1944.
 - b. OFSTB 811-1 and 10-1255-1, dated 22 October 1943 insofar as it applies to this manual. Together with TM 9-811, dated 25 January 1944, this manual completely supersedes OFSTB 811-1 and 10-1255-1.
 - c. The following publications insofar as they apply to this manual. These publications remain in force until such time as they are incorporated in other affected manuals or specifically rescinded: OFSTB 800-21, dated 30 November 1943; OFSTB 1700-32, 1800-3, and 10-1000-22, dated 8 July 1943; WDTB ORD 60, dated 13 March 1944; WDTB ORD 74, dated 8 July 1943; WDTB ORD 126, dated 19 July 1944; WDTB ORD 20, dated 24 January 1944.
 - d. The following 10-series Technical Manuals insofar as they apply to this manual: TM 10-1225, dated 25 October 1941; TM 10-1242, dated 15 August 1942; TM 10-1242 (revised), dated 15 February 1944; TM 10-1255, dated 6 July 1942; and TM 10-1322, dated 3 November 1941. The above 10-series manuals remain in effect until they are incorporated in TM 9-1768A, TM 9-1768B, TM 9-1768C, and SNL G-159, at which time they will be completely superseded.
-

45-TON
TANK TRANSPORTER
TRUCK-TRAILER
M19



WAR DEPARTMENT

• *25 OCTOBER 1944*

RESTRICTED DISSEMINATION OF RESTRICTED MATTER—
The information contained in restricted documents and the essential characteristics of restricted material may be given to any person known to be in the service of the United States and to persons of undoubted loyalty and discretion who are cooperating in Government work, but will not be communicated to the public or to the press except by authorized military public relations agencies. (See also paragraph 23*b*, AR 380-5, 15 March 1944.)

WAR DEPARTMENT

Washington 25, D. C., 25 October 1944

TM 9-768, 45-ton Tank Transporter Truck-trailer M19, is published for the information and guidance of all concerned.

[A.G. 300.7 (2 Jun 44)
O.O.M. 461/Rar. Ars. (10-27-44)]

BY ORDER OF THE SECRETARY OF WAR:

G. C. MARSHALL,
Chief of Staff.

OFFICIAL:

J. A. ULIO,
Major General,
The Adjutant General.

DISTRIBUTION: Armies (10); Corps (10); SvC (10); Depts (10); IBn 9 (2); IC 9, 17 (3); Chief of Tech Svs (2); Gen & Sp Sv Schools (10); Ord Decentralized Sub-O (3); PE's "Mark for Ord O" (5); H & R Points (5); Ord Dist O (5); Ord Regional O (3); Ord Dist Br O (3); Ord Establishments (5); Ord Tk Dep (3).

IBn 9—T/O 9-65, 9-75, 9-315, 9-325.

IC 9—T/O 9-7, 9-9, 9-37, 9-67, 9-76, 9-127,
9-187, 9-197, 9-316, 9-318, 9-327, 9-328,
9-377, 9-500.

17—T/O 17-2, 17-60-1.

(For explanation of symbols, see FM 21-6.)

CONTENTS

U 113
.2
TM 9-768
1944

PART ONE—GENERAL

		Paragraphs	Pages
SECTION I.	Introduction	1- 2	1- 3
II.	Description and data	3- 4	3- 9
III.	Tools, parts and accessories....	5- 9	9- 16

PART TWO—OPERATING INSTRUCTIONS

SECTION IV.	Driving controls and instruments	10- 11	17- 23
V.	Operation under ordinary conditions	12- 14	23- 30
VI.	Operation of auxiliary equipment.	15- 17	31- 36
VII.	Operation under unusual conditions	18- 20	36- 44

PART THREE—MAINTENANCE INSTRUCTIONS

SECTION VIII.	Lubrication	21- 22	45- 65
IX.	New vehicle run in test.....	23- 25	65- 72
X.	First echelon preventive maintenance service	26- 30	72- 85
XI.	Second echelon preventive maintenance	31	85-109
XII.	Trouble shooting	32- 57	109-135
XIII.	Engine description and maintenance in vehicle.....	58- 66	136-151
XIV.	Engine removal and installation	67- 69	151-160
XV.	Fuel system	70- 83	160-189
XVI.	Air intake and exhaust systems	84- 86	190-193
XVII.	Cooling system	87- 94	193-205
XVIII.	Starting system	95- 99	206-212
XIX.	Truck lights and horn system	100-110	213-225
XX.	Battery and generating system	111-115	226-238
XXI.	Truck wiring, circuit breakers, and junction block.....	116-118	238-247

PART THREE—MAINTENANCE INSTRUCTIONS (Contd.)

	Paragraphs	Pages
SECTION XXII. Tachometer and speedometer	119-120	247-249
XXIII. Engine oil system	121-125	249-254
XXIV. Clutch	126-131	254-263
XXV. Transmission	132-135	263-268
XXVI. Auxiliary transmission	136-139	268-272
XXVII. Power take-off	140-143	272-274
XXVIII. Propeller shafts and universal joint assemblies	144-148	275-281
XXIX. Front axle assembly	149-153	281-285
XXX. Rear axle assembly	154-160	285-297
XXXI. Truck service brake system ...	161-179	297-329
XXXII. Parking brake system	180-183	329-334
XXXIII. Truck wheels, hubs, wheel bearings, and tires	184-186	334-341
XXXIV. Springs	187-188	341-344
XXXV. Steering gear	189-193	345-350
XXXVI. Cab, frame, and body	194-208	350-367
XXXVII. Auxiliary equipment	209-217	367-375
XXXVIII. Radio interference suppres- sion system	218-220	376-377
XXXIX. Trailer service brake system	221-231	377-392
XL. Hand parking brake system..	232-234	392-395
XLI. Trailer dolly	235-237	395-397
XLII. Trailer lights system	238-244	397-406
XLIII. Frame	245-252	406-411
XLIV. Trailer understructure	253-255	411-422
XLV. Wheels and tires	256-258	423-429

APPENDIX

SECTION XLVI. Shipment and limited storage	259-261	430-436
XLVII. References	262-264	437-439
INDEX		440-452

RESTRICTED

This manual supersedes:

- a. WDTB ORD 91, dated 13 May 1944, and WDTB ORD 103, dated 10 June 1944.
- b. OFSTB 811-1 and 10-1255-1, dated 22 October 1943 insofar as it applies to this manual. Together with TM 9-811, dated 25 January 1944, this manual completely supersedes OFSTB 811-1 and 10-1255-1.
- c. The following publications insofar as they apply to this manual. These publications remain in force until such time as they are incorporated in other affected manuals or specifically rescinded: OFSTB 800-21, dated 30 November 1943; OFSTB 1700-32, 1800-3, and 10-1000-22, dated 8 July 1943; WDTB ORD 60, dated 13 March 1944; WDTB ORD 74, dated 8 July 1943; WDTB ORD 126, dated 19 July 1944; WDTB ORD 20, dated 24 January 1944.
- d. The following 10-series Technical Manuals insofar as they apply to this manual: TM 10-1225, dated 25 October 1941; TM 10-1242, dated 15 August 1942; TM 10-1242 (revised), dated 15 February 1944; TM 10-1255, dated 6 July 1942; and TM 10-1322, dated 3 November 1941. The above 10-series manuals remain in effect until they are incorporated in TM 9-1768A, TM 9-1768B, TM 9-1768C, and SNL G-159, at which time they will be completely superseded.

PART ONE

GENERAL

Section I

INTRODUCTION

1. SCOPE.

a. These instructions* are published for the information and guidance of the personnel to whom this equipment is assigned. They contain information on the operation and maintenance of the 45-ton Tank Transporter Truck-trailer M19, as well as descriptions of the major units and their functions in relation to the other components of this vehicle.

b. This manual has the following arrangement:

(1) Part One, General, contains description and data. It lists the tools, spare parts, and equipment carried on the vehicle. It also lists organization special tools for the vehicle.

(2) Part Two, Operating Instructions, contains instructions for the operation of the vehicle with description and location of the controls and instruments.

(3) Part Three, Maintenance Instructions, contains information needed for the performance of the scheduled lubrication and preventive maintenance services, and instructions for maintenance operations which are the responsibility of the using organizations (first and second echelons). Stock numbers in this part were obtained from the Organizational Spare Parts and Equipment List of SNL G-159.

*To provide operating instructions with the materiel, this technical manual has been published in advance of complete technical review. Any errors or omissions will be corrected by changes or, if extensive, by an early revision.

(4) The appendix contains instructions for shipment and limited storage, and a list of references which includes standard nomenclature lists, technical manuals, and other publications applicable to the vehicle.

2. RECORDS.

a. Forms and records applicable for use in performing prescribed operations are listed below with brief explanations of each:

(1) **STANDARD FORM NO. 26, DRIVER'S REPORT—ACCIDENT, MOTOR TRANSPORTATION.** One copy of this form will be kept with the vehicle at all times. In case of an accident resulting in injury or property damage, it will be filled out by the driver on the spot, or as promptly as practical thereafter.

(2) **WAR DEPARTMENT FORM NO. 48, DRIVER'S TRIP TICKET AND PREVENTIVE MAINTENANCE SERVICE RECORD.** This form, properly executed, will be furnished to the driver when his vehicle is dispatched on nontactical missions. The driver and the official user of the vehicle will complete in detail appropriate parts of this form. These forms need not be issued for vehicles in convoy or on tactical missions. The reverse side of this form contains the driver's daily and weekly preventive maintenance service reminder schedule.

(3) **W.D., A.G.O. FORM NO. 478, MWO AND MAJOR UNIT ASSEMBLY REPLACEMENT RECORD.** This form will be used by all personnel completing a modification or major unit assembly (engine, transmission, transfer case, and tracks) replacement to record clearly the description of work completed, data, vehicle hours, and/or mileage, and MWO number or nomenclature of unit assembly. Personnel performing the operation will initial in the column provided. Minor repairs, parts, and accessory replacements will not be recorded.

(4) **W.D., A.G.O. FORM NO. 6, DUTY ROSTER.** This form, slightly modified, will be used for scheduling and maintaining a record of vehicle maintenance operations. It may be used for lubrication records.

(5) **W.D., A.G.O. FORM NO. 461, PREVENTIVE MAINTENANCE SERVICE AND TECHNICAL INSPECTION WORK SHEET FOR WHEELED AND HALF-TRACK VEHICLES.** This form will be used for all 1,000-mile (monthly) and 6,000-mile (semiannual) maintenance services and all technical inspections performed on wheeled or half-track vehicles.

(6) **W.D., O.O. FORM NO. 7353, SPOT-CHECK INSPECTION REPORT FOR ALL MOTOR VEHICLES.** This form may be used by all commanding officers or their staff representatives in making spot-check inspections on all vehicles.

(7) **W.D., A.G.O. FORM NO. 468, UNSATISFACTORY EQUIPMENT REPORT.** This form will be used for reporting manufacturing, design, or operational defects in materiel with a view to improving and cor-

Description and Data

recting such defects, and for use in recommending modifications of materiel. This form will not be used for reporting failures, isolated materiel defects, or malfunctions of materiel resulting from fair wear and tear or accidental damage; nor for the replacement, repair, or the issue of parts and equipment. It does not replace currently authorized operational or performance records.

(8) W.D., O.O. FORM No. 7370, EXCHANGE PART OR UNIT IDENTIFICATION TAG. This tag, properly executed, may be used when exchanging unserviceable items for like serviceable assemblies, sub-assemblies, parts, vehicles, and tools.

Section II**DESCRIPTION AND DATA****3. DESCRIPTION (figs. 1, 2, and 3).**

a. **General.** The 45-ton Tank Transporter Truck-trailer M19 is a combination of two units, the 12-ton, 6 x 4 truck M20 and the 45-ton, 12-wheel trailer M9. The unit is designed to recover and transport damaged tanks and materiel weighing up to 90,000 pounds.

b. **Truck.** The 12-ton, 6 x 4 truck M20 is a tandem-rear-axle, or 6-wheel, truck equipped with a rear pintle for towing the M9 trailer. The cab is a closed type on some models and open type on others. A ballast body and a winch are installed on the chassis behind the cab. The winch is operated through a power take-off installed on the auxiliary transmission and is controlled from outside the cab by means of an air-operated clutch control and remote throttle control. Recovery and loading is accomplished by means of the winch. Additional wheel traction can be obtained by filling the ballast body with any available materials such as gravel or sand. The spare wheel and tire are mounted in the forward end of the ballast body, and two stowage boxes are located inside the body at the rear end. A fuel tank is installed on each side of the truck immediately behind the cab. The storage batteries and fuel gate valves are carried in a compartment on each side under the cab doors. The truck is powered by a Diesel engine, which is equipped with a fuel oil burning heater to facilitate cold weather starting.

c. **Trailer.** The 45-ton, 12-wheel trailer M9 has a tandem axle at the rear which carries 8 dual wheels and a front axle which carries 4 dual wheels. A drawbar is provided for towing the trailer. The rear end of the trailer slopes down and two hinged ramps are provided to

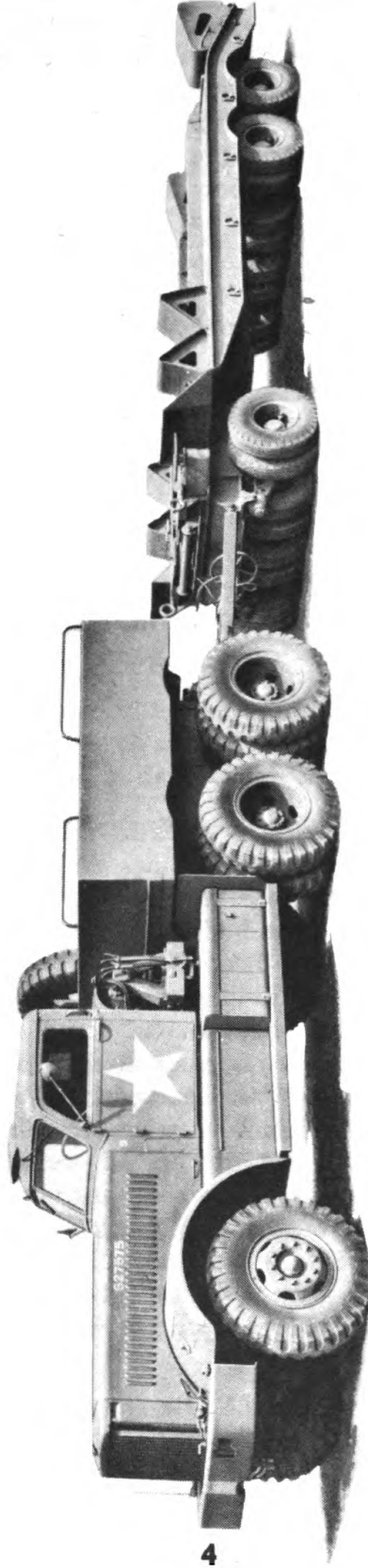

4

RA PD 321349

Figure 1—45-ton Tank Transporter Truck-trailer M19—Left Front View

Description and Data

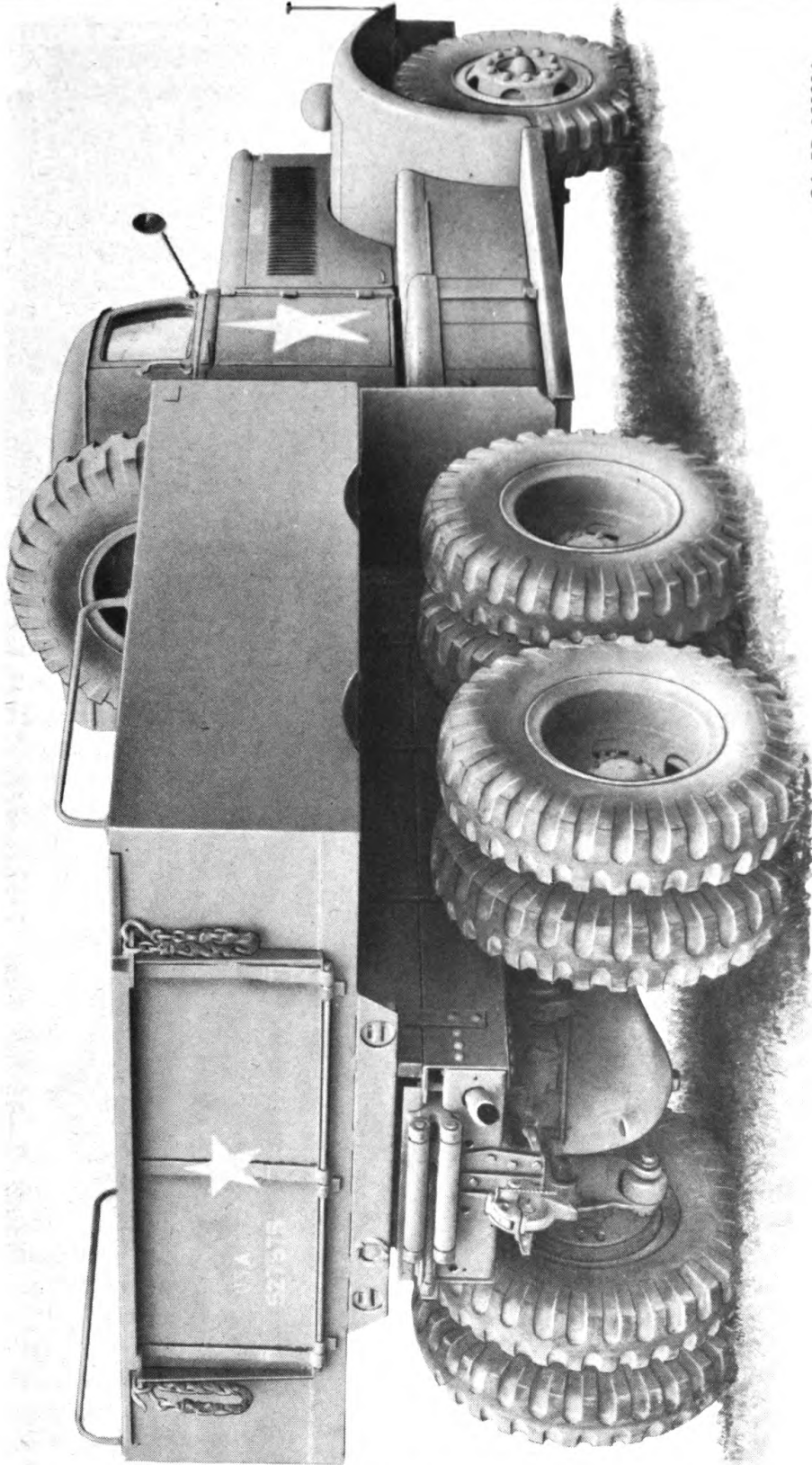

RA PD 321334

Figure 2—Truck-trailer Truck M20—Right Rear View

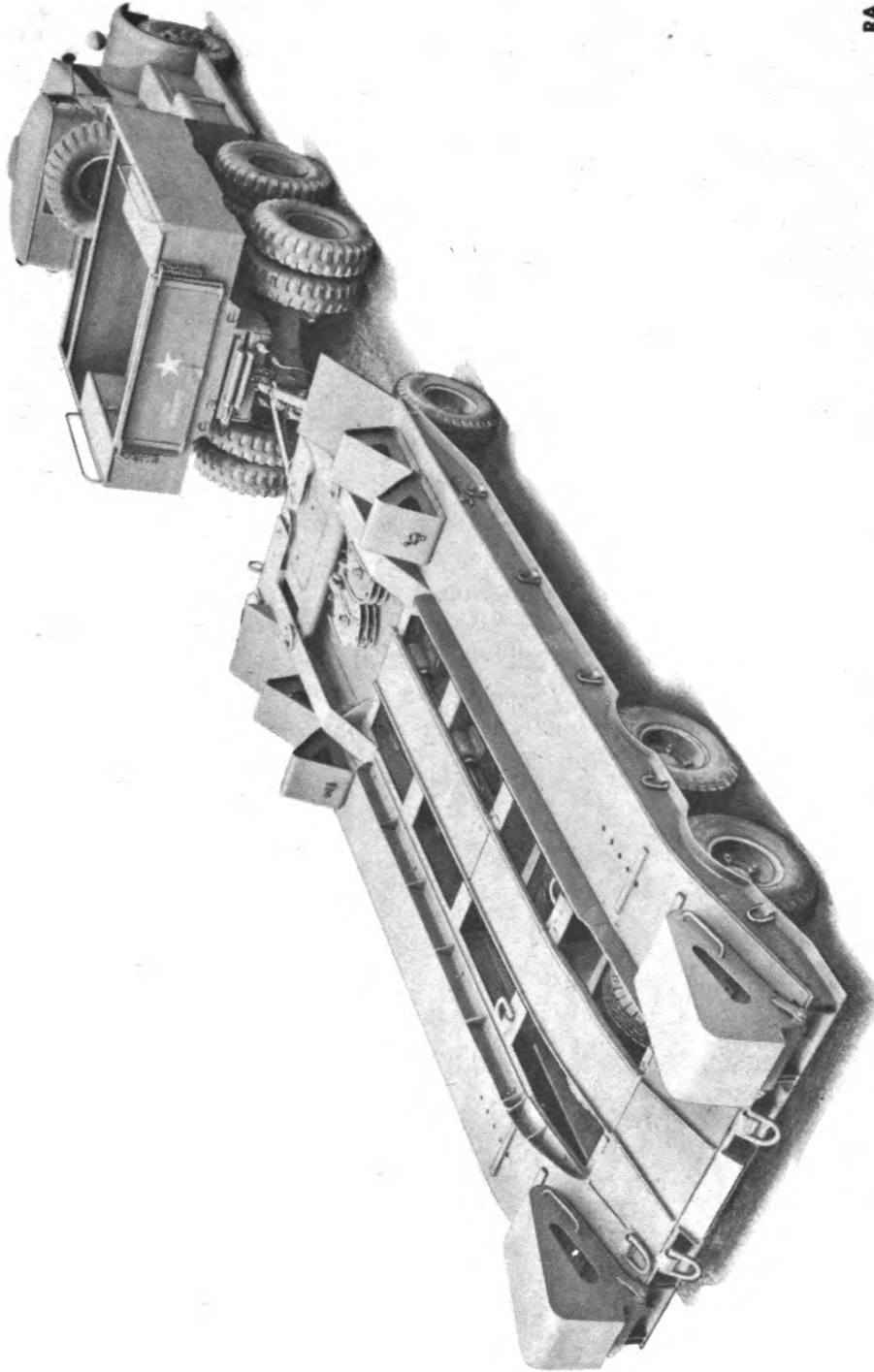

RA PD 321187

Figure 3—45-ton Tank Transporter Truck-trailer M19—Right Rear View

Description and Data

NOMENCLATURE	TRUCK, PRIME MOVER, 6X4	
MAKE AND MODEL	DIAMOND-T MODEL	980
SERIAL NUMBER		
VEHICLE WEIGHT, UNLOADED	LBS.	
VEHICLE WEIGHT, LOADED NOMINAL	45,000	LBS.
MAXIMUM TOWED LOAD	115,000	LBS.
DATE OF DELIVERY		
RECOMMENDED BY MANUFACTURER		
TIRE INFLATION PRESSURE	80 LBS. PER SQ. IN.	
S.A.E. GRADE OF OIL FOR SUMMER USE	30	
S.A.E. GRADE OF OIL FOR WINTER USE	10	
CHECK VISCOMETER FREQUENTLY AS A GUIDE TO CORRECT OIL VISCOSITY		

RA PD 321327

Figure 4—Chassis Plate

facilitate loading. The trailer is equipped with track guides, cable troughs, rollers, and sheaves. Four chock blocks and various anchor chains are carried to secure the tank while it is being transported. The trailer is equipped with an air-brake system and a manual control for setting brakes independently of the truck. A stowage compartment is located at the rear of the trailer.

4. DATA.

a. Truck With Trailer.

Length, over all52 ft 11³/₄ in.
 Weight, net48,600 lb

b Truck.

(1) GENERAL SPECIFICATIONS.

ManufacturerDiamond T
 Model 980 or 981
 Wheelbase 14 ft 11¹/₄ in.
 Length, over-all 23 ft 3³/₄ in.
 Width, over-all 8 ft 5¹/₂ in.
 Height, over-all 8 ft 5 in.
 Wheel size 20 x 9-10 in.
 Tire size 12.00 x 20
 Tire type Mud and snow

General

Tread (center-to-center)—front	75 ⁷ / ₈ in.
—rear	74 in.
Crew	2
Weight of vehicle—net	26,650 lb
Weight of vehicle—payload	18,350 lb
Weight of vehicle—gross	45,000 lb
Ground clearance:	
Front axle (loaded)	13 ¹ / ₁₆ in.
Rear axle “	11 ¹ / ₈ in.
Chassis “	18 ⁹ / ₁₆ in.
Kind and grade of fuel	45 cetene Diesel fuel oil
Approach angle	45 deg
Departure angle	51 deg

(2) FUEL, LUBRICATING, AND COOLING SYSTEM CAPACITIES.

Transmission	18 pt
Auxiliary transmission	17 pt
Rear axle differentials (each)	20 pt
Fuel tanks (total)	150 gal
Cooling system	61 qt
Crankcase	26 qt
Oil-bath air cleaners (each)	2 pt
Winch	8 pt

(3) PERFORMANCE (WITHOUT TRAILER ATTACHED).

Maximum speed allowable	23 mph
Minimum turning circle (dia.)—right	65 ft
—left	72 ft
Fording depth	38 in.
Towing facilities—front	1 pintle, 2 air brake connections
—rear	1 pintle, 2 air brake connections
Maximum towed load	115,000 lb
Maximum grade ascending ability	25 pct
Maximum allowable engine speed	1,600 rpm
Miles per gallon, average conditions with towed load	2
Cruising range	300 miles

c. Trailer.

(1) GENERAL SPECIFICATIONS.

Wheelbase	15 ft 7 in.
Length, over-all, including drawbar	29 ft 8 in.
Width, over-all	9 ft. 6 in.
Height, over-all	4 ft 8 ³ / ₄ in.
Loading height, unloaded	38 ¹ / ₂ in.
Tire size	8.25 x 15

Tools, Parts, and Accessories

Weight—net	22,020 lb
Weight—pay load	90,000 lb
Weight—gross	112,020 lb
Ground clearance	12 in.
Brakes	Air

Section III

TOOLS, PARTS, AND ACCESSORIES

5. PURPOSE.

a. The lists in this section are for information only and must not be used as a basis for requisition. The lists include tools, equipment, and spare parts for both truck and trailer.

6. ON-VEHICLE TOOLS.

a. Truck Tools.

Quantity per Vehicle	Item Name and Stockage Number	Stowage Location
1	EYE, lifting, engine (41-E-626)	Right-hand stowage box
1	HAMMER, machinist's, ball-peen, 16-oz (41-H-523)	Right-hand stowage box
1	HANDLE, wheel stud nut wrench (30-in.) (Budd wheel-44201) (41-H-1517-50)	Right-hand stowage box
1	JACK, hydraulic, 7-ton, with handle (41-J-73-5)	Right-hand stowage box
1	PLIERS, combination slip-joint, wire-cutting (41-P-1650)	Right-hand stowage box
1	SCREWDRIVER, common, heavy-duty, 6-in. blade, integral-handle (41-S-1076)	Right-hand stowage box
1	SCREWDRIVER, cross-recessed type (type 1) No. 2 (for 1/8-in. and 3/16-in. screws) (41-S-1638)	Right-hand stowage box
1	SCREWDRIVER, cross-recessed type (type 1) No. 3 (for 1/4-in. and No. 12 screws) (41-S-1640)	Right-hand stowage box

General



- A—TIRE INFLATION HOSE
- B—TIRE GAGE
- C—HYDRAULIC JACK
- D—JACK HANDLE
- E—OILER
- F—LUBRICATING GUN
- G—WHEEL BEARING NUT WRENCH (FRONT)
- H—WHEEL BEARING NUT WRENCH (REAR)
- J—WHEEL STUD NUT WRENCH (BUDD)
- K—WHEEL WRENCH HANDLE
- L—TOOL BAG
- M—END WRENCH, 3/4-x7/8-IN.
- N—END WRENCH, 5/8-x25/32-IN.
- P—END WRENCH, 9/16-x11/16-IN.
- Q—END WRENCH, 1/2-x19/32-IN.
- R—END WRENCH, 3/8-x7/16-IN.
- S—PLIERS
- T—ADJUSTABLE AUTOMOTIVE WRENCH, 15-IN.
- U—ADJUSTABLE WRENCH, 12-IN.
- V—HAMMER
- W—SCREWDRIVER
- X—TIMING CRANK
- Y—ENGINE LIFT RING
- Z—IGNITION AND TOOL BOX KEY
- AA—TACHOMETER LOCK KEY
- AB—FIRE EXTINGUISHER
- AC—TROUBLE LAMP

RA PD 321591

Figure 5—Truck Tools and Equipment

Tools, Parts, and Accessories

- A—TURNBUCKLE ASSEMBLY
- B—ANCHOR CHAIN
- C—TURNBUCKLE ASSEMBLY WRENCH
- D—ADJUSTABLE TRACK GUIDES
- E—WHEEL BEARING NUT WRENCH
- F—WHEEL BEARING NUT WRENCH LEVER
- G—TACKLE HINGE PIN
- H—HOOK ASSEMBLY
- J—JUMPER CABLE
- K—TIRE WRENCH
- L—TIRE VALVE EXTENSION
- M—JACK
- N—JACK HANDLE

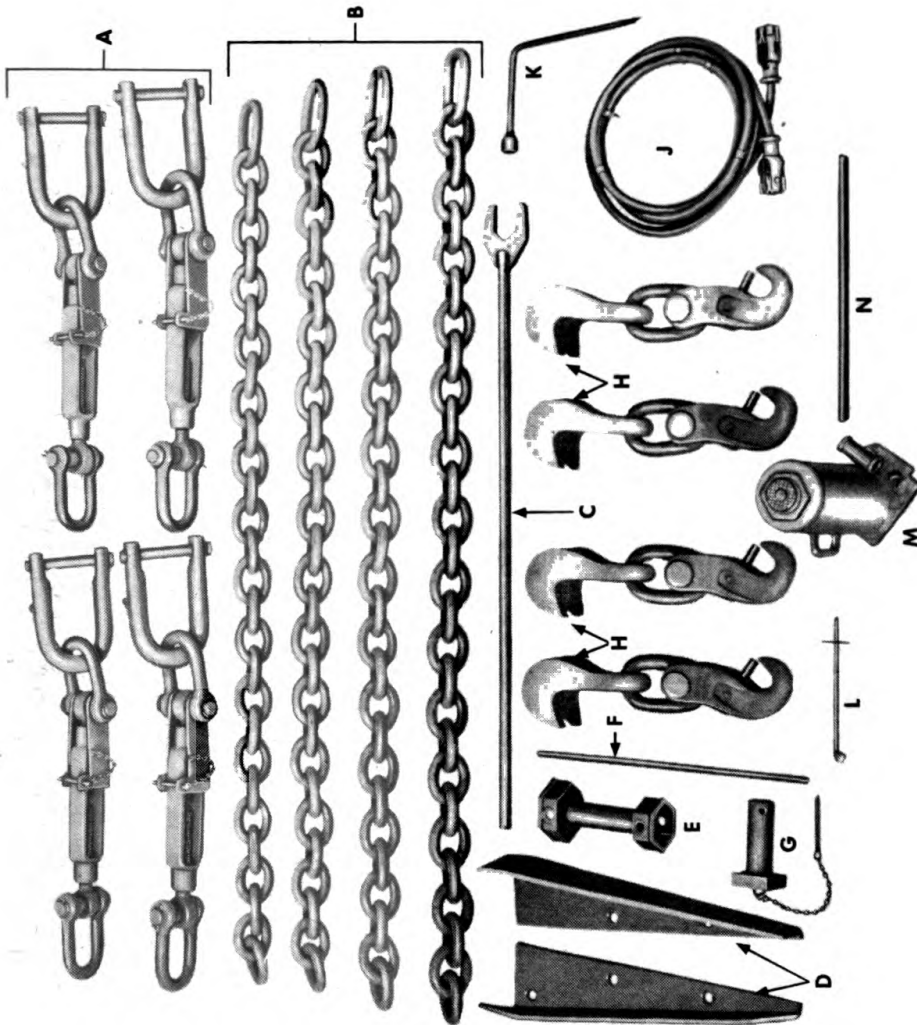

Figure 6—Trailer Tools and Equipment

RA PD 321469

General

Quantity per Vehicle	Item Name and Stockage Number	Stowage Location
1	WRENCH, adjustable, automobile-type, 15-in. (3 ⁵ / ₈ -in. jaw opening) (type 2) (41-W-450)	Right-hand stowage box
1	WRENCH, adjustable, crescent-type (12-in. over-all length) (41-W-488)	Right-hand stowage box
1	WRENCH, engineers', 15-degree angle, double-head, open-end, normal-duty, alloy-steel, ³ / ₈ in.- ⁷ / ₁₆ in. (41-W-991)	Right-hand stowage box
1	WRENCH, engineers', 15-degree angle, double-head, open-end, normal-duty, alloy-steel, ¹ / ₂ in.- ¹⁹ / ₃₂ in. (41-W-1003)	Right-hand stowage box
1	WRENCH, engineer's 15-degree angle, double-head, open-end, normal-duty, alloy-steel, ⁹ / ₁₆ in.- ¹¹ / ₁₆ in. (41-W-1005-5)	Right-hand stowage box
1	WRENCH, engineers', 15-degree angle, double-head, open-end, normal-duty, alloy-steel, ⁵ / ₈ in.- ²⁵ / ₃₂ in. (41-W-1008-10)	Right-hand stowage box
1	WRENCH, engineers', 15-degree angle, double-head, open-end, normal-duty, alloy-steel, ³ / ₄ in.- ⁷ / ₈ in. (41-W-1012-5)	Right-hand stowage box
1	WRENCH, front wheel bearing nut (Timken-Detroit Axle, 3256-L-12) (41-W-3727-500)	Right-hand stowage box
1	WRENCH, rear wheel bearing nut (Timken-Detroit Axle, 3256-C-3) (41-W-2612-25)	Right-hand stowage box
1	WRENCH, wheel stud nut (Budd wheel, 18806) (41-W-3838-30)	Right-hand stowage box
b. Trailer Tools.		
1	JACK, hydraulic, 20-ton w/handle (WAK-951)	Trailer stowage compartment
1	WRENCH, axle nut (Rogers, 2-2 ¹ / ₂ R-H)	Trailer stowage compartment
1	WRENCH, rim nut	Trailer stowage compartment

Tools, Parts, and Accessories

Quantity per Vehicle	Item Name and Stockage Number	Stowage Location
1	WRENCH, turnbuckle	Trailer stowage compartment
1	WRENCH, wheel bearing nut (RBC 2-2½ R-H)	Trailer stowage compartment

7. ON-VEHICLE EQUIPMENT.

a. Truck Equipment.

1	ADAPTER, lubrication, gun (41-E-485-12)	Right-hand stowage box
1	BAG, tool (41-B-15)	Right-hand stowage box
1	BLOCK, snatch (for 7/8-in. wire rope) (19-B-31024)	Left-hand stowage box
1	BOOK, ORD 7-8-9 SNL G-159 (Combined OSP&E, HESP-&E (addendum), and Service Parts Catalog)	Glove compartment
1	BOOK, technical manual 9-768 (additional issue by the Adjutant General is as indicated in FM 21-6)	Glove compartment
1	CONTAINER, metal, spare parts kit (attaching parts: 4 nut, machine screw, hex, S, No. 10 (0.190)—24NC—1 4 screw, machine, rd-hd, S, No. 10 (0.190)—24NC—2 x 1¾ 4 washer, lock, reg, S, No. 10 (0.190) 4 washer, plain, S. SAE std, No. 10 (0.190))	Right-hand stowage box
1	CRANK, starting	Right-hand stowage box
1	EXTENSION, lubricating gun, hose-type, hydraulic, length over-all approx. 12 in. (41-E-485-12)	Right-hand stowage box
1	EXTINGUISHER, fire, in bracket CTS, 1-quart, with bracket (58-E-202)	Mounted in cab
1	GAGE, tire pressure, general-service type (8-G8615)	Right-hand stowage box

General

Quantity per Vehicle	Item Name and Storage Number	Storage Location
1	GUIDE, Lubrication (see Order)	Glove compartment
1	GUN, lubrication, chassis, hand-operated, 15-oz, cap-hydraulic type (41-G-1344-40)	Right-hand stowage box
1	HOSE, tire-inflation, assembly (56-ft, with air chuck and nozzle)	Right-hand stowage box
1	LAMP, trouble light	Right-hand stowage box
1	LIGHT, trouble, assembly (includes lamp, cord, and plug)	Right-hand stowage box
1	OILER, straight-spout, spring-bottom 1/2-pt (13-0-1530)	In bracket
1	ORDER, Lubrication, War Department No. 160 (formerly known as Guide)	In holder
1	SHUTTER, radiator	Right-hand stowage box
1	TAPE, friction (17-T-805)	In spare parts container, right-hand stowage box
1	WIRE, iron (22-W-1067)	In spare parts container, right-hand stowage box

b. Trailer Equipment.

1	BOOK, ORD 7-8-9 SNL G-159 (Combined OSP&E, HESP-&E (addendum) and Service Parts Catalog)	Trailer stowage compartment
1	BOOK, technical manual 9-768 (additional issue by the Adjutant General as indicated in FM 21-6)	Trailer stowage compartment
1	CABLE, lighting, assembly	Trailer stowage compartment
1	HOSE, air, 15 ft long (Bendix-Westinghouse 220900)	Trailer stowage compartment
1	OILER, straight-spout, spring-bottom, 1/2-pt	Trailer stowage compartment
1	ORDER, Lubrication, War Department No. 724	Trailer stowage compartment

c. Salvage Equipment.

4	BLOCK, chock, assembly (RBC-C-B-45-15)	On trailer
---	--	------------

Tools, Parts, and Accessories

Quantity per Vehicle	Item Name and Stockage Number	Stowage Location
1	BLOCK, sheave, anchored, assembly (RBC-A-08758-Y)	On trailer
1	BLOCK, sheave, movable, assembly (RBC-M-08758-Y)	On trailer
4	CHAIN, anchor, assembly	Trailer stowage compartment
4	HOOK, chain, assembly	Trailer stowage compartment
1	PAN, skid, with hook and cable	Trailer stowage compartment
4	SHACKLE, carrier frame, w/cotter chain plate	Trailer stowage compartment
4	TURNBUCKLE, w/screw, assembly (RBC-T-B-08759-Y)	Trailer stowage compartment

8. ON-VEHICLE SPARE PARTS.

a. Truck Spare Parts

3	BELT, fan (cog-type) (33-B-175)	In spare parts container, right-hand stowage box
5	CAP, tire valve (screwdriver type) (8-C-650) G147-01-31577	In spare parts container, right-hand stowage box
5	CORE, tire valve (8-C-6750) G-147-01-40213	In spare parts container, right-hand stowage box
1	LAMP, electric, incandescent, minimum, 6-8 V, single-tungsten, filament, No. 63, 3-cp (17-L-5215) M001-02-13230	In spare parts container, right-hand stowage box
1	LAMP-UNIT, blackout stop, sealed, 1 opening, 6-8 V, 3-cp, assembly (8-L-421) M001-01-07407	In spare parts container, right-hand stowage box
1	LAMP-UNIT, blackout tail, sealed, 4 openings, 6-8 V, 3-cp, assembly (8-L-415)	In spare parts container, right-hand stowage box
1	PIN, cotter, split, steel (assorted in small box) (42-P-5347)	In spare parts container, right-hand stowage box
1	TIRE, spare, 12.00 x 20	On wheel
1	TUBE, spare, 12.00 x 20	Under tire
1	WHEEL, spare, 20 x 9-10	On carrier

General

Quantity per Vehicle	Item Name and Stockage Number	Stowage Location	
b. Trailer Spare Parts.			
2	TIRE, spare, 8.25 x 15		
2	TUBE, spare, 8.25 x 15		
2	WHEEL, spare, 15 x 7		
9. SPECIAL TOOLS.			
a. Tool.			
		Federal Stock Number	
		Manufacturer's Tool Number	
2	EYE, engine lifting, 3/4-16NF-2	41-E-626	TEC-8-108
1	REMOVER, pin, lower, torque rod	41-R-2372-555	TEC-6-429
1	WRENCH, engineers', double-head, 1½ and 1⅝ in., main bearing nuts	41-W-1469-100	TEC-8-114
1	WRENCH, fan clamp nut

PART TWO

OPERATING INSTRUCTIONS

Section IV

DRIVING CONTROLS AND INSTRUMENTS

10. CONTROLS.

a. Truck Controls.

(1) **CIRCUIT LOCK SWITCH (S, fig. 8).** The circuit lock switch, located in the lower center of the instrument panel, provides a means of closing the cranking motor solenoid circuit prior to operating the cranking motor switch. The lock is operated by a key. On some models, the circuit lock switch is not installed.

(2) **CLUTCH PEDAL (Q, fig. 7).** The clutch pedal projects through the toeboard to the left of the steering column. It is used to engage and disengage the clutch.

(3) **HAND PRIMING PUMP (A, fig. 8).** The hand priming pump is located at the extreme left of the instrument panel. It pumps a charge of fuel oil to the starter burner when operated.

(4) **HAND THROTTLE (P, fig. 8).** The hand throttle is located in the lower right center section of the instrument panel. It serves as a hand control to reduce or increase engine speed.

(5) **ACCELERATOR PEDAL (J, fig. 7).** The accelerator pedal or foot throttle, located on the toeboard in the center of the cab, provides a means of regulating the flow of fuel to the engine to increase or decrease engine speed.

(6) **PARKING BRAKE LEVER (P, fig. 7).** The parking brake lever is located to the right of the driver's seat. It is used to apply and hold the parking brake, which is used primarily to hold the vehicle in parked position. When the lever is pulled back, the spring-loaded latch will hold it in its applied position.

(7) **SERVICE BRAKE PEDAL (F, fig. 7).** The service brake pedal projects through the toeboard to the right of the steering column. It actuates the air brake shoes at each wheel. The amount of pressure applied to the pedal determines the degree of braking action on the vehicle. In its normal position, the brakes are released. The brake pedal may be held in engaged position by means of the pedal hold-down latch when vehicle is stopped (G, fig. 7).

(8) **HAND CONTROL VALVE (B, fig. 7).** The hand control valve is mounted on the right side of the steering column. It is used for independent trailer brake control. It can also be applied, when vehicle is parked, to set the trailer brakes.

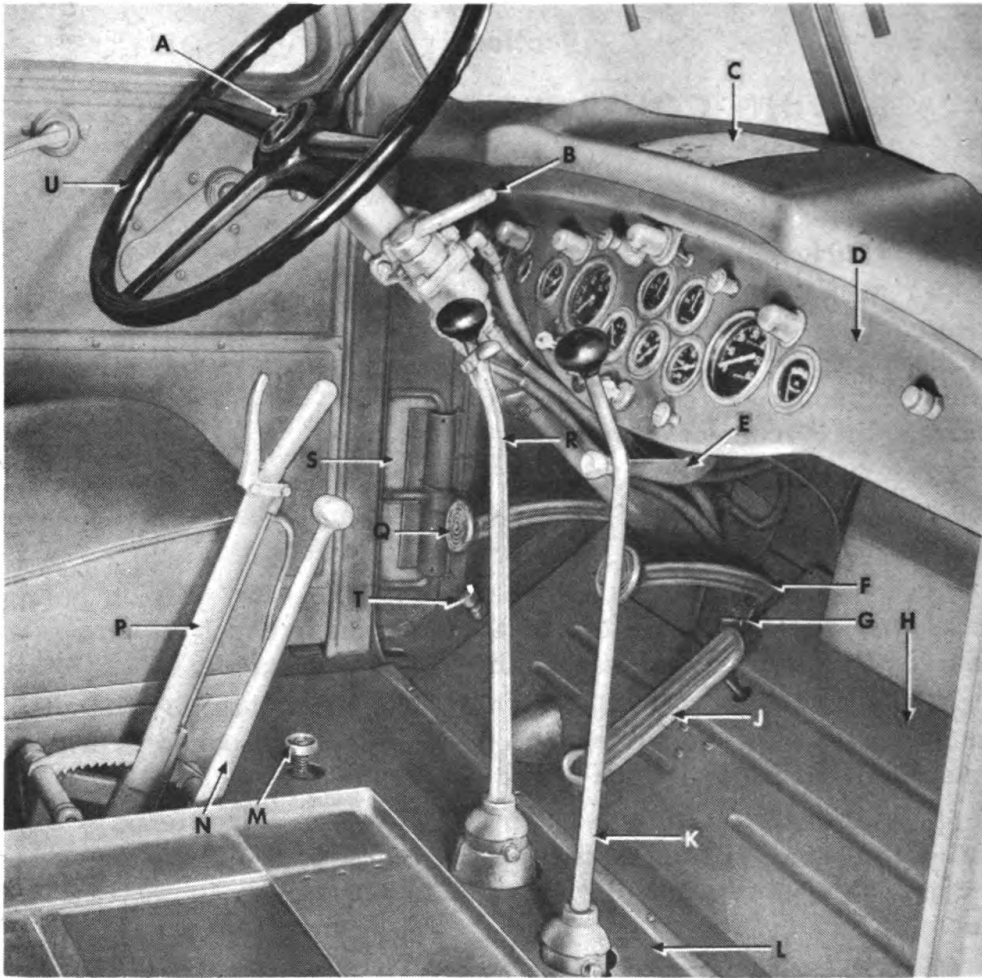

- | | |
|--|--------------------------------|
| A—HORN BUTTON | L—FLOORBOARD |
| B—HAND CONTROL VALVE | M—CRANKING MOTOR SWITCH |
| C—SHIFTING PLATE | N—POWER TAKE-OFF SHIFT LEVER |
| D—INSTRUMENT PANEL | P—PARKING BRAKE LEVER |
| E—COWL VENTILATOR HANDLE | Q—CLUTCH PEDAL |
| F—SERVICE BRAKE PEDAL | R—TRANSMISSION GEARSHIFT LEVER |
| G—PEDAL HOLD-DOWN LATCH | S—COWL SIDE VENTILATOR |
| H—TOEBOARD | T—DIMMER SWITCH |
| J—ACCELERATOR PEDAL | U—STEERING WHEEL |
| K—AUXILIARY TRANSMISSION GEARSHIFT LEVER | |

RA PD 321342

Figure 7—Driver's Controls

Driving Controls and Instruments

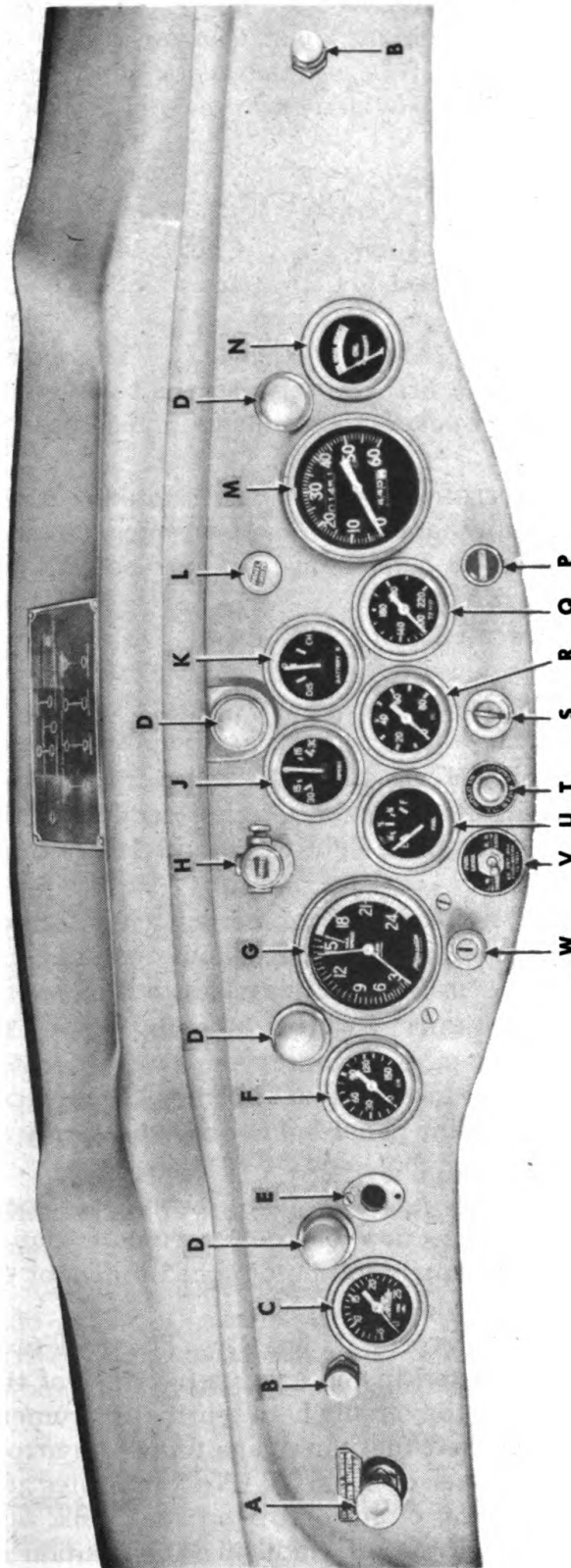

- | | | |
|--------------------------|-----------------------|------------------------------|
| A—HAND PRIMING PUMP | H—MAIN LIGHT SWITCH | Q—HEAT INDICATOR |
| B—WINDSHIELD WIPER VALVE | J—AMMETER | R—OIL PRESSURE GAGE |
| C—FUEL PRESSURE GAGE | K—BATTERY "B" AMMETER | S—CIRCUIT LOCK SWITCH |
| D—INSTRUMENT PANEL LIGHT | L—PANEL LIGHT SWITCH | T—ENGINE STOP CONTROL SWITCH |
| E—TROUBLE LIGHT SOCKET | M—SPEEDOMETER | U—FUEL GAGE |
| F—AIR PRESSURE GAGE | N—VISCOMETER | V—FUEL TANK TOGGLE SWITCH |
| G—TACHOMETER | P—HAND THROTTLE | W—TACHOMETER LOCK |

RA PD 321336

Figure 8—Instrument Panel

(9) **TRANSMISSION GEARSHIFT LEVER (R, fig. 7)** The transmission gearshift lever is mounted on the main transmission in the center of the cab. It is used for shifting all the gears in the main transmission. A reverse latch is provided to prevent accidental shifting into reverse gear.

(10) **AUXILIARY TRANSMISSION LEVER (K, fig. 7)**. The auxiliary transmission gearshift lever is mounted on a bracket on the transmission and projects through the floorboard to the right of the main transmission gearshift lever. It is used for shifting the gears in the auxiliary transmission.

(11) **POWER TAKE-OFF SHIFT LEVER (N, fig. 7)**. The power take-off shift lever is mounted in a bracket between the seats in the cab. It is connected to the power take-off by linkage and is used to shift the take-off gears.

(12) **CRANKING MOTOR SWITCH (M, fig. 7)**. The cranking motor switch is located under the floorboard in front of the driver's seat. It operates the cranking motor by connecting the four batteries in series to provide a 24-volt starting circuit.

(13) **ENGINE STOP CONTROL SWITCH (T, fig. 8)**. The engine stop control is a push-button type switch located in the lower center of the instrument panel. It provides a means of stopping the engine by operating a solenoid switch, which cuts off the supply of fuel.

(14) **MAIN LIGHT SWITCH (H, fig. 8)**. The main light switch is a push-pull switch located at the upper left center section of the instrument panel to control the complete lighting circuit. It has three "ON" positions.

(15) **DIMMER SWITCH (T, fig. 7)**. The dimmer switch is located on the toeboard to the left of the clutch pedal. It is foot-operated and controls the selection of the upper or lower driving light beam.

(16) **INSTRUMENT PANEL LIGHT SWITCH (L, fig. 8)**. The instrument panel light switch is a push-pull type switch located at the top of the instrument panel to the right of center. It provides a means of turning on the instrument panel lights and works only in conjunction with the main light switch.

(17) **TACHOMETER LOCK (W, fig. 8)**. The tachometer lock, located at the lower left center section of the instrument panel, provides a means of resetting the maximum motor speed indicator on the tachometer. It is operated by a key.

(18) **FUEL TANK TOGGLE SWITCH (V, fig. 8)**. The fuel tank switch is a toggle-type switch, located in the lower left center of the instrument panel. It is wired into the circuit between the instrument panel fuel gage and the right and left fuel tank gage units. An arrow to the left of the toggle switch labeled "L. H. TANK" indicates the position of the switch for a reading of the left-hand fuel tank, and an arrow to the right labeled "R. H. TANK" indicates the position of the switch for a reading of the right-hand fuel tank.

Driving Controls and Instruments

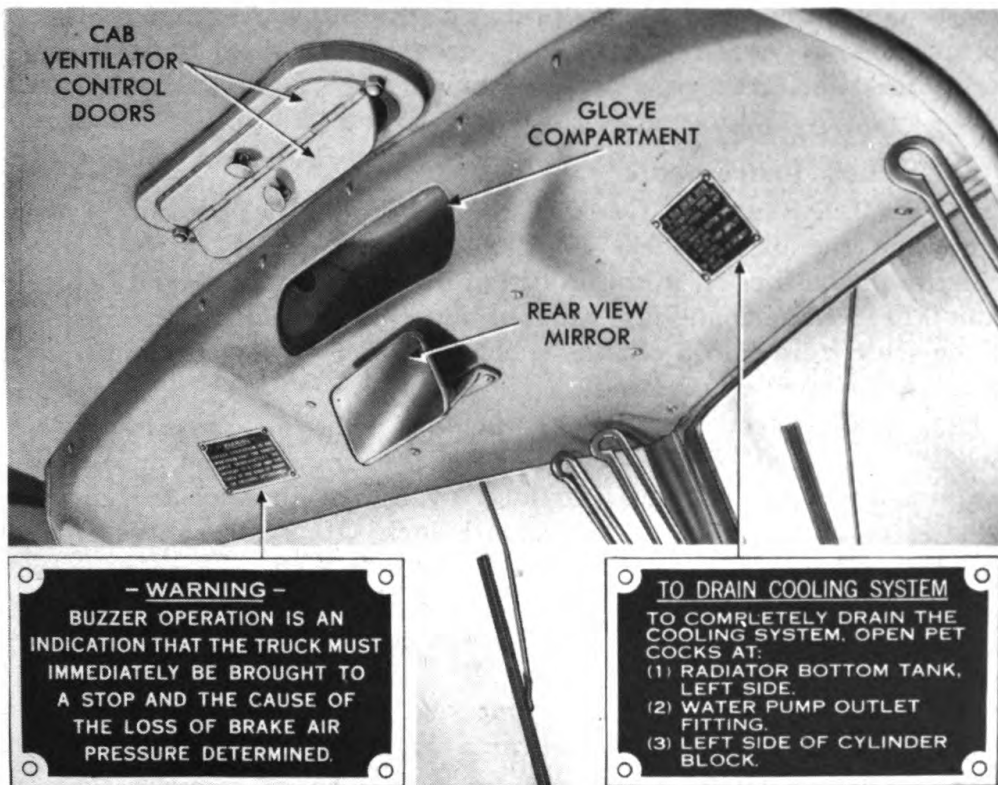

RA PD 321301

Figure 9—Cab Ventilator Control Doors

(19) **WINDSHIELD WIPER CONTROL VALVES** (B, fig. 8). The windshield wiper control valves are located one on each end of the instrument panel. Each valve provides a means of operating the wiper on its adjacent side.

(20) **STEERING WHEEL** (U, fig. 7). The steering wheel, mounted on the steering column in front of the driver's seat, controls the steering gear. The steering gear changes the direction of or steers the front wheels.

(21) **HORN BUTTON** (A, fig. 7). The horn button is located in the center of the steering wheel and provides a means of sounding the horn.

(22) **CAB VENTILATOR** (fig. 9). The cab ventilator, mounted in the cab roof, admits fresh air and ejects foul air. There are two inside doors under the ventilator. The forward door admits fresh air when opened and the rearward door controls the exhaust of foul air.

b. Trailer Brake Control Handwheels (C and F, fig. 177). The brake control handwheel, located on the front main frame member of the trailer, is connected by linkage to the front wheel brake shoes. It is used for setting the brakes manually on the front wheels.

The brake control handwheel, located at the forward end of the left main frame, is connected by linkage to the rear wheel brake shoes and is used for setting the brakes manually on the rear wheels.

11. INSTRUMENTS.

a. Truck Instruments.

(1) **FUEL PRESSURE GAGE (C, fig. 8).** The fuel pressure gage, located at the extreme left of the instrument panel, registers the pressure of the fuel oil in the injection pump head. The scale ranges from 0 to 25 pounds and is graduated into 1-pound units. The portion of the scale from 0 to 5 pounds is colored red to indicate insufficient pressure for engine operation.

(2) **AIR PRESSURE GAGE (F, fig. 8).** The air pressure gage, located in the left center section of the instrument panel, measures the amount of air pressure provided by the compressor to the air braking system in pounds per square inch. Its scale ranges from 0 to 150 and is divided into units of 10 pounds each.

(3) **FUEL GAGE (U, fig. 8).** The fuel gage, located in the lower center of the instrument panel, registers the amount of fuel in the fuel tanks. The dial registers from "E" (empty) to "F" (full) with markers at "1/4" full, "1/2" full, and "3/4" full locations. It works only in conjunction with the fuel tank toggle switch.

(4) **OIL PRESSURE GAGE (R, fig. 8).** The oil pressure gage, located in the center of the instrument panel, registers the pressure of the oil in the engine lubricating system when the engine is running. The scale on the dial ranges from 0 to 80 pounds and is graduated into units of 10 pounds each.

(5) **TACHOMETER (G, fig. 8).** The tachometer, located at the left center of the instrument panel, registers the speed of the engine in revolutions per minute. The highest permissible speed is 1,600 revolutions per minute. An indicating hand (white) indicates the speed at all times and also moves a maximum-speed hand (red) to the highest speed attained. A key is provided to reset the maximum-speed hand when desired.

(6) **MAIN AMMETER (J, fig. 8).** The main ammeter, located just to the left of center of the instrument panel, indicates the rate of electric current flow being applied to right-hand batteries by the generator, or the rate of battery discharge. The scale to the left indicates discharge and ranges from 0 to 30, with a marker at 15 amperes. The scale to the right indicates charge and has the same range and markings.

(7) **BATTERY "B" AMMETER (K, fig. 8).** The battery "B" ammeter, located to the right of the center of the instrument panel, measures the flow of current into or out from the left or "B" batteries. The scale is not graduated and indicates "DIS" (discharge) to the left, and "CH" (charge) to the right.

Operation Under Ordinary Conditions

(8) **HEAT INDICATOR (Q, fig. 8).** The heat indicator, located in the right center section of the instrument panel, records the temperature of the fluid in the engine cooling system. Its scale ranges from 100° to 220° F, and is divided into units of 10 degrees each.

(9) **SPEEDOMETER (M, fig. 8).** The speedometer, located on the right side of the instrument panel, indicates the speed of the vehicle in miles per hour and records both trip and total mileage. The speed scale ranges from 0 to 60 and is graduated into 1-mile units. The figures in the upper panel of the instrument record the total mileage of the vehicle. The figures in lower panel record the trip mileage and can be reset by a knob located on the back of the instrument.

(10) **VISCOMETER (N, fig. 8).** The viscometer is located at the extreme right of the instrument panel. It indicates the condition of the lubricant in the crankcase. Its scale is divided into three sections, "THIN," "IDEAL," and "HEAVY," from left to right. The section marked "IDEAL" is white. The sections marked "THIN" and "HEAVY" are each divided into two parts. The red and yellow checkered part indicates a questionable condition of the lubricant. The red indicates that condition of the lubricant is unsatisfactory for driving.

(11) **LOW AIR PRESSURE BUZZER.** The low air pressure buzzer, which is located under the instrument panel in front of the steering column, gives a warning to the driver whenever the air pressure in the service brake system drops to 45 pounds or less. It is connected electrically to the low pressure indicators and functions only when the circuit lock switch is closed.

Section V

OPERATION UNDER ORDINARY CONDITIONS

12. PREPARING VEHICLE FOR PULLING MAXIMUM LOADS.

a. **General.** The truck and loaded trailer have the proper weight distribution to reduce the slippage of traction wheels when towing the trailer with maximum load.

b. **Weight Distribution.** The recommended weight distribution is approximately as follows:

Weight on front axle.....	10,950 lb
Weight on rear axle (without ballast).....	16,050 lb
Total	27,000 lb
Recommended ballast	16,000 lb
Recommended gross weight (chassis, body, fuel, tools, crew, special equipment, and ballast)	43,000 lb
Recommended gross weight of truck and trailer fully loaded, not to exceed.....	160,000 lb

c. Ballast. The capacity of the ballast body is 3.5 cubic yards, less tool boxes and spare wheel compartment. By filling the body with sand or gravel weighing approximately 3,000 pounds per cubic yard, only 10,500 pounds of ballast will be obtained. If this is not sufficient to handle the load, it is recommended that approximately 4 cubic yards of concrete be poured into blocks to fit the body. The blocks can be fitted with rings for hoisting in or out of the body and should be rested on wooden skids with wooden wedges to prevent shifting. As concrete weighs approximately 4,000 pounds per cubic yard, these blocks will provide the recommended weight for ballast, at the same time providing drainage of the body and allowing sufficient circulation of air to prevent excessive rust and corrosion of metal.

13. USE OF INSTRUMENTS AND CONTROLS IN VEHICLE OPERATION.

a. New Vehicle Run-in Test. Before a new or reconditioned vehicle is placed in service, be sure that the new vehicle run-in test described in paragraphs 23, 24, and 25, has been performed.

b. Before-operation Service. Perform the services in items 1 to 6 in paragraph 27 b before attempting to start the engine. Start and warm-up engine (subpar. c below), and complete the Before-operation Services.

c. Starting Engine.

(1) **PLACE SHIFT LEVERS IN NEUTRAL POSITION.** Apply parking brake to hold vehicle stationary by pulling back on parking brake lever (fig. 7). Place transmission and auxiliary transmission shift levers in neutral (N) position (fig. 11). Make certain power take-off shift lever is in neutral position.

(2) **TURN CIRCUIT LOCK SWITCH ON (S, fig. 8).** Turn key clockwise in circuit lock switch. Switch is omitted on some vehicles, in which case this step may be omitted.

(3) **DEPRESS CLUTCH PEDAL.** Push clutch pedal to floor and hold it there until after engine has started.

(4) **PRESS CRANKING MOTOR SWITCH BUTTON (M, fig. 7).** Press cranking motor switch button; release immediately when engine starts. If engine does not start after two or three trials, release cranking motor switch button and investigate.

(5) **OBSERVE INSTRUMENTS (fig. 8).** After engine has started, slowly release the clutch. Operate hand throttle until engine idling speed is 500 revolutions per minute. Read the gages and instruments. The oil pressure gage must register 30 pounds. If it fails to register, stop the engine immediately and investigate. The air pressure gage must register 70 pounds or above before vehicle is moved. A buzzing

Operation Under Ordinary Conditions



RA PD 321313

Figure 10—Fuel Valve Instruction Plate

sound, which indicates insufficient air pressure for brake operation, will be heard until operating pressure above 45 pounds is reached. If the buzzer sounds while vehicle is being operated, stop vehicle immediately and determine cause of loss of pressure. The ammeter must read positive (+). The battery "B" ammeter must read positive (+). The tachometer should read about 500 revolutions per minute. The water temperature gage should show a gradual rise to 160° to 180°F. Do not move vehicle until temperature is 135° F. Oil viscosity gage should register "IDEAL." If engine viscometer remains in low range after warm-up, stop engine and investigate. The fuel level gage, with toggle switch centered, should read empty. The fuel pressure gage should read approximately 10 pounds.

d. Placing Vehicle in Motion. After the engine has been thoroughly warmed up and checked for satisfactory operation, place the vehicle in motion as follows:

(1) **DISENGAGE THE CLUTCH.** Push clutch pedal to the toeboard to completely disengage the clutch. **CAUTION:** *Disengage the clutch fully to avoid damage and shifting difficulties.*

(2) **SELECT AUXILIARY TRANSMISSION SPEED.** Shift the auxiliary transmission shifting lever into proper position. The selection is based on road conditions and amount of load being hauled. Shift into "LOW" (fig. 11) if heavily loaded, climbing a grade, or where traction is not good. Shift into "DIRECT" or "OVERDRIVE"

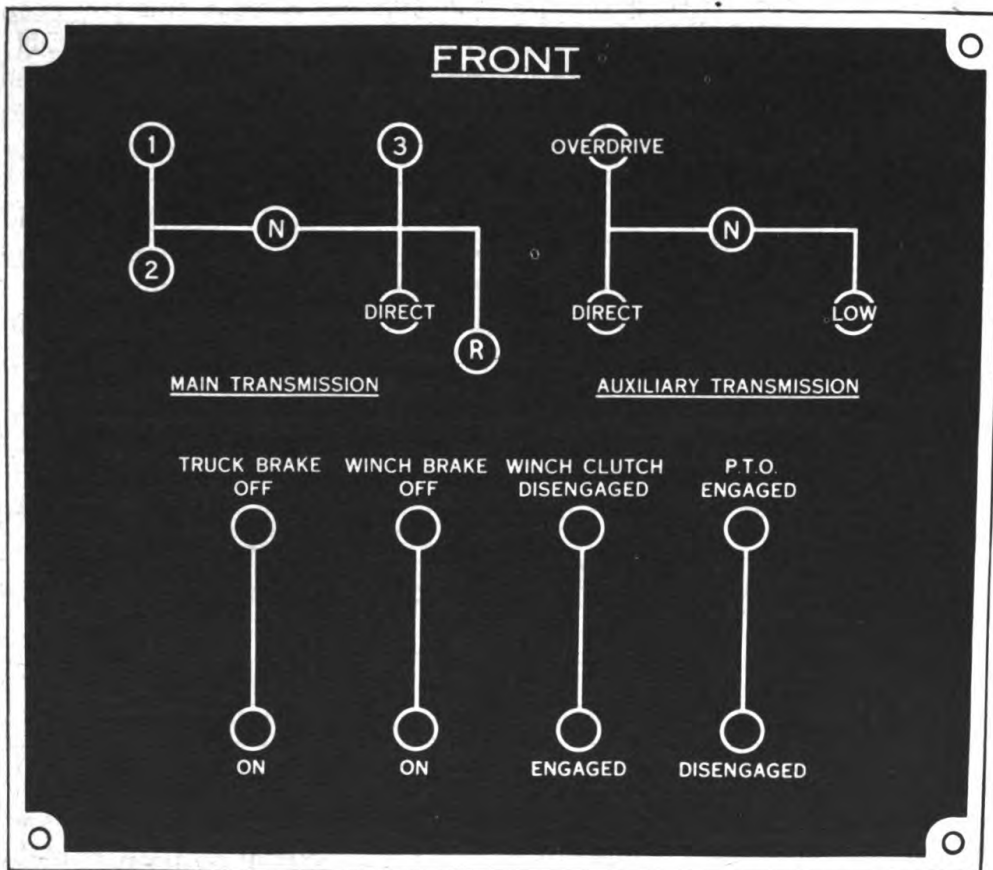

RA PD 321183

Figure 11—Shifting Plate

(fig. 11) when the road is level and the load is light. Truck cannot be driven with auxiliary transmission in "N" (neutral).

(3) **SELECT MAIN TRANSMISSION SPEED.** Shift main transmission shifting lever into first (1) speed position (fig. 11).

(4) **RELEASE THE PARKING BRAKE.** Release parking brake (fig. 7), and push brake lever forward.

(5) **ACCELERATE ENGINE AND RELEASE CLUTCH.** Push down on accelerator pedal (fig. 7) to speed up the engine, and at the same time release clutch pedal (fig. 7) gradually. **CAUTION: Do not engage clutch suddenly.** Feed sufficient fuel to the engine to insure a smooth, even start. Do not race the engine.

(6) **SHIFT TRANSMISSION TO OTHER SPEEDS.** After vehicle has started, speed is increased by shifting the main transmission shifting lever to higher positions shown on the shifting diagram (fig. 11). As the truck increases speed, release the accelerator pedal, disengage the clutch, and move the transmission shifting lever into neutral and then into the second speed position. Release the clutch pedal smoothly

Operation Under Ordinary Conditions

and at the same time accelerate the engine. Repeat this for each higher speed in the transmission until it is in driving gear. **CAUTION: Do not skip positions.** The proper gear speed is determined by the performance of the engine which must operate smoothly without laboring. The speed should be dropped a step by shifting to a lower gear before the engine begins to lose speed by laboring. When shifting to a lower gear, double-clutch (step (7) below) to avoid clashing the gears. **CAUTION: Never force transmission shifting lever into position or shift to lower gears at high engine speeds.** When going downhill, use same gear that would be required in climbing the hill. Speeds should never exceed the maximum shown in the following table:

Maximum Vehicle Speeds at 1,600 Revolutions per Minute Engine Speed

Main Transmission	Auxiliary Transmission		
	Overdrive	Direct	Underdrive
Direct	23.0	17.4	8.7
3rd	13.1	9.8	4.9
2nd	7.1	5.3	2.6
1st	4.1	3.1	1.5

- (7) **DOUBLE CLUTCH SHIFTING TO LOWER GEAR.**
 - (a) Disengage clutch and release accelerator pedal.
 - (b) Move transmission shifting lever into neutral position.
 - (c) Release clutch pedal and accelerate engine to synchronize it with vehicle speed.
 - (d) Disengage clutch once again and shift into lower gear.
 - (e) Engage clutch smoothly while accelerating the engine.
- (8) **SHIFTING TO REVERSE GEAR.** When it is necessary to reverse the truck, stop truck and shift the transmission into reverse gear position (R) shown on shifting plate (fig. 11).

e. Auxiliary Transmission Gear Shifting.

(1) **GENERAL.** The auxiliary transmission shifting lever has three driving positions: "LOW," "DIRECT," and "OVERDRIVE," in addition to "N" (neutral) (fig. 11). It is good practice to operate the vehicle in overdrive or direct range over hard-surfaced terrain where there is easy rolling. On extreme grades or when the conditions are so difficult as to require good traction, the low range should be used, especially when heavily loaded. **NOTE: Do not shift the auxiliary transmission from high to low speed unless the vehicle is standing still or operating at low speed.**

- (2) **GEAR SHIFTING TO HIGHER SPEEDS.**
 - (a) With vehicle moving at any speed, or standing still, dis-

engage clutch and shift the auxiliary transmission shifting lever into neutral.

(b) Engage clutch and accelerate engine above the relative speed of the vehicle.

(c) Disengage the clutch again, and move the shifting lever into the "DIRECT" position (fig. 11) if shifting from "LOW," or into "OVERDRIVE" position if shifting from high.

(d) Engage clutch and accelerate engine to synchronize with vehicle speed. CAUTION: *Shift smoothly, never forcing the shifting lever, as a sudden shock of gear engagement may damage the transmission parts.*

(2) GEAR SHIFTING TO LOWER SPEEDS. With vehicle standing still or moving at low speed, follow procedure outlined in step (b) above, except to move the shifting lever to one position lower instead of higher, as described in step (c) above. CAUTION: *Shifting from high to low when the truck is in motion must be done by this double clutching procedure in order to synchronize the speeds of the engaging gears and prevent damaging them.*

f. **Use of Tachometer in Gear Ratio Selection.** The tachometer is a valuable guide in determining the time to shift gears, and the proper gear ratio to select in either the transmission or auxiliary transmission. Best performance will be obtained with the engine operating between 1,100 and 1,600 revolutions per minute. If the engine speed cannot be maintained in the gear ratio being used, shift down in the main transmission to keep the engine operating between the recommended limits. When shifting up in the transmission, do not select a higher gear until after the engine speed reaches 1,100 revolutions per minute.

g. Stopping Truck.

(1) Release accelerator pedal and depress brake pedal gradually to apply the brakes smoothly.

(2) When truck speed is down to from 5 to 10 miles per hour, disengage the clutch and move the transmission shifting lever into neutral. NOTE: *It is not necessary to move the auxiliary transmission lever to neutral.*

(3) When truck is completely stopped, release clutch pedal, pull back parking brake lever, and release brake pedal.

h. Stopping Engine. Press the engine stop control switch button (fig. 8) and hold it in until the engine stops.

i. Coupling Truck to Trailer.

(1) Open rear pintle hook of truck by removing pintle hook latch cotter pin and raising the latch.

Operation Under Ordinary Conditions

(2) Hold up or block up trailer drawbar at approximate height of truck pintle. Have second man stand near drawbar to give signals to truck operator. Back up truck until drawbar ring can be placed on pintle hook. Close pintle latch and insert latch cotter pin.

(3) Remove dummy couplings from the rear air brake couplings on the truck and from the air lines on the trailer. Connect the emergency coupling on the trailer to the service coupling on the truck. Connect the service coupling on the trailer to the emergency coupling on the truck. Turn the handles of the rear cut-out cocks on the truck.

(4) Insert the lighting cable in the trailer jumper sockets located on the rear of the truck and front of the trailer.

j. Placing Truck With Trailer in Motion.

(1) **RELEASE TRAILER PARKING BRAKES.** Release trailer parking brakes by means of handwheels.

(2) **OPERATE TRUCK.** Put truck in motion, as outlined in subparagraph d. Be careful to start truck moving slowly to avoid jerking the trailer. The over-all length of the unit must be kept in mind as well as the increased weight, whether the trailer is loaded or not.

(3) **BACKING.** Do not attempt to back the trailer and truck in a narrow space or to spot the trailer by backing the truck. The trailer can be backed up in a straight line for short distances only. The most satisfactory way to spot the trailer by backing it, is by connecting the truck front pintle hook to the trailer drawbar eye and running the truck forward and the trailer backward. The truck operator then has better control of the steering angle of the trailer drawbar and can also watch the position of the trailer.

k. Stopping Truck With Trailer.

(1) **STOPPING UNDER NORMAL CONDITIONS.** Remove foot from accelerator pedal. Apply trailer air brakes first, by gently operating hand brake lever at right of steering column. **CAUTION: Never apply trailer brakes after truck brakes.** Almost immediately, depress truck brake pedal to apply brakes on the truck and trailer simultaneously. Disengage clutch when the vehicle speed has been reduced to the engine idling speed and move transmission shifting lever into neutral. When clutch is completely stopped, release clutch pedal, pull back parking brake lever, and release brake pedal. Apply parking brakes on trailer. Do not depend on air brakes for parking.

(2) **USE OF TRAILER HAND CONTROL VALVE.** The trailer air brakes are independently controlled by the hand control valve (fig. 7) and should always be applied before the truck brakes are applied. If trailer brakes are not applied, the trailer may have enough momentum to push the truck forward into a dangerous position. When

going downhill, use the trailer brakes carefully to act as a drag on the truck. If the truck begins to skid, the application of the trailer brakes will help to pull the rear end of the truck back into line. Do not apply trailer brakes too long, in order to avoid skidding trailer also.

1. **Uncoupling Truck From Trailer.** Set parking brakes on trailer and pull back parking brake lever on truck. Turn off the rear cut-out cocks on the truck air lines. Disconnect the trailer air brake couplings from the truck and install the dummy couplings on the truck and trailer air lines to prevent dirt from entering lines. Uncouple the lighting cable from the truck and the trailer jumper sockets, and stow the lighting cable in the trailer. Open the rear pintle hook of the truck by removing pintle hook latch cotter pin and raising the latch. Disengage trailer drawbar eye from pintle hook and drive truck away from trailer while drawbar is held in a position where it will clear the pintle hook.

14. TOWING THE VEHICLE.

a. **Towing to Start Vehicle.** If it is impossible to turn the engine over with the cranking motor, it may be possible to start the truck by towing it. Run a chain or cable through the front pintle hook and attach it securely to towing vehicle. Shift the auxiliary transmission into low range and the transmission into direct range in the stalled vehicle. When the towing truck starts, the driver of the towed truck should disengage the clutch until starting speed is reached. When the vehicles are moving smoothly the clutch should be engaged slowly to turn the engine. When the engine starts, the clutch should be released and the hand throttle pulled out far enough to idle the engine at 800 revolutions per minute. The driver of the towed vehicle should then shift the transmission to neutral and signal the driver ahead to stop. After the vehicles are stopped, the tow chain may be disconnected. When a vehicle is started in this manner, report it to the proper authority. *CAUTION: The driver of the towed vehicle should note the reading of the air pressure gage before his vehicle is towed. If less than 70 pounds pressure is indicated, the air brakes will not be used. Check the condition of the parking brake; if satisfactory, the vehicle may be stopped with this device.*

b. **Towing Disabled Vehicle.** If the vehicle is disabled with no damage to the running gear or the steering gear apparatus, it may be towed in the same manner as described for towing to start the vehicle (subpar. a above). Be sure the vehicle to be towed has brakes. If the brakes are inoperative or the running gear is damaged, it will be necessary to use a wrecker. Lift damaged end of vehicle off ground with wrecker and tow with opposite end carried on its wheels.

Section VI

OPERATION OF AUXILIARY EQUIPMENT

15. WINCH.

a. **Description.** The winch is mounted on top of the frame side rails behind the cab. It is driven from a power take-off, mounted on the auxiliary transmission, through a propeller shaft and chain drive. The torque-control mechanism, installed on the rear end of the drive shaft, prevents excessive cable pull by automatically shutting off the engine through operation of the fuel shut-off solenoid. The controls for operating the winch are located outside the cab on the left end of the winch.

b. **Controls.**

(1) **WINCH JAW CLUTCH LEVER.** The winch jaw clutch lever (fig. 12) is located on the extreme left side of the winch. It moves the jaw clutch on the winch shaft in or out of engagement with the jaws on the drum. When the jaw clutch is disengaged, the drum is free to turn on the drum shaft; when engaged, the drum is locked with the shaft in working position. When the lever is pushed forward, the jaw clutch is disengaged.

(2) **CLUTCH HAND LEVER.** The clutch hand lever is part of a clutch control valve mounted on a bracket on the left end of the winch. It controls the operation of the clutch air cylinder to engage or disengage the engine clutch independently of the clutch pedal in the cab.

(3) **THROTTLE CONTROL** (fig. 12). The throttle control is mounted on a bracket on the left end of the winch, between the clutch hand lever and the drum. It is directly connected to the accelerator linkage and to the control lever on the governor to increase or decrease engine speed when operating the winch.

(4) **DRAG BRAKE HAND LEVER** (fig. 12). The drag brake hand lever is located at the left end of the winch, next to the jaw clutch lever. It is used to apply the drag brake against the winch drum to prevent the drum from spinning when the cable is paying out. It is in "OFF" position when pushed forward.

c. **Operation.**

(1) **EASING TENSION OF CABLE.** Engage the jaw clutch by shifting the jaw clutch lever back (fig. 12). Start the engine. Release the clutch. Place the main transmission lever in reverse gear (R) and the auxiliary transmission lever in neutral (N) position. Shift the power take-off shift lever forward into "ENGAGED" position (fig. 11). **NOTE:** To engage the power take-off, it is frequently necessary to en-

Operating Instructions

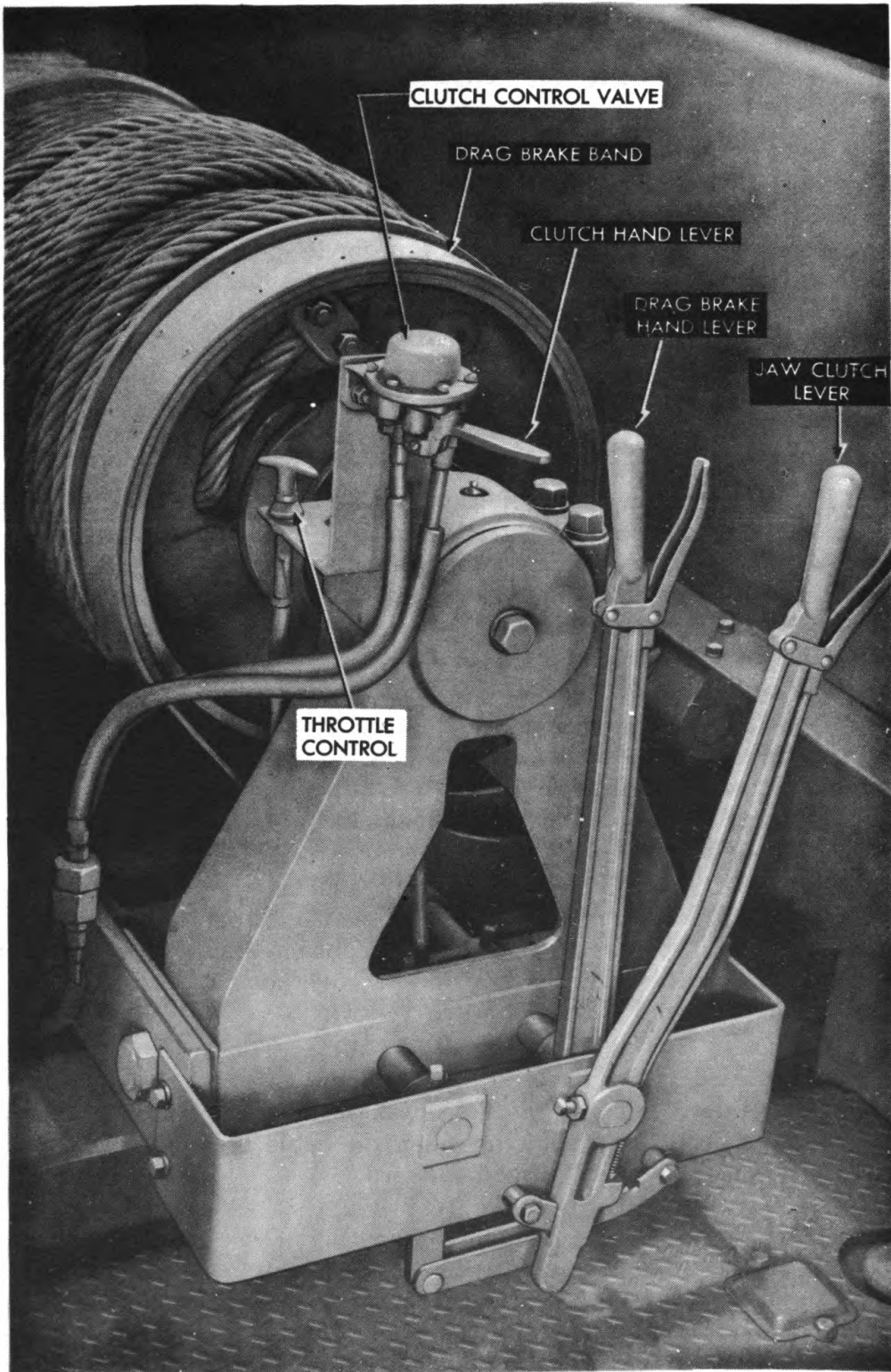

RA PD 321299

Figure 12—Winch Controls

Operation of Auxillary Equipment

gage the engine clutch slightly to cause shaft rotation to permit easy engagement. Engage the engine clutch momentarily to ease off the tension on the winch cable. Release the clutch. Place the power take-off lever in disengaged position by pulling it back (fig. 11). Place the transmission in neutral. Unhook the cable from the front pintle, if it is secured at this point, or from the rear towing cable sheave bracket, if it is secured at the rear. Disengage the winch jaw clutch by shifting the jaw clutch lever forward.

(2) **PULLING.** Pay out enough cable to reach the object to be pulled (step (4) below). Rig for pulling (par. 16 b). Disengage the winch jaw clutch. Start the engine. Apply the service brakes and lock the brake pedal by engaging the pedal hold-down latch (fig. 7). Release the parking brake. Release the engine clutch. Place the main transmission shift lever in proper gear (step (5) below). Make sure the auxiliary transmission is in neutral. Shift the power take-off shift lever forward into "ENGAGED" position (fig. 11). Using the remote control clutch hand lever, or the clutch pedal in the cab, release the engine clutch. Engage the jaw clutch by pulling back the jaw clutch lever. Make sure that the load is ready to be moved. Engage the engine clutch carefully by moving the remote control clutch hand lever, or the clutch pedal in the cab, and at the same time pull up the remote throttle control to accelerate the engine to keep it from stalling. Be ready to stop the winch instantly if necessary (step (3) below).

(3) **STOPPING WINCH.** Move the remote control clutch hand lever, or depress the clutch pedal, which will disengage the engine from the transmission and instantly stop the winch. The winch will be automatically held from paying out by the safety brake band assembly even though it is under a load, providing the winch jaw clutch is engaged. **CAUTION:** *Never disengage the winch jaw clutch while the winch is under a load.* If finished with winch, place transmission gearshift lever in neutral (N) (fig. 11). Place power take-off shift lever in "DISENGAGED" position. Release the engine clutch at the remote control hand brake lever, if engaged at this point. Release the remote throttle control, if engaged.

(4) **LOWERING (PAYING OUT).** If winch is not under load, the cable can be paid out by pulling it off the drum with winch jaw clutch lever in forward position so that jaw clutch is disengaged. While cable is being pulled off, one man must maintain a light pressure on the drag brake, by pulling back on the drag brake lever, to prevent the drum from rotating faster than the cable would turn it. If winch is under a load, the operation of lowering or paying out is accomplished by power drive. Start the engine if it is stopped. Disengage the engine clutch by depressing the clutch pedal or by moving the remote control clutch hand lever if operation is to be controlled from outside of cab.

Operating Instructions

Shift the transmission into reverse (R) gear (fig. 11). Shift the power take-off shift lever forward to "ENGAGED" position (fig. 11), if it is disengaged. Be sure load is ready to be lowered. Carefully engage engine clutch and be ready to stop winch immediately (step (3) above).

(5) **SPEEDS AND SAFE LOADING.** The winch speed is in relation to the transmission speed selected. A high transmission speed gives a high winch speed, and a low transmission speed gives a low winch speed. It is important not to accelerate the engine above 1,000 revolutions per minute while the winch is being operated. To increase the winch speed, shift to a higher transmission speed rather than accelerate the engine excessively. When handling very heavy loads, shift the transmission into low gear. If driving and pulling, shift the auxiliary transmission into low range. Use the winch with the transmission in second gear for medium loads only, and in high gear for light loads only. The winding speed of the winch, with transmission in high gear and engine turning at 1,000 revolutions per minute, is 55 feet per minute for the first layer of cable. If the line pull on the cable exceeds 22,400 pounds, it will cause the torque on the winch propeller shaft to exceed the torque control spring setting. The two parts of the torque control will separate under these conditions, and through the action of the rocker arm, torque control switch box, and engine shut-off solenoid, the engine will be stopped. To start the engine again, disengage the engine clutch to release the torque on the drive shaft, then start the engine. **CAUTION:** *Do not set the torque control to disconnect at higher capacity than that recommended.*

(6) **REWINDING CABLE WITHOUT LOAD.** Engage the winch jaw clutch, if not in engagement, by moving the winch jaw clutch lever back. Start the engine. Release the engine clutch. Place main transmission shift lever in high gear. Shift the power take-off shift lever forward into "ENGAGED" position (fig. 11). Using the remote control clutch hand lever or the clutch pedal in the cab, release the engine clutch carefully. Pull back on cable or attach a slight load so that cable will wind snugly on drum. Guide layers of cable onto drum evenly, stopping winch as often as necessary to adjust coil on drum so that uniform and closely wound successive layers will be obtained. When the last 2 feet of cable remain, stop the winch, place the end of the cable on the front pintle hook if it is led to the front of the truck, or beside the rear cable sheave bracket if at the rear. Slowly engage the clutch until the cable is under a slight tension and secured at the end. Release the engine clutch. Place the power take-off shift lever in "DISENGAGED" position (fig. 11). Place the transmission shift lever in neutral. Allow the winch jaw clutch to remain engaged.

*Operation of Auxilliary Equipment***16. TRAILER LOADING AND UNLOADING.**

a. Preliminary Instructions. Place the trailer and truck on firm ground with the vehicle to be salvaged in line with the rear end of the trailer if possible. The truck must be sufficiently ballasted to move the loaded trailer (par. 12).

b. Rigging. Ease tension of winch cable (par. 15 c (1)), and pull out enough cable to reach the salvaged vehicle (par. 15 c (4)). Wherever possible the snatch blocks provided with the equipment should be used to relieve the load on the cable and equipment. For light loads, use a straight line or one-part line. For medium loads use two-part or three-part line. For heavy loads use the four-part line. When using the snatch blocks, attach the front snatch block to the front of the trailer and the other snatch block to the salvaged vehicle. See that the cable runs between the two trailer sheaves (fig. 177) and down the cable trough in a straight line to the salvaged vehicle. When a salvaged vehicle is off the road or in a position where it cannot be lined up with the back of the trailer, a recovery operation will be necessary in order to bring the vehicle up to the position for loading. Recovery operation can be accomplished by using the cable from the rear of the truck or from the front of the truck. To use the cable at the front of the truck, ease off the cable and lead it forward through the cable brackets on the left-hand frame rail to the front bumper roller (fig. 156). Turn the front bumper roller pin and lift it out of the roller bracket. Insert the cable between the horizontal rollers, and install the front bumper roller pin.

c. Loading and Securing. Fold down the loading ramps at the rear of the tractor. Remove the rear chock blocks from the trailer runways and place them behind the rear wheels of the truck. Set the parking brakes of the trailer. Rig the winch cable (subpar. b above), and attach the cable to the vehicle to be salvaged. On large vehicles, always pass the cable under the vehicle and attach the snatch block at the rear end of the vehicle (or the end which will be at the rear of the trailer when it is loaded). If the snatch block is attached at the front end of the salvaged vehicle, it will be drawn up close to the fixed snatch block, thus preventing the salvaged vehicle from being spotted in the center of the trailer. If the salvaged vehicle can be steered, place a man inside the vehicle to steer it. When the preparations are completed, pull the salvaged vehicle onto the trailer (par. 15 c (2)). Stop the winch when the vehicle is centered on the trailer. Raise the loading ramps. Place the rear chock blocks behind the salvaged vehicle and secure them in a similar manner. Attach the turnbuckles and chains carried in the trailer compartment to the front and rear towing clevises of the loaded vehicle, and to the rings welded on the trailer. Draw the chains tight by turning the turnbuckles.

d. **Unloading.** Set parking brakes on truck and trailer. Lower the trailer loading ramps to the ground. If possible, use a second vehicle to tow the salvaged vehicle off the trailer, and use the winch cable on the truck to check the speed of the salvaged vehicle, operating the winch in reverse (lowering). If second vehicle is not available, pass the winch cable under vehicle and carry it out to a snatch block secured at a point about 50 feet to the rear of the trailer. Pass the cable through the snatch block and lead it back to the rear end of the salvaged vehicle. Attach it to the salvaged vehicle. Remove the turnbuckles and chains and rear chock blocks which secure the vehicle. Pull the salvaged vehicle off the trailer by operating the winch (par. 15 c (2)).

17. FIRE EXTINGUISHER.

a. **Description** (fig. 153). The fire extinguisher is mounted in a clamping bracket which is attached to the back of the cab between the seats on closed cab models and to the driver's side of the cab on open cab models. It is a carbontetrachloride vaporizing extinguisher and is effective for extinguishing fires resulting from burning wood, fabric, oil, grease, gasoline, liquids, or from short circuits. It should also be used on burning electrical equipment such as the generator cranking motor, wiring, and other installations.

b. **Operation.** To operate fire extinguisher, release handle by turning counterclockwise and proceed to pump the extinguisher fluid toward the area near the base of the flames. When using the extinguisher on burning liquids in a container, direct the fluid against the inside of the container just above the burning liquid.

Section VII

OPERATION UNDER UNUSUAL CONDITIONS

18. COLD WEATHER OPERATION.

a. **General.** Operation of automotive equipment at subzero temperatures presents problems that demand special precautions and extra careful servicing from both operating and maintenance personnel, if poor performance and total functional failure are to be avoided.

b. Fuel Oil.

(1) Many fuels suitable for Diesel engines operated in warm weather contain waxes that congeal at temperatures below 0°F. Diesel fuel oil, procured under U.S. Army Specification 2-102, grade X,

Operation Under Unusual Conditions

latest revision, will be used at low temperatures, as it will not precipitate wax at subzero temperatures.

(2) If any emergency necessitates procurement of commercial fuel, extreme care must be taken to see that the cloud point is 10°F lower than the lowest atmospheric temperature anticipated. Otherwise, the fuel will not flow to the injectors in quantities sufficient for satisfactory engine operation.

(3) Water in Diesel fuel will form ice that may stop fuel flow to the fuel pumps. Precautions, such as steps (2), (3), (4), (5), and (6) of subparagraph c, must be taken.

c. Storage and Handling of Fuel Oil.

(1) Be sure that all containers are thoroughly clean and free from rust before storing fuel in them.

(2) If possible, after filling or moving a container, allow the fuel to settle 24 hours before filling vehicle tank from it.

(3) Keep all closures of containers tight to prevent snow, ice, dirt, and other foreign matter from entering.

(4) Wipe all snow or ice from dispensing equipment and from around fuel tank fill cap before removing cap to refuel vehicle. After filling tank, replace cap securely.

(5) Add 1 quart of grade 3 denatured alcohol to the fuel tank at start of winter season, and ½ pint at each refueling. This will reduce the hazard of ice formation in the fuel.

(6) Strain the fuel through any type of strainer that will prevent the passage of water.

d. Keeping Oil in Crankcase Fluid. Several methods for keeping crankcase oil sufficiently fluid for proper lubrication are listed below. Preference should be given to the different methods in the order listed, according to the facilities available.

(1) **PROVIDE PROTECTION.** Keep the vehicle in a heated inclosure when it is not being operated.

(2) **DRAIN THE CRANKCASE.** When the engine is stopped, drain the crankcase oil while it is still hot and store in a warm place until the vehicle is to be operated again. If warm storage is not available, heat the oil before reinstalling. *NOTE: Do not get the oil too hot; heat only to the point where the bare hand can be inserted without burning. Tag the vehicle in a conspicuous place in the cab to warn personnel that the crankcase is empty.*

(3) **DILUTE THE CRANKCASE OIL.** Crankcase oils may be diluted with gasoline or Diesel fuel oil according to their availability, with

preference given to gasoline. One of the two following procedures will be used to provide the engine with properly diluted engine oil for cold starting:

(a) *Using Gasoline as a Diluent.* Fill engine crankcase to the "FULL" mark with the grade of engine oil prescribed for use at temperatures from $+32^{\circ}\text{F}$ to 0°F (par. 22). Add $7\frac{3}{4}$ quarts of gasoline. Run the engine 5 to 10 minutes to mix the lubricant and diluent thoroughly. Stop the engine and note that the level of the diluted oil is above the normal "FULL" mark on the oil gage. This level should be marked on the gage for future reference. The presence of a large percentage of light diluent will increase oil consumption and, for that reason, the oil level should be checked frequently. Use the grade of engine oil prescribed for use between $+32^{\circ}\text{F}$ to 0°F to maintain the oil level to manufacturer's "FULL" mark on the gage during operation. If the vehicle is operated 4 hours or more at operating temperature, re-dilution will be necessary if it is anticipated that the vehicle will be left standing unprotected for 5 hours or more. This can be accomplished by adding engine oil prescribed for use between $+32^{\circ}\text{F}$ to 0°F to the manufacturer's "FULL" mark, then adding gasoline to the dilution mark on the gage described in substep (1) above.

(b) *Using Diesel Fuel Oil as a Diluent.* If Diesel fuel is used as a diluent, drain the crankcase while the engine is still warm and refill, using engine oil prescribed for temperatures between $+32^{\circ}\text{F}$ to 0°F diluted with grade X Diesel fuel oil in the proportion of $7\frac{3}{4}$ quarts of Diesel fuel. The presence of a large percentage of diluent will increase oil consumption and, therefore, check the oil level frequently during operation and maintain it to manufacturer's "FULL" mark on gage with engine oil diluted with Diesel fuel oil as described above. **CAUTION:** *When Diesel fuel oil is used as a diluent, the quantity of diluent necessary for starting is added when the crankcase is refilled and maintained by the addition of diluted made-up oil. Further additions of diluent prior to overnight shut-down are unnecessary.*

(4) If the vehicle is to be kept outdoors, and if the crankcase cannot be drained, shelter the engine compartment with a tarpaulin. About 3 hours before engine is to be started, place fire pots under the tarpaulin. A Van Prag, Primus-type, or other type blowtorch or ordinary kerosene lanterns may be used. With due consideration for the fire hazard involved, the flame may be applied directly to the oil pan.

e. Transmission, Transfer Cases, and Differentials.

(1) SAE 10 engine oil is prescribed for use at temperatures from $+32^{\circ}\text{F}$ to 0°F for the auxiliary transmission control. Use the same oil undiluted for operation below 0°F .

(2) SAE 80 universal gear lubricant, where prescribed, is suitable for use at temperatures as low as -20°F . If consistent temperature

Operation Under Unusual Conditions

below 0°F is anticipated, drain the gear cases while warm and refill with grade 75 universal gear lubricant which is suitable for operation at all temperatures below +32°F without dilution.

(3) After engine has been warmed up as provided in paragraph 13 c, put transmission in low (first) gear, and drive vehicle for 100 yards, being careful not to stall engine. This will heat gear lubricants to the point where normal operation can be expected.

f. Other Lubrication Points. Lubricate wheel bearings and grease cups using No. 2 general purpose grease with the same lubricant at all times. If repacking must be performed at sufficiently low temperature that thorough hand packing cannot be accomplished, No. 0 general purpose grease may be used until temperature returns to above 0°F. Lubricate all other places where No. 0 general purpose grease is specified above 0°F with the same grease below 0°F. When extreme low temperatures are encountered and No. 0 general purpose grease is not satisfactory where specified above, No. 00 O. D. grease (Ordnance Department Specification AXS-1169), may be used. Drain steering gear housing if possible, or use suction gun to remove as much lubricant as possible. Refill with grade 75 universal gear lubricant. For oilcan points where engine oil is prescribed for above 0°F, use special preservative lubricating oil.

g. Cooling System.

(1) For operation in temperatures below +32°F, use antifreeze compound to protect the cooling system against freezing.

(2) Before adding antifreeze compound, drain off the water and look for excessive rust. The cooling system, including the air compressor water jacket, must be clean and completely free of rust (par. 88 b). If the cooling system has been cleaned recently, it may be necessary only to drain, refill with clean water, and again drain.

(3) Inspect all hoses and replace if deteriorated. Inspect and tighten, if necessary, all hose clamps, plugs, and pet cocks. See that radiator does not leak and if found to be leaking, install new radiator before adding antifreeze compound. Inspect for coolant leakage at cylinder head and correct by tightening cylinder head studs or replace cylinder head gasket.

(4) Test thermostat to see that it closes completely (par. 92). Look for evidence of sticking in open or closed position. If thermostat does not open or close completely, does not function freely, or is badly rusted, replace it (par. 92).

(5) When the cooling system is clean and tight, fill with water to about one-third capacity, or 5 gallons. Then add antifreeze compound, using the proportion of antifreeze compound to the cooling system capacity indicated below. The system should be protected to at least 10°F below the lowest expected temperature to be experienced during the winter season.

Operating Instructions

ANTIFREEZE TABLE

Lowest Expected Temperature	Pints of Antifreeze Compound Per Gallon of Cooling System Capacity—NOTE: Capacity, 15½ gal.
+10°F	2
0°F	2½
-10°F	3
-20°F	3½
-30°F	4
-40°F	4½
-50°F	5

(6) After adding antifreeze compound, fill with water, then start and warm engine to normal operating temperature (par. 13 c).

(7) Stop engine and check solution with a hydrometer, adding antifreeze compound if required.

(8) In service, inspect the coolant weekly for strength and color. Rusty solution should be drained, the cooling system thoroughly cleaned, and new solution of the required strength added. **CAUTION:** *Antifreeze compound is the only antifreeze for ordnance materiel. It is essential that antifreeze solutions be kept clean. Use only containers and water that are free from dirt, rust, and oil. Use an accurate hydrometer. To test hydrometer, use 1 part antifreeze compound to 2 parts water. This solution should produce a hydrometer reading of 0°F.*

h. Battery and Electrical Systems.

(1) **GENERATOR AND CRANKING MOTOR.** Check brushes for wear and springs for tension, and see that brushes and commutator are clean. Oil or grease on the brushes or commutator will affect operation of the generator and will prevent the electrical contact required for the large surges of current in the cranking motor required for good starting.

(2) **WIRING.** Check, clean, and tighten all connections, especially the battery terminals. Care should be taken to see that no short circuits are present.

(3) **BATTERIES.** The efficiency of batteries decreases sharply with decreasing temperatures and becomes practically nil at -40°F. When the battery has been chilled to a temperature below -30°F, it should preferably be heated before attempting an engine start, unless a warm slave battery is available. See that the battery is always fully charged, with the hydrometer reading between 1.275 and 1.300. A fully charged battery will not freeze at temperatures likely to be encountered even in Arctic climates, but a fully discharged battery

Operation Under Unusual Conditions

will freeze and rupture at $+5^{\circ}\text{F}$. Do not add water to a battery when it has been exposed to subzero temperatures unless the battery is to be charged immediately. If water is added and the battery is not put on charge, the layer of water will stay at the top and freeze before it has a chance to mix with the acid.

i. Mechanical Maintenance.

(1) **OIL PRESSURE GAGES.** The gage may fail to register pressure due to congealed oil in the tube. Where this condition is experienced, the gage may be prepared for subzero operation. Disconnect the gage tube at the gage and at the opposite end while the oil is hot, and see that the tube is clear. Plug the lower end of the tube with special lubricating grease, then fill the gage tube with grade 3 denatured alcohol and reconnect.

(2) **CRANKING MOTORS.** Wash the throw-out mechanism and gear in dry-cleaning solvent to remove grease and dirt. Heavy grease or dirt may keep the gears from being meshed, or cause them to remain in mesh after the engine starts running. The latter will ruin the cranking motor and necessitate repairs.

(3) **WATER PUMP.** Prior to the advent of cold weather, inspect water pump and service if required.

(4) **FUEL SYSTEM.** Drain fuel tank sump, and drain and clean filters and strainers weekly, or more often according to experience, to remove water and dirt. In an extreme emergency, when using nonstandard fuels, the elements may be removed temporarily from fuel filters if difficulty is experienced with wax clogging the screens and stopping the flow of fuel through the filters.

(5) **AIR CLEANERS.** At temperatures below 0°F , use SAE 10 engine oil, in servicing mesh-type and oil-bath type air cleaners and breathers.

(6) **CHASSIS.** Freezing has a tendency to cause brakes to stick or bind when vehicles are parked at subzero temperatures. Use a blow-torch to warm up these parts if they bind when attempting to move the vehicle. Parking the vehicle with the brake released will eliminate most of the binding. Precaution must be taken under these circumstances to block the wheels or otherwise prevent movement of the vehicle. Inspect the vehicle frequently. Shock resistance of metals, or resistance against breaking, is greatly reduced at extremely low temperatures. Operation of vehicles on hard, frozen ground causes strain and jolting which will result in screws breaking or nuts jarring loose. Disconnect oil-lubricated speedometer cables at the drive end when operating vehicles at temperatures consistently below -20°F . These cables often fail to work properly at these temperatures and sometimes break due to the excessive drag caused by the high viscosity

Operating Instructions

of the oil with which they are lubricated. Grease-lubricated cables should operate satisfactorily at all temperatures providing they are coated with No. 0 general purpose grease and there is no excess grease in the housing. When extreme low temperatures are encountered and No. 0 general purpose grease is not satisfactory, No. 00 O.D. grease, Ordnance Department Tentative Specification AXS-1169, may be used.

j. Starting the Engine.

(1) Prepare engine for starting by following procedure given in subparagraph d above.

(2) Depress clutch pedal.

(3) If vehicle is equipped with circuit lock switch, turn key of switch on. Depress cranking motor switch and at same time operate the hand priming pump plunger located on the instrument panel. **NOTE:** *Do not operate hand priming pump unless cranking motor is being used. To do so would result in unburned fuel being pumped into the intake manifold.*

(4) Release cranking motor switch after 30 seconds, if engine has not started, to allow cranking motor to cool for several minutes before again turning engine over.

(5) When engine fires and continues to run, regulate throttle to idle engine at 800 revolutions per minute.

(6) Observe instruments (par. 13 c (5)).

(7) Place vehicle in low gear and operate at low speed to warm up.

(8) Do not idle engine, when avoidable.

19. OPERATION UNDER HOT AND DUSTY CONDITIONS.

a. Air Cleaners and Filters. When operating in dusty terrain, frequent servicing of all dust catching devices on the vehicle is essential in order to prevent them from clogging. Failure to keep the various breathers, air cleaners, and screens in a clean condition will result in excessive wear of moving parts. Excess grease and oil around lubrication points should be wiped off to prevent grit and dirt from being drawn into bearings and bushings.

b. Maintenance Precautions. When parts are removed for inspection or cleaning, extra precautions must be taken to remove all dust before installing the part. The engine fuel nozzles or any part of the injector system should never be exposed to dirt while they are removed, since the slightest amount of grit is apt to damage them and cause engine failure.

*Operation Under Unusual Conditions***c. Batteries.**

(1) **WATER LEVEL.** In torrid zones, check cell water level daily and replenish if necessary with pure distilled water. If this is not available, any water fit to drink may be used. However, continuous use of water with high mineral content will eventually cause damage to batteries and should be used only in an emergency.

(2) **SPECIFIC GRAVITY.** Batteries operating in torrid climates should have a weaker electrolyte than for temperate climates. Instead of 1.300 gravity, the electrolyte should be adjusted to around 1.210 to 1.230 for a fully charged battery. This will prolong the life of the negative plates and separators. Under this condition the batteries should be recharged at about 1.160.

(3) **SELF-DISCHARGE.** A battery will self-discharge at a greater rate at high temperatures if standing for long periods. This must be taken into consideration when operating in torrid zones. If necessary to park for several days, remove batteries and store in a cool place.

20. SUBMERSION.**a. Immediate Precautions.**

(1) **GENERAL.** When a vehicle has been driven through deep water heavily laden with dirt and abrasives, or completely submerged in water, certain precautions must be taken to avoid serious damage to such units as the engine, clutch, transmissions, axles, universal joints, winch, steering gear, battery, fuel tank, brakes, and wheel bearings. If it is known that water, dirt, and abrasives have contaminated the various units of the vehicle, notify the proper authority at once. Each unit which has been submerged must be completely dismantled, cleaned, and lubricated.

(2) **EMERGENCY PROCEDURE.** In an emergency, each unit should be inspected, cleaned, and lubricated to prevent as much damage as possible.

b. Lubrication and Service. Lubricate the truck and trailer completely (par. 22). Remove filter plugs from storage battery. Check electrolyte for level and appearance. Normal level after immersion indicates that little or no water has entered battery. Clean electrolyte solution, even though slightly high, indicates no absorption of excess dirt or damaging foreign material. If solution is dirty, replace battery. Test gravity (par. 112 b (4)). If the battery is discharged, recharge or replace. Clean fuel filters on engine (par. 72 b). Clean and reoil air cleaners and crankcase breather (par. 22). Remove all wheel bearings (pars. 185, and 257), clean, repack with lubricant, and reassemble. Replace oil seals on wheel hubs (pars. 185 and 257) if they are contaminated with dirt, to avoid damage to seal surfaces and

Operating Instructions

lubricant leakage. Replace the cranking motor, generator, and generator regulator (pars. 96, 97, 114, and 115). Drain lubricant from transmission, auxiliary transmission, and winch. Refill gear cases, using half Diesel fuel oil and half SAE 10 engine oil for flushing oil. Drain rear axles and refill with same flushing oil. Next, with rear wheels on jacks, drive rear wheels for 5 minutes. Run the winch. Drain all units thoroughly and refill with correct grade of lubricant (par. 22).

c. Engine. Drain engine oil and fill crankcase with 10 quarts of Diesel fuel oil and 10 quarts of SAE 10 engine oil, and run engine for several minutes at idling speed with clutch released. Replace oil filters (par. 125). Drain engine and fill with correct grade of oil (par. 22).

PART THREE

MAINTENANCE INSTRUCTIONS

Section VIII

LUBRICATION

21. LUBRICATION ORDER.

a. **Scope.** Reproductions of War Department Lubrication Order No. 160 (figs. 13 and 14) and Lubrication Order No. 724 (fig. 15) prescribe first and second echelon lubrication maintenance above 0°F.

b. **Availability.** A Lubrication Order is placed on or is issued with each item of materiel and is to be carried with it at all times. In the event the materiel is received without a copy, the using arm shall immediately requisition a replacement from the Commanding Officer, Fort Wayne Ordnance Depot, Detroit 32, Michigan.

c. **Responsibility.** Instructions on the Lubrication Orders are binding on all echelons of maintenance and there shall be no deviation.

d. **Intervals.** Service intervals specified on the Lubrication Orders are for normal operating conditions during active service above 0°F. Reduce these intervals under extreme conditions such as excessively high or low temperatures, prolonged periods of high speed, continued operation in sand or dust, immersion in water, or exposure to moisture, any one of which may quickly destroy the protective qualities of the lubricant and require servicing in order to prevent malfunctioning or damage to the materiel.

e. **Temperatures.** Lubricants are prescribed in the "Key" in accordance with three temperature ranges; above +32°F, +32°F to 0°F, and below 0°F. The time to change grades of lubricants is determined by maintaining a close check on operation of the materiel during the approach to change-over periods. Sluggish starting is an indication that lubricants are thickening and the signal to change to grades prescribed for the next lower temperature range. Ordinarily it will be necessary to change grades of lubricants *only when air temperatures are consistently in the next higher or lower range.*

22. DETAILED LUBRICATION INSTRUCTIONS.

a. **Lubrication Equipment.** Each piece of materiel is supplied with lubrication equipment adequate to maintain the materiel. Be sure to clean this equipment both before and after use. Operate lubricating guns carefully and in such manner as to insure a proper distribution of the lubricant.

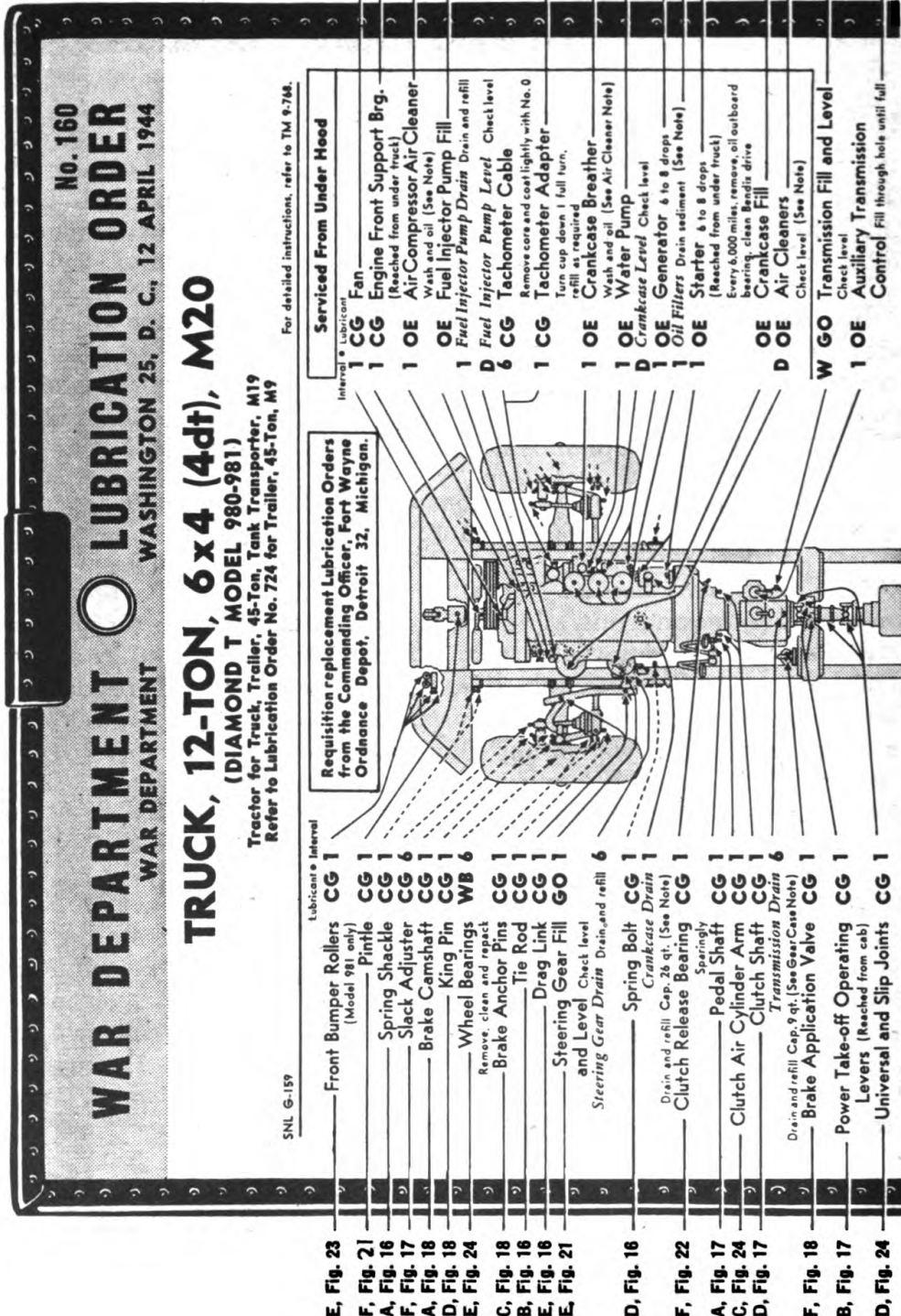
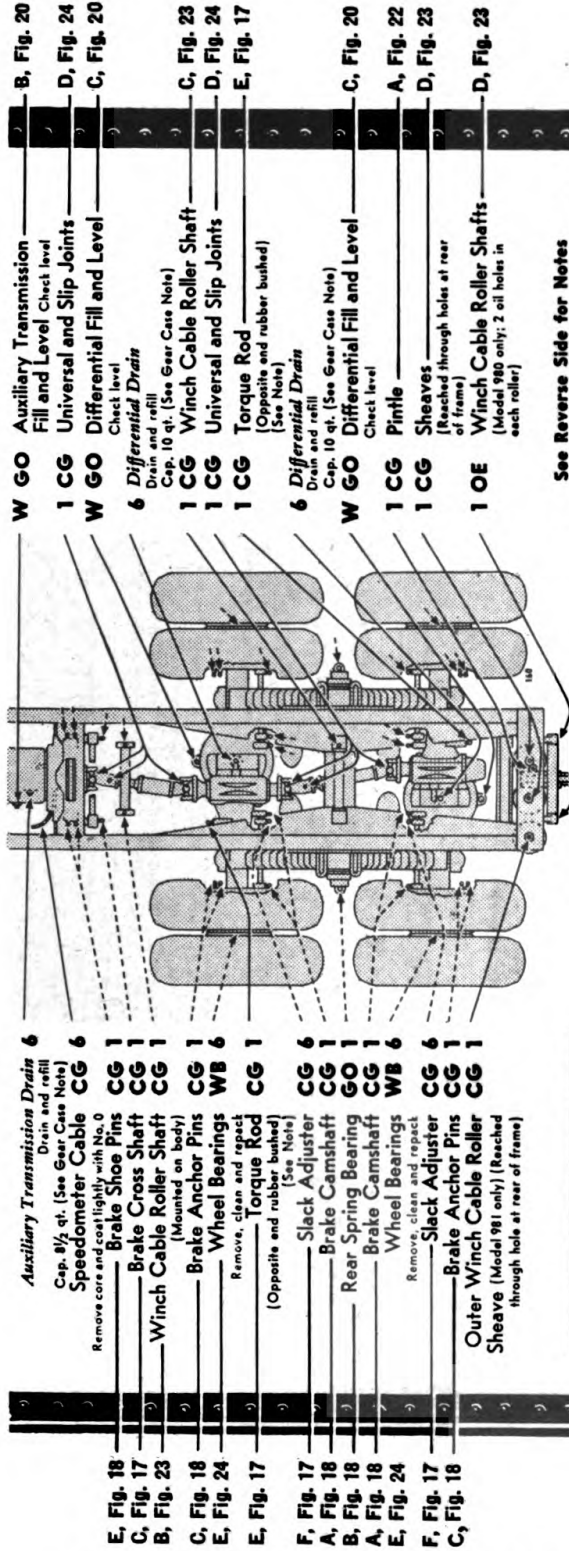

Figure 13—Lubrication Order

RA PD 321186

Lubrication



- W GO Auxiliary Transmission
- 1 CG Fill and Level
- W GO Universal and Slip Joints
- 6 Differential Fill and Level
- 1 CG Winch Cable Roller Shaft
- 1 CG Universal and Slip Joints
- 1 CG Torque Rod
- 6 Differential Drains
- W GO Differential Fill and Level
- 1 CG Pintle
- 1 CG Sheaves
- 1 OE Winch Cable Roller Shafts

- 6 Auxiliary Transmission Drain
- 6 Speedometer Cable
- CG Brake Shoe Pins
- CG Brake Cable Roller Shaft
- CG Brake Anchor Pins
- WB Wheel Bearings
- CG Torque Rod
- CG Slack Adjuster
- CG Brake Camshaft
- GO Rear Spring Bearing
- CG Brake Camshaft
- WB Wheel Bearings
- CG Slack Adjuster
- CG Brake Anchor Pins
- CG Outer Winch Cable Roller Sheave

No. 160—Engine and Chassis Points

See Reverse Side for Notes
Reduce intervals under severe operating conditions.
Lubricate dotted arrow points on both sides.
Opposite points are shown by short arrows.

NOTE—See Reverse Side for Lubrication of WINCH
KEY
THIS SIDE ONLY

LUBRICANTS	LOWEST ANTICIPATED AIR TEMPERATURE	LUBRICANTS	INTERVALS
OE—OIL, engine	above +32°F.	WB—GREASE, general purpose, No. 2	D—Daily
Craticase	+32°F. to 0°F.	PS—OIL, lubricating, preservative, special purpose	W—Weekly
Other Points	below 0°F.		1—1,000 miles
GO—LUBRICANT, gear, universal	SAE 30		6—4,000 miles
CG—GREASE, general purpose	SAE 30		
	SAE 10		
	SAE 10		
	SAE 80		
	SAE 90		
	No. 1		
	No. 0		
	No. 0		
	No. 0		

No. 160 [NOT TO BE REPRODUCED in whole or in part without permission of the Office of the Chief of Ordnance.] CHECK-CHART

RA PD 321186B

No. 160

WAR DEPARTMENT LUBRICATION ORDER

WASHINGTON 25, D. C., 12 APRIL 1944

TRUCK, 12-TON, 6x4 (4dt), M20

(DIAMOND T MODEL 980-981)

SNL G-159.

Clean fittings before lubricating. Lubricate after washing.

To clean parts, use SOLVENT, dry cleaning or OIL, fuel, Diesel. Dry before lubricating.

For detailed instructions, refer to TM 9-768.

Reduce intervals under severe operating conditions.

NOTE— See Reverse Side for lubrication of TRUCK

Requisition replacement Lubrication Orders from the Commanding Officer, Fort Wayne Ordnance Depot, Detroit 32, Michigan.

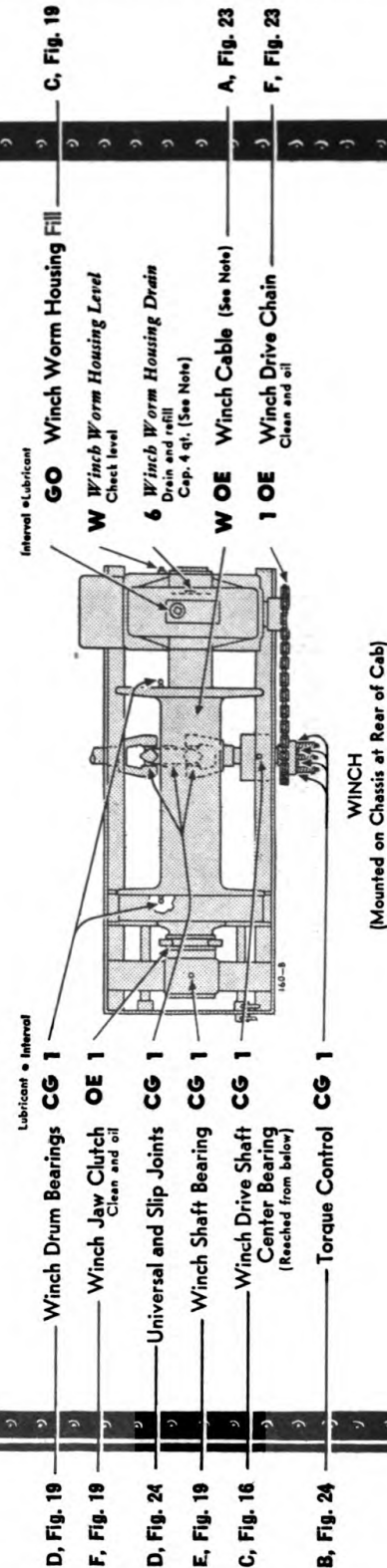

Figure 14—Lubrication Order

RA PD 321184

NOTES

AIR CLEANERS — (Oil Bath Type) Fill to prescribed level. Every 1,000 miles, remove and wash all parts, replace and refill. (Mesh Type) Every 1,000 miles, remove and wash cleaner and cleaning element of air compressor air cleaner and crankcase breathers. Dry and oil, drain excess oil and replace. Used crankcase oil or OE will be used for all air cleaners and breathers above 0°F. Below 0°F, use OE SAE 10.

CRANKCASE — Drain only when oil is hot. Fill to FULL mark, run engine a few minutes and recheck level, if equipped with magnetic drain plugs, clean before replacing.

GEAR CASES — Drain only after operation. Fill to plug level when hot or to 1/2 inch below plug level when cold. If equipped with magnetic drain plugs, clean before replacing. Clean vents every 1,000 miles and after operation in sand, dust or mud.

OIL FILTERS — Every 6,000 miles, while crankcase is being drained, remove element, clean inside of case and install new element.

TORQUE ROD RUBBER BUSHINGS — Every 1,000 miles, apply HB to torque rod bushings where fittings are not provided. **CAUTION:** Do not use oil.

WINCH CABLE — After each use, clean and oil with used crankcase oil or OE. Weekly, if cable has not been used, coat outer coils. Monthly, unwind entire cable, clean and oil.

WINCH WORM HOUSING — Drain only after operation. Fill to plug level when cold. If equipped with magnetic drain plugs, clean before replacing.

OIL CAN POINTS — Every 1,000 miles, lubricate Throttle and Accelerator Linkage, Winch Control Handle, Hinges, Latches, Air Compressor Rocker Arms, Pintle Hook, Lock and Latch,

Winch Control Linkage, Power Take-off Control Linkage, Transfer Case Shift Linkage, Transfer Shaft and other rubbing parts with OE.

DO NOT LUBRICATE — Springs, Air Compressor Crankcase, Injector Pump Governor, Clutch Pilot Bearing, Power Take-off. **DISASSEMBLED PERIODICALLY BY ORDINANCE PERSONNEL** — Brake Governor, Clutch Air Cylinder. (Refer to TM 9-748.)

Copy of this Lubrication Order will remain with the equipment at all times; instructions contained therein are mandatory and supersede all conflicting lubrication instructions dated prior to 12 April 1944.

BY ORDER OF THE SECRETARY OF WAR:
G. C. MARSHALL,
Chief of Staff.

OFFICIAL:

J. A. ULIO,
Major General,
The Adjutant General.

KEY

THIS SIDE ONLY

LUBRICANTS	LOWEST ANTICIPATED AIR TEMPERATURE		LUBRICANTS	INTERVALS
	above +32°F.	+32°F. to 0°F.		
OE—OIL, engine	SAE 30	SAE 10	HB—FLUID, hydraulic brake	W—Weekly 1—1,000 miles 6—6,000 miles
CG—GREASE, general purpose	No. 1	No. 0		
GO—LUBRICANT, gear, universal	SAE 90	SAE 80	PS—OIL, lubricating, preservative, special	
		Grade 75		

No. 160 [NOT TO BE REPRODUCED in whole or in part without permission of the Office of the Chief of Ordnance.] CHECK-CHART

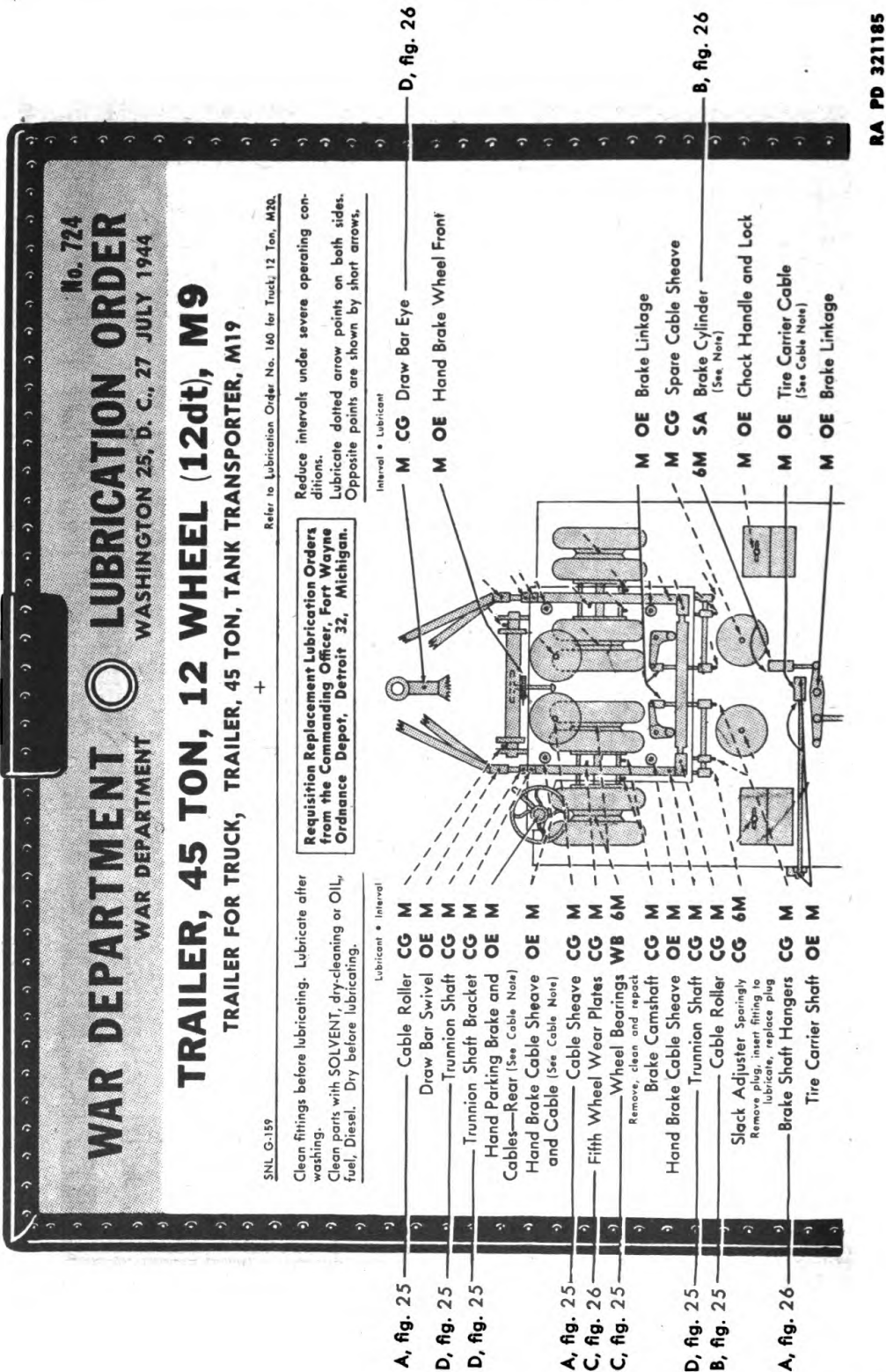

RA PD 321185

Figure 15—Lubrication Order

Lubrication

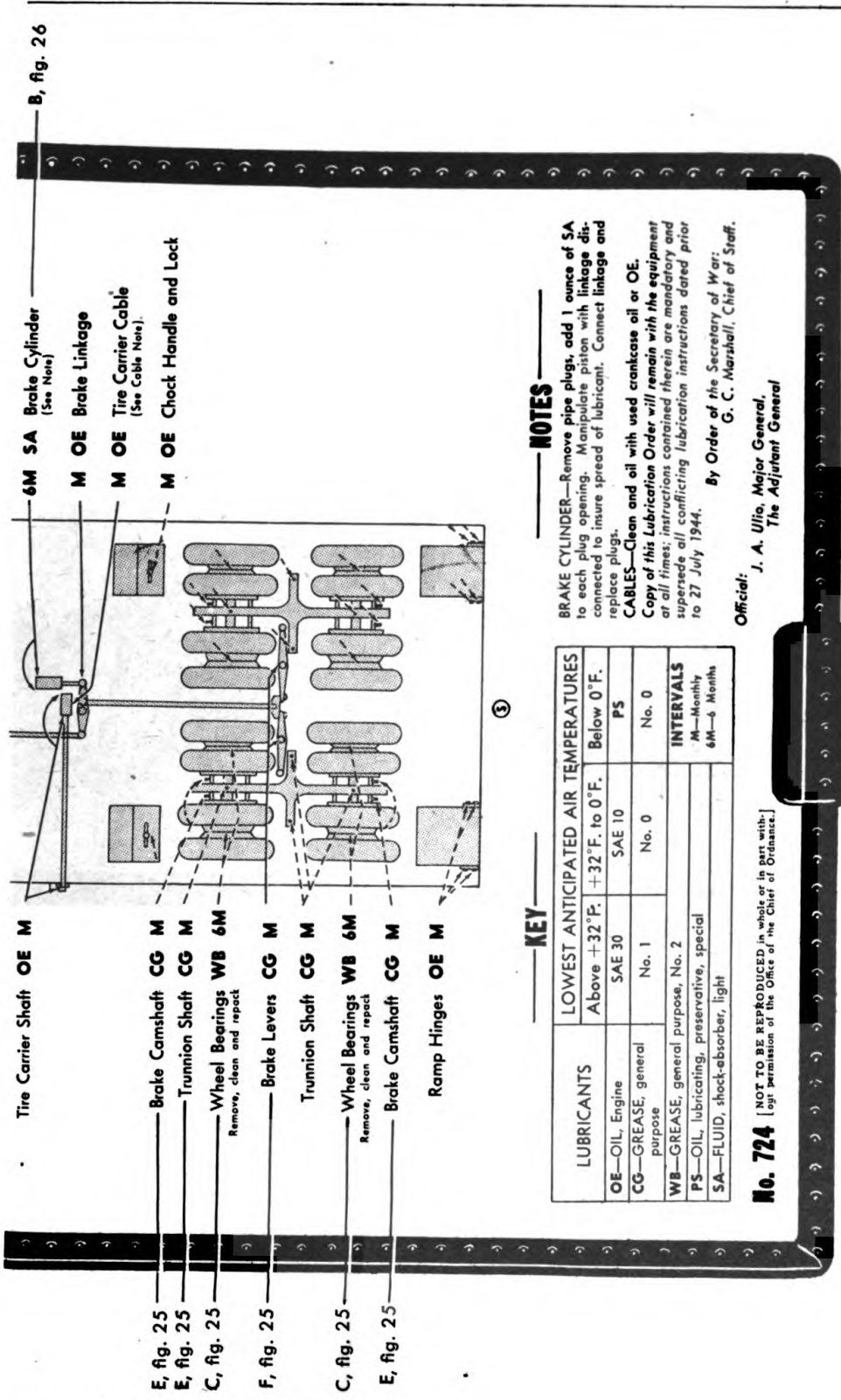

B, fig. 26

6M SA Brake Cylinder
(See Note)
M OE Brake Linkage
M OE Tire Carrier Cable
(See Cable Note).
M OE Chock Handle and Lock

Tire Carrier Shaft OE M
Brake Camshaft CG M
Trunnion Shaft CG M
Wheel Bearings WB 6M
Remove, clean and repack
Brake Levers CG M
Trunnion Shaft CG M
Wheel Bearings WB 6M
Remove, clean and repack
Brake Camshaft CG M
Ramp Hinges OE M

E, fig. 25
E, fig. 25
C, fig. 25
F, fig. 25
C, fig. 25
E, fig. 25

No. 724—Trailer Points

NOTES

BRAKE CYLINDER—Remove pipe plugs, add 1 ounce of SA to each plug opening. Manipulate piston with linkage disconnected to insure spread of lubricant. Connect linkage and replace plugs.
CABLES—Clean and oil with used crankcase oil or OE. Copy of this Lubrication Order will remain with the equipment at all times; instructions contained therein are mandatory and supersede all conflicting lubrication instructions dated prior to 27 July 1944.

By Order of the Secretary of War:
G. C. Marshall, Chief of Staff.

Official: J. A. Ulio, Major General,
The Adjutant General.

KEY

LUBRICANTS	LOWEST ANTICIPATED AIR TEMPERATURES	
	Above +32° F. to +32° F.	Below 0° F.
OE—OIL, Engine purpose	SAE 30	SAE 10
CG—GREASE, general purpose	No. 1	No. 0
WB—GREASE, general purpose, No. 2	No. 0	
PS—OIL, lubricating, preservative, special	No. 0	
SA—FLUID, shock-absorber, light	No. 0	
INTERVALS		
M—Monthly		
6M—6 Months		

No. 724 [NOT TO BE REPRODUCED in whole or in part without permission of the Office of the Chief of Ordnance.]

RA PD 321185B

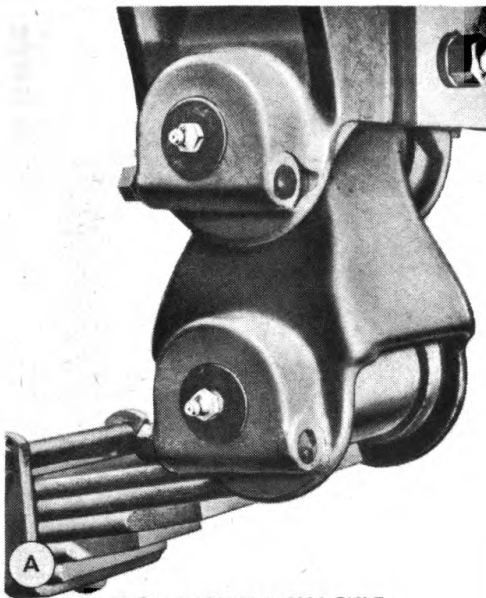

FRONT SPRING SHACKLE

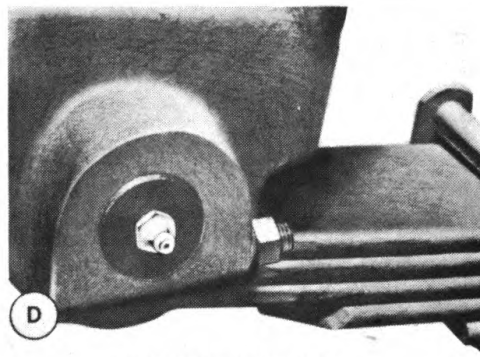

FRONT SPRING BOLT

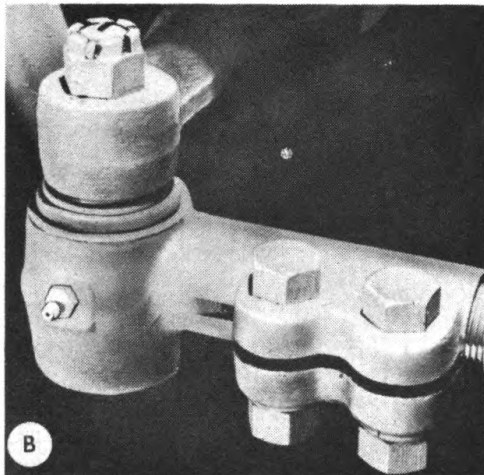

TIE ROD END

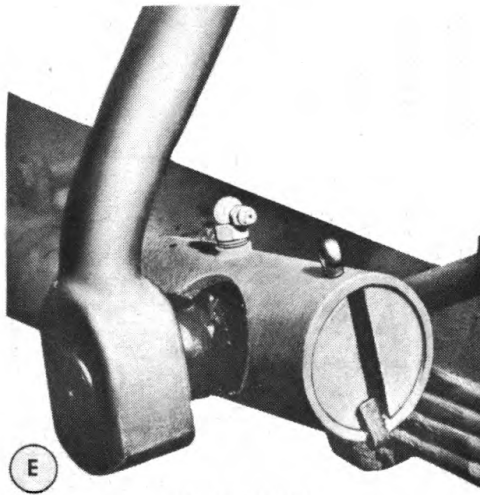

DRAG LINK

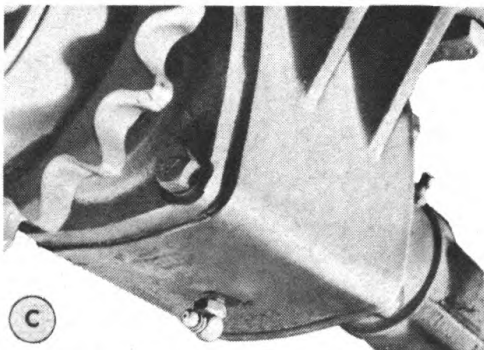

WINCH PROPELLER SHAFT
CENTER BEARING

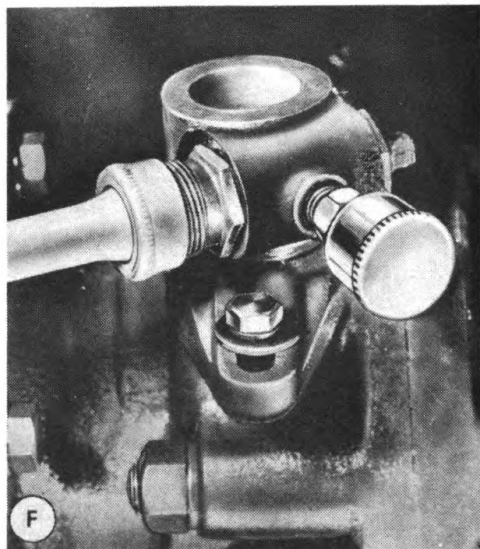

TACHOMETER DRIVE

RA PD 321467

Figure 16—Truck Local Lubrication Views

Lubrication

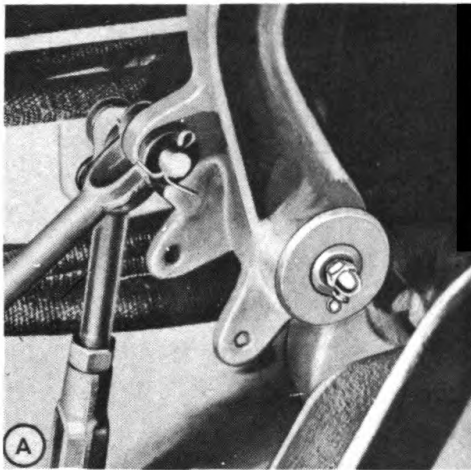

LEVER SHAFT (PEDAL SHAFT)

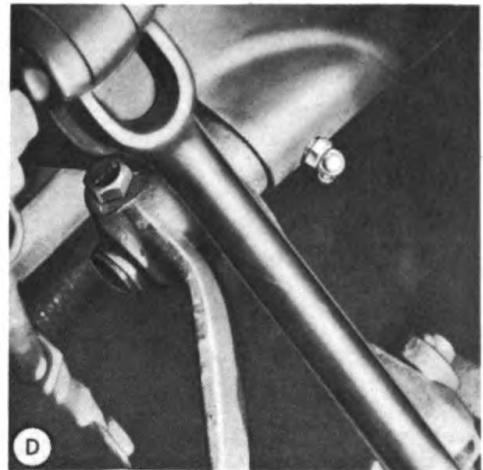

LEVER SHAFT (CLUTCH SHAFT)

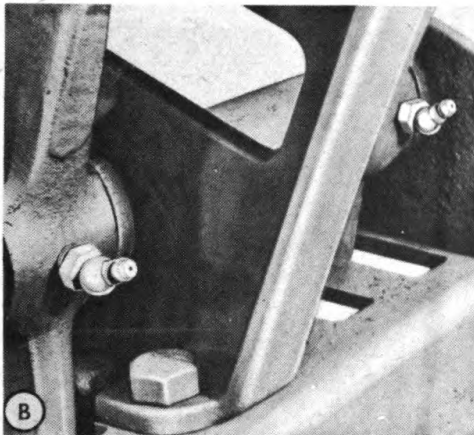

LEVER SHAFT (OPERATING LEVERS)

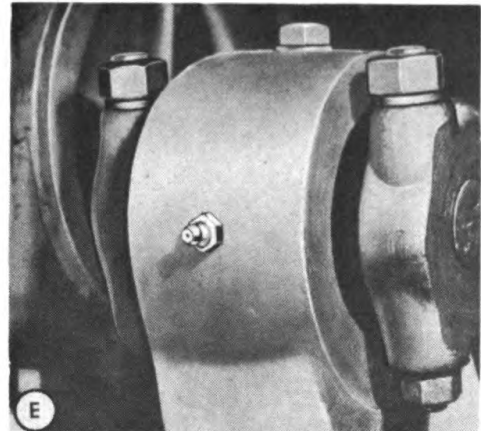

TORQUE RODS

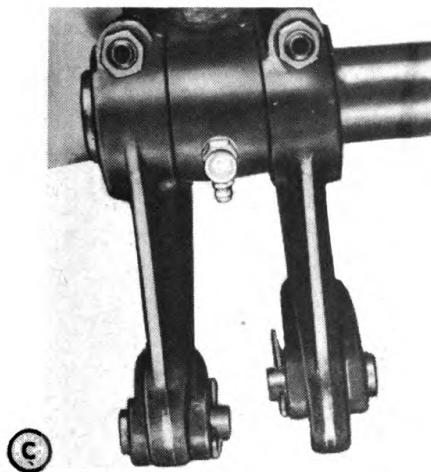

LEVER SHAFT (HAND BRAKE CROSS SHAFT)

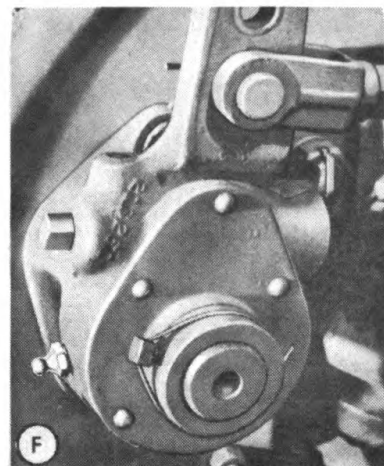

SLACK ADJUSTER
RA PD 321433

Figure 17—Truck Local Lubrication Views

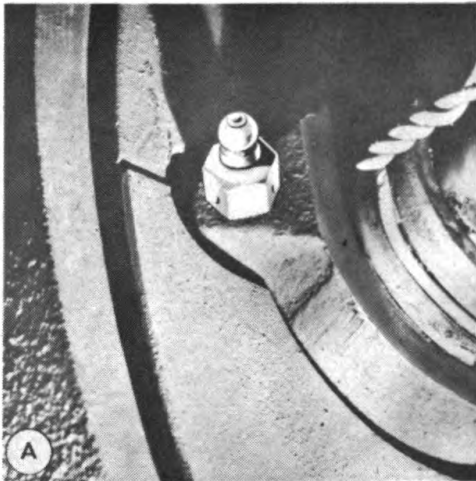

BRAKE CAMSHAFT

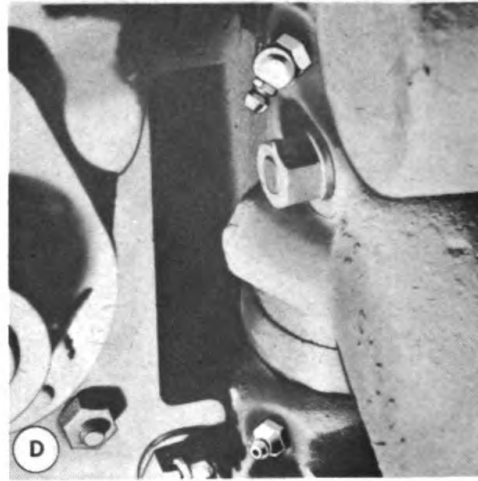

KINGPINS

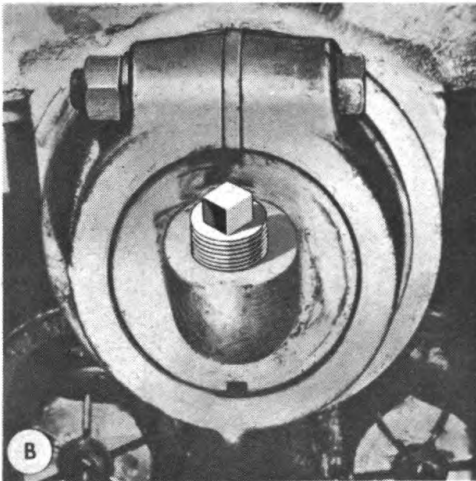

REAR SPRING BEARING

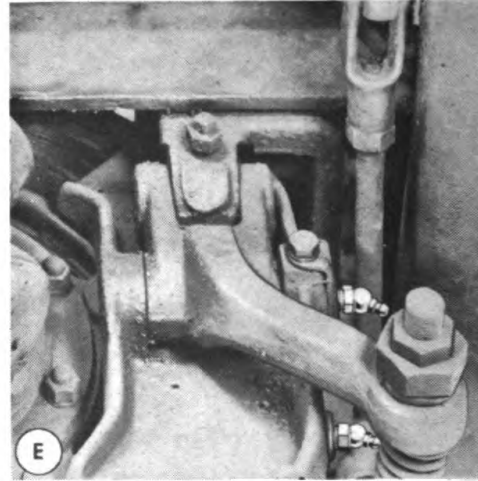

BRAKE SHOE PINS (HAND BRAKE)

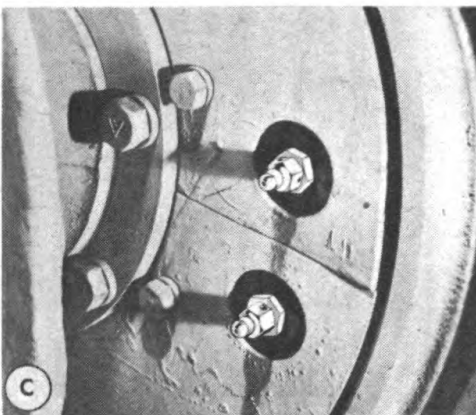

BRAKE ANCHOR PINS

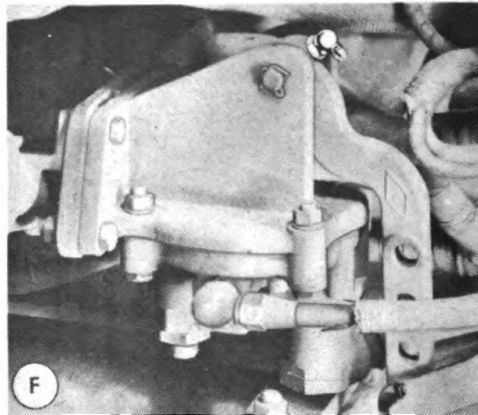

BRAKE APPLICATION VALVE

RA PD 321453

Figure 18—Truck Local Lubrication Views

Lubrication

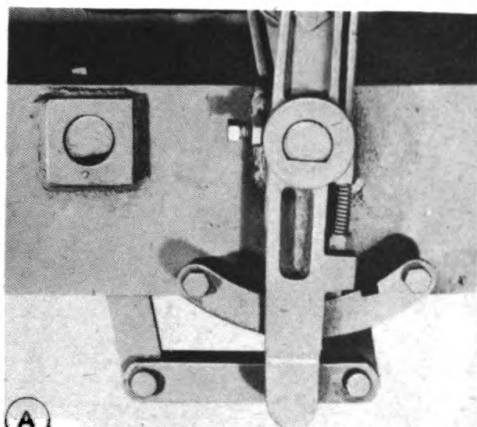

A
LINKAGE (WINCH CONTROL)

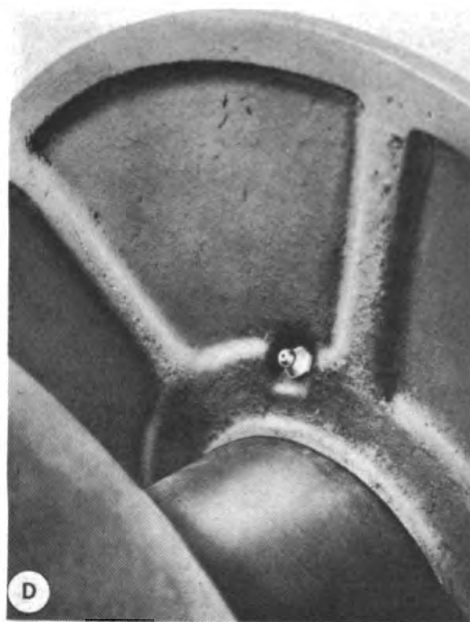

D
WINCH DRUM BEARING

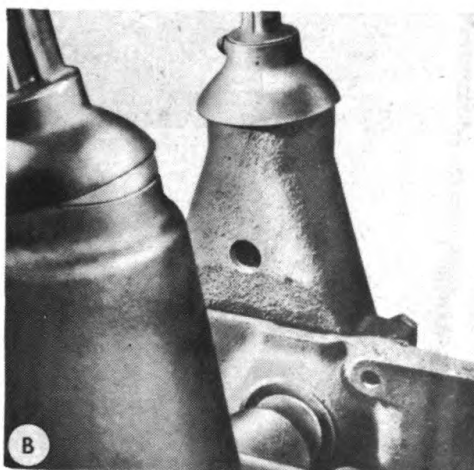

B
LINKAGE (AUXILIARY
TRANSMISSION CONTROL)

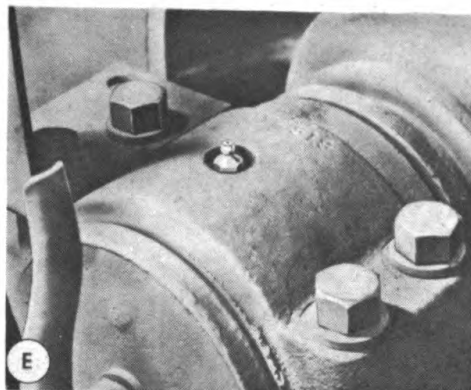

E
WINCH SHAFT

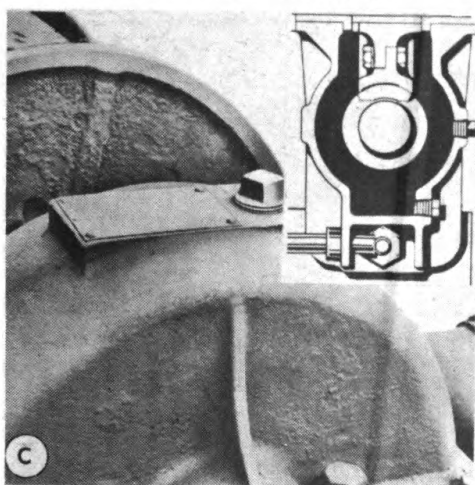

C
WINCH WORM HOUSING

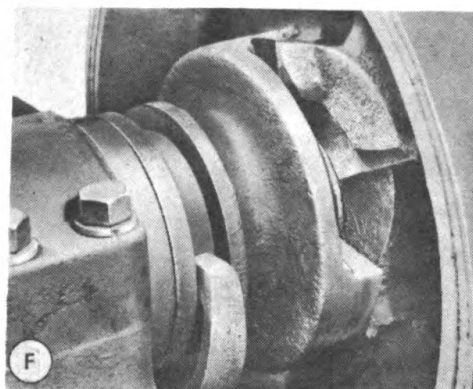

F
WINCH CLUTCH

RA PD 321446

Figure 19—Truck Local Lubrication Views

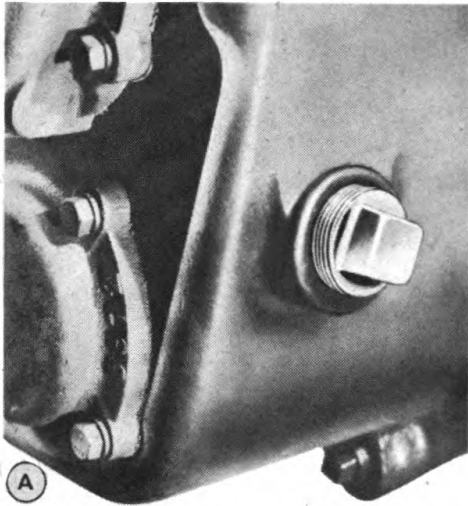

(A)

TRANSMISSION

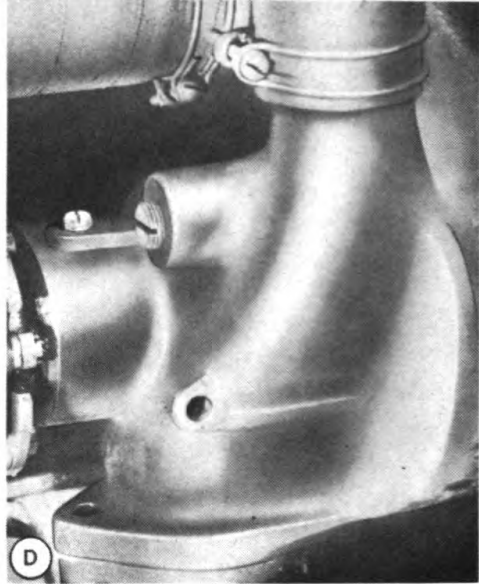

(D)

WATER PUMP

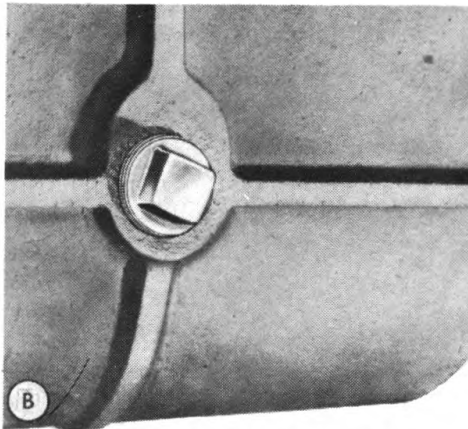

(B)

AUXILIARY TRANSMISSION

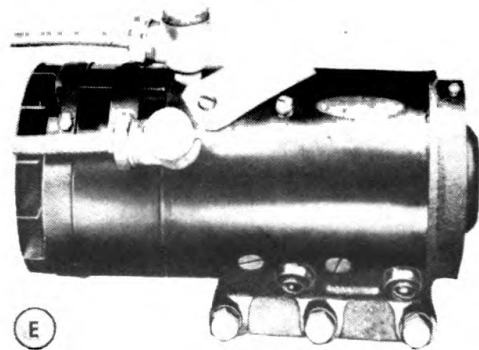

(E)

GENERATOR

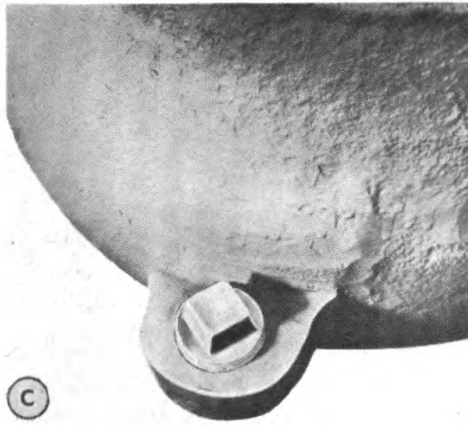

(C)

AXLE HOUSING

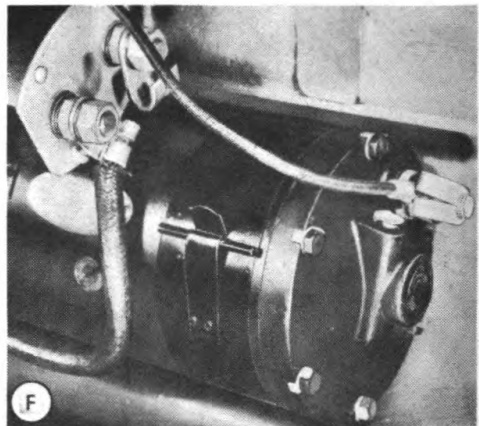

(F)

CRANKING MOTOR

RA PD 321383

Figure 20—Truck Local Lubrication Views

Lubrication

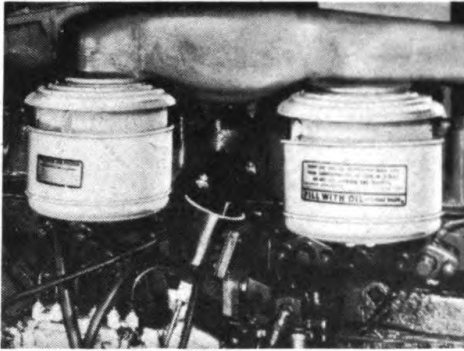

A—AIR CLEANERS



D—OIL FILTERS

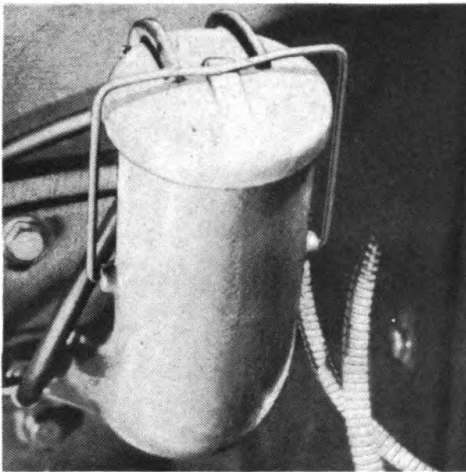

B—OIL FILLER

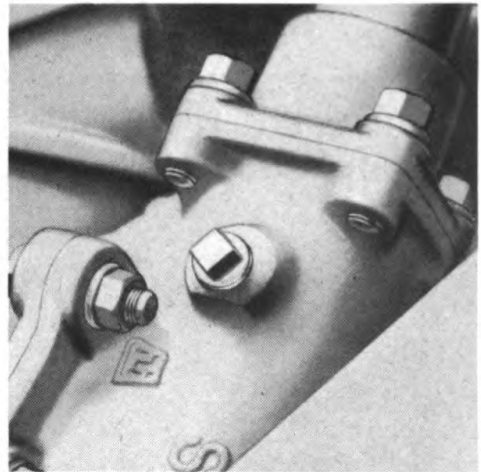

E—STEERING GEAR HOUSING



C—CRANKCASE BREATHER

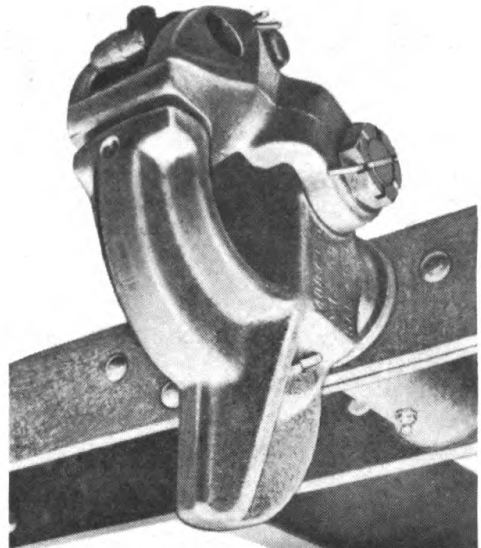

F—FRONT PINTLE HOOK

RA PD 321588

Figure 21—Truck Local Lubrication Views

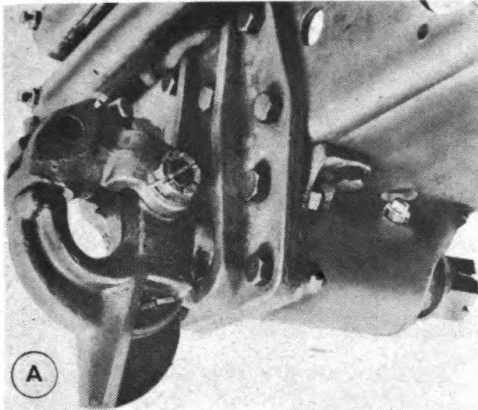

REAR PINTLE

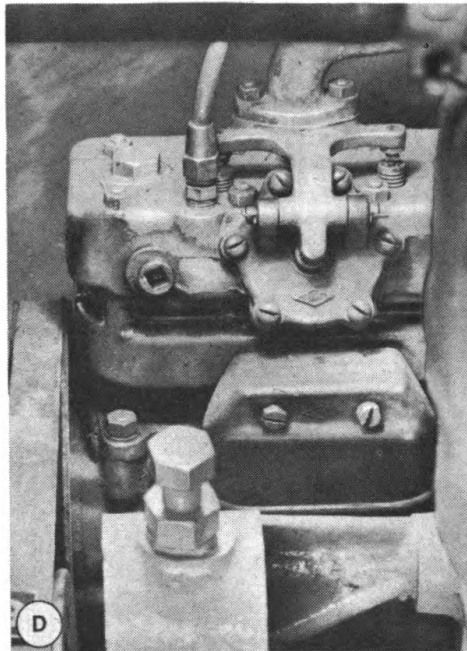

AIR COMPRESSOR AIR CLEANER

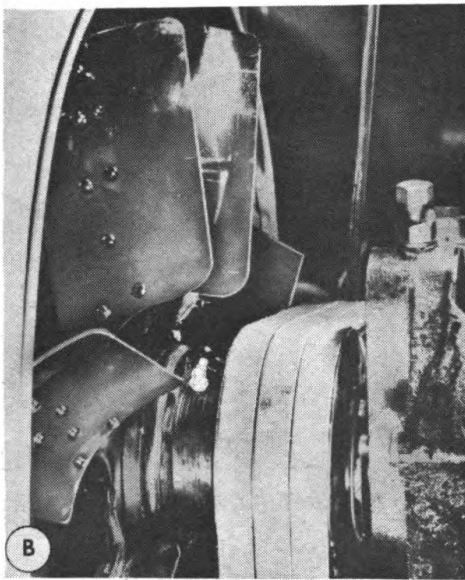

FAN HUB

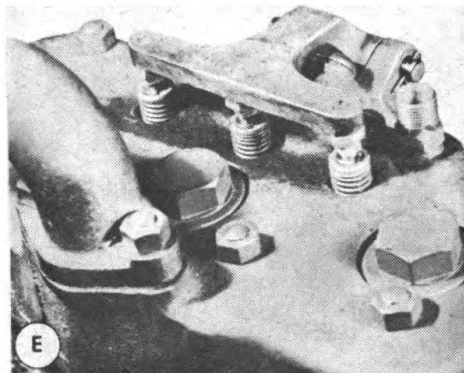

AIR COMPRESSOR ROCKERS

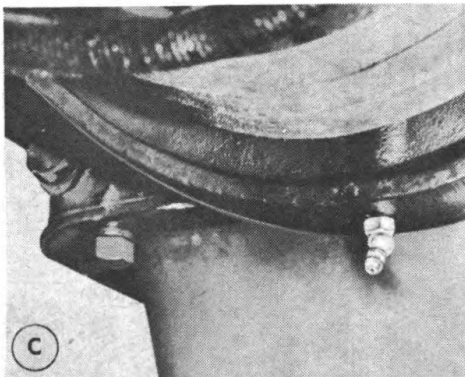

FRONT ENGINE SUPPORT

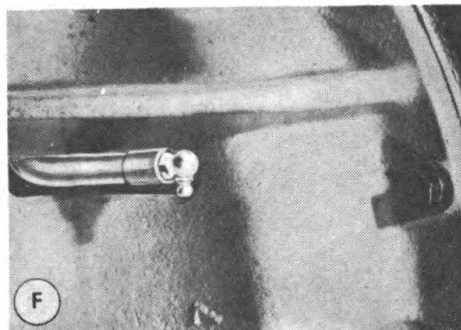

CLUTCH RELEASE BEARING

RA PD 321410

Figure 22—Truck Local Lubrication Views

Lubrication

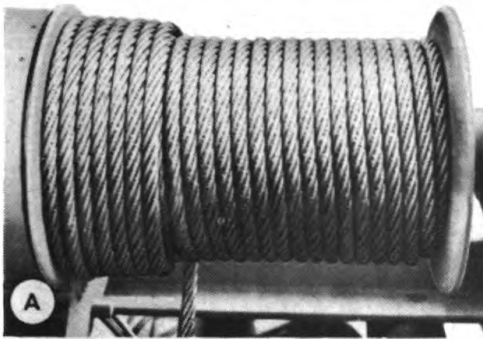

A

WINCH CABLE

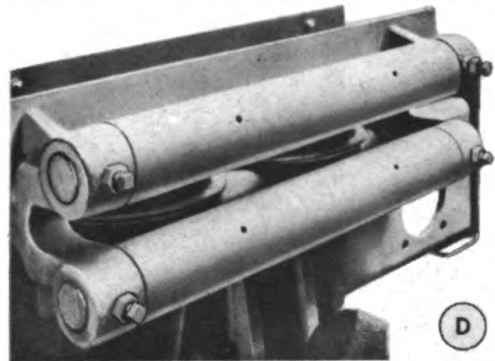

D

WINCH CABLE ROLLER SHAFT (REAR)

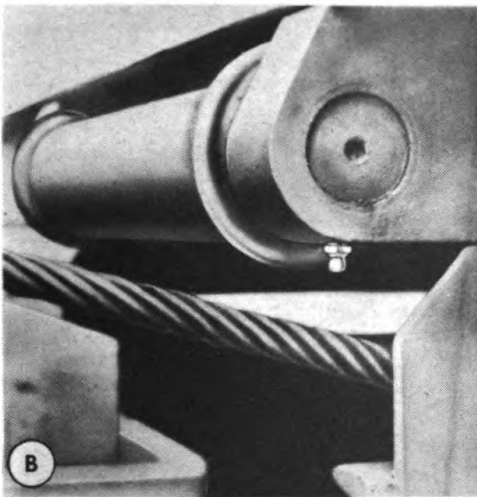

B

WINCH CABLE ROLLER SHAFT (BODY)

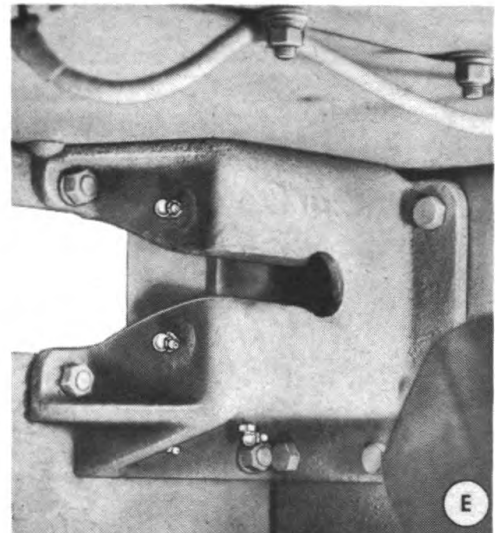

E

WINCH FRONT BUMPER CABLE ROLLER

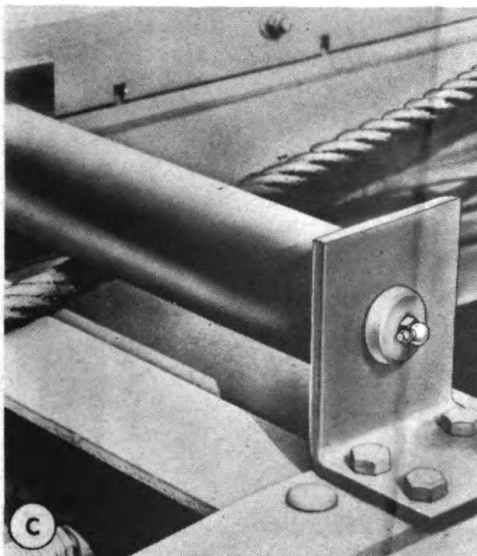

C

WINCH CABLE ROLLER SHAFT (CHASSIS)

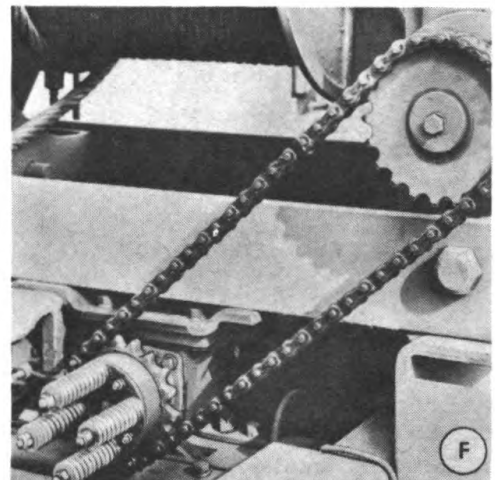

F

WINCH DRIVE CHAIN

RA PD 321437

Figure 23—Truck Local Lubrication Views

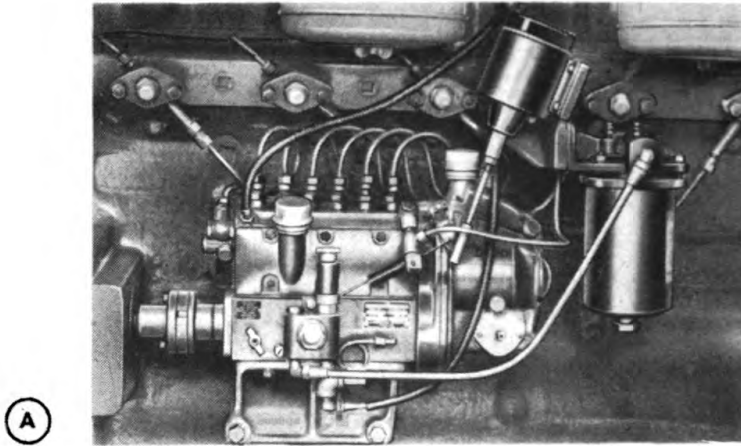

FUEL INJECTOR PUMP

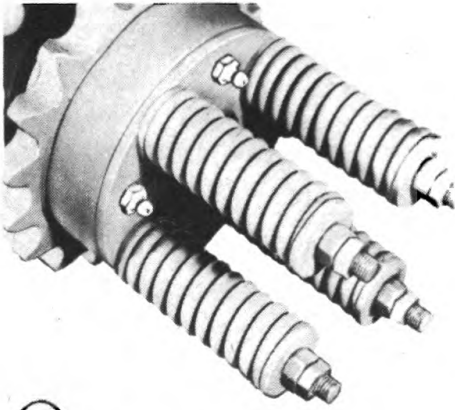

TORQUE CONTROL

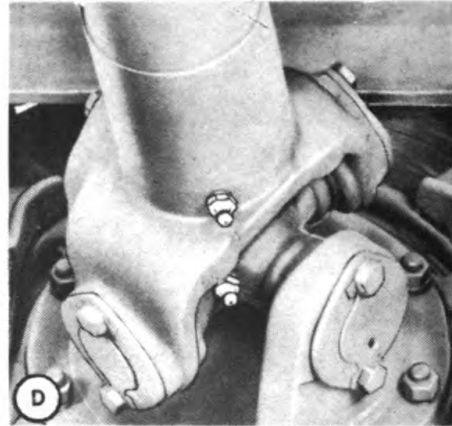

PROPELLER SHAFTS

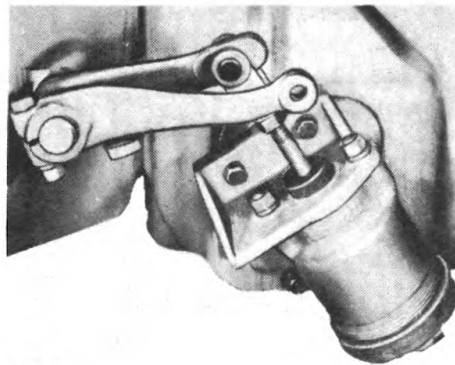

AIR POWER CYLINDER (CLUTCH CYLINDER)

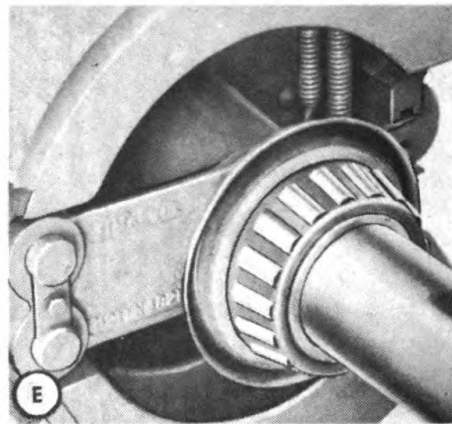

WHEEL BEARINGS
RA PD 321438

Figure 24—Truck Local Lubrication Views

Lubrication

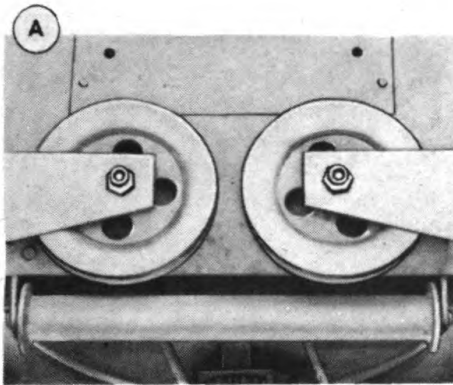

FRONT CABLE ROLLER AND SHEAVE

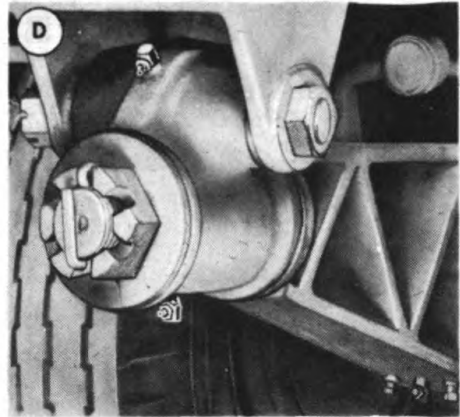

TRUNNION BEAM AND BRACKET

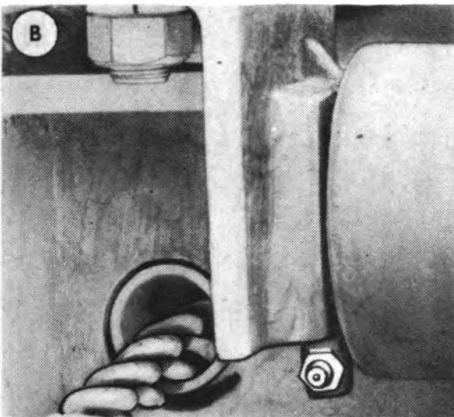

REAR CABLE ROLLER

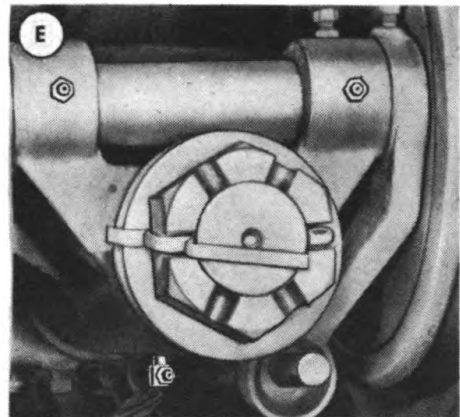

REAR TRUNNION AND BRAKE CAMSHAFT

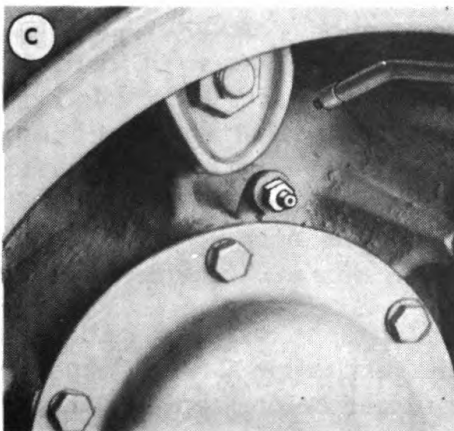

WHEEL BEARINGS

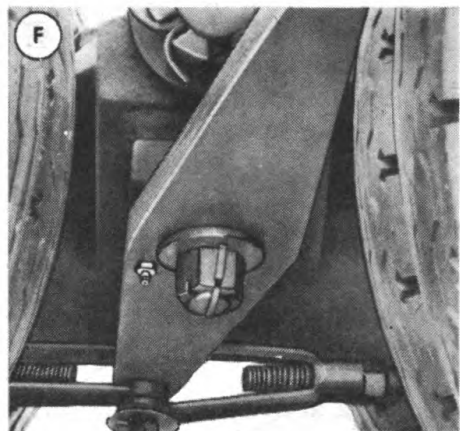

BRAKE LEVER

RA PD 321462

Figure 25—Trailer Local Lubrication Views

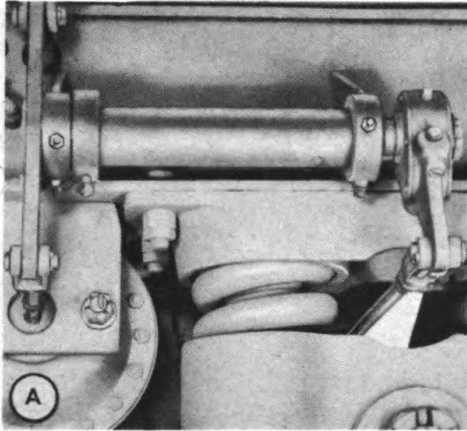

BRAKE SHAFT HANGERS

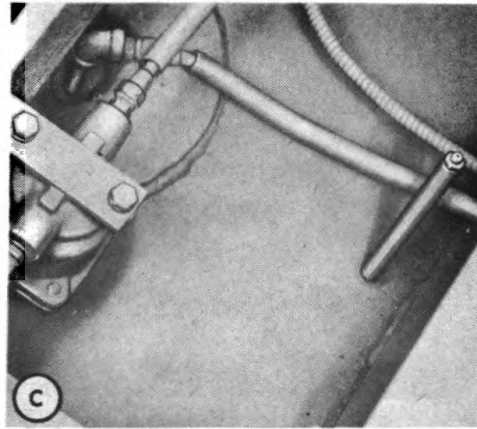

WEAR PLATE

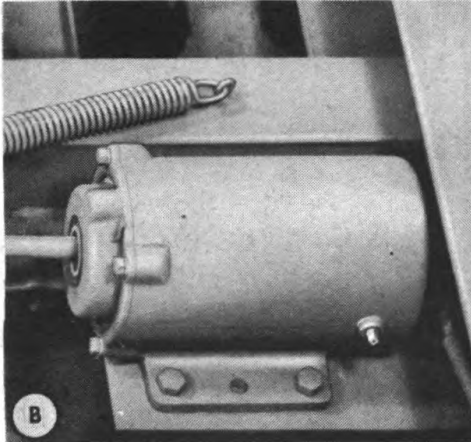

BRAKE CYLINDERS

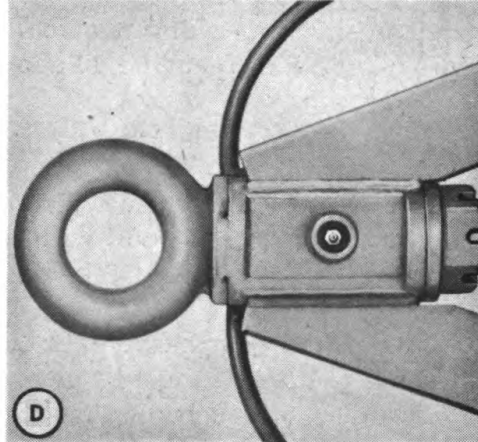

DRAWBAR EYE

RA PD 321411

Figure 26—Trailer Local Lubrication Views

b. Points of Application.

(1) Lubrication fittings, grease cups, oilers, and oilholes are readily located by reference to the Lubrication Order. Wipe these devices and the surrounding surface clean before applying the lubricant.

(2) Where relief valves are provided, apply new lubricant until the old lubricant is forced from the vent. Exceptions are specified in notes on the Lubrication Orders.

Lubrication

c. Cleaning. Use dry-cleaning solvent, or Diesel fuel oil to clean or wash all parts. Use of gasoline for this purpose is prohibited. After washing, dry all parts thoroughly before applying lubricant.

d. Lubrication Notes on Truck Individual Units and Parts. The following instructions supplement the notes on Lubrication Order No. 160:

(1) AIR CLEANERS.

(a) Oil-bath Type. Daily, check level and refill engine air cleaner oil reservoir to level mark. Every 1,000 miles, remove air cleaner and wash all parts.

(b) Mesh Type. Every 1,000 miles, wash curled hair in air compressor air cleaner, dry, and reoil. All air cleaners require used crank case oil or SAE 30 engine oil above $+32^{\circ}\text{F}$, SAE 10 below $+32^{\circ}\text{F}$.

(2) BREATHERS AND VENTS.

(a) Every 1,000 miles, remove crankcase breather cap, wash thoroughly, dry, and reoil with used crankcase oil or SAE 30 engine oil above $+32^{\circ}\text{F}$; SAE 10 below $+32^{\circ}\text{F}$.

(b) Keep gear case vents clean at all times. Axle housings and steering gear vents must be cleaned and kept open. Clean them every 1,000 miles and each time truck is operated under extremely dirty or muddy conditions.

(3) CRANKCASE. Daily, check level and refill to "FULL" mark with SAE 30 engine oil above $+32^{\circ}\text{F}$, or SAE 10 from $+32^{\circ}\text{F}$ to 0°F . Below 0°F , refer to paragraph 18. Every 1,000 miles, remove drain plug from bottom of crankcase and completely drain case. Drain only when engine is hot. Drain thoroughly. If equipped with magnetic drain plugs, clean before replacing. Refill crankcase to "FULL" mark on gage, run engine a few minutes, recheck level and add oil if required. Be sure pressure gage indicates oil is circulating.

(4) GEAR CASES—TRANSMISSION, AUXILIARY TRANSMISSION, DIFFERENTIALS, AND WINCH WORM HOUSING. Weekly, check level with truck on level ground and if necessary, add lubricant to within $\frac{1}{2}$ inch of plug level when cold, or to plug level when hot, except winch worm housing which must be filled to plug level at all times. Every 6,000 miles, drain and refill. Drain only after operation when gear lubricant is warm. If equipped with magnetic drain plugs, clean

before replacing. Refill with SAE 90 universal gear lubricant above +32°F; SAE 80 from +32°F to 0°F; or grade 75 below 0°F.

(5) **OIL FILTERS.** Every 1,000 miles, remove drain plug from oil filter to drain sediment. Every 6,000 miles while crankcase is being drained, remove filter element, clean inside of case, and install new element.

(6) **TORQUE ROD RUBBER BUSHINGS.** Every 1,000 miles, apply hydraulic brake fluid to torque rod bushings. Do not use oil.

(7) **UNIVERSAL JOINTS AND SLIP JOINTS.** Use general purpose grease, No. 1, for temperatures above +32°F, or general purpose grease, No. 0, below +32°F. Apply grease to universal joint until it overflows at the relief valve, and to the slip joint until lubricant is forced from the vent at the universal joint end of the spline.

(8) **WHEEL BEARINGS.** Every 6 months, remove bearing cone assemblies from hub (pars. 185 and 257). Wash bearings, cones, spindle, and inside of hub, and dry thoroughly. Do not use compressed air. Inspect bearing races and replace if damaged. Coat the spindle and inside of hub and hub cap with general purpose grease No. 2, to a maximum thickness of $\frac{1}{16}$ inch only, to retard rust. Lubricate bearings with general purpose grease No. 2, with a packer, or by hand, kneading lubricant into all spaces in the bearing. Protect the bearings from dirt, and immediately reassemble and replace wheel. Do not fill hub or hub cap. The lubricant in the bearing is sufficient to provide lubrication until the next service period. Any excess might result in leakage into the drum. Adjust bearings in accordance with instructions in paragraph 185 b.

(9) **WINCH CABLE.** After each use, clean and oil with used crankcase oil or SAE 30 engine oil above +32°F; SAE 10 below +32°F. Weekly, if cable has not been used, coat outer coils. Monthly, unwind entire cable, clean, and oil.

(10) **OILCAN POINTS.** Every 1,000 miles, lubricate throttle and accelerator linkage, power take-off control linkage, transfer case shift linkage, transfer shaft, winch control handle, hinges, latches, pintle hook, lock and latch, air compressor rocker arms, winch control linkage, and other rubbing parts with SAE 30 engine oil above +32°F; SAE 10 from +32°F to 0°F; or special preservative lubricating oil below 0°F.

(11) **POINTS REQUIRING NO LUBRICATION SERVICE.** Springs, air compressor crankcase, injector pump governor, clutch pilot bearing, and power take-off do not require lubrication.

(12) **DISASSEMBLED PERIODICALLY BY ORDNANCE MAINTENANCE PERSONNEL.**

(a) *Brake Governor.* Once a year, remove the cover plate from

New Vehicle Run-In Test

the brake governor located under the hood and lubricate the valve stem with special preservative lubricating oil.

(b) *Clutch Air Cylinder.* Every 6 months, remove, disassemble, and clean all parts. Inspect parts and replace if worn. Lubricate packing cup, cylinder walls, and piston with O.D. grease No. 0.

e. **Lubrication Notes on Trailer Individual Units and Parts.** The following notes supplement the notes on Lubrication Order No. 724:

(1) **BRAKE CYLINDER.** Every 6 months, remove pipe plugs, add 1 ounce of light shock absorber fluid to each plug opening. Manipulate piston with linkage disconnected to ensure spread of lubricant. Connect linkage and replace plugs.

(2) **CABLES.** Monthly, clean and oil with used crankcase oil or SAE 30 engine oil above +32°F, SAE 10 from +32°F to 0°F. Below 0°F use special preservative lubricating oil.

(3) **WHEEL BEARINGS.** Every 6 months, remove bearing cone assemblies from hub. Inspect bearing races and replace if damaged. Coat the spindle and inside of hub and hub cap with general purpose grease No. 2, to a maximum thickness of $\frac{1}{16}$ inch only, to retard rust. Lubricate bearings with general purpose grease No. 2, with a packer, or by hand, kneading lubricant into all spaces in the bearing. Protect the bearings from dirt, and immediately reassemble and replace wheel. Do not fill hub or hub cap. The lubricant in the bearing is sufficient to provide lubrication until the next service period. Any excess might result in leakage into the drum. Adjust bearings in accordance with instructions in paragraph 185 b.

f. **Reports and Records.**

(1) Report unsatisfactory performance of materiel to the Ordnance Officer responsible for maintenance in accordance with TM 38-250.

(2) A record of lubrication may be maintained in the Duty Roster (W.D., A.G.O. Form No. 6).

Section IX**NEW VEHICLE RUN-IN TEST****23. PURPOSE.**

a. When a new or reconditioned vehicle is first received at the using organization, it is necessary for second echelon personnel to determine whether or not the vehicle will operate satisfactorily when placed in service. For this purpose, inspect all accessories, subas-

semblies, assemblies, tools, and equipment to see that they are in place and correctly adjusted. In addition, they will perform a run-in test on the truck of at least 50 miles as directed in AR 850-15, paragraph 25, table III, according to procedures in paragraph 25 below.

24. CORRECTION OF DEFICIENCIES.

a. Deficiencies disclosed during the course of the run-in test will be treated as follows:

(1) Correct any deficiencies within the scope of the maintenance echelon of the using organization before the vehicle is placed in service.

(2) Refer deficiencies beyond the scope of the maintenance echelon of the using organization to a higher echelon for correction.

(3) Bring deficiencies of serious nature to the attention of the supplying organization through channels.

25. RUN-IN TEST PROCEDURES.

a. Preliminary Service.

(1) **FIRE EXTINGUISHER.** See that fire extinguisher is present, in good condition, full, and securely mounted. Test momentarily for proper operation.

(2) **FUEL, OIL, AND WATER.** Fill fuel tanks and check level of oil in engine crankcase and in injector pump housing, also supply of coolant in radiator. Add oil and coolant as necessary to bring to correct levels. Refer to paragraph 88 b for coolant level. Allow room for expansion in fuel tanks and radiator. During freezing weather, test value of antifreeze and add as necessary to protect cooling system against freezing. **CAUTION:** *If there is a tag attached to filler cap concerning engine oil in crankcase, follow instructions on tag before driving the truck.*

(3) **FUEL FILTERS.** Inspect fuel filters in both battery compartments and on side of engine for leaks, damage, secure mountings, and connections. Remove sediment bowl drain plugs, and drain off dirt and water. If an appreciable amount of dirt or water is present, remove bowls and clean both bowls and elements in dry-cleaning solvent; also drain water and dirt from bottom of fuel tanks. Drain only until fuel runs clean.

(4) **BATTERIES.** Make a hydrometer test of all batteries and add clean water to $\frac{5}{8}$ inch above plates.

(5) **AIR BRAKE RESERVOIRS.** Drain water from all air-brake reservoirs and close drain cocks.

(6) **AIR CLEANERS AND BREATHER CAPS.** Examine intake manifold air cleaners, air compressor air cleaner, and crankcase breather cap to see that they are in good condition and secure. Remove ele-

New Vehicle Run-in Test

ments and wash thoroughly in dry-cleaning solvent. Fill reservoirs to specified levels (par. 22) with new or clean used engine oil and re-install securely. Be sure all gaskets are in good condition and that ducts and air horn connections are tight.

(7) **ACCESSORIES AND BELTS.** See that accessories such as generator, cranking motor, air compressor, fuel pump, water pump, fan, oil, and fuel filters are securely mounted. Make sure that fan, air compressor, and generator drive belts are properly adjusted to have 1-inch finger-pressure deflection (fig. 64).

(8) **ELECTRICAL WIRING.** Examine all accessible wiring and conduits to see if they are in good condition, securely connected, and properly supported.

(9) **TIRES.** See that all tires, including spares, are properly inflated to 80 pounds cool, that stems are in correct position, and that all valve caps are present and finger-tight. Remove objects lodged in treads or carcasses and between duals, and inspect tires for damage. See that spares are secure in carriers.

(10) **WHEEL AND FLANGE NUTS.** See that all wheel mounting lug nuts and axle flange nuts are present and secure.

(11) **FENDERS AND BUMPER.** Examine front fenders and bumper, brush guards, and radiator grille for looseness and damage.

(12) **TOWING CONNECTIONS.** Inspect all towing devices for looseness or damage. See that front and rear pintle connections operate properly and latch securely.

(13) **BODY AND TARPAULIN.** Examine cab for looseness or damage. See that cab doors and battery compartment doors operate properly and latch securely in closed position, and that tarpaulin or camouflage net is secure and not damaged. Examine cab seats, body, stowage boxes, hardware, and all body attachments to see if they are in good condition, and correctly and securely assembled and mounted.

(14) **WINCH.** Inspect winch to see if it is in good condition, correctly assembled, and secure. Test operation of winch control mechanism, see that drive chain and sprockets are not excessively worn, and that the chain and torque control mechanisms are properly adjusted (fig. 164, par. 215 a). Test winch drum brake and see that winch cable is in good condition and securely and evenly wound on drum.

(15) **LUBRICATE.** Perform a complete lubrication of the truck covering all intervals, according to Lubrication Order (par. 22), except gear cases, wheel bearings, and other units lubricated or serviced in items 1 to 13. Check all gear case oil levels and add as necessary to bring to correct level. Change only if condition of oil indicates the necessity, or if gear oil is not of proper grade for existing atmospheric temperature. **NOTE:** *Perform items (16 to 19) during lubrication.*

(16) **SPRINGS AND SUSPENSIONS.** Inspect front springs, rear tandem (bogie) units, torque rods, rear spring bearings and spring seats, to be sure they are in good condition, correctly assembled, and secure; and that oil plugs are present, and oil seals are not leaking excessively.

(17) **STEERING LINKAGE.** See that steering arm, tie rod, and all connections are in good condition and secure, and that gear case is securely mounted and not leaking excessively.

(18) **PROPELLER SHAFTS AND VENTS.** Inspect all propeller shafts and universal joints to see if they are in good condition, correctly assembled, properly aligned, secure, and not leaking excessively at seats or vents. Be sure vent passages are not clogged.

(19) **AXLE AND TRANSMISSION VENTS.** See that all vents are present, secure, and not clogged.

(20) **PRIMER.** Observe primer when performing item 20, to see that it operates properly, that it does not leak, and that it is securely mounted.

(21) **ENGINE WARM-UP.** Start engine, noting if cranking motor action is satisfactory, and if any tendency toward difficult starting is present. Set hand throttle to run engine at fast idle (500 rpm) during warm-up. Observe all starting precautions (par. 13 c).

(22) **INSTRUMENTS.**

(a) *Fuel Pressure Gage.* Fuel pressure gage should indicate fuel pressure in the injector pump head, approximately 10 pounds with the engine operating.

(b) *Air Pressure Gage.* Maximum operating pressure is from 85 to 105 pounds. Low pressure indicator (buzzer) should sound pressure below 45 pounds. Vehicle should not be moved until gage registers at least 70 pounds pressure.

(c) *Tachometer.* Tachometer should indicate engine revolutions attained, and should not exceed 1,600 revolutions per minute.

(d) *Fuel Level Gage.* Fuel level gage should indicate amount of fuel in either tank when selector switch is operated.

(e) *Ammeter (Main).* Main ammeter may show high charge for short period after starting until generator restores to the batteries the current used in starting, and then show a slight positive (+) reading with lights and accessories turned off.

(f) *Ammeter (Auxiliary).* Ammeter should indicate whether or not "B" batteries are being charged.

(g) *Oil Pressure Gage.* Engine oil pressure gage should indicate 45 pounds pressure at 1,600 revolutions per minute and 38 to 40 pounds pressure at 1,200 revolutions per minute with engine at normal operating temperature.

(h) *Temperature Gage.* Temperature gage should indicate tem-

New Vehicle Run-in Test

perature of engine coolant. Correct operating temperature is 160° to 180°F. Maximum safe temperature is 200°F. **NOTE:** *Do not move truck until temperature is in normal operating range.*

(i) **Viscometer.** Viscometer should indicate condition of lubricant in engine crankcase, pointer should be in "NORMAL" range. **NOTE:** *Do not operate engine when viscometer remains in low range after warm-up.*

(23) **ENGINE CONTROLS.** Observe if engine responds properly to controls and if controls operate without excessive looseness or binding.

(24) **HORNS AND WINDSHIELD WIPERS.** See that horns and windshield wipers are in good condition and secure. If tactical situation permits, test horns for proper operation and tone. See if wiper arms will operate through their full range and that blade contacts glass evenly and firmly.

(25) **GLASS AND REAR VIEW MIRRORS.** Clean all body glass and mirrors, and inspect for looseness and damage. Adjust rear view mirrors for correct vision.

(26) **LAMPS (LIGHTS) AND REFLECTORS.** Clean lenses and inspect all units for looseness and damage. If tactical situation permits, open and close all light switches to see if lamps respond properly.

(27) **LEAKS, GENERAL.** Look under vehicle and within engine compartment for indications of fuel, oil, and coolant leaks. Trace any leaks found to their source, and correct them or report them to designated person in authority.

(28) **TOOLS AND EQUIPMENT.** Check tools and On-vehicle Stowage lists (pars. 6, 7, 8, and 9) to be sure all items are present, and see that they are serviceable and properly mounted or stowed.

b. Perform the following procedures (1) to (12) inclusive during the road test of the vehicle. On vehicles which have been driven 50 miles or more in the course of the delivery from the supplying to the using organization, reduce the length of the road test to the least mileage necessary to make observation listed below. **CAUTION:** *Continuous operation of the engine at speeds approaching the maximum indicated on the caution plate should be avoided during the test.*

(1) **AIR PRESSURE.** Observe whether the brake air pressure builds up at a normal rate to specified maximum limit of 105 pounds and then cuts off. Low pressure indicator (buzzer) should sound at pressures below 45 pounds. **CAUTION:** *Do not move vehicle until air pressure has reached 70 pounds.*

(2) **DASH INSTRUMENTS.** Observe all instruments frequently, noting whether they indicate the proper function of the units or systems to which they apply. Speedometer should indicate the vehicle's speed, and odometer should register the accumulating mile-

age. **CAUTION:** *Do not move vehicle until engine temperature reaches 135° F.*

(3) **BRAKES (HAND AND FOOT).** Test foot brakes to see if they stop the truck effectively without side pull, chatter, or squealing. Be sure application valve closes when pedal pressure is released, that there is not an excessive drop in air pressure when brakes are applied, and that roller and pedal clearance is $\frac{1}{16}$ inch. Parking brakes should hold truck on a reasonable incline with one-third ratchet travel in reserve and should latch securely in applied position. **CAUTION:** *Avoid long application of brakes until shoes have become seated. Do not apply full pedal pressure except for an emergency stop.*

(4) **CLUTCH.** Observe if clutch operates smoothly without grab, chatter, or squeal on engagement, or slippage when engaged under full load. Clutch pedal free travel should be 1½ inches, and never less than 1 inch before meeting resistance. **CAUTION:** *Do not ride clutch pedal at any time, and do not engage and disengage new clutch severely or unnecessarily until driven and driving disks have become properly seated.*

(5) **TRANSMISSIONS AND POWER TAKE-OFF.** Gearshift mechanism should operate easily and smoothly; gears should operate without unusual noise and not slip out of mesh when engaged under load.

(6) **STEERING.** Observe steering action for looseness or binding, and note any excessive pull to one side, wander, shimmy, or wheel tramp. See that column bracket and wheel are secure.

(7) **ENGINE.** Be on the alert for any abnormal engine operating characteristics or unusual noise, such as lack of pulling power or acceleration, backfiring, misfiring, stalling, overheating, or excessive exhaust smoke. Observe if engine responds properly to all controls.

(8) **UNUSUAL NOISES.** Be on the alert throughout road test for any unusual noise from body and attachments, running gear, suspensions, or wheels that might indicate looseness, damage, wear, inadequate lubrication, or underinflated tires.

(9) **HALT TRUCK AT 10-MILE INTERVALS FOR SERVICES (10) TO (12) BELOW.**

(10) **AIR BRAKE SYSTEM LEAKS.** With the air pressure at governed maximum 105 pounds and brakes applied, stop engine. There should not be a noticeable drop in pressure in 1 minute.

(11) **TEMPERATURES.** Cautiously hand-feel each brake drum and wheel hub for abnormal temperatures. Examine transmissions, power take-off, and rear axle housings for indications of overheating or excessive lubricant leaks at seals, gaskets, or vents.

(12) **LEAKS.** With engine running, and fuel, engine oil, and cooling systems under pressure, look within engine compartment and under vehicle for indication of leaks.

New Vehicle Run-in Test



Don't be a dope!
**HANDLE
 EQUIPMENT
 RIGHT!**

Joe Dope is now doomed for St. Pete
 He ignored a rule we repeat—
Keep radiators filled
To avoid being killed
Unless you're darned fast on
your feet!

c. Vehicle Publication and Reports.

(1) **PUBLICATIONS.** See that vehicle operator's manual, Lubrication Order, Standard Form No. 26 (Driver's Report-Accident, Motor Transportation) and W.D., A.G.O. Form No. 478 (MWO and Major Unit Assembly Replacement Record), are in the vehicle, legible, and properly stowed. **NOTE:** *U.S.A. registration number and vehicle nomenclature must be filled in on Form No. 478, for new vehicles.*

(2) **REPORTS.** Upon completion of the run-in test, correct or report any deficiencies noted. Report general condition of the vehicle to designated individual in authority.

Section X**FIRST ECHELON PREVENTIVE MAINTENANCE SERVICE****26. PURPOSE.**

a. To insure mechanical efficiency, it is necessary that the vehicle be systematically inspected at intervals each day it is operated and weekly, so that defects may be discovered and corrected before they result in serious damage or failure. Certain scheduled maintenance services will be performed at these designated intervals. The services set forth in this section are those performed by driver or crew before-operation, during-operation, at-halt, and after-operation and weekly.

b. Driver preventive maintenance services are listed on the back of "Driver's Trip Ticket and Preventive Maintenance Service Record," W.D., Form No. 48, to cover vehicles of all types and models. Items peculiar to specific vehicles but not listed on W.D., Form No. 48, are covered in manual procedures under the items to which they are related. Certain items listed on the form that do not pertain to the vehicle involved are eliminated from the procedures as written into the manual. Every organization must thoroughly school each driver in performing the maintenance procedures set forth in manuals, whether or not they are listed specifically on W.D., Form No. 48.

c. The items listed on W.D., Form No. 48 that apply to this vehicle are expanded in this manual to provide specific procedures for accomplishment of the inspections and services. These services are arranged to facilitate inspection and conserve the time of the driver, and are not necessarily in the same numerical order as shown on W.D., Form No. 48. The item numbers, however, are identical with those shown on that form.

First Echelon Preventive Maintenance Service

d. The general inspection of each item applies also to any supporting member or connection and generally includes a check to see whether the item is in good condition, correctly assembled, secure, or excessively worn.

(1) The inspection for "good condition" is usually an external visual inspection to determine whether the unit is damaged beyond safe or serviceable limits. The term "good condition" is explained further by the following: not bent or twisted, not chafed or burned, not broken or cracked, not bare or frayed, not dented or collapsed, not torn or cut, not deteriorated.

(2) The inspection of a unit to see that it is "correctly assembled" is usually an external visual inspection to see whether it is in its normal assembled position in the vehicle.

(3) The inspection of a unit to determine if it is "secure" is usually an external visual examination, a wrench, hand-feel, or a pry-bar check for looseness. Such an inspection should include any brackets, lock washers, lock nuts, locking wires, or cotter pins used in assembly.

(4) "Excessively worn" will be understood to mean worn, close-to, or beyond serviceable limits and likely to result in a failure if not replaced before the next scheduled inspection.

e. Any defects or unsatisfactory operating characteristics beyond the scope of first echelon to correct must be reported at the earliest opportunity to the designated individual in authority.

27. BEFORE-OPERATION SERVICE.

a. This inspection schedule is designed primarily as a check to see that the vehicle has not been damaged, tampered with, or sabotaged since the After-operation Service was performed. Various combat conditions may have rendered the vehicle unsafe for operation and it is the duty of the driver to determine whether or not the vehicle is in condition to carry out any mission to which it is assigned. This operation will not be entirely omitted, even in extreme tactical situations.

b. **Procedures.** Before-operation Service consists of inspecting items listed below according to the procedure described and correcting or reporting any deficiencies. Upon completion of the service, results should be reported promptly to the designated individual in authority.

(1) **ITEM 1, TAMPERING AND DAMAGE.** Look for any injury to truck and trailer and their accessories and special equipment, caused by tampering or sabotage, collision, falling debris, or shell fire since parking. Look within truck engine compartment for evidence of these

conditions and for loose or damaged fuel, oil, coolant, or air lines, or disconnected control linkage.

(2) **ITEM 2, FIRE EXTINGUISHER.** Be sure fire extinguisher is full, nozzle clean, and mountings secure. Remove filler plug to check contents.

(3) **FUEL, OIL, AND WATER.** Check supply of fuel, oil, and coolant; add as necessary to bring to proper levels. *NOTE: Any appreciable drop in levels since After-operation Service should be investigated, and cause corrected or reported.* During freezing weather, when antifreeze solution is in use, if any appreciable addition of water is needed, have antifreeze value tested and added to, if necessary. Be sure spare fuel, oil, and water cans are full and securely mounted.

(4) **ITEM 4, ACCESSORIES AND DRIVES.** Examine units such as fuel pumps, air compressor, generator and regulator, cranking motor, fuel and oil filters, fan, water pump, and air cleaners for looseness, damage, or leaks. Be sure drive belts are in good condition and are adjusted to have approximately 1-inch finger-pressure deflection.

(5) **ITEM 5, AIR BRAKE TANKS.** Examine truck and trailer, air brake reservoirs, air lines and connections for looseness, damage or leaks. Drain water from reservoirs and close drain cocks. Be sure truck to trailer air couplings are securely connected, or if not in use, that they are closed, properly supported, and dummy couplings connected.

(6) **ITEM 6, LEAKS, GENERAL.** Look on ground under vehicle for evidence of fuel, oil, water, or gear oil leaks. Trace any leaks to their source and correct or report them.

(7) **ITEM 7, ENGINE WARM-UP.** Start engine, noting any tendency toward difficult starting. Observe action of cranking motor, particularly if it has adequate cranking speed and engages and disengages without unusual noise when in operation. Set the hand throttle so engine runs at fast idle (500 rpm), and, during warm-up, proceed with following before-operation services. *NOTE: If oil pressure is not evident in 30 seconds, stop engine and investigate.*

(8) **ITEM 8, PRIMER.** When starting engine, if primer is used, observe if operation of primer is satisfactory, and see that the lines are not leaking and electropneumatic switch makes contact.

(9) **ITEM 9, INSTRUMENTS.**

(a) *Fuel Pressure Gage.* Fuel pressure gage should register approximately 10 pounds pressure while engine is running at fast idle during engine warm-up.

(b) *Air Pressure Gage.* During engine warm-up with engine running at fast idle, observe whether or not the air brake pressure builds up at normal rate to 105 pounds pressure, and if governor then cuts off to stop compressing action. Bleed the air pressure down

First Echelon Preventive Maintenance Service

by repeated brake application, and observe whether or not the governor cuts in the air compressor at approximately 85 pounds pressure. Again bleed the air pressure down and observe whether or not the low pressure indicator (buzzer) signals at approximately 45 pounds pressure. **CAUTION: Do not move truck until air pressure gage registers at least 70 pounds pressure.**

(c) *Tachometer.* Tachometer should register engine revolutions per minute with regular pointer. Red pointer indicates and remains at highest engine revolutions attained and should not exceed 1,600 revolutions per minute.

(d) *Fuel Level Gage.* Fuel level gage should indicate amount of fuel in each tank when operated by selector switch.

(e) *Ammeter.* Main ammeter may show high charge for short period after starting, until generator restores to batteries the current used in starting, and then it may show a slight positive (+) reading with lights and accessories off.

(f) *Ammeter.* Auxiliary ammeter should indicate whether or not "B" batteries are being charged.

(g) *Oil Pressure Gage.* Engine oil pressure gage should indicate 45 pounds pressure at 1,600 revolutions per minute and 38 to 40 pounds pressure at 1,200 revolutions per minute with engine at normal operating temperature.

(h) *Temperature Gage.* Temperature gage should indicate temperature of engine coolant. Correct operating temperature is 160° to 180°F. Maximum safe temperature is 200°F. **NOTE: Do not move truck until temperature is in normal operating range.**

(i) *Viscometer.* Viscometer should indicate condition of lubricant in engine crankcase, and should be in "NORMAL" range. **NOTE: Do not operate engine when viscometer remains in low range after warm-up.**

(10) **ITEM 10, HORNS AND WINDSHIELD WIPERS.** If tactical situation permits, test horns for proper operation and tone. Test wipers to see that they operate, and observe whether or not blades contact glass evenly, and arms travel through a full stroke. Inspect for damage.

(11) **ITEM 11, GLASS AND REAR VIEW MIRRORS.** Clean all glass and inspect for damage. Aim rear view mirrors properly and see that they are secure.

(12) **ITEM 12, LAMPS (LIGHTS) AND REFLECTORS.** Clean all truck and trailer lights and warning reflectors, and examine them for looseness or damage. If tactical situation permits, open and close all switches and observe if lamps respond properly, including stop and blackout lamps.

Maintenance Instructions

(13) **ITEM 13, WHEEL AND FLANGE NUTS.** Inspect all truck and trailer wheel rims, and mounting and axle flange nuts to see that they are present and secure.

(14) **ITEM 14, TIRES.** Be sure all truck and trailer tires, including spares, are properly inflated. Truck tires should be inflated to 80 pounds pressure (cool), and trailer tires to 100 pounds pressure (cool). Remove objects lodged in treads, carcasses, or between duals, and inspect for damage.

(15) **ITEM 15, SPRINGS, OR WALKING BEAMS AND SUSPENSIONS.** Inspect truck springs and trailer walking beams for looseness or damage. Examine truck springs for excessive sag and broken or shifted spring leaves, and see that spring rebound clips are present and secure. Inspect trailer walking beam mainsprings, recoil springs, walking beam bracket assemblies, and air brake cylinder carriers, to be sure that they are secure and not damaged.

(16) **ITEM 16, STEERING LINKAGE.** Inspect truck steering gear and linkage to see that they are in condition for safe operation. Pay particular attention to steering arm for cracks, and see that steering gear case is not leaking excessively. See that steering column bracket and wheel are secure.

(17) **ITEM 17, FENDERS AND BUMPER.** Inspect truck front fenders and bumper for looseness and damage.

(18) **ITEM 18, TOWING CONNECTIONS.** Inspect truck front and rear pintle drawbars and retraction springs, pintle locking devices, trailer drawbar and swivel eye, and all towing air and electrical connections, to see that they are in good condition, properly assembled, and securely mounted.

(19) **ITEM 19, BODY, LOAD, WINCH, AND TARPAULINS.** Inspect truck cab and body for looseness and damage. See that doors operate properly and latch securely in closed position. See that any load carried is secure and properly distributed, and that tarpaulin or camouflage net is in good condition and properly stowed or attached. Inspect trailer for damage or loose attachments and if loaded, be sure tank is in correct position, properly blocked, and secure. Examine winch mountings and attachments for looseness and damage. See that winch hand throttle and air control clutch lever are in closed position, winch drum brake in applied position, and cable hook secure.

(20) **ITEM 20, DECONTAMINATOR.** Make sure contaminator is fully charged and securely mounted.

(21) **ITEM 21, TOOLS AND EQUIPMENT.** Be sure all items of both truck and trailer on-vehicle tools and standard and special equipment are present, serviceable, and properly stowed or mounted.

(22) **ITEM 22, ENGINE OPERATION.** Before truck is put in mo-

First Echelon Preventive Maintenance Service

tion, be sure engine has reached minimum operating temperature and idles smoothly. Accelerate and decelerate the engine, and listen for any unusual vibration or noise. Note any unsatisfactory operating characteristics or excessive exhaust smoke.

(23) **ITEM 23, DRIVER'S PERMIT AND FORM NO. 26.** Driver must have his Operator's Permit on his person. Check to see that Standard Accident-Report Form No. 26, MWO Major Unit Assembly Replacement Record, W.D., A.G.O. Form No. 478, vehicle manuals, and Lubrication Order are present in vehicle, legible, and properly stowed.

28. DURING-OPERATION SERVICE.

a. While vehicle is in motion, listen for any sounds such as rattles, knocks, squeals, or hums that may indicate trouble. Look for indications of trouble in cooling system and smoke from any part of the vehicle. Be on the alert to detect any odor of overheated components or units such as generator, brakes, or clutch; for fuel vapor from a leak in fuel system, exhaust gas, or other signs of trouble. Any time the brakes are used, gears shifted, or vehicle turned, consider this a test and notice any unsatisfactory or unusual performance. Watch the instruments constantly. Notice promptly any unusual instrument indication that may signify possible trouble in system to which the instrument applies.

b. **Procedures.** During-operation Services consist of observing items listed below, according to the procedures following each item and investigating any indications of serious trouble. Notice minor deficiencies to be corrected or reported at earliest opportunity, usually at next scheduled halt.

(1) **ITEM 27, FOOT AND HAND BRAKES.** With vehicle in motion, but before attaining any appreciable speed, test truck and trailer brake application valves for proper operation. Foot and hand applied air brakes should stop vehicle effectively with normal pressure or leverage and without pull to one side. Test trailer brake separately (if connected) for effective operation. Hand operated parking brake should hold truck on a reasonable incline, leaving about one-third reserve lever travel. Trailer hand-operated parking brakes should hold trailer securely, and pawls should fully engage in handwheel ratchets when brakes are in applied position. Be sure brakes are free when handwheels are in released position. **CAUTION: When parking on incline with trailer attached, always use chock blocks under tires.**

(2) **ITEM 28, CLUTCH.** Clutch should not grab, chatter, or squeal during engagement, or slip when fully engaged under load. Pedal free travel should not be less than $\frac{1}{2}$ inch before meeting resistance.

(3) **ITEM 29, TRANSMISSIONS AND POWER TAKE-OFF.** Main and auxiliary transmissions and power take-off gears should shift smoothly,

operate without unusual noise, and not slip out of mesh during operation.

(4) **ITEM 31, ENGINE AND CONTROLS.** Driver must be on the alert for deficiencies in engine performance such as lack of usual power, misfiring or stalling, unusual noise or vibration, and indications of overheating or excessive exhaust smoke. Observe if engine responds to all controls, and if controls are excessively loose or binding.

(5) **ITEM 32, INSTRUMENTS.** Observe the readings of all instruments frequently during operation for indication of normal functioning of systems to which they apply. Speedometer should indicate truck speed, and odometer register accumulating mileage.

(6) **ITEM 33, STEERING GEAR.** Note any indication of looseness or binding, pull to one side, wandering, shimmy, and wheel tramp, or unusual noise in truck steering gear.

(7) **ITEM 34, RUNNING GEAR.** Be on the alert for any unusual operating characteristics or noise from truck and trailer wheels, axles or suspension units, that might indicate looseness, damage, or under-inflated tires.

(8) **ITEM 35, BODY, TRAILER AND WINCH.** Note any noise or unusual condition on truck and trailer, that might indicate shifting of body or load, loose or damaged doors, hardware, or special equipment. While winch is in operation, observe if controls engage effectively and if winch functions properly, and if there is any indication of loose linkage, mountings, or controls. Note any unusual noise or unsatisfactory operating characteristics to be investigated at halt, or that should be reported.

29. AT-HALT SERVICE.

a. At-halt Services may be regarded as minimum maintenance procedures and should be performed under all tactical conditions, even though more extensive maintenance services must be slighted or omitted altogether.

b. **Procedures.** At-halt Services consist of investigating any deficiencies noted during operation, inspecting items listed below according to the procedures following the items, and correcting any deficiencies found. Deficiencies not corrected should be reported promptly to the designated individual in authority.

(1) **ITEM 38, FUEL, OIL AND WATER.** Check the fuel, engine oil, and coolant supply to see that it is adequate to operate the vehicle to the next stop. Remove radiator pressure cap cautiously. Do not remove entirely until steam has escaped. When refueling, use safety precautions for grounding static electricity. Fuel tank filler-cap vents must be open, radiator pressure-cap valve must be free, and caps must

First Echelon Preventive Maintenance Service

be replaced securely. Leave sufficient space in fuel tanks and radiator for expansion. If engine is hot, fill radiator slowly while engine is running at a fast idle.

(2) **ITEM 39, TEMPERATURES: HUBS, BRAKE DRUMS, TRANSMISSIONS, AND AXLES.** Place hand cautiously on each truck and trailer wheel hub and brake drum to see if they are abnormally hot. Inspect truck transmissions and rear axle housings for overheating and excessive lubricant leaks.

(3) **ITEM 40, AXLE AND TRANSMISSION VENTS.** Wipe truck axle and transmission vents clean, and inspect them for damage or clogging. Vents must be kept open.

(4) **ITEM 41, PROPELLER SHAFTS.** Inspect truck and winch propeller shafts, center bearing, and universal joints for looseness, damage, or excessive oil leaks. Remove any foreign matter wound around shafts or joints.

(5) **ITEM 42, SPRINGS AND SUSPENSIONS.** Inspect truck front springs and rear axle tandem units to see if they are in good condition, securely assembled, and mounted. Examine rear torque rods to see that torque rod pins and bushings are in good condition and securely mounted. Inspect trailer walking beam and axle suspension units, main and recoil springs, to see that they are in good condition, securely assembled, and mounted.

(6) **ITEM 43, STEERING LINKAGE.** Examine truck steering control mechanism, arms, and joints for looseness and damage. Investigate any unusual steering condition of truck or trailer dolly noted during operation.

(7) **ITEM 44, WHEEL AND FLANGE NUTS.** See that truck and trailer wheel mounting and axle flange nuts are present and secure.

(8) **ITEM 45, TIRES.** Inspect all truck and trailer tires including spares for under inflation and damage. Remove objects lodged in treads, carcasses, and between duals.

(9) **ITEM 46, LEAKS—GENERAL.** Look around engine and on ground beneath truck for excessive fuel, oil, coolant, or grease leaks. Trace any leaks found to their source and correct or report them.

(10) **ITEM 47, ACCESSORIES AND BELTS.** Examine all accessible units for looseness and damage. Be sure fan and air compressor belts have 1-inch finger pressure deflection.

(11) **ITEM 48, AIR CLEANERS.** If operating truck under extremely dusty or sandy conditions, inspect engine and air compressor air cleaners and engine breather cap at each halt, to see that they are in condition to deliver clean air properly. Service as required.

(12) **ITEM 49, FENDERS AND BUMPER.** Inspect truck front fenders and bumper for looseness and damage.

(13) **ITEM 50, TOWING CONNECTIONS.** Examine truck pintle hooks, trailer drawbar and swivel eye to see that they are in good condition, securely assembled, and mounted. Be sure that pintle hooks lock securely. See that air and electrical connections from truck to trailer are securely connected and supported, and that dolly kingpin is secure.

(14) **ITEM 51, BODY, LOAD, AND TARPAULIN.** Examine these items on truck and trailer for looseness and damage. Any cargo must be properly distributed and secured. If trailer is loaded, see that tank is properly positioned and securely chocked. Tarpaulin or camouflage net should be securely lashed if in use; or if not in use, properly stowed.

(15) **ITEM 52, GLASS.** Clean truck windshields and mirrors and both truck and trailer lights and warning reflector glass, and inspect them for looseness and damage.

30. AFTER-OPERATION AND WEEKLY SERVICE.

a. After-operation Service is particularly important because at this time the driver inspects his vehicle to detect any deficiencies that may have developed, and corrects those he is permitted to handle. He should report promptly to the designated individual in authority the results of his inspection. If this schedule is performed thoroughly, the vehicle should be ready to roll again on a moment's notice. The Before-operation Service, with a few exceptions, is then necessary only to ascertain whether the vehicle is in the same condition in which it was left upon completion of the After-operation Service. The After-operation Service should never be entirely omitted even in extreme tactical situations, but may be reduced to the bare fundamental services outlined for the At-halt Service, if necessary.

b. **Procedures.** When performing the After-operation Service, the driver must remember and consider any irregularities noticed during the day in the Before-operation, During-operation, and At-halt Services. The After-operation Service consists of inspecting and servicing the following items. Those items of the After-operation Service that are marked by an asterisk (*) require additional weekly services, the procedures for which are indicated in step (b) of each applicable item.

(1) **ITEM 55, ENGINE OPERATION.** Test engine for satisfactory performance and smooth idle. Accelerate and decelerate engine, and note any tendency to miss or backfire. Listen for any unusual noise or vibration that may indicate worn or inadequately lubricated parts or loose mountings. Note any unusual exhaust smoke. Investigate and correct, or report, any deficiencies noted during operation.

(2) **ITEM 56, INSTRUMENTS.** Check all pertinent instruments to

First Echelon Preventive Maintenance Service

be sure that they operate properly and continue to register or indicate correct performance of the units to which they apply. Inspect them for looseness or damage. Stop engine.

(3) **ITEM 54, FUEL, OIL, AND WATER.** Fill fuel tanks. (See if gage indicates full on both tanks.) Check crankcase oil and coolant supply and add as necessary to bring to correct level. **NOTE: Do not overfill fuel tanks or radiator. Allow room for expansion.** In freezing weather, if it is necessary to add any appreciable amount of coolant, have antifreeze value checked, and add sufficient quantity of solution to protect cooling system against freezing. Be careful in removing pressure radiator cap. Do not entirely remove until steam has escaped, and do not add coolant while engine is hot. Fill all spare fuel, oil, and water cans if supply has been used.

(4) **ITEM 57, HORNS AND WINDSHIELD WIPERS.** Examine horns to see that they are securely mounted. If tactical situation permits, test horns for proper operation and tone. Inspect windshield wiper arms and blades to see that they operate through full stroke, and that blades contact windshield glass firmly and evenly.

(5) **ITEM 58, GLASS AND REAR VIEW MIRRORS.** Clean all truck cab glass and truck and trailer lamp lenses, and inspect for looseness and damage.

(6) **ITEM 59, LAMPS (LIGHTS) AND REFLECTORS.** Inspect all units on truck and trailer for looseness or damage. If tactical situation permits, test all light switches for correct operation and see that all lamps respond properly.

(7) **ITEM 60, FIRE EXTINGUISHERS.** Examine extinguishers for looseness or damage, and see that nozzles are clean. If extinguishers have been used, report them for refill or replacement. Remove filler plug from liquid type to determine contents.

(8) **ITEM 61, DECONTAMINATORS.** Inspect for looseness or damage and full charge; if used, report for refill or exchange.

(9) **ITEM 62, *BATTERIES.**

(a) Inspect all batteries to see if they are clean, secure, and not leaking. Safety-fill vent caps should be finger-tight.

(b) *Weekly.* Clean all dirt from top of batteries. If terminal connections on posts are corroded, clean them thoroughly, and apply a thin coating of grease. Tighten terminal bolts if loose. Check electrolyte level and, if necessary, add clean water to bring level to $\frac{5}{8}$ inch above the top of the separators. Batteries should be secure and not bulging or leaking electrolyte; carrier should be secure, clean, free of corrosion, and well painted. Tighten loose mountings cautiously.

(10) **ITEM 63, *ACCESSORIES AND BELTS.**

(a) Examine all accessories such as fuel pumps, generator, generator regulator, cranking motor, air compressor, fan and shroud, and

water pump, for looseness, damage, or leaks. Inspect drive belts for wear or improper adjustment.

(b) *Weekly*. Tighten or adjust any loose connections, linkage, or mountings on accessories. Fan and air compressor belts should have 1-inch finger-pressure deflection halfway between drive pulleys.

(11) **ITEM 64, *ELECTRICAL WIRING.**

(a) Examine manifold heater wiring to see that it is securely connected, clean, and not damaged.

(b) *Weekly*. Check all accessible low voltage wiring and connections on both truck and trailer for looseness or damage, and be sure wiring is supported so as not to chafe against other vehicle parts.

(12) **ITEM 65, AIR CLEANERS AND BREATHER CAP.** Inspect engine and air compressor air cleaners and engine breather cap to see that they are clean, in good condition, and securely mounted. Clean and service if excessively dirty according to Lubrication Order (par. 22).

(13) **ITEM 66, *FUEL FILTERS.**

(a) Examine fuel filters connected to each fuel tank and fuel filter on engine for looseness, damage, or leaks.

(b) *Weekly*. Remove sediment bowl plugs and drain off accumulated dirt and water. If draining indicates excessive dirt, remove filter elements and clean as outlined in paragraph 72 b. *NOTE: If excessive fuel contamination is evident, report for cleaning of fuel tanks by higher echelon.*

(14) **ITEM 67, ENGINE CONTROLS.** Examine all engine controls for damage, excessive wear, and adequate lubrication.

(15) **ITEM 68, *TIRES.**

(a) Inspect both truck and trailer tires, including spares, for damage and excessive wear. Remove objects lodged in treads and carcasses and from between duals. Check tires for low pressure, proper position of valve stems, and presence of valve caps. Inflate to correct pressures: 80 pounds (cool) maximum in truck tires and 100 pounds (cool) maximum in trailer tires.

(b) *Weekly*. Replace badly worn or otherwise unserviceable truck and trailer tires. Serviceable tires which show abnormal wear should be rotated to other wheel positions. Apparent mechanical defects causing such wear should be reported for attention of higher echelon.

(16) **ITEM 69, *SPRINGS AND SUSPENSIONS.**

(a) Inspect truck front springs and rear tandem (bogie) unit for looseness and damage. Look for abnormal spring sag, shifted leaves, and loose or missing rebound clips and U-bolts. See that rear tandem unit spring seats and torque rods are in good condition and properly adjusted, and that rear tandem units are properly lubricated and oil filler plugs are secure. Examine trailer walking beams and axle as-

First Echelon Preventive Maintenance Service

semblies including brake cylinder carriers and beam mounting brackets for looseness and damage.

(b) *Weekly.* Tighten or report any springs that have abnormal sag, broken or shifted leaves, or loose or missing rebound clips, eye bolts, shackles, and torque rods. Pay particular attention to truck rear tandem spring seats to see that they are secure. Tighten any trailer walking beam assembly or mounting nuts that require weekly tightening as indicated by experience or inspection.

(17) **ITEM 70, STEERING LINKAGE.** Inspect all linkage and joints for looseness, damage, and excessive wear. Investigate any unusual condition noticed during operation. See that all joints and linkage are adequately lubricated, and that gear case is not leaking excessively.

(18) **ITEM 71, PROPELLER SHAFTS AND VENT.** Inspect truck and winch propeller shafts, universal joints, center bearing, and winch torque control for looseness, damage, and excessive lubricant leaks. Remove any foreign matter wound around shafts, universal joints, and winch torque control.

(19) **ITEM 72, *AXLE AND TRANSMISSION VENTS.**

(a) Examine all vents to see that they are present, clean, secure, and not damaged.

(b) *Weekly.* Remove all accessible vents and clean out oil passages.

(20) **ITEM 73, LEAKS, GENERAL.** Look in engine compartment and under vehicle for fuel, oil, coolant, or gear oil leaks. Also look at truck and trailer brake drum and axle flanges for excessive oil seepage. Trace any leaks to their source and correct or report them.

(21) **ITEM 74, GEAR OIL LEVELS.** After units have cooled, check lubricant levels in rear axles, main and auxiliary transmission, winch worm housing, and steering gear housing. Correct oil levels are from lower edge of filler hole to $\frac{1}{2}$ inch below.

(22) **ITEM 75, *AIR BRAKE TANKS.**

(a) Inspect reservoirs on both truck and trailer for looseness and damage. See that all connections are tight, and that air lines are properly supported so as not to chafe on other vehicle parts. Drain water from reservoirs and close drain cocks.

(b) *Weekly.* Have assistant operate all air brake control valves and listen for air leaks. Tighten reservoir mountings and all connections where leaks are heard. Clean oil from all truck and trailer air line rubber hose. Press release valve button on trailer to be sure it operates.

(23) **ITEM 76, FENDERS AND BUMPER.** Inspect truck front fenders and bumper for looseness and damage.

(24) **ITEM 77, *TOWING CONNECTIONS.**

(a) Inspect truck front, rear pintle hook, trailer tow bar, and swivel eye for looseness, damage, and excessive wear. Examine trailer drawbar hinge bolts to see that they are not loose, damaged, nor excessively worn.

(b) *Weekly.* Tighten all towing device mounting and assembly nuts securely. Test truck pintle hook locking devices to see that they operate properly, and that springs and drawbars are not damaged.

(25) **ITEM 78, BODY, LOAD, AND TARPAULINS.** Examine truck body carefully for damage or loose parts. See that cab doors and battery box doors operate properly and latch securely. Any load carried must be properly distributed and securely stowed. Tarpaulins or camouflage nets should be in good condition and securely lashed or stowed. Inspect trailer frame, platform, ramps, and chocks for damage or loose attachments. If trailer is loaded, see that tank is properly positioned and securely chocked.

(26) **ITEM 79, *WINCH.**

(a) Inspect winch assembly for looseness, damage, and excessive lubricant leaks at gear housing. Be sure winch control mechanism operates freely and functions properly, and that drive chain is in good condition, adequately lubricated, and adjusted according to instructions in paragraph 216.

(b) *Weekly.* Check winch gear case oil level, fill gear case, and lubricate jaw clutch and drive chain according to Lubrication Order (par. 22). Test winch brake; it should retard drum from spinning when unwinding cable. While winch cable is unwound, inspect it for damage. Clean entire length with thin oil; and as cables are rewound tightly and evenly, apply a coating of engine oil.

(27) **ITEM 82, *TIGHTEN.**

(a) Tighten any truck or trailer external assembly or mounting nuts or screws where inspection has indicated the necessity.

(b) *Weekly.* Tighten all truck and trailer wheel mounting and axle flange nuts or cap screws; spring U-bolts, shackles, and rebound clips; tandem unit and trailer walking beam and assembly mountings; universal joint companion flanges; engine, transmission, and winch mountings; steering arm or any other mounting or assembly nuts or screws that inspection indicates as necessary on a weekly, or mileage basis.

(28) **ITEM 83, *LUBRICATION.**

(a) Lubricate all points of the truck and trailer indicated on the Lubrication Order as requiring daily attention.

(b) *Weekly.* Lubricate all points which truck and trailer Lubrication Order indicate as necessary on a weekly or mileage basis, or any points where condition and experience indicate need of additional lubrication.

Second Echelon Preventive Maintenance

(29) ITEM 84, *CLEAN ENGINE AND VEHICLES.

(a) Clean dirt and grease from inside of cab, engine compartment, and exterior of engine. Wipe off excess dirt and grease from exterior of both truck and trailer.

(b) *Weekly.* Wash truck and trailer when possible. If not possible, wipe off thoroughly. Inspect paint or camouflage pattern for rust or bright spots which might cause reflections. See that all vehicle markings (unless covered for tactical reasons) are legible. **CAUTION:** *If truck and trailer are driven into water for washing, care must be taken to see that water or dirt does not get into wheel bearings, gear cases, brakes, or on electrical units or wiring.*

(30) ITEM 85, *TOOLS AND EQUIPMENT.

(a) Check truck and trailer stowage lists to see that all items are present (pars. 6, 7, 8, and 9). Inspect items to see that they are in good condition and properly mounted or stowed.

(b) *Weekly.* Clean all truck and trailer tools and equipment, and see that tools with cutting edges are sharp and properly protected and that all items are securely mounted or stowed.

Section XI**SECOND ECHELON PREVENTIVE MAINTENANCE****31. SECOND ECHELON PREVENTIVE MAINTENANCE SERVICES.**

a. Regular scheduled maintenance inspections and services are a preventive maintenance function of the using arm and are the responsibility of commanders of operating organizations.

(1) **FREQUENCY.** The frequency of the preventive maintenance services outlined herein is considered a minimum requirement for normal operation of vehicles. Under unusual operating conditions such as extreme temperatures, dusty or sandy conditions, or extremely wet terrain, it may be necessary to perform certain maintenance services more frequently.

(2) **FIRST ECHELON PARTICIPATION.** The drivers should accompany their vehicles and assist the mechanics while periodic second echelon preventive maintenance services are performed. Ordinarily the driver should present the vehicle for a scheduled preventive maintenance service in a reasonably clean condition; that is, it should be dry and not caked with mud or grease to such an extent that inspection and servicing will be seriously hampered. However, the vehicle should not be washed or wiped thoroughly clean, since certain types of defects such as cracks, leaks, and loose or shifted parts or assemblies are more evident if the surfaces are slightly soiled or dusty.

(3) If instructions other than those contained in the general procedures in step (4) or the specific procedures in step (5) which follow, are required for the correct performance of a preventive maintenance service or for correction of a deficiency, other sections of this manual pertaining to the item involved, or a designated individual in authority, should be consulted.

(4) **GENERAL PROCEDURES.** These general procedures are basic instructions which are to be followed when performing the services on the items listed in the specific procedures. **NOTE:** *The second echelon personnel must be thoroughly trained in these procedures so that they will apply them automatically.*

(a) When new or overhauled subassemblies are installed to correct deficiencies, care should be taken to see that they are clean, correctly installed, properly lubricated, and adjusted.

(b) When installing new lubricant retainer seals, a coating of the lubricant should be wiped over the sealing surface of the lip of the seal. When the new seal is a leather seal, it should be soaked in SAE 10 engine oil (warm, if practicable) for at least 30 minutes. Then, the leather lip should be worked carefully by hand before installing the seal. The lip must not be scratched or marred.

(c) The general inspection of each item applies also to any supporting member or connection and usually includes a check to see whether the item is in good condition, correctly assembled, secure, or excessively worn. The mechanics must be thoroughly trained in the following explanations of these terms:

1. The inspection for "good condition" is usually an external visual inspection to determine whether the unit is damaged beyond safe or serviceable limits. The term "good condition" is explained further by the following: not bent or twisted, not chafed or burned, not broken or cracked, not bare or frayed, not dented or collapsed, not torn or cut, not deteriorated.

2. The inspection of a unit to see that it is "correctly assembled" is usually an external visual inspection to see whether it is in its normal assembled position in the vehicle.

3. The inspection of a unit to determine if it is "secure" is usually an external visual examination, a wrench, hand-feel, or a pry-bar check for looseness. Such an inspection should include any brackets, lock washers, lock nuts, locking wires, or cotter pins used in assembly.

4. "Excessively worn" will be understood to mean worn close to, or beyond, serviceable limits and likely to result in a failure if not replaced before the next scheduled inspection.

(d) *Special Services.* These are indicated by repeating the item numbers in the columns which show the interval at which the services are to be performed, and show that the parts or assemblies are to receive certain mandatory services. For example, an item number in

Second Echelon Preventive Maintenance

one or both columns opposite a TIGHTEN procedure, means that the actual tightening of the object must be performed. The special services include:

1. *Adjust.* Make all necessary adjustments in accordance with the pertinent section of this manual, special bulletins, or other current directives.

2. *Clean.* Clean units of the vehicle with dry-cleaning solvent to remove excess lubricant, dirt, and other foreign material. After the parts are cleaned, rinse them in clean dry-cleaning solvent, and dry them thoroughly. Take care to keep the parts clean until re-assembled, and be certain to keep dry-cleaning solvent away from rubber or other material which it will damage. Clean the protective grease coating from new parts, since this material is usually not a good lubricant.

3. *Special Lubrication.* This applies both to lubrication operations that do not appear on the vehicle Lubrication Order and to items that do appear on such Orders but should be performed in connection with the maintenance operations, if parts have to be disassembled for inspection or service.

4. *Serve.* This usually consists of performing special operations such as replenishing battery water, draining and refilling units with oil, and changing or cleaning the oil filter, air cleaner, or cartridges.

5. *Tighten.* All tightening operations should be performed with sufficient wrench torque (force on the wrench handle) to tighten the unit according to good mechanical practice. Use torque-indicating wrench where specified. Do not overtighten, as this may strip threads or cause distortion. Tightening will always be understood to include the correct installation of lock washers, lock nuts, lock wire, or cotter pins provided to secure the tightening.

(e) When conditions make it difficult to perform the complete preventive maintenance procedures at one time, they can sometimes be handled in sections, but all operations should be completed within the week if possible. All available time at halts and in bivouac areas must be utilized, if necessary, to assure that maintenance operations are completed. When limited by the tactical situation, items with special services in the columns should be given first consideration.

(f) The numbers of the preventive maintenance procedures that follow are identical with those outlined on W.D., A.G.O., Form No. 461, which is the "Preventive Maintenance Service Work Sheet for Wheeled and Half-track Vehicles." Certain items on the work sheet that do not apply to this vehicle are not included in the procedures in the manual. In general, the numerical sequence of items on the work sheet is followed in the manual procedures, but in some instances there is deviation for conservation of the mechanic's time and effort.

(5) **SPECIFIC PROCEDURES.** The procedures for performing each item in the 1,000-mile (monthly) and 6,000-mile (six-month) maintenance procedures, whichever shall occur first, are described in the following chart. Each page of the chart has two columns at its left edge corresponding to the 6,000-mile and the 1,000-mile maintenance respectively. Very often it will be found that a particular procedure does not apply to both scheduled maintenances. In order to determine which procedure to follow, look down the column corresponding to the maintenance due, and wherever an item number appears perform the operations indicated opposite the number.

ROAD TEST

MAINTENANCE	
6000 Mile	1000 Mile
1	1
2	2
3	3

NOTE: *When the tactical situation does not permit a full road test, perform those items which require little or no movement of the vehicle. When a road test is possible, it should be for preferably 4, and not over 6 miles.*

Before-operation Inspection. Perform this inspection as outlined in paragraph 27.

Air Pressure (Build-up, Governor Cut-off, Low Pressure Indicator). During warm-up period, operate engine at fast idle long enough to observe if air brake pressure builds up at normal rate to specified maximum (105 pounds) and that governor then cuts off air from compressor. With engine at normal idling speed, bleed air pressure from system by repeated brake application, and observe if compressor cuts in at about 85 pounds. With engine stopped, continue test to see that low pressure indicator (buzzer) sounds at pressure below 45 pounds. Any abnormal drop in air pressure, except from brake application, should be investigated by making elimination soapsuds test (par. 46 k (2)). **CAUTION:** *Do not drive truck until 70 pounds pressure is shown on the air pressure gage.*

Dash Instruments and Gages.

FUEL PRESSURE GAGE. Fuel pressure gage should indicate fuel pressure in the injector pump head, approximately 10 pounds with the engine operating.

AIR PRESSURE GAGE. Refer to item 2 for specifications and tests.

TACHOMETER. Tachometer should indicate engine revolutions per minute with regular pointer. Red pointer remains at highest engine revolutions attained and should not exceed 1,600 revolutions per minute.

Second Echelon Preventive Maintenance

MAINTENANCE		
8000 Mile	1000 Mile	
		<p>FUEL LEVEL GAGE. Fuel level gage should indicate amount of fuel in either tank when selector switch is operated.</p> <p>AMMETER. Main ammeter may show high charge for short period after starting until generator restores to the batteries current used in starting, and then show a slight positive (+) reading with lights and accessories turned off.</p> <p>AMMETER, AUXILIARY. Ammeter should indicate whether or not "B" batteries are being charged.</p> <p>OIL PRESSURE GAGE. Engine oil pressure gage should indicate 45 pounds pressure at 1,600 revolutions per minute, and 38 to 40 pounds pressure at 1,200 revolutions per minute with engine at normal operating temperature.</p> <p>ENGINE TEMPERATURE GAGE. Temperature gage should indicate temperature of engine coolant. Correct operating temperature is 160° to 180°F. Maximum safe operating temperature is 200°F. <i>NOTE: Do not move truck until temperature is in normal operating range.</i></p> <p>VISCOMETER. Viscometer should indicate condition of lubricant in engine crankcase. <i>NOTE: Do not operate engine when viscometer remains in low range after warm-up.</i></p>
4	4	<p>Horns, Mirrors, and Windshield Wipers. If tactical situation permits, test horns for proper operation and tone. Examine rear vision mirror and wipers to see if they are in good condition and secure. Test operation of wiper motors, and see that wiper blades contact glass firmly and evenly and operate through their full range without indication of loose wiper motor mountings. Adjust rear vision mirrors for correct vision.</p>
5	5	<p>Brakes (Foot, Hand, and Trailer). Operate both truck and trailer brakes at various speeds during road test.</p> <p>FOOT BRAKES. Apply foot pedal sufficiently to stop vehicle in minimum safe distance and observe their effectiveness: any pull to one side, unusual noise, or chatter. Pedal should have 1/16-inch clearance between pedal roller and plunger.</p> <p>TRAILER AIR BRAKES. If trailer is connected, test trailer brakes separately by use of hand application valve and observe their effectiveness. Note any erratic action of trailer that might indicate uneven brake shoe pressure.</p>

Maintenance Instructions

MAINTENANCE		
6000 Mile	1000 Mile	
		<p>TRUCK PARKING BRAKES. Apply parking brake while truck is stopped on reasonable incline. Observe if brake holds vehicle effectively, that lever has one-third ratchet travel in reserve, and latches in applied position.</p> <p>TRAILER PARKING BRAKES. With trailer stopped, apply both front and rear parking brakes and observe if brake handwheels operate freely and brake pawls engage in ratchets securely. Inspect parking brake cables to see that they are in good condition, and securely mounted and attached. Be sure brakes are free when handwheels are released.</p>
6	6	<p>Clutch. Clutch pedal free travel should be not less than 1 inch before meeting resistance. Test clutch for drag when shifting into low gear. Clutch should stop transmission entirely while truck is stationary, and shift should be made without unusual noise. When pedal is depressed, note any unusual noise which may indicate defective or dry release bearing. With transmission in gear, note any tendency to chatter or grab when clutch is engaged, or slippage when fully engaged under load. NOTE: <i>Never allow pedal free play to become less than 1 inch. Adjust according to paragraph 131 b.</i></p>
7	7	<p>Transmissions. With truck in motion, shift through entire gear ranges of both main and auxiliary transmissions, noting whether or not levers move easily. Note if both transmissions operate without slipping out of gear, and if there is any unusual noise or vibration under either light or heavy load.</p>
8	8	<p>Steering. With truck in motion, move steering wheel fully in both directions, and observe whether or not there is any indication of looseness or binding. Note any tendency to wander, shimmy, or pull to one side. See that steering column and wheel are in good condition and secure.</p>
9	9	<p>Engine. Observe engine operating characteristics as follows:</p> <p>IDLE. Engine should idle smoothly without stalling.</p> <p>UNUSUAL NOISES. Listen for knocks and rattles as the engine is accelerated and decelerated, and while it is under either light or heavy load.</p> <p>ACCELERATION AND POWER. Operate the engine at various speeds in all gear ratios, noting if the truck has normal pulling power and acceleration. Note any</p>

Second Echelon Preventive Maintenance

MAINTENANCE	
8000 Mile	1000 Mile
10	10
12	12
13	13
14	14
16	16
17	17

tendency to stall while shifting. Continued heavy ping may indicate a heavy accumulation of carbon.

GOVERNED SPEED. With the truck in an intermediate gear, slowly depress the accelerator to the toeboard and observe the speedometer reading; see that the truck reaches but does not exceed the governed speed specified on the caution plate. Observe tachometer reading and note if the engine attains but does not exceed the specified 1,600 revolutions per minute. *NOTE: If engine exceeds the governed speed on caution plate, refer to "adjust" in item 45.*

Unusual Noise. Be on the alert during road test for any noise that may indicate loose or damaged attachments mounted on the truck, loose cab mountings, floor plates, doors, windshield, or hardware. Listen particularly for indications of loose wheel mountings. While trailer is connected and in motion, have assistant listen for any unusual noise from attachments, walking beam suspension units, or wheels on trailer.

Air Brake System Leaks. Test truck and trailer air brakes for leaks with air pressure at governed maximum. With all brakes applied and engine stopped, there should not be a noticeable drop in pressure within 1 minute. If any pressure drop occurs during this check, test system for leaks by soapsuds method (par. 46 k (2)).

Temperatures. At completion of run, feel brake drums and hubs of both truck and trailer for abnormally high temperatures. Cautiously feel axles (including trailer) and truck transmissions for overheating.

Leaks. Inspect engine compartment and ground under truck for evidence of oil, fuel, and water leaks.

RAISE TRUCK AND BLOCK SAFELY

Gear Oil Levels and Leaks. Remove plugs and inspect truck axles, transmission, and winch gear case to see that lubricant is at proper level, in good condition, and not leaking at seals or gaskets. Add oil as necessary. *NOTE: Safe level is from lower edge of filler hole when hot to 1/2 inch below when cold.* If change of lubricant is due or if condition warrants, drain and refill units according to Lubrication Order (par. 22).

Unusual Noises.
ENGINE, BELTS, AND ACCESSORIES. Accelerate and decelerate the engine momentarily; listen for any unusual

Maintenance Instructions

MAINTENANCE		
6000 Mile	1000 Mile	
		noise in these units that might indicate damaged, loose, or excessively worn engine parts, drive belts, or accessories. Also be sure to locate and correct or report any unusual engine noise heard during the road test.
		TRANSMISSIONS, POWER TAKE-OFF, PROPELLER SHAFTS, U-JOINTS, AXLES, AND WHEEL BEARINGS. With both transmissions in intermediate gear and power take-off engaged, operate these units at a constant moderate speed by use of hand throttle, and listen for any unusual noise that might indicate looseness or unbalance. Also be sure to locate, correct, or report any noise noted during road test.
18	18	Cylinder Heads and Gaskets. Look for cracks in cylinder heads or indications of oil, coolant, or compression leaks around studs, cap screws, and gaskets. CAUTION: <i>Cylinder heads should not be tightened unless there is a definite evidence of leaks.</i> (Whenever cylinder heads are tightened, valves must be readjusted, as in item 19.) If tightening is necessary, use torque-indicating wrench and tighten head nuts in the proper sequence (fig. 33) and to specified foot-pounds tension (par. 62).
	19	Valve Mechanism. Adjust tappet clearance only when necessary, as indicated by valve noise or faulty engine performance.
19		ADJUST. Adjust clearance in proper sequence (par. 63): intake 0.010 inch, exhaust 0.016 inch. See that lock nuts are secure when clearances are last checked. Replace unserviceable valve cover gaskets.
22	22	Batteries. Clean batteries, inspect for leaks, test, and record specific gravity and voltage on each cell on back of Form No. 461. Inspect cables, terminal bolts, and nuts for good condition. Lightly grease and tighten terminals and hold-down nuts. If carriers are corroded, remove batteries, and clean and repaint carrier. SERVE. Fill to correct level $\frac{5}{8}$ inch above top of plates, with clean water.
23	23	Crankcase. With engine idling, observe crankcase, valve tappet covers, timing gear cover, air compressor mounting, and clutch housing for oil leaks. Stop engine; after oil has drained into crankcase, see if oil registers full on bayonet gage. If necessary, add oil to proper level. When an oil change is due or conditions

Second Echelon Preventive Maintenance

MAINTENANCE	
6000 Mile	1000 Mile
24	24
	24
24	
25	25
25	
26	26
27	27

warrant, drain and refill according to Lubrication Order (par. 22). Do not start engine until item 24 is completed.

Oil Filters. Inspect oil filters and lines for good condition, secure mounting, and leaks.

CLEAN. Remove plugs and drain filter bowls.

SERVE. If filter element change is due or condition warrants, service filters according to Lubrication Order (par. 22).

Radiator. Inspect radiator core, shell, mountings, hose, cap, and cap gasket to see that they are in good condition, secure, and not leaking. Be sure overflow pipe is not kinked or clogged. Examine condition of coolant to see whether or not it is so contaminated that cooling system should be cleaned. If cleaning is necessary, clean only according to current directive covering proper procedure and recommended cleaner, neutralizer, and inhibitor materials (par. 88). Clean all insects, dirt, or grease deposits from core air passages and inspect for bent cooling fins. If antifreeze is used and any appreciable amount of water is added, test value of antifreeze and add as necessary. Record value of antifreeze on space provided on work sheet, Form No. 461.

TIGHTEN. Carefully tighten all loose radiator mountings, water connections, hose clamps, and radio noise suppression bonding straps.

Water Pump, Fan, and Shroud. Inspect pump to see if it is in good condition, secure, and not leaking. Examine shaft for end play or bearing looseness. Inspect fan to see if it is in good condition and that blades and hub are secure. Loosen drive belts and examine fan for hub or bearing wear. Leave drive belts loose until adjustment is made (item 29).

TIGHTEN. Carefully tighten water pump, fan assembly, and mounting nuts.

Generator, Cranking Motor, and Switch. Inspect generator, cranking motor, and cranking motor switch to see if they are in good condition, securely mounted, and if wiring connections are clean and secure. Remove generator and cranking motor inspection covers; examine commutators and brushes to see if they are in good condition and clean, if brushes are free in brush

MAINTENANCE	
6000 Mile	1000 Mile
27	
27	
28	28
28	
28	
29	29
30	30
33	33
33	

holders and have sufficient spring tension to hold them in proper contact with commutator, and if brush connection wires are secure and not grounding. Be sure generator radio noise suppression capacitor is securely connected and mounted.

CLEAN. Blow out commutator end of generator and cranking motor with compressed air. If commutators are dirty, clean only with No. 2/0 flint paper (do not use emery) placed over end of wood block, and again blow out with air.

TIGHTEN. Carefully tighten cranking motor mounting bolts.

Air Compressor. Examine compressor to see that it is in good condition, properly alined, and secure. Check unloader valve clearance (0.010 to 0.015 inch). See if governor is in good condition and securely mounted, and if all compressor air and water lines in engine compartment are secure and not leaking.

SPECIAL LUBRICATION. Apply a few drops of engine oil to unloader valve fulcrum pin, and kerosene or dry-cleaning solvent to upper valve stem of governor.

ADJUST. Set unloader valve clearance at 0.010 inch to 0.015 inch.

Drive Belts and Pulleys. Examine drive belts for evidence of fraying, excessive wear, and deterioration. Inspect drive pulleys and hubs to see if they are in good condition and securely mounted. Drive belts should be adjusted to have 1-inch finger-pressure deflection.

Tachometer Drive and Adapter. See if these items are in good condition, correctly assembled, and secure. Inspect the flexible drive shaft for kinks, and connections for indications of oil leaks.

Manifolds and Heat Control. Inspect manifolds for looseness, damage, or exhaust leaks at gaskets. Examine for evidence of cracks or sand holes usually indicated by carbon streaks. Examine heater unit (starter burner) coil, wiring, and condenser to see that they are in good condition, and securely mounted and connected.

CLEAN. Clean heater nozzle and electrode and ground screw (figs. 56 and 57).

Second Echelon Preventive Maintenance

MAINTENANCE		
8000 Mile	1000 Mile	
33		ADJUST. Adjust heater high tension electrode and ground electrode (par. 82) to specified gap ($\frac{3}{32}$ inch). CAUTION: <i>Adjust (bend) ground electrode only.</i>
34	34	Air Cleaners. Inspect intake manifold, governor and air compressor, and trailer brake line air cleaners to see that they are in good condition, securely mounted and connected, and not leaking. Clean and service according to instructions in Lubrication Order (par. 22). Be sure gaskets are serviceable, in place, and that all joints and connections are tight.
35	35	Breather Cap. See that crankcase breather cap is in good condition, secure, and not leaking. Clean and service according to instructions in Lubrication Order (par. 22).
37	37	Fuel Filters, Screens, and Lines. Examine all fuel filters to see if they are in good condition, securely mounted and connected, and not leaking; clean and service according to instructions in Lubrication Order (par. 22). After service, turn on fuel supply and recheck for leaks.
39	39	Cranking Motor. Start the engine, observing if general action of primer and cranking motor are satisfactory, particularly that cranking motor engages and operates properly without excessive noise and has adequate cranking speed; and if the engine starts readily. Also, as soon as engine starts, note whether or not oil pressure gage and ammeter indications are satisfactory.
40	40	Leaks (Engine Oil, Fuel, and Water). With engine running, recheck all points of oil, fuel, and cooling systems for leaks. Trace any found to source and correct or report them.
42	42	Engine Idle. Observe whether engine idles smoothly at normal idling speed (par. 13 c).
43	43	Regulator Unit. Inspect regulator unit to see if it is in good condition, securely mounted and connected, and clean. Be sure radio noise suppression capacitor is in good condition, and securely mounted and connected.
44	44	Power Tire Inflation. Inspect tire inflation connection at engine side of dash to see that it is in good condition and clean. Be sure that cap is present and connected by

MAINTENANCE	
6000 Mile	1000 Mile
45	45
45	
45	
46	46
	46
46	
47	47

safety chain. Note whether or not valve turns easily and is not excessively worn. Examine air hose for deterioration, and check for damage or clogging. Connect hose and test system for proper function when performing Item No. 47. With inflation valve open and governor cut out, see if air pressure will build up to 150 pounds and if safety valve operates at that pressure.

Diesel Fuel Injector Pump. Inspect injector and transfer pumps to see that they are in good condition, correctly assembled, securely mounted, and connections are not leaking. Determine the oil level in pump with the dip stick and add or change oil as needed, as instructed in Lubrication Order (par. 22).

TIGHTEN. Tighten all assembly and mounting bolts and cap screws.

ADJUST. If engine exceeds governed speed on caution plate, adjust fuel injector pump timing (pars. 78 and 79).

Diesel Fuel Nozzles and Lines. Examine the fuel lines and nozzles to see that they are in good condition, secure, and not leaking.

SERVE. Examine the fuel nozzles for correct delivery and fuel leakage as follows: Remove one nozzle at a time, start engine, and observe the pattern and condition of the fuel spray as the throttle is opened to full-load position momentarily. The spray should be normal. **CAUTION:** Take every precaution to keep spray away from personnel. Stop the engine and observe whether there is any "after-dribble" from the spray nozzle. If the spray pattern is not normal or a dribble occurs, the nozzle should be replaced.

SERVE. Exchange all spray nozzles for new or reconditioned and tested nozzles, taking care to tighten all fuel nozzle mounting nuts, cap screws, and line connections securely.

Tires and Rims. Inspect both truck and trailer tires as follows:

VALVE STEMS AND CAPS. Observe if all valve stems are in good condition and in correct position, and if all valve caps are present and installed securely. Do not tighten with pliers.

Second Echelon Preventive Maintenance

MAINTENANCE	
6000 Mile	1000 Mile
47	
47	47

CONDITION. Examine all tires for cuts, bruises, breaks, and blisters. Remove embedded glass, nails, and stones. Look for irregular tread wear, watching for any signs of flat spots, cupping, feather edges, and one-sided wear. Remove tires worn thin at center of tread (or other unserviceable tires), and exchange for new or re-treaded tires. Determine any mechanical deficiencies causing such conditions, and correct or report. Change wheel positions of tires with irregular wear to even-up wear. Front tires worn irregularly should be moved diagonally to rear-wheel positions.

DIRECTION. Directional tires and nondirectional tires should not be installed on same vehicle. Directional tires on rear wheels should be mounted so that the "V" of chevron will point down when viewed from the front. Directional tires on all front wheels and trailer wheels will ordinarily be mounted so that "V" of chevrons will point up when viewed from the front of vehicle.

MATCHING. With tires properly inflated, inspect them to see if they are matched according to over-all circumference and type of tread.

SPARE TIRE CARRIER. See whether or not spare tire carrier is in good condition and secure.

RIMS. All rims and their lock rings or flanges should be in good condition and secure.

47 **TIGHTEN.** Tighten all wheel rim flange or lug nuts securely.

47 47 **SERVE.** With truck and trailer tires properly inflated, 80 pounds (cool) on truck and 100 pounds (cool) on trailer, check over-all circumference of all tires including spares. Select tires to be mounted on duals or on driving axles so they will not have difference in over-all circumference exceeding the 3/4-inch limits specified in current directives and bulletins. Mount all dual tires with the larger tire outside. The valve stems on inner wheels should point out, the valve stems on outer wheels should point in, and stems should be opposite each other. Spares must be matched properly and mounted for use on one of the road wheels at intervals not exceeding 90 days. A convenient time to do this is during these maintenance services. **CAUTION:** *After performing the tire-matching service, do not reinstall wheels until wheel bearing and brake services are completed.*

MAINTENANCE		
6000 Mile	1000 Mile	
48		<p>Rear Brakes. Remove truck and trailer rear wheels (pars. 256 and 257), and inspect and service the brakes as follows: On 6,000-mile maintenance, several wheel bearing and brake items up to 52 are group services and overlap. Perform in best order for economy of time and orderly reassembly. After removing rear wheels, inspect both truck and trailer and service as follows:</p> <p>DRUMS AND SUPPORTS. Clean dirt and grease from drums and supports, keeping dry-cleaning solvent away from linings. Examine drums and supports to see if they are in good condition, securely mounted, and if drums are excessively worn or scored.</p> <p>CAMS AND SHAFTS. See if cams and shafts are excessively worn at points of contact, if camshafts operate freely in collar, and if shafts and collars are worn.</p> <p>TIGHTEN. Tighten brake support cap screws and hub to drum nuts securely.</p>
	49	<p>Rear Brake Shoes (Linings, Anchors, and Springs). Examine truck and trailer linings through inspection openings in drums to see if they are so worn that bolt heads may contact drums within next 1,000 miles of operation. If vehicle linings are not visible, or vehicle has been operated in deep water, mud, or loose sand, remove forward right rear wheel and examine lining for damage. If this lining must be replaced, remove all wheels, check their brakes, and service as necessary, being sure to clean, lubricate, and adjust all removed wheel bearings as described in item 52 for 6,000-mile service.</p>
	49	<p>ADJUST. Adjust both truck and trailer shoes by minor method if necessary (pars. 176 b and 231).</p>
49		<p>With truck and trailer rear wheels removed, see that linings are in good condition, tightly secured to brake shoes, in good wearing contact with drums, free of dirt or lubricant, and not excessively worn. Also see if shoes are in good condition, properly secured to anchors, guides, and retracting springs, and that springs have sufficient tension to return shoes properly to released position. Thickness of lining at most worn point should be enough for at least 1,000 miles of service before bolt heads are likely to contact drums.</p>

Second Echelon Preventive Maintenance

MAINTENANCE		
8000 Mile	1000 Mile	
49		CLEAN. Clean all dirt and grease from linings with wire brush, cloth, or compressed air.
49		ADJUST. After subsequent related items to 60 inclusive are completed, adjust shoes by minor method. If new linings have been installed, adjust by major method described in paragraph 177 d for truck, and paragraph 231 for trailer. Adjust slack adjusters so that diaphragm push rod travel is at minimum, approximately $\frac{3}{4}$ inch, and drum-to-lining clearance is from 0.010 inch to 0.015 inch at toe end of shoes.
50	50	Torque Rods (Bushings and Pins). Inspect truck rear upper and lower torque rods, torque rod pins, and mounting brackets to see that they are in good condition and securely mounted. Coat the exposed surfaces of the rubber bushings with hydraulic brake fluid to prevent hardening and cracking.
50		TIGHTEN. Tighten torque rod pin nuts securely.
51	51	Rear Spring Seats and Bushings. Examine truck rear spring seats and bushings to see that they are in good condition and securely mounted. See that rear spring seat bushings have no side play (par. 160 d), and that these seats are properly lubricated.
51		TIGHTEN. Tighten rear spring seat clamp nuts and rear spring bushing adjusting clamp nuts.
51	51	WALKING BEAMS (MOUNTINGS, SUPPORTS). Inspect trailer walking beams, beam supports, and mountings to see that they are in good condition and securely mounted.
51		TIGHTEN. Tighten cross shaft and longitudinal shaft nuts securely.
52	52	Rear Wheels (Bearings, Seals, Drive Flanges, and Nuts). Inspect and service as follows:
	52	WHEELS. Inspect truck and trailer wheels to see if they are in good condition and secure.
		BEARINGS AND SEALS. Check for looseness of wheel bearing adjustment. Revolve wheels and listen for evidence of dry or damaged bearings. Inspect around flanges and brake supports or adapters for lubricant leaks.

Maintenance Instructions

MAINTENANCE		
8000 Mile	1000 Mile	
		DRIVE FLANGES AND NUTS. Note if truck drive flanges are in good condition, not excessively worn, and if nuts are tightened securely.
52		CLEAN. Disassemble both truck and trailer rear wheel bearings and oil seals. Clean thoroughly in dry-cleaning solvent and examine bearing cups and cones to see that they are in good condition, that the machined surfaces that they contact are in good condition, and if there is any excessive wear.
52		SPECIAL LUBRICATION. When all of the related items are checked to the point where wheel bearings are to be reinstalled, lubricate bearings according to instructions on Lubrication Order (par. 22).
52		ADJUST. After lubricating truck and trailer wheel bearings, reassemble hub and drum assemblies into place and adjust wheel bearings correctly according to paragraph 185 b for truck, and paragraph 256 c (5) for trailer.
53	53	Front Brakes. Inspect truck and trailer brake hose, chambers, push rods and seals, and slack adjusters to see if they are in good condition, correctly assembled, and secure.
53		Remove front wheels and inspect and service as follows: DRUMS AND SUPPORTS. Clean and inspect in same manner as in item 48. CAMS AND SHAFTS. Inspect in same manner as in item 48.
53		TIGHTEN. Tighten the brake support bolts and drum mounting nuts securely.
	54	Front Brake Shoes. Inspect the truck and trailer brake lining in the same manner as the similar inspection in item 49.
	54	ADJUST. Adjust by minor method, if necessary.
54		Inspect the brake shoes, linings, links, guides, and anchors in the same manner as the similar inspection in item 49 on the 6,000-mile maintenance service.
54		CLEAN. Clean all dust from the brake lining with a wire brush, clean cloth, or compressed air.

Second Echelon Preventive Maintenance

MAINTENANCE		
6000 Mile	1000 Mile	
54	54	ADJUST. Adjust in the same manner as in item 49.
56	56	Front Springs (Clips, Leaves, U-bolts, Hangers, and Shackles). See if all items are in good condition, correctly assembled, and secure. Spring clips and bolts should be in place; spring leaves should not be shifted out of their correct position. (This may be an indication of a sheared center bolt.) Note if deflection of both springs is normal and approximately the same. Test hangers and bolts for excessive wear by means of a pry bar.
56	56	TIGHTEN. Tighten all spring U-bolts securely and uniformly.
57	57	Steering (Arms, Tie Rods, Drag Link, Seals and Boots, Pitman Arm, Gear, Column, and Wheel). See if these items are in good condition, correctly and securely assembled and mounted, if steering gear case is leaking lubricant excessively, and if lubricant is at proper level. Pay particular attention to Pitman arm to see if it is securely mounted and not bent out of its normal shape.
57		TIGHTEN. Tighten Pitman arm shaft nut securely. Also tighten steering gear case assembly and mounting nuts or screws, taking care not to disturb adjusting screws and lock nuts. CAUTION: <i>Loosen steering column bracket when tightening steering case mounting nuts, so as not to distort column.</i>
60	60	Front Wheels (Bearings, Seals, and Nuts). Inspect and service these truck and trailer items as follows: WHEELS. Inspect the wheels for good condition. BEARINGS AND SEALS. Inspect for looseness of the wheel bearing adjustment. Revolve the wheels and listen for indication of dry or damaged wheel bearings. Inspect around the brake supports and drums for lubricant leaks.
	60	TIGHTEN. Tighten all wheel flange and drum mounting nuts securely.
60		CLEAN. Disassemble the bearings and oil seals. Clean thoroughly and check the rollers and cups to see that they are in good condition, and that the cups are secure. If cups appear to be in good condition, it is not necessary

Maintenance Instructions

MAINTENANCE	
6000 Mile	1000 Mile
60	
60	
61	61
61	
63	63
64	64
64	
64	64
64	
65	65

to remove them from the hubs unless the bearings must be replaced, in which case new cups should be installed. Also see that the machined surfaces upon which the bearings are assembled are in good condition.

SPECIAL LUBRICATION. Apply in same manner as described in item 52.

ADJUST. Adjust wheel bearings in same manner as described in item 52, and adjust brake shoes as described in item 49.

Front Axle. If front axle appears to be out-of-line, measure distance from front spring eye bolt to center of axle spring pad on each side. (Distance should be equal.)

TIGHTEN. Tighten spring U-bolts securely.

Engine Mountings. Check to see that engine mountings are in good condition and tight. Be sure to check both front engine supports and all rubber mountings to determine that rubber is not separating from its metal backing. If the mounting bolts are loose, tighten them properly, taking care not to overtighten. Remove oil or grease from the rubber mounting. Adjust rubber mounting grease shields. Inspect ground straps for damage and loose connections.

Hand Brakes.

(a) Inspect truck ratchet, pawl, and linkage for damage or looseness; brake disk for scoring; and lining for grease or oil. Examine lining to see whether or not it is loose or worn thin.

ADJUST. Adjust clearance to $\frac{1}{32}$ inch between disk and linings (fig. 139). **NOTE:** *Be sure that the emergency hand brake is free regardless of clearance required.* Hand brake should hold truck when parked with one-third ratchet travel in reserve.

(b) Inspect trailer front and rear hand brake handwheels, ratchets, pawls, cables, and linkage to see that they are in good condition, correctly assembled, and securely mounted.

TIGHTEN. Tighten all cable clamps, support guides, and pawl mountings securely.

Clutch Pedal. Clutch pedal should have not less than 1-inch free travel (lash) before meeting resistance. See

Second Echelon Preventive Maintenance

MAINTENANCE	
6000 Mile	1000 Mile
66	66
69	69
70	70
70	
71	71
71	
73	73
73	
75	75

paragraph 127 for clutch adjustment. Examine to see if pedal is securely mounted to shaft, if clutch linkage is in good condition, and secure. See if return spring has proper tension to bring pedal to correct released position.

Brake Pedal. Inspect to see that brake pedal operates freely and that clearance between pedal and roller is $\frac{1}{16}$ inch.

Air Brake Application Valves. Inspect foot and hand air brake application valves and linkage for damage, looseness, and wear. See that hand control operates freely and that both valves are closed securely when controls are in the "OFF" position.

Air Brake Reservoirs. See that reservoirs on both truck and trailer are in good condition and secure. Drain off water and close cocks.

TIGHTEN. Tighten air brake reservoir mountings.

SERVE. Remove trailer air filter, wash in dry-cleaning solvent, and reassemble. Be sure gaskets are serviceable.

Transmissions (Mountings, Seals, Power Take-off, and Linkage). Examine transmission cases and power take-off to see that they are in good condition, securely mounted, and not leaking at seals and gaskets. Inspect control linkage and shift mechanism for damage or excessive wear.

TIGHTEN. Tighten all mounting nuts and screws securely.

Propeller Shafts. Inspect truck propeller and winch propeller shafts and center bearing to see that they are in good condition, correctly and securely assembled and mounted. See if the universal joints are properly alined with each other, are not excessively worn, and are well lubricated. Examine seals on slip and universal joints for lubricant leaks.

TIGHTEN. Tighten all universal joint assembly and yoke cap screws and companion flanges securely.

Rear Axles.

(a) Inspect truck rear axles to see that the axle housings are in good condition, securely assembled and mounted, and not leaking.

MAINTENANCE		
6000 Mile	1000 Mile	
75	75	(b) Inspect the trailer rear axle assemblies to see if they are in good condition, correctly and securely assembled to walking beams, and properly alined.
76	76	Rear Axle Brake (Chambers, Cylinders, Rod and Seals, and Slack Adjusters). See that these items on the truck and the trailer are in good condition, securely connected and mounted, and that push rod seals are in proper position on the push rods. See that the slack adjusters are adjusted to specifications: paragraph 176 for truck, and paragraph 224 for trailer.
77	77	Rear Springs. Examine truck rear springs, spring clips, leaves, U-bolts, spring seats, and torque rods to see that they are in good condition, correctly and securely assembled and mounted. Be sure deflection of both springs is normal and approximately the same. Test the torque rod pins and bolts for excessive wear by means of a pry bar.
77		TIGHTEN. Tighten spring U-bolts, rebound clips, and spring seat clamp nuts securely.
79	79	Cab and Body Mountings. Inspect cab and body mountings to see that they are in good condition, and secure. Be sure that the springs and rubber mountings are in good condition and properly compressed. These springs and rubber mountings should be neither loose nor compressed solidly.
79		TIGHTEN. Tighten cab mountings evenly and securely, taking care to loosen the steering column clamp before alining or tightening cab. When tightening spring-loaded mounting bolts, do not compress springs fully. After completing this service, be sure to tighten steering column clamp.
80	80	Frame (Side and Crossmembers). Inspect both truck and trailer frames, brackets, side rails, and crossmembers to see if they are in good condition, secure, and correctly alined. If the frame appears to be out-of-line, report condition to designated individual in authority.
81	81	Wiring Conduits and Grommets. Observe these items underneath truck and trailer to see if they are in good condition, properly supported, connected, and secure.

Second Echelon Preventive Maintenance

MAINTENANCE		
6000 Mile	1000 Mile	
82	82	Fuel Tanks, Fittings, and Lines. Inspect fuel tanks, lines, fittings, and connections to see that they are in good condition, securely mounted, and lines and connections are not leaking. Examine filler caps for defective gaskets or plugged vents. See that filler necks are in good condition and that caps fit securely.
82		Remove the fuel tank drain plugs and drain off the accumulated water and dirt in bottom of tanks. Drain only until fuel runs clear. Use necessary precautions against fire.
83	83	Brake Lines (Fittings and Hose). Examine all lines and fittings and air brake hose under both truck and trailer to see if they are in good condition and securely connected and supported so that lines or hose will not chafe against other vehicle parts.
84	84	Exhaust Pipe and Muffler. Examine exhaust pipe to see if it is securely attached to exhaust manifold, that gasket or packing does not show visible evidence of leakage, and that the other end of exhaust pipe is clamped securely to muffler. Inspect muffler to see if it is in good condition and securely mounted. Check tail pipe to see if it is securely clamped to muffler, properly supported, and unobstructed at its outer end.
85	85	Lubrication. If due, lubricate all points of truck and trailer in accordance with Lubrication Order (par. 22) and current lubrication directives, using only clean lubricant and omitting only those items that have had special lubrication during this service. Replace damaged or missing fittings, vents, flexible lines, or plugs.
LOWER TRUCK TO GROUND		
86	86	Toe-in and Turning Stops. With front wheels on ground and in straight-ahead position, use a toe-in gage to determine if adjustment is as specified; it should be $\frac{1}{8}$ inch plus or minus $\frac{1}{32}$ inch. Turn wheels fully in both directions and see if turn is limited by stops. In this position, note if tires clear all parts of vehicle.
87	87	Winch (Clutch, Drive, Brakes, Shear Pin, and Cables). Observe whether or not all of these items are in good condition, correctly assembled, and secure. See

Maintenance Instructions

MAINTENANCE	
6000 Mile	1000 Mile
87	
89	89
91	91
91	
92	92
93	93
94	94

that the winch jaw clutch moves freely and the lever latches securely. Test winch brake, power take-off shift lever, and air control valve to engine clutch and engine throttle to see that they are in good condition and operate correctly. Examine chain and torque control to see that they are in good condition, correctly assembled, mounted, and adjusted (par. 216).

CLEAN AND SERVE. Unwind cable and inspect for broken or frayed strands and for flat or rusty spots. Start truck engine and observe whether or not engine responds to outside throttle control, and air control operates engine clutch correctly. Clean entire length of cable with cloth saturated with thin oil or kerosene. Remove excess oil or kerosene as cable is rewound evenly on drum, and apply a thin film of engine oil. Sample oil in worm gear housing for contamination, and if oil change is due or condition of oil warrants, drain and refill winch housing according to Lubrication Order (par. 22).

Truck to Trailer Brake Hose, Wiring, and Connections. Check brake hose and wiring connections to see that they are in good condition and securely fastened to clips, springs, and brackets so that they will not chafe or interfere with working parts. Check trailer brake shut-off valve to see that it operates properly. **NOTE:** *Always moisten rubber applicator before making connections.*

Lamps (Lights) (Head, Tail, Body, Stop, and Black-out). Operate all truck and trailer switches, and note if lamps respond. Include stop and blackout lights. See if foot switch controls headlight beams properly and if beams are aimed so as not to blind oncoming traffic. Examine all truck and trailer lights to see if they are in good condition and securely mounted, and if lenses are dirty.

ADJUST. Adjust lamp-unit beams.

Safety Reflectors. See if reflectors are all present on both truck and trailer, in good condition, clean, and secure.

Front Bumper. See if bumper is in good condition and secure.

Hood, Hinges, and Fasteners. Inspect hood, hood hinges, and fasteners to see that they are in good condition, correctly assembled, and securely mounted.

Second Echelon Preventive Maintenance

MAINTENANCE	
6000 Mile	1000 Mile
95	95
96	96
98	98
100	100
101	101
103	103
104	104

Front Fenders and Running Boards. Examine front fenders, running boards, and running board battery boxes to see that they are in good condition and securely mounted. See that battery box doors operate properly and lock securely.

Cab (Hardware, Glass, Doors, and Floor Plates). Inspect these items to see that they are in good condition and secure. See that windshields and doors operate properly and close securely.

Junction Block and Circuit Breakers. Check for secure mounting, and see that all wires are securely connected (figs. 85, 86, 88, and 179).

Body. Inspect truck body and trailer platform, ramps, cable guides, and rollers to see that they are in good condition, correctly and securely mounted.

Pintle Hooks. Examine pintles to see if they are in good condition and are securely mounted to frame. Test pintles and latches to see if they operate properly, are adequately lubricated, and if lock pins are present and securely attached by chains. Look particularly for broken springs or worn drawbars.

Paint and Markings. Examine paint of entire truck and trailer to see if it is in good condition, and pay particular attention to any bright spots in finish that might cause glare or reflection. Inspect vehicle markings and identification for legibility. Include identification plates and their mountings, if furnished.

Radio Bonding. See that all units not covered in the foregoing specific procedures are in good condition and are securely mounted and connected. Be sure all additional noise suppression bond straps and internal-external toothed washers are inspected for looseness or damage, and see that contact surfaces are clean. **NOTE:** *If objectionable radio noise from vehicle has been reported, make tests in accordance with paragraph 57. If cleaning and tightening of mountings and connections, and replacement of defective radio noise suppression units does not eliminate the trouble, the radio operator will report the condition to the designated individual in authority.*

MAINTENANCE	
6000 Mile	1000 Mile
124	124
125	125
131	131
132	132
133	133
134	134
135	135
136	136

Tow Hitch (Tongue and Lunette). Inspect trailer dolly, tongue, and lunette to see that they are in good condition, correctly assembled, and securely mounted. See that dolly kingpin is secure.

Air Connections. Inspect trailer air line connections to truck to be sure they are in good condition, not excessively worn, and will couple securely without leaking.

TOOLS AND EQUIPMENT

Tools (Vehicle and Pioneer). Inspect truck and trailer standard and pioneer tools, and trailer special loading and securing equipment to see if they are all present (pars. 6, 7, 8, and 9), in good condition, clean, and properly stowed or securely mounted. Also examine tools which have cutting edges to see that they are sharp. Any tools mounted on outside of truck or trailer which have bright or polished surfaces, should be painted or otherwise treated to prevent rust, glare, or reflection.

Fire Extinguishers. See if fire extinguishers are in good condition, securely mounted, and fully charged. The charge may be determined on gas-type extinguishers by weighing with a scale, and on liquid-type by removing filler plug. Also be sure nozzles are free from corrosion.

Decontaminators. Check to see that decontaminators are in good condition, securely mounted, fully charged, and nozzles free and clean. Inspect refill date on tags; refill is required every 3 months.

First Aid Kit (If Specified). See if first aid kit is in good condition and that all of its items are present and properly packed. Report any deficiencies immediately.

Publications and Form No. 26. The vehicle and equipment manuals, Lubrication Order, Standard Form No. 26 (Accident-Report Form) and W.D., A.G.O. Form No. 478 must be present in truck, legible, and properly stowed.

Traction Devices. Examine tire chains to be sure they are in good condition, clean (if not in use), not excessively worn, protected against rust, and properly mounted or stowed.

Trouble Shooting

MAINTENANCE	
6000 Mile	1000 Mile
137	137
138	138
139	139
141	141
142	142

Tow (Chains, Cables, Bar, and Snatch Blocks). See if the provided towing devices are in good condition, clean, and properly protected against rust when not in use. If snatch blocks are furnished, check to see that they operate freely.

138 138 Spare Shear Pins and Bulbs. See that these items when issued are present in correct quantities; that they are in good condition, and properly stowed.

139 139 Fuel, Oil, and Water Cans. Inspect for damage, leaks, and loose mountings. Caps must be on chains.

141 141 Modifications (MWO's Completed). Inspect the truck and trailer to determine if all Modification Work Orders have been completed and entered on W.D., A.G.O. Form No. 478. Enter any replacement of major unit assembly made at time of this service.

142 142 Final Road Test. Make final road test of truck and trailer, rechecking items 2 to 15 inclusive, and also be sure to recheck the transmission, winch, and driving axles to see that the lubricant is at correct levels and not leaking. Confine this road test to the minimum time necessary to make satisfactory observations. **NOTE:** *Correct or report any deficiencies found during this final test.*

Section XII

TROUBLE SHOOTING

32. GENERAL.

a. This section contains trouble shooting information and tests which can be made to help determine the causes of some of the troubles that may develop in the vehicle used under average climatic conditions (above 32°F). Each symptom of trouble given under the individual unit or system is followed by a list of possible causes of the trouble. The tests necessary to determine which one of the possible causes is responsible for the trouble are explained after each possible cause.

33. ENGINE.**a. Engine Will Not Turn.**

(1) **ENGINE SEIZURE DUE TO INTERNAL DAMAGE.** Make sure transmission is in neutral and crankcase oil is of proper viscosity for prevailing temperature. Attempt to turn engine with hand crank. If it does not turn, seizure due to internal damage is indicated. Notify higher authority.

(2) **CRANKING MOTOR INOPERATIVE.** Check starting system and make necessary repairs or replacements as instructed in paragraph 34.

(3) **INCORRECT OIL VISCOSITY.** Drain and fill with proper grade of oil (par. 22).

b. Engine Turns But Will Not Start.

(1) **SLOW CRANKING SPEED.** Batteries are run down. Check batteries for condition and recharge or replace. Follow instructions in paragraph 35.

(2) **NO FUEL IN TANK.** Fill tank, prime, and start.

(3) **INOPERATIVE FUEL SYSTEM.** Make thorough inspection of fuel system, following procedure in paragraph 36.

(4) **WATER IN FUEL.** Drain system and tanks. Clean, refill, prime, and start.

(5) **INCORRECT GRADE OF FUEL.** If fuel appears to be too heavy to flow through the lines, drain fuel system. Fill fuel system with correct grade of fuel. Bleed system.

(6) **ENGINE COLD.** Use starter burner which operates in conjunction with hand priming pump (par. 18 h).

(7) **AIR CLEANERS PLUGGED.** Clean air cleaners as instructed in paragraph 85 b.

(8) **GOVERNOR STOP LEVER STUCK IN "OFF" POSITION.** Check stop control solenoid and linkage (par. 79).

(9) **WINCH TORQUE CONTROL SWITCH OPEN.** Check rocker arm for sticking. Check adjustment of air gap (par. 215 a).

(10) **AIR IN FUEL SYSTEM.** Bleed system as instructed in paragraph 77 e.

c. Engine Missing Erratically.

(1) **IMPROPER FUEL.** Check fuel with fuel known to be of correct grade. Drain fuel system. Refill and bleed fuel system (par. 77 e).

(2) **WATER IN FUEL.** Drain fuel system. Refill and bleed system (par. 77 e).

(3) **STICKY INJECTION NOZZLES.** Clean faulty injection nozzles (par. 76 c), or replace with new ones (par. 76 d). To determine

Trouble Shooting

which cylinder or cylinders are missing, loosen the nuts which connect the higher pressure lines to injection nozzles, one at a time. If the engine speed drops and the exhaust loses its rhythm, this indicates the cylinder has been functioning. If the engine speed remains the same and the exhaust sounds the same, this indicates the cylinder has been missing. Usually, when testing for a missing cylinder, the injector pump or lines are air-bound, and condition will be corrected by loosening the nuts, which permits the air or gas to escape.

(4) **STICKY INJECTOR PUMP VALVES.** Replace injector pump as instructed in paragraph 74.

(5) **IMPROPER VALVE ADJUSTMENT.** Adjust clearance, using procedure outlined in paragraph 63.

(6) **DIRTY AIR CLEANERS.** Clean air cleaners (par. 85).

(7) **AIR OR GAS BINDING IN FUEL PUMP OR LINES.** Bleed fuel lines (par. 77 e (2)).

d. Increase of Smoke in Exhaust.

(1) **LEAKING CYLINDER HEAD GASKET.** Replace cylinder head gasket (par. 22).

(2) **IMPROPER FUEL OIL.** Check fuel oil against grade known to be correct. Drain, refill, and prime system (par. 77 e (2)).

(3) **DIRTY INJECTION NOZZLES.** Clean faulty nozzles (par. 76 c).

(4) **FUEL INJECTOR PUMP OUT OF TIME.** Check timing as instructed in paragraph 74 c.

(5) **FUEL INJECTOR PUMP DELIVERY VALVES STUCK OR BROKEN.** Install new injector pump (par. 74).

e. Engine Overheating.

(1) **COOLANT LEVEL LOW.** Refill radiator to proper level (par. 88 b).

(2) **COOLING SYSTEM NOT FUNCTIONING.** Follow procedure in paragraph 38 to check source of trouble.

(3) **FAN BROKEN OR BENT.** Replace defective fan (par. 90).

(4) **FAN BELT LOOSE.** Adjust fan belt (par. 90 e).

(5) **BRAKES DRAG.** Correct by following adjustment procedure in paragraph 177 d.

(6) **OIL PRESSURE LOW.** Check source of trouble by proceeding as instructed in paragraph 37 c.

(7) **EXHAUST LINES RESTRICTED.** Check muffler and tail pipe for obstructions.

f. Engine Knocks or Pings.

(1) **PISTON HITTING INLET AND EXHAUST VALVE.** Notify higher authority.

- (2) **WORN ROD AND MAIN BEARING.** Notify higher authority.
- (3) **VALVE TAPPET CLEARANCE TOO GREAT.** Adjust valves to proper clearance (par. 63).
- (4) **WORN PISTON RINGS OR BUSHINGS.** Notify higher authority.
- (5) **LOOSE FLYWHEEL.** Notify higher authority.
- (6) **POOR GRADE FUEL.** Drain, refill, and bleed fuel system (par. 77 e).

g. Engine Stops Suddenly.

- (1) **NO FUEL IN TANKS.** Fill tanks and prime system (par. 77 e).
- (2) **FUEL SYSTEM AIR OR GAS-BOUND.** Bleed system (par. 77 e). Prime and start.
- (3) **BROKEN FUEL LINE.** Replace fuel line; prime (par. 77 e).
- (4) **WATER IN FUEL SYSTEM.** Drain, fill, and prime fuel system (par. 77 e).
- (5) **PUMP NOT WORKING.** Replace fuel supply pump (par. 75).
- (6) **BROKEN FUEL PUMP DRIVING CHAIN.** Check to see if fuel pump drive shaft rotates when engine is turned over by hand. If it does not, notify higher authority.
- (7) **FUEL INJECTOR DRIVE COUPLING LOOSE OR OUT OF TIME.** Check coupling and retime (par. 74 e).

34. STARTING SYSTEM.

a. Solenoid Cranking Motor Switch Fails to Operate When Cranking Motor Switch is Closed.

- (1) Check wiring for loose or corroded connections; clean and tighten as required.
- (2) Test each cell of the batteries with a hydrometer. If any cell is less than 1.220 at 80°F, replace the defective battery. If the switch still fails to operate when cranking motor switch is closed, proceed as in the next step.
- (3) If vehicle is equipped with a circuit lock switch, place a jumper wire between the SW terminal of the cranking motor switch and the top outside terminal of the solenoid. If the solenoid operates when the cranking motor switch is depressed, the circuit lock switch or connecting wires are defective and must be replaced.
- (4) Using a screwdriver with an insulated handle, short the outside top terminal of the solenoid against the frame. If solenoid fails to operate it should be replaced (par. 97). If the solenoid does operate when the terminal is shorted, the switch is all right and a further check is necessary to locate the trouble.

Trouble Shooting

(5) Run a jumper wire from the SW terminal of the cranking motor switch to the ammeter terminal (—A) of the same switch. If the solenoid operates, the cranking motor switch is defective and must be replaced (par. 98). If the solenoid fails to operate, leave this jumper in place and run another wire across the terminals in the ammeter line. If the solenoid operates, the circuit breaker is defective and must be replaced (par. 117). If the solenoid still fails to operate, check the battery for sulphated terminals and cover with a clean coat of petrolatum if necessary.

b. Cranking Motor Switch Solenoid Operates When Cranking Motor Switch is Closed.

(1) Test the solenoid switch with a jumper wire. If cranking motor operates, replace defective cranking motor switch solenoid (par. 97). If cranking motor does not operate, proceed with step (2) below.

(2) Remedy all poor connections, short and open circuits in the heavy cable connecting the battery with the cranking motor, and in the cable connecting the solenoid switch with the cranking motor. Carefully examine and remedy if necessary the ground cable circuit of the battery. If the cranking motor does not rotate the engine crankshaft after performing the preceding steps, replace the defective cranking motor (par. 96). Notify a higher authority if the troubles cannot be corrected.

35. BATTERY AND GENERATING SYSTEM.

a. Batteries. Because the lighting load is connected to one battery (in right-hand battery compartment) there will be some unbalance in the condition of the batteries and the state of charge. The battery in series with that across which the lighting load is connected will receive more charge than the one which is connected to the lights, and therefore will use more water.

(1) **BATTERY CELLS ALL TEST OVER 1.250 SPECIFIC GRAVITY AND WITHIN 15 POINTS OF EACH OTHER.** If battery is normal, no corrective measures are necessary in summer. For cold weather operation, give batteries booster charge if cells are under 1.275.

(2) **BATTERY CELLS ALL TEST UNDER 1.250 SPECIFIC GRAVITY AND WITHIN 15 POINTS OF EACH OTHER.**

(a) *Battery Will Not Hold a Charge.* Replace battery as instructed in paragraph 112.

(b) *Demand From Batteries Exceeds Input From Generator.* Recharge batteries. Check electrical system for short circuits, loose connections, and low generator output. Refer to higher authority for increase in charging rate.

Maintenance Instructions**(3) FREQUENT ADDITIONS OF WATER TO BATTERIES NECESSARY.****(a) *Lighting Load Unbalances Batteries in Same Compartment.***

If the battery in series with that which carries the lighting load is using much more water than the loaded battery in the same battery compartment, it is an indication that the connections to the lighting battery should be changed in accordance with the instruction plate in the battery compartment.

(b) *Excessive Generator Charging Rate.* Refer to higher authority for adjustment of generator charging rate.

(c) *Broken Battery Case.* Replace battery as instructed in paragraph 112.

(4) BULGE IN BATTERY CASE. Caused by excessive temperature due to overcharging. Refer to higher authority for decrease in charging rate.

(5) CORROSION ON BATTERY TERMINALS.

(a) *Excessive Charging Rate Causing Acid to Spray on Terminals.* Remove terminals from posts. Clean posts and terminals thoroughly. Replace cable if terminal is weakened by corrosion. Connect terminals and apply a film of petrolatum to exposed metal. Refer to higher authority for decrease in charging rate.

(b) *Lead Coating on Terminals Destroyed.* Proceed as directed in step (a) above.

(6) BROKEN TERMINAL POST ON BATTERY.

(a) *Loosen Battery Installations.* Replace battery as instructed in paragraph 112.

(b) *Battery Cable Too Short.* Replace battery cable.

b. Generating System. When checking the condition of the generating circuit, start the engine and set the throttle to idle the engine at 800 revolutions per minute.

(1) AMMETER FAILS TO FLICK OR REGISTER CHARGE BUT LEFT BATTERY "B" AMMETER FLICKS OR REGISTERS CHARGE. Replace defective ammeter as flow of current through left battery ammeter indicates that the generating circuit is complete.

(2) AMMETER AND LEFT BATTERY AMMETER BOTH FAIL TO REGISTER CHARGE.

(a) Replace ammeters. If no improvement is observed, proceed as in the next step.

(b) Check all wiring for loose or corroded connections, and clean and tighten as required.

(c) Run a jumper wire from the armature terminal of the generator to the armature terminal of the regulator. If the ammeters register the flow of current, the armature lead from the generator to

Trouble Shooting

the regulator should be repaired or replaced. If the ammeters still show no deflection, proceed as in step (d) below.

(d) Run a jumper wire between the armature terminal and the battery terminal on the generator regulator. If the ammeters show deflection, the generator regulator is defective and should be replaced (par. 115). If the ammeters still fail to show deflection, proceed as in the next step.

(e) Run a jumper wire between the ammeter and the “-A” terminal on the cranking motor switch. If the ammeters show deflection, the wire between the cranking motor switch and the ammeter should be replaced or repaired. If the ammeters still fail to show deflection, proceed as in next step.

(f) Run a jumper wire between the “-A” terminal on the cranking motor switch and the “-A” terminal on the right battery. If the ammeters show deflection, the battery cable between the “-A” terminal on the cranking motor switch and the “-A” terminal on the right battery should be replaced.

(g) Disconnect the generator regulator field wire and ground it. Then disconnect the regulator armature wire and brush it over a good ground. **CAUTION: Do not hold this wire in contact with ground or it will burn out the regulator armature.** If no spark is obtained, the generator is defective and should be replaced (par. 114). If a good spark is obtained, it is an indication that the generator is functioning properly, and the regulator armature and field connections should be replaced before continuing the next step (h).

(h) Disconnect the regulator battery wire and hold it close to the regulator battery terminal. If a good spark is obtained, the regulator is defective and should be replaced (par. 115).

(i) If after making these tests the ammeter registers charge; but the left battery ammeter fails to register, proceed as in step (3) below. If the trouble cannot be located refer to a higher authority.

(3) AMMETER REGISTERS CHARGE BUT LEFT BATTERY AMMETER DOES NOT REGISTER CHARGE.

(a) Repeat steps (a) and (b) as outlined in step (2) above.

(b) Run a jumper wire between the “-A” terminal and the “-B” terminal on the cranking motor switch. If the left battery ammeter shows deflection, the cranking motor switch is defective and must be replaced (par. 98). If the left battery ammeter fails to show deflection, proceed as in step (c) following.

(c) Run a jumper wire between the “B” terminal on the cranking motor switch and the “-B” terminal on the solenoid switch. If the left battery ammeter shows deflection, there is an open circuit in the wire between the cranking motor switch and the solenoid switch.

To determine which parts are defective in this circuit, proceed as follows:

1. Run a jumper wire between the “-B” terminal on the cranking motor switch and the circuit breaker in the line. If the armature shows deflection, the wire between the cranking motor switch and the circuit breaker must be replaced.

2. Run a jumper wire across the terminals of the circuit breaker. If the ammeter shows deflection, the circuit breaker must be replaced (par. 117).

3. Run a jumper wire between the circuit breaker and the cranking motor front terminal. If the ammeter shows deflection, the wire between the circuit breaker and the cranking motor must be replaced.

4. Run a jumper wire between the cranking motor front terminal and the solenoid inside top terminal. If the ammeter shows deflection, the wire between the cranking motor and solenoid is defective and must be replaced.

(d) Run a jumper wire from the left battery cable connection on the front of the cranking motor to the “-B” terminal of the left battery. If the ammeter shows deflection, the battery cable must be replaced. If the ammeter still fails to show deflection, proceed as in steps (e) and (f) following.

(e) Run a jumper wire from the “+B” terminal of the left battery to the “+B” terminal of the cranking motor switch. If the ammeter shows deflection, the battery cable must be replaced. If the ammeter fails to show deflection, proceed as follows:

(f) Run a jumper wire between the “+B” terminal and the left battery ammeter terminal on the cranking motor switch. If the ammeter shows deflection, the cranking motor switch is defective and must be replaced. If the ammeter fails to show deflection, proceed as in step (g) following.

(g) Run a jumper wire from the left battery ammeter terminal on the cranking motor switch to the left battery ammeter. To determine which part of the circuit is defective, proceed as follows:

1. Run a jumper wire from the left battery ammeter terminal on the cranking motor switch and the circuit breaker in the line. If the ammeter shows deflection, the wire between the circuit breaker and the cranking motor switch must be replaced.

2. Run a jumper wire across the terminals of the circuit breaker. If the ammeter shows deflection, the circuit breaker is defective and must be replaced (par. 117).

3. Run a jumper wire between the circuit breaker and the junction block on the cowl. If the ammeter shows deflection, replace the wire between the circuit breaker and junction block.

Trouble Shooting

4. Run a jumper wire between the junction block and the ammeter. If the ammeter shows deflection, the wire between the junction block and the ammeter is defective and must be replaced.

(h) Run a jumper wire between the left battery ammeter and the ground. If the ammeter shows deflection, the ground wire is defective and must be replaced.

(i) If the front battery ammeter still fails to show deflection, report to higher authority.

36. FUEL SYSTEM.

a. Fuel Does Not Reach Cylinders.

(1) **NO FUEL IN TANK.** Check supply of fuel in tanks. Fuel should be drawn from one tank at a time. One tank may be empty if the other tank has an adequate supply.

(2) **GATE VALVE CLOSED.** Check to see that gate valves on side of vehicle with supply of fuel in tank are open.

(3) **AIR IN SYSTEM.** Bleed system to remove air (par. 77 e).

(4) **WATER IN FUEL.** Drain tanks and entire fuel system. Clean, refill, and bleed system (par. 77 e).

(5) **FUEL FILTERS PLUGGED.** Clean filters.

(6) **AIR LEAKS IN LINE.** Check feed lines from tanks to primary filter, from primary filters to fuel supply pump, from fuel supply pump to secondary filter, from secondary filter to fuel injector pump, and from fuel injector pump to nozzles for loose connections, broken nuts, or cracked lines. Tighten loose connections; replace defective parts.

(7) **RESTRICTED LINES.** Check fuel lines for restrictions due to pinched or damaged lines.

(8) **FUEL SUPPLY PUMP DOES NOT OPERATE PROPERLY.** Check pump operation by disconnecting line to the secondary filter. If a good quantity of fuel appears, the supply pump is operating. If not, replace fuel supply pump (par. 75).

(9) **INJECTOR PUMP DOES NOT OPERATE PROPERLY.** Check by disconnecting each high pressure line, one at a time, below nozzle and observing flow of fuel while engine is idling. If supply is not satisfactory, replace injector pump.

(10) **FUEL INJECTOR NOZZLES CLOGGED.** Test injector nozzle (par. 33 c (3)). Clean or replace if dirty or clogged.

b. Fuel Pressure Low.

(1) **LEAKS IN FUEL LINES.** Check fuel lines for leaks from loose connections, broken nuts, and cracked or broken lines. Replace damaged lines.

(2) **CLOGGED FILTERS.** Clean filters.

(3) **FUEL INJECTOR PUMP NOT OPERATING PROPERLY.** Replace fuel injector pump.

(4) **FUEL PRESSURE GAGE NOT REGISTERING CORRECTLY.** Replace fuel pressure gage with one known to be registering correctly.

c. Excessive Fuel Consumption.

(1) **FUEL INJECTOR PUMP NOT TIMED CORRECTLY.** Check timing as instructed in paragraph 74 c.

(2) **FUEL LEAKS.** Check system for leaks due to loose connections or broken lines.

(3) **DIRTY AIR CLEANERS.** Clean air cleaners.

(4) **EXHAUST AND INTAKE VALVES LEAKING.** Refer to higher authority.

(5) **ENGINE RUNNING TOO HOT.** Refer to paragraphs 37 c and 38 a for procedure in locating cause of trouble.

(6) **BRAKES DRAGGING.** Adjust brakes as instructed in paragraph 177 d.

(7) **TIRES UNDERINFLATED.** Fill tires to proper pressure (par. 186).

37. ENGINE LUBRICATING SYSTEM.

a. Engine Will Not Turn Due to Incorrect Oil Viscosity. Drain oil from engine. Fill with oil of correct viscosity for temperature conditions (par. 22).

b. Engine Stops Suddenly Due to Piston or Bearing Seizure. Lack of lubrication will cause piston or bearing failure. Notify higher authority.

c. Engine Overheats.

(1) **OIL LEVEL LOW.** Check oil level and fill to correct level (par. 22).

(2) **POOR GRADE OF OIL.** Drain oil. Refill with correct grade of oil (par. 22).

d. Excessive Oil Consumption.

(1) **OIL TOO LIGHT OR OF POOR GRADE.** Drain oil. Refill with oil of correct grade (par. 22).

(2) **OIL PRESSURE TOO HIGH.** Notify higher authority.

(3) **OIL LEVEL TOO HIGH.** Maintain correct level of oil.

(4) **EXTERNAL LEAKS AT GASKETS OR SEALS.** Renew or tighten as necessary.

(5) **PISTON RINGS BROKEN OR WORN.** Notify higher authority.

(6) **FRONT GEAR CASE LOOSE.** Tighten gear case.

(7) **CYLINDER WALLS WORN.** Notify higher authority.

(8) **ENGINE RUNNING TOO HOT.** Refer to paragraph 38 a for procedure to locate cause.

*Trouble Shooting***e. Low Oil Pressure.**

(1) **LACK OF OIL.** Stop engine immediately and check engine oil level. If level is less than one-third full, fill to full mark and start engine. Check oil pressure. If it does not come up to normal within a few seconds, stop engine.

(2) **OIL PUMP WORN.** Notify higher authority.

(3) **IMPROPER GRADE OF OIL.** Drain oil. Fill to proper level with correct grade (par. 22).

(4) **OIL PRESSURE REGULATOR PLUNGER WORN OR CLOGGED.** Clean or replace (par. 123).

(5) **OIL PRESSURE GAGE NOT OPERATING.** Replace oil pressure gage (par. 123).

38. COOLING SYSTEM.**a. Engine Overheats.**

(1) **LACK OF COOLANT.** Check level of coolant in radiator. Fill to proper level (par. 88).

(2) **FAN BELTS LOOSE.** Adjust fan belts (par. 90 e). Replace if broken (par. 90 d).

(3) **COOLING SYSTEM CLOGGED.** Remove any foreign obstruction which might retard the passage of air through the radiator core. Fill system to capacity. Start engine and accelerate. Water flowing from the radiator overflow indicates clogged radiator. Clean cooling system (par. 88 a). Neutralize and flush system if necessary (par. 88 b and c).

(4) **WATER PUMP NOT OPERATING.** Disconnect hose between pump and engine. Fill both radiator and engine as full as possible with hose disconnected. Start engine. If water fails to flow from pump for a brief period, water pump is inoperative. Replace water pump (par. 89).

(5) **THERMOSTAT STICKING CLOSED.** Remove and check thermostat (par. 92). Replace if it does not open at proper temperatures when tested.

b. Engine Slow to Warm Up.

(1) **THERMOSTAT DEFECTIVE.** Remove thermostat. Test and replace if defective (par. 92).

(2) **HEAT INDICATOR DEFECTIVE.** If gage registers in low range when engine is known to be warm, remove instrument and install an accurate one (par. 94).

(3) **EXTREME TEMPERATURES.** In extremely low temperatures, use of radiator shutters or covers may be necessary.

c. Loss of Coolant.

(1) **DEFECTIVE HOSE CONNECTION.** Inspect hose connections. Tighten leaking connection. If leak persists, replace hose (par. 93).

(2) **RADIATOR CORE LEAKING.** Inspect core. Replace radiator if leak is detected (par. 91). Refer radiator to higher authority for repair.

(3) **CYLINDER HEAD GASKET LEAKING.** If no external leaks are present, remove cylinder head and install new gasket (par. 62).

39. CLUTCH.**a. Clutch Slips.**

(1) **CLUTCH OUT OF ADJUSTMENT.** Adjust clutch as instructed in paragraph 127.

(2) **OILY FACINGS.** Remove clutch driven plates (par. 129 c). Clean in dry-cleaning solvent. Install clutch (par. 130). Trouble may be caused by excessive lubrication of pilot or throw-out bearing. Remove excess grease.

(3) **CLUTCH PEDAL OR LINKAGE BENT OR BINDING.** Disconnect linkage and inspect for bent or binding parts. Replace defective parts (par. 131).

(4) **CLUTCH WORN OR BROKEN INTERNALLY.** If linkage is satisfactory and slippage cannot be removed through adjustment, internal wear or breakage is indicated. Notify higher authority.

b. Clutch Chatters.

(1) **LOOSE OR WORN CONTROL LINKAGE.** Inspect clutch linkage. Replace worn parts. Tighten loose parts.

(2) **INTERNAL DIFFICULTY.** If rattle persists with linkage in satisfactory condition, internal difficulty is indicated. Notify higher authority.

c. Clutch Grabs.

(1) **LOOSE MOUNTING.** Tighten external mounting nuts.

(2) **INTERNAL DIFFICULTY.** If tightening external mounting nuts fails to remove trouble, internal difficulty is indicated. Notify higher authority.

d. Clutch Will Not Release.

(1) **CLUTCH LINKAGE OUT OF ADJUSTMENT.** Clutch linkage bent, binding, or out of adjustment. Adjust linkage to eliminate looseness. Replace defective parts of linkage (par. 131).

(2) **CLUTCH OUT OF ADJUSTMENT.** Adjust clutch as instructed in paragraph 127.

(3) **INTERNAL DIFFICULTY.** If clutch cannot be adjusted to release and linkage is in satisfactory condition and adjustment, internal difficulty is indicated. Notify higher authority.

Trouble Shooting

40. TRANSMISSION.

a. General. Noises which seem to originate in the transmission are frequently found to be caused by some other parts of the chassis driving mechanism. These noises may originate in the engine, the propeller shafting, the rear axles, or in the parking brake disk. They are, in turn, reflected into the transmission, which merely acts as a sound box for the noise. Therefore, before any service work is done on the transmission, a thorough check should be made to try to locate the actual source of the noise.

b. Transmission Noisy.

(1) **INCORRECT OR INSUFFICIENT LUBRICANT.** Check lubricant and lubricate as necessary (par. 22).

(2) **TRANSMISSION CASE LOOSE ON CLUTCH HOUSING.** Tighten case. If noise disappears, further corrective measures are unnecessary.

(3) **INTERNAL DEFECT.** If noise persists after above measures have been taken, report trouble to higher authority.

c. Gears Slip Out of Mesh Due to Internal Defect. Report condition to higher authority.

d. Lubricant Leaks from Case.

(1) **LOOSE CASE BOLTS.** Tighten case bolts.

(2) **INTERNAL DEFECT.** Report condition to higher authority.

e. Gears Fail to Mesh Due to Internal Defect. Report condition to higher authority.

41. AUXILIARY TRANSMISSION.

a. Auxiliary Transmission Noisy.

(1) **LOOSE MOUNTING.** Tighten mounting bolts.

(2) **INCORRECT OR INSUFFICIENT LUBRICANT.** Check lubricant and lubricate if necessary (par. 22).

(3) **PROPELLER SHAFTS LOOSE.** Tighten propeller shaft companion flange bolts. If noise stops, no further correction is needed.

(4) **INTERNAL DEFECT.** If noise persists after the above checks, report the condition to higher authority.

b. Auxiliary Transmission Slips Out of Gear.

(1) **LINKAGE BROKEN OR OUT OF ADJUSTMENT.** Inspect linkage. Replace broken parts. Adjust linkage (par. 137 a).

(2) **INTERNAL DEFECT.** Report condition to higher authority.

c. Lubricant Leaks from Case.

(1) **LOOSE CASE BOLTS.** Tighten bolts.

(2) **INTERNAL DEFECT.** Report condition to higher authority.

d. **Gears Fail to Mesh Due to Internal Defect.** Report condition to higher authority.

42. POWER TAKE-OFF AND WINCH.

a. **Lubricant Leaks from Case Due to Loose Case Bolts.** Tighten case bolts. If leaks persist, notify higher authority.

b. **Gears Fail to Mesh Due to Internal Defect.** Report condition to higher authority.

c. **Gears Slip Out of Mesh Due to Internal Defect.** Report condition to higher authority.

d. **Partial Gear Engagement Caused by Control Rod Out of Adjustment.** Check control rod for wear and adjustment (par. 142 b).

e. **Winch Does Not Hold When Power is Released.** Safety brake is out of adjustment. Adjust safety brake (par. 211 a).

f. **Engine Shuts off When Winch Is Pulling Loads Under Maximum Setting.** Winch torque control is out of adjustment. Check length of torque control springs and gap between rocker arm and torque control switch plunger (par. 215 a).

g. **Drag Brake Does Not Hold Drum.**

(1) **BRAKE BAND WORN.** Replace drag brake band (par. 212).

(2) **BRAKE BAND OILY.** Replace drag brake band (par. 212).

43. PROPELLER SHAFTS.

a. **Propeller Shaft Rattles When Vehicle Is Coasting.** Splines or bearing caps are worn. Replace propeller shaft and attached universal joints (pars. 145, 146, 147, and 148).

b. **Propeller Shaft Vibrates.**

(1) **LOOSE BOLTS AT UNIVERSAL JOINT COMPANION FLANGES.** Tighten loose bolts.

(2) **PROPELLER SHAFT OUT OF BALANCE OR MISALINED.** Replace propeller shaft and attached universal joints.

c. **Backlash In Propeller Shaft.**

(1) **WORN BEARING IN UNIVERSAL JOINT.** Replace assembly.

(2) **LOOSE BOLTS AT UNIVERSAL JOINT COMPANION FLANGES.** Tighten loose bolts.

*Trouble Shooting***44. FRONT AXLE.****a. Hard Steering.**

- (1) **STEERING LINKAGE TOO TIGHT.** Inspect drag link and tie rod joints for wear, adjustment, and lubrication.
- (2) **EXCESSIVE CASTER.** Report to higher authority.
- (3) **TIRES UNDERINFLATED.** Inspect tires and inflate to proper pressure (80 lb).
- (4) **IMPROPER TOE-IN.** Adjust the tie rod (par. 150).

b. Shimmy at Low Speed.

- (1) **TOO MUCH OR TOO LITTLE CASTER.** Report to higher authority.
- (2) **LOOSE FRONT WHEEL BEARINGS.** Adjust (par. 185 b). Replace if adjustment does not correct (par. 185 c and d).
- (3) **LOOSE OR WORN STEERING MECHANISM.** Inspect and adjust (par. 190); or replace ball joints (par. 152), Pitman arm (par. 193), spring shackles (par. 187 b and c), and spring clips (par. 187 d and e).
- (4) **ECCENTRIC WHEELS.** Replace wheel or tire (pars. 184 and 186).
- (5) **TIE ROD LOOSE.** Tighten or replace worn parts (par. 153).

c. Shimmy at High Speed.

- (1) **FRONT WHEELS WOBBLE.** Report to higher authority.
- (2) **RUPTURED OR WEAK TIRE CARCASS.** Replace tire (par. 186).
- (3) **DRAGGING FRONT WHEEL BRAKES.** Adjust brakes (par. 177 d).

d. Wandering.

- (1) **BENT AXLE PARTS.** Report to higher authority.
- (2) **LOOSE FRONT WHEEL BEARINGS.** Adjust bearings (par. 185 b).
- (3) **FRONT BRAKE DRUMS OUT-OF-ROUND.** Report to higher authority.
- (4) **TIRES UNDERINFLATED.** Inflate to proper pressure (80 lb).
- (5) **ZERO OR REVERSE CASTER.** Report to higher authority.
- (6) **EXCESSIVE ERROR IN TOE-IN.** Correct toe-in (par. 150).
- (7) **LOOSE WHEELS.** Inspect and tighten wheel nuts.

45. REAR AXLE.**a. Axle Noises.**

(1) **CONTINUOUS HUM.** Adjust wheel bearings (par. 185 b). Fill axles to level plug with proper lubricants (par. 22).

(2) **COASTING HUM.** Inspect wheel bearings. If source of trouble is not located, report to higher authority.

(3) **PULLING HUM.** Report to higher authority.

b. Backlash.

(1) **LOOSE AXLE SHAFT FLANGE.** Tighten axle flange nuts.

(2) **EXCESSIVE CLEARANCE AT AXLE SHAFT SPLINES.** Report to higher authority.

c. Grease Leakage on Brakes. Inspect seals and replace if faulty (par. 185).

d. Dull Thud in Time With Speed of Truck. This indicates broken gear tooth in axle. Report to higher authority.

46. SERVICE (AIR) BRAKE SYSTEM.**a. Brake Pedal Goes to Floorboard.**

(1) **NORMAL WEAR OF BRAKE LINING.** Adjust brakes (par. 176 b). If worn so that adjustment fails to eliminate trouble, notify higher authority.

(2) **LOW AIR PRESSURE.** Observe pressure as indicated on gage. If less than 70 pounds, start engine and build up pressure. Should pressure fail to build up, check system for leaks (step k (2) below) or inoperative units.

(3) **WATER TRAPPED IN SYSTEM.** Drain reservoir tanks (par. 163).

b. Brakes Drag.

(1) **BRAKE CONTROL ROD ADJUSTED TOO SHORT.** Remove clevis pin and loosen lock nut. Turn yoke counterclockwise to lengthen rod. Tighten lock nut and connect rod.

(2) **BRAKE PEDAL PULL-BACK SPRING WEAKENED OR BROKEN.** Remove spring from brake pedal and replace with serviceable spring.

(3) **WATER TRAPPED IN SYSTEM.** Drain reservoir tanks (par. 163).

c. One Brake Drags.

(1) **GREASE IN BRAKE LINING.** Replace brake shoes (par. 177). Return old shoes to third echelon for relining. Check condition of grease retainers. Replace if defective.

Trouble Shooting

(2) **BRAKE SHOES OUT OF ADJUSTMENT.** Adjust brakes as instructed in paragraph 177 d.

(3) **LINING LOOSENED FROM SHOE.** Replace brake shoes (par. 177).

(4) **BRAKE SHOE SPRING WEAKENED OR BROKEN.** Replace brake shoe spring (par. 177).

(5) **CLOGGED AIR TUBE OR HOSE.** Clean or replace obstructed part.

(6) **WHEEL BEARINGS OUT OF ADJUSTMENT.** Adjust wheel bearings (par. 185).

d. Truck Pulls to Right or Left When Brakes Are Applied and/or Brakes Are Uneven.

(1) **BRAKE ON FRONT WHEEL DRAGGING.** Check and correct as instructed in subparagraph c above.

(2) **BRAKES NEED ADJUSTING OR LUBRICATING.** Adjust (par. 176 b) and/or lubricate brakes (par. 22).

(3) **BRAKES NEED RELINING.** Report to higher authority.

(4) **GREASE ON BRAKE LINING.** Report to higher authority.

(5) **BRAKE SHOE RELEASE SPRING OR BRAKE DIAPHRAGM CHAMBER RELEASE SPRING BROKEN.** Replace broken spring (par. 177).

(6) **BRAKE DRUM OUT-OF-ROUND.** Replace drum (par. 185).

(7) **LEAKING BRAKE CHAMBER DIAPHRAGM.** Replace brake chamber (par. 176 c).

e. Brakes Take Hold Slowly.

(1) **BRAKES OUT OF ADJUSTMENT.** Adjust brakes (par. 176).

(2) **BRAKE LINING WORN.** Replace brake shoes (par. 177).

(3) **BRAKE DRUMS WORN.** Replace hubs (par. 185). Return used parts to higher authority for repair.

(4) **RESTRICTION IN AIR LINE.** Remove obstruction from air line or hose or replace offending part.

(5) **BRAKE MECHANISM NEEDS LUBRICATION.** Lubricate vehicle (par. 22).

(6) **LOW AIR PRESSURE IN BRAKE SYSTEM.** Correct by following procedure outlined in subparagraph a (2) above.

(7) **BRAKE VALVE DELIVERY LOW.** Check brake valve delivery pressure. Adjust brake valve linkage or replace brake valve (par. 166).

(8) **EXCESSIVE LEAKAGE WITH BRAKES APPLIED.** Correct as instructed in subparagraph k (2) below.

(9) **RESTRICTION IN TUBING LINES.** Disconnect both ends of suspected line. Apply air pressure to blow out obstruction. Replace line if impossible to remove obstruction.

(10) **RESTRICTION IN HOSE LINE.** Disconnect both ends of suspected line. Apply air pressure to blow out obstruction. Replace line if impossible to remove obstruction.

f. Brakes Release Slowly.

(1) **BRAKE CONTROL ROD NOT RETURNING PROPERLY.** Check adjustment of control rod. Adjust if necessary (subpar. b (1) above). Check condition of brake pedal pull-back spring. Replace spring if weak or broken.

(2) **RESTRICTION IN AIR TUBE OR HOSE.** Remove obstruction (subpar. e (4) and (9) above) or replace faulty tube or hose.

(3) **DEFECTIVE APPLICATION VALVE.** Replace defective valve (par. 166).

(4) **BRAKE CAMSHAFT BINDING.** Lubricate brake came with engine oil. Do not get oil on lining.

(5) **BRAKES NEED ADJUSTING OR LUBRICATING.** Adjust (par. 176 b) and/or lubricate (par. 22) brakes.

(6) **OBSTRUCTION IN EXHAUST PORT OF BRAKE VALVE, QUICK RELEASE VALVE, OR RELAY VALVE.** Remove obstruction.

(7) **DEFECTIVE BRAKE VALVE, RELAY VALVE, OR QUICK RELEASE VALVE.** Replace defective valve (pars. 166, 170, and 172).

g. Insufficient Brakes.

(1) **BRAKES NEED ADJUSTING, LUBRICATING, OR RELINING.** Adjust brakes (par. 176 b), lubricate brakes (par. 22), or report to higher authority.

(2) **LOW AIR PRESSURE.** Correct as instructed in subparagraph a (2) above.

(3) **BRAKE VALVE DELIVERY PRESSURE LOW.** Check brake valve delivery pressure. Adjust valve linkage or replace valve (par. 166).

h. Brakes Do Not Apply.

(1) **NO AIR PRESSURE.** Start engine and build up air pressure.

(2) **RESTRICTED OR BROKEN TUBING OR HOSE.** Disconnect both ends of restricted line and apply air pressure. Replace line if impossible to remove obstruction or if line is broken.

(3) **DEFECTIVE BRAKE VALVE.** Replace valve (par. 166).

i. Brakes Do Not Release.

(1) **BRAKE LINKAGE BINDING.** Straighten or replace bent parts. Replace worn or broken parts. Lubricate linkage (par. 22).

(2) **BRAKE VALVE NOT RETURNING TO FULL RELEASED POSITION.** Adjust retracting spring tension. Check control rod and pedal to see if either is binding. Free and lubricate binding parts.

(3) **BRAKE VALVE IN APPLIED POSITION.** Move valve to released position.

Trouble Shooting

(4) **BRAKE VALVE DEFECTIVE.** Replace valve (par. 166).

(5) **RESTRICTION IN TUBING OR HOSE.** Disconnect both ends of suspected line and blow out with compressed air. Replace line if impossible to remove obstruction.

(6) **AIR TRAPPED IN FRONT SERVICE LINE BEYOND DOUBLE CHECK VALVE.** This is caused by obstruction, or absence, of vent hole in dummy coupling. Clear vent hole in dummy coupling, or replace dummy coupling with one having vent hole.

j. Brakes Grab.

(1) **GREASE ON LINING.** Report to higher authority.

(2) **BRAKE DRUM OUT-OF-ROUND.** Replace drum (par. 185).

(3) **DEFECTIVE BRAKE VALVE.** Replace valve (par. 166).

(4) **BRAKE LINKAGE BINDING.** Straighten or replace bent parts. Replace broken and worn parts. Lubricate linkage (par. 22).

k. Air Pressure Will Not Rise to Normal (70 to 105 Pounds).

(1) **DEFECTIVE AIR GAGE REGISTERING INCORRECTLY.** Replace gage (par. 165 c).

(2) **EXCESSIVE LEAKAGE.** Start engine and build up as much pressure as possible. Check all connections and units for leaks with brakes applied and not applied. Use soapy water to detect leaks which cannot be felt or heard. Tighten loose connections and replace defective parts.

(3) **RESERVOIR TANK DRAIN COCK OPEN.** Close drain cock on bottom of each tank.

(4) **GOVERNOR OUT OF ADJUSTMENT.** Adjust governor (par. 164 b).

(5) **NO CLEARANCE AT COMPRESSOR UNLOADING VALVES.** Adjust clearance to 0.010-inch minimum, 0.015-inch maximum (par. 162 b).

(6) **FAN BELTS SLIPPING ON COMPRESSOR PULLEY.** Adjust fan belt tension (par. 90 e).

(7) **DEFECTIVE COMPRESSOR.** Replace compressor (par. 162).

l. Air Pressure Rises Too Slowly to Normal (70 to 105 Pounds).

(1) **EXCESSIVE LEAKAGE.** Check for leakage and service or replace defective units.

(2) **CLOGGED COMPRESSOR AIR STRAINER.** Service air strainer (par. 162 b).

(3) **NO CLEARANCE AT COMPRESSOR UNLOADING VALVES.** Adjust clearance to 0.010-inch minimum, 0.015-inch maximum (par. 162 b).

(4) **ENGINE SPEED TOO LOW.** Increase engine speed.

(5) **COMPRESSOR DISCHARGE VALVES LEAKING.** Replace compressor (par 162).

(6) **EXCESSIVE CARBON IN COMPRESSOR CYLINDER HEAD OR DISCHARGE LINE.** Replace compressor or discharge line (par. 162).

m. Air Pressure Rises Above Normal (70 to 105 Pounds).

(1) **DEFECTIVE AIR GAGE REGISTERING INCORRECTLY.** Replace gage (par. 165 c).

(2) **DEFECTIVE GOVERNOR.** Replace governor (par. 164 c and d).

(3) **GOVERNOR OUT OF ADJUSTMENT.** Adjust governor (par. 164 b).

(4) **RESTRICTION IN GOVERNOR TO COMPRESSOR TUBE.** Disconnect both ends of tube and apply compressed air. If impossible to remove obstruction, replace tube (par. 174).

(5) **TOO MUCH CLEARANCE AT COMPRESSOR UNLOADING VALVES.** Adjust clearance to 0.010-inch minimum, 0.015-inch maximum (par. 162 b).

(6) **UNLOADING VALVE CAVITIES OR UNLOADING PASSAGE BLOCKED WITH CARBON.** Replace compressor (par. 162).

(7) **UNLOADING VALVES STUCK CLOSED.** Replace compressor (par. 162).

n. Air Pressure Drops Quickly With Engine Stopped and Brakes Released.

(1) **LEAKING BRAKE VALVE.** Replace valve (par. 166).

(2) **LEAKING RELAY VALVE.** Replace valve (par. 170).

(3) **LEAKING TUBING OR HOSE.** Service or replace line (par. 174).

(4) **COMPRESSOR DISCHARGE VALVES LEAKING.** Replace compressor (par. 162).

(5) **GOVERNOR LEAKING.** Service or replace governor (par. 164).

(6) **EXCESSIVE LEAKAGE ELSEWHERE IN SYSTEM.** Correct as instructed in subparagraph k (2) above.

o. Air Pressure Drops Quickly With Engine Stopped and Brakes Fully Applied.

(1) **LEAKING BRAKE CHAMBER DIAPHRAGMS.** Replace diaphragm chambers (par. 176).

(2) **LEAK IN BRAKE VALVE, RELAY VALVE, TUBING OR HOSE.** Service or replace leaking part.

(3) **DRAIN COCK OR CUT-OUT COCK LEFT OPEN.** Close cock.

p. Compressor Knocks.

(1) **LOOSE DRIVE PULLEY.** Tighten pulley.

(2) **WORN BEARINGS.** Replace compressor (par. 162).

Trouble Shooting

(3) **EXCESSIVE CARBON IN COMPRESSOR CYLINDER HEAD.** Replace compressor (par. 162).

q. Brake Valve "Groans" When Brakes Are Applied. Replace brake valve (par. 166).

r. Relay Valve "Groans" or "Chatters" When Brakes Are Applied. Replace relay valve (par. 170).

s. Quick Release Valve "Blasts" When Brakes Are Released. Replace quick release valve (par. 172).

t. Safety Valve "Blows Off."

(1) **SAFETY VALVE OUT OF ADJUSTMENT.** Replace safety valve (par. 165). Refer original valve to higher authority for adjustment.

(2) **AIR PRESSURE ABOVE NORMAL.** Correct as instructed in subparagraph m above.

47. SPRINGS.

a. Hard Riding.

(1) **INSUFFICIENT LUBRICATION.** Lubricate spring, shackles and bolts (par. 22).

(2) **BOLTS IN SHACKLES OR BRACKETS FROZEN.** Remove and free-up shackle bolts (pars. 187 and 188).

(3) **LOOSE SPRING CLIPS.** Tighten clips.

b. Overflexibility.

(1) **SPRING LEAVES LUBRICATED.** Clean spring with dry-cleaning solvent.

(2) **REBOUND CLIPS BROKEN.** Replace springs (pars. 187 and 188).

(3) **LEAVES BROKEN.** Replace springs (pars. 187 and 188).

48. WHEELS, HUBS, AND TIRES.

a. Hard Steering.

(1) **TIRES UNDERINFLATED.** Inflate to proper pressure (par. 186).

(2) **DEFECTIVE WHEEL BEARING.** Replace defective units (par. 185).

(3) **UNEQUAL CAMBER.** Report to higher authority.

(4) **BENT OR DAMAGED WHEEL.** Report to higher authority or replace wheel (par. 184).

(5) **LOOSE WHEEL.** Tighten wheel nuts.

b. Noisy Operation.

(1) **LOOSE WHEEL NUTS.** Tighten wheel nuts.

(2) **DAMAGED WHEEL.** Replace wheel (par. 184).

c. Air Leakage.

- (1) **VALVE CAP MISSING OR BROKEN.** Replace with new cap.
- (2) **DEFECTIVE VALVE CORE.** Replace with new core.
- (3) **PUNCTURE OR TORN TUBE.** Repair, if possible, or replace tube.

49. STEERING GEAR.**a. Hard Steering.**

- (1) **LACK OF LUBRICATION.** Lubricate steering gear (par. 22).
- (2) **WORN STEERING GEAR PARTS.** Notify higher authority.
- (3) **IMPROPER ADJUSTMENT.** Notify higher authority.

b. Road Shock.

- (1) **STEERING LINKAGE TOO TIGHT.** Adjust drag link and tie rod ends (par. 153).

c. Excessive Drag In Steering Gear.

- (1) **INADEQUATE LUBRICATION.** Lubricate steering gear (par. 22).
- (2) **IMPROPER LUBRICANT.** Drain and refill with proper lubricant (par. 22).
- (3) **GEAR ADJUSTED TOO TIGHT.** Notify higher authority.

d. Catch or Roughness Felt In Steering Wheel.

- (1) **CHIPPED CAM.** Notify higher authority.
- (2) **FAULTY CAM BEARINGS.** Notify higher authority.

50. LIGHTING SYSTEM AND HORN.**a. All Lights Will Not Burn.**

- (1) **DEAD BATTERY.** Recharge or replace battery on right side of vehicle which is connected to lights. Change lighting load to other battery in same compartment as shown on plate in battery compartment (par. 112 b (5)).
- (2) **LOOSE OR CORRODED TERMINALS.** Clean and tighten.
- (3) **LOOSE CONNECTIONS.** Tighten all connections at light switch and junction block.
- (4) **SHORT CIRCUITS.** Examine battery cables and all wiring for bare or worn spots. Replace if necessary.
- (5) **LAMPS BURNED OUT.** If ground cable is loose, it will burn out the lamps.
- (6) **DEFECTIVE LIGHT SWITCH.** Replace light switch (par. 105).

b. Lights Dim.

- (1) **DISCHARGED BATTERY.** Change lighting load to other battery in right side battery compartment, as shown on plate in battery compartment (par. 112). Recharge or replace battery.

Trouble Shooting

(2) **LOOSE OR CORRODED TERMINALS.** Clean and tighten battery terminals. Tighten all connections at light switch and junction block. Tighten ground strap at cranking motor and frame.

c. **One or More Lamp-units Burn Out Continually.** This may be due to loose or broken cable at cranking motor. Tighten or replace cable.

d. **Individual Lights or Circuits Inoperative.**

(1) **LAMP BURNED OUT.** Replace lamp.

(2) **LOOSE CONNECTIONS.** Tighten connections at light and switch.

(3) **BROKEN OR GROUNDED WIRE LEADS.** Replace leads.

(4) **SWITCH INOPERATIVE.** Replace switch.

e. **One Horn Does Not Operate.** If there is no visible damage to wires, make sure all connections from horn relay to inoperative horn are clean and tightened. If above connections are satisfactory, replace horn.

f. **Both Horns Do Not Operate.**

(1) **CHECK LIGHT SWITCH TO BATTERY CIRCUIT.** Turn light switch on and if lights do not operate, current from battery is not reaching light switch "B" terminal. Check circuit for loose connections or damaged wires, and correct as required. If lights do operate, proceed as follows:

(2) **CHECK HORN BUTTON TO RELAY CIRCUIT.** Using a jumper wire, make a temporary contact between ground and horn wire terminal on horn relay. If horn operates, circuit from horn relay through horn button is not operating. Check and repair as required.

(3) **CHECK CIRCUIT BREAKER.** Place a jumper wire across terminals on 40-ampere circuit breaker. Temporarily depress horn button. If horns operate, replace circuit breaker. If horns do not operate, check horn relay as follows:

(4) **CHECK HORN RELAY.** Place a jumper across circuit breaker and horn terminals on horn relay. If horns operate, replace relay. If horns do not operate after above procedure has been completed, replace horns.

51. FRAME.

a. **Excessive Tire Wear.** A sprung frame may cause excessive tire wear. Notify higher authority.

b. **Rear and Front Wheels Do Not Track.** A sprung frame may cause this trouble. Notify higher authority.

52. RADIO INTERFERENCE SUPPRESSION.

a. General. Electrical disturbances which cause radio interference are generally found in loose bonds, loose toothed lock washers, broken or cracked suppressors, loose connections, or faulty filters. The following tests can be made to determine the cause of interference. Place a radio-equipped vehicle about 10 feet from the vehicle to be tested, and use it as a test instrument to localize troubles and to determine when faulty parts or conditions have been eliminated or corrected. The cooperation of the radio operator is required. Determine the circuits causing the noise by checking as follows:

(1) **OPERATE ENGINE WHILE LISTENING TO RADIO.** An irregular clicking, which continues a few seconds after the engine is shut off, is caused by the regulator.

(2) A whining noise, which varies with engine speed and continues a few seconds after engine is shut off, is caused by the generator.

b. Noise Caused by Regulator.

(1) Check all connections to regulator.

(2) Check capacitive-type condenser for tightness.

(3) Check regulator mounting bolts for tightness, and correct placement of toothed lock washers.

(4) After checking as specified in steps (1), (2), and (3) above, test for noise.

(5) If noise is still present, replace condenser attached to regulator. Then test for noise.

(6) If noise still is present, replace condenser attached to generator "A" terminal. Again test for noise.

c. Noise Caused by Generator.

(1) Inspect filter to make certain it is tight.

(2) Check ground cable.

(3) If necessary, replace condenser.

d. Noise Observed Only While Vehicle Is In Motion.

(1) Inspect and tighten bond straps (par. 220).

(2) Inspect and tighten all points where toothed lock washers are used.

53. TRAILER SERVICE BRAKE SYSTEM.**a. Slow Brake Application.**

(1) **LOW BRAKE LINE PRESSURE.** Check air pressure at truck coupling ends. Air supply should not be less than 70 pounds for proper application.

(2) **BENT ROD IN CHAMBER OR CYLINDER.** Straighten or replace rod.

(3) **EXCESSIVE TRAVEL IN CHAMBER OR CYLINDER PUSH ROD.** Adjust brakes.

(4) **RESTRICTION IN LINE.** Clean or replace tubing or hose.

Trouble Shooting

(5) **LEAKING DIAPHRAGM IN BRAKE CHAMBER, OR LEAKING CYLINDER.** Replace diaphragm or tighten bolts.

(6) **BINDING LEVERS AND BRAKE ARMS.** Lubricate and loosen.

(7) **DIRT UNDER RELAY EXHAUST VALVE OR DIAPHRAGM.** Clean relay valve.

(8) **DIRTY AIR FILTER.** Clean air filter.

b. Slow Brake Release.

(1) **DIRTY AIR FILTER.** Clean air filter.

(2) **BRAKE VALVE LEVER ON TRUCK NOT RETURNING FULLY TO STOP.** Adjust truck brake control rod (par. 46 b (1)).

(3) **BINDING CAM OR BINDING SLACK ADJUSTER OR BRAKE ARM.** Lubricate and align properly.

(4) **BRAKE CHAMBER ROD TRAVEL IS EXCESSIVE.** Adjust brake chamber rod (par. 224).

(5) **RESTRICTION IN TUBING OR HOSE.** Clean or replace tubing or hose.

(6) **IMPROPER SEATING OF VALVES.** Clean or replace valve.

c. Emergency Brake Failing to Hold.

(1) **DIRT UNDER EMERGENCY VALVE, DIAPHRAGM, OR VALVE STEM.** Clean or replace emergency valve diaphragm or valve stem.

d. No Brakes on One or More Wheels.

(1) **SHEARED KEY IN BRAKE ARM.** Replace key.

(2) **CLEVIS PIN OUT OF LEVERS OR RODS.** Replace clevis pin.

(3) **BROKEN CAMSHAFT.** Replace camshaft.

(4) **OUT OF ADJUSTMENT.** Adjust brakes (par. 224).

(5) **CHAMBER DIAPHRAGM LEAKING.** Replace diaphragm (par. 24).

(6) **LINING WORN.** Replace shoes (par. 225).

e. One or More Brakes Running Hot.

(1) **RETURN SPRING BROKEN IN HUB.** Replace return spring (par. 225).

(2) **KEY SHEARED IN BRAKE ARM.** Replace key.

(3) **RETURN SPRING MISSING ON LEVERS.** Replace return spring (par. 231).

(4) **RUST ON CLEVIS AND CLEVIS PINS.** Lubricate linkage (par. 22).

(5) **RUSTY ANCHOR PIN.** Lubricate anchor pin (par. 22).

(6) **HAND BRAKE NOT IN COMPLETE "OFF" POSITION.** Release hand brake.

(7) **BINDING BRAKE LEVER OR RODS.** Lubricate brake lever and rods (par. 22).

(8) **BRAKE RETURN SPRING WORN.** Replace brake return spring (par. 225).

(9) **LEVER RETURN SPRINGS LOOSE, NOT ENOUGH TENSION.** Replace spring or lengthen the distance between the two coupling points.

54. TRAILER PARKING BRAKE SYSTEM.

a. One or More Brakes Running Hot.

(1) **HANDWHEEL NOT IN COMPLETE "OFF" POSITION.** Release handwheel.

(2) **WOODRUFF KEY SHEARED IN BRAKE ARM.** Replace key.

(3) **BROKEN OR MISSING RETURN SPRINGS.** Replace return springs.

(4) **RUSTY CLEVIS OR CLEVIS PINS.** Lubricate clevis and pins (par. 22).

(5) **RUSTY ANCHOR PINS.** Lubricate anchor pins (par. 22).

(6) **RODS NOT ADJUSTED PROPERLY.** Adjust rods (par. 231).

b. One or More Brakes Not Holding.

(1) **WOODRUFF KEYS SHEARED IN BRAKE ARM.** Replace key.

(2) **CLEVIS PIN OUT OF CLEVIS AT BRAKE ROD ARM.** Replace clevis pin.

c. No Brakes.

(1) **BROKEN CABLE OR CHAIN.** Replace cable or chain.

(2) **CABLE DISCONNECTED FROM OPERATING SHAFT.** Refasten cable.

(3) **BROKEN CENTER LOWER ROD.** Replace rod.

(4) **BROKEN CENTER UPPER ROD.** Replace rod.

(5) **BROKEN SHEAVE LEVER ROD.** Replace rod (pars. 233 and 234).

55. TRAILER DOLLY.

a. Whipping Trailer.

(1) **WORN DRAWBAR EYE.** Replace drawbar eye.

(2) **LOOSE DRAWBAR HINGE BRACKETS.** Tighten hinge bolts or replace.

(3) **LOOSE DRAWBAR EYE.** Tighten drawbar nut.

56. TRAILER LIGHTS SYSTEM.

a. Failure to Illuminate When Other Lamps Light.

(1) **BURNT OUT LAMP.** Replace lamp.

(2) **BREAK OR GROUND IN CIRCUIT.** Check connections.

Trouble Shooting

(3) **STOP LIGHT SWITCH IMPAIRED.** Check and replace if necessary.

(4) **LAMP LOOSE OR IMPROPERLY MOUNTED IN SOCKET.** Make sure lamp terminals engage socket terminals firmly.

b. Lamps Dim.

(1) **LAMPS LOOSE OR IMPROPERLY MOUNTED IN SOCKETS.** Push lamp fully into socket.

(2) **LAMP BLACKENED.** Replace lamp.

(3) **POOR CONNECTIONS AT SOCKET OR GROUND LEAK.** Check socket, circuit, and insulation.

c. Lamps Go On and Off, or Flicker.

(1) **LOOSE WIRE CONNECTION OR INTERMITTENT GROUND.** Check wires and insulation; repair and tighten.

57. TRAILER WHEELS AND TIRES.

a. Wobbly Wheels.

(1) **LOOSE BEARINGS.** Adjust bearings (par. 256 c (5)).

(2) **BURNT OUT BEARINGS.** Replace bearings (par. 256).

(3) **TIRES NOT MOUNTED TRUE ON RIMS.** Adjust tires on rims (par. 257).

b. Bearings Running Hot.

(1) **IMPROPER BEARING ADJUSTMENT.** Adjust bearings (par. 256 c (5)).

(2) **INSUFFICIENT LUBRICATION.** Lubricate wheels (par. 22).

c. Throwing Grease at Drum.

(1) **OVERLUBRICATED.** Decrease frequency or amount of lubrication.

(2) **WORN FELT GREASE RETAINER.** Replace grease retainer.

d. Throwing Grease at Hub Cap.

(1) **CAP NOT SUFFICIENTLY TIGHTENED.** Tighten cap.

(2) **IMPERFECT GASKET.** Replace gasket.

e. Air Leakage.

(1) **VALVE CAP MISSING OR CAP SEAL BROKEN.** Replace with new cap.

(2) **VALVE CORE LOOSE.** Retighten valve core.

(3) **VALVE CORE DAMAGED.** Replace with new core.

Section XIII**ENGINE DESCRIPTION AND MAINTENANCE
IN VEHICLE****58. DESCRIPTION AND DATA.**

a. **Description** (figs. 27 and 28). The Hercules DFXE is a 4-cycle, 6-cylinder, in-line, Diesel-type engine. The valve mechanism is the overhead type with the valves located in the cylinder head. The crankcase and cylinder block are cast integral to provide maximum rigidity. A three-point flexible mounting supports the engine in the chassis. At the rear, the engine support arms are mounted on brackets which are riveted to the side frame members; the front support rests on spacers inside the side frame members and are secured by bolts to the spacers and side frame members. The engine is cooled by fluid drawn from the radiator by a gear-driven pump, which forces it through a long water manifold into the water jackets of the engine. The thermostat is located above the cylinder head at the front of the engine. The fuel injector pump is mounted on the left side of the engine and is driven by a positive drive coupling. The fuel supply pump, which consists of a mechanically-operated pump unit and a hand-operated priming pump unit, is mounted on the side of the injector pump. To shut off the engine, a fuel shut-off solenoid switch is provided above the rear end of the injector pump. Attached to the rear of the fuel injector pump is the governor. The generator and water pump are installed on the right side of the engine. The water pump is driven by the camshaft gear, and the generator is driven directly through the water pump. The air compressor, which is mounted on the right side of the engine at the front, is driven by the fan belts. Ventilation of the crankcase is through the breather at the rear of the compressor. The cranking motor, mounted on the lower right side of the engine toward the rear, drives the engine through the flywheel gear teeth. Three oil filters are installed on a bracket on the right side of the engine above the generator. The exhaust manifold, in two sections, is bolted to the right side of the cylinder heads. The air intake manifold, bolted to the top of the cylinder heads, has dual air cleaners attached. To aid in cold weather starting, the air manifold is equipped with a fuel oil burning element (starter-burner assembly) which is operated at the same time as the cranking motor.

Engine Description and Maintenance in Vehicle

- A—THERMOSTAT HOUSING
- B—STARTER BURNER ASSEMBLY
- C—AIR CLEANERS
- D—AIR INTAKE MANIFOLD
- E—STOP CONTROL SOLENOID
- F—CYLINDER HEAD (REAR)
- G—FUEL INJECTOR NOZZLE
- H—FUEL FILTER (SECONDARY)
- J—OIL PRESSURE REGULATOR
- K—FUEL SUPPLY PUMP
- L—OIL PAN
- M—FUEL INJECTOR PUMP

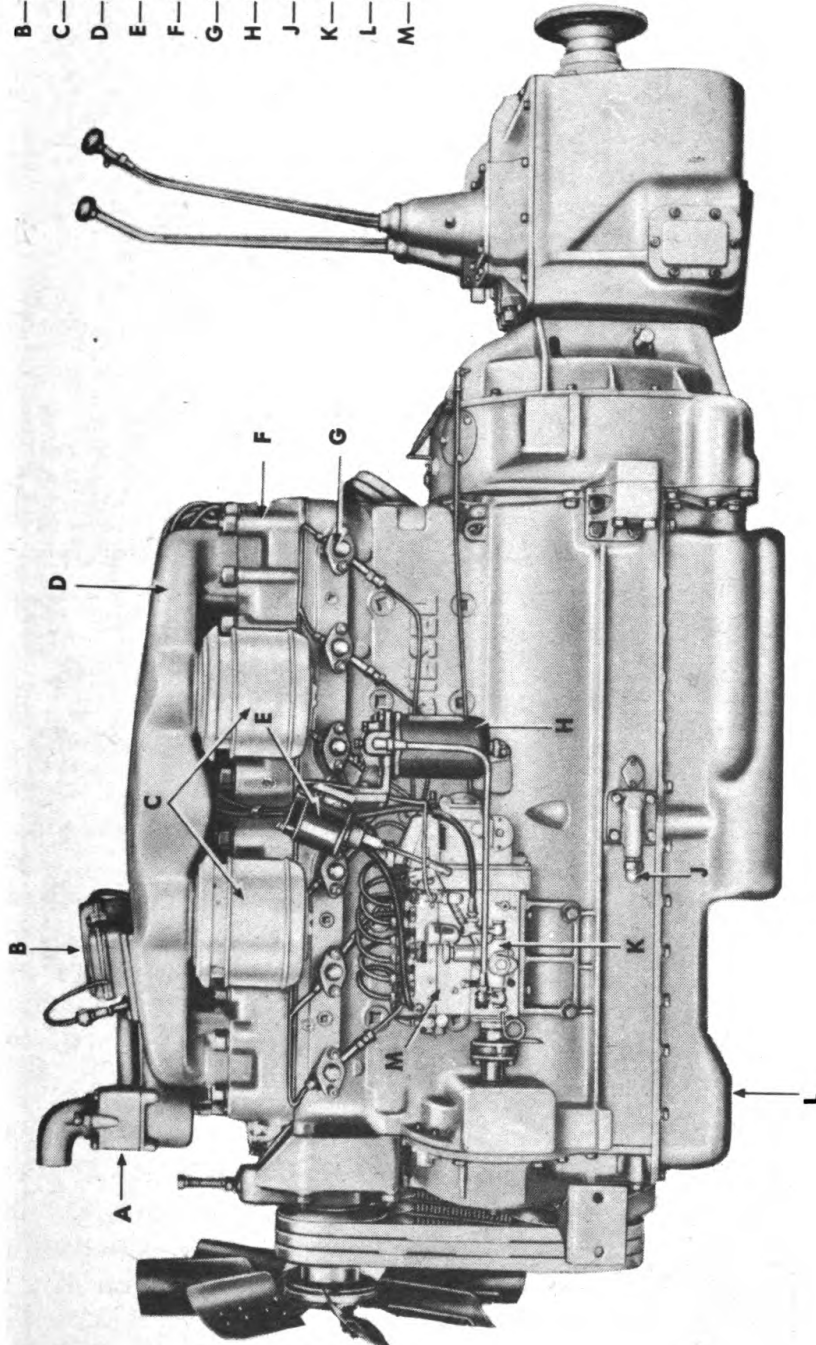

RA PD 321377

Figure 27—Engine—Left Side

- A—EXHAUST MANIFOLD
- B—OIL FILTERS
- C—THERMOSTAT BY-PASS TUBE
- D—FAN
- E—ENGINE CRANKCASE BREATHER
- F—AIR COMPRESSOR
- G—FRONT ENGINE SUPPORT
- H—WATER PUMP
- J—OIL LEVEL GAGE
- K—GENERATOR
- L—CRANKING MOTOR SOLENOID
- M—CRANKING MOTOR
- N—BELL HOUSING
- P—CLUTCH HOUSING
- Q—TRANSMISSION
- R—VISCOMETER
- S—OIL FILLER

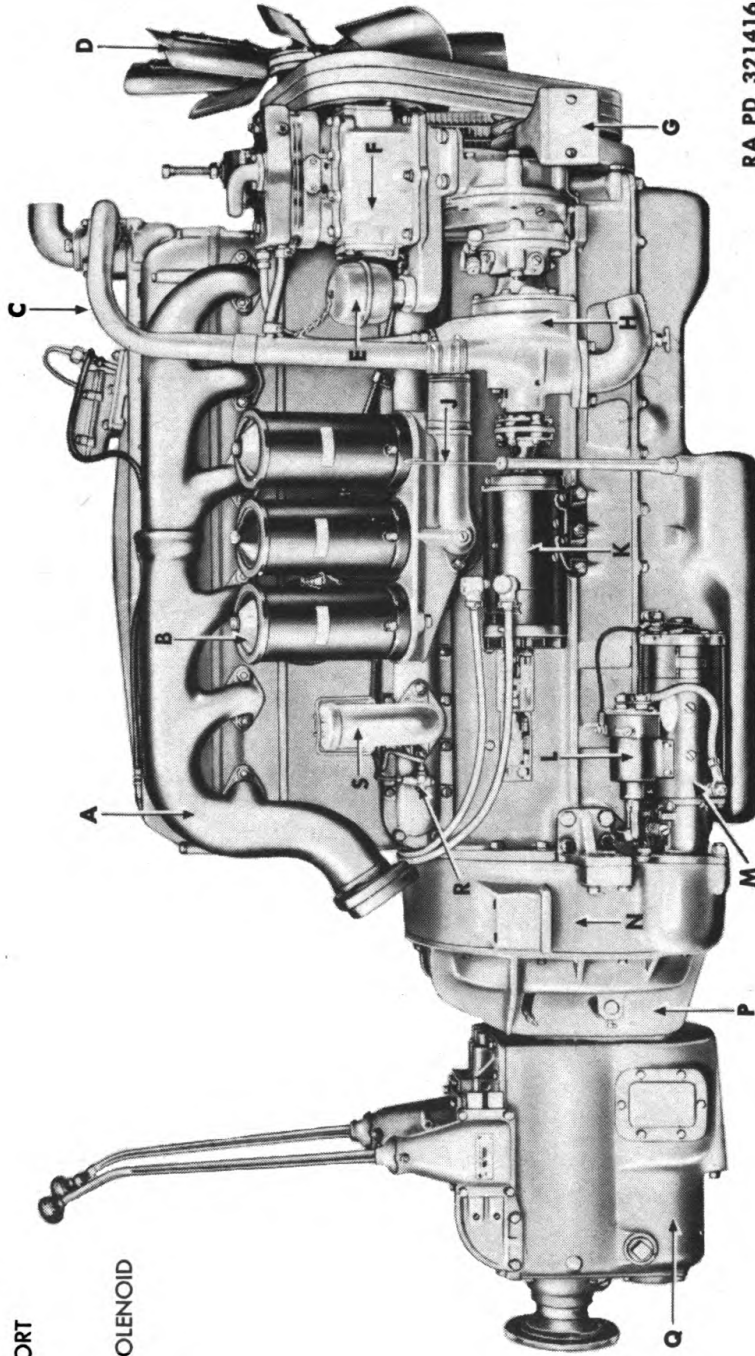

RA PD 321416

Figure 28—Engine—Right Side

Engine Description and Maintenance in Vehicle

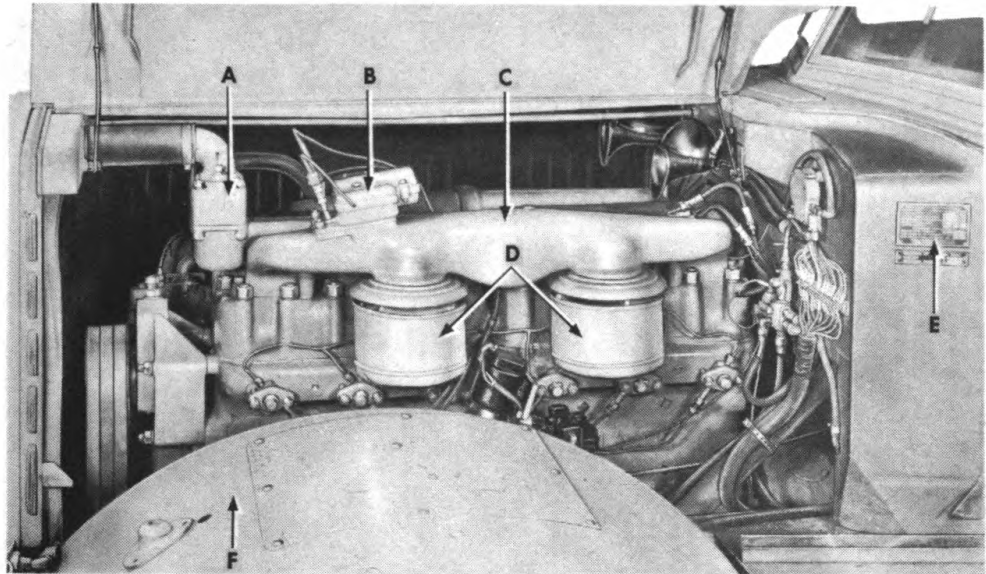

A—THERMOSTAT HOUSING D—AIR CLEANERS
B—STARTER BURNER E—CHASSIS PLATE
C—AIR INTAKE MANIFOLD F—L. H. FRONT FENDER RA PD 321340

Figure 29—Engine Installed—Left Side View

b. Data.

Make	Hercules
Model	DFXE
Number of cylinders	6
Bore	5 ⁵ / ₈ in.
Stroke	6 in.
Displacement	893 cu in.
Net	178
Brake horsepower at 1,600 rpm	201
Governed speed	1,600 rpm
Crankcase capacity	26 qt
Cooling system capacity	61 qt
Fuel	45 cetene Diesel fuel oil
Serial number location.....	Right-hand side of cylinder block at rear of generator

59. INTAKE MANIFOLD.

a. Description (fig. 29). The intake manifold is bolted to the top of the left side of the cylinder heads. Air enters through the two air cleaners which are attached to the manifold. The starter burner element is bolted to the upper side near the front end.

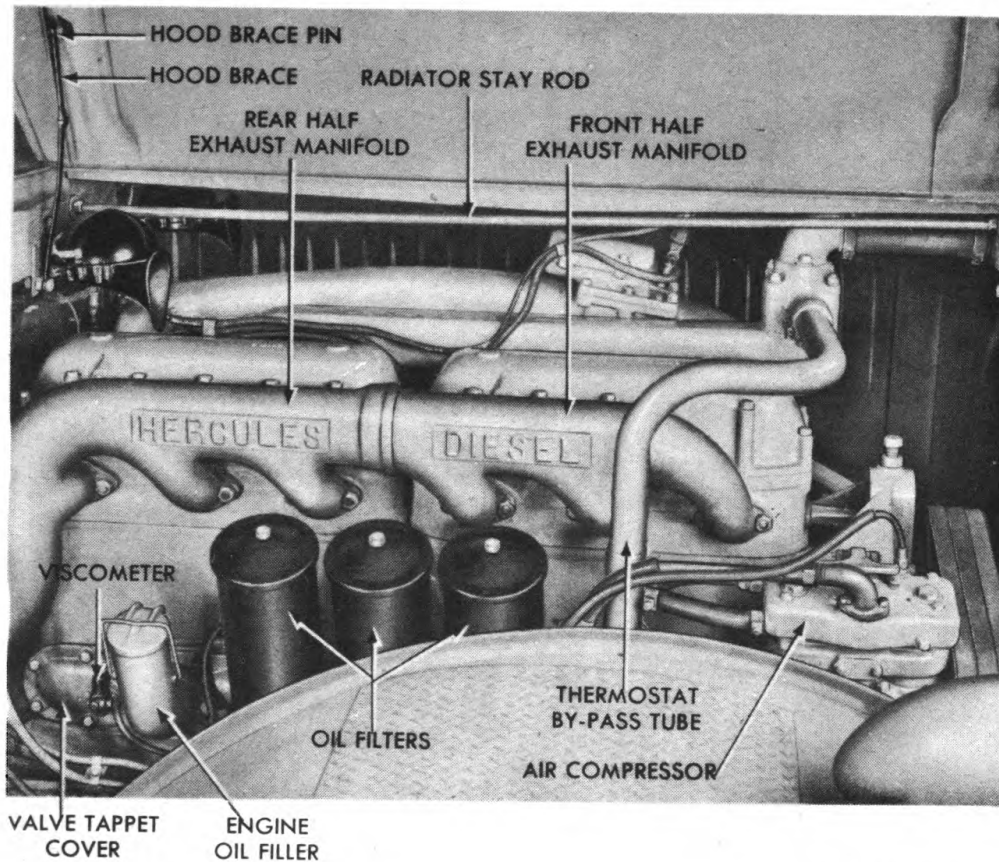

RA PD 321311

Figure 30—Engine Installed—Right Side View

b. Removal.

(1) **REMOVE AIR CLEANERS** (fig. 29). Unscrew the wing screw from each air cleaner and remove the air cleaners.

(2) **REMOVE CYLINDER HEAD COVERS.** Remove the attaching screws and lock washers which secure the two cylinder head covers (fig. 31). Lift off the cylinder head covers and gaskets.

(3) **DISCONNECT STARTER BURNER LINES.** Pull the two wires from the pressure switch terminals (fig. 56). Unscrew the connector on the fuel line from hand priming pump at the T-fitting under the pressure switch (fig. 56). Remove the one starter burner housing cover cap screw which secures fuel oil line and wire clip.

(4) **REMOVE WATER OUTLET MANIFOLD.** Remove water outlet manifold as instructed in paragraph 61 b.

(5) **REMOVE AIR INTAKE MANIFOLD.** Remove the 12 attaching screws and lock washers from the air intake manifold. Lift off the manifold and four gaskets.

Engine Description and Maintenance in Vehicle

(6) **REMOVE STARTER BURNER.** Remove starter burner from the manifold as instructed in paragraph 82 b (1).

c. Installation (figs. 29, 31, and 56).

(1) **INSTALL AIR INTAKE MANIFOLD.** Position four new air intake gaskets and manifold on cylinder heads. Install 12 attaching screws and lock washers. Draw up nuts evenly.

(2) **INSTALL WATER MANIFOLD.** Install water outlet manifold as instructed in paragraph 61 c.

(3) **INSTALL STARTER BURNER.** Install starter burner as instructed in paragraph 82 b (4).

(4) **INSTALL CYLINDER HEAD COVERS.** Install cylinder head covers as described in paragraph 63 c.

(5) **INSTALL AIR CLEANERS.** Place air cleaner in position and tighten wing screw into manifold. Install the second air cleaner in a similar manner.

60. EXHAUST MANIFOLD.

a. Description (figs. 30 and 31). The exhaust manifold is bolted to the right-hand side of the cylinder heads. The front exhaust manifold fits inside the end of the rear exhaust manifold to make a continuous unit. The exhaust manifold carries exhaust gases from the cylinders back to the exhaust pipe to which it is bolted.

b. Removal (fig. 30).

(1) **REMOVE FRONT EXHAUST MANIFOLD SECTION.** Remove the six stud nuts and plain washers which secure the manifold to the cylinder head. Pull the manifold away from the cylinder head and from the rear section of the manifold. Remove the manifold gaskets.

(2) **REMOVE REAR EXHAUST MANIFOLD SECTION.** Remove the three manifold flange bolts, lock washers, and plain washers. Remove the six stud nuts and plain washers which attach the manifold to the rear cylinder head. Pull the manifold away from the cylinder head and pull it forward from the exhaust pipe. Remove the manifold gaskets.

c. Installation (figs. 30 and 31).

(1) **INSTALL REAR EXHAUST MANIFOLD SECTION.** Clean cylinder head parts and manifold parts to remove rust, scale, carbon deposits, and any gasket material. Place new exhaust manifold gaskets on the studs. Position manifold with rear flange against companion flange of exhaust pipe. Install three manifold flange bolts, lock washers, and plain washers, but do not draw the bolts tight. Install six stud nuts and plain washers; then tighten three flange bolts.

(2) **INSTALL FRONT EXHAUST MANIFOLD SECTION.** Clean cylinder head and manifold parts as in step (1) above. Place new gaskets on studs. Place connecting ring over the end of the front manifold. Position front manifold so that it fits inside rear exhaust manifold. Install six stud nuts and plain washers.

61. WATER OUTLET MANIFOLD.

a. **Description** (figs. 31 and 32). The water outlet manifold is a long hollow casting which is bolted to the top of the cylinder heads to the left of the cylinder head covers. Water enters the manifold from the engine through two flanged openings, one for each cylinder head. The thermostat housing is attached to the front end of the manifold by four studs. The heat indicator is inserted into the rear end of the manifold.

b. **Removal** (figs. 31 and 32).

(1) **DRAIN THE MANIFOLD.** Open the drain cock under the radiator and drain the coolant until the water outlet manifold is empty.

(2) **LOOSEN HOSE.** Loosen hose clamps on the thermostat by-pass tube upper hose and the radiator water inlet tube hose. Slide the hose away from the thermostat housing and the radiator.

(3) **REMOVE HEAT INDICATOR.** Loosen connector nut which secures heat indicator to rear end of manifold. Pull out heat indicator.

(4) **REMOVE CYLINDER HEAD COVERS.** Remove attaching cap screws and lock washers from cylinder head covers, and lift off the covers and gaskets.

(5) **REMOVE MANIFOLD.** Remove four attaching cap screws and lock washers from manifold. Lift off water manifold and gaskets.

c. **Installation** (figs. 31 and 32).

(1) **POSITION MANIFOLD.** Place new gaskets on two cylinder head water outlet ports. Position water manifold on cylinder heads. Install four attaching cap screws and lock washers.

(2) **INSTALL CYLINDER HEAD COVERS.** Place cylinder head cover gaskets and cover in position, and install attaching cap screws and lock washers.

(3) **INSTALL HEAT INDICATOR** (fig. 31). Insert heat indicator in opening in rear end of water manifold. Draw up connector nut which secures indicator to manifold.

(4) **CONNECT HOSE.** Work the radiator water inlet tube hose over the tube at the top of the radiator. Tighten the hose clamps. Work the thermostat by-pass tube upper hose over the end of the thermostat housing tube. Tighten the hose clamps.

(5) **REFILL THE COOLING SYSTEM.** Remove the radiator fill cap and fill the cooling system (par. 88 c).

Engine Description and Maintenance in Vehicle

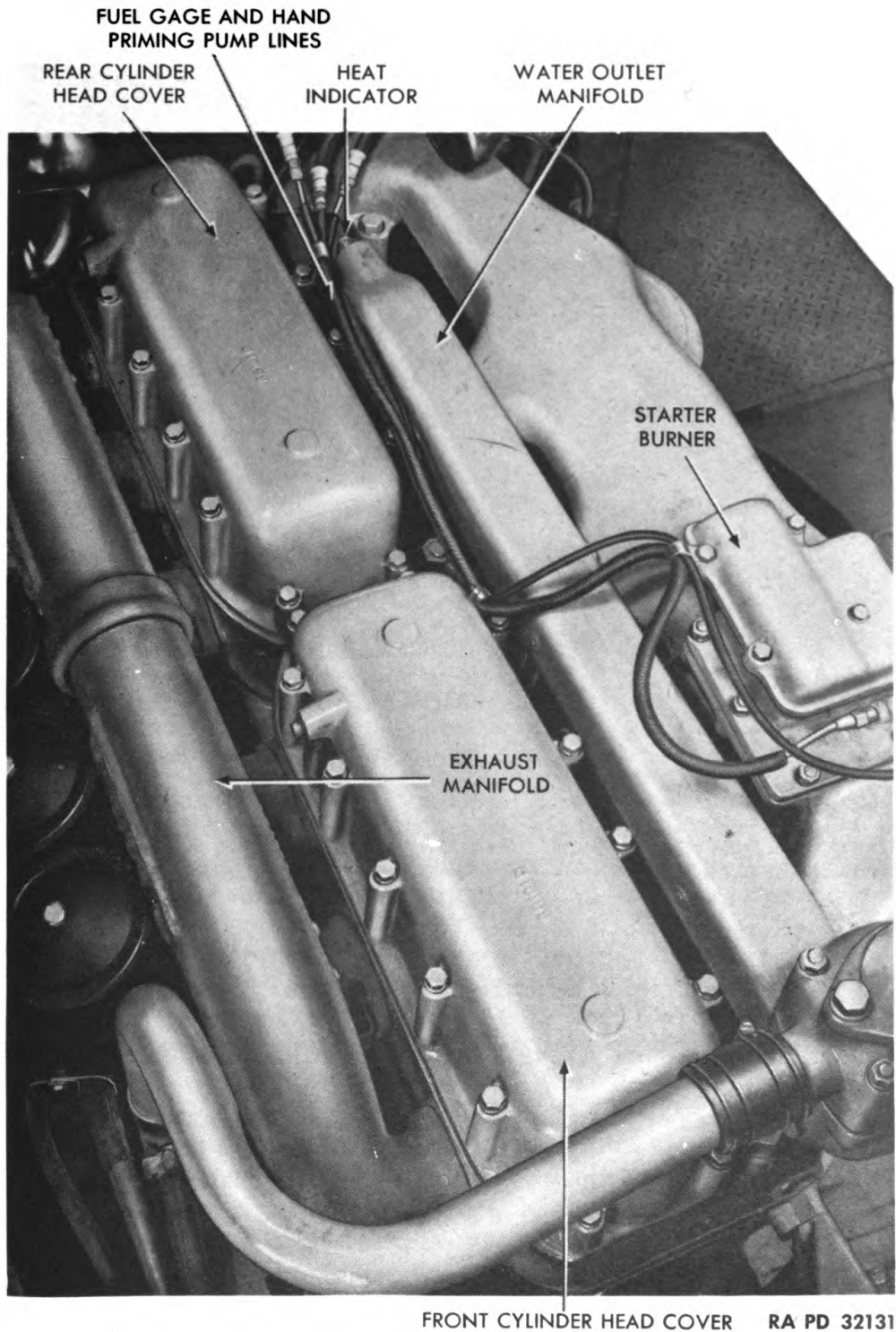
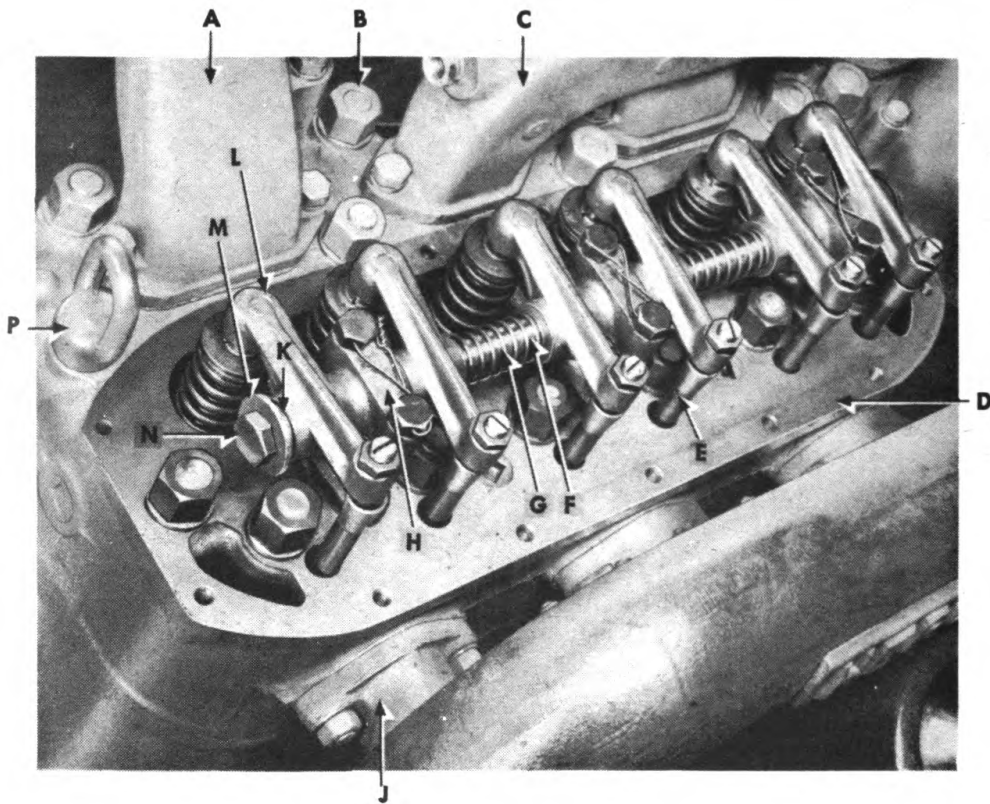

Figure 31—Cylinder Head Covers



- | | |
|---------------------------|---------------------------------|
| A—AIR INTAKE MANIFOLD | H—ROCKER ARM SHAFT BRACKET |
| B—CYLINDER HEAD STUD NUT | J—EXHAUST MANIFOLD |
| C—WATER OUTLET MANIFOLD | K—ROCKER ARM SHAFT OUTER SPRING |
| D—CYLINDER HEAD | L—VALVE ROCKER ARM ASSEMBLY |
| E—VALVE PUSH ROD ASSEMBLY | M—ROCKER SHAFT SPRING WASHER |
| F—ROCKER ARM SHAFT | N—ROCKER SHAFT WASHER SCREW |
| G—INNER SPRING | P—ENGINE LIFTING EYE |

RA PD 321352

Figure 32—Engine Cylinder Head—Cover Removed

62. CYLINDER HEAD AND GASKET REPLACEMENT.

a. Description.

(1) **CYLINDER HEAD** (figs. 31 and 32). There are two cylinder heads, one for the front three cylinders and one for the rear three cylinders. The cylinder heads contain the valve assemblies and the valve push rod assemblies. Attachment of the cylinder heads to the cylinder block is by means of studs and stud nuts. The cylinder heads are enclosed at the top by cylinder head covers.

(2) **CYLINDER HEAD GASKET**. Each cylinder head has a gasket (G509-01-93809) made of solid sheet copper which is annealed to make it as soft as possible.

*Engine Description and Maintenance in Vehicle***b. Removal of Cylinder Head and Gasket.**

- (1) REMOVE ENGINE HOOD. Remove engine hood as described in paragraph 204.
- (2) DRAIN ENGINE COOLANT. Open radiator drain cock and allow coolant to drain.
- (3) DISCONNECT FUEL LINES. Disconnect three fuel lines, which are attached to the cylinder head covers, at the connector nuts above rear of engine.
- (4) REMOVE CYLINDER HEAD COVER CAP SCREWS AND LOCK WASHERS. Lift off covers and gaskets.
- (5) REMOVE WATER OUTLET MANIFOLD. Remove water outlet manifold as instructed in paragraph 61 b.
- (6) REMOVE AIR INTAKE MANIFOLD. Remove air intake manifold as instructed in paragraph 59 b.
- (7) REMOVE EXHAUST MANIFOLD. Remove exhaust manifold as instructed in paragraph 60 b.
- (8) REMOVE ROCKER ARM ASSEMBLIES. Remove rocker arm assemblies as instructed in paragraph 64 b.
- (9) REMOVE PUSH RODS. Lift out push rods from cylinder heads.
- (10) LIFT OFF CYLINDER HEADS. Unscrew cylinder head stud nuts by turning them one-quarter turn, in sequence shown in figure 33. Lift off cylinder heads. Lift off gaskets.

c. Installation of Cylinder Head and Gasket.

- (1) INSTALL GASKETS. Thoroughly clean the upper surface of the engine blocks, and lower surfaces of the cylinder heads, and the surfaces of the gaskets to remove carbon and any foreign matter. Apply sealing compound to the gaskets, and place gaskets carefully over the cylinder head studs. If gaskets are deeply scratched or scored, use new gaskets (G509-01-93809).
- (2) INSTALL CYLINDER HEADS. Lower cylinder heads carefully on the cylinder head studs, being careful to avoid damaging the gasket. Place the plain washers and stud nuts on studs and turn the nuts down finger-tight. Tighten the nuts in sequence (fig. 33). Start with nut No. 1 and progress numerically. Do not tighten nuts the first time around. Use torque-indicating wrench and extension adapter to obtain final tightening of nuts. Go over nuts several times so that wrench indicates 300 foot-pounds when nuts are finally tightened.
- (3) INSTALL PUSH RODS. Place push rods in their openings in cylinder blocks. Make sure lower end of rod fits into valve tappet guide (fig. 36).

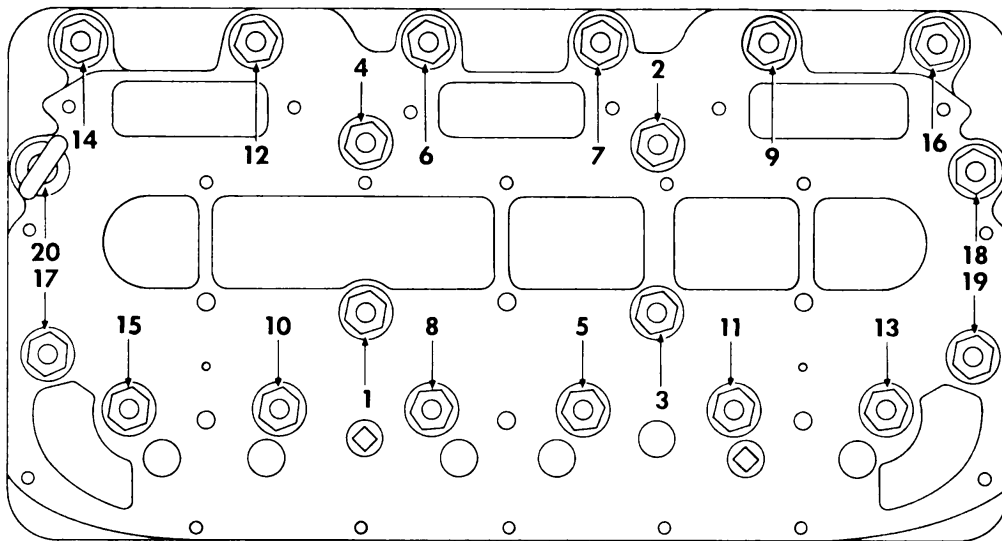

RA PD 321333

Figure 33—Sequence for Tightening Cylinder Head Stud Nuts

(4) **INSTALL ROCKER ARM ASSEMBLIES.** Install rocker arm assemblies as instructed in paragraph 64 c.

(5) **INSTALL EXHAUST MANIFOLD.** Install exhaust manifold as instructed in paragraph 60 c.

(6) **INSTALL AIR INTAKE MANIFOLD.** Install air intake manifold as instructed in paragraph 59 c.

(7) **INSTALL WATER OUTLET MANIFOLD.** Install water outlet manifold with procedure outlined in paragraph 61 c.

(8) **INSTALL CYLINDER HEAD COVERS.** Install cylinder head covers as instructed in paragraph 63 c.

(9) **CONNECT FUEL LINES.** Connect the disconnected ends of the three fuel lines leading from the hand priming pump and the fuel pressure gage by screwing them together at the connector fittings above the rear of the engine.

(10) **INSTALL ENGINE HOOD.** Install engine hood as instructed in paragraph 204 c.

63. VALVE ADJUSTMENT.

a. **Removal of Cylinder Head Covers** (fig. 31). Remove cylinder head cover cap screws and lift off front and rear cylinder head covers and gaskets.

b. **Adjustment of Valves** (fig. 34). Start engine and run until warmed up. Loosen nut on top of rocker arm adjusting screw, and adjust valves by turning adjusting screw. Insert feeler gage be-

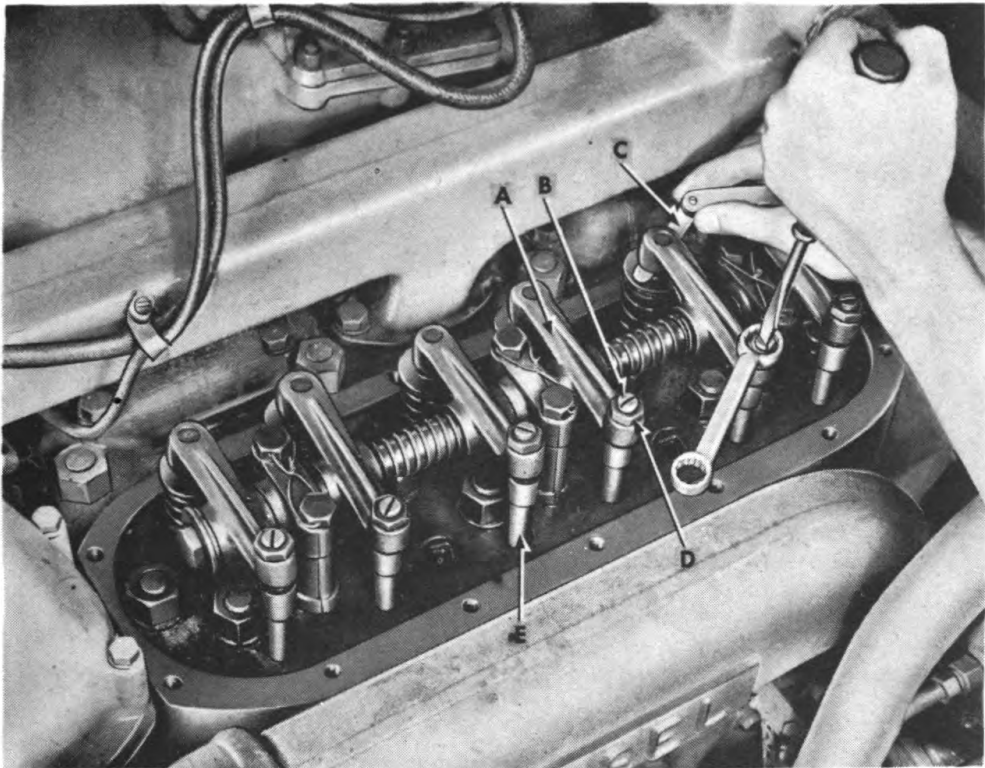

A—ROCKER ARM
B—ROCKER ARM ADJUSTING SCREW
C—FEELER GAGE
D—ADJUSTING SCREW NUT
E—VALVE PUSH ROD

RA PD 321403

Figure 34—Adjusting Valves

tween rocker arm and valve stem. Set clearance of intake valves at 0.010 inch, and exhaust valves at 0.016 inch. Tighten nut on adjusting screw when proper clearance is made.

c. **Installation of Cylinder Head Covers** (fig. 32). Place cylinder head cover gaskets and covers on cylinder heads. Install cylinder head cover cap screws, washers, and lock washers. On the left rear cap screw of the front cylinder head, install cable clip which secures the fuel line from the hand priming pump and the wire from pressure switch to junction block (fig. 32).

64. ROCKER ARM ASSEMBLIES.

a. **Description** (figs. 32 and 35). There are 12 rocker arm assemblies, which operate the intake and exhaust valves of the engine. The rocker arm assemblies pivot on a hollow shaft which is attached by means of shaft brackets to each cylinder head.

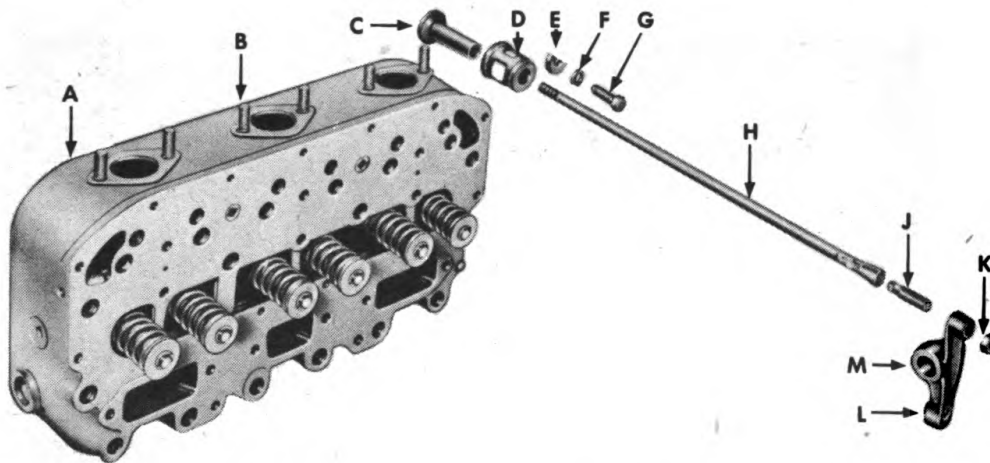

- A—CYLINDER HEAD
- B—MANIFOLD STUD
- C—VALVE TAPPET
- D—VALVE TAPPET GUIDE
- E—VALVE TAPPET GUIDE WASHER
- F—VALVE TAPPET GUIDE SCREW LOCK WASHER
- G—VALVE TAPPET GUIDE SCREW

- H—VALVE PUSH ROD ASSEMBLY
- J—VALVE ROCKER ARM ADJUSTING SCREW
- K—VALVE ROCKER ARM ADJUSTING SCREW NUT
- L—VALVE ROCKER ARM ASSEMBLY
- M—VALVE ROCKER ARM BUSHING

RA PD 321450

Figure 35—Cylinder Head and Valve Push Rod Assembly

b. Removal.

(1) REMOVE CYLINDER HEAD COVERS. Remove cylinder head cover cap screws and lift off front and rear cylinder head covers and gaskets.

(2) LOOSEN ASSEMBLY FROM CYLINDER HEAD (fig. 32). Loosen lock nuts and valve rocker adjusting screws from rocker arm of assembly which is to be removed. Back off adjusting screw in each rocker arm until rocker arm is free. Cut and remove locking wire from rocker arm bracket screws. Progressively loosen bracket screws by one-quarter turns until all screws are loosened. Remove screws and lift the rocker arms, shaft, and bracket assemblies from the cylinder head.

(3) REMOVE ROCKER ARMS FROM ROCKER ARM SHAFT (fig. 32). Remove rocker shaft washer, screws, spring washers, and outer springs from ends of rocker arm shaft. Slide each valve rocker arm, shaft bracket, and inner spring from shaft.

c. Installation.

(1) ASSEMBLE ROCKER ARMS ON ROCKER ARM SHAFT (fig. 32). Position one bracket at center of shaft. Slide a rocker arm, an inner spring, a rocker arm, a bracket, and a rocker arm onto shaft at either

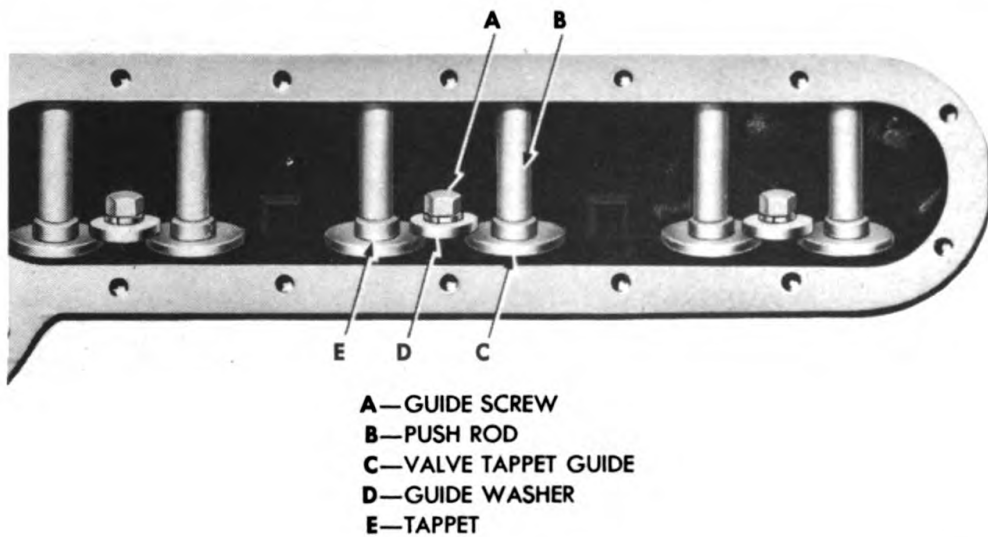

RA PD 321471

Figure 36—Valve Tappet Guide

end and in the given sequence. Install outer spring, spring washer, and washer screw. Slide rocker arms, springs, and bracket on other end of shaft and in given sequences. Install outer spring, washer, and screw.

(2) **INSTALL ROCKER ARM AND SHAFT ASSEMBLY ON CYLINDER HEAD** (fig. 32). Position the assembly on cylinder head with shaft brackets over locating screws and ball surface of adjustment screws in push rod cups. Make sure push rods have not been removed from valve tappets. If necessary, remove tappet inspection plate located on right side of engine block. If necessary, back off adjustment screws until each rocker arm is free. Install rocker arm shaft bracket screws. Install locking wire in screws at each bracket, locking the screws in pairs. Install tappet inspection plate if removed.

(3) **PRELIMINARY VALVE ADJUSTMENT.** The rocker arms are given a preliminary adjustment to provide for operating the engine until it is warm so that valves can be properly adjusted as outlined in paragraph 63 b. Make preliminary adjustment to provide a clearance of 0.021 inch between rocker arm and exhaust valve stems, and 0.015 inch between rocker arms and inlet valve stems.

(4) **INSTALL CYLINDER HEAD COVERS.** Install cylinder head covers as instructed in paragraph 63 c.

(5) **FINAL VALVE ADJUSTMENT.** Make final valve adjustment with motor warm as outlined in paragraph 63 b.

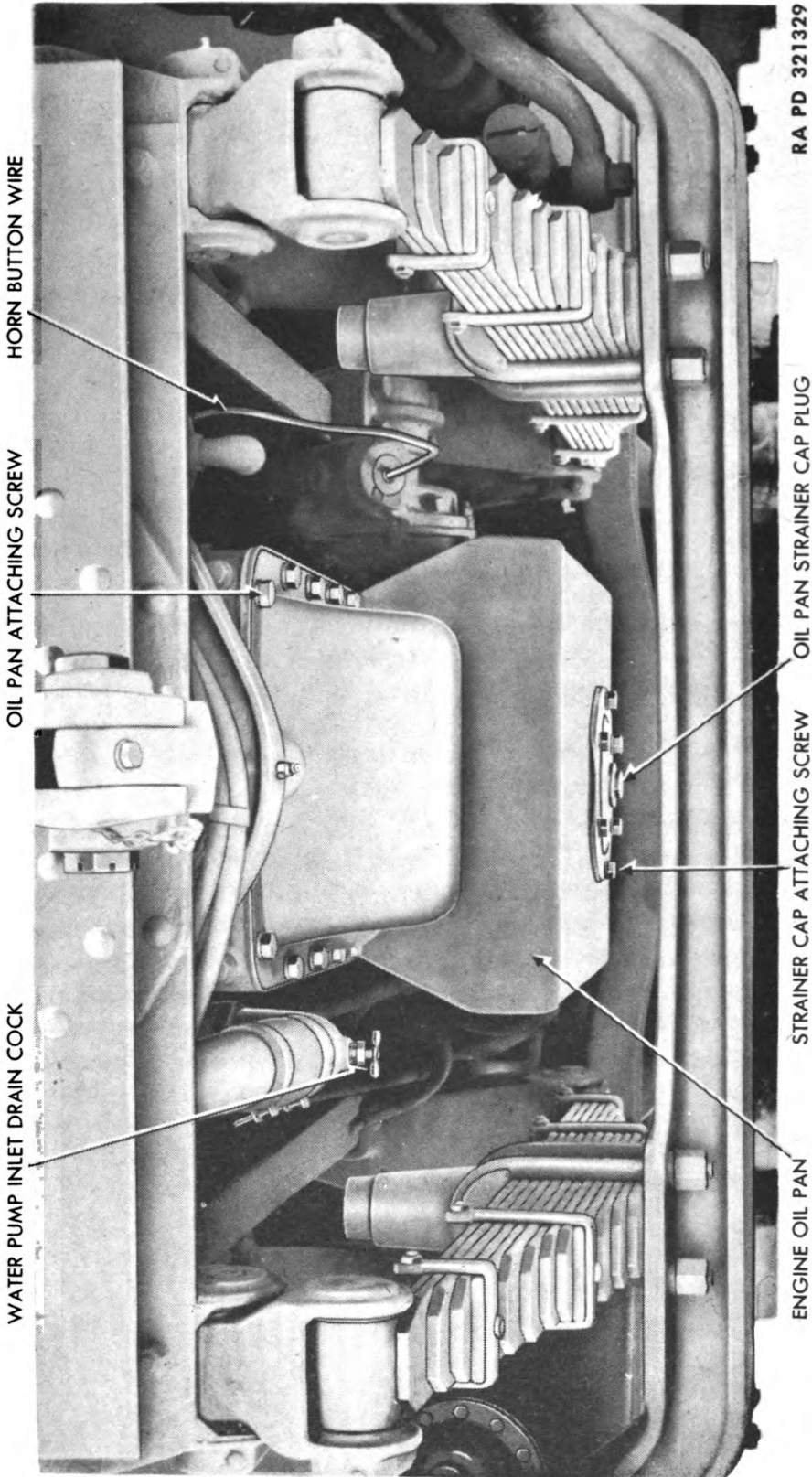

Figure 37—Engine Oil Pan—Installed

Engine Removal and Installation

65. PUSH RODS.

a. **Description** (figs. 32 and 35). The push rods are assembled between the top of the valve tappets and the valve rocker arm. The push rods operate the rocker arms which in turn operate the valves.

b. **Removal.** Remove rocker arm assembly (par. 64 b). Lift out push rods from cylinder block.

c. **Installation.** Place push rods in their opening in cylinder blocks, and make sure lower end of rod fits into valve tappet guide (fig. 36). Install rocker arm assembly (par. 64 c).

66. OIL PAN ASSEMBLY.

a. **Description** (fig. 37). The engine oil pan, which is a reservoir for the engine oil, is attached to the lower side of the engine block. The oil pan contains a fine wire mesh strainer which prevents particles of foreign matter from entering the oil pump suction line. The bayonet-type gage on the right side indicates the amount of oil in the oil pan.

b. **Removal** (fig. 37). Remove drain plug from bottom of oil pan and drain oil. Remove cranking motor (par. 96). Remove bayonet gage. Unscrew gage tube. Remove oil pan strainer attaching screws, and lower the strainer and gasket from oil pan. Support oil pan from below on blocks. Remove cap screws which secure oil pan to engine, and lower the pan to ground.

c. **Installation** (fig. 37). Wash out oil pan thoroughly. Clean oil strainer in dry-cleaning solvent. Install oil pan gasket, coating pan side of gasket with a thin coating of joint and thread compound, type "B." Set oil pan in position and install attaching cap screw and lock washers. Install cranking motor (par. 96 c). Install oil gage tube and bayonet gage. Install oil pan strainer gasket (G156-01-94026) and oil strainer. Install drain plug. Fill crankcase with proper grade of fresh oil until oil is at "4/4" mark on the gage. (Quantity required is 26 quarts.) Run engine about 4 or 5 minutes and stop engine. Allow engine to rest for about 1/2 minute and measure oil level. If oil is not up to "4/4" mark, add enough oil to bring it to this level. Inspect for oil leaks at oil pan.

Section XIV

ENGINE REMOVAL AND INSTALLATION

67. PRELIMINARY INSTRUCTIONS.

a. Removal of the engine from the chassis involves, in addition to common hand tools, the use of a wrecker truck or a chainfall capable of lifting 5,000 pounds. The special engine lifting eyes

(41-E-626) will be used if available. Block the truck to prevent it from moving. Provide wooden blocks of various sizes to block up the engine on the floor, including at least two pieces approximately 12 by 12 by 12 inches, for the front of the engine.

68. ENGINE REMOVAL.

a. Drain Engine (fig. 37). Place a drain pan under engine. Remove oil pan strainer cap plug, and allow lubricant to drain. Install plug.

b. Remove Radiator. Remove radiator as instructed in paragraph 91.

c. Remove Floorboard and Toeboard.

(1) **REMOVE FLOORBOARD** (L, fig. 7). Remove attaching screws from floorboard and lift out floorboard.

(2) **REMOVE TOEBOARD.** Remove cotter pin which secures accelerator pedal rod to bell crank. Remove pedal rod from bell crank. Lift pedal off toeboard. Remove three bell crank bracket bolts which secure bell crank to toeboard. Remove attaching screws from toeboard and lift out toeboard.

d. Remove Auxiliary Transmission Shifting Lever Assembly. Remove auxiliary transmission shifting lever assembly as instructed in paragraph 134 c.

e. Remove Front Propeller Shaft Assembly. Remove bolts from front propeller shaft flange yokes, and lower shaft assembly from vehicle.

f. Disconnect Linkage From Transmission. Disconnect linkage as instructed in paragraph 134 e.

g. Remove Transmission Shifting Lever (fig. 99). Remove the four cap screws which attach shifting lever and housing to transmission. Lift off the assembly. Cover the opening with a clean cloth to prevent anything from dropping into the case.

h. Disconnect Exhaust Pipe. Remove the three cap screws, lock washers, and plain washers which attach the exhaust pipe to the exhaust manifold. Loosen the U-bolt at rear end of exhaust pipe. Work the exhaust pipe back into muffler until it breaks loose from manifold.

i. Disconnect Wiring, Fuel Lines, Oil Lines, and Cables.

(1) **DISCONNECT STOP CONTROL SOLENOID WIRE.** Remove the terminal nut and lift off yellow-red wire from terminal post on top of stop control solenoid. Remove wire clip from solenoid mounting screw.

Engine Removal and Installation

(2) **DISCONNECT STARTER BURNER WIRE** (fig. 56). Disconnect pressure switch to junction block wire from pressure switch on top of starter burner. Remove wire clip from starter burner housing cover.

(3) **REMOVE WIRE CLIP FROM FRONT CYLINDER HEAD COVER.** Remove front cylinder cover rear cap screw, and lift off wire clip.

(4) **DISCONNECT FUEL PRIMING PUMP AND FUEL PRESSURE GAGE LINES.** Unscrew connectors from three fuel lines in front of cowl above engine. Tag the lines to identify lines for installation in same position.

(5) **REMOVE HEAT INDICATOR** (fig. 31). Unscrew coupling nut which secures heat indicator bulb to rear end of water manifold. Pull out the bulb.

(6) **DISCONNECT FEED AND RETURN FUEL LINES.** Unscrew connectors of the feed and return fuel lines on the left frame rail at left side of engine.

(7) **DISCONNECT THROTTLE CONTROL WIRE.** Loosen set screw and remove throttle control wire from throttle rod control collar. Loosen cable positioning clip on left side of engine and pull out cable.

(8) **DISCONNECT TACHOMETER CABLE.** At front right side of engine, unscrew tachometer cable knurled nut from tachometer adapter.

(9) **DISCONNECT GENERATOR WIRES.** Disconnect generator wires at the generator as instructed in paragraph 114 d.

(10) **DISCONNECT CRANKING MOTOR CABLES AND WIRES.** Disconnect cranking motor cables and wires at the cranking motor as instructed in paragraph 96 b.

(11) **DISCONNECT OIL GAGE LINES** (fig. 81). Unscrew connectors on two oil gage lines in front of cowl on right side of engine.

(12) **DISCONNECT WIRING HARNESS FROM BELL HOUSING.** From inside cab, remove two wiring harness clips from top of bell housing.

(13) **LOOSEN SPEEDOMETER CABLE.** Unscrew knurled nut which secures speedometer cable to instrument on panel. Pull cable down until it is slack in order to prevent binding on bell housing.

j. Remove Air Lines. Unscrew connector on air compressor to air reservoir line at the compressor. Unscrew connectors on air compressor to governor line at the compressor and at governor. Remove clips from the line, and lift it out to prevent damage. Unscrew front connectors on air lines to front trailer connections, and bend the air lines down inside right and left frame rails to prevent damage to the lines.

k. Remove Steering Gear.

(1) **REMOVE LEFT FRONT WHEEL.** Remove left front wheel as instructed in paragraph 184.

(2) **REMOVE STEERING WHEEL.** Remove steering wheel as instructed in paragraph 191.

(3) **DISCONNECT STEERING COLUMN** (fig. 83). Remove two bolts from hand control valve clamp (B, fig. 7). Remove clamp and pull hand control valve lines away from steering column. Remove two dash bracket bolts and remove dash bracket cap. Unscrew clutch and brake pedal pads. Work the steering column escutcheon off the end of the steering column (fig. 83). Remove cable clamp screw from clamp on lower end of steering column in front of cowl. Pull out horn wire plug from connector under lower end of steering column (fig. 37).

(4) **REMOVE TRUNNION BOLT** (fig. 147). From underneath the steering gear housing, remove trunnion bolt nut and lock washer. Pull out trunnion bolt from the steering gear and steering gear frame bracket inside the left frame rail. Remove two screws which secure spacer bumper in its seat on front spring (fig. 144). Remove bumper.

(5) **REMOVE REAR OF DRAG LINK FROM STEERING ARM** (fig. 148). Remove cotter pin, spring plug, and bearing seat from rear end of drag link. Place the steering wheel temporarily on the steering column, and turn the front wheels until the steering arm is in a position where it is possible to remove the drag link from the steering arm by tapping the drag link inward. After removing drag link, turn the steering arm until it points down toward end of steering gear. Lift off steering wheel again.

(6) **REMOVE STEERING GEAR.** Support weight of steering gear from below. Remove two steering gear bracket cap bolts, and remove bracket cap from front spring rear hanger bracket. With one man in cab to guide top of steering column, work the steering gear housing forward and remove it at front of vehicle.

l. Remove Bayonet Gage. Pull bayonet gage out of right side of engine to prevent damage.

m. Remove Horn. Remove left horn wire terminal screw and pull off wire. Remove left horn attaching bolts and lift off horn.

n. Lift Out Engine.

(1) **REMOVE MOUNTING BOLTS** (fig. 38). Remove cotter pin castle nut, spring washer, and mounting bolt spring from each of four rear engine mounting bolts. Remove bolts. Remove cotter pin and nut from each of four front engine mounting bolts. Pull out mounting bolts from front engine support, but allow bolts to remain in the support spacers to hold them in place while the engine is being removed.

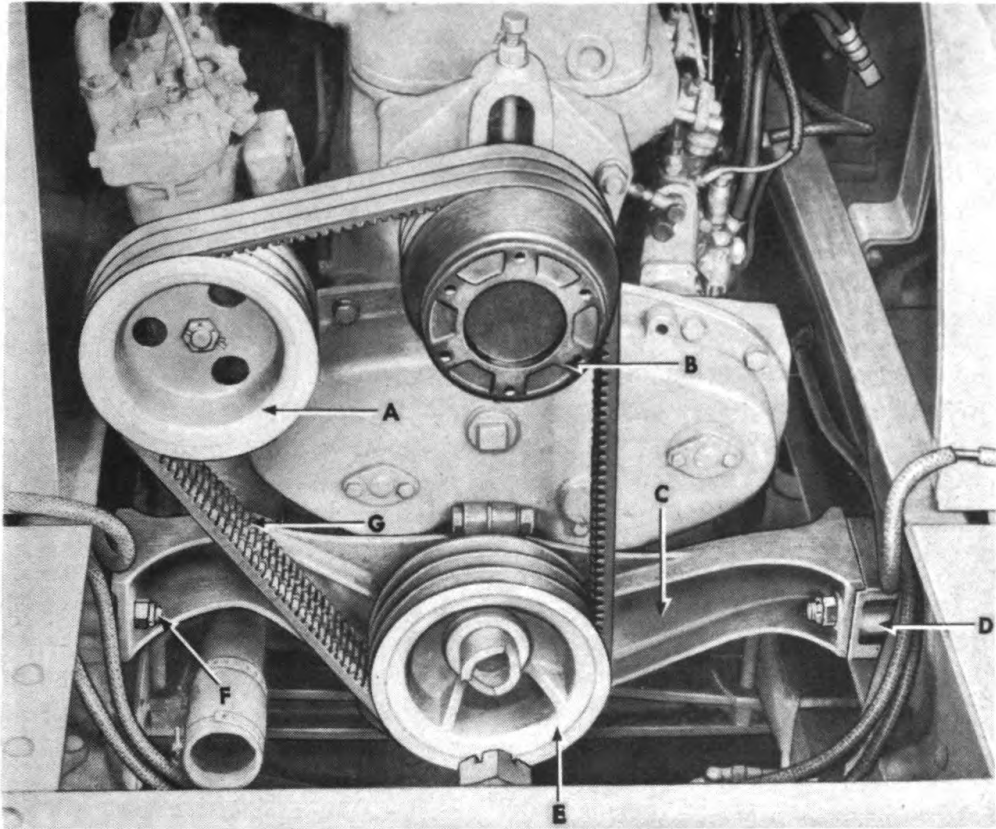
Engine Removal and Installation

A—AIR COMPRESSOR PULLEY
 B—FAN HUB
 C—FRONT ENGINE SUPPORT
 D—SUPPORT SPACER
 E—CRANKSHAFT PULLEY
 F—FRONT ENGINE MOUNTING BOLT
 G—FAN BELT

RA PD 321404

Figure 38—Front Engine Mounting Bolts

(2) **ATTACH LIFTING SLING** (fig. 39). Attach one end of a chain sling to lifting eye (41-E-626) installed on rear cylinder head stud (fig. 32). Pass other end of sling around fan mounting bracket, and secure the front end of the sling.

(3) **LIFT OUT ENGINE** (fig. 39). Place one man in cab to guide transmission and one man on each side of engine. Lift engine until front engine support breaks away from the support spacers. Move engine straight forward and then up. Proceed slowly with removal to avoid damaging parts of the engine. After engine is clear of chassis, place it on the floor, resting on blocks. Do not allow the weight of the engine to rest on the oil pan. Place large blocks on each side under the lugs just behind the front engine support. Place blocks under lowest

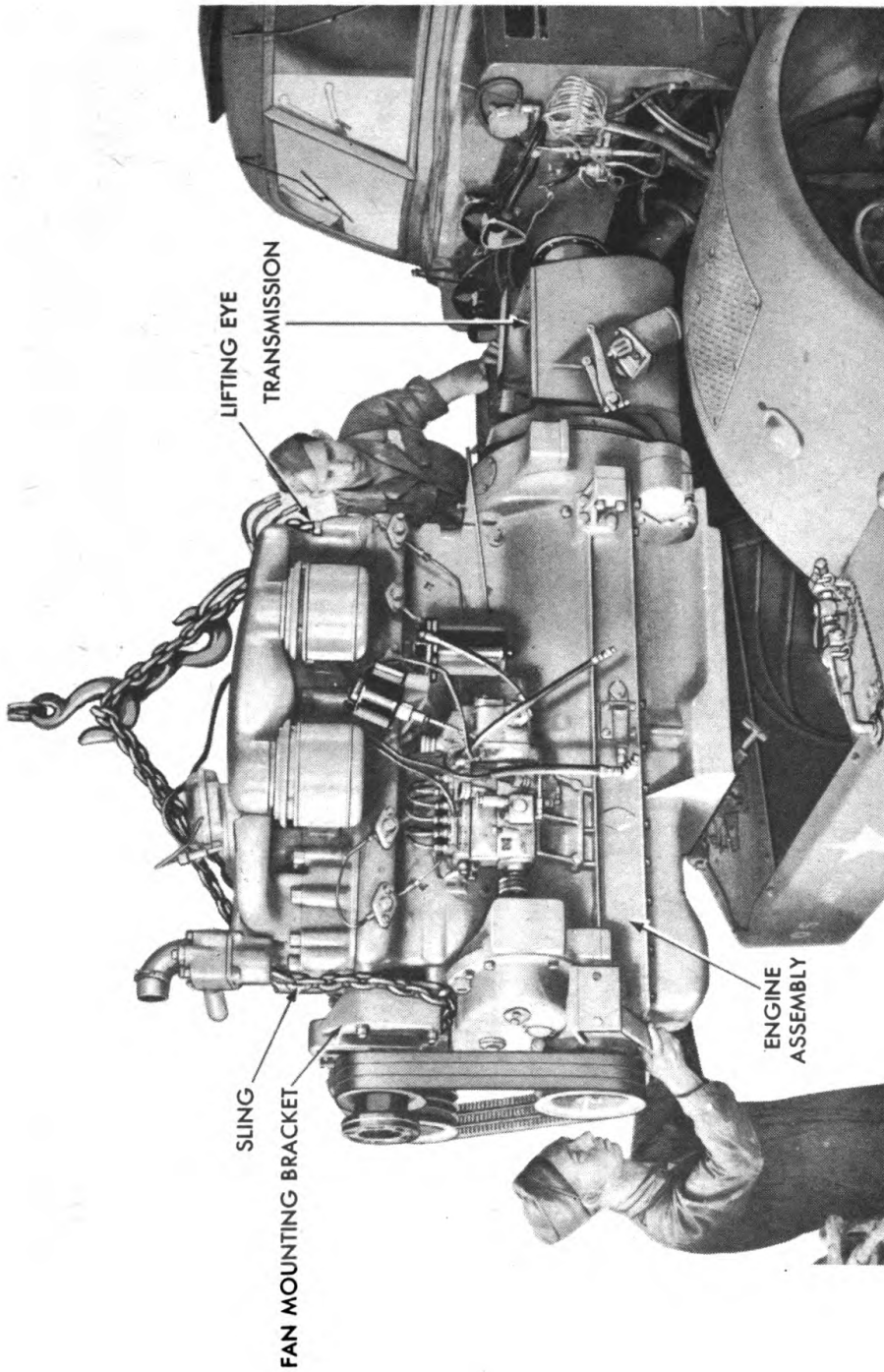

RA PD 321443

Figure 39—Removing Engine, Using Special Lifting Eye (41-E-626)

Engine Removal and Installation

part of clutch housing and under transmission. When engine is level, place blocks under each side at the rear engine support legs to prevent it from falling sideways. Remove chain fall and sling. **CAUTION:** *Do not block front engine support as engine will pivot around the support.*

69. ENGINE INSTALLATION.

a. Attach Lifting Sling. Attach a lifting sling as described in paragraph 68 n (2).

b. Place Engine in Chassis. Lift engine from floor to test balance. Adjust chain if necessary so that transmission is slightly lower than front end of engine. Guide the unit into position slowly, so that parts will not be broken. Before lowering the front end of the engine, see that the front engine support spacers are held in place by the bolts which pass through the frame and part way into the spacers. Guide the rear support lugs onto the rear engine support brackets. Lower the front end until the front engine support is resting on the spacers.

c. Install Engine Mounting Bolts (fig. 38). Raise the rear end of the engine sufficiently to insert the insulator and insulator retainer between the engine and the rear engine support brackets. Aline the holes and insert the rear engine mounting bolts. Place the left side bolts in from above; and install the mounting bolt spring, spring washer, nut, and cotter pin from underneath. Install the right side rear bolt in the same manner. Install the right side front bolt from the bottom with the mounting bolt spring, spring washer, nut, and cotter pin on top. At the front end of the engine, aline the holes of the front engine support with the spacers by prying the engine support forward or back. Tap the front engine bolts into place through the engine support. Install the nuts and cotter pins.

d. Install Steering Gear.

(1) **POSITION STEERING GEAR.** From front end of vehicle, insert steering column and steering gear between left side of engine and frame side rail. Work steering gear into place so that the cam lever shaft fits into the front spring rear hanger bracket. Make sure the steering column passes between the engine and the chassis wiring harness, and between the hand control valve air lines and the left frame side rail. Place the escutcheon plate over the end of the steering column before moving the steering gear all the way up (fig. 83). Install steering gear bracket cap and cap bolts, but do not tighten.

(2) **CONNECT DRAG LINK (fig. 147).** Place steering wheel temporarily on steering column, and move the steering arm until the drag

link and the steering arm ball are in line. Tap the drag link to enter the steering arm ball in the opening. Install the bearing seat and spring plug, but do not adjust.

(3) **INSTALL TRUNNION BOLT** (fig. 147). From inside the left side frame rail, insert the trunnion bolt through the steering gear frame bracket. Place a toothed lock washer between the frame bracket and the steering gear housing. Insert the bolt through the toothed lock washer and the steering gear housing, and install the lock washer and nut, but do not tighten.

(4) **INSTALL THE BRACKET COLUMN CAP** (fig. 83). Place the dash bracket cap in position around the steering column. Install the two bracket bolts, but do not tighten.

(5) **TIGHTEN STEERING GEAR ATTACHING BOLTS**. Aline the steering gear so that it fits into the front spring rear hanger bracket and into the dash bracket. Pry the steering gear to the left as far as possible. Tighten the steering gear bracket cap bolts and the dash bracket cap bolts. Tighten the trunnion bolt.

(6) **INSTALL AIR LINES AND CHASSIS WIRING HARNESS**. Place a wiring clamp around the steering column in front of the cowl to secure the hand control valve air lines and chassis wiring harness. Position the hand control valve on the right side of the steering column. Install hand control valve clamp and clamp bolts.

(7) **INSTALL STEERING WHEEL**. Install steering wheel as outlined in paragraph 191 b. Connect the horn button wire to the horn wire leading from the chassis wiring harness.

(8) **INSTALL FRONT WHEEL**. Install front left wheel as described in paragraph 184 c.

e. Install Air Lines. Bend the two air lines into place at the front trailer connections. Screw the tube connectors to the fittings. Place the air compressor to governor air line in position. Screw the tube connectors to the governor and to the air compressor fittings. Install tube clips which secure the line to the cowl and the right frame side rail. Connect the air compressor to air reservoir line to the air compressor fitting by screwing on the connector.

f. Connect Wiring, Fuel Lines, Oil Lines, and Cables.

(1) **SECURE WIRING HARNESS TO BELL HOUSING**. Install two wiring harness clips which secure wiring harness to top of Bell Housing.

(2) **CONNECT OIL GAGE LINES** (fig. 81). Screw the connector fittings together on the viscometer to gage line and oil pump to gage line above the right frame side rail on right side of engine.

(3) **CONNECT CRANKING MOTOR CABLES AND WIRES**. Connect the cranking motor cables and wires as instructed in paragraph 96 c.

Engine Removal and Installation

(4) **CONNECT GENERATOR WIRES.** Connect the generator wires to the generator as instructed in paragraph 114 e.

(5) **CONNECT SPEEDOMETER CABLE.** Pull the speedometer cable up into position and screw the knurled nut on the fitting at the back of the instrument.

(6) **CONNECT TACHOMETER CABLE.** Screw the tachometer cable knurled nut onto the tachometer adapter at front right side of engine.

(7) **CONNECT THROTTLE CONTROL WIRE.** Insert end of throttle control wire into throttle rod control collar. Tighten set screw. Install cable positioning clip which holds cable to left side of engine behind fuel strainer.

(8) **CONNECT FEED AND RETURN FUEL LINES.** Screw together connector fittings of fuel feed line and connector fittings of fuel return line at left side of engine on frame side rail.

(9) **INSTALL HEAT INDICATOR.** Place heat indicator bulb in the opening at rear of water manifold. Screw in the coupling nut.

(10) **CONNECT FUEL PRIMING PUMP AND FUEL PRESSURE GAGE LINES** (fig. 31). Screw together the connector fittings on the two fuel priming pump lines and the fuel gage line from the cowl with the three matching lines on top of the engine. If identification tags have not been used, trace the lines back to their connection at the engine or at the panel (fig. 40). Connect the line from the fuel pressure gage with the line from the front end of the injector pump. Connect right-hand line from the priming pump with the line from the starter burner, and connect the left-hand line from the priming pump with the line for the bottom of the fuel supply pump.

(11) **INSTALL WIRE CLIP ON FRONT CYLINDER HEAD COVER** (fig. 31). Install the wire clip on the fuel line to starter burner and pressure switch to junction box wire. Insert front cylinder head cover cap screw in clip, and install cap screw through left rear hole of front cylinder head.

(12) **CONNECT STARTER BURNER WIRE** (fig. 56). Connect pressure switch to junction box wire to terminal of pressure switch. Secure the wire, as well as fuel line from hand priming pump to the rear starter burner housing cover cap screw.

(13) **CONNECT STOP CONTROL SOLENOID** (fig. 53). Place yellow-red wire from chassis wiring harness on terminal of fuel shut-off solenoid. Install terminal post nut. Install wire clip securing wire to stop control solenoid mounting bracket.

g. Install Horn. Place left horn in position and install attaching bolts. Connect left horn wire to terminal.

h. Connect Exhaust Pipe. Install three bolts, lock washers, and plain washers which connect the exhaust pipe to the exhaust manifold. Tighten the U-bolt at the front end of the muffler.

Maintenance Instructions

- i. **Install Transmission Shifting Lever** (fig. 99). Place the shifting lever and housing on top of transmission. Install the four housing cap screws and lock washers.
- j. **Connect Transmission Linkage**. Connect transmission linkage as instructed in paragraph 135.
- k. **Install Front Propeller Shaft Assembly**. Install front propeller shaft assembly as described in paragraph 145 c.
- l. **Install Auxiliary Shifting Lever Assembly**. Install auxiliary shifting lever assembly as described in paragraph 137.
- m. **Install Pedal Pads** (fig. 83). Place steering column escutcheon over brake pedal and clutch pedal. Screw on pedal pads.
- n. **Install Floorboard and Toeboard** (fig. 7).
- (1) **INSTALL TOEBOARD**. Place floorboard in position and install attaching screws. Position bell crank bracket on under side of toeboard, and install three attaching bolts. Place accelerator pedal on toeboard with pedal rod through opening in toeboard. Connect pedal rod to bell crank and install cotter pin.
- (2) **INSTALL FLOORBOARD**. Place floorboard in position. Install attaching screws.
- o. **Install Radiator**. Install radiator as described in paragraph 91 c.
- p. **Refill Crankcase**. Refill crankcase as described in paragraph 66 c.
- q. **Record Unit Assembly Replacement**. Make the proper entry on W.D., A.G.O. Form No. 478, "MWO and Major Unit Assembly Replacement Record."

Section XV**FUEL SYSTEM****70. DESCRIPTION AND DATA.**

a. **Description** (fig. 40). The fuel system consists of three sub systems which operate together; the supply system which filters and serves the fuel to the injector pump, the injector system which feeds the fuel to the engine under the proper conditions for firing, and the fuel priming system which aids in cold weather starting. The supply system comprises the two fuel tanks, fuel lines, gate valves, primary filters, mechanically- and manually-operated fuel supply pumps, and secondary fuel filter. The injector system includes the fuel injector pump and six injector nozzles, together with their supply lines from

Fuel System

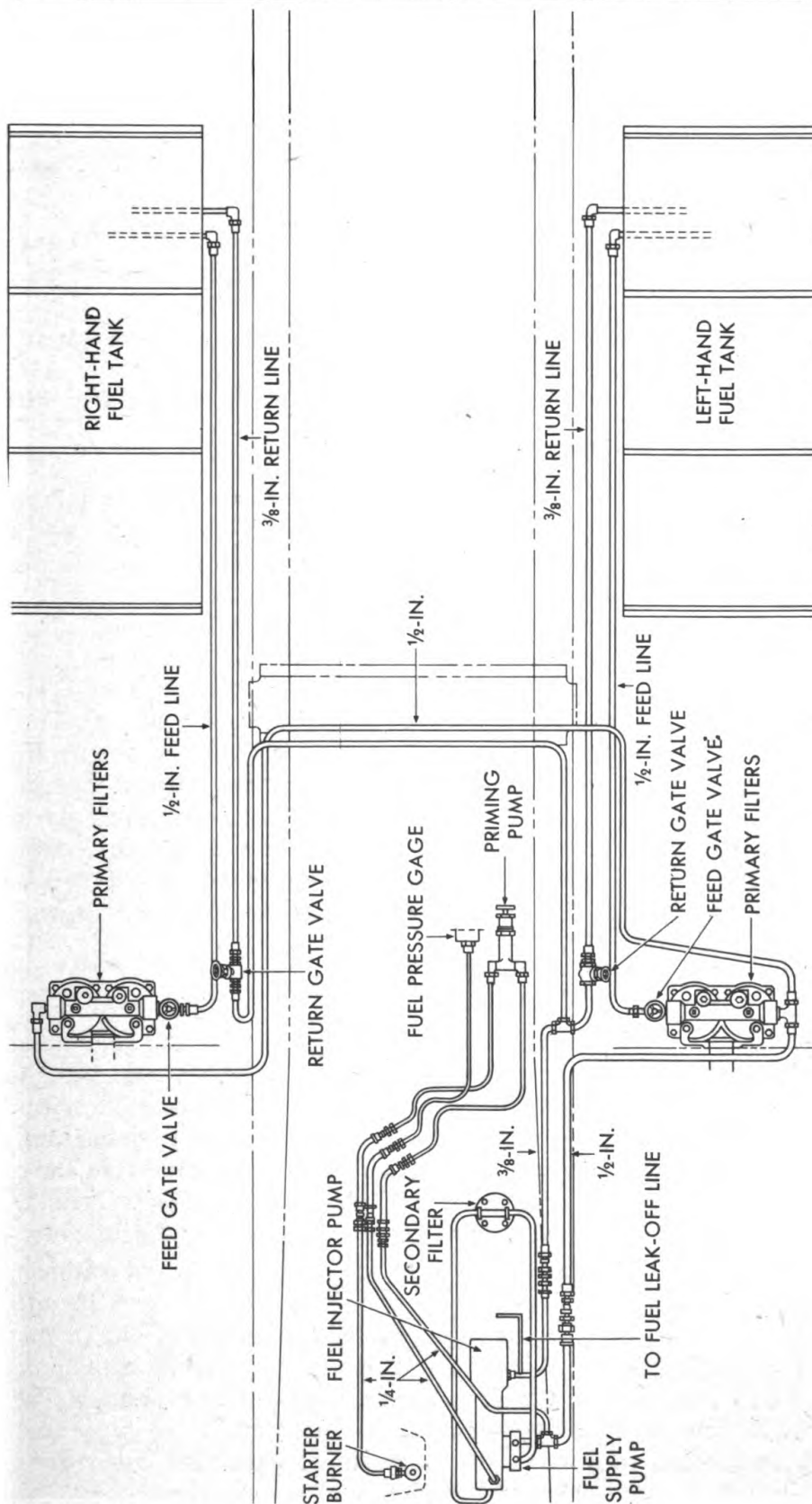

RA PD 321300

Figure 40—Fuel System Piping

the injector pump and fuel leak-off manifold. The priming system consists of a hand-operated priming pump, installed on the instrument panel, which supplies fuel to the starter burner element in the air intake manifold.

b. Data.

Number of tanks	2
Total capacity	150 gal.
Location of tanks	One on each side of chassis frame, back of cab
Number of feed gate valves	2
Location	One on each dual filter in battery compartment
Number of return gate valves	2
Location	One on each return line in battery compartment

71. FUEL TANKS AND GATE VALVES.

a. Description (figs. 41, 42, and 43). There are two 75-gallon fuel tanks, one on each side of the chassis frame, immediately back of the cab. They are located on the running boards and are protected on top by the top shield plates which are clamped down to the running boards to secure the tanks. Each tank has a capped filler opening on top, a drain sump with drain plug, electric fuel gage element, and fittings for a supply and return line. The 1/2-inch feed lines from the two tanks each pass through the primary filters. The two feed lines join at the T-fitting on the left fuel filter, and from this point a single line leads to the fuel supply pump. During operation, fuel must be cut off from one tank by closing both gate valves on one side while the gate valves on the opposite side are left open. The return overflow from the fuel injector pump is returned through a 3/8-inch return line, to the tank from which fuel is being drawn.

b. Fuel Tank Replacement (fig. 41).

(1) **REMOVAL.** Place suitable container under fuel tank and remove drain plug. Allow fuel to drain. Install drain plug. Remove two shield gage unit cover cap screws and lock washers, and lift off cover. Remove gage terminal nut and pull off wire. From underneath vehicle, disconnect feed and return lines from tank fitting by backing off tube connectors. Remove four strap end bolts. Remove fuel tank mud shield cap screws which secure mud shield. Lift off mud shield. Lift off fuel tank shield. Slide tank out on step board and remove it.

(2) **INSTALLATION.** Place fuel tank on step board and slide it into position. Place fuel tank shield over top of tank and install four strap end bolts, nuts, and cotter pins which secure shield straps to step board. Position fuel tank mud shield and install attaching screws. Place feed and return fuel lines on tank fittings, and screw up tube connectors. Place wire fuel gage instrument on gage unit terminal, and install terminal nut. Place shield gage unit cover over

Fuel System

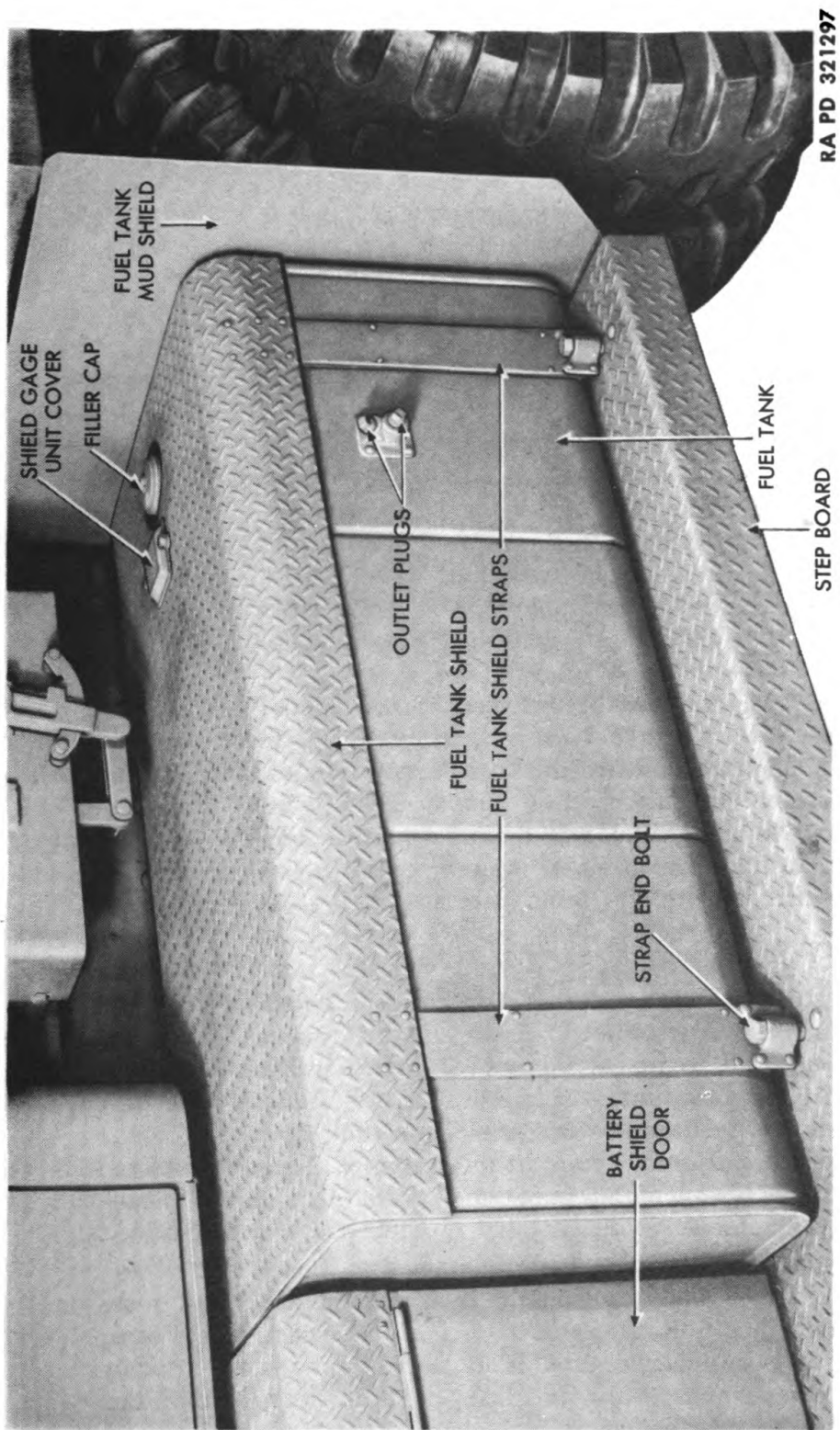

Figure 41—Left-hand Fuel Tanks

opening, and install cap screws and lock washers. Remove filler cap and fill tank with fuel. Bleed system (par. 77 e).

c. Feed Gate Valves Replacement.

(1) **REPLACEMENT OF LEFT-HAND FEED GATE VALVE** (fig. 43). Back off the tube connector from the valve. Unscrew the valve from the valve body. Unscrew the valve body from the filter. Screw the new valve body into the filter. Screw the valve into the valve body. Screw the feed line tube connector to the valve nipple.

(2) **REPLACEMENT OF LEFT-HAND RETURN GATE VALVE** (fig. 43). Unscrew return line tube connector from rear of valve. Unscrew tube connectors from T-fitting ahead of valve. Remove nuts and washers from U-bolt on valve bracket. Remove U-bolt and valve. Place U-bolt around new valve body, and place valve and U-bolt in bracket. Install lock washers and nuts on U-bolt. Connect return line tube connector to rear nipple of valve. Connect two tube connectors to T-fitting ahead of valve.

d. Return Gate Valves Replacement.

(1) **REPLACEMENT OF RIGHT-HAND FEED GATE VALVE** (fig. 42). Replace right-hand valve with procedure outlined in subparagraph c (1) above.

(2) **REPLACEMENT OF RIGHT-HAND RETURN GATE VALVE** (fig. 42). Disconnect two fuel lines by backing off two tube connectors. Remove U-bolt nuts and lock washers. Pull out valve. Place new valve on bracket and position U-bolt. Install U-bolt nuts and lock washers. Screw up tube connectors to nipples on each side of valve.

72. FUEL FILTERS.

a. Description and Data.

(1) **DESCRIPTION** (figs. 42, 43, 44, and 45). There are four primary fuel filters, two in each battery compartment, and one secondary fuel filter on strainer located above and to the rear of the fuel injector pump. All filters are of the cloth-screen type. The primary filters clean the fuel as it leaves the tanks, and the secondary filter cleans the fuel before it enters the fuel injector pump.

(2) **DATA.**

Make	Purolator
Model—primary, right-hand	27264
Model—primary, left-hand	27295
Model—secondary	85664CS
Type	Cloth-screen element

b. Servicing. Close feed gate valve on primary filters. Remove drain plug from bottom of filter and drain fuel oil. Remove four cap screws which secure clamping ring to fuel filter head. Lower

Fuel System

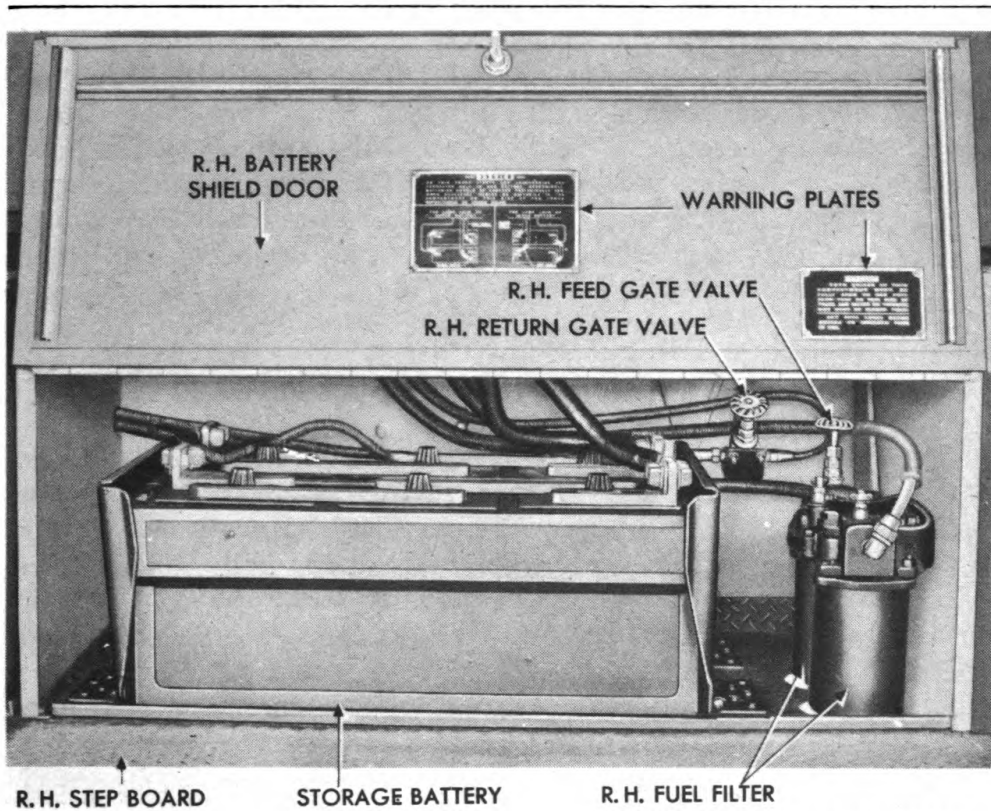

RA PD 321304

Figure 42—Right-hand Fuel Filters and Gate Valves

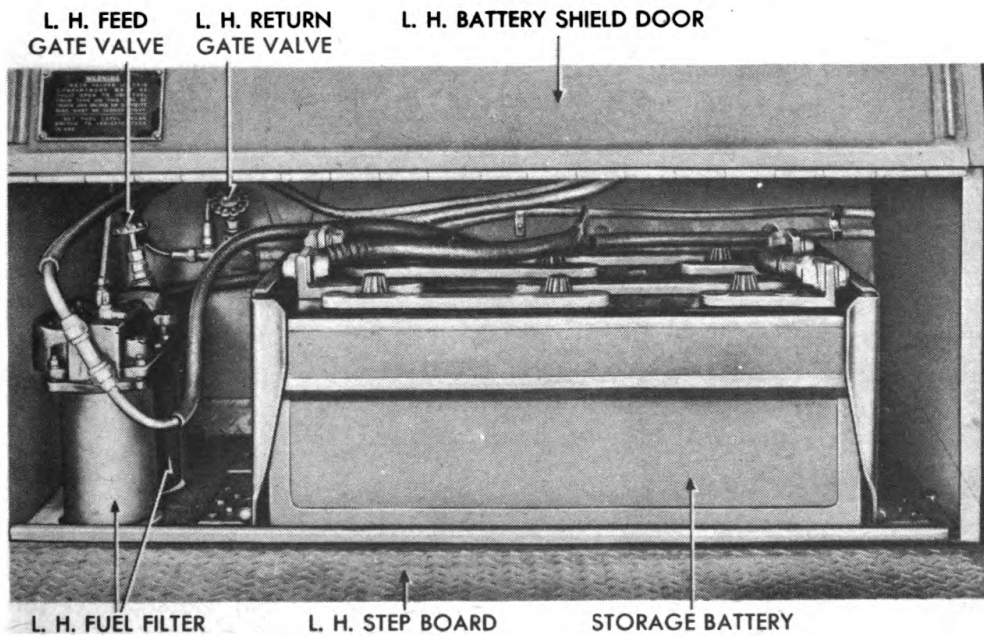

RA PD 321298

Figure 43—Left-hand Fuel Filters and Gate Valves

the case. Unscrew filter element from head. Stop up opening at each end of filter with fingers, and compress filter element so that fuel oil is forced out through cloth, carrying dirt with it. Repeat until most of fuel oil is squeezed out. Soak filter in dry-cleaning solvent, and repeat squeezing action until filter is clean. If there are holes or signs of deterioration, discard filter element and use new filter. Screw filter element on filter head. Place clamping ring against head, and install four cap screws. Replace drain plug gasket with new gasket (G120-01-93955). Remove filler plug, and refill filter with clean fuel oil. Install filler plug. Bleed system (par. 77 e).

c. Replacement of Fuel Filters.

(1) **REMOVE PRIMARY FUEL FILTERS** (figs. 42 and 43). Open battery compartment door. Close feed gate valve. Back off tube coupling nut, and pull tube away from filter. On left-hand filters, back off coupling nuts. Remove from T-fitting two bolts which secure bracket to battery compartment. Remove the drain plugs, and drain fuel oil from each filter. Remove four cap screws from each filter head and lower filter cases. Unscrew filter element from both heads. Unscrew head from gate valve. Pull filter cases from battery compartment.

(2) **INSTALL NEW PRIMARY FUEL FILTERS** (figs. 42 and 43). Place fuel filter head on mounting bracket and install cap screws. Screw filter head on feed gate valve. Install bracket attaching bolts to secure bracket to battery compartment. Place filter cases in openings in battery compartment floor. Screw both filter elements to filter head. Raise filter cases and install attaching cap screws through head. Attach return tube coupling nut to head elbow on right-side filters, and attach both tube coupling nuts to T-fitting on left-side filter.

(3) **REMOVE SECONDARY FILTER.** Remove drain plug and drain fuel oil. Unscrew wing nut, and remove rear air cleaner. Remove two cap screws which secure filter head to mounting bracket. Back off tube connectors from both fuel lines and remove filter.

(4) **INSTALL NEW SECONDARY FILTER.** Place filter against mounting bracket, and install mounting cap screws. Attach tubing, making sure tube from fuel supply pump is attached to elbow at side of head marked "IN," and tubing from front of injector pump is attached to elbow at side of head marked "OUT."

73. FUEL LEVEL GAGE.

a. Description. The fuel level gage system consists of three instruments: the registering unit mounted on the instrument panel, the tank units mounted in right- and left-hand fuel tanks, and the fuel gage toggle switch on the instrument panel. Various positions of the tank unit float arm will cut in the resistance, which permits the current to flow to the calibrated gage and thereby indicates the

Fuel System

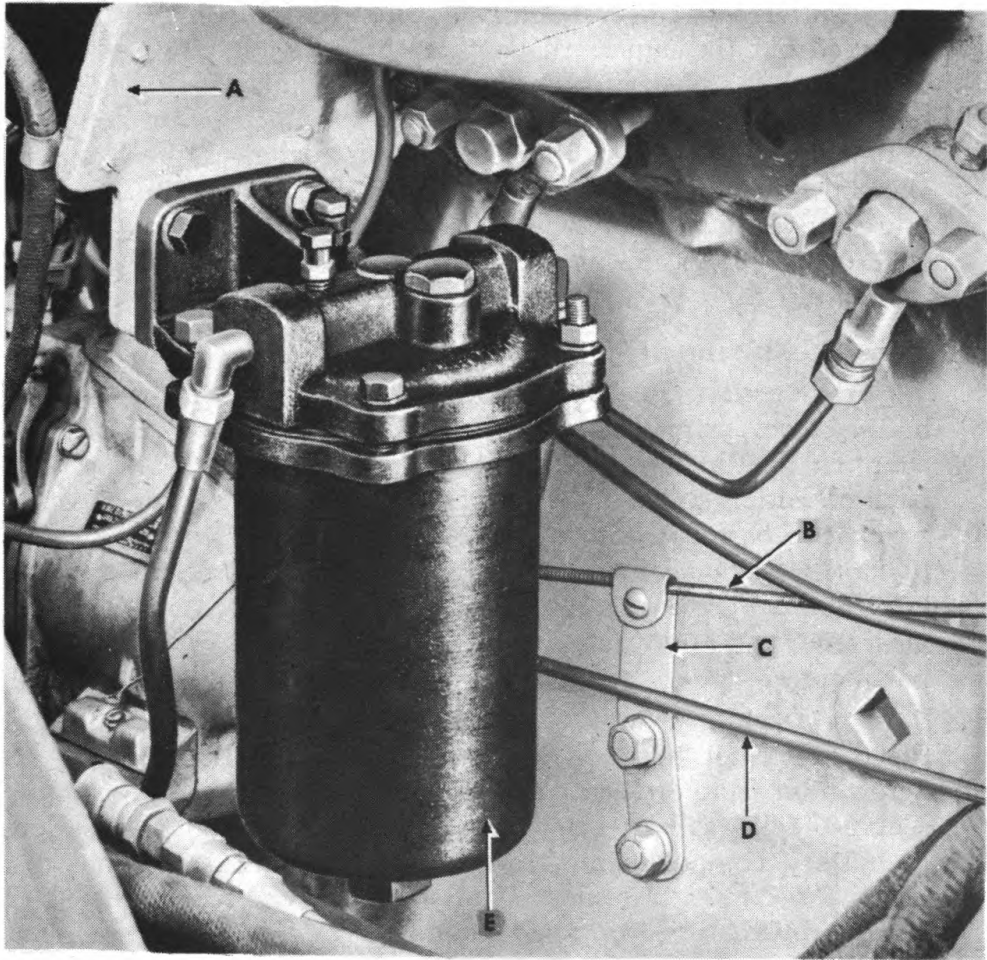

A—BRACKET
B—THROTTLE CABLE
C—CABLE POSITIONING CLIP
D—THROTTLE ROD
E—SECONDARY FILTER

RA PD 321346

Figure 44—Secondary Fuel Filter

amount of fuel in the tank. The two-way toggle switch enables a reading to be taken from each tank separately by connecting the panel gage electrically with either tank unit.

b. Tank Unit (fig. 46).

(1) **REMOVAL (fig. 41).** Remove the cap screws and lift off the shield gage unit cover. Remove terminal post nut and lift off wire from terminal post. Remove five cap screws and lock washers which secure gage to tank. Pry up gage flange and remove gage and gage gasket from tank. Remove gage from opposite tank in similar manner.

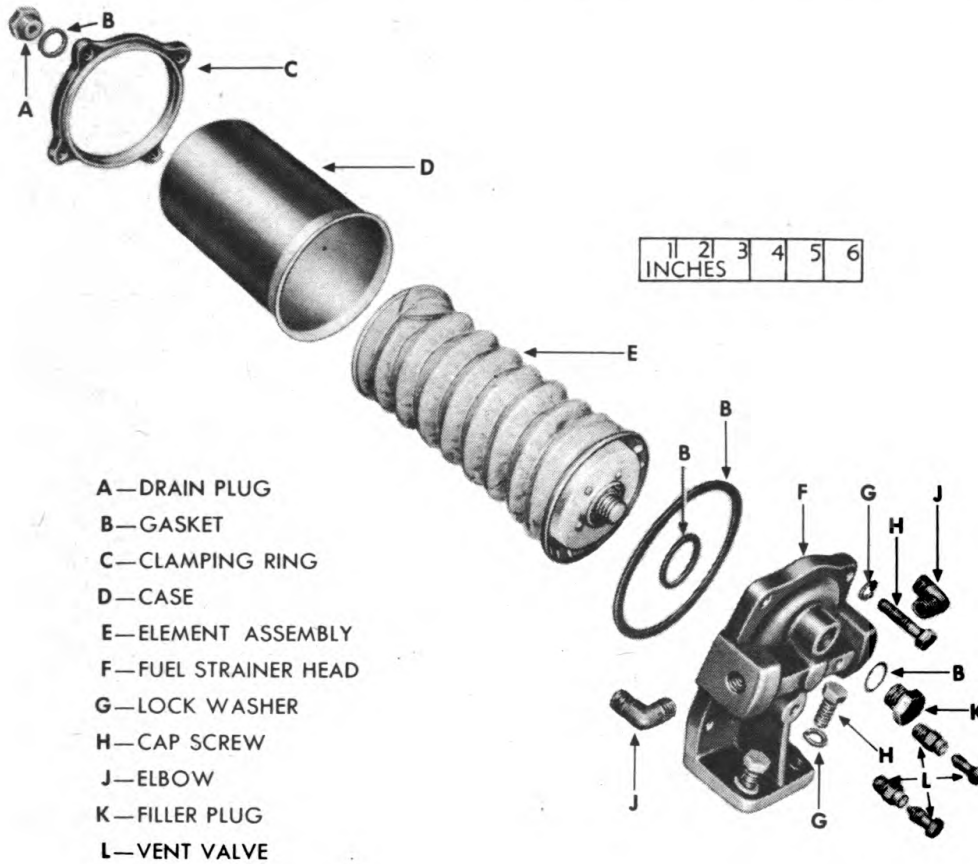

RA PD 321321

Figure 45—Secondary Fuel Filter Assembly

(2) **INSTALLATION.** Insert tank gage unit in fuel tank opening with new flange gasket between gage flange and tank. Install five cap screws and lock washers. Place tank gage wire on terminal post of gage. Install terminal post nut. Place shield gage unit cover in position, and install two cap screws and lock washers.

c. Fuel Gage Toggle Switch (fig. 8).

(1) **REMOVAL.** Disconnect three leads from terminals on toggle switch. Tag the leads to assist in installing correctly. Remove lock nut. Remove name plate. Push out and remove switch from instrument panel.

(2) **INSTALLATION.** Position toggle switch through instrument panel. Position name plate. Install lock nut. Attach three leads to switch terminals in accordance with tags or wiring diagram (fig. 85).

Test switch by placing it in three positions indicated on name plate, observing the instrument panel fuel gage at the same time.

Fuel System



RA PD 77316

Figure 46—Fuel Gage Tank Unit

d. Instrument Panel Gage (fig. 8).

(1) REMOVAL. Disconnect two leads from one terminal and one lead from second terminal on gage. Attach tags to leads to assist in installation. Remove two nuts and two lock washers. Remove retainer bracket. Remove gage from panel.

(2) INSTALLATION. Position gage through instrument panel. Position retainer bracket over two gage stud bolts. Install two lock washers and two nuts. Attach three leads to gage terminals in accordance with tags or color key, following wiring diagram (fig. 85). Operate toggle switch and observe gage readings.

74. FUEL INJECTOR PUMP.

a. Description and Data (fig. 47).

(1) DESCRIPTION. The fuel injector pump is mounted on the left side of the engine and is driven through a positive drive coupling. The purpose of the pump is to meter the fuel accurately and deliver it at timed intervals to the injector nozzles which atomize the fuel as it passes into the respective cylinders of the engine. The injector pump has a camshaft compartment in the lower half and six pump element assemblies in the upper half. The pump elements compress the fuel and force it through the delivery valve, fuel pipes, and spring-loaded nozzles into the engine combustion chamber.

(2) DATA.

Make American Bosch
Type Multiple (six outlets)

b. Removal (fig. 47).

(1) DISCONNECT FUEL LINES. Open left side of engine hood. Disconnect fuel pressure gage to injector pump tube from front end of pump. Disconnect filter to injector pump tube from front of

Maintenance Instructions

- A—FUEL NOZZLE CLAMP
- B—NOZZLE ASSEMBLY
- C—LEAK-OFF LINE
- D—FUEL LINE (INJECTOR PUMP TO NOZZLE)
- E—INSPECTION COVER CAP
- F—STOP CONTROL SOLENOID
- G—FUEL FILTER (SECONDARY)
- H—GOVERNOR
- J—INJECTOR PUMP
- K—CHECK VALVE
- L—OIL FILLER COVER
- M—HAND PRIMING PUMP
- N—FUEL SUPPLY (TRANSFER) PUMP
- P—OIL LEVEL COCK
- Q—DRAIN PLUG
- R—DRIVE COUPLING FLANGE DISK

RA PD 321425

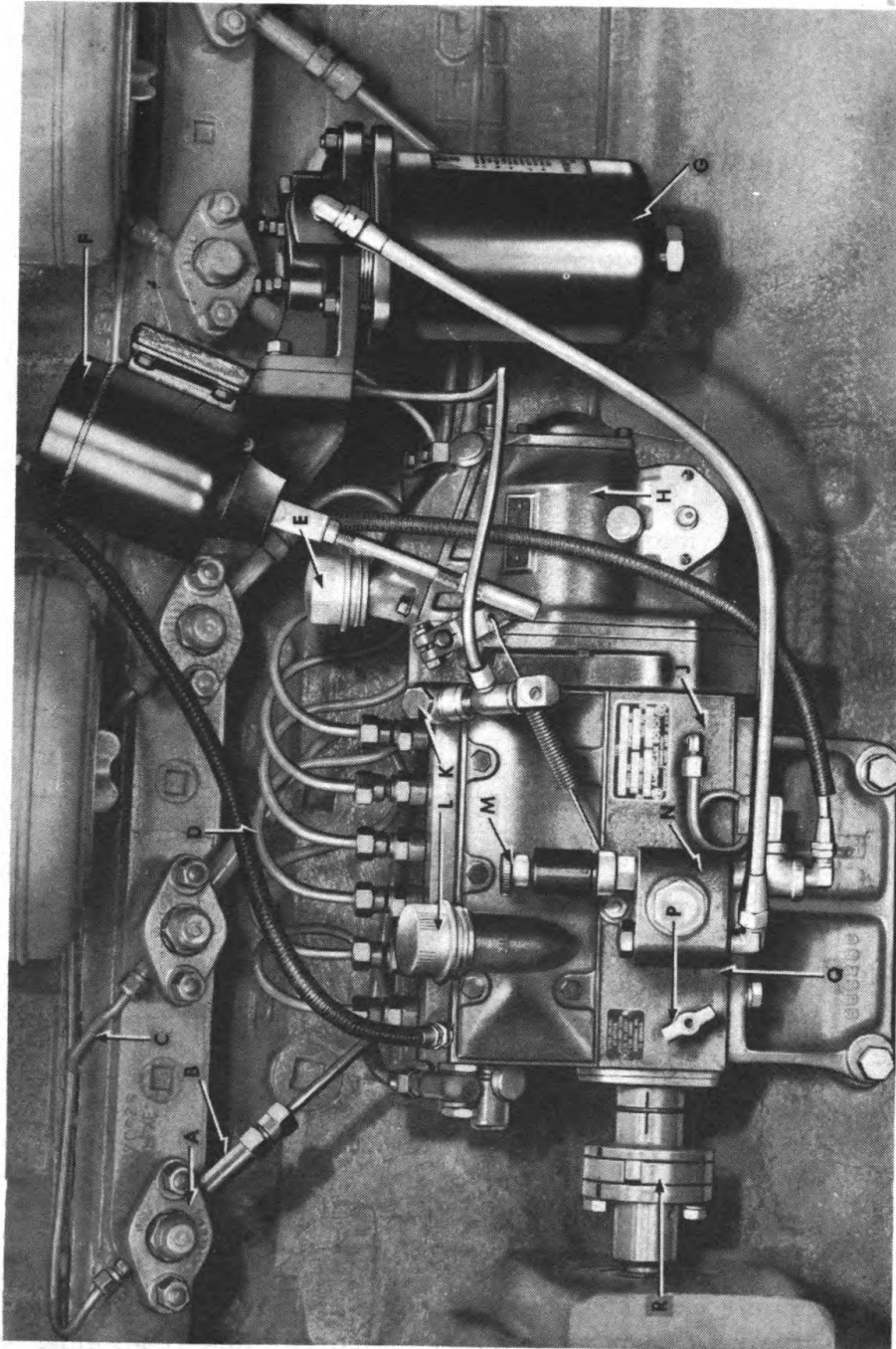

Figure 47—Fuel Injector Pump

Fuel System

injector pump. Disconnect filter to fuel supply pump tube from fuel supply pump. Disconnect starter burner to fuel supply pump tube from fuel supply pump. Disconnect feed and return tubes from injector pump. Disconnect leak-off manifold tube from fitting below check valve. Disconnect injector pump to nozzle tubes at the injector pump.

(2) **DISCONNECT STOP CONTROL SOLENOID.** Remove socket screw nut at lower end of stop control rod, and pull the socket screw from injector pump rack rod (fig. 53).

(3) **DISCONNECT DRIVE COUPLING.** NOTE: *Make sure couplings are marked for fuel injector pump timing before disconnecting couplings* (fig. 47). *If markings are dim, renew marks so that re-assembly can be easily made.* Remove two screws and lock washers from coupling. Remove coupling flange disk.

(4) **REMOVE PUMP.** Remove cap screws, lock washers, and plain washers which attach injector pump to bracket. Lift off injector pump.

c. Installation.

(1) INSTALLATION WITH MARKED COUPLINGS.

(a) *Set Flywheel Timing Marks at Proper Degree.* (All flywheels have a line marked "DC" (dead center) and from this line are graduations indicating degrees of crankshaft travel.) Rotate flywheel by means of hand crank until "DC" mark appears in timing hole in bell housing. Be sure No. 1 piston is just beginning the compression stroke and beginning the expansion which can be determined by observing that the No. 6 cylinder exhaust valve is nearly closed. Rotate engine in direction of degree graduation marks, which is counterclockwise, until the graduation "29°" is directly in line with the mark in the center of the timing hole in the bell housing. This will then leave the crankshaft spotted at "29°" before top dead center, at which point the fuel pump is set for port closing.

(b) *Install Pump on Engine* (fig. 47). Position injector pump on engine. Install mounting cap screws, plain washers, and lock washers which secure pump to bracket.

(c) *Aline and Connect Coupling.* Rotate rear half of coupling until heavy mark on its wide flange coincides with heavy mark on front half of coupling flange. Install the flange disk. Install cap screws which connect two halves of coupling together. Tighten cap screws, making sure alining marks are lined up perfectly.

(d) *Install Fuel Lines* (fig. 47). Connect the injector pump to nozzle tubes at the injector pump. Connect feed line to fitting below

fuel supply pump and connect return line to fitting below check valve. Connect leak-off manifold tube to T-fitting immediately below check valve. Connect starter burner to fuel supply pump tube to upper part of pump forward of the oil filter. Connect the filter to fuel supply pump tube to forward lower end of fuel supply pump. Connect the filter to injector pump tube to the front of the injector pump. Connect the fuel pressure gage to injector pump tube to front end of injector pump.

(e) *Prime Fuel Lines.* Prime the fuel lines as instructed in paragraph 77 e.

(f) *Start Engine.* Start the engine and check its performance.

(2) **INSTALLATION OF NEW FUEL INJECTOR PUMP.**

(a) *Spot Flywheel at Proper Degree.* Spot flywheel as instructed in step (1) (a) above.

(b) *Install Pump and Engine.* Install injector pump on engine as described in step (1) (b) above.

(c) *Aline Marks on Rear Half Coupling and Dust Shield* (fig. 47). Rotate pump shaft by hand until light line on rear half coupling hub is in line with light line on dust shield.

(d) *Bolt Coupling Halves Together.* Install flange disk and coupling cap screws and lock washers. Draw up cap screws, making sure light lines are perfectly in line (step (c) above).

(e) *Install Fuel Lines.* Install fuel lines as instructed in step (1) (d) above.

(f) *Prime Fuel Lines.* Prime fuel lines as instructed in paragraph 77 e.

(g) *Start Engine.* Start the engine and check its performance.

(h) *Mark Couplings.* When engine operates properly, shut down engine. With light chisel and hammer, mark rear hub on outer edge of wide flange with a heavy line corresponding with heavy line on front coupling so these two parts can be lined up perfectly at any future time.

d. **Lubrication** (fig. 47). Drain the injector pump each time the engine crankcase oil is changed. The drain plug is located immediately ahead of the fuel supply pump, and the oil level cock is near the drain plug, but slightly above it. Pour new oil of proper grade (par. 22) into the filter tube until it flows from oil level cock. Close oil level cock and install filter tube cap.

e. **Check Valve** (fig. 48).

(1) **REMOVAL.** Unscrew the return line connector nut from the T-fitting below the check valve. Unscrew the bleed-off manifold tube connector nut from the T-fitting below the check valve. Un-

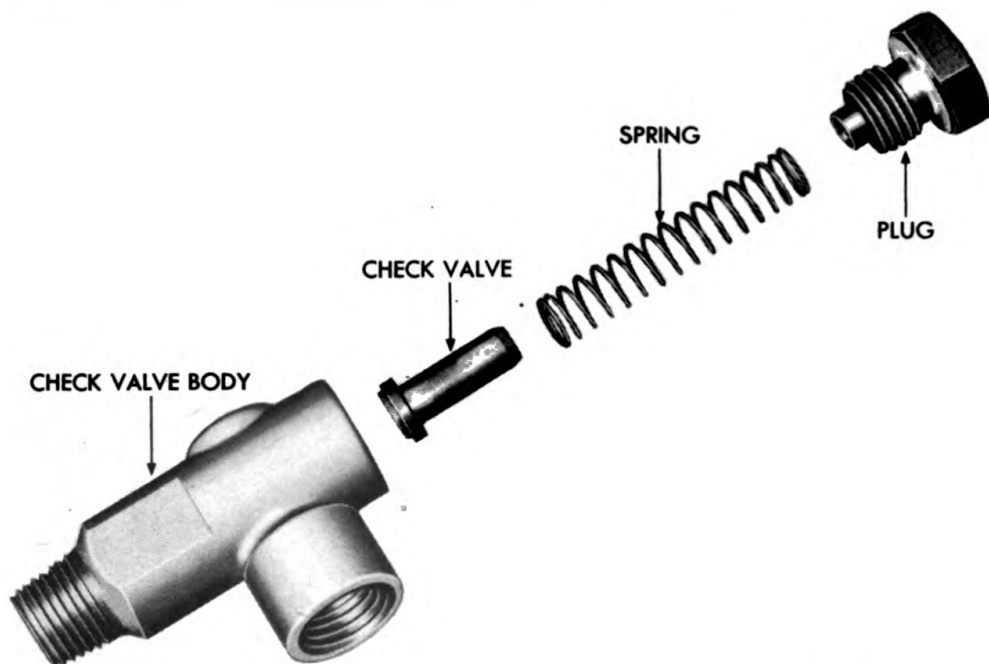

RA PD 321465

Figure 48—Check Valve Assembly

screw the T-fitting from the valve body. Unscrew the check valve body.

(2) **CLEANING.** Carefully unscrew the plug from the valve body, and remove the spring and check valve. Wash all the parts in dry-cleaning solvent. Blow dry with air hose. Insert the check valve in the end of the spring, and place check valve and spring in check valve body. Install plug.

(3) **INSTALLATION.** Screw the check valve assembly into its opening in fuel injector pump. Screw in the T-fitting. Connect the bleed-off manifold tube connector nut to the T-fitting. Connect the return line connector nut to the T-fitting.

75. FUEL SUPPLY PUMPS.

a. Description and Data.

(1) **DESCRIPTION** (fig. 49). The fuel supply (transfer) pumps are of two types: a mechanically-operated piston-type pump driven by the injector pump camshaft, and a separate hand-operated plunger-type priming pump. Both pumps are installed on the side of the injector pump. The mechanically-operated pump draws fuel from the fuel tanks and delivers it to the injector pump. The hand pump is used for priming and for bleeding the lines.

- A—PLUNGER
- B—HAND PRIMING PUMP ASSEMBLY
- C—GASKET
- D—CHECK VALVE SPRING
- E—CHECK VALVE
- F—SPACER
- G—LOCK WASHER
- H—NUT
- J—FUEL SUPPLY PUMP HOUSING

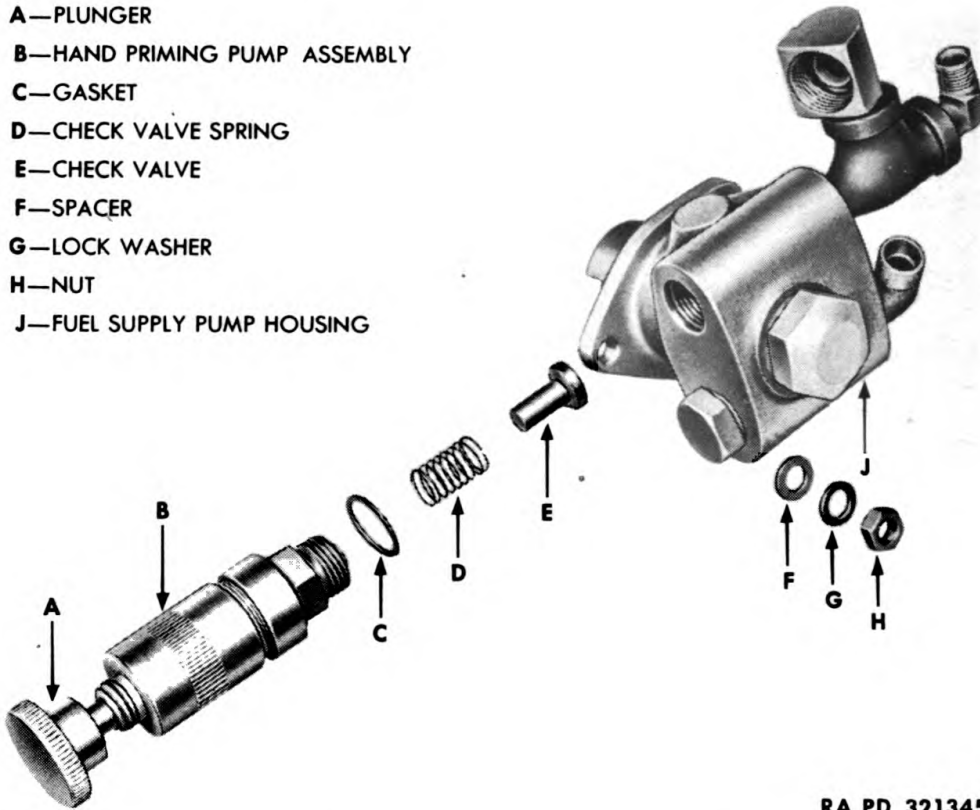

RA PD 321345

Figure 49—Fuel Supply Pump and Hand Priming Pump

(2) DATA.

Make American Bosch
 Type AFP/K (plunger, compensating, variable stroke)
 Size Large
 Location Side of injector pump
 Mounting Flanged, stud-fastened
 Drive Injector pump camshaft
 Type of priming pump Hand, plunger, vertical (over inlet valve)

b. Replacement of Hand Pump (fig. 47). Unscrew hand pump, placing wrench on hex adapter immediately above mechanical pump. Lift out pump, gasket, spring, and plunger. Install plunger and spring in mechanical pump opening. Install hand pump and gasket and screw down tight.

c. Replacement of Mechanical Pump (fig. 47).

(1) REMOVAL. Unscrew feed line connector. Unscrew fuel supply pump to priming pump line at fitting under fuel supply pump. Disconnect fuel line to secondary filter at connector on elbow on bottom

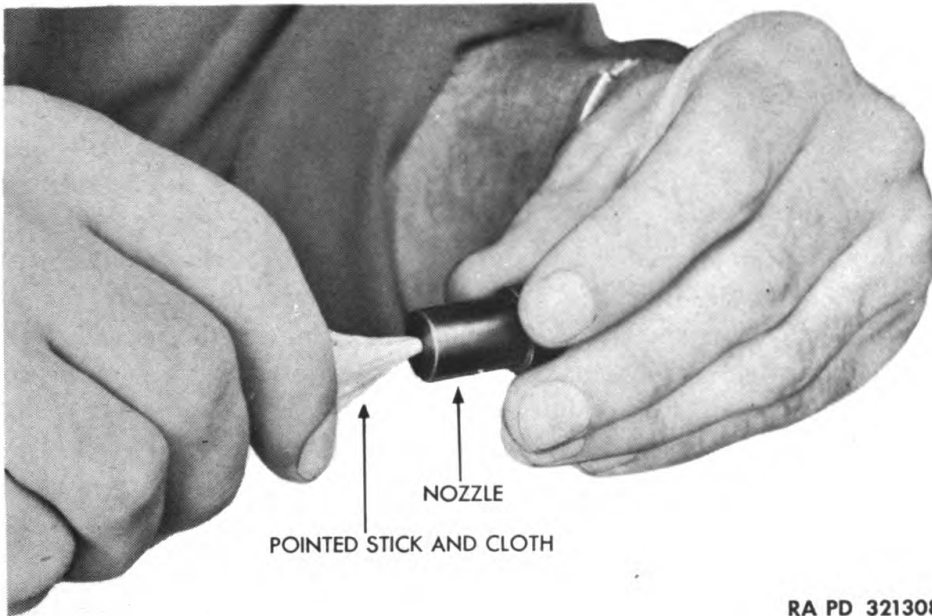

RA PD 321308

Figure 50—Cleaning Fuel Nozzle

of pump. Remove three nuts and lock washers which secure pump to studs and lift off pump.

(2) **INSTALLATION.** Position fuel supply pump in opening in fuel injector pump. Install spacers, lock washers, and nuts on pump mounting studs. Connect the priming pump to supply pump line to the elbow fitting under supply pump. Connect the fuel filter to supply pump line to the elbow on bottom of pump. Connect the feed line to the T-fitting attached to bottom of pump. Prime the pump and lines (par. 77 e).

76. INJECTOR NOZZLES.

a. Description and Data.

(1) **DESCRIPTION** (fig. 47). The injection of fuel into the engine is through six injector nozzles, one for each cylinder. Through hydraulic tube connections, these nozzles are connected to the individual pump elements of the injector pump. The nozzles are the "closed," differential needle (or pintle), hydraulically-operated type. They are termed "closed" because the valve is spring-loaded, seated at the orifice, and opened by hydraulic pressure of injection.

(2) DATA.

Make American Bosch
Type of nozzle Closed, pintle

b. **Removal** (fig. 47). Unscrew the fuel leak-off line connectors from fuel nozzles. Unscrew fuel pump to nozzle tube nut from lower end of each nozzle. Unscrew two stud nuts which secure each fuel nozzle clamp, and pull off fuel nozzle clamps. Pull out each fuel nozzle assembly.

c. **Cleaning and Testing** (fig. 50). Do not disassemble nozzle for cleaning. The only cleaning permitted is without disassembly and is confined to applying a brass-wire brush to the pintle end of the nozzle to remove carbon, or inserting a pointed stick, covered with a piece of soft rag into the fuel nozzle opening to polish the hole (fig. 50). Nozzles should be cleaned when the engine exhaust has an increased amount of black or dark smoke, when there is loss of power accompanied by foul exhaust, when engine runs rough or ragged, when there are irregular fuel knocks, or when the engine is missing on one or more cylinders continuously. After cleaning and installing nozzles, run the engine and observe performance to see if above conditions have been eliminated.

d. **Installation** (fig. 47). Insert fuel nozzle in its opening. Place fuel nozzle clamp on studs, and install stud nuts loosely. Connect leak-off line nuts to nozzles, and connect injector pump to nozzle lines to nozzles. Tighten stud nuts alternately and continuously so that no cocking or distortion of parts will occur. Do not tighten nuts excessively.

77. FUEL LINES.

a. **Description** (fig. 40). The fuel lines consist of the supply lines which carry the fuel from the fuel tanks to the filters, fuel supply pump, fuel injector pump, and to the gage and starter-burner mechanism; the high pressure lines which deliver fuel from the fuel injector pump to the nozzles; and the leak-off and return lines which carry the overflow from the pump and nozzles to the tanks. All fuel lines running between the tanks, fuel filters, and fuel pump are copper or flexible tubing covered with loom. The lines are equipped with brass coupling nuts so that lines can be disconnected and connected easily.

b. **Replacement and Cleaning of Supply Lines.** Disconnect each section of line by unscrewing the connector nuts on the ends. Remove tubing clips. Work tubing from vehicle. If tubing is plugged, apply compressed air at one end to blow obstruction from line. Do not apply air to any line if other end is connected. If a complete tubing assembly is not available for replacement purposes, cut new tubing to same length as original part and bend it on a tubing jig

Fuel System

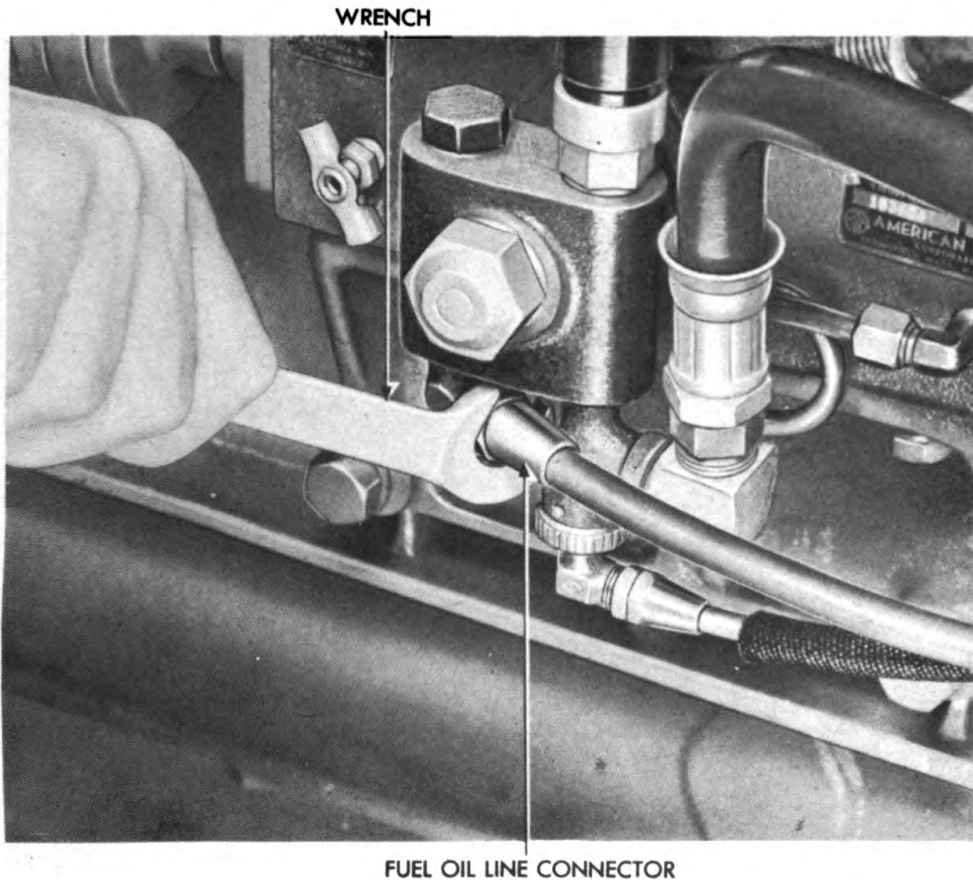

RA PD 321391

Figure 51—Disconnecting Feed Line Connector from Supply Pump

to same shape as original piece. Attach same type of connectors to ends. When installing tubing, place it in position on vehicle and connect ends by screwing on connector nuts. Install clips along length of tubing.

c. **High Pressure Lines** (fig. 47). Disconnect each end of fuel pump to injector nozzle line by backing off connector nuts. Remove line. Clean line by blowing compressed air through it. Place line in original position. Screw up connector nuts at each end to connect tube to nozzle and fuel injector pump.

d. **Leak-off Manifold Assembly Replacement** (fig. 47). Remove the air cleaners. Back off the tubing connectors from the six nozzle assemblies and from the connection tee on the check valve. Remove manifold clamp. Remove the manifold assembly. Place a new manifold assembly in position, and screw the tubing connectors to the nozzles and connection tee. Install manifold clamp. Install the two air cleaners.

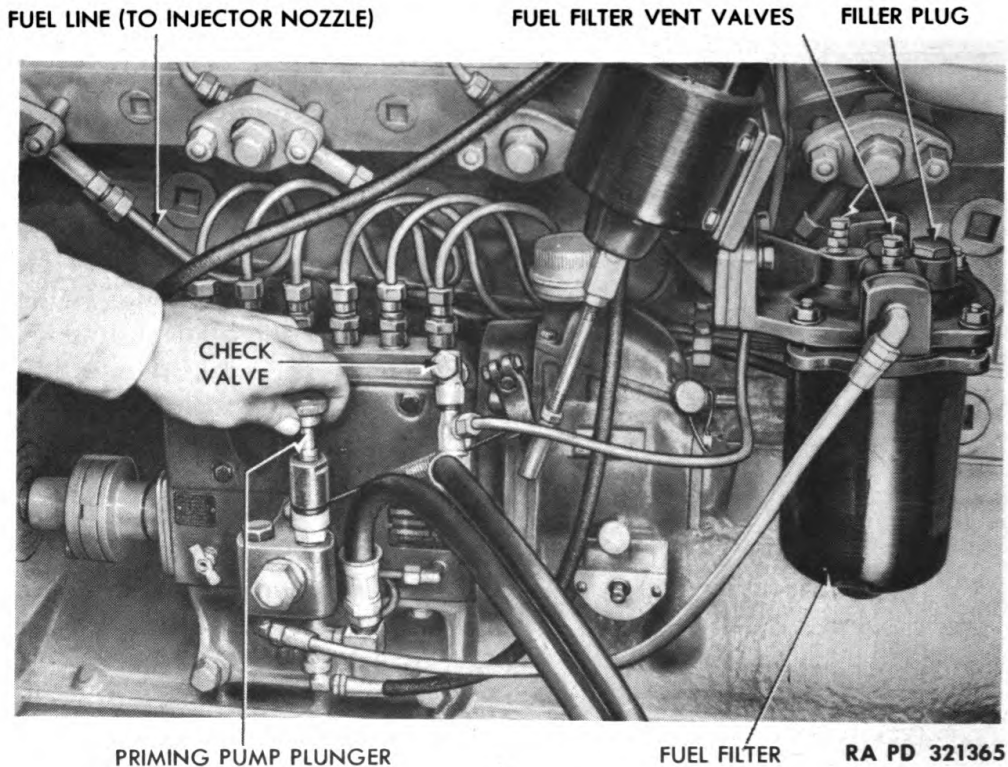

Figure 52—Bleeding Fuel Lines

e. Bleeding Fuel Lines.

(1) **GENERAL.** Air will enter the fuel lines because of loose fittings, replacement of filters or other units, or empty fuel tanks. The system must be bled to remove the air. Usually it is not necessary to open the vents at the various points of the system. Operating the hand priming pump on the fuel supply pump will often clear the lines from the supply pump of air. Should it be necessary to further bleed the system, proceed as in step (2) below.

(2) **BLEEDING PROCEDURE.**

(a) **Bleed Right Side.** Fill both fuel tanks to full capacity. Open the two gate valves located in the forward part of each battery compartment. Open the small vent valves located on top of fuel filters in right-hand compartment until a solid flow of fuel is coming from the vents. If necessary, put a slight amount of air pressure on the fuel tank by blowing into the tank fillers by mouth. **CAUTION: Do not splash fuel oil onto the batteries.** After all air has escaped from the lines and the filters on this side, so that a continuous flow of fuel (free of air) is coming from the vent valves, close the vent valves and the gate valves in this compartment.

(b) **Bleed Left Side.** Gate valves on right side remain closed

Fuel System

and those on left side are opened. Open vent valves on top of filters on left side and clear air from left side as for right side (step (a) above). When operation is completed, gate valves on this side are left open. Bleed the system through the injector pump as instructed in step (c) below.

(c) *Bleed Fuel System Through Injector Pump.* NOTE: The filters in both battery compartments must be cleared of air before the following operation is completed. Open the vent valves on the secondary filter located on the left-hand side of the engine. Using the hand priming pump located on the side of the fuel supply pump, pump fuel from the lines and through the filter until a solid flow of fuel (free of air) comes from the vent valves. Close vent valves and open check valve plug located at the fitting on the rear upper portion of the injector pump. Using the hand priming pump, continue pumping fuel through the injector until a solid flow of fuel is flowing from the check valve plug. Tighten the check valve plug.

(d) *Test Bleeding Procedure.* Operate engine and note operating condition. If engine operation is ragged and condition does not correct itself after reasonable operation, it will be necessary to disconnect the fuel supply pipes at each nozzle and pump fuel through the injector, using the hand priming pump on the fuel supply pump.

78. GOVERNOR.

a. Description and Data (fig. 47).

(1) DESCRIPTION. The governor, which is mounted on the rear of the injector housing, maintains the engine speed within set limits independent of the engine load. It also controls the engine idling speed to prevent stalling, and the maximum speed to prevent racing. The governor operating lever is connected to the throttle lever of the engine and is set to maintain a desired speed under a certain load. When the load changes, the governor acts upon the control rod of the injector pump to provide the proper fuel quantity to maintain the same speed under the new load. The governor must not be removed from the injector pump or adjusted by second echelon personnel except to see that the operating lever is fully closed when adjusting the stop control solenoid linkage (par. 79 b (3)).

(2) DATA.

Manufacturer American Bosch
Type 9VA-250

79. STOP CONTROL SOLENOID AND ENGINE STOP SWITCH.

a. Description and Data.

(1) DESCRIPTION. The stop control solenoid is installed above and to the rear of the fuel injector pump and is connected to the

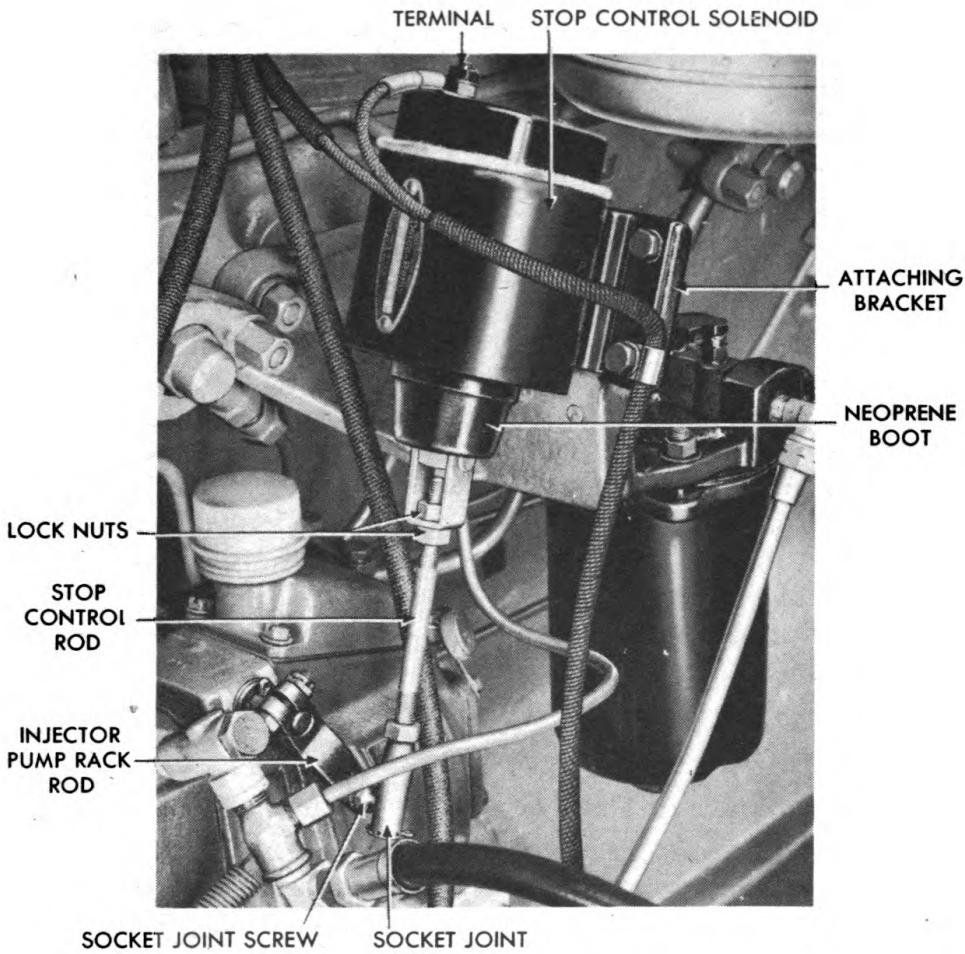

RA PD 321445

Figure 53—Stop Control Solenoid

battery through the engine stop switch on the instrument panel. The solenoid plunger is connected by linkage to the rack rod of the injector pump. When the engine stop switch button is pressed, the solenoid is energized, which results in the rack rod of the injector moving to the stop position. This closes the fuel delivery ports in the injector pump and cuts off the fuel supply to the engine.

(2) DATA.

Manufacturer Delco-Remy
 Model 1118061

b. Stop Control Solenoid Replacement and Linkage Adjustment (fig. 53).

(1) REMOVAL. Unscrew terminal post nut and remove yellow-red wire on top of solenoid. Unscrew socket joint screw from in-

Fuel System

jector pump rack rod. Remove four solenoid attaching screws and lock washers, and lift off solenoid. Do not change the length of the linkage.

(2) **INSTALLATION.** Place new stop control solenoid assembly against mounting bracket, and install four cap screws and lock washers, making sure the wire clip is attached to lower outside screw. Screw the socket joint screw into the injector rack rod. Connect yellow-red wire from junction block to terminal post of solenoid.

(3) **LINKAGE ADJUSTMENT.** Unscrew socket joint screw from injector pump rack rod. Hold stop control rod up into solenoid as far as possible. Loosen lock nut on the stop control rod, and turn rod until it exactly fits between the plunger and the operating lever in raised position. *NOTE: The plunger must "bottom" before the operating lever moves the fuel pump rack rod to the stop position.* Tighten stop control rod lock nuts. Screw the socket joint screw into rack rod.

c. **Engine Stop Switch Replacement (fig. 8).** Remove switch terminal nuts, and remove two wires from terminal posts. Loosen knurled nut on instrument panel. Remove switch through back of panel. Place new switch in instrument panel opening. Screw on knurled nut. Attach two yellow-red wires (fig. 84) to terminals of switch, and install terminal nuts.

80. FUEL PUMP PRESSURE GAGE.

a. **Description (fig. 8).** The fuel pump pressure gage, located on extreme left of instrument panel, indicates fuel pressure in the injector pump head. Pressure while engine is operating should be approximately 10 pounds. Bleeding of air into the fuel system, clogged filters, or valves will cause pressure drop; restricted return lines will cause pressure increase.

b. **Removal.** Unscrew coupling nut on fuel line at back of gage. Remove two nuts and two lock washers from gage stud bolts. Remove retainer bracket. Remove gage.

c. **Installation.** Position fuel pressure gage through front of instrument panel. Position retainer bracket on stud bolts. Install two lock washers and two nuts. Screw fuel line coupling nut on gage fitting.

81. ACCELERATOR AND THROTTLE LINKAGE.

a. **Description (figs. 54 and 55).** There are three means of controlling the engine speed: by the foot-operated accelerator, hand throttle on the instrument panel, and hand throttle mounted on the winch (fig. 12). The accelerator pedal operates a bell crank installed on a bracket underneath the toeboard. The bell crank is

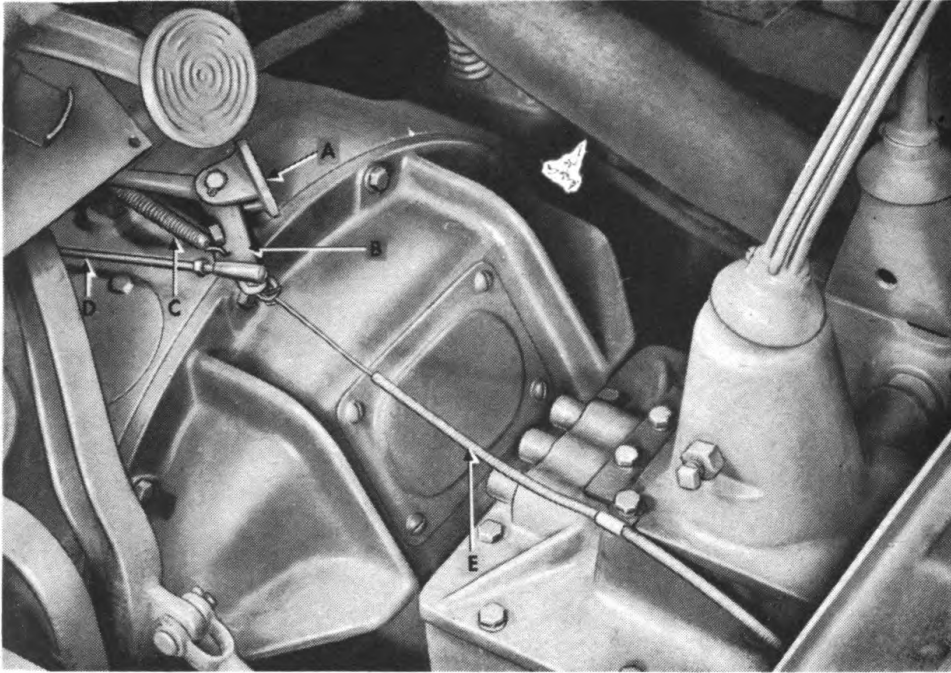

A—ACCELERATOR BELL CRANK BRACKET
 B—BELL CRANK
 C—THROTTLE PULL-BACK SPRING

D—THROTTLE ROD
 E—THROTTLE CONTROL CABLE

RA PD 321324

Figure 54—Accelerator and Throttle Linkage—Floor-board Removed

connected by a rod to the operating lever of the governor. The hand throttle installed on the instrument panel is directly connected by a cable wire to the governor operating lever. The winch-mounted throttle control is connected by cable wire to a lever which operates the throttle linkage bell crank.

b. Adjustment (fig. 55). Disconnect throttle rod from bell crank. Hold governor control lever to fully closed position. Hold accelerator pedal up to full limit. Loosen lock nuts on rear end of control rod. Screw the rear socket joint down or up on rod to lengthen or shorten rod. Tighten lock nut and connect socket joint to bell crank. Adjust throttle control on instrument panel by loosening the screw in the throttle control collar (at side of governor) and sliding the throttle wire forward as far as possible, with governor operating lever in closed position. Tighten screw in collar. Adjust throttle control on winch (fig. 12) by loosening swivel bolt on the idler lever under toeboard and pushing the throttle wire forward as far as possible with governor control lever fully closed.

Fuel System

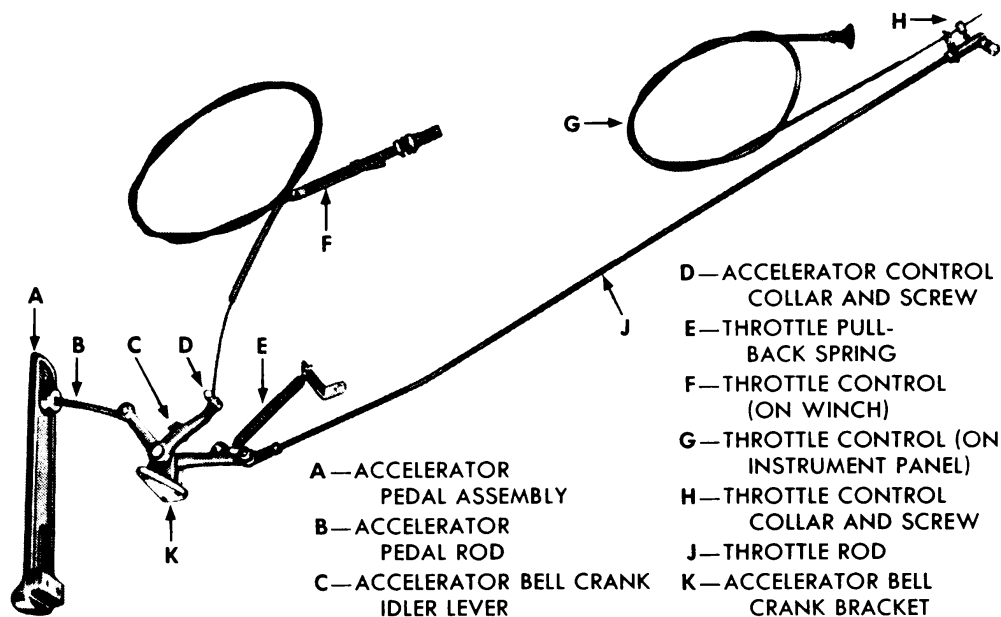

RA PD 321428

Figure 55—Accelerator and Throttle Control Linkage

c. Removal of Accelerator Pedal and Linkage (fig. 54).

(1) **REMOVE ACCELERATOR BELL CRANK BRACKET.** Open left side of hood. Remove cotter pin which secures accelerator pedal rod to bell crank. Remove pedal rod from bell crank. Lift pedal off toe-board. Remove three bell crank bracket bolts. Loosen set screw which secures winch-mounted throttle cable, and pull cable out of idler lever. Unhook pull-back spring from bell crank. Unscrew throttle rod socket joint nut while holding throttle rod socket joint, and pull socket joint away from bell crank.

(2) **REMOVE THROTTLE ROD (fig. 55).** Remove nut from socket joint at forward end of throttle rod. Pull rod away from governor operating lever. Loosen set screw which secures front end of throttle control wire to throttle rod control collar. Pull out wire from collar and clip. Lift out throttle rod.

d. Installation of Accelerator Pedal and Linkage (fig. 54).

(1) **INSTALL THROTTLE ROD.** Place throttle rod in position. Insert end of throttle wire through clip and throttle rod control collar. Tighten set screw in collar temporarily. Insert throttle rod front socket joint in governor operating lever, and install socket joint screw nut.

(2) **INSTALL ACCELERATOR BELL CRANK BRACKET.** Insert throttle rod socket joint in bell crank, and install socket joint nut.

Maintenance Instructions

Hook the pull-back spring into the bell crank. Insert the winch-mounted throttle control cable wire in the accelerator idler lever swivel, and tighten the swivel bolt. Position the bell crank bracket to the under side of the toeboard, and install the three bracket attaching bolts. Place the accelerator pedal on the toeboard. Connect accelerator pedal rod to bell crank.

(3) **ADJUST LINKAGE.** If throttle rod length has been changed, check adjustment. Adjust throttle control (subpar. b above).

e. **Removal of Throttle and Linkage.** Loosen set screw which secures front end of throttle control cable wire to throttle rod control collar. Loosen jam nut from under side of instrument panel which secures throttle control. Loosen screw from cable positioning clip mounted on left side of engine block (fig. 44). Pull out control cable from cowl and instrument panel.

f. **Installation of Throttle and Linkage.** Insert the end of the cable through the instrument panel opening and through the same cowl opening as the speedometer cable. Tighten jam nut against instrument panel to secure throttle control. Insert cable through cable positioning clip on left side of engine (fig. 44) and through the throttle rod control clip and collar (fig. 55). Pull wire forward as far as possible with governor control lever fully closed. Tighten set screw in collar.

g. **Removal of Winch-mounted Throttle and Linkage (fig. 12).** Loosen lock nut which secures throttle control knob to throttle cable, and unscrew knob and nut from cable. Loosen lock nut which secures cable housing to control bracket. Unscrew cap, pull cable from bracket, and remove lock nut. Open left side of hood. Loosen set screw which secures winch-mounted throttle cable to idler lever (fig. 54). Pull out cable from lever. Loosen clip which secures cable to transmission. Pull out control cable from vehicle.

h. **Installation of Winch-mounted Throttle and Linkage (fig. 54).** Position cable between winch and bell crank bracket under toeboard. Screw lock nut into winch end of cable housing. Insert housing into hole in control bracket and install cap. Tighten lock nut. Screw lock nut onto end of cable. Screw control knob onto cable and tighten lock nut. Install cable clip on transmission. Insert front end of cable wire into idle lever swivel bolt. Pull wire forward as far as possible. Tighten swivel bolt.

82. STARTER BURNER ASSEMBLY.

a. **Description (figs. 29 and 56).** The starter burner assembly, which is used to facilitate starting the engine in cold weather, is installed in a housing on the air intake manifold on left side of engine. The unit comprises a spark coil, high-tension electrode,

Fuel System

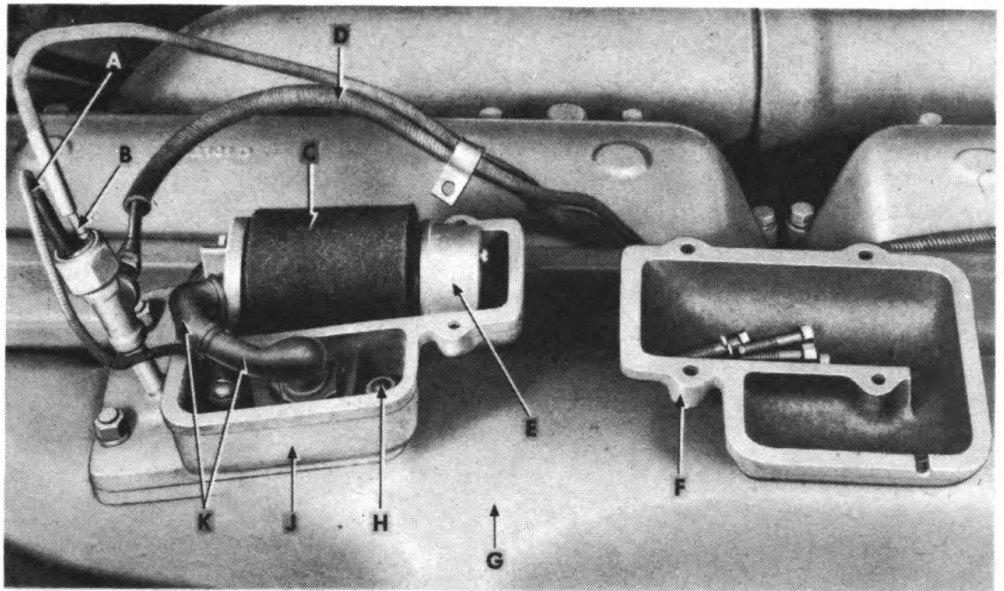

A—PRESSURE SWITCH TO
COIL CABLE

B—PRESSURE SWITCH TO JUNCTION
BLOCK WIRE

C—FELT PADDING

D—FUEL LINE FROM HAND
PRIMING PUMP

E—SPARK COIL

F—STARTER BURNER HOUSING
COVER, REMOVED

G—AIR INTAKE MANIFOLD

H—HOUSING STUD

J—STARTER BURNER HOUSING

K—HIGH TENSION CABLE
INSULATING NIPPLES

RA PD 321320

Figure 56—Starter Burner—Housing Cover Removed

ground electrode, nozzle, and pressure switch. It is supplied with fuel, by a fuel line from the hand priming pump on the left side of the instrument panel.

b. Fuel Nozzle Cleaning (figs. 56 and 57).

(1) **REMOVE STARTER-BURNER HOUSING.** Pull wire leads from pressure switch terminals. Remove starter-burner housing cover cap screws, and lift off housing cover. Back off fuel line coupling nut from T-fitting under pressure switch. Remove nuts from starter burner housing studs. Lift off housing and gasket.

(2) **REMOVE AND CLEAN NOZZLE.** Remove coil (subpar. d below). Remove electrodes (subpar. e below). Cut lock wire, and unscrew nozzle from its seat. Soak nozzle in dry-cleaning solvent. Blow clean with compressed air.

(3) **INSTALL NOZZLE.** Install nozzle in housing and tighten. Install lock wire to prevent nozzle from working loose. Install electrodes (subpar. e below). Adjust electrode gap (subpar. e below).

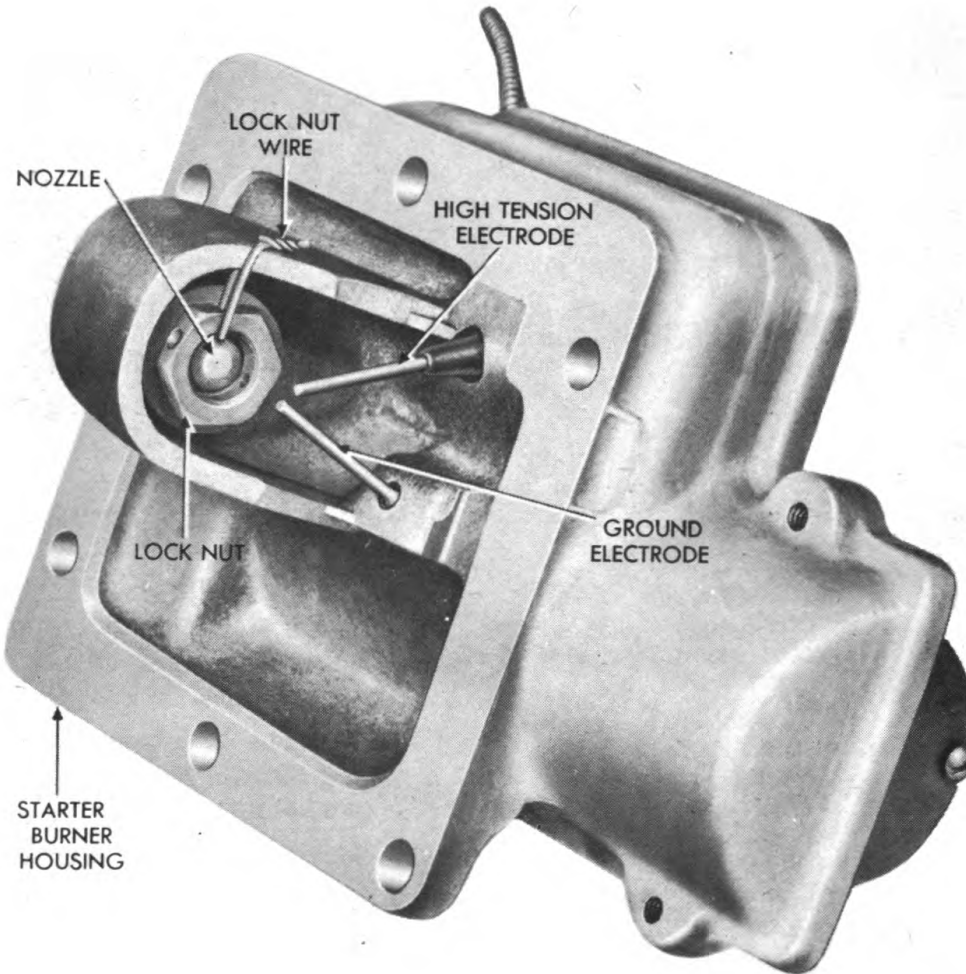

RA PD 321307

Figure 57—Starter Burner Housing Removed

(4) **INSTALL STARTER BURNER HOUSING.** Place new starter burner gasket in position on manifold. Place housing assembly over gasket, and install nuts on housing studs. Connect fuel line coupling nut to T-fitting under pressure switch. Install coil (subpar. d below). Place housing cover over housing, and install cover attaching cap screws. Install wire leads on pressure switch terminals.

c. Electrode Gap Adjustment (fig. 57).

- (1) Remove starter burner housing (subpar. b (1) above).
- (2) Insert $\frac{3}{32}$ -inch feeler gage between tips of high tension and ground electrodes. Bend ground electrode point to give $\frac{3}{32}$ -inch air gap.

Fuel System

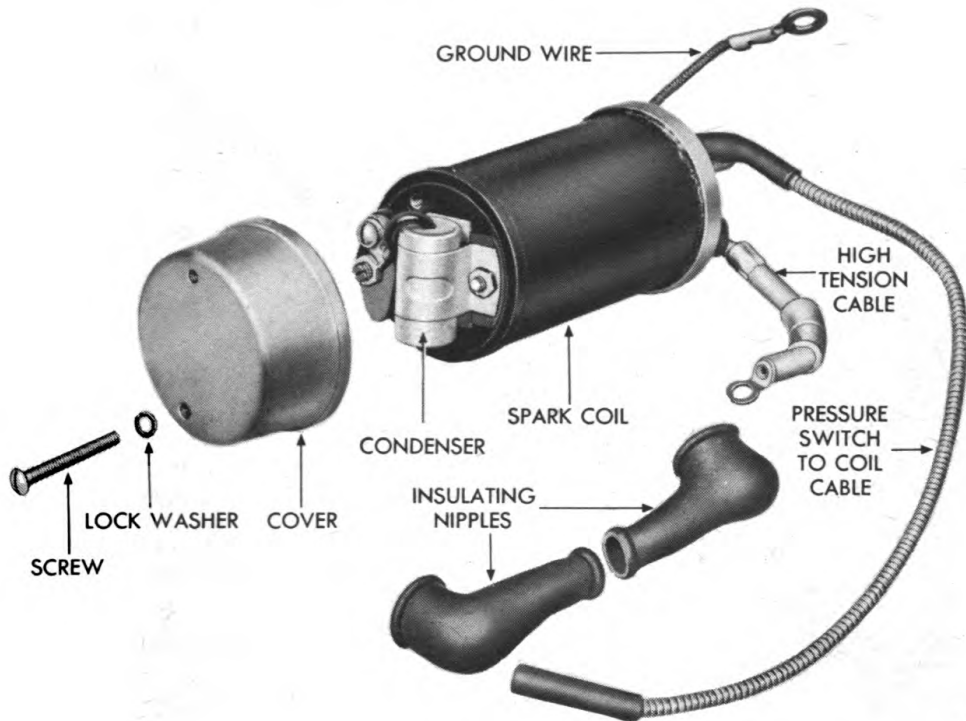

RA PD 321317

Figure 58—Starter Burner Spark Coil**d. Coil Replacement (figs. 56 and 58).**

(1) **REMOVAL.** Pull wire leads from pressure switch terminals. Remove starter burner housing cover cap screws, and lift off housing cover. Remove coil wire leads from spark plug and ground wire screw. Lift out spark coil and felt padding.

(2) **INSTALLATION.** Place coil in starter burner housing. If insulating nipples have been removed from high tension cable, place insulating tube and two insulating nipples on cable. Connect one end of high tension cable to high tension electrode and other end to coil terminal. Connect ground wire to ground terminal of coil and to ground screw in housing. Connect No. 14 armored wire to terminal post of coil and to one of the terminals of the pressure switch. Cover the coil with felt padding, and place housing cover in position over housing. Install housing cover cap screws and lock washers. Install wire from junction block on second terminal of pressure switch.

e. Electrode Replacement (fig. 57). Remove starter burner housing (subpar. b above). Unscrew high tension electrode retainer and lift off retainer gasket. Remove high tension electrode and fish out electrode gasket. Place new gasket and electrode in opening in housing. Place gasket and electrode retainer over electrode and screw

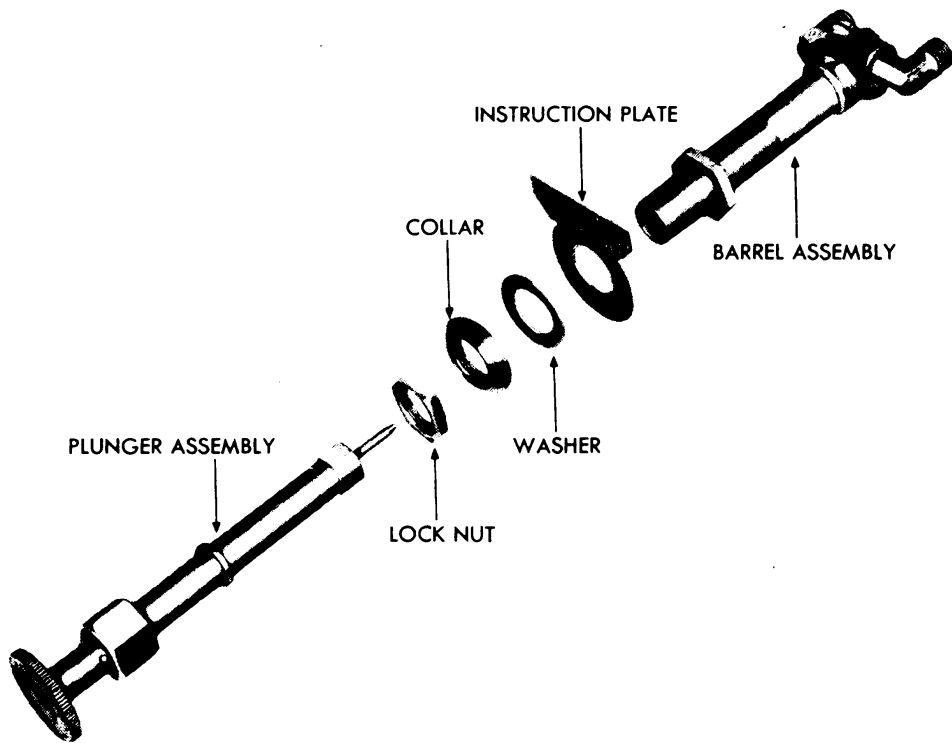

RA PD 321457

Figure 59—Hand Priming Pump Assembly

retainer down tight. Unscrew ground electrode and lock washer from housing. Place ground electrode and lock washer in housing opening and screw tight. Adjust gap between electrodes (subpar. c above).

f. **Pressure Switch Replacement** (fig. 56). Pull wire leads from pressure switch terminals. Unscrew pressure switch from T-fitting. Thread new pressure switch into T-opening and push wire lead terminals over pressure switch terminals.

83. HAND PRIMING PUMP AND LINES.

a. **Description** (figs. 8 and 59). The hand priming pump, installed on the left side of the instrument panel, is used to force fuel oil through the nozzle of the starter burner when the engine is being started in temperatures below 50°F. When the pump is operated by pulling out and pushing in the plunger by hand, it draws fuel oil from the fuel supply pump and delivers it to the starter burner nozzle.

Fuel System

b. Removal (figs. 8 and 59).

(1) **REMOVE PUMP.** Loosen the adjusting nut and pull the plunger out of the body. Unscrew upper lock nut and spacer. Pull off washer and instruction plate. From under instrument panel, back off tubing connector nuts and pull tubing away from pump fittings. Pull body out of hole in instrument panel.

(2) **REMOVE LINES.** Disconnect the two lines from the pump by loosening the tube connectors under the instrument panel. Disconnect the two lines at the connectors in front of the cowl (fig. 124). Pull the lines out of the cowl. Remove clips securing lines to cowl and remove lines. Remove clips which secure pressure line to engine cylinder heads and to starter burner housing cover (fig. 31). Back off connector at the starter burner T-fitting (fig. 56). Remove pressure line. Disconnect supply line from fuel supply pump fitting by backing off connector nut. Remove supply line from engine.

c. Installation.

(1) **INSTALL PUMP (figs. 8 and 59).** Place priming pump body with lock nut in opening in instrument panel, inserting it from the rear. Place the instruction plate and washer over end of body. Screw on the beveled spacer and lock nut. Insert plunger and tighten the adjusting nut. Connect supply line from fuel supply pump to left elbow fitting of pump. Operate pump to see if fuel is being pumped. Connect pressure line to right elbow fitting of pump.

(2) **INSTALL LINES.** Position supply line from fuel supply pump to fitting on pump (fig. 47), and partially tighten connector nut until all lines are installed and threads alined. Position fuel supply pressure line to connector at the starter burner T-fitting, and partially tighten connector nut (fig. 56). Install clips which secure pressure line to engine cylinder heads and to starter burner housing (fig. 31). Insert lines through cowl and position ends of lines to fittings at fuel pump and to connectors at front of cowl (fig. 124). Supply line from fuel supply pump is connected to pipe which is connected to left elbow fitting on hand pump (fig. 47). Partially tighten connector nuts at each end of pipes before tightening any one of the nuts so that pipes and threads are easily alined. After pipes are alined and all connector nuts are properly started on threads, tighten all nuts at connectors and pipe fittings. Position pipes in clips on cowl, and tighten screws which attach clips and pipes to cowl. Check all connector nuts to make sure they are properly tightened.

Section XVI**AIR INTAKE AND EXHAUST SYSTEMS****84. DESCRIPTION AND DATA.**

a. **Description** (fig. 27). The air intake system consists of the two oil-bath air cleaners attached to the lower side of the air intake manifold on the left side of the engine. The exhaust system comprises the exhaust pipe, muffler, and tail pipe, which is attached to the right-hand side frame rail.

85. AIR CLEANERS.

a. **Description and Data** (figs. 27 and 60).

(1) **DESCRIPTION.** The two oil-bath type air cleaners are mounted on the air intake manifold on the left side of the engine. They are used to remove all grit and dust from the air which is drawn into the engine. This is accomplished by drawing the air through a fine metal mesh. Foreign matter flows down to the oil in the lower bowl where it is trapped.

(2) **DATA.**

Manufacturer Air-maize
 Oil capacity (each) 2 pt

b. **Service** (figs. 27 and 60). Loosen the wing screw under the bottom plate, and remove the air cleaner assembly. Pull out the top and skirt assembly, filter element, and baffle plate. Clean out the lower bowl and refill with engine oil up to the bead. Wash the filter element in dry-cleaning solvent. Inspect gaskets and install new ones if damaged. Wash baffle plate, top, and skirt assembly. Place baffle plate in lower bowl. Position filter element on baffle plate. Install top and skirt assembly. Insert screw which projects through bottom plate into lower gasket and through air cleaner assembly. Position air cleaner to air manifold, and tighten wing screw. Service the second air cleaner in the same manner.

86. EXHAUST PIPE, MUFFLER, AND TAIL PIPE.

a. **Description** (figs. 61 and 123). The exhaust pipe, muffler, and tail pipe are located just inside the right-hand side frame rail. The exhaust pipe is bolted to the front end of the exhaust muffler and carries exhaust gases to the muffler. Attachment to muffler is made by inserting the pipe into muffler tube. Tube is tightened by means of a U-bolt clamp. The tail pipe extends from the rear of the muffler through the rear frame rail of the chassis and is clamped to the muffler and to the frame by U-bolts.

Air Intake and Exhaust Systems

RA PD 321309

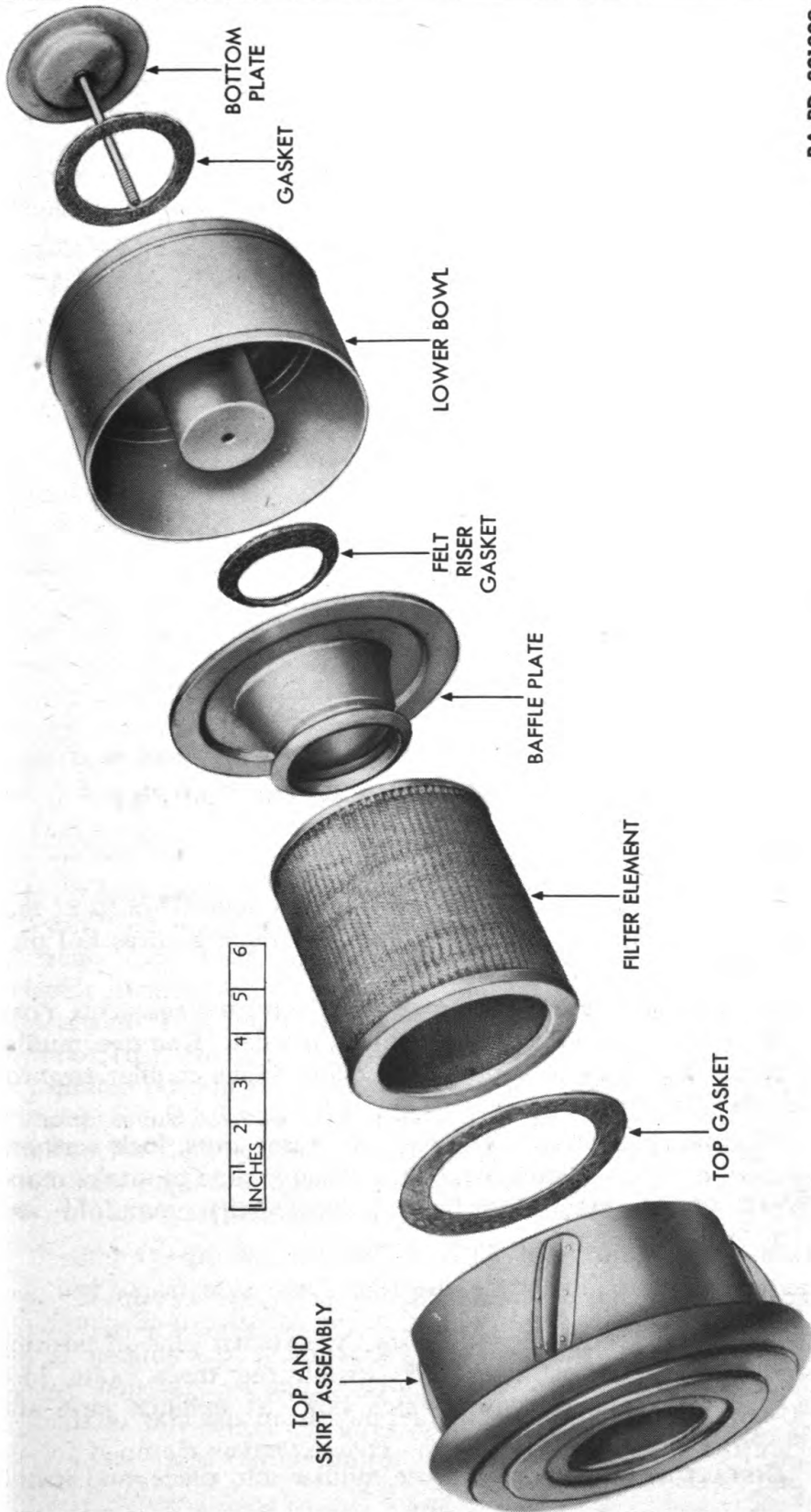
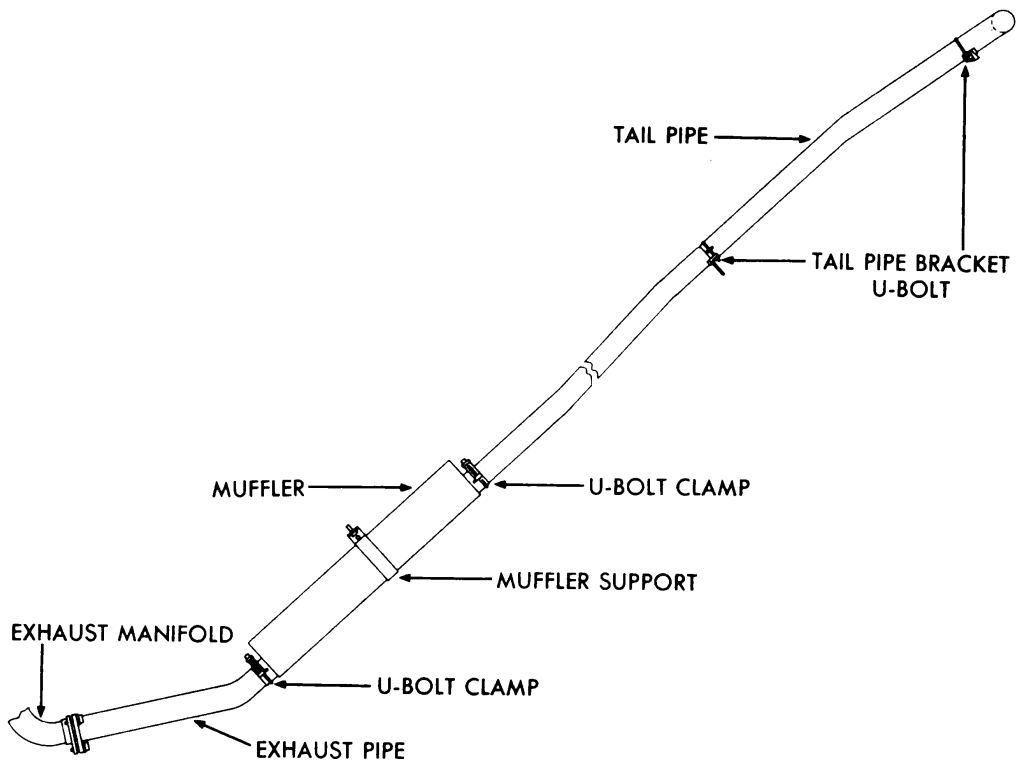

Figure 60—Air Cleaner Assembly



RA PD 321305

Figure 61—Exhaust Pipe, Muffler, and Tail Pipe

b. Removal (figs. 61 and 123).

(1) **REMOVE TAIL PIPE.** Loosen tail pipe bracket U-bolts at rear and center of tail pipe. Loosen U-bolt clamp which secures tail pipe to muffler. Pull tail pipe from rear of chassis.

(2) **REMOVE MUFFLER.** Remove right-hand air reservoir (par. 163 c). Remove U-bolt clamp at front of muffler. Remove muffler support clamp bolt nuts in center of muffler. Move muffler towards rear and lower it from chassis.

(3) **REMOVE EXHAUST PIPE.** Remove three nuts, lock washers, plain washers, and bolts which attach the exhaust pipe to intake manifold. Work the exhaust pipe back from exhaust manifold and remove it.

c. Installation (figs. 61 and 123).

(1) **INSTALL EXHAUST PIPE.** Place the exhaust pipe in position with front end in exhaust manifold. Install the three bolts, lock washers, plain washers, and nuts which bolt the exhaust pipe and manifold together.

(2) **INSTALL MUFFLER.** Raise the muffler into place, and install

Cooling System

the muffler support clamp bolt nuts. Push muffler forward to engage it with the exhaust pipe. Install U-bolt clamp which secures muffler to exhaust pipe.

(3) **INSTALL TAIL PIPE.** Push tail pipe into position in chassis from rear end. Fit forward end over muffler tube. Tighten bracket U-bolts at rear and center of tail pipe. Tighten U-bolt clamp which secures tail pipe to muffler.

Section XVII

COOLING SYSTEM

87. DESCRIPTION.

a. **Description** (fig. 62). The cooling system consists of a radiator, fan, engine-mounted water pump, thermostatic temperature control, and connecting hose. The water pump forces circulation through the system as shown in figure 62. The system is the pressure-cooling type, with a mechanism in the radiator cap to keep the internal pressure several pounds per square inch above atmospheric pressure. Temperature control is of the "cold-circulation" type, in which during warm-up there is free circulation through the radiator and no circulation through the engine water jackets.

88. SERVICE.

a. **Cleaning.** Clean the outside of the fins and tubes of the radiator to remove insects and dirt by blowing with a compressed air hose. To clean inside passages of radiator and block use a cleaning solution made with 1 pound of sal soda or ½ pound of soda ash to 1 gallon of water. Run engine at idling speed to stir up loose rust; then drain cooling system by opening the pet cocks on radiator bottom tank, water outlet fitting, and left side of engine cylinder block. Close radiator, outlet fitting, and cylinder block drain cocks. Fill system with a soda ash mixture. Install radiator cap. Run engine to approximately 180°F, but do not allow solution to boil. Run engine at least 30 minutes. Stop engine and drain cooling system. Flush cooling system (subpar. c below).

b. **Neutralizing.** The cooling system must be free of rust and scale. Use of inhibitors or rust preventive reduces or prevents corrosion of metals, and prevents formation of scale. Clean the cooling system (subpar. a above). Close the drain cocks. Refill system with clean soft water or antifreeze solution, as conditions require (par 18). Add the inhibitor to the cooling liquid. When re-

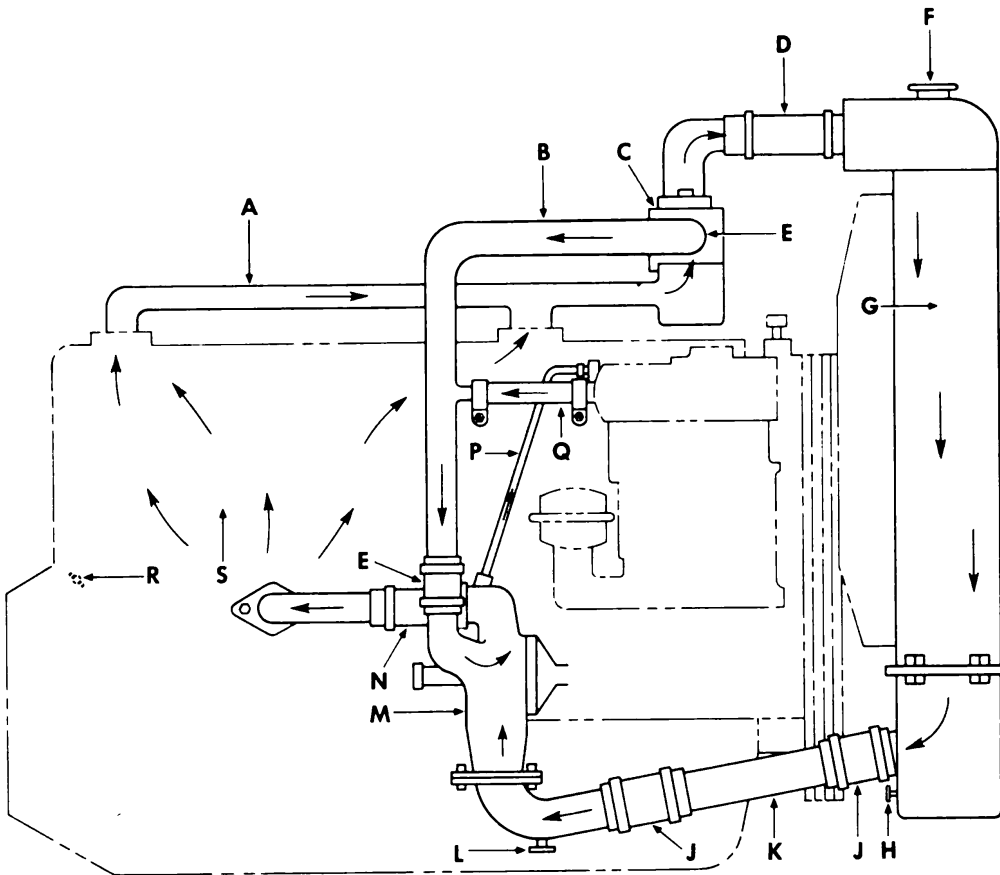

- | | |
|-----------------------------------|---|
| A—WATER OUTLET MANIFOLD | L—WATER PUMP INLET FITTING AND DRAIN COCK |
| B—THERMOSTAT BY-PASS TUBE | M—WATER PUMP |
| C—THERMOSTAT HOUSING | N—WATER PUMP OUTLET HOSE |
| D—RADIATOR WATER INLET HOSE | P—AIR COMPRESSOR INTAKE WATER LINE |
| E—BY-PASS TUBE HOSE | Q—AIR COMPRESSOR EXHAUST NIPPLE HOSE |
| F—RADIATOR FILL CAP | R—ENGINE WATER JACKET DRAIN COCK |
| G—RADIATOR | S—WATER JACKET |
| H—RADIATOR DRAIN COCK | |
| J—RADIATOR WATER OUTLET TUBE HOSE | |
| K—RADIATOR WATER OUTLET TUBE | |

RA PD 321315

Figure 62—Cooling System

filling, bring level of coolant up to point of visibility, to allow room for expansion.

c. **Flushing.** The cylinder block, radiator, and air compressor may be cleaned of excessive sediment by pressure flushing. Loosen the water pump outlet hose (par. 93 b), and open drain plug in cylinder block. Remove thermostat from the thermostat housing

Cooling System

(par. 92 b). Install housing without the thermostat. Use a pressure hose to force water into the block through the water outlet manifold. Continue to force water through until it runs out clear of sediment. Flush radiator by disconnecting radiator hose and applying pressure hose to upper hose opening. Allow water to run until it comes out clear. After flushing, remove thermostat housing and install thermostat (par. 92 c). Tighten water pump outlet hose (par. 93 c (3)). Close drain plugs. Connect radiator hose and tighten hose clamps. Fill system (subpar. b above). Flush air compressor by disconnecting inlet and outlet tubes, and apply pressure hose to intake opening.

d. **Leaks.** Trace source of leak, and if leak is at hose connection, tighten hose clamp or install new hose. If radiator leaks, remove radiator (par. 91 b). Install new radiator (par. 91 c).

89. WATER PUMP.

a. Description and Data.

(1) **DESCRIPTION** (fig. 28). The water pump, located on the right side of the engine, is used to circulate the cooling fluid in cooling system. The pump is driven by the camshaft gear. It is of the centrifugal-packless type with spring-loaded water seals which require no attention.

(2) **DATA.**

Manufacturer	Hercules
Model	88662-DS
Type	Packless
Drive	Gear
Location	Right-hand side of engine

b. Removal.

(1) **DRAIN COOLING SYSTEM.** Open drain cocks under radiator and water pump outlet fitting, and allow liquid to drain.

(2) **REMOVE HOSE TUBES.** Loosen hose clamps on thermostat by-pass tube lower hose, and slide hose up from water pump. Loosen hose clamps from hose on water pump outlet, and slide hose away from outlet.

(3) **DISCONNECT WATER PUMP INLET FITTING.** Remove two inlet fitting bolts and lock washers. Pull water pump inlet fitting and gasket away from water pump.

(4) **DISCONNECT AIR COMPRESSOR INTAKE WATER LINE.** Back off connector nut on the water pump end of air compressor intake water line. Pull line away from water pump.

(5) **REMOVE GENERATOR.** Remove generator as instructed in paragraph 114 d.

(6) **DISCONNECT TACHOMETER CABLE.** Unscrew knurled nut on tachometer cable, and pull tachometer cable out of adapter.

(7) **REMOVE WATER PUMP.** Remove cap screws and stud nut which attach the water pump to the engine. Pull the water pump straight back and remove it.

c. Installation.

(1) **POSITION WATER PUMP.** Place new water pump attaching gasket in place. Place water pump in position behind mounting studs. Push it straight forward. Install the cap screws and stud nut.

(2) **CONNECT TACHOMETER CABLE.** Screw the tachometer cable knurled nut on the tachometer adapter.

(3) **INSTALL GENERATOR.** Install generator as instructed in paragraph 114 e.

(4) **CONNECT AIR COMPRESSOR INTAKE WATER LINE.** Position the air compressor intake water line on the water pump, and screw on the tube connector.

(5) **CONNECT WATER PUMP INLET FITTING.** Place a new gasket and water pump inlet fitting in position on water pump. Install two attaching cap screws and lock washers.

(6) **CONNECT HOSE TUBES.** Slide the thermostat by-pass tube lower hose down on water pump and tighten hose clamps. Slide hose over water pump outlet to engine and tighten hose clamps.

(7) **FILL COOLING SYSTEM.** Fill cooling system as instructed in paragraph 88 b.

90. FAN AND PULLEY ASSEMBLY.

a. Description and Data.

(1) **DESCRIPTION** (fig. 63). The fan is an 8-bladed roller-bearing type, mounted on a bracket at front of engine and belt-driven by three pulley belts which also drive the air compressor.

(2) **DATA.**

Manufacturer	Schwitzer-Cummins
Model	DX5928
Number of blades	8
Drive	Triple V-belts
Fan belt number	N1463F

b. Removal (figs. 63, 64, and 65).

(1) **REMOVE FAN.** Open drain cock under radiator and drain radiator. Remove engine hood and radiator stay rod (par. 204 b). Loosen hose clamps on radiator water inlet and outlet tube hoses. Remove cotter pin and loosen castle nut on each of the two radiator

Cooling System

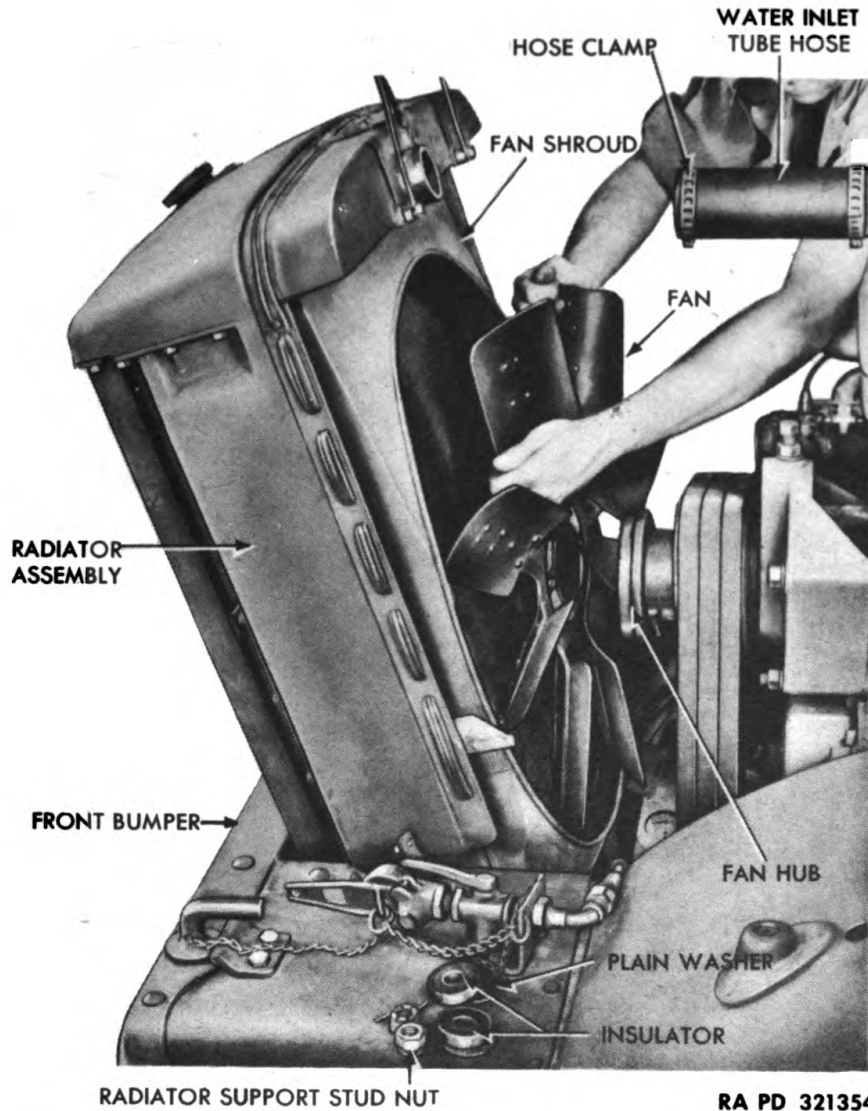

Figure 63—Removing Fan

support studs. Tilt radiator forward. Remove cap screws which secure fan blade to fan hub. Lift off fan blade, gasket, spacer, and second gasket.

(2) **REMOVE THE FAN BELTS** (fig. 64). Loosen clamp washer nut, and loosen adjusting screw jam nut and adjusting screw until the fan belts are slack. Work the fan belts off the air compressor pulley and crankshaft pulley.

(3) **REMOVE THE PULLEY ASSEMBLY.** Remove the adjusting screw. Remove the clamp washer nut and lock washer. Pull the fan pulley assembly forward out of the mounting bracket.

(4) **REMOVE THE MOUNTING BRACKET** (fig. 64). Remove the four studs nuts and lock washers which attach the mounting bracket to the engine.

c. Installation.

(1) **INSTALL MOUNTING BRACKET** (fig. 64). Place the mounting bracket in position on the engine block studs. Install the four lock washers and nuts.

(2) **INSTALL PULLEY ASSEMBLY** (fig. 64). Insert the fan spindle in the mounting bracket opening. Install the lock washer and clamp washer nut, but do not tighten. Screw in the adjusting screw, lock washer, and jam nut through the mounting bracket and fan spindle, but do not tighten.

(3) **INSTALL FAN BELTS** (fig. 38). Place the fan belts over the air compressor fan and crankshaft pulleys. Adjust the fan belts (subpar. e below).

(4) **INSTALL FAN** (fig. 63). Place gasket, spacer, second gasket, and fan on fan hub. Install fan blade cap screws and lock washers. Tilt radiator back to vertical position. Tighten the two castle nuts on radiator support studs. Install cotter pins in nuts. Fit water inlet and outlet hose tubes over radiator inlet and outlet. Tighten hose clamps. Install radiator stay rod and engine hood (par. 204 c). Fill cooling system (par. 88 b).

d. Fan Belt Replacement. Loosen clamp washer nut and back off fan adjusting screw jam nut and screw until the fan belts are slack. Work the fan belts off the air compressor pulley and crankshaft pulley. Work the fan belts off around the fan blades. Install new fan belts by working them over the fan blades. Work belts over fan hub, air compressor pulley, and crankshaft pulley. Adjust fan belts (subpar. e below).

e. Fan Belt Adjustment (fig. 64). Test tension of belts by measuring the amount of deflection when belts are depressed on longest side. Adjust tension to give 1-inch deflection by loosening clamp washer nut and turning adjusting screw, using special wrench. When tension is adjusted, tighten adjusting screw jam nut.

91. RADIATOR.

a. Description and Data (figs 63, 65, and 150).

(1) **DESCRIPTION.** The radiator consists of a fin-and-tube type core, with upper and lower tanks. Air drawn by the action of the fan cools the liquid as it is drawn downward through the radiator. The cooling system is filled through an opening at the top center of the radiator which is closed by a pressure-type cap fitted with gasket (G509-01-94031).

Cooling System

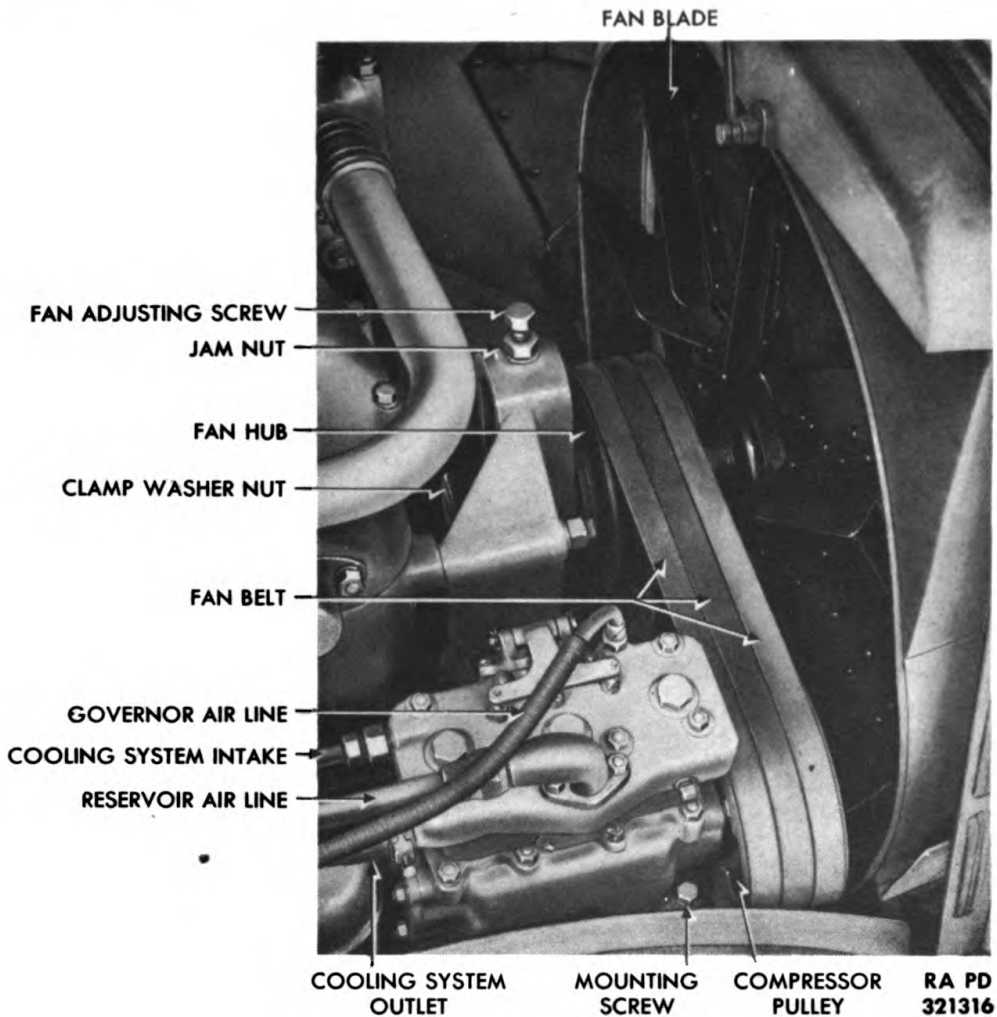

Figure 64—Fan Belt Adjustment

(2) DATA.

Manufacturer Modine
 Model 3758-102
 Type Tube-and-fin

b. Removal (figs. 63 and 150).

(1) **DRAIN RADIATOR.** Open drain cock on bottom of radiator and allow liquid to drain.

(2) **REMOVE ENGINE HOOD AND RADIATOR STAY ROD.** Remove engine hood and radiator stay rod (par. 204 b).

(3) **DISCONNECT BOND STRAP (fig. 150).** Remove cap screw,

Maintenance Instructions

lock washer, and toothed lock washer which secure ground strap to left lower corner of radiator.

(4) **DISCONNECT HOSES.** Loosen hose clamps at radiator end on the water inlet and outlet tube hoses.

(5) **REMOVE SUPPORT STUD NUTS** (fig. 63). Remove cotter pin, castle nut, plain washer, and insulator from each of the two radiator support studs.

(6) **REMOVE FAN BLADE.** Tilt the radiator forward. Remove cap screws which secure fan blade to fan hub. Lift off fan blade, gasket, spacer, and gasket.

(7) **LIFT OFF RADIATOR.** Lift radiator until support studs are clear of radiator support crossmember. Move left corner of radiator to rear as far as possible, and bring right corner forward as far as possible. Lift radiator straight up.

c. Installation.

(1) **INSTALL RADIATOR ON RADIATOR SUPPORT CROSSMEMBER** (fig. 63). Place large flat radiator support insulator on each of two support studs. Lift radiator up to top of bumper in vertical position. Move left side of radiator toward engine and right side away from engine, and lower radiator until it rests on radiator support crossmember. Straighten radiator and insert radiator support studs in their openings. Install rubber insulation, plain washer, and castle nut on each of the support studs, but do not tighten. Tilt radiator forward at the top.

(2) **INSTALL FAN.** Place gasket, spacer, second gasket, and fan on fan hub. Install fan blade cap screws and lock washers.

(3) **TIGHTEN RADIATOR SUPPORT STUD NUTS.** Tighten radiator support stud nuts and install cotter pins.

(4) **CONNECT HOSES.** Work the radiator water inlet and outlet hose tubes over the radiator tubes, and tighten the hose clamps.

(5) **CONNECT BOND STRAP** (fig. 150). Install the cap screw, lock washer, and toothed lock washer which secures the ground strap to left lower corner of radiator. Be sure toothed lock washer is in contact with clean, unpainted metal.

(6) **INSTALL RADIATOR STAY ROD AND ENGINE HOOD.** Install radiator stay rod and engine hood as instructed in paragraph 204 c.

(7) **REFILL COOLING SYSTEM.** Refill cooling system as instructed in paragraph 88 b.

92. THERMOSTAT AND HOUSING.**a. Description and Data.**

(1) **DESCRIPTION.** The thermostat is installed in the thermostat housing attached to the front of the water outlet manifold above the front cylinder head. It is an automatic-type valve which controls the flow of water to the radiator. Its normal position is closed.

Cooling System

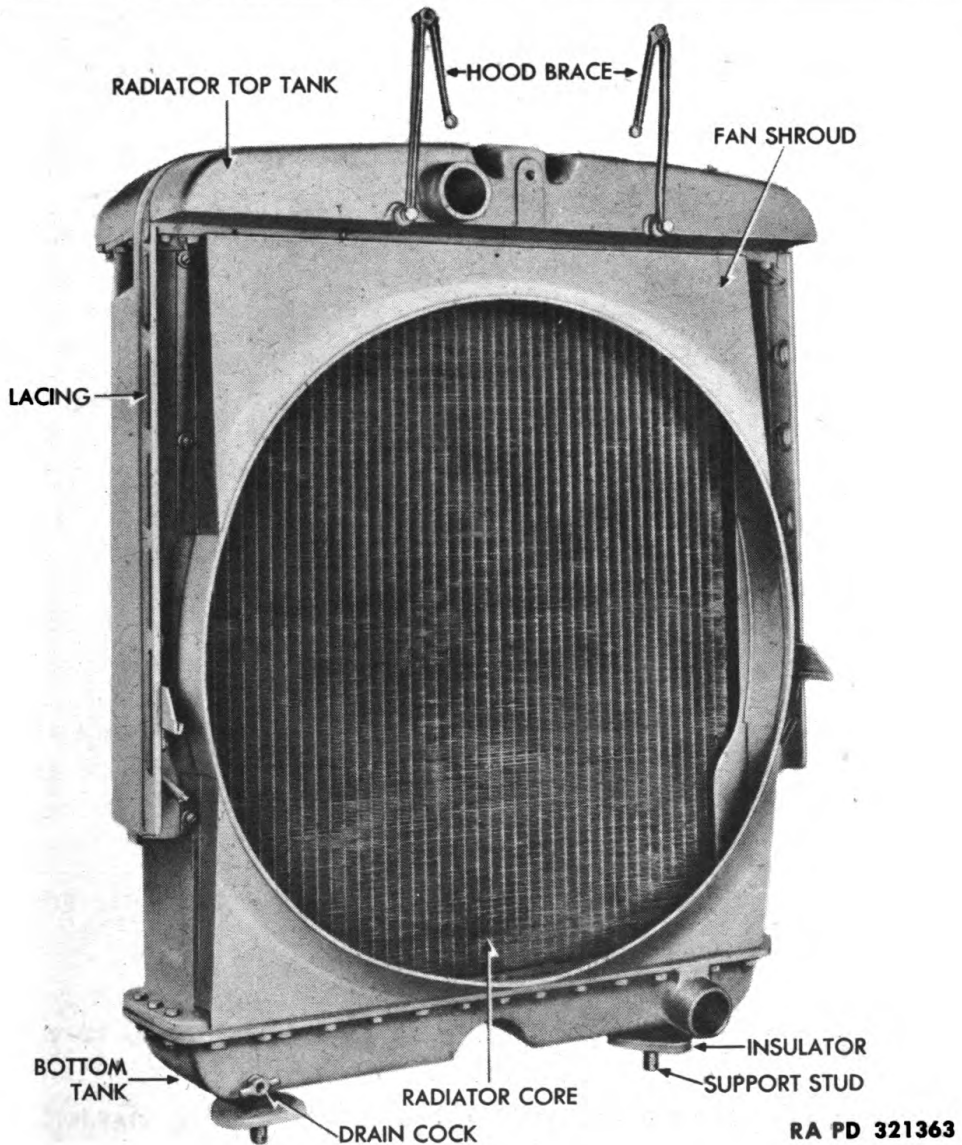

Figure 65—Radiator Assembly

It is designed to be fully closed at 140°F and fully open at 165°F. The thermostat body contains a by-pass which allows some water to pass through to a by-pass tube when the thermostat is closed.

(2) DATA.

Manufacturer	Fulton Syphon
Model	105 HB
Type	By-pass
Opens	165°F
Closes	140°F

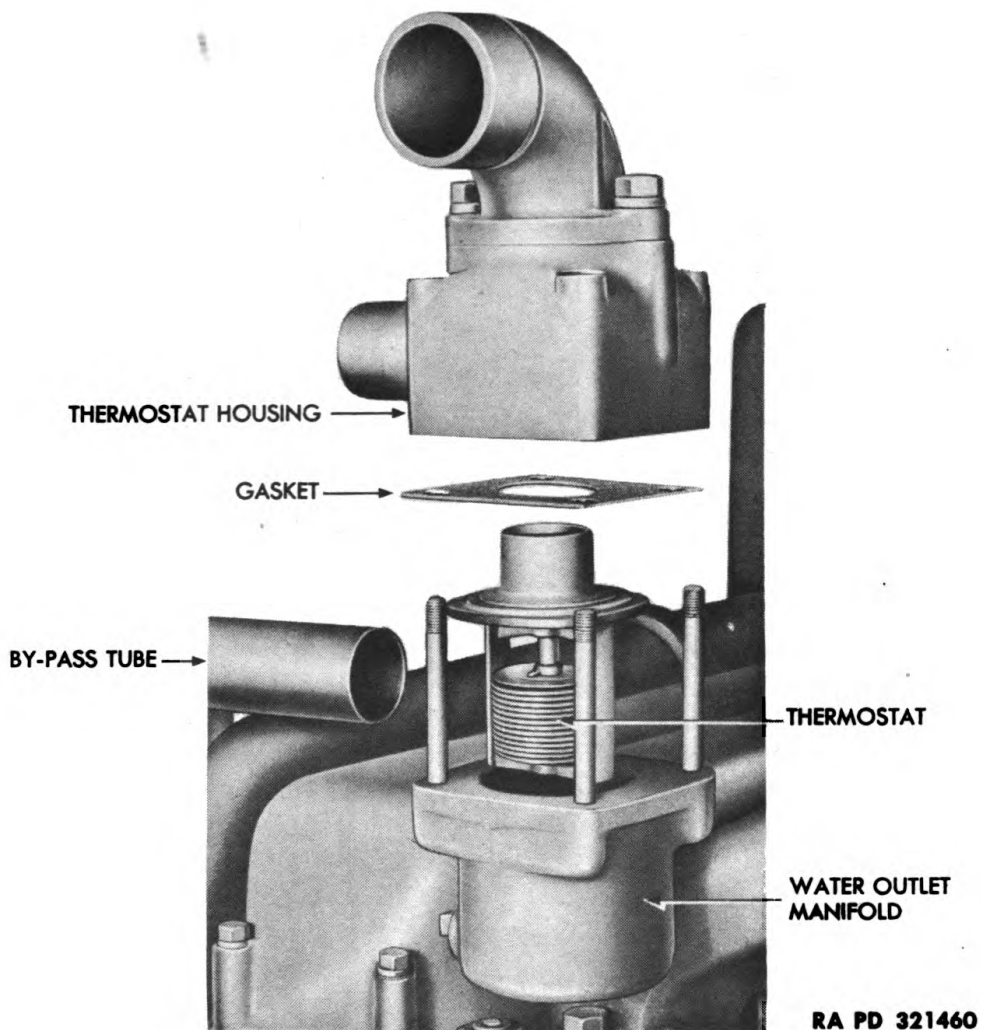

Figure 66—Thermostat and Thermostat Housing Assembly

b. Removal and Test (fig. 66).

(1) **DRAIN COOLING SYSTEM.** Open drain cock under radiator and allow system to drain below level of thermostat.

(2) **DISCONNECT HOSES.** Loosen the hose clamps on the radiator water inlet hose, and work the hose off the engine water outlet fitting. Loosen hose clamps on thermostat by-pass tube upper hose, and work the hose away from thermostat housing.

(3) **REMOVE THERMOSTAT.** Remove four stud nuts and lock washers which secure thermostat housing. Break loose the housing and lift it off studs. Lift out thermostat. Remove gasket.

(4) **TEST THERMOSTAT.** Place thermostat in a container filled with water. Place thermometer or other heat measuring instru-

Cooling System

ment in the water and heat the water. If thermostat does not begin to open within 5° F of 140° F, and is not fully open within 5° F of 165° F, replace it with new thermostat (G512-04-00093).

c. Installation (fig. 66).

(1) **INSTALL THERMOSTAT HOUSING.** Place the thermostat, bellows end down, in opening in water outlet manifold. Place new gasket and thermostat housing in position. Install four stud nuts and lock washers.

(2) **CONNECT HOSES.** Work the thermostat by-pass tube upper hose over the thermostat housing by-pass outlet, and tighten hose clamps. Work the radiator water inlet hose over the engine water outlet fitting, and tighten hose clamps.

(3) **FILL COOLING SYSTEM.** Fill cooling system as instructed in paragraph 88 c.

93. PIPE AND HOSE CONNECTIONS (fig. 62).

a. Description. Connections consist of straight pipe, elbows, and hose of different diameters and lengths which provide for connecting engine water jacket, radiator, air compressor water jacket, thermostat by-pass, and water pump. The hose fits over the connecting pipe and is secured by adjustable hose clamps. Hose connections are kept tight to prevent the loss of coolant. A coat of white lead on the inner surface of the hose under the clamp insures a tight seal. Cylinder water jacket inlet elbow is integral with oil filter assembly bracket.

b. Removal.

(1) **GENERAL.** Loosen clamps by loosening clamp screws. Clamps that have been installed for extended periods of time are often stuck to the hose, and the surface of the hose under the clamps will be stuck to pipes or fittings. If necessary, insert a small screwdriver under clamp to loosen clamp from hose after clamp screw is loosened; then insert screwdriver under end of hose to loosen hose from pipe or fitting. Before starting to replace any part of radiator pipe and hose connections, drain coolant. Open drain cocks located at bottom rear of radiator and at bottom of water pump inlet fitting.

(2) **THERMOSTAT BY-PASS TUBE AND TUBE HOSE CONNECTIONS.** Loosen clamps and tube hose connections at both ends of the tube and at tube fitting end of air compressor water exhaust hose. Pull end of compressor exhaust hose from by-pass tube fitting. Pull upper end of by-pass tube out from upper hose and remove upper hose. Pull by-pass tube from lower hose and remove lower hose.

(3) **RADIATOR OUTLET TO WATER PUMP CONNECTIONS.** Loosen clamps and hose at both ends of radiator outlet tube. Remove cap screws and lock washers which attach water pump inlet fitting to bottom of water pump. Separate fitting from water pump and remove fitting gasket. Remove fitting, radiator outlet tube, and hose at each end of tube.

(4) **WATER PUMP OUTLET HOSE.** Loosen clamps and ends of hose. Remove oil filter assembly bracket as outlined in paragraph 125 c. Remove hose.

(5) **THERMOSTAT OUTLET ELBOW TO RADIATOR INLET.** Loosen clamps and ends of radiator outlet hose. Remove cap screws which attach elbow to top of thermostat housing. Separate elbow from housing and remove gasket. Remove elbow and hose.

(6) **AIR COMPRESSOR EXHAUST NIPPLE HOSE.** Loosen clamps and ends of hose, and pull hose from fittings.

(7) **AIR COMPRESSOR INTAKE WATER LINE.** Loosen and back off water line nut at each end of line, using two wrenches. Hold connector stationary while loosening line nut. Back off both nuts. Pull upper end of line from connection, and lift line from connection at water pump. Remove connections by unscrewing them.

c. Installation.

(1) **GENERAL.** When installing hose, coat inner surface of the hose under the clamp with white lead to insure a tight seal. Arrange clamps on the same hose in similar and accessible positions.

(2) **RADIATOR OUTLET TO WATER PUMP CONNECTIONS.** Position clamps (H006-01-00620) on both tube hose connections. Position a hose on each end of outlet tube. Fit tube and hose on radiator outlet. Insert water pump fitting in hose at other end of tube, position fitting gasket, and install lock washers and cap screws which attach fitting to bottom of water pump. Adjust outlet pipe, hose connections, and clamps. Tighten clamps.

(3) **WATER PUMP OUTLET HOSE.** Position clamps on hose, fit hose on pump outlet, and adjust and tighten clamp at water pump end of hose. Install oil filter assembly bracket as outlined in paragraph 125 d. Tighten clamp at bracket end of hose.

(4) **THERMOSTAT BY-PASS TUBE AND TUBE HOSE CONNECTIONS.** Fit hose connections on each end of by-pass tube, and position clamps on both pieces of hose. Fit tube and tube lower hose to water pump outlet and upper hose to thermostat housing. Position tube so that fitting for air compressor water exhaust hose is alined toward compressor exhaust nipple. Adjust hose and clamps, using new hose clamps (H006-01-00620), and tighten all clamp screws.

Cooling System

(5) **AIR COMPRESSOR EXHAUST NIPPLE HOSE.** Position clamps on hose. Fit one end of hose to fitting on air compressor and other end to fitting on by-pass tube. Adjust clamps and tighten clamp screws.

(6) **THERMOSTAT ELBOW TO RADIATOR INLET.** Position clamps on hose. Fit one end of hose to radiator inlet and insert thermostat elbow in other end of hose. Position gasket under elbow, and install cap screws and lock washers which attach elbow to thermostat housing. Adjust hose and clamps, and tighten clamp screws.

(7) **AIR COMPRESSOR INTAKE WATER LINE.** If connections were removed, reinstall them at water pump and at air compressor. Insert lower end of line in connector at water pump, and then upper end of line in connector at air compressor. Aline nuts to connectors and tighten, using two wrenches. Hold connectors stationary while tightening nuts.

(8) **INSTALL COOLANT.** Install coolant as instructed in paragraph 88 c.

94. HEAT INDICATOR.

a. Description and Data (figs. 8 and 31).

(1) **DESCRIPTION.** The temperature gage, located on the instrument panel, indicates the temperature of the water in the water outlet manifold. It is operated by the engine thermostat unit, which is inserted in the rear end of the water outlet manifold.

(2) **DATA.**

Type Vapor
Range 100°F to 220°F

b. Engine Unit Replacement (fig. 31). Unscrew coupling nut from rear of water manifold. Pull out bulb from manifold. Unscrew knurled nut from back of instrument panel heat indicator gage. Remove rubber grommet from cowl, and pull out tube from cowl. Insert new tube through hole in cowl below left horn. Insert bulb into water manifold, and tighten coupling nut. Insert instrument end of tube in gage and screw in knurled nut.

c. Gage Replacement (fig. 8). Unscrew tube connector nut from gage. Remove two nuts and lock washers which secure gage to bracket. Remove retainer bracket. Pull out gage. Place new gage in opening of instrument panel. Position retainer bracket over gage stud nuts, and install two lock washers and stud nuts. Screw tube connector nut on gage fitting.

Section XVIII

STARTING SYSTEM

95. DESCRIPTION AND DATA.

a. **Description** (fig. 67). The starting system consists of a 24-volt cranking motor and a switch-operated solenoid which operates on four 6-volt batteries. A series-parallel cranking motor switch connects the four batteries in series to operate the cranking motor.

96. CRANKING MOTOR.

a. **Description and Data.**

(1) **DESCRIPTION** (fig. 68). The cranking motor, located on the right lower side of the engine bell housing, is accessible from under the truck. A cranking motor drive, attached to the end of the armature shaft and enclosed in a housing, engages the flywheel gear to crank the engine.

(2) **DATA.**

Manufacturer	Delco-Remy
Type	833
Drive	Dyer
Volts	24

b. **Removal.**

(1) **DISCONNECT CABLES** (figs. 68 and 69). Remove terminal stud nut at commutator end of cranking motor. Remove battery to cranking motor cable and circuit breaker to cranking motor wire. Tape the end of the battery cable to avoid accidental contact. Remove terminal stud nut from inside front (ground) terminal post of solenoid, and remove battery to solenoid cable and solenoid ground wire. Tape the end of the battery cable to avoid accidental contact. Remove terminal stud nut from outside top terminal of solenoid, and remove circuit lock switch to solenoid wire.

(2) **REMOVE CRANKING MOTOR.** Back off the three drive housing attaching stud nuts and lock washers, and pull the cranking motor and drive housing off the bell housing studs.

(3) **REMOVE CRANKING MOTOR SOLENOID.** Remove cranking motor solenoid as instructed in paragraph 97 b.

c. **Installation.**

(1) **INSTALL CRANKING MOTOR SOLENOID.** Install cranking motor solenoid as instructed in paragraph 97 c.

Starting System

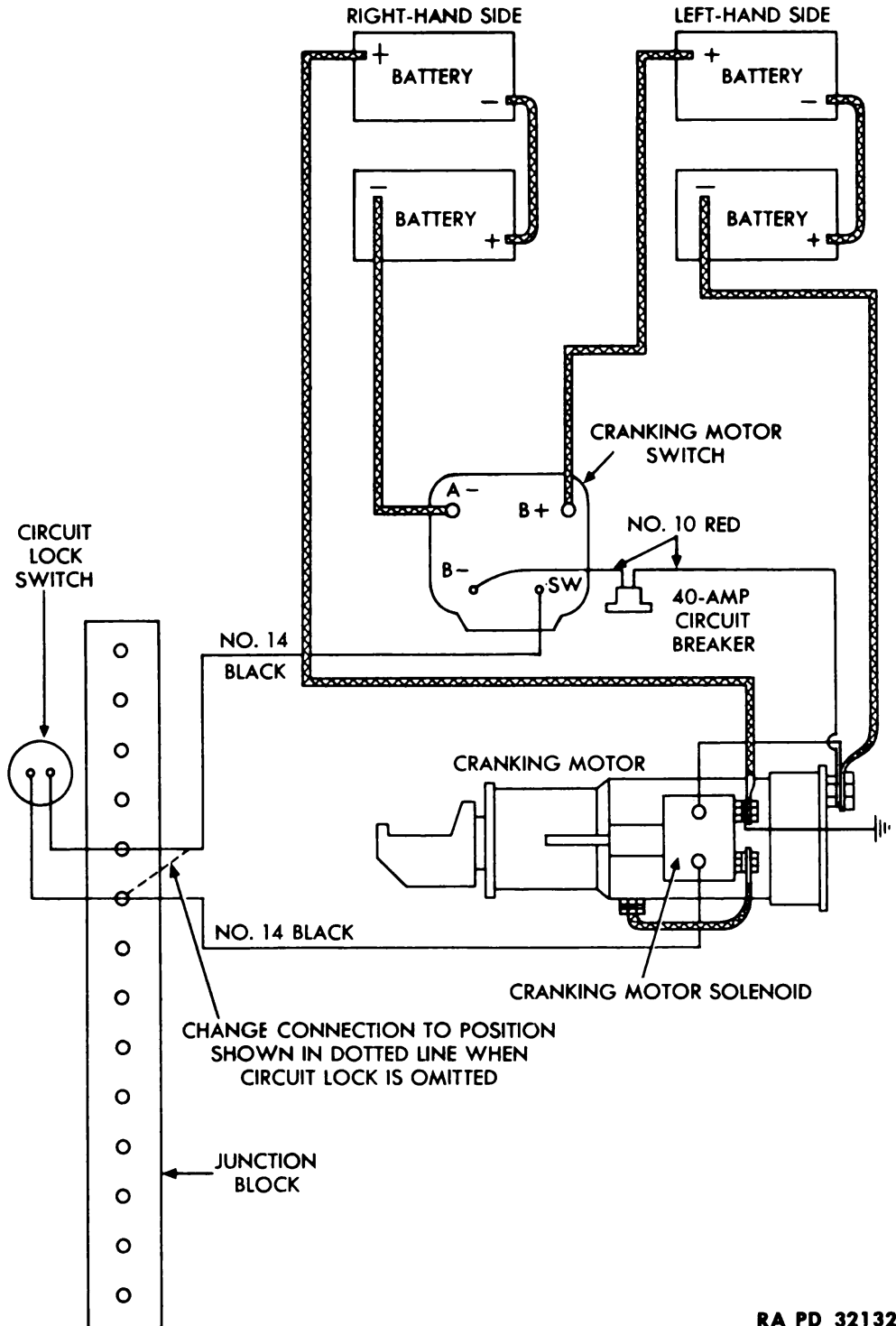

RA PD 321325

Figure 67—Starting System Wiring Diagram

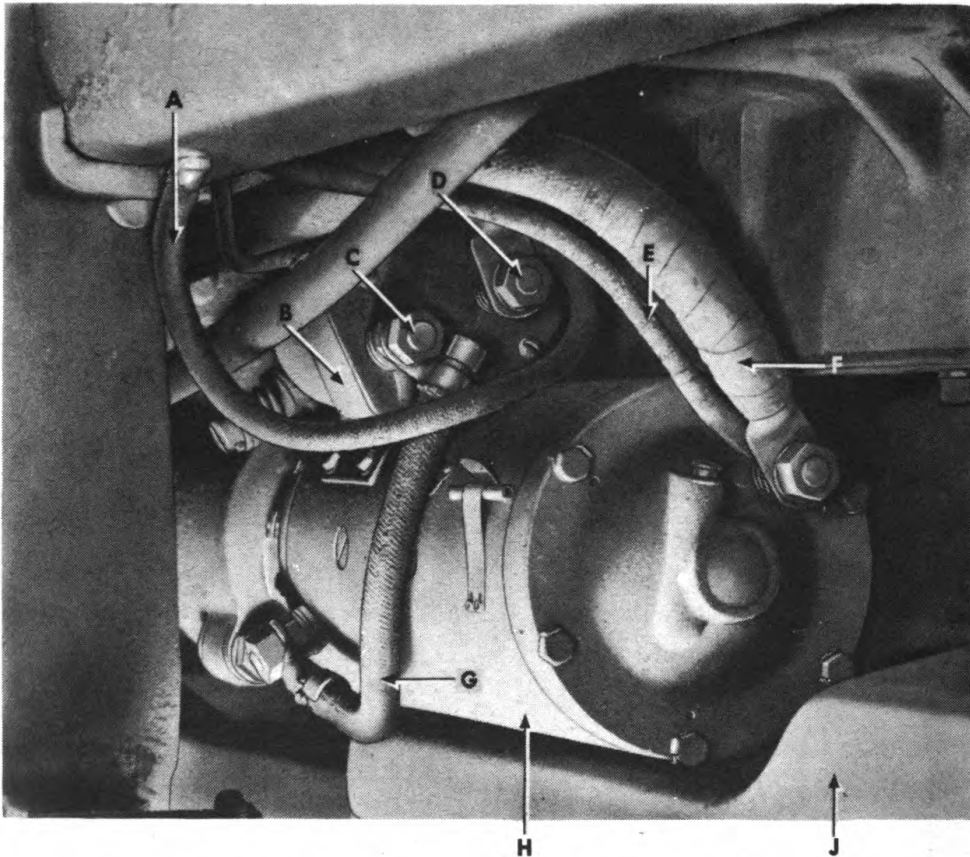

A—GROUND WIRE
 B—CRANKING MOTOR SOLENOID
 C—SOLENOID OUTSIDE FRONT TERMINAL
 D—SOLENOID INSIDE FRONT TERMINAL

E—CIRCUIT BREAKER TO CRANKING MOTOR WIRE
 F—LEFT-HAND BATTERY TO CRANKING MOTOR CABLE
 G—SOLENOID TO CRANKING MOTOR CABLE
 H—CRANKING MOTOR
 J—ENGINE OIL PAN

RA PD 321378

Figure 68—Cranking Motor—Installed

(2) INSTALL CRANKING MOTOR ON BELL HOUSING. Position cranking motor and drive housing on studs in lower right side of bell housing. Install stud lock washers and nuts.

(3) CONNECT CABLES AND WIRES (figs. 68 and 69). Install circuit lock switch to solenoid No. 14 black wire on outside top terminal of solenoid. Install terminal washer, lock washer, and nut. Install ground wire and cable from positive terminal of right-hand side battery on inside front (ground) terminal of solenoid. Install terminal lock washer and nut. Install cable from negative post of left-

Starting System

RA PD 321419

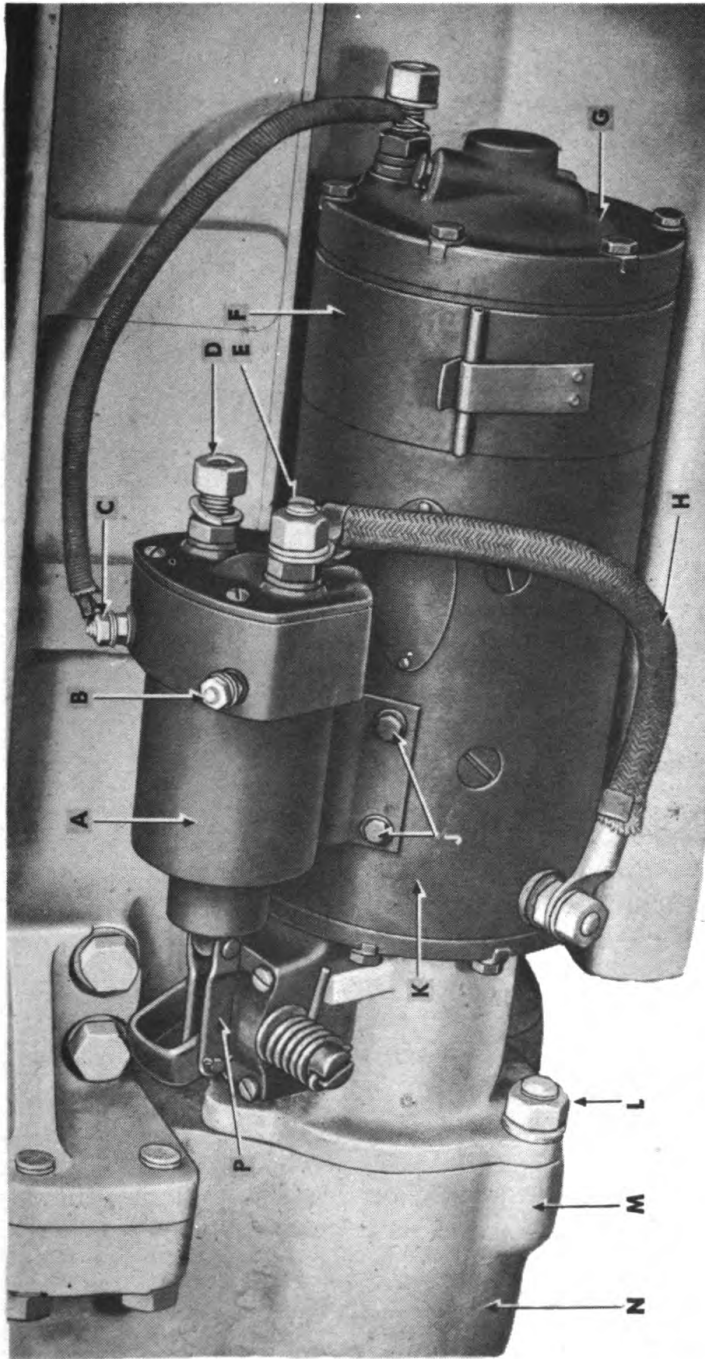

- A—CRANKING MOTOR SOLENOID
- B—SOLENOID OUTSIDE TOP TERMINAL
- C—SOLENOID INSIDE TOP TERMINAL
- D—SOLENOID INSIDE FRONT TERMINAL
- E—SOLENOID OUTSIDE FRONT TERMINAL
- F—COVER BAND
- G—COMMUTATOR END HEAD ASSEMBLY
- H—SOLENOID TO CRANKING MOTOR CABLE
- J—SOLENOID ATTACHING SCREWS
- K—CRANKING MOTOR FIELD FRAME ASSEMBLY
- L—ATTACHING STUD NUT
- M—DRIVE HOUSING ASSEMBLY
- N—ENGINE BELL HOUSING
- P—LINKAGE

Figure 69—Cranking Motor Solenoid

hand side battery and No. 10 red wire from 40-ampere circuit breaker on terminal at front end of battery. Install lock washer and nut.

97. CRANKING MOTOR SOLENOID.

a. Description and Data.

(1) **DESCRIPTION** (fig. 69). The cranking motor solenoid is mounted directly on top of the cranking motor. It shifts the cranking motor drive pinion into mesh with the engine flywheel when the cranking motor switch is depressed, and also closes the circuit between the cranking motor and battery, which supplies power for cranking.

(2) **DATA.**

Manufacturer	Delco-Remy
Model	1118050
Capacity	24-volt

b. Removal (fig. 69).

(1) **REMOVE CABLES AND WIRES.** Remove terminal nut and lock washer from solenoid inside top terminal, and lift off solenoid to cranking motor wire. Remove terminal nut and lock washer from solenoid outside top terminal, and lift off circuit lock to solenoid wire. Remove terminal nut and lock washer from solenoid front inside terminal, and lift off battery to solenoid cable and solenoid ground wire. Remove terminal nut and lock washer from solenoid front outside terminal, and lift off solenoid to cranking motor cable.

(2) **REMOVE SOLENOID.** Remove cotter pin and clevis pin from solenoid linkage. Remove four solenoid attaching screws and lock washers. Lift off solenoid.

c. Installation.

(1) **INSTALL SOLENOID.** Place solenoid on cranking motor, and install four solenoid attaching screws and lock washers. Position solenoid linkage and install clevis pin and cotter pin.

(2) **CONNECT CABLES AND WIRES.** Place solenoid to cranking motor wire on inner top terminal of solenoid and install lock washer and terminal nut. Install circuit lock switch to solenoid wire on solenoid outer top terminal, and install lock washer and nut. Install solenoid ground wire and right-hand battery to solenoid cable on front inside terminal of solenoid, and install lock washer and nut. Install solenoid to cranking motor cable on front outside terminal of solenoid, and install terminal nut and lock washer.

98. CRANKING MOTOR SWITCH.

a. Description (fig. 70). The cranking motor switch is located on a bracket immediately below the floorboard, with the push button

Starting System

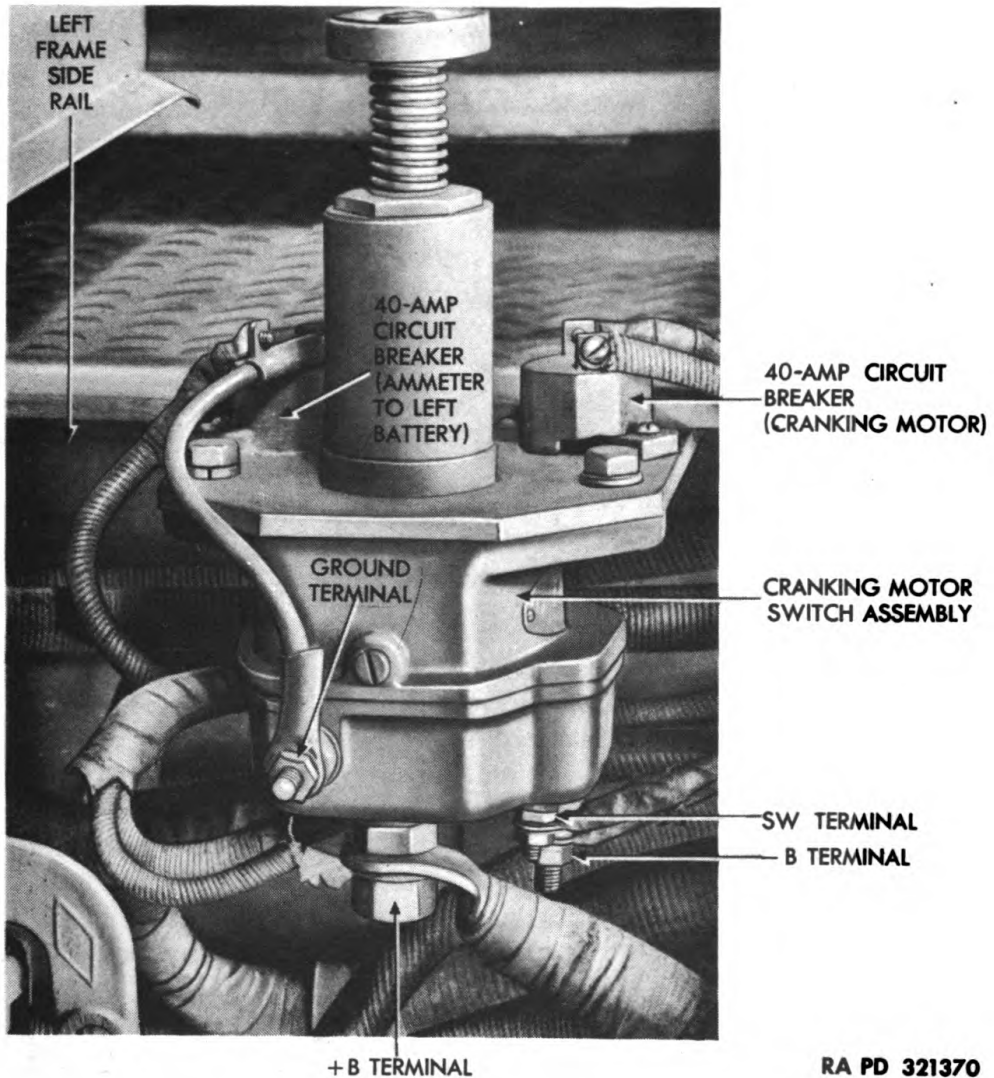

Figure 70—Cranking Motor Switch—Installed

extending through a hole in the floorboard into the driver's compartment. The switch is a foot-operated, series-parallel type. When the button is depressed, it connects the batteries in series for 24-volt cranking motor operation; when released, it connects them in parallel so that the 12-volt generator current will keep them properly charged.

b. Removal (fig. 70).

(1) **REMOVE FLOORBOARD.** Remove floorboard attaching screws. Lift off floorboard.

(2) **DISCONNECT WIRES.** Remove terminal nut and washer from "B+" terminal on bottom right side of cranking motor switch. Re-

move left-hand battery to switch cable and starter burner to switch wire. Tape the end of the cable to prevent accidental contact. Remove terminal nut and lock washer from "A" terminal on bottom left side of switch. Remove right-hand battery to switch cable and No. 8 red ammeter to switch wire. Tape end of cable to prevent accidental contact. Remove front circuit breaker terminal screw, and disconnect No. 10 red circuit breaker to cranking motor wire. Remove rear circuit breaker terminal screw, and disconnect No. 10 green-black circuit breaker to left battery ammeter wire. Remove terminal nut from "SW" terminal at bottom front of switch, and remove No. 14 black circuit lock switch to cranking motor switch wire.

(3) **REMOVE SWITCH.** Remove two attaching bolts, and lift off switch from left frame side rail.

c. Installation (fig. 70).

(1) **ATTACH CRANKING MOTOR SWITCH.** Position cranking motor switch on left-hand side frame rail.

(2) **CONNECT WIRES.** Place No. 14 black circuit lock switch to cranking motor switch wire on the "SW" terminal at bottom front of switch, and install terminal nut and lock washer. Place No. 10 green-black circuit breaker to left battery ammeter wire on circuit breaker terminal at top rear of switch. Install terminal screw. Install No. 10 red circuit breaker to cranking motor wire on circuit breaker terminal at top front of switch. Install No. 8 red ammeter to switch wire, and right-hand battery to switch cable on "A" terminal on bottom left side of switch. Install terminal lock washer and nut. Install left-hand battery to switch cable and starter burner to switch wire on "B+" terminal on bottom right side of switch. Install terminal lock washer and nut.

(3) **INSTALL FLOORBOARD.** Place floorboard in position, and install attaching screws.

99. CIRCUIT LOCK SWITCH.

a. Description (fig. 8). The key-operated circuit lock switch, located at lower center of instrument panel, closes the cranking motor solenoid circuit. **NOTE:** *The switch is omitted on some models.*

b. Removal. Disconnect two leads at back of switch. Remove lock nut and washer from back of switch. Pull switch out of instrument panel.

c. Installation. Place spacer on switch. Position switch into opening in instrument panel. Install washer and lock nut. Connect the two No. 14 black wires from cranking motor solenoid and from cranking motor switch, to terminals of circuit lock switch.

Section XIX

TRUCK LIGHTS AND HORN SYSTEM

100. DESCRIPTION.

a. The lights and horn operate on a 6-volt circuit with current supplied from one of the batteries located in the right battery compartment. The light switch "B" terminal is connected at the terminal block with a lead which comes directly from the negative terminal of either battery. The horn relay is also connected with the switch "B" terminal. Through the light switch, current is supplied to all lights on the truck and to the trailer coupling socket. It is a single wire circuit with the positive battery terminal grounded.

101. INSTRUMENT PANEL LIGHTS.

a. **Description and Data** (fig. 8).

(1) **DESCRIPTION.** The instrument panel lights, four in number, are located respectively in the area of the trouble light receptacle, air pressure gage, ammeters, and viscometer gage. The lights are of the snap-in type, permitting free rotation to position the slot in the hood. Each light is installed as a complete unit with lead. Instrument panel leads are all connected to one terminal on the panel light switch.

(2) **DATA.**

Type lamp.....	Single-tungsten filament
Voltage	6-8 volts
Candlepower	1

b. **Removal** (fig. 8). Disconnect instrument panel leads from common terminal on instrument panel light switch. Pull light unit and lead out of instrument panel.

c. **Installation** (fig. 8). Insert new light unit head (M001-02-13042), through instrument panel, and push unit into hole with hood positioned to illuminate panel instruments. Connect leads to common terminal at instrument panel light switch.

102. BLACKOUT DRIVING LIGHT.

a. **Description and Data** (figs. 72 and 73).

(1) **DESCRIPTION.** The driving lamp is shrouded and is a double-filament type. The upper filament projects the low headlight beam while the lower provides the high beam. The selection of these beams is controlled by a dimmer switch. The light assembly is mounted on the right front fender.

Maintenance Instructions

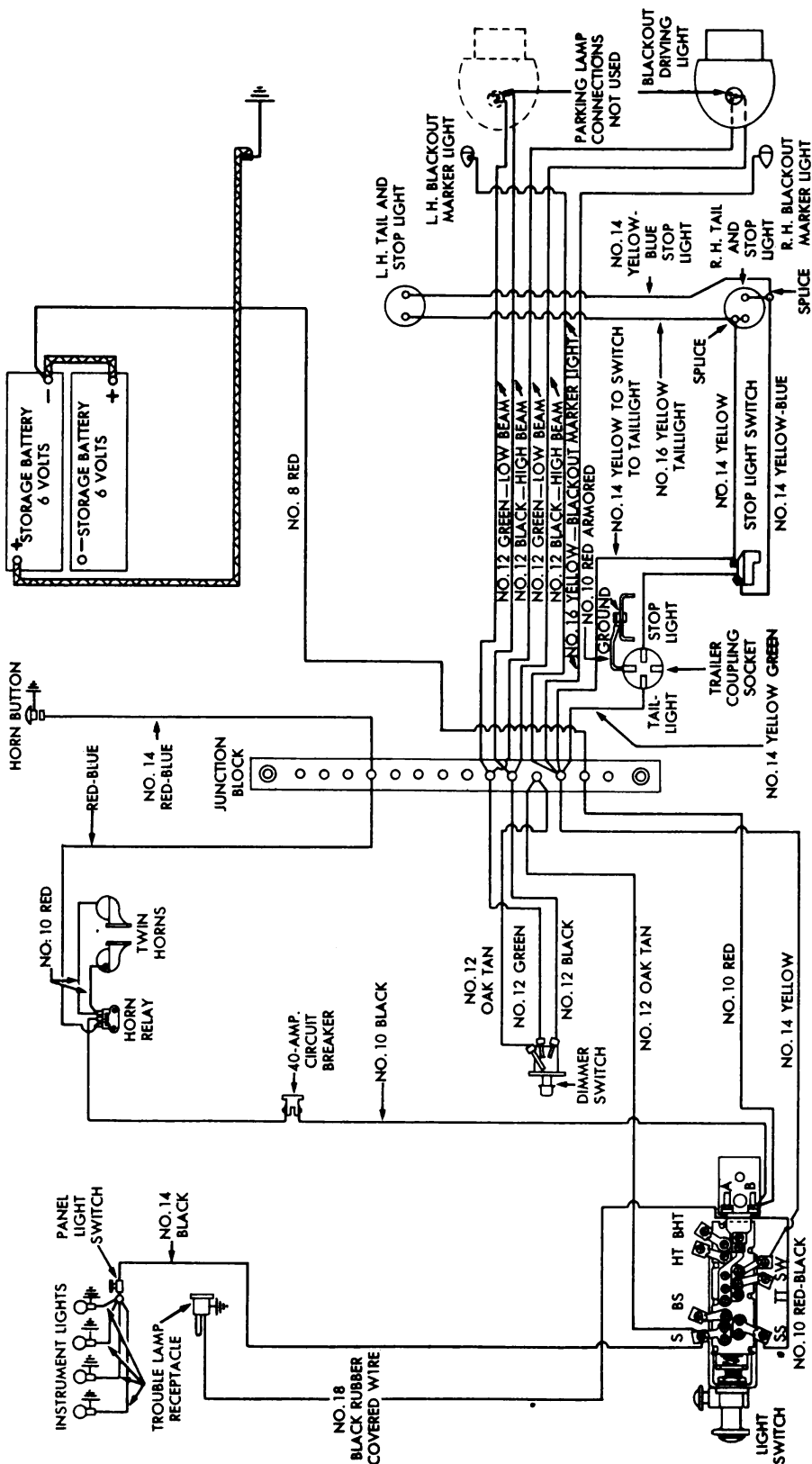

RA PD 321393

Figure 71—Lights and Horn Wiring Diagram

Truck Lights and Horn System

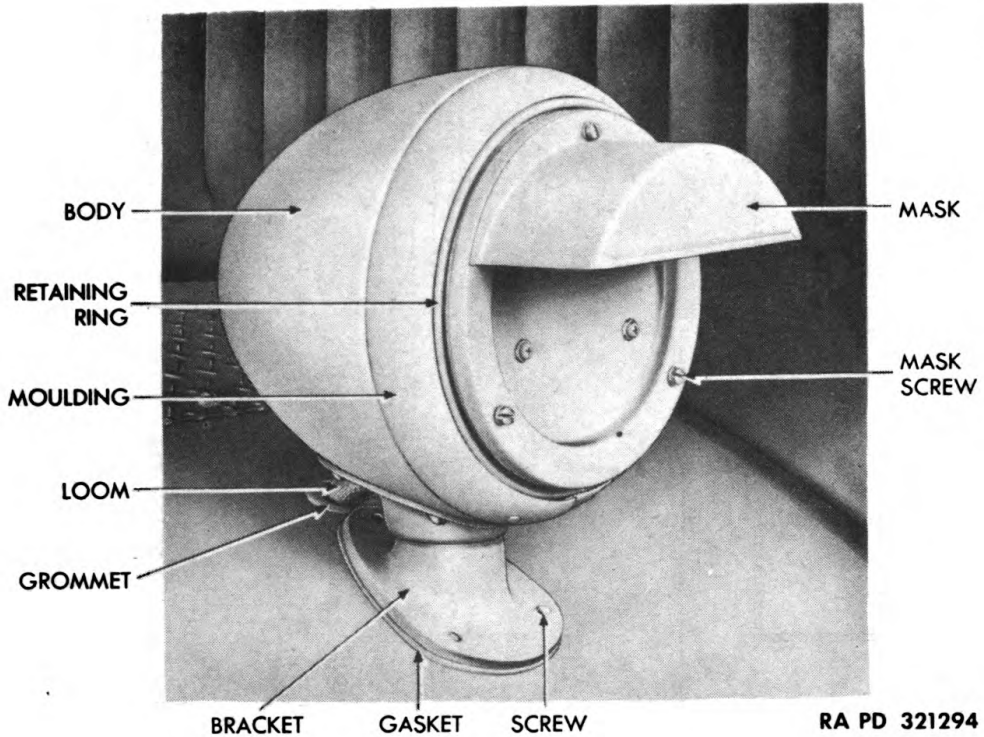

Figure 72—Blackout Driving Light

(2) DATA.

Manufacturer	Guide
Type of lamp.....	Double-tungsten filament
Candlepower, upper beam (driving).....	50
lower beam (passing).....	32

b. Lamp Replacement. Remove screws and lock washers which secure driving light mask to driving light body and remove the mask, gasket, and gasket ring. Push lamp in; then turn to left and remove from socket. To install new lamp (M001-01-07281), push lamp into socket and turn to right to lock it in place. Position mask light housing and make secure by installing lock washers and screws.

c. Removal. Disconnect battery cable leads from headlight. Disconnect ground wire. Remove nut and lock washer which attach light assembly to bracket. Lift assembly from bracket and pull wires from grommet. Remove bracket and gasket by removing screws which attach them to fender.

d. Installation. Position bracket and gasket and install screws which secure it to fender. Position driving light assembly on bracket, and install mounting lock washer and nut. Connect ground wire to

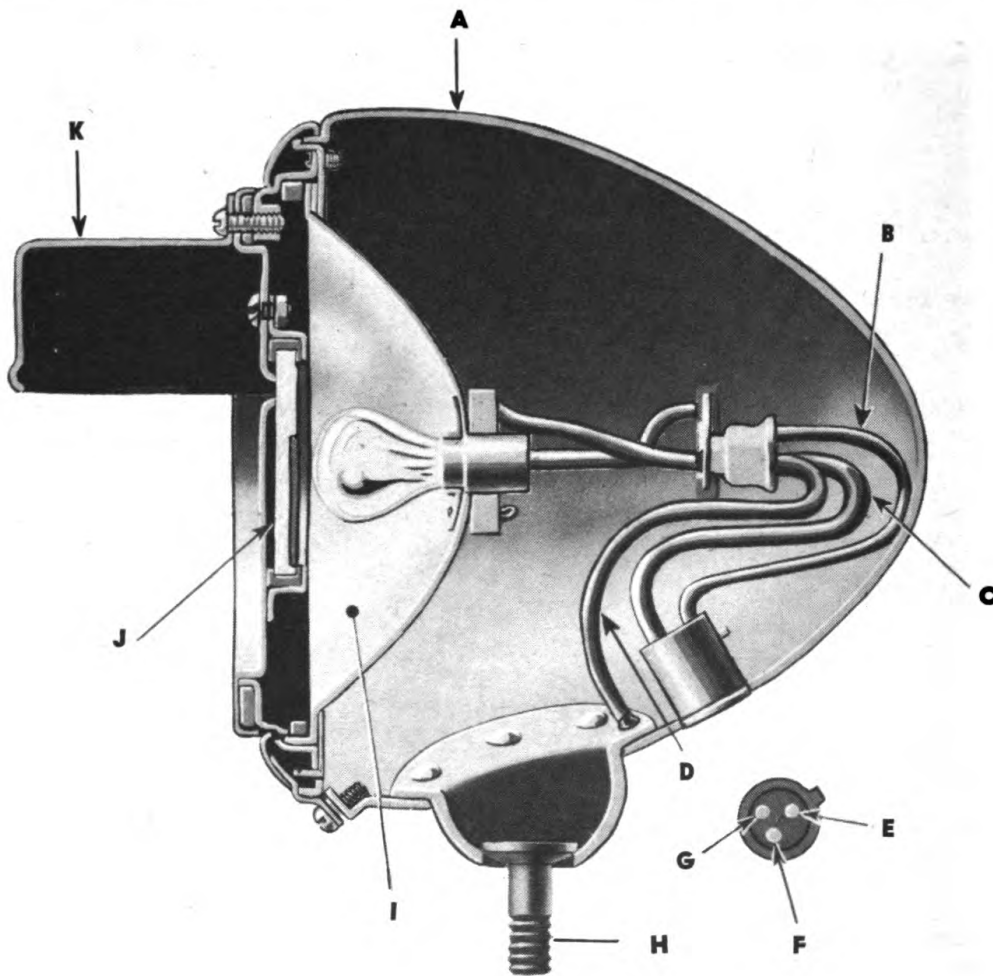

- | | | | |
|---|--------------------|---|---------------------|
| A | HOUSING ASSEMBLY | F | COMMON TERMINAL |
| B | LOWER BEAM WIRE | G | LOWER BEAM TERMINAL |
| C | HIGH BEAM WIRE | H | MOUNTING BOLT |
| D | GROUND WIRE | I | REFLECTOR |
| E | HIGH BEAM TERMINAL | J | LENS |
| | | K | SHIELD |

RA PD 310663

Figure 73—Sectional View of Blackout Driving Light

fender. Connect battery cable leads to driving light. Make sure all connections are insulated and shielding properly secured.

103. BLACKOUT MARKER LIGHTS.

a. Description and Data.

(1) **DESCRIPTION** (fig. 74). Two blackout marker lights are provided: one mounted on each side of the front bumper. The lens in

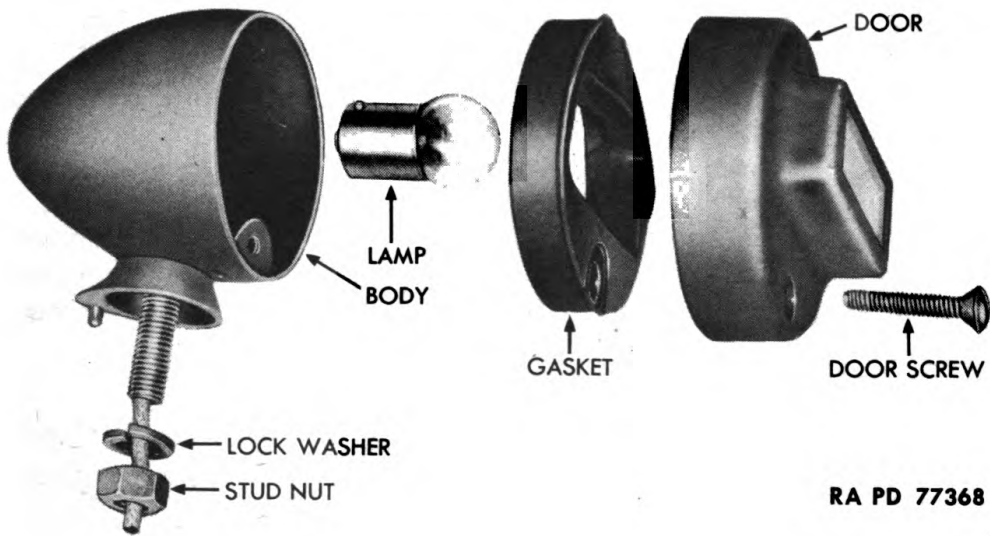

Figure 74—Blackout Marker Light—Disassembled

the door of the light body is covered except for two small translucent triangular portions. The light door and lens are constructed so that the triangles are visible only from a straight-ahead position; thus no beams are cast, and lights serve only as markers. Light contains a single-contact socket.

(2) DATA.

Manufacturer Guide
 Lamp:
 Make Mazda 63
 Candlepower 3
 Base Single contact

b. Lamp Replacement. Remove screw which secures door to body. Remove door. Press in on lamp, turn to right, and remove from socket. Push new lamp (M001-02-13230), into socket and turn to left so that lamp is secured in socket. Position door to body and secure with door screw.

c. Assembly Removal. Disconnect lead from connector on wire from junction block. Remove nut and lock washer which secure light to bumper. Lift light from bracket and pull lead from bumper.

d. Assembly Installation. Thread lead through opening in bumper. Position light on bumper, and install lock washer and nut which attach light to bumper. Connect lead at connector on yellow wire from junction block. Make sure connection is insulated. Turn blackout lights on. Installation is correct if lights function properly.

104. BLACKOUT TAIL AND STOP LIGHTS.

a. Description and Data.

(1) **DESCRIPTION.** Two combination blackout tail and stop lights are mounted at the rear of the truck. The lenses of the blackout taillights are designed to produce two beams. When a vehicle is following at a specified distance, these two beams will merge into a single highly visible beam. The lamps are soldered to a lens retainer, and the lens and filter are crimped to the retainer to form a complete unit. The lamp and lens assemblies are enclosed in a body and door assembly.

(2) **DATA.**

Manufacturer	Guide
Type	Sealed beam
Taillight:	
Model	5933078
Candlepower	3
Base	Single control
Service stop light:	
Model	5933121
Candlepower	3
Base	Double control

b. Lamp-unit Replacement. Remove screws which attach door to light body and remove door. Either lamp-unit assembly is removed by pulling unit from socket. Install new taillight lamp-unit (M001-01-07407), or lamp-unit (M001-01-07408), in socket. Position door on light body and install screws which attach door to body.

c. Removal (fig. 75). The removal of both blackout tail and stop lights is the same. Push in on cable connectors, turn clockwise, and pull from sockets. Remove nut and lock washer which secure cable clip to taillight mounting stud, and pull clip from stud. Remove nuts and lock washers which secure blackout tail and stop light to mounting bracket; withdraw light from bracket.

d. Installation (fig. 75). Position blackout tail and stop light in mounting bracket and install lock washers and nuts. Position cable clip on stop light mounting stud and install lock washer and nut. Push cable connector into sockets and turn counterclockwise into catch.

105. MAIN LIGHT SWITCH.

a. Description and Data.

(1) **DESCRIPTION (fig. 8).** The main light switch is the push-pull type and is located on instrument panel. It controls the complete

Truck Lights and Horn System

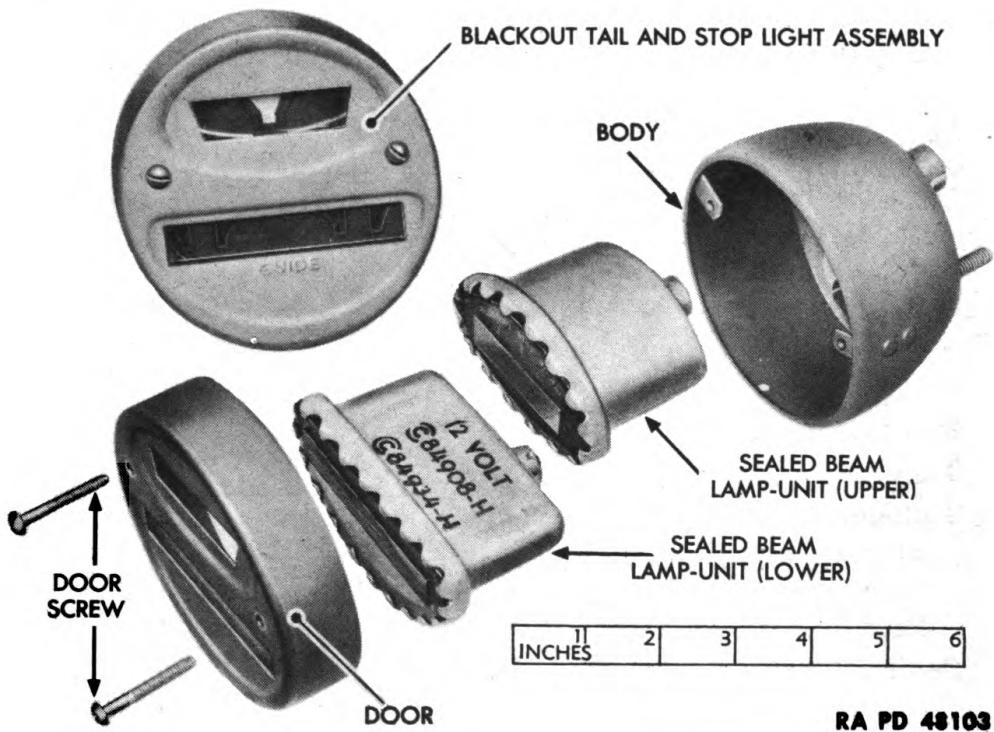

Figure 75—Blackout Tail and Blackout Stop Light—Disassembled

lighting circuit. The switch is locked in first stage (front marker lights on and combination tail and stop lights operating) by a spring plunger lock. This prevents operator from accidentally turning on other lights.

(2) DATA.

Manufacturer Delco-Remy
 Type Push-pull

b. Removal. Disconnect batteries (par. 112 c). Disconnect all wires from switch (fig. 71), placing marked tags on wires as they are removed to insure correct installation. Loosen set screw on knob. Screw knob from switch shaft. Loosen set screw on under side of push button housing. Pull housing from switch shaft. Remove nut and washer from switch collar. Pull switch from reverse side of instrument panel.

c. Installation.

(1) **CONNECT WIRES TO TERMINALS.** Connect wires to switch terminals as follows (fig. 71): black wire from panel light switch and oak-tan wire from junction block to "S" terminal; yellow wire from

terminal block to "SW" terminal; blue wire from contact relay, red wire from terminal block, and black wire from 40-ampere circuit breaker and horn relay to "B" terminal; red-black wire from switch "A" to "SS" terminal.

(2) **INSTALL SWITCH IN INSTRUMENT PANEL.** Position switch to instrument panel, and install washer and lock nut which attach switch to panel. Depress button at side of push button housing into position on switch shaft. Tighten set screw on under side of housing. Screw knob on shaft, and tighten knob set screw.

106. DIMMER SWITCH.

a. Description and Data (fig. 7).

(1) **DESCRIPTION.** The dimmer switch is mounted under the cab floor panel at the left inner side of cab. The main body of the switch is under the floor panel, but the push button extends through into driver's compartment.

(2) DATA.

Manufacturer Delco-Remy
Model DX5897

b. Removal.

(1) **REMOVE TOEBOARD.** Remove toeboard as instructed in paragraph 68 c.

(2) **REMOVAL PROCEDURE.** Disconnect wires from terminals on switch. Remove two screws, lock washers, and nuts which attach switch to floor, and remove switch.

c. Installation.

(1) **INSTALLATION PROCEDURE.** Position switch to floor panel and install two screws, lock washers, and nuts which attach switch to under side of floor panel. Connect oak-tan wire from junction block to "B" (front) terminal. Connect green wire from junction block to "2" (middle) terminal. Connect black wire to "1" (rear) terminal.

(2) **INSTALL TOEBOARD.** Install toeboard as instructed in paragraph 69 n.

107. INSTRUMENT PANEL LIGHT SWITCH.

a. Description and Data.

(1) **DESCRIPTION.** The instrument panel light switch is a push-pull type switch, attached to the instrument panel in upper center area between and above "B" ammeter and speedometer (fig. 8). It operates the four panel lights independently when the main light switch is in the second or the third position.

Truck Lights and Horn System

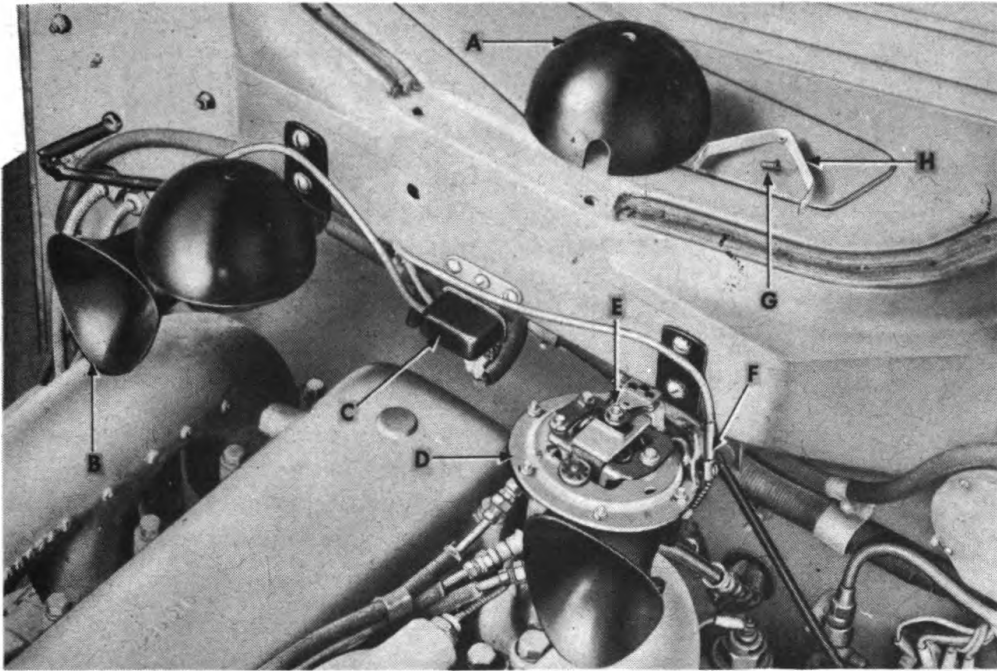

- | | | |
|--------------------------|---|----------------------|
| A—HORN BACK SHELL | D—HORN DIAPHRAGM ASSEMBLY | F—LEAD TERMINAL |
| B—VIBRATOR HORN ASSEMBLY | E—HORN DIAPHRAGM ADJUSTING SCREW AND LOCK NUT | G—SCREW |
| C—HORN RELAY | | H—BACK SHELL BRACKET |
| | | RA PD 321338 |

Figure 76—Horn Adjustment

(2) DATA.

Manufacturer Delco-Remy
Type Push-pull

b. Removal. Disconnect wires from switch. Remove knob from switch shaft. Remove switch retaining nut and lock washer. Remove switch from rear side of instrument panel. Remove spacer collar.

c. Installation. Position spacer collar on switch assembly. Position switch to instrument panel, and secure by installing washer and retaining nut. Install knob on switch shaft. Connect four block rubber covered leads from panel lights to one terminal. To the other terminal, connect the black wire from the "S" terminal of the main light switch.

108. HORN.

a. Description and Data.

(1) DESCRIPTION (fig. 76). Twin horns are mounted on the cowl in the engine compartment. They are the vibrator type with one

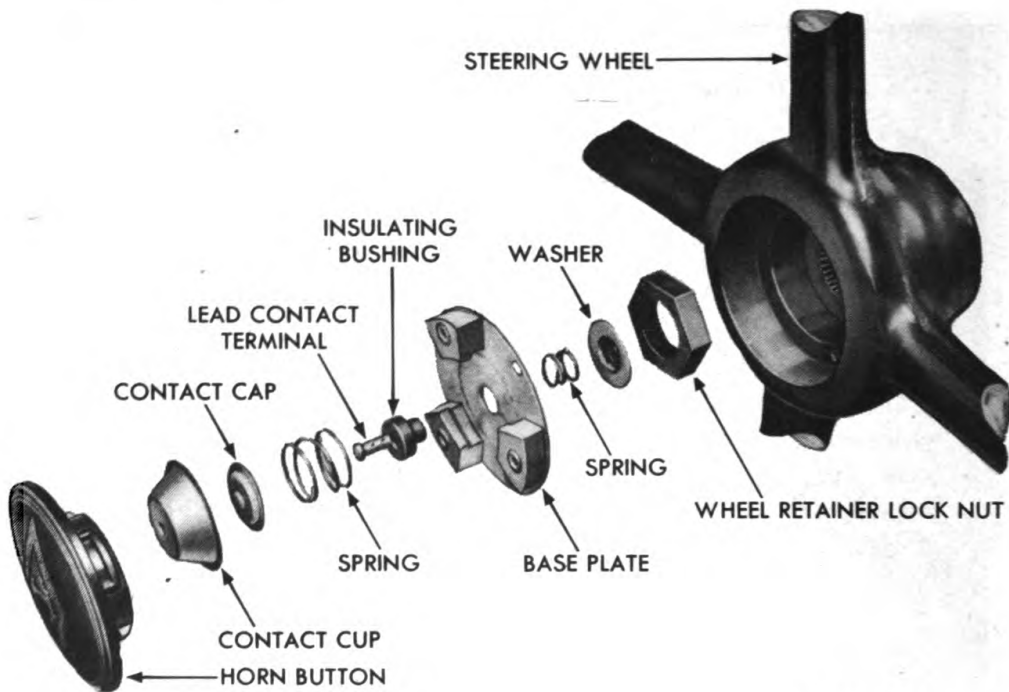

RA PD 321330

Figure 77—Horn Button Assembly—Disassembled

horn adjusted to a low tone while the other is adjusted to a high tone. A relay switch (controlled by the horn button switch) draws current from the light switch "B" terminal to operate the horns. The relay is a standard magnetic switch and is mounted on the cowl between the horns. A 40-ampere circuit breaker to protect the horns from excessive voltage is located on the back side of instrument panel and above the steering column; it is between the air low pressure buzzer and the 5-ampere circuit breaker.

(2) DATA.

Make Delco-Remy
 Model D X 5375

b. Horn Adjustment (fig. 76).

(1) GENERAL. Do not adjust horn tone unless horns have been tampered with or damaged. One horn is adjusted to a high tone and the other to a lower tone. The two pitches are matched at the factory to give the most striking warning.

(2) ADJUSTMENT PROCEDURE. Remove the screw located in the center of horn cover and lift cover from horn. Loosen adjusting screw lock nut. Tighten or loosen adjusting screw until desired pitch is attained. Hold adjusting nut to keep it from turning, and tighten

Truck Lights and Horn System

lock nut. Place cover in position on horn and install screw which attaches cover to horn. Press horn button to check operation.

c. Horn Button Replacement.**(1) REMOVAL OF HORN BUTTON ASSEMBLY.**

(a) *Remove Horn Button* (fig. 77). Disconnect button to horn wire at horn relay switch. Press button down firmly and turn it to right or left to permit holding ears to clear clamping legs on base plate. Lift the horn button carefully so as not to lose small parts and to observe how they should be reassembled. Remove button, contact cap, contact cap spring, and pilot.

(b) *Remove Horn Button Base and Wire*. Remove the screws which hold base plate in steering wheel recess. As an assembly, lift base plate, horn wire bushing, horn wire bushing cup, and horn wire bushing spring out of steering wheel. Pull horn wire and terminal out of passage in steering cam tube.

(2) INSTALLATION OF HORN BUTTON ASSEMBLY (fig. 77).

(a) *Install Horn Button Base and Wire*. Thread a small gage iron wire through passage in steering cam tube, this wire to be used as a fishline for installing button to horn relay wire. Attach upper end of fishline to wire terminal, and pull attached terminal and wire down through tube and out lower end of passage at bottom of steering gear housing. Position base, with insulating ferrule and upper wire terminal, in recess of steering wheel and install attaching screws.

(b) *Install Horn Button*. Position horn button spring, contact cap, and contact cap on base plate. Position horn button contact cap. Depress button firmly and turn it to right or left to secure holding ears of button under clamping legs on base plate. Connect button to relay wire at relay switch. Depress horn button to check installation, and if necessary, correct as required.

d. Horn Replacement.

(1) **REMOVAL** (fig. 76). Disconnect lead from horn terminal. Remove two nuts, bolts, and four lock washers which secure horn to support bracket. Remove horn.

(2) **INSTALLATION** (fig. 76). Position new horn on bracket. Install two bolts, four lock washers, and two nuts. Attach horn wire to horn terminal. Press horn button. Proper sounding of horn indicates correct installation.

e. Horn Relay Replacement.

(1) **REMOVAL** (fig. 76). Disconnect wires from terminals on relay switch. Remove two nuts, two bolts, and four lock washers which attach relay to bracket. Remove switch.

Maintenance Instructions

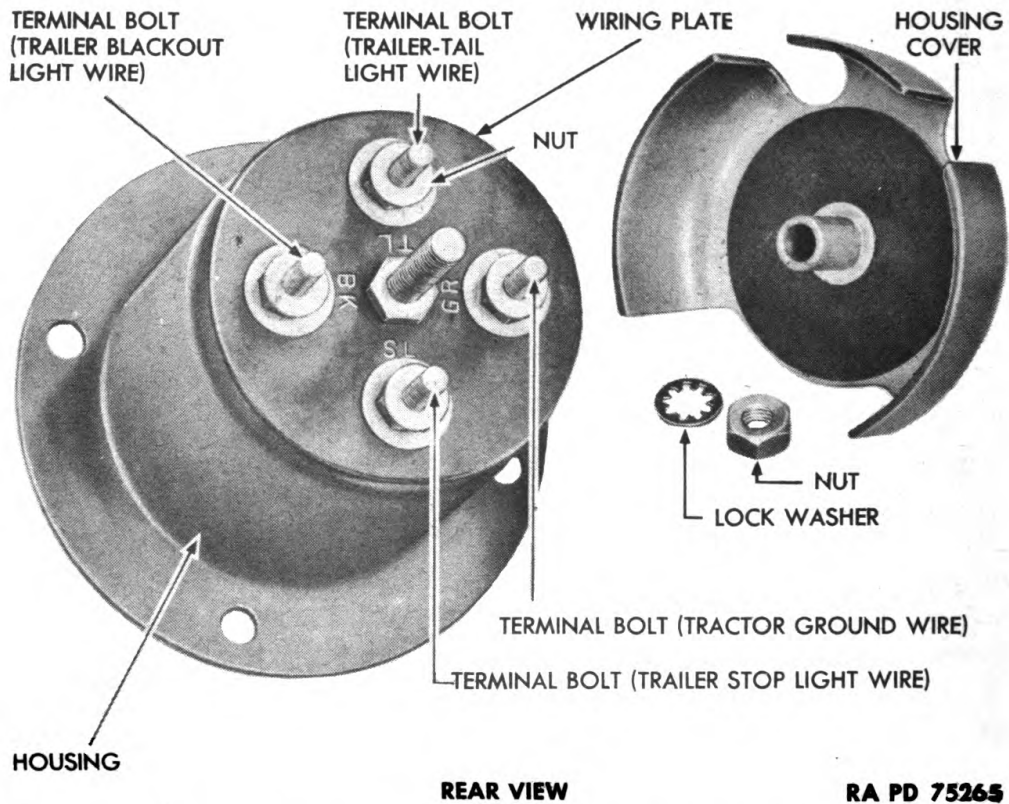
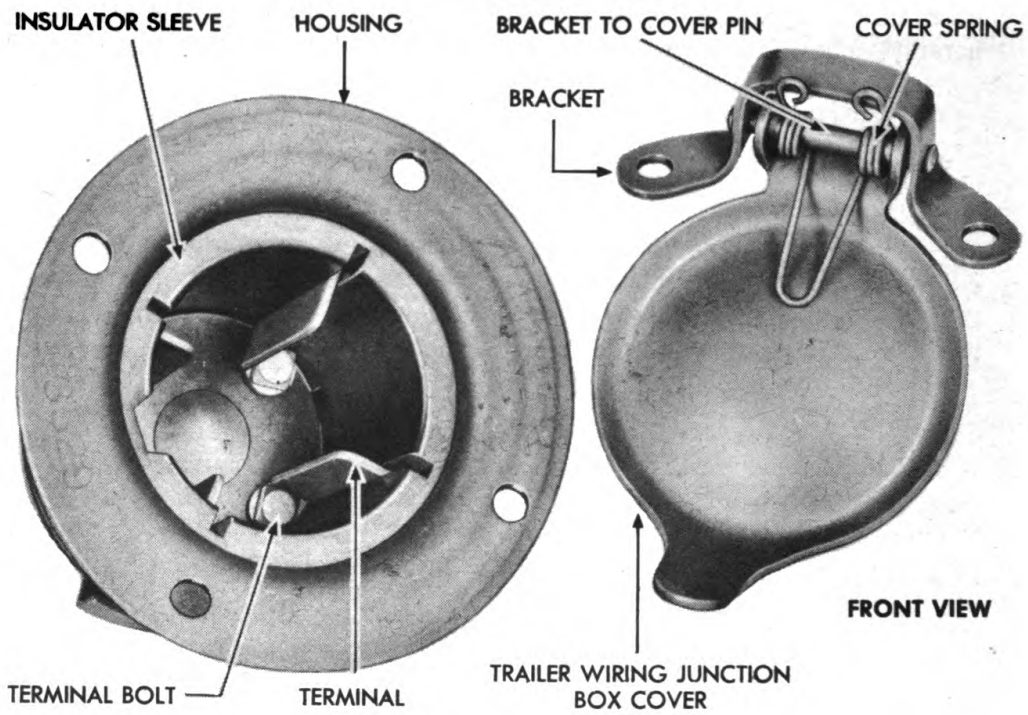

Figure 78—Trailer Jumper Socket Assembly

Truck Lights and Horn System

(2) **INSTALLATION.** Position new relay on bracket. Install two screws, four lock washers, and two nuts which attach relay to bracket. Attach red-blue (horn button) wire to right-hand terminal; attach red (horn) wire to left-hand terminal. Attach black wire (from 40-ampere circuit breaker) to relay middle terminal. Depress horn button. Sounding of horns indicates correct installation.

109. TROUBLE LIGHT RECEPTACLE.**a. Replacement (fig. 8).**

(1) **REMOVAL.** Disconnect lead. Remove two bolts, lock washers, and nuts. Remove receptacle.

(2) **INSTALLATION.** Position receptacle. Install two bolts, lock washers, and nuts. Attach lead to receptacle.

110. TRAILER JUMPER SOCKET ASSEMBLY.**a. Replacement (figs. 159 and 78).**

(1) **REMOVAL.** Remove the four nuts, lock washers, and bolts which attach socket to crossmember, and remove socket cover. Pull socket assembly out of frame, and remove back cover by removing nut and toothed lock washer which secure cover to socket body. Disconnect leads from terminals by removing nuts, washers, and clips which attach leads to terminals.

(2) INSTALLATION.

(a) *Connect Wiring Leads* (fig. 71). Connect yellow-blue wire (from stop light switch) to terminal marked "TL"; yellow green light to terminal marked "TL"; and red armored ground lead to terminal marked "GR." Make cables secure by installing terminal cable clips, washers, and nuts. Position back cover over terminals, and make secure with toothed lock washer and nut.

(b) *Attach Socket to Frame Crossmembers.* Position socket to crossmember. Position socket cover so that holes in cover bracket are aligned with two upper holes in socket mounting flange and with holes in frame crossmember. Install bolts, lock washers, and nuts which attach socket and cover to crossmember; attach ground lead to either of the two lower bolts.

(c) *Test Installation.* Insert trailer male plug into receptacle. Start engine and build up air pressure. Turn lights on and apply brakes. Correct operation of trailer combination tail and stop lights and trailer clearance lights indicates correct installation.

Section XX

BATTERY AND GENERATING SYSTEM

111. DESCRIPTION AND DATA.

a. Description (fig. 79). The truck is provided with a 12-volt generator to supply current to four batteries connected in a series-parallel circuit. The batteries store and supply electrical current during operation of the vehicle. They are connected in a series parallel circuit to provide current of 24-, 12-, or 6-volt potential. A current voltage regulator controls the rate and extent of battery charge, and also prevents the batteries from discharging through the generator when the battery voltage exceeds generated voltage. Current flow is indicated by an ammeter (J, fig. 8) and a "B" battery ammeter is also provided to indicate when the left batteries are not being charged (K, fig. 8). The batteries are mounted in battery compartments on the right and left step boards.

b. Data.

Generator	12-volt, d-c
Number of batteries	4
Circuit	Series-parallel
Circuit control	Current-voltage regulator

112. BATTERIES.

a. Description and Data.

(1) **DESCRIPTION** (fig. 80). Four 6-volt batteries provide current of 24-, 12-, or 6-volt potential. To supply 24-volt direct-current to the cranking motor, the four batteries are connected in series. Except when starting, two batteries are connected in series, and the series groups are connected in parallel to provide a 12-volt potential. Six-volt current for the lighting system is supplied by properly connecting the battery leads to either battery in the right-hand battery compartment. A warning plate, located on right battery compartment door, illustrates the battery cable hook-up for the batteries in the right compartment.

(2) **DATA.**

Make	Auto-Lite
Type (model No.)	DX6046A
Voltage	6
Terminal grounded	Positive

Battery and Generating System

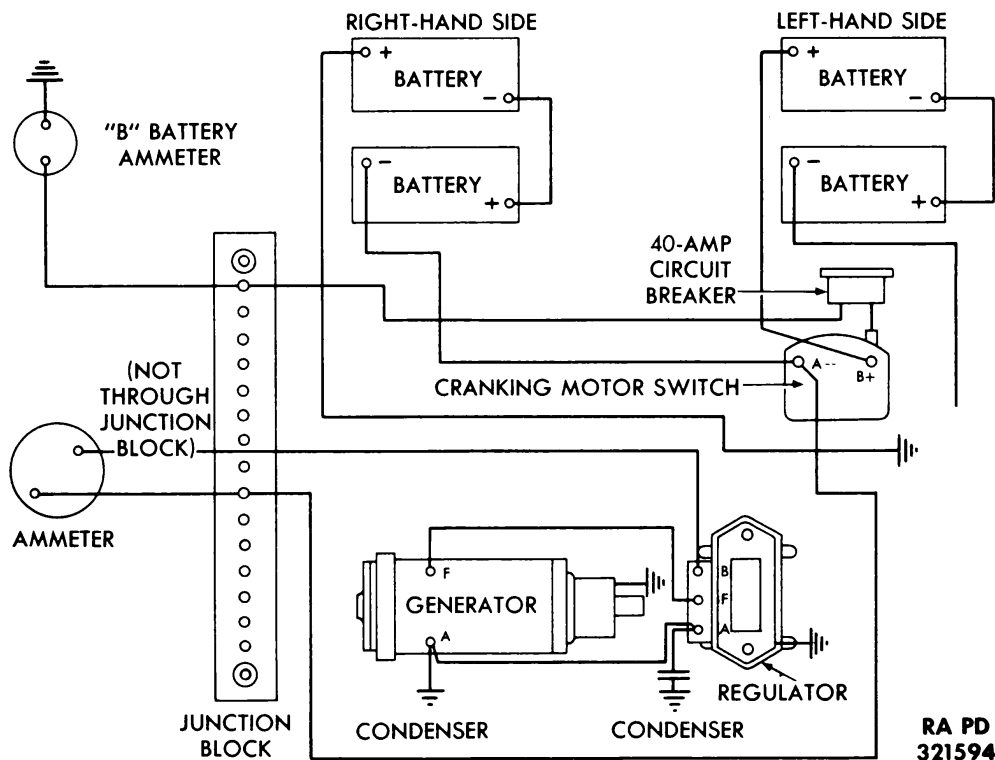

Figure 79—Generating System Wiring Diagram

b. Test and Service.

(1) **ELECTROLYTE LEVEL.** Add distilled water often enough to keep the level of the electrolyte about $\frac{5}{8}$ inch above the top of the separators, or to just below the bottom of the filling well.

(2) **BATTERY TERMINALS.** If any corrosion takes place at terminals, it must be scraped or brushed off. Replace lead-plated parts from which the lead plating is worn or scraped off. A battery terminal connection must be a snug fit rather than a condition of extreme tightness. After cleaning and making battery connections, cover connections with a light film of petrolatum.

(3) **GENERAL CLEANING.** Do not clean batteries by any degreasing methods or with materials that will dissolve the sealing compound. Fuel oil spilled on battery must be wiped off immediately. A solution of 1 pound of soda ash in a gallon of water is satisfactory for removing acid, dirt, and foreign matter from top and sides of battery. Soda ash will neutralize the acid. Make sure the vent plugs are in place and are tight. Do not force soda solution through passages in vents. After exterior parts of battery case have been cleaned, rinse with clear water and dry, using clean rags or compressed air.

(4) SPECIFIC GRAVITY.

(a) *General.* The state of charge of the battery is indicated by the specific gravity of the electrolyte and is determined by hydrometer readings. When the battery is well charged, the specific gravity of the electrolyte is high and the hydrometer will not sink so far into the liquid as when the specific gravity is low. The specific gravity of a fully charged battery is 1.270 to 1.285 at 80°F.

(b) *Hydrometer Readings.* Do not take hydrometer readings immediately after adding water. If the battery is on charge, the water and electrolyte will be mixed after 1 hour. To take a hydrometer reading, insert the nozzle of the hydrometer syringe in the electrolyte then squeeze the bulb and slowly release it, drawing up enough electrolyte to float the hydrometer freely. With the syringe held vertically, the reading on the stem of the hydrometer at the surface of the electrolyte is the specific gravity of the electrolyte. Return the electrolyte to the same cell from which it was taken. Check each cell. If a specific gravity reading for a battery is below 1.225, the battery must be removed from the vehicle to be charged at the bench, or be replaced by a fully charged battery.

(c) *Correcting Hydrometer Readings.* The specific gravity of the electrolyte will vary with the temperature of the electrolyte. Therefore, the hydrometer readings must be corrected for the temperature of the electrolyte in the battery at the time the reading is taken. The correction for each 20°F of temperature variation from 80°F is approximately 0.008 in specific gravity. The following table gives the correction that must be made for various temperatures.

Temperature of Electrolyte, degrees Fahrenheit	Specific Gravity Correction
100	Add 0.008 to hydrometer reading.
80	No correction required.
60	Subtract 0.008 from hydrometer reading.
40	Subtract 0.016 from hydrometer reading.
20	Subtract 0.024 from hydrometer reading.
0	Subtract 0.032 from hydrometer reading.
-20	Subtract 0.040 from hydrometer reading.

(5) INACTIVE BATTERY. If a battery is permitted to stand without charging for long periods of time, severe damage occurs. A battery standing idle is subject to gradual self-discharge. The rate of discharge varies with the temperature, time since charged, and general condition of the battery. Under average conditions a fully charged battery standing idle for 30 days will at the end of that time test approximately 1.230 specific gravity at 80°F. To avoid damage to an idle battery, it should be brought to full charge at the bench at regular 30-day intervals.

Battery and Generating System

- A—BATTERY RETAINER END PLATE
- B—NEGATIVE TERMINAL
- C—NEGATIVE TERMINAL TO CRANKING MOTOR CABLE
- D—POSITIVE TERMINAL TO CRANKING MOTOR SWITCH CABLE
- E—BATTERY CABLE CONNECTOR
- F—END PLATE RETAINER STRAP
- G—BATTERY RETAINER END PLATE
- H—L. H. INSIDE BATTERY
- J—NUT
- K—TERMINAL BOLT
- L—NEGATIVE CABLE TERMINAL
- M—L. H. OUTSIDE BATTERY
- N—POSITIVE TERMINAL

RA PD 321347

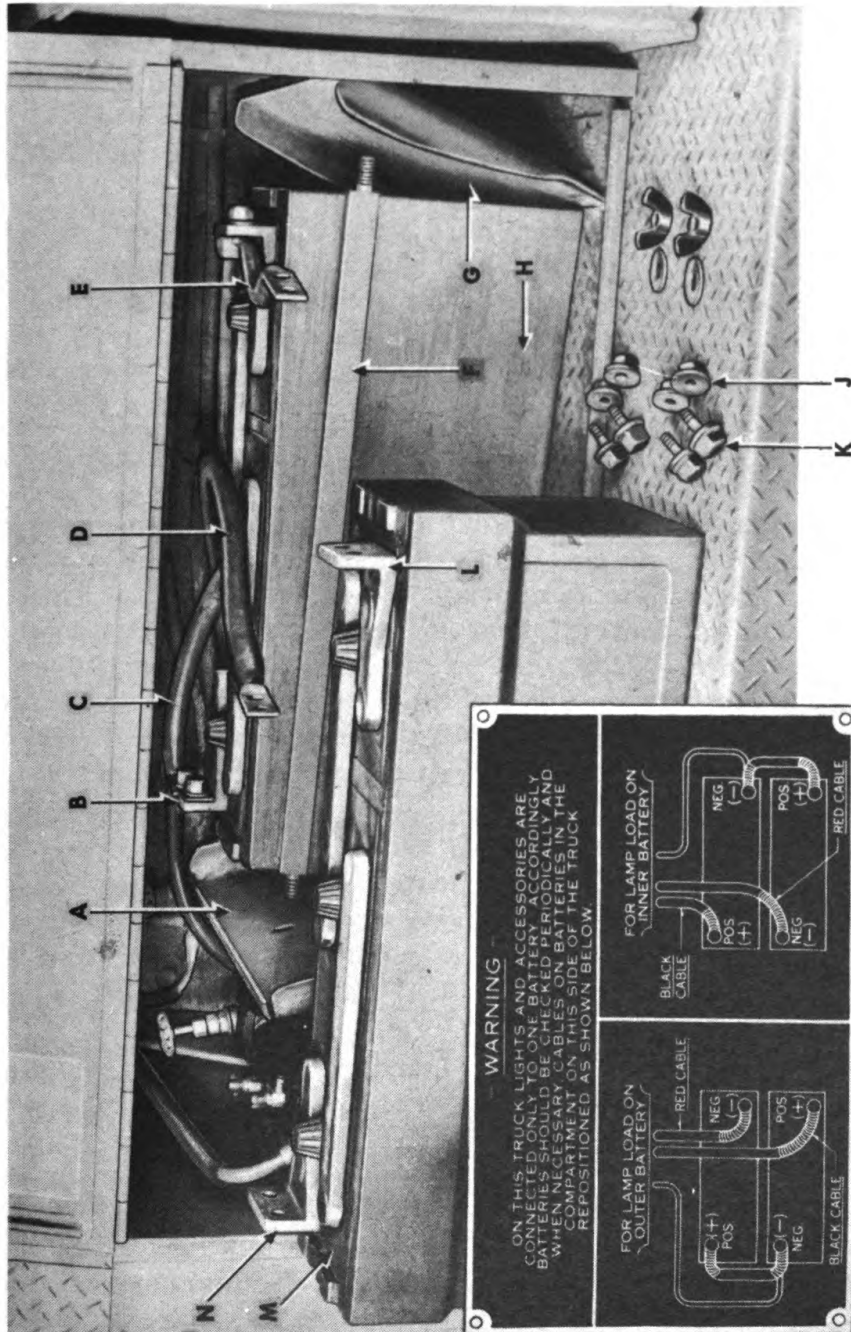

Figure 80—Right- and Left-side Battery Cable Connections

(6) CABLE CONNECTIONS AT BATTERIES IN RIGHT-HAND SERIES GROUP (fig. 80).

(a) *General.* The lighting load is connected across one of the two batteries in the series group on the right side of the chassis. (There is a provision for changing lighting connections to the other battery in the same compartment.) Because of the lighting load connected across one battery, the condition of the batteries and state of charge will be somewhat unbalanced. The battery in series with the one across which the lighting load is connected will receive more charge than the battery which handles the lighting load, and will also use more water. If the battery in series with the one which carries the lighting load is using considerably more water and is maintaining rather high gravity readings in comparison with the loaded battery, the connections should be changed so that the lighting load will be shifted to the other battery.

(b) *Transferring Lighting Load in Right-hand Battery Series Group* (fig. 80). The lighting load is transferred from one battery to the other in the series group by transposing lighting lead and battery jumper cable, and the positive and negative leads at the batteries. Refer to battery cable hook-up plate located on right battery compartment door, and transpose the connections as shown.

c. Removal and Installation of Batteries.

(1) **GENERAL.** When working around batteries, remember that all exposed metal parts are "alive," therefore, do not lay any metal tool or wire across the terminals. When necessary to tighten or loosen the clamped connections at the battery terminals, use a wrench of the proper size. Care must be taken that the wrench does not come in contact with any of the other metal parts of the battery. When removing terminals, remove grounded or positive terminal first. When replacing terminals, replace grounded terminal last.

(2) **REMOVAL** (fig. 80). Disconnect and fasten positive (black) cable away from battery terminals before disconnecting other leads. Disconnect all leads, and remove battery jumper cable by removing nuts and bolts which secure connections at battery terminals. Remove end plate retainer straps by removing wing nuts from ends of strap and removing straps from end plate retainers. Lift batteries from compartment.

(3) **INSTALLATION** (fig. 80). Position batteries in compartment so that positive terminal of one battery is adjacent to negative terminal of other battery. Install end plate retainer straps. Tighten wing nuts to provide a snug fit of retainer plates, rather than extreme tightness. Connect jumper cable to positive and negative terminals at adjacent ends of batteries. The lamp-load cable must be connected with jumper cable. **NOTE:** *Battery to which lamp*

Battery and Generating System

load cable is connected will be the battery to which the positive (black) battery cable is connected. Connect negative (red) cable to negative terminal and positive (black) cable to positive terminal at ends of batteries away from jumper cable.

d. Preparation of Dry Charged Battery.

(1) Remove or destroy any sealing device which may have been used to close or restrict the vent openings.

(2) Fill cell $\frac{3}{8}$ inch above separators with 1.275 at 80°F specific gravity sulphuric acid. Battery and electrolyte must be at a temperature above 60°F, but preferably not above 100°F.

(3) The battery is now ready for use unless it is going into service in temperatures below 0° Fahrenheit. In this case, a 6- to 12-hour charge at 8 amperes will raise the specific gravity of the electrolyte above the danger point of freezing. Constant potential charging may be used if the electrolyte temperature is controlled below 130°F by interrupted charge as necessary.

113. AMMETERS.

a. Description (fig. 8). Two ammeters are located side by side at top center on instrument panel. The ammeter located toward the left is graduated on negative and positive sides with readings "30" and "15," which indicates generator discharging or charging rate. The ammeter located toward the right is identified as the battery "B" ammeter, and is graduated to read "discharge" and "charge," which indicates whether batteries in left side compartment are being charged or discharged.

b. Replacement of Generator Charging Ammeter.

(1) **REMOVAL (fig. 8).** Remove two nuts and lock washers which secure ammeter retainer bracket and remove bracket. Disconnect leads at ammeter, and attach marked tags to leads for reference when ammeter is installed. Remove ammeter at front of instrument panel.

(2) **INSTALLATION (fig. 8).** Position new ammeter in instrument panel, and connect leads as indicated by tags attached to leads during removal. Position retaining bracket over stud bolts, and install washers and nuts which secure bracket and ammeter to panel. Start motor and observe ammeter. Correct operation indicates correct installation. If ammeter indicates discharge when it should indicate charge, disconnect wires and connect them in correct order.

c. Replacement of Battery "B" Ammeter. Follow procedure outlined in subparagraph b above.

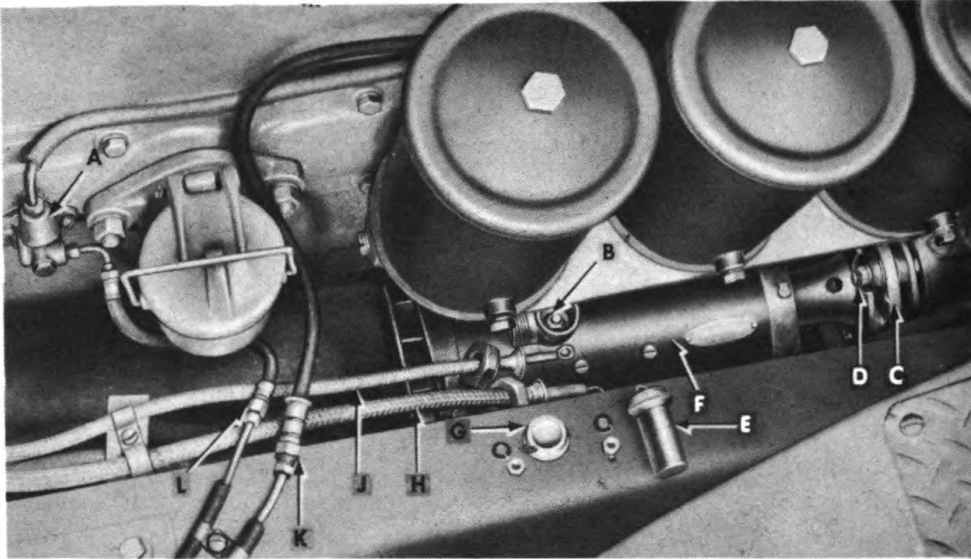

- | | |
|-------------------------------|--|
| A—VISCOMETER | H—REGULATOR TO GENERATOR
ARMATURE TERMINAL WIRE |
| B—FIELD TERMINAL | J—REGULATOR TO GENERATOR
FIELD TERMINAL WIRE |
| C—FLEXIBLE DRIVE | K—OIL PUMP TO GAGE OIL LINE
CONNECTOR |
| D—DRIVE BOLT | L—VISCOMETER TO GAGE OIL
LINE CONNECTOR |
| E—RADIO SUPPRESSION CONDENSER | |
| F—GENERATOR | |
| G—TERMINAL SHIELD COVER | |
- RA PD 321344

Figure 81—Removing Generator

114. GENERATOR.

a. Description and Data.

(1) **DESCRIPTION** (fig. 81). The generator is a 2-brush, 2-pole, 12-volt, shunt-wound type. It is installed on the right side of the engine to the rear of the water pump shaft, which drives it. A conventional head band is provided. Removal of head band gives access to commutator and two brushes. The armature shaft rotates on ball bearings at each end, which are lubricated by two oilers. The function of the generator is to keep the batteries charged and to operate the vehicle electrical system.

(2) **DATA.**

Make	Delco-Remy
Model number	1106654
Rotation	Clockwise at drive end
Volts	12
Type	Shunt wound
Brushes	2

Battery and Generating System

Output (cold)	
Amperes	25
Voltage	13
Revolution per minute	1,300
Brush spring tension	24 to 28 oz
Field current draw	1.2 to 1.27 amp at 12 volts

b. Tests.

(1) **TEST FOR GROUNDED BRUSHES.** Remove cover band. Place test prongs on the insulated brushes and end frame to check for grounded brushes. The test lamp in the test circuit will light if a grounded condition exists. If brush holders are grounded, notify higher authority.

(2) **TEST BRUSH SPRING TENSION.** Remove cover band. Hook a spring scale to brush holder, and pull scale at right angles to holder. Note reading as holder lifts from brush. It should be 24 to 28 ounces. If it does not fall within these limits, notify higher authority.

c. Service.

(1) **INSPECT GENERATOR.** Remove head band. Note condition of commutator. If dirty or discolored, clean commutator (step (2) below). If commutator is rough or out-of-round, or if it has high mica, notify higher authority. Inspect brushes; if worn to one-half original length, replace brushes (step (3) below). Check brush lead connections to be sure they are clean and tight. Install head band.

(2) **CLEAN COMMUTATOR.** Remove head band. Hold a piece of No. 00 flint paper against commutator and crank engine. Blow dust from commutator with a dry air blast. Install head band.

(3) **REPLACE BRUSHES.** Remove head band. Remove brush lead screw. Lift brush arm with hook, and pull brushes from holders. Install new brushes in holder and connect brush lead screw. Brushes must have a 100 percent contact with the commutator. If necessary, cut a strip off No. 00 or No. 000 flint paper the exact width of the commutator, and wrap it tightly around the commutator with the sanded side toward the brushes. Turn the commutator by cranking motor until the brushes are properly seated. Remove flint paper. Blow out dust with dry air blast.

d. Removal (figs. 81 and 82).

(1) **REMOVE BAYONET GAGE TUBE.** Pull out oil pan gage, and unscrew bayonet gage tube.

(2) **DISCONNECT AIR LINES.** Disconnect air compressor to air reservoir line at both ends, and push line to one side out of the way.

(3) **DISCONNECT WIRE CONNECTIONS.** Unscrew cover from field terminal shield. Remove nut and lock washers on field terminal, and lift off regulator to generator field terminal wire. Unscrew

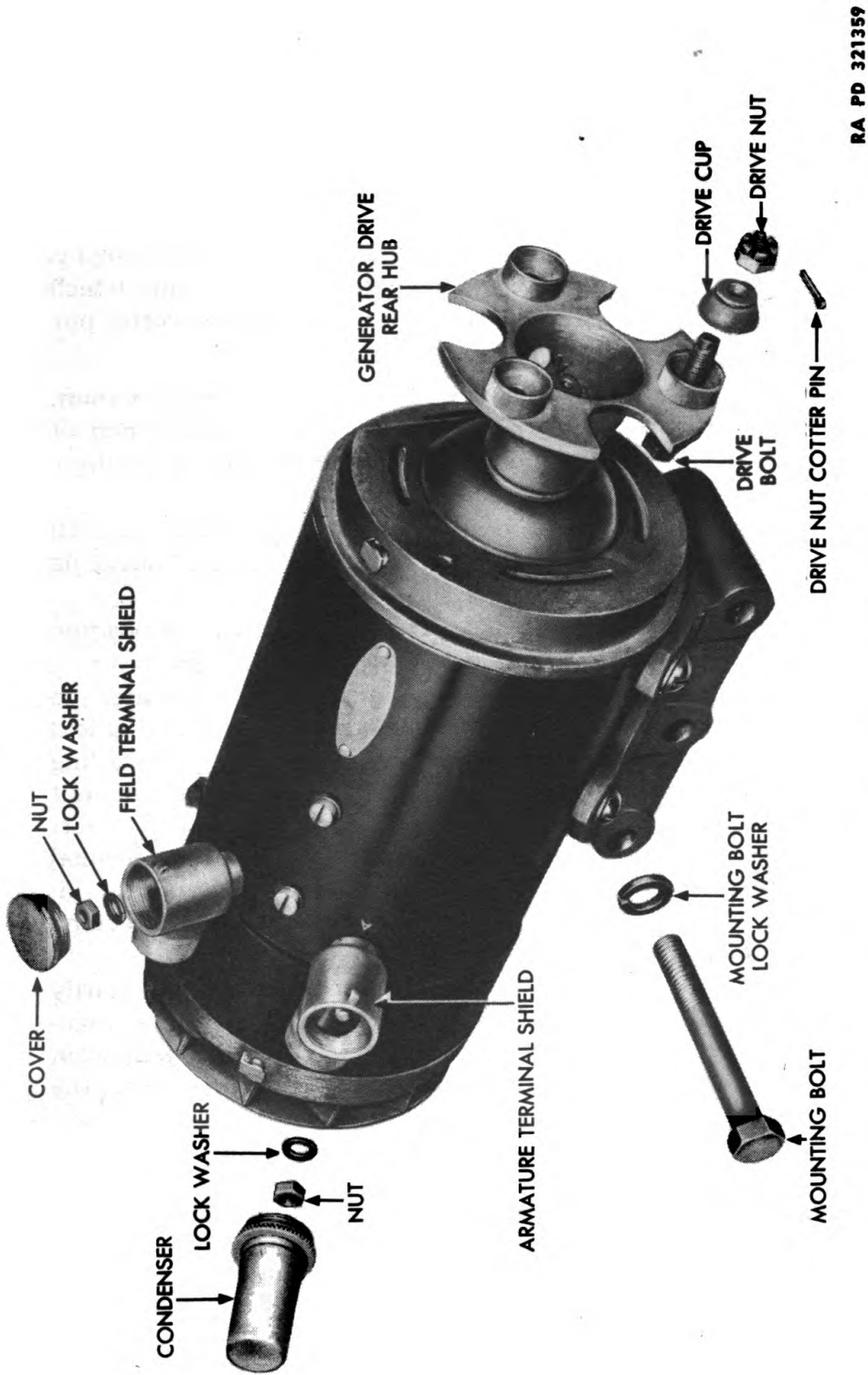

RA PD 321359

Figure 82—Generator—Removed

Battery and Generating System

wire shielding attaching nut, and pull out wire. Unscrew condenser from armature terminal shield. Remove nut and lock washer on armature terminal, and lift off armature terminal wire. Unscrew wire shielding attaching nut, and pull out wire.

(4) **DISCONNECT GENERATOR DRIVE.** Remove cotter pins, nuts, drive cups, and drive bolts which secure generator drive rear hub to flexible dish and front hub.

(5) **DISCONNECT GENERATOR.** Remove mounting bolts and lock washers which attach generator mounting plate to crankcase. Pass generator forward and down between the frame side rail and engine.

(6) **REMOVE REAR HUB.** Remove cotter pin and nut which secures rear hub to generator. Pull off rear hub and remove cotter pin.

e. Installation (figs. 81 and 82).

(1) **INSTALL REAR HUB.** Insert pin in generator armature shaft. Tap hub into position on shaft. **CAUTION:** *Place opposite end of shaft against work bench to prevent driving shaft out of position.* Install nut and cotter pin which secures rear hub.

(2) **ATTACH GENERATOR.** Place generator in position. Install mounting bolts and lock washers which attach generator mounting plate to crankcase.

(3) **CONNECT GENERATOR DRIVE.** Hold flexible disk in position and install drive bolts, drive cups, drive nuts, and cotter pins.

(4) **CONNECT WIRE CONNECTIONS.** Insert the regulator to generator armature of terminal wire in the armature terminal shield rear opening, and attach the lead to the terminal by installing the lock washer and nut. Screw the wire shielding attaching nut into terminal shield. Screw the condenser into the shield. Insert the regulator to generator field terminal wire in the field terminal shield rear opening, and attach the wire to the terminal by installing the lock washer and nut. Screw the wire shielding attaching nut into terminal shield. Screw the cap into the shield.

(5) **POLARIZE GENERATOR.** Place a jumper lead momentarily between the battery terminal and armature terminals of the regulator to allow a surge of current from the battery to the generator, which will correctly polarize the generator with respect to the battery it is to charge.

(6) **CONNECT AIR LINE.** Connect each end of air compressor to air reservoir line.

(7) **INSTALL BAYONET GAGE TUBE.** Screw bayonet gage tube into position. Insert bayonet gage.

115. GENERATOR REGULATOR.

a. Description and Data.

(1) **DESCRIPTION (fig. 83).** The generator regulator is mounted in the driver's compartment on the cowl under the right side of the

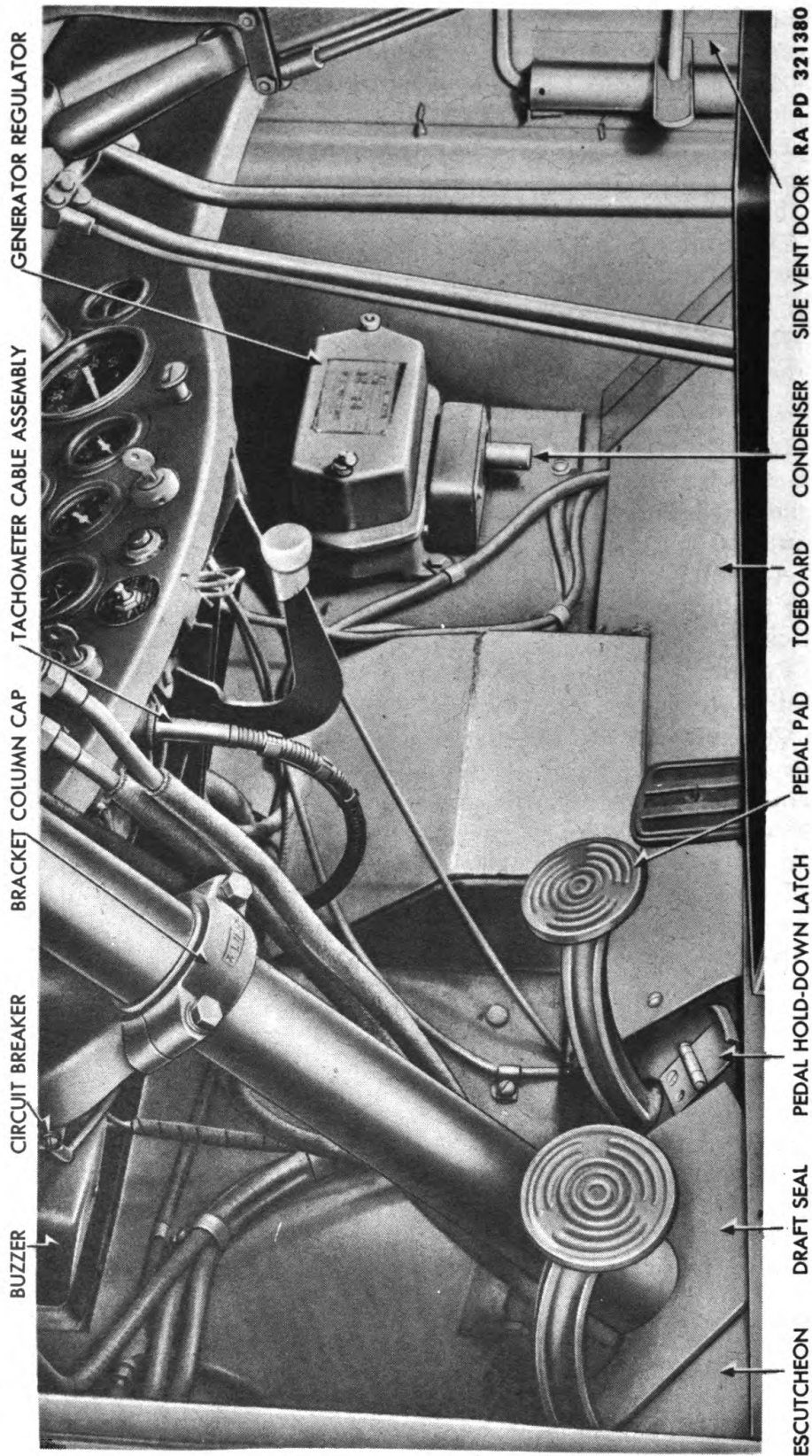
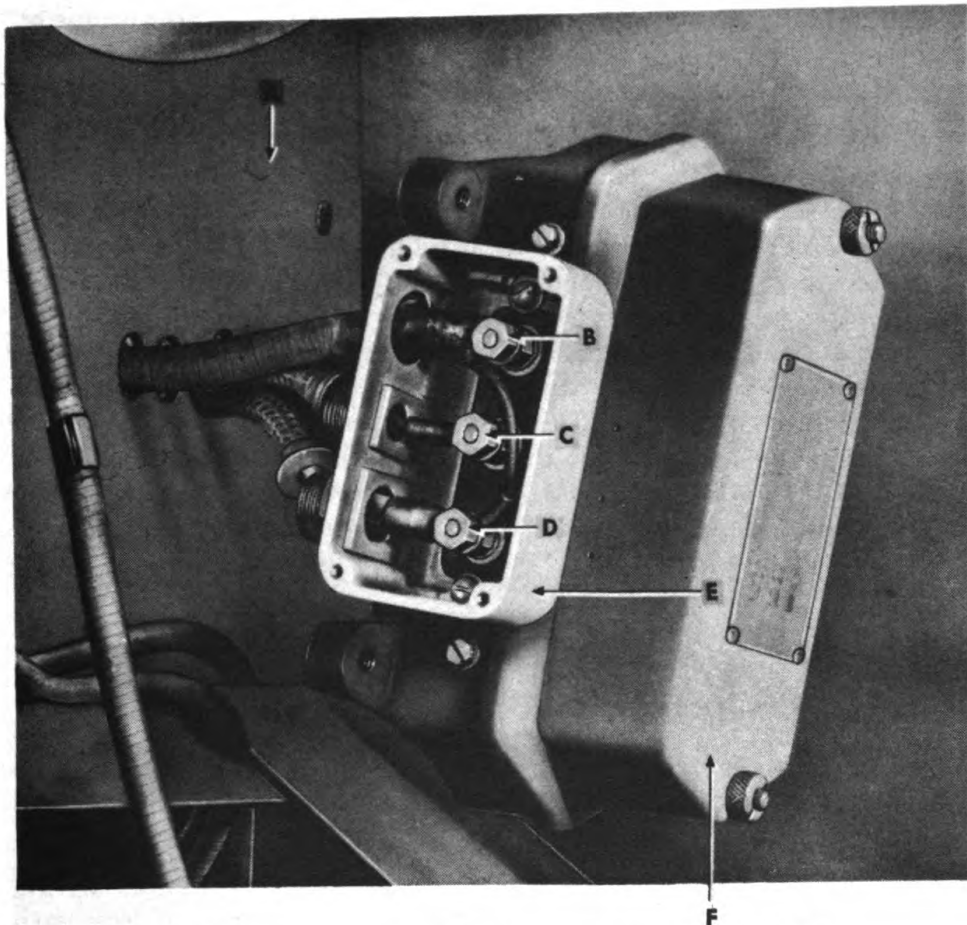

Figure 83—Generator Regulator—Installed



A—COWL C—F TERMINAL E—TERMINAL BOX
 B—B TERMINAL D—A TERMINAL F—COVER

RA PD 321369

Figure 84—Generator Regulator—Removal

instrument panel. It consists of three units: cut-out relay, current limiting regulator, and voltage regulator. The cut-out relay closes and opens the circuit between the generator and battery. The current limiting regulator controls the maximum output of the generator and prevents overcharging the batteries. The voltage regulator controls voltage built up by the electrical system. It prevents damage to lamps, circuit breakers, and other units of the electrical system.

(2) DATA.

Make Delco-Remy
 Model 1118465
 Type 3-unit

b. **Removal** (fig. 84). Unscrew condenser from terminal box cover. Remove terminal box cover screws and cover. Remove terminal nuts, and lift off leads from terminals. Unscrew shielding nuts on wires on engine side of cowl. Remove nuts and lock washers from bolts which secure regulator to cowl. Pull regulator from cowl.

c. **Installation** (fig. 84). Place regulator in position on cowl. Install bolts, lock washers, and nuts which attach it. Insert shielded wire from generator field terminal through cowl and into terminal box center opening. Attach lead to terminal with terminal nut. Insert shielded wire from generator armature terminal through cowl and into terminal box right opening. Insert wires from ammeter and contact relay (which are part of the cowl wiring harness) into left side opening in terminal box. Connect wire from contact relay and wire from generator armature terminal to the "A" terminal of the regulator. Connect the wire from the armature to the "D" terminal of the regulator. Install terminal box cover and screws. Screw condenser into cover.

Section XXI

TRUCK WIRING, CIRCUIT BREAKERS, AND JUNCTION BLOCK

116. WIRING.

a. **Description.** The truck wiring consists of single lengths of wire or cable and the following wiring harnesses: a chassis wiring harness which includes the wires from the junction block to the various points on the chassis, a cowl wiring harness which includes the wire from the junction block to the instrument panel, the dimmer switch wiring harness between the dimmer switches and junction block, and the wiring harness connecting the low pressure indicator buzzer and fuel gage. The wiring is installed in key colors so that identification can be made by referring to the wiring harness diagrams (figs. 86 and 87) and the wiring diagram (fig. 85).

b. Removal.

(1) **REMOVE COWL WIRING HARNESS** (fig. 87). Disconnect battery cables from batteries (par. 112 c). Remove upper wires from junction block. Remove harness clip nuts from left and right side of cowl on engine compartment side. Remove two screws from horn relay terminals and lift off wires. Remove harness clip from instrument panel bracket in center of instrument panel. Disconnect harness wires from instrument panel instruments. Attach tag to each wire to assist in identification for reassembly. Disconnect lead from contact relay and from regulator. Remove rubber grommet from cowl, and pull harness from and through cowl.

Truck Wiring, Circuit Breakers, and Junction Block

(2) **REMOVE DIMMER SWITCH WIRING HARNESS.** Remove three screws and lift off three wires from dimmer switch. Remove nut from harness clip on engine side of cowl. Pull harness out of cowl opening at left corner of cowl. Disconnect three wires from junction block terminals.

(3) **REMOVE CHASSIS WIRING HARNESS** (fig. 86). Disconnect lower wires from junction block. Remove clips which secure harness to left side frame rail. Remove leads from starter burner terminal and stop control solenoid, and from horn button wire at lower end of steering column. Remove clips from wire under left front fender. Disconnect wire from left-hand blackout marker light. Pull harness in from left frame side rail. Remove clips which secure harness to radiator support crossmember. Disconnect wires from right-hand blackout marker light and blackout driving light, and disconnect ground wire from fender. Pull cable inward from right frame side rail. Disconnect harness leads from cranking motor solenoid and cranking motor. Disconnect lead from battery terminal in right-hand battery compartment. Remove clips and pull section of harness to left side of truck. Disconnect leads from cranking motor switch and from circuit breakers on cranking motor switch. Disconnect lead from left-hand fuel tank gage unit and right-hand fuel tank gage unit. Disconnect leads from winch torque control switch. Disconnect leads from stop light switch, trailer brake coupling socket, right-hand tail and stop light, left-hand tail and stop light. Remove clips and work wiring harness from truck.

c. Installation.

(1) **INSTALL COWL WIRING HARNESS** (fig. 87). Insert end of wiring harness containing 11 wires through opening in cowl under horn regulator. Connect leads according to color key, shown on harness diagram (fig. 87) and wiring diagram (fig. 85). Insert end of harness containing two leads to regulator through opening in cowl and connect leads to regulator (fig. 85). Connect two leads to horn relay. Connect leads to junction block terminals in accordance with diagram of junction block (fig. 88). Install harness clips. Install rubber grommet in cowl opening.

(2) **INSTALL DIMMER SWITCH WIRING HARNESS.** Insert wiring harness in cowl opening in left lower corner of cowl. Connect three harness wires to junction block terminals in accordance with diagram (fig. 88). Connect wires to dimmer switch terminals. Install harness clip on engine side of cowl.

(3) **INSTALL CHASSIS WIRING HARNESS.** Position wiring harness along left side frame rail. Place leads to left-hand blackout marker light through opening in left side frame rail. Place leads to right-hand

Maintenance Instructions

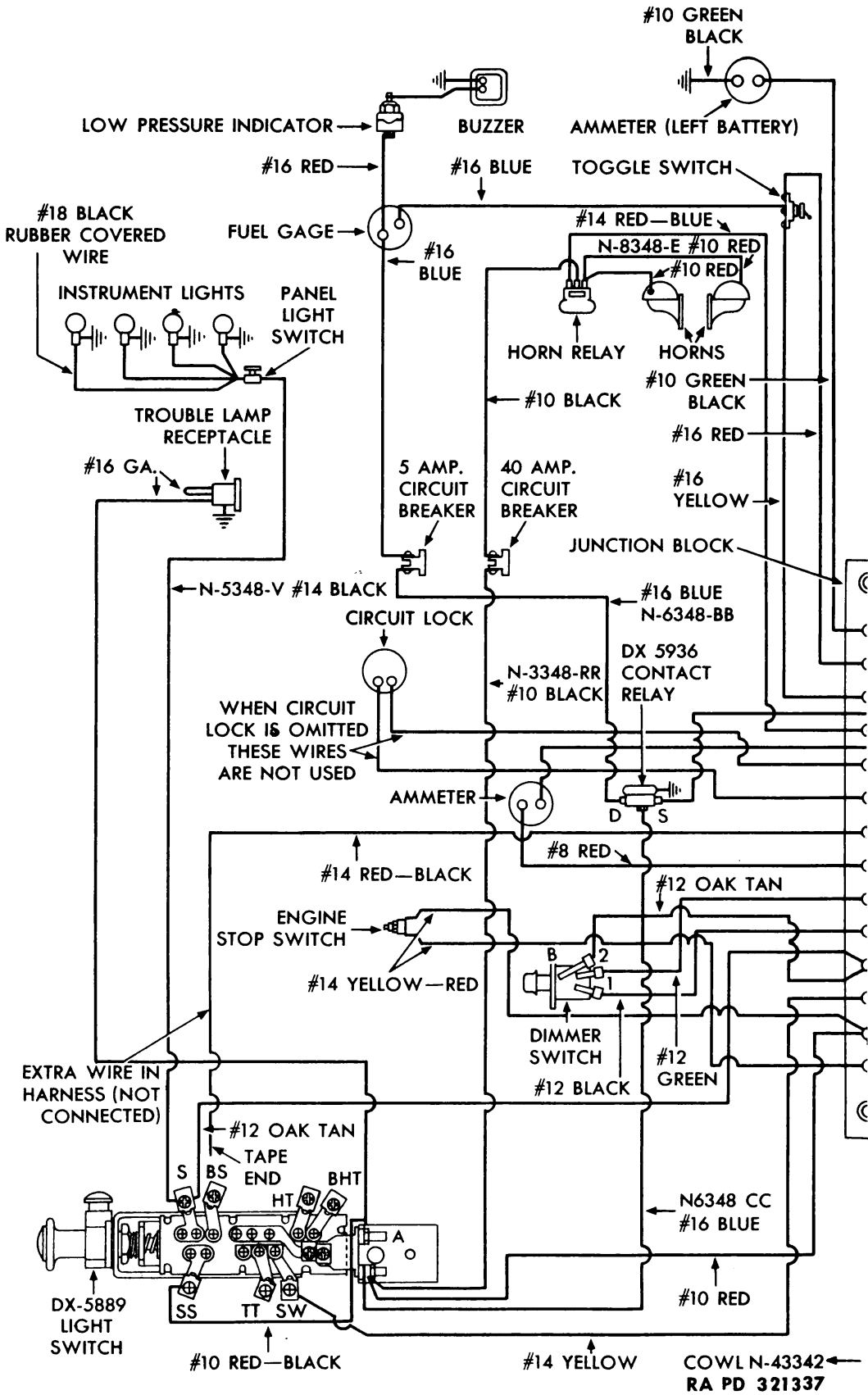
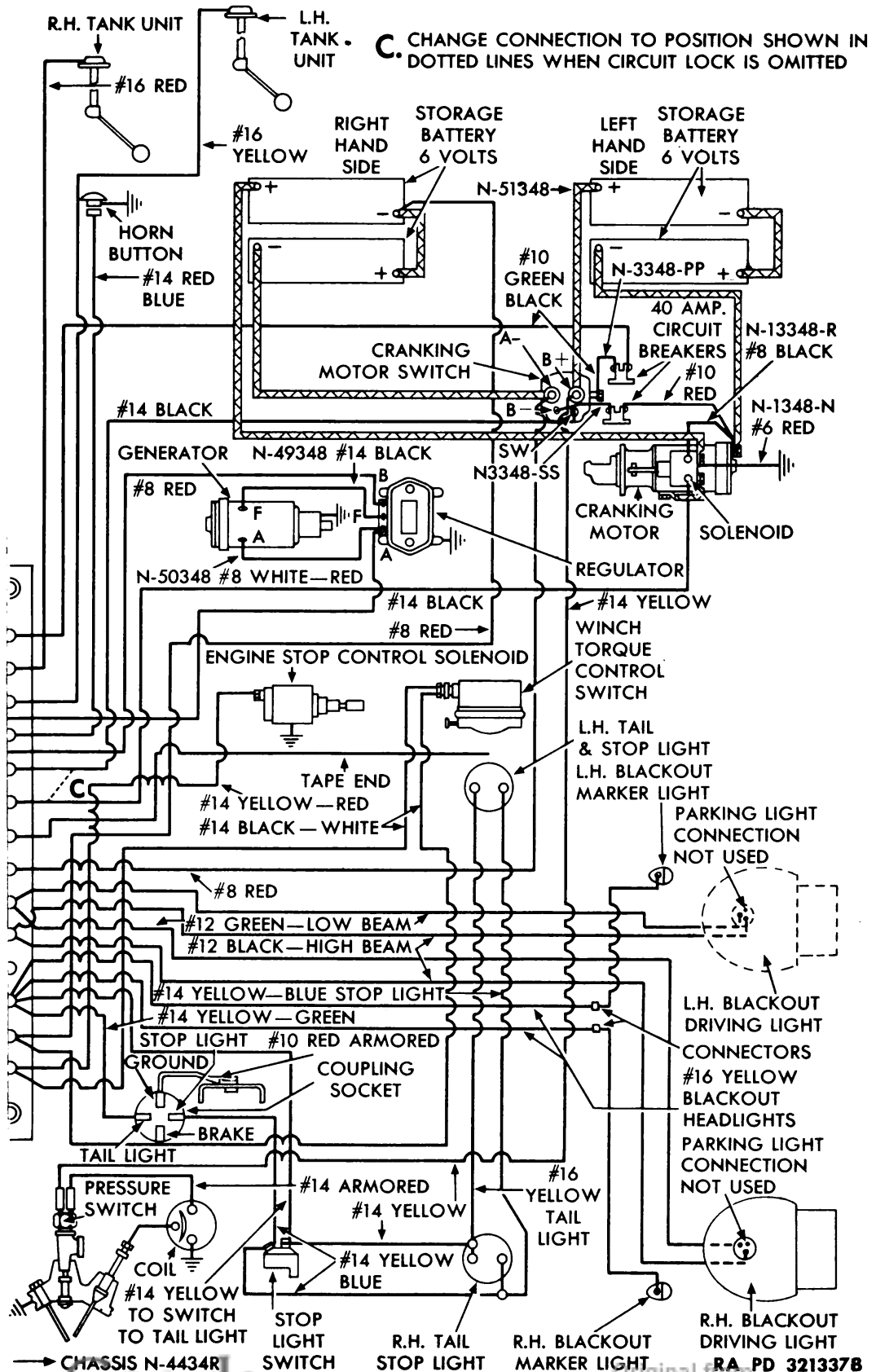
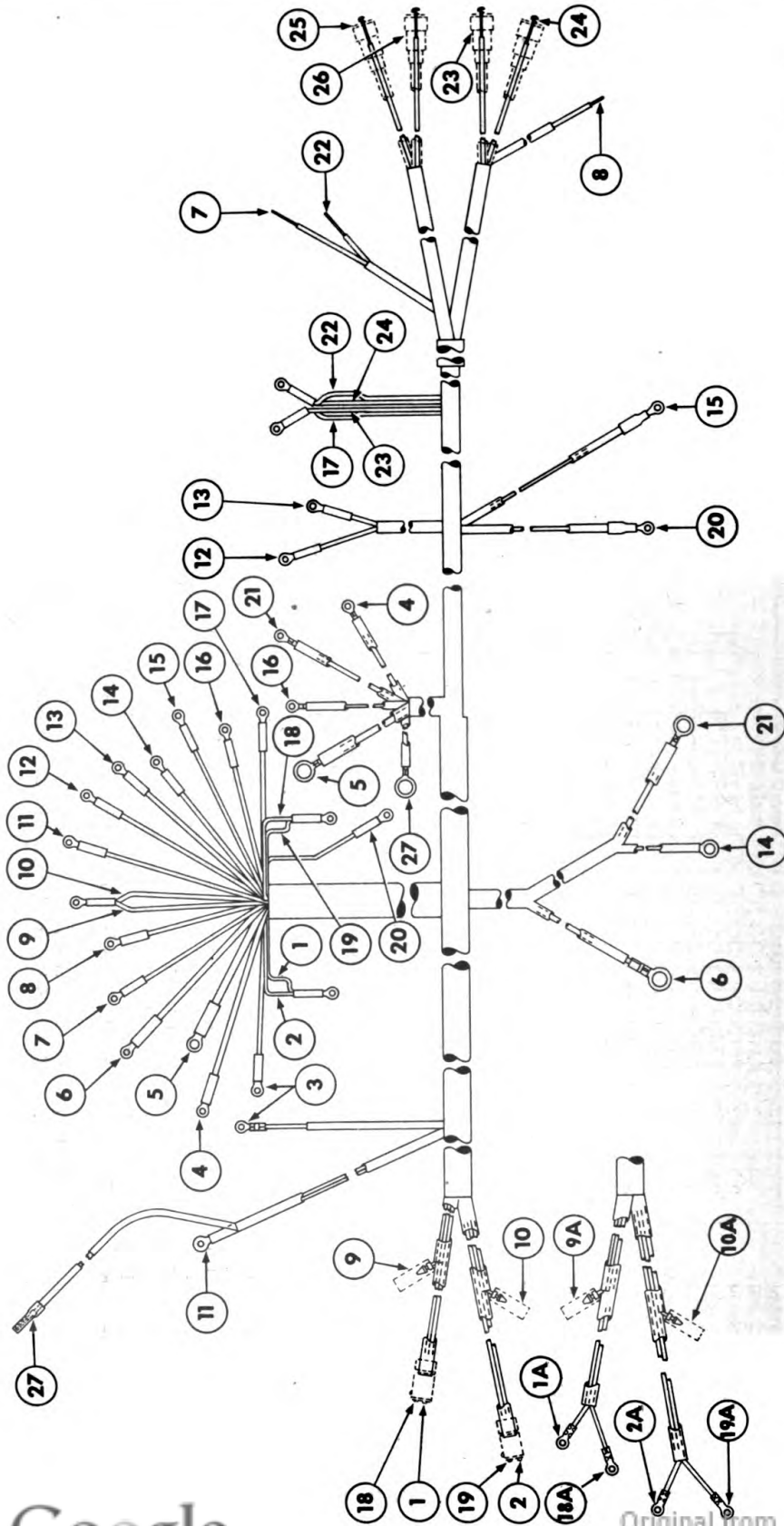

Figure 85

Truck Wiring, Circuit Breakers, and Junction Block



Maintenance Instructions



RA PD 321372

Figure 86—Chassis Wiring Harness

Truck Wiring, Circuit Breakers, and Junction Block

COLOR	WIRE NO.	GAGE	LEAD	LENGTH (INCHES)
GREEN	1	12	JUNCTION BLOCK TO LEFT-HAND DRIVING LIGHT—LOW BEAM	94
GREEN	1A	12	JUNCTION BLOCK TO LEFT-HAND DRIVING LIGHT CONNECTOR—LOW BEAM	96½
GREEN	2	12	JUNCTION BLOCK TO RIGHT-HAND DRIVING LIGHT—LOW BEAM	142
GREEN	2A	12	JUNCTION BLOCK TO RIGHT-HAND DRIVING LIGHT CONNECTOR—LOW BEAM	143¾
RED-BLUE	3	14	JUNCTION BLOCK TO HORN BUTTON	57
GREEN - BLACK	4	10	JUNCTION BLOCK TO 40-AMP CIRCUIT BREAKER AND CRANKING MOTOR SWITCH	74½
RED	5	8	JUNCTION BLOCK TO CRANKING MOTOR SWITCH "A" TERMINAL	83
RED	6	8	JUNCTION BLOCK TO BATTERY—R.H. COMPARTMENT	116
YELLOW - GREEN	7	14	JUNCTION BLOCK TO TRAILER COUPLING SOCKET	242
RED - BLACK	8	14	EXTRA WIRE—JUNCTION BLOCK TO TAPE END	272
YELLOW	9	16	JUNCTION BLOCK TO L.H. BLACKOUT MARKER LIGHT CONNECTOR	85
YELLOW	9A	16	JUNCTION BLOCK TO L.H. BLACKOUT MARKER LIGHT CONNECTOR	87
YELLOW	10	16	JUNCTION BLOCK TO R.H. BLACKOUT MARKER LIGHT CONNECTOR	133
YELLOW	10A	16	JUNCTION BLOCK TO R.H. BLACKOUT MARKER LIGHT CONNECTOR	135
YELLOW - RED	11	14	JUNCTION BLOCK TO STOP CONTROL SOLENOID	74
BLACK - WHITE	12	14	JUNCTION BLOCK TO WINCH TORQUE CONTROL SWITCH	133
BLACK - WHITE	13	14	JUNCTION BLOCK TO WINCH TORQUE CONTROL SWITCH	131
BLACK	14	14	JUNCTION BLOCK TO CRANKING MOTOR SOLENOID	81
RED	15	16	JUNCTION BLOCK TO R.H. FUEL TANK GAGE UNIT	177
BLACK	16	14	JUNCTION BLOCK TO CRANKING MOTOR SWITCH "SW" TERMINAL	72½
YELLOW	17	14	JUNCTION BLOCK TO STOP LIGHT SWITCH	159½
BLACK	18	12	JUNCTION BLOCK TO LEFT-HAND DRIVING LIGHT—HIGH BEAM	96
BLACK	18A	12	JUNCTION BLOCK TO L.H. DRIVING LIGHT CONNECTOR—HIGH BEAM	95½
BLACK	19	12	JUNCTION BLOCK TO RIGHT-HAND DRIVING LIGHT—HIGH BEAM	143
BLACK	19A	12	JUNCTION BLOCK TO R.H. DRIVING LIGHT CONNECTOR—HIGH BEAM	145¼
YELLOW	20	16	JUNCTION BLOCK TO L.H. FUEL TANK GAGE UNIT	150
RED	21	10	40-AMPERE CIRCUIT BREAKER TO CRANKING MOTOR	113
YELLOW - BLUE	22	14	STOP LIGHT SWITCH TO TRAILER COUPLING SOCKET	91
YELLOW	23	14	STOP LIGHT SWITCH TO R.H. TAILLIGHT	120
YELLOW - BLUE	24	14	STOP LIGHT SWITCH TO R.H. STOP LIGHT	117½
YELLOW	25	16	SPLICED L.H. TAIL LAMP TO R.H. TAILLIGHT	54
YELLOW - BLUE	26	14	SPLICED L.H. STOP LAMP TO R.H. STOP LIGHT	55
YELLOW	27	14	PRESSURE SWITCH TO CRANKING MOTOR SWITCH	130½

NOTE: WIRE LEAD NUMBERS HAVING SUFFIX LETTER "A" ARE FOR HARNESS HAVING LUG CONNECTORS IN PLACE OF PLUG-IN CONNECTORS ON LEADS SO NUMBERED.

RA PD 321372B

Legend for Figure 86—Chassis Wiring Harness

RA PD 321306

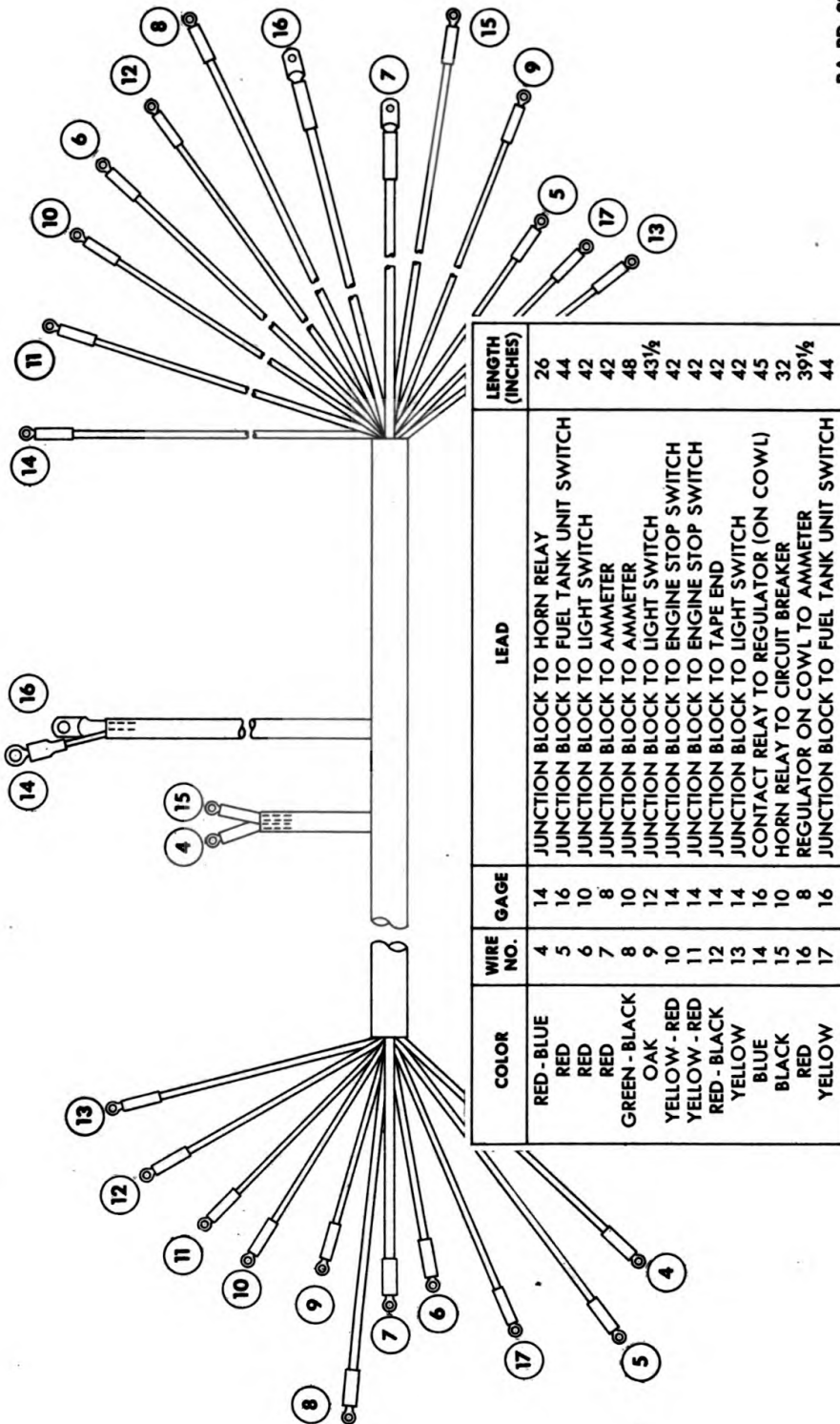

Figure 87—Cowl Wiring Harness

Truck Wiring, Circuit Breakers, and Junction Block

marker light and blackout driving light across radiator support cross-member and through opening in right side frame rail. Place leads to cranking motor and battery across truck at rear of floorboards. Place leads to winch torque control and right-hand fuel gage unit across truck at rear of cab. Place leads to right-hand tail and stop light across truck at rear frame crossmember. Attach clips which secure harness. Attach leads in accordance with chassis harness wiring diagram (fig. 86) and wiring diagram (fig. 85). Connect leads to junction block terminals in accordance with junction block diagram (fig. 88). Connect battery cables to battery (par. 112 c). Test wiring installation by operating all instruments, lights, and horn and observing performance.

117. CIRCUIT BREAKERS.

a. Description and Data.

(1) **DESCRIPTION.** Four circuit breakers are mounted on the vehicle as follows: A cranking motor solenoid circuit breaker and cranking motor switch circuit breaker of 40-ampere rating are attached to the cranking motor switch under floorboard (fig. 70); a fuel gage circuit breaker of 5-ampere rating is attached to instrument panel bracket forward of steering column (fig. 83); a horn relay circuit breaker of 40-ampere rating is mounted forward of the fuel gage circuit breaker.

(2) **DATA.**

Type Thermal cut-out
Fuel gage circuit breaker:
Capacity 5 amp
Model DX5738A
Cranking motor solenoid, cranking motor switch, and horn relay
circuit breakers:
Capacity 40 amp
Model DX5738C

b. Removal. Remove each circuit breaker as follows: Remove both wires from terminals on circuit breaker. Remove the two nuts, lock washers, and bolts which secure circuit breaker to vehicle.

c. Installation. Install each circuit breaker as follows: Position circuit breaker to vehicle. Secure with the two bolts, lock washers, and nuts; connect wire to each terminal on circuit breaker, in accordance with wiring diagram (fig. 85).

118. JUNCTION BLOCK.

a. Description (fig. 124). The junction block installed on the engine compartment side of the cowl provides a convenient terminal point for the wires leading to the instrument panel and chassis.

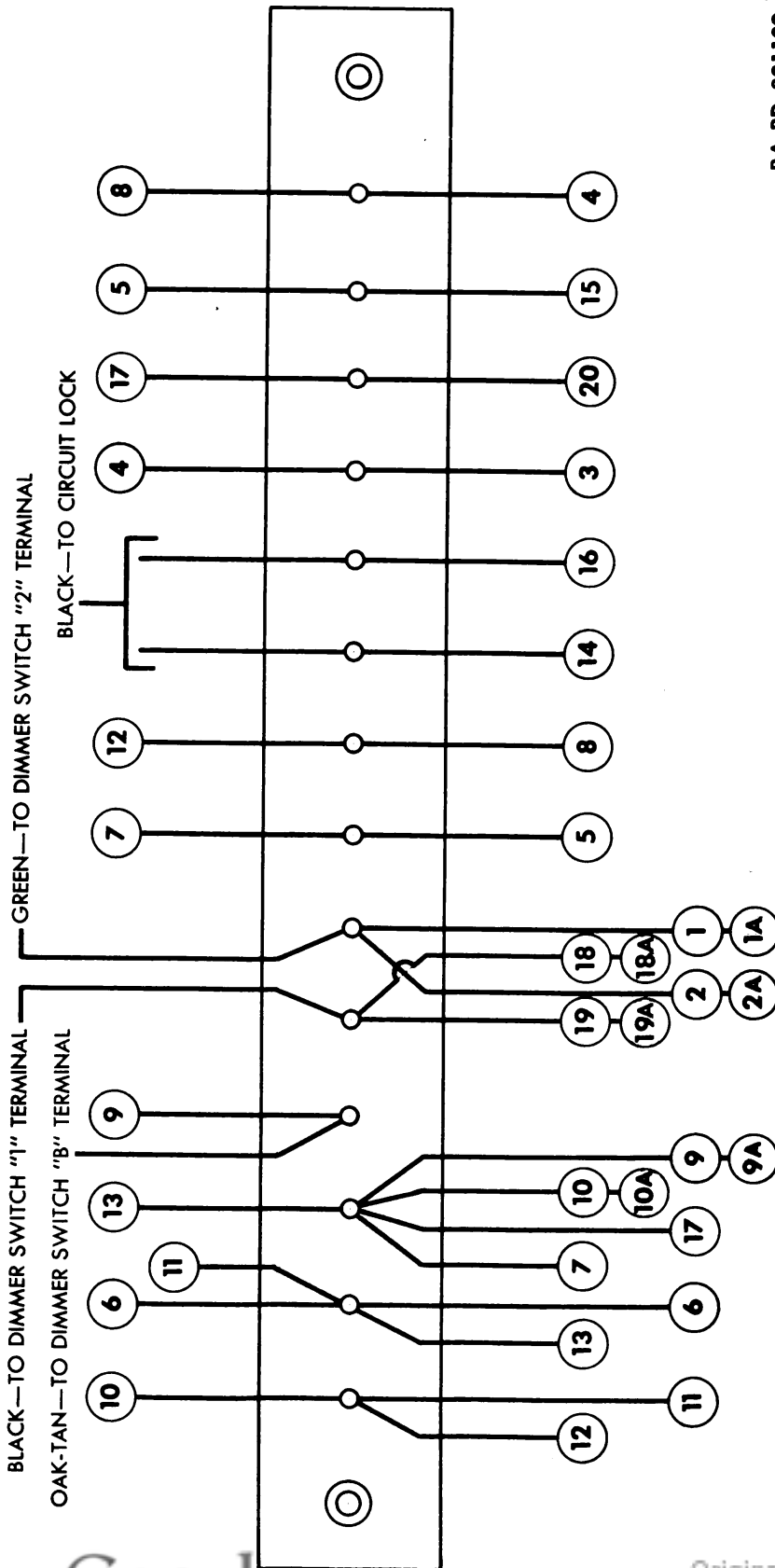

RA PD 321182

Figure 88—Junction Block Wiring Arrangement

Tachometer and Speedometer

b. Removal (fig. 124). Remove junction block terminal post nuts, lock washers, and plain washers. Pull off wires. Remove two bolts, lock washers, and nuts which attach junction block to cowl.

c. Installation (figs. 124 and 88). Position junction block on engine side of cowl. Install bolts, lock washers, and nuts. Place wires of same color on same terminal post in following order: plain washer, lock washer, wire from cowl wiring harness, nut, wire from chassis wiring harness, plain washer, lock washer, nut. Always replace wires in accordance with the original arrangement as shown in junction block wiring diagram (fig. 88).

Section XXII

TACHOMETER AND SPEEDOMETER

119. TACHOMETER.

a. Description and Data (figs. 89 and 8).

(1) **DESCRIPTION.** The tachometer, located on the instrument panel, is driven by a flexible cable from the tachometer adapter on the right front side of the engine. It is used to indicate engine speed in terms of revolutions per minute.

(2) **DATA.**

Manufacturer Stewart Warner
Model DX6043
Range 0 to 2,500 rpm

b. Cable.

(1) **REMOVAL.** Unscrew cable coupling from back of tachometer (fig. 83) and from tachometer adapter on right front side of engine. Remove cable clip. Pull cable from cowl.

(2) **PACKING.** Remove driving cable from housing and dip cable in gear lubricant. Reinstall lubricant-coated cable in cable housing.

(3) **INSTALLATION OF CABLE.** Insert cable through cowl opening. Screw cable coupling to back of tachometer (fig. 83), and screw cable coupling on front end to tachometer adapter. Attach cable clip which secures cable to cowl.

c. Replacement of Instrument (fig. 8).

(1) **REMOVE INSTRUMENT.** Unscrew cable coupling from instrument. Remove two screws, lock washers, and nuts which secure lock housing. Remove two wing nuts and lock washers which secure

Maintenance Instructions

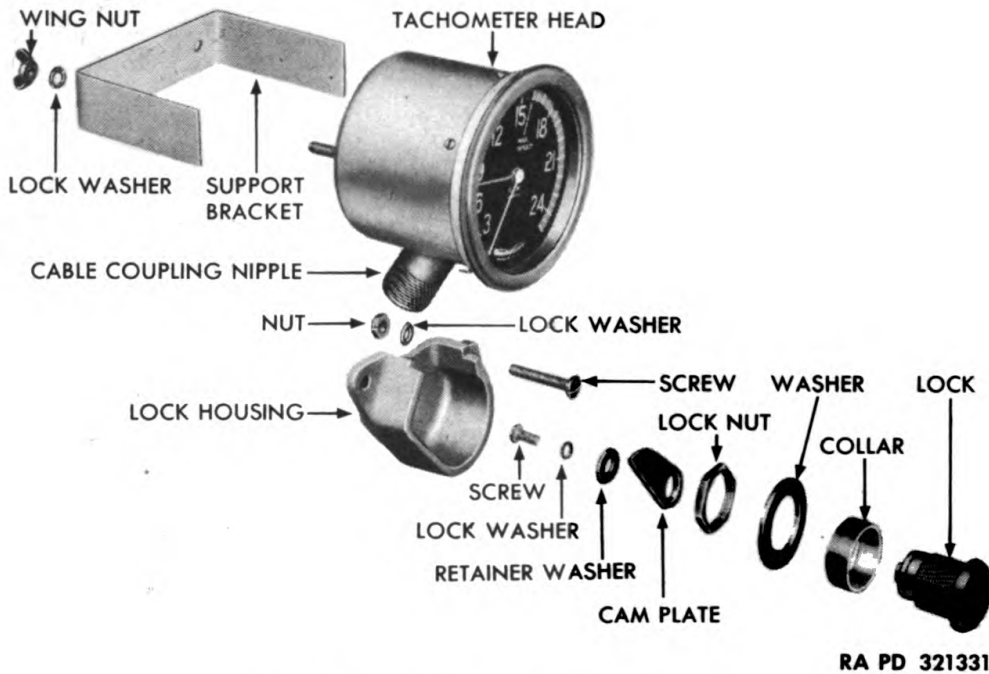

Figure 89—Tachometer Assembly

tachometer head to support bracket. Pull instrument head from panel.

(2) **INSTALL INSTRUMENT.** Position new tachometer on instrument panel. Position support bracket over two stud bolts. Install two lock washers and wing nuts. Position lock housing. Install two screws, lock washers, and nuts. Screw knurled coupling of cable onto back of instrument.

d. **Set-hand Lock** (fig. 89).

(1) Remove set-hand lock. Remove two nuts, lock washers, and screws which secure lock housing to instrument panel. Lift out lock housing. Remove screw, lock washer, and washer from back of lock. Lift off cam plate. Remove lock nut and washer. Withdraw lock. Remove spacer collar.

(2) **INSTALLATION OF SET-HAND LOCK.** Place spacer collar on lock. Position lock through instrument panel. Install washer lock nut. Install cam plate. Install plain washer, lock washer, and screw in back of lock. Position lock housing and install two screws, lock washers, and nuts.

120. **SPEEDOMETER.**

a. **Description and Data.**

(1) **DESCRIPTION** (fig. 8). The speedometer instrument, located on the instrument panel, is driven through a flexible cable from the

Engine Oil System

speedometer adapter in the auxiliary transmission. The speedometer records the speed in miles per hour and the total and trip mileage of the truck.

(2) DATA.

Manufacturer	Stewart Warner
Model	DX5998
Range	0 to 60 mph

b. Cable.

(1) **REMOVAL OF CABLE.** Unscrew cable coupling from speedometer. Pull out and free cable. Disconnect cable from adapter on rear of auxiliary transmission by unscrewing knurled nut and freeing cable. Loosen cable clips and lift cable out of clips. Pull cable out of cowl and remove from vehicle.

(2) **PACKING.** Remove driving cable from housing and dip it in gear lubricant. Reinstall lubricant-coated cable in cable housing.

(3) **INSTALLATION OF CABLE.** Insert auxiliary transmission end of cable through cowl. Position cable in cable clips. Position upper end of cable to speedometer instrument, and screw knurled nut onto instrument. Position lower end of cable to auxiliary transmission speedometer cable adapter, and screw knurled nut onto adapter. Adjust cable through cowl and in cable clamps so that cable is free of sharp bends, and tighten clips.

c. Replacement of Instrument.

(1) **REMOVAL OF INSTRUMENT.** Disconnect cable from instrument by unscrewing knurled nut and pulling cable free. Remove two wing nuts and lock washers at front side of speedometer mounting bracket and remove bracket. Reach behind the instrument panel and push the speedometer out far enough so that it can be gripped with the other hand, and remove it from the panel.

(2) **INSTALLATION OF INSTRUMENT.** Install the new speedometer into place on the instrument panel, and place the mounting bracket behind the panel. Fasten the mounting bracket to the speedometer, using the wing nuts and lock washers. Slide the end of the speedometer cable into the adapter. Aline the knurled nut over the adapter and tighten it securely. Do not force the knurled nut.

Section XXIII

ENGINE OIL SYSTEM

121. DESCRIPTION AND DATA.

a. Description. The engine is lubricated by the forced feed system, with oil forced by an oil pump mounted on the front main bearing cap and driven by the crankshaft gear. The oil is stored in

the oil pan, which has a capacity of 26 quarts. The oil pump pulls oil from the oil pan sump and delivers it under pressure to the crankcase. An adjustable pressure regulator, mounted on the left side of the crankcase, regulates the pressure and allows excess oil to return to the crankcase. An oil pressure gage on the instrument panel registers the pressure of the oil. A viscometer, mounted on the instrument panel, registers the condition of the oil in the crankcase. This panel gage is controlled by the engine viscometer unit installed on the right side of the engine behind the oil filler pipe (fig. 30). The two units are connected by tubing. Three cartridge-type oil filters are installed on a bracket on the right side of the engine to filter out impurities from the oil. The crankcase breather is mounted on the hollow casting which supports the air compressor and is equipped with a wire mesh filter to prevent dust from entering the crankcase.

122. EXTERNAL OIL LINES.

a. Removal of Viscometer and Oil Pressure Lines (fig. 81).

(1) **REMOVE VISCOMETER OIL LINE.** Disconnect nut and uncouple oil line from viscometer gage. Remove oil line clips. Disconnect nut and uncouple line from viscometer instrument on engine. Remove oil line.

(2) **REMOVE OIL PRESSURE LINE (fig. 81).** Disconnect nut and uncouple oil line from oil pressure gage. Disconnect nut and uncouple line from oil pressure pump located on engine right side adjacent to viscometer instrument. Remove line.

b. Installation of Viscometer and Oil Pressure Lines (fig. 81).

(1) **INSTALL VISCOMETER OIL LINE.** Position and couple line to viscometer gage and its opposite end to viscometer instrument located on right side of engine.

(2) **INSTALL OIL PRESSURE LINE.** Position and couple line to oil pressure gage and its opposite end to oil pressure pump, located on engine right side, adjacent to viscometer instrument.

123. OIL PRESSURE GAGE AND OIL PRESSURE REGULATOR.

a. Description (fig. 8). The oil pressure gage (G509-01-94131), located on the instrument panel, registers the amount of lubrication oil pressure developed by the oil pump. The oil pressure may be adjusted by means of the oil pressure regulator, so as to maintain approximately 45 pounds at 1,600 revolutions per minute, or 38 pounds at 1,200 revolutions per minute, with engine warm. The oil pressure regulator is installed on the left side of the crankcase.

Engine Oil System

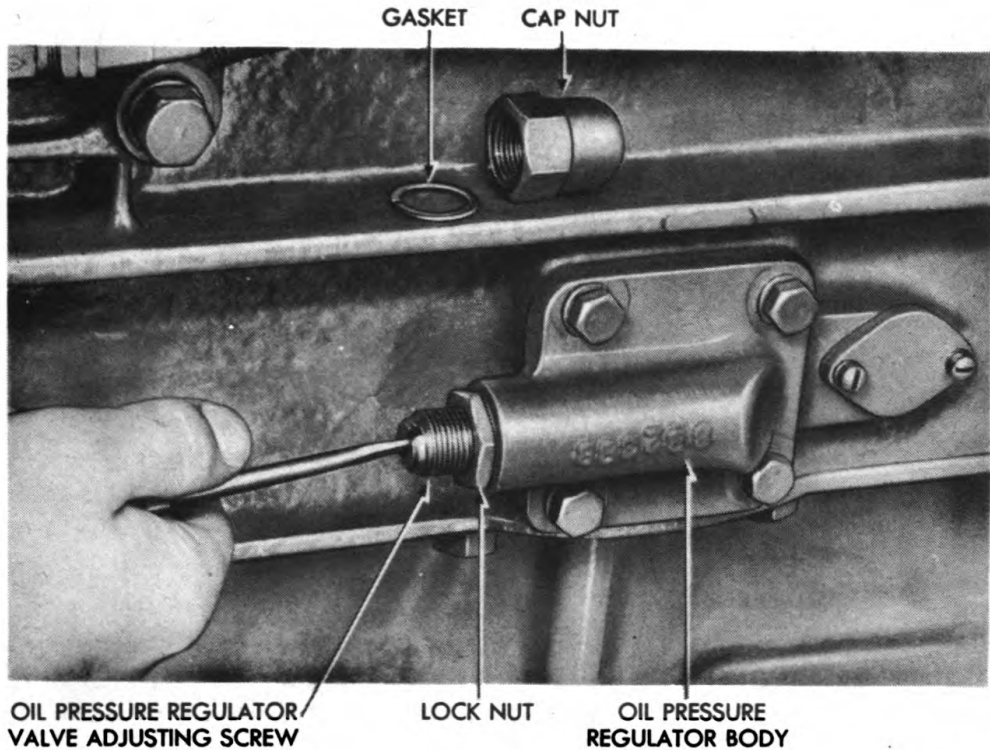

RA PD 321332

Figure 90—Adjusting Oil Pressure Regulator

b. Adjustment of Regulator (fig. 90). With engine warmed and idling, remove acorn nut and washer from oil pressure regulator. Turn adjusting screw in to increase pressure and out to decrease pressure. Observe oil pressure gage reading (subpar. a above).

c. Replacement of Gage (fig. 8).

(1) **REMOVAL.** Back off tube coupling nut from gage. Remove two nuts and lock washers which secure gage to bracket. Remove gage.

(2) **INSTALLATION.** Position gage on instrument panel. Position bracket over gage stud bolts. Install lock washers and nuts. Screw oil line coupling nut onto gage fitting.

124. VISCOMETER.

a. Description (figs. 81 and 91). The viscometer is installed on the right side of the engine crankcase behind the oil filler pipe. It is connected by tubing to a viscometer gage on the instrument panel. The viscometer measures the viscosity of the oil just before it enters the main bearings. The condition is registered on the gage dial as "thin," "ideal," and "heavy." Safe lubrication is assured only when

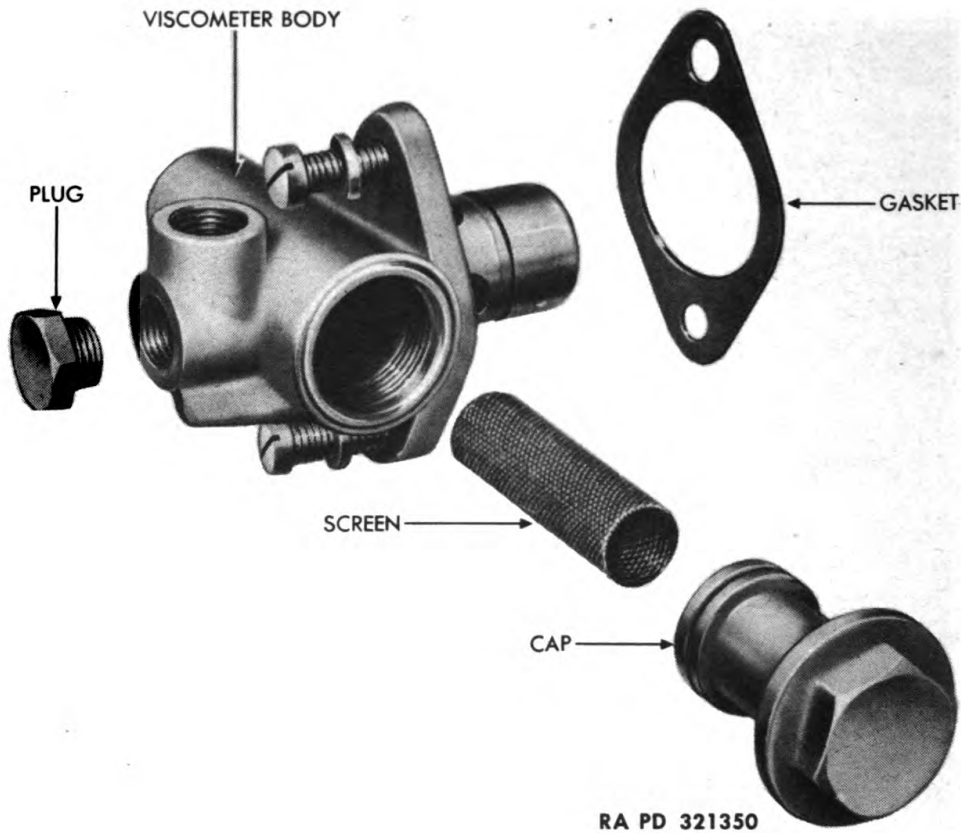

RA PD 321350

Figure 91—Viscometer Assembly—Disassembled

the dial registers "ideal." The temporary "heavy" reading due to starting a cold engine, or "thin" reading due to low idling speed, may be ignored.

b. Removal (fig. 81). Back off oil line connector nuts, and remove oil lines from viscometer. Remove two attaching screws, and lift off viscometer and gasket. Unscrew tube connector nut from viscometer gage, and lift oil line from gage.

c. Service (fig. 91). Remove large plug, lift out filter screen, and remove small plug. Wash and soak viscometer body, screen, and plugs in dry-cleaning solvent until all carbon and oil is softened. Blow out all chambers and screen with compressed air. If compressed air is not available, clean the inside of the resistance tube with a soft wood dowel until tube is clean. Wash both oil tubes in dry-cleaning solvent and blow out with compressed air. Install filter screen, large plug, and small plug in viscometer body.

Engine Oil System

d. **Installation** (figs. 81 and 8). Use new gasket if old gasket is nicked or damaged, and position gasket and viscometer on engine. Install two attaching screws. Connect tubing from panel gage unit to forward opening in viscometer, and tubing from engine oil supply to upper opening of viscometer. Place viscometer gage in instrument panel opening. Position bracket on back of gage. Install bolts, lock washers, and nuts which secure gage. Attach tubing connector nut to gage fitting.

125. OIL FILTERS.

a. Description and Data.

(1) **DESCRIPTION** (figs. 28 and 30). Three oil filters are provided for cleaning the lubricating oil of impurities. The filters are the removable-cartridge type and are installed on the right side of the engine on a hollow bracket. The bracket is cast with an integral inlet and outlet opening for the passage of oil and a separate inlet of the engine coolant, which is connected to the water pump through a short piece of hose tubing.

(2) **DATA.**

Manufacturer	Fram
Type	Cartridge
Number of filters	3

b. Servicing.

(1) **GENERAL.** The oil filters should be serviced at regular intervals as stated in paragraph 22. Servicing consists of either removing drain plug at bottom of each filter to allow sediment to drain out, or, at less frequent intervals, replacing the filter elements and cleaning the filter cases.

(2) **REPLACE FILTER ELEMENT.** Unscrew filter case cover screw and lift cover, gasket, and spring from case. Grasp handle on top of oil filter element and pull element from case. Clean filter case with dry-cleaning solvent. Insert new filter element (G134-01-31615) into case. Place case cover spring, cover, and gasket (G510-01-94041) over filter case and install case cover screw and screw gasket. Check level of oil and add oil if low (par. 22).

c. **Removal of Filter Bracket.** Drain the coolant from the engine by opening the drain plug at the bottom of the radiator. Drain the oil from the filter cases by removing drain plugs from filter cases. Loosen base clamps on water pump outlet hose which connects water pump with bracket. Slide hose forward off bracket. Remove the six attaching stud nuts and lock washers, and lift off bracket and gasket.

d. **Installation of Filter Bracket.** Clean off all traces of gasket from surfaces of bracket and engine. Place new gasket on bracket studs. Place bracket on studs, and install stud nuts and lock washers. Slide water pump outlet hose over end of bracket tube, and tighten hose clamps. Fill cooling system (par. 88 h). Check level of oil, and add oil if low (par. 22).

Section XXIV

CLUTCH

126. DESCRIPTION AND DATA.

a. **Description.** A two-plate, dry-disk type clutch is located between the engine and transmission. It consists of a pressure plate assembly, a double disk-faced driven plate, an intermediate steel driving plate, another double disk-faced driven plate, and a driving surface in the flywheel. The pressure plate assembly, consisting of a conical spring compressed against an adjusting plate and a clutch release sleeve, is attached to the clutch flywheel ring by six flywheel ring adjusting straps and nuts. Pressure plate retracting springs are placed over pressure plate studs and secured with washers and retaining pins. Two clutch disk facings are attached to each driven plate with rivets. The splined hub bore of the driven plates rests on and drives the transmission main drive gear shaft. A clutch pilot bearing (which is packed with a special heat-resistant grease) is pressed into the bore of the flywheel and provides a seat for the transmission drive gear shaft. The clutch throw-out shaft and trunnion levers are located in the clutch bell housing, which is attached to the transmission.

b. **Data.**

Make W. C. Lipe
 Type Two-plate dry disk
 Model Z38-S

Clutch throw-out bearing:

Make BCA
 Type Ball with retainer
 Model CWY-88

Clutch pilot bearing:

Make New Departure
 Type Ball
 Model 7506

Clutch

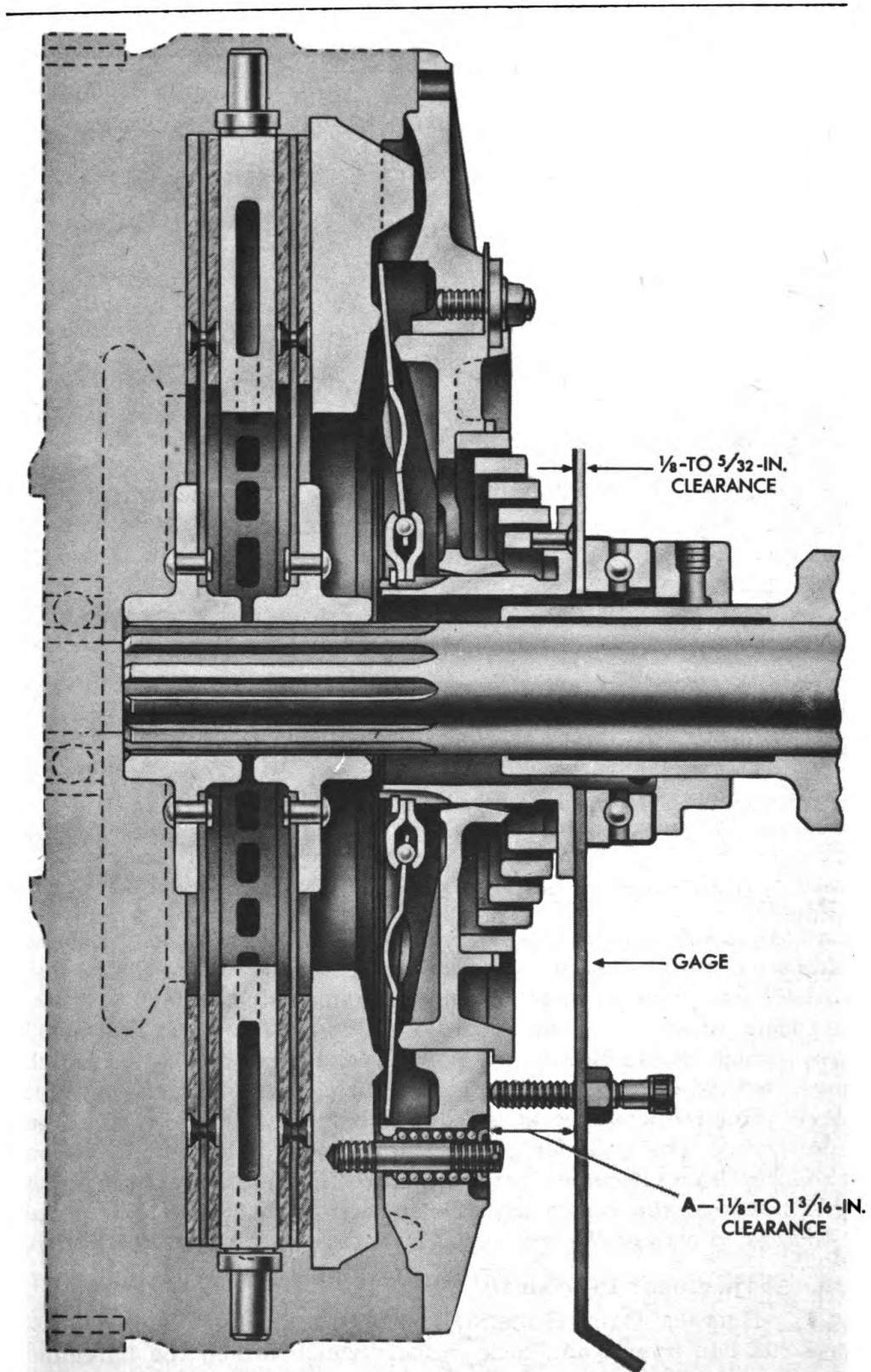

RA PD 321451

Figure 92—Clutch Adjustment

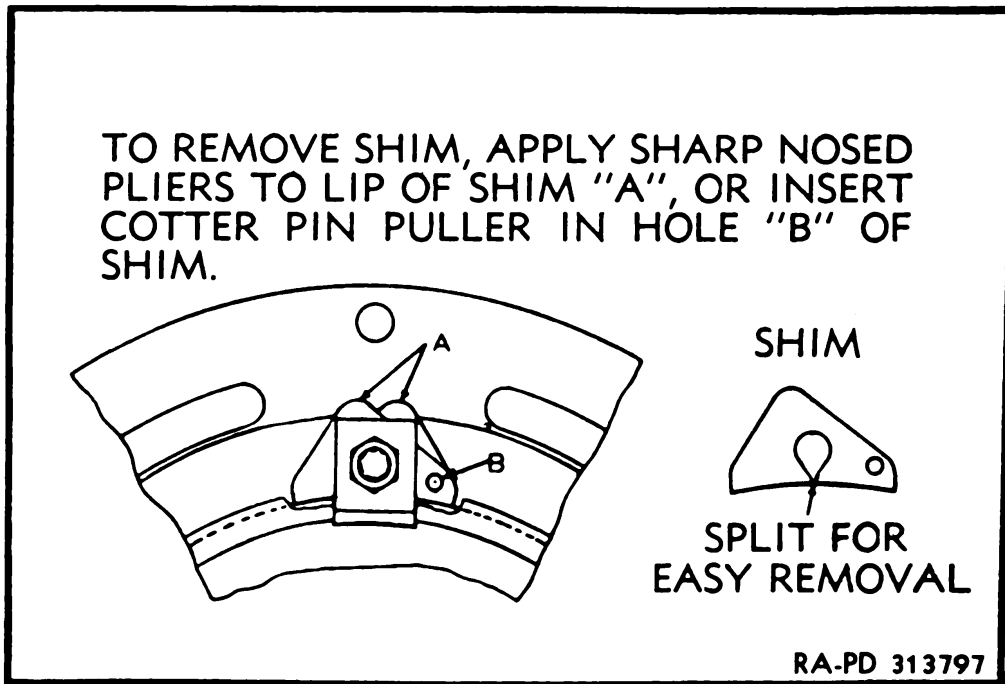

Figure 93—Shim Removal

Adjustment:

- Length of sleeve travel $\frac{9}{16}$ inch
- Dimension "A" from face of flywheel ring to face of release sleeve with clutch engaged $1\frac{1}{8}$ in. + $\frac{1}{16}$ in. to 0 in.

127. ADJUSTMENT (figs. 92, 93, and 94).

a. **General.** The clutch adjustment is made by means of shims held between the adjusting plate and the flywheel ring. As the facings on the driven disk wear, shims must be removed in order to restore the spring pressure to its normal load and to obtain proper free pedal travel, which should be 1 to $1\frac{1}{2}$ inch. As the facings wear, the clutch moves toward the release bearing, reducing the clearance on this sleeve. This reduced clearance will result in a reduction of the free pedal travel. The need for a clutch adjustment is indicated as soon as the free travel becomes less than 1 inch. **CAUTION:** *Do not wait for a clutch to slip before adjusting it, and do not adjust the pedal or linkage to correct the free pedal travel. Always adjust the clutch.*

b. **Adjustment Procedure.**

(1) REMOVE BELL HOUSING HANDHOLE COVER (fig. 94). Remove the cap screws and lock washers which attach the handhole cover located at the bottom of the clutch housing.

Clutch

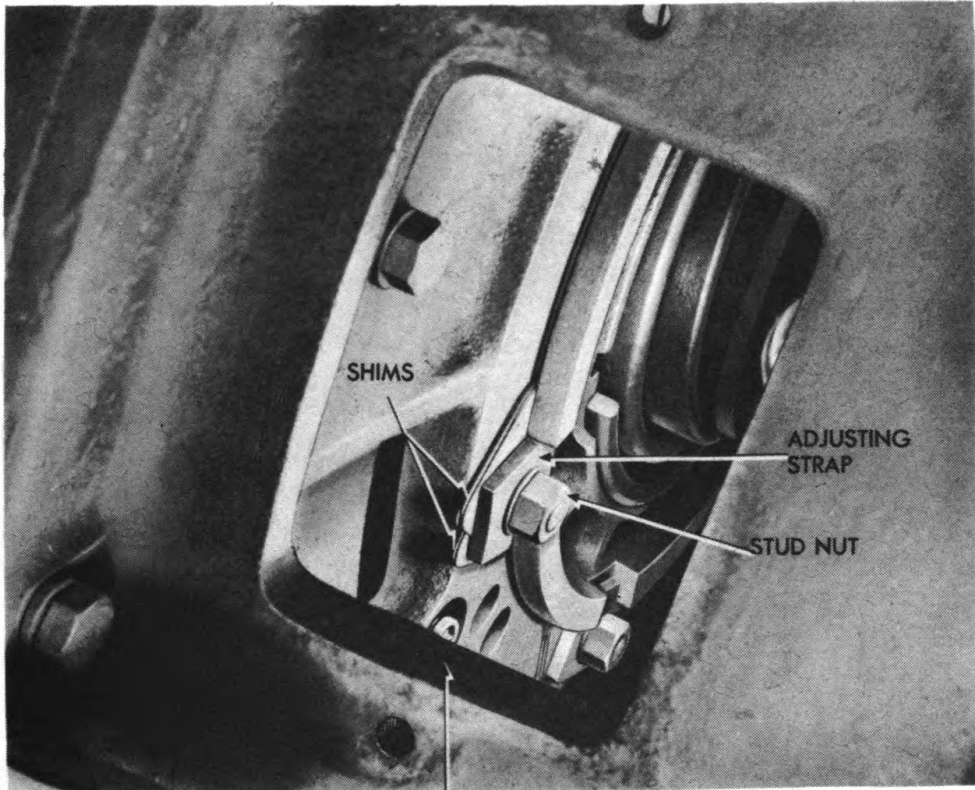

INSPECTION PLATE OPENING

RA PD 321368

Figure 94—Provisions for Clutch Adjustment

(2) **LOOSEN ADJUSTING STRAP NUTS.** Block the clutch pedal in the released position. Loosen and back off, approximately five turns, the six hex nuts which attach the adjusting straps and shims to the clutch flywheel ring. Using the turning crank to turn the engine, align the stud nuts with the handhole opening in the housing.

(3) **ENGAGE THE CLUTCH.** Remove the block from clutch pedal to engage the clutch and to force the adjusting plate out of contact with the adjusting shims.

(4) **REMOVE SHIMS.** Using long-nosed pliers, grip the lip of the top shim under each adjusting strap, and pull them from the flywheel ring studs. Be sure that no portion of the shim removed is left between the adjusting plate and the flywheel ring, and also be sure that the same number of shims are removed from under each adjusting strap. Remove a sufficient number of shims to obtain $1\frac{1}{8}$ - to $1\frac{3}{16}$ -inch clearance between the face of clutch throw-out sleeve and the face of clutch flywheel ring (dimension A, fig. 92); each shim removed decreases clearance by $\frac{7}{64}$ inch.

(5) **TIGHTEN ADJUSTING STRAP NUTS.** Block the clutch pedal in the release position so that the adjusting plate will move into contact with the shims. Tighten each adjusting strap nut. Remove block from clutch pedal permitting clutch to become engaged.

(6) **ADJUSTMENT** (fig. 92). Using the clutch adjusting gage, measure the clearance between the face of clutch throw-out sleeve and the face of clutch flywheel ring gear (A, fig. 92) to make sure that it is $1\frac{1}{8}$ to $1\frac{3}{16}$ inch. If this gage is not available, measure dimension "A" with a straightedge and a scale. The straightedge is held in position between the clutch release sleeve and the release bearing by depressing the clutch pedal to push the release bearing into contact with it. With the straightedge in position, measure the distance between the face of clutch flywheel ring and the straightedge. If the clearance is not adjusted within the specified limits, add or remove shims as required by following instructions outlined above.

(7) **CHECK CLEARANCE BETWEEN THE RELEASE BEARING AND CLUTCH SLEEVE.** Correct clearance between the release bearing (fig. 101) and the clutch release sleeve is $\frac{1}{8}$ to $\frac{5}{32}$ inch. Check this clearance through the clutch housing handhole, after the clutch is properly adjusted, and if it is not within the specified limits, adjust the clutch pedal linkage as required (par. 131 b).

128. CLUTCH RELEASE BEARING REPLACEMENT.

a. Removal (fig. 101).

(1) **REMOVE TRANSMISSION.** Remove transmission as instructed in paragraph 134.

(2) **REMOVE BEARING FROM RELEASE BEARING CARRIER** (fig. 101). Free the clutch release bearing springs. Slide bearing carrier with attached clutch release bearing off main drive gear shaft. Press the clutch release bearing from the bearing carrier.

b. Installation (fig. 101).

(1) **INSTALL BEARING AND BEARING CARRIER.** Using an arbor press, press clutch release bearing assembly on bearing carrier. Slide assembled bearing and carrier onto main drive gear shaft. Attach bearing springs to oil pipe.

(2) **INSTALL TRANSMISSION.** Install transmission as instructed in paragraph 135.

129. CLUTCH AND PILOT BEARING REMOVAL.

a. Remove Transmission. Remove transmission as instructed in paragraph 134.

b. Remove Clutch Pressure Plate Assembly (fig. 95). Remove clutch mounting bolts and toothed lock washers which attach pres-

Clutch

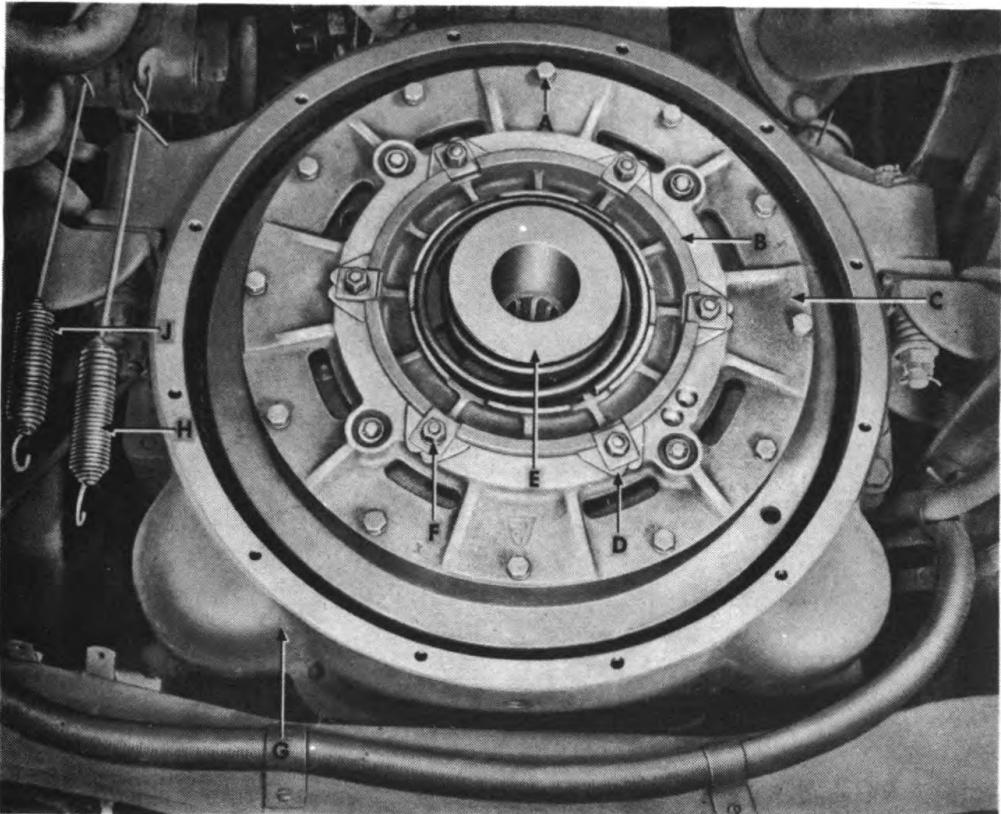

RA PD 321335

- | | |
|---------------------------|---------------------------------|
| A—CLUTCH MOUNTING BOLT | F—FLYWHEEL RING STUD NUT |
| B—ADJUSTING PLATE | G—CLUTCH HOUSING |
| C—PRESSURE PLATE ASSEMBLY | H—BRAKE PEDAL PULL-BACK SPRING |
| D—ADJUSTING SHIMS | J—CLUTCH PEDAL PULL-BACK SPRING |
| E—CLUTCH RELEASE SLEEVE | |

Figure 95—Clutch Installed, Transmission Removed

sure plate assembly to engine flywheel, and lift out pressure plate assembly.

c. **Remove Clutch Disks and Intermediate Plate.** Lift clutch disk (pressure plate side), intermediate plate, and clutch disk (flywheel side) from flywheel.

d. **Remove Pilot Bearing From Flywheel** (fig. 96). Using puller remove clutch pilot bearing from seat in engine flywheel.

130. CLUTCH AND PILOT BEARING INSTALLATION.

a. **Install Pilot Bearing in Flywheel.** When installing clutch pilot bearing into engine flywheel, be sure that bearing is seated perfectly in order to maintain alinement of main drive gear, clutch disk, and pilot bearing. Pack bearing with lubricant. Use a clutch pilot if

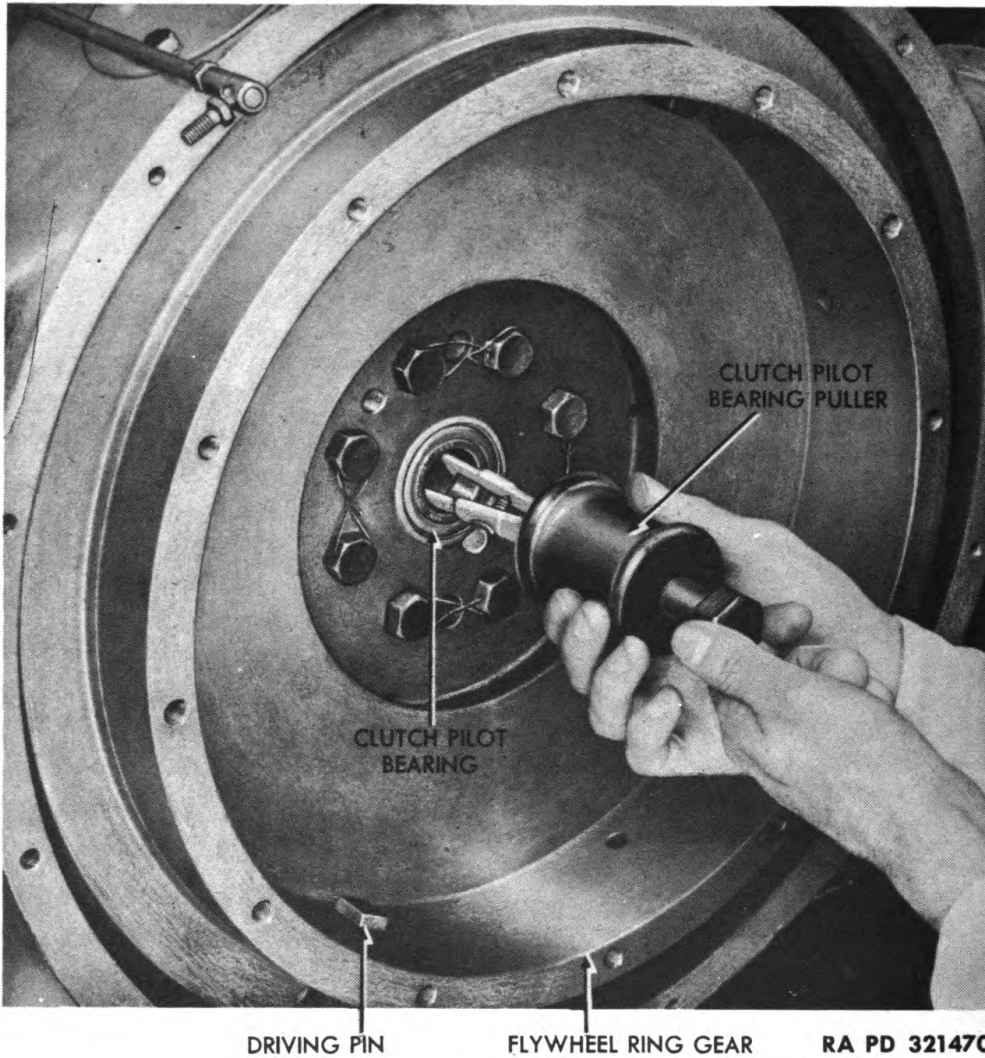

Figure 96—Removing Clutch Pilot Bearing With Puller

available. If pilot is not available, carefully tap clutch pilot bearing into seat in flywheel, using a brass drift. Open side of bearing must face toward engine. Make certain that bearing is started into flywheel evenly before forcing it fully into seat.

b. Install clutch disks and intermediate plate (fig. 97). Check the driving pins in the flywheel ring gear (fig. 96) to make sure the long side makes a 90-degree angle with the face of the flywheel ring gear. This may be checked with a steel square placed on the edge of the flywheel ring gear. Place clutch disk, flywheel side, in the flywheel ring gear, making sure the extended hub side is toward the flywheel. Place the intermediate plate in the ring gear with slots fitted

Clutch

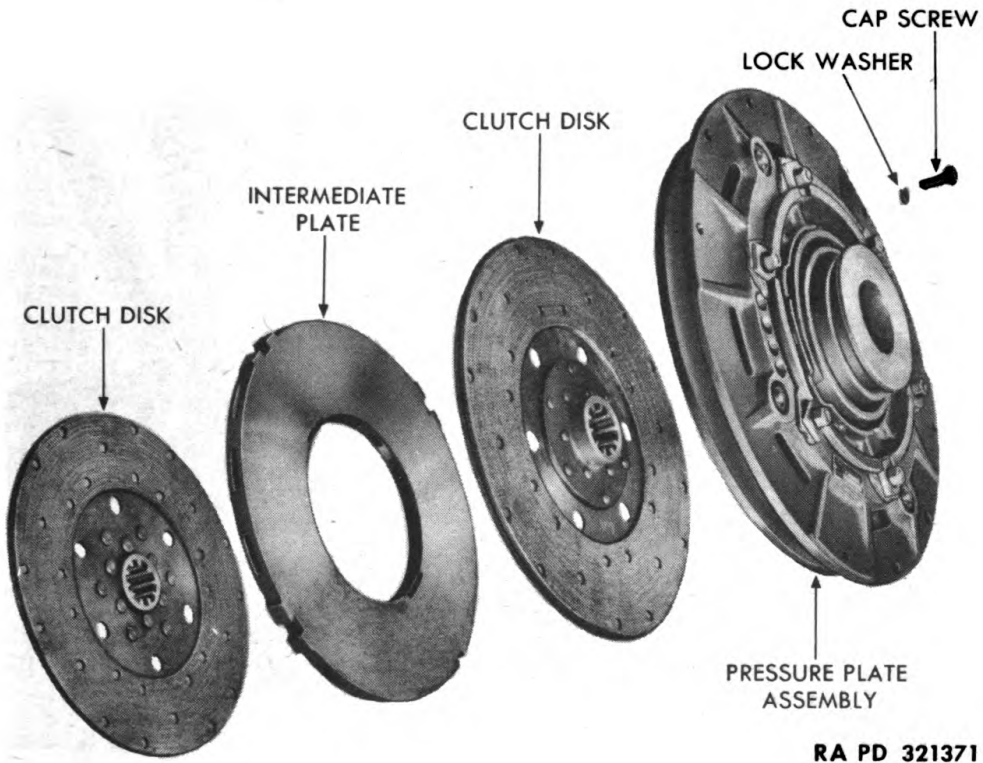

Figure 97—Clutch Assembly

over the driving pins. Install the clutch disk, pressure plate side, with extended hub away from the flywheel. Use a clutch pilot, or spare main drive gear, to align the splines of the disks.

c. Install Pressure Plate Assembly (fig. 97). Position pressure plate assembly against pressure plate side clutch disk in flywheel, and install clutch mounting bolts and lock washers. Before tightening the bolts, bring the clutch disks into perfect alignment. The hub splines of both driven disks must be perfectly aligned with the clutch pilot bearing, and the splines of both disks must align with each other, so that the transmission main drive gear spline can be installed. If a clutch pilot is not available, a spare main drive gear can be used. Insert spline on spare main drive gear or pilot into splines in clutch disk hubs, and push bearing surface on end of main drive gear into clutch pilot bearing. Tighten mounting bolts to securely attach clutch pressure plate assembly to engine flywheel, alternately tightening bolts located on opposite sides of the assembly until all bolts are secured.

d. Install Transmission. Install transmission as instructed in paragraph 135.

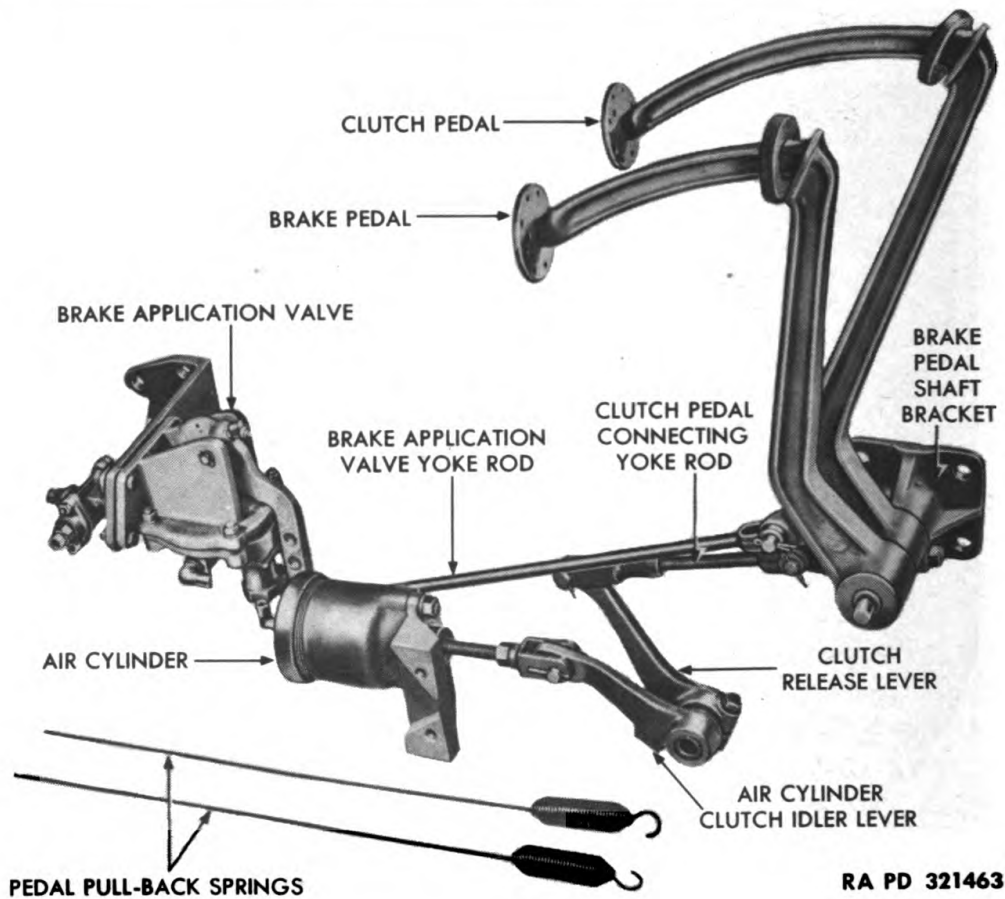

Figure 98—Clutch and Brake Pedal and Linkage

131. CLUTCH LINKAGE.

a. **Description** (fig. 98). The clutch linkage includes the clutch pedal, which is mounted on the brake pedal shaft bracket below the toeboard; the clutch pedal connecting yoke rod; and the mechanism in the front end of the transmission which moves the clutch release bearing carrier forward and back to engage or disengage the clutch. This mechanism consists of the clutch release shaft lever, clutch pedal shaft, and clutch release yoke (fig. 101). The clutch is also controlled by the clutch air cylinder and linkage, which is described in paragraph 179.

b. **Pedal Adjustment.** Adjust the clutch (par. 127), if clearance between release bearing and clutch sleeve is not from $\frac{1}{8}$ to $\frac{5}{32}$ inch (par. 127 b (7)). Adjust length of clutch pedal connecting rod by disconnecting rod end yoke and turning rod end yoke in or out. Then check adjustment again, with rod end yoke connected and pedal fully back against toeboard.

Transmission

c. Linkage Replacement.**(1) REPLACE CLUTCH PEDAL.**

(a) *Removal.* Remove floorboard and toeboard (par. 68 a). Release pedal pull-back springs from spring anchors. Remove cotter pins, and drive out pins which secure connecting yoke rods to clutch and brake pedals. Disconnect rods from pedals. Remove lubrication fitting from end of pedal shaft bracket. Loosen clamp bolts on lower end of pedals, and drive brake pedal and clutch pedal off bracket shaft.

(b) *Installation.* Install new clutch pedal and brake pedal on brake pedal shaft bracket. Tighten clamp bolts which secure pedals to shaft. Install lubrication fitting in end of pedal shaft bracket. Position clutch and brake yoke rods on pedals, and insert yoke pins and cotter pins. Engage pedal pull-back springs with spring anchors. Install floorboard and toeboard (par. 69 n).

(2) REPLACE CLUTCH RELEASE LEVER.

(a) *Removal.* Disconnect clutch pedal connecting rod yoke from clutch release lever. Mark location lines on end of clutch pedal shaft and adjacent boss of clutch release lever. Loosen clutch release lever clamp bolt. Slide clutch release lever off clutch pedal shaft.

(b) *Installation.* Place new clutch release lever over end of clutch pedal shaft. Line up location marks. Tighten clamp bolt. Connect clutch pedal connecting rod yoke to end of clutch release lever.

(3) REPLACE CLUTCH PEDAL CONNECTING ROD.

(a) *Removal.* Disconnect clutch pedal connecting yoke rod from brake pedal and clutch release lever.

(b) *Installation.* Place new clutch pedal connecting yoke rod between the clutch release lever and clutch pedal. Connect both ends of rod. If length of rod has been changed, it is necessary to check the adjustment (subpar. b above).

Section XXV**TRANSMISSION****132. DESCRIPTION AND DATA.**

a. *Description.* The transmission is attached to the clutch bell housing at rear of engine. It has four forward speeds and one reverse. Constant mesh helical gears are used in the three top speeds for quiet operation. First and reverse speed gears are spur-cut. Gears are selected manually by a conventional type gearshift lever in the driver's compartment.

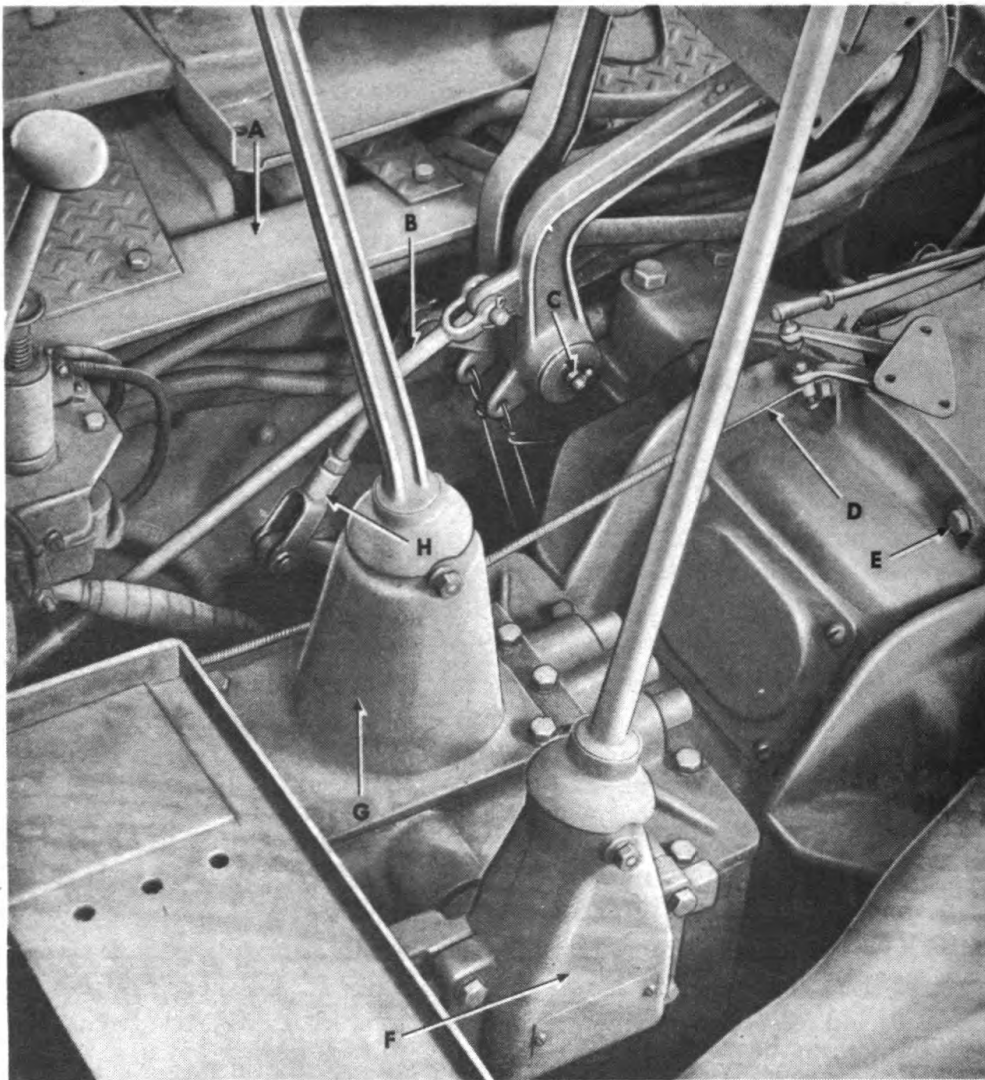

- A—L. H. FRAME SIDE RAIL
- B—BRAKE PEDAL CONNECTING ROD
- C—LUBRICATION FITTING
- D—THROTTLE CONTROL CABLE
- E—TRANSMISSION TO BELL HOUSING MOUNTING BOLTS
- F—AUXILIARY TRANSMISSION GEARSHIFT LEVER ASSEMBLY
- G—TRANSMISSION GEARSHIFT LEVER HOUSING
- H—CLUTCH PEDAL CONNECTING ROD

RA PD 321312

Figure 99—Transmission Installed, Floorboard Removed

Transmission

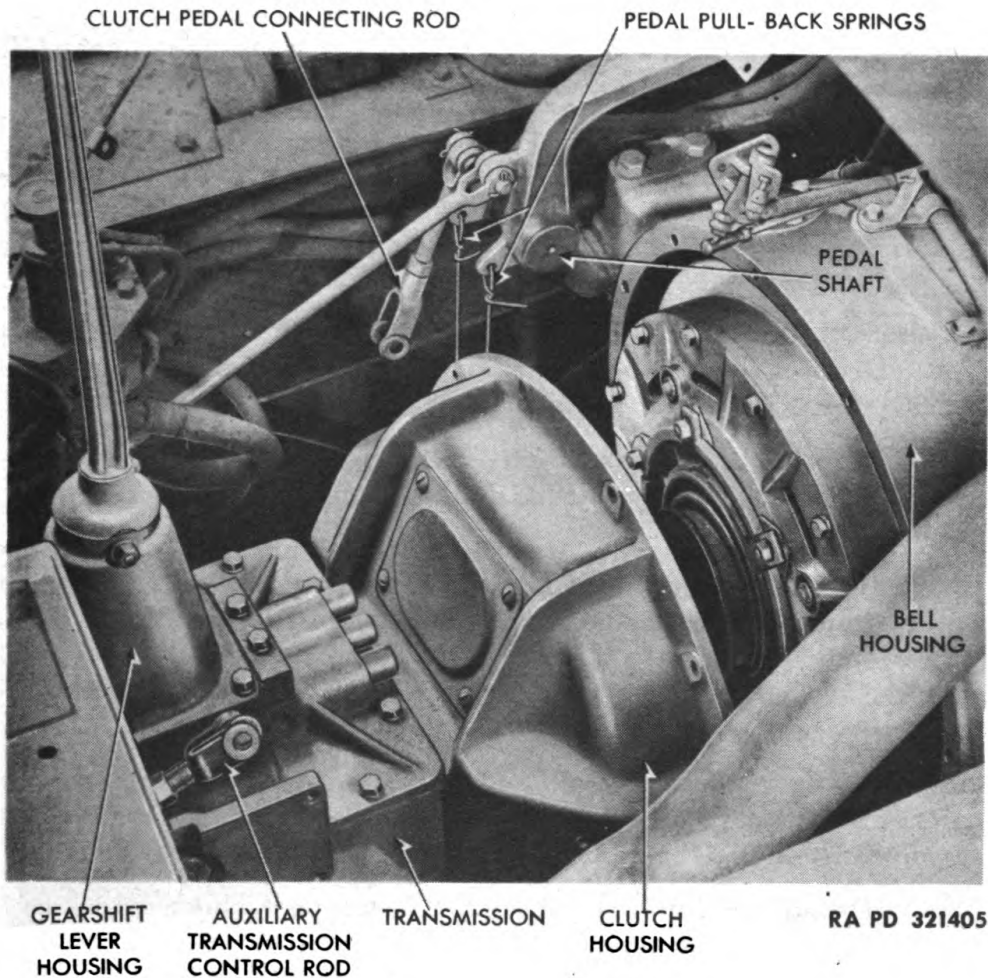

Figure 100—Removing Transmission

b. Data.

Make Fuller
 Model 4B86
 Type 4 speed

(1) GEAR RATIOS:

Direct 1.00 to 1
 Third speed 1.76 to 1
 Second speed 3.27 to 1
 First speed 5.55 to 1
 Reverse 6.58 to 1
 Oil capacity 4½ qt
 Weight less clutch 420 lb

133. SHIFT LEVER AND HOUSING.

a. **Removal** (fig. 99). Remove floorboard (par. 68). Remove four cap screws and lock washers which secure transmission gearshift lever housing to transmission. Lift off gearshift lever and lever housing.

b. **Installation.** Place gearshift lever housing and lever in position over transmission. Install four attaching cap screws and lock washers. Place throttle cable clip on left front attaching cap screw.

134. TRANSMISSION ASSEMBLY REMOVAL (fig. 100).

a. **Drain Transmission.** Remove drain plug from transmission housing sump and drain lubricant. Install plug.

b. **Remove Floorboard and Toeboard** (fig. 7). Remove floorboard and toeboard as instructed in paragraph 68.

c. **Remove Auxiliary Transmission Gearshift Lever Assembly** (fig. 99). Disconnect control rods from low-speed and high-speed shifting bars by removing cotter pins and yoke rod pins. Remove cap screws and lock washers which attach control housing to auxiliary control bracket. Lift off the gearshift lever assembly and control bracket plate.

d. **Remove Front Propeller Shaft Assembly** (fig. 105). Remove bolts from front propeller shaft flange yokes, and lower the shaft assembly from the vehicle.

e. **Disconnect Linkage** (fig. 99). Disconnect clutch pedal connecting yoke rod from clutch release lever by removing cotter pin and yoke pin. Release the clutch pedal and brake pedal pull-back springs from their anchors (fig. 95). Unscrew the lubrication fitting from the end of the brake pedal shaft (fig. 99). Remove the throttle control cable clip from the shifting lever housing cap screw, and disconnect end of cable from throttle control (fig. 54).

f. **Remove Transmission Gearshift Lever and Housing.** Remove transmission gearshift lever and housing as instructed in paragraph 133 a.

g. **Remove Transmission.** Place a jack under the transmission to support it securely in a level position. Remove the transmission to bell housing mounting bolts. Pull the transmission straight back until the main drive gear clears the clutch. Do not allow the weight of the transmission to hang on the main drive gear shaft or the clutch disks will be damaged. Lower the transmission to the ground. If necessary, jack up the left side of the vehicle high enough to allow the transmission to be removed.

Transmission

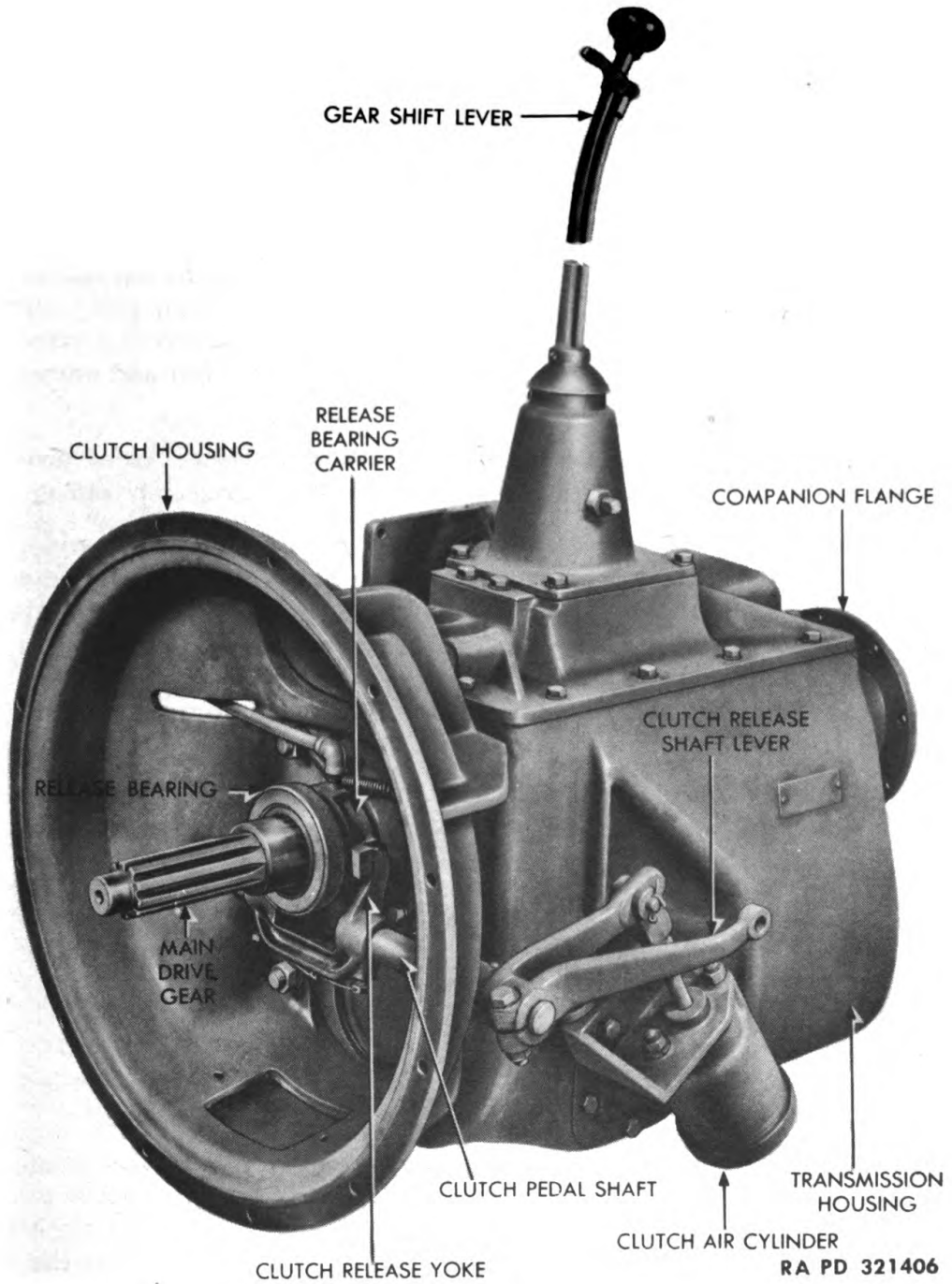

Figure 101—Transmission—Removed

135. TRANSMISSION ASSEMBLY INSTALLATION.

a. **Position Transmission.** Place transmission on transmission jack and locate it under vehicle. Raise the transmission until main drive gear is level with opening in clutch. Enter the main drive gear in the clutch disk spline by pushing it forward carefully. **CAUTION:** *Do not allow the weight of the transmission to hang on the main drive gear shaft or the clutch disks will be seriously damaged.* Place the transmission to bell housing mounting bolts and lock washers in place, and draw up the bolts on opposite sides consecutively and evenly until the bolts are tight. Remove the jack.

b. **Connect Linkage.** Install the lubrication fitting in the end of the brake pedal shaft. Attach the clutch and brake pedal pull-back springs to their anchors. Connect the clutch pedal connecting yoke rod to the clutch release lever by inserting the yoke pin and cotter pin.

c. **Install Front Propeller Shaft Assembly.** Install front propeller shaft assembly according to instructions in paragraph 145 c.

d. **Install Auxiliary Transmission Gearshift Lever Assembly.** Place the auxiliary transmission gearshift lever control bracket plate and gearshift lever assembly in position against the control bracket. Install the cap screws and lock washers which attach the control housing to the auxiliary control bracket. Connect the control rods from the auxiliary transmission to the low-speed and high-speed shifting bars by installing yoke pins and cotter pins.

e. **Fill with Lubricant.** Remove filler plug. Fill with lubricant (par. 22) up to the level of filler plug. Lubricant should run out when unit is at operating temperature. Install filler plug.

f. **Record Unit Replacement.** Make the proper entry on W.D., A.G.O. Form No. 478, "MWO and Major Unit Assembly Replacement Record."

Section XXVI**AUXILIARY TRANSMISSION****136. DESCRIPTION AND DATA.**

a. **Description (fig. 102).** The auxiliary transmission is a gear box mounted in the drive line between the main transmission and the forward rear axle. This unit has three speed selections, which are controlled by a shift lever in the cab. The auxiliary transmis-

Auxiliary Transmission

RA PD 321355

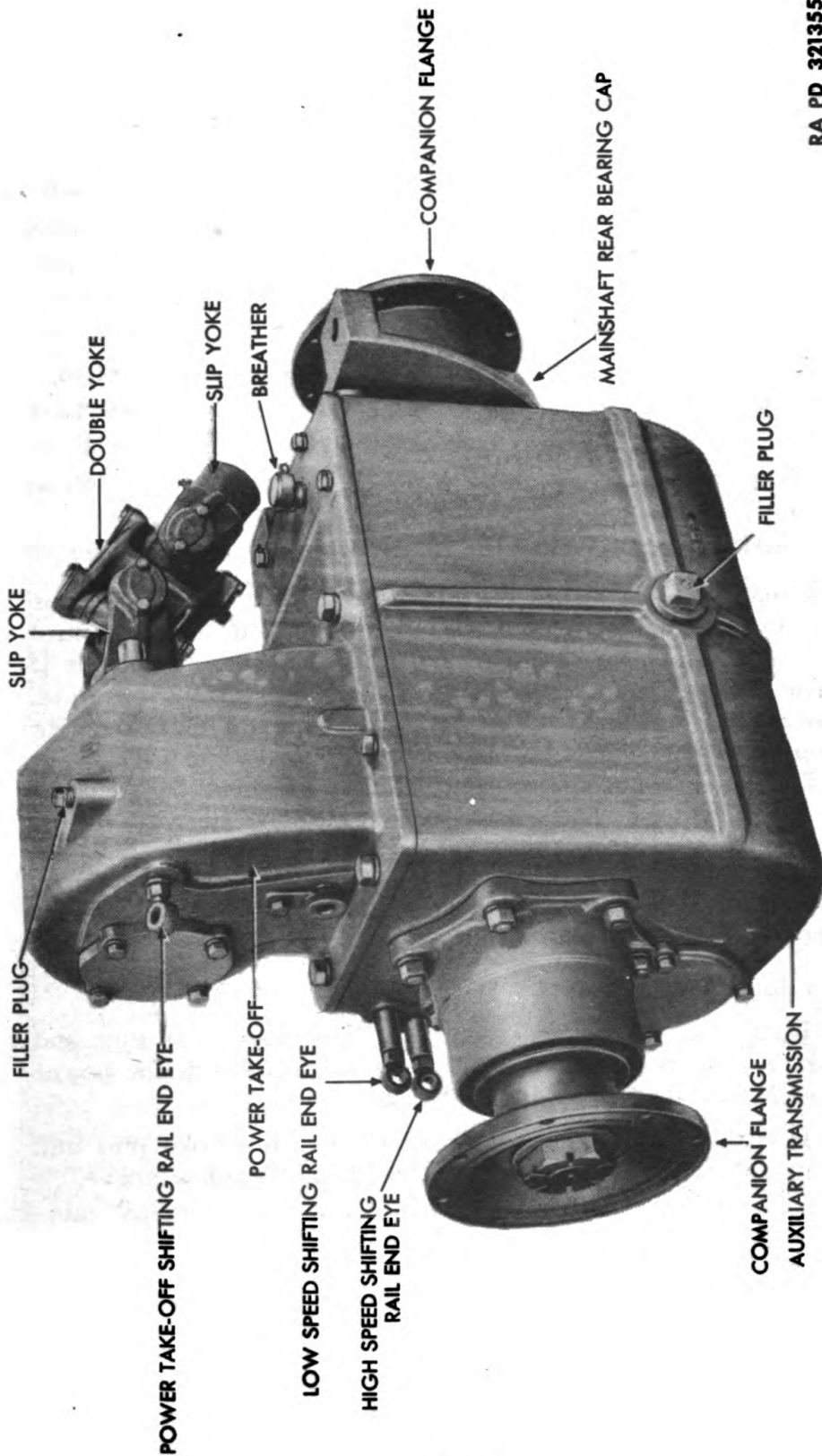

Figure 102—Auxiliary Transmission and Power Take-off—Removed

sion also provides the drive for the power take-off, which is used to operate the winch. The main drive gear of the transmission is engaged at all times with the driving gear in the power take-off.

b. Data.

Make	Fuller
Model	3A86 or 3A92
Type	3 speed
Gear ratios:	
Overdrive	0.77 to 1
Direct	1 to 1
Underdrive	1.99 to 1
Oil capacity	17 pt
Weights, less power take-off	340 lb

137. GEARSHIFT LEVER AND LINKAGE (figs. 99 and 100).

a. Adjustment. Adjustment of the gearshift lever and linkage is made by lengthening or shortening the high- and low-speed control rods by means of the yokes, so that complete gear engagement is made when the gearshift lever is shifted to the various positions. Place auxiliary transmission gearshift lever in neutral position with high- and low-speed control rods disconnected. Adjust length of rods to fit between shifting bars and shifting rail eyes on auxiliary transmission. Connect rods. Drive truck and test shifting adjustment with auxiliary transmission in all speeds.

b. Lever Replacement. Replace the gearshift lever as described in paragraphs 133 a and 135 c.

c. Linkage Replacement.

(1) **REMOVAL.** From underneath truck, remove yoke pins and cotter pins at each end of high- and low-speed control rods and power take-off shift rod. Lower rods from truck.

(2) **INSTALLATION.** Position new rods. Install yoke pins and cotter pins. Adjust rods as instructed in subparagraph a above.

138. REMOVAL (fig. 102).

a. Drain Lubricant. Drain all oil from the case by removing drain plug located at the rear of the case. Permit lubricant to drain and replace drain plug.

b. Disconnect Speedometer Cable. Unscrew speedometer cable coupling nut from fitting on auxiliary transmission.

Auxiliary Transmission

c. **Remove Left-hand Parking Brake Shoe** (J, fig. 137). Disconnect the brake rods from the cross shaft levers on the left and right side of the chassis. Remove three parking brake mounting bolts, and drop the left-hand parking brake shoe.

d. **Loosen Right-hand Parking Brake Shoe** (F, fig. 137). Remove the two inner parking brake mounting bolts on right side, and loosen the outer bolt. Twist the brake shoe assembly.

e. **Remove Rear Flange Yoke**. Remove flange yoke bolts, lock washers, and nuts from rear universal joint flange yoke (G, fig. 137), and drop the flange yoke and the propeller shaft down.

f. **Disconnect Winch Drive Shaft Universal Joint Assembly**. Disconnect winch drive shaft universal joint assembly, as instructed in paragraph 148 b.

g. **Disconnect Control Rods** (fig. 102). Disconnect the high- and low-speed control rods and power take-off shift rod from the auxiliary transmission and power take-off shifting rail end eyes.

h. **Disconnect Front Flange Yoke**. Remove the flange yoke bolts, lock washers, and nuts from the front universal flange yoke, and drop the flange and propeller shaft down. Remove the cotter pin and nut which secure the front companion flange, and pull the companion flange from the auxiliary transmission.

i. **Remove Auxiliary Transmission**. Place a transmission jack under transmission to support it securely, or attach chains and support the weight of the unit from above by a chain fall or wrecker truck. Loosen five transmission front bracket mounting bolts. Remove two rear bracket mounting bolts. Pull transmission straight back until it is clear of front bracket, and lower it to ground.

139. INSTALLATION.

a. **Position Case on Chassis** (fig. 102). Place the auxiliary transmission under the chassis, and raise it by means of a transmission jack. Push the unit forward into position in the front bracket. Install two rear bracket mounting bolts, and tighten five front bracket mounting bolts. Remove the jack.

b. **Install the Front Flange Yoke**. Slide the front companion flange onto the main drive gear. Install the plain washer, nut, and cotter pin. Raise the front universal flange yoke and install the flange yoke bolts, lock washers, and nuts.

c. **Connect Control Rods** (fig. 102). Connect the high- and low-speed control rods to the auxiliary transmission shifting rail and eyes. Connect the power take-off shift rod to the power take-off shift rail eye.

Maintenance Instructions

d. Connect Winch Propeller Shaft Universal Joint Assembly. Connect winch propeller shaft universal joint assembly as described in paragraph 148 c.

e. Install Rear Flange Yoke (fig. 137). Raise the rear flange yoke into position and install the flange yoke bolts, lock washers, and nuts.

f. Install Right-hand Parking Brake Shoe. Twist the right-hand parking brake shoe into alinement and install the mounting bolts, lock washers, and nuts.

g. Install Left-hand Parking Brake Shoe (fig. 137). Position the left-hand parking brake shoe. Install the mounting bolts, lock washers, and nuts. Connect the parking brake rods to the cross shaft levers on left- and right-hand side.

h. Connect Speedometer Cable Position. Position speedometer cable coupling nut on auxiliary transmission fitting and tighten nut.

i. Fill With Lubricant. Remove filler plug and fill with lubricant (par. 22) up to level of plug. Lubricant should run out when unit is at operating temperature. Install filler plug.

j. Record Unit Replacement. Make the proper entry on W.D., A.G.O. Form No. 478, "MWO and Major Unit Assembly Replacement Record."

Section XXVII

POWER TAKE-OFF

140. DESCRIPTION AND DATA.

a. Description (fig. 102). The power take-off is used for driving the winch. It is mounted on top of the auxiliary transmission and is controlled by a shifting lever inside the cab. The power take-off drives the winch through a propeller shaft and roller chain drive. The power take-off housing is integral with the auxiliary transmission cover so that the unit is lubricated directly from the auxiliary transmission. A breather is provided in the case which serves both the power take-off and auxiliary transmission.

b. Data.

Make Fuller
Model 3AX or 3BX
Drive Auxiliary transmission
Speeds 1

Power Take-off

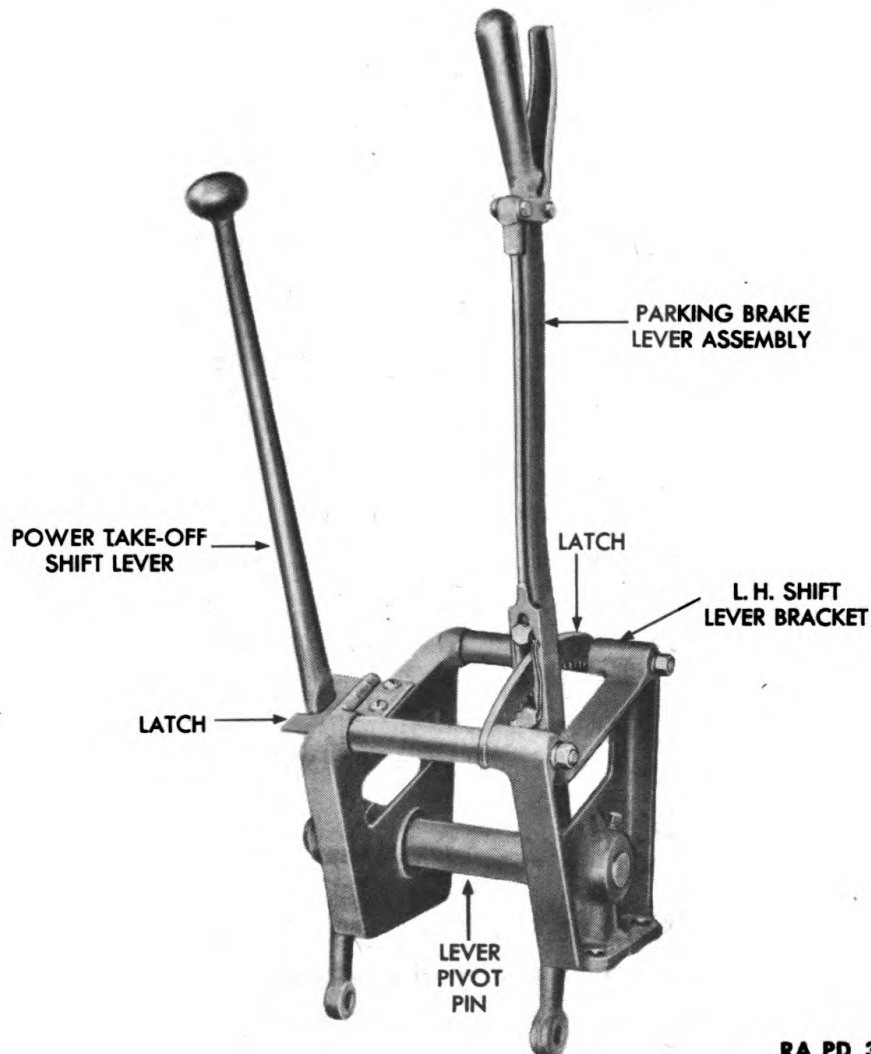

RA PD 321430

Figure 103—Power Take-off Shift Lever and Parking Brake Lever

141. BREATHER.

a. **Description** (fig. 102). The breather, mounted on the top of the auxiliary transmission (power take-off case), prevents the building up of pressure inside the case as a result of heat generated during operation. When the breather becomes clogged, pressure will cause the oil to be blown out past the oil seals.

b. **Service.** Remove the cotter pin and lift off the breather cap. Wash cap in dry-cleaning solvent at proper intervals (par. 22). Install breather cap and insert cotter pin.

142. SHIFT LEVER AND LINKAGE.**a. Shift Lever Replacement (fig. 103).**

(1) **REMOVE LEVER BRACKET.** Remove floorboard attaching screws and lift out floorboard. Remove lever escutcheon screws and lift out escutcheon. Disconnect power take-off shift rod yoke from shift lever. Disconnect parking brake rod yoke from parking brake lever. Remove four bolts, lock washers, and nuts which attach lever bracket to floor and lift out lever bracket.

(2) **REMOVE LEVER.** Remove screw, lock washer, and plain washer from end of lever pivot pin. Drive lever off pin.

(3) **INSTALL LEVER.** Tap lever on end of pivot pin. Install plain washer, lock washer, and nut in end of pin.

(4) **INSTALL LEVER BRACKET.** Place lever bracket on floor and install bolts, lock washers, and nuts which attach bracket to floor. Connect parking brake rod yoke to parking brake lever. Connect power take-off shift rod yoke to shift lever, making sure rod is proper length (subpar. b (2) below). Position lever escutcheon and install attaching screws. Position floorboard and install floorboard attaching screws.

b. Linkage Replacement.

(1) **REMOVAL.** Disconnect shift rod yokes from power take-off shift lever and from shifting rail eye of power take-off. Remove rod.

(2) **INSTALLATION.** Position rod between shift lever and power take-off shifting rail eye. Connect rod yokes, shifting rail eye, and shift lever. Place lever in neutral position with lever engaged by the latch mounted on the lever bracket. Place shifting rail in neutral position. By turning rod yoke, lengthen or shorten rod if necessary to fit exactly between the lever and the shifting rail eye. Connect front rod yoke to the shift lever. Shift lever to engaged position and see if power take-off is completely engaged. The shifting rail should snap into position with the locating ball in the groove of the rail. If this condition is not evident, adjust rod or straighten until lever can be shifted into complete engagement from neutral latched position.

143. REPLACEMENT.

a. For replacement of the power take-off, refer to higher authority.

Section XXVIII

**PROPELLER SHAFTS AND UNIVERSAL
JOINT ASSEMBLIES**

144. DESCRIPTION AND DATA.

a. **Description.** Propeller shafts to transmit power are used between the transmission and auxiliary transmission; between auxiliary transmission and forward rear axle; between the forward and rearward rear axles; and between the power take-off and the winch chain drive sprocket. These are known respectively as the front, rear, interaxle, and winch propeller shafts. The shafts are equipped with universal joints and splined slip joints to allow for variations in the distances between the units which they connect. The male and female joint members are marked with an arrow so that the splines can be reassembled in the correct position to keep the shaft in balance.

b. **Data.**

Number of shafts used	4
Manufacturer:	
Main propeller shafts	Spicer
Main propeller shaft	Gar Wood
Normal lengths of main shafts:	
Transmission to auxiliary transmission	13¾ in.
Auxiliary transmission to forward rear axle	32¼ in.
Between rear axle	27 in.
Diameter of main propeller shaft tube auxiliary transmission to	
forward rear axle	3½ in.
Between rear axles	3 in.
Universal joints:	
Type	Needle bearing
Manufacturer	Spicer
Slip joints:	
Type	Splined
Manufacturer	Spicer

**145. FRONT PROPELLER SHAFT WITH UNIVERSAL JOINT
ASSEMBLY.**

a. **Description** (figs. 104 and 105). The front propeller shaft is a short, solid shaft, with universal joints at each end and a splined slip joint in the center. It is bolted to companion flanges mounted on the transmission and auxiliary transmission.

- A—AUXILIARY TRANSMISSION COMPANION FLANGE
- B—INTERAXLE SHAFT ASSEMBLY
- C—REAR PROPELLER SHAFT ASSEMBLY
- D—FORWARD REAR AXLE COMPANION FLANGE
- E—TRANSMISSION COMPANION FLANGE
- F—FRONT PROPELLER SHAFT ASSEMBLY
- G—AUXILIARY TRANSMISSION COMPANION FLANGE

RA PD 321459

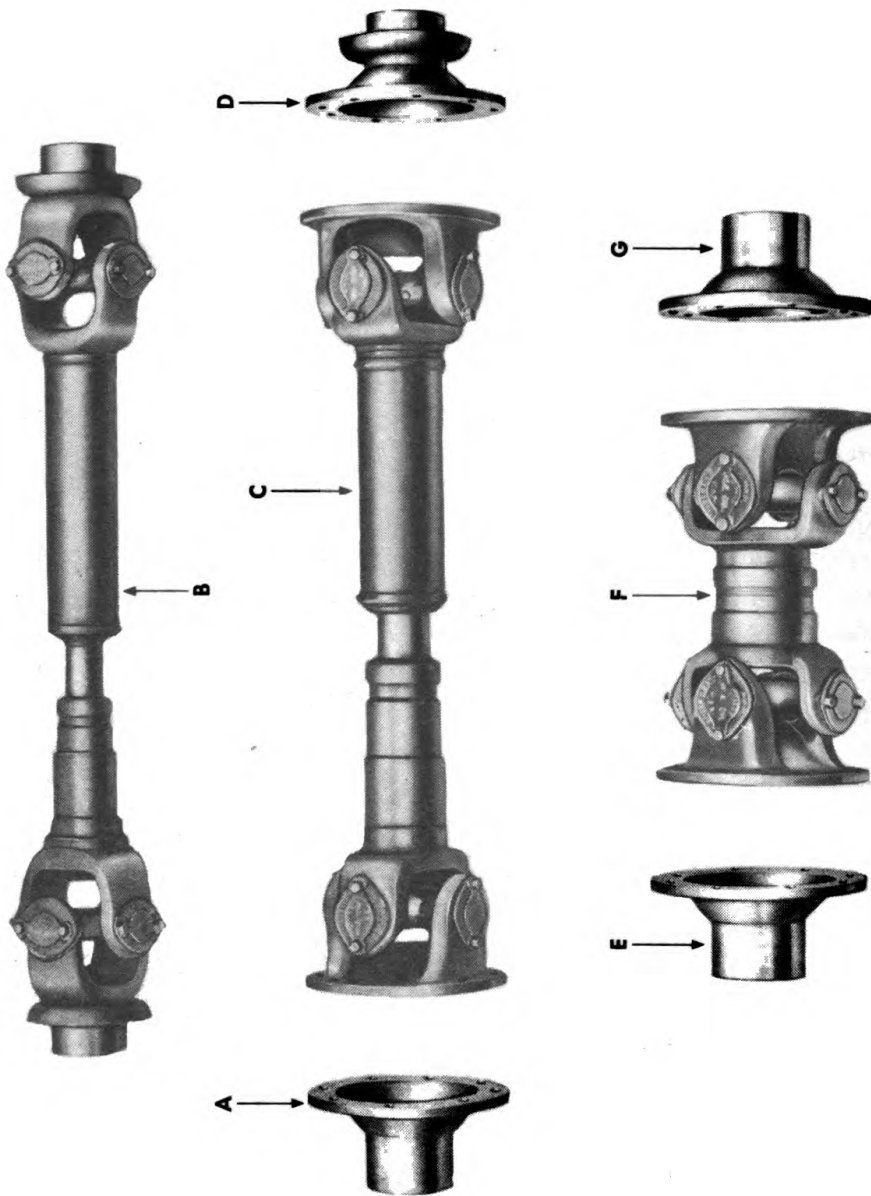

Figure 104—Propeller Shafts

Propeller Shafts and Universal Joint Assemblies

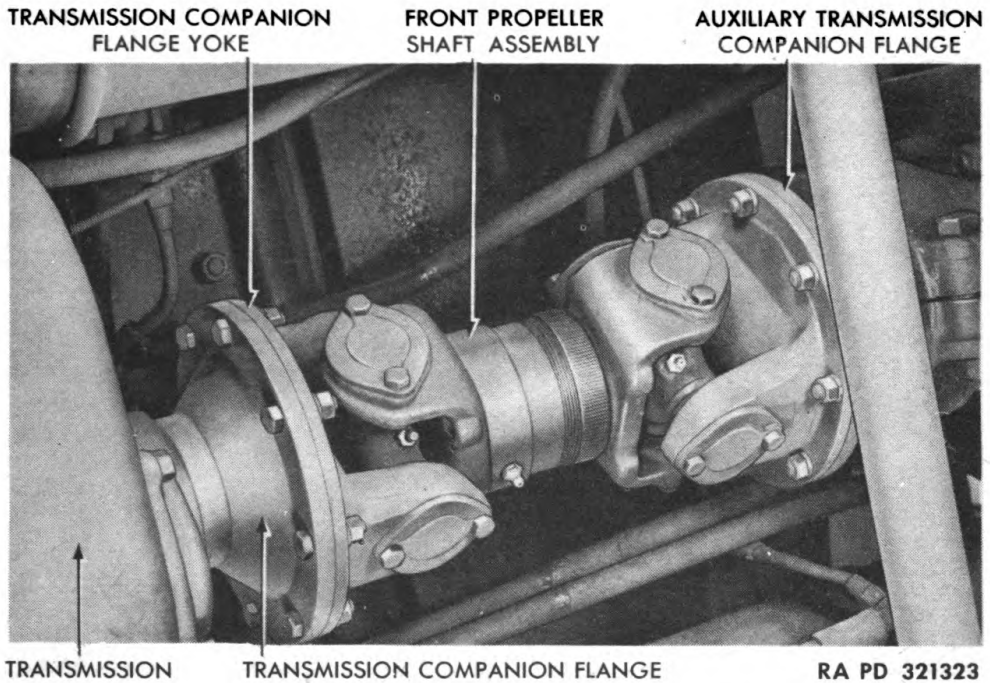

Figure 105—Front Propeller Shaft—Installed

b. **Removal** (fig. 105). Place a support under each end of the shaft. Remove the flange nuts, lock washers, and bolts from the yoke flange and companion flange at either end of the shaft. Separate the flanges and rest the loosened end of the shaft on the support while the flanges at the other end are being separated. Remove flange bolts from opposite end. Remove the shaft and joint assemblies from under the truck.

c. **Installation**. Place supports under the truck to support the shaft during installation. Either end of shaft may be installed first. Position yoke flange on end of shaft against companion flange on transmission and install bolts, lock washers, and nuts. Tighten the nuts gradually on diagonally opposite bolts until all are tightened. Install flange at either end of shaft in the same manner.

146. REAR PROPELLER SHAFT WITH UNIVERSAL JOINT ASSEMBLY.

a. **Description** (figs. 104 and 106). The rear propeller shaft assembly is a tubular-type shaft with universal joints at each end and a splined slip joint to allow for end movement. It is bolted to a companion flange mounted on the forward rear axle and to the parking brake disk.

b. **Removal** (fig. 106). Remove the shaft by following the procedure outlined in paragraph 145 b.

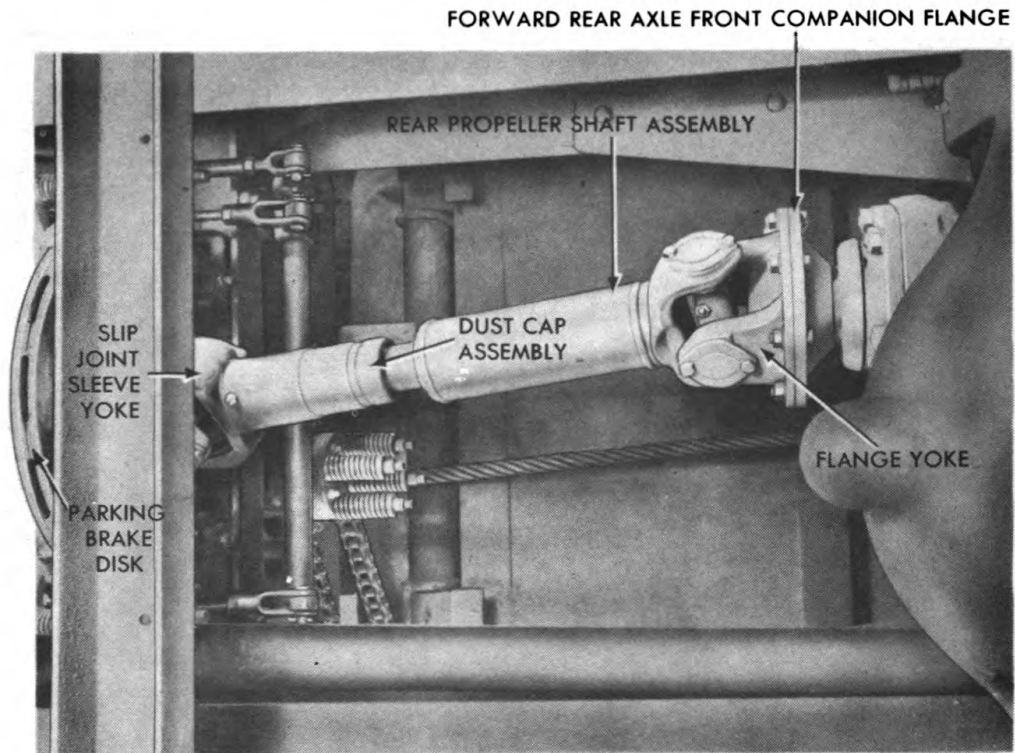

RA PD 321358

Figure 106—Rear Propeller Shaft—Installed

c. **Installation** (fig. 106). Install the shaft by following the procedure given in paragraph 145 c.

147. INTERAXLE PROPELLER SHAFT WITH UNIVERSAL JOINT ASSEMBLY.

a. **Description** (fig. 107). The interaxle propeller shaft is the end-yoke type, and the joint must be disassembled in order to remove it. The shaft is tubular with a splined slip joint to provide for end movement.

b. **Removal** (fig. 107). Bend the lock plate lugs away from the cap screws which attach caps to end yokes. Remove cap screws (two on each side of end yoke which are attached to axles). Lift off the lock and cover plates. Tap on the exposed surface of one of the needle bearing cages until the opposite needle bearing assembly comes out. Tap the exposed end of the trunnion journal until the opposite bearing is free. Slip the trunnion journal from yoke. Repeat the procedure in the opposite end yoke, and remove shaft from under vehicle.

c. **Installation** (fig. 107). Place the journal, which is attached to the yoke at one end of the propeller shaft, into one of the end yokes

Propeller Shafts and Universal Joint Assemblies

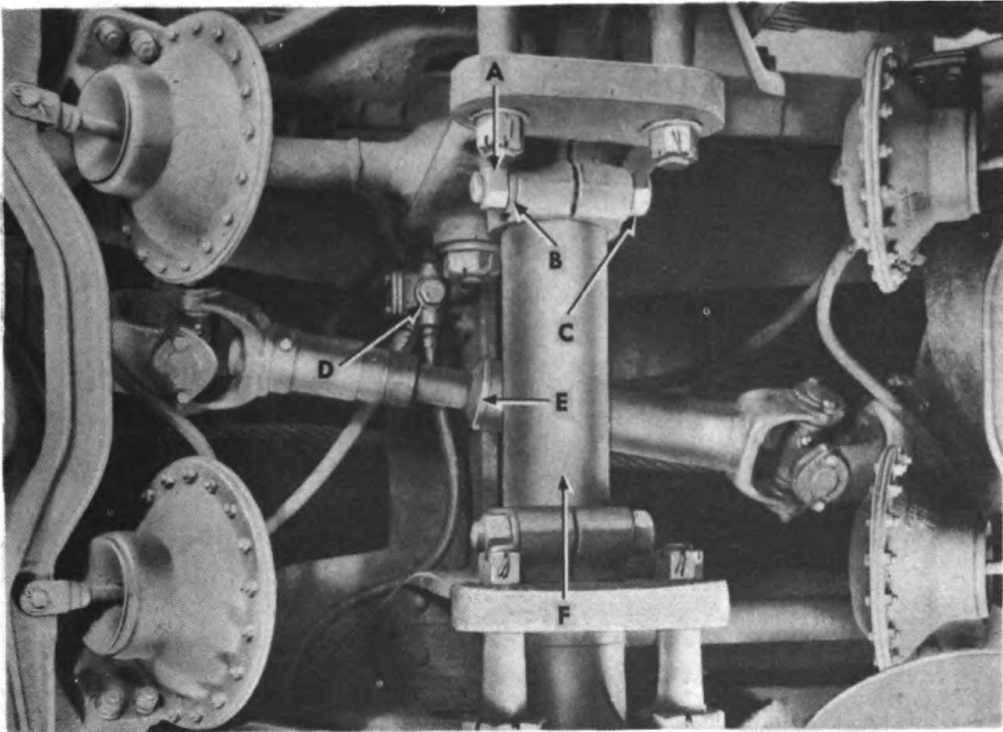

A—NUT	C—CLAMP BOLT	E—INTERAXLE PROPELLER SHAFT
B—LOCK WASHER	D—RELAY VALVE	F—CONNECTING TUBE ASSEMBLY

RA PD 321384

Figure 107—Interaxle Propeller Shaft—Installed

which is attached to one of the axles. Insert bearing from outside of yoke and tap it into place, making sure the groove in the back of the bearing lines up with the cap screw holes. Install other bearing on opposite side of yoke. Connect opposite end of propeller shaft. Install the bearing cover plates, lock plates, and cap screws on the yokes. Bend the lugs of the lock plates against the cap screws to prevent cap screws from coming loose.

148. WINCH PROPELLER SHAFT WITH UNIVERSAL JOINT ASSEMBLY.

a. **Description** (fig. 108). The winch propeller shaft is a splined shaft mounted in a bearing support attached to the under side of the winch base crossmembers. It has a universal joint assembly on the front end, and the winch chain drive sprocket and torque control mounted on the rear end to drive the winch. The universal joint is attached to the power take-off through an end yoke which fits over the output shaft of the power take-off. It is necessary to disassemble the universal joint in order to remove it.

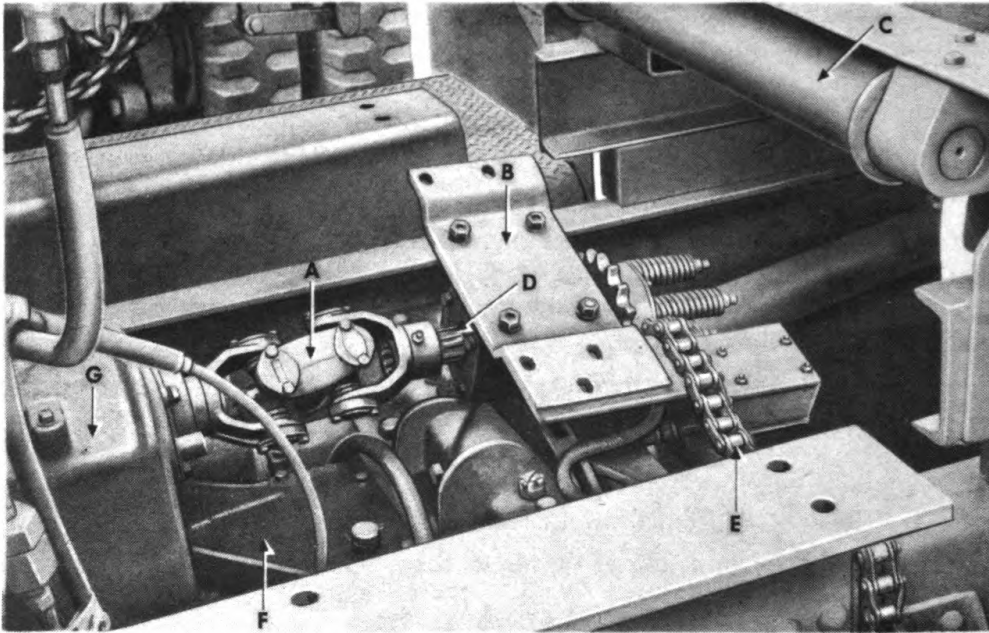

A—UNIVERSAL JOINT ASSEMBLY
 B—SWITCH AND BEARING
 SUPPORT ASSEMBLY
 C—WINCH CABLE ROLLER

D—WINCH PROPELLER SHAFT
 E—WINCH CHAIN
 F—AUXILIARY TRANSMISSION
 G—POWER TAKE-OFF

RA PD 321418

Figure 108—Winch Propeller Shaft

b. Removal.

(1) **DISCONNECT UNIVERSAL JOINT.** Bend the lock plate lugs away from the cap screws which attach caps to end yoke. Remove cap screws (two on each side of end yoke which is attached to power take-off). Lift off the lock and cover plates. Tap on the exposed surface of one of the needle bearing cages until the opposite needle bearing assembly comes out. Tap the exposed end of the trunnion journal until the opposite bearing is free. Slip the trunnion journal from the yoke. Slide the slip joint from the front end of the winch shaft.

(2) **REMOVE TORQUE DRIVE CHAIN.** Remove torque drive chain link and lift chain from sprockets.

(3) **REMOVE BEARING HOUSING.** Remove bolts which attach bearing housing to switch and bearing support. Lower the shaft and bearing housing from the vehicle.

(4) **REMOVE TORQUE CONTROL FROM SHAFT.** Remove cap screw and lock washer which secure cam and sprocket to end of shaft. Pull off torque control and sprocket.

Front Axle Assembly

c. Installation.

(1) **INSTALL TORQUE CONTROL ON SHAFT.** Slide torque control cam and sprocket onto end of shaft. Install cap screw and lock washer which secure the control on the shaft.

(2) **INSTALL SHAFT AND BEARING HOUSING.** Place bearing housing, with shaft assembled through it, on under side of switch and bearing support. Install four bolts, lock washers, and nuts which attach the housing to the support.

(3) **INSTALL TORQUE DRIVE CHAIN.** Place torque drive chain on the sprockets, and connect the ends of the chain together. Adjust chain (par. 216).

(4) **CONNECT THE UNIVERSAL JOINT.** Slide the slip yoke on the end of the propeller shaft. Insert the trunnion in the end yoke. Tap the bearings into place in the end yoke, making sure the groove in the back of the bearing lines up with the cap screw holes. Install bearing cover plates, lock plates, and cap screws on the yokes. Bend the lugs of the lock plates against the cap screws to prevent cap screws from working loose.

Section XXIX

FRONT AXLE ASSEMBLY

149. DESCRIPTION AND DATA.

a. Description (fig. 110). The front axle is of the knuckle-steering type, with an I-section axle beam center with pads on which the front springs rest and to which they are attached. The wheel bearings are carried on the steering knuckles, and a tapered roller bearing between the axle beam and the steering knuckle takes the thrust load of the knuckles. Correct toe-in is obtained by the adjustment of the tie rod.

b. Data.

Make **Timken**
Type **Reverse Elliot**
Model **27454W**
Toe-in **0 to 1/8 in.**

150. WHEEL TOE-IN ADJUSTMENT.

a. General (fig. 109). Toe-in is measured as the distance by which the front wheels are closer together at the front than at the rear. Excessive toe-in will cause rapid tire wear, hard steering, and

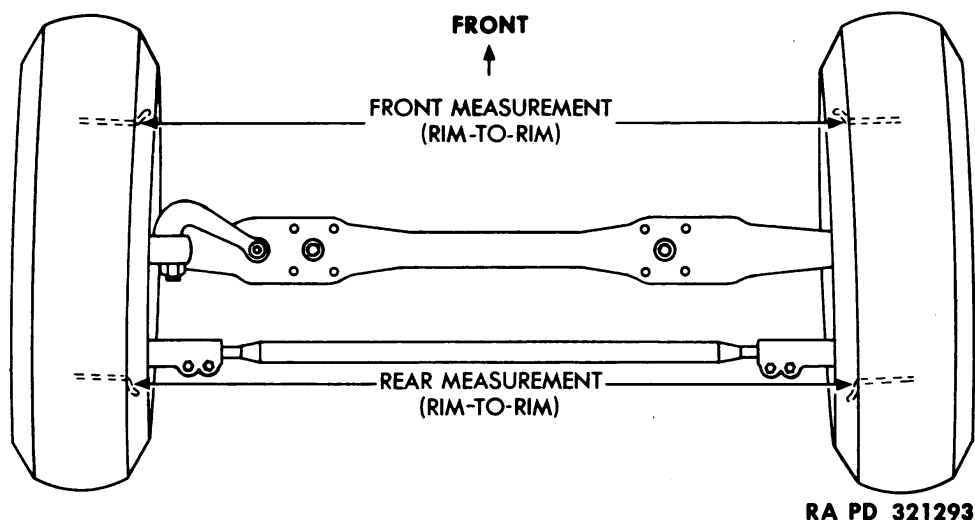

Figure 109—Wheel Toe-in Adjustment

wear on axle parts. Toe-in should be checked at regular intervals and if found incorrect, should be adjusted.

b. Measurement of Toe-in (fig. 109). Position wheels as for straight-ahead driving. Place mark on inside front wheel rims at approximate level of the top spring. Measure the distance between the marks. Move the truck forward until marks are at approximate level of top springs at rear of wheels. Measure the distance between the marks. The front cross measurement should be from 0 to $\frac{1}{8}$ inch greater than the rear cross measurement. Adjust if necessary (subpar. c below).

c. Toe-in Adjustment (figs. 111 and 112). Loosen the two tie rod end clamp bolt nuts at each end of the tie rod, and turn tie rod as required to correctly adjust toe-in. Tighten clamp bolt nuts.

151. FRONT AXLE ASSEMBLY (fig. 110).

a. Removal. Jack or hoist front end of chassis. Remove front wheels (par. 184 b). Remove hub and drum assembly (par. 185 c). Unscrew coupling nuts and free flexible air line hose from two brake chambers. Jack up axle. Disconnect drag link from steering arm (par. 192). Remove eight nuts and lock washers from spring clips. Remove four spring clips. Remove clip spacer and bumper assembly. Lower the axle and remove from center chassis.

b. Installation. Place spring clip spacer assembly on top spring leaf, and place spring clips over spacer and spring. Position axle under chassis. Enter the spring clips in the axle. Install four lock

Front Axle Assembly

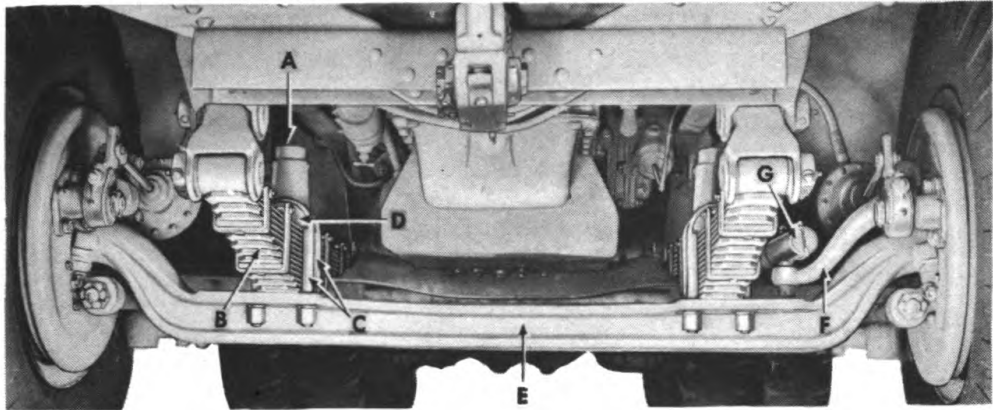

A—SPACER BUMPER	C—FRONT SPRING CLIPS	F—STEERING ARM
B—FRONT SPRING	D—FRONT SPRING CLIP SPACER	G—DRAG LINK
	E—FRONT AXLE	RA PD 321464

Figure 110—Front Axle—Installed

washers and nuts. Position and attach drag link assembly (par. 192 b). Position flexible air line hose in brake chamber couplings and tighten coupling nuts. Install hub and drum assembly (par. 185 d). Install wheels (par. 184 c). Remove jacks.

152. STEERING ARM ASSEMBLY (figs. 110 and 132).

a. Description. The steering arm assembly is attached to the upper end of the steering knuckle at the front left axle assembly. It consists of a forged arm, with a steering arm ball, nut, and cotter pin at the drag link end and a key, nut, and cotter pin at the steering knuckle end. With front left-hand and right-hand steering knuckles connected by the tie rod assembly, any movement transmitted to the steering arm by the steering gear through the drag link simultaneously turns both wheels.

b. Removal (figs. 110 and 132). Disconnect drag link from arm ball assembly (par. 192 a). Disconnect and remove left front slack adjuster (par. 176 d (1)). Remove cotter pin and nut from steering arm at steering knuckle. Tap out steering arm. Remove key.

c. Installation. Position key and install steering arm in steering knuckle. Install nut and cotter pin. Position and attach drag link to steering arm ball (par. 192 b). Install front slack adjuster (176 d (2)).

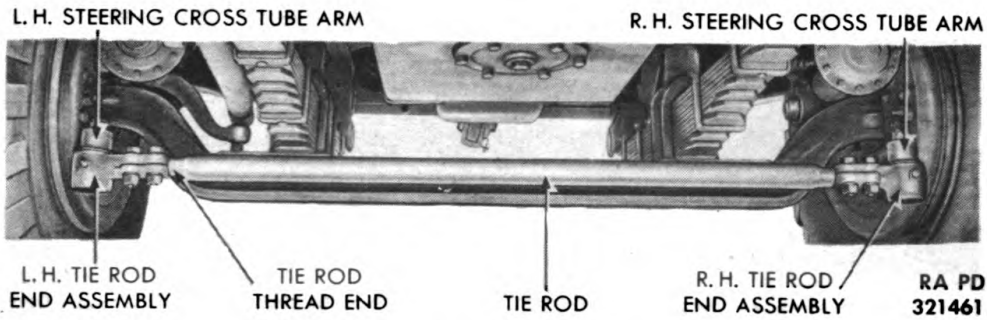

Figure 111—Tie Rod Assembly—Installed

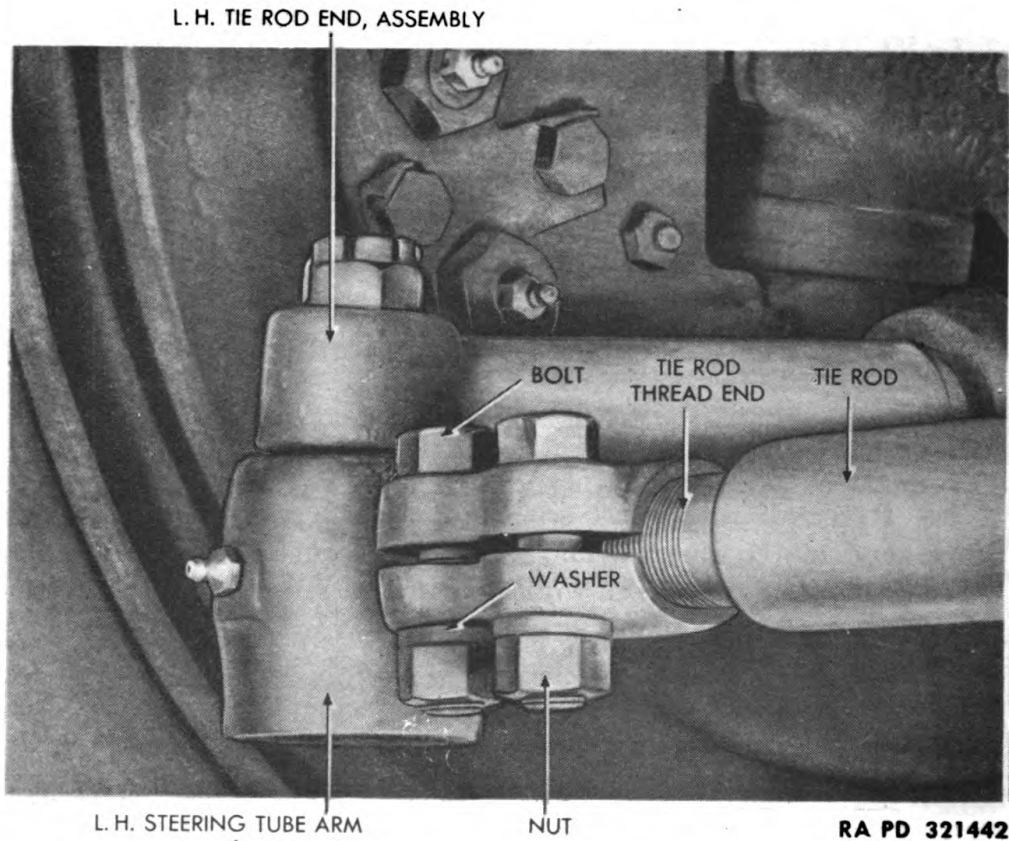

Figure 112—Tie Rod Adjusting Location

153. TIE ROD ASSEMBLY.

a. **Description** (figs. 111 and 112). The tie rod assembly connects the left and right steering cross tube arms and enables the steering motion to be applied equally to both front wheels. The tie rod is threaded with a right-hand and left-hand thread at the ends

Rear Axle Assembly

so that by turning it in the end assemblies, the length can be adjusted to provide the correct amount of toe-in as described in paragraph 150.

b. Removal (figs. 111 and 112). Remove cotter pin, nut, and lock washer which secure each tie rod end assembly to the steering cross tube arms. Tap each arm to free it from the end assembly. Remove tie rod assembly.

c. Installation (figs. 111 and 112). Position tie rod assembly and tap the ends into the steering cross tube arms. Install lock washer, nut, and cotter pin which secure each end assembly to the cross tube arms. Check toe-in adjustment (par. 150).

Section XXX

REAR AXLE ASSEMBLY

154. DESCRIPTION AND DATA.

a. Description. The two rear axles are both driving axles and are similar in construction. The drive is through a double-reduction differential. The differential is mounted on top of the axle housing. Carriers are of the through-shaft type, which means that the pinion shaft passes through the carrier so that power is delivered to the rearward rear axle after passing through the through shaft of the forward rear axle. The axles are full floating and the axle shaft may be removed without raising the wheels from the ground.

b. Data.

Make Timken
 Type Double reduction
 Model SD-462W
 Gear ratio 11.66

155. BOGIE ASSEMBLY.

a. Description (figs. 113 and 114). The bogie assembly is located between the forward and rearward rear axle assemblies and consists of the following: left- and right-hand frame support brackets riveted to chassis frame side rails; connecting tube assembly adjustably positioned through the frame support brackets; two spring seat assemblies adjustable in both vertical and horizontal planes attached to the outside ends of the connecting tube; four removable torque rod end pins, two located in the lower end of the right-hand frame support bracket and two in the lower end of the left-hand frame support bracket; and two removable upper torque rod end pins,

Maintenance Instructions

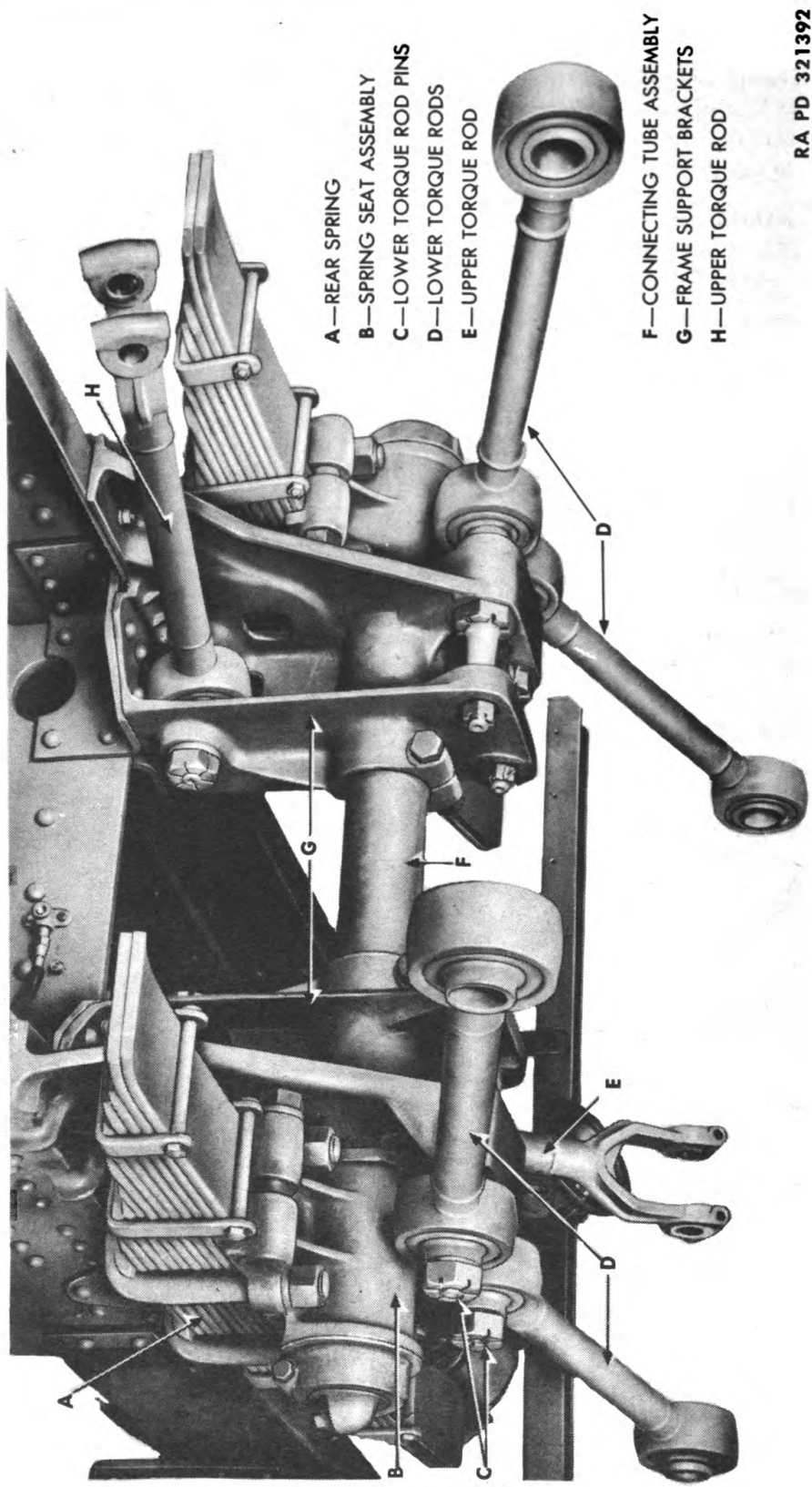

RA PD 321392

Figure 113—Bogie Assembly

Rear Axle Assembly

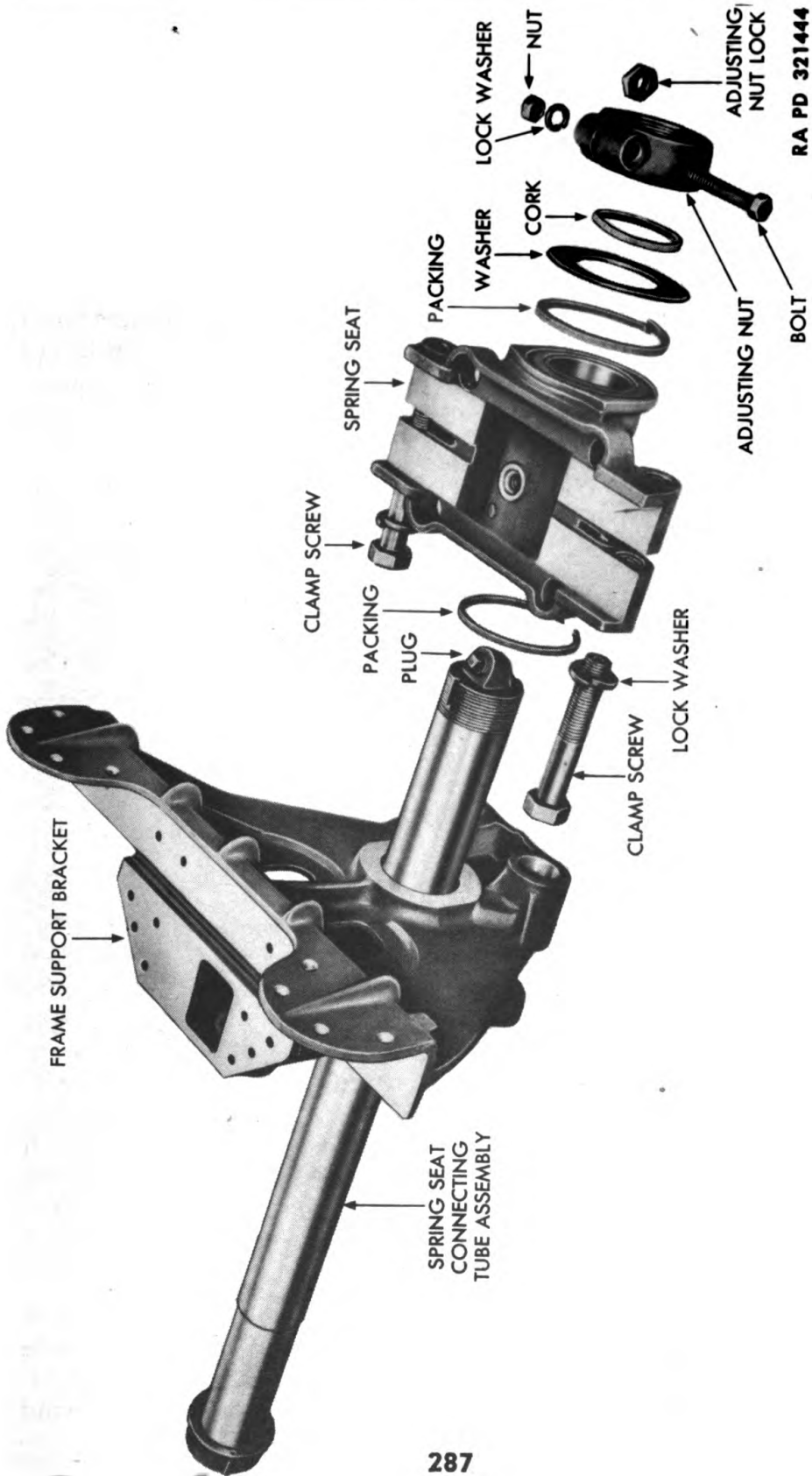

Figure 114—Bogie Spring Seat Assembly

one in the upper end of each frame support bracket. This assembly provides tandem axle suspension with the two rear axles sprung on one set of chassis springs. The springs carry the load and serve as load equalizing members. The spring ends rest in a free position on axle platforms, permitting freedom of movement without twisting action.

b. Removal of Bogie Assembly (figs. 107 and 113).

(1) **REMOVE SPRING SEAT AND REAR SPRING ASSEMBLIES.** Remove spring seat and rear spring assemblies (par. 160 b).

(2) **REMOVE CONNECTING TUBE (fig. 107).** Back off clamp bolt located at under side of each frame support bracket. Push tube through brackets and remove from chassis.

(3) **REMOVE TORQUE RODS.** Remove two upper and four lower torque rods (par. 159 b and c).

(4) **REMOVAL OF FRAME SUPPORT BRACKETS.** The frame support brackets are riveted to the chassis frame. Refer to higher authority for removal.

c. Installation of Bogie Assembly.

(1) **INSTALL FRAME SUPPORT BRACKETS.** The frame support brackets are riveted to the chassis frame. Refer to higher authority.

(2) **INSTALL CONNECTING TUBE.** Position and install connecting tube through frame support brackets. Tighten clamp bolts (figs. 107 and 113).

(3) **INSTALL SPRING SEAT AND REAR SPRING ASSEMBLIES.** Install spring seat and rear spring assemblies (par. 160 c).

156. FORWARD REAR AXLE.

a. Description (figs. 115 and 116). The forward rear axle is forward of the bogie assembly. It is positioned with its spring platforms opened rearward. The axle is connected to the bogie by one upper torque rod and lower torque rods. The differential case on top of the axle provides a yoke connection for the interaxle propeller shaft leading to rearward rear axle; on the forward end it provides a companion flange for connecting the rear propeller shaft assembly. The removal or roll-away of the forward rear axle as an assembly is accomplished after disconnecting the interaxle propeller shaft yoke, rear propeller shaft yoke flange, brake chamber air lines, yoke end of upper left-hand torque rod, and the right- and left-hand lower torque rods.

b. Removal (figs. 115, 116, and 113). Jack or hoist chassis to float both spring ends within spring platforms on forward rear axle housing. Back off coupling nut attaching flexible air line hose to right- and left-hand brake chambers. Remove lower right- and left-hand

Rear Axle Assembly

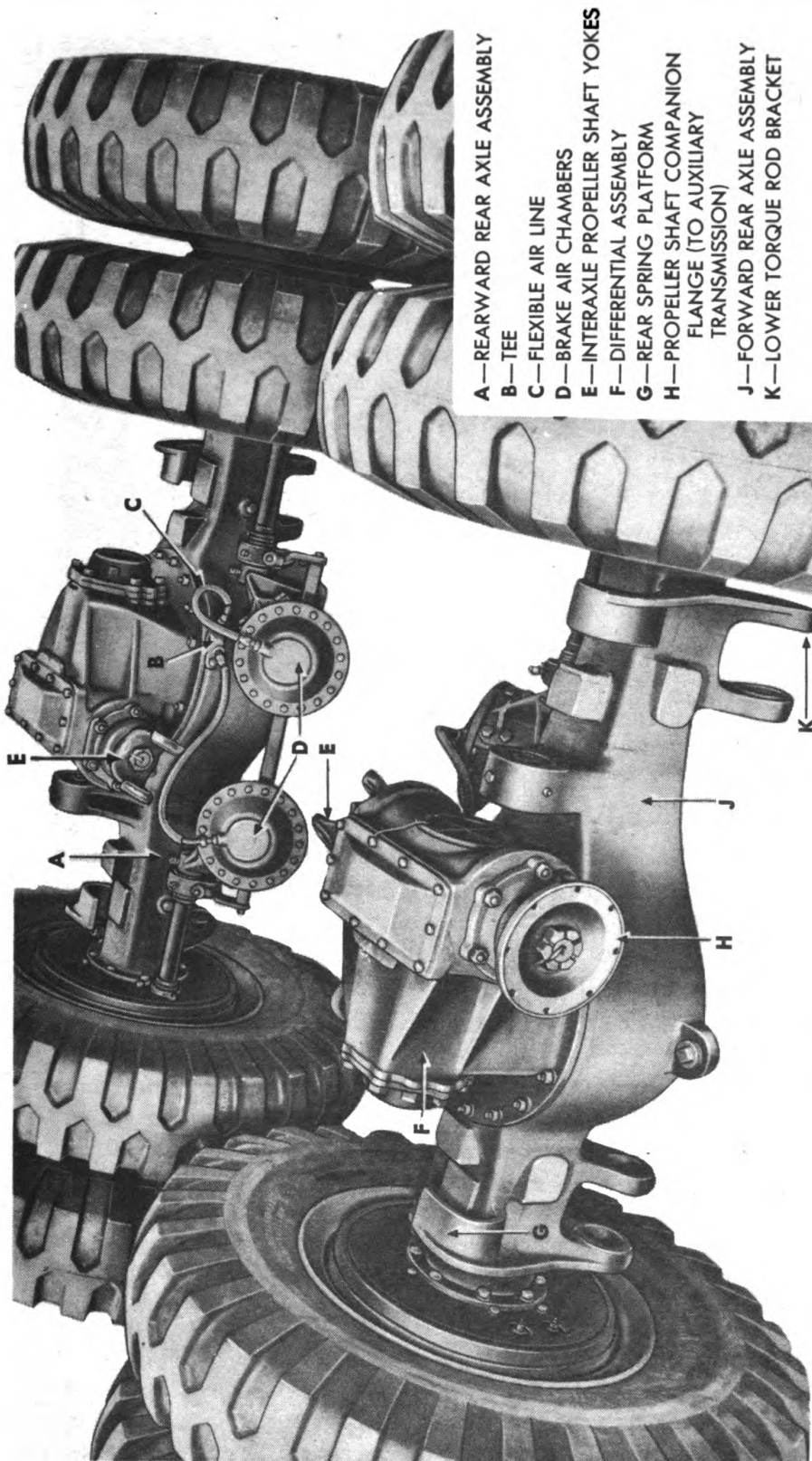

- A—REARWARD REAR AXLE ASSEMBLY
- B—TEE
- C—FLEXIBLE AIR LINE
- D—BRAKE AIR CHAMBERS
- E—INTERAXLE PROPELLER SHAFT YOKES
- F—DIFFERENTIAL ASSEMBLY
- G—REAR SPRING PLATFORM
- H—PROPELLER SHAFT COMPANION FLANGE (TO AUXILIARY TRANSMISSION)
- J—FORWARD REAR AXLE ASSEMBLY
- K—LOWER TORQUE ROD BRACKET

RA PD 321468

Figure 115—Forward and Rearward Rear Axles

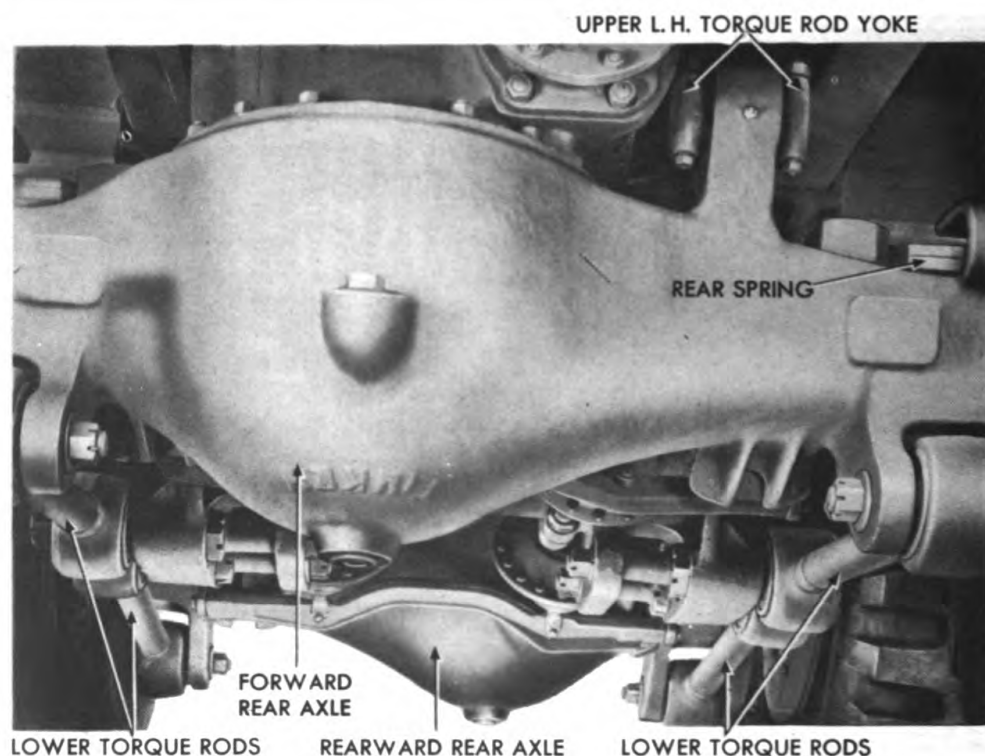

RA PD 321435

Figure 116—Forward Rear Axle—Installed

torque rod pins (par. 159 c). Remove upper left-hand torque rod yoke (par. 159 b). Disconnect front end of interaxle propeller shaft (par. 147 h). Disconnect rear propeller shaft yoke flange from forward rear axle companion flange (par. 146 b). Roll forward rear axle assembly ahead to remove spring ends from platforms. Lift chassis. Turn axle sidewise and roll out.

c. **Installation** (figs. 117 and 115). Hoist chassis and roll the forward rear axles under chassis. Position spring ends for entrance into spring platforms on axle housing. Roll axle assembly into place to position spring ends within spring platforms. Connect upper left-hand torque rod yoke on axle (par. 159 b). Install lower right- and left-hand torque rods on axle (par. 159 c). Connect companion flange of rear propeller (par. 146 c). Connect front end of interaxle propeller shaft (par. 147 c). Position right- and left-hand flexible air line hose into brake chambers and tighten coupling nuts. Release hoist.

157. REARWARD REAR AXLE.

a. **Description** (figs. 117 and 115). The rearward rear axle is located at the rear of the bogie assembly. It is positioned with its spring platforms opened forward and is retained by one upper torque

Rear Axle Assembly

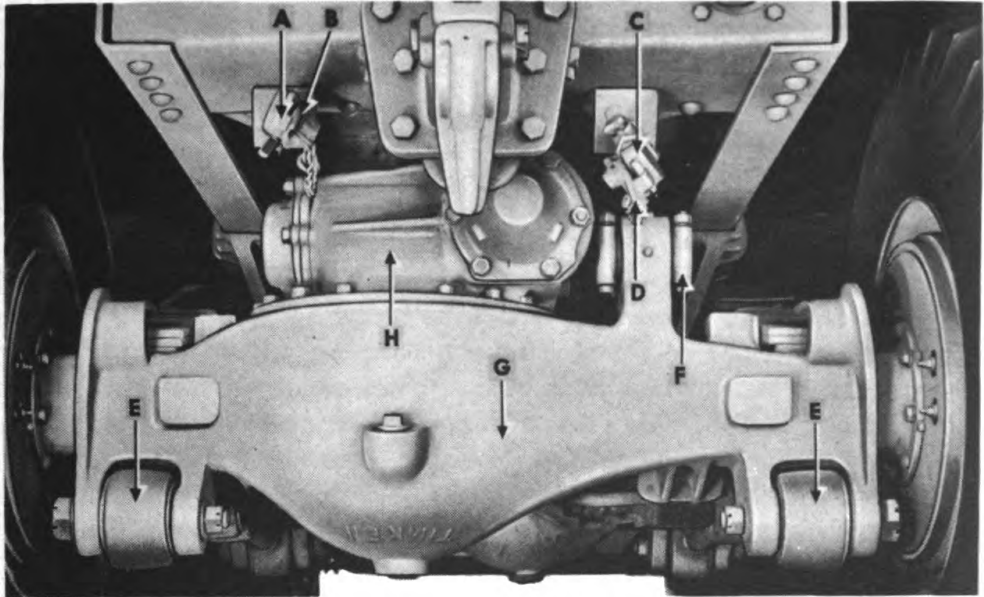

A—REAR L. H. COUPLING	E—LOWER TORQUE ROD
B—L. H. DUMMY COUPLING	F—UPPER TORQUE ROD
C—REAR R. H. COUPLING	G—REARWARD REAR AXLE
D—R. H. DUMMY COUPLING	H—DIFFERENTIAL

RA PD 321417

Figure 117—Rearward Rear Axle—Installed

rod (on right side) and two lower torque rods. The differential case provides a yoke connection for interaxle propeller shaft. The removal or roll-away of the rearward rear axle assembly is accomplished after disconnecting the interaxle propeller shaft yoke, the brake chamber air lines, the yoke end of the upper right torque rod, and the right- and left-hand lower torque rods.

b. Removal (figs. 117 and 115). Jack or hoist chassis to float both spring ends within spring platforms on axle housing. Back off coupling nut which attaches flexible air lines hose to right- and left-hand brake chambers. Disconnect lower right- and left-hand torque rods (par. 159 c). Disconnect upper right-hand torque rod yoke (par. 159 b). Disconnect rear end of interaxle propeller shaft (par. 147 b). Tie the propeller shaft and torque rods to chassis. Roll the rear axle assembly rearward and out.

c. Installation (figs. 117 and 115). Jack or hoist the chassis and roll the rearward rear axle under the frame. Position spring ends for entrance into spring platforms on axle housing. Roll axle assembly back into place and position spring ends within spring platforms. Connect upper right-hand torque rod (par. 159 d). Connect lower right- and left-hand torque rods (par. 159 e). Connect inter-

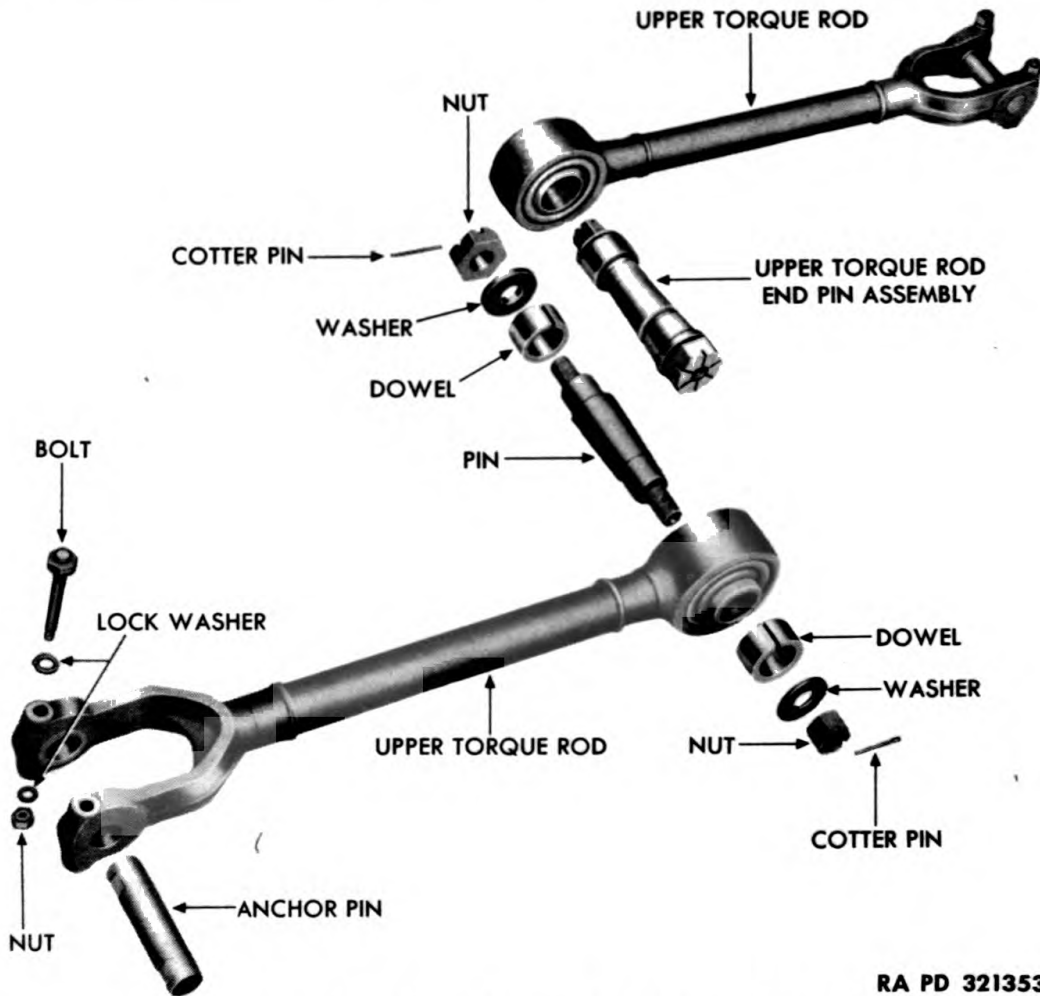

RA PD 321353

Figure 118—Upper Torque Rod Assembly

axle propeller shaft rear yoke. Position right-hand and left-hand flexible air line hose on brake chambers and tighten connector nuts. Release the hoist.

158. AXLE SHAFTS.

a. **Removal** (fig. 142). Remove eight nuts, lock washers, and toothed lock washers from axle end plate. Remove two puller screws and nuts. Remove nuts from screws. Reinstall two screws in end plate tapped holes. Alternately advance screws until end plate is free. Pull axle out a few inches. Remove three split tapered dowels from plate. Pull out axle shaft. Remove gasket.

b. **Installation** (fig. 142). Remove two puller screws from end plate. Place gasket over axle shaft. Position shaft into housing tube. Engage splines. Aline gasket against end plate. Position plate over

Rear Axle Assembly

studs. Push to stop. Install three dowels on studs; install five lock washers on studs; install three toothed lock washers over dowels. Install eight nuts. Install two nuts on puller screws. Hand-screw puller screws to stop. Tighten puller screw nuts.

159. TORQUE ROD ASSEMBLIES.

a. Description (figs. 113, 118, and 119). To maintain axle alignment, six torque rods are connected between the frame support brackets and the forward and rearward rear axles as follows: a left- and right-hand rod between the under side of the rearward rear axle housing and lower rear end of the frame support brackets; a left- and right-hand rod between the lower forward end of the frame support brackets and the under side of the forward rear axle; a left-hand rod between the upper side of the forward rear axle and the upper forward end of the frame support bracket; a right-hand rod between the upper side of rearward rear axle and the upper rear end of the frame support bracket. The four lower torque rods are of the eye type, and the two upper rods are of the eye and yoke type, with the yoke ends of both rods attached, one to the top right-hand axle housing bracket of the rearward rear axle and the other to the top left-hand axle housing bracket of the forward rear axle. The lower torque rods are retained by torque rod end pin assemblies at all eight ends, and the two upper torque rods retained by two torque rod end pin assemblies and by two yoke anchor pins and draw bolt assemblies.

b. Removal of Upper Torque Rod Assemblies.

(1) Remove cotter pin, nut, and washer from each of two upper short torque rod pins at frame support bracket (figs. 113 and 118). Support torque rod. Drive end pin assembly out of rod and bracket and remove with dowel. Remove remaining dowel in bracket. Tie the free end of rod to chassis.

(2) Remove two nuts and lock washers from draw bolts in torque rod yoke (figs. 117 and 118). Turn top nuts clockwise to free draw bolts. Remove draw bolt assembly. Remove anchor pin. Remove rod.

c. Removal of Lower Torque Rod Assemblies (figs. 119 and 113).

(1) Remove cotter pin, nut, and washer from lower torque rod end pin at outer lower end of frame support bracket. Remove cotter pin and lock nut from end pin at inner end. Remove cotter pin and nut from inner face of bracket. Remove torque rod end pin from outer face of bracket. Unscrew nut from pin. Tie free end of rod to chassis.

(2) Remove cotter pin, nut, and washer from outer and inner ends of torque rod end pins at axle housing brackets. Remove rim

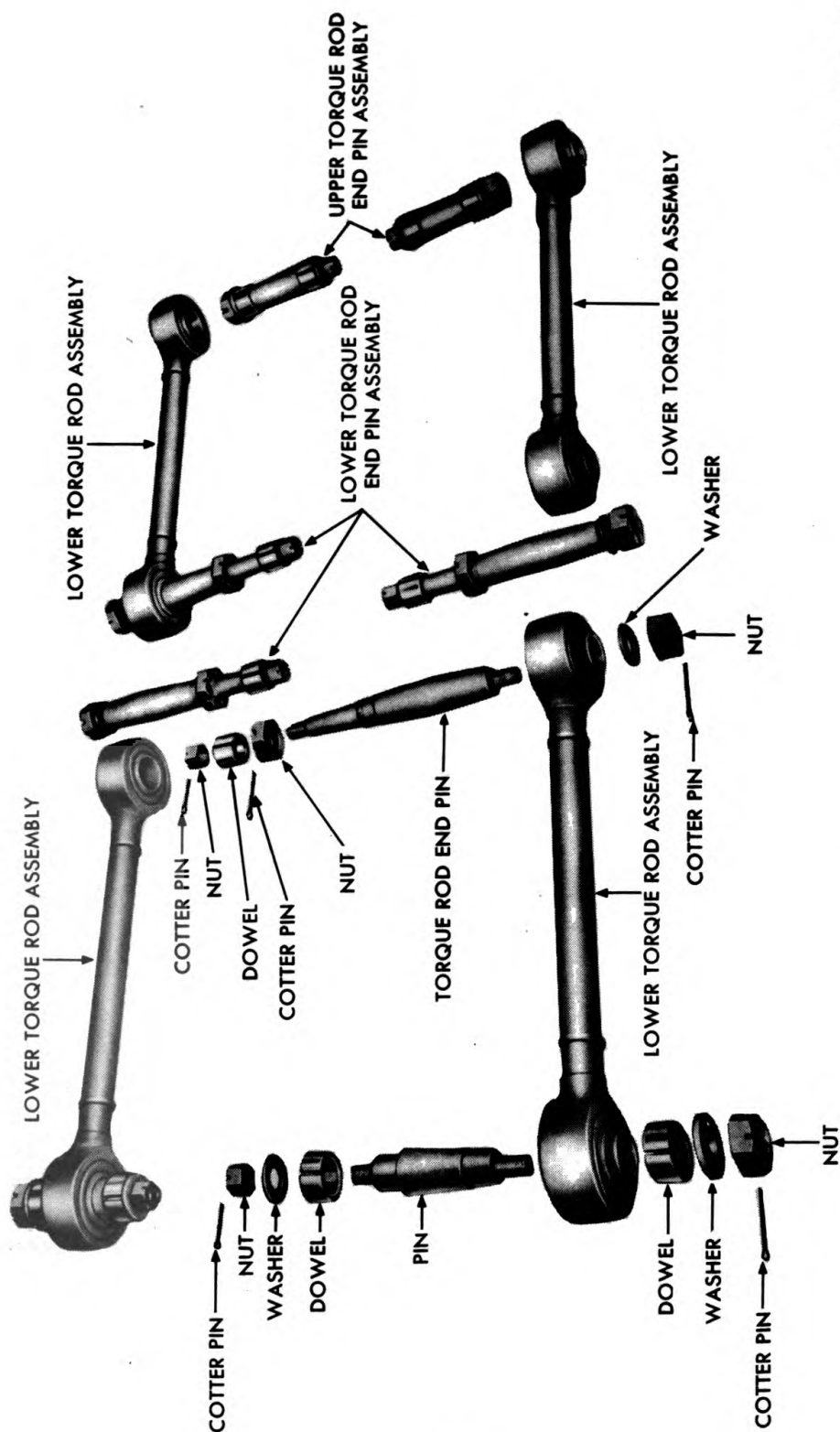

RA PD 321361

Figure 119—Lower Torque Rod Assembly

Rear Axle Assembly

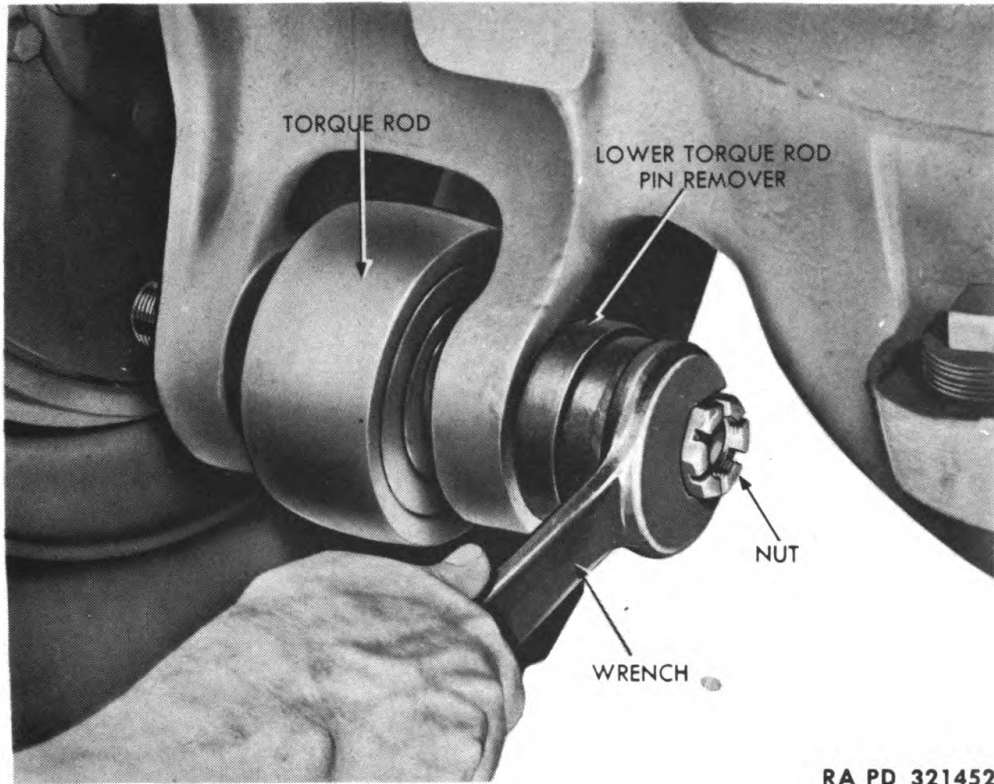

RA PD 321452

Figure 120—Removing Lower Torque Rod End Pin With Remover (41-R-2372-555)

section from the lower torque rod pin remover (41-R-2372-555). Position shell section of remover over rod end pin (fig. 120). Install nut. Turn nut clockwise to free pin. Remove end pin with dowel. Remove remaining dowel.

d. Installation of Upper Torque Rod Assemblies.

(1) Position upper torque rod in upper end of frame support brackets (figs. 113 and 118). Install torque rod end pin. Install dowel at each end. Install smaller washer, nut, and cotter pin at outer end. Install larger washer, nut, and cotter pin at inner end.

(2) Position yoke end of upper torque rod over upper axle housing brackets (figs. 113, 117, and 118). Position and install anchor pin. Back off nut from draw bolt. Position and install two lock washer and draw bolt assemblies. Install two lower lock washers and nuts. Spin top nuts to seat bolts.

e. Installation of Lower Torque Rod Assemblies (figs. 119 and 113).

(1) Hold larger nut within frame support bracket walls (fig. 113). Insert small end of long torque rod end pin through support bracket

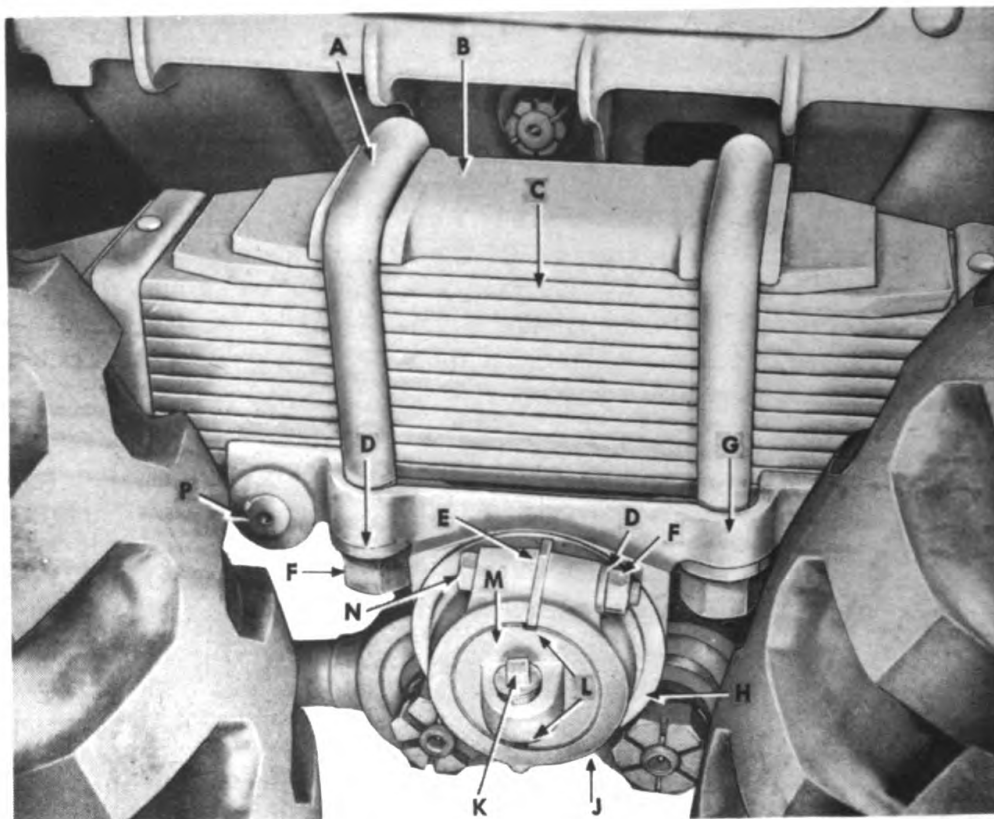

A—SPRING CLIP
 B—REAR SPRING CLIP SPACER
 C—REAR SPRING ASSEMBLY
 D—LOCK WASHER
 E—LOCK PLATE
 F—NUT
 G—SPRING SEAT ASSEMBLY
 H—WASHER

J—CONNECTING TUBE
 ADJUSTING NUT
 K—PLUG
 L—180-DEGREE OPPOSED KEYWAYS
 M—CONNECTING TUBE ASSEMBLY
 N—BOLT
 P—SIDE PLAY
 ADJUSTING BOLTS

RA PD 321431

Figure 121—Spring Seat Assembly

and nut. Tighten larger lock nut. Install cotter pin. Install dowel at inner end. Install nut and cotter pin. Position torque rod on outer end of torque rod end pin. Install washer, nut, and cotter pin.

(2) Position torque rod in lower axle housing bracket (figs. 113, 119 and 120). Install torque rod end pin. Install dowel at each end. Install larger washer, nut, and cotter pin on outer end. Install smaller washer, nut, and cotter pin on inner end.

160. SPRING SEAT ASSEMBLIES.

a. **Description** (figs. 121 and 114). The spring seat assemblies are located on the outside ends of the connecting tube between the forward rear and the rearward rear axles. The seats are adjustable in both vertical and horizontal planes. The seat is recessed to receive

Truck Service Brake System

the spring assembly and is split at each end for side-play adjustment. The removal of the spring and spring seat assembly requires the removal of the forward rear and the rearward rear axle and wheel assemblies.

b. Removal (figs. 121 and 114). Remove forward rear and rearward rear axle and wheel assemblies (par. 156 b and 157 b). Remove bolt, nut, and lock washer from connecting tube adjusting nut. Remove lock plate (fig. 121). Remove adjusting nut. Remove cork seal and washer. Remove spring seat and spring as an assembly. Remove four nuts and lock washers from spring clips. Remove two clips. Remove clip spacer. Back off two clamp screws. Lift off and remove spring assembly.

c. Installation (figs. 121 and 114). Position spring assembly on spring seat. Position clip spacer on top spring leaf. Position and install two spring clips. Install four lock washers and nuts. Install packing in groove at each side of seat. Position spring and seat assembly on connecting tube. Install washer and cork. Install adjusting nut and pull tight. Back off adjusting nut to aline split in adjusting nut with tube keyway. Position lock plate. Install bolt, lock washer, and nut in locking unit. Install forward rear and rearward rear axle and wheel assemblies (pars. 156 c and 157 c). Adjust spring seat (subpar. d below).

d. Adjustment. The springs may be tightened in their seats in both horizontal and vertical planes. The springs must be held tightly on the seats by tightening the spring clip nuts. Side play in seats must be eliminated by tightening the large clamp screws located on the inner side of the spring seat.

Section XXXI

TRUCK SERVICE BRAKE SYSTEM

161. DESCRIPTION AND DATA.

a. Description. The service brake system of both the truck and the trailer are air-controlled. Couplings on the rear of the truck provide for a controlled supply of air to the trailer brake system. The emergency couplings on the front of the truck provide for a supply of air to the trailer or a disabled vehicle when conditions require a front connection. They also provide for a controlled supply of air to the truck system through the controls of a towing vehicle when the truck itself is disabled and is being towed. Air is stored under pressure and admitted by valves to brake diaphragm chambers mounted on the axles. The chambers are connected by rods to slack adjusters which form the mechanical link to the brake shoes.

Maintenance Instructions

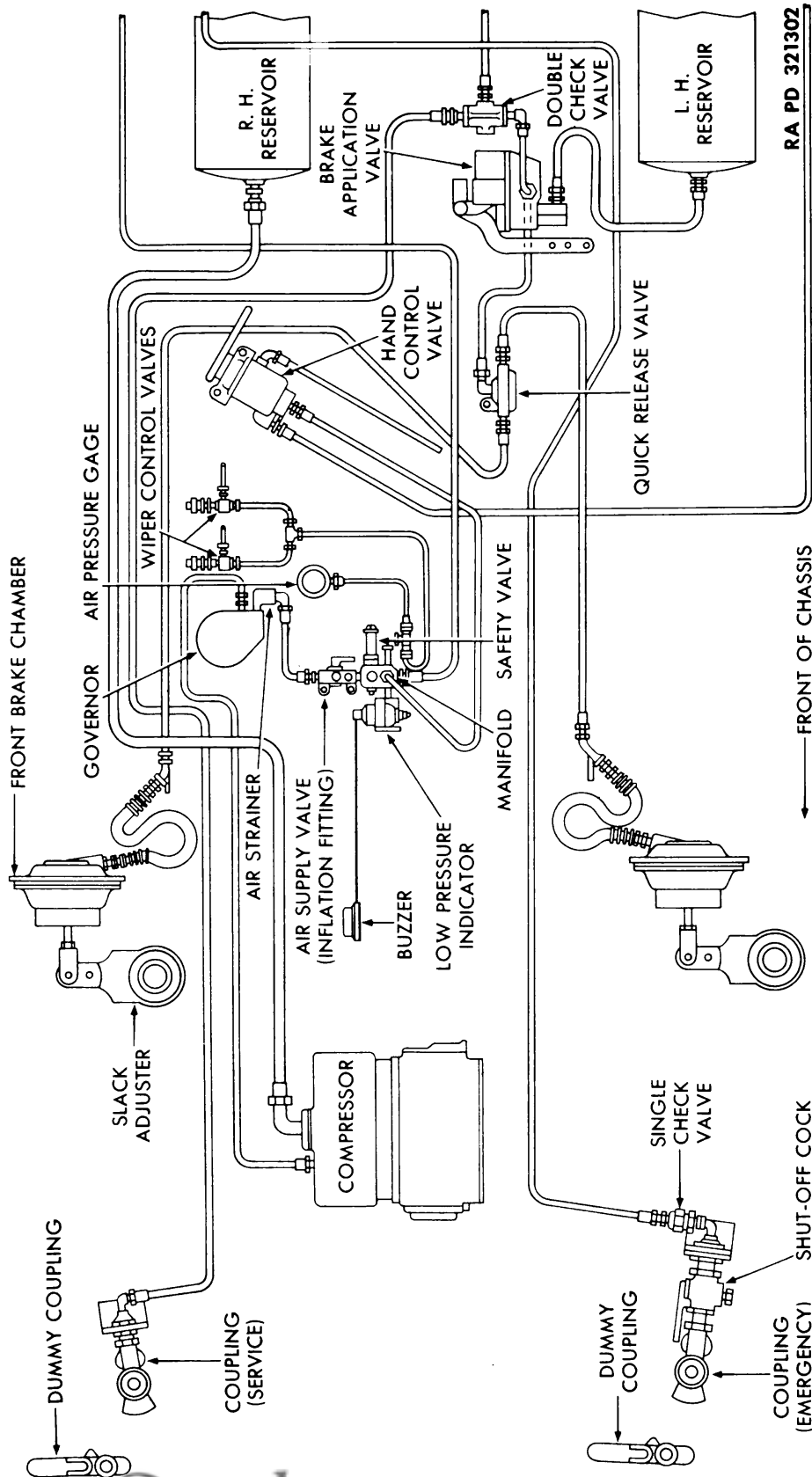

Truck Service Brake System

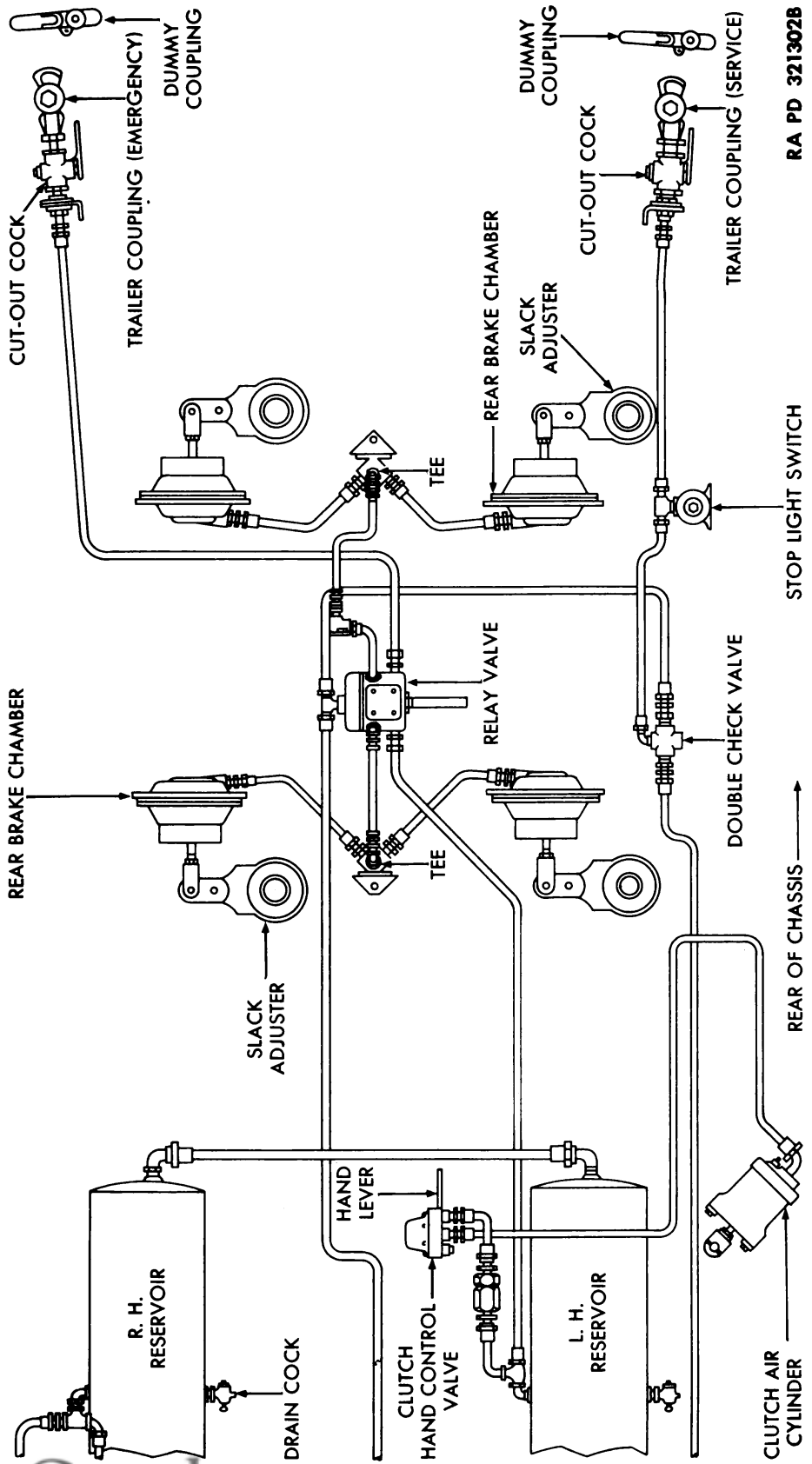

RA PD 321302B

Figure 122—Service Brake System

b. Data.

(1) SERVICE BRAKES.

Make **Timken**
 Type **Internal-expanding two-shoe type—
 air brakes on six wheels**

(2) LINING.

Type **Molded**
 Size:
 Front **17¼ x 4 in.**
 Rear **17¼ x 5½ in.**
 Thickness **¾ in.**

(3) AIR EQUIPMENT.

Manufacturer **Bendix-Westinghouse**
 Governed air pressure **105 lb per sq in.**
 Compressor capacity **12 cu ft**
 Operating pressure **70 to 150 lb**

162. AIR COMPRESSOR.

a. Description (fig. 64). The air compressor is a 3-cylinder reciprocating, high-speed, single-acting type, driven by the fan belts. At a speed of 1,250 revolutions per minute it compresses 12 cubic feet of air per minute. The lubricating system is connected by a copper tube to the engine lubricating system. The liquid cooling system is connected with the engine cooling system and is supplemented by fins on the exterior of the cylinders. The function of the compressor is to charge the air reservoirs with compressed air to operate the brakes and air accessories.

b. Servicing. At proper intervals (par. 22), remove retainer spring which secures curled hair element and strainer parts within air strainer. Remove all parts and clean with dry-cleaning solvent. Coat curled hair element with light oil, and replace parts within strainer. Oil fulcrum pin at proper intervals, and check unloader rocker arm for freeness of motion. Check to see that the clearance of the unloader valve is from 0.010 inch to 0.015 inch, and that the lift of the discharge valve is from 0.042 inch to 0.075 inch. Notify higher authority if these clearances are not within limits.

c. Removal (fig. 64).

(1) GENERAL. Open drain cock at bottom of radiator, and drain fluid from engine cooling system. Remove drain plug from side of compressor cylinder head, and drain cooling fluid from compressor.

(2) REMOVE COOLING SYSTEM, AIR LINE, AND OIL LINE CONNECTIONS (fig. 64). Unscrew connector which secures cooling system inlet to compressor, and pull inlet from compressor. Loosen clamp

Truck Service Brake System

which secures cooling system outlet hose to compressor and pull hose from compressor. Unscrew connectors which secure compressor to reservoir and compressor to governor air lines and pull air lines from compressor. Unscrew connector which secures oil line to compressor and pull oil line from compressor.

(3) **REMOVE FAN BELTS.** Loosen clamp washer nut on fan spindle. Loosen jam nut on fan adjusting screw and turn screw to lower fan and slacken belts. Remove belts from compressor pulleys.

(4) **REMOVE COMPRESSOR.** Remove screws, washers, and lock washers which secure compressor to mount, and lift out compressor and gasket.

d. Installation (fig. 64).

(1) **INSTALL COMPRESSOR.** Position compressor on mount, using a new base gasket, and install screws, washers, and lock washers.

(2) **INSTALL FAN BELTS.** Position fan belts on fan pulleys, crankshaft pulleys, and compressor pulleys. Screw fan adjusting screw until there is 1/2-inch play in fan belts and tighten jam nut. Tighten clamp washer nut on fan spindle.

(3) **INSTALL COOLING SYSTEM, AIR LINE, AND OIL LINE CONNECTIONS.** Position compressor cooling system inlet on compressor and screw on connector. Position compressor cooling system outlet hose on compressor and tighten clamp. Position compressor to reservoir and compressor to governor air lines and screw on connectors. Position oil line on compressor and screw on connector.

(4) **GENERAL.** Close drain cock at bottom of truck radiator, install drain plug at side of compressor cylinder head, and replace fluid in engine cooling system (par. 88 b). Run engine until governor cuts off.

163. AIR RESERVOIRS.

a. Description (fig. 123). There are two air reservoirs, located one on each side of the truck, inside and parallel to the frame side rails. Each is equipped with a drain cock to drain off moisture from condensation and to release the compressed air from the air brake system for the purpose of repairs. The reservoirs store compressed air to operate the service brakes and air accessories. Air from the compressor enters the right-hand reservoir from which it is released to the left-hand reservoir, the air manifold with its accessories, and the left front trailer coupling. Air is released from the left-hand reservoir to the hand control valve on the winch, the brake application valve, and the relay valve.

b. Servicing. Bleed the reservoirs by opening the drain cocks while the engine is running, and see that there is sufficient air pressure to force out all condensation. When all signs of vapor have disappeared from the escaping air, close drain cocks and keep engine

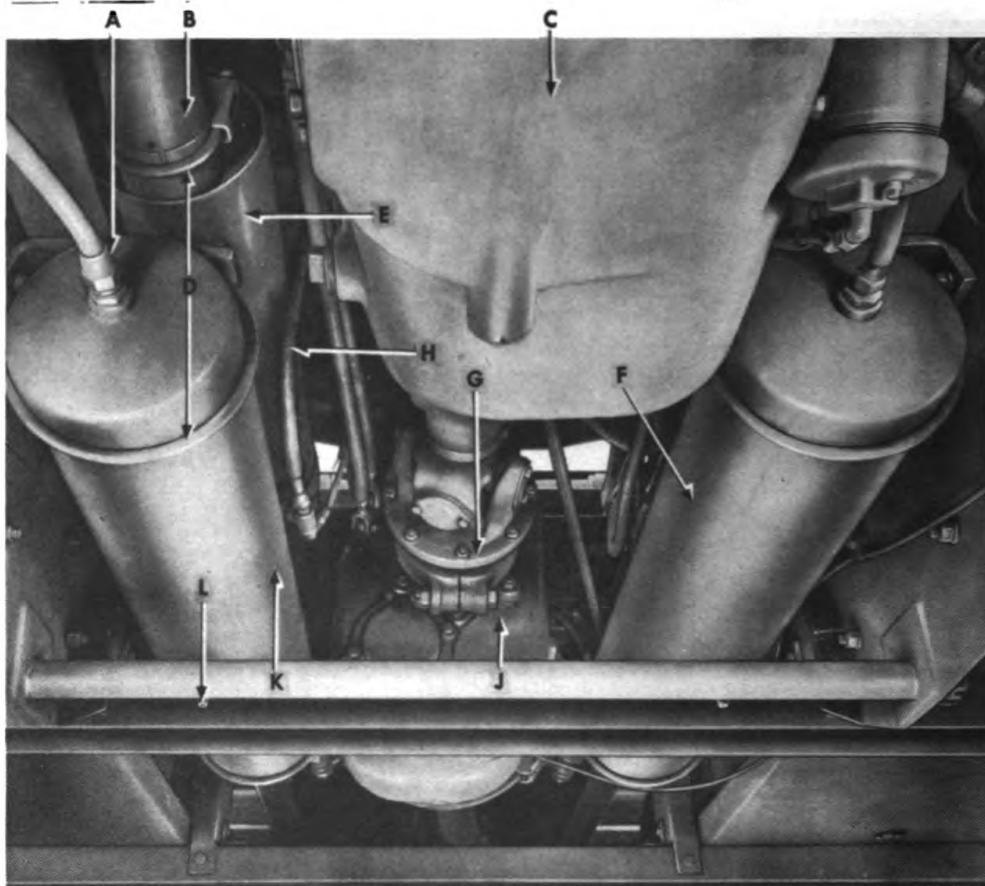

A—RESERVOIR TO COMPRESSOR
AIR LINE CONNECTOR
B—EXHAUST PIPE
C—TRANSMISSION
D—U-BOLT
E—MUFFLER
F—L. H. AIR RESERVOIR

G—FRONT PROPELLER SHAFT
ASSEMBLY
H—RESERVOIR TO AIR MANIFOLD
AIR LINE
J—AUXILIARY TRANSMISSION
K—R. H. AIR RESERVOIR
L—DRAIN COCK

RA PD 321322

Figure 123—Air Reservoirs—Installed

running until governor cuts off to build up air pressure for emergency use. Examine mounting brackets and bolts to see that they are secure.

c. Removal (fig. 123).

(1) **RIGHT-HAND RESERVOIR.** Open drain cock to release air from reservoir. Unscrew connectors which secure reservoir to air manifold line and reservoir to left front trailer coupling line, and pull air lines from reservoir. Unscrew connectors which secure reservoir to compressor and reservoir to left-hand reservoir air lines, and pull air lines from reservoir. Remove nuts and lock washers which secure U-bolts to reservoir brackets. Pull U-bolts from reservoir and slide reservoir from vehicle. Remove air line fittings from reservoir.

Truck Service Brake System

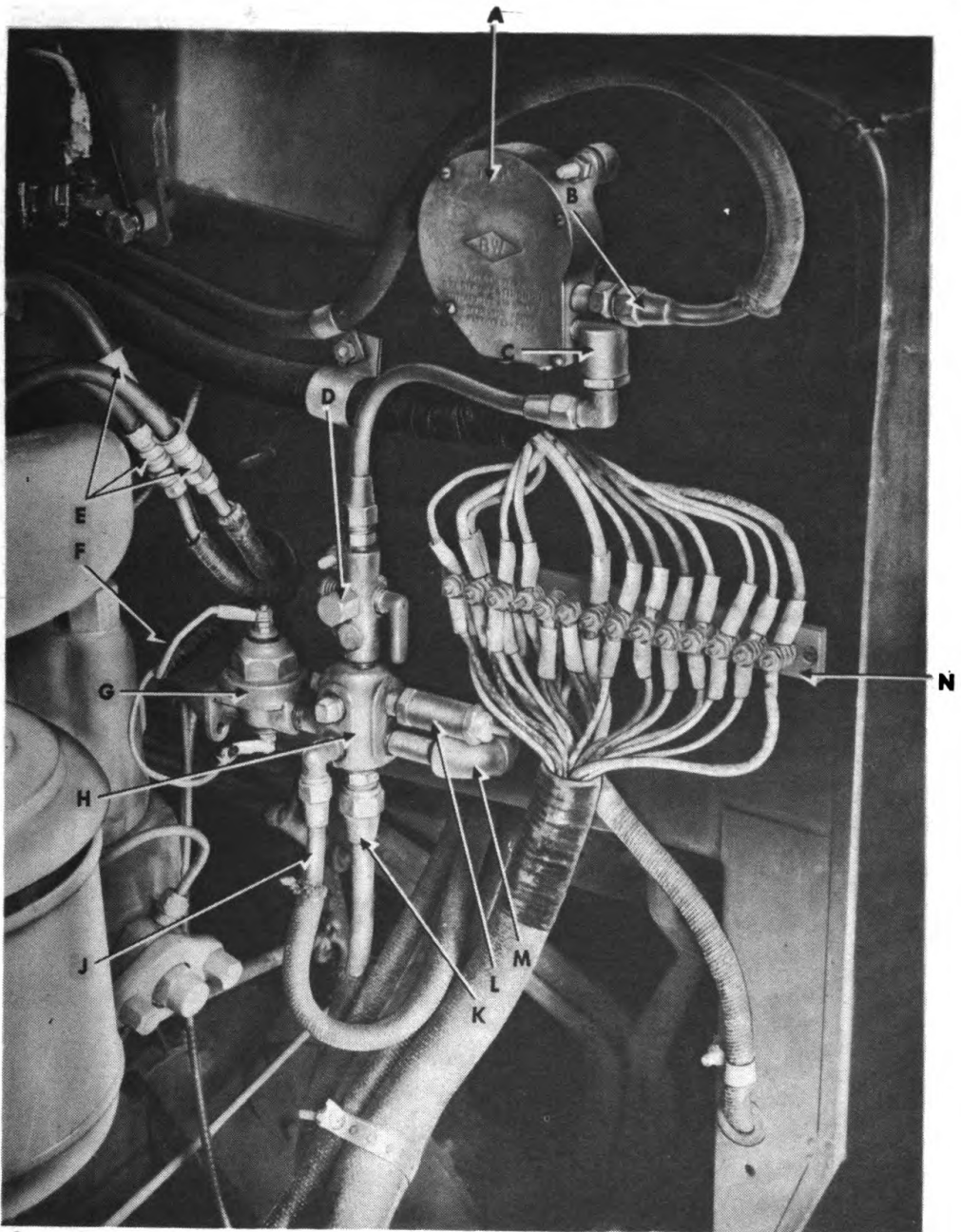

A—GOVERNOR
B—AIR LINE TO COMPRESSOR
C—AIR STRAINER
D—AIR SUPPLY VALVE
E—FUEL LINE CONNECTORS
F—WIRES TO BUZZER
G—LOW AIR PRESSURE INDICATOR

H—AIR MANIFOLD
J—AIR LINE TO HAND CONTROL VALVE
K—AIR LINE TO RESERVOIR
L—SAFETY VALVE
M—AIR LINE TO GAGE AND
WINDSHIELD WIPERS
N—JUNCTION BLOCK

RA PD 321310

Figure 124—Left Side of Cowl

(2) **LEFT-HAND RESERVOIR.** Open drain cock to release air from reservoir. Unscrew connectors which secure reservoir to hand control valve and reservoir to relay valve air lines, and pull air lines from reservoir. Unscrew connectors which secure reservoir to right-hand reservoir and reservoir to brake application valve air lines, and pull air lines from reservoir. Remove nuts and lock washers which secure U-bolts to reservoir brackets. Pull U-bolts from reservoir and slide reservoir from vehicle. Remove air line fittings from reservoir.

d. Installation.

(1) **LEFT-HAND RESERVOIR.** Slide reservoir into position on truck. Slide U-bolts onto reservoir, and attach to brackets by installing lock washers and nuts. Clean all fittings and remove all burrs. Position and tighten connectors which secure reservoir to right-hand reservoir and reservoir to brake application valve air lines. Position and tighten connectors which secure reservoir to relay valve air line and reservoir to two-way control valve air line. Close drain cock.

(2) **RIGHT-HAND RESERVOIR.** Install fittings on reservoir. Slide reservoir into position on truck. Slide U-bolts onto reservoir, and install nuts and lock washers. Position and tighten reservoir to compressor and reservoir to left-hand reservoir air line connectors. Position and tighten reservoir to air manifold and reservoir to left front trailer coupling air line connectors. Close drain cock.

164. GOVERNOR.

a. Description and Data.

(1) **DESCRIPTION** (fig. 124). The governor is located on the left side of the cowl in the engine compartment. It is connected to the diaphragm which operates the compressor unloader rocker arm. When the air pressure reaches 105 pounds, the valves of the compressor are depressed by the unloader rocker arm which interrupts the flow of air from the compressor to the reservoirs. When the pressure in the air system drops to 85 pounds, the valves are released; this re-establishes the flow of air to the reservoirs.

(2) **DATA.**

Manufacturer Westinghouse
 Model 215639

b. Test and Adjustment.

(1) At intervals specified in paragraph 22, turn lever on supply valve below governor to crosswise position (fig. 124). This closes valve. Remove governor to supply valve connector nut. Screw strainer cap from strainer cup. Pull strainer from cup. Wash strainer in dry-cleaning solvent. Assemble and connect governor and open supply valve. Start engine and observe pressures at which governor cuts in and out. (It should cut in at 85 pounds and cut out at 15

Truck Service Brake System

to 20 pounds higher pressure.) If not within these limits, remove case cover. Turn adjusting screw clockwise to raise cut-in pressure or counterclockwise to lower cut-in pressure. Install case cover. Allow governor to cut out and check upper valve for leakage by covering exhaust port with soapsuds. Allow governor to cut in and test exhaust port in same manner. Leakage of a 3-inch bubble in 3 seconds is permissible. In case of excessive leakage, replace governor (subpars. c and d).

(2) When required (par. 22) remove case cover. Lubricate valve stem with a few drops of penetrating oil. Install case cover.

c. **Removal** (fig. 124). Unscrew connector and pull governor to compressor air line from governor. Unscrew connector which secures governor to air manifold air line below manifold air strainer, and pull air line from air strainer. Remove nuts and lock washers which secure governor to studs on cowl, and pull governor from studs.

d. **Installation** (fig. 124). Position governor on cowl, and install nuts and lock washers which secure governor to mounting studs. Position and tighten the governor to air manifold air line connector. Position and tighten the governor to compressor air line connector.

165. SAFETY VALVE AND GAGE.

a. **Description and Data** (fig. 124).

(1) **DESCRIPTION.** The safety valve is screwed into one of the openings on the air manifold on the engine side of the cowl. It prevents the air system from being damaged by excessive pressure in case the pressure control system fails. If the pressure control system is operating correctly, the valve does not function. A coil spring holds the ball valve in its place, while an adjustable spring seat regulates tension. When pressure exceeds 150 pounds, ball lifts from its seat, thus allowing the excess air to escape.

(2) **DATA.**

Manufacturer	Westinghouse
Model	205105
Operating pressure	150 lb

b. **Test and Adjustment.**

(1) **TEST.** Start engine and watch to see that the air pressure gage registers exactly 105 pounds when the compressor cuts out.

(2) **REMOVAL.** Open reservoir pet cocks to drain air from air brake system. Unscrew safety valve from air manifold.

(3) **INSTALLATION.** Screw safety valve into air manifold until tight and firmly seated. Close air reservoir pet cocks, run engine till air governor cuts off, and test valve installation for leaks with soapsuds.

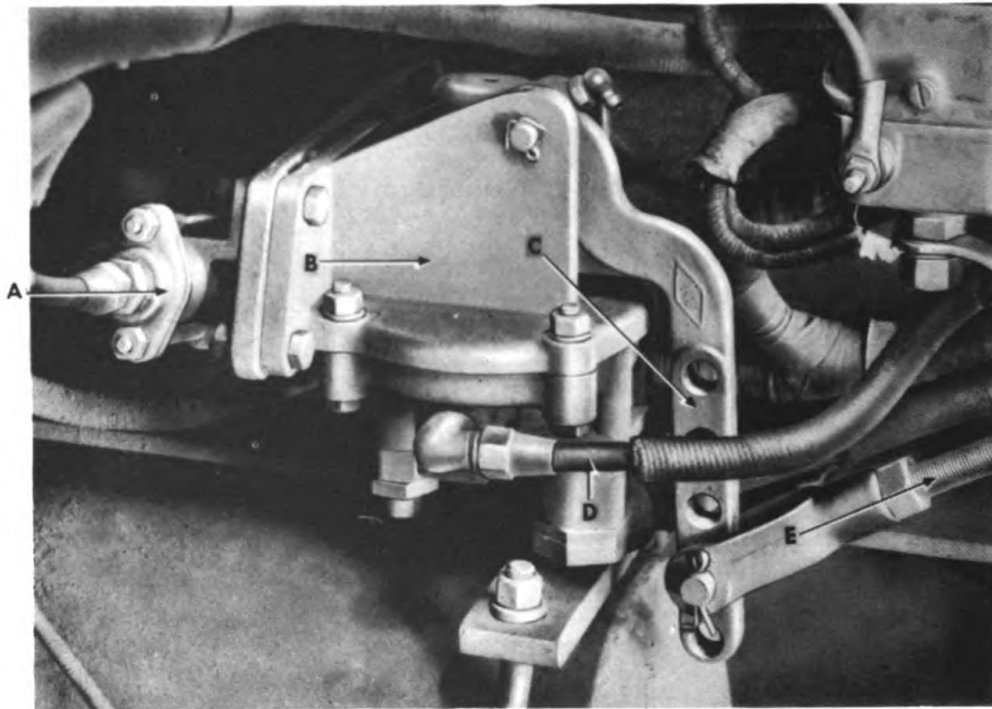

- A—DOUBLE CHECK VALVE
- B—BRAKE APPLICATION VALVE
- C—VALVE LEVER
- D—BRAKE APPLICATION VALVE TO QUICK RELEASE VALVE TUBE
- E—BRAKE PEDAL AIR VALVE YOKE ROD

RA PD 321424

Figure 125—Brake Application Valve

c. Gage Replacement. Open reservoir pet cocks to drain air from air brake system. Unscrew connector which secures manifold to gage air line, and pull air line from gage. Remove nuts and lock washers which secure clamp to gage. Pull clamp from gage, and slide gage from instrument panel. To install new gage, position gage in instrument panel. Slide clamp over mounting studs on gage, and install lock washer and nuts. Connect manifold to gage, air line to gage, and tighten connector. Close pet cocks in air reservoir, and run engine until air governor cuts off. Test gage connection for leaks.

166. BRAKE APPLICATION VALVE.

a. Description and Data.

(1) **DESCRIPTION** (fig. 125). The brake application valve is mounted on a bracket on the inside of the left side frame rail under the driver's seat. It is connected to the brake pedal by the brake pedal

Truck Service Brake System

air valve yoke rod. When the pedal is depressed, the valve admits air to the brake diaphragm chambers to operate the brakes. When the pedal is released, the valve discharges pressure from the brake diaphragm chambers to release the brakes. The amount of pressure built up is in direct proportion to the amount of pressure applied to the pedal.

(2) DATA.

Manufacturer Westinghouse
 Model 216445

b. Removal.

(1) REMOVE LINKAGE. Remove cotter pin and pin which secure brake pedal linkage of brake application valve lever, and pull linkage from lever.

(2) REMOVE AIR LINES. Open air reservoir pet cocks to release air from air brake system. Unscrew connector which secures reservoir to brake application valve air line to brake application valve, and pull air line from valve. Unscrew connector which secures brake application valve to quick release valve air line, and pull air line from brake application valve. Unscrew connector which secures brake application valve to double check valve air line, and pull air line from brake application valve.

(3) REMOVE VALVE. Remove nut, bolt, and lock washer which secure the brake application valve and double check valve to mounting bracket. Remove remaining nuts, lock washers, and bolts which secure brake application valve to bracket, and lift valve from bracket.

c Installation.

(1) INSTALL VALVE. Position brake application valve on bracket and install bolts, lock washers, and nuts which secure brake application valve only to bracket. Position double check valve and install bolt, lock washer, and nut which secure it and brake application valve to bracket.

(2) INSTALL AIR LINES. Position brake application valve to double check valve air line and screw connector on tight. Position brake application valve to quick release valve air line and screw connector on tight. Position brake application valve to reservoir air line and screw connector on tight.

(3) INSTALL LINKAGE. Connect brake pedal air valve yoke rod to one of the holes in the brake application valve lever. Use the same hole as on the original installation.

(4) TEST INSTALLATION. Start engine and build up 105 pounds pressure. Operate brake pedal. Check valve fittings for leaks. Proper brake operation and absence of leaks indicate proper installation. If greater brake action is desirable, connect yoke to one of upper holes

in lever. If less brake action is desirable, connect yoke to lower hole in lever. Lengthen or shorten yoke rod if necessary so that when brake pedal is in released position, the brake rod will fit between the brake pedal and valve lever.

167. HAND CONTROL VALVE.**a. Description and Data.**

(1) **DESCRIPTION** (fig. 7). The hand control valve, used to operate brakes on trailer, is located on the steering column directly below the steering wheel. This valve consists of both an intake and an exhaust valve combined in a single stem. Movement of the lever to the "ON" position forces a piston downward toward an exhaust seat. This acts to close the exhaust valve and open the intake valve. Movement of the lever to the "OFF" position reverses this action, and the exhaust valve opens while the intake valve closes.

(2) DATA.

Manufacturer Westinghouse
Model 215748

b. Removal (fig. 7). Open air reservoir pet cocks to release air from air brake system. Unscrew connector which secures hand control valve exhaust air line to hand control valve, and pull air line from valve. Unscrew connector which secures hand control valve to manifold air line to hand control valve, and pull air line from valve. Unscrew connector which secures hand control valve to double check valve air line, and pull line from valve. Remove nuts, lock washers, and bolts which secure hand control valve clamp to steering column, and lift off clamp and valve.

c. Installation (fig. 7). Position hand control valve and clamp on steering column and install bolts, lock washers, and nuts. Position hand control valve to double check valve air line and screw connector on tight. Position hand control valve to air manifold air line and screw connector on tight. Position hand control valve exhaust air line to hand control valve and screw connector on tight. Close air reservoir pet cocks and run engine until governor cuts off. Test air line connections for leaks.

168. CHECK VALVES.**a. Description and Data.****(1) DOUBLE CHECK VALVES.**

(a) **Description.** Two double check valves are provided, one on the left frame side rail opposite forward rear axle (fig. 126), and the other attached to brake application valve (fig. 125). These valves consist of a free moving piston in a cylinder. The cylinder opens into

Truck Service Brake System

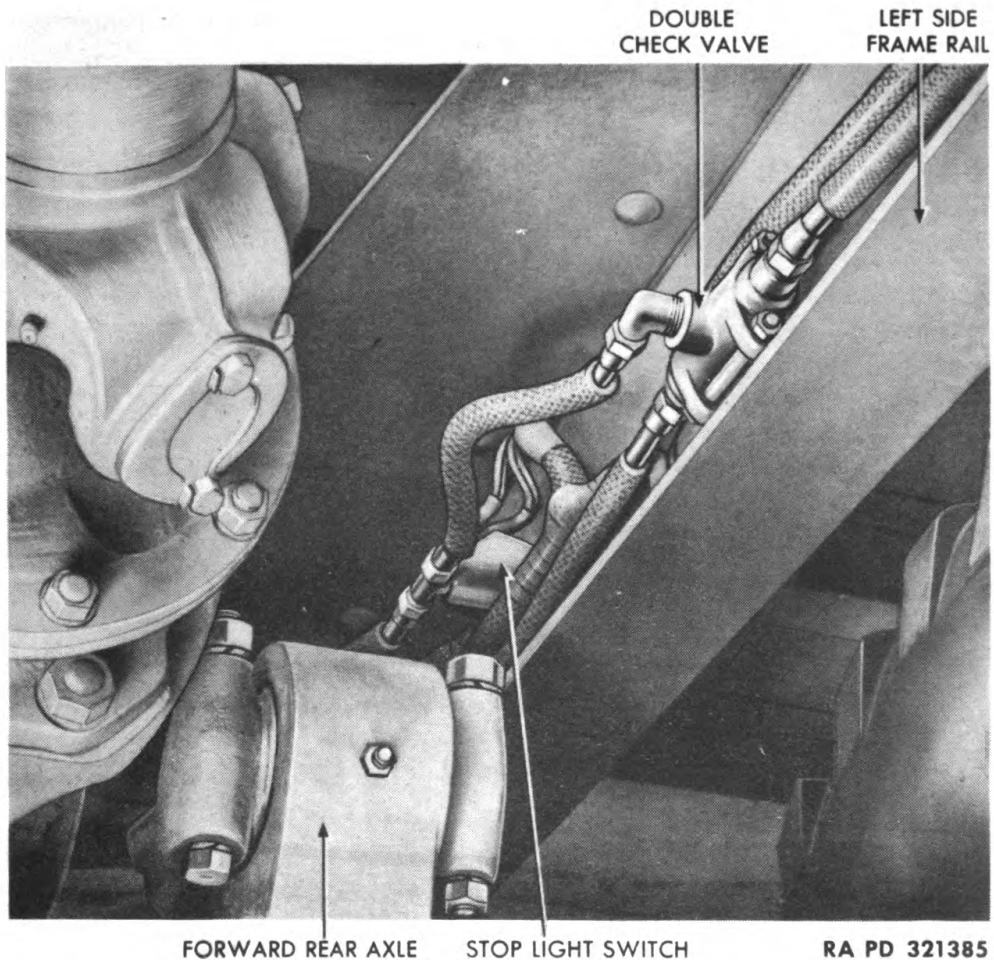

Figure 126—Double Check Valve and Stop Light Switch—Installed

the tube fittings at each end and at the center. When the piston is at either end of the cylinder, free air enters at the opposite end and passes out through fitting at center of cylinder. Pressure from the operation of the brake application valve forces back the piston of the front valve. This permits air to pass to the relay valve to apply rear brakes. Air also passes to a second double check valve and drives its piston backward. This permits air to pass to rear trailer connections to operate trailer brakes. Pressure from the operation of the hand control valve forces back the piston in the rear valve. This cuts off the line relay valve and loads the service line to the trailer. Thus the trailer brakes are applied and the truck brakes remain inoperative. When the truck is being towed, the double check valve operates as follows: Air pressure from the towing vehicle is supplied to the right-hand front connection of the service line. Pressure forces ahead the piston of the front double check valve. This admits air to the relay

valve but not to the front wheel brakes. Air is also admitted through the relay valve to the rear double check valve. This arrangement permits braking control of two or more vehicles while they are being towed.

(b) Data.

Manufacturer Westinghouse
 Model 217698

(2) SINGLE CHECK VALVES.

(a) Description. A single check valve is installed in the air line between the left-hand air reservoir and the clutch hand control valve mounted on the winch. Another single check valve is installed in the air line at the left front trailer coupling (fig. 130). These are both one-way bore check valves. The front valve prevents loss of air from the system should the coupling break while the truck is being towed. The rear valve prevents loss of air from the clutch cylinder in case the air system fails during winch operation.

(b) Data.

Make Westinghouse
 Model—single check valve (front) 220306
 Model—single check valve (rear) 220098

b. Double Check Valves.

(1) REMOVAL.

(a) Double Check Valve (Near Brake Application Valve) (fig. 125). Unscrew double check valve to relay valve air line connector, and pull air line from valve. Unscrew double check valve to right front coupling air line connector, and pull air line from valve. Unscrew double check valve to brake application valve air line connector, and pull air line from valve. Remove nut, lock washer, and bolt which secure double check valve to brake application valve bracket, and lift double check valve from bracket.

(b) Double Check Valve (Near Stop Light Switch) (fig. 126). Unscrew double check valve to stop light switch air line connector, and pull line from valve. Unscrew double check valve to hand control valve air line connector, and pull air line from valve. Unscrew double check valve to relay valve air line connector, and pull air line from double check valve. Remove nut, lock washer, and bolt which secure double check valve to chassis side rail and lift off valve.

(2) INSTALLATION.

(a) Double Check Valve (Near Brake Application Valve) (fig. 125). Position double check valve on brake application valve bracket and install bolt, lock washer, and nut. Position double check valve to brake application valve air line on double check valve and screw connector on tight. Position double check valve to right front

Truck Service Brake System

coupling air line on valve and screw connector on tight. Position double check valve to relay valve air line on double check valve and screw connector on tight. Run motor till governor cuts off. Test line connections for leaks.

(b) *Double Check Valve (Near Stop Light Switch)* (fig. 126). Position double check valve on chassis side rail and install bolt, lock washer, and nut. Position double check valve to relay valve air line on double check valve and screw connector on tight. Position double check valve to hand control valve air line on double check valve and screw connector on tight. Position double check valve to stop light switch air line on valve and screw connector on tight. Run motor till air governor cuts off. Test air line connections for leaks.

c. Single Check Valves.

(1) REMOVAL.

(a) *Single Check Valve in Reservoir to Clutch Control Valve Air Line.* Remove nut which secures reservoir to clutch control valve air line clip to winch frame. Unscrew the two connectors which secure the valve in the air line and lift out valve.

(b) *Single Check Valve at Left Front Trailer Coupling* (fig. 130). Unscrew connector from single check valve adapter bushing. Unscrew valve from nipple. Unscrew adapter bushing from valve.

(2) INSTALLATION.

(a) *Single Check Valve in Reservoir to Clutch Control Valve Air Line.* Position valve in line with longer nut down; screw connectors onto valve until tight. Position air line clip on bolt in winch frame, and install lock washer and nut. Run engine until air governor cuts off. Test air line fittings for leaks.

(b) *Single Check Valve at Left Front Trailer Coupling* (fig. 130). Screw single check valve short nut onto nipple in valve tee. Screw adapter bushing into single check valve. Position air line on adapter bushing and screw on connector. Run engine until air governor cuts off. Test valve connections for leaks.

169. AIR SUPPLY VALVE.

a. Description and Data.

(1) **DESCRIPTION** (fig. 124). The air supply valve is installed at the top of the air manifold on the engine side of the cowl. When the handle of the air supply valve is turned to horizontal position, it cuts off the air governor from the compressor. The compressor operates continuously under these conditions, and pressures as high as the setting of the safety valve (150 lb) may be obtained at the nipple on the front of the valve. Under normal conditions the handle of the valve must be turned so as to be parallel with the valve body.

(2) DATA.

Manufacturer Westinghouse
 Model 220282

b. Removal (fig. 124). Open air reservoir pet cocks to release air from air brake system. Remove nut and lock washer which secure air supply valve to mounting bolt on cowl. Unscrew nut which secures bolt to cowl, and push bolt through cowl. Cut hole in cowl insulation to permit removal of bolt. Remove bolt, spacer, and lock washer. Unscrew valve to governor air line connector, and pull air line from valve. Unscrew valve from nipple on air manifold. Remove adapter bushing from valve.

c. Installation (fig. 124). Screw air supply valve onto nipple in air manifold with arrow pointing up. Screw adapter bushing into valve. Position air supply valve to governor air line on adapter bushing and screw on connector. Insert mounting bolt through cowl, install lock washer, and thread nut onto bolt. Screw bolt through nut and mounting bracket on valve. Tighten nut. Install lock washer and nut which secure air supply valve to mounting bolt. Close air reservoir pet cocks, and run engine until governor cuts off. Test air fittings on valve for leaks.

170. RELAY VALVE.**a. Description and Data.**

(1) DESCRIPTION (fig. 107). The relay valve is attached to the front of the tandem axle crossmember. It can be reached from beneath the truck between the two axles. Used as a relay station, this valve hastens application and release of the rear wheel and trailer brakes. It is operated when air from the brake application valve enters an upper chamber and actuates a diaphragm. Since a large volume of air is required for brake operation, the valve action permits its entry from the air system to the diaphragm chambers, resulting in instant brake action. Immediate brake release is obtained because exhaust air is vented directly to the atmosphere instead of the longer route through brake application valve.

(2) DATA.

Manufacturer Westinghouse
 Model 217383

b Removal (fig. 107). Open air reservoir drain cocks to release air from air brake system. Unscrew front rear axle tee to relay valve air line connector, and pull air line from relay valve. Unscrew left-hand air reservoir to relay valve air line connector, and pull air line from relay valve. Unscrew right rear trailer coupling to relay valve air line connector, and pull air line from relay valve. Unscrew (rear)

Truck Service Brake System

double check valve to relay valve air line connector, and pull air line from relay valve. Unscrew (front) double check valve air line connector, and pull air line from relay valve. Unscrew rear axle tee to relay valve air line connector, and pull air line from relay valve. Remove nuts, lock washers, and bolts which secure relay valve to frame crossmember, and lift relay valve from crossmember.

c. Installation (fig. 107). Position relay valve on frame crossmember and install bolts, lock washers, and nuts. Position air line to (front) double check valve on relay valve and screw on connector. Position air line to (rear) double check valve and screw on connector. Position front rear axle tee to relay valve air line and screw on connector. Position relay valve to rear axle tee air line and screw on connector. Position left-hand air reservoir to relay valve air line and screw on connector. Position right rear trailer coupling to relay valve air line and screw on connector. Close air reservoir pet cocks and run engine until governor cuts off. Test relay valve line connections for leaks.

171. STOP LIGHT AIR SWITCH.

a. Description and Data.

(1) **DESCRIPTION** (fig. 126). The stop light air switch is mounted on the left side frame rail opposite the forward rear axle. It controls the operation of the stop lights on the truck.

(2) **DATA.**

Manufacturer	Westinghouse
Model	215537

b. Cleaning and Testing. Inspect condition of terminals and clean off dirt and grease. Start engine and run until governor cuts off. Operate brake pedal, and have assistant observe if stop lights go on and off when brake pedal is operated. Replace switch when operation is not satisfactory.

c. Removal (fig. 126). Open air reservoir drain cocks to release air from air brake system. Unscrew connector which secures air line to double check valve to stop light switch, and pull air line from switch. Unscrew connector which secures air line to left rear trailer coupling to stop light switch, and pull air line from switch. Remove nut, lock washer, and bolt which secure stop light switch to frame side rail, and lift switch from side rail.

d. Installation (fig. 126). Position stop light switch on frame side rail and install bolt, lock washer, and nut. Position air line to double check valve on stop light switch and screw on connector. Position air line to left rear trailer coupling on stop light switch and

screw on connector. Run engine until air governor cuts off, and test air connections on switch for leaks.

172. QUICK RELEASE VALVE.

a. Description and Data.

(1) **DESCRIPTION** (fig. 127). The quick release valve is attached to the inside of the radiator support crossmember. The valve is attached in the line from the brake application valve to the front wheel brake diaphragm chambers. Function of the valve is to speed up the front wheel brake release by discharging exhaust air to the atmosphere. Thus, time is saved which would otherwise be lost in allowing the exhaust air to travel back to the brake application valve.

(2) DATA.

Manufacturer Westinghouse
 Model 205000

b. Removal (fig. 127). Open air reservoir drain cocks to release air from air brake system. Unscrew quick release valve to brake application valve air line connector and quick release valve to front brake chambers air line connectors. Pull air lines from valve. Remove nuts and bolts which secure quick release valve to front frame crossmember and lift valve from frame. Remove line fittings from valve.

c. Installation (fig. 127). Install air line fittings in quick release valve. Position valve on front frame crossmember, and install nuts and bolts. Position quick release valve to brake application valve air line and screw on connector. Position quick release valve to left front brake chamber air line and screw on connector. Position quick release valve to right front brake chamber and screw on connector. Run engine until air governor cuts off, and test valve connections for leaks.

173. LOW PRESSURE INDICATOR AND BUZZER.

a. Description and Data.

(1) **DESCRIPTION** (fig. 124). The low pressure indicator is mounted on a fitting attached to the air manifold on the engine compartment side of the cowl. It is a safety device which operates as an air-controlled electric switch to sound a buzzer when the air pressure drops below 70 pounds. It automatically opens the circuit to the buzzer when the air pressure rises above this point. The buzzer is installed on bracket under the left side of instrument panel.

(2) DATA.

Manufacturer Westinghouse
 Model 215186

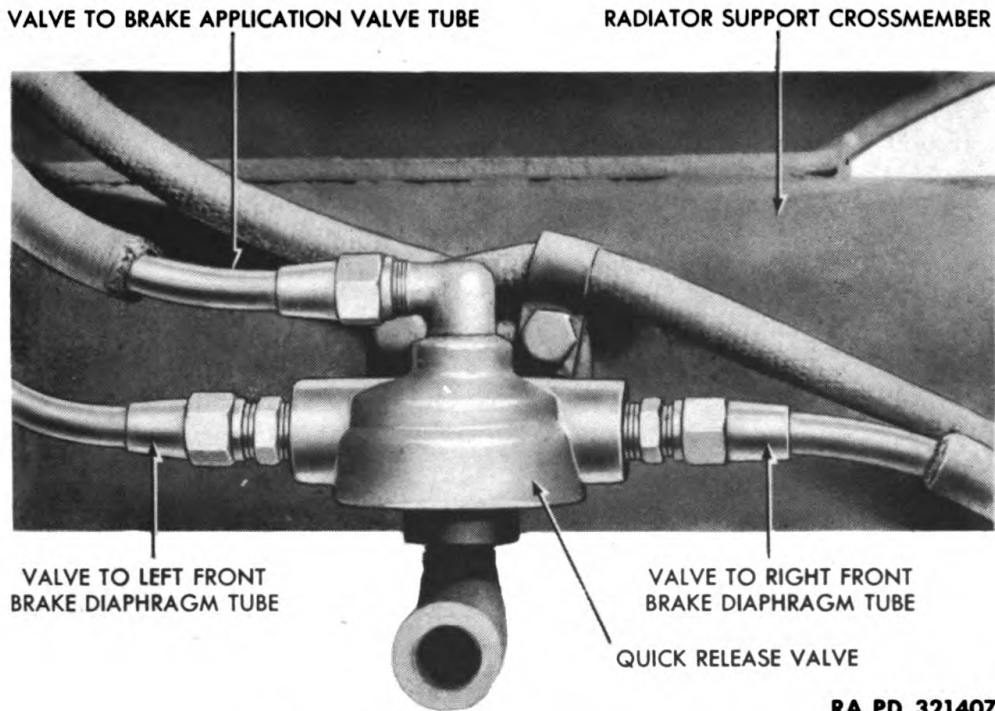
Truck Service Brake System

RA PD 321407

Figure 127—Quick Release Valve**b. Replacement of Low Pressure Indicator (fig. 124).**

(1) **REMOVAL.** Open air reservoir pet cocks to release air from air brake system. Unscrew connectors which secure manifold to air pressure gage and manifold to windshield wiper tee air lines at manifold tee inside dash, and pull air lines from tee. Unscrew tee from manifold nipple. Remove nuts and lock washers which secure buzzer wires to low air pressure indicator, and pull wires from terminals. Remove nuts, lock washers, bolts, and air supply valve spacer which secure manifold and air supply valve to dash. Pull manifold free of dash, and unscrew low air pressure indicator.

(2) **INSTALLATION.** Screw new low air pressure indicator onto manifold nipple. Install bolts, lock washers, nuts, and air supply valve spacer to secure manifold and air supply valve to dash. Position buzzer wires on indicator terminals, and install nuts and lock washers. Install tee on manifold nipple that extends through dash. Position manifold to air pressure gage air line on tee and screw on connector. Position manifold to windshield wiper air line on tee and screw on connector. Run motor until governor cuts off, and test manifold to low air pressure indicator connections for leaks.

c. Replacement of Buzzer (fig. 83).

(1) **REMOVAL.** Remove screw from cover cap and lift off cap.

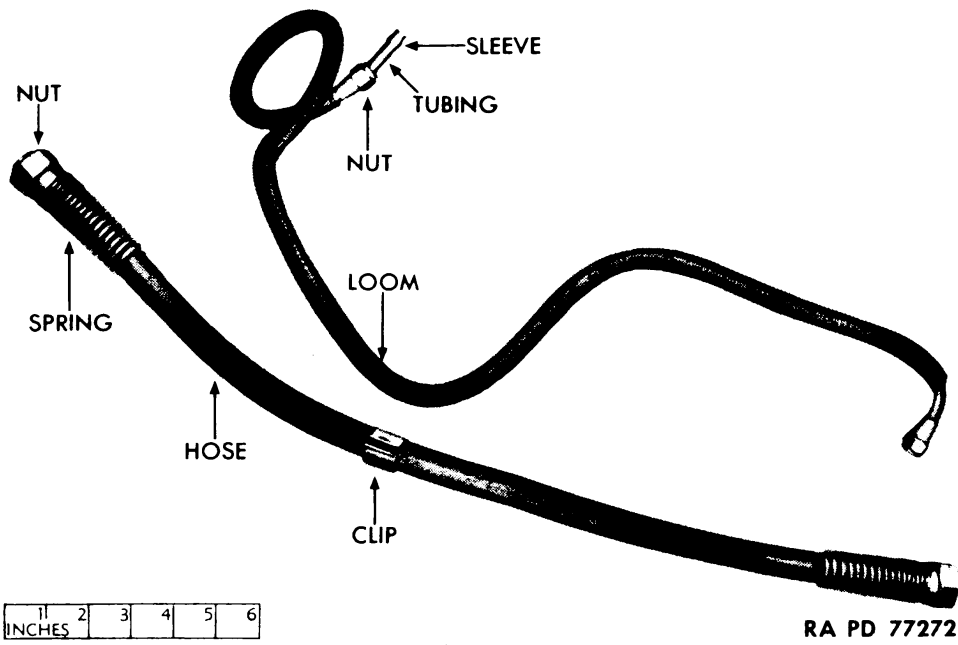

Figure 128—Air System Tubing and Hose

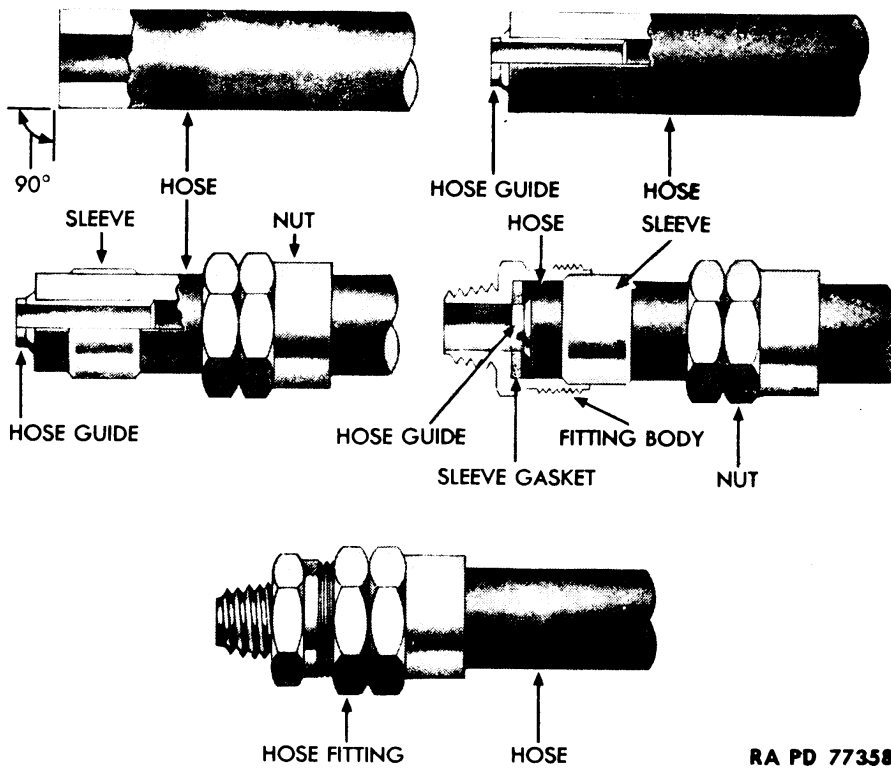

Figure 129—Installation of Fittings on Hose

Truck Service Brake System

Disconnect low pressure indicator to buzzer wire and ground wire. Remove two buzzer attaching screws and lift out buzzer.

(2) **INSTALLATION.** Place buzzer on bracket and install two attaching screws. Connect ground wire and low pressure indicator to buzzer wire. Position cover cap and install cover cap attaching screw.

174. AIR LINES, HOSE, AND AIR MANIFOLD.

a. Description and Data.

(1) **DESCRIPTION** (figs. 128 and 129).

(a) *Tubing and Hose.* Copper tubing is used throughout for the air brake system. The tubing is heat-treated to withstand vibration. Connections are of the sleeve (ferrule)-and-nut type. Points requiring flexible couplings are provided with heavy rubber hose furnished with detachable fittings.

(b) *Air Manifold* (fig. 124). The air manifold is attached to the engine side of the cowl. It consists of a bottom metal block equipped with fittings to which air tubes are connected. Its function is to connect air tubes together so that air pressure in all tubes is equalized.

(2) **DATA.**

Manifold:

Manufacturer	Westinghouse
Model	212322
Tubing	Heat-treated copper
Hose	Heavy rubber
Fittings	Brass nut and sleeve

b. Removal of Air Lines and Hose. Unscrew nut from fitting at each end of tubing or hose. Remove all clips holding tubing or hose to vehicle. Pull tubing or hose from vehicle.

c. Installation of Air Lines and Hose.

(1) **PREPARE NEW TUBING.** If old tubing is not satisfactory, cut new tubing same length as that being replaced. Cut ends square and smooth with file. Slide nut and sleeve (ferrule) on each end. Bend tubing to shape of original piece. Avoid sharp bends. Bend tubing $\frac{3}{8}$ inch in diameter on a 3-inch radius; tubing $\frac{1}{2}$ inch in diameter on a 4-inch radius.

(2) **PREPARE NEW HOSE.** Cut new hose same length as hose to be replaced. Screw hose guide into end of hose. Slide spring (if used) and nut on end of hose. Install sleeve on end of hose. Position sleeve gasket in fitting body and screw nut to body. Repeat procedure to install other end of hose.

(3) **INSTALL HOSE OR TUBING.** Position hose or tubing on vehicle.

Connect nuts to fittings at each end. Install all clips which secure tubing to vehicle.

d. Removal of Air Manifold (fig. 124). Open air reservoir pet cocks to release air from air brake system. Unscrew connectors which secure manifold to air pressure gage and manifold to windshield wiper tee air lines, at manifold tee inside cowl. Pull air lines from tee. Unscrew tee from manifold nipple. Unscrew air supply valve to governor air line connector, and pull air line from valve. Unscrew manifold to hand control valve air line connector and manifold to right-hand reservoir air lines connector, and pull air lines from manifold. Remove nuts and lock washers which secure buzzer wires to air pressure indicator and lift wires from indicator. Remove nuts and lock washers which secure manifold and air supply valve mounting bolts. Lift off manifold and air supply valve spacer. Unscrew air supply valve, safety valve, low air pressure buzzer, and fittings from manifold.

e. Installation of Air Manifold (fig. 124). Install fittings on manifold. Install air supply valve on top of manifold with arrow pointing up. Install low air pressure indicator on nipple at left of manifold and safety valve in upper right-hand port. Slide air supply valve spacer on air supply valve mounting bolt. Position manifold and air supply valve on mounting bolts, and install lock washers and nuts. Position manifold to right-hand reservoir air line on manifold adapter bushing and screw on connector. Position manifold to hand control valve air line on manifold fitting and screw on connector. Position manifold to governor air line on air supply valve adapter bushing and screw on connector. Slide buzzer wires on low air pressure indicator terminals, and install lock washers and nuts. Screw tee for air pressure gage and windshield wiper air lines onto nipple that extends into cab. Position air line to air pressure gage on tee connector bushing and screw on connector. Position air line to windshield wipers on tee connector bushing and screw on connector. Run engine until governor cuts off, and test air connections at manifold and lower governor for leaks.

175. TRAILER AIR COUPLINGS.

a. Description and Data.

(1) **DESCRIPTION** (figs. 130 and 117). Four bracket-mounted trailer air couplings, two at the front and two at the rear of the truck, provide a means of connecting the air brake system of another vehicle to that of the truck. The design of the coupling is such that when two of them are coupled together, pressure is put on two rubber gaskets, making an airtight seal and at the same time providing a

Truck Service Brake System

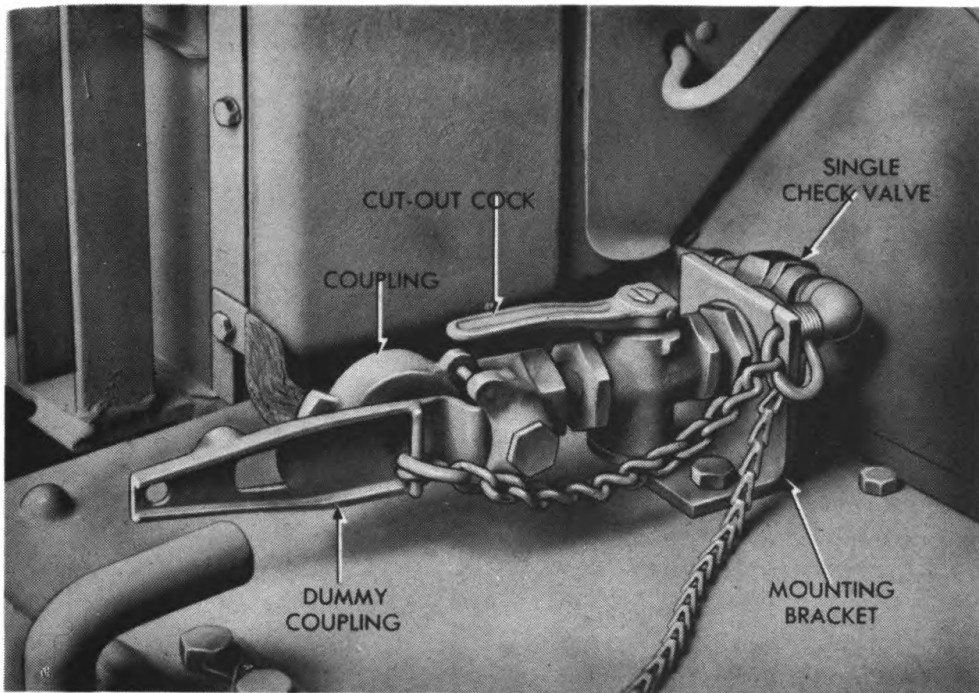

RA PD 321296

Figure 130—Left-hand Front Coupling—Installed

joint which can be easily connected or disconnected by hand. The couplings are normally covered by a dummy coupling to prevent dirt from getting into the lines. The couplings are identified with tags marked "SERVICE" or "EMERGENCY." The right front coupling is vented to prevent air from being trapped in the line.

(2) DATA.

Manufacturer Westinghouse
Model 220303

b. **Removal** (figs. 130 and 131). Remove dummy coupling. Unscrew coupling from cut-out cock nipple or from adapter clamp bushing (at right front coupling).

c. **Installation.** Screw coupling into cut-out cock nipple or into adapter clamp bushing (on right front coupling).

176. BRAKE CHAMBERS AND SLACK ADJUSTERS.

a. **Description and Data.**

(1) **DESCRIPTION** (figs. 132, 133, and 134).

(a) **Brake Chambers.** One brake chamber is attached to the vehicle adjacent to each of the six wheels. The brake chambers serve

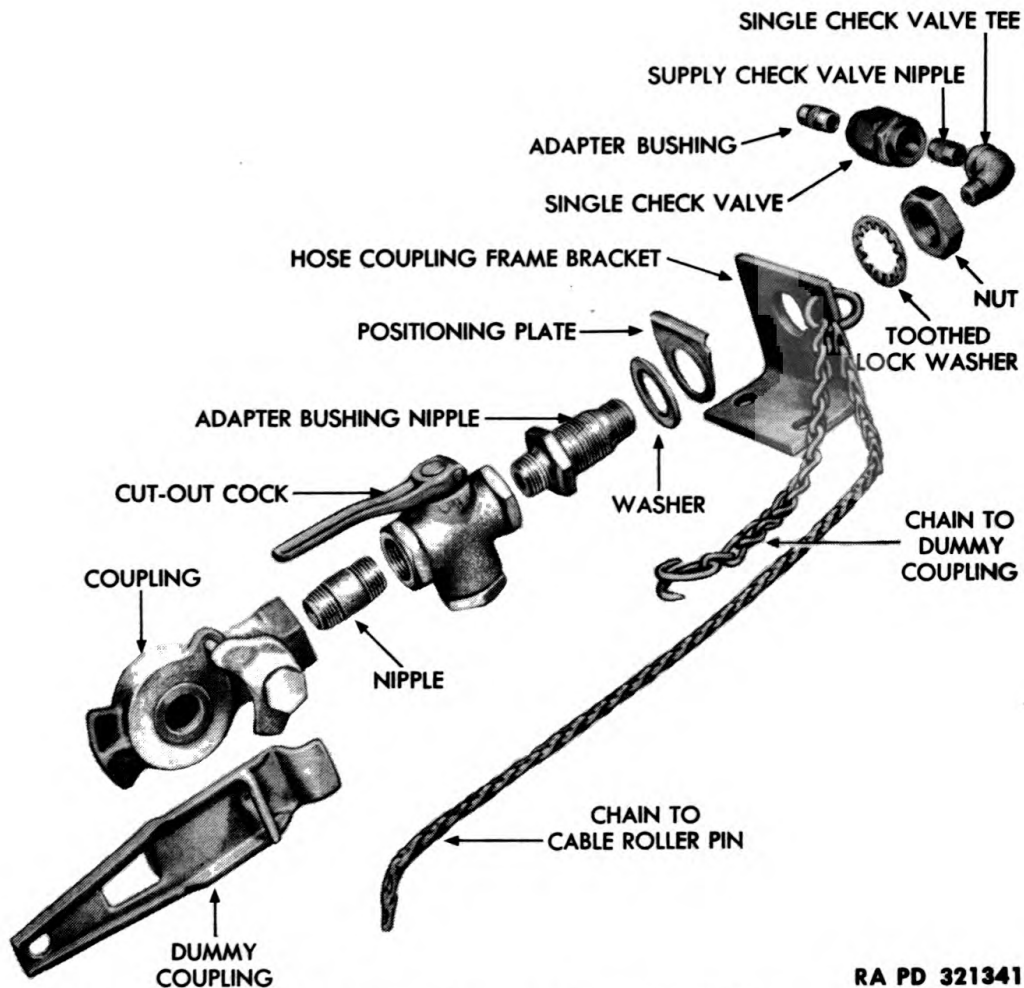

RA PD 321341

Figure 131—Left-hand Front Coupling—Disassembled

to convert air pressure to mechanical motion in applying brakes. Depressing the brake pedal admits air pressure to each diaphragm chamber. Pressure causes diaphragm motion which is transmitted to brake cam by means of a push rod and slack adjuster. When brake pedal is released, pressure is exhausted from the chamber. The brakes are then released by a spring which returns slack adjuster, push rod, and diaphragm to their original positions.

(b) *Slack Adjusters.* One slack adjuster fits on the spline on the shaft of each brake cam. They are the special levers which connect the brake chamber push rods to the brake camshafts. Brake adjustment, to compensate for lining wear, is made with the slack adjuster at each wheel. An adjustable worm meshes with a worm gear within each adjuster. Turning the worm shaft pivots the entire slack adjuster about the shaft of the brake cam. In this way, brake adjustment is made.

Truck Service Brake System

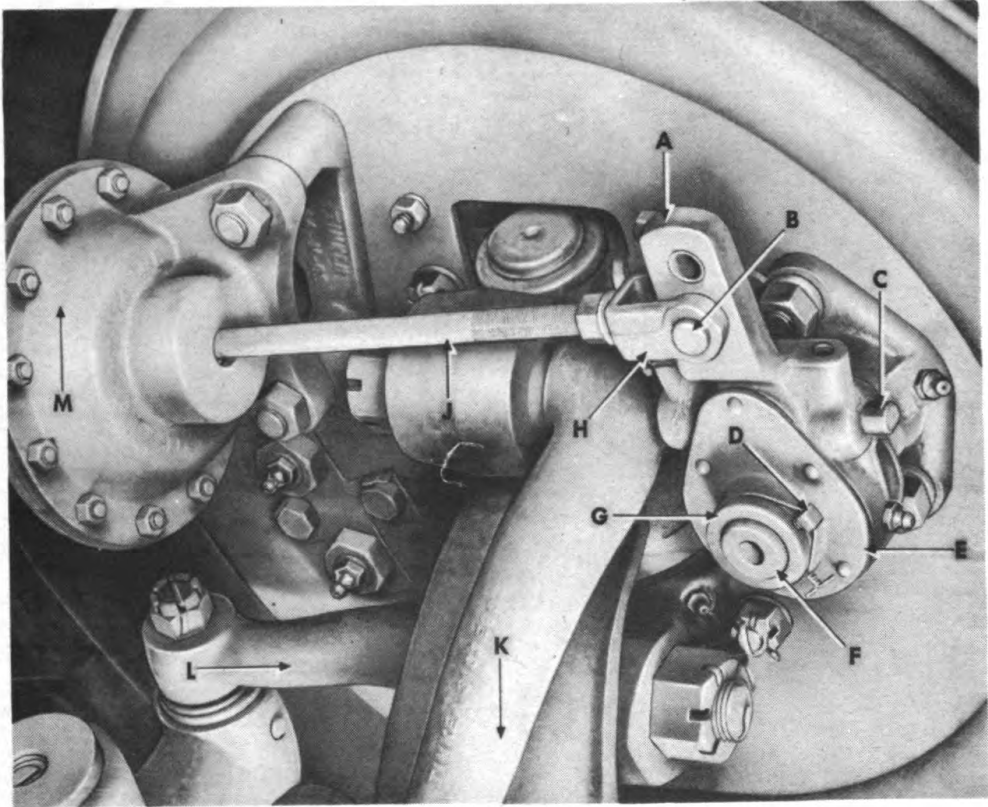

- | | |
|----------------------|---------------------------|
| A—SLACK ADJUSTER ARM | G—COLLAR |
| B—DIAPHRAGM YOKE PIN | H—YOKE |
| C—WORM SHAFT | J—BRAKE CHAMBER PUSH ROD |
| D—COLLAR SCREW | K—STEERING ARM |
| E—SLACK ADJUSTER | L—STEERING CROSS TUBE ARM |
| F—BRAKE CAMSHAFT | M—BRAKE CHAMBER |

RA PD 321348

Figure 132—Front Brake Chamber and Slack Adjuster—Installed

(2) DATA.

Manufacture	Westinghouse
Front brake chamber—right-hand	220410
—left-hand	220409
Diaphragm	200014
Rear brake chamber—forward rear axle, right-hand	216824
—forward rear axle, left-hand	216825
—rearward rear axle, right-hand	216825
—rearward rear axle, left-hand	216824
Diaphragm	200001

b. Adjustment of Slack Adjusters.

(1) GENERAL. In normal brake operations, the lining wear in-

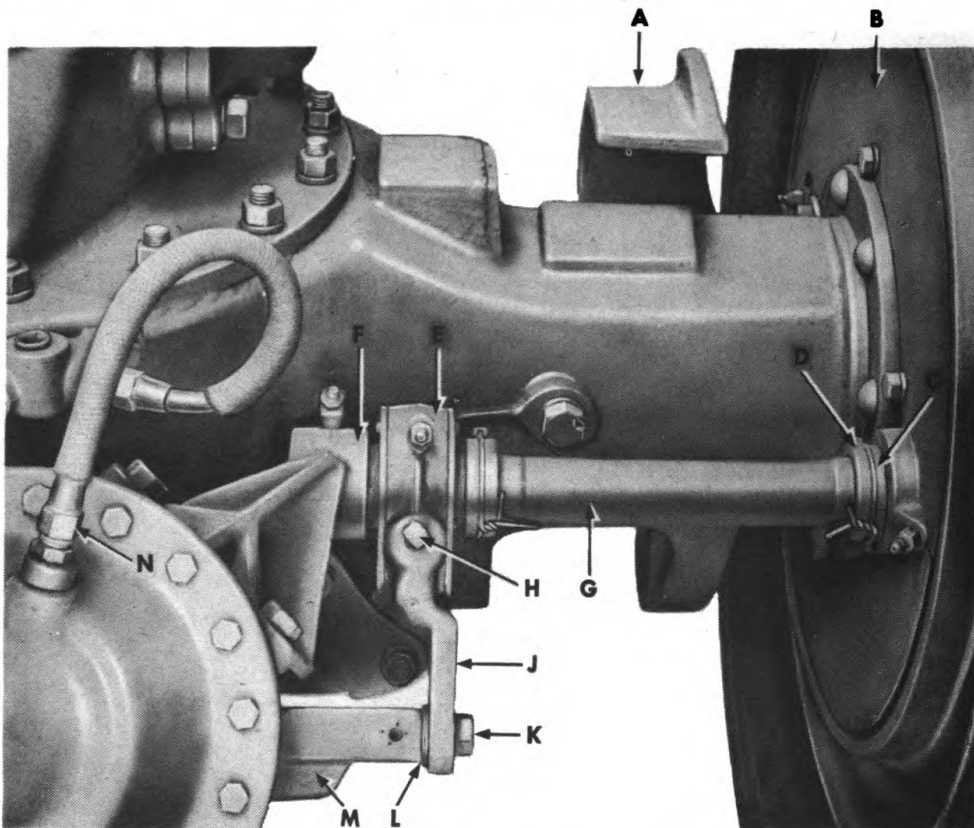

- | | |
|---------------------------|----------------------|
| A—SPRING END PLATFORM | H—WORM SHAFT |
| B—DUST SHIELD | J—SLACK ADJUSTER ARM |
| C—COLLAR | K—BOLT |
| D—COLLAR SCREW | L—WASHERS |
| E—SLACK ADJUSTER ASSEMBLY | M—EQUALIZER BEAM |
| F—SHAFT SUPPORT BRACKET | N—AIR LINE CONNECTOR |
| G—CAMSHAFT | |

RA PD 321409

Figure 133—Rear Brake Chamber and Slack Adjuster—Installed

creases the cam lever travel and the stroke of the push rod. When this travel exceeds maximum limits, brake efficiency is reduced. For this reason, slack adjusters are provided which are adjustable to take up slack caused by normal wear.

(2) PROCEDURE.

(a) *Build up Air Pressure.* Start the engine and operate it long enough to build up a pressure of at least 80 pounds per square inch as indicated on the air pressure gage. Maintain pressure above 60 pounds per square inch during adjustment procedure.

(b) *Jack up Wheels.* Place a jack under axle housing on the side on whichever brake is to be adjusted, and raise the axle so that wheels just clear the ground.

Truck Service Brake System

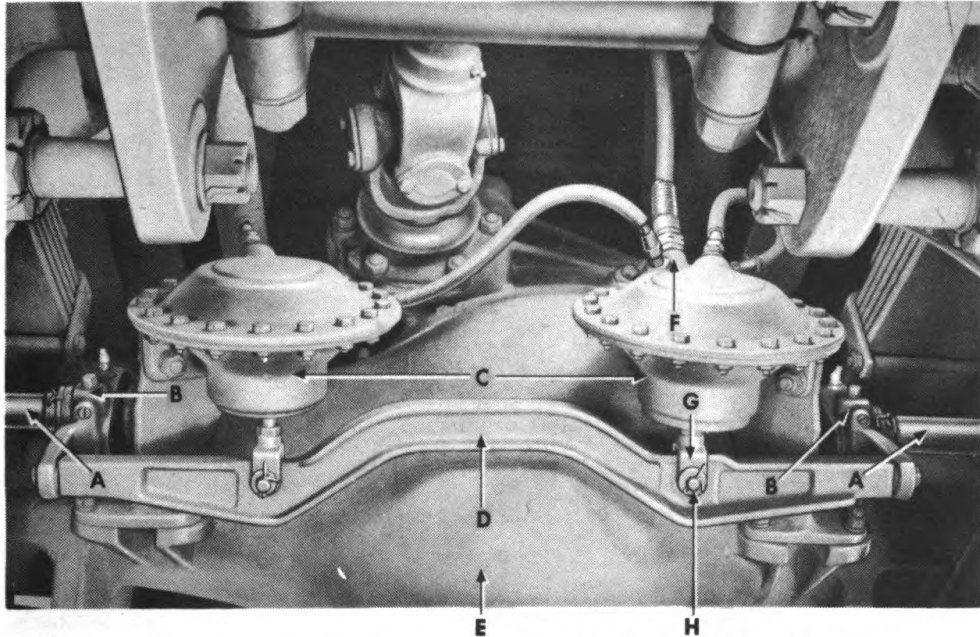

- | | |
|----------------------|---------------------|
| A—CAMSHAFT | E—FORWARD REAR AXLE |
| B—SLACK ADJUSTER | F—REAR AXLE TEE |
| C—BRAKE AIR CHAMBERS | G—YOKE |
| D—EQUALIZER | H—PIN |

RA PD 321436

Figure 134—Forward Rear Axle Brake Chambers

(c) *Adjust Slack Adjuster.* Tighten slack adjuster adjusting worm until the brake shoes are tight against the brake drum. Then back off the worm until wheel is free to turn. Check the adjustment with a feeler gage inserted through the inspection hole in the brake drum to see that there is 0.010 to 0.015-inch clearance at the toe end of the shoe.

(d) *Check Brake Chamber Push Rod Travel.* When the adjustment is made, measure the push rod travel, holding a scale alongside the slack adjuster arm. Then apply the brakes. If adjustment is correct, push rod travel should be approximately $\frac{5}{8}$ -inch for the front brake chambers and must not exceed $1\frac{3}{8}$ inch. The rear brake chambers should have a push rod travel of $\frac{3}{4}$ -inch and should not exceed $1\frac{3}{4}$ inch. If not, recheck brakes.

c. Brake Chambers.

(1) **REMOVAL** (figs. 132, 133, and 134).

(a) *Front Brake Chambers.* Open air reservoir drain cocks and release air pressure. Disconnect air line attached to brake chamber. Remove cotter pin holding yoke pin in brake chamber push rod yoke

and remove yoke pin. Remove nuts and lock washers which secure brake chamber to bracket and lift off brake chamber.

(b) *Rear Brake Chambers.* Open the air reservoir drain cocks and release air pressure. Disconnect air line. Remove cotter pin holding yoke pin in brake chamber push rod yoke and remove yoke pin. Remove four nuts, lock washers, and bolts attaching brake chamber to support bracket. Remove brake chamber.

(2) **INSTALLATION** (figs. 132, 133, and 134).

(a) *Front Brake Chambers.* Slide brake chamber over mounting studs, at the same time engaging the yoke of the push rod with the slack adjuster arm. Fasten the assembly in place with the nut and lock washer. Connect the brake chamber air line to the brake chamber. Install the yoke pin through the push rod yoke and the hole in the slack adjuster arm, and lock in place with cotter pin.

(b) *Rear Brake Chambers.* Install the brake chamber in position on the mounting bracket, at the same time engaging the push rod yoke with the slack adjuster arm. Fasten the assembly in place with four bolts, nuts, and lock washers. Connect brake chamber air line to brake chamber. Install yoke pin through push rod yoke and hole in slack adjuster arm, and lock in place with cotter pin.

d. Slack Adjusters (figs. 132, 133, and 134).

(1) **REMOVAL.**

(a) *Front Slack Adjuster.* Cut lock wire and loosen camshaft collar screw. Remove collar. Using a prick punch, make a mark on the slack adjuster body and also on one of the splines of the brake camshaft so these parts may be assembled in the same relative position. Remove push rod yoke pin and cotter pin and pull out yoke pin. Free the push rod yoke from slack adjuster arm by turning the worm shaft. Slide the slack adjuster off the brake camshaft splines.

(b) *Rear Slack Adjuster on Left Side of Rearward Rear Axle and Right Side of Forward Rear Axle.* Remove bolt and two washers which secure adjuster arm to equalizer beam. Remove collar screw lock wire. Loosen collar screw. Remove six bolts and lock washers from dust shield (fig. 133). Remove dust shield. Expand brake shoes and install wedge to maintain expansion, and free cam from contact with brake shoe cam plates. Cut lock wire on collar screw, and loosen screw on collar next to wheel. Push slack adjuster and camshaft away from bracket and into hub. Use a prick punch to make a mark on one of the splines of the camshaft and on the slack adjuster body so these parts will be assembled in the same position. Pull adjuster free of camshaft and remove.

(c) *Rear Slack Adjuster on Right Side of Rearward Rear Axle and Left Side of Forward Rear Axle.* Remove adjacent brake chamber

Truck Service Brake System

(subpar. c (1) (b) above). Remove brake chamber bracket attaching screws and remove bracket. Remove bolt and washers which attach slack adjuster arm to equalizer bar. Mark the relative positions of the camshaft spline and slack adjuster body. Pull slack adjuster off camshaft.

(2) INSTALLATION.

(a) *Front Slack Adjuster.* Slide slack adjuster on camshaft splines, lining up punch marks on slack adjuster body with mark on brake camshaft splines. Turn worm shaft until the slack adjuster arm lines up with the push rod yoke. Install yoke pin and cotter pin. Adjust brakes as described in subparagraph **b** above.

(b) *Rear Slack Adjuster on Left Side of Rearward Rear Axle and Right Side of Forward Rear Axle.* Slide adjuster on camshaft, with punch marks on camshaft spline in line with punch marks on adjuster body. Insert outside end of camshaft through wheel hub as described in step (1) (b) above. Insert inner end of camshaft in bracket. Tighten outer collar set screw, and lock the screw with wire (fig. 133). Remove wedge and install dust shields. Tighten inner collar set screw, and install lock wire. Install bolt and two washers which secure adjuster arm to equalizer beam. Adjust (subpar. **b** above).

(c) *Rear Slack Adjuster on Right Side of Rearward Rear Axle and Left Side of Forward Rear Axle.* Slide slack adjuster on camshaft, lining up marks on camshaft spline with mark on adjuster body. Turn slack adjuster worm shaft to line up adjuster arm with end of equalizer beam. Install bolt and washers which attach adjuster arm to beam. Install brake chamber attaching bracket. Install brake chamber (subpar. c (2) (b) above). Adjust (subpar. **b** above).

177. SERVICE BRAKE SHOES.**a. Description and Data.**

(1) **DESCRIPTION** (figs. 135 and 136). Two brake shoes are attached to a backing plate inside each of the four brake drums. Two anchor pins hold the adjacent ends of the shoes in place. Opposite ends of the shoes are pulled together by a brake shoe spring. A cam, located between these ends, pivots when the brakes are applied and pushes the ends of shoes apart. This presses the lining, bolted to shoes, against brake drums, and this action creates braking action. When the brakes are released, the cam pivots back to its original position, and the brake shoe spring draws the shoes toward each other. Thus the shoe linings are pulled away from the drums, and braking action ceases. Front shoes are slightly different from rear shoes, due to space limitations which require a shorter lift on the operating cams. Also, front shoes are mounted on eccentric

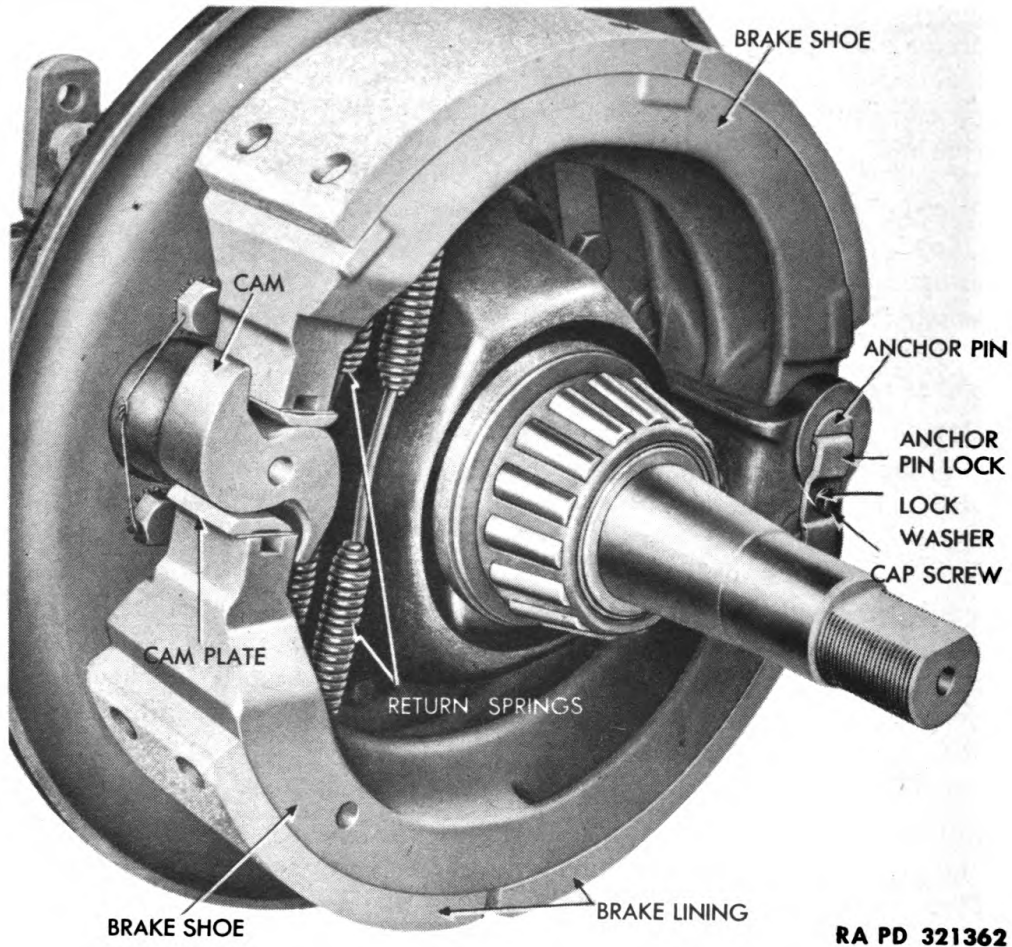

Figure 135—Front Brake Shoes

pins which can be rotated to bring shoes closer to the drum at the anchor pin end.

(2) DATA.

Manufacturer	Timken
Type	Internal-expanding, two-shoe
Lining:	
Type	Molded
Size:	
Front	17¼ x 4 in.
Rear	17¼ x 5½ in.
Thickness	¾ in.

b. Removal (figs. 135 and 136).

(1) REMOVE WHEEL AND HUB. Remove wheel and hub as instructed in paragraph 184 b and 185 c.

Truck Service Brake System

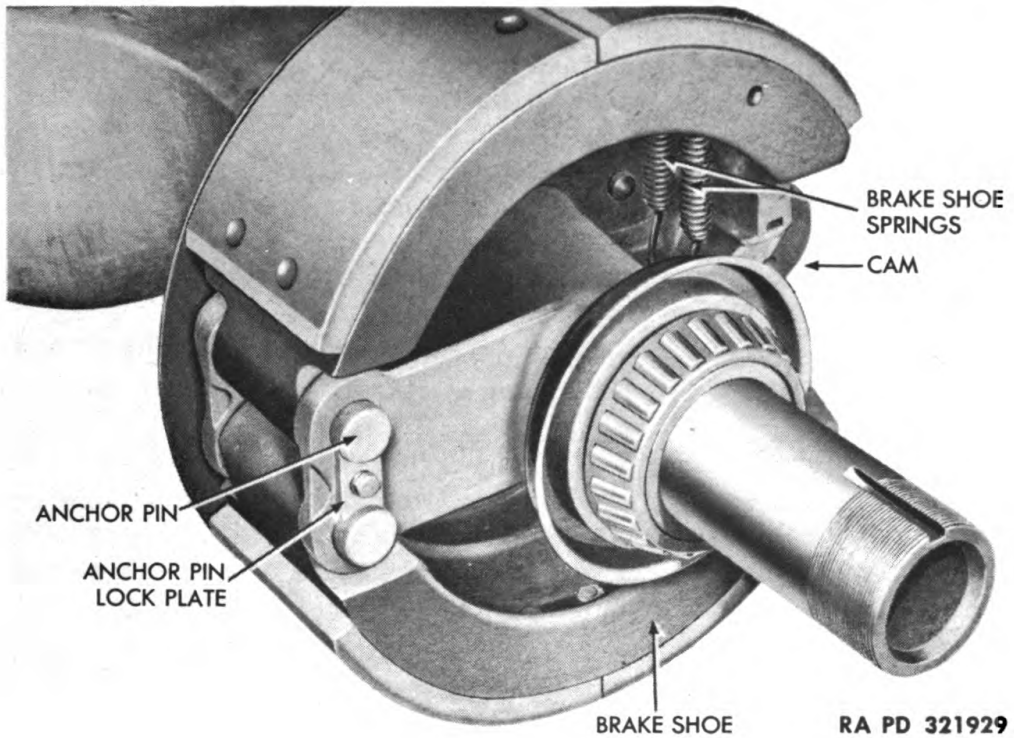

Figure 136—Rear Brake Shoes

(2) **REMOVE RETURN SPRINGS.** Turn slack adjuster worm shaft until shoes are at lowest point on cam. Slide brake shoe springs from holes in shoes.

(3) **REMOVE ANCHOR PIN LOCK.** Remove two anchor pin nuts from inner side of wheel (front wheels only). Remove anchor pin lock screw and lock washer. Lift anchor pin lock from pins.

(4) **REMOVE BRAKE SHOES.** Pull both shoes from anchor pins.

c. Installation (figs. 135 and 136).

(1) **ATTACH SHOES TO ANCHOR PINS.** Position shoes on anchor pins. Position lock plate on pins and shoes. Install lock cap screw and lock washer. Install anchor pin nuts (front brake shoes only) on inner end of pins.

(2) **INSTALL RETURN SPRINGS.** Pull free ends of shoes together. Insert spring ends through brake shoe holes.

(3) **INSTALL WHEEL AND HUB.** Install wheel and hub as instructed in paragraph 185 d.

(4) **ADJUST BRAKES.** Adjust slack adjusters as instructed in paragraph 176 h.

d. **Adjustment.** The adjustment of the brake shoes consists of adjusting to give uniform clearance between the brake lining surface and the face of the brake drum. This is always a preliminary check in adjusting the brakes by means of the slack adjusters (par. 176 b). Start the engine and build up air pressure to at least 80 pounds. Jack up wheel and turn slack adjuster worm until brake shoes are tight against the drum. Back off the worm until wheel is free to turn. Remove inspection hole cover on brake drum. Insert a feeler gage through inspection hole and check to see if there is from 0.010- to 0.015-inch clearance at the toe end of the shoe. If clearance is not within limits, adjust by turning slack adjuster worm shaft until correct clearance is obtained.

178. CLUTCH CONTROL VALVE.

a. **Description** (fig. 12). The clutch control valve is mounted on a bracket on the left end of the winch. It is a hand-operated air valve for controlling the winch and is connected into the air system between the clutch air cylinder and the left-hand air reservoir. When the hand lever of the valve is placed in open position, air pressure is built up in the clutch air cylinder, and when the hand lever is placed in closed position, air pressure to the cylinder is cut off at the valve. By operating the air valve, the operator can engage or disengage the clutch instantly, when there is operating air pressure in the system, thus engaging or disengaging the power line to the winch. The control valve eliminates the need for an operator to remain in the cab to shift the power take-off in and out of engagement when the winch is being operated.

b. **Removal** (fig. 12). Open air reservoir drain cocks to release air from air brake system. Unscrew clutch control valve to air reservoir air line connector. Unscrew clutch control valve to clutch air cylinder air line connector. Pull lines from valve. Remove nuts, lock washers, and bolts which secure valve to bracket and lift off valve.

c. **Installation.** Position valve on bracket and install attaching bolts, lock washers, and nuts. Position clutch control valve to air reservoir and clutch control valve to clutch air cylinder air lines. Tighten air line connectors. Start engine and build up pressure. Test for leaks.

179. CLUTCH AIR CYLINDER.

a. **Description and Data.**

(1) **DESCRIPTION** (fig. 101). The clutch air cylinder is installed on a bracket attached to left side of the transmission. It is connected through the clutch control valve on the winch to the left-hand air reservoir. When the control valve is opened, air pressure in the lower

Parking Brake System

end of the cylinder forces a piston rod outward and by means of linkage on the clutch throw-out shaft, engages the clutch. When the control valve is closed, the air pressure cuts off, causing the piston to return; this disengages the clutch. The clutch air cylinder and control valve are used during the operation of the winch so that the winch can be stopped or started by an operator outside the cab.

(2) **DATA.**

Manufacturer Westinghouse
 Model 205102

b. Removal (fig. 101). Open reservoir drain cocks to release air from air brake system. Unscrew clutch air cylinder to clutch control valve air line connector, and pull air line from cylinder. Remove cotter pin and yoke pin which secure clutch air cylinder yoke to clutch idler lever, and free yoke from lever. Remove screws and lock washers which secure clutch air cylinder to transmission housing. Lift cylinder from transmission housing.

c. Installation (fig. 101). Position clutch air cylinder on transmission, and attach mounting screws and lock washers. Connect yoke to clutch idler lever. Install yoke pin and cotter pin. Position clutch air cylinder to clutch control valve air line and tighten connector. Start engine and build up air pressure until governor cuts out. Test for leaks.

Section XXXII

PARKING BRAKE SYSTEM

180. DESCRIPTION AND DATA.

a. Description (figs. 137 and 138). The parking brake is attached to the power train between the auxiliary transmission and the forward rear axle. Four opposing brake shoes drag on a forged steel disk to provide braking resistance. The brake is operated by a parking brake lever in the cab and is used chiefly for parking. Using the parking brake to halt a moving vehicle exerts a severe strain on all parts of the power train. Therefore it must be used carefully to make an emergency stop in case of service brake failure.

b. Data.

Make Tru-stop
 Type Disk
 Disk diameter 16 in.
 Mounting Between companion flanges in drive line
 Clearance between shoes and disk $\frac{1}{32}$ in.

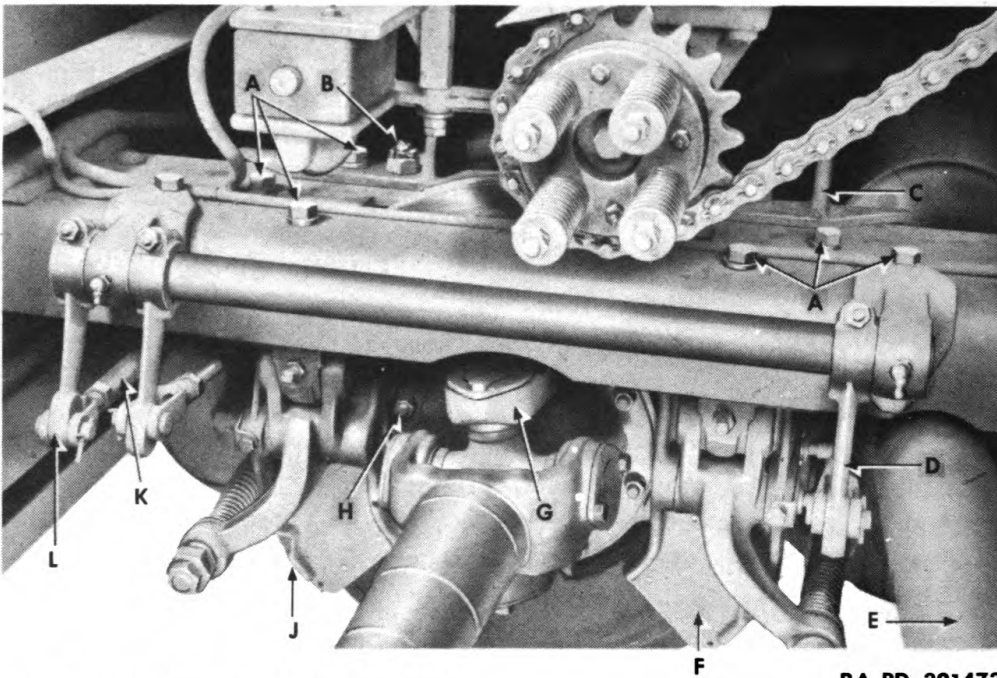

RA PD 321473

- | | |
|---|-------------------------------|
| A—PARKING BRAKE MOUNTING BOLTS | F—R. H. PARKING BRAKE SHOE |
| B—AUXILIARY TRANSMISSION
REAR BRACKET BOLT | G—UNIVERSAL JOINT FLANGE YOKE |
| C—AUXILIARY TRANSMISSION
REAR BRACKET | H—FLANGE YOKE BOLT |
| D—CROSS SHAFT LEVER | J—L. H. PARKING BRAKE SHOE |
| E—TAIL PIPE | K—BRAKE ROD |
| | L—CROSS SHAFT LEVER |

Figure 137—Parking Brake Assembly—Installed

181. SHOES.

a. Description and Data (figs. 137 and 138).

(1) **DESCRIPTION.** Two brake shoes are attached to front of brake, one on each side; and two are attached to rear of brake, one on each side. The shoes are flat and elliptical. The brake lining is attached to each shoe with eight bolts.

(2) **DATA.**

Manufacturer American Cable

Number of shoes 4

b. Adjustment (figs. 138 and 139). Tighten nut "A" so that spring "B" exerts enough pressure to bring lever "C" to stop solidly against lever arm "D" (fig. 138). Insert 1/32-inch feeler gage between front shoe lining and disk, and adjust pull rod "J" to maintain this clearance, first being sure to have parking brake lever in full-release position. Tighten nut "A" so that rear lining has 1/32-inch clearance

Parking Brake System

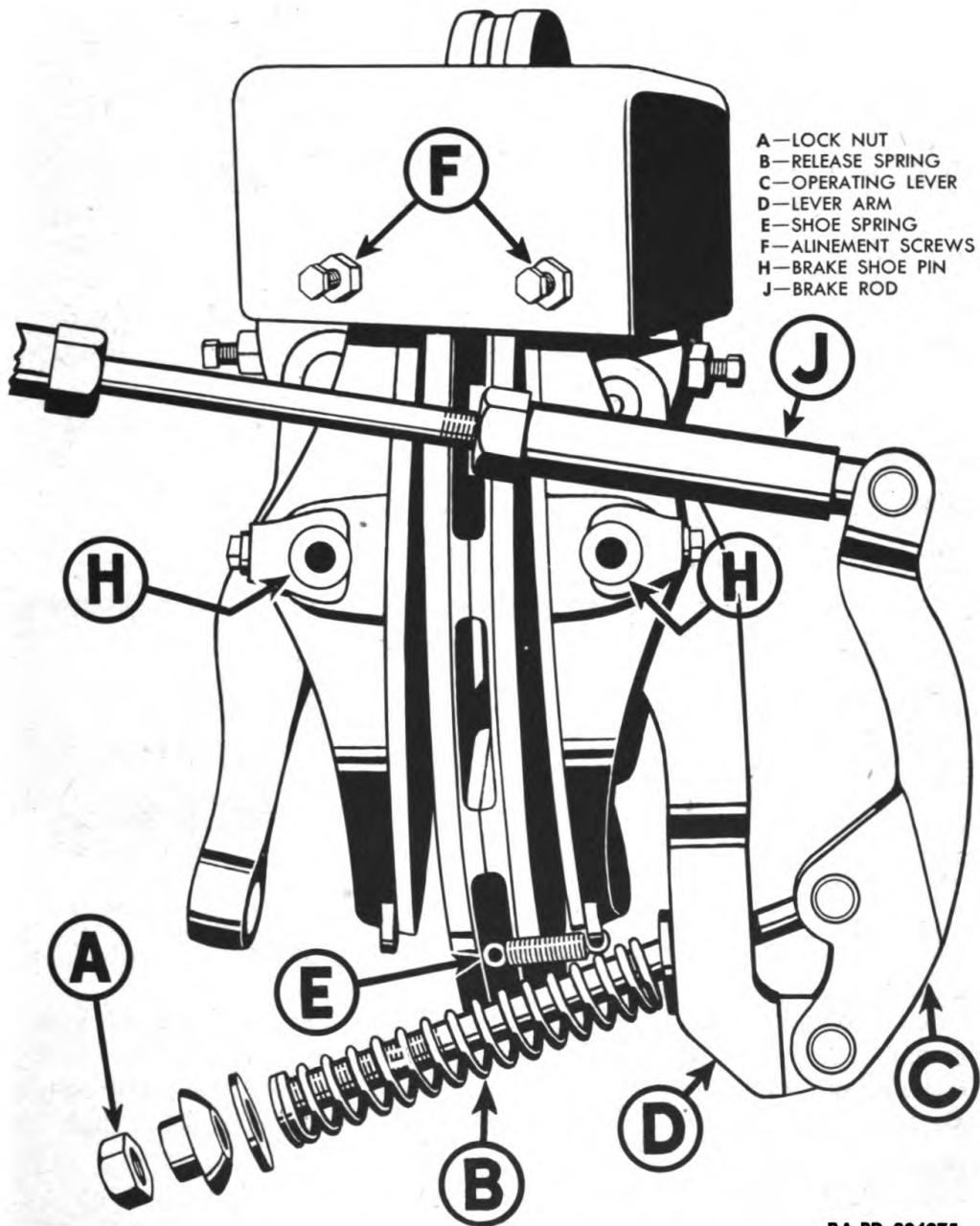

- A—LOCK NUT
- B—RELEASE SPRING
- C—OPERATING LEVER
- D—LEVER ARM
- E—SHOE SPRING
- F—ALINEMENT SCREWS
- H—BRAKE SHOE PIN
- J—BRAKE ROD

RA PD 304975

Figure 138—Parking Brake Assembly

with disk (fig. 139). See that tension spring "E" is in place; then adjust screws so that linings are parallel with disk. Remove feeler gage.

c. Removal (figs. 137 and 138).

(1) **DISCONNECT LINKAGE.** Remove three cotter and clevis pins from brake rods and cross shaft levers.

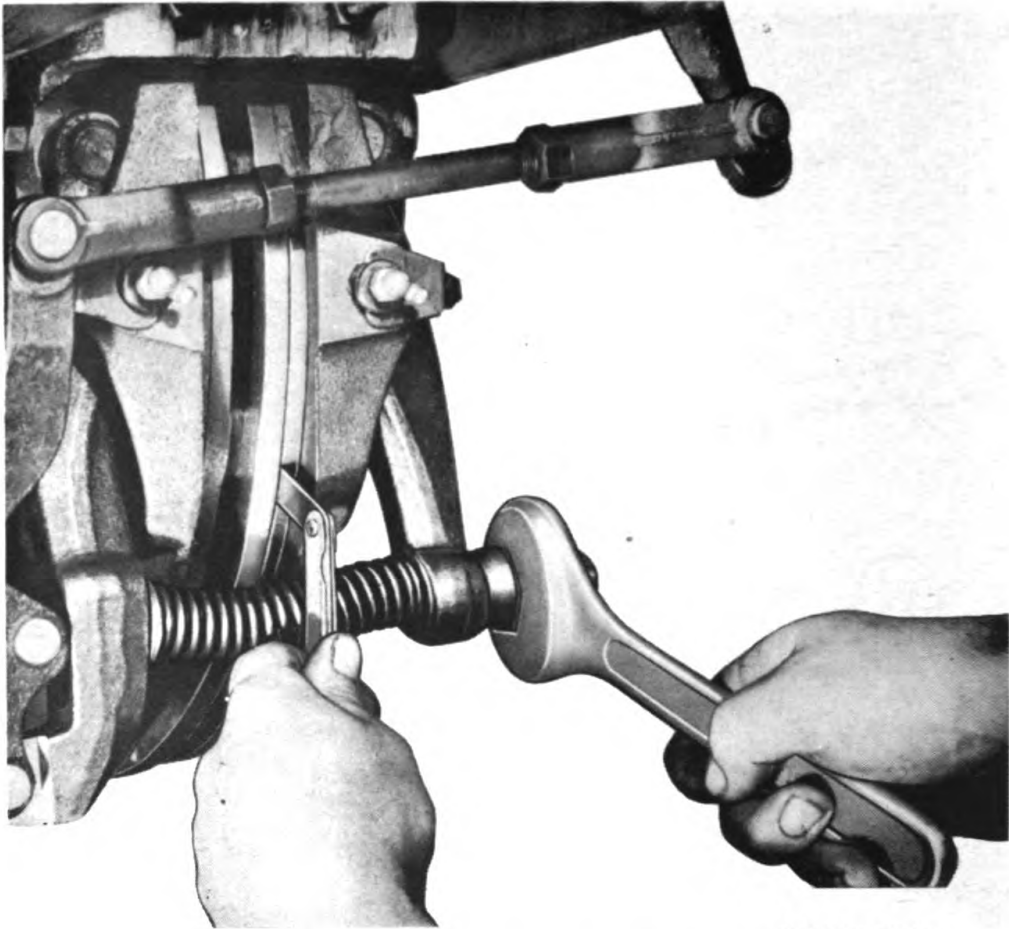

RA PD 304967

Figure 139—Adjusting Parking Brake

(2) **REMOVE BRAKE SHOE ASSEMBLIES.** Remove bolts, lock washers, and nuts which secure the brake shoe assemblies to the frame crossmember and lower shoes from vehicle. To free the right shoe assembly, pry exhaust pipe to one side.

d. **Installation** (figs. 137 and 138).

(1) **ATTACH BRAKE SHOES.** Position brake shoe assembly on left or right side. Install three bolts, lock washers, and nuts which attach brake shoe assemblies to the frame crossmember. **NOTE:** To position right brake shoe assembly, pry exhaust pipe to one side.

(2) **CONNECT LINKAGE.** Connect the three brake rod yokes to the cross shaft levers, and insert yoke pins and cotter pins.

182. DISK.

a. **Description** (figs. 137 and 138). The brake disk is located

Parking Brake System

at the center of the brake assembly between the four shoes. It consists of two flat metal disks welded together at intervals through bosses which are an integral part of each disk. The disk provides a surface against which brake shoes act to stop or hold the vehicle.

b. Removal (figs. 137 and 138).

(1) **DISCONNECT PROPELLER SHAFTS.** Remove cap screws, nuts, and lock washers holding brake disk to the front and rear propeller shaft flange yokes. Lower the ends of propeller shafts.

(2) **DISCONNECT LINKAGE.** Remove cotter pins and brake rod yoke pins from three cross shaft levers.

(3) **REMOVE LEFT BRAKE SHOE.** Remove left brake shoe assembly (par. 181 c (2)).

(4) **LOOSEN RIGHT BRAKE SHOE.** Remove two inner bolts securing right brake shoe to frame crossmember. Loosen outside bolt. Twist brake shoe.

(5) **LOWER THE DISK.** Lower the disk from between the brake shoes.

c. Installation.

(1) **POSITION BRAKE DISK BETWEEN SHOES.** Install left brake shoe (par. 181 d). Insert brake disk from underneath chassis, and twist right brake shoe around into position. Install two inner mounting bolts, and tighten outer mounting bolt of right brake shoe.

(2) **CONNECT PROPELLER SHAFTS.** Support front and rear propeller shafts, and line up holes in flange yokes with holes in disk. Install eight cap screws, nuts, and lock washers through yokes and disk.

(3) **CONNECT LINKAGE.** Position brake rods at cross shaft levers, and install yoke pins and cotter pins.

(4) **ADJUST LINKAGE.** Refer to paragraph 181 b.

183. LEVER AND LINKAGE.

a. Description (fig. 7). The parking brake lever is mounted on a bracket with the power take-off shift lever in the cab. It is connected by an adjustable brake rod to the brake cross shaft lever located at the rear of the parking brake on the left side of the chassis. Two other cross shaft levers are connected by brake rods to the operating levers of the brake shoes. Adjustment of the parking brake lever is made by turning the yoke at the end of the rod. The lever is equipped with a ratchet latch so that the lever will hold the parking brake in applied position.

b. Removal of Lever (fig. 103). Remove the power take-off shift lever and parking brake lever bracket (par. 142 a). Remove the

nuts and lock washers at the upper side of the left-hand shift lever bracket. Loosen bracket set screw. Drive the left-hand shift lever bracket off the pivot pin. Drive the parking brake lever assembly off the pivot pin.

c. **Installation of Lever** (fig. 103). Position the parking brake lever assembly on the lever pivot pin with the latch installed on the bracket studs. Tap the left-hand shift lever bracket on the pivot pin and studs. Install lock washers and nuts on ends of studs. Tighten bracket set screw. Install the bracket assembly on the truck (par. 142 a).

Section XXXIII

TRUCK WHEELS, HUBS, WHEEL BEARINGS, AND TIRES

184. WHEELS.

a. Description and Data.

(1) **DESCRIPTION.** The truck is equipped with 10 identical wheels, which are mounted singly on front and dually on rear hub assemblies. The wheels are the offset-disk type made of cold-rolled steel. Wheels mounted dually are installed in reverse position to each other. The rear dual wheels are attached to the hubs with 10 inner and 10 outer stud cap nuts, the inner nuts having square heads stamped "R" or "L" to indicate that they have right-hand or left-hand threads, and that they are used respectively on the right-hand or the left-hand side of the truck. The outer nuts have hex heads and are marked "R" or "L" to indicate the hand of nut. The front wheels are secured only by the outer hex-head nuts. Tires are secured on the wheel rims by an inner retainer rim and an outer retainer snap ring. An open end of the snap ring is riveted to the inner ring and the two rims must be installed and removed as an assembly.

(2) **DATA.**

Make	Budd
Number	B-45530
Type	Offset disk
Size	20 in. by 9 and 10 in.
Offset	6¾ in.
Bolt circle	11¼-inch diameter
Number of bolt holes	10

b. **Removal** (fig. 140). Set parking brake and block wheels to prevent vehicle from moving. Jack up vehicle until wheel is clear of floor. If wheels are mounted dually, remove the 10 outer hex-head

Truck Wheels, Hubs, Wheel Bearings, and Tires

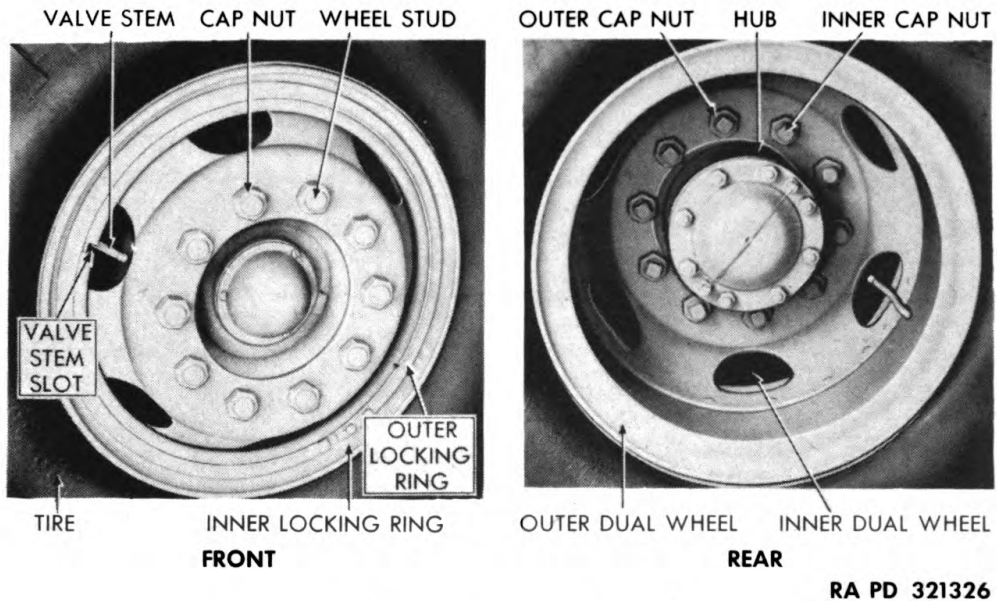

Figure 140—Front and Rear Wheels

stud nuts and remove outer wheel before removing the inner wheel. Remove the inner wheel by removing the 10 inner square head nuts and lifting wheel off hub.

c. **Installation** (fig. 140). Position wheel on hub assembly so that offset in wheel positions tire over brake drum (tire retaining rims will be toward outside end of hub). Install 10 inner square-head nuts, tightening them in opposite positions alternately to insure proper alignment of wheel and hub. **NOTE:** *If front wheel is being mounted, install only front wheel stud cap nut.* When installing outer wheel, position it so that the outer valve stem will not be opposite the inner stem. This will make it easier to inflate tires. Position outer wheel on hub and install outer hex-head nuts, tightening them in opposite positions alternately to insure wheel and hub alignment. Lower wheel to floor and remove the jack.

185. HUBS, DRUMS, AND WHEEL BEARINGS.

a. Description and Data.

(1) **DESCRIPTION** (figs. 141 and 142). The hubs rotate on double sets of opposed tapered roller bearings. The front hub bearings are mounted on the axle shafts of the steering knuckles. The rear driving units are the full-floating type with roller bearing assemblies supported on axle tubes. All wheel bearings are adjustable for wear. A felt oil seal and two retainer washers between the inner bearing cones and brake drum housing assemblies prevent lubricant from

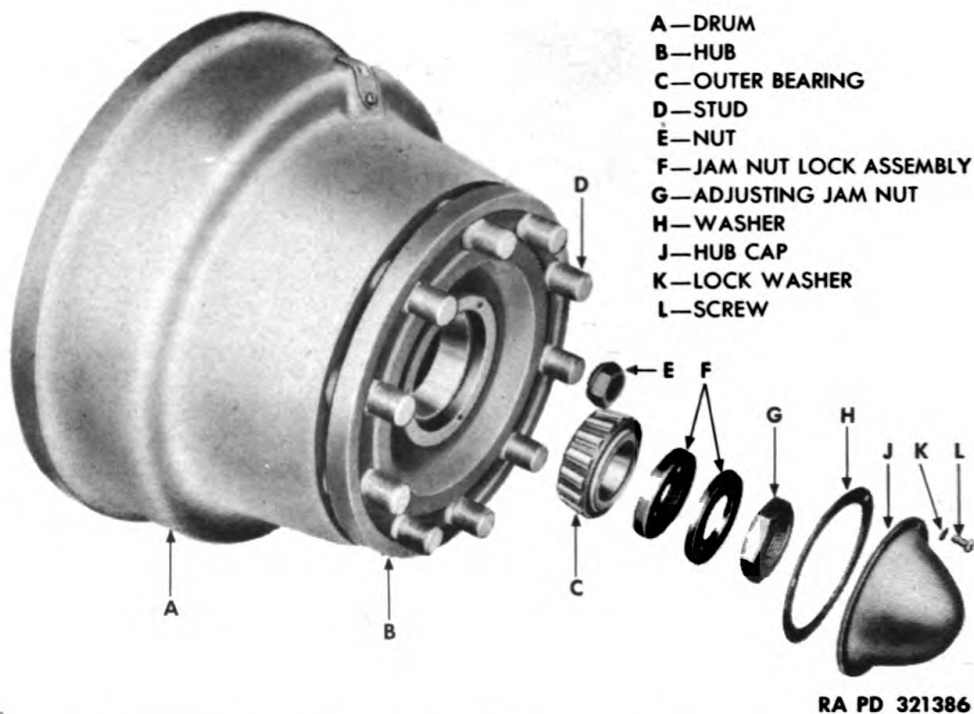

RA PD 321386

Figure 141—Front Hub, Drum, and Wheel Bearing

passing to brake drums. The outer end of rear hubs are sealed by the drive shaft flanges, and front hubs by hub caps.

(2) DATA.

Wheel bearings:

Make Timken

Type Tapered roller

Number:

Front inner bearing 6320 cup, 6379 cone

Front outer bearing 532A cup, 537 cone

Rear inner bearing 732 cup, 759 cone

Rear outer bearing 742 cup, 749 cone

Adjustment 0.002 to 0.005 inch loose

b Adjustment.

(1) REMOVE HUB CAP. Block wheels to prevent vehicle from moving. Use suitable lifting device to raise wheel from floor. If adjusting front wheel bearing, remove hub cap and cap gasket by removing cap screws and lock washers which attach cap to hub. If adjusting rear wheel bearing, remove axle shaft and driving flange as outlined in paragraph 158 a.

(2) ADJUSTMENT PROCEDURE. Remove the adjusting jam nut (bearing outer nut on rear axles) and locking ring (called bearing

Truck Wheels, Hubs, Wheel Bearings, and Tires

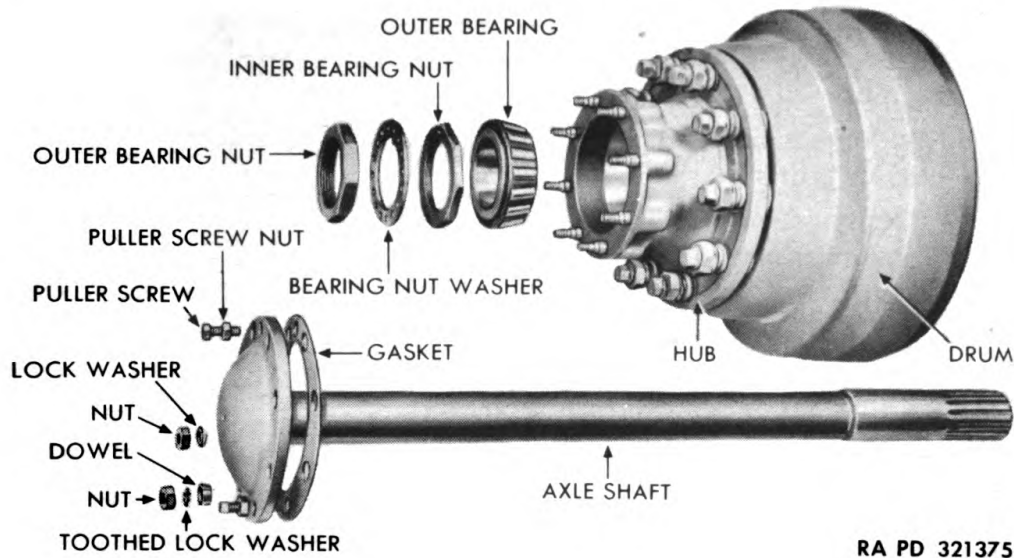

RA PD 321375

Figure 142—Rear Hub, Axle Shaft, Drum, and Wheel Bearing

nut washer on rear axles). Tighten the inner adjusting nut, turning it with the wheel rotating until it binds. Back off the nut enough to allow free rotation of the wheel without end play.

(3) **TEST ADJUSTMENT.** Test the adjustment with a bar used as a lever between the tire and the floor. While working the bar up and down, hold a finger on the outer bearing cage to detect any excessive play or looseness. If the wheel rotates freely and there is a barely perceptible shake, the adjustment is correct. Proper adjustment is from 0.002 to 0.005 inch, loose. Replace the locking washer and bearing outer lock nut, and test the adjustment again. Do not join the lock nuts so tightly that the wheels will bind, nor allow them to be so loose that it is possible to plainly feel the end play in the bearings by shaking the wheel.

(4) **INSTALL HUB CAP.** Cover the end of the axle tube and lock nuts with lubricant, and replace hub cap. If making adjustment at rear hub, install axle shaft as outlined in paragraph 158 b.

c. Removal (figs. 141 and 142).

(1) **FRONT HUB ASSEMBLY.**

(a) *Remove Wheel and Tire.* Follow instructions in paragraph 184 b.

(b) *Remove Outer Bearing Cone and Hub Assembly.* Remove hub cap. Remove adjusting jam nut and jam nut lock assembly. Pry outer bearing cone alternately on each side and remove it from steering knuckle shaft. Slide hub and drum assembly from shaft.

Maintenance Instructions

(c) *Remove Inner Bearing Cone and Oil Seal.* Remove inner bearing cone from knuckle shaft by prying alternately on each side of bearing. Remove the oil seal retainer and dowel assembly, and oil seal assembly.

(d) *Remove Brake Drum from Hub Assembly.* Remove drum from hub by removing jam nuts which attach it to hub.

(e) *Remove Bearing Cups.* CAUTION: *Do not remove bearing cups from hubs until inspection reveals the necessity for replacing them.* Using a brass rod, drive inner and outer cups from hub.

(2) REAR HUB ASSEMBLY.

(a) *Remove Wheel and Tire Assemblies.* Remove wheel and tire assemblies as outlined in paragraph 184 b.

(b) *Remove Axle Shaft.* Remove axle shaft as outlined in paragraph 158 a.

(c) *Remove Outer Bearing Cone and Hub Assembly.* Remove bearing outer nut, nut washer, and bearing inner nut. Pry outer bearing cone alternately on each side and remove it from housing tube. Slide hub and drum assembly from tube.

(d) *Remove Inner Bearing Cone and Oil Seal.* Pry inner cone from housing tube. Remove screws which attach oil seal assembly to axle housing, and remove felt outer retainer, felt, and felt inner retainer.

(e) *Remove Brake Drum from Hub Assembly.* Remove attaching jam nuts and remove brake drum from hub.

(f) *Remove Bearing Cups from Hub.* Remove bearing cups from hub as outlined in step (e) above.

d. Installation (figs. 141 and 142).

(1) FRONT HUB ASSEMBLY.

(a) *Install Bearing Cups.* Install hub in an arbor press, and install inner and outer front bearing caps.

(b) *Attach Brake Drum to Hub Assembly.* Position drum on hub, and install jam nuts which attach drum to hub.

(c) *Install Grease Retainer and Inner Bearing Cone on Shaft of Steering Knuckle.* Install oil seal assembly, and oil seal retainer and dowel assembly. Slide inner bearing cone on shaft and against grease retainer. Pack and cover inner cone with correct lubricant.

(d) *Install Hub and Outer Bearing Cone.* Pack the space in the hub between the two bearing cups with correct wheel bearing lubricant, one-half to two-thirds full (par. 22). Slide hub on knuckle shaft and press hub firmly against inner cone. Pack and cover outer bearing cone with correct lubricant (par. 22). Hold the hub in place, and

Truck Wheels, Hubs, Wheel Bearings, and Tires

press the outer bearing cone firmly into the hub. Install the adjusting nut and jam nut lock assembly, making bearing adjustment and installing hub cap as outlined in subparagraph **b** above.

(e) *Install Wheel and Tire Assembly.* Install wheel and tire assembly as described in paragraph 184 c.

(2) REAR HUB ASSEMBLY.

(a) *Install Bearing Cups in Hub.* Install hub in an arbor press, and install inner and outer rear bearing cups.

(b) *Attach Brake Drum to Hub Assembly.* Position drum on hub, and install jam nuts which attach drum to hub.

(c) *Install Grease Retainer and Inner Bearing Cone on Housing Tube.* Position felt inner retainer, felt, and felt outer retainer on tube and against axle housing. Install screws which attach grease retainer. Pack and cover cone with correct lubricant.

(d) *Install Hub and Outer Bearing Cone on Axle Tube.* Pack the space in the hub between the two bearing cups with correct wheel bearing lubricant, one-half to two-thirds full. Slide hub on tube, and press hub firmly against inner bearing cone. Pack and cover outer bearing cone with correct lubricant. Hold the hub in place and press the outer cone firmly into the hub. Install bearing inner nut, bearing nut washer, and bearing outer nut, making bearing adjustment as outlined in subparagraph **b** above.

(e) *Install Axle Shaft.* Install axle shaft as described in paragraph 158 h.

(f) *Install Wheel and Tire Assemblies.* Install wheel and tire assemblies as outlined in paragraph 184 c.

186. TIRES.

a. Description and Data.

(1) **DESCRIPTION.** Tires are 14-ply, mud-and-snow type tread, bus-balloon type.

(2) **DATA.**

Type	Mud-and-snow type
Number of plies	14
Size	12.00 x 20
Pressure	80 lb per sq in.

b Removal.

(1) **REMOVE WHEEL AND TIRE ASSEMBLY FROM HUB.** Remove wheel and tire from hub as described in paragraph 184 b.

(2) **REMOVE TIRE CASING AND TUBE FROM WHEEL RIM.**

(a) *Deflate Tire.* Using valve cap, remove valve core from valve stem and permit all air to escape from inner tube.

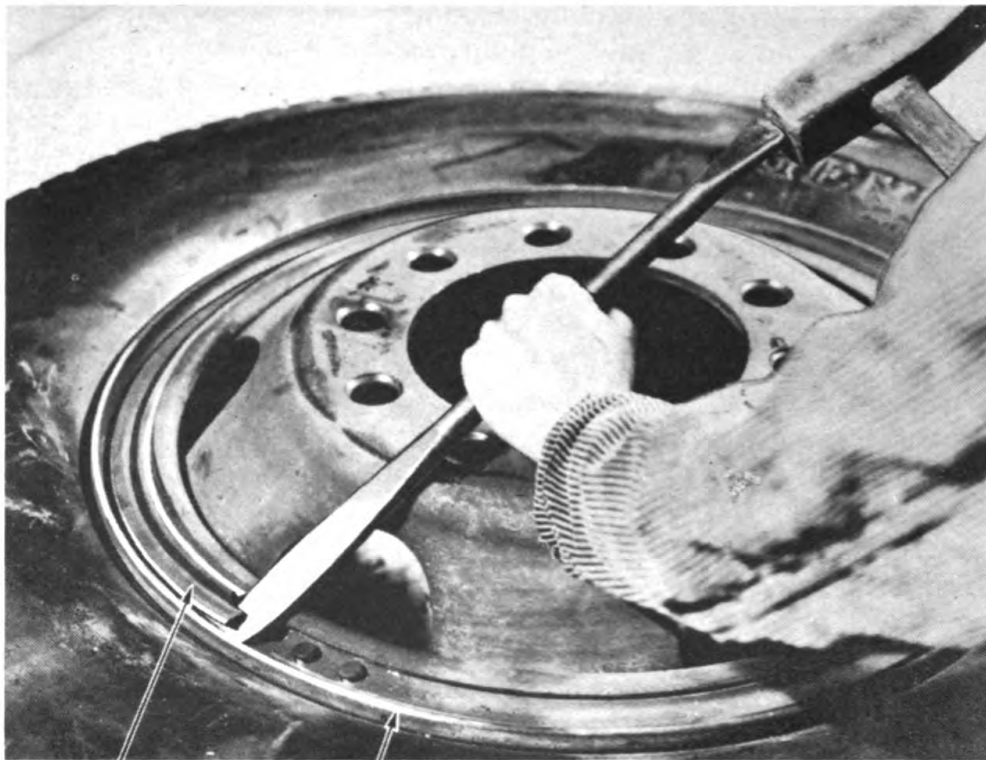

OUTER
LOCKING RING

INNER
LOCKING RING

RA PD 305952

Figure 143—Removing Rim Locking Ring

(b) *Remove Locking Ring Assembly.* The locking ring is an assembly of a solid inner clamp ring to which the outer snap ring is riveted. Assembly must be removed as a unit. Place wheel and tire assembly on floor with lock ring side of wheel up. Loosen tire bead from rim by pounding around inner ring, using a heavy hammer. Drive a flat-tipped tire iron under loose end of outer locking ring, and pry ring out of groove about three-quarters around rim. Lift inner ring off rim, and remove the two rings from rim as a unit.

(c) *Remove Tire From Wheel Rim.* Lift tire casing and tube from wheel rim. Remove tire flap and tube from casing.

c. Installation.

(1) **INSTALL TIRE CASING AND TUBE ON WHEEL RIM.**

(a) *Install Tube and Tire to Rim Flap in Casing.* With all air out of tube, place tube in casing. Insert valve stem through flap, and install flap in casing. Install a new valve core in valve stem, and inflate tube enough to cause tube to straighten up within casing.

Springs

Do not inflate tube enough to spread casing and interfere with installation of tire on wheel rim.

(b) *Position Casing With Tube on Wheel Rim.* Place wheel on floor with lock ring groove up. Position tire on wheel rim with valve stem alined to open slot in wheel rim so that valve stem is pointing toward locking ring groove.

(c) *Install Locking Ring Assembly.* The inner and outer rings must be installed as a unit on wheel rim. About one-fourth of outer ring, at end which is attached to inner ring, must be fitted into groove in rim before inner ring can be laid down on tire bead. With attached end of outer ring in groove and inner ring lying on tire bead, hammer rest of outer ring into groove.

(d) *Inflate Tire.* CAUTION: *Before inflating tire, check lock rings to make sure the outer lock ring is properly seated in lock ring groove.* Rap two small chains, equipped with grab hooks, around tire and rim at two different places. (This will eliminate the possibility of an accident if the locking rings should let go while the tire is being inflated.) Inflate tire to 80 pounds pressure per square inch. Install valve cap on valve stem. Remove small safety chains.

(2) **INSTALL WHEEL AND TIRE ASSEMBLY ON HUB.** Install wheel and tire on hub as described in paragraph 184 c.

Section XXXIV

SPRINGS

187. FRONT SPRINGS AND SHACKLES.

a. Description and Data.

(1) **DESCRIPTION.** The front axle is sprung on two shackled-leaf spring assemblies. These are semielliptical springs with the shackle at the front end. The rear end of the spring is attached to the front spring rear hanger by means of a shackle pin. The forward end is attached to a shackle which is suspended from the front spring front hanger. The spring is attached to the front axle by two clips and a clip spacer and bumper assembly.

(2) **DATA.**

Length	50 in.
Material	Chrome vanadium steel
Leaves:	
Number	13
Width	3 in.
Total thickness	4 $\frac{7}{8}$ in.
Number of rebound clips	4

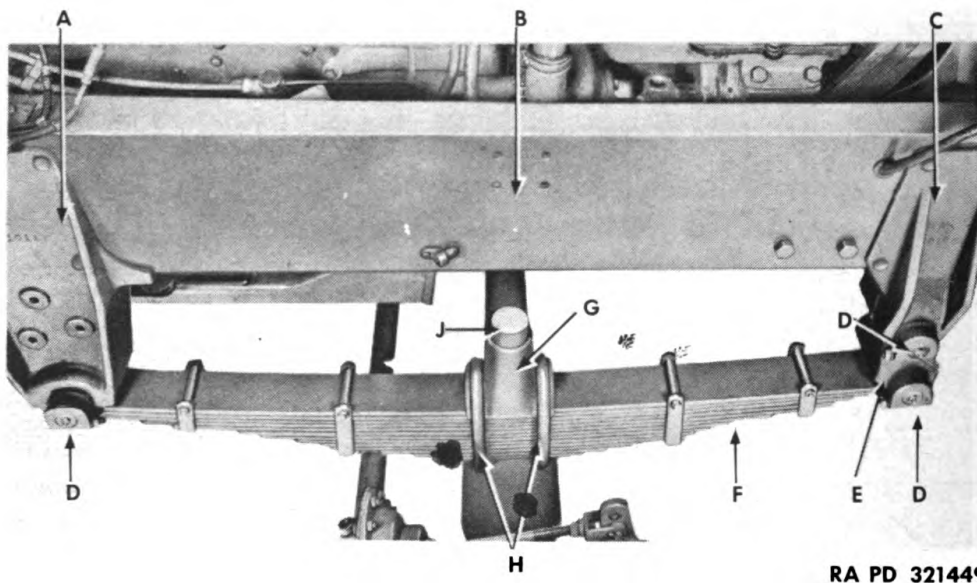

RA PD 321449

- | | |
|-----------------------------|-----------------------------------|
| A—FRONT SPRING REAR HANGER | F—FRONT SPRING |
| B—FRAME RAIL | G—FRONT CLIP SPACER |
| C—FRONT SPRING FRONT HANGER | H—FRONT SPRING CLIP |
| D—FRONT SPRING SHACKLE PIN | J—FRONT SPRING CLIP SPACER BUMPER |
| E—FRONT SPRING SHACKLE | |

RA PD 321449

Figure 144—Front Spring—Installed

b. Removal of Shackle (figs. 144 and 145). Raise chassis frame to relieve tension from spring. Remove shackle pin lock nut, lock washer, and lock from lower end of shackle. Drive out lower shackle pin. Remove shackle pin lock nut, lock washer, and lock at front spring front hanger. Drive out upper shackle pin. Raise chassis clear and remove shackle.

c. Installation of Shackle (figs. 144 and 145). Position shackle in front spring hanger. Insert upper shackle pin. Install shackle pin lock, lock washer, and lock nut. Position front end of spring in shackle. Position and install lower shackle pin. Install shackle pin lock, lock washer, and lock nut. Lubricate shackle pins (par. 22). Release jack.

d. Removal of Springs (fig. 144). Jack or hoist chassis to relieve tension from spring. Remove shackle pin lock nut, lock washer, and lock nut from front spring rear hanger. Drive out shackle pin. Remove shackle pin lock nut, lock washer, and lock from lower end of front spring shackle. Drive out shackle pin. Raise chassis to free the spring. Remove four nuts and lock washers from two spring clips.

Springs

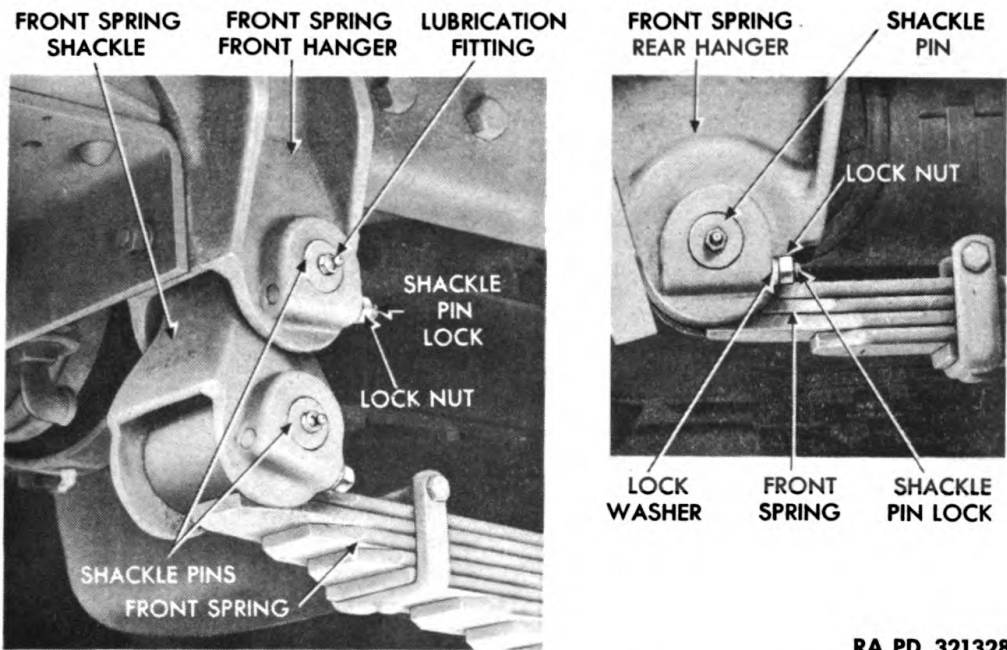

RA PD 321328

Figure 145—Front Spring Connections

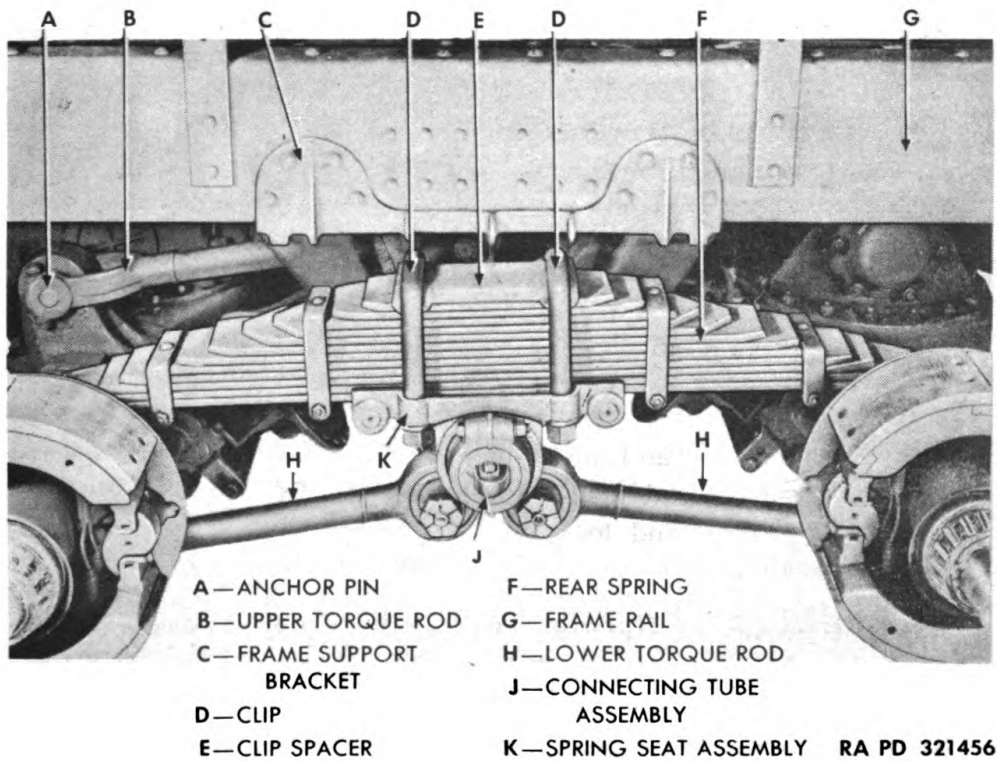

Figure 146—Rear Spring—Installed

Maintenance Instructions

Remove spring clips. Remove clip spacer and spacer bumper assembly. Remove spring.

e. Installation of Springs (fig. 144). Position spring on front axle. Place clip spacer and spacer bumper assembly on the top main spring leaf. Install two spring clips over spacer and springs, with bolt ends through holes in axle. Install four lock washers and take a few turns on nuts. Position front end of spring in shackle at the front spring front hanger. Position and install lower shackle pin. Install shackle pin lock, lock washer, and lock nut. Position rear end of spring in front spring rear hanger. Install shackle pin. Install shackle pin lock, lock washer, and lock nut. Tighten four nuts on spring clips. Lubricate shackle pins (par. 22).

188. REAR SPRINGS.

a. Description and Data.

(1) **DESCRIPTION** (fig. 146). The rear springs are installed in spring seats which oscillate on the connecting tube between the two frame support brackets (fig. 114). The ends of the springs rest on top of the axle housings. The springs act as load equalizing members, carrying the axle load. Twisting action is eliminated by having the spring ends free.

(2) **DATA.**

Length	56¼ in.
Material	Chrome vanadium steel
Leaves:	
Number	12
Width	5 in.
Total thickness	6 in.
Number of rebound clips	4

b. Removal of Spring (fig. 146). Remove forward rear axle (par. 156 b) and rearward rear axle (par. 157 b). Remove spring seat and spring as an assembly (par. 160 b). Remove four nuts and lock washers from two spring clips. Remove clips; remove clip spacer. Back off two clamp screws. Lift off spring.

c. Installation of Spring (fig. 146). Place spring on spring seat. Position clip spacer on top spring leaf. Position two clips over spacer and spring. Install four lock washers and four nuts on clips. Install spring and seat as an assembly (par. 160 c). Install forward rear axle (par. 156 c). Install rearward rear axles (par. 157 c). Alternately tighten clamp screws to adjust spring side play.

Section XXXV

STEERING GEAR

189. DESCRIPTION AND DATA.

a. **Description.** The steering gear assembly is mounted on the frame side rail at the front left-hand side of the vehicle. It extends from the steering arm attached to the left front wheel assembly through the steering gear housing to the steering wheel in the cab. The gear is the tapered-roller twin-lever type; the twin lever, on which the rollers are mounted, is an integral part of the steering shaft. The outer end of the steering shaft is splined and threaded for attachment of the Pitman arm, to which one end of the drag link is attached. The other end of the drag link is attached to the steering arm on the left front wheel. The tapered studs are roller bearing mounted and are supplied in matched pairs. The cam is a worm of variable ratio (hence the name cam) and the grooves are ground slightly higher where the straight-ahead driving action usually takes place. This design provides for closer adjustment of the clearance between the studs and the cam at that point of steering action. The cam is supported on ball bearings in the steering gear housing.

b. **Data.**

(1) STEERING GEAR.

Make	Ross
Type	Roller-mounted twin-lever
Model	T-74
Gear Ratio:	
Straight-ahead driving	23 to 1
Parking	27 to 1

(2) BEARINGS.

Cam	Ball
Tapered stud bearing units	Tapered roller

190. SERVICE AND ADJUSTMENT OF STEERING GEAR.

a. **Service.** At regular intervals, check the drag link for excess slack or end play, and check fit of Pitman arm on steering lever shaft to make sure it is tightly secured on shaft. Keep steering gear housing filled with proper lubricant (par. 22). Hard steering can usually be traced to lack of front end lubrication, underinflation of tires, or damaged steering linkage. These points, in addition to front wheel alinement, should be checked before adjusting the steering gear. Adjust the steering gear only to remove play on it; do not tighten steering gear to correct other steering troubles.

b. Description of Adjustments. There are two principal adjustments and a supplementary adjustment on the stud roller bearing units in the lever shaft. Principal adjustments are: The adjustment of the ball bearings which support the arm in the gear housing, and the adjustment of the tapered studs in the cam groove. If an adjustment is required on the stud roller bearing units in the lever shaft, report condition to higher authority. When making tests and adjustments outlined in subparagraphs **c** and **d** below, free the steering gear of all load by disconnecting the drag link from the Pitman arm ball as instructed in paragraph 192 a.

c. Adjustment of Cam Ball Bearings.

(1) **TEST AND DESCRIPTION OF CAM BEARING ADJUSTMENT.** When studs are loosened in groove and cam bearings are properly adjusted, the steering wheel should turn with a slight drag in all operating ranges. Turn wheel with thumb and forefinger to feel drag. If wheel is extremely free, bearings must be tightened. If wheel turns with more than a slight drag, bearings must be loosened. The bearings are tightened by removal of thin shims from under the housing upper cover plate, and are loosened by installation of shims. The shims are furnished in 0.003- and 0.007-inch thickness and are split at one side to permit removal or installation by separating housing upper cover plate from housing.

(2) **CAM BEARING ADJUSTMENT PROCEDURE.**

(a) *Free Steering Gear of Load.* Disconnect drag link from Pitman arm ball as instructed in paragraph 192 a.

(b) *Loosen Studs in Cam Groove.* Loosen lock nut and back off adjustment screw located at center of gear housing side cover.

(c) *Remove Horn Button Assembly.* Remove horn button as instructed in paragraph 108 c.

(d) *Remove Steering Wheel.* Remove steering wheel as instructed in paragraph 191 a.

(e) *Free Steering Column.* Loosen trailer brake hand control valve mounting bracket. Loosen the steering column dash bracket cap located under the cowl inside the cab.

(f) *Remove or Install Shims.* Remove the stud nuts which attach the jacket tube and flanged collar to upper end of gear housing. Slide the tube and flange up far enough to clear the housing studs. Remove or install shims as required to correct end play of cam. Removal of shims will tighten bearings on cam; installation will loosen bearings. Tighten column flange in position on housing, and check adjustment as explained in step (1) above. If necessary, remove or install shims until cam bearings are properly adjusted.

(g) *Tighten Steering Post Clamp.* Tighten column bracket lo-

Steering Gear

cated under the cowl, and test drag at steering wheel to make sure the steering column jacket is properly alined and is not the cause of excessive drag. Tighten trailer brake hand control valve mounting bracket.

(h) *Install Steering Wheel.* Install steering wheel as instructed in paragraph 191 b.

(i) *Install Horn Button Assembly.* Install horn button according to instructions in paragraph 108 c.

d. Adjustment of Tapered Studs in Cam Groove.

(1) **GENERAL.** Adjustment of studs in cam groove must follow correct adjustment of cam and steering column as explained above. Too much freedom of tapered studs in cam groove shows up as end play (axial movement) of lever shaft, and as backlash at steering wheel or at ball of Pitman arm. This adjustment must be made with steering gear at mid-operating position. Backlash at the end positions of operating range is normal and not objectionable.

(2) **TEST TAPERED STUD ADJUSTMENT.** Test for backlash by turning steering wheel slowly from one extreme operating position to the other. A very slight drag must be felt at mid-operating position.

(3) **ADJUSTMENT PROCEDURE.** If no drag is felt, loosen lock nut on adjusting screw and turn screw clockwise to tighten fit of studs in groove. Recheck adjustment. When adjustment is completed, hold the adjusting screw in position while tightening adjusting screw lock nut. Recheck drag and correct if necessary.

(4) **CONNECT DRAG LINK AT PITMAN ARM.** Connect drag link at Pitman arm as explained in paragraph 192 b.

191. STEERING WHEEL.

a. Removal.

(1) **REMOVE HORN BUTTON ASSEMBLY.** Remove horn button assembly as instructed in paragraph 108 c.

(2) **REMOVE WHEEL FROM CAM TUBE.** Remove wheel nut and lift wheel from cam tube.

b. Installation.

(1) **INSTALL WHEEL ON CAM TUBE.** Position wheel on cam tube and install steering wheel nut.

(2) **INSTALL HORN BUTTON ASSEMBLY.** Install horn button as instructed in paragraph 108 c.

192. DRAG LINK.

a. Removal (figs. 147 and 148). Remove the cotter pins from each end of the drag link shell. Back off the drag link bearing spring

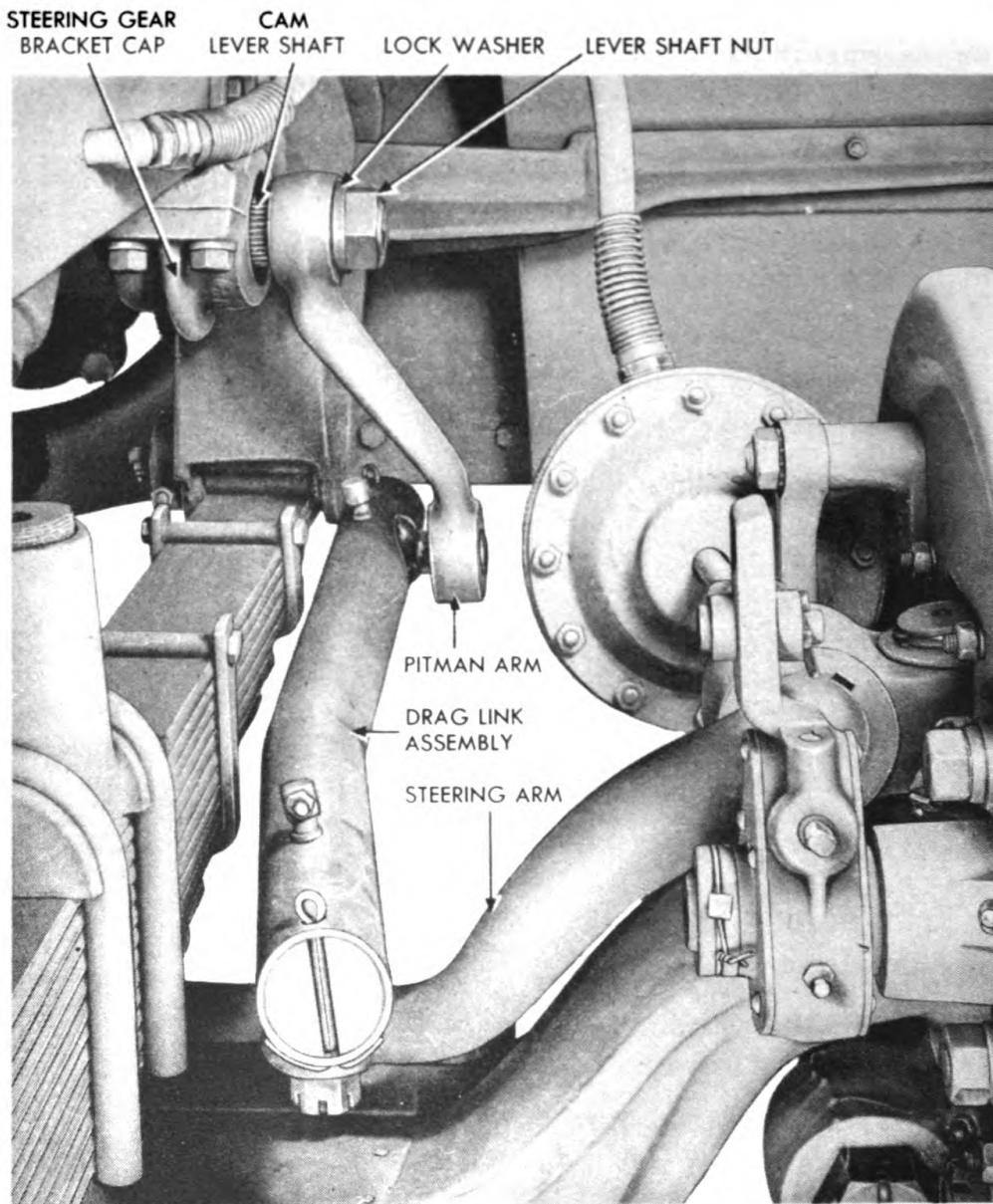

RA PD 321364

Figure 147—Drag Link and Pitman Arm

plugs far enough so that the bearings can be spread a sufficient amount to permit the drag link to be removed from the balls on the steering and Pitman arms. Disconnect front end of drag link from steering arm. Remove rear end of arm, prying arm up from Pitman arm, if necessary, to clear front chassis spring.

b. Installation (figs. 147 and 148). Spread the ball seats in the ends of the drag link so that the drag link may be installed over the balls in the steering and Pitman arms. Force rear end in place if

Steering Gear

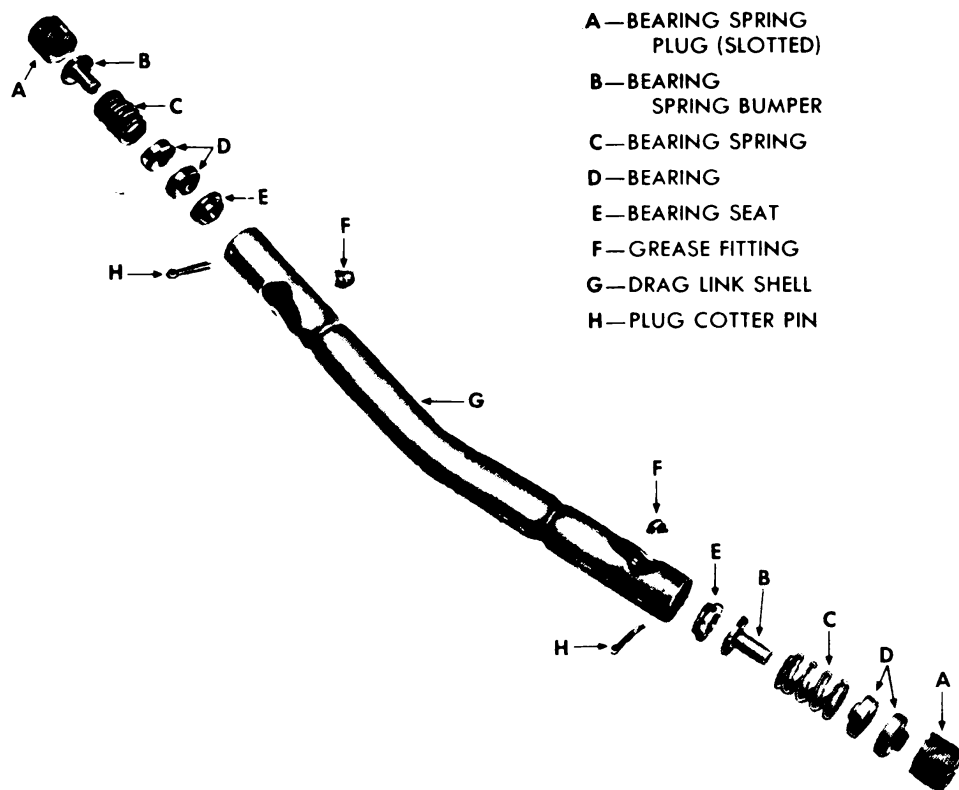

- A—BEARING SPRING PLUG (SLOTTED)
- B—BEARING SPRING BUMPER
- C—BEARING SPRING
- D—BEARING
- E—BEARING SEAT
- F—GREASE FITTING
- G—DRAG LINK SHELL
- H—PLUG COTTER PIN

RA PD 321427

Figure 148—Drag Link Assembly

necessary due to close clearance between the front chassis spring and the Pitman arm. Tighten the plugs on each end of the drag link, and back plug off just far enough to install the cotter pin. This adjustment must be tight enough so that there is no looseness. Install the cotter pins through the holes in the ends of the drag link shell and through the slots in the spring plugs to lock the adjustment.

193. PITMAN ARM.

a. **Removal** (fig. 147). Disconnect drag link from Pitman arm (par. 192 a). Remove nut and lock washer from end of cam lever shaft. Place bar behind Pitman arm up close to cam lever shaft and pry arm outward. Strike Pitman arm inward at stud end, to loosen arm on cam lever shaft.

b. **Installation** (fig. 147).

(1) **GENERAL.** If the Pitman arm is not properly positioned on the steering cam lever shaft the extreme right and left turning positions of the front wheels will not be equal. When the steering gear

is in mid-operating position and the front wheels are positioned for straight-ahead driving, it should be possible to connect the drag link to the ball on the end of the steering arm without making more than a slight change in the steering gear position. If this cannot be done, it will be necessary to remove the Pitman arm and replace it on the splined end of the steering shaft in the proper position.

(2) PROCEDURE.

(a) *Position Gear and Wheels for Straight-ahead Driving.* Turn the steering gear to the right as far as possible and then to the left, counting the total turns of the steering wheel between the two extremes. Turn the wheel back one-half of this total movement. Position the front wheels for straight-ahead driving.

(b) *Attach Arm to Drag Link.* Attach Pitman arm to drag link as described in paragraph 192 b.

(c) *Install Arm on Steering Shaft.* Without making more than a slight change in position of gear and of front wheels, position arm on splined end of lever shaft. Make sure splines are properly meshed and install lock washer, nut, and cotter pin.

Section XXXVI

CAB, FRAME, AND BODY

194. DESCRIPTION.

a. **Cab** (figs. 1 and 149). Two types of cabs are provided. Some of the vehicles are built with a conventional closed cab which has a driver's seat and one crew seat. The closed cab is equipped with a roof ventilator which admits fresh air through a filter screen and ejects foul air. The soft top cab, provided on some vehicles, has a removable fabric top, rear curtain, and side curtains (fig. 149).

b. **Frame.** The frame is riveted construction. Attachments to the frame include the front bumper, front and rear pintle hooks, tandem unit brackets, winch cable idler roller shaft, towing cable roller bracket and cable sheaves, and winch cable brackets.

c. **Body** (fig. 158). The ballast body, mounted on the frame to the rear of the winch, is a welded steel box with a hinged end gate. The body is supported on wooden sills. It contains two covered compartments for stowage of tools and equipment and two open compartments at the front end. Room is provided in the front compartment for carrying a spare tire. The purpose of the body is to carry ballast for improving the traction of the vehicle when towing the trailer with a maximum load as described in paragraph 12.

Cab, Frame, and Body

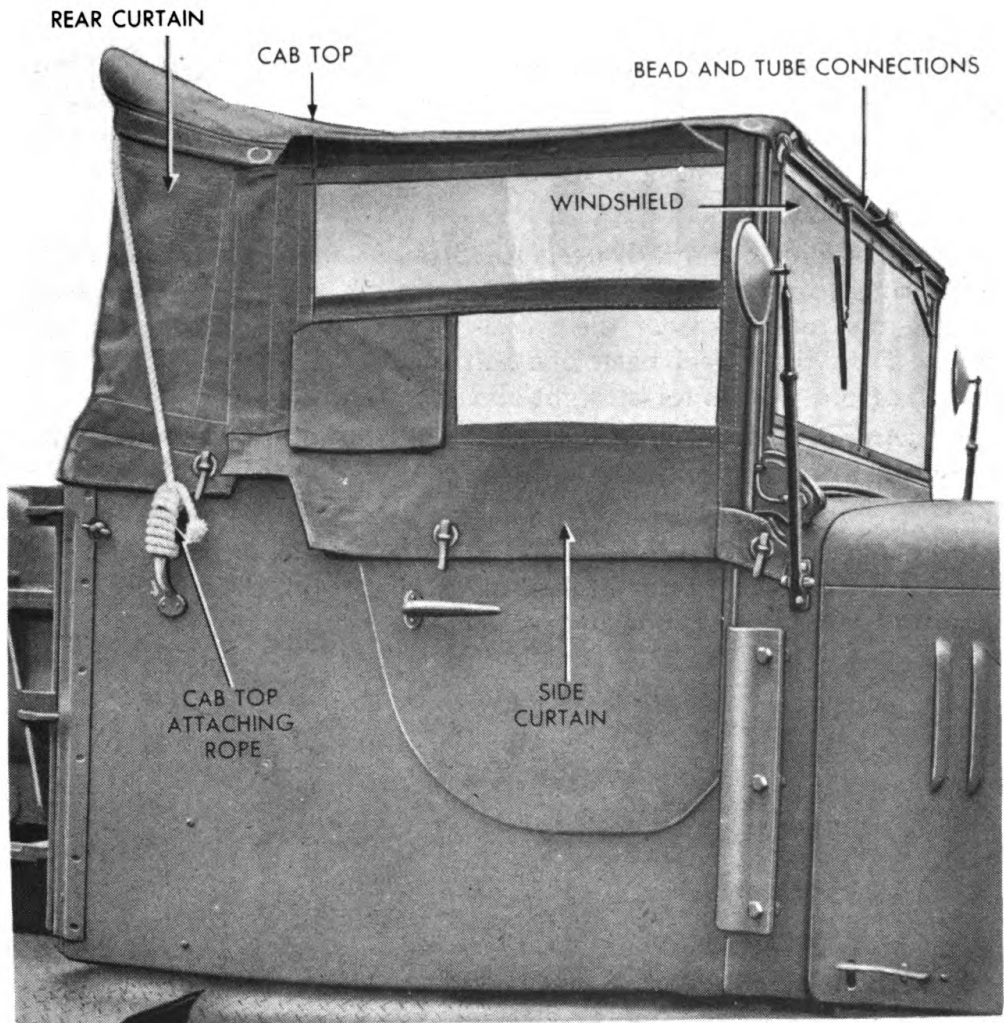

RA PD 321401

Figure 149—Exterior of Soft Top Cab

195. FRONT BUMPER.

a. **Description** (fig. 150). The front bumper is riveted and bolted to the chassis frame in front of the radiator. The front cable rollers for the winch cable are bolted to the left side of the bumper, and the bumper is cut out so that the cable can be led through it.

b. **Replacement.** Cut rivets which secure bumper to chassis frame. Remove bolts. Position new bumper and install bolts, lock washers, and nuts. To rivet bumper in place, refer to higher authority.

196. PINTLE HOOKS.

a. **Description of Front and Rear Pintle Hooks** (figs. 151 and 152).

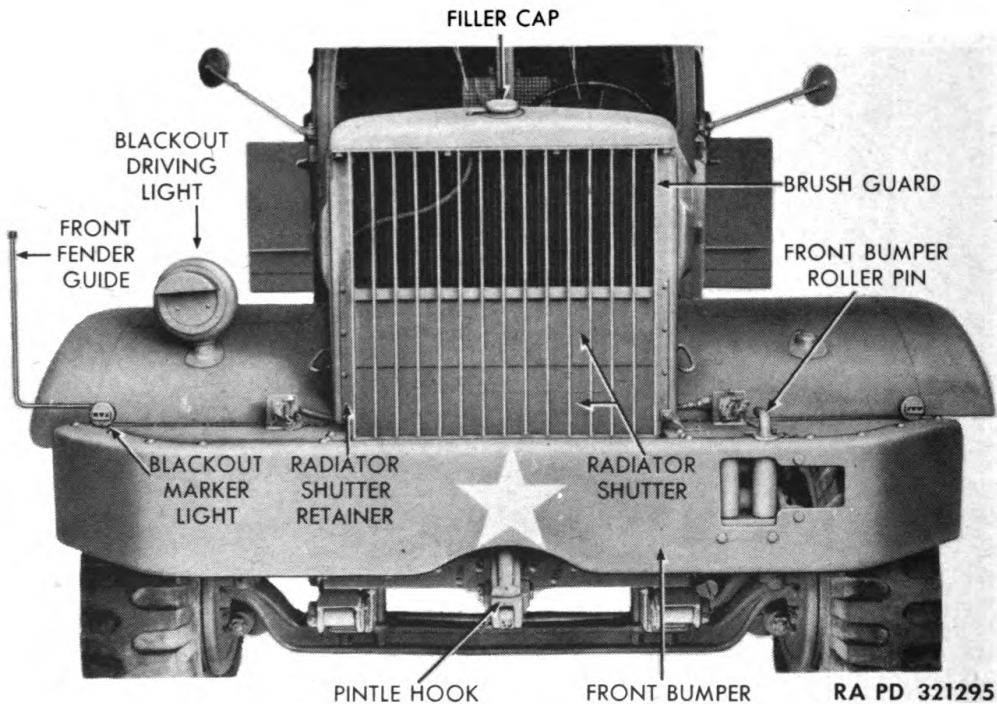

Figure 150—Front End of Truck

(1) The front pintle hook assembly is located on the front bottom crossmember channel assembly. The pintle hook is a forging machined to form a bolt end. The pintle hook assembly consists of pintle hook, latch, lock, and their related controlling parts, which as an assembly is free to turn on its axis and is withdrawn by removing the bolt nut.

(2) The rear pintle hook assembly is centrally located and bolted to the rear frame crossmember and consists of the following: pintle hook, housing lock, and latch with their related controlling parts, which as an assembly permits the free turning of the hook within the housing under compression spring tension. It is withdrawn by removing the bolt nut.

b. Removal of Front and Rear Pintle Hooks (figs. 151 and 152).

(1) **REMOVAL OF FRONT PINTLE HOOK.** Remove cotter pin from pintle bolt nut. Remove nut. Remove inner seat washer. Withdraw and remove pintle hook. Remove outer seat washer.

(2) **REMOVAL OF REAR PINTLE HOOK.** Remove cotter pin from pintle hook bolt nut. Remove nut. Remove inner seat washer. Withdraw pintle hook.

Cab, Frame, and Body

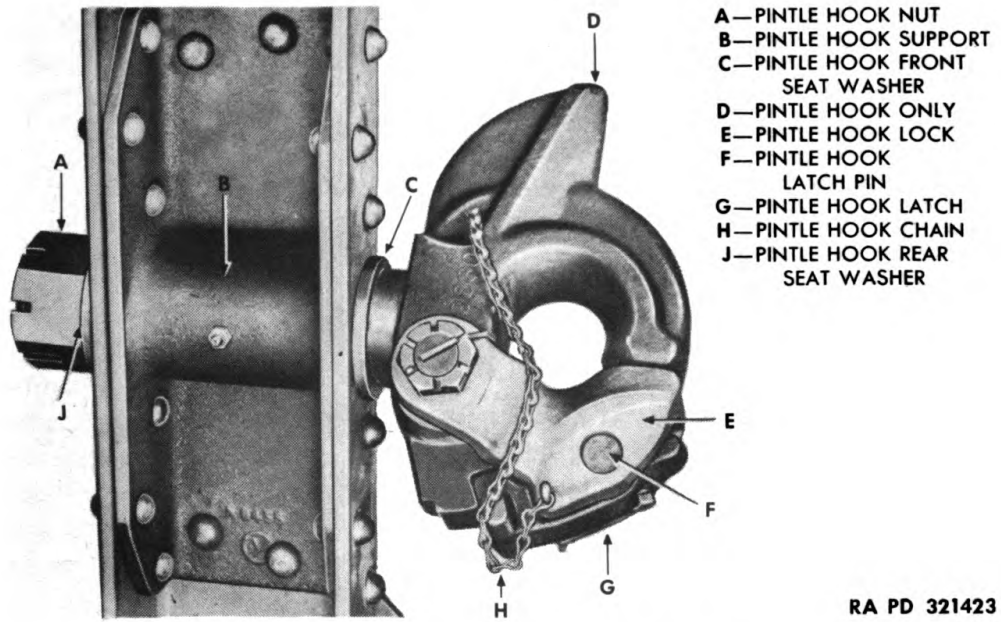

Figure 151—Front Pintle Hook

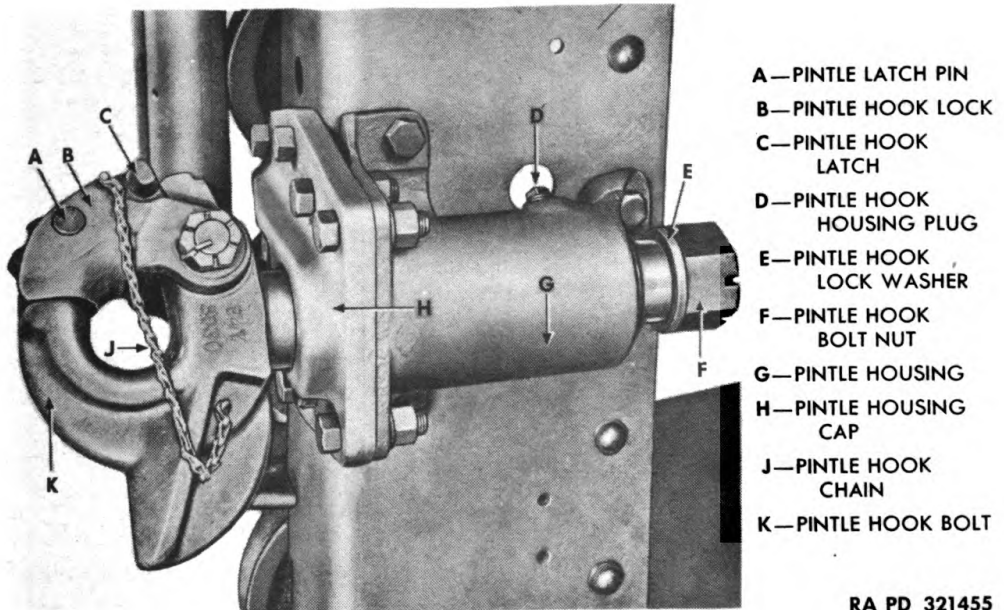

Figure 152—Rear Pintle Hook

c. Installation of Front and Rear Pintle Hooks (figs. 151 and 152).

(1) INSTALLATION OF FRONT PINTLE HOOK. Position outer seat

Maintenance Instructions

washer on pintle hook bolt. Install bolt through support bearing. Install inner seat washer. Install nut. Install cotter pin.

(2) **INSTALLATION OF REAR PINTLE HOOK.** Position and enter pintle hook bolt through housing. Install seat washer. Install nut. Install cotter pin.

d. Removal of Linkage. Remove brake rod yoke pin cotter pins and remove yoke pins at each end of rod. Pull rod out from vehicle. Remove yoke pins from two brake rods at the cross shaft levers. Remove cross shaft bracket mounting bolts, and lift out cross shaft bracket.

e. Installation of Linkage. Place cross shaft assembly on frame crossmember and install mounting bolts, lock washers, and nuts. Position two operating lever brake rods on cross shaft levers, and install yoke pins and cotter pins. Position brake rod between parking brake lever and left cross shaft lever, and insert yoke pins and cotter pins. Place parking lever in released position. Adjust length of parking brake rod, if necessary, by disconnecting front end of rod from parking brake lever, loosening yoke jam nut, and turning yoke to lengthen or shorten rod to remove any slack.

197. SEATS AND CUSHIONS.

a. Description. The driver's seat and the crew seat each consist of a seat cushion, lazy back, and seat frame. The seats and lazy backs are covered with a removable fabric covering.

b. Removal. Lift out seat cushion. Remove four cap screws which secure seat frame assembly to seat box. Lift out seat frame. Remove four bolts which secure lazy back. Lift out lazy back.

c. Installation. Position lazy back on seat frame and install four cap screws. Position seat frame assembly within seat box. Install four attaching cap screws. Drop seat cushion into place.

198. WINDSHIELDS AND CAB WINDOW.**a. Windshields.**

(1) **DESCRIPTION** (fig. 153). In closed cab models, the right- and left-hand windshields are independently operated. Each frame is hinged at the top and swings outward and upward in an arc. Swing arms, one located at each side of frame, guide the windshield and fix it in any position within the arc by means of wing bolts.

(2) **REMOVAL** (fig. 153). Disconnect two swing arms from frame bracket. Open windshield and remove two screws from each of two hinges. Remove windshield.

Cab, Frame, and Body

- A—HOOD TO COWL BOLTS
- B—COWL VENTILATOR
- C—R. H. WINDSHIELD
- D—WINDSHIELD WIPER
- E—WINDSHIELD SWING ARM
BRACKET WING NUT
- F—CAB VENTILATOR
- G—REAR VIEW MIRROR
- H—FIRE EXTINGUISHER
- J—ENGINE HOOD

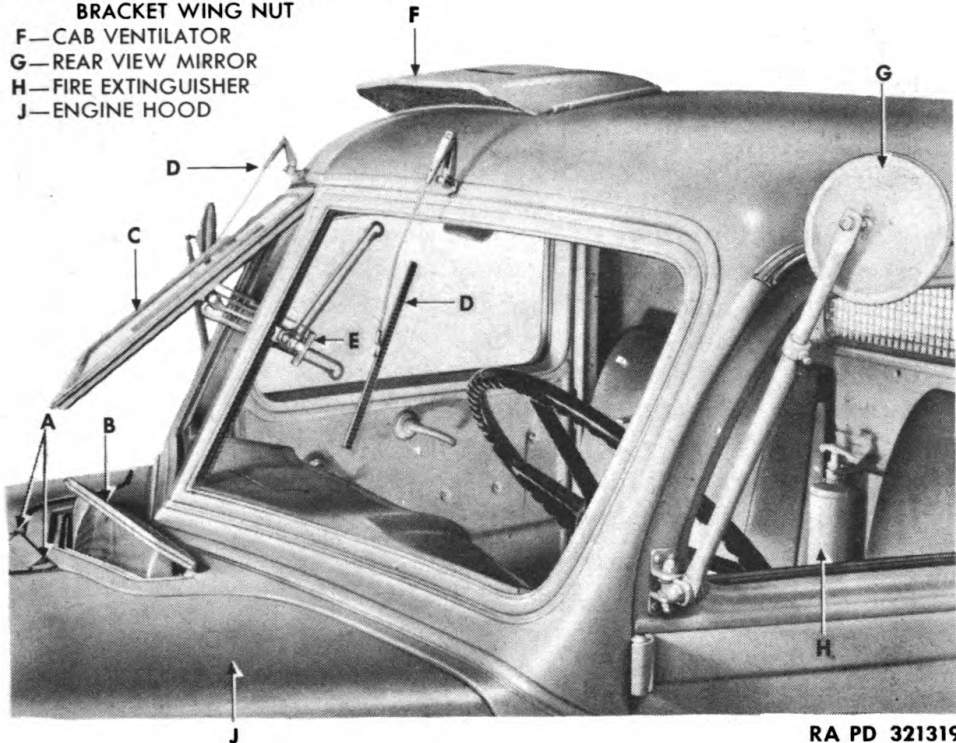

RA PD 321319

Figure 153—Windshield

(3) **INSTALLATION** (fig. 153). Position windshield to align both hinges with screw holes. Install four screws. Position windshield to align with two swing arms, one on each side, and install two screws.

b. Cab Window.

(1) **DESCRIPTION** (fig. 154). Cab models have a cab window in the center of the rear cab panel. The window is protected by a wire screen attached to the outside of the cab.

(2) **REMOVAL** (fig. 154). Remove attaching screws from screen and lift off screen. Pry edge of window weatherstrip free of cab window opening and remove window.

(3) **INSTALLATION** (fig. 154). Set cab window and weatherstrip in cab opening. Pry rubber weatherstrip into position so that metal fits into groove in weatherstrip. Position window screen and install attaching screws.

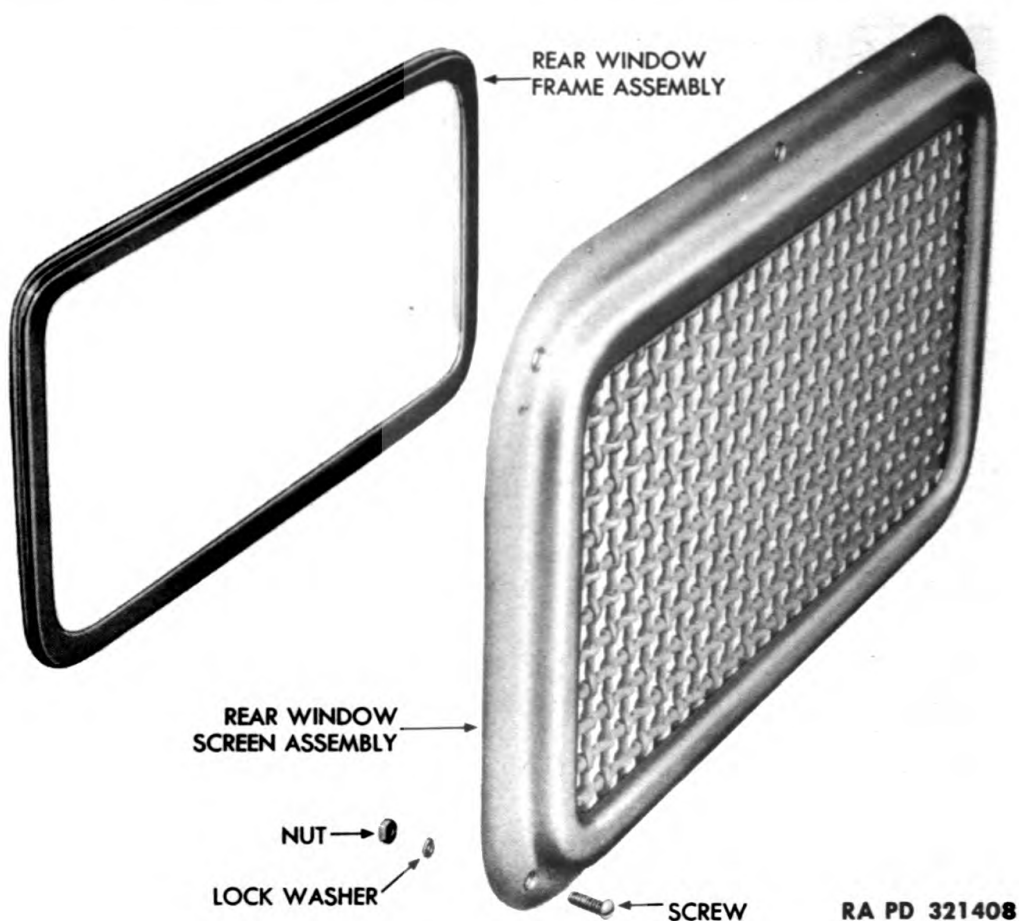

Figure 154—Rear Window

199. WINDSHIELD WIPER ASSEMBLY.

a. **Description** (figs. 155 and 153). The windshield wiper assembly consists of two air motor assemblies within the glove compartment, two wiper arms and extension assemblies each with detachable wiper blade, and two wiper speed control valves located on the instrument panel.

b. Windshield Wiper Blade.

(1) **REMOVAL** (fig. 153). Turn wiper blade to position the hook for withdrawal from wiper arm hook. Withdraw wiper blade.

(2) **INSTALLATION** (fig. 153). Position wiper blade hook to mate with hook in wiper arm. Turn wiper blade to lock in position.

c. Windshield Wiper Arm Assembly.

(1) **REMOVAL**. Remove wiper arm nut. Pull wiper arm assembly free from motor shaft.

Cab, Frame, and Body

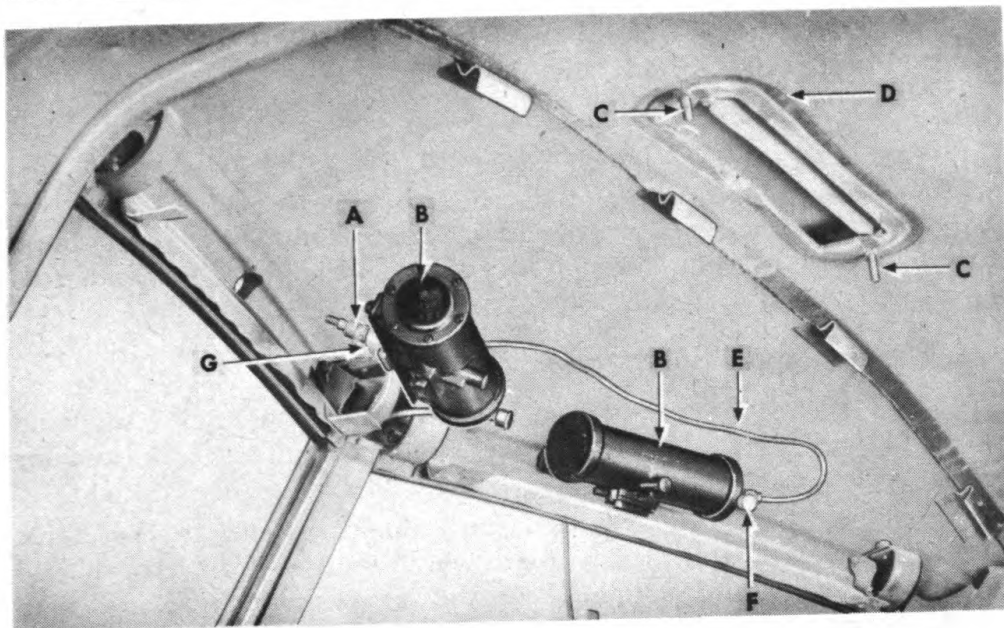

A—SHAFT
B—WIPER MOTOR
C—STUDS
D—GASKET

E—TUBE
F—TUBE ATTACHING NUT
G—INNER SPACER

RA PD 321429

Figure 155—Removing Windshield Wiper Motors

(2) **INSTALLATION.** Position wiper arm extension on motor shaft. Install wiper arm nut.

d. Wiper Motor Assembly.

(1) **REMOVAL** (fig. 155). Remove screws from cab header panel and lift out panel (fig. 9). Remove wiper arm assembly (subpar. c (1) above). Remove nut, outer spacer, and leather washer. Withdraw wiper motor. Disconnect air line. Remove motor. Remove inner spacer.

(2) **INSTALLATION** (fig. 155). Attach air line to wiper motor. Position inner spacer. Position motor shaft through cab frame. Position leather washer and outer spacer over motor shaft. Install lock nut. Install wiper arm assembly (subpar. c (2) above). Install cab header panel and attaching screws (fig. 9).

e. Windshield Wiper Control Valve.

(1) **REMOVAL.** Back out valve stem knob. Unscrew retainer collar and remove with valve stem knob. Disconnect two air lines from valve body. Push out and free valve body.

(2) **INSTALLATION.** Position valve body through instrument panel. Connect two air lines. Position valve stem knob through retainer collar and into valve body. Tighten retainer collar, making adjustment for sufficient thread engagement with lock nut.

200. SHIELDS (fig. 41).**a. Fuel Tank Shield.**

(1) **REMOVAL.** Remove nuts from four strap end bolts. Remove fuel tank mud shield (subpar. b (1) below). Lift off fuel tank shield.

(2) **INSTALLATION.** Place fuel tank shield over fuel tank. Install strap end bolts through straps and step board. Install fuel tank mud shield (subpar. b (2) below).

b. Fuel Tank Mud Shields.

(1) **REMOVAL.** Remove screws which secure fuel tank mud shield to fuel tank shield. Remove nuts, bolts, and lock washers which secure mud shields to step board support. Lift off shield.

(2) **INSTALLATION.** Position mud shield on end of fuel tank. Install bolts, nuts, and lock washers which secure lower end of mud shield to step board support. Install screws which secure mud shield to fuel tank shield.

c. Battery Shields.

(1) **REMOVAL.** Remove floorboard and toeboard (par. 68 e). Remove battery shield attaching screws. Pull out battery shield from chassis.

(2) **INSTALLATION.** Position battery shield over batteries. Install screws which secure shield. Install floorboard and toeboard (par. 69 n).

201. FRONT FENDERS AND FENDER GUIDE.

a. Description (fig. 156). The two front fenders are attached to the front bumper and to the frame side rails by means of brackets. Between the inner edge of the fender and the engine is a removable fender shield with vents for exhausting, from the engine compartment, the air blown back by the fan. A fender guide, to aid the driver in steering the truck in close quarters, is mounted on top of the right fender.

b. Removal of Fenders.

(1) **REMOVE FENDER SHIELD.** Remove screws which secure fender shield to chassis frame rail and clips which secure fuel oil lines. Remove bolts which secure fender shield to fender. Lift out fender shield.

(2) **REMOVE FENDER.** On right fender, remove screw which secures wiring harness clips to fender. Disconnect wires from blackout driving light. Loosen bolts in wiring clips and pull blackout driving light wires free. Remove nut, bolt, and lock washer

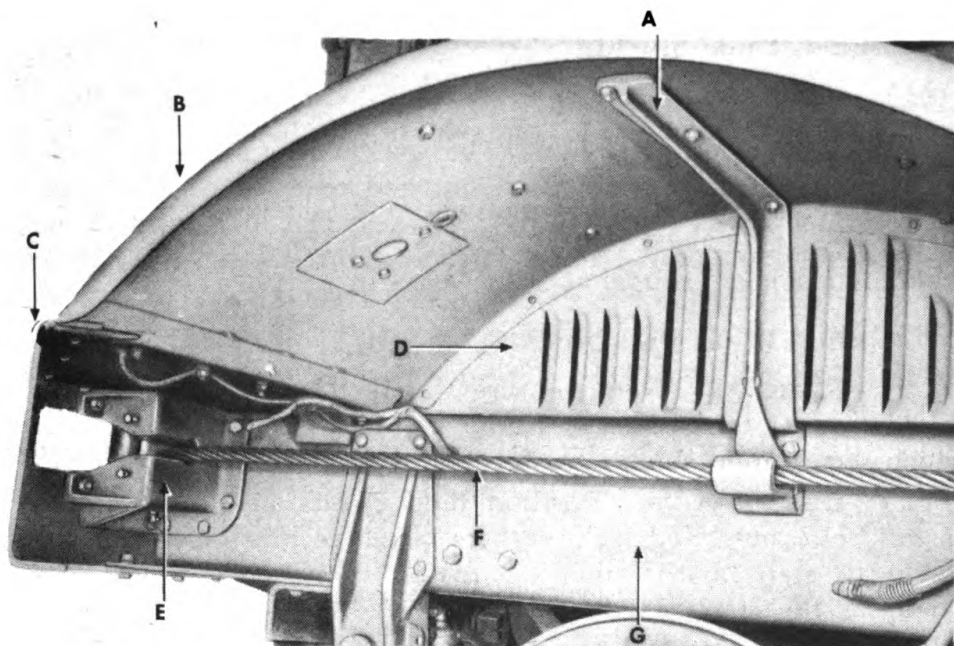

A—FRONT FENDER IRON	E—FRONT BUMPER ROLLER SUPPORT
B—L. H. FRONT FENDER	F—WINCH CABLE
C—FRONT BUMPER	G—L. H. FRAME SIDE RAIL
D—L. H. FRONT FENDER SHIELD	

RA PD 321339

Figure 156—Front Fender—Installed

which secure ground wire to fender. On right or left fenders, remove bolts, lock washers, and nuts which secure fender to front bumper. Remove wiring clips. Remove bolts which secure fender to front and rear fender irons. Lift off fender.

c. Installation of Fenders.

(1) **ATTACH FENDERS.** Place fenders in position. Install bolts which attach fenders to front bumper, and to front and rear fender irons.

(2) **CONNECT WIRES.** On right fender, connect blackout driving light wires at connector. Install wiring clips. Install bolt, nut, and lock washer which attach ground wire to fender. On right or left fender install wiring clips and wires to blackout marker lights.

(3) **INSTALL FENDER SHIELDS.** Position fender shields on frame side walls. Install screws, lock washers, and plain washers which secure shields to frame rails and to fenders.

d. Replacement of Fender Guide. Loosen upper lock nut and remove lower nut from fender guide. Lift guide from fender.

Place end of new fender guide in hole in right fender. Position upper nut and position guide. Install lower nut and tighten.

202. STEP BOARDS.

a. **Description** (fig. 41). The step boards are located on each side of the truck between the front and rear wheels. They provide a step for entering and leaving the truck, and also support the batteries and fuel tanks. The step boards are attached to the truck by means of step board supports which are riveted to the chassis frame.

b. **Removal** (fig. 41). Remove the fuel tank mud shields (par. 200 b (1)). Remove the fuel tank shields (par. 200 a (1)). Remove the battery shields (par. 200 c (1)). Remove the batteries (par. 112 c). Remove the primary fuel filters (par. 72 c). Remove the fuel tanks (par. 71 b). Remove the bolts securing the step boards to the step board hangers. Lift off the step boards.

c. **Installation** (fig. 41). Place the step boards on the step board hangers and install the attaching bolts. Install the fuel tanks (par. 71 b). Install the fuel filters (par. 72 c). Install the batteries (par. 112 c). Install the battery shields (par. 200 c (2)). Install the fuel tank shields (par. 200 a (2)). Install the fuel tank mud shields (par. 200 b (2)).

203. RADIATOR BRUSH GUARD AND SHUTTERS.

a. **Description** (fig. 150). The radiator brush guard is located directly in front of the radiator. It is bolted to the radiator top tank and to the radiator support crossmember. The shutter is a metal plate, located between guard and radiator, and sliding between two bolted and removable radiator side members. It is manually raised or lowered to block or expose radiator according to climatic conditions.

b. **Removal of Radiator Brush Guard** (fig. 150). Remove four cap screws and four lock washers from guard at radiator support cross member behind bumper. Remove two cap screws, two plain washers, and two lock washers from guard at radiator tank top. Remove guard.

c. **Installation of Radiator Brush Guard** (fig. 150). Position guard between radiator crossmember and radiator tank top and align bolt holes. Install four cap screws and four lock washers at lower ends and two bolts, two lock washers, and two plain washers at top.

d. Replacement of Radiator Shutter.

(1) **REMOVAL OF SHUTTER.** Remove radiator brush guard (subpar. b above). Remove eight cap screws and lock washers from

Cab, Frame, and Body

radiator side members. Lift out shutter.

(2) **INSTALLATION.** Position shutter on radiator. Position each of two side members. Install eight lock washers and cap screws. Install radiator brush guard (subpar. c above).

204. ENGINE HOOD.

a. Description (figs. 30 and 153). The engine hood assembly provides a ventilated protective covering over the engine compartment. The center panel of the assembly is bolted at the ends to the cowl and to the radiator assembly. Two louvered side panels are hinged to provide access to either side of the engine. Hood braces are provided to hold panels in open position. The panels are held down by hood fasteners in closed position.

b. Removal (figs. 30 and 153). Release hood fasteners. Lift one side of hood, and remove cotter pins and hood brace pins from upper ends of hood braces. Close hood. Remove brace pins on opposite side in similar manner. Remove hood to cowl bolts. Lift off lock strap. Remove hood to radiator bolts, and lift off lock strap. Lift off hood. Back off hood stay rod nuts, and unscrew stay rod from radiator. Remove nut at rear end of rod at rear of cowl. Pull out stay rod.

c. Installation (figs. 30 and 153). Place nut on each end of radiator stay rod. Insert one end of rod in cowl opening, and thread other end into radiator assembly opening. Install nut on rear end of rod behind cowl, and take up on rear nut until radiator is supported rigidly by rod. Tighten jam nuts at each end of rod. Position hood, and install lock strap at front end of hood. Install hood to radiator bolts. Position lock strap at rear end, and install hood to cowl bolts. Open one side of hood. Install hood brace pins and cotter pins at upper ends of hood braces. Close hood and connect hood braces on opposite side in a similar manner. Latch hood with hood fasteners.

205. CAB VENTILATORS.

a. Description (figs. 153, 157, and 9). The closed cab is equipped with a door-type ventilator on each side and at the top center of the cowl. It is also equipped with an intake and exhaust ventilator located in the roof of the cab. The roof ventilator admits air through a filter screen and ejects foul air. There are two inside control doors under the ventilator. The forward door admits air and the rear one ejects it, when the vehicle is moving.

b. Removal (figs. 157 and 9).

(1) **INTAKE AND EXHAUST VENTILATOR** (figs. 157 and 9). Remove two acorn nuts from twin control door assembly on ceiling

RA PD 321360

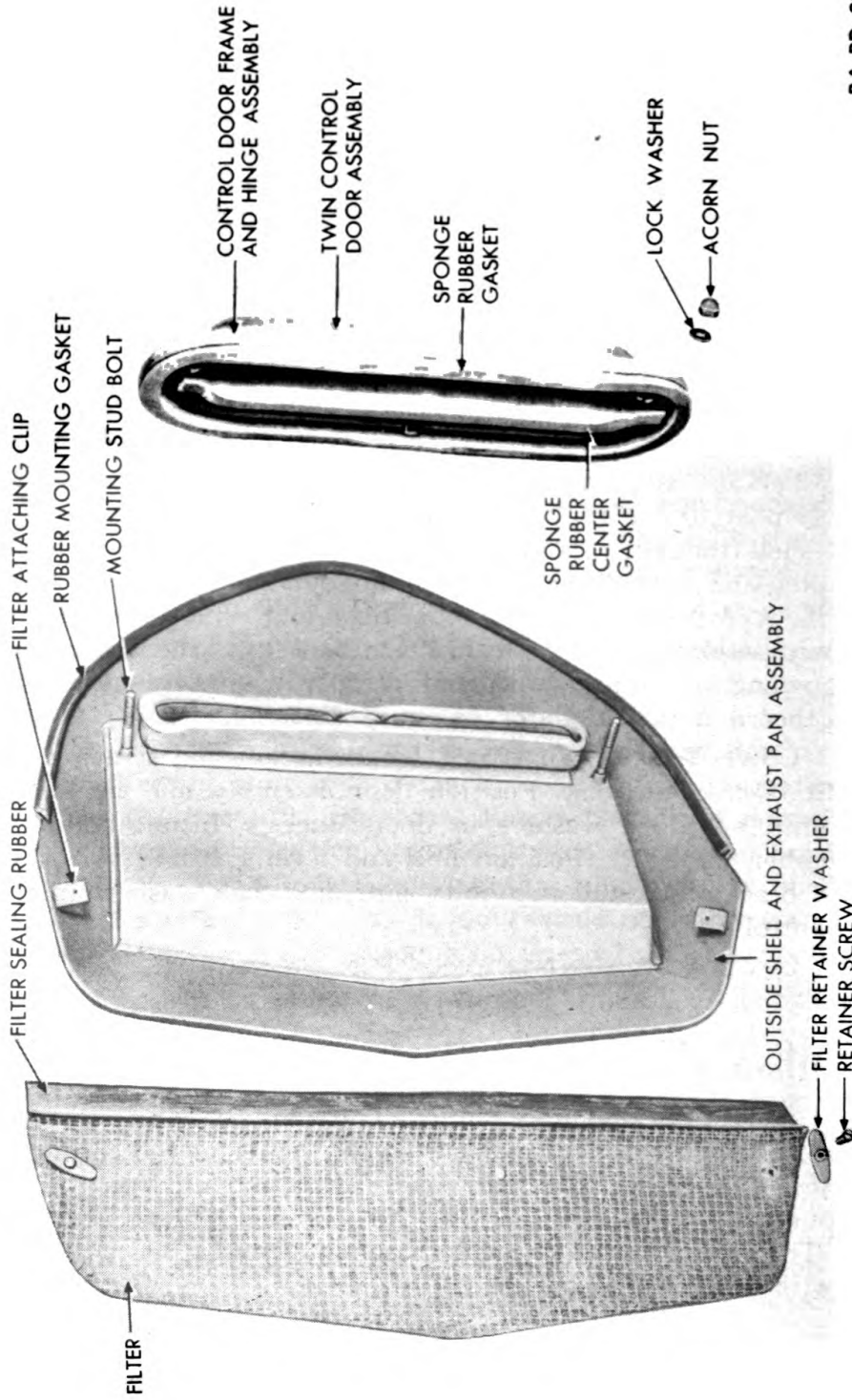

Figure 157—Intake and Exhaust Ventilator

Cab, Frame, and Body

of cab. Free the control door assembly from cemented contact with ceiling. Remove rubber door and center gaskets. Free the outside shell and exhaust pan assembly from cemented contact with cab top. Remove rubber mounting gasket. Remove filter retainer screws and washers and lift off filter.

(2) **COWL TOP VENTILATOR.** Remove two bolts, nuts, and lock washers from hand lever control link. Remove two screws from lever bracket. Remove link and lever. Remove bolt, washer, and nut from bell crank. Remove four bolts, nuts, and washers from cowl door hinges. Remove door assembly. Disconnect drain hose. Remove screen assembly.

(3) **COWL SIDE VENTILATOR.** Close cowl door. Remove spring-tensioned telescope bolt. Remove two hinge pins and lift off ventilator door.

c. Installation.

(1) **INTAKE AND EXHAUST VENTILATOR.** Position filter in the outside shell and exhaust pan, and install retainer screws and washers. Apply cement to the rubber mounting gasket and attach it to the outside shell front edge. Apply cement to cab roof in area of mounting gasket and center gasket. Position outside shell assembly to cab roof. Cement the sponge rubber door and center gasket to the twin door assembly. Apply cement to ceiling in the area around door opening. Position twin control door assembly. Install attaching acorn nuts and lock washers.

(2) **COWL TOP VENTILATOR.** Install gasket and screen assembly. Connect drain hose. Position door assembly and install four bolts, nuts, and lock washers in door hinges. Install bell crank bolt, washer, and nut. Position link and lever. Install two screws in lever bracket. Install two bolts, nuts, and lock washers in hand lever control link.

(3) **COWL SIDE VENTILATORS.** Position ventilator door. Install two door hinge pins. Install spring-tensioned telescope bolt.

206. REAR VIEW MIRRORS.

a. Description (figs. 153 and 9). There are three rear view mirrors; one on each cab door and one in the center of the cab header panel inside the cab. The rear view mirrors mounted on the door are mounted on telescoping arms. All swivel positions are adjustable. The mirror inside the cab is mounted on a bracket and is fitted with a friction swivel joint.

b. Removal (figs. 153 and 9).

(1) **SIDE REAR VIEW MIRRORS.** Remove four screws from support bracket and lift off mirror assembly.

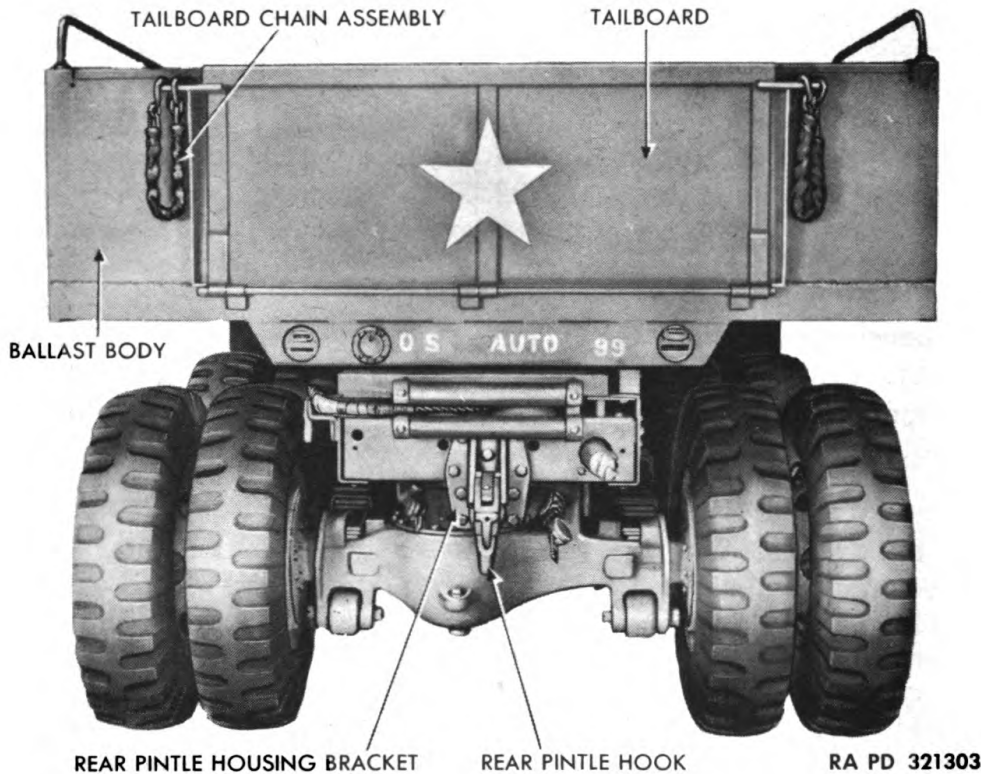

Figure 158—Rear View of Truck

(2) **CENTER REAR VIEW MIRROR.** Remove two screws from mounting bracket and lift off mirror assembly.

c. Installation.

(1) **SIDE REAR VIEW MIRRORS.** Position mirror assembly on cab door. Install four attaching screws.

(2) **CENTER REAR VIEW MIRROR.** Position mirror assembly on cab header panel. Install two attaching screws.

207. BALLAST BODY.

a. Description (fig. 158). The ballast body, described in paragraph 194 c, is secured to the wood sills on the frame side rails with tie-down brackets which are bolted to the chassis frame rails and to the ballast body.

b. Removal. Disconnect the blackout, tail, and stop light cable connectors from the right- and left-hand tail and stop lights. Disconnect the leads from trailer jumper socket assembly terminals. Pull wires back out of ballast body. Remove ballast body tie-down bolts, lock washers, and nuts which attach tie-down brackets

Cab, Frame, and Body

to body and chassis. Attach a rope sling around body at front and rear ends. Raise body clear of chassis.

c. Installation. Hoist body over chassis. Place wood sills in position on chassis side frame rails. Lower body in place and aline it on wood sills. Install tie-down brackets, bracket bolts, nuts, and lock washers. Connect blackout, tail, and stop light connectors. Connect leads to trailer jumper socket terminals.

208. TRUCK CABLE ROLLERS AND SHEAVES.

a. Description. The winch cable, which is led to the rear of the truck between the ballast body and chassis, is carried across horizontal rollers to prevent chafing the cable. A single horizontal roller is installed at the front under side of the ballast body, and an idler roller is installed on the top of the chassis frame at about the center of the body. Double horizontal towing rollers are installed on the chassis frame rear crossmember to give the cable a bearing when it is led upward or downward. Two towing cable sheaves are also installed at the rear to allow the cable to be led to the right or left side of the truck. On the left rear corner of the chassis frame, a sheave is installed to allow the cable to lead forward along the left frame rail to the front bumper cable roller.

b. Front Bumper Roller Assembly (figs. 156 and 150).

(1) **REMOVAL.** Rotate front bumper roller pin and pull it out of bumper. Remove eight bolts, lock washers, and nuts securing front bumper roller support to the front bumper and left frame side rail. Lift out front bumper roller assembly.

(2) **INSTALLATION.** Position front bumper roller assembly in roller support. Position roller support assembly to front bumper and left frame side rail. Install eight bolts, lock washers, and nuts. Insert front bumper roller pin through bumper, and secure pin by rotating.

c. Towing Cable Roller Bracket Assembly.

(1) **ROLLER.**

(a) *Removal* (fig. 159). Loosen lock nuts on roller bracket set screws. Loosen set screws, and drive roller shaft from bracket.

(b) *Installation* (fig. 159). Position roller in bracket, and drive the shaft through bracket and roller. Tighten screws and lock nuts.

(2) **BRACKET.**

(a) *Removal* (fig. 159). Remove nuts, lock washers, and bolts which secure roller bracket to truck frame. Pull roller bracket from truck frame.

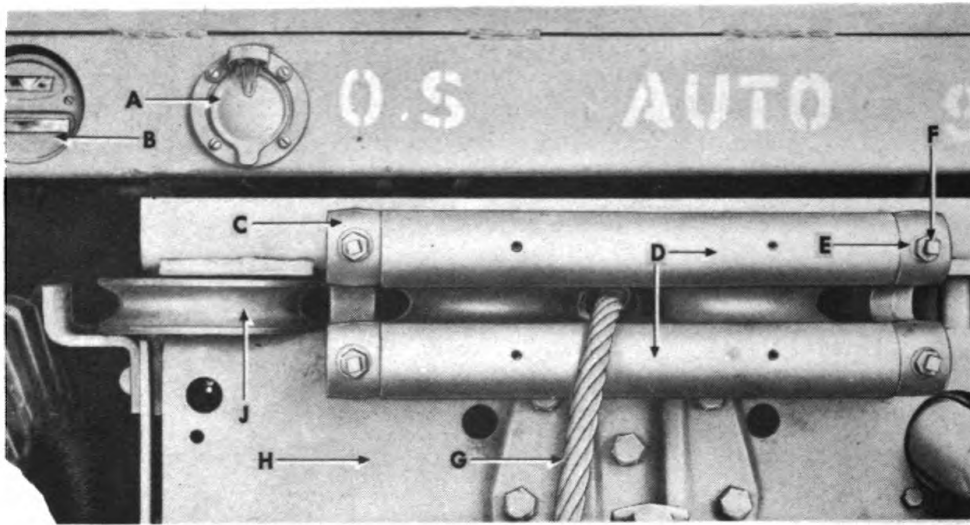

- A—TRAILER SOCKET ASSEMBLY
- B—BLACKOUT TAIL AND STOP LIGHT
- C—CABLE ROLLER BRACKET
- D—CABLE ROLLERS
- E—LOCK NUT
- F—SET SCREW
- G—WINCH CABLE
- H—FRAME REAR CROSSMEMBER
- J—TOWING CABLE SHEAVE

RA PD 321343

Figure 159—Towing Cable Roller Bracket Assembly

(b) *Installation.* Position roller bracket assembly in truck frame. Install attaching bolts, lock washers, and nuts.

d. Cable Idler Roller Assembly.

(1) **REMOVAL.** Remove bracket bolts, lock washers, and nuts. Lift off idler roller assembly. Remove cotter pin and washer at each end of cable idler roller shaft. Drive shaft out of roller and brackets. Remove roller.

(2) **INSTALLATION.** Place roller shaft in roller. Install brackets on each end of shaft. Install washer and cotter pin at each end of roller. Position assembly on chassis and install mounting bolts, nuts, and lock washers.

e. Ballast Body Roller Assembly.

(1) **REMOVAL.** Remove bearing attaching bolts, nuts, and lock washers. Lift off roller assembly.

(2) **INSTALLATION.** Position roller assembly on front of ballast body. Install bearing attaching bolts, nuts, and lock washers.

Auxiliary Equipment

f. Towing Cable Sheaves.

(1) **REMOVAL** (fig. 159). Disconnect ballast body from chassis (par. 207 b). Raise rear end of body about 6 inches and block up underbody frame members. Remove cotter pin and nut from sheave bolt nut. Remove and pull out sheave.

(2) **INSTALLATION**. Insert sheave in position under rear cross-member top channel. Insert sheave pin bolt. Attach nut and cotter pin. Lower body to chassis and install attaching bolts (par. 207 c).

Section XXXVII

AUXILIARY EQUIPMENT

209. DESCRIPTION AND DATA.

a. **Description** (fig. 160). The winch is mounted on brackets which are secured to the frame side rails between the cab and the ballast body. It is powered by the vehicle engine through power take-off, propeller shaft, and drive chain. A torque control mechanism automatically stops the engine when the cable pull becomes greater than 22,400 pounds, and a safety brake automatically holds the load until the engine is started again. The winch controls, an air clutch control, and a throttle control, are mounted at the left-hand end of the winch.

b. Data.

Make	Gar Wood
Model	5M723B
Drive	Power take-off
Cable:	
Length:	
Model 980	300 ft
Model 981	500 ft
Diameter	7/8 in.
Maximum pull:	
(First layer on drum)	22,400 lb
Winch capacity (normal)	40,000 lb
Worm reduction	30 to 1
Diameter of drum	7 in.
Winding speed (1,000 rpm) with main transmission in direct, first layer of cable	55 ft per min

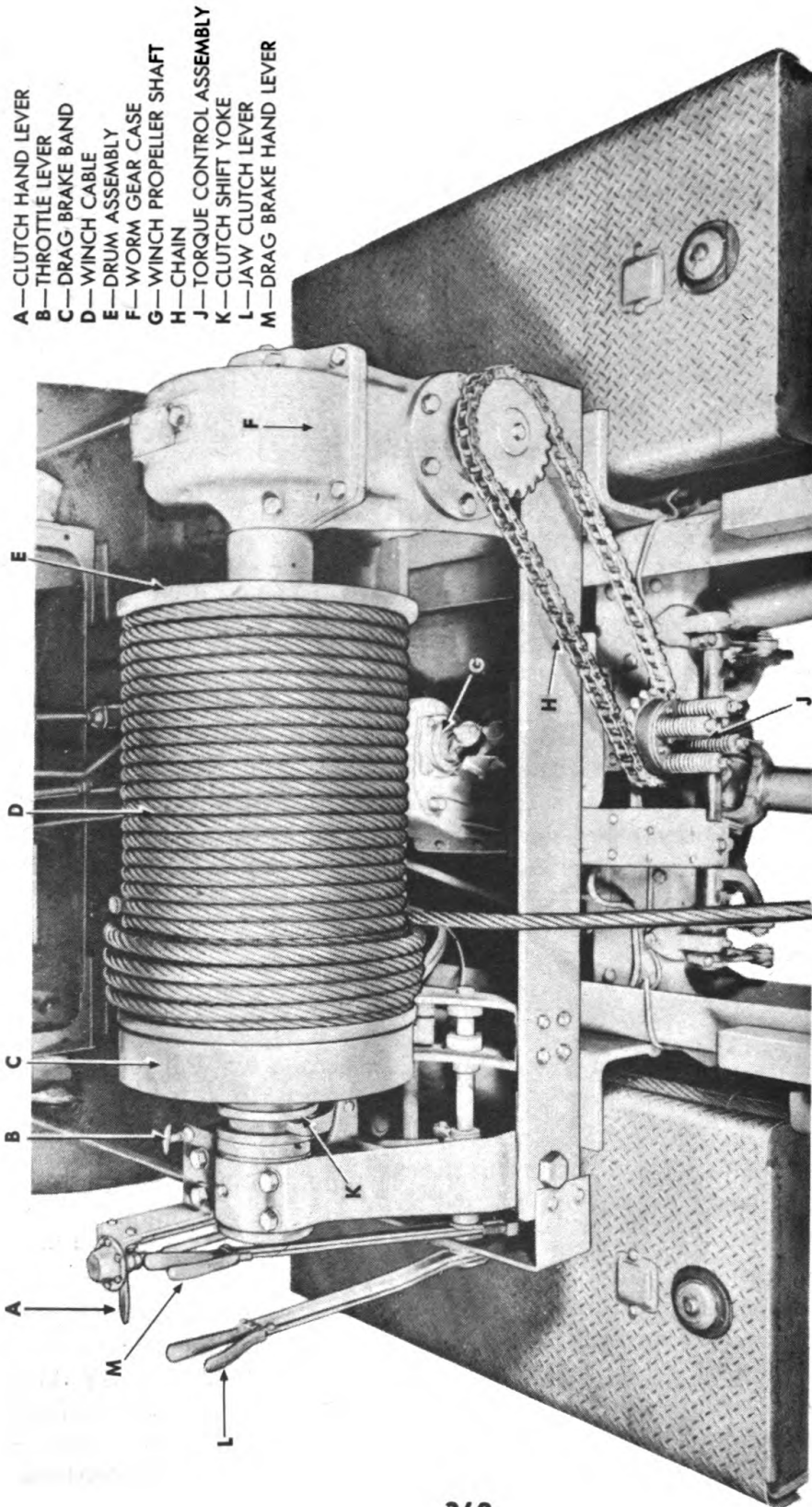

RA PD 321466

Figure 160—Winch Installed

Auxiliary Equipment

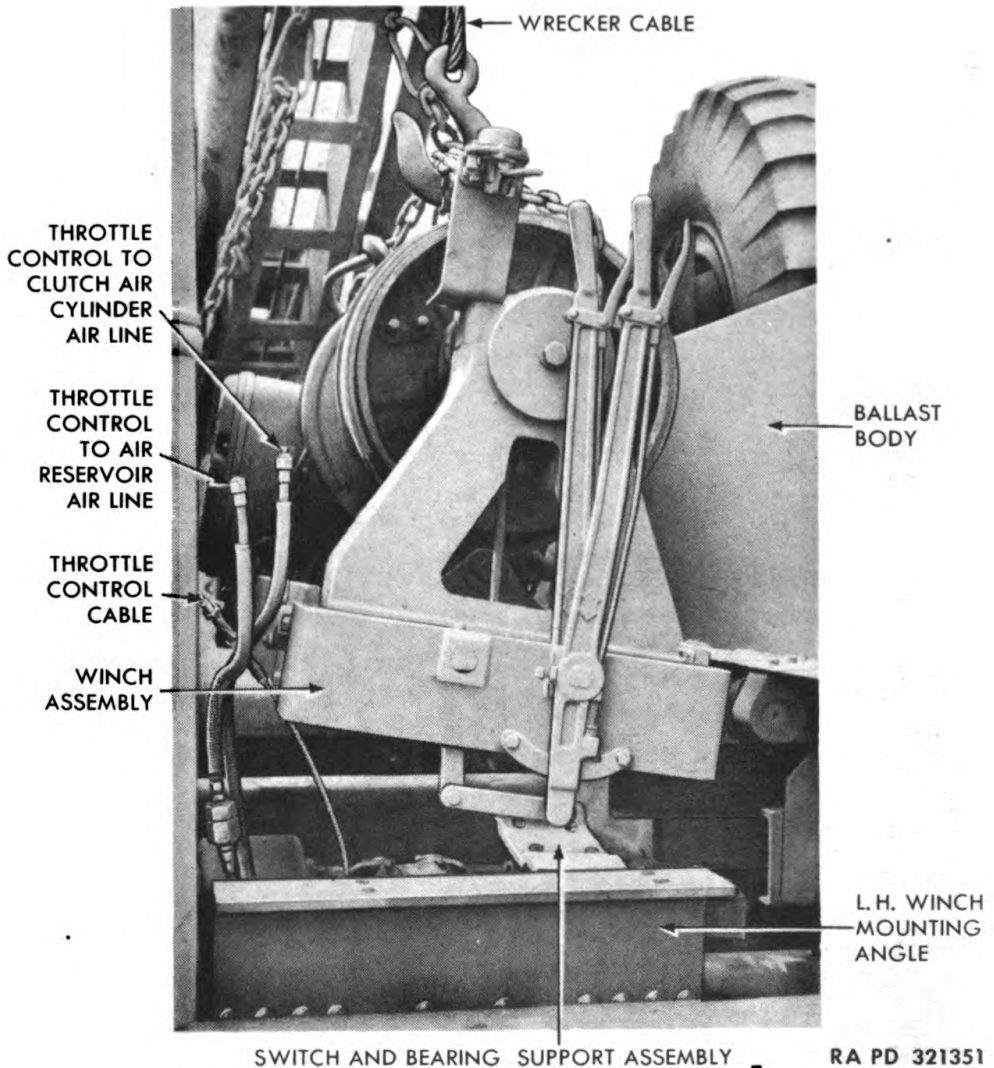
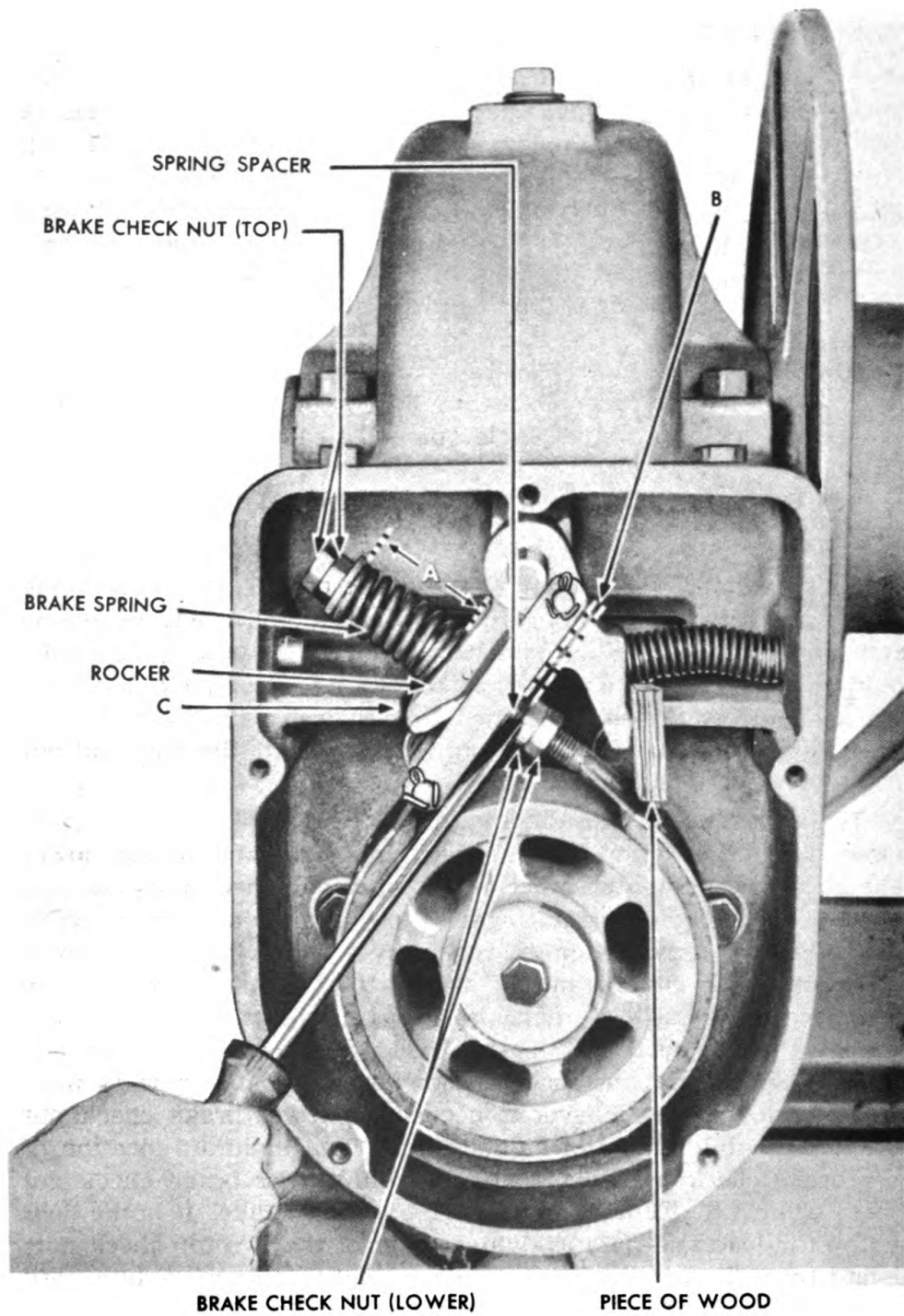

Figure 161—Removing Winch

210. WINCH REMOVAL AND INSTALLATION.

a. **Removal** (figs. 160 and 161). Remove cable (par. 213 b). Remove torque control (par. 215 b). Loosen lock nut which secures throttle control knob to throttle cable, and unscrew knob and nut from cable. Loosen lock nut which secures cable housing to control bracket. Unscrew cap, pull cable from bracket, and remove lock nut. Back off connector nuts which secure air lines to clutch control valve. Remove nut which secures clutch air line clips to winch frame, and lift clips from bolt. Remove nuts, lock washers, and bolts which secure control valve bracket to winch. Fasten air lines and throttle control cable out of the way. Remove nuts, toothed lock washers,



RA PD 343980

Figure 162—Checking Safety Brake Band Adjustment

Auxiliary Equipment

and bolts which secure winch to winch mounting angles. Attach a chain sling around winch drum. Lift winch from vehicle, using wrecker or chain fall.

b. **Installation** (figs. 160 and 161). Lift winch into position on vehicle and install nuts, bolts, and toothed lock washers which secure winch to winch mounting angles. Install torque control (par. 215 c). Position throttle control bracket and install bolts, lock washers, and nuts which secure control valve bracket to winch. Connect throttle control to clutch cylinder air line and throttle control to air reservoir air line, making sure that the inlet line from the check valve is connected to the inlet fitting on the control valve. (The inlet fitting on control valve is off-center.) Screw lock nut into cable housing, insert housing into hole in control bracket, and install cap. Tighten lock nut. Screw lock nut onto end of cable. Screw control knob onto cable, and tighten lock nut. Install cable (par. 213 c).

211. WINCH SAFETY BRAKE BAND ASSEMBLY.

a. **Adjustment** (fig. 162).

(1) **GENERAL.** The action of the brake band is such that brake will automatically apply enough drag to hold a load when the engine clutch is disengaged. When winch is reversed by power, the brake should allow the drum to turn. Test holding power of brake by hoisting a load and suspending it. Then start lowering the load and disengage engine clutch. If brake is properly adjusted, the load will not settle more than 2 inches.

(2) **ADJUSTMENT PROCEDURE.** Remove brake case cover. Loosen outer of two top brake check nuts and outer of two lower brake check nuts. Tighten inner of the top brake check nuts one-half turn. Jam the outer check nut against it to maintain location. With no load on the winch, wedge the rocker over with a piece of wood so that rocker holds contact at "C," figure 162. Use a screwdriver to hold spring spacer up into rocker as far as it will go. For proper adjustment, the dimension "B," figure 162, which is the space between the spring spacer and the inner of two lower check nuts, is $\frac{1}{8}$ inch. Tighten or loosen (whichever is necessary) lower brake check nut (outer) until this dimension is obtained. Then maintain location of lower brake check nut (outer) by jamming lower brake check nut (inner) against it. Remove piece of wood. Test brake. If brake does not stop the load and hold it, tighten inner of the two top check nuts one-half turn. Test brake again. Keep repeating this procedure until brake holds the load.

b. **Removal.** Disconnect winch and move it back from cab to give sufficient clearance (par. 210 a). Remove outer of two upper brake check nuts and back off inner nut. Pry rocker off rocker pin

and at same time pry brake band off brake disk. Hold rocker spring to prevent it from flying off.

c. Installation. Place brake band in position in brake case. Check to see that arrow on rocker arm points in same direction as rotation of disk when winch is pulling, or toward drum on this winch. Tap brake band over brake disk and rocker pin. When band is part way on, install rocker spring on rocker plain dowel and brake case plain dowel. Tap brake band into place. Install outer of two upper brake check nuts. Adjust brake band as instructed in subparagraph a above.

212. WINCH BRAKE BAND ASSEMBLY.

a. Removal. Loosen set screws in collar and slide operating shaft free of brake lever. Remove cotter pin from brake band tight-end pin assembly and drive out pin. Slide brake band assembly from drum. Remove cotter pin from pin which connects brake lever to brake band assembly. Drive out pin and remove lever from brake band.

b. Installation. Aline brake lever with brake band assembly, install pin, and secure with cotter pin. Slide brake band assembly onto drum. Aline long end of band with holes in winch frame, install tight-end pin, and secure with cotter pin. Aline brake lever collar with shaft bearings in winch frame. Drive shaft into position through collar and bearings, and tighten set screws in collar and collars on shaft.

213. WINCH CABLE.

a. Description (fig. 160). A $\frac{7}{8}$ -inch woven wire cable (300- or 500-ft) is carried on the winch drum. It is attached by a U-clamp at the left-hand end of the drum. The free end of the cable is spliced around a steel eye which is equipped with a clevis.

b. Removal. Disengage jaw clutch. Pull out a sufficient length of cable to stake to the ground or otherwise secure. Leaving jaw clutch disengaged, drive vehicle slowly in a straight line until end of cable is reached. Stop truck, remove cable U-clamp, and pull cable free of winch drum and vehicle. See that cable does not kink. Store it in a clean dry place.

c. Installation. Lay cable on ground straight out from rear end of truck. Thread end of cable through rollers and sheaves at rear of truck, over idler roller under center of truck, and under roller at front end of ballast body. Pass cable under drum, thread through hole in left end of drum, and press between clamp studs. Install U-clamp. Secure towing end of cable to front of a vehicle with driver

Auxiliary Equipment

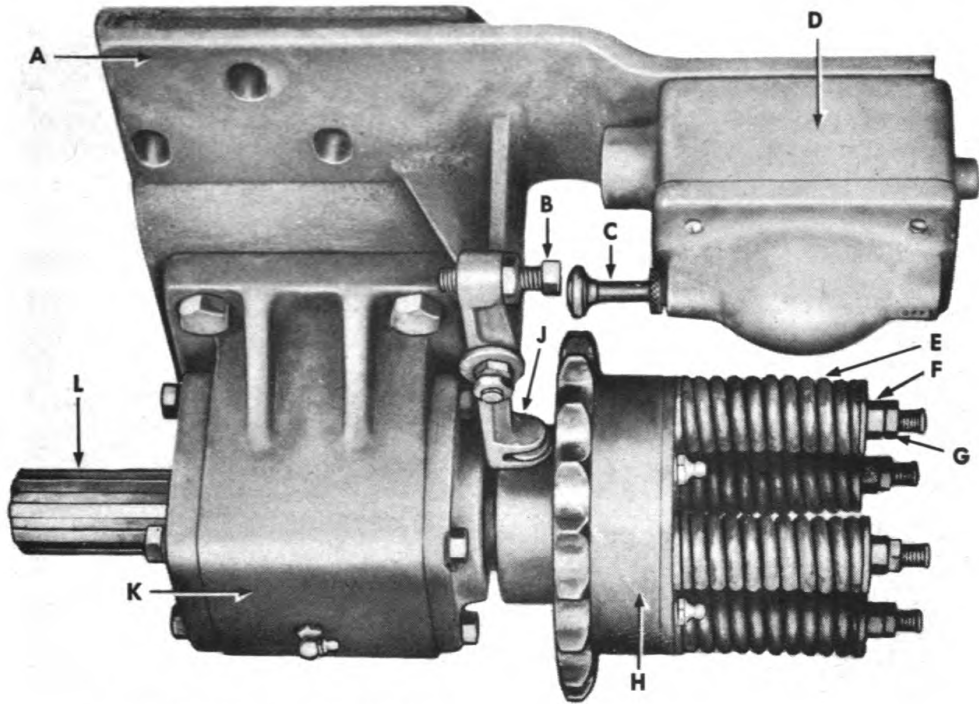

- | | |
|--|-------------------------|
| A—SWITCH AND BEARING
SUPPORT ASSEMBLY | F—NUT |
| B—ROCKER ARM | G—JAM NUT |
| ADJUSTING SCREW | H—SPROCKET |
| C—SWITCH PLUNGER | J—ROCKER ARM |
| D—SWITCH BOX ASSEMBLY | K—BEARING ASSEMBLY |
| E—TORQUE CONTROL SPRING | L—WINCH PROPELLER SHAFT |

RA PD 321402

Figure 163—Winch Torque Control Assembly

to guide it, and keep brakes lightly applied on second vehicle. Start engine of truck and engage winch controls so that cable will be slowly spooled (par. 15 c (6)). Guide cable into even layers with a steel bar or by hammering with a heavy soft-nosed hammer. If cable is dirty or dry, clean it with steel brushes and oil with engine oil as it is wound onto winch drum.

214. WINCH SPROCKET.

a. **Removal.** Remove chain. Remove screw and retainer washer which secure sprocket on worm shaft. Tap sprocket from shaft. Remove key from sprocket.

b. **Installation.** Slide sprocket onto worm shaft with key slots alined and install key. Install screw and washer on end of worm shaft. Install chain.

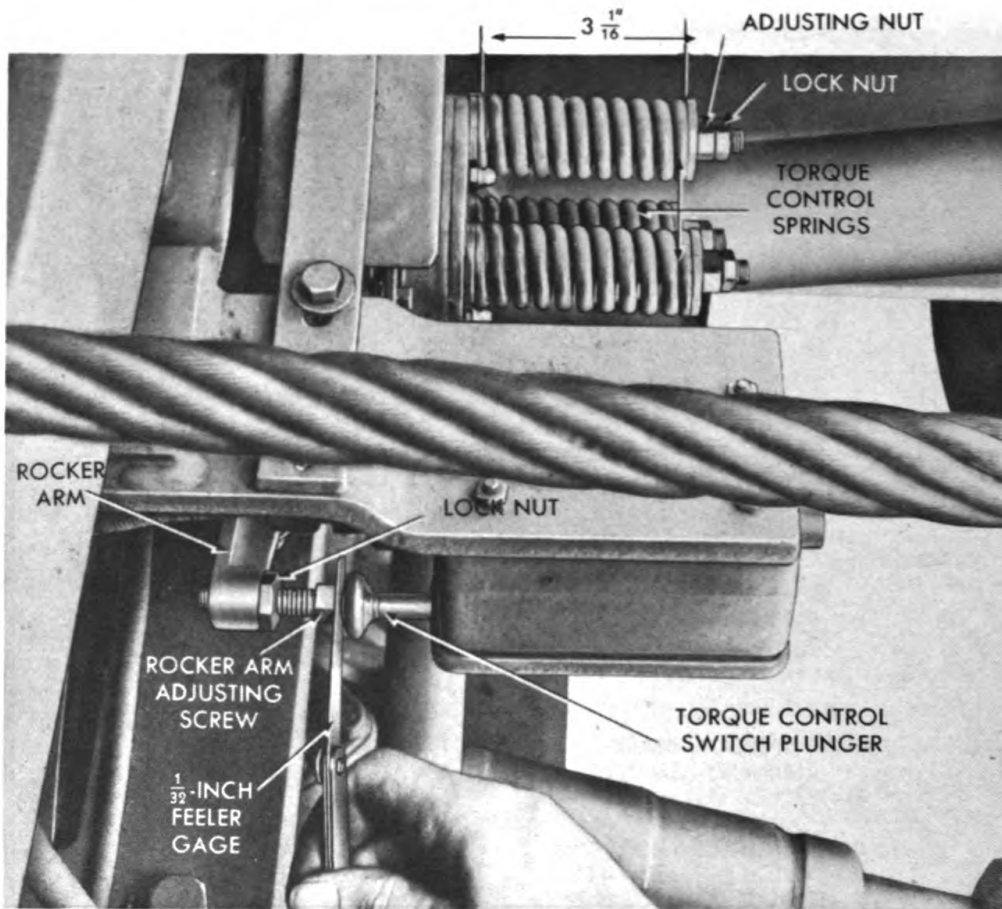

RA PD 321420

Figure 164—Torque Control Adjustments

215. WINCH TORQUE CONTROL ASSEMBLY.

a. Adjustment.

(1) **ADJUST TORQUE CONTROL SPRINGS** (fig. 164). Loosen nuts on torque spring studs. To increase torque pull (pull that can be put on the cable before the torque control will stop the engine), tighten torque spring nuts, giving each no more than one-half turn at a time. To decrease torque pull, loosen torque spring nuts, giving no more than one-half turn at a time. In a new assembly the torque springs are properly adjusted from 22,400 pounds when the distance between the outside of the end spring washer and the torque assembly main body is $3\frac{1}{16}$ inches. Tighten lock nuts after adjustments are made.

(2) **ADJUST TORQUE CONTROL SWITCH** (fig. 164). Remove end of cable from bracket on rear of truck to make sure there is no tension on torque control from cable (par. 15 c (1)). Loosen lock nut on

Auxiliary Equipment

rocker arm adjusting screw. Turn adjusting screw until the clearance between it and the switch plunger is $\frac{1}{32}$ inch when the roller on the torque end of rocker arm is in contact with torque control sprocket. Tighten lock nut.

b. Removal. Remove link from winch chain and lift chain from sprockets (fig. 108). Remove nuts, bolts, and lock washers which secure torque assembly support to winch frame. Pull torque control assembly (fig. 163) from winch propeller shaft.

c. Installation. Position torque assembly support under winch frame and install bolts, lock washers, and nuts, but do not tighten nuts. Install chain on torque and winch drive sprockets. Slide torque assembly to left or right until chain has approximately $\frac{1}{2}$ inch of slack. Tighten nuts to secure torque assembly support to winch frame. Adjust chain (par. 216).

216. WINCH CHAIN ADJUSTMENT.

a. General. A properly adjusted chain has approximately $\frac{1}{2}$ -inch slack.

b. Gross Adjustment (fig. 160). To tighten chassis remove one link. To loosen chain add one link.

c. Fine Adjustment. For finer adjustment, loosen five bolts which secure torque control and bearing mounting plate to winch frame. (Do not loosen bolts holding bearing to mounting plate.) Slide torque control and bearing mounting to left or right until there is a slack of $\frac{1}{2}$ inch in chain. See that sprocket of torque control is alined with sprocket on winch propeller shaft. Tighten bolts to secure mounting plate in position.

217. FIRE EXTINGUISHER.

a. Description (fig. 153). The fire extinguisher is a 1-quart, carbon-tetrachloride type hand-operated pump, mounted in a bracket in the cab between the seats.

b. Removal. Pull top of extinguisher clear of bracket and lift out extinguisher.

c. Installation. Place bottom of extinguisher in lower end of bracket. Push extinguisher back until handle is secured by bracket.

Section XXXVIII

RADIO INTERFERENCE SUPPRESSION SYSTEM

218. GENERAL.

a. Purpose. Automotive electrical systems and ungrounded automotive parts broadcast radio waves which interfere with reception on nearby radios and enable the enemy to locate the vehicle with detecting instruments. This is overcome by a radio interference suppression system.

b. Description. The radio interference suppression system on the vehicle consists of a condenser on the regulator, generator, and the starter burner coil. The condensers cut down radio interference without reducing the efficiency of the vehicle's electrical system.

219. CONDENSERS.

a. Description and Data.

(1) **DESCRIPTION.** A condenser is screwed into the terminal box of the generator regulator (fig. 83), and to the armature terminal shield of the generator. A condenser is attached to the coil of the starter burner assembly (fig. 58). All of these units are easily replaceable.

(2) **DATA.**

Condenser (generator regulator)	1883934
Condenser (generator)	N-1590

b. Replacement.

(1) Unscrew condenser from regulator terminal box (fig. 83). Screw in new condenser. Unscrew condenser from generator armature shield. Screw in new condenser (fig. 81).

(2) Remove the starter burner housing (par. 82 b). Remove spark coil cover (fig. 56). Remove nut which secures condenser to coil. Remove wire terminal screw, and lift condenser wire from coil. Slide condenser out of bracket. Slide new condenser into bracket. Tighten nut on bracket. Install condenser wire on terminal screw and install screw in coil. Position cover on coil and install cover screws. Install starter burner housing (par. 82 b).

220. BOND STRAPS.

a. Description. A bond strap is used to maintain an unbroken circuit between the radiator and chassis frame. The strap is connected to the lower left corner of the radiator and to the front

Trailer Service Brake System

bumper adjacent to it. To insure good contact, a toothed lock washer is used between the bond strap and the metal to which it is attached.

b. Replacement. Remove screws attaching each end of bond strap. Lift off bond strap and toothed lock washers. Position new bond strap. Install toothed lock washer between strap and metal to which it is attached. Paint or grease must be removed to insure a metal-to-metal contact. Install attaching screws.

Section XXXIX

TRAILER SERVICE BRAKE SYSTEM

221. DESCRIPTION AND DATA.

a. Description (fig. 165). The trailer service brake system is air-actuated and is operated in conjunction with the service brakes of the towing vehicle. Two air hoses are coupled to the towing vehicle air brake system; one for the service line, and one for the emergency line. Air is filtered and then passed to the relay-emergency valves, which serve as a relay station to speed up the application or release of the trailer brakes and also provide a means of automatically applying the trailer brakes in case the trailer becomes disengaged from the tractor. Two brake chambers at the front axles convert the energy of the compressed air into the mechanical force necessary to expand the front brake shoes against the brake drum and thus apply the brakes. Two cylinders perform the same function for the rear wheel brakes. A quick release valve releases the air pressure from the braking system when the brakes are released. A reservoir (fig. 166) provides a reserve of air to apply the brakes if the trailer should become disengaged from the towing vehicle.

b. Data.

(1) SERVICE BRAKE.

Type Internal expanding
Power Air

(2) CHAMBERS.

Mounting Rear crossmember of gear frame
Manufacturer Westinghouse
Model WAB 220899
Size 9 in.

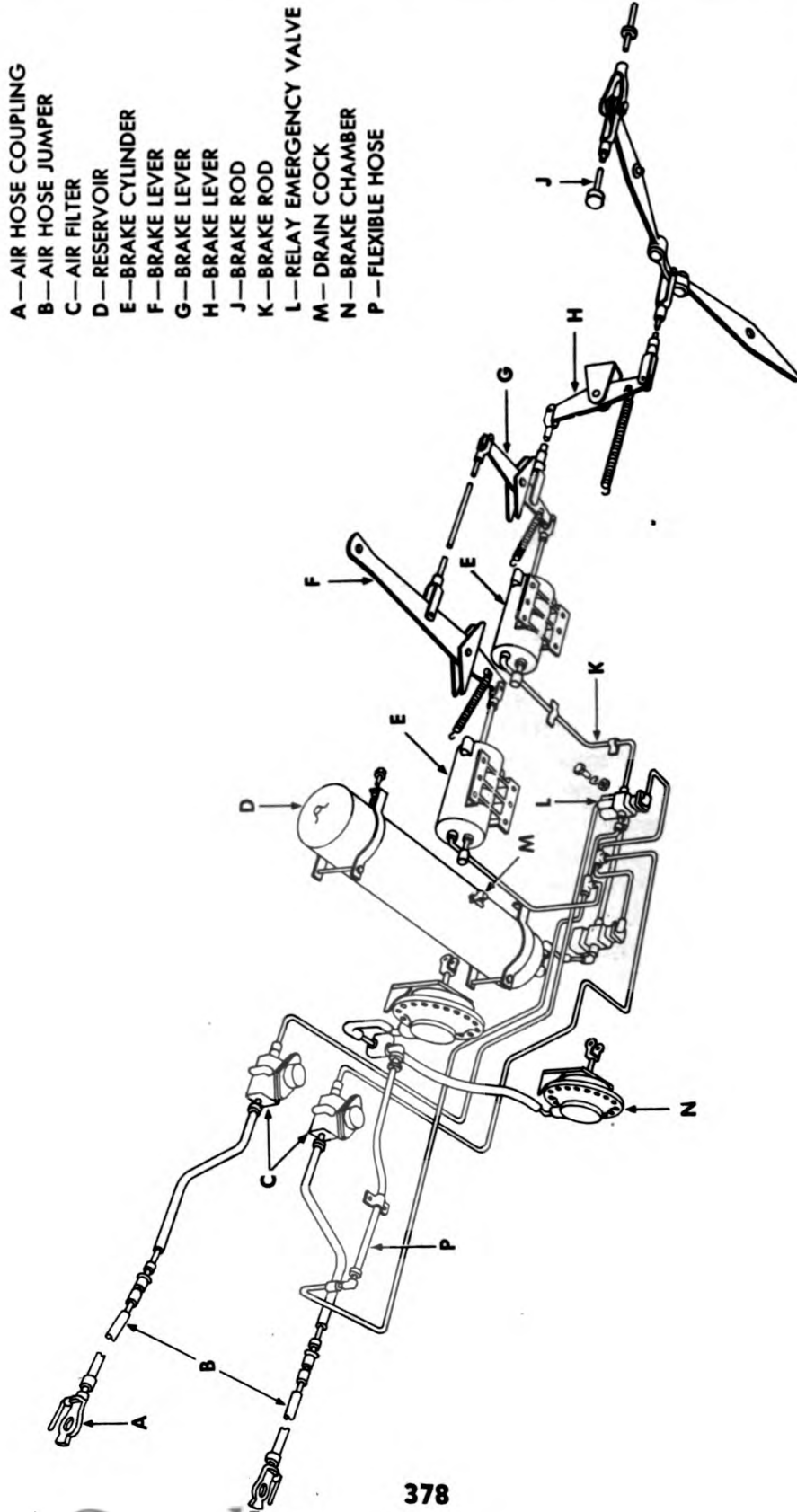

- A—AIR HOSE COUPLING
- B—AIR HOSE JUMPER
- C—AIR FILTER
- D—RESERVOIR
- E—BRAKE CYLINDER
- F—BRAKE LEVER
- G—BRAKE LEVER
- H—BRAKE LEVER
- J—BRAKE ROD
- K—BRAKE ROD
- L—RELAY EMERGENCY VALVE
- M—DRAIN COCK
- N—BRAKE CHAMBER
- P—FLEXIBLE HOSE

RA PD 321434

Figure 165—Trailer Brake System

Trailer Service Brake System

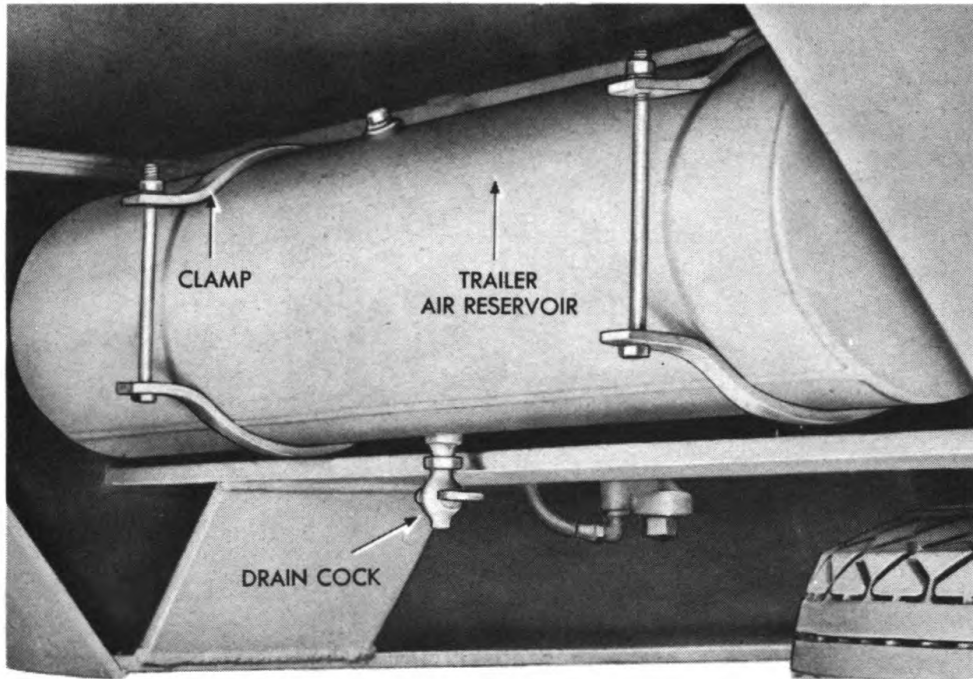

RA PD 321432

Figure 166—Trailer Air Reservoir

(3) CYLINDERS.

Mounting Center horizontal member
 Make Westinghouse
 Model WAB 220878
 Size 6 in.

(4) RELAY EMERGENCY VALVE.

Mounting Right horizontal member
 Make Westinghouse
 Model WAB 220353
 Exhaust fitting WAB 221087

(5) BRAKE LINING.

Make Manhattan asbestos (molded)
 Size 5½ in. x 13½ in. x ¼ in.
 Area—sq in. per shoe 74.25 in.
 Area—sq in. per axle 297 in.

(6) DRUMS.

Make Fruehauf
 Model 565126
 Size 12.255 in. x 5.560 in.

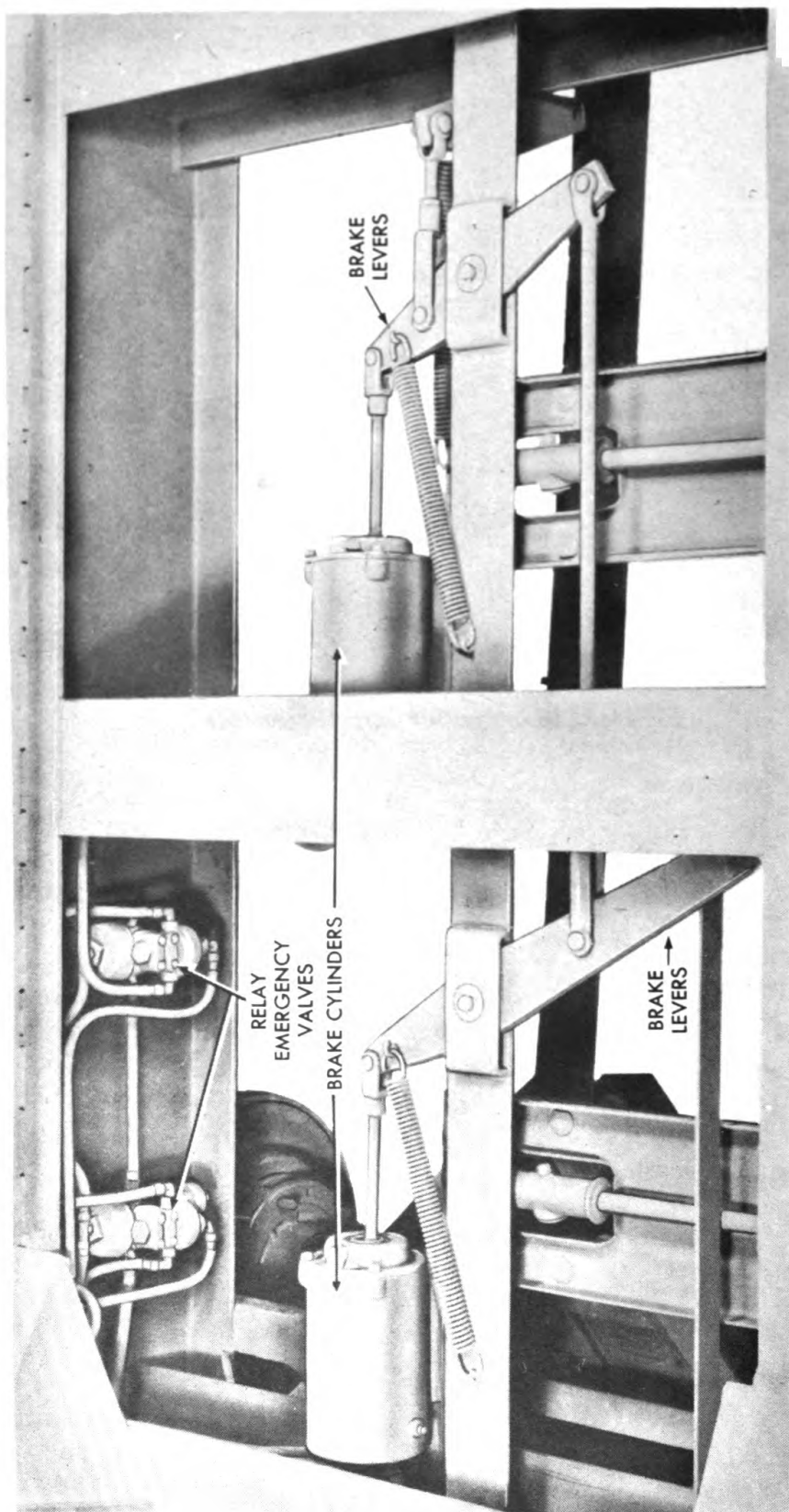

RA PD 321472

Figure 167—Brake Cylinders and Relay Emergency Valves

Trailer Service Brake System

(7) SLACK ADJUSTER.

Make	Westinghouse
Model	217900
Body	D-1½-in. spline

222. BRAKE CYLINDERS.

a. **Description** (fig. 167). The brake cylinders are mounted at the center horizontal member and are connected to the rear brake shoes by a system of levers and rods. When brakes are applied, air from the relay emergency valves enters the cylinder behind the piston assembly, moving it forward. The push rod, moving forward with the piston, operates a lever to which it is connected. This movement is transmitted to the rear brake shoes through the rods and levers. A packing cup washer seals the piston in the cylinder. A filter is located in a port in the cover plate to filter the air drawn into the cylinder when the piston is moved back as the brakes are released. A one-way check valve is located in a port at the opposite end of the cylinder. A felt oiler is located under a special washer in the cover plate.

b. **Maintenance.**

(1) **TEST CYLINDER FOR LEAKAGE.** Apply 60 pounds air pressure in cylinder; then use soapsuds around the cover plate bolting flange. If leakage shows, tighten flange bolts or replace gasket.

(2) **TEST FOR CUP LEAKAGE.** Use soapsuds around cup. If test shows leakage, replace.

(3) **CLEAN FILTER.** Wash curled hair in kerosene, or replace with new hair.

(4) **LUBRICATION.** Follow lubrication instructions in paragraph 22.

c. **Removal.** Remove the tubing nut on tubing connector from air line, which is coupled to front end of cylinder. Remove the clevis pin from cylinder push rod. Remove the four bolts which hold cylinder to cylinder mounting plate, and lift cylinder out.

d. **Installation.** Mount cylinder in position and secure it to mounting plate with four bolts. Secure the cylinder push rod clevis to the lever by means of the clevis pin. Install the tubing nut on tubing connector from air line at front end of cylinder.

223. SINGLE CHECK VALVE.

a. **Description.** A check valve is mounted by means of an adapter in the forward end of each brake cylinder. A ball check within the valve is held against an orifice by a spring. The only maintenance required is to keep the valve seat face free from dirt.

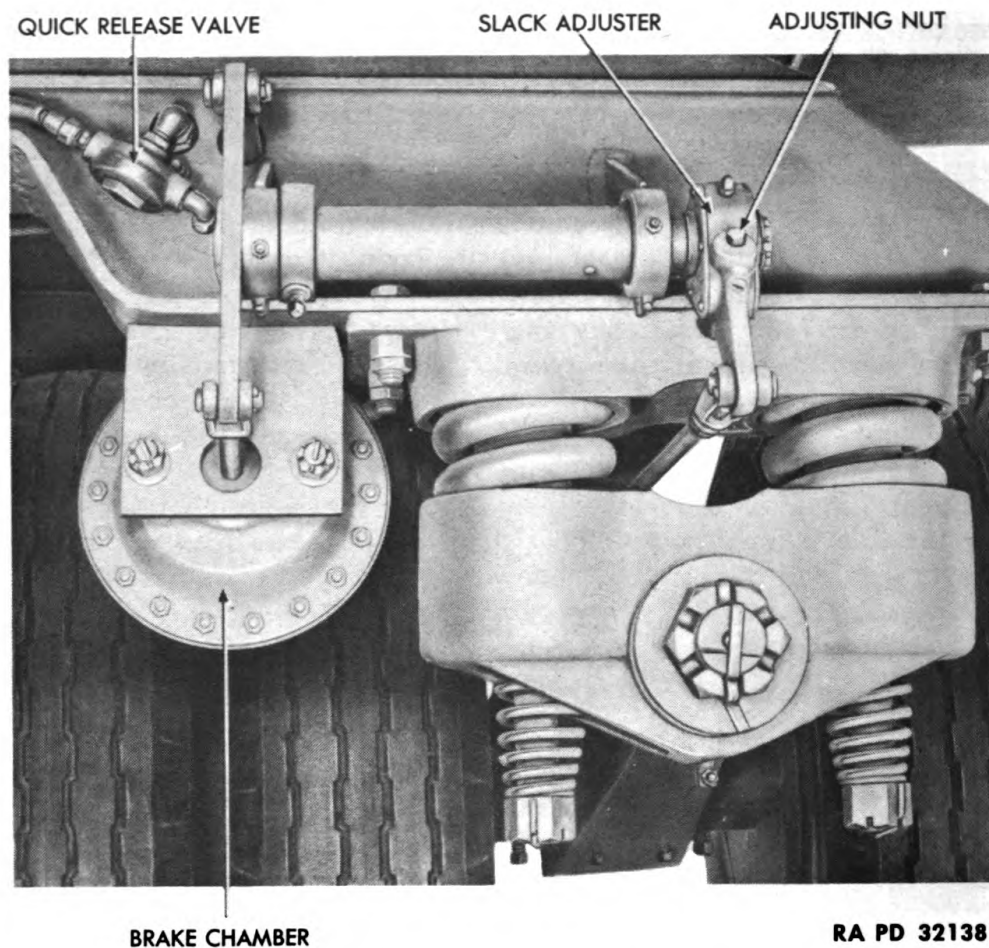

Figure 168—Brake Chamber and Quick Release Valve

b. **Removal.** Unscrew the valve from the adapter; or, if the adapter unscrews, remove both valve and adapter from brake cylinder.

c. **Installation.** Screw the check valve onto the adapter, or screw both check valve and adapter into brake cylinder.

224. BRAKE CHAMBERS AND SLACK ADJUSTERS.

a. **Description** (figs. 168 and 169). A brake chamber is mounted adjacent to the spring assembly of each front suspension unit. The function of the brake chambers is to convert the energy of compressed air, coming from the relay emergency valve, into the mechanical force necessary to expand the front brake shoes against the brake drums and apply the brakes. A push plate within the chamber is connected to a push rod. A flexible diaphragm is mounted behind the push plate. Air pressure from the relay emergency valve enters

Trailer Service Brake System

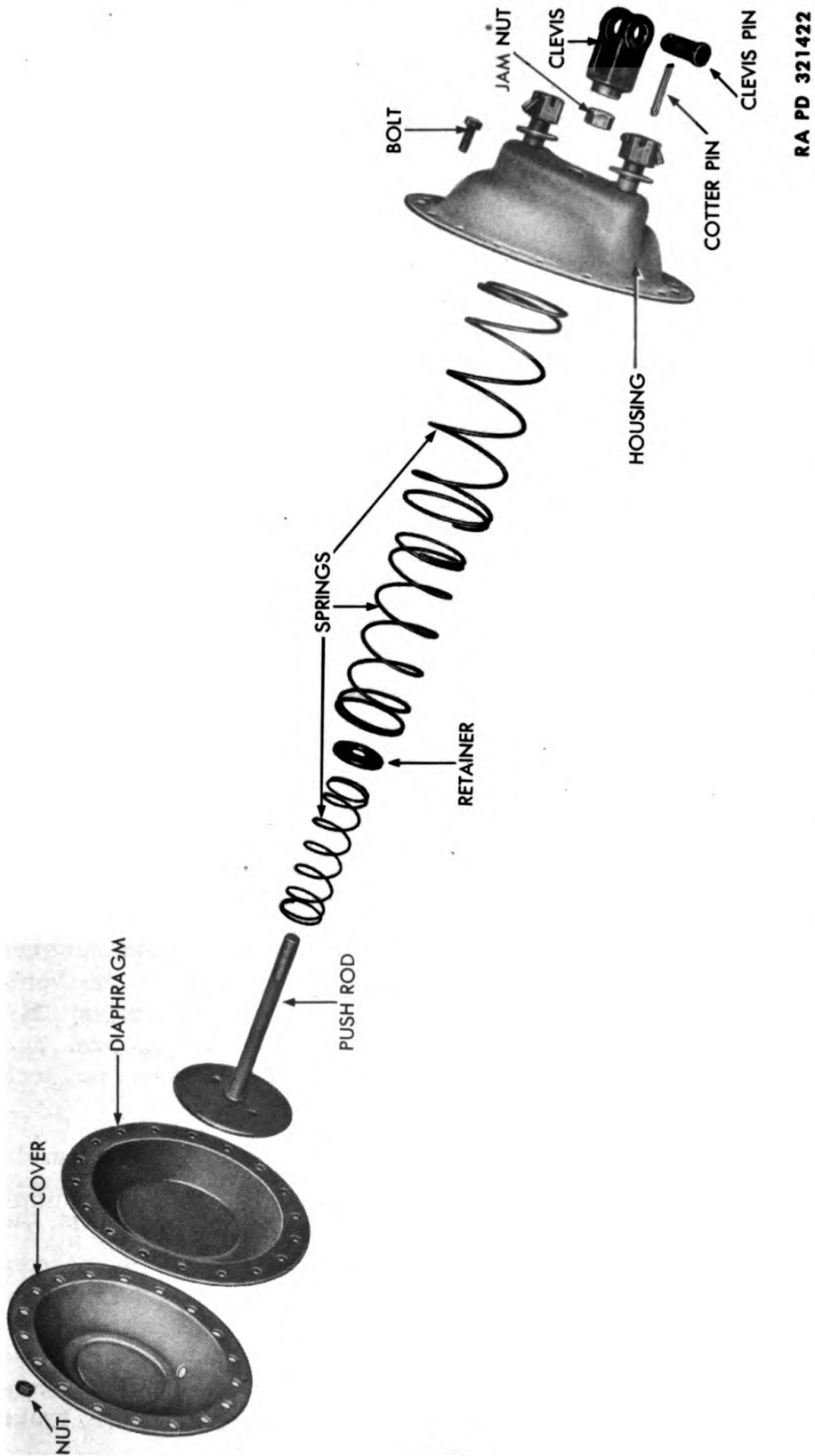

RA PD 321422

Figure 169—Brake Chamber Disassembled

the chamber through a port behind the flexible diaphragm when brakes are applied. The diaphragm moves forward, moving the push plate with its attached rod. The push rod is connected, through a system of rods and levers, to the brake cam. Thus, when the push rod is moved forward, the cam is turned and the brake shoes are expanded out against the brake drum.

b. Adjustment (fig. 168). The stroke of the brake chamber push rod must be adjusted to keep it within the correct limits. The stroke should never be permitted to exceed $1\frac{3}{4}$ inches; when the brakes are adjusted, the stroke should be as short as possible without the brakes dragging. This minimum stroke is usually about $\frac{3}{4}$ inch. Adjustment is made by means of the slack adjuster. To adjust the length of the push rod stroke, place jack under spring bracket and jack up trailer until wheels clear the ground. Turn the slack adjuster adjusting nut in a clockwise direction until the wheels lock. Then turn the nut off until drag on the brake is eliminated. Make the same adjustment on all front wheels.

c. Testing Diaphragm for Leaks. Apply the brakes. Paint the edge of the diaphragm with soapy water. If leakage is detected, tighten the bolts uniformly around the diaphragm until the leak disappears. (Never tighten the bolts to the point where the edge of the diaphragm starts to bulge, as this greatly weakens the diaphragm.) A defective diaphragm is indicated by air escaping around the brake rod when brakes are applied. In that event the diaphragm must be replaced.

d. Brake Chamber Removal. Disconnect the tubing assembly, pull the clevis pin at the brake lever, and remove the two cotter pins and nuts which hold the chamber to its mounting bracket.

e. Replacing Brake Chamber Diaphragm. Place the chamber in a vise and mark the edges for reassembly. Remove the bolts, nuts, and lock washers which secure the cover to the housing. Remove the cover and diaphragm. Install a new diaphragm and again secure the cover to the housing with the bolts, nuts, and lock washers.

f. Brake Chamber Installation. Mount the brake chamber to its bracket by means of the two nuts and cotter pins. Secure the clevis to the brake lever by means of the clevis pin. Connect the tubing to the brake chamber.

225. BRAKE SHOES.

a. Description (fig. 170). Two brake shoes operate within the brake drum in each wheel. They hinge on the anchor shaft and are operated by a cam, which is turned by linkage from the brake

Trailer Service Brake System

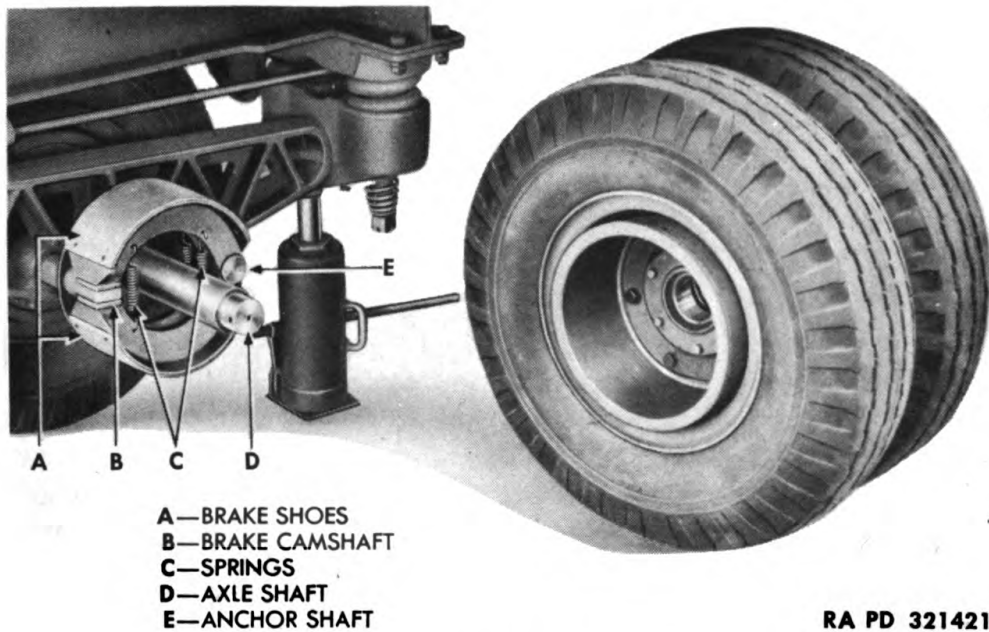

Figure 170—Brake Shoes

chamber when brakes are applied. The cam forces the shoes out into contact with the brake drum.

b. Brake Shoe Removal. Remove the tires, wheel, and brake drum from the axle shaft. Remove the four springs between upper and lower shoes. Lift the upper and lower shoes off the anchor shaft and cam.

c. Brake Shoe Installation. It is essential that both upper and lower brake shoes should be replaced at the same time. Place a heavy coat of wheel grease on both the top and bottom side of cam and around the anchor shaft. Place the shoes on cam and anchor shaft, and couple the four springs to upper and lower shoes. Install the tires, wheel, and brake drum on the axle shaft.

226. TRAILER AIR CONNECTIONS.

a. Description. Two air hoses are provided at the front end of the trailer; one for the service brake line, and one for the emergency line. Hose couplings are mounted on the forward ends of the hose. Dummy hose couplings are mounted on the sides of the drawbar and should be used whenever the hoses are not coupled to the towing vehicle, to prevent the entrance of foreign matter into the braking system.

b. Maintenance. Rubber packing rings which act as gaskets to seal coupled hose are mounted in the hose couplings. When these become worn or distorted, pry out old ring and push in new one.

227. AIR LINES AND HOSE.

a. When air line tubing becomes kinked or damaged, cut out the damaged section and splice in a new one, using brass ferrule-type, 3-piece union.

228. QUICK RELEASE VALVE.

a. Description (fig. 168). The quick release valve is mounted on the rear of the gear frame, adjacent to the right brake chamber. It functions to release the compressed air to the atmosphere when the brakes are released. When brakes are applied, compressed air from the relay emergency valve enters the cavity above the diaphragm of the quick release valve. The air pressure forces the exhaust seat of the diaphragm against the edges of the exhaust port, sealing the exhaust. The compressed air then passes through ports to the brake chambers to apply the brakes. When brakes are released, the spring forces the diaphragm and seat away from the exhaust port, releasing the air pressure in the brake chambers to the atmosphere.

b. Testing for Leakage. Apply the brakes and cover the exhaust port with soapsuds. Leakage is caused either by dirt in the diaphragm exhaust valve seat or by a worn exhaust valve seat. Leakage caused by dirt may be remedied by cleaning the exhaust valve seat. However, if leakage is caused by a worn exhaust valve seat, replace the entire valve assembly (subpars. **c** and **d** below).

c. Quick Release Valve Removal. Disconnect the tubing from the quick release valve. Remove cap screws which hold quick release valve in position. Lift off quick release valve.

d. Quick Release Valve Installation. Mount quick release valve in position and install cap screws. Connect tubing to valve.

229. RELAY EMERGENCY VALVE (figs. 167 and 171).

a. Description. Two relay emergency valves are mounted on the right longitudinal frame member. They serve as a relay to speed up the application or release of the trailer brakes, and also provide a means of automatically applying the trailer brakes in case the trailer breaks loose while the vehicle is being operated. The function of the relay emergency valves is to operate so that the same air pressure will be delivered and maintained in the trailer brake chambers as that delivered by the brake valve on the truck. During normal operation, the relay emergency valve has three positions: applying,

Trailer Service Brake System

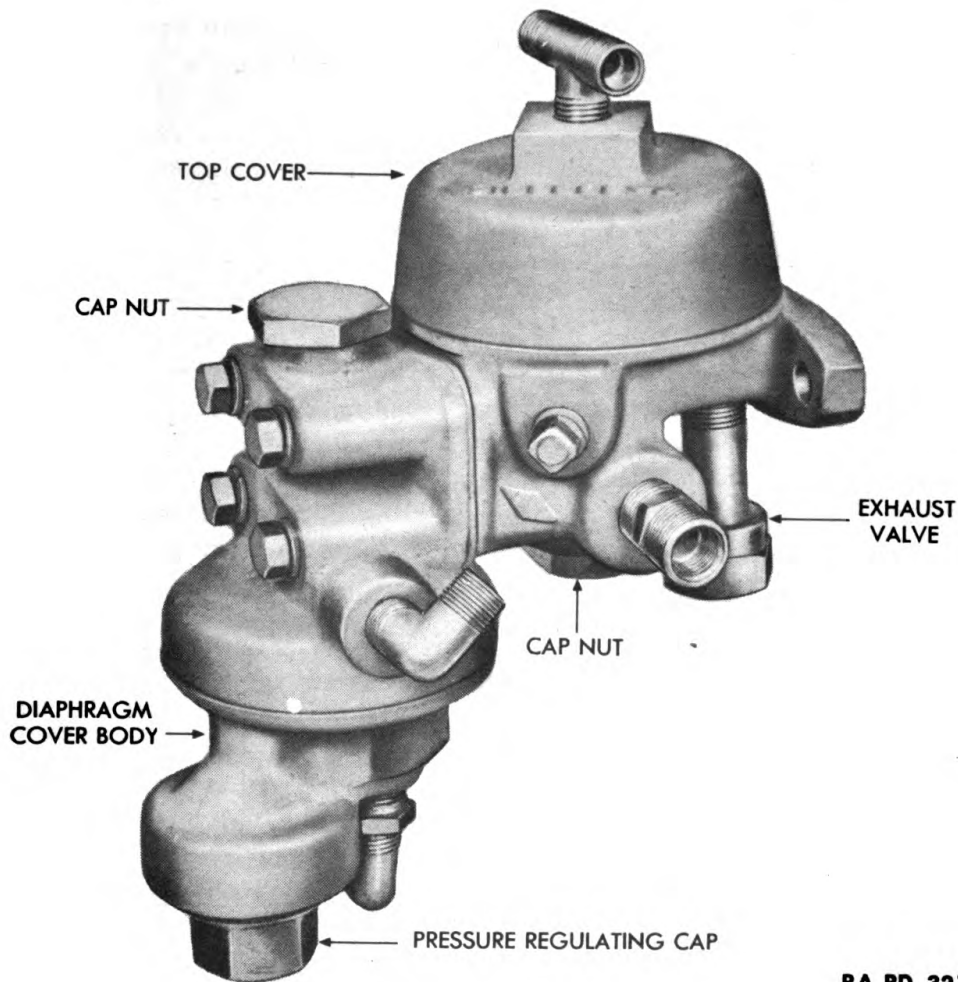

RA PD 321388

Figure 171—Relay Emergency Valve—Removed

holding, releasing. It also has an emergency position which is assured when there is a sudden drop in pressure in the trailer emergency line. This results in automatic application of the trailer brakes.

b. Removal. Disconnect tubing from valve. Remove bolts and nuts which secure valve to frame and remove valve.

c. To Replace Intake Diaphragm. With the valve held firmly in a vise, remove the top cover and spring by turning the hex on the cover. Lift out the diaphragm guide ring. Remove cotter pin, nut, and washer which hold the diaphragm to the guide. Lift out the diaphragm and replace. Secure the new diaphragm to the guide with washer, nut, and cotter pin. Install the diaphragm guide ring. Install the spring and top cover.

d. **To Replace Pressure Regulating Cap Diaphragm.** With valve held firmly in a vise and pressure regulating cap up, remove pressure regulating cap, spring, and diaphragm. Remove stem lock nut. Lift diaphragm and diaphragm follower from stem. Install new diaphragm and install follower on stem. Install stem lock nut. Install assembly in position, and install pressure regulating spring and cap.

e. **To Replace Emergency Line Diaphragm.** With valve held firmly in a vise and diaphragm cover body up, remove diaphragm cover body. Lift out strainer and spring. Remove cap nut. Insert screwdriver into slotted head of emergency valve and, with a wrench, remove diaphragm lock nut from the opposite end of valve stem. Pull out the valve stem from cap nut opening, and the diaphragm from opposite side. Clean the strainer and diaphragm in gasoline. Install a new diaphragm if necessary. Install the valve stem and diaphragm, and screw on the valve stem lock nut holding slotted head of valve with screwdriver. Install cap nut. Install spring and strainer and screw diaphragm cover body into place.

f. **Installation of Relay Emergency Valve.** Position valve on frame and secure with bolts and nuts. Connect tubing to valve.

g. Leakage Tests.

(1) With brakes released, cover exhaust port with soapsuds and look for bubbles. Leakage is caused by supply valve or intake diaphragm not seating properly.

(2) With full pressure in the trailer reservoir, disconnect emergency line between tractor and trailer. Trailer brakes should apply automatically. *This feature should be checked daily.*

(3) Cover emergency line hose coupling at front of trailer with soapsuds to check for leakage. Leakage is caused by emergency line diaphragm not seating properly.

230. AIR FILTER.

a. **Description** (figs. 172 and 173). Two air filters are mounted under a cover plate at the front of the trailer; one for the service line, and one for the emergency line. The filters are designed to remove dirt, water, and oil from the air, thereby increasing the life of the functional parts of the relay emergency valve.

b. **Maintenance.** Filters should be drained by removing plug in bottom of filter (par. 22). Disassemble filter and wash in gasoline.

c. **Removal.** Remove the four cap screws from the cover plate and lift off the cover plate. Disconnect the lines leading to the filters. Remove the bolts which hold the filter to the bracket.

Trailer Service Brake System

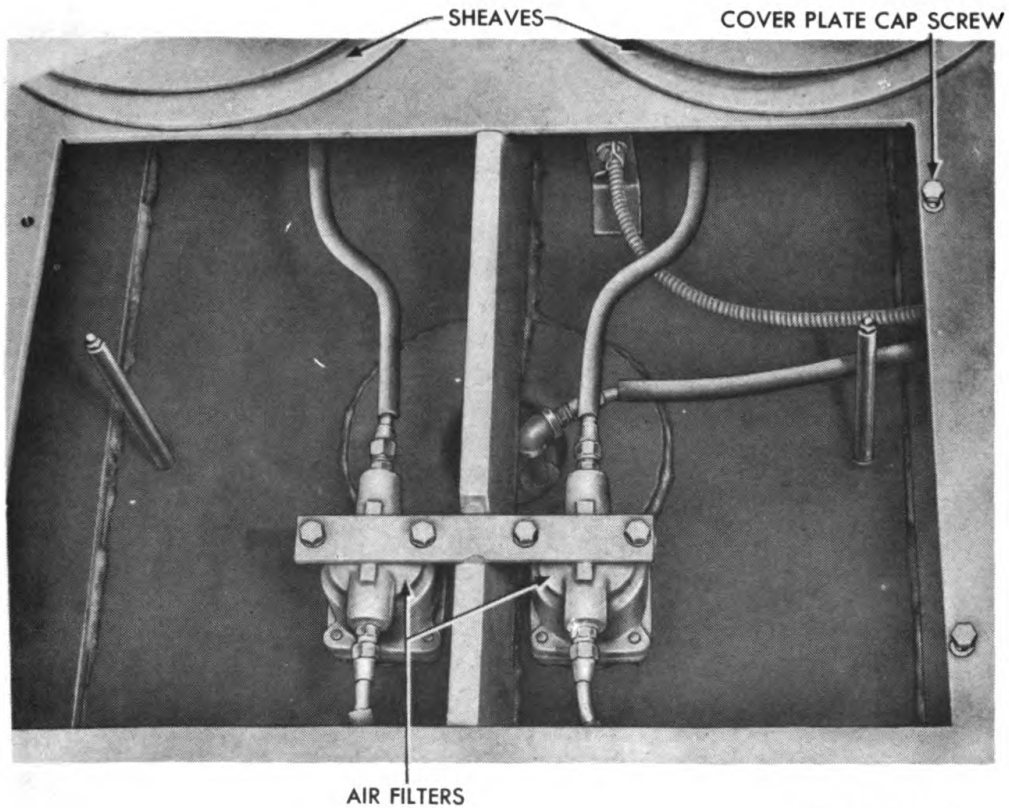

RA PD 321413

Figure 172—Air Filters

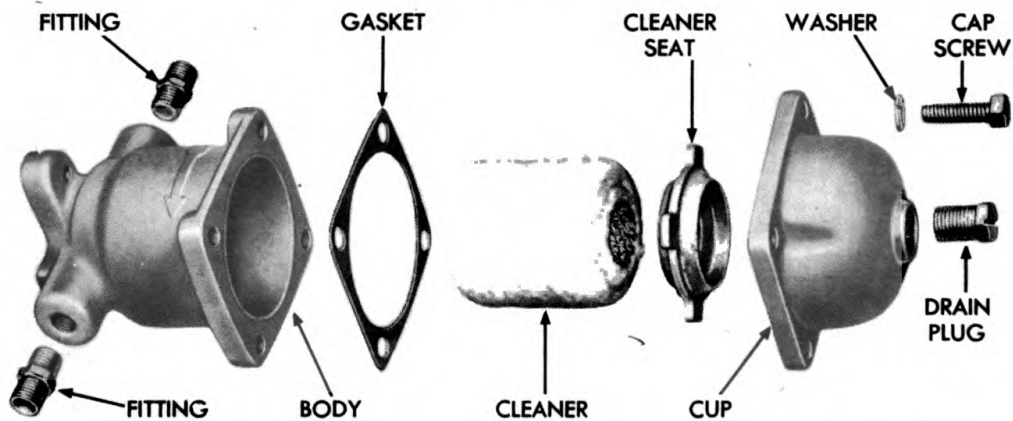

RA PD 321398

Figure 173—Air Filter—Disassembled

d. **Disassembly.** Remove the cap screws which hold cup to upper section of filter. Separate cup from upper section. Remove gasket. Remove cleaner seat and pull out cleaner.

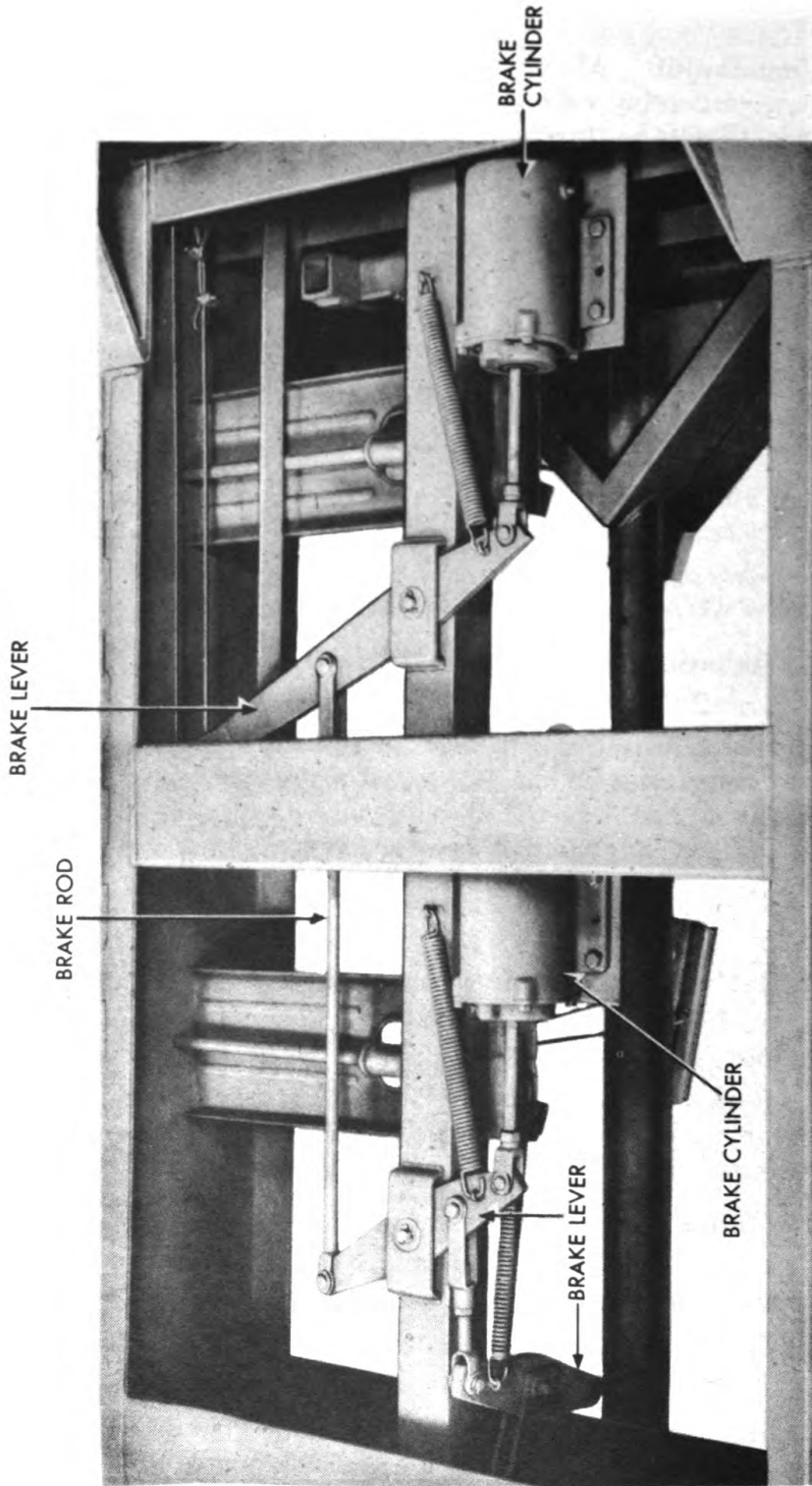

RA PD 321374

Figure 174—Brake Rods and Levers

Trailer Service Brake System

e. **Assembly.** Install cleaner and cleaner seat in upper section. Install gasket. Secure cup to upper section with cap screws and washers.

f. **Installation.** Mount filter in position with arrow on filter pointed toward relay emergency valves and secure with bolts. Connect lines to filters. Install cover plate and secure with four cap screws.

231. CONTROLS AND LEVERS.

a. **Description** (figs. 165 and 174). Brake chambers and cylinders are connected to brake shoes through rods and levers. All brake rods are held to the brake levers by means of a clevis and clevis pin.

b. Removal of Rods.

(1) Remove the pin from the clevis to remove the rods, except for the four short rods which are attached to the cam brake arms.

(2) To replace rod, remove the clevis pin; then holding the rod with a pipe wrench, turn the clevis off the rod.

c. Installation of Rods.

(1) Install the rods in position and secure with clevis pins.

(2) When installing the four short rods which are attached to the cam brake arms, be sure to install front and rear rods in correct location. Front rods have a ball washer welded to their extreme ends, whereas on rear rods the ball washer is $3\frac{5}{8}$ inches from the end.

d. Removal of Brake Levers.

(1) Remove main brake lever by first removing cable; then disconnect clevis pins and springs and remove lever.

(2) Remove center brake lever by disconnecting clevis pins and spring. Remove lever.

(3) Remove rear brake lever by removing nuts and bolts which secure lever to brake links. Remove clevises which connect brake lever to brake rods. Remove lever.

e. Installation of Brake Levers.

(1) Connect clevises to levers with clevis pins.

(2) Secure springs to main and center brake levers.

(3) Secure rear brake lever to brake links with nuts and bolts. Leave a $\frac{3}{8}$ -inch gap between lever and link.

f. **Adjustment.** Place a jack under the trunnion bracket and raise wheels clear of ground. Loosen the two jam nuts on front and rear brake rods and turn each nut about $\frac{3}{8}$ inch. Using a pipe wrench,

shorten the brake rods by turning them in a clockwise direction. Shorten the rods until the wheels lock. Turn the brake rod back until all drag of shoe against brake drum is eliminated. Tighten jam nuts against clevis, and repeat the adjustment on the other side.

Section XL

HAND PARKING BRAKE SYSTEM

232. DESCRIPTION AND DATA.

a. Description (figs. 175 and 176).

(1) Two sets of hand parking brakes are provided, each operated by a handwheel. The handwheel located at the front center of the trailer operates the front brakes. The handwheel located at the front left corner of the frame operates the rear brakes. A dog engages the teeth of a ratchet on each handwheel to hold the brakes in the applied position until released.

(2) On front brakes, a cable carried over two sheaves is wound on the handwheel shaft when brakes are applied. This cable operates over another sheave on a lever at each set of front brakes, which in turn are linked to the brake shoes at each wheel. Winding the cable thus rotates the levers to apply the brakes. The cable is anchored by means of a thimble and anchor plate.

(3) On rear brakes, a chain carried through a guide is secured to the handwheel operating shaft and is wound around the shaft as brakes are applied. A cable secured to the chain is carried over two sheaves at the drop in the frame, around another sheave at the end of the main brake lever, and back to an anchor plate. Winding the chain thus pulls on the main brake lever to operate the levers and rods to the brake shoes in the rear wheels.

b. Data.

(1) FRONT.

General design	U. S. Quartermaster
Cable:	
Length	15 in.
Diameter	1/4 in.
Pull test	1,000 lb

(2) REAR.

General design	U. S. Quartermaster
----------------------	---------------------

Hand Parking Brake System

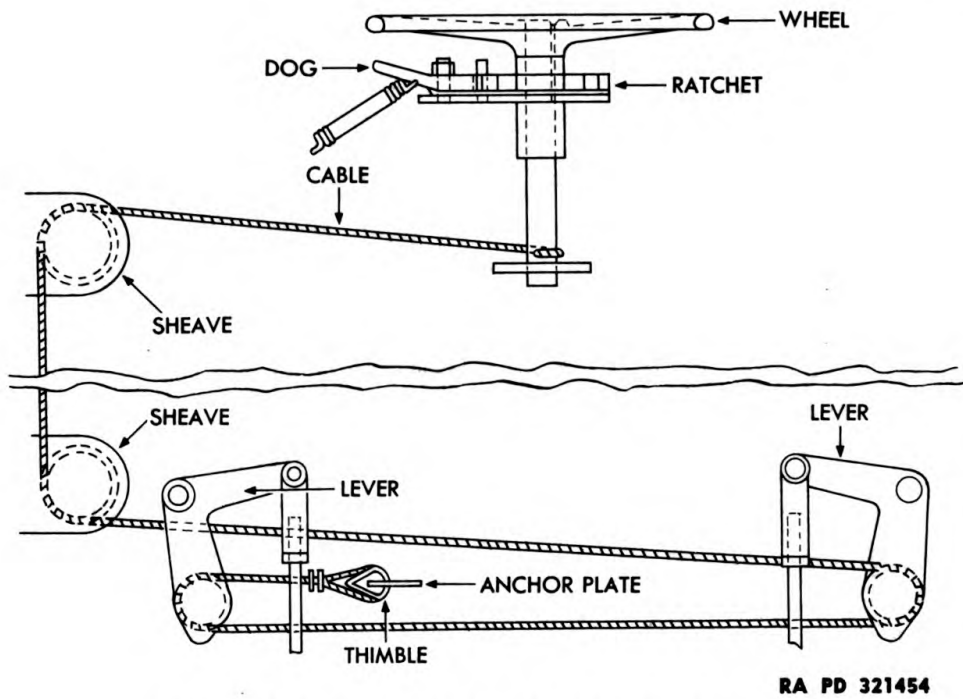

Figure 175—Hand Parking Brake—Front

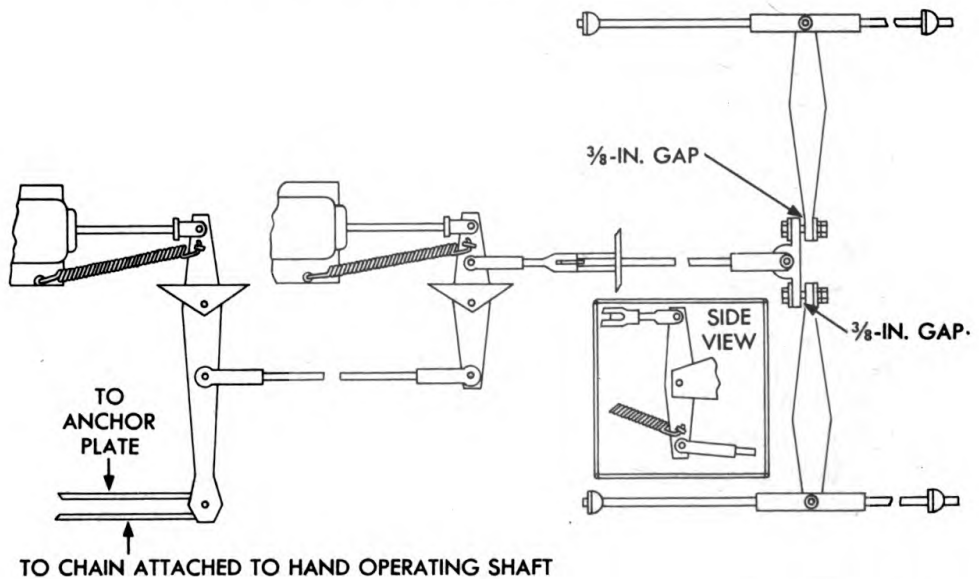

Figure 176—Hand Parking Brake—Rear

Cable:		
Length	10 ft.
Diameter	1/4 in.
Pull test	1,000 lb

233. FRONT PARKING BRAKES.**a. Cable.**

(1) **REMOVAL.** Turn the front brake handwheel until all the cable is unwound from operating shaft. Loosen the hook bolts which hold cable to operating shaft. Remove the two cable clamps from rear end of cable, and pull cable out of sheaves and levers.

(2) **REPLACEMENT.** Place cable hook bolt on operating shaft and tighten. Thread cable through sheave located in front left corner, then on through sheave located in rear left corner. Pass cable under brake lever and push rod on left side, and under brake rod on right side. Thread cable through right side sheave on brake lever, through front, and out at rear. Thread cable through sheave on lever on left side, starting cable through from rear of lever, out and around sheave, and out to front. Thread cable through cable thimble at anchor plate and tighten, using two cable clamps.

b. Sheave Lever.

(1) **REMOVAL.** Remove cable clamps at rear end of cable at the anchor plate. Pull cable out of sheaves of right and left levers. Remove cotter pin and slotted nut from under side of lever. Tap down on lever to remove lever from anchor pin.

(2) **INSTALLATION.** Install lever on anchor pin, and install slotted nut and cotter pin. **CAUTION:** *Make sure right-hand lever is placed on the right side and left-hand lever is placed on the left side.* Do not overtighten slotted nut on anchor pin; tighten nut so there is about $\frac{1}{8}$ -inch up-and-down play. If nut is drawn up too tightly, free movement of lever will be hindered and a binding condition will result, which will retard guide release of both hand and service brakes.

c. Operating Shaft.

(1) **REMOVAL.** Uncouple cable by loosening hook bolt. Remove the cotter pin and flat washer from rear end of shaft and pull wheel and ratchet gear assembly out of mounting brackets. Remove set screw in handwheel, and tap handwheel and ratchet gear off shaft. Drive out square key from shaft.

(2) **INSTALLATION.** Install square key, ratchet gear, and handwheel on shaft and secure handwheel to shaft with set screw. Install handwheel and ratchet gear assembly in mounting brackets, and secure with flat washer and cotter pin. Place cable hook bolt on shaft and tighten.

234. REAR PARKING BRAKES.**a. Chain.**

(1) **REMOVAL.** Turn the rear hand parking brake wheel until all the chain is unwound from shaft. Remove the carriage bolt which

Trailer Dolly

holds the end link to the shaft. Remove the two cable clamps from the rear end of the chain. Spread the cable thimble and remove it from the chain. Pull the chain out of the brake chain guide.

(2) **INSTALLATION.** Thread the chain through the brake chain guide. Install the cable thimble and two cable clamps on the rear end of the chain. Secure the chain to the shaft with the carriage bolt.

b. Cable.

(1) **REMOVAL.** Remove the cable clamps from the ends of the cable. Leave the cable thimbles attached to the anchor plate and brake chain. Pull the cable out of the two sheaves at the drop in the frame and from the sheave at the end of the main brake lever.

(2) **INSTALLATION.** Unwind all of the chain from the shaft. Thread the cable through the cable thimble at the anchor plate and clamp into position, using two cable clamps. Thread cable successively through main brake lever sheave, upper and lower sheaves at the drop in the frame, and through thimble on chain. Pull the slack out of the cable, and install two cable clamps.

c. Handwheel.

(1) **REMOVAL.** Remove the set screw in the handwheel and tap the wheel off the shaft.

(2) **INSTALLATION.** Install the wheel on the shaft with the set screw flange down. Secure the wheel to the shaft by means of the set screw.

Section XLI

TRAILER DOLLY

235. DESCRIPTION.

a. The trailer dolly consists of the gear frame and drawbar assembly (fig. 177). The gear frame is mounted under the front end of the main frame and swivels on a kingpin in the main frame. The drawbar assembly is mounted to the front of the gear frame.

236. DRAWBAR ASSEMBLY.

a. **Description.** The drawbar frame consists of two side angles reinforced with X-type reinforcing angles. A drawbar eye is located at the apex of the frame for attaching the trailer to the towing vehicle. Dummy hose couplings are mounted on the side angles to keep dirt out of the air lines when the trailer hoses are not con-

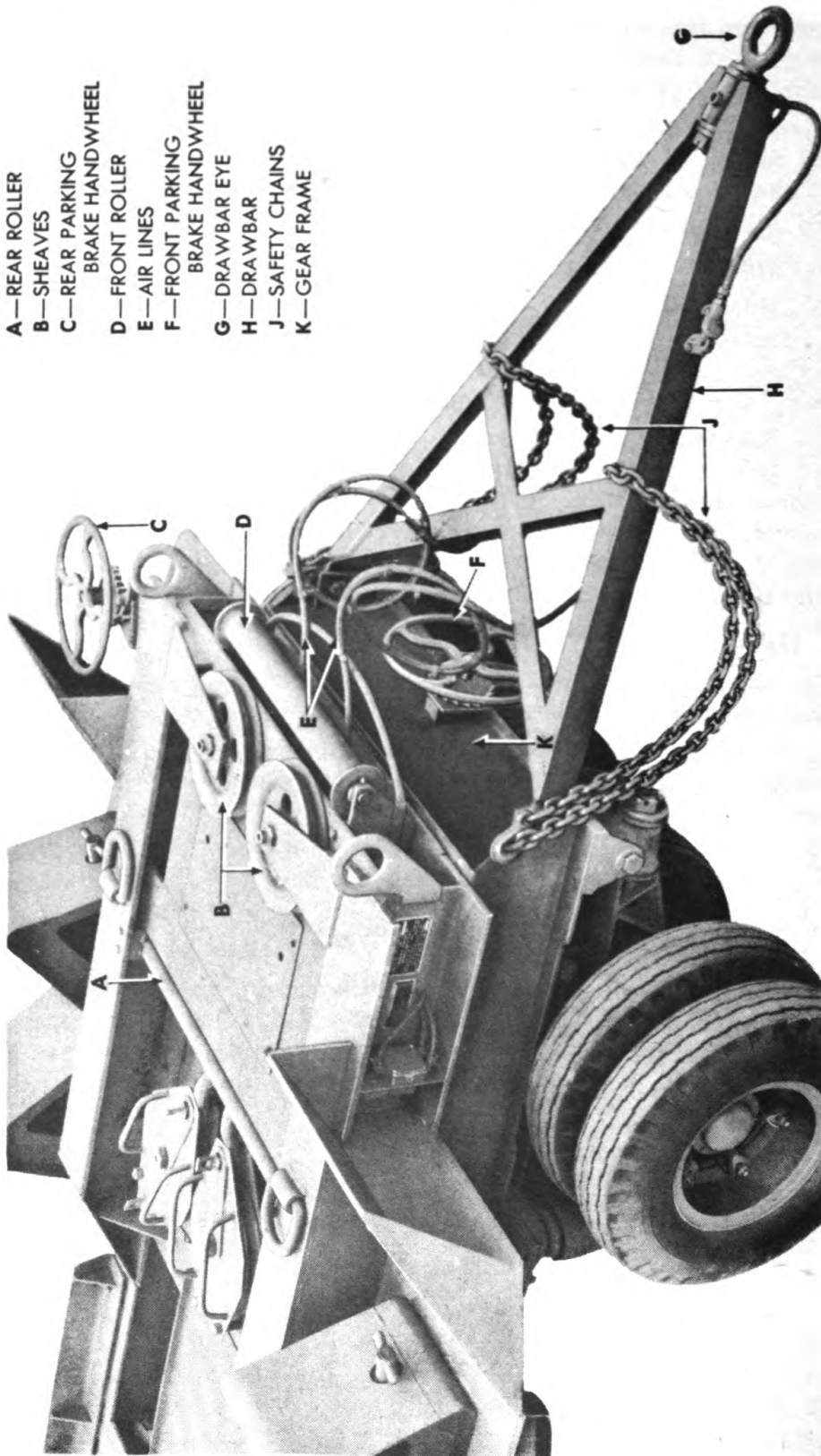

- A—REAR ROLLER
- B—SHEAVES
- C—REAR PARKING
BRAKE HANDWHEEL
- D—FRONT ROLLER
- E—AIR LINES
- F—FRONT PARKING
BRAKE HANDWHEEL
- G—DRAWBAR EYE
- H—DRAWBAR
- J—SAFETY CHAINS
- K—GEAR FRAME

RA PD 321414

Figure 177—Trailer Dolly

Trailer Lights System

nected to the towing vehicle. Two safety chains are attached to the gear frame and are secured to the towing vehicle when the trailer is being towed.

b. Removal. Remove the cotter pins and hinge nuts. Drive out one bolt while holding the drawbar in up position to prevent hinge from binding. Slip a $\frac{3}{8}$ -inch punch or bolt through hinge bracket from which bolt has just been removed to hold the bar up; then drive out the opposite bolt. Pull the punch or bolt from bracket, and lift the drawbar assembly out of the hinge brackets.

c. Installation. Place the drawbar assembly in position at hinge brackets and install hinge bolts. Install hinge nuts and cotter pins.

237. DRAWBAR EYE.

a. Description. The drawbar eye is secured to the forward part of the drawbar and provides a means of securing the trailer to the towing vehicle. Although the eye is spot-welded to the bracket for shipping purposes, the eye provides a swivel when this weld is broken for traversing uneven terrain. There is a bushing in the eye.

b. Removal. Place a wooden horse under the drawbar at the eye end. Remove the cotter pin, nut, and flat washer. Cut the weld which holds the eye to the eye bracket, if this has not already been broken, and pull the eye out.

c. Installation. Put a layer of standard chassis grease over the eye shaft and insert it in the bracket. Install the washer, nut, and cotter pin.

Section XLII

TRAILER LIGHTS SYSTEM

238. DESCRIPTION.

a. General (figs. 178 and 179). The trailer lights system consists of four blackout clearance lights, two combination blackout tail and stop lights, and necessary connecting conductors and junction boxes. The circuit is of the single-wire type with trailer frame serving as the ground conductor. A coupling socket located in the center of the front main frame member provides for connecting the trailer lights system to the current supply of the towing vehicle. During operation, a jumper cable runs from the trailer coupling socket to a socket on the towing vehicle. Trailer lights are controlled at towing vehicle.

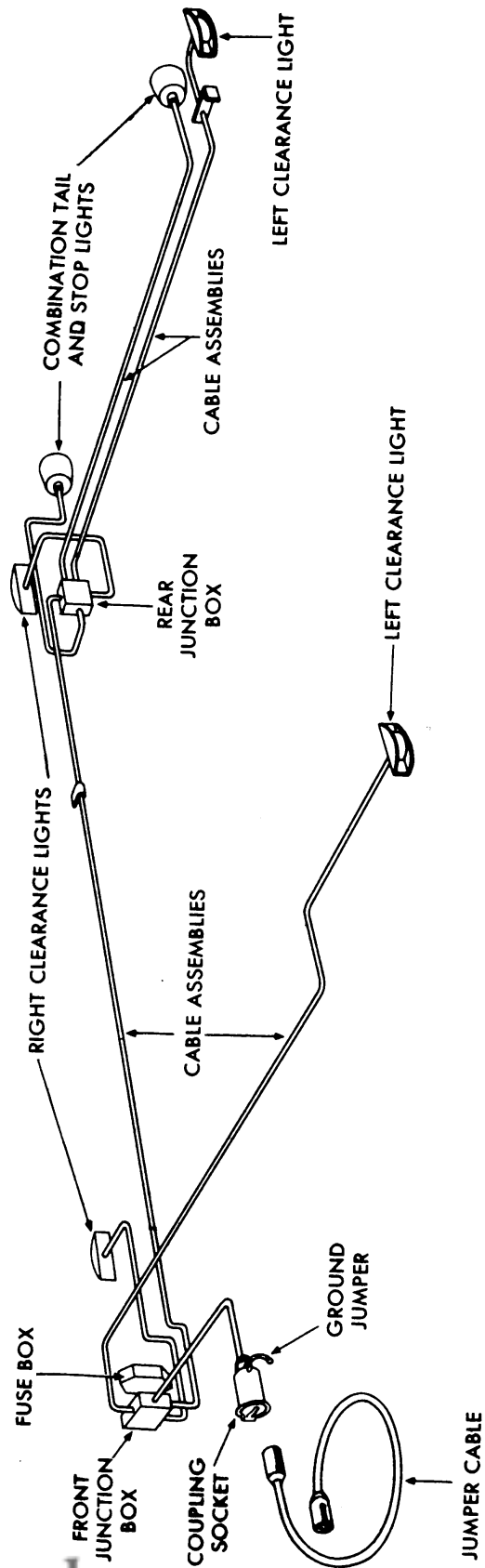

RA PD 321415

Figure 178—Trailer Lights System

Trailer Lights System

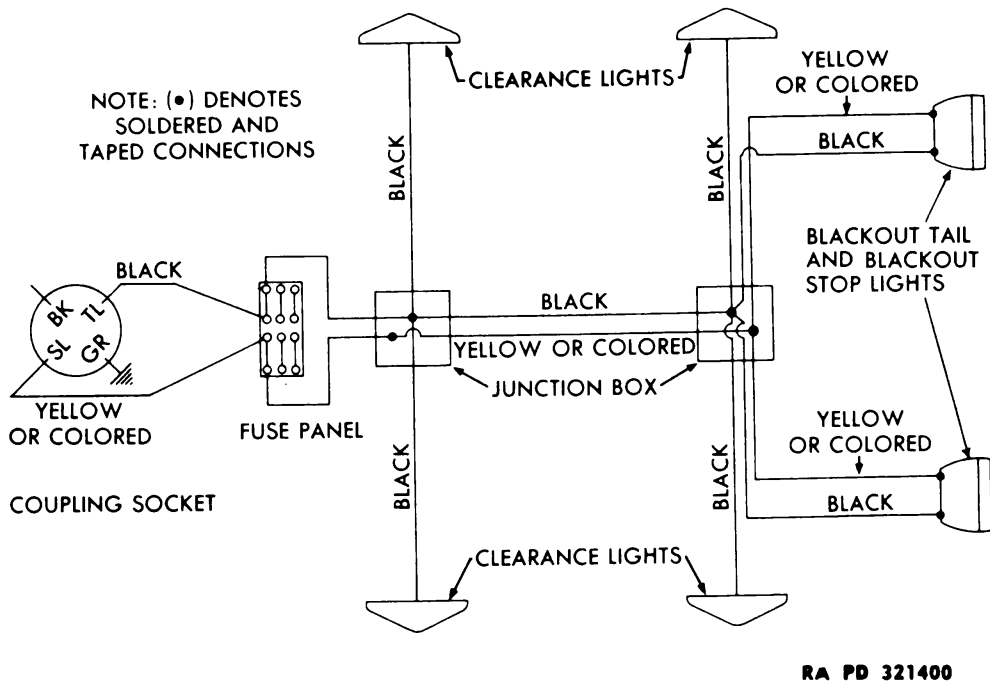

Figure 179—Wiring Diagram

Fuses to protect the trailer lights from excessive voltage are enclosed in a fuse box mounted on right main frame of the trailer above the front wheels.

239. COUPLING SOCKET ASSEMBLY.

a. Description and Data.

(1) DESCRIPTION (fig. 180). The coupling socket is a four-contact socket. The contacts are enclosed in a plastic case, which is in turn enclosed in a steel cylindrical housing with mounting flange. The contacts and plastic case are secured in the housing by four bronze connecting screws and nuts at the base of the cylinder. A fiber plate over the outside base of the cylinder insulates the connecting screws from housing. This fiber plate is also marked to indicate how leads must be connected at receptacle. Only three of the poles are required for trailer circuit; the pole marked "BK" is not used. A steel shield, held in position by a stud located in center of base, protects connections from damage when installed. A cover assembly attached to the flange of the housing protects contacts and plastic case from dirt and foreign matter when jumper cable from towing vehicle is not installed.

(2) DATA.

Manufacturer Warner
Type 4-pole

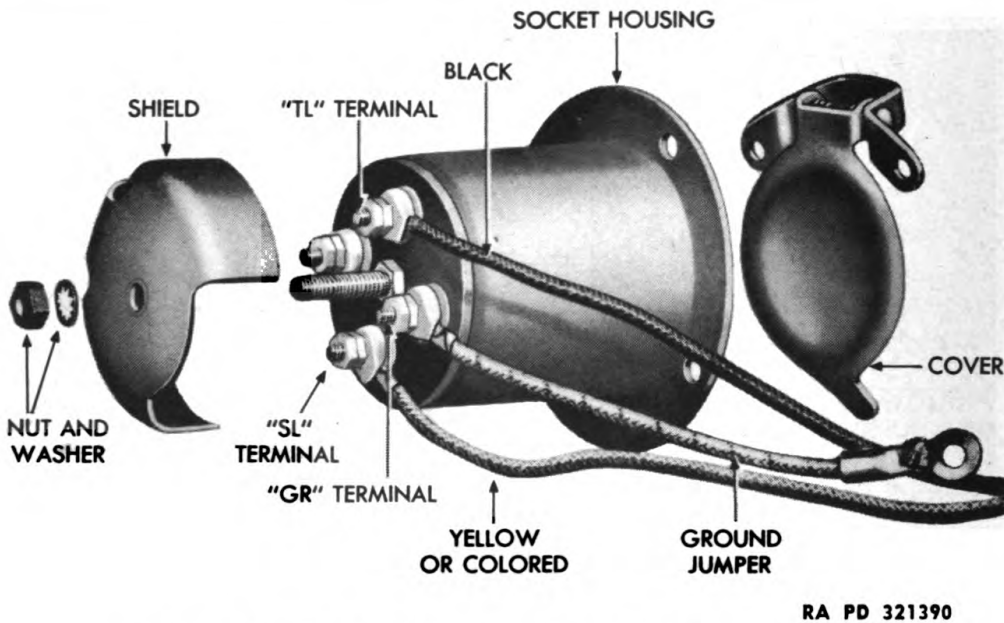
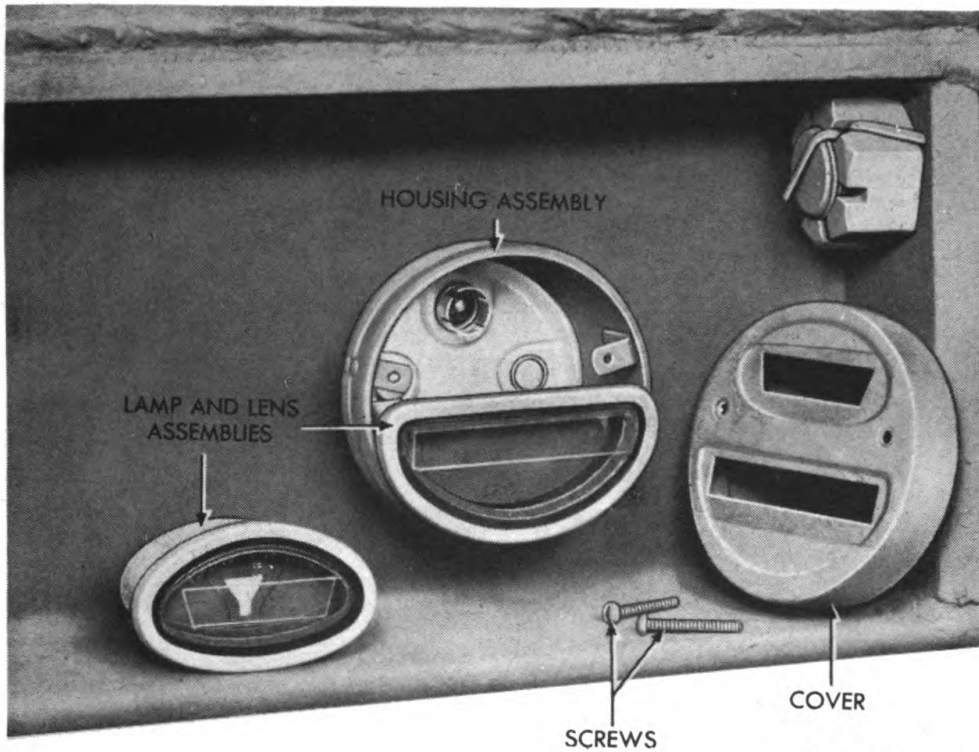

Figure 180—Coupling Socket and Connections

b. Removal of Coupling Socket Assembly. Remove trailer floor cover plate at front of trailer frame. Remove shield plate from over lead connections at base of socket by removing nut and toothed lock washer. Remove nuts, washers, and clips and lift black lead from top connector screw (marked "TL") and yellow (or colored) lead from bottom connector screw (marked "SL"). Remove socket and socket cover assemblies by removing nuts and lock washers from bolts which attach the assemblies to front frame crossmember. Lift socket and cover assembly from front of crossmember. Remove nuts, plain washer, and clip which attach short jumper lead to connector screw marked "GR," and lift jumper from screw.

c. Installation of Coupling Socket Assembly. Attach ground jumper to stud marked "GR." The smaller lug connector on jumper is attached to ground stud. Insert ground wire and socket base through opening in center of frame crossmember with slot in plastic contact case down. Position socket cover assembly on socket flange with cover attaching bracket up and install bolts, lock washers, and nuts. Connect ground jumper to lower bolt toward right side of trailer. A plain washer is used between lug connector and lock washer. Connect yellow cable lead to stud connector marked "SL" and black lead to connector marked "TL." Install coupling shield plate, toothed lock washer, and nut. Install trailer floor cover plate.

Trailer Lights System



RA PD 321356

Figure 181—Combination Tail and Stop Light

240. BLACKOUT TAIL AND STOPLIGHTS.

a. Description and Data.

(1) **DESCRIPTION** (fig. 181). Two combination blackout tail and stoplights are mounted on trailer rear crossmember. The lens of each blackout tail light is designed to produce two beams. When a vehicle is following at a specified distance, these two beams will merge into a single highly visible beam. The lamps are soldered to the lens retainer, and the lens and filter are crimped to the retainer to form a complete unit. The lamp and lens assemblies are enclosed in a housing and cover assembly. Plug-in sockets are single contact.

(2) **DATA.**

Manufacturer	K-D Lamp
Model	KD-959-1-6
Lamp	6 to 8 volt

b. Removal and Installation of Lamp and Lens Assembly.

(1) **REMOVAL.** Remove cover attaching screws and pull cover from taillight housing. Pull lamp and lens assembly from socket.

(2) **INSTALLATION.** Insert lamp and lens assembly in socket. Position cover on housing so that raised part of lens fits in openings

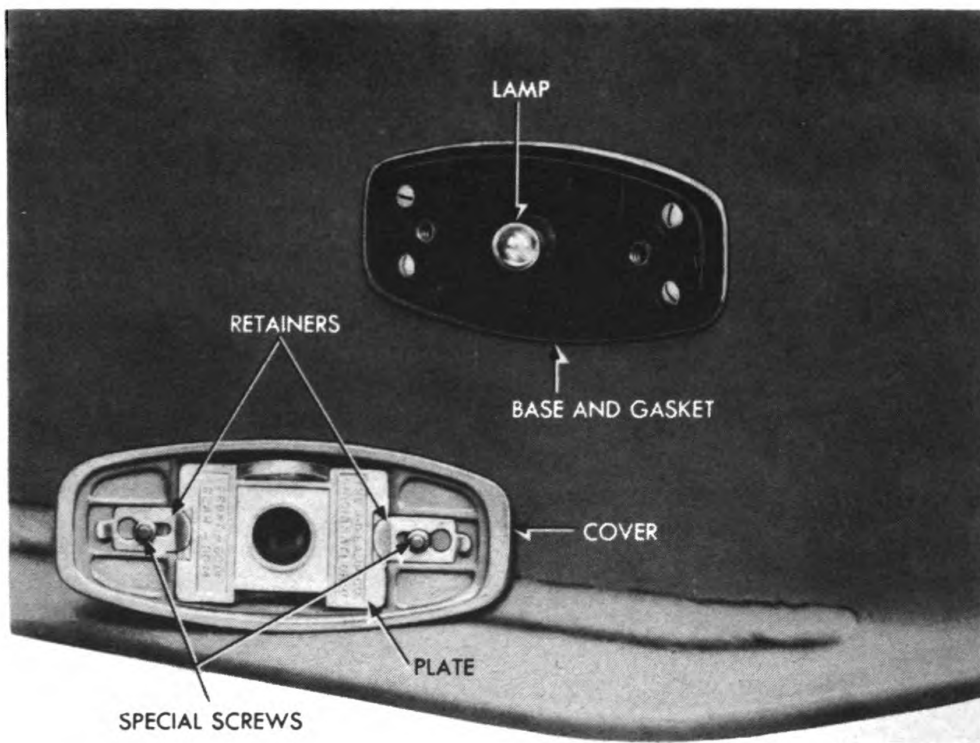

RA PD 321373

Figure 182—Clearance Light, Cover and Lens Assembly—Removed

in cover. Install screws which hold cover in place. Tighten screws only enough to securely hold cover.

c. Removal and Installation of Taillight Assembly.

(1) **REMOVAL.** Attach a marked tag to cable leads to make sure leads will be connected to correct sockets when reinstalled. To facilitate removing connections from sockets, remove lamp and lens assemblies. Disconnect leads by removing plug assemblies from sockets. Remove taillight housing from trailer frame rear crossmember by removing attaching nuts and lock washers.

(2) **INSTALLATION.** Position taillight housing assembly on rear crossmember, and install attaching lock washers and nuts. Connect "plug-in" type connectors to sockets in housing. Install lamp and lens assemblies and housing cover.

241. BLACKOUT CLEARANCE LIGHTS.

a. Description and Data (fig. 182).

(1) The clearance lights are mounted on the frame side members; two near the front, and two near the rear. They are so designed that, when illuminated, they will not be visible from above, but will

Trailer Lights System

be visible for a short distance at approximately trailer level. The light assembly consists of a mounting base and a cover assembly. The lamp socket with lead is a part of the base which is attached to trailer side member. The lens and lens plate are held in the cover by two retaining plates. The cover to base attaching screws is provided with under cuts which serve to hold the lens retaining plates, as well as to attach the cover assembly to the mounting base. The two rear lights have red lenses. The two front lights have blue lenses.

(2) **DATA.**

Manufacturer K-D Lamp
 Model KD-541

b. Removal and Disassembly of Clearance Light Assembly. Loosen two slotted round-head screws and lift cover and lens assembly from mounting base. Remove lamp. Remove cover to base gasket. Remove tap and unsolder lead connection. Remove nuts and lock washers from slotted round-head bolts, and lift light mounting base from frame side member. Remove base to frame gasket. Remove lens and lens plate from cover by removing one of the lens retaining plates and lifting lens plate and lens from cover.

c. Installation and Assembly of Clearance Light. Position base to frame gasket, and mount base on trailer side member. Install round-head bolts, lock washers, and nuts. Solder lamp lead to cable lead, and cover with rubber tape and friction tape. Install lamp in socket in mounting base. Position lens and lens plate in cover, and install lens retaining plates. Position cover to base gasket, and install cover assembly on base with attaching screws.

242. FUSE PANEL.

a. Description (fig. 183). A fuse panel and cover is mounted on the right frame member above the front wheels near the front junction box. The fuse panel provides two rows of three fuses and fuse holders. Two fuses in each row are spares. Both leads of the coupling socket to junction box cable pass through the front junction box and to the fuse panel to provide for a fuse in each circuit before the current reaches any connections or other parts of either circuit.

b. Removal of Fuse Panel. Remove cotter pins and wing nuts and lift cover from attaching studs. Disconnect all leads at panel by removing screws which attach lug connectors to fuse holders. Remove front junction box cover. Remove nut and lock washer from stud bolt which attach both the fuse panel and junction box to trailer frame. Remove nut and washer from stud bolt located above junction box and remove stud. Lift fuse panel from trailer frame and from leads. Remove panel gasket.

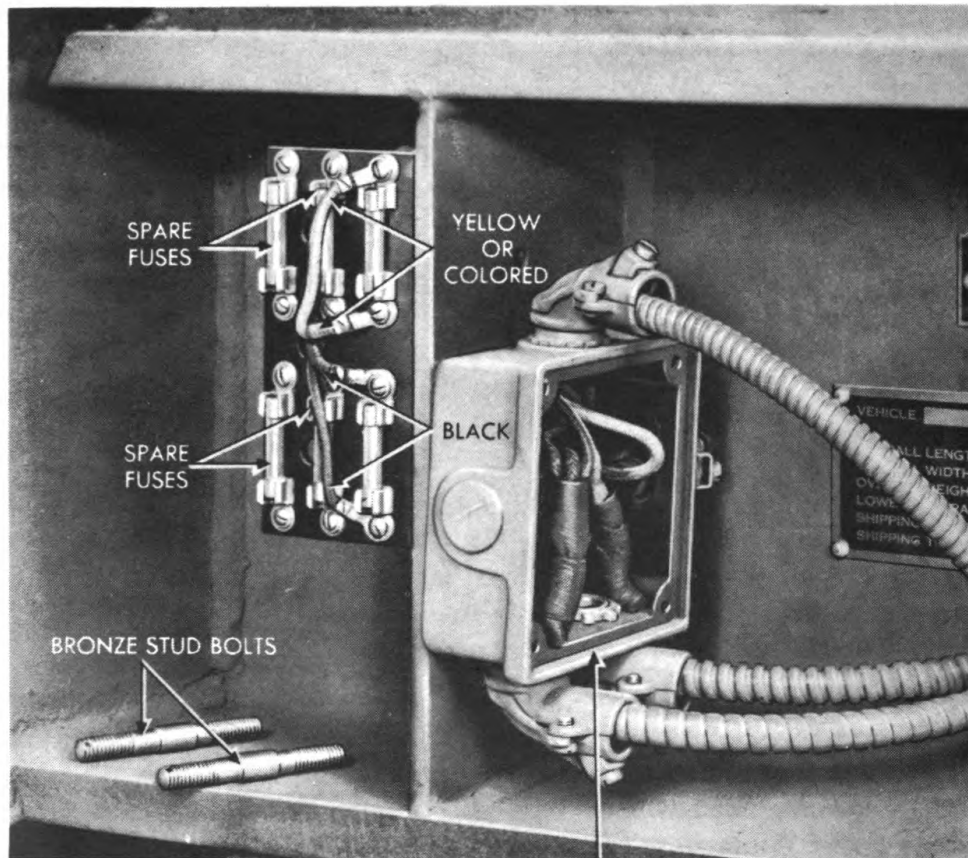

COVER REMOVED FOR ACCESS TO STUD NUT

RA PD 321376

Figure 183—Fuse Panel and Connections

c. **Installation of Fuse Panel.** Insert leads through gasket and fuse panel and install studs, lock washers, and nuts which attach fuse panel and front junction box to right frame member. Connect coupling socket to junction box cable leads to fuse panel; yellow lead is connected to upper row of fuses and black lead to lower row. Connect fuse panel to junction box jumper leads. Install panel cover, wing nuts, and cotter pins.

243. JUNCTION BOXES.

a. **Description.** Two junction boxes are provided for enclosing necessary cable lead connections. Threaded holes in the sides of the boxes are for attaching connectors through which cable leads are inserted, and to which conduit is attached by means of a conduit retaining clamp and screw.

b. **Removal of Junction Box.** Remove junction box cover. Remove tape and unsolder lead connections. Loosen conduit retaining

Trailer Lights System

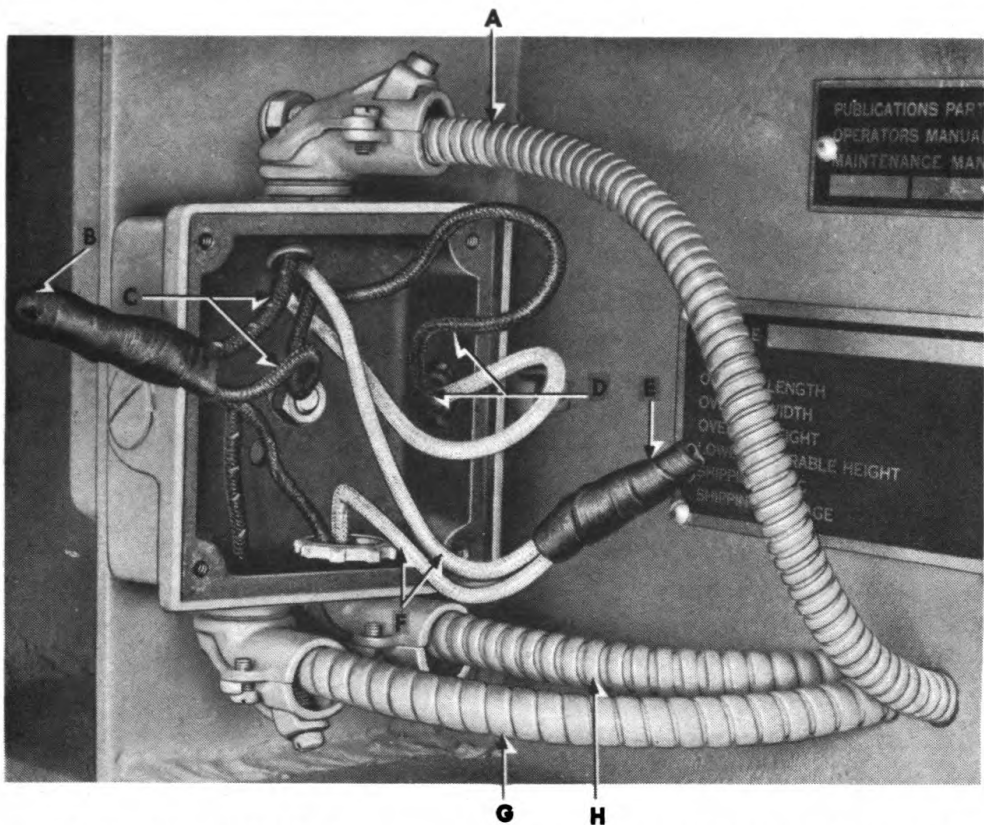

- | | |
|---------------------------------|----------------------------------|
| A—TO LEFT CLEARANCE LIGHT | E—SOLDERED AND TAPED CONNECTION |
| B—SOLDERED AND TAPED CONNECTION | F—YELLOW OR COLORED |
| C—BLACK | G—TO RIGHT FRONT CLEARANCE LIGHT |
| D—FROM COUPLING SOCKET | H—TO REAR JUNCTION BOX |

RA PD 321394

Figure 184—Cable Connections at Front Junction Box

clamp screws and remove conduit and leads. Remove nut and washer which attach box housing to trailer frame. Loosen conduit connector lock nuts, and screw connectors out of box.

c. Installation of Junction Box. Install connectors of type and in positions as required for front or rear junction box installation (figs. 184 and 185). Attach junction box to trailer frame. Insert cable leads through correct connector and with conduit in connector; tighten conduit retaining clamp screw. Install all cables. Solder together all leads having yellow, or colored, insulation and all leads having black insulation. Wrap soldered connections with rubber tape and with friction tape. Install box cover.

244. CABLES.

a. Description. Cable assemblies consist of necessary wires enclosed in flexible conduit. The insulation on all cable leads in the

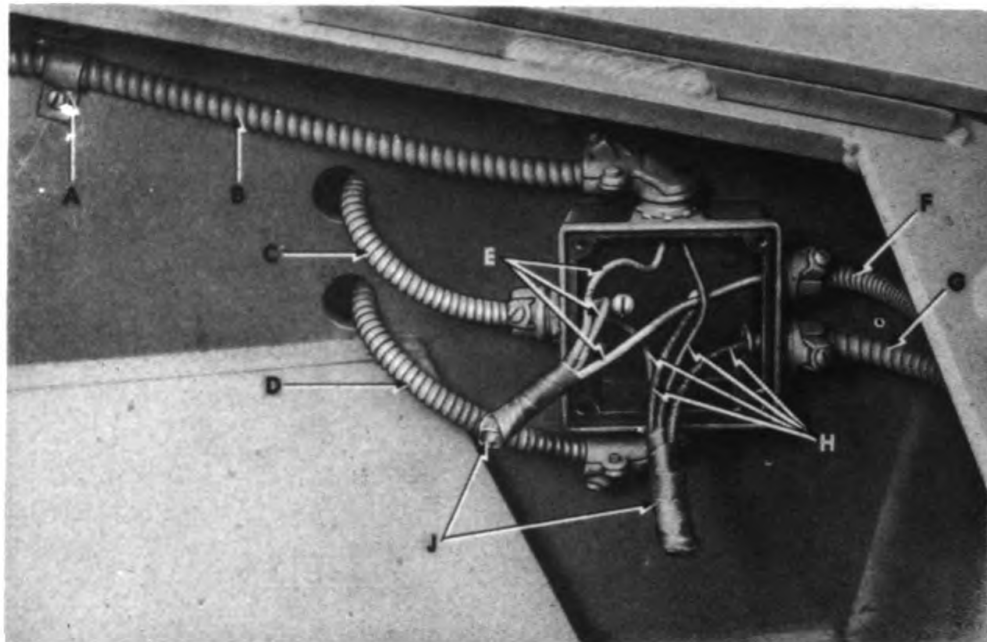

- | | |
|---------------------------------|----------------------------------|
| A—CABLE SUPPORTING CLAMP | F—TO LEFT TAILLIGHT |
| B—FROM FRONT JUNCTION BOX | G—TO RIGHT REAR CLEARANCE LIGHT |
| C—TO RIGHT TAILLIGHT | H—BLACK |
| D—TO RIGHT REAR CLEARANCE LIGHT | J—SOLDERED AND TAPED CONNECTIONS |
| E—YELLOW OR COLORED | |

RA PD 321357

Figure 185—Cable Connections at Rear Junction Box

clearance and taillight circuit is yellow, or colored. The insulation on all cable leads in the stop light circuit is plain black.

b. Removal of Cable. Disconnect cable leads at each end of cable. Disconnect conduit ends, and loosen all cable clamps along the cable. Lift cable from clamps and remove from trailer frame.

c. Installation of Cable. Install cable through passages in trailer frame and in cable supporting clamps. Attach ends of conduit, and then tighten supporting clamp screws. Make necessary cable lead connections.

Section XLIII

FRAME

245. DESCRIPTION AND DATA.

a. Description (fig. 186). The frame provides loading runways for the vehicle to be carried, supported by heavy cross and longitudinal members. Chock blocks are bolted to the runways to block the loaded vehicle. Ramps at the rear can be lowered for loading.

Frame

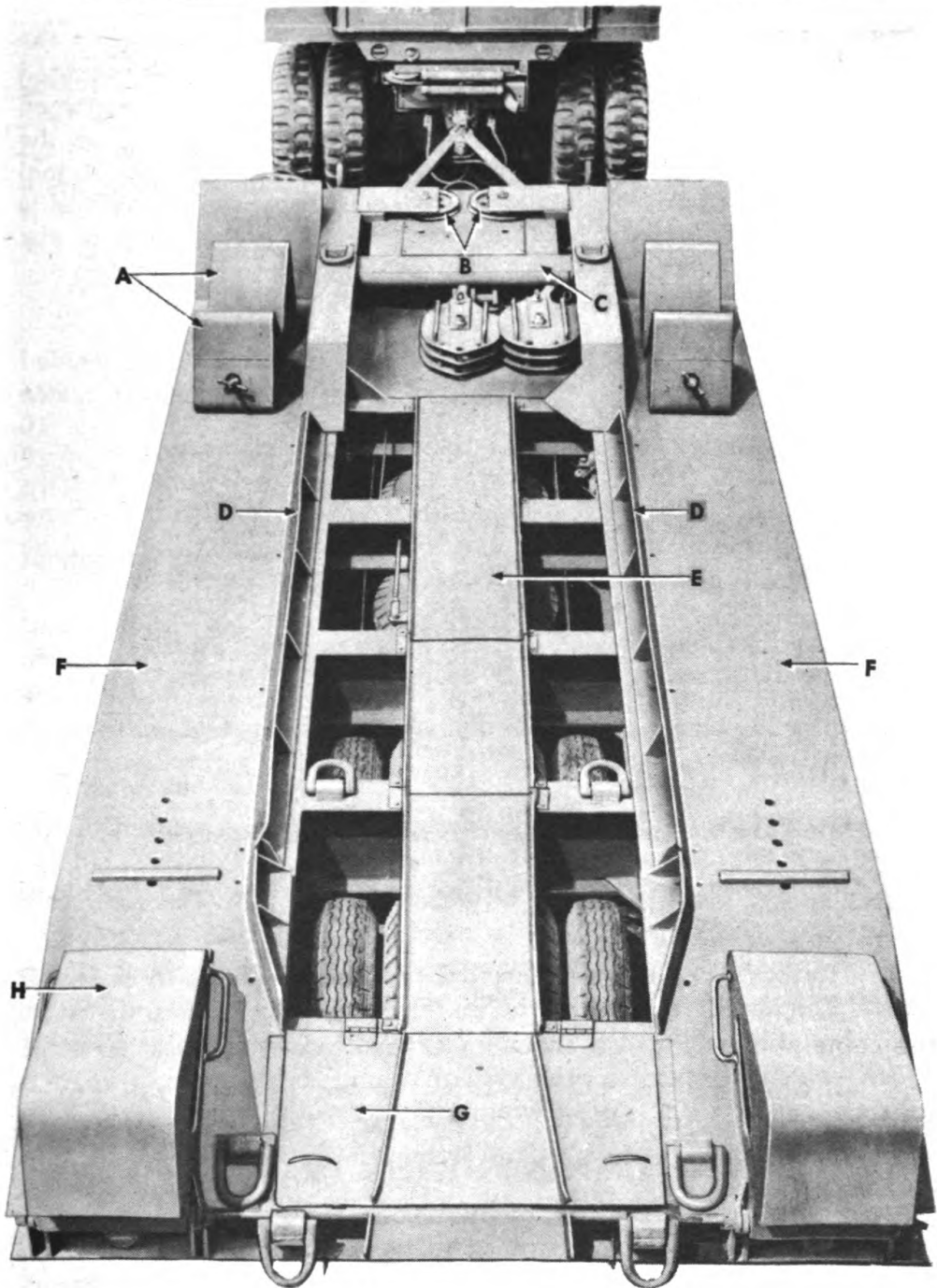

- | | |
|----------------|-----------------------|
| A—CHOCK BLOCKS | E—CABLE TROUGH |
| B—SHEAVES | F—RUNWAYS |
| C—REAR ROLLER | G—STOWAGE COMPARTMENT |
| D—TRACK GUIDES | H—LOADING RAMP |

RA PD 321441

Figure 186—Top View of Trailer

407

Maintenance Instructions

Anchor chains, turnbuckles, and hooks are provided for securing the loaded vehicle to the frame. An adjustable track guide is provided beside each runway. A three-piece cable trough is located between the runways. The forward section of the trough is welded to the frame members. The two rear sections are bolted in place. A tool and stowage compartment is located at the rear of the frame and is provided with a cover. A kingpin connects the forward part of the main frame to the gear frame.

b. Data.

Kingpin	5-in. diam. cast steel welded to apron plates
Lashing rings	10
Loading ramps	2
Chock blocks	4
Winch cable sheaves	2
Construction	Welded throughout
Roller hanger bushing:	
Manufacturer	Fruehauf
Material	63 SAE bronze
Ream diameter	1.255 in.
Outside diameter	1.500 in.

246. CHOCK BLOCKS.

a. Description (fig. 186). Two chock blocks are secured at the forward end of each runway plate by clamp rods, one on each side to block the front of the loaded vehicle, and one on each side to block the rear.

b. Removal. Unscrew the clamp rod wing nut, and unhook clamp rod from runway. Lift chock block off runway.

c. Installation. Place chock block on runway against track of loaded vehicle. Secure to runway with clamp rods. Grease threaded end of clamp rod, and install wing nut.

247. ANCHOR CHAINS AND SAFETY CHAINS.

a. Description. Anchor chains, hooks, and turnbuckles are stowed in the stowage compartment at the rear of the vehicle. These are for the purpose of anchoring the load to the trailer. Hooks should be secured to the load and to bull rings on the trailer, and the chains tightened by means of the turnbuckles.

248. TRACK GUIDES.

a. Description (fig. 186). A track guide is bolted to the runway plate on each side of the trailer. These are adjustable for height and width.

Frame

b. Adjustment for Height. To change the adjustable track guides from high to low position, remove the three cap screws which hold guide to trailer runway and turn so that other side of angle is up. Extensions must be exchanged for those in the stowage compartment when the high guide is used.

c. Adjustment for Width. Two rows of mounting holes on each runway provide for changing width between guides to accommodate different track widths.

249. RAMP ASSEMBLIES.

a. Description (figs. 186 and 187). A loading ramp is mounted at the rear of each runway. In stowed position these are swung up onto the runways and are secured to the trailer by means of hooks. In loading position, they are swung down to the ground and provide ramps for the loading vehicle to move up onto the trailer runways.

b. Removal. Remove the cotter pins and nuts from the hinge plate bolts, pull the bolts, and lift out.

c. Installation. Install the hinge plate bolts, screw on the nuts, and install cotter pins.

250. ROLLER ASSEMBLIES.

a. Description (fig. 186). Two cable rollers are provided for carrying the cable from the tractor. The front roller is attached by means of brackets to the extreme front crossmember of the frame. A guard is mounted in front of it. The rear roller is mounted by means of brackets behind the front cover plate.

b. Removal.

(1) **FRONT CABLE ROLLER GUARD.** Remove the four hex bolts which secure the guard to the frame. Lift off the guard.

(2) **FRONT ROLLER.** One of the brackets which holds the front cable roller is permanently attached. The other bracket is bolted in position. Remove the cover plate, and remove bolts and nuts which secure bracket. Support roller to prevent it from falling.

(3) **REAR ROLLER.** Remove bolts which hold bracket to frame flange and lift out roller.

c. Installation.

(1) **REAR ROLLER.** Install roller in position and bolt bracket to frame flange.

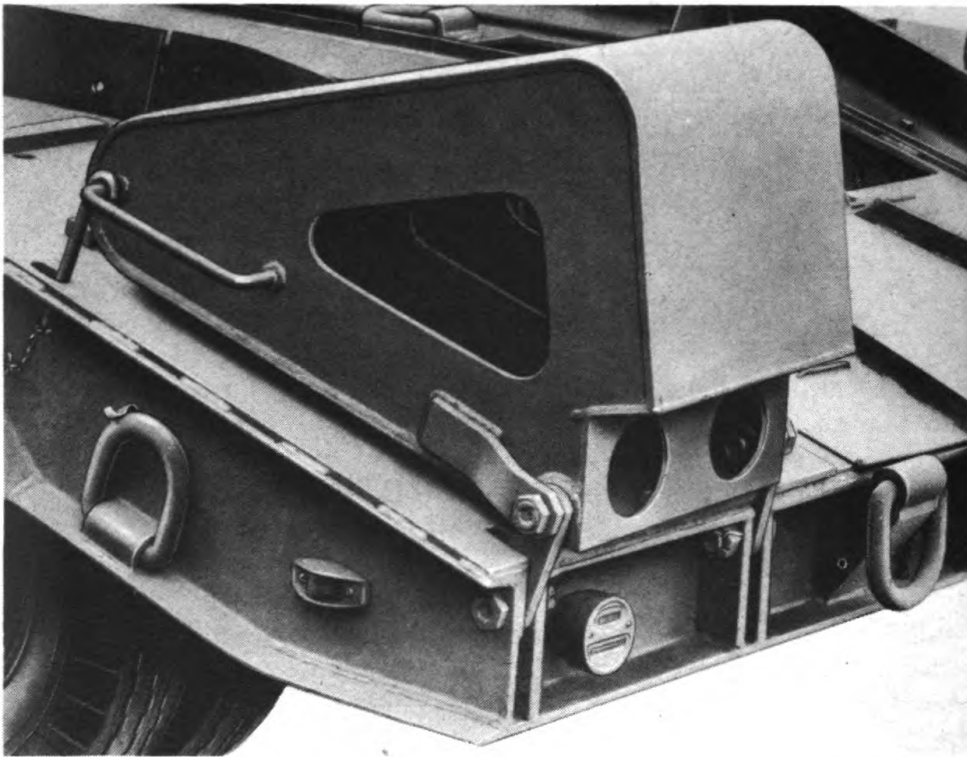

RA PD 321440

Figure 187—Loading Ramp

(2) **FRONT ROLLER.** Install roller in position and bolt bracket in place. Install cover plate.

(3) **FRONT CABLE ROLLER GUARD.** Position guard and install four hex bolts which hold it in place.

251. SHEAVES.

a. **Description** (fig. 186). Two sheaves are mounted in brackets at the forward end of the trailer. They carry the cable from the tractor when loading the trailer.

b. **Removal.** Remove the cover plate. Remove cotter pin and nut from sheave bolt. Lift out bolt, and pull the sheave toward the rear and out of the bracket.

c. **Installation.** Install the sheave in the bracket and insert the sheave bolt. Install the nut and cotter pin. Place the cover plate in position and secure it with cap screws.

Trailer Understructure

252. CABLE TROUGH.

a. **Description** (fig. 186). A cable trough extends between the runways. The forward section is welded in position. The two rear sections are bolted in place and can be removed to provide access to the rear under construction.

b. **Removal.** Remove the bolts which hold the cable trough to the frame, and lift off the cable trough section.

c. **Installation.** Place the cable trough section in position and bolt it to the frame.

Section XLIV

TRAILER UNDERSTRUCTURE

253. DESCRIPTION.

a. The trailer understructure is equipped with axle and trunnion assemblies on which the wheels and tires are mounted. The trunnion assemblies provide freedom of motion for the wheels so that they can oscillate and work up and down as the vehicle passes over irregular terrain. Each front and rear understructure consists of a right and left axle and trunnion assembly. The right and the left axle and trunnion assembly parts are identical except for the brake shoe cams. The cams are designed for right or for left axle and trunnion assemblies, and are not interchangeable; also, the front and rear cams are not interchangeable. Four wheels with brake shoe and drum assemblies are mounted at the front, and eight at the rear. Dual tire and rim assemblies are mounted on all wheels.

254. FRONT AXLE AND TRUNNION ASSEMBLY.

a. **Description** (figs. 188 and 189). The front understructure is provided with a right and a left axle and trunnion assembly with four wheels and eight tires mounted in line across the front of the trailer. Two wheels are mounted on each axle with a trunnion beam supported between them. The ends of the trunnion beams have bearing surfaces so that the beams are free to oscillate. A recoil spring assembly is provided on each trunnion beam rear mounting bracket.

b. **Removal of Front Axle and Trunnion Assembly.**

(1) **LIFT TRAILER.** Using a spread chain, attach a hoist to bull rings located at front corners of trailer frame. Tighten hoist to lift tires off floor.

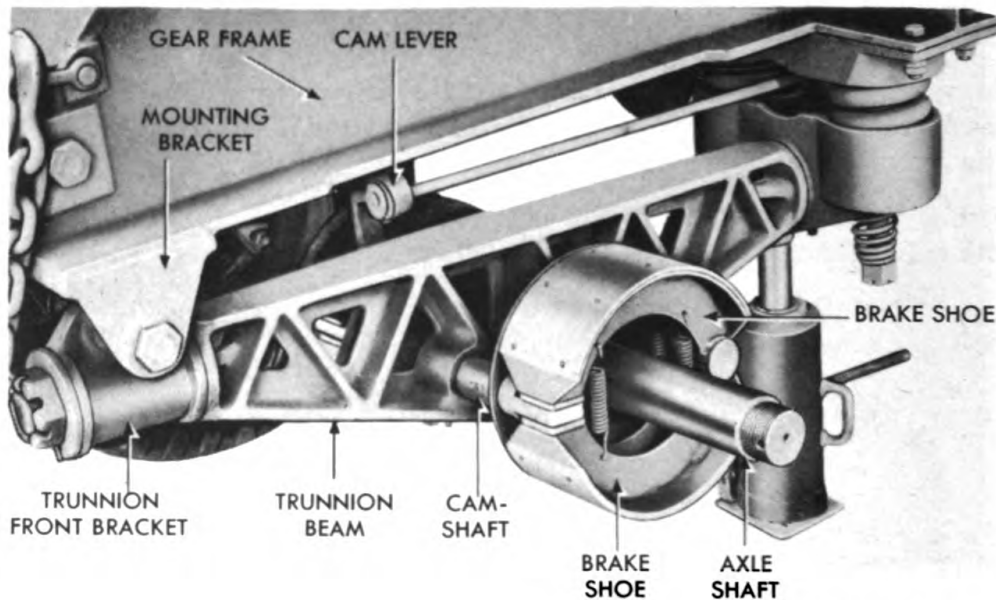

RA PD '321395

Figure 188—Left Front Axle Trunnion—Installed

(2) **REMOVE TIRE AND RIM ASSEMBLIES.** Follow procedures outlined in paragraph 257 h.

(3) **REMOVE HUB AND WHEEL ASSEMBLIES.** Follow procedures outlined in paragraph 256 h.

(4) **REMOVE BRAKE SHOE ASSEMBLIES.** Remove brake shoe return springs, and lift brake shoe assemblies from brake cam shaft and brake anchor shaft. Remove wheel guard plate by sliding plate from brake and axle shafts.

(5) **REMOVE BRAKE ROD.** Loosen jam nut at rod clevis, and screw brake rod from adjustment clevis (fig. 189). Remove jam nut from rod, and slide rod from cam lever.

(6) **LOOSEN FRONT SPRING AND BRACKET ASSEMBLY.** Place a jack under rear end of trunnion beam to support weight of beam and of spring and bracket assembly. Remove jam nuts and nuts from bolts which attach bracket assembly to gear frame.

(7) **LOOSEN TRUNNION FRONT BRACKET.** Place a small A-frame under front end of beam to support beam after bolt is removed which attaches front bracket to mounting bracket. Remove cotter pin, nut, and washer and drive bolt from bracket and mounting bracket. Lift trailer clear of trunnion brackets, and remove axle and trunnion assembly from under trailer gear.

c. Disassembly of Front Axle and Trunnion Assembly.

(1) **REMOVE AND DISASSEMBLE SPRING AND BRACKET ASSEMBLY** (fig. 190).

Trailer Understructure

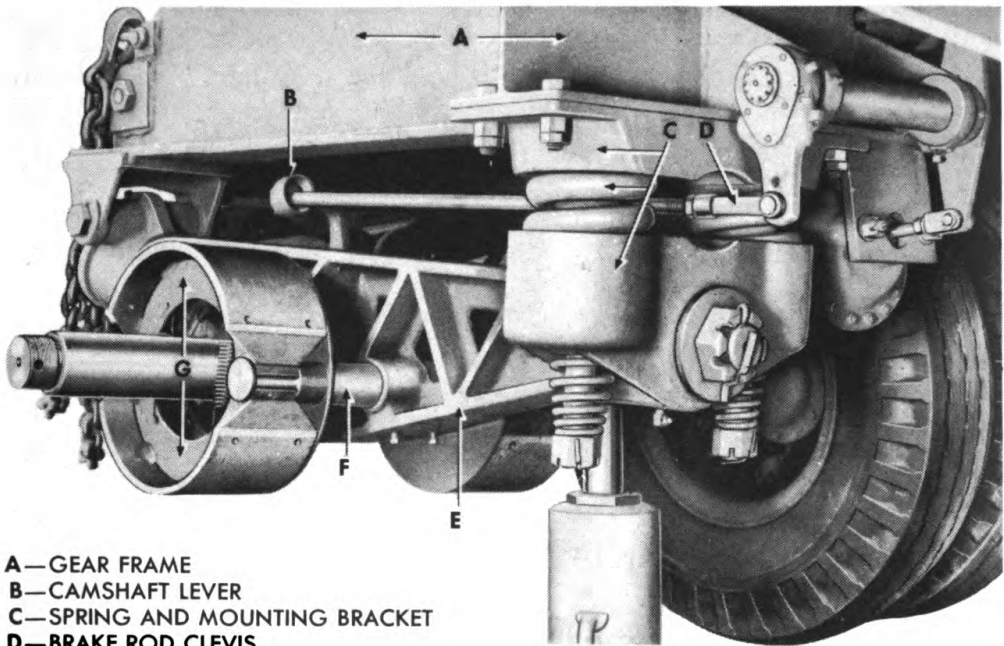

A—GEAR FRAME
 B—CAMSHAFT LEVER
 C—SPRING AND MOUNTING BRACKET
 D—BRAKE ROD CLEVIS
 E—TRUNNION BEAM
 F—ANCHOR SHAFT
 G—BRAKE SHOES

RA PD 321458

Figure 189—Front Spring and Mounting Bracket—Installed

(a) *Remove Bracket Assembly from Trunnion Beam.* Remove cotter pin, nut, and washer and slide bracket assembly from trunnion beam.

(b) *Disassemble Spring and Bracket Assembly.* Remove cotter pins, nuts, and bolts which hold spring and bracket assembly together.

(2) **REMOVE FRONT BRACKET FROM TRUNNION BEAM** (fig. 190). Remove cotter pin, nut, and washer, which hold bracket on beam and slide bracket off beam.

(3) **REMOVE AND DISASSEMBLE BRAKE CAMSHAFT** (fig. 190). Slide camshaft and lever assembly from trunnion beam. Remove collar from shaft by loosening set screw in collar and slide collar from shaft. Install shaft and lever in an arbor press and press shaft from lever. Remove key from keyway. **NOTE:** *The camshaft assemblies and anchor shafts can be removed by hoisting trailer and removing wheel and brake shoe assemblies without removing entire axle and trunnion assembly from under trailer gear.*

(4) **REMOVE BRAKE SHOE ANCHOR SHAFT** (fig. 190). Loosen set screws located below anchor shafts. Clean ends of shaft and examine for burred or damaged conditions. Remove burs with a fine file. Drive shaft from beam in direction so that undamaged end of beam will pass through shaft hole in beam.

RA PD 321426

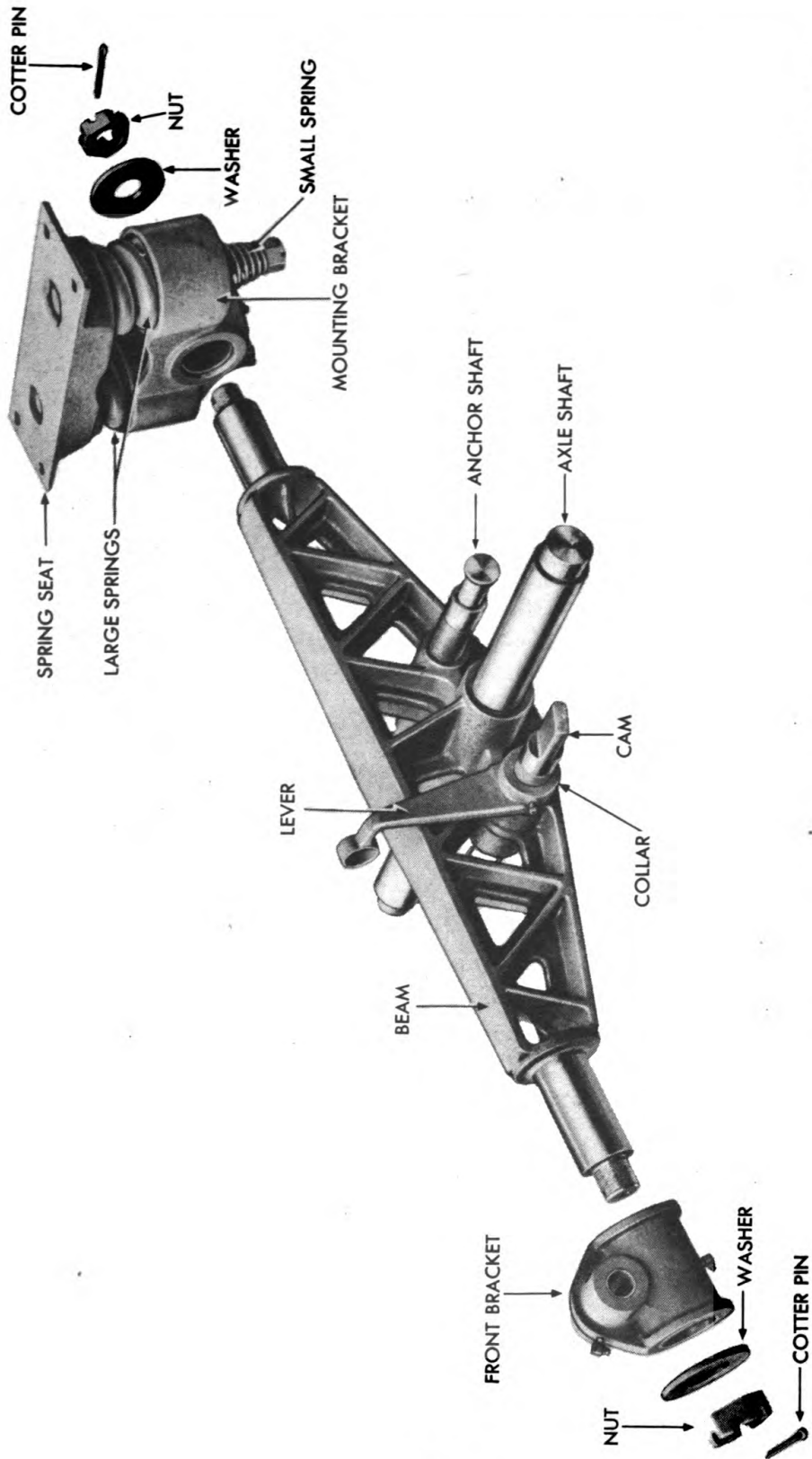

Figure 190—Right Front Axle Trunnion Beam and Brackets

Trailer Understructure

(5) **REMOVE AXLE SHAFT** (fig. 190). Remove axle shaft set screws located under trunnion beam and below axle. Clean and examine axle for burs or damaged condition. Remove small burs with a fine file. Drive or press axle from trunnion in direction so that only undamaged end of shaft will pass through shaft hole in trunnion beam. If shaft is difficult to remove due to rusty condition in axle hole, apply heat to beam and remove shaft before beam is again cool and before shaft absorbs heat.

d. Assembly of Front Axle and Trunnion.

(1) **INSTALL AXLE SHAFT.** Make sure shaft is free of burred or damaged conditions. Apply lubricant to shaft. Install shaft in hole in beam with set screw holes in shaft alined with screw holes in beam. Install and tighten set screws.

(2) **INSTALL BRAKE SHOE ANCHOR SHAFT.** Install anchor shaft in machined hole in beam so that set screw holes in shaft are alined with screw holes in beam. Install and tighten set screws.

(3) **ASSEMBLE AND INSTALL BRAKE SHOE CAMSHAFT.**

(a) *General.* Installation of a right-hand or a left-hand cam will result in an axle and trunnion assembly to be installed on same side of trailer as hand of cam. The cam assembly and installation procedure is the same for either cam.

(b) *Assemble Cam Lever and Camshaft.* Place key in shaft keyway. Install lever on shaft so that lever end offset is toward center of shaft. Tap lever on shaft and over key far enough to install collar. Position collar on shorter end of shaft so that set screw hole in collar is alined with countersunk hole in shaft and install set screw.

(c) *Install Brake Cam and Lever Assembly.* Insert longer end of camshaft through beam camshaft bushing so that lever offset extends over top side of beam, and set screw in lever retaining collar is toward front end of beam.

(4) **INSTALL TRUNNION FRONT BRACKET.** Slide front bracket on front end of beam so that chamfered end of beam hole will be toward center of beam. Install washer, nut, and cotter pin.

(5) **ASSEMBLE AND INSTALL SPRING BRACKET ASSEMBLY ON TRUNNION BEAM.**

(a) *Assembly.* Insert bolts through trunnion spring seat, and place seat and bolt assembly on bench with threaded ends of bolts up. Position large springs over spring guides on spring seat. Place trunnion mounting bracket on large springs. Install small springs. Compress springs and install nut and cotter pin.

(b) *Installation.* Install the assembly on beam so that chamfered end of beam hole is toward center of beam. Install washer, nut, and cotter pin which hold the assembly on beam.

e. Installation of Front Axle and Trunnion Assembly on Gear Frame.

(1) **POSITION TRUNNION ASSEMBLY UNDER GEAR FRAME.** Place a support under gear frame on which front and rear end of axle trunnion will rest while brackets are being alined.

(2) **ATTACH TRUNNION FRONT TO MOUNTING BRACKET.** Lower hoist so that trunnion front bracket can be installed. Position trunnion bracket in mounting bracket, and install bolt so that threaded end of bolt is away from outside. Install washer, nut, and cotter pin.

(3) **ATTACH SPRING AND BRACKET ASSEMBLY TO GEAR FRAME.** Place a jack under rear end of trunnion; lift and position spring seat to gear frame. Install bolts, nuts, and jam nuts which attach the assembly to gear frame.

(4) **INSTALL BRAKE ROD.** Slide brake rod through cam lever and screw jam nut on rod. Screw rod into adjustment clevis located on lever at rear of spring and bracket assembly.

(5) **INSTALL BRAKE SHOE ASSEMBLIES.** Slide wheel guard plate over trunnion shafts. Position brake shoes on cam and anchor shafts, and install shoe return springs. Install inside and outside shoe assemblies.

(6) **INSTALL WHEEL AND HUB ASSEMBLIES.** Install inside and outside wheel and hub assemblies as explained in paragraph 256 c.

(7) **INSTALL TIRE AND RIM ASSEMBLIES.** Install inside and outside tire and rim assemblies as explained in paragraph 257 e. Remove jack and hoist.

255. REAR AXLE AND TRUNNION ASSEMBLY.

a. Description (fig. 191). The rear end of the trailer frame is supported on a left-hand and a right-hand axle and trunnion assembly. Each assembly is provided with two axles mounted in identical axle brackets. The axle brackets are mounted on a trunnion shaft with a rocker beam between them. The axle brackets are free to oscillate on the rocker beam shaft and to move up and down as the rocker beam oscillates on its axis. Two wheels with dual tires are mounted on each axle so that each assembly is provided with four wheels and eight tires.

b. Removal of Rear Axle Trunnion Assembly.

(1) **DISCONNECT BRAKE LINKAGE.** Remove bolt from brake lever and connecting link located below rear cable channel and in front of two center rear tires (fig. 195).

(2) **REMOVE TRUNNION BRACKET SHAFT.**

(a) *Lift Rear End of Trailer.* Place a hydraulic jack under center of frame member to which axle trunnion assembly is attached,

RA PD 321439

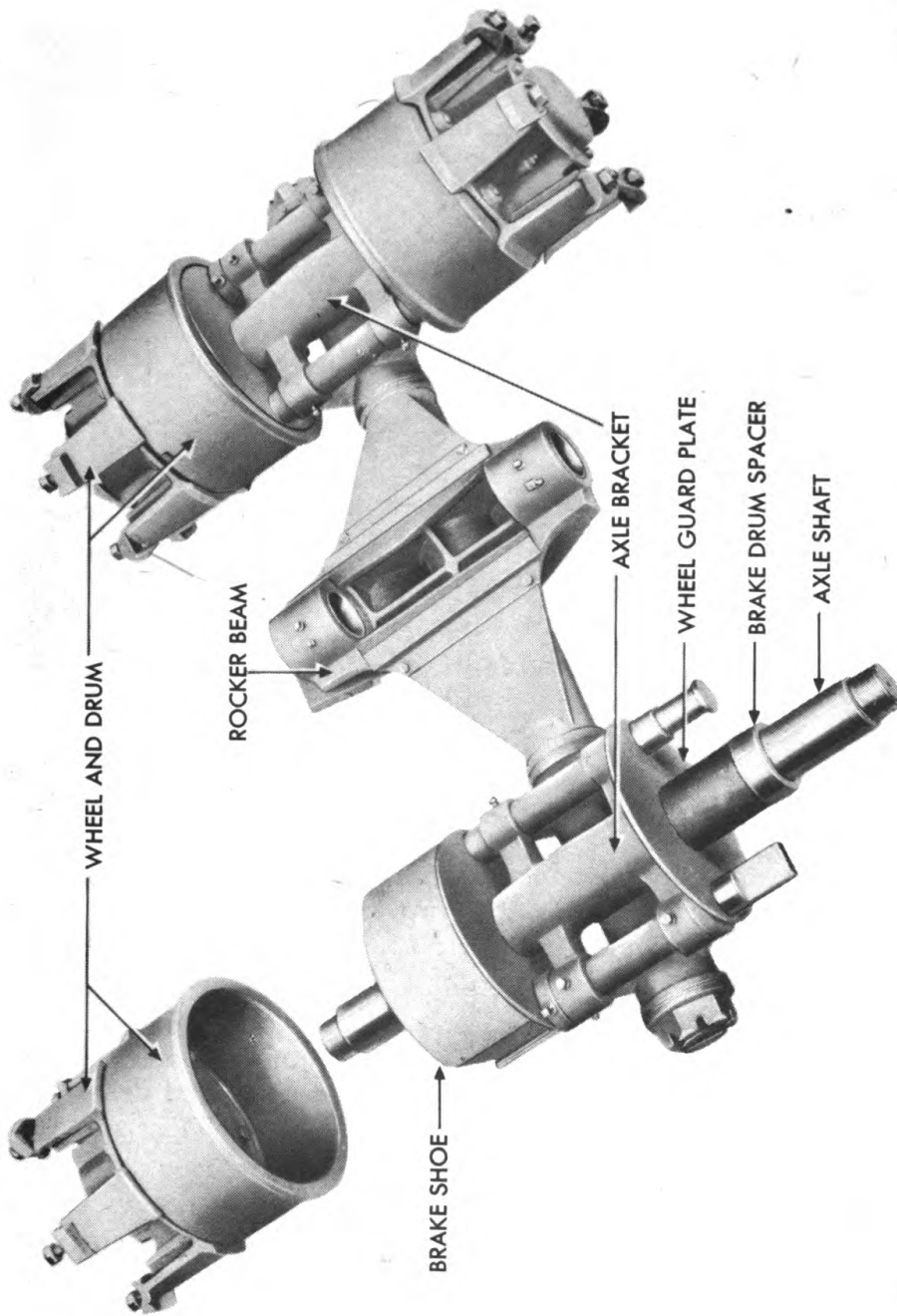
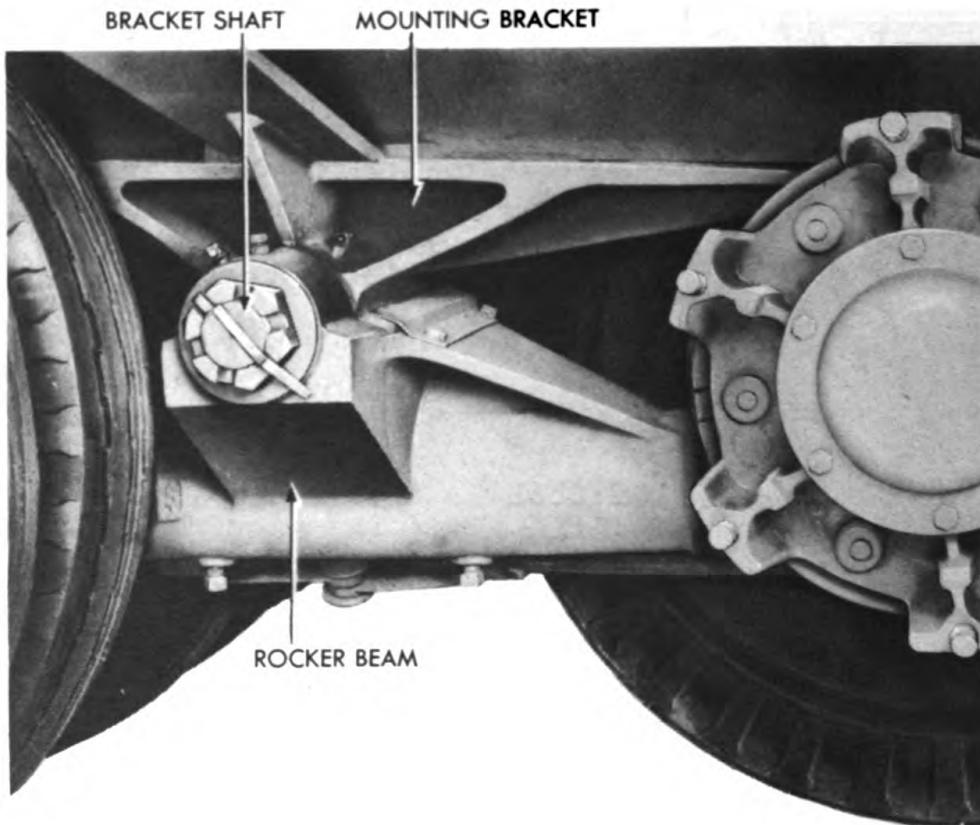

Figure 191—Rear Axle and Trunion Assembly



RA PD 321412

Figure 192—Rear Trunnion Mounting Bracket and Shaft

and lift frame enough to remove weight of frame from bracket shaft. **NOTE:** A hydraulic jack is used to provide control in lifting frame while removing trunnion shaft. The frame must be neither too low nor too high, which would cause trunnion bracket shaft to bind and make removal extremely difficult.

(b) **Remove Bracket Shaft** (fig. 192). Remove cotter pin, nut, and washer from each end of trunnion bracket shaft and drive shaft out of mounting bracket and rocker beam. See NOTE, step (2) above. Adjust jack to prevent shaft from binding.

(3) **REMOVE AXLE TRUNNION AND WHEEL ASSEMBLY.** Using spread chain, attach a hoist to bull eyes at rear of frame. Lift frame enough to permit rolling the axle trunnion and wheel assembly from under frame.

c. Disassembly of Rear Axle and Trunnion Assembly.

(1) **REMOVE TIRE AND WHEEL ASSEMBLIES.** Attach a hoist to trunnion rocker bracket and lift the assembly enough to remove tire

Trailer Understructure

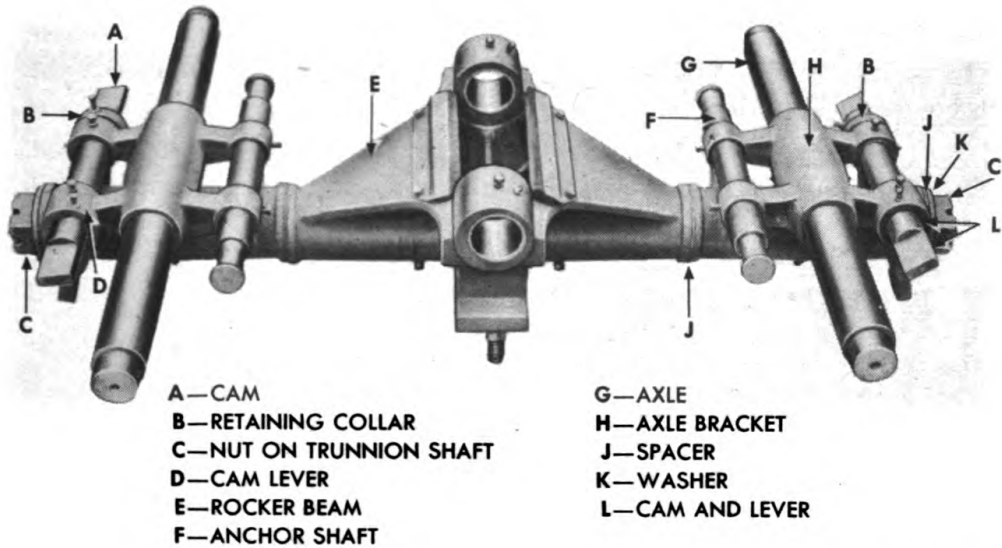

RA PD 321382

Figure 193—Rocker Beam and Axle Brackets

and wheel assemblies. To facilitate handling, remove tire and rim assemblies as explained in paragraph 257 b before removing wheel and hub assemblies as explained in paragraph 256 b.

(2) **DISASSEMBLY AND REMOVAL OF REAR AXLE BRACKETS** (figs. 191 and 193).

(a) **Remove Brake Linkage.** Remove cotter pin and pin which attaches adjustable rod end clevis to brake lever. Lift rear rod assembly from lever and out of rear brake cam lever. Loosen jam nut on front rod assembly, remove clevis and nut, and slide rod from front cam lever (fig. 194).

(b) **Remove and Disassemble Brake Camshaft** (fig. 193). Loosen set screw in camshaft retaining collar, and remove collar from shaft. Slide shaft and lever assembly from axle bracket. Drive or press shaft from lever, and remove key from keyway. Remove and disassemble both cams.

(c) **Remove Axle Bracket From Trunnion Shaft** (fig. 193). Remove cotter pin, nut, plain washer, and bronze spacer washer which hold axle bracket on trunnion shaft. Slide bracket from shaft, and remove bronze spacer washer located next to rocker beam. Remove both axle brackets.

(d) **Remove Anchor Shaft From Axle Bracket.** Loosen set screws which hold anchor shaft in axle bracket, and drive or press shaft from bracket.

(e) **Remove Axle Shaft From Axle Bracket** (fig. 193). Make sure that axle is free of burrs or damaged condition which will make

removal of axle difficult. If necessary, remove burs with fine file. Loosen set screws which hold axle in bracket, and drive or press axle from bracket in direction so that undamaged end of shaft will be forced through bracket.

(3) **REMOVE TRUNNION SHAFT FROM TRUNNION ROCKER BEAM.** Remove set screws which hold trunnion shaft in rocker beam. Examine shaft for burred or damaged condition which will cause shaft to bind during removal. Using a fine file, remove burs. Press or drive shaft from beam in direction so that only undamaged part of shaft will be forced through shaft hole.

d. Assembly of Rear Axle and Trunnion Assembly.

(1) **INSTALL TRUNNION SHAFT IN TRUNNION ROCKER BEAM.** Make sure shaft is free of burs or damage that will make installation difficult. Apply lubricant to shaft and shaft hole in rocker beam. Drive or press shaft into shaft hole in beam so that countersunk holes in shaft will align with set screw holes in beam. Install set screws which hold trunnion shaft in rocker beam.

(2) **INSTALL AXLE SHAFT IN AXLE BRACKET.** Make sure axle is free of burs or damage that will make installation difficult. Apply lubricant to shaft and shaft hole in bracket. Drive or press axle shaft into hole in bracket, so that countersunk holes in shaft are aligned with set screw holes in bracket. Install set screws which hold axle shaft in trunnion bracket. Install axle shafts in two trunnion brackets.

(3) **INSTALL BRAKE SHOE ANCHOR SHAFT IN AXLE BRACKET.** Insert anchor shaft in machined hole in bracket so that countersunk holes in shaft are aligned with set screw holes in bracket. Install set screws which hold anchor shaft in trunnion bracket.

(4) **INSTALL AXLE BRACKET ON TRUNNION SHAFT.** Place bronze spacer washer on trunnion shaft. Slide trunnion axle bracket on trunnion shaft so that brake shoe anchor shaft end of bracket is toward rocker beam. Place bronze spacer washer on shaft next to bracket. Install plain washer, nut, and cotter pin which hold bracket on trunnion shaft. Install both axle brackets as explained above.

(5) **ASSEMBLE AND INSTALL BRAKE SHOE CAMS.**

(a) *General.* Installation of a right-hand or a left-hand cam will result in an axle and trunnion assembly that must be installed on same side of trailer as hand of cam.

(b) *Assemble Cam and Lever.* Place key in keyway and install lever on shaft so that bend in lever is toward long end of shaft from keyway. Align set screw hole in shaft with screw hole in lever, and install set screw which holds lever in place on shaft.

(c) *Install Cam and Lever Assembly.* Make sure the axle shaft brackets and rocker beam are all positioned above trunnion shaft.

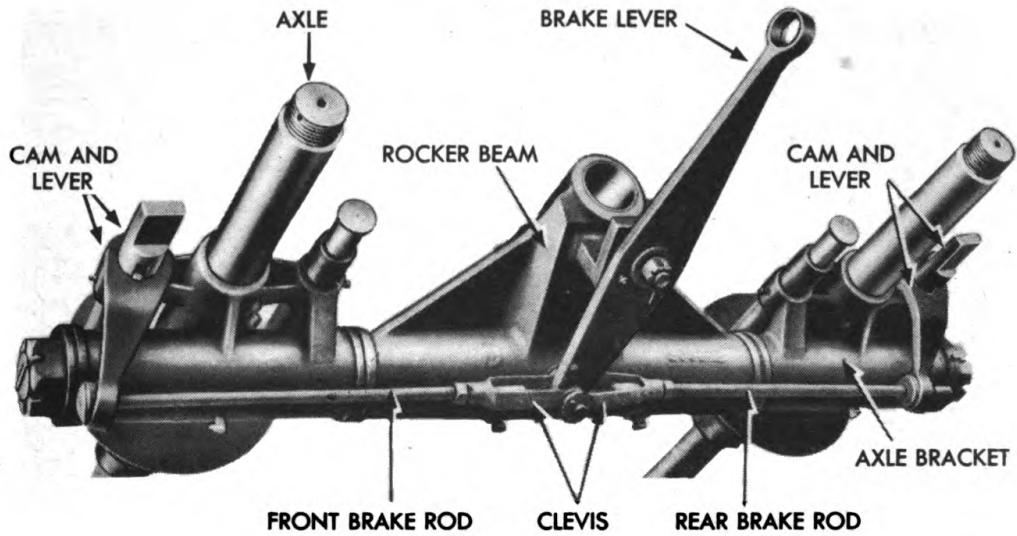

RA PD 321397

Figure 194—Brake Linkage, Right Rear Axle and Trunion

Install camshaft in camshaft hole in axle bracket so that cam lever is on same side of assembly as trunion brake lever bracket on rocker beam. Install retaining collar on end of cam opposite lever so that set screw hole in shaft is alined with screw hole in collar, and tighten set screw. Install both cam and lever assemblies.

(6) **INSTALL BRAKE LINKAGE.**

(a) *General.* Arrangement of rear trunion front and rear brake rods is dependent upon "hand" of cam that has been installed in axle brackets. The cam levers are always toward center of vehicle when the assembly is installed, and the trunion assembly will be on same side of vehicle as "hand" of cam. Using the above facts as a guide, front and rear of axle and trunion assembly are best determined by picturing the assembly as installed in trailer. When a right-hand cam is installed, cam lever is on left side of axle bracket in which it is installed. When a left-hand cam is installed, cam lever is on right side of axle bracket in which it is installed.

(b) *Install Brake Rods.* Insert threaded end of front rod through front cam lever, screw jam nut onto rod, and screw rod into clevis. Insert ball end of rear rod into rear cam lever, and position clevis of each rod on trunion brake lever. Install pin, washer, and cotter pin. **NOTE:** *If lever was removed from bracket on rocker beam during disassembly, install lever on mounting stud so that short end of lever is toward rocker beam.*

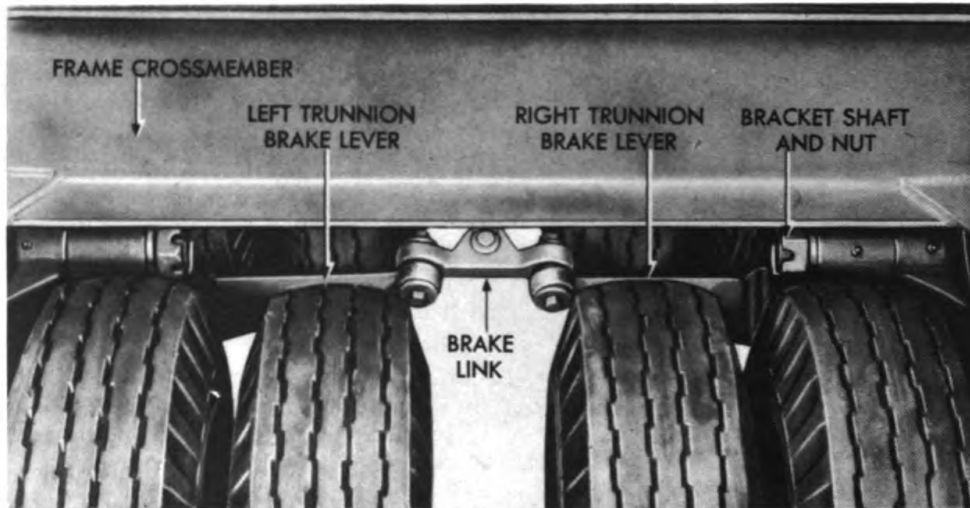

RA PD 321448

Figure 195—Brake Linkage to Rear Trunnion Assemblies

(7) **INSTALL BRAKE SHOE ASSEMBLY.** Slide wheel guard plate onto shafts. Install one return spring at cam end and one return spring at stationary end of shoe assembly. Install shoes on cam and anchor shafts, and install rest of brake shoe return springs. Install all brake shoe assemblies.

(8) **INSTALL WHEEL AND HUB ASSEMBLY.** Follow instructions in paragraph 256 c.

(9) **INSTALL TIRE AND RIM ASSEMBLIES.** Follow instructions in paragraph 257 e.

e. Installation of Rear Axle and Trunnion Assembly.

(1) **ALINE BRACKET SHAFT HOLES.** Position trunnion and wheel assembly under trailer. Lower hoist to rest frame on hydraulic jack to provide better control in raising or lowering frame. Raise or lower frame, and shift trunnion assembly to align shaft holes.

(2) **INSTALL BRACKET SHAFT.** Install plain washer, nut, and cotter pin on one end of shaft. Make sure shaft is free of burred or damaged conditions which would make installation difficult. Insert shaft in rocker beam and mounting bracket holes. Drive shaft through and install plain washer, nut, and cotter pin on inside end of shaft. Remove jack and hoist.

(3) **CONNECT BRAKE LINKAGE.** Install bolt, washers, and nuts which attach trunnion brake lever to brake line located under rear cable through and in front of rear inside wheels.

Section XLV

WHEELS AND TIRES

256. WHEELS.

a. Description and Data.

(1) **DESCRIPTION.** Four wheels are mounted on the front axles, and eight on the rear. Two tires are mounted on demountable rims on each wheel (fig. 195). Brake drums are bolted to each wheel. Each wheel is mounted on two tapered roller bearings.

(2) **DATA.**

Make Fruehauf
 Model 565002
 Size 15 in. dual

b. Removal of Wheel and Hub Assembly.

(1) **REMOVE INNER AND OUTER TIRE.** Follow instructions in paragraph 257 c.

(2) **REMOVE WHEEL AND OUTER BEARING CONE.** Remove hub cap by removing cap screws and lock washers which attach cap to hub. Remove gasket. Remove cotter pin and axle nut, using axle nut wrench. Pull washer off axle. Pull wheel out 1 or 2 inches to start bearing cone off axle. Push wheel back on axle and remove bearing. Slide wheel from axle. Remove brake shoe spacer from axle.

(3) **REMOVE INNER BEARING CONE** (fig. 196).

(a) *Remove Grease Retainer.* Remove cap screws which attach retainer plate to brake drum of wheel hub; remove plate and felt gasket.

(b) *Remove Inner Cone.* Remove inner cone assembly from bearing cap.

(4) **REMOVE BRAKE DRUM FROM WHEEL.** Remove cap screws and lock washers which attach drum to wheel and remove drum.

(5) **REMOVE BEARING CUPS FROM WHEEL HUB.** **CAUTION:** *Do not remove bearing cups unless cups are cracked, chipped, or rough. If bearing cup becomes loose in the hub, replace the hub.* Place wheel on floor. Using a short brass bar, drive cup out. Alternate driving from one side of cup to the other will prevent cocking of cup in cup bore.

c. Installation of Wheel and Hub Assembly.

(1) **INSTALL BEARING CUP.** If cups were removed during disassembly, place wheel in a hydraulic press with cup bore in wheel

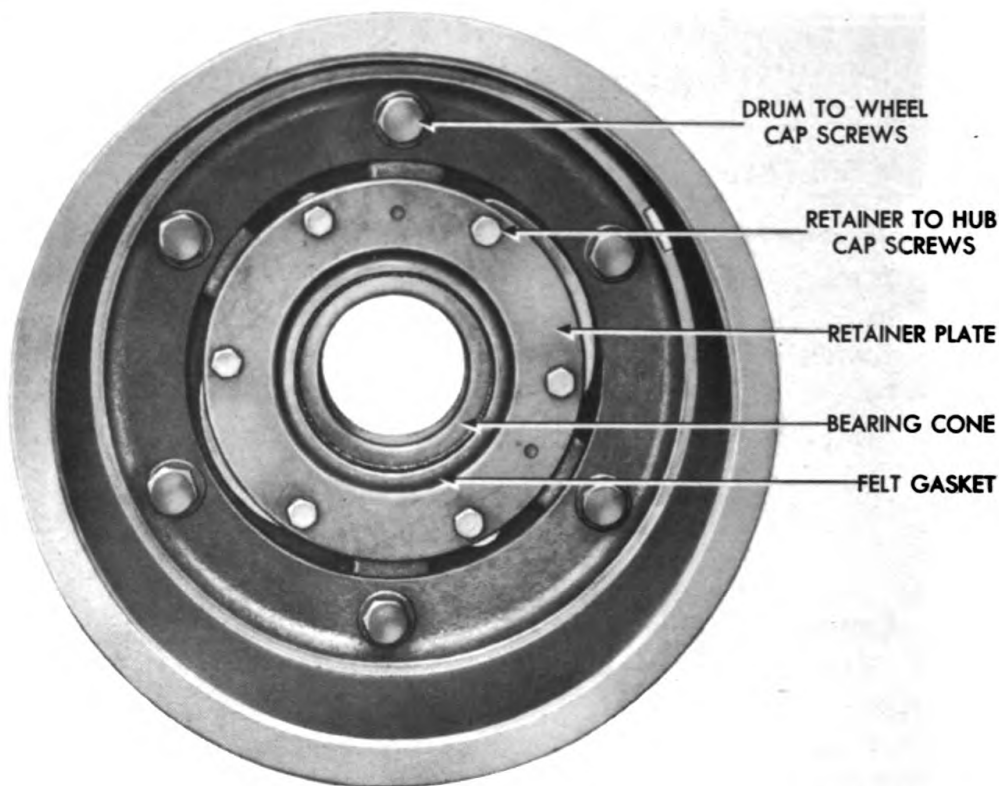

RA PD 321396

Figure 196—Wheel Hub and Drum

up. Position cup in bore so that large diameter of cup is up. Place a sleeve drift on bearing and under press ram, and press cup into bore in hub.

(2) **ATTACH BRAKE DRUM TO WHEEL.** Place drum on inside of wheel and align cap screw holes. Install lock washers and cap screws which attach drum to wheel.

(3) **INSTALL INNER BEARING CONE.** Pack cone assembly with lubricant. Place bearing in hub inner bearing cup, and install felt gasket and retainer plate.

(4) **INSTALL WHEEL ON AXLE.** Make sure brake drum spacer is installed on axle with larger end of spacer toward wheel. Slide wheel and drum and bearing assembly into position on axle. Pack outer bearing cone with lubricant (par. 22) and place on axle and in outer cup in wheel hub. Install washer and nut and adjust wheel bearing as explained in step (5) below.

(5) **ADJUSTMENT OF WHEEL BEARING** (fig. 197). Using wheel bearing nut wrench, tighten nut until wheel drags when turned by hand. Loosen nut on third turn and install cotter pin.

Wheels and Tires

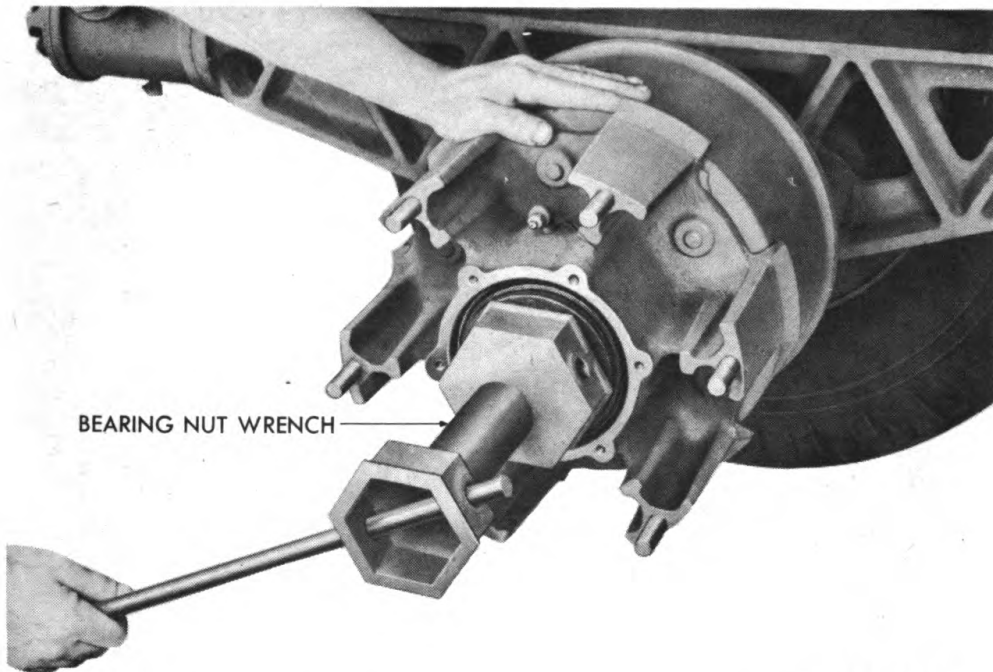

RA PD 321447

Figure 197—Wheel Bearing Adjustment

(6) **INSTALL HUB CAP.** Position gasket and hub cap on wheel hub, and install cap screws which attach cap to hub.

257. TIRES.

a. Description and Data.

(1) **DESCRIPTION.** Tires are conventional casing and tube assemblies of synthetic materials and rubber. Twenty-six are provided, twenty-four being required to operate the trailer while two are held in reserve as spares mounted on carriers. Spares are carried under the cable trough, secured in place by a clamp.

(2) **DATA.**

Size	8.25 x 15—14 ply
Quantity	24 mounted
	2 spares
Air pressure	75 pounds
Spacer	
Diameter	15 in.
Width	3 in.
Rims	15 in. x 7 in.

b. Removal of Tire and Rim Assemblies From Wheel.

(1) **LIFT TIRE CLEAR OF GROUND.** Raise front tires by placing jack under front trunnion spring and bracket assembly, and jack up

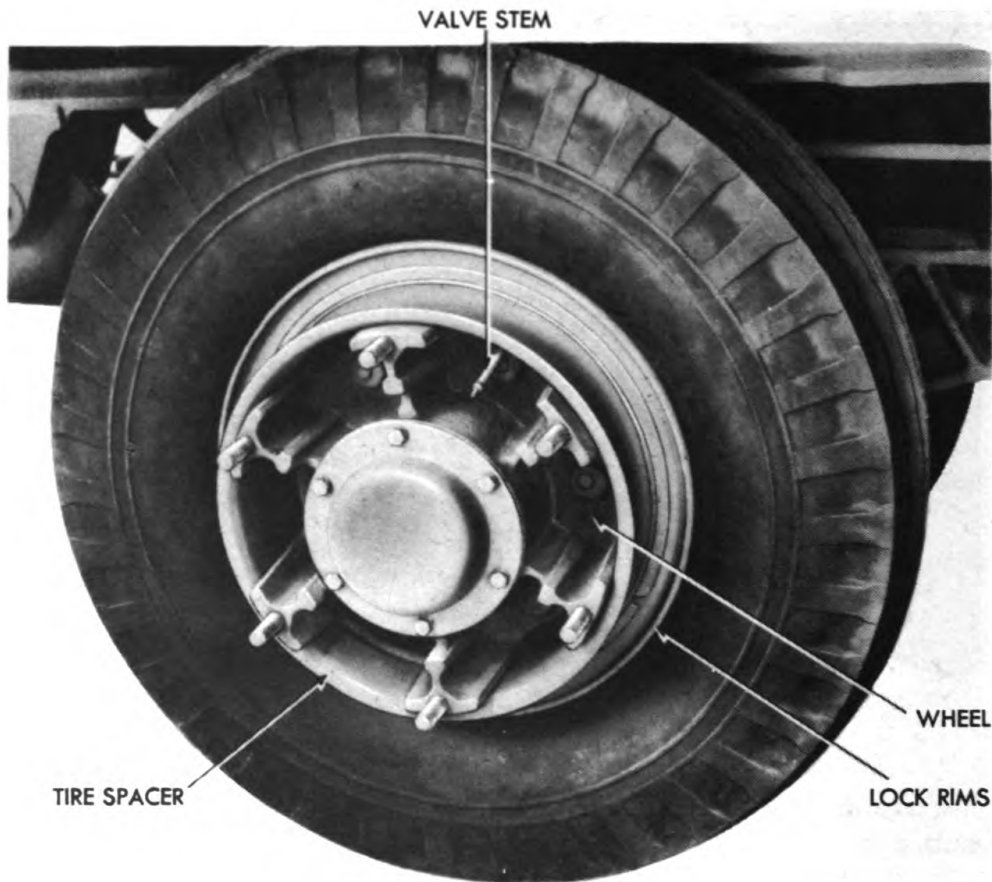

RA PD 321387

Figure 198—Inner Tire and Tire Spacer

trailer until tires to be removed are clear of ground. Raise rear tires by placing jack under axle shaft bracket and jack trunnion until tire is clear of ground.

(2) **REMOVE TIRE AND RIM ASSEMBLIES.** Using tire wrench, remove nuts which hold rim lugs in position. Tap lugs with a light hammer to loosen them from studs; lift lugs from studs. Pull tire and rim from wheel. Tap spacer band off wheel, and remove inner tire and rim assembly (fig. 198). *NOTE: If rear inner tires require removal, remove the rear cable trough section located above rear inner tires.*

c. Removal of Tire From Rim.

(1) **REMOVE LOCK RING** (fig. 199). Place tire on floor with lock ring up. Remove valve core from valve stem, and permit all air to escape from inner tube. Loosen removable ring by tapping around its circumference. Insert a tire tool under lock ring and pry down on re-

Wheels and Tires

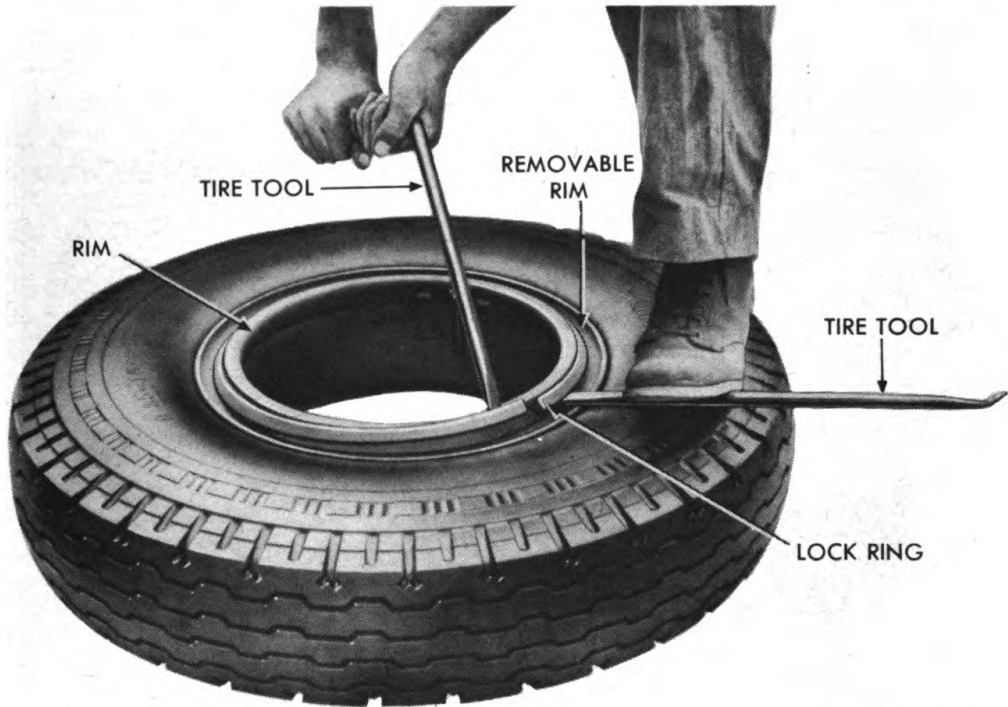

RA PD 321389

Figure 199—Removing Tire Lock Ring

movable rim. Stand on tire tool to hold removable rim away from lock ring. Insert another tire tool in slot on lock ring. Pry end of ring out of groove and over edge of rim. Continue to pry ring from groove until ring is free enough to remove by hand. Remove lock ring and removable rim.

(2) **REMOVE TIRE FROM RIM.** Insert a tire tool through valve stem slot in rim, and push valve stem out of slot and back into tire. Lift tire from rim. Remove tire rim flap from valve stem and casing. Remove inner tube from casing.

d. **Repair of Tubes.** The inner tubes are of synthetic material and must be vulcanized, using materials intended for repair of this type of tube. Do not attempt to repair tubes using cold patch methods.

e. **Installation of Tire on Rim.**

(1) **PLACE INNER TUBE IN CASING.** With all air out of inner tube, place tube in casing. Insert valve stem through tire and rim flap, and install flap in casing. Install a new valve core in valve stem, and inflate tube enough to cause tube to straighten up within casing. Do not inflate tube enough to spread casing and interfere with installation of tire on rim.

(2) **INSTALL TIRE ON RIM** (fig. 200). Place rim on floor with lock ring groove up. Lay tire on rim with valve stem pointing up and

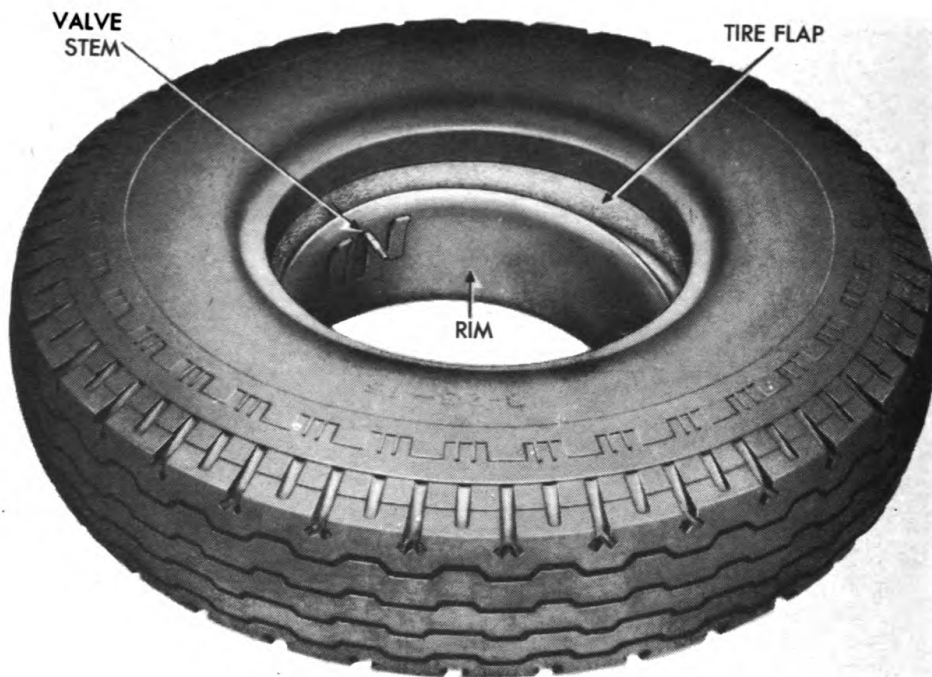

RA PD 321366

Figure 200—Installing Tire on Rim

so that valve stem can be inserted through slot in rim. Permit only curved end of stem to extend through rim so that bead of tire under stem is not held too far down on rim. Lift side of tire near valve stem as high on rim as stem will permit, and hammer inside edge of lower tire bead opposite valve stem to force bead over edge of rim. When lower tire bead passes over edge of rim, the tire will drop onto rim. Pull valve stem entirely through slot. Tap plates welded on each side of stem slot to center valve stem in slot. Check flap at slot to determine if flap is bent or folded at valve stem. If necessary, insert tire tool through slot to correct folded condition of flap.

(3) **INSTALL TIRE RETAINING RINGS.** Place removable rim on tire with curved surface down. Insert a tire tool in rim groove and over removable rim. Pry one side of removable rim down while holding opposite side of rim down by standing on it. Insert end of lock ring in groove, and hammer around circumference of rim to force rim into groove.

(4) **INFLATE TIRE.** **CAUTION:** *Prior to inflating tire, check lock ring to make sure ring is properly seated in lock ring groove.* Rap two small chains, equipped with grab hooks, around tire and rim at two different places. This will eliminate the possibility of an accident, should the lock ring let go during inflation. Inflate tire to 75 pounds pressure.

Wheels and Tires

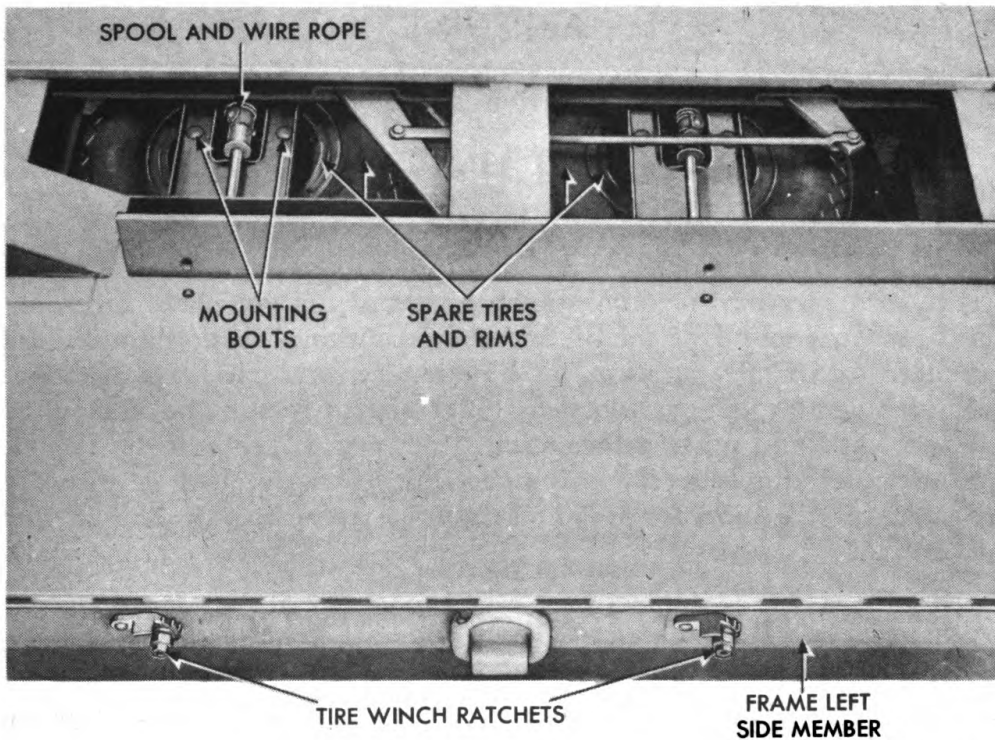

RA PD 321379

Figure 201—Spare Tire Carrier

f. Installation of Tires on Wheel. Position inner tire on wheel with valve stem pointing toward wheel hub and located in slot in brake drum. Place tire spacer on wheel, and position outer tire and rim assembly on wheel with valve stem pointing inward or toward wheel hub (fig. 198). Place tire lugs on studs and install nuts on lugs. Nuts must be tightened evenly by alternately tightening lugs located on opposite sides of the wheel. Lower tire to floor and remove jack. If rear inside tires have been replaced, install rear cable trough.

258. SPARE TIRES.

a. Description (fig. 201). Two spare tires are carried beneath the cable trough. Winches are provided to raise and lower the spare tires, and are operated by the tire wrench. Tires are held in place by a clamp, which is secured by bolts when the tire is raised into position.

b. Removal. Remove the mounting bolts from the clamp. With the wheel wrench, operate the ratchet of the tire winch and lower the tire. Remove the tire from the clamp.

c. Installation. Install the tire on the clamp. With the wheel wrench, operate the winch ratchet to raise the tire. Secure the tire in place by installing clamp bolts through clamp and winch plate.

APPENDIX

Section XLVI

SHIPMENT AND LIMITED STORAGE

259. GENERAL INSTRUCTIONS.

a. Preparation for domestic shipment of the vehicle is the same, with the exception of minor added precautions, as preparation for limited storage. Preparation for shipment by rail includes instructions for loading the vehicle, blocking necessary to secure the vehicle on freight cars, and other information necessary to prepare the vehicle properly for domestic rail shipment. For more detailed information and for preparation for indefinite storage refer to AR 850-18 and FM 9-25.

260. PREPARATION FOR LIMITED STORAGE OR DOMESTIC SHIPMENT.

a. Vehicles to be prepared for limited storage are those ready for immediate service but not used for less than 30 days. If the vehicles are to be indefinitely stored after shipment by rail, they will be prepared for such storage at their destination.

b. If the vehicles are to be placed in limited storage, take the following precautions.

(1) **LUBRICATION.** Lubricate the vehicles completely (par. 22).

(2) **COOLING SYSTEM.** If freezing temperature may normally be expected during the limited storage or shipment period, test the coolant with a hydrometer and add the proper quantity of anti-freeze compound (par. 18 e), to afford protection from freezing at the lowest temperature anticipated during the storage or shipping period. Completely inspect the cooling system for leaks (par. 88).

(3) **BATTERIES.** Check battery and terminals for corrosion and if necessary, clean and thoroughly service battery (par. 112 h).

(4) **TIRES.** Clean, inspect, and properly inflate all tires (par. 186). Replace with serviceable tires, all tires requiring retreading or repairing. Do not store vehicles on floors, cinders, or other surfaces which are soaked with oil or grease. Wash off immediately any oil, grease, gasoline, or kerosene which comes in contact with the tires under any circumstances.

(5) **ROAD TEST.** The preparation for limited storage will include a road test of at least 5 miles, after the battery, cooling system, lubri-

Shipment and Limited Storage

cation, and tire services have been made, to check on general condition of the vehicles. Correct any defects noted in the vehicle operation, before the vehicles are stored, or note on a tag attached to the steering wheel, stating the repairs needed, or describing the condition present. A written report of these items will then be made to the officer in charge.

(6) **FUEL IN TANKS.** It is not necessary to remove the fuel from the tanks for shipment within the United States, nor to label the tanks under the Interstate Commerce Regulations. Leave fuel in tanks except when storing in locations where Fire Ordinances, or other local regulations, require removal of all fuel before storage.

(7) **EXTERIOR OF VEHICLE.** If time permits, remove rust from any part of the vehicle exterior with flint paper. Repaint painted surfaces whenever necessary to protect wood or metal. Coat exposed polished metal surfaces susceptible to rust, such as chains and cables, with medium grade preservative lubricating oil. Close firmly all cab doors, windows, and windshields. Leave rubber mats, such as floor mats, where provided, in an unrolled position on the floor, and not rolled or curled up. Equipment, such as pioneer and truck tools, tire chains, and fire extinguishers, will remain in place in the vehicle.

(8) **INSPECTION.** Make a systematic inspection just before shipment or limited storage, to insure all above steps have been covered, and that the vehicles are ready for operation on call. Make a list of all damaged or missing items and attach it to the steering wheel. Refer to Before-operation Service (par. 27).

(9) **BRAKES.** Release brakes and chock the wheels.

c. Inspections in Limited Storage. Vehicles in limited storage will be inspected weekly for condition of tires and batteries. If water is added when freezing weather is anticipated, recharge the batteries with a portable charger or remove the batteries for charging. Do not attempt to charge the batteries by running the engine. If freezing temperature is expected, add the proper quantity of antifreeze compound to cooling system (par. 18 e) to afford protection from freezing. Look for evidences of vandalism, tampering, etc.

261. LOADING AND BLOCKING FOR RAIL SHIPMENT.

a. Preparation. In addition to the preparation described in paragraph 260, when ordnance vehicles are prepared for domestic shipment, the following preparations and precautions must be taken:

(1) **TIRES.** Inflate tires from 5 to 10 pounds above normal pressure (pars. 186 and 257).

Shipment and Limited Storage

(2) **BATTERIES.** Disconnect the batteries to prevent their discharge by vandalism or accident. This may be accomplished by disconnecting the positive lead, taping the end of the lead, and tying it back away from the battery.

(3) **EXTERIOR.** Cover the body of the vehicle with a canvas cover, if available.

(4) **MARKING CARS.** All cars containing ordnance vehicles must be placarded "DO NOT HUMP."

b. Placing Vehicles on Cars.

(1) **TYPES OF CARS.** Ordnance vehicles may be shipped on flat cars, end door box cars, side door cars, or drop end gondola cars, whichever type is most convenient.

(2) **FACILITIES FOR LOADING.** Whenever possible, load and unload vehicles from open cars, using permanent end ramps and spanning platforms. Movement from one flat car to another along the length of the train is made possible by crossover plates or spanning platforms. If no permanent end ramp is available, an improvised ramp can be made from railroad ties. Vehicles may be loaded in gondola cars without drop ends by using a crane.

(3) **BRAKE WHEEL CLEARANCE.** If flat cars are used, position the vehicle with a brake wheel clearance of at least 6 inches (A, figs. 202 and 203). Locate the vehicles on the car in such a manner as to prevent the car from carrying an unbalanced load. Apply the truck brakes and place the transmission in low gear.

c. Securing Vehicles. In securing or blocking vehicles, three motions, lengthwise, sidewise, and bouncing, must be prevented. Two methods for blocking vehicles on freight cars (figs. 202 and 203) are given below. **NOTE:** *All wheel blocking must be located against the outside wheel of the multiple wheels.*

(1) TRUCK.

(a) *Method 1* (fig. 202). Obtain eight blocks (B). Locate one to the front, and one to the rear of each front wheel. Locate one block to the front of each outside forward rear wheel, and one block to the rear of each outside rearward rear wheel. Nail the heel of each block to the car floor with five 40-penny nails to each block. Toenail that portion of the block under the tread to the car floor with two 40-penny nails. Locate two blocks (D) against the outside face of each wheel. Nail the lower block to the car floor with three 40-penny nails, and the top block to the lower block with three 40-penny nails. When a flat car is used, pass four strands, two wrappings, of No. 8 gage black annealed wire (C) through holes on the wheels and

Shipment and Limited Storage

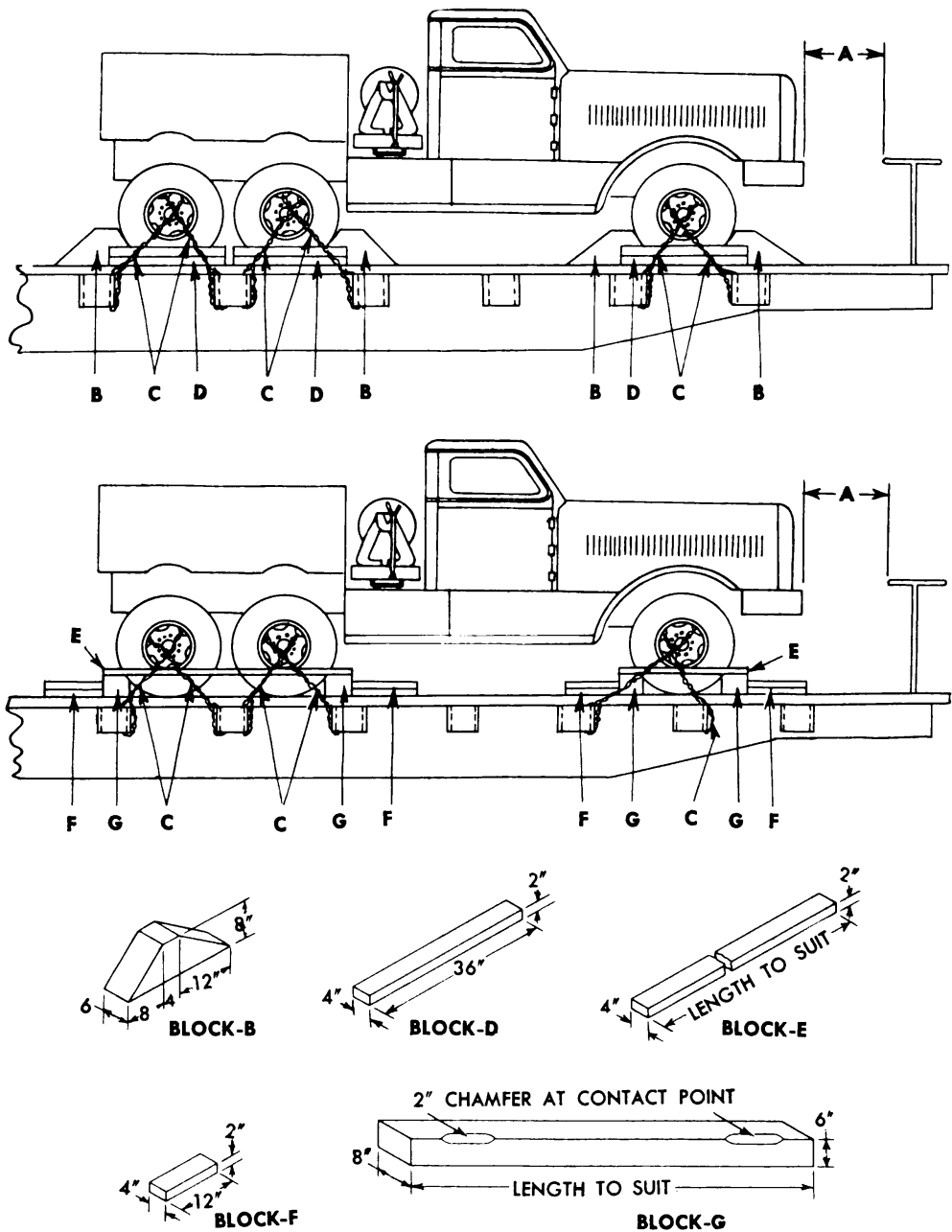

RA PD 341798

Figure 202—Blocking Requirements—Truck

adjacent stake pockets. Tighten the wires enough to remove slack. When a box car is used, this strapping must be applied in a similar fashion and attached to the floor by use of blocking or anchor plates. This strapping is not required when gondola cars are used.

(b) *Method 2* (fig. 202). Place four blocks (G), one to the front and one to the rear, of each set of wheels. These blocks are to be

Shipment and Limited Storage

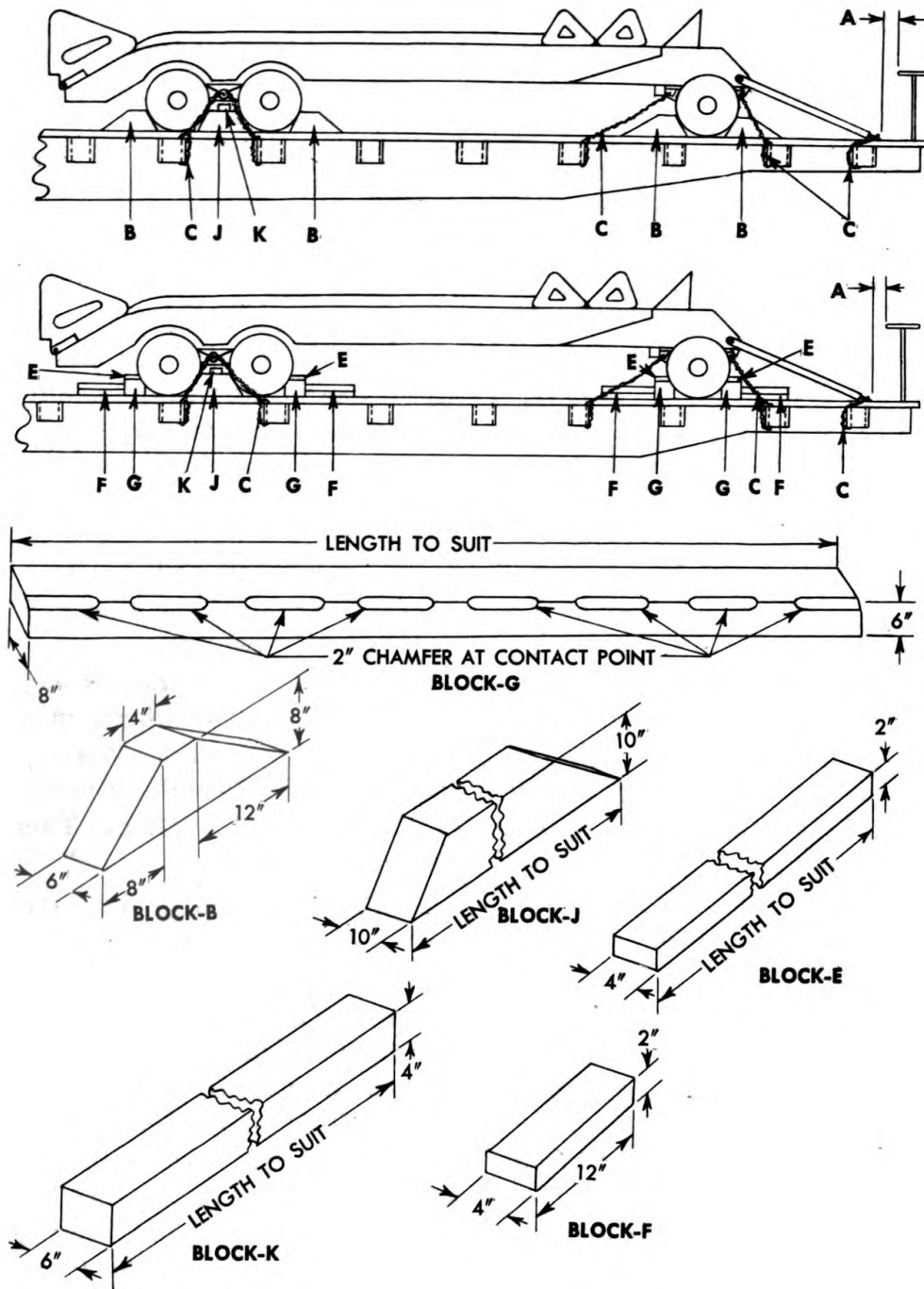

RA PD 343979

Figure 203—Blocking Requirements—Trailer

Shipment and Limited Storage

at least 8 inches wider than the overall width of the vehicle at the car floor. Using 12 blocks (F) as cleats, locate two against the blocks to the front of each wheel, and two against the blocks to the rear of each wheel. Nail the lower cleat to the floor with three 40-penny nails, and the top cleat to the cleat below with three 40-penny nails. Also locate four cleats (E) on the outside of each wheel, securing them to the top of each block with two 40-penny nails. Strap the vehicle to the car with No. 8 gage black annealed wire (C) as described in Method 1 above.

(2) TRAILER.

(a) *Method 1* (fig. 203). Locate four blocks (J), one between each tandem set of rear wheels. Toenail blocks (J) securely to the railroad car with 40-penny nails. Position two cleats (K) on top of each set of blocks (J). Nail the cleats to the blocks with 40-penny nails. Locate four blocks (B), one to the front and one to the rear of each outside front wheel. Locate four more blocks (B), one to the front of each outside forward rear wheel, and one to the rear of each outside rearward rear wheel. Nail the heel of each block to the car floor with five 40-penny nails to each block. Toenail that portion of the block under the tread to the car floor with two 40-penny nails. When a flat car is used, pass four strands, two wrappings, of No. 8 gage black annealed wire (C) around the axle trunnions and through adjacent stake pockets. Tie down the drawbar lunette in a similar manner. Tighten all wires enough to remove slack. When a box car is used, this strapping must be applied in a similar manner and attached to the floor by use of blocking or anchor plates. This strapping is not required when gondola cars are used.

(b) *Method 2* (fig. 203). The second method varies from the first only in the blocking of the wheels. Secure the four blocks (J) and cleats (K) as described in Method 1 above. Place two blocks (G), one to the front and one to the rear of the front wheels. Place two more blocks (G), one to the front of the forward rear wheels, and one to the rear of the rearward rear wheels. Locate eight cleats (F), four to the front and four to the rear of each front wheel. Locate eight more cleats (F), four to the front of the forward rear wheels and four to the rear of the rearward rear wheels. Place the cleats (F) against the blocks (G) in pairs, one on top of the other. Nail lower cleats to the car floor with five 40-penny nails, then nail top cleats (F) to lower cleats (F) with five 40-penny nails. Position four cleats (E) on top of blocks (G) between tires. Nail the cleats in place. Strap the trailer to the car with No. 8 gage black annealed wire as described in Method 1 above.

Shipment and Limited Storage

	Truck	Trailer
d. Shipping Data.		
Length (overall)	23 ft 3 ³ / ₄ in.	29 ft 8 in.
Width (overall)	8 ft 5 ¹ / ₂ in.	9 ft 6 in.
Height (overall)	8 ft 5 in.	4 ft 8 ³ / ₄ in.
Shipping weight	26,600 lb	22,000 lb
Area of car floor occupied by vehicle (approximate)	197 sq ft	282 sq ft
Volume occupied per vehicle (approximate)	1,635 cu ft	1,334 cu ft
Bearing pressure (lb per sq ft of area occupied per vehicle) (approximate)	135	78

References

**Section XLVII
REFERENCES**

262 PUBLICATIONS INDEXES.

The following publications indexes should be consulted frequently for latest changes or revisions of references given in this section and for new publications relating to materiel covered in this manual:

- a. Introduction to Ordnance Catalog (explaining SNL system) ASF Cat.
ORD 1 IOC
- b. Index (index to SNL's) ASF Cat.
ORD 2 OPSI
- c. Index to Ordnance Publications (listing FM's, TM's, TC's, and TB's of interest to ordnance personnel, OPSR, FSMWO's BSD, S and SR's, OSSC's, and OFSB's, and including alphabetical listing of ordnance major items with publications pertaining thereto) OFSB 1-1
- d. List of Publications for Training (listing MR's, MTP's, FM's, TM's, TR's, TB's, MWO's, SB's, WDLO's, and FT's) FM 21-6
- e. List of Training Films, Film Strips, and Film Bulletins (listing TF's, FS's and FB's by serial number and subject) FM 21-7
- f. Military Training Aids (listing graphic training aids, models, devices, and displays) FM 21-8

263. STANDARD NOMENCLATURE LISTS.

- a. **Vehicular.**
Truck, trailer, 45-ton, tank transporter, M19.... SNL G-159
- b. **Maintenance.**
Cleaning, preserving and lubricating materials, recoil fluids, special oils, and miscellaneous related items ORD 5
SNL K-1
Ordnance maintenance sets ORD 6
SNL N-21
Soldering, brazing and welding material, gases and related items SNL K-2

References

Tool-sets, for ordnance service command automotive shops	SNL N-30
Tool-sets (common), specialists and organizational	SNL G-27 (section 2)
Tool-sets (special), automotive and semi-automotive	SNL G-27 (section 1)

264. EXPLANATORY PUBLICATIONS.

a. Fundamental Principles.

Automotive brakes	TM 10-565
Automotive electricity	TM 10-580
Automotive power transmission units	TM 10-585
Basic maintenance manual	TM 38-250
Chassis, body, and trailer units	TM 10-560
Diesel engines and fuels	TM 10-575
Driver selection and training	TM 21-300
Driver's manual	TM 10-460
Electrical fundamentals	TM 1-455
Fuels and carburetion	TM 10-550
Internal combustion engine	TM 10-570
Military motor vehicles	AR 850-15
Motor vehicle inspections and preventive maintenance services	TM 9-2810
Precautions in handling gasoline	AR 850-20
Radio fundamentals	TM 11-455
Sheet metal work, body, fender, and radiator repairs	TM 10-450
Standard military motor vehicles	TM 9-2800

b. Maintenance and Repair.

Cleaning, preserving, sealing, lubricating and related materials issued for ordnance materiel	TM 9-850
Maintenance and care of pneumatic tires and rubber treads	TM 31-200
Ordnance maintenance: Trailer, 45-ton, 12-wheel, M9 (Component of truck, trailer, 45-ton tank transporter, M19)	TM 9-1768C
Ordnance maintenance: Truck, 12-ton, 6 x 4, M20 (component of truck, trailer, 45-ton tank transporter, M19): Engine and engine accessories	TM 9-1768A
Ordnance maintenance: Truck, 12-ton, 6 x 4, M20 (component of truck, trailer, 45-ton	

References

tank transporter, M19): Power train. chassis, and auxiliary equipment.....	TM 9-1768B
Ordnance service in the field.....	FM 9-5
c. Protection of Materiel.	
Camouflage	FM 5-20
Decontamination	TM 3-220
Decontamination of armored force vehicles....	FM 17-59
Defense against chemical attack.....	FM 21-40
Explosives and demolitions.....	FM 5-25
d. Storage and Shipment.	
Ordnance company, depot.....	FM 9-25
Ordnance storage and shipment chart—Group G—major items	OSSCG
Preparation of unboxed ordnance materiel for shipment	SB 9-4
Registration of motor vehicles.....	AR 850-10
Rules governing the loading of mechanized and motorized army equipment, also major caliber guns, for the United States Army and Navy, on open top equipment, pub- lished by Operations and Maintenance De- partment of Association of American Rail- roads.	
Storage of motor vehicle equipment.....	AR 850-18

INDEX

A	Page		Page
Accelerator		description, maintenance, and	
adjustment	182	removal	388
description	181	disassembly	389
operation of pedal	17	Air intake system	190
removal and installation of pedal	183	Air lines	
Accessories		description and data (lines, hose,	
after-operation service	81	and manifold)	317
at-halt service	79	installation	158
before-operation service	74	removal	153
run-in test	67	removal and installation (lines	
Adapter (See Tachometer drive		and hose)	317
and adapter)		Air pressure	
Air brake system		road test	88
road test		run-in test	69
application valves and		Air pressure gage	
reservoirs	103	before-operation service	74
system	91	operation	22
trailer	89	road test	88
run-in test		run-in test	68
reservoirs	66	Air reservoirs	
system	70	description and servicing	301
Air brake tanks		installation	304
after-operation service	83	removal	302
before-operation service	74	Air supply valve	
Air cleaners		description and data	311
after-operation service	82	removal and installation	312
at-halt service	79	Ammeter	
cold weather operation	41	before-operation service	75
lubrication notes	63	description and replacement	231
operation under hot and dusty		operation of main and	
conditions	42	battery "B"	22
road test	95	road test	89
run-in test	66	run-in test	68
Air compressor		Anchor chains and safety chassis	408
description, servicing, and		Auxiliary equipment, description	
removal	300	and data	367
installation	301	Auxiliary transmission	268
road test	97	Auxiliary transmission gear-shift	
Air connections		lever assembly	
road test	108	installation	268
(See also Trailer air connec-		shifting	27
tions)		Axle and trunnion assemblies	
Air couplings, trailer (See Trailer		front	411
air couplings)		rear	416
Air filters			
assembly and installation	391		

Index

B—(Contd.)		Page			Page
Brake hose, truck to trailer, road test		106	Breather cap		
Brake levers		391	after-operation service		82
Brake lines, road test		105	road test		95
Brake pedal			Bumper, description and replacement		351
operation		17			
road test		103	C		
Brake shoes			Cab, description		350
adjustment (parking)		330	Cab ventilators		
data			description and removal		361
parking		330	installation		363
service		325	Cab window		354
description			Cable idler roller assembly		366
parking		330	Cable trough		411
service			Cables		
truck		325	connect		158
trailer		384	disconnect		152
installation			removal and installation (parking brakes)		
parking		272, 332	front		394
service			rear		395
truck		327	Cam ball bearings (steering gear)		346
trailer		385	Chassis, cold weather operation		41
removal			Check valves (brake system)		
parking		271, 331	removal and installation		
service			double		310
truck		326	single		
trailer		385	trailer		382
road test			truck		311
front		100	description and data		
rear		98	double		308
Brake systems, service (air)			single		
description and data			trailer		381
trailer		377	truck		310
truck		297	Check valves (fuel system)		
during-operation service		77	cleaning and installation		173
road test			removal		172
front		100	Chock blocks		408
rear		98, 104	Circuit breakers		245
run-in test		70	Circuit lock switch		
trouble shooting			description, removal, and installation		212
trailer		132	operation		17
truck		124	use in starting engine		24
Brakes, parking			Cleaning		
road test		90	all parts		63
trouble shooting		134			
(See also Parking brake system)					
Breather (power take-off)		273			

Index

C—(Contd.)	Page	Page
Cleaning—(Contd.)		
engine and vehicles, after-operation service	85	41
		93, 95
Clutch		
adjustment	256	
data	254	
description	254	
during-operation	77	
operation	17, 32	
installation (clutch and pilot bearing)	259	
removal, clutch and pilot bearing	250	
replacement	258	
road test	90, 102	
run-in test	70	
trouble shooting	120	
Clutch air cylinder		
description and data	328	
removal and installation	329	
Clutch control valve	328	
Cold weather operation	36	
Controls		
after-operation service (engine)	82	
disconnect gearshift lever control rods	271	
operation (truck)	17	
run-in test (engine)	69	
trailer, dolly	391	
winch	31	
Cooling system		
cold weather operation	39	
description, cleaning, and neutralizing	193	
flushing	194	
trouble shooting	119	
Coupling socket assembly		
description and data	399	
removal and installation	400	
Coupling truck to trailer	28	
Crankcase		
lubrication notes	63	
cold weather operation	37	
road test	92	
Cranking motor		
description, data, removal, and installation	206	
		41
		93, 95
Cranking motor switch		
description	210	
installation	212	
removal	211	
road test	93	
Cylinder head		
description	144	
removal and installation	145	
road test	92	
D		
Decontaminators		
after-operation service	81	
before-operation service	76	
road test	108	
Deficiencies, correction of	66	
Diaphragms		
replacement	384, 387	
testing for leaks	384	
(See also Pressure regulating cap diaphragm and Emergency line diaphragm)		
Diesel fuel injection pumps (See Fuel injector pump)		
Diesel fuel nozzles and lines (See Fuel injector nozzles and Fuel lines)		
Differentials, cold weather operation	38	
Dimmer switch	220	
Disk (brake)		
description	332	
removal and installation	333	
Domestic shipment	430	
Drag brake hand lever	31	
Drag link		
installation	348	
removal	347	
Drawbar assembly		
description	395	
removal and installation	397	
Drawbar eyes	397	

Index

D—(Contd.)		Page	Page
Drive belts, road test	94	truck	13
Drives, before-operation service	74	(See also Tools and equipment)	
Driver's Permit and Form No. 26	77	Exhaust pipe	
Driver's Trip Ticket and Preventive Maintenance Service Record, W.D. Form No. 48	72	connect	159
Drums, description and data	335	road test	105
		Exhaust system, description	190
		External oil lines	250
		F	
		Fan and pulley assembly	
		description, data, and removal	196
		installation	198
		Fan and shroud, road test	93
		Fan belts	
		installation	301
		replacement and adjustment	198
		Fenders	
		description and removal	358
		installation	359
		Filter bracket	
		installation	254
		removal	253
		Final road test	109
		Fire extinguishers	
		after-operation service	81
		auxiliary	375
		before-operation service	74
		description and operation	36
		road test	108
		Flange yoke	
		installation	272
		removal	271
		Floorboard and toeboard	
		installation	160
		removal	152
		Frame	
		description	
		cab	350
		trailer	406
		road test	104
		trouble shooting	131
		Fuel, oil, and water	
		after-operation service	81
		at-halt service	78
		before-operation service	74
		Fuel, run-in test	66

Index

F—(Contd.)		Page			Page
Fuel capacities data		8	Fuel tanks		
Fuel filters			description and replacement	...	162
after-operation service		82	road test	105
description and data		164	Fuse panel		
replacement		166	description, and removal	403
road test		95	installation	404
run-in test		66			
Fuel gage, operation		22			
Fuel injector nozzle			G		
cleaning		185	Gage, oil, pressure adjustment	...	251
description and data		175	Gage, temperature, replacement	...	205
removal, cleaning, testing, and installation		176	Gasket (cylinder head)		
road test		96	description	144
Fuel injector pump			removal and installation	145
description, data, and removal		169	road test	92
installation		171	Gate valves (fuel tank)		
lubrication		172	description	162
road test		96	replacement	164
Fuel level gage			Gear cases, lubrication notes	63
description		166	Gear oil levels		
road test		89	after-operation service	83
Fuel lines			road test	91
bleeding		178	Gear ratio selection, use of tachometer in	28
connect		158	Gears, steering and running, during-operation service	...	78
description, replacement, and cleaning		176	Gearshift lever	270
disconnect		152	Generating system		
disconnect high pressure lines		177	description and data	226
road test		95, 96, 105	trouble shooting	114
Fuel oil			Generator		
cold weather operation		36	description and data	232
storage and handling		37	installation	235
Fuel pressure, before-operation service		74	road test	93
Fuel pressure gage			tests, service, and removal	233
operation		22	Generator regulator, description and data	235
road test		88	Glass, at-halt service	80
run-in test		68	Glass and rear view mirrors		
Fuel supply pumps			after-operation service	81
data		174	before-operation service	75
description		173	run-in test	69
Fuel system			Governed speed, road test	91
description and data		160			
cold weather operation		41			
trouble shooting		117			

Index

G—(Contd.)	Page		Page
Governor (engine)		Instrument panel light switch	
description and data	179,304	description and data	220
removal and installation	305	removal and installation	221
test and adjustment	304	Instrument panel lights, descrip- tion, data, removal, and in- stallation	213
Grommets, road test	104		
H			
Hand control valve		Instruments	
description, data, removal, and installation (fuel system)	168	after-operation service	80
operation (trailer)	17	before-operation service	74
use (trailer)	29	during-operation service	78
Hand parking brake system	392	Instruments, dash	
Hand priming pump		road test	88
description	188	run-in test	69
removal and installation of pump and lines	189	Interaxle propeller shaft	278
Hand pump, replacement	174	Introduction	1
Hand throttle, operation	17	J	
Handwheel (parking brakes)	395	Junction block	
Heat control, road test	94	description	245
Heat indicator		removal and installation	247
data	205	Junction boxes	
description	23, 205	description and removal	404
Horn		installation	405
adjustment	222	L	
description and data	221	Lamp and lens assembly (black- out taillight assembly)	401
installation	159	Lamp replacement (blackout driv- ing light)	215
removal	154	Lamps (light) and reflectors	
replacement of button, horn and relay	223	after-operation service	81
trouble shooting	130	before-operation service	75
Horns and windshield wipers		road test	106
after-operation service	81	run-in test	69
before-operation service	75	Leak-off manifold assembly	177
run-in test	69	Leaks	
Hubs		after-operation service	83
adjustment of cap	336	at-halt service	79
description and data	335	before-operation service	74
installation	338	road test	91, 95
removal	337	run-in test	69, 70
Hydrometer readings (battery)	228	Lighting system, trouble shooting	130
I			
Idle, engine (See Engine idle)		Limited storage	430
Instrument panel gage, removal and installation	169	Linkage	
		connect (transmission)	268

Index

L—(Contd.)	Page		Page
Linkage—(Contd.)		installation	
disconnect (transmission)	266	air	318
removal and installation (pintle hook)	354	exhaust	141,142
replacement (gear shift lever)	270	intake	141
(See also under Transmission)		water outlet	142
Loading and blocking for rail shipment	431	removal	
Low pressure buzzer		air	318
description and data	314	exhaust	141
operation	23	intake	140
replacement	315	water outlet	142
Low pressure indicator		road test	94
description and data	314	Mechanical maintenance	41
replacement	315	Mechanical pump	
Lubricating capacities data	8	installation	175
Lubrication		replacement	174
after-operation service	84	Mirrors (See Glass and rear view mirrors)	
equipment	45	Mountings, road test	
points of application	63	cab and body	104
road test	105	engine	102
run-in test	67	Muffler	
second echelon service	87	description	190
Lubrication notes		installation and removal	192
trailers	65	road test	105
truck	63	MWO Major Unit Assembly replacement record, W.D., A.G.O., Form No. 478	77
Lubrication orders, availability and scope	45		
		O	
		Oil	
		run-in test	66
		(See also Fuel, oil and water)	
		Oil filters	
		description, data, and servicing	253
		lubrication notes	64
		road test	93
		Oil lines	
		connect	158
		disconnect	152
		Oil lines, external (See External oil lines)	
		Oil pan assembly, description, removal, and installation	151
		Oil pressure gages	
		before-operation service	75

M

Main light switch	
description and data	218
removal and installation	219
Maintenance service	
first echelon	72
second echelon	85
special services	86
Manifolds	
description	
exhaust	141
intake	139
water outlet	142

Index

R—(Contd.)	Page	Page	
Records	2	Solenoids	
Reflectors (See Lamps (light) and reflectors)		cranking motor	210
Regulator, oil pressure	250	stop control	
Regulator unit, road test	95	description and data	179
Relay emergency valve		linkage adjustment	181
description	386	replacement	180
installation	388	Spare parts, on-vehicle	15
leakage tests	388	Spare tires	429
removal	387	Speedometer	
Relay valve		description and data	248
description, data, and removal	312	operation	23
installation	313	replacement of instrument	249
Reports and records	65	Speedometer cable	249
Reservoirs, air brake (See Air reservoirs)		Spring seat assemblies	
Rims (See Tire and rim assemblies)		description	296
Road test	88	removal, installation, and adjustment	297
Rocker arm assemblies		road test (seats)	99
description	147	Springs	
removal and installation	148	description and data	
Roller assemblies	409	front	341
Run-in test, new vehicle	65	rear	344
		installation	344
		removal	
		front	342
		rear	344
		road test	
		front	101
		rear	104
		trouble shooting	129
		Springs and suspensions	
		after-operation service	82
		at-halt service	79
		before-operation service	76
		run-in test	68
		Standard Accident Report, Form No. 26	77
		Starter burner assembly	184
		Starting system	
		description and data	206
		trouble shooting	112
		Steering arm assembly	283
		Steering gear	
		description and data	345
		installation	157
		removal	153
		road test	90, 101

S

Safety valve and gage	
description, data, test, and adjustment	305
removal and installation	307
replacement of gage	306
Salvage equipment	14
Seats and cushions	354
Shackles, removal and installation	342
Sheaves	410
Shields, fuel tank and battery	358
Shift lever	
removal and installation	266
replacement of lever and linkage	274
Shipment and storage	430
Shipping data	436
Slack adjusters	
adjustment	321, 384
description	320
installation	325
removal	324

Index

S—(Contd.)	Page		Page
Steering gear—(Contd.)		Tank unit (fuel)	
run-in test	70	removal	167
service and adjustment	345	installation	168
trouble shooting	130	Tapered studs, adjustment	347
Steering linkage		Temperature gage	
after-operation service	83	before-operation service	75
at-halt service	79	road test	89
before-operation service	76	run-in test	68
run-in test	68	Temperatures	
Steering wheel		at-halt service	79
operation	21	run-in test	70
removal and installation	347	Thermostat	
Step boards	360	description and data	200
Stop control solenoid (<i>See under</i>		installation	203
Solenoid)		removal and test	202
Stop light air switch	313	Throttle	
Stop lights (blackout)	218	adjustment of linkage	182
Submersion, precautions	43	description of linkage	181
Switches		operation of control	31
description		removal and installation of	
cranking motor, engine stop		linkage	184
control, main light, dimmer,		Tie rod assembly	
instrument panel light, and		description	284
fuel tank toggle	20	removal and installation	285
engine stop	179	Tire and rim assemblies, removal	
replacement		from wheel	425
engine stop	181	Tires	
pressure	188	after-operation service	82
		at-halt service	79
T		before-operation service	76
Tachometer		description and data	339, 425
before-operation service	75	installation on rim	427
cable	247	wheel	340, 429
description, data, and replace-		removal	339, 426
ment	247	road test	
installation	261	power inflation	95
operation		tires and rims	96
lock	20	run-in test	67
tachometer	22	trouble shooting	129, 135
road test		Toe-in (<i>See Wheel toe-in</i>)	
drive and adapter	94	Tools	
tachometer	88	list of	
run-in test	68	on-vehicle	
use in gear ratio selection	28	trailer	12
Tail pipe		truck	9
installation	193	special	16
removal	192	road test (vehicle and pioneer)	108
Tampering and damage, before-			
operation service	73		

Index

T—(Contd.)		Page	Page
Tools and equipment			
after-operation service	85	fill with lubricant	268
before-operation service	76	installation	
run-in test	69	assembly	268
Torque rod assemblies		shifting lever	266
description and removal	293	transmissions	160
installation	295	operation	
road test (rods)	99	gearshift lever	20
Tow hitch, road test	108	in cold weather	38
Towing cable roller bracket assembly	365	removal	
Towing cable sheaves	367	assembly	226
Towing connections		shifting lever assembly	152
after-operation service	83	road test	90, 92, 103
at-halt service	80	run-in test	70
before-operation service	76	trouble shooting	121
run-in test	67	Transmission and power take-off	
Towing the vehicle		during-operation service	77
road test	109	Trouble light receptacle	225
to start or disabled	30	Trouble shooting, general	109
Track guides		Truck	
adjustment for height and width	409	coupling to trailer	28
description	408	data	7
Trailer		description	3
data	8	spare parts	15
description	3	stopping	28
general specifications	7	uncoupling from trailer	30
rigging, loading, and securing	35	Truck cable rollers, description, removal, and installation	365
spare parts	16	Truck lights and horn system	
unloading	36	description	213
Trailer air connections		(See also Trailer light system)	
description	385	Truck service brake system	297
maintenance	386	Truck with trailer	
Trailer air couplings		data	7
description and data	318	placing in motion and stopping	29
removal and installation	319	Trunnion (See Axle and trunnion assemblies)	
Trailer brake control hand wheels	21	Trunnion bolt, installation	158
Trailer dolly, description	395	Tubes (tires), repair of	427
Trailer jumper socket assembly	225	Turning stops, road test	103
Trailer light system			
description	397		
trouble shooting	134		
Trailer understructure, description	411		
Transfer cases, cold weather operation	38		
Transmission			
connect linkage	160		
description and data	263		
disconnect linkage	152		

U

Uncoupling, truck from trailer	30
Universal joints	
lubrication	64
(See also Propeller shafts)	
Unusual noises	
road test	90, 91
run-in test	70

Index

V		Page	Page
Valve mechanism, road test	92	installation	335
Valves, air brake application (See Air brake)		road test	
		front	101
		rear	99
Vehicle		trouble shooting	129, 135
after-operation and weekly service	80	Winch	
at-halt service	78	after-operation service	84
during-operation service	77	before-operation service	76
placing in motion	25	description and operation	31
preparation for maximum load	23	lubrication	64
run-in test (new vehicle)	24, 65	removal and installation	369
starting engine	24	road test	105
towing	30	run-in test	67
Viscometer		Winch chain adjustment	375
before-operation service	75	Winch drive shaft, disconnect universal joint assembly	271
description	251	Winch propeller shaft	
installation	253	connect universal joint assembly	272
operation	23	description of shaft and universal joint assembly	279
removal and servicing	252	installation of shaft and universal joint assembly	281
road test	89	removal of shaft and universal joint assembly	280
run-in test	69	Winch safety brake band assembly	371
		Winch torque control assembly	
		adjustment	374
		removal and installation	375
		Windshield wiper assembly	
		description; removal and installation of blade	356
		removal and installation of motor assembly	357
		road test (wipers)	89
		Windshield wiper control valve	
		description	21
		removal and installation	357
		Windshields	354
		Wiring	
		connect	158
		description and removal	238
		disconnect	152
		installation	239
		road test (conduits)	104
		(See also Electrical wiring)	

W

Walking beams, road test	99
Water pump	
cold weather operation	41
description, data, and removal	195
installation	196
road test	93
W.D., A.G.O., Form No. 461	87
WD., A.G.O., Form No. 478, road test	109
Weight distribution, maximum load	23
Wheel and hub assembly	423
Wheel bearings	
lubrication notes	
trailer	65
truck	64
description and data	335
Wheel toe-in	
adjustment	281
measurement	282
road test	105
Wheels	
description, data, and removal	334, 423

NON-CIRCULATING BOOK



